

ELECTRONICS WORLD

JUNE, 1960

50 CENTS

HOW TO MEASURE YOUR TAPE SPEED

CITIZENS BAND FIELD-STRENGTH METER

HOW RADAR SPEED TRAPS WORK

CITIZENS RADIO AND THE
SERVICE TECHNICIAN



**DEPTH SOUNDERS
FOR SMALL BOATS**
(See Page 27)



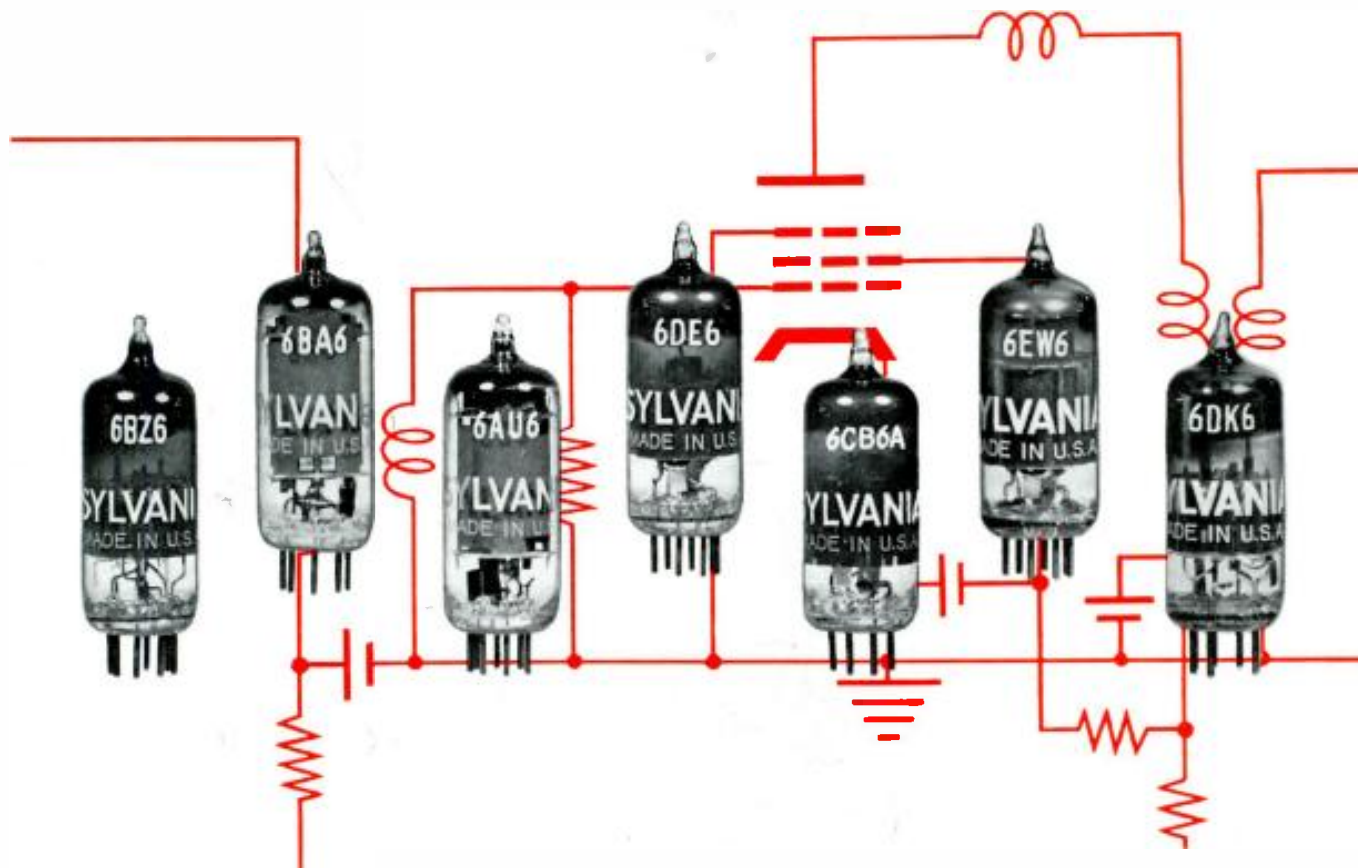

Why are SYLVANIA PENTODES so popular in TV sets?

Why, for example, are they so popular in video-if stages?

Video-if stages are critical with respect to over-all set performance. Must develop sufficient gain to "drive" the picture tube and to give effective agc. Have to deliver "clean" signals, free of hum modulation. When a TV set goes into quantity production, tubes used must be uniform in performance in their specific circuits. Tubes that are sent to the service dealer for that eventual replacement job must be just as good as those supplied to the set manufacturer. Those are some of the reasons why you see SYLVANIA pentodes such as 6BZ6, 6BA6, 6AU6,

6DE6, 6CB6A, 6EW6, 6DK6 in TV set after TV set. They're reliable. And, because of the unique, automated techniques used by SYLVANIA in manufacturing those types, they feature exceptional uniformity from tube to tube, minimum interelectrode leakage and gas, thus a longer life expectancy.

Those are some of the same reasons why, for *original design* and for *replacement*, the popular tubes are SYLVANIA TUBES! Electronic Tubes Division, Sylvania Electric Products Inc., 1740 Broadway, New York 19, N. Y.

SYLVANIA

Subsidiary of **GENERAL TELEPHONE & ELECTRONICS**



Learn Radio-Television Electronics

by Practicing at Home in Your Spare Time

WITHOUT EXTRA CHARGE YOU GET special NRI kits developed to give you actual practice with Radio-TV receiver or broadcasting circuits and equipment. All equipment is yours to keep.

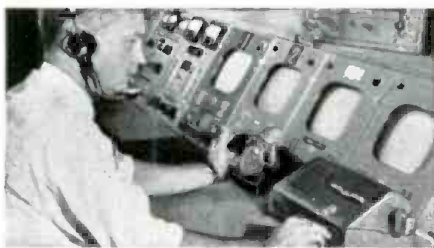
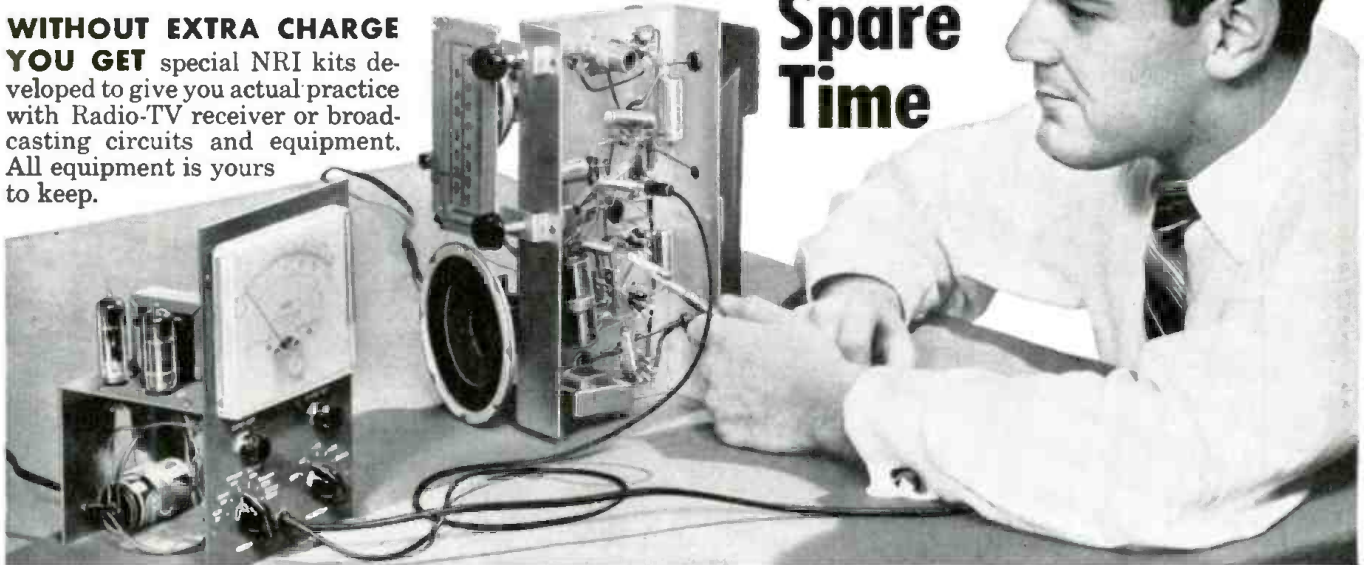

RADIO-TV BROADCASTING (see above) offers important positions as Operators and Technicians. **RADIO-TV SERVICING** Technicians (see below) needed in every community. Their services are respected, their skill appreciated.



Fast Growing Field Offers You Good Pay, Success, Bright Future



J. E. SMITH
Founder

Bigger than ever and still growing fast. That's why Radio-TV has special appeal to ambitious men not satisfied with their job and earnings. More than 4,000 Radio and TV stations. More than 150 million home and auto Radios, 40 million TV sets. Color TV promises added opportunities. For the

trained man, there are good jobs, bright futures in Radio-TV Servicing or Broadcasting. Training PLUS opportunity is the ideal combination for success. So plan now to get into Radio-TV. The technical man is looked up to. He does important work, gets good pay for it. Radio-Television offers that kind of work. NRI can supply training quickly, without expense of going away to school. Keep your job while training. You learn at home in your spare time. NRI is the **OLDEST** and **LARGEST** home study Radio-TV school. Its methods have proved successful for more than 40 years.

Added Income Soon - \$10, \$15 a Week in Spare Time

Soon after enrolling, many NRI students start to earn \$10, \$15 a week in spare time fixing sets. Some pay for their training and enjoy extra luxuries this way. Some make enough to start their own Radio-TV shops. NRI training is *practical*—gets quick results. Easy to understand, well illustrated lessons teach you basic principles. And you **LEARN-BY-DOING** by practicing with kits of equipment which "bring to life" things you study.

Find Out What NRI Offers

NRI has trained thousands for successful careers in Radio-TV. Study fast or slow—as you like. Diploma when you graduate. Mail coupon now. Paste it on a postcard or mail in envelope. **ACTUAL LESSON FREE**. Also 64 page catalog that shows opportunities, shows equipment you get. Cost of NRI courses low. Easy terms. **NATIONAL RADIO INSTITUTE, Dept. OFE Washington 16, D. C.**

N.R.I. TRAINED THESE MEN FOR SUCCESS



"I was repairing Radios by 10th lesson. Now have good TV job." **M. R. LINDEMUTH**, Fort Wayne, Ind



"Doing spare time repairs on Radio and TV. Soon servicing full time." **CLYDE HIGGINS**, Waltham, Mass.

"I had a successful Radio repair shop. Now I'm Engineer for WHPE." **V. W. WORKMAN**, High Point, N. C.



"There are a number of NRI graduates here. I can thank NRI for this job." **JACK WAGONER**, Lexington, N. C.



VETERANS Approved Under G. I. Bills

SEND FOR BOTH FREE

National Radio Institute

Dept. OFE Washington 16, D. C.

Mail me Sample Lesson and 64-Page Catalog FREE. (No salesman will call. Please write plainly.)

Name _____ Age _____

Address _____

City _____ Zone _____ State _____

ACCREDITED MEMBER, NATIONAL HOME STUDY COUNCIL



ELECTRONICS WORLD is published monthly by Ziff-Davis Publishing Company, William B. Ziff, Chairman of the Board (1943-1953), at 434 S. Wabash Ave., Chicago 5, Ill. Second class postage at Chicago, Illinois. Authorized by Post Office Department, Ottawa, Canada, as second-class matter. **SUBSCRIPTION RATES:** one year U. S. and possessions, and Canada \$5.00; Pan American Union Countries \$5.50; all other foreign countries \$6.00.

ELECTRONICS WORLD

JUNE, 1960

VOL. 63 ■ NO. 6

Publisher

OLIVER READ, D. Sc., WIETI

Editor

WM. A. STOCKLIN, B. S.

Technical Editor

MILTON S. SNITZER, W2QYI

Service Editor

SIDNEY C. SILVER

Associate Editor

P. B. HOEFER

Industrial Consultant

WALTER H. BUCHSBAUM

Art Editor

MILTON BERWIN

Art and Drafting Dept.

**J. A. GOLANEK
A. J. LICHOTA, JR.
K. W. PAUL, JR.**

Advertising Director

JOHN A. RONAN, JR.

Advertising Manager

GEORGE E. MORRISSEY

Midwest Adv. Manager

GILBERT J. JORGENSEN

Western Adv. Manager

DON CENA



ZIFF-DAVIS PUBLISHING COMPANY
William Ziff, President; W. Bradford Briggs, Executive Vice-President; Michael Michaelson, Vice-President and Circulation Director; Hershel B. Sarbin, Vice-President; J. L. O'Donnell, Treasurer.

Editorial and Executive Offices
One Park Avenue
New York 16, N. Y. OR. 9-7200



Member
Audit Bureau of
Circulations

MEMBER
INSTITUTE OF



BRANCH OFFICES: Midwestern Office, 434 S. Wabash Ave., Chicago 5, Ill.; Western Office, 9025 Wilshire Blvd., Beverly Hills, Calif., James R. Pierce, manager.

FOREIGN ADVERTISING REPRESENTATIVES: D. A. Goodall Ltd., London; Albert Milhado & Co., Antwerp and Dusseldorf.

First in radio-television-audio-electronics

CONTENTS

ELECTRONICS—GENERAL

Spot News.....	Washington Correspondent	24
Depth Sounders for Small Boats.....	A. Newell Garden	29
Cover Story.....		32
TV Weather Satellite.....		33
Radar Speed Meters & Traffic Controls.....	Walter H. Buchsbaum	42
Recent Developments in Electronics.....		60
Training Soviet Electronic Engineers.....	Prof. N. Bogoroditsky	84
Electronic Crosswords.....	John J. Gill	112
Calendar of Events.....		121

HIGH-FIDELITY AND AUDIO

The New Music-Power Rating (Editorial).....	W. A. Stocklin	8
Compliance of Phono Pickups.....	Peter E. Pritchard	34
1 7/8-ips Tape System for Stereo.....	Milton S. Snitzer	36
Measuring Tape Speed.....	Herman Burstein	38
New Audio Test Report (Harman-Kardon "Citation II", Dynakit PAS-2, Pickering Model 380—EW Lab Tested).....		70
Hi-Fi—Audio Product Review.....		74
Certified Record Revue.....	Bert Whyte	88
Sound on Tape.....	Bert Whyte	113

TELEVISION-RADIO

Interference from Radiating Coils.....	Kenneth Bramham	52
Mac's Service Shop.....	John T. Frye	54
Citizens Radio for Service Technicians.....	Leo G. Sands	55
Speeding Customer Payments.....	Robert Stanley	62
Service Industry News.....		94

TEST EQUIPMENT

Photographing Oscilloscope Traces.....	C. L. Henry	40
A Sweep Generator for Hi-Fi AM.....	Don Stoner	50
New Tube Tester Data.....		68
Transistorized Square-Wave Shaper.....	Paul S. Lederer	82

COMMUNICATIONS AND AMATEUR

Citizens Band Field-Strength Meter.....	Harold Reed	48
Broadcast-Band Converter for Ham Receiver.....	Hartland B. Smith, W8VVD	58
Diode Squelch Circuit.....	E. Dusina	108

ELECTRONIC CONSTRUCTION

Electronic Roast Alarm.....	Dan Peters	46
Magneto Emergency Power Supply.....	Harold Reed	102

DEPARTMENTS

Within the Industry.....	12	Manufacturers' Literature.....	92
Letters from Our Readers.....	20	Technical Books.....	100
What's New in Radio.....	125		

Net Paid Circulation 244,070

Radio & TV News • Radio News • Television News Trademarks Reg. U. S. Pat. Off.
Copyright © 1960 by Ziff-Davis Publishing Company. All rights reserved.

SUBSCRIPTION SERVICE: Forms 3579 and all subscription correspondence should be addressed to Circulation Department, 434 South Wabash Avenue, Chicago 5, Illinois. Please allow at least four weeks for change of address. Include your old address as well as new—enclosing if possible an address label from a recent issue.

CONTRIBUTIONS: Contributors are advised to retain a copy of their manuscripts and illustrations. Contributions should be mailed to the New York Editorial Office and must be accompanied by return postage. Contributions will be handled with reasonable care, but this magazine assumes no responsibility for their safety. Any copy accepted is subject to whatever adaptations and revisions are necessary to meet the requirements of this publication. Payment covers all author's, contributor's, and contestant's rights, title, and interest in and to the material accepted and will be made at our current rates upon acceptance. All photos and drawings will be considered as part of the material purchased.

ELECTRONICS WORLD

men
17-55

**JOB OPPORTUNITIES!
EXCITEMENT!
MONEY!**

All this
can be
Yours as a trained

Electronics TECHNICIAN

**OVER 6,000 FIRMS HAVE EMPLOYED
DeVRY TECH GRADUATES!**

Thousands of companies in the United States and Canada who have employed DeVry Tech men prove two most important facts: (1) Electronics is one of the biggest, fastest growing opportunity fields of our time; and (2) DeVry Tech graduates are "WANTED" MEN.

Whether DeVry Tech prepares you in spare time at home or in its modern Chicago or Toronto Laboratories, your training is designed to get you ready to meet the exacting standards of industry. You get practical training that not only helps to fit you for a job or a service shop of your own—but also gives you a foundation for a career that can be profitable the rest of your life.

You work over 300 learn-by-doing experiments at home, using DeVry Tech's exclusive Electro-Lab method. You build and KEEP valuable equipment. With another DeVry Tech exclusive, you have the benefit of training movies that you can show over and over until basic points are crystal clear. Special texts guide you every step of the way as well.

HOW DeVRY TECH CAN "BLUEPRINT" YOUR CAREER!

DeVry's faculty not only know how to teach Electronics, but they also understand men. They most likely know the type of problems you face. From this staff you get help, advice and understanding. It is this "human" side of DeVry's program that has caused many of our graduates to say: "DeVry Tech not only trains you for a job, they actually help you blueprint a profitable future!"

NO ADVANCED EDUCATION NEEDED!

Why don't you write for FREE FACTS today? Learn how you TOO can be a member of the great fraternity of DeVry Tech graduates across the continent . . . men who were properly trained, encouraged, appreciated and understood! SEND IN COUPON NOW!

EFFECTIVE EMPLOYMENT SERVICE

DeVry Tech's effective Employment Service is available to all graduates without additional cost.

**2 FREE BOOKLETS
Send Coupon TODAY!**

"One of North America's Foremost Electronics Training Centers"



Accredited Member of
National Home Study Council

**DeVRY TECHNICAL
INSTITUTE**
CHICAGO • TORONTO

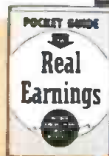

TELEVISION

COMPUTERS

MICRO-WAVES

RADAR

BROADCASTING

**LET DeVRY HELP
YOU PREPARE
AND BLUEPRINT
A SOLID
CAREER IN
THIS
FAST-GROWING
FIELD!**

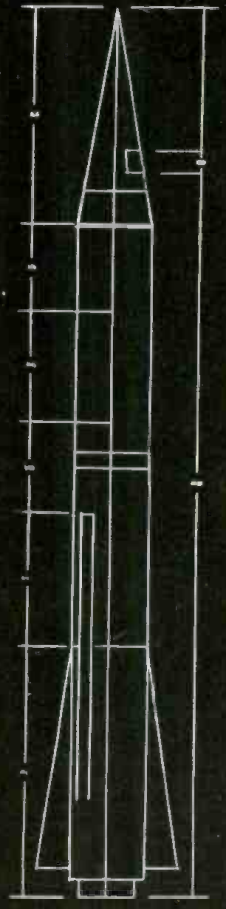

MAIL TODAY FOR FREE FACTS!

DeVRY TECHNICAL INSTITUTE
4141 Belmont Ave., Chicago 41, Ill., Dept. EW-6-Q

Please give me your 2 FREE BOOKLETS, "Pocket Guide to Real Earnings" and "Electronics in Space Travel," also include details on how to prepare for a career in one or more branches of Electronics.

Name _____ Age _____

Street _____ PLEASE PRINT Apt. _____

City _____ Zone _____ State _____

Check here if you face military service.
Canadian residents: Write DeVry Tech of Canada, Ltd.,
2075 626 Roselawn Ave., Toronto 12, Ontario

Remember us? We're still cutting call-backs...



... because I've got new coil heaters. You can wave goodbye to your front-end troubles.
Your CBS 6BQ7A



... because my new plates behave like plates ... not filaments. You can forget your low-voltage rectifier problems.
Your CBS 5U4GB

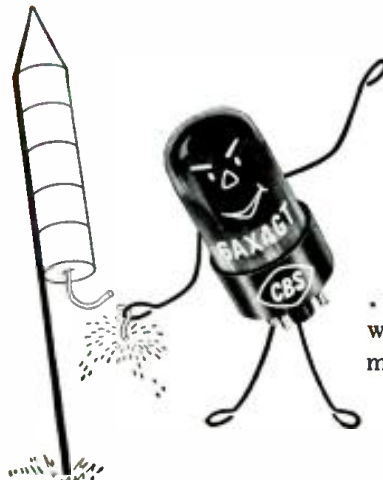

... because you get no fireworks with me. That means no more damper arcing for you.
Your CBS 6AX4GT

... because I like high voltage. So stop worrying about arcs and burnouts.

Your CBS 1B3GT



... because I'm loaded with performance, man. You buy no sync problems with me.
Your CBS 6CG7



TOTAL RELIABILITY ... proved in performance

Yes, we are typical CBS receiving tubes especially designed to cut your call-backs. We offer you *total reliability* ... proved in performance by leading TV set manufacturers — and service technicians too. You can profit more from the *total reliability* of CBS tubes. Just make it a habit always to replace with us ... and with other dependable CBS tubes.



COLUMBIA NEEDLES NOW AT YOUR ELECTRONIC PARTS DISTRIBUTOR

The Columbia phonograph needle line is now available from your local distributor of CBS Electronics products. You'll find it a complete line ... a quality line ... with a famous name, a proud name known and respected by your customers. Ask *your* distributor for dependable Columbia needles.



CBS ELECTRONICS, Danvers, Mass.
A Division of Columbia Broadcasting System, Inc.
Receiving, industrial and picture tubes • transistors and diodes • audio components • and phonographs

ELECTRONICS WORLD

Through
HOME STUDY
or in
RESIDENT CLASSES

ELECTRONICS

— field of opportunity —

the Grantham Communications
Electronics Course prepares you
for your first class commercial
F.C.C. LICENSE

The Grantham home study course teaches you principles of electronics in a simple "easy-to-grasp" manner. Each new principle is explained first in *everyday language* and then, after you understand it, is associated with the proper *technical language*. You learn and remember more, because the emphasis is on *understanding* rather than on memorizing.

This correspondence course is directed toward two major objectives — (1) to *teach* you a great deal about electronics, and (2) to prepare you to *pass* all of the F. C. C. examinations required for a first class commercial operator's license. We teach you step by step and have you practice with FCC-type tests which you send to the School for grading and comment. You prepare for your F. C. C. examinations under the watchful direction of an instructor who is especially qualified in this field.

Grantham training is the easy way to learn more quickly — to prepare more thoroughly — for F. C. C. examinations. And your first class license is the quick, easy way to prove to your employer that you are worth more money.

Get details concerning *how* we can prepare you for your F. C. C. license and *how* that license can help you advance in electronics. Mail the coupon below to the home office of Grantham School of Electronics in Hollywood, Calif., and our free catalog will be sent to you promptly.

offers

interesting and profitable careers in
RADIO AND TV BROADCASTING • TWO-WAY RADIO COMMUNICATIONS • RESEARCH AND DEVELOPMENT • RELAY STATION MAINTENANCE • AUTOMATION ELECTRONICS • TECHNICAL WRITING IN ELECTRONICS • INDUSTRIAL ELECTRONICS • ELECTRONIC COMPUTERS • MILITARY ELECTRONICS • INSTRUMENTATION • TELEMETERING • AERONAUTICAL ELECTRONICS • SPACE ELECTRONICS
and many other
interesting and profitable fields of the present and future

To get ahead in electronics, you must have the proper training and your employer must know that you have that training. Your F. C. C. license is a "diploma" in communications electronics granted by the U. S. Government, and it is recognized as such by employers. Grantham School of Electronics specializes in preparing you to earn this diploma.

HERE'S PROOF... that Grantham students prepare for F. C. C. examinations in a minimum of time. Here is a list of a *few* of our recent graduates, the class of license they got, and how long it took them:

	License	Weeks
Edgar T. Phelps, 931 Hickory Street, Poplar Bluff, Mo.	1st	12
Wayne Hogg, 4830 San Fernando Rd., Glendale, Calif.	1st	20
Robert Watson, Star Route, Box 24, Renovo, Pa.	1st	12
William H. Patchin, 3865 Westview Ave., NW, Canton, Ohio	1st	12
V. Dean DeVore, 309 Bess Street, Washington, Ill.	1st	16
Edward T. Wall, Box 184, Kenly, N. C.	1st	12
James W. Wranich, 4236 Michigan Street, Kansas City, Mo.	1st	20
Robert E. Sullivan, 2475 E. Douglas, Des Moines, Iowa	1st	12
Nelson S. Kibler, 1413 Patrick Henry Dr., Falls Church, Va.	1st	18
Barry L. Ulrich, 1110 Chestnut Ave., Barnesboro, Pa.	1st	14
Jerry E. Milligan, 707 Ragsdale Dr., Milan, Tenn.	1st	12
Robert S. Davis, 2100 - 10 Ave., So., Apt. 12, Birmingham, Ala.	1st	13

If you are interested in details concerning our training, indicate in the coupon below whether you prefer home study or resident classes, and mail the coupon to the School's home office in Hollywood, California — to the address given in the coupon — for free details.

GRANTHAM SCHOOL OF ELECTRONICS

HOLLYWOOD

SEATTLE

KANSAS CITY

WASHINGTON

FIRST CLASS F.C.C. LICENSE IN 12 WEEKS

Grantham resident schools are located in four major cities — Hollywood, Seattle, Kansas City, and Washington, D.C. Regularly scheduled classes in F. C. C. license preparation are offered at all locations. New day classes begin every three months, and new evening classes begin four times a year. The day classes meet 5 days a week and prepare you for a first class F. C. C. license in 12 weeks. The evening classes meet 3 nights a week and prepare you for a first class license in 20 weeks. For more information about the Grantham resident schools, indicate in the coupon the city of your choice and then mail the coupon to the School's home office in Hollywood, Calif. Free details will be mailed to you promptly.

GRANTHAM SCHOOL OF ELECTRONICS
1505 N. Western Ave., Hollywood 27, Calif.



(Mail in envelope or paste on postal card)

To: **GRANTHAM SCHOOL OF ELECTRONICS**
1505 N. WESTERN AVE., HOLLYWOOD 27, CALIF.

Gentlemen:

Please send me your free booklet telling how I can get my commercial F.C.C. license quickly. I understand there is no obligation and no salesman will call.

Name _____ Age _____

Address _____

City _____ State _____

I am interested in: Home Study Kansas City classes
 Hollywood classes Seattle classes Washington classes

O-GC

MAIL COUPON FOR FREE DETAILS — NO SALESMAN WILL CALL →

NEW



THE
TAPE THAT COST
\$9,000,000
TO PERFECT!
SOUNDCRAFT TAPE
WITH THE NEW
FA-4 FREQUENCY
ADJUSTED
FORMULATION

DESIGNED TO MEET THE UNLIMITED CHALLENGE OF
THE MOST EXCITING NEW ERA IN RECORDING HISTORY!

Only years of research... and the most modern and advanced tape manufacturing facilities in the world... could have perfected this tape! Soundcraft's new **FA-4 FORMULATION** is frequency adjusted to provide the superlative sound reproduction demanded in this exciting era of new discoveries and innovations in tape recording. You'll hear "highs" as never before... the full frequency spectrum for perhaps the very first time!

Insist on Soundcraft Tape with the new **FA-4 FORMULATION** before you run another reel through your recorder...you'll never settle for inferior sound reproduction again!

REC-10

REEVES SOUNDCRAFT CORP.

Great Pasture Rd., Danbury, Conn. • Chicago: 28 E. Jackson Blvd.
Los Angeles: 342 N. LaBrea • Toronto: 700 Weston Rd.

...for the Record

By **W. A. STOCKLIN**
Editor



THE NEW MUSIC-POWER RATING

THERE is never a dull moment for those of us who are concerned with the high-fidelity industry. Whether or not the intentions are to add to or eliminate the confusion that exists today in the minds of non-technical individuals who are interested in hi-fi is hard to tell. At least it's exciting and it keeps us on our toes in trying to keep our readers completely informed.

As far back as we can remember, power amplifiers were rated on the basis of a *continuous sine-wave measurement*. In recent times some manufacturers have been specifying *peak power* in their literature. This is not too difficult to understand since both are directly related, with peak power being always twice the value of the continuous power rating with a sine-wave signal.

Since high power in the hi-fi industry has been accepted by the public just as they have accepted the horsepower race in the automotive industry, it seems that the goal of some manufacturers is to develop new methods of rating that will provide higher power figures. Suffice it to say that the EIA (Electronic Industries Association), which is composed mainly of radio, TV set, and packaged phonograph equipment manufacturers, has now published a new rating which is referred to as "music-power rating." This is the sort of power that would be produced by short bursts rather than continuous sine waves. It is interesting to note that the EIA has also standardized this rating as being taken at a power level at which 5 per-cent harmonic distortion is present. This, of course, as we know, is ridiculously high. The hi-fi component manufacturers in the past have quoted in their specifications various distortion levels, but very few would dare to specify a distortion value much over 1 per-cent.

As in all industries it is always advantageous to standardize and credit, of course, should be given the EIA for attaining this one goal. Although many engineers know that this new rating is unrealistic in that it does not provide a true picture of the performance of a power amplifier, we are quite confident that it will be adopted by everyone manufacturing hi-fi equipment. Several companies have already adopted this standard, and since it does show a higher power value, it will probably force all other manufacturers to adopt it in order to eliminate any sales handicaps.

Music power is the power produced by an amplifier with a sudden application of signal and by a measurement taken before the supply voltages have

had an opportunity to drop in value.

However, the new music-power rating standard does not indicate a true comparison between power amplifiers. Just assume we have available a power amplifier with perfect regulation which is rated at a music power of 20 watts. This same amplifier would have a continuous sine-wave rating of the same value, 20 watts. Another amplifier with a 20-watt music-power rating that has a poorly regulated power supply could in no way show a continuous sine-wave measurement near this value. It might, for example, be as low as 10 watts in terms of continuous power.

Let's take a moment and look inside a power amplifier which has a poorly regulated power supply. At extreme low power output, the "B+" voltage is at its maximum value. As the power output is increased, the "B+" voltage will drop and, in addition, the biasing voltages will change. Under these conditions, the maximum power output would be lower than with an amplifier whose supply voltages do not change very much, that is, one with better regulation. So now instead of measuring with a continuous sine wave, assume we take our power measurement quickly before the voltages have had a chance to change. One can see that this power rating might be misleading in that it might be equivalent to that of a much better amplifier.

As we have said before, standardization is always an advantage, but it is unfortunate that this new rating is not quite realistic. The chances are it is too late to change the industry, but it certainly would have been nice and would have gone a long way toward eliminating some of the confusion that exists were all manufacturers to specify dual-power values for each unit, one figure being the music-power rating and the other a continuous sine-wave measurement. For example, 65/50 watts would indicate a music-power rating of 65 watts, while the 50-watt figure would be continuous sine-wave power. Anyone could then make a reasonable comparison. It would be obvious that an amplifier rated at 65/60 watts would provide better high-fidelity reproduction than one rated at 65/50 watts.

We would like to suggest to anyone buying a hi-fi amplifier to make sure first of all just which power is specified—music power or continuous sine-wave power. Then, if only the music-power rating is given, find out from the manufacturer what the continuous sine-wave power is.

-30-

2 Great *knight-kit*® Citizens Band Transceiver Kits

A PRODUCT OF ALLIED RADIO

YOUR CHOICE OF THE FINEST VALUES IN 2-WAY RADIO EQUIPMENT



For Auto-to-Auto
or Auto to
Home or Office



For Farming
Operations



Local Trucking,
Delivery,
Construction Work



Boat-to-Boat,
Ship-to-Shore

YOU BE THE JUDGE OF
knight-kit VALUE!

FREE Examination Privilege

We invite you to take advantage of our exclusive free examination offer. Order a Knight-Kit Transceiver. Examine it on arrival. Inspect the quality of the components, the circuitry, the easy-assembly manual. We're so confident you'll want the kit, we can make this offer: If you're not COMPLETELY SATISFIED, just return the kit for full refund!



Ultra-Selective
Super-Sensitive
The Very Finest

Lowest Cost
Quality
2-Way Radio

Citizens Band Superhet Transceiver Kit

Y-712L BEAUTIFUL STYLING... UNEXCELLED PERFORMANCE

\$79⁹⁵

\$5

Have dependable, economical 2-way radio communication with this top-rated, do-it-yourself transceiver. Has two crystal-controlled transmitting positions; operates at maximum FCC legal power input of 5 watts fully modulated. Superhet receiver is continuously tunable over the full 22 channel band; also has two optional crystal-controlled fixed frequency positions. Works just like press-to-talk intercom—speaker also serves as mike.

Ultra-selective, highly sensitive dual-conversion superhet receiver features built-in adjustable squelch and noise limiter. Sensitivity (manual) is better than 1 μ v for 10 db S/N; crystal, 1/2 μ v. Includes built-in AC power supply. Easy to assemble; has dependable printed circuitry and pre-aligned IF transformers. With distinctively styled high-impact case, 5 x 12 x 12". Complete with all parts, wire-type doublet antenna, and one transmitting crystal (available for any channel from 1 to 22—specify preference). FCC application form is included (license is available to any citizen over 18—no exams to take). See below for DC mobile supply, vertical antenna, etc. Wt., 20 lbs.

Model Y-712L. \$5 Down. ONLY **\$79⁹⁵**

- Y-729L. 3 Ft. Vertical Antenna. 2 lbs. NET..... 6.50
- Y-714L. Mobile Mounting Bracket. 4 lbs. NET..... 5.35
- Y-723L. 6-12 V. Mobile Power Supply. 6 lbs. NET..... 10.95
- Y-769L. Optional Receiving Crystal (specify frequency)... 1.99
- Y-719L. Optional Hand-Held Mike. 1 lb. NET..... 9.50

Top Buy Citizens Band Transceiver Kit

Y-713L

\$39⁹⁵

\$2

Now have your own private 2-way radio system at an amazingly low cost! Consists of easy-to-assemble superregenerative receiver and 5-watt transmitter. Readily fits car, boat or desk. Single, one-switch operation permits talk or listen. Receiver tunes all 22 channels continuously. Built-in AC power supply. Handsomely styled case, 7x10x8". With mike, doublet antenna, and transmitting crystal (specify channel —1 to 22—if you have a preference). See below for antenna, mobile power supply, etc. Shpg. wt., 10 lbs.

Model Y-713L. \$2 Down. ONLY **\$39⁹⁵**

- Y-729L. 3 Ft. Vertical Antenna. 2 lbs. NET..... 6.50
- Y-723L. 6-12 V. Mobile Power Supply. 6 lbs. NET..... 10.95
- Y-724L. Mobile Mounting Bracket. 4 lbs. NET..... 5.35

ORDER NOW

ALLIED RADIO CORP., Dept. 72-F
100 N. Western Ave., Chicago 80, Ill.

Please ship: Y-712L Transceiver. Y-713L Transceiver.
 Y-729L Y-723L Y-714L Y-724L
 Y-769L Y-719L \$_____enclosed

Send latest catalog describing Knight-Kits.

Name _____

Address _____

City _____ Zone _____ State _____

Manufactured and sold exclusively by **ALLIED RADIO**

UNIVERSITY POWRPAGE®
powerful, ultra-compact
soundcasting systems



NEW...TRANSISTORIZED Model PP-1T
tops for every portable use... police, fire, sports, etc.

Features fully transistorized 25 watt amplifier especially designed for low distortion and high stability in any operating conditions. Ruggedly constructed dynamic microphone has controlled response curve for maximum speech intelligibility. Press-to-talk switch gives instantaneous operation, conserves power supply. Special input jack for record player, tuner, or tape recorder... talk/over feature reduces music program level 6 db when microphone button is pressed, allowing voice to be heard over music. Talk/listen switch converts PowrPage into highly directional, sensitive listening device. Powered from standard lantern type batteries. Includes leather carrying strap.



Model PP-1 — Non-transistorized version of PP-1T. Similar in operation. Powersaver press-to-talk switch.

Model PP-2 — Hand-held operation for maximum freedom of action. Slim handle holds pencil batteries. Powersaver press-to-talk switch. Built-in jack can draw 6-12 volts from boat or auto ignition system.

UNIVERSITY LC SERIES
for real high fidelity in
weatherproof speakers



MODEL BLC ... For General Applications
A sensation ever since its introduction... continues to set new standards in high quality p.a. work. Light in weight, shallow in depth, easy to transport. Diameter: 22 3/4". Depth: 9 1/4".



MODEL MLC ... Compact Version for Music and Voice
Especially suited for coverage of moderate-size crowds or areas. Operates easily off existing high fidelity systems for outdoor music at low cost. 12 3/4" w. x 9 1/8" h. x 10 3/8" d.

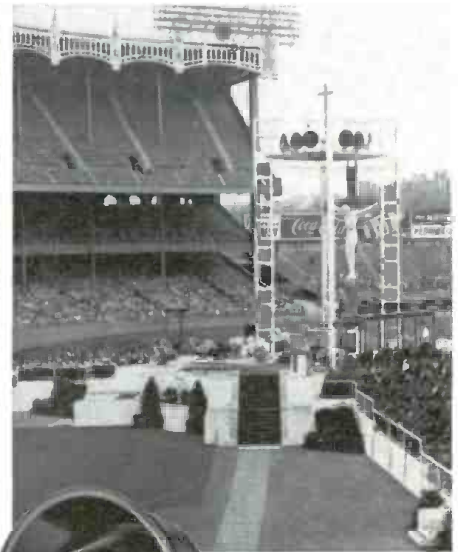

MODEL WLC ... Heavy Duty System
Known throughout the world's stadiums, concert halls, auditoriums and parade grounds for its exceptional full-range performance at higher output levels. Diameter: 33 1/2". Depth: 20".

• horn-loaded • high efficiency • for fixed or mobile applications
ONLY UNIVERSITY OFFERS 3 GENUINE DUAL-RANGE SYSTEMS...with separate bass and treble drivers

For further information and specifications, write Desk S-9
University Loudspeakers, Inc., White Plains, N.Y. A subsidiary of Ling-Altec Electronics, Inc.



ANOTHER WAY RCA
SERVES EDUCATION
THROUGH
ELECTRONICS



6 REASONS WHY RCA TRAINING IN ELECTRONICS

can be the smartest investment
you'll make in your *entire lifetime!*

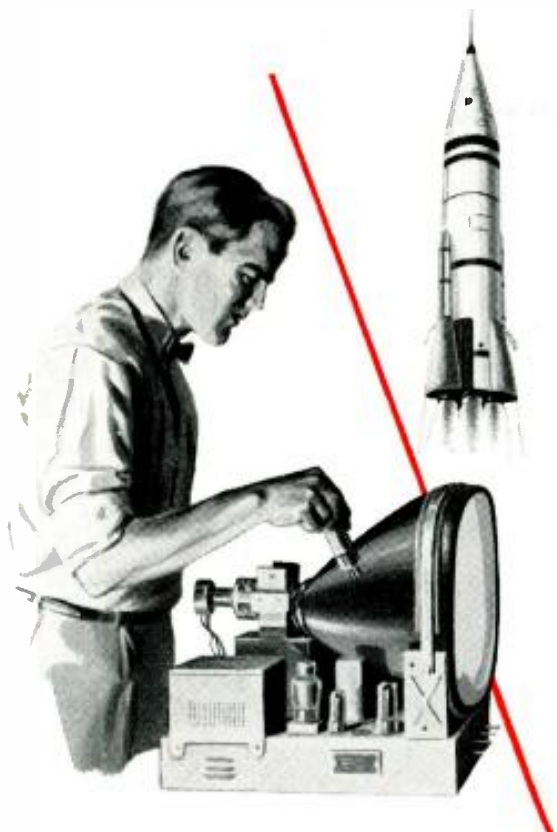

1. You get the finest training-at-home under the supervision of the RCA INSTITUTES, experts in technical training for over 50 years. The very name "RCA" means dependability, integrity, and scientific advance.

2. You get comprehensive training in your choice of four complete, up-to-date Courses... from basic electronics theory to Color TV and Automation.

3. You get Theory, Experiment, and Service Practice starting with the very first lesson... a complete training package throughout the course. No special technical background is required.

4. You get prime quality equipment as a regular part of your Course... equipment that you keep and use on the job. You never have to take apart one piece to build another.

5. You get each study group on a pay-as-you-go basis. Should you wish to interrupt your training at any time, you will not owe RCA Institutes a penny more, unless and until you decide to resume the Course.

6. You get top recognition — worldwide. Graduates of RCA Institutes now work for leaders in the electronics field; many have their own businesses. This record is true tribute to the high quality of RCA Institutes training.

Send for this
64-page Home
Study Catalog
FREE!



RESIDENT SCHOOL Courses in New York City and Los Angeles offer comprehensive training in Television and Electronics. Day and Evening classes start four times each year. Detailed information on request.

RCA INSTITUTES, Inc. Home Study School EW-60

A Service of Radio Corporation of America
350 West Fourth Street, New York 14, N. Y.

Please rush me your FREE illustrated 64-page book "Your Career in Electronics," describing your home training programs. No obligation. No salesman will call.

Name Age.....
please print

Address

City Zone..... State.....

Korean Vets! Enter discharge date.....

CANADIANS — Take advantage of these same RCA courses at no additional cost. No postage, no customs, no delay. Send coupon to:
RCA Victor Company, Ltd., 5001 Cote de Liesse Rd., Montreal 9, Quebec
To save time, paste coupon on postcard.

for the finest in high fidelity kits

ACROSOUND

These popular Acrosound kits are simple and fast to assemble . . . bring the newest sound advancements into your home in a matter of hours! Best of all, Acrosound's easy-to-build, reasonably priced kits save you dollars!



ACRO'S PREAMPLIFIER

A new all feedback preamplifier with low noise, 2 MV referred to phono input, high gain, 60 DB phono and tape, and low distortion, 0.15% 1M for 1.5V out. Extra features include individual bass and treble controls, rumble and scratch filters, phase switch, third channel output, light matrix, and exclusive Mic. Dub switch. Supplied with two low noise 7199 pentode/triode, two 7247 dual triode tubes.....**\$69.50**

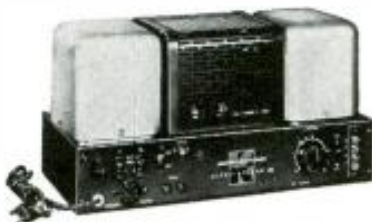

ACRO'S ULTRA LINEAR II AMPLIFIER

This famous 60 watt basic amplifier has long been a favorite of discriminating audiophiles. Acro perfected Ultra-Linear circuitry has been combined with a unique feedback system to provide an amplifier with unusually low distortion, superior feedback stability, and finest transient performance. Construction time is only two hours. Supplied with two EL-34 output tubes, one 12AX7, one 12AU7, and 6Z34 rectifier.....**\$79.50**



ACRO'S STEREO 20-20 AMPLIFIER

A two channel stereo amplifier which provides a full 18 watts in each channel, or a total of 36 watts of low distortion stereo in your listening room. Distortion is only 1.5% 1M at 18 watts per channel, 0.5% at 16 watts. Excellent square-wave and transient performance. Supplied with four EL-84/6BQ5 output tubes, two 12AX7 driver tubes. Finest performance and lowest price for a dual amplifier.

\$69.50

write for information to:

ACRO PRODUCTS CO.

410 Shurs Lane, Phila. 28, Pa., Dept. EW-6

Acro . . . the first name in audio!

Within the Industry

LAWRENCE J. EPSTEIN has been named sales merchandising manager of high-fidelity and professional products for the *Bogen-Presto Division of The Seigler Corporation*. He will be responsible for sales, advertising, and promotion of high-fidelity component equipment, professional tape, disc recorders, accessories, along with broadcast equipment.



Prior to joining the firm, Mr. Epstein was with *United Audio Products, Inc.* of New York and was also associated with *University Loudspeakers, Inc.* and *RCA International*. He has served as a director of the Institute of High Fidelity Manufacturers for several years.

ANTENNA SYSTEMS, INC. has been established in Hingham, Mass. for the purpose of designing, manufacturing, and installing all types of complete antenna systems. The new company is headed by Charles W. Creaser, Jr. . . . The merger of **BELL & HOWELL COMPANY** and **CONSOLIDATED ELECTRO-DYNAMICS CORPORATION** has been approved by the stockholders of both firms . . . Paul Martin Platzman has organized a new company, **ULTRASONIC INDUSTRIES, INC.**, with temporary headquarters at 141 Albertson Ave., Albertson, Long Island. The firm will manufacture a line of ultrasonic cleaners . . . **PLATT SALES, INC.** of New York has purchased the inventory, design, and manufacturing rights of the "Link" mobile radio line from the **GONSET DIVISION**. The "Link" operation will be moved to New York . . . **THE MAGNAVOX CORPORATION** has purchased control of the **COLLARO COMPANY** of Great Britain from the **GREAT UNIVERSAL STORES, LTD.** for an undisclosed sum . . .

CBS ELECTRONICS and **PHILCO CORPORATION** have entered into a cross-licensing agreement covering the manufacture and sale of semiconductors . . . **LAFAYETTE RADIO** has been appointed franchised distributor for **GENERAL RADIO "Variacs"**. The distributor's Industrial Division will handle the product . . . **NATIONAL COMPANY, INC.** of Malden and Melrose, Mass. has announced the acquisition of **SERVO-DYNAMICS CORPORATION** of Somersworth, N. H., which will operate as a wholly owned subsidiary . . . **AUDIO DEVICES, INC.** of New York has sold its silicon rectifier division in Santa Ana, California to the **LARK CORPORATION** of Dallas . . . **ERIE RESISTOR COR-**

PORATION has established **ELECTRON RESEARCH, INCORPORATED** as a wholly owned subsidiary devoted to the manufacture of semiconductor components and devices. The subsidiary is located at 530 W. Twelfth St., Erie, Pa.

HAROLD C. POTTER has been appointed manager of sales of *General Electric Company's* Semiconductor Products Department. He will make his headquarters in the Charles Building, Liverpool, New York . . . **CHARLES H. DAVID** has joined the *Bogen-Presto Division of The Seigler Corp.* as high-fidelity products manager . . . **Amperex Electronic Corp.** has announced the promotion of **GEORGE ELLIOT** to the post of manager, distributor sales and **JOSEPH VIVIANI** as manager, export sales . . . **DR. DON-**

ALD A. DUNN has been named director of the newly formed research division of *Eitel-McCullough, Inc.* He will maintain his offices at the San Carlos, California headquarters of the new division . . . **TERRY P. CUNNINGHAM** is the new director of advertising production and **EDWARD L. SLATER** director of advertising for *Sylvania Electric Products Inc.* . . . *Allied Radio Corporation* has named **MARVIN RUBIN** to the post of merchandising manager of its Chicago-Land stores. He will be responsible for the activities of five stores in the metropolitan area . . . **EARL J. SHELTON** has been appointed director of development of *Eitel-McCullough, Inc.* He was formerly associated with *Raytheon Co.* . . . **JOHN W. MERRITT** has resumed his position as distributor sales manager of *Howard W. Sams & Co., Inc.* He has been on "loan" to the marketing-advertising department of *Bobbs Merrill Company, Inc.* and associated *Sams* companies . . . **LOUIS M. ROBB** is the new manager of market development for the receiving tube department of *General Electric*. He will make his headquarters in Owensboro, Ky.

GEORGE D. HANCHETT has been named coordinator, technical planning, for the *RCA Electron Tube Division*.

Mr. Hanchett, who joined the company in 1942 as a receiving tube design engineer, has been manager, marketing planning, industrial receiving tubes for the past three years. From 1953 to 1957 he was manager, planning, receiving tube marketing-marketing operations department. His other assignments include industrial receiving tube application engineering and field en-



ELECTRONICS WORLD

IMPORTANT: For the man who wants to make big money in Radio-Television!

ONLY SPRAYBERRY TRAINING IN RADIO and TELEVISION

**OFFERS YOU ALL OF THESE VITAL NEW ADVANTAGES
TO HELP YOU EARN MORE MONEY FROM THE START!**

NEW BUSINESS BUILDERS

...through these practical proven plans and ideas we help you make plenty of extra money in spare time while training.

NEW TRAINING EQUIPMENT

...the famous Sprayberry Training kits have been newly engineered by our staff to offer you the latest in Radio-TV Service Techniques!

NEW TRANSISTOR COURSE

... literally millions of new transistor radios are being used. We show you how to make money fixing them!

NEW HIGH FIDELITY

... there's big money to be made installing and servicing Hi-Fi units. Your Sprayberry training now offers you this valuable and profitable preparation!

TRAIN AT HOME—SPARE TIME

WITH THESE **25 BIG COMPLETE KITS OF PARTS & EQUIPMENT**

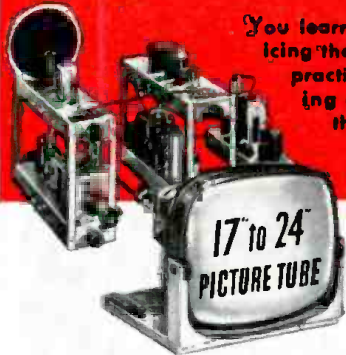

You learn Radio-TV Servicing the best way... the practical way... testing and assembling these modern kits of equipment!

The new Sprayberry Training Television Receiver, built and tested in 5 sections.

Now offered... this fine modern oscilloscope.

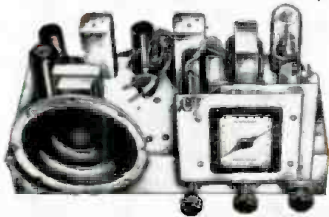

You build this powerful two-band super-heterodyne radio receiver.

You build the new Sprayberry tester—a complete 18-range Volt-Ohm-Milliammeter test meter.



FREE These two big new books are yours free! Find out what Radio-Television offers you... and let us show you how easily you can learn, even without previous experience of any kind. Rush **COUPON** today!

The field of Radio-Television Servicing is such a fast moving industry that the best jobs and biggest incomes always go first to the man with the most modern, complete and up-to-date training. Thanks to constant revision and improvement... Sprayberry Training helps you earn more from the start... and keeps you earning more in the months and years ahead!

Make no mistake! All radio-television training is not alike. The basic purpose behind Sprayberry Training is to prepare you as rapidly and as surely as possible... to make top money servicing Radio and Television sets and equipment. This is where the big money has been for years... and will continue to be in the years ahead.

It's important for you to know that for over 30 years... Sprayberry Training has been preparing ambitious men for success in this interesting and profitable kind of work. Our school has helped hundreds to qualify for the best jobs... or to get started in profitable businesses of their own. Today our student rolls are the largest in our school's history... because the need and demand for Radio-Television Service Technicians has never been more urgent.

Just \$6.00 Starts You

To encourage more men to enter Radio-Television at once... to help fill the great need for trained men... we're making it easier than ever before to start training. Just \$6.00 enrolls you. This liberal offer is naturally limited. Get the facts now

and consider enrollment while these favorable terms are available to you.

KEEP YOUR JOB... while learning

Under the Sprayberry Plan you train entirely at home in spare time. You combine the most modern lesson training with fascinating and invaluable practical work with 25 big kits of parts and equipment that we supply. You get the equivalent of years of shop practice... and you can train as fast or as slowly as you wish. We help you make excellent spare time money while learning... and everything you receive—lessons, books, manuals, equipment—all yours to keep!

This is the Radio-Television industry's most modern and up-to-the-minute training. Sprayberry is the *one* school that gives you personalized attention and takes a real interest in your progress. Remember... just \$6 starts you! Mail the coupon today. Let the facts speak for themselves. Let us send you our new catalog and sample lesson... and *prove* the kind of opportunity that Sprayberry training can open up for you.

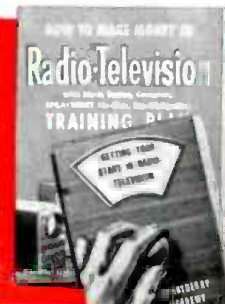

MAIL COUPON—No Salesman Will Call

SPRAYBERRY ACADEMY OF RADIO-TELEVISION
DEPT. 25-M 1512 W. JARVIS AVE., CHICAGO 26, ILL.

Please rush all information on your ALL-NEW Radio-Television Training Plan. I understand this does not obligate me and that no salesman will call upon me. Include New Catalog and Sample Lesson FREE.

NAME..... AGE.....

ADDRESS.....

CITY.....ZONE.....STATE.....

SPRAYBERRY ACADEMY OF RADIO-TELEVISION

Dept. 25-M 1512 West Jarvis Ave., Chicago 26, Ill.

Now...from Sonotone—

4 Big Improvements

in the quality stereo cartridge

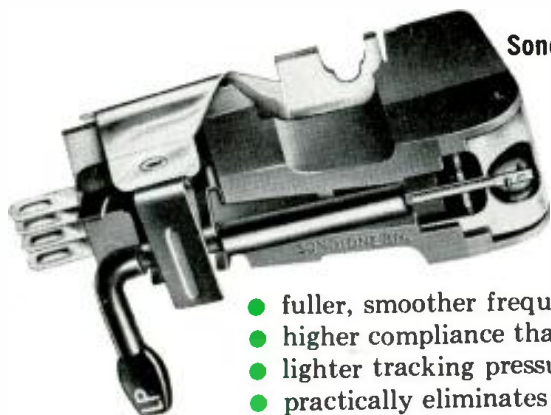

Sonotone 8TA cartridge replaces 8T as industry standard

The new Sonotone 8TA cartridge gives greater than ever stereo performance... has 4 big extras:

- fuller, smoother frequency response
- higher compliance than ever before
- lighter tracking pressure
- practically eliminates dust pile-up

ONLY
\$1450*

Sonotone 10T unitized stereo at lowest price ever

New 10T cartridge sells at record low price of \$6.45.* And it covers the complete high fidelity range. 10T's unitized construction makes it easiest to install, easiest to replace. Low price means more sales—more profits.



SPECIFICATIONS

	8TA	10T
Frequency Response	Smooth 20 to 20,000 cycles. Flat to 15,000 with gradual rolloff beyond.	Flat from 20 to 15,000 cycles ± 2.5 db.
Channel Isolation	25 decibels	18 decibels
Compliance	3.0×10^{-6} cm/dyne	1.5×10^{-6} cm/dyne
Tracking Pressure	3-5 grams in professional arms 4-6 grams in changers	5-7 grams
Output Voltage	0.3 volt	0.5 volt
Cartridge Weight	7.5 grams	2.8 grams
Recommended Load	1-5 megohms	1-5 megohms
Stylus	Dual jewel tips, sapphire or diamond.	Dual jewel tips, sapphire or diamond.

*including mounting brackets

Sonotone makes only 6 basic ceramic cartridge models... yet has sold over 9 million units...used in over 662 different phonograph models. For finest performance, replace worn needles with genuine Sonotone needles.

Sonotone

Electronic Applications Division, Dept. C 1-60
ELMSFORD, NEW YORK



Leading makers of fine ceramic cartridges, speakers, tape heads, microphones, electronic tubes.
In Canada, contact Atlas Radio Corp., Ltd., Toronto

gineering for the sales department.

He is an active ham, W2YM; is a member of the ARRL; and a senior member of the IRE. He will make his headquarters in Harrison, N. J.

RADIO MATERIALS COMPANY, a division of **P. R. MALLORY & CO., INC.**, has broken ground for a new 45,000-square-foot production and research facility in Chicago's new Brynwood Industrial District. Construction is expected to be completed by October... Ground has been broken in Hawthorne, California for a new 210,000-square-foot manufacturing plant which will house the merged facilities and resources of **ELDON MANUFACTURING COMPANY** and **UNGAR ELECTRIC TOOLS**. The new facility will permit consolidation of operations now being conducted in seven separate plants... **OLSON RADIO CORPORATION**, whose head offices are in Akron, Ohio, has opened a new unit at 142 N. High Street in Columbus, Ohio. The 12,000-square-foot store and warehouse will be managed by James Irwin.

W. T. SMILEY has been named national service manager for *General Electric* mobile radio at the company's Communication Products Department in Lynchburg, Va.



He will coordinate the company's "authorized service station" program under which approximately nine-hundred service shops provide technical assistance to the firm's two-way radio customers across the nation.

A graduate of Kansas State Teachers College prior to his new appointment, Mr. Smiley was a service counsellor and conducted seminars for mobile communications technicians on a regional basis throughout the country.

DR. OSKAR E. MATTIAT, well-known scientist in the acoustics field, has been appointed chief scientist of *Acoustica Associates, Inc.* He will make his headquarters at the firm's Los Angeles plant... **THOMAS L. MILLER**, who was formerly associated with the Air Force's Research and Development Command, has joined *Instruments for Industry, Inc.* as director of systems and programs... **W. WALTER JABLON** has been named president of *Mark Simpson Mfg. Co., Inc.* succeeding **MIRYAM SIMPSON**, who has been named chairman of the board... **JOHN M. THOMPSON** has been named vice-president and general manager of *Itemlab, Inc.* of Port Washington, N. Y. He was formerly chief engineer and/or laboratory chief of the Test Facilities Laboratory, Rome Air Development Center at Griffiss Air Force Base... **FRANK MILLER**, vice-president of *Terminal Electronics, Inc.* of New York, died instantly when his twin-engined plane crashed recently in Paterson, New Jersey. He was a well-known amateur radio operator. —50—

ELECTRONICS WORLD

NOW!
at a price
you can afford!

MAKE MORE MONEY in TELEVISION RADIO-ELECTRONICS

**BETTER...MORE COMPLETE...LOWER COST...
WITH NATIONAL SCHOOLS SHOP-METHOD
HOME TRAINING!**

BETTER... Training that is proved and tested in Resident School shops and laboratories, by a School that is the **OLDEST** and **LARGEST** of its kind in the world.

MORE COMPLETE... You learn **ALL PHASES** of *Television-Radio-Electronics*.

LOWER COST... Other schools make several courses out of the material in our **ONE MASTER COURSE . . .** and you pay more for less training than you get in *our course* at **ONE LOW TUITION!**

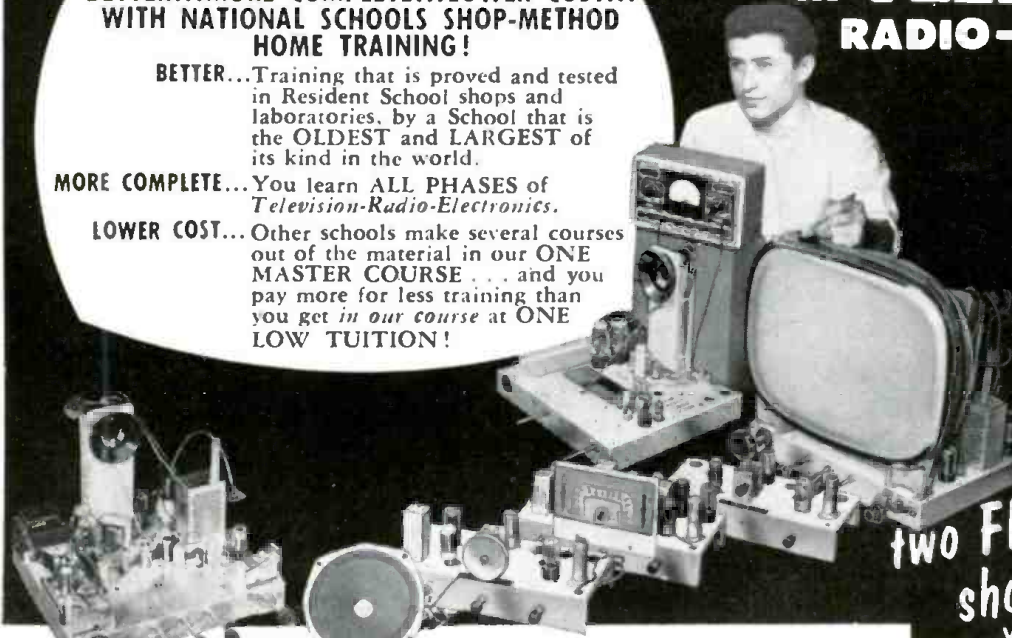

These
two FREE books will
show you how!

You get all information
by mail . . . You make
your own decision . . . at
home! **NO SALESMAN
WILL CALL**

TOP PAY... UNLIMITED OPPORTUNITIES LIFETIME SECURITY CAN BE YOURS!

You are needed in the Television, Radio, and Electronics industry! Trained technicians are in growing demand at excellent pay—in **ALL PHASES**, including Servicing, Manufacturing, Broadcasting and Communications, Automation, Radar, Government Missile Projects.

NATIONAL SCHOOLS SHOP-METHOD HOME TRAINING, with newly added lessons and equipment, trains you in your spare time at home, for these unlimited opportunities, including many technical jobs leading to supervisory positions.

YOU LEARN BY BUILDING EQUIPMENT WITH KITS AND PARTS WE SEND YOU. Your National Schools course includes thorough *Practical* training—**YOU LEARN BY DOING!** We send you complete standard equipment of professional quality for building various experimental and test units. You advance step by step, perform more than 100 experiments, and you build a complete TV set from the ground up, that is yours to keep! A big, new TV picture tube is included at no extra charge.

EARN AS YOU LEARN. We'll show you how to earn extra money right from the start. Many of our students pay for their course—and more—while studying. So can you!

RESIDENT TRAINING AT LOS ANGELES

If you wish to take your training in our Resident School at Los Angeles, the world's TV capital, start **NOW** in our big, modern Shops, Labs and Radio-TV Studios. Here you work with latest Electronic equipment - - professionally installed - - finest, most complete facilities offered by any school. Expert, friendly instructors. Personal attention. Graduate Employment Service. Help in finding home near school - - and part time job while you learn. Check box in coupon for full information.

LESSONS AND INSTRUCTION MATERIAL ARE **UP-TO-DATE, PRACTICAL, INTERESTING.** Every National Schools Shop-Method lesson is made easy to understand by numerous illustrations and diagrams. All instruction material has been developed and tested in our own Resident School Shops, Laboratories and Studios.

SEND FOR INFORMATION TODAY . . . it can mean the difference between **SUCCESS** and failure for you! Send for your **FREE BOOK** "Your Future in Television-Radio-Electronics" and **FREE Sample Lesson.** Do it **TODAY**, while you are thinking about your future. It doesn't cost you anything to investigate!

GET THE BENEFITS OF OUR OVER 50 YEARS EXPERIENCE

Approved for
GI Training



NATIONAL SCHOOLS

Los Angeles 37, Calif.

YOU GET...

- 19 Big Kits—**YOURS TO KEEP!**
- Friendly Instruction and Guidance
- Job Placement Service
- Unlimited Consultation
- Diploma—Recognized by Industry
- **EVERYTHING YOU NEED FOR SUCCESS!**

SHOP-METHOD HOME TRAINING COVERS ALL PHASES OF INDUSTRY

1. Television, including Color TV
2. Radio AM & FM
3. Electronics for Guided Missiles
4. Sound Recording and Hi-Fidelity
5. FCC License
6. Automation and Computers
7. Radar & Micro-Waves
8. Broadcasting and Communications

NATIONAL TECHNICAL SCHOOLS

WORLD-WIDE TRAINING SINCE 1905

MAIL NOW TO

NATIONAL SCHOOLS, Dept RH-60

4000 S. FIGUEROA ST. LOS ANGELES 37, CALIF.

Rush free TV-Radio "Opportunity" Book and sample lesson. No salesman will call.

NAME _____ AGE _____

ADDRESS _____

CITY _____ ZONE _____ STATE _____

Check if interested **ONLY** in Resident School training at Los Angeles.

VETERANS: Give date of Discharge.

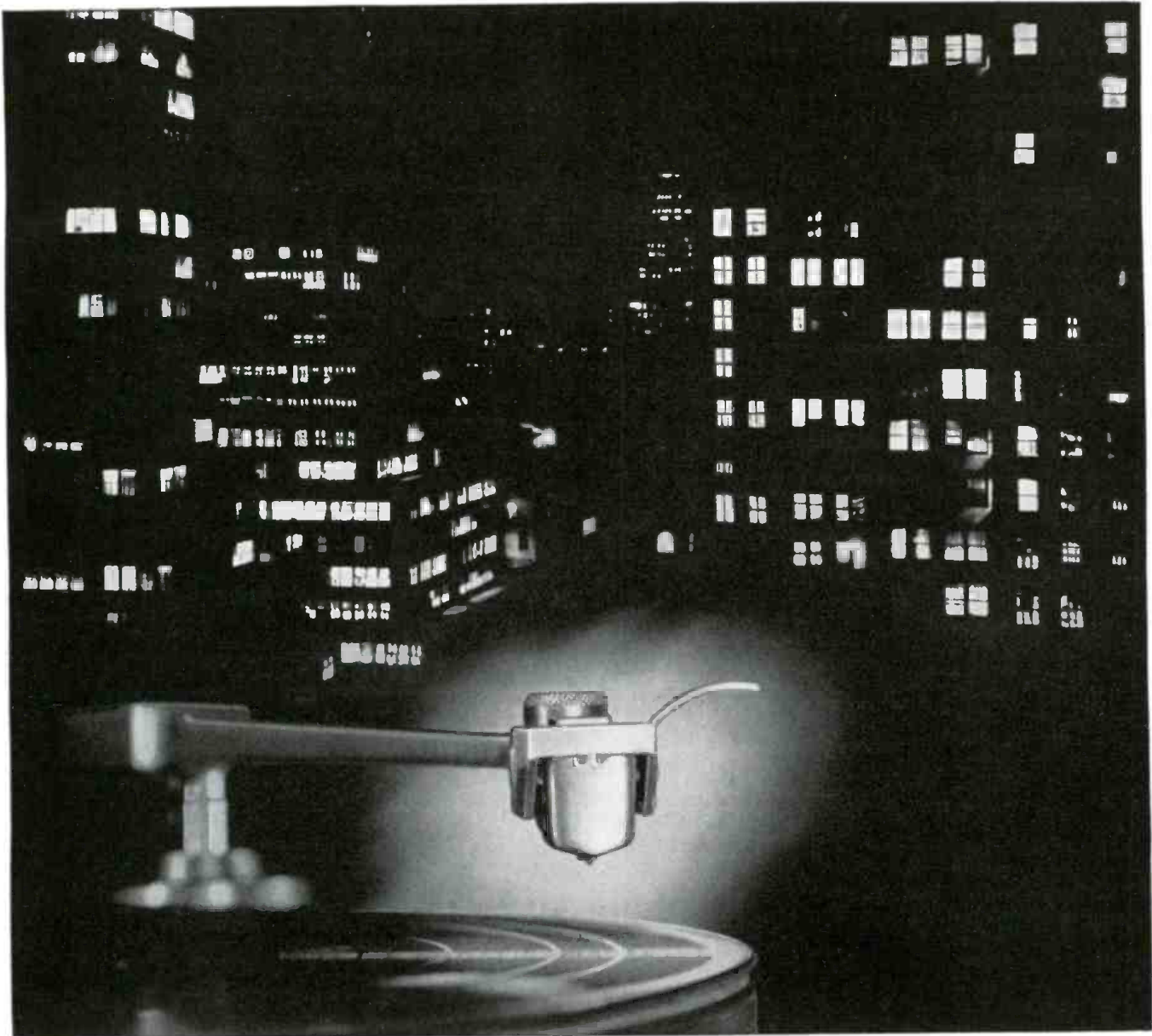

General Electric VR-22 Stereo Cartridge—Superior in the four vital areas

Stop to think for a moment of all the jobs required of a stereo cartridge: It must track, with utmost precision, in not one but two directions. It must separate the two stereo channels inscribed in a single record groove. It must perform smoothly in mid-range and at both ends of the audible frequency spectrum. And it must do all these things without producing noticeable hum or noise. Only a fantastically sensitive and precise instrument like the General Electric VR-22 can do all these jobs successfully.

General Electric's VR-22 is superior in the four vital areas of stereo cartridge performance: (1) **Compliance**—It tracks precisely, without the least trace of stiffness. (2) **Channel separation**—Up

to 28 db for maximum stereo effect. (3) **Response**—Smooth and flat for superior sound from 20 to 20,000 cycles (VR-22-5), 20 to 17,000 cycles (VR-22-7). (4) **Freedom from hum**—The VR-22 is triple-shielded against stray currents.

VR-22-5 with .5 mil diamond stylus for professional quality tone arms, \$27.95*. VR-22-7 with .7 mil diamond stylus for professional arms and record changers, \$24.95*. Both are excellent for monophonic records, too. TM-2G Tone Arm—designed for use with General Electric stereo cartridges as an integrated pickup system, \$29.95*.



General Electric Co., Audio Products Section, Decatur, Illinois

*Manufacturer's suggested resale prices.



GENERAL ELECTRIC

Opportunities in Electronics

Do you know how you can convert your present electronics knowledge into a profitable and interesting career in any of the fields listed here?

Thousands of interesting well paid jobs in electronics must be filled. To fill such jobs, you need sound technical training. An FCC license is convincing proof of technical skill. Send for the three Cleveland Institute booklets offered here. They explain how you can prepare for an interesting and profitable career in electronics. Mail the coupon today—no obligation.

Find out how modern technical training and a Government License (FCC) can lead to profitable employment in any branch of electronics.

good training doesn't cost—it pays!

- **Radar**
- **Guided Missiles**
- **Broadcasting**
- **Aeronautical Electronics**
- **Computers**
- **Automation**
- **Industrial Electronics**
- **Home Electronics**



**Send for these
3 FREE Booklets**

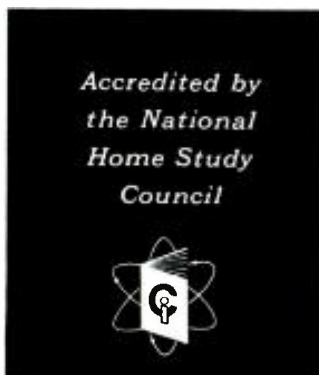

Cleveland Institute of Electronics

Desk RN-42

4900 Euclid Ave.

Cleveland 3, Ohio

Please send FREE Booklets prepared to help me get ahead in Electronics. I have had training or experience in Electronics as indicated below:

- | | |
|---|--|
| <input type="checkbox"/> Military | <input type="checkbox"/> Home |
| <input type="checkbox"/> Radio-TV Servicing | <input type="checkbox"/> Experimenting |
| <input type="checkbox"/> Manufacturing | <input type="checkbox"/> Telephone Company |
| <input type="checkbox"/> Amateur Radio | <input type="checkbox"/> Other _____ |
| <input type="checkbox"/> Broadcasting | |

In what kind of work are you now engaged?

In what branch of Electronics are you interested?

Name _____ Age _____

Address _____

City _____ Zone _____ State _____

RN-42



ARE YOU STILL BUYING

Lots of people, people who buy them as well as sell them, still judge a speaker by the weight of its magnet. "The heavier the magnet, the better the speaker," so the old rule of thumb goes. And when speakers were all pretty much alike, that was probably as good a way as any to grade them.

But speakers, like everything else in electronics, have changed enormously over the past few years. Magnet manufacturers know so much more today about making magnets. The magnets used by Delco have more highly oriented grain structures. They're premium grade, more efficient.

And Delco has improved every other speaker part—from basket to gasket, voice coil to cone. All these parts are now made with new, stronger materials. They work better together. They stand up longer. And Delco Radio's precision engineering

makes possible better magnetic circuits. The result is a greater range of rich, deep, distortion-free sound—sound that you once could get only from more expensive speakers with far heavier magnets.

Delco Radio sells speakers by the *sound* instead of by the pound. May we suggest you contact your Distributor soon.

Here's why Delco speakers give more sound per pound: Quality controlled premium magnets • Efficient pot design provides extremely short magnetic path with minimum magnetic air gap to minimize stray flux • High quality steel in magnetic circuit • Exact ratio of cross section area of magnetic air gap to length of air gap gives optimum energy from magnet • Precision manufacture and assembly of parts make possible greater efficiency from magnetic circuit.

SPEAKERS BY THE POUND?



A

Delco gives you a complete line of Hi-Fi speakers. Illustration A is the 8" Model No. 8007. It offers the most highs, the most lows, the most watts in a medium-priced speaker. Designed for replacement use and high fidelity audio systems.



B

Delco's most popular auto radio speakers: (B)—Model No. 6112, 6" x 9", and (C)—Model No. 6109, Delco's exclusive 4" x 10". All Delco auto radio speakers are life tested to perform under severest climatic conditions. All, including our full line of rear seat speakers, are equipped with quality controlled, premium Alnico magnets.

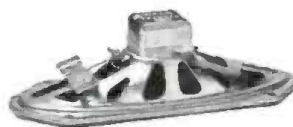

C

DELCO
RADIO
RELIABILITY

Division of General Motors
Kokomo, Indiana

Delco speakers, transistors, transformers and other parts for radios, television and Hi-Fi are available everywhere through Delco Electronic Distributors associated with



This new
BOGEN
GUIDE-BOOK
 tells you how
 to cash in on the
 profitable commercial
 sound market in
PA and INTERCOM

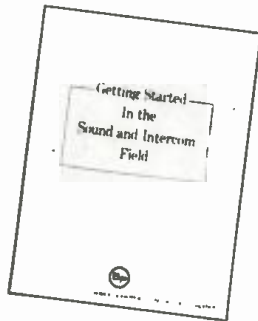

"GETTING STARTED IN SOUND"

16 pages, packed with valuable information, advice, answers to all your questions—discusses qualifications required—how much capital it takes—costs of operation—and, most important, how to get started on a modest investment. This guide book also tells you how to obtain...

VALUABLE FREE SALES KIT TO HELP YOU IN THE FAST GROWING SOUND BUSINESS

FREE sound sales kit contains sales literature—sample solicitation letters—job quotation forms—technical and installation data—product specification sheets—merchandising ideas.

You will also receive additional free material from time to time. And if you are not already dealing with a Bogen Sound Distributor we will also put you in touch with one to serve as your local supply source.

This valuable sales kit will be furnished to you when you send in the special card included in each copy of "Getting Started in Sound."

THIS MAY BE the very opportunity you have been waiting for. Don't miss it! Visit your local Bogen Sound Distributor for your copy of "Getting Started in Sound." It will be the best 25c investment you ever made. If your distributor has not yet received his supply or is sold out, use this convenient coupon. Enclose 25c in coin, and a copy will be mailed to you directly.



BOGEN-PRESTO, PARAMUS, NEW JERSEY EW-6

Yes, I am interested in earning more money in sound systems, so please send me "Getting Started in Sound" by return mail. I enclose 25c in coin.

NAME _____

ADDRESS _____

CITY _____ ZONE _____ STATE _____

Look to Bogen-Presto for the big profit opportunities in sound

BOGEN-PRESTO PARAMUS, NEW JERSEY
 A Division of the Siegler Corporation

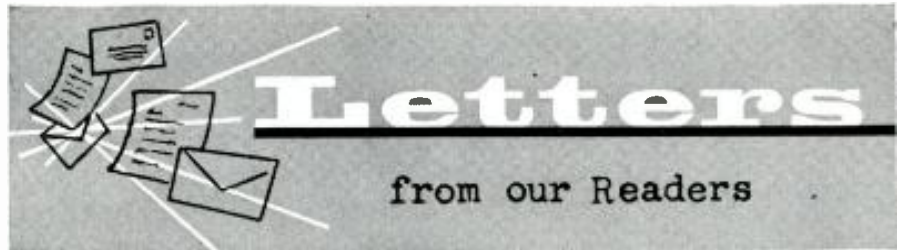

CONDUCTOR SIZE VS CURRENT

To the Editors:

In your February, 1960 issue, an article entitled "Home-Built Power-Line Regulator" by A. V. J. Martin appears in which the following is stated:

"Reference to a wire table will indicate what size wire to use, bearing in mind that the current density should not exceed 2.5 amperes per square millimeter. If no wire table is available, dividing the current by 2.5 will give the wire cross-section in square millimeters."

Some readers may not know what a square millimeter may indicate, others may not have access to metric copper wire tables. The common reference in the United States to the mechanical dimensions of copper wire is mils for the diameter and circular mils for the cross-section. As one square millimeter equals 1973 circular mils, to convert multiply 1973 by square millimeters. The proper wire size then may be found by reference to a copper wire table based on the American Wire Gauge (A.W.G.).

Rarely is current-carrying capacity included in the English copper wire tables. Various texts state that the current density in copper conductors may be from 0.5 to 1.5 ampere per 1000 circular mils. Others state the current density as from 500 to 1000 circular mils per ampere. What may be considered an average for the design of small transformers is 700 circular mils per ampere.

A. C. LANGUIRAND
 Newport, Rhode Island

Thanks to Reader Languirand for these helpful notes.—Editors.

NEW AMPLIFIER STANDARDS

To the Editors:

I have just finished reading your article "New Hi-Fi Amplifier Standard" in the January issue of ELECTRONICS WORLD, and found the contents very interesting and well summarized. However, there are a few points concerning the music power under the "Output Rating" section which were not quite clear to me.

The article stated that usually amplifiers with well-regulated supplies and with fixed-bias (such as from a separate rectifier system) will show little difference between continuous and music power. On the other hand, amplifiers with poor power-supply regulation and self-bias may show a substantial difference.

An amplifier having self-bias with poor power-supply regulation may show a substantial difference between

continuous and music power but this would probably not apply to an ordinarily designed Class A amplifier. Being operated with self-bias, the current change should be rather small, if not negligible, between no signal and full power. The voltage drop on the "B+," therefore, would be almost unchanged for most Class A amplifiers. The power-supply regulation usually does not affect the power output unless it is poorly designed. In such a case, a higher distortion figure would be the result for a given "B+" voltage, but the difference between music power and continuous power should be very little in this case.

Secondly, I believe that most, if not all, of the high-fidelity amplifiers on the market today operating with fixed-bias do not have a well-regulated power supply (a separate rectifier system). Thus, the plate and screen voltages will drop considerably at full power, for the current drain is two to three times greater at full load than at the quiescent state. In other words, usually the amplifiers with fixed-bias show considerable difference between the music power and continuous power ratings unless a laboratory-type low-impedance power supply is used.

It will be interesting to see how the industry and the consumers will accept the new standard, especially the music power output rating. Personally, I still like the continuous sine-wave rating for high-quality component amplifiers.

DAVID T. LEE
 General Electric Co.
 Audio Components Product Section
 Auburn, New York

Regarding the music power rating, we will just have to wait and see as to whether or not the manufacturers go along with this method of rating their amplifiers. No doubt many of them will, irrespective of personal preferences by their own and other engineers. (See editorial, page 8)—Editors.

* * *

UPSIDE-DOWN RECEIVER

To the Editors:

I enjoyed reading your article on "Scatter Radio Communications" in the March issue. It was very informative and interesting. I do have one question, however. Wouldn't the receiver pictured on page 39 work better if it were turned right side up?

JAMES E. BROMLEY
 KTSM, KTSM-TV
 El Paso, Texas

To the Editors:

The REL receiver would undoubtedly

**Now—more profit from a single sale
...than 20 pairs of single-life “D” cells pay you!**



To recharge, just unscrew cap...



and plug overnight into any 110-120-volt AC outlet.

HEAVY-DUTY SONOTONE Rechargeable Flashlight Battery Cartridge

- A new, multi-use adaptation of the patented Sonotone sintered-plate, nickel-cadmium battery used in space missiles and jets.
- Gives at least 3 hours of strong, continuous light from a single charge with PR-6 bulb—or 1½ hours with full-powered PR-2 bulb.
- Dependable in extreme temperature and weather conditions.
- Can be recharged hundreds of times at about ¼¢ per charge.
- Sturdy, leakproof construction — aluminum jacket — electrically shockproof.
- Full-year guarantee under heavy industrial use — backed by Sonotone's leadership of over 30 years in precision engineering and service.

A completely new concept in long-life flashlight power! Replaces and outmodes any two “D” cells, for any purpose, in end-to-end use. Rechargeable overnight simply by plugging into any 110-120-volt AC outlet. Gives users a lifetime of service—gives you more profit than you make from selling 20 pairs of industrial “D” cells! Retail price, Model FC-3, \$9.95. (Also Standard Model FC-2 for home use—light lasts at least 1½ hours with PR-6 bulb — \$7.95 retail.) Order from your supplier now.

Sonotone CORP.

Battery Division, Dept. BI-60
ELMSFORD, NEW YORK

Leading makers of fine transistor hearing aids, ceramic phonograph cartridges, speakers, microphones, electronic tubes, sintered-plate, nickel-cadmium batteries.

SELECTIVITY: $\pm 5\text{Kc}$ at points 6db down!

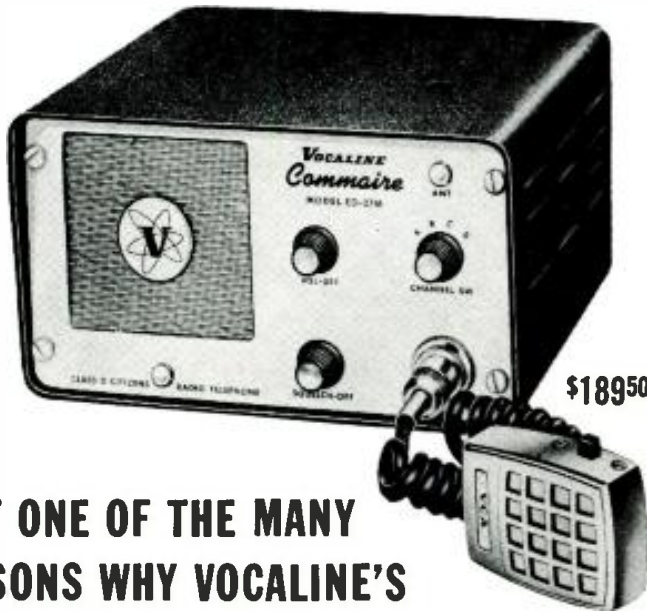

\$189⁵⁰ each, list

JUST ONE OF THE MANY REASONS WHY VOCALINE'S NEW COMMAIRE ED-27M IS THE WORLD'S FINEST* MULTI-CHANNEL CITIZENS BAND RADIO!

Only Vocaline, specialist in unique circuitry for defense projects, could produce a remarkable performer like the ED-27M Commaire multi-channel Class D citizens band radio. This brilliantly-engineered unit assures the same uniform output, sensitivity and selectivity over the entire 22 citizens band channels. Selectivity is ± 5 kc at points 6 db down, sensitivity: 0.3 mv! Audio output is 4.5 watts. Incorporates Vocaline's exclusive "Silent-Aire" squelch with special noise suppression circuit to assure complete silence in stand-by. The receiver is a double conversion superheterodyne with single crystal. For mobile operation, a transistorized power supply affords dependable, economical operation. Supplied with crystal for one channel (additional crystals can be supplied installed at \$5.00 each), push-to-talk microphone, hanger and universal mount. 2 models: 115 VAC-12 VDC and 115 VAC-6 VDC.

*4 CHANNELS

The Commaire ED-27 Single-Channel Citizens Band Radio... in a class by itself:

The single-channel version of the Commaire—proven to be the finest radio in the Class D field. Incorporates the same patented features as the ED-27M. Unequaled for range, signal-to-noise ratio, audio fidelity and dependability. \$179.50 each, list.



VOCALINE
COMPANY OF AMERICA
152 Couffer Street
Old Saybrook, Conn.

Send complete literature to:

Name _____
Address _____
City _____ Zone _____ State _____

operate in this position, but here in the "White Alice" system, it is operated right side up. Other than this, it was a real fine article on a truly pioneer communications system for Alaska.

MARVIN R. WEATHERLY
White Alice Station
Middleton Island, Alaska

Yes, we certainly agree that the receiver would probably work better right side up. Sorry for the oversight.
—Editors.

"RUSH SUPPRESSOR" RELAY

To the Editors:

There seems to be a question as to the exact relay which I used in the circuit described in my article "A 'Rush Suppressor' For Citizens Radio" (January, 1960 issue).

The original relay was removed from a surplus BC-645 IFF unit. A number of tests were conducted here with various commercial relays. The Sigma 5F-2500-S SIL relay was found to operate very nicely in the circuit. Some minor adjustment of the relay was necessary in order to increase its sensitivity and to change the drop-out current. Generally speaking, strive for as fast an operation as possible with no signal being received. For best operation there will be very little difference between the volume control settings to pull in and release the relay when receiving noise only.

JAMES D. GREEN
Chief Engineer
WELO
Tupelo, Mississippi

Thanks to Author Green for his suggestions. In our April "Letters from our Readers" column, we recommended the use of a Sigma 5F-1000-S SIL, which is rated at 1000 ohms and 2.3 ma. This relay closes at a little over 2 volts. The relay recommended by Author Green probably requires a slightly higher voltage to close, being on the order of 3½ volts (2500 ohms at 1.4 ma.). Either of these relays sells for around \$8.00 new and either should be suitable for use in the circuit.—Editors.

HANDY FILAMENT CHECKER

To the Editors:

I am afraid that Nicholas B. Cook would have trouble checking tubes such as the 1U4, the 3V4, and other miniature portable radio tubes in his filament checker (described on page 130 of your January issue). These tubes use pin numbers 1 and 7 for their filaments. Therefore, one would have to run a jumper between pins 1 and 3 and pins 4 and 7 on the 7-pin miniature socket used in the checker in order for it to test these tubes.

HERSCHALL K. COOK
Flint, Michigan

Reader Cook's point is well taken. It is only fair to note that the author claimed the device was useful for a majority of popular tube types. He may not have been particularly concerned with the 1.4-volt miniatures.—Editors.

—50—

a college-level home study program in electronics ...for serious-minded men desiring higher income and status



CREI's Extension Division offers you a college-level home study program in electronics comparable in technological content to advanced residence courses.

CREI has developed a program of home study that is comparable in technological content to advanced residence courses in electronics. The program was developed hand-in-hand with leading companies and Government agencies contributing to the Nation's efforts in electronics, communications, missiles, and space exploration.

This CREI program in Electronics Engineering Technology may be completed in 2 to 4 years, depending on how much of your spare time you can devote to study. The courses are presented in easy-to-understand form. Our instructors will give you personal attention and assist you when you need help.

To qualify CREI graduates for advancement to key technical positions, CREI offers a complete program in electronics, including—

Automation • Instrumentation • Industrial Electronics
Aeronautical Electronics • Guided Missiles • Radar
Servo-mechanisms • Computers • Astronautics • Tele-
metering • Communications • Electronics Manufacturing
Field Engineering

There is a drastic need in the electronics industry for well-educated engineers and technical personnel. Although the great majority of students find ample opportunity for advancement with their present companies, CREI maintains a Placement Bureau to assist graduates and advanced students in finding more desirable positions. For many years, the demand for CREI graduates and advanced students has far exceeded the supply.

.....

Regularly across my desk, comes evidence that CREI's advanced Home Study Program in Electronics has provided an answer both for industry and for far-sighted men, who want to rise to higher levels of achievement. This evidence takes the form of letters from industry leaders and CREI graduates, who express their appreciation for the program and its value in their industry. These letters also state that advancements for CREI men are frequent and extensive. The CREI graduate may enjoy the benefits of new recognition, superior status and higher earnings as a result of his college-level electronics education.

*E. H. Rietzke, President
Capitol Radio Engineering Institute*

A few of the private companies and government agencies whose officials approve CREI for their own personnel:

- | | |
|--|---------------------------|
| U. S. Navy (5,240 enrolled in extension program) | Florida Power & Light |
| Army, Air Force, Marine Corps, Coast Guard | Pan American Airways |
| Columbia Broadcasting System | United Airlines |
| National Broadcasting Company | The Martin Company |
| Federal Electric Corporation | All America Cable & Radio |
| | Voice of America |
| | ... and many others |

QUALIFICATIONS FOR CREI. You qualify if you have a high school diploma or equivalent, and if you have had basic electronic training and practical experience in electronics. Available to Veterans.

Write for our detailed 44-page catalog giving you complete facts, CREI also offers a Residence School program that qualifies graduates for an AAS degree. Day and evening classes.



Mail this coupon . . . today!

CAPITOL RADIO ENGINEERING INSTITUTE

ECPD Accredited Technical Institute Curricula • Founded 1927
Dept. 1106-G, 3224 Sixteenth St., N. W., Washington 10, D. C.

Please send me your course outline and FREE 44-Page Book "Insurance for Your Future in the New World of Electronics" . . . describing opportunities and CREI home study courses in Advanced Electronic Engineering Technology.

- Check Radar, Servo and Computer Engineering Technology
 field of Electronic Engineering Technology
 greatest Communications Engineering Technology
 interest Television Engineering Technology
 Aeronautical Electronic Engineering Technology
 Automation and Industrial Electronic Engineering Technology

Name _____ Age _____

Street _____

City _____ Zone _____ State _____

Check: Home Study Residence School Korean Veteran

To obtain fast, immediate service and to avoid delay, it is necessary that the following information be filled in:

Employed by _____

Type of present work _____

Education: Years high school _____ Other _____

Electronics experience _____



**Latest Information
on the Electronic Industry**

Spot News

By **ELECTRONICS WORLD'S
WASHINGTON EDITOR**

ELECTRONIC PROGRESS BY SIGNAL CORPS CITED—A number of meaningful accomplishments of the Fort Monmouth R and D Laboratory of the Signal Corps were spelled out recently during a report presented at the annual IRE convention in New York. Noted were such developments as the world-wide synchronization-of-clocks experiment with Great Britain, involving atomic clocks; also new frontiers in battery designs, specifically the magnesium types. Additional illustrations of progress were micro-mesa transistors operating at 6000 mc. and macro-mesas capable of 3-watt outputs at 70 mc. Described, too, was a tiny reed relay for transistor applications, which was said to herald new orders of performance, measured by millions of cycles of fault-free positive performance with sensitivities in the low-milliwatt levels.

NINE OUTER-SPACE RADIO SOURCES IDENTIFIED BY NAVY EXPERTS—Nine extra-galactic radio sources, ranging to one-billion light years from the earth, have been located by the Navy with a twin radio telescope. The unique instrument, developed as part of a radio-astronomy program of the Office of Naval Research and the California Institute of Technology, consists of two 90-foot parabola antennas mounted on a 1600-foot-long railroad track oriented east-west. Working in tandem as a radio interferometer, the twin dishes produce a resolving power greater than any radio telescope in operation or under construction. The pioneering work, using this special telescope, is expected to provide new information for astronomers to use in exploring depths of space. For example, a theory may be developed to explain the intense radio noise from colliding galaxies.

INFRARED AIRCRAFT SEARCH EQUIPMENT DEVELOPED—An infrared search track set—electronic eyes—that casts a searching scan around the heavens to disclose presence of enemy aircraft, has been developed for the Air Research and Development Command by ITT. The heat-seeking equipment, with a sensing element cooled to below minus 300 degrees F (liquid nitrogen temperature), is ultra-sensitive to thermal emissions from jets. Optimized to detect wavelengths of heat generated by jet craft, the device is said to be relatively invulnerable to electronic countermeasures or jamming.

"BIRDCASTING" NOW IN VOGUE—Radio now appears to have become really something for the birds. Under a temporary experimental (research) grant, the FCC has authorized the University of Minnesota to mount one-ounce battery-operated transmitters on six ruffed grouse to study their movements. The miniatures, emitting 10-milliwatt pulses continuously at a rate of one or two a second, will operate for one month and the resulting "birdcasts" will be picked up by two receivers manned by biologists in a one-mile area.

REDSTONE MISSILE CARRYING TV STATION FIRED—A 69-foot Redstone ballistic missile carrying a miniature TV station was fired recently by Army troops at the White Sands Missile Range, New Mexico. A camera, housed in a small capsule, ejected during flight, took pictures of the impact of the missile warhead and the resulting damage, which were displayed on a receiver 75 miles away. The pictures were also recorded on video tape. For the story on "Tiros I," our weather-TV satellite, see page 33 of this issue.

OVERSEAS RADIO SETS NOW TOP 165,600,000—At the end of 1959, there were 165,667,000 radio sets in the world outside of this country, its territories, and Canada. This represented an increase of 12 million or 8 per-cent. The biggest rise, 3,300,000 sets to a 26,520,000 total, occurred in Communist Eastern Europe, half of it in the Soviet Union. Communist China was reported to have increased its radio receivers by 1,500,000 during the twelve months to a total of 3,500,000.

FORECAST GLOWING FUTURE FOR ELECTRONICS IN AIR TRAFFIC CONTROL—The electronic needs for future aircraft will be great indeed, according to FAA Administrator E. R. Quesada during an EIA talk in Washington. In addition to automatic controls, the present-day navigation equipment, such as VOR, DME, Loran, and Doppler will have to give way to more sophisticated gear to handle future complex navigation problems. This does not mean that the basic system will change, he added, but rather that equipment of those types will have to be redesigned to take advantage of improvements in the state of the art, to increase reliability and simplicity, and to reduce size, weight, and cost.

-30-

The Sounding Board

World's Toughest Audience Tests, Approves, Selects E-V ULTRA-Compact Units



Recently, in New York, Boston, and Los Angeles nearly 300 sound room personnel of top high fidelity dealers were given the opportunity to spend an afternoon listening to and rating the "sound" produced by three of Electro-Voice's new ultra-compact speaker systems (Regal, Esquire, Leyton) and six other currently popular competitive ultra-compact systems. All nine systems were placed behind an opaque curtain and each listener's selector switch was coded but unmarked so he had no way of knowing which system he was hearing. The result of the listening test was that more than 80% ranked Electro-Voice Esquire and Regal units either first or second. And Electro-Voice's economical Leyton was ranked third by over 50% of the participants—thus outscoring systems at double its price.

Now, we don't think this proves a single thing except that there is a heavy percentage of knowledgeable people in New York, Boston, and Los Angeles who could recognize the clarity and purity of sound that we build into any Electro-Voice speaker system. We long ago discovered that it is impossible to build a speaker that sounds exactly the same to every listener, so we have always strived to create instruments that let our customers listen to the music rather than the speaker.

New Convertible Drivers Bring Public Address Performance to Hi-Fi Levels

The basic characteristics needed to satisfy any critical sound job—wide range, low distortion, and high efficiency—are all combined in E-V's new group of drivers. But there has been one great plus added to the unmatched performance of these units. *The same driver can be used on reentrant horns and in compound horns.* This means that a single driver will fit the famous E-V Compound Diffraction Horn as well as conventional reflector horns. This unusual versatility is accomplished without compromising the performance quality of either horn type.

Engineered with careful attention to detail, these drivers feature such exclusives as: ceramic magnets; edge-wise wound voice coils; and dual concentric

centering. They are easier to install with their push-type polarized connectors and permit easy diaphragm replacement in the field.

If you are planning a P.A. system don't fail to consider these rugged, weatherproof drivers that have eliminated "peaked" response to provide the tonal balance needed for good musical reproduction and the rising frequency

- DC30A  30 Watts
150-10,000 cps
\$27.50 List
- DC30T  30 Watts
With 70.7 V.
Transformer
150-10,000 cps
\$37.00 List
- DC40  40 Watts
140-11,000 cps
\$36.00 List
- DC40T  40 Watts
With 70.7 V.
Transformer
140-11,000 cps
\$46.50 List
- DC50  50 Watts
140-11,000 cps
\$47.00 List
- DC50T  50 Watts
With 70.7 V.
Transformer
140-11,000 cps
\$57.50 List

response necessary for clear, crisp voice projection. Available as listed below as well as with 45-ohm voice coils for high-powered inter-com:

What Does E-V's Magneramic 31 Do That Your Magnetic Cartridge Can't Do?

The stereo cartridge has rightly been termed the "gateway" to your sound system. If the response characteristics of the cartridge lacks fidelity of reproduction, the system performance will not possess the essential brilliance of the recorded sound. Similarly, if the cartridge fails to provide adequate electrical input to the amplifier, much of the recorded definition and authority may be attenuated. The factor of cartridge output influences not only the system gain—but the quality and definition of the sound as well.

In distinct contrast to magnetic type cartridges, the revolutionary, new E-V Magneramic 31 produces an output of 8 millivolts—over 60% higher than most magnetics. Thus, it is possible to play your system at noticeably lower amplifier gain and speaker pad settings. This bonus output is often the difference

between marginal and outstanding performance, particularly when employing low-efficiency speaker systems. Lower amplifier gain settings also reduce the likelihood of introduction of tube thermals and transformer hum into the system. You hear only what is recorded—clean and true-to-life—without the introduction of stray parasites from the amplifier.



First Users of New Model 644 Mike Rave About Performance

The all-new Model 644 Sound Spot Microphone introduced by Electro-Voice early this year has already started to prove itself in its initial installations. Here are just a few of the comments received from sound installers and audio specialists throughout the country:

"Move anywhere on the stage and be heard easily throughout the auditorium"...

"Better pick-up of a band across a football stadium than any parabolic microphone ever tried"...

"By using the 644's we turn up the system to more than needed sound without feedback—but with old microphones we could just barely crack the control open"...

"The anticipated feedback in this installation from any normal application would be tremendous. The 644 was installed and all preliminary tests were amazing"...

The microphone that all these men are talking about utilizes a slotted tube on the front that can actually discriminate between sounds arriving from random directions and reduce pick-up from sides and rear by 20 db or more. This new design concept enables the 644 to offer as much as four times greater working distance than the best cardioids; greatly reduced feedback; retention of "on-mike" presence despite extended working distance; excellent performance out-doors because of elimination of wind noise. Despite the outstanding performance characteristics built into the 644, it is still priced low enough (\$110.00 list) to fit most budgets.

Did You Know?



Depending on the weight of the tone arm, a needle exerts as much as 30,000 to 50,000 pounds per square inch pressure on the record groove. So, it's easy to see why even a slight imperfection in the tip could ruin records in a hurry. Don't take chances with your valuable collection. Always select Electro-Voice Power-Point Needles. The only replacement needle line sold by a manufacturer of high-fidelity equipment.

Want more information on any of the items mentioned in the Sounding Board? Simply check the appropriate boxes below and mail the coupon to Dept. 60N, Electro-Voice, Inc. Buchanan, Michigan.

.....

.....

.....

Electro-Voice[®]
BUCHANAN, MICHIGAN

Introducing a new small-size bi-directional Ribbon Microphone VM-16, Velocity Type.

MODEL VM-16

- Superlative high quality response characteristics.
- Engineered in collaboration with the Technical Research Laboratory of the Japan Broadcasting Corporation (NHK).
- Outstanding results when used for FM broadcasting and high fidelity recording because of its exacting quality of tone reproduction.
- Because of the above superior characteristics, its small size and non reflecting satin-chrome finish, it is ideally suited for TV broadcasting.



MODEL VM-16

SPECIFICATION

Frequency Response: 50-15,000 c/s ± 3 dB
 Output Level: -80 dB (150 ohms/1,000c/s)
 Impedance: 150 ohms, 250 ohms or 600 ohms
 Directional Characteristic: Bi-directional
 S/N: 20 dB or below (in parallel field at 1m gauss)

Directional Characteristic

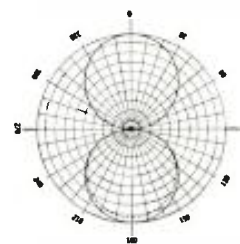

— 500 c/s, 1000 c/s 8000 c/s

AIWA

MODEL DM-20

SPECIFICATION

Frequency Response: 70-10,000 c/s ± 5 dB
 Output Level: -79 dB (150 ohms, 1,000 c/s)
 Impedance: 50 ohms, 150 ohms, 250 ohms, 10 K ohms and 50 K ohms
 Directional Characteristic: Non-directional

Directional characteristic:

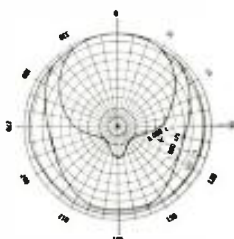

MODEL DM-20

Newly Developed, Economical Dynamic Microphone DM-20

- The DM-20 features a strong diecast body formed after exhaustive acoustical research to achieve reproduction of full audio range.
- Introduces a new plastic diaphragm free from mechanical distortion and physical deterioration.
- An exceptional dynamic microphone for studio broadcasting or recording, resulting in improved, clear and lifelike tone quality.
- Broadens the realism of the tone reproduction in tape recording, well above currently used types of microphone.
- Reasonable price.

AIWA CO., LTD.

Tokyo, Japan

ELECTRONICS WORLD

The specs prove it...your best buy is



B
TV-FM SWEEP GENERATOR
AND MARKER #368
KIT \$69.95 WIRED \$119.95

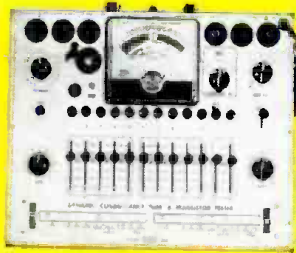

A
DYNAMIC CONDUCTANCE
TUBE & TRANSISTOR
TESTER #666
KIT \$69.95 WIRED \$109.95
Complete with steel cover & handle

C
RF SIGNAL GENERATOR #324
KIT \$26.95 WIRED \$39.95



D
PEAK-TO-PEAK
VTVM #232 &
UNIPROBE
KIT \$29.95
WIRED \$49.95

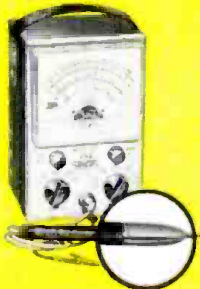

E
COLOR & MONOCHROME
DC TO 5 MC LAB & TV
5" OSCILLOSCOPE #460
KIT \$79.95 WIRED \$129.50
5" PUSH-PULL
Oscilloscope #425:
Kit \$44.95 WIRED \$79.95

A Tests all receiving tubes (picture tubes with adapter), n-p-n and p-n-p transistors. Composite indication of Gm, Gp & peak emission. Simultaneous selection of any one of 4 combinations of 3 plate voltages, 3 screen voltages, 3 ranges of continuously variable grid voltage (with 5% accurate pot.). Sensitive 200 ua meter. 10 six-position lever switches: freepoint connection of each tube pin. 10 pushbuttons: rapid insert of any tube element in leakage test circuit. Direct reading of inter-element leakage in ohms. New gear-driven rollchart. CRA Adapter \$4.50.

B Entirely electronic sweep circuit with accurately-biased inductor for excellent linearity. Extremely flat RF output. Exceptional tuning accuracy. Hum and leakage eliminated. 5 fund. sweep ranges: 3-216 mc. Variable marker range: 2-75 mc

in 3 fund. bands, 60-225 mc on harmonic band. 4.5 xtal marker osc., xtal supplied. Ext. marker provision. Attenuators: Marker Size, RF Fine, RF Coarse (4-step decade). Narrow range phasing control for accurate alignment.

C 150 kc to 435 mc with ONE generator in 6 fund. bands and 1 harmonic band! $\pm 1.5\%$ freq. accuracy. Colpitts RF osc. directly plate-modulated by K-follower for improved mod. Variable depth of int. mod. 0-50% by 400 cps Colpitts osc. Variable gain ext. mod. amplifier: only 3.0 v needed for 30% mod. Turret-mounted, slug-tuned coils for max. accuracy. Fine and Coarse (3-step) RF attenuators. RF output 100,000 uv, AF output to 10 v.

D Uni-Probe — exclusive with EICO — only 1 probe performs all functions: half-turn of probe tip selects DC or AC-Ohms. Calibration without re-

moving from cabinet. Measure directly p-p voltage of complex & sine waves: 0-4, 14, 42, 140, 420, 1400, 4200. DC/RMS sine volts: 0-1.5, 5, 15, 50, 150, 500, 1500 (up to 30,000 v. with HVP probe, & 250 mc with PRF probe). Ohms: 0.2 ohms to 1000 megs. $4\frac{1}{2}$ " meter, can't-burn-out circuit. 7 non-skip ranges on every function. Zero center.

E Features DC amplifiers! Flat from DC to 4.5 mc, usable to 10 mc. Vert. Sens.: 25 mv/in.; input Z 3 megs; direct-coupled & push-pull throughput. 4-step freq.-compensated attenuator up to 1000:1. Sweep: perfectly linear 10 cps — 100 kc (ext. cap. for range to 1 cps). Pre-set TV V & H positions. Auto sync. lim. & ampl. Direct or cap. coupling; bal. or unbal. inputs; edge-lit engraved lucite screen with dimmer control; plus many more outstanding features.

FREE CATALOG shows you HOW TO SAVE 50% on 65 models of top quality professional test equipment. MAIL COUPON NOW!



New Transistor
Portable Radio RA-6
KIT \$29.95
Wired \$49.95
Incl. F.E.T.; less 9V batt.
Prealigned RF, IF
xfmrs; push-pull
audio; 6" spkr.



NEW Power & Bias
Supply for
Transistorized
Eqpt. # 1020
Kit \$19.95
Wired \$27.95

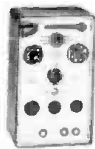

NEW Tube &
CRT Fil.
Tester #612
Kit \$3.95
Wired \$5.95
Fast-checks
radio/TV tubes,
pilot lamps, etc.



Series/Parallel
R-C Combination
Box #1140
Kit \$13.95
Wired \$19.95



Tube Tester #625
Kit \$34.95
Wired \$49.95
• tests 600 mil
series string type
tubes
• illuminated
roll-chart
Pix Tube Test
Adapter.....\$4.50

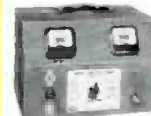

6V & 12V Battery
Eliminator
& Charger #1050
Kit \$29.95
Wired \$38.95
Extra-filtered for
transistor equip.
#1060 Kit \$38.95
Wired \$47.95

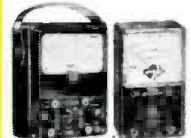

20,000 Ohms/Volt
V-O-M #565
Kit \$24.95
Wired \$29.95
1000 Ohms/Volt
V-O-M #536
Kit \$12.90
Wired \$14.90



33-00 Northern Blvd. L.I.C. 1, N.Y.

Add 5% In the West. © 1959

TURN PAGE FOR MORE EICO VALUES



R-C Bridge & R-C-L
Comparator #950B
Kit \$19.95
Wired \$29.95
Reads 0.5 ohms-
500 megs,
10 mmfd-5000 mfd,
power factor



VTVM Probes

	Kit	Wired
Peak-to-Peak	\$4.95	\$6.95
RF	\$3.75	\$4.95
High Voltage Probe-1		\$6.95
High Voltage Probe-2		\$4.95
Scope Probes		
Demodulator	\$3.75	\$5.75
Direct	\$2.75	\$3.95
Low Capacity	\$3.75	\$5.75

EICO
33-00 Northern Blvd.
L. I. C. 1, N. Y.

EW-6

Show me HOW TO SAVE 50% on Test Instruments
 Hi-Fi Ham Gear. Send free Stereo Hi-Fi
Guide. Send FREE Short Course for Novice License.
Send me FREE Catalog, name of neighborhood dealer.

Name

Address

City Zone State

SEE OUR OTHER ADVERTISEMENT ON PAGE 112

Over 2 MILLION EICO Instruments in use throughout the world. Add 5% in the West.



IF YOU LOVE TO CREATE... BUILD EICO KITS

In **STEREO** and

**Mono HI-FI...
the experts say
your Best Buy
Is EICO**



Stereo Amplifier-Preamplifier HF81†



Stereo Preamplifier HF85t†



**FM Tuner HFT90††
AM Tuner HFT94††
FM/AM Tuner HFT92††**



**100W Stereo Power Amplifier HF89
70W Stereo Power Amplifier HF87
28W Stereo Power Amplifier HF86**



Stereo Integrated Amplifier AF4††



**3-Way Speaker System HFS3
2-Way Bookshelf Speaker Systems
HFS5 and HFS1**



**Stereo Automatic Changer/
Player 1007**

NEW!



- Exclusive advanced systematized engineering
- Latest and finest quality parts
- Exclusive "Beginner-Tested" easy step-by-step instructions
- Exclusive TRIPLE quality control
- Exclusive LIFETIME guarantee at nominal cost

IN STOCK — Compare, then take home any EICO equipment — right "off the shelf" — from 1500 neighborhood EICO dealers throughout the U. S. and Canada.

HF81 Stereo Amplifier-Preamplifier selects, amplifies, controls any stereo source & feeds it thru self-contained dual 14W amplifiers to a pair of speakers. Provides 28W monophonically. Ganged level controls, separate balance control, independent bass and treble controls for each channel. Identical Williamson-type, push-pull EL84 power amplifiers. "Excellent" — SATURDAY REVIEW. "Outstanding... extremely versatile." — ELECTRONICS WORLD. Kit \$69.95. Wired \$109.95. Incl. cover.

HF85 Stereo Preamplifier: Complete master stereo preamplifier-control unit, self-powered. Distortion borders on unmeasurable. Level, bass, & treble controls independent for each channel or ganged for both channels. Inputs for phono, tape head, mike, AM, FM, & FM-multiplex. One each auxiliary A & B input in each channel. "Extreme flexibility... a bargain." — HI-FI REVIEW. Kit \$39.95. Wired \$64.95. Incl. cover.

New HF89 100-Watt Stereo Power Amplifier: Dual 50W highest quality power amplifiers. 200W peak power output. Uses superlative ultra-linear connected output transformers for undistorted response across the entire audio range at full power, assuring utmost clarity on full orchestra & organ. 60 db channel separation. IM distortion 0.5% at 100W; harmonic distortion less than 1% from 20-20,000 cps within 1 db of 100W. Kit \$99.50. Wired \$139.50.

HF87 70-Watt Stereo Power Amplifier. Dual 35W power amplifiers identical circuit-wise to the superb HF89, differing only in rating of the output transformers. IM distortion 1% at 70W; harmonic distortion less than 1% from 20-20,000 cps within 1 db of 70W. Kit \$74.95. Wired \$114.95.

HF86 28-Watt Stereo Power Amp. Flawless reproduction at modest price. Kit \$43.95. Wired \$74.95.

FM Tuner HFT90: Prewired, prealigned, temperature-compensated "front end" is drift-free. Prewired exclusive precision eye-tronic® traveling tuning indicator. Sensitivity: 1.5 uv for 20 db quieting; 2.5 uv for 30 db quieting, full limiting from 25 uv. IF bandwidth 260 kc at 6 db points. Both cathode follower & FM-multiplex stereo outputs, prevent obsolescence. Very low distortion. "One of the best buys in high fidelity kits." — AUDIOCRAFT. Kit \$39.95*. Wired \$65.95*. Cover \$3.95. *Less cover, F.E.T. incl.

AM Tuner HFT94: Matches HFT 90. Selects "hi-fi" wide (20-9000 cps @ -3 db) or weak-station narrow (20-5000 cps @ -3 db) bandpass. Tuned RF stage for high selectivity & sensitivity. Precision eye-tronic® tuning. "One of the best available." — HI-FI SYSTEMS. Kit \$39.95. Wired \$65.95. Incl. cover & F.E.T.

New FM/AM Tuner HFT92 combines renowned EICO HFT90 FM Tuner with excellent AM tuning facilities. Kit \$59.95. Wired \$94.95. Incl. cover & F.E.T.

New AF-4 Economy Stereo Integrated Amplifier provides clean 4W per channel or 8W total output. Kit \$38.95. Wired \$64.95. Incl. cover & F.E.T.

HF12 Mono Integrated Amplifier (not illus.): Complete "front end" facilities & true hi-fi performance. 12W continuous, 25W peak. Kit \$34.95. Wired \$57.95. Incl. cover.

New HFS3 3-Way Speaker System Semi-Kit complete with factory-built ¾" veneered plywood (4 sides) cabinet. Bellows-suspension, full-inch excursion 12" woofer (22 cps res.) 8" mid-range speaker with high internal damping cone for smooth response, 3½" cone tweeter. 2¼ cu. ft. ducted-port enclosure. System Q of ½ for smoothest frequency & best transient response. 32-14,000 cps clean, useful response. 16 ohms impedance. HWD: 26½", 13¾", 14¾". Unfinished birch. Kit \$72.50. Wired \$84.50. Walnut, mahogany or teak. Kit \$87.50. Wired \$99.50.

New HFS5 2-Way Speaker System Semi-Kit complete with factory-built ¾" veneered plywood (4 sides) cabinet. Bellows-suspension. 5/8" excursion. 8" woofer (45 cps. res.) & 3½" cone tweeter. 1¼ cu. ft. ducted-port enclosure. System Q of ½ for smoothest freq. & best transient resp. 45-14,000 cps clean, useful resp. 16 ohms.

HWD: 24", 12½", 10½". Unfinished birch. Kit \$47.50. Wired \$56.50. Walnut, mahogany or teak. Kit \$59.50. Wired \$69.50

HFS1 Bookshelf Speaker System complete with factory-built cabinet. Jensen 8" woofer, matching Jensen compression-driver exponential horn tweeter. Smooth clean bass; crisp extended highs. 70-12,000 cps range, 8 ohms. HWD: 23" x 11" x 9". Kit \$39.95. Wired \$47.95

HFS2 Omni-Directional Speaker System (not illus.) HWD: 36", 15¼", 11½". "Fine for stereo" — MODERN HI-FI. Completely factory-built. Mahogany or walnut \$139.95. Blond \$144.95.

New Stereo Automatic Changer/Player: Jam-proof 4-speed, all record sizes, automatic changer and auto/manual player. New extremely smooth, low distortion moisture-proof stereo crystal cartridge designed integrally with tonearm to eliminate mid-range resonances. Constant 4½ grams stylus force is optimum to prevent groove flutter distortion. No hum, turntable attractions, acoustic feedback, center-hole enlargement. Only 10¾" x 13". Model 1007D: 0.7 mil diamond, 3 mil sapphire dual styli, \$59.75. 1007S: 0.7 mil, 3 mil sapphire, \$49.75. Incl. FET.

†Shown in optional Furniture Wood Cabinet WE71: Unfinished Birch, \$9.95; Walnut or Mahogany, \$13.95.

††Shown in optional Furniture Wood Cabinet WE70: Unfinished Birch, \$8.95; Walnut or Mahogany, \$12.50.

EICO, 33-00 N. Blvd., L.I.C. 1, N. Y. EW-6
Show me how to SAVE 50% on easy-to-build top-quality Hi-Fi. Send FREE catalog, Stereo Hi-Fi Guide plus name of neighborhood EICO dealer.

Name.....
Address.....
City..... Zone..... State.....

Listen to the EICO Hour, WABC-FM, N.Y., 95.5 MC, Mon. to Fri. 7-15-8 P.M., Sat. 11-12 P.M. Ask dealer about EICO's Stereo Records Bonus.
© 1960 by EICO, 33-00 N. Blvd., L. I. C. 1, N. Y.

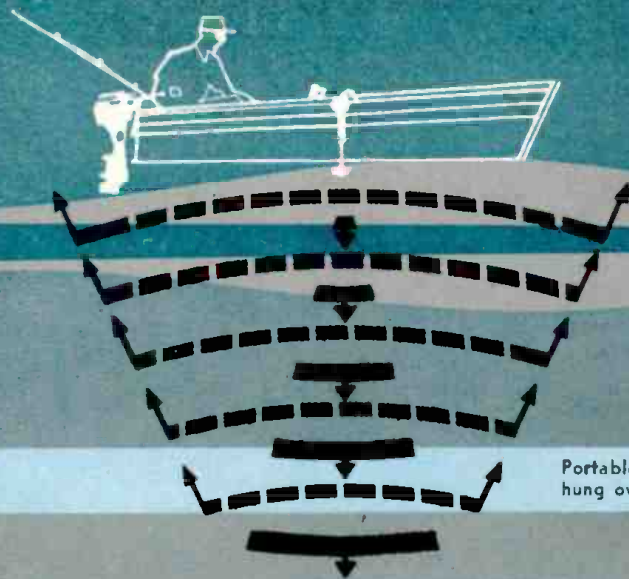

Portable units may even be used in rented boats. Transducer is hung over side to send signals down to detect bottom and fish.

Depth Sounders

FOR SMALL BOATS

By **A. NEWELL GARDEN**
Raytheon Company

Important electronic aid for boatmen—its operation and use, types available, installation and maintenance tips.

THE use of weighted sounding lines to tell the depth of water under a vessel and aid in finding her position was well known even in Biblical times. Among the early records is an account in the Book of Acts (Chapter 27) of a storm-tossed passage across the Ionian Sea when a hand lead line was used to detect the shoaling bottom in time to cast anchor and save the ship from being driven onto a lee shore.

Two-thousand years later the same method was still in use. So common was the hand lead, in fact, that Samuel Clemens borrowed the Mississippi leadsman's two-fathom call for his pen name. Tool of the river pilot and coastwise skipper everywhere was a length of flexible braided line attached to a 7- or 14-pound lead weight. This line was soaked and shrunk to its wet length, then carefully measured for the marks at various fathom depths (1 fathom equals 6 feet). These colorful identifying marks are: 2 fathoms—2 strips of leather; 3 fathoms—3 strips of leather; 5 fathoms—white cotton cloth; 7 fathoms—red woolen cloth; 10 fathoms—leather with a hole in it, etc.

Even in the dark the nearest mark could be identified by its feel. The points so tagged were the "marks"; those depths falling in between were called "deeps" and were estimates.

Carefully coiling the leadline in his

inboard hand, the leadsman from his position in the "chains" at the base of the foremast shrouds would swing the pendulum in a great arc and cast it forward (not without a certain amount of risk to the bow lookout) and then quickly overhaul the line until it was plumb as the ship passed over it.

From the bridge the master, who had slowed the ship to give the lead time to sink to the bottom before the ship overran it, anxiously awaited a colorful report such as "and a half ten, sir" (63 feet). At the command, "Arm the lead," the leadsman squeezed tallow into a recess in the bottom of the weight. On its next probe it came up with sand, mud, gravel, grass, or clean dents from rocks and the navigator could translate these bottom conditions into an estimated position on the chart.

Larger ships operating off shore carried a new sounding machine during the first third of this century but it was a mechanical device unchanged in principle from the one used in the Ionian Sea. The ship was slowed or stopped and a heavy lead weight was payed out from a giant "fisherman's reel" installed on the quarter. The marked steel cable often left its mark in lost fingers and fouled propellers. A variation was the pressure tube which was lowered to the bottom and the depth read on a pressure gauge in-

side a cavity in the lead. Even when properly used and a deep sounding was obtained, it was not too conclusive for the charts of that era grew sketchy farther off shore.

Spurred by the 1912 sinking of the "Titanic" after it collided with an iceberg, Professor B. A. Fessenden continued his studies of the properties of sound in water in an attempt to find a warning system to detect icebergs. While aboard the U. S. Coast Guard Cutter "Miami" in 1914, Dr. Fessenden heard extraneous echoes after transmitting a sonic signal through the water near an iceberg.

A low-frequency signal had very little directional sense. The scientist, although failing to find a positive method for detecting icebergs at long ranges, did translate these observations into the first echo depth sounder. The "Fathometer," as he called it, was installed in the U. S. Coast and Geodetic Survey vessel "Lydonia" in 1924. (Incidentally, "Fathometer" is a trademark of *Submarine Signal Co.* which became part of *Raytheon Co.* in 1948.)

As soon as the new electronic depth sounder had proved itself, the Coast and Geodetic Survey intensified its charting projects. Such a wealth of soundings was accumulated that even the style of charts was changed to show underwater contour curves, ac-

curately defining the submarine profile as authentically as the topographer's charts detail hills and valleys ashore.

Depth-Sounder Operation

The electronic depth sounder is the translation of echo-ranging principles into a system especially adapted for underwater transmission. Even today, some Scandinavian navigators, without radar or electronic aids, sound a sharp blast of the ship's whistle when snowed-in in a steep-walled fjord. Carefully measuring the time for the first echo to return from the rock wall, they can estimate their distance from shore.

In water sound travels much faster, of course, traveling at 4800 feet per second, or almost five times the speed of sound in air; hence, the echo of a sound will return in milliseconds.

The modern electronic depth sounder substitutes a pulse of ultrasonic energy for the ship's whistle and a carefully regulated, constant speed motor or a timing circuit for the stopwatch. The outgoing pulse is applied to a transducer and because of its relatively high frequency (about 200 kc.) travels

straight to the bottom in a conical beam of about 8-10 degrees.

Heart of the transducer is an electrostrictive material. Barium titanate, the most common substance in use today for small-boat units, is formed into round or rectangular molds then fired in ceramic kilns. A voltage is applied during the cooling process to establish an electrical polarity within the crystals.

In the transducer, electrodes are attached to two sides of the crystal and the water face is filled with an epoxy compound which retains its plasticity. When the transmitted signals reach the crystal, they cause it to vary in thickness in response to the voltage applied. This sudden change in thickness is transmitted mechanically to the water through the epoxy sealer, generating a directed compression wave through the water.

The shape of the crystal determines the pattern of the outgoing signal. A round one forms a conical beam; a rectangular one a pyramidal beam. The dimensions of the crystal usually embrace five or six wavelengths to pro-

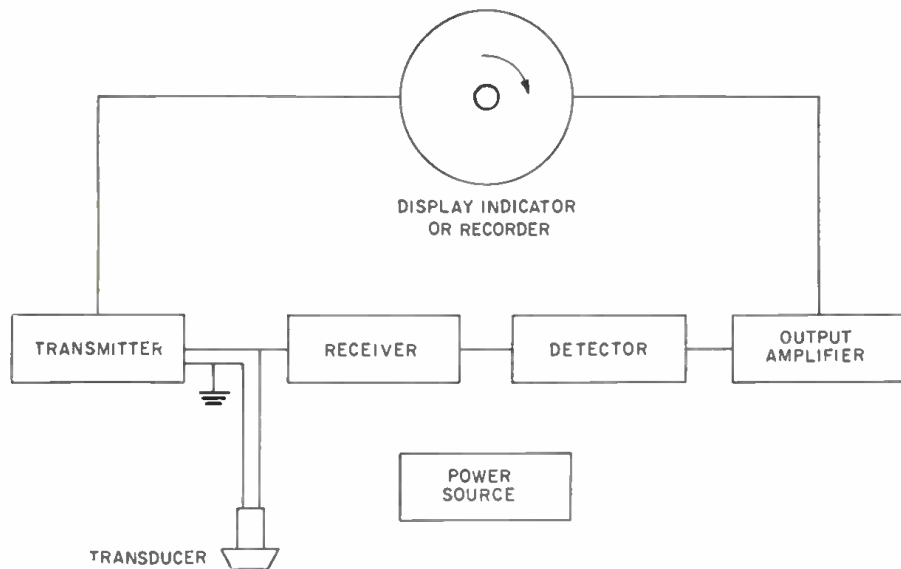

Simplified block diagram typical of most flashing light and recording depth sounders. When rotating arm of timing motor passes the zero mark on adjacent scale, it triggers transmitter which sends out ultrasonic signal through transducer. The echo is received and amplified. When it reaches the indicator, it fires the neon bulb on the rotating arm of the indicator or burns carbon on chart paper in a depth recorder.

DEPTH-SOUNDER MANUFACTURERS

- Aerosonic Marine, Inc., 1212 Hercules Road, Clearwater, Fla.
- Apelco, 213 E. Grand Ave., South San Francisco, Calif.
- Bendix-Pacific Div., 8211 Lankershim Blvd., North Hollywood, Calif.
- Bludworth Marine Div., Kearfoot Co., Inc., 1500 Main Ave., Clifton, N. J.
- Curtiss-Wright Corp., Santa Barbara Div., 6767 Hollister Ave., Goleta, Calif.
- Edo Corp., 13-10 111 Street, College Point, N. Y.
- Electro-Voice, Inc., Marine Division, Buchanan, Mich.
- ERA Dynamics, Inc., 67 Factory Place, Cedar Grove, N. J.
- Heath Co., 305 Territorial Rd., Benton Harbor, Mich.
- Lowrance Electronic Mfg. Corp., 112 E. 13th St., Joplin, Mo.
- Multi-Products Co., Inc., 21470 Coolidge Highway, Oak Park 37, Mich.
- Munston Electronic Mfg. Corp., Beech St., Islip, N. Y.
- Pearce Simpson, Inc., 2295 N.W. 14th St., Miami 35, Fla.
- Raytheon Marine Operations, 319 Roebling Rd., South San Francisco, Calif.
- RCA Communications Div., Camden, N. J.
- Ross Laboratories, Inc., 124 Lakeside Ave., Seattle, Wash.
- Sonar Radio Corp., 3050 W. 21st St., Brooklyn 24, N. Y.
- Stickell Marine Products Co., 1616 Mt. Royal Ave., Baltimore 17, Md.
- White, Wilfred O., & Sons, Inc., 178 Atlantic Ave., Boston 10, Mass.
- Winston Electronics, 4000 N.W. 28 St., Miami, Fla.



Electro-Voice Model 5100

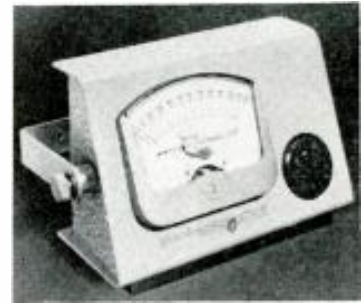

Winston "Depthmeter 400"



Apelco MS-8 "Sea Scope"



White "Transcentury"

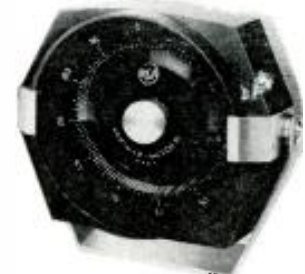

RCA "Depth-O-Meter III"

Curtiss-Wright "Depth Probe"



vide optimum power with directional qualities.

The returning echo wave impinges mechanically against the transducer crystal. Reversing the procedure when transmitting, the crystal changes thickness and registers a fluctuation in the voltage applied to it. This is the electrical echo which is detected and amplified.

Time measurement, which is the basis for determining the depth of water, is usually accomplished by having the outgoing signal energize a small rotating neon bulb as it passes a zero position on the adjacent scale. The motor, whose speed is proportional to time and hence depth, spins the now unlighted neon bulb which is relighted by the returning signal. The position of the bulb when it is again lighted becomes the depth reading which is read against an adjacent dial calibrated in feet or fathoms.

Assuming a flashing light unit in which one revolution is to indicate 120 feet—the outgoing signal will take .05 second to travel the 240 feet down and back. The motor then must carry the neon bulb through one revolution in .05 second or it must rotate at 1200 rpm.

Types of Units

Depth sounders may be classified according to the manner in which the information is displayed. Indicating units give the instantaneous reading at the moment of observation. A recorder gives the present depth and automatically posts the information beside the last reading to accumulate a running record of the submerged topography.

Most indicating units are of the neon bulb variety. All flashing light units must compete with the ambient light—usually bright sunlight reflected from the water. Even a bright sky background can make reading difficult, depending on how the units are installed. Some are fitted with hoods to keep out the sunlight while others of newer design have the raceway for the rotating neon bulb depressed in a specially angled light trap that deflects the outside light. Improved design of the neon bulbs is also making it easier to read flashing-light units.

A variation of the flashing-light indicator is the meter-type device which reports the instantaneous depth with a presentation resembling a voltmeter. Most of these employ multivibrator flip-flop circuits feeding RC circuits. Output is actually an amplitude measurement on a milliammeter or a voltmeter. These can be read in the brightest sunlight but don't provide the boatman with the interpretation of bottom conditions that is possible with flashing light units.

With flashing light units whose neon bulbs rotate through a full circle it is possible to read a dividend depth on the second revolution and add it to the "maximum" reading of the scale. Care must be taken, of course, to avoid confusing a correct shallow sounding for a second-stage deep signal.

Recording units make a profile of the depth on a roll of sensitized paper which is pulled through the machine at constant speed making a plot of depth versus time (time being proportional to the distance the boat has advanced). Passing fish are more apt to be noticed on the graph paper and underwater variations are more easily sensed.

Frequencies of about 200 kc. have been selected for most units designed for pleasure-boat use. This permits a very directional beam. Depth sounders

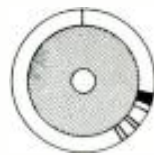

ROCKY BOTTOM

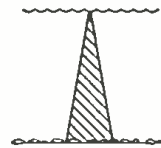

MUDDY BOTTOM

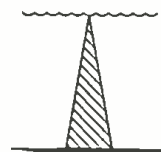

STEEP INCLINE

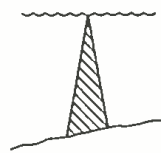

FISH OVER HARD BOTTOM

Interpreting bottom conditions with flashing-light depth sounder. Rocky bottom will return strong echo followed by later flashes as ricochet echoes return to surface. Mud bottoms, poor reflecting surfaces, return weak echoes except with low-frequency units where beam returns a wide echo. A steep incline will cover the dial from the greatest to least reading falling within the cone of the signal. Fish appear as small flashes at depths where they are swimming.

designed for deep water employ lower frequencies, down to 40 or even 20 kc. to generate wider beam patterns so that the roll and pitch of a deep-water vessel will not deflect the signals which take longer to return to the surface in deep water.

The higher frequencies which can be used in shallow-water units, permit smaller devices and have the added advantage of ignoring many of the unwanted background noises, caused by the vessel passing through the water, machinery noises transmitted through the hull, and propeller throb. Increasing

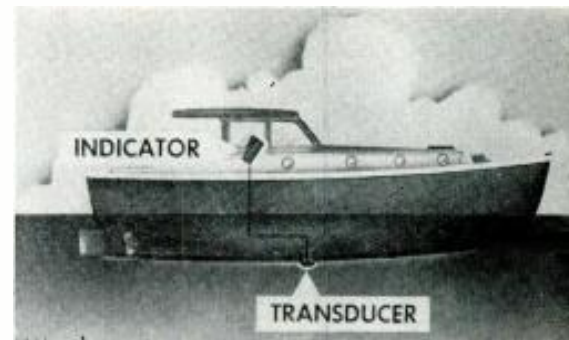

Most small-boat depth sounder installations consist of an indicator placed near the chart table or steering station and the transducer fitted through the hull. In power boats best location is usually from amidships to about two-thirds of the boat's length measured from the bow. Transducers are often recessed in stems of sail boats.

the frequency would seem to be an excellent way to make even smaller depth sounders and keep them free from noise interference. However, there is a practical ceiling on the frequency. The attenuation loss at maximum depth increases with the square of the frequency and can make the signal unusable except when over a smooth, hard bottom which will not absorb any significant amount of energy.

Installation

Installing a modern depth sounder is a relatively simple task and, as there are no r.f. frequencies transmitted, the work need not be performed by FCC license holders. When the boat is out of the water the transducer can be installed, giving due consideration to the hull design, to locate it where it will be as free as possible from the turbulence of the bow, other hull fittings, and the thrashing of the propeller. It must be kept wet, of course, to obtain readings. This further pins down the location in a planing hull. Generally speaking, a spot about two-thirds of the boat's length from the bow and in the garboard strake, next to the keel, is the most acceptable. Leveling blocks, inside and out, are added to shore-up the transducer so that it conforms to the curvature of the hull, which is ordinarily minimal near the keel, and assumes a perpendicular attitude when the boat is underway.

The actual installation consists of drilling a hole through the hull through which the transducer shaft will pass, assembling the transducer and its leveling blocks and bolting them into position using a canvas caulking pad to which a generous quantity of red lead or other plastic seam compound has been applied to seal any possible leaks.

Some manufacturers recommend washing the outboard face of the transducer in a detergent before the boat is launched to minimize the trapping of tiny, troublesome air bubbles on the transducer.

Locating the indicator is even easier. Simply hang its mounting bracket near the steering station or wherever you are most apt to be when you'll need a

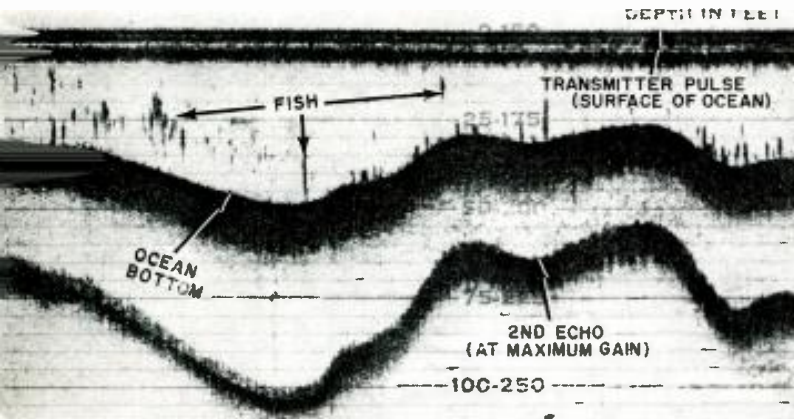

This tracing from a recording depth sounder shows how the unit aids fishermen. Level trace across top is outgoing reference signal. Middle, irregular echo line is the ocean's bottom; lower trace is second echo which is particularly well defined because gain is set at maximum to detect fish. These are speckled above the middle echo and they appear at their actual depths.

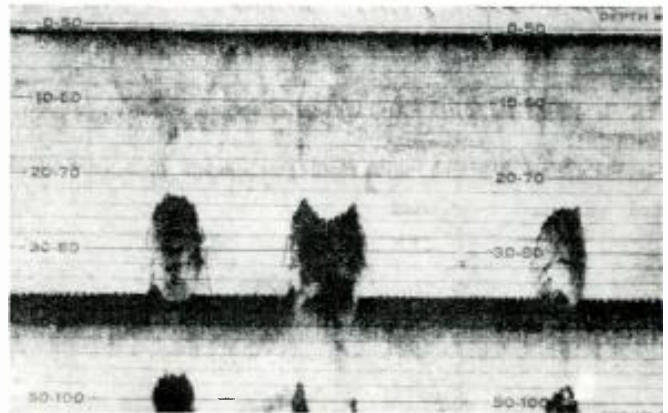

Skindivers hunting the sunken wreck of the SS "Andrea Doria" found it well defined on their recording depth sounder. Repeated images were formed as the boat criss-crossed the wreck to find the highest point before diving started. Giant liner is shown lying on its side in 36 fathoms (216 feet) of water. Divers descended 23 fathoms (138 feet) to reach high side of ship.

sounding. The motor in the depth sounder will set up a limited magnetic field when running. It should be safe to place it as close as two feet from the steering compass but before you mangle the mahogany turn it on and approach the compass with it running to insure that it will not add unwanted deviation to the compass. After all, when you're in a tight spot you'll want them both operating properly with minimal error.

If your indicator is a flashing-light type, shield it from the direct sun as much as possible for easier viewing.

Lead the cable from the indicator to the transducer as far as possible from the boat's engine ignition. Interference may be encountered from the engine which will show as "strays," or sporadic flashes, on the dial. Shielding the transducer lead and installing resistor-type spark plugs will minimize this interference if encountered.

During installation of the transducer cable avoid using staples. A staple accidentally puncturing the cable or a clamp that pinches it too tightly can disrupt signals between the indicator and transducer.

The transducer is matched to the in-

dicator and the length of cable is critical. If you have more cable than you need, coil it down but do not shorten it. If a longer cable is required, the manufacturer can supply a properly mated one.

Plug the cable into the transducer and the leads to the boat's power if your unit is to operate from the boat's starting batteries or mains. Care should be taken to insure the proper polarity. Now you're in business.

At your first opportunity, verify the soundings with a hand lead or a drop-line, then use the depth sounder frequently in good weather to gain confidence in your new navigational aid.

Using a Depth Sounder

Many experts regard the electronic depth sounder as the first electronic aid which the pleasure boatman should purchase. It's a universal tool for all boatmen—even the inland enthusiast and the coastal boatman who stays close to shore and seldom is out after sunset. Its applications as a navigational tool, as an aid in preventing strandings, and as a fishing accessory are all noteworthy.

As a navigational aid, the depth

sounder can give the boatman a quick reading of the depth of water under his hull. By taking the bearing of a fixed point on land, or if necessary, even a buoy, the boatman can lay down this bearing on the chart. Then, roughly estimating his distance off, look for the point on the chart where the observed sounding matches the chart. The sounding should be corrected, if necessary, to reflect the depth of water and not simply the depth of water under the keel. In tidal waters it is also necessary to add a correction to the charted depths to compensate for the condition of the tide. The charts show the least amount of water, the low water condition, so that stand of tide must be added for an accurate comparison.

In some areas, like the Gulf of Mexico, a depth sounding and a bearing combine to make an excellent fix due to the even slope of the sea floor in most areas.

In waters with irregular bottom contours, a line of soundings makes a useful position-finding device. The soundings are read at regular intervals, plotted on tracing paper and then matched against the chart. For example, if you were aboard a boat making a good six knots, you might note the soundings at five-minute intervals over a period of 20 minutes. Draw a course line on a piece of tracing paper and plot the soundings you observed along the track line you just drew. At six knots the soundings will be one-half mile apart. Use the same scale as the chart to plot the soundings on the tracing paper.

Maneuvering the tracing paper into approximate position on the chart and aligning the course line properly with the same true heading on the chart, the track line can be manipulated in the general area until it "fits" the soundings on the chart, thus enabling the boatman to refine his estimated position.

More sophisticated navigators would probably prefer a recording-type depth sounder for this kind of navigation.

(Continued on page 96)

Cover Story

TYPICAL of the large selection of electronic depth sounders that are available to the boatman are the four units shown on our cover. At the top right is the "Heath-kit" Model DS-1, using a flashing-light indicator reading depths up to 100 feet. This hooded, all-transistor kit operates from six standard flashlight cells and one 9-volt battery. The cabinet is made of heavy-gauge aluminum with tongue-and-groove construction.

Below this unit is "The Pilot" dual-beam depth and distance indicator by ERA Dynamics, which combines two crystal transducers in the plastic housing at the right. The flashing-light indicator is divided in half to indicate depths to 140 feet and underwater obstructions lying in the boat's path. The unit, completely transistorized, operates from either its own mercury battery or the boat's d.c. supply.

At the extreme left is an example of a

depth recorder, the Bendix DR-19. This unit uses five scales (up to 300 feet) to show close-ups of ocean bottom contours on economy-sized graph paper just 1.8 inches wide. The transducer sends out 400 soundings a minute at 75 kc. in a 30-degree arc to insure echoes even if the vessel is rolling heavily. The roll chart accommodates 30 hours of operation. The Model DR-19 operates from the boat's d.c. supply.

The Raytheon DE-708 "Angler Fathometer," at the lower right, is a transistorized unit 6 inches in diameter. A three-way bracket permits counter-top, overhead, or bulkhead mounting. The special light trap and high-intensity bulb enable easy daylight viewing. The scale reads from 0 to 120 feet. The DE-708 is completely portable with a self-contained mercury battery. The unit may also be used on an external 12-volt battery.

(Cover Photo by Carl Baker)

TV Weather Satellite

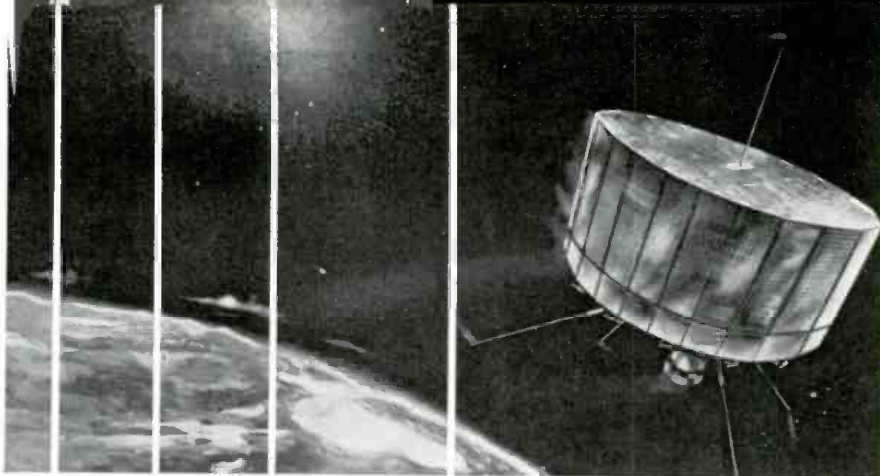

Most elaborate electronics package yet sent into orbit transmits cloud-cover photos to ground-control stations.

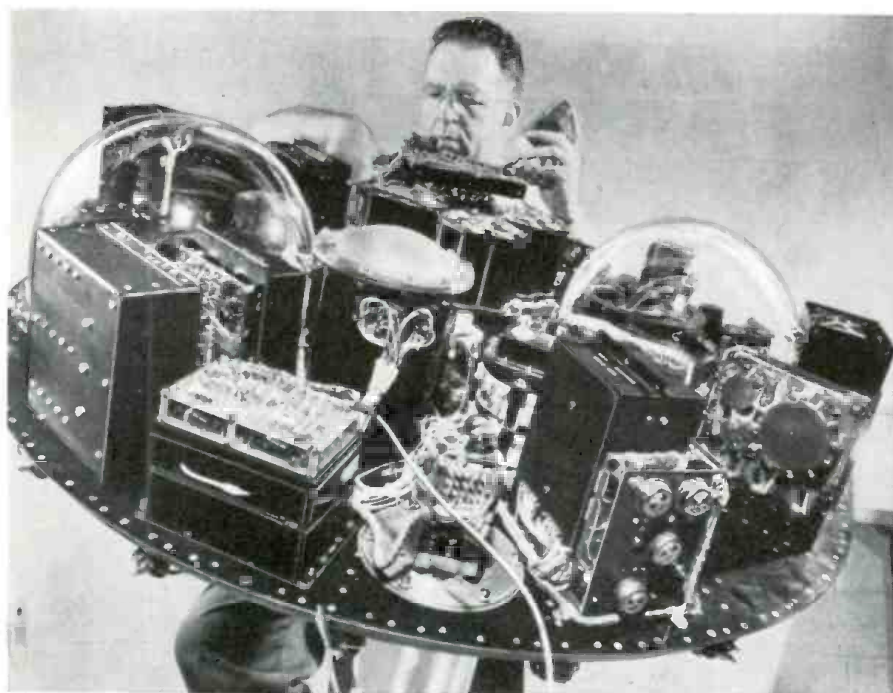

Internal electronic system of satellite is mounted on 42" circular base. In foreground, identified by cylindrical lens extending below base plate, is one of the two TV cameras, surrounded by sub-systems for receiving, transmitting, and switching. Two specially developed magnetic tape recorders are under transparent domes.

A TV weather satellite which gives about an 850 square mile view of the weather picture has been successfully launched as part of the National Aeronautics and Space Administration program. Two television cameras to photograph the earth's changing cloud-cover patterns are mounted in NASA's "Tiros," developed by RCA for the U. S. Army Signal Corps. "Tiros" is the abbreviation of Television Infra-Red Observation Satellite. The satellite fired does not have the infra-red sensors to map relative temperatures of the earth's surface, but a later one will have these sensors.

The path of the satellite, circling the globe from west to east about every 90 minutes at an altitude of about 400 miles, will permit cloud observations throughout a belt extending from the latitude of Santa Cruz, Argentina, in the south, to the latitude of Montreal, Canada in the north. The vehicle is stabilized in space by spinning at the rate of 12 rpm. During its planned op-

Complete satellite is being positioned here for outdoor tests of the solar-cell power supply that covers the sides and top of unit. Engineer is adjusting lens of wide-angle TV camera. Four rod-like transmitting antennas extend from the hub of the circular base. A single upright rod protruding out of the top of the satellite (visible in top drawing) is for receiving. The two TV cameras use special 1/2" Vidicon tubes. In contrast to broadcast-type equipment, the cameras take a series of still pictures, exposed by electrically operated shutters. Exposure time is 1.5 milliseconds.

erating lifetime of 90 days, the satellite is expected to complete 1300 orbits.

One of the two TV cameras has a wide-angle lens which covers a large area but with little definition. This is augmented by a second camera with a narrow-angle lens to pin-point smaller sections of cloud cover and to provide more detailed pictures. Both provide meteorologists with pictures of hurricanes and cyclonic patterns. The resolution is roughly comparable to commercial TV sets and may even show individual cloud types, tornado breeders, and thunderstorms. Mosaics made up of a number of "Tiros" photos should aid meteorologists in making more accurate long-range and immediate weather forecasts.

The information gathered by the TV cameras in individual photographs is stored on 1/2-inch magnetic tape running at a speed of 50 ips in specially designed video recorders within the satellite. This information is then fed, on radio command, to ground stations at Fort Monmouth, N. J. or Keana Point, Hawaii. Ground stations can also take their own pictures. When the satellite is in range, it can be commanded to transmit the TV picture of the moment without being taped.

-50-



Compliance of Phono Pickups

By PETER E. PRITCHARD

Audio Products Sect., General Electric Co.

What exactly is compliance? How high should compliance be? Should vertical compliance be equal to lateral?

Here are answers to these and other important questions.

WHEN reading the various claims made for stereo cartridges, one of the most confusing of the characteristics specified is that of compliance. What exactly is compliance? Is it true that the higher the number the better the cartridge? Should vertical compliance be equal to lateral?

First, what is meant by compliance. Compliance is a measure of the ease with which the stylus may be deflected from its rest position. It is defined in terms of the amount of movement that will result when a given force is applied to the stylus and is usually expressed in millionths of a centimeter deflection resulting from the application of a force of 1 dyne (1 dyne = .00102 gram), that is, $\text{cm./dyne} \times 10^{-6}$.

Unfortunately, the measurement and evaluation of compliance is not as simple as it might appear from the foregoing. For instance, there is little point in measuring compliance statically, because a pickup stylus is in constant motion when in actual use. In order to mean anything, therefore, the measurement must be made dynamically.

A given compliance measure will, in general, be true only for the given conditions under which the measurement was made. Compliance varies with frequency, due to the non-linear frequency characteristics of the damping material, and with amplitude, due to non-linear suspension. The damping materials used in pickups have the characteristic of greater stiffness with higher velocity and, therefore, with higher frequency. This could be likened to the sort of resistance met with when moving one's hand back and forth under water. If the hand is moved slowly, little resistance is felt, but as the speed increases, so does the resistance until it becomes almost impossible to move any faster. A non-linear suspension is one where the displacement of the

stylus is not always proportionate to the force applied (i.e., if the stylus moves .002" when a force of one gram is applied, it may only move an additional .001" when another gram is added).

Compliance and Tracking

It must be apparent by now that the single compliance figure usually quoted for a pickup is, at best, only a very rough guide as to its tracking abilities and can be very misleading. It is quite possible to have two pickups both of which have the same published (and truthful) compliance, as measured at 50 cps and .001-inch amplitude, and yet if tested for compliance at 1000 cps would reveal a difference between them of 2:1. Of course, the pickup having the higher compliance at 1000 cycles would track much better than the other, although both tested equally well at 50 cps. (The apparent lack of compliance and mistracking at mid-frequencies is usually the result of increased mechanical resistance, viscous friction, which is analogous to ohmic resistance.)

As is generally known, compliance is only one of the parameters which affect the tracking ability of a pickup. The thing one is really interested in is how much pressure the record groove walls are required to exert on the stylus under the various conditions of velocity, amplitude, and acceleration encountered during the playing of a record.

The mass of the moving parts of the pickup, as felt at the stylus tip, becomes increasingly important at higher frequencies. Here the ability of the stylus to follow the rapid changes in velocity of the groove is of prime importance. The heavier the moving parts, the more difficult it is for them to accelerate and decelerate with the

ELECTRONICS WORLD

speed required. Under certain conditions (i.e., resonance), mass and stiffness actually aid each other in providing lack of resistance to stylus movement. At all other times, however, the opposite is true.

It would seem, then, that it is highly desirable to have as much compliance as possible at all frequencies. There are, however, many disadvantages in having too high a compliance. If compliance were infinite, then it follows there would be zero restoring force. The stylus would just collapse when placed on the record. Even in the case of a stereo cartridge where the need for good vertical compliance is obvious, it must, nevertheless, not be so high that the stylus is unable to support the pickup arm at the necessary tracking pressure. Indeed, for this reason, the vertical compliance is often kept a little lower than the lateral in stereo pickups of good design. Lateral compliance should also be restricted sufficiently to prevent tone-arm drag from causing serious stylus displacement.

These statements, of course, refer to compliance at very low frequencies or d.c. In practice, compliance always diminishes to some extent as frequency increases. As already mentioned, excessive mass is also responsible for mistracking and if this happens to be (as is often the case) the limiting factor in tracking ability, then there is little virtue in having a compliance value very much higher than that required to allow tracking at this limiting stylus pressure.

How Much Compliance?

It is interesting to see just what compliance is necessary in order to obtain perfect tracking at a given pressure. Correct compliance is determined by two factors: first, the stylus pressure at which the cartridge is to operate and second, the maximum amplitude occurring on the records to be tracked. The minimum permissible compliance will be that which produces a restoring force equal to the tracking force when the stylus is deflected an amount equal to the maximum recorded amplitude. With less compliance (more stiffness), the increased restoring force causes the stylus to lose contact with the groove.

This minimum compliance requirement is obvious in the case of vertical motion where the compliance—amplitude restoring force—subtracts from the tracking pressure. A moment's consideration will show that the same must be true in the lateral direction since the groove walls, being at an angle of 45 degrees, must be balanced by an equal vertical force in order that the stylus remain in contact with the groove wall. This minimum compliance is expressed by the following formula:

$Compliance \text{ in cm./dyne} \times 10^{-9} = (Maximum \text{ groove displacement in cm.} \times 10^9) / (980 \times Stylus \text{ pressure in grams})$.

The maximum groove displacement found on LP and stereo records is about .005 cm. Using this figure and supposing we require our pickup to track at

a pressure of 2 grams, then we have:
 $Compliance = (.005 \times 10^9) / (980 \times 2) = 2.55 \text{ (approx.)}$

Due to other factors such as record warpage, tone-arm drag (and to some extent stylus mass), it would be advisable to add a safety factor of about 50% to this figure, or about 3.75 cm./dyne $\times 10^{-9}$. Note that the above formula shows that we could track at only 1 gram pressure with a compliance of little more than 5 cm./dyne $\times 10^{-9}$. When we start employing such high or even higher values of compliance, the effective mass at the stylus tip becomes the limiting factor in proper tracking.

The maximum recorded amplitude in the vertical direction, as found on stereo records, rarely exceeds .0025 cm. due to the phasing techniques used in stereo recording. For this reason the vertical compliance of a stereo pickup is often reduced to a value as low as half that of the lateral with complete safety. As mentioned before, the stylus has to absorb the tracking force and also most shocks in this direction; it is a distinct advantage where this can be done to have a greater vertical stiffness (i.e., lower compliance).

Methods of Measurement

There are a number of different ways of making compliance measurements, most of which are based on the technique of adding a large mass of known magnitude to the pickup's moving parts such that the mass of these parts is negligible compared to the total mass, which may then be assumed to be equal to the added mass. The system is then driven externally, usually from an audio oscillator. The output from the cartridge is observed and the driving frequency varied until a peak in output

is seen. This indicates the system is being excited at its resonant frequency and the compliance can then be calculated from the following formula: $C = 1 / (4\pi^2 MF^2)$, where $C = \text{compliance in cm./dyne}$; $M = \text{total mass in grams referred to the stylus tip}$; and $F = \text{resonant frequency in cps}$.

A typical compliance meter is shown in the photograph. The rod *A* is free to move about the axis indicated. This rod is driven magnetically via coil *B* and pole pieces *C*. The cartridge to be tested is held in clamp *D* and the rod will rest on the stylus, with a pressure as close as possible to that used during the playing of a record. The coils are energized by a variable-frequency oscillator, the pickup is connected to a v.t.v.m., and the compliance measured as previously described. This meter is so designed that it may be rotated through 90 degrees and used to measure vertical compliance as well.

Methods of measurement differ considerably from manufacturer to manufacturer—both as to the equipment used and the frequency and amplitude at which measurement is made. The Electronic Industries Association is, at present, attempting to reach agreement among its members for the establishment of standards of frequency and amplitude. Such a standard, when it appears, will certainly render compliance specifications much more meaningful.

To sum up, it would seem that the most useful criterion for the customer (and, in many cases, the engineer) to use in judging the merits of such specifications as compliance, mass, etc. is the ability of the cartridge to track heavily modulated records at as low a practical stylus pressure as possible

—50—

A typical compliance-measuring setup. The rod *A* is free to move about the axis indicated. This rod is driven magnetically by coil *B* and pole pieces *C*. The end of the rod rests on the stylus of the cartridge which is clamped at *D*. An audio generator is connected to coil *B* to drive the rod, and an output voltage measurement is taken with a v.t.v.m. connected to the pickup. Photo shows lateral compliance being checked. System may be turned 90° to measure vertical compliance.

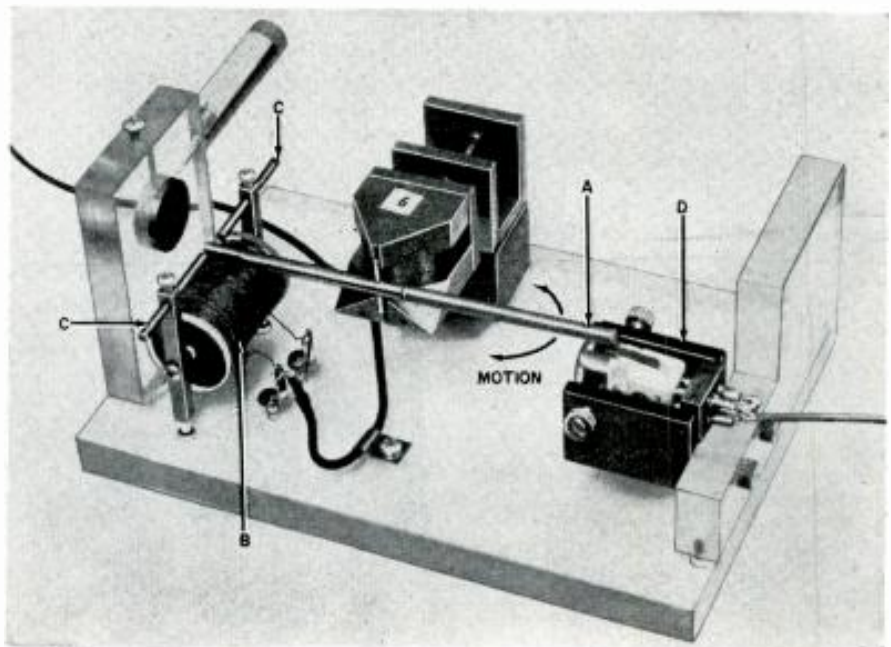

1 7/8-IPS

Fig. 1. Simplified drawing showing how tape is automatically threaded through machine in new CBS-3M tape-cartridge system.

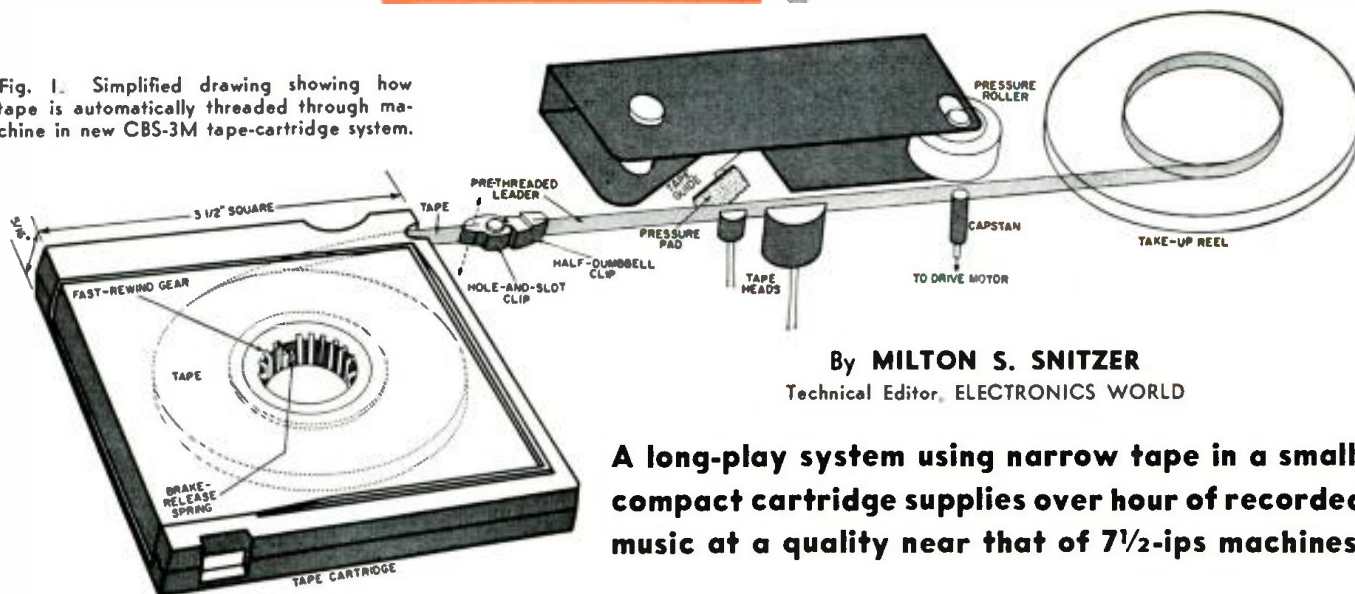

By MILTON S. SNITZER
 Technical Editor, ELECTRONICS WORLD

A long-play system using narrow tape in a small, compact cartridge supplies over hour of recorded music at a quality near that of 7 1/2-ips machines.

Tape System for Stereo

AT a standing-room-only technical session during the recent IRE Convention, Dr. Peter C. Goldmark of CBS Laboratories demonstrated a new tape system developed for Minnesota Mining and Manufacturing Co. This new system, designed for home use, has been the subject of much speculation in the industry for the past few months. (For some details along these lines, refer to Bert Whyte's "Sound on Tape" in this issue.)

Heart of the tape player demonstrated is a small, compact tape cartridge a mere 3 1/2 inches square and 3/4 inch thick. This cartridge is loaded with enough special narrow tape, only 150 mils wide (about 1/2 inch), to play continuously a stereo selection over an hour long. What is more, the player will accommodate five such tape cartridges which are played automatically in much the same way as an automatic record changer plays phonograph discs. Even with the ultra-slow speed of 1 7/8 inches-per-second, performance is claimed to approach the best obtainable 7 1/2-ips machines. The same instrument can also be used as a home recorder when loaded with blank-tape cartridges.

The demonstration conducted by CBS seemed to bear out the claims. At the conclusion of the technical papers a striking A-B test was conducted. One selection from "My Fair Lady" and a portion of the Mendelssohn "Violin

Concerto" had been copied from the original 15-ips tape masters onto the new 1 7/8-ips cartridge. This had then been copied onto a 15-ips half-track tape along with the same selections obtained directly from the master. The final tape was played back to the audience on a professional 15-ips tape machine. It was thus possible to make a direct comparison between the two systems.

Although at least one of the selections was not particularly rich in extreme high frequencies, there was a remarkable similarity of sound when switching between the 1 7/8-ips and the

Fig. 2. Sub-assembly of playback head before coils are mounted on the laminations.

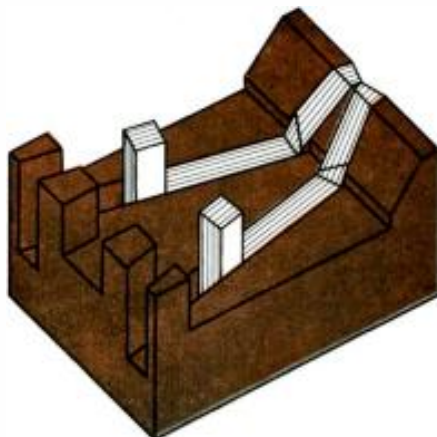

15-ips versions. From where we were sitting in the first row of the large listening room, it was very easy to tell when switching was done but it was not at all easy, at least in some passages, to tell which version we were listening to. No wow or flutter could be heard in either version and good high-frequency response characterized both. CBS claimed an over-all flat frequency response from 30 to 15,000 cps, but this response is at the reduced level of -18 db relative to a level giving 3 per-cent distortion at 1 kc.

The tape machine used for the demonstration was an engineering prototype, and pre-production models of the unit are not expected until later this year. Because of the time required for tooling and actual production, no commercial instruments are expected for the home music market until 1961. Such instruments are to be marketed by Zenith Radio Corp. in the company's console models.

Immediately after the CBS disclosure and demonstration, Ampex Corp. announced that it too has a new recording technique that will make it possible to commercially record and duplicate tapes to play at 1 7/8 ips. According to Herb Brown, Ampex vice-president, it will be at least another "two to three years" before pre-recorded tapes incorporating the new principles are developed to compete with the phonograph record in price and performance. He

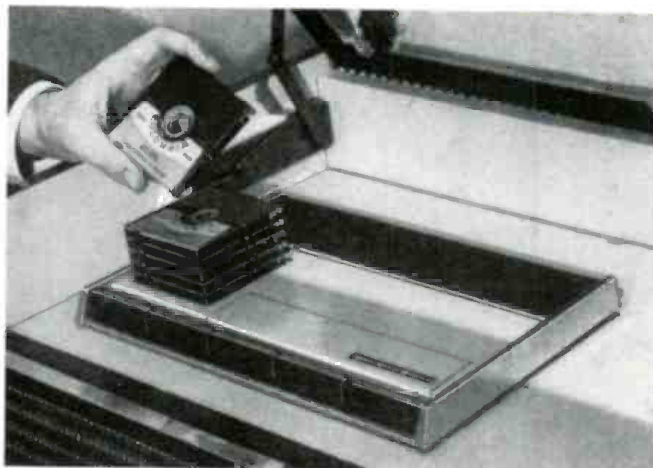
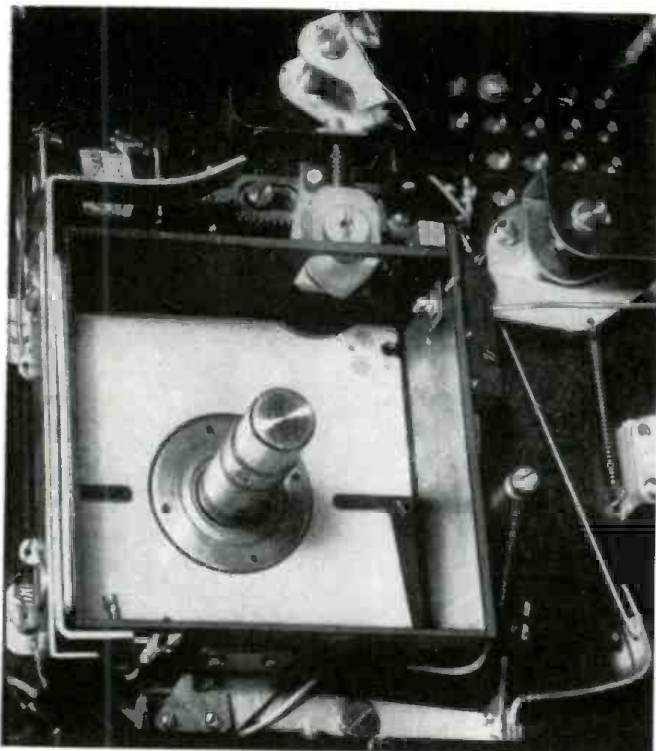

▲ Top view of prototype model of the new tape machine described. Stack of cartridges is pushed down into the square well, and button is depressed in order to begin the automatic operation.

▲ Close-up of the tape well showing the large spindle on which the tape cartridges are loaded. Near the upper right-hand corner may be seen the half-dumbbell clip at end of the leader.

added that the new standard 7½-ips, four-track, reel-to-reel tapes will remain a major factor in high quality home entertainment long after the slow-speed techniques are actively used in commercial production.

At the same time, Brown pointed out that if the industry can agree on a single standard of the basic magazine or cartridge concept, *Ampex* will cooperate by (1) disclosing details on its method of producing slow-speed recordings, (2) license its 1⅞ recording process royalty-free, and (3) make available duplication equipment and conversion kits.

Brown said he foresees "harmonious co-existence" between the tape magazine and the 7½-ips, four-track, reel-to-reel standard since each will appeal to a different segment of an ever-growing market.

Special Tape & Special Heads

One of the reasons for the success of the *CBS* system is the use of a new special magnetic tape, still only in pilot production at *3M*. This tape is 150 mils wide and 1 mil thick. Print-through does not appear to be much of a problem due to the shorter wavelengths that occur at the slow speeds and the special head design that is used. There is provision for three tracks on the tape, each 40 mils wide. Because of the narrow tracks used, head alignment becomes less of a problem. Two of the tracks are used for the conventional left and right stereo channels. The third track was suggested by Dr. Goldmark for use as a *delayed monophonic channel*. With this signal applied to a third amplifier and suitably spaced speaker, the important effect of concert-hall reverberation may be brought into the living room. The tape employed for the demonstration used only

the usual two channels (left and right).

The new tape uses a special softer lacquer formulation that allows better head-to-tape contact with a minimum amount of particle rub-off. Also, smaller oxide particle size and better spread of particles result in less noise and improved high-frequency response.

The 3½-inch-square cartridge contains enough of this tape to play continuously for 64 minutes so that it would be able to handle just about all classical music compositions without interruptions. The entire cartridge in its container occupies only about 4 cubic inches compared to a long-play phonograph record in its envelope which takes up about 20 cubic inches of storage space (12" x 12" x ¼").

Just as important in the new system is a specially designed playback head with the unbelievably narrow head gap of only 1 micron (about 1/25th mil.) This gap is about 3/8th the width of the narrowest gap in common use in present

3¼-ips, quarter-track tape machines. The construction of the head sub-assembly before the coils have been placed on the projecting laminations is shown in Fig. 2. This type of head can be constructed to produce an output of 1.5 mv. up to 15 kc. from a tape having a ½-mil coating thickness.

When questioned about possible wear on a head having such a microscopically small gap, Dr. Goldmark replied that this was not much of a problem for the following reasons. Because of the low running speed of the tape and the softer, smoother tape surface, friction and heat are reduced. Also, a dust cover is used over the entire mechanism so that there is very little abrasive effect from dust particles.

The record head that will be used with the *Zenith* consoles will probably record up to about 9 kc. However, a higher quality but more expensive record head could be made whose re-

(Continued on page 78)

Top view of prototype model of tape machine shown with the protective cover removed.

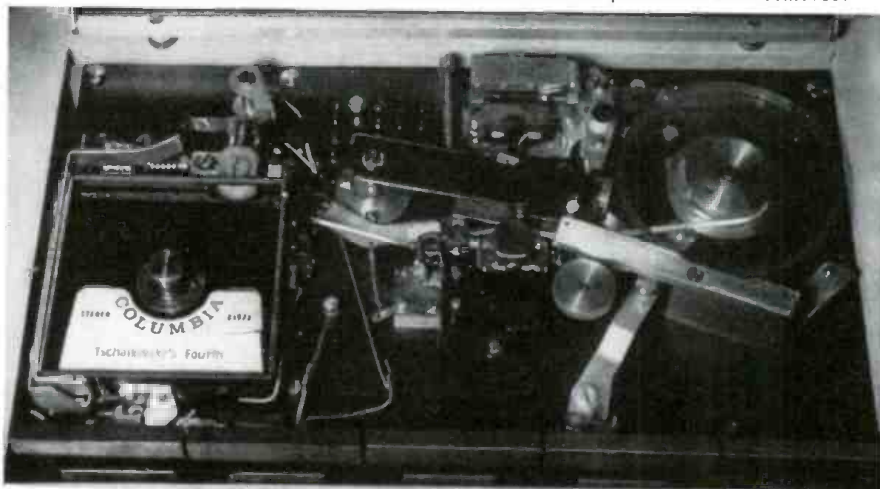



By HERMAN BURSTEIN

Tape-speed accuracy is important for hi-fi reproduction. Here are some simple methods of checking recorder speed.

ACCURACY of tape speed is, or should be, of concern to the individual using a tape machine for high-fidelity reproduction. In the case of phono turntables, the subject of speed accuracy has received adequate attention. For a few cents one can purchase a stroboscopic disc, which is placed on the moving turntable and viewed under a 60-cycle light source to indicate the accuracy of rotation. A substantial number of transcription turntables and even some changers incorporate speed adjustment devices so that one can reduce speed error to zero.

Some turntables have a built-in stroboscope.

Nothing like this exists as yet in the case of tape recorders. To the writer's knowledge, none of the home tape machines, even the most expensive, incorporate a speed adjustment device readily accessible to the operator. None include a built-in stroboscope.

Yet it cannot be argued with any validity that the speed accuracy is less important in the case of the tape machine than in the case of the record player. If anything, tapes are supposed to be a superior medium of sound reproduction and therefore correct speed should be of greater moment in the case of the tape recorder. It might be argued that if one plays back tapes that were recorded on the same machine, the speed error is the same in recording and playback and therefore cancels. But what about tapes that were made on other machines, specifically commercially recorded tapes? Even if one plays only tapes recorded on the same machine, what guarantee

is there that the machine's speed has not changed since the recording was made several weeks, months, or years ago?

The end of this rather ostrich-like attitude toward tape speed appears to be heralded by stroboscopic devices that have appeared fairly recently for measuring tape speed precisely and quickly. Now that the audiophile can ascertain the nature of speed errors in his tape equipment, it can be expected that pressure will mount on the manufacturers of such equipment to increase speed accuracy and to incorporate facile means of adjusting speed.

One of the earliest speed-measuring devices was in the form of a test tape containing three beeps spaced at 5-minute intervals if speed were correct. However, the procedure was a laborious and time-consuming one, and possibly inaccurate if the test tape were stretched (as could happen under the stresses of rapid winding). Moreover, the test tape came on a reel which might be of different size than the operator customarily used and the tape machine might operate at slightly different speed with changes in reel size. Another early device was a tape with stroboscopic markings. This was subject to the same kind of inaccuracy.

The most recent type of timing device is in the form of a stroboscopic wheel that is pressed against the tape so that the two move at the same speed. The wheel bears the same kind of familiar markings as on a strobe for checking phono turntable speed. The beauty of this method is that one measures the speed of the tape in actual operation.

TYPE OF MACHINE	SPEED ERROR (per-cent)	BARs PER MINUTE
Professional	0.2	14
Semi-professional	0.3	22
Semi-professional	0.5	36
Good	1.0	72
Fair	2.0	144
Poor	3.0	216

Table 1. Typical speed errors produced.

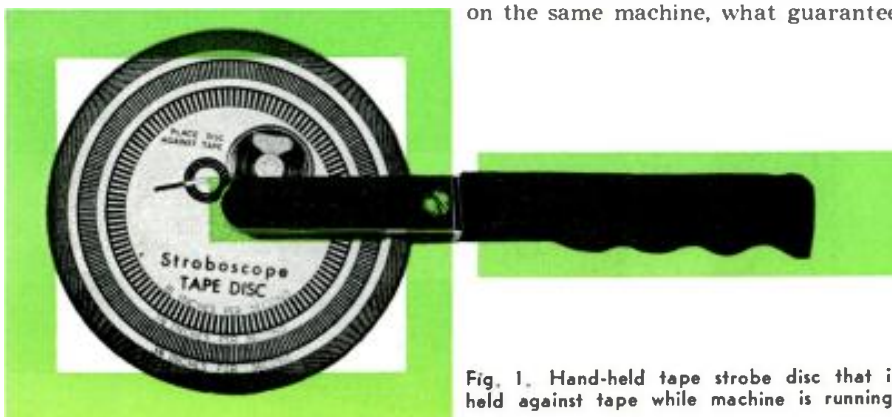

Fig. 1. Hand-held tape strobe disc that is held against tape while machine is running.

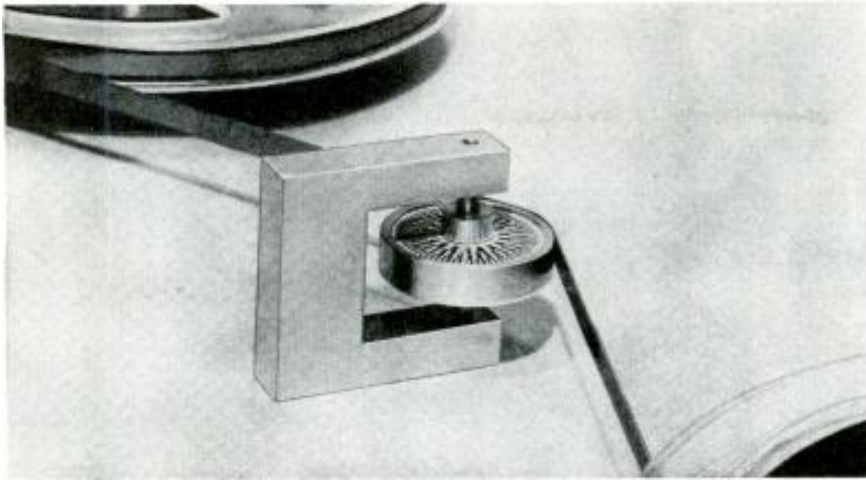

Fig. 2. Another tape strobe unit that may be employed to check for speed accuracy.

Figs. 1 and 2 show two stroboscopic wheels now on the market: the "Stroboscope Tape Disc" made by ORRadio Industries, Inc. and the "TapeStrobe" made by Scott Instrument Labs, Inc. The "TapeStrobe" consists of a U-shaped yoke that holds a rotating shaft, to which the strobe wheel is fastened by a set-screw so that the wheel is the same height above the tape deck as the tape. The unit has sufficient weight so that it will remain in position when placed on the deck and against the tape. According to the manufacturer, one can leave the "TapeStrobe" against the tape throughout the reel without adversely affecting

tape motion; if anything, wow and flutter may be reduced due to the fly-wheel action of the device. Designed for professional use, the wheel is ground with an accuracy of .03%, which exceeds professional standards of tape accuracy, i.e., 0.2%. The "Stroboscope Tape Disc" more nearly resembles the phono strobe in appearance and is designed to be held by hand against the moving tape.

While the strobe pattern may be observed under an ordinary 60-cycle light source (incandescent bulb), a more sharply defined image of the strobe bars is obtained under a fluorescent or neon lamp, because the incandescent

bulb glows somewhat between positive and negative peaks of the a.c.

The pattern of the tape stroboscope is interpreted in exactly the same manner as that of a phono stroboscope, with which many or most audiophiles are acquainted. A stationary pattern of bars signifies that speed is correct. If the bars appear to be moving forward, that is in the same direction as the tape, the speed is fast; in the opposite direction, slow.

To determine the extent of speed error, if any, count the number of bars that appear to be moving past a fixed point during a unit of time. Thus one may hold a pencil point above the strobe and count bars for one minute. An error of 1%, fast or slow, corresponds to 72 bars per minute. *This is true at all speeds.* Other errors are proportional. For example, 36 bars per minute denote an error of 0.5%; or 144 bars per minute denote an error of 2%. If one prefers, he can count bars for one-half minute, making a proportional adjustment in the calculation. Thus 36 bars moving past a point in 30 seconds denote an error of 1%.

What kind of speed error is acceptable? In the case of professional equipment with synchronous motors, it is considered that speed should be accurate within 0.2%. For semi-professional equipment with synchronous motors, errors of about 0.3% to 0.5% are probably acceptable. In the case of high-quality home tape machines
(Continued on page 87)

Shown here is a full-sized reproduction of the stroboscope tape disc used in the Irish (ORRadio Industries, Inc.) tape strobe unit. For those of our readers who want to make their own tape strobe, this disc should be cut out and glued to a circular piece of stiff cardboard, thin wood, or plastic having an outer diameter of precisely $4\frac{3}{4}$ inches. A hole is then drilled in the exact center of the disc. Next, some arrangement should be made to allow the disc to rotate freely.

To use the strobe, simply place the disc against the tape while the machine is running, preferably on the supply reel. Hold the disc steady against the tape without too much pressure and do not allow the disc to actually touch the reel itself. View the markings on the disc under a fluorescent or neon lamp connected to a 60-cycle power source. If the tape speed is correct, one of the rings of bars will appear to stand still. The outer markings are for a tape speed of $3\frac{3}{4}$ ips, the middle markings are for a tape speed of $7\frac{1}{2}$ ips, and the inside markings are for 15 ips speed.

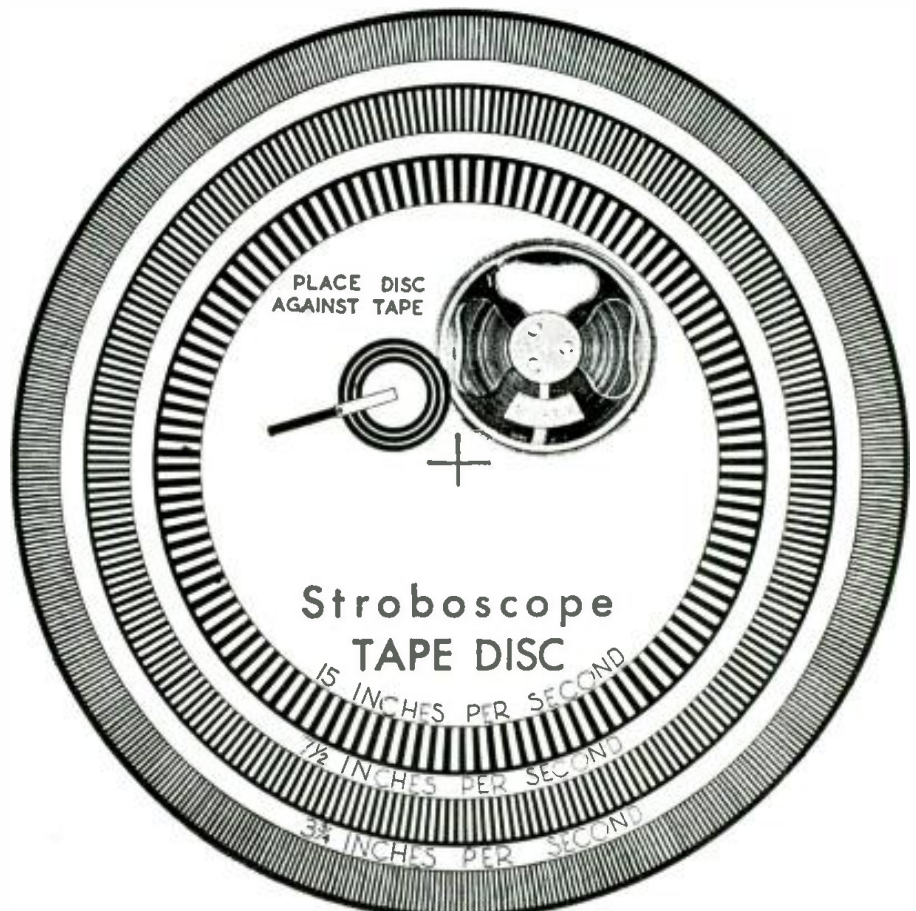

Oscilloscope Traces

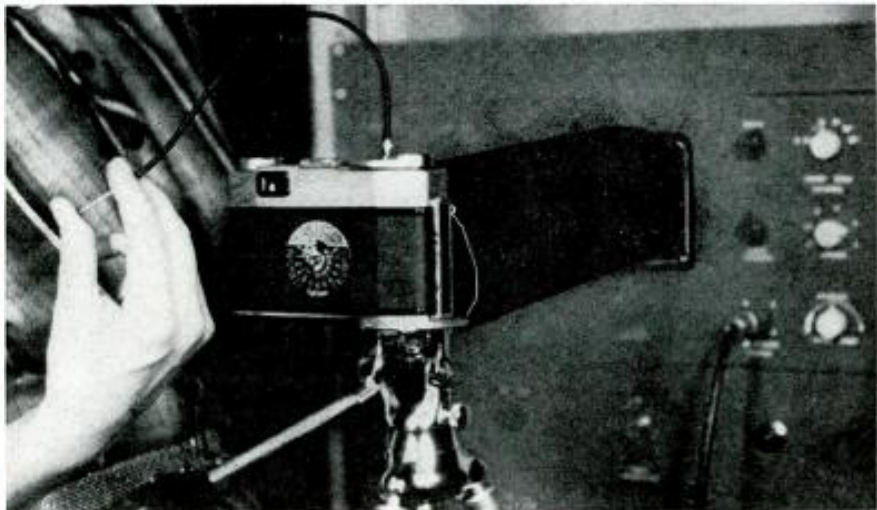

Fig. 1. Photographing the scope trace. A black paper shield is used when the incident light is high. A close-up lens as well as a cable release are necessary accessories for camera.

By C. L. HENRY

Practical help in making a photo record of waveforms. Exposure times and photo processing hints are included.

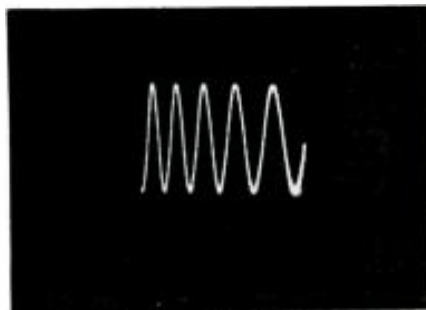
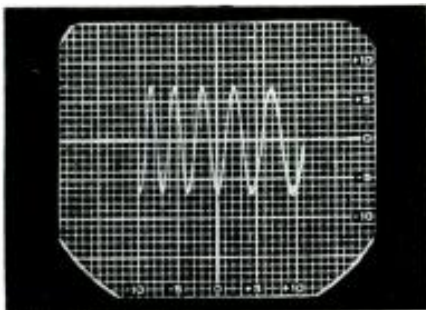

Fig. 2. Typical scope-trace photos. Using a high-contrast film and paper will provide sharp black and white results. Top photo was made with a grid over the print.

WITH the increasing complexity of modern electronics, a better understanding of circuits and waveforms becomes progressively more important. Waveforms must be seen in order to be understood and possibly the best and simplest method for accomplishing this is by means of a photograph. You are probably familiar with the special cameras designed especially for oscillographic photography but few technicians have access to such equipment.

This article will describe the technique of making photographs of oscilloscope traces with a minimum of equipment. Like most technicians and hobbyists you probably have a camera around the house but did you know that this camera, when used properly, will give you good photographs of os-

cilloscope traces? If you must rely on a photo-finisher to make your prints, the cost will still be less per picture than the cost of a color slide. By following the procedure outlined, good photographs can be made with any medium-priced camera, on 35-mm. or ordinary roll film.

Typical Conditions

Before discussing the actual technique involved in taking the pictures, perhaps it would be well to cover the conditions encountered in typical operation. First of all, the main condition for good photography is a bright, sharp trace with no secondary light from nearby parts of the screen. On the typical service scope with recurrent sweep, this means that we must adjust our trace to be bright enough for normal viewing in a lighted room and as sharply focused as possible.

Different phosphors give different results in photography. The P1 phosphor, normal with most scopes, gives a medium-persistence green trace that photographs well with panchromatic film. However, the P11 phosphor is blue and it has short persistence. Most films are inherently more sensitive to this color. We can naturally expect better results when photographing a trace on this type screen. The P7 phosphor is actually a two-layer screen. The basic phosphor of this type screen is blue, very similar to the P11 type. It also has a second phosphor layer which is yellow and has a long persistence characteristic. This yellow after-trace will ruin our best photographic efforts un-

less we eliminate it. We can do this by using a Kodak type C-5 filter on the camera. The C-5 would be best, but it costs \$4.95. A good substitute is the Kodak 80B, used in color photography. The Edmond Scientific Co. also sells a filter that can be used on some cameras; catalogue number 2708 at 50 cents. The addition of this blue filter will eliminate the yellow after-trace on the P7 type screen and make it almost as effective as a P11 type.

From this discussion you may perhaps infer that the P1 or green screen is not particularly suitable for photography. In practice the P1 screen works very well. On recurrent signals, it is as good as the P11 but on non-recurrent, high-speed transients, a P11 screen should be used.

Now to get back to our problem. We have a typical service scope and wish to photograph a trace on it. Assuming that we have a bright, sharp trace, we must be sure that extraneous light does not fog our film during the exposure. To prevent this, be sure that the level of the light at the scope is less than one-tenth the trace brightness. Sometimes in order to fulfill this condition, the tube face and camera lens must be enclosed in a black-paper tube or shield, as shown in Fig. 1.

When you are sure there is no danger of fogging the film, there is one more point to check before making the exposure. The trace on the scope screen must be free from jitter. By this we mean that each successive sweep must occur in the same place. Most oscilloscopes meet this requirement, but in

some cases it may be necessary to add d.c. restoration to the sweep circuit.

We are now ready to set up the camera and make the exposures. Fig. 1 shows the proper setup for making photos from your oscilloscope screen. The camera is mounted on a tripod in front of the oscilloscope at a distance determined by the close-up lens being used (usually about six inches). The next step depends on the camera you are using. If your camera is of the reflex type, you can focus it directly on the test trace, making allowances for parallax if you are using a twin-lens type.

If, on the other hand, yours is a rangefinder or zone-focus camera, you must insert a thin piece of ground-glass in the film gate, as shown in Fig. 3. This groundglass should be about 1/16 inch thick and frosted slightly—on one side only. You can then focus the camera by observing the image on the groundglass. Be sure that the frosted side of the glass is in the same position the film will occupy. This is important, since at the large lens aperture necessary for this type of photography, a slight error in focusing may blur the image on the film. The "Kodak Data Book on Copying" will be a handy source of information on determining

the proper close-up lens to utilize.

After the camera is focused, put in the film, being careful not to change the position of the camera. Adjust the scope to obtain the pattern you wish to photograph if you haven't already done so. Now refer to the appropriate table for the proper exposure with Kodak "Tri-X" film.

If the waveform you wish to photograph is non-recurrent, a different procedure must be followed. In this case, the level of extraneous light must be very low. After all your equipment is ready, open the shutter on the camera and initiate the non-recurrent trace. Then close the shutter. The cathode-ray tube must be gated with the proper signal for this type of photography otherwise the continuous spot on the CRT will fog the film. Follow the exposure table for the proper aperture setting on your camera.

In testing various films, the author has found that the image size on 35-mm. film is adequate for a good print. Since this film is cheaper, easier to handle, and has frame numbers it should be used whenever possible.

Processing Tips

If you do your own black-and-white processing, here are a few tips to im-

prove your results. First of all, if possible, develop the film in Kodak D-11 developer. This will increase the contrast and give more pleasing results. If you cannot do this, use Kodak D-76 and extend the developing time by two minutes. Since we want the greatest possible contrast, the print should be made on a high-contrast paper. The author has found that Kodak "Kodabromide F-5" paper gives very good results. This is the highest contrast paper generally available.

Print out the negatives on 4" x 5" pieces of single-weight paper (it's cheaper) leaving a 1 1/2-inch margin at the bottom of the print to allow a caption to be typed here. Since glossy paper is slick, allow twenty-four hours for the typing to dry, to prevent smearing. If this is not possible for some reason, type the caption on the back of the print.

Further elaborations can be made on the basic print. For instance, if you want a grid superimposed on the oscilloscope pattern it is only necessary to place a standard scope grid over the print when making the exposure with the enlarger. The result will be similar to that shown in Fig. 2. Be sure that the transparent grid is in close contact with the photographic paper. It is best to cover the grid and photographic paper with a thin sheet of glass.

If it is necessary to make a reverse print, that is, a black trace on white paper, Kodak "Super-Speed Direct Positive Paper" can be used in place of "Kodabromide" paper. Chemical reversal is possible when this paper is employed.

By using the method described, you should have no trouble photographing the traces on your scope. Use this method to photograph unusual waveforms for future reference or start your own personal file so that you can interpret any waveform that you may encounter.

REFERENCES

1. Hercock, R. J.: "Photographic Recording of Cathode-Ray-Tube Traces," Ilford Ltd.
2. Hercock, R. J.: "Kodak Data Book on Copying," Eastman Kodak Co.
3. Lewis & Wells: "Millimicrosecond Pulse Techniques," McGraw-Hill Book Co.

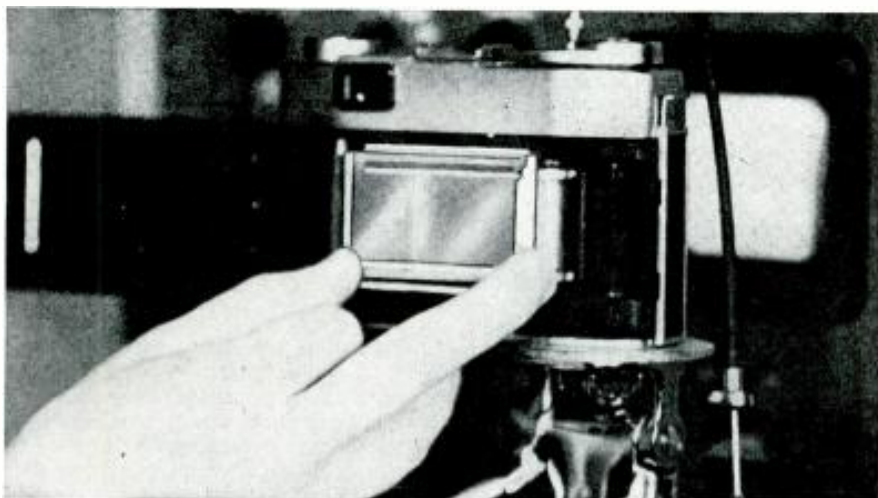

Fig. 3. Focusing a rangefinder or zone-focus camera. The ground-glass is placed in the film gate, the shutter opened, and the image focused. A tripod must be used; incident light must be low.

Table 1. Exposure table recommended for P1 type CRT phosphors.

Conditions: Kodak "Tri-X" film, P1 type phosphor (3BP1, SCPI, etc.)			
RECURRENT TRACES			
Vert. Defl. (in inches)	Horiz. Defl. (in inches)	Cycles (on screen)	Exposure
1/2	2/2	1	f4, 1/5 sec.
1/2	2/2	2	f4, 1/5 sec.
1/2	2/2	4	f4, 1/5 sec.
1/2	2/2	6	f5.6, 1/5 sec.
The same data applies to a vertical deflection of 3 inches and a horizontal deflection of 4 1/2 inches.			
1/2	2/2	1	f4, 1/10 sec.
1/2	2/2	2	f4, 1/10 sec.
1/2	2/2	4	f4, 1/10 sec.
1/2	2/2	6	f5.6, 1/10 sec.
NON-RECURRENT TRANSIENTS			
Conditions: Vertical deflection, 1 1/2 inch; Horizontal deflection, 2 1/2 inch			
Sweep Range	Exposure		
0.1 second	f8, bulb		
0.01 second	f5.6, bulb		
1 millisecond	f4, bulb		
100 microseconds	f4, bulb		
10 microseconds	f2.8, bulb		

Table 2. Exposures recommended by author for P11 type phosphors.

Conditions: Kodak "Tri-X" film, P11 type phosphor (5CP11, 3KP11, etc.)			
RECURRENT TRACES			
Vert. Defl. (in inches)	Horiz. Defl. (in inches)	Cycles (on screen)	Exposure
1/2	2/2	1	f5.6, 1/5 sec.
1/2	2/2	2	f5.6, 1/5 sec.
1/2	2/2	4	f5.6, 1/5 sec.
1/2	2/2	6	f5.6, 1/10 sec.
1/2	2/2	1	f5.6, 1/10 sec.
1/2	2/2	2	f5.6, 1/10 sec.
1/2	2/2	4	f5.6, 1/10 sec.
1/2	2/2	6	f8, 1/10 sec.
NON-RECURRENT TRANSIENTS			
Sweep Range	Exposure		
0.1 second	f8, bulb		
0.01 second	f8, bulb		
1 millisecond	f5.6, bulb		
100 microseconds	f4, bulb		
10 microseconds	f2.8, bulb		
This exposure table is the result of more than 300 exposures. It is intended as a starting point rather than as a final authority. However, after using this exposure data for your first negatives, it can be modified as necessary for best results.			

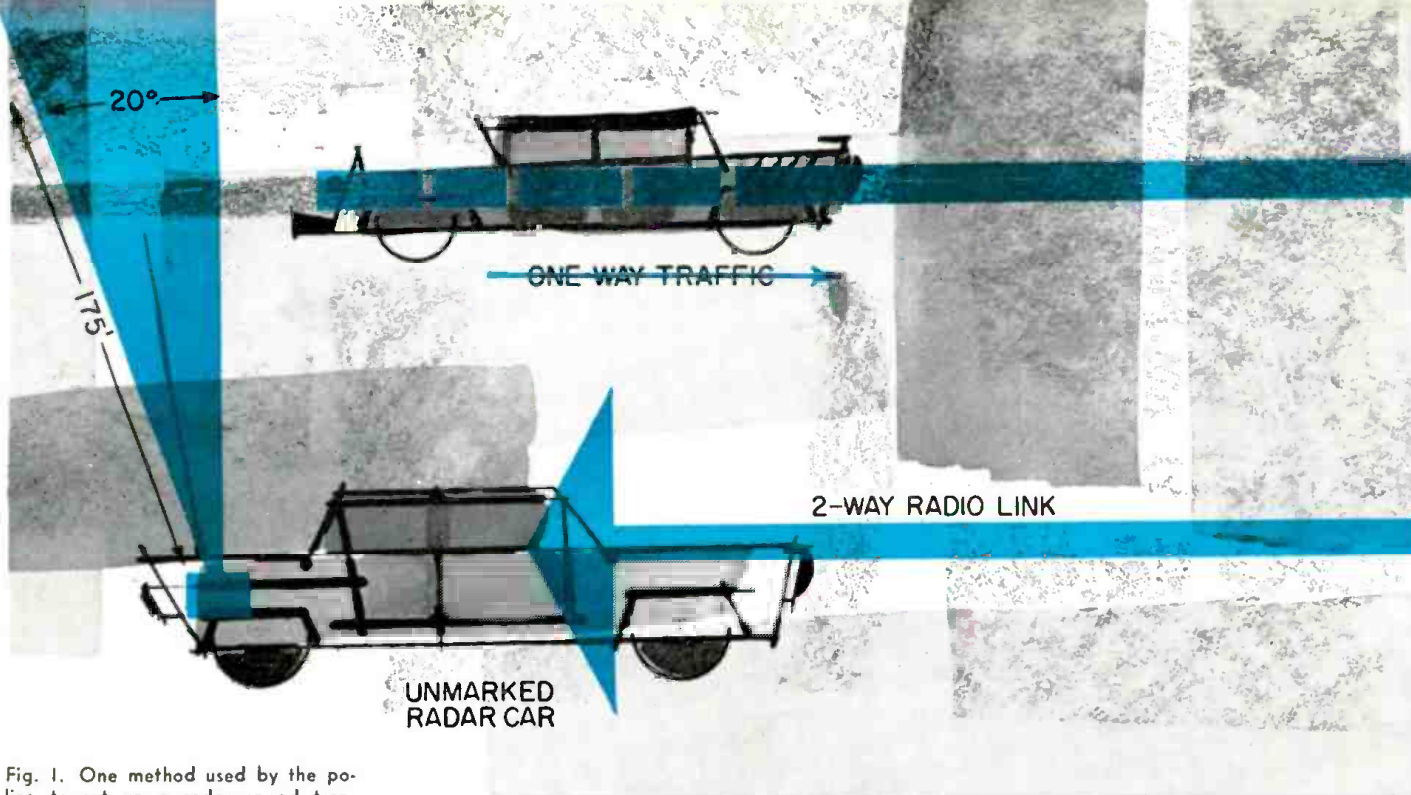

Fig. 1. One method used by the police to set up a radar speed trap.

Radar Speed Meters &

THE days of the white-gloved policeman whose whistle and arms control traffic may be numbered and even the dashing motorcycle officer, nemesis of the speeder, may soon cease to haunt the highways. Instead of the practiced eye of the traffic patrolman, an electronic computer now scans the traffic in all directions and makes on-the-spot decisions on the timing of signal lights. Instead of the motorcycle chase, the argument, and eventual traffic ticket, radar equipment simply, positively, and without a chase hands out tickets with the speed recorded automatically, impersonally, and beyond argument.

The ever-increasing number of cars using our outmoded and overcrowded roads is a major headache to practically every community. While the building of highways always lags behind need, the art of electronics at least per-

mits the most efficient use of available roads.

Second to the problem of congestion is the appalling accident rate. Statistics show that most serious accidents can be attributed either to speeding or driving while intoxicated. Radar is used to reduce speed and even the degree of intoxication can be determined by electronics.

Speed Control Radar

Most of our readers are familiar with the "Doppler effect"—a phenomenon named for the German physicist who discovered it. Doppler's theory states that waves that are radiated or reflected from moving objects will be changed in frequency in accordance with the speed of the moving object.

An everyday example of this is the changing pitch of a train whistle heard by an observer who is standing near

the train crossing. This change of frequency is a function of the sound frequency and speed of the train. In speed-control radar a high-frequency signal is beamed down the road and the reflections from moving vehicles are compared with the original frequency. The "difference" frequency is directly related to the car's speed. In a typical radar, such as used by New York City and State police, the transmitter operates at 2455 mc. and the "difference" frequency for a 10-mile slowpoke will be 73.1 cps while a 100-mph speeder will ring up 731 cps on the electronic speedometer.

The advantages of radar over the conventional "chase" are many. For one thing, chasing a speeding car is dangerous and often results in serious accidents to innocent motorists as well as the participants. In many states the chase must last for at least a mile in order to validate a summons. Even then, arguments and court procedures involve the officer in time-wasting litigation which has the effect of reducing available police manpower—often to a critical point.

When radar is used, there are usually warning signs and the psychological effect alone helps to reduce speeding. Most apprehended speeders plead guilty when presented with a graphic record of their offense and, in New York City at least, radar results in about 95% convictions of those pleading "not guilty." Practically all states have now accepted evidence provided by radar and, in a recent decision, the New York Court of Appeals ruled that radar is a reliable, accurate instrument for measuring the speed of vehicles.

The block diagram of Fig. 2 shows *Eastern Industries'* (East Norwalk,

Fig. 2. Block diagram of the S-band (2455 mc.) speed radar discussed in text.

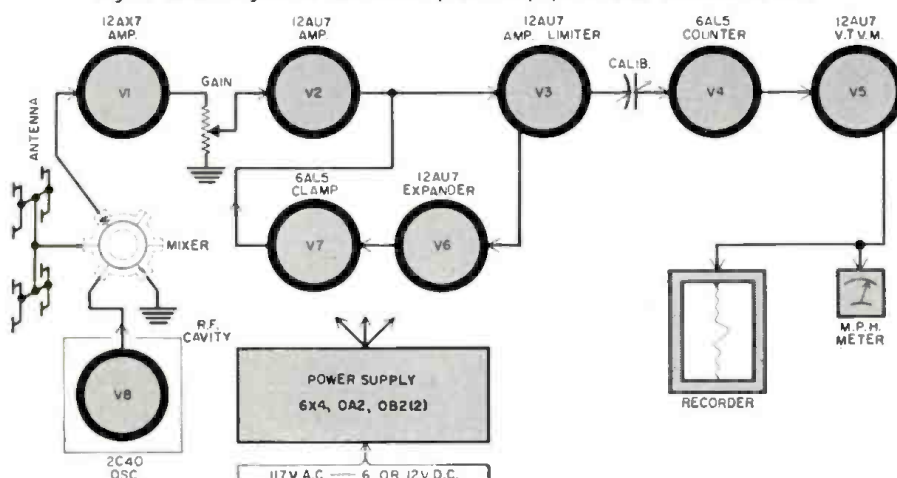

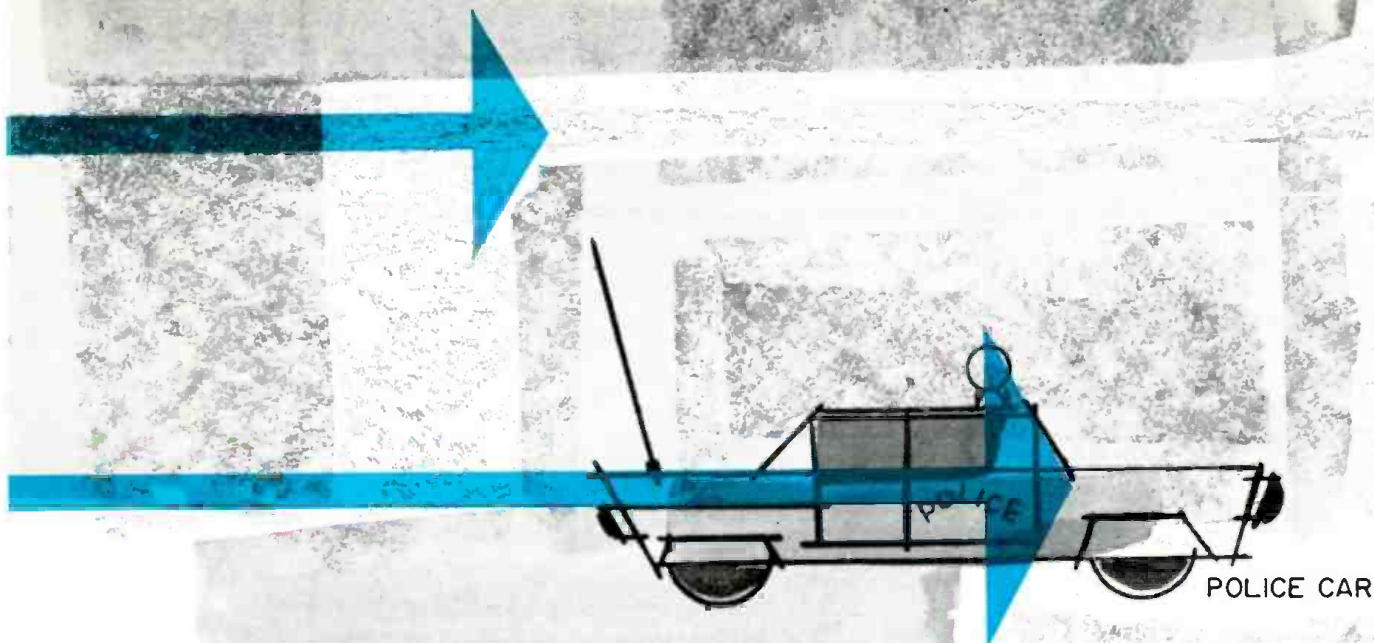

By **WALTER H. BUCHSBAUM**, Industrial Consultant, **ELECTRONICS WORLD**

Traffic Controls / How radar speed traps and speed meters work, and other electronic devices used to control traffic.

Conn.) Model S-2 speed-control radar set. Its operation is typical of most equipment now on the market and is used as an example of the circuits involved in speed-control radar. The 2C40 lighthouse tube furnishes the 2455 mc. signal at about 120 milliwatts of power. A resonant cavity maintains the frequency accurately during the life of the tube. The r.f. signal is applied to an 8-element dipole array which acts as both transmitting and receiving antenna. By using a ring-type power divider some of the transmitted r.f. and some of the reflected signal are mixed in the 1N21 crystal diode and the resulting low-frequency beat is the Doppler, or speed-indicating, signal. This signal, ranging from zero to about 800 cps, is amplified and clipped by the limiter and then passed through a diode and capacitor frequency-counter circuit. The resultant d.c.

voltage corresponds to the frequency and thus to miles-per-hour.

A v.t.v.m. circuit with a remote d.c. meter and, as optional equipment, a strip-chart recorder are calibrated in mph and indicate the speed.

One of the refinements incorporated in this model is the expander and clamping circuit which prevents weak reflections from being passed into the frequency-counting circuit. Unless the output of the V_3 amplifier is sufficient to provide complete limiting, the expander and clamping section will load down the output of V_2 . This assures that a speed reading is obtained only on clear, strong signals and discriminates in favor of the fastest car in a bunch.

The power supply contains a vibrator which is not used when 117-volt, 60-cycle a.c. is available, as is the case in the service shop. Depending on the

model, either a 6- or 12-volt battery serves as the power source.

Speed Radar Installation

The photograph of Fig. 3 shows a radar unit installed in the trunk of an unmarked car belonging to the New York City police. The complete radar unit, including antenna, is contained in a single box, with the antenna section aimed to the rear. To permit operation with the trunk closed, a section of the trunk has been cut out and covered with a plastic which serves as a radome. This arrangement allows the driver to respond to an emergency call without incurring a delay to close the trunk or dismantle the tripod on which the unit is sometimes mounted.

New York State police operate the same radar but with the trunk open because the state resells its police cars and large cut-outs in the trunk would

Fig. 3. Radar set installed in trunk compartment of car.



Fig. 4. Speed-meter indicator and chart recorder employed.

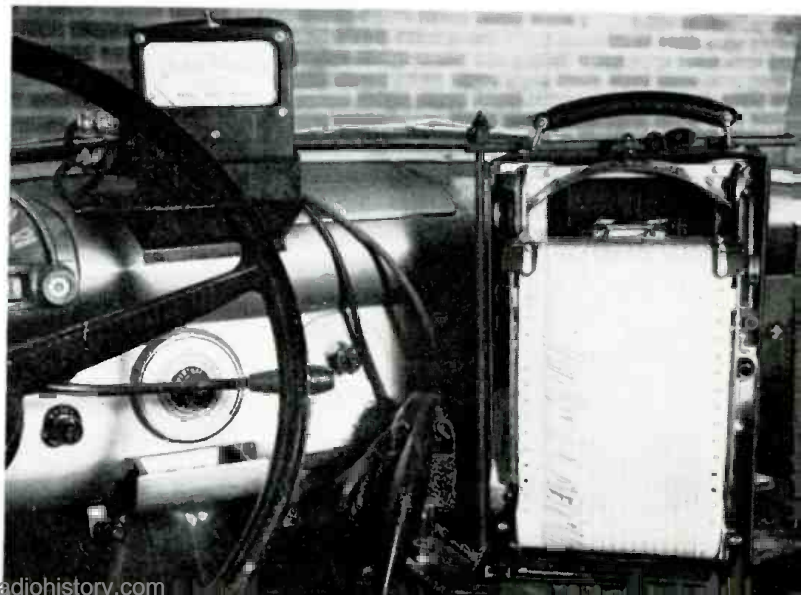

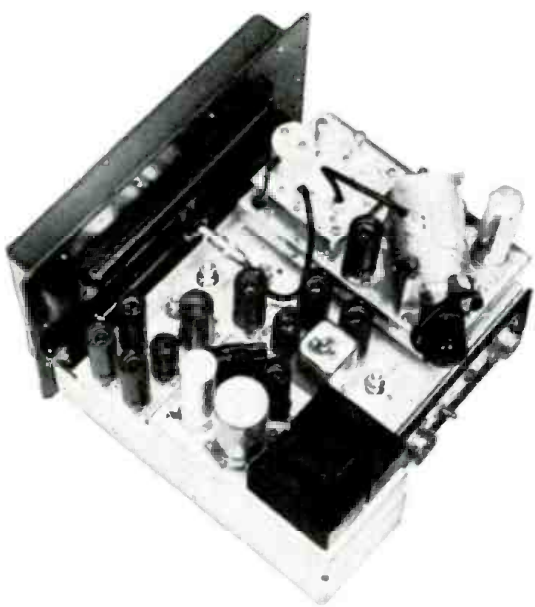

Fig. 5. Top view of the S-band radar. Oscillator cavity is at right rear.

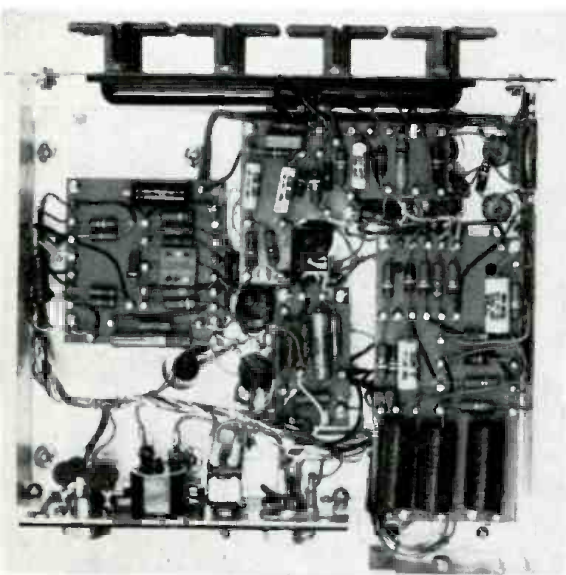

Fig. 6. Under-side of radar. Antenna array has been uncovered in this view.

virtually kill their used-car value. In a typical installation, a newly charged battery is used every day and a separate one is used for the communication radio. New York operates a total of seven radar cars with excellent re-

sults in the apprehension of speeders.

A close-up of the meter and strip-chart recorder, as mounted next to the driver, is shown in Fig. 4. Note the telephone for the two-way radio link which connects the speed-control radar operator with the apprehending patrolman. A typical set-up is shown in Fig. 1. This system is frequently used on a divided roadway where traffic moves in only one direction.

The procedure is for the unmarked car to get into position and calibrate the speed indicator by having the patrol car pass at a fixed speed. Since all patrol car speedometers are calibrated every week, this serves to check out the radar-speed indicator. Another method would involve the use of a tuning fork, but police prefer the patrol-car check since its validity is more likely to be accepted in court. Once the radar car is set up and its gear calibrated, the operator just waits for those who disregard the warning signs "Radar Speed Check Ahead."

When the meter and recorder indicate a speed above the limit, the operator merely picks up the telephone and gives a description of the car and possibly the license number to the policeman waiting ahead. To clinch the case, the description and license number is noted right on the chart, next to the incriminating evidence.

Fig. 7 shows a typical scene of this type only here the radar set is installed on a tripod outside of the car, in plain view of the speeder.

An interview with responsible officers of New York City's radar unit indicates that, surprisingly, servicing is no more of a problem than with their communications gear. When tubes get weak or the battery runs down, the speed indications will be lower than the actual speed, hence this excuse doesn't hold up in court.

Actually, the most frequent maintenance is replacement of the 2C40 oscillator tube. The cavity is designed so that aging of the tube or frequency drift kills the oscillation because of the perfect match and high "Q" that is required. Replacement of this tube and other service work is performed by

qualified personnel who must hold at least a 2nd class FCC ticket. Figs. 5 and 6 show top and bottom view of the radar set and will give our readers an idea of the relative simplicity of the circuitry.

Another widely used speed-control radar is made by *Traffic House, Inc.* of Marshall, Michigan. It operates in the X-band at 10.525 mc. This unit features an r.f. and antenna unit which can be mounted in place of the spotlight at the side of the car. A typical installation of the antenna unit is shown in Fig. 8. The antenna consists of two dielectric rods, driven by short waveguide sections. Inside the car the speed meter hangs from the rear-view mirror. This particular unit uses transistors instead of the amplifier tubes. The complete unit, including the power supply and accessory tuning-fork calibrator, is shown in Fig. 9.

In some cases, the X-band speed radar is used in a single-car set-up. It can be mounted on a patrol car, as in Fig. 8, and when a speeder is detected the officer can give chase at once. Another arrangement would set up the meter outside the car and the officer can then wave the speeder down as he approaches. This type of equipment has a range of up to 600 feet and because of the higher r.f., 10 mph equals 310 cps. Graph recorders can be used with any of the different speed-control radars.

Traffic Control Systems

Up to a few years ago, traffic lights were actuated by a timer located inside the control box and, on certain crossings, by a pedestrian push-button or vehicle-operated weight switch which would provide a green signal for an otherwise rarely used side street. The first step towards improving the flow of traffic on one-way streets was the synchronization of light-control timers to permit cars traveling at an optimum speed to continue on green lights all the way. After the value of this scheme was recognized, new methods for controlling traffic according to requirements of the traffic were tried.

Radio-controlled traffic lights which

Fig. 7. Officer is calling ahead by radio to stop the speeder.



Fig. 8. Installation of r.f. unit of X-band (10,525 mc.) radar.



can be set from a transmitter in a moving fire truck or ambulance were tried. Another radio-control scheme is scheduled for introduction in New York City in the near future. This makes use of a central radio transmitter which would control traffic lights along different main arteries. The idea here is not to turn all lights red or green at the same time but, rather, control the flow of traffic according to the requirements of the morning or evening rush hours, special events, accidents, detours, etc. Receiving gear is already installed along one major road which will serve as a "proving ground" for the entire system.

Eastern Industries supplies a variety of intersection-controlling equipment, ranging from traffic-actuated, time, and manually operated lights up to complex computing systems. One such device is the radar vehicle detector shown in Fig. 10. This unit can be mounted on the overhead arm of a lamp post and contains a complete 2455-mc. Doppler radar set. Its operating principle is the same as that of the speed-control radar, but its circuit is simpler because instead of measuring speed, only the presence of motion is detected. This radar can be used as the sensing element for many different types of traffic-control systems. In its simplest form it is mounted above the approach to an intersection. As a vehicle passes under it, the relay in the radar unit starts to cycle the traffic light into providing the green light for that lane. A timer in the traffic-light control box can make sure that traffic from any one lane cannot tie up the intersection.

This radar unit is also used on turnpikes to count the number of cars. By adding relays for low- and high-speed limits, the radar unit can serve to indicate when traffic in any one lane slows down, when traffic is lighter, etc. This information can then be used to open or close other lanes to accommodate the changing traffic pattern, to indicate toll booth requirements, and warn of dangerous traffic conditions.

Combinations of radar units and traffic-control boxes can provide the



Fig. 10. The overhead radar detector.

optimum red and green cycling for a number of neighboring intersections, as the changing traffic pattern requires. A typical traffic-light control box, based on volume density, is shown in Fig. 11. This unit controls a rather complex intersection and permits adjustment of the number of cars and the time they have to wait, as well as the traffic density at which one or the other direction should be favored. Even the minimum length of the green time and the duration of the change-over period can be determined accurately.

Coupled with overhead radar detectors, magnetic vehicle detectors, and weight-actuated switches, a complete city-wide electronic traffic control can be designed. This system would be able to compute the optimum green time for different main roads at different times of the day, control the side-street traffic lights accordingly and provide alternate green-light routes when traffic piles up in one of the major arteries. Traffic density could be recorded automatically so that planning of one-way and express streets is not delayed by lengthy and costly surveys. In the event of an emergency the over-all traffic computer would have a program ready to clear traffic from vital access roads and expedite the movement of emergency vehicles.

The city of Baltimore has recently installed such a complete traffic-control

system, the main control room of which is shown in Fig. 12. This system contains a master computer which accepts information from 32 overhead radar detectors and is capable of directing over 200 traffic lights in a wide variety of different green-time patterns. Coupled with this system is an emergency communications network which links fire, police, and other emergency stations. Up-to-date weather information is also available and this data can be combined to slow down traffic, speed it up, block certain roads, reduce the number of cars coming into



Fig. 11. Front panel of the versatile traffic controller described in text.

a particular section, detour traffic around obstructions, etc.

The Baltimore installation is tied in by means of connecting cables but another master traffic system using u.h.f. radio to transmit the control signals is also available. Stable, seven-watt transmitters, operating at 980 mc. and using FM, transmit information and control signals between the intersections and the central computer. The predicted range of this system is 3 to 5 miles, but by using a 25-watt amplifier
(Continued on page 117)

Fig. 9. Complete X-band radar. Note dielectric antenna rods.

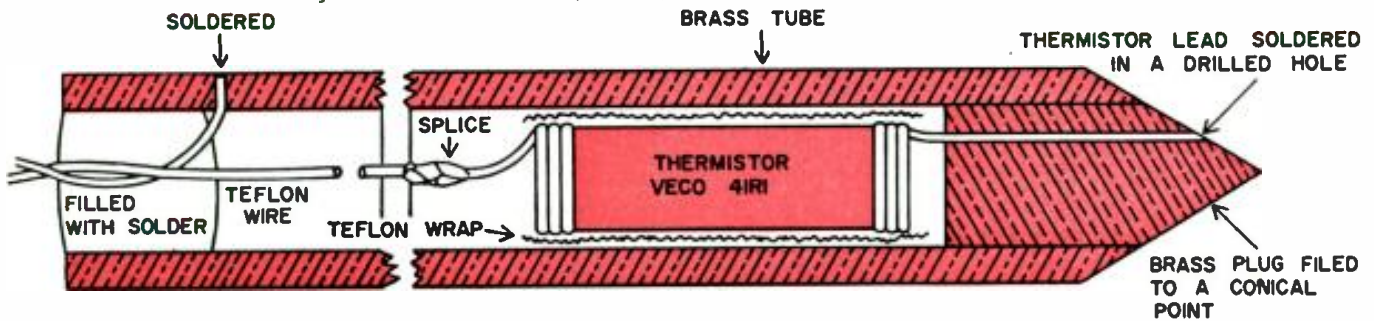

Fig. 12. View of control room of Baltimore traffic department.



Electronic Roast Alarm

Fig. 1. The details of the temperature probe are shown here (not drawn to scale).



By DAN PETERS

Construction of a roast thermometer that sounds a buzzer when the meat reaches desired temperature.

MEAT	COOKED	DEGREES F
Beef Ribs	rare	140
	medium	160
	well	170
Beef Tenderloin		140
Fresh Pork	well	185
Uncooked Hams		150-155
Smoked Picnics		170
Ready-to-eat Hams		130
Ready-to-eat Picnics		130
Lamb	medium	175
	well	180
Veal	well	180
Roast Chicken or Capon		190
Roast Turkey		190

Table 1. Listing of meat temperatures for which the roast alarm is calibrated.

NOW what are you playing with?"

This unappreciative expression is one the electronic gadgeteer frequently hears—particularly from the gals. To combat this attitude, it is excellent diplomacy to occasionally produce an item considered useful by the female of the species. The "Electronic Roast Alarm" is such an item.

The alarm as pictured in Fig. 2, goes one step farther than the conventional roast thermometer, in that it sounds a buzzer when the meat reaches the desired temperature—thus alleviating the frequent "peeks" in the oven necessary with the ordinary roast thermometer.

Two components comprise the alarm; the control box as shown in Fig. 2 and the probe detailed in Fig. 1. Operation of the unit can be easily understood by

Fig. 2. Roast alarm control box with the temperature scale on the front panel.



referring to the simplified schematic diagram of Fig. 4.

The supply voltages are proportioned so that V_1 , V_2 , and CR_1 are normally cut-off when the thermistor is at a low temperature. As seen from Fig. 1 the thermistor is built into the probe which is inserted into the meat. Since V_1 is an $n-p-n$ type, a positive-going voltage on its base is necessary to start conduction. V_2 being $p-n-p$, requires a negative base-to-emitter voltage to start conduction.

A thermistor has a negative-temperature coefficient, that is, its resistance decreases as its temperature increases. Therefore, heating the meat, and thus the thermistor, will result in the base of V_1 becoming more positive. At some critical temperature—determined by the setting of R_1-V_1 will come out of cut-off and begin conducting. The collector current of V_1 causes a voltage drop across R_2 which drives the base of V_2 more negative than its emitter, causing V_2 to conduct.

The collector of V_2 goes more positive and biases CR_1 in the forward direction. The current through CR_1 causes V_1 to conduct more heavily, etc. This action is regenerative and both transistors are driven into saturation. The collector current of V_2 operates the buzzer. Note that once the alarm triggers, the dial loses control and the only way to stop the buzzer is to turn off the supply voltage.

A complete schematic is shown in Fig. 3 and differs from the simplified schematic simply in the addition of the resistors necessary to properly bias

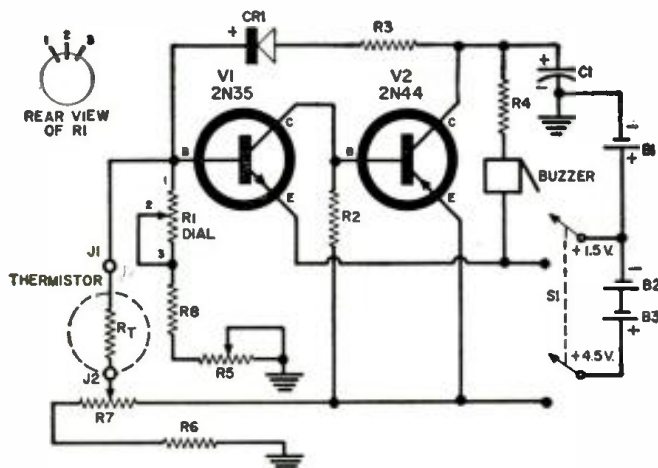

R_T —10,000 ohm linear taper pot (Clarostat A47-10k-S)
 R_2, R_3 —4700 ohm, $\frac{1}{4}$ w. carbon res.
 R_1 —10 ohm, $\frac{1}{4}$ w. carbon res.
 R_4 —5000 ohm pot (any taper)
 R_5 —1000 ohm, $\frac{1}{4}$ w. carbon res.
 R_7 —2500 ohm pot (any taper)
 R_8 —6800 ohm, $\frac{1}{4}$ w. res.
 C_1 —5 μ f., 10 v. miniature elect. capacitor
 CR_1 —1N34 diode (or equiv.)

J_1, J_2 —Miniature jack and plug (Walsco 791 and 790 or equiv.)
 Buzzer—High-frequency buzzer (Johnson Model 114-400)
 S_1 —D.p.s.t. switch (ganged to R_1)
 R_T —Rod-type thermistor (Veco Type 41R1, 10,000 ohm, axial leads. Available at some parts distributors or at local Graybar outlets)
 B_1, B_2, B_3 —1.5-volt penlite cell
 V_1 —“n-p-n” transistor (2N35)
 V_2 —“p-n-p” transistor (2N44)

Fig. 3. Complete circuit and parts listing for the electronic roast alarm unit.

the transistors. Resistors R_5 and R_7 are calibration potentiometers which enable the dial to cover the desired temperature range.

Construction

Because of the nature of the device, constructional details are not critical and any cabinet or chassis size deemed suitable by the constructor should be satisfactory.

The control unit shown in Fig. 2 was constructed in a 4-inch sloping-panel cabinet (Bud AC-610). All components are easily fitted into the case, with most of the components being mounted on a miniature aluminum chassis (Bud CB-1623) inside the case. Three penlite cells (B_1, B_2, B_3) were mounted in battery clips (Acme No. 7). The face of the cabinet is fitted with a special

etched aluminum panel, available at nominal cost from *The Radio Stationers*, 63 Williams Drive, Brandywine, Maryland. The panel carries calibration in degrees Fahrenheit, as well as reference data useful to the cook in determining the proper setting for the type of meat to be roasted. If the constructor elects to use this plate rather than build his own the author suggests writing to the manufacturer who will, in turn, send specific information regarding the plate. This information includes a template of the front panel and enables the constructor to proceed with the construction of the Roast Alarm prior to receipt of the etched panel. *The Radio Stationers* have also informed the author that they will stock a matching knob and the correct potentiometer for R_1 . The cabinet, with

etched plate already attached and holes drilled, will also be stocked, thus offering the builder most of the advantages of a “kit.”

The old American custom of using what was on hand determined the choice of materials for the probe. Construction proceeds as follows. Approximately a 6" length of $\frac{1}{4}$ " o.d. brass tubing is cut and its ends filed square. The tubing used had an i.d. of $\frac{3}{16}$ ". Drill a $\frac{1}{16}$ " diameter hole through one side of the tubing about $\frac{1}{2}$ " from one end. The tubing is then set aside and a piece of $\frac{3}{16}$ " diameter brass rod approximately 1" long is selected. Drill a ± 50 hole lengthwise through the rod. It is not important that the hole be centered. Place one lead of the thermistor through this hole and solder. A length of #24 Teflon-insulated stranded wire is then soldered to the other thermistor lead and the thermistor insulated with a thin sheet or tubing of Teflon insulation. Teflon insulation is necessary because of the temperatures encountered in the oven, and the subsequent soldering operations.

The brass rod is then inserted into the brass tube as shown in Fig. 1 and secured by sweat soldering. File the end of the rod and tube to a sharp point for easy insertion into the meat. A second length of Teflon wire is inserted into the open end of the tubing and soldered in the hole drilled previously.

Filling the open end of the tubing for a length of $\frac{1}{4}$ " or so with solder—to act as a strain relief for the wires and seal the tubing—finishes the probe proper. The only remaining steps are: to twist the two wires together, cut to proper length, and terminate in a plug. The plug is not a necessity, but rather a convenience, in that it enables the probe to be disconnected from the control unit for ease in cleaning. Of course the builder may construct the probe in any manner he chooses. The probe simply serves as a housing for

(Continued on page 98)

Fig. 5. Internal construction of the roast alarm. Note how the transistors and pots are mounted on small chassis.

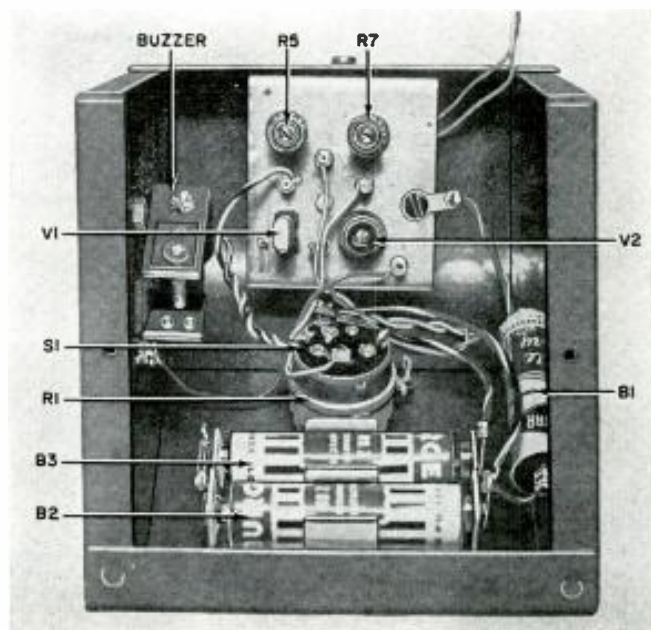
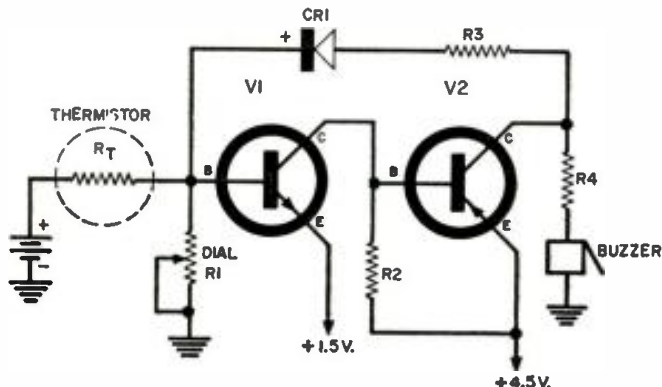

Fig. 4. Simplified circuit diagram of the electronic roast alarm whose complete circuit appears above in Fig. 3. The thermistor is installed in a probe inserted into the roast.





The completely assembled unit. Input current meter and binding posts are at left while field-strength meter and its sensitivity control are at right side of the panel.

Citizens Band Field-Strength Meter

By HAROLD REED

Construction of miniature instrument to check output as well as plate input current of the CB transmitter.

IN construction articles on Citizens Band transmitters and transceivers, it has been suggested that they be adjusted and tested with a dummy load, *i.e.*, one or two #47 pilot lights in place of the antenna. This is desirable for preliminary testing since it prevents needless interference on the band and is a safety measure against off-frequency operation with initial tune-up work. But, what the rig will do with the antenna may be quite different.

The maximum allowable power input to the output stage of a Citizens Band transmitter is just 5 watts. For best coverage, then, we should strive for greatest power transfer from transmitter to antenna. Simply connecting the antenna in place of the dummy load does not necessarily bring about this ideal condition. In fact, greatest radiation from the antenna is not usually obtained without some retuning and possibly pruning of the antenna itself.

A meter that will indicate varying field strength when tuning a transmitter with the antenna connected at a given power input will insure that maximum radiation is being obtained from the antenna. The little instrument described in this article will do just this. It will help the technician in making the necessary transmitter and antenna adjustments and, being of mi-

nute size, may be carried in the tool kit. The Citizens Band operator can use it as a monitor during normal operation of his equipment.

The field-strength section of the device consists of a vertical rod antenna connected to the r.f. coil, L_1 , through capacitor C_1 . Variable capacitor C_2 tunes the r.f. section to the desired frequency. Its tuning range is from approximately 26 to 28 mc. A high-conductance diode, CR_1 , rectifies the r.f.

signal to provide a d.c. current to operate the microammeter, M_1 . Resistor R_1 is the diode load resistor. Capacitors C_4 and C_5 plus choke coil RFC comprise an r.f. filter network. Variable resistor R_2 is used to adjust meter sensitivity and to protect the meter when testing in high intensity fields. The headphone jack, J_1 , provides for aural monitoring to check the audio quality of the radiated signal.

The d.c. input current section of the

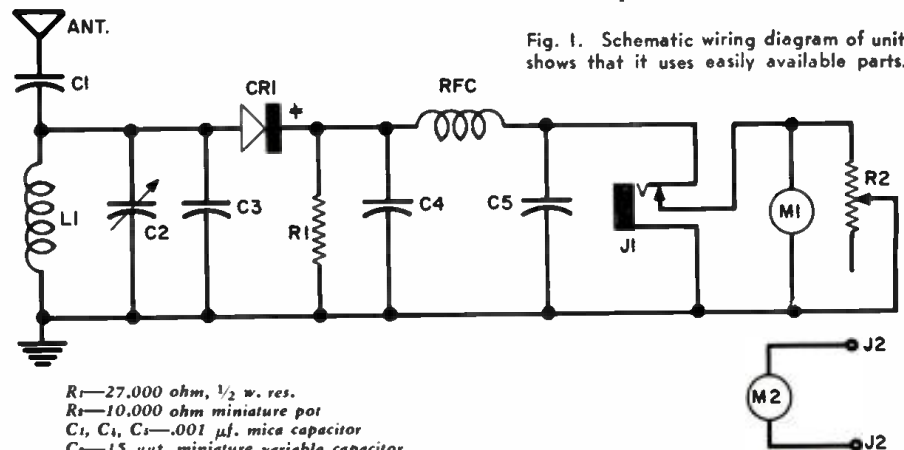

Fig. 1. Schematic wiring diagram of unit shows that it uses easily available parts.

R_1 —27,000 ohm, $\frac{1}{2}$ w. res.
 R_2 —10,000 ohm miniature pot
 C_1, C_4, C_5 —.001 μ f. mica capacitor
 C_2 —15 μ f. miniature variable capacitor
 C_3 —30 μ f. mica capacitor
 CR_1 —Crystal diode (Sylvania 1N56A)
 RFC —2.5 mhy. choke coil
 J_1 —Single closed-circuit phone jack
 J_2 —Binding posts (one red terminal, one black)

M_1 —0.50 μ a. miniature meter
 M_2 —0.50 ma. miniature meter
 L_1 —R.f. coil, 12 t. #18 en. wire (see text)
 $Ant.$ —Antenna, 12" length #14 en. wire
 $Cabinet$ — $5\frac{1}{4}$ " x 3" x $2\frac{1}{8}$ " aluminum box (Bud "Minibox")

unit is similar to the v.t.v.m. which will allow connection of the field-strength meter as shown in Fig. 1.

Construction Details

The instrument is assembled in a aluminum "Minibox." attached to the front section except the antenna jack mounted on the rear half of the cabinet. This can be seen in the photograph. The input current meter binding posts are red and black for polarity identification and are located under the current meter. Their mounting centers are $\frac{3}{8}$ " so they will accept standard dual banana test plugs. The vernier tuning dial is in the center and the meter sensitivity control is mounted immediately under the field-strength microammeter. Wire this control so that it shorts out the meter when turned in the extreme counterclockwise position. The phone monitor jack is above the vernier tuning dial. A small aluminum bracket was made to support the tuning capacitor. This bracket is held to the cabinet by the two bottom mounting screws of the vernier dial.

Coil L_1 is constructed of #18 enameled wire and is self-supporting. It is soldered directly to the terminals of the tuning capacitor. This coil consists of 12 turns and was wound on a piece of $\frac{3}{8}$ " wooden dowel. When removed from the dowel stick its diameter expands to slightly more than $\frac{3}{8}$ ". It was then spread to a length of $\frac{7}{8}$ ". This coil, together with capacitors C_2 and C_3 , spreads the class C and D Citizens Radio band clear across the vernier tuning dial. This range can be adjusted by stretching or compressing the coil. The author's unit tuned from about 26 mc. to 28 mc. between the extremes of the tuning dial.

A grid-dip meter is quite handy for frequency adjustment of the instrument although a signal generator may be used to handle the job.

The rod antenna is a 12-inch length of #14 enameled antenna wire equipped with a banana plug for connecting into the jack at the top of the case.

Testing Methods

Only a qualified licensed operator may make or supervise the following transmitter tests unless the Citizens Band transmitter meets all FCC requirements for units that may be adjusted by non-licensed personnel (see "License Not Needed for Citizens Radio Adjustments" in the December 1959 issue). The instrument may be used separately as a field-strength meter or input current meter or both functions may be performed simultaneously.

As a field-strength meter alone, the device is placed at any location with respect to the transmitter antenna which gives a satisfactory meter read-



ing. Transmitter adjustments with the antenna connected are then made to obtain maximum reading on the meter for any given transmitter power input.

Used solely as an input current meter, the "B+" supply to the transmitter output stage is opened and the meter inserted in this circuit through the meter binding posts. The red binding post connects to the "B+" supply and the black post connects to the transmitter output coil. A v.t.v.m. probe can be connected to the black binding post of the instrument and the v.t.v.m. common, or ground, lead connected to the transmitter chassis. Transmitter adjustments are then made in the usual manner. Power input is the product of the current and voltage readings obtained. The input current of the Citizens Band transmitter will usually be not more than 25 ma. For instance, 25 ma. and 200 volts equals a power input of 5 watts—the allowable maximum.

One of the features of the device is the use of both meters simultaneously. The foregoing procedures are followed

but now the maximum field strength and power input are observed at the same time as transmitter adjustments are made. It is desirable to use long enough test leads on the current meter to place the instrument a little distance away from the transmitter being tested to keep the field-strength meter antenna away from the field of the transmitter tank coil. Test leads about 2 feet long are suitable.

To protect the meter, it is good practice to begin any test with the meter sensitivity control turned to the extreme counterclockwise position which short-circuits the meter. The control is then turned up as required.

The frequency of the transmitter may be checked against a signal generator having sufficient output. After final adjustments are made and maximum meter indication is obtained, the instrument may be coupled to the output of the signal generator. The frequency dial of the signal generator is then varied to again obtain maximum deflection of the field-strength meter. The transmitter frequency is then that indicated by the signal generator dial. For greatest accuracy the signal generator can be checked against a high-frequency receiver and WWV. A grid-dip meter may also be used for this test.

Once the transmitter is installed and adjusted, the Citizens Radio operator may use the instrument as a monitor to check on the performance of his equipment under normal use.

During normal operation the operator may observe the field-strength reading on this device at a given distance from the equipment. He may check audio quality of voice transmissions, while operating his equipment, by means of headphones plugged into the field-strength instrument phone jack. He may even, after observing the field-strength indication, check the device for frequency against a signal generator. Thus the Citizens Radio operator will have a means of knowing whether or not his station is operating properly.

Inside view of the Citizens Radio field-strength meter. Note the use of the three-lug stand-off mounted on the ground post of the meter at left for small parts. The r.f. coil is soldered to the terminals of the variable capacitor.

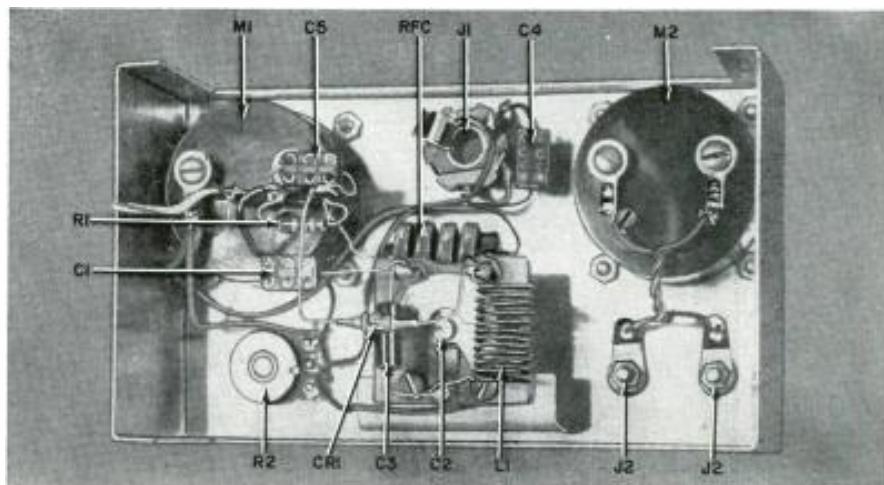

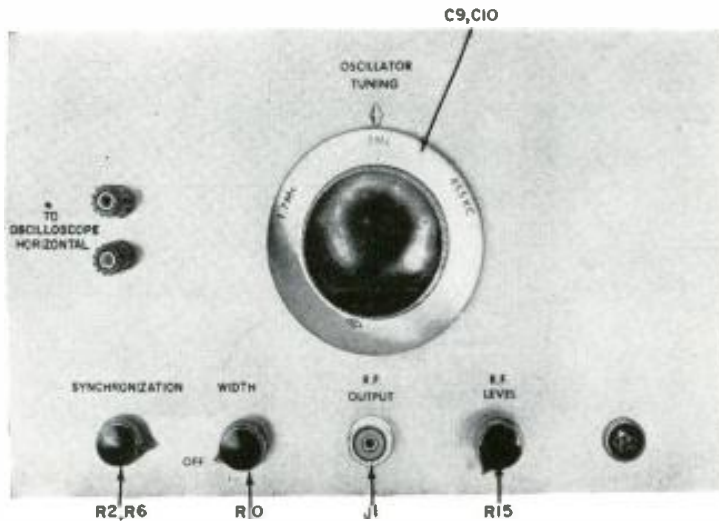

Fig. 1. This simple unit provides the same facilities found in more sophisticated TV-FM sweepers.

A Sweep Generator for Hi-Fi AM

By DON STONER

For broad-band audio on AM, sweep alignment is a virtual must—and you can build the right generator.

SINCE the popularity of FM broadcasting and reception began to rise rapidly over the past few years, AM stations have come to play "second fiddle" to most people interested in high-fidelity results. This attitude is reflected by the design of some combination AM-FM tuners. Even when great pains have been taken to safeguard the quality of the FM section, the AM portion may consist of nothing more than a ferrite-loop antenna, a converter, an i.f. stage, and a detector.

While detailed alignment instructions for FM may appear, the technician is generally instructed to connect a v.t.v.m. across the a.v.c. load resistor for AM alignment and to peak i.f. transformers and other adjustments for maximum reading. Performance leaves much to be desired, as a rule, and this is due, at least in part, to the alignment procedure.

Although many people still believe that there is an "automatic" limit of about 5000 cps as the highest audio frequency broadcast on AM, there are many transmitters that go much higher. So-called "clear channel" stations may transmit as high as 15,000 cps, the top limit in FM. Others may not go as high, but may transmit up to 10 kc. This is frequently true of AM stations affiliated with FM transmitters that devote some attention to the broadcasting of good music.

The increased interest in stereo broadcasting has made the need for

Fig. 2. Circuit of frequency sweeper, r.f. oscillator, and output stage.

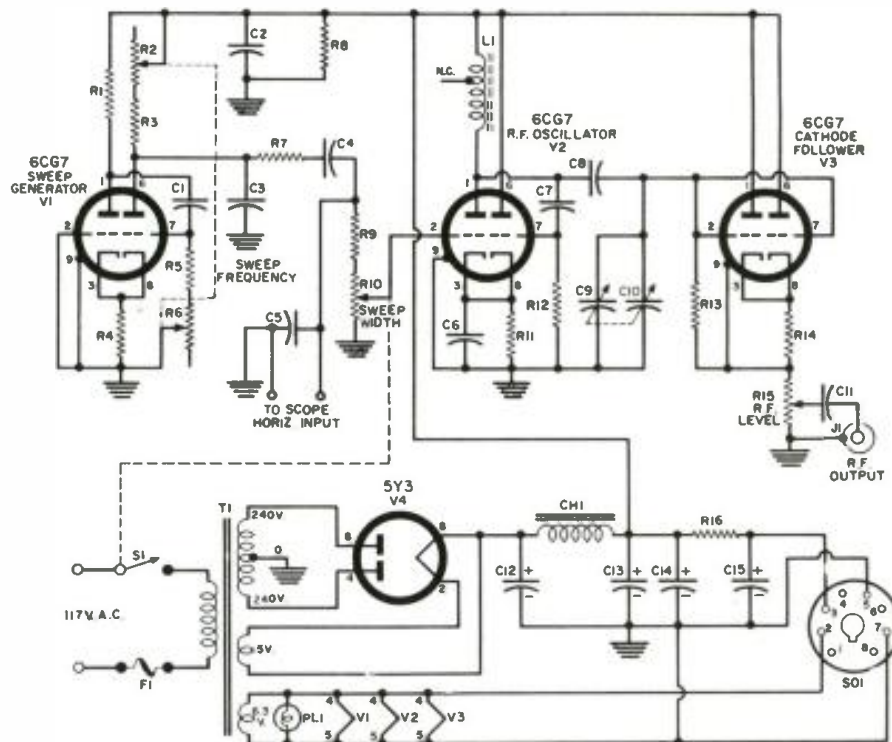

- R₁, R₂—47,000 ohm, 1/2 w. res.
- R₃—250,000 ohm/1 megohm ganged pot (Centralab F1-51 and R2-34)
- R₄, R₁₁—470 ohm, 1/2 w. res.
- R₅—27,000 ohm, 1/2 w. res.
- R₆—470,000 ohm, 1/2 w. res.
- R₇—100,000 ohm, 2 w. res.
- R₈—100,000 ohm, 1/2 w. res.
- R₉—1 megohm, linear taper, pot ("Sweep Width," with switch S₁)
- R₁₀—220,000 ohm, 1/2 w. res.
- R₁₂—1 megohm, 1/2 w. res.
- R₁₃—1000 ohm, 1 w. res.
- R₁₄—10,000 ohm, linear taper, pot ("R. F. Level")
- R₁₅—3900 ohm, 2 w. res.
- R₁₆—22 μf. paper capacitor
- C₁, C₂, C₃, C₁₅—0.01 μf. mica capacitor
- C₄, C₅—2 μf., 200 v. paper capacitor

- C₆—680 μf. silver mica capacitor
- C₇—0.001 μf. silver mica capacitor
- C₈, C₉, C₁₀—Dual 365 μf. var. capacitor (Miller #2112)
- C₁₁, C₁₂, C₁₃, C₁₄—20/20/20/20 μf., 450 v. elec. capacitor (Cornell-Dubilier UPT-222245)
- CH₁—7 hy., 50 ma. filter choke (Stancor C-1277)
- L₁—Ferrite rod antenna (Miller #2004)
- J₁—U.h.f.-type coaxial connector (Amphenol SO-239)
- SO₁—8-pin tube socket (Amphenol 168-015)
- S₁—S.p.s.t. switch ("On-Off," part of R₁₀)
- T₁—Power trans. 240-0-240 v. @ 55 ma.; 5 v. @ 2 amps.; 6.3 v. @ 2 amps. (Stancor PM8402 or equiv.)
- PL₁—#47 pilot light
- F₁—2 amp. fuse
- V₁, V₂, V₃—6CG7 tube
- V₄—5Y3 tube

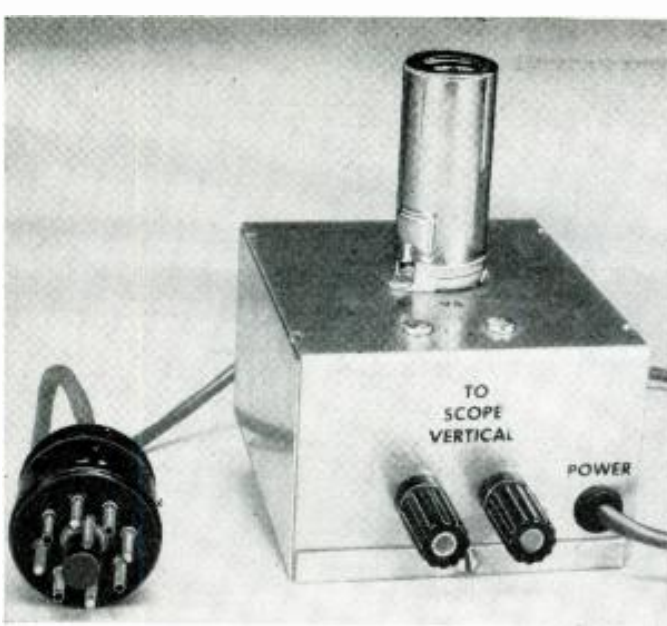

Fig. 3. Accessory probe for the sweep oscillator is used to detect response curve for scope display when alignment or troubleshooting of an individual stage is involved. This unit takes the place of the detector in the AM receiver itself, which performs the same function when an over-all alignment procedure is performed.

better quality in AM and the means of aligning to obtain that quality more pressing. In most stereo transmissions, the FM station is used for one channel and the other channel is sent out on the affiliated AM transmitter. The necessary balance between the two channels is destroyed when frequency response in the AM receiver is drastically reduced and distortion is increased by peak alignment. To understand the importance of alignment, particularly of the i.f. section, let's review the make-up of the AM signal briefly.

The modulating audio signal is applied to an r.f. carrier that is constant in frequency and that is also constant in amplitude when no audio signal is applied. The modulating signal does nothing to the frequency of this carrier, but it causes carrier amplitude to rise and fall as the audio itself goes positive or negative. Presto! Amplitude modulation.

However, something else of importance takes place. When modulation occurs, although the carrier frequency itself does not change, additional signals at other nearby frequencies are produced. For example, when an audio modulating tone of 1 kc. is applied, two new r.f. signals, or sidebands, are created. These appear on each side of the carrier and are displaced from it by the same number of cycles or kilocycles as the original modulating frequency. In other words, if a station carrier at 640 kc. is modulated by a 1-kc. tone, additional r.f. signals at 639 and 641 kc. would appear. If the highest modulation frequency is 15 kc., then sidebands will be generated as high as 15 kc. above the carrier and as low as 15 kc. below it. The total transmission bandwidth is then 30 kc. wide.

In order to reproduce this modulation faithfully, the bandwidth of the AM receiver (particularly of the i.f. amplifier) must also be 30 kc. wide. If the i.f. stage is no more than 10 kc. wide, as may be the case, audio frequencies above 5000 cps will be lost.

Although it is not always practical, depending on the design of the AM receiver, to realign the i.f. section for the entire bandwidth of 30 kc., it is almost always possible to achieve a worthwhile improvement at some sacrifice in gain.

This can be done by stagger tuning; i.e., one i.f. adjustment is detuned slightly from the center frequency in one direction, the next adjustment is tuned off center in the opposite direction, and so on. With an accurate signal generator and a v.t.v.m. as output indicator, the response curve showing the bandwidth can be plotted on graph paper, and replotted as re-adjustments are made.

This process is haphazard and time-consuming. It would be far easier to borrow a technique used on TV receivers, where i.f. bandwidth is an important consideration, and to use a sweep generator while observing the response on an oscilloscope. Unfortunately, there are very few sweep generators available of the type and price that would be practical for a service bench that will operate as low as the frequencies involved in AM reception. The AM sweeper described here (Figs. 1 and 2) was designed to operate in the range between 350 and 1600 kc., which covers all r.f. and most i.f. circuits. In addition, an associated detector probe (Figs. 3 and 4) was designed to assist in troubleshooting, for testing and aligning filters in amateur radio applications, and for general experimentation with tuned circuits.

How It Works

You will note that V_2 (Fig. 2) is employed as a cathode-coupled oscillator. Its frequency is determined by L_1 in conjunction with C_6 and C_{10} . Coil L_1 , a ferrite antenna rod designed for use with transistor portable radios, has a "Q" of 500 at 790 kc. Capacitors C_6 and C_{10} are the two 365- μf . sections of a dual, variable unit, with both sections tied together. The total capacity (730 μf .) allows the coil to resonate as low as 350 kc. To avoid loading the oscillator, the two triodes of another 6CG7 (V_3) are connected in parallel and used

(Continued on page 106)

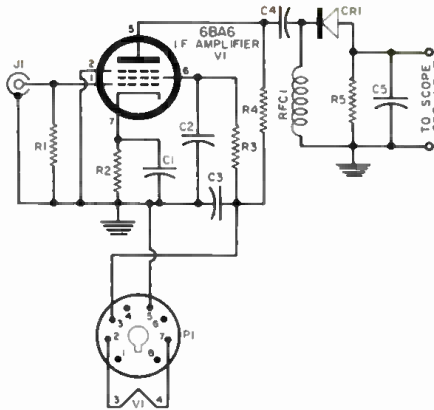

- R_1 —2.2 megohm, $\frac{1}{2}$ w. res.
- R_2 —220 ohm, $\frac{1}{2}$ w. res.
- R_3 —47,000 ohm, $\frac{1}{2}$ w. res.
- R_4 —4700 ohm, $\frac{1}{2}$ w. res.
- R_5 —100,000 ohm, $\frac{1}{2}$ w. res.
- C_1, C_2, C_3, C_4 —.01 μf . mica or paper capacitor
- C_5 —.005 μf ., 200 v. capacitor
- RFC—2.5 millihenrys (Miller #6302 or equiv.)
- CR1—1N34A germanium diode
- PI—8-pin octal plug (Amphenol 86-PM8)
- J1—Coaxial connector (Amphenol SO-239)
- V1—6BA6 tube

Fig. 4. Circuit of accessory detector.

Fig. 5. Underchassis view highlights component layout. Only L_1 may be critical.

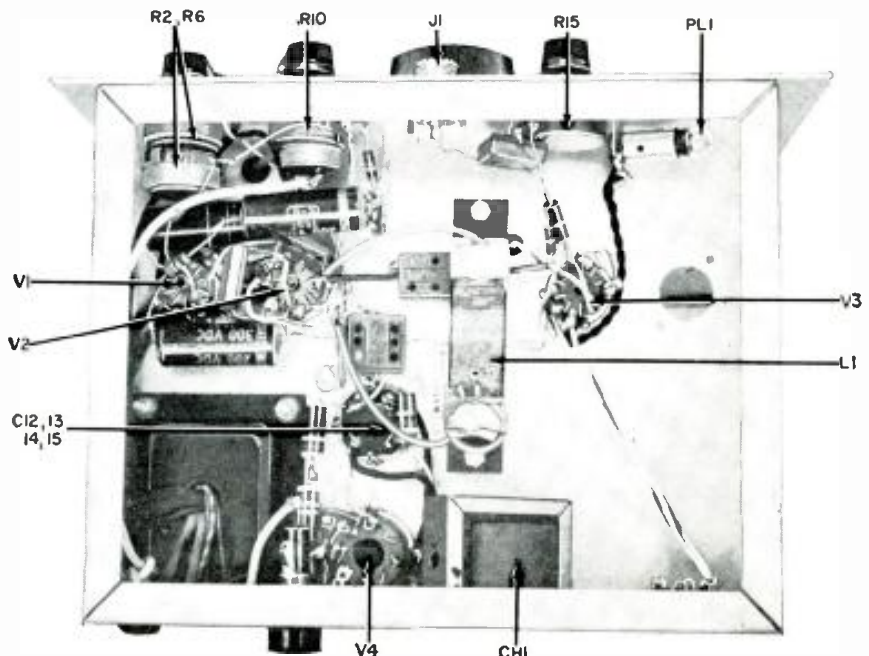

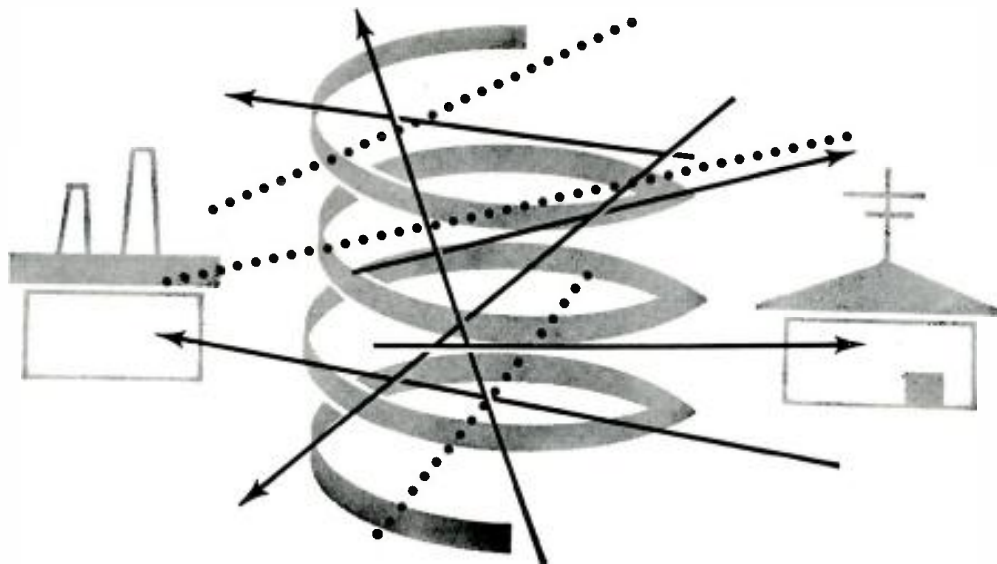

Interference from Radiating Coils

By KENNETH BRAMHAM

Countermeasures for a problem that grows with the use of industrial electro-mechanical equipment.

A SOLENOID de-energizes, a relay "drops out," a magnetic step switch clatters home, and every piece of electronic equipment in the building goes wild. The reason for this interference is that the inductive device being operated is acting as a transmitter, radiating energy to every sensitive circuit within range.

When the effect of such inductive "noise" is merely interference on a radio or TV set, the owner of the guilty device may not be too interested in cleaning up his equipment. However, when the "transmitter" is in an electro-mechanical gadget that is expected to operate with other sensitive equipment, such as electronic computing circuits owned by the same individual, he has a definite stake in suppressing all interference. Noise spikes produced by inductive circuits in adding machines, tape-punches, and the like will introduce random pulses into computing circuits to give incorrect results. Components used in circuits very closely coupled to a radiating circuit and designed for low-voltage operation may be damaged by high-voltage inductive spikes and cause a recurring service problem. The question is no longer whether to clean up the electro-mechanical circuit, but how much suppression to apply and what type of circuit to use.

Before we attempt to suppress inductive noise we should have some understanding of what takes place in an inductive circuit to produce this problem. Whether a coil is used in a relay, a motor control, a tape-punch, or any other electro-mechanical gadget, the basic induction circuit is the same. The coil provides three electrical components: inductance, provided by turns of wire; resistance, provided by the wire alone; and capacitance provided by the individual turns and layers of wire with

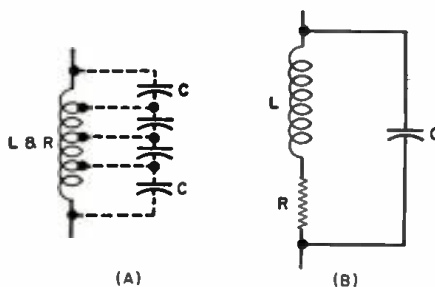
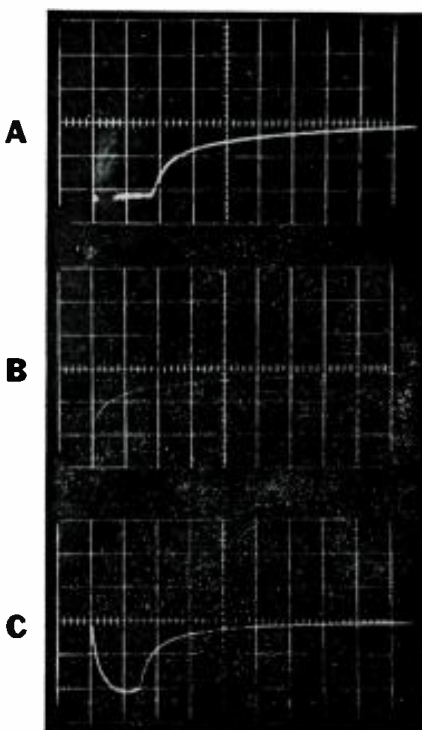

Fig. 1. Every coil (A) has inductance plus other characteristics. These may be represented (B) as added components.

Fig. 2. Actual scope traces show effects of various suppression circuits.



the insulating coating between them acting as the dielectric. This inductance, resistance, and distributed capacitance are shown schematically in Fig. 1A and simplified as lumped constants in Fig. 1B where they become the familiar resonant circuit with series resistance. The resonant frequency of the circuit is determined by the formula: $f_r = 1 / (2\pi \sqrt{LC})$.

Now, without going into too much detail, let us review the operating cycle of a typical coil. Let us assume that a d.c. supply connected to the circuit of Fig. 1B is suddenly removed. The magnetic field created by the supply current in the coil starts to collapse, the flux lines cut the windings of the coil and produce a current in the same direction as the original supply. The coil now becomes a generator whose voltage output has a polarity opposite to that of the original supply, charging the interwinding capacitance and transferring the energy from the coil field to the capacitor dielectric.

When this energy transfer is complete, the procedure reverses and the energy is returned from the capacitor to the coil. This cycle is repeated and would continue indefinitely but for circuit losses due mainly to the resistance. The net result is a gradually damped sine wave of voltage (oscillation) at the resonant frequency of the coil, shown in Fig. 3A. Peak voltage, (V), shown as point B in Fig. 3A, is much greater than the original supply voltage (E), which is interrupted at point A. This is shown by the formulas:

$$\text{Energy (W) in the coil at A} = LI^2/2$$

$$\text{Energy (W) in the capacitor at B} = CV^2/2$$

As this energy is essentially the same in both cases, $LI^2/2 = CV^2/2$. From this relationship, we determine that $V = I \sqrt{L/C}$. Since C is generally very small compared with L, V becomes quite

large in the majority of instances.

The noise produced by an inductive circuit is, of course, transient oscillation, radiated while the coil de-energizes and re-energizes. It is this oscillation that must be suppressed to render the coil harmless to other circuits and components and to reduce radiation below the interference level. Three familiar methods of suppression are shown in Figs. 4A, 4B, and 4D. These simply involve a diode, a resistor, or a capacitor connected across the coil. Modifications of these circuits are shown in Fig. 4C and 4E. Each method is useful and each has its advantages over the others in particular applications.

The diode circuit of Fig. 4A effectively shorts out the interwinding capacitance and reduces the peak negative transient voltage to .3 volt in the case of a germanium diode or .7 volt in the case of a silicon diode. Diode polarity is chosen, as shown, to conduct on the negative spike. Polarity markings across the coil indicate original supply voltage. While this almost complete suppression is effective it does, by reducing the potential across the coil, reduce the current in the circuit, and it increases the time taken for the coil to de-energize. Thus, while this diode circuit gives excellent suppression, it can only be used where drop-out time is not critical.

The resistor circuit shown in Fig. 4B reduces the transient voltage by placing a resistance that is large compared to the coil resistance across the interwinding capacitance. While this is an effective means of suppression, the re-

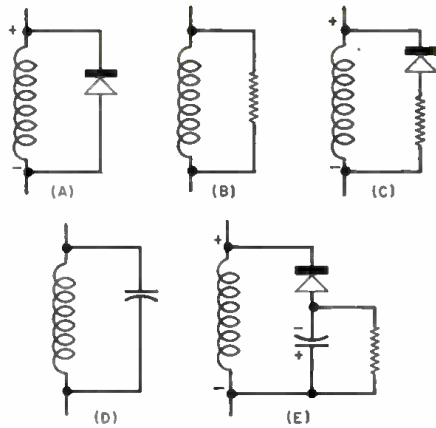

Fig. 4. Three basic suppressor networks (A, B, and D) with two variations (C and E) to meet special conditions.

duced peak voltage (point B in Fig. 3B) across the coil and capacitance in turn reduces the current in the circuit, reduces the damping effect of the coil resistance, and prolongs the time taken (point D) to de-energize the coil.

In many cases the prolonged de-energizing time is not too important but, as this time determines the time taken for an armature and its mechanical parts to "drop out," required operating speed of equipment using the coil must be taken into account when selecting the value of the suppression resistor. As with all of these circuits, we have the choice between fast drop-out or good suppression, and we must strike an optimum condition for the individual need. The reduced-amplitude, damped sine-wave output of this circuit is shown in Fig. 3B.

The diode-resistor combination of Fig. 4C and its waveform (Fig. 3C) is interesting because only one transient voltage spike (point B) is produced after the energizing voltage is removed from the coil. In the perfect coil (without interwinding capacitance), this single spike would occur at the instant the circuit is switched; in practice, the negative spike corresponds closely to the first peak of the LC resonant sine wave.

The rise time of this voltage spike is

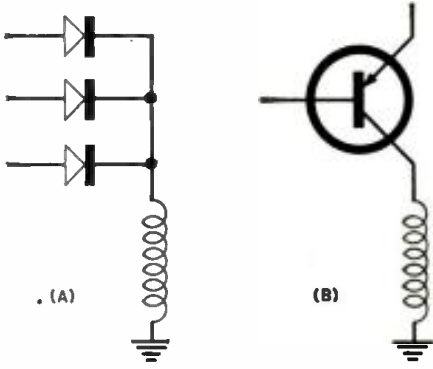

Fig. 5. Limiting transient peaks to protect semiconductors may be the chief consideration in circuits like these.

very short and is therefore easily coupled to other sensitive circuits. After reaching a peak, the transient voltage falls to zero exponentially as the coil de-energizes via the resistor-diode circuit. This voltage finally reaches a very small value at drop-out point D. Again we see that transient sup-
(Continued on page 104)

Fig. 3. Output (A) from a de-energized coil may be altered in various ways (B, C, D, and E) by suppression circuits.

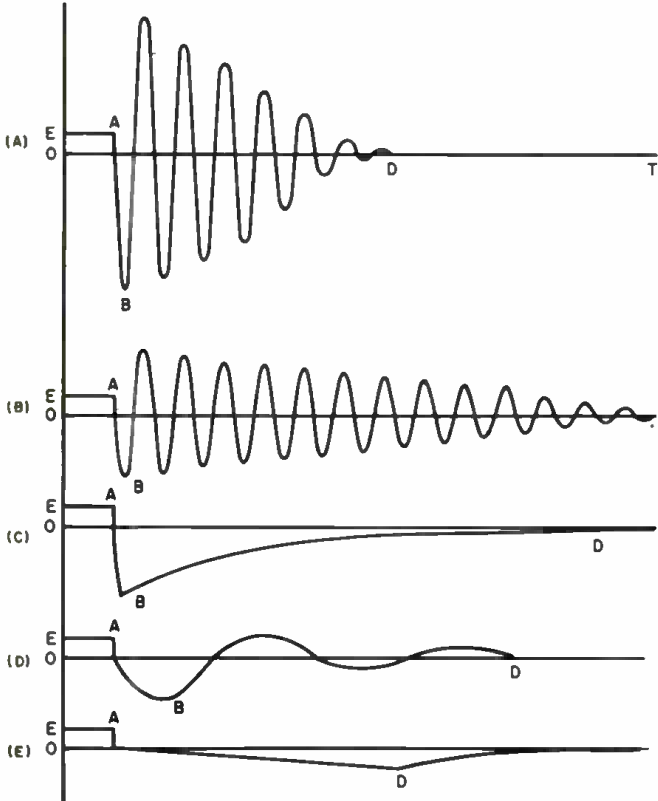
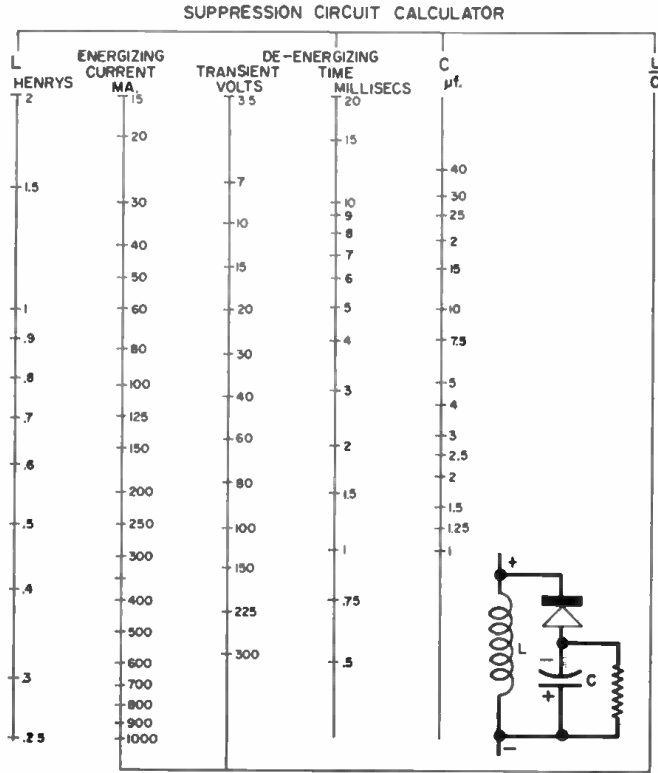

Fig. 6. This nomograph correlates the parameters involved in optimizing a capacitor-diode-resistor suppression network to meet the requirements of a particular situation. It may be used in place of the formulas presented in text.



By JOHN T. FRYE



Dummy Loads

WHEN Mac came back from lunch he found his assistant, Barney, making some measurements on a couple of black, thick-walled cylinders about an inch in diameter and ten inches long. The metallic-coated ends of the hollow rods were thrust into what looked like over-size fuse clips. Looking closely, Mac saw the two objects were really connected in series and fed through a coax connector.

"Before you ask," Barney said, "I'm running some checks on this Global-resistor dummy antenna for my transmitter. These two 36-ohm, 30-watt units—advertised, incidentally, as 50 watt units—connected in series give me a 72-ohm, 60-watt dummy antenna that can be safely overloaded to 100 watts for a short time."

"I suppose with the bands as crowded as they are a ham really needs a good dummy antenna to check his transmitter."

"Right; and a reliable dummy antenna has lots of other uses around a ham shack, such as checking an s.w.r. bridge, testing a coax line for breaks and short-circuits, and running down the source of TVI."

"How's that?"

"You simply wrap the dummy antenna in aluminum foil grounded to the coax shield, and you have a radiation-proof antenna. If you still have TVI, you know it's leaking out the transmitter case, coming out on one of the leads, or feeding back into the line."

"I thought you used light bulbs for dummy antennas."

"We do, but they're not very satisfactory. The cold resistance of an ordinary lamp filament is 7-10% of its operating resistance. For example, a 100-watt bulb will show about 10 ohms cold and about 145 ohms when dissipating 100 watts. Accurate power measurements are impossible with a resistance that horses around like that. Ordinary carbon resistors, of course, can't take the wattage; and ordinary wire-wound resistors are highly inductive, which rules them out for a.c. work. Specially wound 'non-inductive' types can be

used if ticklish measures are taken to compensate for the small reactive components they still display. Still and all, these over-grown composition resistors look like the best way to achieve the high-wattage, non-inductive resistance needed for r.f. dummy loads."

"Hm-m-m, looks to me like they would also be fine for checking out high-powered amplifiers," Mac offered. "You can't run fifty or a hundred watts into speakers here in the shop; yet you need to check the amplifiers at high output level. Hundred-watt resistors at 8 and 16 ohms would be just the ticket. I also happen to know these resistors are used a lot in industrial electronics. I've seen them before, but I don't know much about them."

"Well, if you're interested, I can give you the real low-down on these things," Barney offered. "I wanted to know more about them; so I wrote the manufacturer, the Global Plant of the Refractories Division of the *Carborundum Company* at Niagara Falls. They were most helpful, and here is the dope:

"'Global' is simply the trade name for the entire line of resistor products put out by this company. It does not describe a resistor of certain characteristics. This is important, for many TV men think of a Global resistor as only the varistor with a high negative-temperature coefficient that is used in series-string-filament TV receivers to keep the current down until the filaments warmed up. Actually Global resistors may have negative, positive, or near-zero temperature coefficients. There are five different types that I think could be used for dummy loads, and some are better than others.

"First there's the Type A carbon composition resistor. It has a negative temperature coefficient of .90% per degree C and a negative voltage coefficient not over .05% per volt."

"You mean one of these resistors might have 5% less resistance with 101 volts across it than it had with 1 volt, even though the temperature remained unchanged?"

"That's right, but keep in mind dummy loads are usually 52 or 72 ohms to match the surge impedance of coax feedlines; and the voltage across these values can't go very high before the wattage limit is reached. Type A resistors can be operated at body temperatures up to 135° C or at 400 volts per inch of body length, whichever permits the lower dissipation in a particular resistance value.

"Resistors from the three-watt value up come in the following sizes," Barney said as he glanced at his notes: "½" in diameter from 2" to 8" long; ⅝" diameter, 2-10"; ¾" diameter, 4-18"; 1" diameter, 8-18". The 1" x 18" resistor is rated at 54 watts and comes in values from 2 to 50,000 ohms. You find large Type A resistors in radio transmitters, induction heating units, x-ray apparatus, electrostatic precipitators and dust collectors, and antennas and transmission lines requiring resistive terminations.

"Type B resistors are of a silicon carbide composition. They have a negative temperature coefficient of about .3% per degree C in the low-resistance types and can be operated at body temperatures up to 150° C, which, with room ambients, corresponds to a dissipation of approximately 1 watt per square inch of body-surface area. They come in the same sizes as the Type A resistors and have a similar maximum voltage rating of 400 volts per linear inch. You find Type B resistors in voltage regulators, electrostatic dust collectors, small lightning arresters, and rectifiers. My resistors are of this type."

"How about their voltage coefficient?"

"That's what I was testing. The voltage coefficient is negative and is said to be unimportant below approximately 20 volts per inch but increases with resistivity of the composition and covers such a range that a resistor may increase 2 to 4 times in value when the applied voltage is doubled. I figure that 85 volts r.m.s. across this 72-ohm resistor should produce about 100 watts of dissipation; so I compared the current through the resistor at 40 volts r.m.s. with that at 80 volts and found the current just doubled when the voltage did. This convinces me the voltage coefficient of the low-resistance composition in these units can be ignored even though the *peak-to-peak* voltage across my 20 linear inches of resistance does exceed slightly the 20-volts-per-inch figure mentioned, which I think is d.c. voltage."

"How did the temperature coefficient check out?"

"About as you would expect. I ran the resistors at 100 watts for three minutes and then checked the resistance. It had gone down from 72 to 60 ohms and the resistors were so hot you could barely touch them. After they cooled down, which took some time, the resistance came right back to 72 ohms. I think if I keep my test periods short and possibly put a fan on the resistors, I'll not have to worry about the small

(Continued on page 122)

Service Technicians

Citizens Radio for



By LEO G. SANDS

Author of "Class D Citizens Radio"

A survey of basic circuits for those who will have a genuine opportunity for handling maintenance and service in the CB boom.

WHEN THE INDEPENDENT service operator hears that new opportunities are opening up for him in a diversified segment of electronics, he seldom rejoices. The reason is that, in so many "new" fields, the methods for handling service have been worked out at the start and the independent has been largely excluded. The boom in Citizens Radio, however, carries the promise of a legitimate and substantial market for the independent, on several counts.

To begin with, Citizens Radio is being used by many businesses whose relatively small scale of operation has prevented them from adopting regularly licensed, mobile communications, even where this medium has seemed desirable. Now such communication becomes practical for them. In fact, many TV service businesses fall into this category. One of the reasons for opening up the Citizens Band was to accommodate such potential users as these.

In addition most users, since they do not have to meet any technical qualifications, will depend heavily on outside professional help for service and maintenance. In licensed mobile radio, the equipment manufacturers have pretty much made provision of one kind or another for "after service," which sometimes hampers the activity of the independents. In Citizens Radio, the equipment purchaser is on his own in this respect. If he is one of the numerous users with a relatively small system that does not warrant organizing a separate maintenance section, he has little choice but to seek out a local electronics man—and the independent serv-

ice shop is certainly a natural choice.

Add to this the fact that the service technician can perform much of the work without procuring an FCC license. To facilitate development of this service, the FCC has made exceptions to its usual requirements. Since the holder of a ticket will have higher prestige with potential customers and may be in a position to do a more thorough job, the license is, of course, recommended. However, a start could be made in this field without one. (For more information on this point, see "License Not Needed for Citizens Radio Adjustments," page 84, *ELECTRONICS WORLD*, December 1959.)

The most serious potential obstacle may be a relative unfamiliarity with the equipment. Accordingly a review of circuitry is the first step. Actually, the circuits used in Class D Citizens Radio are quite simple. Comparatively speaking, a television receiver is far more complex.

All CB units combine a simple AM transmitter with a receiver (either superheterodyne or superregenerative) and a power supply in a single enclosure. For economy, certain stages are usually used in both transmitting and receiving functions, being switched from one mode of operation to the other. Power may be derived from an a.c. supply, a vibrator supply for use with a battery, or a combination supply that can be used either with an a.c. or battery source. The receivers may be fixed-tuned or variable-frequency. Most service customers will have fixed-tuned units that are adequate for individual business or convenience purposes.

The transmitters tend to follow the same general plan, which is shown in Fig. 1. Whether they are single- or multi-channel affairs, they are fixed-tuned and crystal-controlled. In a multi-channel set, a front-panel switch selects the appropriate oscillator crystal for each channel.

Fig. 1. The transmitter sections of most CB combinations follow this plan.

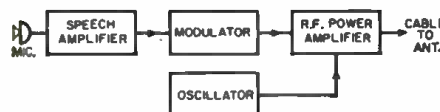

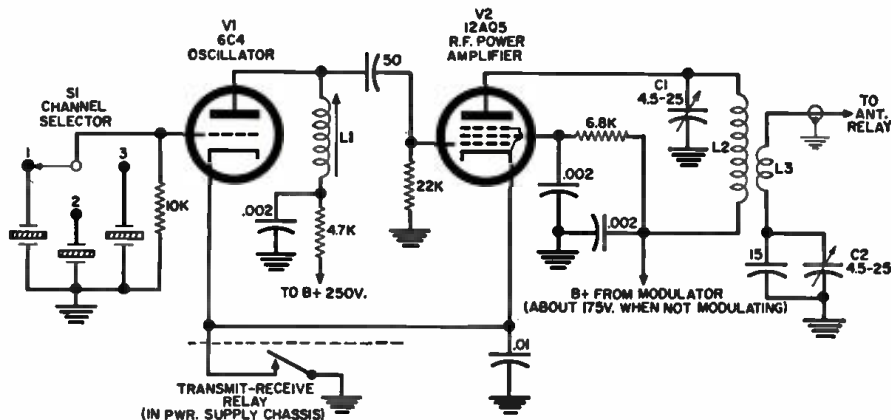

Fig. 2. R. f. oscillator and power amplifier are used during transmission.

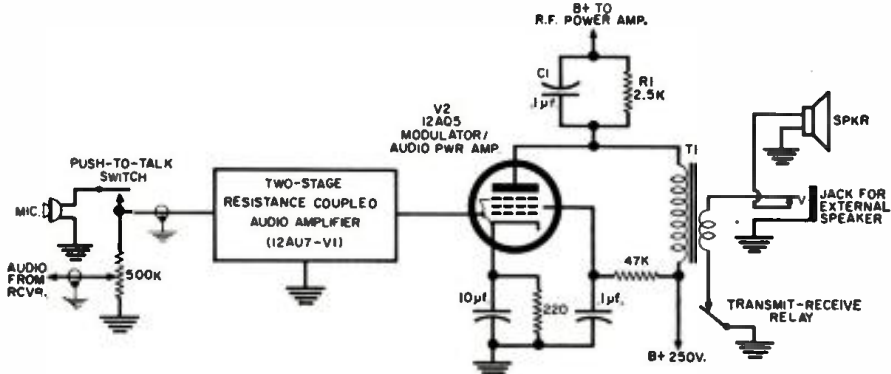

Fig. 3. Amplifier-modulator for transmission feeds speaker during reception.

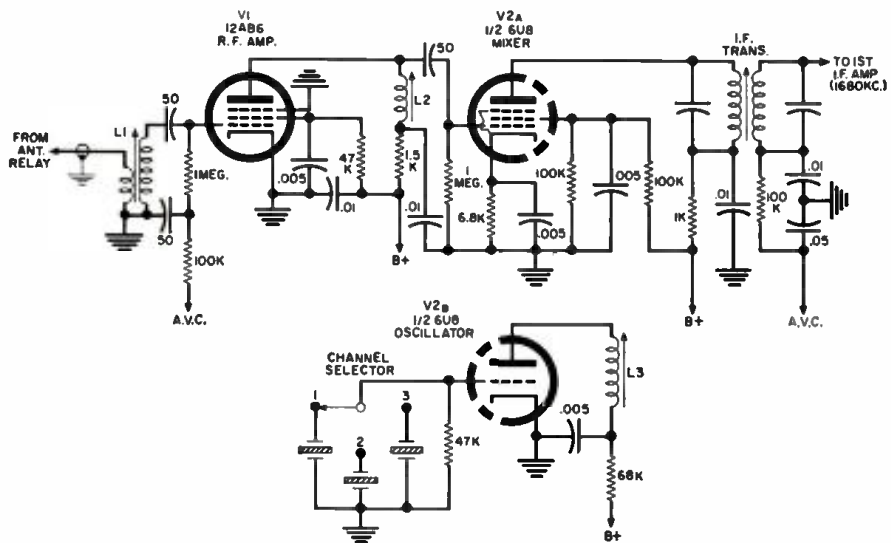

Fig. 4. Superhet receiver design uses r.f. amplifier and crystal oscillator.

Fixed-tuned receivers may use either a superheterodyne or superregenerative circuit. The more expensive sets generally employ a superhet circuit in which the local oscillator is crystal-controlled. There are also some double-conversion types in which both the first and second oscillators are crystal-controlled. (An exception to this is the double-conversion *Vocaline* ED-27, in which only the first oscillator is crystal-controlled and the second is retuned when changing receiving frequency.) In fixed-tuned superregenerative receivers, frequency is set by tuning the detector (an internal adjustment).

In multi-channel, fixed-tuned super-

het receivers, changing channels is accomplished by switching the oscillator crystal. In dual-conversion circuits, only the first-oscillator crystal is switched and the second-oscillator frequency remains the same (with the already noted exception of the *Vocaline* ED-27). In the *Philmore* three-channel superregenerative circuit, the channel switch selects any one of three tuned circuits.

Since the *Globe* CB-100 unit is a typical one with many features also found in other equipment, it is the one that has been selected here for analysis. It can be equipped with crystals for one-, two-, and three-channel operation; it

also presents for study such features as a noise limiter and a squelch circuit in the receiver.

Transmitter Circuit

Of the four tubes used in the transmitter, two are also employed during receiving. The transmitter oscillator uses a single 6C4 triode (V_1 in Fig. 2) whose operating frequency is determined by the overtone crystal connected to its grid. Switch S_1 permits selection of any one of up to three crystals. Each crystal is ground so that its third overtone (fourth harmonic) occurs at the desired operating frequency in the 27-mc. band. Output from V_1 is fed to the grid of r.f. power amplifier V_2 , a 12AQ5. The oscillator plate is tuned to frequency by adjusting the slug of L_1 . Its setting affects oscillator stability as well as grid driving voltage for the next stage.

The plate of the r.f. power amplifier is tuned to operating frequency by the setting of C_1 which, with L_2 , forms a resonant circuit. Antenna loading and matching is determined by the setting of C_2 .

Transmitter tuning is rather simple. L_1 can be tuned for maximum indication while metering voltage at the grid of V_2 , using a v.t.v.m. with its negative prod at the grid. After maximum is reached, the adjustment is backed off slightly so that the crystal will start oscillating every time the transmitter is turned on.

C_1 and C_2 are tuned to provide maximum transmitter output. This output can be metered with an r.f. wattmeter or by observing the glow of a No. 47 pilot lamp (acting as a dummy load) connected across the antenna terminals. The amplifier's plate current should be monitored to prevent input power from exceeding 5 watts.

Modulator Circuit

Preceding the modulator stage, we have a voice microphone (Fig. 3) and a conventional two-stage resistance-coupled voltage amplifier, V_1 , shown here simply as a block, to boost signal amplitude. Characteristics of the microphone and component values in the audio amplifier are such that the frequencies important to speech intelligibility (300 to 3000 cycles) are given preference. Amplified audio is then fed to the r.f. power amplifier.

Amplitude modulation of an r.f. carrier is achieved by raising and lowering the plate and screen voltages of the r.f. power amplifier in step with the audio signal. In this circuit, the audio voltage is developed across the primary of T_1 , as is the case with any output transformer. However the T_1 primary is also in series with the plate and screen of the r.f. amplifier, through R_1 and C_1 . (The actual point of connection has been identified in Fig. 2.) In fact, it is from this connection that the power amplifier for the carrier obtains its "B+" voltage.

As the audio voltage varies, it alternately adds to or bucks out part of the supply voltage going to the r.f. am-

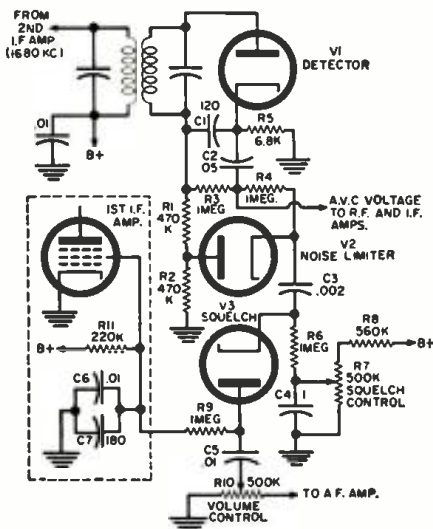

Fig. 5. Detected audio must pass noise limiter and squelch diode to be heard.

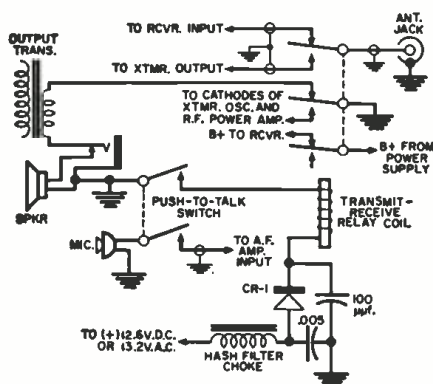

Fig. 6. Pushing one button starts all transmit-receive function switching.

plifier through the T_1 primary, thus causing transmitter output to vary in the form of amplitude modulation.

Dropping resistor R_1 causes the normal "B+" voltage for the r.f. amplifier to be somewhat less than that applied to modulator V_2 (175 volts without modulation, as compared to 250 volts for V_2). However the audio variations are passed on efficiently through C_1 . Thus, with this resistor-capacitor network, a higher percentage of modulation can be obtained.

The modulator stage, since it uses a power-amplifying tube, is made to serve as the audio-output stage when the equipment is used as a receiver. In this function, audio detected from the received signal and amplified is fed to it, as shown, and T_1 serves as a conventional output transformer feeding to the speaker.

Receiver Circuits

A single-conversion superheterodyne circuit is used in the receiver section of the unit we are examining. Fig. 4 shows the r.f. amplifier, oscillator, and mixer stages. Although no direct connection is shown between oscillator and mixer, their proximity to each other (the tubes are in the same envelope) provides adequate coupling. Frequency of the triode oscillator section (V_{22} , 6U8) is determined by the crystals,

each of which is chosen to be 1680 kc. higher in frequency than that of the carrier to be received.

Where operation on one channel only is desired, the slugs of L_1 and L_2 are peaked on the received frequency, while L_3 is adjusted to insure oscillator stability at the desired injection frequency. When the equipment is to be used for two- or three-channel reception, the adjustments of L_1 , L_2 , and L_3 are averaged out to provide comparable, acceptable performance on all channels.

The straightforward, two-stage i.f. amplifier (not shown) is followed by an AM detector diode, a noise limiter, and a squelch circuit, these functions being performed by the three diode sections of a 6B7 tube. As indicated in Fig. 5, diode V_1 is the detector, V_2 the series noise limiter, and V_3 the squelch.

Noise Control and A.V.C.

The audio signal is developed across R_1 and R_2 as well as R_3 . A d.c. voltage is also developed across R_1 and R_2 by the rectifying action of detector V_1 . Capacitor C_2 charges up to the full level of this d.c. voltage, which is negative with respect to ground. The plate of V_2 is connected to the junction of R_1 and R_2 , a point that is less negative than the full voltage across C_2 . Since the cathode of V_2 is connected to C_2 (through R_1), this cathode is more negative than the plate. The plate of V_2 thus being made more positive than the cathode, the diode conducts.

Under normal conditions of reception, the audio signal appearing across R_2 passes through the conducting V_2 and continues, through C_3 , to the rest of the audio circuit. However, when a noise pulse is received, the d.c. voltage at the junction of R_1 and R_2 (plate of V_2) rapidly swings more negative. The voltage at the cathode of V_2 cannot swing negative so rapidly. The long time constant of R_2-C_2 is responsible for a delay. Thus, for the duration of the noise pulse, the V_2 plate becomes more negative than its cathode. The diode stops conducting and thereby blocks

the passage of the audio signal through it. This is called a series noise limiter.

Since the amplitude of the d.c. voltage developed across C_2 depends on the strength of the signal being received, this negative potential is used to provide a.v.c. voltage for the r.f. and i.f. stages.

Squelch & Audio Output

Audio signal that has passed through the noise limiter is then fed through C_3 to the cathode of V_3 , the squelch diode in Fig. 5. When sufficient signal is present, the plate of V_3 is more positive than its cathode. It therefore conducts, permitting the passage of audio signal to C_5 and the volume control.

To permit adjustment for individual conditions of use, the negative voltage present at the V_3 cathode may be varied by the addition of a positive d.c. voltage, which is determined by the setting of squelch control R_7 and obtained from the "B+" supply.

A positive d.c. voltage is also applied to the V_3 plate, through R_8 , from the screen of the first i.f. amplifier. This related stage is shown inside the broken lines in Fig. 5. Since the first i.f. stage is controlled by a.v.c. action, its screen current will be reduced when a signal is being received but will rise under no-signal conditions. This means that screen voltage will rise during reception and fall under weak-signal or no-signal conditions. Since this voltage is coupled to the V_3 plate, the latter conducts when a signal is being received but, because its cathode is more positive than its plate, it cuts off when no usable signal is present. This cut-off condition blocks the passage of random noise to the audio circuits.

The audio amplifier circuitry of the receiver is common to the transmitter. In fact, it has already been shown in the latter capacity in Fig. 3. When receiving, detected audio is fed to the audio amplifier system, and the secondary of output transformer T_1 is connected to the voice coil of the loud-
(Continued on page 124)

Fig. 7. Power supply readily adapts to use with 117 volts a.c. or 12 volts d.c.

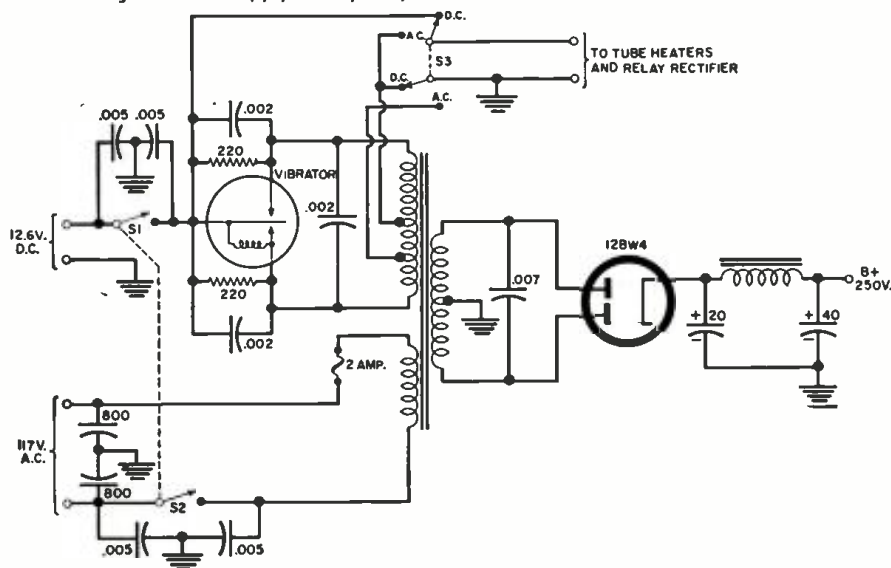

MORE and more ham shacks are being equipped with communications receivers that include only the amateur bands. Although these receivers are hard to beat as far as sensitivity and selectivity are concerned, their inability to pick up AM broadcast stations can, at times, be both frustrating and inconvenient.

Many ham-band-only receivers contain 100-kc. frequency standards, but include no means for checking the accuracy of these devices. Since the average broadcast transmitter stays within a cycle or two of its assigned frequency, those which operate on multiples of 100 kc. make excellent markers against which a calibration oscillator may be compared. Thus, if you can tune the broadcast band, you can keep your crystal calibrator on frequency.

Thanks to the near demise of network programming, plus a slavish adherence to the news-music format by most broadcasters, it is often difficult, nowadays, to find anything but "rock and roll" or "rhythm and blues" on the dial of your a.c.-d.c. midget. Consequently, a sensitive receiver which tunes the broadcast band is a big help when you want to pull in those distant stations that still transmit something more than the top-selling 45-rpm discs.

Maybe you're a sports fan who wants to hear a play-by-play description of a game taking place in a distant city. Or maybe you want to tune in on a newscast from a home town that is several hundred miles away. At any rate, no matter what the reason may be, there are plenty of times when it is desirable to have the broadcast band available on the dial of your amateur receiver.

Fortunately, this can be accomplished easily with a converter similar to the unit shown in Fig. 1. At the flip of a switch, this inexpensive device will

transform your ham-band set into a sensitive, accurately calibrated broadcast receiver.

Circuit

The converter employs a dual-purpose 6EA8 tube which serves as both oscillator and mixer. The oscillator, crystal-controlled for maximum stability, operates at 28 mc. Energy from the oscillator is coupled to the pentode grid of the 6EA8 via C_6 . Broadcast signals coming via C_5 and RFC_1 also reach the grid of the pentode section of the tube where they mix with the output of the oscillator to produce beat frequencies above and below 28 mc. The beats above 28 mc. are amplified by V_{1A} and appear on the dial of the companion receiver between 28.54 mc. and 29.6 mc. For example, a 600 kc. broadcast station will come in at 28.6, a 1200 kc. station will appear at 29.2, and a 1500 kc. station will be found at 29.5. Thus, by mentally adding 28 to the frequency of the broadcast station you wish to hear, you can locate it easily on the dial of the receiver which is acting as a tunable i.f. amplifier.

RFC_1 is an item not usually found in converter circuits, however, it has two very important functions in this particular unit. Without the choke, 28 mc. energy at pin 2 of V_{1A} would be seriously shunted to ground by the relatively low reactance of the broadcast tuning capacitor, C_2 . As a result, the oscillator would be unable to provide sufficient voltage at the grid of V_{1A} for efficient mixing action. Another function of RFC_1 is to provide a high impedance to unwanted external 10-meter signals which might otherwise get into the converter through the antenna circuit.

T_1 , the r.f. antenna coil, is a manufactured component with very high "Q." Do not skimp on the quality of

this part. The better this coil is, the more sensitive the finished converter will be. However, you can wind T_1 and L_1 yourself. Use miniature slug-tuned forms and give the finished inductors a coating of polystyrene coil dope to keep the coils from unraveling.

The converter can be constructed in a 5" x 4" x 3" aluminum "Minibox" without undue crowding of parts. A small aluminum chassis, approximately 2 $\frac{3}{4}$ " x 3 $\frac{3}{4}$ ", must be installed in the box to provide a mounting place for the tube and crystal sockets, the coils, and the antenna jacks. Do not attempt to build the device on an open, unshielded chassis. Performance under these conditions will be unsatisfactory because 10-meter signals picked up on the exposed wiring will leak into the amateur receiver where they will cause unwanted interference to the broadcast stations.

When ordering a crystal, be sure to specify a 3rd overtone 28-mc. unit. A .01% tolerance will be sufficiently accurate, since a discrepancy of 2 or 3 kc. will merely cause the broadcast stations to appear a little to one side of the expected points on the receiver dial. This slight error can be easily corrected by means of the front-panel calibration adjustment with which most ham-band receivers are equipped.

A nearby high-powered broadcast station may have a tendency to overload the converter and cause cross-modulation and birdies on adjacent channels. These unwanted responses can be minimized, however, by leaving the "Local-Distance" switch, S_2 , open when tuning to stations in the vicinity. The closure of S_2 places R_2 in shunt with R_3 and lowers the bias on V_{1A} to increase sensitivity. Unfortunately, the added sensitivity is accompanied by greater susceptibility to cross-modulation. Consequently, S_2 should remain

Broadcast-Band Converter for Ham Receiver

By HARTLAND B. SMITH, W8WVD

Construction of a simple unit that will convert a ham-band-only set to a sensitive broadcast receiver.

The converter is housed in a 5" x 4" x 3" aluminum "Minibox." ▶



open except when you are looking for weak, out-of-town stations.

Since its requirements are quite low, power to operate the converter may be taken from the companion receiver. Make certain that the "B" potential does not exceed 150 volts, otherwise there is likely to be excessive crystal current which will not only cause frequency drift, but may even result in a fractured crystal.

Alignment

Alignment of the finished converter is accomplished in the following manner. Connect the receiving antenna to J_1 . Run a coaxial cable from J_2 to the antenna terminals of the receiver. Throw S_1 to the "BC" position. Close S_2 . Loosen the screw of trimmer C_2 until it is almost ready to fall out of the capacitor. Turn the screws of T_1 , T_2 , and L_1 in a counterclockwise direction as far as they will go.

After a one-minute warmup, set the receiver to 28 mc. A strong carrier from the crystal oscillator should be heard. Adjust the dial pointer on the receiver to read exactly 28.0 mc. when the carrier is tuned on the nose.

Mentally add 28 to the frequency of a local broadcast station. Tune to that spot on the receiver's dial. The station should be heard, although it may come through weakly. Peak the antenna trimmer on the front panel of the receiver, as evidenced by a maximum reading on the set's "S" meter. Now, turn the screw of T_2 clockwise. As this is done, the "S" meter will rise. The correct temporary setting for the slug in T_2 is at the point of maximum "S" meter reading.

If there is no 1600-kc. station within
(Continued on page 120)

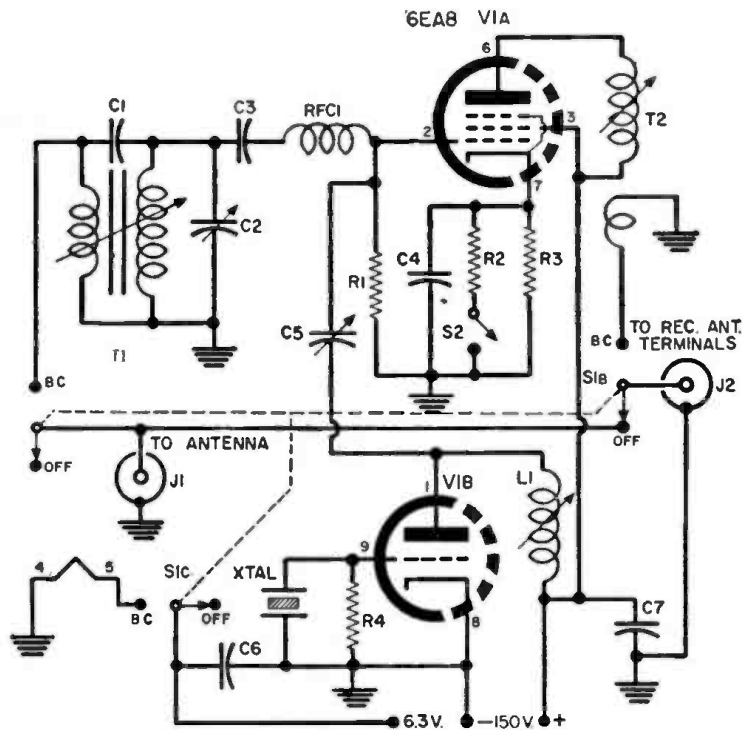

- R_1 —1 megohm, $\frac{1}{2}$ w. res.
- R_2 —2700 ohm, $\frac{1}{2}$ w. res.
- R_3 —30,000 ohm, $\frac{1}{2}$ w. res.
- R_4 —33,000 ohm, $\frac{1}{2}$ w. res.
- C_1 —Part of T_1
- C_2 —15-409 μf . var. capacitor (Allied Radio 61H009 or equiv.)
- C_3 —150 μf . mica capacitor
- C_4 —0.001 μf . disc ceramic capacitor
- C_5 —1.5-15 μf . mica trimmer
- C_6 —0.0047 μf . disc ceramic capacitor
- RFC_1 —21 μh ., 600 ma. r.f. choke (Ohmite Z-28)
- S_1 —3-pole d.t. switch (Mallory 3243J) or equiv.)
- S_2 —S.p.s.t. toggle switch ("Local-Distance")
- J_1 , J_2 —Shielded phono-pin jack
- XTAL.—28 mc., 3rd overtone crystal (.01% tolerance or better)
- L_1 —Osc. coil, 16 t. #24 en., closewound on $1\frac{1}{8}$ " x $\frac{3}{8}$ " dia. coil form (Cambridge Thermionic LS3)
- T_1 —Antenna trans. 550-1700 kc. adjustable iron core unit (Miller A-5495-A, see text)
- T_2 —Output trans. Pri. 17 t. #24 en.; Sec. 7 t. #24 en. closewound on $1\frac{1}{8}$ " x $\frac{3}{8}$ " dia. coil form (Cambridge Thermionic LS3)
- V_1 —6E48 tube

Fig. 1. Complete schematic and parts listing for the broadcast-band converter. A dual-purpose tube serves as both oscillator and mixer. The oscillator is crystal-controlled for stability and operates at a frequency of 28 megacycles.

Top view of the converter unit shown here with the cover removed. Output and input jacks are mounted at the rear.

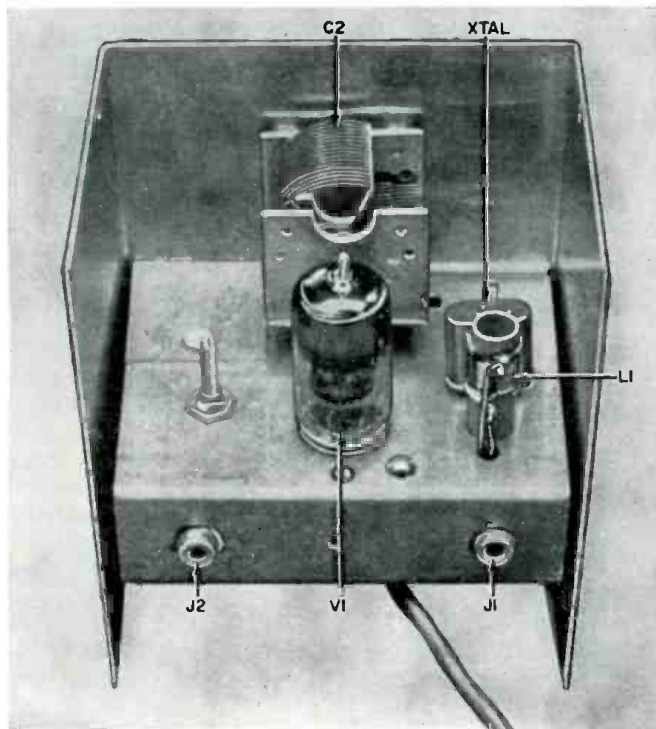

Under-chassis view showing the layout of the components. Short, direct wiring should be employed for the oscillator.

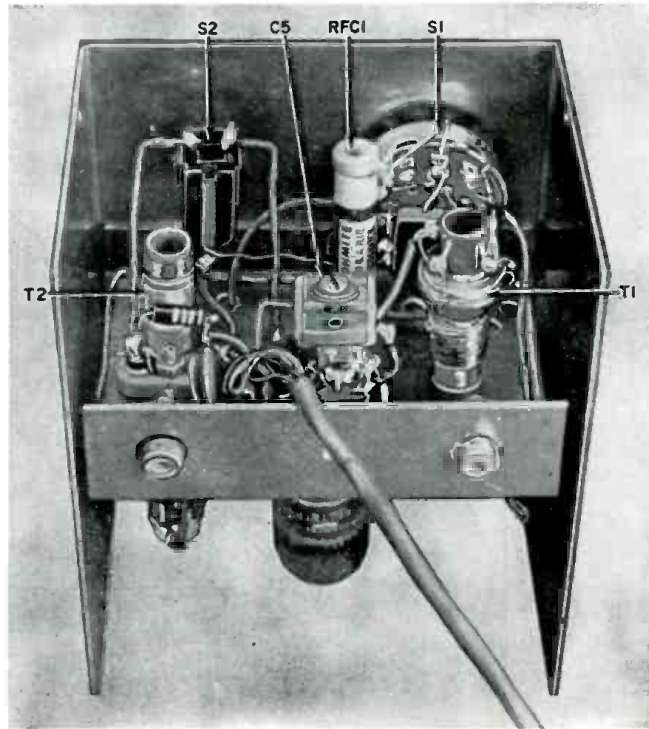



Mobile Electronics Laboratory

One of two mobile electronics laboratories designed for radio propagation studies in isolated areas is shown at the left. Initially developed for recent propagation studies at Cape Canaveral—to determine the design criteria for missile-guidance systems—the 35-foot, \$18,000 trailers are currently being used by the National Bureau of Standards for experiments in Colorado.

Experimental Tube Promises New Power Source

Experimental thermionic tube under development by *Westinghouse* holds promise as a power source for the future. Within the tube, a glowing wire heated to high temperatures emits electrons, causing current to flow in ionized cesium gas in capsule at base of the tube.

Recent Developments in Electronics



Soviet Generator Under Study

A Russian-built thermoelectric generator, used to convert heat from a kerosene lamp into electricity for radios in remote Asian areas, is examined by *Martin Co.* scientists. The company used similar principles in conjunction with a radioisotope heat source and acquired the bulky 20-pound generator in England in order to evaluate Soviet technical approaches. Our readers will recognize the unit as the one we described in the article "Russian Receiver Powered by Kerosene Lamp" in our August 1958 issue.



◀ Giant Radar Antenna

Designed to detect airborne objects, this search radar antenna—located at the Eufaula, Ala. Air Force Station—is the largest of its type in use. The radar is to be a part of the North American Air Defense Command System. Dimensions of the reflector are classified. The four-legged tower section, built by *Blaw-Knox Co.*, has a large platform for operating and maintenance personnel.

Most Powerful Electron Tube

Shown below is the world's most powerful electron tube, expected to help science unlock communications secrets of the space age. The tube, made by *RCA*, weighs about 150 pounds and can produce 5 million peak watts of long-pulse power at 450 mc. It is expected to be used for outer-space communications, missile guidance, radar, and scatter radio.

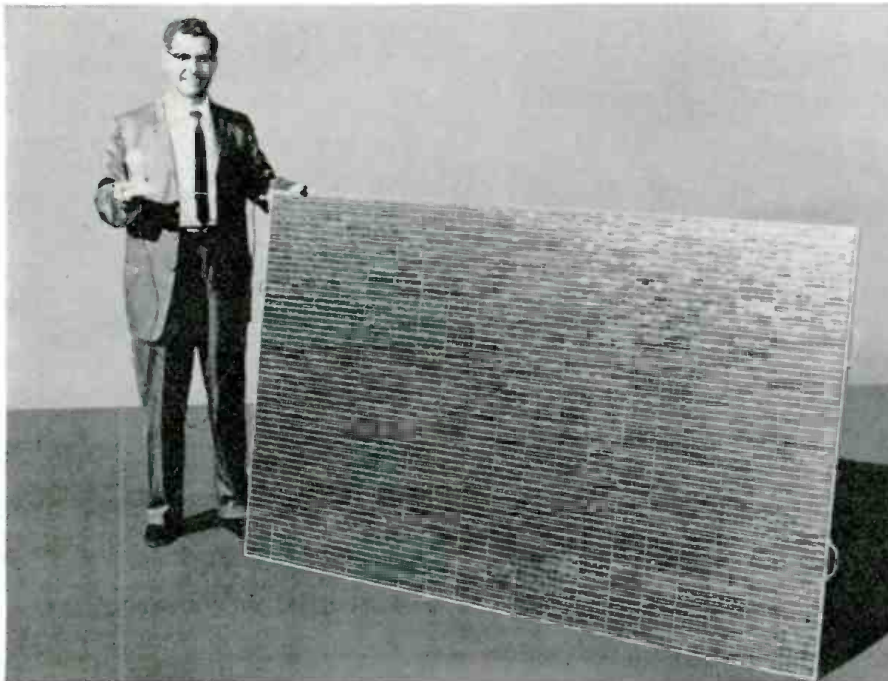

▲ Largest Sun-Cell Panel

The largest solar-cell panel believed ever assembled is shown here. The panel, built by *International Rectifier Corp.*, measures 26 square feet and contains more than 10,000 single high-efficiency silicon solar cells. Panels like these, the company estimates, can be made in mass production quantities for \$2000 to \$3000.

Gas Into Electricity ▶

A thermoelectric generator that converts heat of burning propane gas directly into electricity has been placed on the market by *General Instrument Corp.* Heat from the burning gas is captured in a combustion chamber where it is converted by thermopiles of semiconductor elements directly into electricity, lighting the small lamp shown at the bottom left. The 10-pound "power plant" is designed for remote areas where other sources of electricity are unavailable.

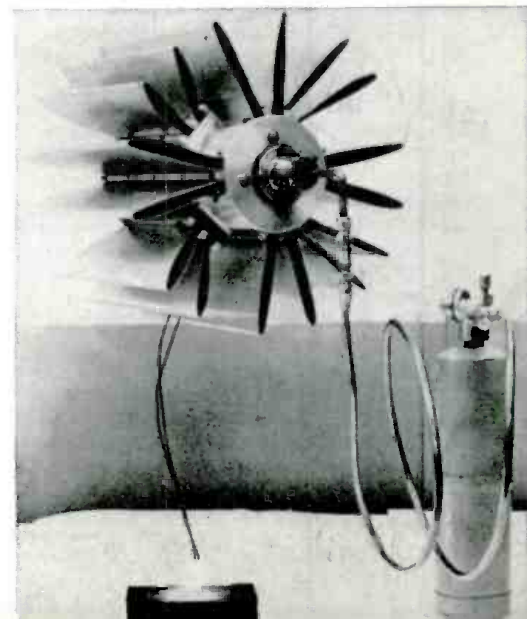

Speeding Customer Payments

By ROBERT STANLEY

Slow payers get that way for a variety of reasons
—but there's a collection strategy for each type.



ONE OF the chief sources of annoyance in an electronic service business, or in most types of business, for that matter, is the snail's pace with which payments come in from certain customers following the mailing out of monthly statements. At best, this slowness causes financial inconvenience. Very frequently, the bad habit can add to the cost of doing business, even create embarrassment.

Since the accepted view is that the shop is entitled to full payment of such accounts by the tenth of the month involved, there is every justification for developing methods to insure that collections are received on time. Many shop owners, who sit idly by while collections falter, are as much responsible for the difficulties they suffer as are their customers. Those who have adopted programs to counteract this headache have generally found a considerable easing of this problem. The techniques they use are varied indeed.

Interest charges. Many service dealers use a line, printed on all statements, calling attention to the fact that they will be entitled to make a late charge or levy interest if payments are not made on time. However, few of them enforce this rule, which largely defeats the effect of the measure.

This statement should appear prominently on all bills and, in the case of chronically delinquent accounts, it should be enforced strictly. Legal technicalities on procedure may vary from one place to another—your accountant or legal consultant is the one to see on this matter—but the amount charged is usually five or six per-cent on unpaid balance. Furthermore it is generally permissible to add on a service charge to each following monthly statement covering whatever unpaid balance remained from the time of the preceding statement.

This procedure appears to be most effective with customers whose greatest failing is simply that they tend to be negligent rather than dishonest. They intend to pay "eventually," but there are other, more pressing debts that must be liquidated first. An accumulating service charge makes their

obligation to you a great deal more pressing. It is true that this technique will lose an occasional customer. However, experience shows—at least from the viewpoint of net profit—that this loss is more than offset by the economic advantage provided by generally speedier collections.

Trading stamps. If you already give trading stamps or do business in an area where surrounding shops have found them to be successful, they can be made to help on the collection problem. Many businesses have an established rule to the effect that stamps will only be issued on cash transactions or, if items or services are charged, only where payment is made by the 10th of the month. This is most effective with people who grow accustomed to paying some merchants promptly while tending to hold others off. If such customers are "stamp collectors," you will find yourself promoted from one category to the next. In many cases, the effectiveness of this method has been found to underwrite the entire cost of trading stamps for all customers.

Such special conditions concerning the issuance of stamps should, of course, be printed on all statements rendered. To avoid misunderstandings and hard feelings, the rule should also be called to the attention of the customer at the time an account is opened or by a special note included with the first statement.

Timing statements. Believe it or not, but actual tests have shown, time and again, that the date on which monthly statements are mailed has a great deal to do with whether people do or do not pay promptly. With many people, the first statements received are those that

are paid promptly. Statements that come in after the cash has run out simply have to await the availability of future funds.

As a general rule, if you are not getting your statements in the mails until the 5th or 6th of the month, your own tardiness may be causing you to suffer from the lateness of others. Firms that mail out regularly on the last day of the preceding month seem to run up the best records for collections rather regularly. Since the situation may differ in some localities from the general one noted here, it is a good idea to check with your local postmaster. He should have a good idea as to when most monthly statements are delivered in your area, and you can plan your own mailing date accordingly.

"Did we make a mistake?" Using the technique of the polite reminder, many firms ask this question on duplicate statement mailings made to all accounts that have not paid by the 14th or 15th of the month. Failure to receive the payment, the note points out, leads the issuing firm to wonder whether some error has been made. There is also a subtle reminder that non-receipt of the customer's check involves some inconvenience, since the firm's own bills must be paid on time, and this is done with funds received, in turn, from customer payments.

Return envelopes. With postage and printing costs what they are today, the automatic use of postage-paid return envelopes on all accounts may be either prohibitive or unrealistic. However, it is a good idea wherever a substantial amount is involved and also with customers who are known, from past experience, to be late. With some careless
(Continued on page 110)

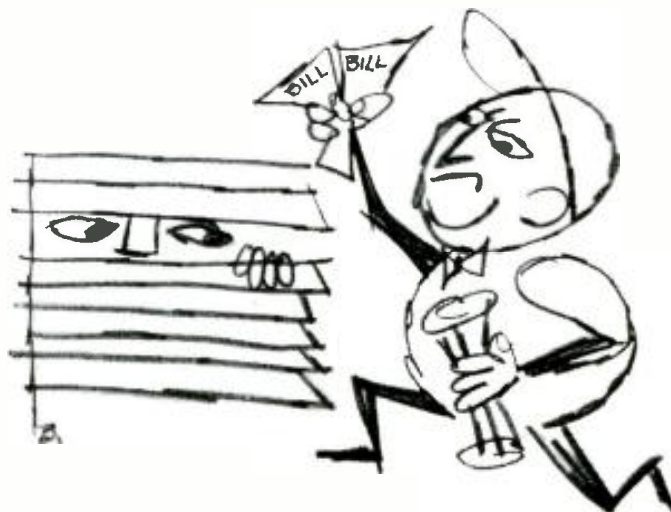

SUCCESSFUL SERVICEMEN



**SAVE
CUSTOMERS**



**SELL MORE
TUBES**



**MAKE
MORE MONEY**

WITH



DYNA-QUIK

DYNAMIC MUTUAL CONDUCTANCE

TUBE AND TRANSISTOR TESTERS

Many thousands of servicemen today insure their professional reputation and make each job more profitable—with B&K testers. Each model is based on actual servicing experience, and combines both speed and accuracy. Each is designed to meet individual servicing needs. Each is a top value, with features that mean more for your money.

Measures true dynamic mutual conductance— not just emission. Makes complete tube test under the actual dynamic operating conditions of the TV set. Tests complete set in minutes. Shows your customer the true tube condition. Sells more tubes right-on-the-spot. Saves costly call-backs. Pays for itself over and over again. It's good business to choose B&K.

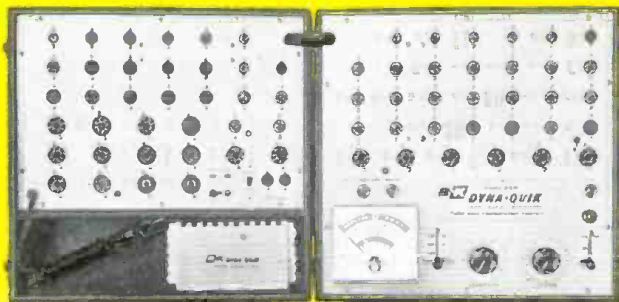

MODEL 650. Fastest and most complete portable Tube and Transistor Tester. Checks over 99% of the tubes most widely used in television receivers. Tests each section of multiple tubes separately for Gm, Shorts, Grid Emission, Gas, and Life. Includes spare sockets and filament voltages for future new tube types. Tests transistors, too. Net, **\$179⁹⁵**



MODEL 675. Completely reliable, long-service Automatic Tube and Transistor Tester. Only 60 indexed phenolic Dyna-Coras test over 99% of tubes most widely used in television receivers. Tests each section of multiple tubes separately for Gm, Shorts, Grid Emission, Gas, and Life. Easily kept up-to-date with extra cards and punch included. Tests transistors, too. Net, **\$169⁹⁵**

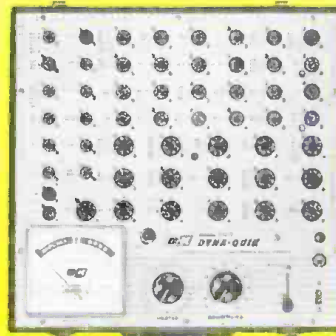

MODEL 550. Low-cost professional model for limited budgets. Provides 52 tube sockets to test more tubes faster, easier. Accurately quick-checks most of the television tubes usually encountered in everyday service work. Tests each section of dual tubes separately for shorts, grid emission, gas content, and leakage. No multiple switching. Big value. Net, **\$119⁹⁵**



See Your B&K Distributor or Send for Bulletin ST24 N

B&K MANUFACTURING CO.
1801 W. BELLE PLAINE AVE • CHICAGO 13, ILL.

Canada: Atlas Radio Corp., 50 Wingold, Toronto 10, Ont. • Export: Empire Exporters, 277 Broadway, New York 7, U.S.A.

HEATH
PRESENTS
18
NEW
ITEMS
for
your
summertime
enjoyment



"ECONOMY" STEREO AM/FM TUNER KIT (AJ-10)

Full fidelity AM and FM reception, plus up-to-the-minute design features are yours at minimum cost with this new Heathkit stereo tuner. Features include: 2.5uv sensitivity for 20 db quieting; individual flywheel tuning; separate magic-eye tuning indicators for AM and FM; AM bandwidth switch; 3-position (off-half-full) automatic frequency control (AFC); FM multiplex adapter output. 14 lbs.

AJ-10 **\$59⁹⁵**

\$6.00 dn., \$6.00 mo.

HI-FI RATED 25/25 WATT STEREO AMPLIFIER (AA-50)

In one handsome package, you get both stereo power and control, with a host of deluxe features. Hi-fi rated at 25 watts per stereo channel (50 watts mono), this new Heathkit design includes channel separation control; new mixed center speaker output; stereo reverse and balance controls; separate tone controls for each channel with ganged volume controls; five switch-selected inputs for each channel (stereo "mag. phono," tape head, 3 hi-level). Extra input for mono "mag. phono." Special outputs for tape recording. Ease of assembly assured by two circuit boards. 30 lbs.

AA-50 **\$79⁹⁵**

\$8.00 dn., \$8.00 mo.

**MIXED LOWS
STEREO CROSSOVER KIT (AN-10)**

Permits using one bass woofer and more economical "wing" speakers for stereo. Delivers non-directional bass of both channels below 250 cps to one woofer; passes higher frequencies to wing speaker. Takes 25 watts per channel; 8, 16 ohm woofers; 8 ohm high freq. speakers. 10 lbs.

AN-10 **\$19⁹⁵**

**Player Kit by Heath—
Mechanism by Garrard**

**MANUAL
STEREO RECORD PLAYER KIT (AD-10)**

Rubber matted heavy turntable is shock mounted, and idler wheels retract to prevent flat spots. 4-pole motor; 16, 33 $\frac{1}{3}$, 45 and 78 RPM; Sonatone 8TA 4-SD ceramic stereo turnover cartridge with diamond and sapphire styli; preassembled mechanism and base. 10 lbs.

AD-10 **\$33⁹⁵**



Quality Stereo at Minimum Cost

ECONOMY STEREO PREAMPLIFIER KIT (AA-20)

A low-cost, versatile stereo preamp-control center. Four inputs each channel accept inagnetic cartridge, crystal or ceramic cartridge, and tuner, tape, TV, etc. Six position function switch gives flexible stereo or monophonic use. Features cathode follower outputs plus hi-level outputs for tape recorder drive, calibrated Baxandall-type tone controls for each channel, clutch-type volume controls, filament balance controls, and accessory AC sockets. Self-powered. Styled in black and gold. 8 lbs.

AA-20 **\$34.95**

PROFESSIONAL RATED 35/35 WATT BASIC AMPLIFIER KIT (AA-40)

Doubles as a superb dual 35 watt stereo amplifier or a full-fledged 70 watt monophonic amplifier. Features a mixed-channels center speaker output for fill-in sound, and individual level controls for stereo. "Stereo-Mono" switch ties both amplifiers to one level control for monophonic use. Dual outputs for 4, 8, 16, and 32 ohm speakers. Paralleling outputs for 70 watt monophonic use matches 2, 4, 8, and 16 ohm speakers. 41 lbs.

AA-40 **\$79.95**
\$8.00 dn., \$8.00 mo.

HI-FI RATED 14/14 WATT BASIC STEREO AMPLIFIER KIT (AA-30) (not illustrated)

14 watts per channel, separate level controls, local/remote power switch, circuit board. Styled like AA-40 above. 21 lbs.

AA-30 **\$45.95**

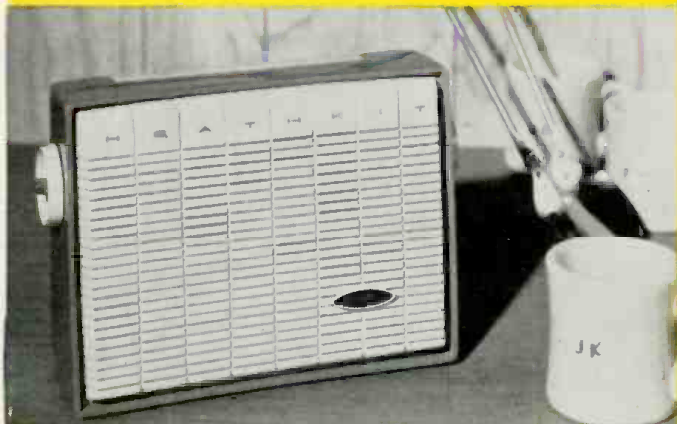

Perfect for Summer Sun and Fun!

6-TRANSISTOR PORTABLE RADIO KITS (XR-2 Series)

Assembled in only a few hours, both of these models incorporate superior design features that will give you portable-listening enjoyment day after day. Vernier tuning control gives smooth, easily-separated station tuning. Large 4" x 6" PM speaker with heavy magnet provides "big set" richness of tone. Operates on standard size "D" flashlight batteries. Six Texas Instrument transistors.

XR-2P (plastic) 6 lbs. **\$29.95**

XR-2L (simulated leather) 7 lbs. **\$34.95**

MOBILE PA SOUND EQUIPMENT

Perfect for political campaigns, advertising, sporting events ... hundreds of PA applications. The 10 watt amplifier operates from any 12 to 15 volt battery. Features an all-transistor circuit for rugged, dependable performance and long life. No warm-up time required. Mounts easily under auto dash. Inputs for microphone and music source. Two channel mixing circuit "fades" auxiliary input when used with microphone supplied ... lets you override music with voice without changing control settings. Outputs for 8 and 16 ohm speakers.

MOBILE PA AMPLIFIER KIT (AA-80) 7 lbs. **\$39.95**

COMMERCIAL SOUND SYSTEM (CSS-1) consists of AA-80 Amplifier; microphone; car-top carrier; one 16 ohm, 15 watt outdoor speaker. 19 lbs. **\$84.95**

COMMERCIAL SOUND SYSTEM (CSS-2) same as above except with 2 speakers. 25 lbs. **\$99.95**

EXTRA HORN SPEAKERS (401-38): As described above 6 lbs. **\$19.95**

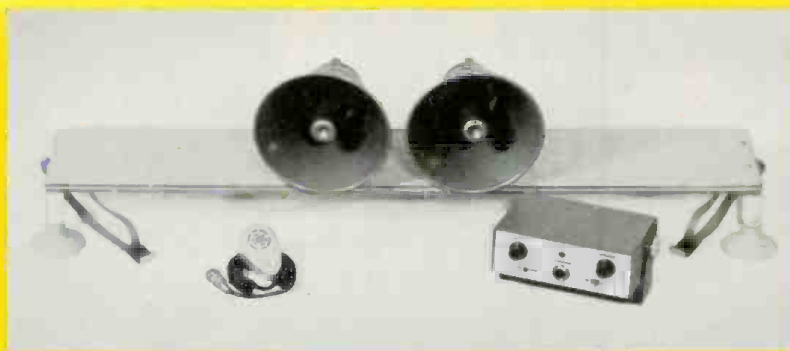

FREE CATALOG

Send for your free Heathkit catalog today ... describes over 150 hi-fi, ham, test, marine, and general kits.



NEW! Citizens Band Transceiver...

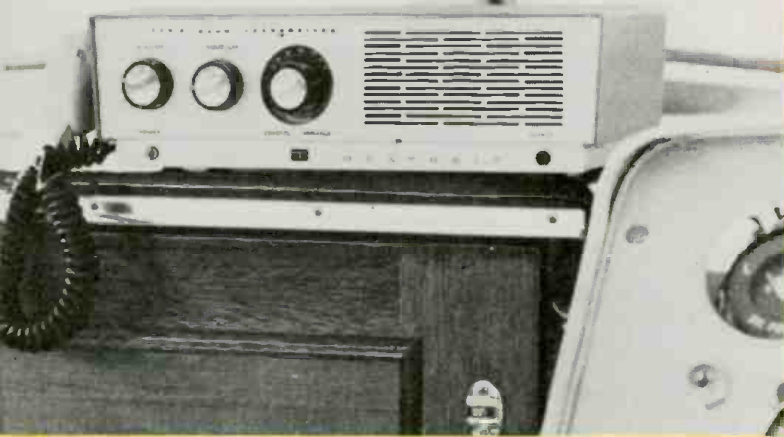

CITIZENS BAND TRANSCEIVER KIT (GW-10)

Now, from Heath, a new 2-way Citizens Band Transceiver with every modern improvement for clear, noise-free operation. The super-heterodyne receiver section may be either crystal controlled on any one predetermined channel, or all 23 channels may be continuously tuned by the front panel tuning knob; a front panel switch selects either crystal or variable control. An automatic "series gate" noise limiter minimizes impulse-type noises (ignition interference, etc.). Adjustable squelch control silences the receiver during "stand-by." Press-to-talk microphone features a coil-cord connection to the transceiver. Transmitter is crystal controlled on any one of 23 assigned channel frequencies chosen. Order model GW-10A for 117v AC operation; order GW-10D for 6 and 12v DC operation, both with self-contained power supply. 11 lbs.

GW-10A or GW-10D **\$62⁹⁵**
each
\$6.30 dn., \$6.00 mo.



3 band "Mariner" TRANSISTOR DIRECTION FINDER KIT (DF-3)

Features nine-transistor circuit, flashlight battery power supply, pre-assembled, pre-aligned tuning section, three bands (beacon-aeronautical, broadcast and marine-telephone), and a new "sense" antenna system that eliminates 180° ambiguity in bearings. Splash resistant. 13 lbs.

DF-3 **\$99⁹⁵**

\$10.00 dn., \$9.00 mo.



For Boating, Fishing, Skindiving

TRANSISTOR DEPTH SOUNDER KIT (DS-1)

Completely transistorized. Indicates depth, type of bottom, and submerged objects, from 0 to 100 feet. Powered by 6 flashlight batteries for complete portability. Transducer included may be mounted through hull, or temporarily outboard. Rugged, splash-resistant cabinet. Adjustable mounting bracket. 10 lbs.

DS-1 **\$69⁹⁵**

\$7.00 dn., \$7.00 mo.



Ten-transistor "Mohican" GENERAL COVERAGE RECEIVER KIT (GC-1)

First kit of its kind to use ceramic IF "Transfilters." Covers 550 to 30 mc on 5 bands, with 5 separately calibrated bands to cover amateur frequencies (including 11 meter citizens band). Powered by 8 flashlight batteries. Built-in 54" whip antenna, tuning meter, headphone jack. 20 lbs.

GC-1 **\$109⁹⁵**

(Less Batteries)

\$11.00 dn., \$10.00 mo.

First of a Series

EDUCATIONAL KIT (EK-1)

Teaches, as you build, the basic "yardsticks" of electronics... opens up fascinating areas of study for youngsters and adults alike. The combination kit and text-workbook gives you a practical demonstration of the principles of voltage, current and resistance, the theory and construction of direct current series and parallel circuits, voltmeter, ammeter and ohmmeter circuits and the application of ohms law to these circuits. The completed meter is used to verify ohms law and the maximum power transfer theorem, one of the most important theorems in electronics. The finished kit, a practical volt-ohm-milliammeter, may be used in a variety of applications. Procedures for checking home appliances and automobile circuits included with the kit. The EK-1 will serve as a prerequisite to following Heathkit Educational kits; get started NOW in this "learn-by-doing" series. 4 lbs.

EK-1 **\$19⁹⁵**



Outstanding Professional Quality...

**MUTUAL CONDUCTANCE
TUBE TESTER KIT (TT-1)**

An impressive list of electronic and mechanical features make this tube tester one of the finest values in the electronics industry. Test Gm (amplifiers) from 0 to 24,000 micromhos. Emission. Leakage. Grid Current (1/4 microampere sensitivity). Voltage Regulators (built-in variable DC power supply). low power Thyratron and Eye tubes. Features 300, 450 and 600 ma constant current heater supplies, Life test. Hybrid tube test, built-in switch-operated calibration circuit. Large, easy-to-read meter. Constant tension, free rolling illuminated chart. Kit includes 7 wiring harnesses. Assembly skill of technician or higher recommended; assembly time, 40 hours average. Black leatherette case with white trim, nylon feet, removable top. A specialized tool of unusual value that will pay for itself many times over. 27 lbs.

TT-1 \$134⁹⁵

\$13.50 dn., \$12.00 mo.



**New Improved Design
TRANSISTOR MOBILE
POWER SUPPLY (HP-10)**

All transistor circuit! Operates from 11 to 15VDC input; at 12VDC provides 600 VDC @ 200ma. or 600VDC @ 150ma & 300VDC @ 100ma simultaneously, at 120 watts. Negative 125V @ 30 ma also provided. Max. ambient temp. 150° @ 120 watts ICAS. Input required: 2 amps idling; 13 amps full output. Includes heavy filtering, remote relay primary control, silicon rectifiers, aluminum heat sinks. 10 lbs.

HP-10 \$44⁹⁵

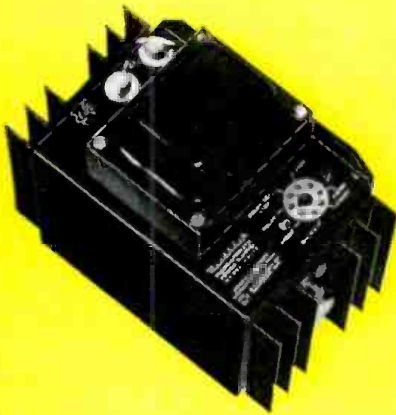

**NEW Six and Ten Meter
TRANSCIVER KITS
(HW-19 and HW-29)**

Combination crystal controlled transmitters and variable tuned receivers operating fixed or mobile on the 6 and 10 meter amateur bands (50-54 mc for HW-29 and 28-29.7 mc for HW-19). Superregenerative receiver pulls in signals of 1 microvolt; transmitter input approximately 5 watts. Built-in 117 VAC power supply, metering jack, press-to-talk switch. 10 lbs.

HW-19 (10 meters) \$39⁹⁵
HW-29 (6 meters) ea.

Less crystal



send today for Your
FREE HEATHKIT® CATALOG

Over 150 items of hi-fi,
marine, amateur, test and general
equipment are illustrated
and described in the complete
Heathkit catalog.



**Heathkit® gives you more
in these 10 ways**

1. BUILDING A HEATHKIT IS EASY—Check-by-step instruction manuals make it virtually impossible for you to fail.
2. BUILDING A HEATHKIT IS QUICK—No complicated, technical jargon for you to decipher; at most, a Heathkit takes only a few evenings to assemble.
3. BUILDING A HEATHKIT IS ECONOMICAL—Mass production and purchasing economies are passed directly along to you, our customers.
4. BUILDING A HEATHKIT IS EDUCATIONAL—As you build, you learn . . . more about electronics, more about the component units and when and where to add them.
5. BUILDING A HEATHKIT IS FUN—Nothing quite equals the sense of achievement you receive when you successfully complete a Heathkit unit and "tune-in" for the first time.
6. YOUR HEATHKIT IS GUARANTEED—Every Heathkit unit is guaranteed to meet advertised performance specifications . . . or your money will be cheerfully refunded.
7. YOUR HEATHKIT IS AVAILABLE ON CONVENIENT CREDIT—Our time payment plan makes it possible for you to order now . . . pay later.
8. YOUR HEATHKIT IS TOPS IN QUALITY—The very finest in electronic equipment comes to you in kit form from the Heath Company.
9. HEATHKIT DEALERS CAN SERVE YOU LOCALLY—Carefully selected Heathkit representatives are available in many localities. The convenience of local Heathkit sales and service costs but a few dollars more.
10. HEATHKIT SERVICE IS CUSTOMER SERVICE—Our staff of technical experts is always ready to answer your questions or help you if you have any difficulty.

A



A subsidiary of
DAYSTROM, INCORPORATED

HEATH COMPANY, Benton Harbor 15, Michigan

ORDERING INSTRUCTIONS

Fill out the order blank below. Include charges for parcel post according to weights shown. Express orders shipped delivery charges collect. All prices F.O.B. Benton Harbor, Mich. A 20% deposit is required on all C.O.D. orders. Prices subject to change without notice.

Please send the following HEATHKITS:

ITEM	MODEL NO.	PRICE

Ship via () Parcel Post () Express () COD () Best Way

() SEND MY FREE COPY OF YOUR COMPLETE CATALOG

Name _____

Address _____

City _____ Zone _____ State _____

Dealer and export prices slightly higher.

PRECISION PERFORMERS



carbon-deposited RESISTORS

When the application calls for accuracy and stability you'll find Aerovox Precision ($\pm 1\%$) Carbon-Deposited Resistors fill the bill perfectly. Manufactured under exacting quality control specifications to assure excellent performance even under adverse operating conditions. **CARBOFILM RESISTORS**... for wide use in circuits where accuracy and economy are factors. Units are protected by a specially formulated Aerovox coating against environmental conditions. Stocked in 300 values in following ratings:

Type	Sizes	Min. Ohms	Max. Meg-ohms
CPS-1/4 watt	0.162D x 1/8" L	7	2
CP-1/2 watt	0.230D x 1/8" L	3	5
CPL-1/2 watt	0.230D x 1/8" L	5,100,000	7.5
CP-1 watt	0.293D x 1/8" L	10	15
CP-2 watt	0.293D x 2 1/4" L	50	100

CARBOMOLD RESISTORS... encapsulated in a strong reinforced moisture and heat resistant plastic these units offer new standards of reliability. Over 500 standard values available from stock as follows:

Type	Sizes	Std. Min. Ohms	Std. Max. Meg.
CPM-1/2	1/4 x .735	10	2.49
CPM-1	1/4 x 1 1/2	10	5.11
CPM-2	1/2 x 2 1/4	30	10

All units marked with type number, RN Number, value and tolerance. Available for "off-the-shelf" delivery from your local Aerovox Distributor.

AEROVOX CORPORATION
DISTRIBUTOR DIVISION
NEW BEDFORD, MASS.

Trademark

New Tube Tester Data

Owners of RCA hole-card automatic testers: here are hole locations to be punched for new tubes.

RCA AUTOMATIC TESTER, WT-110A

TUBE TYPE	HOLE LOCATIONS TO BE PUNCHED	NOTES
1AE4	A7, B1, D6, E3, G2, J3, K2, L1, M2, M6, N1, N6	
1AK5	No test possible.	
1D5GP	A2, B7, D10, E4, G3, J7, K3, L1, M3, M6, N2, N6	
1F5	A2, B7, D5, E4, G3, J7, K6, L1, L6, L7, M3, M6, N2, N6	
1N2	A7, B2, G10, K5, L5, M1, M6, N2, N6	Reject if below 3
1P5	A2, B7, D10, E4, G3, J3, K6, L1, M5, M6, N3, N6	
1T5	A2, B7, D5, E4, G3, J9, K1, L1, M5, M6, N3, N6	
2J2	A2, B9, G10, K10, L5, L6, L7, M3, M6, N2, N6	Reject if below 2
4BE6	A3, B4, C2, C7, D1, G5, G6, I6, I10, J1, K3, L1, L6, L7, M1, M6, N4, N6	
5BS8	A4, B5, C3, C8, D2, D7, F1, G6, I7, I8, J1, K4, L1, L6, L7, M1, M6, N5, N6	Test P1 and P2
5FV8 Triode	A4, B5, C3, D1, G2, I7, I9, J1, K1, L1, L6, L7, M5, M6, N1, N6	
5FV8 Pentode	A4, B5, C8, D9, E7, G6, I7, I10, J1, K3, L1, L6, L7, M5, M6, N1, N6	
6AB8/ECL80 Triode	A4, B5, C3, D2, G1, I6, I10, J5, K7, L1, M5, M10, N2, N9	
6AB8 ECL80 Pentode	A4, B5, B7, C3, D9, E8, G6, I6, I10, J7, K1, K2, L1, M5, M10, N2, N9	
6AM6 EF91	A3, B4, C2, C6, D1, E7, G5, I7, I10, J1, K4, L1, L6, L7, M5, M10, N2, N9	For gas test, see instructions
6AQ4 EC91	A3, B4, C2, D1, G7, I7, I9, J1, K3, L1, L6, L7, M5, M10, N2, N9	
6BT4 EZ40	A1, B8, C7, F2, G6, I6, I10, K6, L5, L6, L10, M5, M10, N2, N9	Test P1 and P2. Reject if below 4. Use special adapter.
6CD7/EM34	A2, B7, C8, D4, E5, F6, G3, J3, K10, L1, M5, M10, N2, N9	For gas test, see instructions. P1—meas. Gm—one eye open, one closed. P2—other eye open, second closed. P3—both eyes open.
6DA5 EM81	A4, B5, C2, D1, E9, G7, J4, K9, K10, L1, M5, M10, N2, N9	P1—Test Gm—eye closed. P2-P3, Eye open.
6DL5 EL95	A3, B4, C2, D1, E6, G5, I6, I10, J6, K5, K6, L1, L6, L7, M5, M10, N2, N9	
6EJ7	A4, B5, C1, C6, C9, D2, E8, G7, I6, I10, J2, K4, L1, L6, L8, M5, M10, N2, N9	
6EH7	A4, B5, C1, C6, C9, D2, E8, G7, I6, I10, J4, K4, L1, L6, L8, M5, M10, N2, N9	For gas test, see instructions.
6ESS	A3, B4, B6, B7, D2, G5, J2, K3, L1, L6, L7, M5, M10, N2, N9	For gas test, see instructions.
6EV7	A4, B5, C3, C8, D2, D7, F1, G6, I7, I10, J1, K6, K7, L1, L6, L7, M5, M10, N2, N9	Test P1 and P2
6EZ8	A5, B4, C1, D2, D7, D9, F6, G3, H8, I6, I10, J2, K6, K7, L1, L6, L7, M5, M10, N2, N9	Test P1 and P2. Reject if below 4.
6FG6/EM84	A4, B5, C3, D1, E6, E7, G9, J2, K10, L1, M5, M10, N2, N9	Reject if below 1. Bands full closed.
6FH6	A7, B2, C8, D5, E4, G10, I7, I10, J10, K5, L1, L6, L7, M4, M10, N2, N9	
6FV8 Triode	A4, B5, C3, D1, G2, I7, I9, J1, K1, L1, L6, L7, M5, M10, N2, N9	
6FV8 Pentode	A4, B5, C8, D9, E7, G6, I7, I10, J1, K3, L1, L6, L7, M5, M10, N2, N9	
6GH8 Triode	A4, B5, C7, C8, D9, G1, I6, I10, J2, K2, L1, L6, L7, M5, M10, N2, N9	
6GH8 Pentode	A4, B5, C7, D2, E3, G6, I6, I10, J2, K2, L1, L6, L7, M5, M10, N2, N9	
6GM6	A3, B4, C2, C7, D1, E6, G5, I7, I10, J1, K6, K7, L1, L6, L8, M5, M10, N2, N9	
6R4 EC81	A4, B5, C3, D1, G8, I6, I10, J4, K6, L1, L6, L7, M5, M10, N2, N9	
6U6	A2, B7, C8, D5, E4, G3, I6, I10, J10, K5, L1, L6, L7, M3, M10, N1, N9	
6V4/EZ80	A4, B5, C3, F7, G1, I6, I10, K4, K5, L4, L6, L9, M5, M10, N2, N9	Test P1 and P2. Reject if below 4.
7C4	A1, B8, C7, G4, K6, L3, M5, M10, N2, N9	
7S7 Triode	A1, B8, C7, D4, G3, I6, I10, J3, K7, L1, M5, M10, N2, N9	
7S7 Heptode	A1, B8, C4, C7, D6, E5, G2, I6, I10, J3, K1, L1, M5, M10, N2, N9	
9X8 Triode	A4, B5, C6, D2, G3, I7, I9, J1, K4, L1, L6, L7, M5, M10, N4, N9	
9X8 Pentode	A4, B5, C1, C6, D7, E8, G9, I6, I7, J1, K6, L1, L6, L7, M5, M10, N4, N9	

The Lid's Off!



JERROLD announces the all printed circuit antenna . . . the first new concept in TV-FM reception in 10 years!

Indoor Antenna—Outdoor Design! Jerrold's new Magic Carpet* is a flat, flexible all printed circuit antenna based on a broad-banded dipole design. Installed indoors in attic, crawl space, closet or any upper level location in the home, it offers performance comparable to a conical type outdoor antenna (mounted in the same location)** at a fraction of the cost.

A report on the Magic Carpet in the May issue of Electronics World states "Gain characteristics across all frequencies are very close to those of standard outdoor conicals." No more need for unsightly rooftop or indoor antenna (up to 30 miles from the TV transmitter). The Magic Carpet opens up a whole new antenna market for the TV and FM Serviceman.

9.95
LIST

Get the full story of the magic of its performance . . . the potency of its sales appeal, see your Jerrold Distributor or write today

JERROLD Electronics Corporation, Distributor Sales Division, Dept. IDS-30, Philadelphia 32, Pa.
Jerrold Electronics (Canada) Ltd., Toronto Export Representative: CBS International, New York 22, N. Y.

↓ (illus. shows upper section of Magic Carpet)

*Trade Mark Patent Pending

**Data certified by American Electronic Laboratories Inc.



New Audio Test Report



Harman-Kardon "Citation II" Stereo Power Amplifier
Dynakit Model PAS-2 Stereo Preamplifier
Pickering Model 380 Stereo Cartridge



Front and rear views of Harman-Kardon's 60-watt stereo amplifier.

"Citation II" Stereo Power Amplifier

IT WASN'T too long ago that *Harman-Kardon* announced the formation of a separate division for the sole purpose of producing hi-fi components in the form of kits that would provide the best available sound reproduction. Stewart Hegeman, well-known engineer in the audio field, was induced to head this new division. Since we have known of Stew and his reputation as a professional audio engineer for quite a few years, we were not too surprised to find that his designs were among the very best.

The first of the units to be released is known as the "Citation II." This is a dual 60-watt stereo hi-fi power ampli-

fier. The unit, which we checked after having built the kit, is the best of all power amplifiers that we have tested over the past years, and if there are any better in performance, we have not had the opportunity of testing them. There are some amplifiers that have come close in performance but none has had distortion quite as low as we found in this new "Citation II."

Admittedly, 60 watts of power per channel is a lot, but just as a 400-horsepower car will usually provide a much more enjoyable ride at 20 miles an hour than a 90-horsepower one, the high-powered amplifier usually performs better at lower levels. No one needs to

operate the unit at full capacity, but it is indeed a pleasant feeling to know that it is available if desired and that it is just loafing at normal listening levels. Basically the design employs a distributed-load output circuit using KT88 beam-power pentodes operating in push-pull with fixed bias. In addition, each channel incorporates three 12BY7A video-output pentodes in all low-level stages for extremely wide frequency response and a minimum of distortion. Multiple feedback loops are incorporated in the circuit, some 30 db in all, in order to lower distortion and maintain good stability. In addition, the unit employs four silicon rectifier diodes in a voltage-doubler arrangement that provides good stability and voltage regulation. A selenium rectifier is used as the separate bias rectifier. For convenience, the amplifier incorporates a built-in meter with a switch arrangement to permit adjustment of bias on each of the output tubes and for proper adjustment of a.c. input-signal balance on the output stages of each channel. No additional meters are required to make final adjustments. The kit even comes with a dummy load resistor which is used during the adjustment procedure.

The construction of the kit was not too difficult although it was time-consuming, requiring about 20 hours to complete the job. Military-type construction techniques are used and detailed instructions and templates are included for making up the wiring harness. Upon completion of the kit, we performed our usual tests and the results were as follows:

The frequency response is basically flat (± 0.8 db) from 4 cps to 105 kc. at 2-watts output. At 60-watts output, the frequency response was similar from 10 cps to 40 kc.

IM distortion measurements were made using input frequencies of 60 and 6000 cps in a four-to-one ratio. The results were .49% at 36 watts and .53% at 60 watts (equivalent sine-wave power). These figures are well below the 1% value which we have been using as our standard and the value where only the most critical ear could discern distortion.

The harmonic distortion measurements proved equally good, values be-

Diagram of the 60-watt amplifier showing only one of the two channels. The other channel is, of course, identical to the one shown.

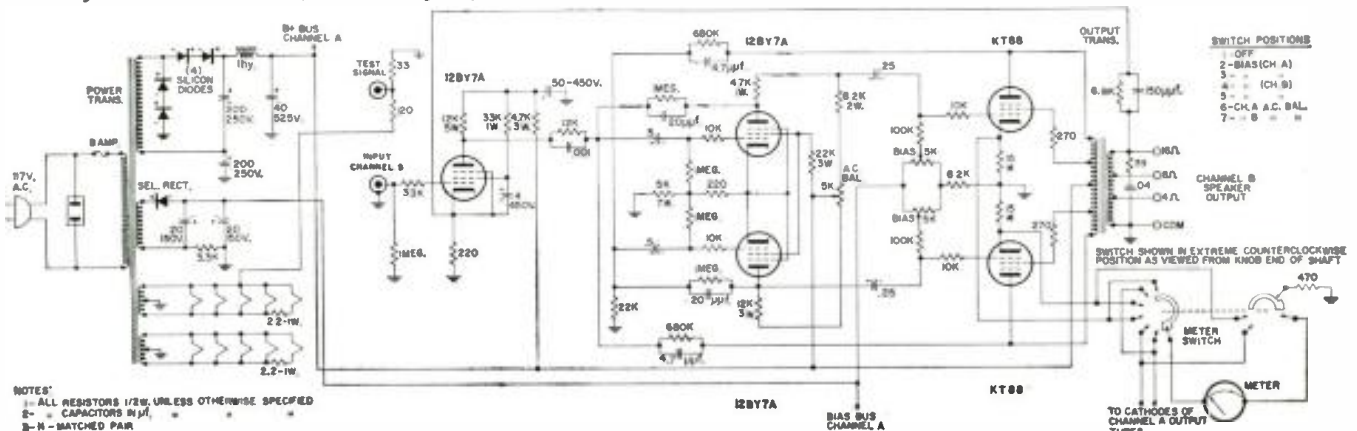

ing 1.12% at 20 cps, .14% at 1000 cps, and 1.30% at 20 kc. These measurements were all taken at 60 watts power output. At lower power outputs, the distortion figures would have been even less than these very low values.

In an effort to see just how little distortion we could get out of the circuit, we interchanged some of the 12BY7A's in the voltage-amplifier stages and then took our distortion measurements once more. At 36 watts equivalent sine-wave output power, IM distortion was the extremely low value of .11%. This value fell slightly to .09% at 50 watts, and then rose very slightly back to .11% at the full rated power output of 60 watts.

The re-checked harmonic distortion figures are .25% at 20 cps, .07% at 1000

cps, and .60% at 20 kc. These measurements are all at 60 watts output. All distortion measurements have been corrected to take into account the residual distortion of the test instruments used. Hence, we can produce a measurable reduction in distortion by hand-picking tubes, but since the original distortion figures were already so low, we doubt very much whether there would be any audible improvement noticed. This would be particularly true at normal listening levels where the distortion figures would be even lower than the above.

The hum and noise was low, being down 68 db from a 2-watt output level. With respect to full output power, hum and noise are down 83 db.

The sensitivity of the amplifier is 1.52

volts for maximum power output. This means that the preamplifier which is to be used with this unit must provide an output of 1.52 volts in order to obtain 60 watts of power. Lower input voltages will result in less output power.

The damping factor of this particular amplifier proved to be 13, which is somewhat less than that quoted by the manufacturer.

We found no ringing or instability and, as the above test results demonstrate, the amplifier should provide the very finest in hi-fi stereo reproduction when matched with other components of comparable quality.

The "Citation II," a husky 60 pounds of hi-fi amplifier, is priced at \$159.95 in kit form and for a factory-assembled unit, the price is \$229.95.

-30-

Dynakit Stereo Preamp



The two printed boards that are employed in this preamplifier may be seen in the bottom view of unit at the left.

THIS IS the first opportunity we have had to check Dyna's new stereo preamplifier kit, Model PAS-2. Like all of Dave Hafler's previous designs, this unit is compact, simple but neat in appearance and, as expected, will provide top quality high-fidelity sound reproduction. The unit incorporates two printed circuit boards. As a result, it is easily constructed. In fact, we are sure many would find the five to eight hours that it takes to assemble the kit enjoyable and well spent.

Although the design is simple, it does incorporate all the major functions that are required in a stereo preamplifier. All the operating controls can be seen in the photograph, and the selector switch, volume control, individual treble and bass tone controls, and various switches are conventional in operation.

The stereo-mono function switch ("blend" switch) warrants some special comments. In addition to the choice of either A or B channels or both A and B combined, it provides a choice of three different stereo characteristics. In the full-stereo position the separation is 44 db, in the semi-stereo position the separation between channels is 17 db. In the minimum-stereo position the channel separation is 9.5 db. Switched resistors connected between the two

separate channels are used to provide this varied selection. Normally, full stereo with maximum separation is most often desired, but there are situations where unusual placement of

speakers or particular room acoustics provide an undesirable "hole-in-the-middle" effect. In situations like this, the use of other than full-stereo operation will fill in the undesirable "hole" and alleviate the problem.

The balance control reduces the gain of one or the other channel, depending on the direction of rotation. The loudness control is quite effective and it is designed to provide boost at the low end of the audio spectrum. A scratch filter is incorporated which has a sharp roll-off above about 7 kc. with response falling off to -18 db at 15 kc.

In addition to the two conventional output jacks that connect to the power amplifiers, this preamplifier incorporates a separate tape output jack for each of the two channels that will provide high-level signals to a tape recorder.

One important feature of the preamplifier is that it is designed around high-gain circuits. This is particularly advantageous in that even the lowest output cartridge can be used with

(Continued on page 118)

Phono-preamp circuits for both channels are on one printed board, tone-control circuits for both are on other board. Rectifier circuits are conventionally wired.

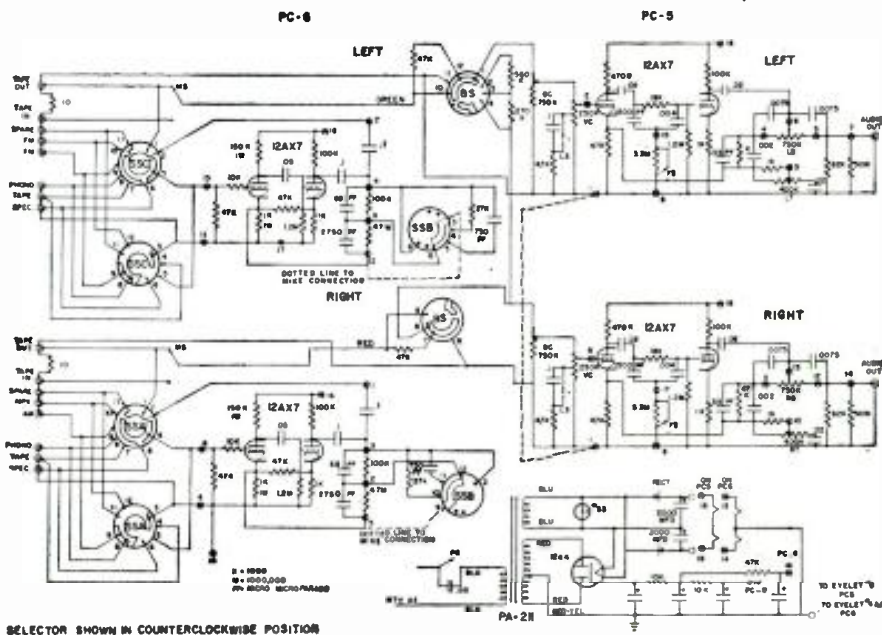

YOU be the judge of
knight-kit[®]
A PRODUCT OF ALLIED RADIO
quality and value



FREE examination privilege

More and more people are finding out how easy it is to build exciting Knight-Kits, how satisfying they are to own, and how much they save.

If you haven't yet enjoyed the experience and fun of building and owning a Knight-Kit, we invite you to take advantage of our free examination offer. Order any Knight-Kit. Examine it on arrival. Inspect the quality of the components, the circuitry, the easy-assembly manual. We're so confident you'll want the kit, we can make this offer: If you're not **COMPLETELY SATISFIED**, just return the kit for full refund.

Order a Knight-Kit now. Know the thrill of the most satisfying build-your-own experience in electronics.

—ALLIED RADIO

knight-kits[®]...



only \$5 down

Y-774 Deluxe 40-Watt Stereo Amplifier, featuring center channel output. Finest amplifier available anywhere in this price range.....\$79.50

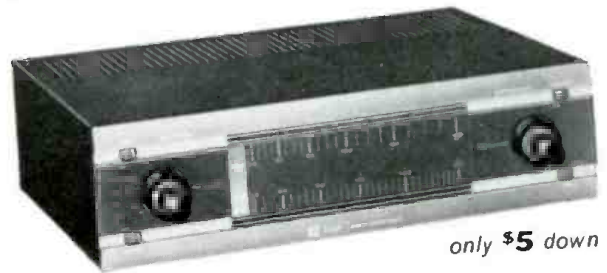

only \$5 down

Y-731 Deluxe FM-AM Stereo Hi-Fi Tuner, with "Magic Eye" tuning for each section; includes Dynamic Sideband Regulation and multiplex add-in feature.....\$87.50

see dozens of other
GREAT HI-FI KITS

- Stereo Deluxe Preamplifier
- 60-Watt Stereo Amplifier
- Stereo Control
- 25-Watt Amplifier
- 18-Watt Amplifier
- 12-Watt Amplifier
- FM-AM Tuner
- FM Tuner
- Speaker Systems, and others



only \$2 down

Y-773 Super-Value 20-Watt Stereo Hi-Fi Amplifier, with special clutch-type dual-concentric level control.

\$44.50

Y-787 FM-AM Hi-Fi Tuner; with AFC and tuned RF stage on FM; includes multiplex jack.

\$49.95

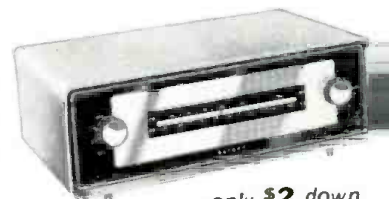

only \$2 down

sold exclusively by

ALLIED

easiest to build...satisfying to own...money-saving



only \$2 down

Y-713 Top value, best-selling Citizens Band Transceiver. Tunable 22-channel super-regenerative receiver, 5-watt transmitter..... \$39.95



only \$2 down

Y-258 4-Band "Span Master" Receiver; exciting world-wide reception; with cabinet..... \$25.95

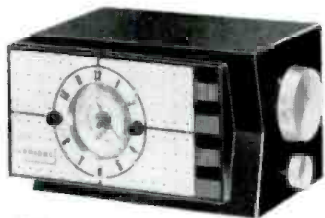

only \$2 down

Y-737 "Ranger" Clock-Radio with Telechron clock, sleep switch and appliance outlet..... \$24.95

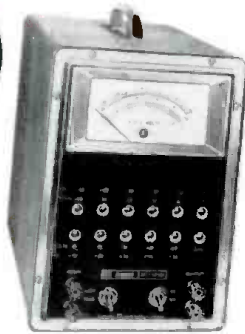

Y-608 Lab quality AC VTVM with amazing Automatic Range Selection; reads as low as 100 μ v. \$99.50

only \$5 down

Y-125 General-purpose VTVM (11 meg input resistance) \$25.75

only \$2 down

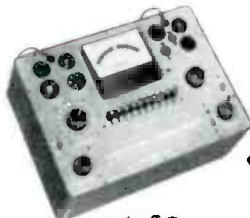

only \$2 down

Y-143 Model "600" Tube Checker (checks over 700 types)..... \$32.95

full selection of
INSTRUMENT KITS

- 5" Oscilloscopes
- Tube Checkers
- RF Signal Generator
- Signal Tracer
- Audio Generator
- Sweep Generator
- Battery Eliminator
- Capacity Checker
- Transistor Checker
- R/C Tester, plus many others

ONLY \$2 DOWN
on orders up to \$50;
\$5 down on orders
up to \$200...

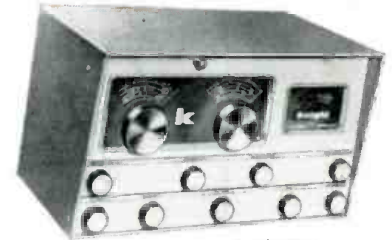

only \$5 down

R-100 Amateur Communications Receiver (Hi-gain, with built-in Q-Multiplier)..... \$104.50



G-30 Amateur Grid Dip Meter (continuous coverage, 1.5-300 mc)..... \$22.95

only \$2 down

other fine
AMATEUR KITS

- 50-Watt Transmitter
- Self-Powered VFO
- 100 kc Crystal Calibrator
- RF "Z" Bridge
- Code Practice Oscillator

plus many other
HOBBYIST KITS

- "Space-Scanner" Receiver
- "Ranger" Radios
- "Ocean Hopper" Radio
- Radio-Intercom
- 5-Transistor Portable
- 2-Transistor Pocket Set
- 2-Way Intercom
- Electronic Lab Kits
- Photoelectronic System
- and many others

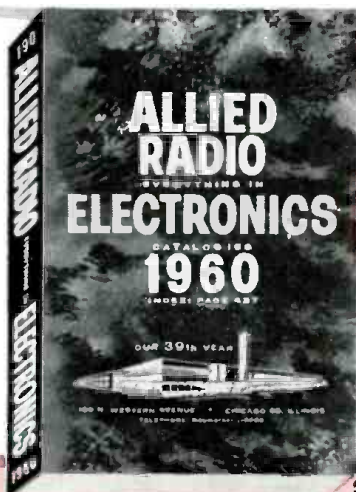

FREE

there's a money-saving **knight-kit** for every need...see them all in the **ALLIED CATALOG**

Write for catalog featuring the complete KNIGHT-KIT line. Order the kit of your choice—judge quality and value for yourself under our FREE examination privilege!

ALLIED RADIO CORP., Dept. 10-F
100 N. Western Ave., Chicago 80, Ill.

Send FREE Catalog featuring Knight-Kits

Name _____

Address _____

City _____ Zone _____ State _____

RADIO

Pioneer in quality
electronic kit
development...

can
you
imagine?

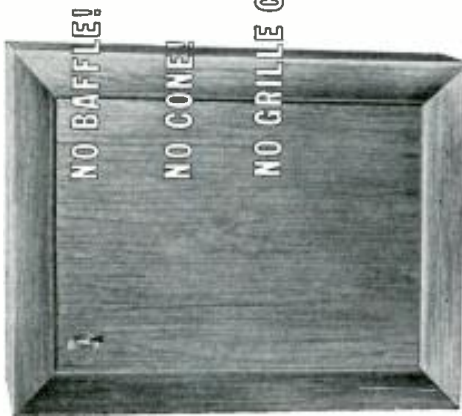

Wafer-thin, the "440" Bi-Phonic Coupler is a maximum range reproducer which differs radically from ordinary loudspeakers. In plain truth... it is a fine musical instrument... for, as in a bass violin, its wall structure is the actual reproducing element. As opposed to boxed enclosures, the free-radiating "440" reproduces the very deepest bass notes with concert clarity, and its spacious projection creates a naturalness matched only by the original performance. Here — is the first new development in speaker design since the beginning of high fidelity.

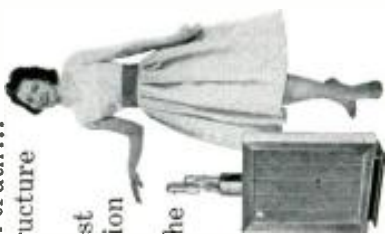

Listen — to the remarkable "440" Bi-Phonic Coupler at your Hi Fi dealer.



Measures only 4½" deep; 24" high and 18" wide.

For complete details and technical information, write for brochure E-60

ADVANCED ACOUSTICS CORP., 67 East Centre Street, Nutley 10, New Jersey

A subsidiary of Electronic Research Associates



ELECTRONIC ORGANS

Electro-Voice, Inc., Buchanan, Mich. has announced plans for two new electronic organs. Designed by Paul McCobb, the "Baron" is a console type organ, while the "Baroness" is a model without the console base. The "Baron" features a specially designed speaker system and tone chamber, a 13-foot



pedal bass, and a dynamically balanced swell shoe. The "Baroness" eliminates the foot pedals and swell shoe.

Both units feature polyphonic note construction, standard-size organ keys, continuously variable tremolo control, variable level control, an auxiliary output for connecting the organ to an existing high-fidelity system, silver and gold clad contacts, printed circuit wiring on military-grade materials, and a variety of hand-rubbed cabinet finishes.

According to *Electro-Voice's* president, Albert Kahn, these two models "are only the forerunners of a complete line of organs to be built by the firm."

EXTENSION SPEAKER

C. and H. Company, 2133 Western Ave., Seattle 1, Wash. is marketing a small speaker system that may be used as an extension speaker for radio re-

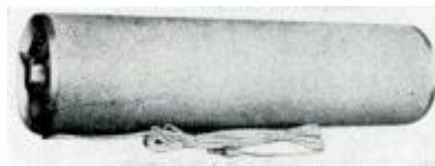

ceivers, TV sets, tape recorders, or phono systems as well as for stereo enhancement. The unit is furnished with a 12-foot extension cord.

ECONOMY CARTRIDGE

Sonotone Corporation of Elmsford, N. Y. has announced the availability of an economy monophonic ceramic cartridge which has been designated as the Model "11T". By utilizing the unitized construction principles employed

in its "10T" stereo unit, the company has developed a one-channel turnover pickup which plays stereo records without damage to the complex grooves.

The "11T" comes complete with mounting bracket and sapphire tips. According to the company this new cartridge incorporates two basic stereo features which assure safe mono reproduction of stereo records. Equal compliance in all directions eliminates the problem of groove breakdown. The other stereo feature is a 0.7 mil jewel tip instead of the usual 1-mil tip used in mono cartridges.

10-WATT STEREO AMPLIFIER

Lafayette Radio, 165-08 Liberty Ave., Jamaica 33, N. Y. is now offering a stereo amplifier with twin-channel controls and 5 watts output per channel. Ganged tone controls provide bass boost and treble cut. Dual concentric volume controls furnish individual or simultaneous action to facilitate channel balancing. The function switch provides for selection of monophonic phono, tuner A, tuner B, stereo phono, phono reverse, stereo tuner, and tuner reverse. Front panel controls also in-



clude a speaker phasing and the power "off-on" switches. Two separate inputs are furnished for each channel.

The amplifier can accept signals from crystal or ceramic phono pickups, tuners, and tape recorders. Tubes used are two 12AX7's, two 6BQ5's, and one 6CA4. Response is specified at 40 to 30,000 cps within 1 db at 1 watt power.

3-WAY SPEAKER SYSTEM

Pilot Radio Corporation, Long Island City 1, N. Y. has announced the availability of a new, ultra-compact, three-way speaker system, the Model PSV-2.

Measuring only 18" high, 15¾" wide, and 9¾" deep, the system provides a frequency coverage from 50 to 16,000 cps. The system includes a 12" low-frequency driver, a 6" mid-frequency cone-type speaker with electromagnetic isolation to prevent acoustic interaction, a 3" cone-type tweeter, and a crossover network.

The sealed enclosure is of special design and provides an acoustic suspension for the high compliance woofer.

er. A critical mass of Orlon fibers provides optimum damping. Impedance is 16 ohms and the system is rated at 30 watts program power. Crossover frequencies are 800 and 8000 cps with 6 db/octave air-core inductance-capacitance crossover network.

STEREO TUNER KIT

The Heath Company, Benton Harbor, Mich. has announced its new stereo tuner in kit form. Designated as "Heathkit" model AJ-10, the unit provides independent AM and FM recep-



tion as well as an output for FM multiplex.

Other features include individual fly-wheel tuning, "magic-eye" tuning indicators, adjustable automatic frequency control (a.f.c.), AM bandwidth control with "broad" and "narrow" positions, separate AM and FM output level controls, and built-in AM rod antenna. Sensitivity is said to be 2 microvolts for 20 db quieting.

TURNER MICROPHONES

The Turner Company, 909 17th St. N. E., Cedar Rapids, Iowa announces two new microphones designed primarily for home stereo recording. According to the manufacturer, the model 304X crystal microphone has a response of 60 to 10,000 cps, and is supplied with desk stand, stand adapter, lavalier assembly, and a 12-foot cable. This microphone also is available as a ceramic unit, known as model 304C.



The model 202D is a dynamic type, high-impedance microphone with similar frequency response. It is supplied with a stand adapter and 12-foot cable. Further information on these new microphones may be obtained by writing direct to the manufacturer.

NEW AUDIO TUBES

General Electric's Receiving Tube Department, Owensboro, Ky. has announced a new line of eleven audio tubes designed to handle every tube function of high-fidelity equipment.

The tubes feature 5-ply plate material in all power output tubes, 3-ply plates for all rectifiers, and 3-ply cathodes. The bonded plate material employs copper to conduct heat rapidly as well as to reflect heat where needed, aluminum to radiate heat, and iron to provide strength. According to G-E, heat in the tubes is thus spread evenly,

June, 1960

Auto Radio Control Replacement is Child's Play

with new **Centralab**®

Exact Replacement Controls

22 brand new units expand the line!



Now more than ever, one source fills all your needs for auto radio replacement controls. Twenty-two new units expand the CENTRALAB line of exact replacements—give you full coverage of every popular radio in use today, including radios used in foreign cars.

But there's more to it than quality! It's more convenient to buy from your electronic parts distributor. Auto radio repair business is easier and more profitable when you don't have to make special trips to the auto parts distributor. Your CENTRALAB distributor will have it!

What about on-off switches for push-button radios? CENTRALAB has the most complete line (SP Series) for Plymouth, Dodge, DeSoto, Chrysler, Ford, Mercury, Lincoln, and Hudson.

A complete control replacement guide for TV and auto radios has been prepared by Howard W. Sams & Co., Inc. Order one from your distributor, and see the wide coverage of exact replacement auto radio controls you get from CENTRALAB.

B-6005

Centralab

THE ELECTRONICS DIVISION OF GLOBE-UNION INC.
910F E. KEEFE AVE. • MILWAUKEE 1, WIS.
IN CANADA: P. O. Box 400 • Ajax, Ontario

CONTROLS • ROTARY SWITCHES • CERAMIC CAPACITORS
PACKAGED ELECTRONIC CIRCUITS • ENGINEERED CERAMICS

75



The Beautiful
Schober
CONSOLETTA
—only small organ with two full 61-note keyboards and 22 stops. Requires only 2'x3'2" floor space! Commercial value approximately \$1600 or more.

BUILD THIS SUPERB *Schober* ORGAN FROM SIMPLE KITS and save over 50%

Give Your Family A Lifetime of Musical Joy With A Magnificent Schober Electronic Organ!

Now you can build the brilliant, full-range Schober CONSOLETTA or the larger CONCERT MODEL with simple hand tools! No skills are needed; no wood-working necessary. Just assemble clearly marked electronic parts guided by step-by-step instructions. You build from kits, as fast or as slowly as you please . . . at home, in your spare time — with a small table serving as your entire work shop.

Pay As You Build!

Start building your organ at once, investing just \$18.94! The superb instrument you assemble is as fine, and technically perfect, as a commercial organ . . . yet you save over 50% on quality electronic parts, high-priced labor, usual store mark-up!

Free Booklet

Send for 16-page booklet in full color describing Schober organs you may build for home, church or school — plus articles on how easy it is to build your own organ and how pleasant it is to learn to play. Also available is 10" LP demonstration record (price \$2.00 — refundable on first order). Send for literature. No obligation and no salesman will call.

THE GREAT
CONCERT MODEL
meets specifications of American Guild of Organists

Mail This Coupon For FREE Schober Literature And Hi-Fi Demonstration Record TODAY!

The Schober Organ Corp., Dept. RN-5
2248 Broadway, New York 24, N. Y.

- Please send me FREE Color Booklet and other literature on the Schober organs.
 Please send me the 10" hi-fi Schober demonstration record. I enclose \$2.00 (refundable on receipt of my first kit order).

Name.....

Address.....

City..... Zone... State....

used where it is needed, and dissipated efficiently where it is not needed.

The new tubes include: type 7408, a power pentode for class A1 operation; types 7581, 7355, 7189-A, 6L6-GC, and 6BQ5, power pentodes for various applications; type 6DZ7, a twin power pentode; types 7025 and 7247, twin triode and double triode respectively; and types 6CA4 and 5AR4, twin diode rectifiers.

STEREO POWER AMPLIFIER

Bogen-Presto Company, Paramus, N. J. is currently introducing the *Bogen DS-265* stereo power amplifier, a unit rated at a total of 130 watts (two 65-watt channels).

The new unit, which comes complete



with enclosure, has a frequency response of 20 to 20,000 cps \pm 1 db. The circuit has ten tubes, an input sensitivity of 2 volts for rated output, an input impedance of 100,000 ohms, and output impedances of 4, 8, and 16 ohms. Distortion is less than 0.5% at rated output.

A similar unit, identical except for power output, is available as the Model DS-225 which offers two 25-watt channels.

Complete specifications and additional information on either or both of these power amplifiers are available from the manufacturer.

AUDIO SIGNAL GENERATOR

Packard Bell Electronics, 12333 W. Olympic Blvd., Los Angeles 64, Calif. has announced its new audio signal generator, Model 50. A dual function (sine and square wave) instrument, the Model 50 is designed for measuring distortion in high-fidelity amplifiers, as well as the frequency response of other test equipment, amplifiers, tone controls, and phono equalizers.

The Model 50 also provides precise



measurement of amplifier input and output impedances and loudspeaker resonant frequencies. It is continuously tunable from 21 cps to 250 cps and can be used for tuning bass-reflex enclosures as well as in determining unknown audio frequencies and the resonant frequencies of LC circuits.

Specifications state that the Model 50 produces 2% or less harmonic distortion from 30 cps to 100 kc., and is accurate to within 2% or better.

JENSEN STEREO CARTRIDGE

Jensen Industries of Forest Park, Ill. has announced the availability of a new ceramic stereo cartridge, the Stereo 53.

The new unit develops a peak response to 25,000 cps and handles 16 cps on the low end. The unit is rated 24 db separation at 1000 cps. The cartridge is being offered in four needle combinations, using either sapphire or diamond styli. The needles are easily removed by grasping the tail piece of the damper on the needle and sliding it forward out of the slot in the nose cone. The cartridge has four terminal pins and is designed to replace a wide variety of pickups in a number of popular units.

Write the manufacturer direct for complete specifications and prices.

CROWN TAPE PLAYER

Crown International, Box 261, Elkhart, Ind. has announced production of the new "Crown-O-Matic" model A-51 monophonic tape player.

Designed for versatile, heavy-duty continuous operation in music systems, the A-51 has three motors, featuring a hysteresis-synchronous drive motor, and ball-bearing reel motors. The unit features an automatic photo-electric self-reversing system, heavy flywheel, straight-line threading, differential

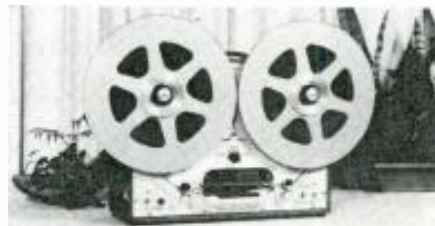

magnetic braking, fast forward and rewind, plug-in preamplifier, and plastic-enclosed relays.

The "Crown-O-Matic" accommodates up to 14-inch reels and plays up to 16 hours of unrepeated time at 3.75-ips speed, or 8 hours at 7.5-ips speed. Speed of 1 1/2 ips can be purchased on special order.

SPEAKER SWITCHING KIT

Centrulub, a division of *Globe-Union, Inc.*, 900 East Keefe Ave., Milwaukee 1, Wis. is offering a dual speaker "fader" control kit. Designed primarily for use in rear-seat auto speaker installation, the WK-300 kit permits gradual reduction of volume on one speaker, while increasing volume on the other, or balances both speakers.

The kit contains a miniature 5-watt wirewound control that is only 1 1/2 inch in diameter, as well as installation hardware and instructions.

100-WATT STEREO AMPLIFIER

Electronic Instrument Co., Inc. (EICO), 33-00 Northern Blvd., Long Island City 1, N. Y. is now producing a new 100-watt stereo high-fidelity power amplifier.

Designated as model HF-89 and available in either kit or factory-wired form, the new component is rated at 50 watts per channel, with an input sensitivity of 0.55 volt for full rated output.



Frequency response is said to be 5 to 100,000 cps ± 0.5 db. At 100 watts output, IM distortion (60 and 7000 cps at 4:1) is reported to be 0.5%. Harmonic distortion at that level is less than 1% from 20 to 20,000 cps within 1 db. Hum level is stated as better than 90 db below full output.

Controls include individual input channel level adjustments, a "service selector" switch, and "off-on" switch. The output stages are "Ultra-Linear" connected, using fixed bias push-pull EL34's with provision for both bias and d.c. balance adjustments. The manufacturer will supply complete data upon request.

AUDIO CATALOGUES

"MICROPHONE FACTS"

Electro-Voice, Inc. of Buchanan, Mich. is now offering copies of its informative newsletter which has been especially prepared for radio, television, and recording engineers by Lou Burroughs.

Individual problems, case histories, new ideas, and developments are discussed in "Microphone Facts." For copies of this publication write Mr. Burroughs, vice-president in charge of broadcast and recording equipment, in care of the company.

"THIS IS STEREO"

Allied Radio Corporation, 100 N. Western Ave., Chicago 80, Ill. has published a new 36-page booklet entitled "This is Stereo High-Fidelity" which is being offered for 25 cents a copy to interested audiophiles.

Prepared by the publications staff of the company, with the editorial assistance of Edward Tatnall Canby, this easy-to-understand booklet is a highly informative guide for anyone who wants the facts on stereo. Written in non-technical language, the booklet illustrates and discusses every aspect of component-type stereo systems.

The introductory section covers the basic elements of good audio reproduction while other sections discuss the basic components used in a stereo music system—their functions and specifications. Various accessories are also discussed.

Copies of the booklet, which is listed as Stock No. 37 K 387, are available from the company direct.

2 for the money

circuit by *Bell* tubes by *Amperex*

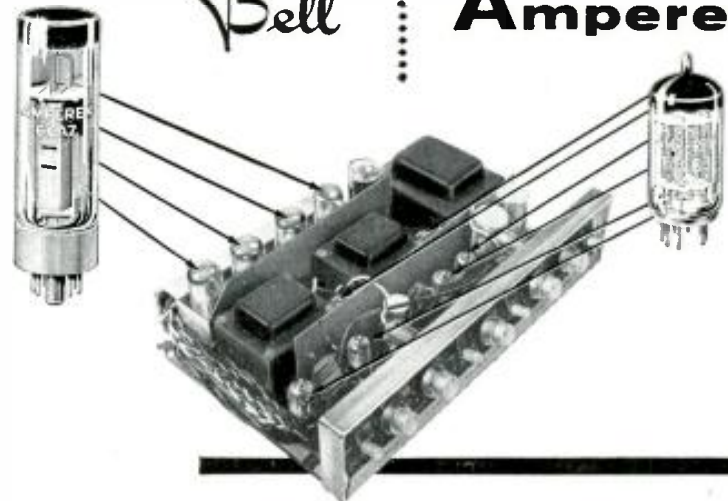

Bell engineers, preliminary to the design of their *Carillon Model 6060, 2 channel, 60 watt Stereo Amplifier*, canvassed the industry for tube types offering something truly exceptional in the way of reliability, low distortion, low noise, low hum and absence of microphonics.

As has frequently been their experience, the people at Bell found these qualities best exemplified by Amperex tubes. Thus, the tube complement of the Bell Model 6060 includes two Amperex 6CA7/EL34's and three Amperex 12AX7/ECC83's in each channel.

These and many other Amperex 'preferred' tube types have proven their reliability and unique design advantages in the world's finest audio components.

Applications engineering assistance and detailed data are always available to equipment manufacturers. Write: Amperex Electronic Corp., Special Purpose Tube Division, 230 Duffy Avenue, Hicksville, L. I., New York.



about hi-fi tubes
for hi-fi circuitry

AMPEREX TUBES FOR QUALITY HIGH-FIDELITY AUDIO APPLICATIONS

POWER AMPLIFIERS

6CA7/EL34: 60 w. distributed load
7189: 20 w., push-pull
6BQ5/EL04: 17 w., push-pull
6CW5/EL06: 25 w., high current, low voltage
6BM6/ECL82: Triode-pentode, 8 w., push-pull

VOLTAGE AMPLIFIERS

6267/EF86: Pentode for pre-amps
12AT7/ECC81: } twin triodes, low hum, noise and microphonics
12AU7/ECC82: }
12AX7/ECC83: }
6BL6/ECF80: High gain, triode-pentode, low hum, noise and microphonics

RF AMPLIFIERS

6ES8: Frame grid twin triode
6ER5: Frame grid shielded triode
6EH7/EF103: Frame grid pentode for IF, remote cut-off
6EJ7/EF184: Frame grid pentode for IF, sharp cut-off
6AQ6/ECC85: Dual triode for FM tuners
6DC8/EBF89: Duo-diode pentode

RECTIFIERS

6V4/EZ80: Indirectly heated, 90 mA
6CA4/EZ81: Indirectly heated, 150 mA
5AR4/GZ34: Indirectly heated, 250 mA

INDICATORS

6FG6/EM84: Bar pattern
1M3/DM70: Subminiature "exclamation" pattern

SEMICONDUCTORS

2N1517: RF transistor, 70 mc
2N1516: RF transistor, 70 mc
2N1515: RF transistor, 70 mc
1N542: Matched pair discriminator diodes
1N87A: AM detector diode, subminiature



RESIST-O-PEDIA

FREE! with any of 5 Handy-Pak Carbon Resistor Assortments
65 to 77 Values

\$46⁸⁰ to \$110⁸⁸ Dealer Net

Convenient "Book Shelf" storage in hard-back binder • Self-indexed



Order from your IRC Distributor

INTERNATIONAL RESISTANCE COMPANY • DISTRIBUTOR SALES DIVISION
414 N. 13th STREET • PHILADELPHIA 8, PA.

CUT HOLES IN RADIO CHASSIS THAT FIT THE PARTS WITH THIS HAND OPERATED NIBBLING TOOL



CUTS ANY SIZE OR SHAPE OVER 7/16"

CUTS—round, square, or irregular holes in radio chassis, shields, or metal cabinets.

NOTCHES—clearance on flat or formed edges for plugs, terminals, or wiring.

TRIMS—undersized holes to fit parts.

CAPACITY—steel—18 ga. (.046) max.
aluminum or copper—1/16"

WILL NOT ADD STRAIN OR DISTORTION
TO THE EDGES, OR TO THE ORIGINAL FORM.

SOLD THROUGH
ELECTRONIC PARTS DISTRIBUTORS
Write for list.

ADEL TOOL CO.

4640 Ronald St. Chicago 31, Ill.

QUIETROLE
NON-INFLAMMABLE - NON-CONDUCTIVE
Spray-Pack
LUBRI-CLEANER
for
TV Tuners
AND ALL OTHER CLEANING & LUBRICATING
JOBS WHERE SPRAY APPLICATION
IS DESIRABLE
manufactured by
QUIETROLE
COMPANY, Inc.
Spartanburg, South Carolina

Either way, make
sure it's QUIETROLE
QUIETROLE
Company

Also available in
2, 4, and 8 oz.
bottles with dropper

In Canada:
CROSS CANADA ELECTRONICS Spartanburg
67 Ontario St., S. Mitchell, Ont. South Carolina

1 7/8 ips Tape System

(Continued from page 37)

sponse was similar to the playback head.

Equalization and Performance

The normal maximum output curve of the replay head, when playing back a new tape at 1 7/8 ips made with a high efficiency record head, is shown in Fig. 3A. With the recording and playback equalization curves shown in Figs. 3B and 3C respectively, a flat response is obtained from 30 to 15,000 cps at -18 db with respect to a 1-kc., 3 per-cent distortion signal. Under these conditions the maximum signal-to-noise ratio at 1 kc. is 54 db, which is about the same obtainable on professional 7 1/2-ips half-track systems. These latter systems, however, are some 6 db better at a 10-kc. signal response than is the new 1 7/8-ips system.

CBS therefore claims that this new system, taking into account the record-

ing and playback equalizations used, approaches 7 1/2-ips performance closely and is entirely adequate for all types of musical selections.

Mechanical Features

One job that the layman or some home users find to be a nuisance is the loading and threading of a tape machine. In this new system, a number of tape cartridges are simply stacked on a wide spindle in a square well, the stack is pushed down to set the mechanism, and a button is depressed. (The spindle reminds us of the one used in some 45-rpm record changers.) The machine then proceeds to thread itself, the heads move into position, the take-up reel starts to wind in the tape, and the tape begins to play.

Then, at the end of a tape, or before this if the user presses the "reject" button, the machine stops and goes into a fast rewind (20 seconds for the entire reel). After the cartridge has been completely rewound, the entire stack of cartridges moves up by the thickness of one cartridge. The machine then proceeds to thread the tape from the

Fig. 3. (A) Maximum output of playback head along with the recording equalization (B) and playback equalization (C) used. All curves apply to operation at 1 7/8-ips speed.

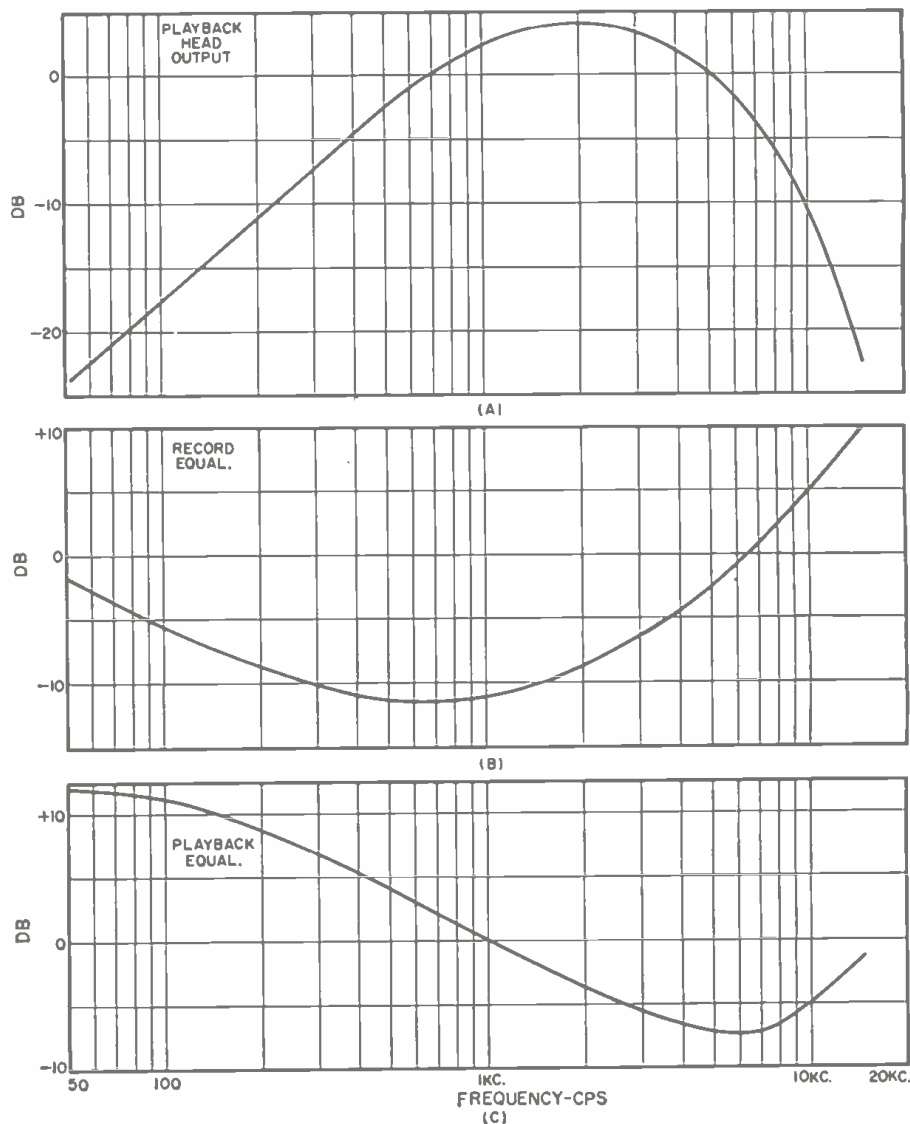

new cartridge through the machine and play it back. How this is accomplished may be seen from Fig. 1 and some of the photographs of the uncovered mechanism.

At the very beginning of the cartridge-loaded tape is a small clip with a hole and slot in it. This clip completely closes up the only small opening in the cartridge housing, thus protecting the tape. At the very end of the pre-threaded leader in the machine is another small clip with what looks like a half of a dumbbell protruding from it. Before the cartridges are loaded onto the machine, the dumbbell clip just extends inside the square well into which the cartridges are to be placed. When the tapes are put in place, the dumbbell clip just fits into the hole-and-slot clip, and the leader can now pull the tape out of the cartridge and through the machine to the take-up reel.

There is a straight-line path between the cartridge opening and the take-up reel so that it is not necessary to use intermediate idlers. A capstan and pressure roller draw the tape through the machine at the required speed of 1 7/8 ips. The take-up reel is driven through a conventional slipping clutch.

In order to prevent the tape from unreeling and spilling off the supply reel during normal handling, some sort of brake is required. This brake is built into the bottom wall of the cartridge in the form of ratchet teeth that are engaged by a simple spring clip. When the cartridge is loaded on the machine, the spindle presses against the spring clip, raises it from the ratchet teeth, and permits the supply reel to rotate freely within the cartridge. Also built into the cartridge hub is a toothed arrangement which acts as a fast-rewind gear. This is driven at high speed to rewind the tape quickly. The entire driving mechanism is carefully built so as to minimize wow and flutter, which is frequently found to be a serious problem at very low running speeds.

Costs and Future

We have no information on the possible costs of the tape cartridges or of the tape machine itself. Our guess is that the cartridge cost will be quite competitive with a stereo phonograph record, but the cost of the machine will probably not be low. Although the over-all mechanism is not much more complicated than a record changer, the tape machine requires more complex linkages from the drive motor and the design must be good mechanically to avoid wow and flutter at the slow tape speed used. Also, the heads themselves are not going to be cheap.

The disclosure and the demonstration by CBS certainly represents a notable technical achievement. What effect the introduction of this system is going to have on the tape industry and on consumers is something we will have to wait for the future to tell. And we don't have our crystal ball with us now.

CONDUCTORS



EXPECT PERFECTION - USE AUDIOTEX ACCESSORIES TO GET TOP PERFORMANCE FROM THEIR HI-FI ... Economy, too!



AUDIOTESTER TEST RECORD



Combination stereo and mono test record checks hi-fi systems from needle to loud speaker. 12" plastic LP; includes detailed instructions. Audiometer Tape: Completely checks stereo and mono tape machines. 7.5 ips; 5" plastic reel.

Record: Cat. No. 30-200 List: \$4.98
Tape: Cat. No. 30-206 (standard tolerance) List: \$6.50
Tape: Cat. No. 30-208 (professional tolerance) List: \$8.25



TAPERASER

Completely removes recording and noise from tapes and 16 or 35 mm magnetic sound film. Actually drops residual noise level below some virgin tapes. Erases tape right on reel (up to 10 1/2" dia.) in 30 seconds.

Cat. No. 30-114 List: \$33.00



PHONO LEVEL KIT

Levels phonographs and turntables for proper reproduction and care of records. Includes bubble type level (accurate to better than 1°) with screws for permanent mounting and four adjustable feet.

Cat. No. 30-226 List: \$3.25



PHONO SPEED TEST KIT

For checking turntable speed. Essential in adjusting for proper pitch. Includes plastic Strobe Disc for all standard speeds (16, 33, 45, 78 RPM) and plastic-encased Neon Strobe Lamp. Also handy for checking 110 v power.

Cat. No. 30-232 Test Kit List: \$2.90
Cat. No. 30-230 Plastic Strobe Disc only List: \$1.65



TELEPHONE PICK-UP

High-output induction device for recording or amplifying both sides of telephone conversation when used with tape machine or sound system. Built-in suction cup attaches to any telephone in an instant.

Cat. No. 30-150 List: \$5.95



Look for this AUDIOTEX SELF-SERVICE RACK at your favorite dealers.

You'll find accessories that improve performance, simplify operation, preserve your equipment. Ask about the complete Phono Accessory & Care Kit for all record playing equipment.

AUDIOTEX MFG. CO.
DIV. OF G C-TEXTRON INC.

- 3225 Exposition Pl., Los Angeles 18, Calif.
- 400 S. Wyman St., Rockford, Ill.
- In Canada: ATLAS RADIO CORP., Ltd., Toronto 19

SEND ME FREE CATALOG OF 170 ACCESSORIES

DEPT. EW-6

NAME _____

ADDRESS _____

CITY _____ ZONE _____ STATE _____



SUPERIOR'S
NEW MODEL 77

VACUUM TUBE VOLTMETER

WITH NEW 6" FULL-VIEW METER

Compare it to any peak-to-peak V. T. V. M. made by any other manufacturer at any price

- ✓ Model 77 completely wired and calibrated with accessories (including probe, test leads and portable carrying case) sells for only \$42.50.
- ✓ Model 77 employs a sensitive six inch meter. Extra large meter scale enables us to print all calibrations in large easy-to-read type.
- ✓ Model 77 uses new improved SICO printed circuitry.
- ✓ Model 77 employs a 12AU7 as D.C. amplifier and two 9006's as peak-to-peak voltage rectifiers to assure maximum stability.

- ✓ Model 77 uses a selenium-rectified power supply resulting in less heat and thus reducing possibility of damage or value changes of delicate components.
- ✓ Model 77 meter is virtually burn-out proof. The sensitive 400 microampere meter is isolated from the measuring circuit by a balanced push-pull amplifier.
- ✓ Model 77 uses selected 1% zero temperature coefficient resistors as multipliers. This assures unchanging accurate readings on all ranges.

SPECIFICATIONS

• DC VOLTS—0 to 3/15 75 150 300/750 1,500 volts at 11 megohms input resistance. • AC VOLTS (RMS)—0 to 3/15/75/150 300 750 1,500 volts. • AC VOLTS (Peak to Peak)—0 to 8 40/200 400/800/2,000 volts. • ELECTRONIC OHMMETER—0 to 1,000 ohms 10,000 ohms/100,000 ohms 1 megohm/10 megohms 100 megohms/1,000 megohms DECIBELS —10 db to +18 db, +10 db to +38 db +30 db to +58 db. All based on 0 db = 0.001 watts (10 mw) into a 500 ohm line (1.73v). • ZERO CENTER METER—For discriminator alignment with full scale range of 0 to 1.5/-7.5/37.5/75/150/375/750 volts at 11 megohms input resistance.

\$42⁵⁰
NET

Model 77—VACUUM TUBE VOLTMETER
... Total Price \$42.50—Terms: \$12.50 after 10 day trial, then \$6.00 monthly for 5 months if satisfactory. Otherwise return, no explanation necessary!

AS A DC VOLTMETER: The Model 77 is indispensable in Hi-Fi Amplifier servicing and a must for Black and White and color TV Receiver servicing where circuit loading cannot be tolerated.

AS AN AC VOLTMETER: Measures RMS values if sine wave, and peak-to-peak value if complex wave. Pedestal voltages that determine the "black" level in TV receivers are easily found.

AS AN ELECTRONIC OHMMETER: Because of its wide range of measurement leaky capacitors show up glaringly. Because of its sensitivity and low loading, intermittents are easily found, isolated and repaired.

Model 77 comes complete with operating instructions, probe and test leads. Use it on the bench—use it on calls. A streamlined carrying case, included at no extra charge, accommodates the tester, instruction book, probe and leads. Operates on 110-120 volt 60 cycle. Only.....



SUPERIOR'S NEW MODEL 79 **SUPER-METER** WITH NEW 6" FULL-VIEW METER

A Combination VOLT-OHM MILLIAMMETER.
Plus CAPACITY, REACTANCE, INDUCTANCE AND DECIBEL MEASUREMENTS.
Also Tests SELENIUM AND SILICON RECTIFIERS, SILICON AND GERMANIUM DIODES.

Specifications

D.C. VOLTS: 0 to 7.5/15/75/150/750/1,500.
A.C. VOLTS: 0 to 15/30/150/300/1,500/3,000.
D.C. CURRENT: 0 to 1.5/15/150 Ma. 0 to 1.5/15 Amperes.
RESISTANCE: 0 to 1,000/100,000 Ohms, 0 to 10 Megohms.
CAPACITY: .001 to 1 Mfd. 1 to 50 Mfd.
REACTANCE: 50 to 2,500 Ohms, 2,500 Ohms to 2.5 Megohms.
INDUCTANCE: .15 to 7 Henries, 7 to 7,000 Henries.
DECIBELS: -6 to +18, +14 to +38, +34 to +58.

The following components are all tested for QUALITY at appropriate test potentials. Two separate BATTERY scales on the meter are used for direct readings.

All Electrolytic Condensers from 1 MF1 to 1000 MF1.
All Selenium Rectifiers. All Germanium Diodes.
All Silicon Rectifiers. All Silicon Diodes.

The Model 79 represents 20 years of continuous experience in the design and production of SUPER-METERS, an exclusive SICO development.

In 1938 Superior Instruments Co. designed its first SUPER-METER, Model 1150. In 1940 it followed with Model 1250 and in succeeding years with others including Models 670 and 670-A. All were basically V.O.M.'s with extra services provided to meet changing requirements.

Now, Model 79, the latest SUPER-METER includes not only every circuit improvement perfected in 20 years of specialization, but in addition includes those services which are "musts" for properly servicing the ever increasing number of new components used in all phases of today's electronic production. For example with the Model 79 SUPER-METER you can measure the quality of selenium and silicon rectifiers and all types of diodes—components which have come into common use only within the past five years, and because this latest SUPER-METER necessarily required extra scale, SICO used its new full-view 6-inch meter.

\$38⁵⁰
NET

Model 79—SUPER-METER ... Total Price \$38.50—Terms: \$8.50 after 10 day trial, then \$6.00 per month for 5 months if satisfactory. Otherwise return, no explanation necessary!

Model 79 comes complete with operating instructions and test leads. Use it on the bench—use it on calls. A streamlined carrying case included at no extra charge accommodates the tester, instruction book and test leads..... Only



GENOMETER

7 Signal Generators in One!

- ✓ R.F. Signal Generator for A.M. ✓ Bar Generator
- ✓ R.F. Signal Generator for F.M. ✓ Cross Hatch Generator
- ✓ Audio Frequency Generator ✓ Color Dot Pattern Generator
- ✓ Marker Generator

A versatile all-inclusive GENERATOR which provides ALL the outputs for servicing:

A.M. Radio • F.M. Radio • Amplifiers • Black and White TV • Color TV

Model TV-50A—Genometer
Total Price \$47.50
Terms: \$11.50 after 10 day trial, then \$6.00 monthly for 6 months if satisfactory. Otherwise return, no explanation necessary.

R. F. SIGNAL GENERATOR: The Model TV-50A Genometer provides complete coverage for A.M. and F.M. alignment. Generates Radio Frequencies from 100 Kilocycles to 60 Megacycles on fundamentals and from 60 Megacycles to 180 Megacycles on powerful harmonics.

VARIABLE AUDIO FREQUENCY GENERATOR: In addition to a fixed 400 cycle sine-wave audio, the Model TV-50A Genometer provides a variable 300 cycle to 20,000 cycle peak wave audio signal.

BAR GENERATOR: The Model TV-50A projects an actual Bar Pattern on any TV Receiver Screen. Pattern will consist of 4 to 16 horizontal bars or 7 to 20 vertical bars.

THE MODEL TV-50A comes absolutely complete with shielded leads and operating instructions.

MARKER GENERATOR: The Model TV-50A includes all the most frequently needed marker points. The following markers are provided: 189 Kc., 262.5 Kc., 456 Kc., 600 Kc., 1000 Kc., 1400 Kc., 1600 Kc., 2000 Kc., 2500 Kc., 3579 Kc., 4.5 Mc., 5 Mc., 10.7 Mc., (3579 Kc. is the color burst frequency)

\$47⁵⁰
NET

CROSS HATCH GENERATOR: The Model TV-50A Genometer will project a cross-hatch pattern on any TV picture tube. The pattern will consist of non-shifting, horizontal and vertical lines interlaced to provide a stable cross-hatch effect.

DOT PATTERN GENERATOR (FOR COLOR TV): Although you will be able to use most of your regular standard equipment for servicing Color TV, the one addition which is a "must" is a Dot Pattern Generator. The Dot Pattern projected on any color TV Receiver tube by the Model TV-50A will enable you to adjust for proper color convergence.

➔ **EXAMINE BEFORE YOU BUY!** ➔
USE APPROVAL FORM ON NEXT PAGE ➔



SUPERIOR'S NEW MODEL TW-11

STANDARD PROFESSIONAL

TUBE TESTER

- ★ Tests all tubes, including 4, 5, 6, 7, Octal, Lock-in, Hearing Aid, Thyatron, Miniatures, Sub-miniatures, Novals, Subminars, Proximity fuse types, etc.
- ★ Uses the new self-cleaning Lever Action Switches for individual element testing. Because all elements are numbered according to pin-number in the RMA base numbering system, the user can instantly identify which element is under test. Tubes having tapped filaments and tubes with filaments terminating in more than one pin are truly tested with the Model TW-11 as any of the pins may be placed in the neutral position when necessary.
- ★ The Model TW-11 does not use any combination type sockets. Instead individual sockets are used for each type of tube. Thus it is impossible to damage a tube by inserting it in the wrong socket.
- ★ Free-moving built-in roll chart provides complete data for all tubes. All tube listings printed in large easy-to-read type.

NOISE TEST: Phono-jack on front panel for plugging in either phones or external amplifier will detect microphonic tubes or noise due to faulty elements and loose internal connections.

EXTRAORDINARY FEATURE

SEPARATE SCALE FOR LOW-CURRENT TUBES: Previously, an emission-type tube testers, it has been standard practice to use one scale for all tubes. As a result, the calibration for low-current types has been restricted to a small portion of the scale. The extra scale used here greatly simplifies testing of low-current types.

Model TW-11—Tube Tester
Total Price\$47.50
Terms: \$11.50 after 10 day trial, then \$6.00 monthly for 6 months if satisfactory. Otherwise return, no explanation necessary.

The Model TW-11 operates on 105-130 Volt 60 Cycles A.C. Comes housed in a handsome, portable Saddle-Stitched Texon Case. Only..... **\$47⁵⁰**

SUPERIOR'S NEW MODEL 82A

Multi-Socket Type

TUBE TESTER



TEST ANY TUBE IN 10 SECONDS FLAT!

- 1 Turn the filament selector switch to position specified.
- 2 Insert tube into a numbered socket as designated on our chart (over 600 types included).
- 3 Press down the quality button—

Model 82A—Tube Tester
Total Price\$36.50
Terms: \$6.50 after 10 day trial, then \$6.00 monthly for 5 months if satisfactory. Otherwise return, no explanation necessary.

THAT'S ALL! Read emission quality direct on bad-good meter scale.

SPECIFICATIONS

- Tests over 600 tube types
- Tests OZ4 and other gas-filled tubes
- Employs new 4" meter with sealed air-damping chamber resulting in accurate vibrationless readings
- Use of 22 sockets permits testing all popular tube types and prevents possible obsolescence
- Dual Scale meter permits testing of low current tubes
- 7 and 9 pin straighteners mounted on panel
- All sections of multi-element tubes tested simultaneously
- Ultra-sensitive leakage test circuit will indicate leakage up to 5 meohms

Production of this Model was delayed a full year pending careful study by Superior's engineering staff of this new method of testing tubes. Don't let the low price mislead you! We claim Model 82A will outperform similar looking units which sell for much more — and as proof, we offer to ship it on our examine before you buy policy.

To test any tube, you simply insert it into a numbered socket as designated, turn the filament switch and press down the quality switch — **THAT'S ALL!** Read quality on meter. Inter-element leakage if any indicates automatically.

Model 82A comes housed in handsome, portable Saddle-Stitched Texon case. Only **\$36⁵⁰**

SUPERIOR'S NEW MODEL 83

C. R. T. TESTER

TESTS AND REJUVENATES ALL PICTURE TUBES

ALL BLACK AND WHITE TUBES

From 50 degree to 110 degree types — from 8" to 30" types.

ALL COLOR TUBES

Test All picture tubes—in the carton—out of the carton—in the set!



Model 83—C.R.T. Tube Tester
Total Price\$38.50
Terms: \$8.50 after 10 day trial, then \$6.00 monthly for 5 months if satisfactory. Otherwise return, no explanation necessary.

- Model 83 is not simply a rehashed black and white C.R.T. Tester with a color adapter added. Model 83 employs a new improved circuit designed specifically to test the older type black and white tubes, the newer type black and white tubes and all color picture tubes.
- Model 83 provides separate filament operating voltages for the older 6.3 types and the newer 8.4 types.
- Model 83 employs a 4" air-damped meter with quality and calibrated scales.
- Model 83 properly tests the red, green and blue sections of color tubes individually—for each section of a color tube contains its own filament, plate, grid and cathode.

- Model 83 will detect tubes which are apparently good but require rejuvenation. Such tubes will provide a picture seemingly good but lacking in proper definition, contrast and focus. To test for such malfunction, you simply press the rej. switch of Model 83. If the tube is weakening, the meter reading will indicate the condition.
- Rejuvenation of picture tubes is not simply a matter of applying a high voltage to the filament. Such voltages improperly applied can strip the cathode of the oxide coating essential for proper emission. The Model 83 applies a selective low voltage uniformly to assure increased life with no danger of cathode damage.

Model 83 comes housed in handsome portable Saddle-Stitched Texon case—complete with sockets for all black and white tubes and all color tubes. Only..... **\$38⁵⁰**

SHIPPED ON APPROVAL NO MONEY WITH ORDER — NO C. O. D.

Try any of the instruments on this or the facing page for 10 days before you buy. If completely satisfied then send down payment and pay balance as indicated on coupon. **No Interest or Finance Charges Added!** If not completely satisfied return unit to us, no explanation necessary.

MOSS ELECTRONIC, INC.

Dept. D-763 3849 Tenth Ave., New York 34, N. Y.

Please send me the units checked on approval. If completely satisfied I will pay on the terms specified with no interest or finance charges added. Otherwise, I will return after a 10 day trial positively cancelling all further obligations.

- | | |
|--|---|
| <input type="checkbox"/> Model 77..... Total Price \$42.50
\$12.50 within 10 days. Balance \$6.00 monthly for 5 months. | <input type="checkbox"/> Model TW-11..... Total Price \$47.50
\$11.50 within 10 days. Balance \$6.00 monthly for 6 months. |
| <input type="checkbox"/> Model 79..... Total Price \$38.50
\$8.50 within 10 days. Balance \$6.00 monthly for 5 months. | <input type="checkbox"/> Model 82A..... Total Price \$36.50
\$6.50 within 10 days. Balance \$6.00 monthly for 5 months. |
| <input type="checkbox"/> Model TV-50A..... Total Price \$47.50
\$11.50 within 10 days. Balance \$6.00 monthly for 6 months. | <input type="checkbox"/> Model 83..... Total Price \$38.50
\$8.50 within 10 days. Balance \$6.00 monthly for 5 months. |

Name

Address

City Zone..... State.....

All prices net. F.O.B., N. Y. C.

Export Division: Rocke International Corp.
13 East 40th Street, New York 16, N. Y.

**GOODHEART'S
GUARANTEED
GOODIES
... super values, too!**



\$850 TEST OSCILLOSCOPE FOR ONLY \$39.50

TS-34/AP. Why modify radar scopes? This is ready to plug into 103V-125V, 10-2500 cy, and use. Checked and OK'd before shipping. In portable carrying case. Less cords (which are easy to make), with reprint of the most important 16 pages of the tech manual. Uses a small pic tube but you look into the hood and thru a magnifying lens that gives the equivalent of a 5" pic and the hood shields external light so you see fast rises. 0-40 db attenuators in 2 db steps are so accurate that you get instructions to use as a VTVM! Video is flat 40-2,500,000 cy. Sweep is contin. variable 10-50,000 cy. BEST OF ALL, there is a "Start-Stop" switch position in which pulses to be viewed each trigger their own sweep, with sweep durations of 5, 50, or 250 microseconds so accurate and linear that you can measure pulse width. INVALUABLE FOR TV PULSE VIEWING! Pulses may be periodic or random, pos. or neg., as low as 0.1 volt, and may vary in width from a line pip to 200 u-sec. AT THIS LOW PRICE, NO ONE NEED DO WITHOUT THIS WONDERFUL SCOPE! **\$39.50** 50 lbs. fob Los Angeles.

SAME, but BRAND NEW, with all cords and complete tech manual, fob Los Angeles... **\$69.50**

TS-34A/AP. No cords or carrying case. Checked and certified equal to new. Same as TS-34/AP except that the triggered sweeps can be varied 4 1/2-B. **\$39.50** 20-50, and 120-280 microseconds.

ONLY \$79.50 FOR 5" DUMONT TEST SCOPE



2241 as illustrated, with line cord, guar. ready to use. Don't be fooled by scopes which are radar calibrators! 2241 is a standard test scope you can use and be proud of. Has Z-axis amp for markers and X-axis amp. for ext. sweeps or to 2000 cycles. Internal sweep 15-30,000 cy. Video response 100 cy to 2 mc. Direct-to-plate terminals and all controls on front panel 10 1/2" wd x 18" h. With reprint of the Dumont Instructional Book. Checked out, certifi. **\$79.50**

Red. 75 lbs. **\$79.50**
FOB Los Angeles.

IMPROVE YOUR RECEIVER \$39.50! SEND ADDRESS ENCLOSE FOR FREE INFORMATION

A TERRIFIC BUY IN XMR POWER SUPPLY & VOLUME-COMPRESSING AUDIO AMPLIFIER

You get a plug-in module 30 W speech amp. that holds output to +5% for input blast of +95% above the 90-95% modulation level. 6-tube chassis includes keyed tone os. and sidetone. Carbon pile for strike-PP 807's, 6 K Ohms out. You also get a plug-in module HV power supply. Puts out filtered DC's of 500 v, 445 ma, 300 v, 175 ma, and 47 v bias. Uses 4 3C22's. You also get two FW selenium supplies w/aging taps and 115 v 60 cy blower, to furnish filtered DC's of 120 v, 1 A and 115 v, 1/2 A. Input 115 v, 60 cy. W/schematic, parts characteristics, and complete instructions. 175 lbs fob Los Angeles, but shipped Transformers at very low rate. 1000 mah tubes, only \$29.50.

Less tubes, you steal it for only... **\$14.95**

TRANSMIT 4 X 400 WATTS A1, A2, A3

AN/FRT-1 complete and brand new. 2 sets available. Four transmitters T-4/FRC can be set up to 4 different frequencies 2-18 mc, crystal or MO. Each emits 400 watts RF in simultaneous operation, all modulated by one MD-1/FRC. All tubes are powered simultaneously by one PP-1/FRC from 220 v, 1 ph, 50/30 cy. Export boxed, w/spares **\$4950.00**

FOB Los Angeles, each complete set... **\$4950.00**

VHF MICROVOLTAGE SIGNAL GENERATOR

LAF-2. 90-600 mc, accuracy 1%. For FCC VHF Mobile and Aircraft service work, can be set within 1/2% by beating crystal-controlled xmr of receiver being serviced. Accurate below 100 mc. Bridge circuit meters output 1-100,000 microvolts. Checked and certified by Standards Lab. With calibration charts, schematic instructions. ONLY... **\$89.50**

12V DYNAMOTOR SPECIAL! Nominal 13v. 23A to 285 v, 500 ma. 1 A and 115 v, 1/2 A. Input ground. At 300 ma is 397 v, 15A in. Brand new! Original pack! fob Los Ang... **\$4.95**

CLOSEOUT! COMPLETE MAR's in warehouse that charges too much, so OUT they go! 3-unit set, exc. cond., w/antenna, plugs, xtl oven, tech-manual, partial reprint. 225-390 mc send/receive, tunes to 220 mc without modification. FOB Hartford, **\$29.50** Conn. All for only

TIME PAY PLAN. NEW DEAL! Any Purchase, pay 25% down, add 10% of unpaid balance for \$10.00, whichever is greater to the unpaid balance and divide by 12 to get monthly payment.

SCHEMATICS/CONVERSIONS, SURPLUS GEAR

List G. NEW! Send long stamped addressed envelope. Includes many Tech Manuals. Add \$5 for check explaining AN Nomenclature. Example of new listings: 20-page book on 1-177, with diagram of MX-949/U socket adapter & tubes, compiled to March 1957. \$5.00. RT-18/ARC-1 schem. & tune-up instr. \$2.00. MAR, 22 pages & 5 large pullout schematics, \$5.00.

Calif. buyers please add 4% when remitting.

R. E. GOODHEART CO.
P. O. Box 1220-A Beverly Hills, Calif.

Transistorized Square-Wave Shaper

By PAUL S. LEDERER

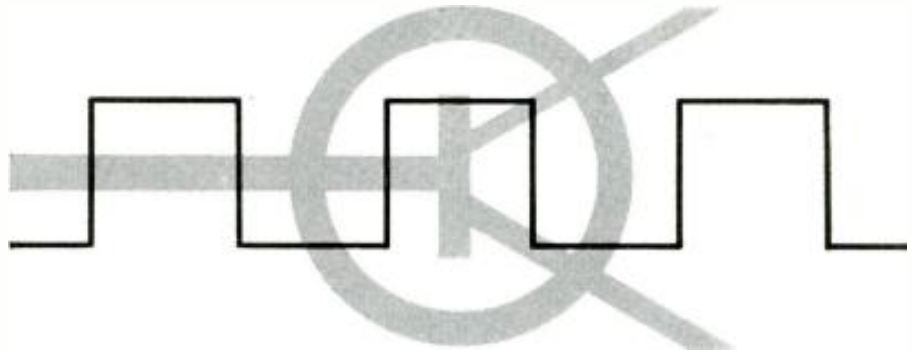

Simple circuit produces good square waves with 5-volt (p-p) amplitude when driven by 3-20 volt sine waves.

SQUARE-WAVE testing is becoming increasingly popular for the checking and servicing of all types of electronic equipment ranging from simple audio circuits to complex wide-band equipment like video amplifiers and radar gear. It not only offers a very rapid method of obtaining network characteristics like frequency response, phase response, and transient response, but also makes it comparatively easy to observe the effects of changes in the network parameters on these characteristics.

The article "Practical Techniques of Square-Wave Testing" by E. G. Louis¹ covered the subject of square-wave testing pretty thoroughly with discussion of the technique, its applications, some of its limitations, and the equipment required. The main pieces of equipment specified by the author were a square-wave generator and an oscilloscope. The article pointed out that while a specially designed square-wave generator is desirable for testing of wide-band equipment in the video frequency range, square waves derived from sine waves by means of a suitable clipper amplifier can be used for applications with narrower bandwidths or lower frequencies.

Most networks encountered by experimenters will be of the low-frequency type and many of their labs are

ready equipped with the required oscilloscopes and sine-wave generators. To use square-wave testing techniques, then, calls for a device which converts sine waves into square waves.

The simplest circuit which performs this function uses biased diodes as peak clippers. Such a circuit and a modification are described in another article². This modified circuit was capable of squaring sine waves of frequencies from 20 to 20,000 cps. In order to get a good square wave (one with a fast rise time) from a simple clipping circuit, an input signal on the order of 50 to 100 volts was required. This is beyond the output capabilities of most audio oscillators.

The transistorized sine-wave clipper covered in an early article³ required a sinusoidal input voltage of only about 3 to 5 volts and appeared to operate up to approximately 25,000 cps. The device generated clipped pulses with slightly rounded edges but information on the rise time was not included.

One vacuum-tube square-wave shaper which was described⁴ used a Schmitt trigger type of double-triode stage to convert the incoming sine wave into a square wave. With about 7 volts input it delivered about 50 volts peak-to-peak. Power supply requirements for this shaper were listed at about 20 ma. at 150 volts.

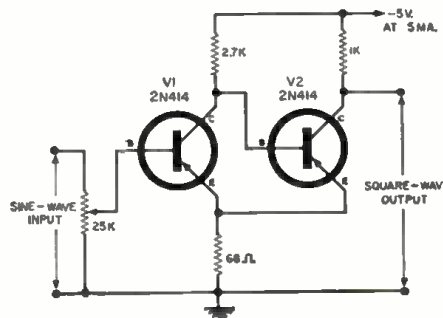
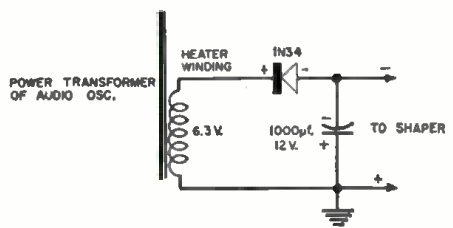

Fig. 1. A Schmitt trigger circuit is used.

Fig. 2. Simple power-supply circuit used.



The author's transistorized square-wave shaper to be described provides a square-wave output of about 5 volts peak-to-peak when driven by sine-wave signal between 3 and 20 volts r.m.s. and requires a power supply delivering about 5 ma. at -5 volts. It is capable of operating over a frequency range of from 20 to about 400,000 cps, producing square waves with a rise time (10% to 90%) of less than 0.5 microsecond.

The circuit uses two transistors and three fixed and one variable resistors. The shaper is essentially a Schmitt trigger circuit. Referring to the schematic of Fig. 1, with no input applied V_2 conducts and keeps V_1 cut off. This is because the base of V_1 , a $p-n-p$ transistor, is more positive than its emitter due to the voltage drop in the 68-ohm resistor which is caused by the emitter current of V_1 . Due to V_1 being cut off, the base of V_2 is supplied with a large negative bias current, causing it to conduct heavily. When a small negative signal is applied to the input of the circuit, it will cause V_1 to start conducting. This, in turn, not only lowers the bias current into the base of V_2 , but also brings the potential of the emitter of V_2 closer to that of its base. Both of these effects augment each other, resulting in a *very rapid* cut-off of V_2 . V_2 remains cut off as long as the amplitude of the negative-signed signal exceeds a small threshold level.

When the input drops below this level, V_2 switches to conduction and V_1 is cut off. For a positive signal, this state persists unchanged. Thus when sine waves are fed into this circuit, sharp square waves will appear at the output, i.e., the collector of V_2 .

V_1 and V_2 are Raytheon 2N414 $p-n-p$ junction transistors designed for high-frequency operation. Their α cut-off frequency is about 7 mc. The potentiometer serves to adjust the symmetry of the square wave to some extent. The output impedance of the shaping circuit is about 400 ohms. The amplitude of the square waves produced by the circuit can be adjusted conveniently by varying the *power supply voltage*. The only precaution which must be observed is not to exceed the maximum allowable collector voltage of -20 volts.

The entire circuit can be mounted on a piece of terminal board measuring 2½ inches square. It is small enough to be built into an existing audio oscillator, if desired. In such a case, the necessary power can be derived from the heater supply, as shown in Fig. 2.

REFERENCES

1. Louis, E. G.: "Practical Techniques of Square-Wave Testing," RADIO & TV NEWS, July 1957.
2. Smith, Mark: "Transistor Switching Circuits," Electronic Design, October, 1957.
3. Jones, G. E., Jr.: "A Square-Wave Shaper," RADIO & TELEVISION NEWS, September 1953.
4. Garner, L. E., Jr.: "A Transistor Sine-Wave Clipper," RADIO & TELEVISION NEWS, May 1953.
5. Garner, L. E., Jr.: "Wide Frequency Range Square-Wave Clipper," RADIO & TELEVISION NEWS, March 1950.

LEARN ALL ABOUT THESE VITAL SUBJECTS
EASILY . . . COMPLETELY . . . ECONOMICALLY

GYROSCOPES FRACTIONAL HORSEPOWER MOTORS ULTRASONICS

announcing three new
RIDER 'PICTURED-TEXT' COURSES

BASICS OF GYROSCOPES ('Pictured-Text' Course)

by Carl Machover

This book is written primarily for the non-specialist: not for the gyro engineer, but for the student, technician, or engineer who comes in contact with the gyroscope in his studies or work. The text is primarily descriptive and mathematics are kept to a minimum. Only a basic knowledge of algebra and trigonometry is needed for an understanding of the material. The material upon which this book is based has been proven successful in teaching engineers, technicians and technical sales people at one of the nation's leading gyroscope firms. Every effort has been made to keep the book technically accurate, while simplifying all ex-

planation. Much of the material in this book, such as the sections on stable platforms, and error sources has never appeared before in book form. It is up-to-date and some of it has only recently been declassified.

CONTENTS: VOL. I—What a Gyro is . . . How it works . . . Vertical Gyro . . . Vertical Gyro Components . . . Directional Gyro. VOL. II—The Rate Gyro . . . The Integrating Gyro . . . Stable Platforms . . . Inertial Navigation . . . Difficulties of Gyro Construction . . . Other Gyro Applications.

#257, 2 vols., soft cover, \$6.60; #257H, cloth, \$7.75.

BASIC ULTRASONICS ('Pictured-Text' Course)

by Cyrus Glickstein

Your progress in electronics requires an understanding of ultrasonics—the new tool of industry. This book utilizing the famous Rider 'pictured-text' technique, makes the subject of ultrasonics completely understandable.

GENERAL THEORY—What is Ultrasonics?; Nature of Sound Waves; Why Ultrasonic Waves are Used; Table of Frequencies and Applications. **EQUIPMENT**—Basic Units of Ultrasonic Equipment; Types of Ultrasonic Generators;

Transistors in Ultrasonics; Pulsed Output; Ultrasonic Transducers; Curie Temperatures; Equivalent Transducer Circuit; Comparative Transducer Types and Characteristics; Associated Equipment.

APPLICATIONS—General Applications; Typical Echo-Ranging Applications, Basic Sonar Principles; Nondestructive Testing; Ultrasonic Cleaning, drilling Soldering, Welding.

#259, 1 Vol. soft cover \$3.50, #259H, Cloth, \$4.60

BASICS OF FRACTIONAL HORSEPOWER MOTORS AND REPAIR ('Pictured-Text' Course)

by Gerald Schweitzer

Do you want to know how to repair fractional horsepower motors? Fractional horsepower motors are used in—air conditioners, fans, refrigerators, washing machines, dishwashers, sewing machines, record changers and turntables, power mowers, power tools and hundreds of other prod-

ucts. You can learn the theory of fractional horsepower motors rapidly and easily from this 'pictured-text' course. You can readily apply this theory to servicing and maintenance as a money-making career, or to save on repair bills of home appliances. #236, \$3.90; #236H, \$4.90.

There are more than 200 Rider titles covering every area of electronics from basic electricity to space age electronics. At your electronic parts distributor, bookstore or write direct:

DEPT. EW-6

JOHN F. RIDER PUBLISHER, INC. 116 West 14th Street, New York 11, N. Y.
Canada: Chas. W. Pointon, Ltd., 66 Racine Rd., Rexdale, Ont.
Europe & British Isles: Chapman & Hall Ltd., 37 Essex St., London. India: Asia Publishing House, Bombay and other cities.

LEADER TEST INSTRUMENTS

Lag-55 Audio Generator Sine Square

new "LEADER" test instrument

A multi-purpose generator for measurements on audio equipment—amplifiers, speakers, networks. Three waveforms: sine, square and complex for all types of measurements including response, distortion, transient and I-M distortion checks. Full range is from 20 to 200,000 cps, output 5 volts with minimum amplitude variation throughout whole range.



OHMATSU ELECTRIC CO. LTD.

2596, 5-Chome, Kamimeguro, Meguro-Ku
Tokyo, Japan
Cable Address "OHMATSUELEC" TOKYO

NOW! A down-to-earth guide to MODERN TEST PROCEDURES

Alternate Test Methods • Cautions • Correct Instrument Usage • Readings • Connections and Control Settings • Test Techniques • Time-Saving Methods ... and all the rest!



Almost anyone can repair TVs, radios and other electronic equipment AFTER the trouble has been located. The trick is to know how to spot troubles in the first place—and that means knowing how to use instruments fast and accurately. Actually, it's amazing what you can do with only a few instruments—providing you know how to use different kinds for the same job; how to select the right ones; where to use them; how to connect them into circuits; how to set controls; how to read them; and how to follow professional test procedures every step of the way. And that's exactly what this new 316-page book with its more than 190 how-to-do-it pictures, procedure sketches and pattern designs teaches you.

IT'S WHAT YOU KNOW ABOUT USING INSTRUMENTS THAT COUNTS!

BASIC ELECTRONIC TEST PROCEDURES by Rufus Turner helps you learn to troubleshoot any circuit, equipment or component in half the usual time. Covers different methods of doing specific jobs. For instance, you learn to check distortion by the scope, rejection filter, harmonic-distortion meter, wave analyzer or audio oscillator methods. You learn to make resistance measurements with a current-meter, a volt-ammeter, a volt-meter, an ohmmeter, or via the bridge method . . . and so on.

Subjects include current checks; power, capacitance, inductance, resistance, AF, RF, phase, distortion, and modulation measurements; tube and semi-conductor testing; audio amplifier tests; sensitivity, RF gain, fidelity, AVC voltage, operating voltage checks, etc.; visual alignment techniques—even transmitter and industrial electronic measurement procedures. Price only \$6.50.

CONSIDER OSCILLOSCOPES for instance!

Simplified explanations of modern oscilloscope techniques show how to use your 'scope as a volt-meter, current meter, variable frequency oscillator, etc., or for making RF, phase or AM measurements; for distortion and deflection checking; square wave testing; visual AM and FM alignment and for many other jobs. Every detail is explained—from making connections to analyzing patterns.

INDUSTRIAL ELECTRONICS, too

STILL ANOTHER BIG FEATURE is the book's usefulness in acquainting you with industrial electronic test techniques — including testing non-electronic phenomena such as strain, pressure, etc.

PRACTICE 10 DAYS . . . FREE!

Dept. RN-60, RINEHART & CO., INC.
232 Madison Ave., New York 16, N. Y.

Send BASIC ELECTRONIC TEST PROCEDURES for 10-day FREE EXAMINATION. If I decide to keep book, I will then send you \$6.50 plus a few cents postage in full payment. If not, I will return book postpaid and owe you nothing. (SAVE! Send \$6.50 with your order and Rinehart pays the postage. Same 10-day guarantee with your money promptly refunded if you're not more than satisfied with book.)

NAME.....

ADDRESS.....

CITY, ZONE, STATE.....

OUTSIDE U.S.A.—Cash with order only. Price \$7.00. Money back if book is returned in 10 days.

Training Soviet Electronic Engineers

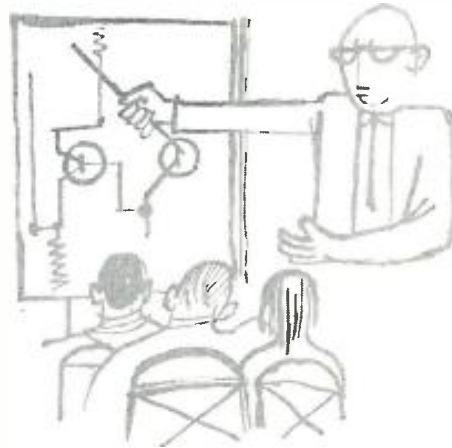

By **PROF. N. BOGORODITSKY**

V. I. Ulyanov (Lenin) Electrical Engineering Institute, Leningrad, U.S.S.R.

Here is an authoritative look at how the Soviets prepare their engineering students for careers in electronics.

EDITOR'S NOTE: There is an intense current interest in scientific and technical education in our own country as compared with current practice in the Soviet Union. We feel sure that our readers, familiar with our own educational system, will be interested in learning something about the Soviet technical educational system.

INDUSTRY demands a great deal from the young engineer embarking on a career in electronics. In the Soviet Union electronics is developing at an exceedingly high rate and it is penetrating into many spheres of science and technology. Its role is especially great in automation. Electronic apparatus is undergoing constant improvement and various recording devices, based on electronic, ionic, and semiconductor phenomena, are finding ever wider application.

Special attention in training young engineers is paid to developing in them the urge to blaze new trails at any job whatsoever and to be persistent in promoting the new and progressive in technology. This creative approach to technology and production is possible only if a person is not merely an engineer but is a well-educated man as well, capable of regarding technological processes from the viewpoint of theory and associating it with the laws of the exact sciences and, of course, economics. The young engineer must be a good experimenter and know the properties and manufacture of the materials used in his line.

The Soviet higher technical school, whose task it is to train engineers, takes into account all these requirements and develops them—especially in

those being trained for work in the field of electronics.

The term "electronics," as applied in the Soviet Union, embraces several spheres.

"Physical electronics" deals with the structure of matter, including molecular phenomena, radiation, and so on. "Chemical electronics" studies the interrelation and reactions of various elements and electromechanical processes. "Biological electronics," the youngest branch of the science, is concerned with the investigation of the electronic processes taking place in living tissues and cells. "Technical electronics" covers the infinite uses of electronic phenomena in technology. This branch is progressing with great rapidity.

The higher technical school trains engineers along two main lines. For work in industrial and radio electronics, experts must possess a thorough knowledge of the theory of electronic, ionic, and transistor instruments and be well versed in the principles of automation and tele-mechanics.

The other line is the training of designers in the field of technical electronics. Such future designers are trained in methods of designing and manufacturing electronic and ionic instruments of various types and the properties of semiconductors. They are also given tasks involving the design and improvement of experimental instruments and units.

College Programs

In order to enter college it is necessary to pass competitive examinations.

in the sets you **SELL...**

Are you satisfied with your mark-ups on transistor radios? Channel Master dealers work on large margins, even on price leaders. Are you selling the brand that does the big volume? Channel Master radio sales are in the top "Big 3". Are you building customer confidence? Channel Master's spectacular Free Replacement Warranty does just that—and it's the fastest sales-closer you've ever seen.

in the sets you **SERVICE...**

... today's fastest-growing favorite in replacement tubes comes in the red, white, and blue Channel Master carton. Each premium-quality tube meets Channel Master's new, higher standards for uniformity, long-life, and performance. Dealers are gladly breaking old habits and making Channel Master their new "first choice" in replacement tubes. That's why Channel Master tube sales are doubling every month, an unprecedented record of growth and acceptance.

Call your distributor today for full details.

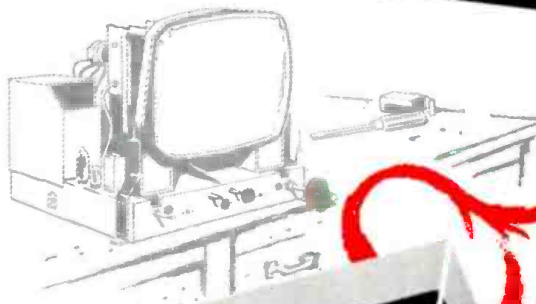
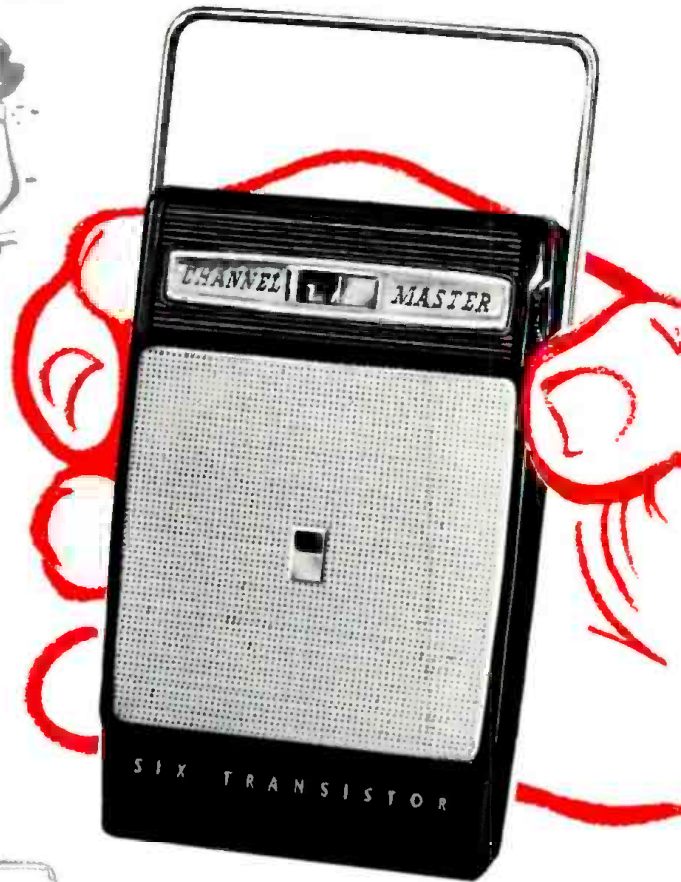

CHANNEL MASTER **QUALITY** **GIVES YOU THE EDGE!**

Copyright 1960 Channel Master Corp.

CHANNEL MASTER works wonders in Sight and Sound
ELLENVILLE, N.Y.

www.americanradiohistory.com

prepare for your career in

ELECTRICAL ENGINEERING ELECTRONICS COMPUTERS RADIO-TV

At MSOE, you can equip yourself for a career in many exciting, growing fields: **MISSILES
RADAR • AUTOMATION
RESEARCH • DEVELOPMENT
ELECTRICAL POWER
AVIONICS • ROCKETRY**

When you graduate from the Milwaukee School of Engineering, you are prepared for a dynamic career as an Electrical Engineer or Engineering Technician. Under a faculty of specialists, you gain a sound technical education in modern, completely equipped laboratories and classrooms. As a result, MSOE graduates are in great demand and highly accepted by industries nationally.

At MSOE you will meet men from all walks of life and all parts of the country — some fresh out of high school or prep school, others in their twenties — veterans and non-veterans.

You can start school in any one of four quarters and begin specializing immediately. Engineering technicians graduate in 2 years with an Associate in Applied Science degree. For a Bachelor of Science degree in Engineering, you attend 4 years. A 3-month preparatory course also is available.



All Soviet citizens who have graduated from high school or a secondary technical school have a right to take part in these competitive examinations. Among those who pass their examinations in Russian, physics, mathematics, and a foreign language, preference is given to those who have a working record. Those who wish can study to be an engineer at a night department, without giving up their jobs. There also exists a system of education by correspondence. The whole course, which includes lectures and practical training, is five and one-half years long.

During the first year students combine studies with full-time work in a related industry where they are engaged directly at the bench and must abide by all the rules and regulations of the given factory. This enables students who have never worked in industry to get a fairly good idea of how various parts are manufactured.

Also during the first year in college students attend lectures, laboratory work, and seminars in social sciences, general chemistry, physics, a foreign language, and mathematics four nights a week.

The subsequent years are devoted to the study of general educational, general technical, and special subjects. The syllabi and schedules are drawn up for the whole course of general educational, general technical, and special subjects with a detailed breakdown of lecture, laboratory, and seminar hours.

The programs are freed from excessive time-consuming detail, leaving more time for going into the basic laws of the given subject and for studying all developments in theory and practice. Great attention is paid to physics and mathematics, as well as to foreign languages—English as a rule.

To ensure a comprehensive general education, a considerable part of the curriculum is devoted to philosophical, social, and political studies. Independent studies, practical training at the bench, and the preparation of a graduation diploma thesis are important elements of the education course.

Industrial Training

The students have two weeks of industrial training during the eighth and ninth semesters and then a 30- to 40-week stretch during the tenth and eleventh semesters. During these training periods the students get acquainted with production sequences, automation systems, parameter-governing methods, necessary engineering calculations, and the methods of designing new units.

During the industrial training period the students select the topics for their graduate theses which are discussed with representatives of the institutes' departments and industrial enterprises. The graduation theses topics usually deal with the elaboration of electronic techniques in radio engineering, automation, tele-mechanics, and other branches or with the design and manufacture of transistor instruments. Often the experimental data

and theoretical conclusions of a graduation thesis prove to be of considerable value to industry. The students present their theses to a state examination commission which meets either at the institute or at the factory or designing office concerned. If the thesis is passed by the commission, the student is graduated with the title of engineer in his chosen field.

Students who have submitted graduation theses on topics suggested by a factory usually receive jobs with that enterprise after graduation.

Besides their course of practical training, many students are members of students' research societies which are organized at all institutes. In their free time the society members engage in experimental and theoretical research in specific scientific or technological problems of electronics. The results of the work are discussed at meetings of the society.

Students displaying the greatest abilities, besides being members of their scientific societies, take part in the research work conducted by institute departments.

All stages of education are open to every Soviet citizen. Instruction both at school and college or university is free of charge. Students of higher education establishments receive state scholarships during the whole period of their studies. Students showing the best progress receive an additional 25 per-cent to their stipend.

Post-Graduate Studies

After two years of work in industry the young engineer can resume post-graduate studies after passing a competitive examination in his field, at a college or university with the object of preparing for research and educational work. During his three-year post-graduate course (at which time he receives a monthly state scholarship of 1000 rubles—approximately \$250 at the "official rate" of 4:1 and \$100 at the "tourist rate" of 10:1), he gets acquainted in detail with the latest achievements in science and technology, studies further philosophical, physio-mathematical, and engineering subjects and carries out research work on a topic selected by himself or recommended by his professor. This latter work is the topic of a dissertation which must represent a treatise of scientific value, elaborating and solving a specific problem in electronics. After receiving the approval of the professor under whom the student has worked, the dissertation is reported by the author at a meeting of the pertinent college department.

This dissertation is then reviewed by professors in various fields and representatives of industry and is presented to the learned council of the institute at a special open hearing at which the student defends the propositions set forth by him in his treatise. A secret ballot is then cast by members of the learned council for awarding the title of Master of Science (Technology).

—50—

FREE CAREER BOOKLET!

If you're interested in any phase of electronics, radio or television, be sure to look into the programs of study offered by the Milwaukee School of Engineering. Just mail the coupon.



MILWAUKEE SCHOOL OF ENGINEERING

Dept. EW-660, 1025 N. Milwaukee St. Milwaukee, Wisconsin

Please send FREE Career Booklet. I'm interested in Electrical Engineering;

- Electronics Computers
- Electrical Power Radio-TV
- Mechanical Engineering

PLEASE PRINT

Name _____ Age _____

Address _____

City _____ Zone _____ State _____

I'm eligible for veterans education benefits. MS-123

Measuring Tape Speed

(Continued from page 39)

which don't have synchronous motors. errors up to 1% can be tolerated. Moderate quality home machines may have errors as high as 2%, while speed errors in excess of 2% represent poor performance.

Table 1 summarizes the speed errors that can be expected from various grades of tape machines and shows the bars per minute for each of the listed speed errors.

You may be wondering why a given bar count denotes a given speed error irrespective of tape speed (15 ips, 7.5 ips, 3.75 ips, etc.). The answer calls for an understanding of how the strobe works. A 60-cycle light source flashes 120 times per second, namely 60 times on positive peaks and 60 times on the negative peaks. Thus it flashes 7200 times per minute. For each tape speed, the number of bars on the strobe wheel are such that 7200 bars per minute will pass by a given point when the circumference of the wheel moves at the correct tape speed. If this number of moving bars is illuminated by an equal number of light flashes, the bars appear to stand still.

However, if the tape and therefore the wheel do not move at correct speed, the number of bars and the number of flashes are unequal, producing the illusion of bars in motion: the direction of these bars depends on whether the speed is fast or slow. If the speed error is 1%, then 1% of 7200 bars, namely 72 bars, appear to pass a given point per minute.

The strobe wheel has a separate ring of bars for each tape speed. The number of bars per inch of circumference of the wheel is different for each speed. To illustrate, consider the strobe pattern for 7.5 ips, which equals 450 inches per minute. Since 7200 bars must move past a fixed point per 450 inches of tape, the number of bars per inch of circumference is 7200/450 or 16. Similar calculations show that at 3.75 ips the ring on the strobe wheel contains 32 bars per inch of circumference; at 15 ips, 8 bars per inch of circumference.

30

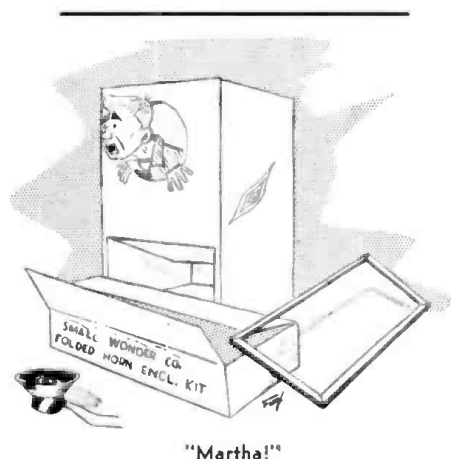

 <p>1 Model T-61 New "Speed Check" Tube Tester Kit</p> <p>Kit Net Price \$49.95 Factory-wired Net Price .. \$69.95</p>	 <p>2 Model C-25 New "In Circuit" Capacitor Tester Kit</p> <p>Kit Net Price \$19.95 Factory-wired Net Price .. \$29.95</p>	 <p>3 Model T-5 New Rapid Filament Tester Kit</p> <p>Kit Net Price \$4.50 Factory-wired Net Price ... \$6.50</p>
---	--	---

...and now **PRECISION**
adds **10** more
value-packed kits
to the **PACO** Line

 <p>5 Model CD-3 New Decade Condenser Kit</p> <p>Kit Net Price \$19.95 Factory-wired Net Price .. \$24.95</p>	 <p>6 Model SR-2 New Resistance Substitution Box Kit</p> <p>Kit Net Price \$8.95 Factory-wired Net Price ... \$11.95</p>	 <p>7 Model RD-5 New Decade Resistor/Divider Kit</p> <p>Kit Net Price \$23.95 Factory-wired Net Price ... \$29.95</p>
 <p>8 Model ST-45 New AM-FM Stereo Tuner Kit</p> <p>Kit Net Price \$84.95 Semi-kit Net Price \$99.95 Factory-wired Net Price .. \$134.95</p>	 <p>9 Model ST-35 New FM Tuner Kit</p> <p>Kit Net Price \$59.95 Semi-kit Net Price \$69.95 Factory-wired Net Price ... \$89.95</p>	 <p>10 Model L2-U New Wide-Range Two-Way Speaker System Semi-Kit</p> <p>Semi-kit, unfinished Net Price \$59.95 Semi-kit, walnut finish Net Price \$69.95</p>



PACO Test Equipment and Hi Fi Kits are produced under the auspices of **PRECISION Apparatus Company, Inc.**, world-famous manufacturer of industrial electronic test instruments and stereo hi-fi components for over a quarter of a century. Write to Dept. P for new complete 1960 PACO Catalog, just off the press. You'll keep it for permanent reference.

PACO ELECTRONICS CO., INC.
70-31 84th STREET, GLENDALE 27, L. I., N. Y.
Kit Division of **PRECISION Apparatus Co., Inc.**

SEE THESE KITS
ON DISPLAY
AT ANY LEADING
ELECTRONIC PARTS
DISTRIBUTOR

free **GIANT** **NEW**

Most complete electronics buying guide in America! Over 100,000 items—stereo, hi-fi, tapes, ham radio at low money-saving prices! 15-day no-risk home trial on any item!

8-TRANSISTOR PORTABLE RADIO

with battery **\$29.95**

Outperforms all portables under \$100! It's a radio, a speaker, a P.A. amplifier. 6½ x 3-9/16 x 1¾". Typical Radio Shack value!

RADIO SHACK CORP.



ELECTRONICS CATALOG
plus every new issue for full year

See the latest and best electronics equipment in Radio Shack's big 312-page book! Mail coupon! Receive your FREE copy plus a FREE subscription to all new issues for a year!

MAIL COUPON NOW

Radio Shack Corp., 730 Commonwealth Ave.
Boston 17, Mass. Dept. 60F6

Send FREE Electronics Catalog—Also every new issue for 12 months, a full year's subscription free.

Name _____
Address _____
Postoffice or City _____ Zone _____ State _____

Special Offer 25¢

Hear these
authentic recordings
of dramatic events
from



"The Amazing World of Short Wave Listening"

narrated by Alex Dreier, Radio-TV "Man on the Go"

- President's voice from outer space!
- Actual capture of a desperate criminal!
- Radio amateur at Little America!
- Ships at sea . . . aircraft in action!



SX-110
receiver
\$159.95

Standard broadcast plus short wave coverage from 1550 kc. to 34 mc. Cal. electrical bandspread.

MAIL
COUPON
TODAY!

hallicrafters

DEPT. 20, CHICAGO 11, ILL.

Gentlemen: Please rush by return mail my recording, "The Amazing World of Short Wave Listening." I enclose 25¢.

NAME _____

ADDRESS _____

CITY _____ STATE _____

CUT HOLES

IN 1-1/2
MINUTES

(OR LESS)

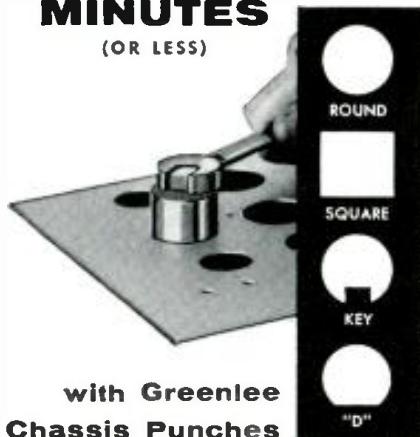

with Greenlee
Chassis Punches

Many sizes . . . quickly make smooth, accurate holes in metal, hard rubber, or plastics . . . for sockets, plugs, controls, meters, panel lights, etc. Easy to use, simply turn with wrench. Write for literature.



GREENLEE TOOL CO.
1782 Columbia Avenue
Rockford, Illinois



CERTIFIED RECORD REVUE

By
BERT WHYTE

I DON'T know how it happened but here it is June already! I should have realized we were getting near the good old summertime as the tempo of record releases has begun to slacken. Summer record releases are not the poor scrawny things they used to be years ago, but they are not "fat cats" either. So reviews will decrease for a while, but boy, oh boy, wait until you see what hits you in the fall!

I've had advance peeks at many companies' release lists and the sheer physical size is staggering, let alone the luscious selection of goodies that will be available for your aural delectation. As you might expect, the stereo disc is fully in command now, but there are still enough good monaural items being released to satisfy those who haven't gone through their metamorphosis yet.

Here is a passing thought directed at those of you who may use summer holiday time to make the change to stereo . . . the place not to skimp or economize is the stereo cartridge. Get the most expert advice you can on this subject and augment this by making comparisons at a reliable components dealer. And if you can possibly do so, abandon the use of a changer and switch to a good turntable. Given a first quality cartridge, arm, and turntable set-up this will aid the over-all sound quality more than any of the other items in the chain of reproduction.

Another thing . . . given a choice between a 100-dollar speaker and a 50-dollar speaker of differing manufacture as opposed to two 50-dollar speakers of similar manufacture, I would choose the two 50-dollar speakers every time. Stereo can be achieved with disparate speakers, but it is so much easier to gain the proper balance and phasing, etc. with as nearly identical speakers as you can obtain. Above all, don't fall for the propaganda that small speakers are entirely adequate for stereo. Sure there are many small units which do a remarkable job, even to admitting that the job they do is all out of proportion to their size. But if you are fortunate enough to have the means and the room and an indulgent missus, buy yourself a pair of monsters and enjoy yourself.

STRAVINSKY

THE FIREBIRD (Complete Ballet)
London Symphony Orchestra conducted by Antal Dorati. Mercury Stereo SR-90226. Price \$5.98.

A major triumph on all counts is this second complete "Firebird" to appear on stereo disc. Dorati has always had an affinity for this work and his performance here shows that he is one of the top interpreters. He is as lyrical as Ansermet when the score demands it, his sense of rhythm is as secure as any, and in the more dynamic sections he makes of it a more exciting experience.

In general this is a bit faster paced than the Ansermet reading, and when he gets to

"Kastchei" and the "Infernal Dance," he becomes positively frenetic. The London players respond magnificently to Dorati's urgings and we must give a special nod to the sensational woodwind playing.

The sound is just wonderful . . . a superb amalgam of crisp instrumental detail with beautifully rounded reverb. Outstanding presence is the result. The directionality was easily discernible but not overdone, the ghost middle channel was well filled, and depth effects were particularly well realized. Frequency and dynamic range are impressively wide.

And once again in refutation to those who say that you can't engrave really low bass frequencies on a stereo disc, please listen to the "Infernal Dance." The huge tympani and bass drum shots will hit you like a physical force. For Stravinskyites and audio nuts alike . . . an outstanding buy not to be missed!

KABELEVSKY THE COMEDIANS (Suite) KHACHATURIAN SUITE FROM GAYNE

Vienna State Opera Orchestra conducted by Vladimir Golschmann. Vanguard Stereo SRV113SD. Special demo price, \$2.98.

This is very likely to be the most popular of Vanguard's fine series of low-cost demonstration discs. "The Comedians" may be considered trite fare by some but few can deny that it has a lot of popular appeal in its colorful scoring. The "Gallop" is the best known section, appearing on pop concert programs without number. Golschmann seems to be in his element with this work. He is very facile, with a fine sense of the rhythmic demands and at the same time can be properly lyrical when needed. He does an equally fine job with the "Gayne" suite except for an inexplicably slow pacing of certain sections, most notably the "Leszinka." Needless to say, the famous "Sabre Dance" gets its due and it generates plenty of excitement.

The sound throughout is first rate. Recorded moderately close but with nice reverb to liven it and lend depth. The stereo directivity is well shown and instrumental separation is excellent. The strings are exceptional in their smoothness and the brass was nice and bright. Good percussion in general with my only quibble that I would have preferred a shade more weight and brightness on the snares. As with most of this series, you can't go wrong for the money.

HANDEL

THE WATER MUSIC (Complete)
Philomusica of London conducted by Thurston Dart. London Stereo SOL-60010. Price \$4.98.

This disc is a real sleeper! No big names or such, but what wonderful music making. This is supposed to be the "Water Music" as close

NEW

LAFAYETTE HE-15 CITIZENS BAND 11 METER 2-WAY SUPERHETERODYNE TRANSCEIVER

MADE IN U.S.A.



**COMPLETELY WIRED
NOT A KIT!**

64.50

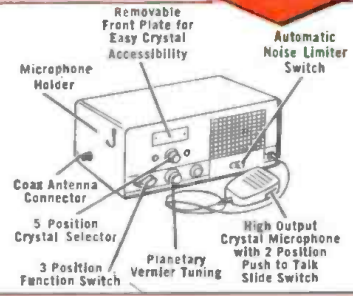

ONLY 5.00 DOWN

Not Superregenerative but SUPERHET!

The Lafayette HE-15 meets all FCC requirements and operates in much the same manner as police and other short wave communications systems. The Transceiver features 5 crystal controlled transmitting channels operating at a maximum legal power input of 5 watts fully modulated. RF stage in both transmitter and receiver. Any one of 5 transmitting frequencies may be instantly selected by the 5 position crystal selector on the front panel. These 5 crystals are readily accessible by means of a removable front plate and this may be easily interchanged with any 5 crystals of the remaining 22 allocated citizens band frequencies.

The Superheterodyne receiver is tuneable over the full 22 channel band with 3 watts audio output. Controls include a 3 position function switch (transmit, receive, and transmit with spring return), planetary vernier tuning plus squelch noise limiter control switch. All coils are ferrite tuned. Output impedance matches 52 and 72 ohm antenna with Amphenol type coax connector for operating into dipole, ground plane or rod antenna. Has large 4" PM speaker; input jack for crystal or ceramic microphone; power receptacle in rear for AC line and 6 or 12 volt external power supply. Transceiver is supplied with single transmitting crystal for channel 9. Complete high output with crystal microphone, and brackets for easy mounting of unit in auto, boat, etc. Operated on 115 volts AC. Addition of 6 or 12 volt power supply (separately supplied) adapts transceiver for mobile operation. Size 5 1/2" H x 6 3/8" D. Shpg wt., 11 lbs.

HE-15 Factory Wired and Tested (Less antenna).....	5.00 Down.....	Net 64.50
HE-19 Whip Antenna.....		Net 3.95
HE-16 Power Supply For 12 Volts.....		Net 11.95
HE-18 Power Supply For 6 Volts.....		Net 11.95



- 5 CRYSTAL CONTROLLED TRANSMITTING POSITIONS
- SUPERHETERODYNE TUNEABLE RECEIVER OVER FULL 22 CHANNEL BAND
- 4 DUAL FUNCTION TUBES, PLUS 2 SINGLE FUNCTION TUBES, PLUS 2 RECTIFIERS FOR 12 TUBE PERFORMANCE
- PLANETARY VERNIER TUNING
- COMPLETE WITH TRANSMITTING CRYSTAL FOR 27.065MC
- MEETS ALL FCC REGULATIONS
- REMOVABLE FRONT PLATE FOR EASY ACCESSIBILITY OF CRYSTALS
- UNEXCELLED RECEPTION ON LAND AND SEA... COMPARES WITH UNITS COSTING 3 TIMES AS MUCH

NEW! LAFAYETTE TELESCOPIC CITIZENS BAND WHIP ANTENNA

- Chrome Plated
- Telescopes From 16 1/2" to 40"
- Mounts Vertically or Right Angle

3.95

An outstanding antenna value. This high quality three section telescoping antenna is designed for attachment directly to your citizens band transceiver. Ideal for point to point service over short distances. Molded base loading coil has a threaded stud with a PL-259 plug—connector for vertical or right angle mounting. Shpg. wt.; 1 lb. HE-19..... Net 3.95



NEW! LAFAYETTE RADIO FIELD INDICATOR

A Must For Ham & Citizens Band Operators

- Provides a Continuous Indication of Transmitter Output • Rugged 200 ua Meter Movement • Completely Portable — Requires no Electricity, Batteries or Transmitter Connection.

7.95

With this rugged, new radio field indicator you can check performance of your marine, mobile or fixed transmitter... actually measures the RF field generated by any transmitter between 100KC and 250MC regardless of power. Features a 200 ua meter movement with a variable sensitivity control. Phone jack at rear of indicator accepts earphones thus providing an aural check of transmitter output. Antenna extends from 3 1/4" to 10 3/4". Powerful magnet on bottom plate allows easy mounting on car dashboard or metal surfaces. Use anywhere... requires no electricity or batteries. Dimensions: (less antenna) 3 1/8" W x 2 1/4" H x 2" D. TM-14..... Net 7.95



NEW! LAFAYETTE "Tiny"

6 Transistor Radio
SENSATIONAL PERFORMANCE
In a Small Package!

19.95

- 6 Transistor Plus a Germanium Diode
- Superheterodyne Circuit • Vest Pocket Size
- Built In Earphone Jack For Privette Listening
- Trouble-Free Printed Circuit

Engineered and constructed with the jewel like precision of a fine watch... true superhet circuit with push-pull audio output powers either the built-in dynamic speaker or the personal-type earphone. Extremely sensitive... built-in ferrite — rod antenna brings in distant stations like locals. Employs standard 9 volt battery for economical service. Housed in smart black and gold rugged plastic case. Measures only 4" x 2 1/2" x 1 1/4" and weighs a mere 10 ounces. Complete with battery, carrying case and earphone. Shpg. wt., 2 lbs. FS-206 "Tiny" 6-Transistor Radio... Net 19.95



PLEASE RUSH ITEMS CHECKED!

- HE-15 CITIZENS BAND TRANSCEIVER
- TM-14 RADIO FIELD INDICATOR
- FS-206 "TINY" 6 TRANSISTOR RADIO
- HE-19 WHIP ANTENNA
- FREE 308 PAGE CATALOG 600

Enclosed Find \$.....(Please include postage to cover shipping)

FREE 308 Giant Size Pages!



Name.....

Address.....

City.....Zone.....State.....

Everything in Hi-Fi and Electronics

LAFAYETTE RADIO,

P. O. BOX 222, JAMAICA 33, N.Y. Dept.

RF-6

FREQUENCY METER

Vibrating REED type. Round 3 1/2" Bake-lite case. Range 57 to 63 cy. @ 110V. Ea. **\$9.95**

BRAND NEW CARTER DYNAMOTOR
INPUT 5.9 VOLTS, OUTPUT 405 V. @ 270 MA. SMALL SIZE. Ea. **\$4.95**

DC AMMETER
TWO INCH 0-10 Amperes
RUGGEDIZED 5 for \$10.00 Ea. **\$2.25**

COAX CABLE
RG2U-52 Ohm Impedance—Fresh Stock—500 feet on sealed wooden spools **\$32.50**
Each
Smaller quantities 7 1/2¢ per ft. Minimum order 25 ft.

NEW VACUUM CAPACITORS

EIMAC VC 12 MMF-32KV Ea. **\$6.95**
EIMAC VC 25 MMF-32KV Ea. **7.95**
EIMAC VC 50 MMF-32KV Ea. **8.95**
JENNINGS JHC-150 MMF-SOKV Ea. **39.95**
JENNINGS 100 MMF-20KV Ea. **12.95**

POWER TRANSFORMER

Primary 110V. 60 cy., Sec 445-0-445V. @ 150 Ma, 25V. @ .4 Amps. 6.3V. @ 6 Amps. 2 1/2 V. 10 Amps. 10,000 V. Insulation. **\$4.95**
Ea. @ 2 Amps. Fully shielded. **\$5.95**
Write for quantity prices

FILAMENT TRANSFORMERS

Primary 110 volts 60 cycle. Secondary **\$3.95**
2 1/2 V. 10 Amps. 10,000 V. Insulation. **\$3.95**
Primary 110V. Sec. 6.3V. @ **\$8.95**
60 Amps Ea.

CHOKE—FULLY CASED

5 HENRY @ 200 Ma **1.95**
5 HENRY @ 250 Ma **2.25**
4 HENRY 400 Mil **3.95**
12 HENRY 500 Mil **8.95**
4 HENRY 900 Mil **12.95**
6 HENRY 600 Mil **8.95**

BRAND NEW OIL CONDENSERS

3 MFD 600 VDC .60	6 MFD 2000 VDC 4.95
4 MFD 600 VDC .75	8 MFD 2000 VDC 5.95
5 MFD 600 VDC .85	8 MFD 3000 VDC 6.95
6 MFD 600 VDC .85	1 MFD 3000 VDC 1.85
8 MFD 600 VDC .95	2 MFD 3000 VDC 3.50
10 MFD 600 VDC 1.19	1 MFD 4000 VDC 3.25
12 MFD 600 VDC 1.50	2 MFD 4000 VDC 6.25
15 MFD 600 VDC 1.70	3 MFD 4000 VDC 8.95
3x3 (24 RAD) 2.80	15 MFD 5000 VDC 39.50
1 MFD 1000 VDC .60	5 MFD 7500 VDC 2.95
2 MFD 1000 VDC .85	1 MFD 7500 VDC 1.95
4 MFD 1000 VDC 1.35	2 MFD 7500 VDC 4.95
8 MFD 1000 VDC 1.95	2 MFD 10,000 VDC 29.95
10 MFD 1000 VDC 2.80	1 MFD 12,500 VDC 19.95
12 MFD 1000 VDC 2.95	1 MFD 12,500 VDC 34.50
15 MFD 1000 VDC 3.50	1 MFD 15,000 VDC 42.50
1 MFD 1200 VDC .45	5 MFD 25,000 VDC 34.95
1 MFD 1500 VDC .75	1 MFD 25,000 VDC 89.95
2 MFD 1500 VDC 1.10	50 MFD 125VAC 2.50
4 MFD 1500 VDC 1.98	10 MFD 330 AC 1.95
8 MFD 1500 VDC 2.95	20 MFD 330 AC 2.95
1 MFD 2000 VDC .85	50 MFD 330 AC 4.50
2 MFD 2000 VDC 1.50	8 MFD 660 AC 2.95
4 MFD 2000 VDC 3.50	2 MFD 600 VDC .50

SIGMA 5F RELAY

16,000 ohm in dual 8,000 ohm coils. SPDT adjustable silver contacts and armature tension. Operates on 500 Microamperes or less Ea. **\$3.95**
Write for quantity prices

RELAYS

GUARDIAN 110V AC, 2 Pole Single Throw (1 N.O. & 1 N.C.) Repl. BC-610 **\$2.50**
24v. AC 4PDT **\$1.85**
ALLIED 110V. AC 4PDT Ea. **\$2.75**
Potter-Brumfield 5M5LS 5000 ohm, 4 Ma. Sens. Ea. **\$2.25**
Allied Relay 110 V. AC. DPST Ea. **\$1.35**
Hermetically Sealed Relay Coil 110V AC 60 cy SPDT Contacts 5 Amps. Ea. **\$1.50**
6 Volt DC DPDT H.S. Ea. **99c**
12 Volt DPDT DC Relay Ea. **\$1.35**
SIGMA type 22RJC 6,000 ohm Ea. **\$2.49**
SPDT, small sealed relay Ea. **\$1.95**
Sealed Relay. SPDT, 6,000 ohm coil Ea. **\$1.10**
G.E. Relay control box contains 6000 ohm relay, sensitivity 2 mls. 10 for \$9.25. Ea. **\$1.10**
LEACH ANT. RELAY 110V. AC Ea. **\$2.95**
DPDT Ceramic Ins. Ea. **\$2.95**

PANEL METERS

STANDARD BRANDS
1 1/2" METERS
0-1 Mil 2.95
0-100 Micro 3.95
2" METERS
0-50 Micro (0-5 scale) 4.95
0-10 Amps DC 2.95
0-20 Volts DC 2.95
3" METERS
100-0-100 Micro Ampos DC 3.95
0-150 Mil DC 3.95
0-12 Volts AC 3.95
0-15 Volts AC 3.95

MISCELLANEOUS SPECIALS

JOHNSON Variable Cond. 250D35 (250MMF 350V) **\$2.50**
CARDWELL Var. Cond. 1000MMF 1700V **\$2.50**
SPERTI Vacuum Switch used in ART13 Ea. **\$1.50**
36 OHM 50 Watt Globar Non-Ind. Res. Ea. **\$1.00**
3-12 MMF Erie Ceramic Trimmers **21c**
NE51 NEON BULBS **\$1.00**
Box of 10
MAGNETIC PICK-UP TOOL gets Nuts, Bolts, Tacks, etc. out of difficult places. **79c**
Each
CUTLER-HAMMER TOGGLE SWITCH **29c**
SPDT (ST42D) 4 for \$1.00. Ea. **29c**
WILLARD STORAGE CELL—2V. 26 Amp hrs. Clear plastic case. Shipped dry. Ea. **\$2.50**
Write for quantity prices on all special items

All merchandise sold on a 10 day money back guarantee Min. Order \$3.00—25% with Order—F.O.B. New York

PEAK

ELECTRONICS COMPANY
66 W. Broadway, New York 7, N. Y., WO-2-2370

as possible to what George the First heard as he floated down the Thames. The performance is outstanding with the slow sections having a lovely grace and the faster ones a sense of bouyant excitement. The players here are all top people with a special tip of the hat to the terrific brass section.

The music was recorded at a very high level and thus when adjusting balance the surfaces become quite noiseless. The sound in general is superb, with exceptional brilliance in all sections and brass that positively coruscates! The frequency and dynamic range is very wide and all is nice and clean. Good stereo effects heightened by the antiphonal scoring. If you like the "Water Music," don't fail to hear this version.

WAGNER

TRISTAN UND ISOLDE (Excerpts)
Birgit Nilsson, soprano; Grace Hoffman, contralto with Vienna Philharmonic Orchestra conducted by Hans Knappertsbusch. London Stereo OS25138. Price **\$5.98.**

Birgit Nilsson is, of course, the brightest new Wagnerian star in the operatic firmament. Her rise has been meteoric and deservedly so, as evidenced by this recording. Hailed as the "new" Flagstad, she seems quite worthy of such comparison. Here is the same soaring sense of ease in the tremendously difficult high registers of the "Liebestod" and the bell-like clarity. Here is rigid dynamic control and effortless expression and expert phrasing, all imbued with the high drama of the piece.

In Act 1, Scene 3 "Isolde's Narrative and Curse," she is aided most competently by contralto Grace Hoffman. Hans Knappertsbusch is an old Wagnerian hand and he is in fine rapport with the artist.

The one disappointment here is the sound of the record. Not that it isn't fine stereo and as clean as most London recordings, but I think it suffers from London's new attempt at ultra-wide range in dynamics. The *pianissimo* sections are miraculous if your system is quiet enough to appreciate them, but even in the climactic parts, there isn't enough of the voice as the whole production is shifted dynamically down in scale. Thus Miss Nilsson's voice is almost obscured at moments and is never really allowed to blossom as it should. I personally wish London would return to its highly successful older method of recording.

SHOSTAKOVICH

CONCERTO FOR CELLO IN E FLAT (Op. 107)

SYMPHONY #1 IN F
Mstislav Rostropovitch, cellist with Philadelphia Orchestra conducted by Eugene Ormandy. Columbia Mono ML-5452. Price **\$4.98.**

New works by Shostakovich are always eagerly welcomed and while, in some instances, the music has not lived up to expectations, in this case the results were happy. The cello concerto is not an immediately ingratiating work, but as it progresses appreciation grows swiftly. The opening is an *allegretto* in which the cello has a very repetitious figure which is taken up by the horns and forms a rather unusual instrumental combination. Later, the work becomes more expositional and not nearly as bleak as the opening. Still further on is very clever use of horn solo, and a little later some obviously Russian folk elements begin to creep in. The cadenza is extremely brilliant and shows the great virtuosity of this cellist. A second hearing of this score is suggested before forming any hard and fast opinions.

The composer was present when the recording was made so presumably Ormandy's accompaniment is to taste. The Shostakovich "First" remains one of his best works and Ormandy affords this a good reading—a bit

slow paced and rather tame, compared to Stokowski's version.

TCHAIKOVSKY

SLEEPING BEAUTY (Complete Ballet)

L'Orchestre de la Suisse Romande conducted by Ernest Ansermet. London Stereo CSA2304. Price **\$17.94.**

Run, do not walk to the nearest record store for this one! This is one of the truly outstanding stereo discs on the market in every respect. Ansermet's performance is faultless . . . his pacing is just right, his dynamics and phrasing ultra expressive. His sense of rhythm is unerring, his lyrical outpourings a joy to the ear. The Suisse Romande play with tremendous verve and polish.

And as for sound it is safe to predict wide usage of this recording as a demonstration special. This is in the best London tradition . . . a great huge sound, superbly detailed yet smooth and round from the judiciously chosen acoustic perspective.

All the stereo attributes are in evidence . . . good directionality, fine center fill, proper depth perspective, sharp instrumental definition. It is odd, but with a really outstanding recording, you are aware you are listening to something special from the very first bars and rarely are you disappointed with the rest of the recording. So it was with this superb set and I am sure you will feel the same.

BEETHOVEN

PIANO CONCERTO #3

Glenn Gould, pianist with Columbia Symphony Orchestra conducted by Leonard Bernstein. Columbia Mono ML5418. Price **\$4.98.**

Very frankly, I've always felt that Glenn Gould was more showman than performer and that his off stage eccentricities were all "part of the act."

Now hearing this Beethoven concerto, I'd listen to this young man playing if he had a chimpanzee on each shoulder. For oddball or not this man has fabulous talent. What impressed me most was his tremendous technical facility coupled with an uncanny ability to project great warmth and vitality in his reading.

The very opening section of the piano, he immediately communicates to you that this is going to be an exceptional performance. His touch is so clean and fingering so precise, that it almost sounds like a different work. He takes the work at a faster pace than most and in this I think he is abetted by friend Bernstein. At any rate, good rapport between them and, in general, Bernstein very sympathetic.

Good sound throughout, very clean and bright, recorded fairly close but with contours softened by spacious acoustics. This must rank at the very top of recordings of choice of this work.

CAN-CAN

Original Soundtrack with Frank Sinatra, Shirley MacLaine, Maurice Chevalier, Louis Jourdan. Capitol Mono W1301. Price **\$4.98.**

It is not often that I review a motion picture sound-track album, but seeing as how we're getting into the silly season and because of the general excellence I thought you might be interested in this. It would be hard to miss the mark with the ole gasser Sinatra, and female member of his "Hollywood Rebels," Shirley MacLaine. They do a number of cute songs together, and then Frankie turns on the Voice with items like "C'est Magnifique." Add then that irrepressible team of "Gigi," Chevalier and Jourdan, and the atmosphere begins to sizzle. Wrap up the whole production with Cole Porter songs and you have a sure winner.

I'll see if I can scare up some more hot weather specials for next month.

CONVERT YOUR CAR RADIO FOR SHORT WAVE RECEPTION WITH ...

MOBILETTE

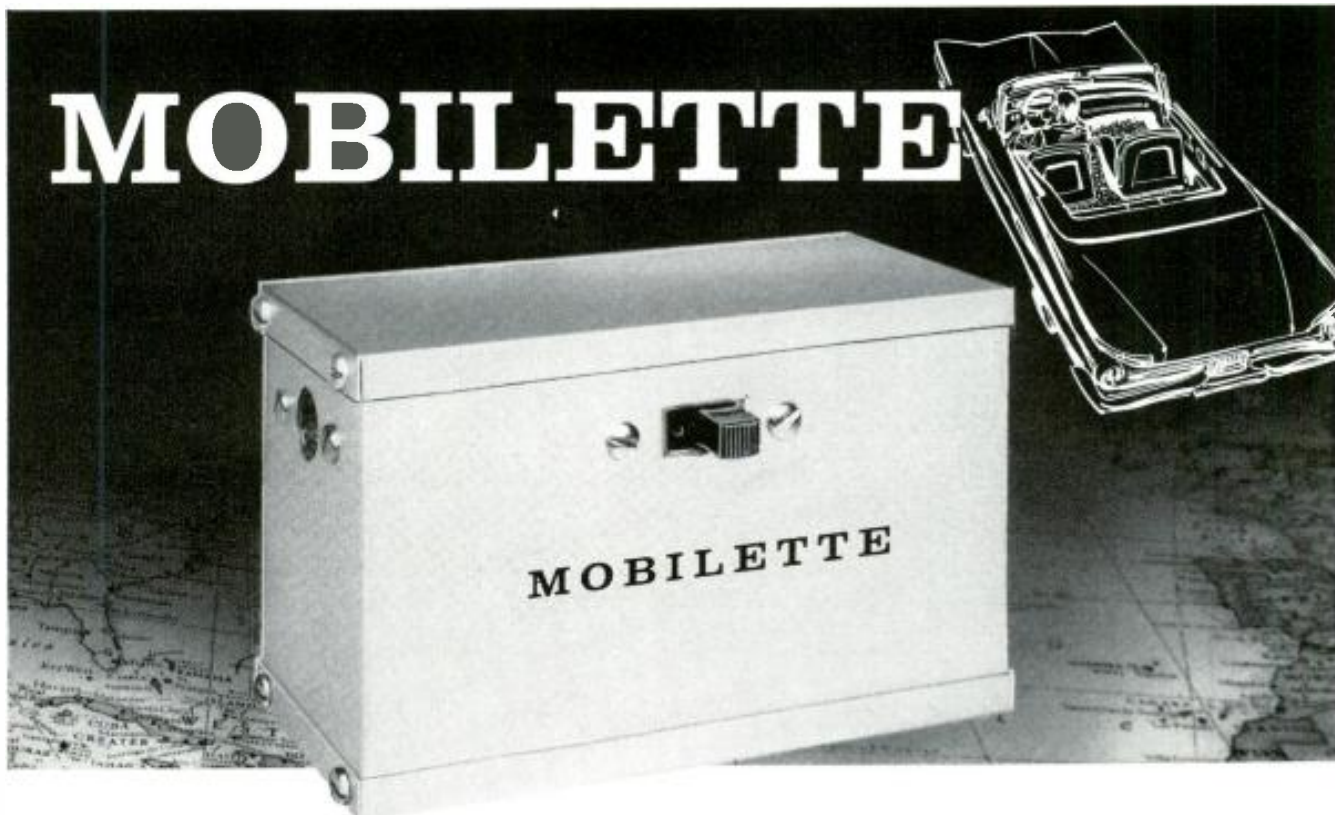

INTERNATIONAL'S ALL TRANSISTOR, CRYSTAL CONTROLLED CONVERTER

Now, in a matter of minutes, your standard broadcast car radio becomes a short wave receiver . . . bringing in stations from coast-to-coast as well as the four corners of the globe.

Designed by International for AMATEURS, CITIZEN LICENSEES, SHORT WAVE LISTENERS, HOBBYIST.

Available in SEVEN frequency ranges covering the Amateur bands, 75 through 10 meters, the Citizens band, and WWV National Bureau of Standards Time Broadcasts.

Three simple steps to install. (1) Remove antenna lead from car radio and plug into input of Mobilette. (2) Plug jumper wire from Mobilette into antenna connection of car radio. (3) Plug power connector into cigarette lighter socket. It's that easy!

Works on either 6 or 12 volts without change. Miniature size.

International Mobilettes cover these short wave bands.

Catalog No.	Frequency
630 — 105	75 meters (Amateur)
630 — 104	40 meters (Amateur)
630 — 106	10 MC (WWV Time Broadcasts)
630 — 103	20 meters (Amateur)
630 — 102	15 meters (Amateur)
630 — 101	11 meters (Citizens)
630 — 100	10 meters (Amateur)
	28.5 — 29.5 MC

Available soon for 6 and 2 meters at slightly higher price.



Complete, ready to plug in and operate . . . only **\$19.95**

Order direct from International. Terms F. O. B. Okla. City. Include postage. Shipping Weight 2 lbs.



18 NORTH LEE — OKLA. CITY, OKLA.

INTERNATIONAL CRYSTAL MFG. CO., INC., 18 NO. LEE
OKLAHOMA CITY, OKLAHOMA

GENTLEMEN: PLEASE SHIP THE FOLLOWING MOBILETTES @ \$19.95 EACH.

CATALOG NO.	FREQ.	QUANTITY
_____	_____	_____

SHIP TO — NAME _____
AMOUNT ENCLOSED _____ ADDRESS _____

INCLUDE POSTAGE WITH ORDER.

A... Always
B... Buy
C... Columbia

CITIZENS' BAND SPECIALS

- BC-620 TRANSCIVER: 20-27 Mc. With spare tubes. Govt. reconditioned as new. Only \$14.95
- BC-683 RECEIVER: 27.3 Mc. Excellent cond. 22.50
- 12 V. DYNAMOTOR: for above BC-603 3.95
- 115 VAC POWER PACK: A Columbia Special. 9.95
- 24 V. DYNAMOTOR: Another best buy 2.95
- 115 VOLT KIT: Only 6.95
- BC-604 MATCHING TRANSMITTER: Excellent. 5.95
- CS-137 CRYSTAL CASE: Two layers construction. Holds up to 120 crystals. New and Like New TWO Crystal Cases for \$7.95 EACH. 9.95
- MOUNTING RACK: For BC-604: New. Only 3.95
- 12 V DYNAMOTOR: for BC-604. Excellent 3.95
- DC PDWER SUPPLY: 6-12-24 Volt. Only 1.95

- CY-139/CPS-1 RANGE AND AZIMUTH INDICATOR**
 This is an offbeat special! 11 Scan 7 dia. Calibrated vertical and horizontal lines. Rugged metal cabinet. Includes: 115V AC power supply. 115VAC. 7-5N7GT. 2-6AC7. 3-3Y6. 3-5U4G. 3-VRI. 1-VRI. 1-6XJ7. Lots of other extras. \$24.95
 Used good 4 ft. h. approx. 11" wide

- SCR-625 MINE DETECTOR BARGAIN**
 Locates that hidden pipe, metal, treasure! Use for parts! With case. Excellent! \$22.50
- SC-1140 CONTROL UNIT FOR ABOVE MINE DETECTOR:** Visual indicator, output meter, compensator knobs, control switch. Used, good. only \$1.95

- DYNAMOTOR DANDIES! TAKE YER PICK!**
 DM-35: Input 12 V. output: 625 V. @ 25 MA. Like new. You can stick up at this \$7.95 price!
 DM-40: 12 V. in. output: 175 V. Excellent 1.95
 DM-34: 12 V. in. output: 220 V. Excellent 3.50
 DM-36: 24 V. in. output: 220 V. Excellent 1.49

- BELL & HOWELL DATA RECORDING CAMERA**
 Contains 16 mm Magazine camera, mirrored lens, crash and filter assy, barometer, clock, compass, 12 VDC direct converter. Records weather data one frame at a time. 17" h. x 9" x 15" w. Brand new. Orig. cost \$800.00 \$14.95
 FOB N. V. state or California

- APR-1 RECEIVER SPECIALS!**
 30 Mc. IF 11.5 V. 60 eye. Like new cond. \$24.50
 Plug-In Units For Above
 TN-1: 30-90 Mc. \$14.95
 TN-2: 90-300 Mc. 14.95 Apr-1 Receiver PLUS
 TN-3: 300-1000 Mc. 14.95 TN-1, TN-2, TN-3 \$52.50

- APR-4 TUNERS—WILL WORK WITH ABOVE REC'R**
 TN-16: 30-90 Mc. \$14.95
 TN-17: 90-300 Mc. 14.95
 TN-18: 300-1000 Mc. 14.95
 TN-19: 1000-1000 Mc. 14.95
- COMBO DEAL!**
 TN-16, TN-17, TN-18, TN-19 \$95.00
- BC-611 HANDIE TALKIE. New. Special. \$49.50
 TS-34 OSCILLOSCOPE: 10-50,000 cycles. Sweep 10 or 250 microseconds. Good cond. \$34.95
 TS-34A AP: Same as above but sweeps can be varied @ 4 1/2, 8, 20, 50, 120-250 microseconds \$39.50

- BC-638 2-METER FREQUENCY METER: 100-150 Mc. AM. Excellent condition \$8.95
 GENERAL RADIO VARIAC: 30 V. 400 cycles. 5 amp. BRAND NEW. Reduced \$1.95
- APT-1 TRANSMITTER: 100-200 Mc. 100 WATT. All including 815A driver, 820B final and 811 diode tube. New cond. \$12.95

- ART-13 XMT: Model T-47. LIKE NEW! Only \$34.50
- TS-305 POWER METER: 220-300 Mc. Excel. cond. \$49.50
- TS-251/APN LORAN TEST SET: Excellent cond. 49.50
- TS-611 5-BAND GUMMY LOAD: Excellent 29.50
- TS-10C/APN TEST SET: Excellent cond. 75.00

All orders FOB Los Angeles. 25% deposit required. All items subject to prior sale. NOTE: MINIMUM ORDER \$3.00. WRITE TO DEPT. R.

ELECTRONICS
 Columbia 2251 W. WASHINGTON BLVD.
 LOS ANGELES 18, CALIF.

TV PICTURE TUBES
 At Lowest Prices

10BP4 \$ 7.95	17BP4 \$ 9.95	21AMP4\$15.75
12LP4 8.50	17CP4 17.00	21ATP4 15.75
14B/CP4 9.95	17EP4 17.60	21AUP4 15.75
160P4 12.00	17FP4 12.50	21EP4 13.50
16EP4 12.75	17LP4 11.50	21FP4 14.50
16GP4 14.50	17TP4 9.95	21WP4 14.50
16KP4 9.95	17TP4 17.00	21WP4 14.50
16LP4 10.95	19AP4 16.00	21ZP4 13.50
16RP4 9.95	20CP4 13.50	24CP4 23.50
16WP4 12.00	20HP4 14.50	24DP4 24.50
16TP4 9.95	21AP4 22.10	27P4 39.95
17A/PA 12.50	21ALPA 15.75	27RP4 39.95

Aluminized tubes \$3.00 for 21" and \$5.00 for 24" and 27" additional. Prices include return of an acceptable similar tube under vacuum.
 These tubes are manufactured from reprocessed used glass bulbs. All parts and materials including the electron gun are brand new.

ALL PRICES FOB CHICAGO, ILLINOIS. Deposit required, when old tube is not returned, refundable at time of return. 25% deposit required on COI shipments. Old tubes must be returned prepaid. Tube shipped Mail Express. Shipped only to Continental U. S. and Canada.

WRITE FOR COMPLETE LIST.
PICTURE TUBE OUTLET
 2922 NORTH MILWAUKEE AVENUE
 CHICAGO 18, ILLINOIS
 Dickens 2-2048

Booklet
 catalog

Manufacturers' Literature

RECTIFIER DATA
 Sarkes Tarzian Inc., 415 North College, Bloomington, Indiana has issued a number of new data sheets covering its line of silicon and selenium rectifiers.

Bulletin #40 carries details on the firm's tube replacement silicon rectifiers, while publications W-15 and D-17 provide data on a number of units which can be used to replace tubes in various circuits. A single sheet lists characteristics of the company's "condensed-stack" selenium units covering the 50 to 500 ma. range.

Any or all of these catalogue sheets are available from the company on request.

JAPANESE SUPPLIERS
 Kurt Bernard Associates, 507 Fifth Ave., New York 17, N. Y. has announced publication of the "Guide to American Importers of Japanese Merchandise."

The directory lists all American importers of Japanese wares and is designed for use by buyers, salesmen, and other executives in the radio, appliance, and general merchandise fields. The 44-page classified Guide contains over 1300 listings covering 52 product categories. It sells for \$3.00 a copy, direct from the publisher.

STANDBY POWER PLANTS
 D. W. Onan & Sons Inc., 515 University Ave., S. E., Minneapolis 14, Minn. has just issued an 8-page book entitled "Standby Electric Plants and Controls"—a guide to the selection and installation of emergency electric power units.

The booklet is being offered free of charge to all consulting, design, and electrical engineers, architects, purchasing agents, etc. The folder outlines the steps to consider in selecting such a plant and includes practical planning and designing suggestions.

When requesting this publication ask for "Sweet's File Folder, 32C/ON."

RECEIVING TUBE MANUAL
 The Superintendent of Documents, U. S. Government Printing Office, Washington 25, D. C. has announced publication of a new tube manual, "Tabulation of Data on Receiving Tubes" by C. P. Marsden, W. J. Keery, and J. K. Moffitt, National Bureau of Standards Handbook 68. This 110-page manual is for sale at \$1.00 a copy.

Tubes are listed by number as well as by type and important parameters. The tabulation is accompanied by a listing of similar tube types and basing diagrams for the tubes listed. According to the U. S. Department of Com-

merce, this manual can help an engineer in narrowing down the choice of tubes to one or a few types. However, it was not practical to give all possible operating conditions or provide the characteristic curves for all tubes in this tabulation. For such detailed information, it will still be necessary to consult tube manufacturers' standard literature.

STORE IMPROVEMENT PROGRAM
 The Electron Tube Division of Radio Corporation of America has issued a special four-color "Store Improvement Guide" to explain the company's new program for independent television service dealers.

The program itself contains more than 35 carefully prepared business and service aids designed to increase the potential of the dealer's store front, sales area and service area as well as special aids for use on service calls.

The complete program are available from authorized RCA tube distributors through the country.

CR TUBE DATA
 Thomas Electronics, Inc., 118 Ninth St., Passaic, N. J. is now offering a six-page data sheet covering its line of industrial and military cathode-ray tubes for use in oscilloscopes, radar displays, flying-spot scanners, video recorders, industrial monitors, TV check tubes, spectrum analyzers, oscilloscope photography, etc.

Both magnetic deflection and electrostatically focused types are covered with characteristics listed in tabular form for easy application.

RADIO-CONTROL CATALOGUE
 Gyro Electronics Co., 36 Walker St., New York 13, N. Y. is offering copies of its 16-page, pocket-size catalogue of radio-control units and components.

This handy publication lists transmitters, receivers, kits, relays, batteries and battery chargers, power supplies, motors, servos and escapements, parts, and accessories. Requests for this free publication should be sent to the company direct.

TIPS FOR TECHNICIANS
 Chicago Standard Transformer Corporation has announced publication of the third edition of its tips for service technicians, "Stan Cor's Corner."

Containing thirty-eight service shop short cuts, the booklet offers illustrated ideas, gadgets, and service hints designed to help save time in the use of bench tools; tool kits; soldering; files and drills; and miscellaneous service hints.

Subject matter includes: "A Large Third Hand"; "Non-slip Gun Grip"; "How to Prevent File Clogging"; hints on rear-seat speaker installations, among others.

Write the company at 3501 W. Addison, Chicago 18, Ill. for a copy of this publication.

RESEARCH HIGHLIGHTS

The National Bureau of Standards has announced the availability of its 1959 Annual Report entitled "Research Highlights of the National Bureau of Standards."

Available from the Superintendent of Documents, U.S. Government Printing Office, Washington 25, D. C. (NBS Miscellaneous Publication 229, price 55 cents), the report covers the most important developments in the research program of the Bureau during 1959. Much of the material is concerned with the new technology of the space age, including various advancements in radio research.

CBS BULLETIN

CBS Electronics, 100 Endicott Street, Danvers, Mass., has issued a new bulletin entitled, "Are You Destroying Transistors?" The bulletin, PA-213, is available from the company's information services department at the above address.

Written by Bud Tomer, the brochure describes temperature and voltage limitations of transistors. Precautions

to avoid accidental abuse are also provided, with emphasis on proper test and soldering techniques. The vital role of the heat sink is noted, and practical effects of wide variations in ambient temperature are described.

MICRO-MODULE WAFERS

The Receiver Bulb Sales Department of Corning Glass Works, Corning, N. Y. has issued a new four-page bulletin on "Fotoceram" micro-module wafers.

The tiny wafers are produced by chemically machining glass to "micro accuracy" from a photographic reduction, then converting it to a ceramic. Full details on the process and available stock patterns are given in the bulletin.

Requests for Bulletin MMW will be honored when made on company letterhead.

DATA ON TEXAS CRYSTALS

Texas Crystals, 1000 Crystal Drive, Fort Myers, Florida has published an 8-page catalogue describing crystals available for various uses, including Citizen Band, radio control, low-frequency applications, and others.

Schematic diagrams of recommended circuits are included.

NEW MANUFACTURING TOOL

J. G. Dorsey & Associates, P.O. Box 45793, Los Angeles 45, Calif. has issued a circular that describes its new "Sircuit Serv-O-Senter." This device is a tool designed to facilitate the assembly

of printed circuit and terminal boards. According to the manufacturer, the device is equally efficient for both prototype and production runs.

CLEVITE TRANSFILTERS

Clevite Electronic Components, Division of Clevite Corporation, 3405 Perkins Ave., Cleveland 14, Ohio announces a series of bulletins and technical papers dealing with various applications of transfilters. Write to the company for the announcement of the literature available.

1960 ELECTION HANDBOOK

Sylvania Electric Products Inc., 730 Third Ave., New York 17, N. Y. has brought out a 50-page booklet that deals with "key issues and men to watch" at this year's presidential conventions and election. In addition to explaining convention procedures and methods of selecting delegates, the booklet contains state-by-state tally sheets so that TV viewers may list the details and results of each ballot. Copies of the booklet may be obtained from any authorized Sylvania dealer.

SELF-LOCKING NUTS

National Radio Company, Inc., 37 Washington St., Melrose 76, Mass. is offering a bulletin describing its new line of self-locking captive nuts. These nuts provide machine-threaded inserts for use in aluminum or brass. The bulletin, No. 58-2SL, includes illustrations and a specifying code.

-30-

MICRO

ELECTRON TUBE

INTRODUCES FOR THE FIRST TIME
ANYWHERE A SELECT STOCK OF USED
TUBES AT A FABULOUS LOW PRICE

37

ea.

\$35

PER
HUNDRED
ASSTD.

FOR any TUBE LISTED

Jan Surplus Tubes!

ALL TUBES SENT POSTAGE PAID
Please send 25c handling for orders under \$5. Send 25% deposit on C.O.D. orders. Send approximate postage on Canadian and foreign orders.

MICRO

ELECTRON TUBE CO.

P.O. Box 55, Dept. EW-6, Park Sta., Paterson 3, N. J.

- Each and every tube is tested in our own laboratory for mutual conductance and life test.
- We guarantee FREE replacement for one year of any tube purchased from us which fails to function efficiently under any or all operating conditions. Prompt refunds are made on any defective merchandise.
- The advertised tubes are not necessarily new, but may be electrically perfect factory seconds or used tubes—each is clearly so marked.

0A2	5X8	6BH6	6SF7	7Z4	19BG6G
0Z4	5Y3GT	6BJ6	6SF7	12A8	19J6
1A7GT	5Y4G	6BK5	6SK7	12AQ5	19T8
1B3QT	6A7	6BK7	6SK7	12AT6	24A
1H4G	6AB4	6BL7GT	6SL7GT	12AT7	25AV5
1H5GT	6AC7	6BN6	6SN7GT	12AU6	25BQ6
1L6	6AF4	6BQ6GT	6SQ7	12AU7	25DN6
1L6	6AG5	6BQ7	6S57	12AV6	25L6GT
1N5GT	6AG7	6BT5G	6T4	12AV7	25W4GT
1Q5GT	6AH4GT	6BZ6	6T8	12AX7	25Z6
1R5	6AM6	6BZ7	6C4	12AX7	26
1S5	6AK5	6C5	6C6	12B7	35A5
1T4	6AL5	6C6	6C8	12BA7	35B5
1U4	6AL7	6C8	6C9	12BE6	35C5
1U5	6AM8	6C9	6D6G	12BF6	35L6GT
1V2	6AN8	6D6G	6CF6	12BH7	35W4
1X2	6AQ5	6C6	6X4	12BQ6	35Y4
2A3	6AQ8	6C6	6X5	12BR7	35Z5GT
2AF4	6AQ7GT	6C6	6X8	12BY7	37
3BC5	6AR5	6C6	6Y6G	12CA5	39/44
3BN6	6AS5	6C6	7A4/XXL	12J5	42
3BZ6	6AS5	6C6	7A6	12K7	43
3CB6	6AT8	6C6	7A7	12L6	45
3CF6	6AT8	6C6	7A8	12Q7	50A5
3CS6	6AU4GT	6C6	7B8	12S7	50B5
3LF4	6AUSGT	6D6E	7C4	12SG7	50C5
3Q4	6AU6	6DQ6	7C5	12S7	50L6GT
3S4	6AU8	6F6	7C6	12SK7	50X6
3V4	6AV5GT	6H6	7C7	12SN7GT	56
4BQ7A	6AV6	6J4	7E6	12SQ7	57
4BZ7	6AW8	6J5	7E7	12V6GT	58
5AS8	6AX4GT	6J7	7F7	12W6GT	71A
5AT8	6AX5GT	6K7	7F8	12X4	75
5AV8	6B8	6K8	7H7	12Z3	77
5AW4	6BA6	6L7	7N7	14A7/12B7	78
5B7	6BC5	6N7	7Q7	14B6	80
5J6	6BC8	6Q7	7X7/XXFM	14Q7	84/6Z4
5T8	6BE6	6S4	7Y4	19AU4GT	117Z3
5U4G	6BF5	6S4	7Y4	19AU4GT	117Z8
5U8	6BF6	6S4	7Y4	19AU4GT	117Z8
5V4G	6BF6	6S4	7Y4	19AU4GT	117Z8
5V6GT	6BG6G	6S7	7Y4	19AU4GT	117Z8

WRITE DEPT. EW-6 FOR OUR FREE COMPLETE LIST OF TUBES & SPECIAL PURPOSE TUBES

IMPORTANT NEW SAMS BOOKS



"Using and Understanding Probes"



Helps you get more out of your test equipment! Rudolf Graf shows you how best to use all types of probes in radio-TV servicing. Includes valuable section on special-type electronics probes and their use in industry, agriculture, medicine, etc., for observing, testing, exploring and measuring. Provides a complete understanding of the use of all probe types: direct, isolation, high-voltage, low-capacitance, rectifying, demodulator, signal-tracing and signal-injection. 200 illustrations; 266 pages;

5½ x 8½". Only..... **\$3.95**

"Servicing Unique Electronic Apparatus"



Cash in on growing new opportunities in electronics servicing. Jack Darr gives you the know-how on such equipment as: Watchmaster watch timer and tester; RF diathermy machines; liquid-flow timers; electronics photoflash units; electric scoreboards; RF heaters; gas-fired boiler controls; garage-door openers; movie sound systems; strobe tuning devices; photoelectric cells; ultrasonic cleaners, etc. Complete; profusely illustrated; 128 pages; 5½ x 8½". Only.....

\$2.50

Timely for TV Antenna Work



Television Antenna Handbook. A practical guidebook for the antenna installer and serviceman. Thoroughly covers needs of each reception area (primary, secondary, far-fringe). Chapters include: the TV signal, characteristics of basic antennas, commercial antenna types, transmission lines, antenna rotators, installation planning, on-location tests, tools and equipment, towers, masts and guying, roof-top

techniques, antenna installation, UHF and color, unusual installations and problems, boosters and multi-set installations, and servicing the antenna system. Most complete and practical book on the subject. 248 pages, 5½ x 8½". 265 illustrations. Only..... **\$3.95**



TV Signal Distribution and Antenna Techniques. Practical and complete information about installation of antenna systems serving two or more TV receivers. Gives procedure and equipment requirements for installations required by hotels, apartments, stores, institutions, trailer parks, community antenna systems. Covers: selection and orientation of antennas, selection of proper distribution systems, reception and special installation

problems, selling systems, making bids and estimates, and other subjects. 176 pages, 5½ x 8½". Only..... **\$2.95**

HOWARD W. SAMS & CO., INC.

Order from your Sams Distributor today, or mail to Howard W. Sams & Co., Inc., Dept. F-10 1720 E. 38th St., Indianapolis 6, Ind.

- Send me the following books:
- "Using and Understanding Probes" (PRG-1)
 - "Servicing Unique Elect. Appar." (SED-1)
 - "Television Antenna Handbook" (TAD-1)
 - "TV Signal Distribution" (DSB-1)

\$.....enclosed. Send Free Book List

Name _____

Address _____

City _____ Zone _____ State _____

■■■■■ (outside U.S.A. priced slightly higher) ■■■■■

Service Industry



JUST FOR A CHANGE, we are going to let service-industry figures talk more directly for themselves than is usual in this space, and we are also going to give somewhat more prominence than usual to minority views, with the first two items on the agenda. These matters are the self-service tube testers and part-time servicers. We have always tried to balance out the prevalent, negative view on each of these by also quoting the other side, and that has not been difficult to do. This month, however, we are fortunate in having exceptionally well presented cases.

The champion of the do-it-yourself testers is Mr. Morton Binder. Since he is sales manager of *Vis-U-All Products*, a manufacturer of DIY equipment, he is obviously an interested party. However, this company is one of those marketing exclusively to service shops through legitimate electronic wholesalers. Also, Mr. Binder is himself a former service professional, with some understanding of the industry's situation. His arguments ran in "NATESA Scope," which gave him space in the interests of seeing all sides of various questions presented, but took no stand itself. We pass his case on, in condensed form, in the same spirit:

"I was in the service business for twenty years; and I hope that during that time I learned something about Mr. and Mrs. TV Set Owner and how they tick. If I learned anything at all it's this: No serviceman can hope to get back lost business. You must *earn* it back.

"How do you go about doing this? No service business can succeed without giving the customer convenience and benefits he can get nowhere else. First of all, let's ask ourselves why the public has fallen for the self-service tester—and let's think in terms of why this is a bad thing for the customer. (We *know* why it's a bad thing for us.)

"The public likes the convenience of self-service testers—they enjoy the do-it-yourself feeling. It gives them a sense of technical competence that you and I know they really do not possess. They feel they are saving money when they use a self-service tester. What they do not seem to realize is that there is a good possibility that a mere tube replacement is not going to put their sets back into operating condition, and that the pharmacist will have no medicine for the headaches that may result from amateur attempts at TV repair.

"Re-educating the public is practically impossible. Self-service tube testing is here to stay. However, in order to render adequate service to the cus-

tomers, self-service testing must become part and parcel of the professional technician's operation.

"The technician must make available a tester that his customers can use themselves, of professional quality, but simple enough to be used by an untrained layman. You must sell him on the advantage he has in using *your* unit—the fact that you are there to answer questions and give advice. You must make sure that your customers are aware that many TV set difficulties are not eliminated by the replacement of tubes.

"You have another advantage. The slot-machine self-service testers are devices for selling only the most common varieties of tubes, usually foreign and reprocessed types. The professional service organization maintains a complete stock of tubes, not just the most common types, and the customer has the assurance they are standard brand items.

"From a purely economic point of view, you will discover this approach to self-service tube testing is a very easy one. More important, it brings the customer into your store and gives you an inside track on his business when his TV set requires more than just tube replacement. The self-service tester has been your enemy only because it has been working for someone else. Put it to work for you."

Defense of Part Timer

As quoted in the "ETAT News," published by TESA of Ohio, Jack Fain, president of TESA of Lorain County, has this to say:

"I find the blanket indictment of any and all Part-Timers foolish and unrealistic. (Let me state here and now that I am a partner in a full-time, fair-sized service operation.) If we are an association of technicians, then the first consideration in judging a man should be his ability in electronics and whether he operates a tax paying business, *not* the number of hours he works at his profession.

"Consider: There are many highly skilled medical specialists who have office hours only once or twice a week. Does this constitute a Part Timer and, by the definition, illegitimate? Of course it does not. His training and experience are what he is judged by, where the AMA is concerned. When you attack the legitimate Part Timer, you are in a sense striking at one of the arms of the body of technicians in this country.

"I'm not worried about the Part Timer's effect on my business. If I were a one-man shop I would still

stand head and shoulders over any Part Timer because I can give faster service even if he is every bit as good a technician as I am.

"The man I worry about is not the legitimate one. I worry about the one that crawls out from under a rock with a tube caddy and proudly announces to one and all that he is a serviceman. He has no bills, no knowledge, no equipment—not even a work bench. This is the man who will eventually wind up as a headline story and thus reflect on my good name.

"So—get that *legitimate* Part Timer into your organization. If he is not charging for his work as he should, educate him. Remember, the more strength your organization shows, the greater will be the club you can wield. There is strength only in Unity."

Distributor Service Policy

The "TSA Service News" of the state of Washington points out that Article IV of the Constitution adopted by the National Electronic Distributors Association defines a "Wholesale Electronics Distributor" as follows: "He is further defined as one who does not provide repair service to the consuming public." The definition is followed by a note which says this section applies only to applications approved after May 19, 1958.

While TSA expresses gratification at this limitation on retail activities by NEDA members, it regrets the escape proviso for earlier members, and hopes that an attempt will be made to bring these in line with established policy.

Of interest in this connection is the advertising of many independent distributors in the organs of local service associations. Such distributors promote the NEDA emblem and membership as assurances of cooperation.

Raytheon House Organ

The *Raytheon Company's* Distributor Products Division in Westwood, Mass., has launched "The *Raytheon Bond*," which is being distributed free to the company's 10,000 bonded dealers throughout the nation. Those interested in receiving the bi-monthly should get in touch with local *Raytheon* distributors concerning details of the bonding program.

Two-Way Radio Training

A leading manufacturer of two-way mobile communications gear, *Motorola*, is now offering a home-study course to qualified technicians in this field. Mobile, portable, and base-station equipment, including the latest transistorized units, will be covered. Basic reference text books, that will be useful throughout the course, are included with the first lesson. For further details, write to the *Motorola* Training Institute, 4501 W. Augusta Blvd., Chicago 51, Ill. An orientation pamphlet, "Introduction to the *Motorola* Two-Way FM Radio Home Study Course," describes the lessons, means of grading, certification upon graduation, and other features. It is also a general index to the rest of the course. —50—

"I certainly wouldn't be without PHOTOFACTS"

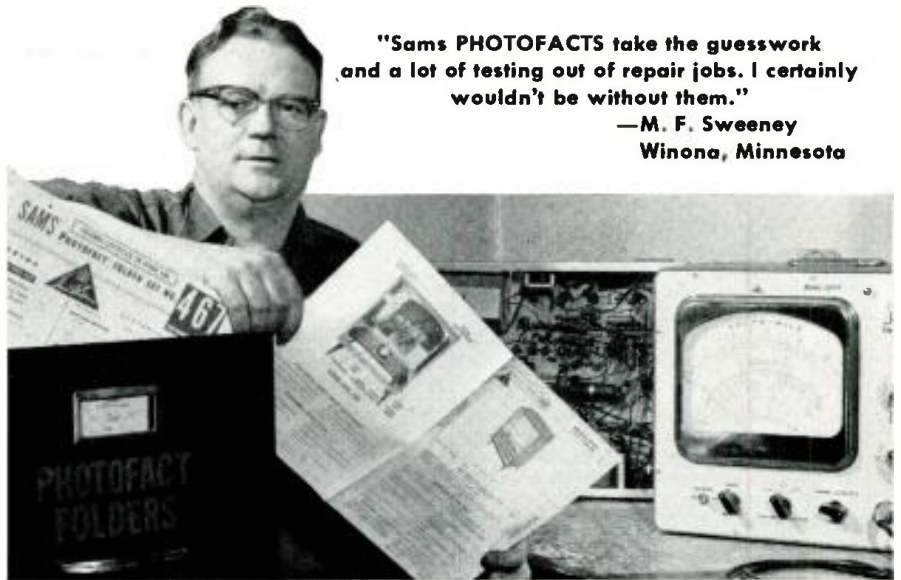

"Sams PHOTOFACTS take the guesswork and a lot of testing out of repair jobs. I certainly wouldn't be without them."

—M. F. Sweeney
Winona, Minnesota

Service Technicians! YOU EARN MORE... YOU RATE with the public when you own the PHOTOFACT® service data library!

You enjoy maximum earnings as the owner of a complete PHOTOFACT Service Data Library! It's inevitable, because no matter how expert you are, you can always *save more time on any job, get more jobs done daily*—EARN MORE, DAY IN AND DAY OUT...

What's more—as the owner of a complete PHOTOFACT Library, you know your customers' sets *best*. You can actually show each customer you have the PHOTOFACT Folder covering his very own set. Result: You command public respect and acceptance which paves the way to more business and earnings for you.

HOW TO STAY AHEAD...

Yes, the truly successful Service Technicians are those who own the complete PHOTOFACT Library, who can meet and solve any repair problem—faster and more profitably. And these men *keep ahead* because they're on a Standing Order Subscription with their Distributors to receive all new PHOTOFACTS as they are released monthly. (They're eligible for the benefits of membership in PEET, too—see below!)

ONLY \$10 DOWN puts the complete PHOTOFACT Library in your shop—and you have up to 30 months to pay. See your Sams Distributor today, or write to Howard W. Sams

NOW IS THE TIME TO JOIN "PEET"

THE POWERFUL NEW PROGRAM FOR QUALIFIED TECHNICIANS

If you now own a PHOTOFACT Library or plan to own one, you can apply for membership in "PEET." It's the first industry program really designed to build powerful public acceptance for the Service Technician who qualifies. Builds enviable prestige and business for its members. Benefits cost you absolutely nothing if you qualify. Ask your Sams Distributor for the "PEET" details, or mail coupon today.

HOWARD W. SAMS & CO., INC.
1724 E. 38th St., Indianapolis 6, Ind.

Send me full details on the new "PEET" Program.

Send full information on the Easy-Buy Plan and Free File Cabinet deal.

I'm interested in a Standing Order Subscription.

I'm a Service Technician full-time; part-time

My distributor is _____

Shop Name _____

Attn: _____

Address _____

City _____ Zone _____ State _____

New! an EASY WAY
to understand the
uses and components
of digital computers



Fundamentals of DIGITAL COMPUTERS

By **MATTHEW MANDL**

Well-known writer on Electronics

Ideal for technicians and engineers without previous training in the computer field: ultra-simplified explanations make advanced math or electrical training unnecessary.

Covers amplifiers, circuits, fundamentals of applications, binary counting, codes, storage systems, programming, etc. Describes, illustrates representative available computers. Discusses servicing and maintenance. 135 schematic diagrams, photos, close-ups of parts. 160-entry glossary. Each passing day sees computers become more important. Post yourself, now!

Prentice-Hall, Inc., Dept. D-EG-89
Englewood Cliffs, N. J.

Send copy of Fundamentals of Digital Computers by Mandl. At end of 10 days I'll either send payment of \$7.95, or return book and owe nothing.

Name _____
Company _____
Address _____

SAY YOU  SAW IT IN
ELECTRONICS WORLD

CITIZEN BAND CLASS "D" CRYSTALS



3rd Overtone: Hermetically Sealed
.005% tolerance—Meets FCC requirements, 1/2" pin spacing—.050 pin diameters. (.093 pins available, add 15c per crystal.) **\$2.95**
ALL 22 Frequencies **\$2.95** EACH
In Stock!

(add 5c per crystal for postage and handling)

The following Class "D" Citizen Band frequencies in stock (frequencies listed in megacycles): 26.965, 26.975, 26.985, 27.005, 27.015, 27.025, 27.035, 27.055, 27.065, 27.075, 27.085, 27.105, 27.115, 27.125, 27.135, 27.155, 27.165, 27.175, 27.185, 27.205, 27.215, 27.225.

Matched crystal sets for Globe, Gonset, Citi-Pone and Hallcrafters Units . . . \$5.90 per set. Specify equipment make.

RADIO CONTROL CRYSTALS

In HC6/U HOLDERS—SIX FREQUENCIES

In stock for immediate delivery (frequencies listed in megacycles): tolerance .005%, 1/2" pin spacing, .050 pin diameter, (.093 pins available, add 15c per crystal.) Specific frequency desired: 26.995, 27.045, 27.095, 27.145, 27.195, 27.255. **\$2.95** EACH
(add 5c per crystal for postage and handling)

Send for FREE CRYSTAL CATALOG #860 WITH OSCILLATOR CIRCUITS

ASK YOUR PARTS DEALER FOR TEXAS CRYSTALS
See big red display . . . if he doesn't stock them, send us his name and order direct from factory.

ALL ORDERS SHIPPED FROM OUR NEW
FLORIDA PLANT 1st CLASS MAIL!

Rush your order to:

TEXAS CRYSTALS

Dept. R-60—1000 Crystal Drive, Fort Myers, Florida
For even faster service phone WE. 6-2100

Depth Sounders for Small Boats

(Continued from page 32)

The recorder, with its permanent graph recorded electro-chemically, can be matched readily with the chart and has the advantage of detecting trends or unusual bottom characteristics which might be missed on an indicating unit unless the boatman has been watching the instrument continuously.

Use of the depth sounder to avert strandings is a specialized application in navigation. In crossing a bar or maneuvering in close quarters there often is little time to refer to the chart. More frequently the general area is known to the boatman and the depth sounder serves to warn if the boat is making leeway off the normal course. It can be an invaluable aid at night when distance to sighted landmarks is deceiving. The friendly wink of the red-eyed depth sounder as it reports a safe sounding gives you reassurance that you're still in the deep channel and are not straying off into shoal water.

Even with corrected charts on board, the depth sounder may be your best aid if you are ever called upon to go to the assistance of a fellow boatman in trouble in a secondary channel or in shoal water. Shifting sand bars following hurricanes and coastal storms frequently change bottom conditions in exposed areas so that even the most recent charts may not be fully adequate.

You'll have to make your approach with due respect to wind and tide and feel your way close enough to lend a hand while watching your depth sounder to keep your own boat out of trouble.

Electronic Fish Finder

Anglers swear by the depth sounder as a fish finder. Commercial fishermen wouldn't sail without one. Dedicated sports enthusiasts have studied game fish through skin divers' masks to learn their habits. They may then use a depth sounder to find rocky upgrades in deep water to stalk big lake trout. The slopes, holes, and tables where the prize specimen abound can be pinpointed even in uncharted inland lakes by making a personal preliminary survey with a depth sounder before casting a line.

Bottom texture is important to the angler who knows which species prefer certain conditions. With an indicating instrument the red flash senses the quality of the bottom almost as effectively as the armed land lead.

A hard bottom will send back a better echo than a soft one. For easier interpretation the sensitivity control should be adjusted to get a good reading with minimum gain. A perfectly flat, hard bottom returns a single bold echo. A rocky bottom deflects the signal so that many secondary echoes are reported after the principal echo is received. Over mud, much of the energy will be absorbed so that a weaker flash will be reported. Deep-sea units op-

erating at lower frequencies signal a broad smear over mud; the thickness of the echo is often an indication of the thickness of the mud layer. A steeply inclined bottom will register as a broad band bracketing the greatest and least depths falling within the cone of ultrasonic energy.

In every case the least depth reported is the minimum clearance to the bottom. Multiple echoes and the true or least depth line are even more recognizable on recording-type units.

Anything that enters the cone of the depth sounder's signal will reflect some energy back toward the transducer. The bigger the fish or the greater their number, the more significant will be their echo which will appear at the fish's depth, somewhere between the outgoing reference signal and the continually reported bottom reading.

Skindivers, in rapidly increasing numbers, are finding depth sounders valuable aids in locating sunken wrecks and other treasure-laden opportunities along the ocean's floor. In more somber applications police and fire departments and civil defense units are using them to find submerged automobiles and drowning victims.

Maintenance Tips

The transducer protruding below the hull is vulnerable to damage from flotsam or from careless handling on a trailer or cradle. Damage to the transducer may be signalled by a water leak around the packing nut inside the hull or, electrically, by decreasing sensitivity or even complete loss of the returning echo.

Transducers, which are made of corrosion-resistant materials, should not be painted as the metallic elements in most paints would shield the transducer and limit the transmission of ultrasonic signals.

Corrosion, the seaman's traditional foe, can be controlled by frequent inspections of the circuitry to prevent the build-up of verdigris on terminals and connectors. Corrosion can cause leakage currents.

Cleanliness and frequent overhauls are most important in recorders which leave a fine carbon dust as a by-product of the recording process. This accumulates beneath the chart like crumbs in an electric toaster. It can disrupt operation if allowed to build up and find its way into the circuitry.

Mercury batteries found in many modern units have a level performance life. However, as the battery nears the end of its useful life and its output begins to wane, the sensitivity of the depth sounder will start to degenerate. Low voltage can also cause reduced motor speed. Accurate soundings depend upon the constant speed of the motor. Soundings that drift may be the result of motor trouble.

Technicians troubleshooting transistorized depth sounders should be careful when testing transistors that voltages applied are within the design limits and of the right polarity. Voltage overloads, which the amateur

FEATURED IN JULY

ELECTRONICS WORLD

- **TAPE'S PROGRESS—
A STATUS REPORT**

How does tape shape-up today—and where is it headed? Here's an authoritative report—covering tape speeds, costs, head and track arrangements, cartridge vs. open reel, equalization, recording level, speed accuracy—and much more.

- **RADIO AIDS TO
AIRCRAFT NAVIGATION**

First article of an important three-part series covering all the commercial equipment currently available to the private flyer for communication and navigation. This installment gives you complete info on low-frequency range and Direction Finding.

- **PNEUMATIC DEVICES FOR
ELECTRONIC CIRCUITS**

The technician who deals with electronic gear that works in conjunction with other non-electronic equipment must have a thorough understanding of the entire picture. Here's a rundown on the role of pneumatic devices that tie in with electronic systems.

- **MOBILE COMMUNICATIONS—
REPAIR OR MAINTENANCE?**

Attention—two-way mobile communication owners! Do you still follow a “call-when-it-quits” service policy—or are you a believer in a systematic maintenance program? This article features a rundown on systematic maintenance—tells you why it works out better for both the owner and the service establishment.

Month after month, **ELECTRONICS WORLD** covers the field of electronics with varied features such as these. It's the kind of coverage that has made **ELECTRONICS WORLD** the largest selling, most authoritative electronics publication in the world.

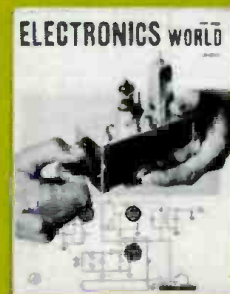

SUMMER SPECIALS

24 HOUR—8 DAY CLOCK

Mfg. by Waltham Watch Co.
 Aircraft Instrument Panel Clock, U. S. Navy. Ideal for Radio Ham Operators.
 8 Day 24 Hour, 2 3/4" Dial. Indicated Civil Date. Short Knob lower left. Continuously running Sweep-Second Hand, Glowing, Luminous painted Numbers and Hands. Excellent Condition. **\$17.50 Ea.**

WATER PROOF SPEAKERS
 U. S. Navy, Horn Type, Heavy Duty. All New Outdoor Permanent Magnet Speakers, with Universal Output Transformer, Voice Input: 6 Watts; 1.40 Ohms, 10 3/4" Dia., 8 3/16" Deep. Weight, in original Cases—23 lbs. **12.95**
 Our Low Price.....Ea.

ANTENNA MASTS
 For Citizen Band, Amateur and FM Radio; Television, etc. Made of Heavy Duty Aluminum in 4 Foot, 10 Inch Sections. Diam.—2 Inches. Weight of each section is appr. 3 Lbs. Make the Mast as high as you wish as each section inter-fits the other. **1.50**
 All New.....Per Section

SURPLUS METER SPECIALS
 Miniature Meter, 0 to 1 Ma., DC.....Ea. **\$2.50**
 2 In. 0 to 1 AC Amp. Meter.....Ea. **2.50**
 2 In. 0 to 15 Volt Meters—600—800 Cy. Ea. **1.50**
 2 In. 0 to 120 Decibel Meters.....Ea. **2.50**
 2 In. Dual Scale 0 to 50—0 to 100 mA, DC.....Ea. **2.50**
 3 In. 0 to 50 MA, DC Meter.....Ea. **2.95**
 3 In. 0 to 100 Ma DC. Meter.....Ea. **2.95**
 3 In. 0 to 200 MA, DC Meters.....Ea. **2.95**
 3 In. 0 to 200 Microamp. Meters.....Ea. **4.95**

SURPLUS TUBE SPECIALS
 610 Glass or Metal; 3RP1 Cathode Ray Tubes; 5Z3 Tubes; of the VR-150 Tubes.....Ea. **75c**

RECORDING BLANKS
 10" Recording Blanks. Make your own Recordings. Aluminum base, Lacquered both sides. Professional quality. All New Stock. **50c**
 Package of 10.....**\$3.00**
 Package of 100.....**\$27.50**

DIAL TELEPHONES
 French type phone made by Conn. Tel. & Tel. Can be used for standard extension phone. With Dial, Excellent Cond. Wgt. 7 lbs. Ea. **\$4.95**

RESET COUNTERS
 Unit Counter, changes by one digit. Reset: 000 to 999. Ideal for counting turns when winding Coils, Transistors and General Counting Work. Size is 4 1/2" x 3 1/4" x 1 1/2" Ea. **\$2.50**

LOW VOLTAGE TRANSFORMER
 This Transformer produces 6, 7, or 8 Volts, AC 20 Amps. Input 115 Volt, 60 Cycles. All New, Weight 11 Lbs.....Each **\$2.95**
 Wkt. 11 lbs. Ea. 4 for.....**\$10.00**

REVERSIBLE MOTOR
 1/40 H. P. Ball-bearing 3450 RPM in Blast-proof case. Needs only a capacitor for starting. All Brand New, 110 V., 60 Cy. Special Low Price. **\$2.50**
 Starting Capacitor.....**\$0.48 Ea.**
 WGT. Approx. 8 Lbs.

HEADSETS
 Trimm. 8000 ohms H. F. Headsets with 4 Ft. Cord. All NEW.....Ea. **\$3.50**

See our previous ad for Special Surplus Items. All prices F.O.B. S. F., Calif. Calif. orders add 3% Tax. No COD's. Remit Full Amount with All Orders.

STANDARD SURPLUS
 1230 Market St., San Francisco 3, Calif.
 Telephone HEMlock 1-3106

ELECTRONICS
PREPARE FOR A GOOD JOB!
BROADCAST ENGINEER
RADIO SERVICING AUTOMATION
TELEVISION SERVICING
BLACK & WHITE—COLOR
 APPROVED FOR VETERANS AND SURVIVORS OF VETERANS
 BUILDING AIR CONDITIONED
 SEND FOR FREE LITERATURE
BALTIMORE TECHNICAL INSTITUTE
 1425 EUTAW PLACE, BALTIMORE 17, MD.

troubleshooter can very easily impose, can permanently damage transistors and require their replacement.

The depth sounder and all other ship-board electronic devices will give surer and longer service if they are cleaned throughout and bench-checked annually.

Schematics and service information are available from most of the manufacturers offering depth sounders.

If you moor your boat in an unprotected anchorage, you will want to consider a unit whose indicator or recorder can be disconnected easily and carried ashore for safekeeping or one that can be recessed into a bulkhead or instrument panel in a permanent and relatively secure installation. If you're a northern, seasonal boatman be sure to remove any internal batteries and disconnect your indicator unit at lay-up time and store it and your other electronic gear in a more favorable atmosphere than the alternate freezing and sweating under the tarp covering your boat.

New Developments

Among recent innovations in depth sounders are transistorized circuits and self-contained batteries for completely portable operation, a depth sounder in kit form, and a small transom-mounted transducer that saves drilling holes in the boat's bottom. And introduced at this year's boat shows: an automatic alarm that rings when a depth below a preset limit is registered, and a two-way depth sounder with a two-element transducer, one to look down in the conventional manner and signal the depth of water under the keel and a second, in the same housing, to look forward of the boat in search of possible underwater obstructions in the boat's path.

To accomplish the dual job, the outgoing signal is duplexed with the sounding signal. The latter is 200 kc. while the scouting signal is about 300 kc. The higher frequency, as mentioned earlier, is used to minimize the bow wave and hull turbulence which contribute the greatest interference in the fore and aft plane. According to the manufacturer, this device can be used to detect floating debris, obstacles, other boats, and the shoreline at distances up to 140 feet ahead.

Just as in so many other areas, electronics has made boating safer and more fun with greater convenience—not just for the millionaire, but for the millions. Low-priced, mass-produced depth sounders can put a "leadsman" on any boat. Instead of the master leadsman's reading every three to five minutes, today's boat owner gets hundreds of accurate readings every minute.

Electronics makes it so much easier to navigate a boat alone—to be in command without the necessity for leaving the wheelhouse to take soundings in thick weather. Even more important, there are no more "deeps," no estimated depths. The depth of water is known continuously and read exactly and correctly to the nearest foot. —50—

Electronic Roast Alarm

(Continued from page 47)

the thermistor to enable its easy insertion into the meat.

Before attempting to calibrate the unit the buzzer must be adjusted. Connect it in series with a 3-volt battery and a milliammeter and adjust the contacts until the buzzer operates reliably at 50 ma. or less. Unless this adjustment is carried out, satisfactory operation cannot be expected from the unit.

Adjusting the calibration potentiometers requires two pans of water, one heated to 140°F and the other to 190°F. If an engraved scale has been purchased, the probe should be inserted into the 140° water with the alarm off. After a 3-minute wait, to allow the probe to reach the temperature of the water, turn on the alarm and slowly rotate the dial until the 140° mark is reached. The buzzer should sound when the dial just reaches this mark. If not, adjust R₁ until the desired condition exists. Next, insert the probe in the 190° water with the alarm off and wait three minutes. Again slowly rotate the dial clockwise and adjust R₂ until the alarm triggers when the knob just reaches 190°. Since R₂ and R₁ interact it will be necessary to repeat these adjustments several times before both calibration points are correct without resetting either potentiometer. This completes the adjustment for the pre-calibrated dial. The remaining calibration marks will now fall in line provided the exact potentiometer called for in the parts list is used.

Calibration of a home-built dial follows similar lines. Place a calibration line at an arbitrary point near the clockwise limit of rotation to represent 140° and a second line near the counterclockwise limit to represent 190°. Calibrating these two points then duplicates the procedure given previously. Intermediate calibration points are best located by placing the probe in a pan of water which is being slowly heated on a stove. As the water reaches the desired calibration temperatures the alarm is turned on and the dial slowly rotated clockwise until the buzzer sounds. Mark the dial with the water temperature at this point. Continue this procedure until the desired number of calibration points are obtained—points every 10° should be sufficient. This completes the calibration and the unit is ready for use.

Insert the probe into a roast, employing the same precautions observed in using a conventional roast thermometer, connect the wire to the control box—located away from the heat of the oven—and set the dial to the desired temperature. The chart of Table 1 will serve as an approximate guide to the proper temperatures. The exact temperatures chosen will depend, to a great extent, on personal preferences. All that now remains is to await the sound of the buzzer signaling a roast cooked to your specifications. —50—

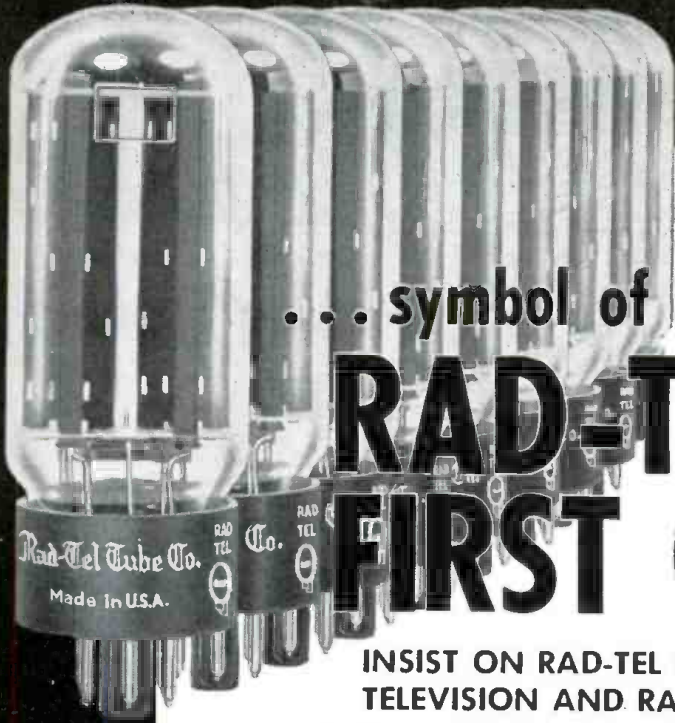

... symbol of

RAD-TEL FIRST QUALITY

RAD
TEL

GUARANTEED

INSIST ON RAD-TEL FOR EVERY
TELEVISION AND RADIO TUBE NEED

70% OFF on BRAND NEW TUBES

GUARANTEED ONE FULL YEAR!

You Can Rely On Rad-Tel's Speedy One Day Service!

Not Used — Not Pulled Out Of Old Sets - Each Tube Individually and Attractively Boxed!

Qty.	Type	Price	Qty.	Type	Price	Qty.	Type	Price	Qty.	Type	Price	Qty.	Type	Price	Qty.	Type	Price	Qty.	Type	Price			
—	0Z4M	.79	—	3CF6	.60	—	5E8	.80	—	6BC5	.54	—	7A8	.68	—	12AU7	.60	—	12DL8	.85	—	17L6	.58
—	1AX2	.62	—	3CS6	.52	—	5EU8	.80	—	6BC7	.94	—	7B6	.69	—	12AV5	.97	—	12DM7	.67	—	17W6	.70
—	1B3GT	.79	—	3CY5	.71	—	5I6	.68	—	6BC8	.97	—	7Y4	.69	—	12AV6	.41	—	12DQ6	1.04	—	19AU4	.83
—	1DN5	.55	—	3OE6	.62	—	5T8	.81	—	6BD6	.51	—	8AU8	.83	—	12AV7	.75	—	12DS7	.79	—	19B6G	1.39
—	1G3	.73	—	3DK6	.60	—	5U4	.60	—	6BE6	.55	—	8AW8	.93	—	12AX4	.67	—	12DZ6	.56	—	19T8	.80
—	1I3	.73	—	3OT6	.50	—	5U8	.81	—	6BF6	.44	—	8BQ5	.60	—	12AX7	.63	—	12EL6	.50	—	21EX6	1.49
—	1K3	.73	—	3Q5	.80	—	5V6	.56	—	6BG6	1.66	—	8CG7	.62	—	12A27	.86	—	12EG6	.54	—	25AU4	.87
—	1L6	1.05	—	3S4	.61	—	5X8	.78	—	6BH6	.65	—	8CM7	.68	—	12B4	.63	—	12EK6	.56	—	25BQ6	1.11
—	1LA6	.69	—	3V4	.58	—	5Y3	.46	—	6BH8	.87	—	8CN7	.97	—	12BA6	.50	—	12EZ6	.53	—	25C5	.53
—	1LC6	.79	—	4AU6	.54	—	6AB4	.46	—	6BI6	.62	—	8CX8	.93	—	12BD6	.50	—	12F5	.66	—	25CA5	.59
—	1LN5	.59	—	4BA6	.51	—	6AC7	.96	—	6BK5	.80	—	8EB8	.94	—	12BE6	.53	—	12F8	.66	—	25C06	1.44
—	1R5	.62	—	4BC5	.56	—	6AF3	.73	—	6BK7	.85	—	10DA7	.71	—	12BF6	.44	—	12FM6	.45	—	25C06	1.11
—	1S5	.51	—	4BC8	.96	—	6AF4	.97	—	6BL7	1.00	—	11CY7	.75	—	12BH7	.73	—	12K5	.65	—	25DN6	1.42
—	1T4	.58	—	4BE6	.54	—	6AG5	.65	—	6BN4	.57	—	12A4	.60	—	12BK5	.70	—	12SA7M	.86	—	25EH5	.55
—	1U4	.57	—	4BW6	.75	—	6AH6	.99	—	6BN6	.74	—	12A85	.55	—	12BL6	.56	—	12SK7GT	.74	—	25L6	.57
—	1U5	.50	—	4BQ7	.96	—	6AK5	.95	—	6BQ5	.65	—	12AC6	.49	—	12BQ6	1.06	—	12SN7	.67	—	25W4	.68
—	1X2B	.82	—	4BS8	.98	—	6AL5	.47	—	6BQ6GT	1.05	—	12AD6	.57	—	12BY7	.74	—	12SQ7M	.73	—	25Z6	.66
—	2AF4	.96	—	4BU8	.71	—	6AM8	.78	—	6BQ7	.95	—	12AE6	.43	—	12BZ7	.75	—	12U7	.62	—	35C5	.51
—	2BN4	.60	—	4BZ6	.58	—	6AN4	.95	—	6BR8	.78	—	12AF3	.73	—	12C5	.56	—	12V6GT	.53	—	35L6	.57
—	2CY5	.71	—	4BZ7	.96	—	6AN8	.85	—	6BS8	.90	—	12AF6	.49	—	12CA5	.59	—	12W6	.69	—	35W4	.52
—	3AL5	.42	—	4CB6	.59	—	6AQ5	.50	—	6BU8	.70	—	12A16	.46	—	12CN5	.56	—	12X4	.38	—	35Z5GT	.60
—	3AU6	.51	—	4CS6	.61	—	6AR5	.55	—	6BY6	.54	—	12AL5	.45	—	12CR6	.54	—	17A4	.67	—	50B5	.60
—	3AV6	.41	—	4DK6	.62	—	6AS5	.60	—	6BZ6	.54	—	12AL8	.95	—	12CU5	.58	—	17BQ6	1.09	—	50C5	.53
—	3BA6	.51	—	4DK6	.60	—	6AT6	.43	—	6BZ7	.97	—	12AQ5	.52	—	12CU6	1.06	—	17C5	.58	—	50C4	.37
—	3BC5	.54	—	4DT6	.55	—	6AT8	.79	—	6C4	.43	—	12AT6	.43	—	12CX6	.54	—	17CA5	.62	—	50EH5	.55
—	3BE6	.52	—	5AM8	.79	—	6AU4	.82	—	6CB6	.54	—	12AT7	.76	—	12DB5	.69	—	17D4	.69	—	50L6	.61
—	3BN4	.63	—	5AN8	.86	—	6AU6	.50	—	6CD6	1.42	—	12AU6	.50	—	12E8	.75	—	17DQ6	1.06	—	117Z3	.61
—	3BN6	.76	—	5AQ5	.52	—	6AU7	.61	—	6CF6	.64	—											
—	3BU8	.78	—	5AT8	.80	—	6AU8	.87	—	6CG7	.60	—											
—	3BY6	.55	—	5BK7A	.82	—	6AV6	.40	—	6CG8	.77	—											
—	3BZ6	.55	—	5BQ7	.97	—	6AW8	.89	—	6CM7	.66	—											
—	3CB6	.54	—	5BR8	.79	—	6AX4	.65	—	6CN7	.65	—											
			—	5CG8	.76	—	6AX7	.64	—	6CR6	.51	—											
			—	5CL8	.76	—	6BA6	.49	—	6CS6	.57	—											

Please Print Plainly

Name

Address

City

SEND FOR FREE TROUBLE SHOOTER GUIDE AND
NEW TUBE & PARTS CATALOG.

NOT AFFILIATED WITH ANY OTHER MAIL ORDER TUBE COMPANY.

RAD-TEL TUBE CO.

55 Chambers St
Newark 5, N. J.

TERMS: 25% deposit must accompany all orders — balance C. O. D.
\$1 HANDLING CHARGE FOR ORDERS UNDER \$5. Subject to prior sale.
Please add postage. No C. O. D.'s outside continental U. S. A.

EW-660

Television RADIO-ELECTRONICS Electricity ELECTRONICS IN NEW SHOP-LABS OF COYNE

**TRAIN QUICKLY! OLDEST, BEST
EQUIPPED SCHOOL of ITS KIND in U.S.**

Get practical training in New Shop-Labs of Coyne. Prepare for a better job and a successful future in a top opportunity field. Advanced education or previous experience not needed. Employment service to graduates.

Enroll NOW—Pay Later

Finance Plan and Easy Payment Plan. Also Part Time Employment help for students

FREE BOOK Clip coupon or write to address below for Free Illustrated Book, "Guide to Careers"—Describes all training offered. No obligation and No Salesman Will Call. Act NOW.

B. W. Cooke, Jr., President

CHARTERED
NOT FOR PROFIT
Established 1899

COYNE ELECTRICAL SCHOOL
1501 W. Congress Pkwy., Chicago 7, Ill.
Dept. AO-6C

Send FREE book "Guide to Careers" and details of all training you offer. However, I am especially interested in:

ELECTRICITY TELEVISION BOTH FIELDS

NAME.....

ADDRESS.....

CITY.....STATE.....

QRZ QRZ QRZ... de ESSCO CB HQTS... TO ALL Citizen Banders with HEATHKIT CB-1 Transceivers

NOW AVAILABLE: A super selective & highly sensitive receiver adaptor, SPECIALLY designed by ESSCO to fit INSIDE the CB-1 transceiver case.

EASY TO INSTALL, only a few wires to connect and a couple holes to drill. Total installation time about one half hour average.

THE ESSCO Adaptor consists of a 6BA6 RF stage, 6BQ6 1st mixer/oscillator band pass filter connected to 6AN8 2nd mixer/oscillator with crystal controlled 3 mc 1st IF, 6BA6 2nd IF at 455 mc using special high gain transformers, & 12AU7 infinite impedance 2nd detector and AVC control tube.

THE ESSCO Adaptor feeds into present CB-1 audio circuits and speaker, & powered from CB-1 power supply. Single dial tuning of ALL 23 CB channels on present tuning condenser and dial. Fabulous adjacent channel selectivity from closely stations which formerly blanketed your super-super receiver. And with a sensitivity and power output that will make operation an extreme pleasure.

THE UNIQUE DESIGN, high grade components and unexcelled master craftsmen workmanship is far better value than one expects from the low introductory price of this factory wired-tuned receiver which is worth many times our low price of **\$37.95**

SPECIAL NOTE: This unit also supplied in it's own desk type case with power supply, audio circuits, 4 in. FM speaker and fabulous S meter circuit. **\$74.95**

"THE C-B NEWS" An info packed bulletin. Will help you obtain the mostest from C-B operation. Send stamped addressed \pm 10 envelope for free copy.

ESSCO C-B HQTS 58 WALKER ST.
NYC 13, N. Y.

engineering degree in 27 mos.

Become an Electronics Engineer. Share rewards awaiting college men... higher income, rapid advancement. Important firms visit Tri-State to interview seniors. Bachelor of Science Degree in 27 months in Electrical (Electronics or Power major), Mechanical, Civil, Aeronautical, Chemical Engineering. In 36 months a B.S. in Business Administration (General Business, Accounting, Motor Transport Management majors). For earnest, capable students. Small classes. More professional class hours. Well-equipped labs. Dorms. Campus. Modest costs. Year-round operation. Enter Sept., Jan., Mar., July. Founded 1884. Write J. H. McCarthy, Director of Admissions, for Catalog and "Your Career" Book.



SO MANY excellent books have been received in our Editorial Office within the last few months that we have despaired of being able to bring you comprehensive reviews of this material within any reasonable span of time. Rather than keep you in the dark about these interesting new titles, we are providing pertinent data about each volume in the most concise form possible with the hope that you will follow up with a more leisurely perusal of the book at your local bookseller.

FOR THE AMATEUR

"abc's of HAM RADIO" by Howard S. Pyle, W7OE. Published by *Howard W. Sams & Co., Inc.*, Indianapolis. 110 pages. Price \$1.50.

This thoroughly practical handbook, written by a former Asst. U. S. Radio Inspector and License Examiner, has the advantage of providing "insider information" for the prospective ham. This volume covers only requirements for Novice tickets and the material is presented in informal and easy to handle form.

"101 WAYS TO USE YOUR HAM TEST EQUIPMENT" by Robert G. Middleton. Published by *Howard W. Sams & Co., Inc.*, Indianapolis. 164 pages. Price \$2.50.

This is another in this publisher's "101 Ways" test equipment series and follows the same format as the service-directed volumes. Written especially for radio amateurs and service technicians who service such gear, the author lists the equipment needed, connections required, test procedures, and how to evaluate results. Included are grid-dip meters, antenna impedance meters, scopes, bridges, simple noise generators, and reflected power meters.

"GLOBAL TIME CONVERSION SIMPLIFIER" compiled and published by *John F. Rider Publisher, Inc.*, New York. 17" x 22" chart in slip case. Price \$1.00.

This two-color chart has been prepared in such a way that time determination is instantaneous and amazingly easy. Anyone who has ever used a "step" chart of the type to be found in railway and airline timetables will have no trouble finding out what time it is anywhere in the world. Large enough to be mounted on the ham shack wall and used without strain.

FOR THE TECHNICIAN

"TV SERVING SHORTCUTS" by Milton S. Kiver. Published by *Howard W. Sams & Co., Inc.*, Indianapolis. 104 pages. Price \$1.50.

This second and enlarged edition is based on actual "case histories" and covers troubles with raster, sound, sweep, sync, video, video and sound, and miscellaneous complaints. Like all of this author's service material, the book is completely practical, straightforward, and concise. A cross-reference index makes it easy to find the specific fault and cure.

"HOW TO TROUBLESHOOT TV SYNC CIRCUITS" by Ira Remer. Published by *John F. Rider Publisher, Inc.*, New York. 116 pages. Price \$2.90.

A practical handbook for both experienced and beginning technicians covers all phases of this important TV circuit. The text provides a comprehensive review of basic requirements and general needs of the sync signal in addition to step-by-step troubleshooting procedures. Profusely illustrated.

"HOW TO USE GRID-DIP OSCILLATORS" by Rufus P. Turner. Published by *John F. Rider Publisher, Inc.*, New York. 99 pages. Price \$2.50.

Since many technicians think of grid-dippers as an exclusively "amateur" item, they fail to appreciate the many jobs they can do in the service shop. The author outlines the many, many uses of this versatile instrument including operating instructions, calculations, etc. A circuit diagram for building such a unit is given along with complete specs on the commercial instruments available.

"HOW TO USE METERS" by John F. Rider & Sol D. Prenskey. Published by *John F. Rider Publisher, Inc.*, New York. 205 pages. Price \$3.50.

This is the second edition of a basic text on the meter art as applied to the newest in electronic equipment maintenance. Meters in all categories are covered along with practical application material for a wide variety of circuitry.

"PRINCIPLES OF FREQUENCY MODULATION" by B. S. Camies. Published by *John F. Rider Publisher, Inc.*, New York. 145 pages. Price \$3.50.

Written by a well-known British engineer, this volume covers the basics of the FM art for the benefit of the technician, student, and intelligent layman. Theory and history are covered along with the more practical aspects of FM applications and equipment.

"F-M SIMPLIFIED" by Milton S. Kiver. Published by *D. Van Nostrand Co., Inc.*, Princeton, N. J. 372 pages. Price \$7.50.

This third edition of a popular and practical text is characterized by a complete revision to bring the reader abreast of the current state of the art. The current surge in FM equipment sales makes this subject of pertinence to both laymen and technicians. The presentation is non-mathematical and provides a penetrating analysis and guide to the construction, maintenance, and operation of a wide variety of FM receivers.

"SERVICING HI-FI AM-FM TUNERS" compiled and published by *Howard W. Sams & Co., Inc.*, Indianapolis. 160 pages. Price \$2.95.

Volume 5 in the series includes a collection of selected "Photofact" folders on AM-FM tuners and receivers produced during 1958-59. Standard notation schematics, resistance charts, cabinet and chassis photos, parts list and replacement data, dial cord stringing information are included along with editorial coverage of cone- and horn-type reproducers with information on speaker design, basic horn styles, and other similar subjects.

"MOST-OFTEN-NEEDED 1926-1938 RADIO DIAGRAMS" compiled by M. N. Beitman. Published by *Supreme Publications*, Highland Park, Ill. 240 pages. Price \$2.50.

Judging from the inquiries received by this magazine there are literally thousands of "heirloom" radio receivers

still being cherished throughout the country. For those interested in repairing rather than replacing these "antiques," this volume of schematics should prove helpful. Most of the "grand old receivers" of pre-World War II are covered.

"MOST-OFTEN-NEEDED 1941 RADIO DIAGRAMS" compiled by M. N. Beitman. Published by *Supreme Publications*, Highland Park, Ill. 192 pages. Price \$2.00.

Like the volume mentioned above this handbook covers "vintage sets" of the immediate pre-war period. The production runs of most of the well-known radio set manufacturers are included. Similar volumes are available for sets made during the years 1942, 1946, 1947, 1948, etc.

"HOW TO INSTALL AND SERVICE AUTO RADIOS" by Jack Darr. Published by *John F. Rider Publisher, Inc.*, New York. 151 pages. Price \$3.25.

This is a revised second edition designed for those who install and repair all types of auto receivers—signal seeking, hybrid, transistor, tube, etc. The author's shortcuts, based on long experience in the field, are especially helpful in eliminating waste time and motion.

"MOST-OFTEN-NEEDED 1959 RADIO DIAGRAMS" compiled by M. N. Beitman. Published by *Supreme Publications*,

Highland Park, Ill. 192 pages. Price \$2.50.

This is Volume R-19 in the radio series and covers the sets produced by some 25 companies during 1959. Schematics, parts list, alignment data, dial stringing tips, etc. are covered for each set in accordance with this publisher's customary treatment.

"TELEVISION SERVICING COURSE" M. N. Beitman, editor. Published by *Supreme Publications*, Highland Park, Ill. 192 pages. Price \$3.00.

This is a home-study manual for the electronic or radio technician who wants to acquire practical TV servicing "know-how." By eliminating circuit basics which the student is presumed to understand, the text is able to get down to the business at hand directly.

"MOST-OFTEN-NEEDED 1960 TELEVISION SERVICING INFORMATION" compiled by M. N. Beitman. Published by *Supreme Publications*, Highland Park, Ill. 192 pages. Price \$3.00.

Volume TV-17 of this publisher's series covers TV sets from *Admiral, Emerson, G-E, Hoffman, Montgomery Ward, Motorola, Muntz, Packard-Bell, Philco, RCA Victor, Sylvania, Travler, Western Auto, Westinghouse*, and *Zenith*. Schematics, alignment charts, tuner and picture tube data, along with servicing hints are included for each model. (To be continued)

IT'S THE NEW MARK II FROM WESTON:



an advanced new design for the
WORLD'S FINEST PORTABLE ANALYZER

Here's an all-new version of the famous WESTON MODEL 980 Volt-Ohm-Milliammeter . . . engineered to offer you

- **INCREASED RANGE.** High-voltage range has been extended to 4000 volts.
- **INCREASED SENSITIVITY.** D-C sensitivity of 20,000 ohms/volt; accuracy within 2% of full scale.
- **IMPROVED SHIELDING.** Cormag® mechanism assures positive magnetic shielding; housing shields against electrostatic interference.
- **GREATER RUGGEDNESS.** Spring-backed jewel movement resists shock, vibration; case is impact-resistant. Ohm-ranges are fuse-protected.
- **SIMPLIFIED CONTROL.** Single dial control for range and function switching.
- **NEW COMPACTNESS.** Size and weight are reduced for maximum convenience and portability.

Order from your local Weston distributor. For information, write to Weston Instruments Division, Daystrom, Inc., Newark 12, N. J. In Canada: Daystrom, Ltd., 840 Caledonia Rd., Toronto 19, Ont. Export: Daystrom's International Sales Division, 100 Empire St., Newark 12, N. J.

DAYSTROM, INCORPORATED
WESTON INSTRUMENTS DIVISION

World leader in measurement and control

Magneto

EMERGENCY

Power Supply

By HAROLD REED



Build this simple d.c. power source in order to replace run-down batteries to energize transistor broadcast sets for emergency Conelrad reception.

RELYING only on a.c.-operated and/or battery-operated radio receivers that will tune to the Conelrad frequencies of 640 and 1240 kilocycles you may, or may not receive the vital information and instructions which would be broadcast via this civilian defense system. Electric service may fail and batteries, when needed most, may be weak or dead simply due to "shelf age."

The electronics worker—whether audiophile, experimenter, service technician, amateur radio operator, or engineer—because of his knowledge of electronics is, fortunately, in a favorable position to receive civilian defense broadcasts under almost any adverse condition. With a little forethought and experimentation he can be prepared for almost any emergency situation.

A study of pertinent conditions at his receiving location should be made to ascertain the necessary requirements to maintain contact with a Conelrad station. A simple, inexpensive receiver requiring minute power, obtainable from the energy sources to be discussed, may be kept handy for emergency duty.

For reception of Conelrad broadcasts on either of the selected frequencies of 640 and 1240 kilocycles, some sort of power for the radio receiver is, of course, necessary. There is an exception to this in some listening locations where the signals radiated on either frequency are strong enough to be received with a simple crystal detector circuit. Note that reference has been made to both frequencies. This is important, since facilities of any particular station may be disrupted, whereas another station transmitting on the other frequency may still be in operation.

A photocell or sun battery is one source of power suitable for operating a small radio receiver. It has its limitations, in that energy is required from sunlight or artificial light and neither may be available.

A so-called free-power circuit may be utilized. With this method, the radio-frequency carrier of a radio station is converted to direct current by means of a crystal diode. The d.c. cur-

rent to power the receiver may be obtained from the station listened to or from another station.

Since a d.c. motor will also function as a d.c. generator, here is another source of emergency power for a Conelrad receiver. One of the miniature motors currently available, when hand cranked, will serve this purpose. A motor with a gear assembly is most suitable because the greater the speed

The magneto power supply is employed when electric service is disrupted and radio batteries are dead. Output terminals are color-coded for polarity identification.

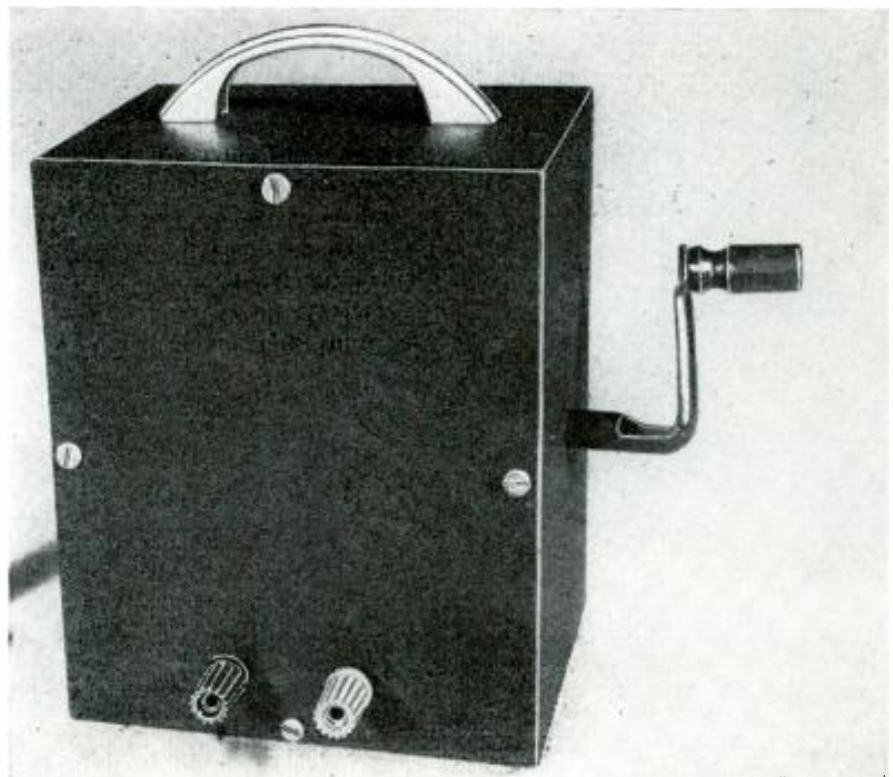

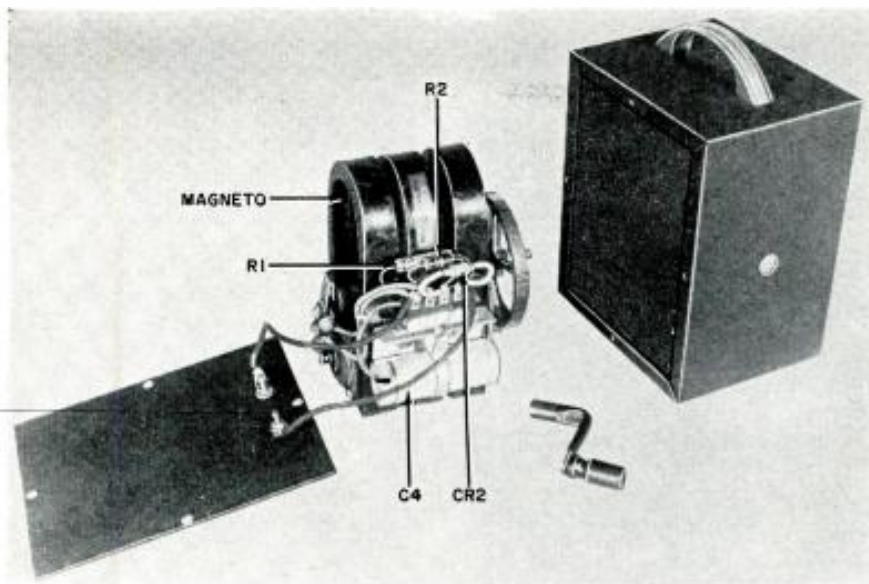

All d.c. rectifier components are attached to the bracket on the magnetic structure.

of rotation, the greater the output voltage.

The reader will find many simple radio receiver circuits in the technical literature to which these emergency power sources may be applied. These simple receiver circuits are not very selective, but need not be, since we are concerned with just two, widely separated frequencies.

Telephone Magneto Power

The author found the old hand-cranked telephone magneto to be one of the best and most reliable power sources for an emergency Conelrad receiver. One of these units may be salvaged from an old wall-type, hand-ringing telephone found in antique shops. They are also available from *Herbach and Rademan, Inc.* in Philadelphia at little cost.

A crystal diode detector, transistor amplifier circuit is shown in Fig. 1. The power to operate the amplifier is supplied by the hand-cranked magneto alternator. The a.c. output from the magneto is rectified by the crystal diode, CR₂. The direct current passing through this diode charges capacitor C₄. No elaborate filter network was necessary. The magneto is quiet in operation and no "hash" or interference was heard in the receiver output even while cranking the alternator. Resistors R₁ and R₂ are used to drop the magneto output to a safe value for the diode and transistor used in the circuit.

The magneto output voltage will vary with different units depending on the magnitude of the magnetic field created by its permanent magnets. This a.c. voltage may be over 100 volts with no load even with a very old unit when cranked rapidly. For the diode and transistor used in the circuit shown, values of 1800 ohms for R₁ and 500 ohms for R₂ were about right.

These resistor values may be employed as a starting point, but play safe, check the a.c. voltage at the mag-

neto output and d.c. voltage at the diode output with a v.t.v.m. while cranking the magneto very slowly. This is especially important when using other circuits and parts than those discussed.

The magneto just fits in a standard 4" x 5" x 6" metal cabinet. Its handle is removable when turned counterclockwise. A 7/16" diameter hole was drilled in the cabinet to allow passage of the handle which was re-installed after the magneto was mounted in place. There are two tapped mounting holes at the bottom of the alternator. Four rubber feet were placed at the cabinet bottom and a small convenient carrying handle is attached to the top.

A small bracket was made from a piece of aluminum and mounted under two large screws which are part of the magneto structure. A four-terminal stand-off is attached to this bracket to support the small parts, as shown in the photograph. This device makes a handy, low-current, general-purpose emergency power supply.

Five leisurely turns of the crank provided clear, steady reception for over 1½ minutes when powering the circuit of Fig. 1 at which time the signal would begin to fade slowly. Another five turns would again recharge the capacitor. The receiver can be operated for long periods without experiencing any wrist fatigue due to cranking. The capacitor charged to a peak potential of 25 volts and discharged at a slow rate.

Very strong signals were received at this location from local stations at distances over 10 miles with a 5-foot length of hook-up wire for antenna and water-pipe ground. With 30 feet of antenna wire strung in the attic, voice broadcasts were intelligible many feet from the phones when laying on the table and stations at greater distance were picked up. Clear, steady signals from several stations were obtained even without a ground. The strongest station also could be heard on a small speaker with suitable output trans-

former. However, for speaker operation, one or two additional transistor stages should be used.

This magneto power source will operate small, commercially available transistor radios. A six-transistor radio belonging to the author was powered by this magneto power supply. Most of the local stations were heard on its small built-in loudspeaker without external antenna or ground. For its full 70-milliwatt output, continuous but only moderate speed cranking was necessary. Weaker stations could be heard on the small earphone supplied with the set.

The magneto power supply can be used to charge one of the rechargeable cells such as used for transistor radios.

A list of parts used in the circuit of Fig. 1 appears in conjunction with the diagram. They are parts that were on hand and are representative of items that may be employed. For example, other r.f. tuning coils, diodes, and transistors may be used. The circuit may be expanded to more transistor stages for loudspeaker operation.

In conclusion, it is recommended that antenna and water-pipe ground terminations be provided at the home location, or locations deemed most safe. In many cases there need not be an outside antenna. It may be sufficient to tack hook-up or bell wire in the attic and carry it through the wall to the basement. Taps may be taken off at several points if desired. The longer the wire, the better. If there is no attic, tack the wire around moulding or string it in the walls. There are numerous ways to provide for antenna and ground.

Just three simple preparations, antenna wire and ground, emergency radio receiver, independent emergency power source, can assure you of receiving vital Conelrad instructions and information under almost any adverse condition.

Fig. 1. The circuit used by the author as a complete self-powered Conelrad receiver.

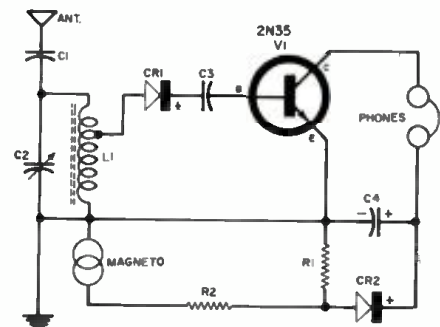

- R₁—1800 ohm, 2 w. res. (see text)
- R₂—500 ohm, 1 w. res. (see text)
- C₁—50 μf. mica capacitor
- C₂—365 μf. var. capacitor
- C₃—1 to .2 μf. mica capacitor
- C₄—500 μf., 50 v. elec. capacitor (Cornell-Dubilier BRH-5050)
- L₁—Transistor antenna coil, 1/2" dia. ferrite rod, tapped to match 600-ohm impedance, 540-1650 kc. (Lafayette MS-166 or equiv.)
- CR₁—1N66 germanium diode
- CR₂—1N34 germanium diode
- V₁—"n-p-n" junction transistor (Sylvania 2N35)
- Magneto—See text

ONE CENT SALE

BUY ONE AT OUR REGULAR LOW PRICE
and GET THE SECOND FOR ONLY 1¢ MORE

CITIZENS BAND TRANSMITTER (27 MC) 5 watt chassis, complete with crystal. \$14.49 each; two for \$15.00.

CITIZENS BAND RECEIVER chassis tunable through all 22 channels. Complete with audio amplifier. \$9.99 each, two for \$10.00.

AMATEUR BAND TRANSCEIVER (144-148 MC) chassis with dual VHF triodes for walkie-talkie radiophone. \$9.99 each, two for \$10.00.

TRANSCEIVER TRANSFORMER: Mike to grid input and plate to low impedance headphone output. Good for telephone handsets. \$1.99 pair, two for \$2.00.

SIGNAL BOOSTER chassis for 27 MC. High gain (20DB) double tuned RF pentode amplifier. Improves performance of any Citizen Band receiver. Complete with tube \$11.99 each—2 for \$12.00.

MICROPHONE High output 200 ohm carbon with terminal lugs. \$1.49 each, two for \$1.50.

COILED CORD 4 conductor 11" telephone cord. Extends to over 4 ft. .99 each, two for \$1.00.

KIT OF PARTS for AM-FM VHF radio receiver. Tunable from 80-200 mc, which includes U.S. satellite frequencies. \$6.99 each, two for \$7.00.

TRANSISTOR AUDIO AMPLIFIER gives 50X voltage gain on low level signals. Operates on 1½ volts. \$3.99 each, two for \$4.00.

CONVERTER (crystal controlled) for 27 MC Citizens Band. Adapts any standard broadcast radio to 27 MC band. Tunes all 22 channels. Complete with tubes and crystal. \$14.99, each, 2 for \$15.00.

ALL MERCHANDISE GUARANTEED
LIMITED QUANTITY—
NO LITERATURE OR CATALOG

Remit in full. Include sufficient postage.
No C.O.D.'s.

VANGUARD ELECTRONIC SALS

Box 12-EW6 Hollis 23, N. Y.

Interference from Coils

(Continued from page 53)

pression is only obtained at the expense of drop-out time. The peak transient voltage can be calculated from the formula: $V = E (R_s/R_c)$, where V is the peak transient voltage, E is the energizing voltage, R_s is the value of the suppression resistor, and R_c is the resistance of the coil.

If the coil's resonant frequency is lowered, we will gain some advantage since this will slow the rise time of the transient voltage and thus decrease the frequency being radiated. This will, as a rule, make the transient output less likely to cause damage or interference. Adding capacitance to the LC circuit, as in Fig. 4D, will lower the resonant frequency and will also, by the formula for peak voltage (V), given earlier, reduce the amplitude of this transient voltage. The disadvantage of this circuit is—again—an increase in drop-out time. The waveform for this circuit is shown in Fig. 3D.

Methods of suppression discussed until now all involve the sacrifice of de-energizing or drop-out time for the sake of reducing the peak amplitude or the frequency of the inductively developed transient voltage. While these reductions in amplitude or frequency tend to minimize the harmful effects of radiation, it is sometimes important that speedy drop-out time should not be sacrificed. The circuit of Fig. 4E provides a means of controlling this drop-out time while still obtaining suppression.

Basically, Fig. 4E can be regarded as a circuit using capacitor suppression, which has been modified by the addition of the diode. While the coil is energized by the supply voltage (polarity shown across the coil), the diode is not conducting. It thus prevents a charge from being taken up by the capacitor.

A capacitor of relatively large value is generally used, so that the circuit will start a cycle of oscillation at a very low frequency when the de-energized coil sends a voltage of reversed polarity through the conducting diode. Once the capacitor has been charged by this reverse voltage, energy cannot be transferred back to the coil, however, to sustain oscillation. This is so because the charge placed on the capacitor, in the polarity shown, cannot pass through the diode back to the coil. The coil will thus remain de-energized after the first transient peak has passed, and the armature will drop out at this point (D) as shown in Fig. 3E.

Since the energy remains in the capacitor, the circuit cannot be used again until the capacitor is discharged. The resistor shunted across the capacitor serves this purpose. The discharge time of this circuit is simply the RC time-constant of the resistor and capacitor. If the resistor is large compared to the normally small resistance of the coil, then the resistor will have no effect on the basic LC circuit. The

fact that a capacitor of large value can often be chosen makes it possible to combine the qualities of good suppression along with fast drop-out time. To conserve space and facilitate mounting, it is often possible to use miniature, low-voltage capacitors although the capacitance is substantial.

Where some values are known and it is necessary to derive the others, the following two formulas may be used: $T = \pi\sqrt{LC}/2$, and $V = I\sqrt{L/C}$; where T is de-energizing time in milliseconds, L is inductance in henrys, C is capacitance in microfarads, and V is peak transient voltage in volts. These formulas are the basis of the handy nomograph in Fig. 6.

A typical application of the nomograph is as follows: The inductance of the coil would be known at the start, as would be the required drop-out time. A straightedge would then be placed so that it cuts the known inductance value in the L column at the left and the desired drop-out time in the fourth column from the left. Where this rule intersects the C column, fifth from the left, the capacitance value required could be read directly. While the rule is still in position, a mark would be made at the point where it intersects the uncalibrated L/C column at the extreme right.

Now the rule is moved so that, at one end, it intersects the point just marked off in the L/C column and, at the other end, it cuts the current column, second from the left, at the appropriate point. The peak voltage rating may now be read where the rule intersects the third column from the left. From this, a safe voltage rating for the capacitor may be chosen.

There are many possible conditions that will determine the choice of the type of suppression circuit and the particular values of components. For example, a maximum voltage that cannot be exceeded may be the primary design consideration, as in the circuits of Fig. 5. Fig. 5A is a typical diode "or" circuit, where any of three inputs must be able to drive a relay without affecting either of the other two inputs. The diodes must be protected against excessive peaks. In Fig. 5B, a transistor drives a solenoid from a pulse of small amplitude. An excessive reverse voltage peak can damage the transistor. Maximum permissible reverse voltage ratings can be matched to drop-out time, where necessary, by using the calculator of Fig. 6, but reversing the procedure already described. If conditions do not permit any reverse voltage at all, the diode suppressor circuit of Fig. 4A must be used.

If it is desirable to check the effectiveness of a suppression circuit, this can be done with an oscilloscope. A wide-band instrument is necessary, preferably with a triggered sweep and a CRT that uses a long-persistent phosphor. The traces obtained as a result of the de-activation of a typical relay coil, unsuppressed and with various types of suppression, are shown in Fig. 2. In each case, the trace begins at

CRYSTAL CONTROLLED CONVERTERS

POLICE • FIRE • COMMERCIAL
• CITIZENS' BAND •

For use with
12 V. Transistor type
car radios
26-50 MC
\$24.95

Complete with crystal and tubes. Requires no high voltage supply. Operates on 12 volts DC. Can be self installed in seconds. Other models for 108-162 MC available.

A practical converter for emergency use with powered home or auto sets. Tunable over 12 MC 26-54 MC or 108-174 MC. **\$13.95**

Also available crystal controlled up to 54 MC. **\$19.95**

Full line of converters & receivers for every application.

ORDER TODAY or WRITE for LITERATURE

KUHN ELECTRONICS
30 GLENWOOD CINCINNATI 17, OHIO

OUT OF SPACE?

You bet we'd be... if we were to tell you all about AUDION'S 'Out of this World Hi Fi Values'

Write for free Catalog

audion
25-W Oxford Road
Massapequa, New York

LORAN R-65/APN-9 RECEIVER & INDICATOR



Used in ships and aircraft. Determines position by radio signals from known transmitters. Accurate to within 1% of distance. Complete with tubes and crystal. Exc. used. Value \$1200.00. Our Price..... **\$79.50**

Cred. less tubes, crystal and visor, but with 3BP1 C.R. tube..... \$29.50
12 Volt Inverter Power Supply for above, BRAND NEW..... \$32.50
28 Volt Inverter Power Supply, exc. cond., \$49.50
Circuit diagram and connecting plugs available.

TS-100AP 'SCOPE

(WORTH \$750)
OUR LOW PRICE **\$29.50**



Can be used with linear sweep or general purpose test scope. Tubes included. Also used with circular sweep as precision range calibrator. Self-contained metal case 8" x 12 1/2" x 1 1/2" deep. For 110 V 50 to 120V cycles AC. Excellent used, like new. Includes tubes, including crystals and C. R. Tube

GOLD PLATED SPECIAL! TS-1/ARR-1 TEST OSCILLATOR

Portable, complete with two 933 tubes, cavity and antenna. BRAND NEW, in metal housing 9 3/4" x 6 3/4" x 7 1/2" high. OUR LOW PRICE, each **\$3.45**

RADIO REMOTE CONTROL RECEIVER



AN/ARW-26. Small size, lightweight. Carrier frequency 6 to 73 Mc. Carrier modulated by audio tone actuates relay. Uses 9 tubes: 2-0003, 2-0002, and 7-3Q4. Battery operated, requires 1-1 1/2 V, 2-6V and 3-67 1/2 V Batts. OUR LOW PRICE, less batteries, LIKE NEW..... **\$9.95**
BRAND NEW, less batteries..... **\$11.95**

NAVY DYNAMIC HEADSET, HI-FI 40 to 14000 cycles, no distortion, complete with cushions, checked out.....

Exc. used..... **\$7.95**

NAVY AIRCRAFT RADIO RECEIVER



ARB/CRV 46151-190 to 9050 Kc in 4 bands. 6 Tube Superhet communications receiver, with local and remote tuning, band change, Sharp and broad tuning, AVC, CW, Illuminated dial. Complete with tubes and dynamo. BRAND NEW..... **\$34.50**
Like New..... **\$26.50**
Power Supply 110 V. AC. Wired..... **\$8.50**

MICROPHONES		
Model	Description	Excellent BRAND NEW
T-17	Carbon Hand Mike	\$5.45
T-30	Carbon Throat Mike	\$3.74
T-45	Army and Navy Lip Mike	1.25
TS-9	Handset	3.88
TS-11	Handset	3.95
TS-13	Handset	4.25
RS-38	Navy Type	4.75

HEADPHONES		
Model	Description	Excellent BRAND NEW
MS-23	High Impedance	\$4.95
MS-33	Low Impedance	4.63
MS-30	Low Imp. (featherwt.)	.90
M-16 U.	High Imp. (2 units)	3.85

TELEPHONES-600 ohm Low Impedance HEADSETS, BRAND NEW, PER PAIR \$3.25
CD-307A Cords, with PL5 plug and JK26 Jack .99
Earphone Cushions for above-pair..... 50

LORAN APN-4 FINE QUALITY NAVIGATIONAL EQUIPMENT



Determine exact geographic position of your boat or plane. Indicator and receiver complete with all tubes and crystal.
INDICATOR ID-68/APN-4, and RECEIVER R-98/APN-4, complete with tubes. Exc. used **\$49.50**
Receiver-indicator as above, BRAND NEW..... **\$79.50**

12 V. Inverter Power Supply for above, BRAND NEW..... \$32.50
28 V. Inverter Power Supply for above, exc. cond., \$49.50

RADIO RECEIVER NAVY TYPE RAY-3



Model AN-PR8N is for 14V DC operation. These receivers are supplied complete with built-in dynamotor, 11 tubes, Weston output meter on front panel, as well as wave antenna and output connection, phone jack, on-off switch. For 14V or 24V, please specify. Like New Condition..... Our Price **\$14.95**

BC-906 FREQ. METER-SPECIAL



Cavity type, 145 to 235 Mc. BRAND NEW, complete with antenna. Manual included. OUR LOW PRICE..... **\$10.88**

WILLARD 6-VOLT MIDGET STORAGE BATTERY



3 Amp. Hour, BRAND NEW, 3 3/4" x 1-13/16" x 2 3/4". Uses Standard Electrolyte..... Only **\$2.95**

2 VOLT BATTERY "PACKAGE"



1-2V. 20 Amp. Hr. Willard Storage Battery, Model #20-2, 3" x 4" x 3 1/2" High..... **\$2.79**
1-2V. 7 prong Synchronous Plug-in Vibrator..... 1.49
1-Quart Bottle Electrolyte (for 2 cells)..... 1.45
ALL BRAND NEW!
Combination Price..... **\$5.45**

SCHEMATIC DIAGRAMS For any equipment on this page, each..... **65c**

BC-603 FM RECEIVER

20 TO 27.9 MC. **\$1495**
Excellent Used.....
BRAND NEW..... **\$16.95**

10 Channel, pushbutton tuning or continuous tuning. Complete with speaker, tubes, switch.

12 or 24V dynamotor for Above, Exc. Used \$4.25..... Brand New **\$5.50**

BC-604 TRANSMITTER-Companion unit for BC-603 Revr above, W/HT all tubes, BRAND NEW..... \$10.95
With Tubes, Used..... \$4.95

SPECIAL! BC-603 FM RCVR CONVERTED FOR ANY FREQUENCY FROM 30 TO 50 MEGACYCLES!

Checked out, perfect working condition, ready for operation. Specify Frequency desired (between 30-50 Mc) when ordering. **\$27.50**

AC POWER SUPPLY FOR BC603, 683

Interchangeable, precision dynamotor. Has On-Off Switch, NO RECVR. CHANGE NEEDED. Provides 220 VDC @ 80 Ma, 24VAC @ 2 Amps..... \$10.49
Complete 240-page Technical Manual for BC-603, 604..... \$2.95

FAMOUS BC-645 TRANSCEIVER

15 Tubes 435 To 500 MC

Can be modified for 2-way communication, voice or code, on ham band 420-450 mc, citizens radio 480-470 mc, fixed and mobile 450-460 mc, television experimental 470-500 mc. 15 tubes, tubes alone worth more than sale price!! 4-7F7, 4-7H7, 2-7E6, 2-6BE6, 2-6X5, 1-12AU6, 3-6A8. Now covers 460 to 480 mc. Brand new BC-645 with tubes, less power supply in factory carton. **\$29.50**

PE-101C Dynamotor, 12/24V input..... \$7.95
UHF Antenna Assembly..... 2.45
Complete Set of 10 Plugs..... 3.50
Control Box..... 2.25

SPECIAL "PACKAGE" OFFER:

BC-645 Transceiver, Dynamotor and all accessories above, COMPLETE, BRAND NEW, While Stocks Last..... **\$42.00**

TG-34A CODE KEYS

Self-contained automatic unit, reproduces code practice signals recorded on paper tape. By use of built-in speaker, provides code practice signals to one or more persons at speeds from 5 to 25 WPM. **\$22.50**

Checked out, exc. used \$18.95

MOBILE-MARINE DYNAMOTOR

Model DM35
INPUT 12V DC. Output: 625 V Dc @ 225 Ma, for pre-selector tank intermittent operation. Price wt. 14 lbs. OUR LOW PRICE, BRAND NEW..... **\$8.45**

OTHER DYNAMOTOR VALUES: Excellent BRAND				
Type	Input	Output	Used	NEW
DM-25	12V 2.2A	250V .050A	4.50	
DA-1A	28V 1.6A	230V .100A	3.95	
DM-28	28V	224V .07A	2.75	4.75
DM-32A	28V 1.1A	250V .05A	2.45	4.45
DM-33A	28V 5A	575V .16A	1.95	3.75
	28V 7A	540V .25A	1.95	3.75
DM-34D	12V 2A	220V .080A	4.15	5.50
DM-53A	28V 1.4A	220V .080A	3.75	5.45
DM-64A	12V 5.1A	275V .150A	7.95	
PE-73C	28V 20A	1000V .350A	7.95	10.50
PE-86	28V 1.25A	250V .050A	2.75	3.85

MOBILE 9-VOLT DYNAMOTOR SPECIAL

INPUT: 9 Volts DC @ 7.5 Amps, OUTPUT: 405 Volts DC @ .095 Amps. May be used for 6 volt operation. BRAND NEW in original carton..... **\$3.95**
BD-7 DYNAMOTOR Input 14V @ 39A. Output 1000V @ .350 A, with starting solenoid, Filter Box and Mounting Base..... Like New \$14.95

SMALL DC MOTORS

All 27V DC Input
Overall 3 3/4" x 1 1/4" Dia.

5069800 Delco PM 250 rpm..... \$4.45
5069790 Delco PM 100 rpm..... \$4.95
5069800 Delco PM 575 rpm, reversible governor controlled with 27V DC Clutch..... \$4.95
5BA10AJ52 145 rpm, reversible..... \$4.45

STANDARD TUBES						
Removed from Brand New Gov't Equipment						
RECEIVING	125G7	.75	807	.95		
6AG5	.35	6J5	.65	813	6.95	
12AT7	.45	6H6	.55	814	2.25	
6AK5	.40	6SL7	.85	815	2.15	
6C4	.25	12A6	.45	826	.44	
6AL5	.35			192B	.29	
6AC7	.55	SPECIAL PURP.			4X-150	5.95
6A8	.32	2C39	3.50	6072	2.50	
6V6	.65	3E29	4.25	1P2A	7.95	

Please include 25% Deposit with Order-Balance C.O.D. or Remittance in Full. 50c Handling Charges on all orders under \$5.00. All shipments F.O.B. Our Warehouse, N.Y.C. All Merchandise subject to Prior Sale and Price Change.

G & G Radio Supply Co.
Telephone: CO 7-4605
51 Vesey St., New York 7, N. Y.

AN/ART-13 100-WATT XMTR

11 CHANNELS
200-1500 Kc
2 to 18.1 Mc
\$4850



Complete with Tubes
Famous Collins Autotune Aircraft Transmitter, AM, CW, MCW. Quick change to any of ten preset channels or manual tuning. Speech amplifier/clipper uses carbon or magnetic mike. Highly stable, highly accurate VFO. Built in Xtal controlled calibrator. PP811s modulate 813 in final up to 90%, class "B". 0-18 Low Freq. Osc. Coil for ART-13..... 7.95
24V Dynamotor for ART-13..... 11.95
Same as above less meter..... 39.50

BC-652A RECEIVER-110t Special! 2000 to 6000 Kc AM Receiver, 2-band, complete with all tubes, 200 Kc Xtal Calibrators, and 12 V Dynamotor. Fine for 80-meter Ham band, Marine, etc. Provides for CW, M.V.C. AVC. Speaker Jack and two Headphone Jacks. Shpg. Wt. 50 lbs. Like new, only..... **\$22.50**

POWER SUPPLY for BC-620, 659, available for 6, 12 or 24 Volts DC. Specify..... **\$6.95**

BC-659 TRANSMITTER & RECEIVER

27 to 38.9 Mc. F.M. Two pre-selected channels crystal controlled. 5 watts. Complete with speaker. **\$11.95**
Less tubes, exc. used..... \$7.95
Antenna for BC-659. Telescoping 20" to 8-Ft..... \$2.95

FM TRANSMITTER-RECEIVER

APN-1. 420 to 460 Mc Air-Port Radio altimeter equipment. Tubes: 2-0B5, 1-12AU6, 1-12SH7, 2-12H6, 1-VR15t. Complete with all tubes. For 27 V DC..... **\$8.95**
BRAND NEW.....

BC-733 VHF 10-TUBE AIRCRAFT RECEIVER

6-channel xtal control. Freq. 108.3 to 110.3 Mc. Dual filter range. Easily converted for tracking Sputniks! **\$8.95**
Brand New complete with tubes..... \$5.95
Dynamotor for above 24 V. New..... \$5.95

BC1206-C BEACON RECEIVER

195 to 420 Kc. made by Satchel - Carlson. Works on 24-28 volts DC. 135 Kc. IF. Complete with 5 tubes. Size 4" x 4" x 6". Wt. 4 lbs. BRAND NEW..... **\$9.99**
BRAND NEW, less tubes..... \$5.95
USED, with tubes..... 5.95
USED, less tubes..... 2.95

ARC-5/R28 RECEIVER

2-meter Superhet. 100 to 150 Mc in 4 crystal channels. Complete with metal case, 11 tubes, BRAND NEW..... **\$24.45**
110V AC Power Sup. Kit for above \$9.75

ARC-5/T-23 TRANSMITTER

100-150 Mc Includes 2-832A, 2-1625 Tubes, BRAND NEW..... **\$21.50**
SPECIAL Limited quantity ARC-5/T23 xmitters. OFFER! Excellent Used, less tubes..... \$5.95
MD-7 MODULATOR for T-23, complete with 4 tubes, LIKE NEW..... **\$9.95**

ARC-5 MARINE RECEIVER-TRANSMITTER

Navy Type Comm. Receiver 1.5 to 3 Mc BRAND NEW with 6 tubes..... **\$16.95**
Navy Type Comm. Transmitter 2.1-3 Mc BRAND NEW with 4 tubes and Xtal MODULATOR for above, new with tubes..... \$5.95

SCR-274 COMMAND EQUIPMENT

ALL COMPLETE WITH TUBES

Type	Description	Used	Like New
BC-436	Receiver 110-550 KC.....	\$12.95	\$14.95
BC-434	Receiver 3-6 Mc.....	9.45	12.45
BC-450	3-Receiver Control Box.....	1.29	1.75

110 Volt AC Power Supply Kit, for all 274-N and ARC-5 Receivers. Complete with metal case, instructions..... **\$7.95**
Factory wired, tested, ready to operate..... \$11.50
SPINDLE TUNING KNOB for 274-N and ARC-5 RECEIVERS, Fits BC-453, BC-454 and others. Only..... **49c**

BC-453 TRANSMITTER-4-5.3 Mc. complete with all tubes and crystal, BRAND NEW..... **\$7.85**
BC-455 TRANSMITTER-5.3 to 7 Mc. Complete with all tubes and crystal..... **\$9.75**
BRAND NEW..... \$13.95
BC-459 TRANSMITTER-7-9.1 Mc. complete with all tubes and crystal..... **\$13.95**

ARC-5/T-19 TRANSMITTER-3 to 4 Mc. BRAND NEW complete with all tubes & crystal..... **\$10.95**
BC-436 Receiver 110-550 KC..... USED \$3.45 NEW \$5.95
RC-481 Transmitter Control Box..... 1.25 NEW 1.49
ALL ACCESSORIES AVAILABLE FOR COMMAND EQUIPMENT

234-258 MC RECEIVER

AN/ARR-2
BRAND NEW 11-tube UHF Tunable Receiver with schematic. Only a few at this low price! Complete with tubes..... **\$8.88**

Send Name, Address on Post Card for FREE CATALOG of Wonderful Surplus Buys!



LEKTRON PENNY SALE!

10 of our BEST SELLERS

- Panel Light Bulbs... 20 for \$1.00 40 for \$1.01
- Carbon Resistors... 60 for \$1.00 120 for \$1.01
- Lucite Boxes... 10 for \$1.00 20 for \$1.01
- Transistor IFS... 10 for \$1.00 20 for \$1.01
- Plugs & Receptacles... 60 for \$1.00 120 for \$1.01
- \$15 Geiger Counter Tube... 1 for \$1.00 2 for \$1.01
- 60 Ceramic Condensers... 60 for \$1.00 120 for \$1.01
- Tubular Condensers... 50 for \$1.00 100 for \$1.01
- Germanium Diodes... 12 for \$1.00 24 for \$1.01
- Tube Sockets... 30 for \$1.00 60 for \$1.01

FREE! PICK ANY \$1.00 POLY PAK® FREE WITH EVERY \$10 ORDER

Your \$1 choice from below (including double paks above)

*This offer is good until July 15, 1960

- 2 HI-Q LOOPSTICKS For 385 mini vari-ables Broadcast band. \$1
- 3 AC-DC SELENIUMS Rectifiers, 110 VAC/DC. Half-wave circuits. \$1
- ELECTRIC MAGNIFIER W/ off-on switch & bulb for precision checks. \$1
- 8 NEON GLO LAMPS Type NE-16 fits in sockets. \$1
- 8 RCA PLUG/JACK SETS Matched pairs. For tuners, amps, re-ceiver. \$1
- 125 HALF WATTERS Carbon resistors. 30 values, 1/2% tol. \$1
- 10-IN-1 PAKETTE Diodes, resistors, electrets, sockets, 11tes, wire, etc. \$1
- 60 DISC CONDENSERS Wide variety, includes NP's, and tubular too. \$1
- 6 SILICON DIODES 1N21, 1N23, etc. \$1
- MIKE TRANSFORMER Mike size. Scaled. 100 ohms to 100,000 ohms. \$1
- \$30 RELAY SURPRISE Popular relay assortment. Guar. satisfaction. \$1
- 6 ROLLS VINYL TAPE In handy pak. 1000 uses. Strong adhesive. \$5-val. \$1
- 50-FT. POWER CABLE For intercoms, speakers. 2 cond. ±18 rubber. \$1
- 60 TERMINAL STRIPS Solder lug type; 1 to 10 lugs. Used in elec. prof. \$1
- 70 COILS & CHOKES HE, ant. osc. slug-tuned & 1/2". 15 types. Reg. #22. \$1
- 75 ONE-WATTERS Resistors incl. precision 1/2%. \$1
- 60 CONDENSER SPEC. Moldeds, mica, ceramic, oil, paper, discs. \$1.50 val. \$1
- \$15 ROTARY PAK Circuit changers. \$1
- "POLY" WIRE PAK 6 25-ft. rolls, plastic ins. ±20 to 30, ass't. \$1
- 10 SIL. XTAL DIODES 1N21, 1N22, etc. \$1
- 40 SUBMINI RESISTORS For transistor circ. \$1
- 4 1N34 DIODES Or equal. Color-coded for 1000's of uses. \$1
- 2 500-MIL RECTIFERS Silicon. "In-hat." \$1
- GIANT SUN BATTERY 1 1/2" long. 100's of sunny & life bulb. \$1
- 40 TRANSISTOR DISCS Condensers incl. .02 and .05 mfd. Dual in-car. \$1
- 7 TRANSISTOR SOCKETS For all transistors \$1
- 4 OUTPUT TRANSFORMERS 500's, etc. Open cased. Some \$2.50 ea. \$1
- SOLDERING IRON 115 VAC/DC; w/air cord set. For hobbyists, etc. \$1
- 6 SLIDE SWITCHES Toggle action. For 115 VAC/DC. Incl. NPST. \$1
- 2 SAPPHIRE NEEDLES 5000 plays. All speed. Fits Astatic car. \$1
- 2 POWER TRANSISTORS 10 watts. For audio circuits in cars. \$1

Minimum Orders \$2

- 70 INSULATED RESISTORS 1/2", 1, 2W. Finest carbons made. 1 & 5% tol. \$1
- 10 PANEL SWITCHES Sensitive. Rotary, power, slide, micro. Reg. #55. \$1
- 60 PRECISION RESISTORS 1/2", 1, 2W. 1% values. \$1
- \$25 TRANSFORMER SPEC. Handy transformer ass't. for hobbyists. re-ceiver. \$1
- 60 RESISTOR SPECIAL W.W. carbon pre-clusion, vari., to 50W. \$1
- 12 VOL. CONTROLS 1/2", 1, 2W. 1% tol. carbon & W.W. for vol. \$1
- 20 TWIST DRILL SET In calibrated case: 1/16 thru 1/4". Elec. drills. \$1
- SUPER POWERED PHONE WORKS. for transistor cord & plug. \$1
- 2 NOBBY TRANSISTORS Mini types. Similar to CK-722, 2N107. \$1
- 40 POWER RESISTORS Vitreous enamel, pure, etc. 10-50W to 10,000 ohms. \$1
- 24 PAINT BRUSHES 6" hand lex. 100% pure bristles. 100's of \$1
- 75 MICA COND'S/R'S Silvers & 1/2", 20 vals. 00025 to .01 and to 1000V. \$1
- \$30 ELECTRO PAK 100ft. to 1000ft. & 4.5V. Duals & triplex too. \$1
- HEARING AID PHONE Crystal. With cord & plug. Use as mike too. \$1
- \$25 SURPRISE PAK Wide variety of radio & pop. electronic parts. \$1
- 70 TUBULAR COND'RS 20 values 0001 to .5 mfd to 1000 VDC. Reg. #31. \$1
- TRANS. RADIO BASIC 10 trans. transistor. \$1
- 40 "SILVER" MICAS 1" & 5/8" Ass't. \$1
- 300-FT. HOOK-UP WIRE 10' thru 21'. Glass-plastic insul.; colors. \$1
- 10 RADIO-TV KNOBS Colored, set screw types too! 1/2" to 1". Some \$1. \$1
- 1500 PCS. HARDWARE Nuts, bolts, brackets, screws, etc. In shop pak. \$1
- WORLD'S SMALL RADIO Germanium kit; tests for hfc. All parts, in-structions. \$1
- 40 MOLDED COND'RS 10' thru 21'. Glass-plastic insul.; pore. \$1
- 10 "GRAIN-O-WHEAT" Lamp; by GE. 1.5VDC; mini work. Worth 25¢ ea. \$1
- 40 TWO WATTERS 10 Radio-TV val. 100 ohms to 500K. 5/8" too. \$1
- ELECTRIC MOTOR 112 VDC; 3000 rpm. Perm. magnet. 100's of uses. \$1
- 1" SQ. CRYSTAL MIKE 100 to 700 cps. Sensitive. For hideaway etc. \$1

FREE GIANT BARGAIN CATALOG WRITE FOR YOURS!

- Clip out & mail
- Check ea. item wanted!
- Return ad with order!
- Avg. wt. 1 lb. per pak!

HOW TO ORDER: Include check or M.O. with sufficient postage; excess returned. C.O.D. orders, 25% down; rated, net 30 days. INCLUDE POSTAL ZONE in address.

LEKTRON 133 Everett Ave. CHELSEA 50, MASS.

what would be point A in Fig. 3. The horizontal (time) and vertical (voltage) deflection scales are different in all three traces, the better to show the nature of the transient waveform.

The pattern in Fig. 2A was produced with no suppression at all. Each horizontal division represents .1 millisecond; each vertical division, 100 volts. The greyish smear at the start of the trace is the high-frequency, high-voltage oscillation that is responsible for the interference. Fig. 2B shows the result of using a diode-resistor combination, as in Fig. 4C, for suppression. Here each horizontal division represents .2 millisecond; each vertical division, only 50 volts. This is essentially the same as the trace drawn in Fig. 3C. Fig. 2C shows the effect of using a diode-capacitor-resistor network. Here each vertical division is only 10 volts. The beginning of the trace is part of a single cycle of low-frequency oscillation. Actually, this waveform corresponds to that drawn as Fig. 3E, except that the horizontal scale has been reduced in the scope photograph to give a notion of waveform shape, which is horizontally expanded in the drawing.

The increase in use of equipment that involves the combination of electro-mechanical and electronic elements is evident. Such equipment is also increasingly coming into the domain of the service technician. To the versatile technician, a working knowledge of transient suppression is most helpful now and is fast becoming essential.

-30-

IHFM ELECTS OFFICERS

RAYMOND V. PEPE, vice-president of James B. Lansing Sound, Inc., was unanimously elected president of the Institute of High Fidelity Manufacturers, Inc. at a general membership meeting held recently in New York.

Serving with Mr. Pepe will be Walter O. Stanton, president of Pickering and Company, as vice-president. He will continue to serve as a director of the Institute.

At the same meeting, plans for the 1960 New York High Fidelity Music Show were unveiled by Milton D. Thalberg of Audiogersh Corporation. The Show will be held at the New York Trade Show Bldg., September 6 through 11 and be open to the public as in past years. Plans include regularly scheduled entertainment by big name talent and a Sunday session for the first time.

A Promotion Committee, headed by Arthur Gasman of British Industries Corp.; a Code of Ethics Committee, chairmanned by Rudy Bozak, R. T. Bozak Mfg. Co.; and a Publicity and Public Relations Committee headed by Albert Forman of "Electronic Technician" were also named by the new president at the meeting.

The Standards Committee has now turned its attention to the matter of establishing standards in the cartridge and speaker fields and will investigate the feasibility of standardizing interconnecting cables for component assemblies.

Headquarters of the IHFM are at 125 East 23rd Street, New York 10, N. Y. Abraham Schwartzman is Executive Administrator of the Institute.

-30-

Sweep Generator for AM

(Continued from page 51)

as a cathode-follower. A potentiometer in the cathode circuit controls the r.f. output.

A third 6CG7 (V_1) is connected as a cathode-coupled multivibrator. A large capacitor in its output plate circuit, C_3 , is charged by the multivibrator output to form a saw-tooth wave. A dual-section potentiometer, R_2 and R_6 , controls the speed of this saw-tooth oscillator, which is continuously variable from 5 to 50 cycles. Use of this control will be explained later.

The output of the sweep generator (V_1) appears across potentiometer R_{10} and across the output terminals for the scope. A portion of the signal on R_{10} is fed to the control grid of r.f. oscillator V_2 . This signal varies the bias on V_2 , and thus causes the frequency to change, at a rate determined by R_2 and R_6 and an amount determined by R_{10} .

The action of V_2 alone is very similar to that of the multivibrator found in the horizontal oscillator of many TV receivers. With R_{10} turned fully counter-clockwise (off), the r.f. oscillator (V_2) is not swept and the entire unit may be used as a single-frequency signal generator for regular radio alignment. The saw-tooth appearing across the scope terminals feeds the horizontal input of an oscilloscope for the time-base synchronization. A 5Y3 (V_4) is a full-wave rectifier that supplies power to the sweeper and also to the detector probe.

The probe (Fig. 4) consists of a broadly tuned amplifier and a crystal detector. The detector output is connected to the vertical input of an oscilloscope. This device is very handy when troubleshooting defective i.f. stages, aligning radios or communication receivers one stage at a time, or for experimenting with filters and tuned circuits. It is not necessary to use when aligning hi-fi AM tuners and radios unless they are badly out of alignment.

Construction

The sweeper was constructed on a 7-inch by 9-inch aluminum chassis (Fig. 5). The probe section is located in the rear, left-hand corner, directly behind V_1 and V_2 . The tuning capacitor (C_6 and C_{10}) stands off the chassis on 1/2-inch pillars. The extra hole in the chassis next to V_3 was for a voltage-regulator tube. This was subsequently found to be unnecessary and was therefore eliminated. Component layout does not seem to be critical, with the possible exception of coil L_1 . This coil should be mounted on 3/8-inch ceramic stand-off insulators to keep it away from the chassis. Naturally the usual precautions of keeping filament wires away from grid connections and components will apply to this unit, to avoid hum pickup. It might be well to mount the filter choke on the top side of the chassis as far away from coil L_1 as possible. The particular choke used

by the author did not induce hum in the coil, but others might.

The detector probe layout is entirely straightforward. Since this unit acts as a preamplifier stage for the oscilloscope, it must be connected with shielded cable or with extremely short wires. The operation of this probe may be checked by connecting its output to a scope and connecting an antenna or length of wire to the input coaxial connector. Random jumping traces should be seen on the scope, indicating radio station pickup.

A three-foot length of coax should be used as a sweeper cable. Prepare it by installing a coaxial connector on one end and a pair of clips on the other end. Another three-foot cable with clips on each end connects the saw-tooth output to the horizontal input on the oscilloscope. Also, make two six-inch coax cables for the input and output of the detector probe.

How to Use the Sweeper

To use the sweeper, connect the vertical input of the oscilloscope across the receiver detector load (usually the volume control). Connect the saw-tooth output from the sweeper to the horizontal input of the scope and place the scope function switch on "external sweep input." Connect the sweeper r.f. output (via the cable) to the oscillator grid of the receiver's mixer tube. Set the oscillator frequency (of the sweeper) to approximately 455 kc. and adjust the r.f. level, sweep width, and synchro-

nization until a swept response-curve trace is observed on the scope. To check the frequency response, loosely couple the output from a regular, accurate signal generator near the mixer. This will put a "birdie" on the trace, similar to a marker used in TV alignment. Grasp the oscillator coil of the AM circuit and observe any changes in the sweep response. If changes are severe, it will be necessary to disconnect the oscillator coil from the mixer tube. In most cases, however, the change will not be significant and it will be just as well to leave the coil in place.

Once a normal i.f. trace is obtained, check the bandwidth at the two points halfway down on either side of the sweep curve. If it is less than 20 kc. wide, stagger the i.f. coil adjustments for the proper bandwidth. It will usually be possible to obtain a satisfactory curve 15 kc. across the top and 20 kc. wide at the half-voltage points. When widening the i.f. amplifier response, you will undoubtedly notice the gain fall off. This is normal whenever the bandwidth is increased.

The sweeper is also useful for troubleshooting of AM radios. Intermittent stages may be isolated by feeding the sweeper into individual stages and connecting the detector probe to the output of each stage. A jumping trace or no trace will quickly pin down the offending stage. Sudden peaks appearing in the response curve indicate regeneration of one or more stages. In addition, the sweeper is extremely valuable

for the alignment of multi-stage communications receivers or single-sideband equipment. In fact, it is difficult to do a top-notch alignment job on crystal filter stages without such a sweeper.

The purpose of the synchronization control (R_2 and R_3) may not be clear. Actually, it controls the frequency of the free-running saw-tooth generator. The setting of this adjustment represents a compromise and depends on the particular oscilloscope you use. Generally, the lower the sweep speed, the more accurate the response curve. At five cycles, the response curve represents a very low-frequency square wave and many scopes do not have sufficient low-frequency response to reproduce it. Of course, if you own a scope with d.c.-coupled amplifiers, there is no problem. As the sweep frequency is reduced (counterclockwise rotation), you will notice that the beginning and the end of the response curve shift vertically with respect to each other. The proper setting for the sync control is just before this distortion becomes objectionable. Since the scope time base is derived from the sweeper, there is no particular synchronization problem.

This sweeper can also be very useful to the ham with the particular alignment problems involved in single-sideband operation. Although space limitations prevent covering such use here, it is discussed in various texts on single-sideband techniques. -30-

Just Out

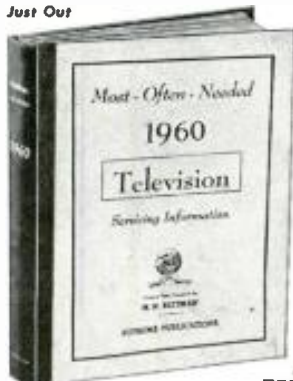

New SUPREME 1960 TV Manual

AMAZING BARGAIN

The new 1960 TV manual is the bargain of the year. Covers all important sets of every make in one giant volume. Your price for this mammoth manual is only \$3. This super-value defies all competition. Other annual volumes at only \$3 each. Factory service material simplifies repairs. Includes all data required for quicker TV servicing. Practically tells you how to find each fault and make needed repair. More pages, more diagrams, more service data per dollar of cost.

TELEVISION SERVICING COURSE

Let this new course help you in TV servicing. Amazing bargain, complete, only \$3, full price for all lessons. Giant in size, mammoth in scope, topics just like a \$200.00 correspondence course. Lessons on picture faults, circuits, adjustments, short-cuts, UHF, alignment facts, hints, antenna problems, trouble-shooting, test equipment, picture analysis. Special, only **\$3**

Companion RADIO COURSE, Introduction to TV

Here is your complete radio training in 22 easy to-follow lessons. Covers fundamentals, fault finding, use of test equipment. Everything in radio. Introduction to TV. Self-test questions. New edition. Special only... **\$2.50**

RADIO VOLUMES

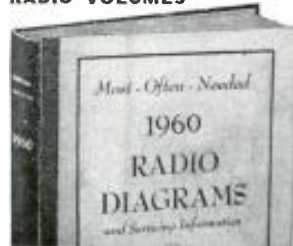

RADIO DIAGRAMS

Supreme is your best source for all needed RADIO diagrams and service data. Covers everything from the most recent 1960 radios to pre-war old-timers; home radios, stereo, combinations, transistor portables, P.M. and auto sets. Sensational values. Only \$2 for many volumes. Every manual has extra large schematics, all needed alignment facts, printed boards, voltage values, trimmers, dial stringing, and helpful hints. Volumes are large in size, 8 1/2 x 11 inches, about 180 pages. See coupon at right for a complete list of these radio manuals. →

COVERS ALL POPULAR SETS

Here is your service data for faster, easier TV repairs. Lowest priced. Best by comparison. Supreme TV manuals have all needed service material on every popular TV set. Helpful, practical, factory-prepared data that will really make TV servicing easy for you. Benefit and save with these amazing values in service manuals. Only \$3 per large, yearly volume.

SIMPLIFIES TV REPAIRS

These giant TV manuals have complete circuits, needed alignment facts, printed boards, servicing hints, production changes, voltage charts, waveforms, and double-page schematics. Here are your authentic service instructions to help you do expert work quicker; and priced at only \$3 per large annual manual. Repair any TV model ever made by having in your shop all 15 volumes as listed in coupon. Your special price for all, only \$42. Or try the new 1960 TV manual to see what an amazing bargain you get for \$3. Send no-risk trial coupon today.



The repair of any television set is really simple with Supreme TV service manuals. Every set is covered in a practical manner that will simplify trouble-shooting and repair. This is the help you need to find toughest faults in a fifty. Most \$3 TV volumes cover a whole year of service material. Now Television Servicing Course will add you in learning TV. Be wise, buy Supreme Manuals only once each year instead of spending dollars every week.

NO-RISK TRIAL ORDER COUPON

SUPREME PUBLICATIONS, 1760 Balsam Rd., Highland Park, ILL.

- Radio Service Course, \$2.50
- 1960 Popular RADIO Diagram Manuals at only **\$2.50** each....
- 1959
- 1958
- 1957
- 1956
- 1955 Radio Manual, only \$2
- 1954
- 1953
- 1952
- 1951
- 1950
- 1949
- 1948
- 1947
- 1946
- 1945
- 1944
- 1943
- 1942
- 1941
- 1940
- 1926-1938 Manual, \$2.50
- Radio and TV Master Index, 25c

Rush today TV manuals checked below and Radio manuals at left. Satisfaction guaranteed.

- New 1960 TV Manual, \$3.
- Additional 1959 TV Manual, \$3.
- Additional 1957 TV, \$3
- 1956 TV Manual, \$3.
- Early 1959 TV, \$3.
- Additional 1955 TV, \$3.
- Early 1955, \$3.
- 1954 TV, \$3.
- 1953 TV, \$3.
- 1952 TV, \$3.
- 1951 TV, \$3.
- 1949 TV, \$3.
- 1948 TV, \$3.
- 1957-58 RCA TV Manual, \$1.50
- New Television Servicing Course, complete... \$3.

I am enclosing \$..... Send postpaid.
 Send C.O.D. I am enclosing \$..... deposit.

Name:
 Address:

Supreme Publications
 Sold by All Leading Parts Jobbers

IN A recent survey of existing squelch circuits, it became apparent that many are real nightmares of complexity considering the very simple task they are required to perform. Some circuits even go to the extreme of using three tubes for a squelch.

Since I wanted a simple squelch, to allow as little alteration as possible in my communications receiver, I turned away from the fancy techniques and developed what I call "the gated diode squelch" which is tubeless, and requires only one diode, five resistors, two capacitors, and one pot. The pot is the squelch control and is placed anywhere on the front panel that fits in with the other knobs. This squelch circuit is adaptable to any receiver which has a.v.c. or a.g.c., whether AM, FM, or other.

The particular constants shown in Fig. 1, however, are optimized for audio-frequency transmissions. The components shown (R_1 , R_2 , C_3) have a time-constant which turns the audio on

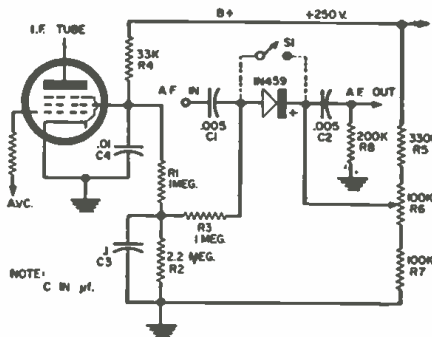

Fig. 1. Gated diode audio squelch circuit.

forward, the diode is a low-resistance path and the audio goes through it readily.

Specifically, C_1 and C_2 are coupling capacitors which feed the audio through the diode but prevent any d.c. currents from passing to affect the diode's gating actions. C_1 is usually already in the receiver as the coupling capacitor between the detector or vol-

tion, the diode is practically an open circuit. However, if there is, say, five volts of a.f. on the anode, the d.c. bias from R_6 must be 6 volts above the d.c. on the anode to keep the anode from going positive on a.f. peaks and conducting. Since the a.f. present at the anode is usually a jumbled mess of signals and noise, adjustment of R_6 will allow all below a certain level to be stopped and only the desired levels will pass.

The d.c. voltage at the anode is a fixed fraction of the voltage put on the high side of R_1 . This value is about 150 volts and for a setting of R_6 , which just stops passage of the audio, about a 10-volt upward change in this 150 volts will cause the diode to conduct and, under these conditions, the audio will pass again.

Now, since the i.f. tube gets a.v.c. voltage, its screen current will drop, (and the screen voltage will rise) when the a.v.c. voltage goes more negative (meaning we've received a stronger

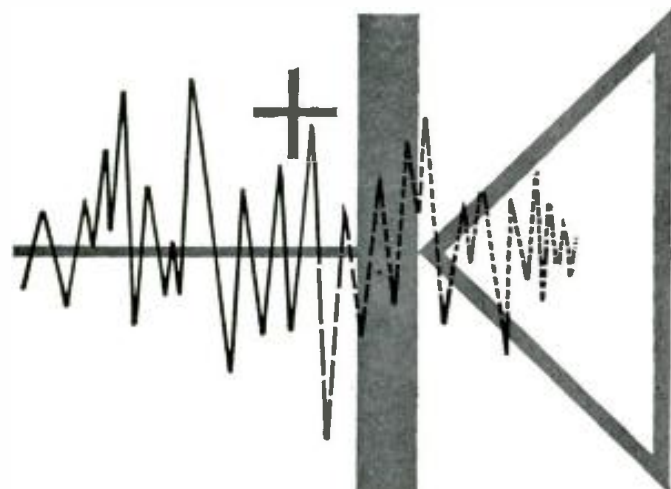

Diode Squelch Circuit

By E. DUSINA

Simple circuit using crystal diode with several resistors and capacitors that can be added to any receiver with a.v.c. bus.

about $\frac{1}{10}$ th second after carrier is received. For pulse receivers, one would have to reduce C_3 to .01 μ f. or less to speed up the turn-on time. This squelch has an advantage in that it can be set fairly close. This means that if, for instance, QRM, etc., was S6 or so on the "S" meter, you could set the squelch threshold at that level, and if the station you wanted to hear was S7 or over, only he would trip open the squelch. This I have found greatly enhances ham communications, because if your party isn't about 6 db above the QRM, you'll have a very hard time understanding him at all, and if he is above, you can enjoy quiet when he isn't transmitting.

The Circuit

Essentially, the principle of operation is that when the diode is back biased, (polarized in the direction of no current flow) it is almost an open circuit so the audio trying to get through it can't pass. When the bias is

ume control and the grid of the first a.f. amplifier. The values of C_1 and C_2 are not at all critical and whatever size coupling capacitor your receiver has is fine. C_3 should be about the same capacity as C_1 , however.

R_5 , R_6 , and R_7 form a voltage divider which allows the wiper arm of pot R_6 to choose any voltage between about +50 and +100 volts. R_6 is the squelch control and the lower the voltage on its wiper, the weaker the signal which will go through the squelch.

On the input side, R_1 and R_2 form a voltage divider to furnish about +60 volts to the anode of the diode. The time-constant of R_1 , R_2 , C_3 is about .1 second, so about $\frac{1}{10}$ th second after a carrier is received, the squelch operates. R_3 carries the d.c. up to the diode without shorting out the audio through C_3 .

All that is necessary now to cause diode gating (or switching), is to set R_6 so that the diode cathode is more positive than the anode. In this posi-

signal). The screen voltage shifts considerably for even small a.v.c. changes so by feeding it to the R_1 - R_2 divider, our squelch will turn on when a carrier is received. Whatever the level of the a.v.c. caused by noise, QRM, etc., all we need to do is set R_6 to squelch it, and all slightly stronger signals will still come through and the receiver will operate normally.

Bypass C_1 is already on the i.f. tube as well as screen resistor R_4 . If a resistor isn't there, or if the one there is less than about 10,000 ohms, R_4 should be installed. With the R_1 - R_2 values shown, the screen voltage of the i.f. tube should be about 150 volts under no-signal conditions.

R_8 is put there because even a good diode has some reverse current; consequently, some weak audio leaks through even when the diode is open. Since this diode leakage resistance is many megohms, the 200,000-ohm resistor effectively allows only one or two per-cent of the leaked audio to get

Locate:
THAT DEFECTIVE CIRCUIT QUICKLY

new
BUZIT
TRANSISTORIZED
SIGNAL TRACER

NO CLIPS OR WIRES
TO MESS WITH

Available at
your favorite jobber

W MODEL BZ1

SIMPLY PRESS SWITCH

- to on position & begin signal tracing; ... by probing into circuit.

SUITABLE FOR VIDEO TRACING

- Buzit transmits many harmonics from AUDIO TO VIDEO RANGE.

• FITS THE POCKET LIKE A PEN
• OPERATES ON TWO PEN LIGHT BATTERIES

Used for trouble shooting

AF CIRCUITS IF CIRCUITS RF CIRCUITS
VIDEO CONTINUITY CHECKS
SPEAKERS -ETC

ONLY **\$810** DLR. NET

WORKMAN TV Products, Inc.
SARASOTA, FLORIDA



Speeding Customer Payments
(Continued from page 62)

people, the intention to make payment may be put aside and forgotten because an envelope or a stamp doesn't happen to be available.

Credit systems. There is a great deal of controversy over the advantages and disadvantages of working through organizations that issue credit cards or use other such systems. However, the local way of doing business or the particular terms of such an organization may make an arrangement worthwhile.

These credit systems generally charge the participating firm a certain percentage of the amount involved. However, if they do not charge much more than five per-cent, if they themselves pay their participants promptly, and if they assume responsibility for collections, this can be a bargain. In many systems now being promoted by local banks, no charge at all is levied on the firm. All credit-account charges are made to the customers who get the credit.

The "get-tough" policy. Since this method is an excellent one for driving customers away (although you may be better off without some of them!), it should be used selectively. There are some people who will just go on taking full advantage of business men with reputations as "soft touches" while firms that are less lenient get first consideration. You don't have to use lethal weapons to let people know that you're not a sucker.

Avoid open accounts. Some chronically late payers get that way because they feel that, especially with large amounts involved, they can't be expected to pay all at once and there is no definite schedule for writing off the debt. When you have a major repair bill, such as a picture-tube job, for a customer known to be a "slow pay," from your own past experience or from a credit report, have a specific time-payment plan ready. Definite, agreed-upon amounts at equally definite intervals give this type much less leeway for stretching things.

Personal relationship. If properly used, a good personal relationship with customers can increase promptness in payments. Where customers are strapped to the point that they can pay off some obligations but not all, they may find it harder to face someone they know, when they are behind in payments to him, than to face relative strangers. Of course this relationship should be developed with discretion. If you get overly friendly with some types, they begin to feel that they can take advantage of "good friends" in a way they would not dare attempt with strangers.

Discretion, in fact, is the key to the success of any of the methods mentioned. Knowing when to use which techniques on which customers is as important as any of the points in the program.



**transistorized
FM receiver**

**build it yourself— MILLER will supply all
the circuit and construction details, and
the hard-to-get parts**

Now, for the first time, you can buy everything required to build a fully portable, high performance FM receiver. Miller distributors are ready with kits containing the i.f. and ratio detector transformers . . . the antenna RF and oscillator coils, variable capacitors, knobs, and the transistors needed to duplicate vacuum tube performance. If you want the attractive metal cabinet and panel shown, your Miller distributor supplies those, too.

The completed receiver has a sensitivity of 2.5 μ v. and such quality features as AFC circuit, vernier tuning, and push-pull audio stage. Full instructions are given for aligning the unit, and placing it in operation.

Ask your Miller distributor for "The Coil Forum," Vol. 1., or write direct.



J.W. MILLER COMPANY
5917 S. Main St., Los Angeles 3, Calif.

Manufacturers of Quality Radio
and TV Equipment Since 1923

ELECTRONICS BOOK SERVICE

will send you your choice of the world's greatest electronics books with a 7-DAY MONEY-BACK GUARANTEE

Here are some of the world's greatest electronics books...chosen carefully by the editors of the Ziff-Davis Electronics Division as among the best in their fields. You'll find top-notch texts and manuals on theory and instruction...important volumes covering every aspect of high fidelity and tape recording...reference books to help you understand such fields as computers, citizens band and electronics experimentation. Each volume is designed to help you get more know-how, greater

enjoyment from your electronics specialty—and each is sent to you with this guarantee: If you are not completely satisfied after reading and studying your books for seven full days, return them and you will receive a complete refund, with no questions asked! Here is the perfect way to build the library every man in electronics must have. A perfect way, incidentally, to solve gift problems too. Simply use the coupon below to indicate your choices and to place your order!

THEORY AND INSTRUCTION

2015. BASIC ELECTRONICS by **BERNARD GROB**. An introductory text on the fundamentals of electricity and electronics for technicians in radio, television and industrial electronics. Exceptionally clear style makes this book ideal for home study. \$9.25

2016. ELEMENTS OF RADIO by **A. MARCUS & WM. MARCUS**. Employing a unique "spiral" method of instruction, this is an excellent one-volume course on the essentials of radio. Over 500 diagrams and drawings. \$7.00

2016. ELECTRONICS DICTIONARY by **COOKE & MARCUS**. Definitions of almost 6,500 terms, abbreviations. An essential volume. \$6.50

2014. BASIC ELECTRONICS by **J. DALY & R. A. GREENFIELD**. Here, in twelve chapters, is a complete general introduction to electronics for technicians who make use of complex electronic equipment in modern laboratories. \$9.00

2009. TELEVISION AND FM ANTENNA GUIDE by **EDWARD M. NOLL & MATTHEW MANDL**. Two antenna experts tell you their secrets of antenna choice and installation for best reception in any area. Loaded with useful tips on improving reception in fringe and difficult areas. \$5.25

2004. FM RADIO SERVICING HANDBOOK. A practical guide to frequency modulated VHF radio receivers, their design, construction, alignment and repair; with chapters on adaptors, aeriavs and hi-fi audio equipment. \$5.00

2025. UNDERSTANDING RADIO by **WATSDN, WELCH & EBY**. Here is the perfect volume for those with little or no technical knowledge who wish to know the fundamentals of radio theory and servicing. Complete explanations of 24 major areas of radio. \$7.95

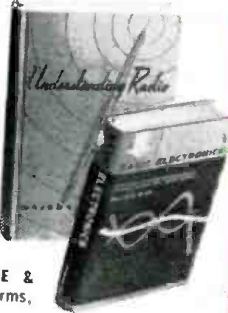

HI-FI AND TAPE

2042. TECHNIQUES OF MAGNETIC RECORDING by **JOEL TALL**. Brings the many aspects of this exciting new field into focus through descriptions of the various recording models, techniques and practical uses in TV, radio, and film. \$7.95

2035. MAGNETIC TAPE RECORDING by **H. G. M. SPRATT**. From the Principles of Magnetism, through Applications of Magnetic Recording, the 14 chapters and two appendices comprising this volume bring you an exhaustive coverage of the field. Covers such applications of recording as TV signal recording, medical and psychological uses, etc., in addition to conventional spheres of music and speech recording. \$8.50

2036. THE PRACTICAL HI-FI HANDBOOK by **GORDON I. KING**. A guide to hi-fi sound reproduction for service engineers and amateur enthusiast. Chapters on amplifiers, loudspeakers, pickups, microphones, record players, disc and recording, and stereophones. \$6.00

2037. REPAIRING RECORD CHANGERS by **EUGENE ECKLUND**. A practical manual on repair of mechanical elements of record changers, including pickups, needles, record changing actions, motors, drives, and tripping, dropping and shut-off mechanisms. Magnetic recorder repairs also covered. Perfect guide for trouble-shooting. \$5.95



42. REVERSE TAPE RECORDER GUIDE by **K. S. TYDINGS**. \$1.95

2039. RIBBONS OF SOUND by **K. A. BARLEBEN**. A perfect introduction to tape recording principles and practices. Paper. \$2.50; 581C—same title in cloth binding. \$3.50

2040. TAPE RECORDERS AND TAPE RECORDINGS. An ideal sourcebook of information on all aspects of tape recording. Covers all fundamentals necessary to realize full potential of your tape equipment. Paper, \$2.95

49. TAPE RECORDER GUIDE by **MARSHALL**. \$1.95

2078. YOUR TAPE RECORDER by **MARSHALL**. \$4.95

2080. HI-FI STEREO FOR YOUR HOME by **ARTHUR WHITMAN**. \$3.50

ZIFF-DAVIS BOOKS



2065. ELECTRONIC EXPERIMENTER'S MANUAL by **DAVID A. FINDLAY**. With a few dollars worth of basic tools and this book to guide you, you can explore the wonder-world of electronics experimentation more completely than ever before. \$4.95

2069. COMPUTERS AND HOW THEY WORK by **JAMES FARNSTOCK**. A fact-filled guidebook to electronic computers. Covers the history of computers and explains the workings of every major computer system ever used. Must reading for career minded students and electronics pros. \$4.95

2072. CLASS D CITIZENS RADIO by **LEO G. SANDS**. First complete book on Citizens Radio operation. Here's the story on the whole field—its history, rules, and everything about how it works. Learn exactly what Citizens Radio is, its applications, what you need, FCC rulings, etc. \$4.95

ZIFF-DAVIS ELECTRONICS ANNUALS

2049. ELECTRONIC KITS DIRECTORY (1960 edition—Paper). \$1.00

2044. HI-FI ANNUAL & AUDIO HANDBOOK (1960 edition—Paper). \$1.00

2045. HI-FI DIRECTORY & BUYERS' GUIDE (1960 edition—Paper). \$1.00

2047. YOUR CAREER IN ELECTRONICS (1960 edition—Paper). \$1.00

2048. ELECTRONICS EXPERIMENTER'S HANDBOOK (1960 edition—Paper). \$1.00

2048C—cloth, \$1.95

2043. STEREO-HI-FI GUIDE (1960 edition—Paper). \$1.00

ASK FOR THESE BOOKS AT YOUR FAVORITE HI-FI OR PARTS DEALER,
OR USE COUPON BELOW FOR SEVEN-DAY MONEY-BACK OFFER

ELECTRONICS BOOK SERVICE

434 South Wabash Ave., Dept. ZW660
Chicago 5, Ill.

Please send me the books listed below. I understand that if I am not completely satisfied, I may return any or all books within seven days for a full refund.

NUMBER	TITLE	PRICE
TOTAL		

(If you need additional space to list more books, attach a sheet of paper with additional list.)

My money order or check for the total above, \$....., is enclosed.*

Please send me your FREE catalog on electronics books.

Name.....

Address.....

City.....

Zone.....

State.....

*On New York City orders, add 3% sales tax. Sorry—no charges, or C.O.D. orders.

Build the BEST BUY in CITIZENS BAND TRANSCEIVERS...

EICO®

#760 (117 VAC) less bracket:
Kit \$59.95. Wired \$89.95.



#761 (117 VAC & 6 VDC): Kit \$69.95. Wired \$99.95.

#762 (117 VAC & 12 VDC): Kit \$69.95. Wired \$99.95.

A thoroughly useful and reliable citizens band transceiver of exemplary electronic, mechanical, & industrial design. Consists of a powerful 5-watt (as defined by FCC), crystal-controlled transmitter & extremely sensitive, highly selective superheterodyne receiver with RF stage & noise limiter. Includes built-in speaker & detachable ceramic microphone. Features pre-set & sealed crystal oscillator circuit elements. Broad tuning permits shifting from any of the 23 citizen band channels to any other simply by changing crystals—no adjustments needed. Built-in variable "pi" network matches most popular antennas. Directly attached base-loaded portable whip, & ground plane (roof) antennas available. The quality & precision of this transceiver is very necessary for consistently dependable operation—increasingly so in the future when citizens band is put to greater use. No exams or special skill needed—any citizen 18 years or older may obtain station license by submitting FCC form, supplied by EICO.

Build the Best 6-TRANSISTOR RADIO RA-6

Kit \$29.95 Wired \$49.95
includes FET, less 9V battery

American-made with finest quality parts. High sensitivity and selectivity. New plug-in type transistors easily removable for checking. Big-set volume and tone with 4" x 6" PM speaker & 250 mw push-pull audio output stage. Built-in Ferrite rod antenna. Pre-aligned RF & IF transformers. Planetary vernier tuning (7:1 reduction) for easy station selection & tuning. High-impedance earphone jack for private listening. Attractive tan leatherette case, retractable handle. Compact: 8½" w, 4½" h, 2½" d. Only 3 lbs.



Build the Best HAM GEAR



New Code Practice Oscillator #706
Kit \$8.95 Wired \$12.95

Rugged battery-operated transistor oscillator circuit with built-in 3" speaker. Front panel (deep-etched satin aluminum) has flashing light, phone jack, pitch control (500-2000 cps), external key terminals, "temporary" key. Panel switch selects Tone, Light, or both Tone & Light. 6½" h, 3¾" w, 2¾" d.



**90-WATT CW
TRANSMITTER* #720**

Kit \$79.95 Wired \$119.95
*U.S. Pat. No. D-184,776

"Top quality" — ELECTRONIC KITS GUIDE. Ideal for veteran or novice. 90W CW, 65W external plate modulation. 80 through 10 meters.



**HIGH LEVEL UNIVERSAL
MODULATOR-DRIVER #730**

Kit \$49.95 Wired \$79.95
Cover E-5 \$4.50
Delivers 50W undistorted audio. Modulates transmitters having RF inputs up to 100W. Unique over-modulation indicator.



GRID DIP METER #710

Kit \$29.95 Wired \$49.95
Includes complete set of coils for full band coverage. Continuous coverage 400 kc to 250 mc. 500 ua meter.

Compare — Judge for yourself — at your neighborhood EICO dealer. For FREE catalog on over 70 models of easy-to-build professional test instruments, hi-fi and ham gear, fill out coupon on Page 27.

Add 5% in the West. © 1960

EICO®

3300 N. Blvd., L.I.C. 1, N.Y.

Electronic Crosswords

By JOHN J. GILL

HERE'S a chance for you to try your hand at a few off-beat terms and definitions. The author has played fair but you may have to resort to the dictionary to spot some of the words involved. If you give up easily, the answer appears on page 121.

ACROSS

1. An electromagnetic device for converting d.c. to a.c. (pl.).
4. Type of switch.
7. Carbon—regulator.
8. Visual test instrument (abbr.).
9. Science dealing with the atom nucleus.
14. Circular "shoe" for vehicles.
15. Unit for 17 across.
17. Current opposer (abbr.).
18. "In case of"
19. To cause a gaseous tube to become conductive.
22. Postscript (abbr.).
23. Mimic.
24. Inductance.
26. Science of measuring angles.
32. Not FM.
34. Chemical used in photocells.
35. Tilt.
36. Solder component.
38. The (Span.).
39. "For example."
40. Upon.
41. Jungle King.
42. Device for transmitting mechanical motion by means of electricity.
44. Twelve inches (abbr.).
45. While.
46. Forward!
48. Winter "footwear."
50. Type of motor (pl.).
51. Variety of agate.

DOWN

1. In math, solving problems by means of ancient Greek theory.
2. When spot size is too big on TV tube, set will do this.
3. Alloy of iron with aluminum, nickel, and cobalt.
4. Noise.
5. Gripping tool.
6. Dry, not sweet.
7. Rhymer.
10. Middle of the winding (abbr.).
11. Type of wire.
12. Common suffix.
13. Reciprocal of reactance.
16. To be "with it" (jive talk).
19. Current (symbol).
20. Signal-to—ratio.
21. Component parts of a tube.
22. Ceramic insulating material.
24. Grid voltage (symbol).
27. Civil Defense agency (abbr.).
28. Direction (abbr.).
29. Dielectric.
30. Amplification factor.
31. Directional antenna (pl.).
33. Myself.
37. Type of setscrew.
40. Particle indicating distance.
43. Companion for "neither."
47. Negative.
48. Knock out (slang).

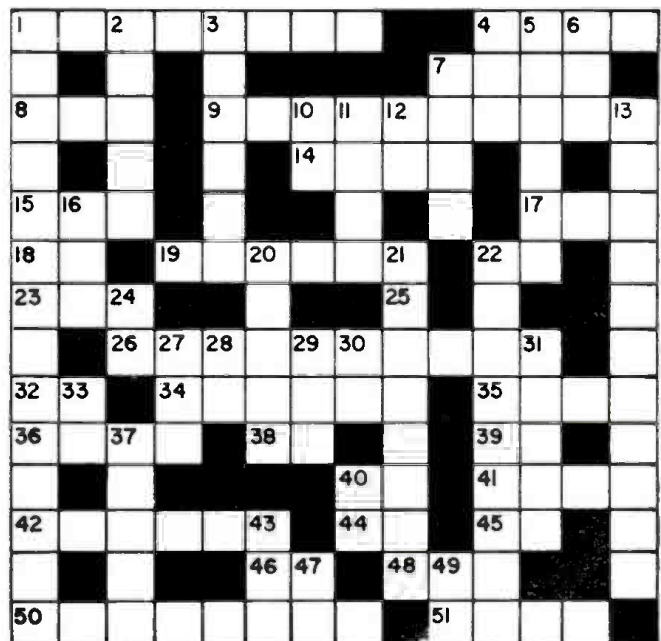

THE Institute of Radio Engineers recently held its national convention in New York and, as usual, presented its members with an imposing number of new developments, disclosed in papers read at many technical seminars. Two new methods of tape playback of recorded music were demonstrated. Both employed variations of the cartridge concept as opposed to reel-to-reel playback. One system was put forth by Marvin Camras of the Armour Research Foundation of Illinois Institute of Technology.

As many readers probably know, Mr. Camras is one of the pioneer workers in the field of magnetic tape recording and holds dozens of patents for his researches. Obviously here is a man deserving of respect.

In brief, the Camras cartridge is designed to operate at 3 3/4 ips using standard 1/4-inch magnetic tape. It is physically quite a bit smaller than the RCA cartridge. It has the unique advantages of being able to be stacked and changed, such as disc records on a changer. The tape is rewound after each play, and there is also a fast-forward and rewind facility if desired. A basic playing mechanism was shown as well as several prototype models of changer mechanisms to handle the cartridge.

Most significantly, the cartridge is so designed that it can be made compatible and playable on conventional reel-type tape machines. It was obvi-

Sound on Tape

By BERT WHYTE

ous that a lot of thought and practical planning had gone into this system and it was something worth exploring since it was not as uncompromising as current cartridge concepts.

But, interesting as the Camras system was, the second cartridge system presented was far more exotic and created a sensation which overshadowed the Camras accomplishment. It was this second system which grabbed most of the headlines. Presented by Dr. Peter Goldmark, father of the LP record, and his colleagues at CBS Research Laboratories, this was an entirely revolutionary concept for the playback of recorded music on tape. (For technical details on the system, see the article "1 7/8-ips Tape System for Stereo" in this issue.)

Visualize, if you will, a completely sealed plastic cartridge about the size of and slightly thicker than a graham

cracker, with a small hole in the middle. Inside is tape only 1/8th inch wide. This tape operates at 1 7/8 ips. The playback mechanism shown was of very compact size and appeared to be of sophisticated design. The cartridges can be stacked on a spindle through their center holes, just like discs, and changed the same way. They play for 64 minutes, then automatically rewind and another cartridge slips into place. If desired, fast-forward and rewind is possible.

The tape itself is never exposed to any handling problems, being sealed in the cartridge. Now all this in itself is interesting but how about this . . . the tape has provision for three channels of sound and this can be in the form of the two outer channels for stereo with the third middle channel an admixture of the stereo channel plus a delay device which would permit individual

REMARKABLE TUBE VALUES AT 1950 PRICES

ALL TUBES INDIVIDUALLY BOXED, CODE DATED AND BRANDED "TRU-VAC"

Typical TRU-VAC® Bargains!

THIS IS A PARTIAL LIST
Thousands More Always In Stock

OY4	2CY5	5J6	6AR5	6BK5	6CQ8	6S7	7A4/XXL	7N7	12BA7	12W6GT	38
OZ4	3A4	5R4	6A55	6BK7	6CR6	6SB7	7A5	7Q7	12BD6	12X4	39/44
1A7GT	3A5	5U4	6AT6	6B17GT	6CS6	6SA7	7A6	757	12BE6	14A7/12B	41
1B3GT	3A15	5U8	6AU4GT	6BN6	6CU5	6SD7GT	7A7	7K6	12BF6	14B6	42
1C6	3AU6	5V4G	6AU5GT	6BQ6GT	6CU6	6SF5	7A8	7X7	12BH7	14Q7	43
1C7	3BC5	5V6GT	6AU6	6BQ7	6D6	6SF7	7B4	7Y4	12BQ6	19	45
1F4	3BN6	5X8	6AU8	6BR8	6DE6	6SG7	7B5	7Z4	12BR7	19AU4GT	50A5
1F5	3BZ6	5Y3	6AV5GT	6B58	6DG6GT	6SH7	7B6	12A8	12B7	19BG6G	50B5
1G4	3CB6	6A6	6AV6	6BY5G	6DQ6	6SJ7	7B7	12AB5	12CA5	19J6	50C5
1H5GT	3Q4	6A8A	6AW8	6BZ6	6F5	6SK7	7B8	12AQ5	12CN5	19T8	50L6
1I4	354	6AC7	6AX4GT	6BZ7	6F6	6SL7	7C4	12AT6	12D4	24A	56
1I6	3V4	6AF4	6AX5GT	6C4	6H6	6SQ7	7C5	12AT7	12F5	25Z6GT	57
1N5GT	4BQ7A	6AG5	6B8	6CB6	6J4	6SR7	7C6	12AU6	12K7	26	58
1R5	4B58	6AH4GT	6BA6	6CD6G	6J5	6T4	7C7	12AU7	12L6	27	71A
1S5	4BZ7	6AH6	6BC5	6CF6	6J6	6U8	7E5	12AV6	12Q7	35	75
1T4	4C86	6AK5	6BC8	6CG7	6J7	6V6GT	7E6	12AV7	12SA7	35A5	76
1U4	5AM8	6A15	6BD6	6CB8	6K6GT	6W6GT	7E7	12AX4GT	12S7	35B5	77
1U5	5AN8	6AM8	6BE6	6C16	6K7	6X4	7F7	12AX7	12SK7	35C5	78
1V2	5AT8	6AN8	6BF5	6CM6	6N7	6X5GT	7F8	12AZ7	12SN7GT	35W4	80
1X2	5AV8	6AQ5	6BG6G	6CM7	6Q7	6X8	7G7	12B4	12SQ7	35Z5	84/624
2AF4	5AZ4	6AQ6	6BH6	6CN7	654	6Y6G	7H7	12BA6	12V6GT	36	11273
2BN4	5BR8	6A07	6BJ6								

1 YEAR GUARANTEED PICTURE TUBES

Brand New Allied A-1 Tubes Brand New
Below listed prices do not include dot. Add Additional \$5.00 Deposit on tube sizes to 20"; on 21" and 24" tubes - \$7.50. Deposit refunded immediately when dud is returned prepaid. Aluminized tubes - \$4.00 extra.

Picture tubes shipped only to continental USA and Canada - All tubes F.O.B. Harrison, N. J.

108P4	7-90	108P4	12-10	12CP4	16-90	19AP4	18-30	21AP4	18-70	21P4	18-30	21P4	18-30
121P4	10-40	108P4	11-90	12CP4	17-90	20CP4	15-90	21AP4	17-90	21P4	18-30	21P4	18-30
148CP4	11-90	108P4	12-10	12CP4	16-90	20CP4	15-90	21AP4	18-70	21P4	18-30	21P4	18-30
160P4	16-00	108P4	11-90	12CP4	16-90	20CP4	17-90	21AP4	18-70	21P4	18-30	21P4	18-30
160P4	11-10	17AP4	13-40	12CP4	13-80	21AP4	21-40	21AP4	17-40	21P4	18-30	21P4	18-30
160P4	16-00	17AP4	13-40	12CP4	16-90	21AP4	18-70	21P4	18-30	21P4	18-30	21P4	18-30

ATTENTION QUANTITY USERS!

Big Discounts Are Yours . . . Call or Write For Our 1000 Tube "Private Label" Special Attention Branding Dept. MGR.

MONEY CHEERFULLY REFUNDED WITHIN FIVE (5) DAYS, IF NOT COMPLETELY SATISFIED! TRU-VAC® PAYS YOUR POSTAGE on orders of \$5 or more in U.S.A. and Territories. Send approximate postage on Canadian and foreign orders. Any order less than \$5 requires 25c handling charge. Send 25% on C.O.D.'s. All orders subject to prior sale.

Complying with Federal regulations, the following statement appears in all Tru-Vac advertising: Tubes appearing in this ad may be FACTORY SECONDS or USED tubes and are clearly marked.

Your best buy . . .

TRU-VAC

35¢

ec.

\$33

PER HUNDRED

For any used or factory second tube!

USED TV CONSOLES

GUARANTEED To Work

When You Receive Them

10" & 12"	\$29
14" & 16"	\$37
17"	\$45
19"	\$59
20" & 21"	\$70

All sets shipped in two cartons to avoid breakage. Sets shipped express to continental U.S.A. and Canada only. F.O.B. Harrison, New Jersey.

FREE BONUS

RABBIT EARS
\$7.95 Value

FREE with each set purchased

GUARANTEE

Only TRU-VAC guarantees to replace free any tube which becomes defective in use within one year of date of purchase.

FREE FUSE CLIP

Sent With Any Order Of \$5 Or More

TRU-VAC Electric Company

Harrison Avenue Box 107 Harrison, New Jersey HUmboldt 4-9770

Visit Our Huge Testing Dept. In The Heart Of Harrison, N. J.'s Electronics Industry

KEEP CANDEE HANDEE!

FREE! Bargain-filled Summer Flyer! Get your copy today!

ARC-5 SPECIALS!
 R-26 RECEIVER: 144 Mc. Excellent ... \$9.95
 R-27 RECEIVER: 6-9 Mc. Excellent ... 9.95
 MD-7 PLATE MODULATOR: Excellent ... 6.50
 COMBO DEAL: Save by buying all three units above for only... **\$24.95**

FAMOUS Q'SER 111
 This is the fabulous one! 100-550 kc. The receiver you've been looking for at only... **\$9.95**

APX-6 TRANSPONDER
 A midjet warehouse of parts! Blowers, three Vee-der-look counters, 1F strips, cavity, over 30 tubes etc. Includes 3E29 tube. Good... **\$9.95**

APN-1 FM TRANSCEIVER
 420-460 Mc. Compl. with tubes. Exc. Ea. \$2.95
 Approx. shp. wt. per unit 25 lbs. TWO for 5.00

AN/APA 3B PANADAPTOR
 115 VAC. Single phase. 400-2700 cycles. 10 Mc. adaptor. Approx. 10 Mc. band width. For conversion dope. See July/59 C.Q. Magazine. Excellent cond. ... **\$14.95**

YOU GOT IT! WE WANT IT! LET'S DEAL!
 We're paying top \$\$\$ for GRC-9; PHC-6, -8, -10; GN-58A; All elect. test equip.

BC-1033 MARKER BEACON RECEIVER
 Freq: 75 Mc. Operates on 28 V. Excellent cond. Two for \$12.95 ONLY **\$2.95**

BC-1023A MARKER BEACON REC'V'R
 Freq: 75 Mc. Operates on 12 VDC. Checked out and in excellent condition. Only... **\$14.95**

BC-611 HANDIE-TALKIE CHASSIS
 Crystal controlled. 3-6 Mc. Brand new. Boxed. WITH antenna, less tubes, crystals. Only... **\$6.95**

BC-733 RECEIVER
 A Sputnik tracker—see C.Q. Magazine Oct/59 for conversion. VHF. 10 tubes. 8-channel. crystal controlled. Freq. 108.3-110.3 Mc. Dual meter range. Excellent condition... **\$5.95**

INTERPHONE AMPLIFIER
 AM-26/ATC. 2H VDC. Complete with dynamotor and tubes. Excellent condition. Only... **\$5.95**

Surplus Conversion Manual No. 2: All conversion dope for above and other surplus items. 125 pages. ONLY... **\$2.50**

RS-36 HAND CARBON MIKE
 With curly cord. Excellent condition... **\$2.95**

A TRIO OF HEADSET BARGAINS!
 HS-23: Hi impedance. Leather covered headband. Brand new. Great buy. Only... **\$4.95**

HS-22: Low impedance. Leather covered headband. Brand new. A. J. J. Candee Special. Only... **5.95**

Hi-Fi Headset: 15,000 cycles. Brand new with chamomile cushions. It's terrific! Only... **7.85**

CD-307A Headset Extension Cord: Brand new. Approximately 5 ft. length. Only... **49c**

R-4A/ARR-2 RECEIVER
 234-258 Mc. 11 tubes. QHP tunable receiver. See Aug/59 C.Q. Magazine for conversion. Excellent cond. TWO for \$5.00 Each... **\$2.95**

All items FOB Burbank, Calif., subject to prior sale. In Calif. add 4% Min. order \$1.95.

J. J. CANDEE CO. Dept. R
 509 No. Victory Blvd., Burbank, Calif.
 Phone: Victoria 9-2411

GREAT SURPLUS VALUES!!

- BC-603 RECEIVER NEW... \$19.00
- R-26/ARC5 REC 3-6 mc New... \$12.95
- R-27/ARC5 REC 6-9 mc New... 12.95
- (above ARC-5's used exc.)... 7.95
- BC-659—TRANSCEIVER with PE-120... 19.95
- T-47/ART-13 TRANSMITTERS... 39.00
- BC-603 AC-SUPPLY... 9.95
- SYNCHROSCOPES MODEL TS-34/AP... 49.00
- SOUND-POWERED DYNAMIC PHONES Pr. 4.75
- REC. MICROWAVE R-111/APR-5... 39.00
- COLLINS CFT 82-Q for Q-5'er compl. w/tubes & instructions... \$5.95
- COLLINS MOD. XFORMER 100 watt 811-1H to 811 final... \$3.95
- RA-62-C POWER SUPPLY A-C for SCR-522 VHF 110/60 cyc. Like new LTD QTY... \$59.50
- KITS only for above. Contains special xformer, rectifier, regulator and connectors w/schematic. SPECIAL ONLY... \$17.00
- GROUND-PLANE VHF ANTENNAS \$9.95
- GOOD FOR CITIZENS BAND FROM 30-200 MC—NEW

SEND FOR NEWEST FREE CATALOG
 \$5.00 Min. - 25% Dep. C.O.D.'S - F.O.B. Conn.
HI-MU ELECTRONICS
 133 HAMILTON ST., NEW HAVEN, CONN.

LOOK
 NO FURTHER... IF YOU'RE UNHAPPY WITH "HI" HI-FI PRICES. WRITE FOR OUR UNUSUAL AUDIO CATALOG. KEY ELECTRONICS CO. 120-C Liberty St., N. Y. 6. Phone CLOverdale 8-4288

manipulation of reverberation characteristics to suit the desires of both taste and room dimension, or more significantly (and this was the consensus), the middle channel can be the third channel of a true stereo recording, utilizing three mikes at the source and then play back through three separate amplifiers and loudspeakers.

Now hold on a minute... for we aren't finished yet... at the 1 1/2 ips speed a frequency response is claimed from 30 to 15,000 cps and a signal-to-noise ratio of better than 50 db! Brave talk indeed, but the joker in this is that the CBS people went right ahead and demonstrated the system and it was very close to being as advertised!

The changer mechanism seemed to work smoothly and accurately and then we heard various musical examples, played first through small amplifiers and speakers of the type one would expect to find in a package unit of modest cost and then through high-powered amplifiers and the big RCA Type LC1A speakers. Finally an Ampex 300 professional tape machine played back a copy of the master tape, at 15 ips, of the same material being played at the 1 1/2 ips speed from the cartridge. On A-B comparison, it took very keen listening to detect which was which... and I was sitting only 7 or 8 feet from the speaker!

By this time all you more erudite tape people are wondering how this can be, for obviously this is flying in the face of present limitations of the tape recording art. The answer is as simple as it is complex. To achieve what they did, CBS had to abandon classical lines of approach and strike out in entirely new directions. This involved, among other things, the creation of an altogether new type of tape, which was done with the cooperation of Minnesota Mining, the "Scotch" tape people. Then a radically new form of magnetic head construction was devised which resulted in a unit with the incredibly tiny gap of one micron! This contributed heavily to the frequency response obtained, along with appropriate circuitry and equalization. New ideas in drive mechanisms were incorporated to insure motional stability at such a slow speed.

Pretty snazzy deal, eh? But before you start running for the door to obtain one of these marvels, or conversely start cussing because your brand-new reel-to-reel tape machine is obsolete, hold on a minute. As with so many experimental devices, it takes a long time to translate a product from the laboratory to where it can be sold as a consumer item. All the units we saw were strictly prototypes and even ultimate licensees of the process could not get a unit with which to experiment. The fancy new tape, which is an absolute requirement, is not and won't be in production for quite some time. Like anything else, there are bugs to straighten out before Mrs. America can get one mounted in a Queen Anne cabinet.

It is also interesting to note the opinions of many people in the tape machine industry... they feel that

although this new development will eventually mean a mass market for tape, since it is expected that the cartridge can be sold as cheaply as present-day records, the reel-to-reel market will continue for a long time and this new process will merely be an adjunct. They go one step farther by pointing out that the new tape formulation and the new head and circuitry ideas are applicable to quarter-inch reel-type tapes, which it is felt will be "ultimate" quality items for the audio enthusiast and those who insist on the highest possible quality.

So, for the present, there is no need to worry about obsolescence of reel-type tape. This market is really beginning to gather momentum and is expected to boom this fall. I think the most important thing about these new developments is this... this should put to rest once and for all those prophets of doom who have been trying to tell us that "tape is dead." Whatever we eventually have—eighth-inch tape, or cartridges, or a flat sheet of tape which is scanned—the recorded tape will be with us a long time. It is much too vital and dynamic a medium ever to wallow in the doldrums of disinterest. While this new idea is certainly intriguing, let me conclude by quoting this statement from the Magnetic Recording Industry Association:

"The MRIA suggests its members pledge protection against unwarranted obsolescence while major strides in the laboratory are being made... today's dominant tape... reel-to-reel, 7.5 ips, will be honored for as long as a market exists... it will always be a dominant influence in the market and its fidelity will always demand and get proper recognition."

So there you have it, friends. Onward and upward with tape!

It would appear that our tape suppliers were so busy with all this fascinating new business that they are having a hard time keeping up with orders and thus my eagerly awaited batch of the new London tapes didn't arrive by this deadline. What we have is just right for summer listening.

THIS IS VIENNA
 Vienna Philharmonic Orchestra conducted by Hans Knappertsbusch. London Stereotape, 4-channel, LC180016. Price \$7.95.

This is a potpourri of Vienna-type items such as "Radetzky March," "Acceleration Waltz," "Tritsch-Tratsch Polka," "Tales From the Vienna Woods," and others, played with great verve and brio by Knappertsbusch and his great orchestra. I do not know the chronology of this tape... whether it was made before or after the Mendelssohn/Schubert tape, but I strongly suspect it was a later effort, for here the brilliance of string tone has been restored as has the bass end. There is more solidity to this sound, and a more forward projection. Directionality is more pronounced, definition remains sharp, but the emphasis still lies in rounded naturalness and good depth. A pleasant tape, but one waits in antic-

Now available at electronics parts stores, hi-fi salons, and record shops!

Stereo-Monophonic
Test Record

Specially packaged
at only

\$1.59

(\$1.98 In Canada)



As a man who is seriously interested in hi-fi, you will certainly want to take advantage of this new and important test record, now on sale at electronics parts stores, hi-fi salons, and record shops. It will enable you to know your system inside-out. As a result, your listening enjoyment will be even greater than ever before.

This Stereo-Monophonic Test Record is the most complete test record of its kind—containing the widest range of essential check-points ever incorporated into one test disc! And, best of all, you need no expensive test equipment when you use this record! Just listen and get the thorough results you want—all checks can be made by ear!

This special test record brings you an extraordinary 2-way value. First, it guides you in evaluating the quality of reproduction your equipment now produces. Second, it specifies the adjustments necessary to get the best recorded sound you have ever heard! This is easily the best value of the year for everyone who owns a hi-fi system—either monophonic or stereo!

NOW ON SALE EXCLUSIVELY AT ELECTRONICS PARTS STORES, HI-FI SALONS AND RECORD SHOPS!

You can be sure this Stereo-Monophonic test record comes as close to perfection as is humanly possible, because the editors of *ELECTRONICS WORLD*—leading technical magazine in the field of electronics—have poured their accumulated know-how into this record. Purchase your record today! (If you find your dealer does not yet have a supply available, ask him to order them for you.)

SPECIAL NOTE TO DEALERS: for information on ordering your supply of records, contact Ziff-Davis Publishing Company, Direct Sales Division, One Park Avenue, New York 16, N. Y.

Here are some of the questions this record will answer for you!

- ✓ *How good is my stylus? Is it worn? Will it damage my records?*
- ✓ *What about my stereo cartridge? Does it have enough vertical compliance so that it won't ruin my expensive stereo records?*
- ✓ *Is my turntable running at the right speed? Is it free of rumble, wow, and flutter?*
- ✓ *What sort of standing waves do I get in my listening room?*
- ✓ *Are my speakers hooked up correctly? Are they phased properly, and is the correct speaker connected to the right stereo channel?*
- ✓ *How perfectly is my system equalized?*
- ✓ *What about separation? Is it adequate?*

Full Color Giant Fold-Out Charts Still Available!

Here's a complete series of colorful, authoritative fold-out wall-charts (originally appearing in the pages of ELECTRONICS WORLD)—yours for only 15¢ each. All in full-color—each suitable for framing.

1. **V.H.F. TV Spectrum and Interference Chart:** Servicing aid for TV technicians and hams—saves hours by tracking down interference.
2. **Hi-Fi Crossover Network Design Charts:** Tells how to build speaker nets for any crossover frequency. Complete coil-winding data, capacitor values given.
3. **Color Codes Chart:** Gives you coding for capacitors, resistors, transformers, resistance control tapers—all in easy-to-use form.
4. **Bass-Reflex Design Charts:** Complete data on building own bass-reflex enclosures for any speaker, including ducted-port enclosures.
5. **Radio Amateur Great Circle Chart:** For Hams and short-wave listeners—gives complete listing and map of amateur prefixes by calls and countries.
6. **Sound:** Fundamental data on all phases of Sound: frequency ranges, sound levels, equal loudness curves. A must for all audiophiles.

ALSO AVAILABLE:

Reprints of:

7. **"Build a Citizens Band Transceiver"**—complete details on building an 11-meter transceiver for Citizens Band service.
8. **"Electrical Shock: Fact and Fiction"**—must reading for everyone whose work or hobby involves electricity. Ideal for utility companies . . . service associations.

IMPORTANT: ORDER BY NUMBER! OUR SUPPLY OF ALL GATEFOLDS AND REPRINTS IS LIMITED. OFFERED ONLY ON A FIRST COME, FIRST SERVED BASIS.

Send 15¢ per selection to

ELECTRONICS WORLD, Dept. N 660

Box 378, Church Street Station

New York 8, New York

SURPLUS

SILICON RECTIFIERS



1N1446	.750 amp.	100 volts	.65
1N1447	.750 amp.	200 volts	.75
1N1448	.750 amp.	300 volts	.85
1N1449	.750 amp.	400 volts	1.00
1N1551	1 amp.	100 volts	.80
1N1552	1 amp.	200 volts	.95
1N1553	1 amp.	300 volts	1.10
1N1554	1 amp.	400 volts	1.25
1N05K7	25 amp.	50 volts	2.50
1N1454	25 amp.	100 volts	3.00
1N1455	25 amp.	200 volts	3.50
1N1456	25 amp.	300 volts	4.00
1N1457	25 amp.	400 volts	4.50
1N1458	35 amp.	100 volts	3.50
1N05R7	75 amp.	50 volts	9.00
1N1466	75 amp.	100 volts	10.00
1N1467	75 amp.	200 volts	11.00
1N1468	75 amp.	300 volts	12.50
1N1469	75 amp.	400 volts	14.00

NO C.O.D.'s. REMIT FULL AMOUNT WITH ORDER.

C & H SALES CO.

2176 E. Colorado St. - Pasadena 8, Calif.

TAPE RECORDERS



HI-FI COMPONENTS SLEEP LEARN KITS

MERITAPE UNUSUAL VALUES
Low cost, high quality recording tape, in boxes or cans. FREE 1960 Catalog
DRESSNER, 69-02 RA 174 St., Flushing 65, N.Y.

NEED MOBILE COMMUNICATIONS?

180 2-Way Radios
LINK Model 2210 SS
152-162 FM Mobile. 12 Volts
\$65 each—Excellent condition—As a matter of fact in operation presently.

Delivery can be immediate.
Call or Write Frank Finley
342 Cayuga St.
Pittsburgh 24, Pa.
Phone: MUSEum 1-8470

GET INTO ELECTRONICS

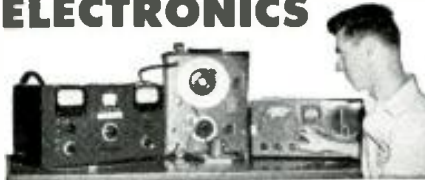

V.E.T.I. training leads to success as technicians, field engineers, specialists in communications, guided missiles, computers, radar and automation. Basic and advanced courses in theory and laboratory. Associate degree in electronics in 29 months. B.S. in electronic engineering obtainable. ECPD accredited. G.I. approved. Graduates in all branches of electronics with major companies. Start September, February. Dorms, campus. High school graduate or equivalent. Catalog.

VALPARAISO TECHNICAL INSTITUTE
Dept. RD Valparaiso, Indiana

ipation for the really outstanding London sound, that will be forthcoming.

LET'S DANCE

David Carroll and his Orchestra. Mercury Stereo, 4-channel, STA600001. Price \$7.95.

This is one of the best sellers in the Mercury catalogue and has achieved considerable fame for its quality of sound and the entertainment it provides—both on two-track stereo and on stereo disc. Now we have it in four-track with virtually no diminution of quality from the two-track, except for a small residual amount of cross-channel modulation. Otherwise nice big, bright band sound with wonderful brass and superbly handled acoustics.

Tape hiss approximates that of the two-channel tape.

GREAT MOTION PICTURE THEMES OF VICTOR YOUNG

Richard Hayman and his Orchestra. Mercury STC60012, 4-track Stereo. Price \$7.95.

Movie music often gets but a passing sneer from the critic and there is perhaps some justification for this attitude. But there are also clever practitioners of this art who, although not penning anything deathless, at least give us some highly entertaining music.

One of the best at his craft was the late Victor Young and on this tape we get a representative sampling of his art. The most famous of all his scores is, of course, "Around the World in 80 Days" and among other tasty creations are "Stella by Starlight," "Love Letters," "When I Fall in Love," "My Foolish Heart," etc. All these and several others are afforded a big, lush treatment from Richard Hayman.

I, personally, find his dependence on a harmonica obbligato an annoyance but for the rest its great swooping strings, colored by expressive woodwinds is just what the music ordered. Stereo effects here are contrived but immensely effective and forgivable with this type of repertoire. All is very clean and wide range, with instrumental definition outstanding. Even in dynamically juxtaposed sections of the tape, cross-modulation was either absent or barely discernible. —30—

AMATEUR COUNCIL FORMED

REPRESENTATIVES of 27 of the more active ham radio clubs in the Greater New York area met recently to form the Hudson Amateur Radio Council, Inc. with an eye to encouraging amateur radio in and around the New York City area.

The Council will sponsor a Convention at the Statler-Hilton Hotel in New York on October 15th with present plans calling for a varied program and manufacturers' exhibits.

Ham Clubs in the Hudson Division, whether ARRL affiliated or not, are invited to join the HARC. Each member club sends two delegates to the HARC meetings to help with planning and coordination.

Details on this new organization are available from Frank Hunter, W2KYV, 115 Emerson Drive, Great Neck, N. Y.

Radars Speed Meters (Continued from page 45)

fier, this range can be increased.

What's Ahead

Future applications of electronics to traffic control include the use of anti-collision radar and electronic car guidance. Various types of radar mounted on the front bumper of a car have been tried out as collision warning. In some of the models a small computer is included which automatically calculates the minimum safe distance, based on the car's speed, and flashes a warning light when the gap is too short. In addition to the warning light, the car's brakes can be actuated automatically if the warning light is not heeded within a pre-set time. To allow for curves, the position of the steering gear is either accounted for in the computer or else the steering gear moves the radar antenna as well as the car.

Electronic steering and speed control of cars travelling on futuristic high-speed roads have been described before. Either buried cables or a series of radar sets above or alongside the highway will receive and transmit control signals which will guide cars within a given lane and steer them as required. A small computer in the car can be programmed by inserting a punched card so that the car is steered to the desired exit. Computers working with the external guidance system would determine the best lane and speed and control all cars to avoid collisions. While this type of electronic traffic control may smack of science fiction, some kind of electronic guidance system for automobiles will undoubtedly be used in the near future.

Conclusion

With little fanfare but with telling effect, electronics has invaded the traffic-control field in recent years. Used in the form of FM radar, electronics has turned into an incorruptible speed control and provides highway police with a safe, simple, and definite means of catching the speeder. Actually, the mere existence of speed-control radar has been a strong deterrent and its use helps to cut down excessive speeds both directly and indirectly by its psychological effect.

The familiar traffic jam is another spot where the electron may help to untangle what the automobile and the highway planners have enmeshed. By controlling the cycling of traffic lights, reporting traffic conditions automatically, and computing optimum traffic patterns, the electronic equipment can provide valuable aid in reducing the traffic snarl. Only the construction of sufficient highways or a reduction in the number of cars using them can ultimately solve the traffic problem, but in the meantime electronic traffic control systems alleviate the situation and promise a smoother traffic flow on the highways of tomorrow.

-30-

DON'T buy an expensive CAR RADIO (unnecessarily)



Cardio master

Converts A Transistor Radio Into A Car Radio



For All Makes of Cars and Trucks

Only \$4.95 with Full Profit Margins



Cardio master is a super powerful permanent magnetic device designed to hold a portable transistor radio in the area of a car's windshield in such a manner as to make it operate as an auto radio. No installation, wiring, additional antennas, or motor suppressors are required. Car's owner can instantly remove a radio from the Cardio master for use as an ordinary portable or to avoid the possibility of theft while the car is parked.

Volkswagen, Opel, Vauxhall, MG, Simca, Fiat, Renault, Ford, Chrysler and General Motors . . . to name a few. Ideal for truck drivers since Cardio master requires no installation, and can be removed instantly.

Increased sale of transistor radio and replacement batteries will add to the BIG profits to be derived from the sale of Cardio master. See your parts jobber or write for bulletin.

MFG. BY R-COLUMBIA PRODUCTS CO., INC. HIGHWOOD, ILL

more

...so much more for everyone... for every application... in the complete line of Stanton Stereo Fluxvalves*.

Here is responsible performance... in four superb models... for all who can hear the difference. From a gentle pianissimo to a resounding crescendo—every movement of the stylus reflects a quality touch possessed only by the Stereo Fluxvalve.

STANTON Calibration
Standard: Model 381 - An ultra linear professional pickup for recording channel, calibration radio stations and record evaluation by engineers and critics from \$48.00

Collectors Series: Model 380 - A precision pickup for the discriminating record collector from \$29.95

Pro-Standard Series: MK II - A professional pickup outstanding for quality control from \$24.00

StereoPlayer Series: Stereo 90 - A fine quality stereo magnetic pickup for the audiophile... \$16.95

LISTEN!... and you will agree Pickering has more for the best of everything in record reproduction—mono or stereo. More Output—More Channel Separation—More in Response—More in Record Life! In short... more to enjoy... because, there's more quality for more listening pleasure. * U.S. Patent No. 2,917,590

FOR THOSE WHO CAN HEAR THE DIFFERENCE



PICKERING & CO., INC. PLAINFIELD, NEW YORK

LISTEN!—Ask for a Stereo FLUXVALVE demonstration at your Hi-Fi Dealer today!

Send for Pickering Tech-Specs—a handy guide for planning a stereo high fidelity system... address Dept. F60

STEREO FLUXVALVE, STEREOPLAYER, COLLECTORS SER. 380, PRO STANDARD SERIES, CAL. CRIB ON STANDARD ARE TRADEMARKS USED TO DENOTE THE QUALITY OF PICKERING COMPANY, INC. PRODUCTS.

AN/ART-13 100-WATT TRANSMITTER

(Government original cost \$1,000.00)

Range 2000 KC to 18,000 KC. Frequencies 200 KC to 1500 KC range is provided by addition of oscillator O-16/ART-13-A. Shipping weight 90 lbs. With Tubes \$29.50 and Meters—Condition Good.....

O-16 Low Frequency Oscillator.....\$5.95

BC-604 FM TRANSMITTER—
20-27.9 MC. Unused.....\$3.95

DM-34 DYNAMOTOR for BC-603
Unused.....\$3.95

DM-35 DYNAMOTOR—Input 12 volts. Out-
put 625 volts, 225 MA
Unused.....\$7.95



TWO 3" GALVANOM-
ETERS — Test Leads,
Multiplier Switch in
hinged carrying case.
BRAND NEW—G.E.
Servo Test
meter.....\$9.95



X-BAND POWER
LEVEL TEST SET, TS-
36/AP, BRAND NEW,
in original packing,
with accessories. Meas-
ures 10 to 30 dbm,
8700-9500 mc. Acq.
cost \$477.00.

ONLY.....\$14.95

HI-FI HEADSETS with Rubber Pads
NEW.....\$7.95

AN/APR-4 38-4000 MC RECEIVER—Utilizes
5 tuning units with direct reading dials in
megacycles. This precision receiver has a wide
and narrow band-width 30 mc I.F. strip which
may be selected at will. An output meter is
provided to measure signal strength. 110V
AC., 60-2600 cycles. Like new—
with 4 tuning units. 38-2200 MC.....\$259.50

NEW CITIZEN BAND—FOR YOUR BOAT,
CAR OR TRUCK, BC-620 FM. 20-27.9 MC
has 2.8 W output. The receiver crystal also
controls the transmitter frequency. Legal be-
cause no multiplying in the final. Separate
receiver and transmitter in one case with addi-
tion of Hand-Set and Power Supply P.E. 120
which operates on 6, 12, or 24 volts. Shipping
wt. 80 lbs. Brand New. (Government
Cost \$700.) OUR PRICE ONLY.....\$34.95

100 ASST. CRYSTALS. Mostly
FT-241 holders.....\$4.95



APN4B — LORAN —
FINE QUALITY NAVI-
GATIONAL EQUIP-
MENT. Marine or Air-
borne LONG RANGE
Navigational equip-
ment! Determine the
exact geographic posi-
tion of your boat or
airplane! Complete
with 12 or 24 volt

\$109.50

installation.....
Less Power Supply.....\$59.50

APN 4-ID6B INDICATOR with 27 Tubes and
5 CP1 Scope tube
Excellent, used.....\$16.95

APN 9-LORAN complete with 12 or 24 Volt
installation.
Excellent.....\$129.95

OSCILLOGRAPH—DU MONT type 224 oscil-
loscope. Operates on 115 volts, 150 watts, 60
cycles. Has synchronization selector, intensity
control, frequency range 0 to 30
kilocycles. Excellent.....\$39.50

OSCILLOSCOPE AND RADAR INDICATOR:
TS-198A/CPM4, 3 inch screen, 25 to 1000
cycles per second frequency range. Operating
power 120 volts, 60 cycle, single phase. Over-
all dimensions without carrying case: 14"x10"x
24". Mfd. by G.E. Shipping Wt.
125 lbs. Used.....\$29.95

WAVEMETERS: With 210 to 275 MC range.
Power requirements 115 volts, 50 to 1800
cycles. Approx. wt. 12 lbs.
Excellent.....\$19.95

Send M.O. or check with order.

Write for Bargain Flyer

R W ELECTRONICS

2430 S. MICHIGAN AVE., DEPT. N
Phone: CAlumet 5-1281 Chicago 16, Illinois

Product Report (Continued from page 71)

plenty of reserve gain. For example, it only requires .001 volt to drive all of the low-level inputs to obtain an output of 1 volt. The sensitivity of the high-level input circuits is .1 volt for 1-volt output.

The frequency response is good. We obtained a response of $\pm 1\frac{1}{2}$ db from 30 cps to 15 kc. This probably could be improved were we to have taken greater pains in adjusting the tone controls for electrical centering.

The RIAA equalization characteristic of the phono input circuit was within $\pm .5$ db from 30 cps to 15 kc.

The tone controls provided adequate boost and attenuation. Treble controls showed a boost of 11 db and an attenuation of 18 db at 15 kc. The bass controls had a range from +19.2 to -21.2 db at 30 cps.

Hum and noise measurements were taken through the low-level circuits with 6 mv. applied and with the volume control set for 1-volt output. Our results are: channel 1, open-circuited input -64.5 db, shorted input -67.0 db;

channel 2, open-circuited input -66.6 db, shorted input -68.9 db. On the high-level inputs with 1 volt applied, the hum and noise averaged 73 db on both channels.

Last but not least are the IM and harmonic distortion measurements. We always look forward to making these tests to see just how little distortion can be obtained in any of the *Dyna* products. It's quite apparent by now that maximum effort is put into the design of these units in order to obtain as little distortion as possible. The results on the unit again bear out this thought. The IM distortion is only .08%, and the harmonic distortion is .01% at 30 cps, .09% at 1000 cps, and .10% at 15 kc. These figures are quite close to the residual distortion of our test equipment, and if designs improve any further, we will have to give thought to much better quality test equipment. Both the IM and harmonic distortion measurements were taken through the high-level circuits and with the volume control adjusted to produce a 1-volt output with a 1-volt input.

This preamplifier is available both in kit form for \$59.95 and factory-wired at \$99.95.

-30-

Pickering Stereo Cartridge

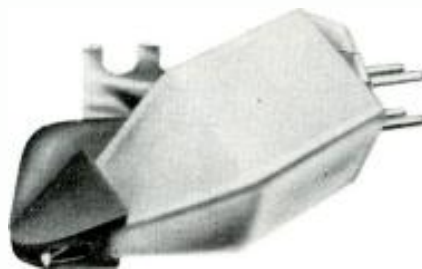

IT SHOULDN'T really be a surprise to anyone that the design of *Pickering* stereo cartridges, like those of many other companies, has improved considerably over the past year or two to a point where one wonders what more

can be done along these lines to provide better hi-fi sound reproduction. The company now has available a number of different pickups at various prices for use with either record changers, turntables, and for 78-rpm and long-play stereo or mono records. Whatever your needs are, there is a specific cartridge and stylus assembly available.

The one we checked is the Model 380A, which is supplied with a yellow plastic "V-guard" stylus assembly designed for use with professional tone arms. It has a .7-mil diamond stylus and is to be used with a tracking force of 2 to 5 grams. The recommended load resistance is 47,000 to 100,000 ohms. All

Performance characteristics of the Pickering 380A stereo cartridge. All tests were made using the Westrex I-A test record, which is considered by Pickering to be down about 3 db at 15,000 cps. Under these conditions, the final frequency response of this cartridge is actually better than that shown on the graph.

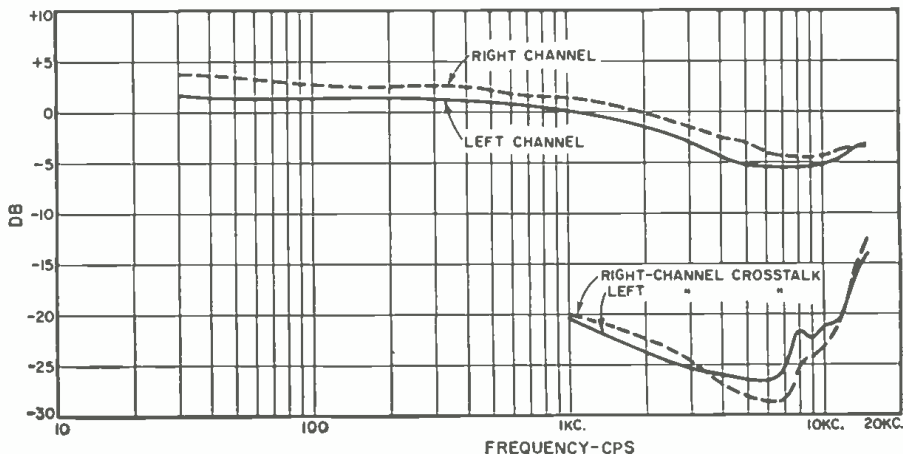

of our tests were made using a 47,000-ohm load and a 3-gram pressure. Like all of the company's cartridges, the one we tested is a magnetic moving-iron type referred to as the "Stanton Stereo Fluxvalve."

It has quite a few outstanding features: (1) high output—10 millivolts at 5 cm. per second (1000 cps) recorded velocity; (2) reasonably flat frequency response; (3) unusually good channel separation.

All of our tests were made using the Westrex 1-A test record and, although it is the most widely used record for testing cartridges today, it is known to be inadequate in many ways. The record has approximately 28-db channel separation, hence, it is impossible to check cartridges beyond this value.

We did find out by visiting Pickering's plant that they have a much better test record, and from measurements taken at the plant, the same cartridge showed a channel separation of 30 db at 1000 cps. Unfortunately, this test record is of their own design and is not available to anyone outside the company.

Of particular interest to those who occasionally play 78-rpm records is the fact that a separate stylus assembly is available and it is a simple task to change from one to the other.

As one might suspect from the test data presented, the listening quality of this cartridge is smooth and clean. It does not have extreme brilliance or what one might call a particularly strident response.

We were particularly pleased with its low needle talk and the freedom from hum pickup. We found that with a stylus pressure of 3 grams, the cartridge provided top-quality sound reproduction with both monophonic and stereo records. Even when playing extremely loud passages, we encountered no tracking problems.

This cartridge, which will fit any conventional tone arm, is available for \$34.50. Another model which will track at between 3 and 7 grams is available for record-changer arms at a price of \$29.85. —50—



"None for me, thanks. Coffee keeps me awake!"

How You Can "GET ON THE AIR" —Without An EXAM!

NEW Class "D" Citizens Radio Handbook Answers ALL Your Questions About:

How to use two-way radios for business and pleasure—to talk from car to car, ship to shore, office to mobile unit, between farm buildings, on hunting trips, and dozens of other useful applications.



Here's how to get the most out of your Class D Citizens Band Radio Set—how to buy and use your equipment for the ultimate in fun and practicality! This new, fully illustrated, easy-to-read book tells you, in layman's language, EVERYTHING the Citizens Band needs to know. Contents include what to buy and how much it will cost... which set will suit your needs best... how to apply for your free license (no FCC examination required).

Discusses transmitters, receivers, antennas, power requirements, and gives you full instructions for installation and maintenance. Tells you how and where you can use your set and includes complete FCC rules and regulations. Contains 180 clear simply-written pages and 72 informative illustrations: only \$4.95 plus few cents for shipping, FREE 7 Day Trial—send no money! Mail coupon at once.



Mail Coupon Today for 7 DAY FREE TRIAL EXAMINATION!

ELECTRONICS BOOK SERVICE

A Division of the Ziff-Davis Publishing Co.
434 South Wabash Avenue, Chicago 5, Ill.
C R W - 60

Please send me _____ copies of CLASS D CITIZENS RADIO and bill me only \$4.95 per copy plus a few cents postage. If I am not pleased with the book, I may return it within 7 days and I will owe you nothing.

CHECK HERE AND SAVE MONEY. I enclose payment for book(s) herewith, and you will pay the postage. (Same 7-day return privilege.)

PRINT NAME.....

ADDRESS.....

CITY.....ZONE.....STATE.....

N.Y.C. Residents. Please add 3% Sales Tax.

MAIL ORDER HI-FI

You can now purchase all your Hi-Fi from one reliable source and be assured of perfect delivery. Carston makes delivery from NY stock on most Hi-Fi, Records and Tape within 24 hours. SEND US A LIST OF YOUR HI-FI REQUIREMENTS FOR OUR WHOLESALE QUOTATION and our FREE wholesale catalogue.

CARSTON STUDIOS

125-TD East 88 St. New York 28, N.Y.

Natural, satisfying music

from a

LEAK STEREO AMPLIFIER

engineering degree in 27 mos.

Become an Electronics Engineer. Share rewards awaiting college men . . . higher income, rapid advancement. Important firms visit Tri-State to interview seniors. *Bachelor of Science Degree in 27 months in Electrical (Electronics or Power major), Mechanical, Civil, Aeronautical, Chemical Engineering. In 36 months a B.S. in Business Administration (General Business, Accounting, Motor Transport Management majors). For earnest, capable students. Small classes. More professional class hours. Well-equipped labs. Dorms. Campus. Modest costs. Year-round operation. Enter Sept., Jan., Mar., July. Founded 1884. Write J. H. McCarthy, Director of Admissions, for Catalog and "Your Career" Book.*



1660 College Ave., Angola, Indiana

PURCHASING A HI-FI SYSTEM?

NOW YOU CAN CHARGE IT!

If you are an International credit card holder. Up to 10 months to pay. No down payment necessary.

**Send Us
Your
List Of
Components
For A
Package
Quotation**

**WE WON'T BE
UNDERSOLD!**

All merchandise is brand new, factory fresh & guaranteed.

AIREX RADIO

CORPORATION

64-R Cortlandt St., N. Y. 7, CO 7-2137

Altec Lansing
Electrovoice
Jensen
Hartley • Stephens
University
Acoustic Research
Janssen
Wharfedale
Karlson Cabinets
Viking
Concertone
Bell • G.E.
Weathers
Harman—Kardon
Eico • Pilot
Sherwood
Acrosound
Quad Ampl & Spkrs
Dual Changer
Bogen • Leak
Dynakit • Fisher
H. H. Scott
Uher Recorder
Thorens (Fr. Td.)
Pentron • Revere
Ampex • DeWald
Sony • Roberts
Challenger
Wallensak
Garrard
Miracard
Glaser-Steers
Rek-O-Kut
Components
Norelco
Fairchild
Pickering • Gray
Audio Tape
Magnecord
Full Line of
Wellcar Cabinets

We'd like to send you these important new books for a 7-day free trial examination

CITIZENS RADIO by Leo G. Sands

Here is the first complete book on Citizens Radio Operation. Ever since the initial use of 2-way radiotelephone by police departments, this field has been growing in importance and application. Now, with more than a million vehicles equipped for its use, Citizens Radio is a major phase of the electronics field. This important new volume covers every aspect of the field—its history, rules, and everything about how it works—in seven big chapters with one hundred major sections. You'll learn exactly what Citizens Radio is, its applications, what equipment you need, the full story on receiver circuits and transmitters, antennas, installation, and maintenance, full FCC rulings, how to apply for licenses, etc. Many illustrations. **\$4.95**



COMPUTERS AND HOW THEY WORK

by James D. Fahnestock

Here is a fact-filled exciting guidebook to the wonderworld of electronic computers, with more than 110 illustrations and easy-to-follow tables in 10 big chapters. Step by step, you'll see and understand the workings of many types of computing machines. This important new book illustrates the basic principles of computers in methods that require no knowledge of electronics. You'll learn all about computer memories, flip-flops and the binary counting system. You'll learn the mathematical language of computers where $1 + 1 = 10$. Other chapters show you how computers use tubes and transistors to make complex logical decisions in thousandths of a second. **COMPUTERS AND HOW THEY WORK** is must reading for career minded students and for electronics pros who want a more complete knowledge of this field. **\$4.95**

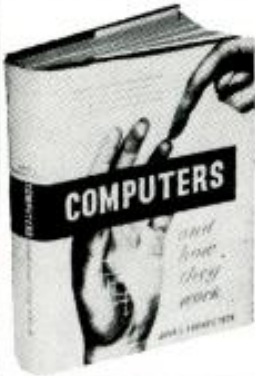

THE ELECTRONIC EXPERIMENTER'S MANUAL by David A. Findlay

With a few dollars worth of basic tools, and this book to guide you, you can explore the magic of electronics experimentation more completely than ever before. In a few short hours, you'll start your first project. You'll learn about every component used in experimentation, every tool, its function and why it is used. There are 8 big sections, each covering a specific phase of construction. There is a giant section of projects you can build, test equipment you'll construct and use in your future work. **THE ELECTRONIC EXPERIMENTER'S MANUAL** will give you the professional know-how you must have no matter what phase of electronics is your specialty. **\$4.95**

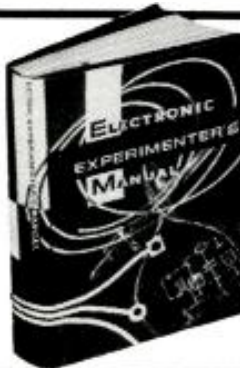

7-DAY FREE EXAMINATION

When your books arrive, read and enjoy their diversity of contents, their thoroughness of coverage. Then after seven days examination, if you decide that they are not everything you want, send them back and receive a complete refund of the purchase price.

USE THIS CERTIFICATE FOR 7-DAY FREE EXAMINATION

ELECTRONICS BOOK SERVICE • A Division of the Ziff-Davis Publishing Co.
434 South Wabash Avenue, Chicago 5, Ill.
Please send me _____ copies of **CITIZENS RADIO** and bill me at only \$4.95 a copy plus a few cents postage.
Please send me _____ copies of **COMPUTERS AND HOW THEY WORK**, and bill me at only \$4.95 a copy plus a few cents postage.
Please send me _____ copies of **THE ELECTRONIC EXPERIMENTER'S MANUAL** and bill me at only \$4.95 a copy plus a few cents postage.
If I don't agree that this is one of the best electronics investments I've ever made, I may return the book(s) within seven days and get a full refund.
\$ _____ enclosed. (SAVE MONEY! Enclose payment with your order and we'll pay the postage.)

Name _____
Address _____
City _____ Zone _____ State _____

ZEW60

Broadcast-Band Converter

(Continued from page 59)

50 miles or so of your location, the following adjustment must be made at night when a distant signal will be available via skywave. Set the receiver to 29.6 mc. Open C_2 until it is at minimum capacity. Slowly turn the screw of T_1 clockwise until a 1600-kc. station pushes the "S" meter as high as possible.

Next, tune in a station near 600 kc. (28.6 on the receiver dial). Peak the signal with C_2 . Adjust the slug in L_1 and retune T_2 until the "S" meter is at maximum. The screw of C_3 may also be tightened slightly, if this adjustment seems to improve sensitivity.

No further alignment is required. You can now put the cover on the converter and mount the unit in a convenient position near the receiver. Whenever you wish to hear a particular broadcast station, merely switch on the converter, tune to the appropriate spot on the 10-meter band, and adjust C_2 for the highest "S" meter reading.

If your antenna happens to be a 10-, 15- or 20-meter beam fed with coax, you'll probably discover that it doesn't provide quite enough output on the broadcast band. Should this be the case, you can boost signals tremendously by pulling the coax out of J_1 just far enough so that the shield becomes disconnected and only the center conductor still contacts J_1 . When employing a 40- or 80-meter antenna, you won't have to resort to this little trick in order to obtain adequate signal pickup.

Even though the converter which has been described is a simple device, it can provide excellent broadcast-band reception. If you take the trouble to construct a similar one, I'm certain that you'll be well pleased with its performance.

With the converter operating as it should, the frustration of not being able to pick up broadcast signals on your ham-band-only communications receiver will disappear. **-30-**



"I called five servicemen. One should be here soon."

Sun	Mon	Tue	Wed	Thu	Fri	Sat
		1	2	3	4	5
					12	
					19	
					26	

CALENDAR of EVENTS

JUNE 7-11

International Congress on Microwave Tubes. Sponsored by Verband Deutscher Elektrotechniker VDE. Program details from Tagungsburo "Mikrowellenrohren," Brienner Strasse 40, Munich 37, Germany.

JUNE 10-26

British Exhibition. Sponsored by Audio Manufacturers' Group of the British Radio Equipment Manufacturers' Assn. New York Coliseum, New York City.

JUNE 20-21

Chicago Spring Conference on Broadcast and Television Receivers. Sponsored by Institute of Radio Engineers. Graemere Hotel, Chicago. Details from IRE, 1 E. 79th St., New York 21, N. Y.

JUNE 20-24

National Inventions Conference and Exhibition. Sponsored by Cleveland Engineering Society. Cleveland Engineering and Scientific Center, 3100 Chester

Ave., Cleveland. Details from the Society at Chester Ave. address.

JUNE 20-JULY 5

1960 Chicago International Trade Fair. Sponsored by Chicago Assn. of Commerce and Industry. Navy Pier Exhibition Hall.

JUNE 22-24

Second National Conference on Electronic Standards and Measurements. Sponsored by National Bureau of Standards, IRE, and AIEE. NBS Laboratories, Boulder, Colorado. Further information from Herbert Finke, Polytechnic Research & Development Co., Inc., 202 Tillary St., Brooklyn 1, New York.

JUNE 26-29

New England Distributor Conference. Sponsored by Distributor Div. of New England Chapter of the Electronic Representatives Assn. (ERA). Details from ERA headquarters, 600 S. Michigan Ave., Room 819, Chicago 5, Ill.

JUNE 27-29

Fourth National Convention on Military Electronics. Sponsored by IRE Professional Group on Military Electronics. Sheraton Park Hotel, Washington, D. C. Program information from Dr. Craig

Crenshaw, Dept. of Army, SIGRD-2, Washington 25, D. C.

JULY 21-27

Third International Conference on Medical Electronics. Sponsored by Electronics and Communications Section of Institution of Electrical Engineers and International Federation for Medical Electronics. Olympia, London. Program information from Dr. L. K. Lusted, University of Rochester Medical School, Rochester, N. Y.

-30-

Answer to Puzzle Appearing on page 112



ELECTRONICS WORLD



SEND ELECTRONICS WORLD EVERY MONTH

name _____

address _____

city _____ zone _____ state _____

Check one:

- 3 years for \$12 2 years for \$9
 1 year for \$5

In the U. S., its possessions, and Canada

- Payment enclosed Bill me

Foreign rates: Pan American Union countries, add .50 per year; all other foreign countries, add \$1.00 per year.

Mail to: **ELECTRONICS WORLD**
Dept. EW 66

434 S. Wabash Ave. Chicago 5, Ill.

FINEST CITIZENS' RADIO AT ANY PRICE!



VIKING
Messenger FROM **\$12975**

- Dozens of features — maximum legal power — excellent range!
- 23 channel Class "D" coverage — choose 1 of 5 by flip of a switch!
- Anyone can operate — license issued by FCC on request!

Designed for 10 watts—limited to 5 for Citizens' Radio outstanding receiver sensitivity and selectivity! Only equipment which lets you operate on any 5 of the 23 available channels without re-tuning. Easy to install in home, business location, car, truck or boat. Built-in Squelch, Automatic Volume Control, and Automatic Noise Limiter. Only 5 3/8" high, 7" wide, and 11 3/8" deep. Complete with tubes, microphone, and crystals for 1 channel.

Available from authorized Johnson Distributors—installation and service at all General Electric Communications Service Stations.

FREE
Color Brochure



WRITE TODAY

E. F. JOHNSON COMPANY
104 Second Ave. S. W. • Waseca, Minnesota
• Please rush me your "Messenger" brochure

NAME _____

ADDRESS _____

CITY _____ STATE _____

Manufacturers of the world's most widely used personal communications transmitters



MYSTERY

There's never any mystery about buying from Walter Ashe... you're always sure of top quality value... and getting exactly the equipment or parts you order!

SUSPENSE

You don't have to hold your breath wondering how long it will take for Walter Ashe to make delivery! Practically every order is shipped the same day direct from Walter Ashe's big, fresh, complete stocks.

SURPRISE

You're in for a big surprise when you get a Walter Ashe's extra big trade-in allowance on your present equipment towards the purchase of any new transmitter or receiver in our 1960 catalog!

The only way we know how to do business with our Amateur friends is to give you the true and complete facts in our catalog... price everything we sell as low as we possibly can... and give you the best possible service on every order you send us. This has been the Walter Ashe policy for 38

years... and it has helped us become one of the Amateur fraternity's biggest and most respected suppliers. We think you'll like our way of doing business... and we know you'll like our famous "surprise" Trade-In Allowances! Try us and see for yourself!

NEW 1960 CATALOG NOW READY!

The Only Radio Catalog Compiled and Designed Entirely With The Needs of The Amateur in Mind!

If you're an amateur, experimenter or a newcomer "coming up"... you're invited to ask for a copy of our brand new 1960 Walter Ashe catalog... just off the press. It's packed from cover to cover with everything that's new and needed... in mobile or fixed station equipment, parts and supplies, transmitters, receivers, test equipment and Citizen Band units. Incidentally, Walter Ashe is one of America's leading suppliers of High Fidelity equipment... and mail the coupon below... we'll rush your copy to you!



You Can Be Sure...

that every piece of used equipment Walter Ashe takes in trade... and later sells... is checked thoroughly and guaranteed to work the same as new. Whether you're trading up to new or in the market for used equipment... you'll always be money and satisfaction ahead at Walter Ashe!

Walter Ashe
RADIO CO.

Dept. R-6-60, 1125 Pine Street, St. Louis 1, Mo.

TIME PAYMENT TERMS AVAILABLE ON ALL EQUIPMENT

"SURPRISE TRADE IN" COUPON

Walter Ashe Radio Co. In Our 38th Year
Your One-Stop Supermarket
Dept. R-6-60, St. Louis 1, Mo.

- Rush New Catalog
- Send lists of guaranteed Used Equipment
- Rush "Surprise Trade-in" offer on My _____

For _____
(Show make and model of equipment desired)
Name _____
Address _____
City _____ Zone _____ State _____

ENGINEERING DEGREE IN SCIENCE MATH 27 or 36 MOS.

Accelerated year-round program prepares for early employment in fields of Science and Engineering. Regular 4-Year program for B.S. Degree completed in 36 months, special engineering degree program in 27. Classes start quarterly—June, September, January, March. Quality education. Graduates employed from coast to coast. Government approved for veteran training. Students from 50 states, 40 countries. 20 buildings; dorms, gym, Campus. Save time and money. Earn board while studying. Write for catalog and complete information.

960 E. Washington Blvd., Fort Wayne 2, Indiana

INDIANA TECHNICAL COLLEGE

GIANT CITIZENS BAND SALE!
Nationally Advertised Transceiver Kits

110 volt kits.....	\$29.95	6 or 12 volt kits.....	\$31.95
Philmore TC-11—115 volt Transceiver Kits.....	\$39.95		
Philmore TC-612—6 & 12 volt Transceiver Kits.....	\$44.49		
Special Offer: \$9 Mobile CB Antenna Free with above Kits!!!			
Antenna Specialists Top Quality Ground Plane Antenna.....	\$15.95		

No. C.O.D.—include postage—order early—send for our latest flyer!!!!

TV ELECTRONIC SUPPLY CO.
4645 S. COTTAGE GROVE CHICAGO 53, ILLINOIS

Mac's Service Shop (Continued from page 54)

resistance change involved here.

"But let me tell you about the Type CX silicon boron composition resistors. They are the ones ordinarily recommended for dummy loads. Their voltage coefficient is negligible, and they have a positive temperature coefficient not exceeding .11% per degree C. They can be operated at body temperatures up to 300° C, or approximately 2½ times the permissible dissipation of Type A resistors. A 1" x 18" CX resistor is rated at 118 watts. These resistors can stand short-duration steady overloads up to 200% with only minor effect. They display a small apparent inductance at low frequencies and a small apparent capacitance at high, depending upon the dimensions. The resistive component holds approximately constant through the medium-high-frequency range.

"They come in the same sizes as the previous types, but they do not have the same resistance range. The ½" and ¾" diameter sizes range from 1/10 to 100 ohms; ¾" diameter, 1/10 to 75 ohms; 1" diameter, .05 to 50 ohms. They are used as dummy antennas for radio transmitters, as resistive terminations for antennas and transmission lines, and as parasitic oscillation suppressors in high-powered transmitters. I might mention that all these resistor types are available with six-inch-long tinned copper wire leads in place of the metalized fuse clip mounting terminals on these."

"How about the other two types you mentioned?"

"The Type A-S is a high-voltage non-inductive resistor with a negative temperature coefficient of .1% per degree C maximum and a voltage coefficient of .025% per volt maximum. The thing that makes these resistors greatly different is that they will take 1.2 kilovolts of a.c. per inch of length or 7.5 kilovolts of pulsed d.c. In addition to being used as dummy loads and antenna terminations, these resistors are used for discharging capacitors, as spark-plug suppressors, as low temperature heater elements, and in radar pulse equipment. In the 1" diameter size, they range from 100 to 450,000 ohms.

"The Type SP is a high temperature, high energy, non-inductive resistor with a maximum temperature coefficient of .15% per degree C and a maximum voltage coefficient of .075% per volt. But these resistors have a continuous watt-rating of 5 watts/square inch surface in a 1000° F ambient and will take a five-second overload up to 50 times their rated wattage. What's more, the r.f. resistance of these units is flat to within 3 db up to 50 megacycles."

"I certainly see that when we have to replace a Globar resistor in a piece of industrial equipment we had better know what we are doing," Mac ex-

claimed. "Did you make any other checks on your dummy antenna?"

"Yes, I wanted to see how frequency-sensitive it was; so I loaded my low-wattage impedance bridge with a precision 72-ohm calibrating resistor at 3.9 megacycles and nulled the bridge. When I substituted the dummy antenna for the precision resistor, the s.w.r. stayed at 1/1. I raised the frequency to 29 megacycles. The s.w.r. went up slightly to 1.1/1. Ten micro-microfarads placed across the dummy antenna brought this down to 1.05/1. Adjusting the bridge for a load of 78 ohms restored the s.w.r. to 1/1. Apparently the r.f. resistance of my dummy goes up slightly with frequency."

"I can see even your Type B resistors are far better than a lamp bulb; so why aren't more hams using them?"

"Because Globar resistors are not available as distributor items. Mine came from surplus. We hams have been told these resistors cannot be obtained in small quantities from the company, but I am advised the company would be willing to supply small orders for these resistors if they are available in over-run from previous customers' orders and are within the minimum billing requirement of \$25. Otherwise the minimum order is for 22 pieces. As an example of cost, my 1" x 10" 36-ohm Type B $\pm 10\%$ resistor sells for \$3.85 at minimum-order prices.

"But good news may be in the offing. I asked the company why they didn't market resistors for dummy loads and they advised they had given thought to bringing out high-wattage resistors equipped with coax terminals in values of 25, 52, 72, and perhaps 300 ohms in 50- and 100-watt sizes, and possibly later in 500- and 1000-watt units. I certainly hope they do; but even if they don't, I now feel I can shop for Globar resistors in the surplus market more intelligently and know what to expect in the way of performance from the ones I acquire."

"Fine!" Mac applauded. "I have always thought a good technician wants the best equipment he can get, but he is also capable of getting the most out of the equipment he has. Now let's go to work."



FREE BOOKLET with FACTS & FIGURES

You can be on the threshold of an entirely new income! One of the biggest booms nowadays is in 2-way mobile-radio communication. Every installation is practically a guaranteed income for some qualified serviceman. These stations must be kept on the air . . . must have FCC-required checks . . . and because they make money for their owners, they can afford to pay well for service.

Lampkin Laboratories, Inc., has made a study of how other servicemen are making money in this business. Now they offer the results of this study to you — in this FREE booklet — so that you can increase your income thousands of dollars. Use the coupon today!



Lampkin instruments are used by thousands of mobile-radio engineers!



LAMPKIN 105-B FREQUENCY METER, RANGE 0.1 TO 175 MC AND UP. PRICE \$260.00 NET.



LAMPKIN 205-A FM MODULATION METER, RANGE 25 TO 500 MC. PRICE \$270.00 NET.

MAIL COUPON TODAY ➔

LAMPKIN LABORATORIES, INC.
MFM Division BRADENTON, FLORIDA

LAMPKIN LABORATORIES, INC.
MFM Division, Bradenton, Florida
At no obligation to me, please send
 Free booklet Data on Lampkin meters
Name _____
Address _____
City _____ State _____

BARGAIN HUNTING? **TV SERVICEMEN!**
Write for SENSATIONAL CATALOG
HENSHAW RADIO SUPPLY
3619 TROOST KANSAS CITY, MO.

A NOTE TO THE HI-FI BUYER
AIR MAIL us your requirements for
on IMMEDIATE LOWEST PRICE QUOTATION
Components, Tapes and Recorders
SHIPPED PROMPTLY AT LOWEST PRICES
WRITE TODAY FOR FREE CATALOG
AUDIO UNLIMITED 714-W Lexington Ave.
New York 22, N. Y.

HI-FI RECORDING TAPE
FREQ. RESPONSE 30-15 KC.
10 DAY MONEY BACK GUARANTEE

	3	10	25
1200' Acetate, each . . .	\$1.29	\$1.17	\$.99
1800' Acetate, each . . .	1.79	1.59	1.45
1800' Mylar, each . . .	2.09	1.99	1.85
2400' Mylar, each . . .	3.29	2.99	2.75

Any assortment permitted for quantity discount.
Add postage—15¢ per spool—25¢ or over 10¢.
IN STOCK—Hi-Fi under mfrs. franchise—A. R., Bell, Bogen, Dynaco, E. V. Eico, ESL, Fisher, Garrard, Kar-Kar, Norelco, Pilot, Rek-O-Kut, Shure, Thorens, United-Dual, Univ., Wharfedale, Wolfensack & many, many other components & tape recorders. Send for low, low return mail quotation. "We Guarantee to Save You Money." Wholesale catalog free.

Hi Fidelity CENTER
1799 N 1st Ave. New York 28, N. Y.

Olson

FREE

Fill in coupon for a FREE One Year Subscription to OLSON RADIO'S Fantastic Bargain Packed Catalog — Unheard of LOW, LOW, WHOLESALE PRICES on Brand Name Speakers, Changers, Tubes, Tools, Hi-Fis, Stereo Amps, Tuners and thousands of other Electronic Bargains.

NAME _____
ADDRESS _____
CITY _____ ZONE _____ STATE _____

If you have a friend interested in electronics send his name and address for a FREE subscription also.

OLSON RADIO CORPORATION
608 S. Forge St. Akron 8, Ohio

POWER SUPPLY KIT!

Pri. 115V, 60 Cy. Sec. 400-0-400 @ 200 ma. 6.3V @ 4 amp. 5V @ 2 amp., 8 by choke. (2) 8 MF 600 V oil condensers. Kit \$7.50

M A R Power Supply

115 V. 60 cyc. input 12-14 VDC. 2 Amp. output filtered and fully housed. SPECIAL \$8.95

★ ★ POWER TRANSFORMERS ★ ★

117 V. Pri., 800 VCT., 200 Ma.; 6.3 V., 5 Amps; 5 V., 2 Amps. \$4.95
 720 VCT., 200 Ma.; 12.6 V., 3 Amps; 6.3 V., 10 Amps; 5 V., 3 Amps. \$3.95
 1400 VCT. 200 ma.; 3 V @ 4 amps; 5V @ 3 amps. \$6.45
 1200 VCT. 600 ma.; 6.3 V @ 30 amps, 5V @ 12 amps. Xtra 6.3 & 5V windings. \$12.50

— TRANSFORMER Buys! —

ALL WITH 115 VOLT PRIMARY
 6.3 V. SEC. 1 Amp. \$1.25 6.3 V SEC. 2 Amp. 2.29
 110 OR 220 PRI 5- 12 V SEC. 2 Amp. 1.49
 7-9 V SEC. 3 Amp 1.59 6.3 V SEC. 15 Amp 3.95
 (can be used for 110/220 step up/down txfm) 12 V SEC. 1 Amp. 1.19
 24V SEC 1 Amp. 24 V 150 VA. 2.69
 Step up/down Transformer 110 V-220 V 10 Amp. 3.99
 Primary 115. sec. 6 V-7 V-8 V, 75 VA. 2.75
 Plate 1250 VCT 500 Ma. PR 1 230V. 11.95

★ RELAYS! RELAYS! RELAYS! ★ ★

110 VAC DPDT. \$2.75 Sigma 3,200-ohm SPDT 2.45
 110 VAC DPDT, Co. famic-Leach 3.45 24 VAC SPDT Sigma 2.45
 12 VDC DPDT 1.35 txfm for 110 VAC 1.65
 24 VDC, 4 PDT. 2.95 115 VAC SPST, dbl. 1.89
 24 VDC DPDT w/ dust cover 2.45 24 VAC DPDT w/ 1.89
 6 VDC SPDT 1.35 24 VDC 3 PDT. 2.45
LARGE STOCK AC, DC RELAYS!

STEPPING RELAYS!

Resettable 12 VDC coils, 3 deck, 10 pos. \$8.95
 w/add. 1A & 1B contact at reset position
 16 deck, 22 position. \$22.50

SOLENOIDS

115V 60 cyc. cont. dty. 22 lb. pull ea. \$5.75
 18 lb. pull ea. \$4.75 8 lb. pull ea. 2.30

Chokes—Fully Cased

6 hy. 100 Ma. \$1.09
 10 hy. 100 Ma. 1.75
 22 hy. 100 Ma. 2.59
 20 hy. 110 Ma. 2.10
 8 hy. 200 Ma. 1.89
 20 hy. 300 Ma. 7.95

TELEPHONE HEADSET

Murdock model H-58U \$3.69
 Boxed. SPECIAL

3 or 4 Wire Telephone Coiled Cords (or specify) Hvy. duty. Each .99c (6 for \$5.50)

RG CO-AX CABLE—UG CONNECTORS

8/U, 100-ft. lengths. \$7.75
 1000 ft. reel. 70.00
 58/U, 100-ft. lengths. 4.75
 59/U, 100-ft. lengths. 4.75
 SO 239 connectors. 3 for 1.25
 PL 259A connectors. 3 for 1.25
 M 359A connectors. 3 for 1.15

OIL CONDENSER BARGAINS

3 x 8 Mfd. 500 V. \$2.75 4 Mfd 1500 VDC. 1.95
 2 Mfd 600 VDC. .45 3 Mfd 1500 VDC. 3.25
 4 Mfd 600 VDC. .69 8 Mfd 1000 VDC. 2.75
 8 Mfd 600 VDC. .90 2 Mfd 2500 VDC. 2.25
 10 Mfd 600 VDC. 1.10 1 Mfd 3000 VDC. 1.75
 15 Mfd 600 VDC. 1.90 3 Mfd 4000 VDC. 7.50
 16 Mfd 600 VDC. 1.75 1 Mfd 5000 VDC. 4.10
 25 Mfd 600 VDC. 3.25 2 Mfd 6000 VDC. 12.75
 1 Mfd 1000 VDC. .55 2 Mfd 10000 VDC. 14.95
 2 Mfd 1000 VDC. .69 1 Mfd 12500 VDC. 18.95
 8 Mfd 1000 VDC. 1.89
 15 Mfd 1000 VDC. 2.95

Esterline-Angus Recorders

Model AW—portable. 0-1 Ma. \$225.00
 Sealed units

SWINGING CHOKE

S-15 hy. 500-100 ma. \$18.95

S-A-L-E! PANEL METERS!

1" METERS
 0-500 Micro-amps. 3.50 0-5 Milli DC. 3.25
 0-100 Milli DC. 3.45 0-100 Milli DC. 3.45
2" METERS
 0-1 ma. 3.50 0-250 Milli DC. 3.95
 0-100 ma. RF. w/shunt 3.25 0-5 Amp AC (scale marked 0-150) 3.25
 0-3 amps RF. 3.25 0-15 Amp RF. 3.95
 0-5 amp DC. 3.25 0-20 Amp RF. 3.95
 0-15 amp DC. 3.25 0-75 Amp AC. 3.95
 0-15 VAC. 3.25 200-0-200 VDC. 3.95
 0-30 Ma DC. 3.25 0-1.5 KV DC. 6.95
 0-300 VAC. 3.25 0-3.5 KV DC. 6.95
 0-7.5 VDC. 3.25 0-300 Amps DC. 6.95
 "S" Meter 4.95 w/shunt 5.95
3" METERS
 0-100 Microamps. 5.95 -10.0 to + 600. 5.95
 0-7.5 VAC. 3.25 0-300 Milli DC. 3.95
 0-15 VAC. 3.95 0-9999 GE 110V. 6.95
 0-150 VAC. 4.45 0-9999 JBT, 230V. 9.50
 0-150 VDC. 4.25 Combs w/freq. meter. \$1.00 ea.
 0-15 Ma. DC. 3.95 JBT, 110 VAC. 17.95
 0-1 Milli (scale 0-50) 4.25 Fram freq. meter. 9.95
 0-100 Milli AC. 3.95 400 cyc. 9.95
 0-1 Milli DC. 4.45

★ ★ SELENIUM RECTIFIERS ★ ★

—FULL WAVE BRIDGE—
 130/110 VAC input 30/24 VAC input
 150 milli. \$1.25 1/2 Amp. \$1.19
 200 milli. 1.75 2 Amp. 2.15
 300 milli. 2.50 5 Amp. 4.95
 500 milli. 3.50 7.5 Amp. 6.45
 12 Amps. 19.75 10 Amp. 7.50

GERMANIUM RECTIFIERS

30/24V input, 30 amps. \$21.95
 SILICON—500 V—500 Ma. \$1.00 ea. (5 for \$5.00)

Remote Control Switchbox w/SPDT & SPST switches, 30 ft. flat 4 wire, 16 gauge cable. \$1.79

AN 131-A ANTENNA

10 ft. 6 in. collapsible to 17" sections. 89c

SELSYNS

115V, 60 cyc. high torque. ea. \$5.95 (pair \$10.50)

Min. Order \$3.00—25% with order F.O.B. New York 10 DAY GUAR. PRICE OF MOSE. ONLY

Advance Electronics

6 West Broadway • New York 7, N. Y. • RectoR 2-0270

Citizens Radio for Service

(Continued from page 57)

speaker. When transmitting, the voice-coil circuit is opened by the transmit-receive relay, and the primary of the output transformer simply acts as a modulation choke, in the manner described earlier.

Control Circuits

Of special interest are the switching and operating devices used to set up circuitry for transmission or reception. These are highlighted in Fig. 6. Pressing the spring-loaded, push-to-talk switch on the microphone places the transmitter in operation. This normally open selector has a double-pole, single-throw arrangement. One pole, when it is depressed, completes the circuit of the transmit-receive relay, through ground. The other pole connects the microphone to the grid of the first audio amplifier (see Fig. 3 as well as Fig. 6).

The transmit-receive relay, through the three pairs of contacts shown directly above the coil in Fig. 6, performs other functions once it is energized. It disables the receiver by removing "B+" from it. On another pair of contacts, it removes the speaker from its connection by opening the circuit to ground, but it connects this ground point to the cathode circuits of the transmitter oscillator and r.f. power amplifier, thus putting them into operation. Finally, it switches the antenna from the receiver input to the transmitter output.

The energizing current for this important relay is obtained from the filament supply when the push-to-talk switch is closed. Since this source may be a.c. under certain conditions of operation, rectifier CR₁ is added to enable the d.c. relay to operate properly. When d.c. voltage is directly provided for the filaments, it passes through CR₁ without difficulty. The filter choke prevents random noise from triggering the relay to transmit at the wrong time.

The Power Supply

Since one unit (or more) in a CB system is likely to be a fixed element near a source of 117-volt a.c. power, but others are likely to be mobile units that will be operated from a battery source, adaptability to either type of supply is important. In the CB unit under consideration, conversion from one type of supply to the other simply involves removing one connecting power cord from the unit and inserting in its place the other cord that is provided. The plug-and-cord combination, in each case, is so wired as to complete the circuit as desired, without other changes. To illustrate the difference between the two types of wiring clearly, however, alternate heater arrangements are shown as being switched through S₁, which does not actually exist, in Fig. 7. Switches S₁ and S₂ do indeed exist, but they are ganged together on the volume control to act as

a single "on-off" switch. Thus the user is not aware of performing any additional function to accommodate power-source differences.

The power transformer of Fig. 7 has two primary windings, the upper one for use with a 12-volt d.c. battery, in conjunction with the vibrator, and the lower one for use with the a.c. line. In either case, an a.c. voltage of the desired level is induced in the secondary of the transformer. The latter feeds a conventional full-wave rectifier and filter network to provide "B+."

When a 12-volt battery is the power source, filament voltage for the tubes is obtained directly from this d.c. supply. In a.c. operation, a portion of the primary winding normally used for d.c. operation now acts as a step-down secondary, energized by the a.c. primary. It provides 13.2 volts of a.c. for the tube heaters.

Variations

Although the inspection of a single CB unit cannot cover all possibilities, it should be clear by now that there is nothing mysterious about the type of circuitry used. Where other manufacturers use slightly different schemes, it is to obtain essentially the same result. The point where the CB-100 is most likely to differ from other sets is in the squelch circuit. Other designs may add a triode as a d.c. amplifier. The input to this triode is generally from the a.v.c. line; thus the output of the d.c. amplifier depends on whether signal is being received or not. With signal being received, this d.c. output is sufficient to bias the audio amplifier (to which it is supplied) so that it conducts and passes audio. With no signal or weak signal, a.v.c. voltage falls; d.c. output of the triode amplifier also falls; and the audio amplifier that depends on this d.c. output for operating bias is cut off.

Service techniques, although obviously important, merit the full treatment of separate articles. The first essential is some idea of what circuits are used and how they work.

KEEP IT CLEAN!

By ROBERT HERTZBERG

EVERY soldered joint you make will be clean and tight if you take one extra second to clean the tip of your iron by wiping it quickly across a brass-bristle brush. Sold primarily for use with suede shoes, small brushes of this type are obtainable in hardware and furnishings stores, are cheap, and last practically forever.



DELUXE TRANSMITTER

Globe Electronics, a division of Textron Electronics, Inc., 22-30 South 34th St., Council Bluffs, Iowa is now offering the "Globe Scout Deluxe," a 6- to 80-meter bandswitching transmitter for 90 watts c.w. and 75 watts phone input power.

The new model incorporates the basic features of the company's Model 680A "Globe Scout" plus a self-contained, built-in power supply. High-level plate modulation is maintained and the final amplifier works straight-through on all bands. Highlighted is the pi-net output on 10-80 meters, super-high efficiency through tuned



link-coupled output on 6 meters, matching into low-impedance beams.

A three-gang loading capacitor provides continuous adjustment from 10 to 80 meters plus greater harmonic and TVI suppression.

The unit is housed in a modern 15 1/4" x 6 1/4" x 11 1/4" cabinet with rolled edges and etched aluminum panel, making it suitable for use in any room in the home. A data sheet on this new transmitter is available on request.

SHELL CADDY-TESTER

Shell Electronics Manufacturing Corp., 112 State St., Westbury, N. Y. has announced its model TC-18 "Tube Caddy-Tester."

This unit is a portable tube caddy with built-in tool storage and a multiple-socket tube tester. More than 800 tube types can be tested, according to



the manufacturer, including 6- and 12-volt vibrators. The tester, which uses three controls, will check each side of multi-purpose tubes, and provides emission tests for all tubes.

MOLDED TRANSISTOR XFORMERS

Microtran Company, Inc., 145 E. Mineola Ave., Valley Stream, N. Y. has recently introduced a new line of ultra-miniature molded transistor transformers which measure 1/4" in diameter and 1/2" high. They weigh 4 grams.

These new units are manufactured

What's



New in Radio

with nickel alloy cores of high permeability, nylon bobbins, and formvar wire. They are designed to meet MIL-T-27A, Grade 5, Class R specifications. Tinned bus leads are supplied, enabling the units to be used for dip soldering in printed circuitry. They may also be mounted flush in a fuse-clip-type assembly.

Electrical ratings provide primary impedances of 400 to 100,000 ohms and secondary impedances of 11 to 2500 ohms. On special order, center taps and 130-degree C construction are available. Wattages range from 2.5 mw. to 8 mw.

"BREADBOARDS"

Dynameans Inc., 1511 West Clark, Burbank, Calif. has developed a pre-etched circuit pattern designed to facilitate experimental and developmental breadboarding.

These inexpensive units, tradenamed

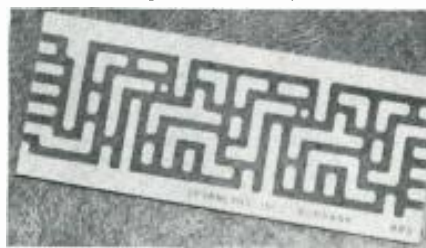

"Dynamaze," are designed to accommodate practically any configuration encountered in transistor circuit design. The circuit board can be used over and over again and eliminates the need for a standard chassis, the mounting of tie-points, the crimping of component leads, etc.

The breadboard measures 2" x 5" x 1/16" with a base material of epoxy glass. The circuit is non-breakable, acid resistant, heat resistant, and washable.

A data sheet outlining the features of this new circuit is available from the manufacturer on request.

PC BOARD HOLDER

Macdonald & Co., 1324 Ethel St., Glendale 7, Calif. has developed a printed circuit board holder which will handle any board up to 8 1/2 inches wide.

The Model 160 adjusts quickly and easily to any working position; horizontal, vertical, or angular. The jaws will permit the board to be worked on on either side without removing it from the holder. The board can be released quickly by means of a knurled nut at the bottom of the holder rod while the quick-locking clamp holds the board firmly when the work is positioned.

The holder takes only 9" x 10" on the workbench. The base is of solid steel and measures 4" x 6" x 1/2".

A data sheet covering this new item for the service shop is available on request. Write to Dept. L-1 at the above address.

POCKET MULTITESTER

Lafayette Radio Corp., 165-08 Liberty Ave., Jamaica 33, N. Y. has introduced a pocket size multitester, model TE-10, that features a 10,000 ohms-per-volt meter with a 3 1/2-inch face, claimed to be the largest ever used on an instrument this size.



Meter ranges cover d.c. volts in five steps, from zero to 6, 30, 120, 600, and 1200, as well as a.c. volts in four steps from zero to 6, 30, 600, and 1200. Direct current may be measured in three ranges to 300 milliamperes. Two resistance and two capacitance ranges are provided. There are five scales for reading db values, from -20 to +63.

The TE-10 uses 1-per-cent precision resistors throughout. It is supplied with color-coded test leads and battery. Case and panel are made of Bakelite. A pigskin carrying case is available as an accessory item.

CB TRANSCEIVER KIT

Grove Electronic Manufacturing Co., 4103 W. Belmont Ave., Chicago 41, Ill. has announced the availability of a CB transceiver in kit form.

The new kit, which is being offered in three models (110 volts, 12 volts, and



6 volts), provides a power input of 5 watts to a class C r.f. amplifier, uses a plug-in third-overtone crystal, AM plate modulation with automatic limiting for less than 100% modulation, an Astatic ceramic microphone, 50- to 75-ohm antenna impedance, superregenerative tuning range of 26.5 mc. to 27.5 mc. The circuit provides a full 2 1/2 watts

NEW FOR CITIZENS RADIO!

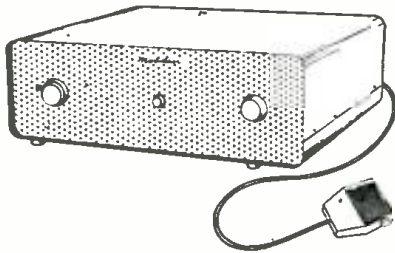

DESIGNED FOR RELIABILITY AND QUALITY, TO MEET THE NEW FCC REGULATIONS. 10-18 MI RANGE! FUNGUS TREATED; FOR CAR-HOME-BOAT 4" x 10" x 8"

PUSH TO TALK • 5 WATT 6 CHANNEL TRANSMITTER-RECEIVER 10 TUBES PLUS SILICON RECTIFIERS; CRYSTALS FOR 2 CHANNELS, PLUS MIKE, LESS ANTENNA

179.75
 MODEL 2700 115 VAC
 MODEL 2712 12 VDC
 TRANSISTOR POWERED

ORDER NOW

DEALERS INQUIRIES INVITED

Mobilair
 LAKELAND ELECTRONICS
 BOX 14, WARSAW, INDIANA

\$200.00 Value -----
**RCA POWER AMPLIFIER plus
 RCA PRE-AMP CONTROL UNIT**

both for only
 either ONE worth every
 penny of it!

\$74⁹⁵

NOT A KIT • FULLY ASSEMBLED
 Direct from Importer to You

STEREO-MATE or COMPLETE MONAURAL

New, exclusive electro-acoustic features include:
 • 20-watt (40-watt peak) power output maintained to limits of audible frequency spectrum
 • Infinitely variable loudspeaker damping factor • Accurate disc record compensation
 • World wide voltage • Frequency response 0.2 db 20-25,000 c.p.s.

2 GUARANTEES—RCA & OURS!



factory overload!

RCA RADIO CHASSIS

for both... REGULAR RECEPTION
 ... both for less than SHORT WAVE RECEPTION

1/2 the price you'd expect to pay

\$34⁹⁵

for either, with these EXCEPTIONAL FEATURES:

- 9 Tubes • 12" Extended Range Speaker
- Golden Throat Tone System • Superheterodyne
- Phono-Jack
- 7 bands wave trap on short wave
- Magic Eye Tuning • 90 to 250 volts a/c
- Separate Treble and Bass Controls
- Short Wave—2.2 mc to 22 mc

WRITE Name, Address in Margin, enclose with Check or M. O. for 25% of order. Freight Ppd.

NEW YORK SALES & SERVICE
 911 Broadway, New York 10, New York

audio output and uses a 4-inch speaker.

For a short time the manufacturer is offering to supply a swivel-base mobile CB antenna without additional charge to those purchasing the kit. Write Dept. EW of the firm for complete details on the transceiver and the antenna offer.

CONTROLLING MULTIMETER

Assembly Products, Inc., Chesterland, Ohio is offering a controlling multimeter that reportedly will guard virtually any critical voltage, current, or resistance. Believed to be the first unit of its kind, the new instrument is



a combination of a conventional multimeter, with the customary ranges, and a continuous reading meter-relay with adjustable set points. Measuring 11 by 6 by 6 inches, it is designed for use in laboratories and industrial processes.

Ranges of the controlling multimeter are: d.c. voltage, 2, 5, 10, 50, 250, and 1000-5000 volts; a.c. voltage, the same; current, 0/100 microamperes, 0/10 milliamperes; 0/100 milliamperes, 0/10 amperes; resistance, to 20 megohms in three scales with center scale values of 12, 1200, and 120,000 ohms.

BATTERY AND CHARGER

B & K Manufacturing Co., 1801 W. Belle Plaine Ave., Chicago 13, Ill. has introduced its new "Pony," a rechargeable battery and plug-in charger for transistor radio operation. The unit reportedly will give over 1000 times more playing hours than regular dry batteries, and is directly interchangeable with miniature 9-volt batteries used in transistor sets.

To recharge the "Pony," the owner snaps it into the charging unit and then plugs that unit into any a.c. electric outlet. For further information, write the manufacturer.

CITIZENS BAND RECEIVER

Browning Laboratories, Inc., Laconia, N. H. has announced its model R-2700 Citizens Band communications receiver.



The set uses five crystal-controlled channels for fast manual tuning and

fine vernier tuning of the entire Citizens Band.

According to the manufacturer, it is the only Citizens Band receiver with communications type tuning calibrated in frequency and channels. A full range adjustable squelch silences the receiver in the absence of signal, while the automatic noise limiter minimizes interference from outside sources. A delayed automatic volume control is said to assure full output from weak signals, yet prevents overload from extremely strong signals. An illuminated signal-strength meter is mounted on the front panel.

DRY LUBRICANT

Strauss Photo Technical Service, Inc., 930 F Street N.W., Washington, D. C. has made available a new dry lubricant, said to have a variety of uses.

Manufactured by Brandywine Photochemical Company, the lubricant is packaged in an aerosol dispenser. It is said to provide an invisible lubricating and protective film that is electrically non-conductive and would therefore be suitable for use on electronic equipment such as relays, switches, rheostats, sockets, dials, and solenoids.

COMPACT TUBE TESTER

Electronic Measurements Corp., 625 Broadway, New York 12, N. Y. is now



manufacturing what it believes to be the smallest, lowest priced complete tube tester today.

The EMC model 211 reportedly will check all octal, loctal, 9-prong, and miniature tubes for shorts, leakage, opens, intermittents, and quality. Magic-eye and voltage regulator tubes can also be tested. The 211 checks each section of multi-purpose tubes separately. Quality is indicated directly on a two-color meter dial using the standard emission test.

The unit is available in kit or factory-wired form. For further information, write to the manufacturer.

TV "AMPLIFRAMES"

Amperex Electronic Corp., Semiconductor and Special Purpose Tube Division, 230 Duffy Ave., Hicksville, Long Island, N. Y. has announced its new "ampliframes" for use in television receivers. Originally designed and used for military applications, "ampliframes" are available for the home entertainment market as a result of newly developed automatic production

ELECTRONICS WORLD

techniques. These new methods achieve a high degree of tube-to-tube uniformity yet enable "ampliframes" to be competitively priced with conventional tubes, and the manufacturer states.

New "ampliframes" include types 6EH7 and 6EJ7. According to the company these new types are of such high and uniform gain that the conventional three i.f. stages in TV receivers now can be reduced to two. For further information, write direct to the manufacturer.

MERCURY CADDY-TESTER

Mercury Electronics Corp., 77 Searing Ave., Mineola, N. Y. has introduced its new model 102-C "Caddy Tube Tester," a portable tube caddy with built-in

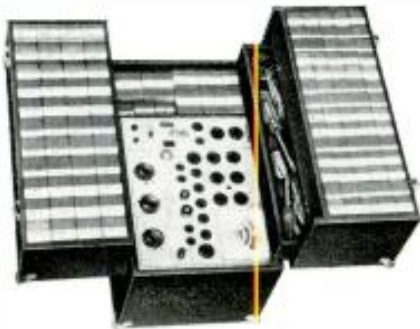

tube tester. The caddy, designed to hold over 125 tubes, also is fitted with a drawer for holding tools and test leads.

The multiple-socket tube tester checks for quality, emission, shorts,

leakages, and gas content on more than 700 tube types. It will also check crystal diodes, power rectifiers, pilot lamps, and fuses. A tube-pin straightener is included, as well as a convenience power outlet on the panel.

SPRAY FREES TV YOKES

Eastman Jewel Corp., Plainview, N. Y. has developed a chemical spray packaged in an aerosol can, that is intended to free yokes that have become frozen on the necks of picture tubes. Designated as catalogue number FYR6, the new chemical combination reportedly will free any yoke no matter how hard it may be stuck.

POWER TRANSISTORS

Delco Radio Division, General Motors Corp., Kokomo, Ind. has announced production of six new power transistors, claimed to be the highest current capacity transistors commercially available. The new line includes types 2N1522 and 2N1523 which are rated at a maximum collector current of 50 amperes. The 2N1518 and 2N1519 are rated at 25 amperes, while the 2N1520 and 2N1521 are rated at 35 amperes.

According to the company, these transistors are characterized by a low saturation resistance. Saturation voltage at 50 amperes in the 2N1522 and 2N1523 is a maximum of 0.5 volt, with a maximum resistance of .01 ohm. These transistors have 80- and 50-volt collector diode ratings and high open

base or breakdown voltage ratings.

The company has also announced the addition of four more transistor types in its TO-37 package. Listed as types 2N1609, 2N1610, 2N1611, and 2N1612, these small, diamond-base transistors weigh less than 0.1 ounce.

TRANSISTOR TESTER

Triplet Electrical Instrument Co., Bluffton, Ohio has announced its new model 2590 transistor tester. This in-



strument will test power and signal transistors under simulated operating conditions. Provision is made for checking I_{cbo} (at 9.5 v.), I_{ceo} (at 9.5 v.) and β amplification (at 3 v.) on both $n-p-n$ and $p-n-p$ types. The unit also checks leakage and forward currents of diodes.

COAXIAL CABLE - LESS THAN 3c Per Ft.!

RG-54 A/U CABLE-

Designed for long life and constant attenuation with polyethylene jacket. 58 ohms .250 OD—

370 FOOT ROLL: **\$10.95**

70 FOOT ROLL: **\$1.95**

RG-8/U—8 Ft. w/PL-259 ea end..... .95

L-101 COAXIAL ATTENUATOR—52 ohm Impedance matching cable and sliding adjustment \$1.95

ID-98/APN—OUTPUT INDICATOR \$1.50

ALL of the above items are part of the TS-10B/APN ALTIMETER TEST SET shown to the right.



TS-10B/APN TEST SET

• Used for checking sensitivity, tuning, antenna systems, calibration and limit calibrations of Altimeters. Consists of 370 Ft. & 70 Ft. of RG-54 A/U Coaxial Cable delay lines, L-101 Attenuator, ID-98 Indicator, two 8 Ft. 1/20" & 1/12" Cables of RG-8/U with PL-259 connectors each end. Also four SO-239 connectors. Complete in carrying case, size: 19 x 15 x 17". Wt.: 36 lbs. (As shown to left)—used—

ALL FOR **\$15.00**

BC-603 — \$14.95 — RE-NEW

BC-603 FM RECEIVER—20 to 27.9 MC. Re-New: \$14.95

BC-604 FM TRANSMITTER—0 to 27.9 MC. Used: \$7.95

BC-684 FM TRANSMITTER—27.891 MC. Re-New: \$7.95

FT-237 MOUNTING for Rec. Trans. Re-New: \$4.95

FT-346 MOUNTING for Receiver only. Re-New: \$4.95

DM-34 DYN. 12V. 1/BC-603-683—U: \$2.95—R-N: \$4.95

DM-35 DYN. 12V. 1/BC-604-684—U: \$6.95—R-N: \$9.95

FT-384 TEST ADAPTER For BC-603-683-923—

Used for testing various Voltages and Alignment of Receivers. Plugs into rear of set; has metering switch & provision for attaching output meter & V.T.V.M. Complete with 6 Ft. Battery Leads and Clips. Prices: USED: \$2.95..... RE-NEW: \$4.95

DATA RECORDER—16 MM CAMERA

Weather Observation Unit containing a sun angle optical system, 16 mm Matazine Camera that takes one exposure at a time and operates from 12 VDC. Mirrored Lens, Graph & Filter Ass'y., Barometer, Clock, Compass, a 10.2 VDC Digit Counter. Unit will record simultaneously on 16 mm film, one frame at a time, the lens exposure picture, and barometer, compass, time, and digit counter readings. With schema for wiring control switches & power plug. Size: 15" L x 9" W x 17" H. Shpg. **\$16.95**
Wt.: 45 lbs. New: \$2.90
Connector Plug



BC-221 FREQUENCY METER

Frequency 125 to 20,000 KC Crystal Calibration in all ranges. Can be used as a signal generator and VFO. Complete with original crystal & calibration book. Voltage required 6 VDC @ .9 amp. & 135 VDC 20 MA. Price—Used—less Modulation **\$79.50**

TS-175 FREQUENCY METER

Same as BC-221 only covers the range of 85 to 1000 MC. With Modulation —Price—Used, Excellent..... **\$99.50**
Metal Cases Only—No Canvas Covers!

AC POWER SUPPLY

F/BC-603-683 — Output: 220 VDC 80MA & 24VAC 2Amps. Tube Rectification; mounts on rear Plug of BC-603-683. Can be adapted to other Receivers. KIT: \$10.00—WIRED: \$14.95

TCK-7 TRANSMITTER

NAVY TYPE—2 to 16 MC in 6 Bands, 400 Watt CW, 100 Watt Phone VFO control on direct reading KC Division Dial, 100 KC Crystal Calibrator, RF stages are Gang Tuned with Digit Counters. Six 3 1/2" Voltage and Current Meters, Overload Relays, Circuit Breakers, etc. Tube line up: 2/613 PP Final, 837 Driver, 837 VFO, Audio 807, 6S07, 6SK7, Calibrator 6SK7, 6SL7, 6SN7. Voltage required: 110 VAC Filaments, 1800 VDC 400 MA, 500 VDC 350 MA, 150 VDC 150 MA, 12 VDC 2 A & 230 VDC. Size: 52 x 25 x 18". Wt.: 285 lbs.; Shpg. wt.: 470 lbs. Complete with Tubes, Manual, & Mic. New: **\$150.00**

ARC-3 RECEIVER—100-156 MC: \$24.95

VHF Crystal Control 8 channel, electric band change, 17 Tubes: 9001, 9002, 12A6, 12H6, 12SH7, 12SL7, 2/12SN7, 3/12SG7, & 6/6AK5. Voltage required 210 VDC 125 MA and 24 VDC. Used **\$24.95**

FREE CATALOG New—write—ask for your Free copy today!

Address Dept. RN • \$5.00 Order Minimum. & 25% Deposit on C.O.D.'s • Prices are F.O.B. Lima, Ohio

Fair Radio Sales P. O. BOX 1105
2133 ELIDA ROAD LIMA, OHIO

BARRY'S JUNE SPECIAL

- Lambda Power Supplies: Model 41—In: 115 VAC @ 60 CPS. Out: 6.3 VAC @ 6 Amps (CT) 9 200 VDC @ \$75.00.
- Model 34—In: 115 VAC @ 60 CPS. Out: 6.3 VAC @ 5 Amps (CT) 6.3 VAC @ 5 Amps (CT) 100 to 350 VDC @ 300 Ma. \$90.00.
- Model 28—In: 115 VAC @ 60 CPS. Out: 200 to 325 VDC @ 100 Ma. \$65.00.
- Philco Reg. Pwr Supply Model PTE-2697. In: 115 VAC @ 60 CPS. Out: 0 to 350 VDC @ 100 Ma. \$45.00.
- Philco Klystron Pwr Supply Model PTE-2179. In: 115 VAC @ 60 CPS. Out: 600 V. @ 100 Ma. \$90.00.
- Philco Klystron Pwr Supply Model 2384. In: 115 VAC @ 60 CPS. Out: Beam: 600 to 600 VDC @ 100 Ma. Out: Reflector: 100 to 600 VDC @ 100 Ma. \$110.00.
- Sola — 30M814 (4 KVA) Constant Volt. Xfmr. In: (95 to 125) or (190 to 250 V.) @ 60 CPS Single phase. Out: 115 plus or minus 1% @ 4000 VA. \$245.00.
- Sola — 30M815 (5KVA) Constant Volt. Xfmr. In: (95 to 125) or (190 to 250 V.) @ 60 CPS Single phase. Out: 115 plus or minus 1% @ 500 VA. \$295.00.
- Johnson — 227 tube sockets for 812, etc. Unused. 95¢ ea. 2 for \$1.80.
- Ucrite Sockets for 829B, 826 3E29, AX9903/5894, 4.65A, etc. Sale price \$1.00.
- Xmtg. Socket Ceramic for 808, 832A, etc. 75¢.
- Johnson Xmtg Socket for 808, 8C22, etc. Johnson #122-244. \$1.40.
- Octal Ceramic Sockets. 15¢.
- 7 Prong Ceramic Sockets for 1625's, etc. 20¢.
- High Power Xmtg. Complete w/push-pull 5736's and 220 VAC 4 KV. P.S. \$490.00
- Imported European Antique Telephones wonderful for Intercum. Decorative. Conversation piece. Has been adv'd for \$40.00. Excel. buy @ \$19.95 each.
- VHF Transmitter. Perfect for 2 meter and/or 1 1/4 meter conversion. Late, modern design. Uses two 6201's into single Amperex 6360 twin tetrode. Xmtg only w/4" x 1/2" tube. Only 2 1/2 lbs. Comp. w/101" chrome antenna. Furnished with water-activated battery (weight: 35 lbs), connection cable, schematic & conv. info. Sale price only \$15.00.
- Sorensen Regulated Power Supply Model 500-BB. 0 to 500 VDC @ 300 Ma.— 6 VAC @ 10 Amps. Input: 115 VAC @ 60 CPS. \$175.00.
- Mobile Signal Generator Model 104-A. Fed. Telephone & Radio Corp.—2 Bands. Low Imp. 148 to 174 High Imp. 148 to 174. Also 300 CPS. tone. Operates from 115 VAC @ 60 CPS or 6V & 180 VDC w/external pwr supply. Unused. Orig. ctng. w/instructions. \$44.00.
- Sylvania Polymeter Type 391. Scales 2 & 4 DC Ranges. Reads up to 1,000 Volts. (Up to 30,000 V. w/Syl. Type 225 Voltage Probe). Resistance up to 10,000 Megs. in ranges. True peak-to-peak readings up to 2,800 Volts. Brand new. orig. box. \$49.00.
- Thordarson Choke. 5 H @ 200 Ma. Hermetically-sealed. Compact. Side insulators 600 V. Insulation. Approx. 115 Ohms DC resistance. 2 1/2" x 2 1/2" x 3 1/2". Wt: 2 1/2 lbs. \$1.00.

New! Lab quality (.5%) AC & DC Ammeters, Microammeters and Voltmeters. Also lab-quality "Meggers." These imported instruments are "Rolls-Royce" quality. Write for Catalog YEW.

- New Westinghouse 1N1169 Silicon TV Rectifiers. Replaces TV Selenium Rectifiers and gives greater life. \$2.25 each.
- RCA TV Remote Control Unit (controls sound & picture) for 1955 & earlier model RCA sets. Makes TV viewing relaxing. \$12.50 (comp w/instructions & manual).
- The U.S. and the World—A Beautiful 2-21" For the home or office. New True Raised-Relief Maps with mountains & valleys you can actually feel. In its own frame, ready for hanging. Rich colors. 28 1/2" x 18 1/2". Made of sturdy Vinylite. These are the maps selected by the U.S. Weather Bureau for display in airport weather stations. Free! Yoursself today! Only \$9.95. (Cat. avail.)
- BC-603 Power Supply. Completely wired. Ready to operate the popular BC-603 Receivers. Uses exact connectors used on BC-603 Revers. 115 VAC @ 60 CPS operations. \$9.95.
- C. R. Tubes Type 38P1 w/matching socket. Removed from equip'm't. Tested O.K. Both tube and socket only \$1.50.
- Tape Recorder Special. \$180.00). Demonstrators available only \$99.50. Fun for parties. Ideal for office. Write for Brochure.
- New! Professional Closed-Circuit TV Camera. For industry, schools, banks, etc. Approx. \$100.00. Most reasonable price for units of this caliber.
- Scintillation Counter. 10 times more sensitive than a geiger counter. Complete w/instructions—ready to operate. Model CAE 1002. Only \$49.95 (cat avail.).
- Sonotone Rechargeable Battery Cartridge Model FC-2. Cartridge is size of two reg. size flashlight batteries. Why shop for replacements when the Sonotone lasts indefinitely by plugging into any AC socket to recharge. \$6.95.
- 2 1/2 H. P. 3450 RPM Continuous Duty DC Motor. 115 VDC @ 1.8 amps. Shpg. Wt.: 30 lbs. Orig. pkg. Exc. buy only \$4.95.
- Leach 115 VAC Relay. 30 Amps contacts. (For switching high-volt. Supply). DPT-2 (N.O.) \$10.00.
- Precision M-3 Infra-Red See-in Dark Sniperscope. Orig. carryng case. Can be mid on rifle. Wt.: 6 1/2 lbs. Price \$120.00 (complete).
- US-23 Infra-Red See-in Dark Sniperscope. (Only item included is a standard light source with simple infra-red filter. (Can't be mid on rifle). Can be carried by hand or shoulder sling straps—comes with case. \$99.00.
- Dual Oil Capacitor in one container. 2 Mfd. @ 1000 VDC plus 6 Mfd @ 800 VDC. \$1.00.
- Choke. Approx. 6 H @ 500 Ma. 26 Ohms DC Res. O.F. const. Wt.: 8 1/4 lbs. \$3.00.
- Heavy-Duty Blower W/Mtg. Bracket. Motor oper. fr 115 VAC @ 60 CPS. Unused. Comp. w/AC cord & plug. Cools 4-400A, 4-1000A tubes, etc. Wt. 5 lbs. Cat. #69D. \$9.95.
- Dual Fil. Xfmr. (D.F.). Pri: 110 VAC @ 60 CPS. Sec: 6.3 VAC @ 12 Amps. 6.3 VAC @ 6 Amps. Wt.: 6 1/2 lbs. Stock #20C-4933. \$2.00.
- Oil Xmtg Caps. 10 MC Continuous Duty DC Motor. 115 VDC. \$3.75.
- G.E. Pyranol Cap. 1 Mfd. @ 6000 VDC. Net Wt. 3 1/2 lbs. \$4.95.
- Hewlett-Packard SHF Test Set Model 623B. New cond. orig. box & call. sheet. \$1100.00.
- G.E. Standing Wave Ratio Meter & Bolometer. \$14.95.
- Scope Xmtg W. E. Pri.: 115 V. @ 50 60 CPS. Sec. (1) 1000 V. @ 8 Ma. (2) 6.3 V. @ 3-2 Amps. See-In Dark Sniperscope. (Only item included is a standard light source with simple infra-red filter. (Can't be mid on rifle). Can be carried by hand or shoulder sling straps—comes with case. \$99.00.
- Shield. Size: 5 3/16" H x 5 1/2" x 2 1/2" Wt. 1 1/4 lbs. Stock #K88877. \$3.75.
- 6 KV RF Transformer. Oil filled. Herm. Sealed. Diagram clearly stencilled on unit. 4 1/2" H x 7 1/2" W x 6 3/4" D. Wt.: 6 1/2 lbs. Raytheon — WX-5394. \$3.95.
- 68" H Relay Racks. 22" W. Overall. 1: 18". Unit has frt & rear doors. Used, good condition. Needs touch up. Shpg. Wt.: 180 lbs. via economical motor fr. \$29.95.
- Silicon Rectifier—350 Ma/130 R.M.S. 50¢ each (10 for \$4.00).
- 130 V. R.M.S. 500 Ma. Selenium Rectifier. Brand new. Radio Receptor. 50¢ each.
- Struthers Dunn 6 VDC Relay. SPST. 1 Amp contacts. SD=181AXX102. 60¢ each; 10 for \$5.00.
- Jaeger Clock Movements—MA-863B. Operates on 1.5 VDC. All you need are hands and dial plate \$1.00 each (10 for \$8.00).
- Edison Thermal Relay. 115 VAC 25 sec. delay. 65¢ each (10 for \$5.00).
- 6383 RCA Hi-Frequency Power Triode. Water or Forced-Air Cooled. Full input up to 2000 Mc. Fil. 6.3 VAC @ 3.3 amps. Plate voltage 1500 Max. @ 400 Ma. 600 Wm. Input. Power 4000 Wm. 1 1/2" overall height. (Brand new. Original RCA JAN cartons. Reg. Net \$130.00. Super-Nect \$50.00.
- Tubes: 6N5-4 \$1.35 ea. (lots of 100: \$1.25 ea.), 6N22 @ \$3.50.
- Brand New Tube Cartons and Stackers. Write for price list and sizes.
- Minimum order \$5.00 150¢ service charge for orders less than \$5.00. All prices F.O.B. NYC. Specify method of shipment if you have preference. All mds insured and guaranteed for cost of mds only. Surplus equipment lab tested O.K.

SPECIALS ON COMPONENTS, EQUIPMENT, TUBES, SEMICONDUCTORS WRITE TODAY FOR THE WINTER-SPRING "GREEN SHEET" CATALOG.

Most diversified tube stock obtainable & semiconductors. What do you need? Quotes answered same day.

SP-600 HAMMARLUND SUPER-PRO RECVR. .54 to 54 Mcs.—\$450.00

We are open Mon. to Fri. 9 to 8 and on Sat. from 10:00 to 2 P.M. . . . Come in and browse . . . we have many unadvertised specials (one of a kind items). Factory authorized distributor for Westinghouse & National Electronics on tubes & Semiconductors. E. F. Johnson, J. W. Hammarlund, National Co., TMS & others.

NC-60 Recvr—Brand New—Sld ctn. \$45.00. Drake J-1A. \$249.50. Johnson Citizen Transceiver—27 Mc. 12C & 117 VAC. Exc. recvr. selectivity & sensitivity. Built-in squelch. \$139.75.

Write for catalog & we will put your name on our mailing list for one year. Tell us what you're looking for if you can't find it here. Tell us what you have in the nature of UNUSED tubes that you wish to sell for cash—also commercial equipment in good working condition. Let's hear from you!!

BARRY'S ELECTRONICS CORPORATION

512 BROADWAY, NEW YORK 12, NEW YORK
Walker 5-7000 Dept. EW-6

An unusual feature is a transistor socket and a set of external leads that permit use of the tester with any type basing arrangement.

Model 2590 has a gray leatherette case and a recessed panel.

PRECISION FILM CAPACITORS

Capcon, Inc., 61 Stanton St., New York 2, N. Y. has made available production quantities of its line of 0.1% tolerance polystyrene and Mylar film capacitors.

According to the manufacturer, these precision capacitors are now available at reduced prices as a result of using a new electronically controlled capacitor winding machine. These units can be supplied in a variety of package forms, all meeting applicable MIL specifications. Capacitances from 1 to 50 μ f., with working voltages from 10 v. to 15,000 v. are available.

The company will supply complete details on request.

30-MC. AMPLIFIER TRANSISTOR

Motorola, Inc., Semiconductor Products Division, 5005 East McDowell Road, Phoenix, Ariz. has announced a new 30-mc. amplifier Mesa transistor. Designed for high-frequency applications, including TV video amplifiers, its low collector cut-off current of 0.2 μ a. makes it usable for critical d.c. direct-coupled amplifier service. It can also be used in transmitters as a low power output or driver multiplier intermediate stage.

Designated as the 2N741, the new transistor is a germanium p-n-p diffused-junction type in a TO-18 package with collector connected to case. Further information is available from the manufacturer.

SERVICE CEMENT

Chemtronics, Inc., 870 East 52nd Street, Brooklyn, N. Y. is offering a new cement for use in radio and TV repair. Listed as catalogue number 502-2, the new item is said to be useful for repairing speakers, as well as for application to Bakelite and glass for cementing loose tube bases, mending plastic cabinets, and bonding parts to a chassis.

The cement is packaged in a two-ounce bottle and is supplied with an applicator brush.

PHOTO CREDITS

Page	Credit
31, 32	Raytheon Co.
33	Radio Corporation of America
35	General Electric Company
37	CBS Laboratories
38, 39 (bottom)	ORR Radio Industries, Inc.
39 (top)	Scott Instrument Labs., Inc.
44 (Figs. 5, 6, & 7), 45 (Figs. 10, 11, & 12)	Eastern Industries, Inc.
44 (Fig. 8), 45 (Fig. 9)	Traffic House, Inc.
70	Harman-Kardon
71	Dyna Company
118	Pickering and Company, Inc.

INVITATION TO AUTHORS

Just as a reminder, the Editors of ELECTRONICS WORLD are always interested in obtaining outstanding manuscripts, for publication in this magazine, covering the fields of audio and high-fidelity and radio-TV-industrial servicing. Articles in manuscript form may be submitted for immediate decision or projected articles can be outlined in a letter in which case the writer will be advised promptly as to the suitability of the topic. We can also use short "filler" items outlining worthwhile shortcuts that have made your servicing chores easier. This magazine pays for articles on acceptance. Send all manuscripts or your letters of suggestion to the Editor, ELECTRONICS WORLD, One Park Avenue, New York City 16, New York.

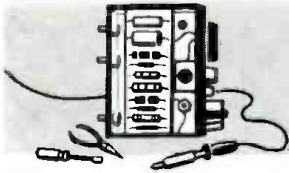

ELECTRONICS MARKET PLACE

RATE: 60¢ per word. Minimum 10 words. August issue closes June 9th. Send order and remittance to ELECTRONICS WORLD, One Park Ave., N. Y. C. 16, N. Y.

RADIO ENGINEERING & INSTRUCTION

ELECTRONICS! Associate degree—29 months. Technicians, field engineers, specialists in communications, missiles, computers, radar, automation. Start September, February. Valparaiso Technical Institute, Dept. N. Valparaiso, Indiana.

ENGINEERING and Art Degrees earned through home study. Electronics, Electrical, Mechanical, Civil, Physics, Business Administration, Accounting, Liberal Arts. When writing, specify course desired. Pacific International College of Arts & Sciences, primarily a correspondence school. Resident classes also carried. 5719-C Santa Monica Boulevard, Hollywood 38, California.

USED Correspondence Courses and Books sold and rented. Money back guarantee. Catalog Free. (Courses Bought). Lee Mountain, Pisgah, Alabama.

LEARN Code. Quality for Amateur or Commercial License. Free Book. Candler, Dept. EW-6, Box 9226, Denver 20, Colo.

HIGHLY Effective home-study review for FCC Commercial phone exams. Free literature. Write: Wallace Cook, "Chief Instructor," Cook's School of Electronics, Dept. "EW," Box 10634, Jackson 9, Miss.

WANTED

CASH For Used Short-Wave Ham Receivers, Transmitters & Accessories. Treger W9IVJ, 2023 N. Harlem Ave., Chicago 35. Tuxedo 9-6429.

CASH PAID! Sell your surplus electronic tubes. Want unused, clean transmitting, special purpose, receiving, TV types, magnetrons, Klystrons, broadcast, etc. Also want military & commercial lab test and communications gear. We swap too, for tubes or choice equipment. Send specific details in first letter. For a fair deal write, wire or telephone. Barry, 512 Broadway, New York 12, N. Y. WALKER 5-7000.

WANT to buy good equipment and accessories? Place a low-cost classified ad in this space.

CYLINDER and old disc phonographs. Edison, Conqueror, Idelia, and Oratorio models. Berliner Gramophones and Zono-o-phones, Columbia cylinder Graphophones, and coin-operated cylinder phonos. Want old catalogues and literature on early phonos prior to 1919. Will pay cash or trade late hi-fi components. Classified, Electronics World, Box 50, 1 Park Ave., N. Y. C. 16, N. Y.

WANTED: Tubes, Diodes, Transistors. Top prices for Klystrons, Thyratrons, Power, TV and Receiving Tubes. Must be unused. Wanted: Laboratory-Grade Test Equipment, Oscilloscopes, Bridges, Signal Generators (microvolts) RF & Audio, Recorders, etc. Commercial (Hewlett Packard, etc.) and military (TS and UPM prefixes). Write us detailed description. Bob Sanett, W6REX, V & H Radio & Electronics, 2053 Venice Blvd., Los Angeles 6, California.

FOR SALE

ORGAN blocking osc transformers; \$1.25 ea. Audio chokes dual 300mh and 320mh; \$1.25 ea., application schem supplied. R. H. Shaw, 5527 13th St. N. W., Washington 11, D. C.

INDUCTORS for Crossover Networks. 118 types in stock. Send for brochure. C & M Coils, 3016 Holmes Ave., N. W., Huntsville, Ala.

GOVERNMENT sells: Surplus Electronics; Test Equipment; Oscilloscopes; Transceivers; Jeeps; Boats; Aircrafts; Misc.—Send for U. S. Depot Directory & Procedure \$1.00—"Government Surplus Sales," Box 425—RT, Nanuet, N. Y.

AUTO Radio Distributor Selling Servicing Becker Blaupunkt, FM-AM, other European, American Sets. Save 30% + Square Electronics, 150-60 Northern Blvd., Flushing, N. Y.

RADIO and television tubes, brand new, 1st quality, original box name brands only. 60% off list. Edison Tube Co., 335 Main St., Metuchen, N. J.

SOMETHING for sale? Place a classified ad in this section. Low-cost, fast results. It's easy.

DIAGRAMS for repairing radios \$1.00. Television \$2.00. Give make, model. Diagram Service, Box 672-RN, Hartford 1, Conn.

TELEVISION Sets \$9.95, plus shipping. Jones TV, Sanatoga, Pa.

GOVERNMENT Surplus Receivers, Transmitters, Snooperscopes, Parabolic Reflectors. Picture Catalog 10¢. Meshna, Malden 48, Mass.

TUBES—TV, Radio, Transmitting and Industrial Types at Sensibly Low Prices. New Guaranteed, 1st Quality Top Name Brands Only. Write for Free Catalog or Call Walker 5-7000, Barry Electronics Corp., 512 Broadway, New York 12N, N. Y.

RADIO & TV Tubes at Manufacturer's prices! 100% Guaranteed! Brand New! No re-brands or pulls! United Radio, Box 1000-W, Newark, N. J.

SURPLUS Walkie talkies, command sets, VHF-UHF, Tech Manuals, Over 5000 items, Catalog 10¢, Bill Slep Company, Box 178, E.W., Ellenton, Florida.

IRE Proceedings 1946 through 1959. Andraud, 247 Drake Avenue, New Rochelle, N. Y., NE 3-7150.

RADIO and Television Tubes—Brand New, 1st Quality, Top Name Brands in original boxes, 60% off list, Free Bonus with orders, Prompt Deliveries; U T C—Box 306, Syosset, N. Y.

NOTICE

In replying to box numbers be sure to address letters to

ELECTRONICS WORLD

1 Park Ave. New York 16, N. Y.

Note: This does not apply to box numbers where city and state are shown.

HIGH-FIDELITY

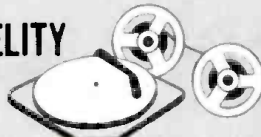

TAPES, Kits, Components, Recorders. Special Quotes. Bayla Co., 1470-E Elmer Road, Wantagh, N. Y.

PRICES? The Best! Factory-sealed Hi-Fi Components? Yes! Send for free catalog. Audion, 25T Oxford Road, Massapequa, N. Y.

DISGUSTED with "HI" Hi-Fi Prices? Unusual Discounts On Your High Fidelity Requirements. Write: Key Electronics, 120 Liberty St., New York 6, N. Y. Cloverdale 8-4288.

RECORDERS. Hi-Fi. Free Wholesale Catalogue. Carston 125-R East 88, NYC 28.

TAPE & RECORDERS

FOUR Stereo component systems to fit every need. Sealed Cartons, Huge Savings. Hi-Fi, Box 183, Paoli, Pa.

TAPE Recorders, Hi-Fi Components. Sleep Learning Kits, Tapes. Unusual Values. Free Catalog. Dressner, 69-02R 174 St., Flushing 65, N. Y.

AMPEX, Concertone, Magnecord, Prestok, Bogen, Tandberg, Pentron, Sherwood, Rek-O-Kut, Scott, Shure, Dynakit, others, Trades. Boynton Studio, Dept. RT, 10 Pennsylvania Ave., Tuckahoe, N. Y.

OVER 245,000 buyers and sellers will read your ad when placed in this space. It costs you only 60¢ per word; minimum of 10 words including your name and address.

RENT Stereo Tapes—over 1,000 different—all major labels—free catalog, Stereo-Parti, 811-L Centinela Ave., Inglewood 3, California.

UNUSUAL Values. Hi-Fi components, tapes, tape recorders. Catalogue; package quotations. Budget Hi-Fi; 83-06F Vietor Ave., Elmhurst, N. Y.

MUSIC

SONGS into Dollars! Share \$33 million dollars yearly for New Songwriters, Songpoets. Any subject, songs composed, Published, promoted by largest firm. Information, appraisal free. Send Nordyke Music Publishers. 6000 Sunset, Hollywood 283, California.

POEMS Wanted for musical setting and recording. Send poems. Free examination. Crown Music, 49-TM West 32, New York 1.

MISCELLANEOUS

CONTRACT Work Wanted. Established compression molding plant in Metropolitan New York area offers well manned and fully equipped plant facilities for molding production. We seek contract work from electronic firms desiring reliable source of supply to pace sales and assembly commitments. Inquiries will be kept in strictest confidence. Write Box #571, Electronics World, 1 Park Ave., New York 16, New York.

MISCELLANEOUS service including stamp hobby from Japan. I'm an industrial designer understanding electronics engineering. Yonehara, 248 Elfuku, Sugunami, Tokyo, Japan.

SHOPPING GUIDE Classified

A HANDY GUIDE TO PRODUCTS, NOT NECESSARILY ELECTRONIC, BUT OF WIDE GENERAL INTEREST.

BUSINESS OPPORTUNITIES

BUY direct from factories! Appliances, Cameras, Watches. Free details! Cam Company, 6810EW—20th Avenue, Brooklyn 4, N. Y.

EARN Extra money selling advertising book matches. Free Samples furnished. Matchcorp, Dept. MD-60, Chicago 32, Ill.

RADIO parts stores & Hi-Fi Salons! Someone "borrowing" your personal copy of Electronics World each month? You ought to be taking advantage of Electronics World convenient re-sale plan. Sell copies in your store . . . performs a good service for your customers . . . with no risk involved. For details, write: Direct Sales Department, Electronics World, One Park Avenue, New York 16, New York.

OVERSEAS Employment. American Firms and United State Government. Comprehensive job information \$2.00. Foreign Opportunities, Box 172, Columbus 16, Ohio.

STAMPS & COINS

WRITE Martin Lincoln, Electronics World, 1 Park Avenue, New York 16, N. Y. for information on how to place a classified ad in this section.

WANTED: Confederate stamps, letters, etc., U. S. letters 1800-1880. Collector offers cash. Address offers or inquiries: O. Spokas, Box 5633, Washington 16, D. C.

PHOTOGRAPHY—FILM, EQUIPMENT, SERVICES

OPTICAL—Science—Math Bargains—Request Free Giant Catalog "CJ"—128 pages—Astronomical Telescopes, Microscopes, Lenses, Binoculars, Kits, Parts. Amazing war surplus bargains. Edmund Scientific Co., Barrington, New Jersey.

WHATEVER your needs, Electronics World classified can solve them. Simply place an ad in these columns and watch your results pour in.

16MM SOUND Films, features and shorts, free catalogue. William Franz, 202 Hazelwood Ave., Pittsburgh, Pa. (Zone 7).

MISCELLANEOUS

17 PROVEN Ways to make money typing at home. Detailed instructions \$1 (refundable). Ryco Service, 210-M Fifth Ave., Suite 1102, New York 10.

FREE! New 1960 catalog of all Photographic Books available; for your copy, send postcard with name and address to catalog, Popular Photography Book Service, One Park Ave., New York 16, N. Y.

BIZARRE Fashions! Illustrated Catalogue, \$1.00. Renee, Box 2804-P, Hollywood 28, Calif.

KEY Chains, personalized ashtrays, smoke sets—hundreds of useful novelties for home, office and gifts. Inexpensive items. Write for free catalog. House of Brand, Dept. EW-2, 3458 Fish Avenue, New York 69, New York.

"WINEMAKING; Beer, Ale Brewing." Illustrated. \$2.20. Eaton Books, Box 1242-Tc, Santa Rosa, California.

AUTOMATIC door operators, new famous make. Only \$59.95. Buy direct. Save! Free literature. Oemsco, Sebring 9, Ohio.



ELECTRONICS WORLD HAS

**A BUYER FOR YOUR USED
EQUIPMENT OR COMPONENTS!**

The 245,000 purchasers of ELECTRONICS WORLD are always in the market for good used equipment or components. So if you have something to sell, let EW readers know about it through our classified columns. It costs very little: just 60¢ a word, including name and address. Minimum message: 10 words.

For
further
information
write:

Martin Lincoln
ELECTRONICS WORLD
One Park Avenue
New York 16, N. Y.

INDEX OF Advertisers

JUNE
1960

ADVERTISER	PAGE NO.	ADVERTISER	PAGE NO.
Acro Products Co.	12	Key Electronics Co.	114
Adel Tool Co.	78	Kuhn Electronics	104
Advance Electronics	124	Lafayette Radio	89
Advanced Acoustics Corp.	74	Lakeland Electronics	126
Aerovox Corporation	68	Lampkin Laboratories, Inc.	123
Airex Radio Corporation	119	Lektron	106
Aiwa Co., Ltd.	26	Micro Electron Tube Co.	93
Allied Radio Corp.	9, 72, 73	Miller Company, J. W.	110
Amperex Electronic Corp.	77	Milwaukee School of Engineering	86
Ashe Radio Co., Walter	122	Moss Electronic, Inc.	80, 81
Audio Unlimited	123	National Radio Institute	3
Audion	104	National Schools	15
Audiotex Mfg. Co.	79	New York Sales & Service	126
B & K Manufacturing Co.	63	Ohmatsu Electric Co. Ltd.	83
Baltimore Technical Institute	98	Olson Radio Corporation	123
Barry Electronics Corporation	128	Paco Electronics Co., Inc.	87
Bogen-Presto	20	Peak Electronics Company	90
British Industries Corp.	119	Pickering & Co., Inc.	117
CBS Electronics	6	Picture Tube Outlet	92
C & H Sales Co.	116	Prentice-Hall, Inc.	96
Candee Co., J. J.	114	Quietrol Company	78
Capitol Radio Engineering Institute	23	RCA Institutes, Inc.	11
Carston Studios	119	R-Columbia Products Co., Inc.	117
Centralab, The Electronics Division of Globe-Union Inc.	75	R W Electronics	118
Channel Master	85	Rad-Tel Tube Co.	99
Cleveland Institute of Electronics	17	Radio Corporation of America	Fourth Cover
Columbia Electronics	92	Radio Shack Corp.	87
Coyne Electrical School	100	Reeves Soundcraft Corp.	8
Delco Radio	18, 19	Rider Publisher Inc., John F.	83
DeVry Technical Institute	5	Rinehart & Co., Inc.	84
Dressner	116	Sams & Co., Inc., Howard W.	94, 95
EICO	27, 28, 112	Schober Organ Corp., The	76
Electro-Voice, Inc.	25	Sonotone Corp.	14, 21
Electronic Chemical Corp.	109	Sprayberry Academy of Radio-Television	13
Electronics Book Service	111, 119, 120	Standard Coil Products Co., Inc.	Third Cover
Essco C-B Hqts.	100	Standard Surplus	98
Fair Radio Sales	127	Supreme Publications	107
Finley, Frank	116	Sylvania Electric Products Inc.	Second Cover
G & G Radio Supply Co.	105	TV Electronic Supply Co.	122
General Electric	16	Teltron Electric Co.	109
Goodheart Co., R. E.	82	Texas Crystals	96
Grantham School of Electronics	7	Tri-State College	100, 119
Greenlee Tool Co.	88	Tru-Vac Electric Company	113
Hallicrafters	88	University Loudspeakers, Inc.	10
Heath Company	64, 65, 66, 67	Valparaiso Technical Institute	116
Henshaw Radio Supply	123	Vanguard Electronic Lab	104
Hi Fidelity Center	123	Vocaline Company of America	22
Hi-Mu Electronics	114	Weston Instruments Division	101
Indiana Technical College	122	Workman TV Products, Inc.	110
International Crystal Mfg. Co., Inc.	91		
International Resistance Company	77		
Jerrold Electronics Corporation	69		
Johnson Company, E. F.	121		



Here is the new Standard Coil Tuner Replacement and Repair Program that enables you to offer better service to your customers at greater profit. Now Standard Coil Products provides the tools that will enable you to cash in on the profitable tuner repair and replacement market.

TUNER REPLACEMENT LISTING IN SAMS PHOTOFAC

Starting in January, Standard Coil tuner replacement listings will appear in all Sams TV Photofact. Tuner replacement information will be right at your finger tips. Standard Coil is the *only* manufacturer ever to provide this service.

NEW TV TUNER REPLACEMENT GUIDE

Lists original equipment TV tuners with the Standard Coil equivalent replacement for each. Also includes major mechanical replacement parts for all Standard Coil Tuners—those used in original equipment as well as the universal replacement. Eliminates all guesswork—minimizes your tuner repair and replacement problems.

48 HOUR FACTORY GUARANTEED REPAIR SERVICE

Standard Coil's special service department set-up assures factory guaranteed repairs—*on a 48 hour in-plant cycle!* All repaired tuners carry a *six month warranty* on defective workmanship and parts failure (excluding tubes). Gives you more time for additional service calls—promptly returns your customer's set to like new operating condition.

DEFECTIVE TUNER TRADE-IN ALLOWANCE

Tuners which can *not* be repaired can be traded in against a new replacement tuner which carries a *full twelve month factory guarantee*. See your Standard Coil Distributor for complete details on how trade-ins can increase your tuner sales and profits—create greater customer satisfaction.

JUMP ON THE STANDARD COIL PROFIT WAGON TODAY!

For additional details, see your authorized Standard Coil Distributor or write to:

Standard

Coil Products Co., Inc.

2085 North Hawthorne Avenue, Melrose Park, Illinois

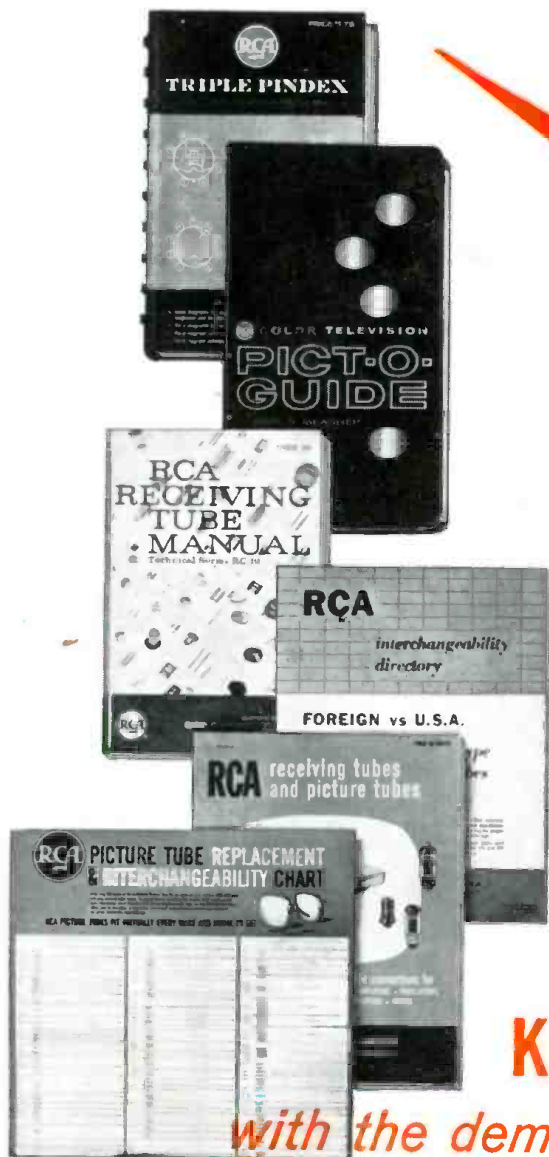

KEEP PACE

with the demands of your profession

A complete, up-to-date library of RCA technical literature is as necessary a tool in your profession as a VTVM. It's a sure, simple, time-saving way to maintain your status as an expert!

1. **RCA TRIPLE PINDEX (\$1.75)** • Base diagrams for 1500 receiving and 400 picture tubes, with cross references to many foreign and industrial types. Triplicate receiving tube breakdown shows you at least 3 diagrams at once.
2. **COLOR TELEVISION PICT-O-GUIDE (\$4.50)** • RCA's John Meagher shows you how to troubleshoot and adjust color TV receivers. Problems are illustrated in full color, with easy-to-follow explanations of how to correct them.
3. **RCA RECEIVING TUBE MANUAL (75¢)** • Technical data on more than 625 receiving tubes, including types for TV, radio, and hi-fi. Clear explanations of tube operation and uses, with many illustrative diagrams and circuits.
4. **RCA INTERCHANGEABILITY DIRECTORY—FOREIGN vs. U.S.A. RECEIVING TUBES** • Lists some 450 foreign receiving tubes (radio, TV, audio), with U.S.A. direct replacement or similar type where available.
5. **RCA RECEIVING TUBES AND PICTURE TUBES BOOKLET (30¢)** • A jam-packed 48-page booklet listing electrical characteristics and socket connections for more than 900 receiving and picture tubes used in standard AM, FM, TV, and audio amplifier sets.
6. **RCA PICTURE-TUBE REPLACEMENT AND INTERCHANGEABILITY CHART** • Lists 88 RCA Picture Tubes, and the 253 industry types they replace. Especially for the service technician.

Check with your Authorized RCA Tube Distributor **THIS WEEK**, to make sure you have *the latest editions* of these important publications—each a standard of the industry.



RADIO CORPORATION OF AMERICA

• *Electron Tube Division*

Harrison, N. J.