

# ELECTRONIC DESIGN

FEBRUARY 9, 1960

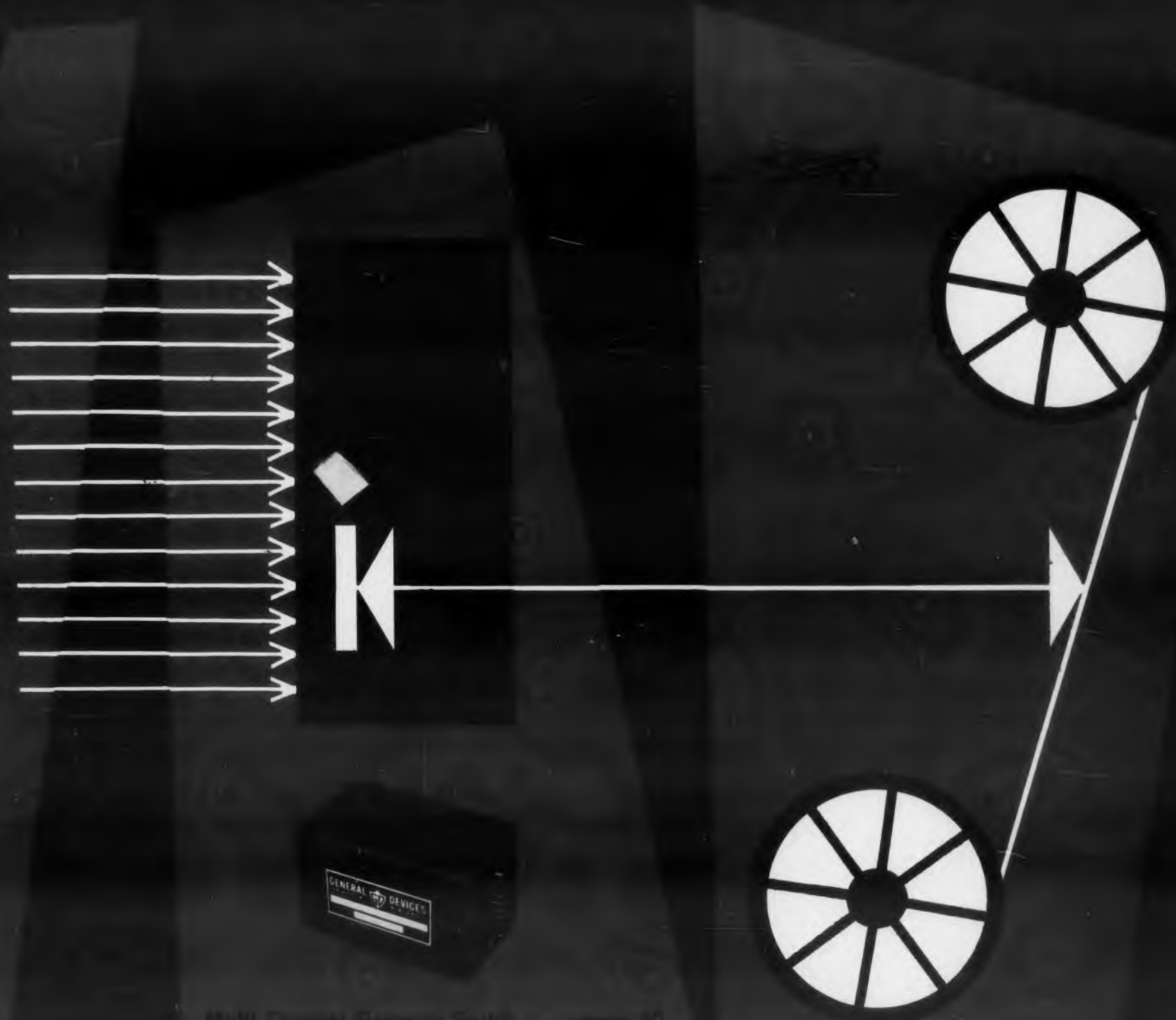

Multi Channel Electronic Switch

# EPON<sup>®</sup> RESIN does it!

Improved GOOD-ALL capacitors have low leakage, high stability—even in extremely humid climates

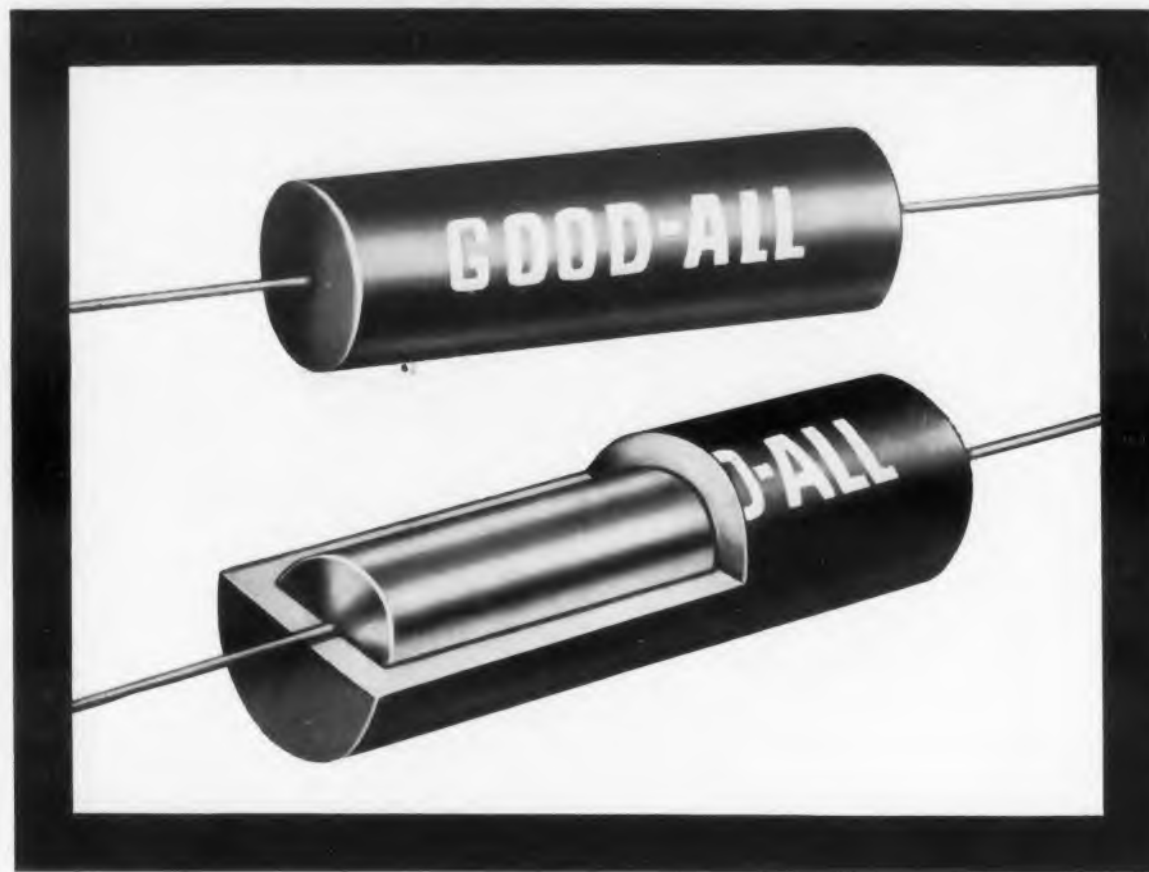

## Here's how:

**E**PON RESIN is helping to set new standards of excellence in a line of 000 UE capacitors made by Good-All Electric Manufacturing Company, Ogallala, Nebraska.

Good-All reports that Epon resin offers superior moisture resistance . . . far better humidity protection than obtained with

conventional molding materials. These capacitors offer rugged, trouble-free performance because Epon resin assures high dielectric strength, low leakage, great resistance to chemical and corrosive attack, and handsome appearance.

For molding . . . for potting . . . for laminating, sealing and encapsulating . . . Epon resins are pre-

ferred because they offer an almost ideal combination of electrical and physical properties.

Write for complete information on the use of Epon resins in protective enamels, tool and die materials, etched circuit laminates, transformer and motor sealing compounds.

## SHELL CHEMICAL CORPORATION

CHEMICAL SALES DIVISION, 380 Madison Avenue, New York 17, New York

Atlanta • Boston • Chicago • Cleveland • Detroit • Houston • Los Angeles • Newark • New York • San Francisco • St. Louis  
IN CANADA: Chemical Division, Shell Oil Company of Canada, Limited • Montreal • Toronto • Vancouver

CIRCLE 1 ON READER-SERVICE CARD



## ELECTRONIC DESIGN

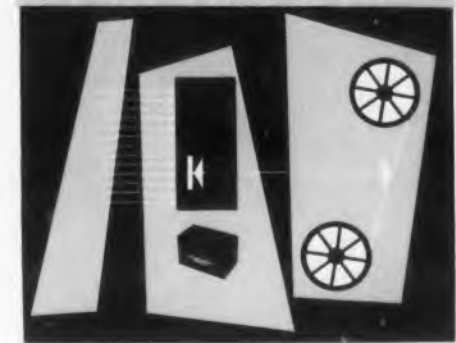

## COVER STORY

### Multichannel Electronic Switch . . . . . p 50

This new switch can sample large quantities of data at high speeds. It can find wide use in telemetry where data must be transmitted to remote points or recorded on magnetic tape.

### Information Theory in the U.S.S.R. . . . . p 94

Paul Green has sketched the development of the science of information theory in the U.S.S.R. He has analyzed Soviet work in mathematics, engineering, filtering and detection as well as cybernetics. His conclusions are well worth noting.

### Practical RC Differentiator Design . . . . . p 30

Lester Saporta and James Rarity have developed curves to simplify the design of RC differentiators. These curves are particularly useful in practical situations when the driving source has a finite impedance and the load has a finite capacity.

### Transistor NOR Circuit Design . . . . . p 26

Mr. Rowe presents a new logic developed specifically to take best advantage of transistors. Combinations of the new NOR logic elements can replace any standard English logic.

### Feedback Circuit Analysis Using Impedance Concepts . . . . . p 36

Here, Mr. Pellegrino presents a new approach to feedback circuit analysis. In a sense, it can be called a visual approach. It enables the design engineer to keep track of his components while he juggles his equations.

# ELECTRONIC DESIGN

DATA REQUEST PROCESS CARD  
Use Before March 19th, 1958



Name \_\_\_\_\_ Title \_\_\_\_\_

Company \_\_\_\_\_

Company Address \_\_\_\_\_ City \_\_\_\_\_ Zone \_\_\_\_\_ State \_\_\_\_\_

For Change of Address: Old Company Name \_\_\_\_\_ Old Company Address \_\_\_\_\_

10	20	30	40	100	110	120	130	140	200	210	220	230	240	300	310	320	330	340	400	410	420	430	440	500	510	520	530	540	
1	11	21	31	41	101	111	121	131	141	201	211	221	231	241	301	311	321	331	341	401	411	421	431	441	501	511	521	531	541
2	12	22	32	42	102	112	122	132	142	202	212	222	232	242	302	312	322	332	342	402	412	422	432	442	502	512	522	532	542
3	13	23	33	43	103	113	123	133	143	203	213	223	233	243	303	313	323	333	343	403	413	423	433	443	503	513	523	533	543
4	14	24	34	44	104	114	124	134	144	204	214	224	234	244	304	314	324	334	344	404	414	424	434	444	504	514	524	534	544
5	15	25	35	45	105	115	125	135	145	205	215	225	235	245	305	315	325	335	345	405	415	425	435	445	505	515	525	535	545
6	16	26	36	46	106	116	126	136	146	206	216	226	236	246	306	316	326	336	346	406	416	426	436	446	506	516	526	536	546
7	17	27	37	47	107	117	127	137	147	207	217	227	237	247	307	317	327	337	347	407	417	427	437	447	507	517	527	537	547
8	18	28	38	48	108	118	128	138	148	208	218	228	238	248	308	318	328	338	348	408	418	428	438	448	508	518	528	538	548
9	19	29	39	49	109	119	129	139	149	209	219	229	239	249	309	319	329	339	349	409	419	429	439	449	509	519	529	539	549
50	60	70	80	90	150	160	170	180	190	250	260	270	280	290	350	360	370	380	390	450	460	470	480	490	550	560	570	580	590
51	61	71	81	91	151	161	171	181	191	251	261	271	281	291	351	361	371	381	391	451	461	471	481	491	551	561	571	581	591
52	62	72	82	92	152	162	172	182	192	252	262	272	282	292	352	362	372	382	392	452	462	472	482	492	552	562	572	582	592
53	63	73	83	93	153	163	173	183	193	253	263	273	283	293	353	363	373	383	393	453	463	473	483	493	553	563	573	583	593
54	64	74	84	94	154	164	174	184	194	254	264	274	284	294	354	364	374	384	394	454	464	474	484	494	554	564	574	584	594
55	65	75	85	95	155	165	175	185	195	255	265	275	285	295	355	365	375	385	395	455	465	475	485	495	555	565	575	585	595
56	66	76	86	96	156	166	176	186	196	256	266	276	286	296	356	366	376	386	396	456	466	476	486	496	556	566	576	586	596
57	67	77	87	97	157	167	177	187	197	257	267	277	287	297	357	367	377	387	397	457	467	477	487	497	557	567	577	587	597
58	68	78	88	98	158	168	178	188	198	258	268	278	288	298	358	368	378	388	398	458	468	478	488	498	558	568	578	588	598
59	69	79	89	99	159	169	179	189	199	259	269	279	289	299	359	369	379	389	399	459	469	479	489	499	559	569	579	589	599

Home Address \_\_\_\_\_ City \_\_\_\_\_ Zone \_\_\_\_\_ State \_\_\_\_\_ For Personnel Ads Only (Nos. 550-599)

# ELECTRONIC DESIGN

DATA REQUEST PROCESS CARD  
Use Before March 19th, 1958



Name \_\_\_\_\_ Title \_\_\_\_\_

Company \_\_\_\_\_

Company Address \_\_\_\_\_ City \_\_\_\_\_ Zone \_\_\_\_\_ State \_\_\_\_\_

For Change of Address: Old Company Name \_\_\_\_\_ Old Company Address \_\_\_\_\_

10	20	30	40	100	110	120	130	140	200	210	220	230	240	300	310	320	330	340	400	410	420	430	440	500	510	520	530	540	
1	11	21	31	41	101	111	121	131	141	201	211	221	231	241	301	311	321	331	341	401	411	421	431	441	501	511	521	531	541
2	12	22	32	42	102	112	122	132	142	202	212	222	232	242	302	312	322	332	342	402	412	422	432	442	502	512	522	532	542
3	13	23	33	43	103	113	123	133	143	203	213	223	233	243	303	313	323	333	343	403	413	423	433	443	503	513	523	533	543
4	14	24	34	44	104	114	124	134	144	204	214	224	234	244	304	314	324	334	344	404	414	424	434	444	504	514	524	534	544
5	15	25	35	45	105	115	125	135	145	205	215	225	235	245	305	315	325	335	345	405	415	425	435	445	505	515	525	535	545
6	16	26	36	46	106	116	126	136	146	206	216	226	236	246	306	316	326	336	346	406	416	426	436	446	506	516	526	536	546
7	17	27	37	47	107	117	127	137	147	207	217	227	237	247	307	317	327	337	347	407	417	427	437	447	507	517	527	537	547
8	18	28	38	48	108	118	128	138	148	208	218	228	238	248	308	318	328	338	348	408	418	428	438	448	508	518	528	538	548
9	19	29	39	49	109	119	129	139	149	209	219	229	239	249	309	319	329	339	349	409	419	429	439	449	509	519	529	539	549
50	60	70	80	90	150	160	170	180	190	250	260	270	280	290	350	360	370	380	390	450	460	470	480	490	550	560	570	580	590
51	61	71	81	91	151	161	171	181	191	251	261	271	281	291	351	361	371	381	391	451	461	471	481	491	551	561	571	581	591
52	62	72	82	92	152	162	172	182	192	252	262	272	282	292	352	362	372	382	392	452	462	472	482	492	552	562	572	582	592
53	63	73	83	93	153	163	173	183	193	253	263	273	283	293	353	363	373	383	393	453	463	473	483	493	553	563	573	583	593
54	64	74	84	94	154	164	174	184	194	254	264	274	284	294	354	364	374	384	394	454	464	474	484	494	554	564	574	584	594
55	65	75	85	95	155	165	175	185	195	255	265	275	285	295	355	365	375	385	395	455	465	475	485	495	555	565	575	585	595
56	66	76	86	96	156	166	176	186	196	256	266	276	286	296	356	366	376	386	396	456	466	476	486	496	556	566	576	586	596
57	67	77	87	97	157	167	177	187	197	257	267	277	287	297	357	367	377	387	397	457	467	477	487	497	557	567	577	587	597
58	68	78	88	98	158	168	178	188	198	258	268	278	288	298	358	368	378	388	398	458	468	478	488	498	558	568	578	588	598
59	69	79	89	99	159	169	179	189	199	259	269	279	289	299	359	369	379	389	399	459	469	479	489	499	559	569	579	589	599

Home Address \_\_\_\_\_ City \_\_\_\_\_ Zone \_\_\_\_\_ State \_\_\_\_\_ For Personnel Ads Only (Nos. 550-599)



No  
Postage Stamp  
Necessary  
If Mailed in the  
United States

VIA AIR MAIL

**B U S I N E S S   R E P L Y   C A R D**

First Class Permit No. 725, Sec. 34.9, P. L. & R., New York, N. Y.

8 CENTS AIR MAIL POSTAGE WILL BE PAID BY

**ELECTRONIC DESIGN  
Statistical Tabulating Dept.**

830 Third Avenue  
New York 22, New York

\_\_\_\_\_

\_\_\_\_\_

\_\_\_\_\_

\_\_\_\_\_

\_\_\_\_\_

\_\_\_\_\_

\_\_\_\_\_



No  
Postage Stamp  
Necessary  
If Mailed in the  
United States

VIA AIR MAIL

**B U S I N E S S   R E P L Y   C A R D**

First Class Permit No. 725, Sec. 34.9, P. L. & R., New York, N. Y.

8 CENTS AIR MAIL POSTAGE WILL BE PAID BY

**ELECTRONIC DESIGN  
Statistical Tabulating Dept.**

830 Third Avenue  
New York 22, New York

\_\_\_\_\_

\_\_\_\_\_

\_\_\_\_\_

\_\_\_\_\_

\_\_\_\_\_

\_\_\_\_\_

\_\_\_\_\_

## SUBSCRIPTION POLICY

**ELECTRONIC DESIGN** is circulated only to qualified electronic design engineers of U. S. manufacturing companies, industrial consultants, and government agencies. If design for manufacturing is your responsibility, you qualify for subscription without charge provided you send us the following information on your company's letter head: Your name and engineering title, your company's main products, and description of your design duties. The letter must be signed by you personally. Any address changes for old subscribers necessitates a restatement of these qualifications. Subscription rate for non-qualified subscribers—\$15.00 for 1 year only.

Hayden Publishing Co., Inc., 830 Third Avenue, New York 22, N.Y.

## CONTENTS

<b>Editorial</b>	25	Public's View of Engineer Shapes U. S. Destiny
<b>Engineering Review</b>	5	Transistorized TV
<b>Washington Report</b>	18	FCC at Year End
<b>Features</b>	26	Transistor NOR Circuit Design, W. D. Rowe
	30	Practical R C Differentiator Design, L. Saporta, J. Rarity
	34	New Visual Recorder
	36	Feedback Circuit Analysis Using Impedance Concepts, G. Pellegrino, Jr.
	40	Multiplier Phototube
	42	Read and Write Transistor Circuits for Magnetic Drums—I, B. A. Mangan
	48	Telemetry Simplified with Angular Position Transducer
	50	Multi Channel Electronic Switch
<b>Ideas for Design</b>	76	Silicon Rectifier Circuit Protects DC Meter
	78	Materials Change Cuts Costs by Two-Thirds
	79	Short Cut to Metal Fabrication
	80	Non-Destructive Transistor "Punch-thru" Test
	81	A Novel Low-Frequency Cathode By-Pass Arrangement
<b>Russian Translations</b>	88	What the Russians Are Writing and Saying
	92	Design of Multivibrator with Self Excitation
	94	Information Theory in the U.S.S.R., P. E. Green, Jr.
<b>Abstracts</b>	102	Analog Solution of Polynomials
<b>Departments</b>	20	Letters
	22	Meetings
	44	New Products
	72	New Literature
	82	Report Briefs
	100	Books
	104	Careers Section
	106	Advertisers' Index

THE LIBRARY OF  
CONGRESS  
SERIAL RECORDS  
FEB 13 1958

copy



HUGHES

G-V Thermal  
Time Delay Relays...

### used in Hughes Airborne Armament Control System

The F-102A all weather interceptor and many other planes in the U. S. and Canadian Air Defense Commands are fully equipped with this system developed and manufactured by the Hughes Aircraft Company. G-V thermal time delay relays are relied upon in all of these systems.

In both military and industrial equipment, G-V thermal relays are providing long, dependable, proven service in time delay applications, voltage and current sensing functions and circuit protection.

Write for extensive application data and catalog material.



**G-V CONTROLS INC.**

18 Hollywood Plaza, East Orange, New Jersey

CIRCLE 2 ON READER-SERVICE CARD



ELECTRONIC DESIGN is published bi-weekly by Hayden Publishing Company, Inc., 830 Third Avenue, New York 22, N. Y., T. Richard Gascoigne, President; James S. Mulholland Jr., Vice-President & Treasurer and David B. Landis, Secretary. Printed at Hildreth Press, Bristol, Conn. Accepted under section 34.64 P. L. & R. authorized. Copyrighted 1958 Hayden Publishing Company, Inc. 30,000 copies this issue.

These



# RELIABLE COMPUTER TRANSISTORS

are:

designed for computer service  
made for computer service  
tested for computer service  
dependable in computer service  
proved in computer service



Raytheon Reliable Computer Transistors (PNP Germanium, in the JEDEC 30 package) are in good supply, and are available to the stringent requirements of new Signal Corps specifications, including electrical, mechanical and environmental tests.

Two hundred of these Transistors (fifty of each type) produced no failures and negligible characteristic change in thousand hour life tests equally divided between operation and storage. Here are typical results for 25 units, type 2N427:

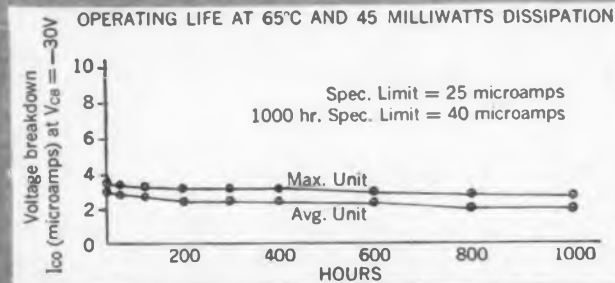
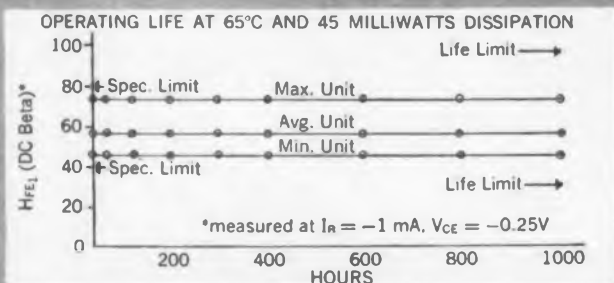

1000 hour storage life tests at 85°C are equally satisfactory

$I_{CO}$  is measured at maximum rated collector-base voltage. Life tests for  $I_{CO}$  and  $I_{BO}$  demonstrate that the maximum ratings for  $V_{CB}$  and  $V_{EB}$  do not decrease with life. All other electrical characteristics important in computer applications are equally well controlled. In addition to the usual 25°C tests,  $H_{FE}$  is controlled at -55°C and at +70°C while  $I_{CO}$  is also checked at +70°C.

In addition, all these Raytheon Computer Transistors measure up to such rigid MIL-T-19500A mechanical and environmental requirements as:

LEAD SOLDER DIP TEST (par. 4.6.23)  
TEMPERATURE CYCLING: 5 cycles from -65°C to +160°C (par. 4.6.24)  
MOISTURE RESISTANCE: tests hermetic seal (par. 4.6.26)  
SHOCK: 500G (par. 4.6.28)

CENTRIFUGE: 20,000G (par. 4.6.29)  
VIBRATION (Fatigue): 10G, 60 cycles (par. 4.6.30)  
VIBRATION (Noise) (par. 4.6.31)  
SALT SPRAY (Corrosion) (par. 4.6.35)  
LEAD FATIGUE (par. 4.6.36)

Type	$V_{CB}$ max. volts	$V_{CE}$ max. volts	$f_{ab}$ ave. Mc	$H_{FE1}$ ave. $I_B = 1 \text{ ma}$ $V_{CE} = -0.25V$	$H_{FE2}$ ave. $I_B = 10 \text{ ma}$ $V_{CE} = -0.35V$	Rise Time* max. $\mu\text{sec}$	Dissipation Coefficient	
							In Air °C/mw	In Sink °C/mw
2N425	-30	-20	4	30	18	1.0	0.4	0.18
2N426	-30	-18	6	40	24	0.55	0.4	0.18
2N427	-30	-15	11	55	30	0.44	0.4	0.18
2N428	-30	-12	17	80	40	0.33	0.4	0.18

\* $I_C = 50 \text{ ma}$ ;  $I_B = 5 \text{ ma}$ ;  $R_i = 200 \Omega$ ;  $I_B = 5 \text{ ma}$ ; Grounded Emitter Circuit;  $T = 25^\circ\text{C}$

CHARACTERISTIC DATA AVAILABLE ON REQUEST



SEMICONDUCTOR DIVISION

Silicon and Germanium Diodes and Transistors • Silicon Rectifiers

Newton, Mass.: . . . . . 55 Chapel St., Blgelow 4-7500  
New York: . . . . . 589 Fifth Ave., Plaza 9-3900  
Chicago: 9501 Grand Ave., Franklin Park, NAional 5-6130  
Los Angeles: 5236 Santa Monica Blvd., NORmandy 5-4221

CIRCLE 3 ON READER-SERVICE CARD

## STAFF

Editor Edward E. Grazda  
Managing Editor J. A. Lipke  
Sr. Associate Editor E. T. Ebersol, Jr.  
Associate Editor G. H. Rostky  
Assistant Editors S. Dresner  
T. E. Mount  
D. S. Viebig  
E. T. Blake  
M. M. Robinson  
B. Patrusky  
Contributing Editors S. H. Hubelbank  
J. M. Montstream  
J. G. Adashko  
E. Brenner  
Editorial Assistants F. Muehleck  
M. S. Buckley  
N. A. Leftwich  
H. E. Dadinis  
Art Director S. Sussman  
Asst. Art Director R. A. Schulze  
Artist S. F. Richter  
Production Manager T. V. Sedita  
Asst. Prod. Manager M. P. Hedrick  
Production Assistant J. Siegel  
Business Manager P. L. Canfield  
Circulation Manager N. M. Elston  
Asst. Circ. Manager A. C. Lovett  
Reader Service E. Hession

## CO-PUBLISHERS

T. Richard Gascoigne  
James S. Mulholland, Jr.

## ADVERTISING REPRESENTATIVES

### Advertising Sales Manager

Bryce Gray, Jr.

New York: Owen A. Kean  
830 Third Avenue Robert W. Gascoigne  
Plaza 1-5530 Blair McClenahan  
Richard Parker  
James P. Quinn  
Charles C. Wadsworth

Chicago: Thomas P. Kavooras  
664 N. Michigan Ave. Berry Conner, Jr.  
Superior 7-8054 Fred T. Bruce

Los Angeles: Robert E. Ahrensdoerf  
5720 Wilshire Blvd. John Quillman  
WEbster 8-3881 Stanley I. Ehrenclou

San Francisco: Stanley Ehrenclou  
260 Kearny Street  
EXbrook 7-0690

# ENGINEERING REVIEW

*For more information on developments described in "Engineering Review," write directly to the address given in the individual item.*



**Only tube used** in this TV chassis is the picture-tube. Thirty-one transistors are employed, and power is provided by two nickel-cadmium batteries that give six hours of set operation, without charging. Picture is comparable to conventional portable.



## **Around the corner**

### **Transistorized TV**

An experimental all-transistor (except picture tube) battery-powered television receiver was recently announced by Motorola, Inc. First such set to be described, it employs 31 transistors and uses two rechargeable batteries which provide six hours of continuous operation away from commercial power. Performance is stated to be equivalent to conventional ac-powered, vacuum-tube sets.

Although the new set draws only twelve watts from its two nickel-cadmium batteries, a quarter of this is needed to supply the picture-tube filament. According to *ELECTRONIC WEEK's* account of this development (Jan. 13, 1958), Motorola's Neil Frihart stated that their biggest "headache" was tuner design. Special (and apparently costly, at present) transistors were required in the "head end" to get good high frequency sensitivity. Motorola wouldn't disclose tuner design or transistor types, but it is understood that a 41.25 mc sound and 45.75 mc video i-f are used and are designed to give somewhat greater gain than present commercial sets in order to compensate for lower tuner sensitivity.

Nickel-cadmium batteries are used because of their ability to hold terminal voltage about constant until discharged. This lessens problems with voltage regulation. Batteries occupy only about 250 cu in. total, with a weight of less than ten pounds. Battery life is based on about 2000 recharging cycles minimum. A total charge takes just two hours while the set is connected to commercial power.

High voltage is supplied to the picture tube anode at 20,000 volts. Originally designed as a square wave oscillator, Motorola engineers found that the high voltage supply worked better driven. The oscillator is now driven from the horizontal output at the scanning frequency of 15,750 cps. First, 12 volts ac is stepped up to 2500 volts, then quadrupled to the anode operating voltage. Horizontal scanning is accomplished by a switching type circuit with power fed to the yoke during retrace.

So far, only two sets have been built. Both were displayed in January at Chicago's Merchandise Mart. While Motorola's aim is to produce a production model of a battery-portable TV, they don't expect to have a model available at a practical price until about 1960.

**VOLTAGE TUNABLE**  
In Thousands—Mc.



**ENGINEERING REVIEW**

**Large-Screen Long-Range Radar Display Pin-Point Targets**

A radar indicator that has the ability to pin-point targets of interest, through expansion of the display in azimuth and range, has been developed at the Research and Development Division of Allen B. DuMont Labs. Inc., of Paterson, N. J. for Lincoln Labs.

The presentation is made on a 16-inch cathode-ray tube with a P7 phosphor and utilizes a conventional 13 scan (range versus azimuth). The equipment will operate with pulsed radar systems of a limited frequency range. With an azimuth display of 350 deg. the range display is zero to 4,000 miles. Expansion of a range sector is variable from a 50 to a 500 nautical-mile sector, and azimuth sectors can be 10 deg minimum and 350 deg maximum. The amount of expansion is selectable. The area to be expanded is automatically intensified on the screen when the equipment is operating in its normal mode.

Inputs to the indicator include radar video, system trigger, and antenna positioning by means of a Land 36-speed synchro system. The range and azimuth calibration markers are generated within the indicator.

**New Magnetic Oxides**

A new class of magnetic oxides, structurally distinct from ferrite, has recently been discovered. These rare-earth-iron garnets are transparent and permit the internal magnetic domain structure to be seen with a polarizing microscope.

The discovery of ferromagnetism in these garnets was first made in France, and then, independently by S. Geller and M. A. Gilileo of Bell Telephone Laboratories, 463 West St., New York City, where the optical and magnetic resonance behavior of the garnets is being studied.

◀ CIRCLE 4 ON READER-SERVICE CARD

**NOW — 2 New Raytheon Backward Wave Oscillators  
DOUBLE FREQUENCY COVERAGE**

*The most complete line in the industry now tunes from 1,000 to 37,500 Mc.*



Specifications—QK518. Frequency: 2,000-4,000 Mc. Rapid electronic tuning by varying delay line voltage from 150-1,500 v. Power output: 0.1 to 1 w. Complete with compact permanent magnet. Approximate maximum dimensions: 10" long, 4 3/8" high, 4 7/8" wide.

Wide, rapid electronic tuning—1,000 Mc. to 37,500 Mc.—is one outstanding performance advantage in Raytheon's extending line of Backward Wave Oscillators. Others are: permanent magnet focusing; high signal-to-noise ratio; operation under conditions of amplitude or pulse modulation.

Raytheon Backward Wave Oscillators are gaining wide acceptance in micro-

wave equipment applications as local oscillators for radar receivers and as signal generators.

Our development laboratories can tailor tubes for specific requirements including narrower band, lower voltage, or higher power for primary transmitter use. Any question you may have will be answered promptly, without cost or obligation.

**RAYTHEON MANUFACTURING COMPANY**

Microwave and Power Tube Operations, Section PT-21, Waltham 54, Mass.

Regional Sales Offices: 9501 W. Grand Avenue, Franklin Park, Ill. • 5236 Santa Monica Blvd., Los Angeles 29, Cal.

Raytheon makes: Magnetrons and Klystrons, Backward Wave Oscillators, Travelling Wave Tubes, Storage Tubes, Power Tubes, Miniature and Sub-Miniature Tubes, Semiconductor Products, Ceramics and Ceramic Assemblies.



*Excellence in Electronics*



## Electronic Device Aids Delicate Eye Operation

Surgeons making the delicate operation of re-attaching retinas are aided by a new electronic device called the Ophthalamo-Electrotome. Detachment of the retina, the innermost coat of light-sensitive cells located in the back part of the eye, can be caused by a blow on the head or other common injury. Retinal detachment rivals the cataract as a cause of blindness. Electronic engineers of Ford Instrument, Div. of Sperry Rand, worked closely with doctors of the New York Hospital-Cornell Medical Center to develop the new electrosurgical control equipment which attaches retinas.

Electrosurgery is a medical operating technique utilizing the electrical knife, which is basically electrodes connected to an electrical power supply. The electrode issues a fine radio frequency current when the power is turned on. It is employed for such ordinary purposes as removing warts to complex, delicate brain operations. Unlike conventional electrosurgical equipment, the Ford device enables the surgeon to control both voltage and frequency and thus prevent burning delicate tissues. This instrument is now being used on research animals at the New York Hospital-Cornell Medical Center.

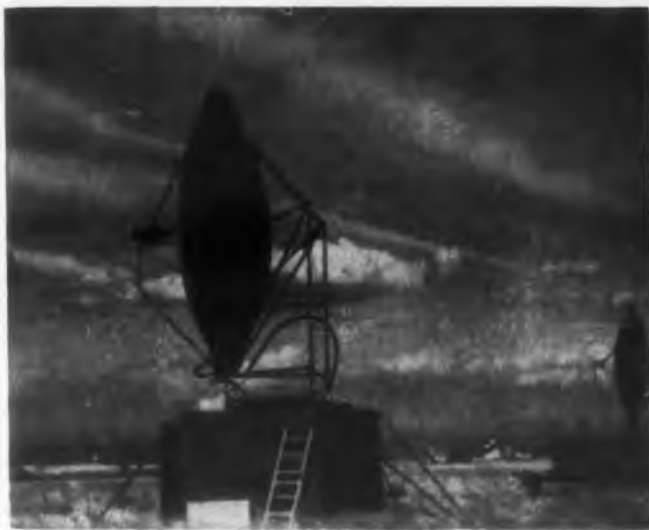

**Nutshell Communication Terminal:** A compact uhf communication terminal can be packed up, moved by air, and quickly put in operation by a few men. Designed by Collins Radio Co., Cedar Rapids, Iowa, the system is on trial at the U.S. Army Electronic Proving Ground, Ft. Huachuca, Ariz. Called the Transhorizon, it has blower-inflated antennas and two metal huts into which all equipment can be packed. These double as shelters when the station is erected. Using tropospheric scatter propagation, the terminal achieves reliable multichannel communication, without intermediate relays, for ranges of 50 to 150 miles. It operates in the 1000 mc band.

# For MISSILE Applications!

## NOW...200, 300, 400 & 500 AMPERE

## DC POWER SUPPLIES

with wide continuously adjustable  
**24 TO 32 VOLT RANGE**

by **PERKIN!**

### APPLICATIONS:

- Centralized Laboratory or Plant DC Power.
- Missile Check-Out and Launching
- Aircraft Engine "Soft" Starting and Testing.
- Battery Charging & Standby Service
- ... and other heavy duty 28 volt DC Power applications.

immediate delivery!

### OUTSTANDING FEATURES:

Automatic Magnetic Amplifier Regulation to  $\pm 1/2\%$ ... No Tubes, Moving Parts or Vibrating Contacts... Remote Voltage Sensing to Provide Regulation at Remote Loads... Wide 24 to 32 Volt Output Range to Compensate for Voltage Drop in Output Cable... Fast Response (0.1 to 0.2 seconds) With No Hunting or Drift... AC Line Voltage Stabilization... No Disturbing Radio Interference... Higher Efficiency, Maintenance-Free and No Warm-Up Time as Compared to M-G Sets... MIL-Type Workmanship & Conservative Design.

There are over 15,000 Perkin units in operation in industry today.

### ADDITIONAL SPECIFICATIONS:

Regulation:  $\pm 1/2\%$  for any combination of line and load changes.  
AC Input: 208, 230 or 460V,  $\pm 10\%$ , 3 phase, 60 cps. Ripple: 1% RMS.  
All units available with dollies for mobility.

### AVAILABLE MODELS:

MR2432-200A, 200 amps • MR2432-300A, 300 amps • MR2432-400A, 400 amps  
MR2432-500A, 500 amps

When you require a power supply, SPECIFY PERKIN,  
for a wider range of standard models and immediate delivery from stock.

Wire factory collect for prices. For a prompt reply on your  
application, write factory on your letterhead.

# PERKIN

PERKIN ENGINEERING CORPORATION

345 KANSAS STREET, EL SEGUNDO, CALIFORNIA • OREGON 8-7215

Leader in Tubeless Magnetic Amplifier Regulation

Immediate Delivery on standard models available from factory and:

New York area office: 25 Great Neck Rd., Great Neck, L.I., N.Y. HUinter 2-8608  
Boston area office: 46 Amesbury St., Lawrence, Mass. MURdock 3-3252

CIRCLE 5 ON READER-SERVICE CARD

OTHER  
**PERKIN**  
STANDARD  
DC POWER SUPPLIES

### 28 Volt Models

Model	Volts	Amps	Reg.	AC Input (60 cps)	Ripple rms
28-9VFM	0-32 V	5	15-20% (24-32V range)	115 V 1 phase	2%
28-10WX	24-32 V	10	$\pm 1/2\%$	100-125 V 1 phase	1%
MR532-15A	2-36V	15	$\pm 1/2\%$	105-125V 1 phase	1%
28-15VFM	0-32 V	15	15-20% (24-32V range)	115 V 1 phase	5%
M60V	0-32V	25	$\pm 1\%$	115V 1 phase	1%
MR1040-30A	5-40V	30	$\pm 1\%$	100-130V 1 phase	1%
28-30WXM	24-32V	30	$\pm 1/2\%$	100-125V 1 phase	1%
28-50WX	24-32 V $\pm 10\%$	50	$\pm 1/2\%$	230 V* 3 phase	1%
MR2432-100XA	24-32V	100	$\pm 1/2\%$	208/230V* 3 phase	1%
MR2432-200	24-32 V	200	$\pm 1/2\%$	208/230V* 3 phase	1%
MR2432-300	24-32 V	300	$\pm 1/2\%$	208/230V* 3 phase	1%
MR2432-500	24-32 V	500	$\pm 1/2\%$	208/230V* 3 phase	1%

\*  $\pm 10\%$ . Also available in 460 V  $\pm 10\%$  AC input. Will be supplied with 230 V input unless otherwise specified.

### 6, 12, 115 Volt Models

Model	Volts	Amps	Reg.	AC Input (60 cps)	Ripple rms
6-SWX	6 $\pm 10\%$	5	$\pm 1\%$	95-130 V 1 phase	1%
6-15WX	6 $\pm 10\%$	15	$\pm 1\%$	95-130 V 1 phase	1%
6-40WX	6 $\pm 10\%$	40	$\pm 1\%$	95-130 V 1 phase	1%
12-15WX	12 $\pm 10\%$	15	$\pm 1\%$	95-130 V 1 phase	1%
115-SWX	115 $\pm 10\%$	5	$\pm 1/2\%$	95-130 V 1 phase	1%
MR18125-S	15-125	5	$\pm 1\%$ †	95-130 V 1 phase	1%††
6125-25**	115-125	25	$\pm 1/2-4\%$	230/460 V 3 phase	5%

\*\*Germanium Rectifier Unit ††Increases to 4% @ 15V.  
†Increases to 2% @ 15V.





(Left to Right) Frank Marshall, Assistant Engineer, Arthur H. Wulfsberg, an Assistant Director of Research & Development, and John Sprengeler, Project Engineer, discuss the use of a General Electric GL-6442 in a power amplifier assembly which is part of the AN/ARN-46 receiver-transmitter unit shown in center foreground.



Disassembled power amplifier from AN/ARN-46. A G-E GL-6442 is used in each of 3 such amplifiers within the TACAN receiver-transmitter unit.

## Collins Airborne TACAN Uses General Electric GL-6442 For Reliable Performance

**E**XCEPTIONAL performance characteristics of General Electric tube type GL-6442 are contributing significantly to the accurate and reliable performance of Collins TACAN equipment, which is capable of operation at altitudes over 70,000 feet.

TACAN provides the military or civil pilot with continuous, precise distance and bearing information for navigation at ranges up to about 200 miles.

The pressurized receiver-transmitter unit of the equipment employs five G-E GL-6442's—ceramic, disc-seal triodes of planar construction—in the frequency multiplier and power amplifier systems. Three of the tubes are used in the pulse-modulated final amplifier. These tubes are mounted in coaxial resonators, tunable over a 1025-1150 mc. range. More than 1 KW peak power output is obtained.

Designed primarily for use in grounded-grid cavity circuits as a plate pulsed oscillator or amplifier up to 4000 mcs., the tube is also useful as a continuous-wave RF power amplifier, oscillator, or frequency multiplier up to 2500 mcs. Typical operation in plate-pulsed oscillator service at 3500 mcs. produces 2 KW peak power output with an average power input of 7.5 watts and a duty cycle of 0.001.

Ratings for other classes of service available on request. For full information on Type GL-6442, call your regional G-E power tube representative. *Power Tube Dept., General Electric Co., Schenectady 5, N. Y.*

*Progress Is Our Most Important Product*

**GENERAL  ELECTRIC**

9545-8481-6

## ENGINEERING REVIEW

### Electronics Spending for Missiles

Who gets what percentage of each dollar being spent for guided missiles? What proportion of the total funds expended takes care of electronics, engines, missile frames, etc.? Some of the answers are now forthcoming from USAF sources. As published in a recent Aircraft Industries Association release, all the money spent by the USAF on both research and production of guided missiles between fiscal 1946 and fiscal 1958 is proportioned as follows: Airframes 35 per cent; propulsion systems 20 per cent; guidance and control 20 per cent; military construction 10 per cent; nose cones 8 per cent; industrial facilities used by contractors 6 per cent; and miscellaneous 1 per cent.

Projecting USAF figures against estimated missile spending by all the services during the 13-year period shows that guidance and control have cost \$1,500,000,000. On the basis of one type of air-to-air missile, one prime contractor divides his production costs as follows: non-nuclear warhead, 3.5 per cent; mechanisms (including gyros, accelerometers, hydraulic servo units, switches, actuators, safety and arming units, etc.) 33 per cent; electronics 43 per cent; electric power source 1.5 per cent; airframe 12.5 per cent; and 6.5 per cent for the solid propellant rocket engine. These costs exclude R & D.

### Tiny Chemical Memory

A chemical memory system which may be able to store 1,000,000 bits of information on a square inch surface is under development at the National Cash Register Company, Dayton, Ohio. Microscopic droplets of photosensitive "solid liquids" are coated on a sheet of paper. When exposed to blue light, they turn a brilliant blue. When exposed to yellow light, they become colorless again.—Thus they can serve as chemical switches, or bistable devices. NCR hopes to have a working model of a chemical memory computer by mid-1959.

◀ CIRCLE 6 ON READER-SERVICE CARD

### Missile Takes A Bromo

Bromo Seltzer can be used to cure missile headaches, too, it was disclosed today by General Electric missile engineers, 3198 Chestnut Street, Philadelphia, Pa. The company is developing nose cones for the top priority Air Force Atlas ICBM and the Thor IRBM at its Missile and Ordnance Systems Department in Philadelphia.

To house recording instruments during test flights of these missiles, GE engineers developed a spherical capsule which is carried in the missile nose cone and is ejected before the nose cone hits the earth. Electrically operated markers help engineers locate the sphere. However, to function properly, these markers must be delayed for a few minutes before operation.

This is where the Bromo Seltzer comes in. Bromo Seltzer, packed around electrical wires, delays completion of the electronic circuit for the few minutes required for operation. Engineers had spent considerable time perfecting various mechanical switches, none of which worked satisfactorily. The engineering headaches involved were extremely annoying until Bromo Seltzer stepped in and cured them.

### Device Counts Fog Particles

A new device to count and measure fog particles has been developed at the U.S. Army Chemical Corps' Chemical Warfare Labs., Army Chemical Center, Md. It is portable, electronically operated and semi-automatic. With this counter, one man can measure and record, with one hand, at an average rate of 3300 particles per hour—as compared with 1250 particles per hour for previous methods. Faster automatic devices are available, but they do not distinguish between fog and other particles. Using electronic "calipers," the operator measures greatly magnified particle images flashed on a screen. Operation of a foot pedal records the size.

CIRCLE 7 ON READER-SERVICE CARD ➤

# ALLIED'S MHJ RELAY

## Built for Shock and Vibration

10-55 cps at 0.125 inch double-amplitude • 55-2000 cps at 20g

Here are the facts:

#### Contact Ratings:

Low level up to 5 amperes at 29 volts d-c or 2 amperes at 115 volts a-c non-inductive or 1 ampere inductive

#### Contact Arrangement:

MHJ-12D: 4 PDT  
MHJ-18D: 6 PDT

#### Temperature:

Minus 65°C to plus 125°C

#### Vibration:

10-55 cps at 0.125 inch double-amplitude  
55-2000 cps at 20g

#### Operating Shock: 100g

#### Weight:

MHJ-12D: 3.0 ounces  
MHJ-18D: 4.2 ounces

#### Insulation:

1000 megohms minimum

#### Dielectric Stress:

1000 volts rms at sea level;  
500 volts rms at 70,000 feet

#### Initial Contact Resistance:

.03 ohms maximum at .01 to 2 amps

#### Operate Time:

10 milliseconds or less  
at rated voltage at 25°C

#### Release Time:

5 milliseconds or less  
at rated voltage at 25°C

Now with  
**5 amp Rating and  
Stabilized Construction\***



TYPE MHJ  
ACTUAL SIZE

\*

Includes materials and processing necessary to minimize contact resistance variations and dielectric deterioration during life due to contact contamination, mechanical wear and shift of adjustments with temperature.

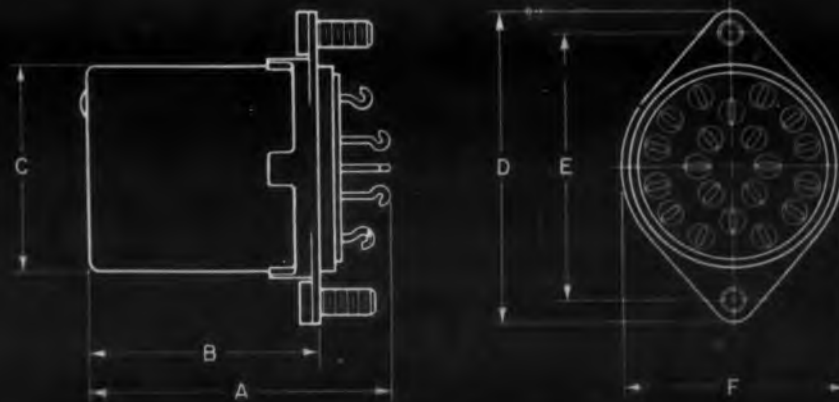

MOUNTING = 6-32 NC-2A THD. (2) STUDS

	A	B	C	D	E	F
MHJ-12D (4 Pole)	1 3/4 max.	1 3/16	1 3/4	1 2/32	1.406	1 1/8
MHJ-18D (6 Pole)	1 3/4 max.	1 3/16	1 3/16	1 1/16	1.562	1 3/16



# ALLIED CONTROL



ALLIED CONTROL COMPANY, INC., 2 EAST END AVENUE, NEW YORK 21, N. Y.



first of the new  
**SANBORN 450's:**  
**UNIT**  
**PREAMPLIFIERS**  
*with Integral Power Supplies*

These new Sanborn Unit Preamplifiers—designed to drive optical recording systems, tape recorders, wide band oscilloscopes, panel meters and other devices—offer you an outstanding combination of performance characteristics, operating versatility and ease, flexibility through interchangeable design, and compactness in either single unit or four-unit rack module packaging. The 1100 Carrier and 1800A True Differential DC types are versatile enough to cover the vast majority of input signal requirements, with practically any type of transducer. (For use with high speed optical galvanometers at frequencies above 500 cps, requiring larger current swings, a transistor output amplifier is built into the 450-1800A and available as optional equipment on other 450's.) Later "450" Unit Preamplifiers will include Servo (demodulator) Monitor, DC Coupling, Logarithmic, Low Level and Dual-Channel DC types. As shown, any "450" can be installed or quickly interchanged in any bay of the four-Preamp module, or in a portable case.

Supplementing the basic specifications, the 450-1100 is a carrier amplifier-demodulator with zero suppression, which provides excitation for and accepts the outputs of various resistance bridge, variable reluctance, differential transformer and other types of transducers. The 450-1800A is a low-noise, low drift, wide band-width, high gain true differential DC amplifier, with front panel controls for smooth gain, position, and internal 2 mv calibration signal. For further data or application information on these new self-contained Unit Preamplifiers, contact your Sanborn Industrial Engineering Representative or write the Industrial Division of Sanborn Company.

**SANBORN COMPANY**  
 175 Wyman St., Waltham 54, Mass.

CIRCLE 8 ON READER-SERVICE CARD

SPECIFICATION SUMMARY	
<b>MODEL 450-1800A TRUE DIFFERENTIAL DC PREAMPLIFIER</b>	
<b>Input</b>	— Impedance: 200K differentially between terminals (balanced) or 100K each input lead to gnd. (single-ended) Common mode rejection: at DC, 100 db; to 60 cps, 94 db; 400 cps, 80 db. Equiv. input drift: $\pm 2$ uv for 24 hours Equiv. input noise: 5 uv peak to peak (0-10 cps), 20 uv (0-1000 cps), 50 uv (0-30 kc)
<b>Output</b>	— <b>Low Power Circuit:</b> Output appears between two cathodes as true push pull signal. Common mode level of cathodes $\pm 2$ volts with respect to ground. Output capability: $\pm 3$ volts into 5000 ohms $\pm 10$ volts open circuit Zero position control not active for this output Freq. response: 3 db down at 30 kc Linearity: 0.1% <b>High Power Circuit:</b> Output appears between two emitters as true push pull signal. Common mode level of emitters $\pm 2.5$ volts with respect to ground. Preferred load: 50 ohms Output: $\pm 2.5$ volts, $\pm 50$ ma Freq. response: 3 db down at 15 kc Linearity: 0.5% Zero position control is operative for high power output ckt.
<b>Gain</b>	— Fixed steps 1000, 500, 200, 100, 50, 20 Gain Accuracy 0.5% for D.C. Smooth gain control covers range between fixed steps
<b>Power Req.</b>	— 115 volts, 60 cps, approx. 50 watts
<b>MODEL 450-1100 CARRIER PREAMPLIFIER</b>	
<b>Carrier Freq.</b>	— 2400 cps (std.); 600, 1200, 4800 cps optional
<b>Carrier Exc.</b>	— approx. 4.5-5 volts, depending on transducer imped.
<b>Transducer Imped.</b>	— 100 ohms min. - 1000 ohms max.
<b>Input Imped.</b>	— approx. 2500 ohms, incl. zero sup. ckt.
<b>Sensitivity</b>	— 100 uv rms from transducer (output imped. 1000 ohms or less) gives 1 volt at output under max. output loading
<b>Output</b>	— preferred circuit: between one active cathode and one reference cathode alternate circuit: between active cathode and ground
<b>Output Voltage Capabilities</b>	— (a) $\pm 3$ volts into 2.2K min. load (b) $\pm 6$ volts into 5K load (c) $\pm 7.5$ volts open ckt
<b>Output Linearity</b>	— better than 0.2% for (a) above
<b>Output Impedance</b>	— approx. 1000 ohms, preferred ckt., 500 ohms alternate output ckt.
<b>Freq. Response</b>	— 3db at 20% of carrier freq.
<b>Zero Suppression</b>	— can suppress 0 to 100% of transducer load (either sense via switch)
<b>Power Req.</b>	— 115 volts, 50-400 cps, approx. 30 watts

## ENGINEERING REVIEW



"Teletac" Sense-of-touch communicator for the deaf. It provides instant message transmittal when the "sender" places his hand on the vibration sending piano-type keyboard (right) with the "listener's" fingers impressed on the five sensitive diaphragms on the receiving unit (left).

### New Vibration Sender Gives the Deaf Word Symbols

A new tactile stimuli device for communicating with the deaf has been designed by a Ramo-Wooldridge Engineer, Joseph Hirsch. With Hirsch's device the speaker works five vibration-sending piano-type keys, and the listener gets the message by resting five fingers on sensitive receiving diaphragms. Immediate reception is accomplished, reports the John Tracy Clinic of Los Angeles; and a duplicate system allows the listener to become the speaker.

Employing two frequencies, the system called Teletac, enables a deaf person to transmit 637 words or symbols. However, the problem of optimum coding is one which will have to be solved. The John Tracy Clinic expects to learn about optimum coding by studying the learning rate of deaf children as they respond to codes prepared by linguists.

### Army Must See Over Thousands of Square Miles

The Signal Corps has just awarded Cornell Aeronautical Laboratory, Inc., a contract to study how to keep an eye on the enemy spread out over thousands of square miles. Combat surveillance, the continuous and systematic watch over a combat area under all conditions of weather, both day and night, has long been a neglected area regarding its capability for both large scale

and limited war. It is expected the study will indicate how improvements in systems of surveillance of a battlefield by radar, infrared, sonic, meteorological, reconnaissance, photographic, and television means can be made. Mobility and wide dispersal are aspects of modern combat tactics that require much information quickly. For example, a profitable target for a guided missile might exist only a brief period at a distance of hundreds of miles. A commander of the future must be able almost instantly to scan a large battle area if he is to take appropriate action.

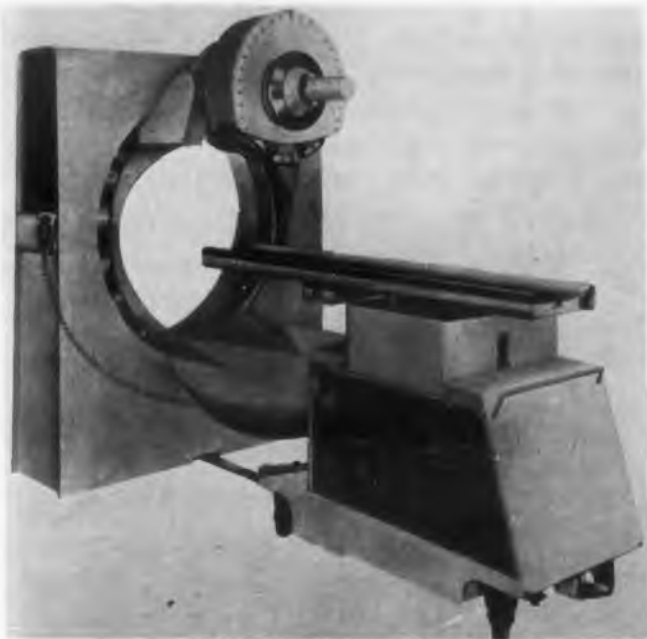

**Cobalt 60 Therapy Unit Treats Deep Cancer:** A new Cobalt 60 therapy unit is now available from the Westinghouse Electric Corp., P. O. Box 416, Baltimore, Md. A source of higher energy radiation is provided to get appreciable doses to deep lying lesions without exceeding the tolerance of the skin and overlying tissues.

The source head can be rotated completely around the patient; the beam being continuously aimed at the axis of rotation. By turning the ring to the desired position, the operator can select any one of the seven cones located in the source head. Six semi-permanent cones are contained in the ring. The seventh position accommodates small interchangeable cones.

Patient contact protection stops rotation immediately if the source head should touch either the patient or table. The device operates without any contact pressure.

Only the arc of travel of the head, and the time of patient exposure are specified by the operator; a speed calculator automatically regulates the speed of rotation of the source head.

A safety device employed by the unit moves the Cobalt 60 capsule along the axis of the treatment head to the "on" position when treatment begins. When treatment is finished the capsule automatically returns to the "off" position.

*New from Clevite!*

# SILICON JUNCTION DIODES

These latest additions to Clevite's complete line of computer and general-purpose diodes offer you the advantages of:

**ULTRA FAST RECOVERY TIME . . . (JAN-256)**  
(Typical: from +5.0 ma to -40v  
. . . 400K in 0.3 $\mu$ s)

**HIGH FORWARD CONDUCTANCE**  
(Typical: 50 ma at 1.5v)

**EXTREMELY LOW REVERSE CURRENT**

**FREEDOM FROM THERMAL RUNAWAY**  
at high voltage and up to 150°C

**RUGGED, HERMETICALLY SEALED GLASS PACKAGE**

**OTHER CLEVITE DIVISIONS:**

*Brush Instruments*

*Clevite Ltd.*

*Clevite Ordnance*

*Texas Division*

*Cleveland Graphite Bronze Co.*

*Clevite Harris Products, Inc.*

*Clevite Electronic Components*

*Clevite Research Center*

*Intermetall G.m.b.H.*

*For complete information,  
write or phone:*

**CLEVITE**  
**TRANSISTOR PRODUCTS**

241 Crescent St., Waltham 54, Mass.  
Twinbrook 4-9330

*A Division of*

**CLEVITE**

CIRCLE 9 ON READER-SERVICE CARD



### Today's series-string circuits

the circuits that cut the bulk out of TV sets, place close tolerances on electron tube filament uniformity. Only a broad background in tungsten metallurgy such as Sylvania's could make possible the production of filament wire with this kind of uniformity.

making material progress in  
the electronics industry

## How controlled-quality tungsten helped put a handle on TV

Trim, lightweight, portable TV is an accepted fact today . . . but, not too long ago, the industry was struggling with the problem of cutting circuitry and bulk, without downgrading set reliability. We, at Sylvania, like to feel that our ability to produce top-quality tungsten wire made the important contribution that made the modern series-string circuit . . . and portability . . . possible.

To prevent premature tube burnout, tubes in series string must offer carefully

controlled heater warm-up. Sylvania tungsten filament wire for this application provides heaters having current variations not exceeding 5%.

Sylvania has achieved this high uniformity by controlling the recrystallization temperature of tungsten and exercising complete process control at every stage of production. For answers to any problems concerning tungsten, molybdenum, or phosphors, call in Sylvania.



TUNGSTEN • MOLYBDENUM • CHEMICALS • PHOSPHORS • SEMICONDUCTORS

SYLVANIA ELECTRIC PRODUCTS INC.  
Chemical & Metallurgical Div.  
Towanda, Penna.

 **SYLVANIA**

LIGHTING • TELEVISION • RADIO • ELECTRONICS • PHOTOGRAPHY • ATOMIC ENERGY • CHEMISTRY-METALLURGY  
CIRCLE 10 ON READER-SERVICE CARD

## ENGINEERING REVIEW

### Large Annunciator System With No Moving Parts Except the Bell

An annunciator system with no moving parts will get its first application in 1958 when the Public Service Electric and Gas Company of New Jersey employs it to monitor 560 critical quantities. Developed by Westinghouse Electric Corp., the system will use modular plug-in magnetic elements rather than relays. In over-all design it will be similar to Cypak static control systems for industrial control applications. Static annunciator systems house several information processing components in a single plug-in module. The unit functions over a voltage range of 75 to 140 volts. Although our source of information didn't so state, we're sure the bells and buzzers still use moving parts.



**New machine test memory plates:** A machine, developed at Radio Corporation of America's research laboratories at Princeton, N.J., tests accuracy of "memory plates" used in electronic computers. Tiny RCA aperture plate in foreground, containing 256 bits of information, enables computers to store more than a million facts in a space little larger than a shoebox and to recall any or all of them in a few millionths of a second. Machine in background, with lights corresponding to tiny holes in the memory plate, can instantly test plate for any flaws.

### More Work for MASER

Harvard University's Gordon McKay Laboratory of Applied Science has developed a three-level, solid state maser. The experimental device, it is hoped, will extend the range of the best radio telescopes. In addition to its potential applications in certain radar systems, it is hoped that the new maser, the first to run successfully in the 21 cm band, will confirm or deny the existence of hydrogen gas, suspected of hovering between the galaxies.

The first maser, a gas type, rather than a crystal type, was proposed and constructed in 1954 by Prof. C. H. Townes at Columbia University. The word stands for "microwave amplification by stimulated emission of radiation."

### Printed-Circuit Institute Formed —Previously Reported by ED

As reported almost a year ago in ELECTRONIC DESIGN (Jan. 15, 1957), the then forthcoming association of printed-circuit manufacturers has now been announced as a reality. Among various things the association is expected to accomplish are recommendations for industry-wide printed-circuit standards.

The association is to be known as the Institute of Printed-Circuits and has established headquarters at 27 E. Monroe St., Chicago 3, Illinois. Elected officers are: president—W. J. McGinley, President, Methode Manufacturing Co., Chicago; vice-president—A. R. Hughes, Electralab Inc.; and treasurer—R. L. Swiggett, V.P., Photocircuits Corp. Directors include Karl Clayton, Tingstol Co., and R. G. Zens, V.P., Printed Electronics Corp.

Mr. McGinley, in announcing the formation of the association, stated that "the objectives of the group will be to develop standards and other educational material to aid the user to purchase and use printed circuits more efficiently and more economically, and to provide an organization for manufacturers in the industry to work together toward common goals." The association has already completed preliminary specifications for standard dimensional tolerances, and has prepared a preliminary draft of a new brochure on *How To Design and Spec-*  
CIRCLE 11 ON READER-SERVICE CARD ➤



ESC WIDE BAND VIDEO TRANSFORMERS have been engineered and developed to offer... subminiature units of unusually wide bandwidth (50 CPS to 8.0 MC). They are used to replace bulkier and more costly components, thereby creating greater economy, and increasing equipment efficiency.

ESC ELECTRONIC COMPONENTS DIVISION specializes

in the design and development of Wide Band Video Transformers to meet your particular applications. Each transformer prototype is accompanied by a comprehensive laboratory report, which includes submitted electrical requirements, photo-oscillograms (which indicate input and output pulse shape and output rise-time), the test equipment used, and evaluation of the electrical characteristics of the prototype.

WIDE BAND VIDEO TRANSFORMERS

ESC PART NUMBER	TURNS RATIO	PRIMARY IMPEDANCE (OHMS)	SECONDARY IMPEDANCE (OHMS)	BANDWIDTH at 1 db POINTS	APPROXIMATE PHYSICAL DIMENSIONS
4001	1:1	600	600	50 CPS to 8.0 MC	1-5/8" OD x 1/2"
		3500	3500	1 KC to 1.5 MC	
		10,000	10,000	1.6 KC to 800 KC	
4002	4:1	1600	100	100 CPS to 320 KC	1-1/8" OD x 3/8"

Transformers Are Supplied With Solder Terminals

Meet All Applicable Mil-Specs

Complete catalog data on request



electronic components division

**ESC**

CORPORATION • 534 BERGEN BOULEVARD • PALISADES PARK, NEW JERSEY

exceptional employment opportunities for engineers experienced in pulse techniques

THE AMERICAN PLATINUM WORKS  
NEWARK, NEW JERSEY

AMERSIL CO., INC.  
HILLSIDE, NEW JERSEY

BAKER & CO., INC.  
NEWARK, NEW JERSEY

EAST NEWARK INDUSTRIAL CENTER, INC.  
EAST NEWARK, NEW JERSEY

HANOVIA CHEMICAL & MANUFACTURING CO.  
NEWARK, NEW JERSEY

IRVINGTON SMELTING & REFINING WORKS  
IRVINGTON, NEW JERSEY

D. E. MAKEPEACE COMPANY  
ATTLEBORO, MASSACHUSETTS

NATIONAL ELECTRIC INSTRUMENT CO.  
ELMHURST, NEW YORK

THE H. A. WILSON COMPANY  
UNION, NEW JERSEY

**ENGELHARD INDUSTRIES ANNOUNCE  
THE CONSOLIDATION OF THE DOMESTIC AFFILIATED  
COMPANIES LISTED ABOVE UNDER A  
UNIFIED CORPORATE MANAGEMENT. THEY WILL  
HENCEFORTH BE DESIGNATED AS DIVISIONS OF  
ENGELHARD INDUSTRIES, INC.**

**ENGELHARD INDUSTRIES, INC.**

AMERICAN PLATINUM & SILVER  
DIVISION  
AMERSIL QUARTZ DIVISION  
BAKER CONTACT DIVISION  
BAKER DENTAL DIVISION  
BAKER SETTINGS DIVISION  
BAKER PLATINUM DIVISION  
CHEMICAL DIVISION

EAST NEWARK INDUSTRIAL CENTER  
HANOVIA LAMP DIVISION  
HANOVIA LIQUID GOLD DIVISION  
IRVINGTON BAKER REFINING DIVISION  
D. E. MAKEPEACE DIVISION  
NATIONAL ELECTRIC INSTRUMENT  
DIVISION  
RESEARCH AND DEVELOPMENT DIVISION  
H. A. WILSON DIVISION

COMPANIES OUTSIDE OF THE UNITED STATES: ENGELHARD INDUSTRIES OF CANADA, LTD., TORONTO • ENGELHARD INDUSTRIES OF QUEBEC, LTD.,  
MONTREAL • ENGELHARD INDUSTRIES, LTD., LONDON • ENGELHARD INDUSTRIEN A.G., ZURICH • GLOVER & GOODE PTY., LTD., MELBOURNE • GLOVER  
& GOODE BASE METALS PTY., LTD., MELBOURNE • SOCIEDAD SURAMERICANA DE METALES PRECIOSOS S.A., BOGOTA • INDUSTRIE ENGELHARD S.P.A.,  
ROME • THE DEVELOPMENT AND INVESTMENT COMPANY OF SOUTH AFRICA, LTD., JOHANNESBURG • ASSOCIATED COMPANIES: AZOPLATE CORPORATION  
CHARLES ENGELHARD, INC. • NUCLEAR CORPORATION OF AMERICA, INC. • SOUTH AFRICAN FOREST INVESTMENTS, LTD. • ACME TIMBER INDUSTRIES, LTD.

## ENGINEERING REVIEW

### *city Printed Circuits.*

The 1958 activities of the IPC are expected to include a comprehensive survey of the size, facilities, and problems of the industry. It will also include special programs of industry promotion and publicity, and a continuation of the work to develop both commercial and precision tolerances for printed circuits.

### **New Integrator Speeds Accurate Color Matching**

A new machine that determines how the average human eye will see a color under various lighting conditions has been developed by William E. White and Dr. David L. MacAdam of Kodak Research Laboratories. It is called a universal digital tristimulus integrator.

Built for use with a spectrophotometer, the device which traces the reflectance curve of the color sample, converts the analogue motion of the spectrophotometer into digital pulses. The pulses are then sent to a digital integrator, which sums them according to a program fed into it by means of a punched tape.

Kodak color research scientists have found that the machine eliminates human error in ordinarily tedious integrations involving thirty computations per curve for each of three tristimulus values. The integrator uses the selected ordinate system. It simultaneously adds up three sets of 200 or more reflectances per sample, thus reducing error inherent in the integration process. It provides a faster, more accurate means of matching color under given physical conditions.

In addition to the sensitivity curves of the human eye, sensitivity of TV receptors or color film can be fed to the machine to provide color matching for a variety of "viewers."

Programs can be fed into the machine to correspond to various lighting conditions, such as fluorescent light, sunlight, and tungsten light. At the same time, reflectance values of the color sample are read by the spectrophotometer.

◀ CIRCLE 12 ON READER-SERVICE CARD





**A Deadhead Pays Its Way:** During tests on a transistorized microphone, response curves were plotted using this artificial life-size head. Because acoustic measurements on microphones require near real conditions, the head was covered with skin-like plastic. Shure Bros., Inc., 222 Hartrey Ave., Evanston, Ill., made "Oscar" to test their 505T magnetic microphone for mobile radio transmitters. The microphone houses a tiny transistorized amplifier which improves sensitivity so much that the 505T can often replace a carbon microphone with no transmitter changes.

**Traveling-Wave TV Antenna:** A unique, advanced type of television antenna will be initiated by Station KGHL-TV in Billings, Montana. Designed at RCA, Gibbsboro, N. J., the antenna has a gain of 15 for high-power TV broadcasting in the vhf-TV band (316000 watts from a 25 kw transmitter). Its unusual electrical design permits transmitted television signals to travel the length of the sectioned antenna as complete waves. This traveling-wave characteristic makes for ideal shaping of vertical patterns, improved circularity and uniform signal distribution, and simpler mechanical construction. The antenna needs no external feed lines. It is available with gains ranging from 8 to 18.



ELECTRONIC DESIGN • February 5, 1958



ELECTRICAL

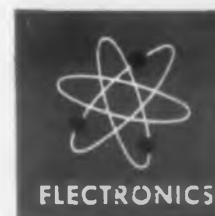

ELECTRONICS

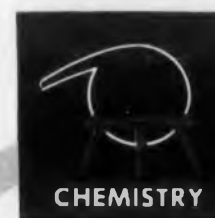

CHEMISTRY



METALLURGY

## CENTER FOR HIGH PURITY FUSED QUARTZ

AMERSIL is the primary source for fused quartz and silica of the highest possible purity. Our fabricated laboratory and production equipment is used in industry wherever such critical purity is required.

A fine service plan is keyed to your requirements.

Here, complete ranges of standard apparatus, crucibles, trays, cylindrical containers and tubing (up to 25" diam.) are available for prompt delivery.



**AMERSIL**  
COMPANY, INC.

FUSED SILICA  
AND QUARTZ

EN

INDUSTRIES

NEW JERSEY

CIRCLE 13 ON READER-SERVICE CARD



## First International Conference On Physics of Electronic and Atomic Collisions

Physicists from the United States and abroad, including a group from the Soviet Union, met at New York University on Jan. 27 and 28 for a conference on the physics of electronic and atomic collisions. The five-session meeting was sponsored jointly by the Office of Naval Research, and NYU. It was the first conference in this country devoted solely to electronic and atomic impact phenomena.

Included in the program were papers by both American and foreign physicists on topics basic to the study of the flight and reentry of missiles and the study of thermonuclear reactions.



**Metallic Chamber:** In the precisely controlled "climate" of a specially constructed chamber attached to an intricate maze of recording and analyzing instruments, scientists and physicians of the National Institute of Arthritis and Metabolic Diseases, are studying various influences on the metabolism of man.

Constructed by Tenney Engineering, Inc., Union, N. J., the metabolic chamber is an airtight room 13 x 9 x 8 ft high with two windows and an outer additional space of 4 x 9 ft to house heaters, cooling coils, and circulation fans. The air circulation in the room is 1300 cfm, allowing complete exchange in less than one minute, with an air velocity less than 50 ft per min due to an entirely louvered ceiling. Through considerable effort, the noise level has been reduced to less than 40 db. Temperatures between 40 F to 120 F and relative humidities of 10 to 95 per cent bring to the chamber climatic conditions as would be encountered in desert, jungle, temperate or semi-arctic zones, which would affect the metabolic changes in man. Sealed passages through the walls are designed to allow for many wires and tubes for physiological measurements, intercommunication, ports for periodic blood sampling, etc.

## diamond polystyrene dielectric capacitors ..... every one a standard!

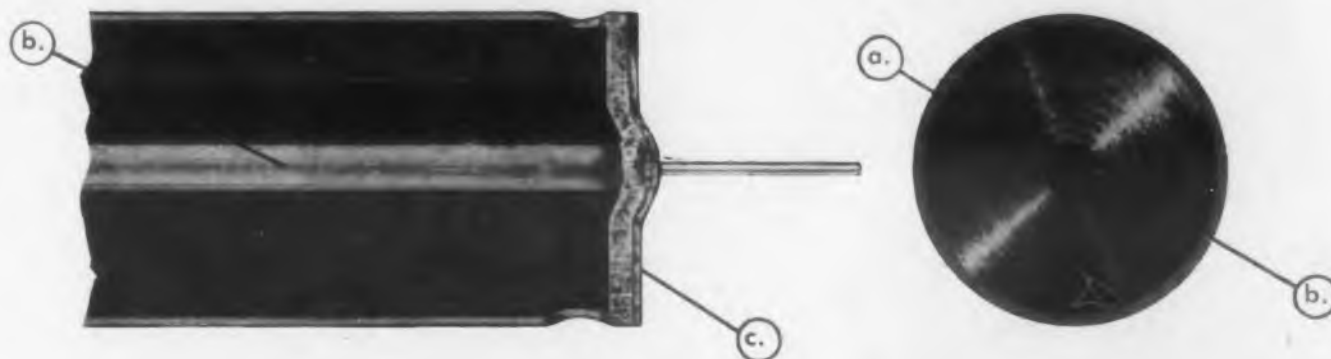

- a. exclusive processing technique assures a void-free, rock-hard winding — insensitive to shock, vibration, and thermal cycling.
- b. a solid core replaces the center hole usually found in wound capacitors . . . as a result of this support, an extremely high order of stability is guaranteed.
- c. solid disc soldered to extended foil replaces the usual weak spiral wire leads . . . tight automatic control of solder attachment provides positive contact over the entire winding cross-section. pull strength is increased to as much as twenty pounds.

these improved manufacturing techniques make the following specifications available at competitive prices:

- long term stability under maximum operating conditions measured in hundredths of a percent.
- temperature coefficient  $-110$  to  $-140$  ppm/ $^{\circ}$ c. — uniformly predictable to  $\pm 10$  ppm/ $^{\circ}$ c.
- insulation resistance at least  $10^{11}$  megohm-microfarads at  $25^{\circ}$ c — a guaranteed minimum of  $10^{12}$  m-m. is available upon request.
- power factor less than 0.02% at  $25^{\circ}$ c.
- tolerance from  $\pm 10\%$  to  $\pm 0.1\%$ .
- new screening techniques increase reliability to substantially higher levels. marginal capacitors which produce early failures are eliminated.

detailed data and additional specifications will be immediately submitted upon inquiry. further refinement of some of the specifications set forth above can be obtained upon special request.

# Diamond<sup>T.M.</sup>

**ELECTRONICS CORP.**

64 White Street, New York 13, N. Y.

Phone: WOrth 6-2972

CIRCLE 15 ON READER-SERVICE CARD



SO EASY TO SLIP ~~IN~~ up!

Here's a "slip up" in the making . . . a fuse of the wrong rating being slipped into a piece of equipment.

This could be your equipment, somewhere out in the field, where you have no control over it . . . or any resulting damage to your firm's reputation if your equipment fails.

Why risk equipment performance and company reputation on a component that invites misuse? It's foolish . . . when you can build complete and lasting protection into your product with Heinemann circuit breakers.

There's nothing to burn out . . . nothing to stock . . . nothing to replace when Heinemann breakers are used. More expensive? Perhaps. Perhaps not. Remember, a Heinemann breaker doubles as a power switch . . . it often eliminates a pilot light . . . and first cost is last cost.

Heinemann's exclusive hydraulic-magnetic principle insures full current capacity and stable must-trip points under a wide range of ambient

temperature conditions. There's no nuisance tripping . . . even on the hottest days.

Available ratings? As low as 10 milliamps. As high as 100 amperes. And an infinite number of standard, odd, and fractional ratings in between . . . one that matches your equipment exactly.

For the full story of Heinemann hydraulic-magnetic protection, request a copy of the Circuit Breaker Engineering Guide, Bulletin 201.



**HEINEMANN**

**ELECTRIC COMPANY**

156 Plum Street, Trenton 2, N. J.

*Circuit breakers*

CIRCLE 16 ON READER-SERVICE CARD

## WASHINGTON REPORT

Herbert H. Rosen

### FCC at Year End

As is customary at the close of the year, the Federal Communications Commission has looked inwardly and summed up its past, present, and future. From the technical standpoint, the Commission has had a busy, although not entirely successful year in terms of missions accomplished.

It is still re-examining its frequency allocations to radio services throughout most of the radio spectrum in light of present and future needs and technical developments. But as these needs and developments advance, this area requires continuing re-examination.

The FCC continues to deal with new spectrum-saving techniques such as offset carriers, single sideband, and split channel transmission. Also tropospheric and ionospheric scatter techniques, and expanding microwave operation. The Commission can look forward to a strong plea from the Electronic Industries Association for some conclusion to the problem of "saving the spectrum." EIA's VP Secrest advises that with all of these techniques at hand, a way should be found in which all of the users of the spectrum will be happy with their allocations. He expects to call for a Government-sponsored study of the problem, and hints that EIA has a scheme up its sleeve that will be a virtual panacea to it.

The growth of the telecommunications industry has further compounded the problems of the FCC. The Commissioners estimate the administrative load they must handle has doubled since WW II. However, there has been little change in the amount of appropriations or the number of people assigned to the job. So, 1958 will bring some new problems. Among these are:

- Service expansion and technical developments which require continuing consideration and keep rules and regulations in a constant state of flux.
- Dearth of frequencies in particular parts of the usable radio spectrum to meet the demand for new or extended services.
- Growing interference and enforcement problems which practically overwhelm the Commission's limited staff.
- Backlogs in processing due to sheer volume of applications.
- Increasing competition for radio facilities extending to nonbroadcast business interests.
- Procedural tactics by parties which delay the providing of new services.

It's going to be a long year.

S.A. 1654

CIRCLE 217 ON READER-SERVICE CARD ►



Here are some of the fine MARS drafting products, imported from West Germany, made to meet the highest professional standards. ● Bright-hued LUMOCHROM pencils come in 24 colors for color-coded drafting and perfect reproduction. ● LUMO-

GRAPH graphite drawing pencils come in 19 degrees. Some degrees available with erasers, some with special chisel points. ● TECHNICO lead holders for color and black graphite drawing have new sure-hold finger grips, with degree markings for quick

identification. Also available with clips for pocket use. ● NON-PRINT pencil and leads let you make notes and sketches that will not reproduce. ● Pencil sharpeners come in STANDARD and "DRAFTSMAN" models; latter with adjustable point length feature.

## your brain's best friends

Thoughts needn't struggle over mechanical hurdles to get down on paper. Tracings convey your ideas and designs most clearly when your drafting is concise and sharp. When it reproduces perfectly.

Like thousands of your col-

leagues, you will find the shortest distance between idea and execution in MARS drafting products. They are your brain's best friends.

For the engineer, architect and draftsman who demands direct and accurate expression, *it's MARS—*

*clear across the board!* Ask for these quality drafting aids at your dealer's.

**MARS**  
**J. S. STAEDTLER, INC.**  
 HACKENSACK, NEW JERSEY



*Golden year for...*



**BLACK MAGIC**

In our 50 years of manufacturing dispersions of colloidal graphite, we've seen the unique anti-friction properties of this basic material make lubricating problems disappear as if by "black magic". As an additive to lubricating oils and greases, as a parting agent in many kinds of casting and as a dry-film lubricant in diverse fields of metal working . . . in application after application . . . it has proved literally more valuable than gold.

Dr. Edward Goodrich Acheson's invention of colloidal graphite over 50 years ago has been followed by a constantly expanding program of fundamental research and product development. Today, with over 50 different dispersions already in use, three laboratory groups at Acheson are pressing toward perfection of whole new families of dispersions and their applications.

**Offices In:**

Boston • Chicago • Cleveland • Dayton • Detroit • Los Angeles • Milwaukee  
New York • Philadelphia • Pittsburgh • Rochester • St. Louis • Toronto

CIRCLE 218 ON READER-SERVICE CARD

The custom dispersing of solids requires specialized facilities and production techniques. Why not take advantage of Acheson's 50 years of leadership in this field?

You will be interested in the number of different dispersed solids, in addition to graphite, that are being used successfully today in industry. Our Products List gives you, in quick-reading chart form, a résumé of Acheson 'dag'® brand dispersions and their typical applications. Send for your copy. Address Department ED-28.

**ACHESON** *Colloids Company*

PORT HURON, MICHIGAN

*A division of Acheson Industries, Inc.*

Also Acheson Industries (Europe) Ltd. and affiliates, London, England

A my

Sin  
and p  
Ajax  
opera  
produ  
tribut  
The M  
made  
Amer  
tric a  
unit,  
millio  
talion  
about  
at For  
where  
Mis  
tion a  
system  
fore, n  
ments  
allele  
sile M  
capac

AMB

Wh  
chain  
tion E  
cision  
tract  
progra  
matic  
New Y  
parts a  
be the  
major  
The  
he ke  
re cor  
nd ai  
Wh  
air tra  
most n  
availa  
or its  
he in  
he ba  
quipr  
ic com  
ot be  
ince t  
ic. The  
pheren  
imple

LECT

## Army Accepts Missile Master

Simple computers; thousands of tubes, parts, and pieces; miles of wire; manpower, and Nike-Ajax missiles are now coordinated into a single operating system called the Missile Master. The production of this target selection and fire distribution system was under the management of The Martin Company. Major contributions were made by Airborne Instrument Laboratories, American Machine and Foundry, Western Electric and hundreds of subcontractors. As a single unit, the Missile Master cost the Army about \$7 million. The land on which it and the Nike battalions sit, roughly \$3 million. And it will be about 18 months before units other than the one at Fort George Meade are made operational elsewhere in the United States.

Missile Master also has a built-in failure detection and prediction system. To be effective, the system must have phenomenal reliability. Therefore, many information paths are duplicated. Elements in which bottlenecks may occur are paralleled. And although some parts may fail, Missile Master can still perform its job at reduced capacity.

## AMB Awards First Contract

What is hoped to be the first award in a long chain of contract awards by the Air Modernization Board has been made to the General Precision Laboratories. The multimillion dollar contract calls for the first part of a three-part program that will ultimately become a semi-automatic data processing and display system for New York's LaGuardia Airport. When the three parts are completed in 1961, the installation will be the model for similar installations in other major airports across the country.

The GPL data processing and display system is the key element in a strand of five. The other four are communications, navigation, data acquisition, and airport improvement.

When combined into one complete system, the air traffic control equipment will embody the most modern and technically advanced concepts available. A deadline date of 1963 has been set for its completion at LaGuardia. Once proven, the individual parts of the system will become the basis for production specifications for similar equipment to be installed in the national air traffic control system. Other systems, however, will not be as extensive as the New York operation, since they handle a much smaller amount of traffic. Therefore, the model system will have to have inherent flexibility to allow reduction in size and complexity with decreasing traffic demand.

All Hughes diodes resemble each other—externally. Germanium point-contact or silicon junction, they are all glass-bodied\* and tiny (maximum dimensions: 0.265 by 0.107 inch). But minute, meticulously controlled variations in the manufacturing process impart individual characteristics to the diodes, make them just right for specific applications. This gives you the

opportunity of selecting from a line which includes literally hundreds of diode types.

So, when your circuitry requires varying combinations of such characteristics as... high back resistance...quick recovery... high conductance...or high temperature operation, *specify Hughes*. You will get a diode with mechanical and electrical stability built in. You will get a diode which

was manufactured first of all for reliability.

\*Nowhere else have glass packaging techniques been developed to a comparable extent, for the Hughes process has many unique aspects. They are difficult to duplicate, yet are instrumental to the manufacture of diode bodies which are completely impervious to contamination and moisture penetration.

For descriptive literature please write: SEMICONDUCTOR DIVISION, HUGHES PRODUCTS  
International Airport Station, Los Angeles 45, California



Creating a new world with ELECTRONICS

HUGHES PRODUCTS

© 1958, HUGHES AIRCRAFT COMPANY

CIRCLE 17 ON READER-SERVICE CARD

# Single New Rectifier Outperforms

## 12 full size conventional stacks!

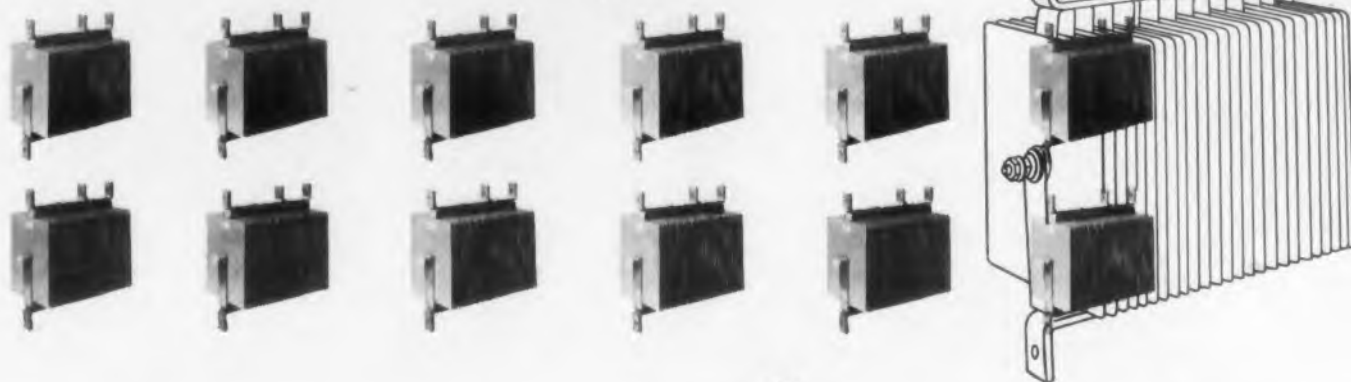
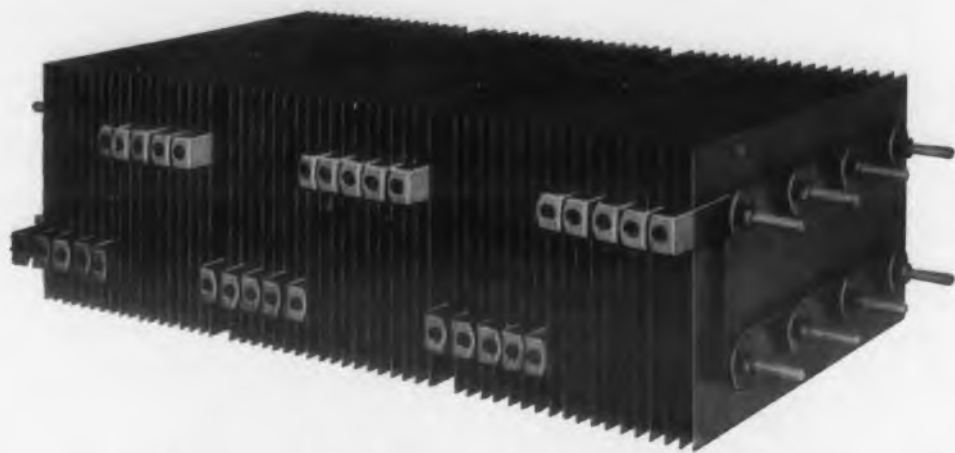

## Radio Receptor **HCD**\* Petti-Sel \*High current density Industrial Type Selenium Rectifiers

*Produced by the improved new vacuum process developed by Siemens of West Germany and now manufactured exclusively by Radio Receptor in the U.S.*

- Smaller cell sizes
- Lower voltage drop
- No artificial barrier
- Negligible aging with an estimated life of 100,000 hours!

Because the exclusive Siemens vacuum process eliminates the need of an artificial barrier layer, it is possible for Radio Receptor to offer smaller cell sizes operating at high current density, yet with lower voltage drop. In actual dimensions this means that just *one* RRco. HCD rectifier measuring 8" x 16" x 25", rated at 26V AC, 4500 amps DC, replaces *twelve* usual stacks 6" x 7 $\frac{1}{4}$ " x 10".

RRco. Petti-Sel rectifiers do far more than save space. They reduce assembly time, require fewer connections and cost less per ampere. Their dependability has been proved for years in European circuits and the outstanding electrical characteristics are not even approached by other standard cells available today. For further information please write today to Section D-10R.

Radio and  
Electronic Products  
Since 1922



Semiconductor Division  
**RADIO RECEPTOR COMPANY, INC.**  
A Subsidiary of General Instrument Corporation  
240 WYTHE AVENUE, BROOKLYN 11, N. Y. • EVERgreen 8-6000

Radio Receptor products for Industry and Government:  
Germanium and Silicon Diodes, Selenium Rectifiers, Theratron Dielectric  
Heating Generators and Presses, Communications, Radar and Navigation Equipment

CIRCLE 18 ON READER-SERVICE CARD

## Letters to the Editor

### Hasten Intelligently on Russian Translations

Dear Editor:

I have read with interest your editorial in the Dec. 1, 1957, issue, "Sputnik Should Spark Translations." Since our firm has experience in this field, I should like to comment on your editorial.

... you are absolutely on the mark when you say that the individual must assume responsibility for keeping abreast of foreign technology and especially Russian technology. Yet, this does not quite get to the heart of the matter, which is that many research scientists and research librarians would like to have these translations while industrial management has not seen fit to include them in its budgets. The fact that you "get an urgent plea for advice on how to get a complete translation," despite the fact that existing translation agencies continue to bombard industry with notices of translations they have made, is amazing. Yet, it is not really a surprise to us, because we have been advertising translations for eleven years and still get queries such as: "Do you mean you translate thus and so?" and "Is it really available in English?" Evidently, many of us don't read very carefully or don't assimilate what we read.

Somehow I find an implied blame laid upon the Government in your editorial, and this I feel to be unfortunate and unfair. We have been publishing cover-to-cover translations of Soviet scientific journals for over eight years. Yet, American industry, with the notable exception of a comparative handful of forward-looking firms, has ignored and still ignores the availability of this material. In sharp contrast, the Government and especially the National Science Foundation since mid-1955 has supported and strengthened this program, and through grants to scientific societies has further expanded it.

I also feel worried about your recommendation for a "crash" program. In spite of the apathy, smugness, and miserliness of American industry, there are currently being published some three dozen Russian scientific journals in complete English translation, available on a subscription basis—a program steadily being expanded with Government assistance. The last thing America needs at this point is a badly conceived "crash" program of translation, begun in haste and panic



## Waldes Truarc Retaining Ring eliminates 7 parts, saves \$8.88 in sub-assembly of aerial reconnaissance camera

Gordon Enterprises, No. Hollywood, California, saved the Navy almost 1 1/2 million dollars on 500 cameras. Gordon rebuilt new, efficient "CA" series out of Navy-owned obsolete models. Critical parts are now held together by Waldes Truarc Retaining Rings.

Truarc Rings are trouble-free, will not change position during operation. Accuracy is limited only by groove and ring dimension tolerances. And standardized Truarc Rings are quickly interchangeable in overhaul which now takes only 11 minutes, can be handled by unskilled technicians.

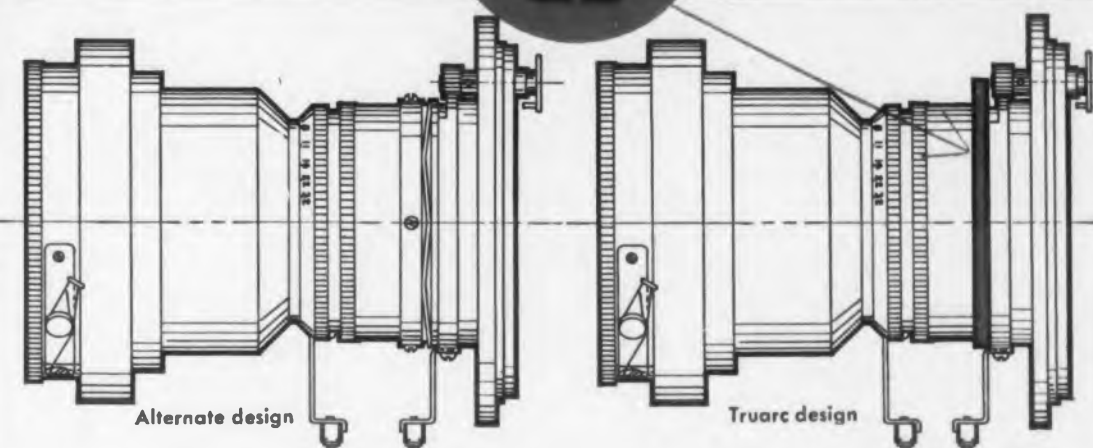

Truarc 5100-287 ring retains shutter speed adjustment mechanism on the Lens Adapter Plate Assembly which mounts and locks the lens

and shutter assemblies accurately to camera body. Alternate design required retaining washer, spring, collar and 4 locking screws.

Weight Saving: 7.25 oz.

Assembly Time Saving: . . . . . 6 1/2 min.

### DOLLAR SAVINGS:

Material . . . . . \$ .93

Fabrication . . . . . 6.88

Inspection . . . . . 1.07

Total \$8.88

and without the expertise which has been developed over the past ten years.

What is needed is a realistic evaluation by American industry of the importance of basic research and foreign research-in-translation for which it must ultimately foot the bill.

The fact that the USSR has a central translation agency should hardly come as a surprise since they also have a central book publishing house, a central committee and a central many other things. We do not operate in that fashion in this country. The way such a program must be shaped here, it would seem to me, is precisely the way in which it has been moving; namely, the seizing of the initiative by people in the translation industry backed up by Government assistance but never forgetting that since industry benefits most largely from any such program, it must loosen its purse strings and make more extensive purchases of existing translations.

Earl M. Coleman, President  
Consultant Bureau Inc., NYC

Mr. Coleman's company, without subsidy, translates *Automatika i Telemekhanika*. Electronic engineers can subscribe by the year or buy single copies. We congratulate such initiative. Until recent grants by the National Science Foundation for translating electronic journals, ELECTRONIC DESIGN was the only organization to publicize regularly what the USSR is doing in electronics.

We do not now propose a crash program for translating journals. We do suggest that there be a crash program to find out what the Russians have written. This includes Soviet books, transactions of symposia, and monographs which are in the U.S., but which no one can read. We feel a scientific and engineering advisory board should be set up to evaluate what should be translated. Where industry obligation ends and government responsibility begins is hard to say. A good part of the electronics industry is supported by government funds. The government determines what industry costs and overhead are allowable. This is just one factor. We do feel that the individual engineer must first press his own management to get translations. It goes without saying that we feel the professional man should be as technically informed on this subject as he can. This means knowing what engineers in the rest of the world are doing.

Whatever you make, there's a Waldes Truarc Ring designed to save you material, machining and labor costs, and to improve the functioning of your product.

In Truarc, you get

**Complete Selection:** 36 functionally different types. As many as 97 standard sizes within a ring type. 5 metal specifications and 14 different finishes. All types available quickly from leading OEM distributors in 90 stocking points throughout the U.S. and Canada.

**Controlled Quality** from engineering and raw mate-

rials through to the finished product. Every step in manufacture watched and checked in Waldes' own modern plant.

**Field Engineering Service:** More than 30 engineering-minded factory representatives and 700 field men are at your call.

**Design and Engineering Service** not only helps you select the proper type of ring for your purpose, but also helps you use it most efficiently. Send us your blueprints today...let our Truarc engineers help you solve design, assembly and production problems...without obligation.

For precision internal grooving and undercutting . . . Waldes Truarc Grooving Tool!



**WALDES**  
**TRUARC**<sup>®</sup>  
**RETAINING RINGS**  
WALDES KOHINOOR, INC.  
47-16 AUSTEL PLACE, L. I. C. 1, N. Y.

Waldes Kohinoor, Inc., 47-16 Austel Place, L. I. C. 1, N. Y.  
Please send new, descriptive catalog showing all types of Truarc rings and representative case history applications. (Please print)

Name \_\_\_\_\_  
Title \_\_\_\_\_  
Company \_\_\_\_\_  
Business Address \_\_\_\_\_  
City \_\_\_\_\_ Zone \_\_\_\_\_ State \_\_\_\_\_ 8D-020

WALDES TRUARC Retaining Rings, Grooving Tools, Pliers, Applicators and Dispensers are protected by one or more of the following U. S. Patents: 2,382,948; 2,411,426; 2,411,761; 2,416,852; 2,420,921; 2,428,341; 2,439,785; 2,441,846; 2,455,165; 2,483,379; 2,483,380; 2,483,383; 2,487,802; 2,487,803; 2,491,306; 2,491,310; 2,509,081; 2,544,631; 2,546,616; 2,547,263; 2,558,704; 2,574,034; 2,577,319; 2,595,787, and other U. S. Patents pending. Equal patent protection established in foreign countries.

CIRCLE 19 ON READER-SERVICE CARD

# NEW!

## thinnest pushbutton switch

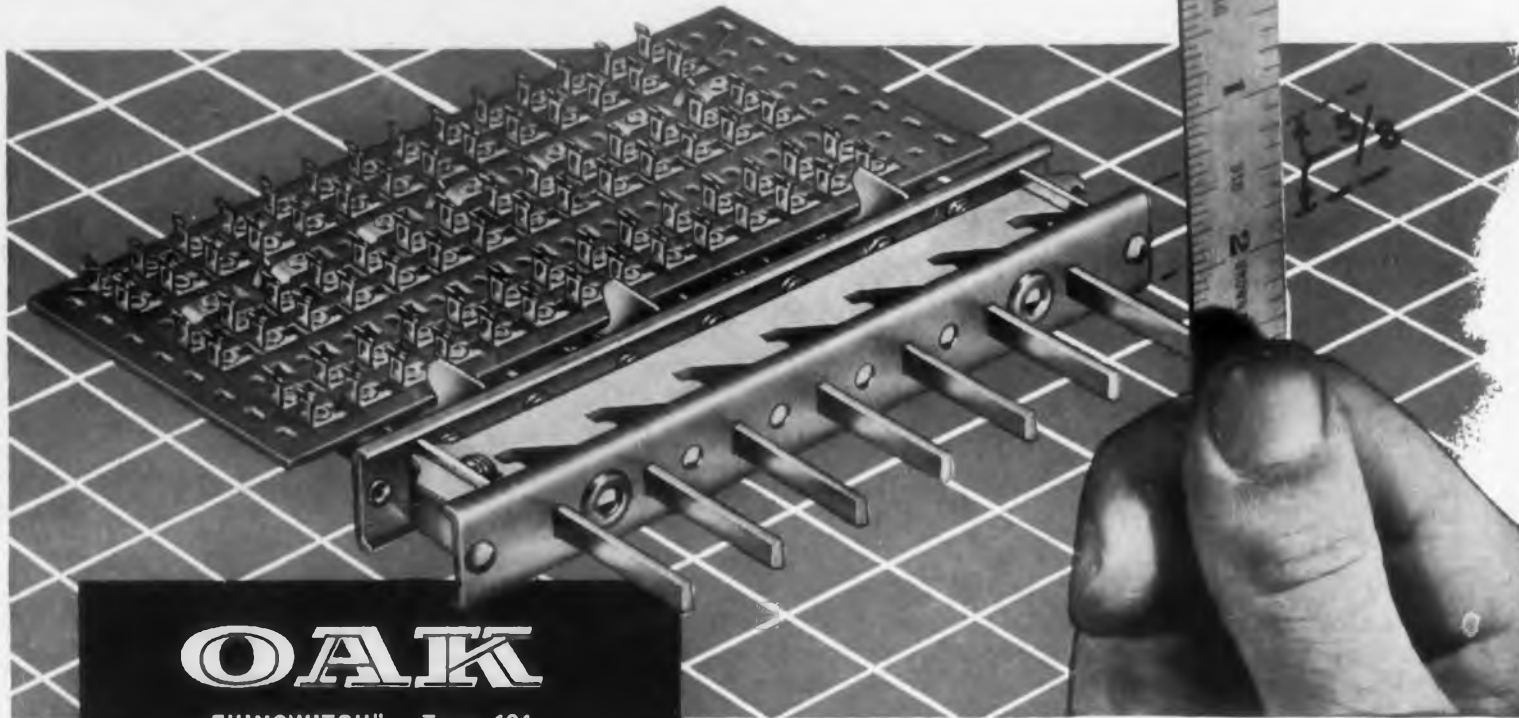

**OAK**  
"THINSWITCH" Type 131

### FEATURES

- Measures only  $\frac{5}{8}$ " thick.
- 1 to 12 buttons, standard, with  $\frac{5}{8}$ " spacing.
- Up to 14 contacts per button.
- "Floating" slider design for smooth, easy operation.
- Famous Oak double-wiping contacts.
- Highest grade phenolic punching stock.

### REQUIRES 45% LESS PANEL AREA!

This new Oak switch is particularly valuable as a spacesaver in keyboards handling complicated, low-current circuits. The Type 131 can be mounted side by side on  $\frac{1}{16}$ " centers, so that a bank of 10 switches, for example, requires only  $6\frac{13}{16}$ ".

Thus, in equipment such as computers, testers, automatic coin devices, and communications gear, the Type 131 offers extra flexibility in laying out panel areas, or actually permits a decrease in the size of the equipment.

Type 131 switches are built to your exact requirements with the same high quality materials and workmanship as other Oak switches. Call in your Oak representative, or write for full technical details.



SWITCHES



ROTARY SOLENOIDS



CHOPPERS



VIBRATORS

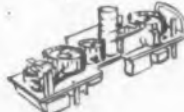

SUBASSEMBLIES

**OAK** MFG. CO.

1260 Clybourn Ave., Dept. D, Chicago 10, Illinois  
Phone: MOhawk 4-2222

CIRCLE 20 ON READER-SERVICE CARD

## MEETINGS

### Feb. 20-21: 1958 Transistor and Solid State Circuits Conference

University of Pennsylvania and Sheraton Hotel, Philadelphia, Pa. Sponsored by the IRE, AIEE, and University of Pennsylvania. Papers will deal with high speed circuits, analytical techniques for system integration, device characterization, high and low power circuits, memory, magnetics, and related topics. For further information send to J. H. Milligan, Jr., Dept. of E. E., New York University, New York 53, N. Y.

### Feb. 20-24: 1958 EIA (formerly RETMA) Industrial Relations Conference

Town and Country Hotel, San Diego, Calif. Collective bargaining in the electronics industry, and technical manpower development and utilization are among the topics to be discussed. For information write to D. H. Stover, Industrial Relations Dept., Electronic Industries Assoc., 1721 De Sales St., N.W., Washington 6, D. C.

### Mar. 16-21: 1958 Nuclear Congress

Chicago Amphitheatre and Palmer House, Chicago, Ill. Sponsored by the AICE, AIEE, IRE, and many others. The congress will include five separate conferences: The Fourth Nuclear Engineering and Science Conference (Mar. 17-21), The Fourth International Atomic Exposition (Mar. 16-21), The Sixth Atomic Energy in Industry Conference (Mar. 17-19), The Sixth Hot Laboratories and Equipment Conference (Mar. 19-20), and The American Power Conference (Mar. 17-19). For more information write to the American Institute of Chemical Engineers, 25 W. 45th St., New York 36, N. Y.

### March. 18-19: Conference on Extremely High Temperatures

Air Force Cambridge Research Center, L. G. Hanscom Field, Bedford, Mass. Sponsored by AFCRC. The purpose of the Conference is to further the exchange of information among those interested in research into temperatures above 30,000 Kelvin. Emphasis will be placed upon theoretical and experimental aspects although the Conference will also cover applications. Write Dr. Heinz Fischer, AFCRC, L. G. Hanscom Field, Bedford, Mass. for details.

#### Mar. 24-27: IRE National Convention

Coliseum and Waldorf-Astoria, New York City. A comprehensive program of 275 papers, covering the most recent developments in the fields of all 27 IRE Professional groups, will be presented in 55 sessions. The high point of the program will be two special symposia on "Electronics in Space" and "Electronic Systems in Industry," to be held Tuesday Evening, March 25. The complete program will be announced sometime in January.

#### Mar. 27-29: Ninth Biennial Electrical Industry Show and Fifth Electrical Maintenance Conference

Shrine Exposition Hall, Los Angeles, Calif. Some of the topics to be discussed are maintenance to prevent breakdown, maintenance of electrical and electronic equipment, and maintenance of lighting to assure peak output. For more details write Paul H. Henrichs, Southern California Edison Co., P.O. Box 351, Los Angeles, Calif.

#### Mar. 31-Apr. 2: Instruments and Regulators Conference

University of Delaware, Newark, Del. Sponsored by the IRE, ASME, AICHE, and ISA. For details send to E. M. Grabbe, P.O. Box 45067, Airport Station, Los Angeles 45, Calif.

#### Apr. 2-4: ASME Conference on Automatic Optimization

University of Delaware, Wilmington, Del. AIEE, IRE, ISA, AICHE with professional groups analogous to the RE will participate in the conference by sponsoring technical papers centered around the theme, "Automatic Optimization." For details write W. E. Vannah, Control Engineering, 330 W. 42nd St., N. Y. 36, N. Y.

#### Apr. 8-10: Symposium on Electronic Waveguides

Auditorium of Engineering Societies Bldg., 33 W. 39th St., New York. Sponsored by IRE, PGED and PGMTT, and the Department of Defense Research Agencies. The symposium will deal with the interaction of electromagnetic fields and electron or plasma beams in general waveguide regions. The symposium covers the fields of electron beams, plasmas, and electromagnetics to compare the rather widely disparate theories and techniques employed to describe the wave phenomena encountered in the interaction of such fields. For further information contact the Polytechnic Institute of Brooklyn, 55 Johnson St. Brooklyn 1, New York.

## New design 50 ohm attenuator 0 to 132 db in 1 db steps— DC to 500 MC

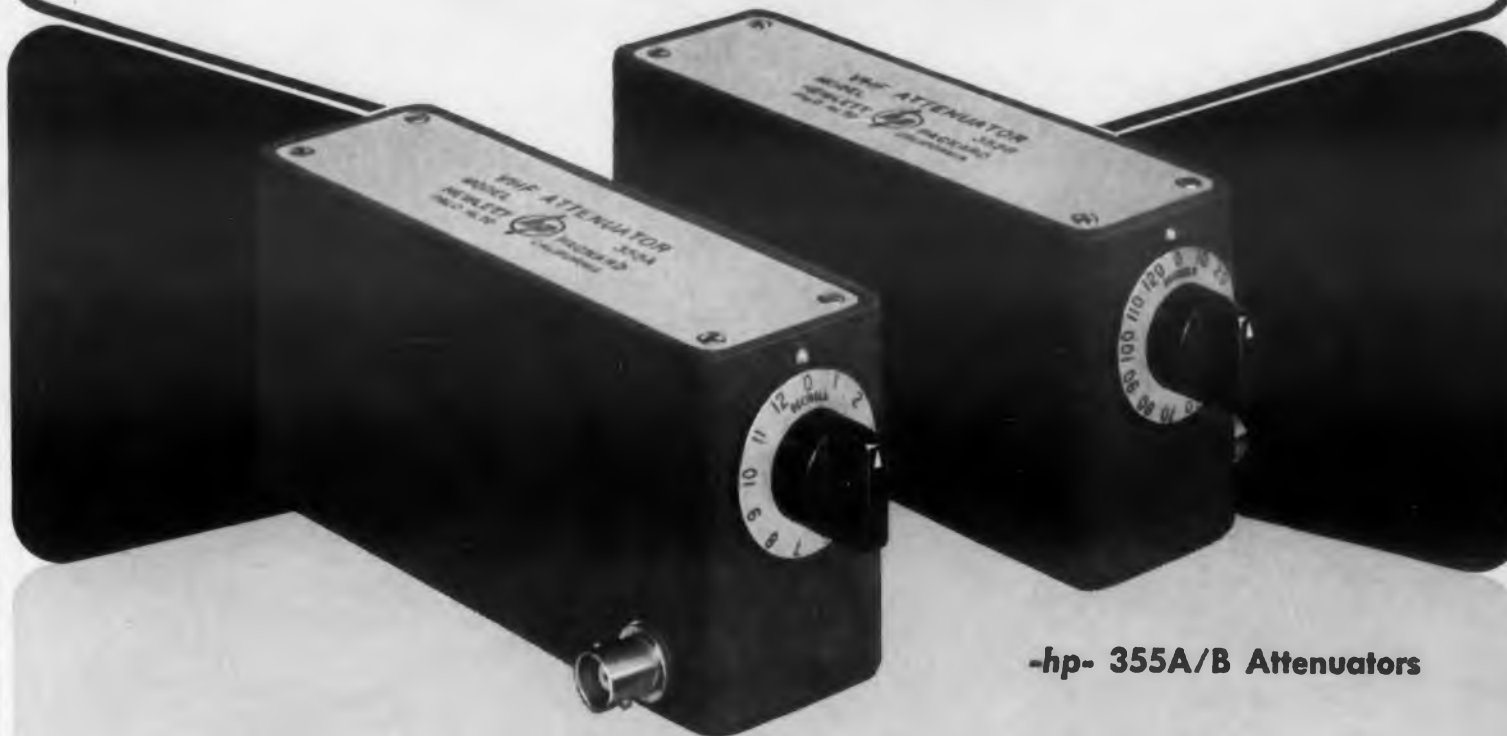

-hp- 355A/B Attenuators

$\frac{1}{4}$  db accuracy full range for low attenuation values. Maximum error at full attenuation 2 db. "One-knob" control. Super compact design—size approximately  $2\frac{1}{2}$ " x  $2\frac{1}{2}$ " x 6".

These are characteristics of the new, rugged, simple -hp- 355A/B attenuators.

-hp- 355A provides 0 to 12 db in 1 db steps. -hp- 355B provides 0 to 120 db in decade steps. Together, 132 db of attenuation from DC to 500 MC is available, with simplest possible controls, pre-

mium accuracy, and no complex setup. A solid-shield 50 ohm connector may be used to interconnect the two attenuators.

These new -hp- attenuators have balanced capacities and completely shielded sections. They are enclosed in a sturdy metal case, yet weigh only  $1\frac{1}{2}$  pounds.

Ask your -hp- representative to show you these practical, minimum-space attenuators this week.

-hp- at IRE, TOP OF ESCALATORS AS YOU ENTER SHOW

#### SPECIFICATIONS

**Attenuation:** -hp- 355A, 12 db in 1 db steps. -hp- 355B, 120 db in 10 db steps

**Frequency Range:** DC to 500 MC

**Overall Accuracy:** -hp- 355A,  $\pm 0.25$  db, DC to 500 MC. -hp- 355B,  $\pm 1$  db, DC to 250 MC,  $\pm 2$  db, 250 to 500 MC

**Nominal Impedance:** 50 ohms

**Maximum SWR:** 1.2 to 250 MC, 1.5 to 500 MC

**Max. Insertion Loss:** 0 at DC, 0.4 db at 60 MC, 1 db at 250 MC, 1.5 db at 500 MC

**Power Dissipation:** 0.5 watt average; 350 v peak

**Connectors:** BNC

**Size:** 2-3/16" wide, 2-5/8" high, 6" long. Net weight  $1\frac{1}{2}$  pounds

**Price:** -hp- 355A, \$125.00. -hp- 355B, \$125.00

Data subject to change without notice. Prices f.o.b. factory

#### HEWLETT-PACKARD COMPANY

4643A PAGE MILL ROAD • PALO ALTO, CALIFORNIA, U.S.A.  
CABLE "HEWPACK" • DAVENPORT 5-4451  
FIELD ENGINEERS IN ALL PRINCIPAL AREAS

 offers over 350 quality electronic test instruments

CIRCLE 21 ON READER-SERVICE CARD

THOMAS A.

# EDISON

**current sensitive  
d.c. relays operate  
on microamps...  
carry load of 1/3 amp**



This meter-type relay is capable of operating on an input power of 25 microwatts—and on even less power in special applications. When the relay is factory-adjusted for the special conditions to be encountered, sensitivities down to 1 microwatt are possible.

Edison sensitive relays can replace a vacuum tube amplifier in many applications, and offer important savings in weight and cost. Because of their low operating power level, they can be run directly from a thermocouple or photocell output—and are ideal for uses involving servo motors operating from vacuum tube plate circuits. Between the input power to the operating coils and the load capacity of its own contacts, these relays make possible a power amplification factor in excess of 500,000 to 1.

For complete data on Edison Sensitive Relays, write for Bulletin No. 3037.

**Thomas A. Edison Industries**  
**INSTRUMENT DIVISION**

55 LAKESIDE AVENUE, WEST ORANGE, N. J.  
CIRCLE 22 ON READER-SERVICE CARD

## MEETINGS

### **Apr. 22-24: 1958 Electronic Components Conference**

Ambassador Hotel, Los Angeles, Calif. Sponsored by the IRE, AIEE, EIA, and WCEMA. With "Reliable Application of Component Parts" as its main theme, the conference has been planned to cover the following general topics: resistors, capacitors, and dielectrics; transistors and solid state devices; component reliability; electron tubes and their application; and progress with materials. For complete information write to David M. Knox, Packard-Bell Electronics Corp., 12333 W. Olympic Blvd., Los Angeles 64, Calif.

### **Apr. 24-26: URSI Spring Meeting**

Willard Hotel, Washington, D. C. Sponsored by the PGAP, PGMT&T, PGCT, PGIT, PGI, and URSI. For information, contact John P. Hagen, Naval Research Lab., Washington 25, D. C.

### **Apr. 30-May 1-2: 7th Region Technical Conference & Trade Show**

Hobbies Bldg., State Fair Grounds, Sacramento, Calif. Write Ewald W. Berger, 3421 58th St, Sacramento 20, Calif. for information.

### **May 1-8: ASTE Tool Show**

Convention Center, Philadelphia, Pa. A complete integrated technical program of papers, panels, seminars, plant tours, and related activities will be offered. For further information, write Richard Gebers, Public Relations Manager, 10700 Puritan, Detroit 38, Mich.

### **May 4-7: 4th National Flight Test Instrumentation Symposium.**

Park-Sheraton Hotel, New York City. Sponsored by the Instrument Society of America. Theme of the Symposium is "More Data Per Dollar." For details write P. O. Box 113, Bethpage, N. Y.

### **May 5-7: AIEE Great Lakes District Meeting**

Michigan State University, East Lansing, Mich.

### **May 5-7: PGMT&T National Symposium**

Stanford University, California. For details, write to Dr. K. Tomiyasu, GE Microwave Lab., 601 California Ave., Palo Alto, Calif.

# EDITORIAL

## Public's View of Engineer Shapes U.S. Destiny

The man in the street's idea of the role of science and technology, until Sputnik, was that they produce miracle pills for piles and more TV's, autos and refrigerators. In case of war, or for defense, we thought mostly in terms of how many planes and ships we would have to buy. Now practically everyone realizes that the quality of the products, not only quantity, is a determining factor.

Scientists and engineers must play one of the most predominant roles in future society. Our destiny depends on engineering and engineers being understood by our government leaders (there are no more than 2 or 3 engineers in the legislature) and by the people at large, who shape public policy. This calls for public relations by the engineer.

In advocating a program of public relations, T. E. Garrigan, in the September issue of the *Pulse of Long Island* (published by the Long Island Section of the IRE), says "... the future of our nation depends, to a great extent, on the public's understanding of how the engineer fits into our economy. A lack of understanding can lead to a deterioration of the quality and quantity of engineers for the future; it can lead to lowering the engineer's social prestige, his monetary remuneration and other factors whose cumulative effect would be harmful to the whole nation."

There is a need for communicating technical information to the layman. Recent surveys report that by and large the public's understanding of science and engineering comes from newspapers. Very few newspapers have science editors who know anything at all about science. As a result, the layman has no deep appreciation or clear picture of what science and engineering is. In some respects he's too gullible; he assumes science can do anything once they set their minds to it. Of course, if he reflects he may become skeptical when he realizes that pills for curing insanity and frustration have been publicized for two years, yet the number of insane and neurotic keeps growing. And where is that color TV set that he read that he was going to have in 1957? We think engineers can do something about this themselves. We congratulate The Long Island IRE members who are, among other things, giving programs for the non-technical public—John R. Pierce packed the auditorium with his fascinating yet informative discussion "Fancies and Fallacies of Space Travel" and planning meetings, tours, and demonstrations for community leaders. They are also slanting publicity releases concerning members and activities to the average citizen. Each engineer is encouraged to actively participate in at least one community activity.

Garrigan says, be a good citizen and you will be a better engineer. We agree.—JAL

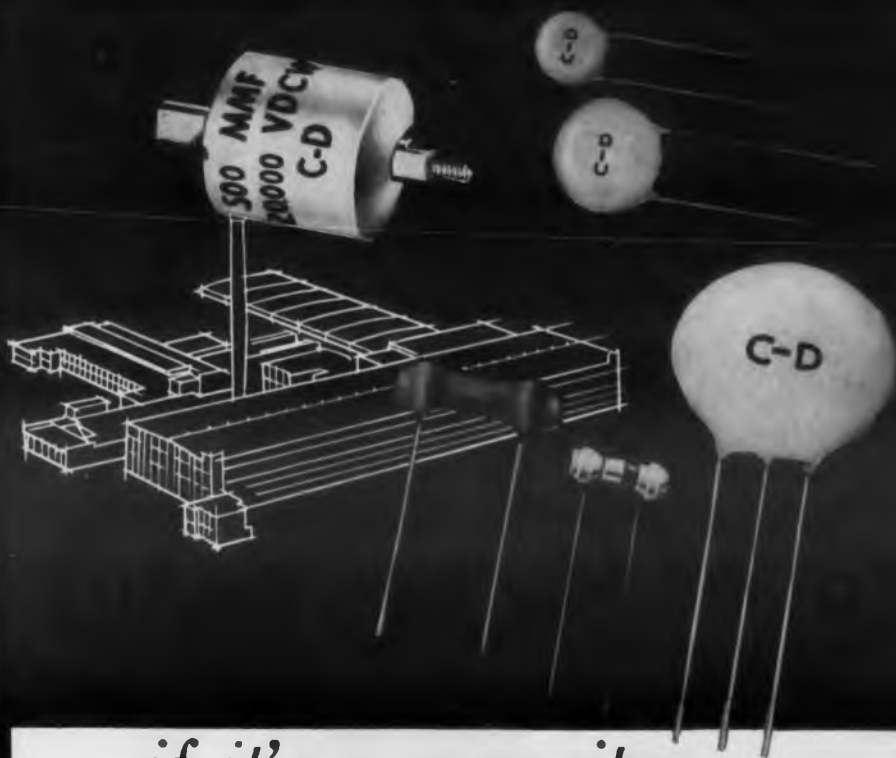

*if it's a capacitor...*

**C-D** *makes it...*

*and makes it better!*

### A Complete Line of Ceramics from a Single Source

C-D Ceramic Capacitors are produced under one roof, with full control over all operations, from start to finish. Whatever types of ceramic capacitors your designs call for, C-D has them... and C-D is your most dependable source.

- **DISC TYPES:** Temperature compensating, close tolerance, general purpose bypass, high voltage, A-C line bypass.
- **TUBULAR TYPES:** Temperature compensating, close tolerance, trimmer.
- **SLUG TYPES:** High voltage.
- **AUTOMATION:** Plug-in termination available in temperature compensating, stabilized capacity, general purpose bypass, close tolerance disc types.
- **SPECIAL DESIGN TYPES:** Feed-thru, standoff, miniaturized.

Engineering samples sent on request. For complete data on C-D Ceramics, write for Catalog No. 616 to Cornell-Dubilier Electric Corporation, South Plainfield, New Jersey.



CONSISTENT HI-DEPENDABILITY  
**CORNELL-DUBILIER CAPACITORS**

SOUTH PLAINFIELD, NEW JERSEY; NEW BEDFORD & CAMBRIDGE, MASS.; PROVIDENCE & HOPE VALLEY, R. I.; INDIANAPOLIS, IND.; SANFORD, FUGUAY SPRINGS & VARINA, N. C.; VENICE, CALIF.; & SUBSIDIARY, THE RADIART CORPORATION, CLEVELAND, OHIO; CORNELL-DUBILIER ELECTRIC INTERNATIONAL, N. Y.

CIRCLE 23 ON READER-SERVICE CARD

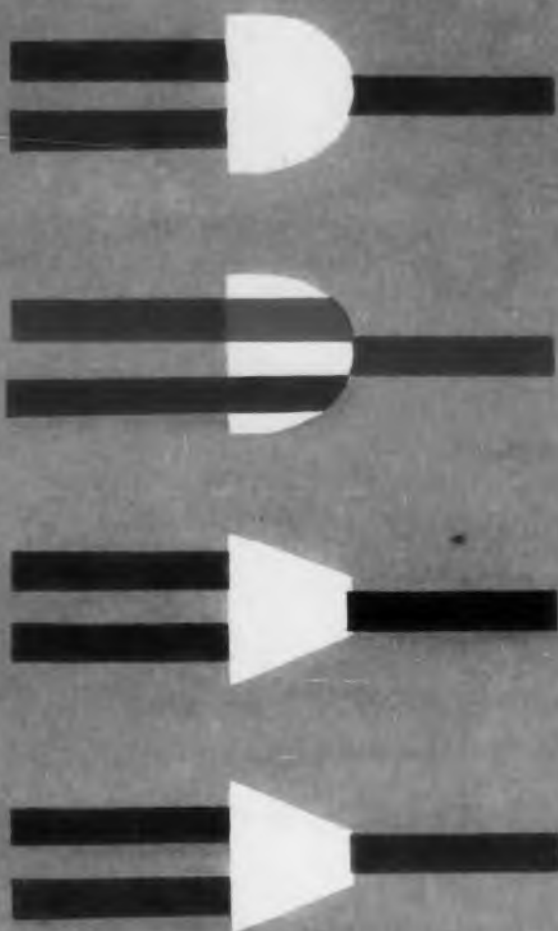

Transistor NOR logic can express all logical operations using only one basic logic circuit. This logic was designed specifically to use the advantages offered by transistors. Fifteen hundred NOR circuits can be packed into a cubic foot.

# Transistor NOR Circuit Design

W. D. Rowe

Westinghouse Electric Corp.  
Buffalo, N. Y.

**T**HE TRANSISTOR NOR circuit was designed specifically to take advantage of transistors with their low power requirements, diminishing cost, and increasing regularity of properties. This logic makes use of a reliable transistor circuit, forming an exceptional combination into a new and powerful tool.

## Basic Transistor NOR Circuit

The basic circuit, shown in Fig. 1, employs a junction transistor in the common emitter configuration—not as a linear device, but as a two position switch. An npn transistor may be used in place of the pnp shown if polarities are reversed. When the input voltage exceeds a certain minimum, of the correct polarity, the transistor switches from its normal cutoff state to saturation.

During cutoff, collector to emitter impedance is extremely high. The supply voltage sees the transistor as an open circuit, so the output is substantially at the supply voltage level.

When the transistor is saturated, its impedance is very low, so the output is held essentially at ground potential. Thus a voltage appears at the output when there is no signal at the input, and conversely there is zero output when there is a signal at the input.

## Basic NOR Logic

In general, a logic device has more than one

input. A multi-input circuit is constructed by simply adding more inputs and input resistors to the transistor base, as in Fig. 2. Here, a signal on any or all inputs will cause the output signal to be absent, while the output is present only if NO inputs are present.

If a voltage signal represents a one, and its absence represents a zero, this transistor circuit can express binary logic. In the binary system, only two numbers, zero and one, can combine to represent all numbers.

Combinations of NOR circuits can express all combinations of logic except time delays. The usual AND, OR, and NOT may be expressed entirely with NOR circuits. Furthermore, a compound logical function does not necessarily require more NOR circuits than so called English circuits.

## NOR Circuit Design

Fig. 2 shows a transistor NOR circuit with an arbitrary number of  $M$  inputs and  $N$  outputs. The equivalent output loading for each prior stage is a resistor,  $RI$  to ground through the base impedance of the transistor. The total output impedance is  $RI/N$ .  $V_{cc}$  is the collector supply voltage.  $V_{bb}$  through  $R_t$  biases the transistor to reduce leakage current,  $I_c$ , to a minimum when the transistor is cut off.  $RI$ , the input current limiting resistor, prevents feedback between inputs. With pnp transistors, the output is a negative signal.

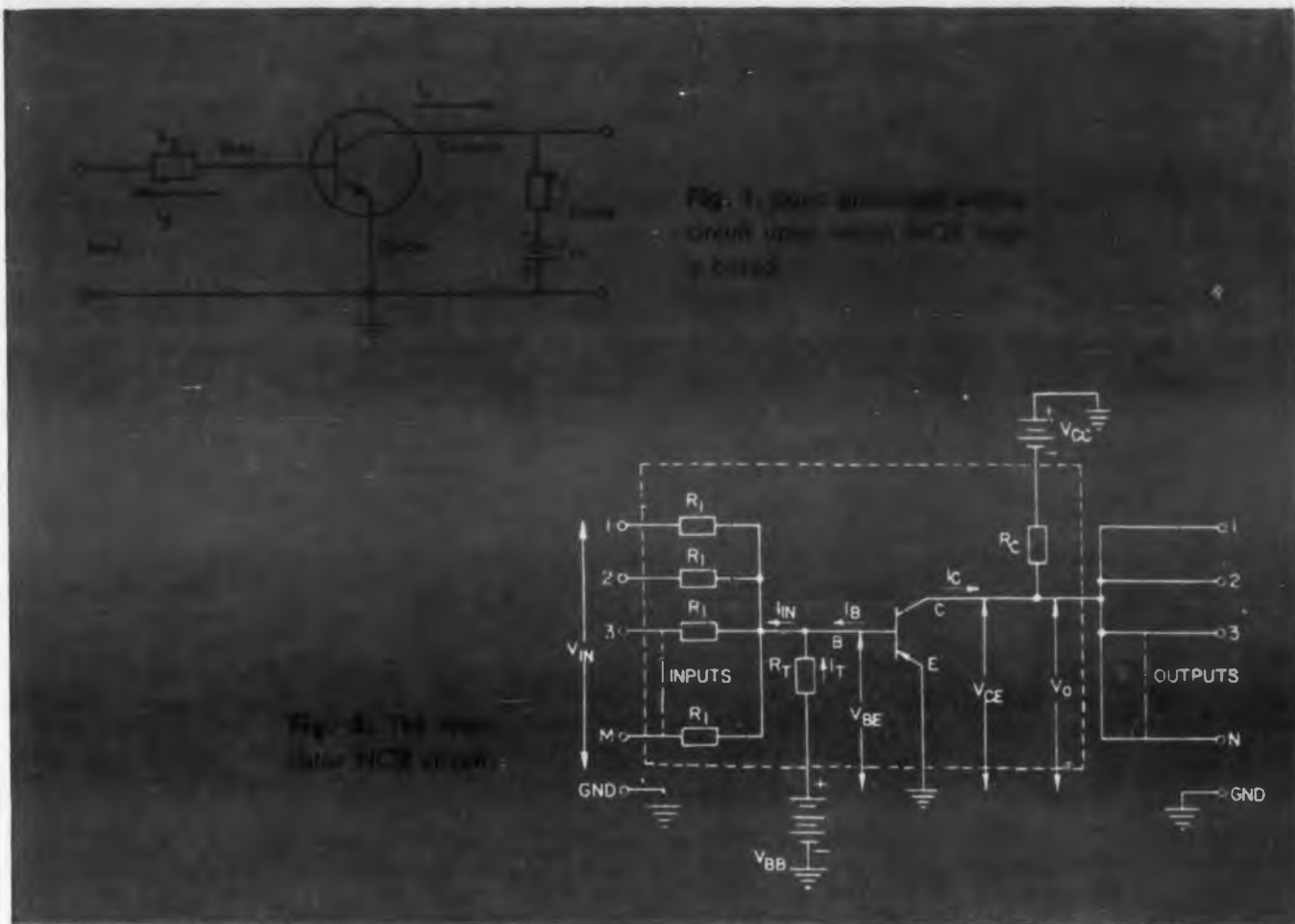
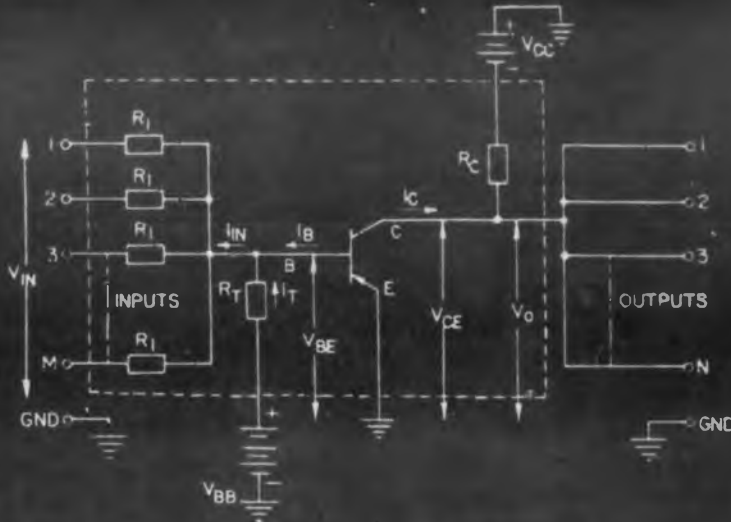

Fig. 1. Basic transistor circuit with input resistor  $R_1$  and collector resistor  $R_c$ .

Fig. 3. The minimum input NOR circuit.



In designing NOR circuitry for a particular transistor type, many transistors should be tested. Test results should provide limits on the design parameters so that few transistors will lie outside these limits. This allows an economical choice of operating parameters with reliability.

#### Loading Limitations

The number of outputs is limited by the loading of the output voltage down to a point where there is insufficient signal for the following stages. The number of inputs is limited by a crosstalk factor which becomes important if  $R_1$  becomes very small.

Fig. 3 shows the circuits to be considered for both input and output loading. In the cutoff condition, the input to transistor  $T_1$  is zero, or certainly no more than  $-0.25$  v. At the maximum operating temperature the cutoff collector current is highest and is  $I_c = \beta(I_{cbo} + I_b) + I_{cbo}$  (1) where  $I_{cbo}$  is the base to collector leakage with the emitter open circuited, and  $\beta$ , the base to collector current gain. If the base current is negative and equal to the magnitude of  $I_{cbo}$  the first term of the expression is zero, and the collector current is reduced to  $I_{cbo}$ . Eq (1) is not valid when  $|I_b|$  exceeds  $I_{cbo}$ .  $I_{cbo}$  is the lowest value of collector current attainable.

Since the transistor is to remain cut off at the highest operating temperature with zero or slightly negative input voltage, the base current

required must be supplied from the bias source  $I_t$ , which can be considered a current source in most cases. This bias current should equal the maximum value of  $I_{cbo}$  at the maximum operating temperature for highest leakage transistor used.

#### Input Loading

Maximum marginal loading on the input of a NOR element occurs when a minimum input voltage  $V_{o\ min}$  is applied to one input while all other inputs are grounded by a saturated transistor as shown in the lower right section of Fig. 3. For this case,  $I_{in}$ , the current supplied by the preceding transistor can be calculated.

$$I_{in} = (V_{be} - V_{o\ min})/R_1 \\ = SI_{b\ min} + \frac{V_{bb} - V_{be}}{R_t} - \frac{V_{be}(M-1)}{R_1} \quad (2)$$

$I_{b\ min}$  is determined by the minimum gain of transistor  $T_2$  for the value of  $I_c$  to be chosen.  $S$  is a factor for a margin of safety to allow for future decrease in transistor gain, as well as other circuit parameter tolerances.  $V_{be}$  is a function of base current. For the low minimum voltage, minimum current case under consideration,  $SI_b$  is less than  $300\ \mu\text{a}$ , and  $V_{be}$  will not exceed  $-0.25$  v. Using these maximum values, the expression for  $I_{in}$  reduces to

$$I_{in} = SI_b + I_t + \frac{.25(M-1)}{R_1} \text{ at } V_{o\ min} \quad (3)$$

#### Output Loading

The output loading case is most extreme if all  $N$  outputs load  $T_1$  simultaneously. Then

$$V_{o\ min} = V_{cc} + (NI_{in} + I_{cbo})R_c = I_{in}R_1 + V_{be} \quad (4)$$

If  $V_{be}$  is much less than  $V_{cc}$ , and  $R_c$  is chosen to allow maximum collector current flow, and if  $I_{cbo}$  is much less than  $I_c$  then

$$N = I_c \left[ \frac{1}{SI_b + I_t + .25 \frac{M-1}{R_1}} + \frac{R_1}{V_{cc}} \right] \quad (5)$$

This gives the number of succeeding NOR circuits which may be connected to  $T_1$  under the worst case of loading. The number of outputs, then depends on  $I_c$ , the corresponding  $I_b$ ,  $I_t$  (or  $I_{cbo}$ ),  $V_{cc}$ , the safety factor  $S$ , the input resistor  $R_1$ , and  $M$ , the number of inputs desired.

A high negative value reduces the negative second term of  $N$ .  $M$  and  $S$  can be specified so the expression for  $N$  is a function of only the transistor to be used and  $R_1$ . The results of Test 2 and common emitter characteristic curves provide corresponding values of  $I_b$  and  $I_c$  and the safety factor. Test  $I_c$  gives the maximum design value for  $I_{cbo}$ .

$I_t$  is designed to be equal to or somewhat greater than the maximum  $I_{cbo}$  to be encountered with a particular transistor. A family of curves of  $N$  vs  $I_c$  may be calculated from eq (5). Different values of  $R_1$  influence the curves. The maximum value of  $N$  occurs at different values of  $I_c$ . Final choice of  $R_1$  and  $I_c$  involves a compromise of desired values of  $M$  and  $N$ , the power dissipation in the transistor, and the total power dissipation.

#### Power Dissipation

Transistor dissipation is maximum when a lightly loaded transistor has a signal from each input, and each input supplies only this transistor. For this case

$$I_{b\ max} = M - V_{cc}/(R_c + R_1) \text{ and}$$

$$P_{diss} = P_{base} + P_{coll} + V_b I_{b\ max} + V_{cc} I_c \quad (6)$$

The maximum power supply dissipation per NOR circuit occurs when the transistor is saturated.

$$P_{supply} = V_{cc} I_c + V_{bb} I_t \quad (7)$$

Final choice of supply voltages is guided by keeping all power levels much less than the maximum allowable transistor dissipation.

#### Crosstalk

Crosstalk is another type of loading which can occur between NOR circuits as shown in Fig. 4.  $T_1$  is saturated, maintaining a low value of  $V_{ce}$ .  $N-1$  of the outputs are connected to other transistors such as  $T_2$  which has the rest of its inputs at full signal. The base voltage of  $T_2$  is high because of the high base current. This high base



voltage  $V_{bo}$  can cause a current  $I_o$  to flow from the collector of  $T1$  to the base of  $T2$ . A total crosstalk current  $I_{ct} = (M-1) I_o$  could flow through the collector of  $T1$  in addition to the normal collector current  $I_c$ ;  $I_{ct}$  should be limited to a small percentage of  $I_o$  to prevent  $T1$  becoming unsaturated and having  $V_{ce}$  rise on the  $N$ 'th output of  $T1$  which must still be at zero signal. An upper limit for  $I_{ct}$  is found by calculating  $I_b = (M-1)(-V_{cc})/(R_o + R1)$ , finding  $V_{bo}$  from Fig. 3, and using this in  $I_{ct} = (N-1)(-V_{bo})/R1$ .

If  $I_{ct}$  is less than  $I_c$  the safety factor margin in  $SI_b$  can allow some additional collector current under these extreme crosstalk conditions.

### Reliability

Five thousand NOR elements were subjected to an aging cycle of 24 hours at 70 C with supply voltages applied, 24 hours at room temperature with voltage, and 48 hours at 70 C with supply voltage and a square wave input signal. Only 5 failed during aging. None failed in service. Power supply fluctuations of 30 per cent and high ripple did not cause malfunction.

### Operating Frequency

In a typical design, using RCA 2N109 transistors, the NOR circuit operated well up to 40 kc. For many slower control processes this speed is sufficient. Certain means of increasing frequency response have been considered.

The first, the use of speed up capacitors in parallel with the input resistors allows a rapid drain for stored holes when coming out of saturation, increases the complexity of the crosstalk and loading conditions by requiring transient analysis; and in actual circuits limits the number of inputs and outputs.

The second method uses diode networks to prevent transistor saturation, but does not allow enough speed up to warrant the extra circuitry.

The third method allows the emitter diode to break down to bring the transistor out of saturation. Although this improves frequency response, insufficient experience with this technique does not yet assure its reliability.

Use of high frequency transistors, driven to saturation, in place of the low frequency units is quite satisfactory. Drift type transistors have been operated easily in the two mc range, and selected units have operated at five mc and higher.

### Advantages and Disadvantages

The NOR circuit is a highly compatible, highly reliable circuit that promises advantage in complex control circuit logic. Here is a summary of the properties.

### Reliability

When transistors are used correctly within specified margins and limits they are extremely

reliable. Since the NOR circuit uses a simple transistor circuit, it is easy to express all the margins and limits. Since only one logic element is used throughout, these margins and limits hold for every circuit in a compound array. Since NOR circuits connect, in general, to other NOR circuits, loading and coupling conditions are easily expressed.

Since the circuit operates as a switch with wide circuit tolerance, most of the disadvantages of linear operation are eliminated.

Every transistor should be completely tested and aged before and after assembly to assure maximum reliability. Marginal checking may be used to detect faulty units long before failure.

Since each circuit is an individual module, a failure in one circuit does not cause operational failure in other circuits.

### Compatibility

Except for three simple rules, these circuits may be connected to each other indiscriminately.

1. Use no more inputs to a circuit than are allowed by the design.

2. Use no more outputs than are allowed by design.

3. Never connect the outputs of two NOR circuits directly together.

Since within the limits of these rules all impedances and loading mechanisms are known, and since each circuit is an amplifier, these circuits are easily compounded.

Furthermore the logic is such that each circuit is independent of preceding or succeeding logic as far as interconnection is concerned.

### Power Requirements

Without special means to limit power supply requirements, typical units with high collector supply voltages require less than 100 mw for operation, while units with power dissipation as low as one mw have been used at lower voltages. A thousand typical units will work on 100 w of unregulated, poorly filtered power. This may not be desirable, but it does work.

### Simplicity of Design

NOR circuits are simply transistor switches coupled together with closely observed margins. Only resistors and transistors are used.

### Logic

All logical functions can be synthesized using only NOR circuits and time delays. In a complex circuit, the final design using these circuits may possibly be simpler than with English circuits. NOR circuit logic techniques are somewhat harder to comprehend at first, but after working with this logic for a short time, one becomes very adept at its application.

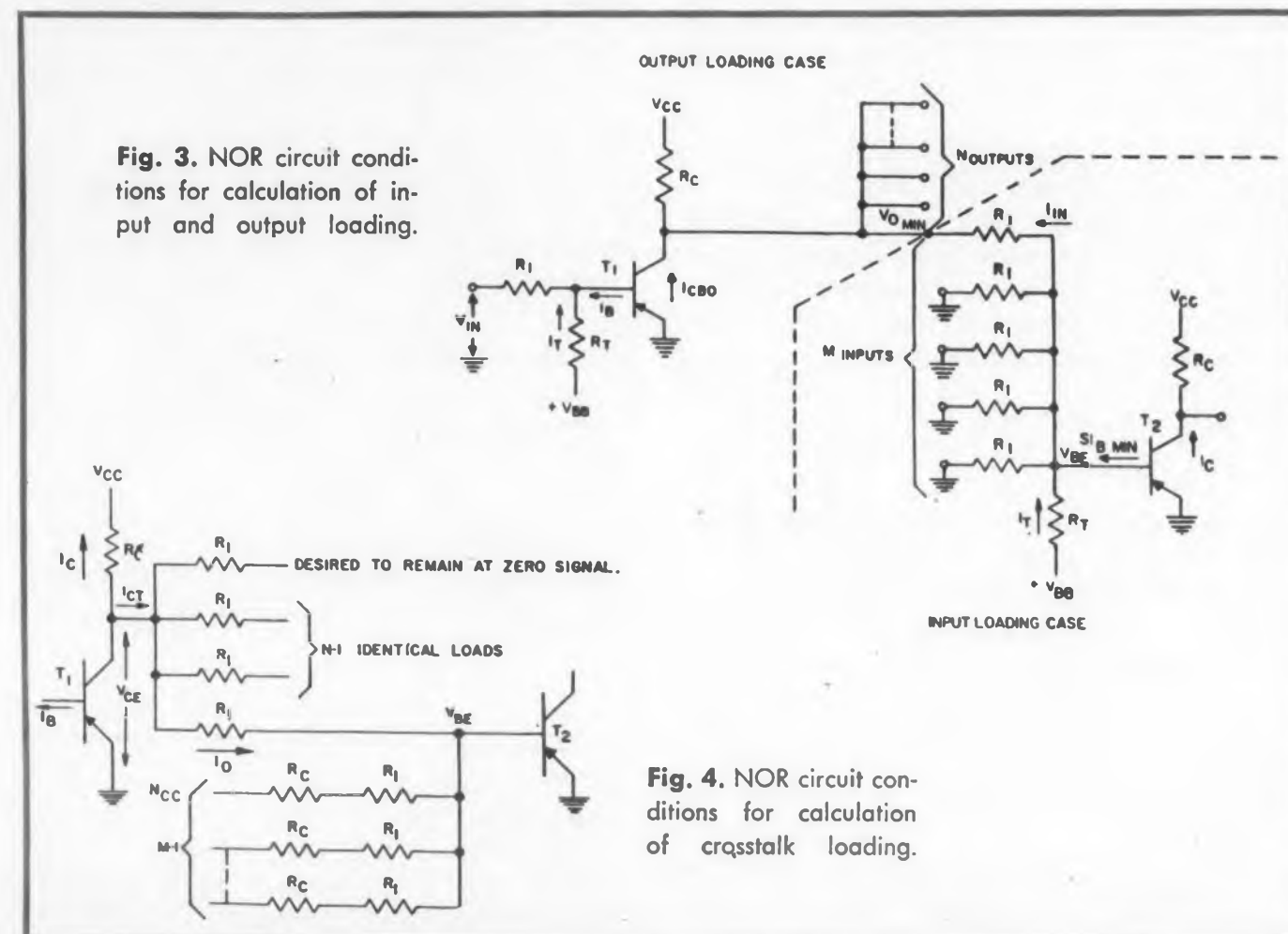

Fig. 4. NOR circuit conditions for calculation of crosstalk loading.

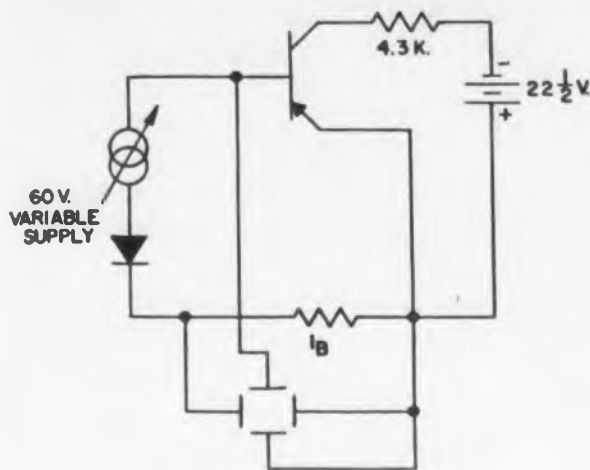

Fig. 5. Test circuit for  $V_{b/b}$  curves.

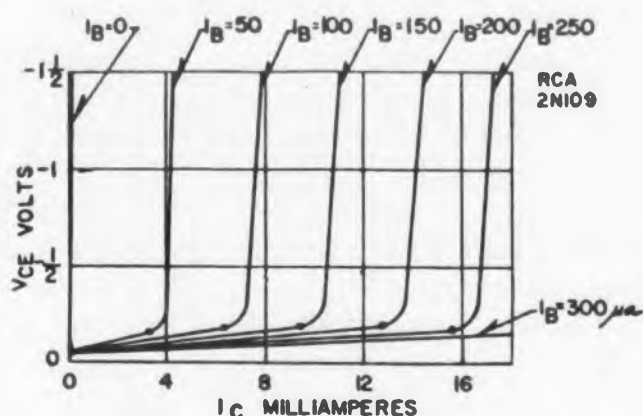

Fig. 6. Common emitter collector characteristics for an RCA 2N109 transistor.

### Physical Embodiment

Several physical structures have been used, all of which seem suitable. One such embodiment consisting of a printed circuit, dipped in epoxy resin, requires a single package for each logic circuit. This allows easy compounding of circuits by dip soldering the units into an epoxy glass printed circuit board with copper interconnections. Using this method, it is possible to pack 1500 NOR circuits into one cubic foot of space, allowing for 150 w dissipation. This is by no means a minimum space factor.

### Components

All resistors are printed, using highly proven materials. Tolerances may be kept to two per cent, though 10 per cent is entirely suitable. Transistors are tested and aged during the entire construction process for maximum reliability.

### Frequency Response

Many of the units constructed with ordinary transistors have a fairly low frequency response; 20 kc seems to be the upper limit. Other types of transistors and some circuit modifications have increased this limit to as high as four mc. Further increases are expected as new transistors are perfected for this application.

### Cost

The cost of individual units compares very favorably with other types of logic circuits.

#### Transistor Test Methods

##### Test 1. Back Collector Current— $I_{cbo}$

a. Find  $I_{cbo}$  at 25 C at a specified collector supply voltage  $V_{cc}$ . Set a maximum limit on  $I_{cbo}$  for this test.

b. Determine the rise in temperature required to double  $I_{cbo}$ , or

c. Test  $I_{cbo}$  at the high temperature limit to determine stability of back current at this temperature. This test is related to Test 4.

##### Test 2. Base to Collector Current Gain—(DC $\beta$ )

a. Fig. 5 shows a plot of transistor characteristics. The horizontal portion of the collector current curves are for the saturated "switch-on" condition of operation. On each curve read the highest value of  $I_c$  just before the transistor becomes unsaturated. These points, on Fig. 6, give values of  $I_c$ ,  $I_b$ , and the resultant current gain.

b. Set a minimum limit on  $\beta$  at a specified collector current.

##### Test 3. Forward Saturation Volt Drop— $V_{ce}$

The voltage drop from collector to emitter at saturation is obtained from the same indicated points. This saturation voltage will become the maximum OFF signal and should be held to less than .25 v.

##### Test 4. Noise Figure—NF

A noise figure measurement is made at maximum allowable collector voltage. The noise figure is defined as noise above thermal noise at 1000 cps with a one cycle band pass, and is expressed in db. A standard noise test meter is used. This test is made at a high collector voltage so the majority of the noise occurs in the collector junction. A high noise figure indicates high points on the collector that can cause failure and/or unstable  $I_{cbo}$  at both low and high temperatures. This test is a measure of reliability.

##### Test 5. Base Input Characteristics— $I_b$ vs $V_{be}$

Using the test circuit of Fig. 5, a curve of  $I_b$  vs  $V_{be}$  may be plotted.

#### Acknowledgment

The author wishes to acknowledge the work of G. H. Royer who helped with the work in the design of the NOR circuit, and L. F. Stringer who has done considerable work in the application of the logic.

#### Bibliography

1. Arithmetic Operations in Digital Computers, R. K. Richards, D. Van Nostrand Co., Inc., New York, 1955—Chapter II, "Boolean Algebra as Applied to Computer Components", pp. 26-50.
2. "Principles of Transistor Circuits," R. F. Shea, John Wiley & Sons, New York, 1953, p. 56.
3. "Junction Transistors Used as Switches," R. L. Bright, AIEE Transactions, 55-156.

From a paper delivered at the 1957 WESCON show, San Francisco, California.

# Beauty

## that's MORE than skin deep

The gleaming finish on BUD Sheet Metal Products adds eye appeal and utility... doesn't hide blemishes. And there's beauty too, in the expert craftsmanship and engineering skills involved. Bud housings, which you can obtain from stock, have innumerable applications in Electronic and Electrical Instrumentations and Controls. It will pay you to investigate the advantages of the hundreds of sizes and shapes we can offer from inventory. Of course, we do special fabrication, too! Illustrated are two real Bud "Beauties"! Perhaps they fit into your production picture.

### BUD SLOPING PANEL "PRESTIGE" CABINETS



Offer high style, custom appearance at standard stock prices. Hinged, perforated top swings back to provide easy access. Top panel swept back for easy viewing. Panel trim bar is removable to permit easy withdrawal of chassis attached to either or both panels. Available in three sizes.

### BUD STANDARD "PRESTIGE" CABINETS



Hinged cover, available in solid or perforated, swings clear of cabinet body. Furnished complete with two supporting channels which can be moved laterally to accommodate any width chassis or mounting platform. Built of 16 gauge steel and flawlessly finished in grey hammer-tone. Three stock sizes.

Write us for details on the "Prestige" cabinet line or see them at your Bud Distributor.



**BUD RADIO, INC.**

2118 East 55th Street,

Dept. ECD,

Cleveland 3, Ohio

CIRCLE 24 ON READER-SERVICE CARD

# Practical RC Differentiator Design

Lester Saporta,  
James Rarity  
New York University

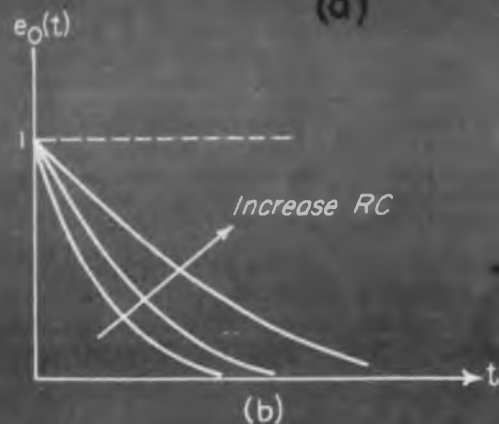
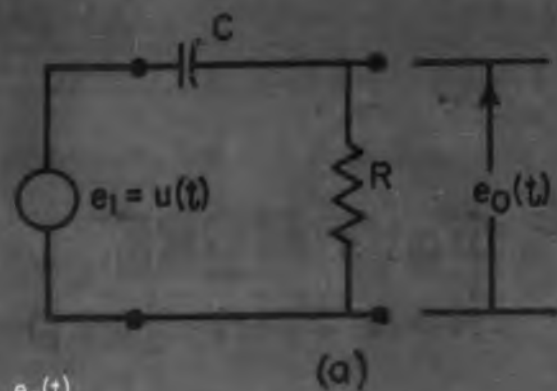

Fig. 1. a—Simple RC Differentiator with zero generator impedance and zero load capacity, b—Step function response for simple differentiator.

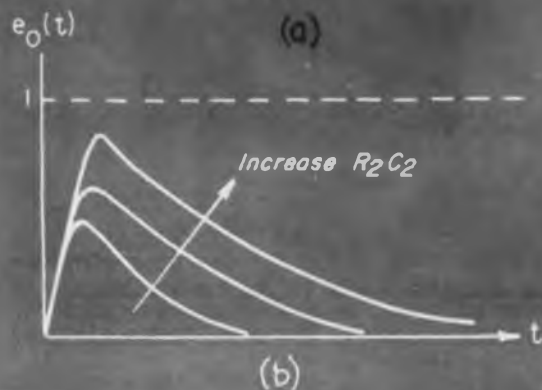
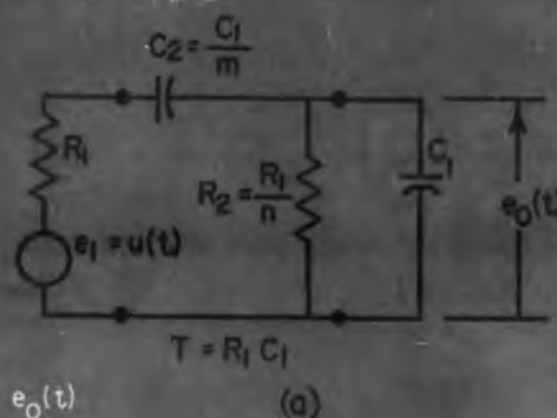

Fig. 2. a—Practical RC Differentiator with finite generator impedance and load capacity, b—Step function response for practical differentiator.

This article considers the design of practical RC differentiators which are driven by a source with finite internal resistance and operating into a load having a finite shunt capacitance

THE STEP function response of the simple differentiator of Fig. 1a is the well-known exponential decay function shown in Fig. 1b. The peak output is always equal to the amplitude of the input step. The output spike may be made as narrow as desired by decreasing either  $R$  or  $C$  or both.

This simple situation holds only under the assumptions that the driving source has zero impedance and that the output drives a zero capacity load. When these assumptions cannot be made the more complex circuit of Fig. 2a must be invoked to describe the operation. Fig. 2a represents a situation often met in practical de-

sign problems where a voltage source of internal impedance  $R_1$  and a load represented by the capacitor  $C_1$  are given and it is desired to interpose a differentiator between them. In this case, as illustrated in Fig. 2b, the peak output of the network and the duration of the output spike cannot be independently specified with complete freedom. If an attempt is made to narrow the output spike by reducing  $R_2$ , a point is reached where the voltage divider action of  $R_1$  and  $R_2$  becomes excessive. A similar situation occurs if the output spike is narrowed by reducing  $C_2$ . Then a loss in output voltage takes place due to the voltage divider formed by  $C_2$  and  $C_1$ .

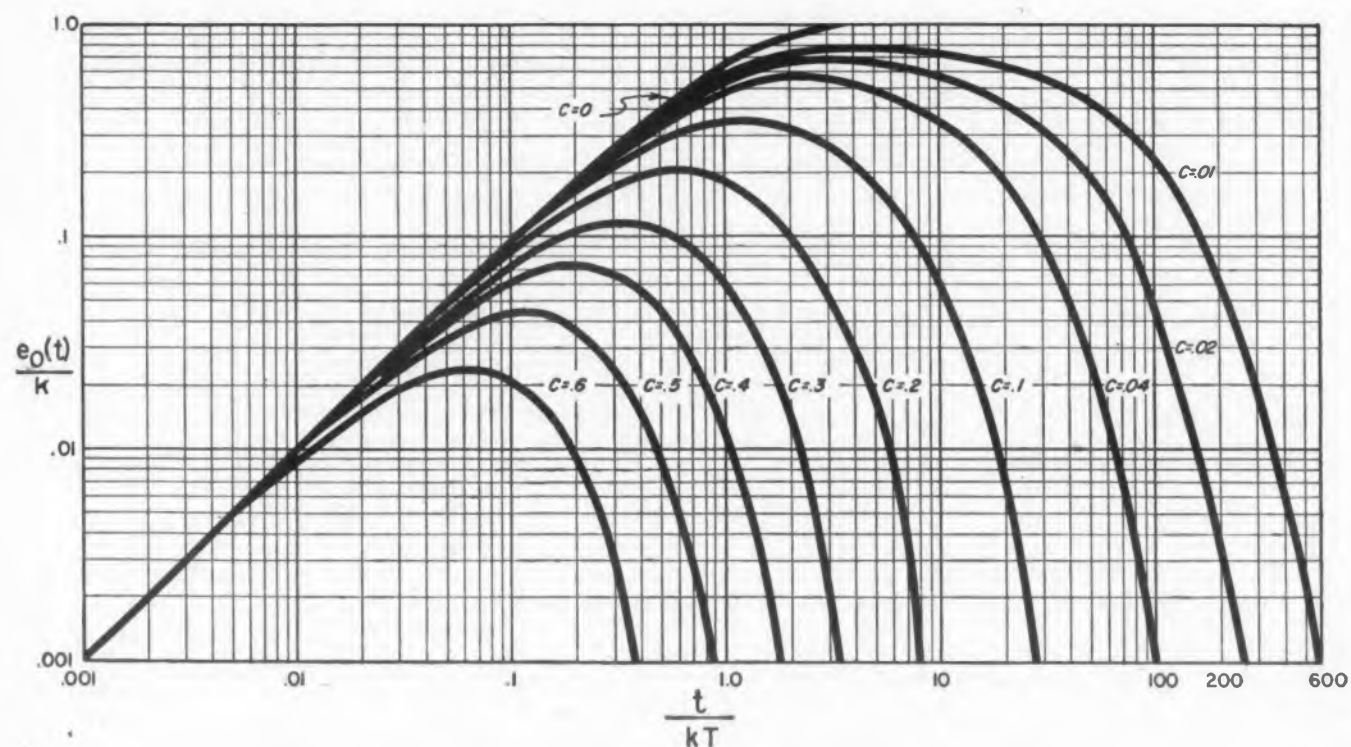

Fig. 3. Normalized step function response of practical differentiator.

It is therefore necessary to establish the relationship between output amplitude and width (or more generally shape).

#### Network Response

The response of the circuit of Fig. 2a to a unit step input can be expressed as follows:

$$\frac{e_o}{k} = \frac{1-\sqrt{c}}{1+\sqrt{c}} \left[ \epsilon^{-\frac{c}{(1-\sqrt{c})^2} \left(\frac{t}{kT}\right)} - \epsilon^{-\frac{1}{(1-\sqrt{c})^2} \left(\frac{t}{kT}\right)} \right] \quad (1)$$

$$\text{where } c = \frac{(n+m+1) - \sqrt{(n+m+1)^2 - 4nm}}{(n+m+1) + \sqrt{(n+m+1)^2 - 4nm}}, \quad (2)$$

a parameter which determines the shape of the curve.

$$k = \frac{1}{1 + (\sqrt{n} - \sqrt{m})^2}, \text{ a normalizing factor. } \quad (3)$$

Since  $m$ , equal to  $C_1/C_2$ , and  $n$ , equal to  $RE/R_2$ , are positive real numbers,  $k$  and  $c$  are positive real numbers subject to the following restrictions:

$$0 < c < 1 \text{ and } 0 < k < 1$$

Eqs (2) and (3) may be inverted to express the physical parameters  $m$  and  $n$  in terms of  $k$  and  $c$ :

$$m = \frac{1}{2} \left[ \frac{c+1}{k(1-\sqrt{c})^2} - 1 \right] \\ = \frac{1}{2} \sqrt{\left[ \frac{c+1}{k(1-\sqrt{c})^2} - 1 \right]^2 - \frac{4c}{k^2(1-\sqrt{c})^4}} \quad (4)$$

$$n = \frac{1}{2} \left[ \frac{c+1}{k(1-\sqrt{c})^2} - 1 \right] \\ = \frac{1}{2} \sqrt{\left[ \frac{c+1}{k(1-\sqrt{c})^2} - 1 \right]^2 - \frac{4c}{k^2(1-\sqrt{c})^4}} \quad (5)$$

For the case when  $k = 1$  eq (4) and (5) reduce to

$$m = n = \frac{\sqrt{c}}{(1-\sqrt{c})^2} \quad (6)$$

#### Design Curves

The parameters  $c$  and  $k$  are useful in obtaining normalized curves of the response. Normalization is accomplished by plotting  $e_o/k$  as a function of  $t/kT$ . This is done in Fig. 3. It is evident that in a plot of this type, the parameter  $c$  determines the shape of the curve while  $k$  is a normalizing factor which multiplies both the time and voltage scales. A value of  $k$  equal to unity results in the largest realizable expansion of  $e_o$  and  $t/T$  for any particular value of  $c$ .

A particular peak output can be achieved with any combinations of  $k$  and  $c$ , if  $k$  is always

## New "OFF THE SHELF" component service cuts system development time by MONTHS!



#### KEY TO COMPONENTS IN THIS TYPICAL ORDER

1. Foundation Board
2. 60 cycle Power Supply
3. 60 cycle servo amplifier
4. 60 cycle servo motor-tachometer
5. Precision potentiometers
6. Mounting plates
7. Precision mechanical components
8. Catalog MDA-58

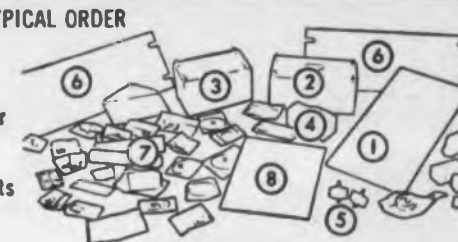

## All of the components for a Control System DELIVERED IN 3 DAYS!

All these precision components—all that was necessary for breadboarding a system—arrived in the same carton, the same day, *just three days* after ordering from SMI's Mechatrol Division. In this case, the development engineer merely ordered what he needed for his new system design from the new catalog—MDA-58—and, there was just one purchase order, one invoice to process.

Component parts of the new line—Mechatronic Development Apparatus—are selected for universal adaptability, as well as for high performance and high quality. In certain cases, to supplement the SMI line, our engi-

neers have selected the quality products of other leading manufacturers and made them part of the program. Whether 60 or 400 cycle, all are "Standards"—carefully evaluated and tested by SMI engineers, and proven by years of service in many different types of applications.

You and your company can take advantage of this new service. You can

get started today, by writing for your free copy of our Mechatronic Development Apparatus Catalog—MDA-58. When it arrives, you select the components you need, send in your order, and receive your shipment within a few days.

But remember, you can't take full advantage of the program without a catalog. Be sure to send for yours.



MECHATROL DIVISION

625 Main Street • Westbury, Long Island, New York  
1000 W. El Segundo Boulevard, Hawthorne, California

CIRCLE 25 ON READER-SERVICE CARD

# REGULATED DC POWER SUPPLIES

## HI-VOLTAGE SERIES



Model 250 S 025

Designed for powering airborne electronics equipment under the most adverse environmental conditions, Arnoux High Voltage DC Power Supplies assure the utmost in reliability. These magnetic-amplifier regulated supplies are available in the range of 108 to 450 volts DC, with current ratings from 50 ma to 800 ma. Other ratings are also available on special order.

## ARNOUX

**Input Power:** 115 volts, 400 cps  
**Regulation:** Input (Variation) Output (% Rated)  
**Line Voltage:**  $\pm 10\%$   $\pm 0.25$   
**Line Frequency:**  $\pm 20$  cps  $\pm 0.1$   
**Load Current:** 20-100%  $\pm 0.1$   
 0-100%  $\pm 0.2$

**Ripple:** Less than 0.05% rms at full load.

**Output Adjustment:** 5% adjustment available on request at slightly higher price.

**Environmental:** Meets specification MIL-E 5272 A for acceleration, vibration, altitude, humidity and temperature operating at 20% to 100% rated load.  
 Also meets MIL-I 6181 B

**Connector:** AN-type connector

**Mounting:** Stud-mounted.

(Write for Bulletin 200)

## LO-VOLTAGE SERIES



Model 5 S 10

Intended for use in precision airborne instrumentation systems, Arnoux Low-Voltage DC Power Supplies are available in both single and dual output. Ranging from 5 to 50 volts at currents up to 10 amperes, these rugged units are hermetically sealed.

## ARNOUX

**Input Power:** 115 volts, 400 cps  
**Regulation:** Input (Variation) Output (% Rated)  
**Line Voltage:**  $\pm 15$  volts  $\pm 0.10$   
**Line Frequency:**  $\pm 20$  cps  $\pm 0.15$   
**Output Load:** 20-100%  $\pm 0.05$   
 0-100%  $\pm 0.10$

**Temperature Stability:** 0.5% per 100 F.  
 (-60°F. to +160°F.)

**Ripple:** Less than 0.1% rms at full load.

**Output Adjustment:** Screwdriver adjustment provides  $\pm 0.5$  volt change. Wider range of adjustment available on request.

**Connector:** Standard AN-type connector, or hermetically sealed header on request.

**Mounting:** Stud-mounted.

**Environmental:** Meets specification MIL-E 5272 A for acceleration, vibration, altitude, temperature and humidity.

(Write for Bulletin 100)

*Designers and Manufacturers of*  
**PRECISION INSTRUMENTATION**



**ARNOUX CORPORATION**

11924 WEST WASHINGTON BLVD. • LOS ANGELES 66, CALIFORNIA

CIRCLE 26 ON READER-SERVICE CARD

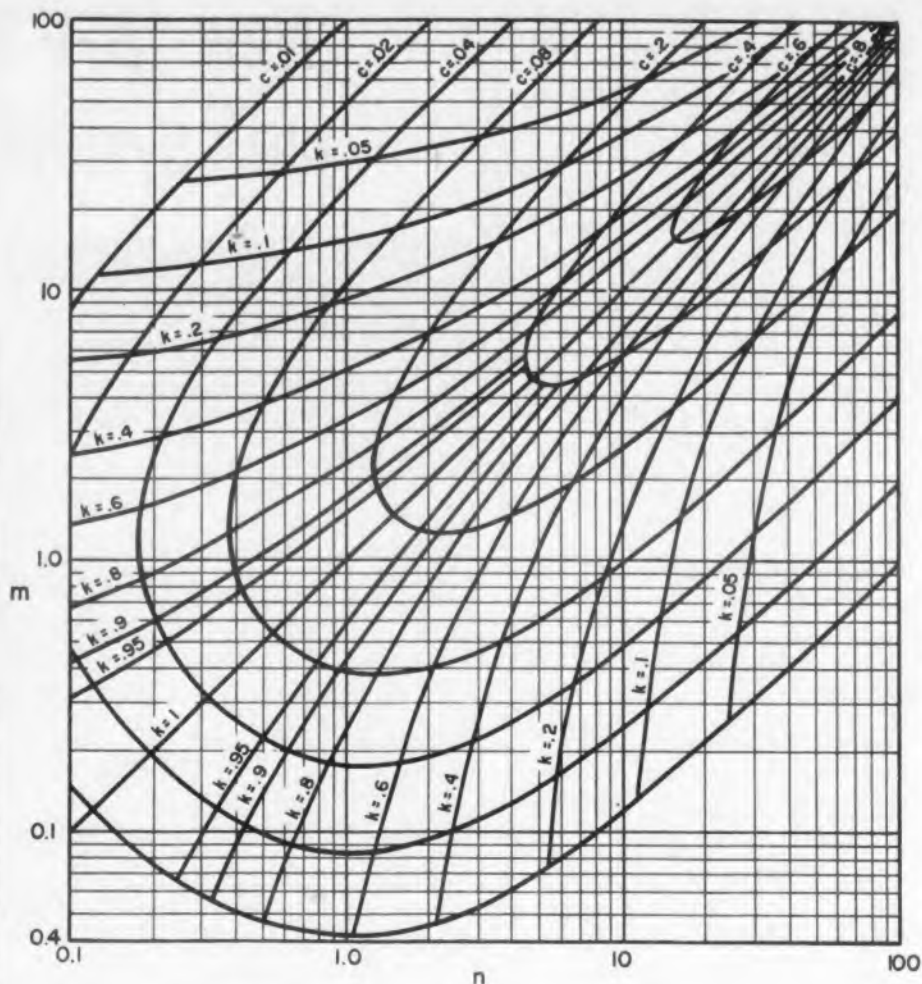

Fig. 4. Parameters  $k$  and  $c$  mapped on the  $m = n$  plane.

chosen less than unity. Referring to Fig. 3 for example, a peak output of 0.205, can be realized with  $c = 0.2$  and  $k = 1$ . The same output of 0.205 can be achieved with  $c = 0.1$ . Since the peak of this curve is .355,  $k$  is  $.205/.355$  or .577. At the same time, the time scale to be applied for  $c = 0.1$  is reduced by the same factor  $k$ , giving a narrower response than that illustrated. This narrowed response, however, is not as narrow as the response achieved with  $c = 0.2$  and  $k = 1$ . For a given output the sharpest response is achieved when  $k = 1$  and, for a given sharpness, the maximum peak output is realized when  $k = 1$ .

Fig. 4 relates  $k$  and  $c$  to the physical parameters  $m$  and  $n$ . The special case where  $m = n$  ( $k = 1$ ) is plotted as a function of  $c$  in Fig. 5.

The curves of Figs. 3, 4, and 5 permit the solution of many analysis and design problems.

#### Sample Problems

**Example 1.** Given the circuit of Fig. 2a with  $R_1 = 1000$  ohm,  $R_2 = 5000$  ohm,  $C_1 = 250$   $\mu\text{f}$ , and  $C_2 = 100$   $\mu\text{f}$ . Find the time of occurrence and the amplitude of the response peak. Find the time at which the response has decayed to one tenth its peak amplitude.

$$T = R_1 C_1 = 1000 \times 250 \times 10^{-12} = 0.25 \mu\text{sec.}$$

$$m = \frac{C_1}{C_2} = \frac{250}{100} = 2.5$$

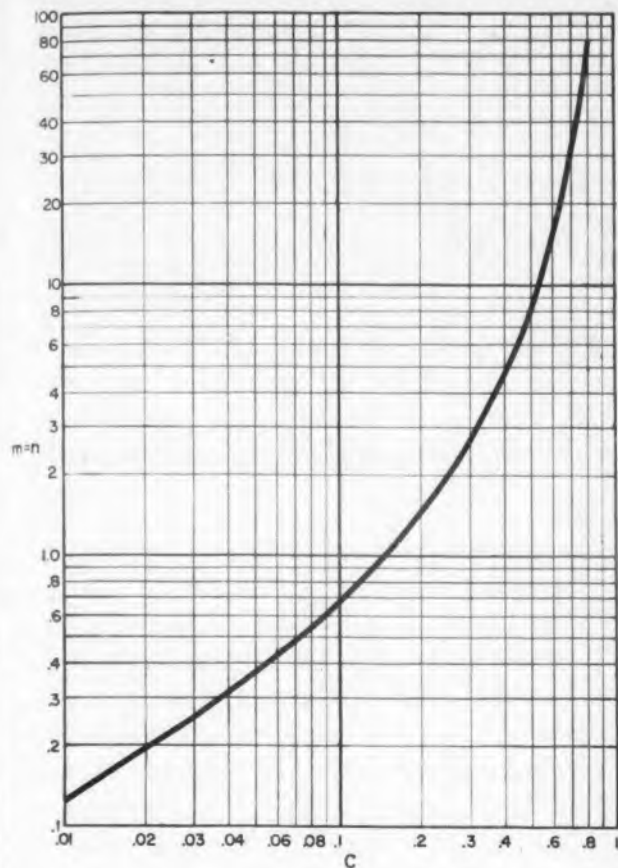

Fig. 5. Parameter  $m$  (or  $n$ ) vs  $c$  for the case where  $m = n$  ( $k = 1$ ).

$$n = \frac{R_1}{R_2} = \frac{1000}{5000} = .2$$

From Fig. 4,  $c = .04$ ;  $k = 0.45$ .

The shape of the response is represented by the curve marked  $c = .04$  in Fig. 3. This curve has a peak value of 0.56 and since  $k = 0.45$  the peak output of the network as a result of an input unit step is  $0.56 \times 0.45 = .25$  volt. The curve peaks at  $t/kT = 2.15$  or at  $t/T = 0.968$ . Since  $T$  is  $0.25 \mu\text{sec}$  the peak occurs at  $t = 0.968 \times 0.25 = .242 \mu\text{sec}$ . The curve has decayed to one tenth its peak value (0.056) at  $t/kT = 38$  or  $t = 38 \times 0.45 \times 0.25 = 4.28 \mu\text{sec}$ .

**Example 2.** Given the circuit of Fig. 2 with  $R_1 = 1000$  ohm and  $C_1 = 100 \mu\text{f}$ . Find the values of  $R_2$  and  $C_2$  which result in the largest realizable peak output consistent with the restriction that the output be less than  $0.06$  v at  $t = 1 \mu\text{sec}$ .

Since the maximum peak output for a given shape of response is required, the condition  $k = 1$  must be used.  $T = R_1 C_1 = .1 \mu\text{sec}$  so that at  $t = 1 \mu\text{sec}$ ,  $t/kT = 1/0.1 = 10$ . The curve which decays to  $0.06$  v at  $t/kT = 10$  is represented in Fig. 3 by  $c = 0.1$ . This curve peaks at  $0.36$  v (since  $k = 1$ ). Fig. 5 shows that  $m = n = 0.68$  for  $c = 0.1$ . Thus  $C_2 = C_1/m = 100/0.68 = 147 \mu\text{f}$  and  $R_2 = R_1/n = 1000/0.68 = 1470$  ohm.

For a reprint of this article circle 27 on the Reader Service Card.

Reprint



## At last! A large-capacity electronic computer you use right at your desk! ROYAL PRECISION LGP-30

### High-speed computation at the lowest cost ever for a complete computer system

No more waiting in line for those answers you need! No more lost time in executing preliminary calculations or modifying equations! Not with the LGP-30! Wheeled right to your desk, operated from a regular wall outlet, LGP-30 allows you to follow your work personally from beginning to end . . . to change formulae on the spot . . . to simulate optimum designs without weeks of mathematical analysis. Thus you get faster answers . . . added time for *creative* work.

**Easy to use.** LGP-30 is a general-purpose stored-program computer — internally binary, serial, single address. Just the few orders in the command structure give complete internal programming. Controls are so simplified, you get an "overnight" feel for your computer.

**Unusual memory capacity.** With a magnetic drum memory of 4096 words, LGP-30 is the most powerful computer of its size yet developed. Fully automatic, it executes self-modifying programs.

**Exceptional versatility and value.** Both the scope of LGP-30's applications and the range of calculations it

can perform are almost limitless. It gives speed and memory equal to computers many times its size and cost, yet initial investment is the smallest ever for a complete computer. Maintenance costs are extremely low . . . service facilities available coast-to-coast.

#### Outstanding features of LGP-30

- Alpha-numeric input-output via electric typewriter or punched paper tape.
- Optional input-output equipment available.
- Unusually large memory — 4096 words.
- Library of sub-routines . . . programs for wide variety of applications.
- Mobile . . . no expensive installation . . . self-cooled.
- Nation-wide sales and service.

For further information and specifications, write Royal McBee Corporation, Data Processing Equipment Division, Port Chester, N. Y.

## ROYAL MCBEE

WORLD'S LARGEST MANUFACTURER OF TYPEWRITERS AND MAKER OF DATA PROCESSING EQUIPMENT

CIRCLE 28 ON READER-SERVICE CARD

FOR MISSILE AND AIRCRAFT SERVO APPLICATIONS

# TRANSI-MAG

3.5 - 6 - 10 - 16 WATT

## SERVO AMPLIFIER

Completely self-contained, this "minimum space" unit requires no external power supply, demodulator or preamplifier. High performance servo loop is obtained without added amplifying elements and achieved by use of stabilized silicon transistor pre-amplifier with a high speed, fast response miniaturized magnetic amplifier output stage. Send for complete data, Bulletin 100-106.

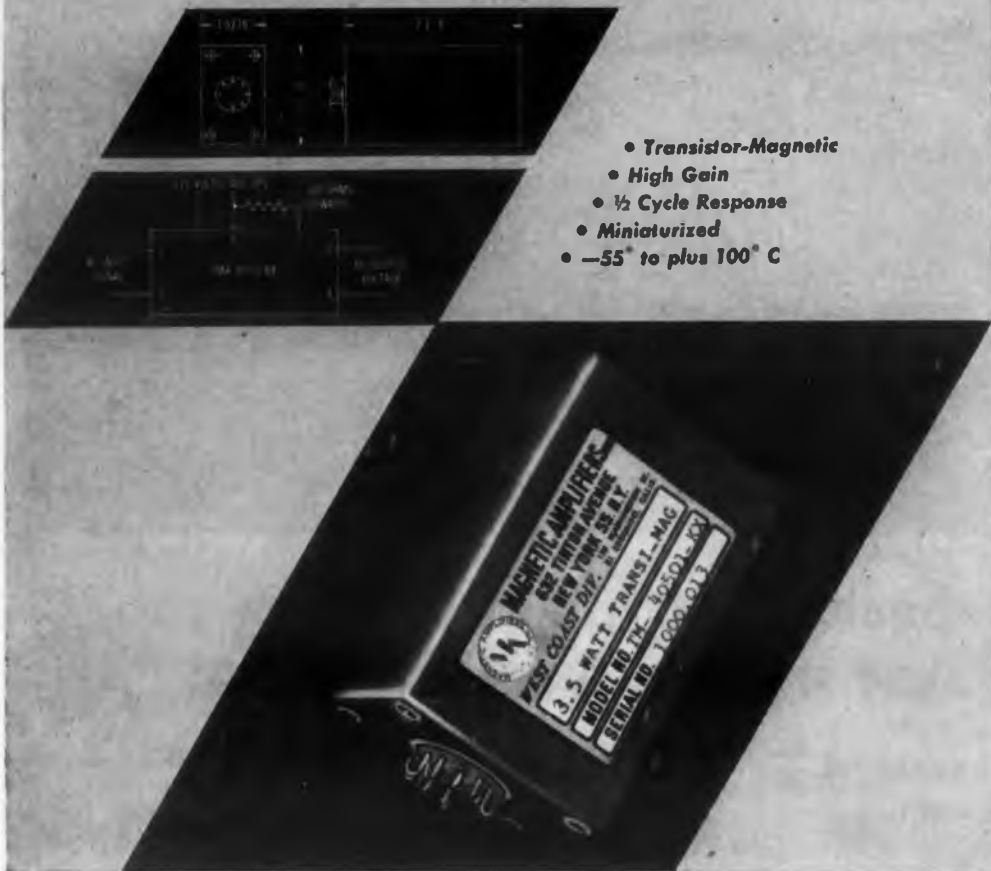

- Transistor-Magnetic
- High Gain
- 1/2 Cycle Response
- Miniaturized
- -55° to plus 100° C

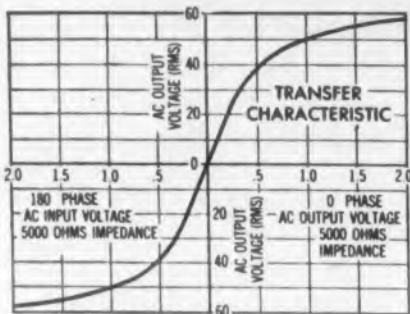

MODEL NUMBER	TMA-40501-KX	TMA-40601-KX	TMA-41001-KX	TMA-41601-KX
MAXIMUM OUTPUT POWER	3.5	6	10	16
TYPICAL MOTOR LOAD	BuOrd Mk. 14 Kearfott R119	BuOrd Mk. 7 Kearfott R110	BuOrd Mk. 8 Kearfott R111	Kearfott R112
REFERENCE SUPPLY	115 volts, 400 cps, single phase			
SENSITIVITY RESPONSE	See transfer characteristics 0.0013 seconds			
AMBIENT TEMPERATURE	-55° C. to +100° C.			
WEIGHT-OZ.	10	14	20	30



### MAGNETIC AMPLIFIERS INC.

632 TINTON AVENUE • NEW YORK 55, N. Y. • CYPRESS 2-6610  
West Coast Division  
136 WASHINGTON ST. • EL SEGUNDO, CAL. • OREGON 8-2665

CIRCLE 29 ON READER-SERVICE CARD



# New Visual Recorder

## *Electroplates on paper*

**T**HIS VISUAL recorder can plot the graphs of up to 12 variables at a rate of 30 points per second per channel. In addition to its telemetering applications, this system can be used in the laboratory for monitoring a large volume of data.

The recorder plots a graph composed of a series of dots. The timewise spacing of the dots depends on the data input rate and the paper speed. These may be set as desired. To interpret the graph, any styli can be connected to write con-

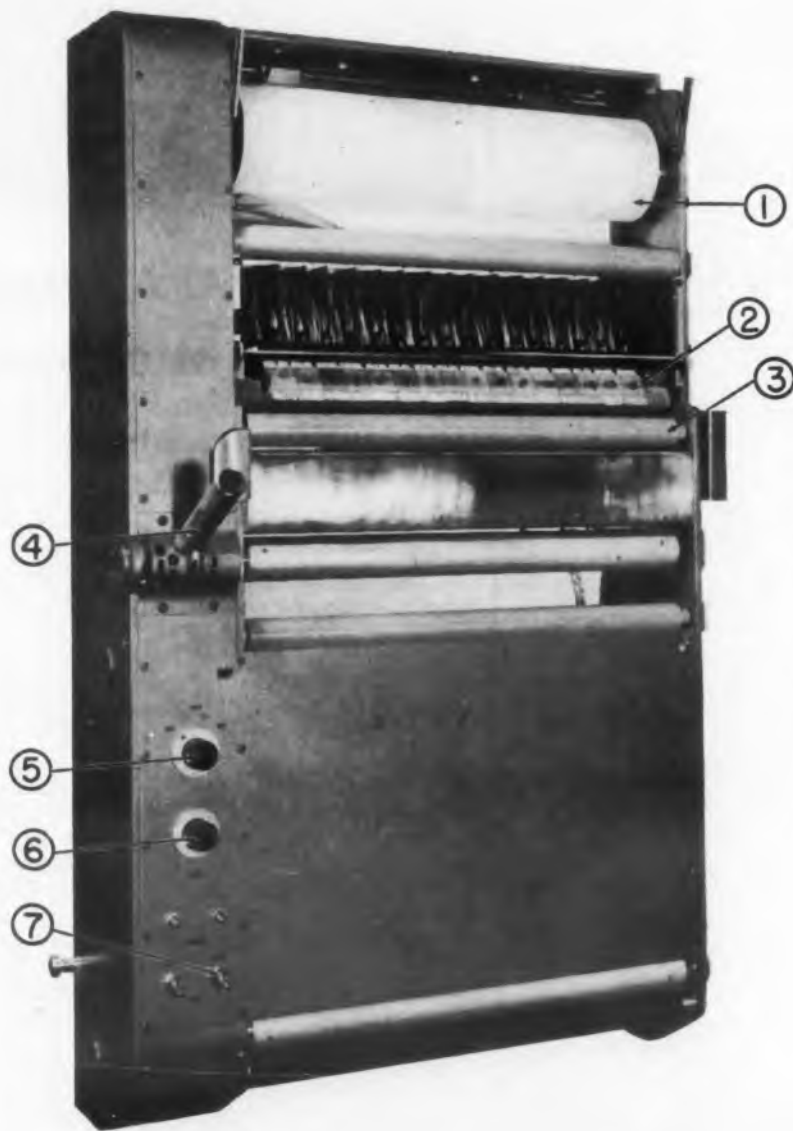

**This visual recorder** can plot 12 variables at up to 30 points per second for each variable. Key—1. paper humidifier, 2. styli recording head (enclosed), 3. heater bar, 4. speed control lever, 5. time marking switch to control interval between ordinate markings, 6. scale marking potentiometer to adjust intensity of modulated scale marking, 7. drive switch to test run the recorder before automatic operation.

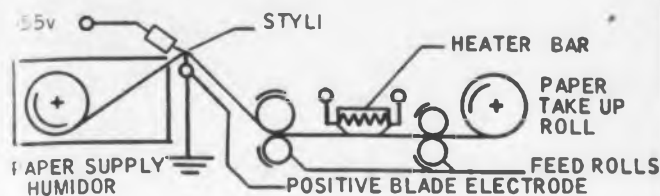

Simplified schematic representation of the visual recorder.

tinuously, thereby drawing scale lines on the paper. These lines can be positioned at any intervals.

Several sets of graphs and calibration lines can be written simultaneously, limited only by the number of relay tree translators available, and the degree to which overlapping of graphs is permitted.

Designed by the Tally Register Corp. of 5300 14th Avenue N.W., Seattle, Wash., this instrument employs some rather unusual recording techniques. Binary input information in any channel is translated by a thyratron driven relay tree which pulses an appropriate stylus. There are 44 styli cast in each of 16 nylon blocks across a 14 inch wide plotting head.

Writing is accomplished by electroplating iron from a positive blade electrode on to Faxpaper, an impregnated paper manufactured in New York City by Hogan Laboratories, Inc. The iron reacts with the paper to produce a dark brown mark.

A steel tape, slowly driven through a rigid guide like a typewriter ribbon serves as the positive electrode.

The paper supply is enclosed in a humidifier to preserve its moisture content. To maintain its current carrying capacity, the paper is not exposed to dry air until just before recording. After this, feed rolls draw the paper across a heater bar to dry the solution and sharpen the mark. A small fan drives the evaporated moisture out to prevent condensation on the writing styli. Paper feed can be adjusted for discrete speeds from 0.5 to 10 in. per second.

For more information on this fast visual recorder turn to the Reader's Service Card and Circle 30.



CONstriction AND EXPANSION TAKE PLACE HERE

**How it works:** Open clamp B; energize coil to constrict magnetostrictive nickel rod; close clamp B; open clamp A; deenergize coil to allow nickel rod to expand and take new position to the left; close clamp A. Repeat cycle until unit has moved desired distance.

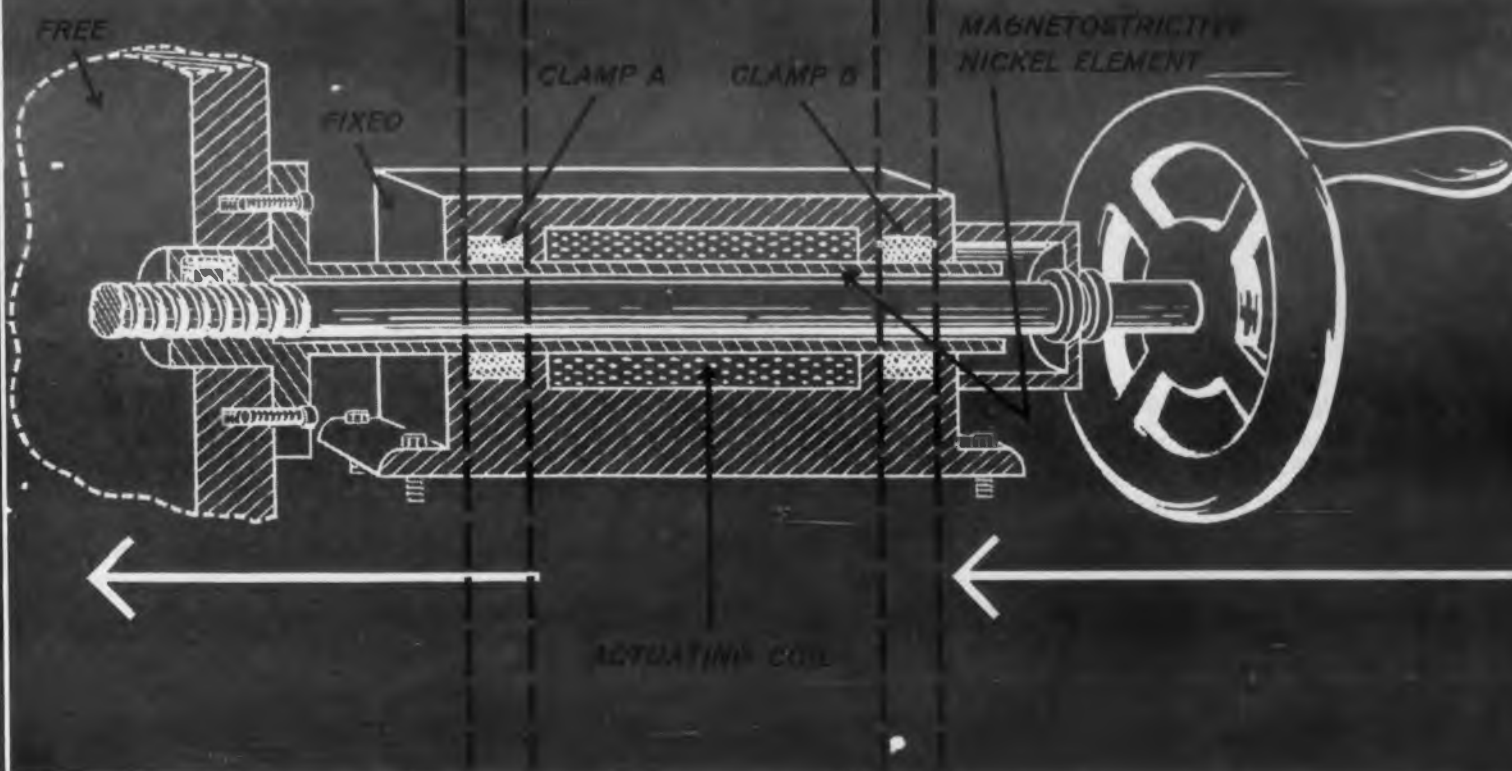

## Novel Inchworm Motor positions work to 0.000,005-inch accuracy

*New heavy-duty micro-feed relies on Magnetostrictive nickel*

Place nickel in a magnetic field and it shrinks.

Remove it, and it snaps back to size.

Magnetostriction is the reason. And nickel exhibits large magnetostrictive length change... added to its rugged mechanical properties and moderate cost. Result: a reliable, versatile engineering material.

Take, for example, the novel "Inchworm" motor manufactured by Airborne Instruments Laboratory, Inc., Mineola, N. Y. An extremely accurate feed mechanism for center-

less grinders, this device uses a coordinated pair of clamps to convert the magnetostrictive expansion and contraction of a nickel rod into linear incremental motion. Powerful motion, too... the "Inchworm" will move a 350-pound load in steps variable up to 0.000,060-inch.

You can see the mechanics of The Inchworm in the illustration above. Electronic controls include standard timing and power circuits to energize the coil and operate the clamps for forward and backward steps. An optional gauge and feedback circuit

allow full automatic control.

Magnetostrictive transducers made of nickel have many industrial uses today... as sonar, vibratory drills, ultrasonic cleaners, homogenizers, soldering devices.

Maybe you would like to explore this growing design field. For recommended materials, get in touch with us. Write for our booklets, *Magnetostriction*, or *Design of Nickel Magnetostrictive Transducers*. They're yours for the asking.

The INTERNATIONAL NICKEL COMPANY, Inc.  
67 Wall Street New York 5, N. Y.



**NICKEL... for magnetostriction**

# NEW FASTENER CATALOG



MANUFACTURERS  
SINCE 1850

- This is really an up-to-date handbook covering the Design and Purchasing of cold headed fasteners and small parts. Loaded with money saving 'Know-How'! Send for your copy of Catalog No. 106.

**JOHN HASSALL, INC.**

2202 WESTBURY, LONG ISLAND, N. Y.

CIRCLE 32 ON READER-SERVICE CARD

DC-AC CHOPPER  
STEVENS ARNOLD INC.  
SOUTH BOSTON, MASS.

**NEW FREQUENCY DOUBLERS**

- Double the sampling rate
- Double the band width
- Eliminate zero offsets

**DC-AC CHOPPERS**

Twenty-two types, both single and double pole.

Long life.

Low noise level.

Extreme reliability.

Write for Catalog.

**STEVENS INCORPORATED ARNOLD**

7 ELKINS STREET  
SOUTH BOSTON 27, MASS.

S A-10C

CIRCLE 33 ON READER-SERVICE CARD

## Feedback Circuit Analysis Using Impedance Concepts

**Gustave Pellegrino, Jr.**  
Norden Laboratories Div.  
Norden Ketay Corp.  
White Plains, N. Y.

IT IS SIMPLER to interpret the gain or transfer function of a feedback amplifier by obtaining the solution in measurable quantities. These quantities are the open circuit gain of each stage and the feedback factor. When these are known, the closed loop gain is easily found from

$$G = \frac{A}{1 - A\beta} \quad (1)$$

where  $G$  is the closed loop gain,  $A$ , the open loop gain and  $\beta$ , the feedback factor.

This method is always applied when the feedback factor is well defined, as in a simple divider network. It is usually overlooked when feedback is applied in a complex manner.

In a two stage, plate to cathode feedback amplifier, (Fig. 1), the feedback resistor  $R_f$ , looks directly into the low impedance cathode of the first stage. In order to apply eq (1), the complex quantity  $Z_k$  must be found. Then the feedback factor is determined from

$$\beta = \frac{Z_k}{Z_k + R_f}$$

Mesh analysis of the equivalent circuit reveals the closed loop gain. The drawback is that every component and tube constant enters the solution. A comparison of the results obtained using mesh analysis and those obtained by solving for  $Z_k$  shows the advantage of the latter.

### Mesh Analysis

Fig. 2 is the equivalent circuit of the plate-to-cathode feedback amplifier. The mesh analysis reveals

$$\text{Gain} = \frac{E_{out}}{E_{in}}$$

In the usual analysis of feedback circuits it is difficult to visualize what is taking place in the circuit. The mathematics beclouds the actual circuit operation. The solution obtained with impedance concepts, while no simpler, helps to explain what is happening in the circuit. It simplifies the choice of design parameters and allows one to see how any term affects the overall design.

$$= \frac{\mu_1 R_{k1} R_{L2} \left[ \mu_2 R_{L1} \left( 1 + \frac{R_f}{R_{k1}} \right) - r_{p2} + (\mu_2 - 1) R_{k2} \right]}{\Delta} \quad (2)$$

where  $\Delta$  is the system determinant.

$$\Delta = \begin{vmatrix} R_{L1} + r_{p1} + R_{k1} (\mu_1 + 1) & -R_{k1} (\mu_1 + 1) \\ -R_{k1} & R_{k1} + R_f + R_{L2} \\ R_{k1} + \mu_2 R_{L2} & -(R_{k1} + R_f) \\ & R_{k1} (\mu_1 + 1) \\ & -(R_{k1} + R_f) \\ & R_{k1} + R_f + r_{p2} + (1 - \mu_2) R_{k2} \end{vmatrix}$$

Equation (2) is the gain solution. The problem still remains, though. It is still necessary to interpret the result and to use it as a tool to obtain the required performance of the amplifier. This equation can certainly be simplified, but the circuit performance is still well obscured.

### Analysis by Solving for $Z_k$

Fig. 3 is a different representation for the same amplifier. If the open loop gain of each stage is known, the only parameter lacking for a closed loop gain solution is the cathode imped-

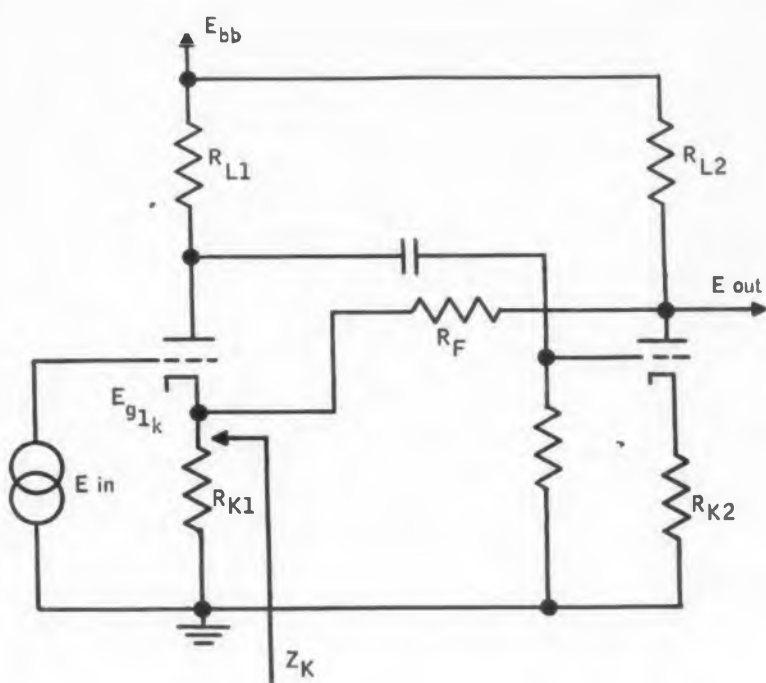

Fig. 1. Plate to cathode feedback amplifier.

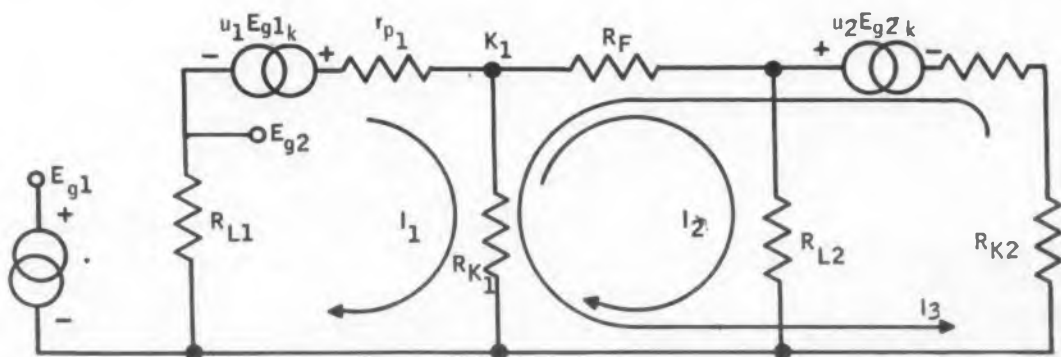
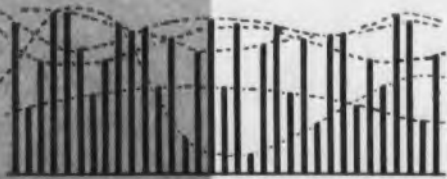

Fig. 2. Equivalent circuit of the feedback amplifier of Fig. 1



# GDI

**LEADING SUPPLIER OF RELIABLE MULTICHANNEL SAMPLING SWITCHES** for data display, instrumentation, telemetering, computers, etc. . . .

- FIRST** in self-lubricating switches with large numbers of channels for high speed sampling with high impedance loads
- FIRST** in metallic switches with low contact resistance, for low impedance loads

**AND NOW THE ADDITION OF A COMPLETELY**

## **NEW ELECTRONIC SAMPLING SWITCH**



With the development of the electronic switch GDI has become the only single source specializing in high speed multi-channel switching devices. GDI's personnel are pioneers in the art of Multi-Channel Telemetering, with detailed experience in applicational problems.

With our new modern building, we are staffed and equipped to design and develop reliable solutions to your switching problems, in the form of complete systems proposals or individual components.



For detailed information and literature  
WIRE OR PHONE

**GENERAL  
DEVICES  
INC.**

P. O. BOX 253 • PRINCETON, NEW JERSEY  
PHONE MONMOUTH JUNCTION 7 4571  
TWX MONMOUTH JUNCTION N J 271X  
OFFICES IN DALLAS, LOS ANGELES, AND CANADA



CIRCLE 34 ON READER-SERVICE CARD

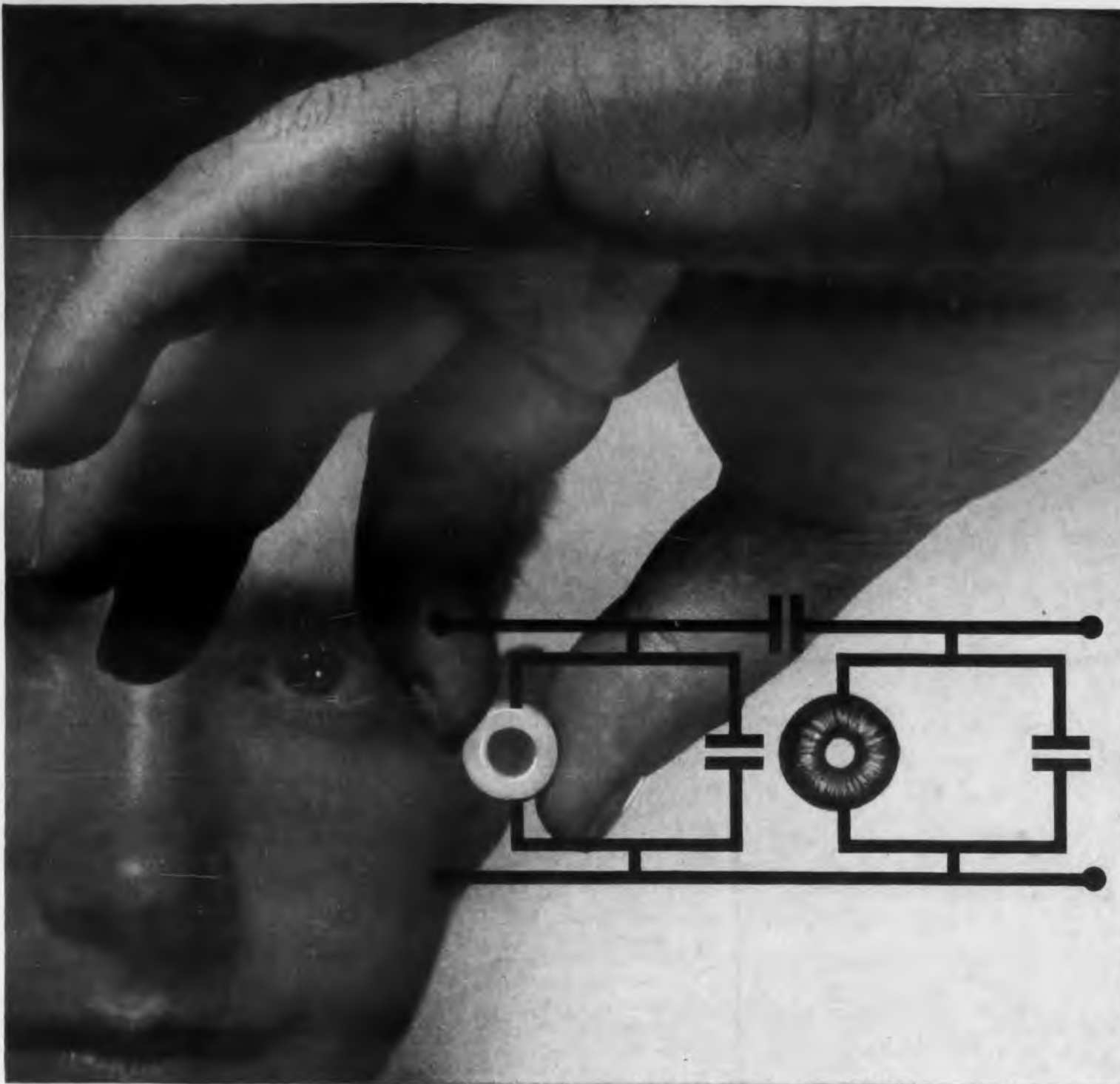

## Now you can use molybdenum permalloy powder cores in miniaturized circuits

When your engineering neighbor talks about "Cheerios" these days, he's apt to be discussing a new breakfast cereal-sized molybdenum permalloy powder core which has found a happy niche as a miniaturized filter component. Guided missiles, which are filling the troposphere these days, typically use these little fellows in their amplifier circuits. Small (down to .300-in. ID), they are tough and easy to use. They also provide a markedly high degree of stability with time, temperature and magnetization.

Made by Magnetics, Inc. (Performance-Guaranteed, of course) they provide the highest permeability and lowest core losses possible in use in filter, audio and carrier frequency circuits. We provide extras, too—you may specify our very

exclusive feature—color-coding. Color-coding tells your assemblers how many turns to put on your cores without the lost time and extra expense of special testing.

Want more facts? There's a brand new bulletin (PC-103A), full of important information. It's yours by writing *Magnetics, Inc., Dept. ED-35, Butler, Pennsylvania.*

**MAGNETICS inc.**

CIRCLE 35 ON READER-SERVICE CARD

ance. If the feedback resistance  $R_f$  is large compared with  $Z_k$ , one may assume a small voltage change applied across the cathode impedance and calculate the incremental current flow  $\Delta i$ . Then  $Z_k = \Delta e / \Delta i$ , and referring to Fig. 1 the equivalent circuit, one finds

$$\Delta i = \frac{\Delta e}{R_k} + \Delta i_p$$

where  $\Delta i_p$  = change in plate current

$$\text{and } \Delta e + \mu, \Delta e_{gk} = \Delta i_p (R_{L1} + r_{p1}) \quad (3)$$

From basic feedback theory

$$\Delta e_{gk} = \frac{\Delta e_{in}}{1 - A\beta} \quad (4)$$

with  $A$ , the overall open loop gain, and  $\beta$ , the feedback factor, is negative for negative feedback.

From the circuit of Fig. 3,

$$\Delta e_{in} - \Delta e_{gk} = \Delta e \quad (5)$$

Solving for  $\Delta e_{gk}$  in terms of  $\Delta e$ ,

$$\Delta e_{gk} (1 - A\beta - 1) = \Delta e$$

$$\text{Hence } \Delta e_{gk} = \frac{\Delta e}{-A\beta} \quad (6)$$

Substituting (6) into (3),

$$\Delta e \left[ 1 + \frac{\mu_1}{-A\beta} \right] = \Delta i_p (R_{L1} + r_{p1})$$

$$\text{and } \Delta i_p = \frac{\left[ 1 + \frac{\mu_1}{-A\beta} \right] \Delta e}{R_{L1} + r_{p1}}$$

$$\text{Hence } \Delta i = \frac{\Delta e}{R_{k1}} + \frac{\Delta e}{(R_{L1} + r_{p1}) \left[ 1 + \frac{\mu_1}{-A\beta} \right]}$$

$$\text{and } Z_k = \frac{\Delta e}{\Delta i} = R_{k1} \frac{R_{L1} + r_{p1}}{1 + \frac{\mu_1}{-A\beta}} \quad (7)$$

The first stage gain is

$$A_1 = \frac{\mu_1 R_{L1}}{R_{L1} + r_{p1} + (\mu_1 + 1) R_{k1}}$$

The second stage gain is

$$A_2 = \frac{\mu_2 R_{L2}}{R_{L2} + r_{p2} + (\mu_2 + 1) R_{k2}}$$

The open loop gain is  $A = A_1 A_2$

The general feedback equation (1) can now be applied directly. The gain of the amplifier, then, is

$$G = \frac{A_1 A_2}{1 - A_1 A_2 \beta} = \frac{A_1 A_2}{1 - \frac{A_1 A_2 Z_k}{Z_k + R_f}}$$

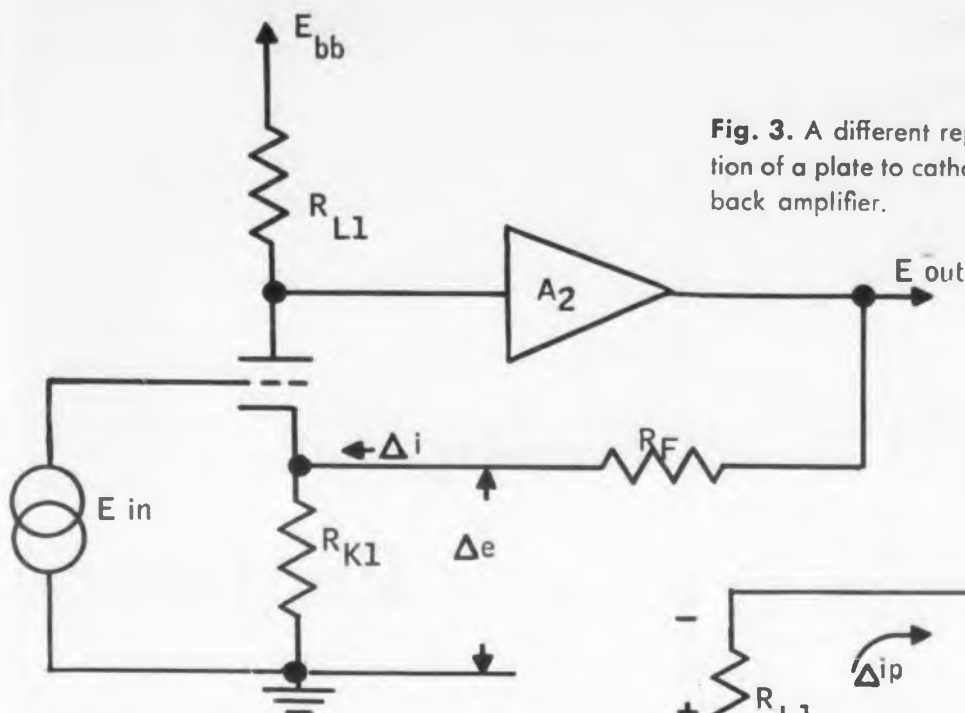

Fig. 3. A different representation of a plate to cathode feedback amplifier.

This expression appears to be superior to that of eq (2), since all the parameters are easy to recognize. For design purposes, it is easy to see how any one term affects the overall gain.

#### Illustrative Problem

In the feedback amplifier of Fig. 3, it is necessary to find the feedback resistor  $R_f$ , for a closed loop gain of 20. The following data are given.

$$\begin{aligned} R_{k1} &= 1000 \text{ ohm} \\ R_{L1} &= 20 \text{ k} \\ r_{p1} &= 40 \text{ k} \\ \mu_1 &= 70 \\ A &= 400 \end{aligned}$$

#### Solution for $\beta$

From  $G = A/(1 - A\beta)$  one finds

$$\beta = -\frac{A - G}{AG} = -\frac{400 - 20}{8000} = -.0475$$

#### Solution for $Z_k$

From (7)

$$\begin{aligned} \frac{R_{Lk} + r_{p1}}{1 + \frac{\mu_1}{-A\beta}} &= \frac{(R_{L1} + r_{p1})(-A\beta)}{\mu_1 - A\beta} \\ &= \frac{(60,000)(-400)(-.0475)}{70 + (-400)(-.0475)} = 12,800 \text{ ohm} \end{aligned}$$

$$\begin{aligned} Z_k &= R_k // 12,800 \text{ ohm} \\ &= 1000 // 12,800 = 928 \text{ ohm} \end{aligned}$$

#### Solution for $R_f$

From  $\beta = Z_k/(R_f + Z_k)$

$$R_f = \frac{Z_k(1-\beta)}{\beta} = \frac{928(.9525)}{.0475} = 18,560 \text{ ohm}$$

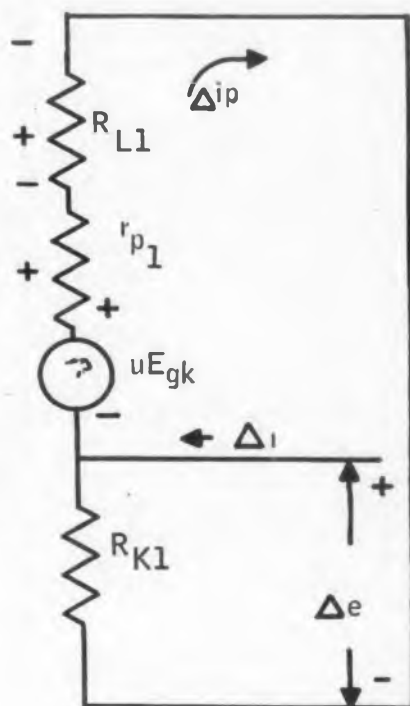

Fig. 4. An equivalent circuit for the representation of Fig. 3.

## newest addition to Panel Chanel's line of wiring raceways.. LOK-SLOT



### WIRES INSERT EASILY

Single wires slip into Lok-Slot quickly. Connectors can be placed on wires *before* assembly, simplifying wiring procedure. Need to change a wire's location? Just lift it out and slip it into the new slot.

### STAY PUT...

Once in place, wires don't pop out. They *can't*, for Lok-Slot's slim throat is a deliberately designed "bottleneck" —for wires you *don't* want out.



### AND COME OUT WHEN YOU WANT THEM

Slanted slot design permits lateral as well as vertical wire movement for precise alignment with desired terminal.

Just pick your wire and lift. Out it comes, without bringing a scramble of leads with it. The others remain securely in place — until you want them.

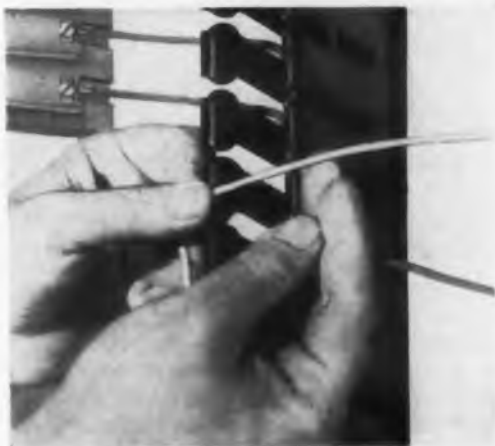

Lok-Slot has all the other fine features of Panel Chanel® wiring raceways. It reduces panelboard wiring time and costs by eliminating bundling and lacing. Made of tough, reinforced phenolic, Lok-Slot won't warp and is fire retardant. It can be cut simply with ordinary tools, requires no special fastening hardware, and comes in a variety of sizes. What's more, the finished job is neat and professional looking, and lasts the life of the equipment.

For full details on Lok-Slot and other Panel Chanel styles, write for your copy of Bulletin S-302.



Lok-Slot and Panel Chanel are tradenames.

# Panel Chanel®

STÄHLIN BROTHERS, INC. • 103 MAPLE STREET  
Belding, Michigan

CIRCLE 36 ON READER-SERVICE CARD



# New trends and developments in designing electrical products . . .

"Work backward"—a new design approach that's bringing the advantages of General Electric permanent magnets to fields traditionally reserved for electromagnets

A new approach to the design of motors, generators, relays, and similar products is making it possible to produce smaller, more efficient and economical units by using permanent magnets, instead of electromagnets.

The new approach is simply to "work backward." That is, design the most efficient magnet assembly first, and then the rest of the component.

In the past, where designers tried to replace electromagnets in these products, permanent magnets often proved uneconomical. Here's why:

The traditional approach was to work the permanent magnet into an existing design for a wire-wound field, to save the cost of new dies and other major manufacturing changes.

Under these conditions, permanent magnets will seldom show to best advantage. But, by using the "work backward" approach, many outstanding results can be obtained.



FIGURE 1—G-E Alnico 5 magnet helps 2-pole motor develop 1/150 hp at 10,000 to 15,000 rpm.

For example, permanent magnets had been limited to fractional-hp applications, such as the 1/150-hp toy-locomotive motor in Figure 1.

But today, through imaginative design and more efficient alloys, permanent magnets are now used for rotors and stators in much larger equipment.

The DC tachometer generator in Figure 2, for example, uses a 2-lb. G-E Alnico 6 stator.

The permanent magnet provides greater reliability and accuracy than copper windings, over wide ambient temperatures. It eliminates an external power source and field regulating equipment. And, there is no replacement problem since the magnet—unlike wire—never burns out.

These are some of the advantages that can be realized from early con-



FIGURE 2—46-frame DC tachometer generator with Alnico 6 stator.

sideration of the permanent magnet in design.

Alone, these can more than justify the cost of redesigning equipment to eliminate wound fields. Yet, there are other advantages that result from the magnet's ability to supply a constant field without external excitation, including:

- Elimination of field interruptions due to power failure.
- Elimination of heat and need for costly cooling equipment and insulation—thus conserving valuable weight and space.
- Elimination of danger from faulty wiring or damaged insulation.

These are important advantages where equipment must be reliable despite severe environmental conditions. But equally important to the designer is the permanent magnet's superior volumetric efficiency. A G-E Alnico magnet can usually supply a given magnetic field in a fraction of the space needed by even the best designed electromagnet.

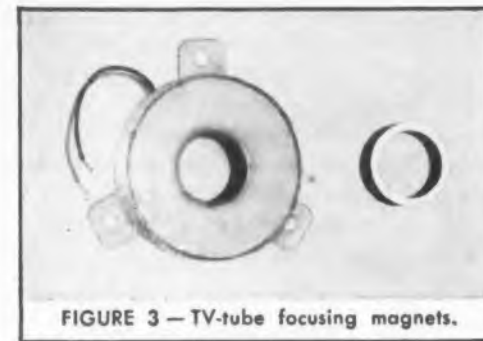

FIGURE 3—TV-tube focusing magnets.

The TV-tube focusing magnets in Figure 3 gives some idea of the savings in space and weight a designer can effect.

The electromagnet weighs 2 lbs., and takes up 16.35 cubic inches. The G-E Alnico 5 permanent magnet weighs just 15 ounces, and requires only 1.30 cubic inches—a space-saving of 87%.

In addition to the problem of economics, two other traditional objections to permanent magnets have also been largely eliminated:

First, early permanent magnets were relatively unstable. But modern permanent magnet materials from improved manufacturing techniques are really "permanent" . . . even under temperature and humidity conditions ruinous to electromagnets.

Second, applications requiring "on-off" field action seemed outside the capabilities of permanent magnets. But modern design techniques have developed practical ways to handle this by shunting flux around the air gap.

With the new high-energy alloys and the development of more scientific design methods, the future for permanent magnets—and the opportunity for designers—is virtually unlimited.

For example, a recent use of the "work backward" approach has, for the first time, made it possible to use powerful Alnico magnets to supply uniform fields in equipment like traveling wave tubes.

General Electric Magnet Engineers have accumulated a wealth of information on the problems of redesigning for permanent magnets. They will share their knowledge with you at any stage of the magnet design project.

For more information, or the services of a G-E Magnet Engineer, write: *Magnetic Materials Section of General Electric Company, 7820 N. Neff Ave., Edmore, Michigan.*

*Progress Is Our Most Important Product*

**GENERAL  ELECTRIC**

CIRCLE 37 ON READER-SERVICE CARD

## Multiplier Phototube



INTENDED for use in the detection and measurement of low-level red and near-infrared radiation, type 7102 multiplier phototube covers the range from about 4200 to 11,000 Å, with a maximum response occurring at approximately 8000 Å, as shown in Fig. 1. Along with this response, the tube achieves a very short time resolution. For an input pulse having a duration of 1 msec or less, the time spread of the pulse at

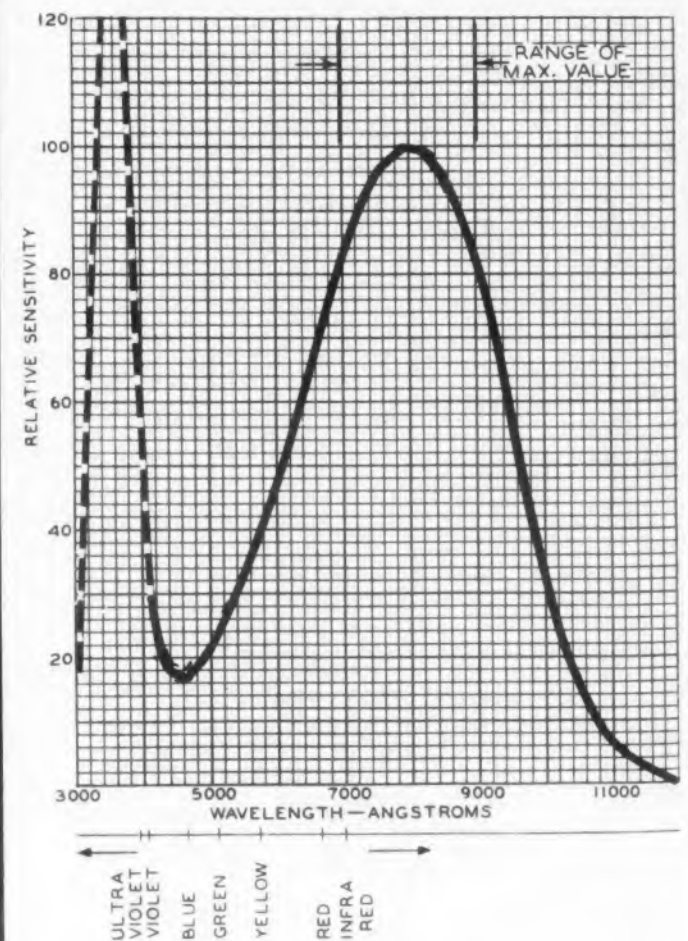
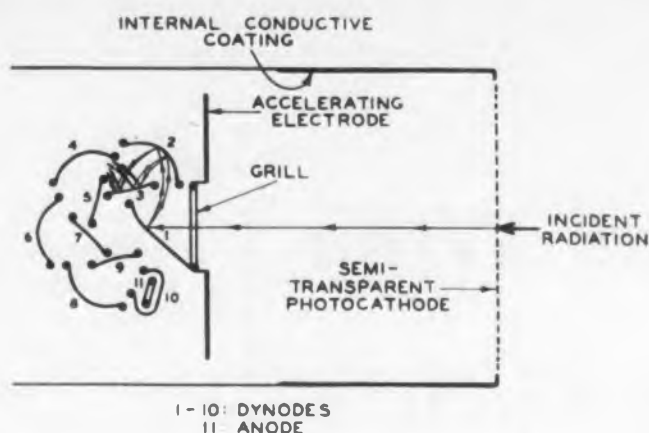

Fig. 1. Spectral response of the phototube achieves its maximum at about 8000 Å. The curve is shown for equal values of radiant flux of all wavelengths.



**Fig. 2.** Construction of the multiplier phototube shown schematically.

## ... high red to near-infrared response

the anode is about 5  $\mu$ sec, measured at 50 per cent of the maximum pulse height. This time spread corresponds to an electron transit-time spread of about 5  $\mu$ sec. The transit-time spread can be reduced to about 2  $\mu$ sec by irradiating only a small central area of the photocathode.

The phototube, built by RCA, is basically a ten-stage, head-on type with a semitransparent cathode having a minimum diameter of 1.24 in. This relatively large cathode permits efficient collection of the radiation from sources of scattered radiation. Ten electrostatic dynode stages utilize the phenomenon of secondary emission to amplify signals composed of electron streams. As shown in Fig. 2, the electrons emitted from the irradiated cathode are directed by fixed electrostatic fields to the first dynode (secondary emitter). This process continues until the electron streams emitted from the last dynode (dynode no. 10) are collected by the anode, providing the current utilized in the output circuit.

Dynode no. 10 is so shaped that it partially encloses the anode, thus serving as a shield to prevent the fluctuating potential of the anode from interfering with electron focusing in the interdynode region. Actually, the anode consists of a grating which allows the electrons from dynode no. 9 to pass through it to dynode no. 10. The spacing between dynode no. 10 and the anode creates a collecting field such that all the electrons emitted by dynode no. 10 are collected by the anode. Therefore the output current is substantially independent of the instantaneous positive anode potential over a wide range. As a result of this characteristic, this multiplier phototube can be coupled to any practical load impedance encountered.

For more information on this phototube, turn to the Reader's Service Card and circle 38.

# RCA RELAYS

Over 325 types



Meet and exceed MIL-R-5757A, B, C  
and MIL-R-25018 (USAF)!

RCA Subminiature Relays are designed to give maximum reliability and superior performance in missile and airborne applications, as well as critical industrial uses.

More than 325 types are now available to meet the most stringent requirements—exceeding MIL-R-5757A, B, C and MIL-R-25018 USAF specifications.

"Getters," an original RCA development  
for lower contact resistance, longer life!

Teflon\* Splatter Shields for positive protection against shorting of contacts!

Dependable, shock-resistant headers result from RCA's long experience in metal-to-glass sealing techniques!

Every RCA Relay is precision assembled and incorporates these important construction features!

- Precision balanced rotary motors for high resistance to shock and vibration.
- Stepped headers on 4 and 6 pole units for greater ease in wiring and inspection.
- Simultaneous switching of full rated loads and dry circuits.

- Special contact ratings for special purposes.

- Plug-in types in 2, 4 and 6 pole units, AC, DC, and Dry Circuit.

Complete, concise information on RCA Subminiature Relays is available in a new 12-page brochure. Mail coupon for your free copy today.

*\*Registered trademark of E. I. Du Pont De Nemours*

RCA Industrial Electronic Products, Dept. C-292, Bldg. 15, Camden, N.J.

Please send RCA Relay Brochure     Have RCA Representative call

NAME \_\_\_\_\_

COMPANY \_\_\_\_\_

TITLE \_\_\_\_\_

ADDRESS \_\_\_\_\_

CITY \_\_\_\_\_

ZONE \_\_\_\_\_

STATE \_\_\_\_\_



Tmk(s) ®

**RADIO CORPORATION of AMERICA**

INDUSTRIAL ELECTRONIC PRODUCTS

CAMDEN, N. J.

CIRCLE 39 ON READER-SERVICE CARD

P&B PROGRESS

HIGH SHOCK CRYSTAL-CASE RELAYS



## 2 NEW RELAYS

**CRYSTAL-CASE SIZE! PERMANENT MAGNET DESIGN.**

**SHOCK: 100g. VIBRATION: 30g 55 TO 2000cps. NO CONTACT OPENINGS.**

**SC NON-LATCHING TYPE**—This micro-miniature relay sets new standards—in design, in performance, in reliability. Yet the SC conforms to standard dimensions and circuitry and may be used to replace ordinary crystal-case relays. A permanent magnet in the structure provides *at least twice the contact pressure found in relays of comparable size.*

**SL LATCHING TYPE**—Unique magnetic latch assures exceptional contact pressure. A 1 watt, 3 ms. pulse to either coil transfers contacts. Transfer time is only 0.5 ms. Has the same exceptional shock and vibration characteristics as the SC.

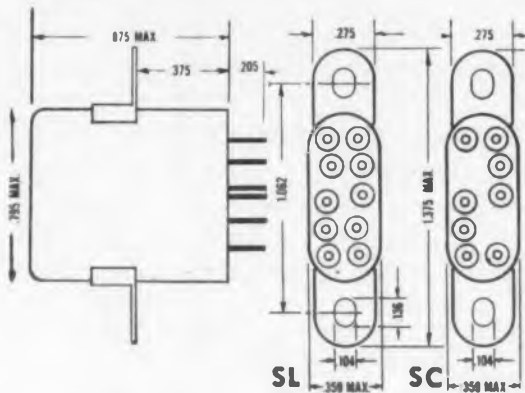

**GENERAL: Insulation Resistance: 10,000 megohms, min.**

**Breakdown Voltage: 1,000 V. RMS.**

**Shock: 100g.**

**Vibration: 30g 55 to 2000 cps.; 0.195" max. excursions from 10-55 cps.**

**Temperature Range: -65°C. to +125°C.**

**Weight: 17.5 grams (5/8 oz.).**

### SC and SL Series Engineering Data

**Operate Time: 3 MS. max. with 550 ohm coil @ 24 V. DC. (SL: 630 ohm coil at 24 V. DC).**

**Transfer Time: 0.5 MS max.**

**Terminals: (1) Plug-in for microminiature receptacle of printed circuit board. (2) Hook end solder for one #20 AWG wire.**

**Enclosure: Hermetically sealed.**

**CONTACTS: Arrangement: 2 Form C.**

**Material: Gold flashed palladium.**

**Load: 2 amps @ 28 V. DC, resistive; 1 amp @ 115 V. AC, resistive.**

**Pressure: SC—13 grams min.; SL—16 grams min.**

**COIL: Power: Approx. 1.0 watt at Nominal Voltage.**

**Resistance: SL—40 to 1400 ohms; SC—35 to 1250 ohms.**

**Duty: Continuous.**

**MOUNTINGS: Bracket, stud and plug-in.**

P&B Standard Relays are available at your local electronic, electrical and refrigeration distributors

# Potter & Brumfield, inc.

PRINCETON, INDIANA · SUBSIDIARY OF AMERICAN MACHINE & FOUNDRY COMPANY  
Manufacturing Divisions also in Franklin, Ky. and Laconia, N.H.

CIRCLE 41 ON READER-SERVICE CARD

# Read and Write Transistor Circuits for Magnetic Drums - 1

This article discusses the integration of transistors in magnetic drum read-write circuits. A general approach to the design of these circuits for high reliability is outlined.

Part I, presented here, will deal with the design of writer circuits. Part II, which will appear in an early issue of ELECTRONIC DESIGN, will cover read preamplifier design.

**B. A. Mangan**

International Business Machines Corp.  
Kingston, N. Y.

## Writer Configurations

FOR our purposes, a discrete-pulse type of recording shall be used in adapting the drum writer to transistors. Fig. 1 depicts a simplified transistor writer capable of operating at a 400-500 kc repetition rate. The prime consideration in designing this circuit is the selection of a transistor that will withstand the back voltage developed across the head and will still be capable of supplying the required current. If a trapezoidal or sinusoidal pulse is utilized, the induced voltage for a specified pulse amplitude will be a minimum. Sufficient voltage

therefore exists across the transistor to allow the peak current to be drawn.

Introducing these pulses prevents the transistor from being driven to saturation. Hence, turn-off delay is eliminated. However, since saturation is not reached, the output current depends on the forward current transfer of the transistor. In a vacuum-tube circuit, this same condition is alleviated to a considerable degree through cathode degeneration.

The same result is accomplished with emitter degeneration, to a much greater extent, by virtue of the low impedance of the

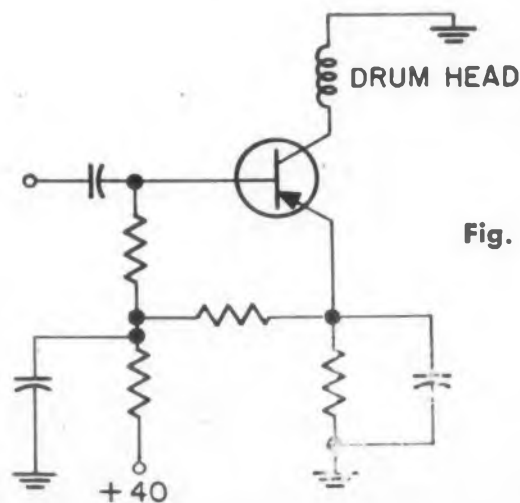

Fig. 1. Simplified transistor writer (magnetic drum).

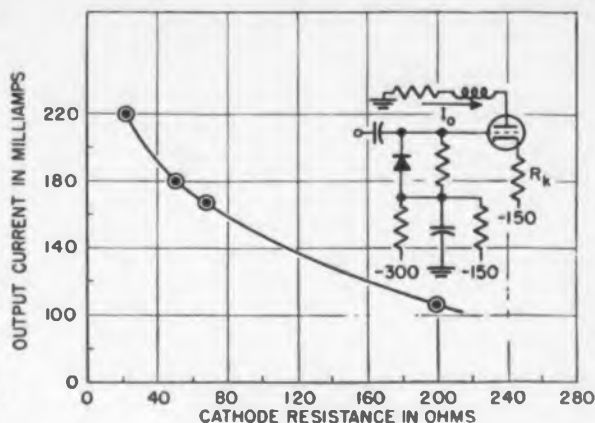
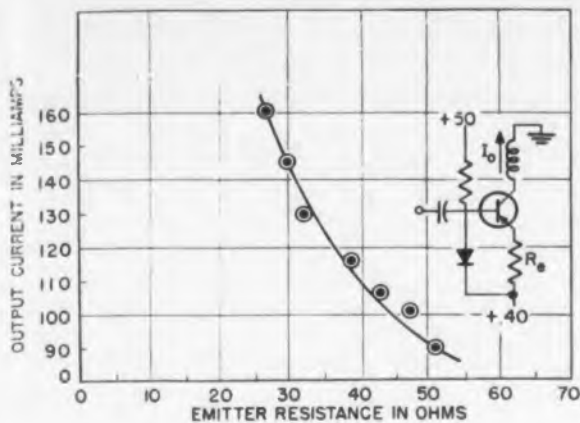

Fig. 2. Comparison of emitter and cathode degeneration.

transistor. Fig. 2 illustrates, by comparison, the amount of degeneration that can be built in. In addition, an emitter resistor tends to stabilize the operating point by reducing the effect of variations in the forward resistance of the emitter-base junction. In transistors of this type, common emitter current ratios (beta) of about 10 are normal. This value of beta helps to minimize the variation in output current since the range of beta must then also be small.

Fig. 3 indicates two methods of obtaining bias for the writer. The first arrangement (a) makes use of the voltage drop across the forward impedance of a diode. This has the advantage of establishing a rather stiff reference for the incoming signal. The selection of  $R$  depends on the bias voltage required and the input impedance of the transistor which it effectively shunts. Since the range of beta is not great, the required bias should be calculated for the value which tends to turn the transistor on. The presence of the diode essentially removes the  $I_{co}$  from bias consideration.

The second bias arrangement (b) has the advantage of using a single power supply. However,  $I_{co}$  must be considered. The proper selection of voltage divider ( $R_2 + R_3$ ) and a bias resistor ( $R_1$ ) will compensate for the worst  $I_{co}$  at the highest expected temperature.

The two major advantages of utilizing a single power supply are:

- Fluctuations in the power supply will be seen at both the base and emitter; hence the effect on the circuit will be a minimum.

- In the event of a power failure, no voltage exists across the transistor, thus preventing damage to the transistor.

A further consideration regarding the general reliability of the circuit is the placement of the head at ground potential. This arrangement results in the elimination of accidental grounding and its consequent catastrophic effects on circuit components.

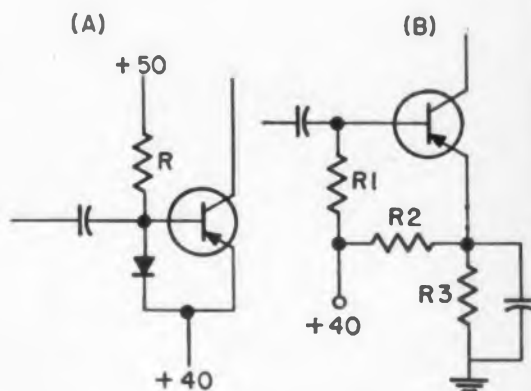

Fig. 3. Two methods of obtaining bias.

# Tarzian

## tube replacement SILICON RECTIFIERS

offer you dependability, ruggedness and long life, often at very little more cost than comparable ruggedized vacuum tubes. One of the five standard types described below will meet the requirements of your application.

S-5011A  
1N1150

### MAXIMUM RATING

Peak Inverse Voltage per Section . . . 1600 Volts Max.  
Peak Rectifier Current per Section . . . 8000 MA Max.  
DC Output Current . . . . . 750 MA Max.  
Ambient Temperature . . . . . 100°C Max.  
Replacement for Types 80, 82, 83, 83V, 5Z3

S-5017  
1N1237

### MAXIMUM RATING

Peak Inverse Voltage per Section . . . 1600 Volts Max.  
Peak Rectifier Current per Section . . . 8000 MA Max.  
DC Output Current . . . . . 750 MA Max.  
Ambient Temperature . . . . . 100°C Max.  
Replacement for Types OZ4, 5X4, 5Y4, 6AX5, 6X5

S-5018  
1N1238

### MAXIMUM RATING

Peak Inverse Voltage per Section . . . 1600 Volts Max.  
Peak Rectifier Current per Section . . . 8000 MA Max.  
DC Output Current . . . . . 750 MA Max.  
Ambient Temperature . . . . . 100°C Max.  
Replacement for Types 5AU4, 5AW4, 5AZ4, 5T4,  
5U4, 5V4, 5W4, 5Y3, 5Z4

S-5019  
1N1239

### MAXIMUM RATING

Peak Inverse Voltage per Section . . . 2800 Volts Max.  
Peak Rectifier Current per Section . . . 5000 MA Max.  
DC Output Current . . . . . 500 MA Max.  
Ambient Temperature . . . . . 100°C Max.  
Replacement for Type 5R4

S-5033  
1N1262

### MAXIMUM RATING

Peak Inverse Voltage . . . . . 4500 Volts Max.  
Peak Rectifier Current . . . . . 2500 MA Max.  
DC Output Current . . . . . 250 MA Max.  
Ambient Temperature . . . . . 100°C Max.  
Replacement for Types 6AU4, 6BL4, 6W4, 12AX4,  
17AX4, 25W4, 6AX4



Send for data sheets on any of the above types.

**Sarkes RECTIFIER DIVISION**  
DEPT. C-1  
415 N. COLLEGE AVE., BLOOMINGTON, IND.  
**Tarzian, INC.**

In Canada: 700 Weston Rd., Toronto 9, Tel. Rogers 2-7535 • Export: Ad Auriemo, Inc., New York City  
CIRCLE 42 ON READER-SERVICE CARD

# NEW PRODUCTS

To provide a complete coverage of ALL new products generally specified when designing electronic original equipment, the New Product section has been extended. To include the larger number of items, products which are best suited to a brief description have been noted at the end of the section.



## GERMANIUM PHOTODIODE

An **Integral Lens** for focussing light on the junction area of this photodiode eliminates the external optics usually necessary. The hermetically sealed germanium device can be used in either the visible or infra-red portions of the spectrum. Typical applications include punched-card or tape reading. Sensitivity is approximately 30 ma per lumen at an ambient temperature of 20 C. Dark current is less than 3.5  $\mu$ a. The sensitive surface measures approximately 1 mm<sup>2</sup>.

Nucleonic Products Co., Inc., Dept. ED, 1601 Grande Vista Ave., Los Angeles, Calif.

CIRCLE 43 ON READER-SERVICE CARD

## DIGITAL TAPE SYSTEM

**150-Inch-Per-Sec** tape speed enables the FR-300 tape system to transfer six-bit alpha-numeric characters at rates up to 90,000 characters per sec, using a 1-in. tape width and 300 bits per in. density. This tape speed, plus the tape's width and packing density, cuts search time to 1/6th of the time previously required. Another feature is the reduction of start and stop times to 1.5 msec. These times are built-in characteristics, allowing a predictable time of response to command. The quick control of the reel motors is provided by a thyatron servo system responding to air-column pressure changes.

Ampex Corp., Dept. ED, 934 Charter St., Redwood City, Calif.

CIRCLE 44 ON READER-SERVICE CARD



KI  
ALA 3A  
ARIZON  
Cires  
MAn  
ARKAN:  
CALIF  
3939  
Sacr  
San  
San I  
COLOR:  
PEarl  
CONNE  
1101  
DELAW  
DIST. C  
2017  
FLORID  
1226  
GEORG  
3133  
IDAHO:  
ILLINO  
2711  
INDIAN  
5420  
IOWA:  
West  
KANSA  
KENTU  
LOUISI  
MAINE  
MARYL  
635  
MASSA  
Midc  
MICH  
1531  
MINNE  
842  
MISSI  
7916  
MONTA  
Wes  
NEBRA  
Wes  
NEVAD  
NEW J  
905  
Engl  
Diar  
NEW P  
107  
Las  
NEW Y  
Tra  
Ass  
NORTI  
P. O  
NORTI  
431  
Day  
AXr  
OKLA  
OREG  
CAp  
PENN  
212  
Pitt  
540  
Upp  
740  
RHOD  
SOUT  
SOUT  
TENN  
TEXA:  
Fl  
2-7  
UTAH  
VERM  
VIRG  
WASH  
MU  
WIS  
D  
WISC  
I  
W



**CONTACT YOUR NEAREST  
KIN TEL ENGINEERING REPRESENTATIVE**

**ALABAMA:** See Ga., Bivins & Caldwell, Inc.  
**ARIZONA:** Neely Enterprises, Phoenix, 641 E. Missouri, Crestwood 4-5431; Tucson, 232 S. Tucson Blvd., Main 3-2564  
**ARKANSAS:** See Texas, E. Lipscomb Assoc.  
**CALIFORNIA:** Neely Enterprises, N. Hollywood, 3939 Lankershim Blvd., Stanley 7-0721; Sacramento: 1317 Fifteenth St., Gilbert 2-8901; San Carlos, 501 Laurel St., LYtell 1-2626; San Diego 6, 1055 Shafter St., ACademy 3-8106  
**COLORADO:** Denver, Lahana & Co., 1886 S. Broadway, Pearl 3-3791  
**CONNECTICUT:** Bridgeport, Yewell Assoc., Inc., 1101 E. Main St., FOrrest 6-3456  
**DELAWARE:** See Md., Horman Assoc., Inc.  
**DIST. OF COLUMBIA:** Washington, Horman Assoc., 2017 "S" St., NW, DEcatur 2-5705  
**FLORIDA:** Orlando, Bivins & Caldwell, Inc., 1226 E. Colonial Dr., CHerry 1-1091  
**GEORGIA:** Atlanta 5, Bivins & Caldwell, Inc., 3133 Maple Dr., NE, CEdar 3-7522  
**IDAH0:** See Wash., ARVA  
**ILLINOIS:** Chicago 45, Crossley Assoc., 2711 W. Howard St., SHeldrake 3-8500  
**INDIANA:** Indianapolis, Crossley Assoc., Inc., 5420 N. College Ave., CLifford 1-9255  
**IOWA:** Eastern: See Ill., Crossley Assoc., Inc. Western: See Minn., Crossley Assoc., Inc.  
**KANSAS:** See Mo., Harris-Hanson Co.  
**KENTUCKY:** See N. C., Bivins & Caldwell, Inc.  
**LOUISIANA:** See Texas, E. Lipscomb Assoc.  
**MAINE:** See Mass., Yewell Assoc., Inc.  
**MARYLAND:** Baltimore 10, Horman Assoc., Inc., 635 St. John's Rd., HOPkins 7-2290  
**MASSACHUSETTS:** Burlington, Yewell Assoc., Inc. Middlesex Turnpike, Phone 7-2561  
**MICHIGAN:** Detroit 35, S. Sterling Co., 15310 W. McNichols Rd., BRoadway 3-2900  
**MINNESOTA:** St. Paul, Crossley Assoc., Inc., 842 Raymond Ave., Midway 6-7881  
**MISSISSIPPI:** See Texas, E. Lipscomb Assoc.  
**MISSOURI:** Kansas City 30, Harris-Hanson Co., 7916 Paseo Ave., HIlard 4-9494  
**MONTANA:** Eastern: See Colo., Lahana & Co. Western: See Wash., ARVA  
**NEBRASKA:** Eastern: See Minn., Crossley Assoc., Inc. Western: See Colo., Lahana & Co.  
**NEVADA:** See Calif., Neely Enterprises  
**NEW HAMPSHIRE:** See Mass., Yewell Assoc., Inc.  
**NEW JERSEY:** Asbury Park, I. E. Robinson Co., 905 Main St., KElllogg 1-3150 Englewood, RMC Assoc., 391 Grand Ave., DIamond 3-5926  
**NEW MEXICO:** Albuquerque, Neely Enterprises, 107 Washington St., SE, Phone 5-5586 Las Cruces, 126 S. Water St., JACkson 6-2486  
**NEW YORK:** New York 21, RMC Assoc., 236 E. 75th St., TRafalgar 9-2023; Syracuse 2, J. D. Ryerson Assoc., Inc., 412 Genesee East, GRanite 6-8344  
**NORTH CAROLINA:** High Point, Bivins & Caldwell, Inc., P. O. Box 5187, Phone 3672  
**NORTH DAKOTA:** See Minn., Crossley Assoc., Inc.  
**OHIO:** Cleveland 21, S. Sterling Co., 4311 Mayfield Rd., EVergreen 2-4114 Dayton 19, Crossley Assoc., Inc., 53 Park Ave., AXminster 9-3594  
**OKLAHOMA:** See Texas, E. Lipscomb Assoc.  
**OREGON:** Portland 9, ARVA, 1238 NW Glison St., CApital 7-1281  
**PENNSYLVANIA:** Camp Hill, I. E. Robinson Co., 2120 Market St., REgent 7-6791 Pittsburgh 36, H. E. Ransford Co., 5400 Clairton Blvd., TUxedo 4-3425 Upper Darby, I. E. Robinson Co., 7404 West Chester Pike, FLanders 2-7017  
**RHODE ISLAND:** See Mass., Yewell Assoc., Inc.  
**SOUTH CAROLINA:** See Ga., Bivins & Caldwell, Inc.  
**SOUTH DAKOTA:** See Minn., Crossley Assoc., Inc.  
**TENNESSEE:** See N. C., Bivins & Caldwell, Inc.  
**TEXAS:** Dallas 9, E. Lipscomb Assoc., P. O. Box 7084, FLeeewood 7-1881; El Paso, 720 N. Stanton, Phone 2-7281; Houston 5, 2422 Rice Blvd., JACkson 4-9303  
**UTAH:** See Colo., Lahana & Co.,  
**VERMONT:** See Mass., Yewell Assoc., Inc.  
**VIRGINIA:** See N. C., Bivins & Caldwell, Inc.  
**WASHINGTON:** Seattle 99, ARVA, 120 W. Thomas St., URdoch 7337  
**WEST VIRGINIA:** Northern: See Pa., H. E. Ransford Co. Southern: See N. C., Bivins & Caldwell, Inc.  
**WISCONSIN:** Eastern: See Ill., Crossley Assoc., Inc. Northeastern: See Minn., Crossley Assoc., Inc.  
**WYOMING:** See Colo., Lahana & Co.

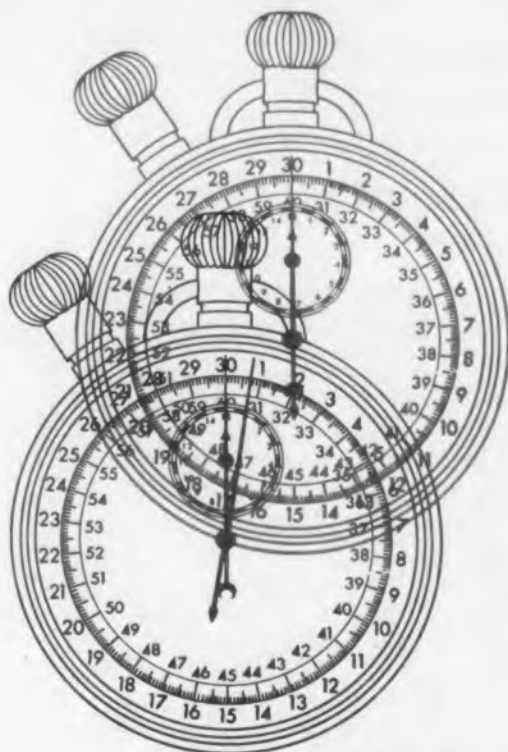

**INSTANTLY...**

**measure and supply DC  
voltages to 0.02%**

*with the new KIN TEL DC voltage standard and null voltmeter*

**LABORATORY ACCURACY.** The Model 301 is an extremely compact and accurate variable DC power supply and calibrated null voltmeter. It employs KIN TEL's proved chopper circuit to constantly compare the output voltage against an internal standard cell. As a DC voltage standard, it combines the stability and accuracy of the standard cell with the current capabilities and excellent dynamic characteristics of the finest electronically regulated power supplies. The self-contained null voltmeter indicates the voltage difference between the supply in the 301 and the DC source being measured, affording simple and rapid measurement of DC voltages to an accuracy of 0.02%.

**PRODUCTION LINE SPEED.** DC voltage measurements can be made as fast as changing ranges on a VTVM. Merely set the direct reading calibrated dials on the 301 to exactly null out the unknown DC input voltage. The reading on the dials then indicates the value of the unknown input voltage to within 0.02%. As a variable DC standard or power supply, the calibrated dials provide instant voltage selection to an accuracy normally attained only with standard cells.

**VERSATILITY.** The KIN TEL Model 301 is ideal for rapid and accurate production calibration of precision measuring instruments and DC power supplies... design of DC amplifiers and complex electronic circuitry... computer reference... versatile precision reference for calibration and measurement laboratories.

Ask for a  
demonstration today!

*0.01% stability*

*0.02% accuracy*

*1 to 501 volts at 20 ma*

*4 accurate null ranges*

*0.002% regulation*

*Less than 100  $\mu$ v ripple*



**IMPORTANT SPECIFICATIONS**

Output Voltage & Current 1 to 501 volts at up to 20ma  
 Full Scale Meter Ranges (Zero Center)  
 DC Output Range .....  $\pm 500$ , 50 volts  
 DC Input Range .....  $\pm 500$ , 50 volts  
 DC Null Meter Range ..  $\pm 50$ , 5, 0.5, 0.05 volts  
 Long Time Stability .....  $\pm 100$  parts per million  
 Output Voltage Calibration .....  $\pm 0.02\%$  or 2 mv  
 Output Hum and Noise ..... Less than 100  $\mu$ v RMS  
 Line and Load Regulation ..... 0.002%  
 DC Output Impedance ..... Less than 0.01 ohm  
 Response Time ..... 0.2 millisecond  
 Model 301 Price \$625.

Representatives in all major cities. Write today for  
demonstration or descriptive literature.

5725 Kearny Villa Road, San Diego 11, Calif., BRowning 7-6700

CIRCLE 45 ON READER-SERVICE CARD

**KINTEL**



**SEARCH  
IDENTIFY  
COMPUTE  
COMMUNICATE  
INTERCEPT**



**Now—from General Electric—tubes to  
military specifications for entire systems!**

This means computers too, because General Electric's 5-Star 6829—the industry's first tube built and tested to a military computer-tube specification—is the final link in the chain.

Here is a twin triode with exceptional ruggedness and reliability—the reliability that only tubes can give. It is specifically intended for ground and airborne military use. Similar in characteristics to standard computer Type 5965, the 5-Star 6829 is designed for high-speed circuits—has high permeance, balanced, sharp cut-off qualities, and low heater power requirement (.45 amp at 6.3 v).

Specify—for military computer applications—tubes backed by General Electric's 7-year record of

primacy in computer-tube development! First manufacturer to design and introduce special computer tubes: General Electric. First builder of high-reliability computer types: General Electric. More G-E computer tubes have been built and installed than any other make. Many G-E 5844's—the first computer tubes—still are operating, *after more than 50,000 hours' active service.*

For computers—for other electronic equipment—G-E 5-Star Tubes, miniatures and subminiatures, offer proved performance, proved dependability, plus a wide range of types to meet every socket requirement. Get further facts from any office of the G-E Receiving Tube Department below.

**EASTERN REGION**

200 Main Avenue, Clifton, New Jersey  
Phones: (Clifton) GRegory 3-6387  
(N.Y.C.) Wlconsin 7-4065, 6, 7, 8

**CENTRAL REGION**

3800 North Milwaukee Avenue  
Chicago 41, Illinois  
Phone: SPring 7-1600

**WESTERN REGION**

11840 West Olympic Boulevard  
Los Angeles 64, California  
Phones: GRanite 9-7765; BRadshaw 2-8566

*Progress Is Our Most Important Product*

**GENERAL  ELECTRIC**

12-11-202

**NEW PRODUCTS**

**Strain Relief Bushing  
Thick Housings**



Type SR-5L strain relief bushing is designed especially for SV, HPN, HPD and SPT wires and will anchor the wire to housings with 1/8 in. thick walls. Snapping into chassis hole, the bushing absorbs pull, push and torque.

Heyman Manufacturing Co.,  
Dept. ED, 100 Michigan Ave.,  
Kenilworth, N.J.

CIRCLE 47 ON READER-SERVICE CARD

**Molded Transformers  
for Metering Applications**



Type CPE molded transformers are for use with watt-hour meters or other applications where high accuracy at low burdens is required. The unit is a windowtype transformer, but can be supplied with round or flat bar primary conductors, or mounting brackets.

Standard Transformer Co., Dept.  
ED, Warren, Ohio.

CIRCLE 48 ON READER-SERVICE CARD

**Seismic Data Processor  
Central Portable System**

The VIP variable Intensity plotter offers central processing office advantages while preserving mobility for the quick processing and

← CIRCLE 46 ON READER-SERVICE CARD

interpretation of seismic data. Components of the system consist of a visual display unit weighing 65 lb, and a computing unit weighing 85 lb.

Texas Instruments, Inc., Dept. ED, 3609 Buffalo Speedway, Houston 6, Texas.

CIRCLE 49 ON READER-SERVICE CARD

### Plastic Wiring Duct Overlapping Closed-Slot



Type C plastic wiring duct features overlapping closed slots over the full length of the duct. Quick access is possible with a cover which snaps or slides in place directly on the duct. Another model, type B, has individual snap-in slots which allow wires to be laid after terminals have been attached.

Panduit Co., Dept. ED, 14461 Waverly Ave., Midlothian, Ill.

CIRCLE 50 ON READER-SERVICE CARD

### Nylon Screws for Miniature Assemblies

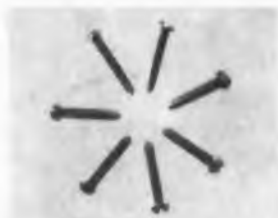

This 2-56 round-head nylon screw, precision-molded to American Standard Thread Specifications, is especially suitable for miniature assemblies where nylon can be used to advantage. Insulation without special washers or bushings, and resistance to corrosion and fungus are featured.

Weckesser Co., Dept. ED, 5701 Northwest Highway, Chicago 30, Ill.

CIRCLE 51 ON READER-SERVICE CARD

CIRCLE 52 ON READER-SERVICE CARD ➤

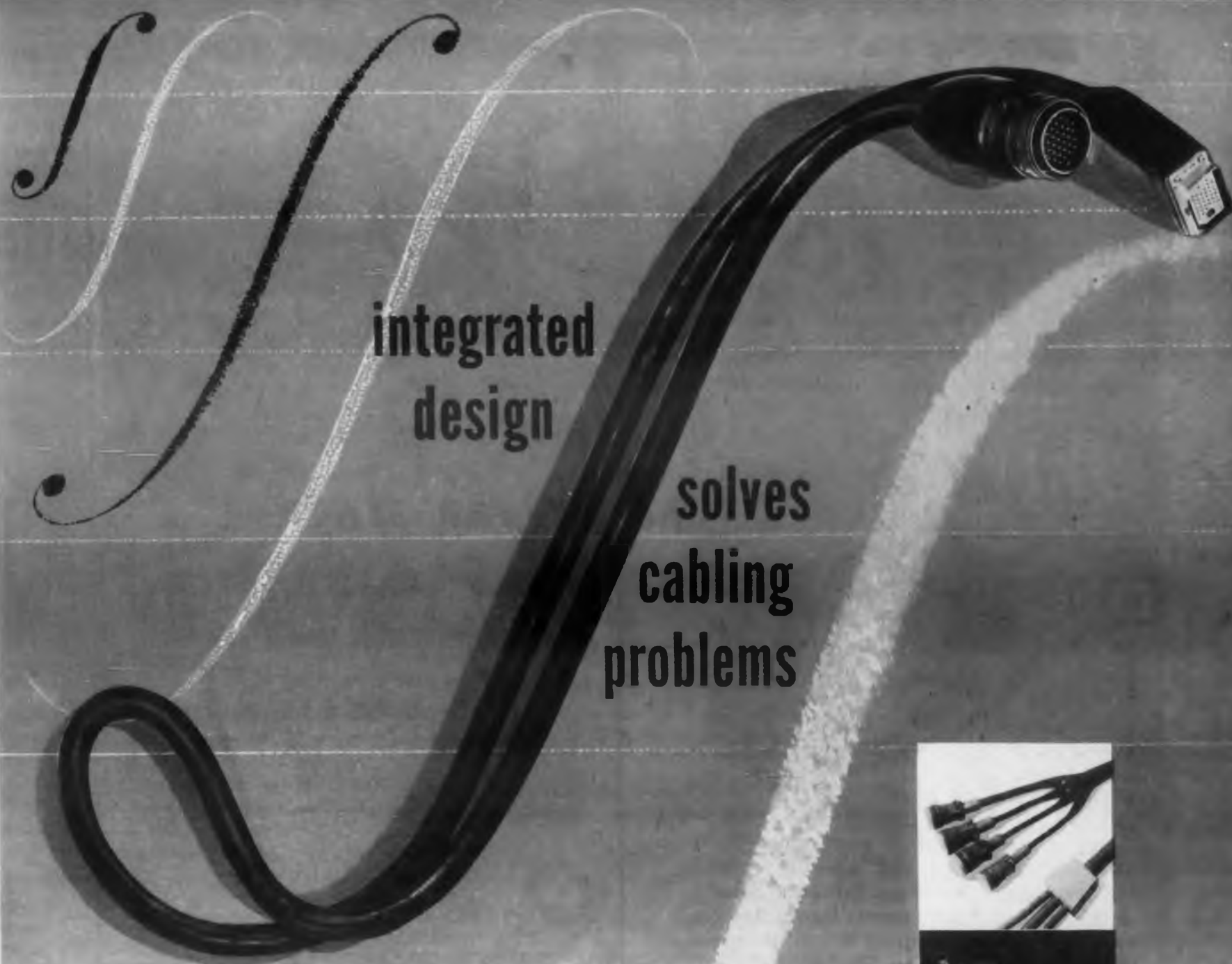

integrated  
design

solves  
cabling  
problems

**P**icture, if you will, an engineer who would rather design electronic cabling than black boxes or space ships—an engineer who fully understands your product and your requirements for electronic cables—an engineer who can integrate your design philosophies into custom cable assemblies—an engineer who can provide, at the right time and in any quantity, cables that are as carefully integrated into your product as is each black box.

The engineer who calls on you from Pacific Automation Products, Inc., is such a man.

Solve your cabling problems by integrating the PAPI man into your planning, and his cables into your product. Phone, write, or wire:

## PACIFIC AUTOMATION PRODUCTS, INC.

1000 AIRWAY, GLENDALE 1, CALIFORNIA Phone: CHapman 5-6871 or Cltrus 4-8677

137 Walnut Hill Village • Dallas 20, Texas • FLettwood 2-5806  
1809 Virginia Ave. • Redwood City, Calif. • EMerson 9-1962  
420 Lexington Ave. • New York 17, N. Y. • LExington 2-5193



ENGINEERS—HERE IS A COMPANY THAT HAS RAISED CABLE DESIGN FROM THE MUNDANE TO A HIGHLY DEVELOPED AND PRECISE SCIENCE. THERE MAY BE A JOB HERE FOR YOU. SEND YOUR RESUME TODAY.

**ADVANCE**  
 —YOUR PRODUCTION  
 —YOUR PROFITS  
 WITH  
**STAMPINGS**



These are actual size advance stampings, which saved production costs.



## PROFITS INCREASE...

when you engineer in stampings. Save on material, labor and assembly costs. Here are just a few of the Advance Stampings, which have been fabricated in various materials to meet tolerance specifications, delivery and price.



- MAXIMUM 4" BLANKS • MAXIMUM 2 3/4" DRAW
- CAPACITY TO 65 TONS

Advance Stamping has been helping metal working industries of various kinds, attain higher production at lower cost, for over 35 years.

Send us your blue prints or samples for quotations. Advance engineers are available to consult on ways to improve your competitive position.

Write for Small Stamping Specialists Brochure



**ADVANCE STAMPING CO.**

12027 Dixie Ave., Detroit 39, Michigan

CIRCLE 53 ON READER-SERVICE CARD

Telemetry Simplified with

# Angular Position Transducer

Fig. 1. Cross section of transducer. The grey area is a stator cylinder of magnetic material in which the coil is imbedded.

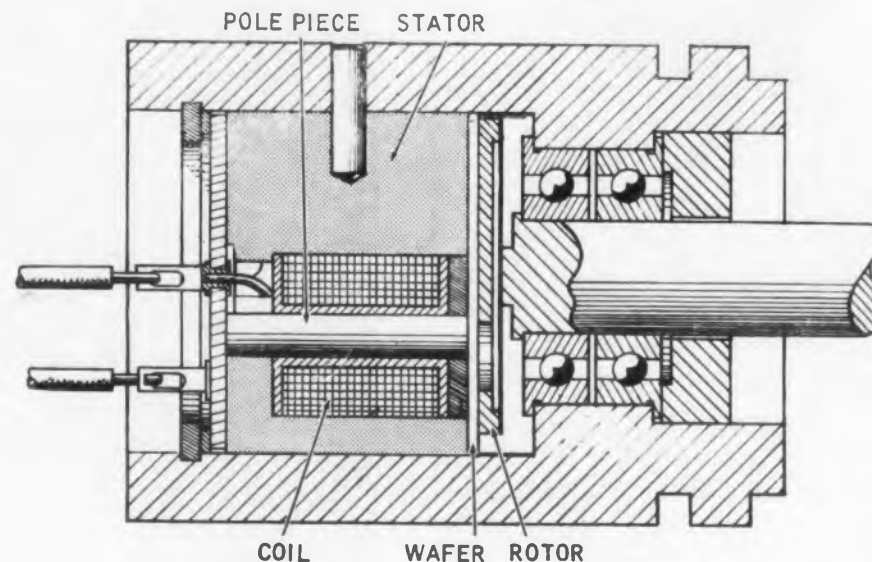

INFINITE resolution and insensitivity to vibration and shock characterize a new type of angular position transducer. Operating on the variable reluctance principle, the transducers are designed for use in telemetry systems where measurements are transmitted as signal frequencies. Rotation of a magnetic rotor varies the amount of ferro-magnetic material in a fixed air gap, and due to the shape of the rotor, a change in the magnetic reluctance varies the frequency of an oscillator in a linear manner.

Developed by Ultradyne Inc., P. O. Box 3308, Albuquerque, N. M., the new transducers function through the use of a single electrical coil and an associated magnetic circuit. A magnetic rotor, which is actuated by the movement of the object being tested, varies the cross-sectional area of a non-magnetic gap which is part of the magnetic circuit. As this area varies, a change occurs in the coil impedance, causing a change in the frequency of the signal generated by the oscillator which contains the coil as a frequency-determining element.

The transducer is housed in an outer shell. A cylindrical magnetic stator is rotatably mounted within the shell. A coil is wound around pole piece, mounted within the stator, and held in position by potting compound. The end of the pole piece opposite the potting compound is in intimate contact with the stator, providing good magnetic conductivity. A tetrafluorethylene resin wafer, several mils thick, provides lubrication between the facing surfaces of the rotor and stator.

A magnetic circuit, consisting of the following elements, is created: pole piece, main body of the stator, the non-magnetic gap between rotor and stator occupied by wafer, rotor, the non-magnetic gap between the pole piece and the rotor—also occupied by the wafer. Variation of the cross-sectional area of this last-named gap while the shaft rotates is one of the basic principles behind the patent applications for the new instruments. In Fig. 2 the rotor is seen to have a number of holes. These holes are located equidistant from the center of the rotor, within close toler-

ances. This distance is such that pole piece lies fairly well within a projection of any of the rotor holes onto the stator when the rotor is in a position slightly clockwise from that shown. When the rotor is in such a position, any magnetic flux leaving the pole piece must traverse a considerable space gap in order to reach the rotor. This, then, is the position of maximum reluctance of the magnetic circuit and the position which gives the coil its minimum impedance. The shape of the non-magnetic portion of the rotor can be chosen to compensate for the non-linear effects on coil inductance usually noticed when the size of the gap is varied.

The transducer is supplied in two models, the T-2-TA and T-4-TA, the latter being temperature

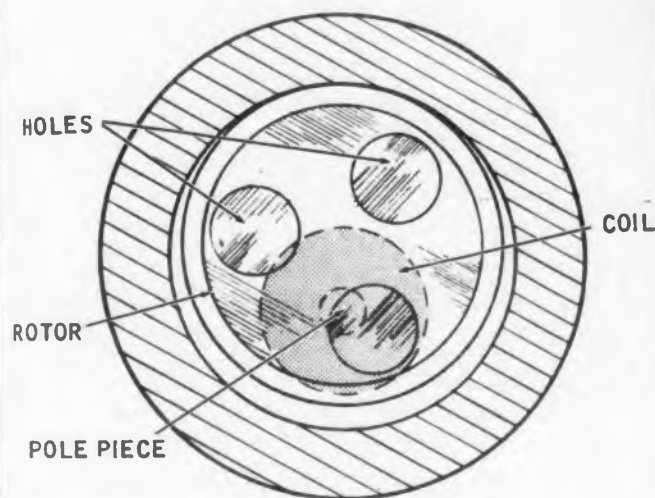

Fig. 2. Diagram showing position of rotor over pole piece. The holes in the rotor compensate for non-linear effects in coil inductance.

compensated over the range of 0 F thru  $\pm 250$  F. Specifications include an angular range of  $\pm 4$  deg to  $\pm 10$  deg, an inductance mid-range value matched to oscillator and tapped at 60 per cent of full inductance. They withstand 18 impact shocks of 30 g's, without damage and without exceeding normal operating tolerances. Operating temperature range is  $-65$  F through  $\pm 250$  F. Error will not exceed  $\pm 3$  per cent of full range output from best straight line.

Sensitivity adjustment is permitted by varying the thickness of the wafer employed, since this dimension controls the length of both the non-magnetic gaps in the circuit. The particles cause a sort of hysteresis in the calibration curves, decreasing instrument accuracy. The tetrafluoroethylene wafer is consequently used as a form of lubrication which will maintain constant length gaps by eliminating the end play caused by particles and compensating for any surface irregularities.

For more information circle 54 on Reader Service Card.



## SPACE SAVING CAPACITOR ... tailored for transistors

**SLIM LIKE A DISC** ... Wafer-thin shape of the Good-All 601PE makes it ideal for upright mounting in tight spaces.

**EXCELLENT TEMPERATURE STABILITY** ... The TC of the 601PE is identical with that of a conventional tubular capacitor.

**MOISTURE TIGHT EPOXY COATING** ... This tough, durable epoxy has exceptionally high dielectric strength and lead entries are tightly sealed.

**ECONOMICAL** ... Competitive in price with ceramic discs in the capacity range of 0.1 MFD and above.

\*DuPont's trademark for polyester film.

TYPE 601PE DIMENSIONS  
(FOR 50 VDC RATING)

CAP. (MFD.)	A	B	D	E	CAP. (MFD.)	A	B	D	E
.01	.310	.800	.187	.187	.1	.650	.850	.375	.225
.022	.359	.800	.187	.187	.15	.671	.900	.375	.260
.033	.531	.650	.312	.171	.22	.718	.900	.375	.296
.047	.531	.700	.312	.203	.33	.812	.950	.500	.312

### SPECIFICATIONS

**Insulation Resistance**—Greater than 75,000 megohms when measured at 100 volts D.C. at 25° C for a maximum of 2 minutes.

**Capacity Tolerance**—Standard tolerance is 20%.

**Winding Construction**—Extended foil (non-inductive) MYLAR® Dielectric.

**Lead Variations**—formed or straight leads.

**Dissipation Factor**—Less than 1% at 1,000 cycles per second at 25° C.

**Dielectric Strength**—100 volts D.C. for 1 to 5 seconds thru a minimum current limiting resistance of 20 ohms per volt.

**Temperature Range**—May be operated at full rated voltage to 85° C. Derate to 50% when operating at 125° C.

Insulation Resistance vs. Temperature  
Degrees Centigrade

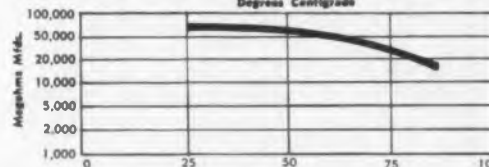

Capacitance Change vs. Temperature  
Degrees Centigrade

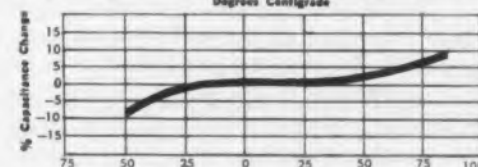

TECHNICAL BROCHURE AVAILABLE ON REQUEST

MANY GOOD-ALL CAPACITOR TYPES ARE NOW AVAILABLE AT YOUR LOCAL DISTRIBUTOR



GOOD-ALL ELECTRIC MFG. CO.

OGALLALA, NEBRASKA

GOOD-ALL

TYPE  
601PE

"SLIM  
LINE"

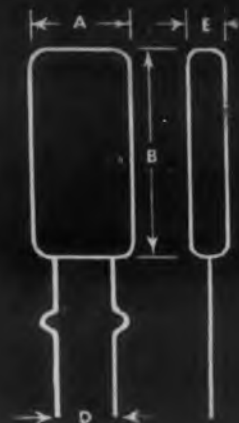

CRIMPED  
LEAD STYLE

CIRCLE 55 ON READER-SERVICE CARD

Economy and Quality with

**NEW**  
**22 Circuit Centralab.**

**MINIATURE SWITCHES**

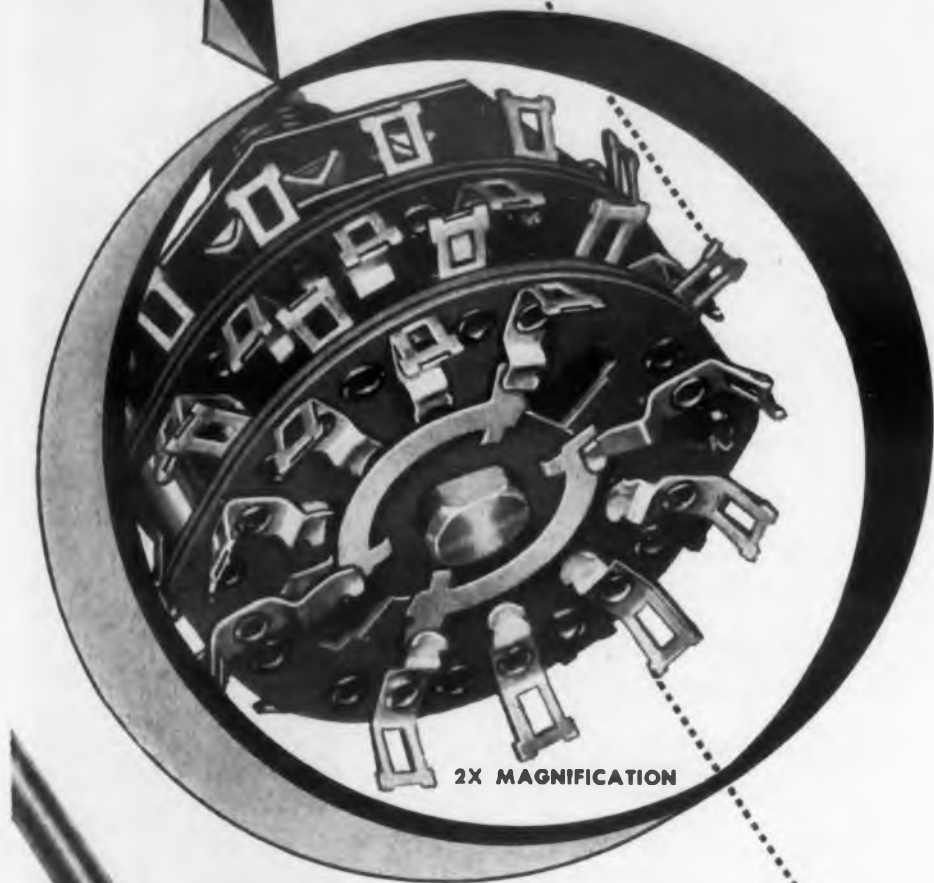

2X MAGNIFICATION

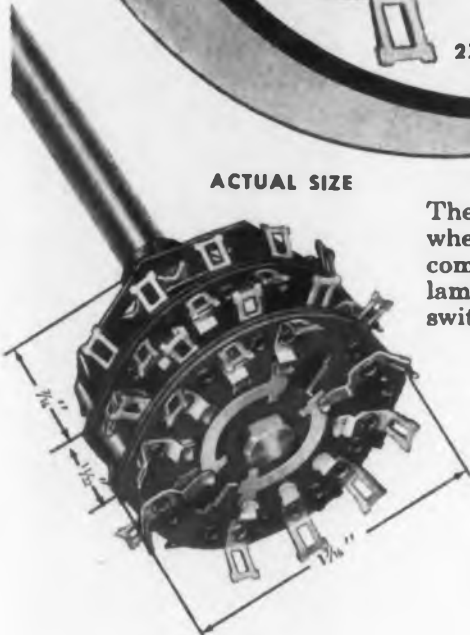

ACTUAL SIZE

These new switches are designed for application where costs must be kept to a minimum without compromising rigid electrical specifications. New laminated construction allows up to 22 separate switch points on a  $\frac{1}{16}$ " diameter.

- Voltage breakdown, 1000 volts R.M.S. Back to back insulated clips, 500 volts R.M.S. Laminated phenolic sections type PBE per specifications MIL-P-3115.
- Current rating 2 amp. at 15 volts DC; 150 milliamps at 110 volts AC (resistive load).
- Minimum life, 10,000 cycles.
- Supplied as single section, double section, or single section with line switch. 2-12 positions per switch.
- AC line switches for single section units in SPST, DPST and SPDT switching arrangements.

For detailed specifications, write for Bulletin EP-90 or contact your Centralab representative.

**Centralab** 

P-5808

A DIVISION OF GLOBE-UNION, INC.  
900A E. KEEFE AVE. • MILWAUKEE 1, WIS.  
In Canada: 804 Mt. Pleasant Rd. • Toronto, Ontario

VARIABLE RESISTORS • PACKAGED ELECTRONIC CIRCUITS • ELECTRONIC SWITCHES  
CERAMIC CAPACITORS • ENGINEERED CERAMICS • SEMI-CONDUCTOR PRODUCTS

CIRCLE 56 ON READER-SERVICE CARD



## Multichannelele

**T**HIS NEW switch is entirely electronic and overcomes many of the shortcomings of mechanical types which are plagued by a short life span at high sampling rates. It is the newest answer to the need for reliable telemetering switches.

The need for reliable switches to sample large quantities of data is a real one. It is surprising that in spite of a pressing need, there are so few highly reliable sampling switches on the market. (See ED, July 15, 1957, p 32.)

This new switch, tradenamed Electrocom, has no moving parts so it can withstand high vibration and acceleration environments and can meet many other military requirements. Manufactured by General Devices, Inc., of Princeton, New Jersey, models are available to provide up to four accurately synchronized poles, sampling rates to 24,000 samples per minute per channel, and up to 24 non-shorting channels with insulation resistance to 100 megohms between any two channels.

The Electrocom accepts inputs in the 0-5 v range with source impedances up to 10 kilohms, and provides output voltages in the same range into load impedances of 25 K or greater. When properly operated, the input-output linearity is about 0.2 per cent. One of its beauties lies in its size. One model weighs less than one pound and measures only 2 x 2 x 3 in.

The block diagram shows how the switch works. A series of sequential gate control pulses establishes the required channel time slots. Input signals are gated to a common output in sequence. The channel on-time can be varied by electrical blanking at the common output point.

If rec  
at the  
Th  
polyf  
chain  
gas t  
the s  
temp  
weigh  
chron  
Mo  
passi  
vices  
elem  
empl  
pulse  
verte  
Fo  
switc

Con  
blar  
or S  
ped  
gen

OUT

Func  
cham  
for s

ELEC

# Electronic Switch

If required, voltage pedestals can be introduced at the output.

The gate pulse generator can use delay lines, polyphase signals, an open ring multivibrator chain, a closed ring counter, a binary matrix, a gas tube chain, or other circuitry depending on the system requirements. The choice depends on temperature, shock, vibration, power, size, weight, speed, switching voltage level, and synchronization requirements.

Models are available which use only simple passive elements, while others use solid state devices, gas tubes, magnetic cores or other active elements, depending on the scanning principle employed. The output, always in the form of pulse amplitude modulation (PAM), can be converted to other forms.

For more information on this high speed switch, circle 57 on the Reader-Service Card.

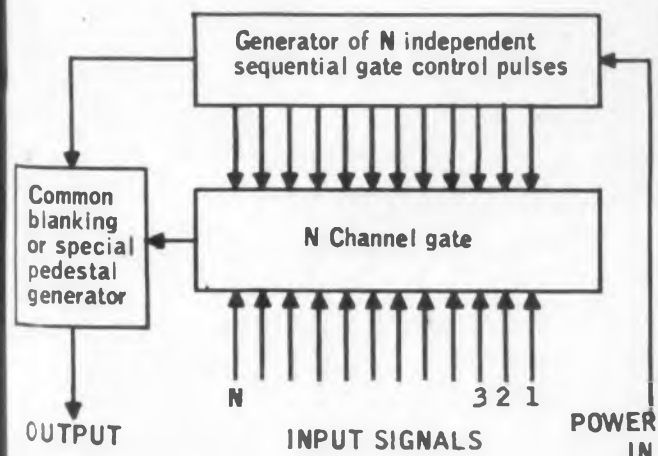

Functional block diagram of the high speed multi-channel switch. One of several principles can be used for sequential switching.



Now... H

**Hoffman**  
**Electronics**  
CORPORATION



SEMICONDUCTOR DIVISION  
930 PITNER AVENUE  
EVANSTON, ILLINOIS  
UNiversity 9-9850

SPECIALISTS IN  
SILICON SEMICONDUCTORS



**Hoffman** Micro-Miniature

# ZENER Silicon Junction DIODES

with **GOLD ALLOY**  
**Ohmic Contacts**

The **GOLD CONTACT**

at the **Heart**  
of this  
**Diode**

assures  
long  
life

## TYPICAL CHARACTERISTICS LOW VOLTAGE MICRO-MINIATURE ZENER DIODES

Hoffman Type Number	GZ1	GZ2	GZ3	GZ4	GZ5	GZ6
Zener Voltage Range: Volts @ $I_z = 5$ mA dc	2.0 to 3.2	3.0 to 3.9	3.7 to 4.5	4.3 to 5.4	5.2 to 6.4	6.2 to 8.0
Zener Impedance:						
Avg. * @ $I_z = 10$ mA dc	45	40	30	25	10	5
Max. @ $I_z = 10$ mA dc	60	55	45	35	20	10

Hoffman Micro-Miniature ZENER Silicon Junction Diodes are made with GOLD ALLOY Ohmic Contacts in order to withstand higher operating temperatures. This line of Hoffman Zener Diodes was developed for *Clipping, Limiting and Regulating* and similar applications where physical mounting space is at a minimum.

Rated at 250 milliwatts at 25°C (ambient temperature) and derated at one (1) milliwatt per degree centigrade above 25°C.

Operating and storage temperature range: -65°C to +200°C. Special selections from Types GZ1 thru GZ6 are available with a tolerance of  $\pm 5\%$ .

Units with ZENER voltages from 8 volts thru 51 volts are available at tolerances of  $\pm 10\%$  and  $\pm 5\%$ . From 56 volts thru 100 volts at  $\pm 10\%$  tolerance.

Write for Hoffman Technical Information Bulletin No. 27-58 for detailed data on this new line of Micro-Miniature Zener Diodes.

CIRCLE 58 ON READER-SERVICE CARD

## NEW PRODUCTS

### Transistor Socket

For use with 3 and 4 pin Jetec 30's



This socket is molded from mica-filled phenolic per Mil M-14, type MFE and is for use with 3 and 4 pin Jetec 30 transistors. The beryllium copper contacts are wrap-around style, silver plated and gold flashed for good contact as well as corrosion resistance.

Grayhill, Inc., Dept. ED, 561 Hillgrove Ave., LaGrange, Ill.

CIRCLE 59 ON READER-SERVICE CARD

### Magnetic Storage Drum

Stores 15,000 binary bits in a small unit



A total storage of 15,000 binary bits in a drum measuring 15 in. in diam and 14 in. high is the primary feature of this unit. Called the HD (high density) file drum, the unit consists of the drum, driving and lubrication system, track-selection mercury relay matrix, linear readout preamplifier, and final writing amplifier. Average random access time provided to any data is 180 msec. The complete drum has 320 tracks, 20 of which are used as spares. The recording heads are assembled in pairs. Mating surfaces of the head pole pieces are optically lapped, and a lubrication system is provided to insure a very small uniform separation between the heads and the drum surface, and therefore very high recording density. The matrix of relays used for track selection are a pressurized, mercury-wetted contact type.

Laboratory of Electronics, Inc., Dept. ED, 75 Pitts St., Boston 14, Mass.

CIRCLE 60 ON READER-SERVICE CARD



Model R

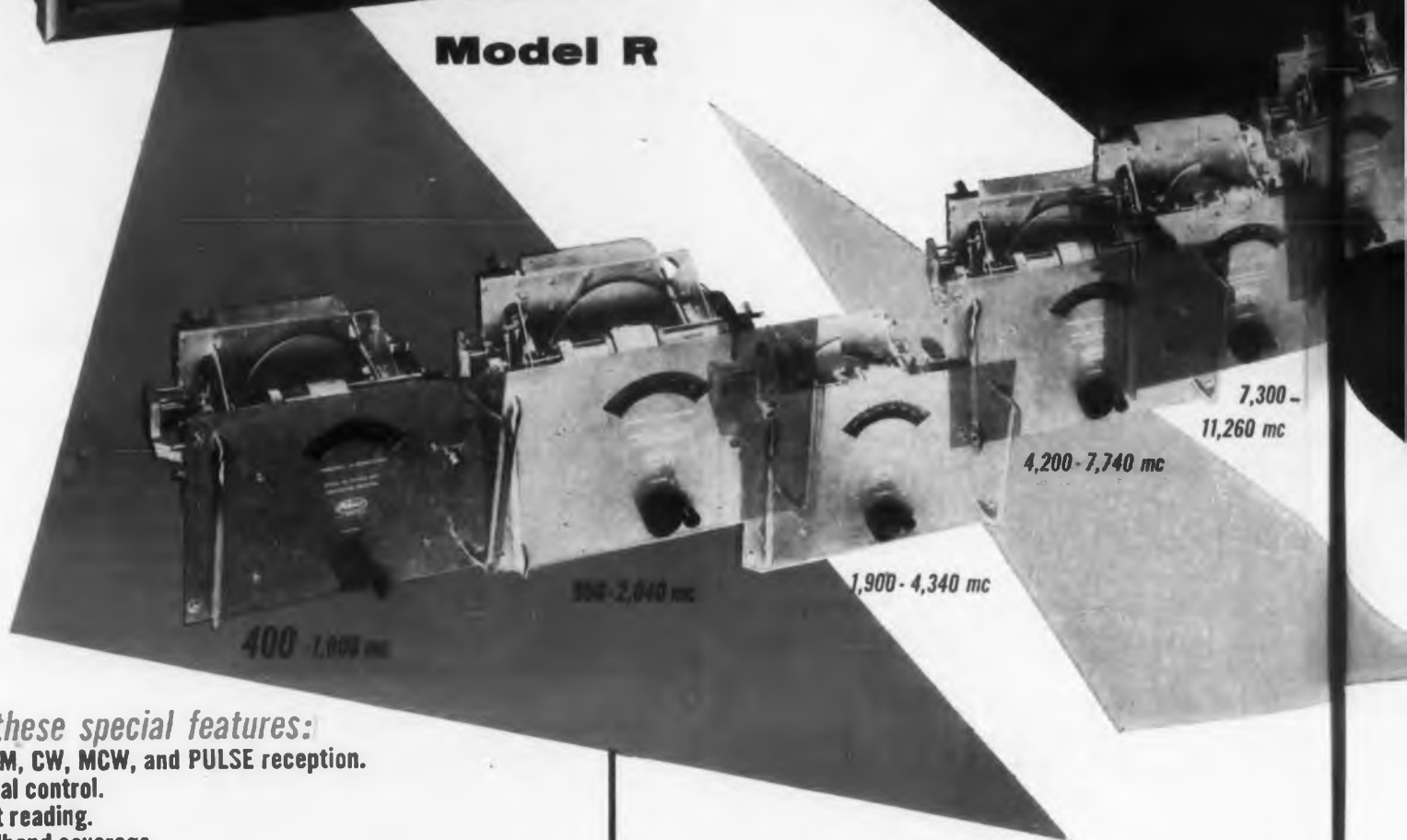

#### Note these special features:

- AM, FM, CW, MCW, and PULSE reception.
- Uni-dial control.
- Direct reading.
- Broadband coverage.
- Output level reading directly in db.
- High sensitivity.
- Seven interchangeable plug-in r-f tuning units cover the entire frequency range.
- Low noise figure; excellent gain stability.
- Microwave preselection, tracked and double-tuned, used in the plug-in tuning units covering the range 400 to 11,260 mc.
- Audio, video, and trigger outputs.
- Special recorder output.
- High video output—low impedance.
- AGC and AFC circuits.

#### For these applications:

- General communications.
- Field intensity meter.
- Frequency meter.
- Measurement of radiation and leakage of microwave devices.
- Measurement of bandwidth of microwave cavities.
- Measurement of relative power of fundamental and harmonic signal frequencies.
- Measurement of noise figure.
- Antenna field patterns.

# NEW

# EXTENDED RANGE MICROWAVE RECEIVER! 400 to 22,000 mc



## SPECIFICATIONS:

Basic Receiver: Model R-B  
Tuning Unit Frequency Ranges:

* Model RR-T	400- 1,000 mc
* Model RL-T	950- 2,040 mc
* Model RS-T	1,900- 4,340 mc
* Model RM-T	4,200- 7,740 mc
* Model RX-T	7,300-11,260 mc
* Model RKS-T	9,500-15,600 mc
* Model RKU-T	14,700-22,000 mc

Signal Capabilities:  
AM, FM, CW, MCW, pulse

### Sensitivity:

- (a) For Model RR-T: Minus 85 dbm  
(b) For Models RL-T, RS-T, RM-T, and RX-T: Minus 80 dbm  
(c) For Models RKS-T and RKU-T: Minus 65 dbm

Frequency Accuracy:  $\pm 1\%$

IF Bandwidth: 3 mc

Video Bandwidth: 2 mc

Image Rejection:

- (a) For Models RR-T thru RX-T:  
Greater than 60 db

Three new r-f tuning units double the frequency range of the well-known Polarad Microwave Receiver. Now more than ever the Model R becomes a basic multi-purpose instrument for microwave research and production in the field, in the laboratory, and in the factory.

This receiver is designed for quantitative analysis of microwave signals and is ideal for the reception and monitoring of all types of radio and radar communications within the broadband 400 to 22,000 mc. It permits comparative power and frequency measurements, by means of its panel-mounted meter, of virtually every type of signal encountered in microwave work.

It is compact and functional, featuring 7 integrally designed plug-in, interchangeable RF microwave tuning units to cover 400 to 22,000 mc; non-contacting chokes in pre-selector and microwave oscillator to assure long life and reliability; and large scale indicating meter for fine tuning control.

Call any Polarad representative or direct to the factory for detailed specifications.

(b) For Models RKS-T and RKU-T:  
Spurious response rejection obtained through the use of a bandpass filter

Gain Stability with AFC:  $\pm 2$  db

Automatic Frequency Control:  
Pull-out range 10 mc off center

Recorder Output: 1 ma. full scale (1,500 ohms)

Trigger Output:  
Positive 10-volt pulse across 100 ohms

Audio Output:  
5 volts undistorted, across 500 ohms

FM Discriminator:  
Deviation Sensitivity: .7 v./mc

Skirt Selectivity:  
60 db - 6 db bandwidth ratio less than 5:1

IF Rejection: 60 db

Input AC Power:  
115, 230 V ac, 60 cps, 440 watts

Input Impedance:  
Models RR-T through RX-T: 50 ohms  
Models RKS-T & RKU-T: waveguide

VSWR: Less than 4:1 over the band

Range of Linearity: 60 db

Receiver Type: Superheterodyne

Maximum Acceptable Input  
Signal Amplitude: 0.1 volt rms, without external attenuation

Video Response: 30 cps to 2 mc

Size: 17" w x 23" d x 19" h

Weight: 180 lbs. for basic unit with one tuning unit.



The first all ceramic Klystron tube for 1600 to 6500 mc POLARAD ZV1009

maintenance  
available by field  
service specialists



**ELECTRONICS CORPORATION**

43-20 34th Street • Long Island City 1, New York

REPRESENTATIVES: Albany, Albuquerque, Atlanta, Baltimore, Boston area (Westwood), Cedar Rapids, Chicago, Cleveland, Dayton, Denver, Detroit, Englewood, Fort Worth, Kansas City, Los Angeles, Philadelphia area (Abington), Portland, Rochester, Seattle, St. Louis, Stamford, Sunnyvale, Syracuse, Washington, D. C., Westbury, Wichita, Winston-Salem, Canada: Arnprior, Ontario. Resident Representatives in Principal Foreign Cities.

CIRCLE 61 ON READER-SERVICE CARD

## Humidity Cabinet

Provides temperature uniformity



Counter-flow controlled relative humidity cabinets are available with dry bulb temperatures from 32 to 185 F and controlled per cent relative humidity from 20 to 98 per cent. Air is mechanically convected horizontally across test chamber by alloy turbo blower. A vapor pressure system used to control humidity assures high temperature uniformity and control of humidity with no wet bulb control-wick to change. True point programming utilizes an automatic dual Microtrol plus a 24-hr timer and wet and dry bulb recorder.

Blue M Electric Co., Dept. ED, Blue Island, Ill.

CIRCLE 62 ON READER-SERVICE CARD

## Solenoid Valve

Entirely enclosed moving parts eliminate leakage



Type SV solenoid valve is specifically designed for high vacuum servicing and features freedom from leakage and high flow conductance. Stem leakage is eliminated, since the moving member is entirely enclosed within the valve body. The seat seal is made by a non-metallic O-ring set into one of two units that comprise the valve disc. When the valve is closed, these units are forced apart by a wedge action, pressing the O-ring against the smoothly machined brass bar body. Leak-proof tightness is tested with a mass spectrometer leak detector. High conductance is the result of straight-through design, very short flow path, and completely unimpeded ports.

Veeco Vacuum Corp., Dept. ED, 86 Denton Ave., New Hyde Park, N.Y.

CIRCLE 63 ON READER-SERVICE CARD

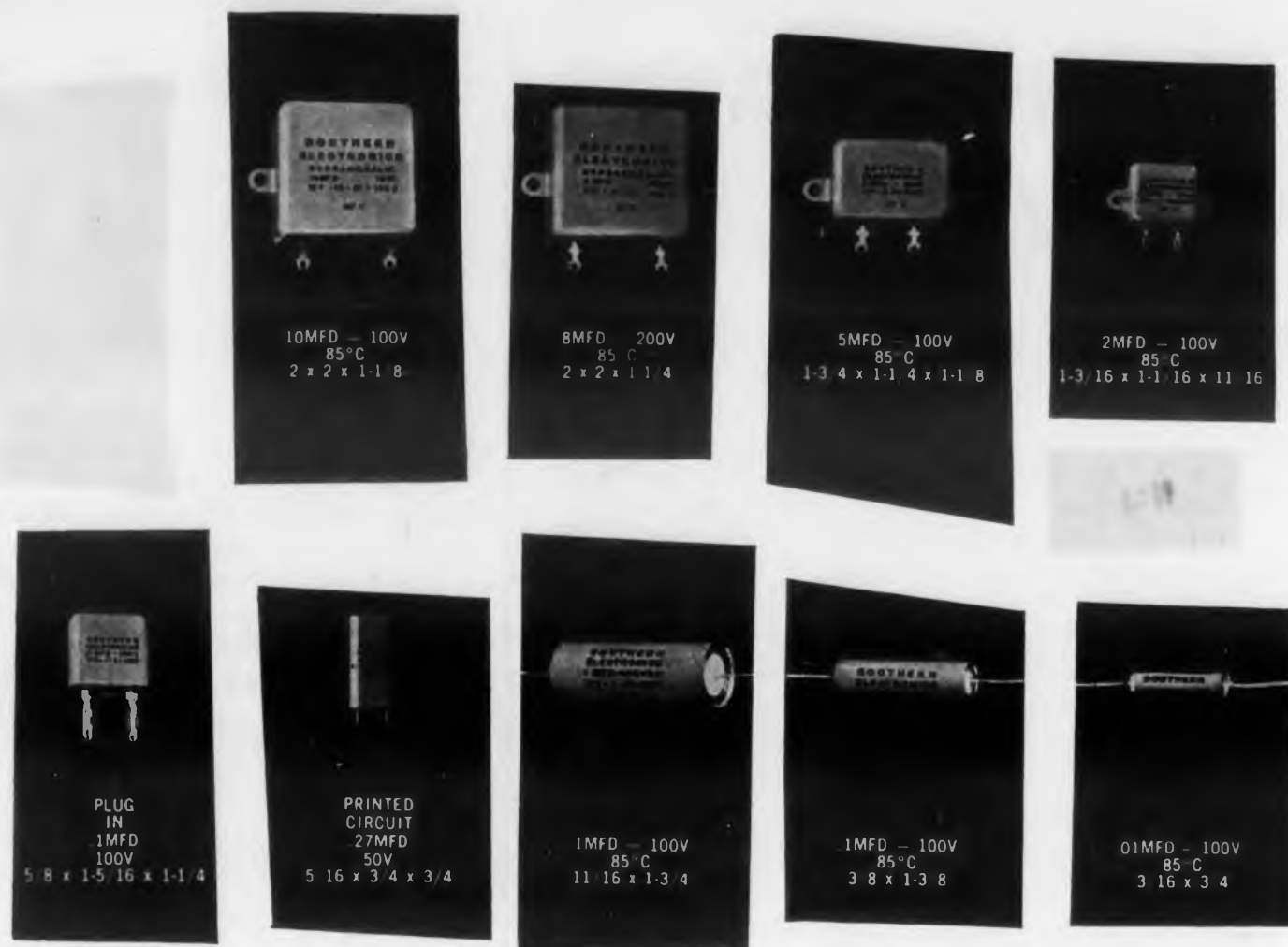

*At last!*  
**Mycon Plastic  
Capacitors**  
*up to 150° C!*

- Reliability proved
- Rated for infinite long life
- Insulation resistance  $1 \times 10^{11}$  OHMS

Wire, write or phone for complete catalog today!

**SOUTHERN ELECTRONICS**  
*Corporation*

150 West Cypress Avenue, Burbank, California  
NEW DISTRICT OFFICE: 1186 BROADWAY, NEW YORK CITY—PHONE: ORegon 9-2770  
PIONEERS IN CUSTOM CAPACITOR ENGINEERING

See us in Booth 2309 I.R.E. Show — New York

CIRCLE 64 ON READER-SERVICE CARD

Derated at 125°C as follows:

100 volts — 50%  
200 volts — 50%  
300 volts — 33½%  
400 volts — 33½%  
500 volts — 20%  
600 volts — 16%

Tested and proved! Only Southern Electronics Corporation has developed a test procedure which insures built-in reliability! For your most exacting requirements—be sure—always specify S.E.C.

**SUPER MYCON CAPACITORS**  
Tolerance to 1%—lowest temperature coefficient. Superior insulation resistance at high ambient temp. Good stability compatible with material.



**NEW PRODUCTS**

**R-F Test Set**

Combined signal generator, dc voltmeter and r-f field strength indicator



A portable test set that functions as a signal generator, dc voltmeter, and rf field strength indicator has been announced. With appropriate adapter plugs, the set will test all two-way radio equipment and will meter 16 transmitter-receiver-exciter functions as well as several functions within the test set. As a crystal-controlled r-f signal generator, the test set covers r-f, hf, vhf, and uhf frequency ranges. Four internal crystal positions are provided. As a 20,000-ohms-per-v dc voltmeter, the set has ranges of 0-3, 0-60, and 0-600 v. When used as a field strength indicator, the set has a 10,000  $\mu$ v sensitivity.

Bendix Aviation Corp., Bendix Radio Div., Dept. ED, Baltimore 4, Md.

CIRCLE 65 ON READER-SERVICE CARD

**Oscillograph**

Designed for routine laboratory test work



Type 542 Dynograph, is a two channel direct writing oscillograph designed to be a practical routine test instrument for laboratory work. Applications include vibration and transient recording beyond the range of the usual direct recorder, geophysical recording, and direct recording of action potentials and electromyograms. The unit features 2 msec deflection time and a sensitivity of 5 mv/cm made possible by combining the Dynograph writing unit with a transistorized amplifier.

Offner Electronics, Inc., Dept. ED, 5320 N. Kedzie Ave., Chicago, Ill.

CIRCLE 66 ON READER-SERVICE CARD

### Telemetry Multicoupler

Operates nine receivers from one antenna



Model 1104 multicoupler provides a means for connecting as many as nine telemetry receivers into a single antenna output. By cascading two couplers, 17 outputs are provided. It was designed for and has been used in the TLM-18 telemetry-antenna. Interchannel isolation is 55-85 db, frequency 216 to 255 mc, bandwidth 30 mc, and gain is 2 db nominal.

Radiation, Inc., Dept. ED, P. O. Box 37, Melbourne, Fla.

CIRCLE 67 ON READER-SERVICE CARD

### Current Transformer

A laboratory type measuring low power factors down to 3 per cent.



This laboratory type current transformer measures power of extreme low power factors down to 3 per cent. It has a phase angle error to 2.4 min leading. Accuracy is 99.5 per cent. The current rating is 500/5 amp and the instrument can be made with ratings from 1 to 10,000 amp. Each transformer is tested for core loss, polarity, voltage, corona, insulation breakdown and aging characteristics.

Nothelfer Winding Laboratories, Inc., Dept. ED, P. O. Box 445, Trenton, N.J.

CIRCLE 68 ON READER-SERVICE CARD

CIRCLE 69 ON READER-SERVICE CARD. >

# NJE OFFERS

## 10 NEW MODELS OF SOLID STATE POWER SUPPLIES TO MEET THE GROWING DEMAND!

MODEL	OUTPUT		RIPPLE RMS MILLIVOLTS	REGULATION (SEE NOTE 1)	INTERNAL	PANEL	DELIVERY	PRICE (INCLUDING METERS)
	VOLTS	AMPS			IMPEDANCE DC - 100KC	HEIGHT (SEE NOTE 2)		
SS-7-15	0-7	0-15	1.0	±0.1% or 3 MV	0.005	3½	75	\$ 880
SS-10-10	0-10	0-10	1.0	±0.1% or 5 MV	0.02	3½	75	700
SS-32-3	0-32	0-3	1.0	±0.1% or 10 MV	0.10	5¼	45	600
SS-32-10	0-32	0-10	1.0	±0.1% or 10 MV	0.04	8¾	45	790
SS-32-20	0-32	0-20	1.0	±0.1% or 10 MV	0.02	12¼	45	1100
SS-1003	50-100	0-1.5	1.0	±0.1%	0.03	5¼	30	490
SS-1503	100-150	0-1.5	1.0	±0.1%	0.06	5¼	10	520
SS-1603	0-160	0-1.5	1.0	±0.1% or 20 MV	0.50	7	15	600
SS-2003	150-200	0-1.5	1.5	±0.1%	0.10	7	30	630
SS-2503	200-250	0-1.5	1.5	±0.1%	0.15	8¾	45	720
SS-3003	250-300	0-1.5	2.0	±0.1%	0.20	10½	60	850
SS-1505	100-150	0-3	2.0	±0.2%	0.04	10½	75	950
SS-1605	0-160	0-3	2.0	±0.2%	0.30	12¼	75	1050

NOTE 1: Regulation figure includes total regulation against 105-125 volts slow or instantaneous input voltage variations, 50-1000 cps input frequency variation, 0-100% slow load variations, and ±25% instantaneous load current steps! When regulation is given as "±% or mv", the larger value governs.



MODEL SS-1503



MODEL SS-1603



MODEL SS-32-3

The enthusiastic reception which greeted our Solid State fully transistorized power supplies encouraged us to expand our stock line, incorporating the most popular of the custom designs of the last 2 years. All designs incorporate our unique short-circuit-proof (not merely short-circuit-protected) power-transistor circuit.

All Information Subject To Change Without Notice.

If power supply size, weight, efficiency, and reliability are important to you . . . you need N J E Solid State! We have developed several hundred special designs (series and shunt regulator configurations) and are prepared to quote on custom requirements.

Write for our new Solid State Catalog SS-3-7.

# NJE CORPORATION

Electronic Development & Manufacturing

343 CARNEGIE AVENUE KENILWORTH, NEW JERSEY

COMPETENT ENGINEERING REPRESENTATION EVERYWHERE

NJE LEADS THE POWER SUPPLY FIELD





Engineered by Tinnerman...

## Pea-size **SPEED CLIP**<sup>®</sup> saves space in missile, makes servicing of transistors easier

Tiny transistors that trigger the controls on a missile or supervise the sequencing on a jet engine are now plugged into pea-size Tinnerman **SPEED CLIPS**.

A thumb-push locks these front-mounting tubular **SPEED CLIPS** into punched holes in circuit panels. There's no soldering or riveting, no need for special tools. Spring-steel fingers hold tight; assure a vibration-free assembly. The fully encaged transistor is provided with excellent heat dissipation and can be readily removed for servicing. The **SPEED CLIPS** can be reused over and over again.

Tinnerman **SPEED NUT**<sup>®</sup> Brand Fasteners can save time and money on your production line, too, whether you require a specially engineered fastener or select one of the 9000 variations of existing designs. **SPEED NUTS** are easy to use, can be applied quickly anywhere along your production line, assuring quality, vibration-proof attachments at low cost.

Discuss your fastening needs with your Tinnerman representative . . . he'll have **SPEED**

**NUT** ideas to help you make an even better product, at lower cost. You'll find him listed in all major telephone directories. Or write to:

**TINNERMAN PRODUCTS, INC.**  
Dept. 12 • P. O. Box 6688 • Cleveland 1, Ohio



CANADA: Dominion Fasteners Ltd., Hamilton, Ontario. GREAT BRITAIN: Simmonds Aerocessories Ltd., Treforest, Wales. FRANCE: Simmonds S.A., 3 rue Salomon de Rothschild, Suresnes (Seine). GERMANY: Mecano-Bundy GmbH, Heidelberg.

CIRCLE 71 ON READER-SERVICE CARD

## NEW PRODUCTS

### Triaxial Connectors

Hold noise radiation to minimum



These connectors are designed for use in high-voltage pulsed circuits where noise radiation must be kept at an absolute minimum. Included in the available type are air-to-air and air-to-oil receptacles, right angle receptacles, double end adapters, and both field assembled and molded-to-cable type plugs. Corona ratings range from 9 kv dc through 15 kv dc and from 12 kv rms through 15 kv rms.

H. H. Buggie, Inc., Dept. ED, Box 817, Toledo 1, Ohio.

CIRCLE 72 ON READER-SERVICE CARD

### Vector Potentiometer

Output voltage has adjustable vector orientation



Model VP-101 Vector-Pot is a 400 cps potentiometer which, when excited from a reference line, develops an output voltage of adjustable vector orientation. The output voltage may be developed in either polar or rectangular coordinates, based on the line voltage as reference. The output components are direct reading. It is principally designed to null out error signals in precision test circuits for servomechanisms, resolvers, potentiometers, synchros, and similar devices. It is widely applicable as an element in custom test rigs designed to measure accuracy of precision components. The company's phase-sensitive null detector is a companion piece of equipment, which, in combination with the Vector-Pot, permits quick assembly of special-purpose test sets for precise measurements.

Dynamic Development Co., Dept. ED, 59 New York Ave., Westbury, N.Y.

CIRCLE 73 ON READER-SERVICE CARD

## High Voltage Capacitors

Ratings from 25 kv to 200 kv



Designed for high-voltage dc filtering, pulse network, voltage doubler, and dc energy-storage applications, this series of uhv capacitors are available in voltage ratings from 25 to 200 kv. Employing the company's standard double-end design, with cast aluminum end caps serving both as mounting means and electrical terminals, these tubular capacitors permit easy installation in compact banks. This type of construction provides a long creepage path, and eliminates terminal flashover. Seven end-cap style combinations are offered to meet various requirements.

Cornell-Dubilier Electric Corp., Dept. ED, S. Plainfield, N.J.

CIRCLE 74 ON READER-SERVICE CARD

## Power Relay

Switches large loads with low coil power



This polarized relay is designed to switch 1 to 2 kw loads in response to momentary 1/4 to 1/2 w signals. Series 61-relay uses a permanent magnet latch in place of mechanical latching devices. This eliminates all but one moving part and thus lengthens the life of the relay. The relay is a dpdt type with four separate contact circuits, and is available in two forms: 61Y (single coil only), two-position, magnetic bias; 61Z (single or dual coil), two-position, magnetic latch-in. Nominal contact rating is 20 amp (resistive) at 28 v dc or 120 v ac, with standard sensitivities of 225 or 450 mw. Minimum life is 100,000 operations when operated not more than once per second.

Sigma Instruments, Inc., Dept. ED, 48 Pearl St., S. Braintree 85, Mass.

CIRCLE 75 ON READER-SERVICE CARD

Important Question No. 3

Which company offers maximum savings on custom-built delay lines?

ESC CORPORATION

In delay lines you want more at "your specifications" of custom engineering service and lab reports available in this field. ESC Corporation offers a wide and variable range of delay lines and custom-built delay lines. The realistic and economical maintenance equipment back-

- 1st in sales!
- 1st company devoted to manufacture of delay lines!
- 1st in research, design and development of custom-built delay lines!
- 1st to submit the most complete laboratory reports with all custom-built delay line prototypes!

ESC CORPORATION 534 BERGEN BOULEVARD

Important Question No. 2

Who submits the most complete laboratory reports with all custom-built delay line prototypes?

ESC CORPORATION

It is a known fact that ESC Corporation's laboratory reports submitted with custom-built delay lines include pulse shape and output and input pulse characteristics.

- 1st in sales!
- 1st company devoted to manufacture of delay lines!
- 1st in research, design and development of custom-built delay lines!

ESC CORPORATION 534 BERGEN BOULEVARD

Important Question No. 1

Who produces more custom-built delay lines than any other company in America?

ESC CORPORATION

- 1st in sales!
- 1st company devoted exclusively to the manufacture of delay lines!
- 1st in research, design and development of custom-built delay lines!

Exceptional employment opportunities for engineers experienced in pulse techniques

ESC CORPORATION 534 BERGEN BOULEVARD • PALISADES PARK • NEW JERSEY

ESC CORPORATION 534 BERGEN BOULEVARD • PALISADES PARK • NEW JERSEY

CIRCLE 76 ON READER-SERVICE CARD

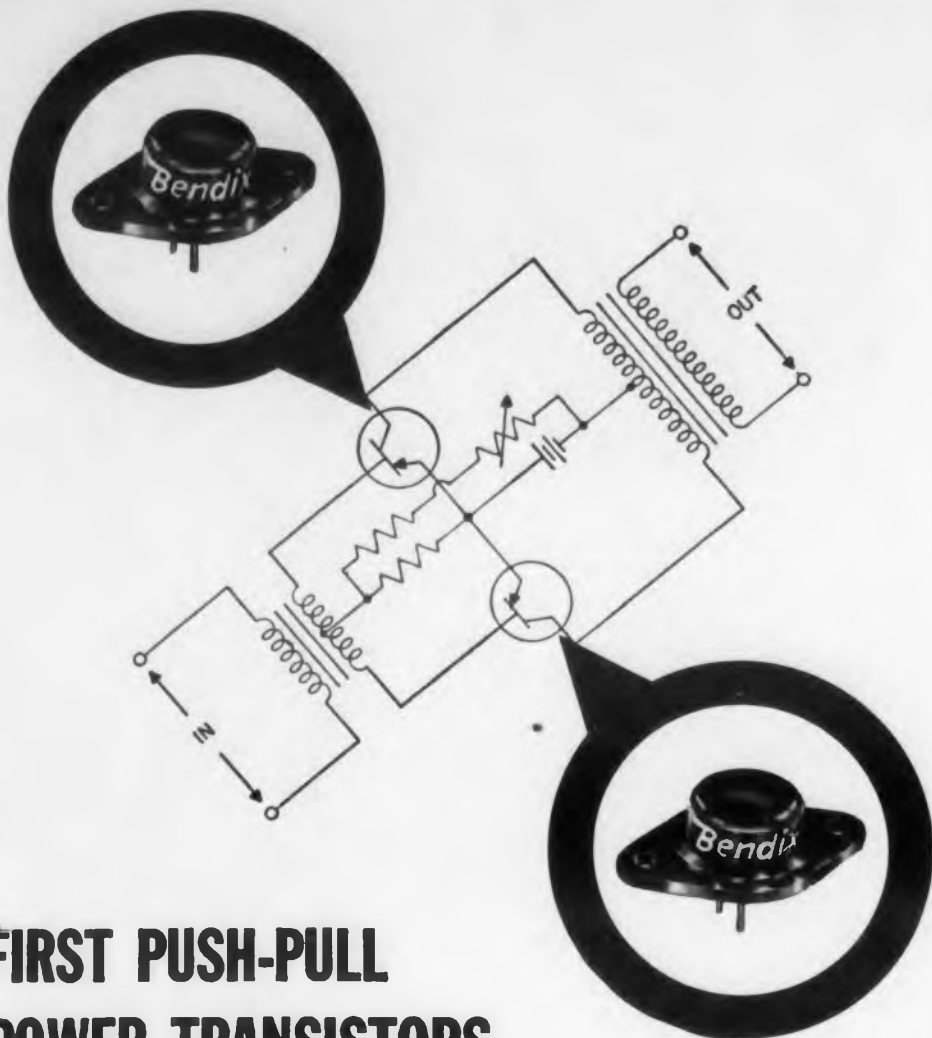

## FIRST PUSH-PULL POWER TRANSISTORS ANNOUNCED BY BENDIX

More big news from Bendix in the power transistor field!

Here—in the new Bendix models 2N399 and 2N401—are the first power transistors specially designed for such push-pull applications as push-pull amplifiers and servo-amplifiers.

Both Bendix transistor types are supplied in matched pairs for high efficiency, low distortion, high-power output (up to 25 watts), low battery drain, low idling current, and low heat production.

Both are in volume production and

ready for your application.

In fact, whatever your need, the complete Bendix power transistor line is designed to provide extra quality at no extra cost on a wide variety of applications. For full details, or for help with circuitry problems, write SEMICONDUCTOR PRODUCTS, BENDIX AVIATION CORPORATION, LONG BRANCH, NEW JERSEY.

West Coast Office: 117 E. Providencia Ave., Burbank, Calif.

Export Sales & Service

Bendix International, 205 E. 42nd St., New York 17, N. Y.

Canadian Affiliate: Computing Devices of Canada, Ltd., P. O. Box 508, Ottawa 4, Ont.

### BENDIX PUSH-PULL TRANSISTOR PERFORMANCE CHARACTERISTICS

#### ABSOLUTE MAXIMUM RATINGS

V <sub>c</sub> Vdc	I <sub>c</sub> Adc	P <sub>c</sub> W	I <sub>b</sub> mAdc	T storage °C	T <sub>j</sub> °C
-40	3.0	25	-150	-60 to +90	+90

#### TYPICAL APPLICATION

(Supply Voltage: 14 Vdc—Quiescent Supply Current: 120 mAdc)

	Load Imped'ce Collector-to- Collector	Source Imped'ce Base-to-Base	Power Output (No Clipping)	Circuit Gain	Efficiency
2N399	40 Ω	40 Ω	8 W	36 db	55%
2N401	48 Ω	40 Ω	5 W	33 db	55%

Red Bank Division



CIRCLE 77 ON READER-SERVICE CARD



## NEW PRODUCTS

### Power Amplifier 100 W Output



Model A-3052 rf amplifier provides up to 100 w output from standard 2-w telemetry transmitters. The amplifier uses a stacked ceramic tube for reliable operation. Temperature range is  $-55$  to  $+75$  C, shock 100 g, vibration 20 g to 2000 cps, altitude to 70,000 ft, and frequency range is 215-235 mc.

Radiation, Inc., Dept. ED, P. O. Box 37, Melbourne, Fla.

CIRCLE 78 ON READER-SERVICE CARD



### Mica Capacitors

Can be assembled in decade box to provide steps of 0.001  $\mu$ f

An assembly of type 980 decade capacitance units in a decade box is available as the type 1419-K decade capacitor. This unit, with a maximum capacitance of 1.11  $\mu$ f in steps of 0.001  $\mu$ f, replaces the older type 219-K. Dissipation factor of the new decades is one-third that of the older units and the long-term stability of capacitance values is better than 0.1 per cent.

Also available are type 505 mica capacitors, of which the decade units and assemblies are comprised. Although using the same construction as the standard capacitors, the type 505's are adjusted to  $\pm 0.5$  per cent and are packaged in a less-expensive case. They are available in a 1-2-5 series extending from 100  $\mu$ mf to 0.5  $\mu$ f. Dissipation factor for the 1000- $\mu$ mf and higher sizes does not exceed 0.0003. They are housed in low-loss molded-phenolic cases and are equipped with both screw-and-lug-type terminals and mounting flanges.

General Radio Co., Dept. ED., 275 Massachusetts Ave., Cambridge 39, Mass.

CIRCLE 79 ON READER-SERVICE CARD

## Malco IS YOUR BEST SOURCE FOR SOLDERING LUGS TERMINALS PRINTED CIRCUIT HARDWARE



### HERE'S WHY:

- Specialized high production techniques afford lowest possible unit cost.
- Precision tooling, rigid quality control assure tolerances to critical specifications.
- Ample stocks of over 1000 different parts permit prompt delivery.
- Malco specializes in a complete line of small stampings for Radio-TV, electrical/electronic and automotive industries.
- Our line includes terminals and printed circuit hardware in loose or in chain form for automatic insertion.

Let Malco show you how you can save on production time and costs. Contact us today.



Request handy reference catalog containing specifications on standard and custom-made lugs, terminals, corona rings, pins, contacts and similar stampings.

Malco TOOL and MANUFACTURING CO.

4027 W. Lake St., Chicago 24, Ill.

CIRCLE 80 ON READER-SERVICE CARD

### DC to DC Converters

Provide up to 500 v at 165 ma from a 12 v supply



These transistorized units are designed to convert 12 v dc to high voltage dc. Transistor reliability is 95 per cent for 10,000 hr of use. A typical receiver supply, shown, produces 250 v dc at 130 ma or 290 v dc at 130 ma from either 12 or 13.6 v dc input. Size of the unit is 3-3/8 x 1-7/8 x 3-1/4 in. A typical transceiver supply produces three outputs of 500 v dc at 165 ma, 270 v dc at 150 ma, and -55 v dc at 10 ma from a 12 v dc input and comes in a 3-1/2 x 5 x 3 in. package.

Universal Transistor Products Corp., UAC Electronics Div., Dept. ED, 36 Sylvester St., Westbury, N.Y.

CIRCLE 81 ON READER-SERVICE CARD

### Variable Resistor Assembly

Plug-in two-in-one and three-in-one units reduce assembly costs



Two and three unit variable resistor assemblies equipped with plug-in mounting brackets have been announced. Available in twelve basic types, each with 17 shaft lengths, the controls eliminate many of the production operations needed to mount separate units. Dipped soldered printed wiring terminals and snap-in metal mounting brackets provide firm support. The controls have been designed with sufficient clearance to allow wires or small cables to pass under them. The solder dipped printed wiring terminals on all types are spaced in accordance with proposed EIA standards.

Stackpole Carbon Co., Electronic Components Div., Dept. ED, St. Marys, Pa.

CIRCLE 82 ON READER-SERVICE CARD

# ONE TEN



## The Magic Mirror One-Ten<sup>o</sup> Aluminized Picture Tube

The Magic Mirror **One-Ten<sup>o</sup>**, the brand-new 110° deflection picture tube, is designed by Tung-Sol to meet the most exacting specifications and performance requirements of manufacturers of portable and light-weight cabinet and table TV sets.

The Magic Mirror **One-Ten<sup>o</sup>** is being produced in types 17BZP4 and 21DAP4. The 17BZP4 is 12 9/16 inches long (three inches shorter than standard 90° tubes), possesses a 155 square-inch viewing area and weighs but 10 pounds. The 21DAP4 is 14 11/16 inches long, has a 262 square-inch area and weighs 20 pounds.

CIRCLE 83 ON READER-SERVICE CARD

The Magic Mirror **One-Ten<sup>o</sup>** needs no ion-trap magnet. It is aluminized by the same unique method that has earned for all Tung-Sol picture tubes their reputation among set manufacturers for pictures of outstanding quality.

 **TUNG-SOL<sup>®</sup>**  
ELECTRON TUBES  
SEMICONDUCTORS

TUNG-SOL ELECTRIC INC., NEWARK 4, N. J.

# NEW

# CTS

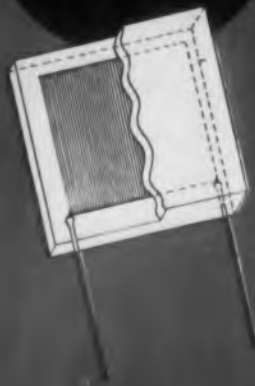

SMALL SPACE FACTOR • MORE STABLE

# Bobbinless PRECISION WIRE FIXED Resistors

*Featuring Unique CTS "Floating" Element*

Another CTS "first". New patented winding process permits resistance elements and contacts to be firmly embedded in epoxy resin, forming a monolithic mass. No bobbin or winding form is used. Wire strain is eliminated.

Burton Bruma Advertising

- **Exceptional Stability**—Permanent change in resistance less than 0.2% under most environmental conditions.
- **Guaranteed Close Tolerance**—Resistors guaranteed to be in tolerance under normal conditions of measurement. Tolerances down to  $\pm 0.05\%$  available in standard sizes depending upon resistance value. Closer tolerances or matched multiples available on request.
- **Low Inductance and Low Capacitance Characteristics** with reproducible uniform frequency response.
- **Less than 0.2% resistance change with humidity** (MIL-R-93 moisture resistance test).
- **Less than 0.2% resistance change with temperature cycling** (MIL-R-93).
- **Withstands extreme vibration and shock** due to unique construction and encapsulation method.
- **Extremely Stable**—Less than 0.3% resistance change with load life or 100% overload (MIL-R-93).
- **Low Temperature Coefficient Wire** available.



RECTANGULAR			
Wattage	Dimensions (Inches)	Resistance (Ohms)	CTS Type Number
0.25	3/4" x 3/16" x 1/4"	1.0-10,000	F3B
0.25	3/4" x 3/16" x 3/8"	1.0-100,000	F3C
0.25	3/4" x 3/16" x 1/2"	0.5-100,000	F3D
0.25	1" x 3/16" x 1/4"	0.5-100,000	H3B
0.5	1" x 3/16" x 3/8"	0.1-100,000	H3C
0.5	1" x 3/16" x 1/2"	0.1-200,000	H3D
0.75	1" x 3/16" x 3/4"	0.1-300,000	H3F
1.0	1" x 3/16" x 1"	0.1-400,000	H3H
1.5	1-1/2" x 3/16" x 1"	0.1-600,000	L3H
2.0	2" x 3/16" x 1"	0.1-1,000,000	P3H
Special	2-1/2" x 1/4" x 2"	0.1-2,500,000	T4P
TUBULAR			
0.1	3/4" x 1/8"	10-5,000	FA
0.5	1" x 1/4"	0.5-25,000	HB
0.5	1" x 3/8"	0.1-250,000	HC
1.0	1-1/4" x 1/2"	0.1-1,000,000	JD

Special dimensions, tolerances, wattage ratings, etc. can be made to your exact specification. Either axial or radial leads available on all rectangular types.

*Write for further details today.*



Founded 1896

**CHICAGO TELEPHONE SUPPLY**  
*Corporation*

ELEHART, INDIANA

**CANADIAN SUBSIDIARY**  
C. C. Meredith & Co., Ltd.  
Streetsville, Ontario  
Phone: Taylor 6-1141

**EAST COAST OFFICE**  
5 Haddon Avenue  
Haddonfield, New Jersey  
Phone: Haddonfield 9-5512  
TWX No. Haddonfield 529  
Phila. Phone: Market 7-3129

**SOUTHWESTERN U. S. A.**  
(Texas, Oklahoma)  
John A. Green Company  
137 Parkhouse Street  
Dallas 7, Texas  
Phone: Riverside 3266

**SOUTH AMERICA**  
Jose Luis Pontet  
Buenos Aires, Argentina  
Montevideo, Uruguay  
Rio de Janeiro, Brazil  
Sao Paulo, Brazil

**WEST COAST SUBSIDIARY**  
Chicago Telephone of  
California, Inc.  
100 Pasadena Avenue  
South Pasadena, California  
L. A. Phone: Clinton 6-7186  
TVA L. A. 118

**KANSAS CITY AREA**  
(Kansas, Iowa, Nebraska,  
Missouri, So. Ill.)  
E. B. Schwerin  
4210 Main Street  
Kansas City, Missouri  
Phone: WE 1-7364

**OTHER EXPORT**  
Sylvan Ginsbury  
8 West 40th Street  
New York 18, New York  
Phone: Penn 6-8830

## NEW PRODUCTS

### Multi-Turn Potentiometer High Resolution



A 7/8-in. diam multi-turn precision potentiometer, series 55 provides up to 20 per cent more winding length in a given 10-turn od. Rated at 3 w, the unit is available in several resistance values up to 100,000 ohms. Low noise level is attained by controlled techniques. Runout and end resistance are at a minimum.

Clarostat Mfg. Co., Inc. Dept. ED, Dover, N.H.

CIRCLE 86 ON READER-SERVICE CARD

### Counting Device Booster Extends Life and Speed



The SD-1 booster is designed to increase the life and speed range of electro-mechanical counting devices as much as 15 times. The booster can be placed several hundred feet from switch contacts and registers in counts of 10 while counting up to 50 units per sec. Equipped with a visual totalizer if desired.

Post Electronics, Products Div., Dept. ED, Beverly, Mass.

CIRCLE 87 ON READER-SERVICE CARD

### Symbols Template 0.25 In. Grid

The No. 315 MIL-STD-15A Template is being manufactured as an adjunct to the recently an-

◀ CIRCLE 85 ON READER-SERVICE CARD

announced No. 314 MIL-STD-15A Template. The No. 315 MIL-STD-15A adheres to all military symbols, but is predicated on the established grid of 0.25 in., while the previously announced No. 314 is predicated on a 0.1 in. grid.

Rapidesign, Inc., Dept. ED, P. O. Box 429, Burbank, Calif.

CIRCLE 88 ON READER-SERVICE CARD

### VHF Transceiver

360 Channels



The DTR-360A is a 360-channel vhf communications transceiver conforming to the requirements of TSO C37 and C38. Transmitter section provides 15 w output on any channel from 118 to 135.95 mc. A double conversion receiver has a sensitivity of 2  $\mu$ v or better on every channel. Single channel simplex, double channel simplex or any cross channel duplex operation can be provided.

Dare, Inc., Dept. ED, Troy, Ohio.

CIRCLE 89 ON READER-SERVICE CARD

### Dipped Mica Capacitors

125 C Rating



Type ADM dipped-mica capacitors are designed for printed-wiring and general purpose applications, and meet requirements of MIL-C-5A and RETMA RS-153. The units feature small size, temperature range of  $-55$  C to 125 C, and narrow temperature coefficient.

Aerovox, Applications Engineering Dept., Dept. ED, New Bedford, Mass.

CIRCLE 90 ON READER-SERVICE CARD

CIRCLE 91 ON READER-SERVICE CARD >

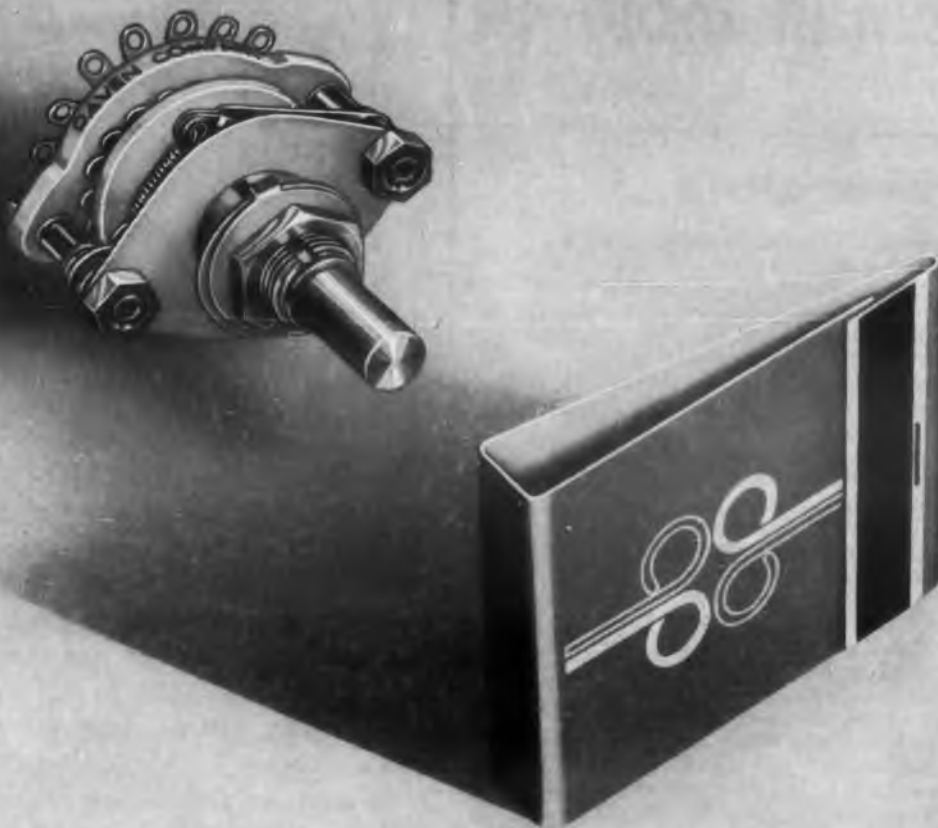

## DID YOU SAY **small?**

Occupying less than 1½ square inches of panel space, this Miniature Ceramic Switch nevertheless contains as many as 18 positions on a single wafer. And it's rugged! Solid silver alloy contacts, rotors, and slip rings provide low and uniform contact resistance. Ceramic parts are silicone impregnated to function under extreme humidity. Sturdy solder terminals are supplied for wiring.

This miniature switch meets and exceeds the electrical and environmental requirements of Mil-Spec S-3786.

Flashover voltage at 60 cycles is 1000 volts peak . . . current carrying capacity is 2 amperes. For guided missiles, airborne radar equipment, portable and mobile ground equipment . . . for any application that requires an extremely small and rugged switch, specify Daven's Series M Miniature Ceramic Switches.

These units can be "ganged" with up to 8 decks with slight mechanical modifications. 2 or 3 poles per deck may also be obtained as standard. Prototypes can be delivered within 2 weeks.

Write for complete information.



THE **DAVEN** CO.

524 West Mt. Pleasant Ave.  
Route 10, Livingston, N. J.

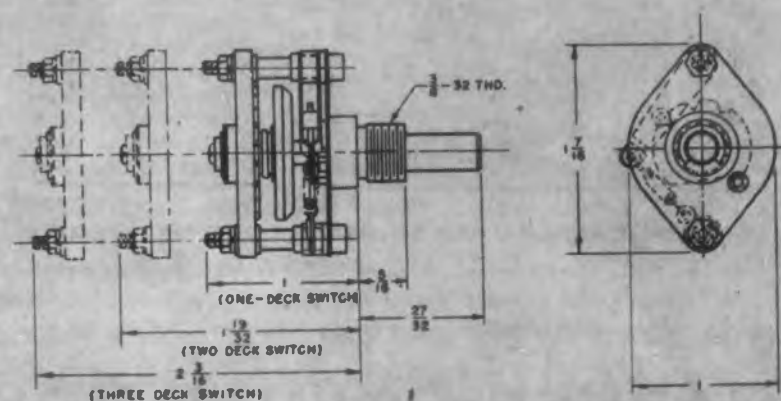

TODAY, MORE THAN EVER, THE DAVEN © STANDS FOR DEPENDABILITY!

THE NAME OF QUALITY



# a-c small motors

## reversible

Barber-Colman reversible motors are adaptable to a variety of control circuits and power requirements. Compact construction and low-inertia rotors make these motors ideal for applications requiring fast reversing. Used extensively in servo-mechanisms, remote switching and positioning, recording instruments, voltage regulators, etc. Available with or without reduction gearing, open or enclosed types. Electronic control of Barber-Colman reversible motors is accomplished by controlling the magnitude and phase of the shading circuit current with respect to the field coil current. Thus, the reversible motor functions as a two-phase motor, with the field coil being connected to one phase of the power supply and the shading coil circuit to the amplifier or second phase. Directional control is achieved by causing the phase of the shading circuit current to lead or lag the field current. Torque is controlled (and indirectly, the speed) by varying the magnitude of the shading circuit current.

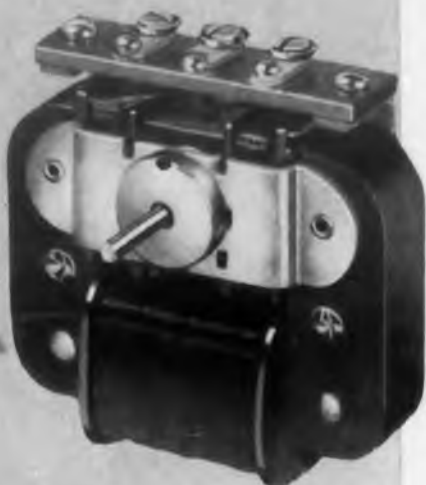

## geared

Barber-Colman a-c shaded pole reversible and unidirectional motors are available with both enclosed and open gear reductions. (Model shown is designed for overhanging loads.) Wide choice of models with wide variety of gear ratios for such applications as vending and office machines, rotisseries, TV tuners, program switches, etc.



## unidirectional

Designed for applications requiring long life and high starting torque. Low-inertia rotors for quick, positive starting. Well suited for driving pumps, vending machines, vaporizers, antenna rotators, fans, blowers, office machines, and the like. Rugged construction, low cost. Synchronous and non-synchronous types available.



### FREE CATALOG HELPS SELECT MOTOR NEEDED

Get the helpful condensed catalog of Barber-Colman shaded pole small motors. Contains complete descriptions of above motors, shows typical specifications, performance characteristics, control circuit diagrams. Write for your copy.



## BARBER-COLMAN COMPANY

Dept. B, 1283 Rock Street, Rockford, Illinois

Small Motors • Automatic Controls • Industrial Instruments • Aircraft Controls  
 Electrical Components • Air Distribution Products • Overdoors and Operators  
 Molded Products • Metal Cutting Tools • Machine Tools • Textile Machinery

CIRCLE 228 ON READER-SERVICE CARD

## NEW PRODUCTS

### Pulse Modulator Three operating modes



Model 63M hard-tube, high voltage pulse modulator is a flexible instrument for experimental tube testing. It is capable of three distinctly different modes of operation: cathode pulsing, modulating-anode pulsing, and grid pulsing. In all modes, it operates anywhere in the range from 30 cps to 12,000 cps and with pulse lengths continuously variable from 0.5 to 30  $\mu$ sec. As a cathode pulser it will pulse from 0 to 50 kv up to 35 amp. As a modulating-anode pulser, it will pulse from 0 to 50 kv into a 25  $\mu$ mf load. As a grid pulser, it will pulse from 0 to 5 kv into a 25  $\mu$ mf load. The equipment has a 55-kv, 0.5-amp power supply with less than 0.1 per cent peak-to-peak ripple.

Levinthal Electronic Products, Inc., Dept. ED, Stanford Industrial Park, Palo Alto, Calif.

CIRCLE 92 ON READER-SERVICE CARD

### Amp-Volt-Ohmmeter

Pocket-size unit measuring down to 0.3 ma



The Elavi-2 meter has a total of 26 measuring ranges. Current ranges are 0.3 ma to 1.5 ma and voltages from 0.15 v (6 v for ac) to 600 v. The instrument has two resistance ranges of 0-1000 ohms and 0-100 k. Frequency range is 15 cps to 10 kc. The meter uses germanium diodes.

Epic, Inc., Dept. ED, 154 Nassau St., New York 38, N.Y.

CIRCLE 93 ON READER-SERVICE CARD

# Somers

## METALLIC TAPES for INDUSTRY

For recording, electronic computing and other applications where close tolerance, controlled surface (less than 10 micro-inches), burr-free slit edge and maximum continuous length are essential, SOMERS quality metallic tapes are a must.

Currently being produced are Nickel, Copper and alloys including Monel, Inconel, Brass, Phosphor Bronze and Nickel Silver and Stainless Steel. Gauges range from .000175" to .010" and widths from  $\frac{1}{8}$ " to 25" depending on thickness.

Whatever your strip problem may be, you'll find satisfaction with SOMERS THIN STRIP. Write for confidential data blank or field engineer.



Somers Brass Company, Inc.

116 BALDWIN AVE., WATERBURY, CONN.  
CIRCLE 229 ON READER-SERVICE CARD

# LOW RESISTANCE OHMMETERS

with test currents never exceeding 110 ma.

The ideal meter for checking fuses, sensitive relay contacts, transformer windings, motors, bus bars, bonding, etc. Entirely self-contained including battery supply.

- **Accuracy:** LRO  $\pm 1\%$  of full scale reading. LRO-1  $\pm 1\frac{1}{2}\%$  of full scale reading.
- **Ranges:** Full scale readings of .1 ohm, 1 ohm and 10 ohms. 100 meter scale divisions. One scale division on .1 range is .001 ohm.
- **Built-in Meter Protection:** In event that resistance is beyond meter range instrument is protected.
- **Low Test Current:** Never exceeds 110 ma., eliminating danger of damage to most sensitive circuitry or components under test.
- In two models:



**MODEL LRO-1.** Commercial version. In polished hardwood case with carrying handle. Test leads. Price: \$175.00.



**MODEL LRO.** Same as LRO-1 but designed to meet critical requirements of military service. In aluminum gasketed case for extra-rugged field service. Price: \$310.00.

Write for descriptive literature...

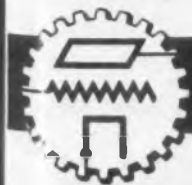

**Industrial Instruments**

89 Commerce Road,  
Cedar Grove (Essex County) N. J.

CIRCLE 94 ON READER-SERVICE CARD

## Synchro System

115-v input rating eliminates stepdown transformer



A more adaptable size 10 115 to 11.8 v 400 cps transmitter and receiver synchro system has been made available. The rated input voltage of the synchro eliminates a stepdown transformer, thereby reducing both system size and weight. Type 10-4081-01 synchro transmitter has an angular accuracy of  $\pm 15$  min. Type 10-4085-07 receiver synchro has 45 min. accuracy error and 1 deg friction error. Transmitter-receiver system has torque gradient of 2900 mg per mm per deg.

John Oster Mfg. Co., Avionic Div., Dept. ED, 1 Main St., Racine, Wis.

CIRCLE 95 ON READER-SERVICE CARD

## Deposited-Carbon Resistors

Flat side provides automation index

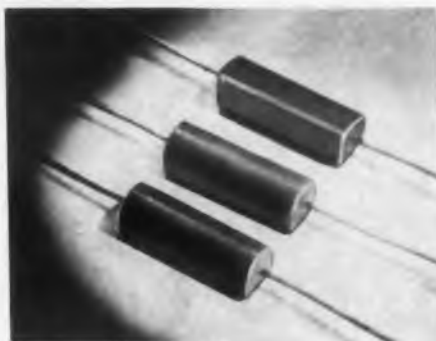

The latest of the series of encapsulated Fixtohm deposited-carbon precision resistors is equipped with a flatted area to serve as an index surface for automation, permitting orientation of marking and leads. The surface may be used as an adhesive mounting for unusual vibration, shock and power requirements.

Type CMF style RN70B 1/2-w Fixtohm is available in a resistance range of 10 ohms to 2.5 meg,  $\pm 1$  per cent tolerance. Power rated at 1/2 watt at 70 C, derated to zero power at 150 C. Insulation resistance is in order of 100,000 meg. Moisture resistance is in order of 1 per cent. Temperature coefficient, maximum, is 500 ppm or 0.05 per cent per ohm degree C.

Clarostat Mfg. Co., Inc., Dept. ED, Dover, N.H.

CIRCLE 96 ON READER-SERVICE CARD

THE MARK OF QUALITY

TTTT  
BARBER  
COLMAN  
TTTT

# d-c small motors

compact, powerful - up to 1/10 hp



## permanent magnet

Only Barber-Colman permanent magnet motors feature *the patented symmetrical, progressive lap winding* which provides true electrical balance, higher efficiency, superior commutation, and low radio noise output. Motor characteristics range from 6 to 115 volts d-c, 5,000 to 20,000 rpm, outputs up to 1/10 hp. Various mountings and shafts available. Ideal for many aircraft or industrial equipment applications.



## split-series

Barber-Colman split-series motors are available in two frame sizes with continuous duty outputs up to nine millihorsepower. Outstanding efficiency due to excellent magnetic design and symmetrical lap-type armature winding. Electromechanical brakes can be supplied for these motors.



## gearhead

Barber-Colman gearhead motors can be used as small actuators to drive switches, programming devices, camera mechanisms, autopilots, and for remote positioning in industrial automation. Standard EYLM motor with gearhead, illustrated, provides up to 10 lb-in. torque output. Gear ratios from 9.5 to 55,446/1.



## with blowers, filters

Barber-Colman d-c motor-blower units quickly dissipate heat from hot tubes, circuit components, and other confined equipment. Air volume for a typical 1½-in. centrifugal unit is 20 cfm at 0 static pressure and 70°F. Voltages range from 6 to 115 volts d-c.

Barber-Colman permanent magnet motors also available with lightweight, compact, integrally mounted radio noise filters.

## TECHNICAL BULLETINS ON COMPLETE LINE OF BARBER-COLMAN ELECTRICAL COMPONENTS

Detailed specifications, performance data, product and circuit drawings on polarized relays, resonant relays, d-c motors, tach generators, choppers. Write for your copy on any or all products.



## BARBER-COLMAN COMPANY

Dept. B, 1883 Rock Street, Rockford, Illinois

Small Motors • Automatic Controls • Industrial Instruments • Aircraft Controls  
Electrical Components • Air Distribution Products • Overdoors and Operators  
Molded Products • Metal Cutting Tools • Machine Tools • Textile Machinery

CIRCLE 97 ON READER-SERVICE CARD



## GENERAL TRANSISTOR'S PRODUCTION

# Breakthru

PNP	NPN	NPN
2N 315	2N 356	2N 444
2N 316	2N 357	2N 445
2N 317	2N 358	2N 446
		2N 447

- NEW MODERN PLANTS
- EXPANDED FACILITIES
- STREAMLINED ORGANIZATION
- STEPPED-UP PRODUCTION
- INCREASED LABOR FORCE
- APPLIED RESEARCH

Modern success stories don't "happen," they're caused — that's why General Transistor started "Operation Breakthru" 10 months ago.

Management recognized that a surge of increased business could strain manufacturing and quality control facilities. Before a bind could develop, "operation breakthru" was inaugurated . . . and can now be called a complete success.

Another modern manufacturing plant was added to General Transistor's 3 plants — this additional facility increases storage area, expands the quality control section and enlarges the manufacturing space. Additional equipment and machinery have been purchased. Technical and labor force have been increased to satisfy the demand of industry.

Operation breakthru is a success — your assurance of continued reliable production, prompt deliveries and realistic prices.

The management and employees of General Transistor wish to thank their customers for making

**GENERAL TRANSISTOR—"THE FASTEST GROWING NAME IN TRANSISTORS"**  
Write today for complete all types list wall chart.



### GENERAL TRANSISTOR CORP.

91-27 138TH PLACE JAMAICA 36, NEW YORK

In Canada: Desser E-E Ltd., 441 St. Francis Xavier, Montreal 1, Quebec  
FOR IMMEDIATE DELIVERY FROM STOCK, CONTACT YOUR NEAREST AUTHORIZED GENERAL TRANSISTOR DISTRIBUTOR OR GENERAL TRANSISTOR DISTRIBUTING CORP. 95-27 SUTPHIN BLVD. JAMAICA 35, NEW YORK  
FOR EXPORT: GENERAL TRANSISTOR INTERNATIONAL CORP.  
91-27 138TH PLACE JAMAICA 35, NEW YORK

## NEW PRODUCTS

### Alternator

A 4-oz. unit developing 14 v, 80 ma at 350 cps



This permanent magnet alternator measures less than 1-in. od and weighs 4 oz. The unit is available in one, two, or three phase output with various frequency ranges. A 6-pole model develops 350 cps, 14 v, and 80 ma at 7000 rpm with less than 5 per cent distortion. A two pole version develops less than 3 per cent distortion.

Eastern Air Devices, Inc., Dept. ED, 385 Central Ave., Dover, N.H.

CIRCLE 99 ON READER-SERVICE CARD

### Ferrite Load Isolator

Handles 50 kw peak from 2.8 to 3.2 kmc



Models S-131 and S-132 ferrite load isolators operate over the frequency band of 2:8 to 3.2 kmc and handle a minimum of 50 kw peak power and 50 w average power transmitted. The vswr is 1.15. Model S-131 has an insertion loss of 1db, an isolation of 22 db and a length of 8 in. Model S-132 has an insertion loss of 0.8 db, isolation of 13 db and length of 6 in.

Uniline, Cascade Research, Dept. ED, 53 Victory Lane, Los Gatos, Calif.

CIRCLE 100 ON READER-SERVICE CARD

◀ CIRCLE 98 ON READER-SERVICE CARD

## Molded Transformers

Miniature units for transistor applications



Designed for transistor, audio and servo applications, these transformers are molded of high temperature epoxy to provide protection against extremes in ambient. Weighing 1/2 oz, the dimensions of the MM-M series is 3/4 x 7/8 x 1/2 in. high. Mounting is by means of standard channel ears, threaded studs, or inserts. Terminal pins are arranged for use with dip soldered printed circuitry.

Microtran Co., Inc., Dept. ED, 145 E. Mineola Ave. Valley Stream, N.Y.

CIRCLE 101 ON READER-SERVICE CARD

## Cathode Ray Tubes

Feature gradient type of post acceleration



Types 5BGP- (T5IP) and 5BHP- (T54P) cathode ray tubes have 5-in. flat faceplates, employ both electrostatic focus and deflection, and incorporate post acceleration by use of a spiral band resistance winding which extends from tube faces to the vicinity of the deflection plates. This type of post acceleration provides good deflection plate linearity and minimum pattern distortion can be obtained. Type 5BGP is 17-1/2 in. long and type 5BHP is 18-1/4 in. long. Both tubes are available with either P1, P2, P7 or P11 fluorescent screens.

Electronic Tube Corp., Dept. ED, 1200 E. Mermaid Lane, Philadelphia 18, Pa.

CIRCLE 102 ON READER-SERVICE CARD

CIRCLE 103 ON READER-SERVICE CARD ➤



MAINTENANCE-FREE

LONG LIFE

INDEFINITE STORAGE

NON-GASSING

HIGH PEAK CURRENTS

SINTERED PLATES

HERMETICALLY SEALED



TUBULAR NICKEL-IRON OR NICKEL CADMIUM



POCKET NICKEL-IRON OR NICKEL CADMIUM



SINTERED PLATE NICKEL CADMIUM



HERMETICALLY SEALED NICKEL CADMIUM



SELF-CONTAINED BATTERY AND CHARGER UNITS

*the new*  
**miniature  
rechargeable  
nickel cadmium**

**BUTTON-CELL**

**BATTERY**

Gulton Button-Cell batteries are available in capacities of 250 and 500 milliampere hours. Each Button-Cell has a nominal capacity of 1.2 volts. Multiple cells are packaged in any desired voltage combination to meet your specifications.

The Button Cell is only one of a complete line of nickel cadmium, nickel iron and battery and charger units from a new source — Gulton Industries Alkaline Battery Division.

**Write today for complete technical information — please mention your application.**



**Alkaline Battery Division**

**Gulton Industries, Inc.**  
METUCHEN, NEW JERSEY

*Quiggle  
Quells the  
Query*



**...where to get the best bandpass filters?**

Major Quiggle\*, KC, AC, DC, MC, fixed his procurement manager with a withering stare. "So now our whole production line is held up," he barked, "while you try to find a good bandpass filter with a flat response between 17 and 20 kcs. And you also insist that it have sharp low and high frequency cut-off," he added.

The manager reeled with the outburst. Never had he seen the old man in such a fury over a simple question of where to get the best bandpass filters.

Quiggle continued, "Haven't you been reading the trade paper advertisements? Why don't you call Barker & Williamson! They've been making filters of all types such as Band Elimination, High-Pass and Low-Pass for years . . . must be experts on the subject, they'll have the answer."

And B&W did have the answer. The Model 360 torroidal bandpass filter was perfect. With a flat response between 17.2 and 20.2 kcs, Quiggle's engineers found many other favorable characteristics when they obtained a spec sheet on the unit by the simple expedient of calling B&W.



\*Now a confirmed customer and friend, name is withheld intentionally

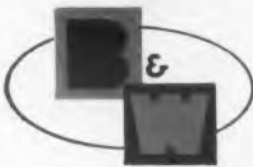

***Barker & Williamson, Inc.***  
Canal Street & Beaver Dam Road, Bristol, Penna.

B&W also design and manufacture filters for: ANTENNAS • RADIO INTERFERENCE • RADIO RANGE • UHF and VHF as well as many special types designed to performance specifications. Available to commercial & military standards.

**CIRCLE 104 ON READER-SERVICE CARD**

## NEW PRODUCTS



### Frequency Time Counter

A versatile instrument which includes preset internal generating as one of its functions

Frequency time counter, model 860, provides present interval generating, timing and counting functions in a compact package. The unit is a completely transistorized instrument with in-line read-out. It contains the shaping, gating, switching, counting and crystal-controlled time base circuitry required to perform counting, timing, frequency measuring, and interval generating functions in a compact package. The unit is a mits direct reading of results without considerations of transducer conversion factors.

Characteristics of the unit include direct measurement of frequency from 0 to 150 kc, frequency ratio determination, period measurements for 1 or 10 cys and time interval measurements for intervals from 10 $\mu$ sec to 100 sec.

Potter Instrument Co., Inc., Dept. ED, Sunnyside Blvd., Plainview, L. I., N.Y.

CIRCLE 105 ON READER-SERVICE CARD



### Meters

1 per cent accuracy achieved on a production line basis.

Featuring 1 per cent or better accuracy, these meters are being manufactured on a production line basis. Spring mounted jewel bearings and infinite point suspension system provide ruggedness. High stability is achieved from +85 to -55 C. Military types exceed MIL-M-10304A specifications and withstand shock and vibration specifications of MIL-T-945. Commercial meters are available in 2-1/2, 3-1/2, 4-1/2 in. Square styles, 4-1/2 in. rectangular style in black phenolic plastic cases, and military meters in 2-1/2, 3-1/2, and 4-1/2 in. round steel cases with acrylic plastic windows and front zero adjusting screws, are also available. Military meters are sealed and ruggedized. All meters have a normal overload characteristic of 5000 per cent.

American Metrix Corp., Dept. ED, 40 Haddon Ave., Camden 3, N. J.

CIRCLE 106 ON READER-SERVICE CARD

FOR...

Slip-On Insulation,  
Instrument Tubing,  
Bundle Sheathing,  
Medical Tubing,  
Pigtails...



USE

**SPAGHETTI  
SLEEVEING**

MADE FROM

**TEFLON\***

PF Spaghetti sleeving has these important advantages:

1. Good dielectric strength (500 to 2000 volts/mil)
2. Excellent electrical properties at high temperatures (500°F) and a wide frequency range
3. Low coefficient of friction. It slips on easily in long lengths of wire up to 3 ft.
4. Eliminates the need for silver coated wire
5. Zero moisture absorption
6. Unaffected by any commercial chemical
7. Stress relieved for negligible shrinkage

25 sizes, 2 wall thicknesses, 10 colors in stock, 100% inspected and controlled dimensionally are available.

Write, wire or call for full details, competent engineering assistance and information on special sizes and walls. PF Teflon\* flexible tubing, heavy-walled tubing and rod stock are also available.

**PENNSYLVANIA FLUOROCARBON CO., INC.**

1115 N. 39th Street, Phila. 4, Pa. EVergreen 6-0603

\*Teflon—DuPont trade name for Tetrafluoroethylene resin

CIRCLE 107 ON READER-SERVICE CARD



750

## SILVER FLAKE

### FOR ELECTRONIC APPLICATIONS

Allows unlimited formulation of conductive metallic paints.

MD 750 Silver Flake pigment, manufactured from pure silver, has proved itself an invaluable ally to manufacturers of electronic components.

This highly conductive pigment is especially adaptable in printed circuits because it allows a wide variance in binder, solvents and fluxes as well as base plate materials.

MD 750 Silver Flake is used in the cementing of end wire on resistors and in the fabrication of silver electrodes as connectors for adhesive type resistors. It may be fired on quartz, mica, steatite, porcelain and ceramics as a base for soldering. It also can be formulated into paints for thermoplastic or thermosetting plastics.

Special types of flake, finer or coarser than the standard MD 750 Silver Flake, are processed for specific requirements.

In general, the applications of MD Silver Flake pigment are limited only by the imagination and ingenuity of the electronics engineer.



## METALS DISINTEGRATING COMPANY, Inc.

GENERAL OFFICES: Dept. S,  
Elizabeth B, N. J.

CIRCLE 108 ON READER-SERVICE CARD

## Motor Alternator

Two outputs with waveform distortion of less than 2 per cent



Model MA-3 motor alternator incorporates a conventional hysteresis type synchronous motor driving a pair of permanent magnet alternators through appropriate gearing. The relationship to line frequency of the two output frequencies is determined by proper selection of gearing. Model MA-3 can develop both 90 and 150 cps outputs from a 400 cps input. Outputs are matched to within 0.1 per cent over the temperature range of  $-55$  to  $+65$  C. Wave form distortion is less than 2 per cent. Separate outputs can be synchronized so that the waves have a definite phase relationship to  $\pm 2$  deg of one another.

Eastern Air Devices, Inc., Dept. ED, 385 Central Ave., Dover, N.H.

CIRCLE 109 ON READER-SERVICE CARD



## Recorder

Traces information instantaneously with 1 per cent accuracy on electrosensitive paper

Model 260 instrumentation recorder presents instantaneously up to eight 11-in. scale traces within 1 per cent accuracy with a transient response of up to 3000 cps. The recorder traces a permanent record of electronic signals on electrosensitive paper which requires no processing and can be reproduced by standard duplicating methods. Recorder accuracy is unaffected by line voltage variations and paper stretch since calibration marks are recorded simultaneously with input signals. Coordinate markers are generated internally and provide 5 per cent amplitude lines and time markers at 1, 0.1, or 0.0167 sec intervals. Provisions are also made for external frequency standards and additional recorder channels if required.

Consolidated Avionics Corp., Dept. ED, Westbury, L. I., N.Y.

CIRCLE 110 ON READER-SERVICE CARD

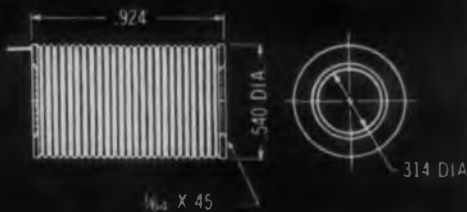

# Too Many Circuits? Too Little Space?

## Use "SUB-MINIATURE" Precision Slip Rings by ELECTRO TEC

If space is a problem in your circuit design, there's an Electro Tec ring assembly that will fit it! And you can be sure of close tolerance, absolute uniformity and the ultimate in miniaturization.

Electro Tec slip rings are produced by an exclusive manufacturing technique that results in accuracy unattainable by conventional fabricating or molding methods.

Electro Tec slip rings and commutator assemblies are a standard specification for thousands of industrial and government applications where precision, low torque friction, superior electrical characteristics, top mechanical strength and absolute tolerance at minimum cost are *a must*.

There is an Electro Tec engineer near you. He will be glad to visit you and help on your design problem.

Pat. No. 2,696,570

Write for illustrated literature.

**ELECTRO TEC CORP.** *Products of Precision*  
*Craftsmanship*

P. O. Box 37B, SOUTH HACKENSACK, N. J.

CIRCLE 111 ON READER-SERVICE CARD



## INERTIAL GUIDANCE SYSTEMS IN PRODUCTION



### INERTIAL PLATFORM

Lightweight and compact, Kearfott four gimbal inertial platforms are characterized by rapid warm-up and alignment. Suitable for manned aircraft or missile applications.



### COMPUTER-AMPLIFIER

For analog or digital data processing. Available with fully transistorized amplifier modules.



### PANEL

Display and control panel for pilot reference or ground support equipment.

Other Kearfott systems feature 18 pound, all attitude platforms with 2 minute warm-up time. Examples of compass systems are conventional or roll stabilized directional gyros and all attitude platforms with 0.25"/hour maximum drift rates.



## KEARFOTT COMPANY, INC.

LITTLE FALLS, N. J.

Sales and Engineering Offices: 1378 Main Avenue, Clifton, N. J. Midwest Office: 23 W. Calendar Ave., La Grange, Illinois. South Central Office: 6211 Denton Drive, Dallas, Texas. West Coast Office: 253 N. Vinado Avenue, Pasadena, California.

# Kearfott

PRECISION  
EQUIPMENT  
CORPORATION  
GPE

CIRCLE 112 ON READER-SERVICE CARD

## NEW PRODUCTS

### Shock Tester Vertical Drop Type

This shock tester will generate with repeated uniformity the 100 g shock test specification over a frequency of 100 to 700 cps. Designated type 1500, the machine will produce a variety of acceleration pulse wave forms, pulse amplitudes, and pulse durations such as saw-tooth, and half sine wave forms. Useful test load is 400 lb max, and drop distance is up to 30 in. The load platform accommodates equipment 30 x 67 in. high.

Barry Controls, Inc., Dept. ED, 935 Pleasant St., Watertown 72, Mass.

CIRCLE 219 ON READER-SERVICE CARD

### Clutch System

Mechanical amplification coupled with an electrical transducer provides fast transmission of very large torques.

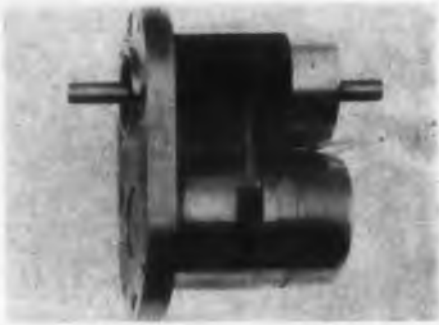

The model A-100-CP clutch pack is the third component released for production of this company's line of speed clutches and brakes. The one-package combination consists of a mechanical pulse amplifier indexing clutch and an electrical transducer. Operating at high shaft speeds and transmitting a minimum torque of 10 in.-lb, the unit features a predetermined delay of very low value. Mechanical delay is as low as 0.001 sec; and electrical delay is 0.0035 sec, providing a combined delay of 0.0045 sec.

The pack consists of indexing clutch, power pack, servo bracket with mounting hardware, and a nylon link. Choice of an index rate of one, one-half or other fraction of a revolution with the option of clockwise or counterclockwise rotation is possible. High shaft speeds and high speed pulsing of 60 cps in standard units are available with higher speeds available in special designs. The frequency of pulses is determined by the angle for which the clutch is set and the shaft speed, allowing for the known delays.

Digitronics Corp., Dept. ED, Albertson Ave., Albertson, Long Island, N.Y.

CIRCLE 220 ON READER-SERVICE CARD

Is  
**PM<sup>2</sup>·X**  
*your answer?*

**GOLD**

Binary ALLOYS      Doped ALLOYS

Tertiary ALLOYS      Eutectic ALLOYS

Let X equal your problem in electronics or atomics. Technic experience is that application of PM<sup>2</sup> (Precious Metal Plating Metallurgy) may be your solution.

### ALLOY GOLD PLATING

Growing complexity of requirements in the electronic and atomic fields brings demand for gold coatings that have qualities other than 24K gold. Technic methods and equipment enable you to meet problems with a new tool — an exact metallurgy which alloys 24K plating gold with trace amounts, or more, of desired elements.

### TECHNIC SERVICE

We engineer and install all your requirements for precious metal electroplating with rigid scientific control. And our specialists are *your* specialists until your installation achieves optimum performance. Send us your problems — old or new — for Technic recommendations.

**PM<sup>2</sup>** Write, wire or call.

682-7

## TECHNIC, INC.

39 Snow Street,  
Providence, R. I.  
Jackson 1-4200  
Chicago Office—7001  
North Clark Street



THE LARGEST ENTERPRISE OF ITS KIND IN THE WORLD

CIRCLE 221 ON READER-SERVICE CARD



# Endurance RATED

## PIC-600 ELECTRIC COUNTERS



Basemount  
Knob reset

- 50 Million Count Life
- 7 watts power consumption—operable in plate circuit of electronic tubes.
- 1000 CPM rating—reliable to 1600 with suitable actuation.
- Quiet—no AC hum.
- Balanced armature—for reliability on airborne equipment.



Panelmount, knob reset



Panelmount, key reset

### Endurance RATED

Stroke Counters.  
Revolution Counters  
Electric Counters  
and Actuators.  
Coil Winding Counters.  
Automatic Batch Counters.

See your  
PIC  
Distributor  
or send  
for  
Catalog.

*Production Instruments*  
DIVISION OF GENERAL CONTROLS CO.

8078D McCormick Blvd., Skokie, Ill.

42 Branch Offices and Representatives  
serving USA and Canada

CIRCLE 113 ON READER-SERVICE CARD

**BREADBOARD KIT.**—Uni-chassis kit consists of a heavy gauge chassis of double deck construction prepunched with mounting holes on the upper deck and with a large number of bolt holes on the lower deck. In addition 22 Unileads of plug-in construction are furnished together with 93 assorted terminations.

Kibbey Instrument Co., Dept. ED, P. O. Box 50, Perkins, Calif.

CIRCLE 114 ON READER-SERVICE CARD

**SLIP CLUTCH.**—A 2-in. long in-line slip clutch has been added to the company's existing line of clutches. Requiring no lubrication, this latest clutch is easily adjusted to transmit from zero to four in.-lb of torque.

Precision Specialties Inc., Dept. ED, 1342 E. 58th St., Kansas City 10, Mo.

CIRCLE 115 ON READER-SERVICE CARD

**TERMINAL BOARDS.**—Three basic sizes, from 5/16 to 1-1/8 in. wide, of boards scribed for easy separation into fifths have been announced. They are available in paper-base phenolic, a cloth-base phenolic, or in an epoxy glass material.

Cambridge Thermionic Corp., 445 Concord Ave., Cambridge 38, Mass.

CIRCLE 226 ON READER-SERVICE CARD

**INTERNAL TIMER.**—The 430 can be supplied with a variety of circuit arrangement, an audible signal, or a hold feature. This particular series is best suited for ranges below 6 hr.

Paragon Electric Co., Dept. ED, Two Rivers, Wis.

CIRCLE 227 ON READER-SERVICE CARD

**POWER TRIODE.**—Having a plate dissipation of 3 kw, type S736 is designed for use as a modulator, amplifier, or oscillator in a-m, f-m, and TV broadcasting, in high-frequency communications systems, and in induction and dielectric heating equipment.

Central Electronic Mfg. Inc., Dept. ED, Denville, N.J.

CIRCLE 116 ON READER-SERVICE CARD

**COOLING FAN.**—Model 1H60 is a rack mounted propeller type, measuring 7 in. high, and 9-1/2 in. wide. Equipped with stainless steel grille, the unit delivers 225 cfm.

McLean Engineering Labs., Dept. ED, P. O. Box 228, Princeton, N.J.

CIRCLE 117 ON READER-SERVICE CARD

**MOTOR-GENERATOR LINE.**—Available in both portable and stationary models, a typical unit has an input of 220 or 440 v 60 cps, and an output of 37.5 kva, 30 kw, 200/115 v, 3-phase, 4-wire, 400 cps, or 500 amp, 28 v dc.

Ideal Electric and Mfg. Co., Dept. ED, Mansfield, Ohio.

CIRCLE 118 ON READER-SERVICE CARD

**MAGNETIC SHIELDING CAPSULES.**—Co-Netic shielding capsules have been designed for miniature reactors and transformers used in transistorized and printed circuits. Closer grouping of components is possible due to shielding effectiveness. Shields can be pretinned for soldering.

Perfection Mica Co., Magnetic Shield Div., Dept. ED, 1322 N. Elston Ave., Chicago 22, Ill.

CIRCLE 119 ON READER-SERVICE CARD

# UHF-MICROWAVE TELEMETERING EQUIPMENT by CANOGA

Canoga Corporation has recently developed and is now manufacturing a complete line of transmitting and receiving antennas for communication and telemetering in the 2200 mc region.



The compact blade antenna has been designed for missiles and supersonic aircraft. It is less than 1 inch high, has very low drag, an all metal leading edge, and provides an omni-directional pattern.

The 8 foot diameter horn fed paraboloid weighs only 82 pounds and provides a 4 degree pencil beam for high gain requirements. Polarization is readily changed from horizontal to vertical. The pedestal includes angle scales, a dual speed drive in azimuth and a single speed drive in elevation.



The conical scanner shown below is installed in 6, 8 or 10 foot diameter paraboloids. Optimum reception of telemetering signals even at long range is obtained by automatic tracking with the narrow beam provided. Horizontal, vertical and circular polarization are available.



FOR ADDITIONAL INFORMATION COMPLETE THE COUPON BELOW AND RETURN TO CANOGA.

**CANOGA**  
CORPORATION  
OF CALIFORNIA

5955 SEPULVEDA BLVD  
VAN NUYS, CALIFORNIA

- ANTENNAS
- RECEIVERS
- RADAR SYSTEMS
- TEST EQUIPMENT
- MICROWAVE COMPONENTS

NAME AND TITLE \_\_\_\_\_  
COMPANY \_\_\_\_\_  
ADDRESS \_\_\_\_\_  
CITY \_\_\_\_\_ STATE \_\_\_\_\_

DESIGN, DEVELOPMENT AND MANUFACTURE TO YOUR SPECIFICATIONS  
CIRCLE 225 ON READER-SERVICE CARD



**SNAPS BACK**

Reclaiming spring forces grip down. Holds it firmly in place against surface.



**NO PINCHING**

Handle back plate design permits grip to lift to 90° position. Keeps fingers free.



**EXTRA STURDY**

Easily attached, each handle is strong enough to lift 200 lbs. with ample safety factor.

## BEST HANDLE YET FOR INDUSTRIAL CONTAINERS, CARRYING CASES OR ELECTRONIC EQUIPMENT!

Meets Military Specifications  
C-4150A and T-945A

There's nothing fragile about this handle! It's strong, rugged, rattle proof, rust and corrosion resistant. Made of tough stainless steel and heavy-gauge anodized aluminum, it will lift 200 lbs. with a big safety factor in reserve.

This Bendix handle has proven its superiority on military and industrial carrying cases, shipping containers and

on electronic equipment. The special grip sleeve will not crack, chip, become sticky or tacky in temperatures from -65° to +160°F. Our patented design eliminates pinching, holds grip firmly against surface when not in use. Attaches easily with nuts and bolts, welding, etc.

Write today for complete specifications and quantity discounts. Bendix-Friez, 1404 Taylor Ave., Baltimore 4, Maryland.

**Friez Instrument  
Division**



CIRCLE 123 ON READER-SERVICE CARD

## NEW PRODUCTS

**TWIN TRIODE.**—The 6021 medium-mu type is designed for oscillator and amplifier service in industrial and communications equipment operating at frequencies up to 400 mc. The 6021 can be operated at full ratings at altitudes up to 60,000 ft without the use of pressurized chambers.

Radio Corporation of America, Tube Div., Dept. ED, Harrison, N.J.

CIRCLE 471 ON READER-SERVICE CARD

**PHOTO ELECTRIC CONTROL.**—The MEK-5500 series is offered as a general purpose control. Specifications include an operating range of 15 ft, relay contacts rated dpdt 5 amp 115 v ac non-ind, and max operations per min of 600.

Machinery Electrification, Inc., Dept. ED, 56 Hudson St., Northboro, Mass.

CIRCLE 124 ON READER-SERVICE CARD

**PRESSURE RECORDING SYSTEM.**—Model 5770 is designed for applications such as production testing of pressure switches. The system sweeps through a pressure range of 0 to 375 psi and prints out the digital value of pressure at which the pressure switches operate.

Beckman Instruments, Inc., Dept. ED, 325 N. Muller Ave., Anaheim, Calif.

CIRCLE 125 ON READER-SERVICE CARD

**MOTOR ANALYZER.**—Model 1061 is designed to produce an efficient system for production quality control of electric motors, solenoids, coils, and magnetic materials. Tests are made for opens, shorts, winding errors, reverse connections, hi-spot to ground, and commutator position.

Automatic Development Co., Dept. ED, 2530 N. Naomi St., Burbank, Calif.

CIRCLE 126 ON READER-SERVICE CARD

**TRANSIT CASE.**—Incorporates a high-strength pressure hinge which provides a means of applying pressure along the hinge-line. Particularly applicable for instrument containers and as pressure-tight shipping cases.

Simmons Fastener Corp., Dept. ED, N. Broadway, Albany 1, N.Y.

CIRCLE 127 ON READER-SERVICE CARD

**GEAR KITS AND WORM WHEELS.**—Spur gear kits and anti-backlash worm wheels have been included in the company's line of precision gears. The anti-backlash worm wheels are designed to run with stock worms.

Pic Design Corp., Dept. ED, 477 Atlantic Ave., E. Rockaway, N.Y.

CIRCLE 128 ON READER-SERVICE CARD

**UHF BLADE ANTENNA.**—Type DM-C7 is designed to operate in the 225-400 mc band for use with communication and data link equipment. The antenna is a high-strength swept-back aluminum blade, with height of 7-3/4 in. from aircraft skin.

Dorne & Margolin, Inc., Dept. ED, 30 Sylvester St., Westbury, L.I., N.Y.

CIRCLE 129 ON READER-SERVICE CARD

AMAZING NEW SILICONE COATING

*Insulates and  
Protects  
Resistors*



### Serviceable to 275°C.

● A special formulation of SICON now protects Corning Glass Works LP resistors against damage from moisture and handling, and acts as an effective insulating coating. It thus guards against dielectric breakdown and subsequent shorting to other parts of TV and radio equipment. SICON does not change the characteristics of the Corning low-power line, and is serviceable to 275°C.

# Sicon®

The Original Silicone Base  
Heat Resistant Finish

● The versatility of SICON as a high temperature protective coating is shown by its remarkably varied use on products of all kinds—resistors, jet engine parts, manifolds, heating elements—and its amazing adherence and color retention when used as a decorative finish for heaters, grills, incinerators, etc. Easy to apply, SICON protects up to 1000°F. in black or aluminum, and up to 500°F. in smart colors.

WRITE FOR BULLETIN NO. CG 100 TODAY  
Dept. B-23

**MIDLAND**  
Industrial Finishes Co.  
Waukegan, Illinois

CIRCLE 130 ON READER-SERVICE CARD

For industrial applications



## Stromberg-Carlson "Push-to-talk" HANDSETS

You'll find many valuable uses for Stromberg-Carlson's "Push-to-talk" telephone handsets in your day-to-day operations. These instruments feature switch assemblies with various spring combinations mounted in the handles, actuated by a rocker-bar lever. A few typical applications:

- **Push-to-talk and Push-to-receive:** for two-way radio communication.
- **Push-to-open and Push-to-close external circuit:** for use with dictating machines and in remote control operations.

You have a choice of two types of handset: No. 28, which is the standard model; and No. 29, a special high-gain, high-efficiency handset with Western Electric receiver and transmitter. Available with either coiled or straight cord.

For complete technical details on these handsets and other Stromberg-Carlson telephones and components for industrial use, send for Bulletin T-5005. Write to:



## STROMBERG-CARLSON

A DIVISION OF GENERAL DYNAMICS CORPORATION  
TELECOMMUNICATION INDUSTRIAL SALES  
116 CARLSON ROAD, ROCHESTER 3, N. Y.  
ELECTRONIC AND COMMUNICATION PRODUCTS  
FOR HOME, INDUSTRY AND DEFENSE

CIRCLE 131 ON READER-SERVICE CARD

**GERMANIUM SWITCHING TRANSISTOR.**—The MN-19 is designed specifically for high reliability requirements. Typical alpha cutoff is 8 mc, and typical rise time is 0.1 usec.

Motorola Inc., Dept ED, 4545 W. Augusta Blvd., Chicago 51, Ill.

CIRCLE 132 ON READER-SERVICE CARD

**FIXED COMPOSITION CAPACITORS.**—Available in 49 different EIA values, series JM cover the range from 0.1 to 18 $\mu$ f. The capacitors feature operating stability, a moderate Q characteristic, and also design simplicity.

Speer Carbon Co., Jeffers Electronic Div., Dept. ED, DuBois, Pa.

CIRCLE 133 ON READER-SERVICE CARD

**CATHODE RAY TUBES.**—Type 5AHP7 is a 5 in. round glass, nearly flat face, magnetic deflection oscillograph tube suitable for visual presentation of low speed, non-recurring phenomena, and featuring electrostatic focus. An aluminized version, type 5AHP7 is also available.

Sylvania Electric Products, Inc. Dept. ED, 1740 Broadway, New York 19, N.Y.

CIRCLE 134 ON READER-SERVICE CARD

**TOGGLE SWITCHES.**—Integral terminal construction and a new step-design case offer ease of wiring and stronger terminals. Series TL include single-pole and two and four-pole circuitry, rated at 20 amps, 30 v dc, resistive load.

Minneapolis-Honeywell Regulator Co. Inc., Micro-Switch Div., Freeport, Ill.

CIRCLE 135 ON READER-SERVICE CARD

**COMPOSITION RESISTORS.**—Coldite 70+ is a series developed for long load life and moisture resistance. The units are available in 1/2, 1 and 2 w models.

Stackpole Carbon Co., Electronic Components Div., Dept. ED, St. Marys, Pa.

CIRCLE 136 ON READER-SERVICE CARD

**CONNECTORS.**—A line of connectors for Foamflex and Styroflex cables has been announced. Complete adapters from Foamflex to RG-8A/U, including feed-thru and bulkhead are available. All connectors are pressurized.

Kings Electronics Co., Dept. ED, 40 Marbledale Rd., Tuckahoe, N.Y.

CIRCLE 137 ON READER-SERVICE CARD

**CERAMIC POWER TETRODE.**—An all ceramic-metal version of the 4X250B, the 4CX250B has greater immunity to damage by mechanical shock and high temperature, lower rf dielectric losses, and greater dimensional stability.

Eitel-McCullough, Inc., Dept. ED, San Bruno, Calif.

CIRCLE 138 ON READER-SERVICE CARD

**MOMENTARY CONTACT SWITCH.**—Designed for high-speed, low force switching, Unimax type 2MJK provides dpdt control with application of approximately two-ounce force. The unit is designed for panel mounting in a single 13/32 in. diam hole.

W. L. Maxson Corp., Unimax Switch Div., Dept. ED, Wallingford, Conn.

CIRCLE 139 ON READER-SERVICE CARD

# computer time saved with

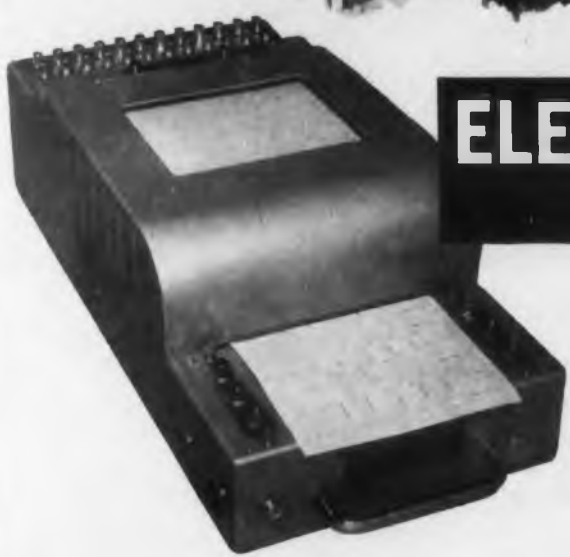

## ELECTROGRAPH

MODEL 420

*Visual editing of tape-recorded intelligence through use of Electrograph records saves many hours of valuable computer time.*

### 24-channel Electrophotographic Recording Oscillograph

Now you can edit telemetered tape-recorded information and select the data to be fed into the data reduction computer. As many as 24 channels of tape signals connected to the Electrograph galvanometers through appropriate discriminators may be recorded simultaneously. The analog record is instantly readable as it is discharged from the recorder. Proper keying of the permanent record to the tape permits visual selection of the data to be placed into the computer.

Records produced by the Electrograph are permanent, requiring no further processing, and may be stored indefinitely without loss of trace definition.

For further information regarding the Electrograph, you are invited to write, wire or call for bulletin CGC-311.

**Century Electronics & Instruments, Inc.**

1333 No. Utica, Tulsa, Oklahoma

CIRCLE 140 ON READER-SERVICE CARD

## LOOK TO TOBE FOR PROGRESS

# electronic interference filters



TOBE brings unequalled experience to the solving of your filtering problems. TOBE'S advanced design-techniques, and the technical data accumulated by TOBE filter specialists over the years, meet your problems with solutions that are quicker, more efficient, and more reliable. For all your filtering needs, look to TOBE DEUTSCHMANN, the oldest name in interference filters.

TOBE FILTERETTES, available in wide range of ratings, sizes and mounting styles, are engineered to operate under the most severe environmental conditions.

*Tobe Exclusives:*

Feed-thru capacitor construction in filterettes.

Miniaturization with maximum quality.

Guaranteed attenuation characteristics—under full-load operating conditions.

We invite inquiries on specific applications. The services of our engineers are always available. Write TOBE-DEUTSCHMANN Corporation, Norwood, Mass., the acknowledged authority on electronic interference—manufacturers of "FILTERETTES".

specify  
**TOBE**  
FILTERETTES

TOBE DEUTSCHMANN • CAPACITOR PIONEERS SINCE 1922

CIRCLE 141 ON READER-SERVICE CARD

# NEW LITERATURE

## Ceramics 142

A 16 page, two color ceramic catalog highlighting high alumina bodies in addition to Steatite, Cordierite, and Zirconite ceramics is available. Included are special sections on standard extrusions, ceramic properties and specifications, and metalizing, plus a clear-cut method of ordering ceramic pieces. Centralab, 900 E. Keefe Ave., Milwaukee 1, Wis.

## Repeat Cycle Timers 143

Bulletin sheet AWH RC-301, describes a line of sub-miniature hermetically sealed repeat cycle timers. These timers meet various military specifications such as MIL-E-5272A and can be supplied with radio interference filtering for dc units when required. The bulletin sheet is clearly illustrated, including charts on cycling times, outline and mounting dimensions, approximate weights, and tabulation of the military specifications. A. W. Haydon Co., Waterbury, Conn.

## Airfoil Centrifugal Fans 144

This publication is illustrated with photographs showing construction details of airfoil fans for all types of ventilating and air conditioning installations. Comparative performance graphs show why greater efficiency and quieter operations are obtained with fans designed on the "Airfoil" principle than with those having conventional blades.

Capacity tables, dimensional drawings, and suggested arrangements are given for each model of fan. Also included in Bulletin 257 are rating tables on "Long-Life" motors, sample fan specifications, the laws of fan performance, and other data useful in engineering ventilator installations. Ilg Electric Ventilating Co., 2850 N. Pulaski Rd., Chicago 41, Ill.

## Reliability Controls 145

This publication is a check list for reliable controls and contains capsule information on a line of relays, thermostats, rotary switches, range switches, motor controls, and "snap-ins." It is designed to provide engineers and purchasing agents with facts about controls for air conditioning, aircraft, appliances, automation, electronics, guided missiles, machine tools, panel boards, and similar applications. The check list also contains a business reply card for the use of those who would like more complete information. Hart Manufacturing Co., 110 Bartholomew Ave., Hartford, Conn.



**\*TRANSLATION: You Can't Beat The Bendix "Supermarket"**

From our "supermarket" of precision components, we offer you these advantages on temperature-compensated tach generators: *Fast delivery* because of volume production; *Laboratory quality* due to extensive test facilities and high-precision manufacture; *Latest developments*, such as miniaturization, integral motors, wider range of temperature compensation, etc. Our complete line assures you of getting tach generators best suited to your needs.

**NOW! FRAME SIZES 10 AND 15 ADDED TO TACH LINE NEW!**

Bendix Tach Generators are linear to within 1/10 of 1% over a wide speed range; are available over a temperature range of -55°C to +125°C with output voltage stable to 1/10 of 1%; motor generators also available.

**Eclipse-Pioneer Division**  
Teterboro, N. J.

**Bendix**  
AVIATION CORPORATION

District Offices: Burbank and San Francisco, Calif., Seattle, Wash.; Dayton, Ohio; Washington, D. C.  
Export Sales & Service: Bendix International Division, 205 E. 42nd St., New York 17, N. Y.

CIRCLE 146 ON READER-SERVICE CARD



# GET THE FACTS

LOW and constant contact drop  
 LOW electrical noise  
 HIGH current density  
 LONG life...



**HIGH PERFORMANCE**



# BRUSHES CONTACTS SLIP RINGS

**& Slip Ring Assemblies**

BRUSH HOLDERS, CONTACT ASSEMBLIES,  
 BRUSH ASSEMBLIES



USED EXTENSIVELY IN:

**SERVOS • GUN-FIRE CONTROLS  
 TELEMETERING • ROTATING  
 THERMOCOUPLE and STRAIN  
 GAGE CIRCUITS • ROTATING  
 JOINTS • DYNAMOTORS**

Wide range of grades available for standard and special applications. Call on our 40 years of design experience to help solve your problems.

**OTHER GRAPHALLOY**

**PRODUCTS:** Unique (oil-free) self-lubricating Bushings and Bearings (applicable -450° to +700°F.; with expansion coefficient half that of steel will not seize shaft at low temperature); Oil-free Piston Rings, Seal Rings, Thrust and Friction Washers, Pump Vanes.



**GRAPHITE METALLIZING CORPORATION**

1046 Nepperhan Ave. • YONKERS, NEW YORK

- Please send data on Graphalloy BRUSHES and CONTACTS.  
 Send data on BUSHINGS.

NAME & TITLE \_\_\_\_\_  
 COMPANY \_\_\_\_\_  
 STREET \_\_\_\_\_  
 CITY \_\_\_\_\_ ZONE \_\_\_\_\_ STATE \_\_\_\_\_

CIRCLE 147 ON READER-SERVICE CARD

## Stainless Fasteners

148

An eight-page condensed guide to stainless steel fasteners normally carried in stock is now available. Thirty-seven different types of standard fasteners are illustrated in the comprehensive two-color brochure. Screws, nuts, bolts, washers, rivets, and government specification "AN" fasteners are included. Allmetal Screw Products Co., Inc., 821 Stewart Ave., Garden City, N. Y.

## Printout Frequency Indicator

149

Frequency Indicator, model 7341B, with printout, provides the first economical answer to frequency, velocity, and rpm measurement problems requiring continuous monitoring and printed readings. It is described in a catalog sheet now available. The sheet gives the design operation data, plus complete specifications. Electro Pulse, Inc., 11861 Teale St., Culver City, Calif.

## Panel Meters

150

The styles and ranges of panel meters in sizes from 2-1/8 to 7-1/4", are shown in 4-page catalog C-22 now available. The catalog is well-illustrated and has complete specifications on all dc types, includes dimensional diagrams, typical scales and data charts. Featured are three clear plastic models: 212P, 250P, 725P. Ideal Precision Meter Co., Inc., 126 Greenpoint Ave., Brooklyn 22, N. Y.

## Relay Symposium Papers

151

Papers presented at the Fifth National Conference on Electromagnetic Relays, Oklahoma State University, Stillwater, Oklahoma, have now been made available in a 132 page booklet. The papers were presented by authors representing relay users, manufacturers, universities, and government agencies, and are complete with tables, graphs, diagrams, and illustrations. Potter & Brumfield, Inc., Princeton, Ind.

## Paper Capacitors

152

Now available is a copy of the Engineering Bulletin No. 2000 on series AG paper tabulars made to preferred number capacitance values of the EIA. As a result of an improvement in end seal design construction, we have found it possible to shorten the length of all capacitors of this general design. The new sizes are shown in Bulletin No. 2000. Sprague Electric Co., North Adams, Mass.



# DELAY LINES

standard or specially designed

# BY TECHNITROL

These extra-compact delay lines assure a minimum of pulse distortion with maximum stability under ambient temperatures . . . and in a minimum of space. They can be had pencil-thin in plug-in, pig tail or fuse-clip mounting. Available cased or dip-coated in epoxy resin as well as hermetically-sealed units for military application . . . with any desired characteristics of impedance or frequency response. Typical are:

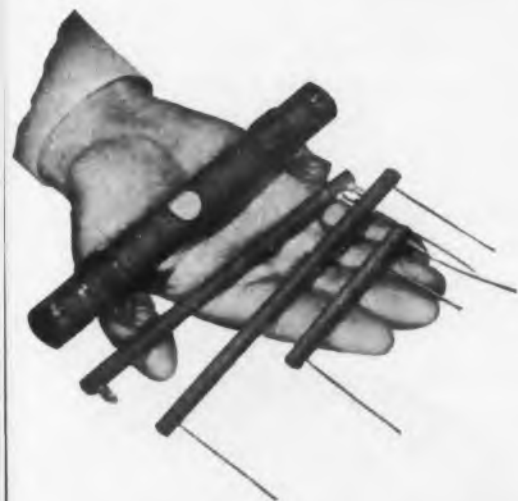

- Delay: 0.01 to 6  $\mu$ s
- Characteristic Impedance: 400 to 5600 ohms
- Band Pass Characteristics: Unique windings furnish maximum band width for given delay per inch.

We are prepared to design lumped constant or distributed constant delay lines for your particular circuit applications.



Write today  
for Bulletin  
ED 174



CIRCLE 153 ON READER-SERVICE CARD

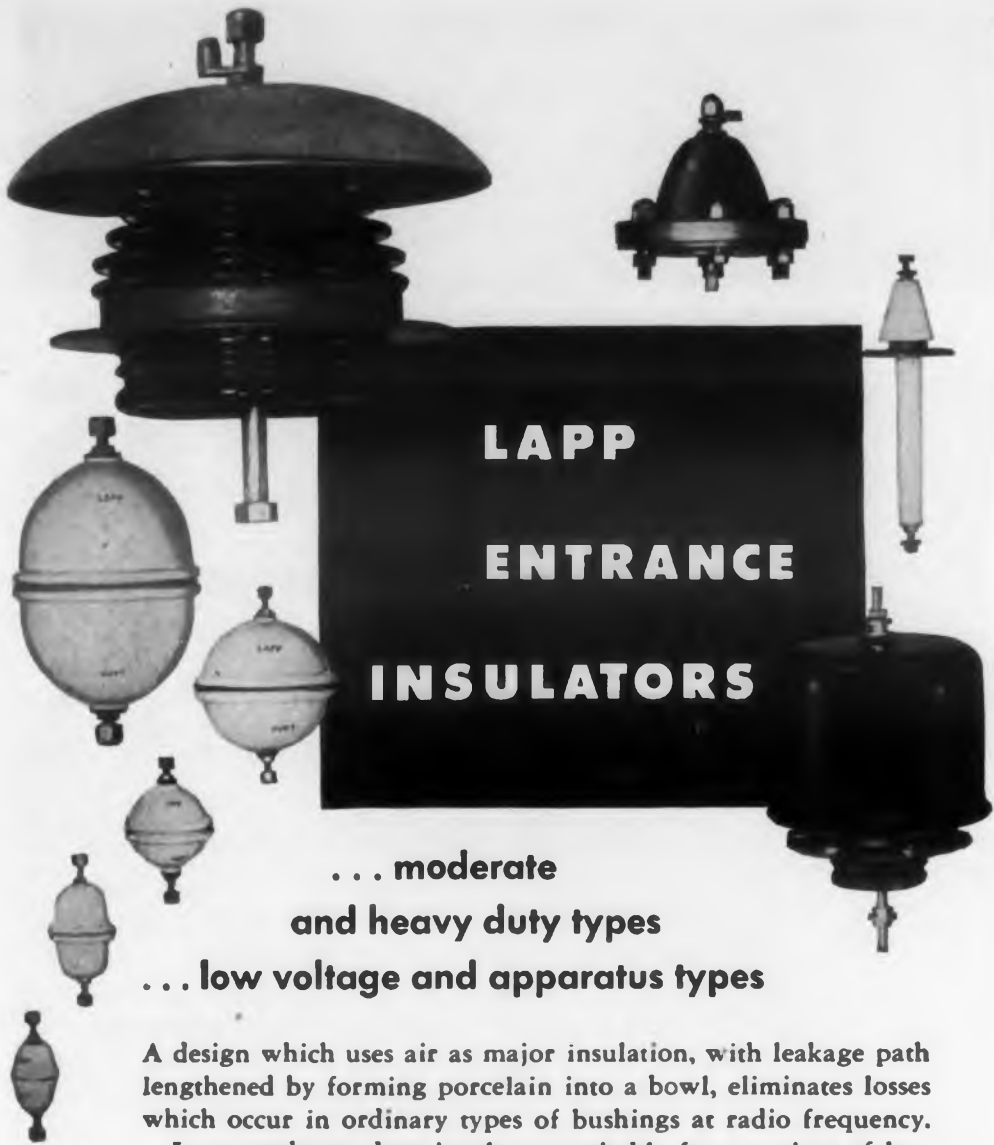

# LAPP ENTRANCE INSULATORS

... moderate  
and heavy duty types  
... low voltage and apparatus types

A design which uses air as major insulation, with leakage path lengthened by forming porcelain into a bowl, eliminates losses which occur in ordinary types of bushings at radio frequency.

Lapp moderate duty insulators, suitable for a variety of low or medium voltage applications, are the standard type bowls for carrying leads through shields, equipment cases, walls, etc., and practically any indoor use where duty is not too severe.

Outdoor units are designed with corrugated surfaces which provide extra leakage distance for use in contaminated atmosphere. Corrosion-resistant hardware.

A wide variety of types of these insulators is now available as catalog items . . . or where requirements necessitate, on special design—for which Lapp engineering and production facilities are excellently qualified. Write for complete descriptive data and specifications. Lapp Insulator Co., Inc., Radio Specialties Division, 104 Sumner Street, Le Roy, N. Y.



# Lapp

CIRCLE 154 ON READER-SERVICE CARD

## NEW LITERATURE

### Cabinet Racks 155

A catalog which contains illustrations, descriptions, technical specifications, and prices of universal cabinet racks and utility desk assemblies is now available. This 28-page catalog describes the 30 in. wide panel racks which are furnished with solid side walls, with open side walls, with front and rear doors, or with rear door only. Par-Metal Products Corp., 32-62 49th St., Long Island City, N.Y.

### Resistance Thermometers 156

A 15-page booklet, entitled "How to Use Platinum Resistance Thermometers in Temperature Measurement, Telemetry, and Control," is now available. This report is believed to be the first compilation of information on platinum resistance thermometers into a single booklet. The basis for temperature measurement with platinum and some of the reasons why platinum has been adopted as an international temperature standard are set forth. Various types and characteristics of specific resistance thermometers are described. Trans-Sonics, Inc., Burlington, Mass.

### Electronic Components 157

A 12-page catalog and a price list of an entire line of imported and American-made miniaturized components plus specialty and audio items is being made available. The catalog lists transistor transformers, miniature broadcast frequency tuning capacitors, a large group of transistor antenna, rf, oscillator, and i-f coils, electrolytic capacitors, and many other items. Argonne Electronics Mfg. Corp., 165-11 South Rd., Jamaica 33, N.Y.

### Plastic Properties Chart 158

Comparative properties of Lexan polycarbonate resin and other thermoplastic molding materials are outlined in a Plastics Properties Chart. Other test data listed includes electrical and physical properties, as well as molding characteristics. General Electric Company, One Plastics Ave., Pittsfield, Mass.

### Telemetry Equipment 159

This 30 page catalog describes and pictures a product line of transducers, telemetry oscillators, digital strain gage indicators, servo converters and automatic data logging instruments. Included are specifications and applications data useful both in military and commercial activities. Datran Electronics, 3615 Aviation Blvd., Manhattan Beach, Calif.

## Flexibility for Designers



### *Adjust-A-Volt* **500BU** VARIABLE AUTO-TRANSFORMER



2-GANG 500BU  
(Also available in 3-gang)

Designed for back-of-panel mounting, the versatile 500BU Adjust-A-Volt variable auto-transformer offers the dependability and flexibility you have been looking for.

Shaft can be adjusted without disturbing rotor and commutator alignment. Terminal board connections allow for either clockwise or counter-clockwise rotation, as well as over-voltage or line-voltage operation.

Ganged units are available to provide increased current output, increased voltages, or for polyphase operation.

Specifications of the 500BU type—input voltage, 115 V; load rating, 1.0 KVA; output—0 to 135 V; output amps max. 7.5 A; driving torque in oz., 20-40. For more data, send for the catalog on the complete Adjust-A-Volt line.

**STANDARD**  
ELECTRICAL PRODUCTS CO.  
2240 E. THIRD ST., DAYTON, OHIO

CIRCLE 160 ON READER-SERVICE CARD



# Krohn-Hite

## WIDE RANGE RC OSCILLATORS



MODEL 440-A

### FEATURING

- **DISTORTION LESS THAN 0.1%**
- **100 MILLION TO 1 FREQUENCY RANGE**
- **PUSH BUTTON RESETABILITY**

### The Krohn-Hite Oscillator Line

Model	Frequency Range	Frequency Accuracy	Distortion	Price
400-A	.009 cps to 1.1 kc	2%	1%	\$375.00
400-C***	.009 cps to 1.1 kc	2%	1%	\$395.00
410-A***	.02 cps to 20 kc	2%	1/10%	\$1050.00
420-A	.35 cps to 52 kc	2%	1%	\$315.00
420-C***	.35 cps to 52 kc	2%	1%	\$345.00
430-AB	4.5 cps to 520 kc	2%	1%	\$145.00
440-A**	.001 cps to 100 kc	1%*	1/10%*	\$550.00
440-B**	1 cps to 1 kc	1/20%*	1/10%	\$950.00

All oscillators except 430-AB and 440-B have both sine wave and square wave outputs. \*Higher at end of range. \*\*Push Button Operation in Models 440 ONLY. \*\*\*Rack panel construction.

For further information on:

- Filters
- Power Supplies
- Oscillators
- Power Amplifiers

write for our free catalog D



# Krohn-Hite CORPORATION

580 MASSACHUSETTS AVENUE  
CAMBRIDGE 39, MASS., U. S. A.

CIRCLE 161 ON READER-SERVICE CARD

## Gold Plating Electronic Parts

162

Reprints of an article recently published by William F. Boyle, Chief Metallurgist, tell how a patented gold plating process has affected savings in the finishing of various electronic parts, over methods previously used. According to Mr. Boyle's article, the gold plating process prevents corrosion, gives an extremely hard surface, is a fine electrical conductor, and is relatively inexpensive to apply. Also discussed are the results of various destructive tests to which the gold plate was subjected, costs as compared to other precious metals electro-plate, equipment required and a step-by-step procedure for bath preparation, operation, maintenance and control. A section treating a typical plating cycle lists the chronological steps which assure best possible results. Sel-Rex Corp., Nutley 10, N.J.

## Shield Grounding Samples

This sample board was planned to provide actual samples of various standard sizes of braid. Samples range in size from 1/8 in. to 11/16 in., plus samples of military braid in widths from 1/16 in. to 1/2 in. To obtain this sample board, write on letterhead stationery to Lenz Electric Mfg. Co., 1751 N. Western Ave., Chicago 47, Ill.

## Electrolytic Grinding

163

Copies of a speech describing the electrolytic grinding of high grade alloys have been made available. The speech was given by Lynn A. Williams before the Metal Removal Seminar of the 1957 SAE Aircraft Production Forum held in Los Angeles on Sept. 30, 1957. Mr. Williams groups the problems of machining the high alloys into three general classes: problems resulting from heat or cold working; problems caused by tearing the metal apart or by not presenting a rigid machining surface, and cutter and tool problems. Exploration of these problems in the light of the applications of electrolytic grinding to the high alloy materials is made. Anocut Engineering Co., 631 W. Washington Ave., Chicago 6, Illinois.

## Tape Wound Cores

164

Illustrated and described in a two-color, 8-page catalog are tape wound cores of high uniformity produced in commercial quantities. The catalog describes the three types of core materials from which the precision-made tape wound cores are manufactured. Test procedures are illustrated and described, standard test limits are given in chart form and graphs. The catalog also contains information on protective boxes, vibration and shock procedures, standard and special core sizes. G-L Electronics, 2921 Admiral Wilson Blvd., Camden 5, N.J.



## LATEST JAZZ ON THEM DEMAND METERS

New General Electric demand meters present a neat case for the Sigma 42RO relay. Demand meters record average power in a given time interval. With more kilowatt hours being consumed every year, the new GE meters record more impulses per unit time so that the utility can know more accurately (and charge for) peak demand.

GE pulses their new demand meters at the necessary rate using the commutator pictured, and a pair of Sigma 42RO relays in an ingenious relay amplifier circuit. This is the point where the pianist above comes in, in his other role as a laboratory standard. He may look like an ordinary fly to you, but it happens that the force he can exert (after a good night's sleep) on a piano key  $\frac{1}{8}$ " long very nearly equals the maximum torque required to drive the SPST commutator contact device. With a torque limitation like this, the brushes are small and as a result the impulse current has to be kept to a minimum. It is: the 42's need only 5 milliamperes AC to switch the burden of the demand meter.

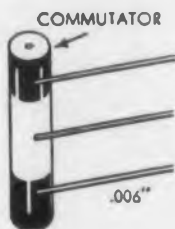

SIGMA  
TYPE 42RO  
RELAY

This virtue of the 42 is commendable in itself. But life tests also show that 100,000,000 impulses (50 million operations) can be transmitted, with an arc-suppressed  $\frac{1}{2}$  ampere, 120VAC inductive load. The 42's are DPDT and another 100 million impulses of operation can be obtained by swapping them and using the other set of contacts to carry the D.M. load. In service, this boosts life expectancy to somewhere between 5 and 25 years, depending on the application.

Although flies as precise as GE's are not easy to obtain\*, standard Series 42 relays are available on order. Price range \$4.60 to \$12.80 list. Bulletin sheets giving pertinent 42 data come simply on request.

\* Sigma once had one on the payroll, but an avaricious cricket did him in.

# SIGMA

SIGMA INSTRUMENTS, INC.

91 Pearl Street, South Braintree 85, Mass.

CIRCLE 165 ON READER SERVICE CARD

Get \$10.00 plus a by-line for the time it takes you to jot down your clever design idea. Payment is made when the idea is accepted for publication. Full information and an "entry blank" can be obtained by circling #166 on the Reader's Service Card.

## Silicon Rectifier Circuit

### Protects DC Meter up to 1000 Times Rated Current

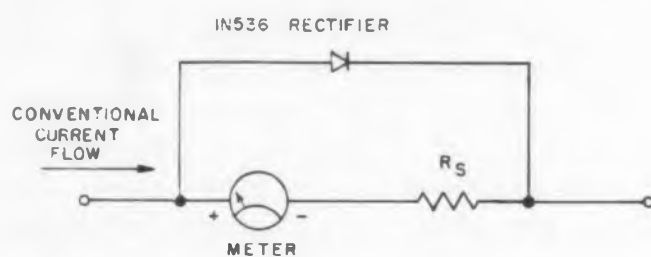

Fig. 2. Ammeter protective circuit employing silicon rectifier.

THE SIMPLE combination of a low voltage silicon rectifier and a resistor can eliminate expensive dc meter burnouts and a plague of bent indicating pointers. In control circuits and in test equipment where the frequent possibility of shorted load circuits exists, this protective circuit clamps meter current to two or three times normal at overloads up to thousands of times full scale current. The effect on meter accuracy is 1 per cent or less at full scale, considerably less at lower currents.

#### The Circuit

The circuit employs the unique forward characteristic of a typical silicon rectifier, the 1N536,

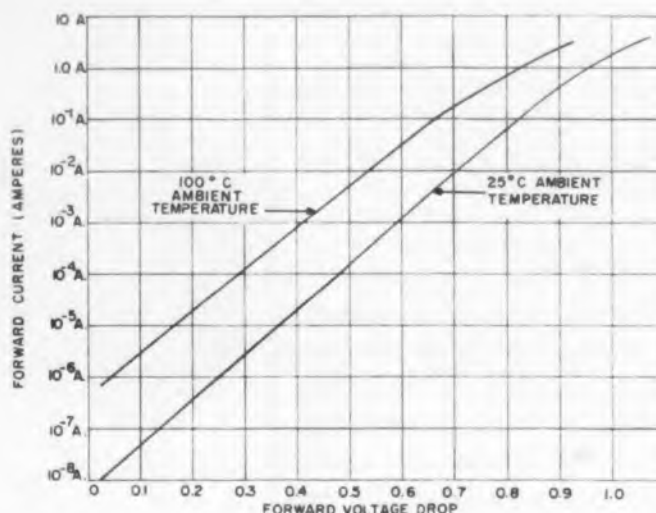

Fig. 1. Typical forward characteristic of G. E. IN536 silicon rectifier.

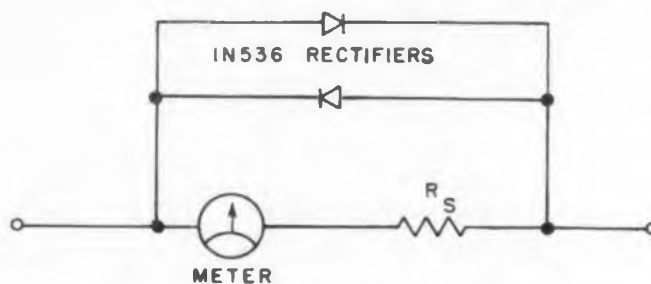

Fig. 3. Protective circuit for zero-center galvanometer.

as shown in Fig. 1. The forward voltage drop below one ampere for this particular rectifier is essentially proportional to the logarithm of the current over a range of approximately 100 million to one.

A rectifier of this type is shunted across the ammeter in the direction of easy conduction, and a proper resistance is inserted in series with the meter to bias the rectifier for optimum protection as shown in Fig. 2.

The value of series resistor  $R_s$  is determined as follows:

$$R_s = \frac{V_{RI}}{I_{FS}} - R_M \quad (1)$$

Where:  $V_{RI}$  = Forward voltage drop of rectifier at shunted current permissible at full scale meter reading (volts).

$I_{FS}$  = Full scale meter current (amperes)

$R_M$  = Internal resistance of meter (ohms)

#### Design Example

For example, assume the meter has a full scale deflection of 1 ma, that its internal resistance is 80 ohms, that the circuit will operate in room ambient, and that the maximum error that the rectifier may introduce on the meter is 1 per cent. Since the maximum percentage error introduced will be at full scale, the maximum shunted current allowable through the rectifier will be  $0.01 \times 1 \text{ ma}$  or  $10^{-5} \text{ a}$ ,  $V_{RI}$  at  $10^{-5} \text{ a}$  is 0.37 v at room temperature on Fig. 1. Using Equation 1,  $R_s = 0.37 / 0.001 - 80 = 290$  ohms. With this resistance inserted in the circuit, 99 per cent of the load current will flow through the meter when 1 ma total flows in the circuit. At load currents less than 1 ma, accuracy will be considerably better than 99 per cent. Where necessary, increased accuracy can be attained by selecting a lower  $V_{RI}$  in the above equation. This will lower the degree of protection somewhat.

At 1000 times full scale current, or 1, the rectifier will draw practically all of the current. The current flowing through the meter,  $I_{OL}$ , under these conditions can be very closely approximated with the following equation:

$$I_{OL} = \frac{V_{R2}}{R_M} + R_s \quad (2)$$

Where:  $I_{OL}$  = Current through meter under overload conditions (amperes)

$V_{R2}$  = Forward voltage drop of rectifier at overload current (volts). Determine from Fig. 1.

At 1 a,  $V_{R2}$  is 0.95 v. Using Equation 2,  $I_{OL} = 0.95 / 80 + 290 = 2.57 \text{ ma}$ , or slightly over 2-1/2 times full scale current. Thus, even at a 1000 fold

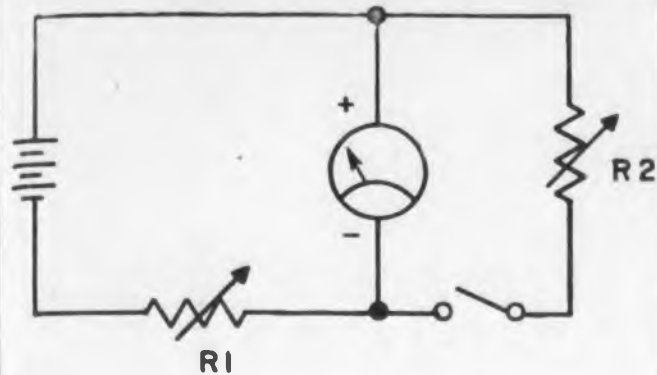

Fig. 4. Circuit for determining internal resistance of ammeter.

overload, meter current does not reach destructive proportions.

#### Broad Applications

Because of its broad current range, the 1N536 may be used to protect current indicating instruments from the microammeter range through into the hundreds of milliamperes. The upper current limit on use of a silicon rectifier is based on the maximum temperature rise of the junction. Thus, the 1N536 is limited to 900 ma continuous dc current at 25 C ambient and 600 ma at 100 C ambient. The worst overload condition that can be satisfactorily handled will be limited by these values. Above this limit, silicon rectifiers of higher ratings are available with similar characteristics so that even high current meters using shunts can be protected at costs very reasonable when compared to the cost of the meters being protected, provided that 0.4 to 0.5 v additional circuit drop is not objectionable. For shunt-type meters, the rectifier and resistor should be connected outside of the shunt and meter connections if maximum accuracy is to be achieved.

Illustrated in Fig. 3 is how zero-center galvanometers may be protected by shunting two rectifiers in opposite directions across the meter and series resistor.

For ambient temperatures between 25 and 100 C, linear interpolation of the characteristics in Fig. 1 may be satisfactorily used.

When the internal meter resistance is not given on the face of the meter or in meter catalog information, it may be satisfactorily determined for these purposes by the following time-honored method illustrated in Fig. 4.

1. Connect the meter in series with adjustable resistance  $R1$  across a constant dc voltage 6 v or higher.
2. Adjust  $R1$  so that the meter reads full scale.
3. Connect adjustable resistance  $R2$  across meter terminals.
4. Adjust  $R2$  so that meter reads half-scale.
5. Resistance of meter will then be equal to  $R2$ .

F. W. Gutzwiller, Application Engineer, General Electric Co., Semi-conductor Products Dept., Syracuse, N.Y.

now, with basic modules build...

#### DIGITAL VOLTMETERS



#### DIGITAL OHMMETERS



#### DIGITAL RATIO METERS



### or a COMPLETE DIGITAL, MISSILE ELECTRICAL CHECKOUT SYSTEM

for measuring DC to 0.01%, AC to 0.1%, Ohms to 0.01%, DC ratios to 0.01% and AC ratios to 0.02%

**Standard, off-the-shelf modules never become obsolete**—provide maximum versatility. As needs change, simply regroup old modules or add new ones. Your system is always current at minimum cost and engineering. Internal construction is also modularized for ease of maintenance.

**Fully transistorized circuits** result in increased reliability, reduced power consumption, low heat dissipation, miniaturized packages, and eliminate radio noise and line transients.

**Important new specifications**—Wider, dynamic ranges cover all voltages from 100 microvolts to 1,000 volts; resistance from 10 milliohms to 10 megohms. Input power frequencies from 50 to 400 cycles. New balance logic speeds down ranging. Automatic AC ranging from 30 to 10,000 cycles. Use of transistors increases switch life by a factor of three.

**Wide selection of input and output modules** for operating printers, IBM punches, etc., can be accommodated without modifications. All contacts are accessible at rear panels with connectors. With plug-in modules, digitized data is provided in printed form, punched cards or tape without modification to basic measuring instruments.



This Short Form Catalog gives complete specifications on both basic and auxiliary modules. Send for it... today.

**ELECTRO  
INSTRUMENTS**

INC.  
3794 Rosecrans Street  
San Diego, California

CIRCLE 167 ON READER-SERVICE CARD



# ENGINEER WANTED



... FOR OVER-DESIGNING!

In the design of his unit, this engineer disregarded cost and used a standard catalog snap-action switch. Investigation by his Company (now bankrupt) disclosed that Cherry Electrical Products would have designed (free) a custom snap-switch with only those switch parts necessary.

## REWARD!

Send details of your switch applications and be richly rewarded with a custom designed snap-action switch to your requirements — nothing extra to run up the cost!

Call or write

**CHERRY ELECTRICAL PRODUCTS CORP.**  
1649-A Deerfield Rd., Highland Park, Ill.  
IDlewood 2-8182  
CIRCLE 168 ON READER-SERVICE CARD

*Completely enclosed  
electrically insulated  
fast response*  
**THERMOCOUPLE**

**OPERATING TEMPERATURE**  
-320°F to 1900°F

Compatible to most liquids — gases and nuclear radiation

A thermocouple that has all of the features of a completely enclosed thermocouple integrally welded to the sheath, i.e., fast response — pressure tight — corrosion resisting — plus the added feature of high electrical insulation between inner sheath and over-tube as obtained by the special ARI ceramic coating.

Write for additional data —  
"Bulletin 3.8.5"

**Aero Research**  
**INSTRUMENT COMPANY, INC.**  
315 NO. ABERDEEN ST., CHICAGO 7, ILLINOIS  
Sales Representatives throughout the United States and Canada  
CIRCLE 169 ON READER-SERVICE CARD

## IDEAS FOR DESIGN

Materials Change Cuts Costs  
by Two-Thirds

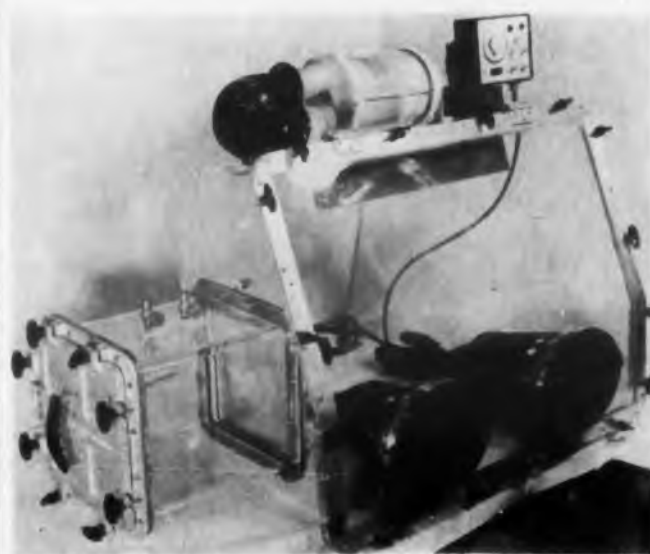

Controlled atmosphere enclosures manufactured by Controlled Atmosphere Enclosures Corp. as redesigned from stainless steel to cast acrylic plastic sheet. This not only reduced cost but achieved functional advantages as well.

By substituting cast acrylic sheet and tube for stainless steel, a Long Island manufacturer of scientific equipment cut his costs by two-thirds. He improved the performance and utility of his product in numerous respects and was better able to maintain delivery schedules.

Controlled Atmosphere Enclosures Corporation, 230-11 141st Avenue, Springfield Gardens 13, Long Island, New York, manufactures hermetically sealed dry boxes and research enclosures for research and assembly operations where an atmosphere protected from humidity, dust or other contaminants is required (see figure).

### Redesign Cuts Cost

Hitherto most such apparatus has been made from stainless steel, with the exception of the detachable front panel which was of glass. This involved a problem of material scarcity, high initial cost of the stainless sheet and high fabrication costs. In addition, the stainless steel seams were soldered, presenting the possibility of a leak during the life of the apparatus.

The Long Island firm now forms its enclosures from a single sheet of 3/8 in. clear Plexiglas cast acrylic. In the same operation, a shallow groove is formed in the front edges of the enclosure walls. Into this groove fits the unique gasket which assures the absolute sealing of the enclosure—a continuous length of vinyl tubing in-

NOW!

**ACE** helps you get  
**FABRICATED**  
**PLASTIC PARTS**  
faster...at lowered costs

New e-x-p-a-n-d-e-d production facilities now give you ACE HIGH QUALITY on all types of screw machine, centerless ground parts and special shapes . . . all colors . . . all materials.

LUCITE • PLEXIGLAS • ACRYLIC • ACETATE  
• BUTYRATE • CAST PHENOLIC • EPOXY RESIN  
• ETHYL CELLULOSE • KEL-F • LAMINATED  
BAKELITE • NYLON • POLYETHYLENE •  
STYRENE • COPOLYMERS • TEFLON

Sizes: 1/8" to 2 1/4" • Lengths: 1/16" to 9"

Write, wire, phone for samples, prices and bulletin listing stock items. Send specifications or blueprints for prompt quotations on specials.

**ace** PLASTIC COMPANY

Extrusion Molders and Fabricators  
91-58 Van Wyck Expressway, Jamaica 35, N. Y. • JAmaica 3-5500  
CIRCLE 170 ON READER-SERVICE CARD

## Faster, Safer Flux Removal

**LONCO**  
*Flux Removers*  
**ESPECIALLY DEVELOPED  
FOR PRINTED CIRCUITS**

Whatever your particular application or problem, there is a fast acting, completely safe Lonco Flux Remover to efficiently handle the job:

**LONCO LN-10**—especially efficient for hot or cold flux residues where fast removal by simple dip is essential . . . completely non-flammable.

**LONCO MC-1136**—designed for fast removal of residue on parts which contain decals, coding, silk screening, fungicidal lacquers, etc.

**LONCO HCR**—for removal of hot residue by simple dip or cold residue by brush, yet harmless to most decals, finishes of all types and plastic parts.

**LONCO 65**—completely neutral, practically odorless remover for use on warm or hot residues immediately after soldering.

**LONCO SPECIAL REMOVERS**—engineered to any application or problem encountered with critical printed circuit boards and assemblies, components, inks, plastics, etc.

All Lonco Removers are either non-flammable or are rated as safety solvents and are in the lowest toxicity range. Available in 1 or 5-gallon cans or 55-gallon drums. Request full information.



**LONDON CHEMICAL CO., INC.**

1531 N. 31st AVENUE • MELROSE PARK, ILLINOIS

Other Lonco Products: SOLDER FLUXES • PROTECTIVE COATINGS • CHEMICAL SOLDER MASKS • CHEMICAL WIRE STRIPPERS  
CIRCLE 171 ON READER-SERVICE CARD

VHF  
and  
UHF



## Unit Oscillators

★ General-Purpose, Unmodulated Power Sources

★ Compact ★ Low-Priced ★ Simple, Straightforward Designs

★ Wide Frequency Ranges ★ Single-Dial Control

★ Accessory Unit Instruments convert to modulated h-f sources, simple standard-signal generators, television test-signal generators, heterodyne null detectors, automatic data presentation systems and many other testing devices

★ Four Unit Oscillators provide continuous range from 50 Mc to 2,000 Mc; priced from \$190 to \$465

★ Unit Klystron Oscillators for 2700 Mc to 7425 Mc

Write for UNIT INSTRUMENT BULLETIN for detailed description of complete line

## GENERAL RADIO Company

275 Massachusetts Avenue, Cambridge 39, Massachusetts, U.S.A.

Broad Avenue at Linden, Ridgefield, N. J. NEW YORK AREA 1000 N. Seward St. LOS ANGELES 30

8055 13th St. Silver Spring, Md. WASHINGTON, D. C. 1150 York Road, Abington, Pa. PHILADELPHIA

1182 Los Altos Ave., Los Altos, Calif. SAN FRANCISCO 6605 W. North Ave., Oak Park, Ill. CHICAGO

In CANADA: 99 Floral Parkway, TORONTO 15

CIRCLE 172 ON READER-SERVICE CARD

flated to 20 lb pressure. The detachable front plate of the enclosure, also of 3/8 in. clear Plexiglas, is clamped over the tubing by phenolic clamps. The pressure of the clamps is distributed uniformly by the inflated tube to assure an even seal along the entire edge.

A unique feature is a transparent square air lock, with hermetically sealed doors, for safe transfer into or out of the controlled environment. This is made from a length of 10 in. Cadco cast acrylic tube (1/4 in. wall) which has been re-formed into a square shape to provide a flat work surface.

Since the air-lock body is formed of one piece, there are no seams to check for possible leakage and the rounded corners afford ease in cleaning. The air lock is strong enough to withstand complete evaluation of the air, which is necessary to prevent contamination of the already controlled atmosphere in the hood during transfer. Contamination of the outside air is also avoided by exhaust valves on the air lock.

### Other Advantages

Aside from cost and availability of material, the advantages of the all-acrylic enclosures are these: there are no seams to check for possible leakage; the complete transparency is an advantage for the many minute operations which are performed within the enclosure; the rigidity and dimensional stability of cast acrylic are assurance against deforming of the flat work surfaces, even under rough treatment; the cast acrylic tube and formed sheet will withstand up to 150 psi and are resistant to most common chemicals.

In radioactive operations, the acrylic enclosure provides protection against low gamma and beta radiations.

### Short Cut to Metal Fabrication

To save weight, reduce fabrication time, and cut cost of airborne sheet metal chassis or cabinets, this modification for sheet metal clips or brackets can often be made.

R. G. Clark, Mechanical Engineer, Radio Corporation of America, Camden, N. J.

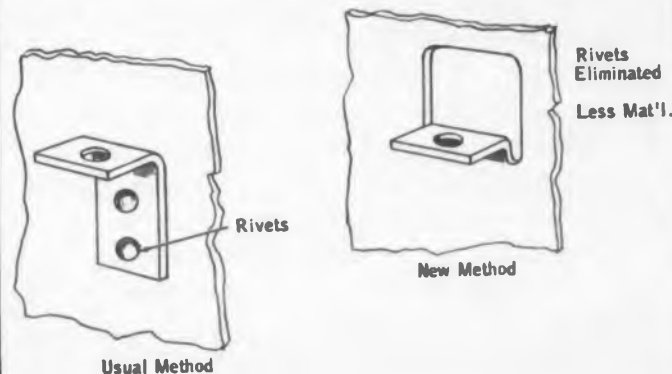

Usual Method

Rivets  
Eliminated

Less Mat'l.

New Method

## Unitize—Miniaturize

WITH

*Vector*

STRUCTURES  
FOR CIRCUITRY

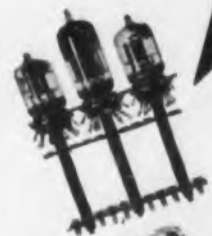

TAKE ONE  
STRIP  
TURRET

Choice of Deck, or Wall type strips in many sizes offers miniaturization, accessibility, ease of assembly and adaptation to semi-automatic machinery.



ASSEMBLE  
IN  
LIP-LOC  
CASE

A sectionalized case with a choice of plugs, quarter turn locks, ventilated or solid wall; with two piece center section or snap-open side ports.



Result  
PLUG IN  
UNIT

For circuit unitization, faster final assembly, stock reduction and ease of equipment maintenance.



VECTOR ELECTRONIC COMPANY  
3352 San Fernando Road, Los Angeles 65, Calif.

CIRCLE 174 ON READER-SERVICE CARD

if  
IT MUST BE  
COUNTED

7365879  
365879  
81326312  
195806743  
430  
26312  
21958067

## THE AMETRON RECORDING COUNTER

Counts Faster, yet accurately.

Records in printed form.

Automatically resets.

Three important reasons why the Ametron Recording Counter is in demand by leading industrial plants and scientific laboratories.

Write for illustrated bulletin B

STREETER-AMET COMPANY  
GRAYSLAKE, ILLINOIS

Branches in Detroit, Pittsburgh, Allentown, Birmingham and Los Angeles

CIRCLE 173 ON READER-SERVICE CARD

THE  
STANDARD  
OF  
ACCURACY  
SINCE  
1888



## RELIABLE! — JOHANSON'S SEALED VARIABLE AIR CAPACITORS

- High Q
- Low temperature coefficient
- Mechanically rugged

Write for complete information

*Johanson*

MANUFACTURING CORP.

18 Rockaway Valley Rd., Boonton, N. J.

CIRCLE 175 ON READER-SERVICE CARD

## Need a Low-Cost Sub-Miniature Switch?

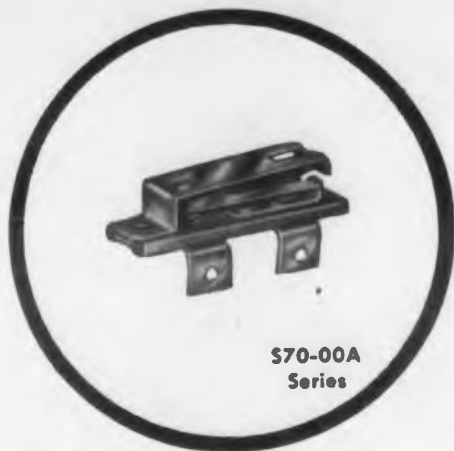

- Small size (1/4" x 9/32" x 1")
- Low movement differential (.003-.007)
- Low cost (\$0.24 range)
- Exacting tolerances.

CALL OR WRITE



**CHERRY ELECTRICAL PRODUCTS CORP.**

1649 Deerfield Rd., Highland Park, Ill.  
Phone: Idlewood 2-8182

CIRCLE 176 ON READER-SERVICE CARD



**FREE** send for the  
most widely used  
**ELECTRONIC SUPPLY GUIDE**

**ALLIED'S**  
COMPLETE 404-PAGE  
1958 CATALOG

send for it!

your buying guide to the world's largest stocks  
of **ELECTRONIC SUPPLIES FOR INDUSTRY**

- Receiving Tubes
- Power & Gas Tubes
- Diodes & Transistors
- Relays & Switches
- Test Instruments
- Meters & Supplies
- AN Connectors
- Metal Chassis Bases
- KNIGHT Public Address Systems

Simplify and speed your purchasing of electronic supplies and equipment at ALLIED. We make fast, expert shipment from the world's largest stocks of everything in Electronics. Manufacturers' prices available on quantity purchases. Send today for your **FREE 1958 ALLIED Catalog**—the complete Buying Guide to Electronic supplies for Industrial and Communications use.

One Complete Dependable Source for Everything in Electronics

**ALLIED RADIO**

100 N. Western Ave., Dept. 69-B8  
Chicago 80, Illinois



our 37th year

Send for  
**FREE**  
Catalog

CIRCLE 177 ON READER-SERVICE CARD

## IDEAS FOR DESIGN

### Non-destructive Transistor "Punch-Thru" Test

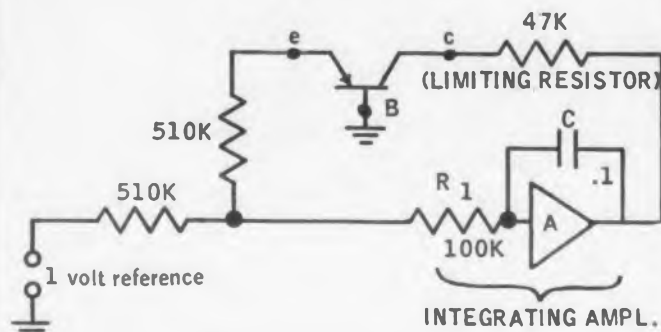

Fig. 1. Circuit for non-destructive determination of "punch-thru" voltage.

A non-destructive means of determining the punch-through voltage of transistors was needed. The circuit shown (Fig. 1) resulted.

#### Circuit Analysis

In this circuit an applied collector-to-base voltage is automatically brought to the punch-through value for the particular transistor under

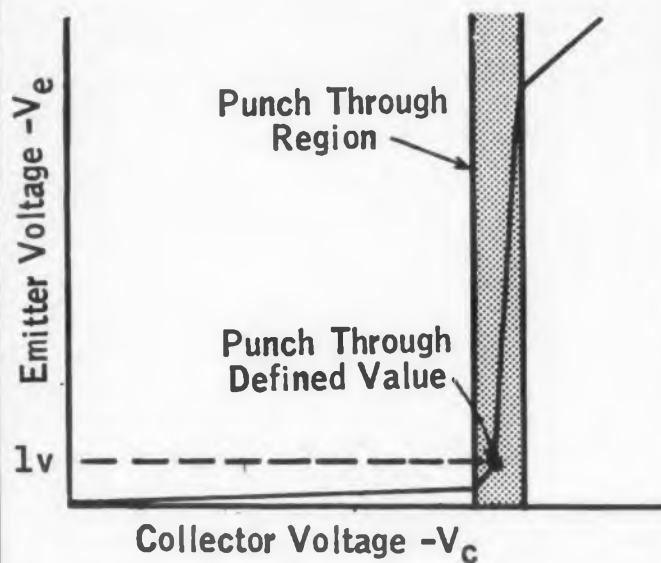

Fig. 2. Typical emitter-collector characteristic showing "punch-thru" region.

test.  $V_c$  is not an exact voltage but covers a slight range (due to the finite slope of  $V_e$  at punch-through, Fig. 2). Punch-through voltage will be defined as the collector-to-base voltage,  $V_c$ , (+ or - depending upon whether the transistor is n-p-n or p-n-p) for which 0.1 v (of same polarity as  $V_c$ ) will appear across  $R_1$ .

The principle of operation is as follows: The input voltage to the integrating amplifier,  $V_i$ , is a function of the 1-v reference (which is positive for p-n-p transistorized negative for n-p-n tran-

## TWO NEW MINIATURE



**GRIPCO**



**FASTENERS**

#### FOR

- Hard to reach assemblies
- Thin metal applications
- Automatic feeding
- **LOW COST** fasteners

Gripco Miniature Pilot Weld and Clinch Nuts, with or without the famous Gripco locking feature, provide low cost fastenings in blind assemblies or as extra threading depth for thin metals. Miniature size ideal where space is limited. Sizes #4 through 1/4" in Miniature Series, fine and coarse threads. Sizes 1/4" through 5/8" are available in standard dimensions.

Large inventories carried for immediate shipment. Brass and Aluminum made to special order.

Write for samples and full details.

**GRIP NUT COMPANY**  
109 Broad Street  
South Whitley, Indiana

120

CIRCLE 178 ON READER-SERVICE CARD



## HOW TO USE THE HOME REPLY FORM

If you wish to inquire about any of the employment opportunities listed in the "Career Section" simply circle the appropriate Reader Service number in the grey (shaded) area of your Reader Service card. Be sure to include your home (or non-business) address in the space provided at the bottom of the card. In this way, the privacy of your inquiry will be protected while still providing the speed and efficiency of **ELECTRONIC DESIGN's** Reader Service card system.

Last year **ELECTRONIC DESIGN** processed more than 60,000 individual reader cards. Now **ELECTRONIC DESIGN** is first to add a confidential inquiry form—one more step to its speeding communications between reader and advertiser.

sistors) and the emitter voltage,  $V_e$ . Prior to punch-through,  $V_i$  is about  $1/2 v$  and  $V_e$  is essentially only slightly above zero, and with the polarity of the reference voltage. As long as  $V_i$  is above zero, the output voltage of the integrating amplifier rises (with phase inverted), thereby increasing  $V_c$  until punch-through occurs. At this time  $V_e = 1 v$  of opposite sign than the reference voltage, and  $V_i = 0$ . Here the integration ceases and the integrating amplifier holds  $V_c$  at the defined punch-through value.

The integrating amplifier utilizes a Philbrick K2 operational amplifier.

Manuel Bardash, Engineer, American Bosch Arma Corp., Garden City, N. Y.

### A Novel Low-Frequency Cathode By-Pass Arrangement

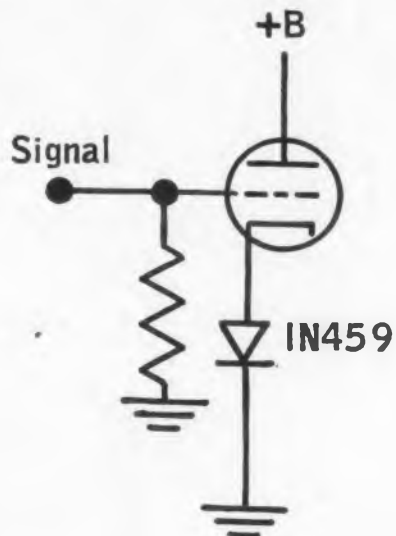

Diode replaces cathode resistor and its associated by-pass capacitor.

By-passing was needed for the cathode resistor of a 12AT7 for very low frequencies (1 to 10 cycles). Standard capacitors were too large; tantalitics were too expensive; electrolytics were not satisfactory over the temperature range required and were not sufficiently reliable; and no negative supply was available for fixed bias.

The solution was to use a silicon diode as the cathode resistor. This arrangement approaches fixed bias and avoids all the objections to capacitors listed above. By-passing is effective down to dc. The effective degeneration resistance in the cathode is the dynamic resistance of the diode (about 5 ohms for the one used). The effective bias is approximately 0.6 v. For various bias levels, diodes may be added in series.

R. B. Hirsch, Engineer, Instruments for Industry, 150 Glen Cove Rd., Mineola, N. Y.

**"BLACK GOLD"** ... the best natural graphite of more than 99% carbon ...

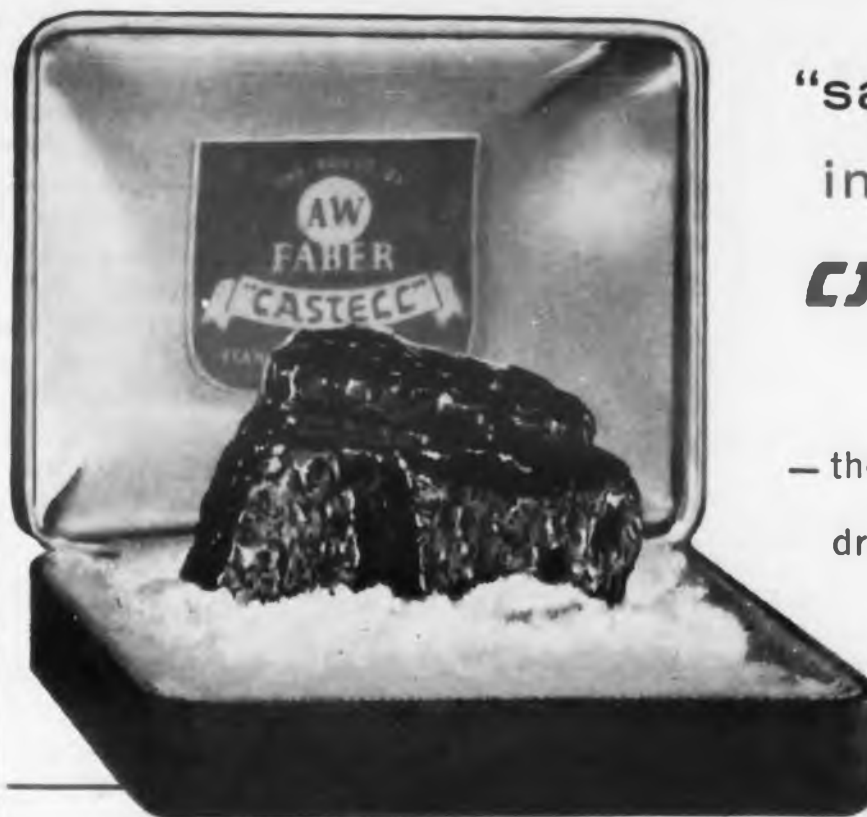

"saturates"  
imported  
**CASTELL**

— the world's finest  
drawing pencil

Mined out of the earth just as any precious mineral,  
**CASTELL "black gold"** graphite tests out  
at more than 99% pure carbon.

In its virgin state it is the purest black known to man. There is no need for us to add foreign oily substances to CASTELL. Nature at her best is beyond improving. Our job is to apply almost 200 years of pencil-making experience to refine this "black gold" into 20 superb tones, 8B to 10H — each degree as uniform as a platoon of West Point cadets.

Make a series of single or multiple pass lines with your favorite CASTELL degree. Now examine them through your magnifying glass. Notice the bold, black, close-textured saturation, the identical width in line after line. You owe it to your career

to use CASTELL, the drawing pencil of the Masters. Good dealers everywhere carry CASTELL. Phone yours today.

**CASTELL LOCKTITE** (with Tel-A-Grade Indicator) for those who prefer a feather-weight holder with degree indicating device. Grips the lead like the jaws of a bulldog to prevent slipping or turning. One hand push-button control reduces graphite stains.

**Imported CASTELL 9030 Lead** — with the identical graphite that made Castell wood pencil world famous. Usable in all standard holders, but a perfect mate with LOCKTITE. Also available in a kaleidoscope of colors. Packed in plastic tube, 12 leads each.

**A.W.FABER • CASTELL**

NEWARK 3, N. J.

*The Proudest Name in Pencils*

Castell in Canada • Write Hughes Owens Co., Ltd., Montreal



PREFERRED BY PROFESSIONALS IN EVERY CIVILIZED COUNTRY ON EARTH.  
CIRCLE 180 ON READER-SERVICE CARD

for maximum reliability

**HOLD**  
and  
**COOL**  
transistors  
with

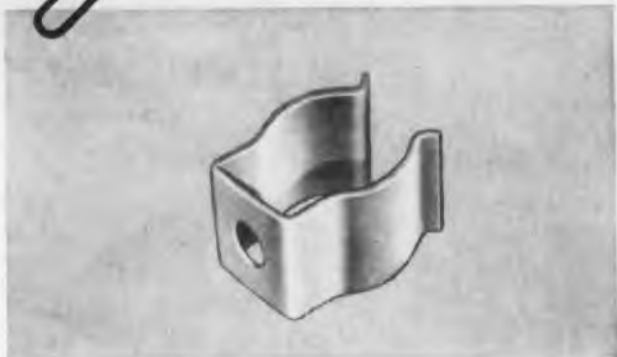

## BIRTCHER TRANSISTOR CLIPS

### MATERIAL

Beryllium #25

### FINISH

Choice of Cadmium,  
black Ebanol or  
Silver plated

### SIZES

Available in sizes and  
modifications to  
retain all popularly  
used transistors.

Birtcher TRANSISTOR CLIPS perform the dual functions of retention and heat reduction. Being made of tempered beryllium copper they grip the transistor securely and hold it in place even under severe conditions of shock and vibration. In addition they provide an excellent heat path to drain off heat into chassis or heat sink.

Write for catalog

### THE BIRTCHER CORPORATION

INDUSTRIAL  
DIVISION

4371 Valley Blvd.,  
Los Angeles 32, Calif.

CIRCLE 179 ON READER-SERVICE CARD



## MOLDED SUB-MINIATURE TOROIDS



STOCKED for immediate delivery

ARE NOW AVAILABLE FROM

Magnetic amplifiers,  
filters, transformers,  
transistorized power  
supply, all to  
customers'  
specifications.



## TOROTEL

P R O M P T D E L I V E R Y



MOLDED TOROIDS  
Ind—5MH to 36H  
STOCKED for  
immediate delivery



UNCASED  
Q values > 260  
Size: 1/4" ID  
OD unlimited

MOST  
ENGINEERING  
SAMPLES  
FURNISHED  
IN ONE WEEK

PRINTED  
CIRCUIT  
TOROIDS

Size .662 OD  
.312 H  
Larger sizes  
available



P R O M P T  
Q U O T A T I O N S  
on stocked or  
special items;  
address:

## TOROTEL, INC.

11505 Belmont, Kansas City 34, Mo., Phone.: South 1-6314

REPRESENTATIVES IN MANY CITIES

CIRCLE 181 ON READER-SERVICE CARD

# REPORT BRIEFS

## Application of Kramers' Theorem

Kramers' theorem is discussed from the matrix point of view. A proof of the theorem is presented for a single atom. The methods of the proof are then applied to many atom systems. It is shown that lifting of Kramers' degeneracy by interatomic multiple interactions in crystals is a consequence of the enlargement of the system to include an even number of particles, rather than a consequence of the nature of the interaction. *Application of Kramers' Theorem to Many Atom Systems*, by A. G. Mencher, M. Sachs and R. Satten, California University, Dept. of Engineering, Los Angeles, Calif., Apr. 1955, 20 pp, microfilm \$2.40, photocopy \$3.30. Order NB 124093 from Library of Congress, Washington 25, D. C.

## Diffraction by an Aperture

The diffraction of a wave by an aperture of any shape in a thin screen is treated by a new method, called "the geometrical theory of diffraction," because it is an extension of geometrical optics which accounts for diffraction. In this method new rays, called diffracted rays, are introduced. They are produced when an incident ray hits the edge of the aperture, and they satisfy the law of diffraction. A field is associated with each ray in a quantitative way, by means of the optical principles of phase variation and energy conservation. In addition "diffraction coefficients" are introduced to relate the field on a diffracted ray to that on the corresponding incident ray. *Diffraction by an Aperture, I*, by Joseph B. Keller, New York University, Institute of Mathematical Sciences, Division of Electromagnetic Research, June 1956, 73 pp, microfilm \$4.50, photocopy \$12.30. Order PB 125232 from Library of Congress, Washington 25, D. C.

## Project Vanguard Minitrack

The "Minitrack" system for tracking an artificial earth satellite, which has been developed as a part of Project Vanguard, is described briefly, and the phase measurement portion of this system is described in detail. *Project Vanguard Report No. 18: Minitrack Report No. 1: Phase Measurement*, by C. A. Schroeder, C. H. Looney, Jr. and H. E. Carpenter, Jr., U. S. Naval Research Laboratory, July 1957, 31 pp, \$1.00. Order PB 131220 from Office of Technical Services, U. S. Dept. of Commerce, Washington 25, D. C.



# STRAITS TIN REPORT

New developments in  
the production, mar-  
keting and uses of tin



The new atomic power plant at Shippingport, Pa., has more than 58 miles of condenser tubes. They're made of an alloy containing from 0.9% to 1.2% tin.

★ ★ ★

Tests show that a new tin-cadmium alloy plating has greater corrosion resistance to salt spray, jet fuels, high temperature synthetic oils, and organic acid vapor than cadmium plating alone. It can be soldered the same way—and just as easily—as standard cadmium plated coatings.

★ ★ ★

Malaya has been the world's largest producer of tin for many years—over two-thirds of the tin consumed in this country is produced there. Straits Tin from Malaya is at least 99.87% pure and known throughout U.S. industry for its reliability and uniformity of grade.

★ ★ ★

A British firm recently developed a new solder paint for hot tinning or soldering stainless steel. The solder is simply painted on the steel and then heated to normal soldering temperature. Tin content ranges from 40% to 100% in the three grades manufactured.



Ask us to send you TIN NEWS, a monthly letter. It will keep you posted on tin supply, prices, new uses and applications.

## The Malayan Tin Bureau

Dept. 13B, 1028 Connecticut Ave., Washington 6, D.C.  
CIRCLE 183 ON READER-SERVICE CARD

## Retarding-Field Oscillator Design Guide

This manual was prepared to expedite design for production of retarding-field oscillators operating over ranges of frequencies. Dimensions, construction details, and drawings of parts for the basic oscillator are included, along with discussions of operating principles and theory of the oscillator. Also treated are the Heil gun prototype, power-coupling systems, resonator structure, repeller, and other parts of the standard oscillator design. Frequency limitation is discussed, and design data for specific frequency ranges with performance characteristics at high and low frequencies are provided. Construction techniques involving hobbing methods, brazing, and preparation of cathodes by compressing properly proportioned mixtures of nickel powder and the carbonates of barium and strontium are described. It is shown that tubes with nickel matrix cathodes reduce more power output at the same beam current than the same structures using oxide-coated cathodes. *Design Guide for the Retarding-Field Oscillator*, E. M. Boone, Ohio State Research Foundation, May 1957, 185 pp., \$4.75. Order PB 131201 from OTS, U. S. Dept. of Commerce, Washington, D. C.

## Helicopter Instrumentation

This volume reports a phase in development of an instrumentation system which would permit precise hovering of a helicopter under adverse weather conditions. Effectiveness of three display systems in an analog simulation of the aircraft in the hovering phase of flight were evaluated. The systems were: Conventional, where helicopter attitude and groundspeed were displayed on separate indicators; Integrated, where attitude and groundspeed combined into a single display; and Quickened, where attitude and other derivatives summed to a single indication of groundspeed through feedback circuitry. The operator was to minimize translational motion while subject to simulated gust disturbances. Among the results it was indicated that the Quickened system was consistently superior in hover precision. Integration of attitude and ground rate information on a single display brought greater precision than separate display. Results of the comparative effect on each display system resulting from imposing control of heading on each test condition are also reported. *Comparative Evaluation of Three Approaches to Helicopter Instrumentation for Hovering Flight*, J. S. Sweeney, A. W. Bailey, and J. F. Dowd, Naval Research Laboratory, June, 1957, 34 pp., \$1.00. Order PB 121979 from OTS, U. S. Department of Commerce, Washington 25, D.C.

# PATCH-CORDS

## for instrumentation



- Molded polyethylene plug body fully insulated
- Permits parallel multiple stacking.
- Ground connection clearly marked.

- One piece beryllium copper spring.
- Solder bonded noise-free connection.
- Fits standard banana jacks.

3/4" double plug stack-up...  
patch cord & test leads



MODELS			SPECIFICATIONS			
Model with Double Plugs	Model (with Alligator Clips)	Model (with BNC connector)	Length	Cable Description	*Color (Plug and Cable)	Nominal Capacity mml./ft.
2BA-18	2BA-AL-18	2BA-BNC-18	18"	Two conductor twisted. 18 gauge wire. 65/36 stranding. Vinyl insulation. Vinyl jacket.	Gray	30
2BA-24	2BA-AL-24	2BA-BNC-24	24"			
2BA-30	2BA-AL-30	2BA-BNC-30	30"			
2BA-36	2BA-AL-36	2BA-BNC-36	36"			
2BB-18	2BB-AL-18	2BB-BNC-18	18"	Shielded microphone cable. Polyethylene insulation. Vinyl jacket.	Gray	25
2BB-24	2BB-AL-24	2BB-BNC-24	24"			
2BB-30	2BB-AL-30	2BB-BNC-30	30"			
2BB-36	2BB-AL-36	2BB-BNC-36	36"			
2BC-18	2BC-AL-18	2BC-BNC-18	18"	Coaxial shielded cable. Polyethylene insulation. Vinyl jacket. RG58C/U.	Black	28.5
2BC-24	2BC-AL-24	2BC-BNC-24	24"			
2BC-30	2BC-AL-30	2BC-BNC-30	30"			
2BC-36	2BC-AL-36	2BC-BNC-36	36"			

\* Color of plug body to match cable unless otherwise specified. The following additional colors on plug body are available for color coding on special order. Black, Red, Green, Yellow, Orange, Blue, Brown, Gray, Violet and White.

### PECO PATCH-CORDS STACK-UP CONNECTING LEADS

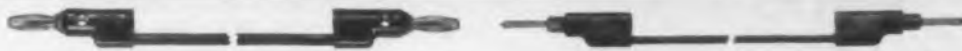

MODEL B (BANANA TYPE)

MODEL P (.080 PHONE TIP)

Ideal for rapid circuit connections. Provides access to additional plugs at end or at side. For use with test equipment. Fits all standard banana jacks. One piece beryllium copper spring for positive long life contact. Extra flexible polyvinyl insulated wire... 18 gauge, stranding 65 x 36 T. C. Wire lead securely solder-bonded to plug. Plug body molded with durable polyethylene insulation. Available in 4", 8", 12", 18", 24" and 36" lengths. Colors: Black, Brown, Red, Orange, Yellow, Green, Blue, Violet, Gray and White.

Specify length and color when ordering.

Miniature patch cords. These provide a greater number of patch cords per given area. Used with test equipment, computers, problem boards, etc. Will fit all standard .080 tip jacks.

Beryllium copper heat treated spring contact, for long life and low contact resistance. Finish, silver plate, gold flash. Extra flexible polyvinyl insulated wire, 20 gauge. Stranding 41 x 36 T. C. Wire lead securely solder-bonded to assembly. Plug body molded with polyethylene. Compact size, extended height above jack, 3/8", diameter 1/4".

Lengths and colors available, same as Model B Patch Cords.



MANUFACTURERS OF ELECTRONIC EQUIPMENT

POMONA *Electronics* CO. INC.

1126 WEST FIFTH AVENUE

POMONA, CALIFORNIA

CIRCLE 184 ON READER-SERVICE CARD



# 2

MORE  
REASONS

WHY

# CIRCUIT

HAS THE

PRECISION

# POTENTIOMETER

YOU NEED



# 1

### TYPES HA-100 AND HA-105

Very short case with slim 1" diameter

**HA-100, 10 turn**

body length: 1 1/4"  
rotation: 3600° - 0 + 4°  
rating: 2 watts  
resistance: 6 std. values, 2500 to 75,000 ohms  
linearity: std. ±0.5%; special to ±0.1%  
terminals: flexible silver plated terminals riveted to case; or rigid turret type available

**HA-105, 5 turn**

body length: 1 1/8"  
rotation: 1800° - 0 + 4°  
rating: 1.5 watts  
resistance: 6 std. values, 1000 to 25,000 ohms  
linearity: std. ±0.5%; special to ±0.1%  
terminals: flexible silver plated terminals riveted to case; or rigid turret type available

### NEW, MINIATURE HELICAL POTENTIOMETERS



# 2

### TYPES HC-100 AND HC-105

Side-mounted turrets, slim 1" diameter

**HC-100, 10 turn**

body length: 1 1/4"  
rotation: 3600° - 0 + 4°  
rating: 4 watts  
resistance: 8 std. values, 500 to 100,000 ohms  
linearity: std. ±0.5%; special to ±0.1%  
terminals: side-mounted rigid turret type

**HC-105, 5 turn**

body length: 1 1/8"  
rotation: 1800° - 0 + 4°  
rating: 3 watts  
resistance: 8 std. values, 250 to 50,000 ohms  
linearity: std. ±0.5%; special to ±0.1%  
terminals: side-mounted rigid turret type

Circuit Instruments Inc., subsidiary of IRC, is big enough to assure you superior quality control, yet flexible enough to meet special needs and fast delivery. Write for data sheets on new HA and HC Types.

# CIRCUIT

INSTRUMENTS INC.

an **IRC** subsidiary

Dept. D, 2801 Anvil Street, North • St. Petersburg, Fla.

FOR ALL PRECISION POTENTIOMETER REQUIREMENTS: MINIATURE • SUB-MINIATURE • MOISTURE SEALED • HERMETICALLY SEALED • BALL BEARING • HIGH PRECISION • HIGH TEMPERATURE  
CIRCLE 185 ON READER-SERVICE CARD

## REPORT BRIEFS

### Resonance in Infinite Gratings of Cylinders

The diffraction by a grating is examined (for spacing large compared to wavelength and dimension of grating element) for wavelengths in the neighborhood of the "Rayleigh" wavelengths. The shape of the elements, and their size in wavelengths is unrestricted. The results, including the effect of interaction, are expressed in terms of quantities relating to single scattering. Some properties of certain determinants formed from single scattered amplitudes are derived. The results are compared with those obtained by other authors, using various restrictions on the parameters. *On Resonance in Infinite Gratings of Cylinders*, by S. N. Karp and J. Radlow, *New York University, Institute of Mathematical Sciences, Division of Electromagnetic Research, New York, N. Y., April 1956, 42 pp, microfilm \$3.30, photocopy \$7.80. Order PB 125225 from Library of Congress, Washington 25, D. C.*

### Human Engineering Handbook

This report contains data on the size and shape of the hand covered by various Army cold-weather handwear. It was intended for use by engineers and designers in the design and sizing of hand-operated equipment. The criteria employed was the hand size of 95 per cent of Army personnel. The information is presented in illustrations with index scales, enabling measurement of dimensions on the picture and reference to the index scale to establish actual size. *Quartermaster Human Engineering Handbook Series II:—Dimensions of the Upper Limit of Gloved Hand Size*, J. L. Kobrick, *Quartermaster Research & Development Center, U. S. Army, Dec., 1956, 198 pp, \$5.00. Order PG 131192 from OTS, U. S. Department of Commerce, Washington 25, D.C.*

### Nonmetallic Ferromagnets

This report reviews a phase of the Air Force's program for development of improved electronic components in general and nonmetallic ferromagnetic materials in particular. The work described had two objectives: measurement of microwave ferrites produced earlier; and conception and initial development of applications for the materials. The theory of ferrites was treated qualitatively and semiquantitatively. Considerable attention was given to the measurement of the permeability tensor components, and a technique was developed for precise comparison of ferrite

characteristics at X-band frequencies. A number of ideas were advanced for ultimate production of finished devices. These included use of a microwave duplexer with a ferrite gyrator and two 3 db hybrid couplers, and an electrically tunable cavity useful for wider range of klystrons. *Non-metallic Ferromagnetic Materials: Part VII-Microwave Ferrites*, H. C. Rothenberg and E. B. Mullen, General Electric Co. for Wright Air Development Center, U. S. Air Force, Dec., 1955, 49 pp, \$1.25. Order PB 131053 from OTS, U. S. Department of Commerce, Washington 25, D.C.

### Visual Changes

Problems of deterioration in performance occurring when observers are required to spend long periods of time in some form of visual observation are reviewed. The study was based on the literature on visual work, and the principles derived can be applied to problems of radar observation. Two different types of prolonged observation are contrasted and the types of impairment resulting from them are identified. One type is the vigilance task, or one involving search for infrequently occurring signals. The other is the active task, which involves the continuous use of the oculomotor system and requires more or less continuous mental operation. *Changes in Visual Performance after Visual Work*, J. Deese, Johns Hopkins University for Wright Air Development Center, U.S. Air Force, Apr., 1957, 29 pp, \$.75. Order PB 131258 from OTS, U. S. Department of Commerce, Washington 25, D.C.

### Industry Planning for Emergency

Proceedings of a conference of industry executives on the problems which might confront industrial management and the nation in the event of an enemy attack have just been published. The volume is available to the public through the Office of Technical Services, U. S. Department of Commerce.

At the conference, 38 high-level industry officials discussed what has been done, is being done, and should be done to insure continuity of industrial production, management, and supply during a national emergency. The meeting was held in February, 1957 under auspices of the Business and Defense Services Administration, U. S. Department of Commerce. *Industry Planning for the Continuity of Production in the Event of Enemy Attack*, Business and Defense Services Administration, U. S. Dept. of Commerce, Feb., 1957, 36 pp, \$.50. Order PB 131300 from OTS, U. S. Department of Commerce, Washington 25, D.C.

# New ASTRON'S reliable sub-miniature capacitors

ENGINEERING BULLETIN  
R M - 3 2 5

**ASTRON** Capacitors

## FLAT AND ROUND MINIATURE MYLAR\* DIELECTRIC CAPACITORS



ASTRON TYPES XPR & XPF capacitors use "Mylar" polyester film as a dielectric. A new series of non-metallic cased units, employ a plastic thermosetting resin end seal to provide a secure bond between leads and case. Series XPR and XPF are for use in applications requiring minimum size, high insulation resistance and exceptional capacitance stability. For added flexibility in design, they are supplied in both flat and round case styles as listed.

PERFORMANCE CHARACTERISTICS AND TEST SPECIFICATIONS

ENGINEERING BULLETIN  
R M - 3 7 5

**ASTRON** Capacitors

## METALLIZED MYLAR\* CAPACITORS



ASTRON TYPE RLR metallized Mylar capacitors combine the advantage of metallized units with good insulation resistance, smaller size, less capacitance change and low power factor. Because the RLR is an uncased unit, sealed with epoxy resin, and wrapped in Mylar tape, its size is further decreased and a reduction in price is effected, compared to conventional style - metallized capacitors.

PERFORMANCE CHARACTERISTICS AND TEST SPECIFICATIONS

ENGINEERING BULLETIN  
T E - 2 5 0

**ASTRON** Capacitors

## "SAFETY MARGIN" ELECTROLYTIC CAPACITORS

for miniaturized low voltage D.C. equipment

- Smallest hermetically sealed electrolytic capacitors (from 3/16" x 1/2" to 1/4" x 3/4")
- Very low leakage characteristics for minimum battery drain
- Long shelf and operating life
- Reliable performance at reasonable price



Astron Types EE (epoxy end fill) and EM (spun end with rubber bushing) sub-miniaturized electrolytic capacitors were engineered especially for transistorized circuits and other compact or miniaturized low voltage D.C. equipment - applications in hearing aids, transistorized pocket radios, miniaturized small corders. The most important features are extremely small physical size and exceptionally low leakage coupled with reliable operation. Astron's "Safety Margin" construction provides reliable performance even under adverse conditions - your guarantee of equipment reliability.

PERFORMANCE CHARACTERISTICS AND TEST SPECIFICATIONS

I. PHYSICAL CHARACTERISTICS:  
Standard sizes are as specified in the catalog listings. Special sizes and types to meet particular applications can be supplied to specification.



II. STANDARD OPERATING TEMPERATURE RANGE:  
20 to +55 C

ASTRON CORPORATION  
255 GRANT AVENUE • EAST NEWARK, NEW JERSEY, U. S. A.

ENGINEERING BULLETIN  
R M - 3 0 0

**ASTRON** Capacitors

## MYLAR\* METALLIZED CAPACITORS



ASTRON TYPE RQL combines in a miniature hermetically sealed case the outstanding attributes of reliability at high temperatures - 125°C without derating - with significant savings of space. They will find their main applications in military reliability equipment and in critical industrial equipment and in specification of MIL-C-18312. Astron's Safety Margin construction is your guarantee of performance under the most difficult conditions.

PERFORMANCE CHARACTERISTICS AND TEST SPECIFICATIONS

PHYSICAL

II. TEMPERATURE RANGE

III. VOLTAGE RATING

IV. CAPACITANCE STABILITY



ASTRON CORPORATION  
255 GRANT AVENUE • EAST NEWARK, NEW JERSEY, U. S. A.

\*Reg. DuPont Trademark

Write today for complete technical information by Bulletin Number.

# ASTRON

C O R P O R A T I O N

255 GRANT AVENUE  
EAST NEWARK, N. J.



WEST COAST WAREHOUSE 9041 WEST PICO BLVD., LOS ANGELES -EXPORT DIVISION: ROCKE INTERNATIONAL CORP., 13 EAST 40TH ST., N. Y., N. Y. -IN CANADA: CHARLES W. POINTON, 6 ALCINA AVE., TORONTO, ONTARIO

CIRCLE 186 ON READER-SERVICE CARD

# WIDE BAND SWEEP GENERATOR...



JERROLD  
MODEL 900  
**\$1260<sup>00</sup>**  
f. o. b. plant

- OUTPUT AGC CONTROLLED
- COMPLETE VOLTAGE REGULATION
- INTERNAL DETECTOR
- INTERNAL OSCILLOSCOPE PREAMPLIFIER
- INTERNAL MARKER AMPLIFIER

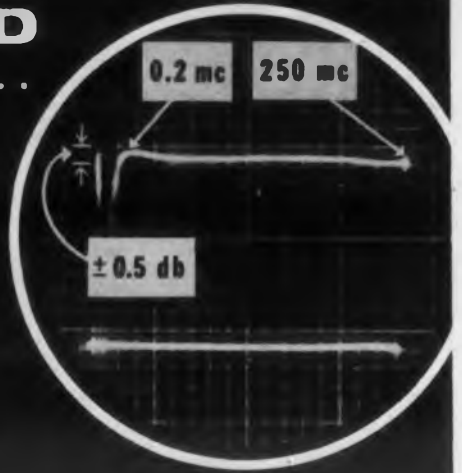

SWEEP WIDTHS—AS WIDE AS 300 MC.  
RANGE FROM—200 KC TO 1,000 MC.

## SPECIFICATIONS

### VHF SWEEP RANGE

Center frequency continuously variable from 0.2 MC to 250 MC. Sweep Width continuously variable from a minimum of 0.1 MC, at any center frequency setting, to a maximum of 250 MC at a center frequency setting of 125 MC.

### UHF SWEEP RANGE

Center frequency continuously variable from 275 MC to 900 MC. Sweep Width continuously variable from a minimum of 0.1 MC, at any center frequency setting, to a maximum of 100 MC at a center frequency of 275 MC, and to a maximum of 300 MC at a center frequency of 850 MC.

For complete information on the Model 900 and other special equipment, write to TED-9

### SOURCE IMPEDANCE

50 ohms—VSWR less than 1.2.

### OUTPUT VOLTAGE

0.3 volts RMS.

### MAX. OUTPUT VOLTAGE VARIATION AT MAX. SWEEP

VHF Range— $\pm 0.5$  db.

UHF Range— $\pm 3.0$  db.

### FREQUENCY MODULATION

60 cycle sinusoidal

**JERROLD**  
ELECTRONICS CORP.  
PHILADELPHIA 3, PA.

CIRCLE 187 ON READER-SERVICE CARD

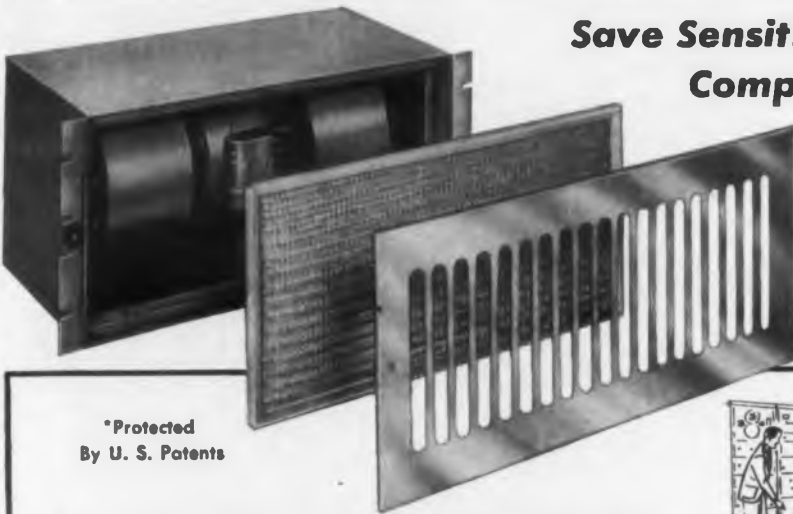

Save Sensitive  
Components!

\*Protected  
By U. S. Patents

## COOL THAT CABINET with McLEAN FANS & BLOWERS\*

RACK MOUNTED FOR EASY ASSEMBLY • FIT STANDARD 19" RACKS  
STANDARD MODELS FOR OTHER RACK WIDTHS AND ANY ANGLE OF AIR DISCHARGE

Over 15 models available  
in panel heights of 3½"  
to 12¼" in increments  
of 1¾" . . . range 80 to  
1200 CFM

Install McLean Fans and Blowers in computers, control units, etc. McLean's small packaged units pressurize cabinet with cool filtered air, keeping dust out. Complete in one unit and ready for use. Standard RETMA notching allows mounting on rack . . . without cutting or fitting. Smart stainless steel grilles . . . easily removable filters.

FREE! 12 Page Cooling Article • 16 Page Catalog • Individual Spec. Sheets

**McLean Engineering Laboratories**  
Princeton, New Jersey • Walnut 4-4440

Agents in  
Principal Electronic  
Manufacturing Areas

CIRCLE 188 ON READER-SERVICE CARD

# PATENTS

## Diode Logic Circuits

Patent No. 2,797,318. Walter S. Oliwa.  
(Assigned to Monroe Calculating Machine Company)

Switching circuits of the type known as diode logic circuits are used extensively in electronic computers. Because of the complexity of computers, circuits which are known as building blocks have been used for performing a logical process. These building block circuits operate usually on two potentials, one of which potentials is a designation of one and the other of zero. The output of such a circuit is one of the two potentials. The diode circuits which have been used in performing such logical processes have certain advantages which have been overbalanced by the difficulty of coupling them together in order to secure a series of logical processes. In other words, the cascading of the diode circuits was made on a multi-level basis rather than on the single signal level.

The circuits disclosed in the patent uses the building block diode logic circuit which perform a large number of logical processes and on a single signal level.

The circuit disclosed in Figure 1 is a basic diode circuit which responds to a formula which may be expressed as  $a$  and  $b$  or  $c$  results in a high potential output. In other words, this circuit results in a high output at 15 when the inputs  $a$  and  $b$  are simultaneously high no matter what the potential of  $c$ , or results in a high output at 15 when the input  $c$  is high no matter what the potential input of  $a$  and  $b$ . Diode 10 and resistor 12 constitutes an "and" circuit and diode 14 and resistor 13 constitutes

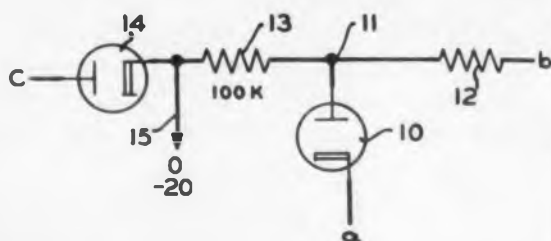

## HEAVY DUTY

*Multiple Arm*

**RELAYS**  
by **SIGNAL**

Versatile — Rugged  
Cast Aluminum Base  
High Shock and Vibration  
Resistant  
Available AC — DC  
Contact Capacities Available  
10; 35; 50 amp.  
Contact Combinations on  
Same Base  
Designed to Meet Many  
MIL Spec's

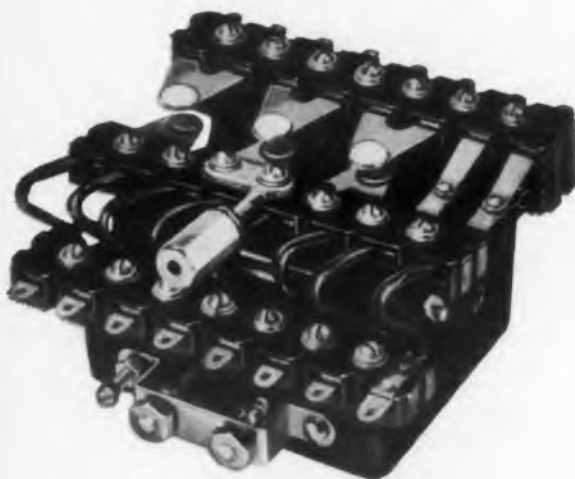

A superior relay that has endured the test of time . . . Specified for many years by America's largest manufacturer of electrical controls and communications equipment.

Engineering  
representatives  
in principal cities

Signal Engineering & Mfg. Co. has changed its name to

*Wheelock* **SIGNALS**

RELAYS



LONG BRANCH, N. J.

CIRCLE 189 ON READER-SERVICE CARD

ELECTRONIC DESIGN • February 5, 1958

an "or" circuit. These inputs *a*, *b*, and *c* may be either zero potential or -20 potential. With this circuit the following combination of inputs of *a*, *b*, and *c* results in an output as designated where high (H) indicates zero potential and low (L) of -20 potential.

21 and resistor 20 is an "and" circuit. With this circuit the application of the following inputs at the designated points results in an output as shown in the following chart where again H is represented by high or zero potential and L represents a low or -20 potential.

Input a	Input b	Input c	Output line 15
L	H	H	H
H	L	H	H
L	L	H	H
H	H	L	H
L	H	L	L
H	L	L	L
L	L	L	L

Input a	Input b	Input c	Output line 15
H	H	H	H
L	H	H	H
H	L	H	H
L	L	H	L
H	H	L	L
L	H	L	L
H	L	L	L
L	L	L	L

Figure 2 illustrates a circuit which responds to the logical equation  $a \text{ or } b \text{ and } c$  results in a high or low output at 22. In this basic circuit diode 16 and resistor 18 is an "or" circuit and diode

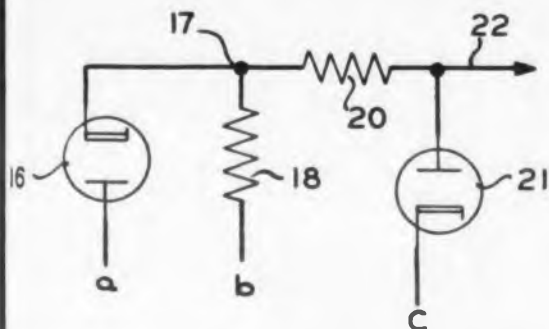

21 and resistor 20 is an "and" circuit. For more complex logical equations, these basic circuits are cascaded and two circuits are illustrated which respond to more complex equations. In the basic and more complex circuits, the resistors are of equal value which is advantageous in that it permits a shorter RC time for the entire circuit then has been possible with the multi-level circuits heretofore used which consists of resistors which increase in magnitude from stage to stage. The value of the resistors are determined from the source impedance of the circuit inputs.



### Ben Har Lacing Tapes — Teflon/Fiberglas

Aircraft fuels demand lacing tapes that can "take it". Ben Har Lacing Tapes can! Especially formulated of two highly inert materials — Teflon\* and Fiberglas\*\*. In Ben Har Tapes the Fiberglas is Teflon coated to give the braid a "tooth". Will not slip after knotting. Ben Har Tapes will not shrink, never cut through insulations. Pliable from -100°F. to 500°F. Wax-free, will not support fungus. Non-absorbent. Four sizes and nine colors — write for prices and samples.

BENTLEY, HARRIS MANUFACTURING COMPANY  
200 Barclay Street Conshohocken 3, Pa.

\*Teflon — DuPont T.M. \*\*Fiberglas — Owens-Corning T.M.

**BENTLEY, HARRIS**

*Flexible*

**LACING TAPES**

CIRCLE 190 ON READER-SERVICE CARD

# NEW

## E-T-A OVERCURRENT CIRCUIT BREAKERS

**Unique tripping  
characteristic assures full  
. . . positive protection!**

- Flexible in application. Dependable performance.
- Available in current ratings of 50ma. -80ma. -100ma. up to 25 ampere
- Calibrated in steps of 100 milli ampere
- Sturdy, compact design
- Available with separate alarm circuits



ASK FOR  
CATALOG NUMBER 28

# E-T-A

PRODUCTS CO. OF AMERICA

5058 N. Elston Ave., Chicago 30, Ill. KI 5-1554

E-T-A Products Co. of Canada, 265 Craig St. W., Montreal 1, Que. UN 1-5998

CIRCLE 191 ON READER-SERVICE CARD

A PROVEN INSTRUMENT FOR  
SENSITIVITY MEASUREMENTS ON TRANSISTORS TO 50 mc

## KAY *Micro*lter

Wide-Band, High-Frequency, Low-Level Vacuum Tube Voltmeter Employing a High Impedance Probe. A Unique Design Utilizes Extremely Wide-Band Amplifiers for Measurement at Higher Frequencies.

The *Micro*lter is a non feed-back type voltmeter. However, stabilization is provided for steady state changes and against line voltage variations.

The unit permits measurement of low level RF signals. A 7-position switch provides full scale steps of 1, .3, .1, .03, .01, .003 and .001 volts, the lowest reading being 250 microvolts. These ratios permit an easily read meter scale.



### SPECIFICATIONS

**Frequency Range:** 100 cycles to 50 megacycles. Direct reading in voltage or decibels.

**Accuracy:**  $\pm 10\%$  of full scale reading.

**Frequency Response:**  $\pm 1$  db.

**Voltage Range:** 1 millivolt to 1 volt full scale in 7 ranges.

**Sensitivity:** Will measure down to 250 microvolts.

**Input Impedance:** Capacitance 5 mmf, resistance loading dependent on frequency (1 megohm at 1 megacycle to 30,000 ohms at 50 megacycles).

#### No Tuning.

The *Micro*lter may be used as a wide-band video amplifier, maximum output approximately .25 volts at 75 ohms. Gains of up to 47 db.

**Power Supply:** Input approx. 190 watts, 117 V ( $\pm 10\%$ ), 60 cps ac. 8+ electronically regulated.

**Price:** \$495.00, f.o.b. factory

Write for Kay Catalog

## KAY ELECTRIC COMPANY

Dept. ED-2

Maple Ave., Pine Brook, N. J.

CAldwell 6-4000

CIRCLE 192 ON READER-SERVICE CARD



мого текста со скоростью, близкой к нашей предель-

ной, следя при этом за

Для

писанному тексту. Затем, сни-

о рекомендовать следую

•  
ния передавае-

## THE DAY OF RADIO

In the last issue of *ELECTRONIC DESIGN* we reported on the All-Union Scientific Session of the A. S. Popov Scientific-Technical Society for Radio Engineering and Electric Communication. Some 2000 scientists and engineers from Russia's largest cities, and from Bulgaria, Hungary, East Germany, China, Poland, and Czechoslovakia, in addition to representatives of the IRE, attended the sessions in Moscow May 20-25, 1957.

In that issue (*ED*, January 22, 1957), we presented the highlights of papers of major interest to electronic designers. We covered the sessions on Information Theory, Semiconductors, and Radio Wave Propagation.

In these pages, we are continuing our coverage of these important sessions with a presentation of the highlights of the sessions on Receiving and Transmitting Equipment, Antenna Apparatus, Wire Communication, and General Radio Engineering.

# What The Russians Are Writing and Saying

J. George Adashko

### SESSION ON RECEIVING AND TRANSMITTING EQUIPMENT

A paper by D. V. Ageev, V. V. Malanov, and K. P. Polov reports on an investigation of a new method of realizing the pulse principle of power amplification at audio frequencies; this method is free of the shortcomings of previously-proposed versions.

S. I. Tetel'baum noted in his paper that the optimum amplitude-phase modulation, proposed in U.S.S.R. in 1939, makes it possible to double the bandwidth of the broadcast signal compared with ordinary amplitude modulation. Normal reception is insured in this method with the aid of radio-receivers designed for ordinary amplitude modulations. It was recommended by the section that this system be tried out soon in one of the Kiev radio broadcasting stations.

A. A. Gorbachev proposed new converters, of the tuned type, for the frequency spectrum of pulse noise, and investigated conversion of the shape of the frequency spectrum of pulsed noise passing through the first linear converter and a variable-threshold amplitude limiter.

A paper by Iu. I. Medvedev was devoted to the method of suppressing pulse noise by disconnecting the low frequency channel of the receiver during the action of the noise and using linear signal spectrum converters before and after this switching operation.

In a paper by Z. I. Model', "Auto-Anode Modulation (AAM) in Short Wave Transmitters" he considered a new method for calculating frequency distortion in transmitters based on the analogy of AAM with the parallel type of anode modulation. The possibility of effecting AAM with nonlinear distortion less than 10% was considered. The use of AAM was proposed for professional shortwave transmitters. (This method, apparently a Soviet innovation, was first proposed by N. G. Kruglov.)

The paper by S. S. Geints contained a description of a balanced anode modulation circuit developed by the lecturer and put into operation in a toll-line shortwave transmitter.

Iu. K. Moiseev devoted his paper to problems of fluctuation noise in receivers, to interstation interference, and to acoustic noise on the in-

telligibility of speech in telephone channels of uhf radio stations.

In a paper "Wide Band Transistor Amplifiers" I. N. Migulin indicated that a suitable discipline for the analysis of amplifier circuits is to use a single system of parameters in common with vacuum tube amplifiers. The use of the above procedure led to the development of simple amplifier circuits with maximum possible gains and bandwidths.

A paper by L. S. Berman pointed out the possibility of increasing the efficiency of a tuned amplifier operating with current cutoff, by using an additional network tuned to the third harmonic. The use of such a transistorized circuit makes it possible to obtain a useful power of 320-340 mw at an efficiency of 87-88 per cent, while the ordinary tuned semiconductor amplifier circuit yields an efficiency of 74-75 per cent and useful power of 140-150 mw.

A paper by V. M. Sidorov was devoted to the investigation of the action of sinusoidal pulses, and fluctuation noise of any level in the reception of fm signals. The effect of types of individual



# how to **CUT COSTS** on small components

If the cost of metal stampings and wire forms figures in your profit picture, let us give you a quotation on your current components. Send us a sample or blueprint . . . and discover how big savings in time and production costs, big gains in precision and uniformity are possible on small components, when Art Wire tackles the job!

Our engineering staff, our production experience, and our modern high speed equipment are always at your disposal. If you wish to learn more about what a wide and versatile range of shapes and parts we can produce for you—at lower cost than you'd guess—just write for our illustrated folder.

## **ART WIRE AND STAMPING CO.**

17 Boyden Place, Newark 2, N. J.

CIRCLE 193 ON READER-SERVICE CARD

stages of the receiver (limiter, frequency detector, filters, etc.) on the noise attenuation was described.

A. A. Magazanik considered asynchronous modes in self-excited oscillators with two degrees of freedom. The fundamental equations of several self-oscillating systems were derived and problems of the stability of the effects of load non-linearity were considered.

A paper by E. P. Khmel'nikski showed the advisability of detuning the tank circuit to obtain a substantial increase in oscillator efficiency. Results of the theoretical analysis of this mode of operation are given and data on engineering design of the circuit are provided. This method was recommended by the session for use in broadcast transmitters at medium and long waves with plate modulation.

A paper by S. N. Krize considered the role of approximate methods for the calculation of transients, the difficulties involved in the accurate calculations of the transients when the pulses have complicated waveforms, and methods of approximate calculations.

V. P. Shasherin showed in his paper that to obtain flat frequency characteristics in multi-stage amplifiers it is better to employ different gains and correction parameters in the individual stages.

Iu. V. Bogoslovski proposed a procedure for calculating the overdriven operating modes of an oscillator; the initial data used in the calculations are the intensity coefficient, the oscillation power, or the dc component of the plate current and the lower cutoff angle.

S. M. Gerasimov devoted his paper to an analysis of the dependence of transistor oscillator parameters on temperature, and to methods of temperature compensation.

A paper by V. M. Rozon "Problems of Construction of Frequency Standards for Transmitting and Receiving Radio Centers" described apparatus consisting of a central precision frequency generator and a synchronous master generator, having a long-term frequency stability on the order of  $(5-10) \times 10^{-8}$ .

S. A. Segal' considered a new method of modulation, from which the non-productive load of the apparatus and of the channel is eliminated, and in which no energy is consumed in the radiation of the entire frequency, so that it is possible to increase the power of the components that carry the information by at least four times. This also eliminates the need for restoring the carrier at the point of reception.

In a paper "Use of Semiconductors in Radio Broadcasting Apparatus," B. S. Semenov indicated that the Institute of Radio Instruments and Apparatus has been continuously studying for



# New MARCONI FM Sig. Gen.

specially designed for

## mobile radio

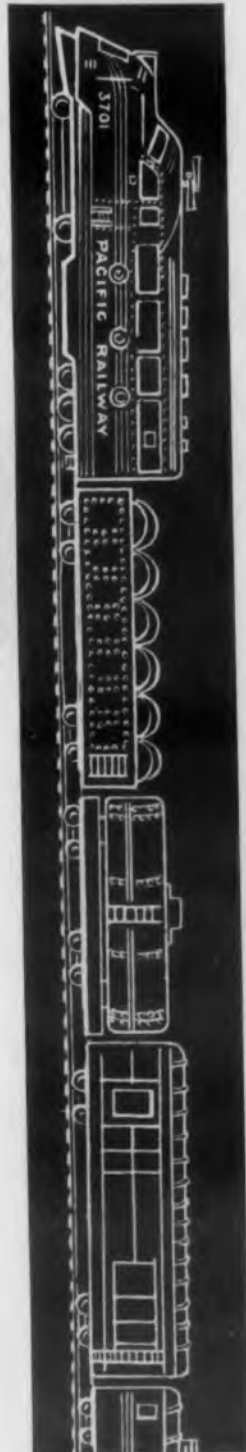

**Covers all mobile bands  
Covers most IF's  
New design technique gives high stability  
and quick warm-up  
Portable—Weight 26 lbs.**

Model 1064/2 has a separate oscillator for each range thus eliminating instability due to band switching. This and other special design features give it frequency stability better than 1 kc/min. at 470Mc and warm-up time of less than 30 min. This new FM Sig. Gen. was designed for the job of development, production and maintenance of Mobile Radio.

#### **SPECIFICATION:**

**Freq.:** 450-470Mc, 118-185Mc, 30-50Mc, 290kc-16Mc.

**FM Deviation:**  $\pm 3.5$  &  $\pm 10$ kc, or to order.

**Output:** .025 $\mu$ V to 5mV. 100mV approx. uncalibrated.

**Stability:** .002% per 10 min.

**$\Delta$ Freq.:** Calibrated to  $\pm 100$ kc.

**Price:** \$650

Model 1065, a companion instrument, measures RF power 0-20W & 0-100W up to 500Mc, AF power 0-3W & FM Deviation 0- $\pm 15$ kc. It is also a multi-range test meter.



### **MARCONI instruments**

111 Cedar Lane • Englewood, New Jersey

CIRCLE 194 ON READER-SERVICE CARD

the past few years, the characteristic parameters of all types of semiconductors suitable for radio broadcast apparatus. Engineering methods have been devised for calculating the various circuit elements of the receivers—low and intermediate frequency amplifiers, automatic gain control, etc.

#### SESSION ON ANTENNA APPARATUS

V. I. Zimina reported the results of a theoretical investigation of the propagation of electromagnetic waves along a tube filled with ionized gas. The conditions under which the corresponding transcendental equation can be solved were considered and the roots of this equation were determined.

A paper "Ballistic Antenna" by A. A. Pirogov considered the conditions of dynamic equilibrium of ballistic antennas, versions of devices for launching and dropping the antenna, and also methods of excitation and fields of application of ballistic antennas for long, short, and uhf waves. The lecturer pointed out that it is possible to



realize complex antenna systems with the aid of ballistic antennas.

The paper by V. I. Talanov was devoted to the method of solving problems concerning the excitation of surface waves over an impedance plane.

M. R. Zelinskaia and N. M. Tseitlin considered a method for direct measurements of losses and directivity coefficients at centimeters and meter waves with the aid of radiometers, based on the extraterrestrial cosmic radiation and on the internal noise of the antenna-feeder system.

It was shown in a paper by P. R. Cherep "Bends in Waveguides with Surface Wave" that the most important practical result of the bend is the supplementary attenuation due to the radiation from the concave bend. Several methods for eliminating the influence of the bend on attenuation have been proposed.

The problem of the passage of an arbitrary cylindrical wave through a bent waveguide of round section with ideal walls was considered in

the paper by N. P. Kerzhentsev. Expressions were derived for the coupling coefficients between the waves, characterizing the phenomenon of the passage of waves of parasitic types over the bend.

A paper by N. K. Gorshkov, B. Z. Katsenelbaum, V. V. Malin, and A. N. Sivov determined the losses of different waves, caused by coating a thin dielectric film with large loss angle on the inner surface of a round metallic waveguide.

I. A. Dombrovski lectured on the theory of regular waveguides carrying mixed types of waves; this theory is based on the method of complex eigenvalues, which extends considerably the capabilities of the classical theory, yielding many formulas for the calculation of the constant phase and of the attenuation of regular waveguides made of various materials.

A paper by V. D. Kuznetsov described a new antenna he developed, for collective reception of television over a frequency range from 48.5 to 230 mc, and also the electrical structural data on the system and the experimental results.

A paper by A. M. Model' was devoted to the choice and description of elements of the antenna-feeder system of multi-trunk radio relay lines. The fundamental requirements that the individual element of the channel must satisfy are discussed.

V. I. Krutikov described a method for broadband matching of the antenna-feeder channel of multi-trunk radio-relay lines. The matching is performed with the aid of a directional coupler and a system of reflecting filters. The method described makes it possible to obtain a very high degree of matching in the pass bands of all the trunks of radio relay lines.

M. E. Gertsenshtein and A. M. Pokras gave a theoretical analysis of the operation of a waveguide coupler, and applied the analytical results to the formulation of a procedure for the design of the coupler.

B. E. Kinber extended the theory of linear antennas to include the case of an antenna that is idealized in the form of a curvilinear filament, and also for the three-dimensional case of a plane or curvilinear antenna.

A. L. Mikaelian and A. K. Stoliarov reported the results of an experimental investigation of transverse ferromagnetic resonance in a rectangular waveguide with ferrite. The parameters of resonant valves, developed by the authors for the three and eight centimeter band and used for measurement and radio-relay line work, are listed.

A. L. Mikaelian and M. M. Koblova considered a new type of coaxial valve system for which ferrites are employed, and reported the results of experimental investigation of the non-mutual at-

tenuation in a transversely-magnetized ferrite-dielectric plate, placed in a coaxial line.

#### SESSION ON WIRE COMMUNICATION

Although containing many papers on information theory and switching circuits, most papers in this section concern telegraphy, facsimile, and wired broadcasting, which are not of primary interest to ED readers.

#### SESSION ON GENERAL RADIO ENGINEERING

Ia. S. Itskhoki in his paper "Minimum Volume of Pulse Transformer" noted that the substantial success in the development of special magnetic alloys jointly with the use of transformer biasing has made it possible to revise the procedure previously used for transformer design. While formerly principal requirement concerned the maximum distortion of the flat portion of the pulse, the new requirement now becomes the miniaturization of the transformer. The condition for the

дною колебаний устанавливается изменением  
производится одновременно на управляющую и  
эквивалентном триодному соединению пентода. Молу-  
Как смеситель лампа  $L_2$  работает в режиме,  
конденсатора  $C_2$  токами управляющей сетки этой  
создается вследствие заряда при работе гетеро-  
гетеродина. Автоматическое смещение на сетке лам-



Описываемый гетеродин прост по устройству  
печивает высокую стабильность частоты

balance of optimum losses in the transformer leads to an expression for the volume of the transformer in the form of a function that takes into account all the structural parameters of the core.

A paper by O. N. Litvinenko considered inhomogeneous transmission lines for shaping pulses of specified forms. In particular, it is shown that it is possible to obtain a linearly-varying voltage or current by means of an inhomogeneous line.

Another paper by O. N. Litvinenko was devoted to the transformation of millimicrosecond pulses by inhomogeneous lines. Infinitely long lines, which do not distort the shape of the input current or the input voltage, are considered. It is then shown how to extend the analysis to include finite lines.

The paper by Iu. B. Sindler and A. S. Nemirovski gave design equations for the noise distribution at the output of radio-relay lines, derived by

comparing the distribution of the sum of the random oscillations with the distribution of the maximum oscillation.

E. Ia. Grinberg noted that to design ladder networks one employs usually the matrix method of the theory of four-terminal networks. However, the calculations can be simplified considerably using the so-called Euler brackets. This makes it possible to establish the necessary effect during the course of calculation, and also to check both the individual stages of the calculations, as well as entire groups of these stages.

In another paper, "Formulas for the Analysis and Synthesis of Simple Multi-Network Filters" E. Ia. Grinberg determined the transfer coefficients of a resonant narrow-band filter and established the quantities that determine the shape of the selectivity curve.

A paper by M. Z. Arslanov was devoted to the investigation of dynamic resonance in a nonlinear oscillating circuit, considered the possibility of using this resonance for selection of pulse signals.

The analysis of the oscillator as a nonlinear self-oscillating circuit was the topic of V. S. Troitski's "Theory of Molecular Oscillator and of the Fluctuations of its Oscillations."

S. I. Averkov and L. A. Ostrovski considered non-resonant power amplification of oscillations propagating in a medium with varying parameters. They concluded that it is possible to detect this effect at radio frequencies and to make practical use of it.

N. N. Lunacharski considered an equation for behavior of the phase of oscillation in a self-oscillating system with an external driving signal.

Iu. A. Driagin described an instrument for measuring low-frequency fluctuations due to the flicker effect, instability of power supply, etc. The instrument makes possible measurement of the spectral density of fluctuations ranging from 0.2 to 2,000 cps.

In a paper "Concerning Systems of Electrical and Magnetic Units" L. B. Slepian indicated that it is possible to obtain complete compatibility between the MKS-Coulomb system and the CGS system, i.e., to establish relationships between the systems that do not depend on  $c$ . For this purpose it is necessary to introduce into the equations for the electromagnetic field a factor  $1/c$ , as proposed by I. G. Kliatskin.

I. L. Bershtein indicated in his paper that by using a phase automatic frequency tuning system, one can obtain high frequency stability of microwaves in a relatively simple manner.

Iu. Ia. Iurov discussed a new balanced mixer for centimeter waves.

A. A. L'vovich discussed the advantages of synchronized oscillators employing thermistors. Such oscillators can be used extensively where high amplitude stability is required.



## This cold cathode trigger tube sets new standards of stability

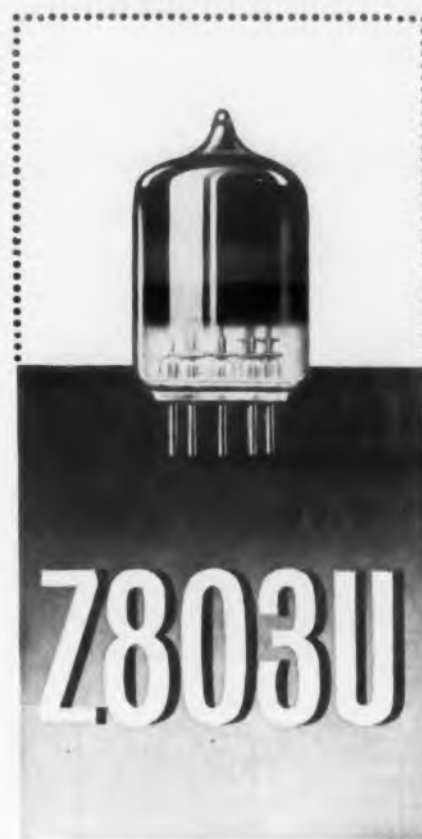

### Z803U Maximum Cathode Current and Trigger Stability

	General operation		Self-extinguishing circuit	
Peak Current	50	100	200	mA
Average Current	8.0	25	0.8	mA
Maximum Averaging Time	15	15	0.5	secs.
Maximum Variation of Trigger Ignition Voltage per 1,000 hrs.	±2	±2	±2	%
Typical Variation of Trigger Ignition Voltage per 10,000 hrs.	<±2	*	<±2	%

\*Over long periods a systematic drift of 0—5% per 1,000 hrs. may be expected.

### Supplies available from: in the U.S.A.

International Electronics Corporation,  
Dept. ED2, 81, Spring Street, N.Y. 12,  
New York, U.S.A.

### in Canada

Rogers Majestic Electronics Limited,  
Dept. JB, 11-19 Brentcliffe Road,  
Toronto 17,  
Ontario, Canada.

With a stability higher than that of previous types, close tolerance characteristics, and a very long life, the Z803U is finding wide application in industry. For example, it is possible with this tube, to construct for the first time, simple cold cathode timers which have an accuracy as high as 2%.

Other recommended features of the Z803U include a priming discharge of about  $10\mu\text{A}$ , ensuring consistent operation in both daylight and darkness; a wide plate voltage working range that enables the tube to operate efficiently despite large supply voltage variations; and instantaneous operation without prior warm-up.



### Z803U Design Notes

Write today to either of the distributing companies for your copy of these useful design notes. The notes include operating advice as well as details of recommended circuitry.



MULLARD OVERSEAS LTD., MULLARD HOUSE, TORRINGTON PLACE, LONDON, ENGLAND

Mullard is the Trade Mark of Mullard Limited and is registered in most of the principal countries of the world.

CIRCLE 195 ON READER-SERVICE CARD

MEV 54

# Mullard

## ELECTRONIC TUBES

used throughout the world

# Design of Multivibrator with Self Excitation

J. George Adashko

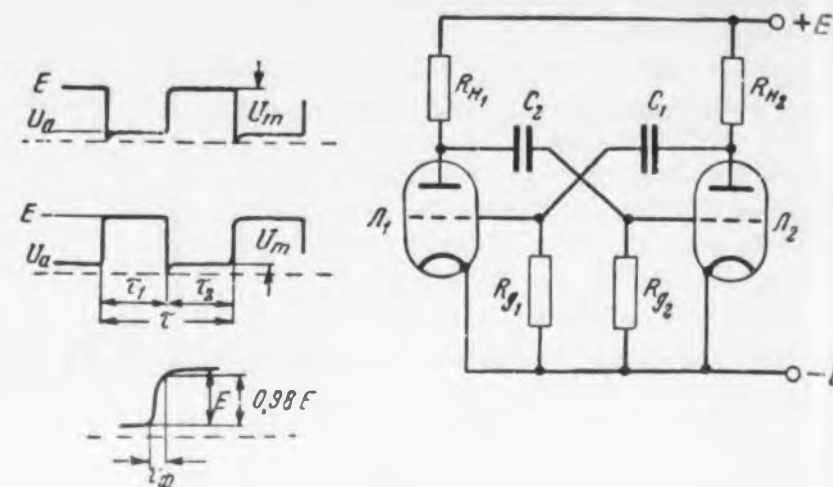

Multivibrator with plate waveforms. The upper waveform is for plate 1.

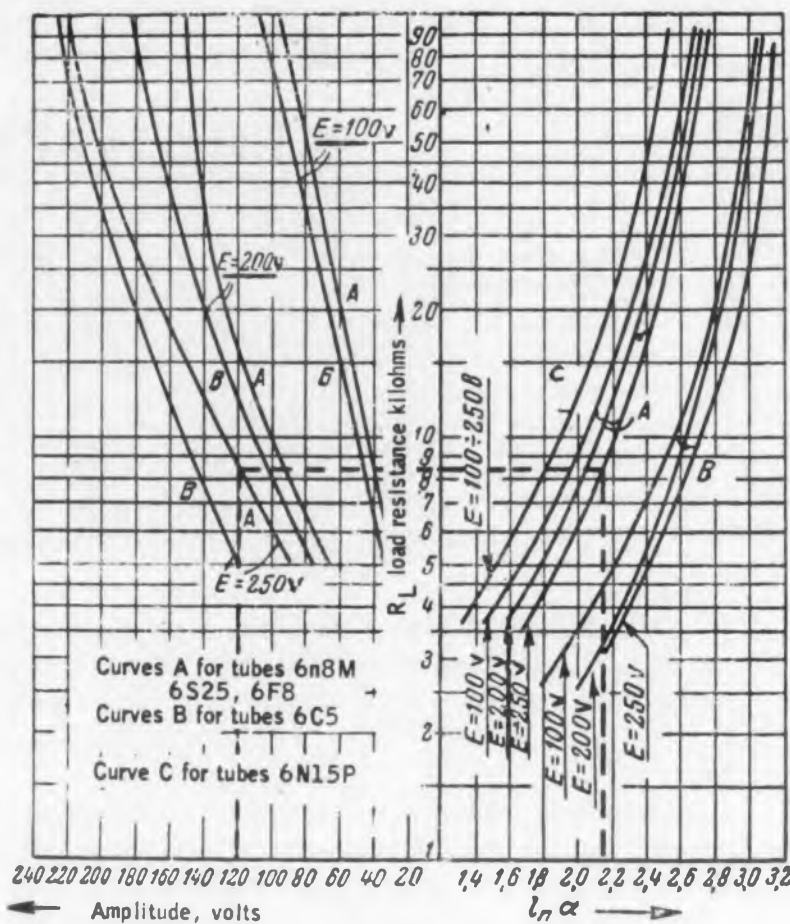

- Equations
- 1)  $\tau = (\ln \alpha) \cdot R_g C$
  - 2)  $f = 4(R_L + R_I) C$
  - 3)  $U_m = \varphi(L, E)$
  - 4)  $\ln \frac{U_m}{E_0} = \varphi(L, E)$

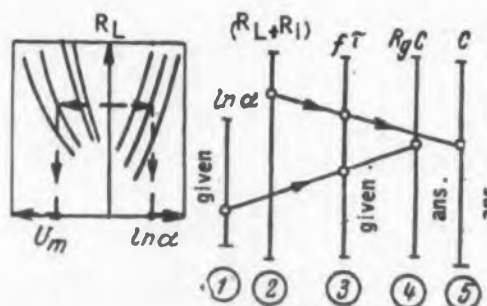

Nomogram for Self Excited Multivibrator

Example  
 given  
 $\tau = 2 \mu\text{sec}$   
 Tube 6N8G  $R_I = 7500$   
 $U_M = 120\text{v}$   $E = 250\text{v}$   
 $f = 15 \text{ kc}$   
 We get,  
 $R_L = 8500$  ;  $\ln \alpha = 2.15$   
 $R_g C = 7 \mu\text{sec}$  ;  $C = 31 \mu\text{mf}$

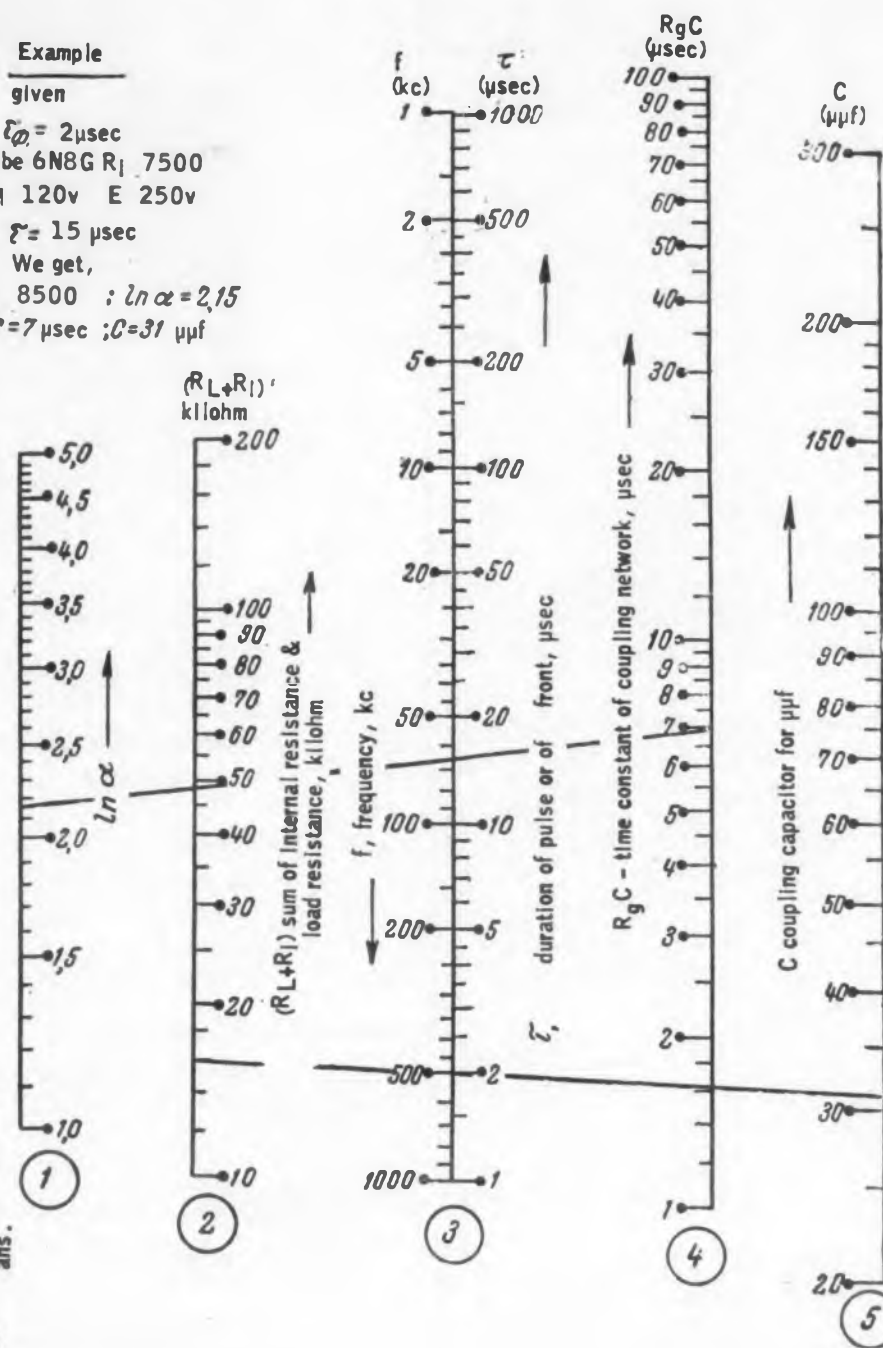

THE PERIOD of a self-excited multivibrator (see Figure) can be found with sufficient accuracy, assuming  $R_L \ll R_g$ , from the following equation:

$$T = \tau_1 + \tau_2 = R_{g1}C_1 \ln \alpha_1 + R_{g2}C_2 \ln \alpha_2 \quad (1)$$

$$\text{where } \ln \alpha = \ln \frac{U_m}{E_{g0}} = \ln \frac{E - U_a}{E_{g0}} \quad (2)$$

(the symbols are identified on the figure);  $E_{g0}$  is the grid cutoff voltage for a given load and given source voltage. The rise time  $\tau_f$  of the pulse front is determined from the expression

$$\tau_f = 4(R_L + R_i)C. \quad (3)$$

The time is measured from the start of the pulse to the instant at which its value reaches 0.98 of the rated amplitude.

The nomogram is based on the above three equations and makes possible the determination of the half period of the oscillations. Located to the left of the nomogram is a plot with which it is possible to determine the values of  $\ln \alpha$  for certain types of tubes, and to determine the amplitude  $U_m$ . If the multivibrator employs other tubes or other voltages, Eq. (2) and the characteristics of the tubes must be used in lieu of the graph to determine  $\ln \alpha$ . To find the oscillation period it is necessary to know, in addition to the parameters and operating condition of the tubes, also the load  $R_L$  in each plate circuit and the time constant of the coupling networks  $R_{g1}C_1$  and  $R_{g2}C_2$ . The nomogram can also be used to design blocked multivibrators.

#### Example

A self-excited multivibrator employs 6N8S tubes (Russian equivalent of 6C8G). Data is given on the nomogram. The pulse repetition rate should be 25 kc. The pulse rise time should not exceed  $\tau_f = 2 \mu\text{sec}$ . The pulse amplitude (120 v) is marked on the left abscissa of the graph, and the curve corresponding to the 6N8S tube at 250 volt supply yields the required load resistance, 8500 ohms. Scale 3 of the nomogram is used to determine the period corresponding to the prf,  $f = 25 \text{ kc}$ , namely  $T = \tau_1 + \tau_2 = 40 \mu\text{sec}$ . Since it is necessary to obtain pulses of duration  $\tau = 15 \mu\text{sec}$ , the remaining part of the period must be  $\tau_2 = 25 \mu\text{sec}$ . The remaining operations are shown on the key of the nomogram.

From Nomogram Collection on Radio Engineering by V. M. Rodionov, Soviet Radio Publishers.

## Industrial Laminates from the company that really knows the electrical and electronics industry—General Electric



Announcing General Electric Textolite 11574

# New self-extinguishing epoxy paper

Ideal for printed circuits, unique paper-base laminate  
quenches fire in one second in UL flame test  
... exceeds NEMA XXX-P requirements ...  
machines freely at room temperature

Do you have a high-reliability application that's too tough for conventional paper-base laminates? Self-extinguishing Textolite 11574 may solve the problem. Check these extraordinary properties:

**Electrical:** one million megohms insulation resistance in humidity.  
**Mechanical:** about twice the flexural and impact strengths of NEMA XXX-P standards. **Physical:** best cold-punchability of any high-pressure laminate General Electric has ever tested; clean, precise pierced and blanked parts.

Consult Sweet's Product Design File, Catalog 2b/Gen for technical data on the full line of reliable Textolite laminates. Fabricated parts come to you from independent local fabricators (listed in the Yellow Pages under "Plastics"), geared to give you speedy delivery. For expert help with special problems, write to Technical Service, Laminated Products Dept., Section ED-8115, General Electric Co., Coshocton, Ohio.

**Textolite**<sup>®</sup>  
INDUSTRIAL LAMINATES  
**GENERAL ELECTRIC**

See our booth in the giant General Electric exhibit at the IRE Show; March 24-27.

CIRCLE 196 ON READER-SERVICE CARD

a complete  
STOCK ROOM  
... in a  
Carrying  
Case!



### New, Low Cost . . . All-Purpose PRECISION DEVELOPMENT KIT

Contains Over 1,000 Instrument Parts

A newly developed, completely integrated, kit and stock room of precision instrument parts and components—for use in all mechanical breadboard, prototypes and servo control system applications. AVAILABLE IN 1/8", 3/16" & 1/4" SHAFT SIZES.

**PIC**...The SUPERMARKET Concept of Precision Instrument Components—Over 6,000 items—from STOCK—for IMMEDIATE DELIVERY.

Three NEW Catalogs Available  
Send for your FREE copies today!

Introductory  
Price

**\$398.00**

(Individual item  
cost—over \$500.00)

Write Today for  
detailed information  
and complete parts list.



**PIC DESIGN CORP.**

Subsidiary of **BENRUS WATCH COMPANY, Inc.**

EAST ROCKAWAY, L.I., N.Y.

Western Office:

7335 Van Nuys Blvd

Van Nuys, Calif.

CIRCLE 197 ON READER-SERVICE CARD



## New TEMP-R-TAPE® C

.002" thick, 2750 v/m  
pressure sensitive TEFLON\* tape  
For -100°F to 500°F applications

TEMP-R-TAPE® C, CHR's newest pressure-sensitive tape, is made of ultra-thin, high dielectric, cast Teflon film to which a silicone polymer adhesive has been applied. Both pressure-sensitive and thermal curing, the adhesive sticks well to any surface over a -100°F to 500°F (-70°C to 260°C) temperature range. Providing an easy-to-apply, extremely thin, high dielectric insulator (2750 volts/mil), TEMP-R-TAPE C was designed for and is now being used in the manufacture of miniature electronic units to withstand Class H and higher temperature requirements. Send for data on TEMP-R-TAPE C and CHR's other extreme temperature, electrical and mechanical pressure-sensitive tapes.

## CONNECTICUT HARD RUBBER

NEW HAVEN 9

\*du Pont TM.

**CHR**

CONNECTICUT

CIRCLE 198 ON READER-SERVICE CARD

# Information Theory in the U.S.S.R.

Paul E. Green, Jr.

Lincoln Laboratory  
Massachusetts Institute of Technology

THEORY OF INFORMATION THEORY IN THE U.S.S.R.

This article is a sketch of the development of the science of information theory in Soviet Russia. For the past two years, the author has tried to follow Soviet publications, past and present, in the field of information theory. Recently he has had opportunities to speak briefly about this subject with several Soviet scientists. This paper will present a history of Soviet information theory as deduced from this material.

Mr. Green has here condensed his 1957 WESCON paper especially for ELECTRONIC DESIGN.

HERE *information theory* is taken to mean the application of statistical notions to problems of transmitting information. This field makes a fairly instructive case study. It is quite unusual to have a body of theory such as this spring up in a short period of several years and immediately attract the interest and activity of such diverse professions as communication engineers, economists, mathematicians, physiologists, linguists and so forth. The reaction to all this in the Soviet was rather interesting, and tells us not a little about their scientific system.

Since 1725, when the Academy of Sciences was founded by Peter the Great, the theory of probability has enjoyed a particularly high quality of attention in Russia. The present pre-eminence of the Russian school, which includes A. N. Kolmogorov, A. Ia. Khinchin, and many others, is a direct legacy from that period, when Peter invited many Westerners, including Euler and N. Ber-

noulli to participate in the intellectual renaissance that he and his Academy were attempting.

Most Western students of communication theory are familiar with the names of Khinchin and Kolmogorov because of two instances of parallelism with the work of Norbert Wiener.

The first of these is the extension of the notions of Fourier analysis to processes with infinite time duration and continuous spectra (such as certain stationary random processes)—the so-called Generalized Harmonic Analysis. This subject was pursued with great success during the decade 1925-1935 principally by Wiener and Khinchin themselves. The second instance—the concurrent development of optimum mean-square filtering and prediction theory by Wiener and Kolmogorov—took place in a wartime environment. Originally, Wiener's study of the subject was classified, and the existence of Kolmogorov's journal article was not known in this country

until Wiener's work was substantially complete. (The difference in method of publication of these works is explained when one considers the extent to which Wiener carried his treatment through to engineering applications.)

It was the variety of technological problems presented by World War II that catalyzed this and other developments in the statistical treatment of communication, detection, and control problems. This was as true in Russia as it was here, but at the time the means at their disposal were much more limited. For example, they had no equivalent to our Radiation Laboratory where most of our early work in this field originated.

During the war the interest of Soviet engineers was attracted to the statistical nature of communication problems, but not on the *information* basis of Shannon and Wiener. This seems to be entirely a Western idea, and as such was for a time in some disrepute.

#### KOTEL'NIKOV'S THEORY

In place of the Shannon theory which treats information as an attribute of the signals generated and transported through a communication system, there appeared in the U.S.S.R. a different sort of statistical communication "theory." This is the study of *potential interference immunity*, enunciated by V. A. Kotel'nikov in his doctoral dissertation of 1946.

Kotel'nikov's dissertation incorporated a number of important ideas that were quite new at the time. He studied communication in the presence of gaussian additive noise. By the use of the inverse-probability or "decision theory" argument employed later by Woodward and Davies, he obtained the result that the receiver having the least probability of error in the presence of white gaussian noise uses the mean-square-difference detection criterion. He called the probability of error (the probability of one possible signal being mistaken for another) the *potential interference immunity*, and computed also the actual probability of error (interference immunity) for several types of systems.

Kotel'nikov's study was an outstanding piece of work for its time. In 1953 he was made an Academician in the Academy of Sciences and he is now director of the Academy's electronics research laboratory, the Institute of Radio Engineering and Electronics, in Moscow.

These are the main developments during the period before 1952. After Kotel'nikov's pioneering effort, Soviet communication engineers seem to have published little of real significance. Their efforts in the theory of communication during this period were mostly applications of the *results* of Kotel'nikov's original study, rather than the use of his *methods* on other problems.

*Continued on next page*

MINIATURIZATION IN CONNECTIONS



 actual size unretouched photo  
of the

**Hubbell**   
interlock connector

...another fine electronic component from

the vast inventories of **Avnet**



WEST EAST

8966 NATIONAL BLVD  
LOS ANGELES 34, CALIF. TEXAS 0 6141  
TWX CULVER CITY 2273

35 N. MOORE ST  
NEW YORK 13, N.Y.  
BEEKMAN 3-5780  
TWX NY 1-4943

CIRCLE 199 ON READER-SERVICE CARD



## yours free, if you can use it

If you are one of the relatively few, highly skilled engineers in America today whose job requires a knowledge of the mysterious, highly specialized alloys used in magnetic, electronic and electrical applications, you'll want this new 64-page booklet.

In it are the two kinds of vital information about these alloys electronic designers need most today—what they will do and where you can get them, fast.

The technical data and case histories for this booklet were compiled by the metallurgical staff of The Carpenter Steel Company. They're giving you, free, the benefits of their own wide experience in producing the

largest selection of these highly specialized alloys ever available from any one steelmaker.

In fact, there isn't a single Carpenter alloy mentioned in this booklet that you can't get in quantity right now.

These same skilled, experienced men are also available for work on special problems with alloys for electronic, magnetic and electrical applications.

Get your free copy of this booklet—and get in touch with the men who wrote it—by sending your request today on your company letterhead.

# Carpenter STEEL

Alloys for electronic, magnetic and electrical applications

The Carpenter Steel Company 145 W. Bern St., Reading, Pa.

Export Dept.: The Carpenter Steel Co., Port Washington, N. Y.—"CARSTEELCO"

CIRCLE 200 ON READER-SERVICE CARD

## WORK OF SOVIET MATHEMATICIANS

In the field of probability, Soviet Russia possesses, in addition to such pure mathematicians as Khinchin, Kolmogorov, Gnedenko, Linnik, etc., a very strong complement of applied mathematicians, who have successfully used statistical theories in such subjects as turbulence (Obukhov, A. M. Iaglom, Monin), scattering of waves (Krasil'nikov, Chernov, Tatarskii), and mean-square filtering and prediction (A. M. Iaglom, Pugachev). Kolmogorov himself has written many papers on applications. There are signs that both groups of mathematicians are interesting themselves in information theory.

It was probably about 1952 that Khinchin first became interested in Shannon's work, in particular the entropy expression. He published in 1953 a survey paper setting forth in clear mathematical language the properties of self- and conditional-entropy of discrete distributions and Markov chains, interpreting them in terms of information.

An active interest in information theory (in the Western sense) by the Soviets seems to date from about the time of the publication of this paper.

Several points in the original Shannon formulation have resisted a rigorous mathematical treatment, notably the fundamental theorem: that there exists a coding scheme that will encode the output of a source of rate  $H$  so that at the other end of a channel of capacity  $C$ , there will be an arbitrarily low probability of error (or "fractional information lost" in some formulations), provided  $H$  is less than  $C$ . Attempts by McMillan and Feinstein in this direction were only partially successful. Recently, Khinchin interested himself in this problem, and provided the most complete and rigorous treatment of the discrete case to date, including proof of this theorem, in a long paper published in 1956. (The two Khinchin papers have recently been republished in English by Dover under the title "Mathematical Foundations of Information Theory.")

Whether Khinchin's interest was originally self-generated and limited to himself or part of a group effort is not clear. But such a combined effort by Soviet mathematicians did evolve, apparently led by Kolmogorov. A seminar on information theory has been in progress for some time, under him. The Soviet probabilists seem to be interested in information theory as a bona-fide new branch of the theory of probabilities. A number of very high quality papers have been published extending and making more precise Shannon's treatment of self- and conditional-entropy.

The Soviet mathematicians seem to be proceeding carefully toward a rigorous, comprehensive treatment of the entirety of Shannon's work. The chances appear good that their studies will



lead not only to a better understanding of existing theory but also to new extensions of it.

### WORK OF SOVIET ENGINEERS

The interest in information theory of people like Khinchin does not seem to have been shared to a significant extent by communication people until about 1954 if publication of journal articles is any criterion. Then, during 1954 and 1955, official recommendation for work on a more general theory of communication came from several highly-placed authors, and from the Academy of Science. For example, in 1954, Kotel'nikov, in an article in the radio amateur magazine "Radio," defined the most important radio engineering problems as "extension of the usable frequency spectrum, semiconductor applications, and a general theory of communications."

Pronouncements such as these do not usually go ignored in the U.S.S.R. Therefore it should not be surprising to observe that a year-by-year list of the number of articles and notes on information theory in the electronics journals shows a sharp upswing beginning about this time: None during 1953, 1 during 1954, 6 during 1955, 12 during 1956, and 9 in the journals received to August 1957. In the 1957 journals received, 14 per cent of all articles and notes were on statistical applications, and 45 per cent of these were on information theory.

The subject matter of almost all these 28 papers breaks down into three fairly specific fields:

- (1) Coding studies,
- (2) Simple bandwidth-compression schemes,
- (3) Channel capacity studies using the vector model.

A concentration of subject matter under so few topics is rather surprising. Most of the tougher and more intriguing byways have been, until recently, untouched. (For example: channel capacity and how to approach it in more difficult type of channels, new coding schemes, cascaded or networked channels, and so forth). The use of statistical decision theory has been conspicuous by its absence in the published literature, even though a form of this approach was used by Kotel'nikov and has also been available in Lawson's and Uhlenbeck's book and in the Woodward and Davies papers where it was related directly to information theory notions.

The published work on coding, which is mostly tutorial, explores the relationship between code length, average information rate, channel capacity and average error probability, in various combinations; but does not give any new insight into the problem of devising better codes. Published work on bandwidth-compression has been limited to velocity-modulated scanning systems for picture transmission.

By and large, the published information

Facts  
about

## STABILINE® Automatic Voltage Regulators



STABILINE type IE (Instantaneous Electronic) is available in 115 volt units — input range from 95-135v. and 230 volt units — input range from 195-255v. STABILINE type IE5101R shown above.

### "Here's how to Build-in Automatic Voltage Regulation"

"No matter how good your control instrumentation is, it is not going to be precisely accurate at all times unless the input voltage is precisely constant.

"You just can't get better automatic voltage regulation equipment than with this STABILINE. At no load, full load or any intermediate stage it maintains constant output voltage regardless of line fluctuations.

"This sensitive, yet ruggedly constructed, automatic voltage regulator is a must component in today's voltage sensitive apparatus."

Three types of STABILINES are available for individual needs:

**Type IE (Instantaneous Electronic)** is completely electronic, instantaneous in action, with no moving parts. Constant output voltage is maintained regardless of line or load fluctuations.

**Type EM (Electro Mechanical)** has zero waveform distortion. Insensitive to magnitude and power factor of the load. Highly efficient.

**Type TM (Tubeless Magnetic)** has no moving parts . . . no tubes . . . no transistors. Ideal for unattended locations or where failure can never be tolerated.

Be sure to see  
SUPERIOR ELECTRIC'S  
Mobile Display  
when it is in your area

Offices: Los Angeles, California • San Francisco, California • Miami, Florida  
Chicago, Illinois • Baltimore, Maryland  
Detroit, Michigan • New York, New York  
Cleveland, Ohio • Dallas, Texas • Seattle, Washington



THE SUPERIOR ELECTRIC COMPANY  
1702 BRADLEY AVENUE, BRISTOL, CONNECTICUT

Please send STABILINE Bulletin S657   
Have your representative call

Name .....

Company .....

Address .....

City ..... Zone ..... State .....

CIRCLE 202 ON READER-SERVICE CARD



# FREE!

## LATEST TERMINAL MANUAL

Here's where you get the answers to your terminal problems and requirements:

This new Sealectro Manual lists hundreds of standard "Press-Fit" stand-offs, feed-thrus, connectors and test jacks, taper-pin receptacles, probes and plugs, and custom fabrications; miniature, sub-miniature and micro-miniature sizes; choice of code colors, lugs, platings; handy specification tables and dimensional drawings; insertion tools and installation procedures.

You can save labor, material, time, trouble and money, with these original and genuine Sealectro "Press-Fit" Teflon terminals. This Manual tells you how.

**WRITE FOR YOUR COPY!**

Be sure you have this Manual at your fingertips. Let us have your specific problem or requirement for engineering collaboration and samples.

\*Reg. Trademark of Sealectro Corporation, originator and pioneer of Teflon terminals.  
 †Reg. Trademark of E. I. Du Pont de Nemours & Co., Inc.



CIRCLE 203 ON READER-SERVICE CARD

theory work of Soviet engineers is a disappointment. On the other hand its quality is steadily increasing. And it is always possible that behind the facade of indifferent work there have already been some substantial achievements that will some day be sprung on the unsuspecting.

#### FILTERING AND DETECTION

The preceding sections have dealt only with Soviet work on the theory of information. This restriction has left unmentioned the progress of work in other related fields which will now be summarized.

There has been steady activity in mean-square filtering since the late 1940's by engineers (for example, V. V. Solodovnikov) and mathematicians (notably A. M. Iaglom and V. S. Pugachev). In the published literature, the use of such techniques for detection problems seems to be very much secondary to their use in automatic control systems. The Soviets have followed closely the few engineering extensions of this theory and have made several original and independent contributions of their own.

Observable work in weak-signal detection has inclined toward the weak side. Some fairly detailed studies of radiometers have been made, but on the other hand, claimed performance for these circuits in radio-astronomy work has run several years behind that attained in the U.S.A., England, and Australia. Published work on correlation detection has been limited to simple schemes for detection of pulses. Several papers on video integrators (or "comb filters") have appeared. Papers on radar detection are seldom seen, probably because of security restrictions.

#### CYBERNETICS

From its initial formulation in 1949 until 1955, cybernetics (which Wiener defines as "control and communication in the animal and machine") was one of the standard whipping boys of the Communist regime. The usefulness of analogy relationships between biological processes and electronic or mechanical ones was denied most emphatically. In the general loosening up after Stalin's death, cybernetics followed shortly after information theory in obtaining official approval. A very large number of articles, many of them in the popular magazines have followed. The subject is currently attracting wide interest, particularly on the popular level where the fascination for cybernetics seems to have somewhat the same motivation as the current popular Soviet interest in science fiction.

Some quite interesting work on mechanical translation has been done, and the same group of people have begun programming computers to play chess.

Soviet linguistics suffered a great decline in the 1940's and 1950's because of political inter-

**3 OUNCE WEIGHT**  
for a **3 WAY VALVE**

*plus—  
inherent minimum  
internal leakage*

Series BF42C  
Operates to 70 psi  
gases or liquids  
Available with  
electrical connectors  
instead of lead wires



*suitable for small actuators  
and instrumentation systems*

you've made so many small coaxial valves, they said, can you make us a really small low-pressure 3-way? Result: By the use of Eckel unique magnetic field features, a 3 oz. 3-way... one-third the weight of previous "smallest" valves. Consumption: only 9 watts at 28V DC.

*On request—Eckel Valves for the Space Age.*



TWX collect  
San Fernando Cal 7632  
Representatives  
in U. S. and Canada

**eckel**  
*valve co.* Dept. L-2

1425 First Street, San Fernando, Calif.

**CIRCLE 204 ON READER-SERVICE CARD**

ference (first in the name of Marr, and later Stalin). The statistical study of languages has never really come to life.

Only a passing mention has been seen of the relationship of thermodynamics and informational entropy. Very few investigations in biophysics or neurophysiology have been reported, and the present author has seen no evidence of Soviet work in the theory of games, the theory of automata, or the sociological or psychological implications of cybernetics.

#### CONCLUSIONS

1) There is no doubt that information theory is at present the object of great interest and activity in the Soviet Union. After a late start, they are already producing results worth studying. The time lag was a deliberate one, probably due to a combination of ideological orthodoxy and a calculated desire to wait and see what results would be obtained elsewhere.

2) Almost all these results have so far come from the pure and applied mathematicians, whose competence in probability has been a matter of historical fact for many generations.

3) Work by communication engineers is still very much exploratory, but is improving rapidly.

4) Lack of communication between mathematicians and engineers seems to have been considerable. The practice, familiar to us, of forming groups of people having a wide spectrum of talents (from the abstract to the engineering application) does not appear to have been used by the Soviets in information theory although in other fields they have applied it quite successfully. The probabilists work at their institutes and the communication people at theirs.

5) There remains the slight possibility that the low quality of observed engineering work is to a certain extent a deception, and that classification according to quality as well as according to subject is practiced in the U.S.S.R.

6) It is important to make some estimate of the possibility that behind the scenes the Soviets have used information theory or related ideas to develop sophisticated new coding, modulation or detection techniques. After due consideration of the available data, the author's feeling is "probably not—yet."

7) Finally, there is a statement often made about Soviet science: that once the top command has decided that the U.S.S.R. should excel in a given field, all that is needed is the official impetus and it is then only a matter of time. All signs indicate that in information theory the impetus has been provided. Meanwhile, it is taking time.

The research in this document was supported jointly by the Army, Navy, and Air Force under contract with the Massachusetts Institute of Technology.

WELL I'LL BE DIPPED... better  
...because the NEW **AMP** SNAPIN

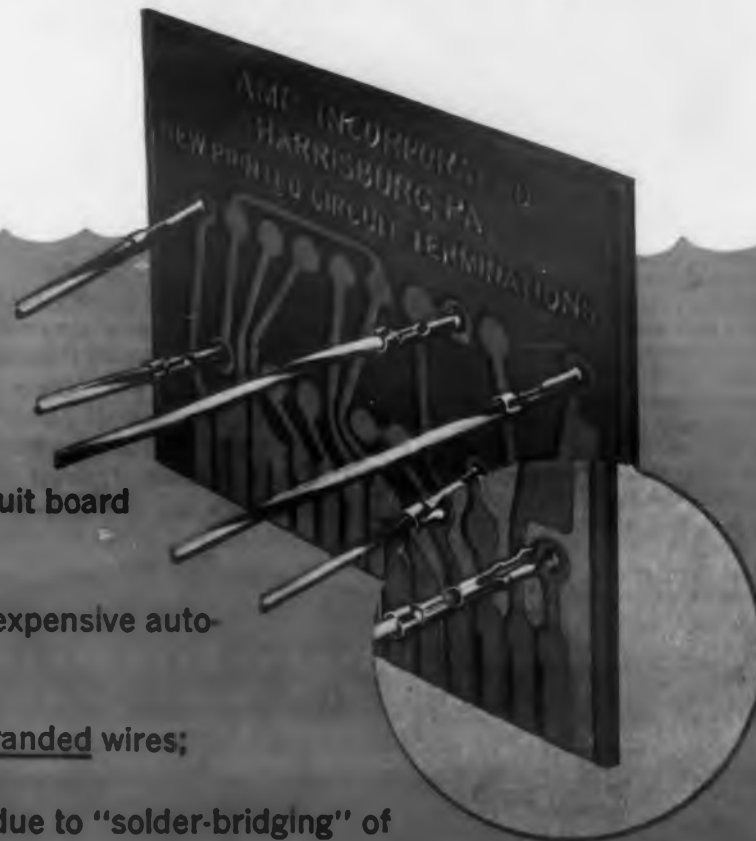

- Gets leads to the printed circuit board in one assembly operation;
- Eliminates an investment in expensive automation equipment;
- Can be applied to solid or stranded wires;
- Eliminates danger of shorts due to "solder-bridging" of insecure leads;
- Has construction details that promote good capillary flow of solder during the dipping process;
- Is self-retaining, with no damage to the printed circuit board during pre-assembly operations;
- Is self-aligning—no further positioning or deformation is required.

*Write today for additional information on the NEW A-MP SNAPIN, the AMP-EDGE Connector and other A-MP products designed for printed circuit applications.*

## AMP INCORPORATED

**GENERAL OFFICE:**  
**3512 Eisenhower Boulevard, Harrisburg, Pennsylvania**

**AMP**

Wholly Owned Subsidiaries: Aircraft-Marine Products of Canada Ltd., Toronto, Canada • Aircraft-Marine Products (Great Britain) Ltd., London, England • Societe AMP de France, Le Pre St. Gervais, Seine, France • AMP—Holland N.V. 's-Hertogenbosch, Holland

Distributor in Japan: Oriental Terminal Products Co., Ltd., Tokyo, Japan

CIRCLE 205 ON READER-SERVICE CARD

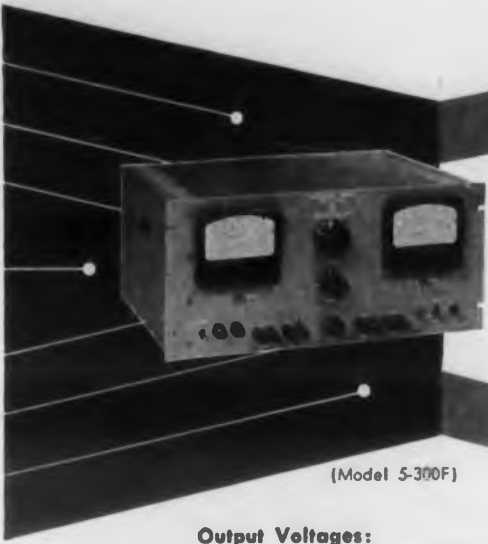

## space-saving D-B power supply

— has 2 independent outputs,  
each closely regulated,  
plus a variable filament supply

(Model 5-300F)

### Output Voltages:

1. 0-500 V.D.C. continuously variable without switching . . . current 300 MA. max.
2. 0-300 V.D.C. continuously variable without switching . . . current 150 MA. max.
3. 4 to 8 V.A.C. unregulated @ 10 amps max. (varied by tapped switch).

### Regulation

For output voltages: 500 V/300 MA=100 MV. change N.L. to F.L.; 300 V/150 MA=60 MV change N.L. to F.L. For line voltage 115 V.A.C.  $\pm$  10%, the voltage change is .1% for 500 V. output, .16% for 300 V.

**Ripple** — both high voltage outputs less than 2 MV. R.M.S.

**Grounding** — either pos. or neg. of either high voltage outputs may be grounded.

All 3 on a chassis only 8 3/4" x 19" x 16", for rack or bench use. Here is a real work-horse for general laboratory use. You get this widely versatile, compact power supply at a saving over separately supplied units. Request literature on Model 5-300F.

## dressen-barnes

DRESSEN BARNES CORP., 250 N. Vinado Ave., Pasadena 8, Calif.

CIRCLE 206 ON READER-SERVICE CARD



Specialists in the Unusual

## Electroplated WIRES

for many different applications

Continuous electroplating methods permit coating of many metals on to wire (or ribbon) in specified thicknesses of plate . . . This very flexible operation makes it possible to designate a desirable base or precious metal with a coating of another metal for its own particular characteristics. In our laboratory Tungsten wire as small as .00015" has been electroplated with Gold. . . . New combinations of plating on wire are being developed by our research staff from time to time. Your inquiry is invited.

Consult us, without obligation, about your specific wire problems.



Write for  
List of  
Products



SINCE  
1901

## SIGMUND COHN MFG. CO., INC.

121 SO. COLUMBUS AVE., MOUNT VERNON, N. Y.

CIRCLE 207 ON READER-SERVICE CARD



## Books

### Principles of Electrical Measurements

*H. Buckingham, E. M. Price, Philosophical Library, 15 E. 40th Street, New York, N.Y. 600 pages, \$15.00.*

Rapid progress in the field of electronics has made many new measurement techniques necessary. The aim of this book is to provide a knowledge of the principles employed in making such measurements and to explain their application. An understanding of the material in this book should prepare a degree candidate for his final examination. It is also useful for Higher National Certificate and Diploma courses.

It is sufficiently comprehensive to be a useful reference source to engineers requiring information on electrical measurements. A suitable proportion of the contents is devoted to topics on potenti-

ometer and bridge methods, measurement which are related to power systems, and the measurements of some non-electrical quantities.

### Handbook of Tri-Plate Microwave Components

*Norman R. Wild, Donald J. Sommers, Jesse L. Butler, Kenneth P. Nelligan, and William J. Wilson, Sanders Associates, Nashua, New Hampshire. 152 Pages, \$3.00.*

This handbook serves as a scientific report of Sanders Associates, Inc. under development contracts of the National Bureau of Standards and the Air Force Cambridge Research Center.

Basic technical information on an advanced form of "flat-strip" microwave

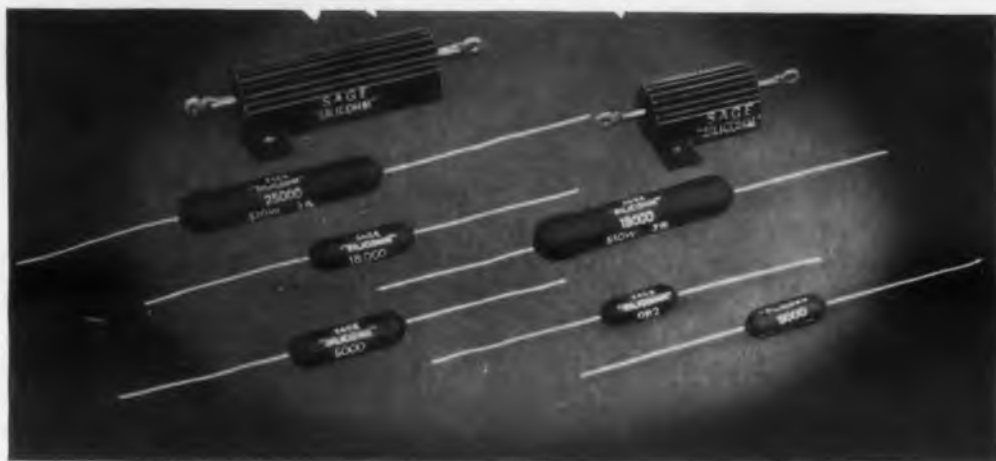

**MINIATURE  
PRECISION  
WIRE WOUND**

## POWER RESISTORS

*for today's critical requirements*

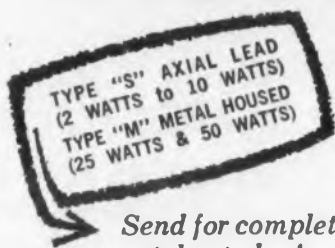

*Send for complete catalog today!*

**MATERIALS AND PROCESS RESEARCH** to yield ever higher quality at moderate cost is given major emphasis at Sage Electronics. Quality control is carefully linked into each step of production. Environmental testing on a continuous basis is the final guarantee of satisfactory standards of reliability as against customer or military requirements.

# SAGE

## ELECTRONICS CORPORATION

309 North Goodman St., Rochester 7, N. Y.

CIRCLE 208 ON READER-SERVICE CARD

ELECTRONIC DESIGN • February 5, 1958

trans  
well  
cove  
miss  
tions  
ricat  
TI  
grap  
engi  
vant  
wav

Rad  
Ame  
1916  
Pag  
T

ELE

transmission line is presented in seven well organized chapters. The authors cover the evolution of flat-strip transmission line, its various forms, applications, measurements, materials, and fabrication techniques.

The book, replete with photographs, graphs, and working formulas enables an engineer to intelligently evaluate the advantages and limitations of these microwave components.

**Radiation Effects on Materials—Vol. I**

*American Society for Testing Materials, 1916 Race St., Philadelphia 3, Pa. 190 Pages, \$4.75; to ASTM members \$3.50.*

This book is a collection of sixteen

technical papers presented at Symposia on Radiation Effects on Materials and on Radioactive Isotopes held in Los Angeles in September, 1956. These meetings were part of the Second Pacific Area National Meeting of the American Society for Testing Materials.

The papers are broadly grouped in four principal categories: Theory, Radiation Facilities and Mechanics of Testing, Fuel and Graphite Materials, and Structural Materials Including Organics.

In the papers on *Problems of Dosimetry* and *The Effect of Radiation on Some Plastics and Elastomers*, the electronics engineer can find useful information on the damage metals, alloys, and plastics undergo from nuclear radiation. In the book as a whole, however, the electronic design engineer will find little of immediate practical value.

**KESTER**  
Formula Number  
**1571**  
Printed Circuit  
**SOLDERING FLUX**  
Write for Sample and Engineering Details  
**KESTER SOLDER COMPANY**  
4266 Wrightwood Avenue • Chicago 39, Illinois  
Newark 5, New Jersey • Brantford, Canada

CIRCLE 209 ON READER-SERVICE CARD

# What is the TOTAL COST of a *plastic part*?



First costs often are only part of the total cost of plastic components. Poorly designed or inaccurately produced plastic parts can mean excessive inspection and assembly costs in your plant and a high failure rate, as well. American's *precision production* saves you money by eliminating these hidden cost factors and thus keeping your *total cost* per part to the barest minimum. That is why so many exacting buyers say, "We turn to American *first* for our plastic parts—because they are precision made."

American Plastics is equipped to give you full line service—injection, compression, extrusion, multiple-shot injection, and low pressure vacuum assisted forming.

Next time you need plastic parts, try American *first*. Others have for over 50 years! Write or wire Dept. ED.



## **AMERICAN PLASTICS CORPORATION**

Subsidiary of Hayden Chemical Corporation  
Executive Offices at 342 Madison Avenue  
New York N. Y.

CIRCLE 210 ON READER-SERVICE CARD

- to build-into your field-testers  
and ground support equipment

## **trio** new miniature LOW-LEVEL AC-DC VT VOLT-OHMMETER



Trio's new general-purpose flexible-design Vacuum Tube Volt-Ohmmeter meets MIL specs, has greater sensitivity than conventional units, maintains 3% AC & DC accuracy over extended temperature ranges, has high versatility and dependability in small size (8" x 5½").

Flexible design enables economical tailoring to your special requirements: special scale plates, auxiliary go/no-go operation, AC range reduced to 10 mv, color and mounting varied, etc.

Ranges: AC & DC: .03 — 300 V; Ohms: 10 to 10M.

AC input Z: 1 meg. DC input R: 11 meg.

Freq. Resp.: 20-5,000 cps. DC zero drift: .5% max on .1 V & higher ranges; 1% on .03 V range.

Power: 115 V, 400 cps.

Write for free "how to" Engineering Guide to Dept. Ed-2, Trio Laboratories, Inc., Seaford, N. Y.

when ordinary instruments are  
too big or inadequate . . .

# **trio**

CIRCLE 211 ON READER-SERVICE CARD



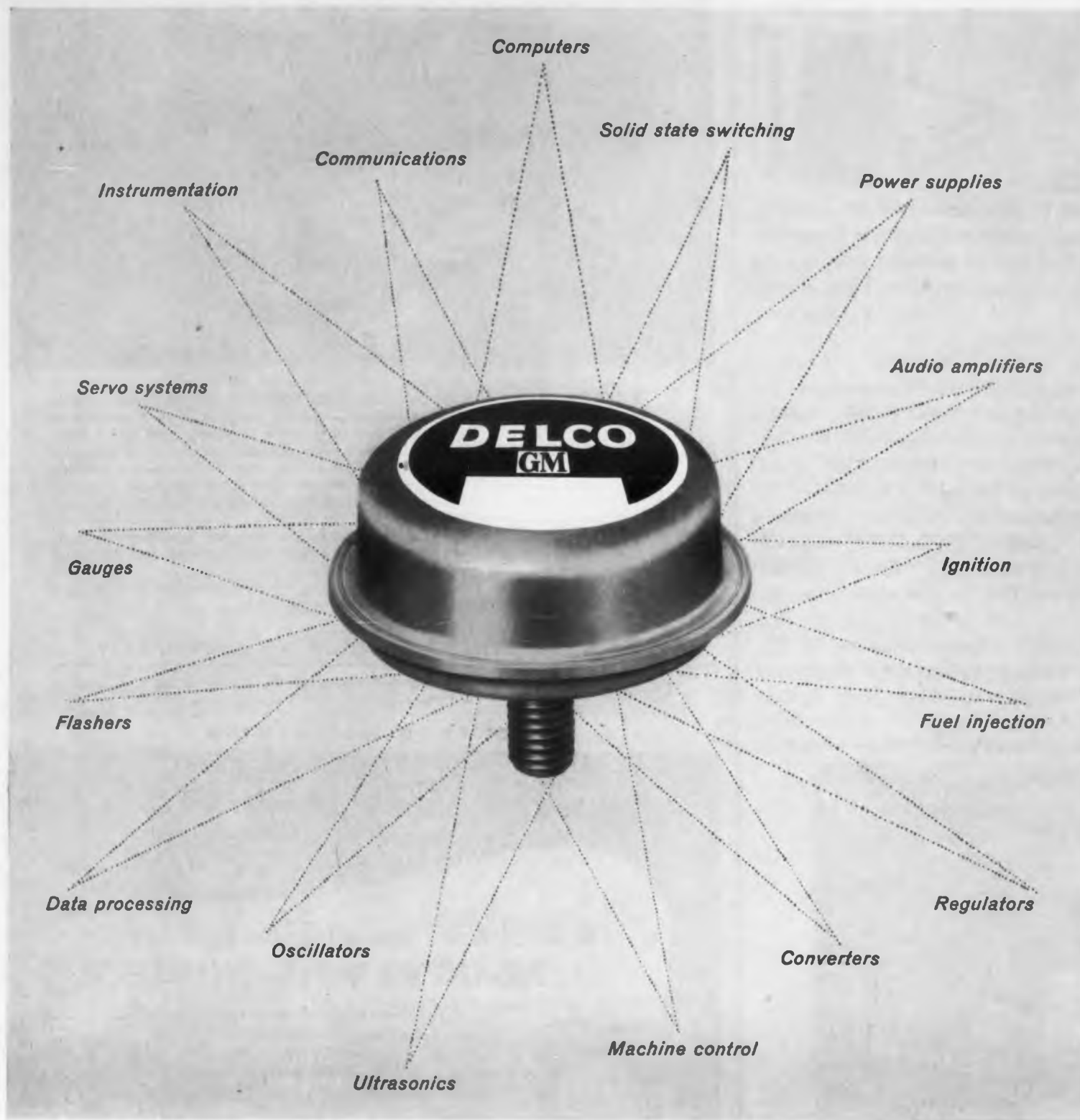

Wherever you require high power, consider

## DELCO HIGH POWER TRANSISTORS

Thousands of Delco high power germanium transistors are produced daily as engineers find new applications for them. In switching, regulation, or power supplies—in almost any circuit that requires high power—Delco transistors are adding new meaning to compactness, long life and reliability.

All Delco transistors are 13-ampere types and, as a family, they offer a collector voltage range from 40 to 100 volts. Each is characterized by uniformly low saturation resistance and

high gain at high current levels. Normalizing insures their fine performance and uniformity regardless of age. Also important—all Delco transistors are in volume production and readily available at moderate cost.

For complete data contact us at Kokomo, Indiana or at one of our conveniently located offices in Newark, New Jersey or Santa Monica, California. Engineering and application assistance is yours for the asking.

**DELCO RADIO**

DIVISION OF GENERAL MOTORS, KOKOMO, INDIANA  
CIRCLE 212 ON READER-SERVICE CARD

## German Abstracts

# Analog Solution of Polynomials

E. BRENNER

THE SOLUTION of  $n$ th order algebraic equations of the form

$$f(z) = \sum_{m=0}^N a_m z^m = 0 \quad (1)$$

where the coefficients  $a_m$  are real numbers is often a tedious procedure, especially when complex roots occur. Such equations are the characteristic equations of linear systems and must frequently be solved for many values of the coefficients  $a_m$ . Many schemes have been developed for the machine solution of such equations using either electrolytic troughs or especially designed electronic equipment. It is possible to solve these algebraic equations using an analog which is built with ordinary, commonly available electrical components.

The schematic diagram shown in the Figure illustrates the principle of a machine which solves equations of the form of Eq.1. For the sake of the desired simplicity, continuity of adjustment of the parameters has been sacrificed so that values can be set of the machine only to three significant figures. The values of the function are represented by ac voltages and by writing the equation in trigonometric form. The solution is obtained when voltages which correspond to both the real and imaginary parts of the solution are equal to zero. In trigonometric form these parts are

$$\text{at } z = z_{k0} = r_k e^{j\phi_0} \\ \mathcal{R}_e f(z) = u_{k0} = \sum_{m=0}^N a_m r_k^m \cos m \phi_0 \quad (2)$$

and

$$\mathcal{I}_m f(z) = v_{k0} = \sum_{m=0}^N a_m r_k^m \sin m \phi_0$$

All transformers except banks 3 and 5 are autotransformers, the coefficients are set by adjusting the tap position. The Transformer bank 5

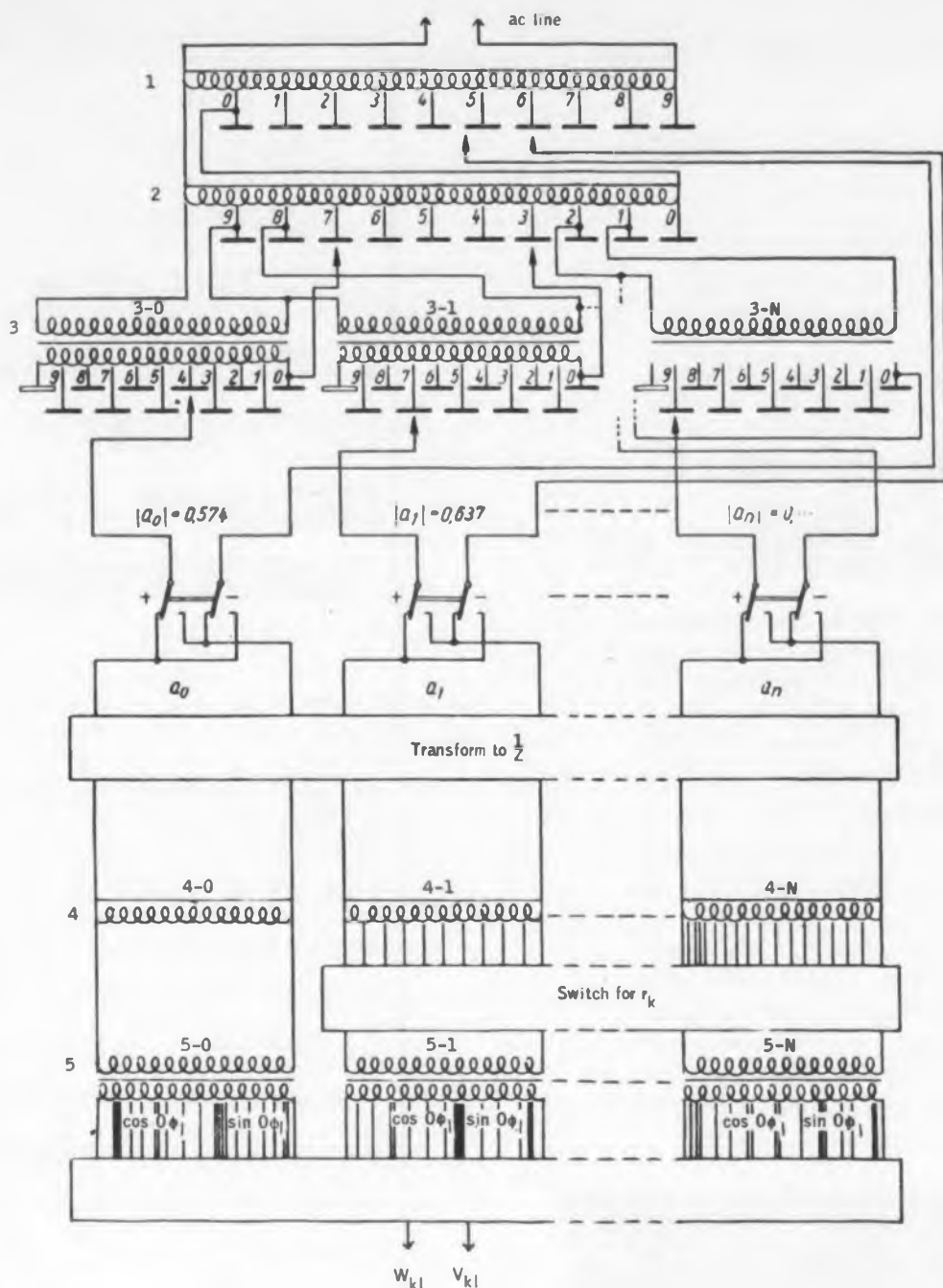

**Schematic of a machine** which solves equations of the form of Eq. 1. The values of the function are represented by ac voltages and by writing the equation in trigonometric form.

has the taps arranged so as to have the ratio of transformation correspond to multiplication by the desired trigonometric function ( $\sin m\phi$  or  $\cos m\phi$ ). The stage which transforms to the variable  $1/z$  is used when a root of the equation has an absolute value which exceeds unity. Elaborate switching arrangements are provided to perform the addition operations which are indicated by Eqs 2 and 3. An oscilloscope is used as the output indicator. A machine of this type was built to solve equations up to the order 8 ( $N = 8$ ).

(Abstracted from an article by H. Adler *Nachrichtentechnik*, Vol. 7, No. 8, August 1957 pp 335-342.)

*Abstracters Note:* The arrangement which is proposed in the above abstract is particularly interesting because no unusual or precision components are required for the construction of the machine. The larger number of components which this device required as compared to other devices which fulfill the same purpose is due to the fact the number of significant figures in the solution is predetermined. While this calls for a large number of transformer banks; precision potentiometers and specially designed phase shift capacitors such as are required in another German machine are eliminated. "Machine solution of Higher Order Polynomials," Abstracted in *ELECTRONIC DESIGN*, Oct. 1, 1957.)—E B.

# New

## transpac<sup>®</sup> transistorized frequency changers

See These  
Products At The  
1958 I. R. E.  
CONVENTION  
BOOTH 2705

### features

- Small, Non-mechanical Design
- High Accuracy
- High Stability
- High Shock, Vibration Resistant
- Consistent, Ready Rated, High Power Design
- Wide Frequency Range
- High Accuracy, Synchronization
- High Shock, Vibration Resistant
- Consistent, Ready Rated, High Power Design
- Wide Frequency Range

power conversion } 60 cps to 400 cps  
                              } 50 cps to 60 cps

Ideal for powering all types of AC operated equipment, gyro and servo mechanisms, magnetic amplifiers, laboratory and industrial applications.

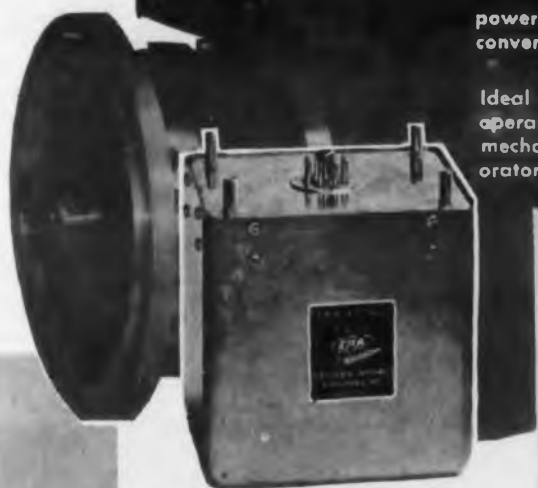

Illustrated: Typical Transpac Frequency Changer and Rotary Equivalent. Note Accessible Circuit Features In Transpac Unit

TRANSPAC transistorized frequency changers are static designs which eliminate the disadvantages inherent in vacuum tube or mechanical equivalents. Special ERA circuitry\* converts the input frequency to DC by means of silicon diodes. This DC in turn is converted to the desired output frequency by means of transistor keyers. Optimum frequency stability is insured by utilizing a small portion of the input signal to synchronize the output frequency.

### STANDARD MODELS

Model No.	Input Freq. (cps)	Output Freq. (cps)	Output Power (VA)	Size Inches	Price FOB Factory
FC645	60	400	50	L	\$185
FC6410	60	400	100	L	275
FC6415	60	400	150	M	365
FC5610	50	60	100	M	275

Case Sizes — L 5-1/16 x 4-5/16 x 5-1/2 Inches  
                  M 5-1/16 x 4-5/16 x 6-13/16 Inches

®Trade Mark Registered  
\*Patents applied for

Units also available in higher power ratings and other frequency ratios.  
Write for literature and quotations on special designs.

Manufactured at ERA's New and Larger facilities.

**Electronic Research  
Associates, Inc.**  
67 Factory Place, Cedar Grove, N. J.



CEnter 9-3000

CIRCLE 213 ON READER-SERVICE CARD

What's it like to be a Creative Engineer at

# IBM

Electronic Circuit Designer Robert G. Hildenbrandt tells why developing circuits for transistorized airborne computers at IBM Owego offers the professional challenge of a lifetime.



"Since joining IBM Owego in 1952, I've seen some amazing developments in advanced electronic circuitry. I'm now leading a six-man team responsible for all circuits within an airborne computer. Challenge? It's tremendous. We're working not only on present systems but those of the future!"

For those who can qualify, developing circuitry for airborne computers offers one of the most challenging assignments in electronics. At IBM Owego, there are excellent opportunities for creative Electronic Circuit Designers experienced in: Transistor circuits for digital computers; high-frequency power supplies; magnetic amplifiers, regulators, storage devices, cathode ray tube display systems; airborne radar system circuits.



Challenging assignments for well qualified E.E.'s, M.E.'s, Physicists and Mathematicians in:

- Digital computer systems and logic
- Radar systems
- Inertial guidance
- Test equipment development
- Electronic circuit design

FOR DETAILS, just write, outlining background and interests, to:

Mr. R. A. Whitehorne, Dept. 555N  
Mgr. of Technical Recruitment  
International Business Machines Corp.  
590 Madison Ave., New York 22, N. Y.

## IBM

## MILITARY PRODUCTS

DATA PROCESSING  
ELECTRIC TYPEWRITERS  
MILITARY PRODUCTS  
SPECIAL ENGINEERING PRODUCTS  
SUPPLIES  
TIME EQUIPMENT

## TELL YOUR PERSONNEL MANAGER ABOUT ELECTRONIC DESIGN'S "CAREER'S SECTION"

If your company is trying to attract skilled electronic design, development or research engineers, tell your Personnel Manager about ELECTRONIC DESIGN. Here is a concentrated audience of 25,000 engineers ready to read about the advantages offered by your plant.

Remember, more than 5,500 ELECTRONIC DESIGN readers inquire every issue—many of them will be interested in your job opportunities.

You can reach them in ELECTRONIC DESIGN'S "Career's Section."

# Senior Engineer Opportunities

in Electronic Packaging and Printed Circuitry Development

Link Aviation, Inc., offers top opportunities in its expanding Engineering program. If you have an engineering degree with at least five years' engineering experience in electronic component packaging, Link has excellent opportunities for you in its new packaging department.

To fill this position, you should have a good knowledge of electromechanical devices, servos, analog computers, printed circuits, and be familiar with the problems associated with cabling large systems.

Link Aviation offers stimulating associations and a friendly working atmosphere. Located in Binghamton near the heart of upstate New York's recreationland only 180 miles from New York City, Binghamton provides "hometown" comfort with big-city conveniences.

Liberal fringe benefit program ... company-sponsored graduate program. For additional information, or to arrange an interview, submit resume to:

**Kenneth T. Viall**  
 Manager of  
 Engineering  
 Employment



**LINK AVIATION, INC.**  
 BINGHAMTON, NEW YORK

CIRCLE 551 ON READER-SERVICE CARD

**TODAY'S TEMPERATURE:**



**IN PHOENIX!**

*...where Motorola offers a high degree of opportunity!*

Phoenix has just 2 seasons: spring and summer. Right now it's spring in Phoenix, with warm, dry, sunny days . . . and crisp, clear nights just cool enough for restful sleep.

Find out more about the outstanding professional opportunity that awaits you in this healthful land of sunshine. Why not work where it's fun to live?



*If you are qualified for one of these positions, write, wire or phone Motorola in Phoenix today!*

**ELECTRONIC ENGINEERS,  
 MECHANICAL ENGINEERS, PHYSICISTS**

System Analysis, Design and Test  
 Radar Communications  
 Navigation Missile Guidance  
 Data Processing and Display  
 Circuit Design, Development and Packaging  
 Microwave Digital and Analog  
 R-F and I-F Transistor  
 Pulse and Video Servos  
 Technical and Specification Writing  
 Printed and Etched Circuitry

Write:  
 Mr. Kel Rowan  
 Western Military Electronics Center  
 Motorola, Inc., Dept. B-18  
 8201 E. McDowell Road  
 Phoenix, Arizona

*Engineering positions also available at Motorola, Inc. in Chicago, Illinois, and Riverside, California.*



**MOTOROLA, INC.**



CIRCLE 552 ON READER-SERVICE CARD



## Sylvania Offers Exceptional Engineers

### NEW PROJECTS, PHYSICAL EXPANSION... PLUS 3 VITAL INGREDIENTS

#### **1st** — work to match your ability

(We're not chest thumpers at Sylvania. But if you're abreast of the latest in the state of the art, you're aware of what's doing — and what's coming — at the Waltham Laboratories.)

#### **2nd** — a chance to exercise individual abilities

(Ask your friends who are already with Sylvania if it's only talk that a man gets ahead at Waltham just as far and as fast as his own abilities take him.)

#### **3rd** — a healthy corporate growth

(Sylvania has never mushroomed uncontrollably — as a result we have never had to cut back drastically either.  $d\$/dt$  has steadily and healthily increased ever since 1909.)

If you're looking for hard work (we make no bones about this) and meaningful reward with a feet-on-the-ground, growing organization, contact Sylvania Waltham today.

#### **SR TRANSISTOR ENGINEERS**

Circuitry, systems, hardware.

#### **SR MECHANICAL ENGINEERS**

Design & packaging airborne & ground electronic & electromechanical equipment. 5-10 years' pertinent experience required.

#### **SR COMPUTER ENGINEERS**

Transistorized digital design, magnetic core memory & input-output systems. Experience required in digital computation & data processing, prototype design, systems evaluation & testing.

#### **SR MICROWAVE ENGINEER**

Development of crystal mixers, detectors, filters, transmission line couplers, harmonic generators & special transmission circuits.

#### **SR SYSTEMS ENGINEERS**

New systems techniques & applications.

#### **MISSILE SYSTEM DEVELOPMENT GROUP LEADERS**

Low noise receivers, pulse transmitters, broad band techniques, antenna arrays, phase measurement & other instrumentation.

#### **MISSILE SYSTEM ANALYSIS GROUP LEADERS**

Radar & antenna system preliminary design.

.....  
Send your resume to  
**GRAYDON A. THAYER**  
(your confidence will be respected)  
.....

WALTHAM LABORATORIES

**ELECTRONIC SYSTEMS DIVISION**

**SYLVANIA**

SYLVANIA ELECTRIC PRODUCTS INC.

100 FIRST AVENUE — WALTHAM, MASSACHUSETTS

# THE BIRTH OF RADAR

According to an old Croatian fable, the first experimental radar station was installed 102,000 years ago last Thursday by a tribe of Cro-Magnons. But no sooner had the station been erected than a dinosaur appeared on the scene and gulped down everyone in sight—everyone but one badly frightened survivor.

"Tell the truth, man," the dinosaur said, "or I'll make Filet Cro-Magnon out of you. What is this mess of bones

and stones you have here?"

"Ra-ra-radar," was the weak reply.

"Tell me another one," the dinosaur snorted. "If this is radar, I'm a ring-tailed brontosaurus. Does it use Bomac tubes?\*"

"No . . . but . . ."

"That does it," the dinosaur said. "Whoever heard of a radar set without Bomac tubes?" He opened his mouth wide.

"Whoever heard of a talking dinosaur?" the man asked. But he was too far inside the dinosaur to hear the answer.

No. 1 of a series . . . BOMAC LOOKS AT RADAR THROUGH THE AGES

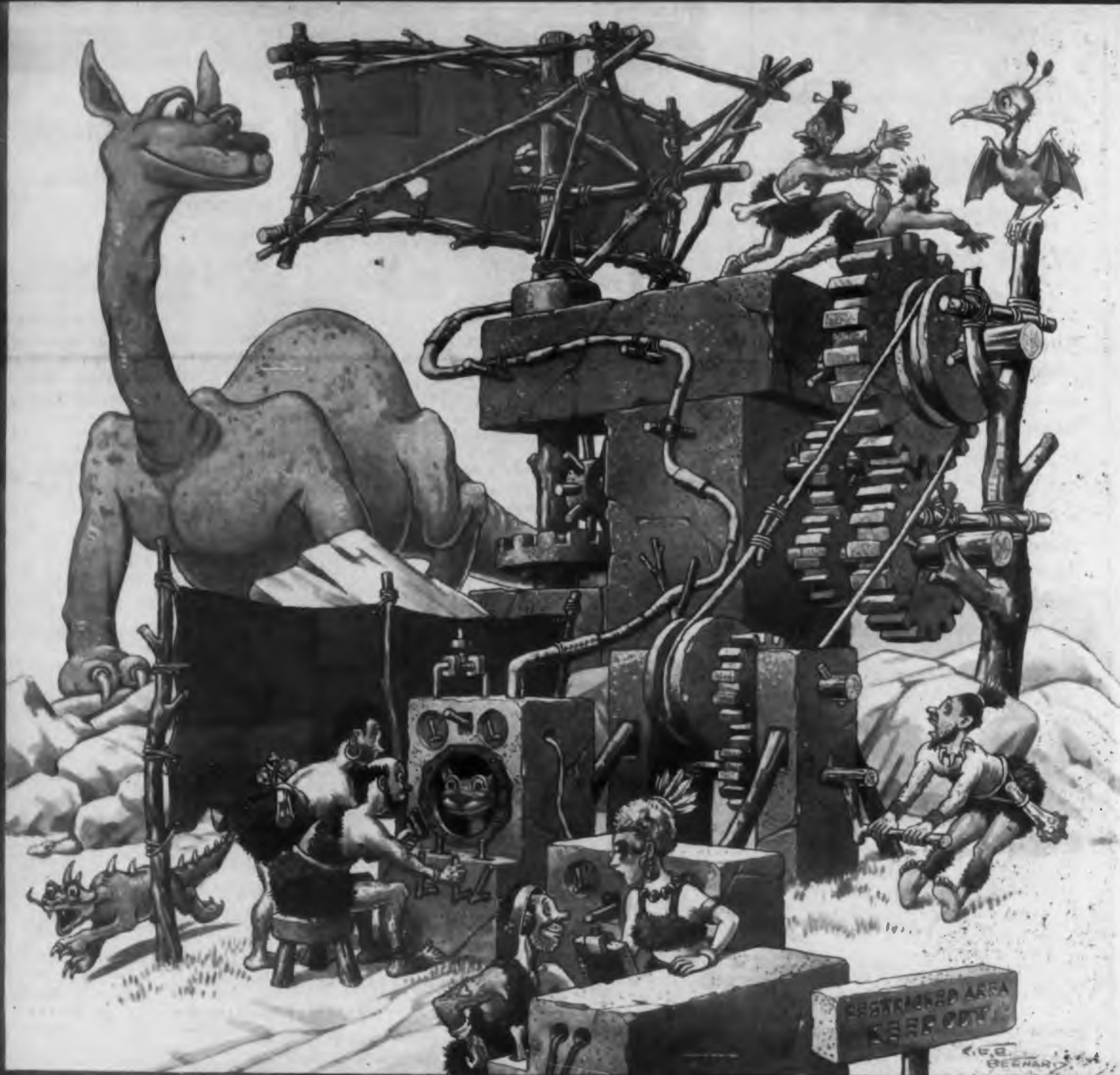

\* Bomac makes the finest microwave tubes and components since the birth of radar

**Bomac** LABORATORIES, INC.



Leaders in the design, development and manufacture of TR, ATR, Pre-TR tubes; shutters; reference cavities; hydrogen thyratrons; silicon diodes; magnetrons; klystrons; duplexers; pressurizing windows; noise source tubes; high frequency triode oscillators; surge protectors.

Offices in major cities—Chicago • Kansas City • Los Angeles • Dallas • Dayton • Washington • Seattle • San Francisco • Toronto • Export: Maurice I. Parisier, 1860 Broadway, New York City.

## ADVERTISING INDEX

February 5, 1958

Advertiser	Page
AMP, Inc.	99
Ace Plastic Co.	78
Acheson Colloids Co.	19
Advance Stamping	48
Aero Research Instrument Co.	78
Allied Control Co.	9
Allied Radio Co.	80
American Plastics Corp.	101
Amersil Co., Inc., Div. of Englehard Industries	15
Arnoux Corp.	32
Art Wire & Stamping Co.	89
Astron Corp.	85
Avnet	95
Barber Coleman Co.	62, 63
Barker & Williamson, Inc.	66
Bendix Aviation Corp., Eclipse Pioneer Div.	72
Bendix Aviation Corp., Freiz Div.	70
Bendix Aviation Corp., Red Bank Div.	58
Bentley, Harris Mfg. Co.	87
Birtcher Corp.	82
Bomac Laboratories, Inc.	106
Bud Radio, Inc.	29
Canoga Corp.	69
Carpenter Steel Co.	96
Centralab Div. of Globe Union, Inc.	50
Century Electronics & Instruments, Inc.	71
Cherry Electrical Products	78, 80
Chicago Telephone Supply Corp.	60
Circuit Instruments, Inc.	84
Clevite Transistor Products	11
Cohn, Sigmund Mfg. Co., Inc.	100
Connecticut Hard Rubber Co., The	94
Cornell Dubilier Electric Corp.	25
Daven Co., The	61
Delco Radio, Div. General Motors	102
Diamond Electronics Corp.	17
Dressen-Barnes Corp.	100
ESC Corp.	13, 57
ETA Products Co. of America	87
Eckel Valve Co.	98
Edison, Thomas A., Instrument Div.	24
Electro-Instruments, Inc.	77
Electro Tec Corp.	67
Electronic Research Associates, Inc.	103
Englehard Industries, Inc. Baker Platinum Div.	16
Englehard Industries, Inc.	14
Faber-Castell, A. W., Inc.	81
G-V Controls	3
General Controls Co., Production Inst. Div.	69
General Devices	37
General Electric Co., Electronic Equipment Sales	8, 46
General Electric Co., Laminated Products Dept.	93
General Electric Co., Metallurgical Products	40
General Radio	79
General Transistor Corp.	64
Good-All Electric Mfg. Co.	49
Graphite Metallizing Corp.	73
Grip Nut Co.	80
Culton Industries	65
Hassall, John, Inc.	36
Heinemann Electric Co.	18
Hewlett-Packard Co.	23
Hoffman Semi-Conductor Div.	51
Hughes Aircraft Co.	19
Industrial Instruments, Inc.	63
International Business Machines Corp.	104
International Nickel Co., Inc.	35

← CIRCLE 215 ON READER-SERVICE CARD



for the **HIGHEST** in **RELIABILITY**

**UTC** products are the most copied in the world. This is only natural, since we maintain the largest laboratories and engineering staff in our field. However, copying alone cannot provide the measure of uniformity and reliability inherent in UTC units. To provide for the maximum in quality and reliability, continuing programs of quality control and quality improvement are constantly maintained in our laboratories.

**WHAT MAKES A TRANSFORMER FAIL?**  
 Illustrated are a few views of the UTC Reliability Laboratory in action... finding the answers.



Turns tested of standard assemblies



Examine terminals on through hole



Chemical section analyzing new materials



Heat proof hydrogen testing



Test tests under extremes of load, heat, and altitude



Measure and control tests on circuit parts



Print plant for all manufacturing material

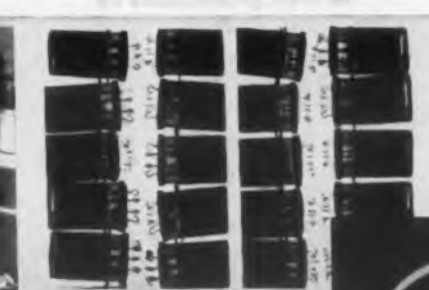

Work on components

Work on components

**IS THIS PROVEN RELIABILITY AND UNIFORMITY IN THE COMPONENTS OF YOUR EQUIPMENT?**

**A large aircraft company...** "Our vendor analysis for past year (thousands of tests) shows zero rejects."

**A large electric company...** "Consistent quality has placed you as our #1 source... are grateful for the aid you have given our own quality control staff."

**A large military electronics company...** "Switching from former vendor to UTC has saved us 18% of transformer and filter cost by reducing manufacturing costs."

**A large instrumentation company...** "We haven't had one field failure in fifteen years' use of UTC parts\*."

\*Over 100,000 units.

*United Transformer Corp.*  
 150 VARICK STREET • NEW YORK 13, N. Y.

Advertiser	Page
Adco Electronics Co.	86
Albaron Mfg. Corp.	79
Alco Electric Co.	87
Alford Co., Inc., Little Falls Div.	68
Alster Solder Co.	101
Alton Tool	45
Alton White Instrument Co.	75
Aluminum Insulator Co., Inc.	74
Alumina Aviation, Inc.	105
Aluminum Chemical Co.	78
Aluminum Engineering Laboratories	86
Aluminum Magnetics, Inc.	34
Aluminum Magnetics, Inc.	38
Aluminum Malayan Tin Bureau	83
Aluminum Malco Tool & Mfg. Co.	58
Aluminum Marconi Instrument Co.	89
Aluminum Metals Disintegrating Co.	67
Aluminum Midland Industrial Instruments Co.	70
Aluminum Motorola, Inc.	105
Aluminum Western Military Electronics Center	91
Aluminum Mullard Ltd.	91
Aluminum NJE Corp.	55
Aluminum Oak Mfg. Co.	22
Aluminum Pacific Automation Products	47
Aluminum Pennsylvania Fluorocarbon Co.	66
Aluminum Perkin Engineering Corp.	7
Aluminum Pie Design Corp.	94
Aluminum Polorad Electronic Corp.	52, 53
Aluminum Pomona Electronics, Inc.	83
Aluminum Potter & Brumfield	42
Aluminum Radio Corp. of America	41, 108
Aluminum Radio Receptor Co.	20
Aluminum Raytheon Mfg. Co., Microwave & Power Tube	6
Aluminum Raytheon Mfg. Co., Semi-Conductor Div.	4
Aluminum Royal McBee Corp.	33
Aluminum Sage Electronics Corp.	100
Aluminum Sanborn Co.	10
Aluminum Sarkes Tarzian, Inc.	43
Aluminum Sealectro Corp.	98
Aluminum Servomechanisms, Inc.	31
Aluminum Shell Chemical Corp.	2
Aluminum Sigma Instruments, Inc.	75
Aluminum Simmers Brass Co., Inc.	62
Aluminum Southern Electronics Co.	54
Aluminum Staedtler, J. S. Inc.	18
Aluminum Stahl Bros., Inc.	39
Aluminum Standard Electrical Products Co.	74
Aluminum Stevens Arnold, Inc.	36
Aluminum Streeter-Amet Co.	79
Aluminum Stromberg Carlson Co.	71
Aluminum Superior Electric Co.	97
Aluminum Sylvania Electric Products, Waltham	105
Aluminum Sylvania Electric Products, Tungsten & Chemical Div.	12
Aluminum Technic, Inc.	68
Aluminum Technitrol Engineering Co.	73
Aluminum Therman Products, Inc.	56
Aluminum Tools Deutchman Corp.	72
Aluminum Toral, Inc.	82
Aluminum Trol Laboratories, Inc.	101
Aluminum Trol Sol Electric Co.	59
Aluminum U-1 Transformer	107
Aluminum Vaco Electronic Co.	79
Aluminum Waco Kohinoor, Inc.	21
Aluminum Waco Rock Signals, Inc.	86



# Can RCA's Preferred Tube-Types Program Give You the Same Important Benefits It Has Given Other Equipment Manufacturers for Almost Two Decades?

## Are You Taking Advantage of this Program?

Many designers and manufacturers of radio and television receivers are by designing their circuits "around" the proved-in-service tube-types on the Preferred list—gaining these big values for themselves and their products:

**Lower Costs...** concentration on the manufacture of fewer types makes possible lower tube production costs, lower warehousing and stocking expense—all of which contribute to lower prices to the equipment manufacturer.

**More Uniform Quality...** operating skills in tube manufacture are increased when production can be concentrated on fewer tube-types and longer runs—results in more uniform tube quality.

**Standardization on Fewer Components...** equipment manufacturers who use Preferred Tube-Types in their designs are able to standardize on fewer accessory parts such as transformers, capacitors, and resistors—results in purchasing, stock, and renewal economies.

**Better Tube Availability...** fewer tube-types make possible better availability and faster delivery schedules to support continuous production of radio, television, and

other electronic equipment.

By the fall of 1957, more than 1600 receiving tube-types had been announced. Yet, the major demand from equipment manufacturers is concentrated in about 100 types. Evaluating engineering data and the preferences of designers, RCA offers its current Preferred Tube-Types list of 62 types for TV and radio receiver applications.

In order to qualify for Preferred listing, a tube-type *must* meet these 4 basic requirements:

**Quality...** it must perform adequately in each function for which it is chosen.

**Versatility...** the tube's characteristics should be suitable to a wide variety of applications.

**Popularity...** it must be among the popular currently used types.

**Economy...** the tube must be adaptable to low-cost, high-quality manufacturing techniques.

*For example... take the quality of the RCA-2AF4-A and 6AF4-A. Preference of these types dictated and justified a continuing program of tube improvements. Today, the 'AF4-A types offer features unsurpassed in the industry: a special cathode that reduces slump, inter-face resistance, and grid emission*

*to provide longer effective tube life; a palladium-plated grid that performs more uniformly; a vacuum-fired plate; silver-plated pins that reduce skin effects; dynamic-life-test sampling for 1000 hrs. at 1000 Mc. Here then is preferred quality and extraordinary value.*

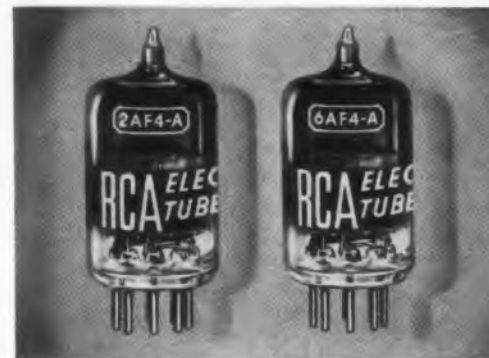

You, too, as a designer or manufacturer of radio and TV receivers for the home market, can benefit from RCA's Preferred Tube-Types Program. Your RCA Field Representative will be glad to discuss its application to your specific designs. *Before you design...* before you specify...ask your RCA Field Representative for the up-to-date list of RCA Preferred Tube-Types. Or, write RCA Commercial Engineering, Section B-18-Q-1, Harrison, N.J.

**EAST:** 744 Broad Street  
Newark 2, N. J.  
HUmboldt 5-3900

**MIDWEST:** Suite 1181  
Merchandise Mart Plaza  
Chicago 54, Ill.  
WHitehall 4-2900

**WEST:** 6355 E. Washington Blvd.  
Los Angeles 22, Calif.  
RAymond 3-8361



**RADIO CORPORATION OF AMERICA**  
Electron Tube Division  
Harrison, N. J.

HAYDEN PUBLISHING COMPANY, INC.  
19 East 62nd Street, New York 21, N. Y.

ELECTRONIC  
DESIGN

February 5, 1958