

May

BROADCAST
WRNY
STATION

25 Cents

Science and Invention

IN THIS ISSUE
"DIRIGIBLES"

By C. E. ROSENDAHL, U. S. N.

Commander of U. S. S. Los Angeles

SEA ANCHOR
FOR AIRSHIPS

See Page 14

Make Money

in a High-Class Business of Your Own



---without Competition!

You can be an exclusive NESTLER representative, and quickly build up a profitable business in Reservicing and Retreading Tires by the world's most modern and successful process.

IF you prefer to spend your life working for somebody else—if you have no ambition to “be your own boss”—do not read this advertisement.

But if you are thrilled by the idea of being an independent business man—of creating profits for yourself instead of just waiting for a pay envelope—then, no matter what your present occupation is, read every word that follows!

A Nestler representative owns his own business. There is a big demand for what he has to offer, because *nobody else* in his locality can offer it—a scientific Tire Service which saves car owners ONE-HALF their tire bills.

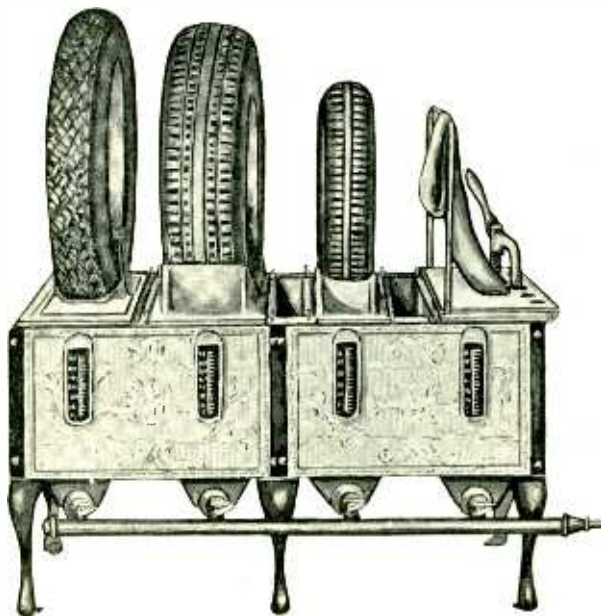

A Nestler 4-Mold Cabinet. No steam. Nestler adjustable molds can handle any size tires. The most successful vulcanizers and garages have found the Nestler Process a great advantage, because it eliminates all buffing, stripping, and cementing.

What the patented Nestler Rubber Fusing Process is

The Nestler Rubber Fusing Process is the only modern, perfect method of repairing and retreading automobile tires. It scientifically welds new rubber to old, without the slightest trace of joint, seam, or crack. A Nestlerized tire will give practically the same mileage as a new one, at ONE-HALF the cost to the owner, and at a substantial profit to the Nestler operator. There are hundreds of busy, money-making Nestler stations all over the world, with *no competition*, because the Nestler Process is fully protected by patents, and each Nestler operator has his own exclusive territory.

Previous Automobile or Tire Experience Not Required

Any red-blooded man with a very little capital can become a successful Nestler operator. Nestler Rubber Fusing equipment is built for life-time service, and the Nestler Manual, given free to every operator, makes every step in retreading tires and repairing blowouts as simple as A-B-C. Many men have started Nestlerizing tires in a garage or basement in their spare time, and have launched into a full-time business of their own after they had gotten a good start and could see bigger profits waiting to be picked up.

Send for this Amazing New Book "The Nestler Plan" --- It's FREE

How tires are Nestlerized—what Nestler equipment consists of—how to get customers—how the Nestler method will make money for YOU right from the start—everything you want to know about Nestler Tire Servicing as a full-time or spare-time business is fully explained and illustrated with photographs in a vitally interesting book, “The Nestler Plan.” Send coupon below for a Free Copy TODAY. And if you are in New York City, call at Nestler headquarters and ask for a free demonstration of the Nestler Process.

Mail This Coupon TODAY!

NESTLER RUBBER FUSING CO., INC., Dept. 25
245 West 55th Street, New York, N. Y.

Without obligation on my part, send me your book, “The Nestler Plan.”

Name

Address

City State

3 Drafting Lessons

Actually free!



to prove you can learn at Home, in spare time!

We have developed a new simplified, rapid way to teach Drafting, and we want to send you three sample lessons *without cost or obligation*. So you can test your own ability to master this fascinating work at home, in your spare time. And see for yourself how quickly and easily you can qualify for a fine, well-paid Drafting position.

Home-training backed with an agreement to get you a DRAFTING JOB at a 50% RAISE —or money refunded

Here is a word-for-word copy of the Contract which we have made with 30,000 men in the past three years. I shall be glad to make the same agreement, backed by our entire resources of \$1,500,000.00 — with YOU!

\$50 to \$125 a week paid to EXPERT DRAFTSMEN

Pick up the want ads of any big-city newspaper and you'll see why we urge men to go into Drafting. 70,000 fine positions advertised in the past year. Draftsmen are urgently needed in Building Construction, Manufacturing, in the Architectural, Mechanical, Electrical, Structural and Automotive industries. Get in touch with me, and I'll tell you how you can get one of these fine jobs.

American School

Guarantee of Position and Increased Pay

To _____

1. WE GUARANTEE to find you a satisfactory position within 60 days after you finish our complete course of home training in Drafting;
- And, further,
2. WE GUARANTEE that said position will pay you a salary of at least 50% more than you are earning today, provided your present salary is less than \$40 per week;

OR FAILING TO DO SO, we guarantee to refund to you immediately the entire amount that you have paid for this training.

O. C. Miller
Director Extension Work

Come Into Drafting!

The ability to read blue-prints and draw plans is the entering wedge to success in all building and manufacturing lines. Learn Drafting and you'll be "sitting pretty." It's INTERESTING work and Draftsmen are a wonderful bunch of fellows. You're bound to enjoy the good-natured atmosphere of a Drafting office and the contact it gives you with important activities and BIG MEN.



The American School

Chartered 30 years ago as an EDUCATIONAL INSTITUTION, and, like the best resident schools and colleges, conducted NOT FOR PROFIT. We offer complete, thorough, up-to-date instruction—prepared by 200 leading Engineers, Executives and Educators. A unique instruction, built to meet the specifications of well-paid jobs as laid down by employers themselves—yet simplified for ready understanding by men with only common schooling.

And we are the first in the home-study field to recognize the need of giving a COMPLETE SERVICE to ambitious men—training plus employment. Which takes you as you are, supplies the equipment you lack, and lands you in the better job you seek. Without risk to you!

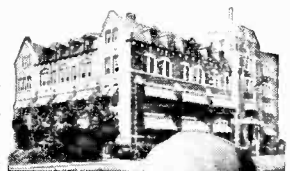

O. C. MILLER
Director Extension Work

This agreement proves our training does make real Draftsmen. It proves that after you finish, there are well-paid jobs available. And you can prepare yourself without losing a day's pay or time, without quitting your job or leaving home!

O. C. MILLER, Director, Extension Work, The American School
Dept. D-526 Drexel Ave. & 58th St., Chicago
I am interested to get particulars of your Job and Raise Guarantee. Also send 3 Drafting Lessons without cost or obligation.

Name _____
Address _____
Age _____ Occupation _____

The American School
Dept. D-526 Drexel Avenue and 58th Street, Chicago

Science and Invention

Formerly **ELECTRICAL EXPERIMENTER**
COMBINED WITH "THE EXPERIMENTER"

EDITORIAL, ADVERTISING AND GENERAL OFFICES:
230 Fifth Avenue, New York City

Published by Experimenter Publishing Company, Inc. (R. Gernsback, Pres.;
S. Gernsback, Vice-Pres. and Treas.; C. E. Rosenfeld, Sec'y.)

Publishers of **SCIENCE AND INVENTION, RADIO NEWS, RADIO LISTENERS' GUIDE, AMAZING STORIES** and **FRENCH HUMOR**

Vol. XVI
Whole No.
181

MAY
1928
No. 1

Editorial Staff

HUGO GERNSBACK, *Editor-in-Chief.*
H. WINFIELD SECOR, *Managing Editor.*
T. O'CONNOR SLOANE, Ph. D.,
Associate Editor.
JOSEPH H. KRAUS, *Field Editor.*
PAUL WELKER, *Radio Editor.*
S. GERNSBACK, *Wrinkles Editor.*
W. J. ROMAINE, *Art Director.*

Contributing Editors

Astronomy—
Dr. Donald H. Menzel, Ph.D., Lick Observatory;
W. J. Lanyon, of the Harvard College Observatory.
Entomology and Allied Subjects—
Dr. Ernest Bade, Ph.D.
Physics—
Dr. Harold F. Richards, Ph.D., Ernest K. Chapin,
M.A., Dr. Donald H. Menzel, Ph.D.
Chemistry—
Raymond B. Waites, Dr. Ernest Bade, Ph.D.
Automotive Subjects—
George A. Luers
Radio—
A. P. Peck, Herbert Hayden.
Magic and Psychic Phenomena—
Joseph Dunninger, Joseph F. Rinn, Edward Merlin.
Foreign Correspondents—
Dr. Alfred Gradenwitz, Germany; Dr. H. Becher,
Germany; C. A. Oldroyd, England; S. Leonard Bas-
tin, England; Count A. N. Mirzoeff, France; Hubert
Slonka, Czechoslovakia; P. C. van Petegem, Hol-
land; Richard Neumann, Austria.

IN JUNE ISSUE

Giant Lizards

Most everyone has seen at sometime or other small lizards, but when it comes to giant lizards, but little is known about them by the general public. Don't miss this remarkable illustrated article.

Spiritualists Exposed

Extremely interesting, illustrated article showing how spiritualists were exposed in Germany.

New Helicopters

Two of the latest designs of vertically rising aircraft operating on the helicopter principle, will be described and illustrated.

Do Animals Think?

Mr. Raymond L. Ditmars, famous expert on animal life, answers the question.

Garden Sprays

Details of how to make and use them.

CONTENTS OF THIS NUMBER

GENERAL SCIENCE

Editorial—A Coming Discovery.....	9
By Hugo Gernsback	
Earthquakes Predicted Hours in Advance.....	10
By James Nevin Miller	
Speeding Up Ocean Travel.....	12
Inventions Wanted?.....	13
Dirigibles.....	14
By Lt. Com. C. E. Rosendahl, U. S. N.	
Controlling Household Pests.....	16
By Dr. Ernest Bade, Ph.D.	
Engine-less Plane Driven by Liquid Air.....	18
By Augustus Post, Famous Aeronaut	
Scientific Progress.....	20
Springtime Garden Suggestions.....	22
Advances in Travel.....	23
The Month's Scientific News Illustrated.....	24
By George W. All	
Wonders of Nature.....	25
Science Frauds Exposed by Uncle Sam.....	26
By K. M. Painter	
New Ideas Exhibited at N. Y. Auto Show.....	28
By H. Winfield Secor	
The Metal Emperor—8th Installment.....	32
By A. Merritt	
Magic—A Monthly Feature.....	34
By Dunninger	
Electricity Helps the Showman.....	36
Can You Answer These Scientific Questions?.....	37
Drawing Table and Utility Cabinet Are Easy to Build.....	38
By Edwin M. Love	
Readers' Forum.....	49
Scientific Humor.....	53
Latest Patents.....	59
The Oracle.....	60
Patent Advice.....	72

CHEMISTRY

Experimental Chemistry and Electrics.....	42
Everyday Chemistry.....	44
By Raymond B. Waites	

RADIO

Croydon Airplane Radio.....	51
Broadcast Programs Now Available to Many Hotel Guests.....	52
New Radio Devices.....	54
Making "Flivver" Cone Unit.....	55
Freak Aerials.....	56
Radio Oracle.....	57

ASTRONOMY

Lifting the Veil of Venus.....	31
By Donald P. Beard	
A Home-Made Reflecting Telescope—Part 2.....	46
By William H. Christie	

AUTOMOTIVE

Advances in Travel.....	23
New Ideas Exhibited at the Auto Show.....	28
Motor Hints.....	35

HOW-TO-MAKE-IT

Drawing Table and Utility Cabinet Are Easy to Build.....	38
Model Department—Monthly Silver Cup Award.....	40
Making a Portable Arc Lamp.....	43
How to Make a Photo Printer.....	45
A Home-Made Reflecting Telescope—Part 2.....	46
How-to-Make-It Department.....	48
Wrinkles, Recipes and Formulas.....	50

AERONAUTICS

Dirigibles.....	14
By Lt. Com. C. E. Rosendahl, U. S. N.	
Engine-less Plane Driven by Liquid Air.....	18
By Augustus Post	

HOW TO SUBSCRIBE FOR "SCIENCE AND INVENTION." Send your name, address and remittance to Experimenter Publishing Co., 230 Fifth Ave., New York City. Checks and money orders should be made payable to Experimenter Publishing Co., Inc. Mention magazine desired, inasmuch as we also publish RADIO NEWS, AMAZING STORIES, RADIO LISTENERS' GUIDE, and FRENCH HUMOR, a weekly. Subscriptions may be made in combination with the other publications just mentioned at special reduced club rates. Send postal for club rate card. Subscriptions start with the current issue unless otherwise ordered. ON EXPIRATION of your subscription we enclose a renewal blank in our last number to you, and notify you by mail. Then, unless we receive your order and remittance of a renewal, delivery of the magazine is stopped.

SCIENCE AND INVENTION is published on the 10th of each month. There are 12 numbers per year. Subscription price is \$2.50 a year in U. S. and possessions, Canada and foreign countries, \$3.00 a year. U. S. coin as well as U. S. stamps accepted (no foreign coin or stamps). Single copies, 25c each. All communications and contributions to this journal should be addressed to Editor, SCIENCE AND INVENTION, 230 Fifth Ave., New York City, N. Y. Unaccepted contributions cannot be returned unless full postage has been included. ALL accepted contributions are paid for on publication. SCIENCE AND INVENTION Monthly. Entered as second-class matter May 10, 1921, at the P. S. Office at New York, N. Y., under the act of March 3, 1879. Additional entry at Dunellen, N. J., and San Francisco, Calif. Title Registered at the Patent Office. Copyright, 1928, by E. P. Co., Inc., New York. The Contents of this Magazine are copyrighted and must not be reproduced without giving full credit to the publication. SCIENCE AND INVENTION is for sale at all newsstands in the United States and Canada. European Agents, S. J. Wise Et Cie, 40, Place Verte, Antwerp, Belgium.

ADVERTISING REPRESENTATIVES—L. F. McCLURE, 720 Cass St., Chicago, Ill.; DAVIES & DILLON, 15 West 10th St., Kansas City, Mo.; HARRY E. HYDE, 518 Drexel Bldg., Philadelphia, Pa.; A. J. NORRIS HILL CO., 5 Third St., San Francisco, Calif.; 412 West 6th St., Los Angeles, Calif.; Leary Bldg., Seattle, Wash.

A HANDY RULE FOR YOU

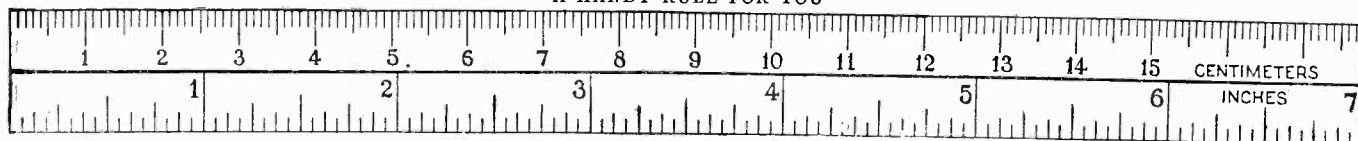



**EVEREADY
COLUMBIA
Dry Batteries**
-they last longer

When you fix the doorbell

WHEN you fix your own or somebody else's doorbell or buzzer, put in Eveready Columbia Dry Batteries. They are the ones that last longer and, by their reliability, protect the operation of the things they operate. Electrical engineers, graduates of the big technical schools, know and use and recommend

them. Big business houses that count the pennies, buy them. Take a leaf from the experience of the engineers and the business-men and you'll be protecting your own reputation as a fixer. Buy Eveready Columbias.

NATIONAL CARBON CO., INC.
New York  San Francisco
Unit of Union Carbide and Carbon Corporation

FOR RADIO: The only way we can beat the Eveready Columbia is to make a special cell for one specific use. That's what we have done in the Eveready Dry Cell Radio "A," No. 7111. Made specifically for use on radio sets using dry cell tubes, and superior in that service.



It Gets My Goat



It gets my goat to see fellows slaving at jobs they don't like for \$20 or \$25 a week. I've got a real message for them—a straight-from-the-shoulder talk. I am sincere. I mean what I say.

Put yourself in *my* hands.

I will show you the WAY.

I am a specialist. I have studied your problems for years.

I have been successful. Thousands of men have put themselves in my hands and WON!

They WON—You can too!

Electricity is the field for you to get in. Coyne Electrical School is the place for you to get the electrical training that will enable you to win.

I will show you how to earn more money.

I will show you the way to power—to a position of responsibility.

I will show you the way to become a big influential man in your community.

I will show you how to gain your own self-respect.

I will show you how to improve yourself generally—how to have more time and money to devote to the things you really enjoy.

I will show you how to care better for those you love—for HER, your wife or your sweetheart or your mother.

I can show you these things as I have shown them to thousands of other men. *Electricity points the way.* Coyne training is the key that opens the way.

I train you in 12 short weeks. Not by correspondence. You come here and work on the actual equipment.

I train you in *all* branches of electricity. When you finish your training you are ready to step into jobs paying \$50, \$60 a week and up, or you can open a shop of your own and become independent.

My employment bureau is at your service for a lifetime. You can earn while you learn. We help many students to secure jobs to earn a good part of their expenses while learning.

Coyne Electrical School is nearly 30 years old. Chicago is the electrical center of the world. Coyne is endorsed by big electrical concerns. The opportunities are unlimited.

I have a 56-page book which covers all the details. I want to send it to you free, and it tells you why I am making a special half-price tuition offer with Free railroad fare to Chicago.

Two types of men will read this advertisement. One of them will be willing to admit that I may have the solution to his biggest problems. He'll investigate further. He'll send for this free book. The other will just turn the page. Perhaps in twenty years he'll find himself still sticking to the same old job.

Why risk losing out? Send the coupon NOW!

Which type are you?!!

Are you going to turn the page—or will you mail the coupon NOW?

My Course Includes Training In
Airplane - Electricity

Not a Correspondence School

COYNE Electrical School

H. C. LEWIS, Pres. Dept. 58-83

500 S. Paulina St., Chicago

Not a Correspondence School but An Institution To Which You Come for Practical Training on Real Electrical Machinery

Send for Free Book

Mr. H. C. Lewis, Pres.,
COYNE ELECTRICAL SCHOOL, Dept. 58-83
500 So. Paulina Street, Chicago, Ill.

Dear Mr. Lewis: Without obligation send me your big free catalog and all details of Free Employment Service, Radio and Automotive Electrical Courses that are included and how many "earn while learning." I understand I will not be bothered by any salesman.

Name.....

Address.....

City..... State.....

Chemistry paves the road to Success!

Some people measure success in terms of money and others in degree of knowledge and culture. Chemistry is the one uncrowded profession today that offers both. America, always a land of amazing opportunities, is especially so now in the field of applied Chemistry. Industries have developed within eight years more rapidly than the output of trained men to conduct them. Every big industry needs chemists and there is a real demand for them immediately.

Earn a Bigger Salary from now on

Good Chemists Command High Salaries

Not only are there boundless opportunities for amassing wealth in Chemistry, but the profession affords congenial employment at good salaries to hundreds of thousands who merely follow out its present applications. These applications are innumerable, touching intimately every business and every product in the world. The work of the chemist can hardly be called work at all. It is the keenest and most enjoyable kind of pleasure. The days in a chemical laboratory are filled with thrilling and delightful experimentation, with the alluring prospect of a discovery that may spell Fortune always at hand to spur your enthusiasm.

You can make yourself independent for life by unearthing one of Chemistry's undiscovered secrets

Do you remember how the tales of pirate gold used to fire your imagination and make you want to sail the uncharted seas in search of treasure and adventure? And then you would regret that such things were no longer done. But that is a mistake. They *are* done—today and every day—not on desert islands, but in the chemical laboratories throughout your own country. Quietly, systematically, the chemist works. His work is difficult, but more adventurous than the blood-curdling deeds of the Spanish Main. Instead of meeting an early and violent death on some forgotten shore, he gathers wealth and honor through his valuable contributions to humanity. Alfred Nobel, the Swedish chemist who invented dynamite, made so many millions that the income alone from his bequests provides five \$40,000 prizes every year for the advancement of science and peace. Herman Frasch, who showed how to extract sulphur, built up a huge fortune. C. M. Hall, the chemist who discovered how to manufacture aluminum, made millions through this discovery. F. G. Cottrell, who devised a valuable process for recovering the waste from blue gases, James Gayley, who showed how to save enormous losses in steel manufacture, L. H. Bakeland, who invented Bakelite—these are only a few of the men to whom fortunes have come through their chemical achievements.

YOU CAN LEARN AT HOME

To qualify for this remarkable calling requires specialized training. Formerly it was necessary to attend a university for several years to acquire that training, but thanks to our highly perfected and thorough system of instruction, you can now stay at home, keep your position, and let us educate you in Chemistry during your spare time. Even with only common schooling you can take our course and equip yourself for immediate practical work in a chemical laboratory.

EASY MONTHLY PAYMENTS

You don't have to have even the small price of the course to start. You can pay for it in small monthly amounts—so small that you won't feel them. The cost of the course is very low, and includes everything, even the chemistry outfit—there are no extras to buy with our course. Our plan of monthly payments places a chemical education within the reach of everyone.

MAIL THE COUPON FOR FREE BOOK

Your name and address on the coupon will bring you by return mail our interesting free book, "OPPORTUNITIES FOR CHEMISTS," and full particulars about the course and what it will do for you. You owe it to yourself to get this book. Send the coupon right now while it is fresh in your mind. Or just write your name and address on a postal and mail to us. But whatever you do, act today.

SEIZE THIS OPPORTUNITY—MAIL COUPON NOW!

Chemical Institute of New York, Inc.

Home Extension Division 5

16-18-S-East 30th Street

New York, N. Y.

Our Course
Will Fit You
For a Position
of Authority

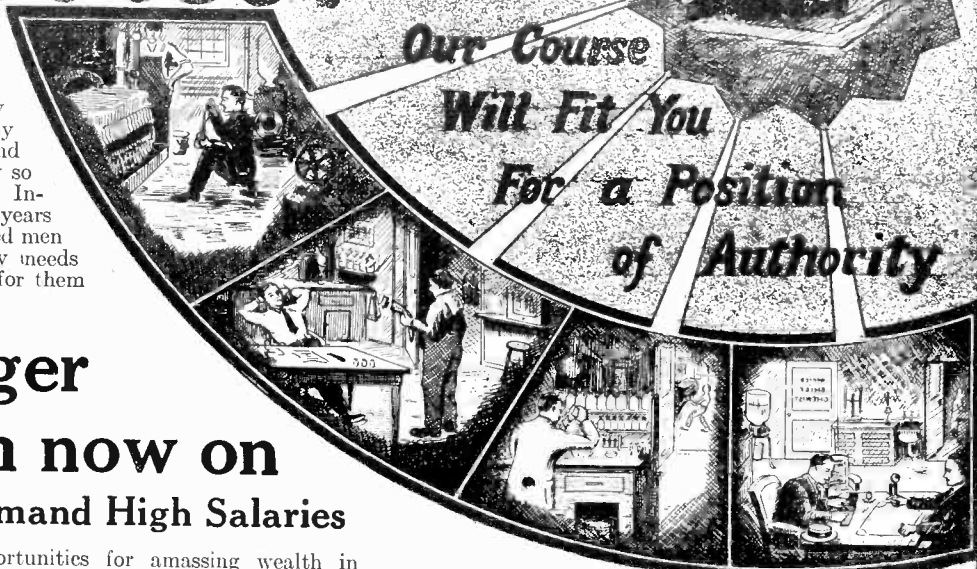

Just a Few Letters From Students Who Have Taken This Course

You will probably be pleased to learn one of the lessons from my course to turn my chemical knowledge to profitable account. I am now making a varnish and paint which undersells the other type products by \$2.60 a gallon, in some cases more. I have been receiving gallon orders from painters during past week which has netted me a profit of \$12.50 for my "spare-time chemical industry." Many thanks for your training thus far.

J. J. KELLY

I am but half-way through your course and am certain that I have saved my Company many times the cost of the course and raised myself in the shareholders' estimation. The knowledge obtained has its immediate practical application and I do not hesitate in saying your course and the personal attention you give is invaluable to the practical man in any business where chemistry plays a part. You may use this letter and my name and address to the furtherance of your good work.

JOHN WALTER

I have not written since I received the big set. I can still say that it far exceeded my anticipations. Since I have been studying with your school I have been appointed chemist for the Scranton Coal Co., testing all the coal and ash by proximate analysis. The lessons are helping me wonderfully, and the interesting way in which they are written makes me wait patiently for each lesson.

MORLAIS COUZENS



T. O'CONNOR SLOANE,
A.B., A.M., LL.D., Ph.D.

Noted Instructor, Lecturer and Author. Formerly Treasurer American Chemical Society and a practical chemist with many well-known achievements to his credit. Not only has Dr. Sloane taught chemistry for years but he was for many years engaged in commercial chemistry work.

EXPERIMENTAL EQUIPMENT FURNISHED TO EVERY STUDENT

We give to every student, without additional charge, his chemical equipment, including fifty-two pieces of laboratory apparatus and supplies, and fifty-two different chemicals and reagents. These comprise the apparatus and chemicals used for the experimental work of the course. The fitted heavy wooden box serves not only as a case for the outfit, but also as a useful laboratory accessory for performing countless experiments.

CHEMICAL INSTITUTE OF NEW YORK, INC.
Home Extension Division 5
16-18-S-East 30th Street, New York, N. Y.

Please send me at once, without any obligation on my part, your free book, "Opportunities for Chemists," and full particulars about the Experimental Equipment given to every student. Also please tell me about your plan of payment.

NAME
ADDRESS
CITY STATE
S-1-5-28

As Red's body heaved against the table his right hand darted to his holster

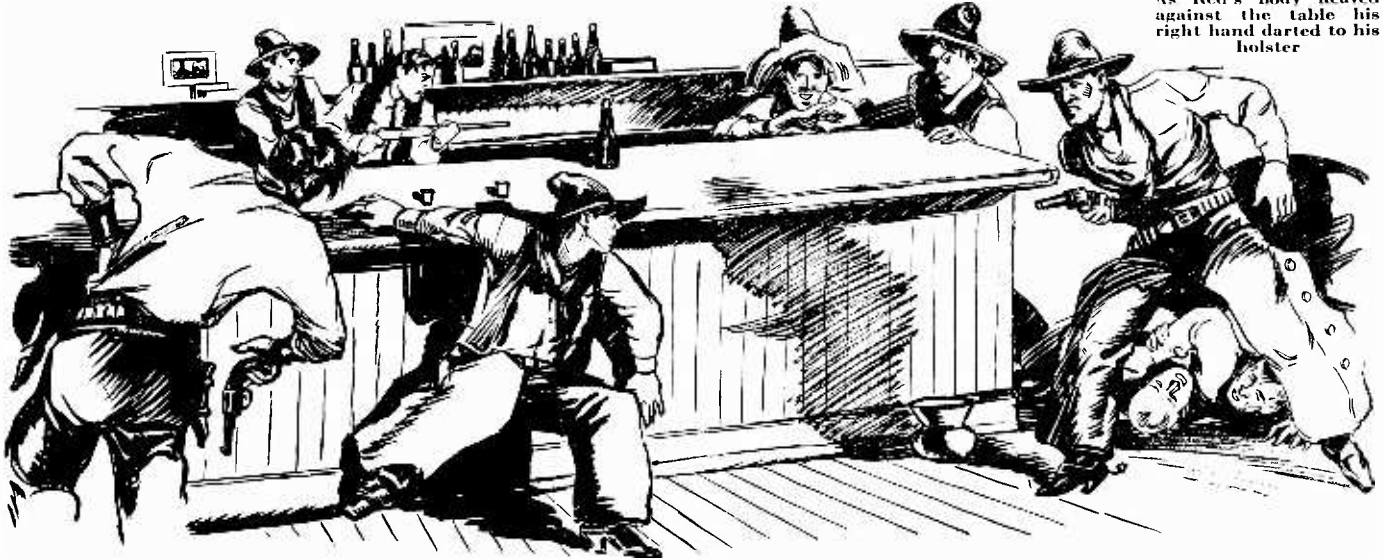

PAINT HORSE RANGE

"Red" was as quiet a cow-puncher as you'd ever want to see, but he never backed away from trouble. So when he learned that a big cattle syndicate was planning to steal Paint Horse Range, he buckled on his six-guns and dared 'em to go ahead

By G. W. BARRINGTON

in the MAY issue of

Fawcett's Triple-X Western Magazine

PRICE
25c

MAY ISSUE
NOW ON
SALE

TRIPLE-X has won the favor of thousands of readers by the accuracy, vividness, and high-speed action of its western stories. In no other magazine of its type can readers thrill to such remarkable feats of horsemanship, exciting cap-

tures, smoking six-guns, desperate battles as portrayed each month in **Triple-X**. **Paint Horse Range** is only one of several top-notch western tales that will win your approval.

Two Great War Stories in the May Issue:

THE PARSON'S WINGS

By RAOUL WHITFIELD

A colorful, nerve-tingling air story by a Yank flyer in the World War.

THE SIX-GUN PACKER

By J. J. KALEX

What happened when a rough-riding, dare-devil, cowboy decided to mop up a German trench in six-gun fashion!

Use
coupon
if your
dealer
is sold
out

TRIPLE-X MAGAZINE (M.Sc.&Inv.)
Fawcett Publications, Inc.
Robbinsdale, Minn.

Inclosed find \$1 (bill or stamps), for which send me Triple-X for the next five months. Or, inclosed, find 25c for copy of the May number.

Name.....

Address.....

City..... State.....

Amazing New Ground Antenna

Gets Everything— Reduces Static

Brings in Faraway Stations Loud and Clear Regardless of Static Conditions

Fans everywhere are replacing their troublesome and static gathering up-in-the-air aerials with the marvelous new GROUND ANTENNA—Aer-O-Liminator. Radio engineers and hundreds of users testify that Aer-O-Liminator gets better long distance reception, almost unbelievable freedom from outside noises, far greater selectivity and marvelously true, clear, sweet tone quality.

John E. Christenson, RADIO ENGINEER, CHICAGO, writes: "I have tested and thoroughly approve the Aer-O-Liminator. I find it increases selectivity and volume without distortion, practically eliminates static, gives good clear tones, both on local and distant stations. I would recommend the use of the Aer-O-Liminator to every radio owner to get the best reception from his set."

FREE TRIAL

Make this thrilling test at our risk!

Install an Aer-O-Liminator (Ground Antenna). Leave your old overhead aerial up. Try out on a night when static is bad. If you do not get a wonderful improvement in reduction from static, greater selectivity and clear, sweet tone without interfering noises, if you can't get good reception on stations that are drowned out by static on your old aerial, you need not pay us a red cent for this test. Send coupon at once for scientific explanation of Aer-O-Liminator (Ground Antenna), proof of performance, and our conclusive iron-bound guarantee, and remarkable Free Trial Offer—Mail Coupon TODAY!

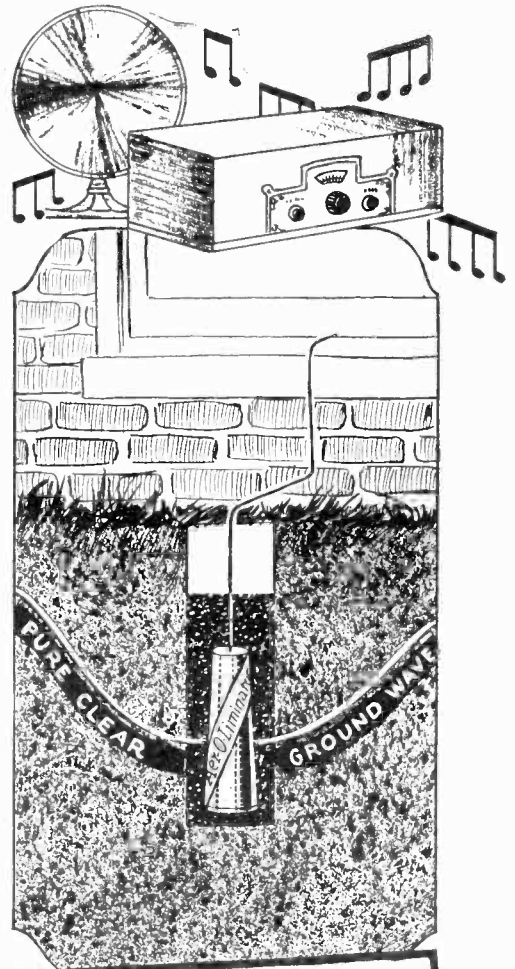

EASY TO INSTALL

Just dig a small hole about 6 inches in diameter and drop Aer-O-Liminator into it.

Aer-O-Liminator (Ground Antenna)

*Endorsed by Foremost
Engineers and Dealers*

CURTAN MFG. COMPANY

Dept. 863-G, 154 East Erie Street, Chicago, Ill.



CURTAN MFG. COMPANY
154 East Erie St., Dept. 863-G, Chicago, Ill.
Please send me at once complete description of Aer-O-Liminator, with details of guarantee. Scientific proof and Free Trial Offer.

Name.....
Address.....
City.....
State.....

Use
this
coupon

Volume XVI
Whole No. 181

Science and Invention

May, 1928
No. 1

HUGO GERNSBACK, *Editor-in-Chief*
H. WINFIELD SECOR, *Managing Editor*
DR. T. O'CONNOR SLOANE, PH.D., *Associate Editor*

Editorial and General Offices 230 Fifth Avenue, New York

"Those Who Refuse to Go Beyond Fact Rarely Get as Far as Fact" HUXLEY

A COMING DISCOVERY

By HUGO GERNSBACK

IT is a rare occurrence when a man, in any branch of science to-day, can announce to the world that within an appreciable time he will make a great discovery, as an explorer, for instance, might set forth to discover the North Pole or to be the first to set foot on top of the Himalayas. In either case, however, he can predict with certainty the result should he succeed. This, however, is comparatively tame, because neither the North Pole nor the top of the Himalayas is unknown; both are very well known.

If, however, a scientist should announce that he would, at a certain predetermined time, discover, let us say, a new gas or a new metal that was as yet undiscovered, and give minute instructions how the discovery could be brought about, this certainly would be classed as a remarkable prediction. Yet, that also has been done in chemistry.

But the idea of predicting the discovery of an entirely unknown world, half the size of our own earth, is a large order. Indeed, it has only been done once before and has gone down in the annals of astronomy as one of the most brilliant achievements of the human mind, of all times.

In 1846, John C. Adams, a young Englishman, and Urbain Leverrier, a young Frenchman, independently announced the position of a supposedly new planet, lying outside of the orbit of Uranus. Neither astronomer worked with a telescope, but simply used celestial mathematics. Adams sent the results of his calculation to the Astronomer Royal of England. He had predicted where in the heavens the new planet should be found, but for some reason no search was made.

Not long after, Leverrier, who had also completed his calculations sent the results to Galle, the Director of the Observatory of Berlin. A search was immediately instituted and within a half an hour, the new planet was discovered very close to the position predicted by Leverrier's calculation; the new planet, which was christened Neptune, was only about 58' away from the calculated spot, a very small amount, astronomically speaking. This was on the night of September 23, 1846. The planet was easily found, because it happens to be a big celestial body having seventeen times the mass of our own earth. Neptune, up to the present day was the last and furthest away of all planets of our planetary system. Its mean distance from the sun is 2,791,600,000 miles. It is so far away from us, that it takes light, coming from it, and traveling at the rate of 186,000 miles a second, four hours and ten minutes to reach us. And it takes Neptune 164.78 years to revolve about the sun. One Neptunian year, therefore, compares to about 164 years on earth.

Leverrier and Adams both had noted for a long time, that the then last known planet, Uranus, showed a number of perturbations which could not be accounted for by the other known planets. Once the exact amount of perturbations were calculated, it became possible to work out by mathematics the position of the perturbing body, which happened to be the new planet—Neptune. The mathematical prediction of an unknown world within the exact area of the heavens at a certain predetermined time will remain one of the greatest triumphs of human achievement.

But history is going to repeat itself. A new world is again to be discovered. It may have been discovered by the time you read these lines. For some time astronomers have been wondering if there was not a trans-Neptunian world, that is, a planet at a greater distance than the colossal interval that separates Neptune from the sun. But inasmuch as Neptune takes so long to make one revolution about the sun, i.e., 164 years, it was not such a simple matter to locate any supposed perturbation of Neptune, supposing that there were any.

Neptune itself, having been discovered in as late as 1846, astronomers have not had much of a chance to observe it adequately. Indeed, there had been previous suspicions that there might be a planet in our system beyond Neptune, and even Leverrier and Adams had thought about this. But came to no tangible results.

Of late, however, a number of astronomers, chief among them the well-known authority, Professor William H. Pickering, have been giving the matter serious attention. Pickering collected all the data available on Neptune and began to plot curves. He found out that the planet Neptune had been perturbed by an unknown body, just as Uranus during the last century had been found to be influenced by the unknown outer planet. But Pickering's job proved to be a far more difficult one than either Adams or Leverrier had contended with, because he had less material to work with than his predecessors; and the amount of time that Neptune had been under observation was comparatively short. Pickering could not be sure that the perturbations of Neptune were not actually caused by the giant planets, Saturn, or Uranus, and he began a long series of mathematical calculations; eliminating first one and then the other known planet from his calculations. In a current issue of *Popular Astronomy*, he announces the results, which briefly are as follows:

The new planet, which he terms "O," is a small one, only about half the volume of the earth. The diameter of the as yet to be discovered planet is 6,300 miles, about three-quarters that of Venus, and one-half again larger than the diameter of Mars. The mass of "O" is nearly half that of the earth, two-thirds that of Venus, and four times the mass of Mars. Being at a much greater distance than Neptune itself, it will be more difficult to locate, and it will need a good telescope to detect it. Prof. Pickering has given exact data where the new planet will be found, and it will be interesting to see how much of an error there was in his calculations when the planet is actually discovered, which it surely will be.

But the most remarkable fact about the new and unseen planet is that it has a totally different orbit from all other real planets. As is well known, all our large planets (some of the asteroids excluded) move about the sun in concentric curves or ellipses. But the new planet moves with such eccentricity, that it actually crosses the orbit of Neptune. That means that during half of the undiscovered planet's year, its orbit is within that of Neptune, and that half of its year it is outside—a remarkable phenomenon.

About 1841, the new planet was within the orbit of Neptune, while by 1850, it had already passed beyond it. At the present time it is in the same position, but on the other side of the sun, as it was in 1850, and within a few more years it will again be inside of Neptune's orbit. For these reasons, Pickering urges that no time should be lost in locating it, as the next perturbation that can be used will be one of Saturn, and will not take place until 1950. Here, then, is a particularly brilliant piece of work of which science can be really proud. It again demonstrates the triumph of mind over matter.

Naturally, the question comes up, if there is a new planet beyond Neptune, why may there not be others perhaps more remote than "O"? We do not know—time alone will tell. What seems certain, however, is that our solar system is closely tied together with other systems, because our own solar system is not at rest by any means, but rushes with great rapidity through the heavens. We do not even know what star or what universe is attracting our own solar system, but no doubt, discoveries such as Pickering's will make the work of future astronomers far easier and simpler, and will help us to solve some of the problems of the universe.

Mr. Hugo Gernsback speaks every Tuesday at 9.30 P. M. from Stations WRNY (326 meters) and 2XAL (30.90 meters) on various scientific subjects

Earthquakes Predicted

Of all the major disasters of natural cause, the earthquake alone has always failed to give some sort of warning of its approaching devastation. In the case of hurricanes, typhoons and tornadoes, the wind usually whips up in advance and the sky darkens, permitting men to find a few moments, at least, in which to seek safety. But the latest earthquake news brings new hope—it offers tidings that finally scientists have been able to devise an instrument that will probe the secrets lying beneath the surface of the ground and receive a sort of radio message from Mother Earth when she is about to produce an upheaval.

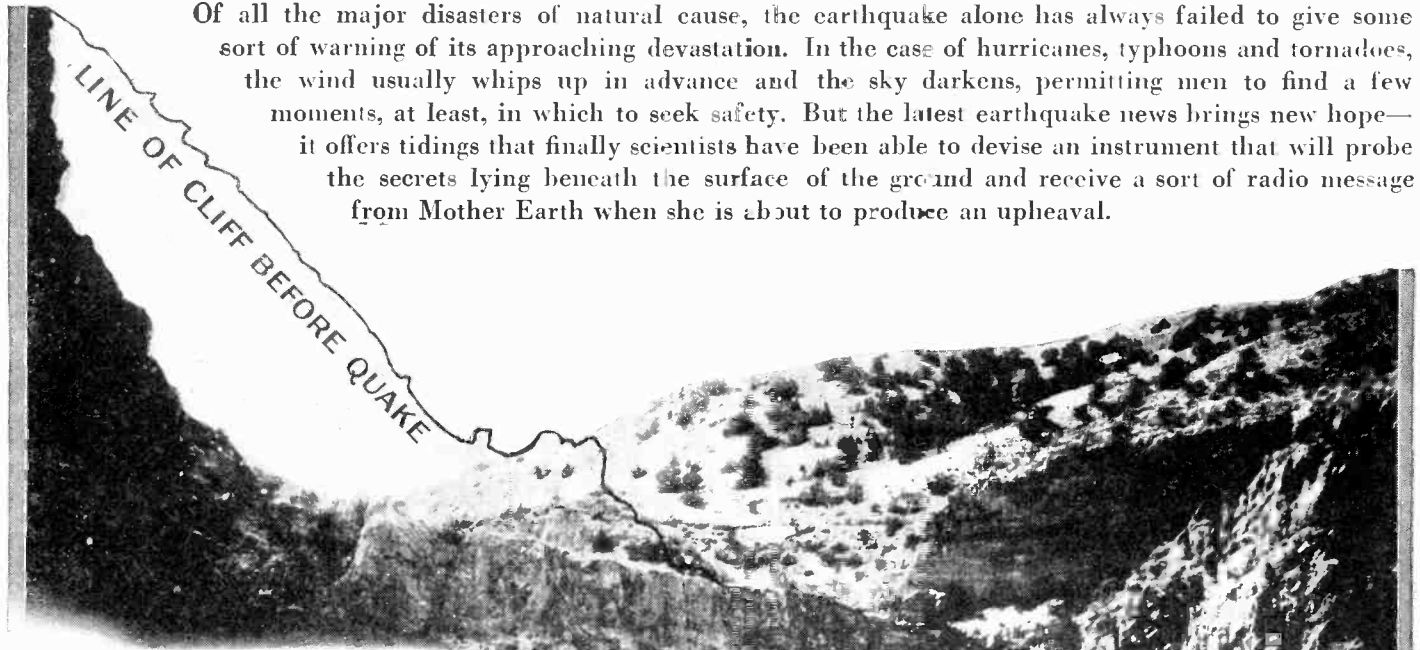

The above photograph shows the differences in a landscape before and after the Montana earthquake of 1923. Of all the major disasters from natural causes, the earthquake alone fails to give some warning of its approach.

THE scientist's centuries-old dream—the hope of predicting earthquakes in advance—is about to become a reality, according to two of the world's foremost students of earth-shock phenomena, Akitune Imamura, professor of seismology at the Tokio Imperial University, and Professor John W. Evans of London.

The importance of their discovery probably is unparalleled in the entire history of man's life on this planet. It should remove entirely the world-wide, blind and unreasoning fear of Nature in her worst mood.

Ever since man has inhabited the earth he has feared earthquakes as being sudden, ruthless calamities, coming absolutely without warning and whisking away the very ground from beneath his feet. Dr. Walter Hough, head curator of the Smithsonian Institution, Washington, pictures man's eternal struggle with Mother Earth's devastating maneuvers as follows:

"The history of civilization and the history of migration has been an urge to get away from the dreadful fear of earthquakes. The Pyramids of Egypt were probably shaped for the purpose of withstanding earthquakes. Indeed, the entire history of architecture is another evidence of man's fear of earth shocks. So as to build with stability he has followed different styles and different plans of construction, hoping one day to discover a certain style and plan that would withstand the earthquake menace."

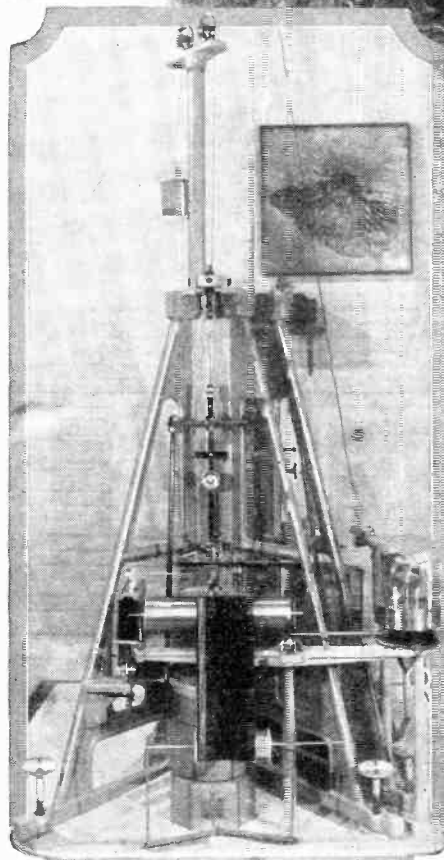
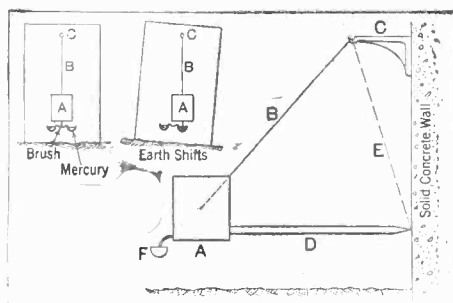

Above is a photograph of the Mainka seismograph, which operates on the principle of mechanical registration. It does not photographically record quakes.

The diagram at the left shows the schematic arrangement of an earthquake predicting instrument. A, is a pendulum, B, tension member, C, pendulum support, D, pendulum boom, E, theoretical axis upon which pendulum vibrates and F, one of a pair of mercury contacts. Two clinographs would be required, one to record tilt coming from the north or south, and the other, for east or west. This tilt occurs from five to thirty minutes before a quake.

"The temples of the ancients withstood the shocks and so did many of their homes. But fear, that terrible specter which has always dogged the footsteps of men, drove them further north until we find them in the Pueblos of New Mexico. There they built securely. It might also be said that the original American Indians, through this continual fear of what Mother Earth could do to them when she shook her skirts, became nomads, living in tent structures that could not harm them if tumbled about their heads."

"We have but to read the beautiful story of the Crucifixion to know that an earthquake of serious force occurred while the horror of Golgatha was taking place. Or Sodom and Gomorrah—archaeology has proved these iniquitous cities were destroyed by earthquakes. Antioch was similarly destroyed by one of the most terrible earthquakes of all history hundreds of years be-



Above is a graphic chart showing method of locating earthquake by drawing arcs from three seismograph stations.

Hours in Advance

By JAMES NEVIN MILLER

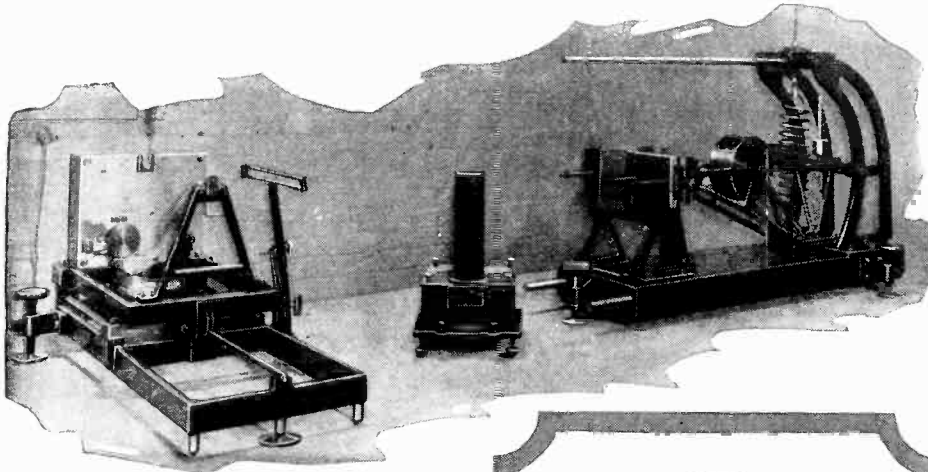

The Galitzen seismograph, the most sensitive instrument used today, is shown above. The registration instrument is shown at the left and the recording device at the right. It registers earthquakes on the magnetic principle.

fore Christ. These disasters provoked the Romans, perhaps, into an onward march."

Of all the major disasters of major cause, the earthquake alone has always seemed to fail to give some sort of warning of its approaching devastation. In the case of hurricanes, typhoons and tornadoes, the wind usually whips up in advance and the sky darkens, permitting men to have a few moments, at least, to seek safety. But earthquake disturbances, born far beneath the earth's crust, can neither be seen nor heard in time for such action. Small wonder that the earthquake is regarded as the most terrible natural calamity—man has been well-nigh helpless in trying to avoid its destructive force.

However, the latest earthquake news offers new hope—it brings tidings that finally scientists have been able to devise an instrument that will probe the secrets which lie beneath the earth's surface and receive therefrom a sort of radio message from old Mother Earth when she is about to produce an upheaval.

Centuries-old in its beginnings is the earthquake drama. The drama consists of three acts. The first act began millions of years ago when, in the process of cooling off, deep cracks or fissures appeared in the earth's underlying strata, causing deep-set lines of weakness for distances virtually impossible to calculate. Due to sedimentation and erosion there is a constant change in po-



The first earthquake indicating device was invented in 136 A.D. by the Chinaman, Choko.

This instrument was known as the seismoscope and the shock of the quake dislodged balls from the dragons' mouths, thus showing the direction of the quake.

sition of the surface materials of the earth, notable in Nature's plan of mountain building, with the result that the subterranean cracks and weaknesses may be subjected to a pronounced strain.

EARTH SHIFTS BEFORE A QUAKE

GRADUALLY they become overloaded on one side with earth materials, causing a sliding and shifting of load, the second act, which culminates in the third, the terrible tremors that man today calls an earthquake. So unexpected and sudden is this trembling of the earth's surface at times that almost in the flick of an eyelash, buildings topple and fall, water and gas mains snap, fires arise through short-circuiting of electric wires, and a paroxysm of horror ensues among the inhabitants of the stricken district. This actual earth convulsion itself

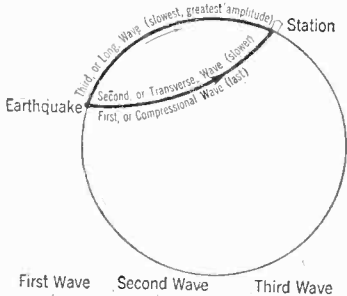

Difference in time of arrival of first and second waves, gives distance from earthquake to station.

A photograph showing the wreckage of a lighthouse in Santa Barbara, California, appears at the right. The great quake of 1925 was responsible for this.

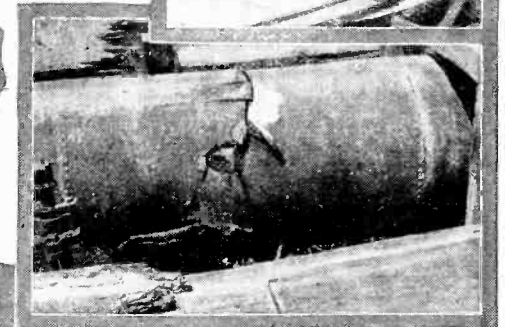

The famous earthquake of 1905, which struck California, ripped apart a 31-inch pipe used as a water main. A photo of this pipe appears above.

is the third and final act in the earthquake drama.

It is the second act, always obscure, and always challenging, which has been investigated by scientists working in their solitary retreats, bending over their instruments which record earthquakes, while trying to discover the age-old mystery of their manner of approach.

Briefly, Prof. Imamura of the Tokio Imperial University, has discovered that there is a slight tilting of the earth's surface, which occurs ordinarily a short time before an earthquake occurs. Four years ago, Professor Evans, famous British scientist, suspected the existence of such a tilt and declared that "the rupture, whatever its nature may be, that gives rise to the actual vibratory shock, is preceded by a strain or distortion of the earth's crust which gradually increases until the stress that causes it is suddenly replaced. The existence of this strain should be evidenced by a progressive sag or tilt of the earth's surface."

It was not until late in 1927, however, that Prof. Imamura gave to the world his proof that such a tilt actually did occur—from one-half hour to five hours before the actual earthquake and that the tilt could be recorded by a delicate
(Continued on page 66)

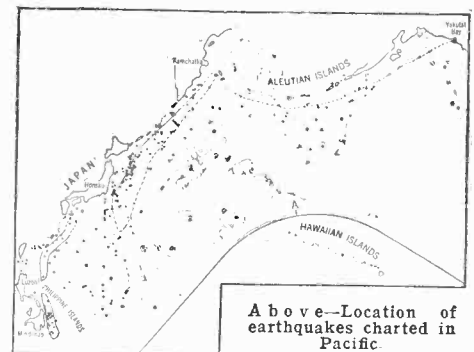

Above—Location of earthquakes charted in Pacific.

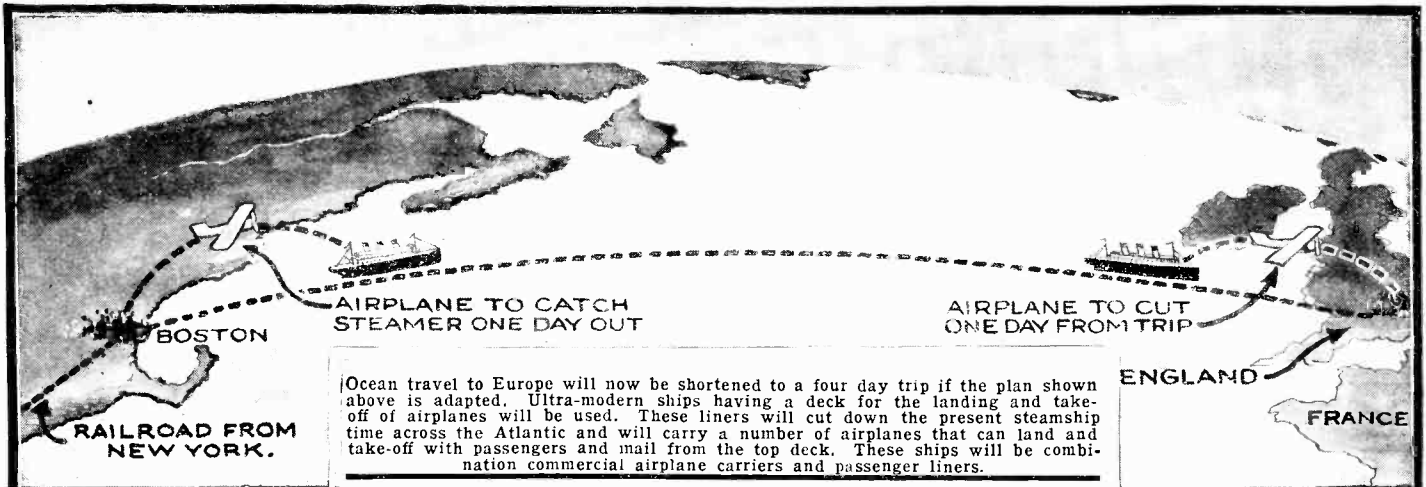

SPEEDING UP OCEAN TRAVEL

Ultra-Modern Ships Will Reduce Transoceanic Steamship Time and Increase Pleasure

ENGINEERS and ship builders have collaborated in cutting down the trans-Atlantic steamship time to a minimum. The photos and diagrams on this page show various ways in which this can be done. At the top of the page we have a proposal which has been submitted to the U. S. Shipping Board by a ship building corporation, whereby the Atlantic Ocean can be crossed in four days time. The ships to be built will be a combination airplane carrier and passenger liner having a speed of 35 knots per hour, faster than the fastest ocean liner of the present time, which attains a speed of 26 knots per hour. These boats are to be 917 feet long, with a beam of 90 feet. There will be space for 1000 tons of cargo, and accommodations for 800 passengers. Ample space for airplanes to land and take-off will be provided, so that the airplane can catch the steamer one day after it has left and leave one day before it has reached port.

All of the super-structure will be erected on one side of the deck, to allow unobstructed deck space for the planes. One desirable feature of the four-day ships is that they will answer the purpose of floating islands for trans-Atlantic fliers. At least, three of the ships would be on the high seas continuously, and at such intervals as to make short hops across the Atlantic possible. Their exact positions would be definitely fixed at specific times, and the flier

At the right is a photograph of the S.S. California, the first electrically operated ocean liner, which weighs 22,000 tons and is the largest vessel of its kind built here.

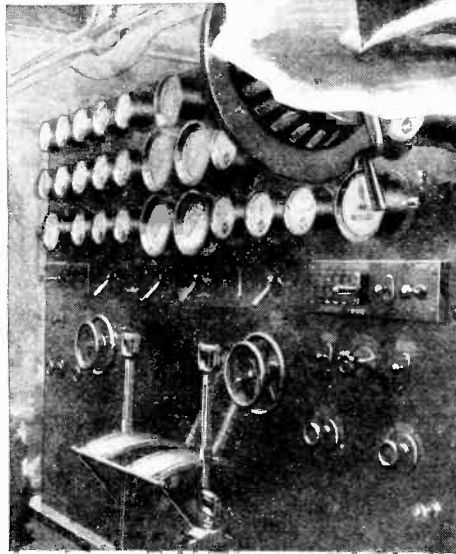
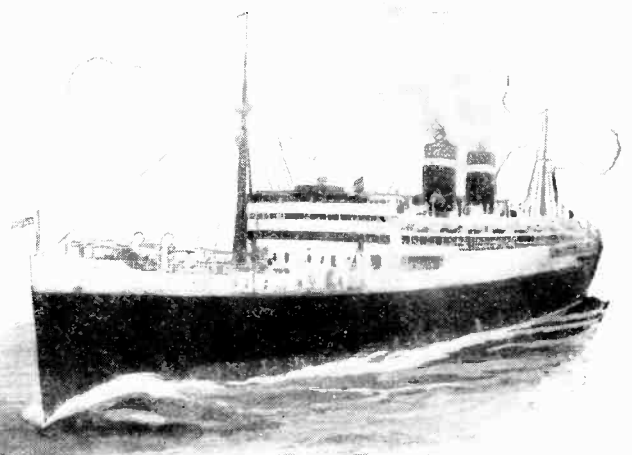

The above photo shows the main propulsion control-board on the S.S. California.

could easily use their decks as a stopping place in mid-ocean.

The S.S. California recently arrived in New York on its trial run from Newport News, Virginia. A maximum speed of 19 knots was established with the new merchant vessel which is electrically operated. The ship weighs 22,000 tons, and is the largest of its kind ever built in this country. Where a ship of the California's tonnage would require 120 men, the new liner requires but three men on watch in the engine room. Small twin turbines driving two generators provide the electrical energy. With this combination, it is possible to develop 17,000 horse-power. The vessel is 600 feet over all, has an 80-foot beam, and a draft of 30 feet. She will soon be placed in operation in the New York to California service, of the Panama-Pacific Line. Several unusual features are the two built-in swimming pools on the open deck, and a garage which will accommodate 140 automobiles. On the run from Newport News, nine men constituted the crew and the quarter-masters stood by a "locked" steering wheel, while the gyro-compass and gyro steering device, adjusted to the main course, held the ship on this course unaided. A view of the main propulsion board of the S. S. California is shown on this page.

The White Star Line has placed an order for a giant motor ship, which will be even larger than the Majestic, at present the biggest ship afloat, the length of the new vessel will be about 1,000 feet and she will be driven by internal combustion engines of the Diesel type. The speed of the new ship is not expected to be remarkably high. Germany, however, is planning to wrest the speed record from the Mauretania and is now building two large liners which when completed are expected to be the fastest passenger ships afloat.

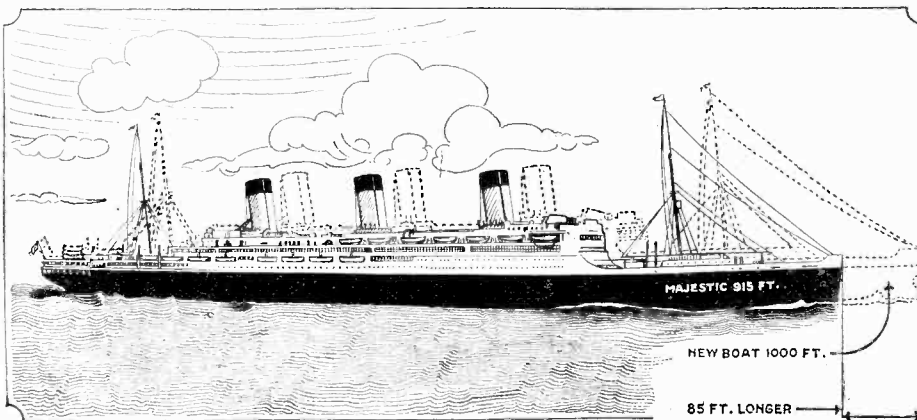

The White Star Line will soon have the largest motorship afloat. Above it is compared with the Majestic, the biggest ship at the present time. The length of the new vessel will be 1,000 feet over all.

INVENTIONS WANTED!

THE primary object that all inventors have in mind when patenting ideas is to realize financial benefits from their inventions; however, it is unfortunate that there are only a small number of inventors who can claim to be successful. Very frequently articles are invented which are not required either by the general public or industry. On this page we have illustrated only a few of the vast number of much needed inventions mentioned in a booklet covering extensively the inventions most needed today and compiled by the Institute of Patentees of London.

An umbrella which can be folded up into a small space and readily carried in the pocket would find a great market today. A luminous paint which can be made cheaply and yet be seen over quite a distance at night is another much needed invention. Signs could be made with this paint, thus doing away with the expense of electricity. Non-skid rubber caps for placing over the end of ladders would prove useful. A camera device which will automatically roll the film and shift a new film into place after each exposure, thus preventing a

double exposure, is much in demand. An efficient, safe and easy method of absorbing carbon dioxide from the air of a room, is a problem for the chemists to solve. Unbreakable, clear, flexible window glass, without a

doubt, would be welcomed in many industries, and also by the general public. A device to prevent water

pipes from freezing would gladden the heart of any suburbanite. A voice-operated typewriter will speed up office work and make for greater efficiency. For some time, a search has been going on for a non-alcoholic temperance drink which will be refreshing and have a "kick," in spite of the fact that it is devoid of alcohol. A cheap self-contained home garbage and refuse destroyer should find a place in every home. A radio-television apparatus which can be bought for a moderate sum is another needed invention,

within the next ten years. A sun-power electric generator and a static eliminator would make millions for their inventors. A vacuum cleaner for chimneys would be a welcome invention. The transmission of power through the air has been the dream of more than one radio and electrical engineer and still remains to be perfected. A family airplane which would be fool-proof would doubtlessly have a wide sale in this country and abroad. A method of taking colored photographs with the ordinary camera is another invention

which is yet to come. A furnace for making electricity directly from coal in an efficient manner would find a place in almost any home. A liquid which will nickle-plate the metal upon which it is rubbed and yet give a durable finish such as that obtained only

by electroplating, is a much needed preparation. A substitute for rubber and also a process or treatment to prevent rubber from aging, will find wide application in the commercial fields and net the inventors big money.

which undoubtedly will be perfected

will find wide application in the commercial fields and net the inventors big money.

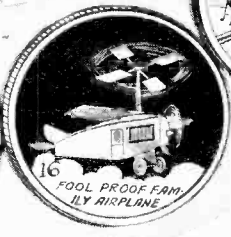
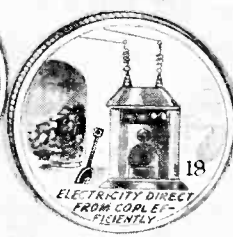
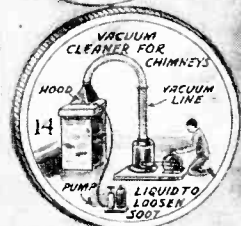
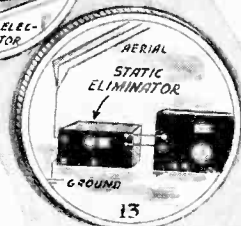
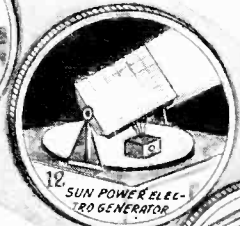



The Commanding Officer of the Giant Tells Here Some of the Little Known That You Have Always Been Curious to Dirigibles? Read What

Lieut.-Commander C. E. Rosendahl, U.S.N.

QUESTIONS ASKED BY H. GERNSBACK, EDITOR, FOLLOWING RADIO TALK OF LIEUT. COM. C. E. ROSENDAHL, U. S. N., FROM WRNY.

1. Q. In your opinion, can a huge dirigible of the Los Angeles' type compete successfully with airplanes in carrying passengers?

A. There is no competition between the airplane and airship if each is properly employed. To use an airship to do the work of an airplane is as extravagant and inefficient as the use of a sea-going steamer on a short coastal run or on ferry boat duty. The airplane is and will probably always be a short range carrier, while the airship is fundamentally a long range vehicle.

2. Q. What do you believe the maximum speed that airships can obtain for commercial traffic?

A. It is believed that a speed of about 100 miles per hour will be attained by dirigibles of future commercial size.

3. Q. What provisions if any have been made in passenger carrying across the oceans to safeguard passengers if airships were forced down into the ocean?

A. An airship in trouble is not necessarily forced down in the ocean—in fact, she would fly as a free balloon, in case all motors failed; but there is extremely little likelihood that all of six or eight individual power plants would fail simultaneously. Airships carry sea anchors similar to surface ship practice. There are many instances on record where German Zeppelins—badly damaged in war—returned safely to their bases. Safety lies with staying with a ship and flying to her base.

4. Q. If lightning struck one of these huge helium-inflated airships, what damage would be done?

A. Even hydrogen-inflated airships have been struck by lightning without any

damage. An airship is a huge, thoroughly-bonded metallic structure, that would readily dissipate an electric charge; added safety being assured by the use of the absolutely non-inflammable helium gas as the inflation medium.

5. Q. Can this country produce sufficient helium for any amount of dirigibles?

A. The United States has practically a world monopoly of the supply of helium. Nowhere else in the world is there a sufficient quantity of helium-bearing natural gas to pay for its production. Recent reports indicate that there is practically an unlimited supply of helium in certain gas-bearing fields in the United States—certainly enough for all the airships we shall operate for scores of years to come.

6. Q. What are the advantages of helium over other lifting gases?

A. Helium is a safe lifting gas in that it will absolutely not combine with any other element and therefore cannot burn nor explode. It is next to the lightest gas known and available for airship inflation. It has 92% of the lifting power of hydrogen, and its much greater safety over hydrogen makes its use of the utmost value.

7. Q. Can an airship, while moored to its mast, outride practically any storm that may come along, including a hurricane?

A. An airship moored to a mast can ride out very severe storms—certainly any containing winds up to the speed at which the ship itself is designed to fly. In the case of hurricanes or tornadoes greater safety lies in taking the air and flying out the storm, just as a steamer puts out to sea in severe storms, heaves to at sea, or runs around severe disturbances.

THE year 1928 will be an unusually important and spectacular one for dirigibles; it is not necessary to consult an astrologist to glean this from the stars, as there are other unmistakable signs already apparent. 1927 saw many triumphs for the airplane—its records are written in history. Outwardly, 1927 was a quiet one for dirigibles; actually, much unseen and vital experimental work progressed and some new construction continued in its early stages. It is on this dirigible or airship phase of aeronautical activity that I wish to discuss briefly.

HEAVIER-THAN-AIR CRAFT DEFINED

MANY people do not distinguish between "heavier-than-air" craft (i.e. airplanes) which must depend on their engines to hold them aloft as well as to drive them through the air, and "lighter-than-air" craft (or dirigible balloons) which are sustained by some buoyant medium such as helium gas and devote practically the entire effort of their engines towards propelling them. Thus the term "airship" is sometimes used indiscriminately for all forms of aircraft. We in the lighter-than-air branch of aeronautics feel that the term "airship" properly should be applied only to lighter-than-air craft, as they are fundamentally "ships" and incidentally ships that float in air. Airplanes are much more widely distributed than airships, and naturally the plane and its habits and character-

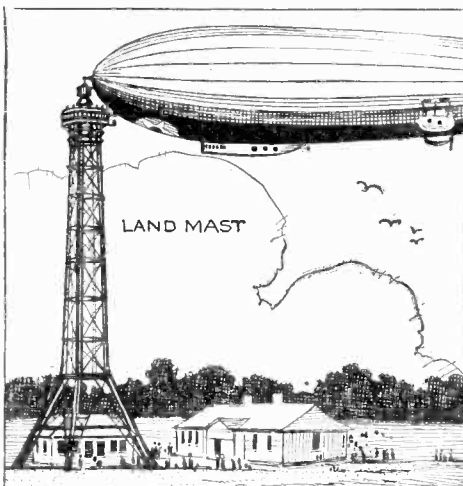

One method of mooring dirigibles is shown above. The ship is tied to a land mast.

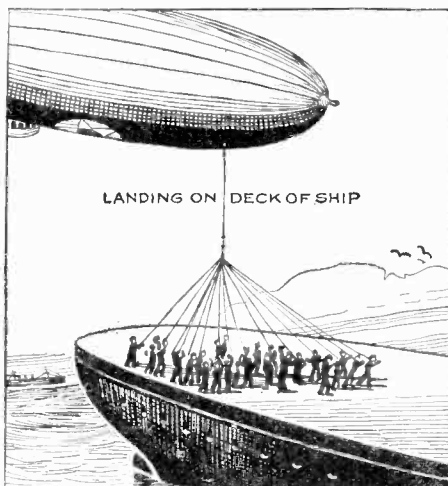

When landing upon the deck of a ship, a number of ropes are employed as shown here.

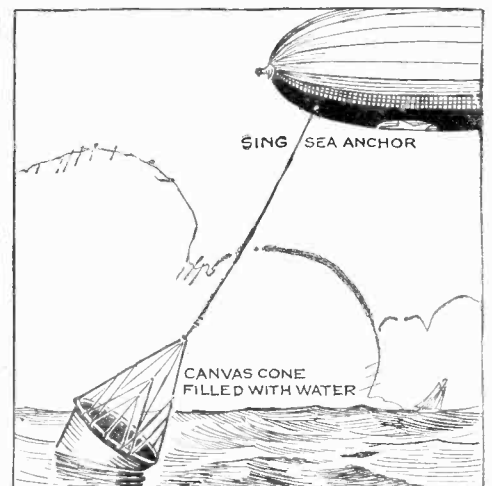

One of the newest inventions is a sea anchor for dirigibles used as shown.

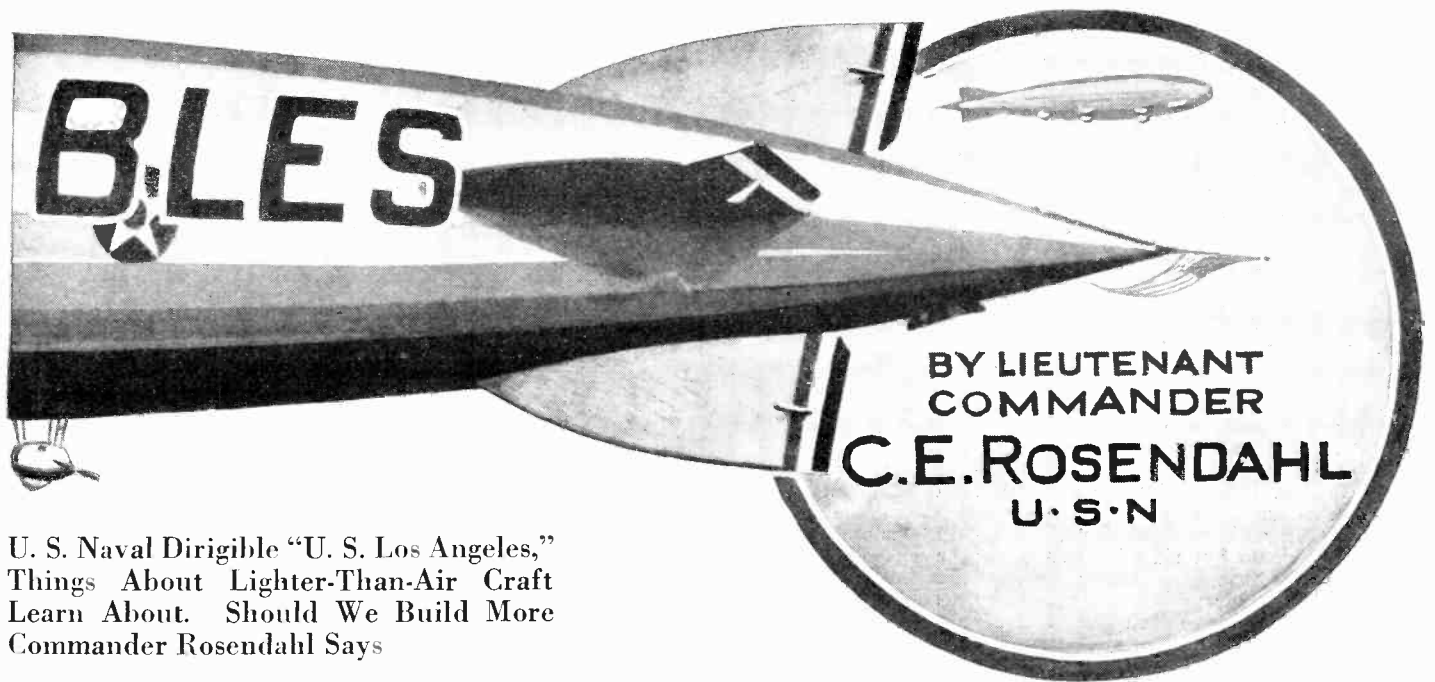

U. S. Naval Dirigible "U. S. Los Angeles," Things About Lighter-Than-Air Craft Learn About. Should We Build More Commander Rosendahl Says

istics have therefore become more commonly known than those of its scarcer cousin, the airship. However, this unfamiliarity with the airship will soon vanish, for the realization is dawning that large airships—often referred to in the past as "Zeppelins"—are essential both to commercial transport and to the national defense.

DIRIGIBLES FOR SAFETY AND COMFORT

MANKIND continues to demand greater speed in transportation—think of the vast amount of effort spent to obtain speed! Is there anyone who hasn't been thrilled at the tales of the magic carpet of the Arabian Nights and its ability to annihilate distance? High speed trains and fast steamships demand extra fare and we continue to patronize and support them. Further increases in railroad and steamship speeds are very expensive and difficult to obtain. As soon as the speediest transport of all—that by air—becomes more generally realized with safety—mankind is sure to take quite liberally to the use of aircraft—particularly its comforts and conveniences may be had simultaneously with the greater speed. Airplanes and airships are this next available means of supplying speedier travel—the airplane for short or moderate distances, the airship for long distances. Airplanes can provide a certain degree of comfort but it is the airship which can supply the maximum of comfort and safety in the air for longer voyages.

EVOLUTION OF THE AIRSHIP
PERHAPS you might be interested in the evolution of the airship. In 1783, that is, about one hundred and forty five years ago, the first balloon flight was made. Men had observed that hot air would rise; therefore by inflating a bag or container of light material with heated air, the container could be made to rise and take with it a basket or car in which to carry the passengers and other loads. Soon man was able to produce hydrogen gas in sufficient quantity to inflate a balloon and since hydrogen is so much lighter than air, it has always been a most efficient lifting gas. Of course, balloons drift with the wind, and man soon became desirous of providing them with motive power so that he might go in any direction independent of the wind. Early effort consisted of rowing with silken oars but of course this method was not practical. In 1852 the first power driven or dirigible balloon was built. It derived its motive power from a three-horsepower steam engine. The modern airship had to wait for the development of the gasoline engine and a light strong material with which to build the structure. It was in 1900 that Count Zeppelin completed and flew his first rigid airship in Germany. Our first American airship was built in 1908.

LIGHTER-THAN-AIR CRAFT CLASSIFIED
AT this point let me classify for you lighter-than-air craft or those forms of (Continued on page 79)

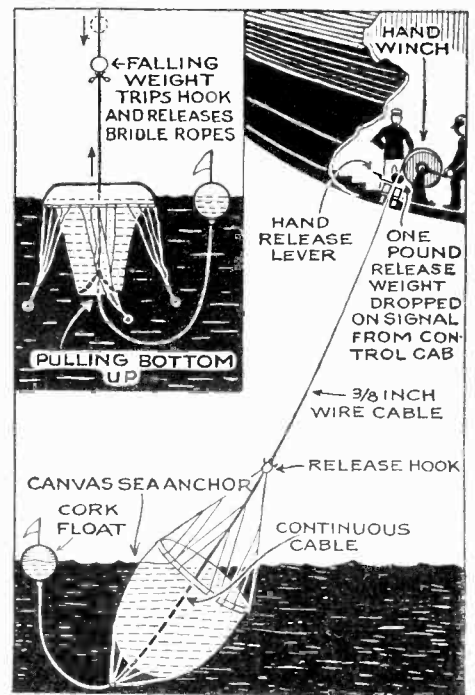

The above illustration gives all the details of the new canvas sea anchor.

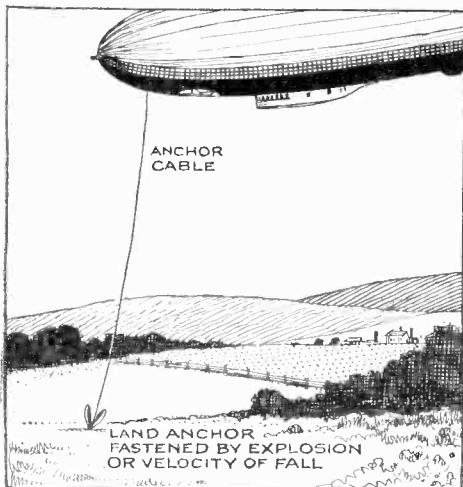

An emergency landing can be effected by using a land anchor which can afterwards be cut loose.

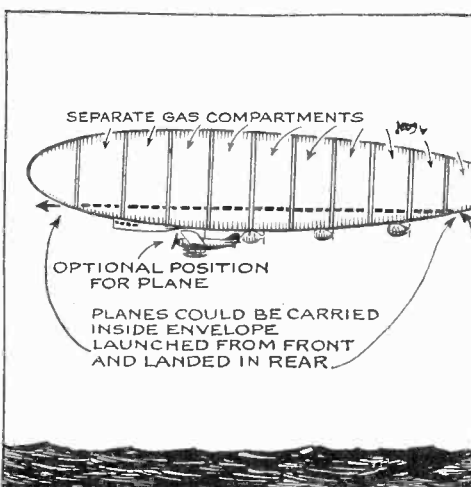

Modern dirigibles have separate gas compartments. The U. S. Navy will fit dirigibles for carrying airplanes.

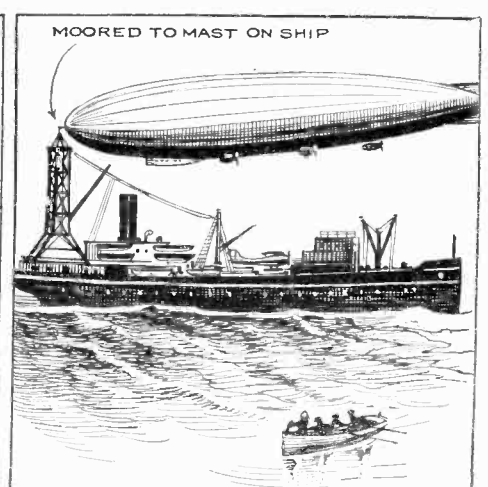

A dirigible can be moored to a special mast on a ship, as was recently done with the "S. S. Patoka."

Controlling House

Information About Pests, How They Live and

By DR. ERNEST

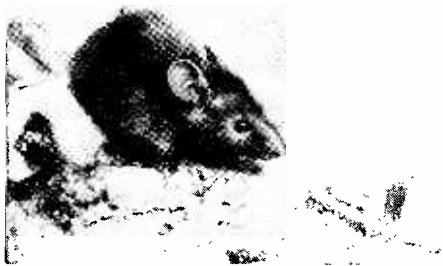

Mice are destroyers of food and transmit diseases. These pests are easily controlled.

QUITE a number of different insects and animals are attracted to the home of man, not only for the shelter offered, but also for the profusion of food available in kitchen and cellar. Once such creatures have made themselves at home, it is very difficult and sometimes almost impossible to get rid of them. They find everything that is necessary for life, and why should they move? They multiply rapidly and soon become such pests that the master of the house becomes disgusted and takes violent measures for their extermination.

Among themselves, the pests of the house battle with more success, but their aid can seldom be used, for it would only be a case of jumping from the frying pan into the fire. It is in this way that the house rat has been practically wiped out by the wandering rat. The former (*Mus rattus*) has been evicted by the wandering rat (*Mus decumanus*), primarily through the aid of ships, by way of which they have overrun the world.

RATS

MANY methods have been proposed for the control of the rat, but almost all processes have only local efficiency. The rat is far too wise and cunning to be taken in by simple means. Then, too, he is suspicious of all new things with which he may come in contact and thus he is able to distinguish the harmful from the harmless, the dangerous from the innocuous. Traps cannot be used successfully for any length of time. If they are of iron, then the rat will not touch the bait, for he does not know iron and must first be made to realize that iron is harmless. For this purpose iron chains and other objects of iron are placed across his path and after he knows that iron is harmless and will not hurt him, iron traps may be more successfully employed.

RAT POISONS

CATS seldom attack rats. It is better to use a dog, especially a terrier. Poisonous bait is also good for only a short time,



Above—the bed-bug which sucks the blood and transmits diseases. Kerosene, or acetic acid may be used for their control.

and if plenty of other food is available, it is almost useless to try to control them by this method. A favorite poison is that obtained from the bulb *Scilla maritima*, a native of southern Europe, which is often cultivated in the window garden. Its action depends upon the crystals of calcium oxalate, known as raphids, and which are thin and sharp, like small double-pointed needles. These needle crystals, when eaten by the rat, penetrate the intestines and kill the pest. The rat is accustomed to the bait by means of ordinary meat balls fried with onions. After the rats have taken a few of these, the bulbs are substituted for the onions. This is a very effective control method. In more recent times the rat bacillus has been used, but this germ is not active over any long period of time. Quick-acting poisons should



Above is the cockroach, a pest which has travelled all over the world to the dismay of man. Borax will help control the pests if applied where they are found.

not be given rats. Other rats see the effect of the poison bait and refuse to touch it.

PLASTER OF PARIS EFFECTIVE

Another good rat poison which is not dangerous to handle is plaster of Paris. The plaster of Paris must be prepared by mixing it with other substances such as flour, sugar and some strong smelling cheese. This poison as well as the above mentioned may also be eaten by mice. A bowl of water is placed next to the plaster of Paris mixture and it is the water which really kills the pest, because the plaster hardens to a brick inside the pest and so kills it.

Various other chemicals can be used as the different types of barium salts such as barium carbonate or barium sulphate. They are used like the plaster of Paris (calcium sulphate). In all these cases a bowl of water should be available to the pests. The various types of fumigants such as cyanides used for control of pests should be avoided. They are far too dangerous for the layman to handle, and for best results a specialist will have to be called. In the proper hands it is an excellent method of control but it can not be used successfully under all conditions.

RATS SPREAD DISEASE

Rats should be killed not only because they are destroyers of food, but also because they are transmitters of disease.

Diseases are transmitted by the rat to fleas, these attack man and transmit the germs. Plagues have been started in this manner.

Far more harmless and much more easily controlled is the house mouse. This creature is only found where it will find a hiding place. For this reason it is seldom discovered in modern dwellings. Cats and mouse traps are quite effective. In fact any type of a trap is almost sure to catch them although some traps are better than others. Rags dipped in turpentine and stuffed into mouse holes drive the pests away.

THE INSECT MENACE

OF still greater economic importance as pests of the home are the insects. There are countless myriads of them and they not only endanger our supply depots, but attack our clothing and our homes, even endangering our health.

One of the pests of the kitchen food supply is the common larder or bacon beetle, a creature about $\frac{1}{2}$ an inch in length. This pest (*Dermestes*) is not bound to any particular food. In nature it takes to decaying matter, both organic debris and manure. Then, too, it is often found on flowers. The larva are usually found in dried material or animal matter, such as dried muscle bundles and tendons, the inner side of dried skins and pelts and furs, bacon and hams. These beetles are found everywhere and have made themselves at home in every place, and since they keep under cover and multiply rapidly, they do much damage not only to foods, but also to carpets, rugs, furs, bolsters, etc. Places infested with these larder beetles may be safely fumigated with 40 grams of carbon bisulphide for each cubic yard of air

in the room. Close all holes and cracks and leave for at least 10 hours. Another safe fumigant to use is formaldehyde. Any kind of a lamp or vaporizer of formaldehyde can be used. Leave this also for at least ten hours in a closely stoppered room where all cracks of windows and doors have been stopped up. A protective method for furs, etc, is the use of insect powders dusted on the articles.

THE SILVER FISH

THE tiny rapid silver fish (*Lepisma*) is seldom considered as a pest unless it is found in very large numbers. It is always



The larder or bacon beetle is a creature about one-half inch in length and may be controlled by fumigating with formaldehyde.

hold Pests

How They Can Be Driven from the Home

BADE, Ph.D.

found where ever foodstuffs are stored, prefers sweets, but also attacks cloth and clothes. The creature lives its life in dusk or darkness and when caught in the light, it hurries back into hiding. It is hard to catch for the body is smooth and it slips easily through the fingers and is gone. It is about a half to three quarters of an inch in length, is built closely to the ground and looks like a silver streak when caught unawares.

In the library the silver fish attacks the back of books in order to get at and eat the glue. It gnaws the paper and leaves only that part which is covered with ink. Starched cloth and silk are also eaten as are the backs of wall papers. There are few things that the silver fish will not take. The greatest damage is always done wherever materials are left undisturbed for long periods as clothes that are stored away. A general control method is the fumigation with carbon bisulphide or formaldehyde. Books may be lightly rubbed over with a cloth dampened with formalin. The formaldehyde gradually evaporates and kills. Cloth that is stored should be sprinkled with naphthalene. This also keeps moths away.

CRICKETS

ATTRACTED to the kitchen by the heat of the range in suburban and country places, is the cricket (*Gryllus*), which hides in cracks and crannies. The males are untiring musicians and they lure the female to them by means of this high and shrill squeak. At night the cricket hunts for food and in the home of many this consists of cakes and sweets, flour and bran, etc. Only during the time of feeding is the music stilled. They are dark brown in color, fat of body and about one inch long. They are hard to get at and the best method for their control is to place a bowl of their favorite food on the floor within their reach. Then, at night, while they are feeding, catch them at the feast and kill them by pouring boiling water over them. If desired a poison food may be prepared consisting of one part of salicylic acid, two parts of powdered borax mixed with nine parts of any of their food.

COCKROACHES

AMUCH greater pest is the cockroach (*Blatta*) of which two species are found in the kitchen the larger one of which has, like the rat, conquered the world, primarily through the aid of ships. The size varies from the small which is about $\frac{3}{4}$ of an inch to the large which may be twice this size.



Slugs are commonly found in cellars and may be effectively destroyed by using powdered lime.

They are brownish red in color, very flat and wide in proportion. The eggs of the roaches are formed into balls and are carried by the female for some time. Then they are deposited into hiding places. The food consists of all edible things, sweets being preferred, but even leather goods are destroyed by them. They may be chased away by sprinkling borax and insect powders around the floors and shelves where they travel. Since these creatures are slim, they enter all cracks, and in order to keep them out permanently, these should be filled with a good crack filler. They may also be killed by the poison food mentioned for the cricket. In addition they may be controlled by a mixture consisting of five parts of plaster of Paris and one of flour, the parts being taken by weight. A mixture of one part of honey and half a part of yeast is also a good poison.



Household pests can only be destroyed by a persistent fight against them. Remember that the eggs may be hatching, even after all the adults have been killed. Persistence in the use of control measures is necessary.

PERSISTENT FIGHT AGAINST PESTS NECESSARY

PERSISTENCE in the use of control measures for any pest is absolutely necessary. The eggs of the pest may be hatching a few days after all adults have been killed

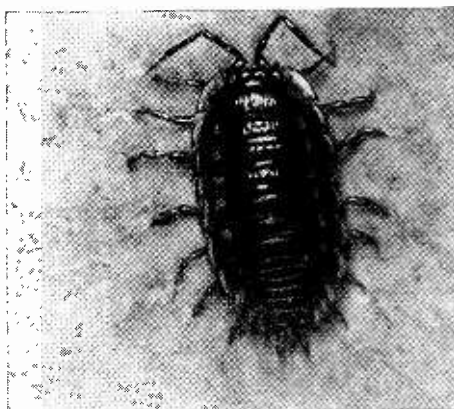

The pill bugs are not particularly injurious but are a nuisance, especially in damp cellars. Since they are slow moving, they are easily exterminated.

and if a second and even a third time control is not used, the pest may be back with renewed vigor.

Insect powders as such may be quite different from each other. Pyrethrum is usually used. This is the powdered part of a

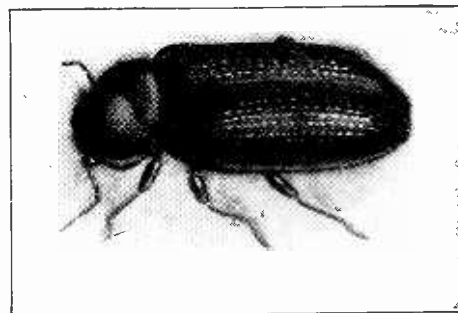

The death watch beetle is about one-quarter inch in length and is very destructive to furniture.

plant, the flower and leaf being usually taken. In addition, powdered sulphur, pepper, tobacco, white lead, borax and others are also used in combination with pyrethrum.

An excellent insect powder is made by mixing equal parts of pyrethrum with borax. If desired a half a part of flower of sulphur may be added. This last is very good for any insect and especially for cockroaches.

PILL BUGS AND SLUGS

PILL bugs and slugs are commonly found in cellars. The latter demand moisture in order to live. On dry ground they secrete slime and give off much moisture which soon causes their death. For the control of slugs, lime is the best chemical that can be used for each slug that comes in contact with the dry powdered lime must die.

The pill bugs are found under stones, bark and other dead and decaying material of field and woods. One form also enters the cellar where its food consists of decaying potatoes, fruit, etc. They really do not do any damage, but they are unwelcome guests. They may be trapped during the night with hollowed carrots, slices of pumpkins, etc., where they will be found next morning, and since they do not run away, they may easily be

killed by stepping on them.

THE BEDBUG

AN entirely different type of pest is the bedbug, a comparatively small insect, wide in body and built flat, in length it may vary from $\frac{1}{4}$ of an inch to slightly larger. The bed bug is not a comparatively recent addition to the sleeplessness of man, being known to the ancient Romans. Since these blood suckers are very flat, they are always found in cracks and crannies, under molding and even under wall paper. They are also found in crevices of beds and furniture. There are many ways in which this pest may be controlled. Kerosene and gasolene may be used to brush the cracks or, which is better, to soak the cracks with the aid of a spray. Acetic acid is still more effective but it can not be used where the acid may

(Continued on page 68)

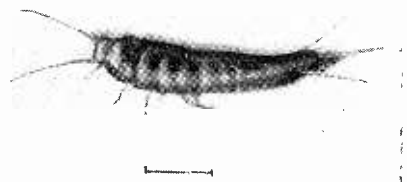

The silver fish is destructive to books and cloth. Formaldehyde fumigation kills this pest.

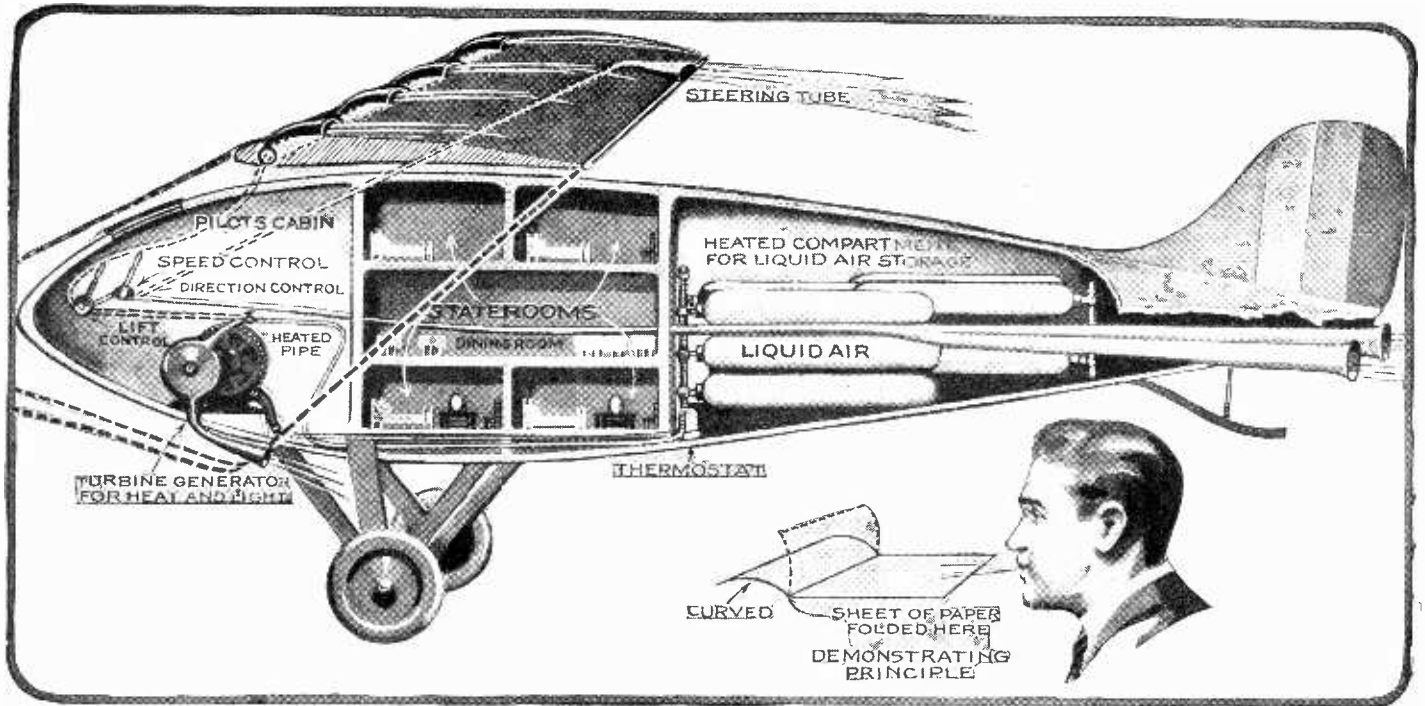

Conception of the proposed type of engineless plane which will obtain its lift by streams of air forcibly ejected through special nozzles mounted along the edge of the wing. Air tubes propel and steer the plane because of the reaction effect. Insert shows the operating principle.

Engine-less Plane Driven By Liquid Air

Propellers and Engines to Be Supplanted by Novel Method Employing Liquid Air for Propulsion and Vertical Lift

By AUGUSTUS POST

WHEN Glenn Curtiss was looking for a landing-place half-way between Albany and New York at the time of the first long-distance flight in this country, May 28, 1910, he found just the place he wanted, a broad expanse of lawn in front of an imposing public building near Poughkeepsie. When we asked permission to make a landing there, the Superintendent, Dr. Taylor, replied genially: "Why certainly, come right in! Here's where they all land!" It was the State Lunatic Asylum.

Even as late as this year, this was the popular notion of the place where flying-machine inventors belonged. Nowadays the public is going crazy over aviation, and the only level-headed ones are the Lindberghs who do the great things and the inventors who dream them. These dreamers, the "crazy inventors," are now looking as far ahead into the impossible, as the Wrights were when they were building a heavier-than-air machine to navigate the air above the clouds. The present-day dreams are of the navigation not only of air but of space, by the application of methods new to flight, including the reaction principle and the utilization of liquid air, one of the most condensed forms of mechanical energy known. The possibility of a fuel-less motor even seems to be coming up over the horizon.

LIQUID AIR FOR PLANE PROPULSION

CURIOSLY enough, the very first engine that we know to have been constructed, Hero's engine, used the reaction principle. Most of us have in our childhood seen this applied, if we owned one of the toy tin boats intended for sailing in bathtubs and fitted with an alcohol lamp and boiler, a jet of steam furnishing the force that pushes it along. A jet of air has been used of late years by two French engineers, Papin and Rouilly, to revolve the



Augustus Post, the author of this article, is a pioneer aviator and aeronautic expert. Mr. Post has been active in aviation circles from the days of Wright's Ft. Meyer flights. As early as 1910 he flew in various meets. As an aid to Alan R. Hawley, the winner of the Gordon-Bennett Balloon Race in 1910, he was lost in Labrador wilderness for ten days. He also drew up the rules for the Raymond Orteig prize won by Charles Lindbergh.

blade of their revolutionary type of helicopter, by forcing an air blast from the rear edge of its propeller blade. This naturally suggests the possibility of driving a machine through the air by the expansion of a gas through specially designed nozzles that would give the maximum thrust. One of

the most concentrated forms of mechanical power may be obtained from the expansion of liquid air. This is expensive, and its efficiency is not yet satisfactorily proved if we consider propulsion alone, but if in addition to the propulsive effect of this rapid exhaust and expansion of the liquid air, these specially constructed nozzles are directed over the upper surface of an aerofoil—or airplane wing—this tends to create an upward lift. This upward lift is easily demonstrated by a familiar experiment with a piece of paper five inches long and two inches wide, creased across at about a third of its length, the short end curved as in the drawing.

Blow above the upper surface of the flat section and the curved section will move up and against the stream of air, demonstrating how the air flowing over the upper surface of an airplane lifts the wing. Liquid air in process of expansion by heat through the properly constructed nozzles over the surface of the airplane wing would in like manner tend to lift it as well as to drive it forward.

HOW LIQUID AIR PROPELLED MOTOR CAR

I HAVE ridden in a steam automobile in which liquid air was used to take the place of steam; it could be used anywhere that compressed air is used for propulsion. It was used with phenomenal success by Dr. Sidney Morton Baruch in driving a liquid air turbine directly connected to the propeller of his aerial torpedo.

One of the advantages of liquid air for aerial flight, and one that at once impresses anyone interested in the long-distance flights of the future, is that it is not necessary to take into the air any machinery for the purpose of generating power, for this generating has all been done on the ground in the process of liquefying, and in a small amount of liquid air we have stored up an

immense driving force. This makes it specially well adapted to "unmanned" planes and aerial torpedoes, and in general in instances when imperative necessity makes cost of no importance.

The air travel of the future, whatever fuel may be used, will probably be carried on not only at the altitudes at present commercially available—which have already added 16 miles to the diameter of the earth, by giving mankind command of 8 miles upward on either side—but at heights far greater than are at present deemed practicable. This is bound to be the case with long flights. The resistance of the air at great altitudes being so much less, much higher speeds would be possible. The "superterranean express" with its enclosed cabin holding apparatus for oxygen-feeding of passengers and the maintenance of normal air-pressure, keeping up a speed of 500 miles an hour, may be here in a comparatively short time, if it but follows along the line of present conservative development. Maj. Gen. J. H. McBrien, President of the Aerial League of Canada, and a former officer of the Royal Air Force, goes even further, predicting a speed of a thousand miles an hour at a period not far distant. Our War Department is experimenting with an airplane to operate at a height of fifty thousand feet, fitted with liquid oxygen flasks and lined with plywood and quilted felt corduroy, to keep out the terrific cold. The airplanes of yesterday were row-boats hugging the shore of the ocean of air; we are bringing into being the Leviathans of the "high" seas of the sky, and it is on these high seas that the future of aviation lies.

ROCKET AIRSHIPS

MAX VALIER, a German astronomer and aeronaut, has been attracting much attention not only at home but abroad, by his statements that we need not be restricted, through our use of the present-day type of flying-machine, to heights of eight or nine miles now possible for flying, but may operate at a hundred miles up, or even more. His ideas are in line with the researches in various countries of Profs. Ziolkowsky, Goddard, Oberth, and von Hoefft, who with other experimenters have brought the idea of "projection into space," appreciably nearer to possibility. As evidence of the resulting change of mind on the part of the public, the editor of as conservative a periodical as the English magazine *Discovery* recently featured a description by Herr N. Valier of his "space-plane," saying

editorially, "We have printed this author's views, not because his proposition should be judged as practical politics of the moment, but rather as opening up possibilities in a field which has as

yet been the subject of a little serious research."

A rocket-ship such as Herr Valier plans, would start at an angle of at least 80 degrees, reaching as soon as possible the thin-air stratum. After 17 seconds the ship is calculated to reach a speed of 400 meters per second at 3,000 meters high; after 35 seconds, at 20,000 meters high, a speed of 800 meters; after 45 seconds at 50,000 meters high and seventy kilometers horizontal distance from the starting-point, the horizontal speed would be 2,000 meters per second. At this rate it would take an hour and a half to go from Berlin to New York.*

Herr Valier answers the objection that his proposed machine could not move through empty space because this has no resistance for power development, by explaining that just as in traveling through the atmosphere the rocket does not rely on the support of air, but moves by its own internal energy

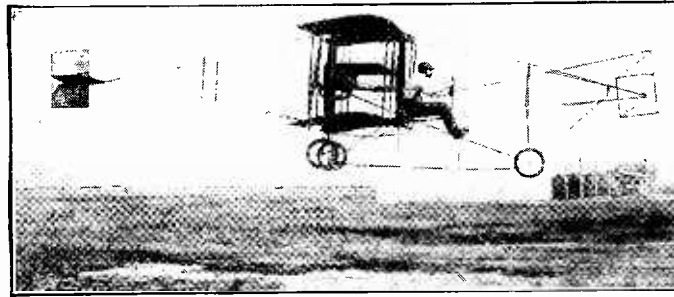

This photo shows Mr. Post piloting one of the first airplanes. Compare this with modern constructions.

through it, so his "space ship" would move forward by means of the expulsion through nozzles as exhaust, of the gas molecules developed by the explosion of the propellant fuel, whereby a continuous recoil would exist to drive the ship onward.

The imagination of writers and artists has always played with the idea of interstellar communication. But it is something really new for the imagination of inventors and engineers to take it into sober consideration, and to make calculations based upon exact data. Herr Valier says:—

"Whether we are able to build rockets of such colossal power that they will be able to force a passage to a point beyond the field of gravity of the earth and other planets, is another question. Today we know the exact formula from which to calculate theoretically the necessary recoil and we know the "ideal terminal velocity" including the overcoming of the air-resistance, of 12,700 meters per second. The real recoil of the rocket is furnished in the product of the forced-out gas-mass per second and its exhaust speed. If the ship itself permits an ideal terminal velocity which is equal to the speed of the exhaust gas, then 63.2% of the total weight of the starting machine must consist of fuel: if double or treble the exhaust speed is to be attained, then must 86.5% or 95.2% respectively of the total weight be fuel, and there remains only from 13.5% to 5% for the actual weight of machine, including cargo.

"Therein lies the greatest difficulty of the whole problem with the present flying-machines; the liquid fuel carried is at most 35%, the tare weight is about 40%, crew 5 to 10%, so 15 to 20% remains for cargo. If one takes a comparatively cheap fuel such as powder, the results are far too small for high exhaust speed (highest 2500 meters per second) and hence insupportable conditions as between fuel, cargo, and tare weight of machine. On the other hand, a very high exhaust speed (4000 to 5000 meters per second) can be obtained from explosions of hydrogen with oxygen and of similar fluid propellants of high kinetic power. These, however, are too expensive, and too heavy, while much regarding their

combustion remains to be investigated. *In fuel lies the greatest practical difficulty, even when the problem is successfully explained theoretically in other directions.*"

It is his belief that only a machine in which the method of working is quite independent of the surrounding air can open the path to the celestial spaces, and then only when it can develop sufficient power and carry fuel in great enough quantity. He thinks that the only method likely to be successful is the rocket system. It is his intention to advance along this path of development by way of the present airplane to the eventual "space-ship," working on the construction of a normal pursuit plane into whose wings will be fitted auxiliary rocket apparatus, thus making it possible to study, *during flight*, the workings of the rocket as a motive power.

It is of course to be understood that if the "space-ship" does really succeed in navigating at these immense heights above the earth's surface, there will be no putting one's head out of the window. At 25 miles up, daylight is faint; the sun is a ball of fire, but the light is not diffused, as there are no dust motes in the air—I have myself experienced an approach to this condition in a balloon flight to an altitude of 24,200 feet, and in an airplane at an altitude of 22,000 feet. Climbing to 50 miles above the earth, the ship would find no more air than would be found under the receiver of the best air-pump; and darkness is practically complete. At a hundred miles, according to Willis Moore in "The New Air World," the temperature is probably 459 degrees Fahrenheit below zero. Conditions for making human life possible must of course be maintained inside the cabin. Man must take his world along with him if he goes beyond the air, just as, under exactly opposite conditions, he manages to take it with him when he goes in a submarine below the sea.

Captain Thomas Scott Baldwin, our famous pioneer of dirigible navigation and construction, who, before he was the world's champion parachute jumper, began his career as an acrobat with Ringling's Circus, told me that the artists who drew the bill-posters displaying men turning somersaults over the backs of elephants always added a few elephants to those over which the men were at the time able to jump, and threw in a few extra somersaults for good measure. But so great is the propulsive power of an ideal that once the picture was drawn, the acrobats set themselves to equal it, and so the fiction became fact. Something like this continually comes to pass in the world of science, and its most picturesque illustration is nowadays in the field of aviation engineering.

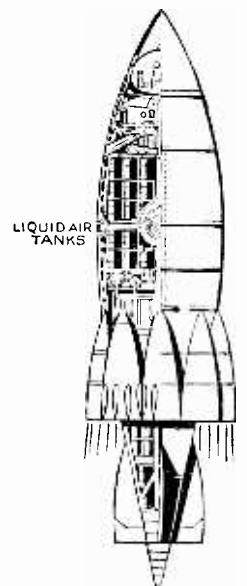

Here is a view of a different style of rocket from that opposite. This is intended for interplanetary communication. The time will come when we will be able to send men to our sister planets in space.

* One kilometer is .621 miles.
† One meter is 3.28 feet.

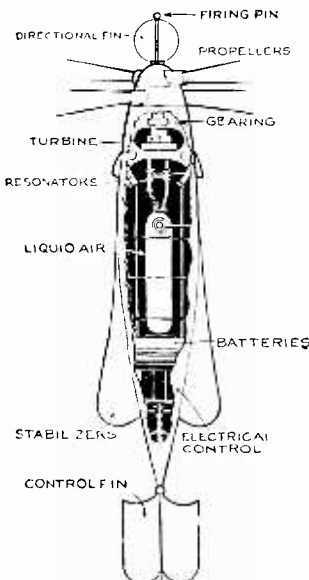

Here is the aerial torpedo designed by S. M. Baruch, employing liquid air for propulsion.

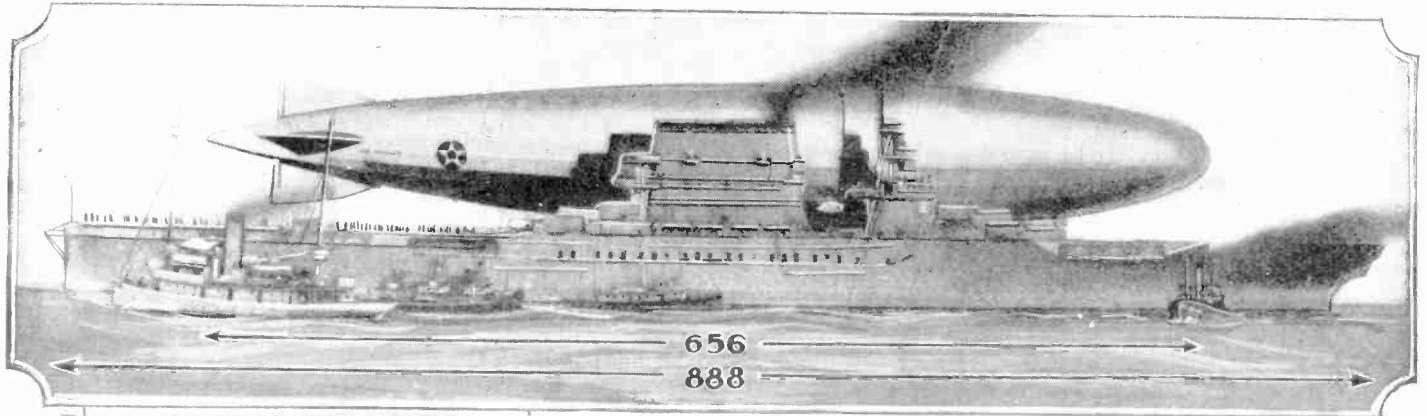

LOS ANGELES LANDS ON SARATOGA'S DECK.—The above photograph shows the giant dirigible "Los Angeles" successfully landed on the deck of the airplane carrier "Saratoga," in the first test of its kind. The photo on the following page shows the ship being hauled down to its place on deck. Figures show relative sizes in feet.

Scientific

A Photographic Picturization of Modern Scientific Advances

It is almost impossible to keep up with the rapid strides taken in the field of science. This is truly a scientific age. On these pages we can portray but a few of the advances made in many different fields.



SUBMARINE LIGHT FOR SEARCHING LAKE BOTTOM—In the search for a missing college student, Gilbert C. Weis, of Indianapolis, brought into use the submersible searchlight indicated in the photo above. This is simply a long tube, darkened on the inside with a bell-shaped housing at the bottom, in which four lamps are placed. The device is operated by two storage batteries. The diagram at the right shows the way in which it is used. It is an improvement over the old style of water telescope, which consisted of a long tube with a piece of plate glass at the bottom. This device can be better used at night than in the daytime.

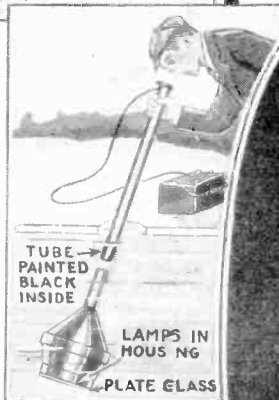

NEW BATH TUB AID—Depending upon how many tanks there are, a device invented by F. J. Cantrel of San Francisco, Calif., will deliver soap suds, fresh water, toilet water, salt water, or what you will. Photo shows three streams in use at same time.

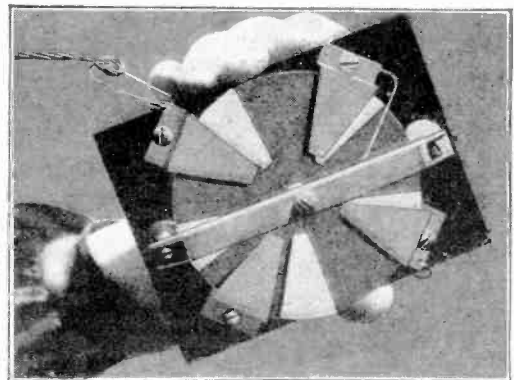
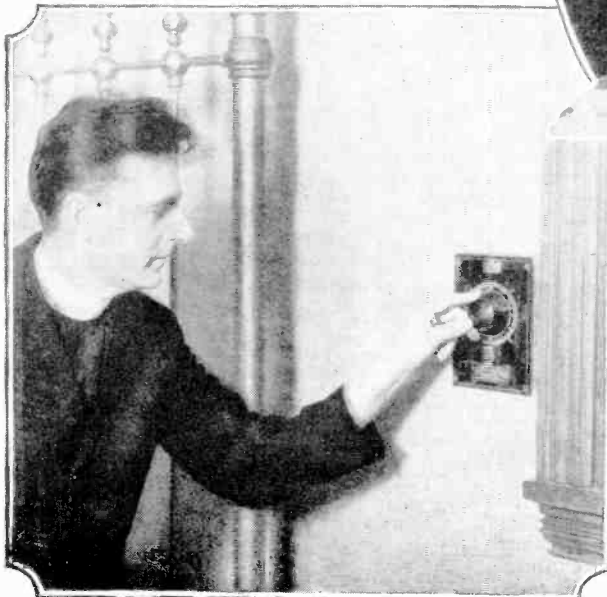

MOTOR OPERATED BY STATIC—Of course, we know that static may ruin a perfectly good radio program in the summertime, but here is a device that will not work unless there is plenty of static present. It is a static motor, and operates from power obtained from the air. The motor is connected in series with the antenna and the ground. This device was built by C. Francis Jenkins, of Washington, D. C. Copyright Harris and Ewing.

MAGNETIC CHESS BOARD—The playing pieces of this chess board are magnetized so as to hold the set to the metal board, regardless of the position of the board.

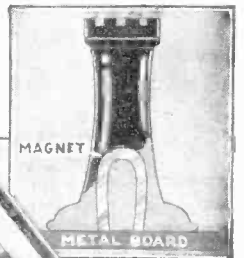

The diagram above indicates how the chess pieces of the magnetic chess board are made. The magnet comes in direct contact with the metal board.

NEW WAKING ALARM—This device was invented by Father Daniel Driscoll of Villanova College, Pa. It is noiseless, but when once set, will operate for fifteen minutes and then stop.

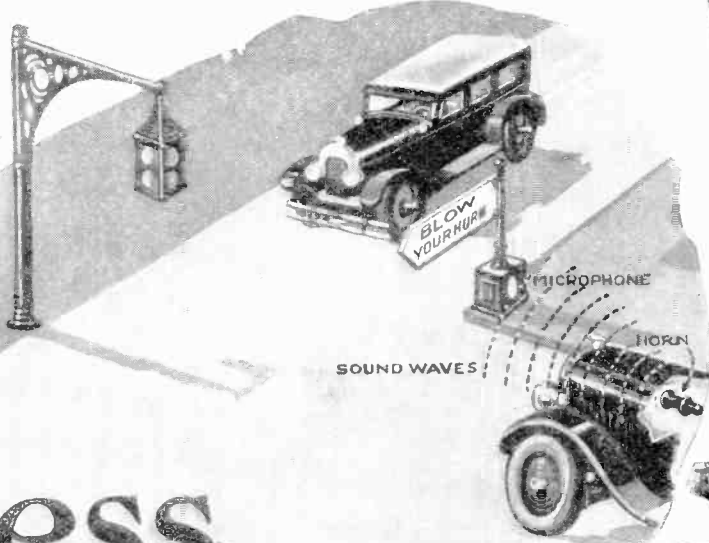
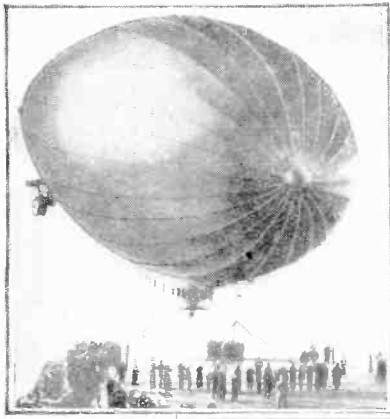

ANTI-AIRCRAFT GUN—This 3 inch anti-aircraft gun has a vertical range of about 5,000 yards, and can be fired at a rate of 25 shots a minute. It has been adopted by the U. S. Army.

Progress

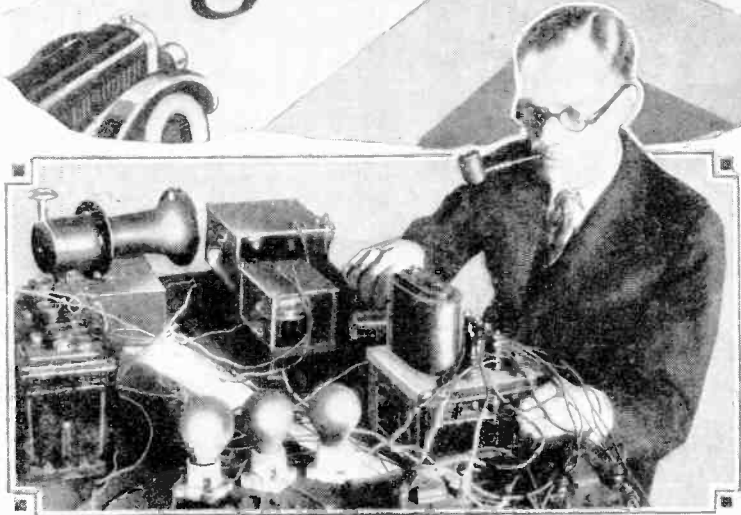
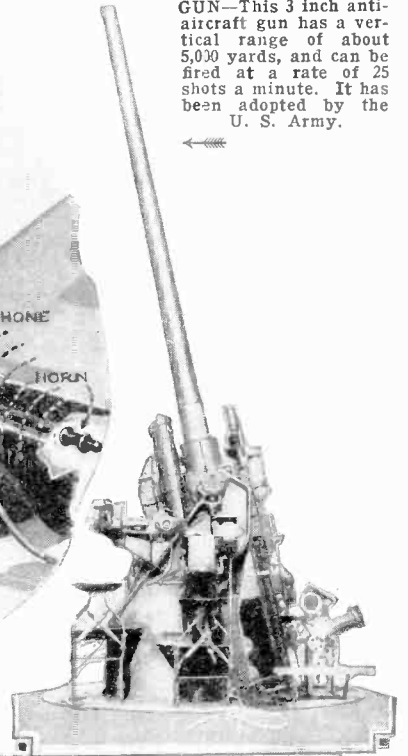

AUTO HORN OPERATES TRAFFIC SIGNALS—The above photograph shows Charles Auler consulting safety engineer with his device which may speed up traffic considerably. An autoist desirous of crossing a main thoroughfare from a side street, draws up to the curb and sounds his horn. These sounds are picked up by a transmitter and then sent through other apparatus, turning on the red light on the main highway and giving the motorist ten seconds to proceed, after which the light switches back again. Picture diagram shows operation.



It is claimed that with the device indicated and demonstrated by Dr. I. S. Falk and Ruth Bilger, that the killing power of diphtheria bacteria can be electrically determined.

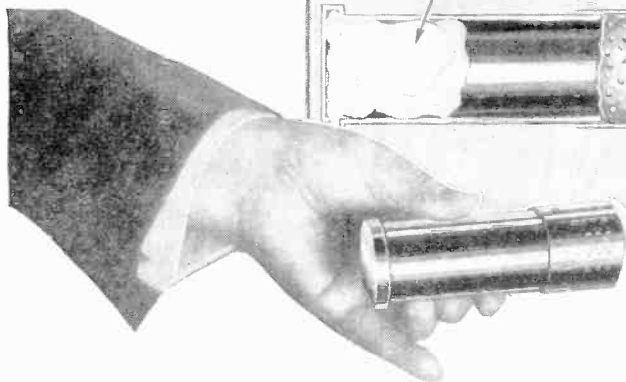
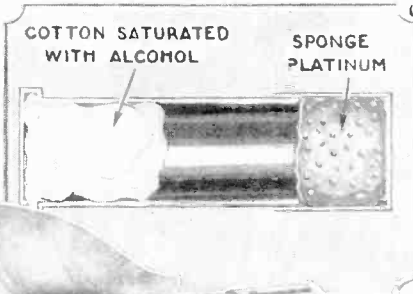

POCKET OVEN—The photograph above and the diagram inset show the invention of Dr. Kalischer. This is a small pocket oven. The fumes from an alcohol saturated wick are absorbed by sponge platinum which incandesces to such an extent that it warms the container. It can operate for twelve hours.

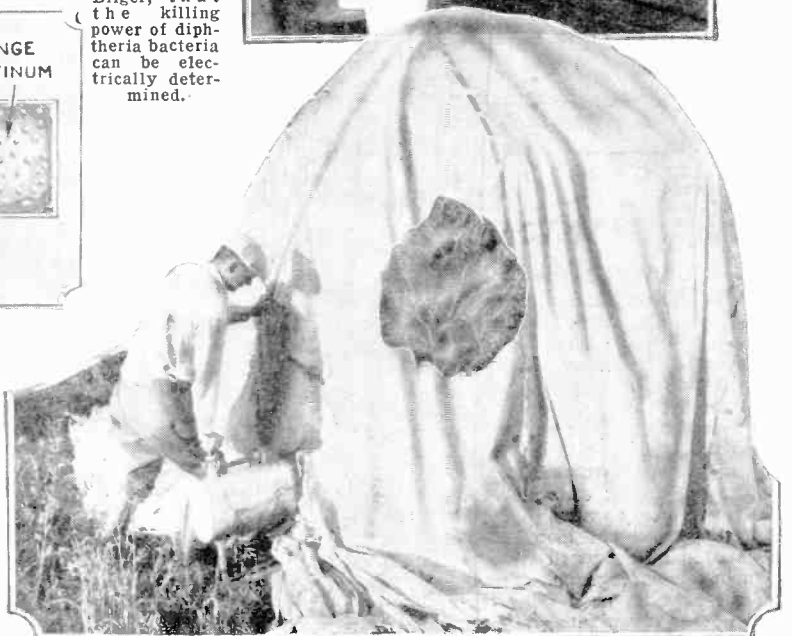

INSECTS GASSED BENEATH CANVAS HOODS—In the Los Angeles region, insects and lava as well as the eggs of insects, are killed by covering the tree with a canvas hood, then pumping a cyanide solution under the tree with a special pump. After this, the cover is removed. Photo Ewing Galloway.

Springtime Garden Suggestions.

A Number of Timely Aids for the Back Yard Enthusiast



Above—Watering a withered plant with the aspirin solution.

ON this page we have illustrated a number of practical springtime garden hints, which we believe will be of interest to many. The devices or processes which have to be employed are of a simple nature and their use should result in better gardening.

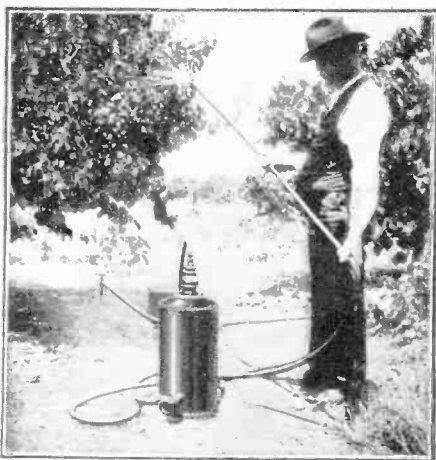

A photograph showing the garden spray in use appears above. Note that the spray nozzle has been fastened to a piece of pipe as an added convenience.

RESTORING DROOPING PLANTS

MANY plants thrive well enough out of doors, but when potted and brought into the house have a tendency to droop and if nothing is done, eventually die. Badly withered plants can be revived and brought to normal by using a weak solution of aspirin, or acetylsalicylic acid as it is known chemically. It is readily soluble in 100 parts of water. Two tablets should be dissolved in each pint of water used. If the solution is slightly warm, the reviving action will be hastened considerably. The whole plant should be drenched with the liquid as shown in the photograph. The aspirin mixture can also be used with surprising results in restoring plants which have become

frost nipped, but here, the solution used should be cold, states S. Leonard Bastin.

MAKING A TREE SPRAYER

A TREE SPRAYER which anyone can easily make at home is shown upon this page. It will save the exertion of the usual hand-pumping operation and the expense of a large motor-driven machine. The spray is operated by water pressure. A metal drum



The above photo shows the plant ten minutes after the aspirin solution was applied.

holding about 8 gallons is fitted with a water-proof bag which contains the spray solution. A connection is made with a hose from the water hydrant to the cask or drum, thus using the water pressure to force the spray from the bag. A length of hose fitted with a spray nozzle is fastened to the top end of the bag. The particular sprayer described here, was made to supply a small orchard of 15 trees, says Mae McKie.



The method of making a goldfish basin from a discarded bathtub is clearly shown above.

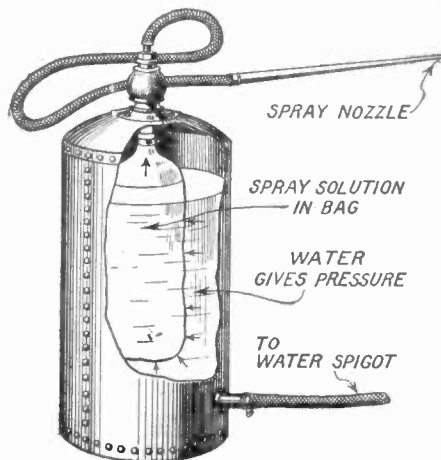

Details of the home-made garden spray are shown in the above illustration.

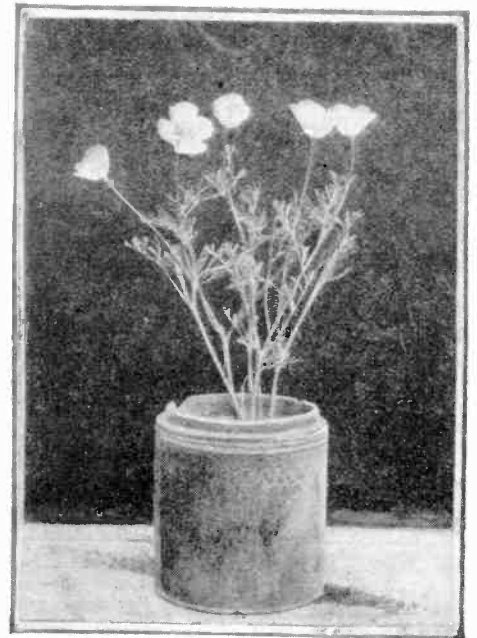

A photograph of the plant taken 25 minutes after aspirin was applied, shows that it was completely revived.

A GARDEN GOLDFISH BASIN

DAMAGED or discarded bathtubs make excellent basins for goldfish and the like when sunk into the ground of a garden, as shown in the illustration. Any holes in



Above we have a photograph of the novel water bouquet described in the text.

the tub should be plugged thoroughly before filling with water. Cover rim with bricks.—P. C. Van Petegem.

A WATER BOUQUET

A VERY pretty way of arranging flowers is in the form of a water bouquet. For this purpose a glass shade of some kind is required and a dish on which this can be placed. Some soft adhesive medium like clay or putty, will now be needed. Put a lump of this into the center of the dish and then insert the stalks of the flowers which are to be used in forming the bouquet. Almost any kind of flowers will do for the (Continued on page 71)

Advances in Travel

Cameraman Snaps Interesting Views of Various Means of Locomotion

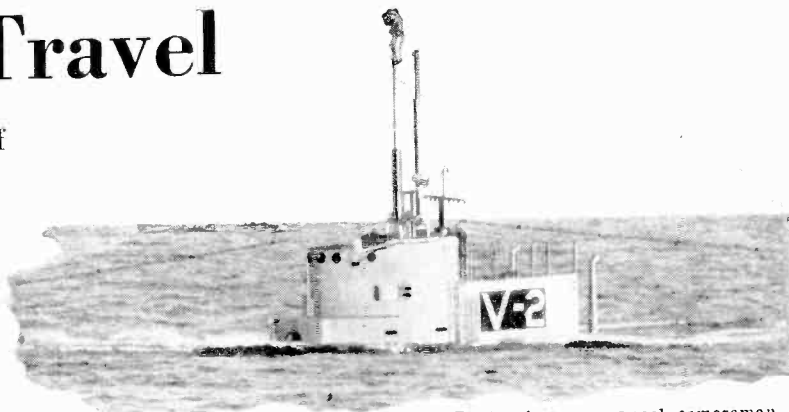
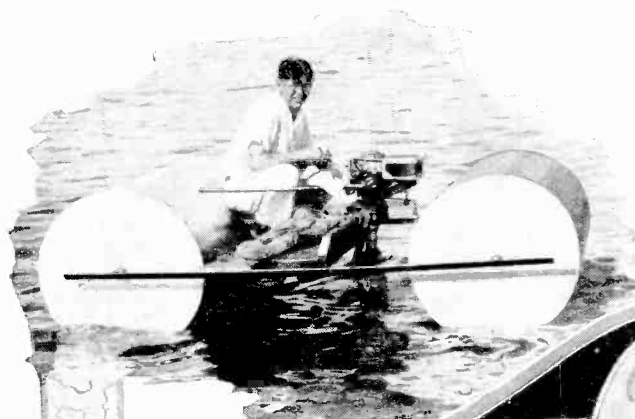
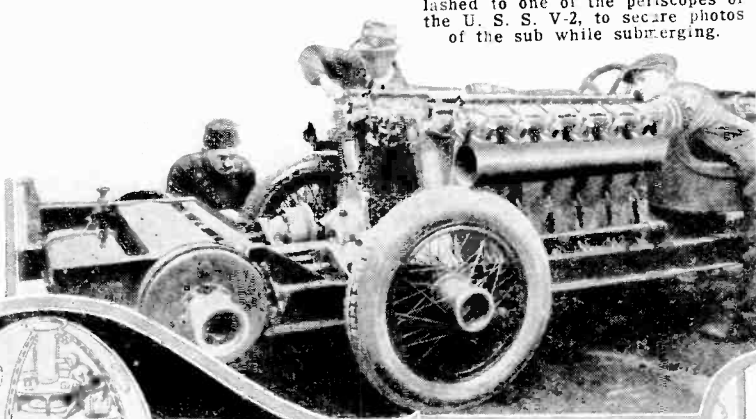

Photo shows news-reel cameraman lashed to one of the periscopes of the U. S. S. V-2, to secure photos of the sub while submerging.



This boat is supposed to roll along on the water. It was built by E. R. Thomas, of Buffalo. Two galvanized iron drums can turn freely on their support. Power is supplied by an outboard motor, located in the center.



Zoom!—225 miles per hour (unofficial) made by Triplex, three-motored auto shown above. The 3,000 H.P. is geared directly to rear axle.

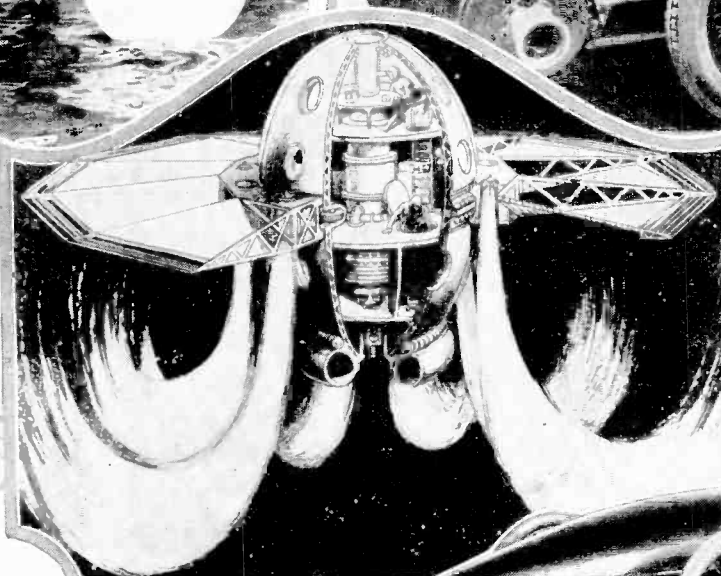

Here is the Bluebird, Captain Campbell's speed devil, which was entered in the International speed trials. Note airplane tail design to prevent swerving at high speeds. Also observe streamlines. This machine made 206.956 miles per hour.

Contrast the automobile shown above, called the Tea-Kettle. Frank H. Marriott's Stanley steamer, which was the fastest thing on wheels in 1906. It made a mile in 28 1/5th seconds on the Daytona Beach. Observe the auto advances made in twenty years.

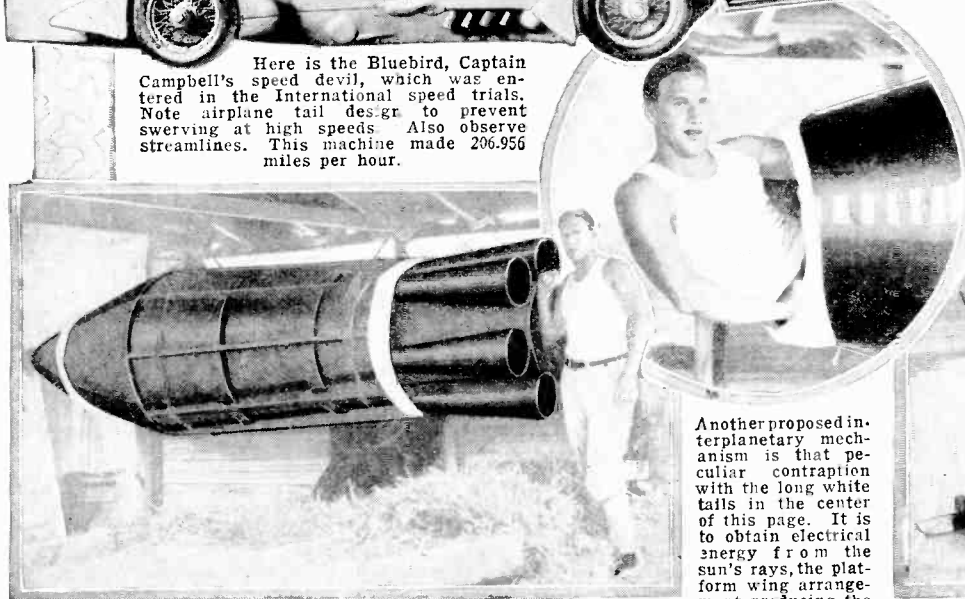

Another proposed interplanetary mechanism is that peculiar contraption with the long white tails in the center of this page. It is to obtain electrical energy from the sun's rays, the platform wing arrangement producing the lifting power. It was designed by Uliniski and is said to be under construction.

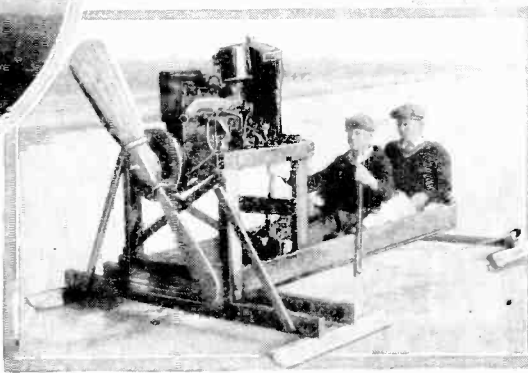

Here is an ice boat made by two youngsters, Ronald Ringsrud and Leonard Murphy, of Elk Point, S. D. Some two-by-fours and a propeller made of spruce, together with an auto engine, produced a speed of 35 miles an hour.

The photograph above shows the torpedo designed by Prof. Robert Condit, in which he expects to take off toward the planet Venus. Explosions drive the mechanism through the air like a rocket. Insert shows the professor in the machine.

The Month's Scientific News Illustrated

By GEORGE WALL

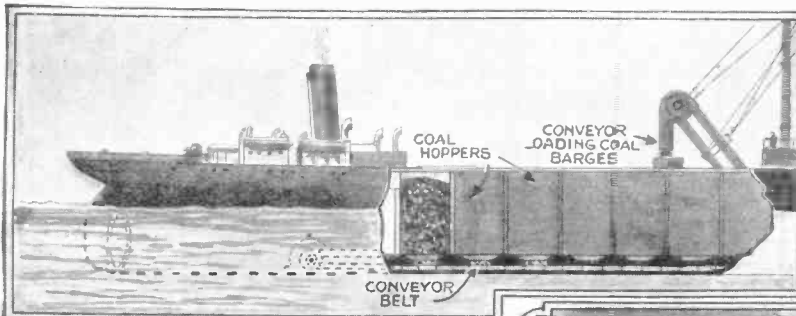

A new self-discharging collier has recently been put in service by a Montreal concern. Features of the boat's design are conveyor belts situated below 40 hoppers holding the cargo, which carry the coal over a boom extending 75 feet out from the vessel's side when discharging. When the boom is not in use, it can be lowered between the hatches and lashed in place. The ship is called the "Coalfax," and has a dead-weight capacity of 3,050 tons. She made a 20-day voyage from England, where she was built, to Montreal, Canada.

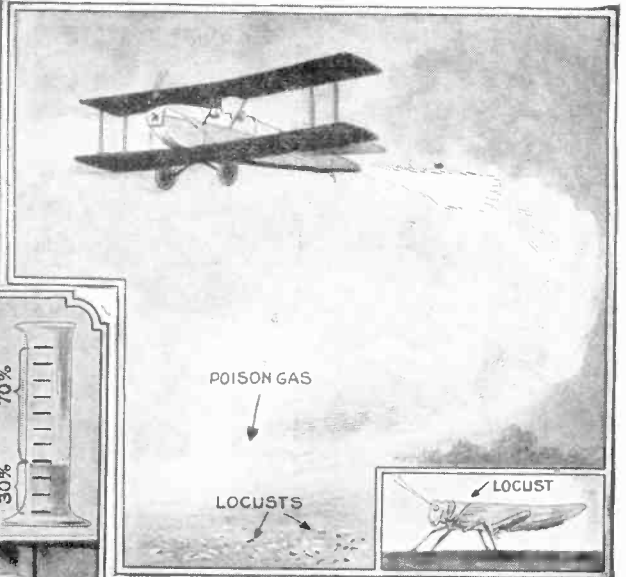

The Egyptian government is taking active measures to combat an invasion of locusts. The young locusts are now in the crawling stage, and efforts are being made to kill them before they reach the flying stage. The British air force is lending assistance in the campaign, and will use poisonous gas emitted from an airplane to destroy these pests.



Tests are being made on a new motor fuel which contains from 20 to 30 per cent of alcohol. This new fuel will give great acceleration on hills, and the engine may be used for a long period of time, without the necessity of grinding valves or removing carbon.

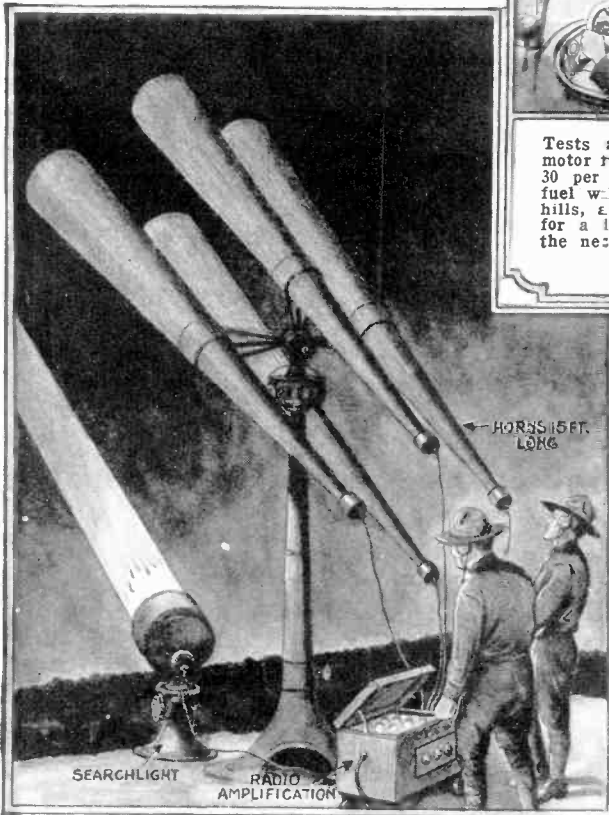

The U. S. Army has perfected a sound locator which picks up a plane 15 miles away. A 15-foot horn picks up the sound made by an airplane, which is further amplified by a bank of radio tubes. At night a searchlight is synchronized with the sound-locator. The horns work in pairs and these are attached to two observers. One for the horizontal, the other for the vertical movement.

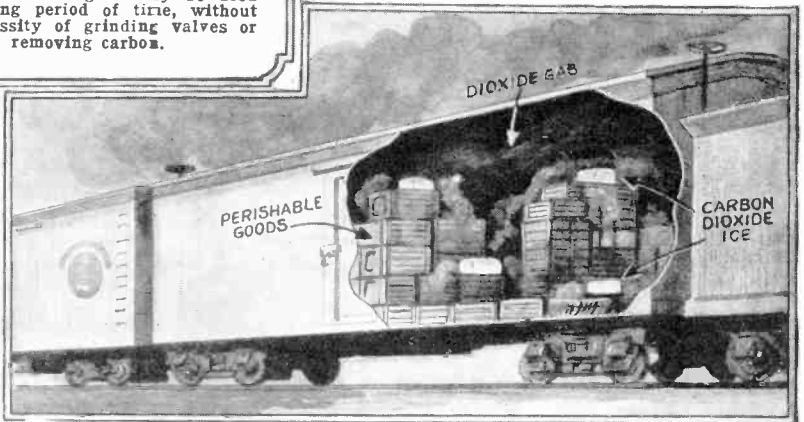

Ice cream and perishable foods are now sent from New York to Cuba and arrive in perfect condition. Solid carbon dioxide "ice" or "snow," so-called "dry ice," is used for the refrigerant. The reduction of this substance by evaporation is only about 10 per cent in 24 hours. The carbon dioxide gas given off, being heavier than air, forms a frigid insulating blanket and keeps warm air away. This new refrigerant is about fifteen times as efficient as water ice.

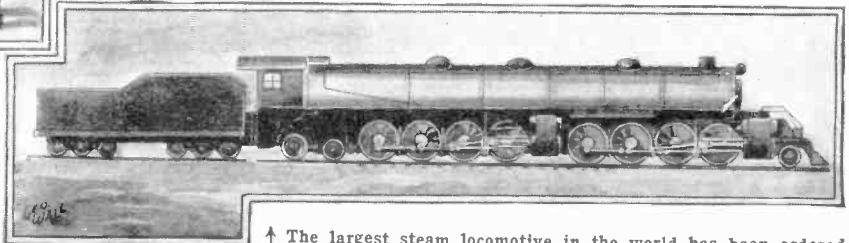

The largest steam locomotive in the world has been ordered by the Northern Pacific Railroad, for use between Mandan, North Dakota, and Glendive, Montana. The Northern Pacific engine will be 121 feet in length, over half as long as a city block. It will be carried by 22 wheels, 16 of them will be "drivers." The engine tender will hold 26 tons of coal and 20,000 gallons of water. The area of the grate will be approximately 183 square feet. The fire-box measures 266 inches x 114 inches. The tender is to be 33 feet long and about 16 feet high, at its front end.

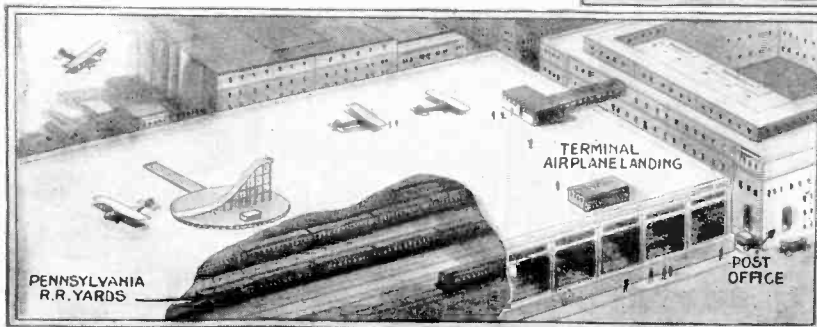

Eight of America's largest railroads are considering plans for constructing airport landing decks above city terminals. The planes would be used in connection with rail transportation. Complete plans have been formulated for railroad terminal landings, at about twenty of the largest cities. Mr. F. Naulty, an aeronautical engineer, has been engaged to work out details of the construction. He is also the originator of the airport landing deck idea as outlined recently by Postmaster General New. It is considered that this method of airplane landing offers the best practical solution of the airport problem in congested communities.

Wonders of Nature

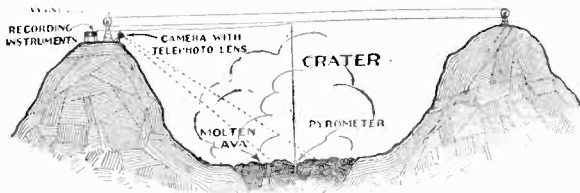

Above—Method of making pictures and recording temperature.



Above photo shows an island in a lake of lava flowing from Kilauea, the Hawaiian volcano now in eruption.

Above is an exceptional night view of the lava fountain.

The above photo shows the Taku glacier in Alaska, first traversed by Rev. B. R. Hubbard and party.

THE world's largest volcano, known as Kilauea is situated in Hawaii and is now in eruption. By means of a telephoto lens it was possible to take the remarkable photographs shown here which give a view of the lake of lava and a night view of the spatter-phase of the lava fountain of the volcano. By means of this lens, Mr. Frank A. Perret, a famous volcanologist was able to take these pictures. The drawing at the top of the page shows the method of taking pictures, and how the temperature of the lava can be measured with a pyrometer suspended upon a cable stretched across the crater.

The photograph at the top of the page to the right, shows a view of the ice covered wilds of the unmapped glacier Taku, in Alaska. Rev. B. R. Hubbard, Prof. of Geology of the University of Santa Clara, California, accompanied by two companions recently crossed this unmapped waste of ice. For over 85 miles they pushed across ice and rock, every step of their journey fraught with dangers. The arrow on the glacier photograph points to Jack Koby, a young prospector, one of the exploring party, as he is seeking a way across the ice.

Below is an architect's drawing of a proposed skyscraper bridge, with a ship passing through the widest span. The huge structure may link Chicago's north and south lake shore drives. Charles Morgan, Chicago artist and architect, has submitted drawings for a mammoth bridge 150 feet wide using skyscrapers 25 stories high as piers. The structure, if built, will be several miles long and present the appearance of a row of skyscrapers connected by arches.

A Remarkable Aqueduct

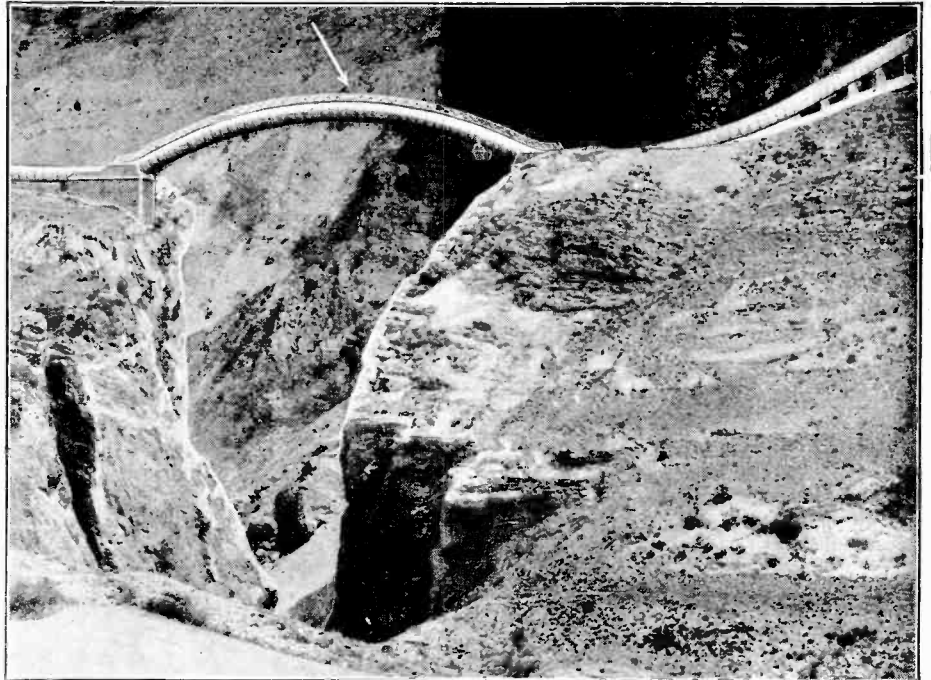

The above photograph shows a great serpentine water conduit used in conjunction with a hydro-electric power plant in the French High Alps. The ruined walls of Vaudois may be seen at the bottom. The water supplies the hydraulic works of the city of Vaudois. Bridging a large gap in the mountains, the overhead water aqueduct is an achievement of modern engineering.

Mammoth Skyscraper Bridge

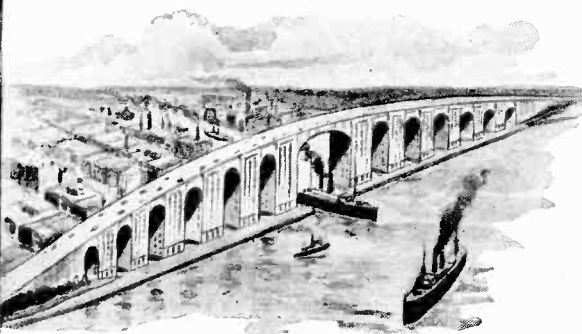
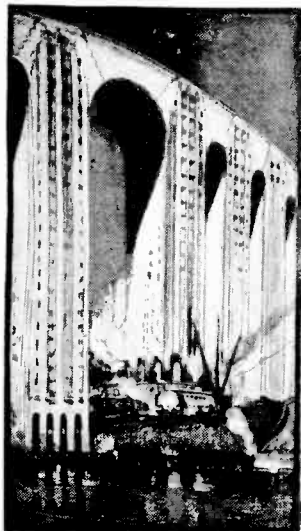

THE huge bridge shown at the left would alleviate traffic conditions in Chicago. Business men would find it convenient to have their offices in one of the skyscraper piers and keep his car in a garage built on the bridge. The center span of the bridge would be wide enough to stretch across the Chicago river and high enough for the tallest boats to pass under. It is suggested that the entire structure be coated with terra cotta, so that when viewed from the city or Lake Michigan, it would appear as a rainbow. Motorists passing through the city, would not find it necessary to thread through the heart of Chicago and the heaviest traffic, as they do at the present time.

Science Frauds Exposed

By K. M.



Above, Postal Inspector D. F. Angier is shown inspecting a number of fraudulent articles. The inspector is directly responsible for running down a large number of these frauds. It is Mr. Angier's job to collect evidence concerning the various articles and submit it to Horace J. Donnelly, the solicitor of the Post Office Department.

BARNUM knew the gullibility of the race, when he said, "There's a fool born every minute," and Barnum proved himself right to the extent of amassing one of the world's largest fortunes. As long as there is a civilization, though it be tenaciously materialistic, there will be credulous individuals who are ready to acknowledge miracles, even in the form of colored water and metal rings "guaranteed" to cure every ailment from adenoids to cancer. As a vaudeville comedian recently said, "In 1776 it was Bunker Hill; in 1928 its 'bunkem still!'"

Marking back to the old medicine road shows, we have the foundation of the "profession" on which the medicine faker has built his profitable business. But with the increased population and growth of cities, the tent show faded into the limbo relegated to the horse and carriage, and the mails became the medium of barter between the medical charlatan and his ever-trusting public. Once more fate has stepped in and hindered his progress, this time in the form of the United States Post Office Department and *SCIENCE AND INVENTION* Magazine, the latter organization conducting a private investigation in line with that under way in the Post Office Department.

WHAT CONSTITUTES A FAKER

LAST year Uncle Sam refused the privileges of the mails to at least 50 of these medical fakers, whose business receipts amounted to over \$5,000,000. When Postal Inspector D. F. Angier, of Chief Inspector Grant B. Miller's Office, undertakes to run these fakers to earth, he considers two problems: Are their remedies deliberate misrepresentations, do the makers know their remedies to be worthless; or are they ignorant, and think they have made a startling discovery? After he has decided the class in which to include the offender, he collects the necessary evidence, and the Bureau of Chemistry then steps in to analyze the wonder-working liquids that cure tuberculosis and cancer with ease—a feat which the medical science has failed to accomplish with drugs.

PENALTY FOR FRAUDULENT USE OF MAILS

WHILE the Post Office Department cannot be nursemaid to childish individuals who expect to find the fountain of youth in a box of pills, they protect the public to the extent of their power, specifically stating that: "The reliability of any person, firm or corporation is not passed on by the Department, and the Department is

not a collection agency and does not undertake to effect the return of any money which may have been lost in unsatisfactory business transactions; but, the Post Office Department does seek to prevent the use of mails in all schemes to defraud, and the Postmaster General may, upon evidence satisfactory to him that any person or company is conducting a scheme for obtaining money through the mails by means of false or fraudulent pretenses, representations, and promises, direct that all mail for this person or company be stamped 'Fraudulent' and returned to the sender. The penalty for using the mails in schemes to defraud is, upon conviction, a fine up to \$1,000 or imprisonment up to 5 years (one or both), and every letter mailed in pursuance of this scheme is considered a separate offence."

A FAKE PYORRHEA CURE

AFTER Inspector Angier has collected evidence, he submits it to the Solicitor of the Post Office Department, Horace J. Donnelly, who conducts the hearings and determines whether or not to issue a fraud order. Postmaster General Harry New takes the final action. This procedure was

ELECTRO-CHEMICAL RINGS
(A Most Preposterous Fraud)

These iron or steel rings have no curative value whatsoever. Note the long list of diseases they are guaranteed to cure.

FRAUD ORDER ISSUED
Against Electro-Chemical Ring Co., Toledo, Ohio

Acidity of Stomach	Nervous Prostration
Adenoids	Neuralgia
After Effects of:	Neuritis
Diphtheria; Scarlet,	Nosebleed
Typhoid, and Malarial	Painful and Excessive Monthly
Fever	Periods
Appendicitis	Polypus
Asthma	Prostatitis
Bright's Disease	Psoriasis
Calculi	Rectal Ulcers
Cancer - Carcinoma	Rheumatic Fever
Cancerous Tumors	Rheumatic Paralysis,
Cataract	Brain, Hair, Eyes,
Chlorosis (Green Sickness)	Ears, Limbs, Pen,
Congestion of Kidneys	Operators, Typewriters
Chorea	Rheumatism, -
Chronic Dysentery	Inflammatory, Gout,
Deposit on Teeth	Lumbago, Articular,
Diabetes	Sciatic, Muscular
Dropsy	Rhinolith
Epilepsy	Salt-rheum
Fatty Degeneration of Heart	St. Vitus Dance
Gall-Stones	Stone in Bladder
Goitre	Syncope
Gravel	Uremia
Headache	Valvular Rheumatism of Heart
Indigestion	Varicocele
Inflammation of Bowels	Venecose Veins and Ulcers
Internal Hemorrhage	White Spots on Nails
Obesity	Whooping-Cough

Above is a magic ring which has no curative properties whatsoever but was advertised to cure 62 ills of mankind from adenoids to cancer. The rings were made of iron or steel and worn upon the finger. They cost about ten cents to manufacture and were sold for \$2.50.

by Uncle Sam

PAINTER

observed in the recent issuance of a fraud order against the makers of Amasol, a concentrated solution for use in the cure of pyorrhea. Consisting of common sheep dip, used to kill parasites, the sale of Amasol spread like wildfire, and in the year which this product was on the market, the maker realized \$48,000 profit.

When Inspector Angier wrote for a bottle of Amasol, he said, "I have a bad case of pyorrhea, so bad, in fact, that I can remove my teeth from the gums and put them back. If your remedy will make my teeth adhere, send me a bottle C. O. D." In sending the remedy the company, in effect, agreed to "grow" teeth, thereby making themselves answerable to the Post Office Department's fraud order.

cial success. The testimonial read: "From the use of your ring I was cured of rheumatism, neuralgia, indigestion, kidney and bladder troubles and heart trouble. I would not do without wearing it for \$1,000, for life is all!"

HOW "ELECTRO-CHEMICAL" RINGS WERE TO BE USED

To ease the minds of those suspiciously

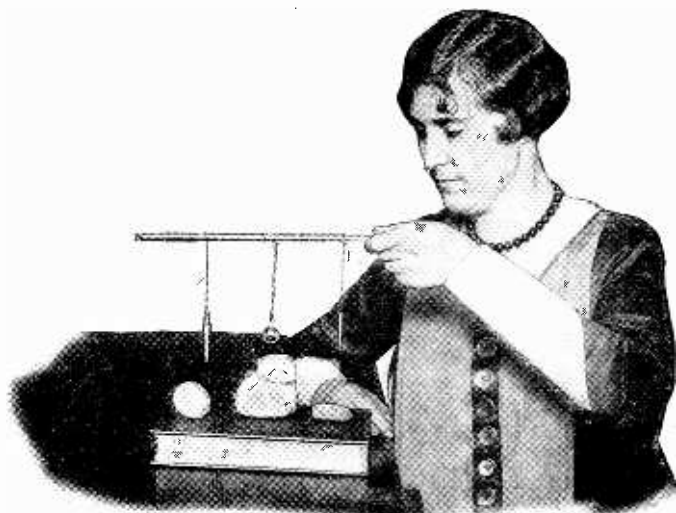

Above are three different types of "sex indicators" which are supposed to indicate the sex, whether dog, peanut or egg.

MANY TESTIMONIALS BONA FIDE BUT WORTHLESS

MANY cases of testimonial givers are bona fide, the sufferer hastening to report a cure as soon as he feels the effect of the laxative or tonic contained in practically all of these remedies. Undoubtedly he is the innocent ally of the medical faker. For instance, "Electro-Chemical Rings" were "guaranteed" to cure diseases caused by acid in the blood. By the aid of a testimonial signed by a "cured" minister of the gospel, this fraud was perpetrated to a finan-

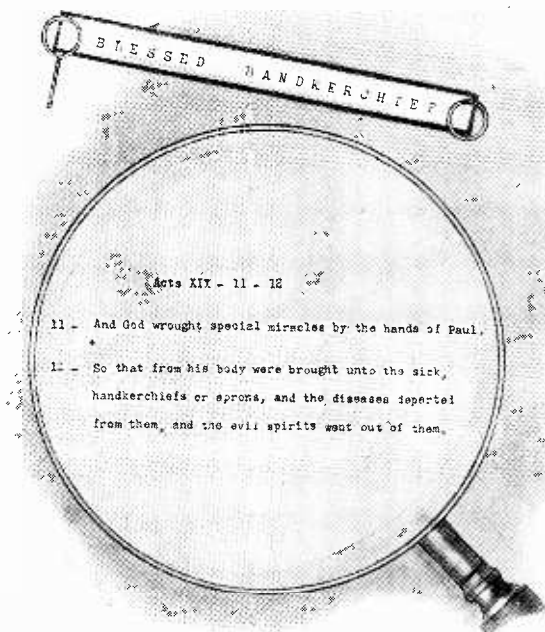

Another fraud known as the "blessed handkerchief" was supposed to contain divine healing power. These kerchiefs were merely unhemmed squares of muslin costing about three cents and selling from \$5 to \$15.

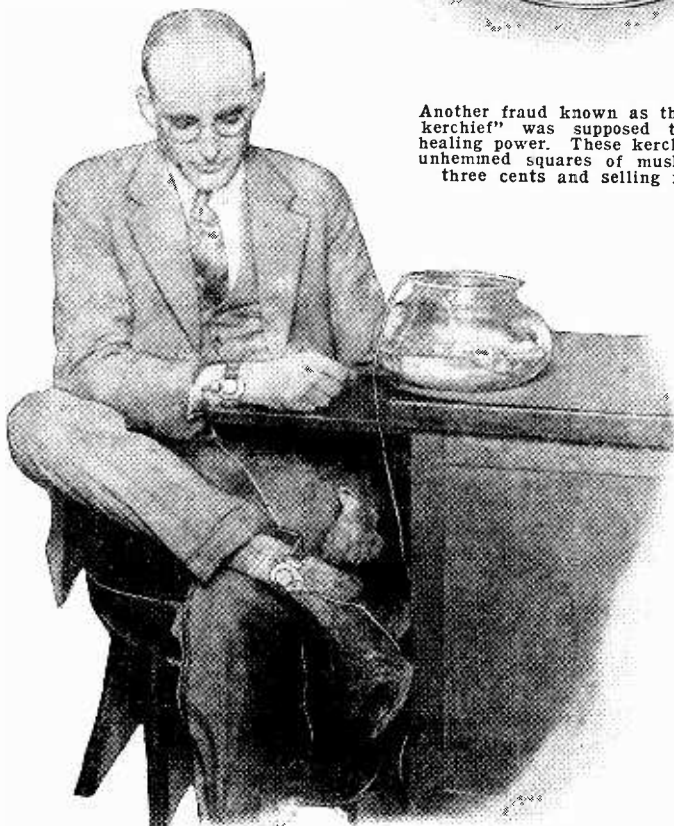

At the left is a photograph of one of the clerks in the U. S. Post Office Department demonstrating the so called "Oxypathor" a "cure-all" which is made of nickle plated gas pipe, containing sand or other inert material, and flexible cords for fastening to the body of man or beast. The pipe is submerged in water, while the patient strapped two contacts to his body, one on the wrist and one on the ankle. The same concern also made an "Animal Oxypathor." The "Oxypathor" costs about \$1.23 to make and retailed for \$35 while the "Animal Oxypathor" sold for \$50.00.

inclined who might wonder at the tarnish caused by these rings which were made of iron or steel—having no curative value whatever—the directions stated: "The ring must be cleaned bright on the inside, at least once a day, when in use. If the deposit on the finger is strong, clean twice a day. Clean inside with a knife, scissors, emery-cloth, fine sandpaper, pulverized pumice-stone or coarse whetstone. Use a small piece of pumice stone, soap and water to clean finger, if deposit will not wash off." Utterly without conscience, the makers of "Electro-Chemical Rings" further advised: "In some cases the acid is so intense and the action of the ring so strong, as to cause a sore under the ring; this is an indication of the greater necessity for wearing the ring; wear it on some other finger or between the first and second joints of any finger on either hand until the finger usually worn on gets well." Manufacturing costs were about 10 cents, while the ring sold for \$2.50.

"OXYPATHOR" A WONDER INSTRUMENT

PERHAPS the greatest fraud of recent years was the "Oxypathor," specializing in the cure of cerebro-spinal meningitis, though also extensively advertised for the cure of milk fever, Texas fever, hog cholera, rheumatism, blood poison. Almost every country community in America had its "Oxypathor," and in addition, hundreds of thousands of these instruments were sold in India, Spain, Egypt, and Africa. The principle of this device was that water had magnetic properties of a curative value and when superficially absorbed by the body, water worked wonders. The "Oxypathor" (a piece of nickle-plated gas pipe filled with sand) need be submerged in water, while the patient strapped two "contacts" (strips of tape, with metal disks) to his body—one to the wrist, the other to the ankle.

Not content with working miracles on humans, this enterprising concern manufactured the "Animal Oxypathor," yet, strangely enough, no provision was made for keeping the animal to be treated in a fixed position, while the "Oxypathor" was working, and contacts were around the fore-legs and body of the animal. The "Oxypathor" cost about \$1.23, and retailed for \$35; while the "Animal Oxypathor" sold for \$50.

FOURTEEN REMEDIES ALL MADE SAME WAY

FOURTEEN different remedies, known generally as "Vegetable Compounds," netted \$300,000 for their brewer. Curing anything from cancer to snakebite, the compounds were ordered according to the ailment—the number from 1 to 14 each representing a dire malady. However, the Bu-

(Continued on page 69)

New Inventions Shown

Recent Refinements Provide Greater

By H. W.

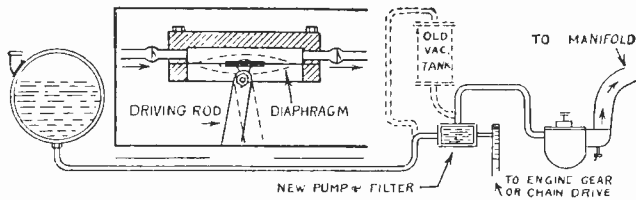

FUEL PUMP—A new system of feeding the gasoline to the engine, which has hitherto only been used on racing cars, is now being installed on many modern automobiles. The system is shown above and does away with the vacuum tank by making use of a small pump. This pump is cleverly constructed and has a flexible diaphragm for pumping. This maintains a constant flow of gas and is much more reliable than the old method of vacuum tank feeding.

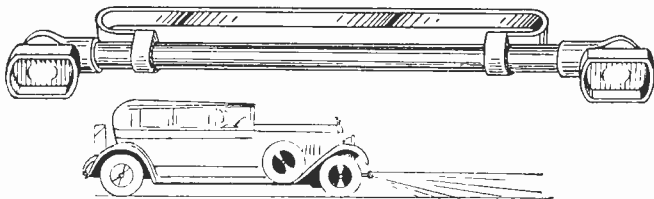

ILLUMINATED BUMPER—A new safety bumper for night driving has recently appeared. The road ahead is clearly illuminated by safety road lights placed on either side of the bumper, as shown above. These lights do not have to be dimmed as the beam shines directly ahead of the tires for more than 500 ft., but does not bother approaching drivers. Furthermore, it is never more than 20 inches off the road. The bumper ends, lenses and reflectors are practically indestructible.

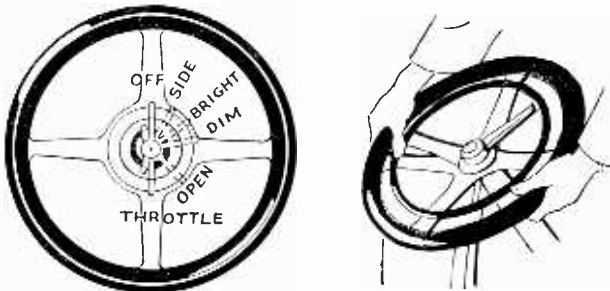

CONTROLS ON WHEEL—Two other novel features seen at the Show were a new steering wheel with a solid steel core having all controls, such as throttle and lights, mounted upon it directly. The other device was a signal ring which is attached to the wheel as shown, and a horn pressure anywhere upon its upper rim closes the circuit operating the horn. The rim lies centrally on the wheel and may be installed in any car.

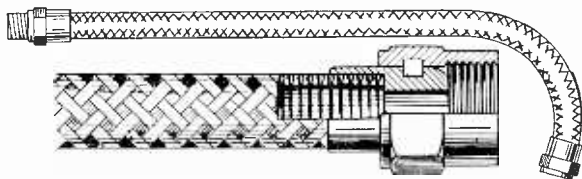

FLEXIBLE METAL HOSE—A New flexible metal tube which will function reliably and is as reliable as solid pipe, is now being manufactured and finds particular use in automobiles. The tubing is all metal and no packing is necessary in making a connection. As it is all metal it does not deteriorate as rubber will. A section of the tubing showing the metal braid construction and swivel coupling appears above.

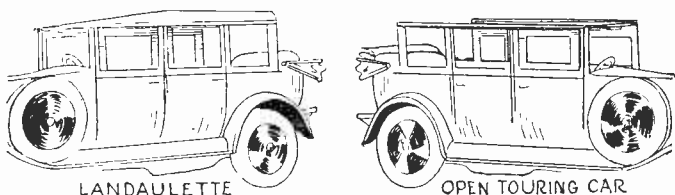

CONVERTIBLE BODY—A progressive firm is now making a convertible car body which can be quickly changed by the driver from an open touring car to a landauette, or vice versa. The transformation can be effected with ease. It is simply necessary to release two thumbscrews and to turn a handle. When the roof has been removed, the windows can be lowered, and the automobile is then transformed into a touring car.

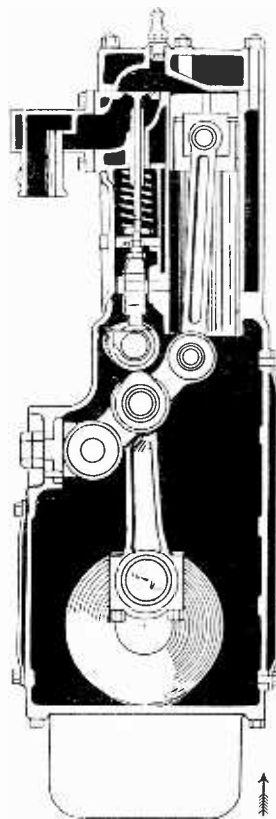

IMPROVED ENGINE—The very latest development in automotive power is shown above. This motor uses a lever which is interposed between the piston and the crank shaft. Superior acceleration, higher compression and a more complete burning of fuel, are a few of the advantages of this new engine.

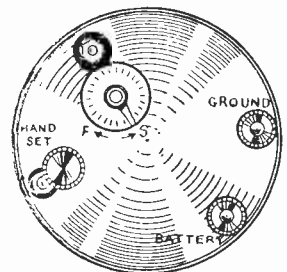
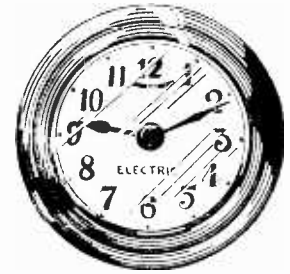

ELECTRIC CLOCK—The value of an automobile clock depends upon its reliability. The electric clock shown above gives the motorist the correct time always. The clock automatically winds itself and is connected to the car storage battery. A jeweled movement and rugged construction insure correct time. It requires no attention from the car owner, for it is wound automatically.

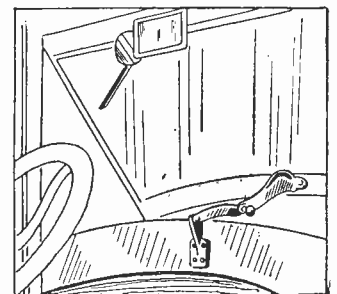
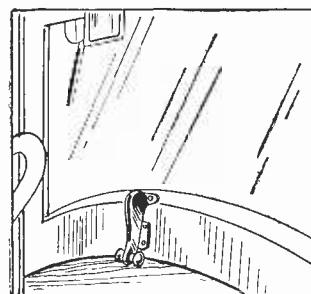

ONE-HAND WINDSHIELD ADJUSTER—No longer does the motorist have to wildly clutch the steering wheel in one hand, while he frantically endeavors to open the windshield. Quite a number of accidents have been caused in just this manner, when the driver either lost control of the car, or failed to notice an approaching car. The small "one-hand" lever shown above permits the windshield to be opened easily. There are several notches which make it possible for the windshield to be locked at various angles.

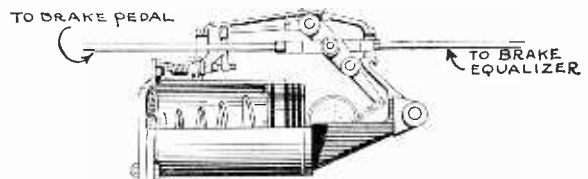

VACUUM BRAKES—A new margin of safety is now assured the automobile driver by the development of an automotive vacuum brake. The slightest touch of the toe on the brake pedal exerts a powerful pull on the brakes. It can be attached to any car and uses the vacuum created by the engine as its source of power. Pressure upon the brake pedal opens a valve in the brake unit, and the operating piston is moved, pulling on the brake rods with a force three times as great as that obtained without this unit.

at New York Auto Show

Motor Car Satisfaction and Efficiency

SECOR

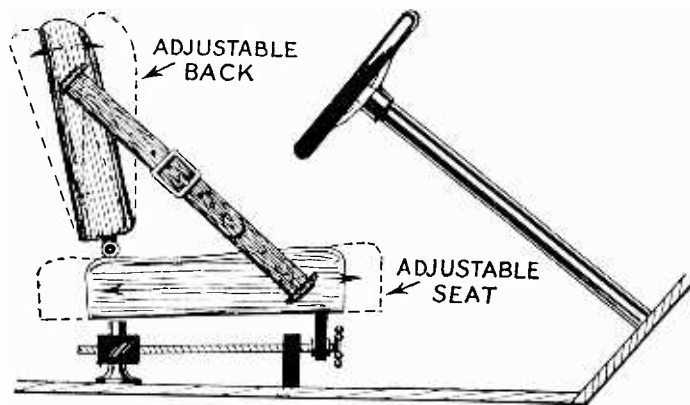

ADJUSTABLE SEAT—At the left is an adjustable seat which will be welcomed by the "long-legged" motorist. In size and shape it is much the same as the ordinary folding seat, but can be easily adjusted. A strap on each side may be tightened or loosened, raising or lowering the back. The distance from the seat to the wheel may also be adjusted by turning a small handle placed at the bottom of the seat, either to the right or to the left, even while occupied.

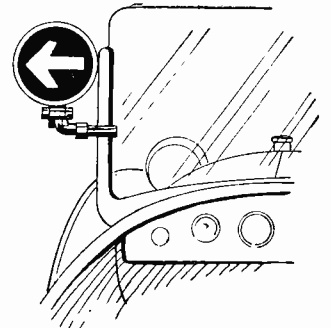

ELECTRIC "TURN" SIGNAL—Above is a view of a new traffic signal which clearly indicates to drivers behind and in front of the automobile when a right or left hand turn or a stop is about to be made. The signal is plainly visible 350 feet away, by night or by day. A rear indicator is also obtainable and is shown installed at the left.

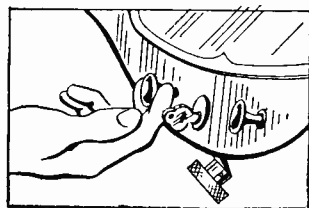

STARTER BUTTON ON DASH—At the left is an illustration showing a view of the dashboard of some of the modern motor cars which instead of having the starter pedal on the floor of the car have the starter control on the dash. Below is a skeleton view of an automobile chassis showing the new "one-shot" system of lubrication.

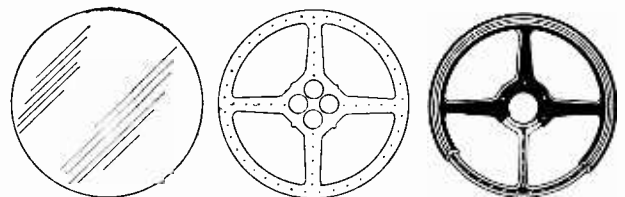
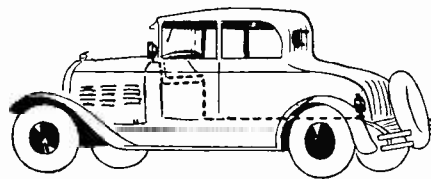
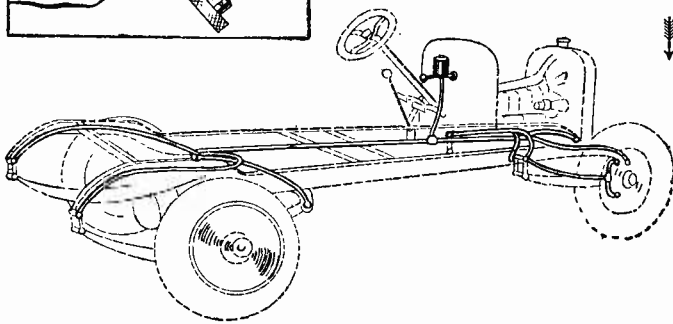

UNBREAKABLE STEERING WHEEL—The safety steering wheel has created quite a sensation in automobile circles. A sheet steel blank is then punched out and perforated as shown below. The finished wheel is then covered with hard rubber. This new wheel can be bent, but does not break.

Electrical Servant Gives No Back-Sass

The photograph below shows Mr. R. J. Wensley making some critical adjustments on the coils of his mechanical servant, which performs various services in response to impulses received from its human master. Pitch pipes or electrically driven tuning forks are used for giving the various commands.

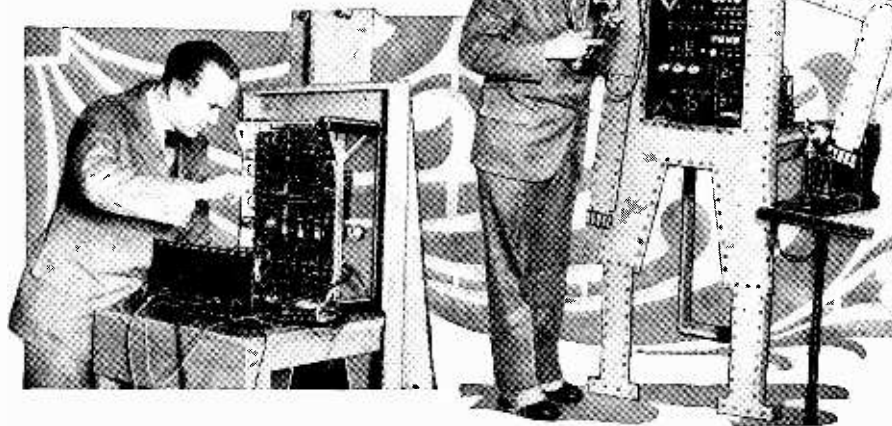

Below is a photograph of the mechanical servant unveiling a picture of George Washington, in New York City.

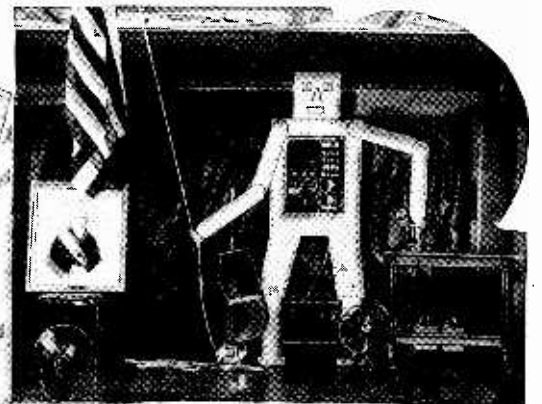

The center photograph shows the inventor with his electrical servant. Mr. Wensley is whistling into the telephone and so commands his mechanical man. The device has come to be known as the Televox, and was further described in the January issue of this magazine.

THE Televox, an electrical servant, which consists of a number of relays and tuned filters, will respond to various signals. This newest electrical handy man will do almost any kind of a job desired. The ordinary telephone can be used to control it from a distance. Sounds that come over the tele-

phone are picked up from the receiver by a sensitive microphone and amplified. The signals may be produced by three pitch pipes, or three electrically driven tuning forks having a low, medium and high pitch. The device was originally devised for starting and stopping electric motors and gener-

ators in a sub-station, but will easily find many applications in our everyday life. The electric servant can be made to close the window, turn on the electric fan, turn off the lights, open the door, and a host of other things and all when directed over the telephone.

Marvels of the Ultra Sound Waves

By RAYMOND B. WAILES

In the July issue of this magazine, we described some experiments which had been done with super sound waves, those high frequency vibrations which are inaudible to the human ear. In Fig. 1 we show a view of the apparatus used to produce these high frequency vibrations of 100,000 to 700,000 per second. As may be seen in Fig. 5, a quartz plate clamped between two sheets of metal is made to vibrate or oscillate at these high frequencies. The quartz plate is covered with a layer of oil which mounds up in the center when the plate oscillates. The oil which thus mounds up will support a weight of five ounces.

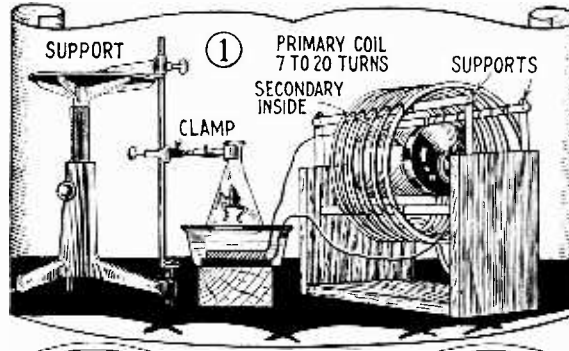

If a flat disc is pressed down on the oil mound, it descends with jerks and bumps, due to the fact that it encounters the loops and nodes of the wavelengths as shown in Fig. 3. The apparatus employed in the present work was developed in the Research Laboratory of the General Elec. Co., at Schenectady. It consists of a 2 kilowatt oscillator, a bank of oil condensers and several pairs of coaxial coils for raising the voltage. Fig. 5 shows in conventional manner, the wiring of the various parts. The use of several coils and of different size quartz plates made it possible to obtain waves with frequencies ranging from 100,000 to 700,000 per second.

In Fig. 2 at the right, a pointed glass rod can be made to vibrate and drill a hole in a sheet of glass pressed against the point. The rod drills its way rapidly through the plate and the microscope shows fine globules of molten glass and finely powdered material. If the plate of glass is pressed lightly against the top of the rod, the surface is etched.

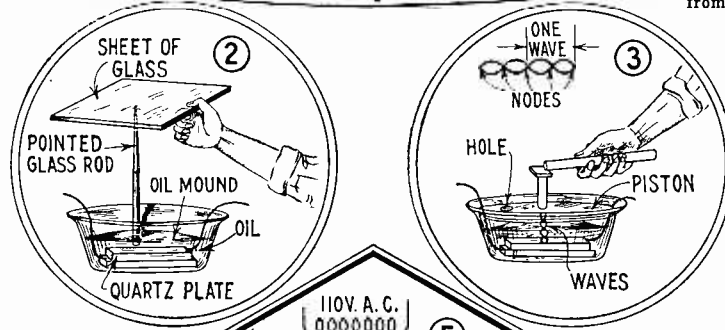

If a test tube is dusted on its inner surface with lycopodium powder, or is coated with molten sealing wax, and then pushed into the oil bath, a beautiful system of concentric circular rings will be formed, as shown in Fig. 6. Permanent rings suitable for wavelength measurements were made with a solid glass rod with sealing wax, brought into contact with the oil.

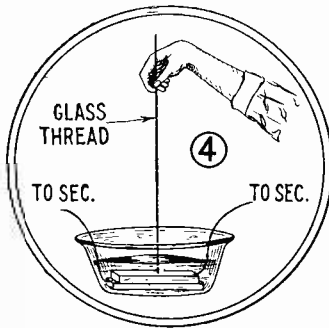
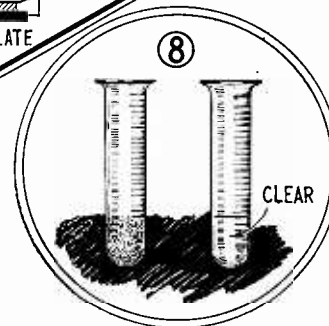
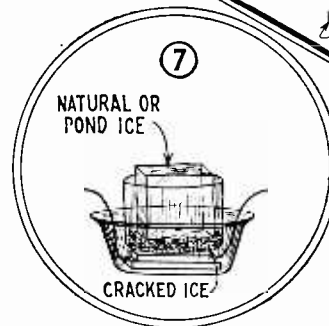
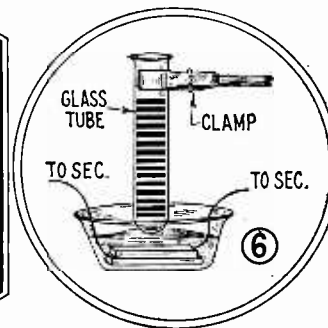
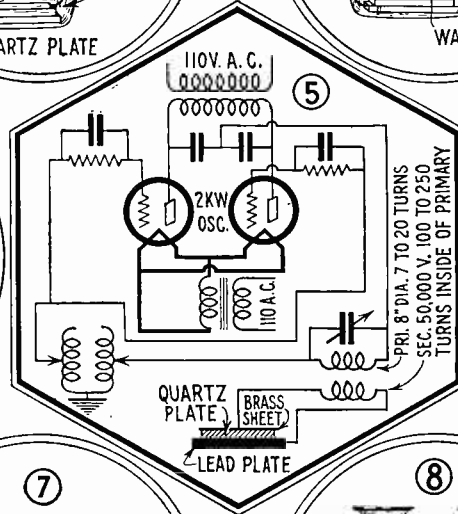
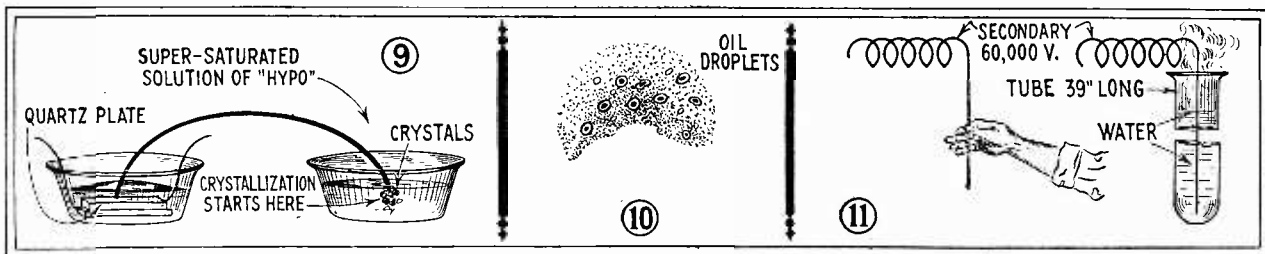

Fig. 4 shows another interesting experiment when a glass thread .008 inches in diameter and 39 in. long, held in the fingers produced a burning sensation, although the thread itself does not become heated. The heat, of course, is developed by friction between the vibrating thread and the skin of the fingers. This same heating effect is noticed when a rod, tube or beaker is held in the fingers and dipped into the vibrating oil bath.



A good proof that natural ice is a single huge crystal is shown by the fact that it does not change when subjected to super sound waves. Artificial ice, however, becomes "snowy" and can be broken with the fingers. This experiment is shown to the left in Fig. 7. Fig. 8 shows how red corpuscles in a physiological salt solution are rapidly destroyed. The turbid liquid becomes as clear as a weak solution of red aniline dye.



A glass thread placed with one end in a supersaturated solution, causes immediate crystallization.

Above is a top view of the oil mound.

One end of the secondary coil which supplies 60,000 volts, can be grasped in the hand.



The above photograph was taken with an ultra-violet light filter and the city of San Jose was invisible, as it was shrouded in a fog.



The photograph above was taken a few seconds afterward on the same day with an infra-red filter and the city can be plainly seen.

Lifting the Veil of Venus

Infra-red Filter Enables Astronomers to See Surface of Planet

By DONALD P. BEARD

THE impenetrability of the dense cloud-envelope that surrounds the planet Venus has for centuries prevented a closer telescopic acquaintance with her surface features. These vague dark cloud areas that obscure the planet's actual surface have recently been photographed for the first time.

An announcement to this effect comes from Prof. Frank E. Ross of Yerkes Observatory, who has been photographing Venus throughout the past summer with filters that transmit selected "light" from the infra-red region of the spectrum.

On June 23, 1927, a telegraphic report from Mount Wilson, California, to Prof. Edwin B. Frost, director of Yerkes Observatory, stated that an extensive cloud area near the south pole of Venus was thus photographed, while other dark cloud areas were showing rapid changes. By study of these photographs Prof. Ross hopes to determine the rotation period of Venus, the inclination of her axis, and perhaps the nature of her surface features.

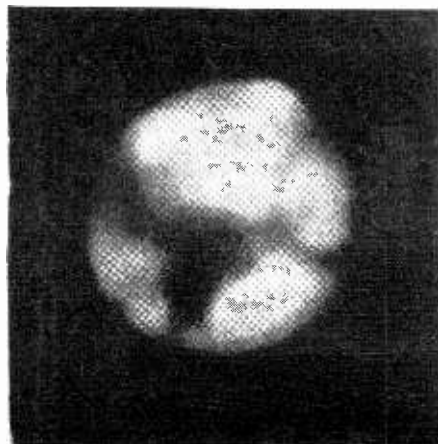

The above photo of Mars was taken with an infra-red filter. Compare this with the photo at the right.

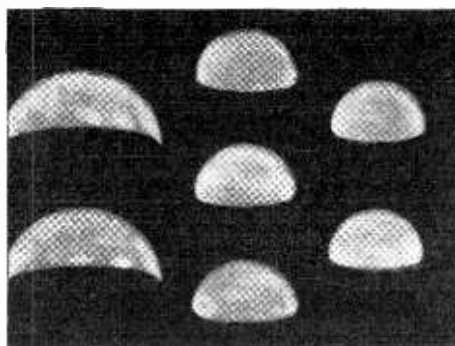

Above are the waning phases of the planet Venus, showing the dark clouded area. Photography, by means of infra-red filters, has recently penetrated this dense cloud envelope.

VENUS POSSIBLY INHABITED

Prof. Edwin B. Frost of Yerkes Observatory has recently expressed belief that high forms of sentient life are "much more likely to exist on Venus than on Mars. Venus is nearer the sun (two-thirds of our distance away) and were it not for the heavy clouds the heat there would be unbearable."

Briefly, Prof. Frost's method was to photograph Venus at intervals throughout her recent apparition (or "elongation," as it is technically termed) with an infra-red filter interposed between the great 60-inch mirror of the Mt. Wilson reflector and a rapid photographic plate. This infra-red filter transmits those long waves of light near the red end of the spectrum at about wavelength 27,200, which play a negligible rôle in ordinary processes of human vision.

Already the infra-red ray has unlocked an amazing domain of research for industrial physicists in practical aspects of technology, as in certain textile processes; in signaling and locating enemy positions in nocturnal war operations; in light therapy applied to cancer and diseased tissues, etc. In the hands of Prof. J. L. Baird of London, recently, these radiations have revealed invisible objects in a dark room, opening up a new field through television, etc., and they

now promise to clear up the mystery of cloud-veiled Venus.

HOW INFRA-RED FILTER WORKS

The technical details involved in this application of the invisible red radiations of the spectrum to planetary photography are too involved to enter into here. In brief, photographs made with an infra-red filter have their images formed by the agency of light which plays almost no part in ordinary visual perception. If the reader will hold a piece of deep red or "ruby" glass before his eyes and carefully examine a sunlit landscape with trees and white buildings, he will behold a scene similar to those depicted in Prof. Robert W. Wood's remarkable photographs of quarries, gardens, an old cathedral in Florence, and other subjects taken in Italy some 15 years ago. In Prof. Wood's infra-red photographs a weird effect similar to moonlight is observed, while the green foliage of trees apparently does not absorb infra-red light, causing them to appear as though covered with frost or white paint.

(Continued on page 64)

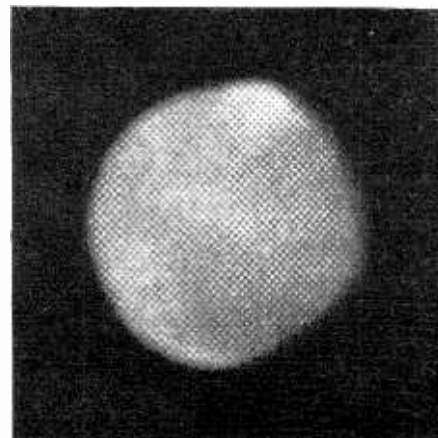

An ultra-violet filter was used in taking the photo shown above, which is about 6 per cent larger than the infra-red ray image.

The Metal EMPEROR

by A. Merritt
Author of "THE MOON POOL", "THE FACE IN THE ABYSS" etc.

(Eighth Installment)

Synopsis

Dr. Louis Thornton is traveling through Tibet with his Chinese servant-cook, Chiu Ming, and two ponies that carried the impedimenta. They come upon a white man who introduces himself as Richard Keene Drake. Drake's father had been very friendly with Thornton. The three decide to carry on and come upon Martin Ventnor, a geologist, and Ruth, his daughter. The latter are guarding themselves against hundreds of soldiers who belong to an age at least twenty centuries back. While escaping they are attacked and would have been exterminated, were it not for the timely intervention of Norhala, a tall, beautiful, metallic-haired woman, whose control over lightning and over heavy metallic blocks was phenomenal. These blocks, at her command, would make a bridge for her to walk on or form themselves into battling monsters to protect

her or obey her every whim. Chiu Ming is killed in the battle, the survivors leaving with Norhala. Ruth and Norhala get on one of the blocks. The others stand upon a second composed of four smaller ones joined together by their own peculiar super-normal power. The platforms speed through space at a terrific rate, arriving eventually in the court of the Metal Emperor. Angered by the influence of Norhala over Ruth, Ventnor raises his rifle and fires at the red ruby-like object he believes to be the brain of the metal monster. He is struck down by a lance of green flame and rendered unconscious. The metal monster gives Norhala the entire company to serve as her toys. She takes them to her home, where she informs Yuruk, her ape-like eunuch attendant, they are not to be harmed. Ventnor talks, then lapses into unconsciousness again. Ruth, after telling about the strange power that holds her enslaved, goes to sleep. Drake and Thornton dis-

course on the metal intelligences, and come to the conclusion that they are guided by some sort of group consciousness, and that they move by super-rapid molecular "steps." Yuruk, because of jealousy, informs Drake of the way back to the city, which Ventnor, in a semi-conscious state, told them was their only hope. Yuruk claims that though the inhabitants of the city were hostile, it is much safer to escape. Leaving Ruth with Ventnor, Thornton and Drake decided to skip away from Norhala. They informed Ruth that Yuruk has learned the meaning of the pistol. After rather spectacular adventures, they come upon the Metal City, where geometrical and intangible forms are seemingly endowed with super-intelligence. The city saw and was alive. Norhala appears unexpectedly and is just as quickly blotted out from sight. They observe the metal hoards and make the acquaintance of the Metal Emperor, to be subsequently brushed out of his presence, after which they glide away rapidly.

CHAPTER XXII

THE BIRTH CHAMBER OF THE HORDE

"PROFESSOR," Drake broke the silence, "this isn't the way to get out. We're going in, going away all the time from the—gates."

"What can we do?" my anxiety was no less than his, but my realization of our helplessness was complete.

"If we only knew how to talk to these Things," he said. "If we could only have let the Disc know we wanted to get out—damn it. I believe it would have helped us!"

Grotesque as the idea sounded, I felt that he spoke the truth. The Disc meant no harm to us. In fact, in speeding us away, I was not at all sure that it had not deliberately wished us well. I could not forget the strangling tentacles of the Keeper of the Cones.

"Pushed us away as though we were children—or the cat," Drake echoed my thoughts. "Shooed us off as though it were saying 'Run along now and play—or you may get hurt!'"

Still up we sped along the shaft. A thousand feet, two thousand feet I knew we must be now above the level of the valley.

"We've got to get back to Ruth! What will she be thinking?—It's night! And what may be happening—what may have happened to her?"

"Drake, boy—we're up against it. We can't help it. And remember—she's in Norhala's home. I don't believe that there's any danger as long as she remains there. And Ventnor ties her fast."

"That's true," he said, more hopefully. "That's true—and probably Norhala is with her."

"I don't doubt it," I said, cheerfully. An inspiration came to me—I half believed it myself. "Another thing. There's not an action here that's purposeless. We're being driven on by the command

of that Thing you have called the Metal Emperor. It means us no harm. Maybe—maybe this is the way out."

"Again the monster shook beneath us. Faster we moved. Louder grew the clangor of the drums, the gongs, the pipes. . . . Now we were close upon the heels of the last fleeing stragglers. We slackened in our stride. We waited until they were close to the gates. I heard the brazen clanging of their valves. Those shut out beat upon them. They dragged themselves close to the base of the battlements, and cowered there, or crept, seeking some hole in which to hide."



"Maybe so." He shook his head doubtfully. "But I'm not sure. Maybe that long push was just to get us away from there. It strikes me that the impulse has begun to weaken. We're not going anywhere near as fast as we were."

I had not realized it, but our speed was slackening. I looked back—hundreds of feet behind us fell the slide.

"There are other passages opening up along this shaft," Drake urged. "I'm not for trusting the Emperor too far—it has other things on its metallic mind, you know. The next opening we get to, let's try to slip into it—if we can!"

I had noticed the openings along the ascending shaft, corridors running apparently transversely to its angled way. I nodded.

Slower and slower became our pace. I glimpsed one of the apertures, a hundred feet above us. Could we reach it? Slower and slower we arose, and nearer it came, nearer—our feet began to slip backward along the steep way. Now the gap was but a yard off. But we were motionless—were tottering.

Drake's arms wrapped around me. With a tremendous effort he hurled me into the corridor. I dropped at its edge, writhed swiftly around, saw him slipping, slipping down, and thrust my hands out to him.

He caught them. There came a wrench that racked my arm in its sockets. But he held. I writhed back into the passage, dragging up his almost dead weight.

For a minute or two we lay, flat upon our backs, resting. I sat up. The passage was broad, silent, apparently as endless as that from which we had just escaped. Along it, above us, under

us, the crystalline eyes were dim. It showed no signs of movement. Drake arose.

"Let's be going," I said.

The corridor stretched straight before us. How far we walked along it, I do not know, mile upon mile, it seemed. It broadened abruptly, and opened into a vast hall.

And this hall was filled with the Horde—was a gigantic workshop filled with them. In every shape, in every form, they seethed and toiled about it. Upon its floor were heaps of shining ores, mounds of flashing gems, piles of ingots, metallic and crystalline. High and low throughout it flamed the egg-shaped incandescences, floating furnaces great and small.

Before one of these forges, close to us, stood a Thing. Its body was a twelve-foot column of smaller cubes. Upon the top was a hollow square formed of even lesser blocks—blocks little larger than the Little Ones themselves. In the center of the open rectangle was another shaft, its top a two-foot square area formed of a single cube. From the sides of the hollow square sprang long arms of spheres, each tipped by a tetrahedron. They moved freely, slipping about upon their curved points of contact,

(Continued on page 74)

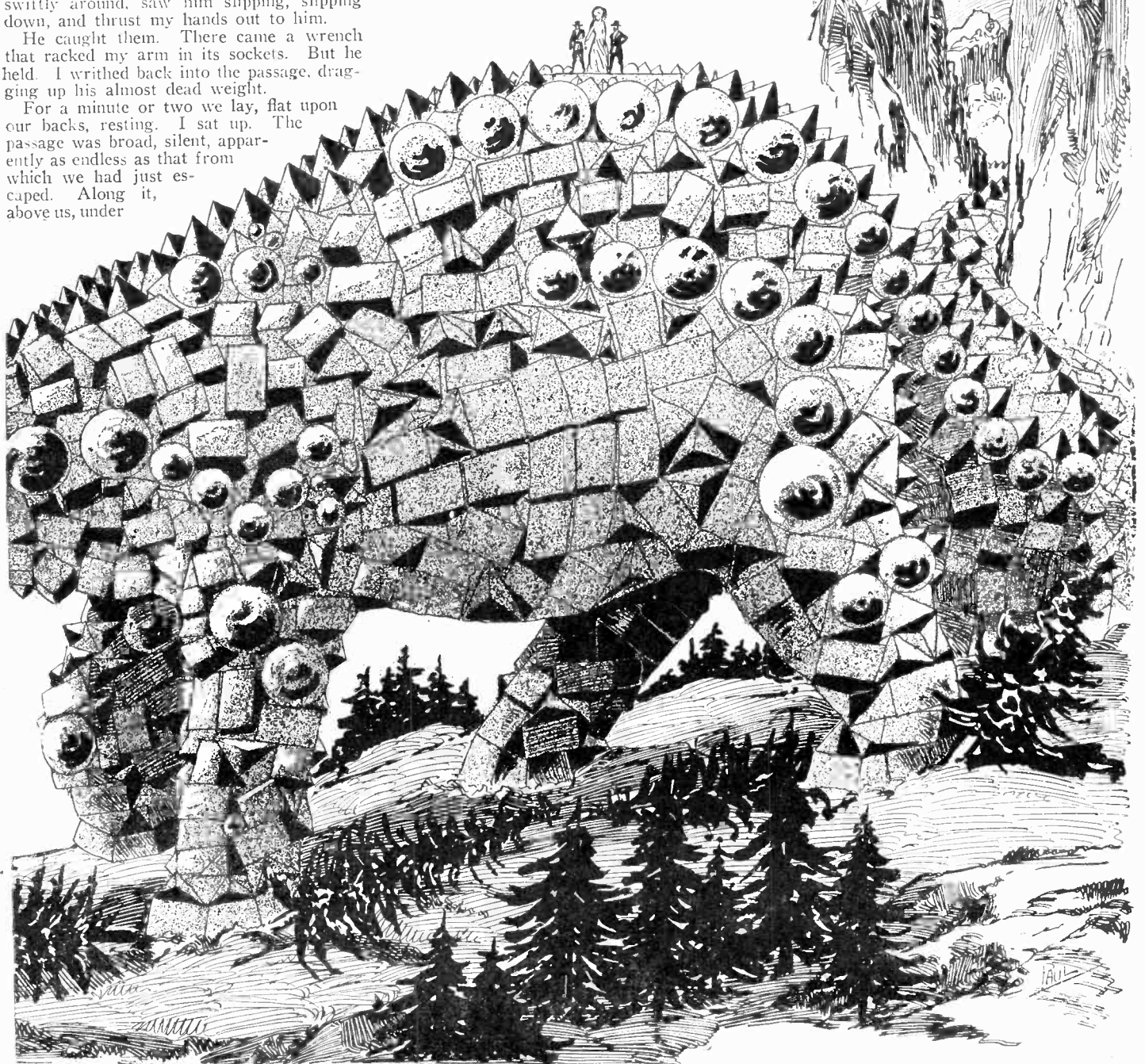

MAGIC By "DUNNINGER"

NO. 62 OF A SERIES

IMPROVED OBEDIENT BALL

FOR a number of years the so-called obedient ball trick has been a favorite deception, particularly among amateur magicians. Its operation being generally

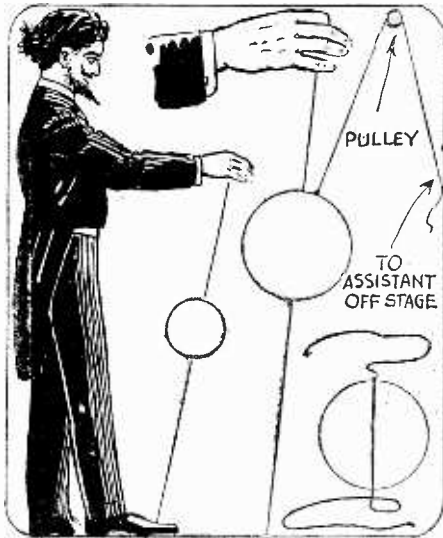

A celluloid ball moves up and down on a string, held between the performer's foot and his hand. Its mystical operation is caused by another string attached to the ball by a wax pellet, and controlled by an assistant.

THE X-RAY EYE

THE magician passes a small pill box, about 4 inches in diameter and 1 inch high to any one of his spectators. Upon turning the lid, the spectator will observe a pointer similar to a clock hand, and the dial of a clock. The spectator turns the hand to any of the twelve numbers he desires, closes the cover, and returns the box to the magician. The latter, without even opening the cover, tells the hour to which the hand has been set. The conjurer may even be blindfolded if the spectators so desire. The illustration below shows why this trick is so relatively simple. An axle runs clear through the box from the hand to a gear in the back. This gear in turn communicates the motion to two others, the last of which is connected directly to what seems to be a manufacturer's trade-mark. The position of this manufacturer's trade-mark with reference to the box, or with relation to another mark on the box indicates the time. With the pill box upside-down, the magician has but to look at the direction in which the manufacturer's stamp is pointing to correctly tell the time. When blindfolded, the box must be held in such a position that the magician can look beneath the blindfold, or else he will have to resort to the sense of touch.



The arrangement of the gears for performing the X-ray eye effect is indicated above.

THE VANISHING TABLE

HERE is an excellent finale to a stage presentation of a magical performance. After the presentation of a series of tricks, the wizard's assistant clears the side-table

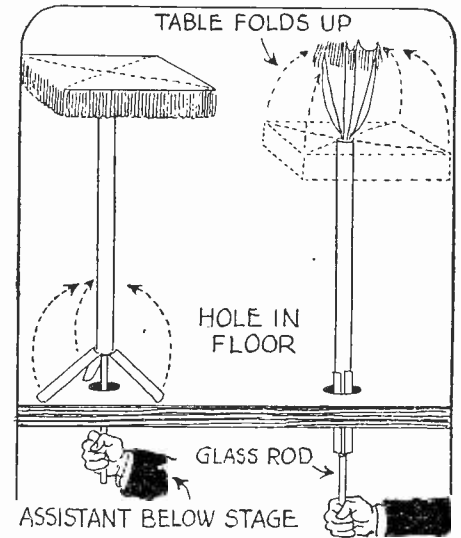

A folding table made as indicated, can be vanished at the end of the performance.

known, it has been discarded from the programs of magical newcomers. In the present method, the possibility of passing the paraphernalia for examination is greatly increased, hence the trick much improved. In effect, a large celluloid ball with a hole drilled through it is shown and then a string is passed through the hole. One end of the string is caught beneath the foot, the other end held in the hand. At the magician's command, the ball will be seen to fall, stop, or rise again.

Explanation: There is nothing about the ball or the string which will not pass an examination. The secret lies in the fact that a very thin thread, passing over a pulley overhead and to an assistant in the wings, is affixed to the ball by a pellet of wax. The wax pellet may be detached whenever and as often as desired.

which the magician has been using during the performance. The conjurer displays a large cloth, holds it in front of the table for but a fraction of a second, jerks the cloth away and tosses it out toward the audience, who see at the same time that the entire table has been mystically vanished in thin air.

Explanation: The table itself is mechanical. The top consists of four ribs, which close up umbrella fashion. These are covered with silk and fringe. The table legs are three metal shells, supporting the metal stand. These shells, when folded to the sides of the table, lie perfectly flat. The stand is held in place by the assistance of a glass rod, reaching up from beneath the stage through a small floor hole no more than 2 inches in diameter. Just as the cloth is held in front of the table, the assistant pulls down on the glass rod, collapsing the table, and pulling it through the hole.

THE COIN IN THE EGG



THIS is quite an effective parlor trick, very easily mastered. A coin is borrowed from anyone in the audience and is marked for identification. An aluminum egg cup, together with an unprepared egg, is then examined. This egg had previously been chosen by someone in the audience. The egg is put in the cup and the whole presented to some member to hold. The coin is then mysteriously vanished, and on breaking

the eggshell is drawn from the center of the egg with the assistance of an examined pair of tweezers. By way of explanation, it might be mentioned that the original coin is secretly placed in a groove in the egg cup made to receive it. A duplicate is vanished, by any of the various methods previously suggested in this publication. As the egg is placed into the cup, the thin shell is broke by the edge of the coin.



Conducted by **GEORGE A. LUERS**

MOUNTING SPOT-LIGHT INSIDE THE CAR

A spot-light mounted inside the closed car, just to the right of the steering wheel, is handy for all seasons, as it does not require the window to be open for use. A second feature of an inside spot light, is the facility for repairing, greasing and adjusting the transmission and clutch.

One owner made up a simple neat bracket as shown in the sketch.

This bracket was made from a strip of quarter inch iron about an inch wide. This was bent by heating in a furnace and forming while hot, that the extension would hold the spot-light close to but clear of the windshield glass. Two quarter inch bolts were used to secure the bracket to the dash. The spot-light used was about four and one-half inches across the face. The control of the light is within easy reach of the driver's right hand.

Obviously, a neat coat of black enamel completes the job.

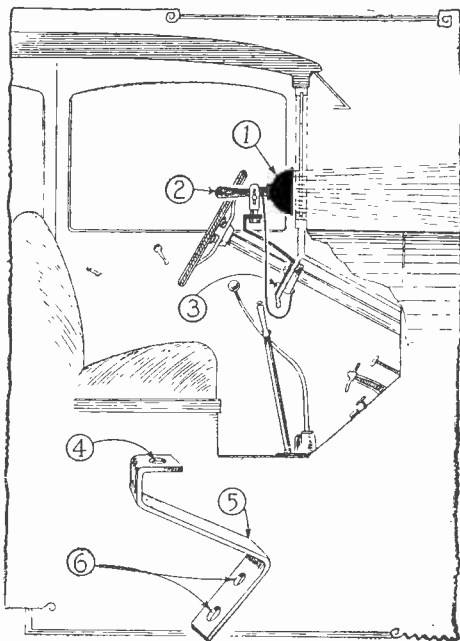

In the above drawing No. 1 is the spotlight, No. 2 shows the convenience of the arrangement, 3 shows the bracket and 4, 5 and 6 show where the holes should be drilled in the bracket iron. The spotlight is mounted to the right of the driver, close to the windshield.

ALEMITE FITTING FOR SPEEDOMETER CABLE

One of the fast moving parts of the car, for which there is no provision for lubrication is the speedometer cable. Obviously failure is to be expected of this member if greasing is neglected.

A simple means to facilitate greasing the cable as devised by one owner is shown in the attached sketch. This means will appeal to other owners, chiefly because it can be made up from scrap parts which are available about the garage.

A 7/8-inch spark plug shell is fitted with a brass bushing and this is tapped out for a one-eighth inch pipe plug. An alemite grease fitting is screwed into this bushing. To grease the cable, it is detached by the coupling nut at the rear, the special alemite fitting is screwed into the nut and the grease gun is applied.

It will be apparent the same fitting will not screw on all types of speedometers, and some require machining and re-threading of the shell. Try this before completing the fitting.

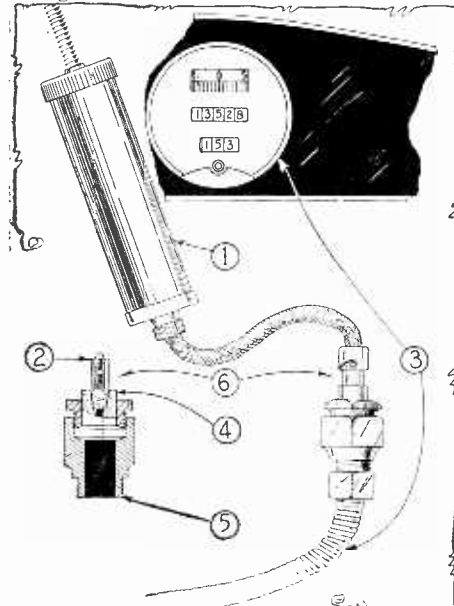

Above—1 is a grease gun; 2, a grease nipple; 3, speedometer cable; 4, brass bushing; 5, spark plug shell; and 6, a grease fitting.

STRAIGHTENING RUNNING BOARD OR FENDER BRACES

A slight collision will invariably bend either a running board bracket or a fender brace. The owner may try to straighten these out by cold bending; however, this is usually too much of a task.

Torch heat will cause the bracket to yield to a slight pressure, either through use of a bending bar or a jack, as shown in the sketch.

If possible, a piece of asbestos paper should be folded to confine the heating to the bent bracket. The torch should be applied until the bracket is a bright red, at which time it is easily returned to position. Quenching with water will tend to harden it or restore its former comparative inflexibility.

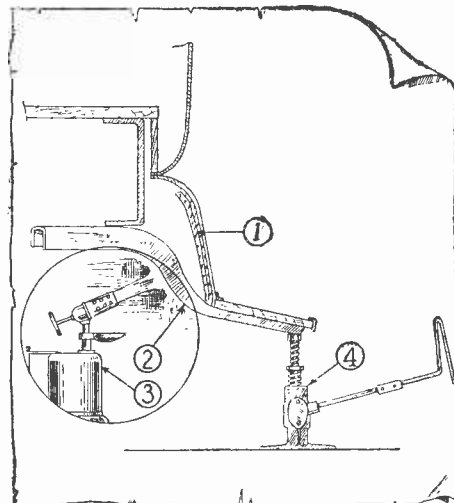

Above—1 is an asbestos sheet; 2, bend in the bracket, 3, blow torch; and 4, the Jack.

DO YOU KNOW—the spares most needed for a tour in remote regions are, one ignition coil, a spare axle and two valves. Data from several touring clubs, show these parts to be the most frequent sources of trouble.

The main advantage of this means for rebending a bracket, is that it avoids the possibility of starting a break or crack in the metal.

USING JACK HANDLE FOR DRAINING OIL SUMP

The owners of those cars having side outlet drains for the oil sump of the engine, will find the suggestion shown in the attached sketch useful and far more satisfactory than having to crawl under, when the oil is to be drained.

The usual folding type of jack handle is used as a tool, when fitted with a special socket, which will fit the pipe plug in the oil sump.

Sockets of the required size are available in the larger accessory stores, however it is possible to make up one from a piece of pipe by heating this and hammering it to shape.

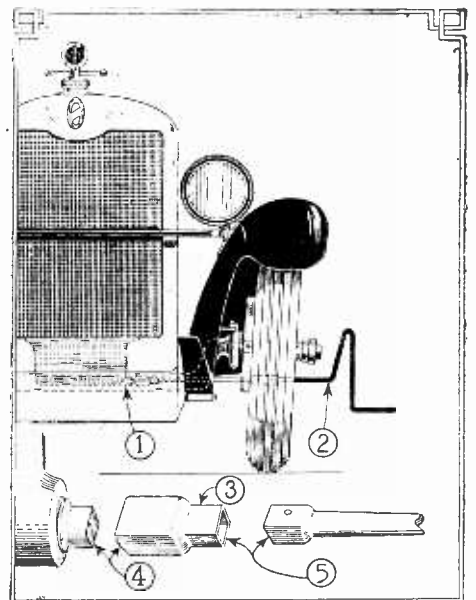

In the above drawing 1 is the side drain outlet in oil sump; 2, folding type jack handle; 3, special socket connections. Numbers 4 and 5 show how the special socket connections are made to fit.

The owner will find this facility one of the most expeditious and clean method of handling an otherwise dirty task. This additionally prompts more frequent oil changing, which is a benefit not to be overlooked.

FITTING COUPE OR ROADSTER FOR EXTRA BAGGAGE

Space for baggage, especially on camping trips, is at a premium on the roadster or coupe. Tents, mattresses and blankets are bulky, but these must be kept out of the rain.

An ingenious idea of one owner to provide stowage space on a coupe, is shown in detail in the attached drawing. The features of this carrier, will be evident without much explanation. (Continued on page 62)

Electricity Helps the Showman

Startling Tricks Carried Out with A.C. Magnets and Oudin Coil

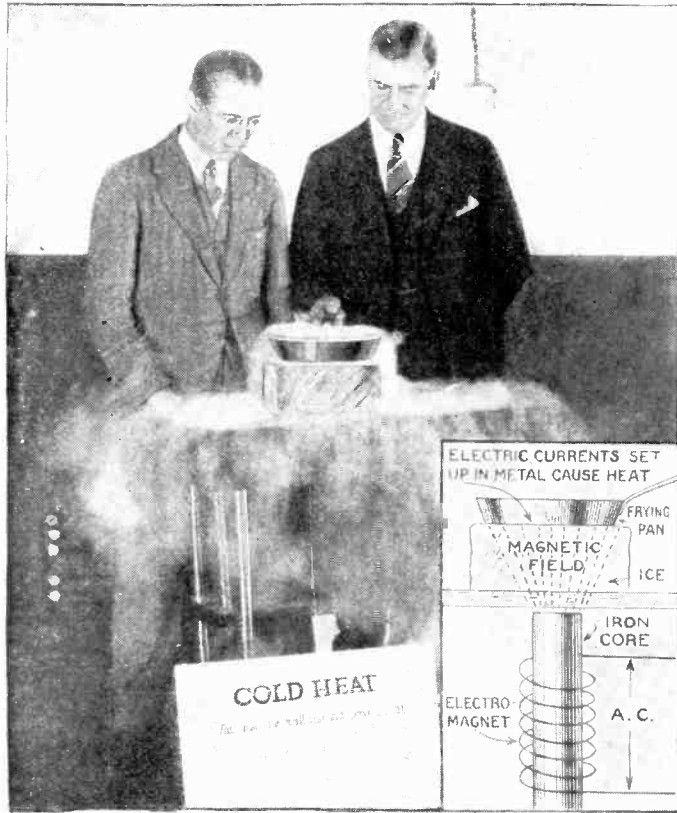

At the left is a photograph showing one of the wonders of the Radio World's Fair. Bernays Johnson is shown frying some sausages on a cake of ice. The insert shows how this feat was accomplished by means of an electro-magnet.

thus generated the heat which Mr. Johnson claimed was coming through the air in the form of cold heat, as the placard shown in the photo testifies. The same trick, of course, was used when lighting the electric bulbs. An A.C. magnet with a laminated iron core served to produce the effect of nullified gravity, which Mr. Johnson her-

Below we see an electric lamp which lighted even when the magnetic field passed through the young man's head.



The phenomenon of magnetic levitation is shown below. Again an A.C. electro-magnet was used.

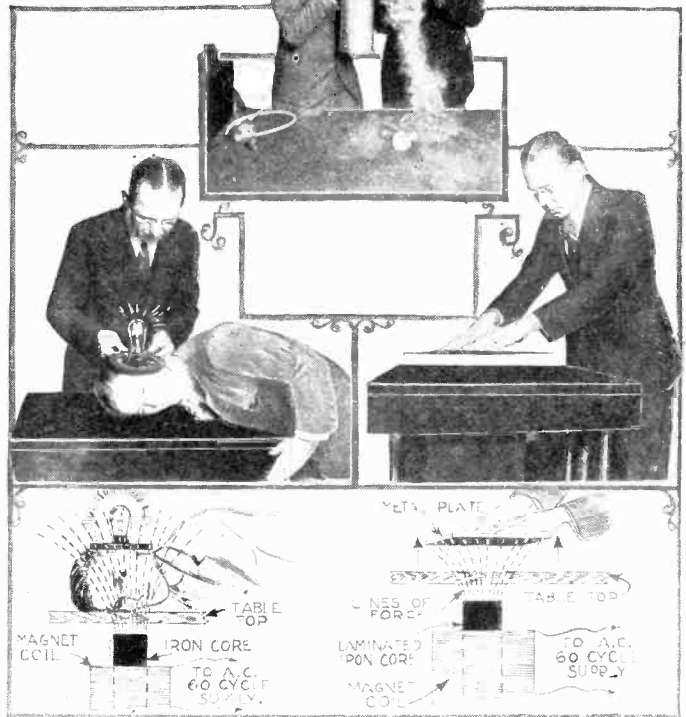

RECENTLY, there appeared at the Radio World's Fair at Madison Square Garden in New York City, a famous radio engineer known as Bernays Johnson. His demonstrations were spectacular and a never-ending source of wonder and entertainment to the huge crowds which flocked to the Garden. As a feature stunt, the exhibitor even allowed a powerful current to pass through his body without apparent harm. As he explained it, he had developed the faculty of being immune to electrical currents, and could stand these 350 amperes of current at a pressure of 2,200 volts, while an ordinary person would immediately be electrocuted. The "miracle man" provided further thrills by holding a small piece of metal in his teeth during the exhibitions, which seemingly melted in his mouth. The photo at the bottom of the page shows the electric chair with its contacts and straps. The diagram next to this photo shows just how it was possible to melt the metal without injuring the performer, or even requiring him to take the slightest amount of current through his body. Since the Fair, Mr. Johnson has gone on the stage with this and other acts, and it is really wonderful to notice the effect that 350 amperes of current at a pressure of 2,200 volts has upon his system. As is well-known high frequency currents can be handled with impunity and

so the lecturer in the present case was in no danger. After the electric chair act is over, Mr. Johnson staggers around on the stage apparently in a state of the utmost physical exhaustion. It behooves the lecturer on high frequency currents to be somewhat of an actor. Bernays Johnson also fried eggs and sausages upon a block of ice, lit lamps held in the hand which were connected to no electrical supply, and even went so far as to defy gravity. A large A.C. electro-magnet with an iron core was used to fry the eggs. The magnetic field set up electric currents in the frying pan and

added as a world startling accomplishment. According to the master-mind, Bernays Johnson, these amazing feats were made possible by the use of cold heat or radio waves which were coming through the ether and performing these miracles. It may be well to mention that when melting the rod of metal, the connection was made to the end of a metal head band; at no time was the rod held in the mouth of the performer, although it could be with sufficiently high frequency to preclude the danger of shocks.

The drawing at the bottom of the page shows just how the metal rod was melted by using an Oudin high-frequency coil, to the secondary of which the metal rod was touched. The other end of the metal rod was connected to a metal headband to which was connected the ground. The photo at the bottom of the page shows Mr. Johnson seated in the electric chair with the rod held in hand.



Bernays Johnson is shown above in the electric chair, holding in his hand the metal rod to be melted.

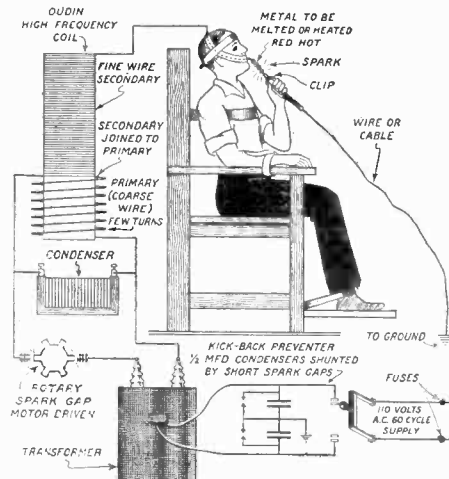

Above we see how it was possible to melt the heavy piece of metal seemingly held in the mouth.

Beauty Aids with Science

The photo below shows a new device for curling the eyelashes. Next to this is a photo showing a new beauty mask. Beauty plaster is applied to the face and is then heated to a high temperature. A small photograph at the bottom of the page shows the hardened mask being lifted from the face.

The photograph below shows a new device for steaming the face. The head is placed in an airtight glass enclosure and steam is then permitted to seep into the enclosure. A tube running to the outer air is placed in the mouth, so that a lady can breathe. These and many other beauty aids were recently demonstrated at a convention held in Chicago.



BEAUTY parlor operators in the United States at a Chicago convention exhibited their latest inventions to aid women in the search for youth and beauty. The latest innovation is to have the face baked. A coating of beauty clay is put on the face and raised to a temperature of 160 degrees Fahrenheit. After the treatment

is over, the beauty mask can be easily lifted from the face, as may be seen in the above photographs. Eyelash curlers are also becoming popular with the fair sex and our photo shows one of these in use. A new massaging apparatus has also recently been perfected. This consists of an airtight glass

enclosure into which steam is allowed to enter. While the steam bath is being administered, the patron breathes through a tube placed in the mouth, having an outlet in the outside air. Rubberized fabric attached to the glass compartment allows the facial steaming apparatus to fit tightly.

Can You Answer These Scientific Questions?

SCIENCE and INVENTION Magazine readers, especially our thousands of friends in schools and colleges everywhere, have frequently testified in their letters to the editors that they obtain invaluable help from the columns of this magazine, in clearing up technical questions which arise daily. It is a recognized fact that everyone today, including those of both sexes, are expected to have a fairly good general knowledge of the latest scientific developments and discoveries. It is quite impossible to obtain this knowledge of the latest conquests in science from text-books, as they are usually revised but once a year, and in many cases not as often as that. You will find the questions below a good challenge to your knowledge of modern science, and we advise you to form your own answer, before you turn to the page referred to in each case.

1. How is it possible for astronomers to calculate and predict the position of a new planet in the heavens? (See page 9.)
2. Explain how the location of an earthquake is figured out by scientists; and what do you know about earthquake predictors? (See page 10.)
3. Can you name ten greatly needed inventions which would bring fame and money to the man perfecting them? (See page 13.)
4. Does a dirigible roll excessively under average flying conditions? Is there a severe vibration felt throughout the airship, due to the engines? Do you consider a dirigible as safe as an airplane? (See page 14.)
5. What household pest can be successfully combatted with borax? How is formaldehyde gas used in fighting insects? (See page 16.)
6. How do you imagine the powerful forces locked up in liquid air can be used to propel an airplane? (See page 18.)
7. How would you apply aspirin to the resuscitation of plants? How would you make a simple yet powerful garden spray apparatus? (See page 22.)
8. How would you measure the temperature of the molten lava in the crater of a volcano? (See page 25.)
9. Thousands of people have bought and tried out "sex-indicators." Are they scientifically workable? (See page 26.)
10. What new means of drawing the gasoline from the tank of a motor car is now being widely used, in preference to the well-known vacuum tank device? (See page 28.)
11. How is it possible to actually photograph a distant scene obscured by fog? (See page 31.)
12. Could you fry eggs on a cake of ice, without any fire? (See page 36.)

Drawing Table and Utility

By EDWIN



The finished drawing table in use.



5



7



9



12

THOUGH a draughtsman or artist may desire a center-supported drawing table, he is likely to hesitate before paying the \$30.00 that an average table costs. For an expenditure of \$10.00 for materials, however, he can build a table with all the desirable features of the store pieces, such as tilt-adjustment and regulation of height, with a constantly level tray, and in addition a very neat little cabinet to stand beside the desk, which will house the usual drawing and coloring equipment.

The top and tray of the table are made from 5-ply stock, with the hinged edges beveled to 45 degrees, as in Figures 1, 2, and 3. Rip a 28 in. length of 1/2 in. hardwood dowel down the center, and glue the halves to the tray edges, forming sides.

Next, build the column, shown in Fig. 4, gluing and nailing it together with the 2 1/2 in. x 2 1/2 in. post inside to keep it square. See Fig. 5. The post yoke, to which the top is hinged, is illustrated in Fig. 6, and is built of 1 1/8 in. x 3 in. stock. Size the end grain of all joining parts, and glue and nail together. When dry, mortise the 3 in. hinges 1/4 in. deep into the upper edge of one side. Lay the yoke on the underside of the top to locate the hinge positions there with the point of a knife, as in Fig. 7.

Now pull the post from the column and finish to dimensions given in Fig. 8. Apply glue to the end rabbets, put glue inside the

yoke at the center, force it over the post, and nail solid.

For the legs, make a cardboard pattern by dividing a piece into 1 in. squares, through which the outlines may be drawn as in Fig. 1. Trace on 2 in. x 6 in. stock, cut saw kerfs every 2 in., and trim to the line with a chisel, as in Fig. 9. Smooth with spokeshave and rasp. The joint ends of two legs are cut at a 60 degree angle, obtained by setting a bevel square across the 6 in. and 10 7/8 in. points on a steel square, and marking the angle on the top edge of each leg. The length must be located at the center of the edge.

Hinge the tray to the top with 2 in. x 2 in. hinges placed 1 1/2 in. from the ends, with pins above the surface, and the tops of the tray edges flush with the table top.

Attach the top to the post yoke with the hinge pins. Make a parallel bar (Fig. 10), screwing on one end a strap hinge as in Fig. 11 to bend around the end. Screw this hinge to the center of the yoke side opposite to the top hinges with the center of the pin 1 1/8 in. below the yoke top. Stand the post with the yoke flat against the top, so as to measure accurately the distance from the center of the top hinge pins to the center of the strap hinge, and lay out on the underside of the tray the point at which the other strap hinge will come an equal distance from the tray hinge pins. Cut off the parallel

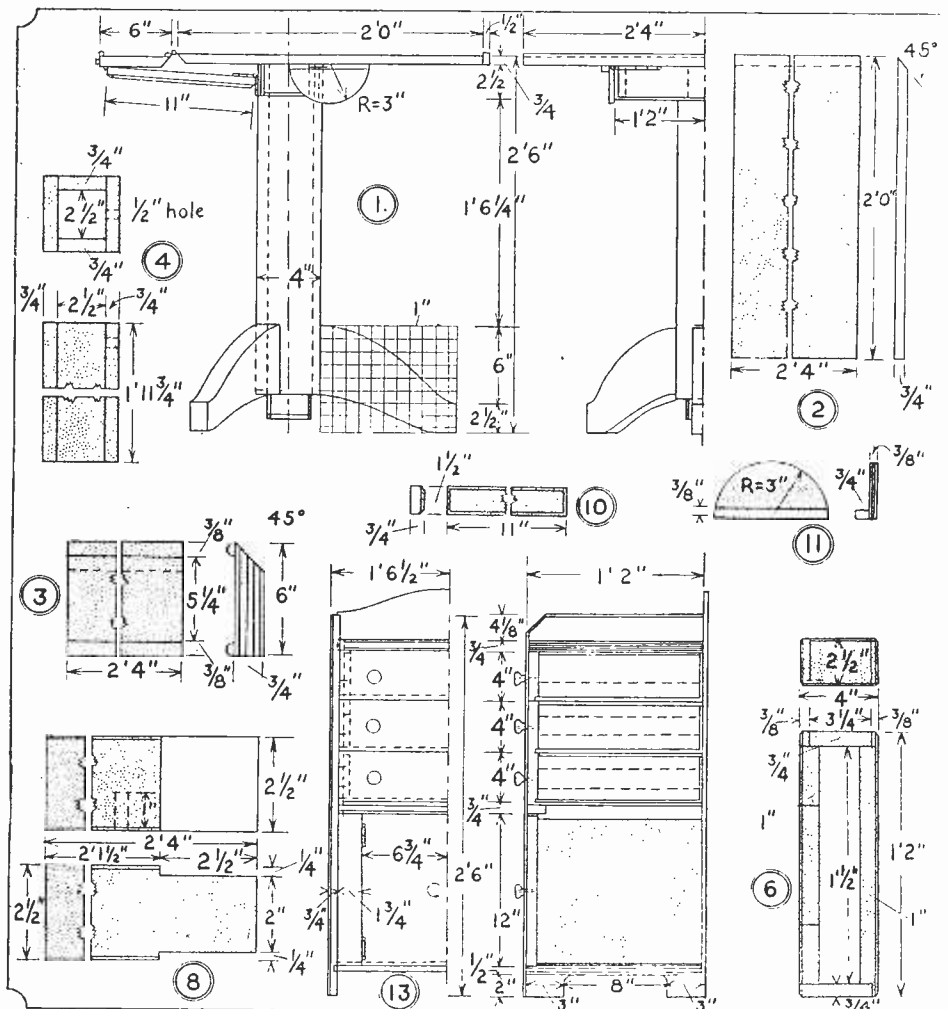

Above—Photo No. 5 shows how the columns are built, No. 7 shows the method used in locating the position of the hinges. In the photograph No. 9 we see how the legs are shaped. Fig. 12 shows the details of the tilting mechanism used in the construction of the drawing table.

In the above illustration, Figs. 1, 2 and 3 give the constructional details of the top and tray of the table. Fig. 4 shows details of the column. The post yoke is shown in Fig. 6. Fig. 8 gives the finished dimensions of the column. Fig. 10 shows the details of the parallel bar. Fig. 11 shows the semi-circular segments and Fig. 13 shows the dimensions of the sides.

Cabinet are Easy to Build

M. LOVE

bar to suit, and apply the hinge. If this is not carefully done, the tray will not remain level at all angles of the top.

Two semicircular segments of 3-ply stock (Fig. 11) glued and nailed to $\frac{1}{2}$ in. \times $\frac{3}{4}$ in. cleats are nailed to the under side of the top, centering on a line with the hinge pins, just clearing the yoke ends. Put on two small clamps as in Fig. 12, driving nails into the yoke top to prevent them from falling off. With these the top can be clamped instantly at any angle.

Nail to the front edge of the top a strip of $\frac{1}{2}$ in. hardwood flooring ripped and dressed to a width of $1\frac{1}{4}$ in., keeping it flush underneath, forming a lip. Glue and brad around the other edges a strip $3/16$ in. \times $5/8$ in., to hide the lamination.

A piece of dowel $1\frac{1}{2}$ in. long, drilled lengthwise to take the bolt of a glass knob, serves as a pin to lock the table at any height.

For the cabinet, get out two sides, as dimensioned in Fig. 14, using 5-ply stock. See also Figures 13 and 15. For drawer slides, rip $\frac{1}{2}$ in. hardwood flooring.

Both upper and lower shelves are 5-ply stock. The lower is rabbeted $\frac{3}{4}$ in. wide to the depth of the second ply, along the front edge, according to Fig. 16. Assemble these with the sides by gluing and nailing as illustrated in Fig. 17. Since the sides may be sprung, square the case by measuring from corner to corner diagonally, and tack

a diagonal strip across the front. The back, shown in Fig. 18, is then put in.

Make the drawer rail dimensioned in Fig. 19, measuring its length by the shell. It, like the hanging stiles shown in Fig. 20, is nailed and glued.

Fig. 21 clearly illustrates the construction of the drawers. Assemble one without the bottom, getting measurements for sides and bottom from the cabinet itself, as in Fig. 22. Try the bottom for a sliding fit, and nail to the frame. Insert the drawer and mark the front length as in Fig. 23, giving a clearance of $1/16$ in.

With the drawers in place, lay the cabinet on its back and scrape the fronts to an even surface (Fig. 24).

Fit and hang the door as indicated. Being so narrow the front edges must be beveled considerably. Place the hinges $1\frac{1}{2}$ in. from top and bottom, put an elbow catch on the left door, and after painting, a frog catch in the edge of the right door, as well as glass knobs on doors and drawers.

Glue and brad the $3/16$ in. \times $5/8$ in. molding along the edges of the sides, shelves, and drawer rail, shown in Fig. 25. Sponge the cabinet and table with a damp cloth to raise the grain, and sand smooth. Both are then ready for finishing.

MATERIAL LIST

- 1pc. 5-ply $\frac{3}{4}$ in. \times 28 in. \times 7 ft. pine veneer, good one side

(Continued on page 93)

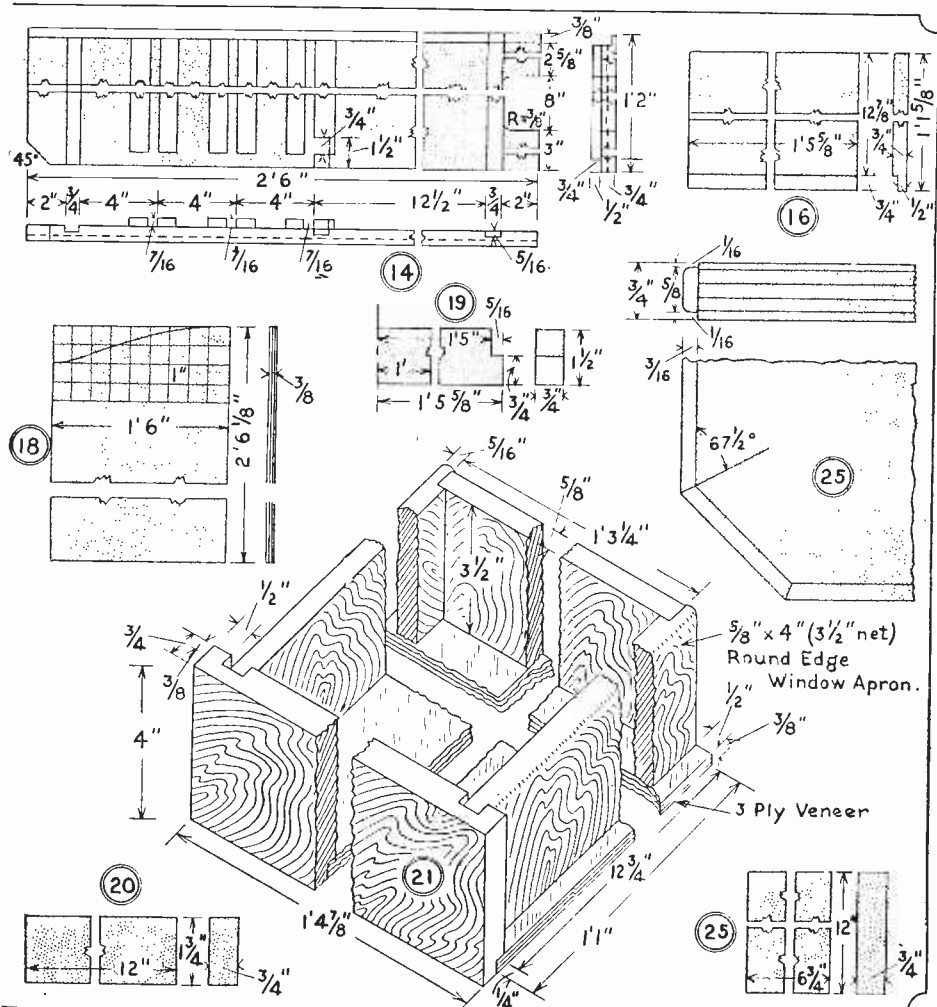
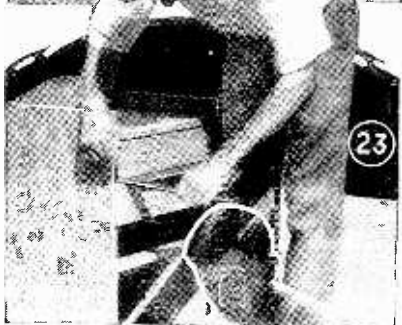
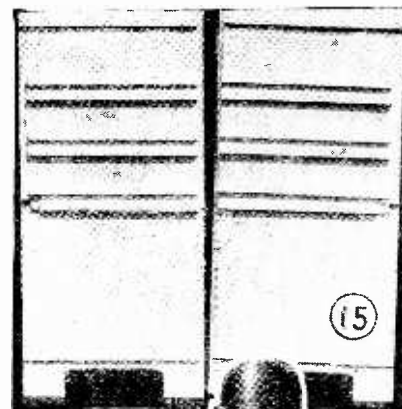
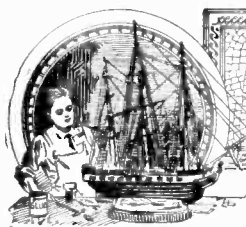

Fig. 14 in the above drawing gives further dimensions of the cabinet size. Fig. 16 shows how the lower shelf is put in place. The back of the drawer is shown in Fig. 18, and the drawer rail in Fig. 19. Fig. 21 shows construction of drawers, and Fig. 25 shows how the molding is glued.



The above photos show successive steps in the construction of the drawing table and utility cabinet. Photo 15 shows the cabinet's sides ready for assembly, No. 17 nailing in the sides, No. 22 getting the drawer length, No. 23 obtaining front lengths of drawers, and No. 24 surfacing the drawer fronts.



Model Department

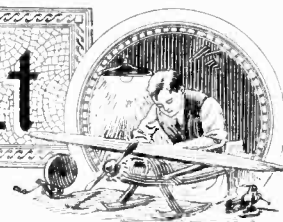

WINS

Airplane Engine

Model Built by Carl Von Bergen of Alliance, Nebraska Similar in Action to Whirlwind Type of Engine; Front View Can Be Seen in Photo at the Right

Trophy Cup

This Month's Award is Made to the Designer of the Engine Shown in Detail on This and the Accompanying Page. See Model Department Contest Rules on Page 68

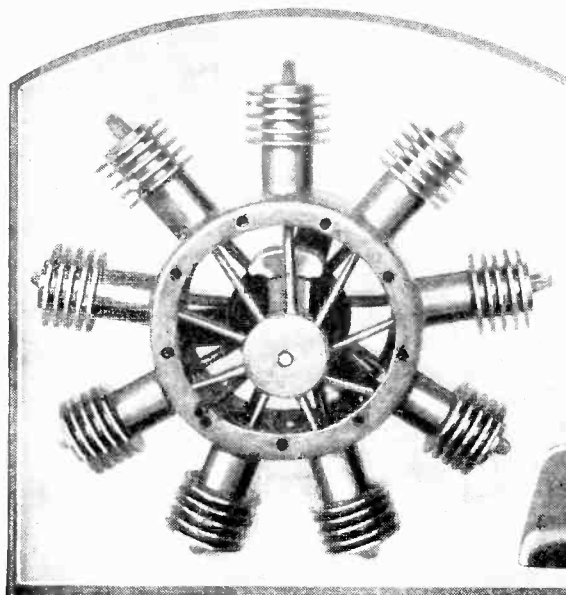
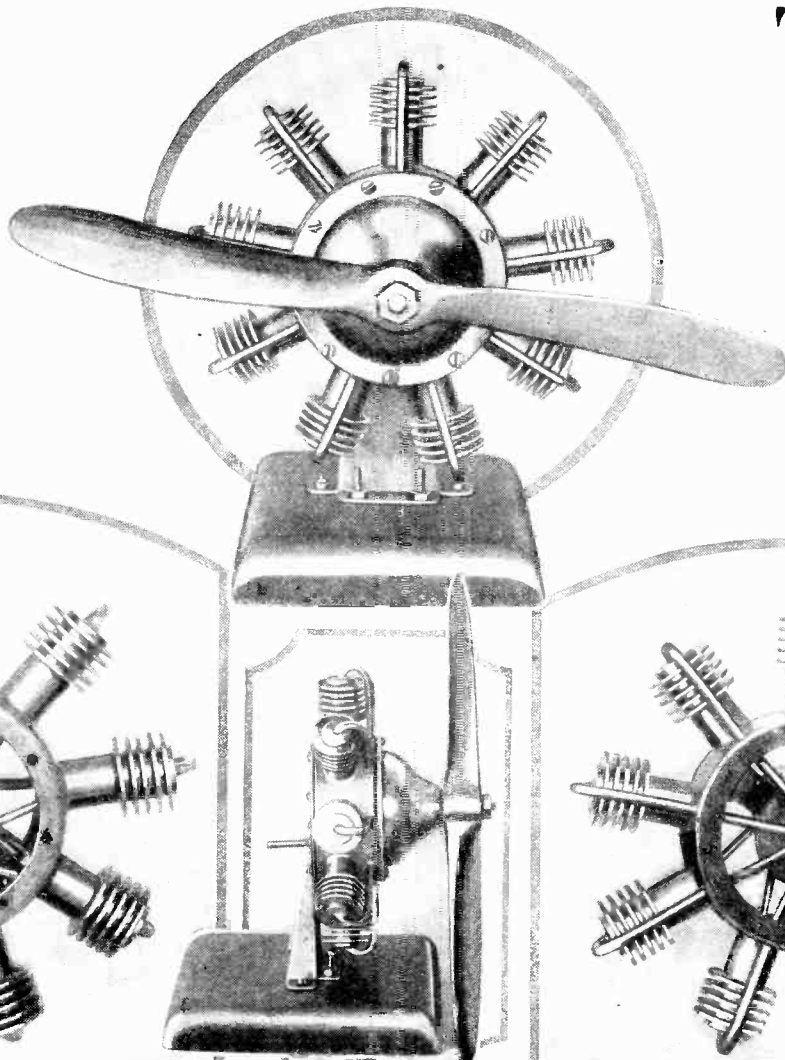

The above photograph shows a rear view of the airplane engine with the case removed. The pipe projecting from behind the case in the photograph at the center is for the air supply.

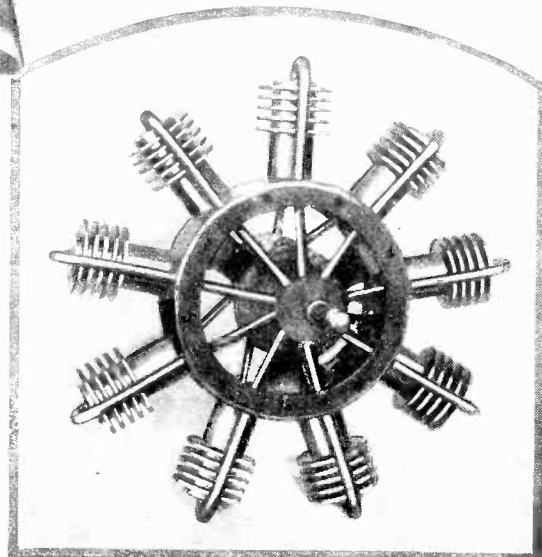

At the left is a photograph of the engine standing on the cup which it won. Above is a front view of the engine with case removed.



The model and the prize.

THE motor illustrated on this page is made nearly entirely by hand, with the possible exception of the crankshaft, the connecting rod bearing, the pistons, and the nose on the crankcase. These parts were turned out on a lathe. The cylinders are pieces of brass pipe, 1/2 inch outside diameter. The crankcase is a piece of sheet brass and the valve sleeves and pipes to the cylinder were made of the same material. All other parts are aluminum, except the crankshaft which is iron and the wrist pins which are made from steel wire, and held in place by punching the metal into the holes with a punch. The motor operates from a source of air supply at a pressure of from 40 to 50 pounds. It will be observed in the construction that one of the connecting rods has a master rod keyed to the piece to which they are all connected. All other connecting rods are movable.

On the accompanying page the complete details of the engine are to be found, and we likewise see the assemblage of this device. The reader will note that the crankcase was made of a strip of annealed brass, 1 1/2 inch by 3/8

inch. The holes were drilled through brass, which was then bent around and soldered. A strip of light material was sweated over the seam on the inside. The pistons themselves are grooved and wound with thread to prevent air leakage. The motor itself weighs but a trifle more than one-half pound, without the base. It could be made a little lighter if aluminum was used throughout, instead of brass, where brass is specified. One experiences no difficulty in turning over the 9 inch propeller, even when blowing into the intake pipe. This gives an idea of how carefully the model was built. The mechanism has no fly-wheel because every ninth part of a revolution we have a power impulse, thus there can be no dead center at any time.

The operation of the motor is as follows: As one piston reaches top dead center, one of the flats on the valve allows the air to flow from the chamber along the flat to a tube, thence to the piston thus forcing it down. On the up stroke, due to the second flat on the valve, the exhaust takes place through a part of the intake pipe, and out through a hole.

Complete Details of Airplane Engine

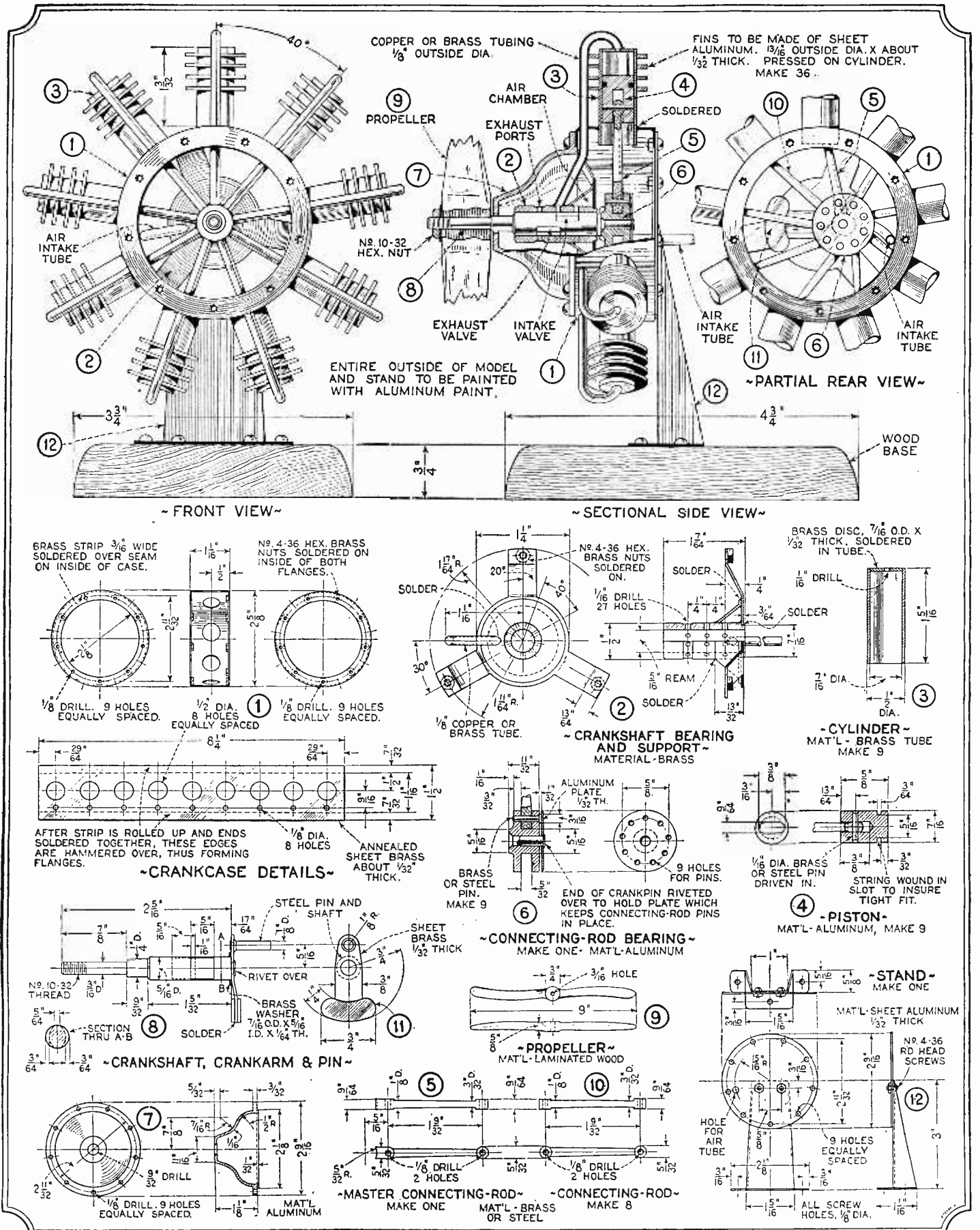

The above illustration shows the details and the assembly of the airplane engine which won the Model Trophy Cup awarded monthly by this publication for the best model submitted during the month. This engine operates

from a compressed air source of supply. As can be seen, the model resembles the Wright-Whirlwind type of engine in that the cylinders are stationary. For this reason it differs from the rotary engines.

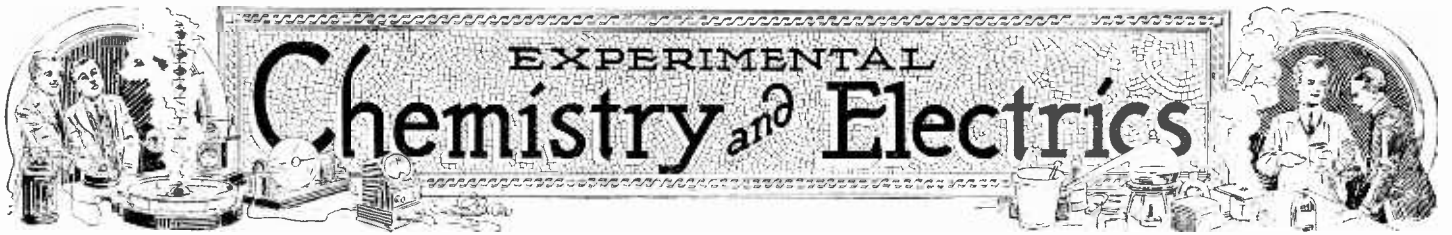

A Miniature Telegraph Set; Its Wiring and Construction

By FAUST C. BACABAC

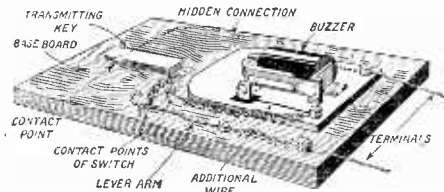
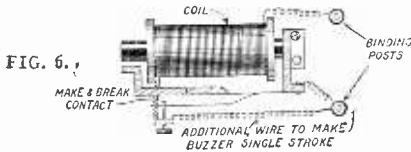

FIG. 5.



The upper figure gives a perspective view of one member of the very simple telegraph set. If the captions are followed out and it is examined in connection with the diagrams and details shown on the right, all will be perfectly clear.

The lower figure shows the arrangement of the electro-magnet, also with captions to explain the action as a sounder.

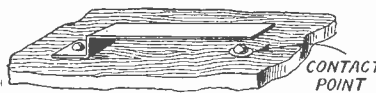
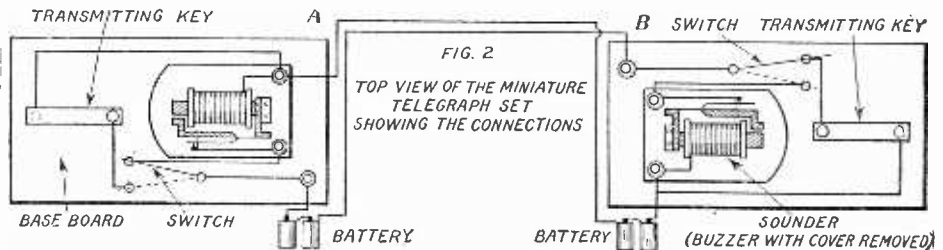
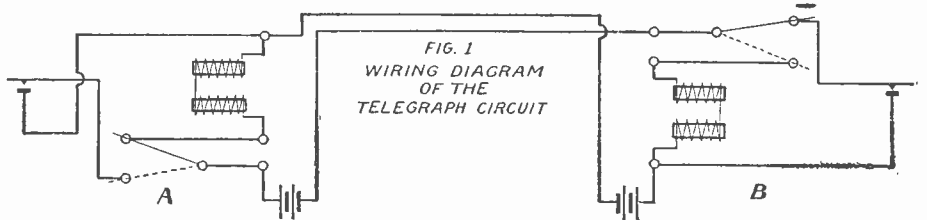

FIG. 3.- TRANSMITTING KEY

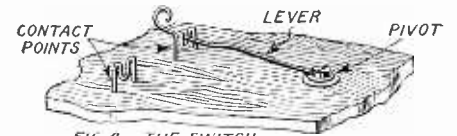

FIG. 4.- THE SWITCH

Fig. 1 shows the circuit of the miniature telegraph set in detail. If it is followed out carefully, and if studied, it will be seen that it takes care of transmitting and receiving, both by the Morse or other audible code. Fig. 2 is a diagram in more detail of the same subject, while below, in Figs. 3 and 4 the very simple transmitting key and the switch are shown so as to make their construction perfectly clear.

A MINIATURE telegraph set which is very useful for students, amateurs, and experimenters can be made from two single coil buzzers. The set is very helpful for students in telegraphy, especially those who are learning the code. A complete diagram of the device is shown in figures 2 and 5.

The buzzers are made single stroke, like all single stroke electric bells, by connecting the base of the contact point (make and break point) and the adjacent binding post by a copper wire (see figure 6). The buzzer with its cover removed, is mounted on a piece of board (7"x4"x1/2") which serves as the baseboard (figures 2 and 4). A transmitting key is made by bending a piece of tin two and a half inches long by one half inch wide into the shape shown in figure 3. It is fastened to the baseboard in front of the buzzer. A two point switch is made and mounted on the baseboard by the side of the buzzer as shown in figures

2 and 5. The two M-shape contact points of the switch are made of copper wire of suitable strength bent into the shape shown in figure 4. They are fastened to the baseboard as shown. The lever arm is so fastened that it may be swung to either point as desired. The other part of the set is made in the same way as the one just depicted. Wood screws will be very convenient for fastening the materials on the baseboard.

Connect stations "A" and "B" as shown in figure 2. Four dry cells (two in each

station) connected in series are sufficient to give the necessary electric current. Figure 1 represents the wiring diagram of the apparatus.

With the position of the switches as shown in figures 2 and 5, a message may be transmitted from station "B" without any perceptible clicking of the armature of the sounder of the transmitting party for no current passes through the local sounder. Likewise a message may be transmitted from station "A" by changing the position of the switches as shown by the dotted lines.

EMERGENCY BRUSH REPAIR FOR GENERATOR OR MOTOR

By RALPH A. LAMBERT

While spending the summer touring in the mountains, one of my generator brushes gave out, and after liming several miles to a garage, I found there was no help, as the proprietor had no brushes! And the next garage was 38 miles away, 6,500 feet down in the valley!

The trouble was remedied, however, with the aid of a hack-saw, drill, and old battery. The dry-cell was broken open and the carbon removed. This carbon is about one inch across and six inches long. A section was cut out somewhat larger than the old brush and filed down to the exact size. The two holes were then drilled in with a hand drill, and the correct angle filed on the com-

mutator end of the brush. Great care must be used in drilling the holes, using very little pressure, as the carbon is so brittle that it cracks very readily. It is well to drill the holes before sawing out the pieces. This is only a temporary job, however, and the proper brush should be put in as soon as possible. The carbon in the dry cells contains no copper, and is of much higher resistance than the copper-impregnated brushes made for auto generators. The result is that the emergency brush will heat quickly, and clog up the commutator with burnt carbon.

However, it is well worth the trouble of making, when you are stranded!

EXPERIMENT WITH AN ARC

By ROBERT L. LEWIS

The following is an account of an experiment which I made.

An open adjustable arc is constructed to operate on 110 A.C. with suitable resistance or choke. If an alternating current magnet is held below the arc while in operation, a very loud noise is heard and the arc is "blown" away from the magnet making a hot torch. If a permanent magnet is used the arc is attracted to one pole and repelled by the other. If a strong direct current magnet is held to the arc a loud sputtering hiss is heard and the arc is again repelled.

Colored glasses must be worn to save the eyes.

Making a Portable Arc Lamp

Cheap Electric Arc Lamps Especially Useful to Photographers

By RAYMOND B. WAILES

AN electric portable arc lamp that is self-feeding and which has a high actinic light value has often been desired by the amateur photographer and experimenter. Such a lamp is easily made and compares favorably with the same type of lamps now on the market which sell for fifteen dollars or more.

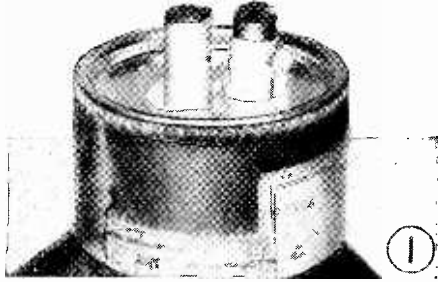

The mould for the rods is made from a cardboard carton. Remove the metal end, if there is one. Wrap the rods with paper before pouring the plaster, so that the holes will be large enough for the carbons to slide back and forth.

The reflector consists of a metal lamp shade of the conical type. If dirty on the inside it should be polished, or if this is not possible, it should be given a coat of a good white zinc oxide paint. The two carbon rods forming the arc are ordinary carbon arc lamp pencils such as used for regular arc lamps. They are held in position by a mass of plaster of Paris which is cast on the smaller end of the reflector-shade.

The mass of plaster of Paris which retains the carbons is poured into a mould made by cutting off a cardboard carton and placing this over the smaller end of the shade. Figure 1 shows how the carbon rods protrude from the bottom of the shade and Figure 2 shows the method of holding the carbon rods in position while the plaster is being poured and is hardening or setting. The carbons should be so placed that they are inclined toward each other at their tip ends; they are not placed parallel with each other. The distance between them at the smaller end of the reflector should be about a quarter of an inch, while the distance at

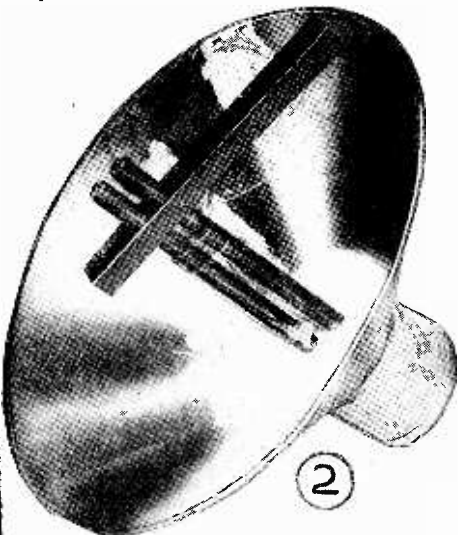

While the plaster of Paris is setting, the carbons are held apart by means of a wooden strip. Enough plaster is used to go well inside the shade so as to give a solid construction.

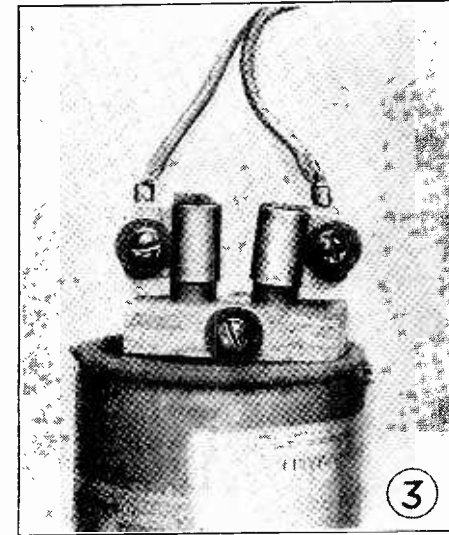

The adjusting clamp and electrical contacts are clearly shown here. Use heavy, yet flexible wires. The clamp is in two pieces, which grip the carbons firmly when the central screw is turned up.

from the carbons, too large for the carbons. This clearance is used as a means for adjusting the distance between the two carbon rods.

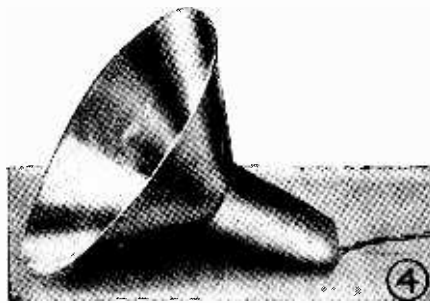

The finished arc lamp. Note the section of inner tube, which serves as handle and protector. The operator might get a severe shock without this protection.

The adjusting of the two rods is carried out by means of two strips of hard wood fastened together with a bolt. The two strips clamp the carbons tightly together as shown in Figure 3. Electrical connections are made with the carbon rods by means of two metal collars or clamps affixed as shown in the same figure. The cardboard carton used as the mould for the plaster of Paris can be left on, after the plaster sets, as shown. Figure 4 shows the completed lamp. A section of an inner tube is cut and fitted over the plaster base and the metallic connectors. The plaster thus serves as a hand grip and also to keep the carbons in position.

The arc lamp described is not made to operate directly from the 110 volt, direct or alternating current, house lighting system. A resistance is needed in series with it. A

direct short circuit across the carbons will occur, causing the fusing or "blowing" of the house fuses if the lamp is operated without resistance from the house current.

The resistance used in series with the lamp can be conveniently taken from an old electric iron. Its electric resistance element is all that is necessary. This will be found to

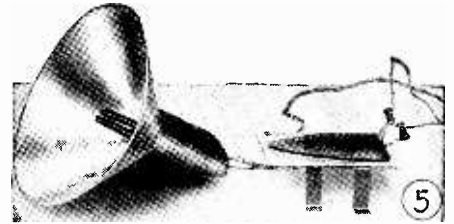

The lamp with the resistance taken from an electric sadiron. The resistance of the lamp decreases with heat, that of the iron increases with heat, and the opposite actions balance, in a sense.

be wound upon and surrounded by mica sheets. If two binding posts are added to the contact strips of the heating, or resistance element and the element is inserted in series with the lamp, it will be found that the lamp will not light, due to the fact that too much resistance is in the circuit. However, if thirty inches of the resistance ribbon is unwound, removed and discarded from the heating element of the iron, the lamp will operate very well. A stand can be made to support the resistance as shown in Figures 5. Here, two galvanized iron strips were used to form a little four legged table with a sheet asbestos top. The heating element from the electric iron rests upon this asbestos. The asbestos sheet prevents the heat given out by the iron from damaging the object upon which it is placed. The resistance wire becomes red hot.

Starting the arc is very simple. With the current ON, touch a carbon rod to the tips of the two carbon rods of the lamp, and then withdraw it. An arc will be formed, and if the resistance is correct and the tips of the carbons are rightly placed, the arc will remain at the tips. If after repeated trials the carbons do not arc, or the arc is not "struck," then they should be moved nearer each other. This is done by adjusting the wooden clamp at the rear end of the carbons. One might also remove several more inches of resistance ribbon from the electric iron resistance, but it should be remembered that removing wire cuts down

(Continued on page 71)



Showing how the arc is struck. A bit of carbon touched to the two ends starts the lamp into action instantly.

Everyday Chemistry

By RAYMOND B. WAILES



What substance is used to make a solution which when used as a wash for artificial hosiery prevents runs?
—This chemical is ordinary alum.



Do you ever eat marble?—Yes, ordinary table salt contains sometimes as much as 1% powdery calcium carbonate. This small amount of impure matter is harmless. Chemically speaking, marble is CaCO_3 .

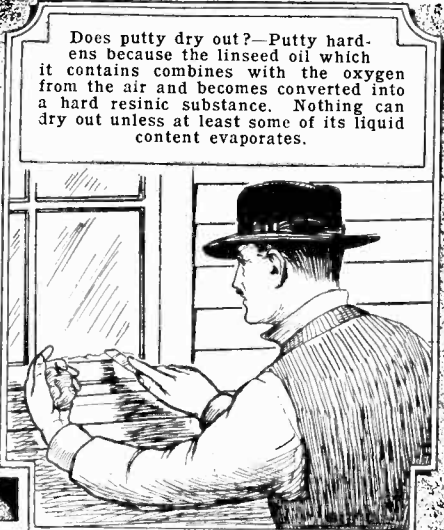

Does putty dry out?—Putty hardens because the linseed oil which it contains combines with the oxygen from the air and becomes converted into a hard resinic substance. Nothing can dry out unless at least some of its liquid content evaporates.

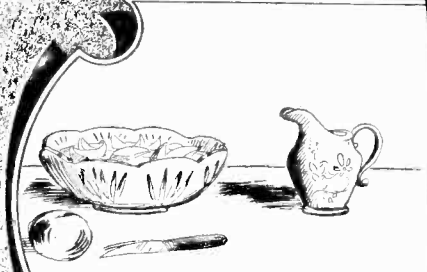

Why does some fruit become dark when sliced?—Because most fruit contains tannic acid, which combines with the iron of the knife blade and forms a soluble black iron tannate. Many inks are made of this substance.



Why are not both wood ashes and coal ashes good fertilizers?—Wood ashes are a good fertilizer because they contain suitable potassium compounds. Coal ashes contain aluminum and silicon compounds but no potassium compounds. Aluminum and silicon are of no benefit.

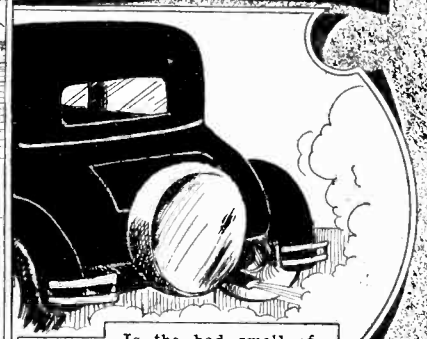

Is the bad smell of an auto exhaust due to carbon monoxide?—No, carbon monoxide has no odor and cannot be detected by smell.

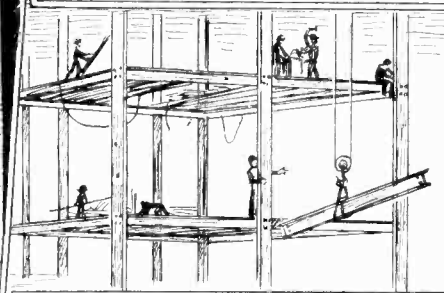

Do bacteria play an important part in the iron industry?—Some iron mines are due to bacteria playing the part of chemists. "Iron bacteria" decompose some forms of iron salts.

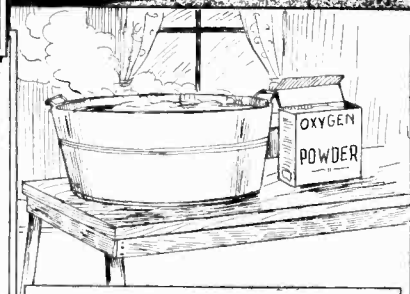

How do oxygen bearing washing powders work?—The oxygen releasing soap powders now on the market contain sodium perborate, chemical sister of ordinary borax, which gives off oxygen when put in water.



How do factories fire-proof to some extent, their wood structures?—Water glass solution sprayed or painted on woodwork acts as a fire-proofing material. Although the wood beneath will ultimately burn it takes some time for it to do so.



Does concrete dry out when it hardens?—The water in concrete does not evaporate into the air but combines chemically with the cement. Consequently, the water remains in the concrete even after it hardens.

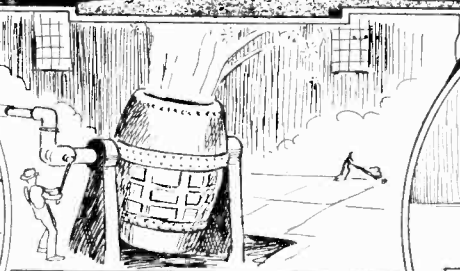

What is the biggest firework sparkler known?—The sparkling portion of the Bessemer converter flame is due to burning particles of iron, and the light of the sparkler is also the result of burning particles of iron.

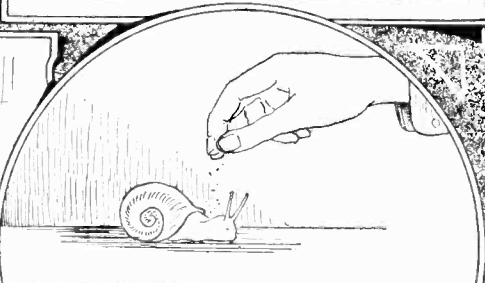

What kills a snail or worm when salt is sprinkled on it?—The liquids within the snail pass through its body to act upon the salt placed on its outside. This is osmotic action and the water in the snail abstracted.

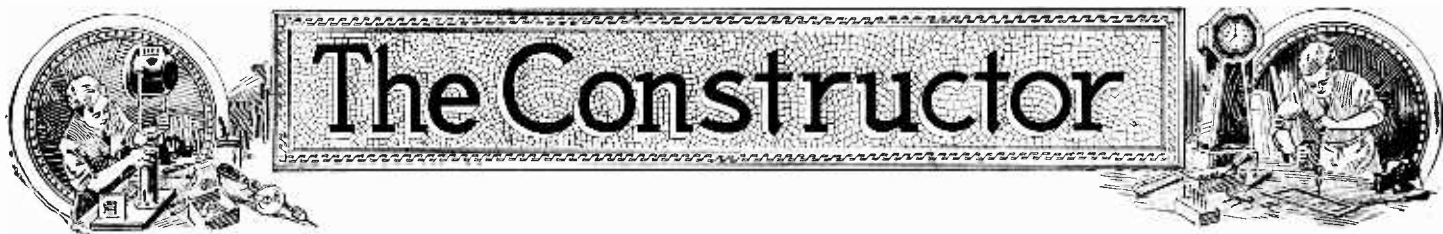

Making A Photo-Printing Machine

By FRANK SCHMID

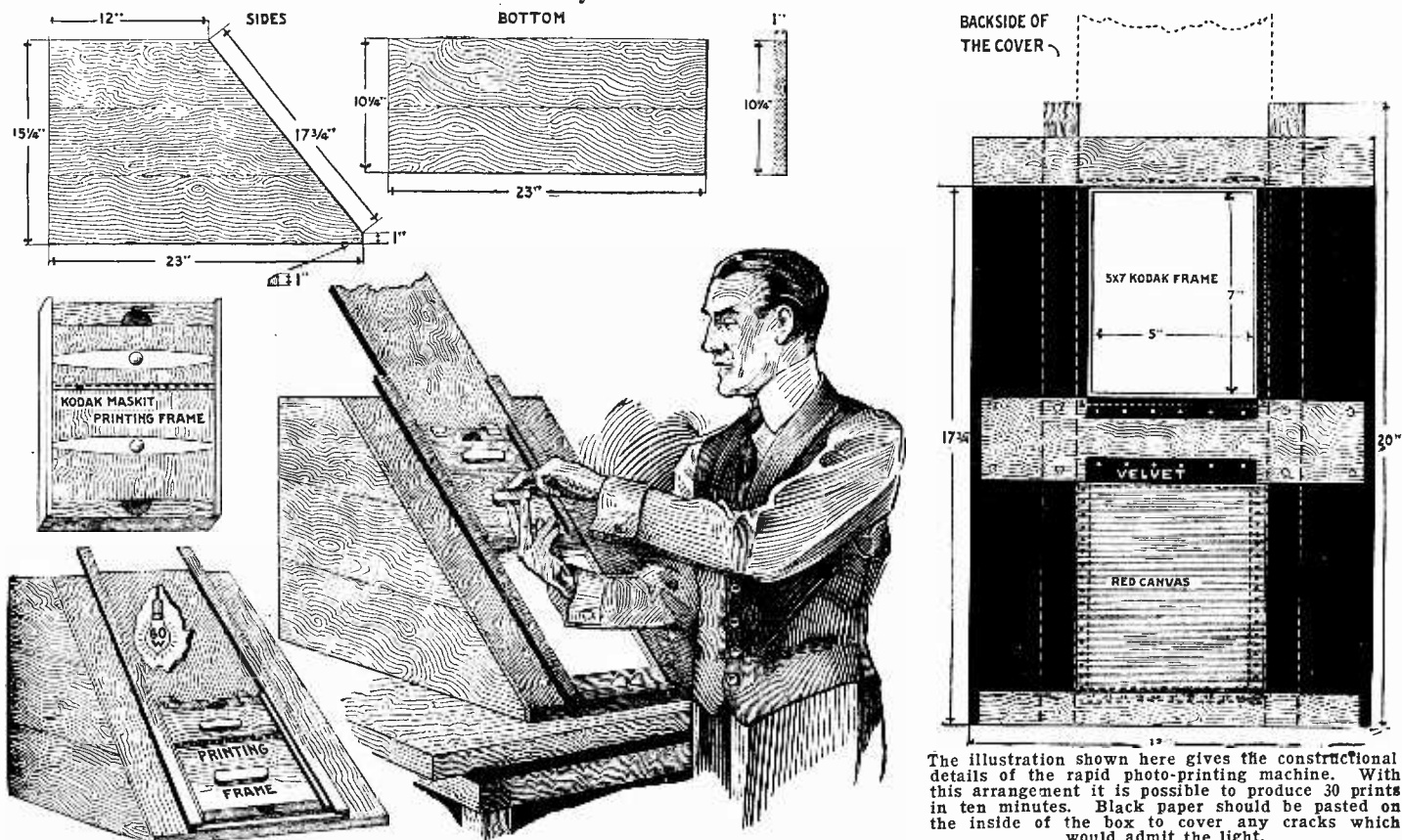

The illustration shown here gives the constructional details of the rapid photo-printing machine. With this arrangement it is possible to produce 30 prints in ten minutes. Black paper should be pasted on the inside of the box to cover any cracks which would admit the light.

THE construction of a photo printing machine is not exceedingly difficult and anyone, at a nominal expense, can make a machine of this nature which will do everything that the expensive manufactured products will. The photo-printing machine shown here is rapid in action and will produce thirty copies in ten minutes by the normal, six to eight second exposure on gas light paper with a 60-watt electric bulb. This bulb should be placed about eight inches from the printing frame, and the use of a

kodak maskit frame, 5 x 7 inches, with clamp improvement for holding the films, is to be preferred. For printing from two films, two glasses should be put in the frame and when using plates, one of the frame glasses should be removed. The finished machine should be lined with black paper in order to cover up all the cracks. A strip of red canvas, placed as shown, provides a dark room red light, when the frame cover is opened. The printing frame should be hinged to the sliding front cover, and it is

well to place strips of felt or velvet around the frame, so as to be sure that no outside light strikes the sensitized paper while printing. Boards about one inch in thickness will perhaps serve best for the construction. The completed outfit is about 20 in. high and 12 in. wide and about 2 ft. long. The printing machine can be easily made for taking larger size plates and films if desired, but the 5 x 7-inch opening should be sufficient for amateur use. All constructional details are shown in the above cut.

SLIPLESS BOOK ENDS

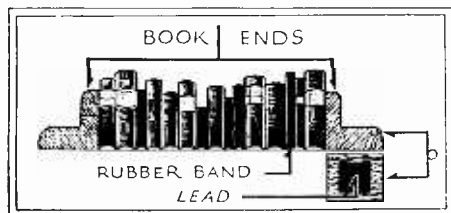

Book ends may be prevented from slipping by filling with lead or by using a rubber band as shown above.

Wooden book ends are usually too light to hold the books in place. A good way to prevent their slipping out of place is to cut a hole at the bottom of each book end and pour in molten lead. The hole may be covered up by pasting a piece of felt over

the bottom of the book end. Another method in which slipping can be prevented is to bore a small hole close to the bottom and nail a rubber band on the bottom of each book end. The elastic tends to tighten and will hold the books firmly in place.—Oscar Wisbey.

TESTS FOR TEXTILES

- (A) Wool when burned smells like burnt feathers.
- (B) Wool can be dissolved in heated sodium hydroxide solution.
- (C) Cotton gives off an acrid smell when burnt.
- (D) Cotton does not dissolve in NaOH.
- (E) Silk dissolves in heated hydrochloric acid, while wool does not.

Louis Fisch, No. 29367.

USING OLD TABLE KNIVES

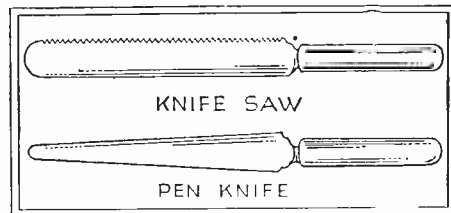

Old table knives can be used for making a knife saw and a penknife or letter opener as shown above.

A knife saw and a penknife or letter-opener can be made from an old table knife. Teeth may be filed or cut into the knife, thus making a saw, or the knife can be ground and tapered for making a letter-opener.

A Home-Made Reflecting Telescope

Part Two—THE MOUNTING

By WILLIAM H. CHRISTIE

THE mounting for your telescope may cost anything from a few dollars to several hundred, depending upon how elaborate you intend to make it and also upon your ingenuity. The following description of a simple mounting will serve as a guide in designing a more elaborate

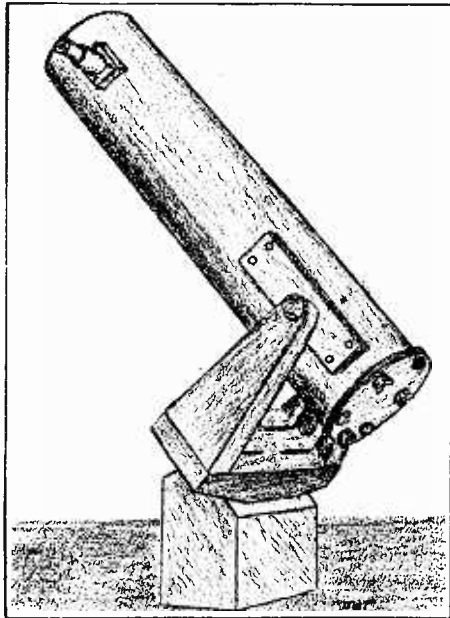

A view of the finished telescope appears above. The mounting may cost from a few dollars to several hundred, depending upon how elaborate it is. (Fig. 11).

one for those who wish to substitute metal castings for the simple wooden parts described here.

The mirror cells are the first to be described. Cut two hardwood disks, one inch or more in thickness; one two inches the other four inches larger in diameter than is the mirror. Clamp these together concentrically and bore three equally spaced $\frac{3}{8}$ " holes, near the edge of the smaller, and through both disks. Countersink the holes in the smaller disk to take the heads of $\frac{3}{8}$ inch machine screws. Draw a circle the size of the mirror on the smaller disk and then securely fasten three hardwood blocks, with screws, outside this line. These blocks should be hollowed to conform to the shape of the edge of the mirror. Small metal plates screwed to the top of the blocks and projecting over the mirror for an eighth of an inch prevent it from falling out. The mirror should now lie snugly between these blocks but it should not be pinched, a little play is preferable.

Obtain three short pieces of vacuum tubing, or heavy air hose, about $\frac{3}{4}$ inches long;—a pile of rubber washers cut from an old inner tube will serve. Put three $\frac{3}{8}$ " machine screws through the holes in the smaller block, screw on a lock nut, then slip the tubing or washers over the screws. Slightly enlarge the holes in the larger disk, pass the screws through these holes, put on a washer, then hold the whole together with three thumb-nuts. See Fig. 8.

For the flat, make a hardwood cylinder equal in diameter to the minor axis of the mirror surface; cut one end off at an angle of forty-five degrees. (See Fig. 9.) Cut another length of the same material to form the upper block. Two circular brass disks will be needed equal in diameter to the above pieces; they should be drilled

and tapped as follows. Drill one with a central hole $\frac{9}{32}$ " in diameter, and drill and countersink three holes for flat-headed screws; hollow out the top of the bevelled block to take the head of a long $\frac{1}{4}$ -inch machine-screw, slip the screw through the hole in the plate and screw the latter securely to the top of the block, where the head of the bolt should be free to turn. Drill and tap a hole for the $\frac{1}{4}$ -inch screw in the center of the other plate, and at three equidistant points drill and tap holes for $\frac{3}{16}$ -inch screws, about $\frac{3}{16}$ -inch from the edge; three other countersunk holes are drilled for wood screws. Bore holes to take the machine-screws through the upper block, corresponding to the holes drilled in the plate, then screw the plate to it. Thread the $\frac{1}{4}$ -inch screw up through the upper plate and solder a nut at the end to serve as a thumb-grip. Pass three $\frac{3}{16}$ -inch screws down through the block and through the threaded holes until their ends press upon the lower plate.

Cut a length of brass tubing into which the upper block will fit snugly, and solder three radial brass strips to this, a little longer than necessary to reach the wall of the telescope tube; drill a $\frac{1}{4}$ -inch hole near the end of each of these strips and then bend the extra length over at right-angles. This forms the "spider" by means of which the cell is supported in the center of the tube. The mirror is held in position by three small brass strips, bent over at the end and screwed to the lower block.

The tube may be a square wooden box arrangement;—anything will serve that will hold the mirrors and lenses in the same relative positions. A tube made of sheet metal by some local sheet metal works will not cost very much and will be neater in appearance, it should have three heavy threaded studs, riveted to the lower end, which pass through holes bored in the larger section of the mirror cell, these serve to bolt the mirror cell securely to the tube.

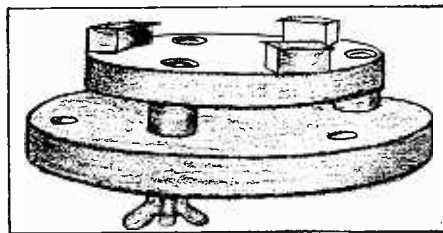

Above are the mirror cells which are made from two hardwood discs and a clamp. (Fig. 8).

Carefully determine the position of the eyepiece and cut a $1\frac{1}{4}$ -inch hole at this point. Drill three $\frac{1}{4}$ -inch holes for the bolts which hold the spider in position, arranging them so that the flat is directly opposite the hole in the tube.

Two pieces of brass tubing, three or four

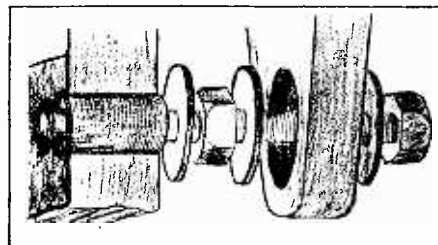

The above drawing shows the method of attaching the flat. Two circular brass discs are used. (Fig. 10).

inches long, form the draw-tube for the eyepiece; one of these is $1\frac{1}{4}$ -inch inside diameter and the other large enough for the former to slide in freely. A brass band fitted inside the smaller tube and filed to the correct thickness allows the eyepieces to be fitted snugly into the draw-tube; if the eyepieces are not all the same size an-

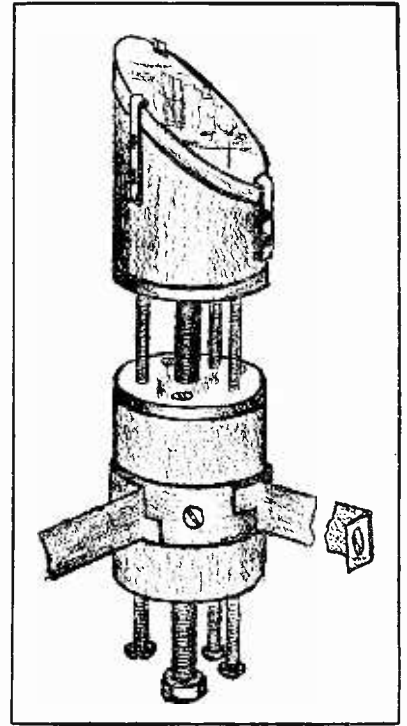

Fig. 9

The mounting for the flat is shown above.

other ring may be fitted in the other end of the tube to take them. Shape a 3-inch square block of wood to fit the tube and bolt.

Place the mirror in its cell and bolt it to the tube. Fasten the flat in position and insert the draw-tube. Now find the point at which the tube balances and draw a line around the tube; on this locate two diametrically opposite points. With these as centers drill two $\frac{3}{4}$ -inch holes. Take two thick pieces of hardwood, about 4 inches by 18 inches for a six-inch telescope, and bore holes in their centers to take a short length of $\frac{3}{4}$ -inch iron pipe. Shape these "cradles" to fit the tube, and bolt them over the two holes. Screw in two short lengths of $\frac{3}{4}$ -inch pipe, with their ends flush with the wood. Build up a substantial fork as shown in the sketch of the completed telescope, bracing it well with angle irons. A piece of heavy shafting forms the principal axis and is threaded, or held by two nuts, in the cross-piece of the fork. The tube is now attached to the fork as shown in Fig. 10, any play being taken up with washers. It will be noticed that the tube is not bound by the bolts, which are clamped to the fork, but is free to turn about them as an axis.

Bore a hole for the shafting through a length of heavy timber such as a 6-inch by 6-inch, or larger, making an angle with the axis of the post equal to the colatitude of the place where the telescope is to be erected. (The colatitude is equal to ninety degrees minus the latitude; e. g., the colatitude of a place $42^{\circ} 30'$ north is $90^{\circ} - 42^{\circ} 30' = 47^{\circ} 30'$.) The top of the post is then cut as shown in Fig. 11, and the post erected in the
(Continued on page 70)

How to make it

ARTICLES OF INTEREST TO EVERYONE

PLIER SPRING

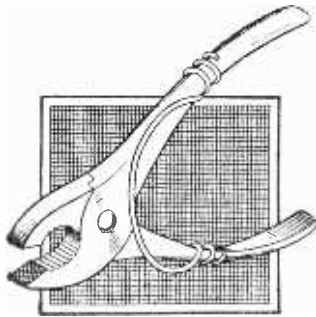

A piece of spring wire fastened to the plier handles provides sufficient spring to keep the pliers open at all times. Equipped in this manner, the pliers do not have to be pulled open whenever a new hold is required.—Contributor kindly send name and address.

REPAIRING FAUCETS

Water faucets which have had the threads stripped off, may be repaired so that they will again render good service. A piece of brass or copper wire is wound in the worn threads and soldered securely in place. This

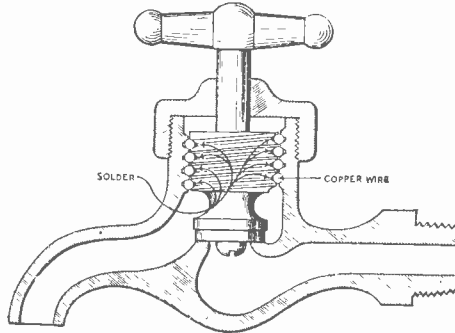

A piece of brass or copper wire is wound in the worn threads of the screw portion as shown above.

should then be smoothed with a file, and you will then have a brand new screw, good for months of additional wear. The drawing shows clearly the method used in repairing faucets.—Douglas O. McKeown.

THE SMOKING PUMPKIN HEAD



A novel display device in which a pumpkin head or dummy can be made to smoke a cigarette is shown here. The details of the valve box, which is placed within the head itself, are shown below. The box is constructed of copper, with three copper tubes arranged as shown. The valves may be made from sheets of thin rubber or stiff cloth fastened by small rivets.

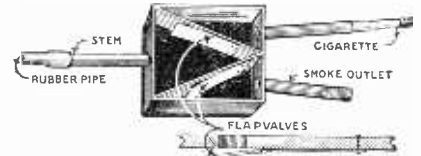

Details of valve box are shown above.

ELECTRIC CHAIR

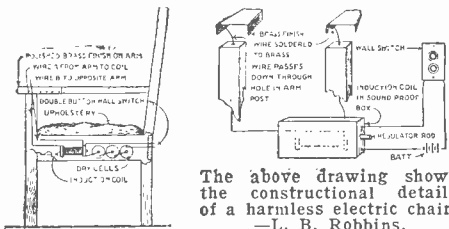

The above drawing shows the constructional details of a harmless electric chair.—L. B. Robbins.

A Library Table Cigarette Cabinet

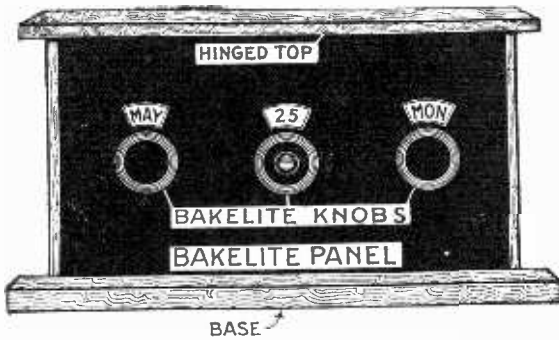

A very novel cigarette cabinet can be made in the form of a small radio receiver, and is a combination cigarette case and daily calendar. The days and months and years are changed by the dials. The complete cabinet is shown at the left.

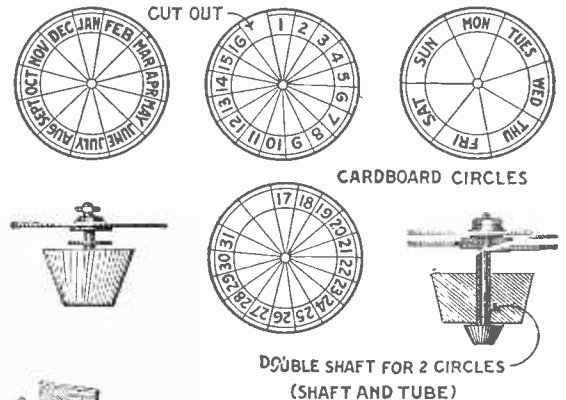

Details of the circular cards are given above. The center indicator for the day of the month is double and is regulated by the center knob. One of the center cards is numbered from 1 to 15, and the other from 16 to 31. After the panel is put in place, a strip of wood should be fixed so that it just clears the circular cards and shafts.—Herman R. Wallin.

A top view of the cigarette case appears below. The cabinet is made of wood and the panel may be made of wood, bakelite or hard rubber. The calendar cards are cut from stiff cardboard. Two ordinary knobs with small shafts for their outer ends are required. The middle knob has a hollow shaft through which another smaller shaft is pushed. One of these double knobs can be obtained from an old type variable condenser equipped with a vernier.

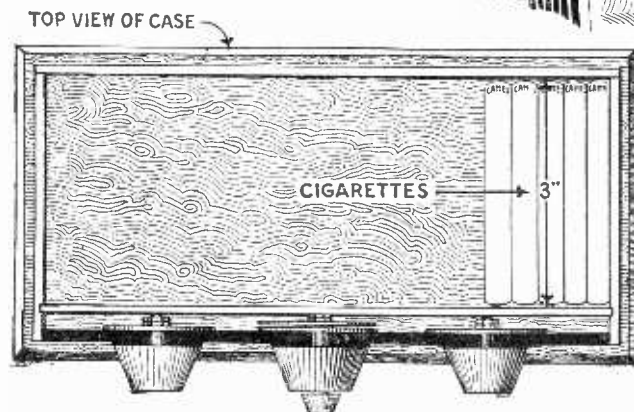

Transferring Drawings and Pictures to Paper

By RAYMOND B. WAILES

FREQUENTLY one wishes to transfer drawings appearing in the daily press to a scrapbook, notebook, or some other cherished volume. Ordinary newspaper clippings rapidly become yellow and even brown with age, due to the iron compounds which the paper contains. If one transfers the cherished drawing by a sort of decalomania process as described in

the back of the paper bearing the picture is rubbed gently but yet firmly with the bowl of a spoon for about half a minute. This

rubbing process is the cause of the transferring of the picture. The solution merely loosens the dried vehicle of the printer's ink, and by rubbing, the ink is transferred from one paper to the other. By carefully lifting up one corner of the paper, one can see just how the transfer is coming about. If a white spot is seen, or the transfer appears faint at spots, these portions should be rubbed more. When the desired intensity is reached, the original paper is lifted from the new, and the transferred picture allowed to dry.

Only one copy can usually be taken. The original drawing is only made a bit fainter by the process, as the above pictures show.



The picture above shows an ordinary newspaper cartoon and the illustration at the left shows the transfer made from the original cartoon. Note that transfer is reversed.

The transfer of any cartoon or printed matter will appear as a reflection of this matter. This, of course, is of no importance unless the reading matter must be legible on the transfer. There are times, however, when legibility is necessary, and this condition may be ob-

tained by making a transfer from the first transfer. This retransfer is made in the same manner in which the original transfer was made, only of course the transfer is used in place of the original print. This second copy is somewhat more indistinct than the first, but if the process is carefully carried out, by a person who has had a little experience with this method, satisfactory retransfers may be produced.

The quality of these transfers, and especially the retransfers, depends somewhat upon the quality of the printer's ink. The length of time since the picture was printed, does not seem to affect results to any noticeable extent.

It has been observed by some that this transfer of a cartoon shifts the objects on the right-hand side of the original, to the left-hand side of the transfer, while objects at the top of the cartoon are not shifted to the bottom of the transfer. At first thought this seems to be an unreasonable discrimination, but a moment's reflection will remove any confusion on this point.

By using this process, pictures may be copied on ordinary paper. Coated stock gives a finer reproduction.

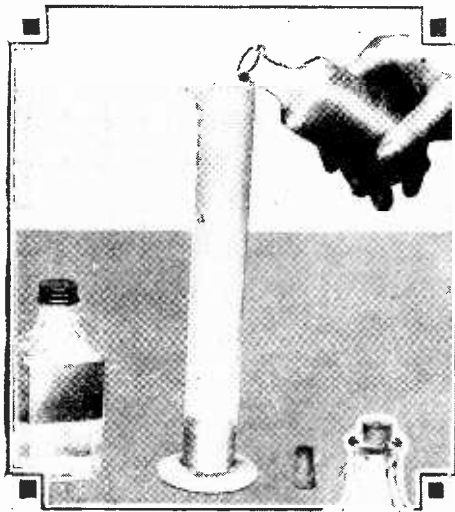

Mix a teaspoonful of spirits of turpentine with a teaspoonful of tincture of green soap. Add two cups of water. Mix. This is very simple, isn't it?

The original cartoon is thoroughly soaked with the picture transfer fluid, by means of a small soft brush. The excess mixture is carefully removed with a blotter.



this article, to a good grade of white rag paper, the drawing can be kept for a much longer time without discoloring.

The solution used in this process is extremely simple and inexpensive to make. If the ingredients are bought at a drug store they will cost about twenty-five or thirty-five cents, and will make about a quart or two of solution. Only several drops of the solution are needed to transfer the drawing to another sheet of paper.

The solution is made by mixing equal parts of spirits of turpentine and tincture of green soap, and diluting the resulting mixture to about 500 times its own volume with water. One may take a teaspoonful of each of the two liquids, mix them together, and then add two cupfuls of water, mix well and bottle. For those scientifically inclined, 5 cc. of tincture of green soap and 5 cc. of spirits of turpentine mixed together, and diluted to 500 cc. with water, will make a very good solution to work with. The solution should be shaken when desired for use.

One should clip the cartoon or drawing—news-paper line drawings make excellent transfer pictures—and apply the solution with a soft brush, wetting the whole of the picture thoroughly. The excess of liquid should then be removed by means of a blotter applied very gently to the picture. The paper bearing the picture is then laid face downward upon the paper to which the picture is to be transferred, and

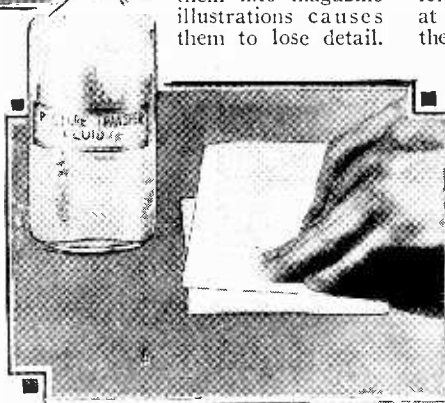

The surplus solution is very gently removed by using clean blotters as shown above. By this time the printer's ink has been softened and the cartoon must be handled carefully.

When the ink of the original cartoon has been softened, the cartoon is placed face downward upon the surface which is to receive it, and rubbed with the back of the bowl of a spoon.

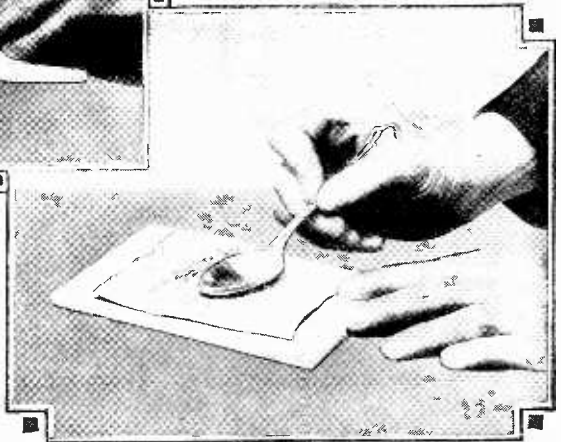

Readers Forum

SCIENCE AND INVENTION desires to hear from its readers. It solicits appreciate opinions on and will science subjects. The arguments pro and con will be aired on this page. This magazine also relishes criticisms, and will present them, whether

caustic or not. So if you have anything to say, this is the place to say it. Please limit your letters to 500 words or less, and address your letters to Editor—The Readers Forum, c/o Science and Invention Magazine, 230 Fifth Avenue, New York City.

caustic or not. So if you have anything to say, this is the place to say it. Please limit your letters to 500 words or less, and address your letters to Editor—The Readers Forum, c/o Science and Invention Magazine, 230 Fifth Avenue, New York City.

SOUND OR NOT SOUND

Editor, SCIENCE AND INVENTION:

Your article "If We Had No Ears!" is not convincing. Why? You and your critics differ on a fundamental definition of sound. You find sound in the vibrating object and the physical results through a conducting medium. Your critics find sound only in the terminal result on a sensorium or nerve apparatus, with distinct emphasis on the mental factor.

If a tree falls on an uninhabited island, does it make a noise? You say distinctly, yes. Drawing a sharp line as they do, they would say, "Yes, the falling tree produces vibrations that, were the appropriate sensorium present, would give the final subjective result, sound. As the sensorium is missing, the final result, sound, also is missing."

WJZ and WEAJ may broadcast till the cows wake up tomorrow; but unless you have the appropriate instrument in your corner, the radiated energy won't register and there is missing the terminal effect due to the instrument.

In like manner, the precisions would say, "The microphone and the phonograph do not register sound or noise, but vibrations that, were the appropriate sensorium present, would result in sound or noise."

"If the rod extending from the bell" in the evacuated bell-jar "should be gripped by the teeth, then the sound will be distinctly heard. This would indicate conclusively," you declare, "that the object within the jar is producing a sound even though we do not hear it."

Again your critics retort, "You are wrong. It indicates conclusively that the object within the jar is producing not a sound, but vibrations that, conducted to a sensorium, produce sound."

From the vibrating bell, through every step of the process to the final mental result, let us say a pleasing musical sound, what part, what parts or should the entire process be considered as sound? Isn't that the question for you and your critics to answer before deciding about the falling tree and exploding bomb?

On page 30 of Laemmle's "Einstein's Relativity Theory," there is a picture entitled, "The earth in a sea of light." The late Edwin J. Houston, professor of physics in the Philadelphia Central High School, declared we could not see light itself. To explain the paradox, he described this experiment: Shoot a beam of light lengthwise through a dustless, dustproof and otherwise clean black box; an observer looking transversely, i. e., across the direction of the supposed beam, cannot find it! "There ain't no sech animile." But streaming from the opposite exit into a dusty room, lo! There is a beam of light. What then is the explanation of the paradox? The energy responsible for the visibility or illumination which we specifically call light, is itself invisible. Something—a ball, a sign, a flag, a speck of dust, a chunk of atmosphere—must get in the way of that energy, to reflect, refract or diffuse it before we call it light.

(Nevertheless it is there even if we can't see it.—EDITOR.)

Everyone of us can perform the experiment on a much grander scale. On a clear, moonless night, with Venus well above the horizon, any one of us standing within the earth's shadow-cone can look transversely across the line that joins Venus and the sun. But not a ray, beam nor streak do we see. Why? Out there in interplanetary space there isn't enough dust or anything else to get in the road of the sun's radiant energy to produce the illumination we properly call light. Clearly, in the picture in Laemmle's book, the sea of "light" is not light, but an invisible energy that becomes light only when something gets in the way.

A precision—and of all men shouldn't a scientist be precise?—will go a step farther. Just as in the case of sound, so he continues for light, viz., until the physical vibration registers in an appropriate sensorium, it should not be called light.

"We cannot see," you continue, "the ultra-violet or the infra-red rays of light, neither are they discernible through any of our senses. We cannot see the X-rays; we cannot hear radio waves if transmitted from the antenna of a broadcasting station. Would any of our readers question the production of any of these?"

Certainly not; but they are questioning your judgment in applying the terms "sound" and "light" to other than the terminal effects. "Inaudible sound," and "invisible light" are contradictions in terms. To your critics, X-rays, ultra-violet and infra-red rays are not light, but forms of vibrant energy that cannot become light unless they produce the subjective result to which the critics restrict the term.

Let us not stop with sound and light, but proceed to smells and tastes and varied tactual phenomena, e. g., hardness, substantial resistance of many kinds. Revolving these phenomena into separate sensations, I may readily derive a solipsistic idealism in which you and indeed everything else in the universe exist only as phenomena in my mind. But this highly subjective world splits or "polarizes" into a seeming-subjective and a seeming-objective world with distinctions not a whit different from those of the real world. You see a brick fall and you dodge

the brick; the solipsist would dodge in the words of Mill, "a permanent possibility of sensation."

Our sturdy common sense cuts the Gordian knot. In some way or other it confirms the realities. No matter how entangled they may be with psychic processes, yet there they stand, independent of the processes. When, however, you put the question, "If every living thing were stone deaf or dead as a door nail, would there exist the special, terminal effect called sound?" The same sturdy common sense answers with an emphatic "No."

RICHARD P. LOCHNER,

Philadelphia, Pa.

(We didn't say "terminal effect called sound," we used the word "sound".)

(The whole controversy around the article "If We Had No Ears" is based entirely on a misunderstanding of what is meant by the term "sound." According to Webster's Unabridged Dictionary, which is used in court today, we find

AMAZING STORIES

A

IN OUR MAY
ISSUE:

A STORY OF THE
DAYS TO COME (A
Serial in Two Parts), (Part
II), by H. G. Wells. Now
that the author has estab-
lished his mechanical
changes and differences and
the corresponding variations and modifi-
cations in the laws of the land, which we
might well enough expect to find in the
days of the future, he turns his atten-
tion, with equal success, to the inevitable
changes in the trend and mode of human
living in this age of mechanical concen-
tration. It is an absorbing study in psy-
chology.

FOUR-DIMENSIONAL ROBBERIES, by
Bob Olsen. If a four-dimensional forceps
could extract gall stones from the human
body without any operation, why couldn't
it be used for other material things—
banknotes and jewelry, for instance? The
far-reaching effects of such a discovery
as a four-dimensional instrument can
hardly be foretold to any appreciable de-
gree. The fields in which such an instru-
ment might be used are necessarily many,
and our author, by this time well-known
to all our readers, has proved himself the
possessor of a fertile mind with a turn
for good writing.

BARON MÜNCHHAUSEN'S SCIENTIFIC
ADVENTURES, by Hugo Gernsback. As
might be expected, the first novelty of
being on Mars and the strangeness of the
place wears off very quickly, and in the
next instalments we find our friends, the
resourceful Baron and his scientific trav-
eling friend, learning all about Mars and
the Martians. The Baron's periodic radio
communications furnish a source of real
scientific information.

And Others.

two definitions. First: the sensations produced through organs of hearing. Second: the physical cause of this sensation. Waves of alternate condensation and rarefaction passing through an elastic body, whether solid, liquid or gaseous, but especially through the atmosphere.

In the first definition, any vibration is not a sound unless the ear is situated somewhere within the range so that it can hear that sound. Coincidentally, vibrations above or below human audibility are not sounds, even if animals can hear them or if they can be recorded and reproduced at lower frequencies.

Medical men today, physicists in general throughout the world, and scientific scholars hold that the second definition is the most informative. It is this second definition which was, therefore, used in developing the article on sound. In this definition all vibrations as described would be sounds, whether sixteen per second or 40,000 per second, to which some human ears respond, but which latter are absolutely meaningless to the majority.

Assuming the first definition to hold, then to a deaf man there is no sound; hence such a thing as sound does not exist, yet that same deaf man can put sound to work. He can make it record. He can make it vibrate a diaphragm or change bands of light. He can feel the diaphragm vibrating and even understand what some of those vibrations represent but, of course, the sound does

not exist for him; hence, he only believes that he is feeling vibration. Those, therefore, that adhere to the first definition, would have us hold that our unfortunate subject is a victim of a strange hallucination.

We cannot hear the language used by ants. We do not know whether dogs or cats speak or converse with each other, but does that mean to say that they do not do so? Supposing a sensitive microphone were able to pick up the noise made by ants (above human audibility range) and suppose it were to heterodyne this noise and bring it down to the limits of audibility as dictated by our individual chorda tympani and the nerves communicating therewith and suppose, subsequently, that we were able to understand the language of these ants, would you have us believe that we are understanding something which does not exist because we could not hear it in the first place?

Our critics are not proven correct when they find sound only in the terminal result on a nerve apparatus.

You state that WJZ and WEAJ could broadcast till the cows wake up, but unless we have the appropriate instruments, we will be unable to hear. Correct—but that does not prove that these stations are not broadcasting, just as the fact that light cannot be seen when it passes through a dustless box, does not prove that the light does not exist therein. Any means of demonstrating the presence of that light, whether by the only one of our senses capable of perceiving it or all of them or a combination thereof or by instruments, proves the presence of that light, and it is light because it produces all of the effects of light, such as those on silver salts, light recorders, spectrum bands, etc.

A scientist is precise and it is for that reason that he accepts the second definition rather than the first, because, what is sound to you, may be inaudibility to me and maybe noise to another party. Modern usage of the words sound or light apply to all effects produced by frequencies in any medium in the bands allotted to the phenomena, sound generally taking from 16 to 40,000 vibrations per second, and light due to ether waves of various frequencies.

Of course, we could argue this question indefinitely, depending entirely on which of Webster's two definitions you choose to accept. If you would be a true scientist you must accept the second.—EDITOR.)

ELECTRIC BELT

Editor, SCIENCE AND INVENTION:

I am enclosing a clipping which I saw in the "Wide World." Whether it is a swindle or not I don't know, but I thought you might be interested.

I think your work in helping protect the credulous public is a great thing.

C. H. B. BULLOCK,
Halifax, Canada.

(Mr. Bullock enclosed a clipping of an electric belt with the usual two electrodes at the back and one at the front and a series of wet cells surrounding the belt. Investigations on electric belts have been conducted by a great many organizations. In so far as their curative properties are concerned, the psychical effect on the wearer is without a doubt the all-important factor. The belt actually does produce a small amount of current, but it is extremely doubtful whether this current is of any value to the human organism whatever. These cells polarize very rapidly, and a short time after they are placed on the belt they lose most of their original kick, after which they must be again removed from the belt and dipped into vinegar. This is the method by which the batteries are charged. Previous issues of SCIENCE and INVENTION Magazine contained exposés on these belts.—EDITOR.)

LIKES MODEL DEPARTMENT

Editor, SCIENCE AND INVENTION:

Contrary to one of the letters published in the Readers' Forum, February issue, I think that the Model Department is a splendid item in your magazine. Although no serious damage would be done by its removal, I think that many of the readers would be disappointed. I am of the same opinion of the other departments mentioned. Magic by Dunninger may not be wholly a scientific phase, but it offers a certain amount of amusement to the readers. I, myself, enjoy the department very much, and I'm sure that the majority of your readers do also. I think that you do very well in your endeavor to meet the approval of all your readers.

I wish you every success. BOYD HARMON,
Salt Lake City, Utah.

(It is always our aim to try to get the approval of the majority of our readers. It is only in this manner that we are able to get a bigger and better SCIENCE and INVENTION Magazine, and it is up to the readers to tell us what they like and what they do not like, so that we can follow their suggestions.—EDITOR.)

Wrinkles

RECIPES & FORMULAS

Edited by S. Gernsback

FIXING SHOE LACES

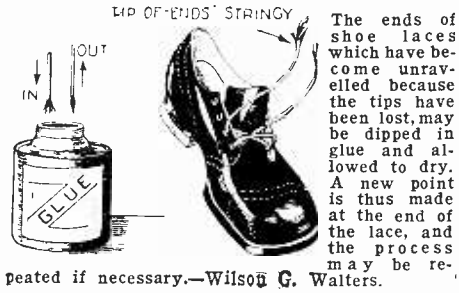

DRAFTING AID

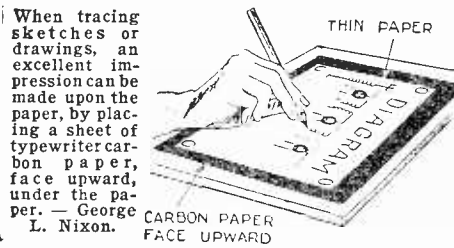

CLEANING THE TYPEWRITER



WIRE KINK

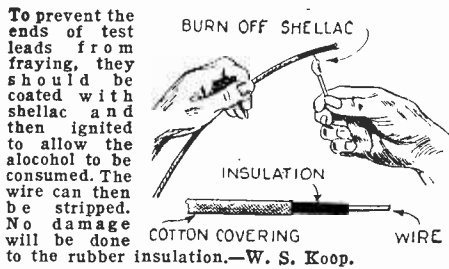

UTENSIL HANGER

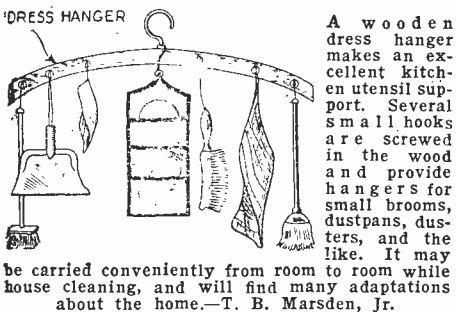

ROLL ATTACHMENT

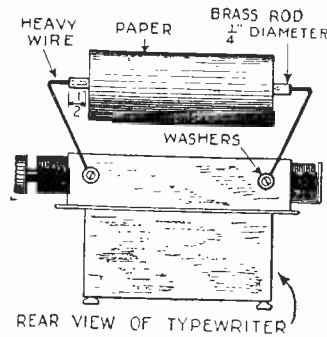

The above illustration gives the details of a paper roll attachment to be used with the typewriter. The paper is fed from the roll as the typewriter knob is turned. This should be especially valuable to radio and telegraph operators, and can be used for taking rough notes directly on the typewriter.—Herman R. Wallin.

MOSQUITO-PROOF DOOR

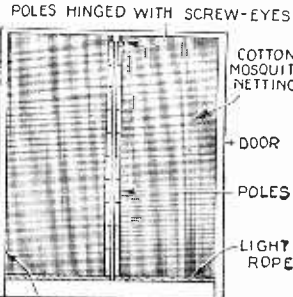

A mosquito-proof door is easy to construct as shown at the right. Cotton mosquito netting is fastened to two sides of the door jamb, slit in the middle and two poles fastened to the ends.—Herman R. Wallin.

SAFETY PIN CONNECTOR

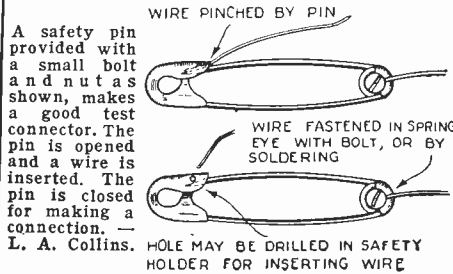

A safety pin provided with a small bolt and nut as shown, makes a good test connector. The pin is opened and a wire is inserted. The pin is closed for making a connection.—L. A. Collins.

ELECTRIC LIGHT SHADE

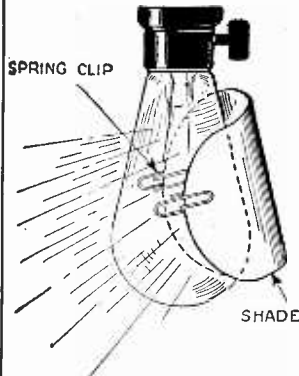

An emergency light shade can be made from two springs clips and a piece of paper or cardboard as shown in the illustration at the left. The shade can be readily adjusted to any position and will fit any size bulb. A number of these shades are very useful around the house and the draughtsman or student will find them useful.—L. A. Collins.

SOLDERING PASTE CONTAINER

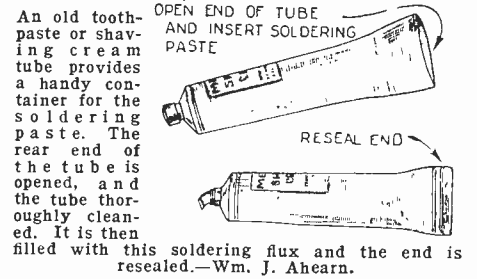

PAINT SPRAYER

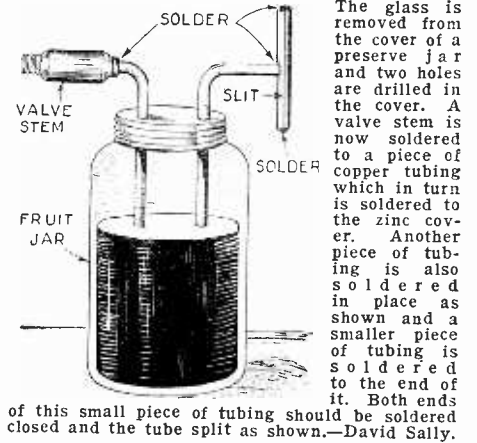

POURING KINK

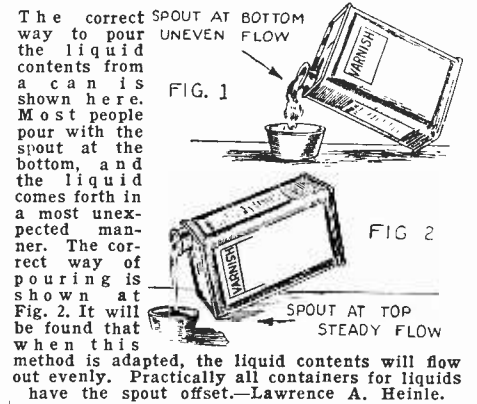

STIRRING ROD HOLDER

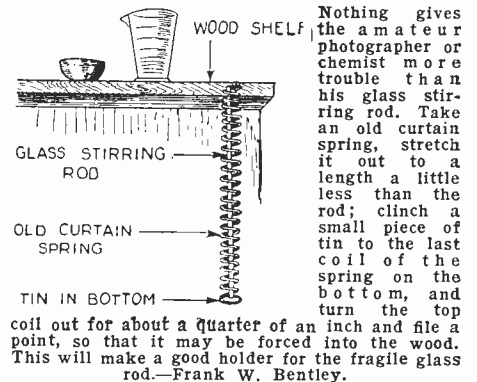

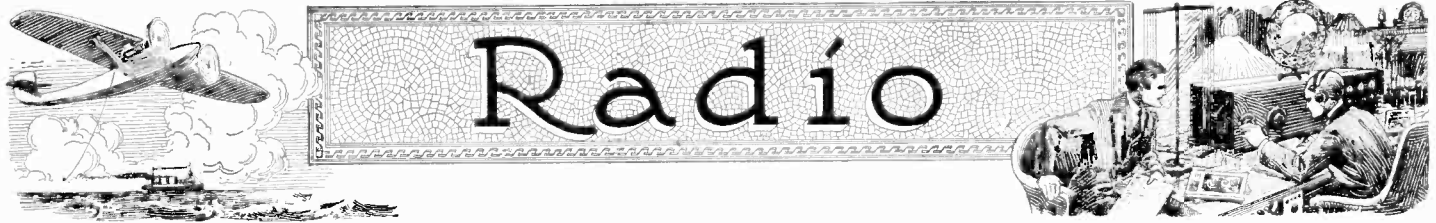

Croydon Airplane Radio

Airdrome Station Uses Remote Control Transmitter and Directive Receiver

There has recently been erected, at the London airport in Croydon, a new radio transmitting station which maintains communication with planes while in flight. The control tower is shown below at the right, and the Bellini-Tosi triangular loops may be seen. A horizontal aerial about 100 ft. long is also used in connection with the station.

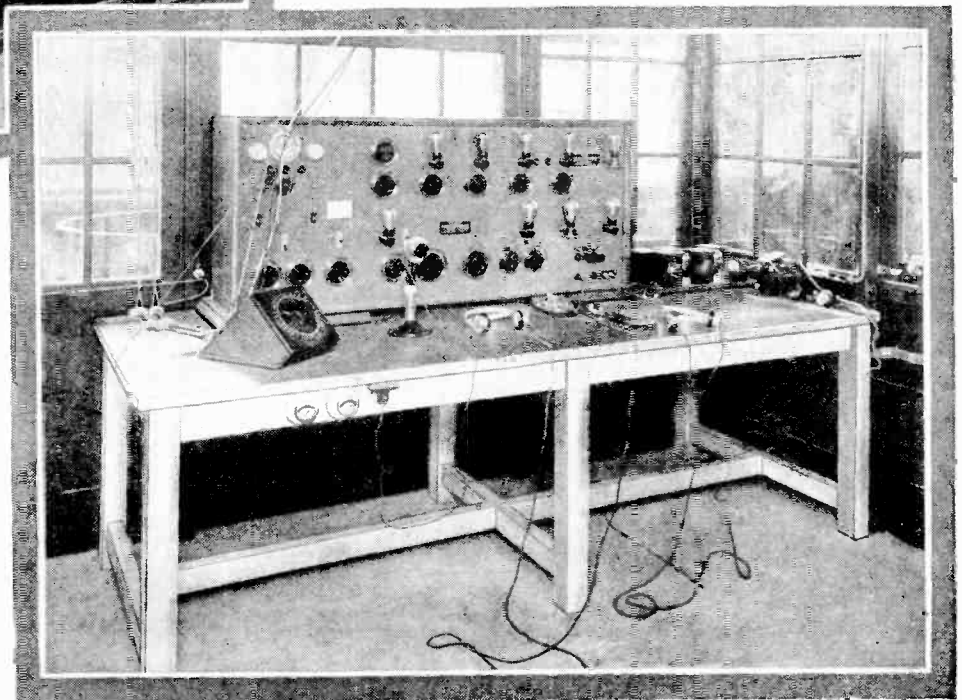
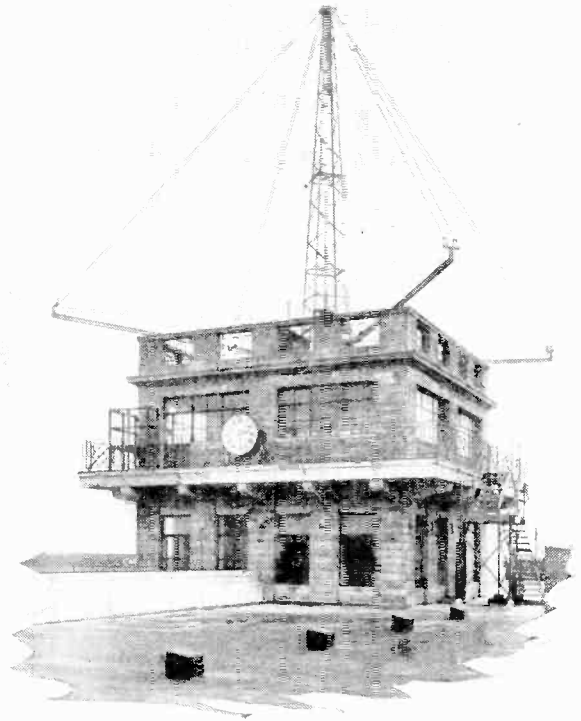
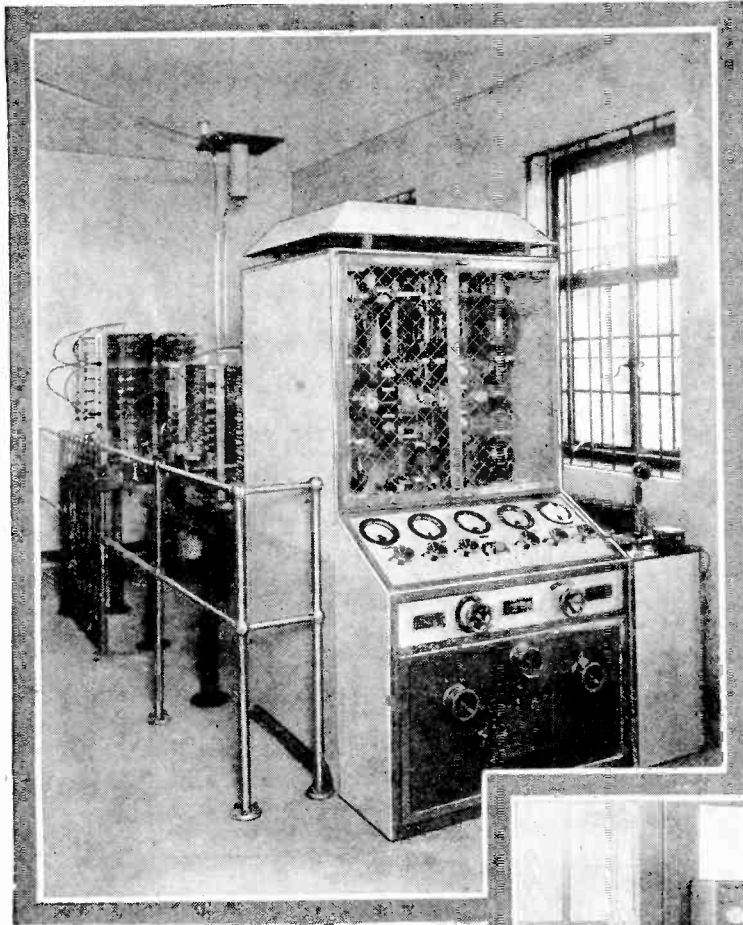

THE photograph above shows a view of one of the four 3-kw. airdrome ground transmitters installed near the airport. The top part of the transmitter contains the various tubes and the controls are arranged on a sloping panel. The transmitter works on any wavelength between 800 and 2,000 meters and can be used with phone, C. W. or I. C. W. At the right we have a view of the receiving set which employs nine tubes. This is placed within the control tower. From this tower, the four transmitters at the radio station, in Mitcham, 2½ miles from the airdrome, are operated by a remote control system, and thus, communication with the airplane in flight is maintained. Each of the four transmitters is rated at 3 kw. and independent drive circuits are incorporated to maintain a constant frequency. The receiving portion of the radio station was specially designed by the Research Department of the Marconi Co. and is remarkably selective. It is so arranged that two or more receivers can be operated on different wavelengths for the reception of telephony and telegraphy on the same aerials. By means of the directional loop shown in the photograph, it is possible to ascertain the position of the airplane while in flight, and the pilot by taking a number of readings can find his bearings even at night or in foggy weather. It is claimed that Croydon now possesses the most complete airdrome radio equipment in the world and has considerably extended its range of communication with other terminal airports and with planes in flight.

Broadcast Programs Now

Radio Receiving Apparatus Supplies

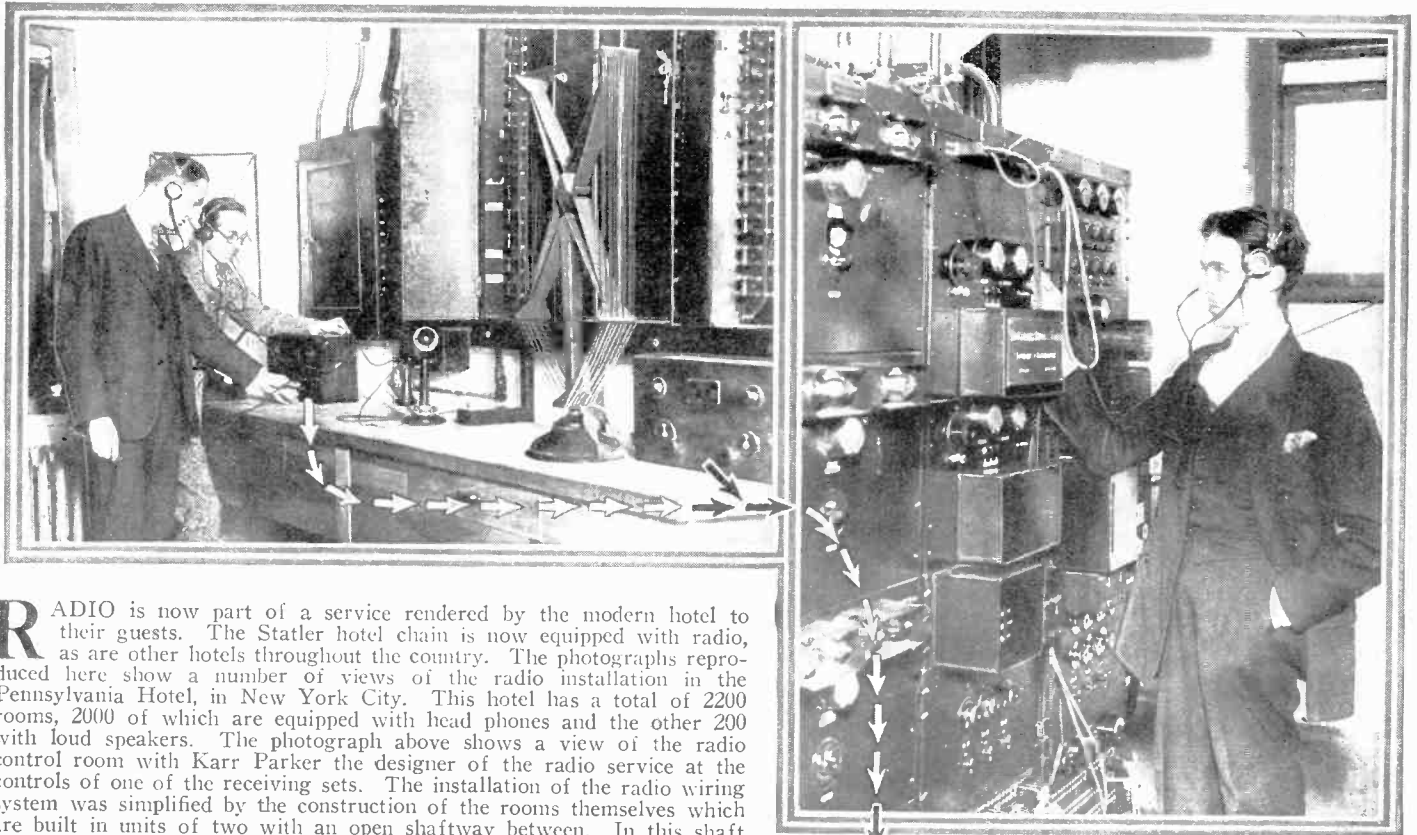

RADIO is now part of a service rendered by the modern hotel to their guests. The Statler hotel chain is now equipped with radio, as are other hotels throughout the country. The photographs reproduced here show a number of views of the radio installation in the Pennsylvania Hotel, in New York City. This hotel has a total of 2200 rooms, 2000 of which are equipped with head phones and the other 200 with loud speakers. The photograph above shows a view of the radio control room with Karr Parker the designer of the radio service at the controls of one of the receiving sets. The installation of the radio wiring system was simplified by the construction of the rooms themselves which are built in units of two with an open shaftway between. In this shaft are placed the steam and water pipes, electric wires and the radio lines. A plan view of the room construction is shown below. To the right and below is a simplified wiring diagram of the radio receiving system showing how either radio lane may be switched out of the circuit and the public address system cut in.

Above is a view of the control board used in conjunction with two radio receivers and public address system.

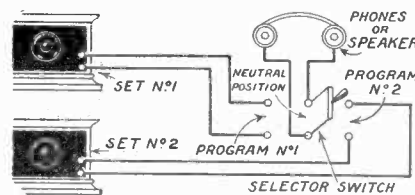
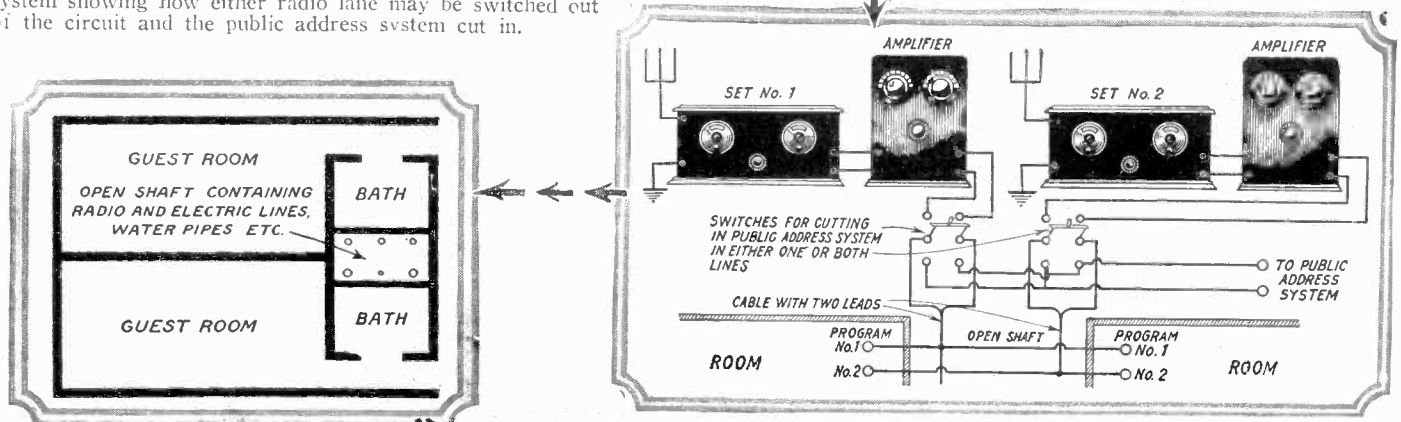

The photo at the left shows one of the guests "listening-in." Above, details of selector switch are given and to the right is a photo showing one of the speakers with the switch on top.

Available to Many Hotel Guests

Programs Day and Night for Patrons

ENTERTAINMENT in the form of radio programs is now available to hotel guests in many of the leading hotels throughout the country. The Statler chain in particular are all equipped with this radio service and the same installation and apparatus has been used in each of them. The installation of the complete system was not as difficult as might be imagined, because the rooms are constructed in units of two as shown on the opposite page. An open shaftway is placed between each pair of rooms and contains all the piping and wiring for the hotel, including the radio cables. Thus, it was possible to install the radio lines without tearing the floors or walls apart. From the wiring in the shaft, leads are taken off and run to the selector switches in the various rooms. The selector switch is simply a double pole, double throw switch, making it possible for the guest to choose between two radio programs. When not in use, the switch is thrown into neutral position. In a room on the top floor of the hotel, are situated two superheterodyne receivers, which pick up two different pro-

grams. These are then amplified and sent through two separate wiring systems to the hotel rooms. In each room is a pair of head phones placed in the bureau drawer. Loud speakers have only been installed in the employees rest and lounging rooms. It would be impossible to install loud speakers in every room because of the fact that 2200 speakers operating at the same time would obviously offer many disadvantages, especially in the summer with the windows open.

The receivers may be operated with either an antenna or loop aerial, and at the present time, two outside antennas are being used at the Pennsylvania Hotel. The installation is flexible, inasmuch as the operator may make special announcements through either radio line, or pick up programs in the hotel, through the use of a public address system. By means of this address system, the operator can tap any event going on in the hotel. An operator is on duty every day from 10 A. M. to midnight and provides the programs for the guests. He can tune in on almost anything being broadcast and switch in on either of

the amplifying units for transmission to the rooms, after making his own announcement, giving program and source of station. The engineers experienced trouble at first with reradiation. The brass piping in the hotel picked up the programs and acting as an antenna system retransmitted them, causing some difficulty. However, this trouble was speedily done away with, and the radio system has been working efficiently ever since.

A variety of programs are offered to the guest, because the operators refer to the programs printed in the newspapers and tune in contrasting offerings. By means of the small selector switch, the guests can choose programs of their own liking. The results so far have proved to be gratifying and hotel owners feel satisfied that the installation is worth many times what it cost. In the Pennsylvania installation 33,674,840 ft. of special wire was used and 5,970,000 ft. of flexible and rigid conduit, 260 radio tubes, 7,700 room switches and 153,860 terminals of different types.

A Piano Reproducer



The photograph at the left shows a young lady attaching a new piano board loud speaker unit to one of the struts of the sounding board. The unit is so constructed that it can be clamped on one of the ribs or struts of the piano and will produce the deep natural tone of the piano sounding board. This unit has the advantage over others of its kind, inasmuch as it does not fasten directly to the sounding board and hinder its proper operation. Excellent reproduction of radio programs is now obtained with the new speaker unit.

6030

Largest Cone Speaker



The photograph above and to the right shows a loud speaker which has been built into the ceiling of the room, above the lighting fixture. This is a cone speaker of large size, said to be the largest one of its kind at the present time. In order to protect the paper cone, the owner has covered it with an artistic grill work, as may be seen in the photo.

Exponential horns, especially of the folded type, lend themselves to many methods of concealment, as further explained in an article which appeared in the April issue.

A Manless Radio Orchestra

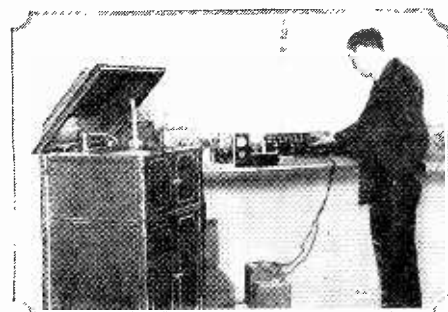

The above photograph shows W. D. Smith at the controls of his radio receiver which picks up the programs for his manless orchestra.

Mr. W. D. Smith has introduced something entirely new to radio with the invention of his so-called "manless orchestra." The orchestra reproduces radio orchestral programs through individual instruments.

Each instrument in the orchestra has a unit attached to it, and thus the instrument responds more readily to the corresponding instrument in the orchestra broadcasting the program. The effect of the orchestra producing music without human players is rather uncanny, but those who have heard the phantom musical ensemble are unanimous in their opinion that it reproduces musical programs with greater fidelity than a single speaker would. The Photograph shows the inventor at the controls of his radio receiver.

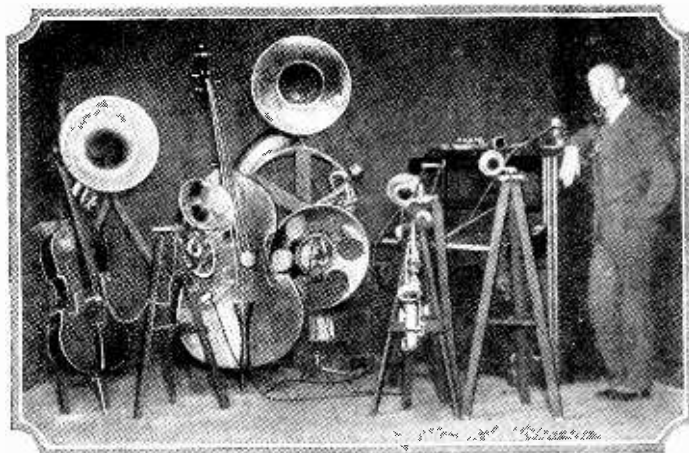

The inventor and his phantom orchestra appear above. It will be seen that each instrument has a separate unit attached to it. With an arrangement of this nature it is possible to reproduce musical programs better than can be done with a single unit.

NEW RADIO DEVICES

Accessories Recently Developed Which Will Be of Value with Any Radio Set

NEW CIRCUIT TESTER

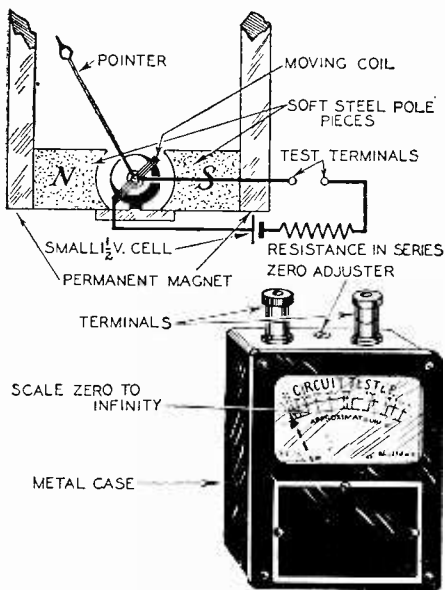

A front view of the new circuit tester, together with a schematic hook-up of the internal connections, are given in the above drawing. The instrument consists of a small D'Arsonval type voltmeter connected in series with a small dry cell. The instrument measures $4\frac{1}{2}$ " x 3" x $1\frac{1}{2}$ " and weighs but 19 ounces. It may be fitted in the pocket and can conveniently be carried anywhere.

A NEW portable direct-reading circuit tester has recently been placed on the market by one of the leading meter manufacturers. The instrument is enclosed in a heavy sheet metal case, which contains also a small flashlight cell. This cell can be replaced by removing the instruction plate on the front of the meter. The scale is divided into fifty uniform divisions of arbitrary value, and resistances up to 10,000 ohms may be calculated. When the terminals are short-circuited, the pointer should indicate full scale, and if not, adjustment may be made by simply turning the zero adjuster on the top of the meter. Besides showing whether or not the circuit under test is complete, the circuit tester also gives one an idea of the ohmic resistance. The instrument is small and may be carried in the pocket.

PORTABLE OHMMETER

A PORTABLE ohmmeter made by the manufacturer of the circuit tester is shown at the right. The instrument is $5\frac{3}{4}$ in. wide, $9\frac{3}{4}$ in. long, and $4\frac{1}{4}$ in. high. The total weight is $3\frac{1}{2}$ lbs. There are four resistance ranges available, .5 to 50 ohms, 5 to 500, 50 to 5,000, and 500 to 50,000 ohms. The battery for this instrument is contained within the case and consists of two flashlight cells. With this portable instrument, resistances may be read, to within an accuracy of 1% of their value.

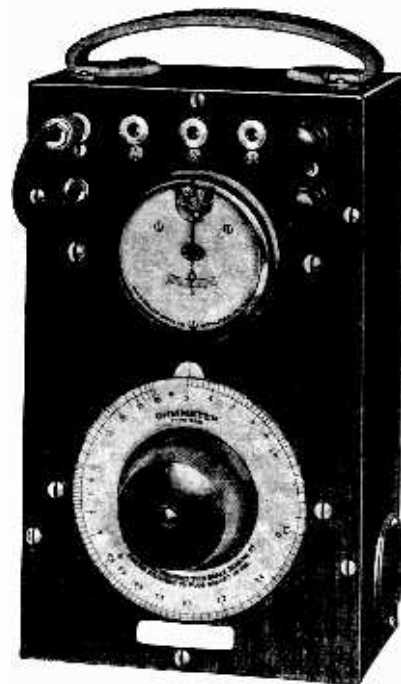

Above is a view of the portable ohmmeter which is housed in a case of black walnut. A leather carrying handle is attached to the top and heavy rubber feet are provided on the bottom of the instrument. The device is a form of slide-wire Wheatstone bridge.

A.C. ADAPTER HARNESS

ONE of the leading Chicago radio manufacturers has recently put on the market an A.C. harness which makes it possible to easily convert your present receiver to A.C. operation, using A.C. tubes. The adapter harness for a five-tube set is illustrated here. The harness contains all the necessary resistors, so that the proper C bias is obtained, and also provides a filament voltage regulator for

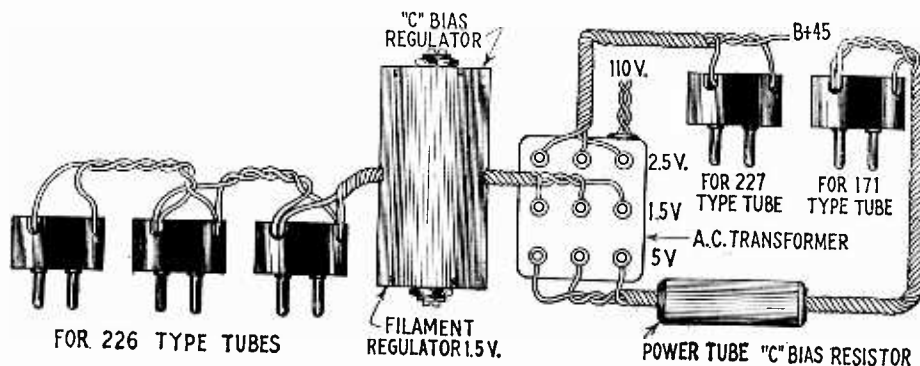

The above illustration shows an A.C. adapter harness for converting sets to A.C. operation.

the 226-type tubes. When installing the apparatus, no structural or wiring changes in the set need be made. Conversion is simple and may be made by anyone in a few minutes' time. The filament leads of the harness should be connected to the corresponding terminals on the filament transformer. The "A" battery binding posts or terminals on the radio receiver are not used.

MIDGET RESISTORS

A CHICAGO manufacturer has placed on the market two types of midget resistors. The 20-ohm center-tapped potentiometer is made for A.C. tubes, and takes up very little space. The resistor is sturdily built and, as it is small, will save much space. A resistor for the filament circuit of 222-type tubes has also been developed. This is a 15-ohm wire-wound resistor, tapped at 5 ohms to provide the correct "C" bias for the tube. The midget resistors will do everything that the larger ones will do.

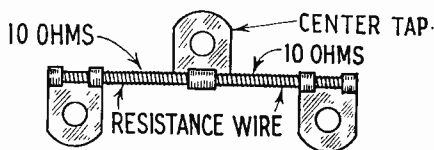

POTENTIOMETER FOR A.C. TUBES

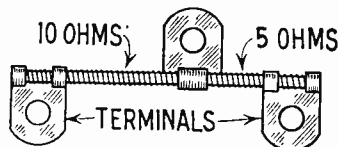

FILAMENT AND GRID BIAS RESISTOR FOR 222 TYPE TUBES

Two of the midget resistors are shown in the above drawing. One is a 20-ohm center tap resistor for the filament circuit of A.C. tubes, and the other is a filament and grid bias resistor for the new 222-type shielded-grid tubes.

POWER RESISTORS

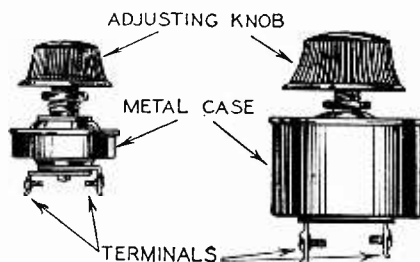

In the drawing above are shown two types of the new variable resistances. The one at the right is for use in "B" eliminator work and is capable of handling 40 watts. The smaller resistance is used as a volume control.

OF the two variable resistances shown in the illustration, the large one is designed to be used in "B" eliminators and in radio transmitters. It is capable of handling 400 milliamperes of current, when adjusted to any resistance less than 250 ohms. The model shown here is of the low range type, having a resistance of 25 to 500 ohms. The smaller resistor shown,

is designed essentially to be used as a volume control in all radio receivers. It has a resistance range from 0 to 500,000 ohms. This resistor will handle up to 20 milliamperes.

The resistors are enclosed in metal cases and have bakelite adjusting knobs for varying the resistance. They are all equipped for one whole mounting.

Names of manufacturers of parts supplied upon request.

Electric Clocks Timed by Radio

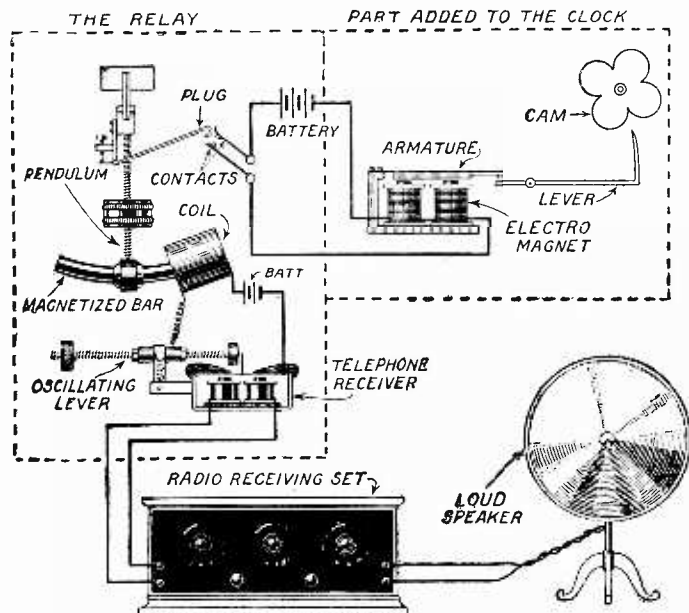

Above is the schematic diagram showing how the electric clock is set by radio. By means of a special relay, the minute hand of the clock can be set right once every day by signals sent out from the Eiffel Tower.

IN France there are now many clocks which are timed correctly once a day by radio signals sent out from the Eiffel Tower. Up to this time a special and com-

plete. The arrangement of the apparatus may be seen in the diagram given here. This system is, of course, not absolutely accurate. —Lucien Fournier.

plicated apparatus was needed to regulate a clock in this manner. Quite recently Mr. Lavet has invented a system of timing clocks by radio which is simple, non-expensive and can be used in every home. Anyone possessing a radio receiver can install this special relay and have it operate the minute hand of a clock, so as to set it right once every day. The regulating signal can be sent out between programs transmitted from the broadcast station. The principal organ of the system is a strong relay placed between the receiving set and the clock. This relay contains a pendulum which makes one hundred and twenty-two oscillations per minute.

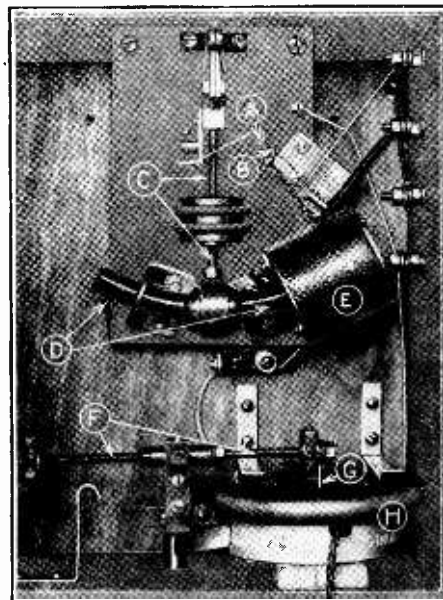

The above photograph shows a close-up view of the relay and other apparatus. An ordinary telephone receiver connected to the radio set operates a lever, as shown in the diagram. The relay contains a pendulum which makes one hundred and twenty-two oscillations per minute.

Making A "Flivver" Cone Unit

By R. EDIS FAIRBAIRN

A SERVICEABLE cone speaker unit may be built for next to nothing by anyone possessing a magnet from a Ford magneto, and a discarded spark coil with a few pieces of scrap metal. The figures tell the whole story, but a few hints on methods may be of value.

Break open the coil box, and dig the coil and condenser out of the pitch filling. Don't break the condenser leads. A couple of these condensers in parallel, with one of the

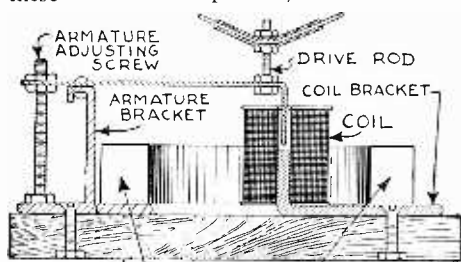

A cross-sectional view of the completed speaker unit is shown above. The finished instrument is mounted upon a piece of hard wood.

coils for a choke, make a satisfactory output filter. But that is something else! The coil is wound in two sections, side by side on the iron core. Pull out the core, and cut the coil sections apart. One of them will be sufficient. Wind off the hair-like enamelled wire on to an empty bobbin. The wire will unwind more easily if you cut down towards the center of the winding with a sharp knife just clear of the stiff edge of paraffined paper and pitch. Put the coil on a large nail, and fix the bobbin in the chuck of a hand drill, and the job can thus be handled very easily.

To make the coil form for the unit, first get a few inches of cold rolled steel $\frac{5}{8}$ " by

$\frac{1}{8}$ ". Wrap a turn or two of thin hard cardboard $\frac{7}{8}$ " wide on this and fix with glue. Make two ends of stiff cardboard, fiber, or hard rubber $1\frac{1}{2}$ " by $\frac{3}{8}$ " and cut a slot in the middle of each so that they can be forced stiffly on to the form center. Make two pairs of fine needle-holes in the end of one of the form ends before cementing the ends on the center. Fix the form, when the cement is hard, in the chuck of a hand drill, with a small bolt through the center of the slot, just tight enough to prevent the form from slipping. Arrange the drill on a box, with the filled bobbin of fine wire on a nail underneath. Fasten the drill so it will not wobble about, and proceed to wind the coil. Let the wire pass between your finger and thumb with slight pressure. Do not attempt to wind evenly; it couldn't be done anyhow. Jumble-wind the coil until full, and anchor the ends in the needle holes. Cut a piece of steel strip $1\frac{1}{2}$ " long, and bend at right angles half an inch from the end. Insert the half inch end in the coil slot with a touch of shellac to make it fast. The inch end of the bracket should have a screw hole bored in it.

For the armature bracket cut another strip of steel $2\frac{3}{8}$ " long. Bend at right angles at $\frac{7}{8}$ " from one end. Bend the other end for $\frac{3}{8}$ ", not at right angles, but rounded, as shown.

Bore the $\frac{7}{8}$ " end for a screw, and in the middle of the rounded part for a small rivet.

For the armature proper, get a piece of steel $\frac{1}{16}$ " thick, or less, $\frac{5}{8}$ " wide, and 3" long. Bend at right angles $\frac{1}{2}$ " from one end. Bore it to pass a piece of 6/32 threaded rod at $\frac{1}{4}$ " behind this bend, and the same size hole at $\frac{1}{4}$ " from the other end. Bore for the rivet at $\frac{7}{8}$ " from the end opposite the bend. Rivet the thin strip on to the rounded top of the bracket. Then insert $1\frac{1}{2}$ " of 6/32 threaded brass rod through the end hole, fixing it to the bot-

tom part of the bracket by rivetting it in, or soldering it. A couple of nuts above and below the armature spring will make adjustment possible, since the rounded part of the bracket permits a certain rocking motion.

Now arrange the coil and armature upon a 6" by 4" piece of hardwood, as in the figure. The bend of the armature enters the slot in the coil form, but must not touch it anywhere. Screw down the brackets. Lay the magnet with one pole upon the coil bracket, against the coil, and the other against the armature bracket. To even it up, insert a packing piece under the pole against the armature bracket, and under the bend of the magnet. Fasten the magnet with a clip of brass or hardwood.

(Continued on page 71)

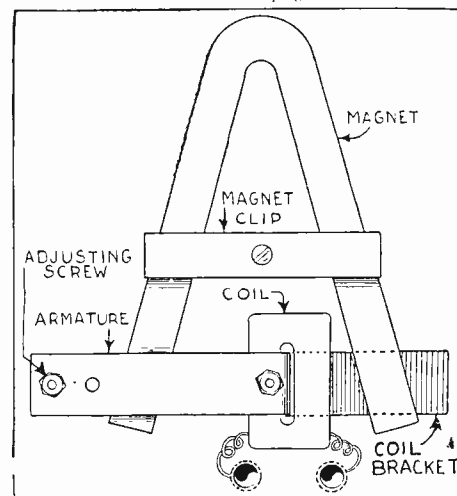

Above is a top view of the unit, showing the location of the magnet, coil, coil bracket, adjusting screw, and the armature.

Try These Aerials

How to Construct Novel Antennas for Indoor Use

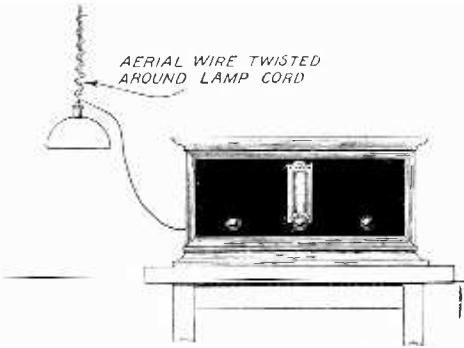

An aerial wire, twisted around the lamp cord, serves as a suitable indoor antenna.

IN radio communication, it is necessary as we all know, to have a device to radiate electric waves and another device to receive these radiated waves. The devices which are used for this purpose are called antennas or aerials. Antennas may be divided into two general classes. Those consisting of one or more wires stretched between two supports are called aerials or antennas, and act as electric condensers. Those aerials which act as electric inductances are called coil antennas or loops, and consist of a number of turns of wire wound on a rotatable frame which gives a directional effect.

In the old days, it was a simple matter to climb upon a roof and erect an aerial of any length desired and in any direction. With

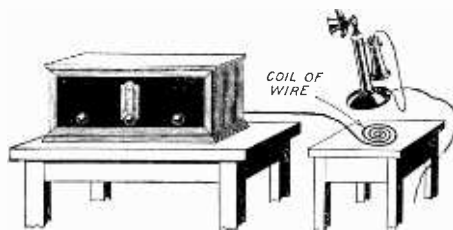

A small coil of wire, placed beneath the base of a telephone, serves efficiently in the capacity of an antenna.

the advent of the modern apartment house and an increased number of radio sets, the antenna problem has become more and more serious, and we are giving here a number of hints for those who cannot have an outside aerial. Any one of these may be used satisfactorily as the antenna.

The electric light wires coming into the house may be used for radio reception and probably furnish the easiest solution to the antenna problem. These lines pick up considerable energy and high frequency currents are induced in them by passing radio waves. However, they should not be connected directly to the set, as they might ground or short circuit. A small fixed condenser should be connected in series with one of the wires, as it forms a barrier to

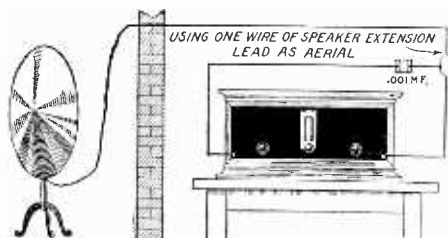

One wire of the loud speaker extension lead may be used as an aerial as shown above.

low frequency lighting currents, but permits the passage of radio frequency currents. A special plug for this purpose may be purchased and is simply screwed into the light socket, the antenna connection being made to a binding post on the plug provided for that purpose. One of the simplest methods of using the electric light lines as the antenna is to simply twist a section of wire around the lamp cord, connecting one end to the radio set, and leaving the other end free.

Telephone wires can also be used in much the same manner, but the connection should preferably be made to the metal box hous-

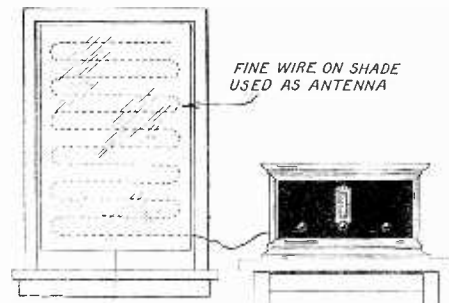

A fine wire zigzagged across the window shade can also be used as an aerial. It should be sewed or otherwise fastened in place.

ing the bell. One of the common methods of using the telephone's wiring as an antenna is to place a metal plate beneath the phone and connect a wire from the plate to the aerial binding post on the set. The use of a metal plate, however, is not necessary and is often a nuisance. The end of a piece of wire can be wound in a coil or spiral fashion and the phone placed directly upon it. In both cases the ground connection should be made to the set as usual. Any inside wiring in the house may be used as an aerial. The door bell wiring system or a wire strung around the molding both serve satisfactorily as antennas. Bed-springs and

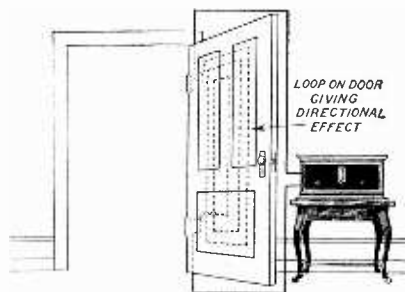

A loop giving directional effect may be wound on a door as shown above.

metallic clothes lines sometimes can be used advantageously.

If a loud speaker extension cord is used with the speaker in a different room from the set, one wire of this cord can be employed as the aerial. A small fixed condenser, having a capacity of about .001 micro-farads is connected in series with one of the leads, one post connected to one of the speaker extension cords, and the other to the aerial binding post on the receiver. Still another method of concealing the antenna is to sew fine wire on one of the window shades, as shown in the illustration. The shade antenna will give good results, and can be rolled up when not in

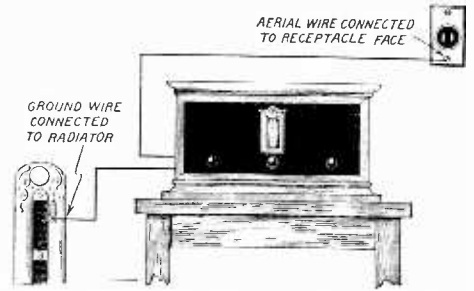

Two grounds are shown as used with the receiver, no aerial being necessary. One wire is connected to the radiator and the other wire to a switch face-plate.

use. By using a door, one can easily construct a loop aerial having directional effects by winding the wire in a spiral fashion. The two ends of the loop can then be soldered or otherwise fastened to the wings of the hinges on the door and two wires led from the other part of the hinges on the door jam to the radio set. Thus there are no loose leads to break as would be the case if the two wires from the loop were brought directly to the receiver. In order to obtain a directional effect, it is simply necessary to swing the door to and fro.

Another good way of concealing the aerial is to wind a fine wire spiral under the rug. This will be found to give good results. During the summer, copper screen doors or large copper window screens may be

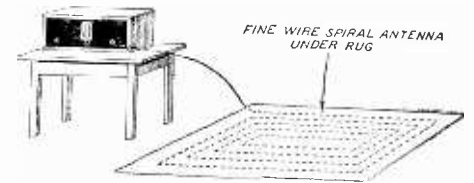

A fine wire spiral, wound under the rug, will not be noticed and can be used as an antenna with radio receivers.

used advantageously as a capacity pick-up for radio signals. A wire leading from the aerial binding post on the radio set is simply connected to some portion of the screen wire. Screens other than copper may be used, but results will probably not be so good. In all of the above mentioned systems, use has been made of an aerial and a ground. However, it is possible to operate the receiver satisfactorily by using two grounds, one wire connected to the radiator or water pipe, and the other to an electric light receptacle, faceplate or any other piece of metal which is grounded. It is doubtful whether the gas pipe can be used as a ground, because there will probably be packing between the joints of the pipe, and especially where the pipe enters the gas meter.

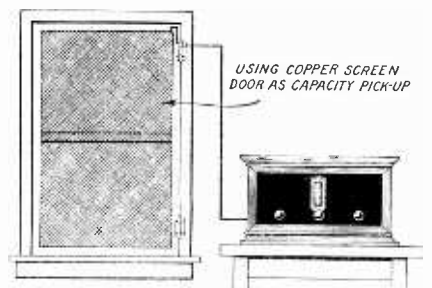

The copper wire on a screen door or large window screen can be used as a capacity pick-up for the reception of radio signals.

RADIO ORACLE

In this department we publish questions and answers which we feel are of interest to the novice and amateur. Letters addressed to this department cannot be answered free. A charge of 50c. is made for all questions where a personal answer is desired.

SHORT-WAVE TRANSMITTER

(619) W. E. Kopeck, Zion City, Illinois, asks:

Q. 1. Will you please publish a diagram of 40 meter wave radio transmitting set?

A. 1. On this page you will find given a schematic diagram of a short-wave oscillating circuit, which is a modification of the Colpitts circuit. The two tuning condensers have a capacity of .00025 mf. each. The antenna coupling coil which is 3" in diameter consists of 1 to 6 turns, depending upon the type of antenna used. L2 and L3 consists of 7 turns each, 3" in diameter. These coils may be wound with No. 14 copper wire or larger. Radio frequency chokes are of the basket weave type and consist of 40 turns of No. 22 S.C.E. wire. These chokes are

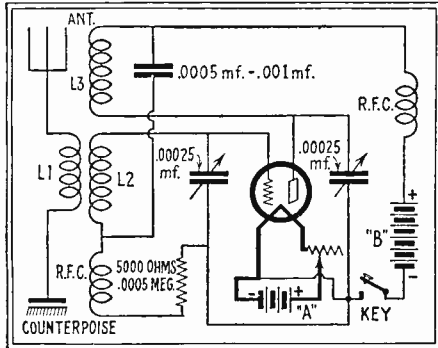

Above is the hook up of the forty-meter short-wave radio transmitter. The circuit is a modification of the Colpitts circuit. A single wire about 30 feet long should be used for the antenna.

1 3/4" in diameter and are wound on 8 pegs. The grid leak should have a resistance of 5,000 ohms, which is equal to .005 megohms. For short-wave transmission, a single wire about 30 ft. long should prove effective. If a counterpoise is used instead of a ground, it should be of about the same dimension as the antenna. A series antenna condenser of about .00025 mf. capacity may be connected between the counterpoise and the coupling coil. A coil, antenna or loop can be used for transmitting over short distances. When the tube is lighted and the key is closed, the transmitter should oscillate, and the condenser settings should then be varied until resonance with the antenna circuit is obtained. A small flashlight bulb, a thermo galvanometer, or a D.C. milliammeter will show the resonant point. The thermo-galvanometer may be inserted in series with the antenna. Maximum deflection indicates resonance. A D.C. milliammeter of 0 to 50 connected in series with the "B" batteries will show resonance by deflecting sharply when the resonant point is passed over.

SKIP DISTANCES

(620) Chas. McCormick, Proctor, Utah, writes:

Q. 1. Will you kindly explain the meaning of "sunset effect" and short-wave skip distances?

A. 1. It has been demonstrated a number of times that short waves are decreased in strength as the distance from the transmitter is increased, until a certain point is reached. At greater distances beyond this point, the signals gradually increase in strength to a maximum. Beyond this point, the strength usually decreases. The distance between the transmitter at the beginning of the rise in signal strength is called a skip distance. This zone is not sharply defined and is found to be longer at night than in the day, and is usually longer in winter than in the summer. In most cases, the skip zone is a region where signals are entirely absent. The shorter the wavelength, the greater the skip zone distances will be. Long waves do not have such skip zones as true attenuation begins at the transmitting antenna. This accounts for the greater distances covered by short waves even during daylight.

During the period of transition from daylight to darkness, "sunset effect" is often observed. About an hour before sunset there will be a noticeable rise in signal intensity, which will drop just about as the sun sets, after which, it will rise until a maximum strength is reached about an hour later. During the night a further

gradual rise in signal strength will go forward, until several hours before sunrise. A "sunrise effect" similar to the "sunset effect" will then be noticed, but the phenomenon will be reversed.

LOUD SPEAKER CONSTRUCTION

(621) R. W. Anderson, Traverse City, Michigan, asks:

Q. 1. Will you kindly give me the essential construction of the new loud speaker which recently was used in throwing sound across the Hudson River.

A. 1. The speaker to which you refer is undoubtedly that which was perfected by the Bell Telephone Laboratories, and is now being used successfully in Vitaphone and Movietone productions. In its present form, the loud speaker is of the horn type. The engineers who developed it say that it is capable of converting into sound about 50 per cent of the electrical energy supplied it. The moving diaphragm or armature of its unit is not made of a magnetic material but consists of a sheet of very light aluminum alloy, about two-thousandths of an inch thick, and so constructed that it moves laterally, somewhat like a piston. Attached to the diaphragm is a small coil of aluminum strip wound edgewise and insulated with varnish. This coil lies in the magnetic field produced by a powerful electromagnet.

Telephone or voice current passing through the small aluminum winding causes the diaphragm to vibrate. The plunger-like motion of the diaphragm and the special shaping of the air chamber between the diaphragm and the mouth of the horn result in an efficiency many times greater than that obtained with other types of loud speakers. The load carrying capacity of the device arises from the fact that the small aluminum coil lies very close to the heavy iron pole-pieces of the field magnet. In addition to its large capacity, the loud speaker is notable for its fine reproducing qualities. It encompasses the range of frequencies from 60 to 6000 cycles per second without distortion and reproduces down to 40 cycles and up to 8000 cycles with a distortion so slight that it is doubtful if the ear can detect it.

POWER OUTPUT

(622) W. R. Mansbridge, So. Norwalk, Conn. asks:

Q. 1. What is meant by power output and how can the maximum output of an audio frequency vacuum tube be ascertained?

A. 1. The maximum output obtainable without the introduction of serious harmonics in the plate wave current is generally considered as the conventional power output of an audio frequency amplifying tube. The method of measuring this output is necessarily a relative or an

arbitrary one, but gives a useful comparison among the various vacuum tubes employed. The procedure is given as follows:

The normal external plate resistance (non-reactive) is inserted in the plate circuit. If the value of this resistance is not specified by the manufacturers, it should be chosen as twice the normal plate resistance of the type of vacuum tube under test. The filament voltage is adjusted to its normal value; and the plate supply voltage is adjusted to give normal plate potential at the plate (that is, equal to the normal plate potential plus the voltage drop in the external resistance). A sinusoidal alternating voltage and a grid bias voltage equal to the maximum alternating voltage are impressed in the grid circuit and are adjusted together until the direct component of the plate current is 5% higher than when the alternating voltage is removed. The power in the external plate resistance due to the fundamental component of plate current is then taken as the conventional power output.

D.C. RECEIVER

(623) Wm. F. Kephart, Clearfield, Pa., writes:

Q. 1. Will you publish a diagram of the Science and Invention 3-tube A.C. D.C. set with an added stage of radio frequency and with tubes lighted direct from the D.C. 115-volt lighting circuit. I wish to use a power tube of the L71-type in the last stage. I desire to have the circuit non-regenerative.

A. 1. On this page you will find illustrated a diagram showing a 4-tube receiver meeting with the above requirements. The detector coil should be placed in a shield and the shield walls should not be any nearer to the coil than a distance equal to the coil's diameter. If no shield is used, the radio frequency and detector coils should be placed at right angles and as far from each other as possible. Type 226 tubes are used in the radio frequency, detector and the first audio stages. A type-171 power tube is employed in the last audio stage. R1 are filament ballasts of the A.C. type rated at 1.05 amperes, R2 is a filament ballast of the half ampere type, R3 is rated at 83 ohms capable of handling 100 watts, R4 has a resistance of 16 ohms and is rated at 20 watts, R5 is rated at 9 ohms and 5 watts. The two tuning condensers have a capacity of .0005 mf. and the neutralizing condenser, a capacity from .000002 to .00002 mf. From the filament end of the secondary of the detector coil to the neutralizing tap the same number of turns should be used as are employed on the primary coil. A variable resistance of 500,000 ohms placed across the secondary of the second audio frequency transformer serves as a volume control. The set can easily be made regenerative by employing a tickler coil. A switch should be installed in series with the A- and B-leads. With the circuit as shown here, it is possible to light all tubes from the direct current line, and to obtain the necessary "C" bias.

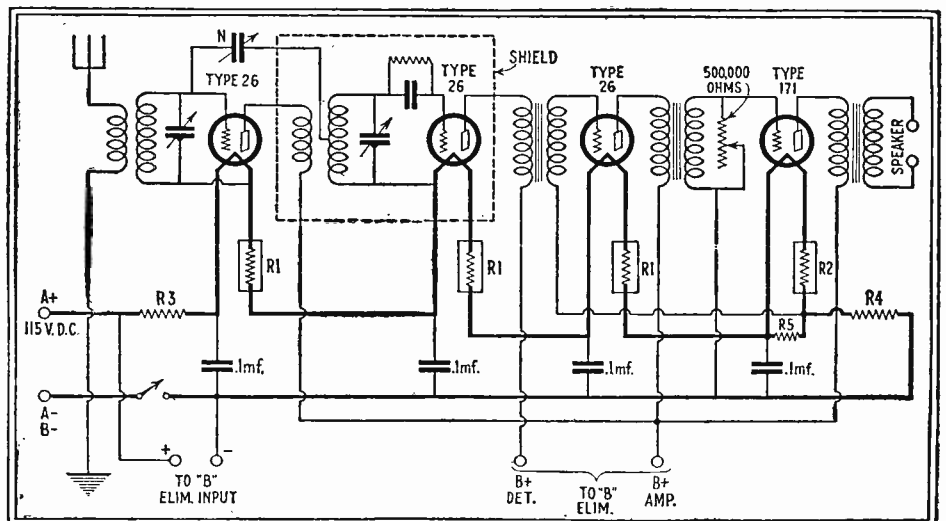

The four-tube receiver employing the original circuit found in the S. & I. three-tube receiver is shown above. It has been designed with series filaments to be lighted from the 115-volt D.C. circuit.

Scientific Humor

TOUGHNESS+TEETH=AGE

PAT: "How do you tell the age of a turkey?"
 MIKE: "By the teeth."
 PAT: "Turkeys have no teeth."
 MIKE: "No, but I have."
 —Ernest Fedcroff.

HOW DO YOU MEAN?

GIRL STUDENT: "Ruth told me yesterday that she had paid ten dollars for a beautiful handkerchief."
 SECOND GIRL STUDENT: "My, that's an awful lot of money to blow in."
 —Andrew Jacob, Rep. No. 9606.

GETTING AWAY WITH IT



HOUSEHOLDER: (from above, disturbed by voices down stairs): "Who's there?"
 BURGLAR (with great presence of mind): "WRNY now closing down. Goodnight everybody."
 —William Short.

SWELL

"Ah, boys!" said the kind-hearted old gentleman. "Where are you taking that goat?"
 "Down to the lake, sir," answered the innocents.
 "Good!" the K. H. O. G. smiles. "To give it a drink I suppose?"
 "Yes, sir, and if you come along with us, mister, you'll see some fun! This 'ere goat's just been an' et a 'ole crate of sponges, and—My, but something's bound to 'appen when he's 'ad a quart or two of water!"
 —J. E. Lovett.



A COLLAR-ARY

CHEMISTRY PROFESSOR: "Name three articles containing starch?"
 BRIGHT STUDE: "Two cuffs and a collar."
 —August Schellenberger.

USE THIS ON JULY 4th—PUNK

"A little bird told me what kind of a lawyer your father was."
 "What did he say?"
 "Cheep! Cheep!"
 "Well, a duck told me what kind of a doctor your father was!"
 —Clifton Ask.

MODERN PHARMACY
FIRST PRIZE, \$3.00

Wotcha doing? Learning the drug business. It must be highly technical. Yes, it is. I am learning to compound stews and assemble sandwiches.
 —George Corbe.

SIMPLE!

LIFE GUARD: "How much can you carry?"
 MERE MAN: "Two hundred pounds."
 LIFE GUARD: "Suppose there was a woman out in the water drowning and she weighed four hundred pounds. How could you save her?"
 MERE MAN: "I'd make two trips."
 —P. J. Higginbotham.

TO ELIMINATE SOME?

DRUGGIST: "Now here's a new thing in lipsticks. There's some sort of a chemical in it to kill the microbes."
 FLAPPER: "But really! I wouldn't want to kill all of the fellows."
 —Gluson Pease.

ALL jokes published here are paid for at a rate of \$1.00 each; \$3.00 is paid for the best joke submitted each month.

Jokes must have a scientific strain and should be original.

Write each joke on a separate sheet of paper and add your name and address to each.

Unavailable material cannot be returned.

"DANGER—DETOUR"

The editor of the By-Town Weekly received from one of the local talent a soul-stirring, heart-throbbing lyric entitled, "I Wonder If She'll Miss Me."
 In due course the would-be poet received reply:
 Dear Sir:—
 "If she does, she should never be trusted with firearms again."
 —W. Harrison LeClair.



EVEN TO THE END

JONES: "I'd like to be cremated, but I'm sure my wife wouldn't like it."
 SMITH: "Why not?"
 JONES: "Well, she's always complaining about my leaving my ashes around!"

WHAT DOES GREEN MEAN?

YOUNG LADY: "Have you any green lipsticks?"
 CLERK: "Green lipsticks!"
 YOUNG LADY: "Yes, a railroad man is going to call on me tonight!"
 —Clifton Ask.

A HEALTHY MISTAKE

A doctor left a thermometer with the wife of a patient, and told her to take her husband's temperature every hour. When he returned in the morning the patient was gone, and the doctor asked what had happened.



"I broke the thermometer," said the woman. "So I used the barometer. It registered 'very dry,' so I gave him about a pint of corn liquor, and he got up and went out and started plowing in the back field!"
 —Clifton Ask.

TRUE ADVERTISING

Jones answered an advertisement and sent a dollar for four pairs of socks. When they arrived Jones looked them over, and then wrote the advertiser: "Socks received. The patterns are vile. I wouldn't be seen in the street with them on."
 Back came the answer: "What are you kicking about? Didn't we guarantee you wouldn't wear them out?"
 —Robert Goldsmith.

ELECTRIFIED HIM

SHE: "My father's an electrician."
 THE BRUTE: "I see, you're his first shock."
 —Joseph Wallace.



FOR NO GOOD REASON

"How is your car running?" asked one motorist of another.
 "That's what puzzles me!" replied the other.
 —Archie Sofman.

SCIENTY SIMON, Scientist

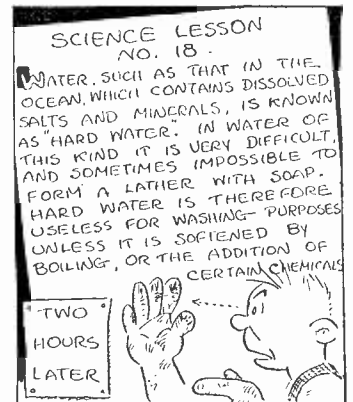
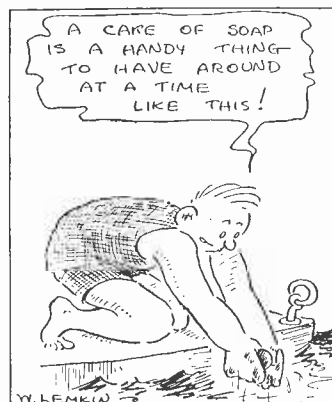



POPCORN SHAKER

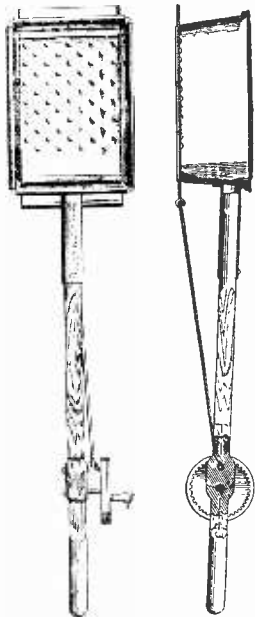

No. 1,633,442, issued to Alex Steger. The popcorn shaker shown above has a reciprocating bottom where by the kernels may be agitated. A crank fastened to the handle moves the bottom of the shaker when it is turned.

ALTERNATING CURRENT RECTIFIER



No. 1,658,647, issued to Levi B. Miller. The invention shown here is a dry rectifier which comprises layers of silicon carbide and graphite, or carbon, joined together. The hook-up is also shown.

FOWL ROOST

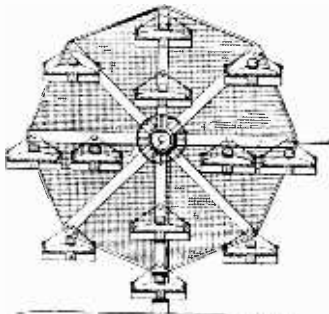

No. 1,658,515, issued to Thomas D. Caton. This improved roost provides a means for accommodating a maximum number of fowls in a minimum space. A number of trays are hung loosely from the sides of a rotatable roost. It is so constructed that the trays and supports may be easily cleaned.

MECHANICAL ANIMALS

No. 1,638,332, issued to Vittorio Gobbato. This invention relates to a mechanism for reproducing the movements of quadrupeds. All body members are capable of life-like motion. One construction of the invention is shown below.

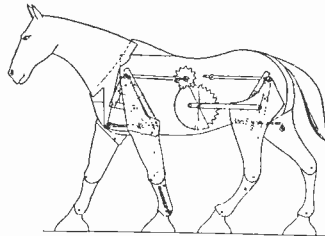

SOUND REPRODUCING UNIT

No. 1,655,403, issued to Paul G. Andres. The sound-reproducing unit shown below comprises a number of sound-reproducers, each having different resonant points. The hook-up is also shown. Each coil is designed to operate a loud speaker.

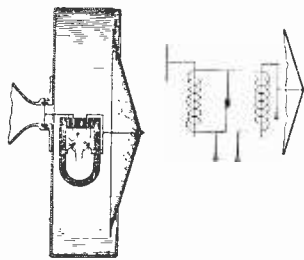

ARTIFICIAL TREE

No. 1,656,310, issued to August Anderson. The artificial tree shown below comprises a base and a trunk, so formed, so as to receive the ends of branches of a natural tree. Teeth are also provided for retaining the branches in their respective sockets.

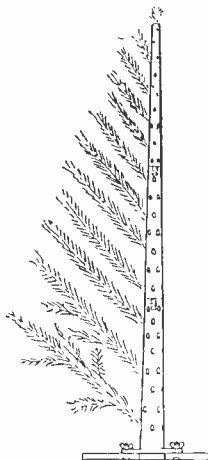

METHOD OF REMOVING METAL CORES

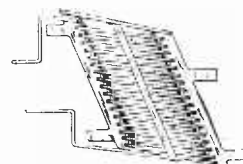
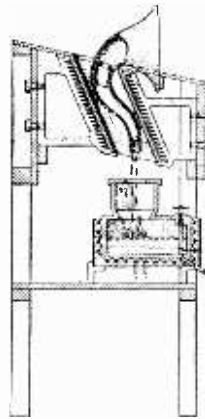

No. 1,656,312, issued to Charles D. Black. This invention relates to molding operations, whereby the fusible metal cores used in the process are melted by means of high frequency alternating electric currents.

TALKING MOTION PICTURE

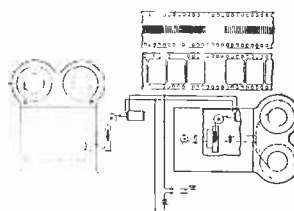

No. 1,654,926, issued to Theodore J. Engel. This invention is a combination of a motion picture camera and a sound recorder, with a light-sensitive element. The shutters on the camera and sound recorder are controlled by electromagnets.

MECHANICAL DANCING DEVICE

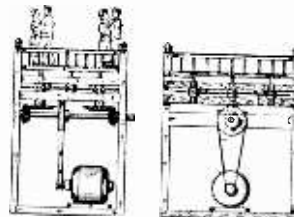

No. 1,655,292, issued to George Przybylko and Stanley Michalek. This device is a toy embodying dancing figures and a means for revolving the same figures. They are mounted on a disc which is turned by an electric motor. The toy may also be manually operated.

INCANDESCENT ELECTRIC LAMP

No. 1,653,365, issued to Charles Frederick Lorenz. The object of this invention is to provide a lamp which will have a concentrated light source and reduce blackening of the bulb to a minimum.

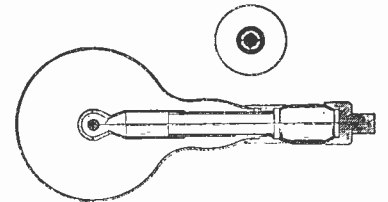

IMITATION FIRE

No. 1,655,987, issued to Hubert Ashley Dickinson. This invention relates to imitation fires, and has two opaque screens behind which rotates another screen, between the outer screens and light source. The light passing through the screen reflects on pieces of broken colored glass and produces the illusion of flames.

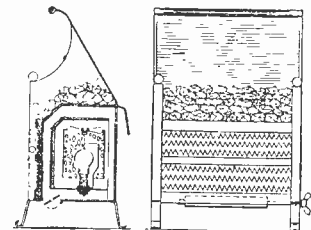

DISPLAYING APPARATUS FOR BEVERAGES

No. 1,654,379, issued to Wincenty Matzka. The device shown below is a dispensing apparatus for beverages which provides a continuous stream or fountain, while affording means for dispensing from a cooled container. The apparatus is encased in glass to display the beverage.

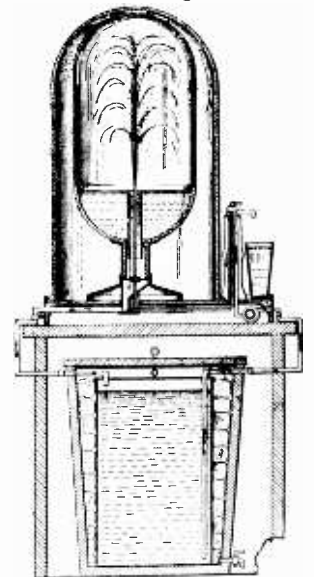

NOTICE TO READERS: The above illustrated and described devices have recently been issued patent protection, but are not as yet, to our knowledge, available on the market. We regret to advise that it is impossible to supply the names and addresses of inventors of the above devices to any of our readers. The only records available, and they are at

the Patent Office at Washington, D. C., give only the addresses of the inventors at the time of application for a patent. Many months have elapsed since that time, and those records are necessarily inaccurate. Therefore, kindly do not request such information, as it is practically impossible to obtain up-to-date addresses. —EDITOR.

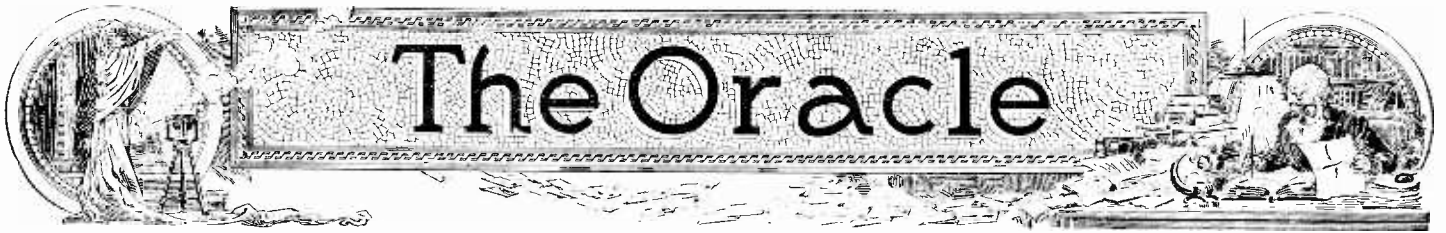

The "Oracle" is for the sole benefit of all scientific students. Questions will be answered here for the benefit of all, but only matter of sufficient interest will be published. Rules under which questions will be answered:

1. Only three questions can be submitted to be answered.
2. Only one side of sheet to be written on; matter must be typewritten or else written in ink; no penciled matter considered.

3. Sketches, diagrams, etc., must be on separate sheets. Questions addressed to this department cannot be answered by mail free of charge.

4. If a quick answer is desired by mail, a nominal charge of 50 cents is made for each question. If the questions entail considerable research work or intricate calculation, a special rate will be charged. Correspondents will be informed as to the fee before such questions are answered.

A.C. TRACTIVE MAGNET

(2246) J. Yust, San Francisco, Calif., asks:

Q. 1. Please illustrate in your columns an A.C. tractive electro-magnet having a three inch stroke and capable of lifting two pounds. This is to be used with the usual 60 cycle 110 volt alternating current circuit.

A. 1. On this page you will find illustrated an electro-magnet of the type mentioned above,

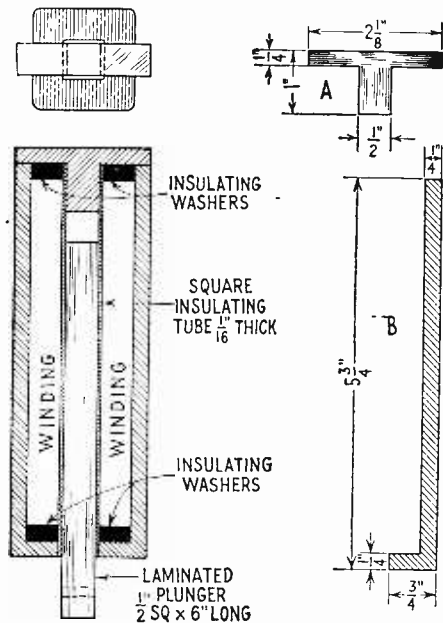

In the above drawing, details of an A.C. tractive magnet are given. This magnet has a 3" stroke and is capable of lifting two pounds.

having a three inch stroke and a two pound pull. The magnet is made of two types of laminations. 62 "L" shaped laminations and 31 "T" shaped laminations are used. The plunger consists of 31 laminations, each 6 inches long. The "T" shaped laminations are shown at A in the diagram, and the "L" shaped laminations at B. All laminations should be cut from silicon steel .015 inch in thickness. It will be noted that the plunger and opening have a square cross-section. The winding is made upon an insulating tube of hard rubber, bakelite, or fibre, and is insulated from the laminations by the washers placed as shown. No. 20 enameled wire is used and it will be found that 13 layers will be necessary, each layer having 160 turns. If the magnet tends to chatter this may be eliminated by using a shading coil which consists of a turn of heavy wire embedded in the stop. All dimensions have been marked upon the drawing.

ALLOY COMPOSITION

(2247) S. Koine, St. Paul, Minn., writes:

Q. 1. Will you please give me the composition of the following alloys: aluminum-beryllium, duralumin and alpac.

A. 1. Alloys of aluminum and beryllium are light and strong and are suitable for use in the manufacture of airplane parts. In the various patents covering these alloys, an alloy of 90 per cent aluminum and 10 per cent beryllium is mentioned and also one of 85 per cent aluminum, 10 per cent beryllium and 5 per cent copper. The composition of the alloy duralumin may vary slightly. One analysis by J. L. Jones, of the Westinghouse Elec. & Mfg. Co., gives the following proportions: aluminum 94.60 per cent, copper 3.90 per cent, iron 0.45 per cent, magnesium 0.75 per cent, silicon 0.21 per cent, and a trace of manganese. In a paper presented before the

Inst. of Mining and Metallurgical Engineers, the composition is given as follows: Copper 3 to 5 per cent, magnesium 0.4 to 1.0 per cent, manganese 0 to 0.7 per cent; aluminum, remainder; iron (as impurities), 0.4 to 1.0 per cent, silicon 0.3 to 1.0. Its density is given as about 2.85. Alpac is an aluminum silicon alloy, fine grained and ductile, containing about 87 per cent aluminum and 13 per cent silicon. It is usually made by the addition of a rich alloy of silicon and aluminum to ingot aluminum. A modification of the alloy is known as "aluminac" and is used for making die castings of aluminum alloy. The silicon-aluminum alloys are difficult to machine, as they tear and cling to the tools, so adding copper has been tried and found to impart better machining qualities.

REWINDING GENERATOR

(2248) H. Ohrt, Flatwillow, Montana, asks:

Q. 1. How can I change my six volt generator into a 32 volt generator?

A. 1. In order to make this change, it will be necessary to rewind both the armature and the field. You will have to use 5.3 times as many turns in the armature slots as there were originally. In order to fit this increased number of turns on the armature, it will be necessary to use a wire with a cross-sectional area about one-fifth the area of the original wire used. The cross-sectional area of the wire for the field windings will also have to be reduced to about one-fifth of the size originally used. The field should be rewound so as to have 5.3 times as many turns as were used originally.

FABRICATED METAL PROPELLERS

(2249) O. D. Osbourne, Mound City, Illinois, writes:

Q. 1. Will you please describe briefly the construction of a fabricated metal propeller, such as used on modern airplanes?

A. 1. Although a great many types of fabricated metal propellers have been constructed the only one which has come into general use is the Leitner Watts type which was developed in England. This propeller is made up of a number of thin sheets, one above the other, one set of sheets being used to form the back face of the blade, and the other the pressure face. The sheets for these two faces were pressed out in dies and were welded together along the leading and trailing edges. In the latest construction, the blades are made separately from the hub, having a cylindrical flange at the hub, so that they may be set at any desired pitch when assembled in the hub. The centrifugal force is taken up by a single shoulder at the end of the blade. The hub consists of a central plug made up externally to a standard form and bored internally to fit the particular engine on which it is to be used. These propellers are usually equipped with steel hubs and aluminum alloy propeller blades. The propeller is quite strong and the aerodynamic efficiency is about equal to that of a wooden one. This type of propeller is used quite extensively in England and France, but in the United States the more efficient, solid metal types are preferred. Mica propellers are now being used on many American planes.

AUTOMATIC SILVER RECOVERY

(2250) B. Insley, Lopez, Penna., asks:

Q. 1. Please give me an outline of the process used in automatically recovering silver from old hypo baths.

A. 1. Of the many methods of treatment those using zinc dust or sodium sulphide are the most popular. The hypo solution is permitted to accumulate until the tank is full, reagents are added, and the desilvered hypo allowed to flow to waste after settling over night. The scheme described here uses the conventional sodium sulphide method but performs the operation continuously and automatically. Waste hypo is allowed to drop into a measuring vessel fitted with an automatic syphon which flushes at a predetermined head. During the flushing operation waste developer and sodium sulphide are

sucked in and the mixture discharged into a reaction vessel. From here the solution and precipitate trickle slowly down a funnel to a settling tank. The precipitate collects as a thick brown sludge below the funnel and is drawn off into a bucket with a perforated bottom covered with absorbent cotton. The clear, desilvered hypo flows to waste from the top.

TELEVISION DISC

(2251) A. Smith, Detroit, Mich., asks:

Q. 1. Can you give me some information in regard to the number of holes which have to be drilled in the discs used with television apparatus? Your book on television mentions fifty holes, but I have read of a number of other machines which use discs having forty-eight or forty-six holes.

A. 1. The number of holes to be drilled in each disc, as specified in the book on television, is fifty, and is the same number which was used in the Bell Laboratory apparatus demonstrated last summer. With any appreciably smaller number of holes than fifty, the grain of the picture will be too coarse. If a greater number of holes than fifty are used, the grain will be finer. The engineers of the Bell Telephone Laboratories have tried both a larger and smaller number of holes than fifty, and finally came to the conclusion that fifty was the best for all around purposes. If forty-eight or forty-six holes are used, the grain of the picture will be made slightly coarser.

SALINITY INDICATOR

(2252) A. R. Mandell, Hartford, Conn., writes: Q. 1. Kindly publish a diagram showing the connections of a salinity indicator, such as that used by the U. S. Navy, employing what is known as the zero method.

A. 1. On this page you will find illustrated a salinity indicator of the Wheatstone bridge type, employing the zero or null method. This system is built about the Wheatstone bridge principle and when the bridge is balanced the galvanometer is balanced to zero deflection. The object of the transformer is not only to furnish a suitable ratio of A.C. volts to the system, but is primarily for the purpose of completely insulating the power supply from the indicator and cell, thus avoiding the possibility of cross currents

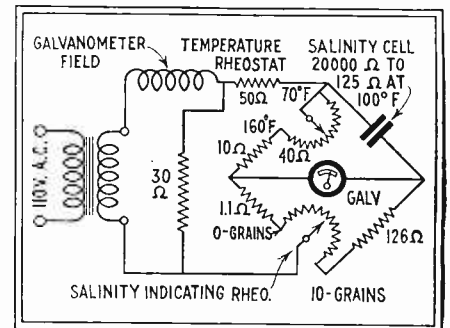

Above—the hook-up of the salinity indicator.

from power line grounds. To obtain an indication of salinity, it is necessary to first set the temperature compensating rheostat to the marked value, approximating the temperature of the feed water, in which the cell is located, and then adjusting the salinity rheostat until the galvanometer shows no deflection. At this setting the grains of salinity per gallon is observed from the calibrated dial of the salinity rheostat. These indicators have been used by the Navy to a great extent for quantitatively measuring the impurities of the feed waters used in the boilers and for determining the quantity of sodium chloride. Many other types of salinity indicators are made at the present time, some being automatic in their action, and furnished with automatic alarm signals and signal lights.

NEVER BEFORE

HAVE REAL BOOKS BEEN SOLD AT SUCH A PRICE!

Yes, REAL BOOKS, not pamphlets, books well printed, well bound, averaging over 150 pages. Colored covers. Average size 4 1/2" x 6". Books to suit every taste. AND EVERY BOOK ONLY 10 cents! You can't go wrong at such a price. Literally Hundreds of Thousands of these books have been sold. Try once—you'll come back for more. 300 titles listed here. Letter behind each book gives you its number of pages. A—300 pages. B—220, C—130, D—96, E—64 pages.



C247

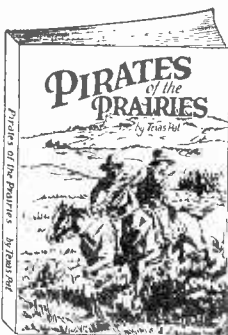

C317

Any Book listed here 10¢ only



N86



C229

Western Stories

- ..C275 The Shawnee's Foe. D
- ..C276 Wild Jim. D
- ..C277 Hawkeve the Hunter. D
- ..C278 Iron Hand. D
- ..C279 Wapakanketa. D
- ..C280 The Forest Avenger. D
- ..C281 Sharp Snout. D
- ..C282 Madman of the Colorado. D
- ..C283 The Panther Denon. D
- ..C284 A New York Boy Among the Indians. D
- ..C285 Deadwood Dick's Big Deal. D
- ..C286 Deadwood Dick's Dozen. D
- ..C287 The Woman Trapper. D
- ..C288 Brimstone Jake. D
- ..C289 The Shawnee Witch. D
- ..C290 Spider-Legs. D
- ..C291 Madman of the Oconto. D
- ..C292 Tiger Eye. D
- ..C293 Red Men of the Woods. D
- ..C294 Red Rattlesnake the Pawnee. D
- ..C295 Hoving Dick. Hunter. D
- ..C296 Snake-Eye. D
- ..C297 Bullet Head. D
- ..C298 The Indian Spirit. D
- ..C299 The Twin Trappers. D
- ..C300 The Silent Trapper. D
- ..C301 Marksman the Hunter. D
- ..C302 Hunters and Redskins. D
- ..C303 The Panther Paleface. D
- ..C304 Bloody Brock. D
- ..C316 Three Fingered Jack. B
- ..C317 Pirates of Prairie. Texas Pat. B
- ..C318 White Falcon. Texas Pat. B
- ..C319 Trail of Gold. Montana Charley. B
- ..C320 Redhawk's Nest. Montana Charley. B

Boys' Detective

- ..N185 The Little Colonel. D
- ..N186 Jack the Tugler. D
- ..N187 The Runaway. D
- ..N188 The Three Boy Detectives. D
- ..N189 A Little Cowboy in New York. D
- ..N190 Flyaway Ned. D
- ..N191 The Duke of Omaha. D
- ..N192 Kefton the Detective. D
- ..N193 Billy the Tramp. D
- ..N194 The Prince of Ventriloquists. D
- ..N195 Cad Metti, the Female Detective. D
- ..N196 Resolute Jack. D
- ..N197 The Twin Ventriloquists. D
- ..N198 Tracked on a Wheel. D
- ..N199 Carusoe Harry. D
- ..N200 The Golden Legacy. D
- ..N201 Nimble Ike's Mystery. D
- ..N202 Mechanic's Son. D
- ..N203 Detective Hanley. D
- ..N204 Lorie or the Phantom Ventriloquist. D
- ..N205 Ten Day Mystery. D
- ..N206 A Detective Enigma. D
- ..N207 Breezy Frank. D
- ..N208 Life in New York. D
- ..N209 Desmond Dare. D
- ..N210 A Remarkable Shadow. D
- ..N211 Tom the Young Explorer. D

Boys' Adventure

- ..B149 Adrift in New York. H. Alger. A
- ..B150 Helping Himself. H. Alger. A
- ..B151 The Store Boy. Horatio Alger. A
- ..B152 The Telegraph Boy. H. Alger. A
- ..B153 The Young Acrobat. H. Alger. A
- ..B154 The Young Explorer. H. Alger. A
- ..B155 Driven from Home. H. Alger. A
- ..B156 Facing the World. H. Alger. A
- ..B157 The Train Boy. H. Alger. A
- ..B158 Facing Death. Horatio Alger. A
- ..B159 Grit. Horatio Alger. A
- ..B160 In a New World. H. Alger. A
- ..B161 Julius the Street Boy. H. Alger. A
- ..B162 Tom the Bootblack. H. Alger. A
- ..B163 The Tin Box. Horatio Alger. A
- ..B164 The Young Outlaw. H. Alger. A
- ..B165 The Young Miner. H. Alger. A
- ..B166 The Young Musician. H. Alger. A
- ..B167 Pacing Death. G. A. Henty. A
- ..B168 Out on the Pampas. G. A. Henty. A
- ..B169 Outward Bound. Oliver Optic. A
- ..B170 Bound to Rise. H. Alger. Jr. A

Adventure

- ..B173 Secrets of Monte Carlo. LeQueux. A
- ..B174 Sheriff of Wasco. Jackson. A
- ..B175 Talking Chances. C. Cullen. A
- ..B178 Pavilion on the Links. R. Stevenson. A
- ..B176 Murderers in the Rue Morgue. E. A. Poc. A

Mystery Stories

- ..C306 Mystery of Crimson Blind. White. B
- ..C307 Mr. Marx's Secret. Phillips Oppenheim. B
- ..C308 Mysterious M. Sabin. Oppenheim. B
- ..C309 Prince of Swindlers. Boothby. B
- ..C310 The Kidnapped President. Boothby. B
- ..C311 Secret of Chinese Jar. F. Hume. B
- ..C312 Dagger of Fate. Richard Marsh. B
- ..C313 Shadow on the Sea. M. Pemberton. B
- ..C314 The Darkest Hour. Louis Tracy. B
- ..C315 A Japanese Revenge. L. Tracy. B
- ..C305 The Man They Could Not Hang. True Story. D

Entertainment

- ..N1 How to Play Rum. E
- ..N2 How to Play Poker. E
- ..N3 How to Play Euchre. E
- ..N4 How to Play Whist. E
- ..N5 How to Play Pinochle. E
- ..N6 How to Play Cribbage. E
- ..N7 How to Play Five-Hundred. E
- ..N8 How to Play Chess. E
- ..N10 Checkers and How to Play It. E
- ..N20 Book of Choice Riddles. E
- ..N29 153 Magic Tricks. E
- ..N32 84 New Card Tricks. E
- ..N31 700 New Toasts. E
- ..N35 Book of 145 Parlor Games. E
- ..N38 New Book of 200 Puzzles. E

- ..N12 Fun, Magic and Mystery. E
- ..N19 Book on Magic Made Easy. E
- ..N67 A Bunch of Limericks. E
- ..N70 Parlor Games. E
- ..N71 Tricks of Magic. E
- ..R88 25 Lessons in Hypnotism. E
- ..B89 Hypnotism. E
- ..R92 Parlor Games and Amusements. E
- ..B95 Magic Made Easy. E
- ..B96 Popular Toasts. E
- ..B102 Puzzles. E
- ..B105 Fun, Magic and Mystery. E
- ..B118 New Book of Card Tricks. E
- ..B119 New Book of Coin Tricks. E
- ..B120 New Parlor Tricks and Magic. E
- ..C271 Book of 100 Games. D
- ..C272 Magicians' Book of Conjuring. D

Best Movie Sellers

- ..N72 The Divine Woman. C
- ..N73 Forbidden Hours. C
- ..N74 The Crimson City. C
- ..N75 Jazz Mad. C
- ..N76 The Campus Flirt. C
- ..N77 Almost a Lady. C
- ..N78 Sensation Seekers. C
- ..N79 New York. C
- ..N80 Cohens & Kellys in Paris. C
- ..N81 Streets of Shanghai. C
- ..N82 You Can't Beat the Law. C
- ..N83 Tillie's Punctured Romance. C
- ..N84 Tell It to the Marines. C
- ..N85 Tracked by the Police. C
- ..N86 The Cat and the Canary. C
- ..N87 Don't Tell the Wife. C

Travel Adventure

- ..C220 In South Seas. Capt. Roosevelt. D
- ..C221 World Cruise. Capt. Lawton. D
- ..C222 Iceberg Patrol. Capt. Lawton. D
- ..C223 On a Submarine. Capt. Lawton. D
- ..C224 Aboard a Destroyer. Capt. Lawton. D
- ..C225 On Battle Practice. Capt. Lawton. D
- ..C226 War Swept Seas. Capt. Lawton. D
- ..C227 Marooned in Tropics. Forrester. D
- ..C228 Boy Scouts in Great Flood. Shaler. D
- ..C229 On Aero Service. Capt. Lawton. D
- ..C230 Along the Yukon. Forrester. D
- ..C231 North of '53. J. Forrester. D
- ..C232 The Lost Liner. Capt. Lawton. D

Detective Stories

- ..B170 Revelations by Inspector Morgan. By Oswald Crawford. A
- ..B171 True Detective Stories. Moffett. A
- ..B172 Confessions of a Detective. Lewis. A
- ..B177 Quintus Oakes. R. Jackson. A
- ..C247 Sherlock Holmes. Conan Doyle. A
- ..C248 Beyond the City. Conan Doyle. A
- ..C249 Case of Identity. Conan Doyle. A
- ..C250 Scandal in Bohemia. Conan Doyle. A
- ..C251 The Redheaded League. Doyle. A
- ..C252 The Sign of the Four. Doyle. A
- ..C253 Giant Detective. Old Sleuth. A

- ..C251 Surgeon of Gaster Fell. Doyle. A
- ..C255 Mill Street Mystery. Sargeant. A
- ..C256 The Bag of Diamonds. Penn. A
- ..C257 The Red Lottery Ticket. Boisgobey. A
- ..C258 The Haunting Shadow. Old Sleuth. A
- ..C259 Joe Phoenix. Police Spy. Atkin. A
- ..C260 Joe Phoenix. Detective. Atkin. A
- ..C261 The Wolves of New York. Atkin. A
- ..C262 Chin Chin. Chinese Detective. By Albert W. Atkin. A
- ..C263 Electro Pete. Morris. A
- ..C264 West Shore Mystery. Old Sleuth. A
- ..C265 The Man Hunt. Dick Donovan. A
- ..C266 Mystery of Hanson Cab. Hume. A
- ..C267 The Abbey Murder. Jos. Patton. A
- ..C268 The Man Who Vanished. Hume. A
- ..C269 Piccadilly Puzzle. Hume. A

Educational

- ..N66 Great Words of Great Men. E
- ..B104 How to Become Beautiful. E
- ..B107 Business-Letter Writer. E
- ..B109 Sparring and Boxing. E
- ..B115 New Book of Proverbs. E
- ..B124 Up-to-date Letter Writer. E
- ..B126 Every Boy His Own Toy-maker. E
- ..B137 Ladies' Model Stancy Work Manual. E
- ..B138 Marriage (Common Sense Points) E
- ..C270 Lover's Casket. E
- ..C273 Gent's Letter Writer. D
- ..C274 Ladies' Letter Writer. D

Full Length Novels

- ..N12 Short Stories. Honore de Balzac. D
- ..N13 The Gold Bug. Edgar Allen Poe. D
- ..N14 Dr. Jekyll & Mr. Hyde. Stevenson. D
- ..N15 Scandal in Bohemia. Conan Doyle. D
- ..N16 My Double and How He Undid Me. D

Love and Romance

- ..B103 How to Make Love. E
- ..B104 Love-Letter Writer. E
- ..B139 The Leighton Homestead. Holmes. A
- ..B140 Maggie Miller. Mary J. Holmes. A
- ..B141 The English Orphan. Holmes. A
- ..B142 Bad Hugh. Mary J. Holmes. A
- ..B143 Rosamonde. Mary J. Holmes. A
- ..B144 Rose Mather. Mary J. Holmes. A
- ..B145 Ethelyn's Mistake. M. J. Holmes. A
- ..B146 Family Pride. M. J. Holmes. A
- ..B147 Millbank. Mary J. Holmes. A
- ..B148 Dora Deane. Mary J. Holmes. A
- ..C253 Kidnapped at the Altar. Libbey. E
- ..C254 Gladia's Two Lovers. Libbey. A
- ..C255 Let the Dancing Girl. Hart. E
- ..C256 Aletha's Terrible Secret. Libbey. E
- ..C257 For Love or Honor. C. Hart. E
- ..C258 The Romance of Enola. Libbey. E
- ..C259 Little Princess. Caroline Hart. E
- ..C240 Sweetheart or Wife? Libbey. E
- ..C241 Love's Rugged Path. Hart. E
- ..C242 Married at Sight. C. Hart. E
- ..C243 Pretty Madcap Dorothy. Libbey. E
- ..C244 The Loan of a Lover. Libbey. E
- ..C245 Vendetta. Marie Corelli. E
- ..C246 The Girl He Forsook. Libbey. E

1000 LAUGHS ON EACH PAGE

CHARLIE CHAPLIN'S CHATTER AND FUNNY SAYINGS

REPS THE DOCTOR FOR AWAY

B132

- ### Humor
- ..N17 Irish Jokes. E
 - ..N18 Hebrew Jokes. E
 - ..N19 Dutch Jokes. E
 - ..N21 After-Dinner Stories. E
 - ..N23 Book of Vaudeville Jokes. E
 - ..N24 Book of Funny Rhymes. E
 - ..N25 Book of Flirtations. E
 - ..N28 New Stage Jokes. E
 - ..N30 Book of 1,000 Conundrums. E
 - ..N32 Red-Hot Jokes. E
 - ..N36 Actors' Jokes. E
 - ..N37 New Book of Monologues. E
 - ..N11 Hebrew Yarns. E
 - ..N44 Side-Splitting Jokes and Stories. E
 - ..N45 Peasly Jokes. E
 - ..N17 Snappy Jokes. E
 - ..N48 Tramp Jokes, Monologues, Recitations. E
 - ..N50 Komikal Joker. E
 - ..N52 Book of Wit and Humor. E

HOW TO ORDER

Select book wanted by checking in front of number. Then take a sheet of paper and list numbers only. Titles of books not necessary on your order.

We do not accept orders for less than \$1.00 (10 books.) No. C. O. D.'s. Remit by Check, Money Order, Cash or Stamps. Add 2c postage for each book, otherwise we send by Express collect. (Foreign postage 4c each book.)

SEND FOR FREE BOOK CATALOG LISTING OVER 2,000 TITLES.

- ..N57 Vaudeville Gags and Jokes. E
- ..N59 Darkey Jokes and Funny Stories. E
- ..N60 Hobo Jokes. E
- ..N64 Boarding House Jokes. E
- ..N69 Coontown Comedy and Fun. E
- ..B99 Farmer Jokes. E
- ..B100 Drummers' Yarns. E
- ..B108 Rattling Ford Jokes. E
- ..B111 Good Time Jokes. E
- ..B112 Prize Jokes. E
- ..B114 Funny Epitaphs. E
- ..B116 New Blackface Minstrel Jokes. E
- ..B117 Italian Dialect Joke Book. E
- ..B123 Hash House Jokes. E
- ..B125 Wine, Women and Song. E
- ..B128 Burlesque and Variety. E
- ..B130 Arkansas 1 Saw. E
- ..B131 You Tell 'em, funny sayings E
- ..B132 Charles Chaplin Chatter and Funny Sayings. E

153 TRICKS of Magic

N29

Learn This Good Paying Trade

Get Into the Automobile Business Where You Can Earn a Good Salary the Year Round—PLUS

Here is where trained men are ALWAYS IN DEMAND. No other trade or business offers so many opportunities for rapid advancement. Splendid positions always open for Stewart-trained men. PREVIOUS EXPERIENCE NOT NECESSARY. All you need is a liking for mechanics. Our COMPLETE SHOP COURSE of Thorough, Practical Training on

Chassis Engines Batteries Ignition Starting Lighting, etc.

will start you on the road to success. You do the work with proper tools under EXPERT INSTRUCTORS.

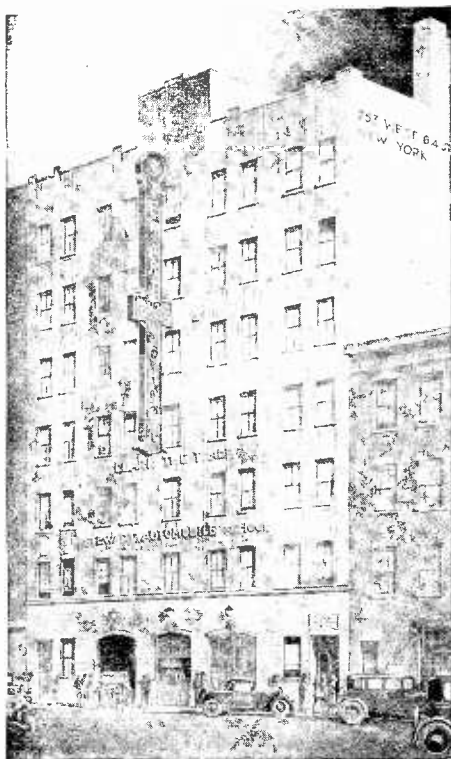

The New Stewart Building

The above illustration is a fair reproduction of the new home of the Stewart Automotive Trade School—founded 19 years ago. It is located in the heart of the Automobile District of New York City. It was specially designed for this purpose. It's fire proof—splendidly lighted—well ventilated—and specially arranged for the convenience of its students. The shop equipment is complete with all modern appliances and facilities. The instructors are the best obtainable.

If you have a liking for mechanics and wish to enter the automobile field and be properly trained—in a city where the demand for skilled men is greater and salaries larger than anywhere else—return the attached coupon and we will mail you our new catalog and information in detail of our system of training—tuition fees, and cost of living in New York while being trained, etc.

Stewart Automotive Trade School

257-E West 64th St., New York City

You may send me your FREE Catalog, illustrating your shops, and complete description of your training methods, terms, etc., without any obligation on my part, whatever.

Name.....Age.....

Address.....

City.....State.....

MOTOR HINTS

CONDUCTED BY GEORGE H. LUERS
(Continued from page 35)

The box-like container is fitted in place of the usual lid to the rear storage compartment. It is made up of sheet iron, bent and fitted to the rear body. The top is also of sheet iron, sloping to the rear. Two wide sheet metal doors on hinges provide access and also permit it to be locked. A closing strip of one inch quarter round, with a felt edge, makes quite a weather-proof job.

Light sheet metal can be used and all joints double seamed as in roof work.

This fixture is detachable as desired, but a neat coat of paint to match the car avoids any unsightliness.

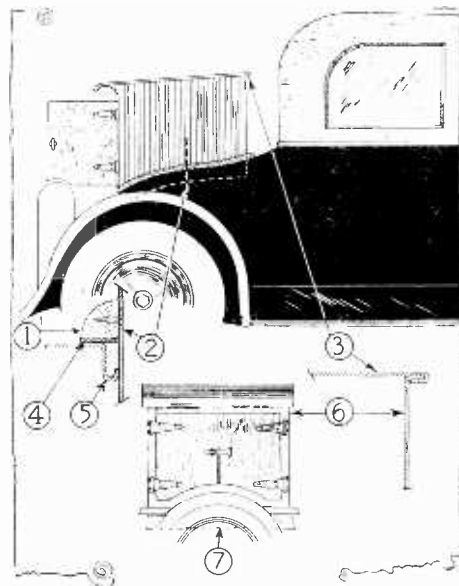

The drawing at the right shows how a coupe or roadster can be fitted for carrying extra luggage. No. 1 is a piece of quarter round molding, 2 is the joint; 3, seam at upper edge; 4, felt strip; 5, body of car; 6, sheet or galvanized iron. Fig. 7 shows a rear view of the baggage carrier now that the summer season is approaching, this idea should prove particularly interesting to all motorists.

Hints for the Mechanic

Mechanics' needs have caused us to start this new department—"Hints for the Mechanic," in which we intend to publish wrinkles useful to mechanics in general. You can help us with this department by writing a brief description of your favorite shop wrinkle and sending this to the editor of this department, together with a pencil or pen and ink sketch of the wrinkle. The ideas published herewith will give you some idea of what we want. Our draughtsmen will make the necessary mechanical drawings, so you need not send us finished drawings. We will pay \$10.00 each month for the best Wrinkle or Hint sent in; others published will be paid for at space rates. Address all letters to Editor, Hints for the Mechanic Department, in care of this magazine.

FIRST PRIZE—\$10.00

SPEED INDICATOR

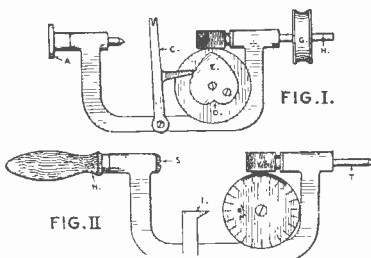

Figs. 1 and 2 above show how a speed indicator can be made from an ordinary sewing machine.

A speed indicator can be made from a sewing machine by removing heart shaped plate E and substituting a graduated disc. The thread spindle is removed and a pointer arranged as shown. The shaft H is pointed and a handle is provided.—Contributor send name and address.

WRENCH CLIP

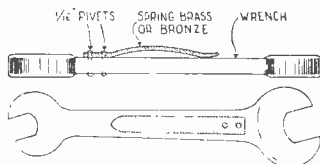

Details of the pocket wrench clip are shown above. Two rivets are used to hold the clip to the wrench.

Small wrenches have a habit of becoming lost or misplaced. The idea shown in the illustration provides a novel clip arrangement for holding the wrench securely in the pocket. The clip is made of spring brass or bronze and is held to the wrench with two 1/16" rivets. It is clipped in the pocket in much the same manner as a fountain

pen or pencil.—Contributor send name and address.

EXTENDING DRILL SIZE

The size of an ordinary drill may be increased by using the following method: If a 1 1/8" hole is to be drilled and a 1" drill is available, the drill may be ground until one side is 9/16". It will then cut a hole to the size wanted. In this manner, holes can be drilled 1/4" larger than the drill size.—Calvin Thompson.

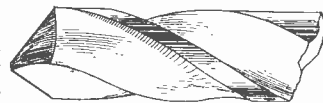

SUBSTITUTE DRILL



In drilling small holes for finishing nails, the head of one of the nails may be cut off and the nail itself used instead of the drill point. It works as well as any drill point would and the hole made is of the exact size wanted.—Richard Simpson.

JOINING LEATHER BELTS



Figs. 1, 2 and 3, in the above illustration, show methods of joining leather belts.

Narrow leather belting may be joined by simply cutting a slit in one end and shaping the other end as shown, at 1 and 2. Fig. 3 shows method of joining wide belts.
—Wilbur S. Stump.

KEEPING SHAFTS BRIGHT

Revolving shafts can be kept bright by simply placing a loop of heavy brass or copper wire over the shaft and applying a few drops of oil. The loop works back and forth keeping the shaft clean.—H. L. Ketcham.

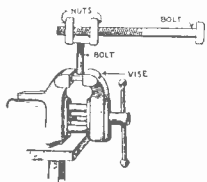
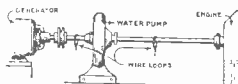

SUBSTITUTE WRENCH

A substitute wrench can be made from two nuts and a bolt as shown in the illustration. The nuts can be adjusted to any size.—Lincoln Robinson.

FEELER GAUGE

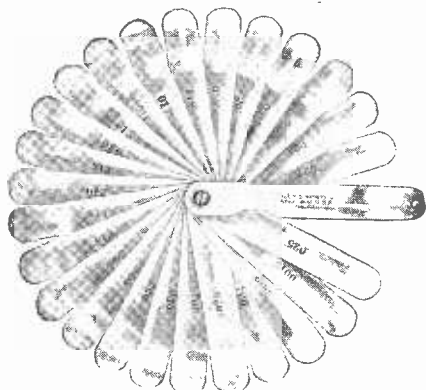

A Handy "Feeler" Gauge

(Manufacturers name on request)

MODEL DEPARTMENT BLUEPRINTS

Correct—Easy to Follow

- 1-2 Horizontal Steam Engine details set \$1.00
- 3-4 Boiler construction for above set \$1.00
- 5 880 Ton Bark 50c
- 6-7 Twin Cylinder Steam Engine and Boiler. set \$1.00
- 8-9 Gasoline Fired Locomotive set \$2.00
- 10-11 U. S. S. Constitution, "Old Ironsides" .. set \$1.00
- 12 13th Century Man-of-War 50c
- 13-14 Chinese Junk set 50c
- 15-16 Electrically driven Automobile set \$1.00
- 17-18 How to Build a Reflecting Telescope .. \$1.00
- 19 Roman Ballista 50c
- 20-21 Simple Steam Engine, set 50c
- 22 "Santa Maria," complete 50c
- 23-24 Model U. S. S. Portsmouth set \$1.00
- 25 Building a Model Tugboat 50c
- 26 Twin Cylinder Marine Engine 50c
- 27-31 U. S. S. Truxton..... \$2.00

Send Orders to

MODEL DEPARTMENT SCIENCE AND INVENTION

230 Fifth Avenue
New York City

Go After the Big-Pay Job!



"Know electricity as experts know it and get an expert's pay"

DON'T be satisfied to worry along in little jobs with little pay. Master the finer points of electrical practice and bring the big-pay job within your reach. The man who knows electricity in all its many phases—the man who has completely mastered the subject from A to Z—can pick his own job and name his own salary. Learn the way to bigger pay. Become an electrical expert. Croft will show you how. Through his famous books he will teach you electricity as experts know it and put you in line for an expert's pay. Fifty-nine thousand men are using these books to step ahead—WHY NOT YOU?

Croft Library of Practical Electricity

8 volumes—3000 pages—2100 illustrations, flexible binding

No method of teaching electricity offers a quicker, surer way to success than the Croft books.

Starting right in with the ABC's of modern electricity, Croft takes you through his books in easy steps. He gives you the boiled-down records of every-day electrical practice in plain words, figures and illustrations. Nothing is left to the imagination—there is no guesswork.



Croft has been through the mill. His knowledge of electricity has been gained by actual shirt-sleeve contact with electrical problems. He knows just what is needed to get ahead. He has poured out all his knowledge—all his experience—in language that anyone can grasp. Yet the text is so scientifically correct that thousands of the highest-paid electrical engineers are using the books as a reference set.

The famous set is, beyond the shadow of a doubt, the last word in practical electrical education. No one who wishes to get anywhere in the electrical field can afford to be without it.

Thousands of Facts at Your Finger Tips

The Croft Library contains three thousand pages, with twenty-one hundred of the clearest illustrations ever put into book form. Each of the eight flexible pocket-size volumes is indexed so that everything you need to know is right at your finger tips.

Croft tells you the things you need to know about motors, generators, armatures, commutators, transformers, circuits, switchboards, distribution systems—installation, operation and repair of electrical machinery—wiring for light and power—wiring of finished buildings—underwriter's and municipal requirements—how to do a complete job, from estimating it to completion—illumination in its every phase—the latest and most improved methods of lighting, etc.

The Standard in Practical Electrical Training

Everywhere the Croft Library is acknowledged as the standard—the leader—in practical electrical training. It is the daily guide of 59,000 highly paid electrical workers and engineers. There is nothing like it. It is the most complete, the best illustrated, the most carefully compiled, the most easily understood library in print today. No matter how much or how little you know of electricity you will find the Croft Library a sound, helpful guide to greater accomplishment.



McGraw-Hill Book Co., Inc., 370 Seventh Ave., New York, N. Y.

Free Examination—No Money Down—10 Months to Pay!

So that you may test our statements, we offer to send the complete library of 8 volumes to you for 10 days' free examination. We take all the risk—pay all the charges. You assume no obligation of any kind—you pay nothing unless you decide to keep the books, in which event you pay \$1.50 in ten days and then \$2.00 a month for nine months.

Send the coupon now and see the books for yourself. It's a little thing to do but it may prove to be the best move you ever made in your life.

Gentlemen: Send me the CROFT LIBRARY OF PRACTICAL ELECTRICITY (shipping charges prepaid), for 10 days' free examination. If satisfactory, I will send \$1.50 in ten days and \$2.00 per month until \$19.50 has been paid. If not wanted, I will return them. (To insure prompt shipment, write plainly and fill in all lines.)

Name

Home Address

City and State

Employed by

OccupationSI-5

Achieve SUCCESS in Radio

New course gives finest instruction obtainable

You Can Learn at Home!



R.L. DUNCAN, Director, Radio Institute of America and author of several volumes in radio.

Good pay from the start, rapid advancement, and phenomenal success—a life profession of fascinating brainwork—that is what Radio holds for the man who knows his subject thoroughly. Since 1909 Radio Institute of America has trained thousands to become successful in the many branches of Radio. Are you going to plod

along at a thirty-five dollar a week job when REAL MONEY is waiting for you in radio?

New Course Finest Ever

Prominent radio men have enthusiastically greeted RIA's new course as the most complete and up-to-date offered today. All this first-quality equipment is furnished FREE WITH THE COURSE—parts for making many practical radio circuits and the Peerless Signagraph for code instruction.

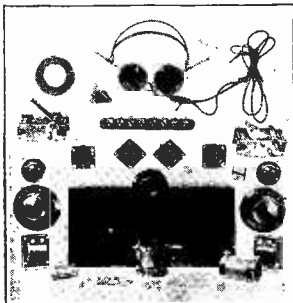

RIA backed by RCA, G-E and Westinghouse

You get all the benefits of instruction conducted by RCA and sponsored by RCA's associates, G-E and Westinghouse. Our employment department is at the service of graduates.

Study at Home!

Moreover you can STUDY AT HOME—when you please and as long as you please.

This new booklet describing the course is just off the press. If you want to learn more about the well paying positions in this fascinating profession send the coupon now for your copy.



RADIO INSTITUTE OF AMERICA
Dept. G-5 326 Broadway, New York City

RADIO INSTITUTE OF AMERICA, Dept. G-5
326 Broadway, New York City

Dear Mr. Duncan:

Please send me your new catalog. I want to know more about your new radio course.

Name.....

Address.....

LIFTING THE VEIL OF VENUS

By DONALD P. BEARD

(Continued from page 31)

When distant objects, say a remote range of hills or some group of buildings, are viewed through an intervening strata of atmosphere they are indistinct and sometimes even rendered invisible by the veil of dust particles and mist particles, which diffuse and scatter the short blue light waves reflected from these objects to the observer's eye.

As will be noted in the accompanying photos by Prof. W. H. Wright, this effect is rendered startlingly apparent through photographs made with selective filters. In the violet light photograph (Fig. 1-a) San Jose, California, a city nestled in the oak-environed Santa Clara Valley west of the Lick Observatory, was invisible, as though shrouded in an ocean fog, although the day was clear. However, in the infra-red image (Fig. 1-b) the buildings and trees in the plain clear to the coast range are minutely rendered.

The same method, applied to Mars with the great 100-inch reflector on Mt. Wilson, yielded to Prof. Wright an image through the violet filter (Fig. 2-a) some six per cent larger than the infra-red image (Fig. 2-b), indicating a Martian atmospheric shell almost 140 miles deep!

When the planet Venus reached her greatest eastern elongation (45 degrees of arc east of

inferior conjunction about July 1st, 1924, gave important results. Dr. Coblentz of the U. S. Bureau of Standards found the volume of infra-red radiations from the dark regions were of abnormally great wavelength; indeed, almost three times greater than that reflected to us from the bright sunlit crescent!

A careful examination by Dr. Coblentz revealed that the amount of planetary heat radiated earthwards at inferior conjunction (E) is very nearly the same as that sent us at superior conjunction (A) when Venus is more than six times as far away, or (Fig. 4) some 67,000,000 miles beyond the sun. (See chart, Fig. 4.)

In short, these observations indicate a nearly uniform temperature over the surface of Venus harmonious with the existence of sentient animal life there. This dense and perhaps permanent cloud-canopy tempers the terrific solar radiation, producing an equable climate of relatively narrow

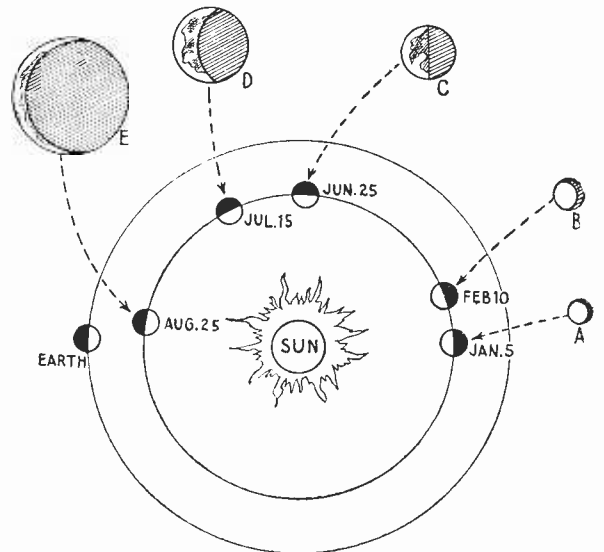

Fig. 4. Diagram of the orbit and successive positions of Venus during the recent apparition. The corresponding phase of the planet as seen from the earth is appended to each of the five principal positions by arrows.

- A—"Full" phase near superior conjunction.
- B—"Gibbous" phase.
- C—"Half-Moon" phase previous to E. elongation.
- D—"Crescent" phase near E. elongation.
- E—"Decrescent" phase just before Infer. conjunction.

the sun) on August 5th, 1927, she achieved her greatest brilliancy. At this time Venus set more than three hours behind the sun, and in the telescope revealed a crescent similar to that of our moon about five days after "new" moon. The weird copper color of the unilluminated portion of Venus seen when the planet is a narrow crescent just before inferior conjunction has been a mystery to observers. On February 28th, 1806, Harding, at Gottingen, Germany, using an 8-inch reflector, saw this dark-side glow—upon which Schroeter bestowed the term *kuentsliche Feuer* (artificial fire)—shining with a reddish-gray color like that of the moon in total eclipse. Now, these observations can be interpreted only in the light of recent discoveries as indicating an enormous volume of infra-red radiations from the dark regions of Venus!

Furthermore, M. Hansky of Russia, about ten years ago, found that the visibility of the "dark light" was greatly excited and augmented during years of sunspot activity, such as 1927. All observers of Venus should have carefully noted the visibility of the dimly lighted area of the planet enclosed in the thin sickle of her narrowing crescent previous to September 10th, 1927, when inferior conjunction occurred.

The dark-side radiation from Venus, when measured by the vacuum thermocouple attached to the great 100-inch reflector located on Mt. Wilson just before and after in-

temperature variations, not unlike that of San Francisco, as a terrestrial example.

The above mentioned fragmentary facts concerning Venus that have been evoked by aid of infra-red photography and the radiometric measures by Coblentz permit us to indulge certain fascinating speculations on life-conditions upon Venus.

Dense cloudiness prevailing over Venus, combined with the appearance of great ice-caps and glaciers about the polar areas of the planet, predicates a planetary development similar to that of the Carboniferous epoch on the earth some ten millions of years ago. Upon our planet this stage was vividly manifest in a vigorous and grotesque flora and fauna; a world dominated by the nightmare saurians of Conan Doyle's "Lost World," while exuberant tree ferns and calamites grew tumultuously beneath a humid, cloud-filled sky from which descended never-ceasing deluges of rain.

Immense glacier sheets extending over thousands of square miles apparently blanket the polar areas of Venus, although Prof. Ross's recent photographs seem to indicate rather an extensive southern cloud area about the south pole. Years ago, De Vico thought he observed mountain peaks on several occasions which apparently upthrust themselves like Jungfraus and Everests, high above the cloud envelope, their everlasting snow-peaks appearing as dazzling diamond-points amidst the billows of grayish vapour.

Could we descend upon Venus in a projectile and emerge upon her surface we would, in the opinion of Dr. Landerer of Vienna, find ourselves at once plunged back into the fantastic scenes of the Jurassic epoch on earth. Overhead the atmosphere would be dense with vapours, while an oppressive steaminess, an overwhelming hot-house heat, would stifle our breath.

Arrhenius of Stockholm, in a masterly analysis of the question, infers that a great part of the Venusian planet is covered with dense swamps more luxuriant than the Amazon jungles, and corresponding to those once on earth, whose complex fossils are preserved in the great Devonian coal stratas. No dust clouds are ever lifted up by the active air currents through the steaming atmosphere of Venus to lend it a distinct color like that of the earth's azure skies. The blinding white reflections from the cloud envelope above reaches the outer spaces, imparting to Venus her high albedo of 92 per cent of absolute reflection. This is an astronomical term expressing the ratio, which the light reflected from an unpolished surface, bears to the total light falling upon it.

The visitor upon Venus would encounter round about him towering tree ferns such as exist only in our parks and conservatories at present, or in warm, fog-shrouded valleys of Australia, Africa, and New Zealand, greatly diminished from their mighty progenitors that towered to heights of perhaps 300 feet. A forest of tree-ferns that flourishes in San Francisco is shown in Fig. 6.

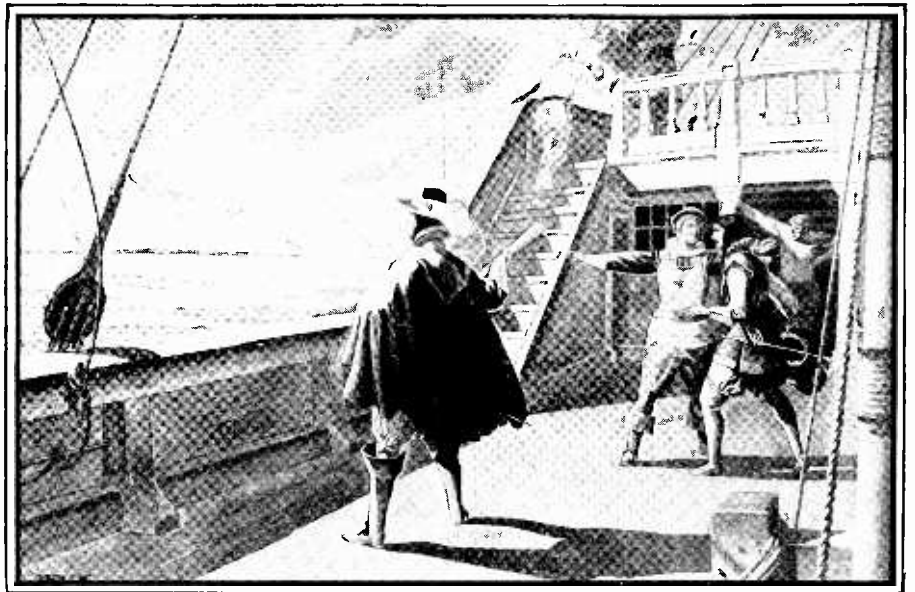

Widening the Telephone Horizon

An Advertisement of the
American Telephone and Telegraph Company



IN THE memory of many now living, Alexander Graham Bell made the apparently rash prediction that the day would come when we could talk to other countries, even across wide expanses of water. That was shortly after the historic conversation between Boston and Cambridge, a distance of two miles.

Bell's vision was made a reality when in 1926 New York and London spoke together in two way conversation, and when in 1927 this service was opened to the public between any point in the U. S. A. and Great

Britain. Since then, Mexico has been brought into speaking distance; important cities of continental Europe have come within the voice horizon of the United States.

Even more important, the Bell System in the United States now embraces 18,500,000 telephones—a growth for the past year of more than 750,000.

We may now converse with each other from practically any point in this country to any other, and may talk beyond our borders and across the sea. That is measurable progress in widening America's telephone horizon.

IN "RADIO NEWS" FOR MAY, 1928

- Seeing Across the Atlantic Ocean
By A. Dinsdale
- Coming—A Program Pool?
By Charles Magee Adams
- Folks, Meet "Mike"
By C. W. Palmer
- What Happens Between the Microphone
and the Transmitter
By G. C. B. Rowe
- Radio Polices a Western City
By J. E. Squires
- The R. F. Booster Unit
By David Grimes
- How to Build an Electrodynamic Loud
Speaker
- How to Build a Linen Diaphragm Loud
Speaker
- A Beginner's Two Tube Receiver

In the remote aeons during which their antecedents ruled triumphant over a saurian-infested earth, a mild and temperate climate apparently prevailed throughout all Europe, Russia, Mongolia and Siberia and as far north as Spitzbergen and Kotzebue Sound, where the builders of coral reefs and tree-ferns, now fossil, dwelt in latitude above 80 degrees north, where at present stretch only desolations of ice. And from the lofty mountain ranges of Venus extensive glaciers would hang in vast sheets, their long fangs of ice depending over deep gorges like those of the Himalayas, whose white turbans sweep the turquoise skies of India.

Perhaps upon our neighbor planet, Venus, the gigantic palms and ferns were ushered in ages after they gave up the struggle on an earth that grew less humid and more sunshiny, and have there attained the stature of our mighty redwoods and firs. The dense clouds mask effectively the Hesperian planet's surface, preserving like a thermostat its equable greenhouse temperatures throughout aeons against the day when a race, now in the womb of time, shall appear and play out its drama upon Venus.

Thus, in a little beam of infra-red "light" reflected to the earth from distant Venus, lies the romantic possibility that man will presently rend aside the tantalizing veil hiding the coy features of the Love-goddess's world.

Travel on "Uncle Sam's" Payroll RAILWAY POSTAL CLERKS MAIL CARRIERS

\$1700 to \$3300 Year—
Many U. S. Government Jobs Obtainable

MEN—BOYS, 17 UP SHOULD MAIL COUPON
IMMEDIATELY

Steady Work No Layoffs Paid Vacations



COUPON

FRANKLIN INSTITUTE
Dept. C-178, Rochester, N.Y.

Sirs: Rush to me, WITHOUT CHARGE, FREE 32-page book with list of U. S. Government positions open to men and women, sample coaching, and full particulars telling how to get them.

Name.....

Address.....

FOREST RANGERS

MEN, get Forest Ranger job; \$125-\$200 mo. and home furnished; hunt, fish, trap, etc. For details write Norton Inst., 1542 Temple Court, Denver, Colo.

LAME PEOPLE

OLD WAY

OUR WAY

Ideal Extension Shoe for any person with one short limb. It costs less. No more unsightly cork soles, irons, etc. Worn with ready-made shoes. Write for booklet.

Robert C. Elsinger, 376 Lexington Ave., N.Y.C.

The Story of Chemistry

FLOYD L. DARROW

within your grasp!

—interesting—

Chemistry—Floyd L. Darrow has presented this subject in a concise, simple manner.

Though a great deal of time and work was consumed in research and study, the book is in a readily grasped form, and it will be nothing at all for you to obtain a good understanding of the subject.

530 PAGES—6" x 9"

The book is beautifully and sturdily bound, with a good supply of interesting illustrations.

The price is a low figure at which to gain such a complete education as it affords.

The Story of Chemistry
Special Price
\$3.98

USE COUPON BELOW

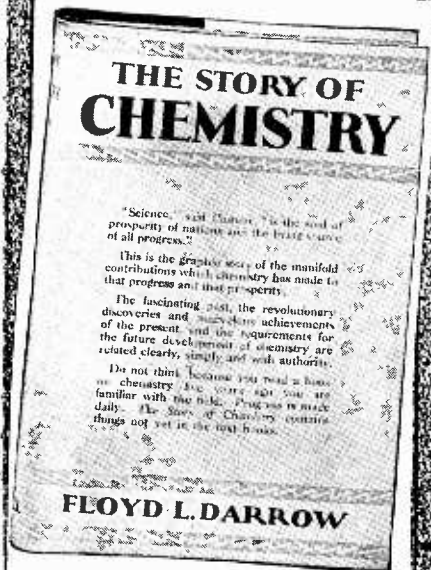

CONSRAD COMPANY, INC.
230 Fifth Avenue, New York City
Gentlemen: I enclose \$3.98—please send me one copy of "The Story of Chemistry."

Name

Address

City, State

EARTHQUAKES PREDICTED HOURS IN ADVANCE

BY JAMES NEVIN MILLER
(Continued from page 11)

instrument called a clinograph, developed by another Japanese scientist, Prof. Ishimoto. With the clinograph a very slight tilting of the earth can be measured even to an accuracy of one part in a million—which is more precise than is necessary in predicting earthquakes of major importance.

Prof. Evans has suggested that a bell might be attached to the new device that would ring automatically and attract the attention of an observer when such a tilting of geological strata occurred. If the observer is satisfied that there is sufficient evidence of an approaching earthquake, a general alarm might be sounded. Prof. Evans explains:

"The interval between the commencement of the warning tilt and the shock is usually brief. But in most cases the interval would be long enough to enable loss of life to be largely, if not entirely prevented."

Prof. Imamura, at a recent international conclave of scientists at Prague, Czechoslovakia, said: "The Earthquake Research Institute of the Tokio Imperial University is attempting to have a network of stations, each equipped with a pair of clinographs and other auxiliary instruments necessary for carrying on the study of earthquake predictions."

Some of the great earth cracks, or "faults," which are the cause of earthquakes, are known simply because they have been responsible already for one or more quakes. There may be many other lines of weakness which remain as yet undiscovered. So no portion of the earth's surface is entirely free from the menace.

There are well-known faults in the vicinity of many of America's largest cities and they may prove far more serious than their activities up to date have indicated. Who knows but what the fault which extends throughout the St. Lawrence valley in New England might one day be responsible for a disastrous quake in Canada, which might affect American cities along the American coast as far south as New York City? In point of fact, New York felt a slight earth tremor, just a few years ago. In addition, the palisades of the Hudson form one side of a geological fault which lies approximately along the line of the river.

An earthquake in the vicinity of New Madrid, Missouri, many years ago, revealed the existence of a fault which, if it became active today, might cause an earthquake in St. Louis, Memphis, or throughout a great stretch of surrounding territory. Nor should the well-known San Andreas fault in the vicinity of San Francisco be forgotten. It extends well into the ocean—an indeterminate but substantial distance.

EARTHQUAKES IN ALASKA

ALASKA compares favorably, or perhaps we should say, unfavorably, with Japan in the matter of frequency of earthquake occurrences. Although many Alaskan earth disturbances are severe, thus far they have done very little damage to life and property because the country is sparsely settled. However, Alaska is growing fast, achieving good roads, increasing its commerce steadily, and with the proposal to build a railway to Alaska from the United States, our most northerly possession is well on the way to a population so substantial as to one day be menaced seriously by earthquakes.

Up to date, science has relied pretty largely on the seismograph in its earthquake calculations. Unquestionably, in conjunction with the clinograph it could be

used to infinitely better advantage. Placed in a concrete block buried in the ground, care is taken to cut off the seismograph thoroughly from all structures, so that the block will be entirely free.

The earthquake's first manifestation is the production of a wave through the earth similar to the action of a sea wave, although of course each earthquake wave is considerably longer and is invisible to the eye. This first wave penetrates the earth's substructure. Shortly thereafter a second wave acts similarly, and finally, a third wave goes around the earth's surface. Occasionally a wave makes a complete circuit of the earth before registering on the instrument.

RECORDS OF THREE STATIONS REQUIRED

THE seismograph records the time ensuing between these various waves. Knowing the intervals and the rate of speed of each wave, scientists can compute the distance of the disturbance. However, it is impossible for one instrument, unaided, to locate the earthquake's position. To locate

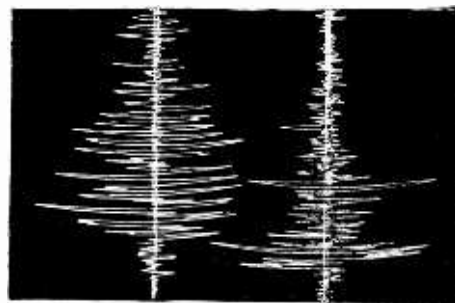

Photographic picture of the earth's movements as recorded by a seismograph during the disastrous Japanese earthquake of September 1, 1923.

an earthquake accurately, the aid of at least three seismograph stations is required. When an earthquake of major importance occurs, America's authoritative earthquake investigation center at the U. S. Coast and Geodetic Survey, Washington, receives telegrams or cables from almost every good-sized station in the world. Whereupon the government experts take an ordinary globe of the world and draw the arc of a circle within the radius extending from each station as a focal point. Where the lines of these arcs cross is the location of the earthquake. This reckoning takes but a short time, but is not precisely accurate—perhaps within two or three degrees of the exact longitude and latitude. The reason is that the small globe itself is not precise enough for minute computation. In fact, were you to stick a pin into the average globe used by seismologists, the resulting pinhole would represent an area on the earth's surface of about six to eight miles in diameter.

The rough position having been determined, the experts study the various seismographic reports that stream in from all parts of the world. Within 24 hours they are prepared to give a far more accurate picture of the earthquake's location—no matter where on the earth's surface the tremor took place. The final computation is a highly technical mathematical process. Taking into consideration the convexity of the earth, an extensive geodetic reckoning measures the distance.

As for the exact mechanical operation of the seismograph—in the Galitzin, the most

sensitive instrument we have today, the magnetic principle of photographic recording is involved. That is to say, when the earth trembles, a tiny finger of light within the device quivers. The finger is directed through a slot onto a moving photographic film known as a seismogram. Thus when the film is developed, the path of the quivering finger reveals itself as an irregular black line.

Seismographs are spread at strategic points throughout the country, as indeed they are in all the important cities of the world. So far as the clinograph is concerned, it now seems important to equip every city in a "fault district" with the instrument so that the population might be warned of an impending earthquake in time to prevent such great catastrophes as the Tokio quake of September 1, 1923, in which more than a hundred thousand lives were lost and a like number of buildings destroyed.

THE CLINOGRAPH

The clinograph might be operated in connection with the weather bureaus of large cities. Many sizable towns today have special committees to deal with emergencies and major disasters. Boston is highly organized in this respect and the people are being trained and mobilized to act efficiently in any disaster of consequence. New York City has a similar organization, as has also Los Angeles.

Did you ever stop to think what would happen if the New York City water supply suddenly were cut off entirely because of an earthquake? In addition to the fire hazard, there is no question but that a large portion of the great city's millions would die of thirst. The nearest adequate water supply is some 40 miles away and a pilgrimage of that length in time to avert catastrophe would be physically impossible for seven million people.

WHAT TO DO IN AN EARTHQUAKE

PICTURE, on the other hand, the situation in the case of the city of the future if a major earthquake were to occur. The committee on public safety would educate the populace through agencies like the school and the press not to fear earthquakes but to prepare for them. The people will have been told that when an earthquake warning reaches them—via the radio, for instance—they are to turn off all electricity and gas jets, to put out all furnace fires, to turn off the water supply and to get out in the middle of the street or in a public park. The police and fire departments will be mobilized to act quickly and efficiently. Traffic will be stopped and people will be warned not to traverse the sidewalks because of the danger from possible falling cornices or bits of masonry. They will be told to get into an automobile, because, strangely enough, that is the safest place in the world to be during an earthquake, since rubber tires and springs take up shock to an amazing degree.

With all life-preserving connections turned off and no open fires to worry about, the fire hazard will be greatly reduced and the city should emerge from the earthquake with no more damage done to it, perhaps, than the shaking down of a few poorly constructed buildings. Concerning these, mention already has been made to the effect that certain authorities believe the pyramids of Egypt were planned to withstand the ravages of earth tremors. For a like reason, the Mayas of Central America constructed their temples in pyramid shape and with exceptionally thick walls.

These ancients were either fortunate or wise, for of all man-made buildings the pyramid form is the best adapted to resist earthquakes. Its low center of gravity makes it practically impossible to tip over or shake down. Fundamentally, the shape provides



- If You Own a Car - You Can Obtain 30 Days' Demonstration

FREE!

No Deposit No C.O.D.

NEW Spark Plug Fires Thru Oil

GREATER Power—Pickup—Speed

The breath-taking courage of the Lydon Company in sending out millions of Lynamite Plugs on 30 Days' Free Demonstration is the biggest sensation of the year. Think of it! No deposit. No C.O.D. 3,000,000 already sold and paid for after 30 Days' Free Demonstration.

Saves \$2 on Every \$10 Spent for Gas

The Lynamite method fires a 20% leaner mixture. Lynamite Plugs give any motor more speed, more power, quicker pickup. They produce a strong hot impact spark instead of the ordinary weak red spark. Ordinary spark plugs become dull and lifeless after a time. Lynamite plugs do not become dull. They last for years. They are so powerful **THEY FIRE THROUGH OIL**—prevent carbon. Let the Filling Stations pay for your new set of plugs. F. E. Erickson, County Treasurer, Tarkio, Mo., says: "I have used the same set of Lynamite Spark Plugs over two years and never had a miss. They have saved their cost because I quit buying spark plugs. They save gasoline and my car has more power than it ever had before." A. I. Etmer of Tyrone, Pa., writes: "I see right away I get more power than before. You surely can tell the difference the moment you put them in." Three million Lynamite Plugs in satisfactory use prove their worth!

Send Coupon for Free Demonstration Set

Simply fill out coupon at once for Free Demonstration set of Lynamite Plugs. Use thirty days entirely at our risk. See what wonderful results you get! Put them to every possible test and **See For Yourself**. Then either send \$1.00 per plug, or simply return them to us. Do not waste one minute—fill in coupon and mail to us Today!

LYDON MFG. CO. DEPT. 863-G
180 N. Wabash Ave., CHICAGO, ILL.

We Pay Our SALESMEN up to \$750.00 per month to give Car Owners a Full Set of LYNA-MITE Spark Plugs on 30 Days' Free Demonstration.

Do you wonder that our Salesmen make volume sales? We believe our new selling plan has no equal in the direct selling field!

Opportunities like this are "few and far between." If you are the man for whom we are looking, you will recognize this immediately. You will make up your mind to find out about our proposition that offers so many out-of-the-ordinary advantages. Then, because you know that quick action means more money, you will fill in the coupon and get it off without delay.

LYDON MFG. CO., Dept. 863-G, 180 N. Wabash Ave., Chicago, Ill.
Kindly rush full set of Lynamite Spark Plugs for my own car. I will use the plugs 30 days and then either send you \$1.00 per plug or return them. The demonstration is FREE. No deposit—No C. O. D.
Send details of your new big-money agency proposition.

Name.....
Address.....
City.....State.....
Make of my Car.....
Year.....No. of Cylinders.....

MILLION DOLLAR MOTORS

Could Not Excel These

Get our New and Enlarged Catalog No. 28 for Handymen, Mechanics, Model Makers and Schools. Bearing, Belting, Books, Brass, Electrical Supplies, Engines, Fibre, Gears, Pulleys and General Supplies.

General Catalog \$25 Refunded First \$2.00 Order

AMALGAMATED SALES AND SERVICE CORPORATION
327 K. South La Salle St., Chicago, Illinois

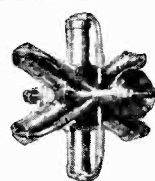

H-B PAINT SPRAY
DOES THE WORK OF FIVE MEN

Paint Spraying Brings Quick, Easy Profits—H-B does work of 5 brush painters. Paints autos, furniture, houses, at lowest prices, with big profits for you. Pays for itself—only \$20 monthly. Easy payment terms brings it. Practically no investment. 30 days' trial. Write for valuable bulletins. **Hobart Brothers Co., Box 5581, Troy, Ohio.**

EASY TERMS. 30 DAYS TRIAL. QUICKLY PAYS FOR ITSELF.

DRAW COMICS!
10 easy, interesting lessons. Full of fascinating instruction. **COMPLETE COURSE \$1**
Sent to you postpaid for WRITE FOR FREE CIRCULAR. **CARLSON CARTOON SERVICE** Dept. T 116 West 39 St. New York

Insure your copy reaching you each month. Subscribe to Science and Invention—\$2.50 a year. Experimenter Publishing Co., 230 Fifth Avenue, N. Y. C.



In One Hour You Can Play a TUNE!

CONN INSTRUMENTS
Care world-famous for easy playing. On the Conn saxophone many who have never played a note have mastered the scale and a simple tune within one hour!

Simplified key system—improved valve and slide actions—perfect scale—remarkably easy blowing in all registers—beautiful tone quality mark all Conn instruments. Get a Conn and have fun from the very start.

Organize a band! Conn will help. Our experienced organizers handle all details, including easy finance plan. A complete band, ready for concert, in 90 days from the first rehearsal!

Send the Coupon Now for the details of band plan, and **FREE TRIAL OFFER** on any Conn instrument.



CONN

BAND INSTRUMENTS
WORLD'S LARGEST MANUFACTURERS

MAIL THIS COUPON

C. G. Conn, Ltd., 556 Conn Bldg., Elkhart, Ind.
Please send complete details of your band plan []. Also send literature and details of free trial offer on

..... (Instrument)
Name.....
St. or R. F. D.
City.....
State, County

the same type of diagonal bracing as is used in ship-building, where the necessary principle is to insure the ship's holding up under the terrific buffeting of the waves.

AMERICAN BUILDINGS QUAKEPROOF

CURIOSLY enough, in America today, our architects are developing a type of structure not unlike those of the ancients. Our new pyramid-like buildings represent the very last word in safeguarding against earth disturbances, even though the form originally was developed as an aid in solving our city traffic problems and to provide more light and air space in our heavily congested streets.

Then again, the art of earthquake-proof construction has seriously engaged the attention of engineers and architects for many years. Indeed, the construction of such buildings will be one of the major topics for discussion by the engineering section of the Pan-Pacific Commercial Conference in Los Angeles in 1928. So it is reasonable to believe that the time is not far distant

when our buildings in great part will be constructed along lines of well nigh perfect security and safety.

It has been suggested, in view of our growing airplane commerce, that it might be desirable to establish landing fields on the tops of big buildings. This general procedure, of course, would seriously hamper efforts towards widespread building of pyramidal earthquake-proof structures. However, the more sensible plan, perhaps, and one for which our grandchildren would bless us, would be to continue the pyramid type of building on a scale as large as possible, and to establish landing fields on the ground over regions where geologists have determined that cracks or faults exist that might slip and do serious damage.

In any case, with predictions of earthquakes seemingly an avowed reality, according to Professors Imamura and Evans, science now holds out to mankind surcease from fear of the one major catastrophe which has defied the best of his "prediction instruments."

CONTROLLING HOUSEHOLD PESTS

By DR. ERNEST BADE

(Continued from page 17)

attack colors and fade them. Pouring kerosene in casters on which the bed stands is useless. The bed bugs simply crawl to the ceiling and drop on the bed and then hide in the bed. It is much better to brush the cracks of the bed and furniture and other suspected hiding places with a mixture consisting of one ounce of corrosive sublimate, one pint of alcohol and one quarter pint of spirits of turpentine. If desired, a sulphur candle may be lit to fumigate the room. Or a little sulphur may be placed in a pan set on a brick in a dish of water and a little denatured alcohol poured over the sulphur, about a small cup full is sufficient. Lighting the alcohol will ignite the sulphur. About two pounds of sulphur for 1,000 cubic feet of space is required. The room should be sealed for eight or ten hours at least. The best way to close cracks around windows or doors is to take old newspapers, soak in

water and press around the cracks. The wet paper will stick tightly for many hours. Here it must also be mentioned that not only are certain metals like silver tarnished, but certain colors are bleached. This must be taken into consideration. Perfectly dry material will not be bleached.

ANTS

OF ants little need be said except that several species become annoying in the home. A syrup made by dissolving sugar in water and adding borax attracts and kills many. Kerosene is also effective when sprayed into their nesting holes or opening through which they enter. This is especially good for ants on the lawn. In the latter case a wad of cotton saturated with kerosene effectively keeps them out. Tartar emetic, one part, mixed with twenty parts of honey is another excellent poison for ants.

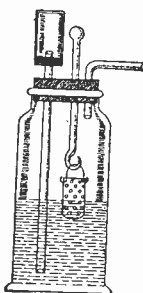

The rat trap illustrated here consists of three hinged parts. AA fall down and catch the rat when the hinged part B holding the bait is disturbed, which releases the holder C, connected by a string to point D, where the hinged ends AA are held in position. When the bait is taken the balance is disturbed, the small block C, shown enlarged, falls out, releasing the string at D and the trap is closed.

The mechanism at the left shows the arrangement for assembling the device to produce gas in quantities. This gas varies in accordance with the chemicals used, and some of the gases produced at constant pressure by such an arrangement can be used for insect extermination.

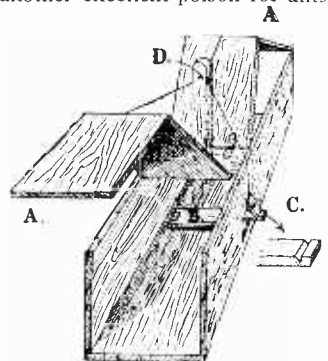

RULES FOR MODEL CONTEST

(Continued from page 40)

1. A handsome trophy cup engraved with your name, will be awarded as the prize for the best model submitted during the month. The decision of the judges will be final and will be based on: A—novelty of construction; B—workmanship; C—operating efficiency of the model as related to the efficiency of the device which the model simulates, and D—the care exercised in design and in submitting to us sketches and other details covering the model.
2. Models of all kinds may be entered. They may be working models or not, according to the subject that is being handled.
3. Models may be made of any available material, preferably something that is cheap and easily obtainable.
4. Models must be submitted in all cases.

Good photographs are also highly desirable and where the maker does not desire the model to be taken apart, legible drawings with all dimensions covering parts that are not accessible must be submitted.

5. Models should be securely crated and protected against drainage in shipment and sent to us by parcel post, express or freight prepaid. Models will be returned when requested.

6. Models for entry in any particular contest must reach this office on or before the 25th of the third month preceding date of publication. For instance, models for the July contest must reach us on or before the 25th of April.

7. Address all entries to Editor Model Department, c/o Science and Invention Magazine, 230 Fifth Avenue, New York City.

Science Frauds Exposed by Uncle Sam

By K. M. PAINTER
(Continued from page 27)

reau of Chemistry analyzed all fourteen of these compounds, and found each to contain the same ingredients—25 per cent alcohol; 25 per cent water; 50 per cent olive oil; and one to four drops of flavoring, which changed the color and taste, constituting the only variation.

Praying on the religiously inclined, John F. and Kate A. Braun sold "blessed handkerchiefs" under the names of Reverend D. R. Schiller and Hulda DeMoth. Kate Braun, alias Hulda DeMoth, blessed the handkerchiefs, which were endorsed by her husband, and mailed to sufferers at a cost of \$5 to \$15. These squares of unhemmed muslin were to be placed over the affected parts, and the individual was instructed to "rest in a reclining posture." Details as to time of treatment were vague—eventually the pair were sentenced to a prison term of three years for their chicanery.

It is a well-known fact that female lima beans are preferable, and this little instrument is especially valuable to the farmer, who may establish the sex of beans before planting," read an advertisement of "Sex Indicators." Probably the name of this device appealed to the public, for the instrument was too absurd to be accepted by even the most generously credulous person. A small wooden ball or arrowhead was attached to a string and the accompanying directions said: "Hold this instrument over any object—if the indicator (ball or arrowhead) describes a circle, the male sex is indicated. If the indicator moves in a vertical direction, the object is female." Several manufacturers put out "Sex Indicators"—several fraud orders have been issued by the Post Office Department.

A solution of ninety per cent hydrant water, 5 per cent salt; and 5 per cent sugar proved highly profitable when advertised as Professor Samuel's Eye Water. All diseases of man were "cured" (according to testimonials) when 2 drops of this liquid were put in each eye four times a day. Depending upon his buyers, Professor Samuel charged \$5 to \$25 for two ounces of his "Eye Water," which cost him about 5 cents a gallon. His product was so generally accepted that he amassed over \$1,000,000 during the time he was in business. After having been released from prison, where he served his sentence for fraud, Professor Samuel has retired from activity and is living comfortably on his profits.

IMPORTANT

TO NEWSSTAND READERS

IN order to eliminate all waste and unsold copies it has become necessary to supply newsstand dealers only with the actual number of copies for which they have orders. This makes it advisable to place an order with your newsdealer, asking him to reserve a copy for you every month. Otherwise he will not be able to supply your copy. For your convenience, we are appending herewith a blank which we ask you to be good enough to fill in and hand to your newsdealer. He will then be in a position to supply copies to you regularly every month. If you are interested in reserving your copy every month, do not fail to sign this blank. It costs you nothing to do so.

To Newsdealer

Address

Please reserve for me copies of SCIENCE AND INVENTION every month until I notify you otherwise, and greatly oblige,

Name

Address

FREE

This Genuine
Ivory
Pocket
Rule



Get out your pencil and copy the Jack right now

← You get this rule for copying this Jack →

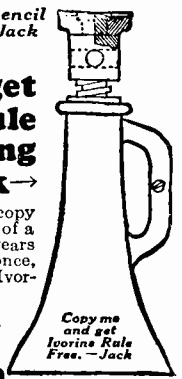

Copy me and get Ivory Rule Free. — Jack

Can you copy it? Try it. How you copy it may give me some idea of what kind of a draftsman you would be. If you are 16 years old or older and will mail me your sketch at once, I will send you, free, and prepaid, a draftsman's Ivory Pocket rule, shown here. This will go to you entirely with my compliments. In addition I will send you my book on Successful Draftsmanship. Don't wait. Copy the sketch now and mail it to me.

Draftsmen Needed In

- Auto Work** The automobile industry is one of the greatest in America. Thousands of draftsmen needed. I'll train you for the work.
- Electricity** Electricity is the coming motive force of the world. Draftsmen are needed in every department of this fascinating work. I'll train you at home. Get a job here.
- Aviation** Aviation is just in its infancy. It is bound to expand to enormous proportions. Draftsmen are essential to it. I'll train you quick at home for drafting position.
- Motor Bus Work** Motor bus building and motor bus transportation have become leading world industries. Hundreds of draftsmen engaged in this work. I'll show you the way.
- Building Work** There will always be building. No structure can be erected without plans drawn by draftsmen. I'll make you an architectural draftsman at home.

Get My Free Pay-Raising Plan

Write to me. I will send you this new book. Not a catalog. My Pay-Raising Plan and Money-Making Advice. I can prove that John Savadge, trained by me, makes \$300 a month. Earl J. Dupree, trained by me, refused \$600 a month because he makes more in his own business. A. H. Bernier, trained by me, earns \$7000 to \$9000 a year. Arthur Dewalt, trained by me, makes more than \$400 a month. D. C. Stroop, trained by me, makes \$475 a month. L. V. Broughten, trained by me, makes \$300 a month.

I can give you many more names of Dobe trained draftsmen who are making big salaries. They wrote to me just as I am asking you to write. They asked for my Free Book. They saw that opportunities in all of the great industries were tremendous for draftsmen. Through drafting you can get into almost any industry you want.

Money Back If Not Satisfied
What could be fairer than that? I don't ask you to take any chances. I train you under a positive Money Back Agreement. If my training does not satisfy you after you have finished you get every penny back.

Earn While You Learn
You can start earning extra money a few weeks after beginning my training. I give you special work and tell you how to make money.

Age or Lack of Education? No Drawback
You do not need previous experience. You do not need to be a high school graduate. My practical home study course gives you just the kind of training you need to become successful. Your spare time is all that is necessary.



"I will train you at home."
Engineer Dobe

If You Earn Less Than \$70 a Week Write Me Today!

ACT NOW Before You Put This Magazine Down. Let me send you my books "Successful Draftsmanship" and "My Pay-Raising Plan." Remember Draftsmen are needed everywhere. That's the kind of profession to get into. Get started now. Get into a better position, paying a good straight salary the year around.

Engineer Dobe 1951 Lawrence Avenue Div. 14-25 Chicago, Ill.

Employment Service

After training you I help you to get a job without charging you a cent for this service. Employers of draftsmen come to me for men because they know that men I train make good.

I Train You at Home, New, Quick, Sure Way

My practical working method makes every step in learning drafting, as clear as a moving picture. That's why I train you so fast to be a draftsman.

You GET THESE FINE QUALITY, GENUINE, IMPORTED DRAFTSMAN'S TOOLS, just as soon as you become my student. No finer tools can be made for practical drafting work.



You get these tools as my student

FREE RULE COUPON!

ENGINEER DOBE
1951 Lawrence Ave., Div. 14-25 Chicago

Here's the sketch. Send me free rule; also send me free of all cost, books "Successful Draftsmanship" and "My Pay-Raising Plan"—how to earn money while learning and proof of big money paying positions.

Name Age

Address

Post Office State

The New POPULAR CHEMISTRY

A MONTHLY CHEMICAL MAGAZINE

Subscribe to The New POPULAR CHEMISTRY! Popular feature articles of interest to every member of the chemist's family. The latest chemical news told in a popular manner. Formulas for the large and small manufacturer. New experiments for the amateur who likes to perform "his own." Articles bearing upon the recent advancements in medicine, vitamins, etc., new uses for X-rays, ultraviolet light, radium, etc., every month.

Three trial copies (back issues), 30 cents. To immediate subscribers for two years (no subscription accepted for less than two years) we will give a free book catalog and a solubility chart showing the solubility of most of the inorganic chemicals in various solvents. Send two dollars for a two-year subscription and the free articles offered above, to

POPULAR CHEMISTRY COMPANY

Dept. YB

Swedesboro, N. J.

DEAFNESS IS MISERY

Multitudes of persons with defective hearing and Head Noises enjoy conversation, go to Theatre and Church because they use Leonard's Invisibly Antiseptic Ear Drops. Tiny Megaphones fitting in the Ear entirely out of sight. No wires, batteries or head piece. They are Unseen Comforts and inexpensive. Write for booklet and sworn statement of the inventor who was himself deaf.

A. O. LEONARD, Inc., Suite 785 70 5th Ave., N. Y.

LAW STUDY AT HOME

Become a lawyer. Legally trained men win high positions and big success in business and public life. Be independent. Greater opportunities now than ever before. Big corporations are headed by men with legal training. Earn \$5,000 to \$10,000 Annually. We guide you step by step. You can train at home during spare time. Degree of LL.B. conferred. LaSalle students found among practicing attorneys of every state. We furnish all text material, including fourteen-volume Law Library. Low cost, easy terms. Get our valuable 108-page "Law Guide" and "Evidence" books FREE. Send for them NOW. LaSalle Extension University, Dept. 5384-L Chicago. The World's Largest Business Training Institution

Insure your copy reaching you each month. Subscribe to Science and Invention—\$2.50 a year. Experimenter Publishing Co., 230 Fifth Avenue, N. Y. C.

NEW LOW PRICE

New Elkhart E Flat Alto

Just what you've been waiting for. This new, first quality Eb Alto Saxophone in beautiful polished brass, engraved, for

Only \$80 Easy Terms

5% Discount for Cash or C. O. D.

Standard key system. Easy fingering. Accurate scale. Marvelous tone and volume. Used by many professionals. New low price brings this most wonderful instrument in easy reach. Learn quickly. Have fun. Make good money, play for dances and shows.

Other Elkhart Models, C and Bb Sopranos, C Melody, Tenor, Baritone or Bass at equally low prices. Also finished in silver or gold at small extra cost. Illustrated Folder-Catalog, sent free on request, shows complete line and prices.

Give this wonderful New Saxophone a week's trial at home. See how easily it plays, and how beautifully. Send full cash with order or 1/4 deposit and we will ship balance C. O. D. Satisfaction guaranteed or money promptly refunded. Easy terms arranged with responsible purchasers. Don't cheat your ambition any longer. You will never have a better opportunity. Order TODAY.

ELKHART BAND INSTRUMENT CO.
10 Jackson Street, Elkhart, Indiana

BUILD YOUR OWN GRANDFATHER'S CLOCK



We furnish blue prints, finishing material and instructions. Buy the works, dial, and pendulum from us at surprisingly low prices.

Make fine profits, extra money building artistic clocks for your friends.

PLAIN WORKS AS LOW AS \$5.00. OTHERS WITH CHIMES AT ALL PRICES. ASK FOR OUR ATTRACTIVE FREE OFFER.

American Chime Clock Co
1679 Ruffner Street
Philadelphia, Pa.

Life's Secrets!

Amazing new book, "Safe Counsel," just out, tells you the things you want to know straight from the shoulder. Gives advice to newly married. Explains anatomy of reproductive organs, laws of Sex Life, mistakes to avoid, diseases, pregnancy, etc. Contains 9 startling sections: 1—Science of Eugenics, 2—Love, 3—Marriage, 4—Childbirth, 5—Family Life, 6—Sexual Science, 7—Diseases and Disorders, 8—Health and Hygiene, 9—Story of Life. In all, 104 chapters, 77 illustrations, 612 pages. Examine at our risk. Mailed in a plain wrapper.

Send No Money

Write for your copy today. Don't send a cent. Pay postman only \$1.98, plus postage, on arrival. Money refunded if not satisfactory.

FRANKLIN PUBLISHING CO.
Dept. 6190, 800 N. Clark St., Chicago, Ill.

Foreign Work

Persons interested in oil, fruit, mining, rubber, railway work in romantic South America, write at once for information.

SOUTH AMERICAN SERVICE BUREAU
14600 Alma Avenue Detroit, Mich.

LEARN CARTOONING At Home—In Your Spare Time

The famous Picture Chart Method of teaching original drawing has opened the door of success for hundreds of beginners. Whether you think you have talent or not, send for sample chart to test your ability, and examples of the work of students earning from \$50 to \$300 per week. Please state your age.

THE LANDON SCHOOL
1460 National Bldg., Cleveland, O.



Get the Big New **QUARTERLY** Edition of **AMAZING STORIES**

150 pages fully illustrated
Large Magazine Size

At All Newsdealers or Direct

EXPERIMENTER PUB. CO.
230-5th Ave. New York, N. Y.

A Home-Made Reflecting Telescope
(Continued from page 46)

ground so that the hole points to the pole of the heavens. If you do not know how to locate this point set the post up so that you can see the Pole Star (Polaris) through the hole; this will not be accurate, as Polaris is a little over a degree from the Pole, but it will be accurate enough for your purpose unless the axes have been carefully arranged at right angles to each other, when greater refinement is justifiable. The shafting now becomes the polar axis of the telescope when set into the bearing, the other axis becoming the declination axis. The meaning of these terms will become clear after you have read the introductory chapters of one of the elementary text books on astronomy that will be recommended later.

The next step is to adjust the mirrors, and this had better be done in the daylight until you become familiar with the process. Fasten the mirrors securely to the tube and, with the eyepiece removed, turn the cell holding the flat until it faces you as you look down the draw-tube, adjusting it with the screws until it appears to be concentric with the tube. Turn it until you see the image of the principal mirror, then further adjust it until this image is central. You may, or may not, see an image of the flat and spider, in the image of the mirror; adjust the tilt of the principal mirror, by the aid of the three adjusting screws, until this image is in turn central. The draw-tube, flat, image of mirror and image of flat should now all be concentric, and an image of the eye should be seen in the image of the flat when you hold it on the axis of the draw-tube about a foot away from the tube.

You are now ready to try out your telescope when night falls. Point it at some star and insert the lowest power eyepiece. The star will probably appear as a disk of light with a hole in it. Slide the eyepiece in or out until the star appears as a brilliant point of light; it will then be in focus. (Don't expect to see the stars as disks, for the most powerful telescopes in existence will not show them thus, they are much too far away. Even the nearest, if magnified ten thousand times, would still appear as though it were two thousand seven hundred million miles away!) If you do see a disk, turn to a star, for the object you have seen is not a star, but a planet, unless there is something radically wrong with your mirror. If the star appears to have "wings" you have either not adjusted the mirrors properly or else the flat is poor. Try to adjust the mirrors until the wings disappear, and if that is not successful try one of the other flats. The flats may now be tested by means of the knife-edge at the focus, with the telescope turned upon a bright star. If your mirror is O.K., any shadow patterns that appear will be due to irregularities in the flat.

Don't expect too much of your telescope at first; remember that you will have to learn how to use it before you can get the most out of it. The eye must also be trained. Don't look at the moon when it is full and expect to see the mountain ranges and craters; look at it when you can view the region about the boundary between the Lunar day and night, called the "terminator," to see them at their best.

If you wish to use your telescope to the greatest advantage learn a little about the oldest of sciences, Astronomy. Let me recommend "Moulton's Introduction to Astronomy," or better still, "Astronomy," by Russel, Dugan and Stewart; the finest book of its kind, which has but recently been published.



New
issue just out

A new issue of *Radio News* is now on the stands for you. To its old readers *Radio News* needs no introduction. To those who are not acquainted with it, it might be well to say a few words regarding its editorial content.

Since the earliest days of Radio—the days of the "attic radio fan"—*Radio News* has been the acknowledged leader in the "fan" paper field. The pages of *Radio News*, now as ever, reflect every new development, every trend of the Industry. For technical Radio men, *Radio News* has ever been a source of real enjoyment. They have learned to place their entire confidence in it.

One interested in Radio can find honest, authentic and unbiased opinions on development and circuits in each monthly issue of *Radio News*.

A NEW ISSUE IS OUT NOW
—DO NOT MISS IT!
Over 120 pages—fully illustrated

At all newsstands—just ask your dealer

EXPERIMENTER PUBLISHING CO.
230 Fifth Ave., New York, N. Y.



Making a "Flivver" Cone Unit

By R. EDIS FAIRBAIRN
(Continued from page 55)

For a drive rod to connect a cone or roll with the unit, use another piece of 6/32 threaded brass rod. This can be affixed to the armature with a couple of nuts, or it may be soldered.

You can hear this unit go into action immediately upon connecting it with your set, and without any paper cone. That connection is right which gives the louder result. A little patience in getting the best adjustment will repay the effort. A free-edge cone can easily be supported by this unit. If the edge of the cone is fastened to something, then the armature spring may be much more flexible than if the cone is perfectly free. You may have to file down the thickness of the armature if it is too stiff. Resonance will be much improved if the unit is mounted in a case of thin wood, but be sure there are no loose joints, or you will get a false vibration.

Springtime Garden Suggestions

(Continued from page 22)

purpose and the effect is improved if a certain amount of foliage is added. Now invert the glass shade and fill this to the brim with water. Let the bouquet down into the water until the dish is resting on the shade. The whole thing may now be turned up the right way for the pressure of the air will keep the water from running out of the shade. The bouquet will appear to be set in a block of ice and a very fine table ornament is secured in this way. The flowers will remain fresh for a long while and when in the end they do fade, it is easy to start the water bouquet again with a new lot of blossoms according to S. L. Bastin.

Making a Portable Arc Lamp

By RAYMOND B. WAILES
(Continued from page 43)

the resistance of the whole circuit, and thus allows more current (amperes) to pass, and if a certain point is reached, either the fuses will blow or the resistance wire will melt. Figure 6 shows the method of striking the arc. No rubber glove is needed. You will not be shocked.

The carbons taper toward one another. The arc will burn at the spot where the carbons are the nearest each other. Consequently, as the carbons burn away, the arc approaches the interior of the shade. It will be found however, that a goodly number of hours service can be gotten from the lamp before the arc recedes or the carbons burn up to the plaster.

For use in photography as a source of artificial light, it will repay the operator to soak the carbons in ferric chloride or uranium nitrate solution and then dry them. These substances cause the arc to emit more light falling in the ultra-violet region of the spectrum. It is this portion of the spectrum which has the highest actinic properties. It is well known that an arc lamp gives harsh shadows in photography. But this type of lamp will not cause harshness if the precaution is taken to bathe the subject all over with the light, by swinging it or playing it around about the subject. The arc is extinguished by blowing it out as one does a candle flame.



FREE To Men Past 40

A WELL-KNOWN scientist's new book about old age reveals facts, which, to many men, will be amazing. Did you know that two-thirds of all men past middle age are said to have a certain seldom mentioned disorder? Do you know the frequent cause of this decline in vitality?

Common Old-Age Symptoms

Medical men know this condition as hypertrophy of the prostate gland. Science now reveals that this swollen gland—painless in itself—not only often cheats men of vitality, but also bears on the bladder and is often directly responsible for sciatica, backache, pains in the legs and feet, frequent nightly risings, and dizziness denoting high blood pressure. When allowed to run on it is frequently the cause of the dreaded disease cystitis, a very severe bladder inflammation.

65% Have This Gland Disorder

Prostate trouble is now reached immediately by a new kind of home treatment—a new, safe hygiene that goes directly to the gland itself, without drugs, medicine, massage, lessons, diet or the application of electricity. It is absolutely safe. 40,000 men have used it to restore the prostate gland to normal functioning. The principle involved in this treatment is recommended by practically all the physicians in America. Amazing recoveries are often made in six days. Another grateful effect

is usually the immediate disappearance of chronic constipation. Usually the entire body is toned up as much of your youthful vigor is restored. These results are guaranteed. Either you feel ten years younger in six days or the treatment costs nothing.

Send for FREE Book

If you have this gland trouble or if you have any of the symptoms mentioned above, you should not lose a day in writing for the scientist's free book, "Why Many Men Are Old At 40." It will enable you to ask yourself certain frank questions that reveal your true condition. Every man past 40 should make this test, as insidious prostate disorder often leads to surgery. This book is absolutely free, but mail coupon immediately, as the edition is limited. Address

The ELECTRO THERMAL COMPANY
4505 Morris Ave., Steubenville, Ohio

If you live West of the Rockies, mail your inquiry to
The Electro Thermal Co.
303 Van Nuys Building, Dept. 45-E
LOS ANGELES, CALIF.

THE ELECTRO THERMAL COMPANY
4505 Morris Ave., Steubenville, Ohio.

Please send me Free, and without obligation, a copy of your booklet "Why Many Men Are Old At 40." Mail in plain wrapper.

Name.....
Address.....
City.....State.....

CHEMISTRY—Learn at home

The Chemical Industry now ranks fourth among the industries of the United States and it offers a splendid opportunity for ambitious men. One of the best ways to prepare for a good position in this fascinating field is through the home-study courses in Chemistry offered by the International School of Chemistry.

These courses are complete and practical because they were prepared by some of the best-known chemists in this country, including ALLEN ROEBERS, B.S., M.S., Ph.D.—Head of Department of Industrial Chemistry, Pratt Institute; L. M. TOLMAN, Ph.D.—Formerly Chief Chemist, Wilson & Co. Now Vice-president, United Chemical and Organic Products Co.; BRADLEY STOCCHTON, B.S.—Head of the Department of Metallurgy, Lehigh University, and OWEN L. SHINN, Ph.D.—Professor of Applied Chemistry, University of Pennsylvania.

INTERNATIONAL SCHOOL OF CHEMISTRY
Division of the International Correspondence Schools
Dept. 6232-E, Scranton, Penna.

Without cost or obligation, please send me full details of your home-study course in CHEMISTRY

Name.....
Address.....

150 TO 300 MONTHLY FROM ONE DAY BATTERY CHARGING

Start a Big Profit-Making Business of your own—On Day Battery Charging. Requires small space and practically no investment. Anyone can successfully operate. Charges batteries in 1/4 the usual time at 1/4 the cost. Every car owner a customer. The HJB One Day Battery Charger will pay for itself on easy monthly payment plan with practically no expense to you—and bring you a handsome profit besides. Write for full particulars in Bulletin M NOW. HOBART BROS. BOX 558 TROY, OHIO

30 DAYS FREE TRIAL ON ABSOLUTE MONEY BACK GUARANTEE!

New Improved SPORS Fountain Pen, 60 Days' Trial. Money back if not pleased

Agents' Sample 65c Sells for \$1.25. Writes like a \$7 Pen
LADIES' OR MEN'S STYLE
Comes in Green Molot or Blue Marble
GUARANTEED 2 YEARS Improved Point
Made 533 in 2 Days
*Sold 44 pens Monday and Tuesday. Pens sell themselves. Rush 2 gross.—Earnest Markle, Pa.
Write for Free Wholesale Catalog.
F. SPORS & CO., 328 Agate St., Lesueur Center, Minn.

SQUAB BOOK FREE

Breed squabs and make money. Sold by millions. Write at once for free 40-page book beautifully printed in colors telling how to do it. You will be surprised. PLYMOUTH ROCK SQUAB CO. 506 H St., Melrose Highlands, Mass.

MEN TO LEARN MOTION PICTURE OPERATING
A big money profession—\$2,000 to \$4,000
MOVIE OPERATORS SCHOOL
61 SPROAT ST. DETROIT, MICHIGAN

1000 NEEDED INVENTIONS

1000 NEEDED INVENTIONS



HERE is a remarkable book for inventors. Nothing like it ever published before. Saves time. Saves work. Saves money. Tells you what inventions are needed now, and what is offered for them. Lists and describes the ONE THOUSAND NEEDED INVENTIONS in these fields: General Problems; Automotive; Mechanical; Electrical; Chemical; Radio; Aviation; Marine. Extra chapter on the TEN MOST NEEDED INVENTIONS.

fields: General Problems; Automotive; Mechanical; Electrical; Chemical; Radio; Aviation; Marine. Extra chapter on the TEN MOST NEEDED INVENTIONS.

FORTUNES FOR IDEAS

This wonderful book may give you one idea that will win you a fortune. If you want to invent—KNOW WHAT INVENTIONS WILL PAY YOU MOST. This book tells you. Compiled at great expense, and edited by Raymond Francis Yates, formerly Managing Editor of a leading scientific magazine. Over 100 pages durably bound.

SEND NO MONEY merely your name and address plainly written and your copy of "1000 Needed Inventions" will be sent you immediately. Pay the postman only \$1.25 plus postage on arrival. Money back after 10 days' examination if desired. Limited edition. Write now. (Outside U. S. \$1.45 cash with order)

BUREAU OF INVENTIVE SCIENCE
DEPT. 75 ROCHESTER, N. Y.



Washington Monument in the Nation's Capital

PATENTS DON'T LOSE YOUR RIGHTS TO PATENT PROTECTION

Before disclosing your invention to anyone send for blank form "EVIDENCE OF CONCEPTION" to be signed and witnessed. As registered patent attorneys we represent hundreds of inventors all over the United States and Canada in the advancement of inventions. The form "Evidence of Conception," sample, instructions relating to obtaining of patents and schedule of fees sent upon request.

LANCASTER & ALLWINE
255 Ouray Building
WASHINGTON, D. C.
Originators of forms "Evidence of Conception."

NEW YEAR - NEW IDEA PATENT YOUR IDEAS
Call or send me a sketch of your invention. Phone LONgacre 3088
FREE Inventors Recording Blank Confidential Advice
U. S. and Foreign Patents secured by **Z. H. POLACHEK** Reg. Patent Attorney Consult. Engineer
1234 Broadway, New York

PATENTS As one of the oldest patent firms in America we give inventors at lowest consistent charge, a service noted for results, evidenced by many well-known Patents of extraordinary value **Book, Patent-Sense, free.**
Lacey & Lacey, 644 F St., Washington, D. C. Estab. 1869

The Metal Emperor By A. MERRITT (Continued from page 33)

and like a dozen little thinking hammers, the pyramid points at their ends beat down upon as many thimble shaped objects, which they thrust alternately into the unwinking brazier and then upon the central block to shape.

A goblin workman, so intent upon, so busy with its forgings!

There were scores of these animate machines. They paid no slightest heed to us as we slipped by them. We passed a company of Shapes which stood two by two, and close together. Their tops were wide and translucent, colorless ingots—the substance it seemed to me of which Norhala's shadowy walls were made, and the crystal which formed the base of the Cones. The ingots passed between the whirling faces, emerged from them as slender, long cylinders and were seized, as they slipped down, by a crouching block, whose place, as it glided away, was instantly taken by another.

In many bewildering forms, intent upon unknown activities directed toward unguessable ends, the composite, animate mechanisms

Station
WRNY
NEW YORK
326 METERS — 920 KILOCYCLES
and 2XAL. 30.91 METERS

is owned and operated by the publishers of this magazine
Our Editors will talk to you several times every week—
See your Newspaper for details
TUNE IN ON WRNY

labored. And all the place was filled with a goblin bustle, trollish racketings, ringing of gnomish anvils and clanging of kobold forges. A clamorous cavern filled with metal Nibelungs!

We came to the opening of another passage, a doorway piercing the walls of a workshop. Its incline, though steep, was not dangerous. We stepped into it, and climbed onward. Far ahead of us appeared the outline of its further entrance, silhouetted against and filled with a brighter luminosity. We drew near, and stopped cautiously at its threshold, peering out.

Well it was, that we had hesitated, for before us was open space—an abyss in the body of the City. The corridor opened into it like a window. Thrusting out our heads, we saw an unbroken wall both above and below. A quarter of a mile away was its opposite side. Over this pit was the misty sky, and not more than a thousand feet above us, and black against the heavens, was the lip of it—the cornices of this great chasm.

Beneath us, at all levels, the Horde threw itself across the abyss in webs of curving arches and girder-straight bridges. Gigantic we knew these spans must be, yet they were dwarfed to slender footways by the distance. Over them moved hurrying companies, from them came flashings, glitterings, prismatic.

PATENTS

TRADE-MARKS—DESIGNS
FOREIGN PATENTS

MUNN & CO. PATENT ATTORNEYS

Associated since 1846 with the
Scientific American

SCIENTIFIC AMERICAN BUILDING

24 West 40th Street
New York City

SCIENTIFIC AMERICAN BUILDING

Washington, D. C.

TOWER BUILDING
Chicago, Ill.

HOBART BUILDING
San Francisco, Cal.

VAN NUYS BUILDING
Los Angeles, Cal.

Books and Information on Patents and Trade-Marks By Request

Associates in all Foreign Countries

A Personal Service for INVENTORS

I maintain an unexcelled organization and thoroughly equipped laboratories, to render the following services.

I PREPARE APPLICATIONS for patents for filing in the United States and foreign countries.

I PLACE INVENTIONS with responsible manufacturers, with whom I am acquainted, under arrangements that are made profitable to the inventor.

I SPECIALIZE in Electrical, Mechanical, Chemical, and Radio Devices.

I INVITE CORRESPONDENCE with reputable inventors, Scientists, Chemists and Physicists, regarding their inventions and uncompleted experiments.

H. R. VAN DEVENTER
Licensed Professional Engineer
Registered Patent Attorney

342 Madison Avenue, New York City

BLUE BOOK ON PATENTS

and Priority Record blank gratis.
MONROE E. MILLER, PATENT LAWYER,
411-6 Ouray Building, WASHINGTON, D. C.
ELECTRICAL AND MECHANICAL EXPERT

WE COMMERCIALIZE INVENTIONS
Communicate with us if you have a patent to sell or wish to buy one.
North American Finance & Development Corp.
Ouray Bldg., opposite Patent Office, Washington, D. C.

MACHINE SHOP

FOR GENERAL AND EXPERIMENTAL WORK
Expert Mechanician in Electrical and Machine Work of all Kinds. Models, Light Manufacturing. Established since 1878. Paul Hoensch, 108 Park Row, near Chambers Street, New York City. If it's mechanical, we make it.

PATENTS Protect your Inventions and Trade-Marks today. Write for illustrated patent book and sketch sheet and terms free. **BRYANT & LOWRY,** 314 Victor Building, Washington, D. C.

Print Your Own
Cards, Stationery, Circulars, Paper, etc. Save money. Print for others, big profit. Complete outfits \$3.85. Job press \$11. \$29. Rotary \$149. All easy, rules sent. Write for catalog presses type etc **THE KELSEY CO., P-47, Meriden, Conn.**

WHY NOT spend Spring, Summer, Fall gathering butterflies, insects. Buy hundreds of kinds for collections. Some worth \$1 to \$1. Simple work with my Instructions, pictures, price list. Send 10¢ (NOT STAMPS) for my Prospectus before sending butterflies. Mr. Sinclair, Dealer in Insects, Dept. 41 Box 1424, San Diego, Calif.



Some golden, plutonic scarlets, others molten blues; javelins of colored light piercing upward from unfolded cubes and globes and pyramids, crossing the bridges or from busy bearers of the shining fruits of the work-shops.

And as they passed, the bridges swung up, and coiled, and withdrew themselves from sight through openings that closed behind them. On their going other spans whipped out, so that always across that abyss a score of shifting webs were hung.

We turned slowly and made our way back along the sloping corridor. A hundred yards, perhaps, we had gone before we stopped, gazing at an opening in the wall beside us. The passage had not been there when we had gone by, of that I was certain.

We peered through it. The passage was narrow. Its pave led downward. For a moment we hesitated, the same foreboding in both our minds. And yet—among the perils that crowded in upon us what choice had we? There could be no more danger there than here.

Both ways were—alive. Both obedient to impulses over which we had no control, and

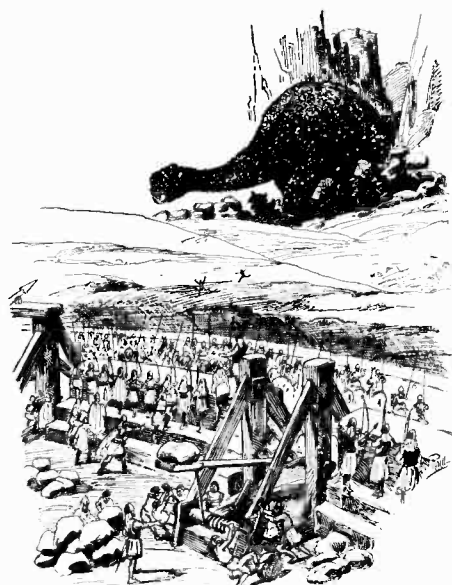

"Set at intervals behind the parapets were squat, powerful engines of wood and metal, and beside them heaps of huge, rounded boulders. Catapults around which swarmed knots of men, fixing the great stones in place, drawing back the thick beams that would hurl the projectiles. From every side came others, dragging more of these balistas, assembling a battery against the monster that menaced their city. . ."

no more way of predetermining than mice in some man-made trap. Furthermore, this shaft also ran downward. And although its pitch was less, and it did not therefore drop as quickly toward that level wherein lay the openings of escape into the outer valley, it did fall at right angles to the corridor through which we had come. We knew that to retrace our steps would but take us back to the forges and thence to the hall of Cones, and the certain peril waiting there for us.

We stepped into the opened way. For a little distance it ran straight, and then turned and sloped gently upward. A little distance more we climbed. And suddenly, not a hundred yards from us, a flood of soft radiance, filled with pearly glimmerings and rosy shadows, gushed out into it.

It was as though a door had opened into some world of luminescence. From it a lambent torrent poured and billowed down upon us. In its wake came music—if music it could be called, the mighty harmonies, the sonorous chords, the crystalline themes and the linked chaplets of notes that were like spiralings of tiny golden star bells.

Toward source of light and sound we moved, nor could we have halted nor with-

PATENTS TRADE-MARKS AND COPYRIGHTS



OUR OFFER: FOR THE PROTECTION OF YOUR INVENTION YOUR FIRST STEP. The inventor should write for our blank form—"RECORD OF INVENTION." This should be signed, witnessed, and returned to us, together with model or sketch and description of the invention for INSPECTION and ADVICE FREE!

Our FIVE Books Mailed Free to Inventors

Our Illustrated Guide Book

HOW TO OBTAIN A PATENT

Contains full instructions regarding U. S. Patents, Our Methods, Terms, and 100 Mechanical Movements illustrated and described.

OUR TRADE-MARK BOOK

Shows value and necessity of Trade-Mark Protection. Information regarding Trade-Marks and unfair competition in trade;

OUR FOREIGN BOOK

We have Direct Agencies in Foreign Countries and secure Foreign Patents in shortest time and at lowest cost.

PROGRESS OF INVENTION

Description of World's Most Pressing Problems by Leading Scientists and Inventors All Communications and Data Strictly Confidential. Interference and Infringement Suits Prosecuted.

IMPORTANT

TO AVOID DELAY MAKE YOUR CASE SPECIAL. YOU SHOULD HAVE YOUR CASE MADE SPECIAL IN OUR OFFICE to save correspondence, secure protection and early filing date in the Patent Office. To secure special preparation of your case send \$25.00 on account with model or sketch and description of your invention.

Our Lawyers Practice in all U. S. Courts and defend Clients in Suits involving Patents, Trade-Marks and Copyrights

OUR ORGANIZATION OFFERS PERSONAL SERVICE

By Experienced Patent Lawyers, Solicitors, and Draftsmen We regard a satisfied client as our best advertisement, and furnish, upon request, lists of clients in any state for whom we have secured patents.

Highest References—Prompt Service—Reasonable Terms

FREE COUPON

WRITE TODAY
VICTOR J. EVANS & CO.

Registered Patent Attorneys

MAIN OFFICES: 715 Ninth St., Washington, D. C.

BRANCH OFFICES: 1007 Woolworth Bldg., New York City; 518-519 Liberty Bldg., Philadelphia, Pa.; 514 Empire Bldg., Pittsburgh, Pa.; 1114 Tacoma Bldg., Chicago, Ill.; 1010 Hobart Bldg., San Francisco, Calif.

Gentlemen: Please send me FREE OF CHARGE your books as described above

Name.....

Address.....



EARLE E. LIEDERMAN, the Muscle Builder
 Author of "Muscle Building," "Science of Wrestling,"
 "Secrets of Strength," "Here's Health," "Endurance," etc.

The Man I Pity Most

POOR OLD JONES. No one had any use for him. No one respected him. Across his face I read one harsh word—FAILURE. He just lived on. A poor worn out imitation of a man, doing his sorry best to get on in the world. If he had realized just one thing, he could have made good. He might have been a brilliant success.

There are thousands of men like Jones. They, too, could be happy, successful, respected and loved. But they can't seem to realize the one big fact—that practically everything worth living for depends upon **STRENGTH**—upon live, red blooded **no-man** muscle.

Everything you do depends upon strength. No matter what your occupation, you need the health, vitality and clear thinking only big strong virile muscles can give you. When you are ill the strength in those big muscles pulls you through. At the office, in the farm fields, or on the tennis courts, you'll find your success generally depends upon your muscular development.

Here's a Short Cut to Strength and Success

"But," you say, "it takes years to build my body up to the point where it will equal those of athletic champions." It does if you go about it without any system, but **there's a scientific short cut.** And that's where I come in.

30 Days Is All I Need

In just 30 days I can do things with your body you never thought possible. With just a few minutes work every morning, I will add one full inch of real, live muscle to each of your arms, and two whole inches across your chest. Many of my pupils have gained more than that, but I **GUARANTEE** to do at least that much for you in one short month. Your neck will grow shapely, your shoulders begin to broaden. Before you know it, you'll find people turning around when you pass. Women will want to know you. Your boss will treat you with a new respect. Your friends will wonder what has come over you. You'll look ten years younger, and you'll feel like it, too.

I Strengthen Those Inner Organs Too

But I'm not through with you. I want ninety days in all to do the job right, and then all I ask is that you look yourself over.

What a marvelous change! Those great squared shoulders! That pair of huge, lithe arms! Those firm, shapely legs! You'll be just as fit inside as you are out, too, because I work on your heart, your liver—all of your inner organs, strengthening and exercising them. Yes indeed, life can give you a greater thrill than you ever dreamed. But, remember the only sure road to health, strength and happiness always demands action. **Start now!**

Send for my New Book, 64 pages and—**IT IS FREE**

"MUSCULAR DEVELOPMENT"

It contains forty eight full-page photographs of myself and some of the many prize-winning pupils I have trained. Some of these came to me as pitiful weaklings, imploring me to help them. Look them over now and you will marvel at their present physiques. This book will prove an impetus and a real inspiration to you. It will thrill you through and through. This will not obligate you at all, but for the sake of your future health and happiness do not put it off. Send today—right now before you turn this page.

EARLE E. LIEDERMAN

Dept. 2705, 305 Broadway, New York City

It
Is
FREE

EARLE E. LIEDERMAN
 Dept. 2705, 305 Broadway, New York City

Dear Sir, Please send me, absolutely **FREE** and without any obligation on my part whatever a copy of your latest book, "Muscular Development."

Name.....

Street.....

City.....State.....

(Please write or print plainly)

drawn had we so willed. The radiance drew us to it, as the sun draws the water drop, and irresistibly the sweet, unearthly music called to us. Closer we came—to a narrow alcove from which the sound and light poured. We crept into it—and went no further.

We peered into a vast and columnless vault, a limitless temple of light. High up in it—strewn manifold, danced and shone soft orbs like tender suns. No pale gilt luminaries of frozen rays were these. Effulgent, jubilant, they flamed—orbs red as the wine of rubies the Djimms of Al Shiraz press from enchanted vineyards, twin orbs rosy white as breasts of pampered Babylonian maids, orbs of pulsing opalescences, and orbs of the murmuring green of bursting buds of spring. Crocused orbs, and orbs of royal coral. Suns that throbbed with singing rays of wedded rose and pearl, of amorous sapphires and topazes. Orbs horn of cool virginal dawns and of imperial sunsets. And orbs that were the fruit of mating rainbows of fire.

They danced, these countless aureoles. They swung and threaded in radiant choral patterns, in linked harmonies of light.

And as they danced, their gay rays caressed and bathed myriads of the Metal Folk beneath them. Under those rays the jewel fires of disk and star and cross leaped and pulsed, and danced to the same bright rhythm.

We sought the source of the music—a tremendous thing of shimmering crystal pipes, like some colossal organ. Out of the radiance around it great flames gathered, shook into sight with streamings and penonings, in banners and bandrols, leaped upon the crystal pipes and merged within them.

And as the pipes drank them the flames changed into sound. Throbbing bass viols of roaring vernal winds, diapasons of waterfall and torrents—these had been flames of emerald. Trumpetings of desire that had been great streamers of scarlet. Rose flames that dissolved into echoes of fulfillment. Diamond burgeonings that melted into silver symphonies, like mist-entangled Pleiades transmuted into melodies.

To these chameleon harmonies the strange suns danced.

And now I realized with a clutch of awe, with a sense of profanation, the secret of this chamber.

Within every pulsing rose of irised fire that was the heart of a disk, from every robust, clipped rose of a cross, and within every rayed purple petaling of a star there nestled a tiny disk, a tiny cross, a tiny star, luminous and symbolized even as those that cradled them.

The metal babes budding like crystals from hearts of radiance beneath the play of jocund orbs. Incredible blossomings of crystal and of metal whose lullabies and cradle songs were singing symphonies of flame.

It was the birth chamber of the Horde!

The womb of the City!

The walls of the niche sparkled out, the glittering eye points regarding us with a most disquieting suggestion of sentinels who, slumbering, had been caught unaware, and who awakening challenged us menacingly. The niche closed—so swiftly that we barely had time to spring over its threshold into the corridor.

The corridor was awake, and threateningly alive. There was none of the twinkling, playful malice in the points now. They glared. Their power darted out, gripped us, and thrust us violently onward. Up it swept us, and on. Far away a square of light appeared, grew quickly larger. Framed in it was the amethystine burning of the great ring girdling the encircling cliffs.

I turned my head. Behind us the corridor was closing.

SKINDERVIKEN Transmitter Units

95c



Two for \$1.75

Have hundreds of uses. Every amateur should have two or three of these amplifiers in his laboratory.

A FEW USES FOR THESE UNITS

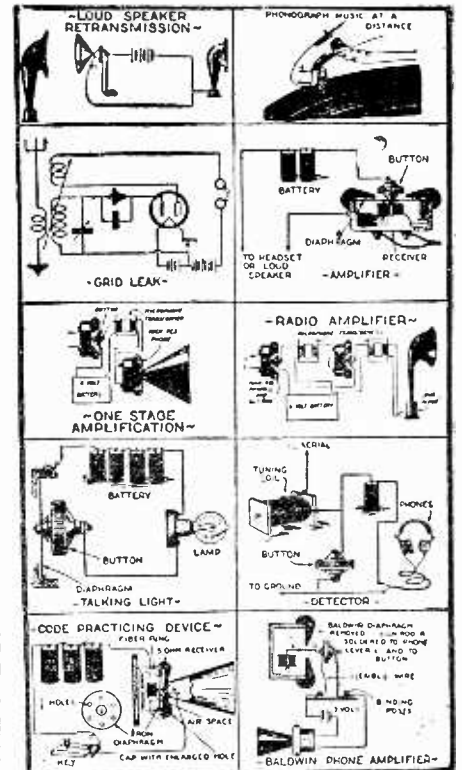

12 PAGE INSTRUCTION BOOKLET

containing suggestions and diagrams for innumerable jobs, furnished with each unit.

WE PAY \$5.00 IN CASH

for every new use developed for this unit and accepted and published by us.

P. G. MICROPHONE TRANSFORMER

A Modulation Transformer specially designed for use with the Skinderviken Transmitter Unit.



\$2.

FOR SALE AT LEADING DEALERS

Or Order Direct, Using Coupon Below

SEND NO MONEY

Order whatever you want. When the postman delivers your order you pay him for whatever you have ordered, plus a few cents postage.

PRESS GUILD, INC. S-5-28
 16-18-S—East 30th St., New York, N. Y.

Please mail me at once.....Skinderviken Transmitter Units, for which I will pay the postman 95c, plus postage, or \$1.75, plus postage, for 2 units.
 Please ship me one P. G. Microphone Transformer, for which I will pay the postman \$2, plus postage.

Name.....

Address.....

City.....State.....

Now the opening was so close that through it I could see the vast panorama of the valley. The wall behind us touched us, and pushed us on. We thrust ourselves against it, despairingly. As well might flies have tried to press back a moving mountain.

Resistlessly, inexorably, we were thrust forward. Now we cowered within a yard-deep niche. Now we trembled upon a foot-wide ledge.

Shuddering, gasping, we glared down the sheer drop of the City's wall.

Its smooth and glimmering scarp fell thousands of feet straight to the valley floor. And there were no merciful mists to hide what was awaiting us. In that brief, agonized glance every detail of the Pit was disclosed with an abnormal clarity.

We tottered on the brink. The ledge melted under our feet.

Down we plunged, locked in each other's arms, hurtling to shattering death far below!

CHAPTER XXIII

THE TREACHERY OF YURUK

WAS it true that Time is within ourselves—that like Space, its twin, it is only a self-created illusion of the human mind? There are hours that flash by on humming birds' wings, there are seconds that shuffle on, shod in leaden shoes.

Was it true that when death faces us the consciousness finds power through its will-to-live to conquer the illusion—to prolong Time? That, recoiling from extinction we re-create, in a fractional moment, whole years gone past, years yet to come—striving to lengthen our existence, stretching out our apperception beyond the phantom boundaries, overdrawing upon a Barmecide deposit of minutes, staking fresh claims upon a mirage?

How else explain the seeming slowness with which we were falling—the seeming leisure with which the wall drifted up past us?

And was this our punishment—a sentence meted out for profaning with our eyes a forbidding place? A penalty for touching with our gaze the Ark of the Metal Tribes—their Holy of Holies—the budding place of the Metal Babes?

The valley was swinging—swinging in slow broad curves, was oscillating dizzily. Slowly the wall slipped upward.

Realization swept over me and left me mazed, only half believing. This was no illusion. After that first swift plunge our fall had been checked. It was we who were swinging—not the valley!

Deliberately, in arcs, like pendulums, we were swinging across the City's scarp. Three feet out from it. And as we swung, we were slowly sinking.

The countless eyes of the watching wall were twinkling, regarding us with an impish mockery. And it was the grip of the living wall that held us, that rocked us from side to side as though giving greater breadths of it a chance to behold us, and that was dropping us gently, carefully, to the valley floor, now a scant two thousand feet below.

A storm of rage, of intensest resentment swept over me; any gratitude I should have felt for escape was submerged in angry humiliation.

Why, if we had sinned, had not execution been done—decently, with respect for us as thinking things? Why, if we had not sinned, had we been thrust so cruelly out to apparent annihilation? Had it all been a jest?

Why dangle us thus—like frightened puppies swung by thoughtless children down the facade of a skyscraper? Was this another jest? Or were we to be lured with false hope of safety only to be more cruelly slain at the end? What relish for all this could exist in this monstrous mass—a mass to which we were as pebbles to a mountain?

Learn Radio for Bigger Pay

GET into this new big-pay live-wire field. Its rapid, enormous growth has astounded the world. A flood of gold is pouring into this new business. Big and little fortunes are coming out of Radio every year. Trained men are needed. Opportunities in twenty different branches—Radio manufacturing, selling, servicing sets in business for yourself, travelling all over the world without expense as an operator on board ship, operator in a broadcasting station, commercial land station operator and many other wonderful positions are explained in my 64-page book *Rich Rewards in Radio*. Get a copy—clip the coupon—it's FREE. There's no obligation. Investigate!

Many Make \$50 to \$250 a Week

Why be satisfied with \$20, \$25, or \$35 a week when the good Radio jobs pay \$50 and all the way up to \$250 a week and offer practically unlimited opportunities for quick financial progress. Study Radio now and in a short time land yourself a real job with a real future.

Easy To Learn at Home This Practical Way

Stay home. I'll train you in your spare time. My practical method, with six big outfits of Radio parts, makes learning at home in spare time easy, fascinating. You can build and experiment with practically every type of receiving set known. No other method can equal it. This course has put thousands of dollars in other fellows' pockets. High school education unnecessary. Boys 16, men up to 65 have mastered Radio this way. Your Money back if not satisfied upon completion.

You can build 100 circuits with 6 big outfits of Radio parts I give you



Made \$588 in One Month

"The training I received from you has done me a world of good. Some time ago, during one of our busy months, I made \$588. I am servicing all makes of Radio receiving sets. I haven't found anything so far that I could not handle alone. My boss is highly pleased with my work. I handle our entire output of sets alone."—Herbert Reese, 2215 South E. St., Elwood, Ind.



\$10 to \$30 a week in spare time while learning

That's what many of my students are making. Pay your tuition out of spare time earnings. This is the famous course that pays for itself. I show you how you can begin earning money almost the day you enroll. C. W. Page, 1807, 21st Ave., Nashville, Tenn., writes: "I picked up \$935 in my spare time, while studying." K. W. Griffith, 2320 Maple St., Little Rock Ark., made \$894.

64-Page Book FREE

Send for it. Clip the coupon. It won't cost you a penny. It has pointed out the way to success to hundreds of fellows. See what Radio has to offer you and how my Employment Department helps graduates get good jobs. There's no obligation. Mail the coupon right now. Address: J. E. Smith, Pres., Dept. 5-T, National Radio Institute, Washington, D. C.

MAIL THIS COUPON

J. E. Smith, President, Dept. 5-T, National Radio Institute, Washington, D. C.

Dear Mr. Smith: Without obligating me in any way, send me *Rich Rewards in Radio*, giving facts and information on money making opportunities in Radio, and explaining your practical, fascinating way of teaching with Six Big Outfits of Radio Parts.

Name..... Age.....
Address.....

How To Work Wonders With Your SUBCONSCIOUS MIND



Give me just 60 minutes and I'll unlock the floodgates of that vast reservoir of mental power—your Subconscious Mind. Note the immediate effect on your business, social, and everyday life.

By DAVID V. BUSH

A VAST reservoir of mental energy! A huge storehouse of brain power! That's the Subconscious Mind.

You've got it. Your friends have it. Everyone has it. But not one in a thousand knows how to use it.

In 60 minutes I can show you exactly how to awaken your subconscious mind—how to harness it—how to make it work for you—how to make it solve problems—how to make it remember things—how to use its vast creative powers to boost your success and double your money-making ability.

In my book, "Functions of the Subconscious Mind," I tell just what the Subconscious Mind is—just how to reach it—just how to control it—just how to get the most out of it. It's simple as A. B. C.

ONLY 50 CENTS

Write today for this amazing book of more than 100 pages, "Functions of the Subconscious Mind." Send only 50 cents in full payment. If you are not delighted, return the book within 5 days and your money will be instantly refunded.

DAVID V. BUSH, Publisher

225 N. Michigan Blvd., Dept. T-01095, Chicago, Ill.



SCIENTIFIC MARVEL LIGHTER—WINDPROOF
What Makes it Light?

All guaranteed. Sample 25 cents. Sample Gold or Silver plated, \$1.00. Does the work of expensive Lighters.

Agents Write for Prices

NEW METHOD MFG. CO.
Box S.1.5 Bradford, Pa.

There is no mystery about CARTOONING



ALL of the famous artists and cartoonists of this country are making thousands and thousands of dollars yearly from their pens. They earned their success through years of work and tedious search for "the right way."

Today, the courses in Cartooning and Illustrating of the International School of Art, by showing you the short cuts, will save you years of work and bring success much sooner than if you stumble along alone.

These courses will not only teach you how to draw, but will also develop your originality. They are acknowledged to be among the best and most modern courses in Cartooning and Illustrating offered today.

INTERNATIONAL SCHOOL OF ART
Division of the International Correspondence Schools
Dept. 6233-E, Scranton, Penna.

Please send me—free—your illustrated booklet which tells how I can succeed as a Cartoonist or Illustrator.

Name.....
Address.....

BE AN AIRPLANE BUILDER, PILOT, MECHANIC



Blue Prints and materials now ready for

builders of the world's famous Lincoln Sport Plane. Send 25c for set constructional details and book, *Flight*.

LINCOLN AIRCRAFT COMPANY
Dept. 5, Lincoln, Nebraska



The funniest comic in America, 'Smatter Pop?' will keep you in stitches from the moment you open it until you have read and reread every page, time and time again. Fifty full-page comics in this edition of 'Smatter Pop?'—Hundreds of real laughs. C. M. Payne sure knows how to get under your skin and bring out every laugh in your system.

Meet "Pop." "Desperate Ambrose," and Pop's little family. They can make you laugh when everything else has failed. Ask your newsdealer or, if he can't supply you, fill in the coupon and mail to us. The funniest comic ever written. Don't miss it! Get your copy now! Barrels of FUN!



APOLOGIES TO C. M. PAYNE

EXPERIMENTER PUB. CO.
230 FIFTH AVE.
NEW YORK CITY

LISSEN---'SMATTER POP IS WHAT I'M
LOOKING FOR. 'SMATTER POP I SAY! SO
DONT HOLD ME UP. DONT HOLD ME UP
MAIL, MY COPY NOW---NOW I SAY---
HERE'S MY QUARTER---MY TWENTY-
FIVE CENTS-----SO RUSH.

NAME
ADDRESS
CITY..... STATE.....

Buy Direct from Swiss Importer and save 30%! 14 Karat Solid Gold Effect Watch
Written guarantee given with this 14-kt. solid gold effect watch, jewelled movement, tested, adjusted, accurate timekeeper, 25-year case, Waldemar knife, chain, also pistol-shaped cigarette lighter. Send no money. Pay postman only \$3.99 for all 4 articles. **JENKINS, 621 Broadway, N.Y., Dept. 65M5**

30 Days' Free Trial
New Models now ready for delivery direct from our factory. Astonishing low prices and terms. Do not buy until you get them. **RIDER AGENTS WANTED** to ride and exhibit sample. Make big money. Many models \$21.50 up. Guaranteed \$1.50 each, wheels, lamps, horns, equipment at half usual prices. Send No Money. Write for our marvelous prices and terms on **RANGER Bicycles**. **MEAD CYCLE CO. Dept. B-107 CHICAGO**

TRAVEL FOR "UNCLE SAM"
RAILWAY POSTAL CLERKS **\$158 to \$225 Month**
Mail Coupon Before You Lose It

Steady Work—No Layoffs—Paid Vacations
Travel—See Your Country
MEN—BOYS 18 UP
Many Government Jobs Open to Women

Franklin Institute, Dept. C 183, Rochester, N. Y.
Sirs: Rush to me, without charge, copy of 32-page illustrated book, "How to Get U. S. Government Jobs," with list of positions obtainable, sample coaching, and full particulars telling how to get them.

Name
Address

Blindly wrathful, I broke Drake's clasp and shook my fists at the twinkling wall, and strove to kick and smite it like an angry child. I cursed it, and dared it to hurl me down to death.

My passion passed and left me trembling. I felt Drake's hand touch mine in encouragement.

"Steady?" he said. "Steady, old boy! It's no use. Thank God we're out of it. Steady! Look down."

Hot with shame for my outburst, weak from its violence, I obeyed. The valley floor was now no more than a thousand feet away. Thronging about where we must at last touch, clustered and seething, was a multitude of the Metal Folk. They seemed to be looking up at us, watching and waiting for us.

"Reception Committee!" muttered Drake grimly.

I glanced away, over the valley. It was luminously clear, yet the sky was overcast, no stars showing. The light was no stronger than that of the moon at full, but it held a quality unfamiliar to me. It cast no shadows. Though soft, it was piercing, revealing all it bathed with the distinctness of bright sunshine. The illumination came, I thought, from the encircling veils falling from the band of amethyst.

And, as I peered, out of the veils and from far away a violet spark appeared. With meteor speed it flew toward us. It landed close to the base of the City and perhaps half a mile away with a flashing of blue incandescence. I knew it for one of the Flying Things, the Mark Makers—one of the incredible messengers.

At its fall the turmoil of the crowding throng awaiting us increases. There came, too, an abrupt change in our own motion. The long arcs lessened, and we were dropped more swiftly.

NORHALA APPEARS

FAR away, in the direction from which the Flying Thing had flown, I sensed another movement, something coming that carried with it subtle suggestion of unlikeness to all the other incessant, linked movement over the pit.

"Norhala!" gasped Drake.
It was Norhala. Robed in her silken amber swathings, hair streaming, she was racing toward the City like some lovely witch, riding upon the back of a steed of huge cubes.

Nearer she raced. More direct became our fall. Now we were dropping as though at the end of an unreeling plummet cord. The floor of the valley was no more than two hundred feet below.

"Norhala!" we shouted; and again and again—"Norhala!"

Before our cries could have reached her, the cubes swerved and came to a halt beneath us. About Norhala surged and slithered and rubbed the Horde—grotesquely catlike. She paid no heed, staring up at us as we fell. In my heart foreboding grew. We were lifted softly out from the wall and were set with no perceptible shock beside her.

"Norhala—" I began and stopped. For this was no Norhala whom we had known. Gone was all calm, banished every trace of unearthly tranquility. It was Norhala awakened at last. Over the blazing eyes the brows were knit in a rigid, golden bar; the delicate nostrils were pinched, the mouth once sweet and red was white and merciless.

What was it that had awakened her—what in awakening had changed the inpouring human consciousness into this flood of fury? A stronger foreboding gripped me.

"Norhala!" My voice was shaking. "Those we left—"

"They are gone! They were—taken!"
(Continued on page 83)



Only a Buescher

GIVES YOU ALL THESE FEATURES

Patented Snap-on Pads—the greatest improvement for beauty of tone—easy to replace—no more cementing. Found only on the Buescher. Patented Automatic Octave Key—always positive. Perfect scale accuracy—every tone always full, clear and true. Hands never moved from one playing position. Easier to play because of many exclusive improvements. Convenient key arrangement simplifies fingering of rapid passages.

BUESCHER

True Tone Saxophone

F. A. Buescher has spent a lifetime perfecting the Saxophone and it is today the leading orchestra and home instrument in America. Used by professionals for better recording.

10 Evenings—One Hour Each

Just a little practice and you'll be surprised at how quickly it "comes" to you. You can be popular socially, be welcome everywhere, be a source of pleasure to yourself and your family, and, if you like, earn money on the side.



You may try any Buescher Saxophone, Cornet, Trombone, Trumpet or other instrument 6 days in your own home, without obligation to keep it. If you like, pay a little each month.

Free Saxophone Book

Illustrates all the various models, and contains pictures of many famous professionals, also first lesson chart. Sent free.

Buescher Band Instrument Co.
2532 Buescher Block (452) Elkhart, Indiana

\$75 to \$125 Weekly
Charging Batteries Starts You

Let me show you how to make big money right from the start. I've prepared a FREE book explaining all details. First week's profit pays for all equipment. You can get all the battery charging business in your community with my Service Station Charger—it's years ahead of ordinary chargers—handles 50% to 70% more batteries. I explain everything—start you in a business of your own and put you on the way to big money. Write for FREE BOOK.

C. F. HOLMES, Chief Engineer, Dept. S.I.
Independent Electric Works
5116 Ravenswood Ave. Chicago, Ill.

FREE BOOK—Just Out

SALESMEN! \$100 WEEKLY
SELL COX HOLDFAST SCREWDRIVERS

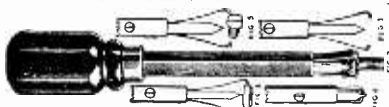

Also made to use in Yankee or Ratchet Handle. Sells on sight to Garages, Radio Men, etc. Self Holding, Self Releasing. Sample and proposition. 50c. S. J. COX, Dept. J, Franklin, Pa.

Learn to Write

I can make a good penman of you at home during your spare time. Write for my FREE BOOK, "HOW TO BECOME A GOOD PENMAN." Your name elegantly written on a card if you enclose stamp. Write today. F.W. TAMBLYN, 424 Ridge Bldg., Kansas City, Mo.

DIRIGIBLES

By LT. COM. C. E. ROSENDAHL

(Continued from page 15)

aircraft which float in the air much as a seagoing vessel does in water. We have: free balloons, which possess no motive power and drift with the wind, the pilot having only up and down control; the kite or captive balloon which floats aloft and is made fast to the earth by a wire cable; then come the dirigible balloons which are of three classes—non-rigid, semi-rigid and rigid.

The non-rigid airship is one whose gas bag contains no internal structure and owes its shape solely to the outward pressure of the gas contained within it. The semi-rigid has a partial internal structure which it relies upon together with the internal gas pressure to maintain its shape. The rigid airship is one whose form is maintained entirely by a rigid skeleton structure. There are a number of non-rigids in this country—our Navy now operates the J-3 and the J-4 for training purposes and our Army has several similar ships called the TC class. Non-rigid airships are of necessity small but can cruise at 55 or more miles per hour for about 12 to 24 hours. They are useful for convoy work, coastal patrol, anti-submarine work, photography and mapping and a number of other purposes.

Semi-rigid airships have a somewhat greater range and greater carrying capacity than the non-rigid and form the intermediate step to the rigid airship. The Navy has no semi-rigids at the present time but the Army operates one, the RS-1, from Scott Field, Illinois. The Italians favor the semi-rigid and it was a ship of this type, the Norge, which carried the Amundsen-Ellsworth-Nobile Expedition over the North Pole in 1926. The rigid airship of which the Los Angeles is an example, has a much greater cruising radius and carrying ability than the other two classes.

WHAT THE DIRIGIBLE HAS DONE

IN order that you may better understand the usefulness of the rigid airship, let me point out a few of its outstanding flights: (a) Small commercial rigid airships operated in Germany both before and after the war and carried 37,000 passengers without accident or mishap. Most of this was even before the war, as the post-war commercial ships had to be delivered to the Allies after only brief German operation. The proof of this commercial venture was that the ships practically always carried capacity loads.

(b) The German L-59 in November, 1917, took off from her base in Bulgaria, carrying a cargo of fourteen tons of medical supplies and small arms' ammunition to the besieged German East African Colonies. Just as the destination was about reached, a radio message was received by the airship stating that the German Colony had surrendered. She therefore returned to her base without landing. Although she had been in the air for almost 100 hours and had traveled about 4,500 miles with her fourteen-ton cargo, upon landing she still had sufficient fuel for an additional forty-eight hours' flight.

(c) The round trip of the British R-34 between England and the United States in July, 1919, was a noteworthy achievement, as that type and size vessel was then already obsolete.

(d) In October, 1924, our American built Shenandoah, modeled after the German 1916 war type but not completed until 1923, cruised across the continent, up the Pacific Coast and returned to Lakehurst, having covered 9,000 miles in many kinds of

COLUMBIA UNIVERSITY

Offers Courses for Home Study in the Following Subjects:

- | | |
|-------------------------|--------------------------|
| Accounting | Essay Writing |
| Algebra | European History |
| American Government | Fire Insurance |
| American History | French |
| American Literature | Geometry |
| Applied Grammar | German |
| Astronomy | Government |
| Banking | Grammar |
| Biblical Literature | Greek |
| Biology | Harmony |
| Botany | History |
| Boy Scouting | Italian |
| Business Administration | Juvenile Story Writing |
| Business English | Latin |
| Business Law | Literature |
| Business Organization | Magazine Article Writing |
| Chemistry | Marketing |
| Child Psychology | Mathematics |
| Composition | Personnel Administration |
| Dramatic | Philosophy |
| English | Photoplay Composition |
| Various Languages | Physics |
| Lyric Poetry | Psychology |
| Contemporary Novel | Public Speaking |
| Drafting | Religion |
| Drama | Secretarial Studies |
| Drawing and Painting | Short Story Writing |
| Economics | Sociology |
| Economic Geography | Spanish, etc., etc. |
| English | |
| English Literature | |

THESE courses have been prepared by our instructors to meet the special requirements of study at home by individuals or groups. While all basic material essential to the full understanding of each subject is fully covered, sufficient elasticity is allowed to permit adaptation to the individual needs of each student. Everyone who enrolls for a Columbia course is personally instructed by a member of the University teaching staff.

The University will send on request full information about these home study courses. A coupon is printed below for your convenience. If you care to write a letter briefly outlining your educational interests our instructors may be able to offer helpful suggestions. Mention subjects which are of interest to you, even if they are not listed above because additions to the courses offered are made from time to time.

HIGH SCHOOL AND COLLEGE PREPARATORY COURSES

Columbia University Home Study Department has prepared courses covering the equivalent of four years of High School study. This complete High School or College Preparatory training is available to those who cannot conveniently undertake classroom work. We shall be glad to send you our special bulletin.

COLUMBIA UNIVERSITY,
University Extension—Home Study Department,
New York, N. Y.

Please send me full information about Columbia University Home Study Courses. I am interested in the following subject: Sci. & In.-5-28.

.....

Name.....

Street and Number.....

City.....State.....

Occupation.....



Former Plasterer Now Earning \$12,000 a Year

"When I enrolled with the International Correspondence Schools, I was a plasterer and I didn't know a thing about blueprints. Today I have my own contracting business and I am able to figure the most difficult jobs and execute them to the satisfaction of everyone concerned. My income is between \$12,000 and \$15,000 a year. It certainly was a lucky day for me when I sent in that I. C. S. coupon."

That's a true story of what just one student of the International Correspondence Schools has done. Every mail brings letters from other ambitious men and women telling of promotions and increases in salary due directly to spare-time study.

One hour a day spent with the I. C. S., in the quiet of your own home, will prepare you for success in the work you like best.

Mail Coupon for Free Booklet

TEAR OUT HERE

INTERNATIONAL CORRESPONDENCE SCHOOLS
Box 6231-E Scranton, Penna.

Without cost or obligation, please send me a copy of your booklet, "Who Wins and Why," and full particulars about the course before which I have marked X:

- | | |
|--|---|
| <input type="checkbox"/> Architect | <input type="checkbox"/> Plumber and Steam Fitter |
| <input type="checkbox"/> Architectural Draftsman | <input type="checkbox"/> Electrical Engineer |
| <input type="checkbox"/> Architects' Blueprints | <input type="checkbox"/> Electric Lighting and Rtwys. |
| <input type="checkbox"/> Contractor and Builder | <input type="checkbox"/> Mechanical Engineer |
| <input type="checkbox"/> Building Foreman | <input type="checkbox"/> Show Card and Sign Painting |
| <input type="checkbox"/> Concrete Builder | <input type="checkbox"/> Business Management |
| <input type="checkbox"/> Structural Engineer | <input type="checkbox"/> Private Secretary |
| <input type="checkbox"/> Structural Draftsman | <input type="checkbox"/> Business Correspondent |
| <input type="checkbox"/> Heating and Ventilation | <input type="checkbox"/> Bookkeeper |
| <input type="checkbox"/> Plumbing Inspector | <input type="checkbox"/> Stenographer and Typist |
| <input type="checkbox"/> Foreman Plumber | <input type="checkbox"/> Higher Accounting |
| <input type="checkbox"/> Sheet Metal Worker | <input type="checkbox"/> Commercial Law |
| <input type="checkbox"/> Civil Engineer | <input type="checkbox"/> Common School Subjects |
| <input type="checkbox"/> Surveying and Mapping | <input type="checkbox"/> Mathematics <input type="checkbox"/> English |
| <input type="checkbox"/> Electric Wiring | <input type="checkbox"/> Illustrating |
| <input type="checkbox"/> Telegraph Engineer | <input type="checkbox"/> Railway Mail Clerk |
| <input type="checkbox"/> Telephone Work | <input type="checkbox"/> Civil Service |
| <input type="checkbox"/> Mechanical Draftsman | <input type="checkbox"/> Mining Engineer |
| <input type="checkbox"/> Toolmaker | <input type="checkbox"/> Gas Engine Operating |
| <input type="checkbox"/> Machine Shop Practice | <input type="checkbox"/> Stationary Engineer |
| <input type="checkbox"/> Chemist <input type="checkbox"/> Pharmacy | <input type="checkbox"/> Textile Overseer or Supt. |
| <input type="checkbox"/> Navigation | <input type="checkbox"/> Traffic Manager |
| <input type="checkbox"/> Salesmanship | <input type="checkbox"/> Automobiles <input type="checkbox"/> Spanish |
| <input type="checkbox"/> Advertising | <input type="checkbox"/> Agriculture <input type="checkbox"/> French |
| <input type="checkbox"/> Window Trimmer | <input type="checkbox"/> Poultry Raising <input type="checkbox"/> Radio |

Name.....

Street Address.....

City.....State.....

Occupation.....

If you reside in Canada, send this coupon to International Correspondence Schools Canadian, Limited, Montreal



FREE CATALOG

Just off the press. Shows 50 items of tents and other specialties for fishermen and motor campers.

L. L. BEAN

89 MAIN ST.,
Freeport, Maine

\$3.99

Precision Mens Strap Watch Direct from Switzerland



Worn by practical men everywhere. Shock proof, weather proof. Perfect time keeper. Radium dial. Tells time in dark. Fine imported full jeweled movement. Rich silver finish. Genuine leather strap. Sold elsewhere for \$10.00. Satisfaction guaranteed. SEND NO MONEY. Pay on delivery \$3.99 plus the postage. JEWELERS CORPORATION, 622 Broadway, New York, Dept. 65F9

weather, basing entirely on mooring masts for over 19 days.

(e) The Zeppelin Dixmude while operated by the French stayed aloft for 118 hours or nearly five days, making the world's record for aircraft.

(f) The Los Angeles, then designated as the ZR-3, on her delivery flight from Germany covered 5,060 miles in eighty-one hours, spanning the actual ocean expanse in sixty-one hours, her average speed being over 62 miles per hour.

(g) Space does not permit me to recount to you here the varied wartime uses to which airships were put, but they were many and important.

(h) It is significant to note that the only successful westbound flights across the Atlantic have been made by airships.

COMFORTS OF AIRSHIP TRAVEL

WHEN it comes to the comforts which airships can provide you may be surprised. In airship travel you ride in a sheltered structure, there is no noise, no vibration, no dirt, no smoke, and the motion, when there is any, is a mild gradual pitch. I have never seen any seasickness in an airship. There are ample comforts for sitting, sleeping, reading, writing, card playing, walking about and exercising and the new airships contemplate even ball rooms. But, of most importance, the airship provides an electric kitchen which can furnish as satisfactory a menu as can be desired. Perhaps airships will never provide swimming pools as huge steamers do, but when you are crossing the Atlantic in two days instead of six you can probably dispense with your daily swim for that period. Fogs, muddy or snow-covered fields present no insurmountable difficulties for airships, and airship flight at night and in darkness is generally even easier than in the daytime.

Airships are not yet wholly perfected instruments but they are capable of many improvements as they become larger—"bigger and better" is a correct slogan for airships up to at least four times the size of the Los Angeles. And what is more important, the efficiency of the airship or the amount of its useful load compared to its "dead" load increases with larger ships. With this increase it becomes possible to add structural strength, more speed and greater performance—all factors of great importance. All this is possible in the light of present principles of design and construction and with the materials now available; the future may and probably does hold new variations and strong lighter materials which will add to increased airship efficiency. We shall even see airplanes carried on airships attachable and detachable in flight, just as a steamer carries smaller power boats.

1928 TO BE AN AIRSHIP YEAR

AND these are some of the reasons I look for 1928 to be an airship year. In England nearing completion are two huge commercial airships of 5,000,000 cubic feet capacity—each twice as large as the Los Angeles and each capable of carrying one hundred passengers in comfort for 4,000 miles. Commander Burney is in the United States today arranging for a probable visit of the first of these two ships to the United States this summer. The second of these ships will be finished in September. Great Britain has built these two large airships to unite her Empire more closely and accordingly has laid out a route from England to India via Egypt; servicing stations and terminal facilities are nearly complete and mooring masts are to be built in Canada as well. By airship from England to Canada will take two and one half days, whereas steamers now require six days; from England to Egypt will require two and one-half days by airship as opposed to six days by steamer; from England to Singapore will

New!



Some of the stories that you will find in this issue—
THE MOON OF DOOM
By Earl L. Bell
THE ATOMIC RIDDLE
By Edward Shears
WHEN THE SLEEPER WAKES
By H. G. Wells
THE PUZZLE DUEL
By Miles J. Breuer, M. D.
and others

AMAZING STORIES A QUARTERLY

Now you can get the large new quarterly edition of AMAZING STORIES.

Tales of other worlds—of other people—stories of great imaginative adventures. Yet each tale has a plausible scientific background. Gems of imagination written by some of the world's most famous authors.

Adventures seldom before conceived—mystical beings— weird happenings—these stories will carry you to dream worlds of the future.

Do not miss this new edition—the AMAZING STORIES QUARTERLY. Over 150 pages—fully illustrated.

50c COPY

At newsstands or write direct

Experimenter Pub. Co.

230 Fifth Ave. New York, N. Y.

EXPERIMENTER PUBLISHING CO.

230 Fifth Avenue, New York, N. Y.

Gentlemen:

Enclosed is 50 cents, for which kindly rush me a copy of AMAZING STORIES QUARTERLY.

Name.....

Address.....

City.....State.....

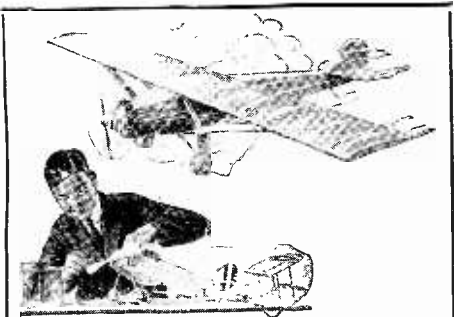

Build and Fly a 3-Ft. Model of LINDBERGH'S

"Spirit of St. Louis"

Plans for Model Airplanes 25c per set
New York Paris Plane, FOKKER North Pole Plane, CURTISS (N4) 2 Biplane, DeHAVILAND Biplane, NC 4 Naval Sea plane, Bleriot-Taube or Nieuport Monoplanes, Cecil Peoll Racer.

This IDEAL New York Paris Monoplane is a perfect copy, 3 ft. size, of the machine in which Lindbergh crossed the Atlantic Ocean. Any bright boy can build this model. The IDEAL Construction Outfit contains everything needed: all parts, fittings, materials and supplies, including careful instructions, plans and diagrams. The model is wonderful: has many features of the original and is guaranteed to fly. Complete Construction \$7.50

Outfit (West of Denver, Colo., and in Canada, price is \$8.00) Ask your dealer or order direct.

New 64-page Book of Model Airplanes Teaches the principles of flying; contains plans and directions for building gliders and racers, and full information about scale Models of real planes; also most complete catalog of materials for model builders. Sent postpaid for 5c

Ideal Aeroplane & Supply Co., Inc. 22-24 West 19th St. New York City



CAN YOU SELL GAS AT 5c PER GAL.?

Any man who can sell gas at 5c. per gallon should write at once to Frank Andrews, Dept. 863-G, 154 E. Erie St., Chicago, Ill. His agents make as high as \$3,000.00 a month. Send for free trial, proof, and \$15.00 a day guarantee to Distributors.



PREPARE FOR AN ART CAREER

—thru the only art school operated as a department of a large art organization, who have actually produced over a quarter million drawings for leading advertisers. Where else can you get so wide an experience? Home study instruction. Write for illustrated book telling of our successful students.

MEYER BOTH COMPANY
Michigan Ave. at 20th St. Dept. 64 Chicago, Ill.

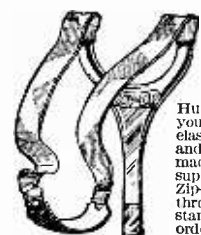

ZIP-ZIP SHOOTER
LET'S GO, BOYS

Hunting, fishing, or camping, wherever you go you will need a Zip-Zip Shooter, elastic and lasting, with plenty of pep and force, scientifically and practically made. See your dealer—if he can't supply you order from us. Zip-Zip Shooter, 35c., or three for \$1.00; send stamps, coin, or money order.

AUTOMATIC RUBBER CO., Dept. BB, Columbia, S. C.

Free Mailing Lists
Will help you increase sales. Send for FREE catalog giving counts and prices on thousands of classified names of your best prospective customers—National, State and Local. Individuals, Professionals, Business Concerns. Guaranteed 99% by refund of 5¢ each.
ROSS-Gould Co. 315 N. 10th St. St. Louis

require eight days by airship whereas twenty-four days are required by steamer—making a 16 day saving possible by airship in this case.

At this very moment in Friedrichshafen, Germany, the birthplace of the Los Angeles, the airship LZ-127 is being rushed to completion and her maiden voyage across the Atlantic to the United States is expected to be made early this summer. This ship, one and one half times the size of the Los Angeles, built largely by popular subscriptions by the German people, embodies many novel and wonderful features of comfort and operation. This ship will probably be operated under a subsidy from the Spanish Government for a commercial run between Spain and the Argentine.

MOORING OF AIRSHIPS

BY joint agreement, our Navy is charged with the development of rigid airships in the United States. The problems of both military and commercial airships have, so far, coincided to a large extent. As our contribution to airship progress, we have conducted many experiments that are about to produce their results within the next six months or so. The greatest problems of airship operation in the past have been those due to undeveloped methods and equipment for handling airships on the ground—in other words, terminal facilities for airships have been inadequate. It is remarkable indeed that airships handled only by man power on the ground, have been able to accomplish as much as they have. However, we are never content to do with man power what we can develop mechanical power to do, and this substitution of machines for the men now used on the ground is the problem we in the United States shall have solved in the near future. We expect soon to make the airship just as available as steamers now are; the airship will not have to be berthed in a shed regularly but will moor outside between flights and go into a hangar only for "dry-docking." Many other interesting and essential problems of operation have been worked out and we shall begin employing them very soon. So it is really but a few months off when we shall see airships become enormously more available and useful.

And what about new construction in the United States? At present our only large airship is the Los Angeles. The last Congress authorized as a part of the five year aircraft building program, two large naval rigid airships of six million cubic feet gas capacity—larger than even the new British ships about to be completed. Unfortunately their construction has not yet been begun—we hope and expect it will be in the immediate future. These ships will embody many novel features of great importance.

It is easy perhaps for you to realize the commercial possibilities of aircraft and particularly of airships. In order to present clearly and briefly what the Naval functions of airships are, I can do no better than to quote from a Congressional report which was rendered only last year. After an exhaustive investigation the report reads partly as follows:

OFFICIAL RECOGNITION OF AIRSHIPS

"THE Committee finds that airships of adequate size hold unquestionable possibilities as adjuncts to the Fleet. Large airships are peculiarly naval as their sphere of greatest usefulness lies over the water; they are essentially long-distance, weight carrying machines, having long radii of action, ability to keep in the air for long periods, superior habitability, the ability to operate at night successfully without the necessity for elaborate lighted airways, and wide range of speed variation to the extent of being able to stop all engines and still remain aloft.

Their principal naval mission will be



Are Behind the Training Hinton gives YOU



WALTER HINTON

1st to pilot a plane across the Atlantic (the famous NC-4). to fly from North to South America. to explore the wild regions of the Upper Amazon by air.

There's Your First Step—That Book!

Don't say "Gosh, there's no way for ME to break into Aviation," until you've read Hinton's FREE Book. It has opened the eyes of hundreds. Many, when they first wrote to Hinton, were skeptical. They didn't realize that Aviation is MORE than a pilot's pastime—MORE than a big, exciting adventure. But they changed their minds in a hurry—and have been glad ever since—the moment they met up with Hinton in the interesting pages of his big, FREE book. Are you, too, willing to listen? Can you stand a great surprise? Will you pause for fifteen minutes to look into Aviation's future—YOUR FUTURE—through Walter Hinton's eyes? If your answer is YES—just use the coupon. It's your signal to Hinton that you want to hear more.

Now's the Ideal Time to Get Into Aviation

The business world has taken to the air in earnest. Letters fly from coast to coast. During the past eighteen months, Ford-Stout planes, operating between half a dozen cities, have already carried more than 20,000 people. And there's a daily passenger schedule from Chicago to San Francisco and between scores of other important centers. Yet our growth in the air has just begun. The unbelievable things you see today will be nothing within five years. And men who today are poor, misplanned, uncared, unknown—will soon be riding on the wings of success. See Aviation's future ahead of the crowd! Get your training **BUSY**—while the industry is young. Get ahead in Aviation before Aviation gets ahead of you.

Get Your "Ground Work" Where You Are—At Home

While others look on and wonder—YOU CAN BE TRAINING. Right at home, in spare time, Hinton will fit you for a job while your chance to grow fast is greatest. Hinton's carefully illustrated course takes you over a plane inch by inch, shows you all about construction, rigging, motors, instruments, theory of flight, air navigation—EVERYTHING. It's the foundation for any one of Aviation's fifty highly-paid branches. Beyond that, Hinton tells you how to get a job; where your training will bring you most. If it's actual flying you seek, he'll even see that your rates are specially reduced. Don't pass this page until you've called for the book below.



Aviator: Institute of U. S. A.
Walter Hinton, President
1115 Connecticut Avenue
Washington, D. C.

Send to Washington—Quick

Aviation Institute of U. S. A.
1115 Connecticut Avenue, Washington, D. C.

Send me at once your big FREE book telling about the opportunities for ME in Aviation and about your method of giving me my "ground work" right at home.

Name Age
Street
City State



ENLIST!

IN America's First Independent Air Force

Organized to give America an independent civilian air organization, for the development of commercial, industrial, and civilian aeronautics. And to furnish the country with a self-supporting volunteer civilian reserve, that will be available for national defense, in time of need.

CIVILIAN DIVISION

Open to all who are interested in seeing America retain first place in the air.

SERVICE DIVISION

Open to American citizens, and to those who have filed their intentions of becoming citizens, between the ages of 16 and 45. This division includes both those who are already pilots or mechanics and those interested in qualifying as such.

Thorough training, as pilots or mechanics, will be offered to members of both divisions, at terms that will be available to all.

Members of the Service Division, only, agree to offer their services to the government, if war or national crises arise, during their enlistment. **NO FURTHER OBLIGATIONS OF ANY NATURE.** All training, uniforms, or drills are entirely optional. They may be taken, or not, during the term of enlistment.

In keeping with our policy of real SERVICE to our members, we offer the following remarkable **VALUES**, upon the receipt of your enlistment fee:

ISSUE No. A-1 (With 3 Year Enlistment)



Our Ground School Text "MODERN AIR CRAFT," by Major Victor W. Page, containing over 350 pages and 500 illustrations, with fly-leaf bearing your name, the signatures of the commanding officers, and General Headquarters Staff, the U. S. V. A. N. solid gold wings same size as shown on coupon below; a gold embossed genuine leather Pass Case and your Identification Pass.

ISSUE No. C-1 (With 1 Year Enlistment)

Our Ground School Manual, "EVERYBODY'S AVIATION GUIDE," by the same author, with 250 pages, 140 illustrations, and 600 questions and answers on design, construction, and operation of all types of aircraft. This book includes the same individual fly-leaf. Same gold wings, Pass Case, and Identification Pass goes with this issue.

Other values to offer. Use coupon below, for immediate enlistment or as application for DESCRIPTIVE LITERATURE.

U. S. Volunteer Air Service 580 Fifth Av., New York City



- Enclosed find \$5.00 for 3-year enlistment fee and Issue No. A-1.
- Enclosed find \$2.00 for 1-year enlistment fee and Issue No. C-1.
- Service Division. Civilian Division.

Name.....

Age.....Address.....

Are you an American citizen?.....

scouting and reconnaissance, augmented by such uses as anti-submarine operations, convoy work, carrying airplanes, transportation of and communication with detached units, and under certain conditions, bombing.

"In the case of the large airship of proved type of construction, built so that interior parts are accessible for repair during flight; filled with noninflammable helium gas; equipped with machine guns for defense or limited offense; and carrying two or more airplanes for self-protection, vulnerability will be reduced to a point where it will not militate against the airship playing an influential role in military operations.

"So decided are the possibilities of lighter-than-air craft, it is felt that we cannot afford to do otherwise than to follow up its present advantage and determine the utility and limitations of rigid airships when employed in active operations with our other naval forces; we have all the necessary facilities and are prepared to go ahead vigorously with the further development of this type of craft. The Committee has found that rigid airship development in this country lags far behind airplane development. The expenditures on airships have been only about 2% of the total expenditures for aviation. It is believed that the construction of the two rigid airships included in the bill will go far toward building up in this country an airship industry which, when it is established on a sound basis, will be in a position to carry forward the commercial development of airships.

"The Committee feels that the least that should be done in this field is to provide for two rigid airships of approximately 6,000,000 cubic feet volume each, to be used as adjuncts to the fleet."

AIRSHIPS NOT TO SUPPLANT STEAMSHIPS

I HAVE no present vision of the sky being darkened by multitudes of airplanes and airships. Nor do I believe we shall ever see steamships rotting alongside their docks nor railroads falling to pieces because of competition from aircraft. Furthermore, all aircraft are still merely instruments of transportation and cannot completely replace any major branch of the armed forces—they cannot do the work of battle-ships and of infantry. However, I do believe that aircraft will become indispensable additional means of transportation for both commercial and military purposes. Aircraft have considerably complicated modern warfare and will remain important auxiliaries as far as we can now see.

It may not be pleasing to our pride to see huge commercial airships flying to and from the United States under foreign flags—years before American ships are in the air. Even last year the National Advisory Committee for Aeronautics was forced to report briefly that the world leadership in the design and construction of rigid airships has passed from the United States to Europe. Our great engineering and scientific resources are unexcelled in the world; our monopoly of the world's supply of the entirely safe helium gas alone gives us a world wide advantage in air-ships.

It is my opinion that huge American-built airships as well as airplanes will prove to be of indispensable commercial value and an auxiliary of high naval value that will add strength and prestige to our American Navy and the American Nation.



Don't

let this happen
in your home

BRIDGE-

by Whitehead

THE REMEDY

Don't kill your bridge partner for making errors—give him a copy of "Bridge," by Whitehead—he'll then become a very valuable partner. Maybe the shoe is on the other foot? Maybe every time you play your life is at stake? Read this little book on Bridge, by Walter C. Whitehead, the renowned authority. Let this expert tell you how to play—complete instructions by a new, easy, illustrated method. Each phase thoroughly and understandingly treated. The best players can learn much from this book. The beginner could find no more able instructor. Large size 9 x 12 inch book—beautiful colored cover—100 pages.

Mail This Coupon Now—Don't Wait!
EXPERIMENTER PUBLISHING CO.
230 Fifth Ave., New York, N. Y.



500 TRICKS—10¢

BE POPULAR—LEARN TO ENTERTAIN
Amaze and mystify your friends. Earn Money at Clubs and Parties. It's easy. No skill required. Our copyrighted book "Fun Magic—Mystery" tells how and explains many Tricks you can do. Also catalogs over 300 Mystifying Tricks—Illusions—Jokes—Puzzles—Books—European Novelties, at Reduced Prices. New 1928 Edition, profusely illustrated, sent postpaid, only 10¢.

LYLE DOUGLAS, Station A-3, DALLAS, TEX.

PROMPT SERVICE—LOW PRICES

BE A DETECTIVE

Earn Big Money. Work home or travel. Make secret investigations. Experience unnecessary. Write Dept. S. A. American Detective System, 2190 Broadway, N. Y.

Radio Wrinkles Wanted!

The Radio Editor, Mr. Paul E. Welker, wants to hear from you, if you have a good idea or wrinkle. Make a pencil or pen and ink sketch of the contrivance, write 50 words or so of description, and mail to the Radio Editor, c/o this magazine.

Experimenter Publishing Co.,
230 Fifth Ave., New York, N. Y.
Gentlemen: Kindly send me copy of "Bridge," by Whitehead. Enclosed is 50¢

Name.....
Address.....
City.....State.....

50¢





WALTER DAMROSCH
Director Damrosch's
N. Y. Symphony, the
entire brass section of
which uses Holtons
exclusively.

HOLTONS are bought—
not sold. We urge and
offer a ten-day compar-
ison of Holton workman-
ship, tone, tune, ease of
playing and exclusive im-
provements with all the
world's other makes. No
obligations, no expense
—for few are the compar-
isons that do not add more
meaning to this name.

Write for the Holton
Free Loan Blank

FRANK HOLTON & COMPANY
326 CHURCH ST. ELKHORN, WIS.

Holton
America's Greatest
Band Instruments

LEARN CARTOONING COMPLETE COURSE \$1

\$100 to \$500 a Week Is Earned by Cartoonists Today
DO YOU LIKE TO DRAW?
Billy Hon's Famous CARTOON
BOOK Will Teach You.



A short road to success for the beginner as well as advanced art student. A simple, complete, up-to-date course in Cartooning, consisting of 30 lessons and over 300 drawings, by Billy Hon, the celebrated newspaper cartoonist.

Sent Postpaid for \$1.00

WASLEY PUBLISHING CO.

210-F West 14th St. Los Angeles, Cal.

PIMPLES

Cleared Up—often in 24 hours. You can be rid of Pimples, Blackheads, Acne Eruptions on the face or body, Barber's Itch, Eczema, Enlarged Pores, Oily or Shiny Skin. CLEAR-TONE used since 1910 in the above conditions—simply magical in prompt results. Write today, get complete story of remarkable success of CLEAR-TONE and read the enthusiastic endorsements.

FREE Just send name for full particulars and free booklet, "A CLEAR-TONE SKIN," that tells all about this quick, simple, easy way to Clear Your Skin.
E. S. GIVENS, 568 Chemical Bldg., Kansas City, Mo.

GET IDEAS From Reading many circulars. We

know a man who reads circulars and found an idea from which he made 300 Dollars. Send 25 cents and we will send you our latest bulletins of the very latest ideas.
A. S. CERVENEC SYSTEM, Box 4, Buffalo, N.Y.

The Metal Emperor

By A. MERRITT

(Continued from page 78)

"Taken! By whom?" I gasped. "Taken by what—these?" I swept my hands out toward the Horde milling around us.

"No! These are mine! These are they who obey me!" The golden voice now shrilled with her passion. "Taken by—men!"

Drake had read my face although he could not understand our words.

"Ruth—" he groaned.

"Taken," I told him. "Both Ruth and Ventnor. Taken by the armored men—the men of Cherkis!"

"Cherkis!" She had caught the word. "Yes—Cherkis! And now he and all his men—and all his women—and every living thing he rules shall pay! And fear not—you two. For I, Norhala, will bring back my own.

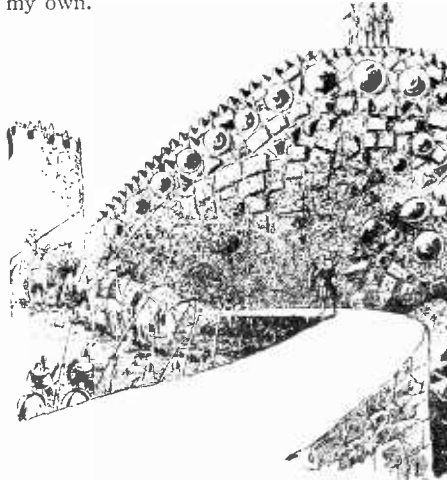

"There was a blare of trumpets. Upon the parapet leaped a man clad all in gleaming red armor. From head to feet the close-linked scales covered him. Within a hood shaped somewhat like the tight-fitting head coverings of the Crusaders, a cruel face stared at us. In the fierce black eyes no trace of fear.

The man in scarlet threw up a hand. "Who are you?" he shouted. "Who are you three that come driving down upon Ruszark through the rocks? We have no quarrel with you!"

"I seek a maid and a man," cried Norhala. "A maid and a man your thieves took from me. Bring them forth! . . ."

"Woe, woe to you, Cherkis, and to all of yours! For I, Norhala, am awake, and I, Norhala, remember! Woe to you, Cherkis, woe—for now all ends for you!"

"Not by the gods of my mother who turned their strength against her do I promise this. I, Norhala, have no need of them—I, Norhala, who have strength greater than theirs. And would I could crush those gods as I shall crush you, Cherkis—and every living thing of yours. Yes—and every unliving thing as well!"

No longer halting was Norhala's speech. It poured from the ruthless lips, flamingly.

"We go," she cried. "And something of vengeance I have saved for you—as is your right."

She tossed her arms high, and stamped upon the back of the cubes that held us. They quivered and sped away. Swiftly dwindled the City's bulk, fast faded its glimmering, watchful face. Above us, crouching against the blast of our going, streamed like a silken banner Norhala's tresses, gemmed with the witch lights and threaded with the flashing strands of beaded jewel fire.

Now we were far out in the Pit. The cubes slowed. Norhala threw high her head. From her throat pealed a trumpet call—golden, summoning, imperious. Thrice it rang forth—and all the Pit seemed to halt and listen.

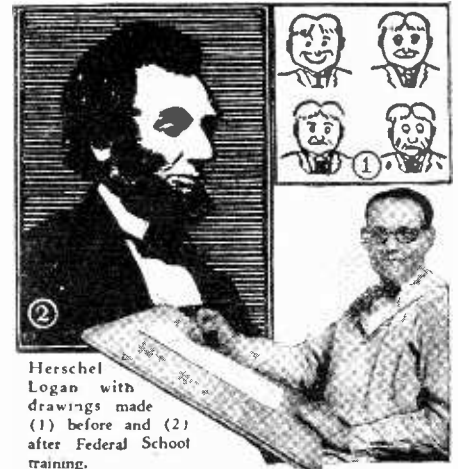

Herschel Logan with drawings made (1) before and (2) after Federal School training.

DRAWING turns INK to GOLD

Herschel Logan's first drawings (1) were very poor. But he was determined to succeed. Obtaining a beginner's position in a publishing house, he studied his Federal Course at night. Today his drawings are seen in National Exhibits. Recently he made \$100.00 over his regular monthly salary. Do you like to draw? Logan did, so he answered an ad like this. Now compare his recent drawing (2) with the small crudely drawn heads he made before he took the Federal Course. Then follow his example and develop your talent.

Mr. Logan is just one of hundreds of young people making good money because of Federal Training. Opportunities in illustrating have never been better. Publishers buy millions of dollars worth of drawings every year. Illustrating is fascinating as well as profitable. The Federal Course includes illustrating, cartooning, lettering, poster designing, window card illustrating, etc. Instructions are written by a specialist in each subject.

Fifty of the nation's leading artists such as Norman Rockwell, Clare Briggs, Fontaine Fox, Neysa McMein and others contribute lessons and drawings especially prepared by themselves; all are included in the Federal Home Study Course.

Do you like to draw? A liking for drawing usually indicates talent which can be developed. Send for our free booklet, "A Road to Bigger Things." It explains the details of illustrating and includes a chart to test your ability. Profit by Logan's success. Send for it now.

Federal School of Illustrating

FEDERAL SCHOOL OF ILLUSTRATING.

5338 Federal School Bldg., Minneapolis, Minn. Please send your free book, "A Road to Bigger Things," together with Test Chart.

Name Age.....

Present Occupation

Address

The Modern Craftsman's Wonder Home Work Shop

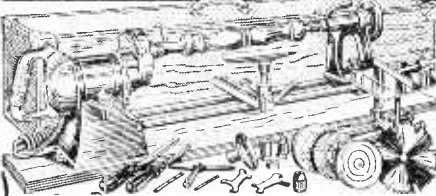

This Wonder Working Set of Craftsman's Tools

Makes Homework Easy! YOU can now make anything on your own private work bench.

RED JACKET

Equipment is a chest full of tools designed by a master for the private use of tool lovers and men who want to build, construct, invent and create at home. Make everything attractive furniture, toys, home and garden improvements, all around manufacturing, repairing.

The Complete Equipment consists of the powerful Red Jacket Motor, with direct drive to the Waco precision wood turning lathe (capacity 9 in. x 34 in.); a bench saw, that has depth and side gauges, scroll and jig saw; and all accessories for both portable and stationary power drilling, buffing, grinding and cleaning. Attaches to any light socket and converts your work bench into a complete private tool and machine shop.

THE WACO GUARANTEE
If Not What You Want When You Get It—Send It Back

ONLY \$10.00 DOWN—Sent on 10-Day Trial FREE CRAFTS COURSE and blue print service tells you how to make things.

Interesting Literature Free
Send the coupon. You will be surprised with all it contains. Beautiful, Instructive, Fascinating, Interesting.

ASK FOR INFORMATION

WACO TOOL WORKS, 542 No. Parkside Ave. Chicago, Ill.
Manager, Dept. 205. Please send me particulars about 10-day free trial, free blue-prints and \$10 down payment.
Name.....
Address.....

Make Money In ELECTRICITY Learn in Los Angeles!

BE an electrical specialist. Gain quick success in this most fascinating and profitable field. Learn at National in the center of tremendous electrical projects costing more than \$100,000,000.00—unlimited opportunities now.

Practical, intensive training by National's job-experience method in 6 to 9 months. All technical essentials included. School endorsed by leaders in electrical industry. You learn all branches of electricity; radio. Million dollar institution; all modern equipment and training facilities. Life scholarship. No age limit. Free employment service. Over 17,000 successful graduates. 23rd year. Big, illustrated 84-page catalog sent FREE. Write today

FREE BOOK

NATIONAL ELECTRICAL SCHOOL
Dept. 291 4006 So. Figueroa. LOS ANGELES CALIF.

TYPEWRITER PRICES CUT

World's best makes—Underwood, Remington, Oliver—prices slashed to almost half.

\$2 and it's yours

All late models, completely rebuilt and re-finished brand new. GUARANTEED for ten YEARS. Send no money—big FREE catalog shows actual machines in full colors. Get our direct-to-you easy payment plan and 10-day free trial offer. Limited time, so hurry today. International Typewriter EX-136 W. Lake St. Dept 517 Chicago

Free Trial

MAGIC Earn \$250 to \$1000 Monthly

New! Different! Teaches you Big Tricks, Illusions, Stage Stunts, "Patent" and the Principles of Magic—Learn at home. Earn \$250 to \$1,000 a month. Write today for special offer. TARBELL SYSTEM, INC 1926 Sunnyside Ave., Studio 14-25 Chicago, Ill.

Followed upon its ending, a chanting as goldenly sonorous. Wild, peremptory, triumphant—it was a mustering shouting to adventurous stars, buglings to buccaneering winds, cadenced beckonings to restless ranks of viking waves, signaling to all the corsairs and picaroon of the elemental.

A cosmic call to loot!

Under that lawless roudade the blocks upon which we rode quivered, and I felt a thousand needle-pointed, roving arrows prick me, urging me on to some jubilant, reckless orgy of destruction.

Obeying that summoning there swirled to us cube and globe and pyramid by the score. By the hundreds. They swept into our wake and followed, lifting up behind us, like an ever rising sea.

Higher and higher arose that metal wave—mounting, ever mounting as other score upon score leaped upon it, rushed up it and swelled its crest. And soon it was so great that it hung over us and shadowed us.

The cubes we rode swerved in their course, and raced with ever increasing speed toward the spangled curtains. Still Norhala's golden chant lured. Higher and ever higher reached the following wave. Now we were rising upon a steep slope, and now the amethystine, gleaming ring was almost over head.

Norhala's song ceased. One breathless, soundless moment and we had pierced the veils. A globule of sapphire shone afar, the elfin bubble of her home. We neared it.

I saw three ponies, with high and empty saddles turquoise-studded, lift their heads from their roadway browsing. For a breath they stood, stiff with terror, then whimpering, raced away.

We were at Norhala's door. We were lifted down. Drake and I sprang to enter.

"Wait!" Norhala's white hands caught us. "There is peril there—without me. You must—follow."

We stared at her. Upon her face was no diminishing of rage, no weakening of determination. The star-flecked eyes were not upon us, they looked over and beyond—coldly, calculatingly.

"Not enough," I heard her whisper. "Not enough—for that which I will do."

We turned, following her gaze. A hundred feet on high, stretching nearly across the gorge, an incredible curtain was flung. Over all its folds was movement—arms of spinning globes that thrust forth like paws, and down upon which leaped pyramid upon pyramid, stiffening, as they clung, like bristling spikes of hair; great bars of clinking cubes that threw themselves out from it like arms, flexed themselves, and drew back into the mass. The curtain was in a ferment. It palpitated with eagerness. It throbbed with desire.

"Not enough!" murmured Norhala.

Her lips parted. From them came another trumpeting—tyrannic and arrogant. The curtain writhed. Out from it spurted thin cascades of cubes. They swarmed up into tall pillars that shook and swayed.

With blinding flash upon flash the sapphire incandescences struck forth at their feet. A score of flaming columned shapes leaped up and curved in meteor flight. Streaming with violet fires they shot back to the valley of the City.

"Hai!" shouted Norhala as they flew. "Hai!"

Up darted her arms. The mighty curtain of the Metal Things pulsed and throbbed, its units interweaving—block and globe and pyramid of which it was woven each seeming to strain at leash.

"Come!" cried Norhala, and led the way into her house. I stumbled over a brown-faced, leather-cuirassed body that lay half over, legs barring the threshold.

We were within the chamber of the pool. About it lay a fair dozen of the armored men. Ruth's defense, I thought with grim

Needed... Radio Set Owners, Builders and "Hams"

The "Radio News Amateurs' Handbook" is needed by all radio set owners, builders, and experimenting "hams." This valuable magazine contains authentic information on all the latest circuits and developments of the industry. Every construction article appearing in this remarkable handbook is written by the most eminent Radio authorities. Each circuit and principle was thoroughly tested and proven before a word of constructional data that appears on these pages was prepared.

The Radio News Amateurs' Handbook is replete with accurate circuits of carefully tested apparatus. The latest, most efficient method of power supply, new approved audio systems, power amplification, all recent receiving circuits, short-wave outfits, transmitting sets—complete constructional data and information on each of these topics.

Anyone interested in Radio will find this magazine a seemingly endless source of valuable information. If your newsdealer cannot supply you mail the coupon below. Don't wait! 116 pages—fully illustrated.

Price 50c.

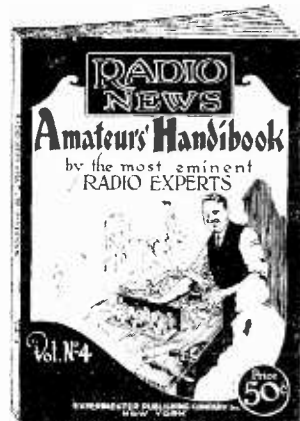

EXPERIMENTER PUB. CO.

230 Fifth Avenue New York, N.Y.

EXPERIMENTER PUBLISHING CO.
230 Fifth Ave., New York, N. Y.

Gentlemen: Enclosed find 50c., for which please send me a copy of the RADIO NEWS AMATEURS' HANDBOOK.

Name.....
Address.....
City..... State.....



DO THIS!
AND MAKE \$5 AN HOUR!
 Absolutely astounding! This novel, simple device—**Securograph!** It protects checks! Now the crooks who robbed \$250,000,000 in one year by raising and forging checks are stumped! All you do is run the rotating wheel across the face of the check and no thief will ever make a nickel by "re-touching" it.

The Amazing SECUROGRAPH
 I want agents all over the country to introduce this unusual, patented article. Sell **Securograph** for \$1.50 and pocket 50c yourself on every sale. J. Morland, of Louisiana, sold ten **Securographs** at a board meeting he was attending. \$5.00 in less than half an hour. This is the only one of its kind! It took me 17 years to perfect this astonishing article. Find out about the **Securograph** now—also full details about the **Security Fountain Pen**.

Write TODAY!—Grab this chance! Write me today! Ask for full details, including information about the sensational **Security Pen**—the wonder fountain pen with the **Securograph** feature. Or quicker, enclose \$1.00 for demonstrating sample of **Securograph**.

Act today! **STAGHLINE**
SECURITY PEN CORP., John H. Krittkson, Pres.
 522 Tenth Street
 Mt. Carmel, Ill.

Orders - Inquiries

60 pages
 Send for FREE COPY

POLK'S REFERENCE BOOK and Mailing List Catalog

Can be Secured by MAIL

Gives counts and prices on over 8,000 different lines of business. No matter what your business, in this book you will find the number of your prospective customers listed. Valuable information is also given as to how you can use the mails to secure orders and inquiries for your products or services.

Write for Your FREE Copy
R. L. POLK & CO., Detroit, Mich.
 Largest City Directory Publishers in the World
 Mailing List Compilers—Business Statistics
 Producers of Direct Mail Advertising

RESHAPE your NOSE
 to beautiful proportions—while you sleep!

ANITA NOSE ADJUSTER
 is SAFE, painless, comfortable. Speedy, permanent results guaranteed. Doctors praise it. No metal to harm you. Small cost.

Gold Medal
 Won 1923

Write for FREE BOOKLET

ANITA CO., 573 Anita Bldg., Newark, N.J.

THE MIDGET SLIDE RULE
 instantly adds, subtracts, multiplies, divides, solves proportion, gives all roots and powers, Logarithms, Sines, Cosines, Tangents, Cotangents, etc. Also gives decimal equivalents, lettered and numbered drill and tap sizes.

More than 110,000 sold, more than 2,000 unsolicited testimonials. The Engine-divided scales are on white-finished aluminum and are grease and waterproof. Diameter 4". Price with instruction book, \$1.50. Pocket Carrying Case, 50c extra. Cash or C.O.D. Catalogue free. Your money back if you are not satisfied.

WILSON SLIDE RULE COMPANY, Stuart, Florida

delight, had been most excellent. Those who had taken her and Ventnor had not done so without paying toll.

A flashing drew my eyes away. Close to the pool wherein we had first seen the white miracle of Norhala's body, two immense purple stars blazed. Between them, like a suppliant cast from black iron, was Yuruk. Poised upon their nether tips the two stars guarded him. Head touching his knees, eyes hidden within his folded arms, the black eunuch crouched.

"Goddess!" he whimpered. "Goddess! Mercy!"

"I saved him," she turned to us, "for you to slay. It was he who brought those who took the maid who was mine, and the helpless one that she loved. Now you shall slay him."

Drake's hand twitched down to his pistol. He leveled the gun at the black eunuch. Yuruk saw it, and shrieked and covered. Norhala laughed.

"He dies before the stroke falls," she said. "He dies doubly therefore—and that is well."

Drake slowly lowered the automatic, and turned to me.

"I can't," he said. "I can't do it. I want to kill him—and I can't."

"Master!" The eunuch writhed toward us. "What I did was for love of the Goddess. I thought if the maid and the blasted one were gone, that you would follow. Then I would be alone with the Goddess once more. Cherkis will not slay them—and Cherkis will welcome you, and give the maid and the blasted one back to you for the arts that you can teach him. Mercy, Masters, I meant no harm—bid the Goddess be merciful!"

"Slay him," said Norhala. "Slay him—one or both of you. It is your right."

"Norhala," I answered, "we cannot slay him so. When we kill, we kill in fair fight. The maid we love has gone. It will not bring her back if we destroy him. We would punish him—yes. But kill him we cannot. And we would be after the maid and her brother quickly."

She looked at us, perplexity shading the anger.

"As you will," she said at last. "But Yuruk has disobeyed me. That of mine, which I committed to his care, he has given to my enemies."

She pointed to the dead. "Yuruk, gather up these carrion and pile them together."

The eunuch arose, and stole out fearfully from between the two stars. He slithered to body after body, dragging them to the center of the chamber, forming of them a heap. One of the Persians was not dead. His eyes opened as Yuruk seized him.

"Water!" he begged. "Give me drink. I burn!"

I felt pity, and lifted my canteen and walked toward him.

"You of the beard," said Norhala coldly, "he shall have no water. Drink he shall have, and soon—drink of fire!"

The soldier's fevered eyes rolled toward her, and read aright the ruthless face.

"Sorceress!" he spat at her. "Cursed spawn of Ahriman!"

The talons of Yuruk stretched around his throat.

"Son of unclean dogs!" whined the eunuch. "You dare blaspheme the Goddess!"

He snapped the soldier's neck as though it had been a rotten twig. At the callous cruelty I stood for an instant, petrified; heard Drake swear wildly, saw his pistol flash up.

Norhala struck down his arm.

"Your chance has passed," she said. "And not for that shall you slay him."

Yuruk threw the body upon the others. The pile was complete.



If You Want Thrills- Popularity-Big Pay LEARN AVIATION QUICK!



ARE you a red-blooded, a daring he-man? Do you crave adventure, popularity, admiration, and the applause of great crowds? Then why not get into the Aviation Industry—the greatest adventure since time began—the greatest thrill ever offered to man?

Think what Aviation offers you. The praise and plaudits of the multitude. And a chance to get in on the ground floor where rewards may be unlimited! Aviation is growing so swiftly that one can hardly keep track of all the astonishing new developments. Air-mail routes have just been extended to form a vast aerial network over the entire U. S. Many Commercial Airlines and airplane factories are now being organized. Men like Henry Ford are investing millions in the future of commercial Aviation for they see its great possibilities.

Easy to Get into Aviation by this Home Study Method

Get into this thrilling profession at once while the field is new and uncrowded. Now—by a unique new plan—you can quickly secure the basic and preparatory training you need to get started in the Aviation Industry at home, in spare time. Experts will teach you the secrets and fundamentals of Practical Aviation—give you all the inside facts that are essential to your success. And, the study of Aviation by this remarkable method is almost as fascinating as the actual work itself.

PICK YOUR JOB!

- Flying
- Airplane Instructor
- Airplane Engineer
- Airplane Repairman
- Airplane Assembler
- Airplane Mechanician
- Airplane Inspector
- Airplane Builder
- Airplane Salesman
- Exhibition Manager
- Airplane Contractor
- Airplane Motor Expert
- Airplane Designer



Send for FREE Book!
 Send coupon for our new free book, just out—*Opportunities in the Airplane Industry*. It is vitally interesting, reads like a romance and tells you things about this astonishing profession you never even dreamed of. Write for your copy today.

AMERICAN SCHOOL OF AVIATION
 3601 Michigan Ave., Dept. 1425 Chicago

AMERICAN SCHOOL OF AVIATION
 3601 Michigan Ave., Dept. 1425, Chicago, Ill.

Without obligation, please send me your FREE Book, *Opportunities in the Airplane Industry*. Also information about your Home Study Course in Practical Aviation.

Name..... Age.....

Address.....

City..... State.....

\$100,000 plus a monthly Salary of \$1,200

was paid to an Inventor through our assistance after we had made a Commercial Model for him.

We have extensive facilities for developing inventions and ideas. A staff of engineers, skilled mechanics, and draftsmen and 10,000 sq. ft. of floor space are at your service if your idea or invention has merit. We can render valuable aid in bringing your invention or idea to a Commercial Success. A simple device often proves a real money maker.

We Make Appraisals and Give Expert Opinions

Also furnish advice to inventors free of charge. We also prepare patent specifications.

A Manufacturer saved \$200,000 by consulting us about the merits of a patented device.

CRUBAN MACHINE & STEEL CORPORATION

Engineers and Manufacturers

54 Varick St. 13-15 Laight St.
New York City



High School Course in 2 Years

This simplified, complete High School Course—specially prepared for home study by leading professors—meets all requirements for entrance to college, business, and leading professions.

20 Other Courses

Over 200 noted Engineers, Business Men, and Educators helped prepare the special instruction which you need for success. No matter what your inclinations may be, you can't hope to succeed without specialized training. Let us give you the practical training you need.

American School
Drexel Ave. & 58th Street
Dept. 1-5234 Chicago

Money Back When You Finish If Not Satisfied

American School, Dept. H-5294 Drexel Ave. and 58th St., Chicago

Send me full information on the subject checked and how you will help me win success in that line.

- | | |
|----------------------------|----------------------------|
| Architect | Electrical Engineer |
| Building Contractor | General Education |
| Automobile Engineer | Lawyer |
| Civil Engineer | Mach. Shop Practice |
| Structural Engineer | Mechanical Engineer |
| Business Manager | Steam Engineer |
| C. P. A. & Auditor | Sanitary & Heating |
| Bookkeeper | Surveyor & Mapping |
| Draftsman & Designer | High School Graduate |

Name.....
Address.....



AIRPLANE

12-inch scale model of Lindbergh's Spirit of St. Louis. Scientifically designed and very realistic. Rises from ground by own power. Flies 30 ft. or more. Easily built without tools. Construction set, with all parts and full directions, postpaid in U.S., only 50c. (no stamps). Satisfaction or money back. Send today.

MANN & BENTON, Chillicothe, Ohio

"Mount!" commanded Norhala, and pointed. He cast himself at her feet. She looked at one of the stars. Something of command passed from her, something it understood plainly. The star slipped forward—there was an almost imperceptible movement of its side points. The twitching form of the black leaped from the floor and was thrown like a bag upon the mound of the dead.

Then out of the violet ovals beneath the upper tips of the stars spurted streams of blue flame. They fell upon Yuruk and splashed upon the heap of the slain. In the mound was a dreadful movement. The bodies stiffened. They seemed to try to rise, and to push away—dead nerves and muscles responding to the blasting energy passing through them.

Out of the stars rained bolt upon bolt. In the chamber was the sound of thunder, crackling like broken glass. The bodies flamed and crumbled.

Where there had been a heap of slain capped by the black cumuch, there was but a little whirling cloud of sad gray dust. Caught by a passing draft, it eddied, slipped over the floor and vanished through the doorway. The blasting stars stood motionless, contemplating us. Motionless stood Norhala, her wrath no whit abated.

"Listen," she spoke abruptly. "You two who love the maid. What you have seen is nothing to that which you shall see—it is but as a wisp of mist to the storm-cloud!"

"Norhala"—I found speech—"when was it that the maid was captured?"

"They came long before dusk," she said. "By the night before, Yuruk had gone to Ruzark, the city of Cherkis. And long before dawn they were on their way hither. The black dog told me."

"But Yuruk was with us here at dawn of yesterday," I gasped.

"A night has passed since then," she said, "and lo! another night is almost gone."

Stunned, I considered this. If it were true—and not for an instant did I doubt her word—then not for a few hours had we lain at the foot of the living wall in the hall of the cones, but for the balance of that day and that night, and another day and part of still another night.

"What does she say?" Drake stared anxiously into my white face.

I told him.

"Yes." Norhala spoke again. "The dusk before the last dusk I returned to my house. The maid was there and sorrowing. She told me you had gone into the valley, and prayed me to help you and to bring you back. I comforted her, and something—of the peace—I gave her. But not all, for she fought against it. A little we played together, and I left her sleeping. I sought, and found you also sleeping. I knew no harm would come to you, and I went my ways—and forgot you. Then came I here again to find Yuruk and these the maid had slain."

Her eyes flashed.

"I honor the maid for the battle that she did," she said, "though how she slew so many strong men I know not. All my heart goes out to her. And therefore when I bring her back she shall no more be plaything to Norhala, but sister. And with you—it shall be as she wills. But woe to those who have taken her!"

From without came a rising storm of thin wailings, insistent and eager. She paused, listening.

"And I have an older vengeance than this to take," she went on. "Long have I forgotten—and shame I feel that I had forgot. So long have I forgotten all hatreds, all lusts, all cruelty—among—those—" She thrust a hand forth toward the hidden valley. "Forgot—dwelling in the great harmonies. Save for you, and what has be-



and now it's TELEVISION

Ten years ago Radio was in its infancy—today TELEVISION is. The possibilities of TELEVISION are every bit as great as those of Radio. And development will probably be much faster, for the basic principles of TELEVISION are closely allied to those of Radio. Much of the fundamental groundwork, therefore, has already been laid. Grow with this infant industry—all the thrills of the experimenter are here just as they were in Radio. Learn all there is to know about this new art. This up-to-date book will give you full details on all that has been done in the development of TELEVISION. Written by the leading authorities—all theories, discoveries, and trends are fully explained and written in an easily understandable way.

BUILD YOUR OWN TELEVISION SET

Complete instructions for building an experimental TELEVISION outfit are given in this remarkable book. Anyone can build his own. Complete apparatus can be bought very reasonably.

Over 112 pages—fully illustrated. Large size 9x12 book

Mail this coupon now! Don't wait—be the first in your neighborhood. You'll get many hours of priceless enjoyment.

Experimenter Publishing Co.
230 Fifth Avenue New York, N. Y.

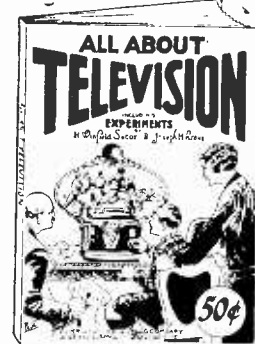

50c

50c

EXPERIMENTER PUBLISHING CO.
230 Fifth Avenue, New York, N. Y.
Gentlemen: Kindly send me a copy of TELEVISION. Enclosed is 50 cents.

Name.....
Address.....
City..... State.....

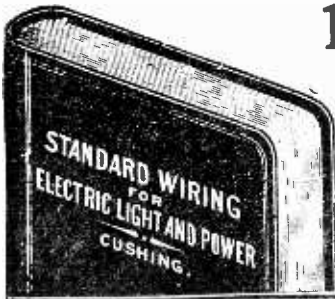

1928 EDITION

Just Out

LEARN WIRING
And Earn \$75-\$100 a Week

NO WIREMAN IS EVER OUT OF A JOB

Thousands of young men have become expert wiremen through the simple rules and tables given in Standard Wiring. All you need to know.

It contains The National Electrical Code explained and illustrated. New illustrated chapters on Outside and Inside Wiring for all systems for both direct and alternating currents; House and Residence Wiring, Garage, Theatre and Moving Picture House Wiring, Shop and Store Wiring and Lighting.

How to install, operate and care for Generators, Motors, Storage Batteries, Electric Ranges, Fixtures, and every kind of wiring device for light, heat and power. Any schoolboy can understand it.

512 Pages—396 Illustrations—96 Tables

Leather Cover, Gilt Edges, Pocket Size \$3.00 Sent Post Paid on Receipt of Price

H. C. CUSHING, Jr.

13 WEST 55th STREET NEW YORK

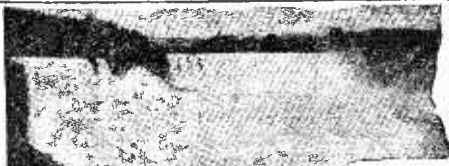

LEARN BY DOING

Every phase of all branches

ELECTRICITY

taught by

Actual Practice

In America's foremost and oldest institution for trade training

No Books Used

Individual Instruction Start Any Day

Write for FREE 64-page catalog

THE NEW YORK ELECTRICAL SCHOOL

40 West 17th St., New York City

\$4.99 22 Cal. Blank Automatic

WITH 100 rounds. You need no license or permit to own this 6-shot automatic. Use for fun or self-defence. Keeps away traps, frightens thieves, scares away dogs—a real home protector. Fool your friends. Same as an expensive automatic in construction, finish, appearance, durability; automatic magazine loading and ejection of cartridges. Instantly and powerful report. Guaranteed absolutely safe. Send no money. Pay expressman \$4.99 for automatic with 100 cartridges. JENKINS, 621 Broadway, New York, Dept 65J5

FREE to BOYS!

Sample copy of OPEN ROAD for BOYS Magazine—50 pages of thrilling stories, pictures, sports, mystery, etc. Also free membership in the WINNIT CLUB—badge button, big outfit, catalog and brand-new plan for making lots of easy money and small prizes. ALL FREE! Funy and boyish even too. No obligations.

Send name and address at once to

WINNIT CLUB 29 Open Road for Boys 248 ROYALTON ST. F11T BOSTON, MASS.

MEN WANTED FOR RAILROADS

Nearest their homes—everywhere to train for Firemen, Brakemen, beginners \$150-\$250 monthly. Promoted to Conductor or Engineer—\$3,000-\$4,000 yearly—highest wages on railroads. Also clerks.

RAILWAY EDUCATIONAL ASSOCIATION, Dept. D79-5 Brooklyn, N. Y.

fallen, I would never have stirred from them, I think. Now, awakened, I take my vengeance. After it is done"—she paused—"after it is over I shall go back again. For this awakening has in it nothing that I love. It is a fierce and slaying fire. I shall go back—"

The shadow of far dreaming softened the angry brilliancy of her eyes.

"Listen, you two!" The shadow of dream fled. "Those that I am about to slay are evil—evil are they all, men and women. Long have they been so—yes, for cycles of suns. And their children grow like them—or, if they be gentle and with love for peace, they are slain, or die of heartbreak. All this my mother told me long ago. So no more children shall come from them to suffer, or to grow evil."

Again she paused.

"My father ruled Ruzark," she said at last. "Rustum he was named, of the seed of Rustum the Hero, even as was my mother. They were gentle and good, and it was their ancestors who built Ruzark when, fleeing from the might of Iskander, they were sealed in the hidden valley by the falling mountain. Then there sprang from one of the families of the nobles, and kin to mine, Cherkis! Evil, evil was he, and as he grew he lusted for rule. On a night of terror he fell upon those who loved my father and slew. Barely had my father time to fly from the city with my mother, still but a bride, and a handful of those loyal to him. They found, by chance, the way to this place, hiding in the cleft which is its portal. They came, and they were taken by—those who are now my people. Then my mother, who was very beautiful, was lifted before him who rules here, and she found favor in his sight, and he had built for her this house, which is now mine.

"And in time I was born—but not in this house. Nay—in a secret place of light where too, are born my people."

A secret place of light! Was it that vast vault of mystery, of dancing orbs, of flames transmuted into music into which we had peered? And was this the explanation of her strangeness? Had she sucked in there with her mother's milk the enigmatic life of the Metal Horde? been transformed into half-human changeling? Become true kin to them? What else could explain—

"My mother showed me Ruzark," her voice checked my thoughts. "Once, when I was little, she and my father bore me through the forest and through the hidden way. I looked upon Ruzark—a great city, and a caldron of cruelty and of evil.

"Not like me were my father and mother. They longed for their kind and sought them. There came a time when my father, driven by this longing, ventured forth to Ruzark, seeking friends to help him regain that place—for these obeyed not him as they obey me. So he could not have marched—as I shall—upon Ruzark.

"Cherkis caught him. And Cherkis waited, for he knew not where to seek my mother nor where they had lain hid.

"Between this city and here the mountains are great, unscalable, and the way through them is cunningly hidden. Though they tortured him, my father would not tell them how to find that way. And after a while my mother stole forth with those who still remained of hers. They left me here with Yuruk. And Cherkis caught my mother!"

"My father was flayed alive, and crucified," she whispered. "They nailed his skin to Ruzark's gates. And when Cherkis had had his will with my mother, he threw her to his soldiers for their sport!

"All of those who went with them, save one, he tortured and slew. That one escaped and told me—who was not yet a budding maid. He called on me to bring vengeance

Weak Men Revitalized BY NATURAL METHODS



STRONGFORT
Builder of Men

Do you flinch and cringe and blush when strong men or women look you straight in the eyes? Are you timid in company? Do you feel afraid to approach people—afraid to ask for a better job?—or for better pay? Are you shy about asking a girl to dance, or do you make up your mind the girl you want won't care for you? Do you pass up a lot of fun because you feel you are not wanted in a party or a crowd of fun-makers?

DON'T BE DESPISED

Don't be laughed at, gossiped about, sneered at, despised. You are to be pitied if you are discouraged and despondent and down with the blues, but who wants to be pitied? You don't. You want to be a manly man—a strong, healthy

chap it is a pleasure to meet and associate with—a fellow that men like to call by his first name—one whose company is craved—a regular fellow. And you can be just such a man, no matter how far down the ladder you've slipped, no matter how you've neglected yourself, no matter what your excesses or your dissipation.

STRONGFORTISM
WILL DO WONDERS FOR YOU

I have made powerful men out of mere weaklings. You can have good health and manly strength. You can have energy and vitality. You can have a clear, unflinching eye and a steady nerve. You want courage, "sand" and pep. All these will be your precious possessions by following in the paths in which I have directed thousands—you can be a real man.

SEND FOR MY FREE BOOK

This FREE BOOK is packed full of inside facts about the human body. It tells how I became the world's outstanding strong man and developer of men. It is a priceless possession, yet I send it ABSOLUTELY FREE! SEND FOR IT TODAY.

LIONEL STRONGFORT
Physical and Health Specialist for over 25 Years

Dept. 471 Newark, N. J., U. S. A.

Send This FREE Consultation Coupon ABSOLUTELY CONFIDENTIAL

Mr. Lionel Strongfort, Strongfort Institute, Dept. 471, Newark, N. J.

Please send me absolutely free my copy of your book, "PROMOTION AND CONSERVATION OF HEALTH, STRENGTH AND MENTAL ENERGY." I have marked (x) before the subjects in which I am most interested.

- .. Catarrh
- .. Colds
- .. Asthma
- .. Headache
- .. Rupture
- .. Thinness
- .. Pimples
- .. Insomnia
- .. Impotency
- .. Overweight
- .. Constipation
- .. Weak Back
- .. Weak Eyes
- .. Rheumatism
- .. Nervousness
- .. Night Losses
- .. Short Breath
- .. Weak Heart
- .. Great Strength
- .. Vital Losses
- .. Lung Troubles
- .. Round Shoulders
- .. Youthful Errors
- .. Manhood Restored
- .. Stomach Disorders
- .. Increased Height
- .. Muscular Development

Private Ailments.....

Name.....

Age..... Occupation.....

Street.....

City..... State.....

HOME-STUDY COURSES

THAT LEAD TO BUSINESS CAREERS

DO YOU WANT an important, high-salaried position? You can have one if you can do the work. LaSalle experts will show you how, guide you step by step to success and help solve your personal business problems thru the time-saving LaSalle Problem Method. Our salary-increasing plan enables you to prepare during your spare hours, without interference with your present duties. Simply mark on the coupon the field in which you desire success, and we will mail you a valuable book describing the opportunities in that field, together with an outline of our salary-increasing plan. Also copy of "Ten Years' Promotion in One." There is no cost or obligation. Find out how the salary-increasing plan starts average men and women on the high road to success and financial independence. Check and mail the coupon NOW.

— — — Find Yourself Through LaSalle — — —
LA SALLE, EXTENSION UNIVERSITY
 The World's Largest Business Training Institution
 Dept. 5384-R Chicago

I should be glad to learn about your salary-increasing plan as applied to my advancement in the business field checked below.

- Business Management
- Higher Accountancy
- Traffic Management
- Modern Salesmanship
- Railway Station Management
- Law—Degree of LL.B.
- Commercial Law
- Industrial Management
- Modern Foremanship
- Personnel Management
- Banking and Finance
- Modern Business Correspondence
- Expert Bookkeeping
- C. P. A. Coaching
- Business English
- Commercial Spanish
- Effective Speaking
- Stenotypy—Stenography
- Telegraphy
- Credit and Collection Correspondence



Name.....
 Present Position.....
 Address.....

PARKS WOODWORKING MACHINES

Cabinet Shop Special No. 10

\$290

with Motor

You ought to have this handy Parks in your shop. Compact, complete machine designed like a big production outfit at one-fifth the cost. Fits in a corner of your basement. Does any kind of cabinet and joinery work. Write for circular.

THE PARKS WOODWORKING MACHINE CO.
 1553 Knowlton Street, Cincinnati, Ohio
 Canadian Factory: 208 Notre Dame East, Montreal

Play the HAWAIIAN GUITAR

Just as the Natives Do

FREE when you enroll
\$15 HAWAIIAN GUITAR and Case

Only 4 Motions used in playing this fascinating instrument. Our native Hawaiian instructors teach you to master them quickly. Pictures show how. Everything explained clearly.

Play in Half Hour
 After you get the four easy motions you play harmonious chords with very little practice. No previous musical knowledge necessary.

Easy Lessons
 Even if you don't know one note from another, the 62 printed lessons and the clear pictures make it easy to learn quickly. Pay as you play.

Free Guitar and Outfit in Genuine Seal Grain Fabricoid Case as soon as you enroll. Nothing to buy—everything furnished. No delay.

Write at Once
 You'll never be lonesome with this beautiful Hawaiian Guitar. Write for Special Offer and easy terms. A postcard will do. A.C.T.

OTHER COURSES: Tenor Banjo, Violin, Tiple, Tenor Guitar, Ukulele, Banjo Ukulele—under well-known instructors.

FIRST HAWAIIAN CONSERVATORY OF MUSIC, Inc.
 9th Floor, Woolworth Bldg., Dept. 140 New York, N. Y.
 Approved as a Correspondence School Under the Laws of the State of New York

Wonderful, new device, guides your hand; corrects your writing in few days. Big improvement in three hours. No failures. Complete outline FREE. Perfect Penmanship Inst., Dept. 44, St. Louis, Mo.

—and he died. A year passed . . . and I am not like my mother and father . . . and I forgot . . . dwelling here in the tranquillities, barred from and having no thought for men and their ways.

"Aie, aie!" she wailed: "Woe to me that I could forget! But now I shall take my vengeance—I, Norhala, will stamp them flat—Cherkis and his city of Ruszark and everything it holds! I, Norhala, and my servants shall stamp them into the rock of their valley so that none shall know that they have been!"

She threw out white arms.
 The Disc had not slain her mother, then—or any of hers? Why had Yuruk told that tale of her mother's mother, and why had he lied to me of their fate? Of course! He had lied to play upon our terrors. To frighten us away.

The wailings were rising in a sustained crescendo. One of the slaying stars slipped over the chamber floor, folded its points, and glided out of the door.

"Come!" commanded Norhala, and led the way. The second star closed and followed us. We stepped over the threshold—

For one breathless moment we paused. In front of us reared a monster—a colossal, headless Sphinx. Like fore legs and paws, a ridge of pointed cubes and globes thrust against each side of the canyon walls. Between them for two hundred feet on high stretched the body, a shifting, weaving mass of the Metal Things. They formed into gigantic cuirasses, giant bucklers, shields and corselets of living mail. From them as they moved came the wailings. Like a headless Sphynx they crouched—and as we waited, they surged forward.

"Hai!" shouted Norhala, "Hai! my companies!"

Out shot a long and slender trunk of the cubes and spinning globes. It nuzzled us, caught us up as an elephant would its mahout and swept us to its crest. I tottered, dizzily, was held fast, and stood beside Norhala upon a little, level, twinkling eyed platform. At her other side swayed Drake.

Through all the monstrous shape throbbed an eager, impatient pulse. Like some huge and grotesque beast, the back of the clustered Things ran for half a mile behind, tapering to a dragon tail that coiled and twisted a full mile toward the Pit. From this back uprose and fell immense, fan-shaped ruffs, thickets of spikes, whipping knouts of bristling tentacles, fanged crests. They thrust and waved, whipped and fell constantly. And constantly the great tail lashed and snapped—fantastically alive.

"Hai!" shouted Norhala once more. From her throat came again the golden chanting—now a relentless song of slaughter.

Up reared the monstrous bulk. Into it ran the dragon tail. Into it poured the fanged and bristling back.

Up, up we were thrust—three hundred feet, four hundred, five hundred. Over the blue globe of Norhala's house the shape bent a gigantic leg. Spiderlike, out from each side of it, thrust half a score of others.

Overhead the dawn began to break. We rushed straight to the line of cliffs behind which lay the city of the armored men—and Ruth and Ventnor.

CHAPTER XXIV RUSZARK

MOOTHLY moved the colossal steed; we rode upon it as easily as though cradled. The columned legs raised themselves, bending from a thousand joints. The pedestals of the feet, massive as foundations for sixteen-inch guns, fell with machinelike precision, stamping gigantically. Under their tread the trees snapped, and were crushed like straw. From far below came

RADIO LISTENERS' GUIDE & CALL BOOK

these are the circuits to build!
 FULL CONSTRUCTIONAL DATA.

Follow the trend of radio—read the **RADIO LISTENERS' GUIDE AND CALL BOOK**. Full constructional data for the above circuits, also for many others. The **RADIO LISTENERS' GUIDE AND CALL BOOK** is the accepted chronicle of the latest developments in the radio world.

Learn how to improve your set by simple little adjustments and changes. Every radio fan or layman should have one of these valuable books in their homes at all times. Besides the constructional data there is a complete and up-to-date list of all radio stations—their owners, call letters, wave length and power (watts), also their locations.

No home is complete without this accurate guide.

The **RADIO LISTENERS' GUIDE AND CALL BOOK** is revised and brought up to date quarterly.

OVER 200 PAGES, FULLY illustrated

If your dealer cannot supply you, order direct

Price only

50c.

ON ALL NEWSSTANDS

or mail this Coupon

CONSRAD COMPANY, INC.
 230 Fifth Ave., New York, N. Y.

Gentlemen: Enclosed find 50c., for which send me a copy of the latest issue of **RADIO LISTENERS' GUIDE AND CALL BOOK**.

Name.....
 Address.....
 City.....State.....

The
SEASIDE
HOTEL



Atlantic City N.J.

To be free minded
and cheerfully disposed
at hours of meat and of
sleep and of exercise is
one of the best precepts
for long lasting.

Francis Bacon
1625

Shoot The Best Gun

The NEW BENJAMIN is the finest air rifle ever made. Unlike all others. Has amazing accuracy--shoots hard and far. It's the original American genuine AIR operated rifle. One to six pump strokes compress air to any desired degree of power. Same force as in air drills and air hammers except you control the shooting force. Never loses force--no springs or levers to get out of order. Makes crack shots quickly, inexpensively. Gives years of delightful recreation with utmost safety.

\$5 at your dealer's, or \$5 sent postpaid. Write!

The **NEW BENJAMIN** AIR RIFLE

FREE Get "The Shooter's Art" at once--tells how to hold, aim and handle rifles; helps you guide others in correct knowledge of guns. Gives facts that make crack shots. Gives safety and common sense instruction par excellence all life. Yours FREE! **SEND NOW!**



America's Original Air Rifle
Outshoots All Others
BENJAMIN Get Surprising Offer!
Air Rifle & Mfg. Co., 617 N. Broadway, St. Louis, Mo.

Electrical Engineering

Course for men of ambition and limited time. Over 5000 men trained. Condensed course in Theoretical and Practical Electrical Engineering. Including subjects of Mathematics and Mechanical Drawing. Students construct motors, install wiring, test electrical machinery. Course designed to be completed in one college year.

BLISS ELECTRICAL SCHOOL

Prepare for your profession in the most interesting city in the world. Catalog on request.
145 Takoma Ave., Washington, D.C.

FREE TO YOU

Choose ANY **\$20 Musical Instrument**

Yes, we will give you free a \$20.00 quality Violin, Tenor Banjo, Hawaiian Guitar, Banjo, Sanjo-Guitar, Cornet, Guitar, Mandolin or Banjo-Mandolin. Learn to play by note. We teach men, women, boys and girls by mail. Amazing new, simplified method. A few cents a day pays for Lessons. Instrument and first lesson sent on FREE TRIAL. Over 500,000 successful pupils. Write today. No obligation.

CHICAGO CORRESPONDENCE SCHOOL OF MUSIC, INC.
1632 No. Halsted St. Dept. 693, Chicago, Ill.

the sound of their crashing. The thick forest checked our progress less than tall grass would that of a man.

Our trail was marked by deep, black pits in the forest's green, clean cut and huge as the mark upon the popped valley. The foot-prints of the Thing that carried us.

The wind streamed and whistled. A lammergeier swooped down on wide funeral wings. It peered at us, and soared away toward the cliffs.

"There will be no carrion there for you when I am through, black eater of the dead!" whispered Norhala.

Steadily grew the dawn light. From Norhala's lips came again the chanting. And now that paean and the reckless pulse of the monster we rode, began to creep through my own veins, and through Drake's too, I knew. A jubilant pulse streamed up, throbbing through us. The pulse--sang!

Closer and closer came the cliffs. Down, and crashing down, fell the trees, the noise of their fall accompanying the chant of Norhala, like wild harp chords. Now the cliffs loomed overhead. The dawn had passed. It was full day.

Cutting through the towering granite scarps was a rift. Black shadows clustered in it, thickly. Straight toward that cliff we sped. The little platform on which we stood began swiftly to lower. Down we sank and down--a hundred feet, two hundred. Now we were not more than two score yards above the tree tops.

Out shot a neck from that which bore us, a tremendous serpent, crested with the pyramids, its immense head coroneted with them. For hundreds of feet it stretched ahead of us, and for twice as far behind a monstrous, lizard-shaped body writhed.

We rode now upon a glittering blue metal dragon, spiked and knobbed and scaled. The weird steed of Norhala, flattening and thrusting out to pierce the rift.

The rift enclosed us. Lower we dropped. That upon which we rode became a metal torrent roaring through the chasm. A deeper blackness enclosed us--a tunneling. Through that we flowed. We darted out of it into a widening that was filled with wan light drifting down through a pinnacle-fanged mouth miles on high. The cleft shrunk. A thousand feet ahead was a crack, a narrowing so small that barely could a man pass through it.

The metal dragon halted.

Norhala's chanting changed, and became again the arrogant clarioning. Close below us the huge neck split. The part that had broken off formed into a colossal pillar out of which, instantly, scores of arms thrust forth. Over these arms great globes raced. After these flew other scores of huge pyramids. The manifold arms grew rigid. Quiet for a moment, a metal Briareus, it stood.

Then at the tips of the arms the globes began to spin--faster, faster. Upon them the pyramids opened into a host of blazing blue stars. The cleft leaped out in a flood of violet light.

Now for another instant the stars which had been motionless, poised upon the whirling spheres and joined their spinning. Cyclopean pin wheels, they turned, and then, again as one, they ceased. More brilliant now was their light and dazzling--as though in their whirling they had gathered greater force.

From the stars came hurricanes of lightnings. A cataract of electric flame poured into the crack and splashed and guttered down the granite walls.

The face of the precipice smoked and split. It was whirled away in clouds of dust. The crack widened. Lightnings these were--and more than lightnings. Lightnings keyed up to an invincible, annihilating weapon that could rend and split and crumble to atoms the living granite.

H. E. DOERR, Chief Mechanical Engineer for the Scullin Steel Company, says:

"The International Correspondence Schools have made it possible for men in all walks of life to secure an education which they could never have procured in any other way.

"I credit whatever success I may have attained to my course of study with the I.C.S. Had I not taken the course I would probably still be a molder's helper or possibly a molder.

"If any aspiring man will strive, as thousands of I.C.S. students have done, he will be rewarded with success."

Every day, in office, shop and factory, you will find men who are being given better positions and larger salaries because they are studying at home in spare time with the International Correspondence Schools.

An I.C.S. Course helped H. E. Doerr to rise from molder's helper to chief mechanical engineer. It enabled Jesse G. Vincent to rise from tool-maker to Vice-president of the Packard Motor Car Company. It helped George Griebler to rise from a stone-mason to the owner of a business paying \$12,000 a year. And it will help you too, if you will only make the start.

Mail the Coupon for Free Booklet

INTERNATIONAL CORRESPONDENCE SCHOOLS

"The Universal University"
Box 6230-E, Scranton, Penna.

Without cost or obligation, please send me a copy of your booklet, "Who Wins and Why," and full particulars about the subject before which I have marked X:

BUSINESS TRAINING COURSES

- | | |
|--|---|
| <input type="checkbox"/> Industrial Management | <input type="checkbox"/> Business Correspondence |
| <input type="checkbox"/> Personnel Management | <input type="checkbox"/> Show Card and Sign Lettering |
| <input type="checkbox"/> Traffic Management | <input type="checkbox"/> Stenography and Typing |
| <input type="checkbox"/> Accounting and C.P.A. | <input type="checkbox"/> Civil Service |
| <input type="checkbox"/> Coaching | <input type="checkbox"/> Railway Mail Clerk |
| <input type="checkbox"/> Cost Accounting | <input type="checkbox"/> Common School Subjects |
| <input type="checkbox"/> Bookkeeping | <input type="checkbox"/> High School Subjects |
| <input type="checkbox"/> Salesmanship | <input type="checkbox"/> Magazine and Book Illustration |
| <input type="checkbox"/> Secretarial Work | <input type="checkbox"/> Cartooning |
| <input type="checkbox"/> Spanish <input type="checkbox"/> French | |
| <input type="checkbox"/> Advertising | |

TECHNICAL AND INDUSTRIAL COURSES

- | | |
|---|--|
| <input type="checkbox"/> Electrical Engineer | <input type="checkbox"/> Architect |
| <input type="checkbox"/> Electric Lighting | <input type="checkbox"/> Architects' Blueprints |
| <input type="checkbox"/> Mechanical Engineer | <input type="checkbox"/> Contractor and Builder |
| <input type="checkbox"/> Mechanical Draftsman | <input type="checkbox"/> Architectural Draftsman |
| <input type="checkbox"/> Machine Shop Practice | <input type="checkbox"/> Concrete Builder |
| <input type="checkbox"/> Railroad Positions | <input type="checkbox"/> Structural Engineer |
| <input type="checkbox"/> Gas Engine Operating | <input type="checkbox"/> Chemistry <input type="checkbox"/> Pharmacy |
| <input type="checkbox"/> Civil Engineer | <input type="checkbox"/> Automobile Work |
| <input type="checkbox"/> Surveying and Mapping | <input type="checkbox"/> Airplane Engines |
| <input type="checkbox"/> Metallurgy <input type="checkbox"/> Mining | <input type="checkbox"/> Agriculture and Poultry |
| <input type="checkbox"/> Steam Engineering <input type="checkbox"/> Radio | <input type="checkbox"/> Mathematics |

Name.....

Street Address.....

City.....State.....

If you reside in Canada, send this coupon to the International Correspondence Schools Canadian, Limited, Montreal

Insure your copy reaching you each month. Subscribe to SCIENCE AND INVENTION--\$2.50 a year. Experimenter Publishing Co., Inc., 230 Fifth Avenue, New York City.



100 POWER MICROSCOPE

Study wonders of insect, plant, other unseen worlds. Invaluable to Boy Scouts and experimenters. No toy, but a real instrument with imported lenses and mirror, complete in case.

\$4.50

250 POWER MICROSCOPE

Laboratory type, for Physicians, Dentists, Doctors, and general professional work. Plus quick adjustment by knurled nuts both sides of tube. Special device protects slides from breakage. Triple divisible objective gives different powers and large clear field of great depth. Square stage with Clips. Adjustable iris diaphragm, with plane and convex mirrors. Adjustable stand. A precision microscope complete with handsome case.

\$16.50



Catalog Free
Apparatus Engineering Co.
Dept. A, 342 Madison Ave
New York City

MAKE YOUR RADIO AN ELECTRIC SET with a TOWNSEND "B" Power Unit \$6.85

at a cost of only

6.85

Why pay up to \$450 or more to own an electric set when you can quickly and easily make your own set all electric in this new, surprisingly inexpensive way?



APPROVED by the Laboratory tests of Radio News, Popular Radio We show you how. Write for full information

Townsend Laboratories
713 Townsend Street - Dept. 35

Chicago, Ill.

A CHANCE TO START YOUR OWN BUSINESS

Either Full Time or Spare Time AS OUR REPRESENTATIVE Making Metal Toys and Novelties, a new industry in America, offers you great opportunity for Big Profits. Demand exceeds supply for Toy Soldiers, Animals, 5c. and 10c. Store Specialties, Ash Trays, Auto Radiator Ornaments, etc. We co-operate with you in selling goods you make, also buy them from you. Small investment puts you on Road to Success. WE FURNISH COMPLETE OUTFITS AND START YOU IN WELL-PAYING BUSINESS. Absolutely NO experience necessary and no special place needed. A chance of a lifetime for man with small capital. ACT AT ONCE if you want to handle Big Wholesale orders now being placed. Write for free catalog and full information. METAL CAST PRODUCTS CO. Dept. E, 1696 Boston Road New York



I POSITIVELY GUARANTEE

to increase your arms one-half inch in size, chest one full inch; strength 25 per cent, health 100 per cent, in one week's time, by following my instructions and using my exerciser 10 minutes mornings and at night. Send \$1.00 for complete course and exercisers. Satisfaction guaranteed or \$1.00 refunded.

Prof. J. A. DRYER
Box 1850-Z Chicago, Ill.

FREE--Radio Catalog

To Dealers--New, illustrated 1928 Wholesale Radio Catalog gives lowest prices on accessories, kits, parts, and sets. Features master-built single control radio sets for both battery and all electric operation. Full showing of "A" and "B" Eliminators and thousands of other great values. Write on business letterhead for this free book today.

Hamilton-Carr Radio Corporation
711 W. Lake Street Dept. 382 Chicago, Ill.

LE PAGE'S GLUE Handiest Tool in Your Workshop In bottles, tubes and cans

THIS CLASS PIN 30c.
12 or more, Silver plate, Single pins 50c ea. choice 2 colors enamel, 3 letters, date, Sterling Silver, 12 or more 50c ea. Single pins 50c ea. Free Cat. shows Pins, Rings, Emblems 25c to \$8.50.
995 METAL ARTS CO., Inc., 773 Portland Ave., Rochester, N.Y.

Steadily the cleft expanded. As its walls melted, the Blasting Thing advanced, spurning its flaming torrents. Behind it we crept. The dust of the shattered rocks swirled up toward us like angry ghosts. Before they reached us they were blown away by strong winds streaming from beneath us.

On we went, blinded and deafened. Interminably, it seemed, poured forth the hurricanes of blue fire. Interminably the thunder bellowed.

There came a louder clamor—chaotic, dulling the thunders. The sides of the cleft quivered and bent outward. With the roar of falling worlds they split and crashed down. Bright daylight poured in upon us, a flood of light toward which the billows of dust rushed, seeking escape.

And the Blasting Thing shook—as though with laughter!

The stars closed. Back ran globe and pyramid. They slid toward us, and joined the body from which they had broken away. Through all that re-united mass ran a wave of jubilation.

We glided forward out of the cleft. There was a burst of sunlight, strangely yellow after that incessant violent volleying.

I felt a shifting movement. Up and up we were thrust. I looked behind me. In the face of a sky-climbing wall of rock, smoked a wide rift. The billowing dust clouds streamed out of it, pursuing, threatening. The cleft precipices quivered with agony.

Higher we rose and higher. "Look!" whispered Drake.

Less than five miles away was the place of the armored men—Ruszark, the City of Cherkis.

And it was like some ancient city come to life out of long dead centuries, a page from conquering Persia's time crumbled book. Built around and upon a low mount, it stood within a valley little smaller than the Pit. The plain was level, as though once it had been the floor of some primeval lake. The hill on which the city stood was its only elevation. I caught the glinting of a narrow stream beyond it, meandering. The valley was ringed with precipitous cliffs falling sheer to its floor. We advanced.

The city was almost square, bulwarked by double walls of hewn stone. The first ramparts were raised a hundred feet. They were turreted and parapeted and pierced with gates. A quarter of a mile behind them the inner walls uprose.

The city covered about twenty square miles. It ran upward in broad terraces. It was very fair, decked with blossoming gardens and green groves. Among the clustering granite houses, red and yellow roofed, tall spires towered. Upon the mount's top was a broad, flat plaza on which were great buildings, marble white and golden roofed, temples I thought, or palaces—or both.

And running to Ruszark, out of the steads that surrounded it, were scores of little figures. Here and there among them I glimpsed horsemen, arms and armor glittering. All were racing to the gates and to the shelter of the battlements.

Nearer we drew. From Ruszark's walls came a faint sound of gongs, of drums, of shrill pipings. Upon the walls hosts were gathering, hosts of swarming little figures whose bodies glistened. From above them came gleamings—the light striking upon helms, spears and javelin tips.

"Ruszark!" breathed Norhala, eyes wide and red lips smiling. "Lo—I am before your gates! Lo—I, Norhala, am here—and was there ever joy like this!"

Her flaming hair whirled and snapped. From all her sweet body came white-hot furious force, a withering perfume of destruction. She pressed against me, and I trembled at the contact.

(Continued on page 92)

AVIATION



-in all its phases!

Complete instruction course in three volumes. Every point of aviation efficiently and thoroughly treated. Subjects covered in these volumes—



MODERN AIR CRAFT

700 Pages
500 Illustrations

Contents of each chapter—
I. Aircraft Types, II. Lighter-than-Air Craft, III. Early Airplane Designs, General Design Considerations, IV. Design and Construction of Aerofoils, V. Arrangement, Fabrication and Braising of Airplane Wings, VI. Airplane Fuselage and Landing Gear Construction, VII. Airplane Power Plant Types and Installation, VIII. Aviation Engine Design and Construction, Air-Cooled Engines, IX. Aviation Engine Design and Construction, Water-Cooled Engines, X. Aviation Engine Auxiliaries, XI. Aircraft Propeller Construction and Action, XII. Airplane Equilibrium and Control Principles, XIII. Uncrating, Setting Up and Aligning Airplane, XIV. Inspection and Maintenance of Airplanes and Engines, XV. Details of Modern Airships and Airplanes, XVI. Seaplanes, Flying Boats, Amphibians and Other Aircraft, XVII. Some Aspects of Commercial Aviation, XVIII. Aircraft Instruments and Aerial Navigation, XIX. Standard Nomenclature for Aeronautics, Report No. 240, Part I.

This book is written in simple, understandable language.

PRICE \$5.00



AVIATION ENGINES

This treatise, written by a recognized authority on all of the practical aspects of internal combustion engine construction, maintenance, and repair, fills the need as no other book does. The matter is logically arranged; all descriptive matter is simply expressed and copiously illustrated, so that anyone can understand airplane engine operation and repair even if without previous mechanical training. This work is invaluable for anyone desiring to become an aviator or aviator mechanic.

274 PAGES

PRICE \$1.25

A. B. C. OF AVIATION

This book describes the basic principles of aviation, tells how a balloon, or dirigible is made, and why it floats in the air. Describes how an airplane flies. It shows in detail the different parts of an airplane, what they are, and what they do. Describes all types of airplanes and how they differ in construction, as well as detailing the advantages and disadvantages of different types of aircraft. It includes a complete dictionary of aviation terms and clear drawings of leading airplanes.

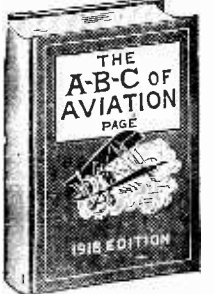

PRICE \$1.25

Remit by cash, stamps, check, or money order. No C.O.D.'s

We Pay Postage On All Books

CONSRAD COMPANY, Inc.
230 FIFTH AVENUE NEW YORK

MONEY-MAKING DEPARTMENT

\$1.00 to \$7.00 Per Hour for Your Full or Spare Time

New Household Device washes-dries windows, sweeps, cleans walls, scrubs, mops. Costs less than brooms. Over half profit. Harper, 630 Third St., Fairfield, Iowa.

Don't worry with small profits and unknown articles! Backed by tremendous national advertising, hundreds of Noga salesmen are making \$500 to \$1,000 monthly. Right Now, World's longest wearing suits, \$12.50. Amazing wear demonstration makes big, steady sales certain. Write today for Free Kit, full instructing literature. Noga Clothing Mfg. Co., Dept. CS-5, Reading, Pa.

Women Representatives Wanted. New invention prevents shoulder straps slipping. No more discomfort. Women adore it. Write for particulars and free offer. Lingerie "W" Company, 95 Oak St., North Wingham, Conn.

\$114 week Protecting Friends from Check Raiders. Sell Security Combination Postal Pens and Check Protectors—also new Security Graphs. Advertise Saturday Evening Post. Write for details including Free Demonstrator Offer. Security Pen Corp., 1101 N. Mt Carmel, Ill.

Men—large permanent income spare or full time \$8.00 advance commission for you. Our quality suits, topcoats, fast sellers at Two for \$34.50. \$20 sales outfit given Free. Write Morley Tailors, Dept. 1305, 64 W. 23rd St., New York.

We Start You Without A Dollar, Soaps, Extracts, Perfumes—Toilet Goods, experience unnecessary. Carnation Co Dept. 593, St. Louis, Mo.

Agents—We start you in business and help you succeed. No capital or experience needed. Spare or full time. You can easily earn \$50-100 weekly. Write Madison Products, 566 Broadway, New York, N. Y.

I Pay Men \$15.00 day to demonstrate amazing new Perfection Door Closer. Half price of competitors—works better. Big profits for you. Silent footless handle. Heavy-duty doors—absolutely prevents slamming. Free Home, Store, Office buys. Get Demonstrator Free. Write Perfection Co., Bloomfield, Ind.

No Dull Times Selling Food. People must eat. Federal distributors make \$3,000 yearly up. No capital or experience needed. Guaranteed sales; unsold goods may be returned. We furnish sample case, license and Free Exclusive territory. Ask now! Federal Pure Food, W. 2311 Archer, Chicago.

\$1,000 Reward if this is not the greatest money-making house to house proposition ever known. N. R. G. tablets wash clothes in 10 minutes without rubbing. Free Samples. N. R. G. Co., W. 232 W. Superior, Chicago.

Earn \$100 weekly selling America's lowest priced shirts & neckwear. 15% advanced commissions. Elaborate Outfit Free. Howard, Dept. 235, 1213 Van Buren, Chicago.

Woman! Sell Feminine Wonder Products. Big profits. Rubber Aprons, Sanitary Belts, Steeps, Shadow Skirts. You cannot fail. American Rubber Products, Dept. 575, Pittsburgh, Pa.

Foreign Positions—Men interested going romantic South America. Good pay. Expenses paid. South America Service Bureau, 14,600 Alma, Detroit, Mich.

Direct Representative—smarrest Mary Rose frocks, biggest variety, unmatched prices, \$5 to \$10 daily. Experience unnecessary. Rodasi Co., 465 Rodasi Bldg., Cincinnati, Ohio.

\$75.00 Weekly. Pay daily. Talking orders. New Patented Linen Tablecloth. Olcioto. No laundering. Free sample. Jones Specialty Co., 804 No. Clark, Chicago.

If I show you an all Virgin Wool Suit, tailored-to-order, valued at \$35, that you can sell for \$22.00, make \$13.00 yourself, you will absolutely Free. Complete selling outfit, will you give me your proposition a trial? P. C. King, 2238 South La Salle, Chicago, Ill.

Fire! We'll make you fire prevention expert and pay you \$3.00 an hour soon as you start. No investment or experience. Permanent business of your own. Reserve district now. Miracle Fire Chemical Corp., 15 Williams Ave., Carbondale, Pa.

Stop check frauds. Be protection expert. \$5 hourly. Low price-pocket check writer. Equals \$60 machines. Merchants fascinated prospects. Quickest seller. Arnold Corp., Flint, Mich.

Agents—Just Out! \$8.88 for Men's Suits! Anyone can sell! Commission \$3. Dept. E-13, Dept. Wayne, Ind.

\$50 to \$200 weekly selling genuine Diamonds, Watches, jewelry through illustrated catalog. Cash or Credit. Liberal proposition. Free outfit return mail. Write Sterling Diamond & Watch Co., Nationally known Jewelers, Est. 1879, 1940 Broadway, Dept. A-12, New York.

Agents make \$5 to \$10 an hour taking orders for newly invented fountain pens, holds three times much ink as other pens. Unbreakable! You can see through it. Solid gold point. Sells for \$3.00, worth double. Liberal advance commission. Write for free quick money-making plan. Bonded Reservoir Pen Co., Dept. 505, 147 Nassau St., New York.

Why not sell us your spare time, \$2.00 an hour, \$19.70 daily easy full time. Introduce 15 months Guaranteed Hosiery—47 styles, 39 colors for men, women, children, including latest "Silk to the Top" Ladies' Hosiery. Sport; Men's Fancies. No capital or experience needed. We furnish samples. Your own Silk Hose Free. New Plan. Mascabee Hosiery Co., Park 9284, Cincinnati, Ohio.

Agents \$300 a month. We feed the world. Groceries, teas, coffee, food specialties, perfumes, family medicines. Over 400 daily necessities. Steady profitable repeat business \$3.00 hour part time. Samples furnished. Harley Company, Desk E 2584, Dayton, Ohio.

Slickers Plain—\$7.98 Hat Free. also full line leatherettes, rayons, rain-top coats, for men, women and children. Outfit free. American Waterproof, Dept. P. C., 724 Roosevelt, Chicago.

Agents \$240 month. Sell finest line silk hosiery you ever saw. We furnish outfit. Free silk hosiery for your own use. Write today for samples and state size of hose worn. Betterknit Textile Co., Silk 1035, Greenfield, Ohio.

We pay women \$6.00 an hour to wear exquisite Fifth Avenue dresses and show them to friends and neighbors. Experience unnecessary. Write today to Fifth Avenue Styles, Dept. 1005, Scranton, Pa.

America's Greatest Tailoring Line Free! 130 large Swatch Samples—All Wool—Tailored to Order—Union Made—Sensational low price. Get outfit at once. Address Dept. 422, Goodwear, 844 W. Adams, Chicago.

Punchboard Salesmen Take Notice. New fascinating game "Excitement." Can be used all states. \$200 weekly easy. One minute sales talk. Pay daily. Cigar Stores Novelty Co., Dept. P., Peoria, Ill.

Great neckwear line now free! Features finest quality neckwear at factory prices. Unnecessary. Write today to Fifth Avenue Neckwear, E-125, Covington, Ky.

Agents wanted to advertise our goods and distribute free samples to consumers. 90c an hour; write for full particulars. Cincinnati Products Co., 1664 Monmouth, Cincinnati, Ohio.

65% of all Men past middle age, authorities say, have prostate gland disorder. Now a scientific treatment. Free book. Address Thermanids, Steubenville, Ohio, or 303 Van Nuys Bldg., Los Angeles, Calif.

I pay one dollar for old hot-water bottles. That's where you make your fortune. My sensational health-protector is the greatest selling wonder in existence. Startling invention. Every home buys. Nobody can refuse. My unique plan guarantees success. Write for great surprise. Pres. Lobl Mfg. Co., Dept. P. C., Middleboro, Mass.

Sell new Alligator and Tu-Color Leatherette coats. Big variety \$2.65 up. Hat Free. \$15.00 daily sure. New spring outfit free—Silverstone, 2035A Charleston, Chicago.

Guaranteed salary and commission selling specialty retailers. Enormous opportunity. Liberal percent. Income by repeats. Distributor, Box 1029 Cedar Rapids, Iowa.

Used Typewriters. Underwoods, Remingtons, L. C. Smiths late models with modern improvements at less than half. \$2.00 down. 10 day Free trial and year pay plan. See for catalog and particulars. International Typewriter Exchange, Dept. 538, 184 West Lake Street, Chicago.

Palms—What secrets are revealed in your hands—if you only knew! Analyze your friends and sweethearts character. Learn to read other prints and become an expert. We show you how. Amazing. Profusely illustrated. Great fun and profit. Send just 60 cents to St. Johns System, Department 2C, 418 St. Johns Place, Brooklyn, N. Y.

Wavy Hair in 10 minutes. "Waveen" new wonder preparation changes straightest hair into lustrous, soft waves. Sensation of New York. Be your own hairdresser. Absolutely greaseless and harmless. Large bottle sent postpaid on receipt of \$1.00. Beauty Co., 365 F Lincoln Place, Brooklyn, N. Y.

Thrills—Mystery—Romance—greatest offer made. Eleven pocket-size books, exciting, gripping stories. Bargain offer extraordinary. While they last, only \$1.00 for complete set. Fisher Printing Co., 793 Kearney, Arlington, N.J. \$25.00 daily selling colored Raincoats and Slickers, Red, Blue, Green, etc. \$2.95. Hat Free. Pay daily. Outfit Free. Elliott Bradley, 238 S. Wells, Dept. AF-5, Chicago.

Can You Sell Gas at 5c. per Gal.? My Distributors make \$750.00 per month. Send for details and my \$15.00 a day guarantee to Distributors. Frank Andrews, 150 E. Erie, Chicago.

Sell Broadcloth Shirts—four for Five Dollars. Liberal Commission. Samples Free. Stock or made to measure shirts. Men's shirt Co., 479 E. Tremont Ave., New York.

Agents earn big money taking orders for our beautiful Dress Goods, Silks, Wash Fabrics, Hosiery, Fancy Goods, 1000 Samples furnished. The National Importing Co., Dept. E89, 73 Broadway, New York City.

IF IT'S NOT HERE WRITE US! Here is a new service for the convenience of our readers. If you are looking for certain articles not listed, write P. C. S. Information Dept., Dept. 46th St., New York. For each item to be investigated, please enclose 10c. to cover cost of postage.



TO SQUARE-DEAL ADVERTISERS ONLY
If you do business on the basis of "satisfaction or money back" write us. For rates in this and other magazines address Publishers Classified Service, 9 East 46th St., New York.

Now! \$5,000 year easy! Sell Gibraltar Shirts! Finest quality. Lowest prices. Defy competition! Liberal daily commissions. Send today for free outfit containing large assortment shirt samples. Gibraltar Shirt Co., Dept. V-7, 22nd Street, New York.

Women—Wanted for Traveling Position, not married, entirely unencumbered, with high school education, between 25 and 40. Salary, bonus and transportation. Give full information first letter. Salesmanager, 46 W. Oak St., Chicago.

Women, Men take orders \$3.95 colored raincoats, give \$1.50 hat free. Dresses, sports coats, whiting and sellers. Pay daily. Free outfit, Superbuilt, Box 453-S, Chicago.

Agents \$240 month. Bonus besides. Sell finest line silk hosiery you ever saw. Auto furnished. Credit given. Write for samples. Wilknit Hosiery Co., Dept. 1435, Greenfield, O.

Start Mail Order Business of your own home. We supply catalogs with your address on Wincholt Sales Co., Box 3, Woodbine, Penna.

66 Miles on 1 Gallon. Wonderful New Vapor Humidifier and Gas Saver. All autos. Distributors wanted everywhere. 400% Profits. I Free. Critchlow, B-374, Wheaton, Ill.

Homework—Women wanting to obtain money-making bona-fide kind, write us for information enclosing stamp. Eller Co., Dept. 75, 296 Broadway, N. Y.

Local Partner Wanted. Every City, Town and Village. New Plan. 3 Shirts Free and \$7.00 an Hour. Amazing values. Fashion Wear Shirts, Desk 58, Cincinnati, Ohio.

Amazing new 3-in-1 Lingerie Combination for women making sensational hit \$1.00 daily easy. Spare or full time. Free Outfit. Don't Wait. Write French Fashion Co., 9 North Franklin, Chicago.

New invention beats vacuum sweeper and all its attachments. Electricity unnecessary. All complete \$2.95. Over 100% profit. Morgan, Mfr., 797 Grimes St., Fairfield, Iowa.

Women—Earn \$16 dozen sewing aprons. Experience unnecessary; no selling. Easy, steady work, materials cut. Addressed envelope brings details. Goshen Dress Co., Dept. 560, Goshen, N. Y.

Men—\$7.50 an hour spare time. Bargain all-wool stylish suits and top coats at \$13.75. Sell every man! \$3.75 advance commission for you. Write for expensive sample case—It's Free! Canterbury Tailors, Dept. Y-7, 20 West 22nd Street, New York.

Be a Real Estate Expert. \$5,000-\$15,000 yearly. Experience unnecessary. I'll teach you everything. Connect with my chain of real estate experts. Write for FREE booklet. National Real Estate Institute, Dept. 500-M, Fort Smith, Ark.

Knitrupt and Kummage Sales. Make \$50 daily. We start you, furnishing everything. Permanent business. Free details. Distributors, Dept. 279, 429 W. Superior, Chicago.

Agents \$240 month. Dri-Klean-it removes dirt, grease, tar, all one operation. Cleans car for 10c. No soap or water used. Car looks like new. Wonderful seller. Free demonstrating sample. American Accessories Co., Desk 235, Cincinnati, Ohio.

New lines just out. Everything in hosiery, underwear and rayon lingerie for women, children. Beautiful, irresistible Catalog and Samples now ready. New special big money plans. Cash bonus, service awards, rapid promotion. No capital needed. Choice territories going. Rush reply to World's Star Knitting Co., 135 Lake St., Bay City, Mich.

We are in touch with the best and most reliable schools in America. If you are interested in art, engineering, electricity, radio, aviation, or any kind of business training, we will help you find what you want. Please enclose 10c. to cover cost of postage and direct advice of prominent school expert. Address School Dept., P. C. S., 9 East 46th St., New York.

EARN WHILE YOU LEARN
Learn electricity at home through complete, practical courses written by well-known electrical engineers. Indorsed by Edison and Steinmetz. Write for Free Booklet. INTERNATIONAL CORRESPONDENCE SCHOOLS, Dept. 1226-B, Scranton, Penna.

Hotels Need Trained Executives. National demand for trained men and women; past experience unnecessary. We train you by mail and put you in touch with big opportunities. Write at once for particulars. Lewis Hotel Training Schools, Suite AU-W637, Washington, D. C.

Men, get Forest Ranger jobs! \$125-\$200 month and home furnished; hunt, fish, trap. For details, write Norton Institute, 270 Temple Court, Denver, Colo.

Avoid those embarrassing mistakes in English by studying at home in spare time. New method shows you instinctively which word to use and how to use it. Write for Free Booklet. INTERNATIONAL CORRESPONDENCE SCHOOLS, Dept. 1225-B, Scranton, Penna.

Want U. S. Gov't Position? commence \$115-\$250 month? Men-women, 18-55, trained at home in three weeks. Write Instruction Bureau, 137 Arcade Bldg., St. Louis, Mo.

Big Pay Jobs open in Automotive field. Learn how to test equipment with real shop tools in eight weeks. Satisfaction guaranteed. Write quick for special tuition offer. Mesweeny Auto Schools, Dept. 21-E, Cleveland, O. and Cincinnati, O.

Men qualify Forest Ranger Position! start \$125 month; cabin and vacation. Patrol the forests; protect the game. Write Mokane Institute, Dept. M-44, Denver, Colo.

Learn drugless healing at home. Interesting, very profitable profession readily and quickly learned by spare time home study. Millions of patients waiting. Practise in your own or patient's home. Earn while you learn! Quick new method of teaching—by use of motion pictures. Send 4c. postage for Free introductory course. American University, Bolstead Bldg., Chicago.

Make Money in Building. \$12 to \$16 a day regular scale. Much more for trained men. Learn at home, valuable book "How to Read Blue Prints." Mailed free. Chicago Tech. College, 118 East 20th Street. (2135), Chicago, Illinois.

MONEY SAVING DEPT.
Bargain! Established manufacturer has odd lot of 938 fine \$1.50 silk ties. Beautiful patterns, will sacrifice at 3 for \$2.00. Postpaid with free order. State colors wanted. Money back if not satisfied. Miller Tie Co., 5563 Waterman Avenue, St. Louis, Mo.

Be a Magician! Astonish and mystify everybody. Simple when you know how. Secrets of the great magicians at last revealed. Write for a copy of our grand expose. Only \$1.00 for set if you promise to keep 3 keys. Jeff Parks, 349 Lincoln Place, Brooklyn, New York.

No more bother with "B" Batteries. Get perfect reception direct from light socket. Perfect eliminator works on any type of set. Hooked up in one minute—works automatically. No "extras" to buy. Thousands of enthusiasts here. Price only \$5.95—less than a set of good "B" batteries. Send \$1.00. We ship C.O.D. for balance \$4.95 plus free catalog. Carroll Sales Co., 3244 Boudinot, Cincinnati, Ohio.

Amazing 112 page illustrated book "All about Television" tells how you can see by radio. Send only 50c! Experimenter Co., 230 Fifth Avenue, New York.

FOR THE READER
Money—Do you need it? New illustrated book gives 67 tested plans to make spare-time money without investment. Mail 50c to V. O. Fisher, 797 Kearney, Arlington, N. J. (Please mention the name of this magazine when writing.)

Agents—Why work for others? Go into mail order Agents business yourself. Get our famous course—explains everything about starting your own business. Wonderful spare-time money-maker! Pay postman only \$3.98. Satisfaction guaranteed. Quinton 365 Lincoln Place, Brooklyn, N. Y.

Boys! Send for Free Copy "Illustrated Science and Mechanics" Magazine. I'll show you how to make money during vacation months. Write Schoen, 110 N. Franklin, Chicago.

Make More Money—Full or spare time. Secrets of successful agents and salesmen revealed. Send 10 cents for next 3 big, illustrated issues of my book, containing over 100 money-making ideas and opportunities. R. Bernard, 1200 Jackson Street, Cincinnati, Ohio.

Send 25c for Five Issues of French Humor a weekly magazine full of live, clean illustrations and jokes right from France. Newstand price 50c. French Humor, 230 Fifth Ave., N. Y. C.

Make Extra Money Writing Stories in Spare Time. Learn secrets of writing and selling stories, photoplays, songs, poetry, etc. My book—published new every month—tells how. Send 25 cents for next 3 issues. Richard Abbott, 22 East 12th Street, Cincinnati, Ohio.

Latest! "101 New Ways to Make Money!" There's extra cash for you in needlework, mending children, cooking, painting, business, making things, etc. Written by a housewife who made a fortune in spare time. We send this 32 page volume on approval. Just send name and pay postman \$1.98. If not worth \$30 a week to you, return book any time and \$1.98 will be refunded. Alto Co., 20 East 42nd Street, New York.

Write for your money-making opportunities



The Quad

Super Elto

4 Cylinder Outboard Motor

OLE EVINRUDE'S sensational new achievement. Develops 18 H. P. — easily drives stock racing boats better than 35 miles per hour. Drives sturdy runabouts 25 m. p. h. Absolutely vibrationless. Dual ignition, dual carburetion, instant starting. Terrific, zooming acceleration, exceptional handling ease. Weighs only 92 pounds. Send for free book on the *Three Great Super Eltos*. Describes the 4-cylinder *Quad*, the new B Class *Speedster* and the famous *Service Twin*. Write today.

ELTO OUTBOARD MOTOR CO.
Ole Evinrude, President
Mason Street Department 48 Milwaukee

Don't Envy the Plumber

BE ONE
\$11.00-\$16.00 PER DAY and work EVERY day, is the Plumber's wage.

Every skilled workman will tell you that Plumbers have the best of it. WINTER and SUMMER the Plumber is busy at top wages. No skilled Plumber is ever out of a job—compare his opportunities with any trade, plus the opportunities of having your own shop.

We teach you Plumbing with TOOLS (not books) under Licensed Master PLUMBERS in one of the finest equipped schools in America. We make you a Plumber, every branch is taught thoroughly—Lead Work—Blue Print for plan reading—all other tricks.

LEARN IN 8 TO 12 WEEKS without previous experience.

If you are making less than \$60.00 a week you owe it to yourself to investigate. Get FREE catalog that tells in pictures and words how we teach this trade. Special dates now.

UNIVERSAL PLUMBING SCHOOL
2057 Troost Ave. KANSAS CITY, MO.

CHEMISTS

Our new catalog, listing 5,000 Chemicals, 2,500 illustrations, Laboratory Apparatus and 1,000 books, sent on receipt of 50c.

LABORATORY MATERIALS CO.
635 East 71st St., Chicago, U.S.A.

Learn Photography at HOME

Make money taking pictures. Prepare quickly during spare time. Also earn while you learn. No experience necessary. New easy method. Nothing else like it. Send at once for free book, *Opportunities in Modern Photography*, and full particulars.

AMERICAN SCHOOL OF PHOTOGRAPHY
Dept. 1425, 3601 Michigan Ave. Chicago, U. S. A.

ANY BOOK IN PRINT

Delivered at your door. We pay the postage. Standard authors, fine editions, new books, all at biggest savings. Be sure to send postcard for Clarkson's catalog.

FREE This catalog is a short course in literature and is so used by some of America's leading universities; 300,000 book lovers buy from it. Free if you write now.

DAVID B. CLARKSON THE BOOK BROKER
551 CLARKSON BLDG. CHICAGO, ILL.

DRAW CARTOONS

TURN YOUR TALENT INTO MONEY
Cartoonists earn from \$50 to \$250 per week—some even more. Remarkable new Circle System of Drawing teaches you in half the usual time. Send for booklet and sample lesson plate explaining full details of the Course. No salesman will call.

THE NATIONAL SCHOOL OF CARTOONING
628 Penton Building Cleveland, Ohio

The Metal Emperor

(Continued from page 90)

Again the monster shook beneath us. Faster we moved. Louder grew the clangor of the drums, the gongs, the pipes.

Now we were close upon the heels of the last fleeing stragglers. We slackened in our stride. We waited until they were close to the gates. I heard the brazen clanging of their valves. Those shut out beat upon them. They dragged themselves close to the base of the battlements, and cowered there, or crept, seeking some hole in which to hide.

With a slow lowering of its height, the Thing we rode advanced. Now its form was that of a spindle upon whose bulging center we three stood.

A hundred feet from the outer wall we halted. We looked down upon it, not more than fifty feet above its broad top. From that vantage-point I could see regiments of soldiers crouching behind the parapets, companies of archers with great bows poised, arrows at their cheeks, hundreds of leather-jerkined men with stands of javelins at their right hands, scores of spearsmen and men with long, thonged slings.

Set at intervals behind the parapets were squat, powerful engines of wood and metal, and beside them heaps of huge, rounded boulders. Catapults around which swarmed knots of men fixing the great stones in place, drawing back the thick beam, that would hurl the projectiles. From every side came others, dragging more of these ballistas, assembling a battery against the monster that menaced their city.

Between outer wall and inner battlements galloped squadrons of mounted men. Upon this inner wall the soldiers clustered as thickly as on that between us and it, and prepared as actively for its defense.

The city seethed. From it arose a humming, a buzzing, as of some immense angry hive.

I visualized the spectacle we must present to those who looked upon us—this huge incredible Shape of metal, alive with quick-silver shiftings, this, as it must have seemed to them, hellish mechanism of war captained by a sorceress and her two familiars in form of men. There came to me dreadful visions of such a monster looking down upon the peace reared battlements of New York—the panic rush of thousands away from it—

There was a blare of trumpets. Upon the parapet leaped a man clad all in gleaming red armor. From head to feet the close linked scales covered him. Within a hood shaped somewhat like the tight-fitting head coverings of the Crusaders, a cruel face stared at us. In the fierce black eyes no trace of fear.

The man in scarlet threw up a hand. "Who are you?" he shouted. "Who are you three that come driving down upon Ruzsark through the rocks? We have no quarrel with you?"

"I seek a maid and a man," cried Norhala. "A maid and a man your thieves took from me. Bring them forth!"

"Seek elsewhere for them then," he shouted. "Turn now and seek elsewhere. Go quickly, lest I loose our might upon you and you go forever!"

"Little man whose words are so big!" laughed Norhala. "Fly who thunders! What are you called, little man?"

Her raillery bit deep. "I am Kulun," shouted the man in scarlet armor. "Kulun, the son of Cherkis, and captain of his hosts. Kulun—who will cast

S. Gernsback's RADIO ENCYCLOPEDIA



Over 25,000 copies in the stiff binding already sold

Now! in limp suede leather binding \$5.00

IN KERATOL BINDING \$2.

The most valuable of Radio Books—S. Gernsback's Encyclopedia—now the most beautiful. This foremost Radio Encyclopedia is now offered in this luxurious new binding to meet the demand for a more handsomely bound volume. The limp Suede Leather Edition sells for \$5.00. The Keratol-leather stiff binding still can be had for \$2.00.

Remember—this is an encyclopedia—not a dictionary! It took over two years of intensive labor to compile it. It is the first Radio Encyclopedia ever published.

S. Gernsback's Radio Encyclopedia contains the meaning of every word and phrase used in the entire Radio Art. Every circuit, part and apparatus is thoroughly explained. A complete cross index is just one of the many features of this remarkable book.

There are 1,930 definitions—549 diagrams, photographs and drawings—all simple and easily understood. The book is nearly an inch thick and measures 9 x 12 inches.

S. GERNSBACK
230 Fifth Avenue New York City

S. GERNSBACK 5-S-1
230 Fifth Ave., New York City
Gentlemen:

Kindly send me one copy of *The Radio Encyclopedia*. I will pay postman on delivery.

Limp suede leather binding \$5.00 plus postage
 Keratol-leather binding \$2.00 plus postage
(check which binding you want)

Name.....
Address.....
Town.....
State.....

Wonderful New Invention!

Coins Money for Hustlers

Here's the most sensational profit-maker ever offered—and I'll prove it. I guarantee every word and statement in this advertisement to be absolutely true. Our proposition is a simple invention, yet an absolute mechanical necessity to every auto owner—one that will net you

233-1/3 % PROFIT

or more on every sale. Five sales mean \$8.75 net for you, and each sale takes from 5 to 10 minutes only! No heavy sample case to carry, your pocket will hold enough for a day's work. You don't have to look for customers, for wherever an auto is, or can be driven—at Ball Parks, Circuses, Fairs, etc., you've got a live prospect, and he'll get the idea the minute you show him your demonstrator.

"Ride Air" Spring Cushion Shock Absorbers take the place of all snubbers and expensive shock absorbers. Can be installed by anyone. A Ford takes 5 minutes—no holes to bore—no bolts. Sells at \$2.50 to \$8.00 according to car (one size fits all makes); your profit 233-1/3% on each sale. \$20 a day is an easy average for hustlers. Write for your FREE SAMPLE now.

C. F. HAMILTON
Desk N5
530 W. 27th St.
Los Angeles, Cal.

20 a Day

Sample FREE



We start you in business and help you succeed

New plan. No experience or capital needed. We furnish everything. Spare or full time. You can easily make

\$50-\$100 weekly

Write at once
Madison Shirt Man'rs., 564 Broadway, New York

\$100 a Week for Taking Pictures

We Furnish Camera and Teach You How

Men and Women Everywhere! Make Big Money!

FREE BOOK Explains opportunities as Motion Picture Camera Man, Portrait, News or Commercial Photographer. You can learn at home or in our New York Studios, Spare or full time.

N.Y. Institute of Photography, 10 W. 33rd St., N.Y. Dept. 82

10 DAYS FREE TRIAL - MONEY BACK IF NOT SATISFIED

THE NEW INKOGRAPH SELF FILLER

The Perfect Writing Instrument

Writes with ink easy as a lead pencil. Won't skip, blot, scratch, leak or soil hands. Inexpensive. Flow of ink in proof hand, never dries.

Makes three carbon copies with original in ink. Guaranteed—Send No Money. Pay postman \$1.50 plus postage.

INKOGRAPH, CO., Inc.
199-305 Centre St., New York City

AGENTS Send for an Inkograph or sales plan booklet which shows how to make big money.

See Miles Away! with Big 3 1/2 Ft. Telescope

Brings distant people and objects close to your eyes. Wonder telescope opens over 3 1/2 ft. long. 5 big sections, brass bound. 8-power sections. Ideal for sports, camping, travel.

5 DAY TRIAL 5 Sections 8-Power

Read numbers on freight car miles away.—A. C. Palmer.

FREE CARRYING AND SHOULDER STRAP

SEND NO MONEY

On arrival pay postman \$1.85, plus postage of \$3.00. Or send \$1.85 and we pay postage. Try 5 days. Money refunded if not delighted. Send today.

FERRY & CO., DEPT. 1255 CHICAGO, U. S. A.

A SHIP MODEL FOR \$4 98

Build an exact replica of the historic Santa Maria, the Mayflower or the La Plinta with your own hands. We will furnish the parts complete for only \$4.98 plus a few cents for postage. No tools needed, except a small hammer. Parts for the Constitution (old Ironsides) may be had for \$6.98. Write for our illustrated catalog.

MINIATURE SHIP MODELS
Dept. S-7, 3618-24 Baring St., Phila., Pa.

your skin under my mares in stall for them to trample, and thrust your red flayed body upon a pole in the grain fields to frighten away the crows! Does that answer you?"

Her laughter ceased, and her eyes dwelt upon him.

"The son of Cherkis!" I heard her murmur: "He has a son! A son—"

"Kulun," she cried. "I am Norhala—daughter of another Norhala and of Rustum, whom Cherkis tortured and slew. Now go, you spawn of unclean toads—go and tell your father that I, Norhala, am at his gates! And bring back with you the maid and man! Go, I say!"

(To be continued)
SECOND SERIAL RIGHTS

\$21,000.00 for Spirits

Dunninger, who writes exclusively for SCIENCE AND INVENTION Magazine and who is the Chairman of our PSYCHICAL INVESTIGATION Committee, will personally pay \$10,000.00 to any medium or spiritualist who can present any psychical manifestation in so-called spiritualism, that he will not explain or that he cannot reproduce by natural means.

More than two years ago SCIENCE AND INVENTION Magazine offered a prize of \$1,000.00 to anyone who could demonstrate his or her ability to communicate with the spirits or to give some definite form of a psychical demonstration which in itself was not trickery.

The result has been that mediums and spiritual organizations have been afraid to place proofs before us. Those weak attempts which have been made to demonstrate psychical phenomena were almost instantly proven fraudulent, and no medium has dared to contradict our findings.

In view of these facts, should we not consider all mediums fraudulent?

To the \$10,000.00 which has been offered by Joseph F. Rinn through this publication for Spiritual proofs and the \$1,000.00 in addition offered by SCIENCE AND INVENTION Magazine we now add Dunninger's \$10,000.00.

So now we have a total of \$21,000.00 offered for proofs of Psychical Manifestations. Spiritualists—get busy.

Drawing Table and Utility Cabinet Are Easy to Build

By EDWIN M. LOVE

(Continued from page 39)

- 1 pc. 3-ply 3/8 in. X 18 in. X 6 ft. pine veneer, good one side
- 1 pc. 5/8 in. X 4 in. X 10 ft. round edge pine apron, sanded
- 1 pc. 2 in X 6 in. X 4 ft. pine, S4S, sanded
- 1 pc. 1 in. X 9 in. X 6 ft. pine, S4S, sanded
- 1 pc. 1 in. X 3 in. X 4 ft. pine, S4S, sanded
- 1 pc. 3 in. X 3 in. X 2 ft. 6 in. pine, S4S, sanded
- 1 pc. 1 1/2 in. X 3 in. X 2 ft. 6 in. pine, S4S, sanded
- 1 pc. 3/16 in. X 5/8 in. X 8 ft. pine or hardwood flat molding
- 1 pc. 3/16 in. X 5/8 in. X 12 ft. pine or hardwood flat molding
- 1 pc. 1/2 in. X 2 ft. 6 in. hardwood dowel
- 1 pc. 1/2 in. X 2 in. X 2 ft. 6 in. hardwood flooring
- 2 pc. 1/2 in. X 2 in. X 3 ft. 6 in. hardwood flooring
- 1 pair 3 in. X 3 in. loose pin butts
- 3 pair 2 in. X 2 in. loose pin butts
- 1 pair 4 in. strap hinges
- 9 pair 1 1/2 in. glass knobs
- 1 3/8 in. frog catch
- 1 small elbow catch

TOOL LIST

Wood saws—several kinds—compass, fine cut, etc.
Wood chisels—several sizes.
Rule and small steel square.
Nail set.
Screw drivers—several sizes.
Hammer—claw type (carpenters.)
Brace and set of wood bits.
Hand drill and set of twist drills.



Choose as Your Profession Electrical Engineering

Electricity offers a brilliant future to the young man who is about to choose his career. Never before has there been such wonderful opportunity in this great field. Big paying positions in electrical

B. S. Degree in 3 Years work the world over are open to trained men—men who possess specialized, practical knowledge. Come to the

School of Engineering of Milwaukee—the largest, the best equipped electrical school of its kind in America. Here you are trained in both theory and practice by a faculty of experts. You learn in large, finely equipped laboratories. If you have 14 high school credits or equivalent, you can become an Electrical Engineer with a Bachelor of Science degree in 3 years. If you have not finished high school you can make up the credits you lack in our short intensive Junior Electrical Engineering course.

Practical Electrical Education

Learn by the thorough, approved scientific methods which our twenty-three years of specializing enable us to give you. In addition to Electrical Engineering, the following complete courses are given: A.C. and D.C. Armature Winding—Wiring and Testing—Practical Electricity—Commercial Electrical Engineering—Junior Electrical Engineering (Technical High School Course), Automotive Electricity, Electrical Refrigeration, and Radio Sales and Service.

EARN WHILE YOU LEARN

You can earn money to help defray part of your expenses while learning. Our wonderful co-operative plan brings an Electrical Career within the reach of every ambitious man. Our Free Employment Department secures positions for those students who wish to earn part or all of their expenses. In addition, the Department will help you get a good position in the Electrical industry when your training is completed. Daily Broadcasting W.I.S.N.

New Term Opens May 7th

Big Book FREE

Mail the coupon today for our big new illustrated catalog. Mention the course that interests you most and we will send you special information. Read about the school that trains men for practical and quick success. See how easy it is for you to get the training that will enable you to step to a splendid position and a handsome income. Mail in coupon right NOW. No cost or obligation.

SCHOOL of ENGINEERING of Milwaukee

Founded 190

Dept. S.I.-528

Jackson & E. Wells Sts. Milwaukee, Wis.

-----MAIL COUPON NOW-----

SCHOOL OF ENGINEERING OF MILWAUKEE
Dept. S.I. 528, Jackson and E. Wells Sts., Milwaukee, Wis.

Please send me, without cost or obligation, full particulars of the electrical course I have checked, and your big Free Book telling about your institution and how it will fit me for a big position in the electrical field. Also tell me about your Earn-While-You-Learn Plan.

(Be sure to check courses interested in)

- Electrical Engineering, B. S. Degree in 3 Years.
- Commercial Electrical Engineering, 1 Year.
- Junior Electrical Engineering, 1 to 2 Years.
- Master Electrician, 6 Months.
- A.C. and D.C. Armature Winding, 3 Months.
- Light, Motor Wiring and Testing, 3 Months.
- Automotive Electricity, 3 Months.
- Refrigeration, 3 Months.
- Radio Sales and Service, 3 Months.
- Home Study Laboratory Service.
- I am interested in your "Earn-While-You-Learn" Plan

Name.....Age.....

Address.....

City.....State.....

Education.....

Opportunity Ad-lets

YOU will find many remarkable opportunities and real bargains in these columns. It will pay you to read and investigate the offerings made every month by reliable firms, dealers and amateurs from all over the country. No matter what you may be seeking, whether supplies, automobile accessories, the opportunity to make money, or anything else, you will find listed here the best and most attractive specials of the month.

Advertisements in this section twelve cents a word for each insertion. Name and address must be included at the above rate. Cash should accompany all classified advertisements unless placed by an accredited advertising agency. No advertisement for less than 10 words accepted.

Ten per cent discount for 6 issues, 20 per cent discount for 12 issues. Objectionable or misleading advertisements not accepted. Advertisements for the July issue must reach us not later than May 5th.

EXPERIMENTER PUBLISHING CO., INC., 230 Fifth Avenue, New York, N. Y.

Advertising Agencies

24 Words—355 Rural Weeklies \$12.20. Ad-Meyer, 112-S1 Hartford, St. Louis, Mo.

Agents Wanted

Earn \$25.00 daily. Sell colored slickers, raincoats, \$2.95. Hat FREE. White trimmed trench coats. Spring overcoats, outfit free. H. Clark, 232 So. Wells, Dept. D11-5, Chicago.

Garage Men—Use Aloy-Num Pistons, all sizes, all motors, wonderful improvement. Power-Speed-Wear, light weight. Be our agent. Better results. Big Profits. L. N. Egge, Mfg., 7701 S. Main St., Los Angeles, Calif.

Men and Women Wanted to sell subscriptions in their own communities. Can make a dollar an hour in spare time. Two leading magazines. Help given to beginners. Write for information at once. Agency Dept., Experimenter Publishing Co., 230 Fifth Avenue, New York City.

New Invention—400% profit. Liquid quick mend for fabrics and Hosiery. Stops runs. Every woman buys. Hundred other fast sellers. J. E. Johnson Co., Dept. 865, 1129 Wentworth Ave., Chicago.

\$10 Every Day. Will send sample of new Wringer Nap with Big Steel Plate on approval. Convince yourself at our risk. Kleaneze, Dept. M19, Delphos, O.

Big bunch mail. Year 15c. Catalogues, magazines. Kentucky Agency, Covington, Kentucky.

Your own business! \$100 weekly sure. Novel Suction Ash Receiver. Sells on sight. Used in auto, home, office. Quick sales. Send for details, or 50c for attractive sample with four selling plans. Dept. CT-910, Gordon Co., 110 E. 23rd St., New York.

Don't sell for others. Employ agents yourself. Make your own products. Toilet Articles, Household Specialties, etc. 500% profit. Valuable booklet free. National Scientific Laboratories, 1375-W Broad, Richmond, Va.

Strange Invention. Pays \$25 daily. Keeps telephone and iron cords from tangling and kinking. Prevents iron scorching. Saves electricity. Samples free. Never-knot, Dept. 5K, 4503 Ravenswood, Chicago.

Send name, address on postcard. Free introductory copy Modern Salesology Magazine. 1000 money making opportunities offered by big reliable firms; no obligation. Salesology Magazine, Desk B219, 500 No. Dearborn, Chicago.

Mirrors resilvered at home. Costs less 5 cents per square foot; you charge 75 cents. Immense profits plating autotools, reflectors, tableware, stores, refinishing metalware etc. Outfits furnished. Details FREE. Write Sprinkle Plater, 955, Marion, Indiana.

Gold Leaf Window Letters and Script Signs. No experience; 500% profit. Samples free. Meyer writes 5 days profits \$141.36. Consolidated, 69-B, West Van Buren, Chicago.

\$50.00 Weekly easy, applying Gold Initials on Automobiles. No experience needed. \$1.45 profit every \$1.50 job. Free Samples. "Radio Monograms," R1043, Washington, Boston, Mass.

Agents Wanted to sell Men's Hats direct from factory. Write for catalog. Model Hat Mfg. Co., Dept. M-11, East Orange, N. J.

\$10 daily silvering mirrors, plating and refinishing lamps, reflectors, auto, beds, chandeliers by new method. Outfits furnished. Write Gummetal Co., Ave. D, Decatur, Ill.

Rummage sales make \$500.00 monthly. We start you, furnishing everything. Experience unnecessary. Monarch, Desk 4, 409 Division, Chicago.

Just Out—New Patented Apron. No strings or straps—\$20.00 a day every day; over 100% profit; commissions daily. Write for free offer. Sta-Put Co., Dept. 505, St. Louis, Mo.

Agents—Best seller; Jen Rubber Repair for tires and tubes; supersedes vulcanization at a saving of over 800 per cent; put it on cold. It vulcanizes itself in two minutes and is guaranteed to last the life of the tire or tube; sells to every auto owner and accessory dealer. For particulars how to make big money and free sample, address Amazon Rubber Co., Philadelphia, Pa., Dept. 601.

\$60—\$200 a week. Genuine Gold Letters for store windows. Easily applied. Free samples. Liberal offer to general agents. Metallic Letter Co., 441 B., North Clark, Chicago.

Big money and fast sales. Every owner buys gold initials for his auto. You charge \$1.50; make \$1.35. Ten others daily easy. Write for particulars and free samples. American Monogram Co., Dept. 71, East Orange, N. J.

Succeed With Your Own Products. Make them yourself. Formulas, Processes, Trade-Secrets. All lines. Catalog, Circulars free. D. Thaxly Co., Washington, D. C.

Make \$25.00 daily selling colored Raincoats and Slickers, Red, Blue, Green, etc. \$2.95—Hat Free, Commissions daily. Outfit FREE. Elliott Bradley, 230 So. Wells, Dept. AD-5, Chicago.

Airplanes, Aviation

Biggest, Best Catalog Model Airplanes, Parts, Supplies; 5c. Postpaid. Ideal Company, 23 West 18th Street, New York.

Model Airplane Engines: $\frac{1}{2}$ h. p. in 3 lbs.; 1 h. p. in 5 lbs. Stationary Engines: $\frac{1}{2}$ h. p. in 10 lbs.; 1 h. p. in 15 lbs. Circulars free. DYNAMIC MFG. CO., First Nat'l Bank Bldg., Chicago.

Send dime for 12-inch mounted propeller and circular on 1-foot three-foot model aeroplane. No selling. Aero Shop, 3050 Hurbit Ave., Detroit, Mich.

Join National Society for Promotion of Aviation, one of America's fastest growing Aviation Societies. No dues, assessments, extras of any kind. \$3.00 covers all costs. You receive beautiful pair silver wings, home study lessons on aviation flight principles with drawings, diagrams, dictionary of aviation containing 200 aviation terms, definitions. Aeronautical dope sheets giving valuable data on 400 airplanes, airplane motors. In lesson form, not a book. Enroll now, enclosing \$3.00. Everything will be mailed immediately. N.S.P.A., No. 412 6th St., Dept. C81-112-6th St., Los Angeles, Cal.

Airplanes—Send for free cuts and Plans of our wonderful two Place, Companion type, small, high life wing monoplane and information. How to build this ship, and be sure it will fly, also Propeller literature. Crawford Airplane Mfr., Seal Beach, Calif.

Books

Do you want to make more money? The Business Guide containing 544 pages and over 100 illustrations shows you how or it costs you nothing. Gives the facts you usually guess at, buy for, or neglect to look up. Send \$3.00 in full payment or write for further details. Glendon Roy, River, Ohio.

Business Opportunities

Want to make a dollar an hour in your spare time? Send for full information, Agency Dept. Experimenter Publishing Co., 230 Fifth Ave., N. Y. C.

Sell By Mail!—Books, novelties, bargains; large profits! Particulars FREE! E-Elfro, 525 South Dearborn, Chicago.

Print 250 Signs or Pictures an hour without press, type or machinery. Sample and particulars 10c. Straco, 1015½, Springfield, Ohio.

Free Book. Start Little Mail Order business. Hadwll, 5A-74 Cortlandt Street, N. Y.

Amateur Cartoonists: Make money in spare time with new cartoon selling plan. Write Smith's Service, Wentauch, Wash.

Learn Collection Business. Good income, quick results. Interesting booklet, "Skillful Collecting," free. National Collectors Assn., 303 Wehrle Bldg., Newark, Ohio.

Chalk Talks

Laugh producing program, \$1.00. Catalog free. BALDA ART SERVICE, Dept. 1, Oshkosh, Wis.

Cameras and Photography Supplies

Make money in Photography. Learn quickly at home. Spare or full time. New plan. Nothing like it. Experience unnecessary. American School of Photography, Dept. 5333, 3601 Michigan Avenue, Chicago.

Chemistry

Attention Chemical Experimenters! 100 chemicals consisting of complete selection for the experimenter's laboratory. Chemicals of highest quality obtainable. Sufficient quantities for hundreds of experiments. Apparatus with this outfit to perform many experiments. Really ideal for any laboratory. Price \$4.75. 50 pieces high grade chemical apparatus containing most essential equipment for laboratory. Worth three times price asked. Our price \$7.00. Postage prepaid. Send money order or C. O. D. to Pines Chemical Co., 1524 St. Marks Ave., Brooklyn, N. Y.

Learn Chemistry at Home. Dr. T. O'Connor Sloane, noted educator and scientific authority, will teach you. Our home study correspondence course fits you to take a position as chemist. See our ad on page 6 of this issue. Chemical Institute of New York, 16 E. 30th St., New York City.

\$4.00—Astounding Chemical Offer—\$4.00. Chemical outfit consisting of 100 different expensive laboratory chemicals. Generous quantities of each, including apparatus, prepaid anywhere United States, all for \$4.00. Cash or C.O.D., only one to a customer, easily worth \$20.00. Chemicals guaranteed Pure. Send order early to The Swimmer Chemical Company, Est. 15 years, 1500 St. Marks Avenue, Brooklyn, N. Y.

(Chemistry continued)

Your Chemical problems solved and working process furnished for Five Dollars. Write me. W. Stedman Richards, Consulting Chemist, Box 2102, Boston, Mass.

Only a Dime! "Amateur Chemist" magazine. See radio activity experiments, etc. Thompson-Allen Laboratories, 310 W. Pine, Shamokin, Pa.

Your chemical problems solved and working process furnished for Five Dollars. Write me. W. Stedman Richards, Consulting Chemist, Box 2402, Boston, Mass.

Correspondence Courses

Used correspondence school courses sold on repurchase basis. Also rented and exchanged. Money-back guarantee. Catalog free. (Courses bought). Lee Mountain, Pisrah, Alabama.

Detectives

Detectives Earn Big Money. Travel. Excellent opportunity. Make secret investigations. Great demand everywhere. Experience unnecessary. Write American Detective System, 2190 Broadway, N. Y.

Electricity

Electric Fun! Seventy stunts, 110 volts, \$1. Cuttinez, Campbell, Calif.

Engines, Motors, Dynamos

Make Electric Motors—half and one horse-power. A. C. induction motor winding models show connections plain sight. Learn quick easy. Dept. C, Gaines Bros., Gainesville, Texas.

For Boys

"The Boy Electrician" pocket size, 75 illustrations, 30c. J. Tillberg, Proctor, Vermont.

For Inventors

Inventions Commercialized. Patented or Unpatented. Write Adam Fisher Mfg. Co., 265 Enright, St. Louis, Mo.

Unpatented Ideas Can Be Sold. I tell you how and help you make the sale. Free particulars (Copyrighted). Write W. T. Greene, 808 Jenifer Bldg., Washington, D. C.

Patents Obtained under cooperative payment plan. Write for particulars. W. E. Beck, Registered Patent Lawyer, 853 Jenifer Bldg., Washington, D. C.

Inventors. Use our special service for presenting your invention or patent to manufacturers. Adam Fisher Mfg. Co., 265-A Enright, St. Louis, Mo.

Safety First. Photostat registration of your idea, or invention, leaves you free to negotiate in safety before patenting. Particulars free. Blueprint-Photostat Co., Patent Department, 4 Branford Pl., Newark, N. J.

Time is important in applying for Foreign Patents. Information free. Inquiries solicited. Chester Brown, Registered Patent Attorney, 510 Van Buren Street, Chicago.

Advice Free. Patents procured—reasonable—efficient service. 25 years experience. Chester Brown, Registered Patent Attorney, 510 Van Buren Street, Chicago.

Inventors—We Build Models. Send us your rough idea. Our master mechanics will develop it for you into a practical working model. Thirty years successful experience doing this very thing. Best shop equipment. Expert advice. Confidential service guaranteed. Rank reference furnished. Send for free booklet "The Road to Success." Crescent Tool Co., Dept. D, Cincinnati, Ohio.

Inventors—you can protect and sell your own unpatented ideas, without cost. Full directions, legal blanks, and copy Inventors Handbook. Postpaid \$1.00. Nazro H. Reynolds, Box 365, San Francisco, California.

Formulas

Formulas—170 money-makers and big illustrated catalog 20c. Ideal Book Shop, (D) Park Ridge, Ill.

For Sale

Field Glasses 5X—\$7.95; Luger Carbine Stocks \$15.00; Used Cotts \$14.75; Colt Magazines 45 Auto 75c; Erectors \$1.20. Send stamps for catalog. Hudson Sporting Goods Co., 50 Warren St., New York City.

Health

Quit Tobacco! Tobacco or Snuff habit cured or no pay \$1.50 if cured. Sent on trial! Write Frances Willard, Box 796, Los Angeles, Calif.

Help Wanted

Men—Experience unnecessary; travel; make secret investigations; reports; salaries; expenses. Write American Foreign Detective Institute, 301, St. Louis, Mo.

Distributors—No canvassing; no capital. Homey, Roseta, Pa.

Help Wanted Instructions

Earn \$25 Weekly. Spare Time. Writing for Newspapers and Magazines. Experience unnecessary. Copy-right Book. "How to Write for Pay" Free. Press Reporting Institute, 987, St. Louis, Mo.

How to Entertain

Plays, Musical Comedies and revues, minstrel music, blackface skits, vaudeville acts, monologs, dialog, recitations, entertainments, musical readings, stage handbooks, make-up goods. Big catalog free. T. S. Denison & Co., 623 So. Wabash, Dept. 99, Chicago.

Insects Wanted

Cash paid for butterflies, insects. See Sinclair's Advertisement on page 74.

Instruction

Learn Chemistry at Home. Dr. T. O'Connor Sloane, noted educator and scientific authority, will teach you. Our home study correspondence course fits you to take a position as chemist. See our ad on page 6 of this issue. Chemical Institute of New York, 16 E. 30th St., New York City.

Railway Postal Clerks. \$158.00 to \$225.00 month. Steady work. See your country. 25 men, 18 up coached free. Write immediately, Franklin Institute, Dept. C16, Rochester, N. Y.

Amateur Chemists, Build your own Laboratory. We furnish Chemicals. Write for our price list. East Orange Chemical Co., 180 Amherst St., East Orange, N. J.

Men Wanted who can drive car, to qualify for U. S. Government Chauffeur-Carrier (truck drivers) jobs: \$141-\$175 month. Write Ozmert Instruction Bureau, Dept. 293, St. Louis, Mo.

Work for Uncle Sam. Get Government Jobs. Men—women, 18 up. Commence \$95 to \$158 month. Steady work. Short hours. Paid vacation. No layoffs. Pull unnecessary. Common education sufficient. Candidates coached without leaving home. Full particulars and 32 page book—FREE. Write immediately. Today sure. Franklin Institute, Dept. C4, Rochester, N. Y.

Inventions Wanted

Inventions Commercialized. Patented or Unpatented. Write Adam Fisher Mfg. Co., 205 Enright, St. Louis, Mo.

Machinery and Tools

Concrete Building Block Machines and Molds. Catalog free. Concrete Machine Co., 5 N. First St., St. Louis, Mo.

Magic and Games

Free with \$25 order our large die box. Send 20c for our large catalogue of tricks, puzzles, wigs, sensational escapes. Oaks Magical Co., Dept. 519, Oshkosh, Wis.

Magical Goods

Card tricks, coin tricks, hypnotism, ventriloquism. Instruction 64 page books, 10c each. G. Fenner, 2401 Jefferson, Louisville, Ky.

Magic—For something new and different, send 10c for large magical catalogue. Sterling Magic Shop, Box 33, Danville, Va.

Male Help Wanted

Firemen, Brakemen, Baggage-men, (white or colored), sleeping car, train porters (colored), \$150-\$250 monthly. Experience unnecessary. 897 Railway Bureau, East St. Louis, Ill.

Men, Get Forest Ranger Job: \$125-\$200 month and home furnished; hunt, fish, trap. For details, write Norton Inst., 1511 Temple Court, Denver, Colo.

Immense Profits making French plate mirrors; patented process; easily learned. Plans free. Wear, Excelsior Springs, Mo.

Miscellaneous

Comic Pen & Ink Sketch made from your photo for \$1.00. Send snapshot and state hobby. Photo returned unharmed. Cartoonist, M. Ashenbrenner, 308 Tayco Street, Menasha, Wis.

Angle Calculator. All angles and sides. Trigonometry not needed. Fraction Table. Add, subtract. Automatically reduces lowest term. \$1.00 each, both for \$1.50. G. O. Matter, Board of Trade Bldg., Portland, Oregon.

Beautiful Registered Bull Pups, \$15. Bulldogs, 501 Rockwood, Dallas, Texas.

Forms to cast Lead Soldiers, Indians, Marines, Trappers, Animals, 151 kinds. Send 10c for illustrated Catalogue. H. C. Schiercke, 1034-72nd St., Brooklyn, N. Y.

"Psychic Truth" (Introducing the TRUTH unveiled of mystery and occult dressing.) World wide circulation. Send \$1.00 "Oracle of TRUTH," 92 Lovell, Worcester, Mass.

Canadian Camp Sites on Georgian Bay given away absolutely free. Just pay for deed \$10. Number limited. Send today. Robinson, 35 Burris, Hamilton, Canada.

Movie Mail

Envelopes with canceled stamps attached addressed to prominent Hollywood movie stars from all over the world; 25 all different, postpaid for \$1.00 supply limited. Edwin T. Van Wart, Dept. C, P. O. Box 381, Los Angeles, Cal.

Moulds

Moulds Making Toys. See ad on page 97. Miscellaneous, H. C. Schiercke.

Musical Instruments

Violins—Deep, Mellow, Soulful—on easy credit terms. High grade, wonderful instruments of my own make. Development of many years' experience. Write for book, Gustav A. Fleming, 512 University Building, Seattle, Washington.

Old Coins

California Gold, quarter size, 27c; half-dollar size, 53c Columbian nickel and catalogue, 10c. Norman Shultz, Box 716, Salt Lake City, Utah.

Old Money Wanted

\$2 to \$500 Each paid for hundreds of Old or Old Coins. Keep all old money. It may be very valuable. Send 10c for new illustrated coin value Book \$3c. Guaranteed Prices. Get Posted, we pay Cash. Clarke Coin Company, 14 Street, Letoy, N. Y.

Patent Attorneys

Wanted Ideas. Demand for novel devices however small. If patentable may be the means of your independence. Patents obtained. Sales negotiated. Advice free. Inventors Service Bureau, Box 1648, Washington, D. C.

Patents: Much valuable information in our illustrated book on patents and trademarks sent free with sketch sheet. Send your invention for inspection and opinion. Write today, Bryant & Lowry, 314-A Victor Bldg., Washington, D. C.

Patents. Booklet free. Highest references. Best results. Promptness assured. Watson E. Coleman, Patent Attorney, Washington, D. C.

Richard E. Babcock, Patent Lawyer, Washington Loan & Trust Bldg., Washington, D. C., Booklet.

Monroe E. Miller, Ouray Bldg., Washington, D. C. Patent Lawyer, Mechanical, Electrical Expert. Booklet and Priority Record blank gratis.

Patents—Send for form "Evidence of Conception" to be signed and witnessed. Form, fee schedule information free. Lancaster and Allwine, Registered Patent Attorneys in United States and Canada, 242 Ouray Bldg., Washington, D. C.

Unpatented Ideas Can Be Sold. I tell you how and help you make the sale. Free particulars. (Copyrighted). Write W. T. Greene, 809 Jenifer Bldg., Washington, D. C.

Patents. Time counts in applying for patents. Don't risk delay in protecting your ideas. Send sketch or model for instructions or write for free book, "How to Obtain a Patent" and "Record of Invention" form. No charge for information on how to proceed. Communications strictly confidential. Prompt, careful, efficient service. Clarence A. O'Brien, Registered Patent Attorney, Security Bank Building (directly across street from patent office), Washington, D. C. See page 73.

"Inventor's Advisor," Valuable Patentbook sent free. Labiner, 3 Park Row, New York.

Patents obtained under Co-operative Payment Plan. Write for particulars. W. E. Beck, Registered Patent Lawyer, 952 Jenifer Bldg., Washington, D. C.

Get your own patents. Forms, complete instructions \$1. Cuttingbros., Campbell, Calif.

ADAM E. FISHER, Registered Patent Attorney, in business 25 years; references; personal attention and promptness assured; Dept. E. 205 Enright, St. Louis, Mo.

Patents. Free advice, personal service of registered Attorney, former Patent Office Examiner. Booklet. Albert Jacobs, 728 Barrister Bldg., Washington.

Patent, Trade-Marks, Copyrights. Reliable services by an experienced practitioner devoting personal attention to each case. Inquiries invited. Reference furnished. B. P. Fishburne, Patent Lawyer, 525-D McGill Building, Washington, D. C.

Patents Procured; Trade Marks Registered—A comprehensive experienced, prompt service for the protection and development of your ideas. Preliminary advice gladly furnished without charge. Booklet of information and form for disclosing idea free on request. Irving L. McCathran, 202 Owen Bldg., Washington, D. C., or 41-T Park Row, New York.

Inventors who derive largest profits know and heed certain simple but vital facts before applying for Patents. Our book Patent Sense gives those facts; free. Lacey & Lacey, 644 F St., Washington, D. C. Established 1869.

Patents

Inventions Commercialized. Patented or Unpatented. Write Adam Fisher Mfg. Co., 205 Enright, St. Louis, Mo.

Patents Wanted

Inventions Commercialized. Patented or Unpatented. Write Adam Fisher Mfg. Co., 205 Enright, St. Louis, Mo.

Mr. Inventor—If you have a patent or invention for sale, write Bartley, 38 Court St., Bangor, Me.

Photography

Have you a Camera? Write for free sample of our big magazine, showing how to make better pictures and earn money. American Photography, 118 Camera House, Boston, 17 Mass.

Photoplays Wanted

\$\$\$ For Photoplay Plots. Stories accepted any form, revised, criticized, copyrighted, marketed. Estab. 1917. Booklet free. Universal Scenario Co., 223 Western & Santa Monica Bldg., Hollywood, Calif.

Printing, Engraving and Multigraphing

200 Letterheads and 100 Envelopes, \$1.10, postpaid. Oberman Company, Box 1268, Chicago.

Printing Outfits and Supplies

Print your own cards, stationery, circulars, paper, etc. Complete outfits \$8.85; Job Presses \$11, \$29; Rotary \$149. Print for others, big profit. All easy, rules sent. Write for catalog presses, type, paper, etc. Kelsey Company, P-6 Meriden, Conn.

\$2.00, delivered, 250 each, 8 1/2 x 11 letterheads, envelopes. Samples? Williams Presses, Box 1025, Portland, Maine.

Radio

Eliminator Kits \$17.75. Knock-down transformers \$2.50. 30H chokes \$1.75. Write for lists. Radio Parts Sales Co., Orange, N. J.

Bulb B Eliminators, 22 1/2-45, 67 1/2, 90-135V taps, steel case, bronze finish. Silent—\$9.00. Guaranteed. "A" Eliminators, No-Battery \$16.50. Chargers—Catalog. Electro-Chemical Company of America, Indianapolis.

Be the licensed radio doctor in your community. \$7-\$10 spare time evenings. Our co-operative plan procures all the work you want. Secure franchised territory now. Write for booklet. Co-Operative Radio Doctors. Dept. S, 131 Essex St., Salem, Mass.

Salesmen Wanted

Sell us your spare time. Solicit subscriptions for two leading magazines in your city. You can make a dollar an hour easy. Write for full information, Agency Dept., Experimenter Pub. Co., 23 Fifth Ave., N. Y. City.

We Pay \$48.00 a Week, furnish auto and expenses to introduce our soap and washing powder. Russ-Beach Company, Dept. A185, Chippewa Falls, Wis.

Punchboard Salesmen, \$200 Weekly. Liberal plan assures sales. Latest assortments. Nothing to carry. Pull commissions on repeats. M & L Sales Co., 182 No. Wabash, Chicago.

Punchboard Salesmen, 2 hours daily. \$100 every week. New line. Lowest prices. Pull commission on repeat business. Catalog Free. Puritan Novelty Co., 1409 Jackson, Chicago.

A Good Line: Suitable for all or part time. Can be sold in big cities or small towns any place. Every business needs envelopes in different sizes, weights and qualities. Many buy in large quantities. Our line includes stationery and is very complete. The samples are flat, carry easily, weigh little, look good; prices reasonable. Offer. American Envelope Co., Mexico, Mo. would like our offer.

Song Poems

Song Poem Writers, Write Sequela Songwriters' Service, Sherman Branch, Los Angeles, Calif.

Song-poem Writers. Address Monarch, 236 West 53th, Dept. 133, New York.

Song Writers

Free—"Song Writers Guide." Beaver, D21-622 Goodell, Green Bay, Wis.

Songwriters Substantial Advance Royalties are paid on publishable work. Anyone having original ideas for songs may submit poems for examination and free advice. Walter Newcomer, 1674 Broadway, New York.

Stamps and Coins

Powerful Magnifying Glass Free with Approvals. Send Ad. Premium Stamp Co., 1931 Harrison Ave., New York City.

Tricks and Novelties

Books on Magic Tricks, Games, Conundrums, Riddles, Egyptian Dream Book, Mystic Fortune Teller, Stage, Vaudeville, Irish Jokes, 10c. Three for 25c., coin. Verles Specialties, 5632 Inwood, Chicago.

Typewriters

Typewriters, all standard makes, \$10 up. Fully guaranteed. Free trial. Write for complete illustrated lists. Northwestern Exchange, 121 N. Francisco Ave., Chicago.

THEN

Know your Radio Repair your Radio Set yourself--it's easy!

No matter how much or how little you know of your radio receiver, this new "Radio Trouble Finder" book is going to be a big help.

It explains the common and special faults of all the standard receivers of today; tells how to recognize instantly, by various methods, where the trouble lies and also gives special simple tests by which you can determine what is wrong with your receiver. Then for each particular fault there is explained the proper procedure for correcting it.

Book Contains 64 Pages
Size, 6 x 9, Illustrated
Handsome 2 Color Cover

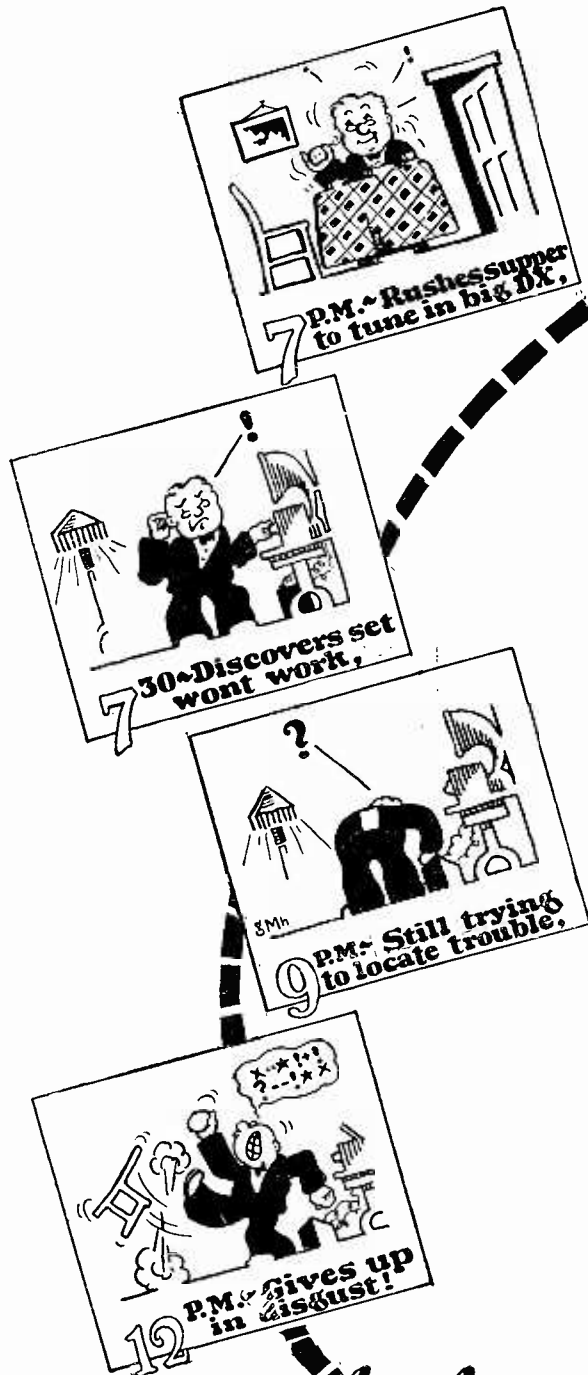

he bought the

25c
the copy
Sold on All Newsstands

THE CONSRAD CO., Inc.

230 Fifth Avenue

New York, N. Y.



Let These Guides

Solve Your Problems

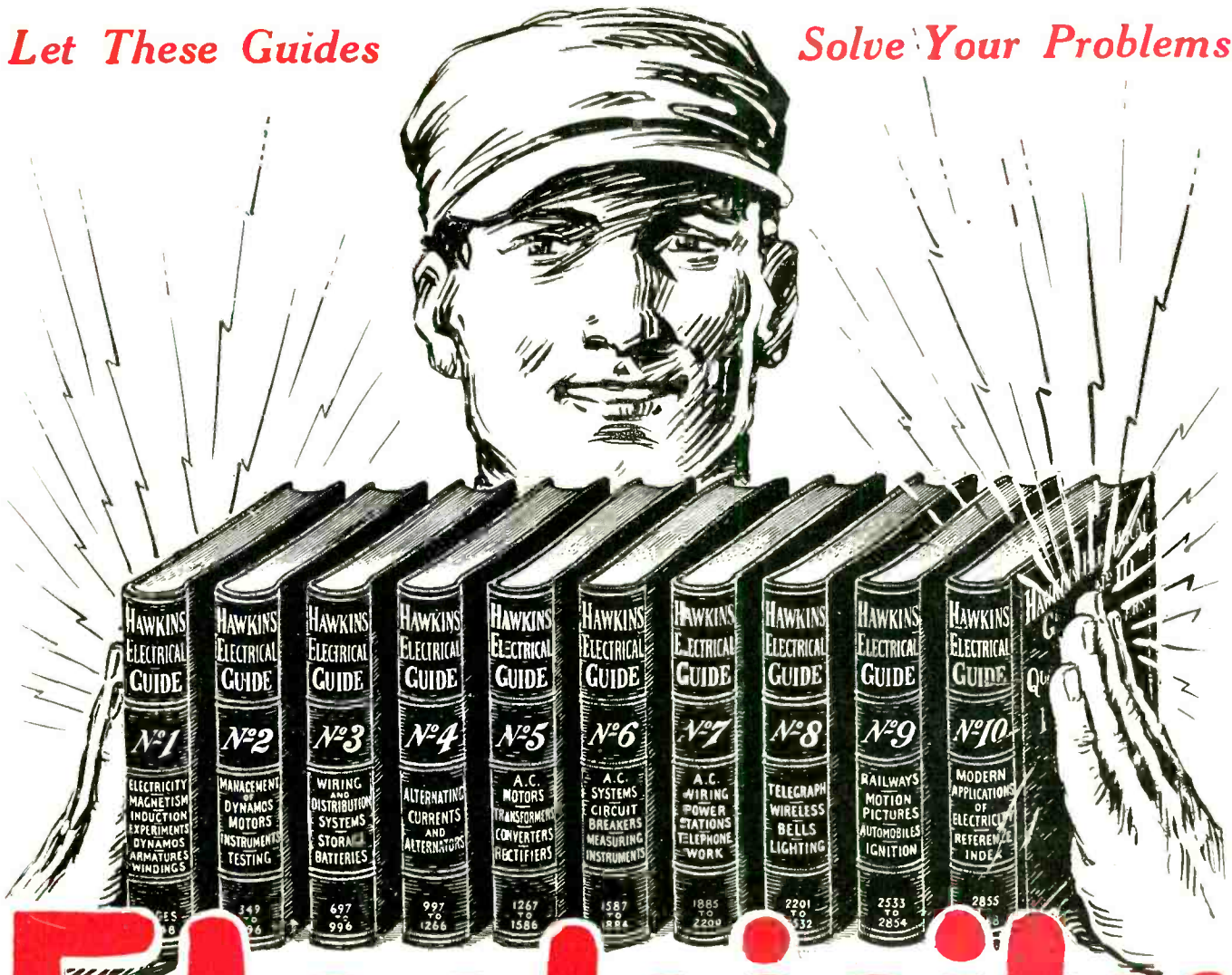

Electricity at your finger ends

HAWKINS ELECTRICAL GUIDES

IN TEN
VOLUMES

3500 PAGES
4700 PICTURES

\$1.00 A VOLUME
\$1 A MONTH

SEND NO MONEY-SEND ONLY THIS COUPON

Know the facts in Electricity. They mean more money and better position for you. Hawkins Guides tell you all you need to know about Electricity. Every important electrical subject covered so you can understand it. Easy to study and apply. A complete practical working course, in 10 volumes. Books are pocket size; flexible covers. Order a set today to look over.

LEARN ALL ABOUT

Magnetism—Inuction—Experiments—Dynamoes—Electric Machinery—Motors—Armatures—Armature Windings—Installing of Dynamoes—Electrical Instrument Testing—Practical Management of Dynamoes and Motors—Distribution Systems—Wiring—Wiring Diagrams—Sign Flashers—Storage Batteries—Principles of Alternating Currents and Alternators—Alternating Current Motors—Transformers—Converters—Rectifiers—Alternating Current Systems—Circuit Breakers—Measuring Instruments—Switchboard—Wiring—Power Stations—Installing—Telephone—Telegraph—Wireless—Bells—Lighting—Railways. Also many Modern Practical Applications of Electricity and Ready Reference Index of the ten numbers.

SHIPPED FREE

Not a cent to pay until you see the books. No obligation to buy unless you are satisfied. Send Coupon now—today—and get this great help library and see if it is not worth \$100 to you—you pay \$1.00 a month for ten months or return it.

THEO. AUDEL & CO.

65 West 23rd Street, New York City.

Please submit me for free examination, HAWKINS ELECTRICAL GUIDE (Price \$1 a number). Ship at once, prepaid, the 10 numbers. If satisfactory, I agree to send you \$1 within seven days and to further mail you \$1 each month until paid.

Name.....

Occupation.....

Employed by.....

Home Address.....

Reference.....

S. I., May

Win a NASH

Sedan or
\$1400⁰⁰
Cash ~ Solve this Puzzle ↘

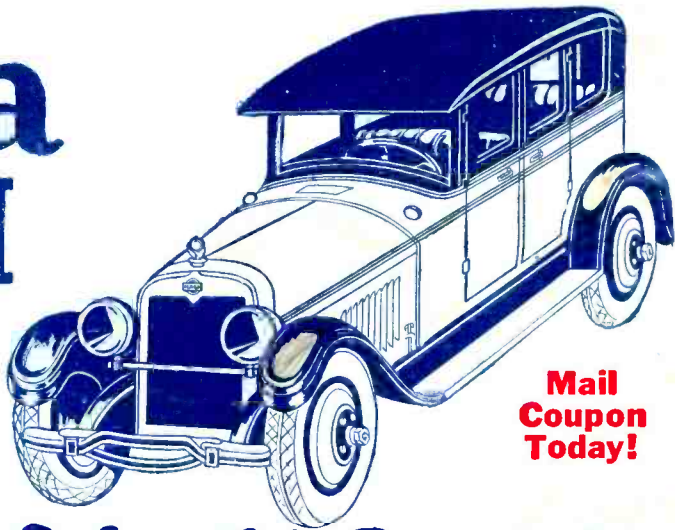

**Mail
Coupon
Today!**

Someone who answers this ad will receive, absolutely free, a fully equipped Landau Model Nash Sedan, or full value in cash if preferred (\$1,085.00). In addition to this Nash Sedan we are also giving away, absolutely free, a latest model Chevrolet Coach or its cash value (\$595.00), a Brunswick Prismatone Phonograph, a Six Tube, Single Dial Freshman Radio Receiving Set, a Corona Portable Typewriter and many other valuable prizes—besides Hundreds of Dollars in Cash. This offer is open to anyone living in the United States, outside of Chicago.

SOLVE THIS PUZZLE

The numbers in the squares to the right spell four words. The alphabet is numbered. A is 1, B is 2, C is 3, etc. Can you make out what the four words are? When you do this, send me your answer right away. It may mean winning the Nash Sedan or \$1,400.00 in cash.

9
23
9
12
12
8
5
12
16
25
15
21

**\$315.00 in Cash Extra
for Promptness**

In addition to the two automobiles, the many other valuable prizes and Hundreds of Dollars in Cash, we are also offering a Special Prize of \$315.00 in Cash for Promptness. First prize winner will receive \$1,400.00 in cash, or the Nash Sedan and \$315.00 in cash. In case of ties duplicate prizes will be awarded each one tying. Get busy right away. Solve the puzzle and send me your answer together with your name and address written plainly. **EVERYBODY REWARDED.** Address

M. L. BOEING

Dept. 3795

323 So. Peoria St., Chicago, Ill.

MAIL COUPON RIGHT AWAY

M. L. Boeing, Mgr., Dept. 3795
323 S. Peoria St., Chicago, Ill.

The answer to the puzzle is...

My Name _____

Address _____

*I will
help you*