

June

25 cents

# Science and Invention

FORMERLY  
ELECTRICAL EXPERIMENTER

*How to build*  
**A RADIO OUTFIT  
IN YOUR SUITCASE**

*See Page 152*





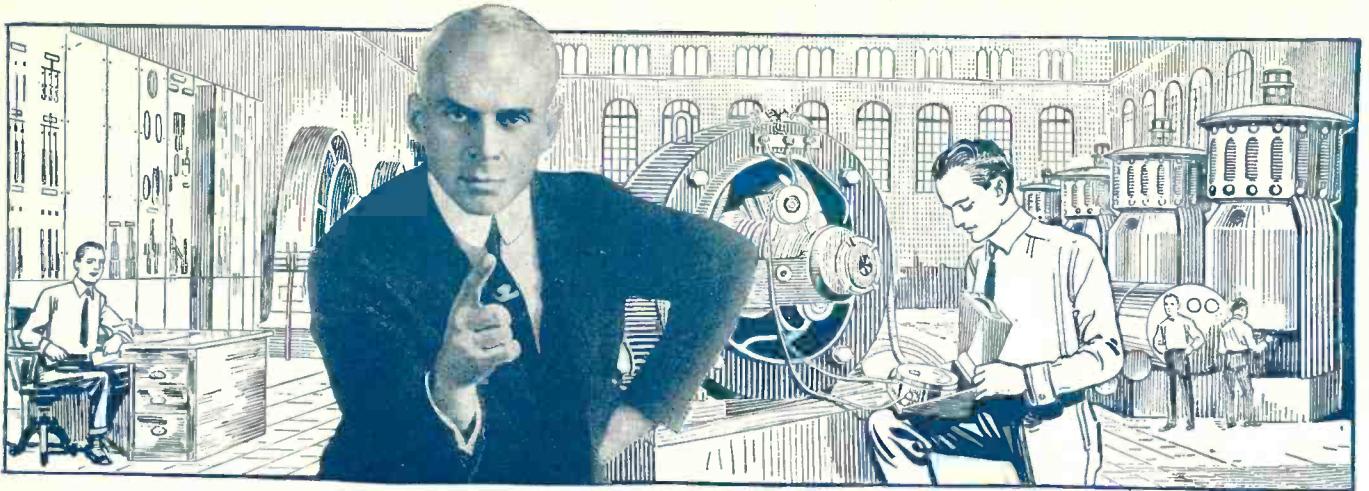

# Electricity Needs You I WILL TRAIN YOU AT HOME

Stop right here. This is YOUR opportunity! Electricity is calling you, and the Electrical Business is in for a tremendous increase. But it needs more trained men—at big pay. By my Home Study Course in Practical Electricity I can train you for these positions.

## Earn \$70 to \$200 a Week

You've always had a liking for Electricity and a hankering to do electrical jobs. Now is the time to develop that talent; there's big money in it. Even if you don't know anything at all about Electricity you can quickly grasp it by my up-to-date, practical method of teaching. You will find it intensely interesting and highly profitable. I've trained and started hundreds of men in the Electrical Business, men who have made big successes. YOU CAN ALSO

BE A BIG PAID

## ELECTRICAL EXPERT

What are you doing to prepare yourself for a real success? At the rate you are going where will you be in ten years from now? Have you the specialized training that will put you on the road to success? Have you ambition enough to prepare for success, and get it?

You have the ambition and I will give you the training, so get busy. I am offering you success and all that goes with it. Will you take it? I'll make you an ELECTRICAL EXPERT. I will train you as you should be trained. I will give you the benefit of my advice and 20 years of engineering experience and help you in every way to the biggest, possible success.

CHIEF ENGINEER  
COOKE

Chicago Engineering  
Works

Dept. 2-A, 2150 Lawrence Av.  
CHICAGO, ILL.

Dear Sir: You may send me entirely free and fully prepaid, a copy of your book, "How to Become an Electrical Expert," and particulars about your Home Study Course in Electricity.

Name.....

Address.....

City..... State.....

**Valuable Book Free** My book, "How to Become an Electrical Expert," has started many a man on the way to fortune. I will send a copy, free and prepaid, to every person answering this advertisement.

**Act Now!** Good intentions never get you anywhere. It is action, alone, that counts. NOW IS THE TIME TO ACT.

L. L. COOKE, Chief Engineer

**CHICAGO  
ENGINEERING  
WORKS**

2150 LAWRENCE AVENUE  
Dept. 2-A Chicago, U. S. A.

## FREE!

### BIG ELECTRICAL OUTFIT

A fine outfit of Electrical Tools, Instruments, Materials, etc., absolutely FREE to every student. I will also send you FREE and fully prepaid —Proof Lessons to show you how easily you can learn Electricity and enter this splendid profession by my new, revised and original system of Training by Mail.

### RADIO COURSE FREE

Special newly-written wireless course worth \$45.00 given away free.

### Free Use of Laboratory

I have a large splendidly equipped Electrical Laboratory where you can come at any time for special instruction without charge. Several competent assistants — practical engineers — are in charge.

### Earn Money While Learning

I give you something you can use now. Early in my Home Study Course I show you how to begin making money in Electricity, and help you get started. No need to wait until the whole course is completed. Hundreds of students have made several times the cost of their course in spare time work while learning.

**The Cooke trained man is the "Big-Pay" man**

**Was  
\$100**

**FREE TRIAL**

**Over a Year  
To Pay**

**Now  
\$55**



**Over  
950,000  
Sold**

*A Finer Typewriter at a Fair Price*

# Send No Money!

No money in advance. Not a cent! Simply make your request via the coupon below if you want this brand new Oliver Typewriter for five days' free trial in your own home or office. Use this Oliver for five days as if it were your own. Type all your letters or any other work with it. Put it to every conceivable test. Compare it with any \$100 typewriter on the market. Compare it for simplicity of construction. For beauty of finish. For ease of operation. For speed. For neatness of work. Then if after five days' free trial you do not

wish to keep the typewriter for any reason whatsoever, simply send it back to us and you won't be out one cent for the free trial. If, on the other hand, you decide that it is the finest typewriter, and you wish to keep it, then pay \$3 after trial and then at the easy rate of only \$4 a month. This is the open, free trial offer we make to you on the Oliver to let you see for yourself that if any typewriter is worth \$100 it is this splendid, speedy Oliver No. 9, our latest model and the finest we ever built.

- Famous Users of the Oliver**
- Columbia Graphophone Co.
  - Otis Elevator Company
  - National City Bank of N. Y.
  - Boston Elevated Railway
  - Hart, Schaffner & Marx
  - U. S. Steel Corporation
  - New York Edison Company
  - American Bridge Company
  - National Cloak & Suit Co.

**Save \$45** For \$55 you can now obtain the identical Oliver Typewriter formerly priced at \$100. We are able to save you nearly half because of our radically new and economical method of distribution. You now deal direct with the factory, eliminating all unnecessary selling expenses. Were it not for this simplified method of distribution, we would be compelled to maintain the \$100 price. But this way gives you a standard \$100 Oliver, brand new, not second-hand or rebuilt, at about half the price of any other new, standard typewriter.

**Mail the Coupon Now**

Check the coupon now to get the Oliver for five days' free trial in your own home or office. Keep it or return it. If you decide to keep it, pay \$3 after trial, then \$4 per month. Or return it at our expense. If you prefer to have further information before sending for a FREE TRIAL Oliver, check the coupon. But do one or the other now and save \$45.

Canadian Price \$79

**The OLIVER**  
Typewriter Company  
676 Oliver Typewriter Bldg., Chicago, Ill.

**THE OLIVER TYPEWRITER COMPANY,**  
676 Oliver Typewriter Bldg., Chicago, Ill.

Ship me a new Oliver Nine for five days' free inspection. If I keep it, I will pay \$55—\$3 after trial, then at the rate of \$4 per month. The title to remain in you until fully paid for.

My shipping point is.....  
This does not place me under any obligation to buy. If I choose to return the Oliver, I will ship it back at your expense at the end of five days.

Do not send a machine until I order it. Mail me your book—"The High Cost of Typewriters—The Reason and the Remedy," your de luxe catalog and further information.

Name.....  
Street Address.....  
City.....State.....  
Occupation or Business.....

# Science and Invention

Vol. X  
Whole No. 110

June, 1922  
No. 2

FORMERLY  
**ELECTRICAL EXPERIMENTER**

233 FULTON STREET-NEW YORK

Published by Experimenter Publishing Company, Inc. (H. Gernsback, Pres.; S. Gernsback, Treas.; R. W. DeMott, Sec'y), 53 Park Place, New York  
Publishers of **SCIENCE AND INVENTION**, **RADIO NEWS**, and **PRACTICAL ELECTRICS**

## Table of Contents for June

POPULAR SCIENTIFIC ARTICLES	
A VACATION-TIME RADIO RECEIVER (See article page 152).....	Front Cover
From a painting by Howard V. Brown	
EDITORIAL .....	117
By H. Gernsback	
ELECTRIC FARM DE LUXE.....	119
By H. Winfield Secor, E. E. Associate Member, American Institute of Electrical Engineers.	
TELEPHONE AIDS PUBLIC SPEAKER.....	120
AUTOS IN THE UNITED STATES.....	121
By Charles Nevers Holmes	
DR. HACKENSAW'S SECRETS—No. 6—THE SECRET OF THE TELAUTOMATON.....	122
By Clement Fezandic	
FREDERICK WINSOR—FIRST GAS INVENTOR.....	123
By Edwin Irvine Haines, B. S.	
THE RAY OF HERCULES.....	124
By Russ Simonton	
UNITED STATES HAS GREATEST ENERGY RESOURCES.....	125
POPULAR ASTRONOMY—MARS NEAR OPPOSITION IN JUNE.....	126
By Isabel M. Lewis, M. A., of the U. S. Naval Observatory, Washington, D. C.	
NEW "MOVIE" CARICATURES.....	129
NEW TYPEWRITER WRITES WORDS.....	129
By Marjorie G. Bowne	
MEASURING HEART AND MUSCLE ACTIONS.....	130
By Felix J. Koch	
PERPETUAL MOTION AT LAST?.....	131
CARILLONS IN BELGIUM.....	132
By Marinus Cook	
BUILDING A COLOR ORGAN.....	133
By Manuel Comulada, Instructor of Acoustics, U. S. Army Music School, Washington, D. C.	
A LIBRARY IN YOUR VEST POCKET.....	134
WOOD ALCOHOL—HOW TO DETECT IT.....	134
By Dr. Ernest Bader	
PLANTS AND ANIMALS THAT FORECAST THE WEATHER.....	135
By Dr. Ernest Bader	
THE SMELL ORGAN.....	136
By Joseph H. Kraus	
DEMONSTRATING ATOMIC STRUCTURES.....	137
PHOSPHORESCENT LIGHT OBTAINED FROM VIOLET RAYS.....	137
PRIZE CONTESTS	
MOTOR HINTS—\$50.00 IN PRIZES FOR IDEAS.....	138
HOW-TO-MAKE-IT DEPARTMENT—\$30.00 IN PRIZES OLD CLOTHES PIN CONTEST—\$5.00 PRIZE.....	147
WRINKLES, RECIPES, AND FORMULAS—Edited by S. Gernsback—\$5.00 Monthly Prize.....	150
AUTOMOBILES	
AUTOS IN THE UNITED STATES.....	121
By Charles Nevers Holmes	
MOTOR HINTS—\$50.00 IN PRIZES.....	138
ELECTRICITY	
ELECTRIC FARM DE LUXE.....	119
By H. Winfield Secor, E. E.	
TELEPHONE AIDS PUBLIC SPEAKER.....	120
DR. HACKENSAW'S SECRETS—No. 6—THE SECRET OF THE TELAUTOMATON.....	122
By Clement Fezandic	
THE RAY OF HERCULES.....	
By Russ Simonton	
UNITED STATES HAS GREATEST ENERGY RESOURCES.....	
By Felix J. Koch	
BUILDING A COLOR ORGAN.....	
By Manuel Comulada	
DEMONSTRATING ATOMIC STRUCTURES—ELECTRICALLY.....	
By Archie Richardson	
A VACATION-TIME RADIO RECEIVER.....	
By Robert E. Lacault	
RADIO FOR THE BEGINNER—No. 4—SHOOTING TROUBLE IN THE RADIO RECEIVER.....	
By Armstrong Perry	
HOW TO MAKE STORAGE "B" BATTERIES.....	
By Joseph E. Kraus	
RADIO-FREQUENCY AMPLIFICATION FOR AMATEUR RECEPTION.....	
By Arthur H. Lynch	
RADIO BROADCAST.....	
By Joseph H. Kraus	
RADIO ORACLE—QUESTION AND ANSWER BOX.....	
By Joseph H. Kraus	
RADIO ARTICLES	
ELECTRIC FARM DE LUXE.....	119
By H. Winfield Secor, E. E.	
DR. HACKENSAW'S SECRETS—No. 6—THE SECRET OF THE TELAUTOMATON.....	122
By Clement Fezandic	
CHURCH BROADCASTS OWN SERMONS.....	151
By Archie Richardson	
A VACATION-TIME RADIO RECEIVER.....	152
By Robert E. Lacault	
RADIO FOR THE BEGINNER—No. 4—SHOOTING TROUBLE IN THE RADIO RECEIVER.....	154
By Armstrong Perry	
HOW TO MAKE STORAGE "B" BATTERIES.....	155
By Joseph E. Kraus	
RADIO-FREQUENCY AMPLIFICATION FOR AMATEUR RECEPTION.....	156
By Arthur H. Lynch	
RADIO BROADCAST.....	158
By Joseph H. Kraus	
RADIO ORACLE—QUESTION AND ANSWER BOX.....	159
By Joseph H. Kraus	
CHEMISTRY AND ELECTRO-CHEMISTRY	
FREDERICK WINSOR—FIRST GAS INVENTOR.....	123
By Edwin Irvine Haines, B. S.	
PRACTICAL CHEMICAL EXPERIMENTS—PAPER No. 2—QUALITATIVE ANALYSIS.....	139
By Prof. Floyd L. Darrow	
EXPERIMENTAL ELECTRO-CHEMISTRY—Second Paper of a New Series.....	141
By Raymond B. Wailes	
WRINKLES, RECIPES, AND FORMULAS—Edited by S. Gernsback.....	149
CONSTRUCTOR ARTICLES	
BUILDING A COLOR ORGAN.....	133
By Manuel Comulada	
BUILDING A DOUBLE NECK HARP-GUITAR.....	142
By C. L. Edwards	
POLARISCOPE MADE FROM A MICROSCOPE.....	144
By Dr. Ernest Bader	
IDENTIFYING CHEMICALS UNDER THE MICROSCOPE.....	145
By Dr. Ernest Bader	
HOME-MADE ELECTRIC COOKING UTENSILS.....	146
By Raymond B. Wailes	
ASTRONOMY	
POPULAR ASTRONOMY—MARS NEAR OPPOSITION IN JUNE.....	126
By Isabel M. Lewis, M. A.	

SCIENCE AND INVENTION is published on the 25th of each month at 53 Park Place, New York. There are 12 numbers per year. Subscription price is \$2.50 a year in U. S. and possessions. Canada and foreign countries \$3.00 a year. U. S. coin as well as U. S. stamps accepted (no foreign coin or stamps). Single copies, 25 cents each. A sample copy will be sent gratis on request. Checks and money orders should be drawn to order of EXPERIMENTER PUBLISHING CO., Inc. If you change your address notify us promptly, in order that copies are not misdirected or lost. All communications and contributions to this journal should be addressed to: Editor SCIENCE AND INVENTION, 53 Park Place, New York. Unaccepted contributions cannot be returned unless full postage has been in-

cluded. ALL accepted contributions are paid for on publication. A special rate is paid for novel experiments; good photographs accompanying them are highly desirable.

SCIENCE AND INVENTION. Monthly. Entered as second-class matter at the New York Post Office under Act of Congress of March 3, 1879. Title registered at the Patent Office. Copyright, 1922, by E. P. Co., Inc., New York. The Contents of this Magazine are copyrighted and must not be reproduced without giving full credit to the publication.

SCIENCE AND INVENTION is for sale at all newsstands in the United States and Canada; also at Brentano's, 37 Avenue de l'Opera, Paris. Member of the Audit Bureau of Circulation.





# THERE IS A MASTERKEY

Do you recall one of those rare moments in life when the veil is lifted for a moment, when a breath of inspiration comes like a flash, when the future seems to be suddenly illuminated, when you feel a mastery stealing into hands and brain, when you see yourself as you really are, see the things you might do, the things you can do, when forces too deep for expression, too subtle for thought, take possession of you, and then, as you look back on the world again, you find it different, something has come into your life—you know not what, but you know it was something very real?

There is a power which can unlock the secret chambers of success and throw wide the doors which seem to bar men from the Treasure house of Nature. This may seem to be too good to be true, but remember that within a few years science has placed almost infinite resources at the disposal of man. Is it not possible that there may be other laws containing still greater possibilities?

You need not acquire this power. You already have it. But you want to understand it; you want to use it; you want to control it; you want to impregnate yourself with it, so that you can go forward and carry the world before you.

And what is this world that you would carry before you? It is no dead pile of stones and timber; it is a living thing! It is made up of the beating hearts of humanity and the indescribable harmony of the myriad souls of men, now strong and impregnable, anon weak and vacillating.

It is evident that it requires understanding to work with material of this description; it is not work for the ordinary builder.

If you, too, would go aloft, into the heights, where all that you ever dared to think or hope is but a shadow of the dazzling reality, you may do so. Upon receipt of your name and address, I will send you a copy of a book by Mr. Bernard Guilbert Guerny, the celebrated New York author and literary critic. It will afford the inspiration which will put you in harmony with all that is best in life, and as you come into harmony with these things, you make them your own, you relate with them, you attract them to you.

But be careful that you do not miss this wonderful opportunity because of its great simplicity. Get your letter in the mail today; it will take but a moment, but it may be the supreme moment, in which you may discover the secret for which the ancient alchemists vainly sought, how gold in the mind may be converted into gold in the heart and in the hand!

The book is sent without cost or obligation of any kind, yet many who have received it say that it is by far the most important thing which has ever come into their lives.

CHAS. F. HAANEL, 222 Howard Bldg., St. Louis, Mo.

## This Advertisement

*contains a message of such transcendental importance that no reader of Science & Invention, whether, man, woman, or child, should fail to answer it.*

14

# RADIO FORMULAE AND DIAGRAMS

14

Schematic Wiring Diagrams, Measurements, and Tables for the Advanced Radio Student



All Formulae and Diagrams Printed on Heavy Paper in Black and Blue and contained in a two-color envelope 9 x 12 inches

## CONTENTS

Measurement of Capacity of a Condenser (Substitution Method). Calibration of a Variable Condenser. Two Diagrams and Curve. . . . . No. 1  
Measurement of Inductance of a Coil or Circuit. Two Methods—Two Diagrams. . . . . No. 2  
Measurement of Distributed Capacity of an Inductance. Diagram and Curve. . . . . No. 3  
Measurement of Fundamental Wavelength of an Antenna. Three Methods. Three Diagrams. . . . . No. 4  
Measurement of Wavelength of Distance Transmitting Station. Two Methods. Calibration of a Receiving Set. Two Diagrams. . . . . No. 5  
Measurement of Effective Antenna Capacity. Two Methods. Two Diagrams. . . . . No. 6  
Measurement of Inductance of Antenna and a Third Method of Measuring Effective Capacity of Antenna. One Diagram. . . . . No. 7

Measurement of Antenna Resistance. Substitution Method. . . . . No. 8  
Schematic Wiring Diagram of Regenerative Audion Receiving Set Suitable for Receiving High Power Undamped Wave Stations. Connections shown are those used in most Navy and Commercial Receivers. . . No. 50  
Schematic Wiring Diagram of Signal Corps Type SCR-68 Radio Telephone Transmitting and Receiving Set No. 51  
Schematic Wiring Diagram of Type CW-936 (Navy Submarine Chaser) Radio Telephone and Telegraph Transmitter and Receiver. . . . . No. 52  
Schematic Diagram of Type SE 1100 (Navy Flying Boat) Radio Telephone and Telegraph Transmitter. . . No. 53  
Table giving the value of LC (Product of Inductance and Capacity) for wavelengths from 300 to 20,000 meters. Inductance in Microhenries. . . . . No. 100  
Table same as above but with Inductance in centimeters. . . . . No. 101

## PRICE 50c Prepaid

Either Direct from us or for sale by the following responsible Dealers:

- |  |   |   |  |
|--|---|---|--|
| Alamo Sales Corp., Indianapolis, Ind.          | Fergus Electric Co., Zanesville, O.             | Nat'l Radio Institute, Washington, D. C.      | Sanda Electric Co., Wheeling, W. Va.         |
| Amer. Electro Tech. App. Co., N. Y. City       | Findley Electric Co., Minneapolis, Minn.        | New England Motor Sales Co.,                  | Sayre-Level Radio Co., Phila., Pa.           |
| Amer. Hdw. Stores, Bridgeport, Conn.           | Fleron & Son, M. M., Trenton, N. J.             | Greenwich, Conn.                              | Schmidt & Co., R., Rochester, N. Y.          |
| Andrae & Sons, Julius, Milwaukee, Wis.         | Fuller Co., Seth W., Boston, Mass.              | New Era Shop, Milwaukee, Wis.                 | Sears, Roebuck & Co., Chicago, Ill.          |
| Anthraxite Radio Shop, Scranton, Pa.           | Galveston Wireless Sup. Co., Galveston, Tex.    | Newman-Sterra Co., Cleveland, O.              | Service Radio School, Washington, D. C.      |
| Atlantic Radio Co., Boston, Mass.              | Hall Electric Co., Wm., Dayton, O.              | Nichols Radio Sup. Co., Bwlg. Green, Ky.      | Shotton Radio Mfg. Co., Scranton, Pa.        |
| Bamberger & Co., L., Newark, N. J.             | Hatfield Electric Co., Indianapolis, Ind.       | Nola Radio Co., New Orleans, La.              | Smith Norotoy Elec. Inc., Charlotte, N. C.   |
| Banister & Pollard Co., Newark, N. J.          | Heustis, A. E., Fitchburg, Mass.                | Noll & Co., E. P., Philadelphia, Pa.          | Smith Radio Labs., Sarnia, Ontario, Can.     |
| Benwood Specialty Co., St. Louis, Mo.          | Hickson Electric Co., Rochester, N. Y.          | Northern Radio & Elec. Co., Seattle, Wash.    | So. California Elec. Co., Los Angeles, Cal.  |
| Bluebird Electric Shop, Newark, N. J.          | Hiro Wireless Supply Co., Marion, Ill.          | Northwest Radio Serv. Co., Seattle, Wash.     | Southern Elec'l Sup. Co., San Diego, Cal.    |
| Brode Electric Co., Los Angeles, Cal.          | Holt Electric Util. Co., Jacksonville, Fla.     | N. S. W. Bookstall Co., Sydney, Australia     | Southwest Radio Sup. Co., Dallas, Tex.       |
| Brown, J. Edw., Glenbrook, Conn.               | Hughes Elec'l Corp., Syracuse, N. Y.            | Parent Electric Co., New York City            | Sprott-Shaw Schl., Vancouver, B. C.          |
| Bullock's, New York City                       | Jenkins, Lester I., New Bedford, Mass.          | Paramount Radio Sup. Co., Atlantic City       | Sterling Electric Co., Minneapolis, Minn.    |
| Burham & Co., Deptford, S. E. 8, Eng.          | Karlova Radio Corp., Rock Island, Ill.          | Paul's Electric Stores, Me. Ford, Ore.        | Stubbs Electric Co., Portland, Ore.          |
| California Elec. Co., San Francisco, Cal.      | Katzenbach & Co., F. S., Trenton, N. J.         | Pearlman's Book Shop, Washington, D. C.       | T. & H. Radio Co., Anthony, Kans.            |
| Carter Electric Co., Atlanta, Ga.              | Kendall Co., W. D., Worcester, Mass.            | Penn. Marconi Wireless Schl., Phila., Pa.     | Tuska Co., C. S., Hartford, Conn.            |
| Cattou, Neill & Co., Honolulu, T. H.           | Keubler Radio Co., Toledo, O.                   | Penn Radio Apparatus Co., Reading, Pa.        | United Elec. Stores Co., E. Pittsburgh, Pa.  |
| Central Radio Co., Independence, Mo.           | Killoch Co., David, New York City               | Phila. Schl. of Wireless Tele., Phila., Pa.   | United Elec. Stores Co., Bradock, Pa.        |
| Central Radio Co., Kansas City, Mo.            | King Radio Co., Pittsburgh, Pa.                 | Piedmont Electric Co., Asherille, N. C.       | U. S. Radio Co., Pittsburgh, Pa.             |
| Chase, Geo. H., Newport, R. I.                 | Klaus Radio Co., Eureka, Ill.                   | Pioneer Electric Co., St. Paul, Minn.         | Warner Bros., Oakland, Cal.                  |
| Chicago Radio Ap. Co., Chicago, Ill.           | Kluge, Arno A., Los Angeles, Cal.               | Pitts. Co., F. D., Boston, Mass.              | Western Radio Co., Kansas City, Mo.          |
| Cleveland Co., L. W., Portland, Me.            | Krause & Co., A. F., Los Angeles, Cal.          | Pitts. Radio & App. Co., Pittsburgh, Pa.      | Western Radio Elec. Co., Los Angeles, Cal.   |
| Cloud & Son, Macy, Ind.                        | Kusel Co., D. & F., Watertown, Wis.             | Pitts. Radio Sup. Co., Pittsburgh, Pa.        | Wheeler Green Electric Co.,                  |
| Con. Radio & Elec. Corp., New York City        | Lehigh Radio Co., Bethlehem, Pa.                | Port Arthur Radio Lab., Port Arthur, Tex.     | Whitall Electric Co., Rochester, N. Y.       |
| Cutting & Washington, New York City            | Liberty Incandescent Supply Co., Pittsburg, Pa. | Post Office News Co., Chicago, Ill.           | White Co., The., Columbus, Ga.               |
| Daily Battery & Equipment Co., Pittsburgh, Pa. | Liberty Radio Sup. Co., Chicago, Ill.           | Precision Equipment Co., Cincinnati, O.       | White & Boyer Co., Washington, D. C.         |
| Delaney-Felch & Co., Pawtucket, R. I.          | Linze Elec'l Sup. Co., St. Louis, Mo.           | Radio Development Co., Springfield, Mass.     | White & Bro., Frank, Canton, Ill.            |
| Detroit Electric Co., Detroit, Mich.           | Luther, H. E., Detroit, Mich.                   | Radio Distributing Co., Newark, N. J.         | Williamson Elec. Co., Seattle, Wash.         |
| Dewey Spt. Goods Co., Milwaukee, Wis.          | McCarthy Bros. & Ford, Buffalo, N. Y.           | Radio Equipment Co., Boston, Mass.            | Wilmington Elec. Spec. Co., Wilmington, Del. |
| Doubleday-Hill Elec. Co., Pittsburgh, Pa.      | McMillan Bros., Pittsburgh, Pa.                 | Radio Equipmt. & Mfg. Co., Minneapolis, Minn. | Wilson Co., Harold K., Grundy Center, Iowa   |
| Dreyfus Sales Co., New York City               | Manhattan Elec. Sup. Co., N. Y. & Chic.         | Radioelectric Shop, Cleveland, O.             | Winner Radio Co., Aurora, Colo.              |
| Duck & Co., Wm. B., Toledo, O.                 | Marshall-Gerken Co., Toledo, O.                 | Ray-D1-Co., Chicago, Ill.                     | Wireless Press Co., Canton, O.               |
| Dunn, J. J., Pasadena, Cal.                    | Meter Elec'l Const. Co., Oshkosh, Wis.          | Reuter Electric Co., Cincinnati, O.           | Wireless Press, New York City                |
| Electric Motor & Eng. Co., Canton, O.          | Meyberg Co., Leo J., San Francisco, Cal.        | Reynolds Radio, Providence, R. I.             | Wolfe Electric Co., Omaha, Neb.              |
| Electro Importing Co., New York City           | Mohawk Elec'l Sup. Co., Syracuse, N. Y.         | R. I. Elec. Equipmt. Co., Milwaukee, Wis.     | Y. M. C. A., Los Angeles, Cal.               |
| Elite Electric Shop, El Paso, Tex.             | National Radio Corp., Atlanta, Ga.              | Rose Radio Supply, New Orleans, La.           | Zamoiski Co., Jas. M., Baltimore, Md.        |
| Erle Book Store, Erle, Pa.                     |   | Roy News Co., Fre'k J., Toronto, Can.         | Zilbert Bros., Nashville, Tenn.              |

Consolidated Radio Call Book Co., Inc., 98 Park Place, New York City



# Hello Boys!

A.C. Gilbert's Own Column

**T**HIS month I am going to ask your indulgence while I take all the space in my column to tell you something of my own story.

My reason for this is that I want my boy friends (and I think I may count more of these in the world than any other single individual) to know what I have been through myself and why I feel that every boy should be trained for skill, adeptness, knowledge, popularity and leadership.

I am not very far past boyhood myself. It seems only yesterday that I landed at the little university in Oregon from my boyhood home in northern Idaho.

I was interested in three outside things: athletics, sleight-of-hand and scientific experiments.

In the Northwest I went in for wrestling, got beaten the first year, and the second year won the Pacific Coast championship.

I also went in for pole vaulting and broke the Northwest record, beside winning the track championship of that section.

Then I went to Yale, won the "Y" in three different branches, took the wrestling championship of the United States, took first honors as all-around gymnast, and twice broke the world's pole vaulting record.

But all the time I devoted every possible spare moment to my scientific experiments. This work of making science understandable, fascinating and useful to boys helped me earn my way through college and led me into my life work of making mechanical toys.

This is a lot for a man to talk about himself, you will admit. But I want you to know these things to see therein where I got the inspiration to build the Master Hand Library for Boys which my publishers are now offering.



A.C. Gilbert



The Real Story of a Real Boy



A Story for Wide-awake Fathers

## Keeping Up With Father

In which Jim Craig tells how he got new power of leadership

**WE** HAVE a new game at our house, my two brothers and I. We call it "Keeping Up With Father." We just hit on the name all of a sudden on last Christmas Day while we were going through the pictures and titles of ten corking books that father had smuggled in on the quiet and put with my presents. It sounds funny, but we couldn't "see" our other presents for a while.

You want to know about that game and why we named it.

Well, father is a very busy man, but he knows a tremendous lot of interesting things about science, and engineering, and chemistry, and magic, and wireless, and electricity, and athletics. He had always been keen about magic and tricks of all kinds. So he got us to like these things, too.

Then he discovered that set of books which let us right into a lot of wonderful secrets.

Here are some of the things we learned: How to understand the wonders of the Radio Telephone and Broadcasting and how to build your own Wireless Outfit. How to train to become a champion athlete, to be a champion pole vaulter, high jumper or broad jumper.

How to do the strange rope tricks of the Davenport Brothers, who, as you know, made everybody think they had spiritualistic powers until their secrets were exposed.

How to master the secrets of Hydraulic and Pneumatic Engineering, Coin Tricks and Chemistry, how to do some of the amazing tricks that made such magicians as Herrmann and Kellar famous.

How to build all kinds of wonderful and useful things at home with a few tools and a carpenter's bench.

How to be able to talk about big inventions intelligently and explain them to others.

The set contains these ten wonderful volumes:

Radio Telephone and Broadcasting, Boy Athletics, 66 Stunts with the Electric Motor, 75 Electrical Toys and Tricks, Chemistry, Hydraulic and Pneumatic Engineering, Signal Engineering, Carpentry, Knots and Splices, Coin Tricks.

I think I have told you enough about these books to make you long to possess a set yourself. But, to give you any real idea of all the splendid information there is in these books, is quite beyond me. Just think of having a quick answer to all the questions that come up in the wonderful fields covered by these volumes.

I only hope for your sake that someone will give you this great set of books. And I'll bet you right now, that if your father gets this marvelous Boy's Library for you, he will have just about as much fun with it as you do.

But here! I haven't told you the name of this set, or who wrote it.

It is called the Master Hand Library (ten books in all), and it was got up by Mr. A. C. Gilbert. You know, the man who invented the building sets ( Erector ) and all those other sensible toys we get for Christmas and Birthday and Vacation presents—I mean the mechanical ones that teach us engineering and carpenter work, and wireless and magic and chemistry.

Believe me, he knows how to write for boys! He ought to, for he was "some boy" himself.

That game I told you about—"Keeping Up With Father"—is more fun than anything we ever played. That's pretty strong when you think of football, hockey and all that.

But this is another kind of fun. It is planning and building and doing experiments in wireless and chemistry and everything else that men do.

It beats school learning all to pieces, and you haven't any idea what a lot of interesting things, which you never dreamed of before, you can get from Mr. Gilbert's books in almost no time.

JIM CRAIG.

### Don't Send a Single Nickel

**FATHERS,** mothers, sisters, brothers, aunts! You have read Jim's own story. He knows what he is talking about because he has read Mr. Gilbert's fascinating books from cover to cover and in his spare moments has gathered a perfectly surprising fund of information and inspiration on the things of popular science which every man must know to be well-rounded.

Jim didn't tell you, but they have wrought a wonderful change in him. His father tells us he has gone ahead with leaps and bounds—so far as popularity is concerned—since he began reading and using the Master Hand Library. Jim wasn't naturally a leader, but somehow he seems to be chosen now for the job whenever the boys get together. He seems to be always a few steps ahead of the procession.

But how about the Boy *you* have in mind? Don't you think these books would make a great present for him?

It is all very simple. Just send the coupon by next post *without any money*, and we will send you the entire set of ten books for five days' free examination. You see, it costs you nothing to look them over.

Then, if you decide (as we are very positive that you will) that Mr. Gilbert's Master Hand Library is "just the thing" for Bob or Bill or Jack or all of them, send only \$3.50 and the set is yours to give him or them. It is ready for immediate shipment.

Upon receipt of your coupon we will send you, with Mr. Gilbert's compliments, a copy of his 160-page book, "Boy Engineering," in which you will find many interesting and

fascinating things. This book is yours free of all charge, whether you buy the Master Hand Library or not.

Send This Coupon Today



MASTER HAND PUBLISHING COMPANY New Haven, Conn.

Please send me A. C. Gilbert's Master Hand Library for Boys. If, after five days' trial I like it, I agree to send \$3.50 in complete payment for the ten volumes. If, for any reason I am disappointed, I will return the set at your expense and owe you nothing.

Name.....

Address.....

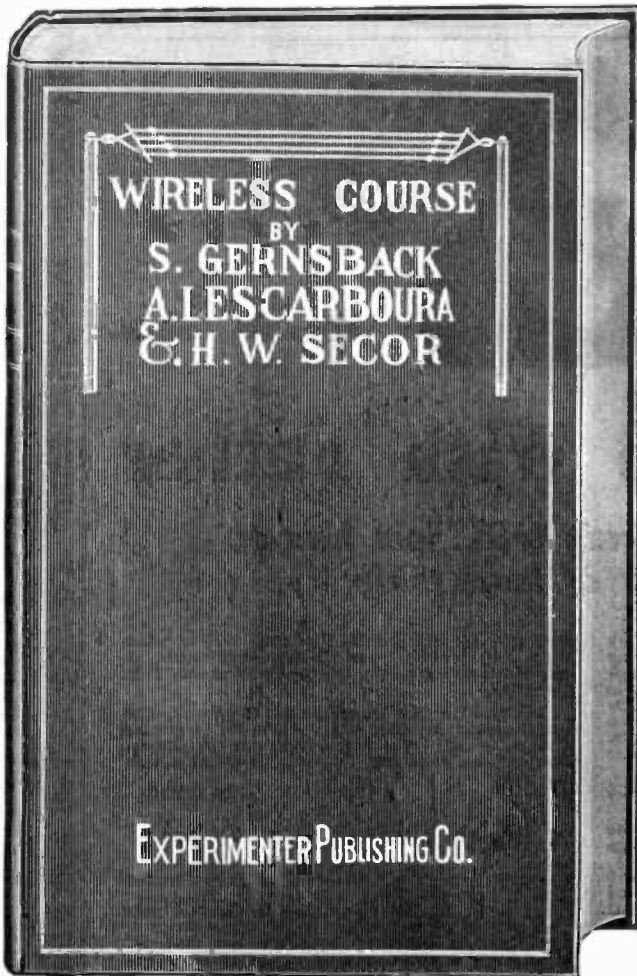

# WIRELESS COURSE

## in 20 Lessons

By

S. GERNSBACK, H. W. SECOR,  
A. LESCARBOURA

Beautifully Stiff Bound  
in Red Cloth  
Gold Stamped  
Size 7 x 10 inches  
160 Pages  
20 Lessons  
360 Illustrations  
30 Tables  
Price \$1.75 Prepaid



Exactly the Same Books  
But Soft Bound,  
and not Gold Stamped  
Price \$1.25, Prepaid

## The Experimenter Publishing Co., Inc.

53 PARK PLACE  
NEW YORK, N. Y.

**T**HIS Course has been considerably revised in order that it meet some of the many important changes which have occurred in Radio Telegraphy and Telephony within recent years. Much valuable data and illustrations concerning the Vacuum Tube has been added. This comprises the theory of the Tube as a detector and as an amplifier, and in addition has been included modern amplification circuits of practical worth. Incidentally, space has also been devoted to the development of the Radio Compass as operated and controlled by the United States Navy with its consequent great aid to present-day navigation.

The beginner and general student of radio will find this Course of great value in securing the necessary fundamentals of a most fascinating and instructive vocation, or avocation—as the case may be. Radio holds out considerable inducements as a career.

*The Publishers*

The Experimenter Publishing Co., Inc.  
53 Park Place, New York, N. Y.

Enclosed find  \$1.75  
 stiff  \$1.25 for which send me one copy of  
 soft bound WIRELESS COURSE. Postpaid.

Name .....

Town .....

Address .....

State .....

S.I. 6-22





# Become a Radio-trician

**Learn at home the greatest profession of today and the future. Become a master of radio installation, operation, maintenance repair, mechanics, design, inspection, salesmanship and invention.**

**T**HE world is aflame with Radio. Never before in the history of the country has an industry leaped to the forefront as rapidly as this great, new science. Hundreds of thousands of radio receiving sets are in operation—tens of thousands of sending stations will be erected—and this enormous craze is permanent. Even today manufacturers are months behind their orders! Improvements are being made every day which must increase the demand for radio equipment to even *greater* proportions than now.

Men of foresight, men of vision know what this means. Never before has there been such an opportunity. Radio-tricians are needed today everywhere. More and more will be needed as the demand for radio installation, radio operation, radio maintenance, radio repair, radio salesmanship becomes greater and greater.

Wherever you go, there are hundreds of radio sets to be installed—wherever you go, thousands upon thousands of dollars worth of radio equipment is being sold—wherever you go, there are radio sets to repair; and if you seek adventure, there are radio sending stations calling to you from ships and land stations all over the world.

## The Pioneer School

The National Radio Institute has a record of over

8,000 students. It is the pioneer school. It teaches every phase of radio from the ground up. It teaches by means of actual practice, actual assembling of a radio outfit, actual operation of radio equipment. It teaches by problem and principle so that National Radio-tricians are in demand everywhere.

Here is a profession which is paying enormous earnings to men all over the country today—a profession that will make hundreds of men wealthy—a profession far more lucrative than that of any other technical or mechanical employment you can secure.

## What will you do?

The world is aflame with radio. What are you going to do to "cash in" on the demand for men, for equipment, for experience? Are you going to sit idly by wondering what it is all about, or are you going to make the most of this, the greatest opportunity presented to men of ambition in 50 years?

Write at once for the complete catalog to the National Radio Institute. This is the turning point in your life. Upon your decision *this instant* may depend your entire future. Mail the coupon, or write a letter NOW—for *your own sake!*

## NATIONAL RADIO INSTITUTE

*Radio Headquarters*

Dept. 1083

N. W., Washington, D. C.

NATIONAL RADIO INSTITUTE, *Radio Headquarters*  
Dept. 1083 N. W., Washington, D. C.

Please send me your book telling how I can become a Radio-trician through your Home Study Course, in my spare time. I am enclosing 10c (stamps or coin) to cover cost of packing and mailing.

Name .....

Address.....City.....State.....

# LEARN ELECTRICITY

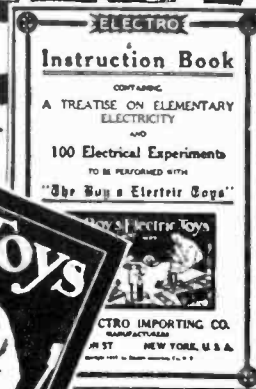
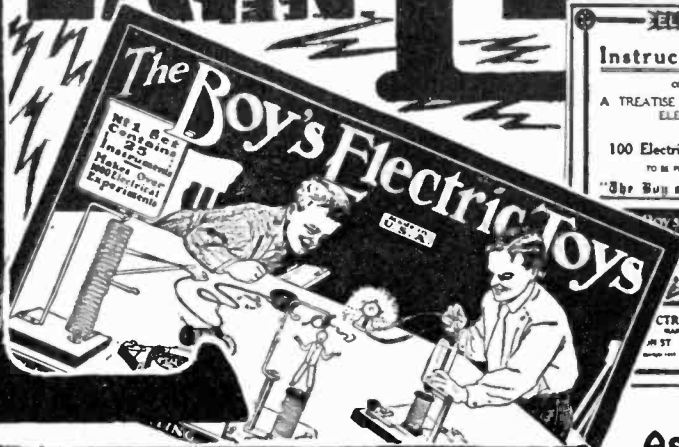

## The BOY'S ELECTRIC TOYS

As Shown  
**\$7.50**  
Complete

Teaches you all the principles of electricity by the "Learn by Doing" Method. Entertaining, Instructive, More Fascinating than any game. The most complete electrical experimenters' outfit that has ever been put on the market.

### Valuable Electrical Instruction Book With Each Outfit

With each outfit we furnish free a very comprehensive book of electrical instruction. All the fundamentals of this fascinating science are clearly explained so even a layman can understand every word. Profusely illustrated. The instructions for building the apparatus are given in such a simple and easily grasped manner that anyone can make them without the least trouble. Over a hundred experiments that can be performed with the outfit are listed in the instruction book, nearly all of them illustrated with superb drawings.

### A Sample of What You Can Do With This Outfit

This illustration, made from an actual photograph, shows only a very few of the many instruments that can be made with the Boy's Electric Toys: Electric Pendulum, Electric Telegraph, Current Generator, Electric Dancing Spiral, Galvanometer.

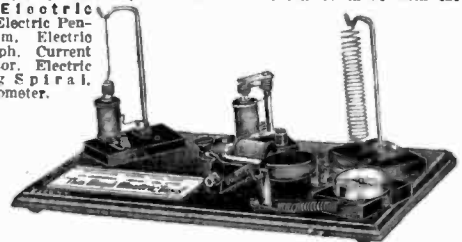

The outfit contains 114 separate pieces of material and 24 pieces of finished articles ready to use at once.

Among the finished material are included: Chromic salts, lamp socket, mercury, core wire, iron filings, three spools of wire, carbons, machine screws, flexible cord, wood bases, glass plate, paraffine paper, binding posts, screw-driver, etc., etc.



### Teaches You How To Build Electrical Apparatus

THE BOY'S ELECTRIC TOYS contains enough material to make and complete over twenty-five different electrical apparatus without any other tools, except a screwdriver furnished with the outfit. The box contains the following complete instruments and apparatus which are already assembled:

Student's chromic plunger battery, compass-galvanometer, solenoid, telephone receiver, electric lamp. Enough various parts, wire, etc., are furnished to make the following apparatus:

Electromagnet, electric cannon, magnetic pictures, dancing spiral, electric hammer, galvanometer, voltmeter, hook for telephone receiver, condenser, sensitive microphone, short distance wireless telephone, test storage battery, shocking coil, complete telegraph set, electric riveting machine, electric buzzer, dancing fishes, singing telephone, mysterious dancing man, electric jumping jack, magnetic geometric figures, rheostat, erratic pendulum, electric butterfly, thermo electric motor, visual telegraph, etc., etc.

Shipment guaranteed within 24 hours.

## SEND NO MONEY

We have so much confidence in this set that we desire to ship it to you C. O. D. with the privilege of inspection. It does not cost you one cent to take a good look at the outfit, and see if it comes up to your expectations. If it does, pay the postman \$7.50, plus shipping charges. If it does not, you need not accept it, and we will pay the return charges as well.

**THE ELECTRO IMPORTING CO.**  
236 Fulton St., N. Y. City

ELECTRO IMPORTING CO.,  
236 Fulton St., N. Y.

As per your advertisement, ship to me at once, C.O.D., the Boy's Electric Toys with privilege of inspection. It is understood that if I do not like the outfit I can refuse it.

Name .....

Address .....

City ..... State .....

S.I. 6-22



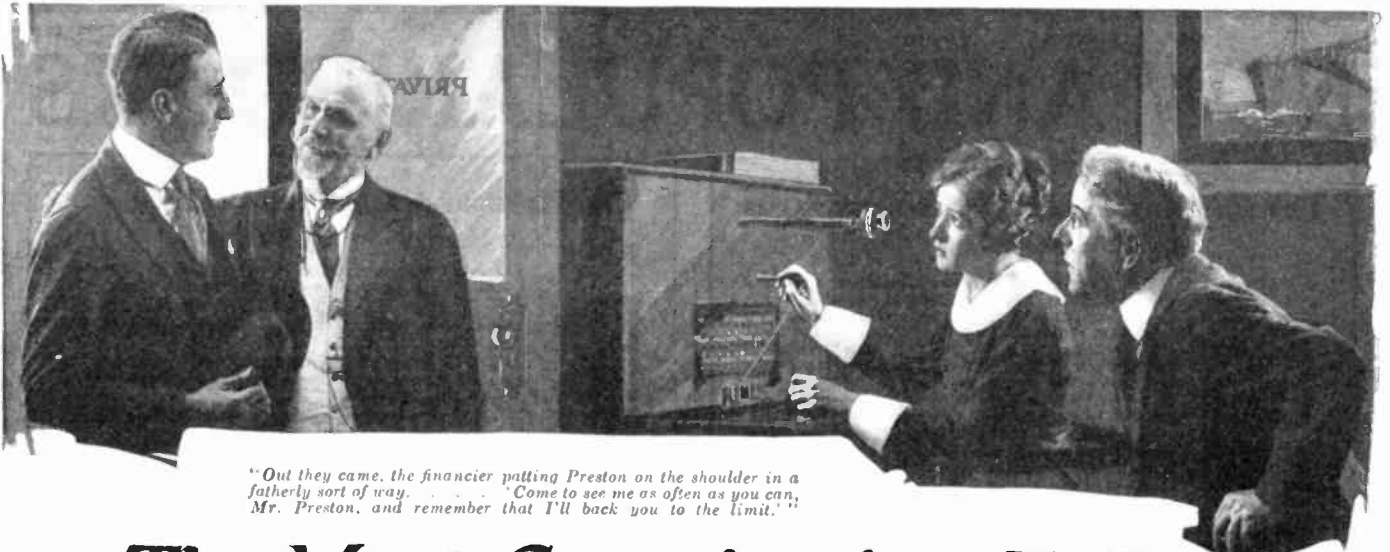

"Out they came, the financier patting Preston on the shoulder in a fatherly sort of way. "Come to see me as often as you can, Mr. Preston, and remember that I'll back you to the limit."

# The Most Convincing Talker I Ever Met

Everywhere this man goes, people shower him with favors and seek his friendship. Things which other people ask for and are refused, he gets instantly. How he does it is told in this amazing story

LET me ask you this: There is a big business deal to be put through. Putting it through depends wholly on getting the backing of a great financier.

But this man is bitterly opposed to your idea and to your associates. Seven of the most able men and women in all America have tried to win over this financier. They failed dismally and completely.

Now, could you, a total stranger to this man, walk in on him unannounced, talk for less than an hour, and then have him give you a signed letter agreeing to back you to the limit?

Could you?

ASTOUNDING? Yes! But it WAS done. And I'll tell you how. For a long time the directors of our company had felt the handicap of limited capital. We had business in sight running into a million dollars a month. But we couldn't finance this volume of sales. We simply had to get big backing, and that was all there was to it.

Because of trade affiliations, one man—a great financier in New York—controlled the situation. But how to win him—that was the question. No less than five men and two women—all people of influence and reputation—had tried, and been turned down cold and flat.

Well, we were talking it over at a board meeting, when one of our directors announced that he knew of only one man who could possibly put through the deal—a man by the name of Preston.

So it was agreed that Preston was to be sounded out at luncheon the following day. He proved to be a fine type of American. At 34 years of age he had become president and majority stockholder of a thriving manufacturing business rated at three-quarters of a million dollars.

Preston was deeply interested, as anyone would be over the prospect of closing such a big deal. The director in question said casually, "Why don't you run down to New York and take a shot at it, Preston?" Preston looked out of the window for a moment and then quietly answered, "You're on."

I WENT along with Preston simply as a matter of form to represent our interests. Aboard the 10.25 train out of Chicago we headed for the smoker and got to talking with the crowd there.

Then I noticed something. Preston had dominated them all. Everyone was eagerly hanging on his words. No sooner would he stop talking than one of the men would start him up again. And as the men dropped off at stations along the way they gave Preston their cards, with pressing invitations

to look them up. No doubt about it, Preston was THE man aboard that car.

And so it went all the way to New York. Everyone who met Preston took a great liking to him the instant he spoke. They seemed to be eager for his companionship—wanted to be with him every minute, openly admired him, and loaded him with favors.

The next morning we called on the great financier—the man who was so bitterly against us and had flatly turned down seven of our shrewd, influential representatives.

I waited in the reception room—nervous, restless, with pins and needles running up and down my spine. Surely, Preston would meet the same humiliating fate?

But no! In less than an hour out they came, arm in arm, the financier patting Preston on the shoulder in a fatherly sort of way. And then I hear the surprising words. "Come to see me as often as you can, Mr. Preston, and remember that I'll back you to the limit!"

AT the hotel that night sleep wouldn't come. I couldn't get the amazing Preston out of my thoughts. What an irresistible power over men's minds he had. People actually competed for his attention, anticipated his wishes, and eagerly met them. What power! . . . Then the tremendous possibilities of it all—think what could be done with such power!

What was the secret? For secret there must be. So the first thing next morning I hurried to Preston's room, told him my thoughts, and asked him the secret of his power.

Preston laughed good-naturedly. "Nothing to it—I—well—that—is—" he stalled. "I don't like to talk about myself, but I've simply mastered the knack of talking convincingly, that's all."

"But how did you get the knack?" I persisted.

Preston smiled, and said, "Well there's an organization in New York that tells you exactly how to do it. It's amazing! There's really nothing to study. It's mostly a knack which they tell you. You can learn this knack in a few hours. And in less than a week it will produce definite results in your daily work.

Write to this organization—the Independent Corporation—and get their method. They send it on free trial. I'll wager that in a few weeks from now you'll have a power over men which you never thought possible. . . . Write and see for yourself." And that was all I could get out of the amazing Preston.

WHEN I returned home I sent for the method Preston told me about. It opened my eyes and astounded me. Just how he had won over the financier was now as clear as day to me. I began to apply the method to my daily work, and soon I was able to wield the same remarkable power over men and women that Preston had.

When you have acquired the knack of talking convincingly, it's easy to get people to do anything you want them to do. That's how Preston impressed those people on the train—how he won over the financier—simply by talking convincingly.

This knack of talking convincingly will do wonders for any man or woman. Most people are afraid to express their thoughts; they know the humiliation of talking to people and of being ignored with a casual nod or a "yes" or "no." But when you can talk convincingly, it's different. When you talk people listen and listen eagerly. You can get people to do almost anything you want them to do. And the beauty of it all is that they think they are doing it of their own free will.

In committee meetings, or in a crowd of any sort, you can rivet the attention of all when you talk. You can force them to accept your ideas. It helps wonderfully in writing business letters—enables you to write sales letters that amaze everyone by the big orders they pull in.

Then again it helps in social life. Interesting and convincing talk is the basis of social success. At social affairs you'll always find that the convincing talker is the center of attraction, and that people go out of their way to "make up" to him.

Talk convincingly and no man—no matter who he is—will ever treat you with cold, unresponsive indifference. Instead, you'll instantly get under his skin, make his heart glow and set fire to his enthusiasm.

You can get anything you want if you know how to talk convincingly. You've noticed that in business, ability alone won't get you much. Many a man of real ability, who cannot express himself well, is often outdistanced by a man of mediocre ability who knows how to talk convincingly. There's no getting away from it, to get ahead—merely to hold your own—to get what your ability entitles you to, you've got to know how to talk convincingly!

THE method Preston told me about is Dr. Law's "Mastery of Speech," published by the Independent Corporation. Such confidence have the publishers in the ability of Dr. Law's method to make you a convincing talker that they will gladly send it to you wholly on approval.

You needn't send any money—not a cent. Merely mail the coupon, or write a letter, and the complete course, "Mastery of Speech," will be sent you by return mail, all charges prepaid. If you are not entirely satisfied with it, send it back any time within five days after you receive it and you will owe nothing.

But if it pleases you, as it has pleased thousands of others, then send only three dollars, the Special Price, in full payment. You take no risk. You have everything to gain and nothing to lose. So mail the coupon now before this remarkable offer is withdrawn. INDEPENDENT CORPORATION, Dept. L-1106, 22 West 19th St. New York.

## FREE EXAMINATION COUPON

**Independent Corporation**  
Dept. L-1106, 22 West 19th St., New York

Please send me Dr. Frederick Houk Law's "Mastery of Speech," a course in Business Talking and Public Speaking in eight lessons. I will either remail the Course to you within five days after its receipt, or send you \$3 (the special price) in full payment of the course.

Name .....

Address .....

# NEW AND POPULAR BOOKS

## The How and Why of Radio Apparatus

H. W. Secor, E. E.



This newest book on radio matters fulfills a distinct gap in wireless literature in that, while the treatment is made as understandable and as free from mathematics as possible, it at the same time incorporates a wealth of technique and instruction for the Radio Amateur—the Radio Operator—the Installation and Designing Expert—as well as teachers and students of the subject in general.

A glance at the following list of chapters gives but a very scant idea of the extensive and useful radio knowledge provided in its text:

The Induction Coil; The Alternating Current Transformer; Radio Transmitting Condensers; The Spark-Gaps; Radio Transmitting Inductances; Radio Receiving Tuners; Radio Receiving Condensers; Detectors; Telephone Receivers; Radio Amplifiers; Construction of a Direct Reading Wavemeter and Decrementer; Antenna Construction; The Calculation and Measurement of Inductances; Appendix containing very useful tables, covering all subjects treated in this very unusual book.

Cloth bound in Vellum de Luxe. Gold stamped and hand sewed; has 160 pages. Size of book 6 x 9 inches. **\$1.75**  
The How and Why of Radio Apparatus. Postpaid...

## A Thousand and One Formulas

By S. Gernsback



A Laboratory Hand Book for the Experimenter and for Everybody who wants to "do things."

A Book, brimful with very important and priceless information, collected and selected for years.

The recipes and formulas are classified in such a manner as to be available at once, without long research.

Here are some of the chapter headings:

Cements and Glues; Compositions of All Kinds; Glass and Glassworking; Inks; Leather Polishes; Metalcraft; Perfumery; Soaps and Extracts; Photography; Blue Print and other Paper; Plating; Pyrotechny; Polishes and Stains; Varnishes and Paints; Various Cleaning Formulas; Wood-craft; Chemical Laboratory Hints and Experiments; Mechanical Laboratory Hints and Experiments; Electrical Laboratory Hints and Experiments.

Besides there are a score of tables and hundreds of Illustrations and Diagrams. Book is cloth bound in Vellum de Luxe. Gold stamped and hand sewed. It contains 160 pages. The paper has been especially selected to stand rough handling in laboratories. Size 6 x 9 inches. **\$1.75**  
A Thousand and One Formulas, as described. Postpaid

## Design and Construction of Audion Amplifying Transformers

Radio and Audio Frequency Type

This latest and important book by Mr. Edward T. Jones, late Associate Editor of Radio News, will be of great interest to all radio amateurs throught the land. The transformers shown in these books have never been described in print before, and have usually been considered a manufacturer's secret. Anyone who has several vacuum tubes cannot afford to do without this book because it will enable him to build the necessary amplifying transformers very readily. The designs are very simple and rugged, and anybody can make them without trouble.

The book is printed on good paper and has an attractive cover in two colors. Paper bound. Size 5 in. x 7 in. Contains many illustrations, diagrams and working data necessary to build the transformers.

Price, Postpaid, 25c



## Wireless Course in 20 Lessons

By S. Gernsback, A. Lescarboursa and H. W. Secor, E. E.

A course that tells you everything you want to know about "Wireless," starting off in lesson No. 1 by explaining the Principles of Electricity. By simple, easy stages, this wonderful Course takes you into "Wireless" by the use of such simple language so skillfully used that of necessity you must understand every word. There is a whole lesson devoted to the Theory and Mathematics of this epoch-marking subject. The last lesson is devoted to a history of Wireless.

More than 50,000 of this course sold  
Eighth Edition

Size of book is 7 x 10 1/4 in., 160 pages, 350 illustrations, 90 tables.

Red cloth bound, gold stamped Wireless Course, as described. Postpaid... **\$1.75**



## Experimental Electricity Course in 20 Lessons

By S. Gernsback and H. W. Secor, E. E.

A Course on the theory and practice of Electricity for Experimenters. One of the most complete and comprehensive treatises of this special subject ever published. Written by the same authors as the famous "Wireless Course."

Every phase of experimental electricity is treated comprehensively in plain English. New experiments are described and explained and nearly every application of Electricity in modern life is given in simple language.

Size of book is 6 x 9 in. 128 pages and more than 400 illustrations.

Stiff cloth cover, per copy. Postpaid... **\$1.25**



## Two Remarkable Books

Book No. 1—How to Make Wireless Sending Apparatus . . . 35c.  
Postpaid.

Book No. 1 contains 100 pages, size 7 x 5 in., and 88 illustrations.

Book No. 2—How to Make Wireless Receiving Apparatus . . . 35c.  
Postpaid.

Book No. 2 contains 100 pages, size 7 x 5 in., and 90 illustrations.



Written and published entirely for the wireless enthusiast who wants to make his own radio apparatus. Only strictly modern instruments are described and the illustrations and descriptions are so clear and simple that no trouble will be experienced in making the instruments.



# THE EXPERIMENTER PUBLISHING CO.

Book Dept. 53 Park Place

NEW YORK

These Books Are for Sale Also at the Following Dealers

Amer. Technical App. Co.  
235 Fulton St., N. Y. C.  
Baker Taylor Co.  
354 Fourth Ave., N. Y. C.  
E. P. Noll Co., 21 N. 7th, Phila., Pa.

Benwood Co., Inc.  
3424 Olive St., St. Louis, Mo.  
Continental Radio Supply Corp.  
6 Warren St., N. Y. C.

F. S. Katzenback  
35 E. State St., Trenton, N. J.  
McDevitt & Wilson  
30 Church St., N. Y. C.  
Geo. Parezo & Co., Washington, D. C.

R. H. Macy Co.  
New York City  
Manhattan Elec. Supply  
17 Park Place, N. Y. C.  
Southern Elec. Co., San Diego, Calif.

John Wanamaker  
New York, N. Y.  
Marconi Wireless Tel. Co.  
Montreal, Canada



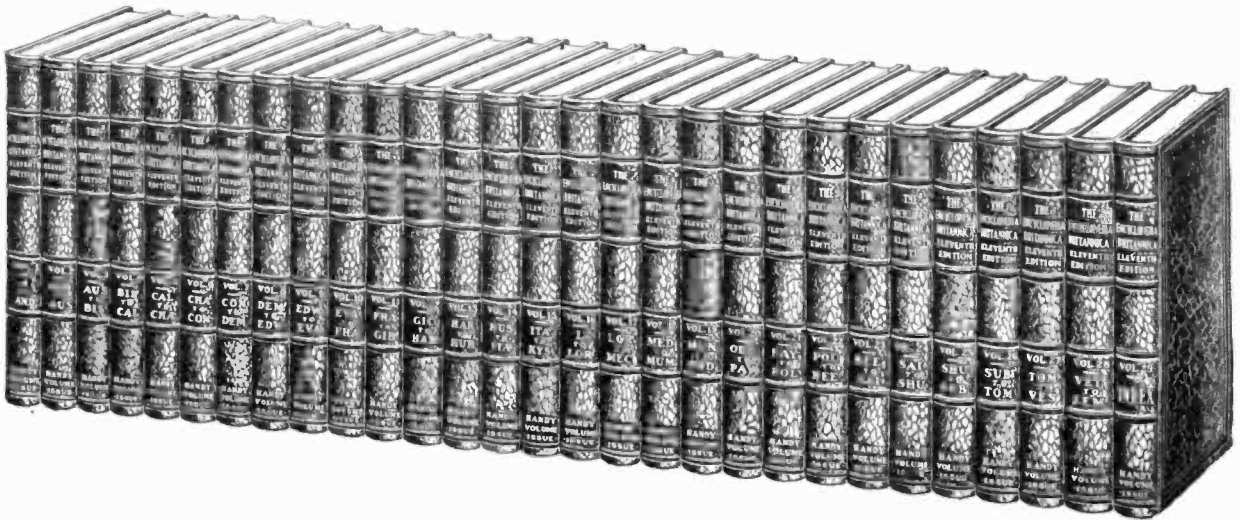

## Why Do Men Build Bookshelves in Their Homes?

**A** FAIR question, isn't it? Why does a man when he builds his own home carefully provide space for bookshelves in his living room, in his library or den in the same manner as he builds pantry shelves, closet shelves or shelves in his medicine cabinet? The answer is a simple one, the obvious one. To put books in, of course, in the same manner as pantry shelves are to put food on, closet shelves to put clothes on and shelves of the medicine cabinet are to put medicine in.

But there's more of an answer to the question. A man puts bookshelves in his home or buys bookcases because he knows that either are as necessary in his home as pantry shelves or closet shelves. He knows that books are as vital a necessity to every man and his home as his food and his clothes and medicine.

### The Corner Stone of Every Home Library

In the same manner as a man chooses his food for the good it is going to do his body, and his clothes for their serviceability, he chooses the books to put in these shelves for their ability to feed and strengthen the mind; books that clothe the man and his family with knowledge and give protection against ignorance. He probably has not unlimited means, so he must choose with utmost care to give his family such books as will be of the most value day in and day out. He is not interested in having books that simply look nice on the shelves. He insists that the books he selects must represent a worth while investment in knowledge; books from which he and his family can obtain a definite, material and lasting benefit.

He selects and purchases first the Encyclopaedia Britannica and builds his library around this great work. Why?

Because it furnishes him with authoritative information on every conceivable subject written by the greatest authorities the world affords.

Because it gives to every woman information which she needs to keep posted on the events of this intensely interesting world.

Because it furnishes the son and daughter of the family the information to satisfy the children's expanding minds and supplements their school studies.

Because the Encyclopaedia Britannica has been for generation after generation, since 1768, the standard encyclopaedia of the world.

### The Luxury of India Paper

He chooses the Encyclopaedia Britannica because it is well made from the physical standpoint. It is printed on the genuine India paper, which makes the Britannica far more usable than any encyclopaedia ever was before. The beautiful and serviceable bindings make it a book that he is proud to have in his library and to be seen by his friends.

The Encyclopaedia Britannica is sold on easy terms of payment, a small amount with the order and moderate monthly payments. Every family can thus afford the Britannica and have in the home the greatest means to knowledge ever put in the hands of mankind. Send for the large illustrated booklet describing the Britannica, and giving its attractive prices and terms of payment.

# THE ENCYCLOPÆDIA BRITANNICA

SIGN AND MAIL THIS COUPON TODAY.

*A Small First Payment Brings You This Complete Set of 29 Volumes, 44,000,000 Words, 30,000 Pages, 15,000 Maps and Illustrations. The Balance Is in Monthly Payments. Send for Free Booklet.*

Sears, Roebuck and Co.  
CHICAGO

Sears, Roebuck and Co., Chicago, Ill.

Gentlemen: Please send me, free, your illustrated Book No. 26AF, giving full information about the Encyclopaedia Britannica. Also tell me the price and the terms for a set of the Britannica printed on genuine India paper.

Name .....

Postoffice .....

R. F. D. Box  
No. .... No. .... State .....

Street  
and No. ....

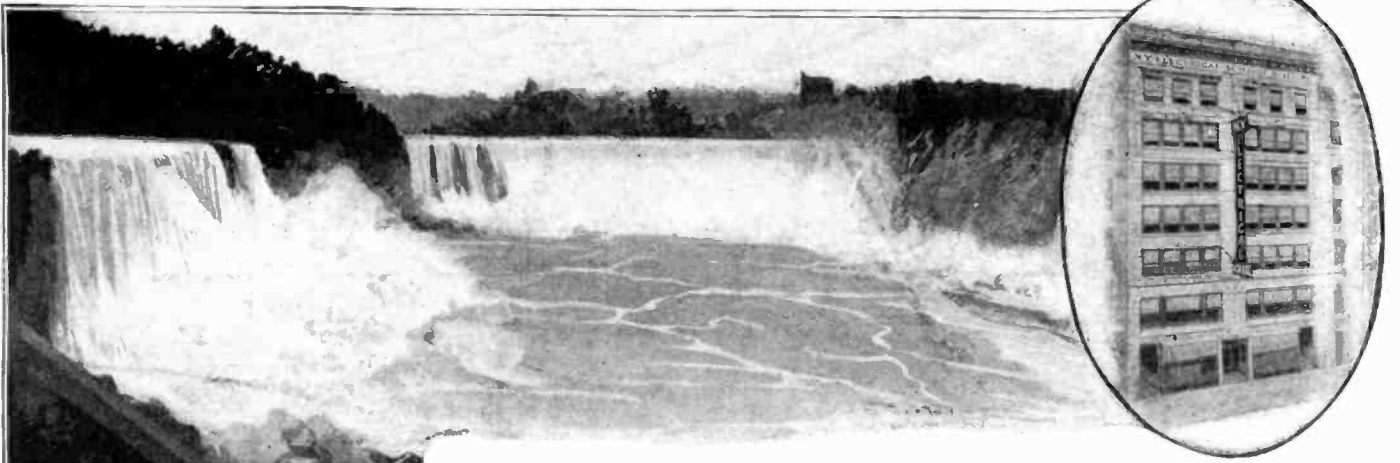

# Master Electricity By Actual Practice

The only way you can become an expert is by doing the very work under competent instructors, which you will be called upon to do later on. In other words, *learn by doing*. That is the method of the New York Electrical School.

Five minutes of actual practice properly directed is worth more to a man than years and years of book study. Indeed, Actual Practice is the only training of value, and graduates of New York Electrical School have proved themselves to be the only men that are fully qualified to satisfy EVERY demand of the Electrical Profession.

## The Only Institution of the Kind in America

At this "Learn by Doing" School a man acquires the art of Electrical Drafting; the best business methods and experience in Electrical Contracting, together with the skill to install, operate and maintain all systems for producing, transmitting and using electricity. A school for Old and Young. Individual instruction.

### Over 7,400 Graduates are Successful Men in the Electrical World

No previous knowledge of electricity, mechanics or mathematics is necessary to take this electrical course. You can begin the course now and by steady application prepare yourself in a short time. You will be taught by practical electrical experts with actual apparatus, under actual conditions.

The N. Y. E. S. gives a special Automobile Ignition Course as an advanced training for Auto Mechanics, Garage Men and Car Owners. The course covers completely all Systems of Ignition, Starters, Lighting and other electrical equipment on automobiles, motor boats, airplanes, etc.

*Let us explain our complete courses to you in person. If you can't call, send now for 64-page book—it's FREE to you.*

# New York Electrical School

29 West 17th Street, New York

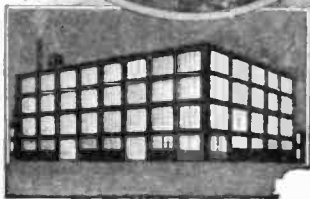
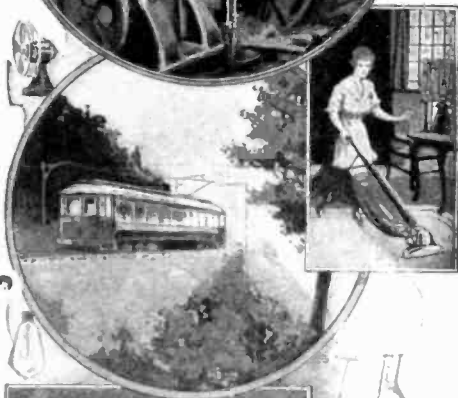
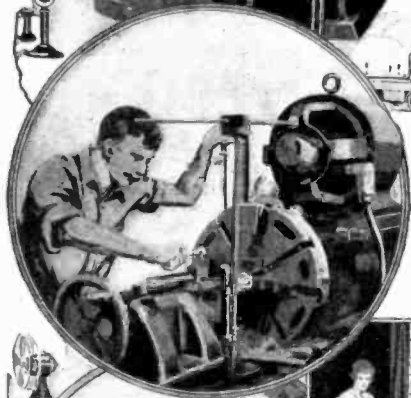
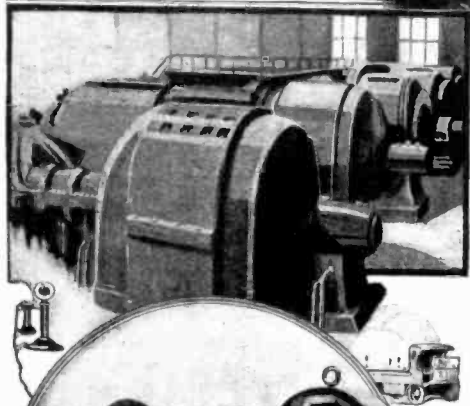

New York Electrical School  
29 W. 17th St., New York, N. Y.

Please send FREE and without obligation to me your 64-page book.

..... NAME  
..... STREET  
..... CITY ..... STATE

H. GERNSBACK, - EDITOR

H. WINFIELD SECOR, - ASSOCIATE EDITOR

T. O'CONOR SLOANE, Ph. D., - ASSOCIATE EDITOR

*"Those Who Refuse to Go Beyond Fact Rarely Get As Far As Fact"—HUXLEY*

## The Radio Science

**T**HE youngest of all of our sciences—the science of radio—now less than thirty years old, has perhaps made greater strides than any other branch of physics in the history of the world. When we consider that less than thirty years ago, the word wireless had not been invented, and if we look about us today, and see what great changes have been wrought by the young giant, we are struck with wonderment and awe, but when we contemplate the wonders of the new art, we as a rule pay little attention to the whole.

Most people, particularly in these days of radio broadcast, are wont to think that when the word radio is mentioned, it means nothing but a concert or a speech broadcasted by radio telephony, or perhaps a message flung into space by radio telegraphy. To the scientist, however, these two branches of radio are today the least important. It is true that new achievements are being evolved every day in radio telegraphy and radio telephony, but the fundamentals of these two branches remain roughly the same. The waves which our broadcasting stations are sending out today are not much different from those of Marconi's early days, with the exception that Marconi used the so-called damped or interrupted waves, whereas we now use the undamped, or continuous waves. The broadcast feature is only a stunt or variation of something that has been known for over a decade. We could have had broadcast entertainments ten years ago, but no one had thought of doing it.

Poulsen invented the first radio telephone in 1902, but it never came into practical use by the public at large. While interesting to the general public, radio telephony holds little to interest the scientist because there are few features in it that have not been well known for many years. There are, however, other phases that are today of great interest to the scientist, and which will be of the greatest interest to the public, once it takes hold of the ideas and sees its possibilities.

We have, for instance, a distinct branch in radio termed radio-telematics. This art embraces all subjects where objects are caused to move about without the use of wires or other connecting means, by radio waves. We have thus the radio controlled automobile that is steered from a distance, and the United States Navy even has experimented with the radio controlled battleship not so long ago when one of the big ships was started, steered and stopped in a well defined manner in the open ocean. It is possible and entirely feasible today to send ships across large bodies of water such as lakes, and even oceans, without a human soul on board. All controls, whether it be the rudder, propeller, or steering device, are regulated by radio. It is possible to thus steer a ship clearly across the ocean in as safe a manner as if the captain and crew were aboard for protection. The ship will send out hourly signals by which its path can be plotted by the shore observer for the entire route. In order to avoid collisions, fog horns can be sounded every five minutes for the entire trip, because no means have yet been found to tell by apparatus the existence of a fog on the distant ocean. For that reason the fog horn would sound in broad daylight as well. These, of course, are only suggestions of what can be done. In war time the art of radio-telematics is of tremendous importance.

Future wars will be fought not with men but with machines. Ships and airplanes will be sent out without crews, while battleships will bombard the enemy fleet by radio if necessary. The course and maneuvers of the battleship will be guided from a distant airplane. The airplane observer could plot, for instance, the location of the enemy fleet, and change the firing range of his own ships, while we can send radio guided airplanes over the enemy fleet, or over the enemy territory and drop bombs at will, all by radio. The more horrible such an idea becomes, the better, for the reason that if war comes to a stage where it is too terrible, there will be no more wars. It will be the best insurance against war.

One of the latter day inventions in radio is the exploration of the earth by means of radio waves. A new branch in radio has lately been created—the art of radio prospecting. In Germany, where coal mines are becoming more and more depleted new veins are found by means of radio waves. These are sent underground, and by means of certain instruments it is possible for observers to note when the sounds received in their receivers are not of the usual intensity, and by means of charts and other devices the location of the coal veins can be readily ascertained. The soundings, therefore, are made entirely by radio waves. Of late, in Italy the same thing has been done in prospecting for ores. By means of super-sensitive vacuum tubes and certain condenser arrangements, radio waves affected by mineral deposits are received thru the ground, and it becomes a simple matter to locate new mines. It is even possible to correctly judge the depth of the mineral deposits by means of radio waves. This branch of radio bids fair to become an exceedingly important one. It will not only be useful in locating hidden mineral deposits, but buried treasures as well. It will no doubt be used also to locate sunken ships in the ocean when the time comes. At the present moment, it is almost impossible to accurately determine the position of a sunken ship. Radio will prove a great boon here, because the ship can then be found with absolute accuracy.

It may come as a surprise to most people that radio waves are material. Once upon a time there was a theory that radio waves were nothing but an electro-magnetic disturbance in the ether. We are slowly but surely coming away from this. We are leaving behind us the ether, which we do not find necessary any longer. On the other hand, recent discoveries tend to prove that radio waves are just as material as an ocean wave. Because we cannot see a radio wave does not prove that it is non-material, and its weight may be so small that to express it in figures would stagger the imagination, but it certainly is material, the same as a light wave is material. This is not theorizing but stating facts as we understand them today.

From sending out radio waves as we do today, the next step naturally will be sending out power by radio, long predicted by Tesla and other investigators. When we look at the sun and think how many billions of horse-power are sent out every second, by means of light waves, we have no reason to refuse belief that radio waves could do likewise, once we knew the key to the problem. There will be much less loss in energy when we send out radio waves, because when we use no conductor there is no resistance, such as exists in ordinary conductors. Of course, we have not today succeeded in developing the transmission of power, but we already do know that radio waves sent out by means of a few dry cells, and a spark coil may travel all around the earth and further. We know this because as we increase the sensitivity of our receiving apparatus our receiving range becomes greater and greater. Thus, for instance, in recent tests, we have seen where amateur stations operated by less than one kilowatt were heard clearly in Europe where to cover the same distance, the commercial radio companies use over 1,000 kilowatts.

If radio waves are material, the next logical step naturally would be sending materials by radio, a not at all impossible prediction. As we come to understand our electronic world to a higher degree, we know that a piece of copper and a piece of bread are identically the same substance in every way except that the electrons and nuclei are grouped differently. It is then not impossible to predict that once we have the key, we can send a carload of coal across the ocean by radio if we so desire. We are still a long way off from the solution of such a problem but we are getting nearer to it. We are already doing this same thing in laboratory experiments, where X-rays are used, which rays are particles of matter and which are shot out into space passing easily thru walls or iron doors as if these did not exist.

H. GERNSBACK.



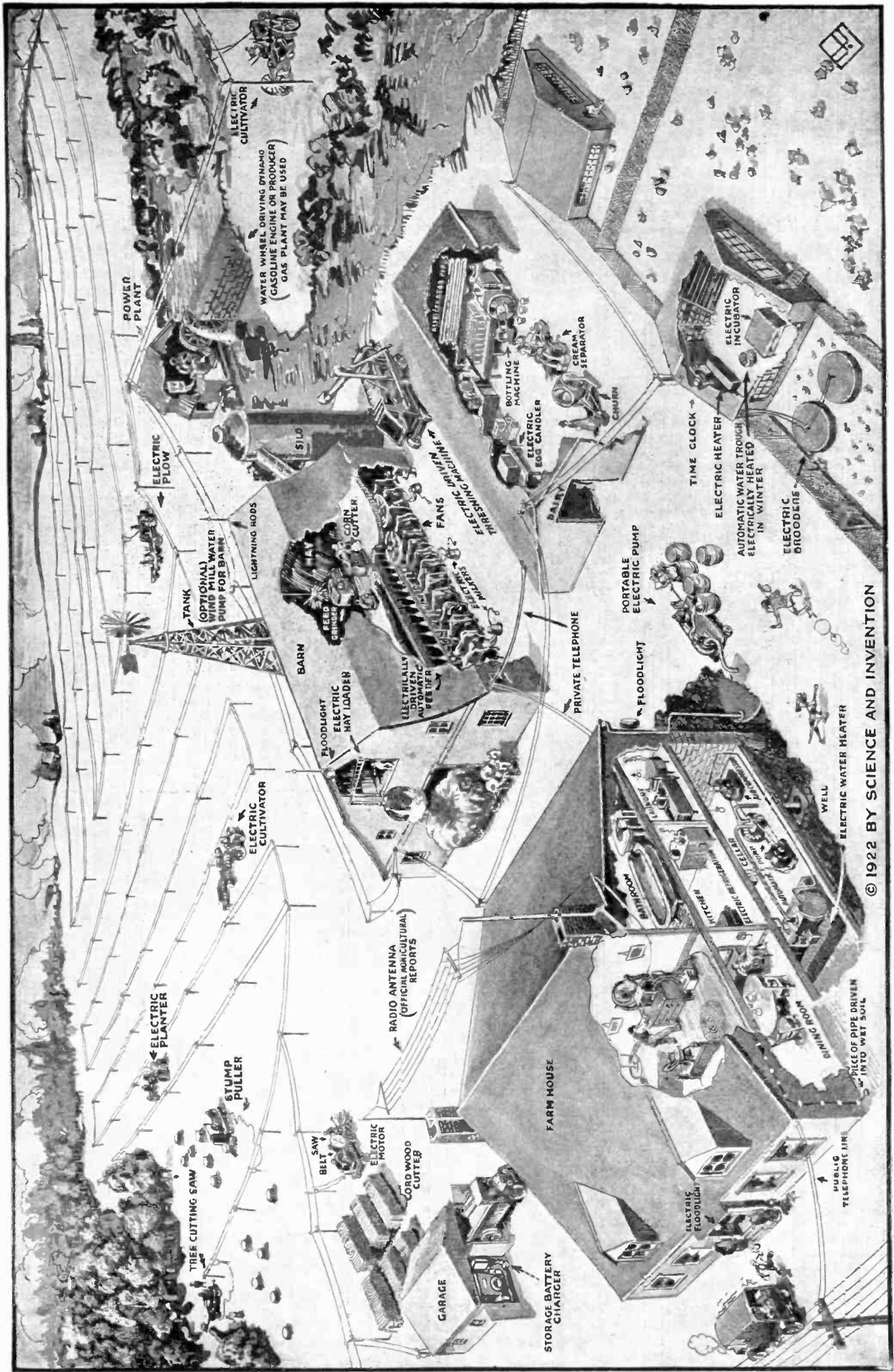

© 1922 BY SCIENCE AND INVENTION

Scene on the Electric Farm de Luxe. Electricity is Rapidly Becoming the "Jack of All Trades" About the Modern Farm. The Use of the Electric Current for Cultivating the Fields is Being Adopted More in Europe, Especially Germany, Than it is Over Here, But This Application of Electricity to the Farmer's Needs is Dependent Mostly Upon a Low Kilowatt-Hour Rate, Where Central Station Supply is Depended Upon.

# Electric Farm de Luxe

By H. WINFIELD SECOR

THE accompanying illustration shows some of the more common electrical conveniences and utilities in use on many of our modern farms today. Electric plows, cultivators, and planting machines are not so commonly in use in this country as they are in Germany and several other foreign countries, but it will probably not be a great while before American farmers, especially where electrical energy can be purchased at low cost, as in the western part of the United States, in districts served by low-priced hydro-electric central station service, will be using these machines for tilling their fields.

The gasoline engine has come into very popular favor for driving tractors and other farm machinery, but owing to the rather high cost of gasoline today, and providing the scheme suggested by some of the country's leading engineers is put into practice, whereby the various groups of states may be served by a vast and highly efficient series of central station distribution systems, the one interlocking with the other, we shall probably see at a not very distant date electric power as the king of all powers on the farms, as well as in the cities. Electric power on the farm does its work well, for all of the motors and other apparatus used for performing every conceivable kind of work that the farmer has on his hands, operate at high efficiency with very little loss. We shall probably use gasoline propelled automobiles for some years to come, in preference to the electric storage battery type, except where trucking is concerned or for short distance runs, for the reason that the electrical engineers have not so far given us a storage battery which will carry the car more than seventy to eighty miles on one charge.

A farmer who wishes to electrify on a small scale, can do so in one of several ways, and at a reasonable cost at that. He has the choice of at least three tried and proven methods of generating his own electric current, viz., 1—by using a water wheel or turbine to drive the dynamo; 2—by utilizing a wind-mill driven dynamo; 3—by employing a gasoline engine driven dynamo. Further than this it may be satisfactory from an economical point of view for him to purchase electric current from the local central station service, when all of the costs of maintenance and repairs have been carefully computed for the first year or else for a few years. Gas producer plants suitable for small power production are available, and have a higher efficiency than a gasoline engine and dynamo plant. Where a great deal of wood is available for fuel, it is even possible that it would pay to use a steam engine and boiler to drive the dynamo. Most of these schemes for driving a dynamo from which to develop the electric current, require the addition of a small storage battery, so as to keep a steady voltage for the lamps. An exception to this rule is a gasoline engine-dynamo outfit—described several months ago in this journal, which has such a finely regulated governor on it, that no storage batteries are required, and the company manufacturing it, one of the largest in America, claims that the lights are absolutely flickerless.

The relative efficiency of various forms of electric generating plants is what the farmer is interested in no doubt, as these figures really form the basis for his decisions in most cases, altho local conditions sometimes mould his final opinion as to

just what may be the best form of power plant for his particular location. For medium sized hydro-electric plants, the gross or over-all efficiency expressed in per cent of mechanical power converted into electrical power is approximately 50 per cent. For large hydro-electric plants, this efficiency runs as high as 56 per cent to 60 per cent. The efficiency of a gasoline engine-dynamo plant is approximately 21 per cent; for a gas producer plant and dynamo, it is about 25 per cent, and for a steam-electric plant, the efficiency runs quite low—not more than about 7 per cent to 8 per cent—excepting for very large and well designed steam power central stations, where the over-all efficiency or the ratio between the heat units in the coal fired in the boilers, and the watts electrical output available on the consumer's lines may reach 12 per cent, as is the case with the Interboro Rapid Transit Company's power plant in New York City.

A great many of the small-sized electric generating plants sold for farm use, especially those intended for lighting purposes only, operate on a potential of 32 volts; others run up to 50 to 60 volts, while some use the standard central station potential of 110 volts, all of these plants delivering direct current invariably. From an engineering point of view, if we were going to install a plant on a farm tomorrow, we would not think of using

## Some Articles Appearing in the May Issue of "Practical Electrics."

*A Power Battery.* By H. Gernsback.

*Open Circuits in Auto Systems.*

*Automatic Telegraph Recorder.*

*Secret Telephony.*

*World Without Electricity.*

*Summer Time Electrics.* By H. Winfield Secor, Assoc. Member American Institute of Elec. Engineers.

anything else but 110 volts, except if the plant was to be used simply for the purpose of lighting lamps in a house or possibly another building nearby. This potential has been found by electrical engineers to be very suitable from many different points of view. For example, the copper conductors can be much smaller than for any of the low voltage systems, of 32 to 50 volts, even the more storage battery cells may have to be used, and it is advisable to distribute current for distances up to 1,000 feet with a 110-volt potential, without suffering too severe a drop in voltage along the line. Two hundred and twenty volts D. C. would be preferable from the writer's experience, for distribution to distances over 500 feet, but are objectionable for several reasons. Apparatus, especially household cooking utensils, etc., are not always built for this voltage, and there is more danger of an injurious shock from the 220-volt circuit, especially where cattle are concerned, and furthermore, there is a greater strain on all electrical machinery, especially motors used on 220 volts. But 220 volts is one of the standard potentials for common dis-

tribution and thousands of motors are performing their work thoroly well every day.

This only refers to the distribution factor from the viewpoint of the average small farmer; the large farmer is in a class by himself, and when we come to such vast tracts of land as we find in the western part of the United States where farms of several thousand acres are found, it may often be advisable to use a voltage of several thousand, and to distribute this from the generating plant and then step it down by means of transformers placed on poles about the fields, etc. In England and in several other countries, there have been some apparently favorable results obtained by subjecting the growing plants to a high-tension, high-frequency electric discharge, which is permitted to leak into the earth from a series of wires carried along over the crops at a height of several feet from the ground. Articles on this phase of agricultural developments have appeared in this journal from time to time, and presumably there is a lot to be learned in this direction which will warrant the attention of the scientific farmer.

## The Electrified Farmhouse

In the farmhouse today, no matter in what part of the country it is situated, we are very likely to find quite or nearly all of the conveniences which the city dweller enjoys. These include the usual kitchen and living room appurtenances, such as electric clothes washer, lights, fans, food chopper, dish washer, sad irons, table cooking utensils, such as chafing dish, coffee percolator, toaster, etc. In the more pretentious electric farmhouse, we often find an automatic electric water-pump and storage tank system, using compressed air to force the water up thru the various rooms with one or more bathrooms, as well as an electric refrigerator in the kitchen, a small motor working periodically and automatically as required, a pump connected with an ethyl-chloride circulating and condensing system for the refrigeration in question.

Radio of course is to be found on farms by the thousands everywhere, for what information does this not give us? the weather report for a day or two ahead, the correct time twice daily, and valuable agricultural and market reports prepared under the official direction of the government, and now being broadcasted in all farming districts, both in radio telegraph code and by radiophone or speech.

## Enter Electricity—the Barn Workman

The farmer of yesterday stands amazed, perhaps, when he pays his first visit to the modern scientific farm where electricity works hand in hand with Man. It is not so unusual nowadays for large cow barns, especially those on dairy farms, to be equipped with electric fans to keep the flies from bothering the cows, and also to circulate the air and thus reduce odors, and make the air more refreshing for the animals.

Electric milking machines are used on most of the large dairy farms where they multiply the work accomplished by one man several fold. Not only is it a case of accomplishing the work of four or five men with one milking machine and one man, but the milk is handled in a perfectly sanitary manner, and not left standing around the cow barn for

(Continued on page 170)

# Secret Phone Aids Public Speakers

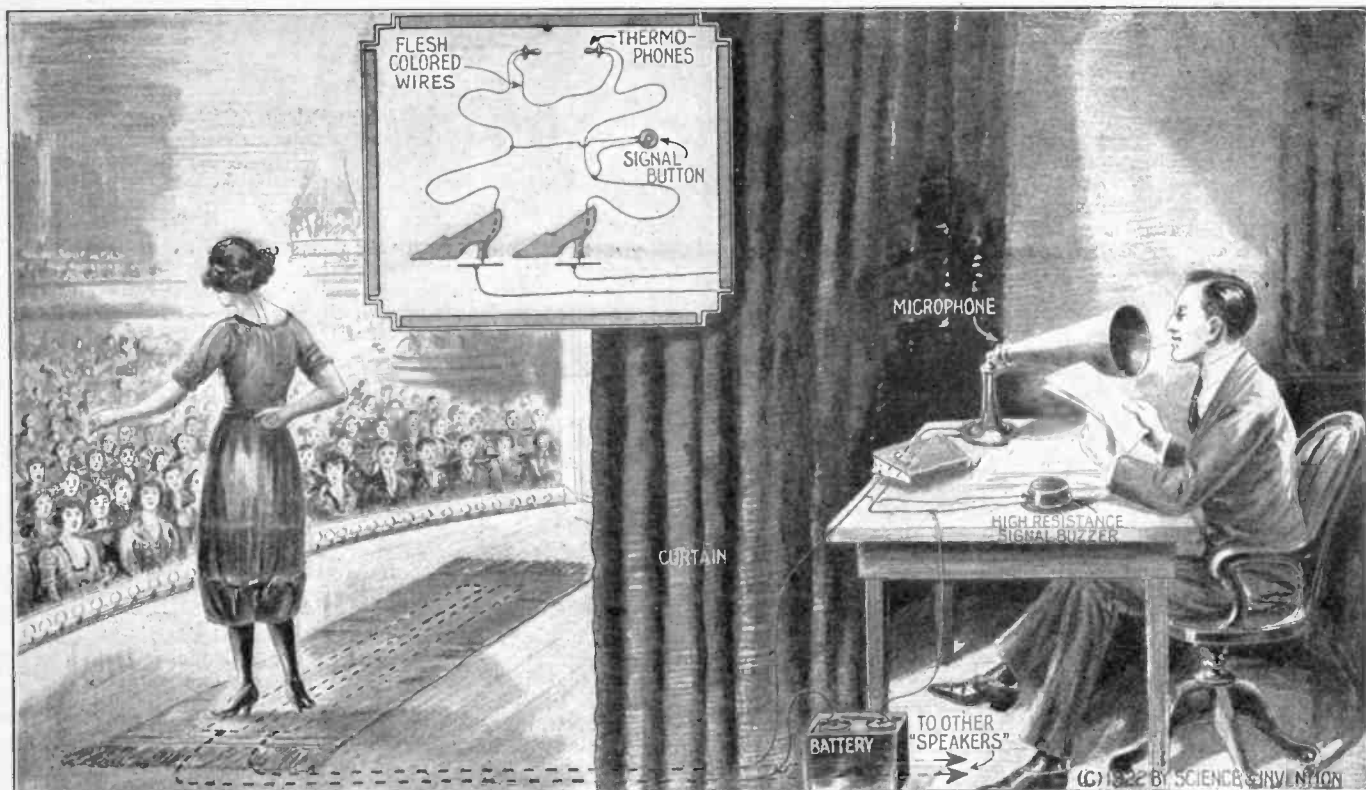

A New Use for the Telephone is Here Shown, and This Idea Possesses Many Possibilities, Not Only for Stage Purposes, But for General Entertainment and Magical Acts as Well. One of the Inventor's Principal Ideas is to Utilize this Telephone System, Where Several Inexperienced Speakers Are to Give the Same Talk at Several Different Places Simultaneously. The Person Reading the Speech Slowly is Behind the Curtain at One of the Theaters, and Any Number of Circuits May be Connected to the Microphone Instrument, as the Diagram Shows. The Speaker, Who May be a Young Lady Capable of Speaking Before an Audience, But Who May not be Able to Memorize a Long Speech, Has a Pair of Small Telephone Receivers, Such as Thermo-phones, Fixed In Her Ears and Hidden by Her Hair. Two Thin Flesh-Colored Wires Lead from These Telephone Receivers Down the Back of Her Neck, Thence Under the Dress to Two Metal Points in the Heels of Her Slippers, Which Points Make Contact Thru the Rug With Two Metal Plates Running Along Underneath it.

**Y**OU have often listened to the silver-tongued orator as he extolled the merits and attributes of some particular person or philosophy, but hereafter you cannot always be quite certain that the speaker before the curtain possesses the wonderful gift of oratory that would seem to be his, for a new scientific bombshell has been thrown into our midst by one William Dobson, of Rockford, Ill., who has obtained a patent on the ingenious, albeit tricky, orators' telephone depicted in the accompanying illustration.

Mr. Dobson's patent shows the wires leading up to a telephone head-set with no apparent attempt at disguising it, presumably from the fact that one of his plans is to enable several speakers at different locations, such as in different rooms or in different auditoriums, to give the same speech simultaneously, having their lines read to them slowly by a master reader behind the scenes in one of the buildings or rooms. But this arrangement lends itself admirably to private, as well as theatrical acts, where long speeches or other recitations are to be made and not only this, but pseudo mind-reading acts can be staged with this scheme, by having confederates or assistants among the audience, who telegraph or otherwise transmit the necessary information about a certain person, etc., back to the stage.

In some of the mind-reading acts the assistant has a dictagraph secreted in the vest pocket of his coat, or else hung on the vest just under the coat, and when he leans over, for example, to ask what song you would like played by the lady pianist on the stage, your voice is picked up by the ultra-sensitive microphone in his coat pocket and transmitted telephonically over wires running down to metal contact points fitted in the heels of his shoes, which complete the circuit thru metal plates hidden under the carpet in the aisle.

## Just a Few July Articles

*Cooking With the Sun's Heat.*

*What Is Paper Made of?*

*50,000 Degrees Fahrenheit! How It Was Produced.* By Prof. Gerald L. Wendt. Illustrated.

*A Tunnel thru the Earth!* By Clement Fesandic.

*New Cold Light for the Movies.* By Edwin Haynes.

*Science Tells Musically Talented.* By A. H. Kolbe.

*How Bones Grow.* By C. M. Lancaster, D.C., Ph.C.

*A Bicycle Canoe.*

*Do Plants Have Eyes?*

*How I Hypnotize Animals.*

*How Natural Colored "Movies" Are Made.* By Joseph H. Kraus.

*The Coal Bin of New York City.*  
*What the Coal Strike Means.* By Charles Nevins Holmes.

*The usual large "Radio Section" will contain valuable articles of interest to beginners and professionals alike.*

These plates are connected with wires running to the stage and the information is received telephonically (all unbeknown to those in the audience) by the lady pianist, for example, who the next moment starts playing the piece you have named. Of course she must have an excellent memory of the songs of the different nations, including folk-songs and others.

Following up this phase of Mr. Dobson's invention, the tiny thermo-phone receivers can be employed, which measure but a little more than 1 inch in length by  $\frac{1}{4}$  inch in diameter, so as to fit within the ear. Where fancy dress, including a turban is worn, even a watch case telephone receiver of standard pattern can be secreted and never noticed, the thin, flesh colored wires passing down the back of the neck to the two metal contact points on the heels of the performer, a circuit being completed thru these points to two metal plates or strips secreted under the mat or carpet on which the performer sits or stands. A lady speaker is well adapted for this part of the performance, as the hair can always be arranged so as to cover the ears and thus preclude any possibility of the thermo-phone receivers being noticed. She might even wear a low cut evening gown, the two thin flesh-colored silk insulated wires being led down the back of her neck under her gown to the metal contact points, in the heel of her pumps.

This patent includes provision for the person in front of the curtain to signal back to the reader or prompter if, for example, he reads the lines too fast or if the speaker may want a line repeated. A push button is placed in the back of the gown or coat, if the speaker is a man, and when this button is pressed by the speaker nonchalantly placing his hand behind his back, a buzzer on the reader's table sounds. One buzz may indicate "read slower": two buzzes "repeat," etc.



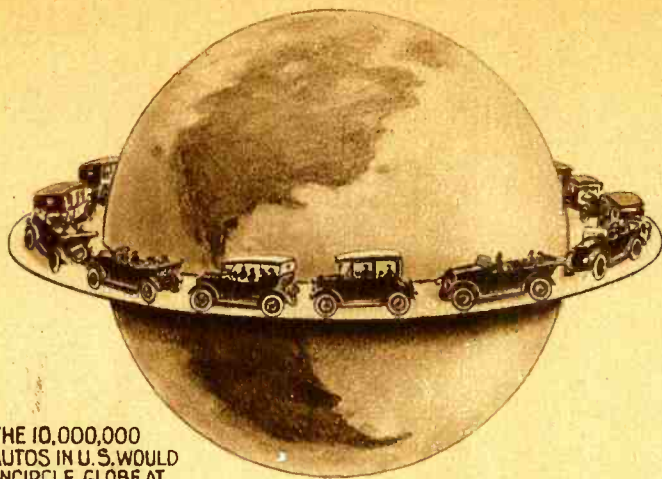

THE 10,000,000 AUTOS IN U.S. WOULD ENCIRCLE GLOBE AT EQUATOR



EVERY 11TH MAN IN U.S. OWNS AN AUTO TODAY

FULTON ST. TO BATTERY



EIFFEL TOWER 984 FT.

1,400 FT. HIGH



1,300 FEET WIDE

2,700 FEET LONG

GREAT PYRAMID

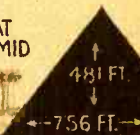

481 FT.

756 FT.

(C) 1922 BY SCIENCE AND INVENTION

The Ten Million Active Automobiles in the United States Today Are Here Shown Molded into One Giant Auto, Which is Shown in Comparison to a Section of New York City Extending from the Battery to Fulton Street, a Distance of 2,700 Feet. This Giant Auto Would Stand 1,400 Feet High, and Measure 1,300 Feet in Width. It Would Make the Eiffel Tower Look Like a Pigmy, and Would Far Outrank in Size the Great Pyramid, Shown at the Right. As Mr. Holmes Points Out in His Article, the Automobiles in the United States Figure Out in Such a Ratio, That Every Eleventh Person Owns One Today. In Other Words Every Eleventh Man Could Invite the Ten People Without Cars to Ride, Providing He Had a Large Enough Car.

# Autos in the United States

By CHARLES NEVERS HOLMES

**M**OST of us can remember when the automobile was a novelty. Today, this horseless vehicle has generally superseded the horse-drawn vehicle. As short a time ago as in 1915, there were about 1,750,000 automobiles in the United States, and, only one year later, 2,423,000 of them. In the year 1917, we possessed more than 3,500,000 such vehicles; in 1918, more than 4,900,000; and, in 1919 and 1920, their number increased, respectively to about one million and two millions. In the year 1921, there were 8,887,572 automobiles in this country, and it seems a safe estimation to predict that, towards the close of 1922, we shall possess, approximately, ten million automobiles.

This rapid increase in the number of automobiles is also shown in the state of New York, from 156,000 in 1915 to 651,000 in 1921. This is an increase of more than three times as many as there were in the year 1915. And it is probable that the people of New York state possess today about 750,000 automobiles. In other words, if the population of New York state is at present 10,500,000, then, it possesses one automobile for every fourteen people. Compared with this, the

United States has one automobile for about every 11 people. And the State of Ohio is not far behind the State of New York in the number of such vehicles, for it possessed, in 1921, about 617,000 cars. Next, there comes the State of Pennsylvania with 570,000 cars, while other states having more than half a million of active automobiles are California and Illinois. That is to say, there are five states that possess, altogether, at this present time, about 3,200,000 automobiles, or, approximately, one-third of all the cars in the United States.

According to statistics in 1921, the State of Nevada had the smallest number of automobiles—10,464. And, next to Nevada there came Delaware—18,300. With respect to the production of passenger automobiles in this country, that amounted to 818,000 in 1915, with a value of \$566,000,000; to 1,883,000 in 1920, with a value of \$1,809,000,000; and, at present, it is probable, to a yearly number approximating 2,000,000, with a value approximating \$2,000,000,000.

If this estimation of present production and value is correct, then, the average value of each automobile would be about \$1,000. And, respecting the total number of active automobiles in the United States—approximately 10,000,000—if all of these cars were

placed lengthwise in a straight line, each car touching another one, they would extend about 23,675 miles. Now, since the equatorial circumference of our earth is 24,899 miles, these ten million active automobiles in the United States would form a girdle of cars, lacking only about 1,224 miles of completely encircling our world, at its equator.

The yearly output of motor cars in the United States has been increasing at a tremendous rate, and this year will see more automobiles built and on the road than ever before. When we stop to think that every eleventh person in this country owns a motor car, we can readily see how this will shortly affect traffic conditions along our highways, especially those roads in the vicinity of large cities, such as New York, Philadelphia, and Chicago.

There are many problems to be taken up by our road commissions in various parts of the country with respect to widening the highways, or of opening up new highways. Take for example, the motor roads leading out of New York City for one hundred miles or more in every direction; on a holiday and over week ends, these roads during the summer months at least, are so filled with autos that they run in perfect strings.





© 1922 by Science and Invention

"The Tel-Automatic Lady Was Holding 'Dope' Peters Clasped in Her Arms as Tightly as if Held in a Vise." The Possibilities of Tel-Automatics Are Forcibly Demonstrated in the Radio-Controlled Torpedo, Shown in the Photograph at the Right. This is the Glavin Radio-Controlled Device Which Was Shown at the New York Radio Show a Short Time Ago, and at the New York Hippodrome.

## Doctor Hackensaw's Secrets

By CLEMENT FEZANDIE

No. 6—THE SECRET OF THE TEL-AUTOMATON



(AUTHOR'S NOTE. *Tel-automata*,—that is to say—mechanisms which can be worked at a distance by radio, have been successfully constructed in recent years. It is possible to explode mines from a distance, or to direct the course of boats and torpedoes. There is no reason why it should be impossible to construct a tel-automatic girl like the one mentioned in this story, and control her actions from a distant building by means of radio apparatus.)

### CHAPTER I.

"WELL, doctor, here I am again," cried Silas Rockett. "I've come for another interview."

"All right, Silas," replied Doctor Hackensaw, smiling.

The reporter took his pencil and note book from his pocket, and proceeded to business.

"I understand," said he, "that you have been doing something lately with *tel-automata* operated by radio, that is to say, automatic devices which can guide torpedoes and other things from a distance."

"You are right, Silas, I have been experimenting with such apparatus, and not for war purposes only, but for the far

more important acts of peace. I see no reason why mankind should not be relieved of all its drudgery and also of its dangerous and unhealthy occupations. Every time I see a factory worker condemned to breathe unhealthy gases, or a farmer perspiring in the hot sun, I wonder how it is that our scientists have not yet devised machines that could be operated at a distance by wireless and relieve human beings of all such toil."

"What do you mean?"

"I mean that it is a shame to see women have to scrub floors, wash clothes, etc., when automatic machines could just as well do the work. It is likewise a shame that a farmer should have to clean out stables, plough fields, dig ditches, weed his garden patch or pick his berries in a broiling sun, when he could do the work just as well lying comfortably in the shade of a tree and working a radio apparatus that would control the machines that are doing the work for him."

"But doctor, that is a pipe dream! No scientist that ever lived could construct such a machine."

"Indeed?" observed Doctor Hackensaw, with a peculiar smile. "Perhaps you would be interested in seeing a demonstration by

one of my tel-automata. They say that every inventor has his pet inventions, and I must confess that mine are my tel-automatic devices, for they are bound to relieve human labor of its worst drudgery. But ocular proof will tell you more than words."

So saying the doctor placed himself at a peculiar key-board, somewhat resembling that of a typewriter, and pressed down certain of the keys. A moment later a large Saint Bernard dog entered the room, wagging his tail, and looked up into his master's face.

"That's a fine animal you have there, Doctor Hackensaw," remarked Silas Rockett. "Is he pure St. Bernard?"

"His hide is," replied the doctor.

"His hide?—What do you mean?" asked Silas, puzzled.

"I mean that that animal you see here is composed principally of rubber and steel, and the only genuine part of him is the hide, including the head. You will admit, however, that he looks very lifelike."

"You mean to say that dog isn't alive?" cried the reporter in astonishment. "It doesn't seem possible. It is true I noticed something peculiar in the animal's style of walking, and now that you speak of it, I

(Continued on page 178)



# Frederick Winsor--First Gas Inventor

By EDWIN IRVINE HAINES, B. S.

THAT "History is neglectful" is a time-worn complaint. For nearly a century and a half the scientific world, not to mention the general public, has given credit to one William Murdoch, a Cornish mechanic, as being the discoverer of coal gas and the first man to invent an apparatus for its successful manufacture and distribution. Everyone has heard of William Murdoch. His name is as familiar to science as that of Christopher Columbus is to the school-boy.

Those who are curious or skeptical may find in the New York Public Library a little book, yellow with age, entitled, "A Historical Sketch of the Origin, Progress, and Present State of Gas Lighting," published in London, in 1827, wherein is to be found the only record of Frederick Winsor's great achievement with dates said to be earlier than those of William Murdoch's invention by eight years.

A great deal concerning the life of Frederick Winsor is unfortunately missing. No one knows when and where he was born or when he died. The only record we have of his life is sadly lacking in these details. But what little can be learned about him is indeed a revelation.

We first hear of Frederick Winsor as a teacher in a Sunday school in the little English hamlet of Soho, a suburb of the present city of Birmingham, in 1789. In those days Sunday schools were "confined to teaching the art of reading" so that the poor illumination as furnished by tallow dips caused grievous inconvenience and injurious eyesight to the scholars in the dark winter days.

One evening a certain scholar by the name of Thomas Carpenter noticed that "the air from the coal stove burned very

bright and vigorous." Directing the attention of his teacher, Mr. Winsor, to the discovery the "learned and scholarly gentleman" started a series of experiments in his leisure hours.

Frederick Winsor was a public-spirited man. Here was something that might be used to the advantage of humanity as well as to the scholars of the Sunday schools. He had no money to speak of, but what little he had he decided to spend on experiments with "the brightly burning air" of the coal stove.

For an interval of thirteen long years nothing was heard of Frederick Winsor, and the biographer forgets to mention how he lived or to what extent his experiments had progressed. That, somewhere in dingy old London, the genius was working with dogged energy and persistence upon his discovery there can be no doubt. Nor was he aware that during this period a rival had arisen who, for many years afterwards, was to receive the credit that was rightfully his own—the first man to discover illuminating gas and a process to manufacture it commercially.

In 1797—said to be some years after Mr. Winsor's original discovery—a wealthy mechanic of the same town of Soho, William Murdoch by name, had also experimented with coal gas and had used it to illuminate his home and offices at Redruth in Cornwall. And he was enabled to exhibit his invention on a large scale in 1802, and to obtain the interest of certain influential members of Parliament as well.

In the same year, however (1802), "Mr. Winsor's Patent Gas Light and Coke Scheme," as it was called, commenced to attract public interest to such an extent that Edmund Burke, the great Irish orator of the House of Commons, characterized

the city of Birmingham as "the toy shop of Europe." But Winsor was poor and unheard of, had no money to exploit his invention, and therefore his "scheme" was treated with contempt and ridicule.

That Dean Swift, one of the world's greatest satirists, realized that Winsor was being robbed of his discovery, is shown by a remark that he made at the time, "Oh, give me honest fame, or give me none."

Having raised some money by selling to the public some stock in his National Light and Heat Company, Winsor publicly exhibited at the Lyceum Theatre in London, in 1804, his method of using illuminating gas, and three years later succeeded in lighting a portion of Pall Mall.

"His statements were combatted," says an old scientific journal of that day, "and those who scrutinized his calculations pointed them out as fallacious and absurd."

When we consider how Mr. Winsor's company in after years became a great organization, the attacks of the "yellow journals" of that time appear ridiculous. But they had very serious consequences for the inventor, and, what was even of more importance, they blocked the advancement of science for twelve years.

The London press was exceptionally vindictive in its attacks upon Winsor. "Circumstances will surely undeceive these subscribers," said one newspaper, "and prove the utter impossibility of realizing felicitous prospects. How often has the love of gain induced men to give a willing ear to the flattering and delusive tales of projectors?"

Said another, "His experiments have demonstrated to be most egregiously erroneous."

The grammar seems also to be erroneous. (Continued on page 199)

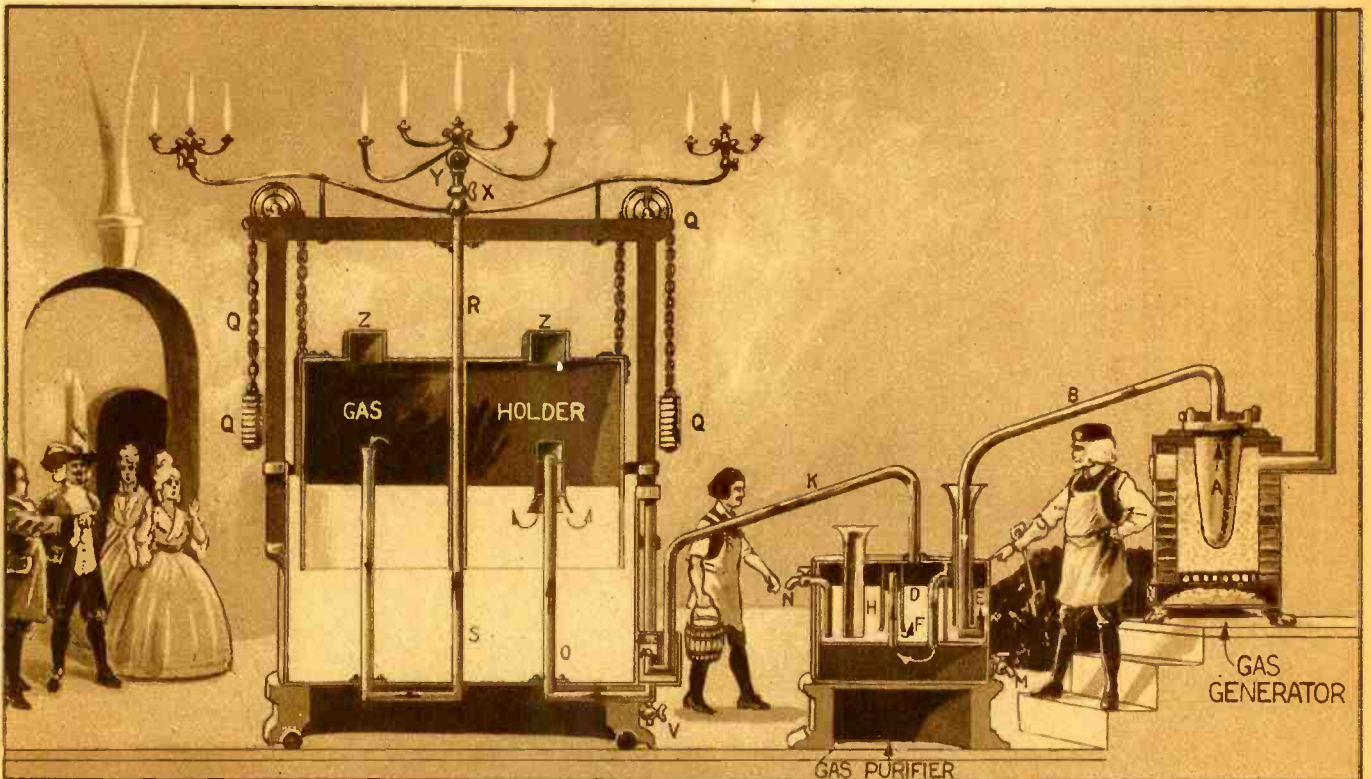

The Above Cut Shows an Experimental Gas Plant of Ancient Days. The General Parts Are Described in the Article. The Gas Generator is Seen on the Right; the Next Object is a Purifier, and the Gas is Purified by Lime, While Tar Collects in the Bottom of the Vessel, and is Withdrawn from Time to Time. Thence the Gas Goes into the Gas Holder at the Left, Which is Provided With Bonnets ZZ Over the Outlet Pipe and Counter Weights QQ. The Other Parts Are Self-Explanatory, the Letters of Reference Being Reproduced from an Ancient Cut. A Very Interesting Feature of This 1810 Gas Plant is the Rat-Tail Burner, Several of Which Are Shown Lighted. This Was Before the Days of the Flat Flame Burner, Now in Use.



# The Ray of Hercules

By RUSS SIMONTON

"ELEVEN hours!"

The speaker, a tall man with that faint stoop of shoulders which marks the scientist the world over, dropped the telephone receiver on its hook and sank into his chair at the table about which sat five others—the greatest scientists in America.

"Eleven hours!" he ejaculated again. "Hercules has sent his last warning. At noon tomorrow he will strike, he says, and annihilate every living being in New York. The wireless operator will hold the message secret as long as he can but the amateurs are sure to catch it and telephone the newspapers. This is our last chance to save the city from destruction."

Those familiar with the dignified and severe Horace Butler, man of science, would hardly have recognized the man as he leaned his arms on the table. His eyes stared into space as though they saw hidden, horrible things. Deeper than the gathered lines of anxiety at mouth and eyes, were the thin, cruel tracings, only produced by worry prolonged through sleepless nights and days of ceaseless thinking.

Every face about the table bore marks of the same character. These men were weary beyond ordinary endurance and yet held keyed and tense for action by the same agonizing emotions.

"Gentlemen," Julius Grant, professor of physics of a great university, broke the painful silence which had followed But-

ler's words, "Gentlemen, eleven hours must be enough. Before noon tomorrow we must accomplish what we have failed to do in five days. Within this room are the scientific brains of America. We must—we will—capture this fiendish madman and draw the fangs of his machine before they close about the city. Let us begin again. Can you think of no plan yet untried? You, Wilson?"

Silently, a man at the far end of the table shook his head.

"Oliver? Braithwaite? Johns?"

The weary, painful headshake of negation traveled from one to another around the table.

"No matter how impossible it may sound. Some plan," pleaded Grant, "Coleman, suggest something."

He to whom the query was addressed spoke slowly.

"I have," he began. Instantly the eyes of all were upon him. Each man felt the stir of returning hope and hung breathlessly upon his words. "I have heard that a friend of mine has perfected a device that might help us. He is in New York. It is a wild hope, but—"

The interruption was from every side: "Send for him!"

Forty minutes later, James Dunwood, appearing fresh and dapper in contrast to the unshaven and weary men in the Hotel Vermont room, stood before them.

There were no greetings; no introductions.

Grant spoke at once. His voice was harsh as two bits of sandpaper rubbing.

"Coleman has told us a little of your work and your discovery," said he, "You know, or must have guessed, the terrible situation which confronts us. For five days we have battled with a phantom horror. We have until tomorrow noon to find and render it harmless. Failing—not a living soul will be left in New York!"

"Monday the Naval Radio Station received a wild radiogram, addressed to 'The People of New York,' and calling upon them to compel their mayor to distribute the funds of the city among the poor under pain of annihilation. Obviously the sender, who signed himself, 'Hercules,' was a crazy man and the newspapers wrote humorous articles about his bombastic message while the police made a casual and half-hearted search for the unknown.

"But each day since there has been a similar warning until today New York is quaking with a superstitious terror. What the people do not know, and what we are keeping secret is, that, on the day of the first warning, 'Hercules,' sent by radio to each of us here a message which proved to us that he has indeed the power to make New York a city of the dead."

He paused and lifting a paper from the table read it aloud:

"Tell the people they must obey the master. Explain to them in words they

(Continued on page 190)

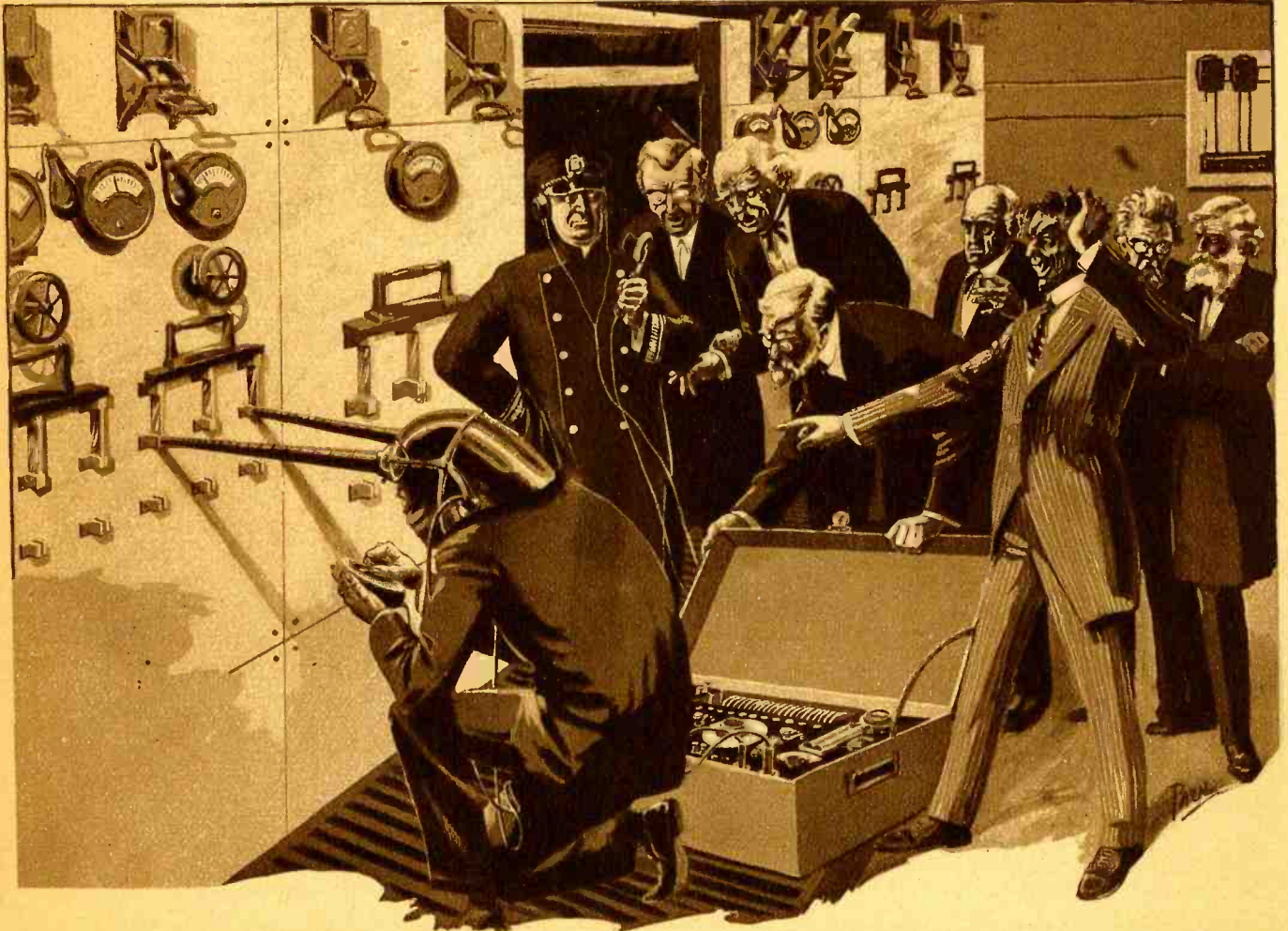

© 1922 by Science and Invention

Coleman slipped the mask over his head and took up the rubber block with the tiny lever. "What do you see?" hoarsely demanded Butler. "A woman with two children clinging to her," said Coleman. His tones, a little distorted by the mask, seemed unreal, "They are crying" . . .



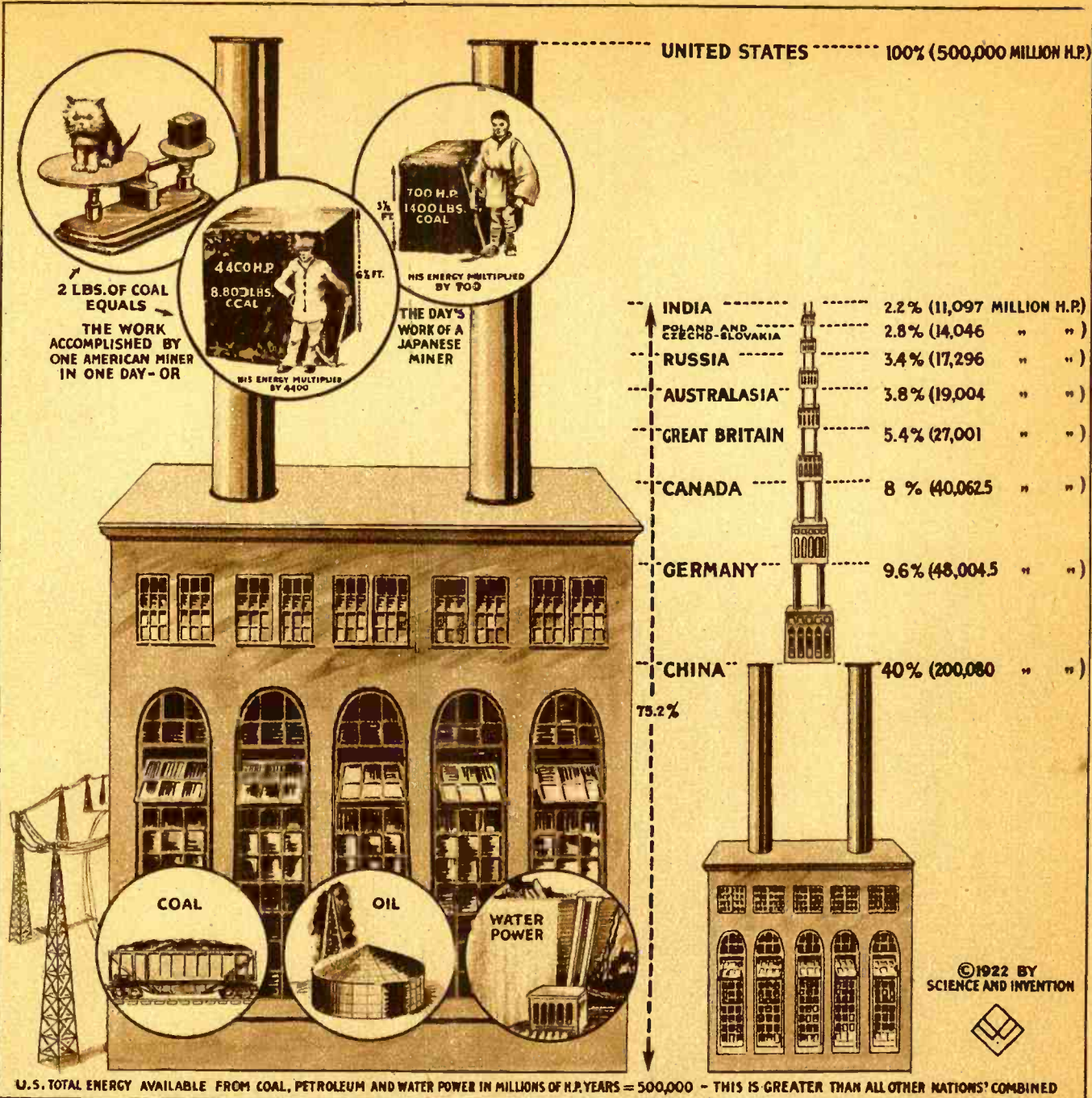

No Other Nation Has the Energy Resources Possessed by the United States, According to the Calculations of a Scientific Expert, Whose Article Appears Below. All of the Energy Resources Combined of the Various Countries Cited at the Right of the Photo Diagram, are Equivalent Only to About Three-Fourths of That Possessed by the United States. The Figures Here Given Are for the Energy Resources from Coal, Oil and Water Power. There Are, of Course, Many Other Resources, Which Make the 75 Per Cent. Ratio for All the Foreign Countries Combined, Many Times Smaller Than This Figure. The Small Inset Figures Show the Work Accomplished and the Equivalent Energy Available from the Coal Mined by an American and Also a Japanese Coal Miner. Two Pounds of Coal Give Approximately One Horse-Power-Hour; the Average Man Can Exert One-Tenth Horse-Power per Hour, and So the Energy Available from Two Pounds of Coal When Burned in the Boiler of a Modern Electric Generating Station, Will Do as Much Work as That Performed by the Miner All Day.

# U. S. Has Greatest Energy Resources

**D**R. THOMAS A. BEAD of the U. S. Bureau of Mines has reduced the power of the United States to terms of energy-resources and undertaken to prove that no other country is one-fiftieth as strong. He recently appeared before the student body of Georgetown University and expounded his deductions, saying: "The real basis of power of a nation is its energy-resources, rather than its man-power strength. The modern way to use the energy of a man is to utilize it as we employ the little detonator of the big explosive shell; the little charge sets

off the big one and does an amount of work far in excess of its own capacity. "The power output of an average workman is about one-tenth of one horse-power. The energy expended by a coal miner in an eight-hour day thus amounts to about that available from two pounds of coal. A Japanese miner, who gets out 1,400 pounds of coal a day, thus multiplies his energy by 700. It is somewhat like planting one grain of wheat and having 700 grow from it. The American miner gets out 8,800 pounds of coal in a day and so multiplies his energy by 4,400. "There are 41,000,000 wage earners in

the United States, and their rated output is a little more than 4,000,000 horse-power, or only nine times the potential energy output in the form of coal of 100 miners. The power minerals, coal and petroleum, and water power are, therefore, the real sources of strength in an industrial civilization. "Just where the United States stands on this basis is best brought out by some comparative figures which may be stated in millions of horse-power years. Taking the estimates of probable and possible available coal, petroleum and water power in the principal countries and reckoning

(Continued on page 203)



# Popular Astronomy

By ISABEL M. LEWIS, M. A.

of U. S. Naval Observatory, Washington, D. C.

**F**OR about six weeks this summer from June 1st to July 15th the planet Mars will outshine all stars and planets in the heavens with the exception of Venus. As we gaze upon the almost startling splendor of the red planet this June we can readily credit the story that at certain close oppositions in the past the extraordinary brilliancy of Mars created a panic among the ignorant and superstitious, who read in its baleful red light a dire prophecy of misfortunes to come.

Every two years Mars comes into opposition with the sun. The earth, Mars and the sun are then in line, with the earth between Mars and the sun. In the alternate years Mars comes into conjunction with the sun. It is then on the far side of its orbit with the sun between the planet and the earth. On the average the

## Mars Near Opposition in June

planet's distance at opposition is 48,600,000 miles (its mean distance from the sun 141,500,000 miles, less the mean distance of the earth from the sun, 92,900,000 miles). At conjunction with the sun the average distance is 234,400,000 miles (141,500,000 miles + 92,900,000 miles). As a result of this great change in distance from the earth its brightness differs enormously between conjunction and opposition. The orbit of Mars is also very eccentric as compared to that of the earth. When the planet is in perihelion, which is the point in its orbit nearest to the sun, it is 26,000,000 miles nearer to the sun than when it is in aphelion, which is the point in its orbit farthest from the sun.

If the planet chanced to be at or near perihelion at the same time that it is in opposition, it will be 26,000,000 miles nearer to the earth than it is when opposition occurs near the aphelion point of its orbit. Oppositions that occur when the planet is near perihelion are therefore called favorable oppositions, while those that occur when the planet is near aphelion are unfavorable oppositions. The closest possible approach of Mars to the earth at favorable oppositions is a little under 35,000,000 miles. At the average opposition it is about 48,000,000 miles from the earth and at the most unfavorable oppositions over 62,000,000 miles. The closest oppositions of Mars always occur in August because it is in this month that Mars passes its perihelion. Favorable oppositions occurred in 1877 when Mars approached within 35,000,000 miles of the

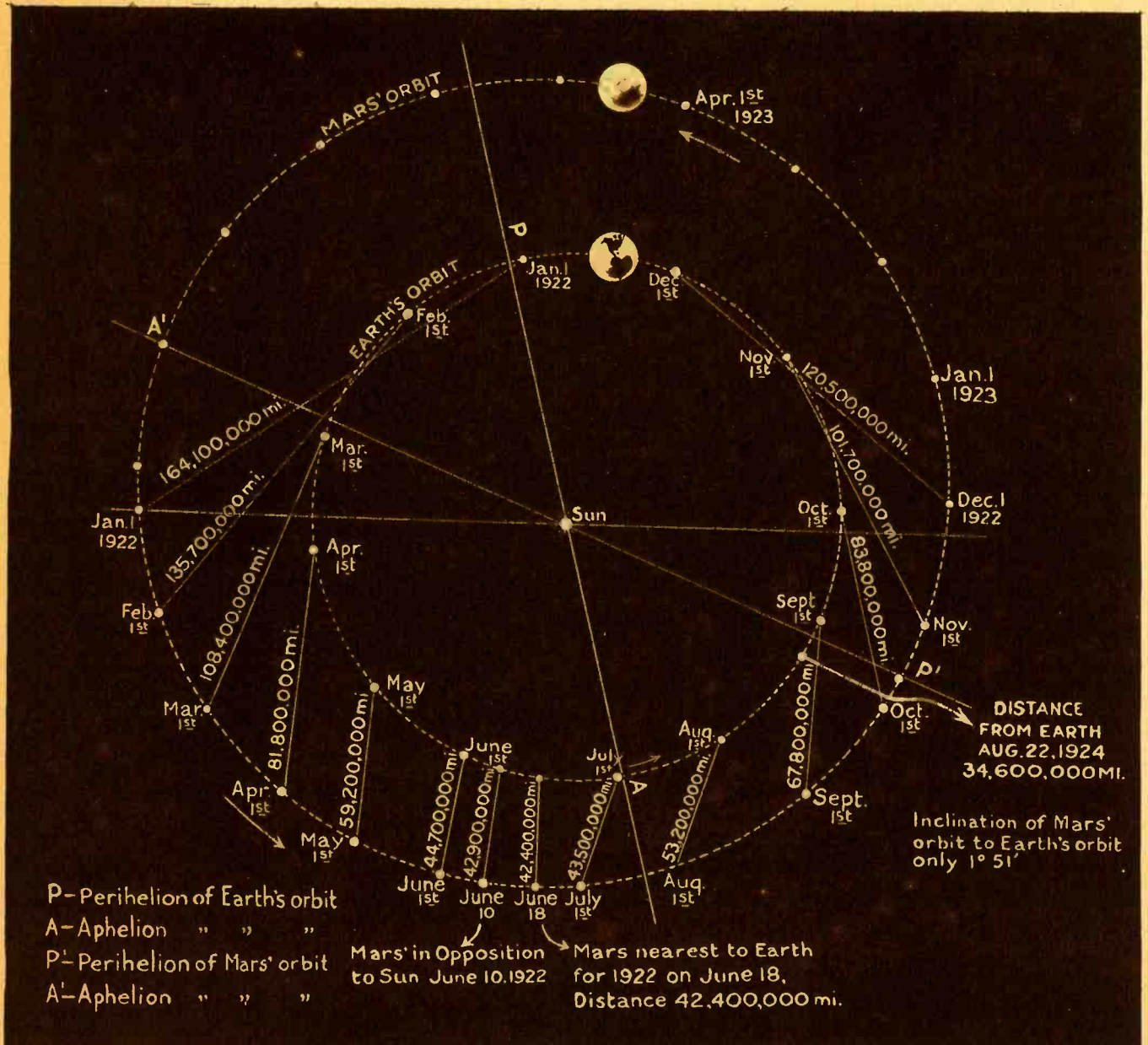

In This Illustration, We See the Two Orbits of Earth and Mars Respectively. It Will be Seen That Mars is on the Outer Track While the Earth is on the Inner. Both Planets Move Roughly at the Same Speed, but Mars Must Traverse a Much Greater Distance Than the Earth in Order to Complete One Revolution Around the Sun. Periodically After a Lapse of Many Years, the Two Planets Pull Very Close Together, the Nearest Distance That They Ever Came Together Being 34,600,000 Miles. This Opposition Will be Reached on August 22, 1924. This Year, on June 18th, Mars and the Earth Will Come Together at a Close Opposition, the Distance Being 42,400,000 Miles, Which is the Nearest the Two Planets Will Approach for the Present Opposition.

© 1922 by Science and Invention



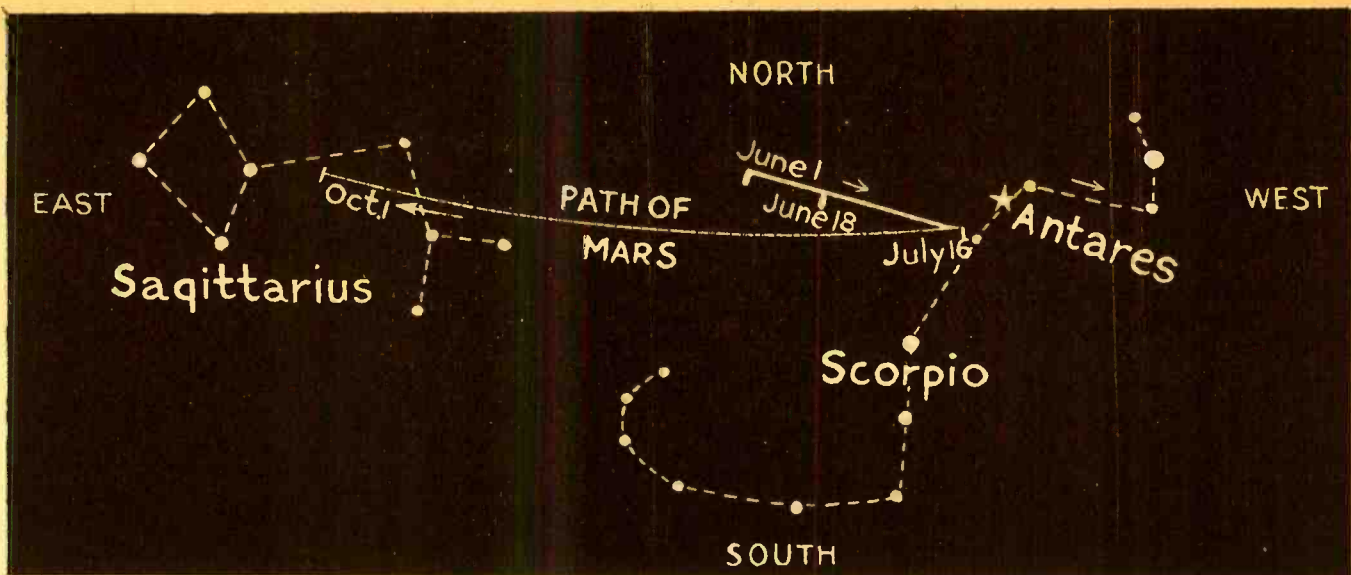

© 1922 by Science and Invention

By Studying the Plan on the Opposite Page, the Path of Mars in the Heavens Will Become More Apparent. It Will be Seen That from June 1st to July 16th, the Planet Mars Will Describe an Arc Through the Skies and from July 16th to October 1st Will Seem to Travel Backwards. By Studying the Chart on the Other Page it Will be Seen That Both Planets Are Traveling in the Same Direction and That on June 1st the Two Planets Will Have Caught Up With Each Other, but After That the Earth Rolls Along Quite Rapidly, While Mars Follows Far Behind. This Accounts for the Apparent Retrogression of the Planet in Our Skies Which is not Real, but Only Apparent. This Chart is to be Held in an Inverted Position with Top Toward North.

earth; in 1892 when the nearest approach was also 35,000,000; and in 1909 when its nearest approach was 36,200,000 miles. A most favorable opposition will occur in August, 1924, when the distance of Mars from the earth will be 34,600,000 miles which is very close to its nearest possible approach. These favorable oppositions occur every fifteen or seventeen years. Oppositions immediately following or preceding such oppositions by two years, are also more favorable than the average and such an opposition occurs on June 10th of this year. The nearest approach of Mars to the earth for this apparition will be 42,400,000 miles on June 18th. If the two orbits lay exactly in the same plane the nearest approach would be on the date of opposition but as the plane of Mars' orbit is inclined to the plane of the earth's orbit by a small angle the nearest approach occurs either a few days before or after opposition.

It is at favorable oppositions of Mars that the astronomer is most likely to discover new details of surface markings or other features of interest concerning the ruddy planet. It was in August, 1877, that Prof. Asaph Hall, Sr., discovered the two minute satellites of Mars, Phobos and Deimos, with the then new 26-inch refractor of the U. S. Naval Observatory. It was at the same opposition that Schiaparelli announced the discovery of the far-famed canals of Mars and he confirmed his discovery at the somewhat less favorable opposition of 1879 when Mars was 44,800,000 miles distant at its nearest approach.

The nearest approach of Mars to the earth at the opposition of this year, 42,357,000 miles on June 18th, is the closest that Mars has been to the earth since the favorable opposition of 1909. Its nearest approach to the earth at various opposi-

tions has been 47,500,000 miles in 1911, 57,800,000 miles in 1913, 67,700,000 in 1915, 61,400,000 miles in 1918 and 54,100,000 miles in 1920. The oppositions of 1916 and 1918, occurring in February and March respectively, were particularly unfavorable, as the planet was then near aphelion.

At the present apparition Mars is far more favorably located for observation in the southern hemisphere than in the United States and Europe and it is hoped that the astronomers at the Cape of Good Hope and in Argentina, Australia and New Zealand will avail themselves of the opportunity to observe the planet within a few degrees of the zenith. On June 1st Mars will be in the constellation of Scorpio about fifteen degrees east of Antares, the "Rival of Mars," so called because there are times when this first magnitude star is exactly equal to Mars in brightness as well as in color. As if to mock its rival at its present apparition, however, Mars decreases its distance from Antares as it increases in brightness during June. It attains its maximum brightness the middle of June when it is a fraction brighter than Jupiter and more than twenty times brighter than Antares. Tho it begins to decrease slightly in brightness, at the last of the month it continues to outshine Jupiter until the middle of July. Its distance from Antares decreases steadily until it reaches a stationary point only three degrees distant from Antares on July 16th. At this time it outshines Antares thirteen fold and is exactly equal to (Continued on page 185)

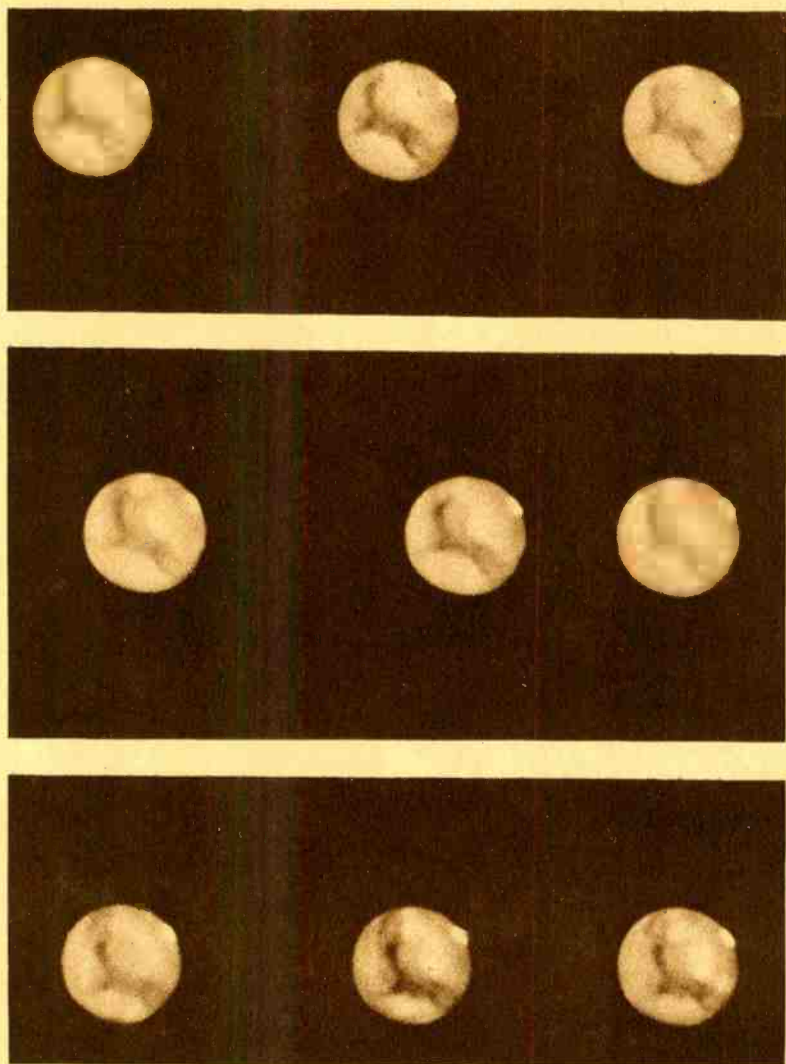

Several Successive Photos of Mars Taken at Short Intervals, Showing the Effect of the Axial Rotation of the Planet. Note the Shift of Markings Across the Disk Due to its Rotation. The White Capped Pole is Caused by Ice. These Photos Were Taken by Prof. E. E. Bernard with the 40" Telescope of the Yerkes Observatory.



# FREAK MOVIES



THE latest acquisition in the motion picture field is the making of caricature movies in a manner heretofore thought impossible. In the system, the exact details of which have not yet been disclosed due to pending patent claims, a motion picture camera provided with special lenses and distortion mirrors is employed. The unique novelty of these distorted pictures makes them widely popular for illustrating nursery rhymes, and for putting figures of speech into the visible form, the system is unsurpassed.

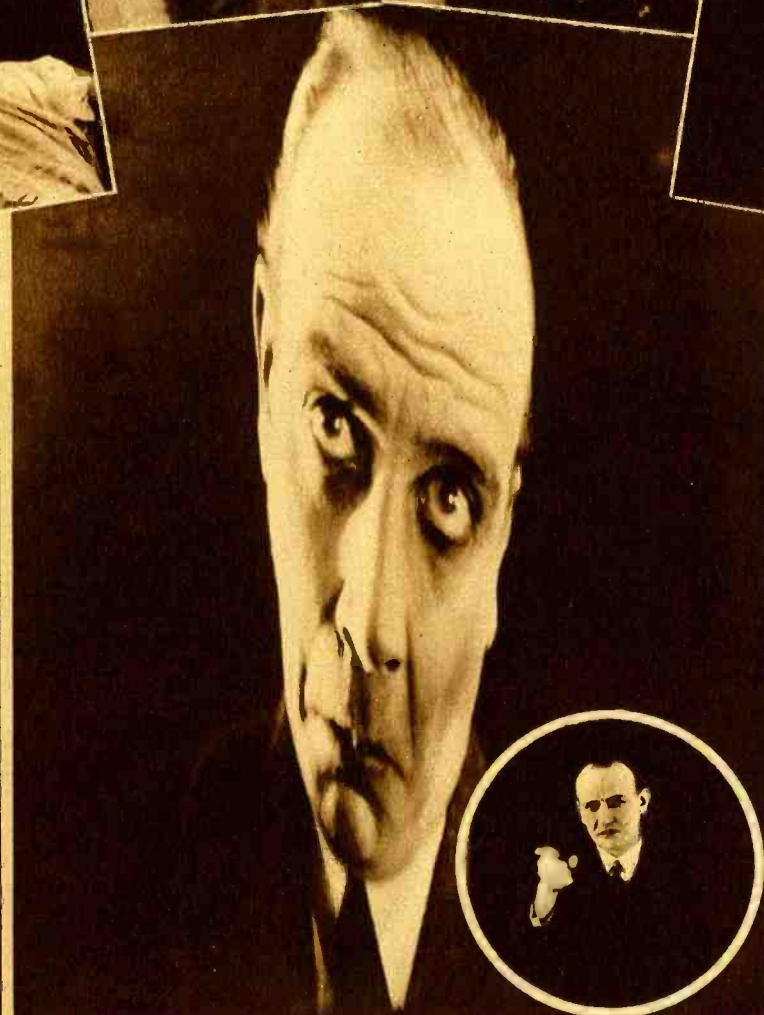

ABOVE photographs from a motion picture caricature by means of lenses and distortion mirrors are shown. "They say" is its title. This is a tale of two gossips. In the center photo is an odd facial expression obtained by the same system of the campaign speaker shown in the circle. He had just completed the sentence with "But there is no need of making a long face before investigating the matter" and of course the action suits the words. The third scene at the bottom of the illustration is the nursery rhyme picturized. "There was a crooked man, And he had a crooked leg," etc.

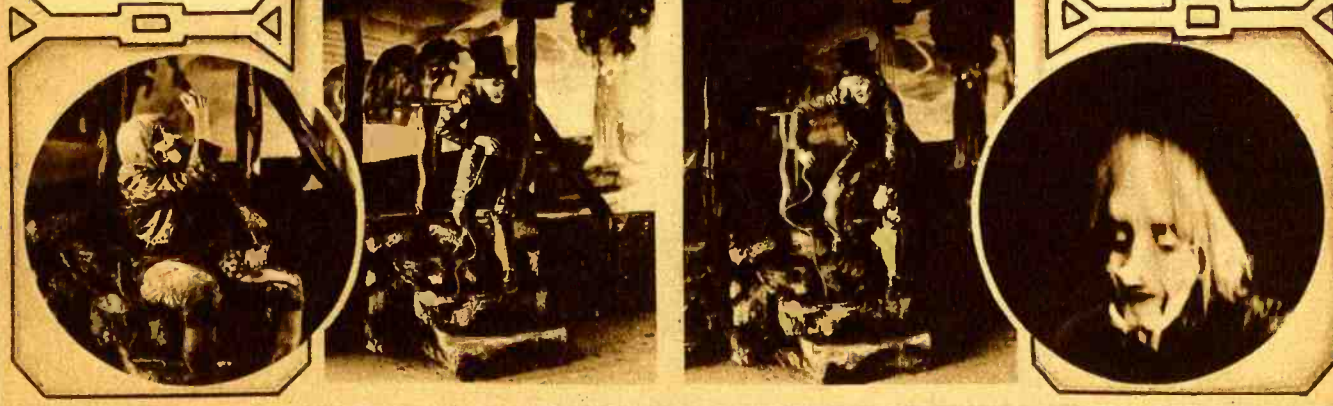

# New "Movie" Caricatures

**I**N the new motion picture caricatures, shown on the opposite page, some of the strangest reproductions imaginable become possible. Unfortunately the complete details of the apparatus are not available at the present time. The photographs are taken generally against a dark background, thru a special system of lenses, and by reflection from a specially arranged distortion mirror.

The mirror itself resembles on a small scale those found at the summer beach resorts, and the photographs taken thru the special lenses are distorted by the mirror. Strange to relate, the various twists and shapes made possible in this manner, may be accurately located upon the individual so that features such as the head itself may become elongated, without affecting any appreciable change in the rest of the body, or

the effect may even be localized upon the eye, nose, forehead, ears, or, in fact anywhere desired.

In one of the motion picture reproductions in which this system was demonstrated, a campaign speaker was trying to convince his listeners of the seriousness of his logic. He told the audience how he had helped to better the community, and then added "—and I can say without danger of a swelled head, that I am the man, etc.—" and forthwith his head swelled grotesquely. Further on in the speech he says, "—and may seem like a pigmy—" and again the camera changes the figures of speech to laughable, altho sometimes serious scenes.

The campaign speaker in the illustration is shown in both his original make-up and as the camera distorts him. At the top of the same illustration four pictures carica-

turing the talk of two gossips in the motion picture satire called "They say—," show not only a distortion of the head and face, but also of parts of the body.

Where the pictures best lend themselves to illustrating features of stories is in the picturizations of old nursery rhymes. At the bottom of the accompanying page of photographs we see four pictures extracted from the motion picture play "There was a crooked man, and he had a crooked leg—," note the crooked stile, and in fact, everything else in the picture is crooked. Most remarkable is the fact that the crookedness of the features of individuals in the story may change without apparently affecting the background, or otherwise changing the scenery and without the necessity of building new crooked scenery in order to obtain the desired effects.—Photos courtesy Pathé News.

# New Typewriter Writes Words

By MARJORIE GORDON BOWNE

**M**ANY people have the impression that the stenographer leads a dry, uninteresting, routine life. Nothing could be further from the case, as will be evinced by the fact that year by year more young women enter the field, full of enthusiasm and vitality.

The most noticeable thing about the young woman in business, is her ability to accept the new thing and adapt it to her old methods, thereby increasing her efficiency. Every office worker prides herself

Pictures at Right Show Front and Rear Views of New "Word-Writing" Typewriter. The Carriage Is Reset By the Finger Operated Lever at Right of Keyboard.

The Keyboard of the "Word-Writing" Typewriter Is Shown Below, the Special Keys Being Those Enclosed By the Dotted Line. Paper Can Be Moved Up or Down By Pressing Keys.

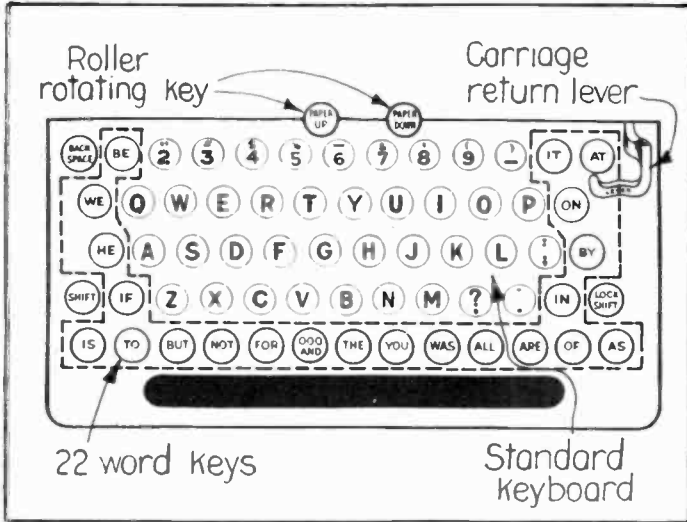
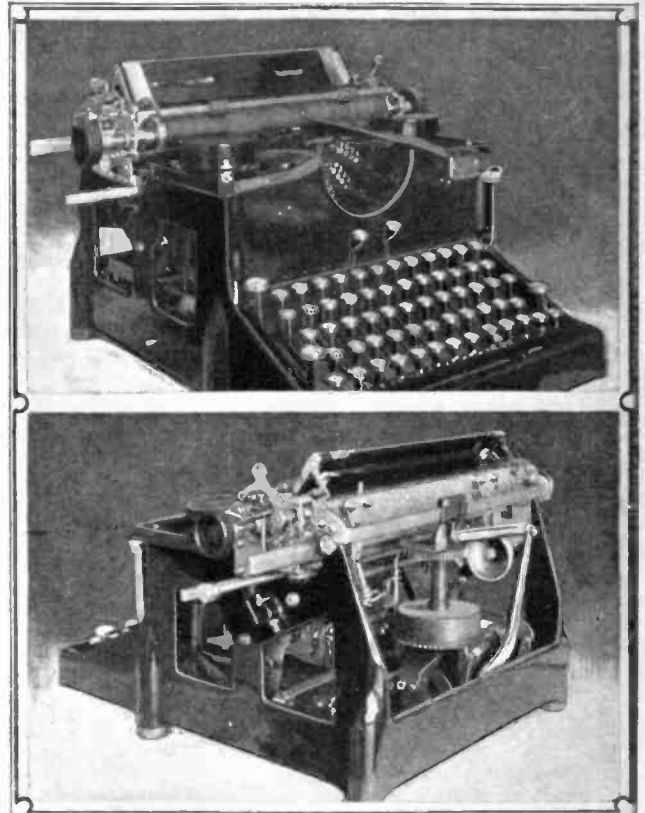

on efficiency, some even carrying it to such an extent as to appear ridiculous.

The other day a new type of instrument to increase the speed and incidentally lighten the labor of the day's work, came to my attention. It is a typewriter, which actually seems human. It does not need to have each separate key pressed in order to evolve such simple words as "and," "if," "on," "to," "the," etc. The words and parts of words are formed thus:

It will write these words of its own accord when only one key is depressed, instead of the two or three which would be necessitated on the typewriters in common use to-day. To many people this itself would be a marvel, but the machine has also been improved in many of the mechanical parts such as the roller and carriage return.

But all this is moving too fast. Let us go back and trace the construction of the new mechanism, bit by bit.

Like most great things, the evolution of this unique machine was simple. It began years ago on a little farm in Ohio where Wesley Henry Bennington was born. From the first, he had a desire to invent, but as he grew older the realization that before he could do anything he must know something arrived, and he went to the Ohio Northern University where he worked his way through, specializing in sciences and law. Immediately upon graduation the need of money drove him to a nearby law office where he worked as a stenographer.

It did not take Mr. Bennington long to note the fact that the English language has but 26 letters, and, therefore, it must of course have numerous repetition of a single letter in sentences.

Working upon this hypothesis, he eventually developed the present marvel, which works as previously described.

The word combinations will be seen in the accompanying diagram of the keyboard. These twenty-two words alone would greatly increase the speed with which the typist could write her letters, but when we stop to consider the added benefit of the word combinations such as land, hand, sand, etc., which may all be typed by merely striking the first letter and the "and" key, we realize the tremendous advance which will be marked by the inauguration of these typewriters in the offices thruout the land.

The more technical advantages of the newest invention lie in the fact that the carriage release may be worked without the typist raising her hands from the keyboard, and that the platen roller is so constructed that the writing may go in any direction, upward, downward, forward, backward, or diagonally.



# Measuring Heart and Muscle Actions

By FELIX J. KOCH

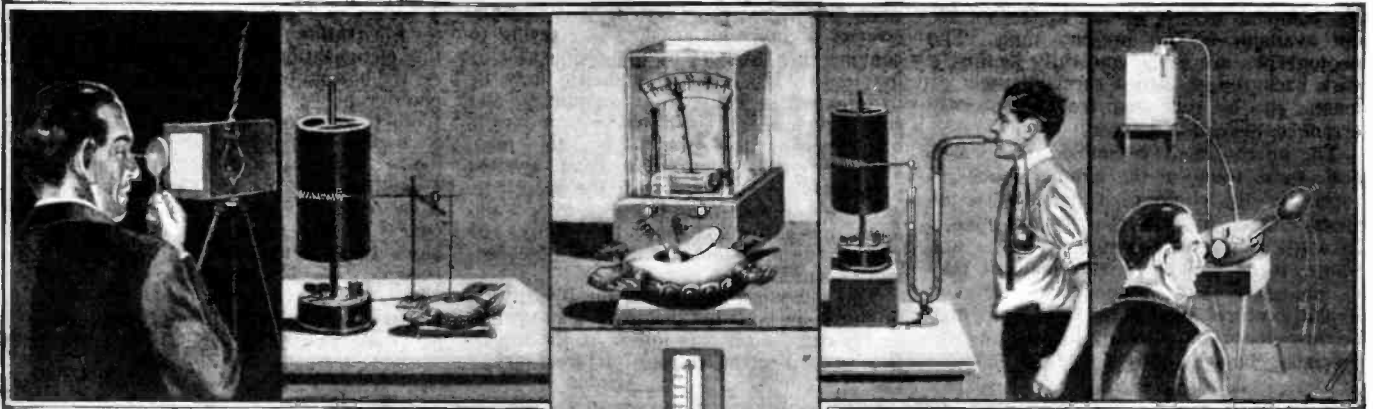

Illustration 1.—An Incandescent Lamp Placed Within a Box Open at One End, which End is Covered with Red Cloth, and This in Turn With a Sheet of Glass, is Used in Observing the Blood-Vessels of the Eye.

Illustration 2.—Recording the Heart-Beats of a Turtle on a Revolving Drum. A Bent Hook Made from a Needle is Inserted Into the Muscle at the Apex of the Heart, and Connected by a Lever to the Recording Stylus.

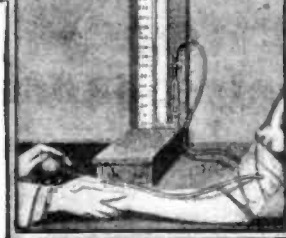

Illustration 3.—One of the Methods for Demonstrating the Presence of Minute Electrical Currents Set Up by Heart Contractions, is Shown Above. Below This We See the Practical Application of the Sphygmomanometer. This Records Blood-Pressure (Illustration 4).

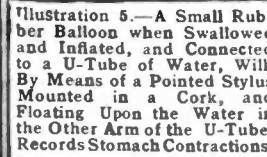

Illustration 5.—A Small Rubber Balloon when Swallowed and Inflated, and Connected to a U-Tube of Water, Will, By Means of a Pointed Stylus Mounted on a Cork, and Floating Upon the Water in the Other Arm of the U-Tube, Records Stomach Contractions.

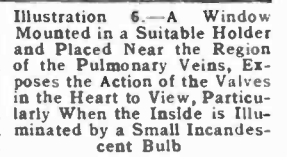

Illustration 6.—A Window Mounted in a Suitable Holder and Placed Near the Region of the Pulmonary Veins, Exposes the Action of the Valves in the Heart to View, Particularly When the Inside is Illuminated by a Small Incandescent Bulb

**I**N a quiet little research laboratory, away from the corridors and lecture-rooms frequented by the undergraduates and graduate students at the Medical College of the big municipal University of Cincinnati, Professor D. E. Jackson is conducting a series of experiments to determine just exactly the sort of *machines* we humans may be—the sort of *stuff* we are composed of, by making use of some of the most delicate scientific instruments known to the modern civilized world.

Let us consider the apparatus for permitting the subject of such observations to see the blood-vessel at the rear of his own eye. (Illustration No. 1.)

As nearly as this instrument may be described it consists of a fair-sized box covered with a cloth coating of red, because of the effect red produces on the eyes of the persons who may use it. The front of this box consists of a sheet of translucent glass. Behind that glass a strong electric light does what it can to pierce the dimming pane; thus giving the observers in charge of the test exactly the strength of beam—as they call it—which they may desire. A brass disk with a pin-hole aperture is used in the observations.

The subject takes this disk in hand and holds it squarely before the eye. He focusses the gaze so that he looks thru the pin-hole toward the box. The gaze fully focussed thus, the patient next proceeds to move the brass plate about rapidly and with as nearly a perfect circular motion as he is able to produce. Doing this with the plate a few inches from the eye, he seeks to watch for the converging and interlacing network of the blood-vessels in this organ.

It is little short of marvelous what wonders of the eye will be revealed in this way!

Nearby there is another apparatus, whose ulterior object is to permit studying the amount of electric current which may be generated by the heart-beats of a turtle.

To the practical layman it would seem that there is no great amount of sense in this. To the scientist the experiment spells incalculable value.

In the turtle one finds, on a reduced scale, many of the conditions which exist in Man. Apply your law of ratios, employ your multiplication table, and you will be surprised at the deductions which may be made.

## Finely Graduated Instruments Employed by a Municipal University of the Mid-West

This, however, is not to be a story of deductions from the experiments in point; but, rather, of the apparatus involved. (Illustration No. 2.)

A common land turtle, the sort a country boy in perhaps any part of the Anglo-Saxon world can find for you, is taken and made fast to the biologist's bench in the laboratories here.

A very sharp probe is then thrust into the creature's brain and this just as swiftly as the attendant may know how, in order that the turtle may be spared all possible pain and yet there be no recourse to anesthetics or other drugs which might confuse results, or even go so far as to combine with the effects of the sudden shock and kill the animal before experiments had really been begun.

The turtle is brought thus to the immobile state required for the work to follow: the experimenter takes a small tubular saw, designed for just such experiments as these, and cuts a small, round hole in the shell of the creature. Lifting the trap-door made in this way, he exposes the turtle's heart to view.

Lifting this heart very carefully then, by the aid of his dissecting forceps, he inserts a simple pin-hook in the end of the ventricle of the organ. There is a thread attached to the hook. One end of that thread continues on from the pin fastened in the muscle of the heart to the short end of a simple lever.

The other end of the lever extends to a moving drum. The surface of this drum is coated with a smoked paper.

What follows explains itself very nearly: As the heart beats on, the drum turns. As the drum turns, the smoked paper records the beats.

After the record is made the paper is removed and dipped in shellac as a fixative so that it may be handled and filed away. It is kept until the research experts wish to mate it with innumerable other records of the sort.

"Not to enter on the medical side of the story of results from the experiment," Dr. Jackson said, "let me summarize by stating that upon these results the effects of drugs upon the heart when directly applied to its surface may be seen and recorded.

"Doctors deduce this from results obtained thru the device fixed to the turtle. Then they apply similar drugs to the patient."

Dr. Jackson indicated another delicate instrument near.

"That is what we call a sensitive *galvanometer*," he said. (Illustration No. 3.) An Einthoven galvanometer is used.

"It is one of the most sensitive instruments in the world.

"Basically, there is a wire vibrating back and forth and forth and back, between two magnets. Current developed by muscular contraction of the heart is used to actuate it. It thus registers the heart-beats, and records it photographically. The electrodes attached to the body in the region of the heart carry the effects of its action over the wires attached to them. On the photographic record, if the heart is acting normally, one gets a wave-series of a specific sort. If not, one gets waves which show exactly the variations from the normal. Comparing these with the records made by the hearts of men, when acting under various conditions, such as the respective types of heart-trouble might produce on the heart-beat of Man, it is not at all difficult for even the tyro in medicine to diagnose certain disorders in the patient."

Not far from this equipment attached to the heart of the humble turtle, Dr. Jackson has mounted an apparatus of an entirely different sort. For want of any better name, it is called the *stomach-contraction device*. (Illustration No. 5.)

A small rubber balloon—much the same sort that children delight in—is attached, by means of a rubber tube, to a water-manometer. This latter, it may be explained here, is a glass tube made in the familiar U-shape. The lower half of the tube is filled with water in the course of the experiments.

At one end of the tube there is a cork

(Continued on page 173)

# Perpetual Motion at Last?

**W**E are overjoyed, at last, to let you in on the latest Get-rich-quick scheme. All you have to do is to invest \$25.00 or so in the stock of the Perpetual Motion, Power, Heat & Light Co., of Jersey City, New Jersey, which company has evolved a most remarkable model of a perpetual motion power plant, and the gold will roll your way so fast within a few years that you will have a string of Packards lined up in your backyard, one painted a different color for each day in the week, and you can smoke one dollar Havanas, and drink the best boot-leg whiskey, with never a fear about going over the hills to the poor-house, all according to the inventor.

This company has been endeavoring to educate the American public, poor dubs that they are, meaning of course the public, for four long years, to the astounding and epoch-making transformations which await the whole world tomorrow when this marvelous mechanical master-piece, invented by one Richard Uram, gets on the job, spinning our dynamos and turning the wheels of industry.

One of the editors made a special trip to Jersey City to see this marvelous machine demonstrated, and also went prepared to write out a good sized check for a liberal block of stock in the greatest idea of the century, if he became convinced of the practicability of this power producer which had fooled 'em all, thrown learned engineers and scientists into the discard and brought the perpetual motion inventors into the front ranks of applied electro-mechanical science.

The day the writer called to see this machine demonstrated, the inventor was still waiting for some more mercury (he has been tied up waiting for this mercury for four years already), about a ton of it being required to operate the machine.

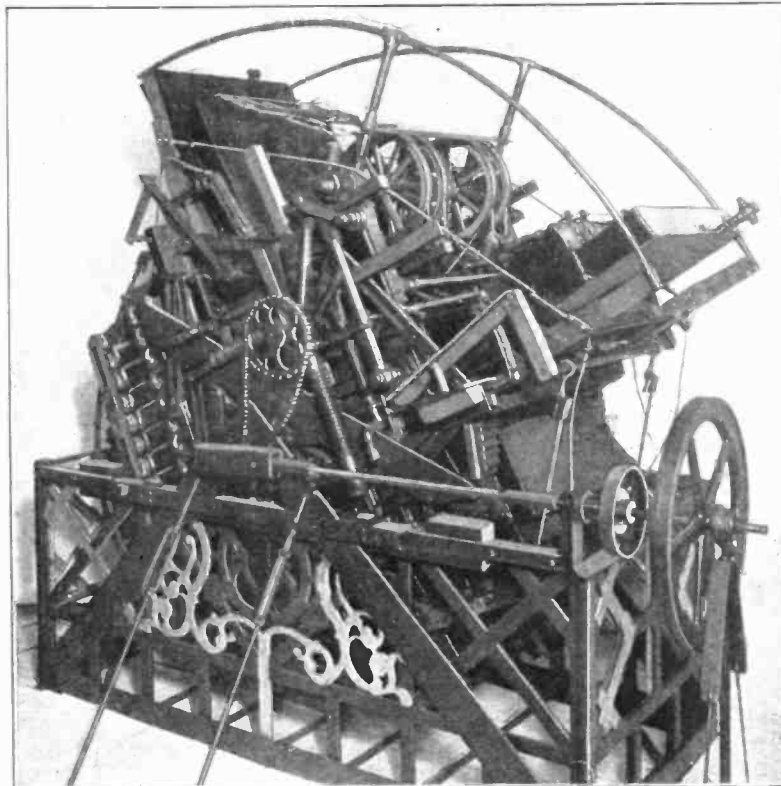

Here's the Perpetual Motion Machine that Its Inventor Claims Will Revolutionize the World. The Machine Stands Six Feet High. It is Supposed to Oscillate Back and Forth and Generate "Free Power" Once the Mercury Filled Tanks Are Released and Start Functioning.

The inventor obliged, in part at least, by removing the blocks from the machine, and by simply giving a slight push the machine swung back and forth on its bearings, which bearings the inventor claimed were absolutely frictionless (?) and the machine appeared to be very delicate, at any rate.

Before going any further it should be said, that the editors do not believe in perpetual motion, in the accepted sense of the word, and are in fact convinced that you cannot get something for nothing. Referring to the accompanying chart—diagram of the machine, figure at left shows the machine just before one of the mercury tanks X has been raised. When this tank is raised to start the machine, the mercury in the other tanks, takes the position as shown at center, and there being greater weight on the right hand side now, the whole contraption will operate clock-wise about the center shaft, until it has moved thru about 90 degrees, as at right,

3 feet wide. The inventor of the machine, who is also the president of the company, endeavoring to sell stock in the greatest free energy invention since the days of the Ptolemys, is particularly peeved at Prof. Garrett P. Serviss, well known scientist and writer, who edits the scientific column of one of New York's leading newspapers, and challenges him "to prove that his machine is a fake, and that he is not what he claims to be, the benefactor and liberator of humanity." Furthermore, the inventor puts himself on record "as being such a benefactor and liberator of humanity, and that further he is able to prove to anyone, including the Mayor and City Commissioners of his city; as well as the Governor of New Jersey, the President and Congress of the United States, and all or any of the engineers, that he can construct a perpetual motion power plant with a capacity of 1,000,000 H.P., for the sum of (Continued on page 174)

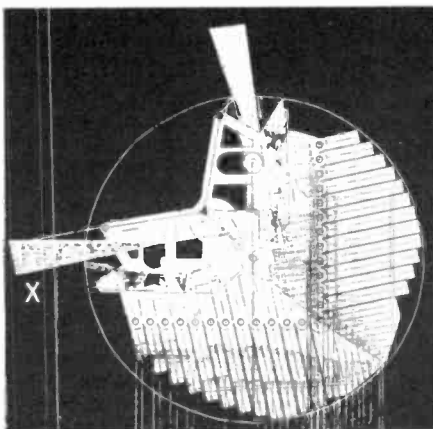

Note Position of Mercury Tank "X," Also Positions Occupied by Other Mercury Filled Tanks.

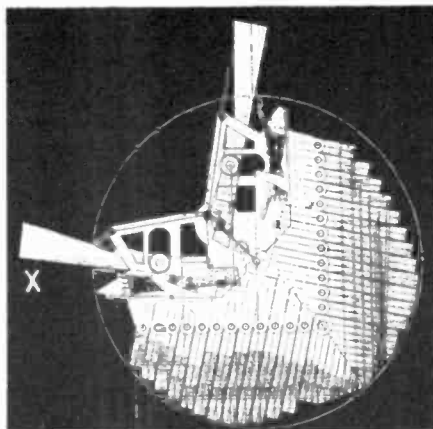

Large Tank "X" Has Been Released; Mercury Passing to Right, Overbalancing Machine.

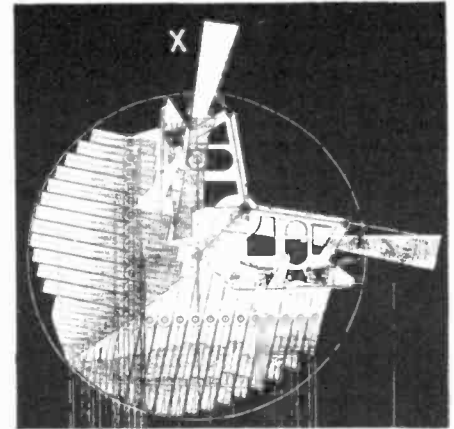

Machine Has Moved Thru 90°. Reversing Mercury Tank at Side Brings Drum Back.

# Carillons in Belgium

By MARINUS COOK

**T**HE Germans committed an unpardonable crime against the soul of the Belgian nation when, during the war, they carried away hundreds of bells from church towers, steeples and belfries to convert them into cannon. For there is nothing the Belgian loves more than to hear the breezy tunes that come tripping thru the air every fifteen minutes of the day (and the night) from these carillons, or to listen to the carillon concerts which are given from time to time, or to attend the annual contest between the celebrated *carilloneurs* of the country.

On market days the carillons announce the "peace of the market," an old medieval custom, and play from twelve at noon till one o'clock. Hundreds of people either listen as the bells play one tune or hymn



a short jingle of ten to twelve notes is given.

To this end each of the bells of the carillon is provided with a hammer which strikes the bell at the outside. These hammers are so fastened to iron bars that they can be easily lifted. Steel wires run from these hammers downward to a room where they are connected with wooden pegs placed in a row. These pegs are comparable with the keys of a piano and rest against a revolving iron drum in which are a large number of holes. Into these holes metal pins can be placed in such a way that when the drum revolves these pins push the wooden keys from their places. The result will be that a pull on the steel wire is effected and the hammer is lifted. When the drum continues to turn, the pin releases the key, and the

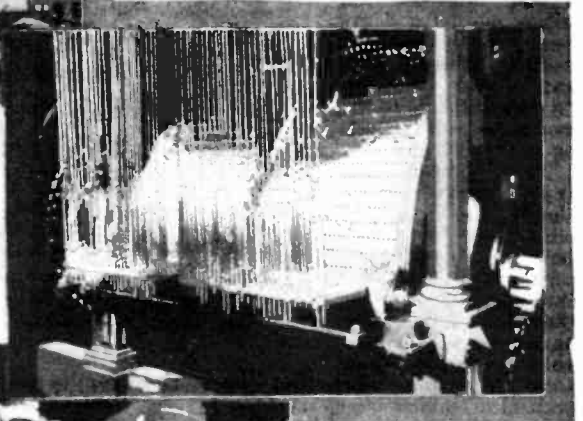
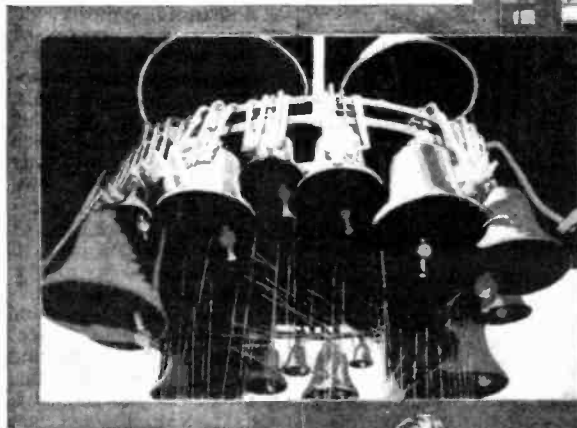

Belgium Loves Its Carillons, Several Views of Which Are Shown in the Accompanying Illustration. Holland is also an Admirer of the Musical Bells. A Complete Carillon of the Better Class Consists of a Series of Tuned Bells Ranging from Thirty to Fifty in Number. These Bells are Played by Hammers or also Clappers Actuated by Steel Wires Connected with a Keyboard.



Jef Denyn, the Carillonneur of Malines, Belgium, is Shown at the Keyboard of His Famous Carillon in the Left-hand Illustration. The Size of the Larger Bells is Seen in the Right-hand Photo, while the Top Photo Shows a Typical Carillon Tower. The Automatic Player Drum, Shown Above, Contains 7,200 Peg Holes.

after another, or go about their business, their thoughts keeping time with the pleasant music in the high air.

In Belgium and Holland carillons are national institutions, and no town is considered of any importance which does not possess a more or less complete set of bells. In Belgium alone there are ninety-seven complete carillons and in Holland one hundred and fifteen.

A complete carillon consists of a number of bells, ranging from thirty to fifty, producing tones which are related to each other in the same way as the tones of a piano: prime, minor and major second, minor and major third, fourth and augmented fourth, fifth, minor and major sixth, minor and major seventh, octave, etc. The size of the bells is determined by their tone and the timbre or volume of sound they are expected to produce. Usually the lighter bells are suspended highest and the heavier bells lowest. This arrangement causes the charming effect of carillon music upon the listener. The lighter tones seem to flow over the heavier ones, like the

lighter ripples on the crest of heavier waves, and when heard at a distance these lighter tones seem to skip lightly about. It is most unlike other music, and one must have heard it to appreciate its unique nature. The total weight of all the bells of a carillon runs from ten to fifteen tons. Carillons are played in two ways, and for two different purposes. First mechanically, for the purpose of indicating time. The method usually followed is this: at the full hour a complete stanza of some hymn or song is given, followed immediately by a number of peals from a heavy bell, usually not in the carillon, indicating the hour, two peals at two o'clock, five at five o'clock, etc. At half hours a shorter tune is played followed by one peal from the heavy bell, and at the quarter hours only

hammer up in the bell chamber will fall down on the bell, thus producing the tone.

The pegs in the drum can be arranged in such a way that it will play a tune, working on the same principle as a player piano, or, better still, as an old-fashioned music box. In many towers this drum is set in motion with weights and regulated by a pendulum, but electricity is slowly displacing the old-fashioned way. I have seen a pendulum which had the respectable length of sixteen feet. The drum in the illustration has 7,200 peg holes.

On special days, on the birthdays of members of the royal family, on national holidays, on market days, and on many other occasions, concerts are given during which popular tunes, old medieval hymns and patriotic songs are played by the carillonneur. One can witness on these days the strange sight of people dancing in the streets to the tune of a melody played by the bells from some tower. Carillon concerts are very popular in Belgium, and

(Continued on page 175)



# Building a Color Organ

By MANUEL COMULADA

INSTRUCTOR OF ACOUSTICS, ARMY MUSIC SCHOOL, WASHINGTON, D. C.

The Principle of the Color Organ is Well Illustrated by the Apparatus Here Shown, and the Scientific Experimenter Will Find This Machine a Very Interesting One Indeed. The Helmholtz Resonators Respond to the Note Sung, and Cause an Electric Circuit to be Closed Thru a Lamp.

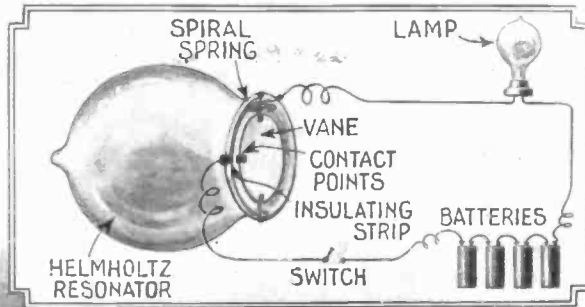

The Diagram at the Center of the Illustration Shows the Electric Lamp Circuit Together with Battery, and Delicately Pivoted Mica Vane Mounted on a Helmholtz Resonator, so as to Close the Electrical Circuit When the Resonator Responds to its Corresponding Note.

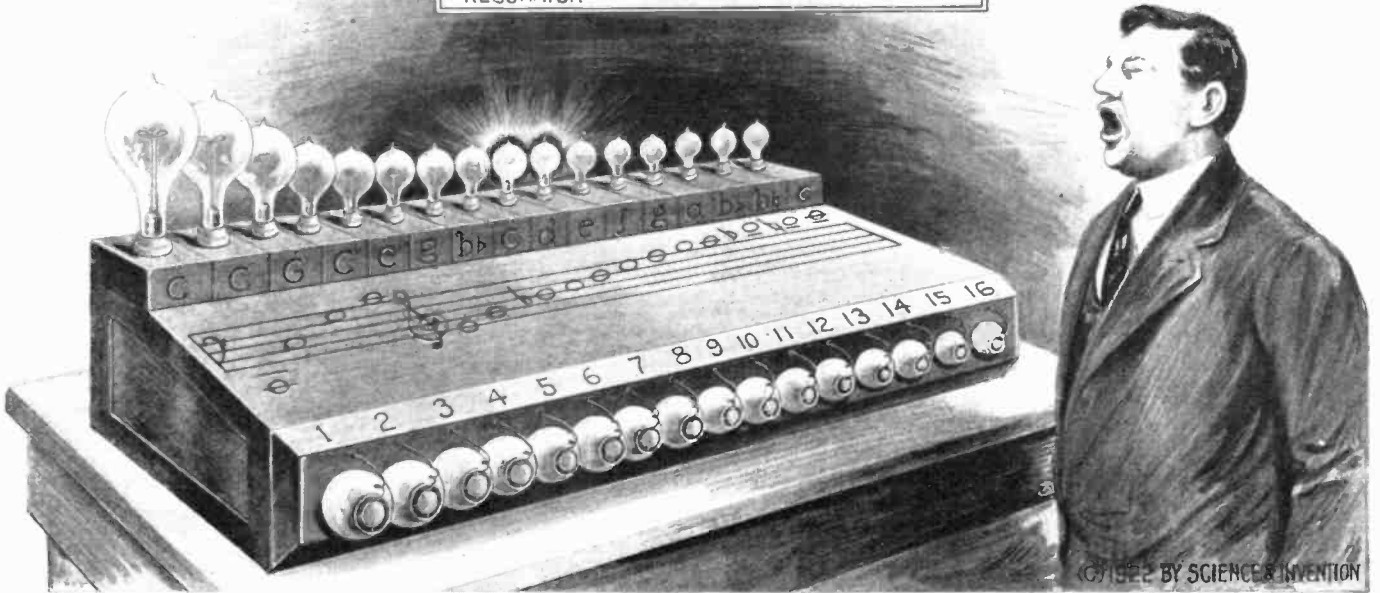

CHAS. E. BY SCIENCE & INVENTION

**N**EARLY all musical sounds are composites of a series of higher partials or overtones, which are superposed on the fundamental sound produced by blowing a pipe like that of a flute, clarinet or trombone, as well as sounds of strings excited by friction like the violin, or by striking as is the case with piano strings.

The position, number and relative intensities of these partials present with every musical sound causes the various tone qualities of musical instruments. The flute when softly played has very few of these partials present, hence the suavity of tone of its lower register. Again, when very high sounds are produced in the upper register of this instrument, there are practically none of these partials present, giving us sounds very much the same as to tone color or quality.

On the other hand if we blow an oboe, altho of the same pitch as the flute, its sounds are very rich and of a decided and distinct tone color, due to the great number and relative intensities of its partials or overtones.

With the clarinet we have effects due to its cylindrical body (hyperbolic cylinder) connected with an elastic beating reed; the odd numbered partials of the harmonic series are far stronger than the even numbered, hence the peculiar sound given by this instrument, characteristic of the sounds produced by pipes stopped at one end.

Many musicians who are serious enough to study the science of acoustics know the above facts in regard to musical instruments, but are unable to know how many of these partials are present, and what their position in the gamut of the harmonic series of each individual instrument, to account for its tone color.

By means of an apparatus like the Harmonicophone we should be able to solve

## The Harmonicophone Shows Notes and Harmonics Sounded

this very same problem. A saxophone player wishes to know how many overtones or partials, he produces with a particular sound and tone color; the instrument is blown directly in front of the Harmonicophone, which is tuned to correspond with the period of vibration of the fundamental sound of each musical instrument under test; the fundamental as well as the overtones present are received by the diaphragms whose natural periods correspond or synchronize with the rate of vibration produced by each of the simple sounds present.

By selecting a standard scale set of Helmholtz resonators, the device can be employed as a home type color organ, the lamps being colored different for each note. As the different notes are sung or played the corresponding lamps flash up.

A complete set of Helmholtz resonators are secured to a board or other suitable rack in the form of an instrument. Each of these Helmholtz resonators has a vane fitted across its mouth between two pivot points or bearings. This vane is further fitted with a spiral hair spring so that the position normally occupied by the vane is at right angles to the opening in the resonator. At one edge of the vane, a small silver or platinum contact point is rigidly secured and mounted on a piece of insulating material; adjusted so that it can touch this contact is another piece of silver.

In Helmholtz resonators there is a tendency for a vane placed across the mouth to assume a position parallel with the

opening, or in other words, to close that opening whenever the resonator is excited. This same principle is made use of in one of the very latest designs of electro-dynamic submarine-torpedoes controlled acoustically, which device is described in the April issue of this journal, page 1152, U. S. patent No. 1,390,768.

When the flute, violin or other instrument is played, each individual or fundamental note will effect the attuned resonator and the vane in the mouth of the resonator will close, forming a circuit between the two points on the vane and insulating stand, thus lighting the lamp connected in series with the points. Of course, for each particular musical instrument a different harmonicophone would have to be constructed to synchronize with the sounds produced, and it is advisable to secure several sets of resonators, shaving a tiny bit off the duplicate set and a little more off the triplicate set, which makes for a greater possibility of locating the harmonics and overtones and registering these accurately. The instrument is merely in its suggestive stage and altho experiments have been conducted with the same, the complete scale chart has not been calculated or experimented upon.

Scientific experimenters will be interested in this machine not only as a color organ or harmonicophone, but also from the viewpoint of everyday physics, for the principle of this sound actuated relay, which is moreover selective, in that it responds only to the note to which the resonator is tuned, will be found useful in many branches of the electrical and mechanical arts. It would pay those interested in this whole affair, and particularly in its operating principle, to procure a copy of the patent cited above, which describes an electro-dynamic submarine-torpedo controlled by sound.



The Newest Idea in Pocket Libraries is That Devised by Admiral Bradley A. Fiske. The Words May be Typewritten and Then Reduced by Photography, so as to be Almost Invisible to the Naked Eye. They Are Then Magnified by Using the Pocket Lens Holder Shown in Comparison With an Ordinary Book at the Left, and Also in Use by Admiral Fiske in the Center Photo. A One Hundred Thousand Word Novel May be Printed in This Manner on Five Strips of Paper, Measuring 6 x 1 1/2 x 1-16 in., and Can be Slipped Into the Vest Pocket, as Shown by the Dotted Lines in the Center Photo.

## A Library in Your Vest Pocket

**I**N the illustration herewith is shown the Fiske pocket reading machine. Its inventor, Admiral Bradley A. Fiske, produced this machine in order to create an easy way of reading without too great a strain on the eyes. The machine is very small and consists of a light frame of aluminum in which a strip of paper containing the reading matter slides. The characters on this strip of paper are reduced by photo-engraving means until they are only one one-hundredth the height of ordinary typewritten characters. In order to read these almost invisible letters, a powerful magnifying glass is fitted to the upper part of the frame, this magnifier being adjustable across the frame, so that any line in the four columns (printed on each side of the paper strips) can be read. A knurled knob on the side of the frame, when turned by the forefinger, moves the paper strip steadily up or down to bring new

lines into position under the magnifier. This pocket library, as it might be called, in view of the fact that 100,000 words, which is equivalent to an ordinary novel, can be printed on both sides of five paper strips, as shown in the accompanying illustration, these strips slipping into vest pocket. The reading instrument folds up and is but 6 1/4" long by 1 1/2" wide by 1/4" thick, the weight being about five ounces. One of the features of this pocket library machine devised by Admiral Fiske, lies in the fact that one may easily prepare their own copy on a typewriter, have it reduced photographically at any photo-engravers, by any photographer or for that matter do it themselves with a suitable reducing camera, these reduced prints then being ready to place in the machine and read at any time. This arrangement should work out very nicely indeed for professional men, not to mention everyday men and women, who are interested in gen-

eral literature. Doctors, engineers and other professional men may typewrite or have typewritten certain data, formulae, etc., and after having these reduced photographically, the 6"x1 1/2" paper strips can be carried in the pocket or in a portfolio, and a remarkably large wordage can be carried in this manner almost unnoticeably, with regard to weight or bulk. Another feature of Admiral Fiske's invention is that books and periodicals may be printed at very small cost; instead of going into a book shop and having to part with from two to four hard-earned dollars just for the sake of reading the famous Spianard's book, "The Four Horsemen of the Apocalypse," or "Why Girls Leave Home," we will put down six cents on the counter and demand a copy of our favorite best seller, or if we feel real wealthy, we will extricate \$2.00 and demand a whole encyclopedia de luxe—and get it.

## Wood Alcohol—How to Detect It

By DR. ERNEST BADE

**A** PRODUCT of the dry distillation of our northern hardwoods such as maple, birch and beech, is wood alcohol. The wood cut into cords, is seasoned for one year before it is placed on iron cars and rolled into a large, airtight chamber, the retort. The doors are hermetically sealed, and the whole is then gradually heated. In about two hours the heat in the oven is so great that water begins to distil over together with a small quantity of acid. Six hours later the pyro-

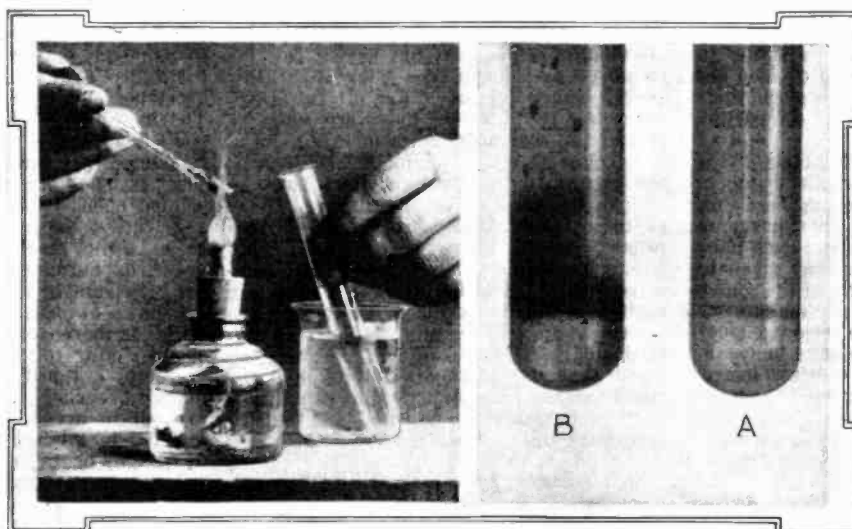

ligenous acid comes over and continues to distil for the next 12 hours. This substance

Copper Wire Spiral is Heated Red and Plunged into the Mixture to be Tested for Wood Alcohol. Test Tubes A and B Show the Presence and the Absence of Wood Alcohol. The Contact Rings in Both Cases Can be Seen, the One Without the Wood Alcohol is Hardly Distinguishable While the Other Tube, Containing the Wood Alcohol, Shows a Heavy Ring, Red in Color, and of Some Thickness, Together with Reddish Flocks Above the Point of Contact.

contains tar, heavy oil, acetic acid and wood alcohol. This (Continued on page 176)

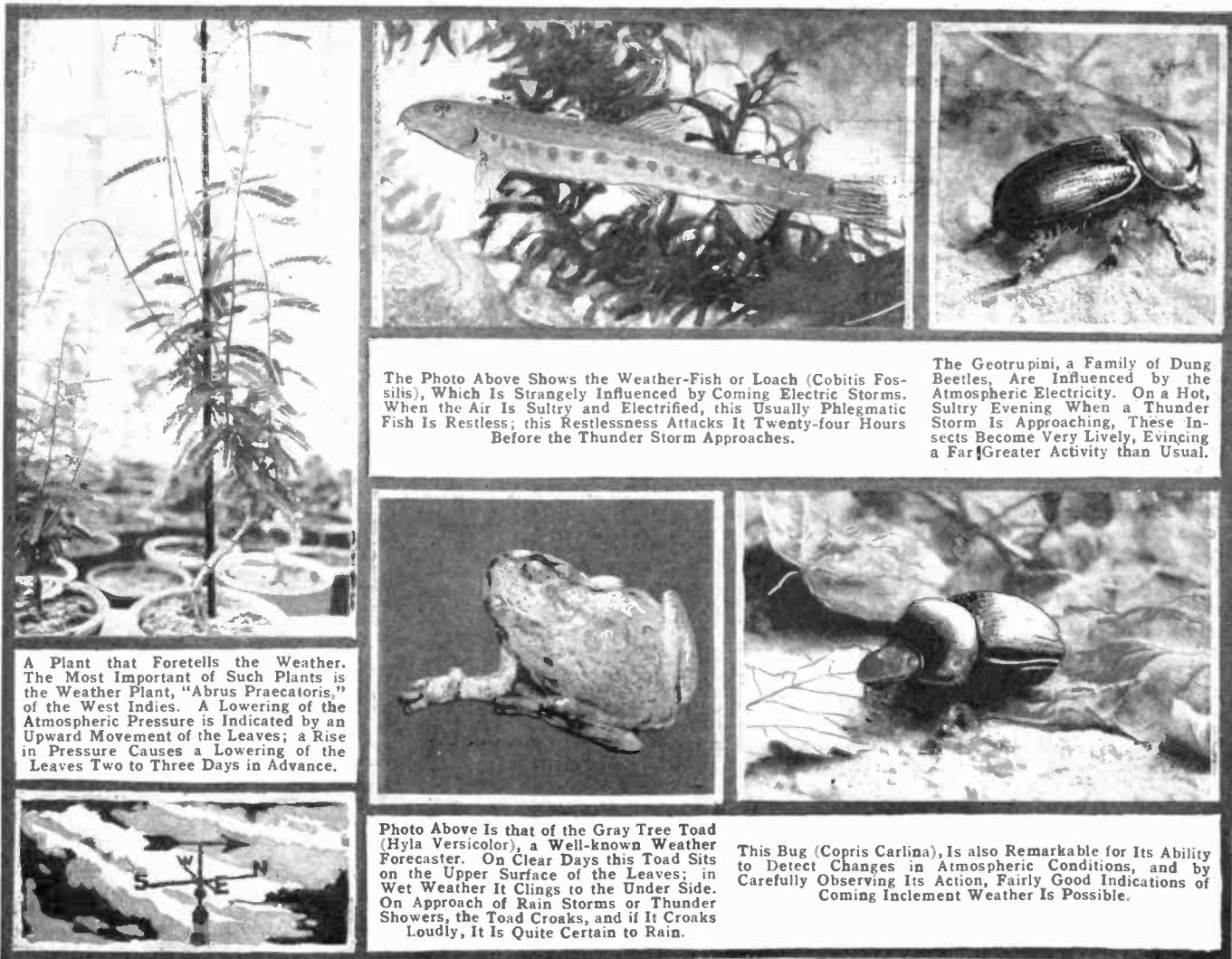

A Plant that Foretells the Weather. The Most Important of Such Plants is the Weather Plant, "Abrus Praecatoris," of the West Indies. A Lowering of the Atmospheric Pressure is Indicated by an Upward Movement of the Leaves; a Rise in Pressure Causes a Lowering of the Leaves Two to Three Days in Advance.

The Photo Above Shows the Weather-Fish or Loach (*Cobitis fossilis*), Which Is Strangely Influenced by Coming Electric Storms. When the Air Is Sultry and Electrified, this Usually Phlegmatic Fish Is Restless; this Restlessness Attacks It Twenty-four Hours Before the Thunder Storm Approaches.

The Geotrupini, a Family of Dung Beetles, Are Influenced by the Atmospheric Electricity. On a Hot, Sultry Evening When a Thunder Storm Is Approaching, These Insects Become Very Lively, Evincing a Far Greater Activity than Usual.

Photo Above Is that of the Gray Tree Toad (*Hyla versicolor*), a Well-known Weather Forecaster. On Clear Days this Toad Sits on the Upper Surface of the Leaves; in Wet Weather It Clings to the Under Side. On Approach of Rain Storms or Thunder Showers, the Toad Croaks, and if It Croaks Loudly, It Is Quite Certain to Rain.

This Bug (*Coprins Carlina*), Is also Remarkable for Its Ability to Detect Changes in Atmospheric Conditions, and by Carefully Observing Its Action, Fairly Good Indications of Coming Inclement Weather Is Possible.

# Plants and Animals That Forecast The Weather

By DR. ERNEST BADE

**T**HE science of meteorology and its attempted weather forecasting, have long since discarded the prevalent superstitions regarding the influence of the heavenly bodies, especially the moon, on the conditions of the weather. Even the old rules of thumb have been abandoned, they could not stand the test of science. There are absolutely no methods by which one is able to tell what the weather will be at some future time. In spite of all things, a grain of truth is hidden in these old superstitions, and they can be explained by the simple fact that all changes of the weather are, necessarily, preceded by some well known phenomena. In this way these rules only confirm a change already taking place, without distinguishing between cause and effect.

Altho it is impossible to tell what the condition of the weather will be days and weeks ahead thru the lack of definite phenomena, it is possible to recognize many signs of Nature, which, when correctly interpreted, will show an unusually close connection with the changes in the weather, since the organisms of many animals are sensitive to approaching atmospheric conditions.

The Geotrupini, a family of dung beetles, are influenced by the atmospheric electricity. On hot, sultry evenings, when a

thunder storm is approaching, these insects become very lively, evincing a far greater activity than on any other evening. The night before a rainy day, even tho the weather is warm and soft and the sky is clear, one can seek in vain for them. They do not appear. In this respect these beetles are living barometers, and far more dependable than the instrument.

It is a fact that some insects can perceive sound waves whose frequencies exceed that of the highest tones audible to the human ear. Ants, bees, and other colony-forming insects seem to possess methods of communication not perceptible to man. In the face of such facts, it is not only possible but probable that some animals can sense the electric waves sent out by a distant thunder storm. Electrified atmosphere, ionized air, pressure as well as moisture and temperature, are perceived, and by certain combinations of such phenomena, reflexive reactions are set in motion producing an excessive stimulation and activity, thus incidentally "forecasting" approaching atmospheric changes.

The weather-fish or loach (*Cobitis fossilis*), is another animal which is strangely influenced by coming electric storms. When the air is sultry and electrified, this usually phlegmatic fish, is restless and this restlessness attacks it 24 hours before the thunder storm approaches. Storm,

rain, and snow, when unaccompanied by electric displays of one sort or another, have no effect on this fish.

Birds also are possessors of a discriminating sense for the electricity of the air. Many observations have been made that birds sitting on a tree, suddenly flew away just before the tree was struck by lightning. If, during a thunder storm, one seeks shelter under a tree, one is safest where the birds are sitting. Should the birds fly away, it is high time to leave the vicinity as quickly as possible.

It is generally known that the tree toad, *Hyla*, is a weather forecaster. It seems probable that a simple farmer, who saw and understood the occurrences of Nature, first brought this animal into his service. On clear days the tree toad prefers to sit on the upper surface of the leaves, in wet it clings to the under side. If the rain is prolonged, it takes to the water. But its forecasts have been much discredited since it is not absolutely trustworthy in captivity. Only for the coming of storm or thunder showers does it croak, and if loud croaking is continued one can be pretty sure that rain will come.

The leech also possesses the peculiar property of forecasting atmospheric changes, and it is certainly curious that it is just as sensitive as the best barometer.

(Continued on page 175)



# The Smell Organ

By JOSEPH H. KRAUS

WHICH one of us has not listened to the enrapturing tones of the church organ, or the pipe organs in motion picture play houses, and not awakened to its appeal? A short time ago a new color organ came into being and delighted or saddened the hearts of those who watched the harmonious blending of the colors on the screen. This organ had no music accompanying it, but the colors themselves and the geometrical figures and combinations which they assumed, were the inspiring features. This machine was described in the last issue of this journal.

Now, however, an entirely new organ has been developed, which instead of inspiring and thrilling audiences by sound, or by affecting the screen, so that the spectators see the color harmonies, translates music into corresponding odors.

The suggestion comes from Dr. Septimus Piesse, a French chemist, who claims that every perfume produces its own particular effect on the end organs of smell terminating in the mucosa, or mucous membrane lining the nose. These organs are called the olfactory cells, and just as every note has its effect upon the ear and as the colors have their effects upon the retina of the eye, so this transposed music—this music of smells—will have its effect upon the olfactory organs. The range of

notes has been carefully plotted, the heavier odors being assigned to the low notes, and the sharp pungent odors to the high notes. Thus, starting with the bass clef three octaves below middle C, the musical notes, and the odors assigned to them, are as follows:

## BASS CLEFF

- C, patchouli
- D, vanilla
- E, clove bark
- F, benzoin
- G, frangipane
- A, storax
- B, clove
- C, sandalwood
- D, clematis
- E, rattan
- F, castoreum
- G, pergulaire
- A, balsam of Peru
- B, carnations and pinks
- C, geranium
- D, heliotrope
- E, iris
- F, musk
- G, pois de senteur
- A, balsam of tolu
- B, cinnamon
- C, rose

## TREBLE CLEFF

- C, rose
- D, violet
- E, cassia
- F, tuberose
- G, orange flower
- A, new mown hay
- B, aurone
- C, camphor
- D, almond
- E, Portugal
- F, jonquil
- G, syringa
- A, tonka bean
- B, mint
- C, jasmine
- D, bergamot
- E, citron
- F, ambergris
- G, magnolia
- A, lavender
- B, peppermint
- C, pineapple
- D, citronel
- E, vervain
- F, civet

Of course, the combination of these odors will create a smell entirely different from any of the individual qualities of the various perfumes and it is necessary that, in the soft, dreamy compositions, the odors

blend harmoniously. Discords will have a decidedly unpleasant effect but inasmuch as the composers did not dwell upon discords to any great extent, the audience will be saved the rather unusual embarrassment of smelling disagreeable combinations. Some music, would perhaps have to be changed and the odors carefully graduated so that in the smells wafted over the audience no particular perfume will predominate, except when the loud pedal, or rather, in these smell organs, the strong odor pedal is trod upon.

It is, therefore, up to the perfumer to combine the mixtures in much the same way as an artist blends colors, or as a good florist makes up his bouquet. If it is desirable to insert a little contrast into the bouquet, the appropriate blossoms or grasses are used, and so the perfumer, likewise would have to employ the proper aromas.

The arrangement of the apparatus is such as to include five or more octaves of odors, arranged as shown in our illustration. These odors have been discovered and placed in their particular locations after painstaking research, the odors being arranged in bottles and sprayed up into the air by an atomizer-like action.

In each of the bottles, we may note the atomizer or sprayer attachment. These

(Continued on page 171)



In Our May Issue, We Described the Latest Idea in Color Organs, and Now We Have the Pleasure of Introducing the Newest Noiseless Organ—it Delights You Not With Wonderful Rhapsodies in Sound, But With Wonderful Musical Combinations Expressed by Delicately Graduated Odors. Dr. Septimus Piesse, a French Chemist, is Sponsor for This New "Smell Organ," and He Has Worked Out the Elaborate Scale of Notes and Corresponding Odors, Which Are Shown Marked in Their Proper Positions on the Musical Staff in the Illustration Above. On the Right is a Musical Composition Combining Harmonious Smells in the Form of Chords.

# Demonstrating Atomic Structures

THE theories of to-day regarding the structure of an atom assume that there are one or more electrons negatively charged, which are in motion about a central positively charged nucleus. Many attempts have been made to show the structure of these atoms and wooden models as well as glass figures have been built for laboratory purposes. Few have ever attempted to make the model structure living, or to show these electrons moving. A machine

when it is energized, and when current is likewise allowed to pass thru the mercury, causes a rotation of the mercury in the wooden tray. Into this mercury are dropt one or more steel balls as required in the experiment.

magnetic lines of force. Sometimes one of the little steel balls will start from the outside and apparently try to escape from the system. At other times a ball will fly out of the system entirely. For best results current in the solenoid and current passing thru the tray should be regulated and the mercury should be kept strained; its surface at all times must be clean.

The effects obtained could, for instance, be likened to disturbances due to X-rays when a cathode-ray hits an atom of plat-

At the Right, We Have Two Steel Balls Placed in Mercury in the Atom Machine. One Ball is Stationary and the Other Rotates in a Spiral Manner Around It. This Latter Ball Then Assumes a Stationary Position, While the First Ball Gyrates. Below is the Effect of Three Balls in the Same Field.

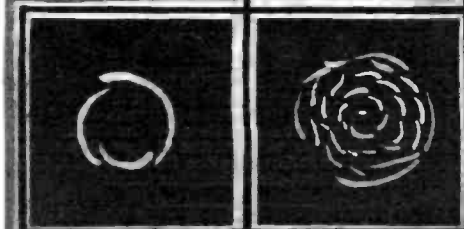
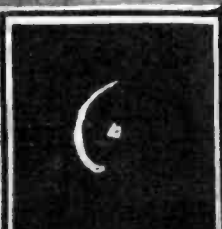

In the Center We See a Photograph of the Atom Machine. It is a Large Coil of Wire Having a Center Core of Iron. Current Thru a Lamp Bank is Fed to This Coil. Immediately Above it is a Hard Rubber Tray Sealed Within a Wooden Container and Mounted on Suitable Supports. It Has Five Iron Nails Projecting Thru It.

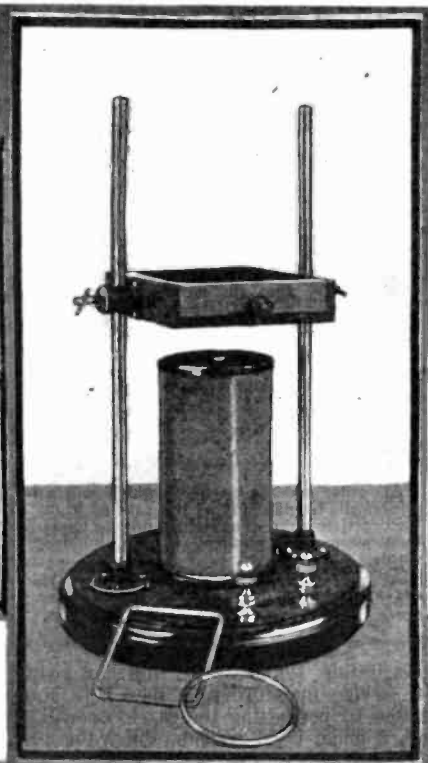

At the Left is a Photograph of Two Balls in Motion Taken Before Either Has Had a Chance to Assume a Stationary Position. Below is the Novel Effect Sometimes Produced When One of the Steel Balls is Suddenly Thrown Out of the Field or Another Ball is Permitted to Enter the Field.

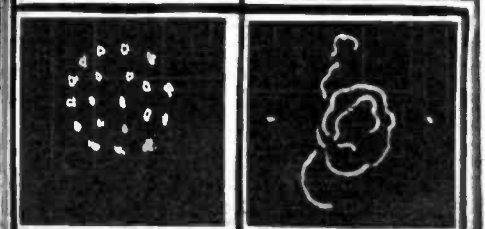

These Nails Provide For the Access of Current to Mercury, Which is Placed in the Hard Rubber Tray. Consequently There is a Magnetic Stress Set Up in the Mercury, Which is Cut by the Magnetic Force Produced by the Coil. Suitable Grips for Holding the Flux Concentration Rings Are Found Under the Tray.

made by one of the leading scientific instrument manufacturers, following the suggestions of Prof. R. R. Ramsey of Indiana University, brings to the attention of students the possibility of interpreting electronic movements, so that they will conform with almost every modern teaching.

Essentially this instrument consists of a large magnet mounted upon a base. Two uprights hold a tray of wood above this magnet, which tray is coated on the inside with hard rubber. Thru the bottom of this tray project five small points of iron, one at the center, and the other four equidistant from the center point, and from each other. The center point is connected to one terminal and the four other electrodes to the other terminal of a direct current source capable of passing five or six amperes thru the trough when mercury is placed in it. The electro-magnet,

When two balls are placed on the rotating surface they do not rotate about the center as one would expect, but one ball will remain stationary for a moment, while the other rotates spirally around it. This rotating ball then comes to rest and the first commences its gyrations. With three balls the motion is more complex. Each takes its turn at the center, and the other two rotate, and so on; as more balls are added, a different movement is established until enough are added when the motion becomes very complicated. It has been suggested that this movement approximates planetary motion. If a ball is allowed to come in from the outside, there is a great disturbance of the entire system. This is noted particularly when rings, and the outfit is supplied with several, are snapt into their respective grips on the under side of the trough. These iron rings serve to concentrate the

inum; or when the ball tries to escape from the system the illustration could be taken as an example of a photo-electric effect, or ionization produced by hot bodies. In case the ball flies out from a normal rotating field, we could use the illustration as an explanation of *alpha*-rays being shot out from a radio-active substance, and when a ball starts out at irregular intervals tangentially and is caught over the magnetic field outlined by the ring, the ball could represent the *alpha*-particle and the escape of the *beta*-rays and the *gamma*-radiations could be explained as being due to the disturbance in the atom demonstrated by the rearrangement of its electrons. Countless other scientific similes will suggest themselves to the experimenter as he changes the height of the tray or varies the magnetic flux or else the current density in the trough containing the mercury.

## Phosphorescent Light Obtained From Violet Rays

A completely dark auditorium was flooded with invisible ultra-violet light which caused faces and clothes of the audience to shine with ghostly phosphorescent light when Prof. R. W. Wood of the Johns Hopkins University address the annual meeting of the American Institute of Chemical Engineers, recently at Baltimore, Md., and demonstrated some of the wonders of high-power ultra-violet radiations.

Teeth and eyes shone with great brilliancy and gave off bluish white light. But those in the audience with artificial teeth were detected by the ultra-violet rays. Imitation teeth do not phosphoresce

and appear as black as charcoal, as do articles of china and white porcelain.

The lens or "pupil" of the eye is also phosphorescent—that is, it actually emits visible light when illuminated by the invisible ultra-violet rays. Dr. Wood explained. This phosphorescent light, which is sent out by the lens, passes into the eye as well as out into the room, and, falling upon the retina, produces the curious optical illusions which make the entire room appear as if filled with a luminous haze of pale lavender color.

In producing high power fluorescence and phosphorescence, Prof. Wood employs in his work a very powerful quartz

mercury arc lamp. Quartz glass is transparent to the mystic invisible ultra-violet radiations which are given off by the lamp.

This apparatus was developed during the war by Prof. Wood, who held a commission as major in the Science and Research Division of the Air Service. The ultra-violet lamp was adapted to secret signaling at night, for marking landing fields for night-flying aircraft, and as a position light for ships in a convoy *running dark*. The distant lamp could be picked up only by the aid of a special wide angle telescope provided with a phosphorescent screen in the eye-piece.



# MOTOR HINTS

## First Prize \$25.00 CHARGING CUT-OUT GOOD ALARM RELAY

Procure a combination charging cut-out and current-voltage regulator. Disconnect the shunt coil from the series coil. Connect one end of a shunt coil to the ground, and the other end to the dead side of igni-

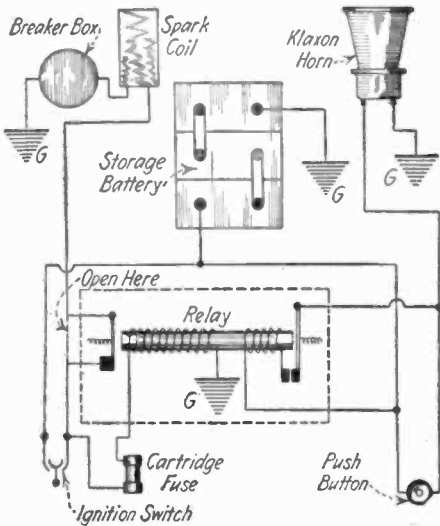

A Thief-proof Circuit—the Double Wound Relay Being a Battery "Charging Cut-out." The Cartridge Fuse is the Secret Switch, and is Put in Place when Parking the Car, and Removed when the Owner is Ready to Start the Car.

tion switch thru a secret switch. Leave the series winding and the cut-out contacts (normally open) in series, and shunt these with a push-button. Break the ignition circuit in a convenient place and connect to the regulator contacts (normally closed). Decrease the air gaps on both, and increase the spring tension slightly on the regulator contacts only.

When thief closes the ignition switch the shunt coil receives the current thru the ignition and secret switches. Core is magnetized and opens ignition circuit and closes the horn circuit. Even if the ignition circuit is opened again, the klaxon or other motor-driven horn continues to blow, its contacts held closed by the magnetic flux supplied by the series coil. To stop the horn, it is necessary to close the contact at the secret push button which shunts the relay and opens the contacts. If the ignition switch remains on, the horn cannot be stopped. This must, therefore, be turned off to start the car successfully.

Contributed by JOS. OSWALD.

## Second Prize \$15.00 USING FORD COIL WHEN "YOURS" BURNS OUT

Since most cars are equipped with battery ignition, and as often happens, there is considerable trouble with ignition coils

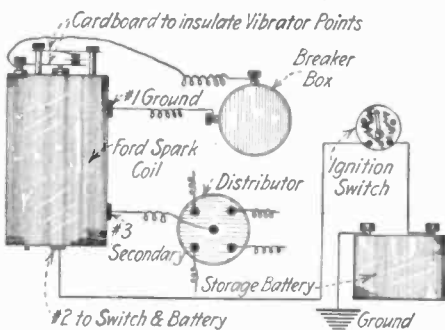

This Diagram Shows How a Ford Coil can be Used with a Regular Distributor and Breaker Box to Replace a Burnt Out Coil.

## NOTICE TO CONTRIBUTORS

**K**INDLY note a change in this contest. For the coming months we would like to receive from our contributors articles on the following subject:

### ELECTRICITY ON THE CAR

We believe that there are hundreds of new electrical ideas that can be incorporated in the car that our readers would like to know of. What we are particularly interested in are novel stunts, new devices, new kinks, and new hints made possible by the electric current.

In order to win a prize the first requisite is that the device or suggestion be practical. The term **PRACTICAL** will be the keynote of this contest.

You will be more apt to win a prize if you will design the device yourself, and make a photograph of it, sending the same to us. Ideas are all right, but the reader wants to see that the device actually has been made, and **WORKS**.

The following prizes will be paid:

FIRST PRIZE.....	\$25.00
SECOND PRIZE.....	15.00
THIRD PRIZE.....	10.00

All other accepted articles which win no prizes will be paid for at the rate of \$1.00. Each article submitted should not be longer than about one hundred to two hundred words.

Address all manuscripts to **EDITOR "MOTOR HINTS,"** care of this publication.

necessitating tying up of the car, while the service man orders a new coil, some method of permitting the car to operate in such a pinch is of considerable value.

This trouble can be easily remedied by a Ford ignition coil which will give service equal to the best coil. The method of making the device is quite simple. Solder wires to the Ford coil, as shown in the illustration. No. 1 is a ground fastened to any metallic part of the car; 2—the lead to the ignition switch, and then to the battery; and 3—the lead to the distributor, which should be of heavy rubber covered (ignition cable) wire. It is necessary that the vibrator points be opened, and a piece of cardboard inserted between the contact adjusting screw, and the contact point on the vibrator. The screw is then tightened down to hold the cardboard in place. The device has given very efficient service, and in fact a coil broken down replaced in this manner has not been changed for the regular article for quite some time. The system is particularly serviceable because the Ford coils can be purchased in nearly every town, regardless of its size; whereas the regular spark coils for the machine may take several weeks before they reach their destination in out of town places.

Contributed by R. V. SAVAGE.

## Third Prize \$10.00 MAGNETO "THIEF-PROOF" TRICKS

One of the simple ways to make your auto thief-proof is to cut off the ignition current between the armature of magneto and the spark plugs. This is easily done by removing magneto conducting rod H. The current instead of being distributed to spark plugs will simply jump safety gap. As there is no spark at spark plugs your engine will not run however many times it may be turned over.

Another simple way to make your auto thief-proof is to turn magneto safety gap cover spring, H2, until it hits the steel magnet, thus making the safety gap zero. As an electric current will always take the path of the least resistance it will

pass from spring H2 to steel magnet, instead of across spark plugs. As there is no spark at the spark plugs your engine will not run, however many times it may be turned over.

Contributed by  
**EVERETT D. MIDYETTE.**

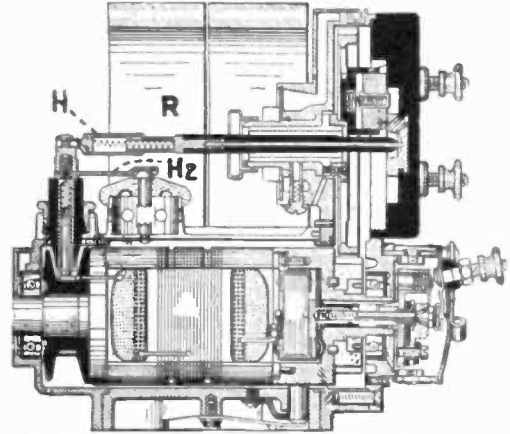

The Magneto Feed Rod "H" is Removed and Carried in the Pocket when Leaving the Car. The Spark from the High Tension Magneto Will Jump the Safety Gap but Never Reaches the Distributor. Another Stunt is to Turn the Safety Gap Cover Spring, so that it Touches the Steel Magnet, thus "Short-circuiting" the Gap.

## CLEVER CARBURETOR LOCK

This device consists simply of one piece of brass or copper wire about 1/8 inch in diameter, and bent as shown in the illustration. The only tool which is required to install this device is a 1/8 inch twist drill. The wire is so arranged that when it is lifted and turned back along the top of the carburetor (motor side), it is invisible to the unknowing person; at the same time it holds the cork afloat in the off position. This keeps the needle valve of the carburetor closed. The wire may be quickly turned to the on position, and the bent end drops down over the side.

Contributed by T. R. STEIN.

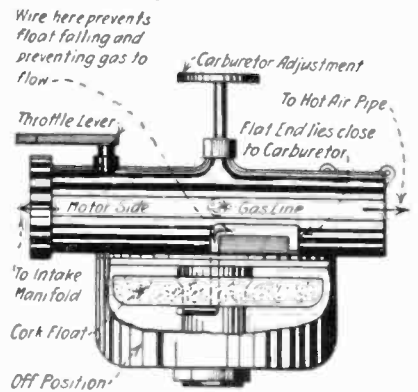

Here end of wire drops over edge of bowl and prevents jarring into off position.

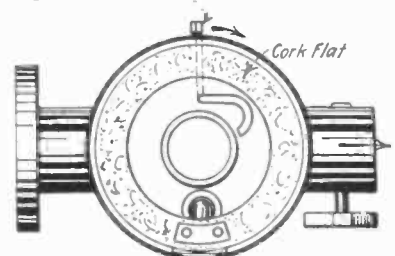

A Simple Carburetor Lock Made from a Piece of Wire, Bent so that when Lifted and Turned Back it Holds the Cork Float in the "Off" Position, thus Keeping the Needle Valve Closed.

# Practical Chemical Experiments

By Prof. FLOYD L. DARROW

QUALITATIVE ANALYSIS—SECOND PAPER

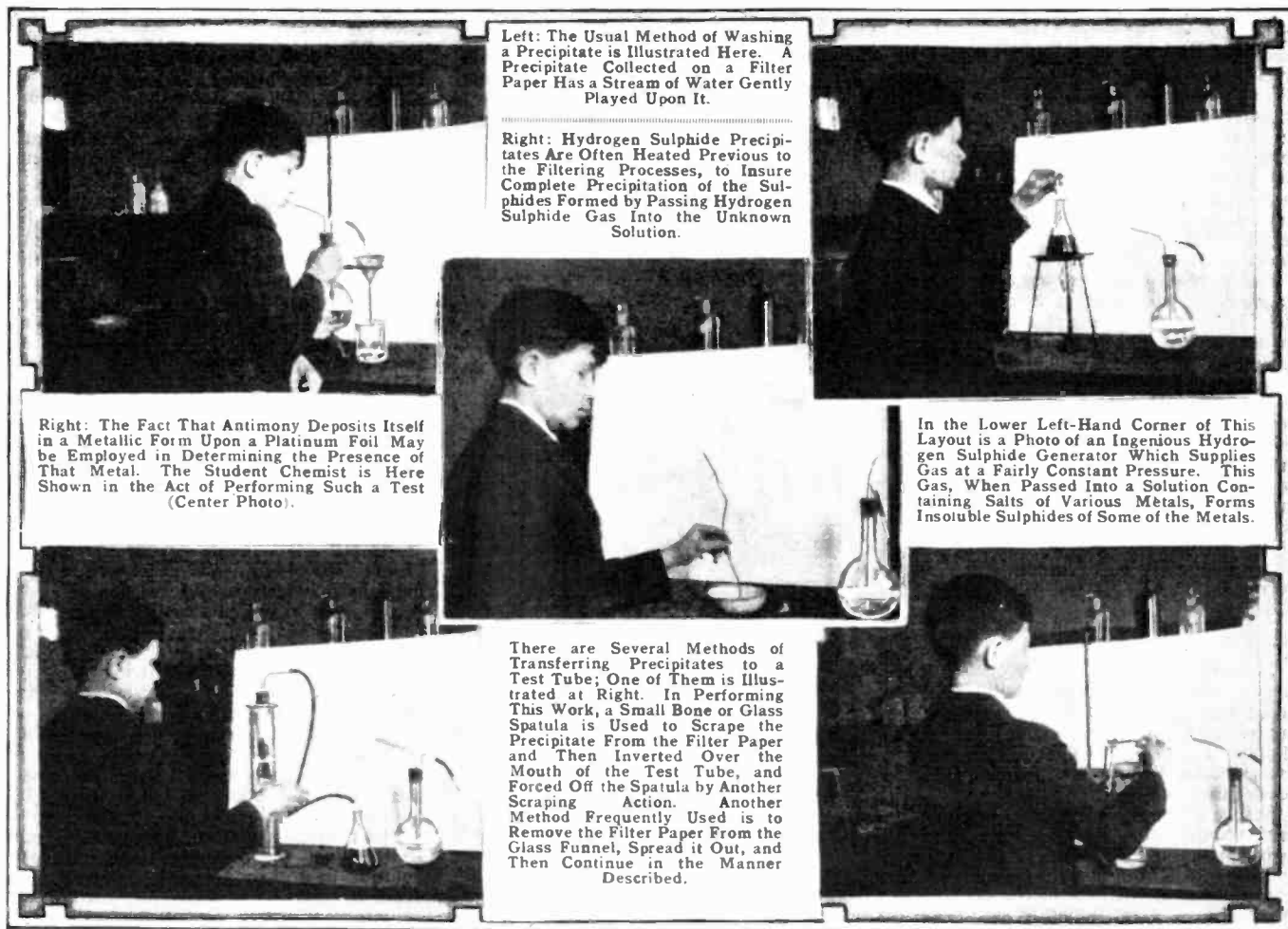

**I**N the last article we had just finished the preliminary experiments on the metals of Group I and were ready for their systematic separation.

*Analysis:* In an Erlenmeyer flask or beaker place a mixture of 10cc. each of solutions of silver, mercurous and lead nitrates. Add dilute hydrochloric acid until upon vigorous shaking or stirring no further precipitation occurs. The white precipitate is a mixture of the chlorides of these metals.

The next step is to filter, catching the filtrate in a clean beaker. This filtering may be done with or without suction. Test the filtrate for complete precipitation by adding a drop of hydrochloric acid. No precipitate should form. If one should form, however, it shows that not enough of the group reagent, *i.e.*, hydrochloric acid, was added the first time, and it will be necessary to add more and refilter, using the same filter as before.

Wash the precipitate on the filter by pouring *cold* water thru it. Usually hot water would be used, but you will recall that lead chloride is soluble in hot water. Fill the filter with water and allow it to run completely thru. Then repeat once.

*Lead:* Taking advantage of the fact that lead chloride is soluble in hot water, heat about 5cc. of water to boiling and pour it thru the precipitate.

Right here we might in passing point out that Qualitative Analysis is largely a matter of differences of solubility. It has been one of the chief duties of the chemist to determine these differences, and then embody them in a systematic procedure for

the separation of the metals. Of course the identification of a particular element depends, after some compound of it has been separated, upon a characteristic test.

The hot water will in this case dissolve the lead chloride, but not the silver and mercurous chlorides. The filtrate, which should have been caught in a clean test tube, is divided into two portions. To one of them add dilute sulfuric acid and a white precipitate of lead sulphate will form. At this point nothing but lead could be present in the filtrate which you have obtained by pouring hot water thru the precipitation.

It is worth while to see just why this is true. To begin with hydrochloric acid will precipitate only silver, mercurous and lead chlorides. Even if salts of all the other metals had been present in the mixture that you took, none of the other chlorides would have been precipitated, for the simple reason that only silver, mercurous and lead chlorides are insoluble. Then of these three chlorides only lead chloride is soluble in hot water. So you see every other metal would be excluded. Peculiar, isn't it, that a metal may be thus run down?

Now, if you have not forgotten that you still have another portion of the filtrate produced by passing hot water thru the precipitates, add to it a few drops of a solution of potassium chromate or potassium dichromate, sometimes called bichromate, and you will obtain a heavy precipitate of lead chromate, usually called *chrome yellow* and an important pigment.

In an unknown solution these precipi-

tates are perfectly conclusive of the presence of lead. Since lead chloride, however, is somewhat soluble even in cold water, lead will also be found in the second group, as you will see.

*Silver:* Before proceeding to separate the silver and test for it, you must remove all of the lead chloride from the precipitate remaining on the filter paper by repeatedly pouring hot water thru it. Continue to wash the precipitate until the washings give no reaction with potassium dichromate. The washings may be thrown away.

Now pour over the precipitate remaining on the filter 2 or 3 cc. of ammonium hydroxide thoroughly moistening it. To the filtrate add dilute nitric acid until an acid reaction is obtained with litmus paper. A white precipitate of silver chloride will appear upon the addition of the acid. This is the proof of the presence of silver.

What has happened is this: The ammonium hydroxide dissolves the silver chloride, but not the mercurous chloride, another difference of solubilities. But the double compound of silver chloride and ammonia, which forms and passes thru into the filtrate, is easily broken up by the nitric acid with the consequent precipitation of silver chloride.

*Mercurous Mercury:* We speak of mercurous mercury, because, as has already been pointed out, mercury forms two series of salts, mercurous and mercuric. Mercuric chloride had it been present, as it might be, would not appear here because, unlike mercurous chloride, it is soluble. It must be looked for in the next group.



At the same time that you poured ammonium hydroxide thru the filter, you observed that the residue turned black. This is due to a complex combination between the mercurous chloride and the ammonia, and is usually taken as sufficient proof of the presence of mercurous mercury.

To be perfectly sure make a hole in the bottom of the filter and rinse the black precipitate into a test tube. Allow the precipitate to settle. Then decant, *i. e.*, pour off, the liquid as completely as possible. Dissolve the precipitate by boiling in a very little aqua regia, a mixture of three parts of concentrated hydrochloric acid to one part of concentrated nitric. Dilute the solution with an equal volume of water and test it for mercury by adding a solution of stannous chloride. The mercuric chloride, which has formed by the solution in aqua regia, will be reduced by the stannous chloride first to mercurous chloride and then to metallic mercury, if enough of the reagent is added. A gray precipitate will appear. This is conclusive proof of the presence of mercury.

At this point it will be excellent practice to have some friends prepare an unknown solution containing some or all of the metals of Group I, which you will analyze. At first liberal quantities of each salt should be added followed by unknowns containing much smaller quantities. In this way you acquire experience in manipulation and procedure and, most important of all, sharpen your powers of observation.

## GROUP II

This is known as the Hydrogen Sulfide Group, because hydrogen sulfide is the group reagent. Altho this is a foul smelling gas, you will soon become used to it. Its odor is never absent from the qualitative laboratory and no chemist feels at home in its absence.

Before proceeding with this group, your first requirement will be some sort of hydrogen sulfide generator. An ordinary hydrogen generator may be employed, but it is not automatic. A better one can be made from a large mouthed bottle and a lamp chimney, as shown in Figure 1. The chimney must be able to fit inside the neck of the bottle. Into the constriction in the chimney fit a perforated lead disc to support the iron sulfide. In the top insert a one-hole rubber stopper carrying a glass elbow tube. About an inch from the top of the chimney place a support made by twisting together two pieces of heavy aluminum wire and projecting so as to catch on the edge of the bottle. Attach to the elbow tube a length of rubber tubing and glass delivery tube. To regulate the flow of gas the rubber tubing must carry a pinch cock.

To charge the generator place lumps of ferrous sulfide upon the lead disc until the chimney is two-thirds filled. Put dilute sulphuric acid into the bottle until it is somewhat more than half full; upon opening the pinch-cock the acid will rise until it reaches the iron sulfide. It will then begin to generate hydrogen sulfide gas and push the air from the chimney above. When the pinch cock is closed, the gas exerting pressure downward will force the acid from the chimney and stop the action. The action is sometimes slow in starting,

but when once going you will never lack for a supply of the reagent.

This group is divided into two sub-groups.

**Sub-Group A:** The metals of this group are mercuric mercury, lead, bismuth, copper, and cadmium. The sulfides of these metals are insoluble in a reagent known as *yellow ammonium sulfide*.

**Sub-Group B:** To this group belong arsenic, antimony, tin, gold and platinum. The sulfides of these metals are soluble in yellow ammonium sulfide, but are reprecipitated as sulfides upon the addition of dilute hydrochloric acid to the solution.

The metals of both sub-groups form sulfides with hydrogen sulfide which are insoluble in cold dilute acids. And it is

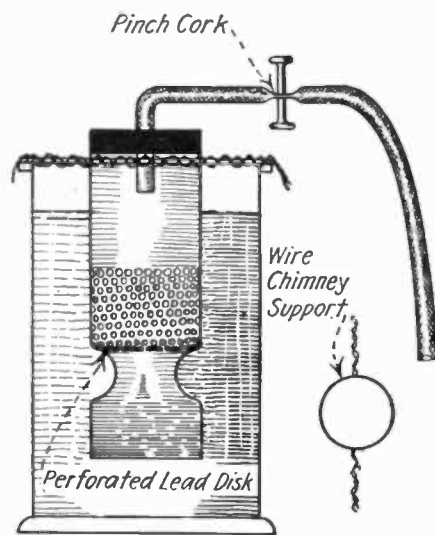

Home-Made Sulfide Generator Made from a Glass Lamp Chimney and a Large Mouthed Bottle. A Perforated Lead Disc Is Placed Inside the Lamp Chimney. Fig. 1.

this insolubility that puts them in a group by themselves. Taking copper sulfate as an example you will observe from the following equation,



that in the precipitation of the metallic sulfide an acid also is set free, sulfuric acid in this case. Now the sulfides of the metals of this group are insoluble in the acids formed at the time of their precipitation. Other metallic sulfides cannot be precipitated by hydrogen sulfide, because while many of them are insoluble in water they will not precipitate in the presence of the acid that would be set free at the same time. Again we see that it is differences in solubility that determines the grouping of the metals.

**Yellow Ammonium Sulfide:** This reagent is prepared by bubbling a slow stream of hydrogen sulfide thru a tall cylinder or bottle of strong ammonia water for some time, *i. e.*, until a distinct yellow tinge appears. Then dissolve in it a considerable quantity of powdered sulfur. This gives a decidedly yellow solution having the formula  $(\text{NH}_4)_2\text{S}_x$ . The  $x$  stands for any amount of sulfur required in a chemical reaction.

## PRELIMINARY EXPERIMENTS— (Sub-Group A)

**Mercuric Mercury:** Into 10 cc. of a dilute solution of mercuric chloride (corrosive sublimate) pass a slow stream of hydrogen sulfide as long as a color change appears in the precipitate. Warm the contents of the test tube or flask and allow the precipitate to settle. Pour off the clear liquid and wash three or four times by decantation, *i. e.*, by pouring in cold water, shaking, allowing to settle and then decanting the wash water.

The black precipitate is mercuric sulfide. Just as the compound of mercurous chloride and ammonia was dissolved in aqua regia, so may this be. Dissolve it in a very little boiling aqua regia, cool the solution and add stannous chloride. As before a grayish precipitate of metallic mercury will form.

**Lead:** Warm 10 cc. of a solution of lead chloride made by shaking the salt with cold water for some time. As already stated lead chloride is slightly soluble in cold water. Into the warmed solution pass hydrogen sulphide as long as a precipitate seems to form. Allow the lead sulfide to settle, decant, wash, and boil with 1 cc. of dilute nitric acid. Add a few drops of ammonia hydroxide and then potassium dichromate. A yellow precipitate of lead chromate will form.

**Bismuth:** In preparing your solution of bismuth chloride a white precipitate of bismuth-oxy-chloride may form but this will do no harm. Into 10 cc. of the warmed solution pass hydrogen sulfide. Allow the precipitate of bismuth sulfide to settle, decant, wash and boil with 1 cc. of dilute nitric acid. To the solution of bismuth nitrate add two or three drops of dilute sulphuric acid and then ammonium hydroxide. The precipitate that forms is a basic oxide of bismuth. Filter and wash the precipitate upon the filter paper by pouring water thru it once. Allow three or four drops of dilute hydrochloric acid to fall upon the precipitate and catch the solution in a clean test tube. To this add from 10 to 20 cc. of water and a white precipitate of bismuth oxychloride will form.

**Copper:** Subject 10 cc. of a dilute solution of copper sulphate to exactly the same treatment as was given the solution of bismuth. Upon the addition of ammonium hydroxide to the clear solution a beautiful deep blue color will appear, even if only traces of copper are present. This is taken as proof of the presence of copper.

**Cadmium:** Precipitate cadmium sulfide in the usual way. Filter and wash the precipitate upon the filter once or twice. Then make a hole in the bottom of the filter paper and wash the precipitate thru with the least possible amount of dilute nitric acid. Boil the mixture and to the solution of cadmium nitrate thus produced add two or three drops of dilute sulphuric acid followed with enough ammonium hydroxide to give an alkaline reaction. Now add hydrochloric acid until an acid reaction occurs and then a pinch of iron filings. Boil for a short time and then pass hydrogen sulfide into the solution. A yellow precipitate of cadmium sulfide will appear.

In the next article we shall take up the systematic analysis of the metals of Group II.

(To be continued in next issue.)

## Atoms Not Alike, Says Prof. Harkins

The first successful experiments in splitting up a chemical element into two weighable portions which have different properties have been reported by Prof. William D. Harkins, of the department of chemistry of the University of Chicago.

"What we have considered elements are not actually elementary," says Prof. Harkins. "For more than a hundred years it has been considered that all of the

atoms of a single element are exactly alike. It is now found that most elements consist of two or more—usually not more than seven—different kinds of atoms. Each of the species or kinds of atoms which make up a single element is called an 'isotope,' which means that it acts exactly like all of the other species of atoms which constitute the same element.

"Thus lead, considered to be an ele-

ment, is found to consist of isotopes which act almost exactly like ordinary lead, and are only appreciably different in that their atoms are heavier or lighter than the average weight of an atom of ordinary lead. That lead consists of isotopes whose atoms weigh 206, 208, 210, 212 and 214 was first recognized by the English chemist, Soddy, nearly ten years

(Continued on page 172)

# Experimental Electro-Chemistry

By RAYMOND B. WAILES

NO. 2—PROPERTIES OF IONS: DEGREE OF DISSOCIATION

THE presence of ions in a liquid results in that liquid being capable of conducting an electric current. Such a substance as sodium chloride (common table salt), in the dry or solid form is devoid of ions. Pure water is devoid of ions, but if the salt and the water are mixed, or the salt dissolved in the water, ions of sodium and chlorine are

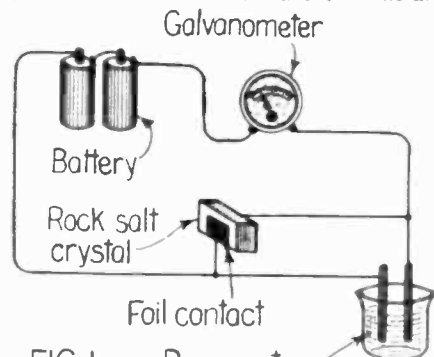

FIG. 1 Pure water

Electrolytes Conduct Electricity Because of the Ions Which They Contain. Pure Water and Salt Contain no Ions but When Mixed, Ions Are Formed. Water is Necessary for Ionization.

formed, and the resulting sodium chloride solution or electrolyte will readily pass an electric current.

A battery and an indicating instrument such as a galvanometer or sensitive ammeter is connected as shown in figure 1, with electrodes which are immersed in distilled (or rain) water. Wires connecting the electrodes with tin foil strips attached to the surface of the crystal of rock salt (sodium chloride) are also included in the circuit. Under the above conditions, the indicating instrument will not respond to the local battery for no current flows thru the circuit. This is because the liquid and the crystal are devoid of ions. Now, if the crystal of rock salt be dissolved in the water, ions will be formed, and the liquid will be rendered conductive.

Certain substances ionize (the act of yielding ions) or produce more ions than other substances. Figure 2 shows an apparatus set up which will readily bring home this fact. Three glass tubes A, B and C are cork stoppered at each end. At S short metal electrodes are thrust thru. At the other end of the glass tubes and thru the corks movable wire electrodes are inserted. These movable electrodes, ME, should be capable of being inserted thruout the length of the glass tubes. Small flashlight battery lamps, L, are connected in series with each glass tube as shown. The entire three lamps with their tubes are then connected

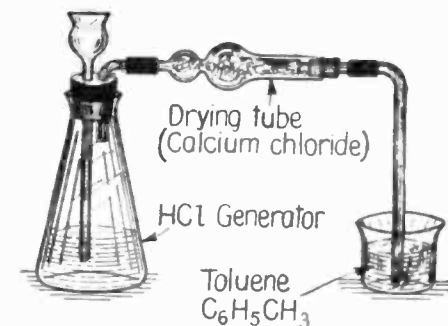

FIG. 3

Hydrochloric Acid Gas Dissolved in Toluene (Toluol) Will Not Form an Electrolyte.

in parallel, the whole being fed by a storage battery as indicated.

The glass tubes A, B and C should be filled with the following solutions respectively:

Tube A, concentrated hydrochloric acid, 18 grams to 500cc water.

Tube B, 24.5 grams of strong sulphuric acid dissolved in 500cc of water.

Tube C, 15 grams of 99 per cent. acetic acid dissolved in 500cc of water.

Each of the above solutions contains one gram equivalent of replaceable hydrogen, and are called normal solutions. They contain 1.008 grams of such hydrogen per liter.

Substances (such as normal solutions) which contain the same weight of hydrogen atoms do not always possess the same properties. The property of dissociation, or the splitting up of molecules to form ions, for instance, varies widely among different acids or solutions of normal strength. Because of this variation of dissociation, the electrical conductivity

of the needle will swing away from the zero point to a greater distance with hydrochloric acid than it will with acetic acid.

Pure water does not conduct an electric current. The chemical formula for water

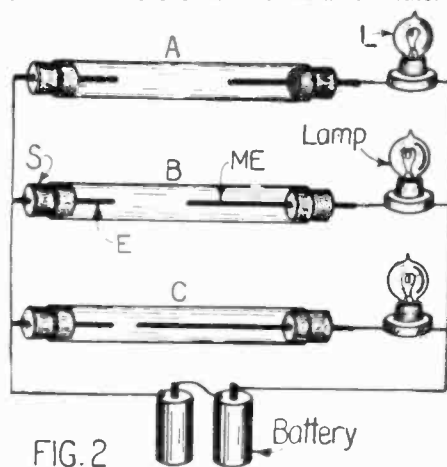
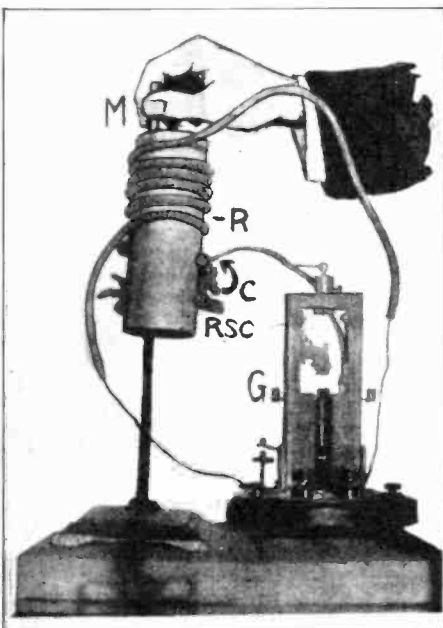

FIG. 2

The Electrical Conductivity of Electrolytes is Governed by the Degree of Ionization. Each Lamp Burns at a Different Brilliancy With Different Electrolytes in the Successive Tubes A, B and C.

is H<sub>2</sub>O. Hydrogen atoms are present, but hydrogen ions are not. This is the reason why pure water does not conduct an electric current. It is the ion which transports the electric current.

All acids ionize and all acids contain hydrogen ions. Hydrochloric acid is really hydrochloric acid gas dissolved in water. The pure dry gas does not conduct electricity, as can be shown by the following experiment. Hydrochloric acid gas is generated (fig. 3), passed thru a tube of calcium chloride to dry it and then passed into dry toluene (toluol). The gas will dissolve, but the resulting liquid will not conduct an electric current for the hydrogen atoms of the hydrochloric acid have not yet developed hydrogen ions. The liquid immediately conducts electricity upon the addition of water to it. The generating flask should contain 25 grams of sodium chloride and 50cc of sulphuric acid. Care should be taken to keep the battery jar or electrolyzing vessel containing the toluene at a distance from the gas generator, for toluene is inflammable. The toluene used should be water free, which can be accomplished by shaking with calcium chloride. Water, then, is necessary for ionization.



An Interesting Experiment With a Solenoid Made from a Rubber or Glass Tube Coiled Around a Drum. An Electrolyte Fills the Tube and is Connected with a Galvanometer. A Magnet Plunged Into the Solenoid Causes a Current to Flow.

varies so that with the apparatus set up as shown in figure 2, the lamps will light equally as bright only after adjusting the movable electrodes, ME. It will be found, that, with the movable electrodes pushed into the tubes and offering equal surface exposure, or with the same length of electrode surface in the solutions, the lamps will glow with varying brilliancy. It can be seen that hydrochloric acid conducts the current the best, sulphuric acid next, while acetic acid conducts the current but poorly. The cause of this is the degree of ionization. Altho the same weight of replaceable hydrogen atoms present in each tube (for all acids contain hydrogen atoms), there are not the same number of hydrogen ions (and it is the ions which conduct the current) present, because the different molecules do not split apart or ionize to the same degree. Instead of lamps, a milliammeter can be inserted in each branch of the circuit and the deviation or deflection noted. Using this instrument,

Electrolytes Behave Similar to Metallic Conductors

Because an electrolyte is a liquid and conducts electricity, a natural question to be asked would be, "Does it behave similarly to a solid or metallic conductor?"

(Continued on page 166)

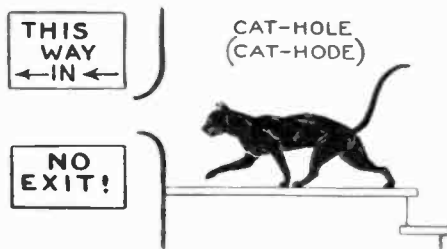

Have Trouble in Distinguishing Between Cathode and Anode, Cation and Anion? This Little Ditty will Enlighten and Refresh Your Memory.





# THE CONSTRUCTOR

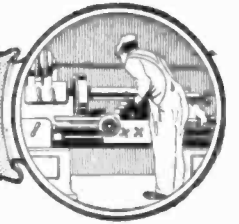

## Building a Double Neck Harp-Guitar

By C. L. EDWARDS

**T**HE following description explains the correct way to assemble the parts of the Harp-Guitar shown in the drawings and, in addition, describes the general process of Musical Instrument Building so that any Regular Guitar, Lyre-Guitar, Bass Guitar, Mandolin, Zither, Lute, Ukulele, Autoharp, Celestaphone, or Guitar-Mandolin, can be easily assembled, as the methods of bending wood, gluing, clamping, purfling, inlaying, etc., are practically the same, and the various clamps, forms, etc., can be easily designed for each instrument.

In general tops or sounding boards are made of spruce or clear Northern pine.

Sides, backs, necks, fingerboards, etc., are generally made of rosewood, cherry, mahogany, walnut, birch, maple or similar woods.

Fingerboards are generally dark to show frets and position marks better.

Bridges, frets and string nuts can be made of metal, bone, hard wood, ivory, etc.

Always use first quality, well seasoned stock.

Hard wood string nuts and bridge and metal frets are recommended for the harp-guitar.

Cross braces and blocks are made of hard or soft wood to suit the instrument according to the strain they have to withstand.

Celluloid, ivory, pearl, metals and fancy woods are used for ornamental work.

All these supplies can be obtained from wood mills doing cabinet work.

### Gluing Directions

Never use fish glue or any kind of prepared glue, always use the best cabinet makers' glue freshly prepared. Keep the glue pot clean. Try test pieces. No. 21, often. Do all your gluing in a place that is both warm and dry: never glue cold or moist pieces. When heating wood pieces have the heat strike equally on all sides to prevent warping. Don't try to work upon a piece while glue is drying.

When gluing two parts together, put the glue on the cooler part, but have both warm. Slightly roughen the surfaces to be glued. Fill the pores of end grains with thin glue; let this dry, and scrape smooth before applying the regular glue. Clean off the surplus glue and any that oozes from between the joints at once with a damp cloth or scrape smooth when dry.

### Assembling Directions

Top No. 1 and back No. 5 are shown only a little past the center line. The other side, not shown, is precisely the same.

Have flat boards about  $\frac{1}{4}$  inch thick with one straight edge. Lay drawings of top No. 1 on one of the boards with center line on the straight edge. Cut the board to outline of top No. 1. Do not cut out sound hole. Make four of these. They are to be called "Patterns".

Using the first pattern lay out body form No. 17, the pattern forms the inside line of the body form. This work had better be done on a band saw to keep sides square.

It is best to make the body form of several thin boards laid with the grains crossing and glued together.

The top No. 1, back No. 5 and sides No. 14 can be made 3-16 inch thick.

Staining, if needed, should be done, wherever possible after the final smoothing of the wood. If the grain of the wood rises, smooth down again.

When clamping or holding work always use pads of some kind to prevent bruising it. To prevent drying glue from sticking to whatever it is resting upon, put paper between work and the gripping device or table and scrape the paper off when the glue is dry.

Make two sides No. 14, the head block No. 6; the latter to be  $4\frac{1}{2}$  inches deep and of tough hard wood; made tail block No. 7,  $5\frac{1}{4}$  inches deep and of hard wood; make cross braces C, D, E, F, G on top No. 1 and H, I, J, K, and center strip No. 9 on back No. 5, also of maple or other hard wood. Cross braces C, D, E, G, I are  $\frac{1}{2}$  oval in cross section, gradually thickening towards center, tapering suddenly to knife edge at ends. Braces F, H, J, K and center strip No. 9 are flat and of the same thickness along their entire length.

Center strip No. 9 is not used where back No. 5 can be made in one piece.

Make about 40 clamps like No. 16; then procure about 80 spring clothes pins, and a piece of iron pipe with thick sides about 4 inch-6 inch diameter and 12 inch long. Have outside of pipe clean.

Make bending blocks No. 18 and cross brace of any wood.

Make two string nuts No. 12 and bridge No. 3 of very hard wood and then right and left necks No. 10 including heels; make finger boards No. 11 without frets and plates No. 13; make plates and finger boards a little longer and wider than shown.

Make top No. 1 of one piece if possible, otherwise of two pieces glued in center. Let the edges extend  $\frac{1}{4}$  inch beyond drawing. Glue cross braces in place, using weights or other means to hold the braces in place while drying.

Make back No. 5 in a similar way, let edges project  $\frac{1}{4}$  inch, only do not glue cross braces in place until the back has been heated to a very high temperature so that it is hot clear thru and very dry, then still keeping it at this temperature, glue cross braces in position, keeping it at the same temperature until glue is dry. A small room heated excessively is a good place for this. When cross braces are fast, remove from the heat. Moisture will re-enter the wood and swell it sideways; it cannot swell on the side upon which the cross braces are located, but will do so on the other side, thus curving the whole back, and giving it a better appearance and tone. Now glue No. 9 between braces.

The back can be bowed also by making the cross braces thicker, cutting them to required curve and gluing them to the back. This makes a heavier construction, but obviates the excessive heating required in the other method.

Screw body form No. 17 together, leaving about a  $\frac{1}{8}$ " gap at each end. Now measure the inside of the body form from

end to end by a thin flexible strip or shim. Cut sides No. 14 to this length.

Heat the piece of iron pipe until it will almost scorch thin soft wood. Moisten the piece that is to be the inside of one side No. 14, roll the moistened part on the hot pipe until it is flexible, then put in place in the body form, it must touch the body form along its full length, use clamps if necessary.

Treat the other No. 14 in the same way, put bending blocks No. 18 and cross brace in position and screw ends of body form together until ends of sides No. 14 butt together tightly.

Glue head block No. 6 and tail block No. 7 in place, let them project beyond sides at each edge, glue gluing strips No. 8 in place, holding with spring clothes pins, then carefully level tops of gluing strips and sides, lay top No. 1 and back No. 5 in place, if cross braces touch gluing strips, trim braces off.

Take pieces of strong closely woven tape about  $\frac{1}{2}$  inch or  $\frac{3}{8}$  inch wide and glue across sides and over gluing strips. Place about 3 inches apart. These are No. 22.

Lay the back No. 5 in position, mark where inside of gluing strips comes. Varnish or shellac inside of back, but do not put any glue on the place where the back glues to the gluing strips or sides.

Glue top No. 1 in position by putting two patterns over the top and two on the opposite side to prevent bruising wood of top and sides. Fasten with clamps No. 16, then varnish or shellac the sides and top on the inside, first removing bending blocks and replacing with a stick, remove all loose pieces from sides or top, replace bending blocks, and fasten back in same way, or the process can be reversed and top put on last.

Take out bending blocks and cross brace thru sound hole, trim projecting edges of top and back, cutting dove-tails for necks so that the necks are flush with the top No. 1 and 5 inches apart, center to center at ends.

Take the fret scale No. 15, if it is longer than dimension, put in a hot, dry place until it shrinks, if too short, put in a moist place, when right, put on finger board with end touching front of string nut. The 12th fret should be over where the center line of necks meets body line; the body is the assembled top, sides, and back. Carefully mark positions; make saw cuts narrower than frets; hit bottom of frets on edges with corner of chisel to make little projections that will grip the wood, then hammer them into saw cuts with some soft material, do not drive in from the end.

Another way is to make saw cuts wider than frets and fasten with shellac.

Make some kind of a head-brace; now glue the neck to the body and the projecting end of finger boards to top by taking any kind of a clamp that will reach one arm thru the sound hole and press against the under side of top, the other arm pressing down on the finger board to hold it tightly against the top; put head brace in at this time. This should be mortised and glued to necks.

A filler strip of some ornamental material is fitted and an end peg put in place.

(Continued on page 164)

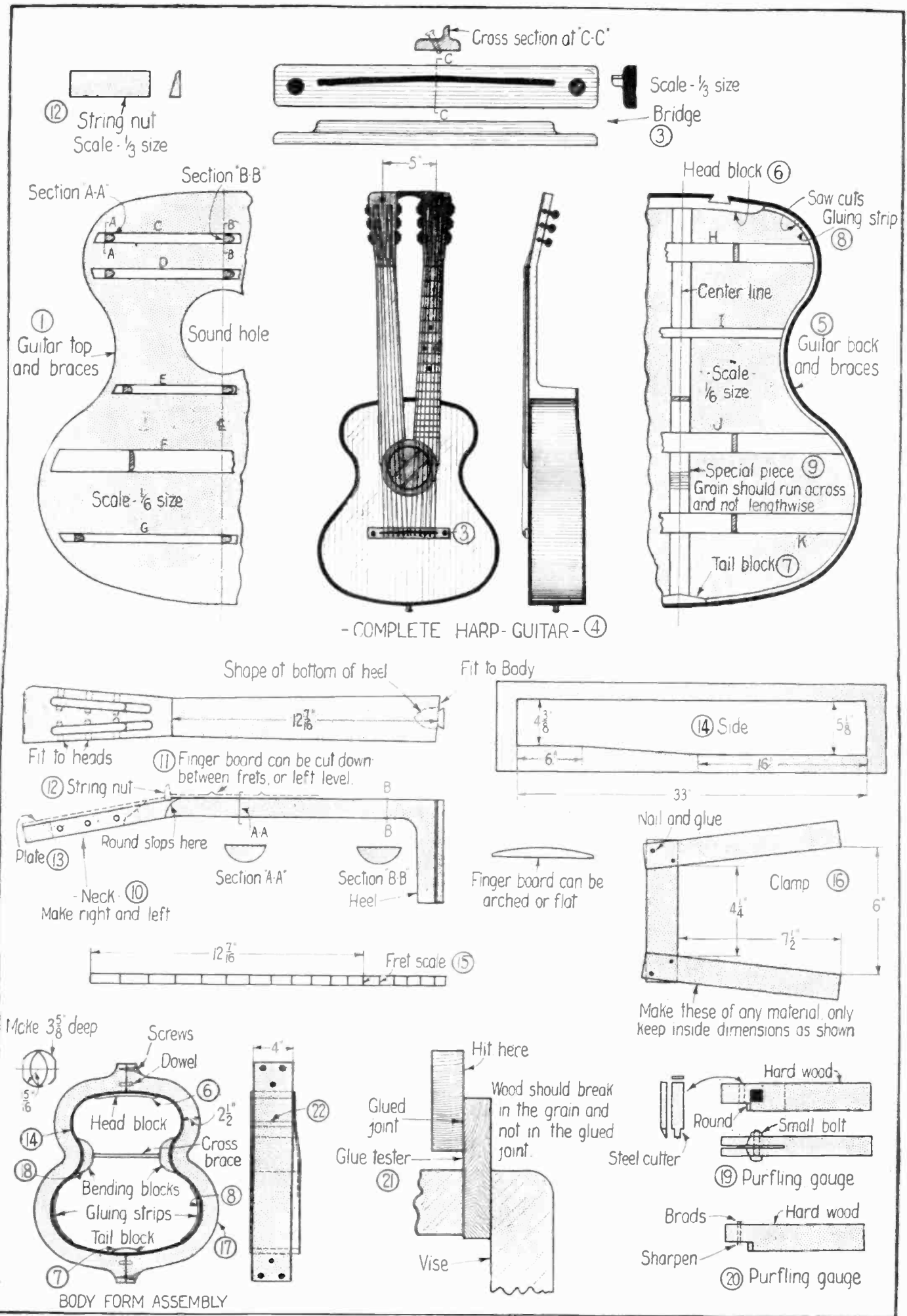

The Accompanying Article and the Illustration Above Explains the Details for Building a Double Neck Guitar.

© 1922 by Science and Invention



# Polariscope Made From a Microscope

By DR. ERNEST BADE

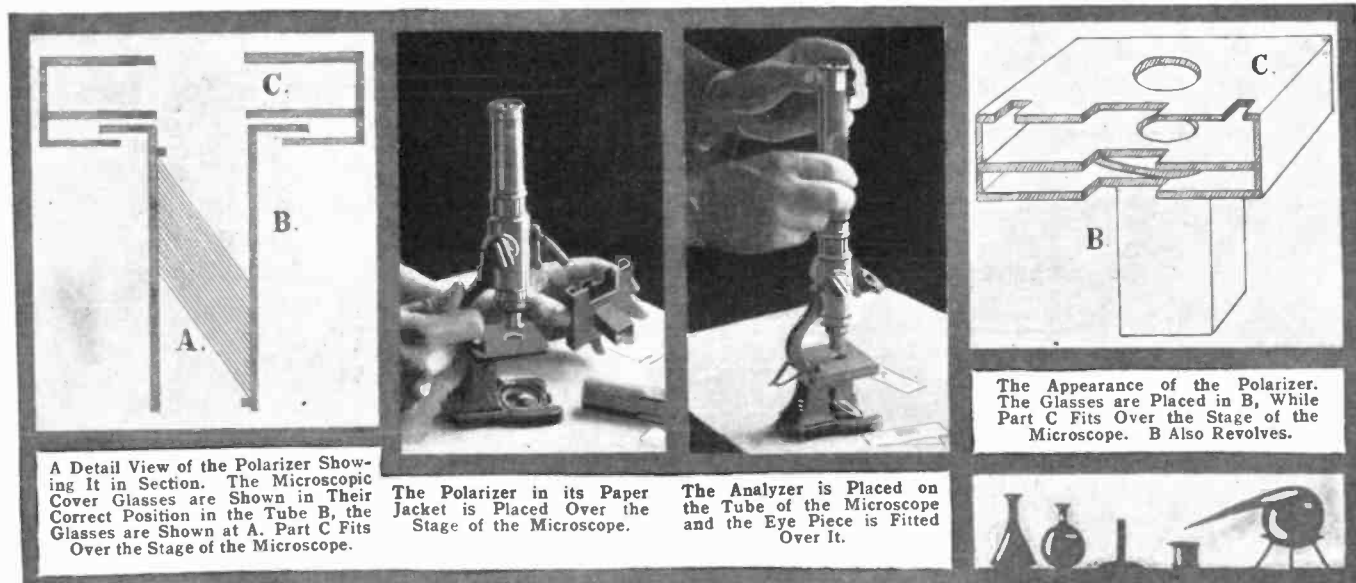

A Detail View of the Polarizer Showing It in Section. The Microscopic Cover Glasses are Shown in Their Correct Position in the Tube B, the Glasses are Shown at A. Part C Fits Over the Stage of the Microscope.

The Polarizer in its Paper Jacket is Placed Over the Stage of the Microscope.

The Analyzer is Placed on the Tube of the Microscope and the Eye Piece is Fitted Over It.

The Appearance of the Polarizer. The Glasses are Placed in B, While Part C Fits Over the Stage of the Microscope. B Also Revolves.

**T**HE flaming hues of the rainbow, hidden in the commonest chemical salts and substances, stand revealed in the *polariscope*, an instrument which resolves ordinary waves of light into oscillations in one direction or plane. Its action is like a grating which screens a beam of light so that only those rays the plane of whose waves are parallel with it, can pass, while all others are reflected to one side. If two such gratings are used, and if they are both parallel, light will pass, but if one is vertical to the other, it is extinguished.

In order to examine an object by polarized light, it becomes necessary to employ two such gratings, one for the polarizer and the other for the analyzer. The former is inserted below the object and the latter above it. A perfect prism of Iceland spar (Calcite) is usually employed, but two bundles of thin glass plates, such as microscopic cover glasses, answer the purpose just as well. One bundle is inserted just below the stage of the microscope which polarizes the light rays by reflection. The other bundle, which is the analyzer, is placed on the tube of the microscope with the eyepiece on top of it, and transmits the light.

When the polarizer and analyzer are parallel and a double refracting crystal is

placed on the stage of the microscope, the background and the crystal will both be illuminated; turning either the polarizer or the analyzer thru an angle of 45 degrees causes the background to be darkened, due to the extinguishing of the light waves. But the light passing thru the crystal will be made to vibrate in a different plane; its plane of polarization will be rotated. This prevents the complete extinction of the beam of light by the analyzer and results in a most gorgeous color display.

The materials necessary for changing the microscope into a polariscope are a few pieces of cardboard, some glue, and half an ounce of microscopic cover glasses. The glasses should be rectangular, dimensions of  $\frac{3}{4}$  by 1 inch are satisfactory. Eighteen of these are carefully cleaned with a dry and soft piece of linen—all those which are not perfectly clean and free from specks are worthless—and placed in a cardboard tube  $1\frac{1}{4}$  inches in length. Here they must make an angle of 35 degrees with the axis of the tube.

To hold this rectangular tube in position under the stage, a jacket of cardboard is made which fits snugly about the stage. In order to make it possible to turn the lower tube on its axis, which is a necessity, a cardboard collar is attached to the tube. Below this flange is another collar,

and this is glued to the jacket which prevents it from falling out. In this way the polarizer is made revolvable.

The analyzer tube is made exactly like the polarizer, but this tube is held within another, which is snugly fitted over the tubing of the microscope. Above the analyzer is a short tube into which the eyepiece can be slipped.

The most important requirement now to be fulfilled is good illumination. This can easily be obtained when it is remembered that light diminishes with the square of the distance. A weak source of light, a short distance from the microscope, together with a bulls-eye condenser—a double convex lens—can, under these conditions, be used.

It is also advisable to employ small magnifications. The lower the diameter, the brighter will the view be. Crystals seldom require more than a hundred diameters, while fifty may be more than sufficient. With the aid of a substage condenser it is possible to enlarge 500 times.

For bringing out various color effects it is advantageous to place a thin piece of mica on the object. To obtain the greatest possible variety of colorations, those of different thicknesses should be employed and only those used which exhibit even

(Continued on page 201)

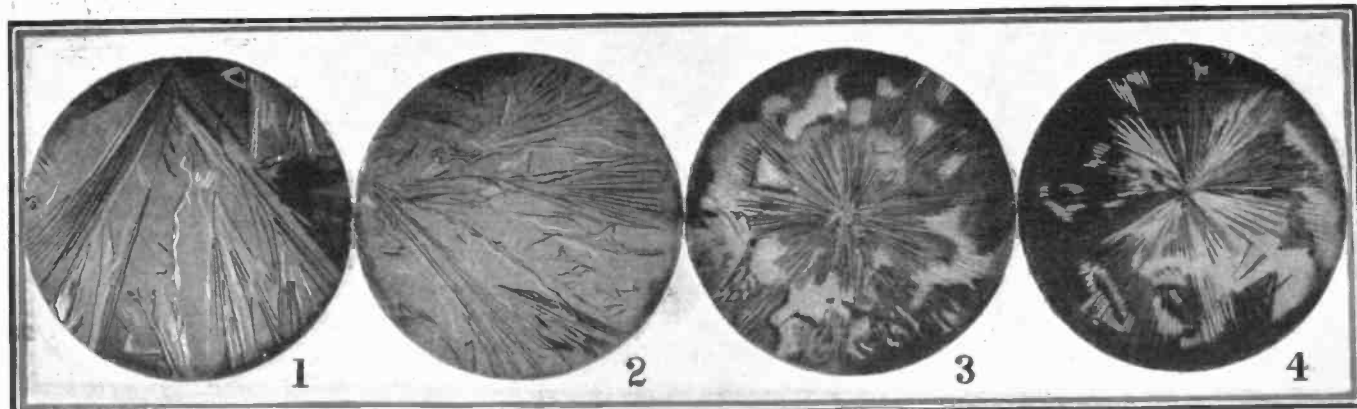

Tartaric Acid Shows a Wealth of Detail and Color in Their Crystal Skeleton When the Analyzer and the Polarizer are Crossed.

Tartaric Acid Shows an Imperfect Crystal Skeleton under the Microscope, When the Analyzer and the Polarizer are Parallel.

Aluminum Chloride with Analyzer and Polarizer Parallel Simply Shows the Details of the Crystal.

Aluminum Chloride with Analyzer and Polarizer Crossed, Shows the Crystal Broken Up into a Maltese Cross with a Dark Background.

# Identifying Chemicals Under the Microscope

By DR. ERNEST BADE

SOME of the greatest of our industries are built around crystallizable and crystallized products, and the art of crystallization has already been brought to a fine degree of accuracy. The requirements are more exacting to-day than they were in former years. This is clearly shown in the present refinement of sugar. But the most precious gem material, such as tiny

exactly rare, are uncommon in Nature. Many disturbing factors are only too often encountered, which have reacted unfavorably in their production. One such factor, and an important one, is an excessively rapid deposition or growth. Under such a condition imperfect crystallization almost invariably occurs, and this usually shows itself in the direction of crystallization which is greatest in one plane.

as demanded by the six classes of crystal systems. For this reason the characteristic shape which a substance will assume under certain well established conditions, will always be the same for that salt.

In order to become familiar with the extraordinary beauty of salts crystallizing in a plane, it is only necessary to dissolve a very small quantity of the chemically pure salt in a drop of water. It is most

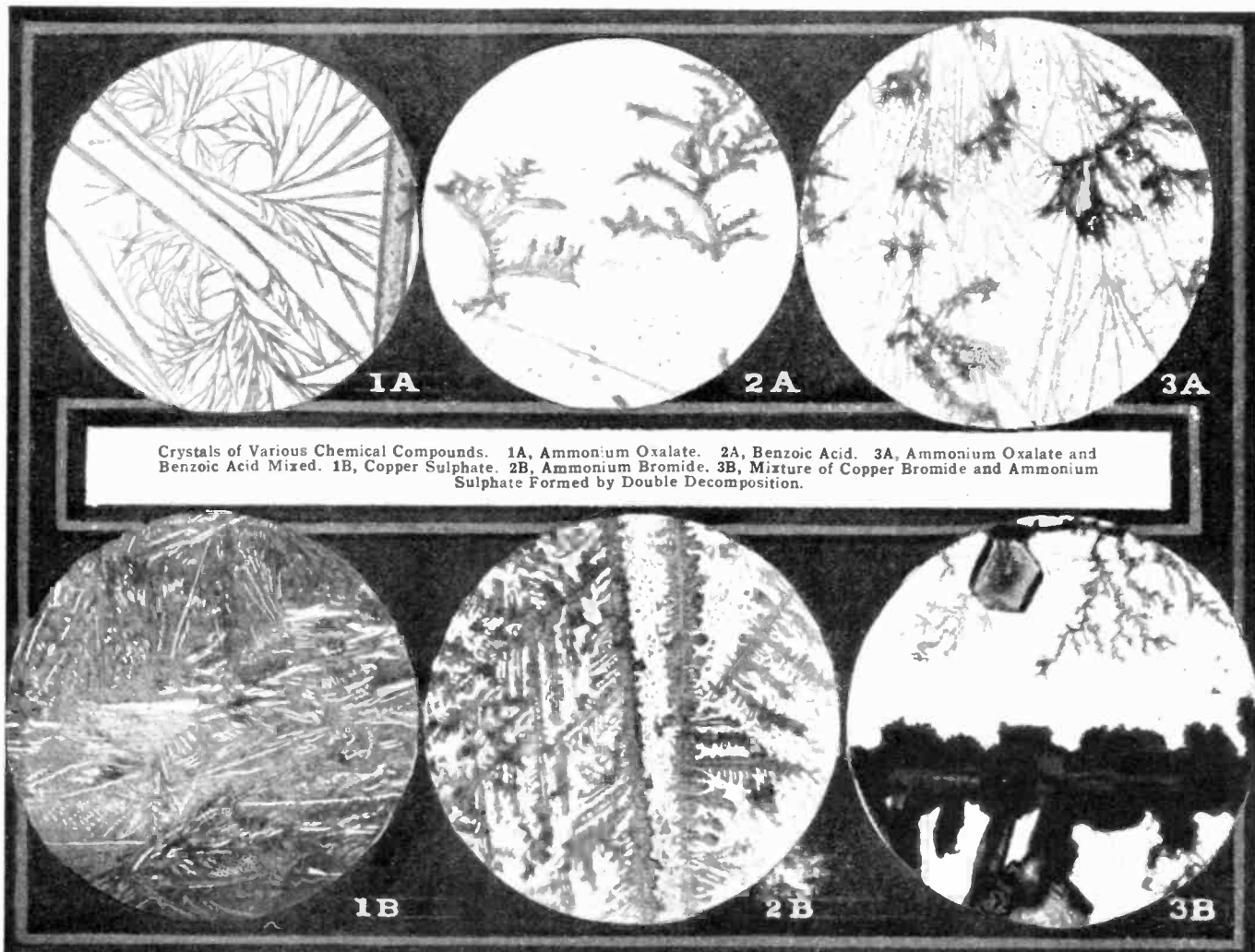

Crystals of Various Chemical Compounds. 1A, Ammonium Oxalate. 2A, Benzoic Acid. 3A, Ammonium Oxalate and Benzoic Acid Mixed. 1B, Copper Sulphate. 2B, Ammonium Bromide. 3B, Mixture of Copper Bromide and Ammonium Sulphate Formed by Double Decomposition.

diamonds, large rubies, etc., are also made to crystallize under artificial conditions in the laboratory.

But all these substances are three-dimensional, having very perceptible length, breadth and thickness. In this condition they assume a characteristic form if left uninfluenced by outside factors during the process of growth. Their shape is determined by the rate of growth and also by the way in which the molecules arrange themselves at that particular time. The slower this process the more perfect will the final crystal be, especially if undisturbed, since then the molecules arrange themselves evenly and continuously, altho not uniformly on all their faces. The law is that their shape, altho definite in a certain crystallizable substance, differs in different materials.

Perfect specimens of crystals, altho not

Here the predominant form of the crystal is not so prominently three-dimensional. Its main axis is along its length, and its second in its width, while its third axis, its height, which, of course, must be present, is almost infinitesimal as compared with the usual notion of crystal shape. These forms, so produced thru crystallization in one direction with excessive speed, show peculiar and wonderfully artistic designs. Some are barred, cross or star-shaped, while others are netted, arborescent or radiating and undulating in their form.

Altho the natural form of the substance is symmetrical, due to the peculiar arrangement of the particles, it is not constantly the same for each substance, since the plan of crystallization permits more or less variety in form. But these lie within certain well established limits

convenient to place a drop of the solvent upon the glass slide of the microscope, and then to drop into it a tiny fragment of the salt. A piece the size of a common pin head will usually be more than sufficient. Then place it where it will be warm, but not too hot, so that the water will evaporate slowly. Putting the slide with its contents in the direct rays of the sun will do the trick nicely. Should a microscope be unavailable, a high power hand lens will be found to give some good results, but it must at least enlarge 9 or 10 diameters.

With little difficulty three general types of crystallized substances will be found, one producing tiny crystals, which are more or less rare, and two more common types, one of which produces barred or starred forms, while the other produces

(Continued on page 202)



# Home-Made Electric Cooking Utensils

A HANDY and extremely valuable electric cooking device is the so-called electrically heated fireless cooker. A photograph of one of these cookers is reproduced herewith as well as a diagram showing how anyone in half an hour or so, can rig up a very satisfactory cooker of this type. All that is required is a tin or other container, such as a water pail for the inner compartment, while a somewhat larger container made of wood or other material is required, so as to leave a space between the two chambers of at least 3" all around. This space is then filled with hay, asbestos or mineral wool packed down with a stick to act as a heat insulator. Mineral wool or broken-up and well packed sheet asbestos will serve the purpose very well indeed. The corner which may be hinged or simply arranged to clamp on to the top of the cooker by means of a pair of hasps, should be of double construction, about 3" thick, the space being filled with the same heat insulating material as that used in the cooker itself. If this cover is simply made of wood an inch or so thick, then a pad filled with the heat insulating material employed and about 3" thick, is made so as to fit tightly into the top of the inner compartment in order to preserve all of the heat possible.

This cooker can be built in different sizes of course, the larger it is made the greater amount of heat required in order to start the vegetables and other foods cooking. The electric heating unit may be a sad iron turned upside down and placed at the bottom of the cooking chamber, or it may be one of the well-known electric

disk heaters, which come in several different sizes from a few hundred watts up to 1,500 watts consumption. Where the wires pass thru the heat insulating material, they may be carried thru a porcelain tube, packing this tube tightly between the wires with asbestos, etc. The principal thing to keep in mind is that the cooking chamber must be kept as nearly air tight as possible. This fireless cooker compartment may be used in the regular way, where the foods are heated up on the ordinary stove until the water boils thoroughly, and then placed in the cooker; or they can be heated electrically to the boiling point, usually requiring about twenty minutes to one-half hour, and the current is then turned off, when they will continue cooking until done, possibly several hours later. The most delicious oatmeal and similar foods, including potatoes, are cooked in the fireless cooker. The oatmeal may be left in all night and will be free from the lumpiness commonly encountered. With

a little ingenuity, the electric mechanic can rig up an alarm clock, so as to open the electric heating circuit after the current has been on for say thirty minutes, or other periods of time previously determined to be sufficient for certain sizes of roasts, or quantities of potatoes, etc.

## Electric Tea and Coffee Pots

The accompanying photograph as well as the diagram A, B, C and D, show how electric tea and coffee pots may be arranged by the home mechanic. The photograph shows an electric coffee or tea pot in which the heating element is composed of the resistance ribbon pro-

duced from an old electric sad iron. The diagram A shows one way of making an electric tea or coffee pot. Here a false bottom is placed in the lower part of the tea pot, and this is soldered all around to the tin or copper. If the pot is of aluminum or agate wear, this style of mounting cannot be used, but a different scheme will have to be employed. The heating unit for this purpose may be rated at anywhere from 300 to 500 watts.

One scheme provides an enclosed heating unit. This may be made from resistance wire, such as German silver or "Advance" wire, and which wire is insulated with mica or asbestos between the windings, so as not to produce short-circuits. The whole affair is enclosed in a copper or tin container about 5" or 6" long, and about 1/4" by 1", the seams are soldered with hard solder, so that the whole heating unit can be immersed in the water.

In the diagram at Fig. B, the position (Continued on page 168)

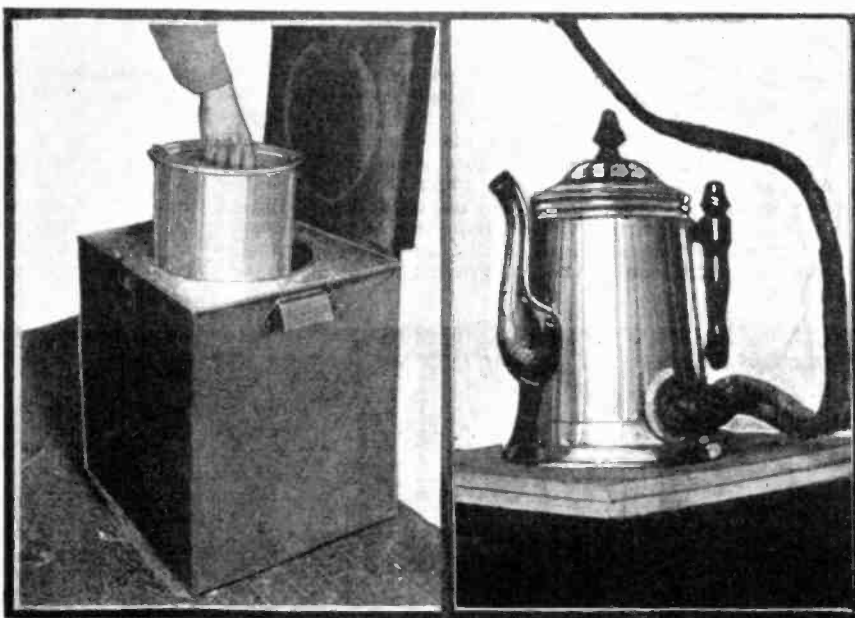

Home-Made Electric "Fireless Cooker."

Coffee Percolator With Electric Heater.

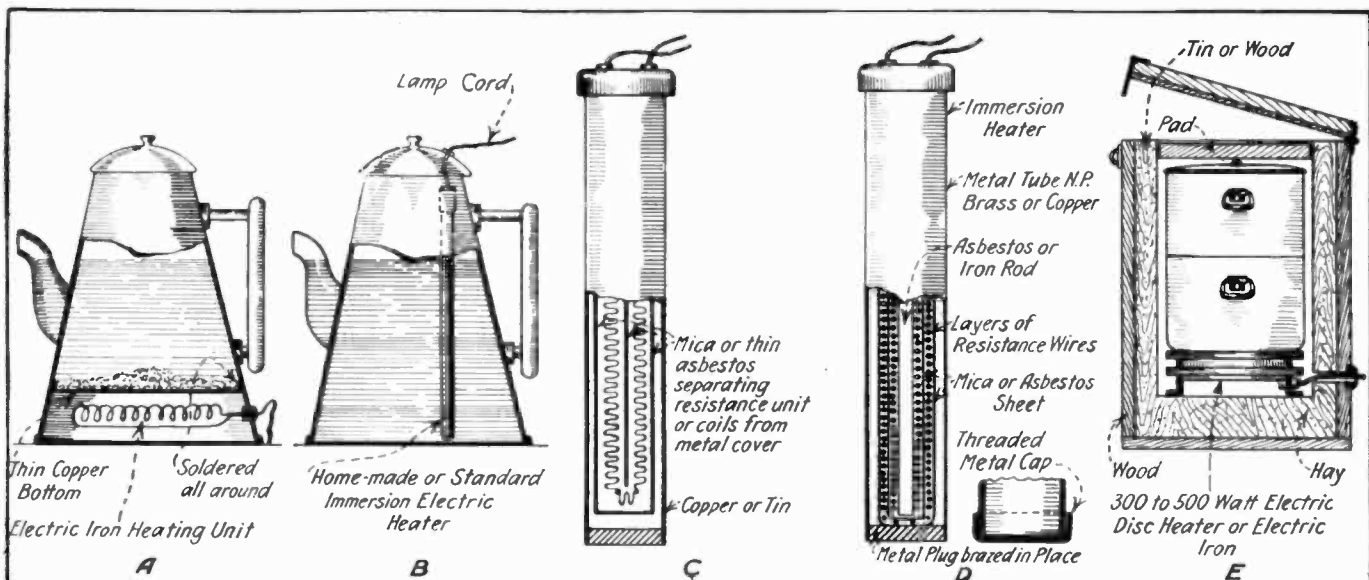

The Illustration Herewith Shows How Home-Made Electric Cooking Apparatus May be Made. At the Left We See an Electric Coffee Pot, While the Center Detail Drawings Show Two Forms of Electric Immersion Heaters, Suitable for Heating Water or for Use in Coffee and Tea Pots. An Electric "Fireless Cooker" is Observed at the Extreme Right.

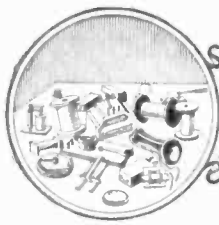

# HOW-TO-MAKE-IT



This department will award the following monthly prizes: First prize, \$15.00; second prize, \$10.00; third prize, \$5.00. The purpose of this department is to stimulate experimenters toward accomplishing new things with old apparatus or old material, and for the most useful, practical and original idea submitted to the Editors of this department a monthly series of prizes will be awarded. For the best idea submitted a prize of \$15.00 is awarded; for the second best idea a \$10.00 prize, and for the third best a prize of \$5.00. The article need not be very elaborate, and rough sketches are sufficient. We will make the mechanical drawings. Use only one side of sheet. Make sketches on separate sheets.

## FIRST PRIZE, \$15.00

### ELECTRIC DOOR OPENERS

The following description and diagram shows a quick method of unlocking and throwing open the door of the shop or laboratory without the use of keys. A

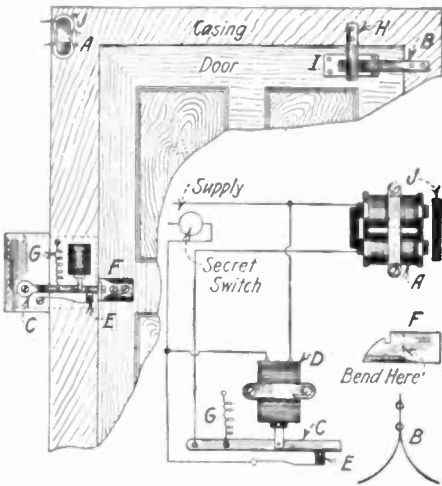

Useful Home-Made Electric Door Opener.

secret switch in the form of a nail head or loose board located where the owner can quickly depress it without detection does the trick.

When the switch is closed, the electro-magnet A draws the door closed, in order to release all friction from the bar C caused by the compressed spring B, which throws the door open after the bar has cleared the catch F, and broken the circuit of the electro-magnet A at the contacts E by the action of the coil D, which the switch also operates. D is a spool having a hole thru the center, a little larger than the core of an old Ford spark coil or iron bolt, and wound for the circuit to be used—110 volt or battery. The position the core is to assume in the coil should be where the pull of the coil is the greatest. A cigar or other box should be placed over the mechanism operated by D.

The spring G should be adjusted to nearly compensate for the weight of the core, so that the bar will rest lightly in the catch, F. The contacts and spring at E should be adjusted to follow each other and break just as the bar clears the catch.

The coils at A are similar in construction to D with the exception of having a laminated or solid U-shaped core inserted in them. They are mounted near the top of the door casing with the pole piece J fastened to the door directly opposite the poles of the coils. The distance between poles and pole piece should be about 1/16 inch when the door is closed.

Spring B is made of two pieces of spring steel each 1 inch by 1/16 inch by 12 inches, fastened together at one end and shaped as shown in the illustration. H and I are pieces of iron screwed to the door and door casing for the spring to slide against.

Contributed by K. STRICKFADEN.

## SECOND PRIZE, \$10.00

### BURGLAR AND FIRE ALARM

This burglar alarm, which acts also as a fire alarm, takes the place of an open circuit relay, and is made as follows:

Two electro-magnets such as those found on an old telegraph sounder, or an antique door bell, are mounted upon a wooden board. On the same board a bent corset spring, the bend illustrated diagrammatically in the illustration here, is also fastened. To this corset spring is riveted a piece of soft iron bar, so that it will rest directly over the electro-magnets, and, of course, be at right angles to the corset steel in much the same relation as that of the soft iron strip of the armature on the sounder. The very end of the corset steel is then bent upward to serve as a catch for another L-shaped piece of spring to which a contact point has been fastened. This contact point is in apposition with another contact, rigidly mounted on the board. It therefore becomes obvious that whenever the circuit is closed to such a relay, the electro-magnets become energized, and attract the soft iron pole piece. This causes the spring to move downwardly, releasing the contact spring which closes the circuit

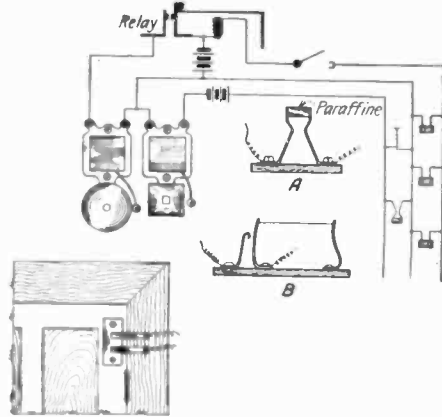

Valuable Burglar and Fire Alarm Circuit.

to one of the bells. The circuit to the other bell then closes; can of course be equipped with push buttons, floor treads, thermostats, or door contrivances as illustrated on the sketch herewith. As a matter of fact, any of these devices may be placed in either one or the other of the circuits, particular attention being paid to their intended use. If placed in the circuit of the relay, then the device will cause the bell to ring, and cannot be turned off, even if desired, except by re-setting the relay. If put into the other circuit, the operation of the bell is intermittent, that is, as long as the circuit is closed, the bell will ring, and the moment the circuit is again reopened the bell becomes inactive.

For fire alarms I have found that the most efficient circuit closers are either a piece of paraffin placed between two contacts, as illustrated in A, the paraffin melting whenever the temperature of the room reaches a certain point, or two pieces of spring brass tied together with a piece

of thread, as illustrated in B, in which the flame must actually strike and burn the string before the signal is given.

The former device is very good in cellars, or rooms normally kept relatively cool, where regular thermostats are neither desired nor required. The latter contrivance is of marked value in hen-coops, hot houses and in kitchen, or other parts of the house likely to be damaged by fire, yet normally kept quite warm. Ordinary dry cells will act very well in this device. The door alarm consists merely of two spring pieces of brass nailed to the door jamb, and a piece of brass secured to the door under the contacts. When the door is opened the circuit is closed by the brass strip upon it. The springs should be kept clear of this brass strip by a distance of at least one-eighth of an inch. In this manner the door may be opened slightly without danger of setting off the alarm.

Contributed by

T. HARTLEY HALSTEAD.

## THIRD PRIZE, \$5.00

### LET THE PHONOGRAPH WAKE YOU

The only materials needed besides the alarm clock are a thin pin and a piece of silk thread about 6 inches long.

The pin, with its head cut off, is pushed into the felt of the turn-table until it projects for about half an inch. A small loop is made in the thread at one end and the other end is tied to the alarm key of the clock in a figure eight fashion, so that when the key turns the thread will be wound up. The mode of operation is as follows:

The phonograph is partly wound up and a record placed on the turn-table with the brake released for a turn or two, until the needle engages in the record groove. By gentle pressure of the hand, the turntable is stopped from revolving, the brake still being open. The small loop of the thread is then slipped over the projecting pin in the felt.

In the morning, as the alarm goes off, and the key turns, it will pull the thread

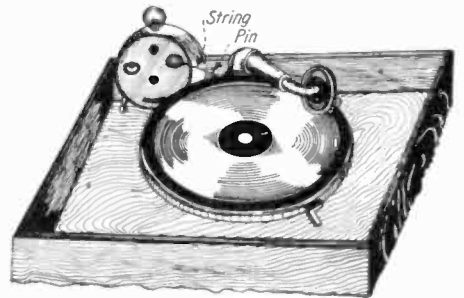

Why Not Let the Phonograph Wake You in the Morning? An Alarm Clock Starts It Off.

free of the pin, thus permitting the turntable to revolve, since the release brake is open. If the phonograph has an automatic stop, both the start and finish will be entirely automatic. It is advisable to remove the gong from the clock.

Contributed by

C. BLOOM.

# Finding the Area of Irregular Surfaces

VERY often one is confronted with the problem of determining the area of an irregular figure; for example, the land inclosed within a field, a diagram of which has been plotted to scale; the area of the indicator diagram of the effective pressures acting on the piston of a steam or gasoline engine, etc. To determine these values

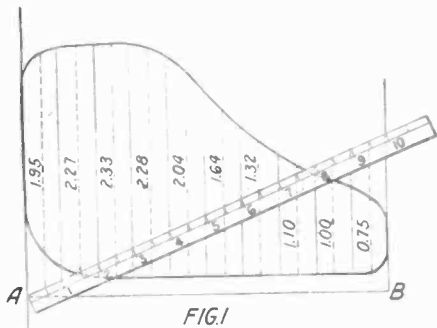

Measuring the Area of Irregular Surfaces is a Problem Met with Quite Frequently in Everyday Engineering Matters, Particularly in Steam Engine Work. Fig. 1 Above Illustrates a Conventional Steam Engine Indicator Diagram, Showing the Successive Pressures per Square Inch of Steam in a Cylinder at Various Points of the Stroke. A Scale is Laid on the Figure in Such a Position that the Diagram or Curve May be Divided Off Into, Say Ten Equal Divisions; the Average of the Successive Pressures is then Readily Determined by Adding All the Pressures Together and Dividing this Sum by Ten. Multiplying this Value by the Length AB Gives the Area.

with speed and reasonable accuracy, any of the following methods are to be recommended:

Figure 1 illustrates a conventional indicator diagram from one end of a steam engine cylinder. The method of procedure is clearly shown. A scale or ruler is so laid on the figure that it may be divided into say ten equal divisions. At every half division a line is erected perpendicular to the base line AB. Dividing the figure into ten strips gives a fair average, and, moreover, dividing by 10 can be effected by merely shifting the decimal point. (Obviously, however, the approximation more closely approaches the actual value when a greater number of divisions are made.) The average height of the figure is found by measuring to scale each of the perpendicular lines, adding them all together and dividing their sum by 10. Multiplying this value by the length, AB, gives the area of the diagram.

As an example, consider Figure 1. The length AB may correspond on a reduced scale to the travel of the piston in the cylinder, and the vertical lines represent, to a known scale, the pressure per square inch of the steam in the cylinder at the various points of the stroke. The mean or average height (in this case  $1.95 + 2.27 + 2.33$ , etc. = 16.68. Dividing by 10, gives 1.668 as the average) indicates the mean pressure "P" of the steam in pounds per square inch, thru the stroke (the strokes being the term applied to the distance moved

thru by the piston from its extreme position at one end of the cylinder to a corresponding position at the other end). If A denotes the area of the piston in square inches, then the total force exerted by the steam on the piston is  $P \times A$ , and the work done by this force in acting thru a length of stroke L is  $P \times A \times L$ . If N denotes the number of strokes per minute, the work done per minute by the steam = PLAN. But the unit of power used by engineers, and called a Horsepower, is 33000 foot pounds per minute. Hence the Horsepower of the engine =  $\frac{P \times L \times A \times N}{33000}$

When the required area is not symmetrical about a line, and its boundary is an irregular curve, lines are drawn touching the curve; two of these, AB and CD (Figure 2), may be made parallel to each other and AC, BD drawn perpendicular to AB and CD.

As before, the base AB is divided into a number of equal parts, the mid-divisions measured to scale and all added together, and the sum divided by the number of equal divisions. This gives the mean or average height of the figure, which value is multiplied by the length AB to obtain the required area.

## Other Methods

By weighing: Draw the figure to some convenient scale, or, if possible, full size, on thick paper or cardboard of uniform thickness. Cut the figure out carefully, using scissors or sharp pen-knife. Also cut a rectangular piece of known dimensions from the same sheet; weigh the rectangular piece on a sensitive balance, and from this weight and the known dimensions of it, calculate the weight of a square inch of the material. Then weigh the irregular figure, and knowing the weight of a unit area, the area of the figure can be calculated by dividing the former by the latter.

In its simplest form, a home-made planimeter consists of a rigid metallic wire bent to the shape of an inverted "U," one end of which terminates in a round sharp point, the other in a knife edge. (Figure 3.) The distance between the center of the edge A and the point B may be made any convenient length, say 5 or 10 units. (It is well to choose a length that is a convenient multiplier, as every result is obtained by multiplying a found value by the length AB.) Probably the best arrangement is to make the arm AB adjustable, so that its length may be varied. The arm can then be made any convenient length and it enables the instrument to be used, not only for small, but also for comparatively large diagrams.

Procedure to determine the area of a figure:

(1st) Estimate approximately the center of area, and through this point draw a straight line across the figure.

(2nd) Set the instrument so that it is roughly at right angles to the straight line, having the point B at the center of area estimated at first. When in this position a mark is made on the paper by the knife edge A. Holding the instrument in a vertical position, the point B is made to pass from the center to some point on the periphery of the figure, then to trace once around the outline of the figure until the point on the periphery is again reached, then to the center or starting point again. At this position a mark is again made with the knife edge A. Now measure the distance from this mark to the first one and multiply this value by the length of the arm AB to get the area of the figure.

The result will be obtained more accurately, if, after the point B arrives at the center, the figure is turned on the point B as a pivot thru about 180 degrees, and the periphery traced as before but in the opposite direction. With care this

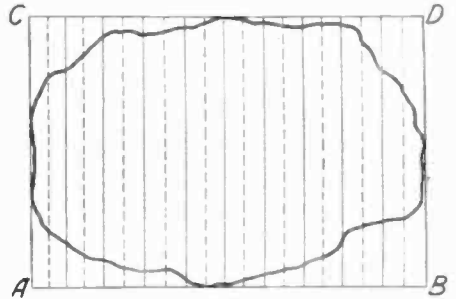

FIG. 2

In Measuring this Irregular Surface Which May be that of a Lake, Piece of Land, Et Cetera, the Vertical and Horizontal Boundary Lines Are Drawn as Shown, and an Equal Number of Divisions Spaced Off Along the Base Line AB. The Heights of All the Mid-divisions Are Measured by a Scale, Added Together and the Sum Divided by the Number of Equal Divisions. This Average Height of the Figure, Multiplied by the Length AB, Gives the Required Area.

should bring the edge A either to the first mark or very near to it. The nearness of these marks depends to some extent upon the accuracy with which the center of the figure has been estimated. The area by this procedure is the product of AB and the average distance between the first and third marks.

If the knife edge, A, should slip, the accuracy of the result would be affected. To prevent this, the knife edge must be made very sharp, using an oil stone; mounting a small weight W directly above the edge and on the arm AD, helps considerably.

The simplest possible planimeter is one operating on the above principle, using a common pocket knife as the instrument. The knife must have two blades at opposite ends of the handle. One of these is fully extended, the other opened only half way or 90 degrees with the handle. One can see that this is a modification of the above type. To use it, the best procedure is as follows:

First, draw a known area to full scale. (For example, a square of 2 inches on a side, making an area of 4 square inches.)

Then proceed as with the above instrument to determine the distance between the first and second marks. Measure this distance. Since the figure was known to have an area of 4 square inches, the distance between the marks must be equivalent to an area that size, and hence  $\frac{1}{2}$  of that distance is equivalent to an area of 1 square inch. Let us assume that this value is  $\frac{1}{2}$  inch. Taking the irregular figure, trace around its periphery and measure the distance between the first and second marks (assume it is 3 inches). Now since you know an area of 1 square inch gives a value of  $\frac{1}{2}$  inch, the area of the figure in question must be 6 square inches.

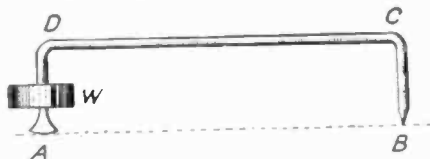

FIG. 3.

Probably the Simplest Form of Home-made Planimeter Consists of a Rigid Metallic Wire Bent to the Shape of an Inverted U, as Here Shown, One End of this Wire Terminating in the Round Sharp Point B, and the Other in a Flat Knife Edge A. Its Use is Described in the Article Herewith.

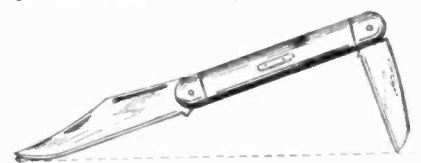

FIG. 4.

A Simple Pocket Knife Planimeter, Which May Prove Useful in an Emergency. One of the Blades is Opened Fully, While the Second Blade is Opened but Half Way or 90° With Respect to the Handle.





EDITED BY S. GERNSBACK

# Useful Clothes Pin Wrinkles

By JAMES R. SPENCEE

THE accompanying drawings show a number of useful novelties made from wooden clothes pins. There must be many other wrinkles of practical everyday value utilizing wooden clothes pins. We, therefore, announce a prize of \$5.00 for the best idea employing wooden clothes pins. Descriptions should not be over 50 words, and written in ink or else type-written. Sketches should be made on same piece of paper as description, together with name and address of contributor. Photographs are welcome of course, instead of sketches, where this is convenient. All contributions to the "Clothes Pin Contest" must be in by July 20th. If two or more contestants send in the same idea, \$5.00 will be paid to each. Address all letters to Editor, Clothes Pin Contest, care of Science and Invention Magazine, New York City.

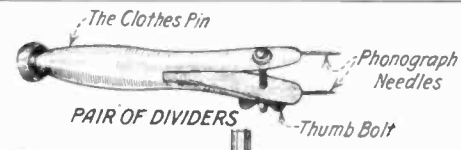

PAIR OF DIVIDERS

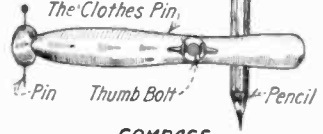

COMPASS



CLAMP FOR GLUEING SMALL JOBS

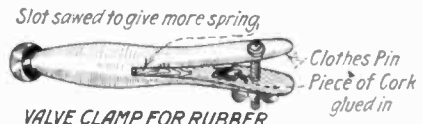

VALVE CLAMP FOR RUBBER HOSE IN CHEMICAL WORK



SWITCH HANDLE

KNOB



HAND VICE

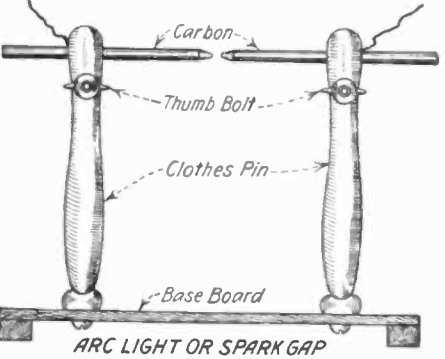

ARC LIGHT OR SPARK GAP

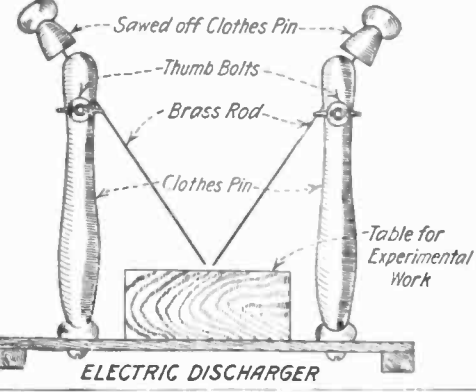

ELECTRIC DISCHARGER

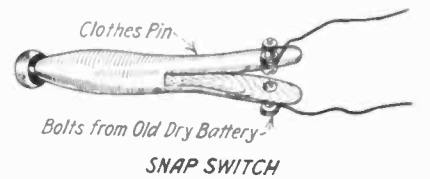

SNAP SWITCH

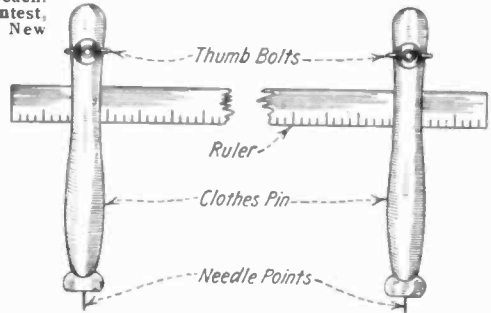

BEAM COMPASS

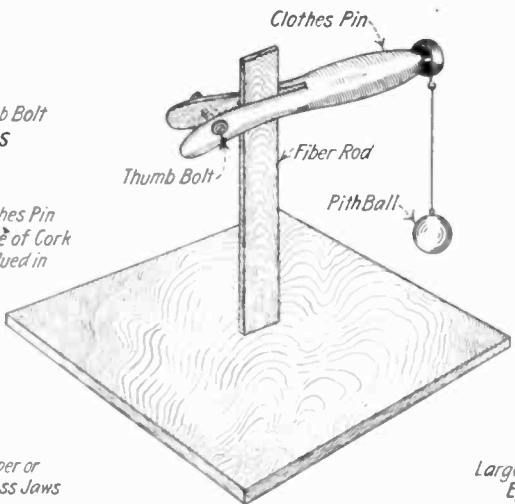

INSULATED STAND

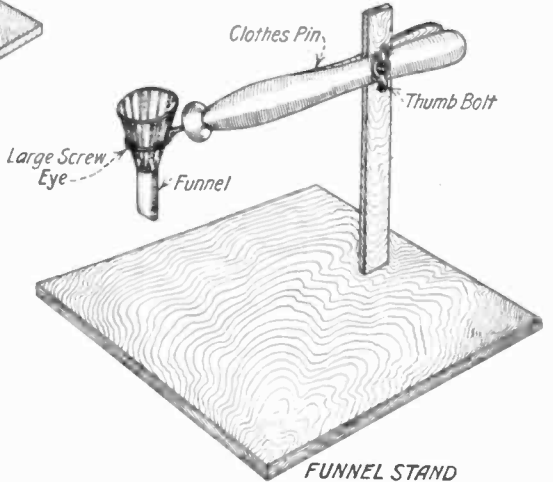

FUNNEL STAND

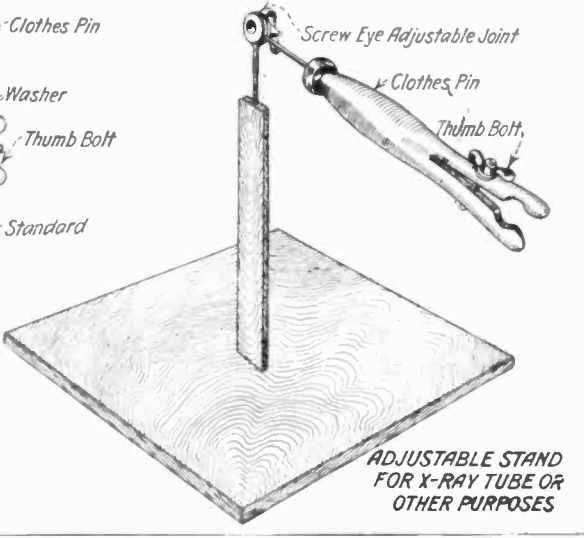
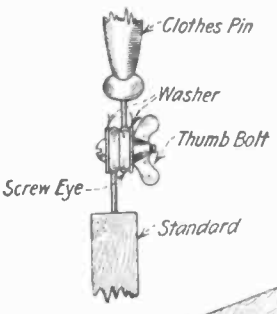

ADJUSTABLE STAND FOR X-RAY TUBE OR OTHER PURPOSES

## THIS MONTH'S \$5.00 PRIZE

## A CLOWN THAT KICKS ABOUT

In the first place you must cut your clown from paper in this manner. Cut out the body and head all in one piece and then cut the two arms and legs separately. You might

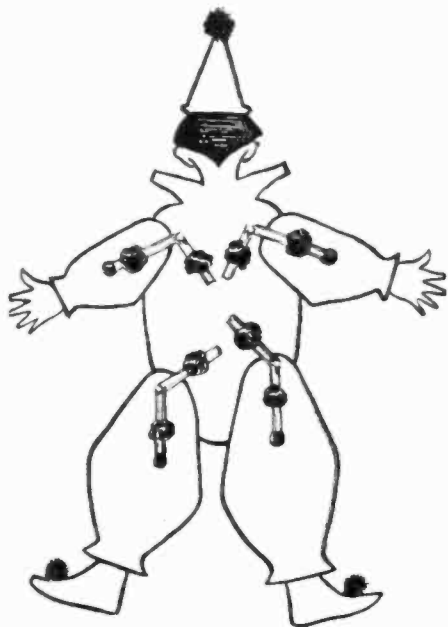

This Clown Kicks Like the Real One at the Circus—Thanks to His Joints Made of Match Sticks, Which Are Afterward Moistened. The Broken Wood Swells, Causing Them to Straighten Out.

sketch in the face of the clown and also put in what you like to show his hands, feet and clothes. Place the body and head of the clown face downward on the table. Now secure a stick of sealing wax and

four wooden matches. Each of these matches should be broken in half in the middle so that the parts are only half separated. When the matches are bent over at right angles there should be about half the fibers of wood holding the two ends together. Now place one arm on either side of the body and place the legs in the right positions. Let the ends of the arms and legs overlap a little on to the body.

Now place the matches so that in each case one half is on the body, and the other half on the limb. Fix both ends of each match with a spot of sealing wax so that it will be something like a hinge held firmly at either side.

The time has now arrived to make the clown come to life. On to a plate pour a very little water and then carefully take up the clown and put him match side downwards on to the water. Soon a very surprising thing takes place, for the arms and legs of the clown start to jerk about in a most comical manner. In fact, the little man looks just as if he had come to life. Probably you would be interested to know the cause of these movements. You will remember that the matches were not actually broken in two pieces and what happens is this: When the water gets at the wood fibers that join up the matches these start to swell. As soon as this happens the matches begin to straighten out to something like their original shape and it is this fact which brings about the movements. The lively little clown will continue kicking and waving his arms about for quite a while and you will find him most amusing to watch.

Contributed by

S. LEONARD BASTIN.

## THE PAPER PARACHUTE

Take two strips of paper about 5 inches long and  $\frac{1}{2}$  in. wide. Twist them together up to a length of about 3 in. and fold the two wings of 2 in. left over to

the right and left, so that the whole looks like the letter Y.

If you let this twisted paper fall from a certain height to the floor, it will turn in the air like a turbine with a vertical axis, turning so swiftly that the eye cannot distinguish the two wings.

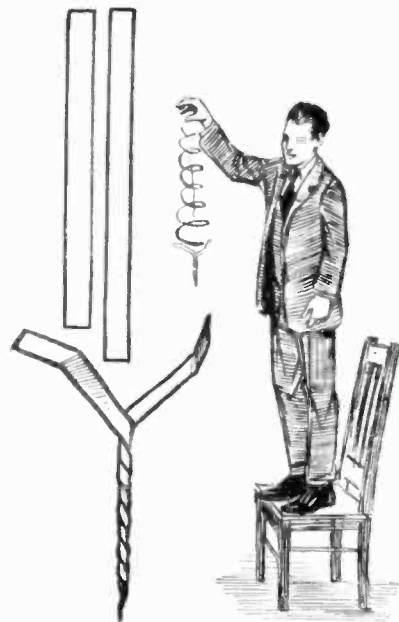

When this Twisted Paper Parachute is Dropped, it Turns in the Air Like a Turbine.

This rotating motion is given the apparatus by the air resistance working upon the wings, which are slightly inclined toward the horizon.

If the air is calm you may drop the winged parachutes from a window, using different colored paper to obtain a very beautiful effect.

Contributed by

AL. ANTOIN.

# Everyday Chemistry

By G. B. ASHTON, B. S. Ch. E.

**V**ERY few of us realize what an important part the chemist and chemistry play in our everyday life. Let us follow an ordinary man from the time he crawls from his bed in the morning until he jumps into it at night. We will note a few of the chemical things that influence his life.

On arising we should (we won't say we do) practise deep breathing. Low and behold a chemical reaction. The oxygen in the air taken into the lungs unites with carbon derived from various substances that we have eaten. When we exhale the oxygen comes out, every two atoms bringing with it one atom of carbon. Thus we exhale carbon-dioxide. A process of combustion, a chemical reaction has taken place and the heat that keeps the spark of life aglow has been generated. Thus a chemical reaction is the basis of life itself.

Eventually we pull on our socks. In these hard times, the chances are that they are not pure silk, but artificial silk produced by a chemical process. Our sock might have been gun-cotton, a high explosive if the chemist had not changed the process slightly. Gun-cotton and artificial silk are both made from nitrocellulose, or cotton treated with nitric acid. But say our socks are pure silk or any other material, even then the chemist has made possible the dyes that give them color.

We pull on our shoes made of leather tanned by a chemical process.

If we wield the Gillette or straight

blade and harvest the crop of whiskers, we come in contact with chemistry. The chemist has made possible the high grade steel that holds the keen edge on the razor. We look into the mirror and see our reflection. There would be no reflection had not the chemist discovered and perfected the process of making silver stick to glass.

We lather our face with soap made from fats, oils and alkali by a chemical process. After we have finished shaving, we apply the scented toilet water. Oh boy! that flower garden odor! We imagine we see the flower garden where the flowers grew from which the perfume was extracted. A beautiful place. But the chances are we should have imagined a dirty coal pile, smoking coke ovens for that is the source of most of our perfumes to-day. It isn't roses, carnations and orange blossoms, which have supplied the perfumes, but products from dirty ill-smelling coal tar by chemical process.

We eat our breakfast, little thinking that the chemist can tell us the food value of everything we eat. If the breakfast is up-to-date, it is planned on a scientific basis worked out by the chemist—so much protein, so much fat, so much sugar, etc.

As we start to the office, we press down on the starter of our car and the chemicals (thru an electro-chemical action) in our storage battery crank the car for us. Gasoline a chemical mixture, mixes with air, the mixture explodes, runs the engine and carries us to work on rubber

tires developed and perfected by chemists.

When we buy our morning paper, chemistry enters again. The cent we spend is made of copper refined by chemists. The printer's ink and the paper it is printed on are made possible by chemists.

All day long we come in contact with the results of chemistry. The pen we write with, the ink it is filled with, the paper we write on, the purified water we drink, and many other things are results of chemistry.

After the day's work we visit a picture show, little thinking that the film that makes the picture possible is a first cousin to our artificial silk socks, both products being nitrocellulose.

After the show most of us will go home for a good night's rest. We enter the house and turn on the light. The tungsten filament in the light bulb glows brightly. Who of us think of the chemist who spent the greater part of his life developing a process for refining the tungsten so as to form the filament in the bulb. Even the glass bulb is the result of chemistry.

The day is done and it is time for us to jump into our bed. Where is the chemistry here? The bed may be made of iron, the chemical element that has meant so much to man ever since the stone age. The sheets between which we crawl are made white by a chemical bleaching agent.

Thus we get some little idea of the important part that the chemist and chemistry play in our everyday life.



# RADIO DEPARTMENT



## Church Broadcasts Own Sermons

By ARCHIE RICHARDSON

The Beautiful Edifice Shown Here is that of the First Baptist Church at Shreveport, La. Note the Radio Tower and Antenna Atop the Building.

This Church Broadcasts Sermons Via Radio to Hundreds of Smaller Churches Thruout the Southwest, Hundreds of Which Are at Present Without a Pastor.



**T**HE first powerful radio broadcasting station in the world to be installed in a church will soon be completed in the 10-story tower of the First Baptist church at Shreveport, La.

The station will have a normal radius of 1,500 miles, but under favorable conditions may be picked up from coast to coast, and by ships at sea. It will use a 200 watt set, sending on a 360 meter wave length.

Sermons, lectures, choir and congregational singing, organ recitals, chime concerts, and a daily news service will be among the features available to those having receiving sets. The auditorium, the largest in the city, will be used as a civic center, and the world's most noted singers and lecturers will be heard here. Their programs and lectures will be broadcasted.

Several hundred small churches thruout the southwest, most of which have no pastor, are installing receiving outfits, and their congregations will worship with the congregation of the Shreveport congregation.

The church, built at a cost of \$500,000, was dedicated Sunday, April 23. It is one of the largest Baptist churches in the world, having 51,000 square feet of floor

### Feature Articles in June "Radio News"

*World's First Wireless Telephone News Service.* By Maurice E. Pelgrims.

*A Portable Receiving Set in a Suitcase.*

*Radio Talking Moving Pictures.*

*Is Radio Threatening the Phonograph and Theatre?* By H. Gernsbach.

*Amplifying Transformer.* By C. Chandler Pidgeon.

*A Coupled Tuner for Long Waves.* By Raymond Evans.

*Designing and Building C. W. Power Transformers.* By E. T. Jones.

*Design of an Audion Control Cabinet.* By Glenn E. Flint.

*The Lackawanna Railroad Radio Experiments.* By David W. Richardson.

*How to Use the Vacuum Detector.* By Arthur H. Lynch.

space and a seating capacity for 8,000 people.

Eventually all the larger churches will broadcast sermons, and who can tell but that this will not be the better method of listening to the preacher? Then every house will be a house of worship as well as a home as it should. During unfavorable weather, it will not be necessary to encourage the development of coughs and colds, but merely to recline in an easy chair, after the filaments of the audions have been turned on, and listen to the sermon as it surges thru the ambient ether.

Very expensive churches will no longer be necessary, but the minister who places his sermon in such a manner as to create more than usual interest, will be the one to whom we will all listen, and instead of having the church supported by the voluntary contributions of its members, contributions will be solicited from those who desire that such broadcasting be continued. Those living in isolated country sections will undoubtedly flock to the church, and those physically unable to attend the sermons, will find great solace in the radio transmissions.



# A Vacation-Time Radio Receiver

By ROBERT E. LACAULT

**A** REAL radio fan cannot conceive of a vacation without a radio set. This is particularly true in my case and ever since I listened to radio signals with the aid of an electrolytic detector, since 1910, I have never failed to carry with me some form of

standard dry cells in the "A" battery compartment of the cabinet, to furnish the necessary filament current for the tubes. The plate voltage is obtained from two 22½ volt "B" batteries of small size.

Figs. 1, A, B, C show the front panel, and a sectional as well as a top view of

over a length of ½", as shown in Fig. 6B. Another stick 19" long should be provided with small holes beginning ¼" from one end and spaced ¾" from each other, as shown in Fig. 6A. In each of these holes a pin or nail may be pushed to adjust the tension of the wires in the loop

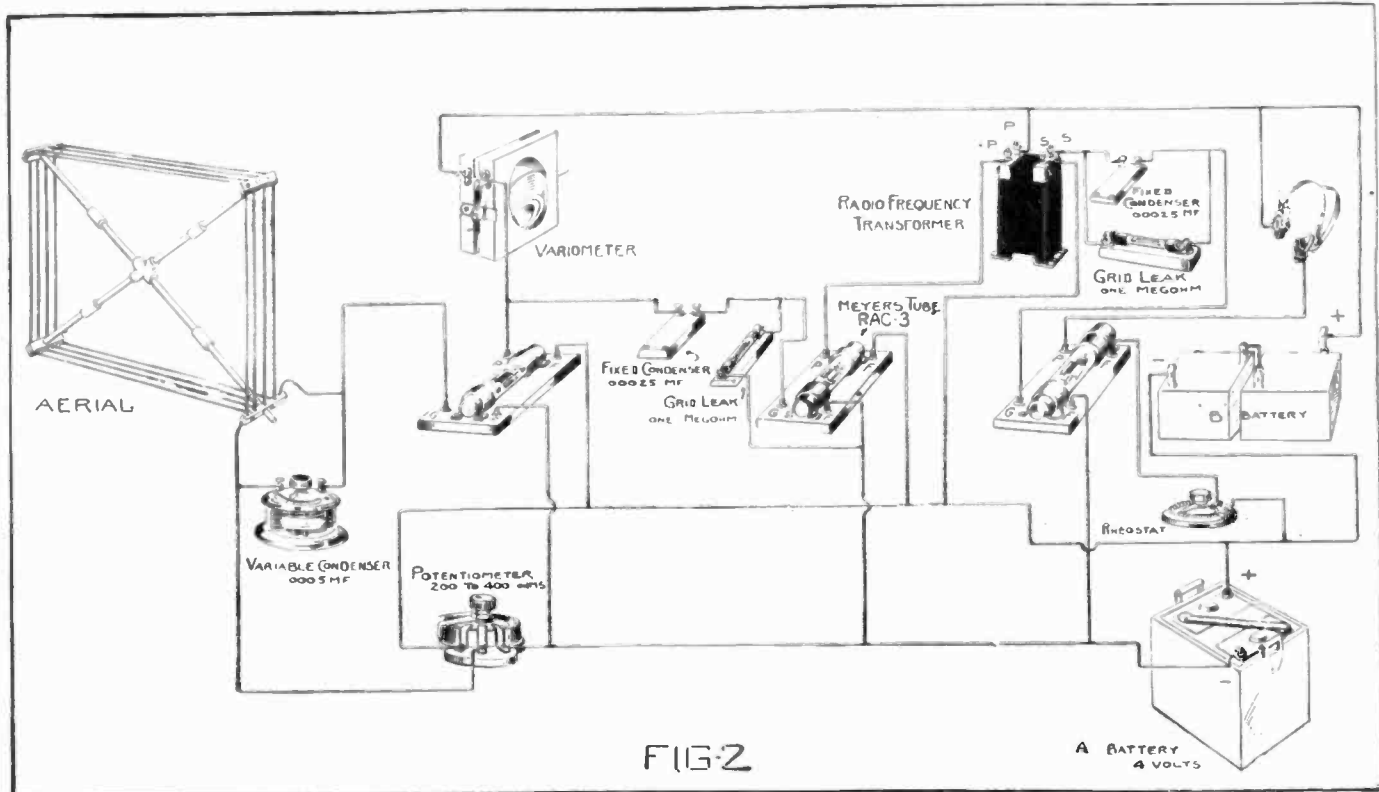

Perspective Diagram Showing All the Connections to the Terminal Posts of the Various Radio Instruments Used in the Vacation-time Radio Receiving Set Here Described by Mr. Lacault. This Set Utilizes a Small Loop Aerial, as the Front Cover Illustration and Diagram Herewith Show, This Loop Being Shunted by a Variable Condenser for Tuning to Different Wave Lengths. The Amplifier Comprises Two Stages of Radio Frequency, With a Radio Frequency Transformer Connected as Indicated in the Diagram. Three Vacuum Tubes Are Used. These Operate on Four Volts Filament Potential, Which May be Supplied by a Two-Cell Storage Battery or Else Dry Cells. The 'Phones Used Should Have 2,000 to 3,000 Ohms Total Resistance for the Set.

radio set during all my vacations. This year, intending to visit many points, and wishing to carry as little baggage as possible, I designed the compact and efficient little receiver described here. With it, is used a loop aerial which may be folded so as to take up a minimum space and avoid the necessity of installing an outdoor aerial which takes too long a time and is not always easy to construct. I hope this may be of some value to amateurs.

The wave-length range of this outfit covers from 180 to 500 meters, which is the most interesting scope since it includes the wave length of both amateur and broadcasting stations. The receiver consists of a loop aerial shunted by a variable condenser; a regenerative effect being obtained by means of a variometer connected in the plate circuit of the first amplifier tube, as shown in the diagram, Fig. 2. The amplifier comprises two stages of radio frequency, one using iron core transformers, such as may now be obtained in any radio shop. In order to save space and weight, small vacuum tubes are used. These require four volts on the filament supplied by means of a small storage battery having the electrolyte rendered unspillable by the addition of proper absorbents, glass wool, etc. Such small batteries are used in medical apparatus and in portable lamps. In case one prefers to use dry cells, he may do so by mounting four

the cabinet, with the various parts composing the receiving set and the amplifier. On the top of the panel are the three tubes, and below may be seen the knobs of the rheostat and potentiometer. The two dials are those of the variable condenser and the variometer. The radio frequency transformer, grid leak and grid condenser, as well as the coupling condenser are mounted on the back of the panel and also on the top of the cabinet. The special compartments for the "A" and "B" batteries are screwed thru the sides of the cabinet, as shown in Fig. 1B, and should be so fixed as to exactly accommodate the battery to be used. The whole outfit which is 5½ inches wide, takes little room in the suitcase, which may be used also to carry clothes and other necessary accessories of every vacationist, as may be seen in the illustration on the cover of this magazine.

## The Loop Aerial

After designing several types of folding loop aerials, the one shown in Fig. 6 was found to be the simplest and best adapted for the purpose. It consists of eight pieces of round stick 1" in diameter, four of them being 18" long and provided at one end with a piece of brass tubing into which they fit tightly; a small nail is passed thru both to prevent the tubing from sliding back. Three other sticks 18½" long should be turned down to ½"

and also to permit the erection of the frame and the mounting of the winding. In the center where the two arms of the frame meet, a cross-piece of brass tubing supports the sticks. This cross-piece may easily be made by soldering three lengths of tubes together, if it is not possible to buy it ready made in a hardware store.

To obtain best results with a loop aerial, for the reception of short wave-lengths, the wire should be wound with a space of about 1 inch between the turns. In order to keep this spacing and at the same time to permit the rapid removal of the complete winding, the following scheme was devised: The wire is clamped at each corner of the loop between two strips of bakelite or other insulating material, so that the complete winding may be folded to occupy little space and at the same time to retain its shape. The size of the bakelite strips is shown in Fig. 4. Five strips should be provided with a 1 inch hole in the centre so as to pass over the ends of support sticks and three with a ½ inch hole in order to stop the end pieces and maintain them in the proper position.

At three of the corners of the loop the bakelite strips supporting the winding are stopped by the small piece provided at the end of the sticks, while at the fourth corner the strips may slide down along the stick. When the first three pieces are in place, the fourth is pushed up to the end

of the stick provided with holes, and the pin is pushed thru one of these to obtain the proper tension of the wire, and keep the bakelite end pieces in place, as shown in Fig. 5. The insulating strips are clamped together by means of screws and nuts, when the wire has been set in place. On one of the end pieces two of the screws should be replaced by small binding posts.

The best wire to use for the winding of the loop is flexible stranded conductor of small diameter, which may easily be rolled around a piece of cardboard without breaking, as stiff wire would. The easiest way to wind the loop before clamping it, is to set up the frame first and prepare the necessary bakelite strips and screws; the end piece sliding along one of the sticks is stopped by the pin inserted in the hole nearest to the center. Only two of the screws fixing the strips together should be set in on one side, loosely enough to enable the wire to be inserted between the strips on the other side as shown in Fig. 7. When two turns are made on one side, the two screws are mounted in their holes and the others removed to permit the winding of the two other turns, the wire being properly spaced and adjusted when the four turns are all in place.

As may be seen in the diagram, no filament rheostat is used for the amplifier tubes, as this is not necessary with the type of tube used: a potentiometer regulates the potential applied on the grids thru the loop winding. The rheostat for the detector tube is not absolutely necessary, altho it sometimes improves the reception. The variometer used in the plate circuit of the first tube is a standard one, which if built by the amateur himself, should have 50 turns on the rotor and 50 on the stator and No. 22 wire should be used for this winding. In order to save space on the panel the mountings for the Myers tubes were removed from the standard socket, and fixed upon the panel itself.

The Suitcase Radio Receiving Set Particularly Designed for the Use of Vacationists, is Shown Here in Front, Side and Plan Views. The Panel on Which the Switches and Vacuum Tubes Are Mounted, Should be Made of Bakelite or Fibre.

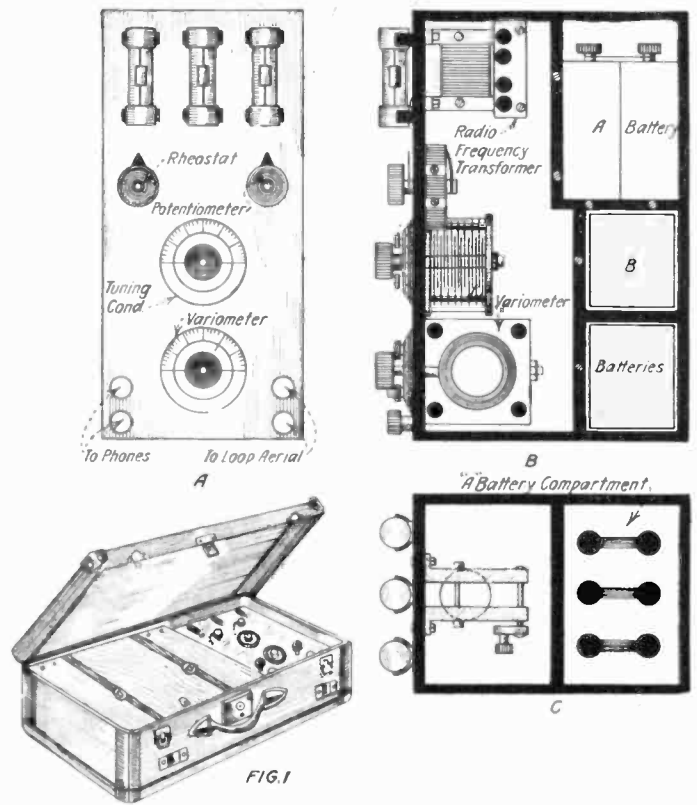

In the diagram, Fig 2, are shown the various parts of the set with the values of the condensers and other elements. Two stages of radio frequency amplification are used before the detector, providing great sensitiveness, and sometimes giving better results with the loop aerial than are obtainable with an outdoor antenna and regular regenerative set. Of course

the intensity of the signals heard in the telephone is not as strong as if two steps of audio frequency amplification were added after the detector, without any radio frequency amplification before, but the range obtainable in the second case is much more limited than in the first.

When building the set it will be found that the easiest way to make the "lay out" of the panel is to first trace on a piece of paper, the dimensions and spaces of the various parts and positions of the screws. This paper may then be stretched and fixed over the bakelite panel, and the various holes drilled thru both, insuring the proper spacing for the screws. The paper may then be removed and the rheostats, condenser and other instruments mounted and wired. No dimensions are given in the sketch showing the set as this depends upon the particular suitcase in which the receiver is to be installed. If desired, the set may be built as a separate unit enclosed in a cabinet with a handle for transportation.

In conclusion, I would say that with such a receiver, signals from amateur stations about 200 miles distant have been received quite often, while radiophone transmissions from broadcasting stations have been picked up quite clearly at a distance of almost 100 miles.

Where the experimenter may wish to use an ordinary aerial instead of a loop, he will of course gain greatly in the range over which he can receive. An aerial 100 ft. long comprising one or two wires, will give best results with this set. A piece of fine magnet wire will do for a temporary aerial, tying a string to one end of it, and a stone or other weight to the free end of the string. The stone is then thrown over a high tree limb, carrying the string with it, and the aerial wire can then be pulled taut. Insulators, such as a porcelain cleat or two, should be placed between the cord and antenna wire. The lower end of the antenna may be connected directly to the receiving set, or else be anchored with an insulator to a peg or other object. A fine wire dropped out of a hotel window, would also serve as a temporary aerial, using a steam or water pipe for a ground connection.

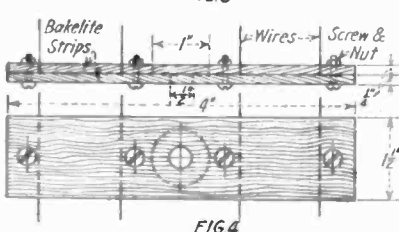
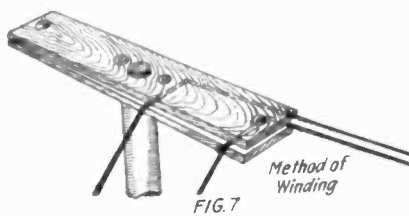
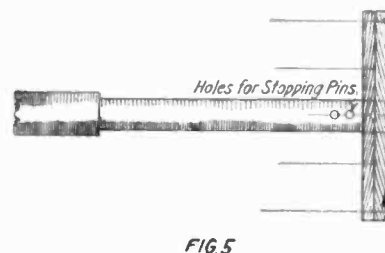
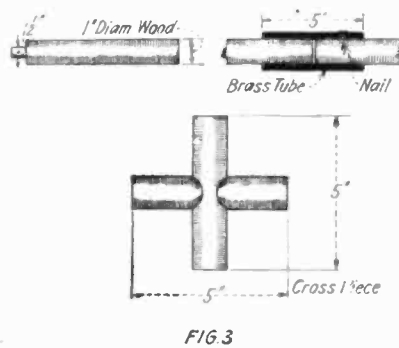
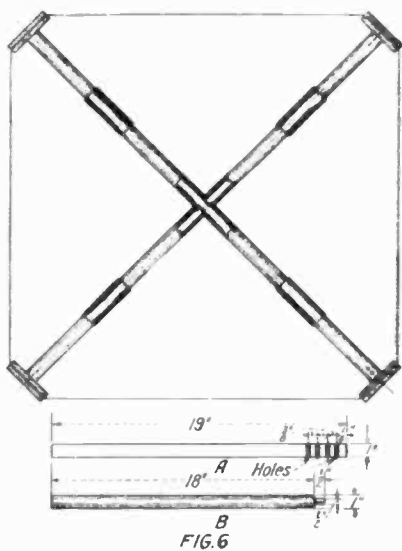

Details of Construction for the Loop Aerial to be Used With the Vacation-time Radio Set, Are Given in the Drawing Above. A Series of Holes Are Drilled Thru the End of One of the Cross Sticks, so That the Aerial May be Pulled Tight and a Nail Inserted Behind the Spreader on This Particular Leg to Hold the Wires Taut.

# Radio for the Beginner

By ARMSTRONG PERRY

NO. 4.—SHOOTING TROUBLE IN THE RADIO RECEIVER

**A** BEGINNER'S experience with a radio receiver is as full of troubles as the course of true love. The causes are many but the effects may be roughly classified under four headings: (1) Nothing doing. (2) Sounds in the 'phones too weak. (3) Music, voices or signals interfered with by miscellaneous noises. (4) Electrical, mechanical and chemical accidents.

There are three general types of radio beginners, and the ultimate result of the troubles depends upon the type of the beginner who handles them. One beginner will assume, when anything happens, that it is due to some fundamental defect of his apparatus. He begins his trouble-shooting by taking his receiver all apart and by the time he gets thru, his outfit looks as tho he had shot the trouble with a whiz-bang. More passive folks just give up helplessly and wait for someone to tell them what to do. They do not have to wait long. Omniscient amateurs by the score are just waiting, not only to tell them all about it, but also to do the job free of charge. *Tout ensemble* they will do things to a radio station that even Trouble Shooter No. 1 never thought of. After they have been choked off, things can possibly be put to rights again at an expense ranging from 400 to 1,000 per cent. of the original cost of the installation. Genuinely competent amateurs can often be found, but they are seldom the first to volunteer, for they know how much may be involved and they are modest.

The third type of beginner, when something happens that he does not understand, does what any sensible man does when he is lost in the woods. First, he sits down and thinks things over. He studies a chart if he has one and gets his bearings as accurately as he can. Finally, he proceeds cautiously in a definite direction, making sure not to repeat any mistakes that he may have made previously.

Most radio troubles are due to simple causes that can readily be discovered and remedied. When a receiver that has been functioning all right suddenly becomes silent, the most probable explanation is that there is nothing in the air at the moment that it can bring in. First, consult your log book or a list of scheduled broadcasts, tune to the strongest station that should be transmitting at the time, adjust the crystal detector or the vacuum tubes at their most sensitive point, and listen. Possibly all transmission in your area has been stopped to give a distress signal the right of way. If so, code signals will probably be heard at intervals, proving that the receiver is acting. If it brings in one signal there is no reason why it should not bring in any other that is within its tuning and receiving ranges—that is, on a wave length that the receiver will tune to, and strong enough. The only thing to do is to tune and wait.

If the receiving apparatus really is struck dumb and will not bring in any sound at all during a long period of careful tuning and listening, the trouble may be due to any one of a number of things. One common cause just now in this latitude is: summer. In the summer, atmospheric conditions interfere often, tho not all the time, with satisfactory radio reception. The difficulty can be overcome by taking the receiving outfit to South America, where it is now winter, and then bringing it back here after summer time comes down there. I am going to try this as soon as my cime bank is full.

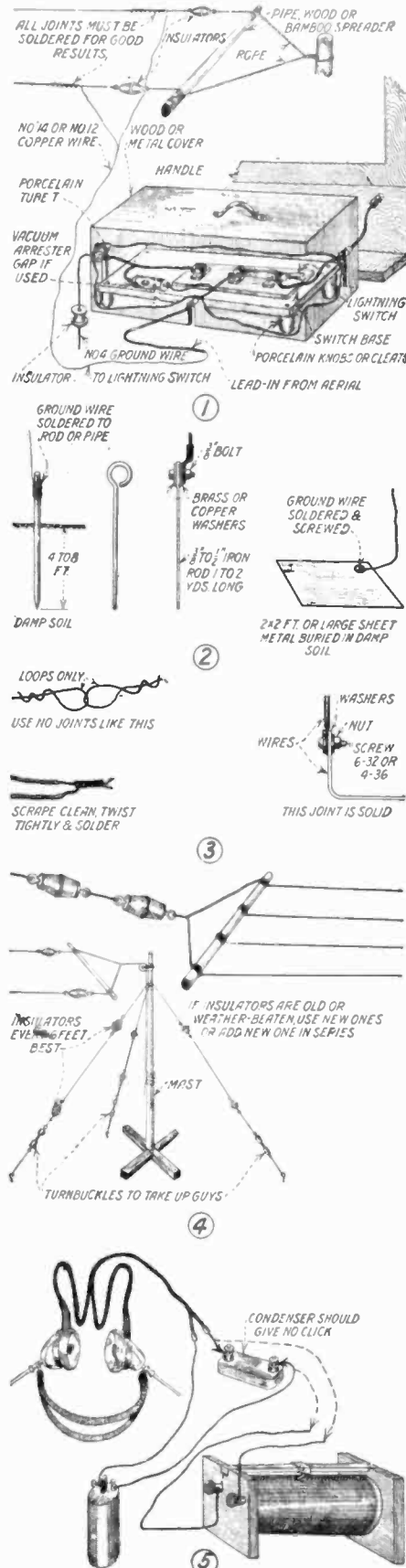

Fig. 1 At Top, Shows How to Install Aerial Grounding Switch Outside Window. Fig. 2 Shows How Ground Rod and Joint is Made. Fig. 3 Illustrates Poor and Good Joints in Wires. Fig. 4 Gives Hints on Aerial Insulators and How to Place Them, While Fig. 5 Depicts Simple 'Phone and Battery Test for Determining the Condition of Condensers, Tuning Coils, Etc.

A cheaper remedy which helps at least a little is to go over the whole outfit from the tip of the antenna to the point where the water pipe, or whatever the ground wire is attached to, enters the earth. Any metal that is exposed to the air gradually accumulates a coating of dust and dirt, and many metals oxidize. This means that any antenna will gradually lose some of its efficiency. Cleaning it may help. Often a new wire can be installed for a dollar. It is said that an antenna will lose no more than 20 per cent. of its efficiency from exposure. Whether the gain of that much is worth the expense and labor of putting up new wire is a matter for the owner to decide.

Even more energy may be lost from insufficient insulation than from weathering of the wire. If only single insulators have been used between the antenna and guy wires and the points of support, it is worth while to put up two or three in series and thus make sure that the maximum amount of antenna current goes down to the receiver. If the sagging of the antenna has brought it into contact with roofs, wires, branches or other objects, it should be adjusted so as to remedy this fatal condition. An antenna that touches a conductor is as leaky as an umbrella with nothing but ribs.

Losses due to loose connections are common. Respice and resolder every joint where wire connects with wire. Trying to pass electricity into a corroded wire is worse than trying to light a wet stick of wood. Inside the receiver it is possible, tho improbable, that soldered joints may have broken loose. More often loose nuts can be found and tightened. Phone cords may be worn or broken. The tips may be loose inside the ear pieces. In looking for and correcting such defects the greatest care must be used not to disconnect or break the tiny wires used for some purposes in radio apparatus.

The ground connection is as important to the success of the radio set as the kitchen drain is to the culinary department. In our navy's largest station the resistance in the ground system is only one ohm, which is 3,000 times less than the resistance in an ordinary radio head set. If it is desirable to reduce the resistance to this point when operating with power all the way up to 500 kilowatts, it surely is necessary to keep it down when dealing with the weak currents that flow thru a receiver. Use a good-sized wire, or two or three of them. Scrape the radiator or water pipe bright where they are attached, and solder the joints thoroly.

When there is any reason to suspect that tuning coils are broken, they can be tested by making them a part of a single electric path which runs also thru a weak dry battery and a single or double 'phone set. The 'phone should be at your ear, and one tip of its cord should be attached to one terminal of the battery. The other terminal of the battery is attached to one end of the suspected coil. The other end of the coil connects with the other tip of the 'phone cord. This last connection should be made and broken two or three times, by touching the tip to the wire, to see what happens. If there is a good click in the 'phones each time, the coil is all right so far as the passage of current is concerned. This test will not reveal broken insulation, which allows bare wires to touch and short-circuits some of the turns. The latter condition would not pre-

(Continued on page 166)



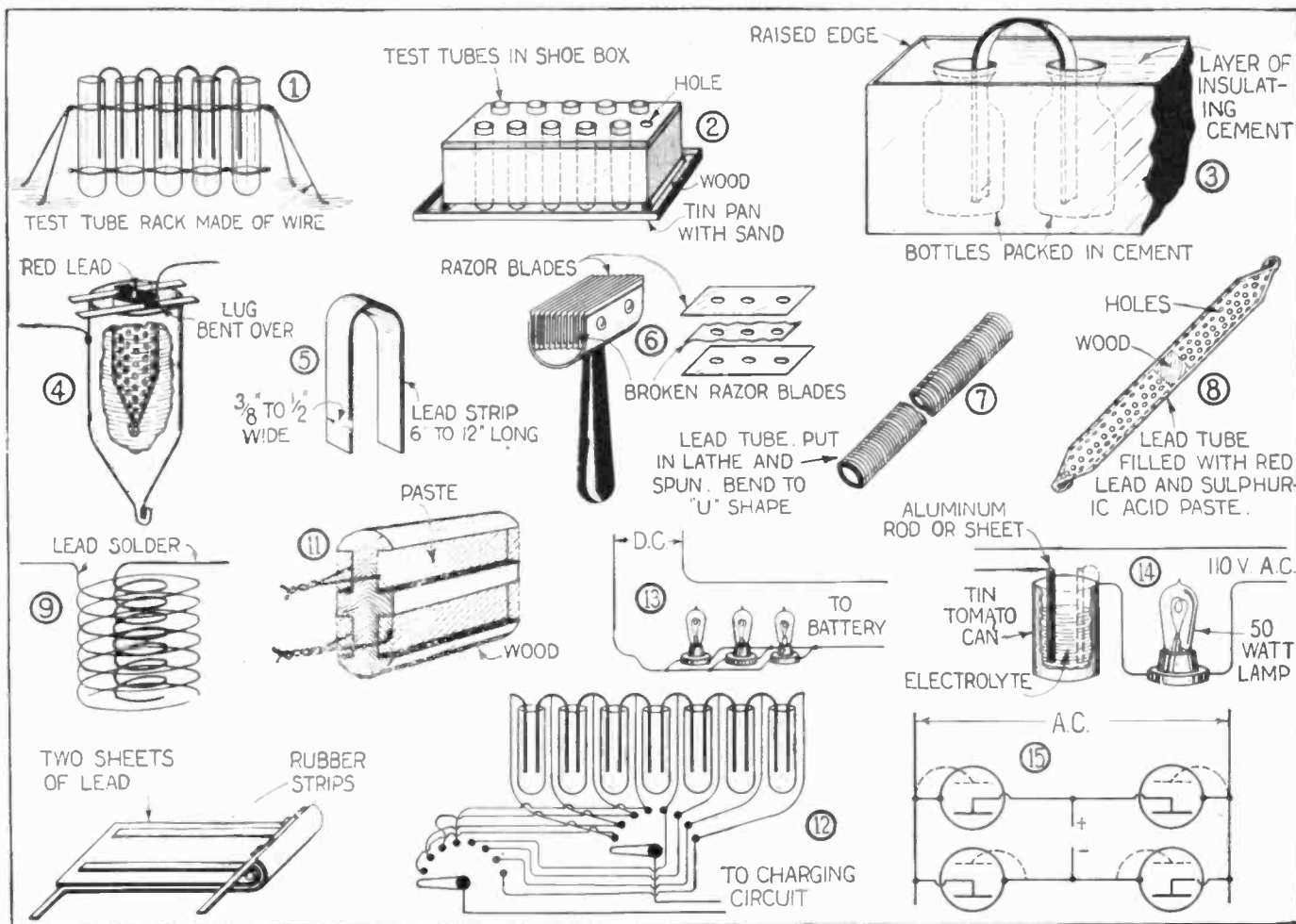

Now That Vacuum Tube Amplifying Receivers Are Coming Into Extensive Use, and in View of the Fact That the Dry "B" Batteries Are Not so Efficient After They Have Begun to Age Somewhat, and Also as They Frequently Give Rise to Noise, Due to Loose Connections or Weak Cells in the Regular Sealed Block Batteries, the Storage "B" Battery is Rapidly Coming into Favor. A Great Variety of Ideas Are Here Illustrated and Described, for Making Your Own Storage Batteries for the Plate Circuits of Vacuum Tube Receiving Sets.

# How to Make Storage "B" Batteries

By JOSEPH H. KRAUS

TODAY with audion circuits so prevalent, it is absolutely essential that suitable plate batteries be supplied. No doubt every radio enthusiast has from time to time found that his "B" battery runs out just when he most needs it. This happens on a Sunday evening more often than it does on week days. Whether there is a "B" battery "Jinx" or not, the writer does not care to discuss, but it is very annoying indeed to have this occur, as it did on several occasions when the scene was all set for a concert. It is rather strange that but few amateurs have a storage "B" battery operating in their audion circuits, more particularly so, because the expense attached is trivial, scarcely more than a new "B" battery. The amount of work is very slight indeed, and the charging is accomplished in less than three hours when once the "B" battery has been built, and charged and discharged several times, so as to "form" it. These cells give 2 volts each, average potential.

First, a word or two in reference to the jars or containers. Test tubes do the work admirably. Small sample pill bottles answer the purpose, as do larger bottles. For materials, lead strip, lead pipe, wood, and lead solder can be employed. Many methods will be given so that the needs of every experimenter will be met, regardless of the materials on hand.

## The Battery Jars

For example, a series of test tubes may be mounted in a wire rack (1) made as

illustrated in our diagram. The same test tubes can be placed in wooden test tube racks, or holes may be punched thru both sides of a paper shoe box, the tubes being then pushed thru the holes thus punched. This entire box with its test tubes is placed upon two strips of wood in a tin tray containing sand, the latter to absorb any acid leakage, as shown in figure 2. Paraffin may be poured into the paper box, making all into a unit. The test tubes required can vary in size from one-half inch in diameter and two and one-half inches long, to three-fourths of an inch in diameter and six inches long. Another method of making the test tube-rack is to place the test tube in a small box and pour some paraffin into the box, between the tubes.

Still another method is to pour paraffin into the bottom of the shoe box, to a depth of about one-half inch, and with the test tubes hanging very loosely from the cover, lower them into the paraffin which should be kept warm. The tubes will, of course, assume a vertical position. The paraffin is now allowed to cool. Now pour a new layer of the same thickness into the box, thru a hole cut in the cover. Repeat this until the box is filled to the top and it will give a solid en bloc formation. This by no means completes the tube-rack constructions, as still other ways have been found which act efficiently. For instance, we can place a number of small bottles in the paper container and pack cement around them. The top of the cement is then flushed with the tops of the

bottles and a turned up edge is left at the edges and corners of the box. The cement top is then given a coat of acid proof paint. The last method to be here described is a tube rack or container in which the tubes are made of lead. Secure sections of three-fourths inch lead pipe six inches long. Clinch these at the end and turn the ends over, making them watertight. Then solder a piece of lead to this pocket thus formed, and mount in either paraffin or cement.

## Making the Plates

We now come to the formation of the plates. The simplest are strips of lead three-eighths or one-half inch wide and from six to twelve inches long. Bend these in the form of U's as in figure 5. These are slipped into the test tubes. The variation in size is given because the test tubes vary in their diameter and length. The lead U's are inserted into the test tubes or bottles, as illustrated in figure 1.

For better results a lead pipe three-eighths of an inch in diameter is placed in the lathe, upon a dovel rod. A tool made as shown in figure 6 comprising a number of Durham Duplex or Gillette razor blades, separated from each other by the thickness of a blade (which in this instance is formed by a broken blade), are clamped into a suitable holder as illustrated. This tool is then placed against the lead tube as it rotates in the lathe. The tool will cause small ridges to form on the tube, giving it a

(Continued on page 177)

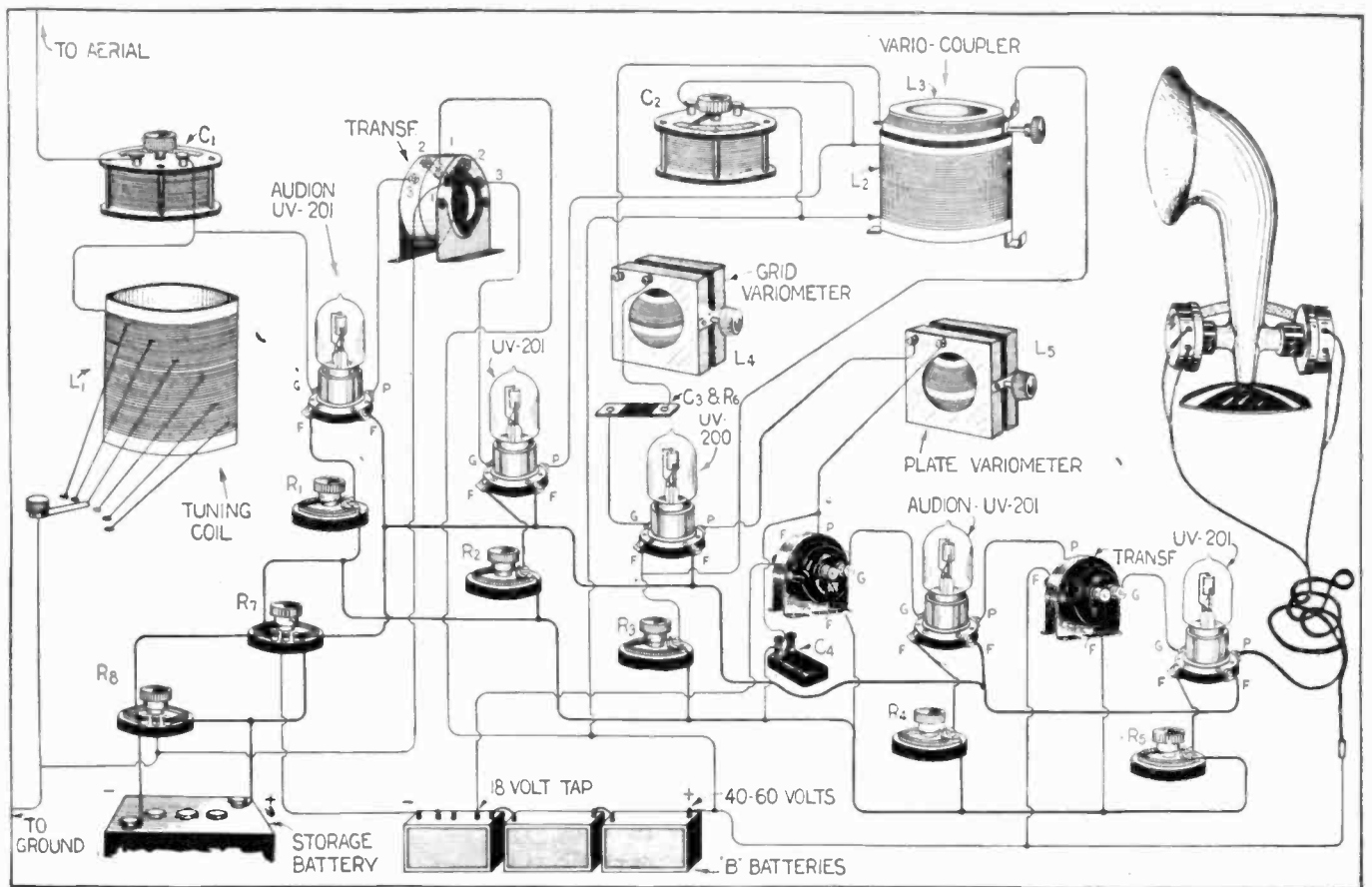

FIG. 2. COMBINED RADIO-AUDIO FREQUENCY AMPLIFIER CIRCUIT (Non-Reradiating)

Storage Battery (6V-60 Ampere-Hour Size) or Larger.  
 "B" — Standard 22.5 Volt Plate Batteries, With 18 Volt Tap.  
 C 1 — Variable Antenna Series Condenser (.0006 Mfd. Max.).  
 C 2 — Variable Condenser (.0001-.005 Mfd.).  
 C 3 — Grid Condenser (Fixed or Variable) .00025 Mfd.  
 C 4 — Telephone Condenser, Size Optional.  
 L 1 — Simple Tuning Coil, Either Tapped or Fitted With a Slider.  
 L 2 — Primary of Vario-Coupler.

L 3 — Secondary of Vario-Coupler.  
 L 4 — Grid Variometer.  
 L 5 — Plate Variometer.  
 R 1, 2, 3, 4, 5 — Standard Filament Rheostats.  
 R 6 — Standard Grid Leak, .5 to 2 Megohms.  
 T — Head Telephones or Loud Talker.  
 R 7 and R 8 — Standard "A" Battery 400 Ohm Potentiometers.

# Radio-Frequency Amplification for Amateur Reception

By ARTHUR H. LYNCH

**R**ADIO-FREQUENCY amplifiers are becoming more and more popular and a new method has been devised by one of our large corporations wherein radio-frequency intervalve transformers may be employed over a range of wave lengths heretofore impossible.

Radio-frequency amplification differs from audio-frequency amplification in that the incoming signal is greatly augmented from a local source of power *before* it is rectified by the detector tube or crystal detector as the case may be, rather than before rectification takes place.

The current developed in a radio receiving set from a very remote or low powered transmitting station is sometimes insufficient to operate a telephone or "loud speaker." Where such signal intensity is found it sometimes happens that the detector tube does not function and therefore audio-frequency amplification is impossible. The purpose of radio-frequency amplifiers is to build up the incoming signal to a point where the detector tube will function properly. After this point has been reached, audio-frequency amplification may be satisfactorily employed in order to produce a signal of almost any desired intensity. Receiving stations located at a comparatively short distance from transmitting stations do not require radio-frequency amplifiers because the detector is acted upon by the incoming waves suffi-

ciently, to produce satisfactory operation. From this it will be observed that radio-frequency and audio-frequency amplification play two entirely different rôles in radio reception.

In practice, it has been found that more than two stages of audio-frequency amplification generally prove unsatisfactory, for the reason that tube noises and inductive disturbances from power, trolley and telephone lines are greatly amplified along with the incoming signal tending to greatly distort the ultimate tone quality. This is found more especially where radio telephone communication or broadcasting reception is being carried on. More than two stages of audio-frequency amplification are not required where a suitable signal is introduced in the detector tube even though a "loud speaker" is to be employed, with the exception, of course, of large public halls, where power amplifiers should be employed. The object then of radio-frequency amplification is to provide, as we have said, a substantial signal in order that the detector tube may give satisfactory results.

Heretofore, radio-frequency amplification has not been given very serious consideration by many experimenters for the reason that many transformers were necessary in order to cover a reasonably broad band of wave lengths. The problem of developing a single transformer suitable for operation over a broad wave length

range has been a serious one and radio engineers have but recently perfected a system for enabling the experimenter to take advantage of this method of effecting communication over exceptionally long distances.

Some of the circuits for use in connection with radio-frequency amplifiers are indicated here and mention is made of those which have proven satisfactory during severe tests over the band of wave lengths indicated. We are not so much concerned with the reception of particularly long waves (5,000 to 25,000 meters) and circuits for this use have been purposely left out. Most of the difficulty experienced to date with radio-frequency amplification has been on the shorter rather than the longer wave lengths and we may very well confine our discussion to the former.

Fig. 1 illustrates one of the most suitable methods for employing a single stage of radio-frequency amplification in conjunction with a regenerative receiving circuit wherein a vario-coupler and twin variometers are employed.

## Circuits Recommended for Amateur Use

It will be observed that several changes must be made in a regenerative receiver which has already been wired, in order to introduce the radio-frequency amplifying tube and transformer as well as the

stabilizing arrangement illustrated in the accompanying diagram.

The stabilizing arrangement is merely an "A" battery potentiometer shunted across the 6 volt storage battery having its movable arm connected in the grid circuit to provide a variable negative potential for the grid of the radio-frequency amplifier tube. This stabilizer as indicated in the diagram by R3-R4 is a standard "A" battery potentiometer arranged to provide accurate regulation of the plate voltage of the detector tube. Where radiotrons are used with this circuit UV-200 is found best as the detector and UV-201 as the amplifier. More than 28 volts should not be applied to the plate of the detector tube although as much as 60 volts may be imposed upon the amplifier tube satisfactorily.

The method of using radio-frequency amplification in combination with audio-frequency amplifiers and an outdoor antenna may be observed in Fig. 2 which is a radical departure from existing receiving circuits. As may be seen, a simple tuning coil, provided with either a slider or inductance switch is connected in series with a variable condenser, the antenna and ground. Around the active turns of this coil the connections for the first stage of radio-frequency amplification are made.

This simple antenna tuning arrangement provides an energy absorbing circuit which may be tuned to the wave length of the desired incoming signal. The signal thus selected is carried through the radio-frequency amplifier circuit and the primary of the vario-coupler to the detector tube. Here it is rectified and brought to an audible frequency current which in turn

is passed thru two stages of audio-frequency amplification, providing ample signal strength for the operation of a "loud speaker" over very long distances. As may be observed two stages of radio-frequency amplification are available although a single amplifying transformer is employed. In this circuit the primary of the vario-coupler is shunted by the condenser C2 and this shunt circuit coupled to the secondary of the vario-coupler and the grid variometer circuit, form the primary and secondary of a tuned radio-frequency transformer having an air core.

Regeneration is accomplished and controlled by means of the variometer in the plate circuit of the detector tube and this precludes the possibility of oscillations finding their way back into the antenna circuit, offsetting a common source of interference.

In employing this circuit, the first two tubes should not be permitted to oscillate but should be permitted to amplify the incoming signal as greatly as possible without being brought to the point of oscillation. In some circuits the negative side of the 6 volts storage battery is grounded to stabilize the operation and reduce the tendency of regenerative receivers to howl, but this should not be done where the circuit shown in Fig. 2 is employed.

The connections for all of the above circuits are plainly indicated and no difficulty should be experienced by the experimenter even though his knowledge of radio is rather limited. The connections to vacuum tube sockets are indicated rather than the conventional symbol indicating vacuum tubes themselves for the reason

that many experimenters find it difficult to tell which of the prongs on a vacuum tube are connected to the grid, plate or filament elements.

The radio-frequency amplifying transformers are shown, provided with three terminals on both primary and secondary windings. Connection between terminals 1 and 3, with terminals 2 and 3 short-circuited, is for the transformer's shorter range. (200-500 meters); where these terminals are not short-circuited the longer range of 500-5,000 meters is available. These transformers have a turn ratio of one to one and either side may therefore be employed as the primary. In any case terminal 3 of both windings should be connected to the high potential side of the circuit with relation to the VT elements. For instance, terminal 3 of the primary is connected to the plate of the first amplifier tube and terminal 3 of the secondary is connected to the grid of the second amplifier tube. The grid bias for the amplifier tubes is provided by the potentiometer R7. These circuits have been found to give very satisfactory results and their use is particularly recommended to amateurs. R7 is merely an "A" battery potentiometer, providing accurate adjustment for the detector plate voltage.

[As these circuits are patented the patentees permit the user himself to assemble the parts into the above circuits for amateur, experimental and broadcast-reception only. This concession under its patents is given to develop a scientific interest in the radio art. The privilege is withheld from those who would assemble the parts into a set for sale. Additional information concerning the proper apparatus to use in these circuits will be supplied on receipt of stamped and self-addressed envelopes.—Editor's note.]

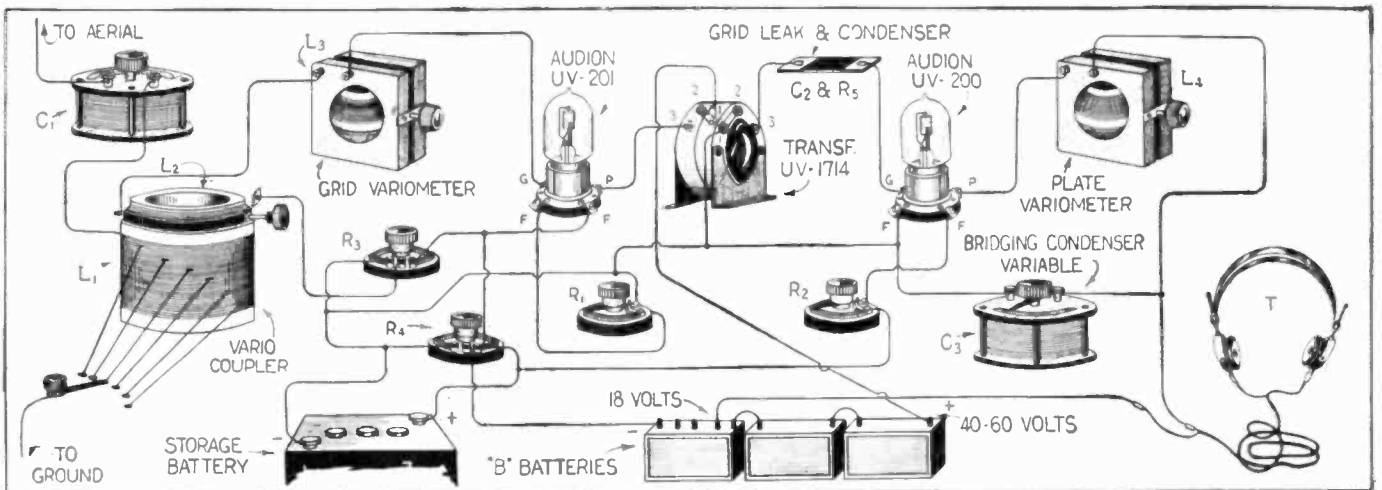

FIG. 1. VARIOMETER-REGENERATIVE CIRCUIT WITH 1-STAGE RADIO FREQUENCY AMPLIFIER

- Storage Battery (6V-60 Ampere-Hour Size) or Larger.
- "B"—Standard 22.5 Volt Plate Batteries, With 18 Volt Tap.
- C 1—Variable Antenna Series Condenser, UC-1820 (.0006 Mfd. Max.).
- C 2—Grid Condenser (Fixed or Variable), .00025 Mfd.
- C 3—Telephone Condenser, Size Optional.
- L 1—Primary of Vario-Coupler.
- L 2—Secondary of Vario-Coupler.

- L 3—Grid Variometer.
- L 4—Plate Variometer.
- R 1, R 2—Standard Filament Rheostats.
- R 3, R 4—Standard "A" Battery 400 Ohm Potentiometers.
- R 5—Standard Grid Leak Resistance, .5 to 2 Megohms.
- T—Head Telephones.

# British and Dutch to Be Linked by Radiophone

The Netherlands Telegraphic Apparatus Works recently gave a number of representatives of the press an opportunity of witnessing an exhibition of wireless telephony between Holland and England. The demonstration was held at Amsterdam in one of the rooms of the Stock Exchange, and in London at Marconi House. The experiments were very successful, although regular services between the two countries are out of the question for some time to come.

The telephone service between Paris and Berlin, and indeed between places which are much farther apart, is of course an everyday affair, but the possibility of communication with England has to be re-

garded as a fresh victory for technical science, as unless wireless telephony is established, conversation with England would have to take place by means of cables in the North Sea. Cables, however, inevitably act as condensers of electricity, and as a result the cable itself absorbs much of the electric current, leaving an insufficient quantity to transmit articulate sounds to the other side. In telegraphy, a solution of this difficulty has been found, but owing to technical difficulties, long cables seem unsuitable for long-distance conversation by telephone, and the only solution of the question therefore lies in wireless telephony.

If the only point in question were the

establishment of wireless telephony between any two given points in Holland and England, such a scheme would not be worth noticing. The object to be achieved, however, is much more far-reaching. Every subscriber in either of the two countries should be able to speak with any person in the other country. If, for instance, the editor of any Dutch paper desires to speak with an English paper, this ought to be possible by means of an ordinary apparatus on his desk.

The two companies are convinced that the results of the experiments will be of great value to trade and industry, and will greatly facilitate business transactions.



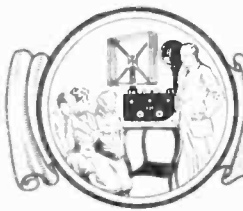

# RADIO BROADCAST



There are, without a doubt, many radio telephone broadcasting stations thruout this country which have not appeared on last month's list, more than the few additional ones we have to offer. In the last issue of this journal, we requested the assistance of our numerous readers in plotting new radiophone broadcasting stations, and placed particular stress on the request that phone stations only be included in this list. It seems, however, that the radio amateurs are interested merely in listening for one particular station, and are satisfied if that station comes in clearly and distinctly. A few have, how-

ever, tried to see how many phone stations they could hear, and have forwarded such lists to the attention of the editors.

We wish to acknowledge receipt of letters from the following: B. M. Kane, M. R. Sothern, B. R. Connolly, M. J. Mayer, C. B. Brown, A. C. Matthew, J. B. Pierce, F. X. Raven, B. Backby, Jack Edwards, A. L. Tusca, L. P. Lowell, A. Hodge, F. W. Bonner, J. R. Nogel, S. Levine, M. Hugo, C. MacDonald, R. H. Learned, John Egan of the International Telephone Company, C. N. Hill of Doubleday Hill Electric Co., Paul Gardner, Anthony Ciavarella of the Church of the Covenant, Mr. Tuttle of the

San Francisco Examiner, Robert T. Andrae of the Northern Ontario Light & Power Co. Ltd., F. W. Elliott of the Broadcasting Station of the Palmer School of Chiropractic. We trust the coming month will bring many more of these letters.

Address all communications to—Editor Radio Broadcast, c/o Science and Invention Magazine, New York City. The map locations here given are to be used on the large supplement map furnished with the May issue of SCIENCE AND INVENTION MAGAZINE.

Location	Station Name	Call	Wave Length, Meters	Map Location
Albany, N. Y.	Shotton Radio Mfg. Co.	WNI	360	J-47
Austin, Texas	University of Texas	WCM	360	Z-29
Baltimore, Md.	Jos. M. Samoiski Co.	WKC	360	N-46
Buffalo, N. Y.	McCarthy Bros. & Ford	WWT	360	K-43
Canton, Ohio	Daily News Printing Co.	WNB	360	M-13
Chicago, Ill.	City of Chicago	WBU	360	M-35
Cincinnati, Ohio	Crosley Mfg. Co.	WLV	360	P-38
Every evening, programs of music, news and lectures. Impromptu program.				
Cleveland, Ohio	Cleveland Radio Association			L-41
Detroit, Mich.	Police Department	KOP	360	L-39
(The editors think that this call letter for a police department station is rather appropriate. Policeman—Cop—Kop.)				
Erie, Pa.	Electrical Equipment Co. 703 State Street	WJT	360	L-42
No regular program.				
Granville, Ohio	Dennison University	WJB	360	N-40
Located in Licking County.				
Gridley, Calif.	Precision Shop	KFU	360	M-4
Houston, Texas	Hurlburt-Still Electrical Co.	WEV	360	AA-28
Indianapolis, Ind.	Hathfield Electric Co.	WOH	360	O-37
Jefferson City, Mo.	Missouri State Marketing Bureau	WOS	360	O-31
Kansas City, Mo.	Western Radio Co.	WOO	360	P-29
Lansing, Mich.	Stewart W. Seeley	WHW	360	K-38
McKeesport, Pa.	K. & L. Electric Co., 427 Olive Street	WIK	360	N-43
Daily 6.30-7.00 P. M. Tuesdays and Thursdays 9.30-10.30 P. M. Sundays 1.30-2.30 P. M. Maximum range 500 miles.				
Memphis, Tenn.	Riechman-Crosby Co.	WKN	360	U-34
Montreal, Can.	Marconi Telegraph Co. of Canada, Ltd.	VCA	360	F-46
New Lebanon, Ohio	Nushawg Poultry Farm	WPG	360	O-39
Pine Bluff, Ark.	Pine Bluff Co.	WOK	360	V-31
Pittsburgh, Pa.	Newspaper Print Co.	WPB	360	N-42
No regular program.				
Pomona, Calif.	Pomona Fixture & Wiring Co.	KGF	360	T-6
Rochester, N. Y.	The Rochester Times-Union	WHQ	360	J-44
San Francisco, Calif.	San Francisco Examiner Newspaper	KUO	360	O-3
Spokane, Wash.	Doerr-Mitchell Electric Co.	KFZ	360	C-10
St. Louis, Mo.	St. Louis University	WEW	360	O-33
Washington, D. C.	Church of the Covenant	WDM	360	O-45
Station maintained by Thos J. Williams, Inc., of New York. Operator Anthony Ciavarella. Church services. This station broadcasts on Sundays only at 11.00 A. M., 3.30 P. M. and 8.00 P. M. Maximum distances heard 900 miles to the north and south as far as Miami, Florida.				
Wichita, Kan.	Cosradio Co.	WEY	360	R-26
Yakima, Wash.	Electric Power & Appliance Co.	KQT	360	D-7
Yakima, Wash.	Foster-Bradbury Radio Store	KFV	360	D-7
Youngstown, Ohio	Columbia Radio Co.	WMC	360	M-42

Two steamships find their way to this month's list: S.S. America call letters KDOW, working in conjunction with 2-XJ. This ship has telephoned via radio when hundreds of miles from New York, which message was picked up by the land station at Deal Beach, and transmitted via telephone lines to New Canaan, Conn. At this point, by speaking into a regular telephone transmitter, the voice was carried by land lines back to the American Tel. & Tel. Company station at Deal Beach, and then radioed across the waters to the vessel, establishing in this way telephonic communication between the ship at sea and the shore telephone.

The S.S. Concord of the Colonial Navigation Company, call letters KNC, is also equipped with a radiophone transmitter. Not broadcasting regularly.

## CORRECTIONS

Washington, D. C., White & Boyer Co., WJH call letters were not given. The Doubleday Hill Electric Co. operate two stations, and the information should read as follows:

Washington, D. C., Doubleday Hill Electric Co., WMU, 360 meters, instead of KQV as listed on our previous map.

Pittsburgh, Pa., Doubleday Hill Electric Co., KQV, 360 meters. Discrepancy is announced in the call letters of the Ohio State University, one writer having declared that this station at Columbus, Ohio, having call letters 8-YO on our original list, is using the call letters AB-4.

Our list next month will without a doubt contain further information con-

cerning the nature of the broadcasts of most of the stations here listed. From time to time, we will publish an additional list complete up to date, and if the reader hears of any broadcasting station now not listed, he will render assistance to other radio fans as well as himself by sending the same to us. This is the reader's map, and those who are interested in the subject of radio are entirely responsible for its growth. Make it the best ever.

Revised Map Locations of stations published in the May issue appear in this list reprinted by request:

Location	Station Name	Call	Wave Length, Meters	Map Location
Akron, Ohio	Radioart Store Station	8 UX	190, 200	M-41
Anacostia, D. C.		NOF, NSF	350	O-46
Austin, Texas	State University	5 XU	360	Z-26
Berlin, N. H.	Y. M. C. A.	1 BKP	200	G-49
Charlotte, N. C.	Southern Radio Corp.	WBT	360	T-42
Chicago, Ill.	Westinghouse Station	KYW	360, 485	M-35
Cincinnati, Ohio	Precision Equipment Co.	WMH	360	P-39
Cleveland, Ohio	Cox Mfg. Co.	8 ACS	200	L-41
Cleveland, Ohio	W. R. Cox	WHK	360	L-41
Columbus, Ohio	Ohio State University	8 YO		
		AB-4	275	O-40
Dallas, Texas	Police Department	WRR	450	X-26
Davenport, Iowa	Palmer School of Chiropractic	WOC	360	M-33
Dayton, Ohio	McCook Army Station	WFO		O-39
Deal Beach, N. J.	American Tel. & Tel. Co.	2 XJ		M-48
Denver, Colo.	Fitzsimmons General Hospital Station	DD 5	325	O-20
Denver, Colo.	Reynolds Radio Co.	9 ZAF	360	O-20
Denver, Colo.	W. D. Pyle	9 WD	200	O-20
Denver, Colo.	Y. M. C. A. Station	9 YAL	485	O-20
Detroit, Mich.	Detroit News	WWJ	360	L-39
Fairfield, Ohio	U. S. Army Station	WL 2		O-33
Fort Worth, Texas	Fort Worth Record	WPA	360, 475	X-26
Hamilton, Ohio	Doron Bros. Electrical Co.	WRK	360	O-28
Jersey City, N. J.	Hudson City Radio Club	2 CBK	200	L-48
Jersey City, N. J.	Hudson City Radio Shop	2 BPG	200	L-48
Jersey City, N. J.	Jersey Review	2 IA	200	L-48
Jersey City, N. J.	New Jersey Wireless Telephone Co.	WNO	360	L-48
Lincoln, Neb.	University of Nebraska	9 YY	375	N-27
Los Altos, Calif.	Colin B. Kennedy Co.	KLP	360	O-3
Los Altos, Calif.	Colin B. Kennedy Co.	6 XAC	200	O-3
Los Angeles, Calif.	C. R. Kierulff	KHJ	360	T-6
Los Angeles, Calif.	Western Radio Electric Co.	KOG	360	T-6
Madison, Wis.	University of Wisconsin	WHA	360, 485	K-33
Mamaroneck, N. Y.	Experimental Station	2 BQH	200 to 1,200	L-48
Medford Hillside, Mass.	American Radio Research Co.	WGI	360	J-50
Newark, N. J.	L. Bamberger & Co.	WOR	350	M-48
Newark, N. J.	Westinghouse Test Station	2 SAI		M-48
Newark, N. J.	Westinghouse Electric & Mfg. Co.	WIZ	360	M-48
New York City		2 AYZ		
		2 BHY		
		2 KP		
		2 ADK	200	L-48
New York City	Hudson Radio Club			
New York City	Shipowners' Radio Club	WDT	360	L-48
New York City	John Wanamaker	WWZ	360	L-48
N. Y. Harbor, N. Y.	Fort Wood, Governor's Island	WVP	1,450	L-48
Oakland, Calif.	Hotel Oakland, Western Radio Inst., Preston D. Allen	KZM	360	O-3
Parkersburg, Pa.	H. A. Beale	3 XW	200	M-46
		3 ZO		
Pasadena, Calif.	J. J. Dunn & Co.	KLB	360	S-6
Pawtucket, R. I.	Delancey, Felch & Co.	1 OJ	200	K-50
Pawtucket, R. I.	Standard Radio & Elec. Co.	1 XAD	290	K-50
Philadelphia, Pa.	Gimbel Bros.	WIP	360	M-47
Philadelphia, Pa.	T. F. Howlette	WGL	360	M-47
Philadelphia, Pa.	Strawbridge & Clothier	WFI	360	M-47
Philadelphia, Pa.	John Wanamaker	WOO	360	M-47
Pittsburgh, Pa.	Westinghouse Electric Co.	KDKA	360	N-42
Portland, Ore.	Willard P. Hawley	7 XG	200	E-5
Portland, Ore.	Northwestern Radio Mfg. Co.	7 XF		E-5
Portland, Ore.	The Oregonian	KSW	360	E-5
Richmond, Ind.	Richmond Palladium Newspaper Co.	WOZ	360	O-38
Ridgewood, N. Y.	Broadcasting Corp. of America for Times Publ'g. Co.	WHN	360	L-48

(Continued on page 164)

# Radio Oracle

In this Department we publish questions and answers which we feel are of interest to the novice and amateur. Letters addressed to this Department cannot be answered free. A charge of 25c is made for all questions where a personal answer is desired.

## Dry Cells on an Audion

(17) Monferd Rockwood, Akron, Ohio, inquires:

Q. 1. Can I use dry cells to light the filament of my audion bulb?

A. 1. If you must use dry cells for lighting the filament of your vacuum tube, four cells should be used, connected in series, or, better

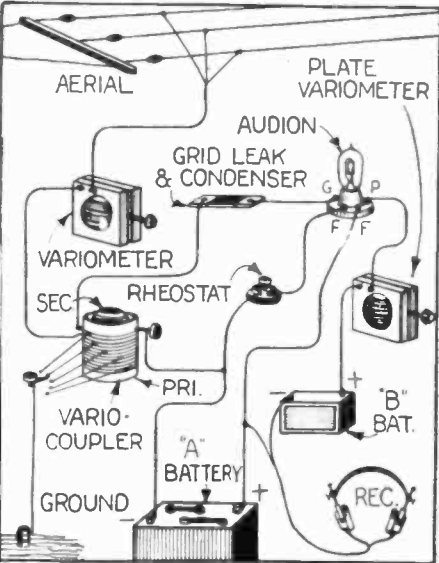

Query 17.—A Short Wave Regenerative Receiving Set, Using Two Variometers and a Variocoupler for Tuning.

still, eight cells in two sets of four each, connected in series parallel. However, a storage battery would be much more satisfactory.

Q. 2. Please give hook-up of 2 variometers, a variocoupler and an audion detector.

A. 2. The hook-up which you requested is given here.

Q. 3. How far can I receive with this set?

A. 3. The distance you could receive with this set depends upon many factors. You could probably receive radiophone messages from a distance of 100 miles. However, this is only approximate.

## Loose Coupler and Audion

(18) Max Hughes, Hexie, Ark., asks:

Q. 1. Can an audion tube be used with a loose coupler, and can I receive radiophone concerts with this set?

A. 1. An audion detector may be used in connection with a loose coupler.

It will be possible to hear radiophone concerts within a radius of approximately 75 miles with this set, providing you use an aerial at least 100 feet long, and as high above the ground as possible.

Q. 2. Please give a hook-up of this set.

A. 2. The hook-up is given herewith.

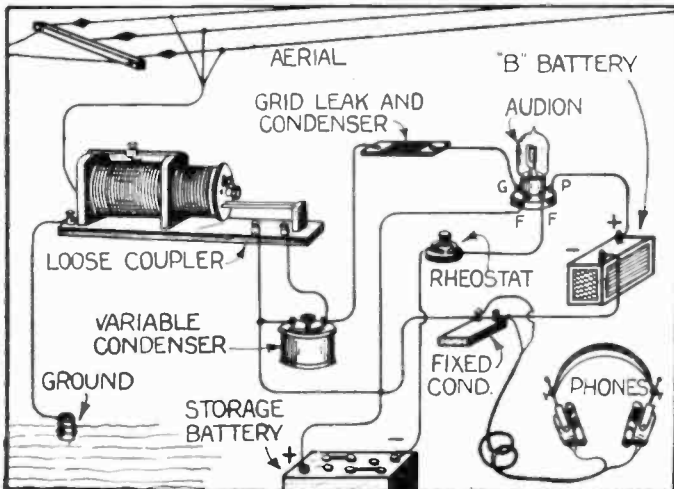

Query 18.—Above is Given the Circuit for a Loose Coupler Used in Connection with an Audion Detector.

Query 23.—To the Right is Shown a Non-regenerative Hook-up, Using a Variocoupler for Tuning.

## Audions Made From Auto Lamps

(19) Walter Schols, Sioux City, Iowa, asks:

Q. 1. Where can I secure double filament auto lamps?

A. 1. The two filament electric lamps described in the 1918 issue of this journal, by R. U. Clark are no longer made.

Q. 2. Can I use these as audions?

A. 2. The editor of this department and the associate editor conducted a series of experiments with several of these lamps built to order. These experiments were fully described in one of the early issues of Radio News. In no event did we ever obtain results which would be considered worth the trouble and expense incurred. Altho the Brooklyn Navy Yard station, a few miles away, was heard at one time, no other station was brought in regardless of how amplified by regular vacuum tube systems.

## To Receive Newark Broadcast Station

(20) Willard A. Phillips, Scranton, Pa., asks:

Q. 1. Can you advise the apparatus necessary to receive Newark and eastern or western stations from here—in other words, about 150 miles—in almost all weather conditions?

A. 1. For receiving radio music and lectures from New York you will need an audion outfit. You may find that you will need a two-stage amplifier in addition to the detector and the tuning coil and other apparatus. The distance is not great, from the standpoint of radio; but usually the novice is not satisfied with results that would be considered pleasing to one who had had long experience with radio. Radio men are satisfied with a clear and understandable tone, but one beginning with radio usually wants the music to be as loud as a phonograph would make it. When you consider that the energy passes thru the ether for many miles before reaching the receiving antenna, you will understand that it must be amplified considerably in order to make loud tones. Then again, the amount of energy picked up by an antenna is very close to nothing, about 50 to 100 microamperes on the average.

In addition to the amplifier you may wish to have a loud-speaker. This, at your distance, ought to give you music loud enough to dance by, except at times when atmospheric conditions are very bad. During the season of thunder showers and excessive static there will be evenings when you will be able to hear little if anything, but at other times everything will be all right.

We suggest that you secure catalogs from several advertisers and talk with local people who are using radio. Gradually you will emerge from the confusion into which their technical terms throw you, and obtain a reasonably clear idea of what you want. You may begin with a very cheap set and then build up the outfit, learning as you increase expenditures. You are too far from transmitting stations to begin very cheaply tho, but we think \$75 would start you all right, without the necessity of purchasing anything that you would have to throw away as your outfit developed.

There is a big advantage in having a good pair of phones. Baldwin phones are excellent, but very hard to obtain at present. For local work, a 50-cent phone will be almost as loud as a Baldwin; but as the distance increases a sensitive phone becomes a necessity if you are looking for good results.

## Spark Coil Transmission

(21) Lawrence Wadsworth, Minneapolis, Minn., asks:

Q. 1. Can a radio receiving set be used to detect the approach of automobiles, by means of the waves sent out by the ignition spark coil?

A. 1. If this were true, most radio amateurs would hear nothing at all but the tune of auto-

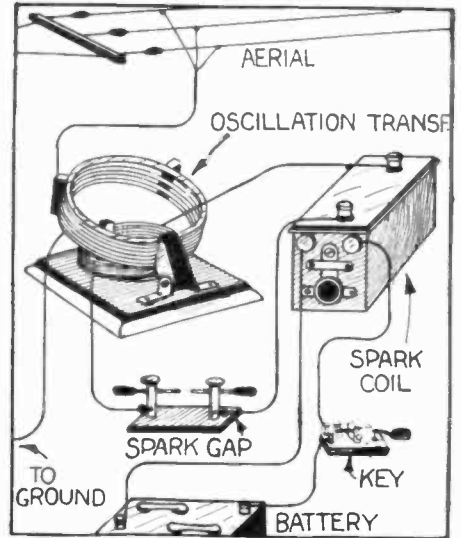

Query 21.—A Circuit Using an Oscillation Transformer in Connection with a Spark Coil and Gap for Spark Transmission is Shown Above.

mobile spark coils. However, if the car was very close to the aerial, say separated by about one foot, it could probably be heard.

Q. 2. Please give hook-up of a spark coil and oscillation transformer for transmitting.

A. 2. The hook-up of the spark coil is given herewith.

## Radio Contest

(22) Paul F. Wilbur, Syracuse, N. Y., asks us to return his receiving set which was entered in our "Simplest Radio Outfit" contest.

A. 1. Owing to the fact that many of the sets entered in the contests have no names with them, we will have to ask you to write again, describing your outfit, and if possible, sending a sketch or photograph of it.

## Will this Circuit Regenerate?

(23) John H. Waack, Minneapolis, Minn., requests:

Q. 1. A hook-up of a variocoupler and an audion detector set.

A. 1. The hook-up is given herewith.

Q. 2. Will this circuit regenerate?

A. 2. No.

Q. 3. Which side of the secondary of the variocoupler should be connected to the rheostat?

A. 3. It does not make any difference.

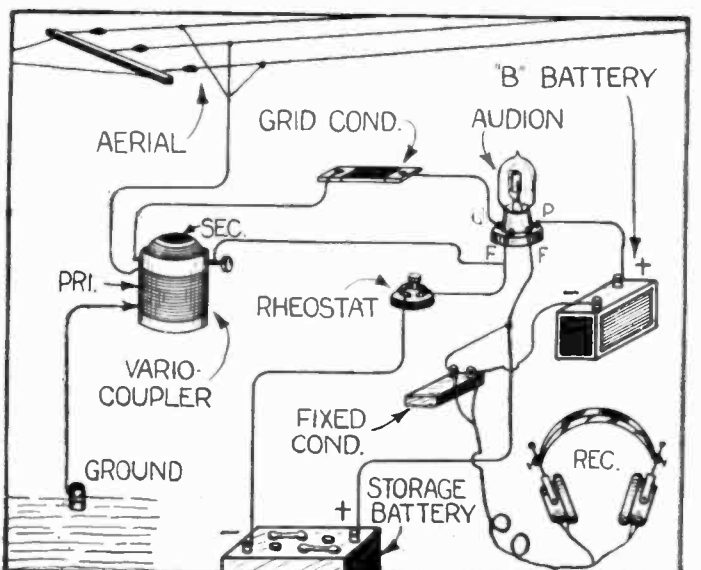



# LATEST PATENTS

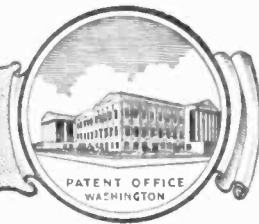

PATENT OFFICE  
WASHINGTON

## Mechanical Hand

(No. 1,409,415 issued to Wilhelm Shimmel)

The citizens of the German Republic are coming forward with new

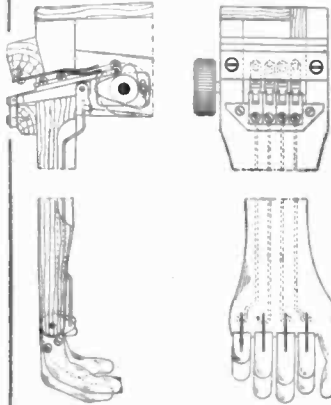

inventions. A rather ingenious device is illustrated here. This is a mechanical hand adapted to play key instruments of any kind, and may be used for advertising purposes, by placing the automatic member in a shop window together with the piano on which it plays. The hand is remarkably similar to a human hand. The fingers are pivoted and are controlled by means of individual levers: these levers in turn are actuated by cam-like devices driven by an electric motor. In this manner the keys of the instrument are struck by the fingers. The entire mechanical device is, of course, attached to a figure seated in a chair in front of the instrument. Means for moving the hands laterally are likewise provided for.

## Surf Board

(No. 1,404,790 issued to Henry Howard Newby)

The board is narrow in width, and has two floats mounted thereon

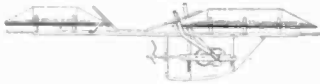

spaced apart and held in place by straps. The board is likewise provided with a saddle having a seat and a back rest. From the bottom of the board a rigging depends. This houses the gears and the propeller. The gears are operated by levers having a ratchet connection with the drive shaft. The free ends of the levers are within reach of the rider, so that the latter may operate them to impart motion to the propeller, and hence drive the board thru the water.

## Centrifugal Diving Apparatus

(No. 1,405,996 issued to Joseph Charles Freeze)

We wonder how this peculiar diving apparatus will work after it has been built. The entire structure is

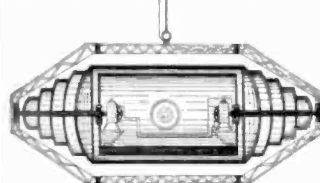

guarded by a steel girdered frame to which frame is attached a ring by means of which the vessel is to be lowered into the water, and raised therefrom. At the ends of the frame are bearings for shafts which support the weight of the vessel.

Thru one of these shafts the cable for current supply enters. The apparatus is provided with two shells, the innermost one being held rigidly by gyroscopic stabilizers. The device is equipped with two watertight doors, which are used for entering the vessel; each door is likewise provided with lenses thru which objects under water may be seen or photographed. The lens on the inner shell is, of course, stationary, but the one on the outer shell rotates with the shell, the frame-work acting as a shutter. The centrifugal force produced by rotation of the outer shell and the compressed air at the ends of the vessel should counteract the water pressure, according to the inventor's claims.

## Combination Motion Picture Projector and Phonograph

(No. 1,408,620 issued to Ferdinand V. Madaler)

This method of synchronizing motion pictures with phonographic music is very simple. The turn-table of the phonograph and the motion picture apparatus are both controlled by the same motor which is secured to the main shaft. A suitable slot is provided upon the phonograph record into which the needle of the producer fits. The

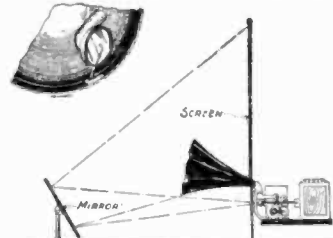

motion picture film is set into the projecting machine and the motor started. The pictures are then thrown upon a mirror and from thence reflected to a screen. Inasmuch as the horn of the phonographic reproducer is placed in front of and below the screen, it becomes obvious that the entire mechanism may be controlled by one individual and the voice seemingly comes from the actors themselves.

## Advertising Device

(No. 1,405,304 issued to Hugh Kenneth MacDougall)

Ingenious advertising devices will never cease to attract attention. One of these is the subject of a patent recently granted. In this de-

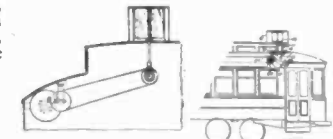

vice a fan is mounted upon the roof of a car in a special holder, so that the blades or vanes are acted upon by the air when the car is moving forward. Half of the bladed area is shielded, so that the air only acts upon one blade at a time, consequently causing motion in one direction. This windmill arrangement connects with a gear inside the car, and then drives a belt turning a disc. Upon the latter disc a lateral pin is located. This pin drives a Geneva wheel intermittently, causes the advertisements arranged upon a polygonal drum to rotate. The drum extends the entire length of the car.

## Snow-Removing Machine

(No. 1,408,471 issued to Elbert E. Ricks)

In this snow-removing machine a

steam engine is mounted on truck wheels. This steam engine provides the power for driving the snow-remover forward and also for supplying a stream of steam whereby the snow is melted rapidly, and, according to its inventor, permitted to

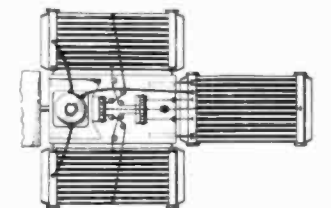
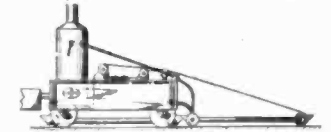

run to water. Each of the reducers or snow-melting devices includes rectangular or appropriate cross-section ends connected together in radiator fashion by parallel pipes; the under sides of the tubes are perforated for the emission of steam downwardly. The ends of these reducers are likewise provided with an upwardly inclined shoe or scoop.

## Boat Construction

(No. 1,408,178 issued to Virgil Sidney Downing)

A boat similar to this recently made quite a record. In its construction, air ducts are found in the top, and air channels are formed in its hull. The latter are so shaped and situated as to effect a lifting and propelling action, when air is forced rearwardly thru the channels. The air thus discharged from the channel is caused to produce a film beneath the rear portion of the boat, as air rushes past in a considerable stream. This produces an air cushion, so to speak, upon which



the boat rides. Due to the lifting action of the waves acting on the hull of the boat when the boat is traveling at a considerable speed, its bow also rises. Consequently, almost the entire vessel is supported by an air pad. The engine drives an air propeller which is the means of propulsion of the vessel.

## Sound Post

(No. 1,408,707 issued to John William McGrath, Jr.)

This sound post has been designed to improve the tonal quality of a violin. It will be appreciated that any vibration imparted to one of the strings is transmitted to the body of the instrument, then to the sound post, and so conducted to the opposite side of the instrument. In order to lengthen the vibratory period, an attachment has been made to the sound post. This is a sort

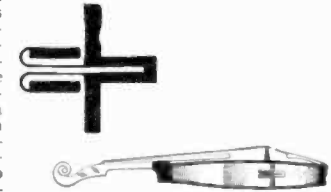

of pronged fork arrangement provided with curved extended portions at the ends of which are weights. Consequently the weights vibrating because of the impulse which the sound post imparts to them set up another vibration.

## Ship Salvaging Apparatus

(No. 1,404,921 issued to James N. Adams)

There are few systems which will rescue vessels now lying at the bottom of the ocean or in waters ordinarily inaccessible to the diver who has to operate within 300 feet of the surface and usually not more than 75 feet. In this system, a method different from the usual ship salvaging schemes is employed, in that heavy cables anchored to the keel of the vessel and passing thru a special channeled-duct arrangement are attached to arrow-shaped steel. These members are surrounded by cork in order to make them float. To these floats, other floats of considerably smaller design are attached. Should the ship meet with accident and sink, the smaller floats rise to the surface of the water. Each of these, and there are large numbers arranged upon the vessel, are marked with letters or figures such as "3, midship"; "1, aft port," etc., and are connected to arrow-shaped hooks. When the salvaging vessel comes upon the scene, it attaches a special anchoring device to each of the cables leading to the arrow-shaped floats. This cable device slides along the thinner cable to the larger float and grips the ar-

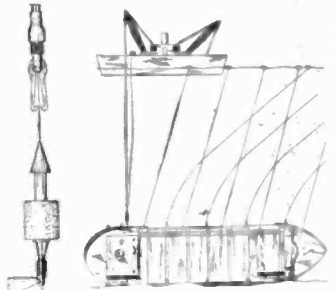

row securely attached to the ship by heavy chains. Traction upon the cables so inserted permit of the raising of a vessel.

## Trouser Creasing Device

(No. 1,409,633 issued to Herman S. Willis)

In this trouser creasing device a metallic rod or bar is so formed as to taper to a fine V-shaped edge when viewed in cross-section. When



in practice, the foot of the wearer of the trousers is inserted thru an arc-shaped portion of the member, while the rod or bar extends inside of the trouser so that the sharp edge is directly behind the front crease of the trouser, or directly in back of the position where that crease is to be made. Two spring clips, one at either end, are then clamped into place, thus holding the trousers fixed and an electric iron of the roller type is simply run up and down the trouser leg, so as to form a straight and accurate crease.



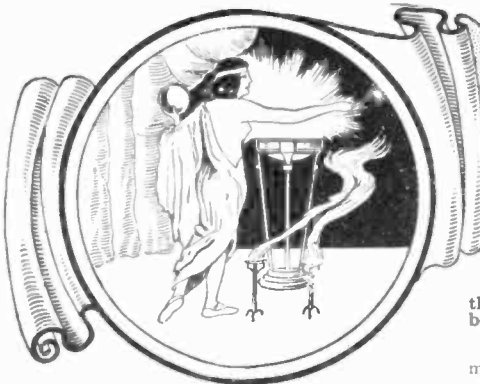

# THE ORACLE

The "Oracle" is for the sole benefit of all scientific experimenters. Questions will be answered here for the benefit of all, but only matter of sufficient interest will be published. Rules under which questions will be answered:

1. Only three questions can be submitted to be answered.
2. Only one side of sheet to be written on; matter must be typewritten or else written in ink, no penciled matter considered.
3. Sketches, diagrams, etc., must be on separate sheets. Questions address to this department cannot be answered by mail free of charge.
4. If a quick answer is desired by mail, a nominal charge of 25 cents is made for each question. If the questions entail considerable research work or intricate calculations a special rate will be charged. Correspondents will be informed as to the fee before such questions are answered.

## Query on Tin

(1222) A. A. Aruckey, Chicago, Ill., asks:  
 Q. How can I separate the ingredients of tin?  
 A. Tin is an element and is so found in Nature. It is no composed of two different ingredients.  
 It can be melted in a ladle over a fire. Keep the heat low.

## Oxidizing Brass and Copper

(1223) Blue Star Service Bureau, Delavan, Wis., writes us:  
 Q. Please give me formulas for solutions to use in oxidizing brass and copper.  
 A. The following solutions may be of value: Dissolve 6 drams of ammonium carbonate and 3 drams of copper acetate in 8 ounces vinegar and evaporate to one-half the volume. To this add 72 grains of ammonium chloride and 18 grains of oxalic acid.  
 Heat and mix with the evaporated solution obtained as above, clean copper article and boil it in this mixture until covered with a yellowish brown coating. Remove and buff.  
 For coloring either copper or brass, dip in solution of 2 ounces of sulphur and 2 ounces of potassium chloride and 1,000 ounces of water. The article may also be immersed in a solution of ferrocyanide of potassium, strongly acidulated with hydrochloric acid.

## Tesla's Gas Turbine

(1224) L. B. Wynne, Indianapolis, Ind., inquires:  
 Q. Where can I obtain data and detailed information on Dr. Tesla's gas turbine?  
 A. You might write to Dr. Tesla, at 8 West 40th Street, New York City, and ask him where you could find the most concise and accurate account of his gas turbine, and also the alternators which you are interested in. You can obtain the patent numbers from Dr. Tesla. You might refer to Sewall's "Wireless Telegraphy," which is now out of print, but which most public libraries have on file, where a fair account of the Tesla radio power transmission scheme is given. A number of patents have also been issued on his "radio power transmission system"; and copies of these can be obtained at 10 cents each from the U. S. Patent Office. This office is likewise in a position to give you a list of the numbers of these patents, if you will write to them at Washington, D. C., and tell them just what class of patents issued to Dr. Tesla you are interested in.

## Electro-Plating

(1225) H. B. Aarens, Chicago, Ill., asks:  
 Q. 1. What is the name of the book on electroplating recently reviewed by you?  
 A. 1. This book is called "The Modern Electro Plater," by Coggeshall.  
 Q. 2. How are plaster articles plated?  
 A. 2. Under ordinary circumstances a plaster article is coated with graphite before it is electroplated.  
 Sometimes the plaster article must be varnished several times before this coating process takes place. Coggeshall describes this method as well as the method of plating.

## Die Casting Query

(1226) E. F. Ahlin, Leavenworth, Wash., asks:  
 Q. Please give formula of a suitable metal which can be employed in the die casting of tin soldiers.  
 A. We would advise any of the following compositions:  
 1. Tin, 8 parts; lead, 6 parts; antimony, 1/2 part by weight.  
 2. Lead, 3 parts; antimony, 1 part.  
 3. Lead, 75 parts; antimony, 23 parts; tin, 22 parts.  
 4. Lead 10 parts; antimony, 2 parts; bismuth, 1 part.

## Dry Storage Batteries

(1227) Miner E. Harris, Beatrice, Nebr., asks:  
 Q. 1. How do the dry storage batteries compare with the wet?  
 A. 1. The essential feature of a dry storage battery is that the space between the plates is filled with glass wool, which is saturated with the electrolyte. These batteries are

not really dry batteries, but are moist. Their advantage lies in the fact that if the battery upsets, the acid will not be spilled, as would happen when an ordinary wet battery is used. The ampere-hour loss, due to such semi-solid electrolyte is about 20 per cent.

## Interesting Argument on the Senses

(1228) Leo J. Scanlon, N. S., Pittsburgh, Pa., asks:  
 Q. 1. (a) Are the senses of taste and smell the perception of vibration of any substance? Does mustard, having a keen taste, vibrate at a much higher rate than sugar, which has a dull or pleasant taste? Are the different degrees of taste between these two due to a different rate of vibration in the objects possessing such taste?  
 (b) Are excessively high rates of vibration the cause of the lack of taste in some objects?  
 A. 1. The senses of taste or smell are not perceptions of vibration of the substance. If that were the case, it would be possible to stimulate the nerve-endings of the tongue and nose and produce odors. It is quite likely that some time in the future a method will be discovered whereby certain electrical changes will result because of the odor given out by the substance, but the manner in which this will be done is not thru the reception or perception of vibration. A small quantity of musk placed in one corner

due to the combination or compound formed. Nevertheless, we can duplicate natural odors to the extent at least of fooling our olfactory nerves, by mixing various coal tar products.

Q. 3. Do the particles composing the hand vibrate at a much higher rate than usual when exposed to heat, thus causing the hand to vibrate at the same rate as the said source of heat, after contact with the hand? Is a "fever" the particles of the body vibrating at a rate higher than usual; and inversely, "chills," a slower rate? Are there overtones of heat and cold, such as when the feet become numb? Are the atoms of the feet vibrating at such a low rate of speed that the brain cannot perceive the vibrations, or cold?  
 A. 3. What the effect in the nerves of the fingers is, is likewise not known, and whether the nerve impulse propagation is due to an electrical stimulus, or to chemical or transitional changes, has not yet been determined. A little over a year ago, a series of articles on the senses appeared in this journal, in which the touch, taste, smell, and sight and the electrical theory of nerve impulse transmission were discussed. In each touch-spot on the skin is found a net-work of nerve-endings, terminating in what the anatomist calls a "touch corpuscle." Stimulation of these touch corpuscles announces that fact to the brain. There are certain touch-spots for heat, others for cold, just the same as there are taste buds on the tongue in different regions for the different tastes, bitter, sweet, sour and salt, and combinations of these together with the olfactory perception of the odor, gives the epicure his remarkable ability of smelling and tasting. The particles of the body do not vibrate in fevers, or in chills, the fact is purely physiological, and the result of destruction by disease germs. It is a known fact that nerves do not respond as well when under the influence of cold. Consequently, freezing definite areas enables painless operations to be conducted (see article on anesthetics in the May issue of SCIENCE AND INVENTION). This upsets your theory on the atoms of the feet vibrating at a low rate of speed.

## IMPORTANT

### TO NEWSSTAND READERS

In order to eliminate all waste and unsold copies it has become necessary to supply newsstand dealers only with the actual number of copies for which they have orders. This makes it advisable to place an order with your newsdealer, asking him to reserve a copy for you every month. Otherwise he will not be able to supply your copy. For your convenience, we are appending herewith a blank which we ask you to be good enough to fill in and hand to your newsdealer. He will then be in a position to supply copies to you regularly every month. If you are interested in receiving your copy every month, do not fail to sign this blank. It costs you nothing to do so.

.....  
 To..... Newsdealer  
 Address.....  
 Please reserve for me..... copies of SCIENCE & INVENTION every month until I notify you otherwise, and greatly oblige.  
 Name.....  
 Address.....

of the room may soon be noted in any part of the room, the odor having been wafted around is due to the presence of infinitesimal particles of the musk were given off and float easily in the air. Consequently, the second part of your first question is also answered.

Q. 2. Is the smell of any object really infinitesimally small particles of said object floating in the air? Are the different odors the result of the difference in the rate of vibration of these particles comprising the "odor" as stated above? Compare the smell of ammonia and that of a rose. Are there odors which we cannot perceive, due to the rapidity or slowness of vibration of the component atoms of a substance having such odor, in the same sense that we cannot hear overtones or undertones in music?  
 A. 2. The smell of objects, as stated before, is due to the presence of infinitesimal particles of that object floating in the air, and if there is any difference in vibration, the difference is not on the part of the particle of the substance, but on the nerve whose endings, passing thru the cribiform plate of the ethmoid, imbed themselves in the mucous membranes lining the nose. We do not believe that odors are due to the rapidity or slowness of vibration of component molecules or ions of substances having such an odor, but

Q. 4. Is it possible that there exists matter in a concrete form, but vibrating at such a high rate as to be imperceptible to the human eye? What about radium, ether of interspace? Does the intensity of light depend upon the rate of vibration of, or upon the volume of, electrons given off the source of light? Or is the intensity of vibration of all light the same, with some other factor determining the intensity of the light, eliminating that of distance? I refer to the Dim-a-lite sockets, which are being extensively advertised. Must all matter vibrate in order to be visible to the eye?  
 A. Are light and heat one and the same, namely, vibration? Is light only a higher rate of vibration of electrons than heat, and is cold a slower rate of vibration than heat?  
 Has there been discovered a way to accelerate the vibrations of any object? I am not considering that of heating an object, to increase the vibrations, if such is possible.

A. 4. There are many vibrations which are imperceptible to the human eye. The vibrations in the ether of light or electricity are entirely too rapid, sound waves cannot be seen, also they may be perceived by the auditory nerves, when those sound waves come within the range of audibility. For the human being, this range is from 16 to 40,000 vibrations per second, the intensity of light does not in any way depend upon the rate of vibration, if that light is of one definite color. White light, being a combination of all the colors, will comprise different periods of vibration. The intensity depends more upon the volume of the source of light.

Altho all matter vibrates, it is not always the vibration of the matter which enables the eye to see the substance, it may be reflection of the light from the matter, which reacts upon the rod and cone layer of the retina of the eye. These either electrically or physiologically transmit that record to the brain where the image is reconstructed. The method of doing this has not been definitely ascertained. Light and heat are both vibrations, but they are not the same. It is possible that one results from the other, due primarily to the speed of vibration. Unfortunately, no method has been discovered which will accelerate the vibration of the molecules of any object.

**Bug Poison**

(1229) E. R. Heintz, Passaic, N. J., wants:  
 Q. 1. A formula for a liquid to kill flies, roaches, etc., but which is non-poisonous to food.  
 A. 1. There is no liquid of which we know that could be sprayed on food and which would kill flies without itself injuring the food and making it acquire a peculiar taste, or, in other words affecting the health if the food is eaten.  
 You can rid a room of flies quickly by placing some pepper on a hot pan, and setting the same on the stove or heater. This will stupefy the flies, causing them to fall to the floor, and may subsequently be swept up and destroyed.

**Rain Gage**

(1230) Fortunato Recit, Jr., Brownsville, Texas, wants to know:

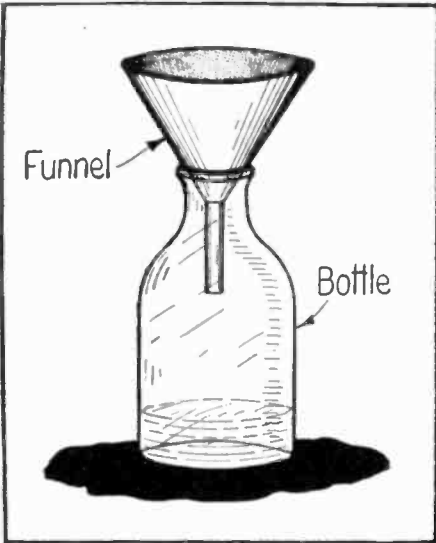

With this Simple Apparatus the Depth of Rainfall can be Readily Measured and Computed.

Q. 1. The correct way to figure the depth of rainfall, using the bottle and funnel illustrated, to collect the water.  
 A. 1. The area of the bottom of the bottle, multiplied by the depth of the water in the bottle, divided by the area of the mouth of the funnel, equals the depth of rainfall.

**Inflating Toy Balloons**

(1231) C. A. Frolich, Elizabeth, N. J., asks:  
 Q. 1. How to inflate toy balloons.  
 A. 1. Balloons can be inflated by various means either from pressure gas or hydrogen, which latter gas may be generated by either the electrical method or by the action of acid on zinc or on iron scrap. We have inflated several toy balloons in the latter manner and have found that they are very light and ascend rapidly.  
 Q. 2. How to plate parts of a piano without removing them from the frame?  
 A. 2. A very good plating solution is made as follows: Take a freshly prepared paste made of two parts of freshly precipitated silver chloride and three parts of potassium bitartrate. All the rust must be removed and the article, if possible, may be washed with a hot solution of caustic soda and rinsed with water. The paste can be applied with a cork. The freshly precipitated silver chloride may be procured by dissolving crystallized nitrate in distilled water in the proportion of 1 to 10, and adding to the solution a solution of sodium chloride of similar strength, continuing to add the latter until no further precipitate is formed. Filter and wash the precipitate by adding water from time to time.

**Fish in a Chemical Garden**

(1232) Elmer Ludwig, Chicago, Ill., asks:  
 Q. 1. Can fish live in a chemical garden?  
 A. 1. Chemical gardens, when made, should have the chemicals taken out of the solution, if fish are to live in them, and the entire solution replaced by pure water. Altho fish may live in them, it is not advisable that you place them in this garden, because, in a short time, there will be nothing left of the same, as the motion of the fish will at once destroy the picturesque precipitates.  
 A double fish globe is the most advisable, so arranged that the fish may swim around on the inside or the outside compartment of the globe, and the chemical garden remain in the other compartment. Then there is no need of replacing the solution with water.

**Fire Extinguisher**

(1233) Morris Foucher, Esq., Fairmont, W. Va., asks:  
 Q. 1. If crude carbon tetrachloride may be used instead of the pure article in a fire extinguisher.  
 A. 1. We would advise that you use the pure carbon tetrachloride because it does not damage fabrics, furniture, or ceilings, with which it may come in contact, altho it will re-

move a varnished surface from a polished table. This damage, however, is not very detrimental, and could easily be repaired.

**Making Bees Hibernates**

(1234) W. J. Fitzgerald, Wolcott, N. Y., wants to know:  
 Q. 1. If bees could be forced to hibernate, in this way reducing their food consumption in the winter.  
 A. 1. Your suggestion of attempting to make bees hibernate is rather interesting, and we would like to know exactly what would happen under the circumstances. We would therefore advise that you take several lots of bees, and place them in different compartments, surrounding one of these hives, which in this instance should be well covered by a non-heat-absorbing material, such as sawdust, or asbestos; pack with ice, and, with a thermometer in the hive, registering maximum and minimum temperatures, at about 32 degrees or lower (prefer the adjustable), watch the results and record them carefully.

You may find that the bees in the winter time will in this manner diminish their food supply. We doubt very much if they can be caused to hibernate, for, if that were the case, Nature would not endow them with the peculiar facility of storing up food during the entire summer for use in winter, and we are of the opinion that it will take several hundred generations of urgent breeding and cross-breeding of the bees to finally secure a bee capable of such hibernation. The same is true of many other animals, and altho some of them do hibernate, the majority equipped with facilities for storing food, put an ample supply aside for winter use. It is quite likely that food consumed could be cut down in this manner.

**Lighting a Lamp "Wirelessly"**

(1235) Francis W. Frecker, Mt. Vernon, Ohio, asks:  
 Q. 1. How to light a lamp without wires by inducing the current to it by means of a transformer, and asks for the data on a transformer for this work.

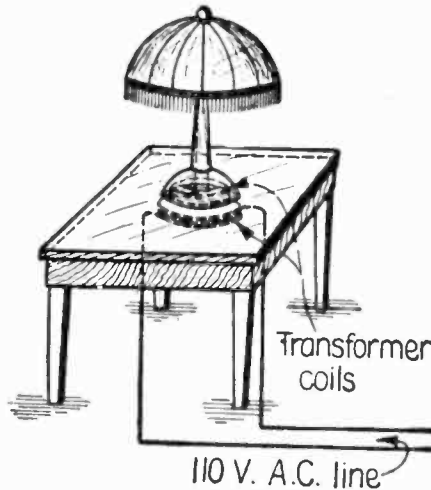

A "Wireless" Table Lamp Which Will Prove Very Mysterious to the Uninitiated—the Answer to the Riddle Lies in the Fact that Two Transformer Coils Are Utilized, a Primary Coil Under the Table and a Secondary Coil Placed in the Hollow Base of the Lamp. A Potential Sufficient to Light the Lamp is Transferred from the Primary to the Secondary Coil by Electro-magnetic Induction.

A. 1. Your system is quite possible, but we doubt very much whether we can furnish you with data for the transformer, inasmuch as the losses here are so large.  
 We would advise that if you use alternating current, you just make two coils of wire, one of about 700 turns of No. 15 double cotton covered wire into which an iron core may be inserted, and the other with fewer turns but heavier wire, and test out with an ammeter the current you obtain in the second coil. This will give you a working basis for your experiment. The coils should just fit over 1 inch square sheet iron cores.

**Compressed Air**

(1236) G. A. Frund, St. Louis, Mo., wants to know:  
 Q. 1. If air is drawn directly from a tank of compressed air, and used to run an engine, what will be the effect on the temperature of the air?  
 A. 1. The expanding gas will become colder as it expands and exerts energy. This is due to a phase of what is sometimes conservation of energy.  
 Q. 2. Since a rise in temperature results in a rise in pressure, what is the relation between these two?  
 A. 2. Air tends to expand in such ratio as to give a pressure of one pound per square inch for each 32 degrees Fahrenheit rise in temperature.  
 Q. 3. If an engine generates 100 horse-power, and only 50 horse-power is used, will the remaining 50 horse-power be available for other use?  
 A. 3. Yes.

**Selenium Cells**

(1237) Venancio F. Lim, Philippine Islands, asks:  
 Q. 1. How to determine the size of fuse wire to use in a motor circuit?  
 A. 1. Determine the resistance of the motor and also the current consumption in amperes, then use the formula  $C = \frac{E}{R}$ .  
 Q. 2. Action and purpose of a selenium cell.  
 A. 2. This has been described time and again in this publication. Selenium is an element which has the faculty of reducing its electrical resistance when subjected to light rays. It is, therefore, used in fire alarms and hundreds of other effects, such as transmitting a photograph by wire, etc., in fact any place where it is necessary that a ray of light will perform an electrical function, the selenium cell being used as the intermediary. So far all results are tentative and experimental.

**Making Blue Print Paper**

(1238) Edwin Beck, Esq., Herrick, Ill., wants:  
 Q. 1. The formula for blue print paper, giving blue lines on a white ground.  
 A. 1. The formula is given herewith:  
 Salt ..... 3 oz.  
 Ferric chloride ..... 8 oz.  
 Tartaric acid ..... 3 1/4 oz.  
 Gum Arabic ..... 25 oz.  
 Water ..... 100 oz.  
 Dissolve the gum arabic in half the water, and dissolve the other ingredients in the other half and mix. Apply with sponge or brush to the paper, and dry rapidly. Two minutes is the usual exposure. It is developed in a saturated solution of potassium ferrocyanide. Later the print is immersed for two or three minutes in:  
 Sulphuric acid ..... 2 oz.  
 Hydro-chloric acid ..... 8 oz.  
 Water ..... 100 oz.

**Iceless Refrigerators**

(1239) Andrew A. Fair, Esq., Sioux City, Iowa, says:  
 Q. 1. That he has been experimenting with iceless refrigerators, using the principle of evaporating water for reducing the temperature, and says that the temperature does not go low enough.  
 A. 1. It is all a question of how good a vacuum you produce. Your efficiency will probably be very low.

**Iron Plating**

(1240) Robert L. Patrick, Beloit, Wis., writes to this department for:  
 Q. 1. The directions for iron plating.  
 A. 1. The solution consists of:  
 Water ..... 1 gal.  
 Ferrous Ammonium Sulphate ..... 14 oz.  
 The ferrous ammonium sulphate is dissolved in hot water, and the resulting solution should be neutral, or very slightly acid.  
 The anode surface should be in excess of the area to be plated. As pure iron as is possible to obtain should be used for this anode. If it shows a tendency to become covered with a black substance, it should be removed and thoroly cleaned.  
 Because of the ease with which hydrogen is liberated in iron solutions, the current density should be quite low. Less than one volt pressure is sufficient for most work.  
 The same directions for the cleaning of the articles to be plated, as used in all plating work, should be followed in this case.

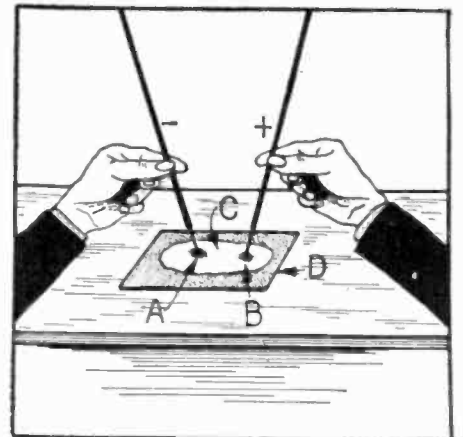

Using Pole-test Paper to Determine the Positive and Negative Wires of an Electric Circuit.

**Polarity Test Paper**

(1241) E. E. Gower, Hagerstown, Md., writes the Oracle Department:  
 Q. 1. Please give me formula for making polarity test paper.  
 A. 1. Procure some red litmus paper, and soak in a solution of one tablespoonful of salt, to a tumbler of water, hang this up to dry thoroly. When dry, use as follows: Moisten slightly, and place ends of wire about 1/4 inch apart, on the paper. A blue spot will appear at the negative wire, and a deep red spot at the positive wire.

# CONN RADIO CONCERTS

from  
*Ocean to Ocean*

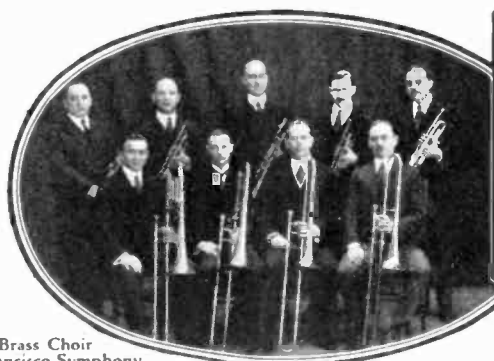

Pictured here are some of the artists appearing in Conn Radio Concerts. Above—Frank Westphal's Rainbow Garden Orchestra. Chicago.

Brass Choir  
San Francisco Symphony  
Orchestra

CONN radio concerts have taken the nation by storm! Our programs of March 17, April 14 and May 19 by America's leading dance orchestras and nationally famed soloists have occasioned universal admiration for Conn enterprise.

Isham Jones, Joseph Smith, Frank Westphal, Hal Nichols, D. C. Rosebrook and

their orchestras have already played; Benne Henton, Charles Randall, John Leick, Mabel Keith Leick and Fred Tait have given solos. More of their calibre are to appear.

Travelers on shipboard 1500 miles from the Atlantic and Pacific coasts, people in Northern Canada and in Central America are enjoying the same music heard throughout the United States.

**Think of it—Conn Ltd. is entertaining people by wireless a quarter of the way around the globe**  
Write for further information on forthcoming radio concerts and watch for local announcements of dates.  
Programs are broad-casted from:

**New Saxophone Book, FREE:** Tells why Conn saxophones are easiest to play; why the world's great artists prefer Conns; how to use saxophones singly and in quartets and larger combinations. Explains exclusive features which give better tone, perfect scale. You can learn to play a tune in one hour! Write now for book and details of Free Trial, Easy Payment Plan.

656 Conn Building C. G. CONN, LTD. Elkhart, Indiana  
Agencies in All Large Cities

Conn New York Co., 233-5-7 W. 47th St. Conn Chicago Co., 62 E. Van Buren St. Conn Detroit Co., 243 E. Grand River Ave.  
Conn Seattle Co., 1609 Third Ave. Conn New Orleans Co., 317 Baronne St. Conn Portland Co., 127 Tenth St. (Oregon)  
Conn Cleveland Co., 1220 Huron Road  
Conn Atlanta Co., Auburn and Ivy Sts.



Ernest Pechin  
Cornet Soloist



Mathew Amatore  
Saxophone Soloist



John Dolan  
Cornet Soloist



Simone Mantia  
Euphonium Soloist



Eugene LaBarre  
Cornet Soloist



WORLD'S  
LARGEST MANUFACTURERS  
OF HIGH GRADE BAND AND  
ORCHESTRA INSTRUMENTS



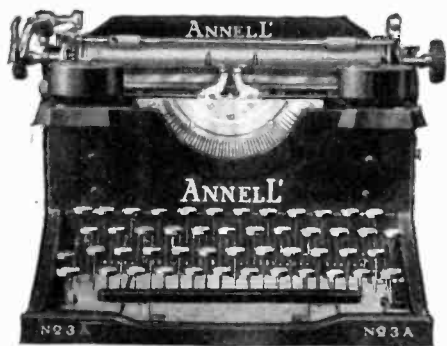

## \$4 Down Brings This Brand-New Typewriter

Pay the balance in small monthly payments. We will ship the typewriter to you for ten days' free trial.

The Annell' is Standard in size, appearance, construction and mechanical operation, with an action so smooth and a touch so responsive as to be a source of constant pleasure to the experienced operator, and making the progress of the novice immeasurably easier. It turns out beautiful work. The type is clear, clean-cut, hard; the alignment and spacing are utterly perfect. The speed is unlimited; no operator can crowd the Annell'. Extremely simple in construction, it is trouble-proof, sturdy, and will last a business lifetime. It embodies the ideas and experience of mechanical geniuses who have been making typewriters and typewriter improvements for generations.

### Every Operating Feature

The Annell' has every late-style feature and modern operating convenience — each letter completely visible as written (together with all the previous writing), Back Spacer, Tabulator, Two-Color Ribbon, Right- and Left-Hand Shift Key, Shift Lock, Margin Release, Adjustable Line Spacing, Adjustable Margin Stops, Paper Release, Automatic Line Spacer on Carriage Return, Adjustable Paper Fingers, etc., also the 42-key, 84-character Universal Keyboard. Rubber cover and all extras shipped with each machine.

### Big Saving—Over a Year to Pay

We are the only company selling a Standard 42-key, 4-Row, Brand-New Typewriter direct to the user by mail at practically the wholesale price of other high-grade typewriters. Our remarkably low price and monthly payment plan enable you to buy a brand-new typewriter easily and conveniently—over a year to pay.

### Fully Guaranteed

We protect you with an ironclad guarantee against any flaw in material or workmanship.

### No Risk—10-Day Free Trial

We will prove its high-grade quality by sending the Annell' to you for ten days' trial. Use it on any of your work. If not satisfactory, return the machine to us. We will refund the express charges and any money you have paid, and the trial will cost you nothing. You are the only judge. Could anything be fairer?

### Send for Information, or Send the Coupon

Send coupon or a postal today for full information about the greatest of all typewriter offers. Don't miss it. Act now.

**ANNELL' TYPEWRITER CO.**  
636 No. 230 East Ohio Street, Chicago

### NOT AN ORDER - MAIL TODAY

ANNELL' TYPEWRITER CO.  
636 No. 230 East Ohio Street, Chicago.  
Send me complete information about your wonderful typewriter offer. This places me under no obligation.

## BE A REAL MAN!

LOOK LIKE ONE AND FEEL LIKE ONE

Broaden your shoulders, deepen your chest, enlarge your arms, and get a development that will attract attention. Fill yourself full of energy and be powerful.

My New Book  
"Muscular Development"  
Will Explain How

This book is illustrated with 26 full-page photographs of myself and of some of the world's finest developed athletes I have trained. It will interest and benefit you greatly.

Send 10c (stamps or coin) for a copy NOW, today, while it is on your mind.

EARLE LIEDERMAN, Dept. 206, 305 Broadway  
NEW YORK CITY



**STAMMERERS**  
FOR 55 YEARS we have successfully corrected stammering by our simple and natural method. Individual instruction. Write for free booklet. S. L. ROBBINS, Director  
BOSTON STAMMERERS' INSTITUTE  
246 Huntington Ave., Boston, 17 Mass.

# War Department on Helium

Editor, SCIENCE AND INVENTION:

In your issue of April, 1922, appears an article entitled "Airship Roma Falls and Burns Up." In this you state that there is one question uppermost, perhaps, in the minds of many and that is why the non-inflammable helium gas was removed from the *Roma* just a few days before the accident and the dangerous hydrogen gas replaced in her gas compartments. You are informed that the airship *Roma* was never filled with helium and that, therefore, the helium was not removed. This suggestion was doubtless gained through the fact that the navy operated a small blimp, namely, the C-7, with helium. This is the only lighter-than-air craft of any kind that has ever been operated with helium.

There was in existence some 2,300,000 cubic feet of helium. This represents the total amount ever recovered. This helium was produced by funds contributed equally from the Army and from the Navy and one-half of it belonged to the Navy and was required for experimental purposes by the Navy. The share belonging to the Army amounted to 1,160,000 cubic feet and as the gas capacity of the *Roma* was 1,200,000 cubic feet, it can be readily seen that the Army did not possess enough helium to fill the *Roma*. The average gas consumption of the *Roma*, disregarding the loss of gas in flight, was about 12,000 cubic feet per day.

The *Roma* was constructed for the use of hydrogen. In fact, all lighter-than-air craft developed abroad are constructed for the use of hydrogen. All development in these countries has been based on the premise that they would never have helium in sufficient quantities available for them. This development has progressed steadily and with great success. The United States is far behind these countries in the development of lighter-than-air equipment. The *Roma* was purchased in order that a study might be made of its construction and operation with a

view to learning whether or not airships of this type were desirable for our use. The United States has never contemplated relying exclusively on foreign design, but it is certainly desirable that we secure the best available information and that we take advantage of foreign research and construction in order to assist the development of our home industry at a greatly reduced expenditure in time and money. The *Roma* was designed and built for the use of hydrogen, and as such was expected to develop certain characteristics. Had the United States filled this airship with helium, it would have operated under conditions not contemplated in its original design and new features would have been introduced which would have interfered with the calculations necessary for study. The information gained from the operation of the *Roma* would have been fundamental and the necessary corrections for the use of helium instead of hydrogen would have been made in the design of new and improved equipment.

The United States must keep abreast of foreign development with the means furnished and if this nation desires to take advantage of what appears now to be a monopoly of helium and to make such helium available in sufficient quantities, this policy will be welcomed by the Air Services of the Army and the Navy. Due consideration must be given to the fact that the supply of helium in the whole world is definitely limited and that after having based all our development of lighter-than-air craft on helium, we might ultimately have to revert to the use of hydrogen and start our experimentation all over again after the rest of the world had learned to operate lighter-than-air craft safely and successfully with hydrogen.

H. M. HICKAM,  
Major, Air Service,  
Chief, Information Division.

## Building a Double Neck Harp-Guitar

By C. L. EDWARDS

(Continued from page 142)

Glue bridge No. 3 in place so that if the center lines of the necks were permitted to cross the bridge, the distance would be nearly 12 7/16" from the center of 12th fret to front of bridge.

Put wood screws where the ornaments at each end of the bridge are to be, to hold bridge while glue is drying, then take screws out.

Position marks are shown in one neck, these are made slightly larger than a wood bit of required diameter and the sides are sloped at a uniform taper all around.

Bore a little ways into the wood with the wood-bit, then force ornaments in place, using shellac to bind metal ornaments to the wood. Glue is used to fasten wood and a mixture of two parts shellac in two parts spirits of camphor and 6 to 8 parts of 90% alcohol to fasten celluloid to wood. There are, however, many prepared mixtures that will serve all purposes.

Round ornaments can be used in many

places, but irregular pieces may also be used, in which case a chisel is used to cut the hole for the piece.

To remove material for purfling, make tools like No. 19 or No. 20. No. 19 has an adjustable cutter, the cutter is made the width of the purfling and set to required depth.

The tool is operated like a marking gauge; slivers not removed by the cutter can be taken out by a bent awl shaped to chisel edge.

The harp-guitar would look well with round ornaments as shown and with bands of celluloid around top and bottom and upon sides to cover all joints and an ornamental plate placed on bottom of heel.

The builder, however, should use his own taste in ornaments.

To fit strings, file very small grooves in string nuts and bridge. Be sure that the strings have a bearing at the very beginning of the grooves, otherwise they will "chatter." If string nuts and bridge are too high, file them off.

Do not have any nails, brads, screws, etc., anywhere in the body or elsewhere if it can be avoided.

Finish the harp-guitar in varnish or shellac or any other finish desired, in order to close the pores of the wood and keep moisture out.

## Radio Broadcast

(Continued from page 158)

Roselle Park, N. J.	Radio Corp. of America...	WDY	360	M-47
Sacramento, Calif.	J. C. Hobrecht.....	KVQ	360	N-4
San Jose, Calif.	Chas. D. Herrold.....	KQW	360	P-4
Schenectady, N. Y.	General Electric Co.....	WGY	360	J-47
Schenectady, N. Y.	Union College Radio Club...	WRL	360	J-47
Seattle, Wash.	Excelsior Motorcycle Co....	KHQ		C-6
Seattle, Wash.	Northern Radio Elec. Co....	WJO	360	C-6
Seattle, Wash.	Post Intelligencer.....	KFC	360	C-6
Springfield, Mass.	Westinghouse Station.....	WBZ	360	J-49
Stockton, Calif.	C. O. Gould.....	KJO	360	O-4
Washington, D. C.	Doubleday Hill Elec. Co....	WMU	360	O-45
Washington, D. C.	White & Boyer Co.....	WJH		O-45



# Go as High as You Like No Limit to Salaries in Aviation

No other industry offers the wonderful chances for big money-making that the Airplane Industry offers to ambitious men. Many more trained men will be needed to fill big paying jobs. The airplane has come to stay—it will soon be a part of our everyday life. The men who get in now are the ones that will cash in big. Look at the "big fellows" in the automobile game today. They represent power and wealth because they got in early—you can do the same in Aviation and you have an advantage because you can be trained before you start.



Delivering Newspaper "Extras" by Airplane

## Thousands of Airplane Mechanics Will Be Needed

The airplane industry is going forward by leaps and bounds. Transportation—passenger carrying and mail carrying lines are being opened up everywhere. This means men—men—men! Trained men only are wanted—men who know what's what. Get ready now to make big money. The industry is calling for real red-blooded fellows—heed the call—*now* is the time to get started—while the industry is still in its infancy.

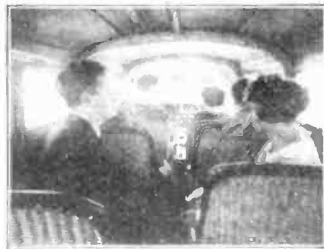

A New Seven-Passenger Airplane

**Here Are a Few Jobs That Will Pay \$50.00 to \$250.00 a Week:**  
 Aeronautical Instructor    Aeronautical Engineer    Aeronautical Contractor    Airplane Repairman  
 Airplane Mechanician    Airplane Inspector    Airplane Salesman    Airplane Assembler    Airplane Builder

## Learn at Home In Your Spare Time

Keep right on with the work you are doing now. A little of your spare time is all you need. Our Special Course

is simplified for home instruction and is endorsed by airplane manufacturers, aeronautical experts, aviators and the leading aero clubs. Any man who can read English can understand it. The Lessons are self-explanatory and are made plain as day with Blueprints, Diagrams, etc. Our Advisory Council and Instructors are behind you all the time giving you everything you must know. The entire field of Practical Aeronautics and Science of Aviation is laid right before your eyes. You are bound to succeed with this training. This means for you a man's size job with a man's size pay.



A New Job—The Aerial Postman

## Big Book of Opportunities FREE!

Send for our big free book showing just what is going on in the Airplane Industry. It also shows what other men have done in this fascinating field and what you can do, too. It gives a list of some large manufacturers and dealers in airplanes and some of the jobs that are open to trained men. With the book we will send you a special offer that you will be glad to know about. This special offer may be withdrawn at any time without notice. *Send the coupon now and take advantage of this offer.*

**American School of Aviation**  
 Dept. 219B    3601 Michigan Ave., Chicago



**AMERICAN SCHOOL OF AVIATION**  
 Dept. 219B  
 3601 Michigan Ave.  
 Chicago

Without obligation on my part you may send me your book entitled "Opportunities in the Airplane Industry" and your SPECIAL Limited offer.

**Mail This Coupon For FREE BOOK**

Name.....  
 Address.....  
 City..... State.....



View in an Airplane Factory

# Radio for the Beginner

By ARMSTRONG PERRY  
(Continued from page 154)

vent signals, from being heard but it would reduce the coil's efficiency in tuning. Such damage can usually be repaired by putting shellac on the exposed parts of the wires.

The miscellaneous noises that interfere with the sounds you want to hear come from various sources. The neighbor's small boy with a spark coil transmitter can make more racket than a whole Grand Opera company. He should be put on a daylight-saving schedule. He can also set fire to houses in the vicinity just by neglecting simple precautions. It has been done. Organization and instruction are essential where beginners *agitate the ether*.

Regenerative receivers around the town may let loose a flock of "canary birds," that will sing you into a perfect frenzy. Often unknown to their operators they start transmitting on their own account when they are supposed to be receiving only. A well-known radio man attempted at a recent conference to arouse sentiment in favor of a law that would prohibit such interference, but he made little headway because a competitor got the floor immediately afterward and intimated that this was an attempt to run his apparatus off the market, and that anyhow the first speaker's apparatus was just as bad.

The vacuum tubes in your own set may bark and howl at you like your dog when

you lock him in the barn. Skilful operation is the answer to this, unless there is a mistake in the installation. If that is the trouble, then the manufacturer should state the remedy. Connecting plus wires to minus terminals will make as much trouble as trying to drink and talk at the same time.

Atmospheric disturbances, so-called "static" or X's, that make themselves heard loudly and persistently, especially in the summer, are not yet under the control of radio manufacturers. The man who invents a device that will sidetrack them will make a million.

When government, commercial or amateur stations, properly operated according to the laws and regulations governing them, interfere with radio listeners, it may be due to their being so near that their waves force oscillations on the receiving station. Fine tuning may reduce the trouble. A loop aerial assists in getting rid of interfering stations, provided they are not in a line with the station that is listening and the one that is sending. The loop can only be used effectively with vacuum tube receivers. It is pointed toward the station that the listener wants to hear from and when in that position brings in but feebly, if at all, signals from stations to the right or left.



**FREE**  
Trial strip  
of Tirro.  
Mail coupon below

## Golfers

**Protect your fingers this new way**



Tirro protects the fingers from callouses and blisters. Just the correct width to do the job right. Better, by far, than a glove. Keep a spool always in your golf trousers.

Use Tirro, too, for a grip on a tennis racket; to hold torn cloth together; for repairing quickly the things ordinarily discarded. Sticks to anything—and waterproofed. "Wonderful!" you'll say.

Three Sizes: Small, 15c; Medium, 25c; Large, 50c  
At Drug Stores

S.I. 6-22

**Tirro MAIL THIS For Free Strip**

**BAUER & BLACK,**  
2500 Dearborn St., Chicago  
Mail me a strip of Tirro.

Name .....

Address .....

City ..... State .....

## HOW TO PAINT SIGNS AND SHO' CARDS

Our book gives a complete course of instructions, enabling anyone to learn to paint good signs. WHY NOT MAKE YOUR OWN either for your business or for others?

**CONTENTS:** Alphabets, Composition, Color Combinations, How to Mix Paints, Show Cards, Window Signs, Banners, Board and Wall Signs, Ready Made Letters, Gilding, Commercial Art and Tricks of the trade—Contains 100 alphabets and designs. Cloth Bound, size 7 x 5 inches, price \$1.00 postpaid.  
J. S. Ogilvie Pub. Co., 214 Rose St., New York

**Oh Boy! 25 Miles Per Hour!**

is record of our stock car, using our special 1922 motor. Any body can assemble this car. Send 30 cents for plans, instructions and price list of parts.

**SYPHER MFG. CO.** 156 Sypher Bldg., Toledo

## Experimental Electro-Chemistry

By RAYMOND B. WAILES  
(Continued from page 141)

Numerous experiments requiring the simplest of experimental apparatus can be cited to show that liquid electrolytes follow the laws which govern solid conductors.

A solenoid or coil of liquid electrolyte can readily be fashioned by filling several feet of rubber tubing with the electrolyte and winding the same around a cardboard tube. The ends of the rubber tube can be corked or sealed with wax, and connection made to the interior liquid by means of wires passing thru these seals. The apparatus is shown in figure 4, connected to a galvanometer. A sensitive ammeter will serve as well. The cardboard tube is shown at C, the ringstand R and the ringstand clamp, RSC.

If a magnet M be thrust into the interior of the cardboard tube, or electrolytic solenoid, the indicating instrument will immediately respond. This is in accordance with the laws governing solid or metallic conductors, for the same effect will be perceived when the liquid solenoid is replaced by a similar coil of wire connected as before.

### Migration of Ions

During electrolysis, negative ions proceed toward the anode or positive electrodes, and are called anions, while the cations, or positively charged ions, proceed toward the cathode or negative pole or electrode.

A convenient method of differentiating between anions and cations, or anode and cathode, is by a unique animal story. A certain cat could only come into the house thru a hole in the screen door, but could not go out by the same method because of the conical shaped screen hole which it made the first time on its passage in. The negative current of a battery is the incoming current. The significance between the cat, the hole and the negative current is: Cat-Hole, which, interpreted, means Cat-Hole. The in, or negative side of a battery or pair of electrodes is therefore readily understood to mean the cathode

(Cat-Hole—cat can only come in) when the novice recalls the antics of the cat.

If a solution of copper sulphate be electrolyzed, or subjected to the action of an electric current, using copper plates or electrodes, the color of the solution around the anode (positive) readily suggests that something has left the solution about it. Copper ions, which are positively charged and are therefore called cations, because they proceed toward the cathode, impart a blue color to water, when dilute solutions are made. Proceeding as they do toward the cathode, the cause for the decolorization about the anode is readily understood.

## WORK While Learning Electricity

Get Our Free Offer

**S. & H. ELECTRICAL WORKS**  
Dept. F-2, 308 So. Green St., Chicago, Ill.



MODEL STEAM ENGINES and BOILERS. New and enlarged edition (1922) of our illustrated catalogue now ready, showing many new features such as fittings for Model Warships, working Model Searchlights, larger Model Boilers, etc. Full line of working miniature Engines, Boiler Fittings of all sizes, Model Makers' Supplies, etc. Catalogue and Handbook 20c. (Refunded on first order.)

The Batho Manufacturing Co., Dept. 2  
5214 Woodland Ave. Philadelphia, Pa.

## LEARN PIANO

SHORT COURSE. EASY TO LEARN  
PLAY BY NOTE IN 8 WEEKS

WRITE for Sample Lessons, Veins of Gold, Beautiful Santa Barbara Scenic Views, ALL FREE

O. A. SCHMAHL, MUSIC SERVICE  
BOX 441-E Santa Barbara, California

**STAMPS!** 50 All Diff. British Guiana, Cuba, China, India, Jamaica, Japan, Portugal, Venezuela, etc., only 7c! 100 all diff., 10c; 1000 all diff. fine collection in itself, \$2.50, 100 diff. U. S. 25c; 1000 hinges, 10c. 50% approvals sent every order. List free. I Buy Stamps! L. B. Dover, Dept. C, Longmont, Colo.



# FREE RAILROAD FARE

LEARN

ELECTRICITY

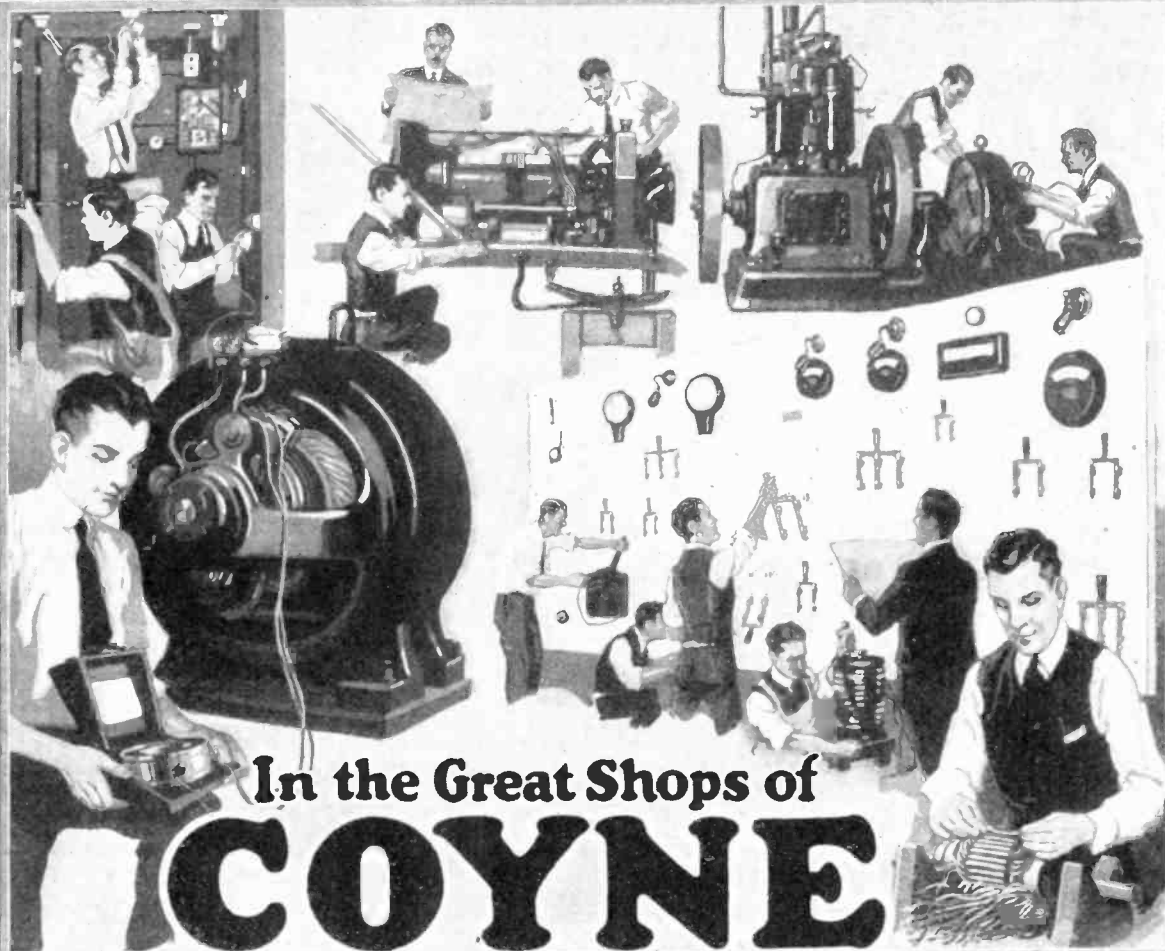

In the Great Shops of

# COYNE

Make this the most profitable and enjoyable summer of your life. Come to Chicago, the greatest summer resort city in the country on beautiful Lake Michigan, and greatest electrical center in the world. We will pay your railroad fare from any place in the United States. See the country at our expense. And at the same time become a skilled electrical expert in the great shops of Coyne.

## LEARN IN 3½ MONTHS

No books or useless theory. You are trained on \$100,000 worth of electrical equipment. Everything from door bells to power plants. You work on motors, generators, house-wiring, autos, batteries, radio, switchboards, power plants—everything to make you an expert ready to step right into a position paying from \$45 to \$100 a week. Learn Electricity in the electrical center of the world. Here you see the mighty power plants, the great electrical manufacturers and marvelous electrical sign displays. You truly live with electricity in Chicago.

## Great Summer Resort City

Chicago, situated on beautiful Lake Michigan, is the Nation's summer playground. Marvelous boulevards, beautiful parks, bathing beaches, zoos, lake trips, amusement parks. Coyne is near lake and bathing beach. Chicago's Daylight Saving Time gives you a chance to enjoy these things by daylight.

## EARN WHILE YOU LEARN

Our Employment Department helps place students in jobs to earn a part or all of their expenses while studying. No charge for this service. Hundreds have worked their way through. The catalog explains fully.

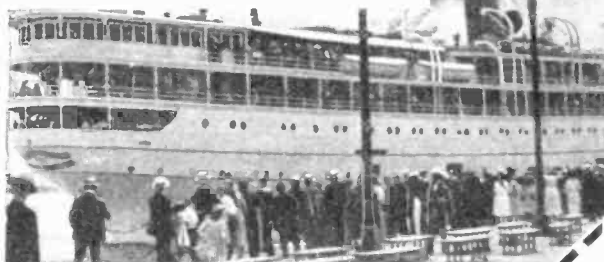

One of Chicago's Many Pleasure Boats

## Training Complete

The whole world of electricity is open to the Coyne trained man. He is trained completely. He can make big money as power plant operator, superintendent, telephone man, construction work, auto, truck or tractor electrician, battery man, radio expert, or he can go into business for himself as electrical contractor, dealer, auto ignition expert, battery business, and make from \$3,000 to \$20,000 a year. Hundreds of our graduates today are making big money and you can do the same if you grasp this opportunity—act now. Send for full particulars today.

## 3 FREE Courses

Besides paying your railroad fare we include with your regular course: (1) A complete course in auto, truck and tractor electricity and storage batteries. Greatest outlay of auto electrical equipment in the country. (2) Complete training in Business Management—trains you thoroughly to run a business of your own. (3) Course in Radio—the marvel of the age. Constructing, installing and operating—build your own set. Every student is given a life scholarship—he can stay as long as he likes and return whenever he likes.



B. W. COOKE

PRESIDENT

# COYNE

TRADE AND ENGINEERING SCHOOL

Dept. 26, 39-51 E. Illinois Street

Chicago, Ill.

## Greatest Offer Ever Made

This is the greatest offer ever made by a school and it is for a limited time. Our departments may soon be filled and the offer withdrawn.

## Send Coupon NOW

Don't delay a minute—send that coupon in right now for our big free catalog and full particulars of this wonderful offer.

B. W. Cooke,  
President,  
Coyne Trade  
& Engineering  
School, Dept. 26,  
39-51 E. Illinois  
St., Chicago, Ill.

Dear Sir:—Please send me free your big catalog and full particulars of your Special Offer of free railroad fare and 3 extra courses.

MAIL THIS FOR QUICK ACTION ON OUR OFFER

Name.....  
Street.....  
City.....

# If you really want to be a BIGGER MAN

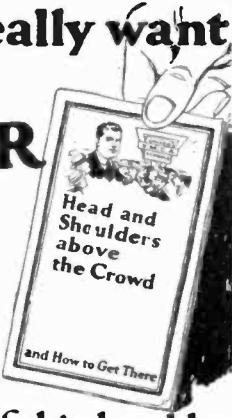

## Ask for a free copy of this booklet

It is a frank, man-to-man discussion of personal development that we are glad to send every ambitious young man. It does not paint any "blue-sky dreams" that you cannot realize, but it tells how we are helping thousands of young men to make the most of their study hours. We will also give you the "Six Reasons" why you should select the United Y. M. C. A. Schools to help you to qualify for greater responsibility, more congenial or better-paying work, and larger manhood. Our friendly counsel is free.

Tear Out and Send This Slip

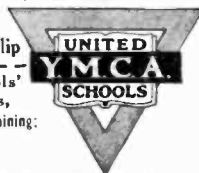

United Y. M. C. A. Schools' Correspondence Courses, or positions for which they afford training:

- |                       |                            |
|-----------------------|----------------------------|
| Accountant            | Machine-Shop Practice      |
| Advertising Man       | Leadership Courses         |
| Agricultural Courses  | Locomotive Operator        |
| Architect             | Mathematical Courses       |
| Auto Mechanic         | Mechanical Engineer        |
| Banking               | Plumber                    |
| Better Letters        | Poultry Husbandry          |
| Bookkeeper            | Radio Operator             |
| Building Construction | Radio Engineer             |
| Business English      | Railroad Engineering       |
| Business Law          | Salesman                   |
| Business Organization | Secretarial                |
| Civil Engineer        | Short-hand and Typewriting |
| Civil Service         | Steam Engineering          |
| Concrete Engineer     | Structural Drafting        |
| Dairy Farming         | Surveyor                   |
| Draftsman             | Tool Designing             |
| Electrician           | Tractors and Farm          |
| Electrical Engineer   | Machinery                  |
| Factory Management    | Traffic Management         |
| Farm Management       | Use of the Slide Rule      |
| Foreign Languages     | Are You an ex-Serviceman?  |
| High School Courses   |                            |
| Foremanship           |                            |
| Highway Engineering   |                            |

### United Y.M.C.A. Schools

375 Lexington Ave. New York City.

Without obligating me, please advise regarding the course.

Name .....  
Age and Occupation.....  
Full Address.....  
64-Ju (Please write plainly)

## FINE OLD VIOLINS



### On Easy Payments 30 Days Free Trial

allowed, no matter where you live. If not more than pleased with our values return violin AT OUR EXPENSE—and no harm done. Ability to play the violin brings social and financial success. Get a violin with a rich, mellow tone and it will create in you a desire to master it.

### Free! Magnificent Album-Catalog

containing portraits of the world's greatest violinists since Paganini's time, a half-tone of "Stradivarius in His Workshop," and the romantic story of "The King of Musical Instruments." A postal brings all to you FREE—no obligations. CREMONA VIOLIN SHOP, Dept. C-51, Chicago

### THE MIDGET "FIVE-IN-ONE" SLIDE RULE



is a combination Mannheim, Log-Log, Add and Subtract, Polyphase, and Binary Slide Rule. It will instantly add, subtract, multiply and divide any combination involving whole numbers, fractions, decimals and mixed numbers. Gives every possible root and power of every quantity. The graduations are printed on metal, coated with white celluloid, and grease and waterproof. While it is the most versatile calculator ever invented, its operation is simple and easily understood. Diameter 4 inches.

Price with 16 page Instruction Book, \$1.50. Leatherette carrying case 50c extra. Cash on Delivery. Your money back if you are not satisfied.

GILSON SLIODE RULE CO. Niles, Mich.

### Printing Catalog

Cards, circulars, labels, book, paper. Press \$12. Largest \$35 job press \$150. Save money. Print for others, big profit. All easy, rules sent. Write factory for press catalog, TYPE, cards, etc. THE PRESS CO., D-47, Meriden, Conn.

## Home-Made Electric Cooking Utensils

(Continued from page 146)

of this metal-enclosed heating unit or else a regular standard electric immersion heater, is indicated inside the coffee or tea pot. Diagram D shows how a home-made immersion heater may be made from a piece of brass pipe suitably capped at the lower end. Copper or brass pipe may be used, but if brass is employed it should be thoroly nickel-plated. The lower end may be sealed tightly against water by brazing a metal plug in the end of the pipe, or else by fitting a threaded cap on the end. The resistance coil may comprise one or two layers of proper sized German silver or other resistance wire, with a layer of mica between each layer, starting the winding over a rod of iron or asbestos about 1/4" in diameter. After trying out the heater thoroly and making sure that the proper amount of wire is contained in it, so that it will not burn out on 200 to 300 watts, the top of the pipe may be sealed up, taking proper care to insulate the wires. The correct length of wire to use for a certain sized heater is determined in an approximate manner by passing the current from the 110 volt circuit thru different lengths of it and noting the length of the wire when it becomes just red hot. Some of the resistance wires on the market will stand nearly a white heat without burning out or oxidizing abnormally.\*

The number of feet of wire, as well as the resistance, the current and the voltage may be readily computed, when any two of these factors are known by applying Ohm's Law, which states that the voltage required to force a given current thru a certain resistance is found by multiplying the resistance in ohms of the coil or grid, by the current required; the current in amperes is found by dividing the voltage applied by the resistance in ohms of the coil or grid; the resistance of the grid is found by multiplying the ohms per foot by the number of feet of wire or ribbon employed or vice versa; while the resistance in ohms for a given case is found by dividing the applied voltage by the current passing, as indicated by an ammeter. Also the resistance required in the grid is computed by dividing the voltage on which the apparatus is to operate, by the current in amperes. The carrying capacity in amperes of each size of resistance wire is given in the wire tables referred to, and which can be had for the asking. Heating units designed to be operated on either A. C. or D. C. should be wound non-inductively.

\*The addresses of companies supplying various kinds of resistance wire suitable for building all kinds of electric cooking utensils, as well as furnaces and soldering irons, etc., will be supplied by the editors on receipt of self addressed and stamped envelope. The catalogs supplied by these companies contain tables giving elaborate data as to the heating temperature at different currents in amperes for all sizes of the different wires, so that anyone can determine just how much wire and what size they will need for any specified consumption in watts or amperes at a given voltage.

### CORRECTION NOTICE

In the Popular Astronomy article appearing on pages 28 and 29 of the May issue, there was an error made in the following statement, which appears in the second paragraph of the center column on page 29. The sentence beginning, "Venus and Mercury are the only two planets in the solar system that may have conditions at all similar, etc.," should have read, "Venus and Mars, etc." This error is a typographical one, and would have been noticed at once by even casual readers, for it is corrected at the end of the paragraph.

## AETACO Honeycomb COILS

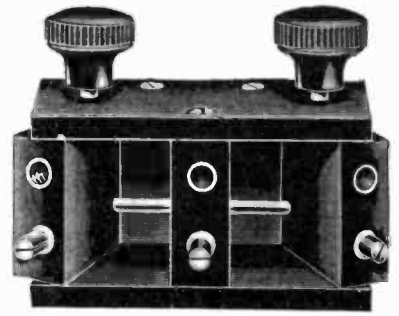

Our own manufacture and fully guaranteed. Complete with flexible leads for connection, and will not loosen up in varying the position of the coils attached. AETACO Type A-1 Triple Coil Mounting, \$5.00

Plank-a-Tone Complete Set, \$25.00  
King Am-plitone, \$12.00  
Arkay Horns, \$5.00

The Largest and most complete stock of Radio Sets in the U.S.—all the best makes: Radio Corp., Western Electric, Grebe, Paragon, Acme and Westinghouse. Murdock, Brandes and Federal Head Pieces.

Cabinets, Bakelite, Dials and a complete stock of all parts for making sets.

Send 10c for large Illustrated Catalog

AMERICAN ELECTRO TECHNICAL APPLIANCE CO.  
227-229-235 Fulton St., New York

## Get a Copy of this Book

### How to TAKE VIOLET RAY TREATMENTS AT HOME



Tells you how to conquer weaknesses caused by impoverished blood, poor circulation and disordered nerves. How to energize every cell and tissue to healthy activity and build a healthy, well-developed body.

Sent Without Obligation

It is the most complete book ever prepared on the home treatment of disease by Violet Ray method.

### RA-TONE

THE VIOLET RAY FOR THE HOME  
Is the most highly developed home treatment of its kind available at any price. You can read in our book of the marvelous results obtained in more than a hundred ailments and can expect similar benefits. Merely send stamps to cover mailing.

RA-TONE ELECTRIC CO.  
619 Park Place West, Detroit, Mich.

Demonstrators and Distributors Wanted

We want an intelligent man or woman in every community to demonstrate Ra-Tone treatment. All or part time. Fine opportunity for exclusive sales distributors.

\$400

3000 Ohms



IMMEDIATE DELIVERIES—POST PAID  
Audibility Unsurpassed—Money Back if Dissatisfied  
Antenna Wire-7 Strand Tinned 150 Ft., \$1.60

TOWER MANUFACTURING COMPANY  
5 STATION ST., BROOKLINE, MASS.

## TYPEWRITER SENSATION



### \$4 or \$5 a month will buy

Any Standard Make Guaranteed TYPEWRITER With Every Modern Writing Convenience.

Write Today For Illustrated Catalog Explaining Try-Before-You-Buy Plan.  
SMITH TYPEWRITER SALES CO.  
(Free Trial) 738 -218 No. Wells St., Chicago, Ill.

# Quick Success in Electricity!

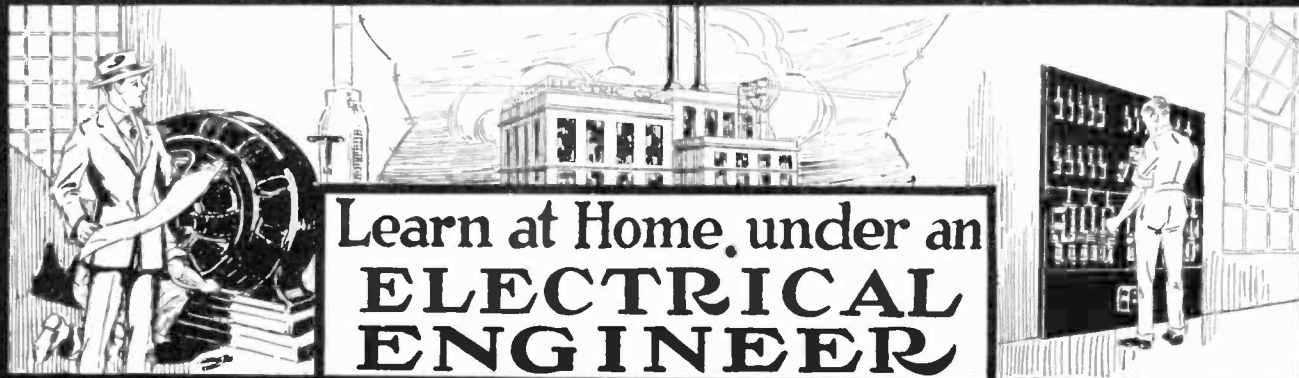

Learn at Home, under an  
**ELECTRICAL  
ENGINEER**

## Wicks Trained Men Make Big Money



**A. W. WICKS**  
Elec. Engineer  
Formerly with the General Electric Co., Former General Manager of company manufacturing J. E. M. Electric Motors, also formerly with Fairbanks, Morse & Co. Now Consulting Engineer, also Director of the Wicks Electrical Institute.

Electricity, the greatest force in the world—offers you “Big Money” and “Quick Money” if you have the ambition to go and get it. Let me train you in electricity—at home—in your spare time—no matter where you live. I can quickly fit you to qualify as an expert electrician earning \$2000.00 to \$4000.00 a year. You don’t have to go to school. You don’t have to serve time as an apprentice. You start drawing the big pay as soon as you are qualified.

I am an authorized Electrical Engineer. So far as I know I am the only man with the degree Electrical Engineer to offer a Home Study Course in Electricity. My Electrical Engineering experience has covered a period of twenty-five years with some of the leading engineering and industrial corporations in this country. This wide and varied experience is the secret back of the success of my students.

### Qualify to Fill One of These Big Paying Positions

- Chief Electrician \$300 per month and up
- Sub-Station Operator \$200 per month and up
- Electrical Contractor Unlimited
- Maintenance Electrician \$250 per month and up
- Power Plant Supt. \$200 to \$1000 per month
- Electrical Wireman \$150 to \$200 per month
- Meter Tester \$150 to \$200 per month
- Electrical Sales Engineer Unlimited
- Supt. Elec. Installation \$250 to \$500 per month
- Traveling Elec. Inspector \$200 per month and up

### Why Wicks Trained Men Are Successful

Wicks trained men succeed where other men fail because they are trained thoroughly from the ground up. They have been trained under an Electrical Engineer. They have the knowledge gained of 25 years of experience behind them. Wicks trained men can’t go wrong—they know only one way to do things—the right way.

Mail Coupon for **FREE Book**

Get the Special Rate



Send the coupon to me today—it will bring you my new big book “Opportunities in the Electrical Field.” If you are interested in your own future you will want this book. I will also send you full particulars of my method of training—show you why Wicks training brings quick success. You will also find out about my Special Tuition Rate now in force. Act at once.

### New Easy Method

My new easy method knocks out all the unnecessary frills and gives you real, practical electricity—the money-making facts that you can cash in on. I teach both why and how through practical problems—the kind of problems you will meet later in your everyday work.

### FREE Electrical Outfit and Tools

Big outfit containing material, apparatus and tools FREE. I know the value of the right kind of tools, so I want my students to start out with the very tools they will need on the job. This outfit contains everything—there are no extras for you to buy.

### Great Opportunities In the Electrical Industry

Just stop and think what electricity means to us in our everyday life and you will realize why there is such a big demand for electrically trained men. The whole world depends on the electrician. Electric Light Companies, Municipalities, Manufacturers and Contractors are paying bigger wages than ever and still need more men to fill big jobs.

**A. W. Wicks, E. E., Pres., WICKS ELECTRICAL INSTITUTE**  
2197 Michigan Avenue, Dept. 219-B, Chicago, Ill.

**A. W. Wicks, E. E., Pres., WICKS ELECTRICAL INSTITUTE**  
Without any obligation send me your Big New Book, “Opportunities in the Electrical Field,” and full particulars regarding your method of training.

Name.....  
Address.....  
City.....  
State.....



## Beacon Lights of Business

**A**LONG perilous coasts, lighthouses throw their guiding rays far into the night to warn the mariners and help them safely past the shoals.

Business, too, has its beacons. They are the *advertisements*, which throw a powerful light to guide you in your buying. They show you what to buy, where to buy and when to buy.

Spend a few minutes running through the advertisements in this publication. Then buy the products that have proved up in the light of advertising.

Manufacturers who advertise deliberately focus thousands of eyes on their products. Their wares must be *good*, their values *honest* and their prices right or they could not advertise successfully.

In the advertisements you see products that have made good under the critical inspection of buyers. These products are *full value* products. They return you dollar for dollar. Buy them

Let the beacon of advertising guide you as it is guiding so many astute buyers.



*Then you can know that every cent you spend buys its full quota of value.*

## Electric Farm de Luxe

By H. WINFIELD SECOR

(Continued from page 119)

flies and dirt to contaminate it. In the barn we frequently find the corn sheller and fodder cutter driven by electric motor as well as a feed grinder. A cider press may be rigged up with a little ingenuity also, and some barns are equipped with an electric hay loader, which lifts large quantities of hay from the wagon or motor truck up into the hay loft with ease and swings it thru the door. A load of hay can be discharged in a few minutes by means of such a device. It is often necessary to talk between the house and the barn or other buildings, and it will be found very advantageous to run a few wires between the farm buildings and connect to these an individual telephone system. Of course the modern farm has a Bell or other commercial company telephone in the house—that goes without saying. The radio receiving set may be operated by the farmer himself while some delegate this honor to the rising "young Edison" of the family.

### The Electric Dairy Maid

"Miss Electricity" is Queen of all she surveys in many modern dairies, especially those of large size. Here we find electric motor-driven cream separators, bottle washing and filling machines, butter churns, electric egg candlers, for testing the quality of eggs (alho these devices are sometimes placed in an egg sorting and packing room attached to the henery). An electric ice machine for the dairy is practical, and no doubt, when electricity becomes more well-known on our farms, this feature will be utilized to a very considerable extent, as the cost of ice when it has to be purchased, has been increasing each year. Of course, some farms have their own ice house and the privilege of cutting lake ice at a very economical cost during the winter months. Some farmers and dairymen are enabled to cut their ice bill down when they are blessed with a nearby brook or spring of any size, a suitable milk cooling house being built over the spring or brook, into the water of which the cans of milk are placed. Some ice has to be purchased invariably even with these cold water facilities.

The electric henery of today employs the mystical current in many cases for automatically feeding and watering the chickens, and in the winter electric heaters and water heaters are frequently provided. One of the most important things that electricity has done for chicken raising is the lengthening of the short winter days, by lighting the henery up to about 9.00 o'clock at night. The simplest way to arrange for the lights to flash on at sunset and to cut them off at the desired hour, is by means of an electric time switch, several forms of which are available from electric contracting and supply houses. The young electrically inclined scion of the family or the farmer himself can with slight ingenuity rig up a time switch of his own by using an alarm clock to open the switch. The feature of the regular commercial time switches, is that the circuit is closed and opened exactly according to the settings of the time dial provided on them. About a year ago some enterprising chicken fancier gave us an article which was published in the columns of SCIENCE AND INVENTION, describing the wonderfully increased egg production occasioned by placing a phonograph in the henery, and giving the chicken a blast of jazz every day or evening. At any rate, the scientific farmer might try it

### 30 DAYS FREE TRIAL \$10 Worth of Records FREE



Simply wonderful! The limit of value giving! Just think! **AGENUINEDAVIS PHONOGRAPH** on 30 Days' Free Trial, and on terms as low as **\$2 A MONTH** in case you decide to buy. Magnificent instruments in quartered oak or mahogany piano finished cases, equipped with the finest worm gear motors, rich toned machines— at less than half the standard prices—and \$10 worth of records **FREE**.

#### Send No Money

Just a postal with your name and address. Only a limited number of machines shipped on this extra-liberal offer. Better act quickly. This is a life-time opportunity.

DAVIS, Dept. C-51  
6101 MAY ST., CHICAGO



**AGENTS** \$60—\$200 a week. Free Samples **GOLD SIGN LETTERS** for store fronts and office windows. Anyone can put them on. No experience necessary. Big demand. **LIBERAL OFFER TO GENERAL AGENTS.**  
**METALLIC LETTER CO., 433Y, N. CLARK ST., CHICAGO**

## The Smell Organ

By JOSEPH H. KRAUS

(Continued from page 136)

atomizers are actuated by keys on the piano. Pressure upon any one of the keys closes a circuit, which operates a solenoid, or suction type magnet, the latter releasing a valve and permitting compressed air from an air compressor and storage tank to blow the odorous vapor upward. In back of the individual spray nozzle is a funnel shaped pipe likewise connected to a compressed air supply source. These create a constant draft of air blowing the odors upward and this draft is further facilitated by large rotary exhaust fans at the rear of the theatre. The strong pedal under the piano keyboard connects with the air supply compartment and operates an auxiliary valve which admits a further supply of air and consequently increases the amount of perfume and directly increases the strength of the odor.

It is possible that in order to rid the room quickly of any odor whatever ozonized air may be permitted to pass into the funnels.

\* \* \* \* \*

It may be interesting to note that Dr. Septimus Piesse was somewhat anticipated by Mr. H. Gernsback in his scientific novel, "Baron Münchhausen's New Scientific Adventures" where he spoke of the same apparatus as far back as June, 1916. See page 93 of the *Electrical Experimenter*, June, 1916. He said there, as follows:

"The next act was almost entirely lost upon us. From what I could grasp from our host, it was a wonderful symphony of odors. It is well known to you that every smell, odor or scent causes a certain mind reflex or association; thus you are aware of the fact that certain perfumes or scents produce certain emotions upon our nerve centers. Certain scents will immediately conjecture a definite trend of thought upon you, all depending upon the intensity of your feelings. In the present day humans, this faculty of *correctly* associating thought with certain scents is as yet but little developed. With the Martians, it seems very highly developed; each scent, every moderation of scent has a certain well defined meaning.

"This is how the *symphony of scents* was enacted. Perforated pipes were placed on top of the railing of all the tiers. This piping ran continuous thru the entire house, while large supply mains led to a mixing and generating plant behind the scenes. The scents and perfumes were led in large mixing chambers, here to be blended scientifically by accomplished artists performing the *symphony*. By means of pumps the scents were driven into the perforated pipes, but a few feet away from the audience, who thus simultaneously was enveloped in clouds of invisible scents and perfumes. The *clouds* came at times in puffs, at times they were sustained, sometimes they were long drawn-out, changing from one scent into another. We could detect a certain rhythm thruout, and from the ecstatic expression on the Martians' faces we understood how deep their feelings were during the performance, which lasted well over half an hour.

"Upon us the full meaning was, of course, lost, for we did not understand it all, but just the same our sensations were delightful in the extreme and exceedingly pleasant. Just exactly what the feelings of the Martians were, and just what mental pictures or emotions the various scents produced upon their nerve centers, we have, of course, no means of knowing, but we knew that their systems responded very powerfully to the performance."



## Our new terms on the CROFT LIBRARY

Save you \$8 and give you 10 months to pay

WE have clipped \$8.00 off the price of this popular electrical library—made it \$19.50 instead of \$27.50, a reduction of about 30%. And more than that, we are offering the easiest terms we have ever made on the Croft books. You now pay, *not* \$5 a month *nor* even \$3 a month, but the sum of \$1.50 in ten days and the balance at the rate of *only* \$2 a month. This gives you ten full months to complete your payments.

The new price and the new terms make the Croft Library the biggest bargain in sound electrical training ever offered to the industry.

Was  
**\$27.50**  
Now  
**\$19.50**

NO course, no set of books, offers a quicker, surer method of mastering electricity than the Croft Library. It is founded on practice—on work as it is actually done. It is jammed from cover to cover with the kind of hard-headed, pay-raising facts you want. Written so that the beginner can easily understand it, yet so sound, so thorough that it is the daily guide of thousands of highly paid electrical workers and engineers.

Croft shows you how to master the finer points of electrical practice. He teaches you electricity as experts know it and puts you in line for an expert's pay.

## The Croft Books will help you win a big-pay job

EVERYWHERE the Croft Library is acknowledged as the standard—the leader—in practical electrical training. Go into the home or shop of any man who has made a success in electricity and nine times out of ten you will find somewhere a well-thumbed set of Croft. Croft and Success go hand in hand. If your electrical training is obtained from these great books you are certain to win your way to the top.

### Titles and Scope of Books

Volume One—Practical Mathematics, 358 subject headings. Tells you how to use mathematics as a tool.

Volume Two—Practical Electricity, 1,000 subject headings. The basic principles of all electrical practice.

Volume Three—Practical Electricity, 1,100 subject headings. A continuation of Volume Two.

Volume Four—Electrical Machinery, 1,400 subject headings. Contains what every electrical man wants to know.

Volume Five—Central Stations, 509 subject headings. All phases of central station operation are covered.

Volume Six—Wiring for Light and Power, 1,700 subject headings. Tells how to do the big and little jobs right.

Volume Seven—Wiring of Finished Buildings, 1,100 subject headings. The very meat of wiring practice.

Volume Eight—Practical Electric Illumination, 1,000 subject headings. Lamps and the art of lighting properly.

### Practical Electricity Taught by an Expert

Croft gives you only the boiled-down records of every-day electrical practice. His knowledge of electricity has been obtained through actual shirt-sleeve practice, and because he knows your problems he is able to tell you in clear, understandable language the best way to solve them.

Starting right in with the ABC's of modern electrical practice, he takes you through his books in easy steps. He gives you the secrets of success in electricity in plain words, figures and illustrations.

### Examine them for 10 days FREE

We want you to test our statements—we want you to compare the Croft books with others. Fill in and mail the coupon attached and we will send you the entire set of eight volumes for ten days' Free Examination. We take all the risk—pay all charges. You assume no obligation—you pay nothing unless you decide to keep the books. Then \$1.50 in ten days and the balance at the rate of \$2 a month. Send the coupon NOW and see the books for yourself.

### Send no money—just the coupon

#### FREE EXAMINATION COUPON

McGraw-Hill Book Co. Inc., 370 Seventh Ave., New York  
Gentlemen:—Send me the LIBRARY OF PRACTICAL ELECTRICITY (shipping charges prepaid), for 10 days' free examination. If satisfactory, I will send \$1.50 in ten days and \$2 per month until \$19.50 has been paid. If not wanted, I will write you for return shipping instructions.

Name .....

Home Address .....

City and State .....

Firm or Employer .....

Occupation .....

(Fill in all lines)

**"The Handy Sterling"**

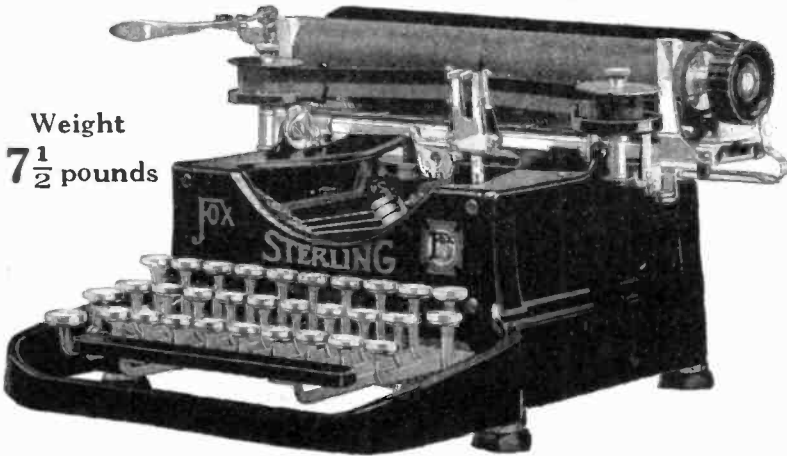

Weight  
**7 1/2 pounds**

**The New Fox-Sterling Portable**

A REAL TYPEWRITER, built on the most approved typewriter principles, complete in every detail, speedy and efficient in operation, yet light enough to carry anywhere.

**ONLY**  
**\$3.00**  
**DOWN**

**Direct from Factory to You**

There is now no reason why anyone should be handicapped for want of an efficient writing machine. Our special easy payment offer now places this wonderful little typewriter within the reach of everyone. Remember, this is not a big cumbersome cast iron machine, nor is it a "rebuilt" machine. It is a high class portable typewriter, every part of which is made complete in our own factory from the very best materials and by highly skilled mechanics. The completed machine is shipped BRAND NEW direct from factory to you. It weighs only 7 1/2 pounds, but more important still is its superior writing ability. It will do your work neatly, rapidly, and with an ease that will surprise you.

**10 Days Free Trial**

Decide whether you want the Sterling, not after casual inspection, but after a thorough test of 10 days under your own conditions. If you are not more than satisfied with it you are under no obligations whatever to keep it, and the ten days' trial will not cost you a penny.

**Easy Payments**

You have almost a year to pay. Add to your capacity for earning, learning, and producing results by using the best modern equipment to help you.

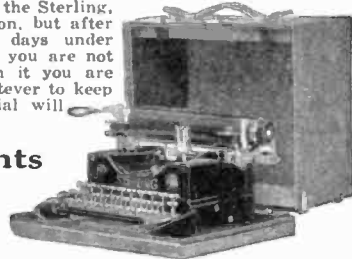

**Description**

Height only 6 inches. Weight only 7 1/2 pounds. Handsome Carrying Case furnished FREE. Machine frame solid one-piece aluminum; entire machine beautifully finished in bright nickel and black enamel. Ball bearing carriage; 84 characters and 28 keys; Universal arrangement. Wonderfully light, speedy key action; makes fine carbon copies; segment shift light and quiet; shift lock, back spacer in keyboard; margin release in keyboard. Wide carriage takes official envelopes; automatic line space lever for one or two spaces or writing on ruled lines. Fast rotary escapement, easily adjustable paper fingers and margin stops. Triple feed rolls; black and red ribbon. Complete in every detail.

**Send Coupon Now**

Don't put this matter off. Mail in the coupon today or send your name and address in a letter or on a postcard. We will send you the full particulars of this offer the day we hear from you. Mail the coupon or write now.

**FREE COUPON**

FOX TYPEWRITER CO.  
Dept. 2325  
Grand Rapids, Mich.  
Gentlemen:—

Please mail me at once full particulars of your Free Trial and Easy Payment Offer on Fox-Sterling.

Name.....  
Address in Full.....

**FOX TYPEWRITER CO.**

Dept. 2325 Grand Rapids, Mich.

**Atoms Not Alike, Says Prof. Harkins**

(Continued from page 140)

ago, and this was confirmed by the American chemist, Richards, who made extremely accurate determinations of the atomic weights of some of these isotopes.

"While it was thus considered that the very heavy elements—such as lead and radium—are mixtures, attempts to separate such elements into their different isotopes all proved failures."

About 1912 Sir J. J. Thomson found accidentally, by using what is known as the positive ray method that the light element neon, one of the very rare gases in the atmosphere, consists of two kinds of isotopes, of atomic weight 20 and 22, but he did not seem to feel that this was definitely proved. In 1915, when Prof. Harkins first decided to attempt to separate an element into parts, he decided that the best element for this purpose was chlorine, another light element. It happens that this element—a greenish yellow gas—is now best known by the fact that it was the first poison gas used in warfare by the Germans.

Prof. Harkins has developed the rule that any element which consisted of only one kind of atoms would have an atomic weight equal almost exactly to a whole number. And this is now known as the "whole number rule." Chlorine, of all the light elements, had an atomic weight farthest from a whole number, and this seemed to indicate that it contained large percentages of at least two different isotopes, which are more elementary than the element, so called. What is called the ordinary or chemical atomic weight is simply the average weight of all of the atoms in an element in terms of hydrogen, which is the lightest of all elements. The atomic weight of hydrogen was formerly taken as equal exactly to unity, but was later set at a number 1.0078, which is only 0.78 per cent. greater than unity. This difference has a remarkable significance, which will be mentioned later.

Experiments were begun in 1916 and would have proved successful much earlier than was actually the case, if they had not been interrupted by the war. However, in January, 1920, Harkins and Broeker had separated about a third of an ounce of chlorine which has an atomic weight different from that of ordinary chlorine, and this separation has since been repeated by Harkins and Hayes. This is the first definite separation of an element into parts, which has ever been demonstrated.

"Though the elements are almost all mixtures, the percentage of the mixture has thus far been found to be the same no matter where the element is found upon the surface of the earth," says Prof. Harkins. "To explain this fact the English physicist, Aston, advances the hypothesis that these elements have been thoroly mixed in the sea. However, that this cannot be the true explanation is seen, when it is considered that the element nickel, consisting of two isotopes of atomic weight 58 and 60, has the same average or chemical atomic weight in the meteorites (58.68) as it has on earth, or the mixture has just the same composition in both, as found by the American chemist, Baxter. This indicates either that the material of the earth and that of the meteorites must at one time have been very thoroly mixed together, or that these are just the proportions in which the atoms were formed when they were built up from hydrogen.

**Tires With 500 Nail Holes Leak NO Air**

A new puncture-proof inner tube, which in actual use was punctured 500 times without showing the loss of any air when tested by a tire gauge, has been invented by Paul B. Coats, an electrical engineer of Chicago. It is inflated with air and has the same appearance as the regular inner tube, yet it removes all the necessity of changing tires until the casings are entirely worn out. Cars using these tubes are making from 8,000 to 12,000 miles without removing a tire from the wheel. A wonderful feature of this new tube is that it can be produced and sold at about the same price as the ordinary tube. Mr. Coats has turned over all his rights on this invention to the Milburn Puncture Proof Tube Co., Dept. D-14, Milburn Bldg., 330-335 W. 47th street, Chicago, who wants to place these tubes in a few cars in your locality. They will make a very liberal offer to any one who wishes to try them at the company's risk, until a distributor is appointed for your territory. —Advertisement.

**Free Book**

Containing complete story of the origin and history of that wonderful instrument—the

**SAXOPHONE**

This book tells you when to use Saxophone—singly, in quartettes, in sextettes, or in regular band; how to play from cello parts in orchestra and many other things you would like to know. The Saxophone is the easiest of all wind instruments to play. You can learn to play the scale in an hour and soon be playing popular airs. It will double your income, your pleasure and your popularity. Three first lessons sent free. Nothing can take the place of the Saxophone for **Home Entertainment, Church, Lodge or School, or for Orchestra Dance Music**. You may try any Buescher Saxophone, Cornet, Trumpet, Trombone or other instrument 6 days. If satisfied, pay for it by easy payments. Mention instrument interested in when sending for Free Book.

**BUESCHER BAND INSTRUMENT CO.**  
Makers of Everything in Band and Orchestra Instruments  
604 Buescher Block ELKHART, IND.

**Easy to Play  
Easy to Pay**





## Measuring Heart and Muscle Actions

By FELIX J. KOCH

(Continued from page 130)

float; this is attached, in turn, to a very delicate wire. That wire, in its own turn, connects with a writing point, which registers its message upon a sheet of smoked material mounted on a drum as a rule.

When making the tests of the stomach, under observation, the balloon, deflated and pressed to its smallest dimensions, is swallowed by the patient. It is then filled with air, admitted thru the rubber tube aforesaid, which is attached at the proper time to the manometer. Each and every move of the stomach affects the balloon proportionately. Each and every move produces an action on the balloon's surface, which, in its own turn, is "written" on the drum.

"It becomes obvious," Dr. Jackson suggested, as he placed the balloon in the stomach of one of his associates for the purpose of demonstrating the experiment, "that if the device shows that a stomach refuses to contract properly something must be amiss there.

"In experimental work its service is of incalculable value. New as it is, it has already occasioned experts to wonder that no one should have hit upon it—for its special purposes—half a dozen or more centuries ago."

Omitting ultra-technical details of a device for measuring blood-pressure, the next device which we saw centered its activities about an ordinary column of water, so placed that it could be dealt with very readily. This column is set into action for the experiment by connecting it with a patient or subject. A rubber cuff is placed about the arm of the subject and tubing from it then connects this cuff with the column of water.

"You see," Dr. Jackson puts it, in explanation of what the experiment actually consists, "the pressure of the blood in the arterial system of a human being exists, thruout life, under what engineers would call various heads. Now every time the heart beats a certain quantity of blood is forced upon that basic head, all in addition to what was there before. This addition—this heaving of the new upon the other—causes a wave, which ripples or passes thru the mass.

"The device under discussion measures both the innate or original head of pressure and it measures the rise and the fall of these wec waves of variation which are the results of the individual beats of the heart.

"We place our rubber cuff," and he indicated it, a plain band or other cuff, connected with the tall column of the water by means of tubing. "The cuffs are then pumped full of air until reaching a pressure about equal to that of the general blood head in the body.

"Once this point has been reached, it needs just a little skilful adjustment of the pressure, of the devices suggested, and one may ascertain exactly the point at which the wave coming from the heart-beat is barely able to pass beyond the cuff. This point marks to the doctor the highest pressure to which the blood in that arterial system is subjected." (Illustration No. 4.)

Perhaps the most striking of heart experiments put into operation in the laboratory, as there comes a need of it, uses the heart of a horse, so mounted that water may be pumped thru the same, exactly as blood would have passed thru it, under pressure of a simple rubber bulb. This circulation is maintained in the presence of all of the students as long as possible.



## If He Had Passed It Up

He Would Still Be A Laborer At \$2 A Day. No Money, Nothing Ahead But Hard Work, Longer Hours—And Regrets. But He Didn't Pass It Up

He decided to learn Mechanical Drawing. He buckled down to work with the Columbia School of Drafting. When he had a quiet half hour to spend he spent it—as a wise man spends money—to get full returns.

**MADE \$275 EXTRA IN 3 DAYS.** He recently received \$275 for one drawing that only took him three days to draw.

**NOW HOW ABOUT YOU?** Are you working up hill or down? Count the money in your pay envelope next pay day. You'll find the answer there.

**MAKE \$35 TO \$100 A WEEK.** We will train you to be an expert Draftsman in your spare time at home by mail. There's lots of room for you if you act now.

**PROMOTION IS QUICK. WE'LL QUALIFY YOU** for a high-salaried position in the drafting field and keep you in touch with openings for Draftsmen in the big machine shops, industrial plants and United States Government

departments. Men who start as Draftsmen are often advanced to Chief Draftsmen, Chief Engineers, Production Managers and so on.

**GET THE RIGHT TRAINING.** Mr. Claffin, the founder and director, stands personally in back of the Columbia School of Drafting. You spend no time in long-winded theories—useless and expensive to you. You start on actual drawing work the day you receive your first lesson.

**YOU NEED NO PREVIOUS TRAINING.** The course is easy to understand and easy to follow. Many students are qualified even before they complete the course.

**SUCCESS CALLS MEN OF ACTION ONLY.** If you are a man of action clip the coupon now and show that you are a man of action. Keep right on top of this opportunity to make real money. Don't go looking for a pair of scissors. Tear the coupon off and mail it right now. We have a special offer for those who reply promptly. Get started now.

## What We GIVE You

**PRACTICAL PROBLEMS.** You are carefully coached in practical Drafting work.

**WE HELP YOU GET A JOB.** We help you get a position as a practical Draftsman as soon as you are qualified.

**PERSONAL INSTRUCTION AND SUPERVISION THROUGHOUT THE COURSE.** You receive the personal instruction and help of Roy C. Claffin, president of the Columbia School of Drafting and a practical Draftsman of many years' experience.

**DRAFTSMAN'S EQUIPMENT.** We furnish you with a full set of Drawing Equipment and

### U. S. Civil Service Commission Needs Draftsmen

The following are a few of the many positions open in Government Departments from time to time. The salaries are starting salaries, subject to increase. Practically all of them carry a bonus of \$210 a year additional.

Architectural Designer	.....\$4,000
Chief Draftsman (Aeronautical) Naval Aircraft Factory, per day	.....\$15.04
Aeronautical Draftsman, Field Service of Navy Department, \$5.20 per day to \$12 per day.	

Drafting Instruments as shown in the picture below when you enroll. You keep both sets on completing the course.

**CONSULTATION PRIVILEGES.** You are free to write us at any time for advice and suggestions regarding your success.

**DIPLOMA.** The diploma we give you on completing the course attests to your proficiency as a Draftsman. It is an "entering wedge" to success.

**FREE SUBSCRIPTION TO DRAFTSMAN'S PUBLICATION, "THE COMPASS."** You are given free a subscription to our helpful, inspiring publication "The Compass."

## FREE BOOK

Send in this coupon today. Immediately on receipt of it we will send you our book, "Your Future in Drafting," which tells you all about our new method of teaching Mechanical Drawing and gives full details of our special offer to those who reply promptly.

## COLUMBIA SCHOOL OF DRAFTING

ROY C. CLAFLIN, President

Dept. 1756, 14th & T Sts., N. W.

Washington, D. C.



### FREE Drafting Outfit

We give you free with our course this professional drafting outfit. It is yours to keep when you complete the course.

### FREE BOOK COUPON

Columbia School of Drafting,  
Dept. 1756 14th and T Sts., N. W.,  
Washington, D. C.

Enter my name for a free subscription to "The Compass" and also send me without charge your illustrated book on Drafting, telling me how I can secure your complete Home Study Course and your help in securing a position as Draftsman.

Name.....  
Address.....  
City.....State.....

**Just Published!**

# A Unique Booklet on Selecting Your Piano

**W**OULD'N'T you like to know what artists themselves insist upon in a piano? Are you familiar with the factors that should govern piano selection? Would you be a competent judge of piano worth? Then send for this new booklet: "Those Who Know and What They Say." On page after page well-known musical folk—pianists, teachers, vocalists, composers, directors—discuss their ideas and ideals of piano quality. They explain how, in the Krakauer Piano, they have found every attribute of the truly artistic instrument. No one contemplating the purchase of a piano can afford to miss reading this booklet. Send for your copy today.

## KRAKAUER PIANOS

*"A Half Century of Quality Production"*

**KRAKAUER BROS.,**  
213 Cypress Ave., New York City

Please send booklet "Those Who Know and What They Say."

NAME .....

ADDRESS .....

Dr. Jackson took a spare horse heart from the refrigerator and demonstrated once more, as he loves to do.

"In order to learn, thru the experiment, just what occurs inside the heart while the blood is passing, it is necessary that one look inside the heart just at that moment of course. That would mean that we must have a *window* in some tube, or other device to be projected into the heart at the time.

"We employ the left side of the heart for the experiment. We insert our window in the upper end of this half, about the point where the pulmonary veins enter.

"This window is really a brass tube, with a wee slit closed by glass at the bottom. In order that we may see things beyond the glass, the very tiniest sort of an electric light bulb is inserted into the chamber of the heart to be studied, wires being inserted from below. The light is lit; the water is forced thru the heart and action proceeds substantially as it would were the horse still alive." (Illustration No. 6.)

Dr. Jackson led to another section of the laboratory.

"Possibly you may not know just what this is," he said.

"We call it the *plethysmograph*. It is just another device for testing the blood-pressure; more convenient in certain cases than the other instrument yonder and a check upon the rest of our devices to such ends.

"Once you understand its operation, it is really simple. It is built around a metal can. You place your hand in the can and then a packing makes the interior of the box air-tight.

"There are two tubes to the device which facilitate procedure from this point onward. The one is an air-vent, to be used when air is to be readmitted. The other connects with a rubber tube reaching to a tambour and stylus which records the message wanted in due course on a drum.

"Attached to the second tube, inside this air-tight can is a rubber disk. It is fitted to the patient's arm before actual testing begins and when all things are secure the air is exhausted. The can interior is air-tight, as has been described. The tambour is then started, recording its movements on the drum, and the traveling sheet gives the record of the pulsations."

### Perpetual Motion at Last?

(Continued from page 131)

\$80,000,000, and that the only cost of upkeep is for lubrication, at the rate of 13c per hour for each horse-power, and that the plant will pay for itself in less than one month." He further offers "to pay \$500.00 to charity, should he fail to prove his statements," all of the above statements being sworn to in an affidavit which he is distributing on a circular advertising his company's *free power* scheme.

The final statement in his sworn affidavit is to the effect that he only needs additional capital for the sole purpose of loading additional mercury into the machine, to make it ready for exhibition, for which purpose he is offering stock at 10c per share with a par value of \$100.00, and he pledges the mercury to belong to these investors.

Just to show our readers that we have the right spirit and a big heart, we will double his offer, and will pay \$1000.00 to Mr. Ulram's company, or give it to charity, whichever he may elect on the day that this machine starts oscillating, and

(Continued on page 176)



**6000 MILES AT 1/4 THE COST**

**Don't Miss This Chance To Buy United Economy Tires**

at these phenomenal prices. Reconstructed from highest quality stock with expert workmanship. We unqualifiedly guarantee adjusted replacement if not perfectly satisfactory for 6000 miles. Our tube values unequalled.

**THIS IS YOUR BIG OPPORTUNITY**

Size	Tire	Tube	Size	Tire	Tube
Rellner 30x3	\$4.90	\$1.40	34x4	\$8.00	\$2.35
Free 30x3	5.90	1.65	34x4	9.00	2.50
With 32x3	6.40	1.75	35x4	9.50	2.60
Every 31x4	7.25	1.90	36x4	10.00	2.75
Tire 32x4	7.80	2.00	35x5	10.50	3.00
33x4	7.90	2.25	37x5	11.00	3.25

State whether you want straight side or clincher, plain or non-skid. Send \$2.00—deposit for each tire; \$1.00 deposit on tubes; balance O. O. D., subject to examination, or 5 per cent discount if full amount is sent with order.

**United Economy Tire Co.**  
780 Eighth Av., New York, Dept. S



**DIAMONDS WATCHES CASH OF CREDIT**

**Genuine Diamonds GUARANTEED**

Our Diamonds are distinctive in fiery brilliancy, blue white, perfect cut. Sent prepaid for your **FREE EXAMINATION**, on Charge Account.

**SEND FOR FREE CATALOG**

There are over 2,000 illustrations of Diamonds, Watches, Wrist Watches, Pearls, Mesh Rings, Silverware, etc., at Reduced Prices. Catalog explains everything.

**WRIST WATCH \$2.25 A Month**



**PRICES ARE DOWN**

Our IMMENSE BUYING POWER for our Chain of Stores in leading cities and our large Mail Order House enables us to make lower prices than small concerns. We invite comparisons. You will be convinced that you can do better with **LOFTIS**. Money back if not satisfied.

**LIBERTY BONDS ACCEPTED AT PAR.**

**LOFTIS BROS & CO.** 1875-6  
ESTD 1868

**THE NATIONAL JEWELERS**  
Dept. A-22 108 N. Stato St.  
CHICAGO, ILL.  
STORES IN LEADING CITIES

## Carillons in Belgium

By MARINUS COOK

(Continued from page 132)

during the early days of the war, when Belgium for a large part was still free from the invaders, the carillons were a mighty means of keeping up the spirit of the people. Jef Denyn, the carillonneur of Malines, whose picture is given here, played daily—until the enemy silenced his bells—from his high position his patriotic songs, and, in spite of the thunder of heavy guns, his carillon thundered out into the high atmosphere that Flemish battle song: "The Flemish Lion—They Shall Not Tame Him!" Below, thousands of people standing in the market place were singing with his bells.

When a carillon is used for free-hand playing, no hammers are used, but the clappers of the bells instead. They are connected by means of their steel wires with a keyboard, usually installed immediately under the bell-chamber. This keyboard consists of as many wooden handles as there are bells overhead, and is arranged in the same way as the keyboard of a piano, with this difference, however, that the keys lie much farther apart and the space between the upper and the lower row of keys is considerable. When the carillonneur plays, he deals the handles, corresponding to the notes of his music, rather forceful blows with the fist. This sends them down and brings the clappers against the inside of the bells and so produces the desired tones. The clappers are provided with springs, which draw them back immediately to prevent any lingering or false after-sound.

With his feet the artist rings the heavier bells which produce the lower or *hum* notes, and to see a carillonneur thus work frantically with hands and feet, while the whole room is filled with pealing thunder, and the tower trembles and vibrates, convinces one that the player must love his art, for unlike any other artist, he cannot see his audience, and cannot even hear what he plays, the heavier bells dominating at this short range, all other sound.



# Guardians of the Circuits

The telephone at your elbow seems so simple an instrument, it does its work so quietly and quickly, that it is difficult to realize the vast and complex equipment, the delicate and manifold adjustments, the ceaseless human care "behind the scenes" in the central offices.

Behind the scenes is the terminal of all the underground and overhead lines on the streets and highways. Here are the cable vaults; the great steel frames containing the thousands of separate wires and fuses for the subscribers' lines; the dynamos and storage batteries; the giant switchboards through which your telephone is connected with the other thirteen million telephones in the Bell System.

And here, in charge of this equipment, are the guardians of the

circuits—the wire chief and his assistants—master electricians and experts in telephony. Their first duty is the *prevention* of "trouble." By day and by night they are constantly testing the central office equipment, the overhead and underground lines, the subscribers' individual wires. And when, from some cause beyond control, "trouble" does occur, nine times out of ten it is repaired before the telephone subscriber suffers the slightest inconvenience.

It is the skill of the men behind the scenes, together with scientific development and construction, efficient maintenance and operation, which make it possible for you to rely upon the telephone day and night.

## Plants and Animals That Forecast the Weather

By DR. ERNEST BADE

(Continued from page 135)

If the weather is fair and clear, the leech lies curled up on the base of the container, or swims in regular and slow movements thru the water. But if a thunder shower or storm is approaching, the animal becomes restless, it circles with irregular rushes thru the water, and bends and distorts its body in the most varied ways. If the atmosphere threatens rain or snow, the leech will crawl to the edges of the tank where it will remain until the weather becomes fair and clear.

Plants are also members of this unique congregation of weather forecasters. The most important of these is the weather plant, *Abrus precatoris*, of the West Indies. Its leaves are arranged like those of the locust. By careful observations, changes can be foretold. A lowering of the atmospheric pressure is shown by an upward movement of the leaf and its leaflets, a raising of the pressure is shown by a lowering of the leaves. These changes can sometimes be discerned for two or three days in advance of a change in the weather.



" BELL SYSTEM "

AMERICAN TELEPHONE AND TELEGRAPH COMPANY  
AND ASSOCIATED COMPANIES

One Policy, One System, Universal Service, and all directed toward Better Service

**WANTED**  
RAILWAY MAIL  
CLERKS

\$1600 to \$2300  
A YEAR

Men—Boys—Over 17—should write at once

Rapid advancement. No "lay-offs." THE POSITION IS YOURS FOR LIFE.  
Common-sense education sufficient. Political influence NOT REQUIRED.

Write immediately for schedule showing the places and dates of ALL coming Government examinations. Do it to-day.

FRANKLIN INSTITUTE, Dept. E180, Rochester, N. Y.



HUNDREDS OF RAILWAY MAIL CLERKS APPOINTED YEARLY  
FRANKLIN INSTITUTE, Dept. E180, Rochester, N. Y.

This coupon, filled out as directed, entitles the sender to free specimen questions; a free copy of our book, "Government Positions and How to Get Them"; a list of Government positions now obtainable, and to consideration for Free Coaching for the examination here checked.

COUPON

.... Railway Mail Clerk (\$1600 to \$2300)  
.... City Mail Carrier (\$1400 to \$1800)  
.... Bookkeeper (\$1340 to \$1800)  
.... Rural Mail Carrier (\$1800 to \$2600)  
.... Postoffice Clerk (\$1400 to \$1800)  
.... Customs Positions (\$1100 to \$2000)

Name..... Address.....  
Use this before you lose it. Write plainly.





**\$3 DOWN brings genuine UNDERWOOD**

Yes, only \$3 down puts this genuine standard Shipman-Ward Rebuilt Underwood in your home. Then—small monthly payments, or if convenient, pay cash. Either way you get the world's standard typewriter at a big cash saving.

**WHY PAY RENTAL?**

Think of it! You pay little more than rental, and the machine is yours! We offer the same three models of the Underwood Typewriter which are being made and sold by the Underwood Company today. The only difference is that Shipman-Ward machines are priced lower and are rebuilt like new by experts. You can't tell them from brand new machines. Visible writing—the FULL LINE of typewriting is visible at all times. STANDARD 4-HOW SINGLE SHIFT KEY-BOARD. Two color ribbon, back spacer, stencil device, automatic ribbon reverse, tabulator, etc.

**TEN DAYS' FREE TRIAL**

See for yourself! Try the typewriter ten days. You must be satisfied or the entire transaction won't cost you a penny. Act today. Get our big illustrated catalog and full particulars. Write NOW.

**FREE TRIAL COUPON**

**Typewriter Emporium SHIPMAN-WARD MFG. CO.**  
A-216 Shipman Bldg., CHICAGO

Send by return mail Bargain Offer No. A216 of a Standard Visible Writing Underwood. This is not an order and does not obligate me to buy.

Name.....  
Street or R. F. D. No.....  
Postoffice..... State.....

**YOU CAN PLAY THE HAWAIIAN GUITAR JUST LIKE THE HAWAIIANS!**

Because Our Native Hawaiian Instructors Will Help You

Our method of teaching is so simple, plain and easy that you begin on a piece with your first lesson. In half an hour you can play it! We have reduced the necessary motions you learn to only four—and you acquire these in a few minutes. Then it is only a matter of practise to acquire the weird, fascinating tremolos, staccatos, slurs and other effects that make this instrument so delightful. The Hawaiian Guitar plays any kind of music, both the melody and the accompaniment.



**FREE** Our complete course of 52 lessons includes **FREE** a beautiful Hawaiian Guitar, all the necessary picks and steel bar and 52 pieces of music. *Special arrangement for lessons if you have your own Guitar.*

Just **TEAR OUT** and mail today

First Hawaiian Conservatory of Music, Inc.  
233 Broadway (Woolworth Building) NEW YORK

Please send me full information about your 52 easy lessons and **FREE GUITAR OFFER**.

Name.....  
Address.....  
Town..... State..... S. I. - 6

**"BOW LEGS and KNOCK-KNEES" UNSIGHTLY**  
Send for booklet showing photos of man with and without the **PERFECT LEG FORMS**.  
**PERFECT SALES CO.**  
140 N. Mayfield Ave., Dept. 50, Chicago III.

**Perpetual Motion at Last?**

(Continued from page 174)

converting nothing into something; in other words, *free energy*, whatever that is, into electric light, heat and power.

On the day we inspected the perpetual motion machine, the inventor had the tanks filled with water, and stated he had almost enough mercury, in fact just about enough then to fill 'er up, and that he hoped to turn 'er loose, about the next day, or the day thereafter.

**Wood Alcohol—How to Detect It**

By DR. ERNEST BADE

(Continued from page 134)

is fractioned and neutralized. The average yield of the wood alcohol is 10 gallons of 82 per cent. alcohol for every cord of wood used.

This alcohol, methyl alcohol by name, is a violent poison when taken internally. It can readily be detected in a number of ways. Its boiling point is 66° C. and is just as inflammable as grain alcohol, which boils at 78° C. Both give a blue flame. Wood alcohol mixes in all proportions with both water and ethyl or ordinary alcohol.

Wood alcohol can readily be identified on oxidation, formaldehyde being formed, and its detection in ethyl alcohol is based on this fact. Ethyl alcohol is also oxidized, but here a different product, acetaldehyde, is obtained.

In order to detect methyl alcohol when it is present in ethyl alcohol, an ounce or so of the liquid to be analyzed is taken and about a dozen drops, more or less, is distilled directly into a test tube receiver. No elaborate apparatus is necessary for this purpose. The distillate is then diluted with water until the mixture consists of about 10 per cent. of alcohol.

Then a spiral of ordinary copper wire, wound from a piece about a foot long, is heated to redness at the top of a Bunsen burner flame, and plunged into the liquid in the test tube. This process is repeated five or six times, the tube being kept cooled in a glass of water. In this way the methyl alcohol is oxidized by the hot copper oxide formed on the wire. The test tube is now dried on the outside, and heated to boiling for two or three minutes. Filter if necessary, cool, and add two drops of a 0.5 per cent. aqueous resorcinol solution and shake. (Altho resorcinol is expensive, a few grams will last several years.) Slowly and carefully pour the solution on about 5 c.c. concentrated sulphuric acid in another test tube so that the two solutions do not mix.

Let the tube stand for two or three minutes, and if wood alcohol was present to as small an extent as one-tenth of 1 per cent., which is equivalent to some twenty drops in a quart, a rose-red contact ring will be formed where the two liquids meet. If the tube is now gently shaken, red flecks or specks will be seen.

A simple test for the detection of *pyridine base*, a denaturant of alcohol, is a solution of cadmium chloride. A little cadmium is dissolved in concentrated hydrochloric acid, and the whole mass boiled and finally evaporated to dryness. A 5 per cent. solution of the resultant anhydrous cadmium chloride is made. Five c.c. of this solution and an equal quantity of the liquid to be tested are taken and thoroly mixed. After standing about ten minutes an abundant crystal precipitate is produced if pyridine, bone oil, is present.

**Improve your Figure**

**Control Your Nerves—Enjoy Life Be Free from Nagging Pains and Ailments**  
How? Correct your posture and strengthen your muscles and nerves by using for a little while this gentle, easy, natural support. Nearly 200,000 have done it with the wonderful

**Natural Body Brace**

Overcomes weakness and organic ailments of women and men. Brings restful relief, comfort, ability to do things, health and strength.

**Develops Erect Graceful Figure**

Does away with the strain and pain of standing and walking; replaces and supports misplaced internal organs; reduces enlarged abdomen; straightens and strengthens the back; corrects stooping shoulders; develops lungs, chest and bust; relieves backache, curvatures, nervousness, ruptures, constipation, after effects of Flu. Comfortable—easy to wear.



**KEEP YOURSELF FIT**

EVERY MAN with heavy abdomen, rupture, stooping shoulders, backache, shattered nerves or other spinal trouble, should wear my brace.

**Wear it 30 Days Free At Our Expense**

Write me in confidence today, stating your condition and desires. I will answer quickly and send illustrated booklet, measurement blank and our very liberal proposition.

**HOWARD C. RASH, Pres. Natural Body Brace Co.**  
286 Rash Building, Salina, Kansas

**WURLITZER** 20 YEARS INSTRUMENT MAKER  
**Free Trial**  
Any musical instrument sent on a week's free trial with complete outfit, case, self-instructor, etc. No obligation to buy.  
**Monthly Payments**  
Easy terms, only a few cents a day.  
**Send for Catalog**  
Free. Shows all instruments. Trial blank enclosed.  
**Rudolph Wurlitzer Co., Dept. A125**  
117 E. 4th St., Cincinnati 120 W. 42nd St., New York  
700 Jackson Blvd., Chicago, 250 Stockton St., San Francisco

**READ THIS! ACT QUICK!**  
**MAKE MONEY**  
MAKE SHOW CARDS & SIGNS  
**EARN \$10.00 to \$25.00 DAILY**—salary, or have own shop and independence. Easy to learn by our new complete course with individual correspondence instruction. Course includes hand lettered show cards and large assortment of **BRUSHES FREE**. Graduates established in paying sign shop, or good paying "Jobs" await them. **WRITE TODAY** for illustrated matter, price and terms.  
**Empire SI Art Institute, Inc.** 2050 Amsterdam Ave. NEW YORK CITY.

**CUSTOM TAILOR MADE TO FIT YOUR INDIVIDUAL CAR**  
Made in our custom shops after your order is received. We ship ordinarily in 2 or 3 days. Perfect fit guaranteed when correct name, year and model of car is given. You can easily apply it yourself. We furnish instructions and all necessary tools, welts and fasteners. Our Catalog No. 10 with samples is free for the asking.  
**LIBERTY TOP & TIRE CO., Dept. E-4, Cincinnati, O.**

**MATHEMATICS TAUGHT BY MAIL**  
Spare time home study courses in Arithmetic, Geometry, Algebra, Trigonometry.  
**J. A. HARDING**  
76 Brighton Ave., Highland Park, Mich.

Can you afford to **STAMMER?** or **STUTTER?**  
It ruins many chances for promotion. Send postage for large free book "The Correction of Stammering and Stuttering." Methods successful for over a quarter-century. **THE LEWIS INSTITUTE**, 40 Lewis Bldg., 77 Adelaide St., Detroit, Mich., U.S.A.

## How to Make Storage "B" Batteries

By JOSEPH H. KRAUS

(Continued from page 155)

rough file-like surface, but all the ridges should be maintained in parallel relation to each other. These grooves should be considerably deeper than those found in the regulation bastard file, or about a thirty-second of an inch. The tubes are then cut into the desired length as in figure seven, bent in the form of a U, and inserted into two adjacent test tubes or bottles, much the same as in figure 1. In both figure 5 and 7, it is necessary to charge and discharge the "B" battery at least ten times in order to "form" the lead.

A still better method of making the plates, is to drill holes in lead tubes of the same diameter with a rather small size drill, or punch holes into the tubes with a nail. A dowel is then inserted into the tube so that it rests one inch from the center of the tube. Into the open end, a paste made of litharge and sulphuric acid, in the proportion of one part of acid and four parts of water, is tightly rammed into place, and the end of the tube is clinched over. This side is then marked with a negative sign. The dowel is removed and some glass wool is packed into the tube from the other opening, so that the thickness of the glass wool is about two and one-half inches. This latter step is not imperative, however, but it enables the paste for the other end to be packed in rather tightly. Any other substitute, such as wood (a short piece of dowel rod) sealing wax, or in fact just clinching the tube alone suffices and can be used in place of the glass wool. Into this open end a paste made of sulphuric acid and water in the same proportion as described before, namely, one part of acid and four of water, is made; but red lead is used this time as the solid substance. After this paste has been forced into place into the other end of the tubes, they are clinched over and the entire thing bent into the shape of a U. In some cases it may be desirable to bend the lead tubes into the shape of a sharp angle U, closing the loop of the U immediately by hammering it together and then packing each leg as described, clinching the ends or pouring molten lead into them.

For another type of cheaply constructed battery, the plate may be made of grooved wood. Into this grooved wood, thru a hole drilled laterally two pieces of lead solder are pushed. These lead solder strips are used as leads for the battery. Both halves of the grooved wood are then filled with paste, one of the halves on either side with red lead, and the other with litharge, as illustrated in figure 11.

There are occasions when batteries of high ampere-hour capacity are needed. In this event two lead strips nine inches long and about five inches wide are provided with lugs. Two thin rubber strips cut from an old inner tube of an automobile tire separate the two lead strips. Two more slices of rubber are laid on top of the second lead strip. The lead is then rolled up and the cylinder thus formed is pushed into the test tube (10).

There is one more style of battery in which the lead container made as described heretofore, is employed as one plate. Another small piece of pipe flattened at its end, is bent over, clinched, and filled with red lead paste. This lead pipe has two lugs which extend vertically from the top and which may be bent over so that two parallel pieces of wood on top the battery

(Continued on page 188)

"I have watched the progress of the International Correspondence Schools almost from the very beginning. To me their rapid growth is easily understood, because I realize the practical value that is back of them and know something too of the success attained by many ambitious men throughout the country who have taken their courses."  
—THOMAS A. EDISON.

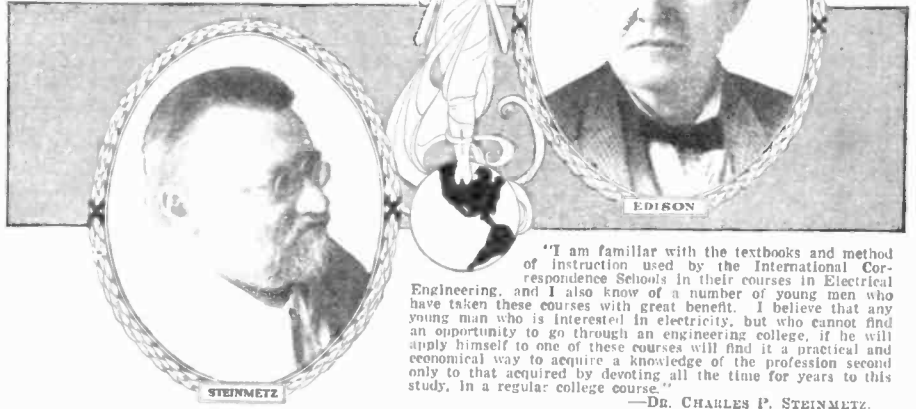

"I am familiar with the textbooks and method of instruction used by the International Correspondence Schools in their courses in Electrical Engineering, and I also know of a number of young men who have taken these courses with great benefit. I believe that any young man who is interested in electricity, but who cannot find an opportunity to go through an engineering college, if he will apply himself to one of these courses will find it a practical and economical way to acquire a knowledge of the profession second only to that acquired by devoting all the time for years to this study, in a regular college course."  
—DR. CHARLES P. STEINMETZ.

# What Would Their Advice Be Worth to You?

**S**UPPOSE you have a knack for things electrical—that you realize what a wonderful opportunity for earnings and advancement the field of Electricity offers. What, then, would it be worth to you to have Edison and Steinmetz, the two foremost figures in the electrical world, tell you of a thorough, practical plan by which you can acquire, right at home, the training you need for success?

Here is their advice, based on years of familiarity with the instruction given by the International Correspondence Schools and on personal knowledge of I. C. S. trained men in their employ:

"I know of the success attained by men who have taken your courses," says Edison. "It is a practical and economical way to acquire a knowledge of the profession," says Dr. Steinmetz. Read their full statements above.

For 30 years the I. C. S. has been training men at home in their spare time for success in Electricity and 300 other subjects. It is training over 130,000 men and women right now. It is ready and anxious to prepare you for advancement in Electrical Engineering or any special branch of it—

or in any other line that appeals to you.

Pick the position you want in the work you like best, then put it up to us to prove how we can help you. Here is all we ask—without cost, without obligation, mark and mail this coupon.

TEAR OUT HERE  
INTERNATIONAL CORRESPONDENCE SCHOOLS  
BOX 6247-B SCANTON, PA.  
Without cost or obligation, please explain how I can qualify for the position, or in the subject before which I have marked an X in the list below:—

- |   |   |
|---|---|
| <input type="checkbox"/> ELEC. ENGINEER           | <input type="checkbox"/> BUSINESS MANAG'MT      |
| <input type="checkbox"/> Electric Lighting & Rys. | <input type="checkbox"/> SALESMANSHIP           |
| <input type="checkbox"/> Electric Wiring          | <input type="checkbox"/> ADVERTISING            |
| <input type="checkbox"/> Telegraph Engineer       | <input type="checkbox"/> Railroad Positions     |
| <input type="checkbox"/> Telephone Work           | <input type="checkbox"/> ILLUSTRATING           |
| <input type="checkbox"/> MECHANICAL ENGR.         | <input type="checkbox"/> Show Card & Sign Ptg.  |
| <input type="checkbox"/> Mechanical Draftsman     | <input type="checkbox"/> Cartooning             |
| <input type="checkbox"/> Machine Shop Practice    | <input type="checkbox"/> Private Secretary      |
| <input type="checkbox"/> Toolmaker                | <input type="checkbox"/> Business Correspondent |
| <input type="checkbox"/> Gas Engine Operating     | <input type="checkbox"/> BOOKKEEPER             |
| <input type="checkbox"/> CIVIL ENGINEER           | <input type="checkbox"/> Stenographer & Typist  |
| <input type="checkbox"/> Surveying and Mapping    | <input type="checkbox"/> Cert. Pub. Accountant  |
| <input type="checkbox"/> MINE FURN or ENGR.       | <input type="checkbox"/> TRAFFIC MANAGER        |
| <input type="checkbox"/> STATIONARY ENGR.         | <input type="checkbox"/> Cost Accountant        |
| <input type="checkbox"/> Marine Engineer          | <input type="checkbox"/> GOOD ENGLISH           |
| <input type="checkbox"/> ARCHITECT                | <input type="checkbox"/> Com. School Subjects   |
| <input type="checkbox"/> Contractor and Builder   | <input type="checkbox"/> CIVIL SERVICE          |
| <input type="checkbox"/> Architectural Draftsman  | <input type="checkbox"/> Railway Mail Clerk     |
| <input type="checkbox"/> Concrete Builder         | <input type="checkbox"/> AUTOMOBILES            |
| <input type="checkbox"/> Structural Engineer      | <input type="checkbox"/> Airplane Engines       |
| <input type="checkbox"/> PLUMBING & HEAT'G        | <input type="checkbox"/> Mat' mat'ies           |
| <input type="checkbox"/> Sheet Metal Worker       | <input type="checkbox"/> Navigation             |
| <input type="checkbox"/> Text. Overseer or Supt.  | <input type="checkbox"/> Agriculture            |
| <input type="checkbox"/> CHEMIST                  | <input type="checkbox"/> Poultry                |
| <input type="checkbox"/> Pharmacy                 | <input type="checkbox"/> French                 |
|   | <input type="checkbox"/> Spanish                |
|   | <input type="checkbox"/> Banking                |
|   | <input type="checkbox"/> WIRELESS               |

Name \_\_\_\_\_  
Street \_\_\_\_\_  
Address \_\_\_\_\_ 2-1-22  
City \_\_\_\_\_ State \_\_\_\_\_

Occupation \_\_\_\_\_  
Persons residing in Canada should send this coupon to the International Correspondence Schools Canadian, Limited, Montreal, Canada.

## Can You Fill This Job?

are mechanically inclined WRITE TODAY for FREE 72 page illustrated book; tells all you want to know about World's Greatest TRADE SCHOOL and opportunities for men. If you like working on cars I will make you an amazing offer. No colored students accepted.

Before finishing AUTO MECHANICS course at the SWEENEY AUTO SCHOOL Runney is grabbed by the American Radiator Co. at \$150 a month. Big concerns can't wait—need Sweeney trained men Now. Sweeney System of Practical Experience—no books; TOOLS, real work—eight weeks—puts men QUICK into jobs \$100 to \$400 monthly—from chauffeurs to garage managers. NO PREVIOUS EXPERIENCE NEEDED. If you

**LEARN A TRADE**  
**Sweeney**  
SCHOOL OF AUTO-TRACTOR-AVIATION  
138 SWEENEY BLDG. KANSAS CITY, MO.

**TYPEWRITERS**  
We Save You 50%  
BUY OR RENT. 6 Months' Rental Applies on Purchase  
All standard makes. Prices from \$10 up. Rebuilt by famous Young Process. Machines absolutely good as new. Iron-clad guarantee. Ten days' free trial. Six months' "endurance test." Largest stock in America for selection. Write for details of wonderful bargains and liberal terms.  
YOUNG TYPEWRITER CO., Dept. 255, CHICAGO

**Palmer Marine Motors**  
Engines to suit your boat. Two cycle, one and two cylinders, 2 to 6 H.P. Four cycle, one, two, three, four and six cylinders 2 to 75 H.P. Prices from \$75 to \$3600. Four cycle, 2 H.P., \$98; suitable for Row Boats and Yacht Tenders.  
Catalogue free.  
PALMER BROS., Box 1, Cos Cob, Conn.

# 21 Jewel Burlington

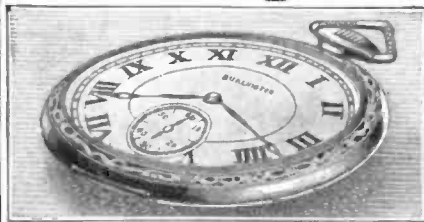

Adjusted to the Second 21 Ruby and Sapphire Jewels  
Adjusted to Temperature 25 Year Gold Strata Case  
Adjusted to Isochronism Your Choice of Dial  
Adjusted to Positions (Including Montgomery R. E. Dial)  
New Ideas in Thin Cases

## Only \$1.00 Down

Only One Dollar Down will buy this masterpiece of watch manufacture. The balance you are allowed to pay in small, easy, monthly payments. A 21-Jewel Watch—is sold to you at a price much lower than that of other high-grade watches. Besides, you have the selection of the finest thin model designs and latest styles in watch cases. Write for FREE Watch Book and our SPECIAL OFFER today.

### Write While This Special Offer Lasts

Get the Burlington Watch Book—write today. Find out about this great special offer which is being made for only a limited time. You will know a great deal more about watch buying when you read this book. You will be able to "steer clear" of the over-priced watches which are no better. Write for watch book and our special offer TODAY!

**Burlington Watch Company**  
Dept. A533, 19th St., and Marshall Blvd., Chicago

# Earn BIG MONEY as a Cartoonist

### \$3,000 to OVER \$100,000 a YEAR

now earned by successful cartoonists. Never before has the demand for cartoonists been so urgent or their earnings so great. Newspapers, Magazines, Advertising Agencies, Movie Industries—thousands of high-salaried opportunities are right now open to the new cartoonist in this fascinating field.



## Learn At Home This Easy Way

YOU can now easily learn in your spare time at home to draw the comic strips, political cartoons, caricatures and animatschs, which are in such big demand. No matter what your experience or education has been, this original method quickly teaches you to draw splendid, salable cartoons.

Send for This WONDERFUL FREE BOOKLET

Learn more about the amazing opportunities for you in this fast-growing uncrowded field. An intensely interesting booklet has just been prepared which is crammed full of valuable information about Cartooning—stories of the famous cartoonists, history of cartooning, details about every branch, a thorough explanation of the method which enables you to enter this field and thousands of other equally important facts. Sent without obligation upon request. Write TODAY.

WASHINGTON SCHOOL OF CARTOONING  
Room 1035 | Marden Building Washington, D. C.



Wonderful, new device, guides your hand; corrects your writing in few days. Big improvement in three hours. No failures. Complete outline FREE. Write C. J. Ozment, Dept. 44, St. Louis, Mo.

# Be an Artist

Comics, Cartoons, Commercial Newspaper and Magazine Illustrating, Pastel Crayon Portraits and Pastels. By Mail or Local Classes. Write for terms and List of successful students.  
Associated Art Studios,  
A 26 Flatiron Bldg. New York

## Dr. Hackensaw's Secrets

By CLEMENT FEZANDIE

(Continued from page 122)

see something queer about his eyes, though the eyelids move every once in a while."

"Cootie is the result of some of my earliest experiments with tel-automata," remarked Doctor Hackensaw. "but I am very fond of him, and he differs from most dogs in this, that I can absolutely depend upon his doing what I wish him to do."

"It seems impossible," said Silas, "that merely pressing those keys should make this dog walk, wag his tail, or move his head at will."

"Here, let me show you!" cried the doctor. "Cootie, beg!" he commanded. The dog sat up on his haunches. "Now bark!" The dog barked as requested. "Now howl three times." The animal howled! "Now whine!" The creature whined. "Now roll over twice and bark again!" The dog obediently performed the motions ordered and then regained its feet.

"Well Silas, are you convinced?" asked Doctor Hackensaw gaily, as he ceased manipulating the keys of his machine and turned to the incredulous reporter.

"I can't even believe my eyes!" exclaimed Silas. "Why, this is real magic! I never imagined such a thing could be possible. How in the world do you accomplish it, doctor?"

"It is simplicity itself. You probably know that all the actions of the body, however complicated they may seem, are performed solely by contraction and relaxation of the muscles. The body of an animal contains hundreds of these muscles, but there was no need of my encumbering my automaton with all of these. A few of the most important were all I needed. These muscles are worked by wireless, each muscle being arranged to receive its proper impulse only when a certain key of my keyboard is depressed, when I release the key, the muscle relaxes. Press down this key, and the dog opens its mouth, closing it when you release the key. To simplify matters, the dog's head is pivoted and can be partially rotated. For running I have a small motor installed in the animal. As the motor revolves, the legs are lifted and lowered in turn and perform the act of running. A gyroscope keeps the animal properly balanced."

"But how about the barking?"  
"That, too, is very simple. I have a small phonograph inside the dog. The record is a roll of film constituting a phonograph of the various sounds a dog makes. I have also added a few phrases such as 'How do you do?' 'Yes', 'No', etc.—I will show you."

Turning to the dog, Doctor Hackensaw commanded: "Shake hands with the gentleman, Cootie!"

Cootie obediently approached the reporter, sat down on his haunches and presented a paw, saying as he did so: "How do you do?"

"Pretty well, thank you, Cootie," replied the reporter without thinking, and then he burst into a laugh. "That's one on me, doctor," he cried. "I was taken in that time. The words sounded so natural I didn't perceive anything out of the way in hearing a dog speak."

"Can you say anything else, Cootie?" asked Silas.

"Yes," replied Cootie, wagging his tail. "What else can you say?"  
"Give me a piece of sugar," said Cootie, ending up with a joyful bark.

"That's really wonderful, doctor!" exclaimed Silas.

"The phonographic records are of course interchangeable," explained Doctor Hackensaw.

# Do Your Own Wiring and save 50%

You Can Become an Expert Wireman, and Secure a License, by Following the Simple Rules

IN THIS 1922 EDITION



400 PAGES ILLUSTRATED

The National Authority for 28 Years

All the necessary rules, tables and illustrations needed for every kind of inside and outside wiring and construction for both direct and alternating currents, in accordance with the Underwriters' rules. The most complete and accurate book on wiring published.

Leather Cover. Pocket Size. \$2.00 Sent on receipt of Price.

H. C. Cushing Jr.  
8 West 40th St. New York

## Why Good Dancers Are Popular

Everyone admires and wants to dance with the person who knows the latest steps. There is no need of being a wallflower! By my remarkable, new, easy method, anyone can learn the newest dances at home in a few hours. Much less expensive than from a personal teacher. No music or partner needed. So simple even a child can learn quickly. 60,000 have learned dancing by mail. Your own success is guaranteed.



To prove I can quickly and easily make you an accomplished dancer, I will send you FREE, in plain cover, a lesson in Fox Trot, Secret of Leading and How to Gain Confidence. For nulling of free lessons, send 10c. Learn in private—surprise your friends. Act now and be a good dancer soon!  
ARTHUR MURRAY, Studio 245, 100 5th Ave., N. Y.

## Electrical Engineering

men with training are in demand. For more than a quarter of a century this school has been training men of ambition and limited time for the electrical industries. Condensed course in Electrical Engineering enables graduates to secure positions and promotions. Theoretical and Practical Electricity. Mathematics. Steam and Gas Engines and Mechanical Drawing. Students construct dynamos, install wiring and test electrical machinery. Course with diploma complete.

### In One Year

Over 3000 men trained. Thoroughly equipped, fireproof dormitories, dining hall, laboratories, shops.  
Free catalog. 30th year begins Sept. 27, 1922  
BLISS ELECTRICAL SCHOOL  
406 TAKOMA AVE., WASHINGTON, D. C.

## BLUE PRINT READING

Can you read blue prints? If not, learn how. It will help you hold your job—it will get you a better job—it will earn you more money. Special courses for each trade. Write for Catalog B, stating trade. Also free blue print.

BE A DRAFTSMAN—Earn \$35-\$100 a week. We train you quickly at home on the pay as you study plan. Book and tools FREE. Write for catalog G.  
COLUMBIA CORRESPONDENCE SCHOOL EST. 1904  
Dept. 18, Drexel Bldg., Philadelphia, Pa.

## FREE BOOK Learn Piano!

This Interesting Free Book shows how you can become a skilled player of piano or organ in your own home, at one-quarter usual cost. Dr. Quinn's famous Written Method is endorsed by leading musicians and heads of State Conservatories. Successful 25 years. Play chords at once and complete piece in every key, within 4 lessons. Scientific yet easy to understand. Fully illustrated. For beginners or teachers, old or young. All music free. Diploma granted. Write today for 64-page free book, "How to Learn Piano or Organ."  
M. I. Quinn Conservatory, S. I. 46, 598 Columbia Road, Boston, 25, Mass.

## ARE YOU BASHFUL, TIMID

Self Conscious, Embarrassed in Company. Let us tell you how you can overcome these troubles and acquire Poise, confidence, assurance and a magnetic personality. Address The Veritas Science Institute, 1400 Broadway, New York, Desk 15.



**SAVE MONEY ON GUARANTEED MOTORS**



**Buy Direct from Headquarters**

By buying direct from us you save from 25% to 40% on new Columbia motors, and as high as 50% on Fuerst-Friedman rebuilt motors. You save retailer's profit — you save retailer's high sales cost—and you get motors fully guaranteed for one year.

No matter what your motor requirements are, from tiny buffing motors to heavy-duty factory motors, we have a new or rebuilt motor to suit your exact needs. And the cost is from 25% to 50% less than you would pay elsewhere. Send for our big free motor book—see for yourself the savings you get by buying from us. It tells all about our twenty years of successful motor service—all about many vast engineering projects we have handled. Ask for Book No. 20—the price regulator on new and rebuilt motors.

Electrical Machinery of all kinds promptly repaired or taken in exchange

**THE FUERST-FRIEDMAN CO. CLEVELAND, OHIO**

"Reliability Built In"

**COLUMBIA MOTORS**

**OVER \$200 PROFIT Weekly Above Expenses**

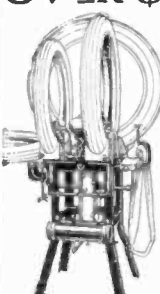

All over the U. S. and Canada, we are establishing vulcanizing service stations. We instruct you and furnish the most modern methods and equipment—

**THE ANDERSON Known the World Over**

We have 34 schools in U. S. and 4 in Canada. One is near you. School pays you \$5 per day while learning to operate the station which you start in your town or elsewhere on small capital.

Write for full particulars TODAY

**THE ANDERSON STEAM VULCANIZER CO.**  
Manufacturers of Modern Tire Repair Equipment  
114 Williams Bldg. Indianapolis, Ind., U. S. A.

**"ELECTRO-CONDITE" STARTLES THE WORLD**



Thousands of people are marveling at the wonderful performance of the "Electro-Condite" Converter. Clarifies, purifies, sterilizes, matures and melows most kinds of beverages. Makes hard water soft, etc. May prevent poisoning.

Send \$5.00 for device with 5 days trial money-back guarantee or ask for circular.

Best grade Proof Hydrometers, \$1.00 each prepaid.

**A-B-C LABORATORIES Co.**  
Dept. X, 200 West 72d St., New York

**NEW SINGLE PHASE A. C. MOTORS**

1/2 H.P. — 110 volt, 60 cycle, 1725 speed, complete with cord, plug and grooved pulley, \$13.00	3/4 H.P. \$ 47.00
1 H.P. 58.00	1 1/4 H.P. 62.00
1 1/2 H.P. 76.00	2 H.P. 89.00
3 H.P. 108.00	

Include pulley and base.

**ONE YEAR GUARANTEE**

1/2 H.P. and larger, 110 220 volt Rep. Ind. Type

Satisfaction guaranteed or money refunded

Illustrated Catalog of Motors and Supplies FREE

**HYRE ELECTRIC CO., 631-Y So. Dearborn St., Chicago**

**SEND FOR THE INTERNATIONAL CATALOG**

Factory to Consumer direct—PAY ONLY ONE PROFIT

Our net price list of auto bodies and body supplies at WHOLESALE PRICES. Save big money by buying DIRECT FROM FACTORY



For Ford and Chevrolet—prices from \$27.85 up

**INTERNATIONAL BODY WORKS**  
914 W. Ohio Street. Dept. 4, Chicago, Illinois

saw, "so I can vary Cootie's vocabulary as I please—make him speak—French or Chinese, tell funny stories, sing, whistle, imitate musical instruments, and the like."

"A dog like that would be worth a fortune in vaudeville," observed the reporter.

"I may exhibit Cootie some time," replied the doctor, "but I am not quite ready for publicity yet. The existence of Cootie is still a secret, and I will tell you in confidence, Silas, that I have another automatic figure just completed that will throw all the performances of this dog in the shade. But even to you I don't dare to breathe a hint of this marvel, as I am afraid somebody else might get wind of it and steal my laurels."

**CHAPTER 2**

Three months had elapsed since the events chronicled in the last chapter, and Doctor Hackensaw was seated in his study gazing into an open wood-fire and musing.

A bitter disappointment had come to him. The tel-automatic figure of which he had vaguely spoken to Silas Rockett, had been stolen from him. One of his assistants, a master-mechanic familiarly called "Dope" Peters, had one day mysteriously disappeared, taking with him the apparatus and the keyboard that controlled it.

Then, a month later, Silas Rockett had been sent abroad to report to his newspaper on a series of daring daylight robberies that were astounding all Europe. The most marvelous tales were told about the criminal or gang of criminals. Their leader seemed to be a beautiful veiled lady, always dressed in the height of fashion. Their specialty seemed to be jewelers' windows. In broad daylight, in the most crowded thoroughfares, she would suddenly plunge her fist through a jeweler's plate-glass window, rapidly snatch up the most expensive articles on display and run off with them. The most fantastic stories were afloat about this mysterious lady. It was said that she possessed the strength of ten ordinary men, and if any one attempted to hold her, a single blow from her fist sent him sprawling. She was also gifted with the speed of a deer. It was reported that once on a boulevard she was chased by a police auto going sixty miles an hour, but she ran so fast that the police could not keep up with her. One man even declared that one night he had seen her stand by a house, then suddenly elongate herself until she stood as high as the second story window, then gradually pull her elongated body in through the window.

Her last exploit had been to make off with a tube of radium valued at one hundred thousand francs, since then nothing more had been heard from her for over a week, and people were wondering in what city her next exploit would be chronicled.

Doctor Hackensaw was reading these accounts with a grim frown, when the door of his office opened and in burst Silas Rockett, deeply tanned from his ocean voyage.

"Why Silas, I'm glad to see you back!" cried Doctor Hackensaw, heartily. "I suppose you caught your mysterious lady-thief."

"No," said Silas. "I didn't get a glimpse of her, and as luck would have it, the thefts stopped before my steamer reached France."

"She must have heard of your coming!" exclaimed Doctor Hackensaw jocularly. "She ran away because she was afraid you might catch her."

"I think you're half right, doc," said Silas. "It's my firm belief the girl has left Paris and come to New York. Have you read in this morning's paper about the panic in the Knickerbocker Opera House last night?"

"No, I haven't seen the papers yet." "From all accounts there was a special

**Make Your Marriage A Success**



Marriage always means misery to the unfit. Ask yourself—before you propose to some pure, innocent girl, whether you are fit to be her husband and the father of her children—and whether your offspring will be healthy youngsters—a joy and blessing to you both, or sickly, defective little ones; a constant reproach to you as long as you live. What you are your children are bound to be and your weaknesses will be increased as you pass them along to your children, who may live to curse you for their inheritance of woe. This is the inflexible law of Heredity. You cannot avoid it. You dare not overlook it. **THINK** now before it is too late and resolve to

**Fit Yourself For Matrimony**

You are not fit if you are weak, sickly and under-developed. You dare not marry and ruin some trusting girl's life if

**STRONGFORT The Perfect Man**

Youthful Errors, Bad Habits or Excesses have sapped your vitality and left you a mere apology for a real man. Don't think you can save yourself with dope and drugs. Such unnatural materials can never remove the cause of your weaknesses and will surely harm you. The only way you can be restored is through Nature's basic Laws. She will never fail you if you will sit at her feet and learn her ways.

**My Methods Restore Men**

My entire life has been dedicated to a study of Nature's Laws. I have applied her wonderfully effective principles to my own person and have gained the world's award as the most perfect specimen of physical and health attainment. These are the same marvelous, restorative, uplifting elements that I want to apply in your case and fit you for the Responsibilities of Marriage and Parenthood. I want to help you—I can help you with

**STRONGFORTISM The Modern Science of Health Promotion**

Strongfortism—Nature's First Assistant, has lifted thousands of weak, ailing, discouraged men out of the bog of despair and placed them on the Straight Road to Health, Happiness and Prosperity. Strongfortism has restored the manhood they thought lost forever and has given them renewed confidence, vitality, success and fitted them for the joys of life. It can do the same for you irrespective of your age, occupation or surroundings.

**Send For My Free Book**

The experience and research of a lifetime are contained in my wonderfully instructive book, "Promotion and Conservation of Health, Strength and Mental Energy." It will tell you frankly how you can make yourself over into a vigorous specimen of vital manhood. It will teach you how to fit yourself to be a Father and be a credit to your wife and family. Just mark the subjects on the free consultation coupon on which you want special confidential information and send to me with a ten-cent piece (one dime) to help pay postage, etc. It's a man-builder and a life-saver. Send for my free book Right Now—TODAY.

**LIONEL STRONGFORT**  
Physical and Health Specialist  
Dept. 843 Newark, N. J.  
Founded 1895

**FREE CONSULTATION COUPON**

MR. LIONEL STRONGFORT, Dept. 843, Newark, N. J.—Please send me your book, "Promotion and Conservation of Health, Strength and Mental Energy," for postage on which I enclose a 10-cent piece (one dime). I have marked (X) before the subject in which I am interested.

- |                       |                     |                        |
|-----------------------|---------------------|------------------------|
| • Colds               | • Increased Height  | • Impotency            |
| • Catarrh             | • Pimples           | • Manhood Restored     |
| • Asthma              | • Blackheads        | • Falling Hair         |
| • Hay Fever           | • Insomnia          | • Weak Eyes            |
| • Obesity             | • Short Wind        | • Gastritis            |
| • Headache            | • Flat Feet         | • Heart Weakness       |
| • Thinness            | • Stomach Disorders | • Poor Circulation     |
| • Rupture             | • Constipation      | • Skin Disorders       |
| • Lumbago             | • Biliousness       | • Dispondency          |
| • Neuritis            | • Torpid Liver      | • Round Shoulders      |
| • Neuralgia           | • Indigestion       | • Lung Troubles        |
| • Flat Chest          | • Nervousness       | • Prostatitis          |
| • Deformity (Descr.)  | • Poor Memory       | • Rheumatism           |
| • Successful Marriage | • Youthful Errors   | • Muscular Development |
| • Female Disorders    | • Vital Losses      | • Great Strength       |

Name.....

Age..... Occupation.....

Street.....

City..... State.....

# SENT FREE ON TRIAL

Don't miss this remarkable offer. No deposit required. Mail the coupon below and we will ship you, prepaid, for five days' examination, the greatest set of electrical instruction books ever published—

## A Complete Electrical Library

comprising twelve bound volumes, containing over 1,000 illustrations with scores of tables, charts, diagrams, working problems and questions as follows. Each book is a complete, individual unit.

- Fundamentals of Electricity and Wiring.
- Magnetism and Commercial Application of Magnets.
- Standard Circuits for Telephones and Telephone Switchboards.
- Motors and Installation.
- D. C. Generators and Armature Winding.
- Alternating Current Theory.
- A. C. Apparatus and Machinery, Transformers, Gasoline and Gas Engines.
- Gasoline and Gas Engines, Lubrication, Cooling, Governing, Valve Gearing, Stationary Engines and Testing.
- Practical Business Arithmetic for Electricians.
- Mensuration and Elementary Mechanical Drawing.
- Arithmetic of Applied Science.

With all orders for the entire 12 books we include free—no extra charge—two complete treatises on "Theory of Direct Current" and "Electric House Wiring," thus giving you a complete Library and Training Course in every branch of electricity. These great electrical instruction books have been approved and adopted by high schools, vocational, manual training and continuation schools. Books measure 7 x 10 inches, and are bound in red cloth, gold embossed.

### SAVE \$20.50 NOW

The regular price of this wonderful electrical library complete is \$40.00. While our remaining sets last you can save  $\frac{1}{2}$ . But do not delay.

For any single book or part of the set send cash with order—\$2.00 for each volume, which will be promptly refunded if you return same. Or simply mail the coupon below and we will send you the full set, including the two special courses "Theory of Direct Current" and "Electric House Wiring" on five days' free trial. We pay charges. No deposit required. We take all the risk. Return the set at our expense if not perfectly satisfied. **ACT QUICKLY.**

### FREE TRIAL COUPON

ELECTROFORCE PUB. CO.,  
417-421 Marshall Street, Milwaukee, Wis.

Send me your Complete Home Training Electrical Library including 12 printed volumes and the two special treatises for five days' examination. I will either return the books in 5 days or remit \$2.50 and will send you \$1.00 each month until I have paid \$19.50 in all.

Name.....  
Address.....  
City..... State.....

## Headache?

### Change it to Comfort the RenuLife Way

For the dull, annoying pain of a chronic headache, the sharp recurrent stab of neuralgia or the headache that throbs and pains constantly, RenuLife Violet Ray offers quick relief.

It gives immediate relief, reaches the source of the trouble and remedies the cause. By saturating every cell, nerve and fibre of the body with highly remedial electricity, waste tissues are eliminated, and nature is allowed to build up new strength and vigor wherever disease has been.

## RenuLife Violet Ray

treatments are pleasant and give no sensation of shock or pain. The youngest child or most feeble invalid can take and enjoy RenuLife Violet Ray. This scientifically approved treatment can be used in your own home whenever needed. It covers a great range of ailments and does its work thoroughly and well. Send coupon today.

RenuLife Electric Company  
1206 Newberry Bldg., Detroit, Mich.  
Send me without obligation full information on RenuLife Violet Ray and your free book "Health."

Name.....  
Address.....

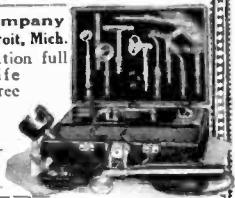

**LOOK 50¢ LOOK** Wonderful instrument. Greatest thing yet. Nine separate articles in one. Everybody delighted with it. Odd, curious and interesting. Lots of pleasure as well as very useful. It is a double Microscope for examining the wonders of nature. It is also an Opera Glass, a Telescope, a Burning Lens, a Reading Glass, a Telescope, a Compass, a Pocket Mirror, and a Laryngoscope—for examining eye, ear, nose and throat. It is worth all the cost to locate even one painful cinder in the eye. Folds flat and fits the pocket. Something great—you need one. Don't miss it. Sent by mail, with 300 page Novelty Catalog, ONLY 50c or 3 for \$1.25 JOHNSON SMITH & CO., Dept. 841 3224 N. Halsted St., CHICAGO

all-star performance last night, and Society, with a big S, was out in full fig—and not very much more than the traditional fig-leaf either, if you leave out the diamond tiaras and necklaces. Well, it appears that some clever crook thought an opera house was a better place to steal jewels from than a jeweler's window or safe.

"At any rate, at the most exciting moment of the performance, a dense smoke arose from the main tier of boxes. Instantly there was a panic and shouts of 'fire!' You know what a theatre panic is, doctor—'Sauve qui peut!' is the cry. Women are hustled and trampled on. Well, some one seized the opportunity to make a rich haul of jewelry. Dozens of wealthy women had their diamond necklaces and other jewelry snatched away, but in the uproar and confusion they could do nothing. From all their accounts, it appears that the jewels were taken by a mysterious veiled lady—probably a man in disguise, for she was more muscular than the average man, and knocked over several men who tried to grasp her.

"She carried an electric lantern with her to help her in her work, and it is my private opinion that this woman and the mysterious jewel-thief of Paris are one and the same person, whether a man or a woman I don't know, but I propose to find out, and I want you to help me, doctor."

"Me?"  
"Yes, I don't forget the clever work you did with your apparatus for intensifying smells, and I want you and your smell-ometer to help me out in this case."

Doctor Hackensaw shook his head. "The case is more complex than you imagine, Silas," he said, "I know all about this mysterious lady—in fact I may say that I have known her since her birth."

"You have?" cried Silas Rockett, hugely surprised. "Who is she then?"

Doctor Hackensaw paused a moment, then said: "The mysterious veiled lady who plundered the Paris jewelers, and who started the panic at the Opera House last night and made off with the jewels, is here he hesitated.

"Go on, doctor, please," begged Silas. "who is this mysterious personage?"

The doctor's eyes twinkled. "She is known," said he, "only under the name of VARIOLA HACKENSAW."

"Variola Hackensaw?" repeated the reporter, gazing earnestly at the doctor to see if he had gone crazy; "what do you mean?"

"I mean that this veiled lady is not a real girl at all. She is a mechanical girl I constructed in my workshop, and she is worked by wireless, just as my dog was. She is my tel-automatic girl, and the real criminal is 'Dope' Peters, the man who formerly worked for me, and who stole this automatic lady from me. It was he who had nicknamed her Variola Hackensaw."

"Is it possible?"

"Yes, when I first heard of these diamond robberies in Paris, and especially when I heard of the speed of the mysterious lady and her extensible arms and legs. I knew that Variola must be at the bottom of the mischief. She too, is knife-proof and bullet-proof, and she alone could pass through dense smoke unharmed, since she does not breathe. I knew that she was back in town last night, for I caught on my radio set certain signals that were used only in the machine I made for controlling her motions, unfortunately I had no apparatus left that would inform me what she was doing. The thief, of course, took the controlling mechanism when he took the girl."

"But doctor, you don't mean to tell me that all these thefts were accomplished by a mechanical girl who walks the streets like an ordinary woman, but whose movements are really controlled by a master-criminal who sits at a typewriter and moves her artificial muscles by wireless waves?"

## Make \$1,000 Easy! FROM EVENING WORK

Skidmore of Ohio started last Nov. Has made \$3000 to date! Greatest proposition of century. Grasp it quick! Make \$30 to \$50 a week doing work at home evenings.

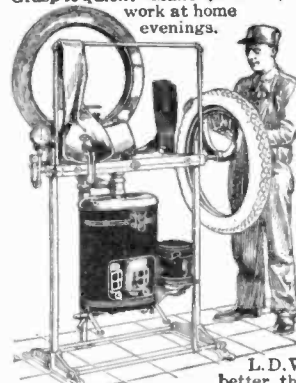

### Stick To Your Job

Make big money on side. Turn spare hours into cash with my new home outfit. Vulcanize automobile tires. Mend tubes. Repair gum boots and rubber goods of all kinds. Do thriving neighborhood business. Many men started economically.

L. D. Weiss, O., running better than \$15 daily. C. L. Jones, W. Va., averaging more than \$47 day during past six weeks, and so on.

### Little Money Starts You!

Write me. Get my help. Begin now. Season just opening. Tire repair work galore everywhere. I furnish everything, including machine, tools, clamps, materials and directions. No experience needed. Everything plain and easy. All instructions learned in one evening. Can't go wrong. Marvelous proposition. Wm. Howe, Mo., says: "Biggest little machine I ever saw." Steve Marchand, Texas, writes: "Am having wonderful results with your machine." Others are making extra money—you can too!

### Mail Postal To Me, Tonight!

Get full details. It's a proposition you can handle. Place machine anywhere—garage, shed, basement. Has wonderful capacity. Work is easy, pleasant and fascinating. Starts you in big paying business. Puts you on road to independence. Send quick for full information. Address me personally. M. Haywood, Pres.

### Haywood Tire & Equipment Co.

1261 Capitol Ave. Indianapolis, Ind.

**ENINGER WILL SAVE**  
\$40 **BIG MONEY SAVINGS FOR YOU**  
Used and rebuilt motorcycles, single and twins, \$25 to \$100. Used bicycles, \$5.00; tanks, \$2.00. \$10.00 All machines guaranteed in good working order. New bicycles and motorcycles at Factory prices. You save dealers' profits. Motorcycle and automobile tires too, \$3.00. Complete line of parts and accessories.  
Doninger Cycle Co., Rochester, N.Y.  
**YOU 25 TO 50 DOLLARS**

SEND STAMPS FOR CATALOG

**MODEL STEAM ENGINES** and boilers for boats and experiments. Boiler fittings, valves, pressure gauges. Write for descriptive circular, Model Machine Shop Co., 415 East 71st St., New York City.

**CHARGE**  
**YOUR OWN BATTERY**  
You can do it—without removing your battery or even disconnecting terminals. The Valley Battery Charger will end your battery troubles. Plugs in on lamp socket; clamps to battery. Cannot overcharge or harm battery. Price \$16.00. Send for booklet.  
Valley Electric Company  
Department 3, ST. LOUIS, MO.

**"Lighting Fixtures"**  
Ready to Hang (Direct from Manufacturers)  
Completely wired, including glassware. New designs.  
Send for catalog No. 20  
Send for dealers' proposition  
**ERIE FIXTURE SUPPLY CO.**  
Sta. C Erie, Pa.

**LEARN WATCH REPAIRING**  
You can learn by our modern and original system of instruction every part of the Watch Repairing Trade at home as good as better than at a shop. You can earn money while learning and secure a well paying position or start in business after completing our course of instruction. Good watch repairers are always in demand and earn from \$30 to \$65 per week. For particulars apply to the  
MILWAUKEE SCHOOL OF WATCH REPAIRING, 166 Mason St., MILWAUKEE, WIS.

"Precisely! You have hit the nail on the head! This girl, whom I had designed to help mankind, has been used by 'Dope' Peters to plunder men and women. I had made the girl with extensible arms and legs, so she could scrub a ceiling or paint a house without having to climb a ladder. I gave her a speed of one hundred miles an hour and the strength of twenty horses so she could plough a field or draw a carriage at will, yet so delicate is her mechanism that she can walk a baby in her arms all night and sing it to sleep."

"But doctor, how can 'Dope' Peters know how to steer her, unless he is walking beside her?"

"The girl has six eyes and the same number of ears," explained the doctor. "You see, the operator, working at a distance of a mile or more, must know everything that is taking place in front of the girl, behind her and on each side, as well as above her and below her. Hence she has an eye and an ear on top of her hat, one below her knee, in front of her, and four others around her waist. By radio telephone and television apparatus the operator sees and hears all that is taking place around the girl, and hence knows how to steer her properly."

"Then this tel-automatic girl, as you call her, has everything but brains."

"She has brains, too," replied the doctor. "In fact she had very good ones when first constructed—she had *mine*. Now she has only 'Dope' Peters' brains to work her."

"You say she sings?"

"Yes, and speaks, too. Like my tel-automatic dog she is provided with a phonographic record containing short phrases such as 'Excuse me,' 'Certainly,' 'Thank you,' etc., and a few songs. A touch of the proper key and the controlling instrument makes her say the phrase desired."

"Then she is an improvement on the everyday 'flapper'—"

"Yes, because her talking is strictly limited. In other respects, she is absolutely noiseless, even when running at full speed. But come, we have no time to lose if we hope to catch the girl. Call a taxi."

A few minutes later, Silas and the doctor descended from the cab at a vacant store in Union Square.

"Why in the world have you come here?" asked Silas.

"Because 'Dope' Peters worked his apparatus from here last night. My one hope is that he has not yet left town and yet I should not like to find him here now, as he would not hesitate an instant to put a bullet into me."

So saying, Doctor Hackensaw inserted a bent wire into the lock of the door, and had it open in a jiffy.

"How did you manage to learn the fellow's address?" asked Silas.

"I located him by means of his wireless signals. I have very delicate instruments for determining the direction and distance from its origin of any wireless wave. With these and with an accurate real-estate map of New York City I can locate the spot from which any wireless call proceeds. This apparatus, scientists call the radio compass. 'Dope' Peters worked his apparatus from here."

The two men cautiously made their way through the vacant building and ascended to the third story. Here another locked door faced them, which the doctor carefully opened as before. Then he uttered a cry of joy. No one was present in the room, but in one corner reposed the coffin-like box in which the tel-automatic girl was kept. And near it, on a table, was the wireless apparatus with the keyboard that controlled the motions of the automaton.

"Hurrah!" cried Doctor Hackensaw, and sitting down at the instrument, he pressed one of the keys. As he did so,

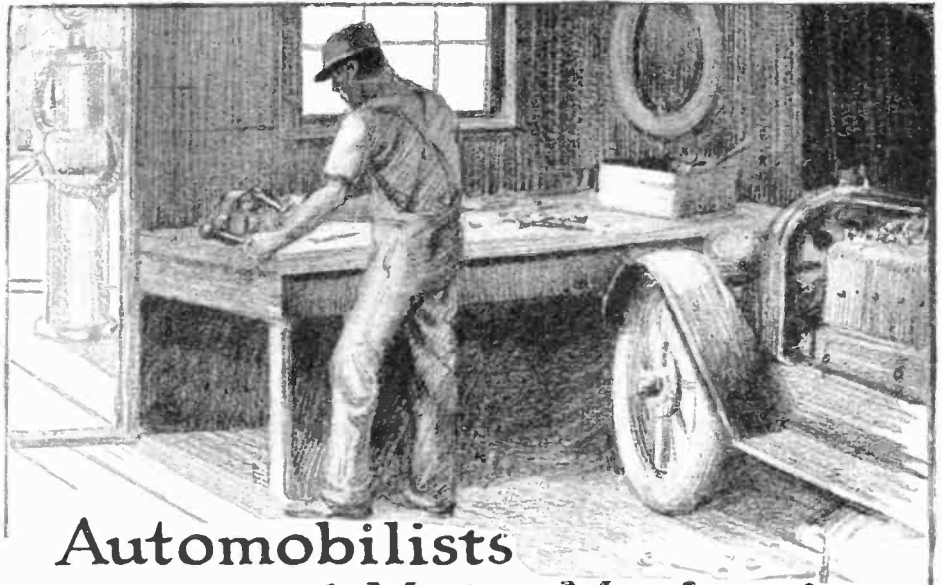

## Automobilists and Motor Mechanics

**Starrett**



Thickness Gage No. 71

Contains six leaves particularly adapted for adjusting motor tappets. Also useful for gaging slots. The six leaves have, respectively thickness of .0015, .002, .003, .004, .006 and .015. Auto mechanics have been looking for this tool.

who know Starrett Tools prefer them for their superior quality, more efficient design, greater durability and dependable precision.

When they buy Starrett Tools they know they're getting value for every penny spent. Illustrations and complete descriptions of the entire Starrett line of fine tools are given in the Starrett Catalog No. 221-E and special Supplement of new tools. Copies free on request.

THE L. S. STARRETT CO.

*The World's Greatest Toolmakers*  
Manufacturers of Hackensaws Unexcelled  
ATHOL, MASS.



**Starrett**

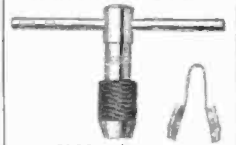

T-Handle Tap Wrench No. 93

An extremely handy tool for holding practically all small tools to be turned by hand. New clamp construction insures firm grip on tool. Heat treated jaws guarantee durability.



# Use Starrett Tools

## Small Cash Payment-Balance Easy Terms



### \$20 Puts an HB Charger in Your Shop

Balance in easy monthly payments. HB Battery Charging will carry your overhead. No repairs, no renewals, steady, money-making service. Costs you 4c to 12c per battery, customer pays 75c to \$2.00. Quicker, better service with an HB, at lowest cost, means Big Monthly profits for you. Sold on money-back guarantee. Sizes for 8, 10, 16 or 32 batteries. Let us recommend size to fit your needs. Write today. Ask about HB Air Compressors, Motor Grinders, Tire Buffers, Lighting Generators, Ball Bearing Motors, etc.—all sold on easy payments. Equip your shop to make more money. Write us.

HOBART BROS. CO.

Box S6

TROY, OHIO



**Battery Charging Pays \$1500 to \$3000 a Year**



**ACHROMATIC TELESCOPE MADE UPON NEW SCIENTIFIC PRINCIPLES.** Positively such a good Telescope was never sold for this price before. Eastern Telescopes are made by one of the largest manufacturers of telescopes in America; we control entire production; measure closed 8 inches and open over 2 1/2 feet in 4 sections. They are nicely brass bound, with scientifically ground lenses. Guaranteed by the maker. Every sojourner in the country or at the seaside resorts should certainly secure one of these instruments, and no farmer should be without one. The scenery just now is beautiful. A Telescope will aid you in taking views. Objects are brought to view with astonishing clearness. Sent by mail or express, safely packed, prepaid, for only 99 cents. Our new Catalogue of Watches, etc., sent with each order. This is a grand offer and you should not miss it. We warrant each telescope just as represented or money refunded. Send 99 cents today. To dealers 6 for Four Dollars.  
**EASTERN NOVELTY CO., DEPT. 67, 172 E. 93d STREET, NEW YORK.**



*Why haven't  
you clipped  
this coupon?*

It takes but a moment to mark the career of your choice, sign your name, clip out and mail the coupon printed below.

Yet that simple act has started more than two million men and women toward success.

In city, town and country, all over the world, men are living contented lives in happy, prosperous homes—because they clipped this coupon.

In every line of business and industry, in shops, stores, offices, factories, in mines and on railroads, men are holding important positions and receiving splendid salaries—because they clipped this coupon.

You too can have the position you want in the work you like best, a salary that will give you and your family the home, the comforts, the little luxuries you would like them to have. No matter what your age, your occupation, your education, or your means—you can do it!

All we want is the chance to prove it. That's fair, isn't it? Then mark and mail this coupon. There's no obligation and not a penny of cost. It's a little thing that takes but a moment, but it's the most important thing you can do today. Do it now!

**TEAR OUT HERE**  
**INTERNATIONAL CORRESPONDENCE SCHOOLS**  
BOX 6249-B SCBANTON, PA.

Without cost or obligation, please explain how I can qualify for the position, or in the subject before which I have marked an X in the list below:—

- |   |   |
|---|---|
| <input type="checkbox"/> <b>ELEC. ENGINEER</b><br>Electric Lighting & Bys.<br>Electric Wiring<br>Telegraph Engineer<br>Telephone Work   | <input type="checkbox"/> <b>BUSINESS MANAG'M'T</b><br>SALESMANSHIP<br>ADVERTISING<br>Railroad Positions<br>ILLUSTRATING<br>Show Card & Sign Ptg.<br>Cartooning<br>Private Secretary<br>Business Correspondent<br>BOOKKEEPER<br>Stenographer & Typist<br>Cert. Pub. Accountant<br>TRAFFIC MANAGER<br>Cost Accountant |
| <input type="checkbox"/> <b>MECHANICAL ENGR.</b><br>Mechanical Draftsman<br>Machine Shop Practice<br>Toolmaker<br>Gas Engine Operating<br>CIVIL ENGINEER<br>Surveying and Mapping<br>MINE FOR'N or ENGR.<br>STATIONARY ENGR.<br>Marine Engineer | <input type="checkbox"/> <b>GOOD ENGLISH</b><br>Com. School Subjects<br>CIVIL SERVICE<br>Railway Mail Clerk<br>AUTOMOBILES<br>Airplane Engines<br>Mathematics<br>Navigation<br>Agriculture<br>Poultry   |
| <input type="checkbox"/> <b>ARCHITECT</b><br>Contractor and Builder<br>Architectural Draftsman<br>Concrete Builder<br>Structural Engineer<br>PLUMBING & HEAT'G<br>Sheet Metal Worker<br>Text Overseer or Supt.<br>CHEMIST<br>Pharmacy           | <input type="checkbox"/> <b>WIRELESS</b><br><input type="checkbox"/> French<br><input type="checkbox"/> Spanish<br><input type="checkbox"/> Banking   |

Name \_\_\_\_\_  
Street \_\_\_\_\_  
Address \_\_\_\_\_ 2-1-22  
City \_\_\_\_\_ State \_\_\_\_\_

Occupation \_\_\_\_\_  
Persons residing in Canada should send this coupon to the International Correspondence Schools Canadian, Limited, Montreal, Canada.

**Keystone Institute**  
Automotive Course

A splendid opportunity to learn the automobile business by comprehensive instruction and actual practice. Your success assured after finishing our course, whether as mechanic, salesman or garage owner. Complete equipment, expert instructors, every modern facility for a thorough knowledge in this ever-growing field. Day and night courses. Write for full information to—"Address Principal."  
133 N. Fourth Street, Reading, Pa.

**PUZZLED?**

*We Can Solve Your Technical Problems*

All branches of engineering; research, analysis, reports and data of all kinds. Expert engineers are in charge of all our departments. Write for information, stating your particular problems.

**TECHNICAL SERVICE BUREAU**  
143 West Broadway New York City

the cover of the box slowly opened, and out stepped what appeared like a beautiful young lady, richly but modestly dressed, a veil over her face completely concealing the fact that it was of tinted rubber, not of flesh and blood.

"Silas," cried the doctor, "Let me introduce you to Variola Hackensaw! However, as we haven't a moment to spare, I'll proceed to business at once. I want to give 'Dope' Peters a taste of his own medicine, so I'll station the girl in the store downstairs to meet him when he returns."

Uttering these words the doctor played a tune on the keyboard, the girl responding promptly to every touch of the keys. She walked slowly across the room, put out her hand at the proper moment, turned the knob, opened the door, and a moment later her steps could be heard descending the stairs.

Doctor Hackensaw and Silas, by looking in the six mirrors attached to the machine, each receiving impulses by wireless from one of the girl's six eyes, could see every object around her, while the six ears transmitted any sounds.

The doctor steered the girl into a dark corner of the store, and then the ears transmitted by wireless amplifier the sound of the turning of a key in the lock.

"There's our man, Silas!" whispered the doctor. "We arrived just in time." A moment's pause ensued as the two men watched in the mirrors, the entrance of "Dope" Peters into the store. The doctor worked feverishly at the keys of the instrument for a moment, and then jumping from the instrument bounded downstairs, crying:

"Come along, Silas, quick! She's got him!"

The two men hastened downstairs, and as they arrived in the store an astonishing sight met their eyes. The telautomatic lady was holding 'Dope' Peters clasped in her arms as tightly as if held in a vise. He was a powerful man and was struggling desperately, but he was no match for the girl, who was squeezing him with a deadly grip. By the time Doctor Hackensaw managed to press the button that released the girl's grasp, the villain fell from her arms to the floor unconscious.

"Now Silas," said Dr. Hackensaw, "I have one job more to finish. I know you will condemn me for letting the fellow go, but if, as he promised, he gives up all his booty, the amount is so enormous that its restitution is worth something. Besides I shall keep an eye on the fellow and see that he earns an honest living hereafter."

"As for you, Variola," he continued, turning to the telautomatic figure, "I am sorry to say there is too much risk in leaving you in existence. When I think of what an unscrupulous criminal might make you do in the way of committing murders, incendiarism, bomb-outrages and thefts, I cannot consent to let you live for a single hour. You are more dangerous than a carload of dynamite, or even than a really-truly flesh and blood girl!"

And, seizing a fireman's ax that hung on the wall, the doctor chopped off the head of the telautomatic lady, and then proceeded to dismember the body.

Five minutes later the wonderful piece of mechanism, over which he had toiled for years, was but a mass of broken springs, wires and splinters!

**COAST-TO-COAST RADIOPHONE PLANNED**

Radio telephone conversation with New York probably will be attempted from the new signal corps station opened recently at the Presidio army post, San Francisco, Calif. This station will be the most powerful on the Pacific coast.

Immediate communication with army posts at Omaha, Neb., and Honolulu has been planned. Officers said they should have no trouble reaching New York.

**It Will Pay You to Own a MONARCH JUNIOR Lathe**

*"The Biggest Little Lathe Built"*

There are hundreds of things made of metal or wood, for the shop, automobile and home, that you can make with a MONARCH JUNIOR lathe

This sturdy dependable small engine lathe, guaranteed to do work with 1/1000 of an inch accuracy, was especially designed for inventors, experimenters and small shop owners who need a lathe of their own.

It is easy to learn to operate the MONARCH JUNIOR and even beginners can't jam it. It is equipped in every detail same as the big MONARCH and is guaranteed to do all small work that any other lathe will do.

You can find room for a MONARCH JUNIOR practically anywhere in a small shop or work-room in your home. Write today for catalog and full information about this remarkable—low priced engine lathe.

The Greatest Achievement in Lathe Building  
**MONARCH JUNIOR \$225** With Bench  
9 in. Engine Lathe **225** Legs

**THE MONARCH MACHINE TOOL CO.**  
418 Oak Street - - - Sidney, O.

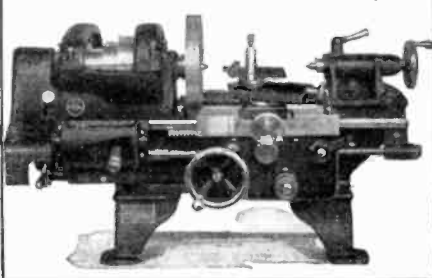

**FREE HERE'S MORE MONEY for YOU**

**150 Home-Study Books**  
Each of these sure pay-raising self-help books is a complete course of instruction. They cover Electricity, Automobile, Machine Shop, Carpentry, Painting, Engineering, Railroad and twenty other trades. A postcard brings yours.  
**F. J. Drake & Co., Publishers**  
1009 Michigan Ave., Chicago

**ALL MAKES**

Underwoods, Monarchs, Remingtons, L. C. Smiths, Oliviers, Royals, Coronas **AT REDUCED PRICES. \$20.00**  
Prices as low as...  
Write for our Catalog No. 15  
**BERAN TYPEWRITER CO.**  
Dept. 21, 58 W. Washington Street, Chicago

**UNION UNION CHESTS ARE BETTER CHESTS**

Quality is the keynote of the line of Union Tool Chests. They are built in more than fifty different patterns and sizes for all mechanics. Writing today for our illustrated catalogue is the first step toward preventing loss, theft and damage of tools.  
**UNION TOOL CHEST CO., 36 Mill St., Rochester, N. Y.**

**Learn Sign Lettering in 20 Hours!**

Using our New Method Patented Mechanical Device—no stenils. Having a business of your own earning from \$2,000 to \$6,000 a year lettering store windows, show cards, barns, roofs, walls, fences and signs of all kinds. Students can have established business doing finest of work in 30 days. We guide you step by step. Absolute satisfaction guaranteed. Write today. Details Free.  
**AMERICAN SCHOOL OF LETTERING**  
Dept. 1 Omaha, Nebraska



Write for book, "How to Become a Good Penman," and beautiful specimens. Free. Your name on card if you enclose stamp.  
**F. W. Tamblin, 424 Ridge Bldg., Kansas City, Mo.**

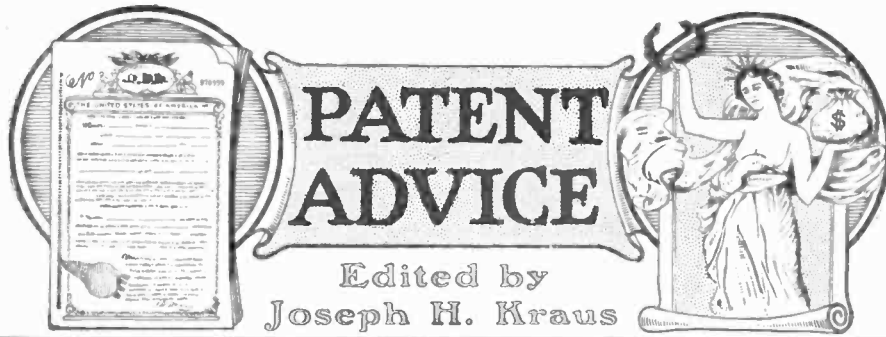

Edited by  
Joseph H. Kraus

In this Department we publish such matter as is of interest to inventors and particularly to those who are in doubt as to certain Patent Phases. Regular inquiries address to "Patent Advice" cannot be answered by mail free of charge. Such inquiries are published here for the benefit of all readers. If the idea is thought to be of importance, we make it a rule not to divulge all details, in order to protect the inventor as far as it is possible to do so.

Should advice be desired by mail a nominal charge of \$1.00 is made for each question. Sketches and descriptions must be clear and explicit. Only one side of sheet should be written on.

**Pocket Radio Set**

(595) Edward H. Fallows, New York City, asks whether he should patent an idea of a pocket radio set.

A. Very recently (the prize winner was announced in the April issue of SCIENCE AND INVENTION, and others are to follow) a contest for the cheapest radio set was in progress in this journal. In this hundreds of pocket sets were entered. Such devices are not unusual, and there is nothing exceptionally clever in them. They do not give efficient results, neither do they receive radio telephonic communications successfully over any appreciable distance. Therefore we do not advise your constructing a device of this nature, except as an oddity or for the unique value such a machine would have. We would not advise patent proceedings.

**Film Break Signal for Motion Picture Machine**

(596) E. F. Hayland, Los Angeles, Calif., enters a sketch of a rather elaborate method of signaling to be used in motion picture projectors, so that the film, when broken, signals the operator and turns off the arc or other light. He asks our opinion.

A. Altho we consider your system to be of some value, its intrinsic costs are far too great in comparison with the results obtained from such a machine. We doubt very much whether this device will secure even a dozen customers from all of the modern motion picture theatres. You must admit that one dozen sales for about 50,000 motion picture houses does not make it a very profitable proposition. There are, furthermore, several projectors already equipped with a similar system, but not nearly as elaborate as yours, yet giving identical results.

**Carburetor Lock**

(597) Thomas Fitzsimons, Mount Vernon, N. Y., asks our opinion of an auto lock in the carburetor supply line in form of a locking valve.

A. Your idea of a lock between the gasoline and the carburetor is nothing new, and fully covered by patents. It is a simple matter for a thief to get around this lock as all that is necessary is to lift the hood, snap off the lock itself and put a rubber connection between the gas supply line and the carburetor. Furthermore, lifting the hood every time the car is to be locked is not a very pleasant job on a cold or rainy day. An invention recently patented in which there is a lock between the carburetor and the intake manifold and which lock communicates directly with the dash, is a far better device, yet it is not thief-proof.

**Advertising Clock**

(598) Alfred Furry Bir., Michigan, asks advice on an advertising clock in which both the time and the advertisement are projected from behind upon a ground glass screen. The clock is to rotate the signs slowly, which, by the way, are to be mounted upon a circular disk. He requests our opinion.

A. You have invented nothing new at all. Right here in New York in the motion picture theatres clocks in which the time is projected on a small screen alongside of the motion picture screen and upon the face of which clock advertising slides appear, may be seen. These function in exactly the same manner as in your system, namely, the advertisement is placed upon small slides mounted in a circular disk, which disk is turned by clockwork, the clock incidentally being the one from which the image is projected upon the screen. The films, instead of moving slowly, are jerked around and remain in position for one and a half minutes.

**Circuit Breaker**

(599) Wm. Carter, Charlestown, W. Va., requests patent advice on a circuit breaker with one moving part.

A. We are unable to inform you definitely whether or not a patent upon your circuit breaker would be advisable. There are many circuit breakers upon the market today selling from \$4.00 to \$6.00, which have been so designed that there is only one or two moving parts in each of them.

Inasmuch as your description is not definite enough to warrant a more satisfactory reply, we would advise that you be a little more explicit in writing again.

**Telegraph Recorder**

(600) Roy Cusick, Coatesville, Pa., requests advice on a telegraph recorder, saying in part: "The device consists of a motor, an ordinary sounder and paper tape."

A. The system which you have devised for recording telegraph messages is not new by any means. This has been employed for the past fifteen or sixteen years in all its various forms, and therefore we doubt very much whether you could obtain a patent on the same. Incidentally such a device is extremely inefficient when compared with modern devices used for a similar purpose.

**Railway Gate Closing Apparatus**

(601) Louis Cemen, Manchester, N. H., submits sketches of electrical circuits for operating railway gates by the train as it enters certain blocks. He asks whether the circuits will work.

A. The circuits which you desire to employ will of course work, but instead of using a ground return, we would advise that you use the railway track.

We do not believe that the invention which you have in mind will be of financial benefit, but inasmuch as you have not requested our opinion of the device, we will not enter into the discussion of its drawbacks. The circuits are, however, electrically feasible.

**High Speed Motion Picture Camera**

(602) Victor E. Carlson, Ontario, Cal., asks whether an attachment to motion picture cameras to increase the speed of successive exposures would be marketable.

**U.S. PATENTS**



**Don't Lose Your Rights**

Before disclosing your invention to anyone send for blank form "Evidence of Conception" to be signed and witnessed. A sample form together with printed instructions will show you just how to work up your evidence and establish your rights before filing application for patent. As registered patent attorneys we represent hundreds of inventors all over the U. S. and Canada in the advancement of inventions. Our schedule of fees will be found reasonable. The form "Evidence of Conception" sample, instructions relating to obtaining of patent and schedule of fees sent upon request. Ask for them,—a post card will do.



255 OURAY BLDG.,  
WASHINGTON, D. C.

"Originators of form Evidence of Conception"

**PATENTS**

**TO THE MAN WITH AN IDEA**

I offer a comprehensive, experienced, efficient service for his prompt, legal protection and the development of his proposition.

Send sketch, or model and description, for advice as to cost, search through prior United States patents, etc. Preliminary advice gladly furnished without charge.

My experience and familiarity with various arts frequently enable me to accurately advise clients as to probable patentability before they go to any expense.

Booklet of valuable information and form for properly disclosing your idea, free on request. Write today.

**RICHARD B. OWEN, Patent Lawyer**  
164 Owen Building, Washington, D. C.  
2276-3 Woolworth Bldg., New York City

**PATENTS TRADE-MARKS AND COPYRIGHTS**

Before disclosing an invention, the inventor should write for our blank form, "RECORD OF INVENTION." This should be signed and witnessed and if returned to us together with model or sketch and description of the invention we will give our opinion as to its patentable nature. Electrical cases a specialty.

Our illustrated Guide Book, "HOW TO OBTAIN A PATENT," sent Free on request. Highest References Prompt Attention Reasonable Terms

FREE COUPON

**VICTOR J. EVANS & CO., Patent Attorneys**

Chicago Offices:  
1114 Tacoma Bldg.

Pittsburgh Offices:  
514 Empire Bldg.  
New York Offices: 1001 Woolworth Bldg.

Philadelphia, Offices:  
714-715 Liberty Bldg.

San Francisco Offices:  
Hobart Bldg.

MAIN OFFICES: 779 NINTH, WASHINGTON, D. C.

Name .....

Address .....

## INVENTORS, ATTENTION! THE PATENT OFFICE

is 70,000 cases behind and matters getting worse.  
The patent office has made over 8½ million dollars for the government and there is no valid excuse why inventions which mean so much to

**NATIONAL PROSPERITY**  
and mark the forward progressive spirit in our economic and industrial life **SHOULD NOT BE KEPT UP TO THE HOUR.**

**THE WORLD OF INVENTION**  
a Live Progressive Magazine devoted to the interests of the inventor and the official organ of the

**NATIONAL INSTITUTE OF INVENTORS**  
a co-operative society of over 3,500 inventors is offering \$200 in prizes for suggestions relative to relief from the patent office conditions so detrimental to the inventors' interest.

Write for full particulars

**WORLD OF INVENTION**  
8 E. 14th Street, New York City, N. Y.

# CAN YOU

think of a simple, practical idea that will fill one of the many requests we have on file for new inventions? It may mean a fortune for you. Thousands of things are needed **RIGHT NOW**. YOUR brains can help. Send today for our great new book—"Inventions and Trade Marks, Their Protection and Exploitation" and learn more about making money from ideas than you ever knew before. It tells many things that are wanted, too.

A postal will do—  
it is free.

**PATENTS ADVERTISED For SALE FREE In INVENTION And MANUFACTURING SUPPLEMENT.**

Published for the man with an idea. Send for free sample copy. One year's subscription 50c

**AMERICAN INDUSTRIES, INC.**  
225 Patent Dept., WASHINGTON, D. C.

We help our clients, without charge, to get the dollars out of their ideas—having facilities none others possess.  
Advice free. Don't delay—get the book at once.

A. Modern motion picture machines can operate two, three, four, and even ten to twelve times as fast as they do today. For instance, the Novograph machine takes pictures twelve to seventeen times as fast as the ordinary camera. In other words, where in the ordinary camera sixteen pictures are taken per second, in the Novograph 160 pictures are taken in the same length of time. This, when projected at the normal projection speed, gives us the effect of slow motion.

As many as 3,000 pictures per second have been taken. Under these conditions bullets in flight have been photographed. Absolutely nothing is gained in speeding up projection, as the eye cannot see any more than sixteen frames per second distinctly, and due to the retention of the images, a motion picture effect is obtained.

### Adding Machine and Cuban Patents

(603) Leo Chaviano, Cumanayagua, S. C., Cuba, asks whether a much simplified adding machine similar to but in no way resembling the Burroughs adding machine or in fact any other, could be patented. He also desires to know if a Cuban patent will protect him in the United States.

A. An adding machine which does the same work as the Burroughs adding machine but much simplified, could without doubt be patented. Whether or not you can secure a manufacturer to build this device for you, depends largely on your own initiative and how good the idea is. A patent issued by the Cuban Government will not protect you in the United States.

### Microphone Amplifier

(604) H. Biegeleisen, New York City, asks for advice on a microphonic amplifier in which the box, over the receiver diaphragm, is filled with carbon granules. He requests our opinion.

A. Altho the contrivance which you have designed may be patentable, we doubt very much whether you could realize any sale upon the idea, in that it has been experimentally described hundreds of times in both this magazine and *Radio News*, in myriads of different styles. Frankly speaking, we do not advise a patent upon the same as the results are far inferior to those obtained by other agencies now upon the market.

Today a person can secure a Skinderviken transmitter button for about a dollar, attach this to his telephone, and "your" amplifier is complete.

### Magnetic Screw Driver

(605) Joseph H. Barron, Manown, Penna., asks for patent advice on an electrically magnetized screw driver.

A. There is absolutely nothing new or novel in your idea of an electrical screw driver, and therefore we would not, under any circumstances, advise application for a patent upon the device.

### Baker's Trimming Wheel and Street Indicator

(606) Joseph Bierkamper, Kittanning, Penna., submits a sketch of a baker's trimming wheel with name imprinted thereon and an automatic car street indicator.

A. The baker's trimming wheel which you have devised is quite a clever idea. If you can now arrange some system whereby the name in the wheel could be rapidly changed, we believe you will have a marketable article. The street indicator is absolutely worthless. At every insulation joint an arc would occur, and perhaps cause fuses to blow in the car.

We do not advise applying for a patent upon the latter idea.

### Non-Heating Handle and Toy

(607) Mr. Barron, Manown, Pa., asks whether we would advise a patent on a non-heating handle for utensils or upon a toy derrick. He further requests the names of books showing articles upon which prospective inventors may work.

A. We do not believe that you can obtain a patent on either your non-heating handle or toy derrick, and even if you could we would not advise patenting either of the devices.

With reference to books on "articles to invent," we would advise that you write to each patent attorney listed in our magazine and ask for full descriptive literature.

### Faucet Attachment

(608) Joe Bradera, Atascadero, Calif., submits a diagram of a single faucet attachment for sinks and the like now equipped with two faucets. He requests patent advice.

A. The idea which you have advanced, namely, a double faucet for sinks and the like may be novel, but it is by no means a wonderful invention, and we doubt very much whether the sales of such a device will ever warrant its patenting, should it ever be placed on the market. Neither can your device compare with a new attachment recently placed upon the market in which there are telescoping tubes with a spigot near the center and rubber cup-like grips at the ends.

# Dr. T. O'Connor Sloane Will Teach You CHEMISTRY Right In Your Own Home



DR. T. O'CONNOR SLOANE, A. B., A. M., LL. D., Ph. D., Educational Director, Chemical Institute of New York, formerly Treasurer, Chemical Society and a Practical Commercial chemist as well as a noted instructor.

Good chemists command high salaries. Industrial firms of all kinds pay tempting salaries to get the right men. Salaries of \$10,000 a year are not unusual for chemists of exceptional abilities. The work of the chemist is extremely interesting. If you are fond of experimenting, take up chemistry. If you want to earn more money, the way is open through our Course in Chemistry.

**You Can Learn at Home**  
Dr. Sloane will teach you Chemistry at home in a practical, intensely interesting way. Our Course is remarkably simple. No special education required—if you can read and write plain English you can thoroughly understand and master every lesson.

### Easy Monthly Payments

The price of our course is very low and the tuition includes everything, even the chemistry outfit—there are no extras to buy with our course. You can pay in small monthly amounts as you go along.

### Experimental Equipment Given to Every Student

We give to every student, without additional charge, the chemical equipment he will need for his studies, including forty-two pieces of laboratory apparatus and eighteen different chemicals and reagents. The fitted, heavy wooden box serves as a carrying case and as a laboratory accessory for performing experiments.

### SPECIAL 30-DAY OFFER

In addition we are making a special offer for a short time only. Write to-day for free book, "Opportunities for Chemists" and full details of our special offer.  
**CHEMICAL INSTITUTE OF NEW YORK, Inc.**  
(Home Ext. Division 6), 140-O, Liberty St., N. Y. City

# PATENTS

If you have an invention and desire to secure a patent, send for our Free Guide Book, **HOW TO GET YOUR PATENT**. Tells our Terms, Methods, etc. Send model or sketch and description for our opinion of its patentable nature.

**RANDOLPH & CO.**  
Dept. 172 Washington, D. C.

# PATENTS—TRADEMARKS

Thirty-five years' experience. Send model sketch for opinion as to patentability. Free or "Inventors Guide." Highest references and personal attention assure best results.

**FRANKLIN H. HOUGH**  
520 Washington Loan & Trust Bldg., Washington, D. C.

# INVENTORS

who derive largest profits know and heed certain simple but vital facts before applying for **PATENTS**

Our book **Patent-Sense** for Inventors and Manufacturers, gives those facts: free. Write Lacey & Lacey, 644 Washington, D. C.

**ESTABLISHED 1869**

# MR. INVENTOR

WE can develop that IDEA and build that working MODEL for you. Consult us—with our staff of expert engineers, and thoroughly equipped experimental machine shops, we can develop any invention into a commercial proposition, whether mechanical, electrical or automotive—simplify and perfect it, and **MAKE IT WORK**. Designing, building and testing gasoline motors a specialty. Experts on automatic labor saving machinery. Mechanical drawings made from sketches or specifications. [All business confidential and absolute secrecy guaranteed.]

**E.L.K. MFG. CO., Inc.** New York  
1926 Broadway

# PATENTS

Formerly Member Examining Corps. U. S. Patent Office.  
**PATENT LAWYER**  
McGill Bldg., Washington, D. C.

Patents, Trade Marks, Copyrights, Patent Litigation

Handbook for Inventors, "Protecting, Exploiting and Selling Inventions," sent upon request.

# PATENTS

Hand Books on Patents, Trade Marks, etc., sent free. Our 77 years of experience, efficient service, and fair dealing, assure fullest value and protection to the applicant. The Scientific American should be read by all inventors.

**MUNN & CO.,** 618 Hanna Bldg., Cleveland, O.  
Tower Bldg., Chicago, Ill.  
Scientific American Bldg., Washington, D. C.  
611 Shuman Bldg., Cleveland, Ohio  
Hobart Bldg., 582 Market St., San Francisco, Cal.

## PATENTS Secured

Prompt service. Avoid dangerous delays. Send for our "Record of Invention" form and Free Book telling How to Obtain a Patent. Send sketch or model for examination. Preliminary advice without charge. Highest References. Write TODAY.

**J. L. JACKSON & CO.**  
301 Ouray Bldg., Washington, D. C.

## TELEGRAPHY

( Morse and Wireless) and RAILWAY ACCOUNTING taught thoroughly. Big salaries; great opportunities. Oldest, largest school. Endorsed by Telegraph, Railway, Radio, and Government officials. Expenses low—opportunities to earn large portion. Catalog free. **JODGE'S INSTITUTE.**  
14 Street, Valparaiso, Ind.



## THE BUSINESS FOR YOU!

Make and sell Crispettes. Delicious confection. Everybody loves them. Can't get enough. Come again and again for more. Easy to make. I furnish everything. Raw materials plentiful and cheap. Profits enormous.



Quick success possible anywhere—cities, small towns, villages. Amazing market—crowded streets; surging throngs at fairs, carnivals, parks, etc.; wholesale to grocers, bakeries, druggists, and so on. Possibilities unlimited! Need no experience. Little capital starts you on the road to phenomenal earnings.

**Write—Get My Help—Begin Now**  
Others are making money—lots of it. Letters just received during this year tell of wonderful successes. You can succeed, too. Start is all you need. I'll gladly help you. Furnish everything—complete outfit, materials, secret formula, full directions, wrappers, etc. Send post card for illustrated book of facts. Tells how to start. Explains most successful methods. Gives all information needed. It's free. Write now!

**LONG EAKINS COMPANY**  
653 High Street Springfield, Ohio

## BARGAIN SALE

**2 TIRES \$1.50 FOR \$1.15**

**Free Tube with each Tire**

THINK OF IT! TWO TIRES AND TWO TUBES FOR THE ORDINARY PRICE OF ONE TIRE. And these tires are good. Not "double treads"—not "slightly used"—but reconstructed tires. Each tire heavily reinforced with brand-new tread. Each looks like new. Good for 10,000 MILES OF SERVICE. Our guarantee is another tire at half price. This special offer covers only present stock. Order at once to avoid disappointment.

Size	1 Tire	2 Tires	Size	1 Tire	2 Tires
30x3	\$7.00	\$11.50	32x4 1/2	\$13.50	\$22.75
30x3 1/2	7.95	13.50	32x4 3/4	13.95	23.30
32x3 1/2	9.00	15.30	34x4 1/2	14.45	23.75
31x4	10.00	16.75	35x4 1/2	14.95	24.30
32x4	11.50	19.60	36x4 1/2	15.45	25.30
33x4	12.25	20.75	35x5	15.90	26.05
34x4	13.25	22.30	37x5	18.45	26.40

Send \$1 deposit for each tire. Balance C. O. D.—subject to examination. If not satisfied, return tires and secure full refund, 5% discount for full amount with order. Order NOW—this offer is special.

**JEAN TIRE COMPANY**  
607 So. Paulina St. Chicago, Illinois



## SEXUAL KNOWLEDGE

320 Pages ILLUSTRATED Cloth  
By Winfield Scott Hall, M.D., Ph.D.  
**SEX FACTS MADE PLAIN**

What every young man and Every young woman should know  
What every young husband and Every young wife should know  
What every parent should know

**\$1.00** Table contents and commendations on request  
Postpaid Mailed in plain wrapper

**AMERICAN PUB. CO.**  
645 Winston Bldg., Philadelphia

## A JOB

No need being out of work. With our Course on Practical Electrical Engineering we give free instruction on house wiring and building wireless sets. Begin earning big money in your neighborhood in two weeks. Free 56-page book. DEPT. 10A. **WORLD TECHNICAL INSTITUTE, Jersey City, N. J.**

## 12 Months to Pay

You can easily earn money for the small payments. Parents often advance first payment to help buy a **RANGER**, 44 styles, colors and sizes. **Factory to Rider prices. Delivered FREE**, express prepaid, for **30 DAYS' TRIAL**. Terms to suit—cash or easy payments. Lamps, wheels, horns, repairs and equipment at half usual prices. **SEND NO MONEY**. Write today for our big, Free Ranger Catalog and marvelous prices.



**Mead Cycle Company** Dept. 10A Chicago  
Write us today for free catalog

## Popular Astronomy

By ISABEL M. LEWIS, M. A.

(Continued from page 127)

Jupiter in brightness, which is now to be found in the western evening sky in the constellation of Virgo. After this date Mars moves steadily eastward and by October 1st is just north of the little dipper in Sagittarius, the next constellation east of Scorpio.

At this opposition it is late summer and early fall in the northern hemisphere of Mars. As the year of Mars is equal to nearly two of our own in length, the Martian seasons are about twice as long as the terrestrial seasons. The summer solstice of the northern hemisphere of Mars occurred on December 26, 1921, and as the canals are most numerous immediately after the summer solstice there will not be many visible at or near the time of opposition in June which comes near the early fall of the northern hemisphere. The autumnal equinox of Mars occurs on June 26th. The southern hemisphere of Mars will therefore be nearly as favorably placed for observation as its northern hemisphere. The north polar cap has entirely disappeared and the south polar cap will be enveloped in clouds, which will break away about the time of the autumnal equinox, revealing the dazzling polar snows beneath. The southern hemisphere of Mars will be better placed for observation at this opposition than it has been for many years and as the canals will be neither plentiful or conspicuous at this time Martian observers are planning to devote their attention to the larger surface markings such as the Syrtis Major. The change in color of the southern seas from a grayish tint to a marked green color is expected to be very noticeable at this time. At the apparition of 1920 very noticeable cloud formations were noted by a number of observers over the Syrtis Major. Such observations of cloud formations are important as it may be possible to determine from observations of clouds the direction and velocity of the Martian winds.

Martian snow storms are expected to appear in the northern hemisphere about April 12th which corresponds to the Martian date, August 19th, and to last for two of our months. Such storms have been followed by extensive light frosts in the past. These phenomena are plainly visible in the form of haze or mist concealing familiar markings.

Prof. W. H. Pickering, who has observed Mars systematically for years both at the Harvard College Observatory Station at Arequipa, Peru, and in recent years under exceptionally clear skies in Mandeville, Jamaica, believes that much excellent work can be done by amateurs in observing the planet Mars with telescopes of very moderate size. He urges amateurs as well as professional astronomers to send drawings of the planet at the present apparition for the Report of the Associated Observers of Mars to Mandeville, Jamaica. Regular reports of observations of Mars at each opposition of the planet have been made for a number of years and observers in widely separated parts of the globe are engaged in the work. The cooperation of observers in the southern hemisphere will be particularly valuable during the present apparition of the planet, as it is so near to the southern horizon for observers in the northern hemisphere that it will not be seen by them to the best advantage. A series of six drawings of the planet requiring only one hour each are desired of as many observers as possible who possess suitable telescopes for the work. These drawings will be made chiefly between the dates of May 10th and July 20th when the planet is best placed for observation following the directions given

# Health! Energy! Strength!

At last there is a quick and inexpensive way to physical power—glowing health—pulsing vitality. Electricity in its most scientific and efficient form for the human system. A wonderful Violet Ray of tremendous curative nature. Not a Vibrator—not a current to shock your system—not a massaging device. A powerful penetrating RAY of ENERGY that heals and invigorates. Endorsed by every doctor, scientist, physical culture and beauty expert.

A remarkable book on health and beauty via

## Vi-Rex Violet Rays

Sent to you FREE



We have just published a remarkable book for free distribution. This book explains in detail the manifold uses of Violet Rays in treating almost every known human ailment. This book also contains charts and diagrams of the nervous system, and organic locations, and fully describes just how the Violet Ray works its many seeming miracles, written in a simple style—devoid of all technical language.

## 10-day free trial will prove all we claim

Use it in the privacy of your home. Day by day you will see the difference in your physical fitness—the condition of your sinews and muscles **WE WANT YOU TO BENEFIT** by this great modern invention and offer you our book on perfect health and a ten day trial of the Vi-Rex machine FREE. Just fill in and send the coupon below.

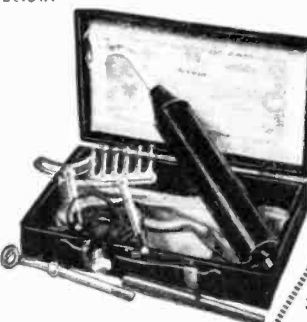

**Vi-Rex Electric Co.**  
Dept. 46  
326 West Madison St.  
CHICAGO

**VI-REX ELECTRIC CO.**  
Dept. 46  
326 West Madison St.  
Chicago, Ill.

Illustration shows complete VI-REX Violet Ray outfit for home treatment.

Please send me, without any cost or obligation your free book describing your Violet Ray Machine and details of your free trial offer.

Name.....  
Address.....  
City.....  
State.....

# Read Code With Your Eyes!

## Not With Your Ears!

Finch Radio Relay Permits Messages to be Copied on Paper Tape With Unerring Accuracy, at Any Speed and Over Any Distance.

DID HE GET IT, OR NOT?



THE OLD WORRISOME WAY

Why worry about reading code when you can read from a tape at your leisure. How nice it would be to have a graphic record of news dispatches, market reports, etc. The Finch Radio Relay, which is now licensed for non-commercial use, makes this possible. It is inexpensive, easy to operate and absolutely reliable. Tremendously sensitive, yet rugged and fool-proof. May be used in connection with any vacuum tube receiver.

If you can't read code let the Finch Radio Relay read it for you. If you listen only to the broadcasting you are missing a lot of interesting things.

PRICE OF RELAY \$75.00  
STANDARD TAPE REGISTER \$40.00

Literature describing other uses for the Finch Radio Relay gladly furnished upon receipt of stamp. Patented and Patents Pending.

**FINCH RADIO MFG. CO.**  
303 Fifth Ave. New York City  
Dept. S6

**THE NEW FINCH WAY**  
EVERY MESSAGE  
PERMANENTLY RECORDED



for making such drawings in previous reports of Associated Observers.

At the present opposition of Mars, observers at the Mt. Wilson Observatory will probably apply the method so successfully applied to Venus for determining the composition of the atmosphere of the planet. By using a wide dispersion for the spectral lines it is possible to separate the lines in the spectrum of the planet that originated in its own atmosphere from lines originating in the earth's atmosphere. In this way it has been found that oxygen and water-vapor do not appear in appreciable quantities in the atmosphere of Venus. The results of similar tests of the atmosphere of Mars will be awaited with great interest especially since the present evidence as to the existence of water-vapor on Mars is decidedly contradictory.

Prof. Pickering has recently been making some observations of the appearance of terrestrial markings viewed from considerable altitudes above the surface with a view to the interpretation of color changes on Mars. He finds as a result of these observations that the appearance of salt water is radically different from that of fresh water. New England lakes viewed from a balloon appear black when not directly reflecting the sun's light. Salt water viewed vertically from moderate elevations appears a dark grayish green color tho salt water in the tropics is a most decided blue in color. All fresh waters do not appear black when viewed from above. Volcanic waters and many lakes show beautiful greens and blues. Terrestrial vegetation, he also finds, sometimes appears black or gray as well as green when viewed from high elevations.

If extensive bodies of water exist on Mars they must be extremely shallow, since not enough snow exists in the polar caps to fill a moderate sized ocean only a few feet in depth. When the north polar cap of Mars melts it is surrounded by a black line which is generally considered to be a true liquid surface. The Syrtis Major has been observed to turn blue for a few days at a time, following what is apparently a flood, but this color is only transient. It is believed that the color changes of this extensive marking, the most conspicuous on the planet, are due to vegetational growth chiefly, tho it may be at times flooded with water like a marsh. It is expected that there will be a very marked change in all of the southern maria or tracts of vegetation as they are believed to be, from gray to green at the present apparition. The most extensive tracts of vegetation lie in the southern hemisphere of Mars. At the present apparition of Mars it is expected that the northern boundaries of these southern maria will gradually move northward as spring advances in the southern hemisphere.

All of these seasonal changes that are continually observable upon the Martian surface, the melting polar caps, the changes of surface markings that cover areas of many square miles from grays to greens or blues or blacks, the appearance and disappearance of extended white areas of mists and haze all seem to point to but one conclusion, that vegetation flourishes on Mars as well as upon the earth. What other interpretation can be placed upon the extensive and conspicuous surface changes that attend the comings and goings of the Martian seasons? And where vegetation flourishes one expects to find evidence of organic life as well. Does the tiny reddish ball that we view in the telescope splashed with orange and yellow, green and blue and greenish gray and black, crossed by elusive fine lines and capped with white represent a struggling world of life and death, growth and decay such as our own?

# HOMCHARGE

## YOUR BATTERY

### for A Nickle

A perfect rectifier at last, fully automatic and foolproof in every respect. It can be operated by anyone.

## THE HOMCHARGER

connects to any alternating current socket, gives a taper charge—will fully charge any "A" battery overnight. It is self-polarizing. Connect your battery either way and it will always charge. Automatically disconnects battery when power is interrupted. Restarts charging when connections are restored. Adjustable for wave form, frequency and voltage. Contains only one moving and two wearing parts, lasting thousands of hours, replaceable as a unit for \$1.00. The highest charging rate, greatest efficiency, and simplest of any rectifier selling for less than \$100.00. Bulletin 628 proves it. Ask for your copy.

Manufactured in sizes for charging three or six cell batteries from both alternating and direct current circuits. Cannot injure battery—will last a lifetime—approved by underwriters—satisfaction guaranteed. For sale by all radio, electrical and accessory dealers or shipped express prepaid for purchase price—

\$18.50 (\$20 West of the Rockies)

Attention Motorists

Send for special Bulletin 58, showing how easy it is to "Homcharge" your battery.

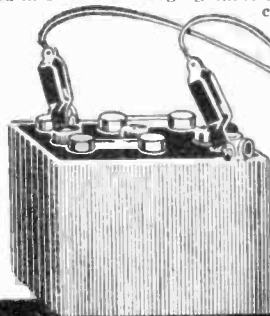

**THE AUTOMATIC ELECTRICAL DEVICES CO.**

116 West Third Street CINCINNATI, OHIO

Canadian Distributors: Powley & Moody, Ltd., Toronto

# Crystal or Vacuum Tube Detection with the same set

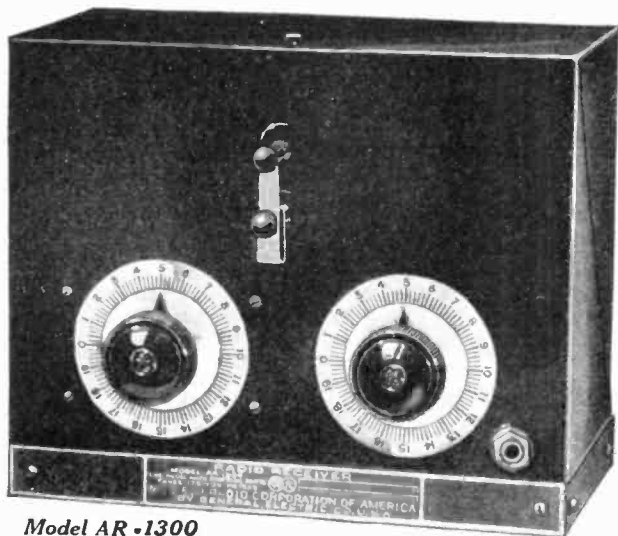

Model AR-1300

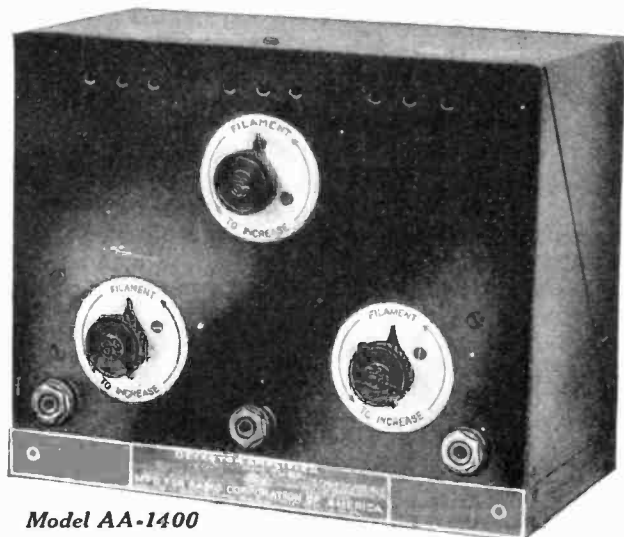

Model AA-1400

These two sets (radio receiver Model AR-1300 and Detector Amplifier Model AA-1400) meet the demand of the novice who wishes to start with a simple crystal detector and later to pass on to vacuum tube detection and amplification at minimum cost.

Radio receiver Model AR-1300 is a new tuner for the broadcast enthusiast. Used as a crystal detector it is a complete receiver. Used with Model AA-1400, here shown, the crystal detector is switched off and amplification is controlled by regeneration.

Detector Amplifier Model AA-1400 consists of a vacuum tube detector and two stages of audio-frequency amplification. It

is especially adapted for use with receiver Model AR-1300 to increase the strength of broadcasted concerts. The individual filament control permits close regulation of the received energy. Distortion of broadcasted music is avoided by a special high-frequency resistance across the secondaries. Three telephone jacks insure ideal selectiveness ranging from simple tube detection to two stages of amplification.

PRICES (NOT INCLUDING ANTENNA, TUBES, AND BATTERIES)

<i>Radio receiver Model AR-1300</i>	. . . . .	<i>\$50.00</i>
<i>Detector Amplifier Model AA-1400</i>	. . . . .	<i>75.00</i>
		<i>Total for Combination \$125.00</i>

See these New G. E. Products at Your Nearest Dealer



Sales Department, Suite 1805  
233 Broadway, New York City





"Superior" 2000 ohms, weight 14 oz. complete with headband and polarity indicating cord \$8.00

## BRANDES 'PHONES REST ON WISE HEADS

The experienced radio man knows that a good pair of sensitive 'phones is half of the receiving outfit. You may have a good aerial, a good tuning coil and a perfect detector, but what happens after your signals or music reaches the 'phones? Do your 'phones make the most of the weak currents that pass through them? The experienced radio man knows that he cannot depend upon appearance; he wants performance. That is the reason he insists on Brandes *Matched-Tone\** Headsets. They nurse in that long distance "stuff" that you cannot get with ordinary 'phones. Be sure that you start right with Brandes.

Standard Since 1908

SEND 5c FOR CATALOG E

Used as standard equipment by the leading manufacturers

### C. BRANDES, Inc.

Room 714, 237 Lafayette Street, New York, N. Y.

Australian Agents  
International Electric Co.,  
55 Courtney Place, Wellington, N. Z.

Chicago Office  
33 South Clinton Street,  
Chicago, Ill.

Member Radio Section Associated Manufacturers of  
Electrical Supplies

\*Reg. U. S. Pat. Office.

# BRANDES Matched-Tone HEADSETS



Type R-1  
3000 Ohms  
Price  
\$12



## Now in Production!

THE Dictograph Products Corporation has for many years taken an active part in the development of radio transmitting and receiving units.

All Dictograph radio headsets are made, complete, in the famous Dictograph factories, using the same materials and workmanship that have made the Detective Dictograph, the Acousticon for the Deaf, and the Dictograph System of Telephones the standard of the world for sensitive receiving and loud speaking.

We are now scheduling deliveries for June and subsequent months. Wire orders to your jobber or inquire direct to Radio Department—

### DICTOGRAPH PRODUCTS CORPORATION

CHARLES H. LEHMAN, *President*

220 West 42d Street

New York City

*Branches all over the world*

## Wait for the new DICTOGRAPH RADIO LOUD SPEAKER

Absolutely the best yet—New principle—Dictograph quality—Competitive price—Deliveries in July

If you want to hear, use  
**KRYSTAL-KLEER**  
on your detector. Price one dollar at your dealer's or send half dollar P. M. O. for sample sufficient for fifty crystals.  
**The KRYSTAL-KLEER Company**  
5229 Broadway, New York City  
**Puts PEP in the Detector**

**J. Skinderviken**  
TRADE MARK  
Skinderviken Transmitter Button  
U. S. and Foreign Patents  
**J. SKINDERVIKEN**  
*Inventor and Sole Manufacturer*  
\$1.00  
154 W. Randolph St. Chicago, Ill.

## How to Make Storage "B" Batteries

By JOSEPH H. KRAUS

(Continued from page 177)

jar will suspend the lead container in the sulphuric acid, as shown in figure 4. The electrolyte in these batteries, is sulphuric acid in the proportion of one part of acid and five of water, after which any evaporation of the liquid in the storage batteries is corrected by the addition of distilled water.

### Charging

With reference to charging these batteries, there are many suggestions which would be of value. The "B" battery may be charged with a storage cell, in which event, it is desirable, to make a multiple point switch, as shown in figure 12. This will permit the battery to be charged in groups, and an ammeter registering charge and discharge should be inserted into the circuit.

For charging from 110 volt, direct current circuits, a lamp bank is inserted in series with the "B" battery as in 13, and for alternating current, tin cans and aluminum plates answer the purpose, or glass jars and lead and aluminum plates may be employed. In 14, a 50 watt lamp is connected in series with the "B" battery. Suspended in the tin can of the ordinary "tomato" type, is an aluminum rod or sheet. The can is then filled with saturated solution of ammonium phosphate, sodium phosphate, or sodium bicarbonate. Acidulated water may be used. Instead of using a tin can, a glass container may be employed and the lead plate inserted into the glass jar, in place of the tin can. The lead plate is shown in dotted lines. This sort of a rectifier will rectify only one-half of the alternating current wave, and for full rectification the circuit shown in 15, should be used. Here again tin cans are employed, or lead plates may be used, the latter shown by dotted lines. After the battery is first made it will have to be charged and discharged several times. Subsequently ten minute chargings will suffice.

### NEW METHOD OF VULCANIZING INDIA RUBBER

From Akron, the Great Rubber City of Ohio, comes an invention of Mr. Frank O. E. Stone's for vulcanizing india rubber. The inventor uses an easily fusible alloy, of which many are known. An alloy of bismuth, lead and tin is typical and cadmium as a fourth constituent still further reduces the melting point. The articles to be vulcanized are immersed in the melted metal whose temperature is kept at the vulcanization point. An alloy is used whose melting point is slightly above the vulcanization temperature. The metal is allowed to solidify after the articles are immersed and is then kept at the vulcanization temperature until the article is considered cured, when the metal is melted and the articles are removed. The excess heat required to melt the metal is so little that it does not injure the india rubber.

We are indebted to the inventor for the following interesting table of fusible alloys.

Tin	Bismuth	Lead	Cadmium	Antimony	Melts
2	5-8	4	1-2	...	140 F.
26	48	19	13	...	158 F.
3	8	5	...	...	174 F.
2	5	3	...	...	197 F.
3	8	5	...	2	224 F.
1	1	..	...	...	330 F.

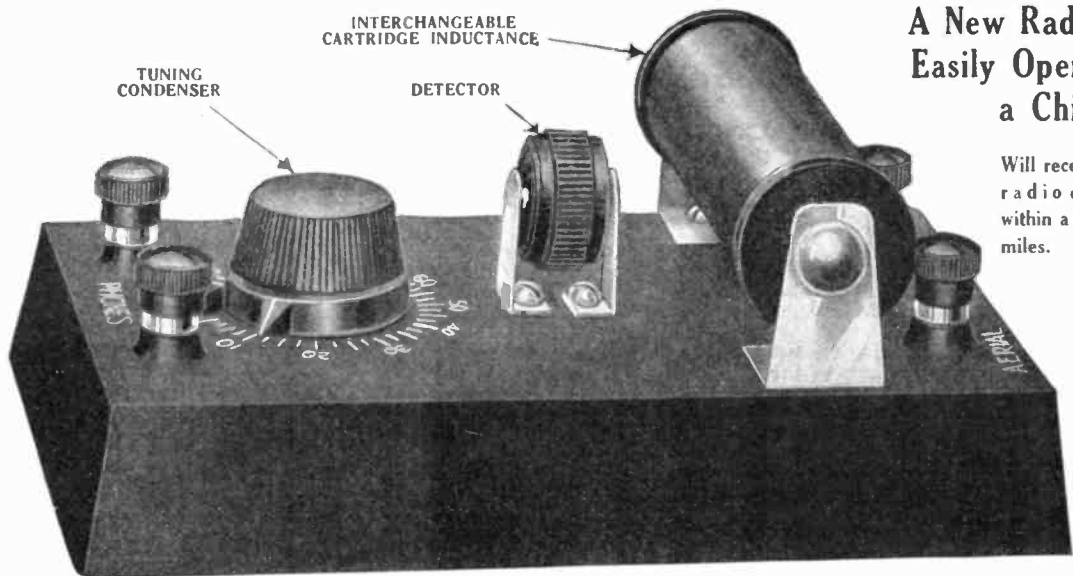

**A New Radiophone  
Easily Operated by  
a Child**

Will receive broadcast  
radio entertainments  
within a radius of fifty  
miles.

PATENTS  
PENDING

**Price \$12.50**

(Without Phones)

# NATIONAL AIRPHONE

(MODEL G)

This set has been perfected by experts in the design of Radio Receiving Apparatus—to meet the very exacting requirements that the most recent developments in the Radio Art have made necessary.

## Outstanding Points of Superiority:

1. Most Compact Radiophone Receiving Set Made:  $6\frac{1}{2}$ " long,  $4\frac{1}{4}$ " wide,  $2\frac{3}{4}$ " high.—small enough to put in coat pocket or desk drawer.
2. Rugged construction throughout, nothing to get out of order, insuring long life in service.
3. Entire casing constructed of hard rubber composition. No wood, no warping, no losses through leakage.
4. Ultra-sensitive Foolproof Detector; entirely enclosed in composition case. Air and dust proof, no fussy minerals, no Catwhisker, no balls nor spring. To adjust for maximum sensitivity simply rotate the black disk slowly.
5. Elimination of all switches, current taps and switchpoints prevents loss of electrical energy.
6. Use of interchangeable cartridge coils gives wide range over which radiophone broadcast or radio telegraph signals can be heard. 25 miles or over for radiophone concerts; up to 1000 miles for telegraph signals depending upon coils used.
7. Two Cartridge tuners, wave length 150 to 400 meters supplied with each outfit, one takes in general broadcasting stations (360 meters), the other from 500 to 1000 meters.
8. Variable Mica Condenser used is acme of simplicity—high capacity, impossible to short-circuit.
9. Anyone without previous experience can operate a NATIONAL AIRPHONE, no delicate adjustments necessary, no fussing.

We are now ready to assign territory to Jobbers and Dealers who will appreciate the advantages of a well designed serviceable and efficient outfit.

TRADE MARK **NATIONAL AIRPHONE CORPORATION** REG. U.S. PAT. OFF.

16-22 Hudson St.  
NEW YORK



Insist on Getting

**U. S. EAGLE GALENA, 25 Cents**

**U. S. EAGLE GOLDENA, 35 Cents**

**Mounted U. S. Eagle Galena or Goldena } 2-in-1, 50 Cents**

Patent Applied for

Marvelous Crystals of sensitivity; Improve your Radio Reception by the use of these Crystals. No better on the American Market. Each Crystal is packed in a container and labeled U. S. Eagle Galena or U. S. Eagle Goldena.

Attractive proposition for dealers and jobbers. Immediate shipment. Will use your own labels on request. Also in bulk.

EVERYTHING IN RADIO SUPPLIES SEND FOR CATALOGUE

**U. S. RADIO CO. of PENNA., Inc.**

Distributors and Manufacturers of Radio Apparatus

Corner Ferry and Diamond Streets Pittsburgh, Pa., U. S. A.

**The Ray of Hercules**

By RUSS SIMONTON

(Continued from page 124)

can understand that I, the modern Hercules, have solved the problem of atomic destruction and harnessed to my control the power of the very universe itself. Tell them I have broken the atom and can release the energy that composes it. Tell them that with the lead from a bullet or a spoonful of road dust for my supply of atoms, my instruments will release the energy of a thousand Niagaras.

"Say to them that this energy is in the form of a destructive ray that will instantly resolve into nebulous vapor the flesh and bone of a human body and that I have it under perfect control so that I can make it flow along a copper wire as you cause electricity to flow.

"Each wire of the maze that threads across and under the streets of this city and each telephone and electric light, at the hour I am ready, will become a radiator of the ray of Hercules, blasting with instant death all living things within its course.

"I am the Twentieth Century Hercules and my strength will set humanity free of its shackles when humanity has been shown what is real strength."

Grant laid down the sheet. "He signed the message, 'Hercules,'" he continued, "and he followed it with sufficient mathematical data to convince us that he has truly solved the world problem and can perform the dread miracle he threatens. I—"

From the street below there broke a strange roaring bellow, shot through with the shrill cries of newsboys calling an extra edition.

"The crowd has received the last warning," exclaimed Grant. "Dunwood, this creature has announced his ultimatum. He will strike at noon tomorrow unless we can prevent him. We are at the end of our resources. Radio experts have failed to trace with their wireless compasses and direction finders, the source of his messages. The police and the militia have scoured the city and its suburbs in vain. Coleman says you have made electrical waves visible to the eye. If that is true there is the single chance that you may succeed where all of us have failed!"

Apparently unmoved by the impassioned words, Dunwood smiled faintly.

"Disease and cure: poison and antidote," he said quietly, "Gentlemen, armor plate followed on the heels of dynamite. Atomic destruction this time and on its heels to combat it, electrical vision."

He mused a moment.

"Last night I completed the work I began twelve years ago. I have made vibrations of ether lower than those of light visible to the eye. You need not be told that when a bar of spring steel is made to vibrate slowly our eyes detect motion; that when its speed increases to thirty beats a second we hear some of the lowest tones of sound, and that as its speed reaches 20,000 beats a second the higher tones are reached and that beyond this frequency our ears are comparatively insensible to sound.

"Light, the most rapid vibration of matter of which we have knowledge, travels in waves that speed through the ether at 186,000 miles a second and, striking our eyes, convey images to us and produce the phenomenon we call 'sight.'

"Between the tremendously rapid waves of light and the slow waves of sound there lie the vibrations of electricity that we cannot see, feel or know in any way except by the work they accomplish. I should say, 'we could not know,' until last

(Continued on page 192)

"THERE'S MONEY IN IT"

AT HOME

**LEARN TELEGRAPHY**

AT HOME

**MORSE AND WIRELESS**

**The Omnigraph Automatic Transmitter**

will teach you either the wireless or Morse code—at home in half usual time and least possible expense. Connected with Buzzer or Sounder, it will send you thousands of messages at any speed you desire. Used by the U. S. Government and leading universities, colleges and radio schools.

Three models—\$14 to \$30. Send for free catalog.



**OMNIGRAPH MFG. CO.**

26-L Cortlandt Street New York

We also manufacture the Omnigraph Radio Receiving Set. A complete Vacuum Tube Set including Tube, pair of very sensitive phones, with head band and cord, safety switch, aerial wire, insulators, ground clamp. Completely wired. Enclosed in a portable mahogany finished cabinet, handsome enough for your parlor or living room. Price, \$48.00. Sold with a moneyback guarantee, the same as its brother—The Omnigraph Transmitter.

**10c. Charges Your Storage Battery At Home F-F Booster**

Which is a Full Wave Magnetic Rectifier for 105-125 Volt 60 Cycle A. C. Current. Leave Battery right in Your Car. Snap Clips of Charger on Battery Terminals. Turn Switch, lock garage door, knowing Your Battery will be charged in the Morning. **AMMETER** shows Current Flowing, eliminating All Guess Work. No Skill required. Complete Compact Self-Contained Portable Automatic Charging Unit. Lasts Lifetime. Adjustable Renewable Infusible Carbon Electrodes Rectify Current Uninterruptedly. Starting Car Quick, requires Fewer New Batteries. **Booster** thus Saves more than its Cost. Don't think Your Battery is dead, worn out, simply because it will not start Your Car. Buy a **Booster & Fill It With Life. A Booster Saves You Money. PRE-WAR PRICES:** Type 6—charges 6 volt Battery at 6 amperes \$15 Type 12—charges 12 volt Battery at 5 amp \$15 Type 20—charges 20 volt Radio Batteries \$15 Type A—charges Both A & B Batteries \$20 Type 166—charges 6 volt Battery 12 amps \$24 Type 1612—charges 12 volt Battery 7 amps \$24 Type 1626 Combination Type Charges Both 6 & 12 volt Batteries at 12 & 7 amperes \$36 The Larger Types are recommended for heavy Batteries or where time is limited. Shipping Weights Complete with **AMMETER & BATTERY CLIPS**, 12 to 15 lbs. Order from Your Dealer, or Send Check for Prompt Express Shipment; include Postage & Insurance Charges for Parcel Post Shipment, or Write us to Ship Type desired **C.O.D.** Order Now or Write Immediately for Free Descriptive **BOOSTER** Bulletin 12. **F-F ROTARY RECTIFIER** For **GROUP CHARGING** Charges Up To 36 Cells. Full Wave, Automatic Dependable Economical. Other Apparatus For Farm Lighting & D.C. Circuits. Write for Free Descriptive **ROTARY** Bulletin 12A.

**The France Manufacturing Co.,** General Offices & Works, Cleveland, Ohio, U. S. A. Canadian Representative: Battery Service & Sales Co., Hamilton, Ontario, Canada

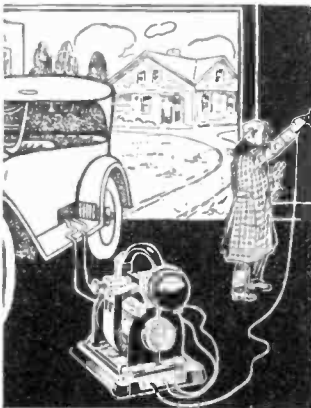



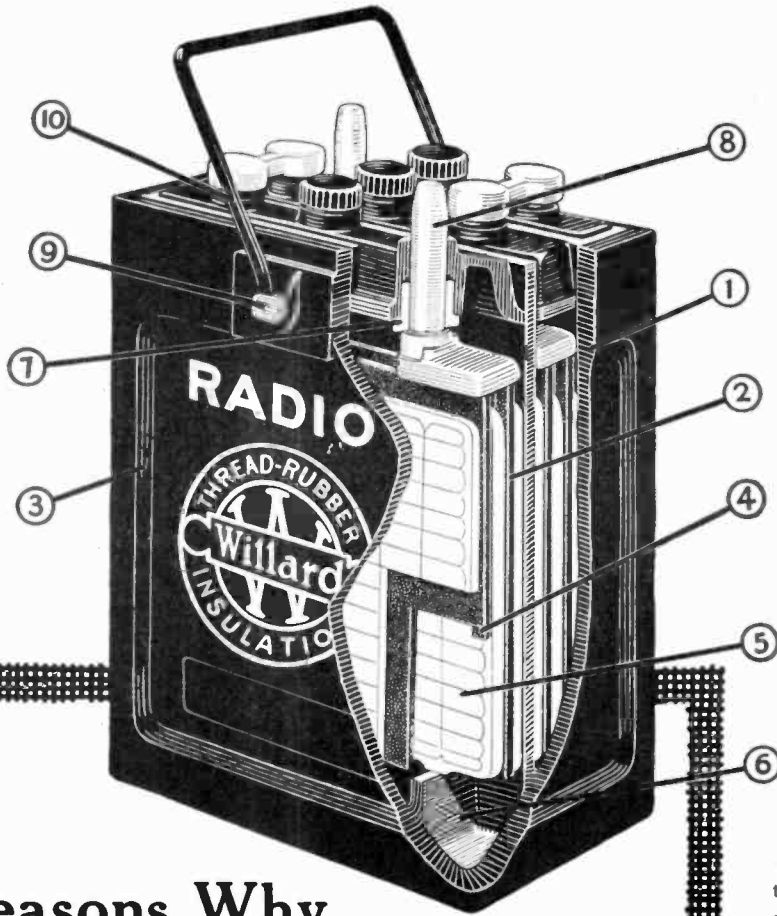

The Willard All-Rubber Radio "A" Battery (shown here) is designed especially for radio use.

## Ten Reasons Why The Willard All-Rubber Radio "A" Battery is Better

These reasons, back of the success of this specially designed battery, are as definite as those responsible for the success of the Willard Threaded Rubber Battery, which is now standard original equipment on 195 makes of cars and trucks. Ask for particulars from your dealer or at the nearest Willard Battery Station.

The Willard Radio "B" Battery is a 42-volt rechargeable storage battery, with leak-proof glass jars and Threaded Rubber Insulation. Assures freedom from frying and hissing ground noises.

**WILLARD STORAGE BATTERY COMPANY**  
Cleveland, Ohio

*Made in Canada by the*

Willard Storage Battery Company of Canada, Limited, Toronto, Ontario

**Willard** THREADED RUBBER BATTERY

**1** The rubber case is made in one piece, thoroughly insulating the battery from cells to ground and from cell to cell, and effectively preventing all ground noises.

**2** Plates are insulated with Threaded Rubber Insulation, which by reason of its uniformity allows every part of each plate to do an equal share of work.

**3** Battery is shipped in absolutely Bone-Dry condition so that it is brand new when you get it.

**4** Insulators are made with special heavy ribs to meet the special requirements of the radio battery.

**5** Plates are extra heavy to provide current at steady voltage for considerable periods.

**6** Sediment chambers are large to eliminate all possibility of short circuits at plate bottoms.

**7** Posts are sealed by soft rubber gaskets, so that solution cannot seep out between post and cover.

**8** Terminal posts are high to permit easy grip of battery clamps.

**9** Brass knobs sunk into the sides of the rubber case provide a firm hold for the handle.

**10** Handle made of a heavy rod furnishes easy means of carrying the battery.

## Hook Up With a WIZARD BATTERY

A special made "moisture proof" "B" battery of guaranteed long life—a veritable power house. As high in quality as it is low in price.

No.	Size	Wgt., Lbs.	Volts	Price
1623—Plain,	2x3½x2½	1	22½	\$1.00
1623—Variable,	2x3½x2½	1	22½	1.20
1625—Plain,	4x6½x3	5	22½	1.85
1625—Variable,	4x6½x3	5	22½	2.25
1626—Plain,	8x6½x3	10	45	3.75
1626—Variable,	8x6½x3	10	45	4.15
1630—Variable,	3x6 x2½	2½	27	1.80
1632—Variable,	5x6 x2½	3½	45	2.80



**"THE MAGIC POWER HOUSE"**

At your dealer or write direct

**WIZARD BATTERY CO.**  
173 Lafayette Street, New York City

## RADIO MEN NEEDED!

THERE is at present a great demand on this school for men trained in Radio. Manufacturers of Radio equipment are constantly asking for men for various positions at high salaries. Thus far the demand has exceeded the supply.

*We can train you in a short time to qualify for one of these positions.*

Complete course covering Arc, Spark and Vacuum Tubes systems.

**Y.M.C.A. RADIO SCHOOL**  
152 East 86th St., New York City

## Bradleystat

REGISTERED U.S. PAT. OFF.  
PERFECT FILAMENT CONTROL



**\$1.85**  
Add 10c for postage

The best radio set fails with poor filament control. The Bradleystat eliminates verniers, steps, loose contacts, etc. Over 10,000 used per week.

Get yours today.

**Allen-Bradley Co.**

279 Greenfield Ave.

Milwaukee, Wis.

## The Ray of Hercules

(Continued from page 190)

night when through the filters and lenses of my apparatus, I made the waves of electricity behave exactly like those of light.

"Briefly—I saw through copper wires as you see through the tubes of telescopes. Electricity conveyed the images to my eye that light conveys to yours this moment. In my Long Island laboratory, I sat and watched the crowds on Broadway, looking over, or rather, through the wires that connected my telephone with the telephone of a friend in the Hotel Gigantic. I stood—"

"We have but ten hours left!" broke in Grant. "Did you bring the instruments you must have? Let us begin!"

Before the doors of the great central power station stood three high-powered automobiles with engines throbbing. Police were in each machine. At every police precinct station in New York there were similar squadrons. They had been there all night poised and ready for instant pursuit the moment a little group of men laboring behind the marble switchboard of the station should determine the whereabouts of "Hercules," the man who threatened New York.

At the switchboard, within hands' reach of the complicated system of wires and cables over which every ampere of electricity used in all the city flowed, the seven men who had met in the Hotel Vermont the day before, and with them the commissioner of police and the chief engineer of the power plant, were gathered.

On the floor rested a mahogany chest, the size of a steamer trunk, with its lid thrown back disclosing the black rubber and gleaming nickel plate of electrical apparatus. From this chest extended two green silken cords, like those of a telephone, but larger and not so flexible, leading to a curious black, goggle-like mask that covered all but nose and mouth of a man crouched before the board.

The mask made its wearer's head resemble that of a great beetle. Two conical tubes projected before the eyes and the constant manipulations of a little lever, set on a block of hard rubber he held in his hands, caused the tubes to lengthen and shorten like the stiff antennae of some insects.

Eagerly the others of the party watched him, peering now at this and now at that wrist-thick switch bar of polished copper carrying hundreds of amperes of electricity from generators and dynamos to the factories and homes of the city.

The clock on the wall tinkled mechanically as the electrical impulse from the Naval Observatory corrected it and set its hand upon the hour.

"Eleven o'clock! A single hour more!"

Grant spoke. His words were a prayer that found frantic echo in the hearts of the weary men who surrounded him.

The man with the mask straightened to his feet and tore it off, revealing himself as Dunwood, not the debonair and confident Dunwood of the day before but a haggard, wild-eyed creature.

"One of you try it!" he cried.

Coleman slipped the mask over his head and took up the rubber block with the tiny lever. Mastering himself with evident effort, Dunwood bent to the instrument chest on the floor and made adjustments among the micrometer screws and switches that lined its upturned lid.

"What do you see?" hoarsely demanded Butler.

"A woman with two children clinging to her," said Coleman. His tones, a little

(Continued on page 195)

## Wireless for Everybody

The Little Wonder Portable Radio Set



that you saw in the "movies," the daily papers, etc. Simple to install and operate.

Just the thing for Boy Scouts, Campers and for use on bicycles, etc. Complete in every respect and guaranteed to give complete satisfaction.

Just connect your aerial ground and phones and you are ready to receive messages. Tunes to 800 meters and receives telegraph messages within 1,000 mile radius and wireless telephone messages within 30 mile radius.

Type S8 (receiving set only)..... **\$7.50**

Dealers! Write for attractive offers

**RADIO SERVICE & MFG. CO.**

World's Tower Bldg., Room 604-S  
West 40th Street New York City

## The Best Protection Against Lightning

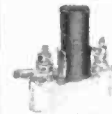

**"JACOBUS"**  
VACUUM AERIAL PROTECTOR

Type J. S. W.

Approved by the National Underwriters to replace lightning and ground switches

**Eliminates Switches.** Receiving stations equipped with JACOBUS Protectors do not require lightning or ground switches. Protection every minute of the day and night. No worry about throwing switches.

**Good for Innumerable Discharges.** Discharges of lightning or static on the JACOBUS do not affect its life. After conducting a discharge to the ground the tube is ready for another operation. Does not weaken or in any way affect the efficiency of the set.

\$2.00 From All Dealers or Sent Direct

**APEX ELECTRICAL SPECIALTY CO.**

INCORPORATED

79 ORANGE ST., NEWARK, N. J.



**Globe Radio Batteries**  
DESIGNED ESPECIALLY FOR WIRELESS

SAVE YOU 50% OF USUAL COST AND YOU GET AN UNCONDITIONAL WRITTEN 2-YEAR GUARANTEE

Compare the prices below with those of any other make of battery. You will find a marked saving in the Globe Battery and the guarantee is backed by an old established organization.

Volts	Amps.	Price	Volts	Amps.	Price
6	40	\$10.00	6	80	\$14.50
6	60	12.50	6	100	15.00

Shipped Fully Charged Ready for Installation  
Begin now to get 100% battery service at half cost by sending us your order to-day.

**GLOBE BATTERY COMPANY**  
1219 S. Wabash Ave., Dept. S, Chicago, Ill.

## HENRY J. RAPHEL RADIO ACCESSORIES

Head Phones in Stock

Vario-couplers and Variometers

D. C. Battery Charger, \$12.50

Mail Orders Filled Promptly

303 Pearl Street, New York City

## MAKE YOUR OWN RADIO SET

It's simple, anyone can do it. Everybody is making them. Get music, speeches, etc., out of the air. We will mail you complete instructions, blueprints, etc. Send only \$2.00 today.

**AMERICAN UTILITIES CO.**

Box F429. Excelsior Springs, Mo.

# THE "RICO" TRI-POLE

## DOUBLE HEAD 'PHONES



PATENTS PENDING

mark a new advance in telephone receivers. These receivers are built on a radically different plan than all other receivers. *The pull on the diaphragm is where it should be—in the mathematical center of the diaphragm.*

RICO receivers "talk for themselves." A trial will convince you. Super-sensitive, especially designed for broadcast work—sounds are brought in sharp and clear. Not a receiver of extraordinary sensitiveness, but an all around receiver whether used for broadcast radio telephone work, or for long distance radio telegraphy.

### OUTSTANDING MECHANICAL FEATURES

Lightness. Stability. Aluminum shells. Non-rusting diaphragms. Guaranteed tungsten magnets. Neat black mercerized cord. Head band adjustable not only to every size head but *the two bands are adjustable as well*; the only head band made in this manner. Sanitary soft rubber covering that can be washed, and will not catch the hair—especially appreciated by ladies.

RESISTANCES: 2,000 and 3,000 ohms. Can be made up to 6,000 ohms if desired.

PRICES { "Rico" TRI-POLE Head Sets, 2,000 ohms, \$6.50  
 { "Rico" TRI-POLE Head Sets, 3,000 ohms, 7.50

DELIVERY beginning May Twentieth. We have an especially attractive proposition to jobbers and dealers.

Wire or write to

**RADIO**  
**INDUSTRIES**  
 CORPORATION

131 Duane Street

New York City



# "RASCO HAS IT!"

THE Radio Specialty Co.—"Rasco" for short—is probably the most unique supply house in the United States, if not in the world to-day. This company makes a specialty of small orders, no order being too small to get immediate and prompt attention for the simple reason that most of our orders are small. The reputation of this house was built upon service. Ask any of your acquaintances what they think of Rasco goods, Rasco service, Rasco promptness! Thousands of unsolicited testimonials on file to prove that we serve the public best! Be sure to get our great catalogue, containing several hundred different parts, which is illustrated below.

**ORDER DIRECT FROM THIS PAGE. ALL GOODS SENT PREPAID IN 24 HOURS**

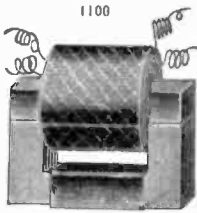

### "RASCO" AUDIO FREQUENCY TRANSFORMER

We have compared many of the present transformers on the market but have finally decided upon a type that is the most efficient one we have seen so far. The best amplifying transformer is that in which the impedance of its primary is equal to or exceeds the impedance of the plate-to-filament circuit of the tube in which it is connected.

We guarantee this transformer to equal any one on the market.  
No. 1100 "Rasco" Audio Frequency Transformer (not assembled) each prepaid .....\$2.65

### ANTENNA CONNECTOR

This antenna connector is made entirely of aluminum. It is light and will not rust. The only connector of its kind. The 4 antenna wires go to the upper holes; the lower hole takes the lead-in. Don't solder your aerial, don't have loose connections. Dimensions 2" high, 1 3/4" wide, 3/8" thick.  
No. 999. Connector, each. \$0.35



9.9



### PANEL KNOBS

No. 6241 is well made and has a good corrugation. Its dia. is 1", height is 3/2". The shank is 3/4" high.  
No. 6241, Knob, each. ....\$0.08



838

### MARCONI KNOB

Has a central hole of 5/32" and seat to hold the screw. dia. is 1 1/4", height 3/4".  
No. 838, Marconi Knob, each. ....\$0.15



### RASCO POSTS

These are our very own patterns, from our own designs and look mighty handsome on any instrument. The top knobs are of composition, the bottom parts brass nickel plated polish.  
No. 202 is nickel plated at bottom part.



130

029



"Rasco" Binding Post, 8/32 thread, each, \$0.10; doz., \$1.00.  
No. 202, Post, each, ....\$0.08  
Nos. 650 and 651 made entirely in composition with a hexagonal brass nut in center.  
No. 650 has 8/32 machine screw. No. 651 has bottom wood screw.  
No. 650, Post, each, ....\$0.08  
No. 651, Post, each, ....\$0.08  
Dozen, each style, ....\$0.90

### BRASS NICKEL POSTS

No. 029, Binding Post, each, ....\$0.05  
No. 030, Binding Post, each, ....\$0.04



### RASCO SWITCH POINTS

Nickel plated and polished. The following have been found the most popular.

No. 1 1/4" x 1/4", 6/32 thread, ea., \$0.03; doz., 35c  
No. 2, 3/16" high, 1/4" dia., 6/32 thread, ea., \$0.03; doz., 35c.  
No. 3, 3/16" x 3/16", 4-36 thread, ea., \$0.03; doz., 35c.  
No. 4, 1/2" dia.; 3/8" thick; stem 6/32, ea., \$0.03 1/2; doz., 40c.  
No. 5, 3/8" dia., 3/16" thick; stem 4-36, ea., \$0.03 1/2; doz., 40c.  
No. 6, 3/16" dia.; 3/16" thick; stem 4-36, ea., \$0.03 1/2; doz., 40c.  
No. 7, 3/16" dia.; 1/4" thick; stem 4-36, ea., \$0.03 1/2; doz., 40c.  
No. 75, Switch Stop, 3/8" long, 4-36 thread, complete with nut, ea., \$0.05; doz., 50c.  
No. 76, New style Switch Point, to be pressed into bakelite panels with forced fit. Wire is soldered to pin end. Head 3/4"; dia., 1/16" thick, ea., \$0.03 1/2; doz., 40c.  
No. 77, same as above, but head is 1/4" dia. x 3/16" thick, ea., \$0.03 1/2; doz., 40c.



### THE RASCO BABY DETECTOR

In presenting this little Detector, we feel sure that it fills a place never taken before by any small detector. It does a variety of things and does them all well and better than the base is solid, black composition. Mounted on same is a nickel holder and binding post which holds a fluted hard rubber knob with its sliding rod member. The outstanding part of the Detector, is the patented nickel detector cup and binding post. The knurled cap unscrews and you place the Galena Crystal in the cup, then replace the knurled cap and the galena crystal is held secure. The circular hole in the cap exposes enough of the crystal for ordinary purposes.  
No. 1898, Rasco Baby Galena Detector. Price, prepaid .....\$0.50  
No. 1899, Rasco Baby Detector with Galena and Radioelectric Crystals. Price, prepaid .....\$0.75

### PANEL SWITCH LEVER

New style switch lever with lock fork. It is impossible for this lever not to make positive contact at all times. The blade radius is 1 1/4". Blade is nickel plated and polished. Fork is phosphor bronze. The lock fork holds the screw (in which it rotates), securely. A loose contact is impossible.  
No. 200, Switch Lever, complete as illustrated. ....\$0.30



200



This wire is recognized as the only thing for winding coils for Radio instruments. Particularly recommended with our No. 343 Variocoupler Rotor, for vario-couplers, banked windings, etc.  
No. 323, Litz Wire, 20 No. 38 strands, enameled double silk wire, per foot, \$0.02; per 100 feet, \$1.15

No. 890, Litz Wire, 10 strands No. 38 wire, per foot, \$0.01; per 100 feet, \$0.75.  
No. 891, Litz Wire, 16 cables of three strands No. 38 wire, per foot, \$0.03; per 100 feet, \$2.25.

### LITZ WIRE

**NOTE: This page contains only a few of our 300 specialties.**

### PANEL KNOB

This is a very distinctive knob and can be used on dia. panels, switches, condensers, etc. It is exceptional and well made. Dia. 1 1/16"; height 11/16"; comes with 8/32" bushing.  
No. 815, Knob, each, ....\$0.18



815



### VARIOCOUPLER ROTOR

This rotor is used by all up-to-date amateurs. Is accurately turned of hard wood and is used as a secondary coil. It takes any finish, either shellac or stain and can be drilled readily for any size hole. Large hole 2" dia. Width of spool is 2". Total dia. 3 3/4".  
No. 343 Variocoupler Rotor, each .....\$0.75

343



### "RASCO" NAME PLATES

Our name plates are of brass with a black background. Letters are polished nickel.  
No. 827, Name Plate, each .....\$0.05



839

Order by name and number.

807 "Phones".....\$0.05	810 "Ground".....\$0.05
809 "Aerial".....\$0.05	812 "Primary".....\$0.05
811 "Secondary".....\$0.05	814 "Detector".....\$0.05
813 "Audion".....\$0.05	866 "On".....\$0.05
865 "Off".....\$0.05	840 "Increase Current" (Left).....\$0.10
839 "Increase Current" (Right).....\$0.10	834 "Series".....\$0.05
813 "Vacuum Tube".....\$0.05	830 "Receive".....\$0.05
831 "Transmit".....\$0.05	820 "2nd Step".....\$0.05
821 "3rd Step".....\$0.0	827 "Tickler".....\$0.05
819 "1st Step".....\$0.05	825 "Plate Variometer".....\$0.05
826 "Grid Variometer".....\$0.05	835 "B Battery".....\$0.05
823 "Secondary".....\$0.05	817 "Output".....\$0.05
836 "A Battery".....\$0.05	824 "Primary Condenser".....\$0.05
818 "Innut".....\$0.05	828 "Parallel".....\$0.05
829 "Telephone".....\$0.05	837 "+".....\$0.05
833 "Detector Tube".....\$0.0	841 "(Blank)" (takes pen or pencil writing).....\$0.05
822 "Coupling".....\$0.0	Price of all of our name plates in dozen lots, 50c, with the exception of the two "Increase Current"
808 "Load'g Coil".....\$0.0	

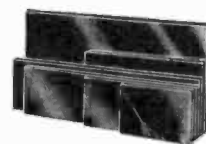

### BAKELITE PANELS

We list below six panels, the sizes of which have been selected after carefully checking up many dimensions of the most popular radio apparatus on the market. Note particularly that our prices are anywhere from 25 to 50% lower than those quoted by most other concerns. The reason is that we buy these panels in very large quantities, and we do not cut sheets to order. Remember always that when sheets are cut to order they cost you at least 50% more than our prices, because you must pay for the cutting and the necessary waste. Note also that we ship these panels prepaid. This alone amounts to a considerable saving.

No. 350	6" x 12" x 3/16" thick	each	.....\$1.90
No. 351	6" x 18" x 3/16" "	"	..... 2.85
No. 352	9" x 12" x 3/16" "	"	..... 3.00
No. 353	12" x 18" x 3/16" "	"	..... 5.65
No. 354	6 1/2" x 19 1/2" x 3/16" "	"	..... 3.50
No. 355	6" x 7 1/2" x 3/16" "	"	..... 1.20

### "RASCO" LUBRICATED PANEL SWITCH

A radio switch that has two nuts at the end is a monstrosity, for the reason that it will never stay put. Our patent spring fork holds the switch handle always under uniform tension, at the same time it insures the best contact possible. New wiping contact which covers every point of the switch point. Another new improvement is the lock fork, which can assume three different positions to accommodate the switch to various thicknesses of panels.  
No. 1921 "Rasco" Switch, as illustrated, each \$0.50.



1921



### KNOBS

These knobs are favorites with all experimenters. The size of both is: dia. 1 1/8", height 3/8".  
No. 4451 comes with 8/32 and 10/32 bushing.  
No. 4451, Knob, each, ....\$0.06  
No. 199 (screw length 3/8") Knob, each .....\$0.10

4451

199

### NAVY KEY KNOB

This navy key knob is now used on all standard wireless keys. It gives the right swinging motion and rests the fingers. It is a favorite with all advanced amateurs. Once used always used. The screw is 8/32 and will fit all keys.  
No. 748, Key Knob, each, ....\$0.28



748

### THREADED BRASS ROD

We carry two styles, 6/32 and 8/32 thread. Only 6" lengths sold. No others.  
No. 8032, Threaded Brass Rod 8/32 thread, per 6" length .....\$0.08  
No. 6032, Threaded Brass Rod, 6/32 thread, per 6" length .....\$0.06

## THE "RASCO" CATALOG

CONTAINS 50 VACUUM TUBE HOOK-UPS

Complete hook-ups of all important vacuum tube circuits are given in clear diagrams with complete explanation. Just to name a few—The V.T. as a detector and one-step amplifier; regenerative circuit; De Forest ultratuner; V.T. to receive undamped and spark signals; Armstrong circuits; one step radio frequency amplifier and detector; three stage audio-frequency amplifier; short wave regenerative circuits; V.T. radio telephone; 4-stage radio frequency amplifiers; radio and audio frequency amplifier, inductively coupled amplifier; Armstrong superautodyne; radio frequency amplifier and crystal detector; etc., etc. The catalog contains 200 illustrations. On account of its great cost, it cannot be distributed free of charge. Mailed only upon receipt of 15c in stamps or coin.



**98 PARK PLACE, NEW YORK CITY**

**DEALERS**  
Get Our Special Proposition

Factories  
Brooklyn, N. Y.—Elkridge, Md.

# The Ray of Hercules

(Continued from page 192)

distorted by the mask, seemed unreal. "They are crying."

He slipped the lever the fraction of an inch along the graduated circle on the block.

"Now a factory . . . idle machines . . . girls gathered in groups . . . one reads a newspaper to the others. Now I see the East River and the boats. I seem to be in a high place looking down upon them."

On and on he spoke, feverishly twisting the lever back and forth along its dial, bringing first this and that scene into focus exactly as an opera glass is adjusted for varying distances. Everywhere that copper wires bore electricity to its work in the city Coleman could see. Like scenes in an old fashioned panorama, he could gaze upon all the pathos and comedy, the strange jumble of misery and happiness, work and play that makes the life of a city. So delicate was the adjustment Dunwood had provided for his amazing device, that the little lever enabled the observer to guide his sight along even the branch lines that led from the feeder lines.

The clock on the wall ticked away the minutes—"Quarter past eleven." Suddenly Coleman cried out—

"I see the city hall . . . a mob . . . waving arms . . . someone speaks from the steps . . . he urges them to something . . . Now I am in the mayor's office. Men are pleading with him . . . Now back to the crowd. The police are beating them back with clubs."

"Central Park . . . black with people . . . A Hudson tube station . . ."

My God! They are fleeing the city! A mob surges about the stairway . . . men and women trampled under foot."

Trembling with haste, Coleman stepped to a new section of the board and swung the focusing lever with a motion almost vicious to a new point on the dial. Inexorably the clock hands pushed toward noon. Every eye swayed anxiously between clock and man. There was silence for several minutes.

"I have it!" Coleman shouted. "I've lost it! There! No, no! It is gone again!"

His fingers twitched on the adjusting lever. Dunwood, on his knees, was busy at the instrument case on the floor. Had not Coleman's cry fixed the attention of the others and made them, for the instant, insensible to any sound save that of his voice, they must have heard Dunwood laugh lightly and wondered to hear laughter at such a time.

The ponderous generators below rumbled their song in unison, but outside the sullen murmur of the city grew louder and its even tone was broken by the rise and fall of many voices shouting in some distant place. Precious seconds passed.

"Ah!" Coleman's long drawn sigh was triumphant. "Ah! This is the place. No mistaking this weird assortment of instruments . . . hotel room . . ."

Instantly the chief engineer was leafing the blue printed pages of the power system chart he held, tracing the course of the circuit which began with the switch bar at which the goggles of Coleman's mask were directed. The commissioner  
(Continued on page 197)



## The HOME RADIO

### How to Make and Use It

By A. HYATT VERRILL

At last! A simple explanation of the making and use of a home radio outfit. Every step in construction is carefully directed and illustrated with numerous working diagrams. Get your copy today. A cloth bound book. Postpaid for 75c. "Broadcasting Guide" 25c.

RADIO EDUCATIONAL SERVICE  
200 I—5th Ave.—R 416 N. Y. C.

FREED-EISEMANN RADIO CORPORATION  
255 Fourth Avenue  
New York U.S.A.

Manufacturers of the  
NATIONALLY FAMOUS  
**MARVEL**

REG. U.S. PAT. OFF.

COMPLETE WITH \$15.00  
ANTENNA OUTFIT

Our 3 Factories are dedicated to the manufacture of the best kind of Radio Apparatus—every set and separate part carrying our unqualified guarantee. If your dealer cannot supply you, write direct.

# DUCK'S NEW CATALOG No. 16

275 Pages A Catalog Deluxe

"Over fifty pages of the latest hook-ups [wiring diagrams], and invaluable and up-to-date data and information on radio, including important instructions for building antenna."

"Send 25c in coin carefully wrapped for your copy of this wonderful book, the most unusual and complete catalog ever put between the pages of two covers. Not sent otherwise. It is not only a catalog, but a wonderful text book on radio. Enormous cost and tremendous demand prevent further distribution at a less retainer."

Never in the history of radio has there been such a catalog.

The radio data and diagrams embracing upwards of fifty pages gives the experimenter more valuable and up-to-date information than will be found in many textbooks selling for \$2.00, and \$1.00 could be spent for a dozen different radio catalogs before you could gather together the comprehensive listing of worth while radio goods found in this great catalog. A brief summary of the radio goods listed in this catalog:

The entire radio catalog of the Radio Corporation, with a wealth of scientific and technical data on C.V. transmitting sets, and all the diagrams for the assembling of these sets; the complete Remler catalog, which embraces 25 pages, the Westinghouse, Elmhurst, Federal, DeForest, Clapp-Eastman, Brandes, Connecticut Company, Thordarson, Turney, Magnavox Company catalogs, the best products of Adams-Morgan, Signal and countless other manufacturers, including our own complete line of radio apparatus, and many individual items and parts used in radio work today.

## DEALERS

We want live responsible dealers in every city and town in the United States, both for the sale of our extensive line of radio apparatus and all other worth while lines of radio goods on all of which we can quote attractive dealer's discounts. We can offer you facilities and advantages that no other radio house can offer.

## Duck's New Type "CQ" Receiver

An Epoch Making Contribution in Radio Reception Combining the Utmost Selectivity and Simplicity of Operation

Our new Type "CQ" receiver with detector and two step amplifier is truly a Deluxe Receiver. Cabinet of genuine mahogany, handsomely finished in its natural color, Formica panel. All connections from rear. No set offered to the public today combines so many dominating features. On the basis of intrinsic worth we are warranted in asking twice the price. Extreme simplicity in operation, sharp and selective tuning, clear and sweet reception of music and speech, the entire elimination of body capacity effects, none of the minutely painstaking adjustments characteristic of so many receiving sets on the market, permanence of adjustment—these are among the dominating and much to be desired features that characterize our "CQ" Receiver.

Type "CQ" \$85.00  
Receiver

In tests here Schenectady, N. Y., Atlanta, Ga., and Newark, N. J., from 400 to 700 miles distant came in with sufficient strength to be audible in any part of a room 12x15 feet. Chicago, Pittsburgh and Indianapolis were plainly audible in receivers.

Pamphlet describing this receiver mailed for 2c in stamps. This rule necessary to prevent avalanche useless queries.

Note—The above Receiver is complete excepting the usual accessories. These comprise detector and amplifier bulbs, \$18.00; two "B" batteries, \$3.50; storage battery, \$15.00; antenna material approximately \$12.00 a head set as selected. Western Electric from stock at \$15.00.

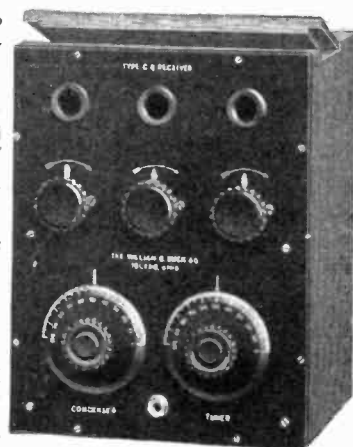

Send only 25c for copy of this wonderful catalog. You will need no other when you have Duck's, and you cannot find in all others combined what you will find in Duck's Wonder Catalog.

The WILLIAM B. DUCK CO., 231-233 Superior St., Toledo, Ohio

**NOW READY! The Fourth Edition of the NOW READY!**  
**Consolidated Radio Call Book**

**Very Greatly Enlarged**  
**With Seven Two-Color Radio Maps**

280 pages (88 pages more than the 3rd edition), better paper, stiff covers, etc.  
**25,000 Copies**



Some of the special information contained in the new book: All Amateur Radio Calls of the United States and Canada; Every Vessel, Coast Station, and Radio-Compass Station in the World; Radiophone Broadcasting Stations of the United States; Every High-Power Station in the World; Special Land Stations of the United States; Time Signals, Hydrographic and Weather Reports of the United States and Principal Foreign Countries; International Abbreviations; Assignment of International Calls; Press Schedules; Radiogram Rates; Cable Rates; International Morse Code and Continental Signals; and Complete General Information covering Distress Calls, International Safety Signal, Use of 800-Meter Wave Length, Amendments and Changes in Various Governmental Regulations, How to Determine Charges on Radiograms, Free Medical Advice by Radio to Vessels, and much other useful information.

The Consolidated Radio Call Book is the only book in print officially listing all the Radio calls as issued by the Bureau of Commerce. Every vessel and land station in the world is represented and listed alphabetically, according to name of vessels or land stations, and according to call letters. The New Radiophone Broadcast Section is particularly complete and gives all available information concerning Calls, Wave Lengths, Programs, etc.

**Every Amateur Call in the United States and Canada Is Listed**

**SPECIAL RADIO MAP SECTION**

Contains Five Two-Color Continental Maps showing All Stations throuth the World Handling Commercial Traffic with their Calls; a Two-Color Map showing the Amateur Radio Districts of the United States and the Principal Radiophone Broadcasting Stations with their Calls; and a Map of the United States Weather Forecast Zones.

The third edition of 10,000 copies was exhausted in two weeks. The fourth edition is selling just as quickly. Don't wait until it is all gone. Order at once, either direct from us or from your favorite dealer.

**Price \$1.50 Prepaid**

Order Direct from us or for sale by the following responsible Dealers:

- |  |  |   |   |
|--|--|---|---|
| Alamo Sales Corp., Indianapolis, Ind.        | Fergus Electric Co., Zanesville, O.              | Nat'l Radio Institute, Washington, D. C.      | Sands Electric Co., Wheeling, W. Va.          |
| Am. Electro Tech. App. Co., N. Y. City       | Finley Electric Co., Minneapolis, Minn.          | New England Motor Sales Co., New England      | Sayre-Level Radio Co., Phila., Pa.            |
| Amer. Hdw. Stores, Bridgeport, Conn.         | Fleron & Son, M. M., Trenton, N. J.              | Greenwich, Conn.                              | Schmidt & Co. R., Rochester, N. Y.            |
| Andrae & Sons, Jullus, Milwaukee, Wis.       | Fuller Co., Seth W., Boston, Mass.               | New Era Shop, Milwaukee, Wis.                 | Sears, Roebuck & Co., Chicago, Ill.           |
| Andrae & Sons, Jullus, Mason City, Iowa      | Galveston Wireless Sup. Co., Galveston, Tex.     | Newman-Stern Co., Cleveland, O.               | Service Radio School, Washington, D. C.       |
| Anthracite Radio Shop, Scranton, Pa.         | Hall Electric Co., Wm., London, Canada           | Nichols Radio Sup. Co., B'wg Green, Ky.       | Shotton Radio Mfg. Co., Scranton, Pa.         |
| Atlantic Radio Co., Boston, Mass.            | Hatfield Electric Co., Indianapolis, Ind.        | Noia Radio Co., New Orleans, La.              | Smith Novotoy Elec. Inc., Charlotte, N. C.    |
| Bamberger & Co., L., Newark, N. J.           | Heustis, A. E., Fitchburg, Mass.                 | Noll & Co., E. P., Philadelphia, Pa.          | Smith Radio Labs., Sarnia, Ontario, Can.      |
| Banister & Pollard Co., Newark, N. J.        | Hickson Electric Co., Rochester, N. Y.           | Northern Radio & Elec. Co., Seattle, Wash.    | So. California Elec. Co., Los Angeles, Cal.   |
| Benwood Specialty Co., St. Louis, Mo.        | Holt Electric Util. Co., Jacksonville, Fla.      | N. S. W. Boostall Co., Sydney, Australia      | Southern Elec'l Sup. Co., San Diego, Cal.     |
| Bluebird Electric Shop, Newark, N. J.        | Hughes Elec'l Corp., Syracuse, N. Y.             | Parent Electric Co., New York City            | Southwest Radio Sup. Co., Dallas, Tex.        |
| Brode Electric Co., Los Angeles, Cal.        | Jenkins, Lester I., New Bedford, Mass.           | Paramount Radio Sup. Co., Atlantic City       | Sprott-Shaw Schl., Vancouver, B. C.           |
| Brown, J. Edw., Glenbrook, Conn.             | Karlawa Radio Corp., Rock Island, Ill.           | Paul's Electric Stores, Medford, Ore.         | Sterling Electric Co., Minneapolis, Minn.     |
| Bullcock's, York, Neb.                       | Katzenbach & Co., F. S., Trenton, N. J.          | Pearlman's Book Shop, Washington, D. C.       | Stubs Electric Co., Portland, Ore.            |
| Bunnell & Co., J. H., New York City          | Kendall Co., W. D., Worcester, Mass.             | Penn. Marconi Wireless Schl., Phila., Pa.     | T. & H. Radio Co., Anthony, Kans.             |
| Burham & Co., Deptford, S. E. 8, Eng.        | Keubler Radio Co., Toledo, O.                    | Penn. Radio Apparatus Co., Reading, Pa.       | Tuska Co., C. S., Hartford, Conn.             |
| California Elec. Co., San Francisco, Cal.    | Killoch Co., David, New York City                | Phila. Schl. of Wireless Tele., Phila., Pa.   | United Electric Stores, E. Pittsburgh, Pa.    |
| Carter Electric Co., Atlanta, Ga.            | King Radio Co., Pittsburgh, Pa.                  | Piedmont Electric Co., Asheville, N. C.       | United Elec. Stores Co., Braddock, Pa.        |
| Catton, Neill & Co., Honolulu, T. H.         | Klaus Radio Co., Eureka, Ill.                    | Pioneer Electric Co., St. Paul, Minn.         | U. S. Radio Co., Pittsburgh, Pa.              |
| Central Radio Co., Independence, Mo.         | Kluge, Arno A., Los Angeles, Cal.                | Pitts. Co., F. D., Boston, Mass.              | Warner Bros., Kansas City, Mo.                |
| Central Radio Co., Kansas City, Mo.          | Krause & Co., A. F., Detroit, Mich.              | Pitts. Radio & App. Co., Pittsburgh, Pa.      | Western Radio Co., Los Angeles, Cal.          |
| Chase, Geo. H., Newport, R. I.               | Kusel Co., D. & F., Watertown, Wis.              | Pitts. Radio Sup. Co., Pittsburgh, Pa.        | Wheeler Green Electric Co., Los Angeles, Cal. |
| Chicago Radio Ap. Co., Chicago, Ill.         | Lehigh Radio Co., Bethlehem, Pa.                 | Port Arthur Radio Lab., Port Arthur, Tex.     | Whitall Electric Co., Rochester, N. Y.        |
| Cleveland Co., L. W., Portland, Me.          | Liberty Incandescent Supply Co., Pittsburgh, Pa. | Post Office News Co., Chicago, Ill.           | White Co. The, Columbus, Ga.                  |
| Cloud & Son, Macy, Ind.                      | Liberty Radio Sup. Co., Chicago, Ill.            | Precision Equipment Co., Cincinnati, O.       | White & Boyer Co., Washington, D. C.          |
| Con. Radio & Elec. Corp., New York City      | Linze Elec'l Sup. Co., St. Louis, Mo.            | Radio Development Co., Springfield, Mass.     | White & Bro., Frank, Canton, Ill.             |
| Cutting & Washington, New York City          | Ludwig Houmel & Co., Pittsburgh, Pa.             | Radio Distributing Co., Newark, N. J.         | Williamson Elec. Co., Seattle, Wash.          |
| Daily Battery & Equipment Co., New York City | Luther, H. E., Centerville, Ia.                  | Radio Equipment Co., Boston, Mass.            | Wilmington Elec. Spec. Co., Wilmington, Del.  |
| Delaney-Felch & Co., Pawtucket, R. I.        | McCarthy Bros. & Ford, Buffalo, N. Y.            | Radio Equipmt. & Mfg. Co., Minneapolis, Minn. | Wilson Co., Harold K., Grundy Center, Iowa    |
| Detroit Electric Co., Detroit, Mich.         | McMillan Bros., Pittsburgh, Pa.                  | Ray-Dl-Co., Cleveland, O.                     | Winner Radio Co., Aurora, Colo.               |
| Dovey Spt. Goods Co., Milwaukee, Wis.        | Manhattan Elec. Sup. Co., N. Y. & Chic.          | Reuter Electric Co., Cincinnati, O.           | Wireless Mfg. Co., Canton, O.                 |
| Doubladay-Hill Elec. Co., Pittsburgh, Pa.    | Marshall-Gerken Co., Toledo, O.                  | Reynolds Radio, Denver, Colo.                 | Wireless Press, New York City                 |
| Dreyfuss Sales Co., New York City            | Meter Elec'l Const. Co., Oshkosh, Wis.           | R. I. Elec. Equipmt. Co., Providence, R. I.   | Wolfe Electric Co., Omaha, Neb.               |
| Duck & Co., Wm. B., Toledo, O.               | Meyberg Co., Leo J., San Francisco, Cal.         | Riverside Laboratory, Milwaukee, Wis.         | Y. M. C. A., Los Angeles, Cal.                |
| Dunn, J. J., Pasadena, Cal.                  | Mohawk Elec'l Sup. Co., Syracuse, N. Y.          | Rose Radio Supply, New Orleans, La.           | Zamoiski Co., Jas. M., Baltimore, Md.         |
| Electric Motor & Eng. Co., Canton, O.        | National Radio Corp., Atlanta, Ga.               | Roy News Co., Fre'k J., Toronto, Can.         | Zibart Bros., Nashville, Tenn.                |
| Electric Importing Co., New York City        |  |   |   |
| Elite Electric Shop, El Paso, Tex.           |  |   |   |
| Erle Book Store, Erie, Pa.                   |  |   |   |

Published by

**Consolidated Radio Call Book Co., Inc.**  
 96-98 Park Place, New York City





## WIRELESS TELEPHONE

**BROADCASTING** stations are now in operation at important centers all over the country. You can easily receive these interesting daily programs with an ABC wireless receiving UNIT. ABC UNITS come to you ready-to-operate and complete in every detail. They are built on the sectional system, so that you can increase the range of your station at any time. Ask your radio or electrical dealer about this and other exclusive features of ABC UNITS. If he cannot supply you, send us his name and address and enclose ten cents, for a copy of our Catalog.

Request Catalog 56.

**JEWETT MFG. CORP.**  
342 Madison Avenue, New York City



**THE BEST LOUD SPEAKER IS YOUR Phonograph when used with the "Easy" RADIO - PHONOGRAPH CONNECTOR**



Just slip the sound box (reproducer) off your talking machine and replace it with the "Easy" Connector. Then your head phone will fit the connector perfectly. Phonograph horns are scientifically made to give the greatest possible amplification. Your complete receiving outfit can be placed in the record compartment of your phonograph. Then your RADIO apparatus becomes a beautiful piece of furniture instead of an unsightly conglomeration of parts—does not in any way harm the phonograph for playing records.

No. 2 Model, now ready, fits all Victor Phonographs and Victrolas, and all other machines with tone arm same as Victor. Sent anywhere postpaid for **\$1.50**

**DEALERS:** Radio and phonograph dealers are making big money on the rapid sale of this item. Every phonograph owner is a sure buyer. The discounts are attractive. Deliveries almost immediate. Orders filled in rotation.

**BOYD FULLER & CO., 8460 Grand River Ave., Detroit, Mich.**

**Our Genuine Skinderviken Transmitter Button**



Is invaluable for Wireless and experimental purposes for sound transmission.

Price \$1.00 postpaid with instructions

Free literature.

**K. Electric Co.**

15 Park Row New York

**BEACON RADIO**

Can Supply You With All Radio Parts and Sets

**BEACON RADIO & ELECTRIC CO.**  
246 Greenwich St., near Park Place  
NEW YORK CITY

**RADIO INVENTIONS WANTED**

Useful radio inventions will be purchased by large manufacturer, either before or after filing patent. And their own patent attorney and expert will aid wireless experimenters and inventors to patent and commercialize their ideas. Write fully what you have, sending sketches and description. All correspondence held strictly confidential. Address: **P. O. Box No. 291, New York City.**

**The Ray of Hercules**

(Continued from page 195)

of police raised the receiver of the telephone which by his orders connected directly with every metropolitan police precinct station.

"A small hotel just make out its sign Sherwood, I think."

A second's pause, and then—"It's on the map!" cried the chief engineer. He shouted an address. Almost before the words were free of his lips, the police commissioner had called them in to the telephone, flung down the instrument and was running top speed to the automobiles palpitating outside. A moment later and the sirens were shrilling as they speeded through the traffic.

The remainder of the group crowded close to Coleman. As a man in a trance he droned on:

"The whole wall is covered with instruments and a table is loaded with them. I see a powerful transformer and a battery of audion bulbs like small electric lamps. They are glowing red. The apparatus resembles that of a wireless telephone but it is far more complicated. There is no one in sight."

"You don't see Hercules?" ejaculated Butler.

"There is no one," repeated Coleman. "In the center of the room, almost beneath the light through which I seem to be looking, there is a curious clock mounted on a tall box. I see the hands of the clock. Beside the clock is a drum wound with wire—"

Grant turned away suddenly and paced the floor. Once, twice, three times he walked the length of the switchboard panel. At the point farthest from the group he turned slowly and calmly contemplated his fellow scientists.

"They knew the truth and they might have fled," he muttered to himself. "Fled and saved their skins. But they stayed to fight the phantom and to keep this death watch on the city. Odd, this fellow Dunwood should have come with his uncanny invention to fight an uncanny menace when all other hope was gone. Odd coincidence—"

Involuntarily he turned his eyes in the direction of his thoughts and caught sight of Dunwood, behind the others and invisible to them, his shoulders shaking and his face convulsed by suppressed and silent laughter.

"Nerves," thought Grant. "Nerves breaking under the strain. Hysteria."

He opened his lips to call to the man and checked the cry as he heard the wall clock ring out noon and hard on its note, the monotonous, mechanical tones of Coleman.

"The clockwork has started and the drum revolves. Slowly the front of the box is rising, pulled up by the wire on the drum. There is no one in sight. The box is almost open."

Now a shadow on the floor. It is the police. They must have broken the door. The commissioner is in the front, revolver in hand.

"The box is open! Something moves within! God! An old man—a crippled old man is crawling—"

A long drawn scream broke through the power plant. Louder it grew, mounting in terrifying peaks of demoniacal laughter.

"Look again!" laughed the mad voice. "Look again! Look closer, fool!"

Aghast, they stared in horror at Dunwood. Arms above his head and fingers spread fanwise, his face distorted by insane fury, he screamed at them. They listened, paralyzed with surprise.

# MAGNAVOX Radio

*Everyone will envy you these evenings of pleasure*

To enjoy the thrills of a Magnavox Radio is a matter of progressiveness rather than wealth.

The average family, when alive to its possibilities, can and will secure the simple, dependable equipment which gives the home circle the inexhaustible resources of wireless entertainment.

No wireless receiving set is complete without the Magnavox Radio.



*Radio brings it, MAGNAVOX tells it*

Attached to any commercial receiving set, the Magnavox Radioreproduces every sound in full volume, transforming wireless telephony from a scientific "fad" into a universal home service.

The Magnavox Radio makes it possible for you to hear all that is in the air as if it were being played by your phonograph.

*Any radio dealer will demonstrate for you, or write to us for descriptive booklet and name of nearest dealer.*

**The Magnavox Co.**  
Oakland, California  
N. Y. Office: 370 Seventh Ave.  
Penn. Terminal Bldg.

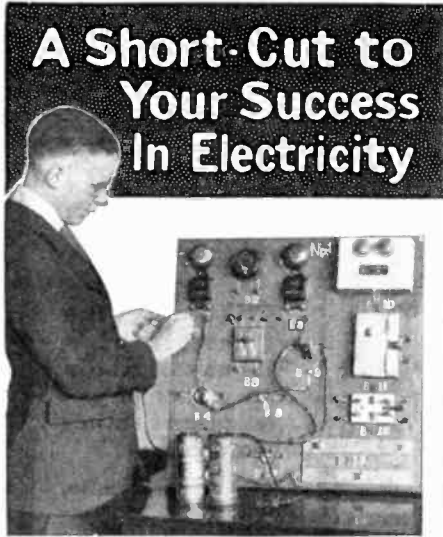

## A Short-Cut to Your Success In Electricity

**FREE \$500.00 ELECTRICAL LABORATORIES SENT TO YOUR HOME**

NOT toys—but real actual-size, expensive units of electrical apparatus are mailed to you without extra charge while learning. The illustration shows one of the new home-laboratory outfits. As fast as you have completed the work of one laboratory, another is sent, until you have mastered the entire field. You, therefore, advance step by step, from simple electrical experiences to complicated, intricate, important practical work.

### Learn Electricity This New Way

You can get the finest electrical training at home in your spare time. You need not leave your job, your friends, your home. This wonderful new home-laboratory training course in Practical Electricity brings this great, big technical school to your very door—into your very room. It develops ability, step by step, and leads you to every reward the great field of electricity can offer. Our large faculty of experts offer you a short cut that combines theory and practice, eliminating all the non-essentials. The plan is so simple—so logical—so carefully arranged, and also so interesting, that in a surprisingly short time you will have made yourself a master of technical electricity.

### The Rich Electrical Field

The electrical field is rich in opportunities for the trained man. Billions of dollars are invested in this great industry. Trained experts are in demand and handsome salaries are paid. You can easily master the work through our "home-laboratory" plan of home study so that you can step into the industrial field without additional coaching.

**SAVE \$65.00**

Send the coupon today for a copy of "The New Way to the Electrical Profession," giving full information on our "home laboratory outfit" method of home study. You will be surprised to see how easy it will be for you to secure your electrical training. Just fill out the coupon today and make the start toward a great future in the electrical field and also learn how to save \$65.00. Mail the coupon now.

Extension Division

**SCHOOL of ENGINEERING of Milwaukee**

Dept. SI-65

415 Marshall Street Milwaukee, Wis.

Extension Division,  
School of Engineering,  
Dept. SI-65, 415 Marshall Street,  
Milwaukee, Wisconsin.

Please send me my copy of "The New Way to the Electrical Profession," giving details of your home laboratory method of study in Practical Electricity. This request obligates me in no way.

Name .....

Address .....

Town ..... State .....

Age ..... Education .....

"Look closer, fool," he shrieked. "Not a man, fool! Not a man! A monkey! Brought to death by a monkey! Ha, ha! An ape to kill a city of fools! Throw the switch, Hercules! Throw the switch! Throw it, Hercules! Throw it as I taught you!"

Butler and Grant leaped for the madman. His screaming ceased and he did not struggle in their grasp. Coleman, engrossed by the thrilling drama he watched over the miles of wire, continued, undisturbed.

"It is a baboon . . . a gigantic beast . . . It crawls through the opening . . . blinks its red eyes . . . now stands upright . . . leaps toward the instruments . . . the police are shooting . . ."

"Throw the switch, Hercules! Slay fools in their folly!"

The laughter pealed again and Dunwood, eluding his startled captors with a single lurch, leaped with incredible agility and grasped in both hands the copper bus bars carrying a potential of 30,000 volts a few feet above his head.

Even as Coleman spoke—"The ape falls across the table dead!" a circuit breaker whirred and clicked and a loud-tongued alarm bell placed to give warning of a short circuit became clamorously active.

Its ringing was the requiem of Dunwood, lifeless across the bus bars, the sole human victim of the ray of Hercules. [The End]

### NEW SWISS RADIO PLANT

A high-powered, loud-speaking wireless telephone station is being installed at Lausanne, Switzerland, by means of which it is planned to hold daily communication with the Eiffel Tower in Paris. The apparatus will be capable of receiving messages from London, Berlin and even the United States.

## RADIO DEALERS—MANUFACTURERS

Attractive prices and prompt deliveries on coils, parts and completed receiving sets.

**Tuning Coils**

**Secondary Coils**

**Vario-couplers**

**Primary Coils**

**Rotors**

**Coils Wound to Order**

Beautifully finished and efficient complete sets from **\$1.25 to \$35.00**

Write for Price List

**Ra-Tone Electric Co.** 619 Park Place West  
Radio Department Detroit, Mich.

## RADIO DEALERS AND MANUFACTURERS

We have them—all parts needed for the radio trade promptly delivered.

Send us your requirements for prices

**SMITH ENGINEERING CO.**

One Union Square New York City

## PAPER TUBES FOR WIRELESS

ALL SIZES ON HAND FOR IMMEDIATE DELIVERY WHOLESALE AND RETAIL

**BAEHM PAPER CO., INC.**  
219 FULTON ST., NEW YORK  
Bet. Church and Greenwich Sts.

## Science and Invention LEADS in RADIO RESULTS

Read This Unsolicited Letter from the Radio Specialty Company and Be Convinced That Science and Invention is the Greatest Result-Getter for Radio Advertising

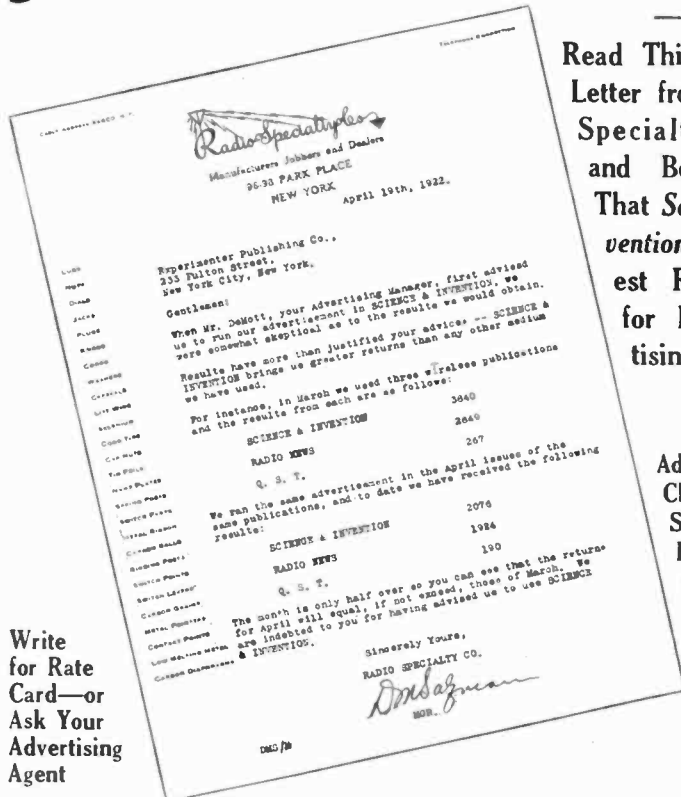

Write for Rate Card—or Ask Your Advertising Agent

**Experimenter Publishing Co., Inc.**  
53 Park Place, New York City

Advertising Forms Close the 20th of Second Month Preceding Date of Issue

## RADIO SET AT CUT-RATE

**\$12<sup>50</sup>**

for a famous  
**LITTLE  
WONDER**

**RADIO  
OUTFIT**



A complete receiving unit, with Western Electric headset, aerial and insulators—everything necessary for the full enjoyment of the wonders of wireless, without the use of batteries or any additional apparatus. Enclosed in an attractive oak cabinet, Flemish finish—5x6x3½ inches deep.

### Full Instructions Given

An extremely practical set for amateurs and others. Complete diagrams and instructions furnished so that anyone can set up and operate. Aerial can be put up indoors, if desired, by attaching to the moulding of a room—or outdoors, by suspending a wire from a window. Receives telephone messages and music within 30-mile radius and wireless telegraph messages at a distance of several hundred miles. Ideal for campers—or for use on autos, motor boats or bicycles. Send for it today at this special cut-rate price—\$12.50 complete.

Radio Equipment Catalog on Request

**PENINSULAR CHANDELIER CO.**

Radio Dept. 10

1450 Broadway Detroit, Michigan

## WIRELESS CATALOGUE

The unprecedented influx of business with its resultant increase in detail has made it absolutely impossible for us to properly compile and print a new catalogue.

We have just received from the printer, however, a complete list of apparatus, comprising several hundred items.

This, together with our DELIVERY INFORMATION SHEET, will be sent to you on receipt of 2c postage.

**A.H. CORWIN & CO.**  
4 West Park St. Dept. A  
Newark New Jersey

## Amateur and Professional WIRELESS OPERATORS NEED

**SOLDERALL, 25c per Tube**  
Pat. October 3, 1911  
and **TORCH,**  
**\$1.50**



A Paste That Turns Into Metal When Heated

A match will do it, but best results can be obtained by using our new improved torch. Requires no acid or soldering iron. Joins or repairs wires, metal or metal-ware. Sold by Hardware and Electrical Stores, or sent by us postpaid.

**SOLDERALL, Dept. E**

129 Sussex Avenue, Newark, N. J.

Dealers Send for Quantity Prices Beware of imitations with similar names.



## "AERIAL WIRE" SPECIAL

150 Feet No. 14 Copper Wire. . . . \$1.00

100 Feet Stranded Copper Wire. . . \$1.00

**EMPIRE RADIO EQUIPMENT CO.**

271 WEST 125th STREET, NEW YORK CITY

## Frederick Winsor— First Gas Inventor

By EDWIN IRVINE HAINES, B. S.

(Continued from page 123)

In 1809 Winsor applied to the English Parliament for the incorporation of his company re-named the London and Westminster Chartered Gas Light and Coke Company, the capital to be raised by public subscription amounting to £200,000 (\$1,000,000). But William Murdoch had also formed a company and brought about a Parliamentary investigation, claiming priority by right of discovery.

The old records of this investigation are extremely ludicrous, charging Mr. Winsor as "visionary" and the execution of his plans as "fraught with considerable danger." He was asked if his plan "would not hurt our fisheries, oil, and tallow trades? What will become of our tallow candle makers, lamp lighters, and chimney sweeps? Will not the gas catch fire if it comes in contact with the air? Will not your plant blow up the city?" etc.

Frederick Winsor answered them all calmly and patiently, altho his application for a charter was refused.

In 1810 Mr. Winsor applied directly to the king for another charter, the company to be capitalized at £200,000 (\$1,000,000), of £10 (\$50) per share, which was to be raised by public subscription within three years. This was finally granted.

The company leased a large wharf in Cannon Row, Westminster, where experiments were steadily carried on. These experiments were very expensive, however, and "absorbed nearly all of the deposits of £10 per share."

Clouds that obscured the prospects of the company, however, were rapidly disappearing. In 1815, it became a "body politic," or, as we would call it today, a public utility corporation. Large funds now poured into the treasury, and its capital was increased to £400,000 (\$2,000,000).

Starting with only one consumer in 1810, by 1822 the first gas company had distributed its mains thruout London and nearby towns, and had erected "gas stations" in nine other cities.

Of course it was only natural that rival companies should spring into existence, including that of William Murdoch. But Winsor was a financier as well as an inventor. He had learned by bitter experience that rivals were dangerous. So along later day methods of "high finance" he bought them out, or obtained stock control, and converted them into subsidiaries of his own corporation.

While the apparatus used in the "first gas plant" of Frederick Winsor was, of course, crude and rudimentary compared with that utilized today, yet it was effective in those times and manufactured a fair quality of gas, all things being considered.

The retort in which he distilled his coal was an iron vessel, similar to a pot with a lid, well-fitted and bolted to the top. To the center of this lid a pipe was fixed to convey the gas to his condensing vessel which was a circular cistern, conical in form, and broader at the bottom than at the top. The latter was divided into two or three separate compartments, the plates forming the divisions being perforated with a large number of holes in order to subdivide the gas as it passed thru them, with some idea of purifying it.

In the early experiments the gas thus produced was "in a very impure state and produced headaches to those who inhaled it." Later Mr. Winsor used lime and water to purify his gas, while the pipes that conveyed the gas from the apparatus to the meters were made of lead and subsequently of copper.

## RADIO TELEPHONY

AND

## TELEGRAPHY

SIMPLY EXPLAINED  
AT HOME BY MAIL

IN 20 LESSONS

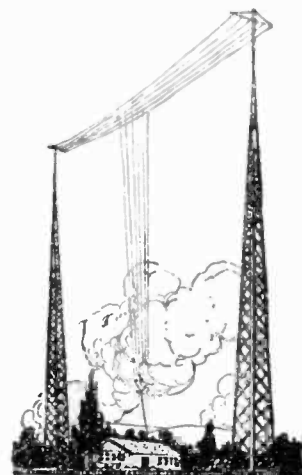

## Complete Instruction

for Wireless Communication  
and Installation of Radio Stations

Operators are in great demand the world over at large salaries. TRAVEL without expense. Our experts will teach you WIRELESS TELEPHONY and TELEGRAPHY, quickly at your home; and we will assist you in obtaining a splendid position.

## Learn the Wonders of Radio!

Be among the first. Get the cream. The greatest opportunity of the age is now offered you. Do not delay!

Anyone can learn this fascinating work and the price is small, payable monthly if desired.

Write at once for our **SPECIAL PRICE**

and terms, including all text books and a complete AUTOMATIC WIRELESS OUTFIT for practice given you free.

A complete Radio Vacuum Tube Receiving Set furnished students at wholesale price.

We were an OFFICIAL TRAINING SCHOOL during the War for the U. S. Merchant Marine

## The Joseph G. Branch INSTITUTE OF ENGINEERING

Branch Building

3917 Grand Boulevard  
CHICAGO



# ELECTRICAL EXPERIMENTERS!!

# SKINDERVIKEN TRANSMITTER BUTTON

## MOST SENSITIVE MICROPHONE

**Y**OU can easily make a highly sensitive detectophone by using a Skinderviken Transmitter Button to collect the sound waves. You can build your own outfit without buying expensive equipment.

Think of the fun you would have with such an instrument! It's very simple, too, and inexpensive.

You can install an outfit in your home and hear the conversation being held all over the house. You can connect up different rooms of a hotel. *This outfit was used by secret service operatives during the War. It is being used on the stage.*

So much for its commercial adaptations! You can procure apparatus of the same type.

AS A  
**PREMIUM**

**M**R. H. Gernsback, editor of this magazine, who is the dean of electrical experimenters, said: "In the writer's opinion, obtained by actual elaborate tests, the Skinderviken Transmitter

Button is probably the most efficient device of its kind on market today, due to its simplicity and other outstanding features. Should have a great future."

The same circuit connections apply to all experiments, regardless of how the transmitter button is mounted.

The Skinderviken Transmitter Button operates on one or two dry cells. It often happens that two cells produce too

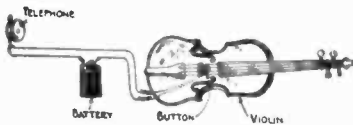
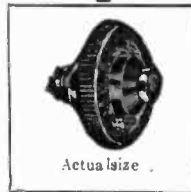

One of the main advantages of the Skinderviken Transmitter

Button lies in its ultra-sensitiveness. You can place it in any position you like. It is the greatest invention in micro-phones and has won recommendations from men of high standing in the scientific world. It is being used all over the world. You can mount it most anywhere. Card board boxes, stove pipes, stiff calendars and hundreds of other places will suggest themselves to you. The buttons cannot be seen by any one in the room as they are so small and light. Only a small brass nut is exposed to the view.

The only instruments needed to complete a detectophone outfit, in

much current and the sounds are deafening. We recommend either one fresh cell or two worn out cells.

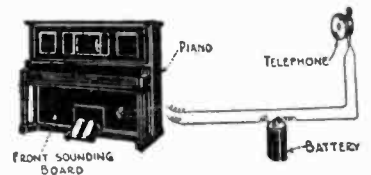

We have acquired a limited amount of these Transmitter Buttons and offer same free to our subscribers as a Premium, with a one year subscription to SCIENCE AND INVENTION. These Buttons sell everywhere for \$1.00 and are worth it. We send you one prepaid upon receipt of the coupon below and the subscription price of our magazine. Do it today.

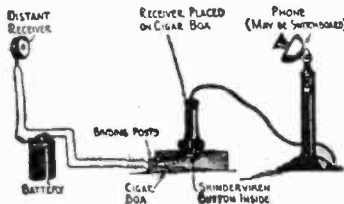

addition to a Skinderviken Transmitter Button are a receiver, battery, and, if desired, an induction coil.

## EXPERIMENTER PUBLISHING CO.

53 PARK PLACE  
New York, N. Y.

### USE THIS COUPON

EXPERIMENTER PUBLISHING CO.  
53 Park Place, New York, N. Y.

Gentlemen:

Enter my order for one year's subscription for SCIENCE AND INVENTION, and send me as special premium, free of charge, one Skinderviken Button.

Enclosed find \$2.50 (Canadian and Foreign \$3.00)

Name .....

Address .....

Town .....

State .....

S.I. G-22



## Are You Young at 40?

What you should know about the glands of your body

You have observed that some men of 70 appear to be younger in activity than other men of 40 to 50. There is a vigor, an alertness, a commanding appearance much admired and coveted by the man who knows he is much younger in years. Perhaps the most common cause of ebbing strength and vigor which takes the spring out of the step and confidence out of the bearing, is the disturbed condition of an important gland. Even men of iron constitution are not exempt from the slow decline which is the result of this amazingly common irregularity. For those who would like to know its characteristics we have published, for limited complimentary distribution, an ethically accurate, educational, interesting book.

## You will know the truth by test of reason

You may have a copy by simply requesting it. Its message may prove of unsuspected value to you. It clearly explains this vital gland and its functions, and how its disturbed condition may cause sciatica, backache, painful and tender feet, interrupted sleep, and other extremely uncomfortable and often serious conditions. It will tell you of Thermanalid, a simple means by which the essential of a new hygienic principle, done into convenient form, corrects this prostate gland condition and its attendant health faults. (One should not confuse this new idea with massage, movements, diets, electric rays, drugs, etc.) Followers of the great Metchnikoff and other investigators in the science of long life endorse this means. The record of its success, covering a period of nearly five years, is incontrovertible. The book is free. Simply address.

The ELECTRO THERMAL Company  
4503 Main Street, Steubenville, Ohio

## EARN MONEY AT HOME

YOU can make \$15 to \$60 weekly in your spare time writing show cards. No canvassing or soliciting. We instruct you by our new simple Directograph system. pay you cash each week and guarantee you steady work. Write for full particulars and free booklet.

WEST-ANGUS SHOW CARD SERVICE  
67 Colborne Building Toronto, Can.

1.25<sup>c</sup>  
By MAIL



## QUESTIONS and ANSWERS

Electricians' Examinations  
Diagrams symbols, tables, notes and formulas for preparation for license.

AARON SHAPIRO  
132 W. 24th St. N. Y. City

## Polariscope Made from a Microscope

By DR. E. BADE

(Continued from page 144)

tints. But such films, while an aid, are not an absolute necessity.

The application of such a polariscope is most desirable in mineralogical and petrological investigation. In a more modified form it is used in sugar analysis and in diabetic diagnosis and in chemical investigations. It has also proved its usefulness in the detection of strains in glass, and recently polarized light has been used to determine the original color value of old paintings.

### How to Make Objects Suitable for the Polariscope

The wonderful symmetry and the regular beauty of crystallizable substances is unsurpassed. Thousands of minute forms of the most varied shapes become visible under the microscope. Delicate, feathery crystals, graceful spears and sheaves of grass, rosettes and other decorative suggestions make their appearance. All are inherently characteristic, all produce peculiar designs of their own, and all are eminently suitable for designs.

In addition to the beauty of form, the attractiveness of color strikingly illustrates the wonders of the crystal world. The complimentary colors produced are only made visible by polarized light with the aid of the polariscope. This not only shows the detail of the crystal shape, but also shows rings and brushes in an indescribable play of colors.

By simply rotating either the analyzer or the polarizer changeable and harmonious colors, gorgeous in hues and perfect in purity, are observed. Some show the effect most strikingly when the analyzer and polarizer are crossed, while others show it at different angles of rotation.

Suitable objects can easily be made. All that is required are glass slides and a few chemicals. The glass slides can be used over and over again, while the chemicals are necessarily thrown away after they have been used, *but one gr. of a chemical is sufficient for 50 or more experiments!* The greater the quantity used, the denser and more obscure will the result be. Therefore, only small quantities are required. Never be satisfied with one experiment but dissolve the salt in water again and again.

It is an easy matter to change the conditions for crystallization. The crystals themselves are produced by the slow evaporation of the liquid from a cold saturated solution. A little of the salt is placed upon the slide and covered with a drop of water. Then, after placing the slide in a cool situation, a tumbler is inverted over it. This will retard evaporation and keep dust away. Perfect crystals are thus obtained. It is sometimes advantageous to get small ones. These are obtained by stirring the solution when the first crystals make their appearance. Then they are spread over the entire glass, in which position they are more conveniently observed.

From a hot saturated solution no well formed crystals will be obtained, but rather "crystal skeletons." These have the most peculiar shapes imaginable, and their color effect is very remarkable. Here, after a small quantity of the salt has been covered with a drop of water, it is heated over an alcohol flame until the salt begins to crystallize out. Care must be taken that the heating is stopped as soon as the crystals begin to form, otherwise crystallization will take place too rapidly. Under this latter condition, rosettes of wonderful form are produced which give very beautiful color effects when polarized. Here it is advantageous to flatten the drop of solution as much as possible.



## JOHNSON'S WOOD DYE

### For Coloring Wood

WITH Johnson's Wood Dye inexpensive soft woods, such as pine, cypress, fir, etc., may be finished so they are as beautiful and artistic as hardwood.

Johnson's Wood Dye is very easy to apply—it goes on easily and quickly, without a lap or a streak. It penetrates deeply, bringing out the beauty of the grain without raising it—dries in 4 hours and does not rub off or smudge.

Johnson's Wood Dye is made in fourteen beautiful shades, all of which may be easily lightened or darkened—full directions on every label.

Insist upon Johnson's Wood Dye—there's no substitute.

## FREE-This Book on Home Beautifying

This book tells how to finish wood in artistic stained and enameled effects. Gives practical suggestions on making your home artistic, cheery and inviting. Tells just what materials to use and how to apply them. Includes color card—gives covering capacities, etc. Use coupon below.



S. C. JOHNSON & SON, Dept. S1 6.  
Racine, Wis. (Canadian Factory—Brantford)

Please send me free and postpaid your Instruction Book on Home Beautifying and Wood Finishing.

The best dealer in paints here is.....  
MY NAME.....  
MY ADDRESS.....  
CITY & STATE.....



**Your Boy's Happiness**

is one of your first considerations. Get **THE BOYS' MAGAZINE** for him. He needs this great boys' periodical. Parents owe it to their sons to give them clean, interesting and instructive reading that will make them self-reliant, manly and courageous.

**An 8 Months' Trial Subscription for Only 50c**

(This is 1/2 the regular price)

Each issue of **THE BOYS' MAGAZINE** contains from two to four splendid serial stories and from twelve to twenty thrilling short stories, besides special departments devoted to Radio, Mechanics, Electricity, Popular Science, Athletics, Physical Training, Stamp Collecting, Outdoor Sports, Amateur Photography, Cartooning, etc. Beautiful big pages with handsome covers in colors. Profusely illustrated throughout. A big lot of jokes and Comic Drawings. Eight issues equal 20 big volumes, which would cost, as books, at least \$20.00. A special feature is the award of \$220.00 in cash prizes for the best amateur work in many subjects. There is no reason why YOUR boy should not win some of these prizes. Remember, only 50 cents for eight months. If you are not satisfied we will refund your money promptly, and without question. Remit in stamps if more convenient.

(On sale at all newsstands, 15c a copy.)

----- TEAR OUT HERE -----

**THE SCOTT F. REDFIELD CO.,**  
7143 Main St., Smethport, Pa.

I accept your special half price introductory offer and enclose 50 cents, for which send **THE BOYS' MAGAZINE** for eight months to

(Write name and address plainly)

Name .....

Street or R. F. D. ....

City ..... State .....



**40,000 Opportunities in Hotels**

YOU can have one of these well-paid, pleasant executive positions—40,000 of them in the big hotels of the United States—now America's Fourth Largest Industry. Statistics show that **ONE IN EVERY TEN HOTELS WILL HAVE AN OPENING FOR A MANAGER THIS YEAR.** Thousands of other positions are also open to those who qualify through training.

The Lewis School guarantees to give you the valuable knowledge that it has taken some of the most successful hotel men years to obtain—men who are now making \$5,000 to \$50,000 a year. All of your training will be under the personal direction of Clifford Lewis—a hotel expert of national reputation. A few spare-time hours a week given to the simple, clear lessons of the course will give you the training for a good position, a fine living, and a handsome salary. The training will in no way interfere with your present work or recreation.

Send today for **FREE BOOK** "Your Big Opportunity." Don't wait a minute—you may lose the opportunity of a lifetime. Mail the coupon NOW. Your whole future may depend on it.

FOUNDED 1916

**LEWIS HOTEL TRAINING SCHOOL**  
Clifford Lewis, Pres. Room 3415 Washington, D. C.

**FREE COUPON**

LEWIS HOTEL TRAINING SCHOOL  
Room 3415 Washington, D. C.  
Send me without obligation the **FREE BOOK** "Your Big Opportunity."

Name ..... (Please Print Name)

Street .....

City ..... State .....

**Send To-day for the "Electrical Worker's Friend"**

An electrical book of 66 motor drawings with complete instructions for rewinding and reconnecting A. C. motors. **Special at \$4.00**  
Or write for full particulars of this valuable book  
**SMITH & SMITH PUBLISHING CO.**  
Dept. B., 7428 Hermitage St., Pittsburgh, Pa.

It is sometimes possible to melt the salt. Here no definite crystal shape will be distinguished, but when observed with the polariscope, wonderful effects will be noted.

All salts are not adapted for showing color effects with the polariscope, and of these the most common are table salt, potassium chloride, potass. iodide, potass. bromide, ammonium chloride, silver chloride, zinc chloride and alum. They crystallize in the regular or isometric system of crystallization which produce crystals optically inactive like glass. Many other salts crystallizing in the other five systems will be found to give color effects.

Lead acetate and potassium ferrocyanide belong to the tetragonal system. They give good polariscope objects. Sodium nitrate, a member of the hexagonal system, is not a specially striking object. Barium chloride, potassium ferricyanide, potassium nitrate crystallize in the orthorhombic system. Sodium carbonate and ferrous sulphate crystallize in the monoclinic system. Copper sulphate and potassium dichromate belong to the triclinic system.

Other salts giving excellent results are:

- Bismuth nitrate
- Cadmium chloride
- Ammonium oxalate
- Ammonium bichromate
- Manganese sulphate
- Sulphanilic acid
- Milk sugar
- Tartaric acid
- Stannous chloride
- Citric acid
- Aluminum chloride
- Potassium carbonate
- Ammonium carbonate
- Ammonium sulphocyanide
- Acetanilide
- Lead acetate
- Sodium sulphate
- Ammonium molybdate

It is rather difficult to keep some of these salts indefinitely without proper precautions. The method used in keeping them will usually have to be found by trial. If the salt is insoluble in xylol and Canada balsam, it is imbedded in this after it has been thoroly dried. Others can be imbedded in cedar oil, while some can be kept by simply covering them with a cover glass and surrounding the cell so formed with vaseline. In each case care must be taken that the glass covers all parts of the crystallized salt, otherwise moisture will be absorbed by the exposed portion and spoil the object.

**Identifying Chemicals Under the Microscope**

By **DR. ERNEST BADE**

(Continued from page 145)

curving, spiral like or arborescent forms. When two salts, which react among themselves, are mixed, two totally different types of crystals will result, due to the reaction which they have undergone. Here crystal A when observed alone gives, say, a lattice work. Crystal B, alone, diagonal bars. When these two are mixed and a chemical reaction takes place, two new salts will be formed, C and D, but C then might produce crystals and D arborescent forms.

If these two salts do not react, then each of the salts crystallizes out according to its individual characteristics. But due to interference these two salts become slightly distorted altho the underlying shape of each is still perfectly recognizable.

When a number of substances have been studied under the microscope, they can easily be identified with accuracy.

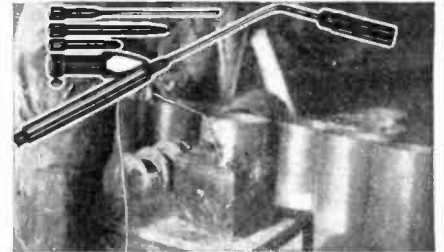

**A Torch with Hundreds of Profitable Uses**  
**TORIT ACETYLENE TORCH No. 13**

Produces a Hot Instant Flame. For radiator and battery repairing, for soldering electrical connections, pots, pans, etc.; for preheating fenders, tempering tools, joining brass tubing, removing rusty bolts and nuts; for light brazing and hundreds of other uses.

**A Practical Outfit for Every Mechanic Uses Acetylene Gas Only**

Complete with 4 different tips and soldering copper, rubber tubing and tank connection **\$7.50**

**ST. PAUL WELDING & MFG. CO.**  
172 West 3d Street St. Paul, Minn.

**NEW MOTORS** FOR ALL PURPOSES  
STANDARD MANUFACTURERS PROMPT DELIVERY  
**ALL SIZES UP TO 5 H.P.**

**We Specialize In Small Motors & Generators**

ALL PHASES AND FREQUENCIES IN STOCK AT ALL TIMES  
Largest exclusive Mail Order Small Motor dealers in the world.

**CHAS. H. JOHNSTON, Box 172 West End, Pittsburgh, Pa.**

**WIRELESS, TELEPHONE GENERATORS**  
500 VOLT - 100 WATT - 3400 R. P. M.  
FOR MOUNTING MOTOR GENERATOR SETS.



**BLANK CARTRIDGE PISTOL**  
Protection against Burglars, Tramps, & Dogs



Well made and effective; modelled on latest type of revolver; appearance alone is enough to scare a burglar. When loaded it may be as effective as a real revolver without danger to life. It takes standard .22 Cal. Blank Cartridges obtainable everywhere. Price 50c. Superior quality \$1.00 post-paid. Blank Cartridges, by express, 50c per 100. **SPECIAL—Add 50c and receive "The Bulletin"** newest and best Magazine for whole year. Exciting stories, unusual news items, popular science, magic, mirth, mystery, money-making wrinkles, big money prizes, free \$1,000 Insurance Policy, etc. etc. Address **"THE BULLETIN"**, Dept. 841, RACINE, WIS.

**MAKE MONEY AT HOME**

YOU can earn from \$1 to \$2 an hour in your spare time writing show cards. Quickly and easily learned by our new, simple "Instructograph" method. No canvassing or soliciting; we teach you how, guarantee you steady work at home no matter where you live, and pay you cash each week.  
Full particulars and Booklet free  
**AMERICAN SHOW CARD SCHOOL**  
110 Ryrie Building Toronto, Can.

**Big Band Catalog Sent FREE**



Anything you need for the band—single instrument or complete equipment. Used by Army and Navy. Send for big catalog, liberally illustrated, fully descriptive. Mention what instrument interests you. Sold by leading music dealers everywhere.  
**LYON & HEALY**

**FREE TRIAL—EASY PAYMENTS** 79-99 Jackson Boulevard CHICAGO

**5 Master Keys**

Only keys of their kind in existence—(patented). Open and test thousands of different locks. Tell you instantly if your door or padlocks are burglar proof. Serve in emergencies, too. Thousands of sets in daily use among detectives, policemen, contractors, locksmiths, firemen, mechanics, travellers, home and hotel owners, etc. Give feeling of security and protection worth many times their cost. Novel key chain FREE. Send \$1 today.  
**MASTER KEY CO., 114 Manhattan Block, MILWAUKEE, WIS**



# TYPEWRITERS

Famous No. 9  
**OLIVER \$38.90**  
Pay Only 10 Cents a Day



SLASHING cut and UNUSUAL terms to sell at once a big stock of the Famous No. 9 Oliver, two color, back spacer, latest model. Every one reconstructed for "A" grade showing, to stand up under SEVEREST strain.

**Any Child Can Operate It**  
**Book of Instructions FREE**

Will serve the busiest stenographer; will delight the beginner. Use this famous typewriter for 6 days, on your own work under your own conditions, then if satisfactory it is yours on our easy payment plan—only 10 cents a day, \$3.00 per month.

**5 DAYS FREE TRIAL—GUARANTEED 5 YEARS**  
Send only \$3 with order. Remember we will take machine back and refund your \$3 if you don't like it. We stand behind our guarantee—we've been in business 16 years—CASH PRICE \$38.90 or \$41.90 on payments.

**MAIL COUPON NOW**

International Typewriter Exchange  
177 N. State St., Dept. 32, Chicago  
Ship typewriter F. O. B. Chicago, I enclose \$3.00 deposit and agree to remit \$3.00 per month for 13 months, title to remain in your till \$41.90 is paid. If not satisfied after 5 days, I will return and receive refund of deposit.

Name..... P. O.....

Shipping Point..... State.....  
ABOVE PRICE OR TERMS SUBJECT TO WITHDRAWAL WITHOUT NOTICE

## Now Make Your Bike a Motorcycle

You, too, can do it easy and in 30 minutes time—no special tools or knowledge required. Your old bike and the Shaw Motor Attachment give you a speedy, dependable motorcycle at a small cost. 2 1/2 H.P. motor. Runs from 4 to 40 miles an hour!

**The Shaw Attachment FITS ANY BICYCLE**

Easy to control, pleasing to ride, economical to operate. Thousands in daily use. Ironclad guarantee.

**WRITE TODAY** for full information about this wonderful Attachment and the Shaw Super-Motorcycle, which we also manufacture.

**SHAW MFG. CO.**  
Galesburg, Ia. Dept. 46

# CASH PRIZE CONTESTS!

Our Lists show over 70 CONTESTS and over \$100,000 IN CASH PRIZES each month. Send for Bulletin No. 24. Thomas & Co., Publishers of Lists, East Haddam, Conn.

**Six Machines in One**  
—bench grinder, polisher, buffer, sander, drill and saw, for working in wood and soft metals.

Handles 4" and 5" grinding wheels; 6" saws; 6" and 8" sand discs, and 3/8" chuck. Top easily removed. Mountable on separate base with motor. Extremely compact; highly serviceable; decidedly practical.

**ONLY \$37.85** Not a toy. Height, 10". Weight, 31 lbs. Easily driven with 1-4 h. p. motor. Sued for Printers, Cabinet and Pattern Makers, Musical Inst. Mfrs., Furniture Repairmen, Shipping Depts., Manual Training Schools, Laboratories, Private Shops, etc. Machine fully guaranteed.

**W. & J. BOICE, Dept. E, 114 23d Street, Toledo, Ohio**

# LEARN ENGINEERING

Courses, 3 months to 2 years—practical, technical training under experts. Not a Trade School, but a practical, technical college teaching electricity, steam, gas, auto-electric, armature winding, drafting. Extensive laboratory and shop. Degrees awarded. Day and night sessions. Enroll any time. Finlay Engineering College, 1003 Indiana Ave., Kansas City, Mo.

# RADIO For Everybody

What do you want to know about Radio? Hook-ups, diagrams, laws, codes, code-work, definitions, testing instruments, use of equipment—everything you want to know fully explained and answered in the Quiz Book. New edition now ready. Read this wonderful book for the best way to use your equipment, instruments—or to prepare for Government examinations for Operator's license, etc., etc. Price only \$1.00. Money-back guarantee. Send for it today.

**National Radio Institute, Dept. 1103, Washington, D.C.**

# U. S. Has Greatest Energy Resources

(Continued from page 125)

them thus, they line up something like this, the figures being in millions of horse-power years:

	Coal	Petro-leum	Water Power	Total H.-P. Yrs.	Per Cent of U. S. H.-P. Yrs
United States.....	500,000 400	37	500,437	100%	
China.....	200,000 60	20	200,080	40%	
Germany.....	48,000 2	23 1/2	48,004.5	9.6%	
Canada.....	40,000 40	22 1/2	40,062.5	8%	
Great Britain.....	27,000 (?)	1	27,001	5.4%	
Australasia.....	19,000 (?)	4	19,004	3.8%	
Russia.....	17,000 280	16	17,286	3.4%	
Poland and Czech-Slovakia	14,000 45	1	14,016	2.8%	
India.....	11,000 70	27	11,097	2.2%	

"No other country has as much as one-fiftieth part of the total energy-resources as the United States, and it is quite evident that many parts of the globe never can support an industrial civilization of any magnitude, for they simply have not the resources of energy.

"Countries differ greatly in the degree to which they have developed their resources. The United States had resources before 1492 even greater than now, because they were all unused. Japan, on the other hand, is an example of a country that has developed its very limited resources to a large extent.

"Japan's energy resources are less than one five-hundredth part of those of the United States."

**STATEMENT OF THE OWNERSHIP, MANAGEMENT, CIRCULATION, etc., required by the Act of Congress of August 24, 1912, of SCIENCE & INVENTION, published monthly, at New York, N. Y., for April 1, 1922.**

State of New York, County of New York, ss. Before me, a notary public in and for the State and county aforesaid, personally appeared Hugo Gernsback, who, having been duly sworn according to law, deposes and says that he is the Editor of the SCIENCE & INVENTION and that the following is, to the best of his knowledge and belief, a true statement of the ownership, management (and if a daily paper, the circulation), etc., of the aforesaid publication for the date shown in the above caption, required by the Act of August 24, 1912, embodied in section 443, Postal Laws and Regulations, printed on the reverse of this form, to wit:

1. That the names and addresses of the publisher, editor, managing editor, and business managers are: Publisher, Experimenter Publishing Co., 233 Fulton St., New York City; Editor, Hugo Gernsback, 233 Fulton St., New York City; Managing Editor, Harry Winfield Secor, 233 Fulton St., New York City; Business Manager, R. W. DeMott, 233 Fulton St., New York City.
2. That the owners are: (Give names and addresses of individual owners, or, if a corporation, give its name and the names and addresses of stockholders owning or holding 1 per cent. or more of the total amount of stock.) Experimenter Publishing Co., Hugo Gernsback, Sidney Gernsback, H. Winfield Secor, R. W. DeMott, Dr. T. O'Conor Sloane, Mrs. Catherine Major. (All of the above of 233 Fulton St., New York City.) M. M. Finucan, Hartford Bldg., Chicago, Illinois.
3. That the known bondholders, mortgagees, and other security holders owning or holding 1 per cent. or more of total amount of bonds, mortgages, or other securities are: (If there are none, so state.) None.
4. That the two paragraphs next above, giving the names of the owners, stockholders, and security holders, if any, contain not only the list of stockholders and security holders as they appear upon the books of the company but also, in cases where the stockholder or security holder appears upon the books of the company as trustee or in any other fiduciary relation, the name of the person or corporation for whom such trustee is acting, is given; also that the said two paragraphs contain statements embracing affiant's full knowledge and belief as to the circumstances and conditions under which stockholders and security holders who do not appear upon the books of the company as trustees, hold stock and securities in a capacity other than that of a bona fide owner; and this affiant has no reason to believe that any other person, association, or corporation has any interest direct or indirect in the said stock, bonds, or other securities than as so stated by him.

H. GERNSBACK.  
Sworn to and subscribed before me this 4th day of April, 1922.  
Joseph H. Kraus, Notary Public, Queens County Register's No. 2951; New York County Register's No. 3337; New York County Clerk's No. 439. (My commission expires March 30, 1923.) (Seal.)

# An Easy, Fascinating Way to Learn CHEMISTRY AT HOME



**BECAUSE** of conditions which grew out of the war, there never was a time in the history of America when chemists were in such demand as now.

Good salaries await the right men. No work is more interesting—no other profession offers greater opportunities.

For 30 years the International Correspondence Schools have been training men in just your circumstances for success in Chemistry and over 300 other subjects. They will help you prepare right at home for a position in the line of chemical work you like best—or in any other work that appeals to you. Thousands of men have stepped into fine jobs through I. C. S. training.

Let the I. C. S. help you, too. Choose the work you like best in the coupon below, then mark and mail it today. This doesn't obligate you in the least, and it will bring you the full story of what the I. C. S. can do for you.

----- TEAR OUT HERE -----

INTERNATIONAL CORRESPONDENCE SCHOOLS  
Box 6248-B, Scranton, Penna.

Without cost or obligation, please send me complete information about the subject before which I have placed an X:

<input type="checkbox"/> CHEMISTRY	<input type="checkbox"/> High School Subjects
<input type="checkbox"/> Pharmacy	<input type="checkbox"/> Advertising
<input type="checkbox"/> Mechanical Engineering	<input type="checkbox"/> Salesmanship
<input type="checkbox"/> Civil Engineering	<input type="checkbox"/> Bookkeeping
<input type="checkbox"/> Architecture	<input type="checkbox"/> Civil Service
<input type="checkbox"/> Electrical Engineering	<input type="checkbox"/> Railway Mail Service
<input type="checkbox"/> Stationary Engineering	<input type="checkbox"/> Traffic Manager
<input type="checkbox"/> Drafting	<input type="checkbox"/> Business Management
<input type="checkbox"/> Surveying	<input type="checkbox"/> Certified Public Accountant
<input type="checkbox"/> Automobiles	<input type="checkbox"/> Airplane Engines
<input type="checkbox"/> Stenography	<input type="checkbox"/> Wireless

Name.....  
Address.....  
Occupation.....

## AGENTS \$6 a Day

Should be easily made selling our Concentrated Non-Alcoholic Food Flavors, Soaps, Perfumes and Toilet Preparations. Over 100 kinds, put up in collapsible tubes. Ten times the strength of bottle extracts. Every home in city or country is a possible customer. Entirely new. Quick sellers. Good repeaters. Not sold in stores. No competition. 100 per cent. profit to agents. Little or no capital required. Elegant sample case for workers. Start now while it's new. Write today—a post card will do—**FREE** for full particulars.

**AMERICAN PRODUCTS CO., 6576 American Bldg. Cincinnati, O.**

## ELECTRICITY LEARN AT HOME

Send for catalog which tells how Burgess Home Training men and boys to get good jobs and keep them.

**Burgess Electrical School, Dept. S-6, 745 E. 42 St., Chicago.**

# Opportunity Ad-lets

**YOU** will find many remarkable opportunities and real bargains in these columns. It will pay you to read and investigate the offerings made every month by reliable firms, dealers and amateurs from all over the country. No matter what you may be seeking, whether supplies, automobile accessories, the opportunity to make money, or anything else, you will find listed here the best and most attractive specials of the month.

Advertisements in this section twelve cents a word for each insertion. Name and address must be included at the above rate. Cash should accompany all classified advertisements unless placed by an accredited advertising agency. No advertisement for less than 10 words accepted.

Ten per cent. discount for 6 issues, 20 per cent. discount for 12 issues. Objectionable or misleading advertisements not accepted. Advertisements for the August issue must reach us not later than June 22.

**The Circulation of Science and Invention is over 160,000 and climbing every month**

EXPERIMENTER PUBLISHING CO., INC., 53 Park Place, New York City, N. Y.

## Aeronautics

**Model Aeroplanes that fly.** Buy your complete outfit, scale drawings, fittings, compressed air motors and all the best model aeroplane supplies from The Wading Bird Manufacturing Co., established 1900. Our new 52-page catalog illustrated, 24 latest models and designs. Send 5c for your copy. Wading Bird Manufacturing Co., 672 H Broadway, Brooklyn, New York.

**Boys get flying model aeroplane free.** Write to Aero Shop, 3050 Huribut Ave., Detroit, Mich.

## Agents Wanted

**Only One Policy a Day Means \$130 per month profit;** same on renewals. Policy pays \$5,000 death; \$25 weekly benefit for injury or sickness. Premium \$10 yearly. Full or spare time. Easy seller. Write quick for territory. Underwriters, Dept. N 19, Newark, N. J.

**Prepare and sell your own products—Formulas by experts.** Trade secrets, manufacturing processes. Catalog free. D. Thaxly Co., Washington, D. C.

**Big profits. Sell Plate Glass Wind Deflectors, Rear View Mirrors, Aluminum Foot Scrapers and 20 nationally advertised accessories.** Car owners, Dealers, Garages buy one to gross. Write quick for illustrated catalog and agency prices. Rapid Sales Corporation, 13-D, Grand Rapids, Michigan.

**A Business of your own—Make sparkling glass name plates, numbers, checkerboards, medallions, signs; big illustrated book FREE.** E. Palmer, 513 Wooster, O.

**Agents—Big returns.** Fast office seller; particulars and samples free. One Dip Pen Co., 12 Daily Record Bldg., Baltimore, Md.

**Agents, \$60 to \$200 a Week.** Free Samples. Gold Sign Letters for Store and Office Windows. Anyone can do it. Big demand. Liberal offer to general agents. Metallic Letter Co., 433Z N. Clark St., Chicago.

**Steady Income.** Big profits—Repeat orders—Your pay in advance—\$5 to \$15 daily introducing new style guaranteed hosiery—must wear or replaced free. Experience unnecessary. You write orders we deliver and collect. Outfit furnished, all colors and grades including silks. Mac-O-Chee Mills Co., Desk 286, Cincinnati, Ohio.

**Only one sale a day means \$200 per month!** Five sales, \$1,000 per month! Marvelous new adding machine. Retail \$15. Work equals \$350 machine. Adds, subtracts, multiples, divides automatically. Speedy, accurate, durable, handsome. Five-year guarantee. Offices, stores, factories, garages, buy one to dozen. A fortune for live agents. Write quick for protected territory and free trial offer. Lightning Calculator Co., Dept. W, Grand Rapids, Mich.

**Earn Big Money Fast** applying Lithogram Initials to automobile doors. Every owner buys. \$1.35 Profit on each sale. Full particulars mailed. Lithogram Company, 19-S, East Orange, N. J.

**Free.** Formula. Catalog. Laboratories. Boylston Building, Chicago.

**Make \$25 to \$50 week** representing Clow's Famous Philadelphia Hosiery, direct from mill—for men, women, children. Every pair guaranteed. Prices that win. Free book "How to Start" tells the story. George Clow's Company, Desk 27, Philadelphia, Pa.

**Agents Coining Money** selling Universal Gas Saver for every gas stove. Wonderful device. Cuts gas bill in half. Big profits. Write quick. Moore Gas Saver Co., Topeka, Kan.

**Glarescope—New auto accessory,** just out, nothing else like it on the market; \$15.00 to \$20.00 daily easy; retail at \$2.00, write for exclusive proposition. American Reflector Co., Dept. 45, Hammond, Ind.

**\$75.00 to \$150.00 weekly.** Free samples. Lowest priced gold window letters for stores, offices and autos. Anybody can do it. Large demand. Exclusive territory. Acme Letter Co., 2807 Congress, Chicago.

**Sales Representative wanted** in every county to give all or spare time. Position worth \$1,200 to \$3,000 yearly. No previous experience or capital necessary. Write for full particulars. A. F. Silver-Chamberlin Co., Clayton, N. J.

**Big money and fast sales.** Every owner buys gold initials for his auto. You charge \$1.50; make \$1.35. Ten orders daily easy. Write for particulars and free samples. American Monogram Co., Dept. 71, East Orange, N. J.

**Agents—New Invention.** Harper's Ten-Use brush set and fibre broom. It sweeps, washes and dries up stairs, windows, scrubbs and mops floors and does 5 other things. Big profits; easy seller. Free trial offer. Harper Brush Works, Dept. Z, Fairfield, Iowa.

**Agents.** Our soap and toilet article plan is a wonder; get our free sample case offer. Ho-Ro-Co., 138 Locust, St. Louis

**Agents Wanted.** To sell postage stamps, large profits, sample sets 25c; make use of your spare time and earn extra money. Chas. T. Egner, 1335 Pike St., Phila., Pa.

**Agents Wanted—Brand new article** with wonderful sales possibilities. Applicants must be big enough to handle County rights on exclusive basis. Our contract assures you a permanent and substantial business. Sample, fifty cents. Money refunded if we do not connect. Dept. 17, Bethlehem Utilities Co., Bethlehem, Pa.

## Agents Wanted (Continued)

**Your chance to make big money** resilvering mirrors, auto reflectors, metalplating. Outfit furnished. Write for particulars. International Laboratories, Dept. 25, 309-311 Fifth Ave., New York.

**Agents and Distributors wanted,** Radio Gaslighters, fastest 25c seller today, sample 10 cents, \$9.00 per gross direct from manufacturer. Ignition Products Co., Inc., 12-E Union Square, New York.

**Tempered Copper, 80 per cent. Copper Chisel, Cuts Steel.** Unaffected by Heat. Big Seller. Send 25c for Agent's Sample and Full Particulars. Wm. J. Eberle, A. M. & M. Bank Bldg., Milwaukee, Wis.

**We wish representatives** in every community to secure subscriptions for Science and Invention, Radio News and Practical Electric. This is a wonderful opportunity for Amateur Radio Enthusiasts to make big money quickly. Write Experimenter Publishing Co., Inc., 233 Fulton St., New York City.

## American Made Toys

**Manufacturers wanted** for large production and home-workers on smaller scale for Metal Toys and Novelties, Toy Soldiers, Cannons, Cowboys, Indians, Buffalo Bills, Wild Animals, Whistles, Bird-Whistles, Race-Horses, Prize-Fighters, Wagtail Pups. Put and Take Tops and hundreds of other articles. Hundreds and thousands made complete per hour. No experience or other tools needed. Bronze Casting forms complete outfit from \$5.00 up. We buy these goods all year, paying fixed prices. Contract orders placed with manufacturers. Exceptional high prices paid for painted goods. An enormous business for this year offers industrious men an excellent opportunity to enter this field. Write us only your mean real business. Catalog and information free. Metal Cast Products Co., 1695 Boston Road, New York.

## Automobile Accessories

**Ford Sport Model Fenders.** Something new and very classy. Ask for Complete Description. Star Supply Company, Lima, Ohio.

**Anti-Glare Automobile Driving Goggles—Clear glass**—neat—quick seller—roadway ahead in full view—day and night—no blinding from approaching car headlights—delightful, safe, restful for touring—eyes protected from sun—cost 35c per pair manufactured for you. Sells at \$2.00. Jobbers pay 80c. Dealer \$1.20. Four late broad patents, orders on hand, 900 pairs—settling estate only reason for sacrificing. Also anti-sun glare and anti-snow glare and sleep goggles. A year around business—mail order and agency—big demand—patents 15 years to run—all at appraised value—\$13,500. Terms can be arranged with responsible party—investigate at once. O. M. O. Estate, Trenton, Pa.

## Books

**Hypnotism—Banishes disease;** controls others; astounding exhibitions possible. 25 easy lessons \$1.00. "Mind-reading" (any distance); simply wonderful, wonderfully simple, 30c. Satisfaction guaranteed. Book Catalog and "Hypnotic Wonders" free. Science Institute, ES 1014 Belmont, Chicago.

**"Schemer Magazine."** Alliance, Ohio prints big profit schemes; one subscriber making \$25,000 from three; another \$10,000 from one. Try your luck; year only \$1.00; three months .25c.

**Vibrations—Light—Color—Sound.** Literature Free—Stevens Publishers, 212 Stockton, San Francisco.

**Radio explained in plain English.** Contains valuable information for purchasers, broadcasting station locations, rules for installing equipment and international code. Illustrated, 30c (cash). Radiophone Co., Patton Bldg., Milwaukee, Wis.

**Any book you want at cut-rate prices.** Don't buy until you see our bargain list. Send postal for free copy. Midwest Book House, Dept. 21, 58 West Washington Street, Chicago, Ill.

**Sexology Books** only for professional and advanced student readers. Forel, Krafft-Ebing, Kisch, Ribbe, Ellis, Freud, Key and other authorities. Sent in sealed envelope. The Modern Book Society, 228 W. 52nd St., N. Y. City.

**Free.** Upon request I will send you illustrated literature describing the following entitled books: Astrology, Character-Reading, Clairvoyance, Concentration, Entertainment, Healing, Hypnotism, Mechanics, Mesmerism, Mysticism, Occultism, Personal Magnetism, Salesmanship, Success, Seership, Mediumship, Will, Yoga Philosophy, Gazing Crystals, etc. A. W. Martens, J. O. O., Burlington, Ia.

**Books for Sale** on Occultism-Mysticism-Theosophy-Advanced Thought-Mental Science-Horoscopes and Hermetic Philosophy. List Free. The Grail Press, 712 G St., N. E., Washington, D. C.

**Perpetual Motion,** by Percy Verance. A history of the efforts to discover same from earliest days to the present, together with a scientific discussion regarding the possibility of its ultimate achievement. Profusely illustrated, 357 pages. Price postpaid, \$2.00. The Enlightenment Specialty Co., 305 Fourth St., Edwardsville, Ill.

**Back issues** of this and other magazines supplied by Boston Magazine Exchange, 107 Mountfort St., Boston.

## Automobiles

**Automobile Owners, Garagemen, Mechanics, Repairmen,** send for free copy of our current issue. It contains helpful, instructive information on overhauling, ignition troubles, wiring, carburetors, storage batteries, etc. Over 140 pages, illustrated. Send for free copy today. Automobile Digest, 541 Butler Bldg., Cincinnati.

## Business Opportunities

**Hypnotism.** Dr. Bradi's wonderfully successful method, \$1.10. Mesmer's \$5.00. Secret, \$1.10. "Auto-Magnetism" banishes disease. Creates Magnetic Energy, \$1.10. All three add \$2 coupon, \$3. Self-Culture Society, SE 516 Salem, Glendale, Calif.

**Enter a New Business.** Earn \$3,000 to \$6,000 yearly in professional fees making and fitting a foot specialty, openings everywhere with all the trade you can attend to; easily learned by any one at home in a few weeks at small expense; no further capital required; no goods to buy; job hunting, soliciting or agency. Address Stephenson Laboratory, 18 Back Bay, Boston, Mass.

**Be Independent.** We teach by mail how to manufacture unexcelled Toilet Preparations. Earn while you learn. Results guaranteed. Particulars free. School of Cosmetics, Box 4, Omaha, Neb.

**Get Into Business for Yourself!** Establish and operate "New System Specialty Candy Factory" in your community. We furnish everything. Money-making opportunity unlimited. Either men or women. Candy Booklet free. W. Hilmyer Ragdale, Drawer 129, East Orange, N. J.

**Successful Money Making Enterprises.** Regular \$1.00 book sent for 50c, postpaid. Package of games, 15c. Prentiss, Dept. S., Hillsboro, Ala.

**Join National Institute Inventors,** 118 Fulton, New York City, strong protective membership society. Will secure, develop, manufacture, market patents. Dues \$10. Booklet free.

**Dollars yearly in your backyard.** No mushroom dope. Particulars free. Metz, 313 East 89th, New York.

**Increase Your Sales by Mail!** See advertisement under Mailing Lists, Martineck Company.

**Will pay cash** for sole right to novelty idea or invention that retails for 10c. Address Lock Box 66, Station F, N. Y. City.

**Make \$15 daily** in manufacturing Meerschaum pipes. This is a one-man proposition. Send \$2 money order for details. G. Heilscher, 111 W. Main St., Seattle, Wash.

**\$50 to \$100 per Week** spare time. We have a business for you. Our complete instructions enable you to start immediately. By return mail, one dollar. Howard Company, Box 67, Times Plaza Sta., Brooklyn, N. Y.

**Good income spare time** refinishing chandeliers, brass beds, autos by new method. Experience unnecessary. Write for free samples showing finishes. Gunmetal Co., Ave. "D," Decatur, Ill.

**Be a Detective.** Travel. Excellent opportunity. Fascinating work. Experience unnecessary. Particulars free. Write American Detective System, 1968 Broadway, N. Y.

**Chemical Expert** will furnish formulas and trade secrets. All lines. Lists free. W. L. Cummings, Bldg., 258 Gordon Ave., Syracuse, N. Y.

## Charters

**Save** incorporating expenses and taxes and avoid personal liability by organizing your company on the regular common law plan under a declaration of trust; any one, anywhere, can fill in National Standard Forms (prepared by recognized attorneys) and begin doing business same day. Pamphlet B-58 free. C. S. Demaree, Legal Blank Printer, 613 Walnut, Kansas City, Mo.

## Chemistry

**Chemists!** Send sixty cents for year's subscription to "Chemical Pointers" (illustrated), catalog, and chemicals ( fifty cents' worth). Wright Laboratory, Caldwell, N. J.

**Analytical Chemistry Sets,** with burettes, standard solutions, indicators, etc. \$5.00 up. Buildings Free. Scientific Products Company, Holmead & Park Road, Washington, D. C.

**Chemical Science.** Three copies, 25c. January-March issues, 20c. Chemical Science, Swetsboro, N. J.

**Learn Chemistry at Home.** Dr. T. O'Connor Sloane, noted educator and scientific authority, will teach you. Our home study correspondence course fits you to take a position as chemist. See our full page ad on page 208 of this issue. Chemical Institute of New York, 140 Liberty Street, New York City.

**How to Make Fireworks,** 25c coin. Columbia Publishing Co., 1345 Park Road, Washington, D. C.

**"How to Make and Use a Small Chemical Laboratory,"** 100 pages, illustrated. Construction of laboratory furniture, electric furnace, balance, generators; inorganic chemistry, glass blowing, etc., fully explained, 75c. prepaid. Send for illustrated list of laboratory supplies and books, free. D. Altman Company, 225 East 110th Street, New York.







# Aspirin

Then It's Genuine

Unless you see the name "Bayer" on tablets, you are not getting genuine Aspirin prescribed by physicians for 21 years and proved safe by millions. Always say "Bayer."

Aspirin is the trade mark of Bayer Manufacture of Monoaceticacidester of Salicylicacid.

**Clear Tone FOR PIMPLES**

Your skin can be quickly cleared of Pimples, Blackheads, Acne Eruptions on the face or body, Enlarged Pores, Oily or Shiny Skin. **\$1,000 Cold Cash says I can clear your skin of the above blemishes.**

**FREE** WRITE TODAY for my FREE Booklet—"A CLEAR-TONE SKIN"—telling how I cured myself after being afflicted for fifteen years.

**E. S. GIVENS, 168 Chemical Bldg., Kansas City, Mo.**

**GOES DIRECT TO THE HEART OF THE SEX QUESTION**

# SEX

Facts other sex books don't dare discuss are plainly told in "Where Knowledge Means Happiness." Creates a new kind of married love. One reader says:

*It contains more real information than all other sex books put together.*

Sent in plain cover, by return mail, for \$1.00. Cash, money order, check or stamps.

Copyright 1921

**COUNSEL SERVICE, Dept. 39, 257 W. 71st St., New York**

**DEAFNESS IS MISERY**

I know because I was Deaf and had Head Noises for over 30 years. My Invisibile Antiseptic Ear Drums restored my hearing and stopped Head Noises, and will do it for you. They are Tiny Megaphones. Cannot be seen when worn. Effective when Deafness is caused by Catarrh or by Perforated, Partially or Wholly Destroyed Natural Drums. Easy to put in, easy to take out. Are "Unseen Comforts." Inexpensive. Write for Booklet and my sworn statement of how I recovered my hearing.

**A. O. LEONARD**  
Suite 369, 70 5th Avenue -- New York City

**PRICELESS SEX KNOWLEDGE**

Insures a Happy Married Life. We sell only the best books. "Sex Force" \$1.60 postpaid. "Sex Advice to Women" \$1.35 postpaid. Both books \$2.75. Many other books. Send stamp for catalog.

**SMETANA AND COMPANY, Orosso, Mich.**

### Patent Attorneys

Inventors should write us for our book, "How to Obtain a Patent" which clearly sets forth what may be patented and the necessary steps to protect an invention. It describes the procedure in Patent Office and tells about assignments, licenses and trade-marks, and gives many useful facts about patents which every inventor should know. Many persons well versed in patent matters have pronounced the book the best of its kind they have ever read. It is written so you can understand it. Copy sent free upon request. Talbert & Talbert, Patent Lawyers, 458 Talbert Bldg., Washington, D. C.

Patent application filed on partial payment plan. Trade-marks, copyrights, etc. Milo B. Stevens & Co., 694 F Street, Washington, D. C. Estab. 1864.

Patents procured—trade marks registered—A comprehensive, experienced, prompt service for the protection and development of your ideas. Preliminary advice gladly furnished without charge. Booklet of information and form for disclosing ideas free on request. Richard B. Owen, 130 Owen Building, Washington, D. C., or 2278-T Woolworth Bldg., New York.

Patents—Trademarks. Before disclosing an invention, the inventor should write for my blank form "Evidence of Conception." This should be signed, witnessed and returned to me with sketch or model upon receipt of which I will promptly render opinion as to patentable nature and send booklet on Patents. Highest references. Prompt attention. Reasonable terms. Clarence C. O'Brien, Registered Patent Lawyer, seventh floor, South-ern Bldg., Washington, D. C.

Monroe Miller, Ouray Building, Washington, D. C., patent attorney, mechanical and electrical expert. Best quality of work and results. Moderate charges.

Patent your invention. But note: a patent is no better than its claims. Be sure your patent is as good as your invention. Patent claims skillfully drafted by Lamb & Co., Patent Attorneys, 1419 G Street, Washington, D. C.

Inventors—Send for form "Evidence of Conception" to be signed and witnessed. Form fee schedule, information free. Lancaster & Allwine, 242 Ouray Building, Washington, D. C.

Patents. H. F. Lowenstein, McLaehlen Building, Washington, D. C. Send full description of invention for personal advice on how to proceed and estimate of costs.

Protect your rights. Write for "Record of Invention" which contains forms to establish evidence of conception of your invention. Prompt personal service. Preliminary advice without charge. J. Roney Kelly, 612 V Columbian Bldg., Washington, D. C.

Patents. Herbert Jenner, patent attorney and mechanical expert, 622 St. Washington, D. C. I report if patent can be had and its exact cost. Send for circular.

Patents Secured. Prompt service. Avoid dangerous delays. Send for our "Record of Invention" form and Free Book telling How to Obtain a Patent. Send sketch or model for examination. Preliminary advice without charge. Highest references. Write today. J. L. Jackson & Co., 249 Ouray Bldg., Washington, D. C.

Patent, Trade-Mark and Copyright Specialist. Write at once for free Duplex Conception Form. Personal service. P. E. Jones, Lawyer, 509C E. 7th St., Washington, D. C.

Patents, Trade Marks, Designs and Copyrights. Registered firm of attorneys-at-law. Careful, prompt, personal service assured. Moderate fees. Full information free upon request. Gross & Collings, 608 Ouray Building, Washington, D. C.

Inventors write me about patents. My fees payable monthly. Booklet free. Frank Fuller, Washington, D. C.

Patents—Prompt, personal, efficient service by an attorney-at-law, skilled in all branches of Patent Practice. Over 12 years actual experience; full information upon request. B. P. Fishburne, 350 McGill Bldg., Washington, D. C.

Millions spent annually for ideas: Hundreds how wanted! Patent yours and profit! Write today for free books—tell how to protect yourself, how to invent, ideas wanted, how we help you sell, etc. 212 Patent Dept., American Industries, Inc., Washington, D. C.

Patents. Send for free booklet. Highest references. Best results. Promptness assured. Send model or drawing for examination and opinion. Watson E. Coleman, patent attorney, 624 F St., Washington, D. C.

### Patents for Sale

Anti-Glare Automobile Driving Goggles—clear glass—neat—quick set—roadway ahead in full view—day and night—no blinding from approaching car headlights. Delightful, safe, restful for touring—eyes protected from sun—cost 35c per pair manufactured for you. Sells at \$2.00. Jobbers pay 80c; dealer \$1.20. Four late broad patents, orders on hand 900 pair—settling estate only reason for sacrificing. Also anti-sun glare and anti-snow glare and shop goggles—a year around business—mail order and agency—big demand—patents 15 years to run—all at appraised value—\$13,500—terms can be arranged with responsible parties. Investigate at once. O. M. O. Estate, Tarantum, Pa.

Auto Signal, visible all directions, advance of danger; manually operated, illuminated, disappearing; right, left, slow, stop, fits any vehicle, advertises itself. F. A. Cox, 27 West Ohio St., Chicago.

Patent for sale, outright or royalty, Electric Bowling Machine. Install on any regulation alley, use finger or hand balls. Plays the same as regular game. No pin boys. Address, Max A. Drews, 481 15th Ave., Milwaukee, Wis.

### Postcards and Pictures

No. 8x10 Kodak enlargement, beautifully colored, \$1.00. Kodaklin, 387 Bellevue Place, Milwaukee, Wis.

### Printing

Better Printing—1,000 Letterheads, Envelopes, statements or cards \$2.75. Gum labels. Multigraph letters \$4.50 M. Samples free. Howlett's, Dept. A, Paris, Ill.

Everything Printed. Low run specialties. Samples, Quality Printery, Marietta, Ohio.

### Rubber Stamps

Rubber Stamps. All Kinds. Three lines in nifty metal case, self-inking \$2.00. McCaddon Company, Zanesville, Ohio.

### Salesmen Wanted

57 miles per gallon made with new patented gasoline Vaporizer. Write for particulars. Vaporizer Co., Pukwana, S. Dak.

Salesmen. Sell our products direct to consumer. Write today. Mme. Yarbrough Mfg. Co., Winston-Salem, N. C.

### Short Stories, Manuscripts Wanted

Earn \$25 Weekly, spare time, writing for newspapers, magazines. Experience unnecessary; details free. Press Syndicate, 566 St. Louis, Mo.

Short Stories, poems, plays, etc., are wanted for publication. Literary Bureau, 165 Hannibal, Missouri.

Ambitions Writers send today for Free copy. America's leading magazine for writers of photoplays, stories, poems, songs, instructive, helpful. Writer's Digest, 637 Butler Building, Cincinnati.

### Song Poems Wanted

Write a Song Poem. Love, mother, home, come or any subject. I compose music and guarantee publication. Send words today. Edward Trent, 679 Reaper Block, Chicago.

Write the words for a song. We will compose music, secure copyright and print. Submit poems on any subject. Seton Music Company, 920 S. Michigan Ave., Room 111, Chicago, Ill.

Song Poems Wanted. Submit manuscript to New Era Music Co., 117 St. Louis, Mo.

Wonderful proposition for song, poem or melody writers. Ray Hildebrer, D115, 4040 Dickens Ave., Chicago.

### Stamping Names

Make \$19 a Hundred stamping names on keychecks. Send 25c for sample and particulars. Ex Kaytag Co., Chicago, N. Y.

### Stamps and Coins

California Gold, quarter size and German 5 pf. 30c, Villa coin and catalogue 10c. Homer Schultz, King City, Mo.

California Gold, quarter size, 27c; half dollar size, 53c. Columbian nickel and catalogue, 10c. Norman Schulz, Box 146, Colorado Springs, Colo.

Stamps—20 Unused, all Different. Free. Postage, 3c. Mention paper. Quaker Stamp Co., Toledo, Ohio.

55 All Different Stamps, including China, Japan, French Colonies, etc., given to applicants for our high grade approval selections. Send references and 2c stamp to the Edgewood Stamp Co., Dept. 1, Millford, Conn.

### Telegraphy

Telegraphy (Morse and wireless) and railway accounting taught thoroughly. Big salaries. Great opportunities. Oldest, largest school. All expenses low—can earn large part. Catalex free. Dodge's Institute, O St., Valparaiso, Indiana.

### Typewriters

Typewriters, all makes, slightly used, \$20 up. Easy payments. Free trial. Express prepaid. Guaranteed two years. Typex Company, Rosedale, Kansas.

### Wanted to Buy

We positively pay full value for old or new jewelry, watches, diamonds, crowns and bridges, dental gold, silver, platinum, gold or silver ore, magneto points (old or new) war bonds and stamps, old false teeth. Send by mail or express. We hold packages 4 to 12 days and return same at our expense if our offer is not satisfactory. United States Smelting Works. (The Old Reliable) 120 So. State St., Dept. 73, Chicago, Ill.

Mail old gold, unused postage, war and thrift stamps, liberty bonds, silver, platinum, diamonds, jewelry, watches, false teeth, magneto points, etc., new or broken. Cash immediately. Held ten days, returned if unsatisfactory. Ohio Smelting Co., 206 Lenox Building, Cleveland, Ohio.

### War Relics and Weapons

For Dens. Relics collected from Europe's battlefields. Guns, helmets, medals, etc. Catalogue and War Photos 10c. Lieut. Walsh, 50 Fort Greene, Brooklyn, N. Y.

### Wireless

This is Real Service—Panels cut to order, smooth sawed edges. We cut them exactly to size and ship the same day your order is received. 1/2-in. thick, 1 1/2c per square inch; 5/16-in. thick, 2c; 3/8-in. thick, 3c; 7/16-in. thick, 3 1/2c; 1/2-in. thick, 4c. Why pay more? These radio panels are made of the highest grade black fibre. This material possesses high dielectric strength, is inexpensive, unbreakable and easy to work. Our special offer, radio panels 6x8 1/2-in., 50c; 6x12 1/2, \$1. We also carry a complete stock of fibre rod and tubes, the real thing for electrical insulation. Special prices quoted upon application. We pay postage. Radio Instrument & Panel Co., Box 75, Cicero, Illinois.

A-1 Galena—Perfect—tested and guaranteed; imbedded in special metal; price 35c. AA-1 Galena (Genuine) 50c. postpaid. National Specialties, 328 Union St., N. Y. C.

Build Radio Sets. We supply parts or complete units. Catalog 15 cents. Easily understood assembly drawings. Crystal Detector Set, Non-regenerative Receiver, Regenerative Receiver, 2 Step Amplifier 25 cents each. All five \$1.00. No stamps accepted. Hatfield Airfone Company, Owego, N. Y.

Build your own Radiophone Receiver. Complete Blue Prints Crystal Set \$1.00. Audion Set \$4.00. Radiophone Transmitter \$1.00. Satisfaction guaranteed. Experimenters' Information Service, 45 Pinehurst Ave., New York. Bulletin X on request.

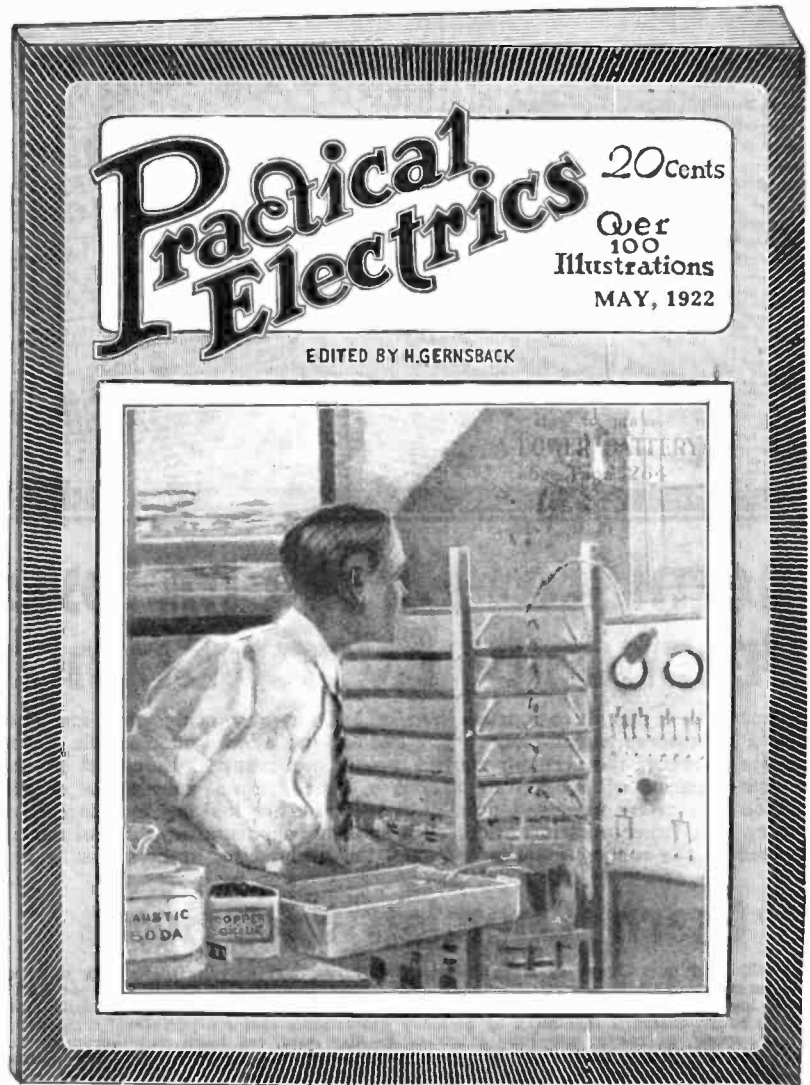

**Practical  
Electrics** 20cents  
Over  
100  
Illustrations  
MAY, 1922  
EDITED BY H. GERNSBACK

**100 Articles  
Over 100 Illustrations**

FOR SALE  
AT ALL NEWS  
STANDS

20c.  
The Copy  
\$2.00  
A Year

Canada and Foreign  
\$2.50 A Year

SEND  
20c. FOR  
SAMPLE  
COPY  
TODAY

SEE COUPON BELOW FOR  
SPECIAL OFFER

## “The Electrical Magazine for Everybody”

**P**RACTICAL ELECTRICS is probably the most novel magazine of its kind ever conceived. It is personally edited by H. Gernsback, editor of SCIENCE & INVENTION and RADIO NEWS. Mr. Gernsback, who founded the old MODERN ELECTRICS as well as the ELECTRICAL EXPERIMENTER, knows thoroughly what the public wants and has wanted for many years. In presenting this new magazine he but heeds the thousands of letters received by him to establish a new 100% electrical magazine that will beat the best that was in MODERN ELECTRICS and ELECTRICAL EXPERIMENTER.

Electricity covers such a tremendous field that the man who does not keep abreast with it does himself a great injustice. PRACTICAL ELECTRICS covers that field from every angle. It is written in plain every-day language that all can understand. It portrays the

entire electrical development of the month faithfully in non-technical language. It caters to everyone interested in electricity, be he a layman, an experimenter, an electrician or an engineer—each will find in this magazine a department for himself and plenty more.

The March-April issue now on the news-stands contains 48 pages and over 100 different articles and over 100 illustrations, with an artistic cover in two colors. Professor T. O’Conor Sloane, Ph.D., is associate editor of the magazine.

### Leading Articles in March-April Number

Telegraphic and Telephonic Transmission of Pictures. Antique Electric Motors. Electricity from Fruit and Vegetables. Old and New Measurement of Light. Induction Test for Locating Armature Troubles. Artificial Lighting.

### PRIZES

This magazine offers a number of prizes, as follows:

\$50.00 Burnt-out Fuse Contest.  
\$3.00 for the best picture of your electrical workshop.

\$3.00 for the best article on Elec-Tricks, the new department.

\$3.00 for the best “short-circuit,” the semi-humorous department.

In addition to this, the magazine pays high prices for all electrical experiments, electrical articles, etc.

See Current Issue for Full Details.

This issue also contains articles by some of the greatest living electrical writers, workers and students and the magazine will prove a revelation to any one interested in electricity.

Inasmuch as the new magazine has a circulation of only 27,000 copies, we urge you to place your monthly standing order with your newsdealer at once. Or if you wish, fill out the coupon below for your subscription and take advantage of our special offer.

Every issue besides its many other features contains the following departments:

- “New Things Electric”
- “Experimental Electrics”
- “Electrical Digest”
- “Junior Electrician”
- “My Laboratory”
- “Elec-Tricks”
- “Motor Electrics”
- “Short Circuits”
- “How and Why” (Questions and Answers.)

Make all checks payable to: “Practical Electrics Co.”

### SPECIAL OFFER

Gentlemen:

Although your regular price is \$2.00 per year, you will accept my subscription at \$1.75 per year (Canada and foreign \$2.25) I enclose the money herewith and I have written my name and address in margin below.

**PRACTICAL ELECTRICS CO., 53 Park Place, New York**

**CHEMISTS PREDICT STARTLING NEW ERA**  
Sun's Rays, Earth's Rotation and Atomic Energy in Matter to Be Used.  
SEE REVISING OF BIBLE  
Light Like Firefly's May Be Produced by Chemistry, American Society Hears.

**DEMAND FOR INDUSTRIAL CHEMISTS INCREASING.**  
It is probably not far wide the mark to assert that there more than 12,000 chemists are employed in the United States today and the percentage which is constantly increasing. Dr. Charles E. Monroe of the National Research Council and the University of the George Washington University at the opening of the evening conference school for the N. C. A. recently made a special reason for this the active competition for which we are going on within and without our country. It has been pointed out that the manufacture of any article dependent chemical change the course must be carried on under a chemical supervision.

**SAUSAGE GETS ATTENTION OF CHEMISTS**  
Is One of Many Topics in Pictorial Drawing

**URGES USE OF CHEMISTRY AS BUSINESS AID**  
Chemistry in the Home  
The pages of our great-grandmother were handed down to her daughter or her son. No one thought of calling it a book. It was a family record. It was the good house and industry. It was the good house and industry. It was the good house and industry. It was the good house and industry.

**AMERICA'S FUTURE BEFORE CHEMISTS**  
Jr. E. F. Smith Urges Upon Associates Recognition of Nation's Claims.  
4,000 EXPERTS TO ATTEND  
Sessions Will Be Held at Columbia University Next Month—Scientists to Speak.

**CHEMICAL SCIENCE MAY CUTSHOE PRICES**  
New Methods in Tanning to Be Discussed by Experts at Meeting of American Society.

**CHEMISTRY EXPERT HEADS 'CLEAN CLOTHES' COLLEGE**  
In Eleven Weeks He Teaches How to Remove All Traces of Hardship From Linen and Makes Student a Real Laundryman.  
Described That City Miles to a of Gasolene.  
EYE SHOWN  
Side on American  
of S  
F

**CHEMISTS IN MONTREAL LEARN OF NEW GLASS**  
Said to Admit Unlimited Light and Bar All Heat.

# Chemists Are Employed To-day In Practically Every Branch of Industry

All industry to-day is three-fourths chemical. Every day brings new announcements of new ways in which chemistry is employed in business and industry. The sudden and almost unbelievable expansion of the chemical field in the United States has increased the need for trained men in our country. Industrial plants of all kinds pay tempting salaries to get good men—salaries of \$10,000 to \$12,000 a year are not unusual for chemists of exceptional abilities. If you want a profession that offers unlimited possibilities—if you are looking for more money—if you like fascinating work—take up chemistry. No other vocation offers such splendid opportunities for real money and rapid advancement. Chemistry is now recognized as the coming great science and the demand for trained men is increasing every month.

## Learn Chemistry At Home

**Dr. T. O'Conor Sloane Will Teach You.**

We will teach you Chemistry right in your own home, and in your spare time, in a practical and intensely interesting way. Our home study course written by Dr. T. O'Conor Sloane is practical, logical and remarkably simple. Endorsed by leading scientific and educational authorities. The entire course is illustrated by so many experiments that are performed right from the start that anyone, no matter how little education he may have, can learn and thoroughly master every lesson. Dr. Sloane teaches you in your own home with the same individual and painstaking care with which he has already taught thousands in the class room. And Dr. Sloane personally examines and corrects all examination papers, pointing out your mistakes and correcting them for you. His personal training will be of inestimable value to you in your future career. If you really want to learn Chemistry and will honestly apply yourself to our lessons, our course will give you just as thorough and just as complete an education in general chemistry as you would have received had you been able to attend College.



## Easy Monthly Payments

You can pay in small monthly amounts as you go along. The price of our course is very low and includes everything, even the chemistry outfit—there are no extras to buy with our course. Our plan places a chemical education within the reach of everyone. No matter what your income is, you can meet our low terms, and you do not have to give up your present employment while learning.

## Experimental Equipment Given To Every Student



We give to every student, without additional charge, this chemical equipment including everything you need for the entire course with the exception of a few pieces of apparatus which we teach you how to make. You couldn't buy so complete an outfit anywhere for one cent less than \$20.00. There are forty-two pieces of laboratory apparatus and supplies and eighteen different chemicals and reagents all enclosed in a fitted heavy wooden box with hinged front and cover. This hand-finished box serves not only as a case for the outfit but as a laboratory accessory for performing countless experiments.

## Special 30 Day Offer

Besides furnishing the student with his Experimental Equipment as described above, we are making an additional special offer for a short while only. You owe it to yourself to find out about it. Write today for full information and free book "Opportunities for Chemists." Send the coupon right now while it is fresh in your mind. Or just write your name and address on a postal and mail it to us. But whatever you do, act today before this offer is withdrawn.

## Chemical Institute of New York, Inc.

Home Extension Division 6

140-D LIBERTY STREET, NEW YORK CITY

Dr. Sloane, Educational Director of the Chemical Institute of New York, is one of this country's foremost authorities on chemistry. He was formerly Treasurer of the American Chemical Society and is a practical chemist with many well-known achievements to his credit. Not only has Dr. Sloane taught chemistry for years, but he was for a long while engaged in commercial chemistry work.

Many people would pay big money to have Dr. Sloane teach them chemistry. You can secure his services and personal training without one cent of extra expense by enrolling with the Chemical Institute of New York.

**CHEMICAL INSTITUTE OF NEW YORK**  
Home Extension Division 6  
140-D Liberty St., New York City.

Please send me at once without any obligation on my part, your free Book "Opportunities for Chemists," and full particulars about the Experimental Equipment given to every student. Also please tell me about your plan of payment and your special 30 day offer.

NAME .....

ADDRESS .....

CITY .....

STATE .....

S. & I. 6-22



Let These Guides

Solve Your Problems



# Electricity at your finger ends

## HAWKINS ELECTRICAL GUIDES IN TEN VOLUMES

3500 PAGES  
4700 PICTURES

\$1 A VOLUME  
\$1 A MONTH

SEND NO MONEY—SEND ONLY THIS COUPON

Know the facts in Electricity. They mean more money and better position for you. Hawkins Guides tell you all you need to know about Electricity. Every important electrical subject covered so you can understand it. Easy to study and apply. A complete, practical working course, in 10 volumes. Books are pocket size; flexible covers. Order a set today to look over.

### LEARN ALL ABOUT

Magnetism—Induction—Experiments—Dynamoes—Electric Machinery—Motors—Armatures—Armature Windings—Installing of Dynamoes—Electrical Instrument Testing—Practical Management of Dynamoes and Motors—Distribution Systems—Wiring—Wiring Diagrams—Sign Flashers—Storage Batteries—Principles of Alternating Currents and Alternators—Alternating Current Motors—Transformers—Converters—Rectifiers—Alternating Current Systems—Circuit Breakers—Measuring Instruments—Switchboards—Wiring—Power Stations—Installing—Telephone—Telegraph—Wireless—Bells—Lighting—Railways. Also many Modern Practical Applications of Electricity and Ready Reference Index of the ten numbers.

### SHIPPED FREE

Not a cent to pay until you see the books. No obligation to buy unless you are satisfied. Send Coupon now—today—and get this great help library and see if it is not worth \$100 to you—you pay \$1.00 a month for ten months or return it.

THEO. AUDEL & CO.,  
72 Fifth Ave., New York City

Please submit me for free examination, HAWKINS ELECTRICAL GUIDE (Price \$1 a number). Ship at once prepaid, the 10 numbers. If satisfactory, I agree to send you \$1 within seven days and to further mail you \$1 each month until paid.

Name.....

Occupation.....

Employed by.....

Home Address.....

Reference.....





# COME to MILWAUKEE

**I** NVESTIGATE—compare—write to any big business concern in Milwaukee for information about us—or to any of the big electrical organizations in the United States—and you will surely decide to come to Milwaukee, on old Lake Michigan, for your training, at America's Greatest Institution of Electrical Education.

*Built on the Corner—Stone of Personal, Individual Service to every student*

## SCHOOL of ENGINEERING of Milwaukee

### Learn More in Less Time at Less Cost

The only school advertising in this magazine that is authorized to confer the degree of Bachelor of Science upon graduates of its Electrical Engineering College. Our equipment is the most elaborate, complete and up-to-date of any electrical school in America, and includes wiring, testing, D. C. and A. C. motor generator, armature winding and transformer, starting, lighting and ignition, storage battery and chemical laboratories, drafting and designing rooms. Unique laboratory equipment originally designed and patented by us, housed in our most modern steel and concrete fire-proof structure. Our complete facilities afford to every student ample opportunities for actual practice.

No matter how young or how old you are, no matter how little or how much general schooling you have had, no matter whether you want to master every branch of electricity and become an Electrical Engineer or desire only to become a highly skilled and well-paid shop worker at

one particular kind of electrical work—there is a place for YOU in one of our many classes of students who are learning to be Electrical Engineers, Electrotechnicians, Practical Electricians, Motor Generator Repairman, Electrical Draftsman, Automotive Electricians, etc., etc.

We do not use our students to make secret profits for ourselves by selling the work they do and the things they produce in the shops.

Don't even think of enrolling with any other school until you have written direct to headquarters for full information about the particular kind of training you are interested in. Choose from the list below. Then mark and mail the coupon TODAY.

S. of E. graduates make big salaries everywhere in the great electrical field. Our Employment Department will help to secure profitable employment with opportunities for advancement.

### EVERY INSTRUCTOR A SPECIALIST

These are some of the experts whose teaching has supplied thousands of high-salaried men to the electrical industry through this school—many of whom in overalls and jumpers stand at your elbow teaching and explaining while you learn by doing. The only way you can fail to learn is to refuse to learn:

- |                                  |                             |
|----------------------------------|-----------------------------|
| Oscar Werwath, E.E.              | C. H. Ferguson, B.S., Ph.B. |
| Francis A. Vaughn, B.S.          | W. E. Hennig                |
| Willard C. Hartman, A.B., A.M.   | C. F. Parske                |
| Ben A. Bovee, B.S.               | Chas. D. Prinz              |
| Howard D. Matthews, B.S., E.E.   | J. M. Peterson              |
| Asher C. Ball, B.S., LL.B.       | A. L. Suddith               |
| Arthur A. Koch, M.S., Ph.D.      | E. L. Helz                  |
| Esther H. Shapiro, A.B.          | C. E. Pettingill, B.S.      |
| Fred W. Kratzer, B.S.            | James T. Baker              |
| H. L. Bowman, B.S.               | Louis Franklin, A.B.        |
| Edward H. Weste, B.S.            | A. W. Grissom, A.B.         |
| M. J. Maers, B.S.                | George L. Hoadley, M.E.     |
| Frank C. Schroeder, B.S. in C.E. | R. E. Porter, B.S.          |
| H. Rickeman, A.B.                | W. H. Bleck, B.S.           |
| Peter C. Winther, B.S.           | Chester C. Aiken            |
| W. E. Boren, A.B.                | W. B. Neepor                |
| E. L. Consoliver, M.E., B.E.     | C. M. Ploetz                |
| J. G. Zimmerman, B.S., E.E.      | V. M. Murray                |
| F. C. Raeth, M.T.D.              | High Murren                 |
| George B. Haverson, A.B.         | H. S. Wise, M. A.           |

### New RADIO Course Practical, Condensed

Special Short Course on the New Marvel

### RADIOPHONE and WIRELESS TELEGRAPHY

Join our Day or Extension Classes NOW

#### AUTOMOTIVE ELECTRICIAN—Learn At Home

A complete and thoroughly practical course, including every phase of electric starting, lighting, ignition, storage battery work for automobiles, trucks, tractors, motorcycles, airplanes, etc. An invaluable training for any progressive garage man.

#### ARMATURE WINDING—Learn in 3 Months

The theory and actual practice of armature winding, giving you a complete mastery of this fascinating subject. One of the best paid branches of work in the electrical industry.

#### ELECTRICAL DRAFTING—Learn in 9 to 12 Months

Easy, interesting, pleasant work that is earning big salaries for our graduates all over the world.

#### PRACTICAL AND THEORETICAL ELECTRICITY Learn in 6 Months

For the man or youth who cannot spare the time or money to enroll for more intensive and higher training, this course is ideal. We positively guarantee that as a student in one of these classes you will learn Practical Electricity in the shortest possible time—no matter how much you pay for your instruction. This course teaches you everything you need to know to go into business for yourself either as the owner of an electrical shop or as an electrical contractor.

#### ELECTROTECHNICS—Learn in 1 to 3 Years

This elaborate course prepares the student for entrance to our College Course for Electrical Engineers. Electrotechnicians are a special type of electrical experts qualified to fit electricity to the demands of modern industry and for such positions as superintendent of maintenance, director of construction, superintendent of installation and testing, electrical equipment salesman and automotive electrotechnician.

#### ELECTRICAL ENGINEERING—Learn in 3 Years (36 Months)

Bachelor of Science degree conferred on graduates. Full provision is made for making up deficient high school credits. It is the Electrical Engineers who have given to the world the thousands of fortune making inventions in the electrical field. No man with this training can fail to realize his highest ambitions in life.

#### SCHOOL OF ENGINEERING OF MILWAUKEE

Dept. 126, 415 Marshall St., Milwaukee, Wisconsin

Please send me, without cost or obligation, your big free illustrated book and details of the course which I have indicated below.

Course.....  
 Name.....  
 Address.....  
 City..... State.....  
 Age..... Education.....

**MAIL COUPON NOW**

Mail the coupon today for our Free Illustrated catalog. Tell us what course interests you most and we will send you special information. Find out about the great opportunity in Electricity today. Learn how we can help you to a permanent and lasting success. Don't put it off! Mail the coupon now!

**SCHOOL of ENGINEERING of Milwaukee**  
 Dept. 126, 415 Marshall Street Milwaukee, Wisconsin