

Radio Enters the Home

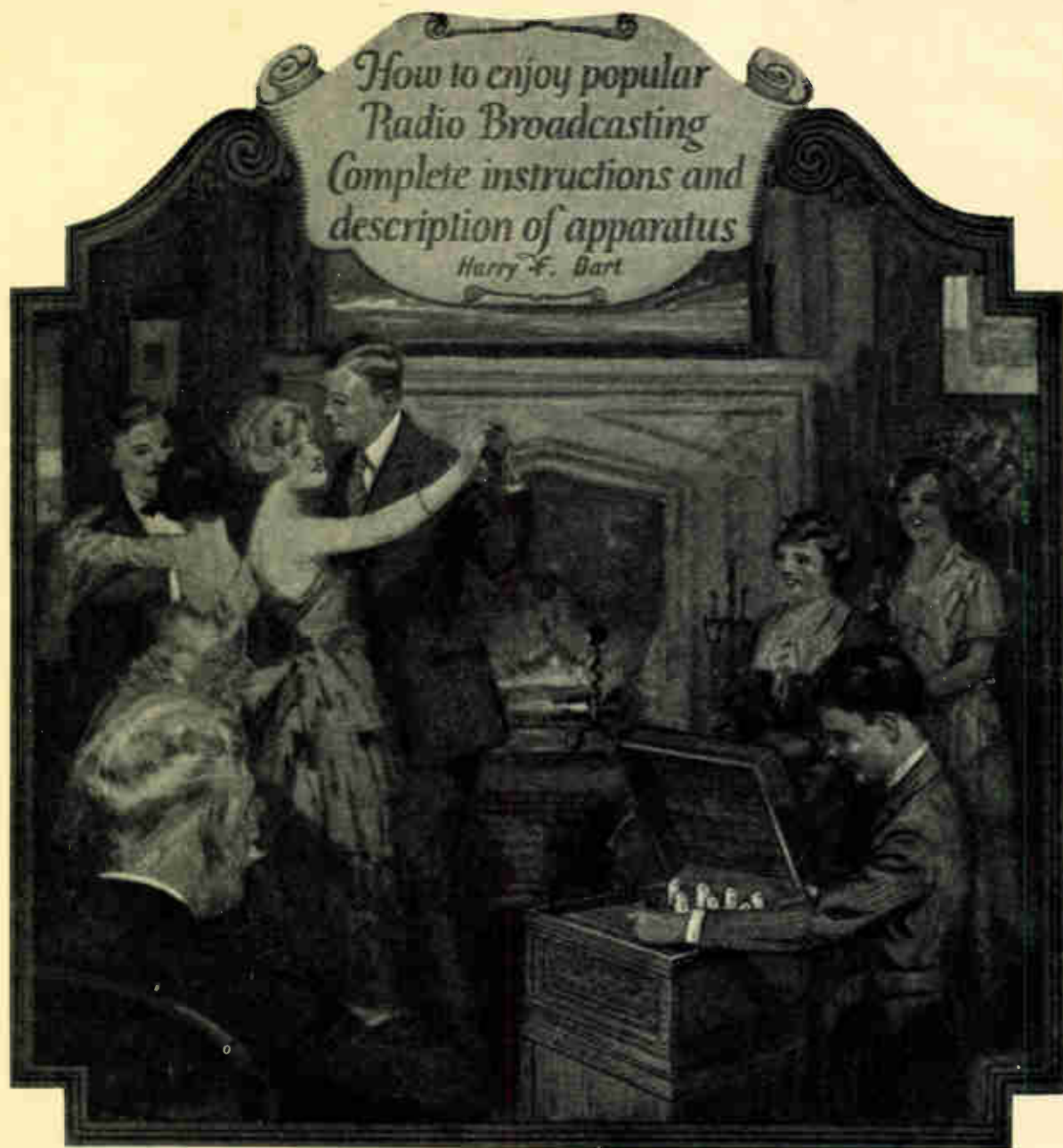

For those who desire to be entertained with concerts, lectures, dance music — as well as for the Radio amateur

Radio  **Corporation**
of America

SALES DEPARTMENT
WOOLWORTH BUILDING NEW YORK

RADIO ENTERS THE HOME

How to enjoy popular radio broadcasting. With complete instructions and description of apparatus.

For those who desire to be entertained with radio concerts, lectures, dance music, and for the radio amateur and experimenter.

PRICE THIRTY-FIVE CENTS

June 1, 1922

Reprinted by The Vestal Press Ltd. Vestal NY 13850 USA
from an original in the collection of
Lauren Peckham, Breesport NY 14816



SALES DEPARTMENT
233 Broadway New York City

DISTRICT OFFICE
10 South La Salle St. Chicago, Ill.

Notes: Thirty-five cents was the price of the book when it was originally published in 1922.
The original Patent License and Errata sheets are on page 122 in this reprint edition.
Readers are invited to write to The Vestal Press for a complete catalog of reprinted materials in various fields of historical interest.

PATENT LICENSE

To meet and develop the interest of amateurs of the radio art, the purchaser of parts from us is given the privilege of assembling those various parts in the circuits shown and described in this catalogue, and covered by the patents listed below, among others, but only for his own amateur and experimental use, including broadcast reception of music and other entertainment but not broadcast transmission, and not for sale.

This license is not given to agents, jobbers, dealers, manufacturers, professional assemblers, etc., as to do so would defeat its purpose.

Nor is any license hereby granted to combine any parts purchased from the Radio Corporation of America with parts or partially assembled sets made by others.

UNITED STATES PATENTS

803,684	963,173	1,201,270	1,356,763
841,387	1,104,073	1,213,250	1,360,168
876,996	Re.14,380	1,219,215	1,375,447
879,532	1,113,149	1,219,216	1,377,405
904,222	1,137,315	1,231,764	1,384,108
924,827	1,137,714	1,282,439	Re.13,789
933,263	1,195,632	1,325,865	



CONTENTS

INTRODUCTION

PART ONE

RECEPTION

	Page
What Everyone Should Know About Broadcasting.....	6-7
Broadcasting Station	8
The Five Fundamentals of Radio Reception.....	9-10
Classes of Apparatus and Their Application.....	11-12
Radio Broadcasting Receivers.....	12-34
The Aeriola Grand.....	29-33
Complete Radio Telephone Receiving Sets.....	35-36

PART TWO

ACCESSORIES

Simple Receiving Circuits.....	38-39
Audio Frequency Amplification.....	40-42
Radio Frequency Amplification.....	43-45
Radiotron Vacuum Tubes and Their Use.....	47-48
Aeriotron Vacuum Tubes.....	49
Variable Condensers for Receiving Circuits.....	50-51
Receiving Accessories	52-55
Receiving Antenna Equipment.....	56-59
Storage Batteries for Radio Use.....	60-61
Storage Battery Chargers	62
Radio Receiving Apparatus of Quality.....	63-67

PART THREE

TRANSMISSION

Radiotron Transmission	69
The Practical Use of Transmitting Tubes.....	70-72
Transmitting Tube Circuits.....	73-82
Radiotron Transmitter Vacuum Tubes.....	83-84
Kenotron Rectifier Vacuum Tubes.....	85
Transmitting Apparatus	86-94
Condensers for CW Transmitting Sets.....	95-96
Complete Amateur Transmitting Sets.....	97-98

PART FOUR

INFORMATION

A Scientifically Constructed Amateur Station.....	100-101
General Information for the Amateur.....	102
Radio Laws and Regulations of the U. S.....	102-103
CW on Amateur Wavelengths.....	103
National Electric Code Radio Rules.....	104-106
Vacuum Tube Precautions.....	107
Technical Terms Used in Radio.....	108-110
Price List of Radio Apparatus.....	111-114
Notice to Purchasers.....	115
The Wireless Man's Bookshelf.....	116
Useful Data	117-128

COPYRIGHTED 1922.

BY

RADIO CORPORATION OF AMERICA



Section of Radio Assembling Room at Immense Plant of General Electric Company, Schenectady, N. Y.

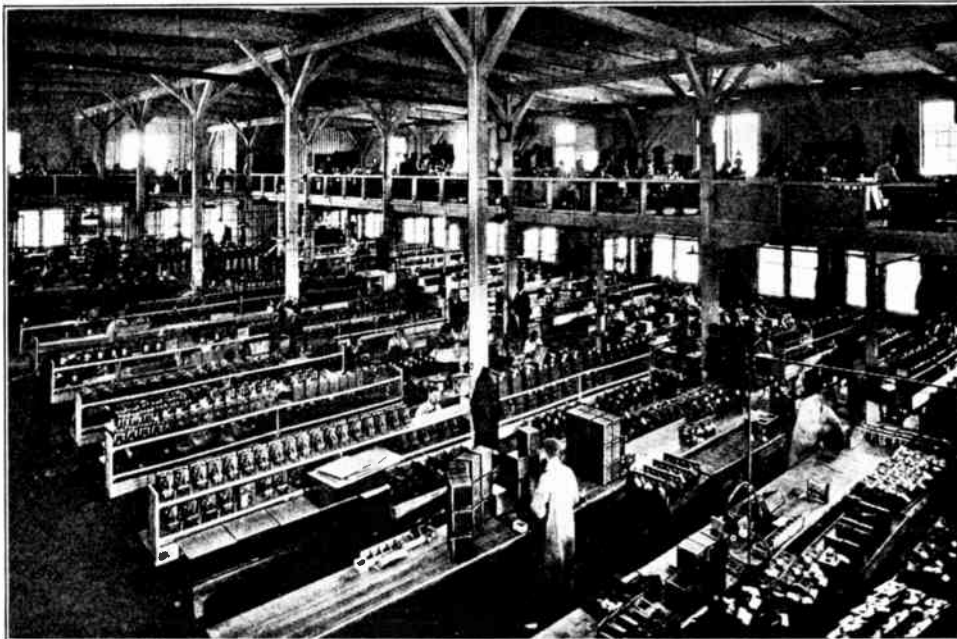

Completing Sets at the Westinghouse Electric and Manufacturing Company's Radio Works, Springfield, Massachusetts

Introduction

Radio Enters the Home RADIO has placed a new, inspiring and powerful resource at the disposal of civilization.

With magic touch it has relieved isolation and neglect on land and sea.

It has given the voice of hope and salvation to ships and passengers whose despair and tragic fate formerly were shrouded in silence.

It has brought new romance into the world to replace the exploits of Paul Revere and John Paul Jones. It travels swift as light, not through one valley, or on one lonely sea, but to the world at large on the wings of the ether.

Radio answers the call for more liberal education of nations and peoples, and permeates the remote places of the earth with the cultivating influence of music.

Radio telephony, following closely upon the heels of radio telegraphy, is sweeping the country, carrying into the homes of rich and poor alike a modern facility of pleasure and education which is binding the people together in a new and democratic brotherhood.

A richer and more complete home-life, with mental stimulus and pleasant relaxation, has been made possible through broadcasting and its receiving corollary, the radio telephone receiver.

First Taste of Broadcasting To the Westinghouse Electric & Mfg. Company is accredited the first successful attempt at organized broadcasting. This took place on November 2, 1920, at Pittsburgh, Pa., when "KDKA" broadcasted the Harding-Cox Presidential returns to thousands of expectant citizens.

Later, at the New York Electrical Show of October, 1921, a prominent artist sang to an audience of listeners in thousands of homes in and around New York. She was amazed when there came back through the ether to the concert room immediate requests for an encore. While the major-

ity, with their telephone receiving sets, merely listened, the request for the encore came from many amateurs who were equipped with sending sets.

In a like manner, nearly 200,000 radio enthusiasts, located hundreds of miles away from the ringside at Jersey City, received reports, round by round, of the Dempsey-Carpentier bout.

From a national standpoint, however, the full significance of radio telephony becomes apparent when it is possible for the President of the United States to address the people of the country clearly and impressively on special occasions. The suggestion has already been made in Congress that the debates of both upper and lower houses be broadcasted by radio.

In the great centers where broadcasting is in full swing, where theatrical stars and famous speakers have been heard by families sitting, miles away, around their own fireside, life has literally been made over for boys and girls, their fathers and mothers, the strong and well, the blind and the bedridden. Radio concerts have become the order of the evening in tens of thousands of American homes within the radius of the broadcasting stations.

Advanced scientific and engineering efforts have simplified radio receiving of concerts to the point where anyone, without experience or study, can enjoy the new national resource.

Not only have home concerts become a national pastime, but dancing to the music of famous orchestras playing in person for the benefit of radio "fans," has established itself as a permanent recreation.

From the oldest to the youngest—fathers and sons listening to baseball scores—mothers and daughters to the brief fashion talks—the whole family to some church service—farmers to the crop and weather reports—lawyers, doctors, clerks, messengers, captains of industry—all equipped for some feature of this new and amazing thing called radio broad-

casting. No art or science has ever, nor probably ever can, touch the lives of all the people more intimately.

With broadcasting rapidly reaching a national and comprehensive stage, the time is not far distant when every home in the United States, from hut to mansion, will be equipped to "listen in" while the Government makes its reports of crop and weather conditions, while the news of the day is briefly recited, while statesmen plead for united action, while famous artists sing to a larger audience than they have ever known, while splendid bands and orchestras inculcate the taste for music.

Today, clocks and watches are being checked by the U. S. Navy radio, while

both the Department of Agriculture and Post Office Department are communicating with the whole nation through radio.

These reports, like the fashion talk to women, bedtime stories for children, baseball scores and concerts constitute at the various broadcasting stations a definite program, running on a schedule announced in newspapers and usually covering the day from ten o'clock in the morning until ten at night. And when the listeners want to retire they merely turn off a switch.

For the sick in hospitals small watch-case telephone receivers are placed near each bed, and the patient "listening in" may enjoy broadcasting without disturbance to a neighbor.

WHAT EVERYONE OUGHT TO KNOW ABOUT BROADCASTING



The American Boy has taken to Radio with an enthusiasm probably greater than any other subject of the day.

THESSE pages are designed to show you how you can have musical entertainments in your home, the things you ought to know about broadcasting, what a radiophone broadcasting receiving set consists of, how to install and operate one, the things you ought to know so that you can select the type of set suited to your purse and your particular locality.

For the novice, who knows nothing of the technique of radio and simply wants to enjoy

the popular advantages of listening to news, lectures and concerts, the only question which he needs to settle for himself is whether his home is near a broadcasting station. These stations already spot the whole country, but, naturally, the radius of none of them is national.

At the time of this writing there are active, licensed high-powered broadcasting stations in Newark and Jersey City, N. J., New York City,

N. Y., New Haven and Hartford, Conn., Springfield and Medford Hillside, Mass., Washington, D. C., Pittsburgh and Philadelphia, Pa., Indianapolis, Ind., Toledo and Cincinnati, Ohio, Detroit, Mich., Chicago, Ill., Madison, Wis., Omaha and Lincoln, Nebr., Minneapolis, Minn., Kansas City, Mo., Denver, Colo., Los Altos, Pasadena, Los Angeles, Hollywood, Oakland, Sacramento, San Francisco, San Jose, Stockton and Sunnyvale, Calif., and Seattle, Wash. More stations are being opened every day.

The Government operates the stations that send crop and weather reports, while others are operated by manufacturers, newspapers, department stores, public spirited bodies, municipalities, etc.

It is a very simple matter to ascertain whether you are within reasonable radius of one of these stations. Wherever you see 'Radio Corporation of America sets or apparatus in a window or advertised over a dealer's name, you can get a quick answer to this simple, but at present, important question.

Variable Range Versus Reliable Range All the stations, in the present state of development, have a variable range and a reliable range. There have been many amazing achievements in transmitting, as, for instance, when amateurs flashed messages from this country to Scotland. Amateurs have been responsible in large measure for the present development of the art, but while they, with their thorough knowledge, based upon experimentation, are daily achieving the extraordinary, those interested in reception of popular broadcasting are naturally more concerned with the average, reliable transmission from the broadcasting stations.

The number of miles any receiving set will cover in its operating radius is subject to variations caused by such factors as the location of the station itself—whether, for instance, it is located in the open country or is surrounded by buildings with steel frame works. Where this is the case, the range of a given receiver is found to be somewhat shorter than under the above conditions. For this very reason, in the catalogue sections of this book, the ranges given for receiving sets are conservatively estimated.

Formed in response to a suggestion of representatives of the United States Government, the Radio Corporation of America has steadfastly pursued a policy based upon a sense of responsibility to the public. The distributors of R.C.A. sets and apparatus have been selected carefully and these distributors, as well as the dealers through whom they sell to the public, may be relied upon to give expert advice in the matter of selecting suitable equipment for every need.

No Technical Knowledge Is Required Between the "amateur" — a term that has become synonymous with experimenter, enthusiast, expert—and the nov-

ice—the latter constituting the very large part of the public keenly interested, but interested only in the telephonic, non-technical reception of broadcasting—there is a considerable gulf. The amateur who, after studying the code, receives his first intelligible message in telegraphic code, thrills to a sense of scientific or mechanical proficiency. Technical portions of this book and catalogue are for the amateur.

The family group, unconcerned and uninterested in code or technical study, thrills in its turn to an entirely different emotion—an emotion responsive to the dramatic realization that it is now possible to spend an evening in your own home with great artists entertaining you "in person;" with news of the day coming to you before it is printed in a newspaper; with statesmen and lecturers replacing each other in the program designed to please you.

While it is possible to use the smaller, inexpensive telephone receiving sets when near a broadcasting station, the larger sets give greater radius. With some sets, there is no more need for study or adjustment than in the case of a phonograph. It is merely a matter of moving an indicator until you hear what you want to hear—a résumé of the day's news, weather reports, time signals from a central observatory, such as the one located in Washington, D. C., market reports, special lectures by medical authorities on sanitation and hygiene, lectures by Government officials, timely political discussion, opera, music—whatever the program may happen to be.

Brushing up Conversationally Occasionally, you may hear someone say that the concert last evening was not quite up to standard, because of "static."

Stripped of technicalities, "static" is a natural atmospheric interference. Radio waves in their passage through the ether travel in waves similar to the waves at the seashore. Short wave lengths are used for short distance, low power work. Long wave lengths are employed for long distance, high power work. "Static" is caused by stray, natural, electrical discharges, traveling through the same medium. It is difficult to tune them out of the way. They are natural little violators of man-made traffic laws. Science is working hard to harness them. They are more prevalent by day than by night, far more troublesome in summer than winter.

One difficulty, which has previously been experienced in radio broadcasting when applied to concert work, was that of securing proper loud-speaking devices—devices which would give forth sufficient volume of sound so as to be heard in a large room by a great number of people. In this connection, a new class of amplifying and loud-speaking apparatus is now finding favor in radio concert work.

THE BROADCASTING STATION



A famous star singing to the "unseen audience" from radio receiving station.

AT present there are perhaps 125 to 200 radio telephone broadcasting stations in the United States which are regularly sending out news and entertainments to the hundreds of thousands of listeners who have receiving apparatus. They are located in the larger cities, which is essential for two reasons: that their programs may reach the largest number of people possible and that artists of recognized ability may be secured to join the other entertainers.

A broadcasting station is generally divided into two or more rooms. The studio, with its piano, phonograph and other equipment for the artists, resembles the music room to be found in a home, except that the ceiling and walls are generally covered with some cloth or material which will eliminate any reverberating sounds or echoes.

One or more small "pick up" instruments known as microphones, mounted on standards, are usually the only pieces of electrical apparatus to be found in this room. Wires from these convey the voice or music into another room, which in many cases is at quite a distance from the studio. The latter resembles a laboratory with its various pieces of electrical apparatus, transmitting vacuum tubes, panel boards, storage batteries, etc. Here the music or speech is put through a number of steps of amplification by means of smaller vacuum tubes which increases the volume of the sound waves thousands of times. The amplified speech currents then enter another bank of vacuum tubes, known as modulators or molders of the electric waves sent through the ether.

Vacuum tubes, made in the same manner

and containing the same number of elements as the small tubes used for receiving, but much larger and therefore capable of handling more power, usually are used for radio broadcasting.

Direct current at a high voltage is necessary for the operation of a transmitting station. To obtain this, a low voltage alternating current, such as used for lighting purposes in the home, is boosted to a high voltage by means of a motor-generator. This voltage is then applied to a number of vacuum tubes. The electric power supplied to these tubes causes electrical oscillations in the aerial wire system known as the antenna, and the antenna in turn radiates electrical waves which are molded to the form of the inflexions of the voice or of music, by other tubes termed modulators.

The power used at a broadcasting station is measured by the energy delivered to the antenna system, rather than the energy taken from the power lines. For this reason the rated power of a broadcasting station seems rather low to the uninitiated.

Many of the broadcasting stations employ 500 watts of radiated energy, which is equivalent to nearly one horsepower. However, one of the largest broadcasting stations in the United States, located in Schenectady, New York, and owned by the General Electric Company, has facilities for greater power, but this is used only for special experimental tests. The masts used to support the antenna at this station are 183 ft. high and have been erected on the roof of a five story building.

Operators at broadcasting stations must possess the faculty of clear diction; they must be able to carry on a conversation in moderate tones sufficiently modulated and at low enough speed to insure correct and faultless reception at all the receiving stations.



A corner of the Radio Corporation—Westinghouse Station "WJZ".

The average range of the several high power broadcasting stations now in existence is 100 to 500 miles, although the stations maintained by the Westinghouse Electric and Mfg. Co., the General Electric Co. and the Radio Corporation of America have been heard over several thousand miles. In one instance an operator on board a ship more than a thousand miles at sea received a complete concert from a broadcasting station near New York with great enough intensity to pass it over the ship's telephone lines to 25 different staterooms at the same time.

It is estimated there are between 500,000 and 750,000 receiving sets in use, and artists at the larger broadcasting stations have had their entertainment heard by more than one hundred thousand people simultaneously.

As previously explained, the range of a receiving station depends upon a number of variable factors and the distances pointed out here have been covered by receiving stations employing sensitive apparatus, involving several stages of vacuum tube amplification. These facts should be considered in purchasing radio receivers.

THE FIVE FUNDAMENTALS OF RADIO RECEPTION

MOST of us know that there are various types of apparatus for the reception of radio broadcasting. Some of these "sets," as they are called, are more sensitive than others. Sensitivity, in the sense we apply it to receiving sets, is a quality analogous to power in transmitting apparatus. Most receiving sets, have five distinct functions—intercepting, tuning, detecting, amplifying and reproducing. It will be helpful to us later, when we consider receiving sets as complete units, if these functions are understood.

Intercepting

"Antenna" and "Ground," the externals of a radio receiving set, intercept the broadcasted signals and lead such energy as they collect to the receiving set by means of wires. In practice the ground usually consists of a wire connecting a certain binding post or terminal connection on the set with a water pipe, or other metallic conductor which leads to the ground. The antenna, in its simplest form, may consist of a single bare wire, thoroughly insulated from adjacent objects, seventy-five to one hundred and twenty-five feet long and raised horizontally to the earth as high as possible. This also is connected with the receiving set by means of a wire called the lead-in; details for the installation of the ground and erection of antenna are furnished in printed directions which accompany every set sold by the Radio Corporation of America.

Tuning

All radio broadcasted speech or other signals arrive at the receiving antenna on a definite radio wave length, that is, the wave length to which the broadcasting station is adjusted or "tuned." Every sound we hear, therefore, is carried through space by electrical waves, but these electrical waves are not audible to the human ear until, first, they have been "tuned in" at the receiver, and second, made audible by the "detector" and the head telephone. The radio transmitting station does



Every living room of the average home becomes a radio receiving station.

not radiate a "sound wave." It radiates an electrical wave which serves to carry through space the inflexions of the human voice or of music or of telegraph signals.

Tuning, as applied to radio, means the manipulation of wave changing controls on the receiving set so that the apparatus may be adjusted for a maximum signal from the broadcasting transmitting station. Once the receiver has been tuned to the wave length of the distant station, no further tuning manipulation is necessary for the reception of the entire concert. Nor is tuning a difficult operation for the beginner; all that has to be done is to turn the controlling knobs or levers on the tuning elements until the signal is heard loudest.

Detecting

The detector rectifies or "changes" the energy received by the radio set into a form of energy which will produce an audible sound in a reproducer such as the head telephone or loud speaker. There are two classes of detectors, mineral crystals, and vacuum tube detectors. A vacuum tube detector is better

than the crystal detector because it is much easier to adjust and it performs its functions with greater efficiency as it amplifies incoming radiophone signals many times.

A receiving set equipped with a crystal detector is known as a "crystal receiver"; a receiving set which employs a vacuum tube detector is called a "vacuum tube receiver"; a receiving set using a vacuum tube detector which has special means for amplifying signals is called a "vacuum tube regenerative receiver."

Amplifying

Amplifying devices are used when the receiving set is far removed from the broadcasting station, or when it is desired to have the received signals actuate a loud speaking device.

The essential of an amplifying device is the vacuum tube. Each vacuum tube utilized in such apparatus (not to be confused with the detector tube) is known as one "step" of amplification.

Amplifier tubes operate on an electrical principle analogous to the mechanical principle of a firearm. Pulling the trigger of a gun requires very little physical energy, yet it releases a terrific energy stored in the shell in the form of powder. When energy is impressed on the amplifier tube, it "triggers off," from a battery storing electrical energy, a given signal having many times the energy of the original.

In some receiving sets, the tubes are so placed as to amplify the signal before it is fed to the detector tube. This is called "radio frequency amplification." In other sets, the tube

is made to amplify the signal after it has passed through the detector. This is known as "audio frequency amplification." Where extreme amplification is desired, the set may contain amplifier tubes in both positions.

Reproducing

The function of the reproducer is to convert the energy which has been passed through the various apparatus described above from electrical pulsations into sound waves. A pair of head telephones constitute one type of reproducer. Another is the loud speaker, consisting of a sensitive telephonic reproducer attached to a suitable sound chamber or horn.

A very slight vibration from the head telephone will suffice to convey the sound to the ear. On the other hand, a loud speaker, to make the signal audible over an entire room, must have a diaphragm vibrating vigorously. Obviously, a loud speaker requires a signal of much greater intensity than a telephone headset, and it is one of the functions of amplification to furnish this louder signal.

General Remarks

The strength and quality of the audible sound made by the reproducer is directly dependent upon how well each of the five functions is performed by the receiving set.

Crystal receivers do not amplify signals; they simply tune, and rectify or change the energy at the detector and pass it directly to the reproducer, which is invariably a head telephone set.

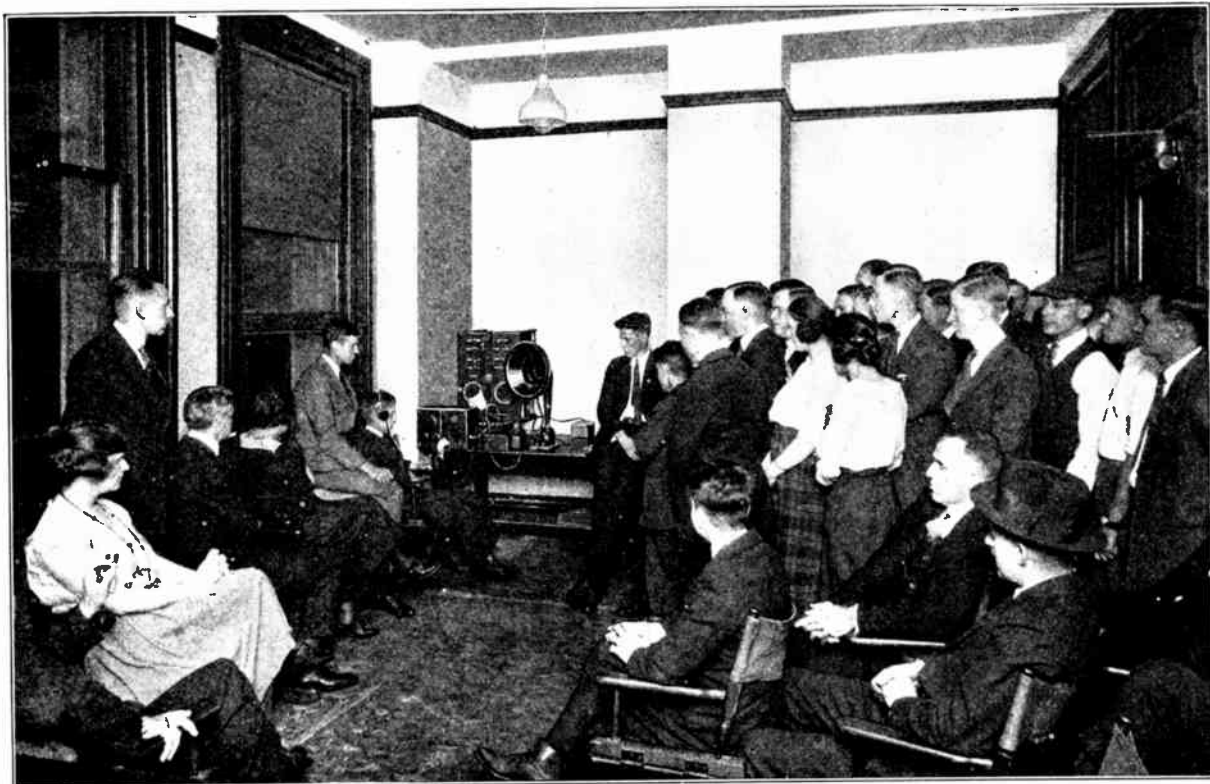

The Radio Concert becomes a reality by the use of a combination receiver-amplifier unit in conjunction with a loud speaker.

CLASSES OF APPARATUS AND THEIR APPLICATION

ONCE any of the telephone receiving sets, intended for concert reception, is installed in your home, there is no need for technical knowledge. The usual questions that are asked can be briefly answered here:

"How much will it cost and what distance will it carry?" "Do city conditions differ from those of the country in regard to radio reception?"

In general it may be said that there are four classes of radio apparatus, each one designed at a specific price and for a specific use. These are:

- (1) The simple circuit crystal type receiver which may cost from \$18 to \$50, and which may receive effectively from five to twenty-five miles, according to skill in setting up antenna, and atmospheric conditions.

Crystal detector apparatus necessitates the use of an outdoor aerial, and reception is accomplished by means of head telephone receivers.

- (2) This class of apparatus may be said to be practically the same as Class 1, except in this instance we depart from the simple crystal detector to the vacuum tube detector, with an improvement in receiving qualities. The cost in this instance may range from \$65 to \$100.

It is also necessary to employ the outdoor antenna, as well as the head telephone receivers. It is not possible in this instance to make use of loud-speaking devices, for the energy received by the single vacuum tube detector is not strong enough to handle the loud speaking device unless the set is located within 2 or 3 miles of the transmitting station.

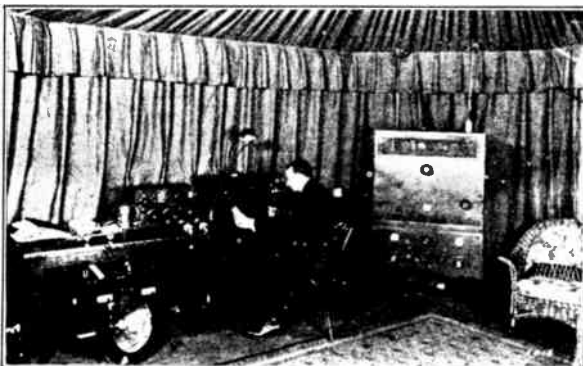

The "Man in the Moon" in action at "WDY" Broadcasting Station formerly at Roselle, N. J.

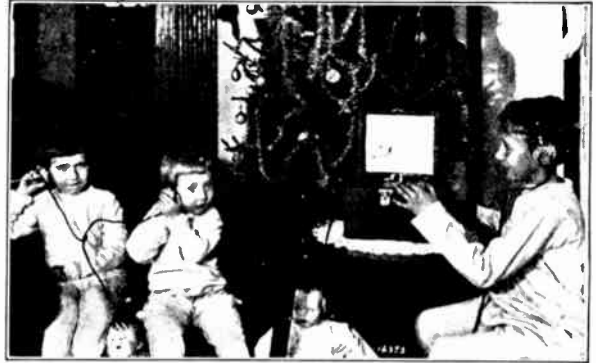

Bed time stories and music by radio have delighted thousands of little tots within a radius of several hundred miles from Newark, N. J. and New York.

- (3) In this class, it is also necessary to use the antenna and ground contact of the other systems mentioned. But much greater efficiency is obtained because vacuum tube amplification is employed. Receivers of this type usually consist of a receiving or tuning unit, a vacuum tube detector and two stages of vacuum tube amplification. This type of receiving equipment may cost from \$150 to, possibly, \$300. It has a much greater range of operation than the other types, and will function quite well up to 100 miles, although under exceptional receiving conditions, as much as 1000 miles may be obtained, employing the head telephone receivers.

It is also possible, in this instance, to employ a loud speaker and thus eliminate the head telephone receivers, thereby permitting a roomful of people to hear radio. The extra two stages of amplification permit this, for they increase the original intensity of a signal to such a point as to effectively operate the loud speaker.

- (4) This is the de luxe type of radio receiver, usually embodied in a complete cabinet, similar to that of the phonograph. All necessary instruments are enclosed in the cabinet and the tuning and adjusting devices are greatly simplified. It is designed for the use of the technically uninformed general public. A unit known as the "Aeriola Grand" is now on the market which incorporates these desirable features, and which is sold for \$350.

RADIO BROADCASTING RECEIVING OUTFITS

AERIOLA JR. RECEIVER, MODEL RE

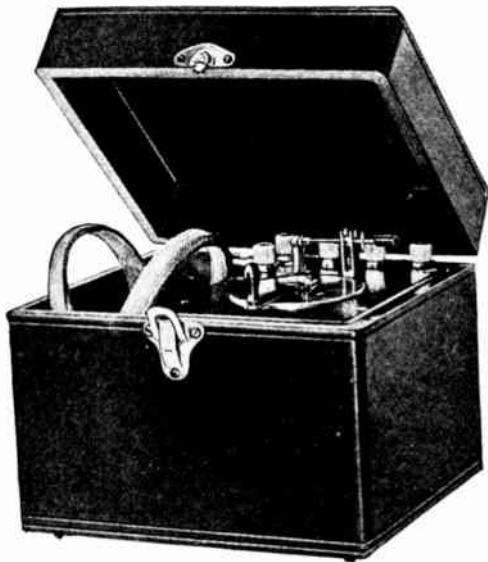

Aeriola Jr. is compact, inexpensive, requires no batteries, and is easy to operate

AERIOLA JR. is a complete Radio receiving outfit designed and manufactured by the Westinghouse Electric and Manufacturing Company. Its range varies from ten to twenty miles. Any one who can operate a talking machine or a camera can operate an Aeriola Jr.

Simple Adjustments

No technical knowledge is required. The only adjustments necessary include the occasional finding of a "sensitive spot" on the crystal detector and the simple turning of a tuning control arm to obtain the maximum intensity of reception.

The complete receiver is built in a very substantial and attractive wood cabinet which has a compartment for storing the telephone receivers when the set is not in use.

The tuning elements and the crystal detector are mounted on a black panel which forms the top of the receiving set when the cover is lifted. All the metal parts are finished in nickel. Under the tuning control arm, there is a calibrated dial. Where the receiving station is within range of several broadcasting stations operating on different wave lengths, it is possible to determine just what setting is necessary in order to hear any of the stations at a given time by noting the position of the

tuner control arm with relation to the calibrated dial. With Aeriola Jr. there is no maintenance cost. Once the antenna has been erected and the ground connection made according to the instructions given, it is only necessary to adjust the detector and rotate the tuner control arm until radio signals are heard in the head telephone receivers. The wavelength range of Aeriola Jr. is particularly adapted to broadcasting reception on the 190-500 meter wavelength band.

Reliable and Inexpensive

Aeriola Jr. includes everything necessary for this type of receiver—a tuner, a fixed condenser, a supersensitive crystal detector, and a high grade set of head telephones. In order to secure the best results from this outfit it is but necessary to follow the directions given in another section of this book and devoted to the erection of the antenna and securing the ground connections.

The entire design assures a degree of selectivity and reliable operation not usually found in this type of receiver.

Aeriola Jr. may ordinarily be employed for receiving from the broadcasting stations up to a maximum distance of 20 miles. Under some circumstances this range may be increased; often the Aeriola Jr. will pick up broadcasting over distances up to 35 miles.



The farmer located within easy distance of a broadcasting station may use Aeriola Jr. to advantage for the reception of market and weather reports.

Aeriola Jr. Makes an Ideal Set for the Beginner. It is Portable, Compact and Inexpensive. Requires no Batteries of any Kind.

OPERATING INSTRUCTIONS FOR AERIOLA JR.

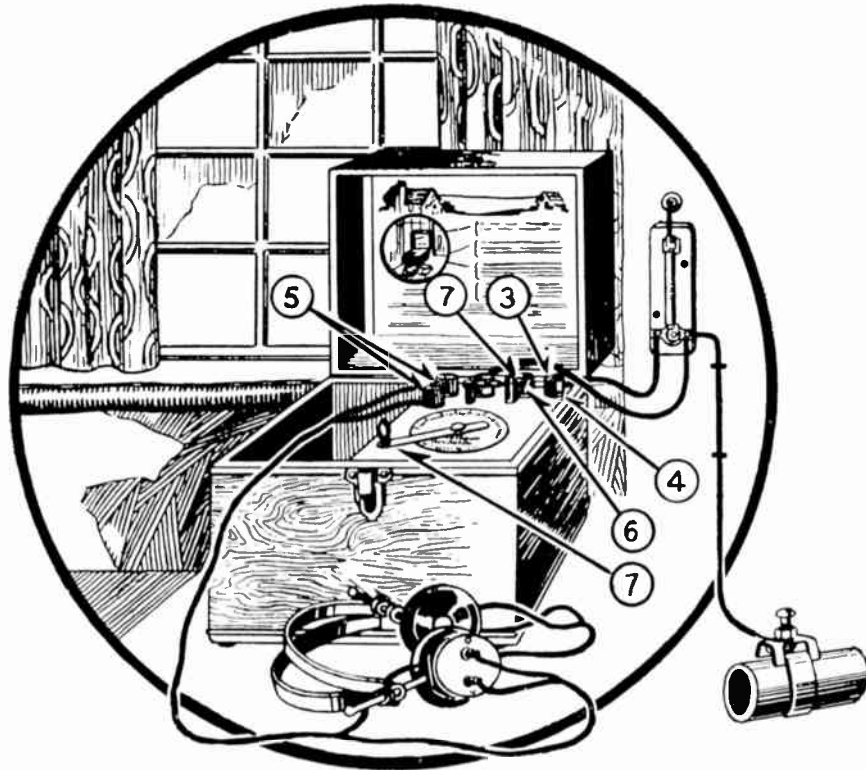

Text numbers correspond with above diagram.

- No. 1. First, refer to accompanying sketch, then erect antenna and place protective device in position as described on page 56.
- No. 2. Connect a wire leading from terminal marked R on protective device to binding post indicated by arrow for stations below 350 meters.
- No. 3. For stations between 350 and 500 meters, connect the above wire to this post.
- No. 4. Connect this post with terminal G of protective device.
- No. 5. Connect telephone receivers to these two posts. Adjust detector by pulling movable crystal away from stationary crystal and then allowing it to come in contact again at various points. While making this

adjustment, rotate tuning handle (6) slowly over the scale, listen until sound is heard in the telephone receivers. Temporarily stop adjustment of detector and manipulate tuning handle until maximum strength is obtained. Leave tuning handle in this position and readjust detector. After a short time, the operator will become skillful in finding delicate adjustments on this crystal detector. Various stations may be heard by simply rotating the tuning handle over scale.

Note: As crystals are rubbed together, a black deposit appears on the movable crystal, decreasing the sensitivity of the set. This deposit may be scraped off lightly with a knife. Further precautions regarding the care of crystals are pointed out in part 4 of this book.

Complete Aeriola Jr. Broadcasting Receiver, Model RE, 190-500 Meters, with Head Telephone Receivers, Spare Crystals, Antenna Equipment and Full Instructions \$32.50

Aeriola Jr. Broadcasting Receiver, Model RE, as above, less Antenna Equipment \$25.00

Dimensions: 7 in. x 8½ in. x 7¼ in.

Weights: Net, 5 lb.; Shipping, 10 lbs.; with Antenna Equipment, 17 lbs.

NOTE: For Prices of other Complete Receiver Combinations, see page 35.

RADIO BROADCASTING RECEIVER, MODEL ER-753



"Listening in" with Radio Receiver, Model ER-753

ALL that radio broadcasting has to offer from the opera to dance music, from discourses by world-famed lecturers to bed-time stories for the youngsters, is brought into your home by this simple receiving set. You listen to the news of the day, market reports and time signals sent out by United States Government stations; you hear popular entertainers in person singing their hits of the day, or telling jokes; in a word, the world's celebrities become visitors to your home and friends of your family. And best of all you need learn no code or have any electrical knowledge—simply run a wire into the air and connect another in the ground and you have at your command, news, instruction and entertainment.

Compact and Portable

The unit may be used with the antenna equipment described in the following pages and which may be installed by either novice or expert in a very short time.

The front panel is made of a high-grade insulating material radially embossed as shown in the accompanying illustration. By merely sliding this panel from its normal position, the metal cabinet may be opened to receive the telephone headset supplied. This arrangement makes the set completely portable. When it is not in use, it may be closed up so that there are no exposed loose wires.

An indicator on the front of the panel is turned when it is desired to hear signals from different stations. By means of this simple control you change from one station to another and bring in signals from any station at

their greatest strength. At the same time possible interference from other stations is avoided.

This practical receiver covers a band of wave lengths from 180 to 700 meters in two steps. The antenna connections for these two ranges are clearly indicated on the front panel. These ranges are from 180 to 400 and 300 to 700 meters respectively.

This outfit is sold with one pair of telephone receivers, but several pairs may be employed in conjunction with the four point telephone jack UD-486. Where this jack is used each pair of telephone receivers should be connected with a telephone plug UD-824. The method of employing this jack and plug system is fully described elsewhere.

Easy to Install and Operate

Radio receiver ER-753 may also be used in conjunction with the amplifying apparatus described in this book. When the proper antenna is used and the distance from a broadcasting station does not exceed 20 or 25 miles, the addition of vacuum tube amplifying apparatus in this instance, permits the use of a Vocarola loud speaker or the phonograph attachments described on page 55.

This receiving outfit is complete and is so simple that even a child can easily learn to operate it. Within its range amateur and commercial stations can be heard, but its greatest application is found in securing at a very small cost all the enjoyment radio broadcasting makes possible.

This compact receiver is a product of the General Electric Company.



Radio Receiver Model ER-753 is furnished with a pair of high grade Head Telephone Receivers.

A compact and effective receiver for short distance reception.

Ideal for use in cities served by a local broadcasting station.

OPERATING INSTRUCTIONS FOR RADIO RECEIVER ER-753

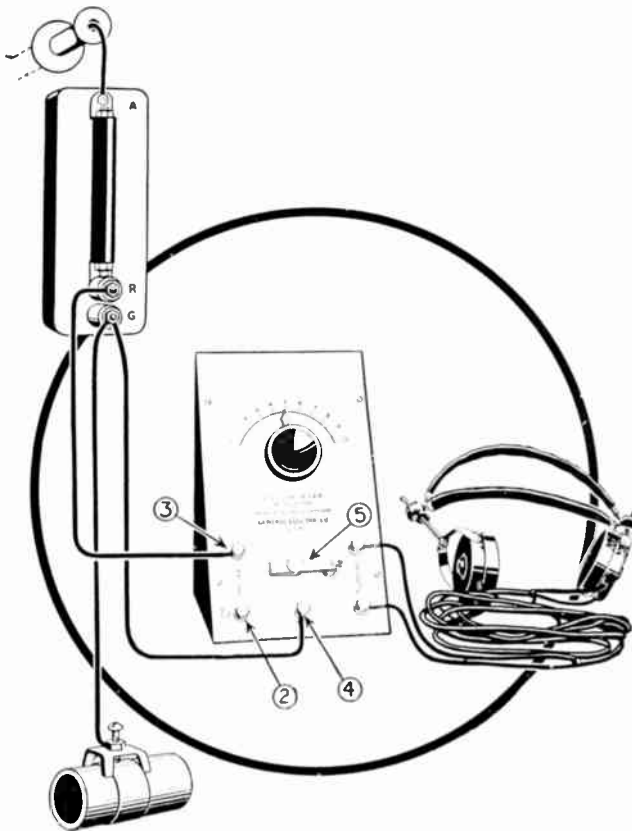

Text numbers correspond with above diagram.

- No. 1. First, refer to accompanying sketch, then erect antenna and place protective device in position as described on page 56.
- No. 2. For 180 to 400 meter range, connect a wire from terminal R of protective device to this binding post.
- No. 3. For 300 to 700 meter range, connect this post to terminal R of protective device.
- No. 4. Connect this post with terminal G of protective device.
- No. 5. Adjust detector movable arm and thumb screw until minerals just touch each other. Slowly move large knob pointer over scale. When signals are heard make further adjustment of the movable contact on the detector.

Note: As crystals are rubbed together, a black deposit appears on the movable crystal, decreasing the sensitivity of the set. This deposit may be scraped off lightly with a knife. Further precautions regarding the care of crystals are pointed out in Part 4 of this book.

Complete Radio Broadcasting Receiver, Model ER-753, 180-700 meters, with Head Telephone Receivers, Antenna Equipment and Full Instructions \$25.50
Radio Broadcasting Receiver, Model ER-753, as above less Antenna Equipment. \$18.00

Dimensions: 8 in. x 5½ in. x 5 in.

Weights: Net, 5 lbs.; Shipping, 10 lbs. with Antenna Equipment, 17 lbs.

NOTE: For Prices of other Complete Receiver Combinations, see page 35.

RADIO CONCERT RECEIVER, MODEL AR-1375



A High Grade Crystal Receiver of superior workmanship

Operates on all practical wavelengths of amateur and broadcast stations

Wavelengths 170 to 2650 meters

THIS receiver was designed by the Wireless Specialty Apparatus Co. to fill the need for a high-class crystal receiver covering a wavelength range of 170 to 2650 meters, thus permitting the reception of broadcasted concerts as well as daily time signals sent by Arlington (Radio, Va.) on a wavelength of 2500 meters. The entire unit is built in an artistically finished metal case, having a bakelite dilecto front panel. The set is sold complete with a pair of highly sensitive telephone receivers.

Wave Changing Switch

A wave change switch having three positions is mounted on the left hand side of the panel, providing three distinct wavelength ranges; 170-410, 350-965, 925-2650 meters. Variations between the lower and upper portions of these three ranges can easily be obtained by manipulating the tuning knob found in the center of the front panel.

The tuning knob is provided with an indicator which moves over a graduated dial engraved directly upon the front panel itself.

This knob is used to bring in desired, and to cut out undesired stations.

The crystal detector employed with this outfit is mounted directly on the front panel and is of the "catwhisker" type, provided with a very sensitive crystal.

Binding Post Feature

The binding posts on this outfit are of unique design. To connect external wires, it is merely necessary to push down on the top, insert the end of a wire and then release the top. The wire is then automatically held in place by a strong tension spring. This type of post is the simplest and most effective brought out to date.

The receiver is provided with a metal cover which is held in place by two snap catches. One end of the receiver case is removable and forms a suitable receptacle for the telephone receivers when the set is not in use, or when it is being carried about.

An added feature of Receiver AR-1375 is that provisions are made to connect a vacuum tube amplifier unit for loud speaker operation.

OPERATING INSTRUCTIONS FOR RADIO CONCERT RECEIVER MODEL AR-1375

Numbers Correspond to Diagram

- No. 1. First, refer to accompanying sketch, then erect antenna and place protective device in position as described on page 56.
- No. 2. Connect a wire leading from terminal marked R on protective device to binding post marked ANT.

- No. 3. Connect a wire leading from terminal G on protective device to terminal marked GND on receiver. Connect telephone cord tips to terminals marked TEL.
- No. 4. For wavelengths between 170-410 meters, place wave change switch at point A. Most broadcasting reception will be heard with the switch in this position.

OPERATING INSTRUCTIONS (Continued)

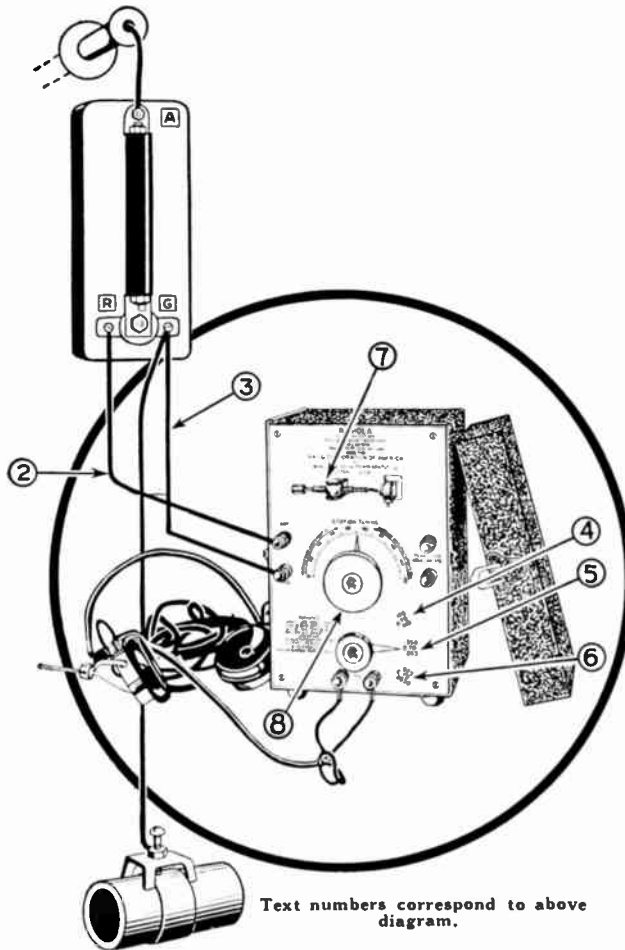

No. 7. After wave change switch has been set for the desired wavelength range, adjust detector by pulling movable spring-point away from crystal and then allowing it to come in contact again at various points. While making this adjustment, rotate tuning knob (8) slowly over the scale, listening until sound is heard in the telephone receivers. Temporarily stop adjustment of detector and manipulate tuning knob until maximum sound is obtained. Leave tuning knob in this position and readjust detector. After a short time the operator will become skillful in finding delicate adjustments on this crystal detector. Once the detector is properly set various stations may be heard by simply rotating the tuning handle over scale.

Note: A black deposit sometimes forms on detector crystals, decreasing the sensitivity of the set. This deposit may be scraped off lightly with a penknife.

No. 5. For stations between 350 and 965 meters, turn wave change switch to point B. This range includes commercial stations, radio compass stations and many Naval stations.

No. 6. For wavelengths between 925 and 2650 meters turn wave change switch to point C. This range includes Naval stations and special commercial stations, as well as Arlington (Radio, Va.).



Radiola AR-1375 is portable, rugged and remarkably sensitive. The Ideal Receiver for all around work.

Complete Radio Concert Receiver, Model AR-1375, 170-2650 Meters, with Head Telephone Receivers, Spare Crystals, Antenna Equipment and Full Instructions \$47.50
 Radio Concert Receiver, Model AR-1375, as above, less Antenna Equipment 40.00
 Dimensions—9¾ in. x 7 in. x 7 in.
 Weights—Net, 7 lbs., Shipping, 12 lbs. With Antenna Equipment, 18 lbs.
 Note—For prices of other Complete Receiver Combinations see page 35.

AERIOLA SR. RECEIVER, MODEL RF



Aeriola Sr. has become famous as a highly satisfactory and easily operated vacuum tube receiver.

LIKE the Aeriola Jr., the Aeriola Sr. is a Westinghouse product designed to fill the popular demand for an inexpensive set for broadcasting reception with a greater range than that of Aeriola Jr. Aeriola Sr. makes use of the Regenerative Circuit. This circuit in conjunction with a vacuum tube detector amplifies radiophone signals many times beyond the strength obtainable with a simple circuit. The outstanding feature of Aeriola Sr. is the fact that the filament of the vacuum tube may be operated from a single dry cell, the telephones being energized by what is termed a "B" or plate battery of 20 volts or more.

Aeriola Sr. for the Farmer

Aeriola Sr. will be found especially useful to the farmer for the daily reception of market and weather reports. These messages are sent out by the U. S. Government stations on a wavelength of 485 meters and are received like regular telephone conversations. It is not necessary for the farmer to know the telegraph codes. Thus this instrument proves of great value to the great farming centers of the United States which are served by local radiophone broadcasting stations.

In addition to its longer receiving range, Aeriola Sr. possesses the added feature of a more delicate tuning adjustment. This reduces the possibility of interference from undesired stations. Aeriola Sr. is portable. The upkeep

expense is very small. Like Aeriola Jr. its wavelength range is from 190 to 500 meters.

Aeriola Sr. includes the receiver or tuner, an Aeriotron detector tube and a pair of head telephone receivers.

Aeriola Sr. for the Boy Scouts

Aeriola Sr. receives over comparatively long distances from low-powered transmitting stations and lends itself particularly for communicating between Scout troops and headquarters or sections of the same troop located in different places.

The set may be carried by one Scout without overburdening him, whether he is on a long hike or not. The Aeriola Sr. with the necessary batteries for its operation, the insulators and wire for making the antenna as well as the wire used for the ground connection may all be placed in a haversack. The total weight is less than 15 pounds.

In addition to being very sensitive, this outfit is easy to operate and is not subject to irregularities sometimes found in fragile receivers.

A well-trained troop can set up the antenna, make the ground connection and have a receiving station in operation in a few moments.

Erecting the Antenna

The simplest way to erect an antenna when afield is the following: Attach an insulator to a long piece of string. This insulator and string is then used as a sling and hurled by a Scout over a branch of a tree or any other convenient object. When the insulator reaches the ground on the opposite side of the tree, it



It is easy for the Boy Scout Signal Officer to erect a temporary aerial over a tree branch.

is merely necessary to attach the antenna wire and pull on the string. When the antenna is high enough simply fasten the string to the trunk of the tree or other convenient support.

For communicating over short distances, the ground connection may be made by merely laying a piece of rubber-insulated copper wire along the ground for a distance of about 40 or 50 feet. This arrangement does away with the necessity of driving rods into the earth.

However, where the station is to be set up near salt water or in a salt marsh, it is more effective to connect the ground wire with a piece of metal of large surface and to place the metal either in the water or the damp earth. The length of the aerial for such a receiving set may be from 50 to 150 feet.

Easy to Install Antenna

In one of the accompanying illustrations a Scout is shown casting an insulator attached to a string over the branch of a tree. In another illustration a group of Scouts are gathered about a receiving station using the antenna suspended from the tree.

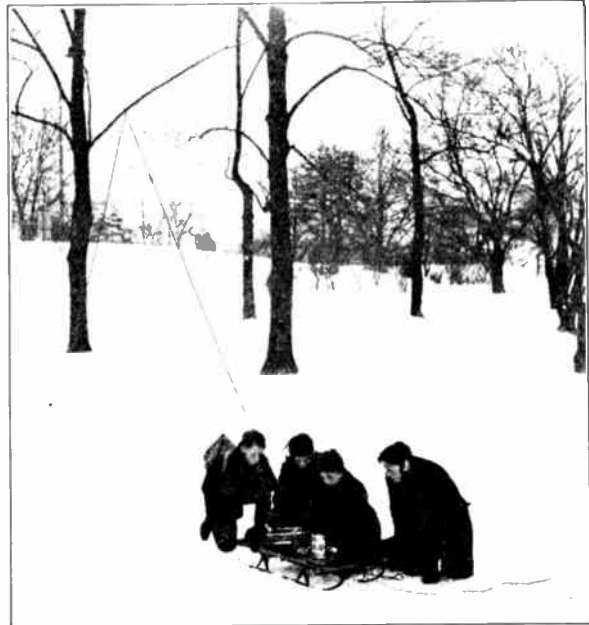

The Aeriola Sr. has been used by Scout Troops with entire satisfaction. Because it is sensitive, compact and inexpensive, it is the ideal receiving outfit for use in connection with their outdoor manoeuvres.



A typical Boy Scout Troop about to depart for a Saturday morning's winter march. The central Scout carries the complete Aeriola Sr. Receiver outfit in his knapsack.

OPERATING INSTRUCTIONS FOR AERIOLA SR.

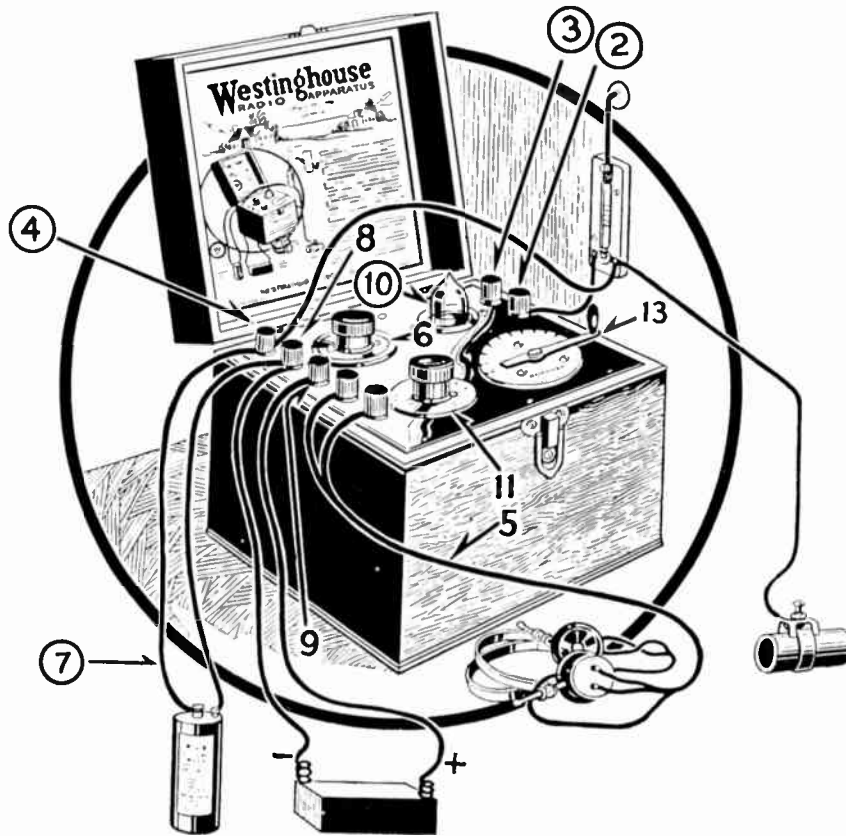

Text numbers correspond with above diagram.

Numbers Corresponding to Diagram

- No. 1. First, refer to accompanying sketch, then erect antenna and place protective device in position as described on page 56.
- No. 2. Connect a wire leading from terminal marked R on protective device to binding post indicated by arrow for stations below 350 meters.
- No. 3. For stations between 350 and 500 meters, connect the above wire to this post.
- No. 4. Connect this post with terminal G of protective device.
- No. 5. Connect telephone receivers to these two posts.
- No. 6. Turn rheostat as far as it will go toward tail of arrow.

- No. 7. Connect to positive (center) terminal of the single 1.5 volt dry cell.
- No. 8. Connect to negative (outside) terminal of the single 1.5 volt dry cell and negative terminal (—) of 22.5 volt plate battery.
- No. 9. Connect to positive terminal marked (+) of 22.5 volt plate battery.
- No. 10. Insert Aeriotron Vacuum tube in receptacle provided. Note that the four holes in base which receive prongs of tube are not all alike, one being larger than the rest, thus permitting insertion of tube in but one way. Be sure prongs register with holes and then press in firmly.
- No. 11. Place "Tickler" pointer at zero point of scale.
- No. 12. Turn rheostat (6) toward point of arrow until vacuum tube shows dull red. Do not try to burn too brightly as this materially reduces the life of the filament.
- No. 13. Rotate tuning handle slowly over the scale, meanwhile listening until sound is heard in the telephone receivers. Adjust to best position, then increase "Tickler" (11) until maximum strength of signal is obtained. If tickler is turned too far toward maximum position, signals will lose their natural tone and reception of telephone signals may become difficult.

Note: This terminal is also connected to terminal G of the protective device.

Complete Aeriola Sr. Broadcasting Receiver, Model RF, 190-500 Meters, with One Aeriotron WD-11-D Vacuum Tube, One Filament Dry Cell, One Plate Dry Battery, Head Telephone Receivers, Antenna Equipment and Full Instructions. \$75.90

Aeriola Sr. Broadcasting Receiver, Model RF, As Above, Less Batteries and Antenna Equipment \$65.00

Dimensions: 7 in. x 8½ in. x 7¼ in.

Weights: Net, 6 lbs.; Shipping, 12 lbs.; with Antenna Equipment and Batteries, 25 lbs.

NOTE: For Prices of other Complete Receiver Combinations, see page 35.

SHORT WAVE REGENERATIVE RECEIVER, MODEL RA

THIS short-wave tuner, a product of the Westinghouse Company, has been designed to meet the needs of those who require the best form of receiving set available for broadcast reception. Particular attention has been paid to the fact that some Radio enthusiasts desire to carry on experiments of their own, and to incorporate various parts of their receiving equipment. For this reason the terminals are so arranged that either a crystal detector or a vacuum tube detector may be employed. For the former, type DB crystal detector, described on page 52, is recommended, for the latter, type DA Vacuum tube detector and two stage amplifier unit described on page 21.

Wide Variety of Uses

It has been customary for the novice in Radio to begin with a crystal detector, later adopting vacuum tube detection. As the type RA Receiver will give satisfaction with either method, it forms an ideal unit. The type RA tuner, as used in connection with the average antenna, has a wavelength range of 180 to 700 meters. This range therefore includes practically all that the average person cares to hear—in a word everything from amateur messages and broadcasted music to ship signals.

This receiver requires but one major adjustment in order to bring in desired stations and cut out undesired stations. Tuning, as this operation is called, is effected by turning the tuner knob. A minute adjustment of this circuit is obtained by what is known as a "vernier" condenser, which is connected in parallel with the antenna condenser. When a vacuum tube detector is used with this tuner advantage is taken of the amplifying qualities of the Armstrong regenerative circuit. In this case the degree of amplification is controlled by a small knob marked "ticker."

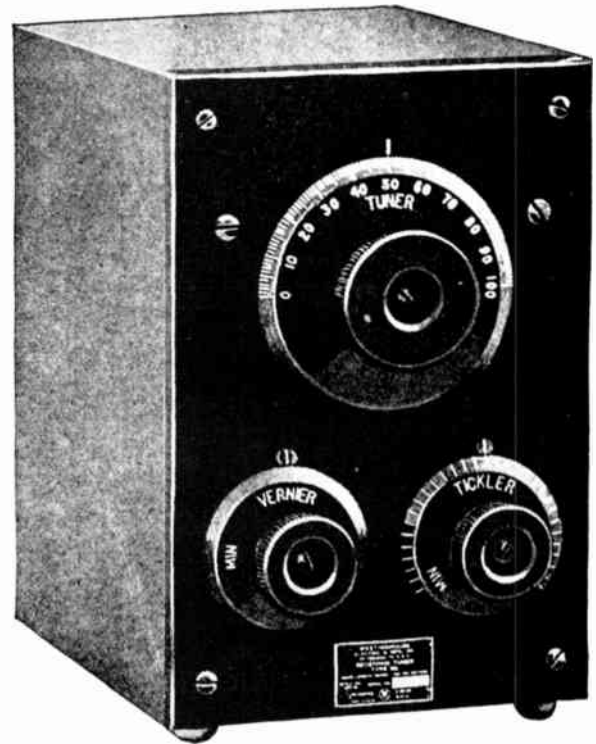

Model RA Tuner is a high grade Westinghouse product.

SPECIFICATIONS

- Panel**—Micarta, finished in black matte.
- Cabinet**—Natural polished mahogany.
- Dials**—Polished black micarta with beveled edges. Markings filled in white.
- Knobs**—Moulded black composition.
- Condensers**—Rotary plate type, air dielectric. Stationary plates are soldered to three supports, thus making excellent electrical contact and insuring permanent alignment.
- Coils**—Single layer wound on micarta tubes. Movable part of variometer connected to stationary coil through wire "pigtail."
- Tickler Coil**—Wound on same tube as stationary coil of variometer, and suitable taps are insulated with varnished cambric tubing and brought out to a dial switch.
- Binding Posts**—Moulded insulated posts, brought out at rear.
- Fittings**—Exposed metal parts on front of panel are brass, nickel-plated. All other screws are black finished.
- Wiring Diagram**—A wiring diagram showing all connections is furnished, together with complete instructions.

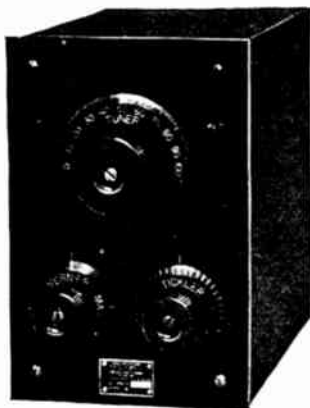

Tuner RA, with Crystal Detector DB and Head Telephones UD-790 complete the Receiver.

OPERATING INSTRUCTIONS FOR MODEL RA TUNER

When Used With Westinghouse Crystal
Receiver Combination No. 5

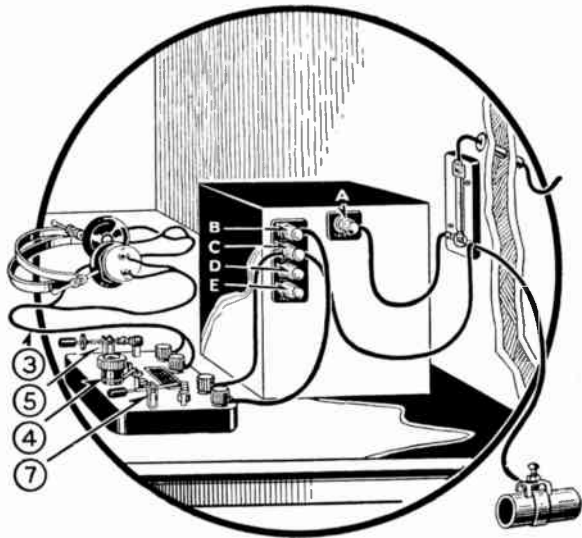

Text numbers correspond to above diagram.

No. 1. First, refer to accompanying sketch, then erect antenna and place protective device in position as described on page 56.

No. 2. Make connections as shown above, taking care that the two wires leading to the protective device do not lie close together. These wires should be as short as possible. All wiring may be made with No. 18 rubber-covered copper wire. Carefully remove the cover from both ends of each wire used, scraping clean with a knife, placing the end thus cleaned under the terminal caps shown and tighten cap.

No. 3. Connect head set as shown.

No. 4. Place dial switch in position shown.

No. 5. Adjust pressure type crystal by clasp- ing black handle and pulling the movable crystal away from the stationary one and let it come in contact with it at various points. Crystals should come together with firm pressure. While trying various points,

turn the tuner knob (6) slowly over the scale, listening at the same time for sounds in the telephone receivers.

No. 7. By changing the dial switch (4) to the other position this detector may be used. The flexible wire with special tip should be brought into contact with the various points on the stationary crystal, at the same time manipulating the tuner handle (6) as explained under (5) until the sound is loud- est.

No. 8. Vernier knob may be used as a fine adjustment on tuner knob (6).

No. 9. This knob is not used in this set and should be placed at minimum.

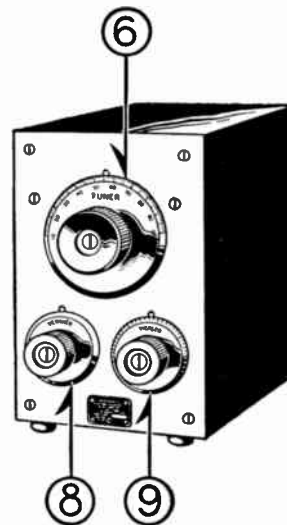

Text numbers correspond to above numbers.

Note—Terminals A, B, C, in upper diagram correspond to antenna, detector, detector-ground. D and E to tickler and plate when the unit is used with amplifier Model DA.

Complete Short Wave Regenerative RA, with Crystal Detector, Model DB, Head Tele- phone Receivers, Antenna Equipment and Full Instructions \$90.00

Short Wave Regenerative Tuner Only (Model RA), with Instructions \$68.00

Dimensions of Tuner: 9½ x 8½ x 6 in.

Weights: Net, 6 lbs.; Shipping, 10 lbs.; with Complete antenna equipment as above, 25 lbs.

NOTE: For Prices of other Complete Receiver Combinations, see page 35.

DETECTOR AND TWO-STAGE AMPLIFIER, MODEL DA

THIS unit is designed along advanced engineering principles and is especially adapted for the use of those who have not made an extensive study of radio but who desire to receive over ranges greater than those of Aeriola Jr., or the RA receiving sets when used without any external amplifying units. Within a very attractive mahogany cabinet equipped with a hinged cover all the elements necessary for a vacuum tube detector and two-stage audio frequency amplifier are found. This device when used in conjunction with the type RA short-wave regenerative tuner described on page 21, forms a combination for radio reception of a very high order for the non-technical user.

Three Vacuum Tubes Are Employed

The amplifier acts as a magnifier of the signals received by the detector. With each stage of amplification the incoming signals are magnified many times, so that with this detector and two-stage amplifier, signals which at times cannot be heard with simpler sets, may be received with ease on a loud speaker.

Vacuum tubes require two batteries for their operation, one for the heating of the filament, known as the "A" battery (in this case a storage battery of 6 volts with a capacity from 40 to 130 ampere hours), and the other a dry battery of 40 to 60 volts known as the "B" battery. For the best results it is necessary to regulate the amount of current supplied by the storage battery to the filament of the vacuum tube. In type DA unit are two rheostats, one of which regulates the current in the detector tube, and the second that regulates the supply to both amplifying tubes.

Three Controls Provided

Three telephone jacks are mounted on the panel and are arranged to control the internal circuits according to the desire of the operator. Thus, by inserting the telephone plug in the first jack the signal is received with the detector tube alone. With the plug in the second jack we have one stage of amplification. The second stage of amplification is made available by inserting the plug in the third jack.

A screened window is provided in front of the panel in order that the operator may observe the brilliancy of the vacuum tubes. All the vacuum tube sockets are mounted on the same base which in turn is mounted on heavy rubber shock absorbing supports.

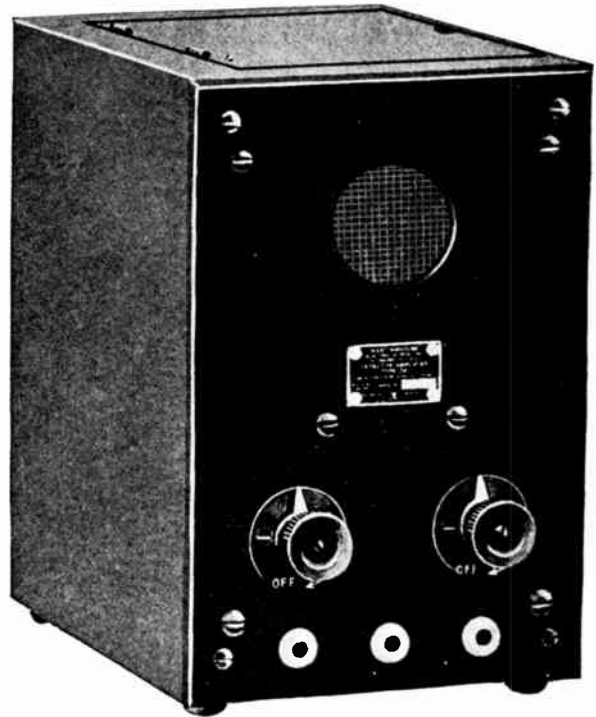

Amplifier DA is the logical graduating step for owners of Tuner RA previously described.

The cabinet is mounted on rubber feet to prevent scratching of the table or desk upon which it is placed.

This instrument will be found entirely satisfactory for amplifying weak radio signals and producing loud signals when used in conjunction with a Vocarola loud speaker (Model LV) for entertainment.

SPECIFICATIONS.

- Panel—Micarta finished in black matte. An opening protected by metal gauze is provided for ventilation and to give a visual indication of the tubes in operation.
- Cabinet—Natural mahogany, varnished and polished. Door provided in top for ready inspection and replacement of vacuum tubes.
- Knobs—Moulded black composition.
- Rheostats—Continuously variable type with open circuit position. Polished nickel pointers.
- Sockets—Metal on micarta base with tangential contacts. Shock-proof mounting.
- Binding Posts—Moulded insulated posts, brought out at rear.
- Amplifying Transformers—Closed core type, designed for maximum efficiency with standard tubes.
- Wiring—Covered with varnished cambric tubing. All wiring neatly done. All connections soldered.
- Shielding—Instrument completely shielded on all sides, eliminating capacity effects from operator's body.
- Wiring Diagram—A wiring diagram showing all connections is furnished, together with complete instructions.

Detector and Two-Stage Amplifier, Model DA, less Vacuum Tubes, Batteries and Telephone Plug \$70.00

Dimensions: 9½ in. x 8½ in. x 6½ in.

Weights: Net, 10 lbs.; shipping, 15 lbs.

NOTE: For Prices of other Complete Receiver Combinations, see page 35.

SHORT WAVE REGENERATIVE RECEIVER, MODEL RC

Combining RA Tuner and DA Amplifier
in One Cabinet

For Broadcast-
ed news, music,
concerts

A Highly
Sensitive
Long Distance
Receiver

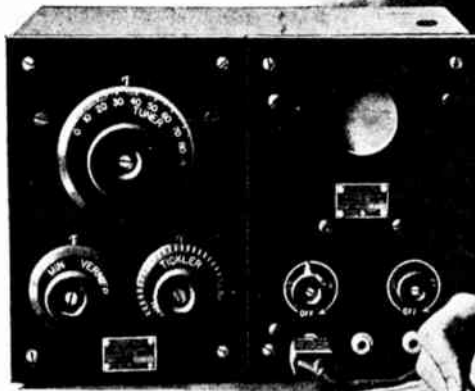

THE radio broadcast enthusiast or amateur who desires a modern, compact, portable and efficient receiver for general reception, will find these requisites in Model RC short wave regenerative receiver. It is an ideal instrument for use with loud speaking devices and has already found great favor throughout the entire country.

Long Distance Features

This receiver comprises a combination of the type RA short wave regenerative tuner, and type DA detector and two stage audio frequency amplifier described on preceding pages. Distant radio telephone, amateur and ship stations may be received on any wavelength within the range of 180 to 700 meters. The addition of Load Coil, model CB, allows the reception of signals on wavelengths between 1800 and 2800 meters where an average amateur outdoor antenna is used. This makes the set suitable for the reception of Arlington (Radio, Va.) time signals, which are broadcasted on 2500 meters at noon and 10 p. m., Standard 75° Meridian time, each day over distances of several hundred miles.

Broadcasting may be received on either de-

tector alone or with one or two stages of amplification by simply changing the head telephone plug connection. Where a Vocrola loud speaker is employed, the entire family may enjoy radio concerts without the use of telephone receivers. The set is metal-lically shielded so as to prevent undesired noises caused by capacity effects between the set itself and the operator's body.

The specifications for this receiver are identical to those of the RA tuner and DA detector and amplifier, with the exception that both units have been incorporated in one cabinet. All binding posts are mounted on the rear of the panel, permitting connections to be readily made. A wiring diagram and complete instructions accompany each instrument.

Dimensions—Height, 9½ in.; depth, 8½ in.; width, 18 in.

Weights—Net, 15 lbs.; shipping, 22 lbs.

Radiotrons Give Best Results

It is recommended that the Radio Corporation's detector and amplifying tubes Radiotron UV-200 and Radiotron UV-201 be used with these instruments.

OPERATING INSTRUCTIONS FOR MODEL RC RECEIVER

Numbers Correspond with Diagram

- No. 1. First, refer to accompanying sketch, then erect antenna and place protective device in position as described on page 56.
- No. 2. Connect a wire leading to this post from terminal R of protective device.
- No. 3. Connect a wire between this post and terminal G of protective device.
- No. 4. Turn rheostats as far as they will go toward tail of arrow.

- No. 5. Connect positive (+) terminal of 6 volt storage battery to terminal (+A—B. BAT.) of receiver.
 - No. 6. Connect negative (—) terminal of storage battery to terminal marked (—A. BAT.) of receiver.
 - No. 7. Connect one positive and one negative terminal of 22.5 volt dry batteries together.
 - No. 8. Connect remaining negative terminal of 22.5 volt batteries to terminal (+A.—B. BAT.) of receiver.
 - No. 9. Connect remaining positive terminal of 22.5 volt battery to terminal marked +AMPL. B. BAT.
 - No. 10. Connect terminals marked +DET. B. BAT. and terminal +AMPL. B. BAT., together.
 - No. 11. Open door in top and insert three radiotron type UV-201 amplifier tubes in sockets. Catch pin inside of tube base with slot in socket, press down and turn into place.
 - No. 12. Insert telephone plug in right hand jack and turn both rheostats (4) toward point of arrow until all tubes burn brightly.
 - No. 13. Rotate tickler midway between stops.
 - No. 14. Rotate tuner knob slowly over scale, listening for sounds in telephone receivers.
- Receiver is very sensitive to adjustments of the tuner knob and care should be taken not to move it too rapidly or the signal will be lost. Signals on short wave lengths will be received near the lower end of the scale, whereas the wave length increases toward the upper end of the scale. Broadcasting stations are generally tuned in between 20 and 40. When the signal is heard its intensity may be increased by

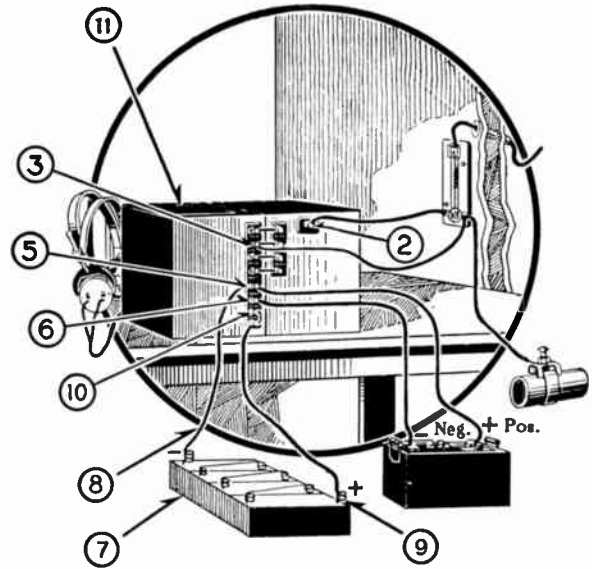

Text numbers correspond to above diagram.

manipulating "Vernier" in one direction or the other and by adjusting the tickler (13). Further adjustment may be made by manipulation of the filament rheostats (4).

For those who desire to operate with a soft type detector tube, radiotron UV-200 may be inserted in the socket at the rear of the cabinet instead of the UV-201, but it is then necessary to alter the connections as illustrated below.

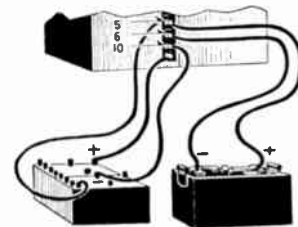

Method of connecting Filament and Plate Batteries.

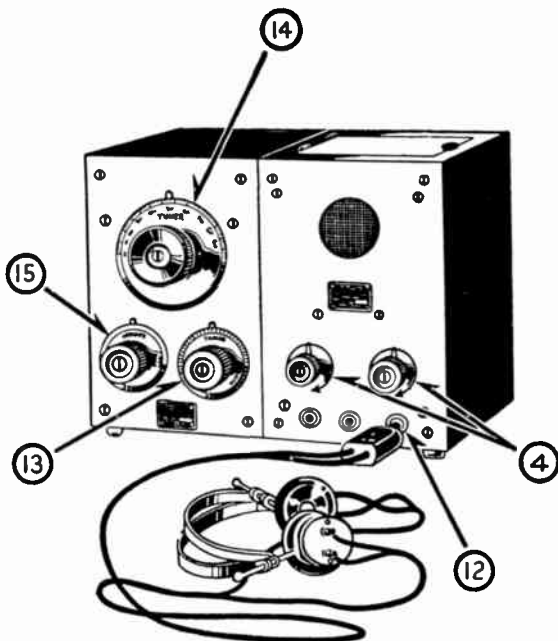

Text numbers correspond with above diagram.

Complete Short Wave Regenerative Receiver with Detector and Two-Stage Amplifier, 170-700 meters, Model RC, with Load Coil, one Radiotron Detector Tube, two Radiotron Amplifier Tubes, one six-volt Storage Battery Model 6HR-9, Telephone Plug, two "B" Plate Batteries, Vocarola Loud Speaker, Rectigon Battery Charger (5 ampere size), Receiving Antenna Equipment, and Full Instructions \$261.75

Short Wave Regenerative Tuner, Model RC, less all above Equipment, \$132.50

**Dimensions—9½ in. by 8½ in. by 8⅛ in.
Weights—Net, 15 lbs.; shipping, 22 lbs.; with above Equipment, 150 lbs.**

NOTE—For prices of other Complete Receiver Combinations, see page 35

RADIO RECEIVER, MODEL AR-1300

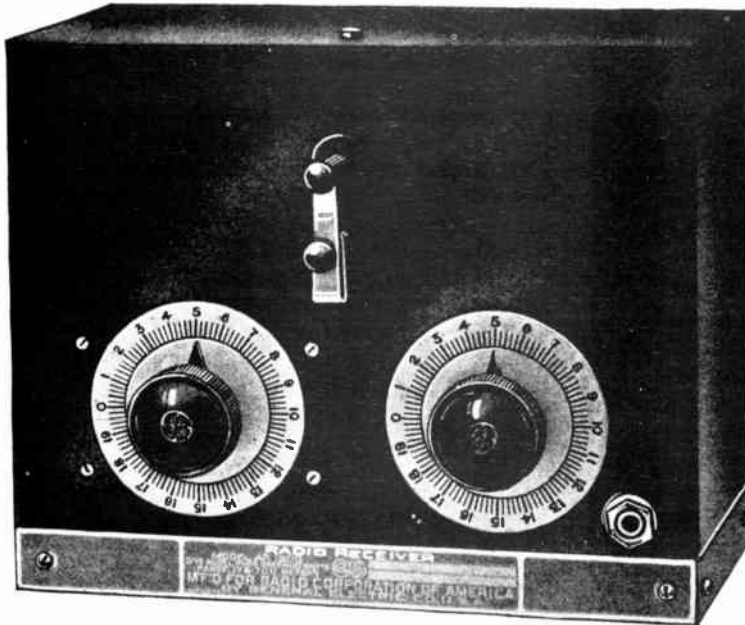

A rugged, compact and efficient unit for crystal or vacuum tube reception.

THIS compact and highly efficient receiver is of the single-circuit type, with a continuously variable air condenser for tuning. Because it is provided with regenerative coil for amplification and oscillation, it is suitable for the reception of all types of radio signals over the wavelength range of 180 to 700 meters. This meets the requirements of present day broadcasting.

The receiver, which is manufactured by the General Electric, is built upon the standard EZKASE plan, which determines the size of

case and arrangement of terminals to suit the various standard amplifier and detector instruments.

The variable air condenser is a special type arranged to operate an automatic switch which changes the inductance in the circuit. Therefore a continuous rotation of 360° is utilized for the entire wavelength range.

Crystal or Vacuum Tube Detection

A sensitive crystal detector is provided on the receiver, and a jack for plugging in the telephone receivers. For crystal detector operation, therefore, the unit is complete in itself, and needs no further units except the telephone receivers and the antenna.

Receiver AR-1300 can be used in connection with an external amplifier unit as embodied in Detector Amplifier, Model AA-1400, described on the following pages. When so used, the crystal detector is switched off and the intensity knob is turned to control amplification by regeneration.

The receiver is enclosed in the EZKASE, which serves the dual purpose of an electrostatic shield and a protection against mechanical injury.

Rear section of case is readily detached after pressing release button on top of case.

Receiver AR-1300, when used in combination with amplifier AA-1400 and the Vocarola loud speaker, furnishes all that the average home requires for Broadcast reception at medium cost of installation and operation. Moreover, the entire family may "listen in."



DETECTOR-AMPLIFIER, MODEL AA-1400

DETECTOR-AMPLIFIER AA-1400 is a compact and easily operated amplifier unit. It is also a product of the General Electric Co. and consists of a vacuum tube detector and two stages of audio frequency amplification enclosed in a neat metal EZKASE.

It is especially adapted for use with Radio Receiver AR-1300 when it is desired to greatly increase the strength of the broadcasted concerts such as would ordinarily be received with the simple crystal type detector.

Individual Filament Control

An important feature of Model AA-1400 is the individual filament control system, that is, the three vacuum tubes employed here (a detector and two stages of amplification) are furnished with separate rheostats, thus enabling the operator to obtain individual stage control of the received energy.

Plug and Jack Selection

Another operating feature is the selectiveness furnished by the three telephone jacks. The left hand one is for plugging in on the detector tube only, the middle jack furnishes detection and one stage of audio frequency amplification, while the right hand jack gives maximum amplification output, i. e., detection with two stages of amplification.

This feature will be found useful where it is desired to decrease the intensity of signals when receiving from high powered stations over short distances.

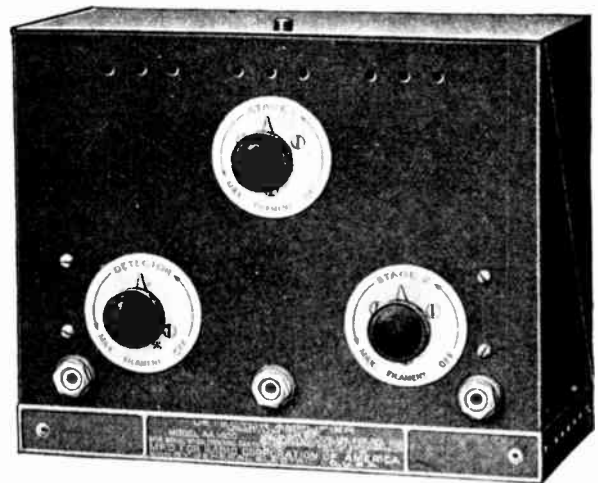

Detector-Amplifier AA-1400 has unusual features of amplification.

Reception may also be continued in emergency with the detector, or the detector and one stage of amplification when the battery has become discharged to such an extent that it will not properly operate the filaments of the three tubes, although this practice should not be generally followed. Means are provided by which the loud speaker is automatically disconnected from the circuit when the telephone plug is placed in a jack.

Distortion Practically Eliminated

Distortion of broadcasted music or speech and consequent lack of tone qualities so common with many receiving systems is practically eliminated by AA-1400.

The electro-static shielding afforded by the metal case of this instrument as well as the AR-1300 eliminates all disturbances caused by the proximity of the hand or body to the instruments.

Complete Regenerative Radio Broadcasting Receiver, Model AR-1300 and Detector, Amplifier Model AA-1400, One Radiotron Detector Tube, Two Radiotron Amplifier Tubes, Head Telephone Receivers, Six Volt Storage Battery Model 3LXL-9, Three Plate Batteries, Vocarola Loud Speaker, Tungar Battery Charger (5 Ampere Size) Telephone Plug, Receiving Antenna Equipment and Full Instructions \$250.25

Regenerative Radio Broadcasting Receiver Model AR-1300, 170-700 Meters, Less All Above Equipment \$50.00

Detector-Amplifier, Model AA-1400, Less Tubes. \$75.00

Dimensions: 11 in. x 9½ in. x 9 in.

Weights: Net, 13 lbs. Spring, 25 lbs.

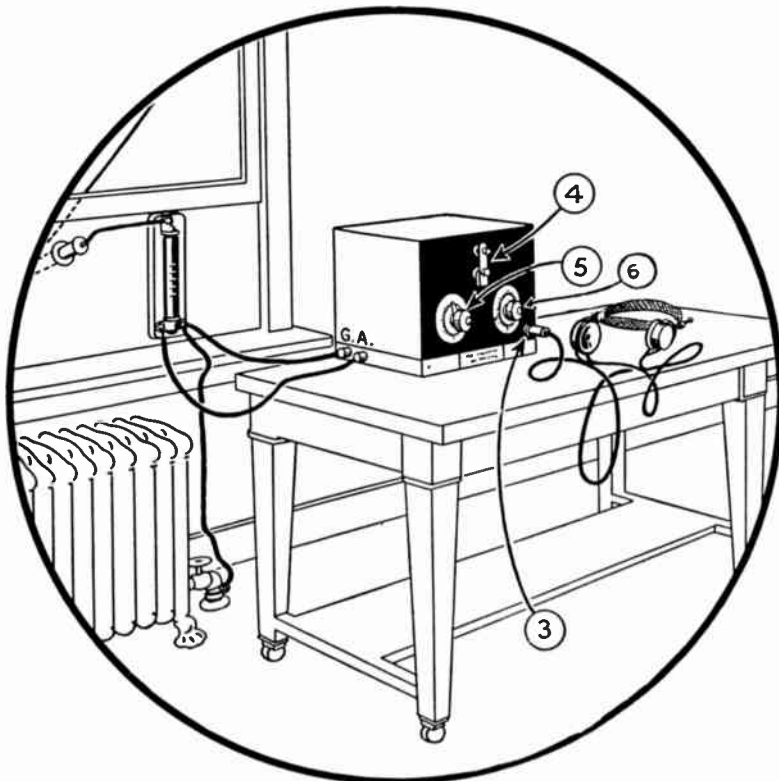

Text numbers correspond to above numbers.

OPERATING INSTRUCTIONS FOR RADIO RECEIVER AR-1300

Numbers Corresponding to Diagram

- No. 1. First refer to accompanying sketch, then erect antenna and place protective device in position as described.
- No. 2. Connect receiver as shown in accompanying illustration.
- No. 3. Insert telephone plug in jack at right hand side of receiver.
- No. 4. Adjust crystal detector and rotate tuner arm until signals are heard.
- No. 5. Make further adjustment of crystal detector so as to obtain the most sensitive position.
- No. 6. Intensity control does not function with this receiver when a crystal detector is used and it should therefore be left at the zero position.

Note: As crystals are rubbed together, a black deposit appears on the movable crystal, decreasing the sensitivity of the set. This deposit may be scraped off lightly with a knife.

G. E. Regenerative Radio Broadcasting Receiver Model AR-1300, less Head Telephone Receivers and Telephone Plugs\$50.00

OPERATING INSTRUCTIONS FOR DETECTOR-AMPLIFIER AA-1400 USED WITH RADIO RECEIVER AR-1300

- No. 1. Make connections as shown in illustration.
- No. 2. Separate crystal detector minerals.
- No. 3. Insert a Radiotron UV-200 in the left hand socket, and two Radiotrons UV-201 in the remaining two sockets.
- No. 4. Turn filament control knobs almost entirely around to the left, bringing the filaments to their proper temperature.
- No. 5. Insert telephone plug in left hand jack and set intensity knob on receiver at zero position.
- No. 6. Tune with wavelength knob on receiver until signals are heard with maximum intensity.
- No. 7. Slowly rotate intensity knob until a maximum signal strength is obtained.

Note: A loud speaker may be connected to the output terminals on right hand end. The loud speaker is automatically disconnected when using head telephones.

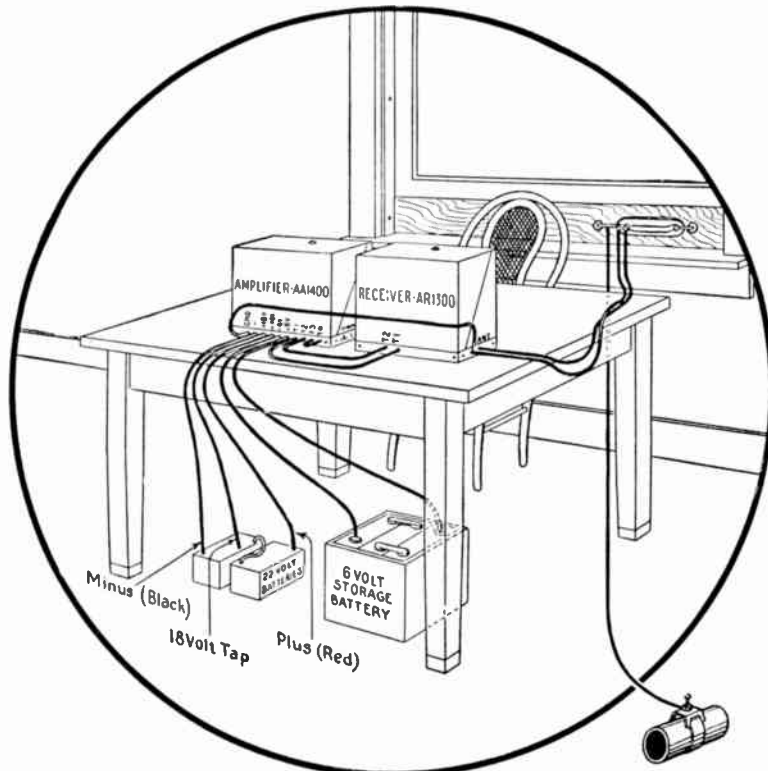

G. E. Detector-Amplifier, Model AA-1400, Less Tubes and Batteries\$75.00

THE AERIOLA GRAND

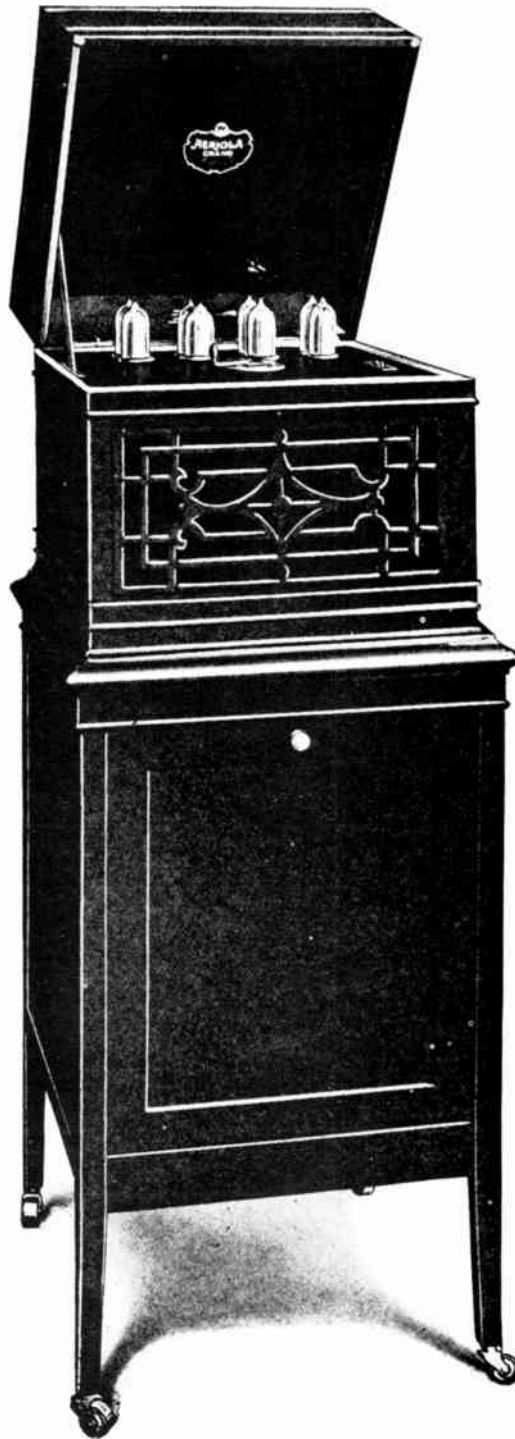

Simplicity of manipulation
and elegant appearance
make the Aeriola
Grand a popular
receiver



An instrument which may
well be accorded a place
in the most discrimi-
nately equipped
apartment



AERIOLA GRAND BROADCASTING RECEIVER, MODEL RG

Introducing a De Luxe Design in Broadcasting Receivers.

Aeriola Grand offers all that may be desired of modern radio telephone broadcasting. Its use makes possible the radio dance, the radio concert, the radio party.

HERE indeed is the ideal radiophone receiver for home entertainment. For simplicity of operation and compactness, it is unequaled and holds a leading position in the field of radio broadcast reception. Any man, woman or child can easily operate it without the slightest technical knowledge. A simple snap switch starts or stops it and a **single** tuning lever controls the wave length range. This high grade instrument is a product of the Westinghouse Electric and Mfg. Co.

Combines All Radio Essentials

The Aeriola Grand has been especially designed to receive broadcasting stations operating on the standard wave of 360 meters, but provision is made for an additional range up to 550 meters.

All the essentials of radio detection, amplification and loud speaking are embodied in this popular instrument. By means of the loud speaking chamber the entire family may hear broadcasted music and other entertainments. In fact, the complete outfit is arranged in a cabinet very similar to that of the conventional phonograph cabinet.

With Aeriola Grand it is only necessary to

connect the antenna and ground wires, turn the current on by means of a small snap switch and tune in the desired signals with a single control handle. A special plug is provided for reducing the volume of the incoming signals when the broadcasted concerts are too loud.

Automatic and uniform heating of the filament of the detector and three amplifier vacuum tubes used for reception in the Aeriola Grand is obtained by means of four ballast tubes.

The workmanship of the Aeriola Grand is unsurpassed. Its parts are housed in a highly polished mahogany cabinet, artistically constructed. Indeed, the instrument forms a valuable addition to the furnishings of any home.

Aeriola Grand is shipped complete with one detector tube, three amplifier tubes, four ballast tubes and the necessary "B" battery. To complete the installation, a 6 volt, 80 ampere-hour storage battery and a Model AD Antenna Outfit are required.

Anyone Can Install Aeriola Grand

Suitable stands are furnished for Aeriola Grand if desired. These stands are richly finished and harmonize in every way with the Aeriola Grand.

NOTES ON OPERATION OF AERIOLA GRAND

THE Aeriola Grand is a complete radio receiver and loud speaker combined, in a high grade mahogany cabinet. It is designed for use in homes near high power broadcasting stations operating on wave lengths below 500 meters. The distance from such a station, under average conditions, should not exceed 50 miles.

The instrument is well adapted for use by the novice. A push button switch, for turning the current on and off the vacuum tube filaments, and a single tuning lever completes the control. The method of amplifying has been developed to a degree where practically no distortion exists. The reproduction of clear speech and music is one of the outstanding features of the Aeriola Grand.

The Batteries

The vacuum tubes employed in the Aeriola Grand are designed for use with a six volt storage battery for lighting the filaments. The small dry batteries used for supplying the necessary plate voltage for the vacuum tubes are mounted within the cabinet of the Aeriola Grand itself. These dry batteries will give



The specially designed mahogany cabinet holds the storage battery and spare parts.

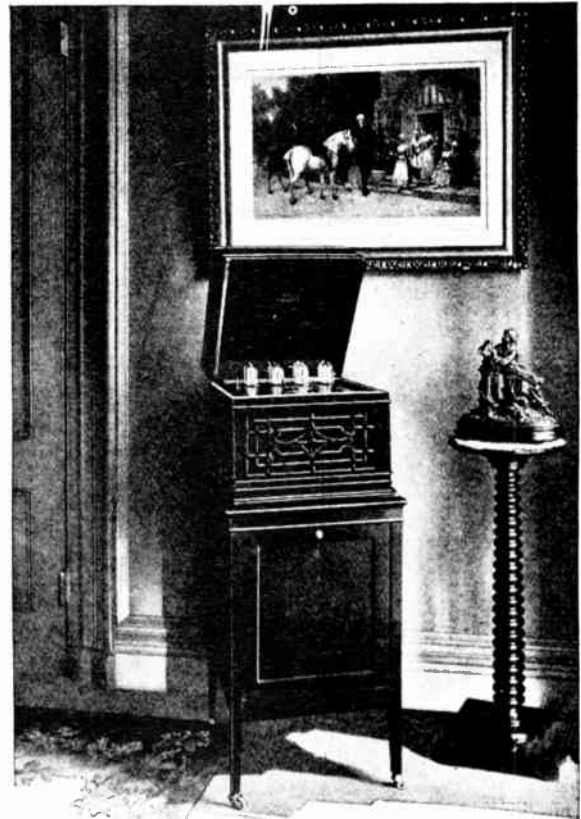

As a home entertainer, Aeriola Grand has no equal.

several months of service, after which, replacement is easily accomplished. There are four of them connected in series and secured by a retaining clamp.

Ballast Tubes

Ballast tubes are used in this receiver instead of the ordinary filament rheostats. The characteristics of the ballast tube filament is such as to automatically maintain a constant value of voltage on the vacuum tubes, thus doing away with four rheostat controls which would otherwise be necessary.

The Battery Charger

The storage battery used for the Aeriola Grand is not included with the set, but can be procured from the dealer. This storage battery should have a capacity not lower than eighty ampere hours. Where alternating current is available a very convenient method for lighting the filaments of the Aeriola Grand is obtained by employing a suitable storage battery and a Tungar or Rectigon battery charger.

An arrangement is possible by which a single switch may be used to connect the storage battery with the filaments of the vacuum tubes, or to charge the battery or to cut it off entirely.

Installation

If the Aeriola Grand is to be installed less than 10 miles from a broadcasting station it is not always necessary to use all three stages of amplification, for the sound intensity is apt to be too great. To offset this possibility the



Simplicity of operation has made Aeriola Grand the most popular Receiver for use in large cities served by radio telephone broadcast transmission.

front, left-hand amplifier tube should be removed from its socket. In its place the socket plug found in the dummy socket at the rear of the panel should be inserted. The withdrawn amplifier tube may then be placed in the receptacle formerly occupied by the plug. This arrangement reduces the number of tubes acting as amplifiers as well as the volume of the received sound.

The Aeriola Grand performs most satisfactorily in residential sections of cities where broadcasting stations operate. Caution should be used in attempting to make installations in the heart of large cities, for unless an antenna is relatively free from the screening effect of nearby buildings, especially steel-framed buildings, a marked decrease in signal strength is apt to result. However, installations made within a few miles of a broadcasting station will, of course, function even under such unfavorable conditions.

The Antenna System

The satisfaction derived from the performance of the Aeriola Grand depends largely on the care used in erecting the antenna system. The antenna should consist of a single wire 75 to 150 feet long, suitably insulated, as de-

scribed in Part 2. Other forms of antennae may be used, according to circumstances. In some locations indoor antennae may be employed satisfactorily. For private residences the antennae should be at least 30 feet above the ground and in apartment houses this wire should be at least 15 feet above the roof. In any event, the antenna wire should not come closer than 10 feet from trees, smokestacks, towers, cupolas, etc. The antenna wire should not be strung above trees or behind tall buildings if any other arrangement is possible.

The Ground Connection

The ground wire is as important as the antenna wire, and if possible, should be connected to a water pipe on the same floor as the instrument itself. In many cases equally good results may be obtained by connecting the ground wire to a steam or hot water radiator, rather than wiring a great distance to the water pipe.

Service by Local Dealer

The Aeriola Grand has been designed for people having little or no technical knowledge of radio, but nevertheless an arrangement should be made with the local radio dealer to have the equipment inspected at regular intervals. A service arrangement of this character can be made with a responsible dealer and it offsets the possibility of overtaxing any part of the equipment, assuring at the same time satisfactory results under all conditions.

Testing of Vacuum Tubes

In purchasing vacuum tubes, either for the Aeriola Grand or any other type of receiving instrument, it is advisable to have these tubes tested by the dealer in order to be perfectly sure they are in good condition and were not damaged during transportation.

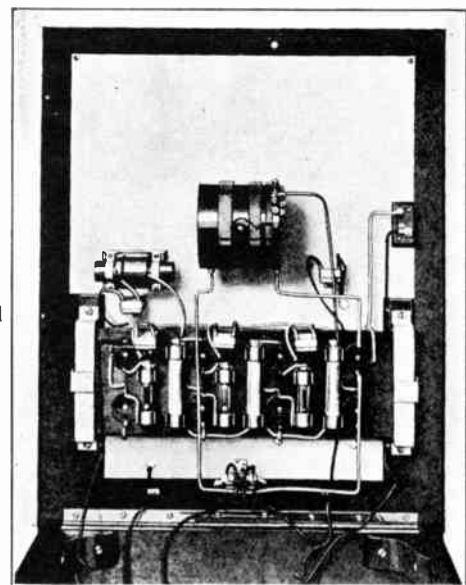

An Interior View of the Aeriola Grand Receiver

OPERATING INSTRUCTIONS FOR AERIOLA GRAND

Numbers Correspond with Diagram

- No. 1. First, refer to accompanying sketch, then erect antenna and place protective device in position as described on page 56.
- No. 2. Place Aeriola Grand on table or stand and connect wire as shown herewith. The two wires connecting the Aeriola Grand to the protecting device should be separated by at least one foot. No. 18 rubber-covered wire may be used for connections. The rubber covering on each end should be carefully removed and the wire scraped with a knife until bright. The clean bare wire should then be placed under the terminal caps and these caps screwed tightly into position.
- No. 3. The wire from terminal R of the protective device connecting to terminal A of the Aeriola Grand should be removed and connected to terminal B when signals below 350 meters are desired.
- No. 4. Press the black button of the snap switch, thus disconnecting the battery.

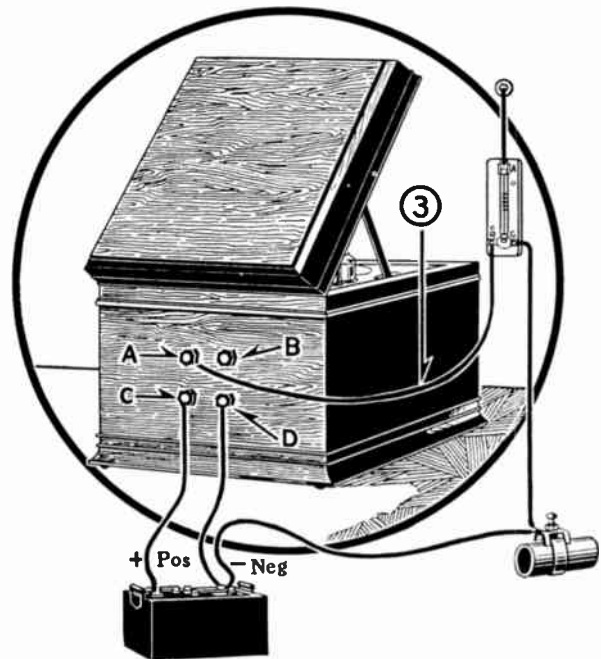

Illustrating easy method of connecting aerial ground and filament storage battery.

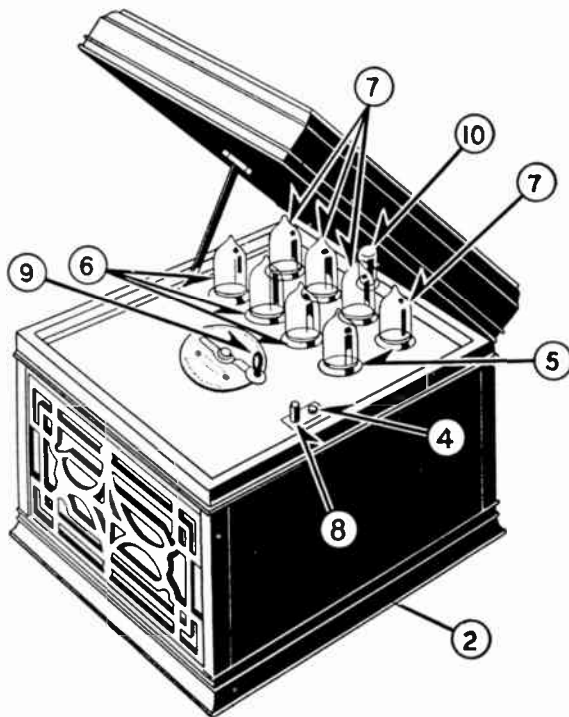

Text numbers correspond to above diagram.

- No. 5. Insert Model WR-21-D Aeriotron detector tube into the right hand front socket so that stamped trade mark is facing toward front of cabinet. Tube should be pressed firmly into socket.
- No. 6. Insert three Model WR-21-A Aeriotron amplifier tubes in the remaining front sockets.
- No. 7. Insert four Model WB-800 ballast tubes in rear sockets. Be sure that pins register with holes and press firmly into place.
- No. 8. Press red button of snap switch (4) clear down. All Aeriotron filaments should now be lighted.
- No. 9. Slowly rotate tuning handle over the scale until sound is loudest.
- No. 10. This plug should be used to replace the front left-hand tube if the broadcasting station is so near as to make the sound abnormally loud.

Caution: Always press black button of snap switch (4) when not using instrument, as this conserves battery energy.

Complete Aeriola Grand Broadcasting Receiver, Model RG, and Mahogany Stand, 150-550 meters, with six volt Storage Battery, Model 6HR-9, Rectigon Battery Charger (6 ampere size), Receiving Antenna Equipment and Full Instructions.	\$409.50
Aeriola Grand Broadcasting Receiver, as above, less Stand, Storage Battery, Charger and Receiving Antenna Equipment.	\$325.00
With Stand	\$350.00
Mahogany Stand Only	\$35.00

Dimensions: Receiver Cabinet, 21 in. x 17½ in. x 14½ in. Stand, 31¾ in. high x 22¾ in. x 19¾ in.

Weights: Net 50 lbs.; Shipping 70 lbs., with Stand 140 lbs.

NOTE: For Prices of other Complete Receiver Combinations, see page 35.

COLLAPSIBLE LOOP ANTENNA MODEL HG-1380

(For Indoor Reception).

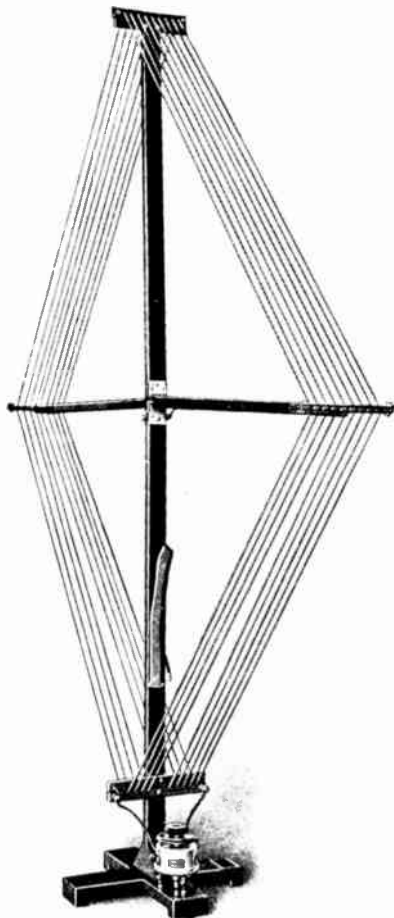

IN general, loop antenna reception is found advisable for use in congested areas where interference from a number of transmitting stations operating at the same time, is experienced. The reason for this is that the loop antenna responds only to signals from stations in the direction in which the loop points.

One of the difficulties experienced in loop reception, is that the distance over which signals may be heard is considerably reduced, unless suitable amplifiers are employed.

Loop reception, however, in the highly perfected state it is found in to-day, is so simple of operation that it is merely necessary to point the loop in the direction of the desired transmitting station, turn on the current and control the reception by a single adjustment. This adjustment is performed by a condenser generally mounted on the base of the loop as shown in the accompanying illustration.

The frame of the loop illustrated is artistically finished in mahogany and is entirely collapsible. The arms are rotated into position on hinges and the assembly is held rigidly in place by two metal hooks. The wire used for the winding of the loop is passed through bakelite cross arms fitted with milled slots. This wire is flexible and rubber covered. An outer covering of woven material is provided to resist wear when the loop is assembled, taken down, or carried about.

This loop has been designed for radio broadcasting reception and when used in conjunction with the UC-1820 variable condenser and any of the detector-amplifier units described in this book with the necessary batteries, forms a complete short distance receiving station for broadcasting use, which marks a distinct advance in the radio art.

While it is possible that loud speaking results may be realized over short distances with such combinations, it is not always to be expected when only audio-frequency amplification (as supplied by all the amplifying units listed elsewhere) is employed. Such results, however, are common where the energy of the incoming signal is built up by means of radio frequency amplification before it is passed on to the detector tube to be rectified and thence amplified by audio frequency units. The construction of radio frequency amplification circuits from component parts is fully described on pages which follow.

Interference from static is greatly decreased by the use of the loop antenna for reception.

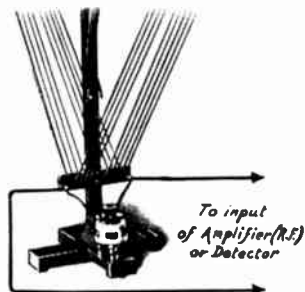

Upper figure shows loop in action.

Figure at left shows method of connection to receiving instruments.

Figure at right shows loop folded when not in use for reception.



COLLAPSIBLE LOOP ANTENNA, MODEL HG-1380, less variable condenser \$25.00

Dimensions: Height opened, 4 ft. 10½ in.; closed 2 ft. 9 in.; base, 12 x 12 in.

Weights: Net, 4 lbs.; shipping, 10 lbs.

COMPLETE RADIO TELEPHONE RECEIVER SETS

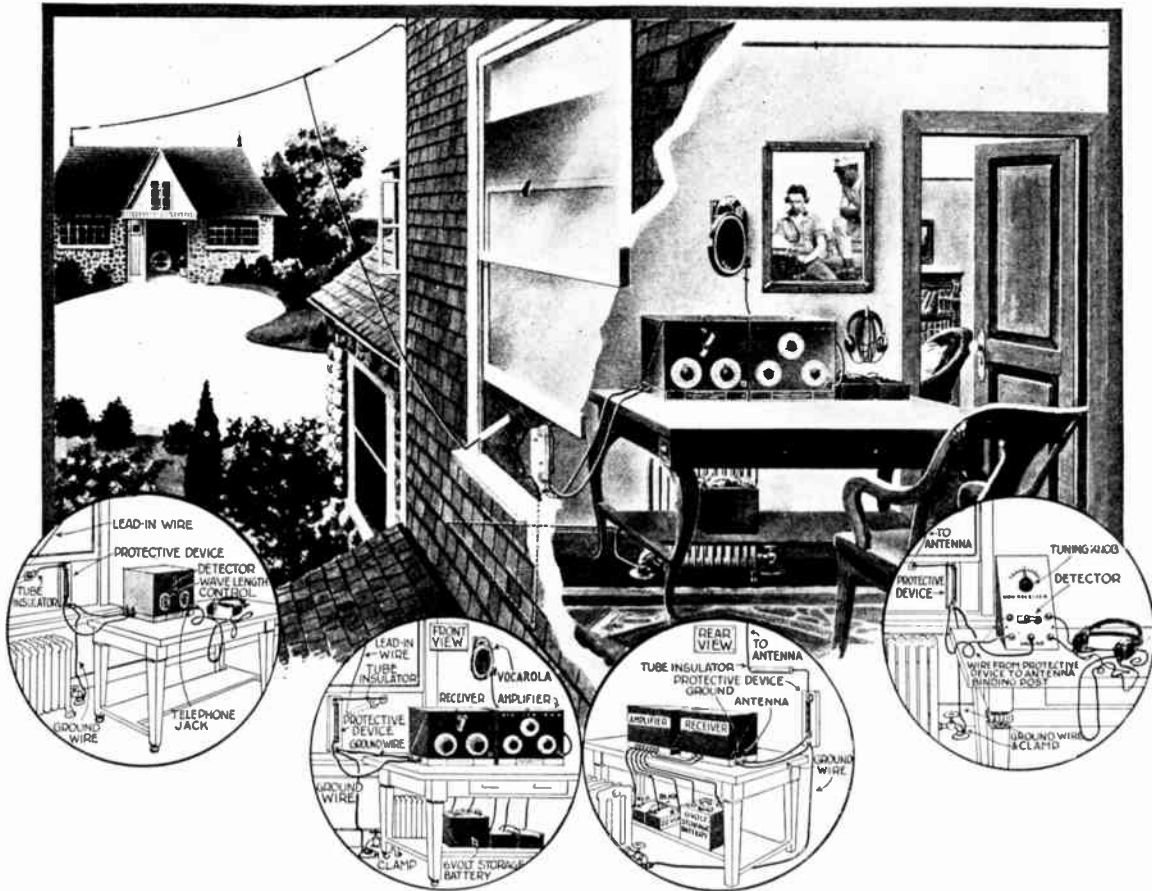

Illustrating the general set up of receiver combinations. The extreme left hand cut show GE Receiver AR-1300 as a crystal receiver, the next cut shows GE Receiver AR-1300 in combination with Amplifier AA-1400, the next cut shows the method of battery connection when using these two units. The extreme right hand cut shows GE Crystal Receiver AR-753 in operating position.

RECOMMENDED RECEIVER COMBINATIONS

IN determining the necessary equipment for a Broadcast Receiving Station the following combinations of apparatus will be found helpful. Any unit may be bought separately. The complete combinations are indicated merely to guide those who wish to purchase a complete receiving set. Thus the technically uninformed enthusiast avoids the risk of buying unnecessary parts.

Westinghouse Aeriola Grand Combination No. 1		Westinghouse Aeriola, Sr., Combination No. 2	
RG	Aeriola Grand Receiver, with Stand, 150-550 meters, comprising one Aeriotron Detector, three Aeriotron Amplifiers, four Ballast Vacuum Tubes, and four "B" Batteries	RF	Aeriola Sr., Receiver, 190-500 meters, with Brandes Telephones and one W-D-11 Aeriotron Detector Tube
	\$350.00		65.00
6HR-9	Storage Battery, 6 volts, 100 A.H.		One Dry Cell for Aeriotron Filament
	24.00		.40
AD	Receiving Antenna Equipment	AD	One "B" Battery, 22.5 volts Receiving Antenna Equipment
	7.50		3.00
285168	Rectigon Battery Charger, 6 amperes		7.50
	28.00		Total.....
	Total.....		\$75.90
	\$409.50	Westinghouse Aeriola Jr., Combination No. 3	
		RE	Aeriola Jr., Receiver, 150-700 meters, with Brandes Telephones and spare crystals
			25.00
		AD	Receiving Antenna Equipment
			7.50
			Total.....
			\$32.50

Westinghouse Regenerative-Vacuum Tube Receiver Combination No. 4

RC	Short Wave Regenerative Receiver, 170-700 meters, less tubes	\$132.50
CB	Load Coil	6.00
UV-200	One Radiotron Detector	5.00
UV-201	Two Radiotron Amplifiers	13.00
6HR-9	Storage Battery, 6 volts, 100 A. H.	24.00
UD-790	Brandes Telephones	8.00
UD-824	Telephone Plug	1.75
	Two "B" Batteries	6.00
AD	Receiving Antenna Equipment	7.50
LV	Vocarola (Loud Speaker)	30.00
285168	Rectigon Battery Charger, 5 amperes	28.00
Total		\$261.75

Westinghouse Crystal Receiver Combination No. 5

RA	Short Wave (Regenerative) Tuner, 170-700 meters	\$68.00
DB	Crystal Detector	6.50
UD-790	Brandes Telephones	8.00
AD	Receiving Antenna Equipment	7.50
Total		\$90.00

General Electric Regenerative-Vacuum Tube Receiver Combination No. 1

AR-1300	Radiophone Receiver, 170-700 meters	\$50.00
AA-1400	Detector—2-step Amplifier, less Tubes	75.00
UV-200	One Radiotron Detector	5.00

Illustrating the Westinghouse Regenerative-Vacuum Tube Receiver Combination No. 4.

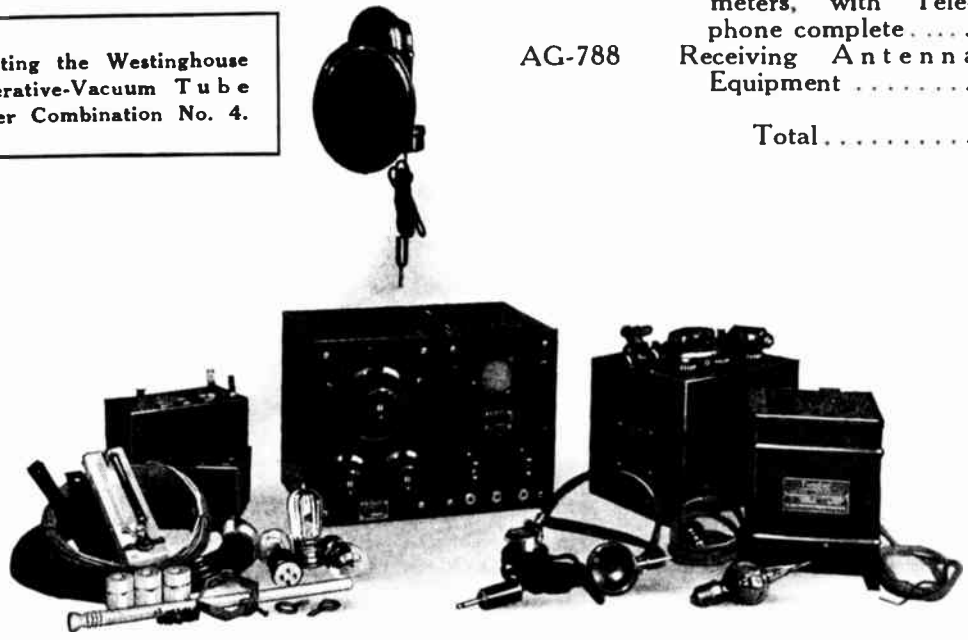

UV-201	Two Radiotron Amplifiers	13.00
UD-790	Brandes Telephones	8.00
3LXL-9	Storage Battery, 6 volts, 80 A. H.	23.00
2156	Three "B" Batteries, each 22.5 volts	9.00
LV	Vocarola (Loud Speaker)	30.00
219865	Tungar Battery Charger, 5 amperes	28.00
UD-824	One Telephone Plug	1.75
AG-788	Receiving Antenna Equipment	7.50
Total		\$250.25

General Electric Crystal Receiver Combination No. 2

AR-1300	Crystal Radiophone Receiver, 170-700 meters, complete	\$50.00
UD-790	Brandes Telephones	8.00
AG-788	Receiving Antenna Equipment	7.50
Total		\$65.50

General Electric Crystal Receiver Combination No. 3

ER-753	Crystal Radiophone Receiver, 300-700 meters, with Murdock Telephone Receivers	\$18.00
AG-788	Receiving Antenna Equipment	7.50
Total		\$25.50

Wireless Specialty Crystal Receiver Combination No. 1

AR-1375	Crystal Radiophone Receiver, 170-2650 meters, with Telephone complete	\$40.00
AG-788	Receiving Antenna Equipment	7.50
Total		\$47.50

PART TWO

Receiver Accessories

With Data on

Receiving Circuits

Audio Frequency Amplification

Radio Frequency Amplification

Vacuum Tubes and Their Use

Receiving Antenna Equipment

Special High Grade Receivers

And other information for the

Radio Enthusiast desiring to

assemble experimental units

RECEIVING CIRCUITS

A Simple Vacuum Tube Circuit

CONTRARY to general opinion, receiving circuits in which vacuum tubes are employed are quite simple. The following descriptions include several standard receiving circuits which have proved satisfactory after long usage and which may readily be made up by the experimenter who follows the simple directions.

Fig. 1 is a simple receiving set, wherein a loose coupler is used for tuning. As will be seen, there are two distinct coils in a loose coupler, one called the primary, L 1, and the other the secondary, L 2. One end of the primary is connected to a binding post which in turn is connected to the antenna. The other end of the winding is free, but a sliding contactor is provided in order to connect as many turns between the binding post to which the end of the coil is attached and the free end as may be necessary. This sliding contact is indicated in the diagram by an

ous tubes require different values of resistance in this position. The Radio Corporation grid leaks (UP-509 to UP-527) with the mounting UX-543 are recommended for this work.

The opposite side of the loose coupler is connected to the negative side of the Filament of the vacuum tube indicated in the diagram by F—. Where a vacuum tube is used in conjunction with a Radio Corporation socket UR-542, this connection is made to one of the binding screws on the vacuum tube socket marked F. To this post, as will be seen, two other connections—one from the minus or negative pole of the six volt storage battery, indicated by "A", and the other from one outside terminal of the "A" Battery Potentiometer, R2, are made. The opposite side of the "A" Battery is connected to one terminal of the Filament Rheostat, R, the second terminal of the rheostat being connected to the vacuum tube socket, UR-542, at the point F+. The re-

Figure 1
A simple vacuum tube receiving circuit employing a loose coupled tuner.

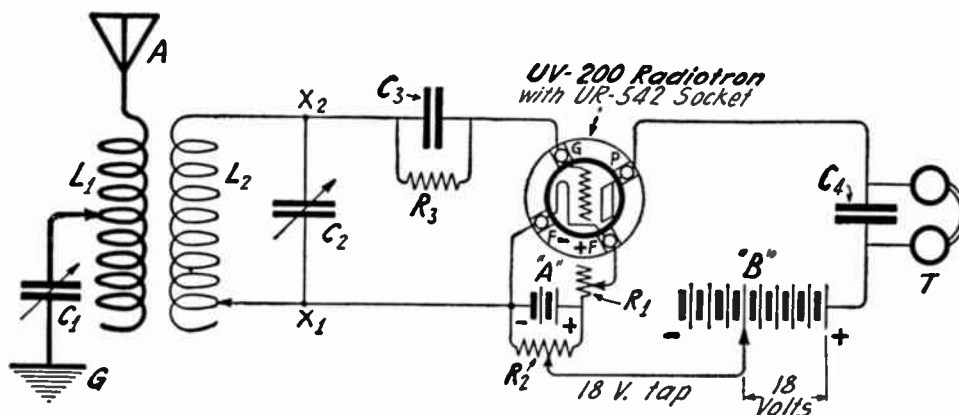

- C 1—Variable condenser, .0006 mfd. max. UC-1820.
- C 2—Secondary tuning variable condenser .001, .005 mfd., UC-1819.
- C 3—Grid condenser (fixed or variable), .00025 mfd., UC-567 with UX-543 mounting or UC-1820 variable condenser.
- C 4—Telephone condenser, fixed, value optional. UC-569 with UX543 mounting.

- L 1—Primary of any loose coupler (sometimes called receiving transformer).
- L 2—Secondary of loose coupler.
- R 1—Filament control rheostat, PR-535.
- R 2—"A" battery potentiometer, PR-536.
- R 3—Standard grid leak resistance, .5 to 2 megohms, UP-516, 519 or 523 with UX-543 mounting.
- T—Telephone receivers, Western Electric No. 1002-A.

arrow. A switch is often employed instead of the slider. Such a switch is made with many contact points, each point being connected to a different part of the primary or secondary winding. For the most satisfactory tuning, a variable condenser, C-1, should be inserted between this slider or switch and the ground connection.

A variable condenser, C-2, is placed between the two terminals of the secondary. As indicated by C-3, a small condenser, called a Grid Condenser, because it is inserted in the grid circuit, is placed between the Grid terminal (marked "G") of the socket, UR-542, and one terminal of the secondary.

For the best reception some vacuum tubes require what is known as a grid leak resistance. This is shown in the diagram R-3. Vari-

maining outside terminal of the Potentiometer is connected to the positive or plus side of the "A" battery. This Potentiometer is provided with a third terminal which is connected to the 18-volt tap of the "B" battery (Burgess No. 2156). The positive terminal of the "B" Battery is connected to one side of the condenser C-4 with the opposite side of this condenser being connected to the terminal P of the vacuum tube socket, UR-542. The tips of the telephone cords are also connected, one each to the binding posts of the condenser C-4. This completes what is known as a straight vacuum tube detection circuit. A great improvement over this circuit is obtained by using the arrangement shown in Fig 2, although it is not quite so simple.

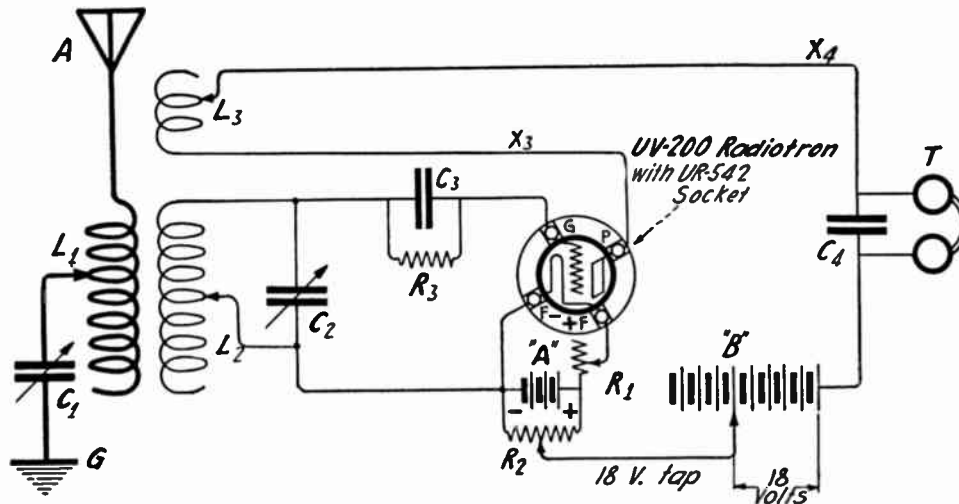

Figure 2
A simple vacuum tube circuit similar to Figure 1 but employing a "tickler" coil for regeneration.

- C 1—Antenna tuning variable condenser, .0006 mfd. max. UC-1820.
- C 2—Secondary tuning condenser, .0001-.005 mfd., UC-1819.
- C 3—Grid condenser (fixed or variable), .00025 mfd., UC-567 with UX-543 mounting or UC-1820 variable condenser.
- C 4—Telephone condenser, value optional, UC-569, with UX-543 mountings.
- L 1—Primary of loose coupler.
- L 2—Secondary of loose coupler.
- L 3—Tickler coil.
- "A"—6-volt filament lighting battery. Exide, 3-LX-9-1.

- "B"—20 to 30-volt plate battery. Burgess No. 2156.
- R 1—Standard Filament rheostat, PR-535.
- R 2—Standard "A" battery potentiometer, 04-536.
- R 3—Standard grid leak resistance .5 to 2 megohms, UP-516, 19 pr. 23 with UX-543 mounting.
- T—Telephone receivers, Western Electric No. 1002-A.

Note: Where the UC-1820 is used for the grid condenser no UX-543 mounting is necessary for inserting the grid leak resistance as this condenser is equipped with clips which will fit any of the RC standard grid leak resistance.

A Simple Regenerative Circuit

In Fig. 2 it will be observed that all the important elements are identical to those shown in Fig. 1. However, this arrangement permits very much greater selectivity in receiving as well as providing for amplifying the incoming signals by what is known as the regenerative method.

The only difference between Fig. 1 and Fig. 2 is, that a coil of wire L3, is connected in the circuit between the two points indicated by X3 and X4. This coil is used to carry the current back to the secondary of the loose-coupler and when properly adjusted causes amplification to take place. This coil is called a "tickler" coil. Its size depends upon the particular class of receiving to be

carried on. The size of this coil for these various applications may be obtained by referring to any good book written for wireless experimenters. This circuit forms what is known as a standard regenerative receiver. In some instances the value of the "tickler" or feed-back circuit is made variable. There are several ways of varying this value. Regeneration is generally controlled in this type of circuit by changing the position of L3 with relation to L2, or varying the inductance of the circuit itself.

Amateur Regenerative Circuit

Fig. 3 shows the circuit generally used where a vario-coupler and two variometers are employed as the variable tuning elements in regenerative receivers. This character of receiving equipment is more or less confined

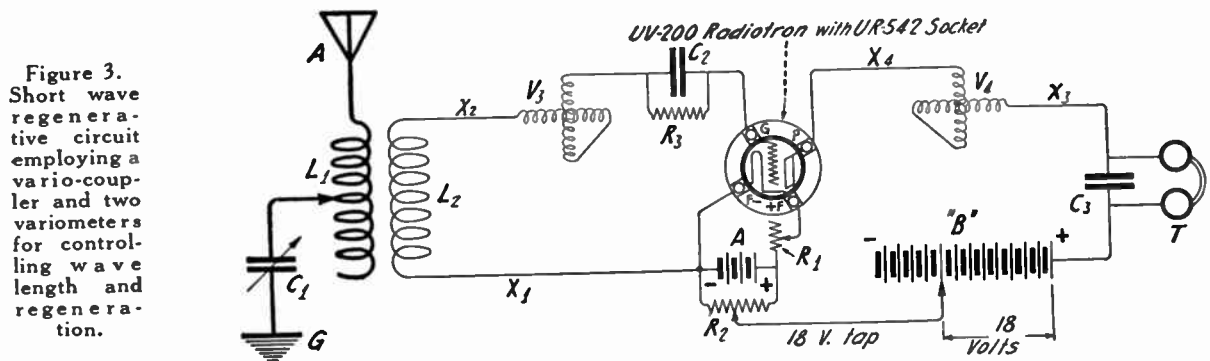

Figure 3.
Short wave regenerative circuit employing a vario-coupler and two variometers for controlling wave length and regeneration.

- C 1—Antenna variable condenser, .0006 mfd. max., UC-1820.
- C 2—Grid condenser, fixed or variable, .00025 mfd., UC-567 with UX-543 mounting or UC-1820 variable air condenser.
- C 3—Telephone condenser, value optional, UC-569, with UX-543 mounting.
- "A"—6-volt filament lighting battery, Exide, 3-LX-9-1.
- "B"—20 to 30-volt plate battery, Burgess 2156.
- L 1—Primary of any vario-coupler.
- L 2—Secondary of any vario-coupler.
- L 3—Grid variometer.

- L 4—Plate variometer.
- R 1—Standard filament control rheostat, PR-535.
- R 2—Standard "A" battery potentiometer, PR-536.
- R 3—Standard grid leak resistance, .5 to 2 megohms, UP-516, 519 or 523 with UX-543 mounting.
- T—Telephone receivers, Western Electric, 1002-A.

Note: Where the UC-1820 is used for the grid condenser it is not necessary to use the mounting UX-543 for the grid leak resistance, for the condenser is fitted with mountings for standard R.C. grid leak resistances.

to short waves from 150 to 600 or 700 meters. It will be seen that the inductance, L-2, in this case is not shunted by a variable capacity as was the case in Figs. 1 and 2. However, the variometer, V-1, is employed which comprises one stationary and one movable coil, is arranged so that the rotation of the movable coil with reference to the stationary coil has the effect of increasing or decreasing the wavelength of the circuit and permits a very selective control.

From the points indicated by X-1 and X-2, by making a comparison of Figs. 2 and 3, it will be found that Fig. 3 differs from the first two only in that the condenser, C-2, is not used and the variometer V-3, is placed between the upper terminal of the secondary of the loose-coupler and the grid condenser.

The third tuning circuit which controls the regeneration or amplification is also made vari-

or procuring the parts which go to make up the units and assembling them. For the benefit of those who desire to assemble their own equipment the circuit shown in Fig. 1 is very strongly recommended for use in sections where receiving stations are closely located to one another. In congested city districts near the broadcasting stations, shunt a wire across the points X-3 and X-4, leaving out the tickler circuit. The circuit depicted in Fig. 4 is quite similar to those shown in Fig. 2 and Fig. 3, but two stages of amplification have been added. As may be observed this form of amplifier circuit may be added to any form of receiving circuit and need not be confined to the arrangement shown in Fig. 4.

It should be observed from a comparison of the last three circuits under consideration that where the audio frequency amplifiers are

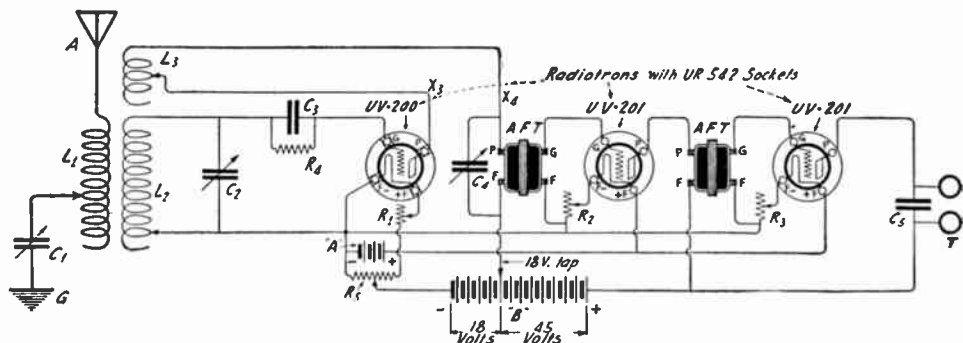

Figure 4. Standard regenerative receiving circuit employing two stages of audio frequency amplification.

- C 1—Variable antenna tuning condenser, .0006 mfd. max., UC-1820.
- C 2—Secondary tuning variable condenser, .0001-.005 mfd., UC-1819.
- C 3—Standard tubular grid condenser, UC-567 with UX-543 mounting or UC-1820 precision variable air condenser.
- C 4—Bi-pass condenser, variable, UC-1819 or UC-1820
- C 5 Telephone condenser, value optional, UC-569, with UX-543 mounting.
- L 1—Primary of loose coupler.
- L 2—Secondary of loose coupler.
- L 3—Ticker coil.
- R 1, 2 and 3—Standard R. C. Filament control rheostats, PR-535.
- R 4—Standard R. C. grid leak resistance unit, .2 to 5 megohms UP-516, 519 or 523, with mounting UX-543.

- S—Standard R. C. Vacuum tube sockets, UR-542.
 - AFT—Standard R. C. Audio-frequency amplifying transformers, UV-712.
 - T—Telephone receivers, Western Electric, 1002-A.
 - "A"—6-volt filament lighting battery, Exide, 3-LX-9-1.
 - "B"—20 to 100-volt plate batteries, made of several Burgess 2156 units connected in series, with a tap taken off at the 18-volt point for operation of the detector tube.
- Note: When UC-1820 precision variable air condenser is used for the grid condenser no mounting UX-543 is needed for the grid leak, for the mounting is made as a part of the condenser. It will accommodate any of the R. C. Standard grid leak resistances.

able by means of a variometer, V-4. This variometer is placed in the circuit between the points marked X-3 and X-4. It takes the place of the coil L-3 in Fig. 1, and forms one method of changing the value of this tertiary or plate circuit.

Where it is desired to use some form of loud-speaking device or where the distance over which signals are to be received is exceptionally long, the experimenter must use some method of increasing the intensity of the received signal. The most common method for accomplishing this is found in what is termed, "audio frequency amplification."

Where the experimenter wishes to take advantage of audio frequency amplification, there are two means at his disposal, namely: purchasing the amplifying units fully wired and ready for connecting them in the circuit,

brought in play, the place ordinarily occupied by the telephone receivers is taken by the input circuit of the first stage of amplification, and a variable condenser is substituted for the fixed condensers shown in the other three circuits, to increase the stability of operation. In other respects the fundamental parts of all three circuits are identical.

Regeneration, in this system, is obtained and controlled by the same method described in connection with Figs. 2 and 3. In Fig. 4 a standard method of regeneration is illustrated, but the arrangement shown in Fig. 3 may be employed. The circuit as in Fig. 4 shows a pair of telephone receivers in use, but it is often desirable to use a loud speaking device in their stead.

In order to employ a loud speaker it is merely necessary to remove the telephone receivers from the circuit and connect the two terminals of the loud speaker in their place. Adjustment of the variable condenser, C-4, may be used to clarify the tone of the signals. Some loud speakers require a battery for their operation, but the vast majority will function directly from the amplifier. Where the loud speaker does require such a battery, the directions which accompany the device must be strictly adhered to, in order to prevent the possibility of ruining the internal mechanism and connection may generally be made to the six-volt storage battery marked "A".

The effect of using two stages of amplifi-

speaker" is employed or where extraordinary distances are being covered.

Where such amplifiers are used it is often found desirable to use less than the maximum amplification. To accomplish this ordinarily, it is necessary to alter several of the connections. An automatic system has been devised utilizing multi-bladed telephone jacks functioning with the conventional telephone plug. The blades and the jacks are so connected to the circuit that the necessary units are included when the plug is inserted in position.

Amplifier Circuit with Plug and Jack Control

The circuit arrangement shown in Fig. 5 is one employing standard Radio Corporation

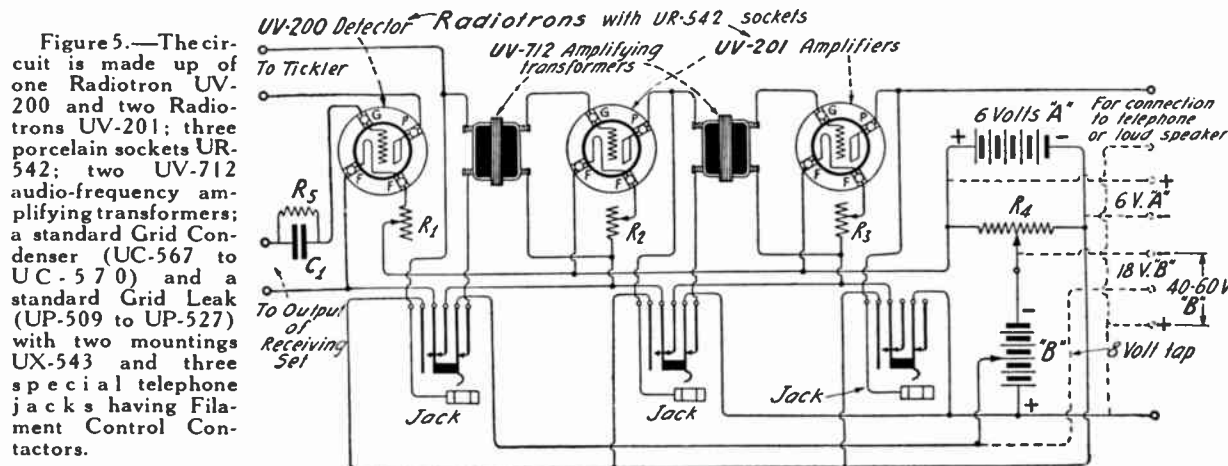

Figure 5.—The circuit is made up of one Radiotron UV-200 and two Radiotrons UV-201; three porcelain sockets UR-542; two UV-712 audio-frequency amplifying transformers; a standard Grid Condenser (UC-567 to UC-570) and a standard Grid Leak (UP-509 to UP-527) with two mountings UX-543 and three special telephone jacks having Filament Control Connectors.

cation is to increase the intensity of the incoming radio signal, whether it be speech, music or code, many times. Each step of amplification increases the signal a certain number of times, depending upon the design and use of the amplifier, so it may be seen that where each step amplifies from six to ten times, the result of using two stages is an increased energy of from approximately 36 to 100 times its original value. In estimating the amplification factor of audio frequency devices it is safe to assume that the higher the voltage applied to the plates of the amplifier tubes, the greater is the resultant amplification. This does not hold true with detector tubes.

Regenerative Amplifier Circuit

The arrangement illustrated in Fig. 4 may be used for obtaining satisfactory results over very long distances and it is recommended because it is simple to assemble and operate. This system is now being used by a great many experimenters throughout the world and one need have no fear of its dependability, where the values for the different units comprising the layout are properly followed.

Many modern receiving equipments include one or two stages of audio-frequency amplification. This is especially true where a "loud

amplifying parts, with Western Electric telephone jacks. When the plug is inserted in the first jack the detector tube alone functions; when the plug is inserted in the second jack the detector tube and the first amplifying circuit function together; when placed in the third jack three tubes are made to operate. As may be seen from the diagram, the Filament as well as the other circuits are operated by merely inserting the plug.

Where this layout is desired, the circuit should not be made to include the batteries indicated in the diagram, but should be made to run to a series of terminals or binding posts indicated by the dotted lines in the diagram.

Regulation of the voltage on the plate of the detector tube is accomplished by means of a Potentiometer shunted across the "A" battery with the arm connected to the negative terminal of the "B" battery. This Potentiometer when connected to the 18 volt tap of a Standard Burgess No. 2156 plate battery permits a voltage regulation of from 18 to approximately 24 volts. With some detector tubes it is necessary, in order to obtain best results, to connect to the 22.5 volt lead of the plate battery instead of the 18 volt lead. This is especially so with batteries which have been in use for a considerable period. In this case the voltage range is from approximately 22.5 volts to 28 volts.

FOR GENUINE AMPLIFICATION
TONE FREQUENCY INTERVALVE AMPLIFYING TRANSFORMER

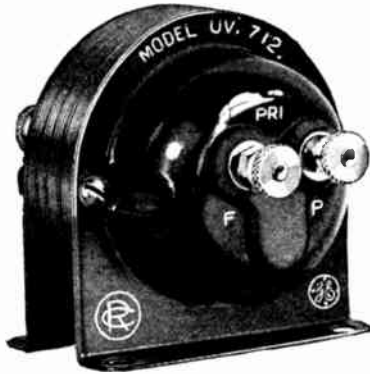

Ideal for Broadcast Amplification

It is a well known fact that for maximum amplification the characteristics of an intervalve tone frequency amplifying transformer must be such as to fit the output impedance of the preceding tube in a cascade amplifying set. There is an allowable variation of the constants of the transformer when loaded on the secondary by an amplifying tube, but nevertheless, the maximum signal is obtained from a transformer designed especially to fit the output impedance of the tubes with which it is used.

Designed for Radiotron Vacuum Tubes

Prior to the introduction of Transformer Model UV-712, amateur experimenters were compelled to employ intervalve transformers of various characteristics, none of which had been designed specifically for the Radio Corporation's detector tube, Radiotron UV-200, and the amplifier tube, Radiotron UV-201. Transformer UV-712 not only has been designed to fit these vacuum tubes, but special

care has been taken to reduce the transformer losses to the lowest possible minimum.

Thousands Now in Use

The accompanying illustration shows the new amplifying transformer, of which there are several thousand now in daily use. Transformer UV-712 has been designed and manufactured strictly on a quality basis. It is precisely the same type used in the Corporation's commercial types of radio receiving sets. It is not to be compared with other types in which efficiency has been sacrificed to obtain compactness or to reduce manufacturing costs. Many experimenters report that the introduction of UV-712 into their receiving sets, has resulted in such a marked increase of signal audibility as to be nothing short of marvelous.

In general, a tone-frequency amplifier transformer should occupy the same position in the output circuit of a vacuum tube as the receiving telephont. The terminals P and F of Transformer UV-712 may be connected to the plate circuit terminals which ordinarily are connected to the telephone receiver. The secondary terminals should connect to the grid and filament of the following tube of a multi-stage amplifier.

In radio amplifier circuits using Transformer UV-712, the insulation of all apparatus connected to the secondary must be as perfect as possible. Leakage from the grid to the filament of amplifier tubes through the socket, mounting, panel, wiring or otherwise, will decrease the amplification. The lead from terminal G should be kept reasonably short and in cascade amplifier sets adjacent transformers should not be mounted too close; a separation of at least four or five inches should be allowed.

PHYSICAL CHARACTERISTICS

- | | |
|---|---|
| 1. Totally enclosed | 4. Overall length, $3\frac{7}{8}$ in. |
| 2. Net weight, 1 lb. $4\frac{1}{2}$ oz. | 5. Overall height, $2\frac{3}{4}$ in. |
| 3. Shipping weight, 1 lb. 7 oz. | 6. Base area, $2 \times 2\frac{3}{4}$ in. |

ELECTRICAL CHARACTERISTICS

1. Ratio of Secondary to Primary Turns, 9/1.
2. Useful frequency range, 60/3000 cycles.
3. Allowable current on each winding, 10 milliamperes.
4. Test voltage between windings and between core and windings, 300 volts at 60 cycles.
5. Terminal voltage limit of secondary winding, 300 volts.

Model UV-712 is the only transformer designed specifically for use with Radiotrons.

AMPLIFYING TRANSFORMER, MODEL UV-712 **\$7.00**
 Dimensions: $2\frac{3}{4}$ in. x $3\frac{7}{8}$ in. x 2 in. Shipping Weight: 1 lb. 7 oz.

RADIO FREQUENCY AMPLIFICATION

With The RCA Radio Frequency Intervalve Transformers

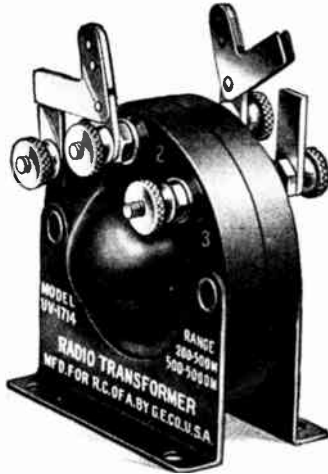

Model
UV-1714,
range
200 to 5000
meters

Greater
Receiving
Range
with
Less Distortion



Model
UV-1716,
range
5000 to 25000
meters

Amplification in radio reception means increased signal audibility. The current developed in a radio receiving set from a distant transmitting station is not always of sufficient intensity to operate a telephone or a loud speaker. It is for this reason that radio frequency, audio frequency amplification or a combination of both must be resorted to. The radio frequency amplifier consists of a group of vacuum tubes in cascade, interconnected by specially designed transformers which increases the intensity of the signalling current in its original form. The audio frequency amplifier, on the other hand, amplifies the output of a detector tube which has changed the amplified high frequency current to a form which will operate a telephone receiver.

Where receiving sets are located within a comparatively short distance from a broadcasting station, ample signal strength may be secured by the use of a vacuum tube detector and a two-stage audio-frequency amplifier. However, where the receiving station is more remote, the incoming signal must be built up in order to properly actuate the detector tube. This building up of signal energy is accomplished by radio frequency amplification.

Ordinarily, very weak signals influence the detector so slightly that there is little or no rectification. Under this condition, audio frequency amplification is not always effective.

In general, more than two stages of audio frequency amplification proves unsatisfactory, for there is then a tendency to over-amplify tube noises and inductive disturbances from nearby lighting circuits.

The radio frequency method of amplification described here increases the strength of the in-

coming antenna current through successive stages until it becomes of sufficient intensity to enable detection to take place. Then with the addition of one or two stages of audio frequency amplification a current of sufficient strength will be generated which may be used to actuate either telephone receivers or loud speaking devices.

The design, however, of a radio frequency transformer suitable for amplification of signals at both long and short wavelengths has always presented a difficult problem, and it is only with the introduction of the Radio Corporation of America's new radio frequency transformers that amateurs and experimenters may take advantage of this means of amplification.

The radio frequency amplifier circuits illustrated and described here have been fully tested, and with the apparatus listed the broadcast enthusiast, the amateur and experimenter can at once enjoy radio reception without the necessity of using a high antenna, at the same time insuring minimum of interference from undesired stations.

Radio frequency amplification also permits the use of frame or loop aeriels and provides, even with such limited antennae, a signal of great enough intensity to function properly with audio frequency amplifiers for the operation of loud speakers, within certain limits. It is particularly suited to the reception of radio music and speech for it tends to eliminate the distortion resulting from the use of several stages of audio frequency amplification. For the longer wave lengths, two or three stages in cascade will produce a very strong signal from foreign stations using an average amateur antenna for receiving.

In former attempts to obtain radio frequency

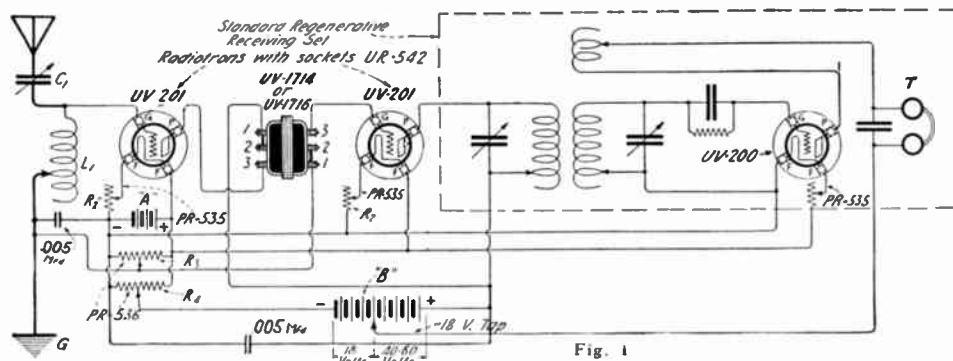

Fig. 1

"A"—Storage battery (6V-80 ampere-hour size or larger).
 "B"—Standard 22.5 volt plate batteries, with 18 volt tap.
 C—Variable antenna series condenser, UC-1820 (.0006 mfd. max.).

L 1—Simple tuning coil, either tapped or fitted with a slider.
 R 1, R 2—Standard filament rheostats, PR-535.
 R 3, R 4—Standard "A" battery potentiometers, PR-536.

NOTE:—The circuit within the dotted lines is a standard regenerative circuit.

amplification, it has been impossible to obtain maximum results on certain wave lengths without sacrificing on others. This is because transformers with characteristics which would be desirable for the long waves would not function properly on the shorter waves and vice versa. With Model UV-1714, a range of 200 to 500 meters is provided. To permit this very broad range, a tap has been made on each winding and connected to the terminal marked "2." For short wave reception, that is, from 200 to 500 meters, the connections illustrated in the accompanying diagrams are to be used. For the longer range of 500 to 5000 meters, the metal strap on each side of the transformer is disconnected and the entire windings from the terminals "1" to the terminals "3" are used.

2-Stage Radio Frequency Amplifier Circuit

Fig. 1 illustrates a satisfactory circuit for use in connection with several stages of radio frequency amplification for the reception of continuous waves.

In this case the antenna is tuned to the wave length of the desired signal and this selected signal is amplified through the primary of a

standard receiving set connected to the plate circuit of the last frequency amplifier tube. It is then transferred through the secondary circuit to the detector tube, in which regeneration may be controlled as desired.

One decided advantage of using the circuit shown in Fig. 1 is that the oscillations in the detector tube circuit cannot find their way back through the radio frequency amplifier to the antenna circuit, therefore the antenna cannot radiate energy. If potentiometer R-3 is not used, the filament rheostat should be placed in the positive leg of the filament circuit instead of the negative.

Combined Radio-Audio Frequency Circuit

For general reception when an average outdoor amateur antenna and radio frequency amplification are used, the circuit shown in Fig. 2 is most highly recommended. This arrangement is quite similar to that shown in Fig. 1, but instead of the standard regenerative receiver, a vario-coupler and twin variometer receiver is employed, and two stages of audio-frequency amplification have been added for operating a loud speaker.

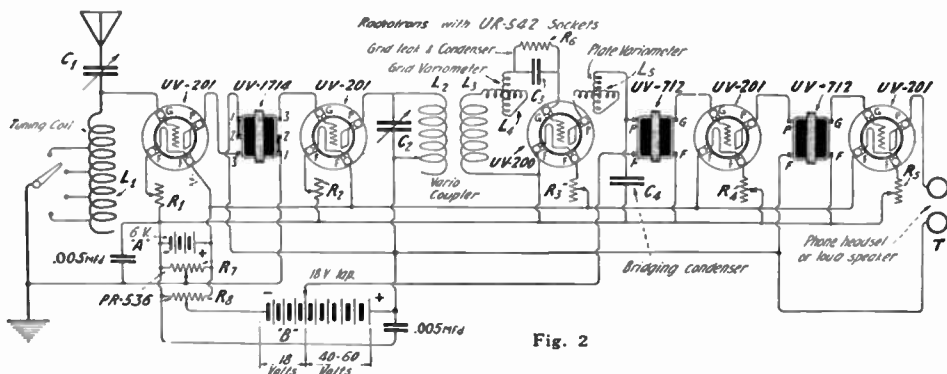

Fig. 2

"A"—Storage battery (6V-80 ampere-hour size or larger).
 "B"—Standard 22.5 volt plate batteries, with 18 volt tap.
 C 1—Variable antenna series condenser, UC-1820 (.0006 mfd. max.).
 C 2—Variable condenser, UC-1819 (.0001 - .005 mfd.).
 C 3—Grid condenser (fixed or variable) .00025 mfd., UC-567 with UX-543 mounting or UC-1820.
 C 4—Telephone condenser, size optional, UC-567 to UC-570, with mounting, UX-543.
 C 5 and C 6—.005-.01 mfd.

L 1—Simple tuning coil, either tapped or fitted with a slider.
 L 2—Primary of vario-coupler.
 L 3—Secondary of vario-coupler.
 L 4—Grid variometer.
 L 5—Plate variometer.
 R 1, 2, 3, 4, 5—Standard filament rheostats, PR-535.
 R 6—Standard grid leak, .5 to 2 megohms, UP-516, 519 or 523, with UX-543 mounting.
 T—Head telephones.
 R 7 and R 8—Standard "A" battery potentiometers, PR-536.

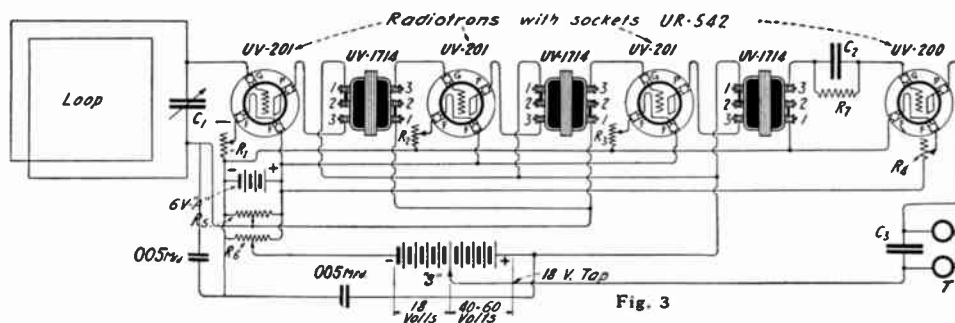

Fig. 3

- "A"—Storage battery (6V-80 ampere-hour size or larger).
- "B"—Standard 22.5 volt plate batteries, with 18 volt tap.
- C 1—Variable loop tuning condenser, UC-1820, .0006 mfd. max.
- C 2—Grid condenser (fixed or variable), .00025 mfd., UC-567, with mounting UX-543 or UC-1820.
- C 3—Telephone condenser, UC-567 to UC-570, with mounting UX-543. The use of this condenser is optional.

- Loop—Fully described above.
- R 1, R 2, R 3—Standard filament rheostats, PR-535.
- R 4, R 5—Standard "A" battery potentiometers, PR-536.
- R 6—Standard grid leak .5 to 2 megohms, UP-516, 519 or 523, with UX-543 mounting.
- T—Head telephones.

As is the case with the former circuit, the circuit shown in Fig. 2 utilizes separate antenna tuning, by means of the simple tuning coil L_1 . This tuning coil permits the antenna circuit to be adjusted to resonance with the desired incoming signals, and the signal, thus selected, is carried through the radio frequency amplifier circuit and the primary of the vario-coupler to the detector tube circuit, where it is rectified and brought to an audible frequency. This audio-frequency current is then passed through two stages of audio frequency amplification.

In using this circuit, the first two tubes should not be permitted to oscillate, but merely to amplify the incoming signal, for the oscillation and regeneration is most satisfactorily controlled by tuning the detector tube plate variometer in the customary manner. Where this circuit is employed DO NOT GROUND the negative lead of the 6-volt "A" battery. If potentiometer R-7 is not used, the filament rheostat should be placed in the positive leg of the filament circuit instead of the negative.

Loop Antenna and 3-Stage Radio Frequency Amplifier

Fig. 3 shows a method of reception using a loop antenna and three stages of radio frequency amplification. This type of receiving set will bring in signals over several hundred miles and interference is considerably reduced, as the loop possesses properties which enable signals to be received from a given direction to the exclusion of unwanted stations. Static is also considerably reduced.

A very satisfactory loop for this purpose may be made by using a frame three feet square wound with five or six turns of No. 14 B. & S. lamp cord, each turn being spaced $\frac{1}{2}$ to $\frac{3}{4}$ of an inch. A tap should be provided on each turn. The loop should be shunted by a variable condenser (UC-1820) having a capacity of .00004 to .0006 mfd.

With this arrangement, the incoming signals are of an intensity slightly greater than is ob-

tained with an ordinary amateur antenna and a single detector tube. By the addition of two stages of audio frequency amplification, we have a method of obtaining a greater signal intensity than is possible with the outdoor antenna, while the interference from undesired stations is considerably reduced. For fine tuning, the condenser shunted across the active turns of the loop should be equipped with a vernier, although this is not absolutely essential.

Where a radio frequency amplifier of two or more stages is desired, it should be built in a metal box, or in a box lined with metal, and should preferably have a separate compartment for each radio frequency amplifier tube and its transformer. In completing such an amplifier, it is also important to ground the negative side of the filament battery, except with single circuit tuners, to the metal case or metal lining. This insures stability.

In general, the foregoing instructions also apply to the radio frequency intervalve transformer, UV-1716, which is designed for use in connection with long wave reception. The turn ratio, however, in this transformer is approximately 1 to 3 for the reason that a step-up is advantageous for the long wave range. No intermediate tap is used on this transformer as it functions satisfactorily over the entire wave length range of 5000 to 25,000 meters.

Note: In figures 1, 2 and 3 it will be observed that there are two additional condensers each designated with a capacity of .005 mfd. It has been found that the use of these considerably improves radio frequency amplification.

Features of Both Models

1. Receiving ranges may be doubled and even tripled.
2. News and music broadcasted by distant stations are received with remarkable clearness.
3. Distortion is greatly reduced.
4. Selectivity is considerably increased.

- 5. Vacuum Tube noises are practically eliminated.
- 6. These transformers are designed especially for, and will function at maximum efficiency only, when used with Radiotron Amplifier Tube UV-201.

Physical Characteristics

Model UV-1714

- 1. Base Dimensions 2 9/16" x 1 11/16".
- 2. Overall Height 2 3/4".
- 3. Net Weight 7 oz.
- 4. Shipping Weight 10 oz.

Model UV-1716

- 1. Base Dimensions 2 9/16" x 2 1/4".
- 2. Overall Height 2 3/4".

- 3. Net Weight 12 oz.
- 4. Shipping Weight 1 lb.

Electrical Characteristics

Model 1714

- 1. Ratio of primary to secondary turns, 1 to 1.
- 2. Tap on each winding provides for two wave length ranges: 200 to 500 meters and 500 to 5000 meters.
- 3. Especially designed for use with Radiotron amplifier tube UV-201.

Model 1716

- 1. Ratio of primary to secondary turns, 1 to 3 (approximate).
- 2. Entire wave length range 5000 to 25,000 meters available without taps.
- 3. Especially designed for use with Radiotron amplifier tube UV-201.

Radio Frequency Amplifying Transformer, 200 to 5000 meters, Model UV-1714... \$6.50
 Radio Frequency Amplifying Transformer, 5000 to 25,000 meters, Model UV-1716... 8.50

GRID LEAKS FOR RECEIVING SETS

The grid of any vacuum tube, whether employed as a detector or an amplifier, is the controlling member of the tube, that is to say, it controls the current flowing between the plate and filament. The character of the control depends directly upon the bias potential maintained upon the grid. Thus one value of grid potential will be found most suitable for radio detection, while still another value must be maintained to secure maximum amplification. The requisite bias potential for varied conditions of use may be obtained in several ways, the most common of which are: (a) to insert in series with the grid circuit a small battery usually called a "C" battery; (b) to tap one terminal of the grid circuit from a fixed resistance in series with the filament rheostat through which the filament current flows; (c) to employ a GRID LEAK connected across the grid condenser or the grid and the filament.



ance of two megohms (2,000,000 ohms) and a grid current of one microampere, the bias negative potential will be two volts.

Different detection and amplification circuits require grid leaks of different values and in order that the experimenter may have access to a complete line of resistance units from 100,000 ohms to 6,000,000 ohms, the Radio Corporation has standardized a number of different values which are certain to meet all the requirements for radio reception.

The proper capacity for the grid condenser should be determined by experimenting with different values between .0002 and .0004 microfarad.

The function of the grid leak is to present a leakage path across the grid condenser so that the potential of the grid member in respect to a terminal of the filament may be maintained at some desired value. The potential maintained on the grid is computed by Ohm's Law and it is therefore equal to the grid current times the grid resistance. With a grid resist-

The grid leak unit which will give the proper biasing potential on the grid may vary between 1/2 megohm (500,000 ohms) and 3 megohms (3,000,000 ohms). Various values can be obtained by purchasing three of the Radio Corporation grid leak units, approximating 1/2, 1 and 2 megohms, respectively. The experimenter can then try three values by employing them singly, in series, in parallel or in series-parallel. Eight or more different values between 1/2 to 3 1/2 megohms may in this way be obtained.

The Radio Corporation Grid Leak Units are manufactured in the following sizes:			Model	Ohms	Megohms	Model	Ohms	Megohms
Model	Ohms	Megohms	UP-512	200,000	.2	UP-520	1,250,000	1.25
UP-509	50,000	.05	UP-513	250,000	.25	UP-521	1,500,000	1.5
UP-510	100,000	.1	UP-514	300,000	.3	UP-522	1,750,000	1.75
UP-511	150,000	.15	UP-515	400,000	.4	UP-523	2,000,000	2.
			UP-516	500,000	.5	UP-524	2,500,000	2.5
			UP-517	600,000	.6	UP-525	3,000,000	3.
			UP-518	750,000	.75	UP-526	4,000,000	4.
			UP-519	1,000,000	1.	UP-527	5,000,000	5.

Grid Leak Mounting, Model UX-543... \$0.50
 Grid Leak Units, Models UP-509 to UP-527... .75

RADIOTRONS FOR RELIABLE RECEPTION

RADIOTRONS form the center of a system of radio communication which would be entirely impossible without them. These vacuum tubes are manufactured by the General Electric Co. and the Westinghouse Lamp Company for the Radio Corporation of America. There are so many shining examples of great distances covered by Radiotron reception and transmission that enumeration here would be impossible. With a single Radiotron, experimenters in Florida and another in Cuba have listened to the concerts sent out by a radio broadcasting station located in the vicinity of New York City.

The Radiotron detector tube was used by Mr. Paul F. Godley in his successful attempt to hear American amateur transmitting stations at the station he erected in Ardrossan, Scotland.

The electrical characteristics of all Radiotrons are practically uniform. This is made possible by the highly standardized method of production utilized by the manufacturers at their various factories for the production of Radiotrons. For this reason, the experimenter, in using Radiotrons, is assured of a uniform reliability, as every tube is made to pass a severe test and is rejected unless the high standard set for it is obtained.

There are many functions for the Radiotron to perform in connection with radio reception and only its great versatility permits it to be confined to two forms which cover perfectly the varied tasks they are called upon to perform. These two forms are the detector and amplifier Radiotrons UV-200 and UV-201, respectively.

THE UV-200 DETECTOR TUBE

Radiotron UV-200 may be called upon to perform a great variety of duties as shown in the accompanying illustrations. In any receiving circuit either simple or complex, Radiotron UV-200 is the detector which embodies all the characteristics necessary for faultless performance. The circuits which appear throughout this book show some of the common uses made of this wonderful vacuum tube which has made communication over thousands of miles a fact by means of the code and speech to say nothing of music. Where long distances are to be covered, where stability of operation is desired, where long life and its resultant low cost are desired, where detector tubes of uniform characteristics are required for critical receiving adjustments, in fact wherever real results



PRICE—\$5.00

Overall dimensions, 1 3/4 in. x 4 1/4 in. Shipping weight, 1 lb.

are sought, there is but one answer to the detector tube question—Radiotron UV-200.

The Radiotron UV-200 is made with a standard four prong bayonet base designed to fit the Radio Corporation standard VT sockets UR-542, and UP-552.

How to Use Radiotron UV-200

In using Radiotron UV-200 for a detector, a grid condenser of approximately .00025 mfd. or thereabouts should be connected in series with the grid. Many experimenters prefer a variable grid condenser which is of value in regenerative circuits. In addition to the grid condenser one of the Radio Corporation's standard grid leaks should be connected across the grid condenser as shown in diagrams. In this case the Radio Corporation's standard Grid Leak and Condenser Mountings, UX-543 should be employed.

Note: Where a variable grid-condenser is used, the UC-1820, fully described on page 50, is recommended; with this condenser no grid leak mounting is required, for the condenser is fitted with a mounting which will hold any of the Radio Corporation's standard grid leaks.

Where the desired voltage is not more than 22 1/2, the "A" Battery Potentiometer PR-536 permits an extension of the life of the "B" battery. When the normal voltage of the 18 volt tap is too low, the connection from the potentiometer may be made to the 22 1/2 volt tap, thus using the cells between the 18 volt tap and the 22 1/2 volt tap previously idle.

It is sometimes necessary to use more than 22 1/2 volts with the UV-200 and when this is the case, instead of connecting the lead through the potentiometer to the 18 volt tap of the plate battery it should be connected to the negative or 22 1/2 volt terminal of the plate battery. This permits an adjustment of from 22 1/2 to about 28 volts on the plate circuit.

Voltages in excess of 28 to 30 should not be applied to the plate of a Radiotron UV-200.

If the experimenter prefers to adjust the filament by indicating instruments, it should be done by a voltmeter and not by an ammeter. All tungsten filaments show a decrease of current during their life and if constant current is maintained in the filament rather than constant voltage across it, the life will be greatly decreased and no better signals obtained. The normal voltage to be maintained at the filament terminals of RADIOTRON UV-200 lies within the range of 5 to 5.4 volts.

RADIOTRONS FOR SATISFACTORY AMPLIFICATION

Radiotron UV-201

WHERE it is desired to use loud speakers, in order to eliminate the necessity of listening to radio with the head telephones, sufficient energy must be provided to actuate the loud speaking device. A most suitable means for providing this energy is found in audio frequency amplification, which is the combination of Radiotrons and amplifying transformers functioning with a local source of current.

The incoming radio signals affect the vacuum tube in such a way as to draw current from the local source; this local current is then used to actuate the loud speaking device.

As may be seen from the following description, the amplification factor ordinarily obtained where this method is employed is between 6 and 10; so that for each stage of amplification, the incoming signal is multiplied from 6 to 10 times. Where several stages are used, the signal may reach 36 to 100 times its original intensity.



PRICE—\$6.50

Overall dimensions, 1 3/4 in. x 4 1/4 in. Shipping weight, 1 lb.

RADIOTRONS FOR AUDIO AND RADIO FREQUENCY AMPLIFICATION

Radio frequency amplification differs greatly from audio frequency amplification in that the increase of the signal intensity takes place before it has been reduced to suitable characteristics for operating a telephone receiver or loud speaker. Both radio and audio frequency amplification and circuits illustrating their most valuable uses, may be found in the section of this book devoted to receiving circuits.

For such circuits, the Radiotron UV-201, may be counted upon for reliable performance. Radiotron UV-201 may be used in any circuit where vacuum tubes are used as amplifiers. This remarkable amplifying tube has been designed to function with the Radio Corporation's audio frequency transformer UV-712 and the radio frequency amplifying transformers UV-1714 and 1716, both described elsewhere in this book.

The normal plate voltage of Radiotron UV-201 is 40, although increased amplification is possible with plate voltage up to 100. With 40 volts on the plate, the amplification constant

varies between 6.5 to 8, but with 100 volts on the plate, this constant is from 8 to 10. The output impedance of Radiotron UV-201 varies in value from 15,000 to 25,000 ohms, with 40 volts on the plate and from 10,000 to 15,000 with 100 volts on the plate, the normal filament current for Radiotron UV-201 is approximately one ampere. The filament is designed for operation from a 6-volt storage battery with a standard filament rheostat in series.

To obtain maximum amplification with UV-201, means should be provided for imposing negative potential on the grid although good amplification may be secured without this special provision. The requisite negative grid potential for this purpose may be secured by connecting a "C" battery of 2 or 3 volts in the grid circuit shunted by a 200 to 400 ohm potentiometer, or by placing a 2 ohm resistance in series with the negative terminal of the filament and connecting the "low potential" terminal of the tuner secondary to include this resistance in the grid circuit.

Important Facts Concerning UV-201

Because the UV-201 has been designed for use especially with the Radio Corporation's audio and radio frequency transformers, circuits employing these standard units are found to give absolute satisfaction, even under severe operating conditions. The Radiotron UV-201 permits very great amplification without distortion. This feature is especially desirable where reception is carried on at short wavelengths. Heretofore, it has been a very difficult problem to obtain vacuum tubes and radio frequency amplifying transformers which would give satisfaction on the wavelengths used for amateur communication. The perfection of the Radiotron with its allied units now permits radio reception over distances hitherto considered impossible, on all wavelengths.

Circuits and data fully covering the application of Radiotron UV-201 to both Radio Frequency and Audio Frequency Amplification as well as various combinations of both have been presented at length in previous pages.

AERIOTRON VACUUM TUBES

(Westinghouse Products)

Aeriotron Amplifier Tube Model WR-21-A, for Use with Aeriola Grand Receiver

This is a specially designed and carefully selected tube for use in the amplifying circuits of the Aeriola Grand and may be placed in any of the three front receptacles from left to right.

The filament current for this tube is approximately .8 of an ampere and the drop across the filament is about 4 volts. A six volt storage battery with a rheostat or ballast tube control will, therefore, furnish satisfactory power for heating the filament to its normal operating temperature.

The plate impedance of this tube is from 60,000 to 80,000 ohms, making it adaptable to resistance coupled amplification.

WR-21-A Amplifier Tube for Aeriola Grand Receiver \$7.50

Dimensions: 4½ in. x 1¼ in.

Weights: Net, 4 oz.; Shipping, 1 lb.

Aeriotron Detector Tube. Model WR-21-D, for Use with Aeriola Grand Receiver

This tube is designed especially for use with the Aeriola Grand Receiver and when so used gives excellent receiving results. It is provided with a special base which prevents its being used in equipment with which it will not properly function. Aeriotron WR-21-D has a green tip marking and is designed for use as the detector tube in Aeriola Grands, and should be placed in the right-hand front receptacle.

The filament current for this tube is approximately .8 of an ampere and the drop across the filament is about 4 volts. A six volt storage battery with a rheostat or ballast tube control will, therefore, furnish satisfactory power for heating the filament.

Aeriotron Detector Renewal Tube, Model WR-21-D for Aeriola Grand Receiver . . . \$7.50

Dimensions: 4½ in. x 1¼ in.

Weights: Net, 4 oz.; Shipping, 1 lb.



Aeriotron Ballast Renewal Tube Model WB-800 for Aeriola Grand Filament Circuits

This vacuum tube has been especially designed for use with the Aeriola Grand Receiver. It functions as a control element in the filament circuit of the detector and amplifier tubes. By the use of these control tubes, accurate adjustment of the filament current is automatically taken care of and filament rheostats are not required.

Aeriotron Ballast Renewal Tube, Model WB-800 for Aeriola Grand Filament Circuit, \$3.50

Dimensions: 4½ in. x 1¼ in.

Weights: Net, 4 oz.; Shipping, 1 lb.



Aeriotron Detector Tube Model WD-11, For Use with Aeriola Sr. Receivers

Aeriotron Detector tube, Model WD-11, is designed for use with the Aeriola Sr. Receiver. It is provided with a special base to preclude the possibility of its being placed in a circuit other than that for which it has been designed.

The filament current consumed by this tube is .25 of an ampere which may be supplied from a single 1.5 volt standard dry cell. However, it is inadvisable to connect the tube directly across the terminals of such a battery, and for this reason a suitable rheostat for controlling the filament temperature is provided with the Aeriola Sr.

The WD-11 Aeriotron tube operates quite satisfactorily as a detector when 22.5 volts are applied to its plate.

Aeriotron Detector Renewal Tube, Model WD-11 for Aeriola Sr. Receiver \$8.00

Dimensions: 4½ in. x 1¼ in. **Weights:** Net, 4 oz.; Shipping, 1 lb.

Caution: The Aeriotron WD-11 has a special coated filament and must not be burned brighter than a D.U.I. RFD.

VARIABLE CONDENSERS FOR RECEIVING CIRCUITS

General

A VARIABLE condenser is an essential element for sensitive reception.

In general, variable condensers afford a reliable and simple method of altering the values of receiving circuits in order to bring about a point of resonance, thus enabling one to select, at will, stations operating on different wave lengths.

When two or more circuits are in resonance they are of the same electrical wave length and the altering of the values of capacity or inductance in them to secure a certain wave length is called tuning.

When one desires to receive from a transmitting station, it is necessary to tune the receiving instrument to resonance with the wave length of the station one wishes to hear—whether it be radio telephony or radio telegraphy.

There are so many types of variable condensers, each designed for a certain purpose and a few remarks may be of value in assisting the experimenter to make a correct selection for the various types of receiving circuits commonly employed.

Different usages require condensers of various designs and the types described here are of unusual construction, providing a degree of accuracy and reliability hitherto unattained, and may be relied upon to fill every need.

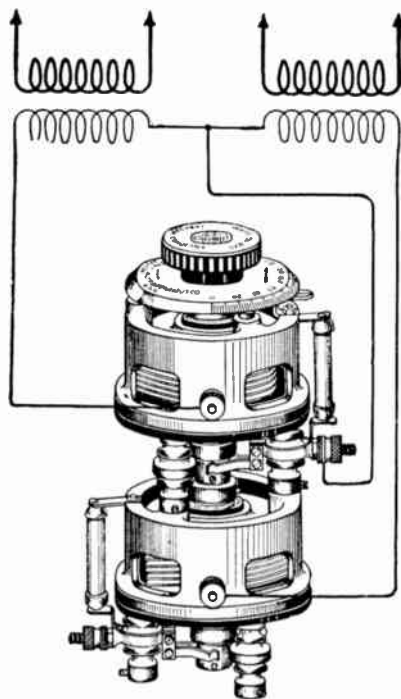

Illustrating the use of two Faradon UC-1820 nested on a single shaft for controlling two circuits simultaneously

FARADON PRECISION VARIABLE CONDENSER MODEL UC-1820

In any radio circuit where a variable capacity from .00004 to .0012 mfd. is required, the Faradon Condenser UC-1820 will be found indispensable. This condenser has a capacity range from .00004 to .0006 mfd., but it is so constructed that it is possible to join two condensers together controlling them from a single dial knob. By such an arrangement, three distinct maximum capacities may be found by the condenser units of .0003, .0006, and .0012 mfd. respectively, as shown in the accompanying sketches.



Faradon UC-1820

Adding Other Capacities

Additional capacity variations may be obtained by adding to the variable condenser unit the Radio Corporation's tubular condensers UC-567-8-9-70 having capacities of .00025, .0005, .001, and .0025 respectively, the variable condenser acts as a vernier in this instance. The UC-1820 is provided with clips into which these fixed condensers may be placed. With these condensers it will be seen that the capacity range of the UC-1820 combination cannot be duplicated by any other condenser or combination of condensers now on the market.

There are quite a few important properties that may be obtained by the chain connected condensers. One very marked advantage is that the system will permit simultaneous tuning of two circuits with one knob.

If the circuits have a common lead an inductance may be connected between the fixed system of one condenser to the common movable system and a second equal inductance system may be connected between the fixed system of the second unit to the movable system as shown

in the figure on previous page. If the dial is rotated the periods of both circuits will vary simultaneously.

Construction

The movable and fixed elements comprising the UC-1820 are die castings exact to 1/1000 of an inch. The housing of the condenser is likewise cast with great exactness. The movable element is fastened to a steel shafting. This shafting is fitted with bronze bearings and a suitable arrangement is provided for the centering of the fixed and movable elements. The spacing between the plates is 10/1000 of an inch. The insulation between the fixed and movable systems for their relative support has been reduced to a minimum area in order to avoid dielectric losses. Connection from the movable system is made from a double split brush fitted to one of the base insulators.

Clip Mounting Feature

The clip mounting, in addition to furnishing possible variations of capacity by the use of fixed condensers as previously described, furnishes a ready means for inserting a standard Radio Corporation grid leak resistance. (UP-507 to UP-509) where the UC 1820 is used as a variable grid condenser. This method permits a rapid change of grid leak resistance as well as a variable grid capacity, making for very accurate control of this circuit.

This condenser may be mounted in any position and provision is made to allow for panel thickness up to 5/16 of an inch, or on a base of any thickness.

Faradon Condensers have an efficiency of over 99—7/10% and they represent a standard of quality and efficiency that is rarely attained in any electrical device.

Faradon Precision Variable Condenser

Model UC-1820 \$7.50

Capacity: .00004—.0006 mfd.
Dimensions: 4 in. by 3 3/4 in.
Weights: 10 oz. Shipping 2 lbs.

**FARADON VARIABLE MICA CONDENSER
 MODEL UC-1819**

It is impossible to realize without having used one of these condensers, the satisfaction it makes possible in any form of receiving circuit for accurate, reliable and selective operation. A very marked difference between variable condensers of the older type and this new condenser is the fact that the capacity from minimum to maximum is increased in a uniform manner dependent upon the position of the variable element with respect to the fixed or stationary element. This relation is controlled by rotating a single calibrated control knob.

Wide Range of Capacities

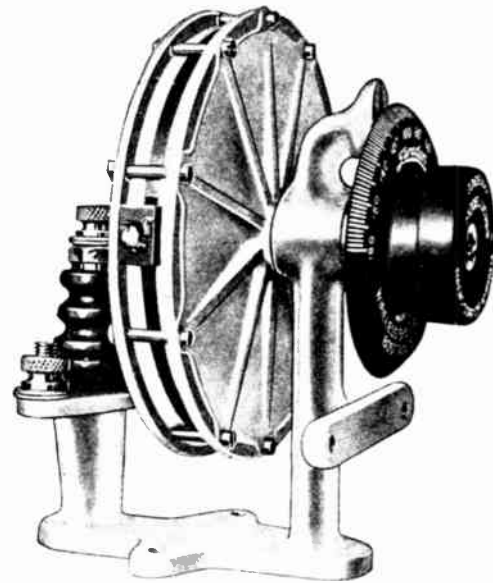

Faradon UC-1819 for fine receiving work

Another and equally astounding fact concerning the Faradon UC-1819 is the very great range of capacity it covers—from .0001 to .005 mfd., which is a ratio of 50 to 1. No other condenser of similar size covers any such range as this.

A special grade of selected mica forms the dielectric of this condenser which is vastly different from the forms of mica condensers heretofore used, in that the capacity is continuously variable while the older types were variable in certain fixed steps, necessitating changes in the wiring or operated by a switching device.

Scientifically Constructed

The Faradon UC-1819 is the embodiment of advanced construction methods coupled with supreme engineering technique. Every detail has been scientifically considered and the completed unit marks a new period in radio reception. Here, at last, is a condenser which may be counted upon to perform satisfactorily under the most trying receiving conditions.

The Faradon UC-1819 condenser is of the form shown in the accompanying illustration. It lends itself to any style of mounting, for it may be attached to the surface of any panel up to 5/16 of an inch in thickness with the shaft projecting through or it may be screwed to a base where that form of mounting is preferred. In either case an indicator is included to facilitate the lining up of the rotary element with the calibrated dial knob.

**Faradon UC-1819 Variable Mica Condenser,
 \$8.75**

Capacities: .0001—.005 mfd.
Dimensions: 4 1/2 in. x 6 in. x 4 1/4 in.
Weights: 14 oz. Shipping 2 lbs.

COMPONENT PART TWO STAGE AUDIO-AMPLIFIER MODEL AA-485

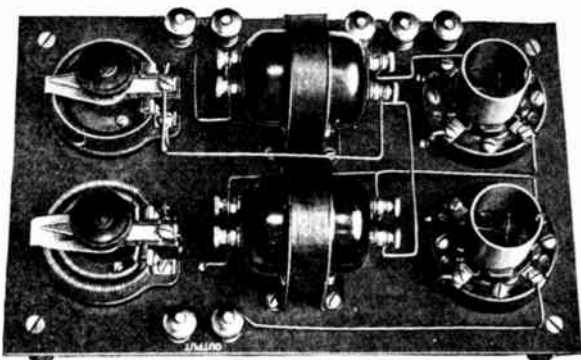

Special Stabilizer Control eliminates distortion of speech and music.

HERE is the ideal instrument for the advanced amateur who wishes to carry on experiments in amplification and thus study at first hand the action of various forms of radio receiving circuits.

Audio-Amplifier AA-485 is exceptionally well adapted for this purpose, for it is an open-wired set of very simple make-up incorporat-

ing unusual features of design and workmanship. It consists of two stages of audio frequency amplification and is made up of standard RCA receiving units, designed to function in perfect accord.

All the units are mounted on a strong bakelite dilecto panel, which in turn is supported by heavy legs. The units are placed in positions which are scientifically correct.

Terminals for the connection of the storage and plate batteries, as well as the input and output circuits, are conveniently located and distinctly marked, so as to preclude the possibility of making wrong connections. An "A" battery potentiometer is provided in order that the grid bias potential may be controlled, avoiding distortion, and to adapt it to various operating conditions.

Two Stage Component-Part Audio Frequency Amplifier, Model AA-485 \$45.00

Dimensions: 12½ in. x 7⅞ in. x 5 in..

Weights—Net, 5½ lbs.; Shipping, 7 lbs.

Note—For prices of Complete Receiver Combinations, see page 35.

TYPE DB CRYSTAL DETECTOR, STYLE NO. 307216

IN the base of this detector what is known as a blocking condenser is connected across the telephone terminals, thus making a very compact and complete unit.

The two types of detectors used on this unit are what is known as the "Pressure" type and the "Cat Whisker" type. In the former two selected minerals are held in pressed contact with each other. In the second type but a single crystal is used, the adjustment being made by means of a fine wire which may be moved about the crystal to locate sensitive spots.

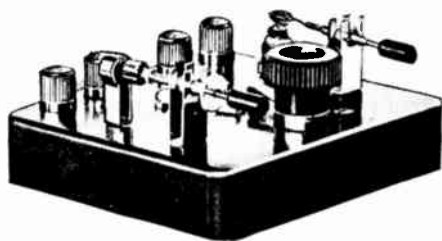

Westinghouse Supersensitive Crystal Detector, Model DB \$6.50

Dimensions: 4⅝ in. x 4¼ in. x 2 in.

Weights: Net, 1 lb.; Shipping, 1½ lbs.

Spare Crystals (Pressure Type) Model DE, \$1.00

Spare Crystals (Cat Whisker) Model DD, \$1.00

Note: Crystal Detector, type DB, may be very satisfactorily employed with any standard receiving outfit and it has been specially designed for use with the type RA Tuner, described in the first part of this book.

PORCELAIN SOCKET UR-542



THIS socket has been specially designed to meet the need for a reasonably priced socket which should at the same time be constructed of the very best insulating material obtainable, and should bear the stamp of quality throughout. It is a direct duplicate of the type used in commercial radio sets.

Porcelain is the ideal material for use in these devices, on account of its low specific inductive capacity and its high insulating qualities. Production in great quantities enables us to keep the selling price unusually low.

Model UR-542 is designed to accommodate RADIOTRONS UV-200, UV-201 and UV-202, as well as KENOTRON UV-216.

PORCELAIN SOCKET, UR-542 \$1.00

Size: 2¾ in. x 2 in.

Shipping Weight: 8 oz.

**"A" BATTERY POTENTIOMETER
PR-536**



It is impossible to over-estimate the desirability of using a potentiometer in connection with the Radio Corporation's gas-content detector, Radiotron UV-200. Only in this way can proper detector action and resulting increase of signal audibility be obtained.

It is inadvisable to use any type of potentiometer across a standard "B" battery, as it will exhaust the cells in a relatively short time. To overcome this difficulty the Radio Corporation developed this instrument.

In appearance, POTENTIOMETER PR-536 closely resembles the Radio Corporation's Rheostat PR-535. It is provided with three contacts. Two of these are shunted across the "A" battery, while the third is connected to a tap on the negative side of the plate battery, giving eighteen volts. This connection gives a plate voltage variation from eighteen to twenty-four volts.

"A" Battery Potentiometer \$2.00

Dimensions: 2 in. x 1 1/2 in. x 2 7/16 in.

Shipping Weight, 1 lb.

**BAKELITE SOCKET
UP-552**



Some amateurs may prefer to use a Bakelite socket rather than our standard porcelain socket, Model UR-542, described on page 52. This socket has enjoyed unusual popularity for several years past. It is durably constructed and of fine appearance. One particular feature is the ease with which connection may be made, since the connecting clamps are unusually accessible and provide ample space for permanent contacts. Socket UR-542 will take Radiotrons UV-200, UV-201 and UV-202.

Bakelite Socket, UP-552 \$1.50

Dimensions: 1 1/2 in. x 1 1/2 in. x 1 1/2 in.

Shipping Weight, 1 lb.

TUBULAR GRID AND PLATE CONDENSER

There has been an insistent demand in the amateur field for fixed condenser units of various capacities, suitable for amateur receiving sets. The Radio Corporation of America has evolved the four models herein listed, which are designed to fit its Standard Grid Leak Mounting. These condensers are recommended for use in the grid circuit, or as a by-pass condenser in the plate circuit, of standard vacuum tube receiving sets. They are especially useful as a unit of fixed capacity to be shunted to any standard variable air condenser.



The complete condenser unit is sealed in a glass tube fitted with end caps, in the same manner as the Standard Grid Leaks. Every amateur station should have at least one complete set for general experimental purposes. Nothing equally satisfactory to the four models listed here has been produced for mounting in receiving set cabinets, for if one value of capacity is found unsatisfactory for the purposes at hand, another suitable value may be immediately inserted in its place.

Dimensions: 1 7/8 in. x 3/8 in.

Shipping Weight: 4 oz.

AN INDIVIDUAL COLOR FOR EACH CAPACITY

Condenser, UC-570—.0025 Mfd., White	\$2.00
Condenser, UC-569—.001 Mfd., Orange	1.50
Condenser, UC-568—.0005 Mfd., Green	1.35
Condenser, UC-567—.00025 Mfd., Black	1.20
Condenser Mounting, UX-54350

**THE FOUR POINT TELEPHONE JACK
MODEL UD-486**



ONCE a radio broadcasting receiving set has been installed, it does not take long for one's friends to hear of it and they are wont to drop in of an evening to hear something of the concerts and news which may be received from the ether. In such cases, it is desirable to provide some means to permit these friends to listen without interfering with one's own pleasure. A more convenient way for connecting several sets of radio head receivers than the UD-486 cannot be made.

As may be seen from the illustration, this little unit is merely connected to the receiving set by two wires. There are little openings on its face through which the sets of head receivers may be plugged in.

Ordinarily, the connecting of more than one pair of telephones is a rather difficult task for the cord tips cannot be joined together very readily. By connecting each pair to the telephone plug UD-824, however, any desired number of head sets up to four may be put in operation by using the four point telephone jack.

The interior connections on this jack are so arranged as to permit connection of one to four pairs of telephones at will. The UD-486



By using the four-point jack and double plugs illustrated here, many persons may listen in.

will accommodate four plugs; each plug is in turn connected to a pair of receivers so that four sets may be used. As each set is made up of two individual receivers, it may be seen that eight persons may listen simultaneously using a single receiving set.

When one or more plugs are withdrawn from the four point jack the circuit is automatically rearranged to leave the telephone receivers connected to the remaining plugs in an operative condition.

**Four Point Telephone Jack,
Model UD-486 \$7.25**

Dimensions: 4½ in. x 2¼ in. x 2 in.

Weights: Net, 5 oz.; Shipping, 1 lb.

**SINGLE AND DOUBLE TELEPHONE
PLUGS, MODELS UD-824 AND UD-825**



Single Plug, Model UD-824

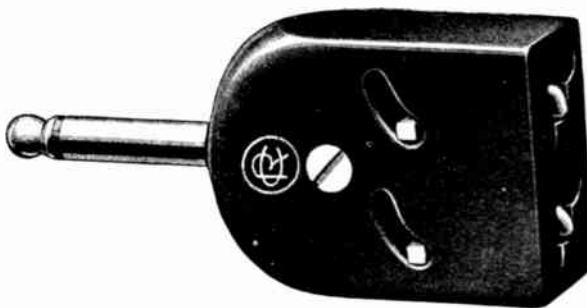

Double Plug, Model UD-825

THESE telephone plugs are so connected that ordinary telephone cords may be inserted in them without having to take off the cord tips. The plugs are particularly useful in connection with radio where multi-stage amplifiers are used, for, without the necessity of making special soldered connections, the user has at his disposal a ready means for applying any pair of telephone receivers to a plug and jack system.

There are two models: one for connecting a single pair of telephone receivers, one for use with two pair. To apply these plugs it is merely necessary to place the cord tips in the openings provided and locking them in place by moving the tip sleeve.

**Single Telephone Plug,
Model UD-824 \$1.75**

Double Telephone Plug, \$2.60
Model UD-825

“VOCAROLA”—THE LOUD SPEAKER

WHERE broadcasted music and speech is being received and it is desired to have volume enough to fill a room so that many persons may hear, the Vocarola may be employed to advantage. It is but necessary to remove the plug of the telephones from the jack in the amplifier unit, placing the loud speaker plug in its place.

Vocarola is equipped with a supersensitive sound producing device which changes the incoming electrical impulses into sound waves. This sounding element is attached to an attractively finished tone chamber in the form of a horn from which the sound emerges.

The Vocarola, when used with suitable amplifying equipment, furnishes music and speech with a tone clarity identical to that of the transmitted music or speech.



Vocarola, Model LV.

Vocarola Loud Speaker, Model LV \$30.00

Dimensions—10 in. x 8 in. x 7½ in.

Weights—Net, 2 lbs., Shipping, 5 lbs.

PHONOGRAPH LOUD SPEAKER ATTACHMENTS

These attachments are provided with a six-foot telephone cord and an attachment plug which may be inserted in the jack of the amplifier.

Where these loud speaker attachments are employed, it is necessary to use amplifiers just as it is necessary to do so in using the Vocarola described above.

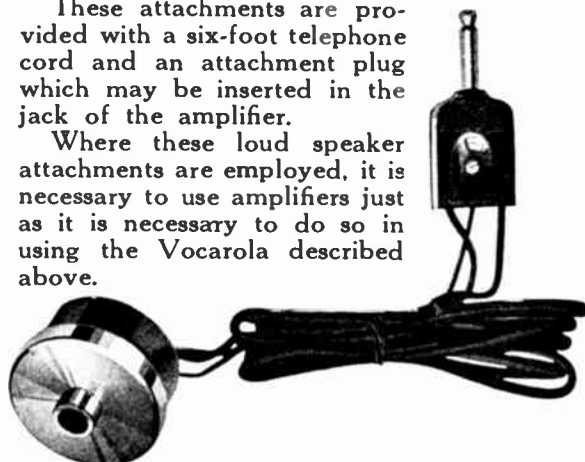

BY employing a phonograph attachment it is possible to convert your phonograph into a loud speaking device for radio reception where the music is to be heard by a number of people throughout the room.

In order to use this new attachment it is but necessary to remove the reproducer or “sound box” as it is called, from the tone arm of the talking machine, replacing it by the phonograph attachment which is designed to easily slip into place. There are two models, one for Victrolas and the other for Graphonolas. The Victrola model, in addition to fitting Victor machines, will fit any other talking machine having the same size tone arm.

Victrola Loud Speaker Attachment, Complete with Cord and Plug, Model LS \$18.00

Graphonola Loud Speaker Attachment, Complete with Cord and Plug, Model LS 18.00

Dimensions: 2¾ in. x 3 in.

Weights: Net 1 lb.; Shipping, 1½ lbs.

Note: In ordering, the make of phonograph should be specified.

RECEIVING ANTENNA OUTFITS

(With Complete Instructions For Installation)

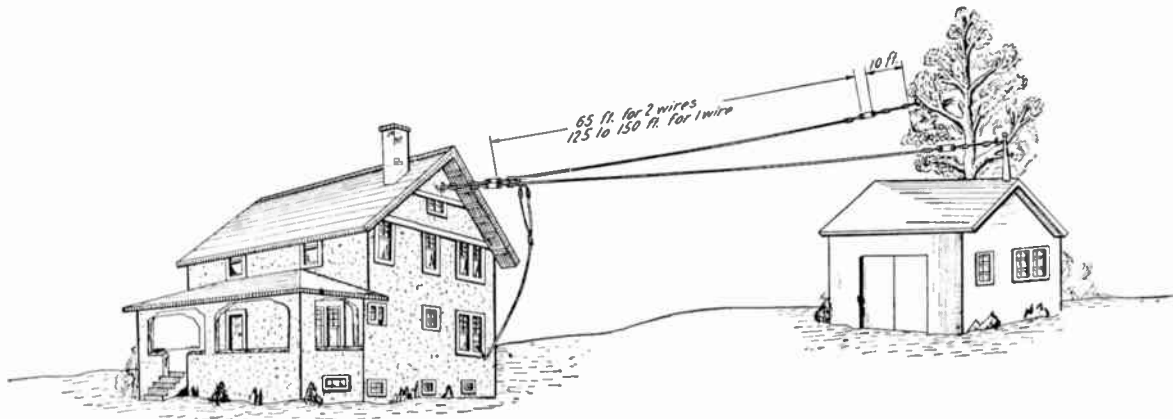

Fig. 1—Illustrating method of installing a one or two wire antenna for broadcast reception.

THESE antenna outfits have been especially designed for the radio broadcasting sets described in this catalog. The following instructions apply in general to all classes of receivers but especially to broadcasting reception.

Selecting the Location

The number of miles over which a given broadcasting receiving outfit will respond depends upon a number of important factors. In order to get the most satisfactory results with any of the receiving outfits described here the antenna, or aerial, as it is sometimes called, should consist of one or two wires 50 to 150 feet long. Good reception often can be obtained with two wires of a shorter length, separated from each other by three-foot wooden spreaders. See Fig. 3. Care should be taken to keep the antenna as far as possible from trees and buildings, especially where the latter have a steel frame-work, and the lead-in wire should never be brought down a narrow air-shaft. Where an antenna is supported by a house at one end and a tree at the other end, care should be taken to have an insulator, such as provided with Model AD outfit, extend a distance of at least 10 feet beyond the tree's branches. Where one end of the antenna is fastened to a building having a metal roof this same precaution should be followed, for should the antenna come in contact with the objects mentioned, the incoming signals will be reduced in strength by electrical leakage.

Raising the Antenna

The method of raising the antenna after the location has been decided upon, where a single wire antenna is to be used, is as follows: Take one of the screw eyes furnished with the antenna equipment in the building or tree, which is to support the free end of the antenna, that is, the end away from the receiving out-

fit. A piece of copper wire is passed through this screw eye as shown in Fig. 2. This wire is then left long enough to extend 10 feet beyond the roof of the building or the branches of the tree holding the screw-eye and to it is attached an insulator. The other end of this insulator is used for fastening the end of the antenna wire itself as shown in Fig. 2.

The wire is then run from this point to a point directly beneath that section of the house in which the receiving set is to be placed. This end of the antenna is put in place by inserting another screw eye in some part of the house, preferably as high as possible. In this instance the insulator is attached to the antenna wire at a point estimated to be approximately 10 feet from the side or roof of the house. To the opposite end of this insulator is connected another tie wire as illustrated in Fig. 2. The opposite end of this tie wire is then drawn through the screw eye on the house, and fastened by twisting. In this way by tightening the second tie wire the antenna is raised above the ground. It should not be drawn too tight, but a certain amount of slack should be permitted.

The Lead-In Wire

The end of the wire leading to the receiving set must be fastened to the end of the antenna wire before the antenna is raised from the ground. The connection between these two wires is made as follows:

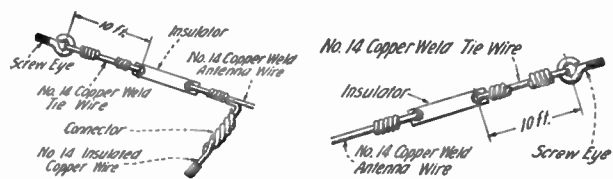

Fig. 2—To the left shows method of connecting the antenna to the lead-in wire. To the right shows the free end of the antenna and manner of fastening to support.

A metal connector is supplied with this type of antenna outfit. In its original condition it resembles two hollow, metal tubes fastened together. Through one of these tubes the end of the antenna wire passes in one direction while the end of the insulated lead-in wire, from which six inches of the insulation has been removed, passes through the other tube in the opposite direction. By grasping each end of this connector with a pair of pliers and twisting, the two wires are bound together in this metal sleeve in the manner shown in Fig. 2 eliminating the necessity of soldering.

The lead-in wire should run in as near a direct line as possible from the antenna to that part of the house in which the receiving set is to be placed. Right angle turns in the lead-in wire should be avoided, in so far as possible. Where it is necessary to have the lead-in wire run along the side of a building it should be raised on porcelain knobs as shown in Fig. 4. This wire should be isolated from surrounding objects as far as possible.

Where the lead-in wire is to enter the building it is essential to bore a hole in the wall (if the building is frame), or through the window casing in other types of buildings. This hole may be drilled with a $\frac{5}{8}$ -inch bit. The insulating bushing furnished with these outfits is then inserted in this hole through the building. The hole through the building should be made on an angle as shown in Fig. 4. The lead-in wire is then passed through the tube from the outside and a small loop should be left outside the building to permit the rain water to drop off both the lead-in and the insulating bushing.

Description of Window Board

A suitable method for making connections from a radio receiving antenna is illustrated by Fig. 4. This method is especially desirable in apartment houses for the reason that it obviates the necessity of drilling holes through the wall or window frames.

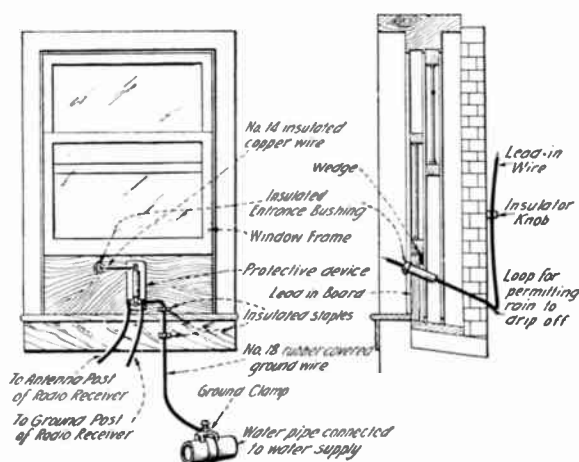

Fig. 4—Window board arrangement for leading in antenna wire to instrument.

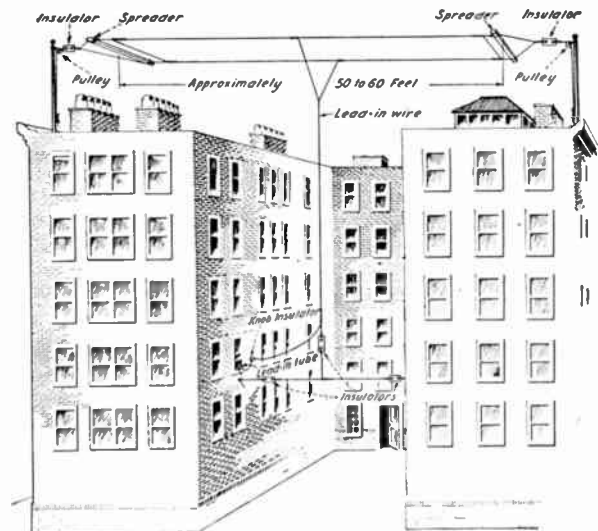

Fig. 3—Illustrating a method of installing an antenna on the roof of an apartment house.

A piece of board 10 or 11 inches wide and just long enough to extend across the window is held in place by a wedge placed at either side of the window casing as shown. A hole is drilled through the board and the lead-in insulator passed through this hole. The protective device is screwed directly to this board in the position indicated and the lead-in wire is permanently attached to the terminal A of the protective device. The terminals R and G of the protective device are used for connection to the receiving set and the latter is also connected to the ground wire as described elsewhere.

Where this method is employed, the window may be opened or closed without interfering with the lead-in wire or the wires running to the receiving apparatus, and the protective device may be attached to the board without in any way mutilating the window casing or walls of the house.

The Installation of the Protective Device

This device is used to protect the receiving instruments as well as the house itself from possible damage caused by lightning flashes. It is a combination of a very small spark gap and fuse. It should be placed in some inconspicuous place, either on the wall or under the window frame, not far from the point at which the lead-in wire enters the building. The lead-in wire is fastened to one terminal of the protective device as shown in Fig. 4. To the other two terminals are connected the wires which run to the receiving set. It will be noticed in Fig. 4 that one of these two terminals is made to carry two wires. The second wire is called the ground wire and is made from a portion of the 50 feet of rubber-covered ground wire, supplied with the antenna equipment. This wire may be run through the house by using some of the insulated staples supplied with the outfit.

Attaching the Ground Clamp and Running the Ground Wire

The ground clamp is a strip of metal made to fasten around a pipe and held in place by a clamping device. It is important that the pipe itself be scraped very clean, either by a knife, file or a coarse grade of sand-paper. After being sure that the pipe to which the clamp is to be attached is thoroughly cleaned, the ground clamp may be installed. It must fit over the pipe as tightly as possible. The ground wire, which runs from one terminal of this clamp to the protective device, as shown in Fig. 4, should be as short as possible. As is the case with the antenna lead-in wire, the ground wire should be as free from angles as possible, the ideal condition being found when the ground wire is very short and straight. With these instructions and references to the accompanying illustrations no difficulty should be experienced in erecting an antenna which will give satisfaction under almost any conditions.

The Protective Device

The protective device does away with the necessity of having a large antenna grounding switch on the exterior of the building and precludes the possibility of the operator forgetting to throw this switch when the receiving equipment is not in use. This protective device is more thoroughly described on page 59.

In large cities it is sometimes difficult to find a location where either a single or double wire, as shown in Fig. 1, can be erected. Fig. 3 gives a very good idea of the method which may be used in placing antennae on apartment houses or office buildings. Where the building is 100 feet high or more and the receiving outfit is to be located on one of the lower floors, a single wire running from the roof to a point opposite, the location of the receiving apparatus will suffice to cover the ranges previously mentioned with regard to the sets described in this catalog. Where a building is lower than this it is sometimes advisable to run a wire across the roof supported by any convenient object such as a water tower, a clothes pole, or a high chimney. This wire is then connected to the lead-in wire which may be run to the receiving outfit. Where this method is employed care must be taken to keep both the flat-top section of the antenna as well as the lead-in wire as far as possible from adjoining buildings.

The details of any receiving antenna may be worked out from observation of the foregoing instructions and no difficulty should be experienced in getting satisfactory results.

The following antenna outfits comprise everything essential for installation. The outfits are packed complete with full instructions.

Westinghouse Receiving Antenna Outfit



- Antenna Outfit Model AD.....\$7.50**
 Includes 150 feet No. 14 Copper Weld Antenna Wire.
 50 ft. No. 18 Copper Ground Wire.
 50 ft. No. 14 Copper Lead-in Wire.
 1 PA Protector.
 1 Entrance Bushing.
 2 Antenna Insulators.
 2 Screw Eyes.
 1 Ground Clamp.
 3 Porcelain Knobs.
 1 Connector.
 12 Insulated Staples.

G. E. Receiving Antenna Outfit

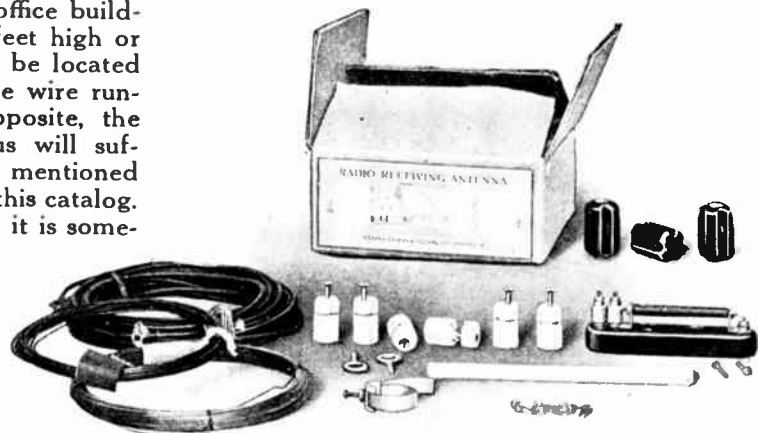

- Antenna Outfit, Model AG-788.....\$7.50**
 Includes 175 feet No. 14 Copper Weld Antenna Wire.
 50 feet No. 14 Copper lead-in wire.
 25 feet No. 14 Copper Ground wire.
 1 Protector.
 1 Porcelain Entrance Bushing.
 3 Antenna Insulators.
 3 Screw Eyes.
 1 Ground Clamp.
 3 Porcelain Knobs.
 12 Insulated Staples.
 8 Wood Screws.

RECEIVING ANTENNA PROTECTIVE DEVICES

THESE devices are standard units supplied with R. C. receiving antenna outfits. However, they may be used satisfactorily with any other type of receiving antenna equipment. Their purpose is to supply a means for protecting the receiving station as well as the building in which it is located from any serious effects which might be caused by lightning.



The G. E. Vacuum Type Protector Model UQ-1310

Heretofore, it has been necessary to have a large switch mounted on the outside of the building with a heavy wire running to an outside ground connection. Although this switch formed a satisfactory method for carrying electrical charges to the earth, there was always the possibility of the operator forgetting to throw the switch after he had finished receiving. With the protective device no such possibility as this can arise, for there is no switch to be thrown. Once it has been installed it functions without further attention.

Two types of antenna protective devices are available. Model UQ-1310, illustrated above, is the vacuum type; Model PA, shown below, is the fuse type. Both are suitable for receiving purposes, but not for transmission.



The Westinghouse Fuse Type Protector Model PA

G. E. Receiving Antenna Protective Device, Model UQ-1310.....\$2.50

Westinghouse Receiving Antenna Protective Device, Model PA.....\$2.00

Dimensions: 7½ in. x 2½ in. x 1½ in.

Weights: Net, 10 oz.; Shipping, 1 lb.

LOAD COIL MODEL CB (1800-2800 METERS) FOR USE WITH RC RECEIVER OR RA AND DA COMBINATION

BY using this coil in conjunction with the RC Receiver or the RA tuner, and DA amplifier previously described, it is possible to receive signals on wave lengths up to 2800 meters. This is particularly valuable as it enables one to hear the time signals from the United States Navy Station at Radio, Va. for distances of several hundred miles. Watch repair shops and jewelers will find this twice-a-day service from the United States Observatory in Washington invaluable for checking watches and clocks as the time may be received with less than one-tenth of a second error. Dealers throughout the country are availing themselves of this service, some going so far as to arrange small time balls for their windows by which passers-by are given an opportunity to check their watches.

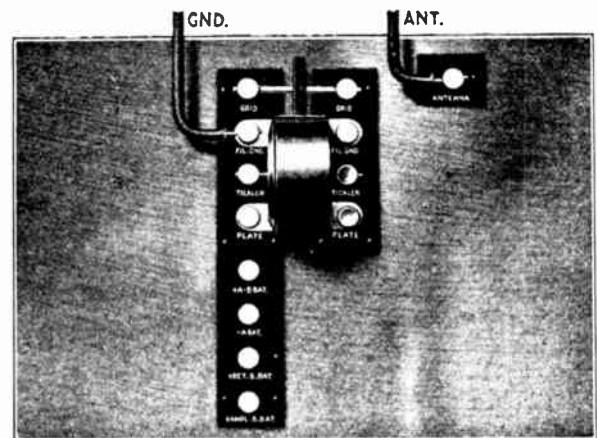

Illustrating the method of connection for CB Load Coil in conjunction with Model RC Receiver

For wavelengths between 170 and 700 meters the switch arm shown in the center of the picture should be raised. For wave lengths between 1800 and 2800 meters it is but necessary to push down on this arm. The CB Load Coil is arranged to supply the necessary inductance for both the antenna and tickler circuits.

Caution—It is essential that the ground wire (G & D) be connected exactly as shown in the accompanying illustration.

Load Coil, Model CB, 1800-2800 Meters, \$6.00

Dimensions: 6 in. x 4 in. x 5 in.

Weights: Net, 8 oz.; Shipping, 2 lbs.

STORAGE BATTERIES FOR RADIO USE

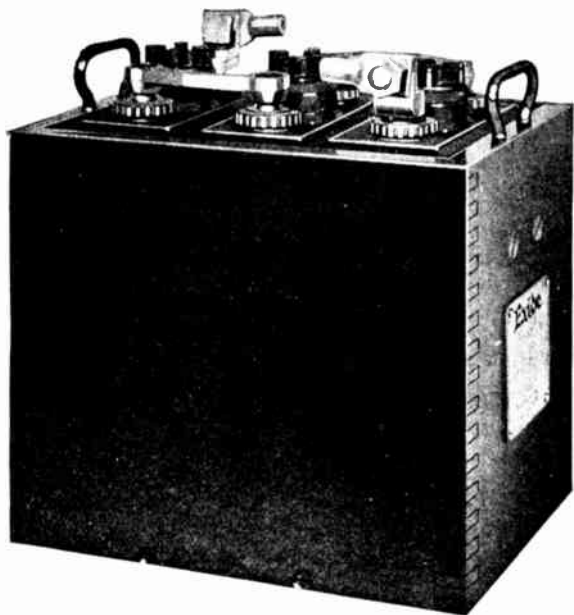

Exide Battery, Model 3LXL-9

WHERE vacuum tubes are used for receiving, the filaments must be heated by a storage battery. It has been common practice among Radio Amateurs to use almost any type of storage battery they can lay hands on, regardless of its capacity or design. Storage batteries, like every other electrical device, in order to function satisfactorily, must be designed with a given purpose in view. A very heavily constructed storage battery is not suitable for radio service as it is too heavy to be transported conveniently to a charging station, and a battery of too light construction, such as the automobile starting, lighting and ignition battery, will not give satisfactory life in this type of service.

Especially Designed for Radio Work

In vacuum tube receiving sets, the number of tubes generally employed is from one to three. The normal current consumption of each tube is approximately one ampere. It is obvious, therefore, that a storage battery for most satisfactory operation with radio must be capable of delivering the required ampere hour capacity at the rate of one to three amperes when in use. Most amateur stations are used intermittently and for this reason the duration of a single charge in the storage battery is considerably increased.

In order to provide a suitable storage battery for radio work, the Radio Corporation of America offers to the field the Exide bat-

tery, which has given entire satisfaction in marine service since wireless equipments were first installed on ship board.

This battery—the Exide—has behind it 34 years of battery-building experience. Its manufacturer, The Electric Storage Battery Company, since the beginning of the storage battery industry, has built storage batteries for every purpose, and this knowledge and experience have been put to good use in designing a battery especially for vacuum tube operation.

In this class of service batteries must be capable of withstanding numerous complete cycles of charge and discharge at low and intermittent rates.

The separators are made of a selected quality of hard and durable wood subjected to a special "treating process" which eliminates elements which would injure the batteries.

The jars and covers are made of the tough, semi-flexible "Giant Compound Rubber" and are practically unbreakable under service conditions.

Service Station Advantage

A very distinct advantage of this battery for radio work is that the user may call upon any of the Exide Service Stations, which thoroughly cover the United States and Canada, and extend into all civilized foreign countries, to have his battery properly charged, or for other service.

For domestic use the Exide batteries are shipped assembled, sealed and charged, and all ready to go into service. For export use, these batteries are especially packed for export shipment and are shipped assembled, sealed but unfilled, and they can readily be filled and put into service at destination.

The ampere hour capacity of the Exide Radio Battery varies as it does with all storage batteries, according to the current being consumed. The following table shows what may be expected of these batteries in vacuum tube work:

Ampere-Hour Capacity Rate of Discharge

Type	Intermittent
3LXL-5	40 Amp. Hrs.
3LXL-9	80 Amp. Hrs.
3LXL-13	120 Amp. Hrs.

Specifications

Type	Length	Width	Height	Weight	Charging rate at start	Charging rate at finish
3LXL-5	5-11/16"	7-5/16"	9-5/8"	24 1/2 lb.	6 amp.	3 amp.
3LXL-9	9- 1/16"	"	"	42 1/2 "	13 "	6 "
3LXL-13	12- 7/16"	"	"	59 1/2 "	18 "	9 "

Storage Battery, Model 3LXL-5 \$17.50

Storage Battery, Model 3LXL-9 \$23.00

Storage Battery, Model 3LXL-13 \$30.00

Prices packed for Domestic Shipment, f.o.b. Factory, Philadelphia.

THE WESTINGHOUSE UNION RADIO "A" BATTERY

THE Radio Corporation of America takes pleasure in offering to the Radio public the Westinghouse Type H.R. Radio Battery, and feels warranted in backing the claims made by the Westinghouse Union Battery Company for their product.

It was decided, after an extensive investigation and research in the radio field in conjunction with the largest manufacturers, to produce series of special radio batteries of entirely new design, rather than a conversion of previous types.

These Radio Batteries embody the most advanced engineering principles and the finest materials and workmanship possible in a battery. They are backed by the immense resources of the Westinghouse Air Brake Company, and affiliated Companies, and are built to meet and live up to the standard of quality and service established by its sponsors during the last 50 years.

Features of Design

Heavy positive plates— $3/16$ " thick—are used to insure ample capacity and long life. High rests to insure ample mud space and acid space are provided in order that the battery may function longer without recharging, while wide plate spacing reduces to a minimum the internal discharge. This feature alone justifies a special design as it helps limit the loss of power when the Radio equipment is not in service.

To prolong the life of the Radio Battery—rubber sheets are used on both sides of the positive plates—thereby retarding the breaking down of the separators. A rubber covered cable is moulded into the post thereby enabling connections to be made several inches from the battery and eliminating poor connections and corrosion.

Acid will settle in a fine spray on the top of the cells while the battery is being charged and in most batteries will seep between the jars, through the case and then on to the table or desk—destroying the finish or covering—but Westinghouse engineers have eliminated this on the type "HR" by completely sealing all cells together at the top so that the acid may be seen at once and wiped away.

Storage Battery Model 6-HR-5 \$18.00



Westinghouse Battery Model 6-HR-9

Westinghouse Service

"Westinghouse Attention" is the improved type of service available at Westinghouse Battery Service Stations.

It is founded on Westinghouse ideals and guided by the experience of experts. Being based upon a fundamental plan, it is uniform everywhere.

It is co-ordinated by a comprehensive, factory-operated service organization which covers the entire country and insures that there shall be no falling away from the rigid standards.

Type "HR" Batteries ordered from the Radio Corporation will be delivered fully charged from the nearest Westinghouse distributor, thus insuring the user a battery that has been freshly charged and is instantly ready for use.

Ampere Hour Capacity

Type	Volts		Amp. Hrs. at 3 Amps. Intermittent Rate.		
6-HR-5	6		50 A. H.		
6-HR-9	6		100 A. H.		
6-HR-13	6		150 A. H.		
	Charging rate				
	Length	Width	Height	Weight	Start Finish
6-HR-5	$5\frac{7}{8}$	$7\frac{3}{8}$	9 13/16	30	4 1.75
6-HR-9	$9\frac{1}{4}$	$7\frac{3}{8}$	9 13/16	46	7.75 3.5
6-HR-13	$12\frac{5}{8}$	$7\frac{3}{8}$	9 13/16	65	11.75 5.25

Storage Battery Model 6-HR-9 \$24.00

Storage Battery Model 6-HR-13 \$33.50

Prices, packed for domestic shipment, f.o.b. nearest Westinghouse Battery Distributor.

RADIO BATTERY CHARGERS

TUNGAR BATTERY CHARGERS



MANY vacuum tube receiving sets require a storage battery for illumination of the tube filaments. When only a source of alternating current is available, the simplest and least troublesome device for battery-charging is the General Electric Company's Tungar Rectifier. Two sizes are recommended.

The 2-ampere Tungar has a capacity of 15 watts and will charge a 3-cell storage battery at 2 amperes or a 6-cell storage battery at one ampere.

The 1-battery Tungar has a capacity of 45 watts and will charge a 3-cell storage battery at 5 amperes, or a 6-cell, or two 3-cell batteries at 3 amperes.

- 2-AMPERE TUNGAR, Model No. 195529... \$18.00
- 1-BATTERY TUNGAR, Model No. 219865... \$28.00
- RENEWAL BULB No. 195528 for Tungar Model No. 195529 \$4.00
- RENEWAL BULB No. 189048 for Tungar Model No. 219865 \$8.00
- Weights: No. 195529... 8 lbs.—No. 219865... 15 lbs.
- No. 195528... 4½ lb.—No. 189048... 3 lbs.

RECTIGON BATTERY CHARGERS



THE Rectigon Battery Charger, manufactured by the Westinghouse Elec. Mfg. Co., forms a very satisfactory means of charging the filament storage battery from an alternating current source. There are no moving parts to this instrument and it is simple, safe and economical.

Style No. 282395, the 2½-ampere capacity Rectigon, is suitable for charging a 40-ampere-hour storage battery from 110-volt, 60-cycle mains. All the larger batteries should be charged with Style No. 285168, which is capable of delivering six amperes.

- 2½-AMPERE RECTIGON, Model No. 282395. \$18.00
- 6-AMPERE RECTIGON, Model No. 285168. \$28.00
- RENEWAL BULB No. 277681 for Rectigon No. 282395 \$4.00
- RENEWAL BULB No. 289414 for Rectigon No. 285168 \$8.00
- Weights: No. 282395... 9¼ lbs.—No. 285168... 21 lbs.
- No. 277681... ½ lb.—No. 289414... 3 lbs.

It is only necessary to connect the Chargers to any 60-cycle alternating current (110 volts) electric light socket, and attach the low voltage direct current terminals to the battery.



Illustrating the simplicity of battery charging when A. C. is available.

The outfits are so designed as to give rated normal currents at normal line voltage to 3 cells and about 2/3 this current at normal line voltage to 6 cells.

RADIO RECEIVING APPARATUS OF QUALITY

THE Radio Corporation of America is in a position to present to Experimenters and to the Laboratories of Colleges, Universities and High Schools, equipment which incorporates the highest quality of material and workmanship and the latest technique in radio design.

The radio receivers and accessories listed in the following pages were designed and manufactured under the supervision of one of America's foremost radio receiving experts. Experimenters desiring to purchase receiving apparatus of the last degree of refinement are urged to investigate this line of equipment. The wavelengths covered by these receivers range from 150 to 8,000 meters. By the use of the loading inductances listed, these sets can be adapted for reception up to 20,000 meters. Appropriate binding posts are mounted on the receiving cabinets and by removing a short circuit strap, these load coils can be inserted in both the primary and secondary circuits.

All controls are mounted on Bakelite panels and the complete apparatus is contained in an oak box. Suitable detector and amplifier units are also provided.

Radio engineers about to make precision measurements in laboratory research work should investigate the high class variable condensers described on the following pages. These represent the highest grade of workmanship and will retain their calibration with extremely slight variation throughout their operating life. Additional high grade apparatus will be added to this catalog from time to time to meet the demand for instruments of superior performance. All receiving apparatus and accessories described herein are licensed for amateur or experimental use only.

RADIO RECEIVER, IP-500



THE IP-500 Receiver is one of the most efficient receivers manufactured. The circuits are designed to give the highest possible efficiency.

Normal wavelength range: 300 to 6,800 meters. This receiver is equipped with six binding posts, normally short-circuited for 300 to 6,800 meters to which loading coils may be attached for the reception of wavelengths up to 23,000 meters. The proper loading coils are: Primary, 50; Secondary, 50; Tickler, 30 millihenries. This receiver possesses a high degree of selectivity, but it is also provided with an untuned or "standby" circuit. It is especially adapted for use in laboratories, and by ad-

vanced radio clubs, where a receiver is desired which is the last word in perfection of design and finish.

A switching mechanism permits the use of either of two tuned circuits on an untuned or tuned secondary.

The coils used in the receiver are bank-wound inductances of high-frequency cable, wound on threaded bakelite tubes. The assembled coils are impregnated in vacuum and baked. The individual sections are automatically connected, entirely disconnected and opened, or entirely disconnected and individually short-circuited, by a mechanism operated by the inductance switch. By this means every coil in the receiver has a natural period when connected with its leads and switch points which is less than the shortest wavelength in the range of the receiver. This eliminates the reception of parasitic signals, reduces the absorption of the desired signal by the coils, forces the energy into the detector, and minimizes interference on all wavelengths.

The condensers are of the self-balanced plate type. Insulating bushings are entirely absent in their construction. Their calibration is constant and their losses extremely low.

The receiver is mounted under a 1/2-inch Bakelite-dilecto panel. The containing box is of 5/8-inch oak. A switch is provided for vacuum-tube reception, and also to protect the detector during transmission.

RECEIVER, IP-500, INCLUDING HIGH GRADE CRYSTAL DETECTOR \$595.00

Overall dimensions: 23 in. x 11 in. x 14 1/2 in.

Shipping weight: 87 lbs.

RADIO RECEIVER, IP-501

THE IP-501 Receiver shown in the accompanying illustration is a compact unit containing the radio frequency and detecting circuits in a single case.

Normal wavelength range: 300 to 7,500 meters. This receiver is equipped with six binding posts (normally short-circuited for 300 to 7,500 meter reception) to which loading coils may be attached for the reception of wavelengths up to 21,000 meters. The proper loading coils are: Primary, 50; Secondary, 100; Tickler, 30 millihenries.

The receiver is similar in mechanical design to the IP-500, with the untuned circuit omitted. The capacity coupling between primary and secondary circuits is eliminated in this type by heavy sheet copper boxes separately enclosing the two circuits.

The panel is of Bakelite-dilecto. The coils are bank-wound inductances, of high frequency cable wound on threaded Bakelite-dilecto tubes, impregnated and baked.



RECEIVER, IP-501, INCLUDING HIGH GRADE CRYSTAL DETECTOR \$550.00

Overall dimensions: 20 in. x 11 in. x 9 in.

Shipping weight: 55 lbs.

DETECTOR AND ONE-STEP AMPLIFIER, TRIODE A

THE amplifier control box shown in the illustration contains vacuum tube detector and amplifier circuits and their controls. A switch permits the use of either the detector or the amplifier. Continuous control of the detector between the damped and undamped methods of reception is obtained by an adjustment in the receiver itself. Amplification is obtained by means of a transformer interlinking the detector and amplifier. Separate rheostats and ammeters are provided with each. The degree of amplification is controlled by the amplifier rheostat. The amplifier is of a type entirely new to the radio art, operating on the principle of low frequency resonance and variable input impedance.

The detector and amplifier have shock-proof mountings that entirely eliminate "noise" due to mechanical vibration. These in turn are mounted on a Bakelite-dilecto panel, and the whole encased in an oak box.

The best of materials and workmanship are employed in the construction of this control unit. It is rugged, and with proper care will have an indefinitely long life in service. It presents the best solution of modern radio problems, and is designed and manufactured in accordance with the best radio engineering practice.

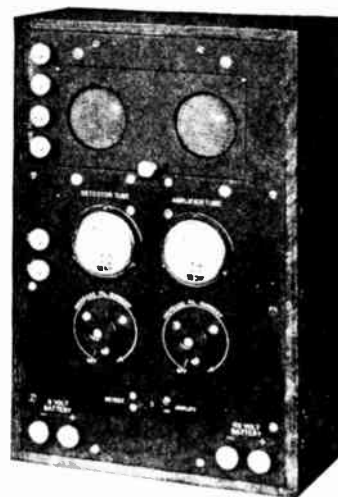

DETECTOR AND 1-STEP AMPLIFIER, TRIODE A \$190.00

Overall dimensions: 14½ in. x 9½ in. x 6¼ in.

Shipping weight: 20 lbs.

TWO-STEP AMPLIFIER, TRIODE B



THIS two-step amplifier is a compact unit of the resonance low-frequency type. It provides a maximum of amplification due to the transformer design, which is greatly superior for radio reception to other types on the market. The input impedance of each tube is automatically controlled by the filament rheostat.

The apparatus consists of two vacuum tube receptacles, two filament control rheostats, and two amplifying transformers. Shock-proof mountings protect the vacuum tubes from "noise" due to mechanical vibration.

The apparatus is mounted on the rear of a Bakelite-dilecto panel and enclosed by an oak box. At the bottom of the panel are terminals for connecting the 6-volt filament and the 40-volt plate batteries. At the lower left of the panel are the two input binding posts for connection to the receiver equipment. At the right of the panel are two binding posts for connecting telephones.

TWO-STEP AMPLIFIER, TRIODE B \$95.00

Overall dimensions: 11¾ in. x 7½ in. x 6¼ in.

Shipping weight: 12 lbs.

CONSTANT IMPEDANCE AUDIBILITY METER, IP-306



AN audibility meter is an essential piece of apparatus in all comparative tests of receivers and telephones, for the reason that it reduces the strength of signals to a definite standard basis of numerical comparison; thus, unit audibility, or an audibility of one, is the strength of a signal which is just audible. By means of a variable shunt around the telephones it is possible to reduce the strength of signal to unit audibility. If the proportional current passing through the shunt is known, the number of times audibility of the signals can readily be determined, provided that at the same time an impedance is introduced in series with the detector output, so as to maintain constant the total impedance across the detector.

The meter is beautifully finished in a hardwood box, with a bevelled Bakelite-dilecto top, on which the audibility is directly engraved. Connection is readily afforded by four binding posts, two for the receiver circuit, and two for the telephones. The taps and contact arm are of polished nickel, so that the instrument makes an attractive, as well as an invaluable, addition to any radio station or laboratory.

AUDIBILITY METER, IP-306 \$135.00
 Dimensions: 8 in. x 8 in. x 3½ in. Weight: 4 lbs.

RECEIVER LOAD COILS

WE offer a high-grade, compact and efficient load coil in three different values, namely, 30, 50 and 100 millihenries. These coils consist of two Bakelite-dilecto side pieces, between which is mounted a highly efficient wave-wound coil of high-frequency cable. The electrostatic capacity of the coil is extremely low. The side pieces are finished square, forming a base for the coil. Close coupling between two or more load coils is possible, as their rear surfaces are flush and close to the plane of the coil.



The coils are ideal units for loading the receivers listed in this catalogue, and in fact any type, to long wavelengths, as they are efficient and permit easy and very wide variation of coupling. A pair of these coils, used in conjunction with two variable air condensers of the types shown on page 67, constitute a receiver. Their values are constant and they may be used as standards and for general experimental purposes.

LOAD COIL— 30 Millihenries. Dimensions: 1 in. x 5½ in. x 5¾ in. \$10.00
LOAD COIL— 50 Millihenries. Dimensions: 1 in. x 5½ in. x 5¾ in. 15.50
LOAD COIL—100 Millihenries. Dimensions: 1 in. x 5½ in. x 5¾ in. 21.50
 Shipping weight: 2 lbs.

PRECISION VARIABLE AIR CONDENSERS



TYPES

- IP-300, .005 mfd.
- IP-301, .003 “
- IP-302, .0015 “
- IP-303, .0007 “

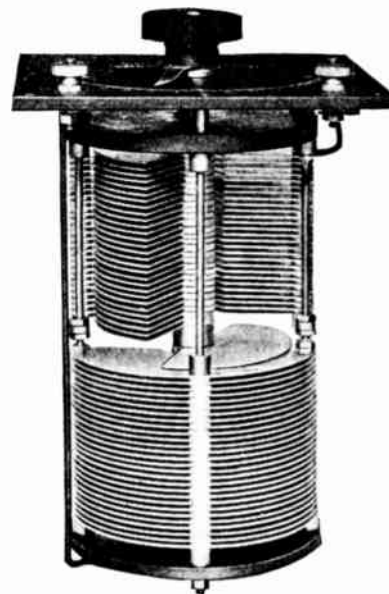

THESE condensers are built in the four different capacities listed below. They are all of the balanced type and will hold any adjustment regardless of the position in which they are placed.

The .005 mfd. condenser shown in the illustration contains a total of 56 semi-circular fixed plates and 58 semi-circular variable plates. The smaller capacity condensers have a correspondingly smaller number of plates. The plates of the upper half of the condenser are mounted on the opposite side of the shaft from the similar lower plates, thus effectively balancing the system mechanically.

The plates are hard aluminum, 1/32 in. thick. The air space between plates is 3/32 in.

The plates are separated by aluminum washers accurately machined. The rods supporting the stationary plates are of brass. The movable plates are mounted upon a steel shaft. The system is fastened to two circular Bakelite-dilecto end pieces, the upper of which is, in turn, fastened to the Bakelite-dilecto top of the condenser. The unit may be easily lifted from the case by the removal of eight screws. On the Bakelite-dilecto top is the rotary control knob and pointer, which is provided with an engraved 180° scale. Two nickel-plated binding posts are provided for making connections to the condenser.

These condensers are mounted in neat oak boxes, and are provided with calibration charts.

VARIABLE AIR CONDENSER—TYPE IP-300, CAPACITY .005 MFD.....	\$90.00
Dimensions: 7 1/8 in. x 7 1/8 in. x 7 5/8 in. Shipping weight: 15 lbs.	
VARIABLE AIR CONDENSER—TYPE IP-301, CAPACITY .003 MFD.....	72.00
Dimensions: 7 1/8 in. x 7 1/8 in. x 8 3/8 in. Shipping weight: 12 lbs.	
VARIABLE AIR CONDENSER—TYPE IP-302, CAPACITY .0015 MFD.....	45.00
Dimensions: 5 1/2 in. x 5 1/2 in. x 8 3/8 in. Shipping weight: 7 1/2 lbs.	
VARIABLE AIR CONDENSER—TYPE IP-303, CAPACITY .0007 MFD.....	41.50
Dimensions: 5 1/2 in. x 5 1/2 in. x 4 3/4 in. Shipping weight: 6 lbs.	

PART THREE

Vacuum Tube Transmission for the Radio Amateur and Experimenter

With Data on

Radiotron Transmission

Kenotron Rectification

Transmitting Tube Circuits

Transmitting Apparatus

RADIOTRON TRANSMISSION

THE USE OF RADIOTRONS IN EXPERIMENTAL CONTINUOUS WAVE TELEGRAPH AND TELEPHONE SETS

CURRENT literature devoted to amateur radio activities affords sufficient evidence that the era of continuous wave transmission has arrived. It has long been known that continuous wave sending apparatus would provide a greater radio transmission range than a spark transmitter of the same power to the antenna, and also that the use of continuous waves would permit the adoption of more efficient methods of reception than the spark system.

The only suitable form of undamped wave generator for short wave transmission is the oscillating vacuum tube. The expenditure of large sums of money in painstaking research conducted by America's foremost scientific experts has enabled the production of reliable and efficient power tubes—**RADIOTRONS**—which may be employed as generators of continuous oscillations, of any frequency used in radio communication. The vacuum tube is better adapted to radio transmission at wavelengths in the region of 200 meters than the spark system, for the spark system has certain inherent characteristics which place a very definite practical limit upon the amount of energy that can be put into an antenna at short

wavelengths and therefore at high frequencies.

The vacuum tube transmitter using the Radio Corporation's Power Tubes is comparatively simple, both in point of construction and in operation. It is no more difficult to adjust and to maintain than a spark transmitter, and it has many points of advantage over the spark set. There are, however, certain precautionary measures which must be considered in vacuum tube operation, and it is one of the objects of this bulletin to place before the amateur such information as will enable him to secure the

maximum results from a tube set. Moreover, as the operation of the tube transmitter becomes better known among amateur experimenters, it will occupy the premier position in amateur radio work.

Two prime advantages of continuous wave telegraphy should not be lost sight of; namely, the high

degree of selectivity, and the greatly increased range obtainable. It is usually possible to transmit two or three times the distance that can be covered by a spark set of the same antenna power, and in addition interference is reduced to an absolute minimum.

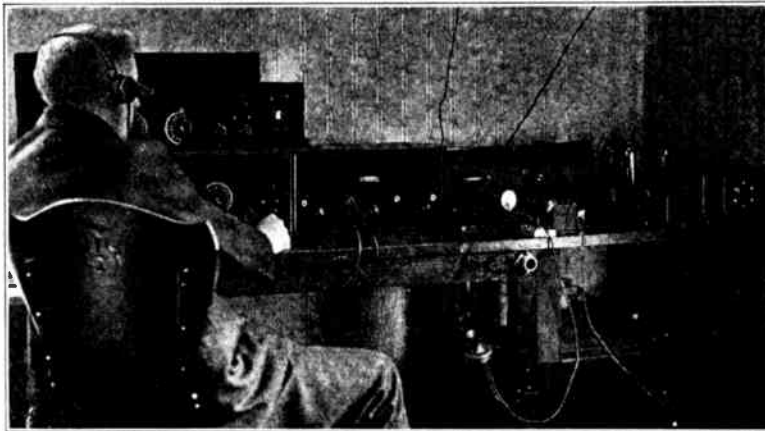

Station "8ZG" of Salem, Ohio, Equipped with a 100-Watt Radiotron Vacuum Tube Transmitter Made Up of RCA Parts.

CONTINUOUS WAVE TELEGRAPHY (C. W.), INTERRUPTED CONTINUOUS WAVE TELEGRAPHY (I. C. W.) AND RADIO TELEPHONE TRANSMISSION

EVERY up-to-date radio experimenter wants a radio telephone; he will also want a long-distance radio telegraph set. With the same set, using the Radio Corporation's Power

Tubes, the amateur can telephone to the neighboring stations over moderate distances, and by shifting a few switches he can adapt the set for continuous wave telegraph transmission and

cover distances by telegraphy three to four times those possible by radio telephony. This is the modern way of doing things in the amateur station, and today there are already several thousand RADIOTRON Power Tubes in use at amateur stations throughout the United States.

The Vacuum Tube Transmitting not only permits wireless telephony, but also enables the amateur to make use of modulated or interrupted continuous wave telegraphy. Thus, if the energy supplied to an antenna by an oscillating tube set is modulated by a microphone transmitter, telephonic communication is possible; or if the antenna oscillations are modulated by a buzzer or preferably by some form of rotary grid chopper, the antenna will ra-

diate wave trains similar to those sent forth from the antenna of a spark transmitter. By a suitable arrangement of controls, either C. W. transmission, I. C. W. transmission or telephony may be had from the same set, simply by shifting a few switches.

In transmitting to crystal detector receiving stations with a tube transmitter the grid circuit is modulated by a rotary "chopper." Such a chopper is nothing more than a rotary interrupter designed to interrupt the grid circuit of an oscillating tube from 600 to 1,000 times per second. Tests have demonstrated that a tube set modulated in this way gives the same reception efficiency as a quenched spark set of the same power to the antenna.

SOURCES OF ENERGY FOR TUBE TRANSMISSION

A VACUUM power tube requires a low voltage source to heat the filament and a high voltage source to energize the plate or anode circuit. The requisite e.m.f. for the plate circuit may be obtained in three ways:

- (1) From a high voltage D. C. generator.
- (2) From a rectified A. C. Source, using the Radio Corporation's KENOTRON, or two electrode, rectifier valves.
- (3) From an A. C. Source directly applied to the plate (self-rectification circuits).

If only a D. C. source, such as 110 or 220 volts, is available, a high voltage D. C. generator should be obtained. The motor should be supplied with slip rings to provide an alternating E.M.F. for the filament (through the medium of a step-down transformer). The generator should provide high voltage D. C. according to the rating of the power tube.

Amateurs having access to an A. C. source only should obtain an A. C. transformer and two of the Radio Corporation's KENOTRON Rectifier Valves arranged in a suitable circuit to rectify both valves of the A. C. cycle. The transformer should be provided with a high

voltage secondary for the plate circuit supply and with two additional secondaries providing a step-down voltage to light the filaments of the Power Tubes and Rectifier Valves. In addition, a reactance and condenser must be supplied to smooth out the ripple in the plate current, as shown in Figure 4.

In the third method two RADIOTRON Power Tubes may be connected in a type of circuit in which alternating current of suitable voltage can be applied directly to the plate circuits of the tubes. The tubes then act simultaneously as rectifiers and oscillators, using both halves of the impressed A. C. cycle. This is called the self-rectification method. By means of a smoothing-out reactance of suitable design, the variation in amplitude of the antenna oscillations may be reduced to a minimum value, giving all the advantages of C. W. transmission. The self-rectification circuit is recommended for telegraph use only. A suitable D. C. source obtained either from a Rectifier Unit or a D. C. generator should be used for telephony.

NOTE ON C. W. POWER TRANSFORMERS

THE use of separate transformers for the lighting of power tube filaments is highly recommended for the reason that it is only by using such an arrangement that voltage variation in the different circuits is made possible. Where a combination transformer having a single primary winding connected to the power source is used, variation of the voltage is only possible in this primary winding and the sec-

ondary windings, regardless of their number, are all affected at the same time. The cost of individual transformer units for this work is approximately 75 per cent. higher than the cost of a single transformer designed to perform a multiplicity of duties. However, more satisfactory operation results and the former is recommended.

THE PRACTICAL USE OF TRANSMITTING TUBES

Although the principles of construction and operation in the larger power tubes are no different from those applying in the case of the smaller ones, many effects that are negligible in the latter are somewhat magnified in the case of the larger tubes, and certain precautions are therefore necessary. The majority of accidents to power tubes and to their auxiliary apparatus occur during the period of development of circuits and testing and adjustment, rather than during operation, and a little

care in making these adjustments will prove of advantage.

The following points, briefly enumerated, are all of importance and should be studied by the amateur before putting his set into operation. Limited space prevents us from giving in detail the reasons for some of the instructions herein laid down, but the amateur may be assured that they are the result of practical observation and experiment and that he cannot well afford to ignore them.

MODULATION OF AN OSCILLATING TUBE'S OUTPUT

One method of modulation employed in a vacuum tube radio transmitting equipment utilizes a tube as a modulator in addition to the oscillator tube, the plate current for these two tubes being fed through an audio-frequency reactor. In a radio telephone transmitting equipment the degree of modulation is of equal importance to the amount of antenna current as far as the strength of the received speech is concerned. The antenna ammeter does not usually indicate whether the output is being modulated in a normal manner. One simple

method of keeping a check on this is to insert a miniature lamp in the plate circuit of the modulator. This flashes up when the microphone is spoken into and acts as an operating indicator of the microphone and modulation circuits. A type of lamp should be chosen that will show a low degree of brilliancy with the plate currents obtained on the tube used. Even for the 5-watt size of tube such lamps are easily obtainable. Automobile types of miniature lamps are recommended.

SAFETY GAPS AND GENERAL PROTECTIVE MEASURES

In order to guard against excessive transient voltages in connection with RADIOTRONS UV-203 and UV-204 a protective gap should be provided at or near the socket terminals between the grid and terminal and one of the filament terminals. One-sixteenth of an inch is correct for UV-203 and one-eighth of an inch for UV-204.

Occasionally in the parallel operation of RADIOTRON power tubes, ultra high frequency oscillations develop in the plate and grid circuits, which prevent the realization of full

output, and cause excessive plate and grid currents. This effect may be avoided by inserting an inductance of a few micro-henries (10 turns in one layer on a tube one inch in diameter is suggested) in one or more of the individual grid leads of each tube as close to the grid terminal of the socket as possible. The protective gap mentioned in a paragraph above should be placed between this coil and the grid terminal of the socket. The best arrangement is to mount the gap directly on the socket terminals and one terminal of the coil directly to the grid terminal of the socket.

TUBE SUSPENSION

The life of RADIOTRON power tubes may be prolonged by mounting them in the proper position. RADIOTRONS UV-202 and UV-203 should be operated in a vertical position, whereas RADIOTRON UV-204 may be operated in either a vertical or horizontal position. If mounted horizontally, the plates should lie in a vertical plane, with the seal-off tip down.

OSCILLATING CIRCUITS

In powerful C. W. transmitting sets the circuits should be so arranged that the center tap on the filament coil and also the negative lead of the direct current high voltage source are both at ground potential relative to high frequency potentials in order to insure safety.

Great care should be taken to thoroughly insulate the grid and plate leads to the tube and the coil sections connected to these leads or any apparatus in them.

INADVISABILITY OF FORCING POWER TUBES

IT is unwise to overload a RADIOTRON power tube continuously, as its operating life will be seriously curtailed. It is a much better plan and more economical to operate two tubes in parallel than it is to force one tube to deliver a power output far in excess of what it is rated for; in fact great economy will result from burning tubes slightly below normal brightness. For instance, it can be shown that to double the filament emission will reduce the operating life of the tube to one-fourth, whereas, by operating the filament at 95% of its rated voltage, the life will be doubled.

When first testing the circuit, or when the set has not been operated for some time, it is wise to cut down all voltages to one-third

of the normal voltage. This will greatly reduce the possibility of burning out the tube through a wrong connection which has been overlooked, as a fault will then instantly be detected before the damage is done.

In a radio telephone transmitting circuit of the usual type a modulator tube is employed and a buzzer is often substituted for the microphone when it is desired to send out interrupted continuous waves. This imposes voltage strains on the oscillator tube and if an over-voltage is also applied to its plate the voltage between grid and filament may be excessive. The protective gaps described in a previous paragraph are a safeguard against breakdown due to this voltage.

RESISTANCE OF THE ANTENNA AND GROUND CIRCUIT

Remember it is the antenna charging current at the transmitter that produces the signals at the receiver, and in order to get a large antenna current with tube sets, the resistance of antenna systems must be reduced to a minimum. In addition to the usual metallic earth plate a counterpoise, consisting of a number of wires spread on the ground underneath the

antenna will materially reduce the total antenna resistance. The antenna should be constructed and supported so that its electrical period will not vary through swinging, for, as will be seen, most of the tube circuits shown in this catalogue use the antenna as the capacity element of the oscillating system.

FILAMENT EXCITATION OF POWER TUBES

The filaments of power bulbs are preferably energized by alternating current, which gives an added factor of safety and prolongs the filament life.

In adjusting the temperature of a filament the amateur should always use a voltmeter rather than an ammeter, and the voltmeter should be connected directly to the socket connections, in order that the voltage drop across the filament may be measured. If tung-

sten filaments are operated at constant voltage rather than constant current, it may increase their life by 300%.

If alternating current is not available the filaments may, of course, be energized from a D. C. source of suitable E. M. F. It is emphasized, however, that the life of a vacuum tube is considerably prolonged by A. C. filament excitation, and particularly if the filament voltage is maintained at constant value.

LOCATION OF THE TELEGRAPH KEY IN C. W. CIRCUITS

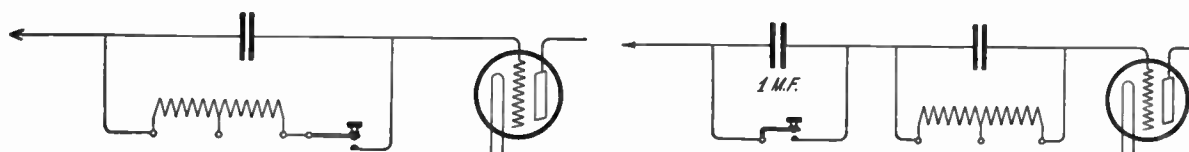

The proper location of the telegraph key in C. W. transmitting circuits is determined by the size of the RADIOTRON power tubes used. In circuits employing one or more UV-202 RADIOTRONS, satisfactory keying can be obtained by inserting the key in series with the grid leak resistance as shown in the diagram.

If, however, one or more UV-203 RADIOTRONS are used, the most satisfactory keying will be obtained if a 1 mfd. condenser is inserted in series with the parallel circuit containing the grid leak resistance and grid condenser, and the key shunted around the 1 mfd. condenser as shown above.

TRANSMITTING TUBE CIRCUITS

TO show the radio amateur or experimenter how to utilize RADIOTRONS in certain of the well-known oscillating circuits, there is given on the following pages a set of circuit diagrams for radio transmission, together with the component parts of a set for either 5, 50 or 250 watt tubes. Power tubes can be used in a variety of circuits, but the ones shown have been found to give maximum efficiency. Current radio literature discloses numerous tube transmitting circuits which will be found serviceable.

The attention of the amateur who does not possess a high voltage D. C. motor generator set to supply plate voltage is directed to the self-rectification telegraph circuits shown, in which RADIOTRONS may be energized directly from an A. C. source. In these circuits power tubes act simultaneously as rectifiers and oscillators. A suitable source of D. C. may be obtained from an A. C. source by the use of the Radio Corporation KENOTRON Rectifier Valves.

CIRCUIT NO. 1

Figure 1 shows a simple, yet modern type of radio telephone circuit, wherein two Radiotron power tubes are connected in parallel as oscillators. The plate circuit is energized by using full wave Kenotron rectification from an A. C., 110 volt supply. The antenna energy is modulated for radio telephony by the Radio Corporation of America's Magnetic Modulator.

CIRCUIT NO. 2

Figure 2 illustrates a method for using Radiotrons UV-202 or 203 for C. W. and I. C. W. radio telegraphy from a D. C. supply. The filaments of the transmitter tubes in this case are heated by a storage battery and the voltage necessary for the plates is supplied by a special motor generator according to the rating indicated at the foot of the page describing this circuit. Where I. C. W. is employed, the Radio Corporation of America's Grid Chopper Model PX-1638 is employed.

CIRCUIT NO. 3

Figure 3 illustrates a full wave self-rectifying transmitter for C. W. telegraphy using A. C. as a source of power throughout. This circuit is applicable to 5 and 50 watt Radiotrons, UV-202 and UV-203, respectively. The plate circuit is energized from the Radio Corporation of America's new high voltage transformer, which is designed to operate from a source of 110 volt, 50 or 60 cycle A. C.

CIRCUIT NO. 4

Figure 4 illustrates one of the correct methods for employing a 10-20 or 50-100 watt radio telephone set, using two Radiotrons UV-202 or UV-203, one as an oscillator and the other as a modulator. Two of the Radio Corporation of America's Kenotrons, Model UV-216 or Model UV-217, provide D. C. plate excitation from an A. C. supply. An R. C. A. microphone transformer with "side tone" winding is used to control the grid potential of the modulator tube, which in turn varies the energy imposed upon the antenna circuit.

CIRCUIT NO. 5

Figure 5 illustrates a circuit specially designed to provide constant antenna frequency. This is desirable because it prevents changes in

the wave length of the transmitting station and permits consistent operation over longer distances than is otherwise possible. Two Radiotron power tubes are employed as oscillators, their plates being energized by the Kenotron Rectifier combination, which provides full wave rectification from the A. C. supply.

CIRCUIT NO. 6

Figure 6 shows a typical radio telephone transmitting circuit, employing three Radiotrons UV-203 as oscillator, modulator, and speech amplifier, respectively. Plate excitation is obtained from a D. C. high voltage generator and the plate potential for normal operation should range between 750 and 1000 volts. This circuit may be employed for C. W., I. C. W., or radio telephone transmission.

CIRCUIT NO. 7

Figure 7 illustrates a typical circuit for use in connection with four Radiotrons UV-202 and four Kenotrons UV-216. Two of the Radiotrons act as modulators and two act as oscillators, while the four Kenotrons permit full wave rectification from the A. C. supply. The Radio Corporation of America's Power Transformer provides the filament and plate current for the eight tubes.

CIRCUIT NO. 8

Figure 8 illustrates a suitable arrangement for using full wave rectification for four Radiotrons UV-202 and four Kenotrons UV-216. This is a constant frequency circuit of the same character illustrated in Fig. 5. The coupling arrangement between the oscillation transformer and antenna inductance permits an accurate adjustment by means of the Special Faradon Condenser UC-1846 which provides three different capacities.

CIRCUIT NO. 9

Figure 9 shows a radio telegraph self-rectifying transmitting circuit for two Radiotrons UV-204. The energy supply for this circuit must be A. C. and individual transformers for filament heating and plate supply are used. A circuit of this character may be employed to communicate over long distances by self-rectified continuous wave telegraphy.

FIG. 1. Radio Telephone Circuit, Using Full Wave Rectification From A. C. Supply and Magnetic Modulator

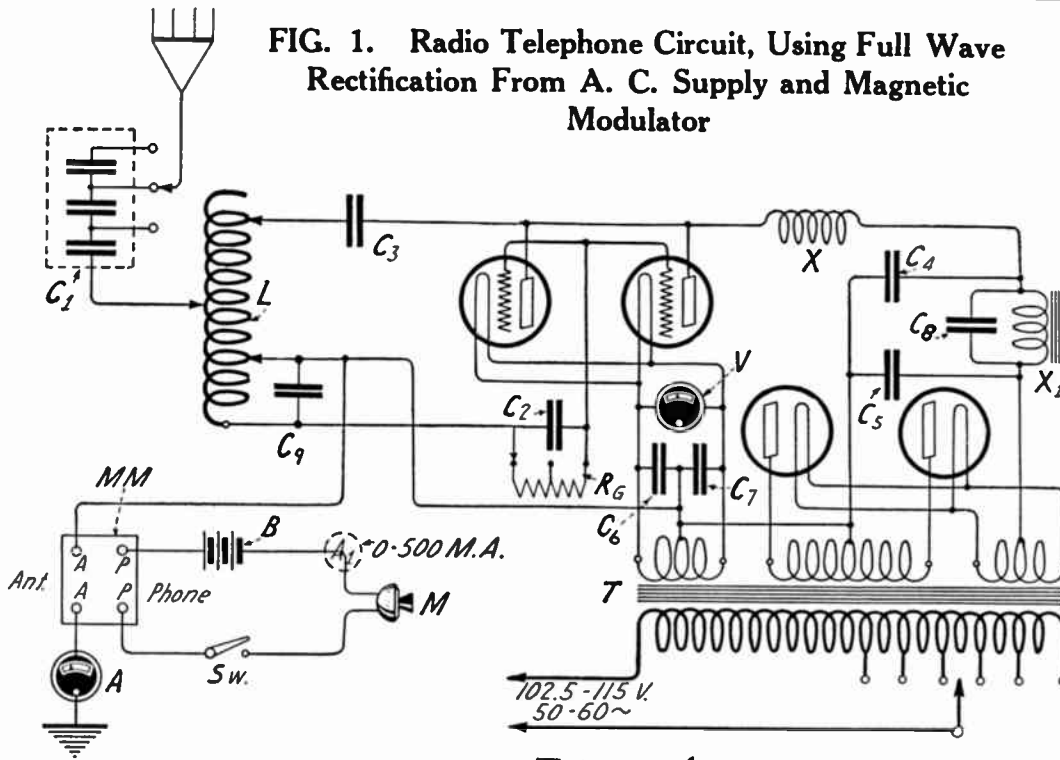

Fig. 1

LIST OF MATERIAL	Circuit Symbol	RATING OF RADIOTRONS			
		5-WATT TUBES		50-WATT TUBES	
		Model	Price	Model	Price
1 One or more RADIOTRON Power Tubes		UV-202	\$8.00 each	UV-203	\$30.00 each
2 One or more RADIOTRON Power Sockets		UR-542	1.00 "	UT-541	2.50 "
3 Two KENOTRON Rectifier Tubes		UV-216	15.00	UV-217	53.00
4 Two KENOTRON Tube Sockets		UR-542	2.00	UT-541	5.00
5 Antenna Series Condenser	C ₁	UC-1015	5.75	UC-1015	5.75
6 Magnetic Modulator	MM	(See Note 1)		(See Note 3)	
7 Magnetic Modulator Battery	*B	6 Volts		6 Volts	
8 Microphone	†M	WE-284-W		WE-284-W	
9 Antenna Ammeter	A	UM-530	6.00	UM-533	6.25
10 Grid Condenser	C ₂	UC-1014	2.25	UC-1014	2.25
11 Blocking Condenser	C ₃	UC-1014	2.50	UC-1014	2.50
12 Filter Condenser	C ₄	2-UC-490	5.00	2-UC-490	5.00
13 Filter Condenser	C ₅	(In parallel)		(In parallel)	
	C ₆	2-UC-490	5.00	2-UC-490	5.00
		(In parallel)		(In parallel)	
14 Transmitter Grid Leak	R _g	UP-1719	1.10	UP-1718	1.65
15 A. C. Filament Voltmeter	V	0-15 Volts		0-15 Volts	
16 Power Transformer	T	UP-1368	25.00	UP-1016	38.50
17 Radio Frequency Choke	X	UL-1655	3.85	UL-1655	3.85
18 Filter Reactor	X ₁	UP-1653	12.50	UP-1654	18.00
19 Oscillation Transformer	L	UL-1008	11.00	UL-1008	11.00
20 Microphone Milliammeter	A ₁				
21 Microphone Battery Switch	SW	S. P. S. T.		S. P. S. T.	
22 Filament By-Pass Condenser	C ₆ & C ₇	2-WE-21-R		2-WE-21-R	
		(As shown)		(As shown)	
23 Trap Condenser	C ₈	WE-21-U		WE-21-U	
24 Grid Tuning Condenser	C ₉	UC-1831	9.00	UC-1831	9.00

NOTE 1:—Proper Size of Magnetic Modulator

No. of Tubes	UV-202	No. of Tubes	UV-203
1	UT-1643	1	UT-1357
2	UT-1643	2	UT-1367
3	UT-1357	3	UT-1367
4	UT-1357		

* Four Dry Cells or 6-Volt Storage Battery.
 † Western Electric No. 284-W is recommended.

REMEMBER—It is not necessary to purchase a motor-generator if you have a source of 110-volt A. C. lighting current, for it can be converted to D. C. by using KENOTRON rectifiers.

FIG. 2. C. W. and I. C. W. (Grid Chopper) Circuit for Operation From D. C. Supply With Radiotrons UV-202 or UV-203

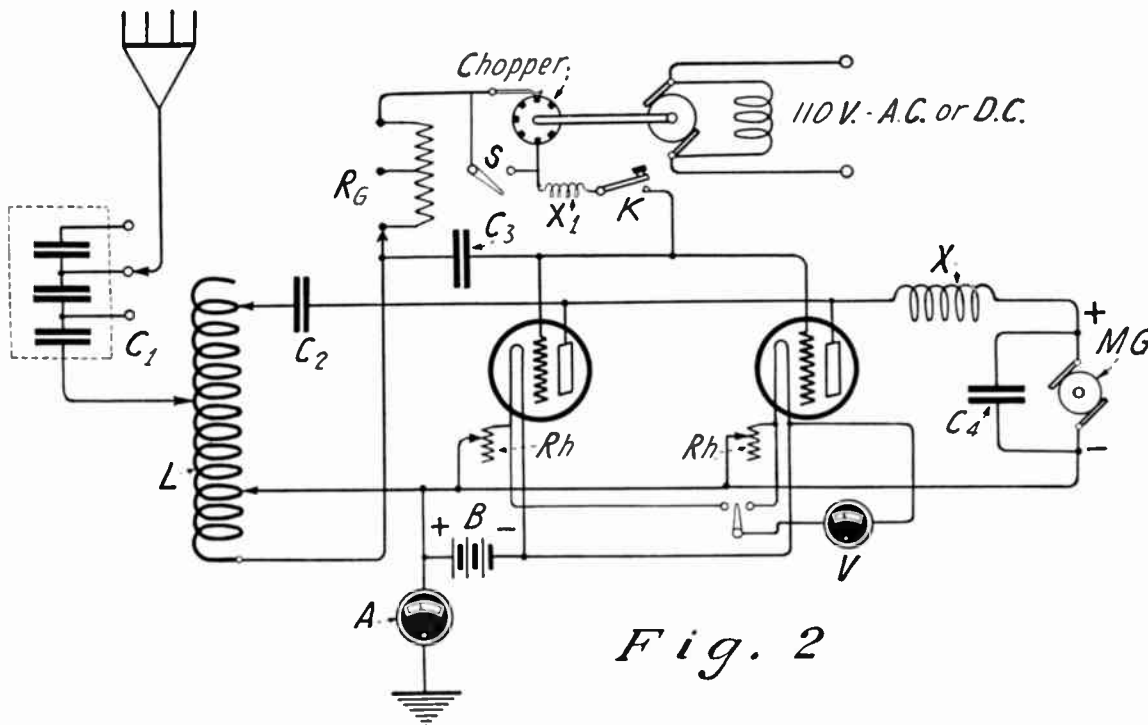

Fig. 2

LIST OF MATERIAL		Circuit Symbol	RATING OF RADIOTRONS			
			5-WATT TUBES		50-WATT TUBES	
			Model	Price	Model	Price
1	One or more RADIOTRON Power Tubes		UV-202	\$8.00 each	UV-203	\$30.00 each
2	One or more RADIOTRON Tube Sockets		UR-542	1.00 "	UT-541	2.50 "
3	Oscillation Transformer	L	UL-1008	11.00	UL-1008	11.00
4	Antenna Series Condenser	C ₁	UC-1015	5.75	UC-1015	5.75
5	Blocking Condenser	C ₂	UC-1014	2.50	UC-1014	2.50
6	Transmitter Grid Leak	R _g	UP-1719	1.10	UP-1718	1.65
7	Grid Condenser	C ₃	UC-1014	2.50	UC-1014	2.50
8	Transmitting Key	K	UQ-809	3.00	UQ-809	3.00
9	Chopper	Chopper	PX-1638	7.25	PX-1638	7.25
10	Radio Frequency Chokes	X	UL-1655	3.85	UL-1655	3.85
11	D. C. Filament Voltmeter	V	O-15 Volts		O-16 Volts	
12	Filament Rheostat	Rh	PR-535	3.00	PT-537	10.00
13	Filament Battery	B	10 Volts		12 Volts	
14	Protective Condenser	C ₄	UC-490	2.50	UC-490	2.50
15	Motor Generator	MG	(See Note 1)		(See Note 1)	
16	Antenna Ammeter	A	UM-530	6.00	UM-533	6.25
17	Radio Frequency Choke	X ₁	UL-1655	3.85	UL-1655	3.85
18	Switch for CW Telegraphy	S	S. P. S. T.			

NOTE 1:—Rating of Motor Generators

UV-202

No. of Tubes	Watts M. G.	Plate Volts
1 or 2	100	350
2 or 4	200	350

UV-203

No. of Tubes	Watts M. G.	Plate Volts
1	200	750-1000
2 or 3	500	750-1000

REMEMBER—In general a grid chopper gives the same kind of a signal at the receiving station as a spark set, but usually over much greater distances.

FIG. 3. Method of Using 5- or 50-Watt Radiotron Power Tubes With 60-Cycle A. C. Source for C. W. Tone Telegraphy—(Full Wave Self-Rectification)

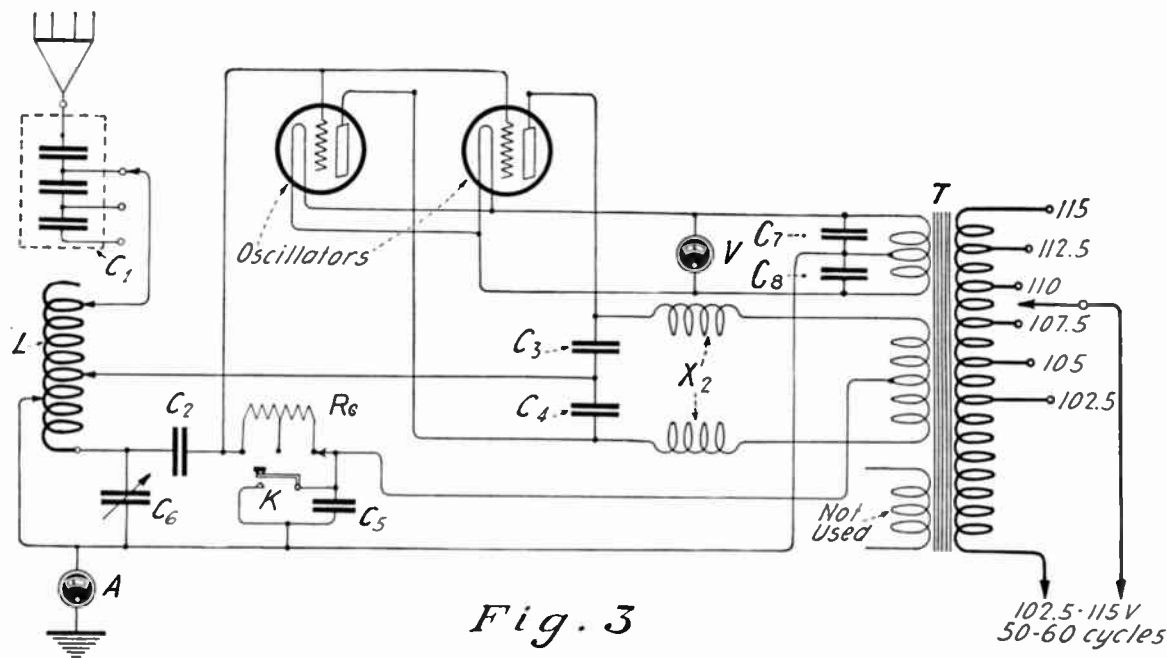

Fig. 3

LIST OF MATERIAL	Circuit Symbol	RATING OF RADIOTRONS			
		5-WATT TUBES		50-WATT TUBES	
		Model	Price	Model	Price
1 Two RADIOTRON Power Tubes (Note 1)		UV-202	\$16.00	UV-203	\$60.00
2 Two Power Tube Sockets		UR-542	2.00	UT-541	5.00
3 Power Transformer	T	UP-1368	25.00	UP-1016	38.50
		(See Note 1)			
4 Oscillation Transformer	L	UL-1008	11.00	UL-1008	11.00
5 Two By-Pass Condensers	C ₇ , C ₈	UC-1014	5.00	UC-1014	5.00
6 Grid Condenser	C ₂	UC-1014	2.50	UC-1014	2.50
7 Grid Leak	R _g	UP-1719	1.10	UP-1718	1.65
8 Antenna Series Condenser	C ₁	UC-1015	5.75	UC-1015	5.75
9 A. C. Filament Voltmeter	V	0-15 Volts		0-15 Volts	
10 Antenna Ammeter	A	UM-530	6.00	UM-533	6.25
11 Key	K	UQ-809	3.00	UQ-809	3.00
12 Radio Frequency Chokes	X ₂	2-UL-1655	7.70	2-UL-1655	7.70
13 Keying Condenser	C ₅	UC-1014	2.50	UC-1014	2.50
14 Grid Tuning Condenser	C ₆	2-UC-1014	5.00	2-UC-1014	5.00
15 By-Pass Condensers	C ₇ & C ₈	In Series or (UC-1831) variable WE21-R (Connected as shown)		In Series—Fixed or (IUC-1831) variable WE21-R (Connected as shown)	

NOTE 1:—Transformer UP-1368 is capable of handling a total of four UV-202 tubes in a self-rectifying circuit. In order to obtain a 20-watt set, it is only necessary to add two additional UV-202 tubes, one in parallel with each of the tubes shown in the circuit.

REMEMBER—When using a motor-generator for plate supply to one or more power tubes, be sure that the watts output of the generator is sufficient to supply all the tubes. Do not use a 15-watt generator for plate supply to a 50-watt RADIOTRON. A table indicating the generator watts output for various numbers of tubes is shown under Fig. 2.

FIG. 4. Complete Diagram for Low Power Radio Telephone Set, Using Constant Current Modulation System with 5 or 50-Watt Radiotron Power Tubes Operating From 110-Volts A. C. Supply.

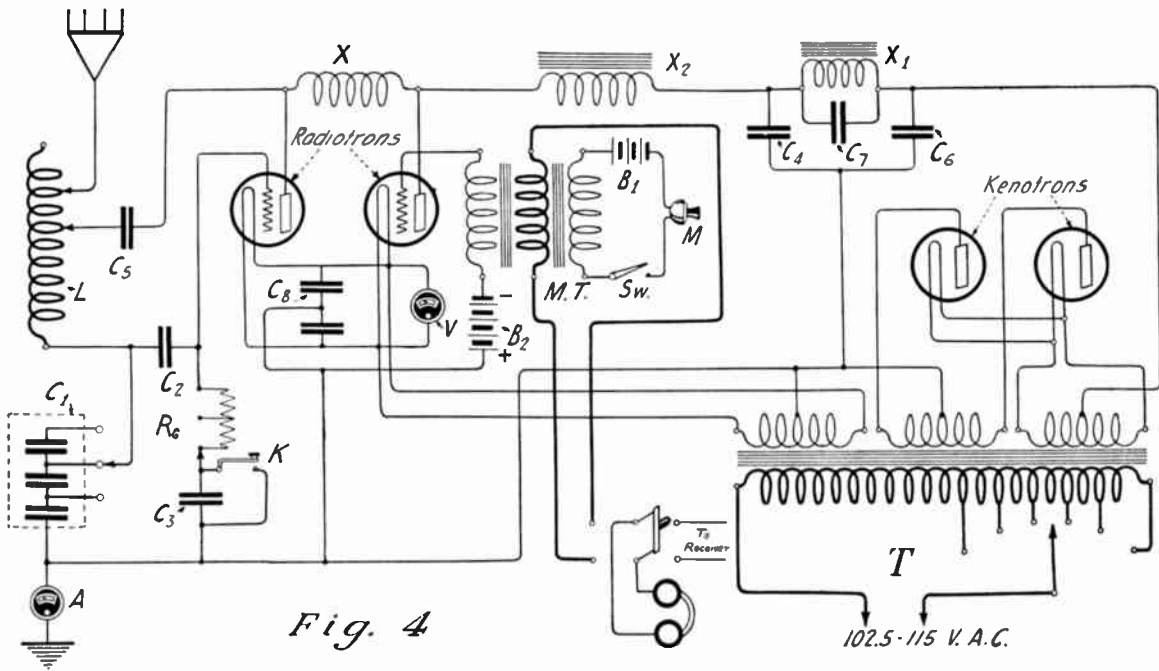

Fig. 4

LIST OF MATERIAL	Circuit Symbol	RATING OF RADIOTRONS			
		5-WATT TUBES		50-WATT TUBES	
		Model	Price	Model	Price
1 Two RADIOTRON Power Tubes.....		UV-202	\$16.00	UV-203	\$60.00
2 Two Power Tube Sockets.....		UR-542	2.00	UT-541	5.00
3 Power Transformer.....	T	UP-1368	25.00	UP-1016	38.50
4 Oscillation Transformer.....	L	UL-1008	11.00	UL-1008	11.00
5 Two KENOTRON Rectifier Tubes.....		UV-216	15.00	UV-217	53.00
6 Two KENOTRON Tube Sockets.....		UR-542	2.00	UT-541	5.00
7 Radio Frequency Choke Coil.....	X	UL-1655	3.85	UL-1655	3.85
8 Plate Reactor.....	X ₂	UP-415	5.75	UP-415	5.75
9 Filter Reactor.....	X ₁	UP-1653	12.50	UP-1654	18.00
10 Filter Circuit Condensers.....	C ₁ -C ₈	2-UC-490	5.00	2-UC-490	5.00
11 Microphone Transformer.....	MT	(In parallel) UP-414	7.25	(In parallel) UP-414	7.25
12 Microphone Transmitter.....	*M	WE-284-W		WE-284-W	
13 Microphone Battery.....	*B ₁	6 Volts		6 Volts	
14 Microphone Switch.....	SW	S.P.S.T.		S.P.S.T.	
15 Grid Bias Battery.....	†B ₂	44 Volts		44 Volts	
16 A. C. Filament Voltmeter.....	V	O-15 Volts		O-15 Volts	
17 Transmitter Grid Leak.....	R _G	UP-1719	1.10	2-UP-1718	3.30
18 Antenna Series Condenser.....	C ₁	UC-1015	5.75	(In Series) UC-1015	5.75
19 Antenna Anmmcter.....	A	UM-530	6.00	UM-533	6.25
20 Blocking Condenser.....	C ₅	UC-1014	2.50	UC-1014	2.50
21 Grid Condenser.....	C ₂	2-UC-1014 (In Series)	5.00	2-UC-1014 (In Series)	5.00
22 Key Condenser.....	C ₃			UC-490	2.50
23 Trap Condenser.....	C ₇	WE-21-U		WE-21-U	
24 Filament By-Pass Condensers.....	C ₈	2-WE-21-R (Connected as shown)		2-WE-21-R (Connected as shown)	

* Four Dry Cells or 6-Volt Storage Battery.
 † Two Blocks of Burgess' Battery 22½ volts each, No. 2156.

REMEMBER—All of the energy of your power tubes can be efficiently delivered to your antenna on wave lengths of 200 meters and lower.

FIG. 5. Radio Telephone or Telegraph Circuit, Using Full Wave Rectification From A. C. Supply With Constant Frequency (Intermediate) Circuit and Magnetic Modulator

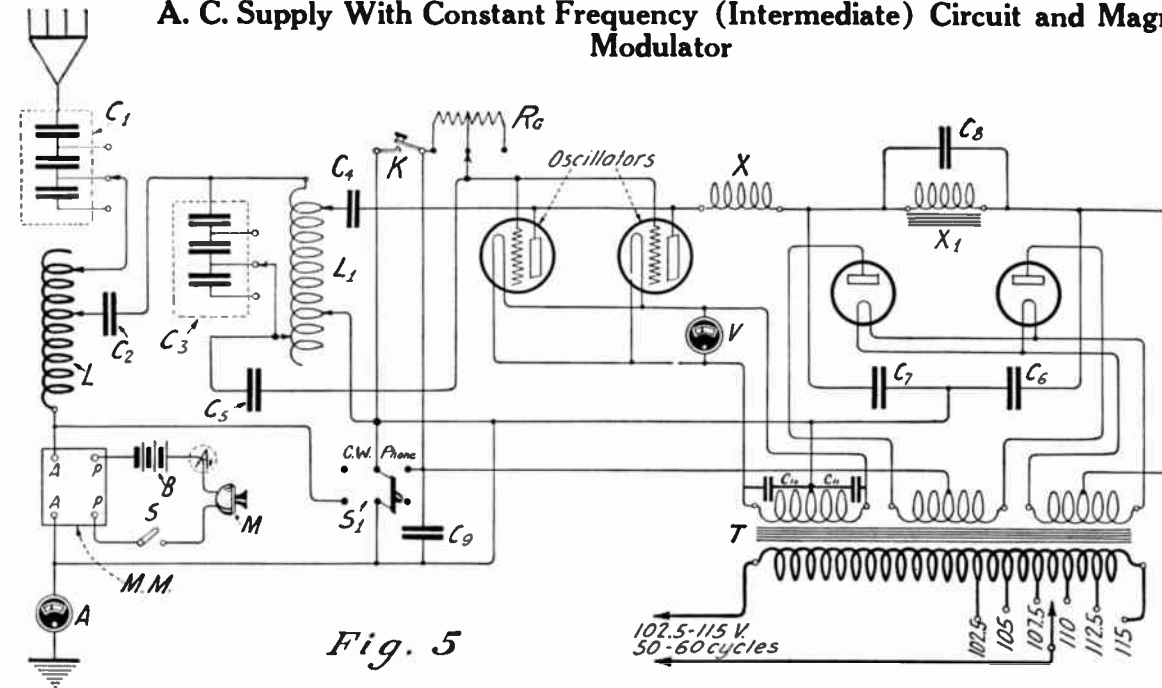

Fig. 5

LIST OF MATERIAL		Circuit Symbol	RATING OF RADIOTRONS			
			5-WATT TUBES		50-WATT TUBES	
			Model	Price	Model	Price
1	Two RADIOTRON Power Tubes.....		UV-202	\$16.00	UV-203	\$60.00
2	Two RADIOTRON Power Sockets.....		UR-542	2.00	UT-541	5.00
3	Two KENOTRON Rectifier Tubes.....		UV-216	15.00	UV-217	53.00
4	Two KENOTRON Tube Sockets.....		UR-542	2.00	UT-541	5.00
5	Antenna Series Condenser.....	C ₁	UC-1015	5.75	UC-1015	5.75
6	Magnetic Modulator.....	MM	(Note 1)		(Note 1)	
7	Magnetic Modulator Battery.....	B	6 Volts		6 Volts	
8	Microphone.....	M	WE-284-W		WE-284-W	
9	Antenna Ammeter.....	A	UM-530	6.00	UM-533	6.25
10	Coupling Condenser.....	C ₂	UC-1803	5.00	UC-1803	5.00
11	Intermediate Shunt Circuit Condenser.....	C ₃	UC-1015	5.75	UC-1015	5.75
12	Blocking Condenser.....	C ₄	UC-1014	2.50	UC-1014	2.50
13	Grid Condenser.....	C ₅	UC-1014	2.50	UC-1014	2.50
14	Filter Condenser.....	C ₆	2-UC-490 (In parallel)	5.00	2-UC-490 (In parallel)	5.00
15	Filter Condenser.....	C ₇	2-UC-490 (In parallel)	5.00	2-UC-490 (In parallel)	5.00
16	Trap Condenser.....	C ₈	WE-21-U		WE-21-U	
17	Grid Leak.....	R _g	UP-1719	1.10	UP-1718	1.65
18	A. C. Filament Voltmeter.....	V	O-15 Volts		O-15 Volts	
19	Radio Frequency Choke.....	X	UL-1655	3.85	UL-1655	3.85
20	Filter Reactor.....	X ₁	UP-1653	12.50	UP-1654	18.00
21	Oscillation Transformer.....	L ₁	UL-1008	11.00	UL-1008	11.00
22	Antenna Inductance.....	L	UL-1008	11.00	UL-1008	11.00
23	Key.....	K	UQ-809	3.00	UQ-809	3.00
24	Key Condenser.....	C ₉	UC-1014	2.50	UC-1014	2.50
25	Signal Switch.....	S ₁	S.P.D.T.		S.P.D.T.	
26	Microphone Battery Switch.....	S	S.P.S.T.		S.P.S.T.	
27	Power Transformer.....	T	UP-1658	25.00	UP-1016	38.50
28	Filament By-Pass Condenser.....	C ₁₀	WE-21-R		WE-21-R	
29	Filament By-Pass Condenser.....	C ₁₁	WE-21-R		WE-21-R	
30	Microphone Milliammeter, 0-500 Milliamps.....	A ₁				

NOTE 1:—Proper size of Magnetic Modulator

No. of Tubes	UV-202	No. of Tubes	UV-203
1	UT-1643	1	UT-1357
2	UT-1643	2	UT-1367
3	UT-1357	3	UT-1367
4	UT-1357		

REMEMBER—It is not necessary to purchase a motor-generator if you have a source of 110-volt A. C. lighting current, for it can be converted to D. C. by using KENOTRON rectifiers.

FIG. 6. D. C. Radio Telephone Circuit, Using Radiotrons UV-203 for the Oscillator, Modulator and Speech Amplifier, With 1,000 Volts D. C. Plate Supply

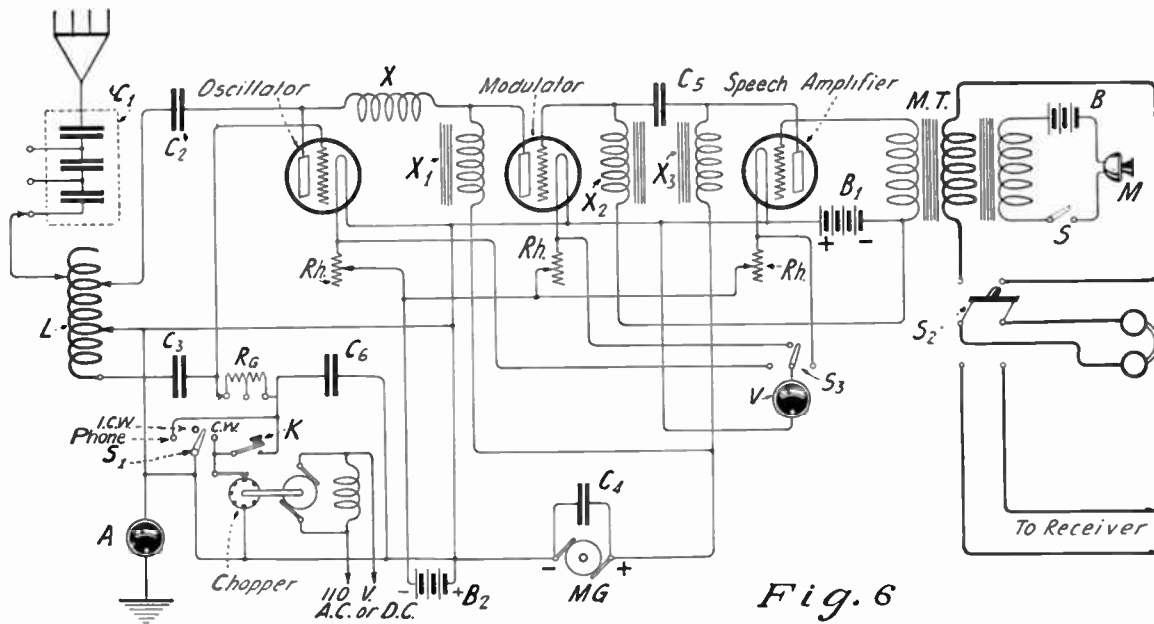

Fig. 6

LIST OF MATERIAL	Circuit Symbol	RATING OF RADIOTRONS 50-WATT TUBES	
		Model	Price
1 One RADIOTRON "Oscillator".....	OSC	UV-203	\$30.00
2 One RADIOTRON "Modulator".....	MOD	UV-203	30.00
3 One RADIOTRON "Speech Amplifier".....	SA	UV-203	30.00
4 Three Sockets.....		UT-541	7.50
5 Oscillation Transformer.....	L	UL-1008	11.00
6 Antenna Series Condenser.....	C ₁	UC-1015	5.75
7 Antenna Ammeter.....	A	UM-533	6.25
8 Blocking Condenser.....	C ₂	UC-1014	2.50
9 Grid Condenser.....	C ₃	UC-1014	2.50
10 Transmitter Grid Leak.....	R _G	UP-1718	1.65
11 Radio Frequency Choke.....	X	UL-1655	3.85
12 Plate Reactor.....	X ₁	UP-415	5.75
13 Modulator Grid Reactor.....	X ₂	UP-415	5.75
14 Amplifier Plate Reactor.....	X ₃	UP-415	5.75
15 Protective Condenser.....	C ₄	UC-490	2.50
16 Motor Generator.....	MG	Note 1	
17 Grid Bias Battery.....	*B ₁	44 Volts	
18 Amplifier Coupling Condenser.....	C ₅	UC-489	1.60
19 Microphone Transformer.....	MT	UP-414	7.25
20 Microphone Battery.....	†B	6 Volts	
21 Microphone Transmitter.....	M	WE-284-W	
22 D. C. Filament Voltmeter.....	V	0-15 Volts	
23 Keying Condenser.....	C ₆	UC-1014	2.50
24 Key.....	K	UQ-809	3.00
25 Chopper.....	Chopper	PX-1368	7.25
26 Three Filament Rheostats.....	Rh	PT-537	30.00
27 Microphone Switch.....	S	S.P.S.T.	
28 Signal Switch.....	S ₁	S.P.D.T.	
29 Side Tone Switch.....	S ₂	D.P.D.T.	
30 Filament Battery.....	B ₂	12 Volts	
31 Voltmeter Switch.....	S ₃	T.P.S.T.	

NOTE 1:

RADIOTRONS UV-203

No. of Tubes	Watts M. G.	Plate Volts
1	200	750-1000
2 or 3	500	750-1000

* Two Blocks of Burgess' Battery, No. 2156.

† Four Dry Cells or 6-Volt Storage Battery.

REMEMBER—The life of RADIOTRON power tubes depends upon proper operation. Do not use a greater voltage on the filament than that specified, and do not overload the plate by using an excessive plate voltage, that is IF YOU WANT LONG LIFE.

FIG. 7. Radio Telephone Circuit, Using Four Radiotrons UV-202 and Four Keno-
trons, UV-216, for Telephony, With Constant Current System of Modulation

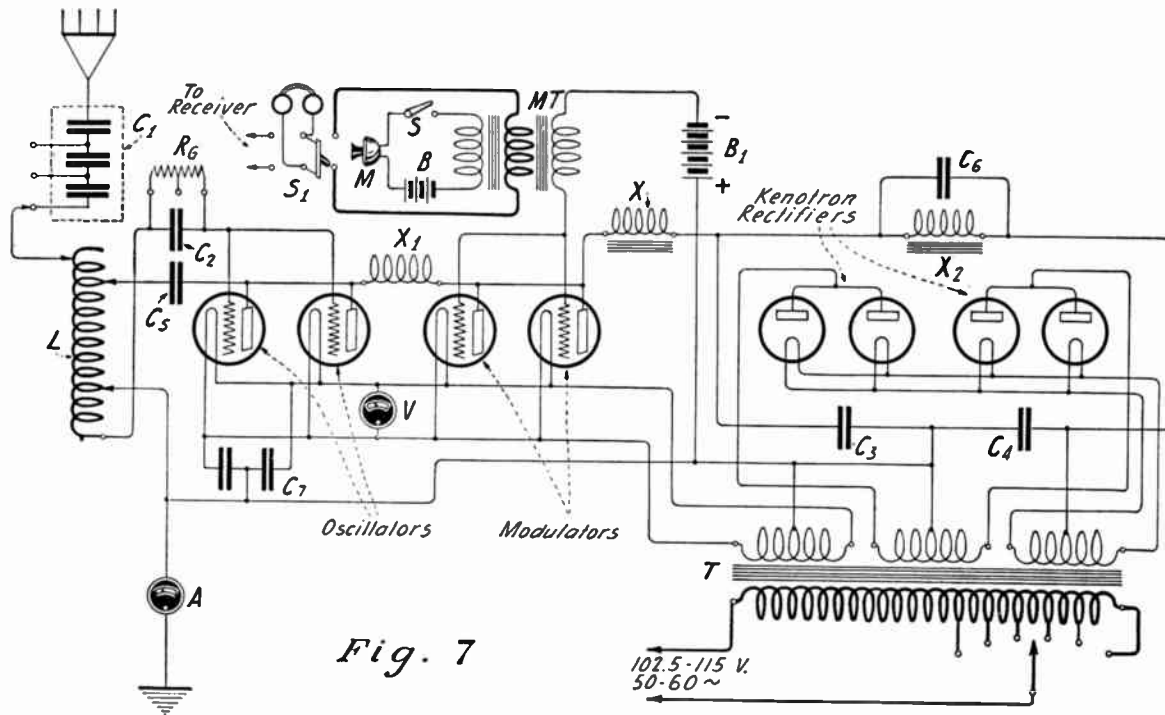

Fig. 7

LIST OF MATERIAL	Circuit Symbol	RATING OF RADIOTRONS 5-WATT TUBES	
		Model	Price
1 Two RADIOTRON Oscillator Tubes.....		UV-202	\$16.00
2 Two RADIOTRON Modulator Tubes.....		UV-202	16.00
3 Four KENOTRON Rectifier Tubes.....		UV-216	30.00
4 Eight Sockets.....		UR-542	8.00
5 Antenna Series Condenser.....	C ₁	UC-1015	5.75
6 Antenna Ammeter.....	A	UM-530	6.00
7 Grid Condenser.....	C ₂	UC-1014	2.50
8 Transmitter Grid Leak.....	R _g	UP-1719	1.10
9 Oscillation Transformer.....	L	UL-1008	11.00
10 Radio Frequency Choke.....	X ₁	UL-1655	3.85
11 Plate Reactor.....	X	UP-415	5.75
12 Microphone Transformer.....	MT	UP-414	7.25
13 Microphone Battery.....	*B	6 Volts	
14 Microphone.....	M	WE-284-W	
15 Grid Bias Battery.....	†B ₁	44 Volts	
16 Power Transformer.....	T	UP-1368	25.00
17 Filter Reactor.....	X ₂	UP-1653	12.50
18 Filter Condenser.....	C ₃	2-UC-490	5.00
19 Filter Condenser.....	C ₄	(In parallel) 2-UC-490	5.00
20 Blocking Condenser.....	C ₅	(In parallel) UC-1014	2.50
21 A. C. Filament Voltmeter.....	V	0-15 Volts	
22 Microphone Switch.....	S	S.P.S.T.	
23 Side Tone Switch.....	S ₁	D.P.D.T.	
24 Trap Condenser.....	C ₆	WE-21-U	
25 Filament By-Pass Condenser.....	C ₇	2-WE-21-R	

* Four Dry Cells or 6-Volt Storage Battery.
† Two Blocks of Burgess' Battery No. 2156.

REMEMBER—Power tube filament should be burned at constant voltage rather than constant current. This will prolong their useful life.

FIG. 8. Constant Frequency Circuit, Using Full Wave Rectification for Four Radiotrons UV-202 and Four Kenotrons, UV-216 for Telegraph and Telephone (Chopper and Magnetic Modulator)

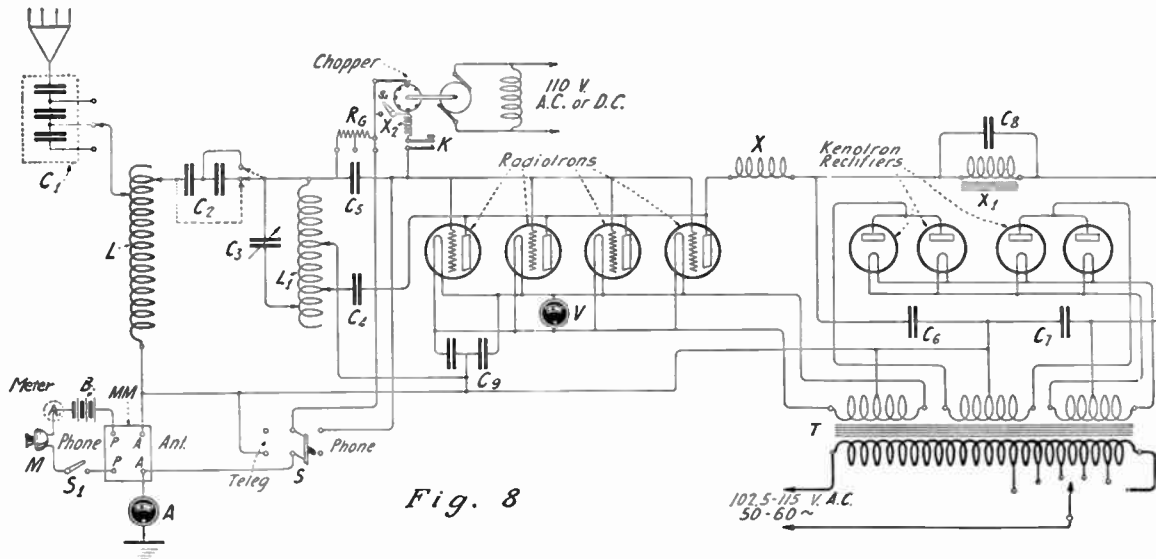

Fig. 8

LIST OF MATERIAL	Circuit Symbol	RATING OF RADIOTRONS 5-WATT TUBES	
		Model	Price
1 Four RADIOTRON Power Tubes.....		UV-202	\$32.00
2 Four KENOTRON Rectifier Tubes.....		UV-216	30.00
3 Eight RADIOTRON Sockets.....		UR-542	8.00
4 Antenna Series Condenser.....	C ₁	UC-1015	5.75
5 Magnetic Modulator.....	MM	(See Note 1)	
6 Magnetic Modulator Battery.....	*B	6 Volts	
7 Microphone.....	M	WE-284-W	
8 Antenna Ammeter.....	A	UM-530	6.00
9 Coupling Condenser.....	C ₂	UC-1846	10.00
10 Intermediate Shunt Circuit Condenser.....	C ₃	UC-1831	9.00
11 Oscillation Transformer.....	L ₁	UL-1008	11.00
12 Blocking Condenser.....	C ₄	UC-1014	2.50
13 Grid Condenser.....	C ₅	UC-1014	2.50
14 Filter Condenser.....	C ₆	2-UC-490 (in parallel)	5.00
15 Filter Condenser.....	C ₇	2-UC-490 (in parallel)	5.00
16 Antenna Inductance.....	L	UL-1008	11.00
17 Transmitter Grid Leak.....	R _g	UP-1719	1.10
18 A. C. Filament Voltmeter.....	V	0-15 Volts	
19 Power Transformer.....	T	UP-1368	25.00
20 Radio Frequency Choke.....	X	UL-1655	3.85
21 Filter Reactor.....	X ₁	UP-1653	12.50
22 Telegraph-Telephone Switch.....	S	D.P.D.T.	
23 Grid Chopper.....	Chopper	PX-1638	7.25
24 Telegraph Key.....	K	UQ-809	3.00
25 Radio Frequency Choke.....	X ₂	UL-1655	3.85
26 Microphone Milliammeter, 0-500 Milliamps.....	A ₁	WE-21-U	
27 Trap Condenser.....	C ₈	2-WE-21-R (In series)	
28 Filament By-Pass Condenser.....	C ₉	S.P.S.T.	
29 Microphone Switch.....	S ₁	S.P.S.T.	
30 Switch for CW-ICW Telegraphy.....	S ₂		

NOTE 1:—Proper Size of Magnetic Modulator

No. of Tubes	UV-202	No. of Tubes	UV-203
1	UT-1643	1	UT-1357
2	UT-1643	2	UT-1367
3	UT-1357	3	UT-1367
4	UT-1357		

*Four Dry Cells or 6-Volt Storage Battery.

REMEMBER—The life of the filament of RADIOTRON power tubes is dependent upon its temperature. A 3 per cent. increase in filament current will halve the life of your tubes, and a 3 per cent. decrease will DOUBLE THE LIFE.

FIG. 9. Self-Rectifying C. W. Telegraph Circuit, Using Two UV-204 Radiotrons 250-Watt Power Tubes

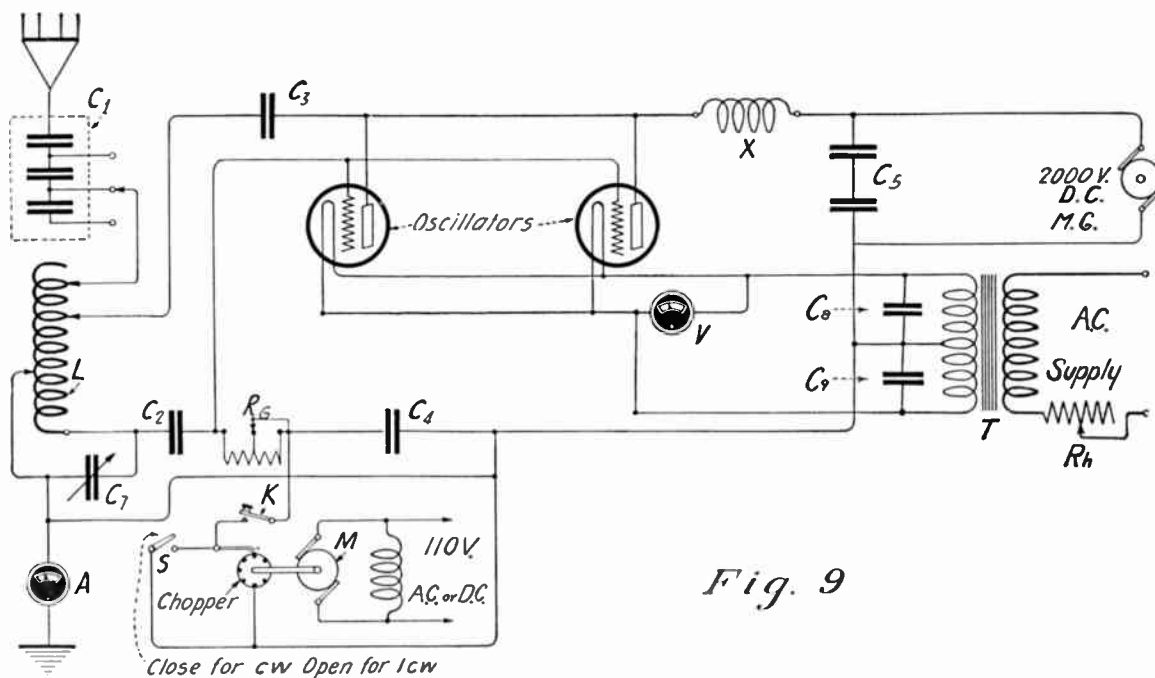

Fig. 9

LIST OF MATERIAL	Circuit Symbol	RATING OF RADIOTRONS	
		Model	Price
1 One or Two RADIOTRON Power Tubes.....		UV-204	\$110.00 each
2 Tube Mountings.....		UT-501-502	2.00 pair
3 Antenna Series Condenser.....	C ₁	10 amps. (See Note 2)	
4 Oscillation Transformer.....	L	UL-1008	11.00
5 Tuning Condenser.....	C ₂	UC-1831	9.00
6 Blocking Condenser.....	C ₃	UC-1806	7.00
7 Grid Condenser.....	C ₄	UC-1014	2.50
8 Radio Frequency Choke.....	X	UL-1655	3.85
9 Smoothing Condenser.....	C ₅	2-UC-490 (in series)	5.00
10 Grid Leak.....	R _g	UP-1718	1.65
11 Keying Condenser.....	C ₄	UC-1014	2.50
12 Chopper.....	Chopper	PX-1638	7.25
13 Key.....	K	UQ-809	3.00
14 Filament Transformer.....	T	(See Note 3)	
15 Filament Rheostat.....	Rh	(G.E. Cat. 1916228)	
16 Filament Voltmeter A. C.	V	0-15 Volts	
17 Antenna Ammeter.....	A	0-10 amps.	
18 Signal Switch.....	S	S.P.S.T.	
19 By-Pass Condenser.....	C ₆ & C ₇	2-WE-21-R	
20 Motor Generator.....	MG	(See Note 1)	

NOTE 1:—The high voltage generator for the above transmitter should be capable of delivering .5 ampere at from 1500 to 2000 volts.

NOTE 2:—New condenser, .0003, .0004 and .0005 mfd., 10 amps. at 200 meters. Do not use UC-1015. Information on request.

NOTE 3:—400 watt 12/6 V Transformer, 50-60 cycles, 110/220 volts—not stocked by R. C. A.

REMEMBER—On any tube or group of tubes delivering over 50 watts of alternating current energy, or operating at a plate potential above 2,000 volts, a safety spark gap should be provided between the grid and filament terminals at or near the tube socket or mounting. This gap should be adjusted to between 1/32 in. and 1/4 in., depending upon the plate voltage employed and the number of tubes and types of tubes used.

RADIOTRON UV-204—250-WATT TRANSMITTER

RADIOTRON UV-204 is the most powerful tube of the RADIOTRON series at present sold for experimental transmission purposes. This tube is equipped with a special filament which gives exceptionally long operating life, and it will be widely used by experimenters desiring to obtain large oscillating outputs. It is particularly adapted for experimental measurements in laboratories and in powerful C. W. radio telegraph and telephone sets for experimental use. Several experimenters using one UV-204 in oscillating circuits have obtained antenna charging currents of from five to six amperes.

UV-204 will be found serviceable in the self-rectifying and other circuits shown elsewhere in this book, and such a circuit will ap-

peal to experimenters because of its simplicity.

Two points are worthy of special mention—namely, the large current input to the antenna that can be obtained with these tubes, and the greatly increased operating life over former tubes of this type.

This tube has been used constantly at the official broadcasting station of the Bureau of Standards. It was also employed in the powerful radio telephone set installed by the Radio Corporation in the Delaware, Lackawanna and Western Railroad Radio Station at Hoboken, New Jersey, which sent out the news of the Dempsey-Carpentier Boxing Bout. The Radio Corporation of America employs the same tube in its new types of commercial radio telegraph and telephone sets.

METHOD OF SHIPMENT

Each RADIOTRON UV-204 is packed for shipment in a separate crate, the dimensions of which are approximately 11 in. x 11 in. x 25 in. high. The net weight of the tube is approximately 1¼ pounds, and the shipping weight, crated, 7½ pounds.

The tubes are suspended in the crate by ticking.

The safest way to store the tubes is in the crates as received.

Do not expose the tubes to the weather.

Handle the crated tube and the tube itself with the same consideration as any piece of expensive glassware.

ELECTRICAL AND MECHANICAL DATA

Overall Dimensions . . . 5 in. x 14¼ in.
Base—Special End Mountings—

UT-501 and UT-502
Voltage of Filament Source 12 V.
Filament Terminal Voltage 11 V.
Filament Current 14.75 Amp.
Plate Voltage 2000 V. Normal
Amplification Constant 25
Plate Current25 Amp.
Watts Output 250 Normal

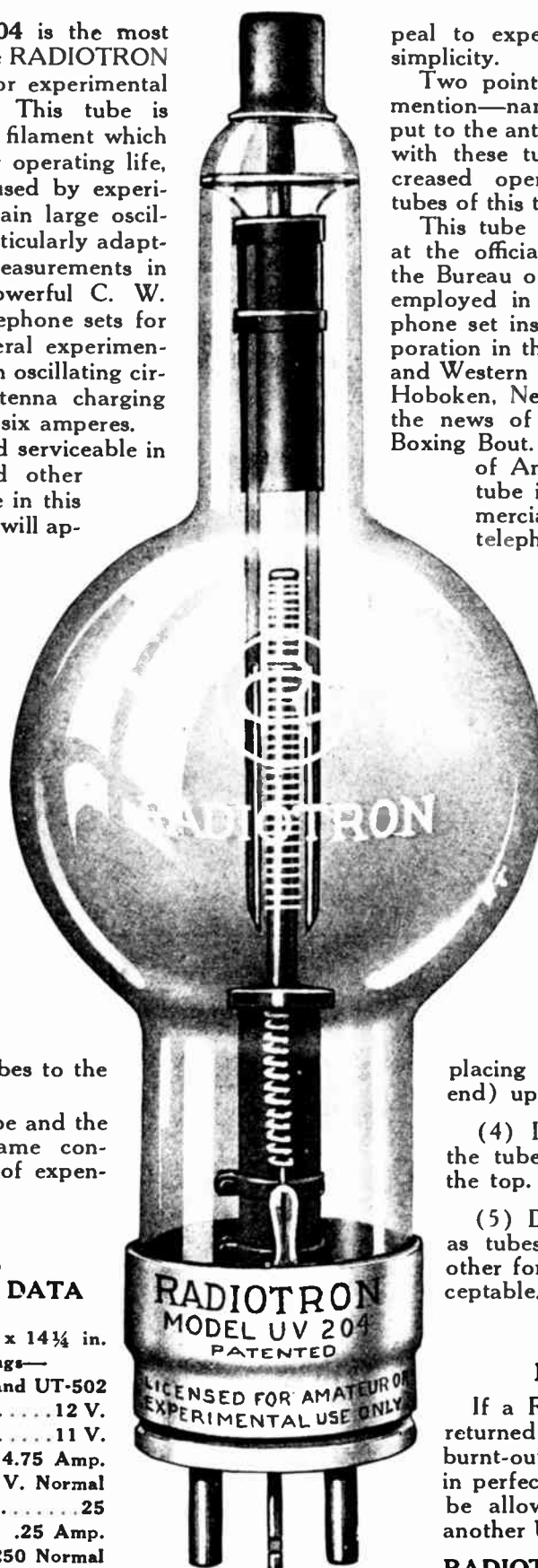

HOW TO UNPACK UV-204

(1) The slats on one side of the crate are fastened with screws. Open this side of the crate by means of a screw-driver.

(2) Remove the three screws which secure the upper strip of ticking and slip the ticking off the upper end of the tube. Then remove the tube from the crate.

(3) In crating a tube to be returned, simply reverse the operations,

placing the cathode (the large end) up.

(4) Instructions for operating the tube are inside the crate at the top.

(5) Do not destroy the crate, as tubes returned to us in any other form of packing are not acceptable.

REPLACEMENT

If a RADIOTRON UV-204 is returned to our warehouse with a burnt-out filament, but otherwise in perfect condition, a rebate will be allowed on the purchase of another UV-204.

RADIOTRON UV-204, \$110.00

RADIOTRON UV-203—50-WATT TRANSMITTER

THE 50-watt RADIOTRON is universally used by amateurs for long-distance telephony and telegraphy. Two 50-watt tubes connected in a self-rectifying or in straight D. C. plate excitation circuit will give antenna currents of three to four amperes at amateur wave lengths.

A single tube operated from a D. C. source or a rectified A. C. source will put two and a half to three amperes in the amateur's aerial. Hundreds of these tubes are already in use at amateur transmitting stations throughout the country, and distances up to 1900 miles have been covered by using two tubes in parallel in an appropriate oscillating circuit.

Since these tubes have been specially designed with a view to securing uniformity, several of them may be operated in parallel and large antenna charging currents may thus be generated. Using a number of RADIOTRONS CV-203, speech may be sent out over ranges of hundreds of miles.

A suitable power transformer for use with the 50-watt RADIOTRON is described on page 89.

This tube is a favorite with experimental laboratories.

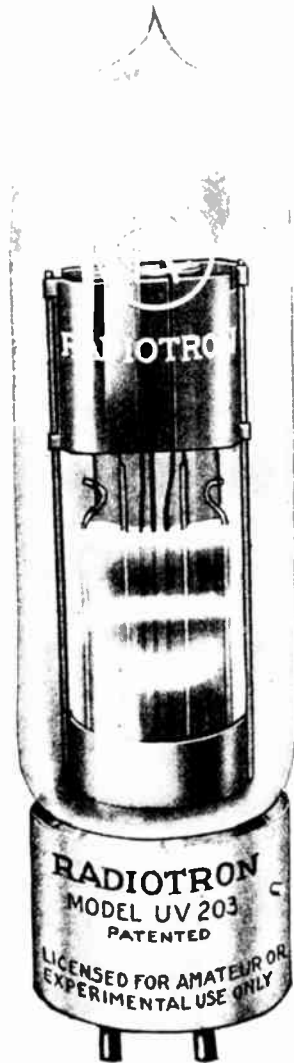

ELECTRICAL AND MECHANICAL DATA

Overall Dimensions	2 in. x 7 1/2 in.	Plate Voltage	1000 V. Normal
Base	Four Prong Special	Plate Current15 Amp.
Voltage of Filament Source	12 V.	Amplification Constant	15
Filament Terminal Voltage	10 V.	Watts Output	50 Normal
Filament Current	6.5 Amp.		

SHIPMENT

RADIOTRON UV-203 is shipped to the customer in a standard wooden box in which the bulb is suspended in a special way to protect it from mechanical shocks or vibration. Shipping weight: 1 1/2 lb.

RADIOTRON UV-203 \$30.00

RADIOTRON UV-202—5-WATT TRANSMITTER

THIS transmitting tube is a popular one for low power radio telephone sets and for amateur C. W. telegraph sets for transmission up to distances of two hundred miles. Two 5-watt tubes in parallel will put from one and one-quarter to one and three-quarters amperes in the amateur's antenna. Using one of these tubes as a modulator and the other as an oscillator for experimental radio telephony, distances up to forty miles can be covered, and at least four times that distance when the two tubes are connected in parallel for C. W. telegraphy. Four or five 5-watt RADIOTRONS can be operated in parallel with increased range.

The 5-watt tubes may also be used as power amplifiers in radio receiving circuits. The energy amplification obtained therefrom is particularly useful for the operation of loud speakers.

ELECTRICAL AND MECHANICAL CHARACTERISTICS

Overall Dimensions	2 1/8 in. x 5 in.	Plate Voltage	350 V. Normal
Base	Four Prong Standard	Plate Current045 Amp.
Voltage of Filament Source	10 V.	Output Impedance	4000 Ohms
Filament Terminal Voltage	7.5 V.	Amplification Constant	8
Filament Current	2.35 Amp.	Watts Output	5 Normal

SHIPMENT

RADIOTRON UV-202 is shipped in a standard cardboard carton in which the tube is well protected from mechanical shock or vibration. Shipping weight: 1 lb.

RADIOTRON UV-202 \$8.00



KENOTRON RECTIFIER, UV-217

KENOTRON UV-217 is primarily intended for use with the 50-watt power tubes, to produce a D. C. plate supply from an A. C. source. It is rated at 150 watts. UV-217 should be used in connection with POWER TRANSFORMER UP-1016, listed on page 89. The combination of these two units constitutes the simplest and most practical means of obtaining direct current for the plate circuit excitation of power tubes. Remember that these rectifier valves are manufactured with the same care and accuracy as RADIOTRON power tubes, under the supervision of the same experts.

The output energy from this KENOTRON Rectifier is at a maximum when the load is such that the D. C. potential is between 900 and 1100 volts. At no load, under an A. C. voltage of 1250 volts, the D. C. voltage will rise to about 1750. On short circuit, the current will rise to about three-quarters of an ampere. It is recommended, therefore, that the D. C. circuit from the KENOTRON system be properly fused, so as to protect the KENOTRONS in case of short circuit.

Using two KENOTRONS UV-217 in a full wave rectification circuit, the D. C. current and watts output will be doubled, but the voltage at which maximum output can be obtained will be between the same limits. The output drops slightly at lower and higher D. C. voltage. This assumes a fixed A. C. input voltage of 1250.

KENOTRON UV-217 is identical in appearance with RADIOTRON UV-203, and it may be used in the same type of socket, Model UT-541. There are, of course, no connections to the grid binding post of the socket.

ELECTRICAL DATA

Voltage of Filament Source.....	12 V.
Filament Terminal Voltage.....	10 V.
Filament Current.....	6.5 Amp.
A. C. Input Voltage.....	1250 V.
D. C. Output.....	150 Watts at 1000 Volts D. C.

SHIPMENT

KENOTRON UV-217 is shipped to the customer in a standard wooden box in which the tube is suspended in a special way to protect it from mechanical shocks or vibration. Shipping weight: 1½ lbs.

KENOTRON UV-217..... \$26.50

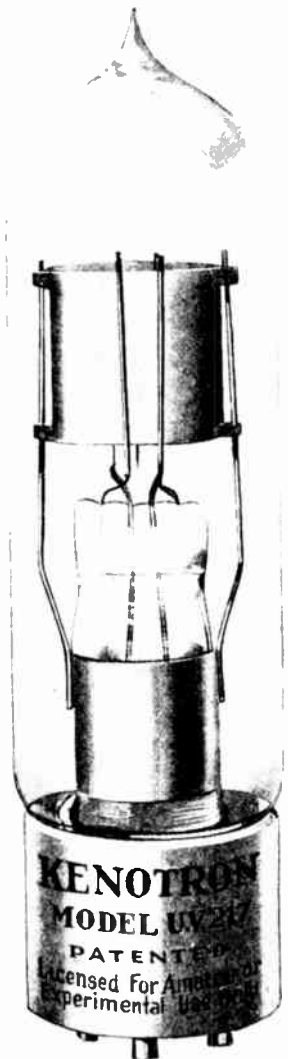

KENOTRON RECTIFIER, UV-216

KENOTRON UV-216 is primarily intended for use with the 5-watt power tubes, and is rated at 20 watts. The output energy is at a maximum for these tubes when the load is such that the D. C. voltage is between 350 and 400 volts. Using two tubes in a full wave rectification circuit the D. C. current and the watts output will be doubled, but the voltage at which maximum output can be obtained will be between the same limits. The output drops slightly at lower and higher D. C. voltages, so that at 200 and 550 volts it is about 15 watts per tube. This assumes a fixed A. C. input voltage of 550. If the A. C. input voltage is raised, the voltage at which maximum power is obtained will be increased correspondingly. This will decrease the life of the KENOTRON, and lower the factor of safety.

At no load, under the A. C. voltage specified above, the D. C. voltage will rise to about 750 volts. On short circuit the current will rise to about 100 milliamperes. The insulation of the KENOTRON is designed to withstand the first condition, and the anode will take care of the excess energy of the second condition for a considerable time.

KENOTRON UV-216 is identical in appearance with RADIOTRON UV-202, and it may be used in the same type of socket, Model UR-542.

A special Power Transformer, Model UP-1368, has been developed for use with the 20-watt KENOTRON and the 5-watt transmitting tube.

Shipping weight: 1 lb.

ELECTRICAL DATA

Voltage of Filament Source.....	10 V.	A.C. Input Voltage.....	550 V.
Filament Terminal Voltage.....	7.5 V.	D.C. Output, 20 Watts at 350 Volts D.C.	
Filament Current.....	2.35 Amp.		

KENOTRON UV-216..... \$7.50

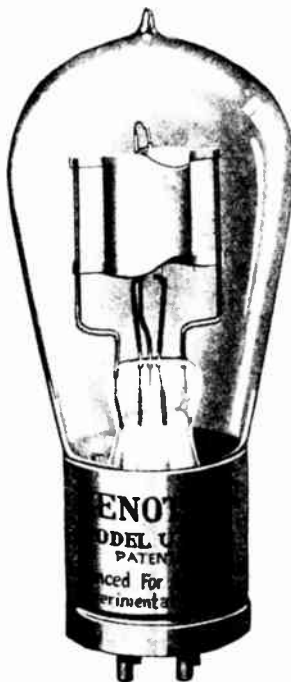

PORCELAIN SOCKETS, UT-541 AND UR-542

These two sockets have been specially designed to meet the need for a reasonably priced socket which should at the same time be constructed of the very best insulating material obtainable, and should bear the stamp of quality throughout. They are direct duplicates of the types used in commercial radio sets.

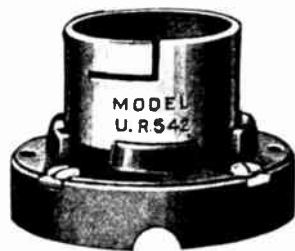

UR-542

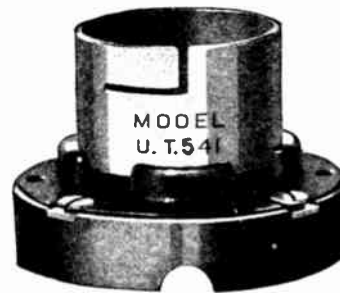

UT-541

Porcelain is the ideal material for use in these devices, on account of its low specific inductive capacity and its high insulating qualities. Production in great quantities enables us to keep the selling price unusually low.

Model UR-542 is designed to accommodate RADIOTRON UV-200, UV-201 and UV-202, as well as KENOTRON UV-216. Model UT-541 is designed for RADIOTRON UV-203, the 50-watt power tube, and KENOTRON UV-217, the 150-watt rectifier tube.

PORCELAIN SOCKET, UR-542 \$1.00

Dimensions: 7 $\frac{1}{8}$ in. x 6 $\frac{1}{4}$ in. x 9 $\frac{3}{8}$ in. Shipping Weight: 8 oz.

PORCELAIN SOCKET, UT-541 2.50

Dimensions: 3 $\frac{3}{8}$ in. x 2 $\frac{3}{4}$ in. Shipping Weight: 1 lb.

END MOUNTINGS FOR UV-204

FILAMENT END, UT-501
PLATE END, UT-502

These mountings are designed not only to furnish perfect contact with the elements of RADIOTRON UV-204, but also to act as a substantial support for the tube itself.

One end of the tube is slipped into mounting UT-501, which carries contacts for the Filaments and grid connections. The other mounting, UT-502, makes contact with the plate of the tube.

Both ends are firmly held by spring clips. On the filament-end mounting is a safety gap for protecting the tube from transient voltages which might arise if the circuits were not properly adjusted, or if a lead wire were accidentally removed.

Each mounting is provided with two screw holes so that the tube may be mounted in either a vertical or horizontal position.

PLATE END
UT-502

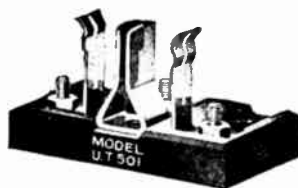

FILAMENT END
UT-501

END MOUNTINGS UV-501-502

Each \$1.00
Per Pair 2.00

ANTENNA AMMETERS

An antenna ammeter is a positive necessity in a C. W. transmitting set. Only by the use of such a meter can the amateur hold proper check on the operation of a tube transmitter. At a considerable expense the Radio Corporation has developed a type which, in addition to being low-priced, provides long operating life.

These ammeters are of the hot wire type. They have been designed with a view to accuracy and sensitivity to slight current variations; moreover, particular care has been taken to insure their remaining accurate through a long period of use.

As shown in the illustration, the ammeters are so constructed that they may be mounted flush with the transmitting panel, and are of the back-connected type. A special adjustment for taking care of temperature variations has been provided.

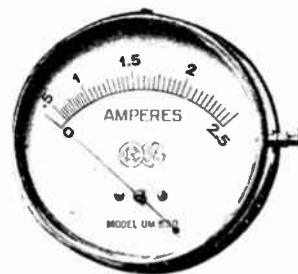

UM-530

Dimensions: 2 11/32 in. x 3/4 in.

Length of Studs: 3/4 in.

Shipping Weight: 1 lb.

AMMETER, UM-530—0-2.5 amp . . . \$6.00

AMMETER, UM-533—0-5.0 amp . . . 6.25

FILAMENT RHEOSTATS, PR-535 AND PT-537



FIRE-PROOF FEATURE
 Body is composed of insulating material containing a large percentage of asbestos, thereby reducing fire hazard.

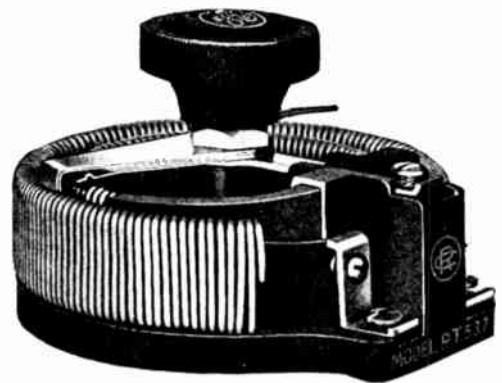

RHEOSTAT, Model **PR-535**, consists of a moulded base, approximately 2½ in. in diameter, on which are secured two concentric windings held securely in place by clamping screws. Connection is made to these windings by means of two sliding contacts of phosphor bronze, which form a circuit between the outside and inside windings.

Model **PR-535** is designed for use with **RADIOTRONS UV-200, 201, 202** and **KENOTRON UV-216**.

Rheostat, Model **PT-537**, is designed for use with the **UV-203** and **UV-204 RADIO-TRON** transmitting tubes, as well as with **KENOTRON UV-217**. In general the design is the same as Model **PR-535**, but with increased dimensions.

RHEOSTAT PR-535 GIVES FOUR DIFFERENT RESISTANCE VALUES DEPENDING ON CONNECTIONS

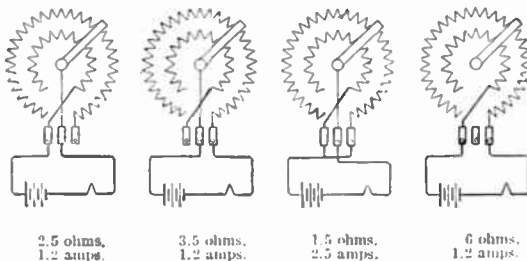

Filament Rheostat, PR-535 \$3.00
 Size: 2 in. x 2½ in. x 2¾ in. Shipping weight: 1 lb.

RHEOSTAT PT-537 GIVES FOUR DIFFERENT RESISTANCE VALUES DEPENDING ON CONNECTIONS

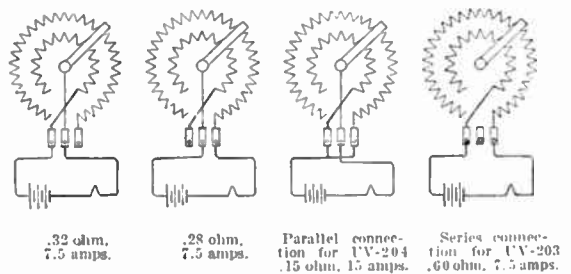

Filament Rheostat, PT-537 \$10.00
 Size: 4¼ in. x 4½ in. x 2¾ in. Shipping weight: 2 lbs.

MOTOR GENERATORS FOR V. T. TRANSMISSION

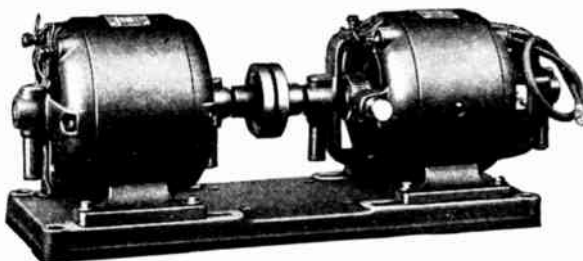

Model **ME**—100 Watts

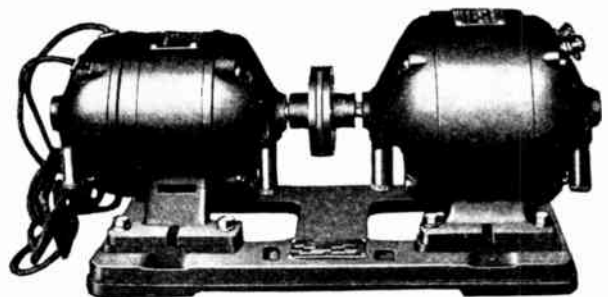

Model **MH**—250 Watts

Where it is desired to employ motor generator to obtain the required plate excitation in Radiotron transmission, the Radio Corporation of America offers two Westinghouse units having the ratings of 100 and 250 watts respectively.

- Motor Generator, Model **ME**, 100 watts, 500 volts D. C., 110 volts, 60 cycle, single phase
 Motor, complete \$85.00
- Motor Generator, Model **MH**, 250 watts, 1,000 Volts D. C., 110 volts, 60 cycle, single phase
 Motor, complete \$170.00

OSCILLATION TRANSFORMER, UL-1008

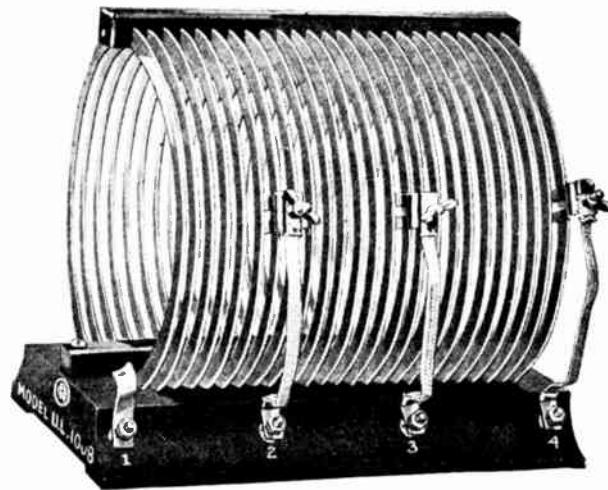

Clips may be attached to and removed from turns with minimum effort.

Positively hold their position on the coil, and cannot be accidentally moved or detached.

THIS transformer was developed primarily for use in circuits utilizing RADIOTRONS as generators of radio frequency oscillations. It may be used, however, in any set-up using conductively coupled circuits, such as an oscillation transformer coupling the primary and secondary circuits in spark transmitters.

The transformer consists of 25 turns of .060 in. x 3/8 in. copper strip, nickel-plated, with edges rounded, mounted on a wooden base which includes four binding posts, to three of which are secured flexible conductors and clips for selecting tap points on the transformer.

The clips supplied for tapping on the transformer have been specially designed to overcome the difficulties which have been experienced in the past with such connections. These clips are readily connected to or taken off the turns of the transformer and when secured to

the transformer by tightening the wing nut are positive in holding their position on the coil. These clips were developed primarily for use with commercial transmitters, so that the TRANSFORMER UL-1008 includes the same form of clip as the Radio Corporation's commercial transmitters. This feature is of fundamental importance, since it is believed that these clips are the first to be developed which include the above features of design.

All metal parts of the transformer are nickel-plated. The base has a polished black finish, and the overall appearance of the unit is very pleasing.

The coil is liberally designed to withstand the potentials developed in circuits utilizing RADIOTRONS. Holes are provided in the base to permit mounting the transformer in any desired place.

OSCILLATION TRANSFORMER, UL-1008 \$11.00

Dimensions: 7 7/8 in. x 6 1/4 in. x 9 3/8 in. Shipping Weight: 7 lbs.

TRANSMITTING GRID LEAKS, UP-1718 AND UP-1719

THE purpose of these grid leaks is to limit the potential accumulating on the grid of an oscillating tube and thus govern the output to the antenna and also the character of the antenna oscillations.

These resistors consist of a conductor wound upon a heat-resisting silicate compound body developed to resist sudden and extreme temperature changes without becoming cracked, weakened, or in any way injured. After being

wound upon this compound it is embedded in a blue vitreous enamel which is fused to a dense, uniform, glassy structure at a temperature of about 1,000 degrees Centigrade.

A metal foot is provided at each end of the grid leak to which the resistor windings are connected, and through which external connections are made. In addition, a mid-tap is provided for securing half the resistance of the whole unit.

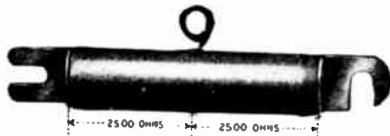

UP-1719

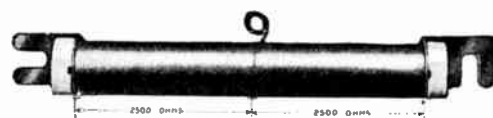

UP-1718

GRID LEAK, UP-1719 \$1.10

For use with 5-watt RADIOTRONS. Resistance—5,000 ohms, with mid-tap at 2,500 ohms. Dimensions: 5 in. x 1 1/4 in. Shipping Weight: 1 lb.

GRID LEAK, UP-1718 \$1.65

For use with 50-watt and 250-watt RADIOTRONS. Resistance—5,000 ohms, with mid-tap at 2,500 ohms. Dimensions: 8 1/2 in. x 1 1/2 in. Shipping Weight: 1 lb.

POWER TRANSFORMERS FOR TRANSMITTING TUBE SETS

Model UP-1368
Model UP-1016

Maximum Input 325 Watts
Maximum Input 750 Watts

For 5-Watt Tubes
For 50-Watt Tubes

IN designing the above transformers the engineers of the Radio Corporation have given the amateur radio experimenters two rugged and flexible units which can be utilized in numerous RADIOTRON circuits.

The transformers permit operation from a 50/60 cycle alternating current source for (1) continuous wave telegraphy, on either a self-rectification circuit, (2) interrupted continuous wave telegraphy, with or without KENOTRON rectified A. C., (3) radio telephony.

The use of alternating current provides an excellent and flexible means of supplying power for continuous wave telegraph and telephone sets. It is especially adaptable for the amateur radio experimenter because a wide range of experimentation is opened to him, at a low first cost. These units have no maintenance cost, and their life is unlimited. The advantages over a motor generator set are obvious. Continuous wave energy may be supplied the antenna from an A. C. self-rectification circuit such as shown on page 76. Rectified A. C. may be obtained from such a circuit by rectifying the plate supply with KENOTRON rectifying tubes, see page 85.



The model UP-1368 transformer has sufficient capacity to handle safely one to four UV-202 RADIOTRONS as oscillators. Model UP-1016 will supply one or two UV-203 RADIOTRONS as oscillators. A winding is provided for lighting the filaments and a winding for the plate source. In addition, a filament winding for the KENOTRON filaments is supplied.

ELECTRICAL CHARACTERISTICS

MODEL UP-1368

Plate Winding: Output 175 watts, 1,100 volts between outside wires, midtap at 550 volts.

RADIOTRON Filament Winding: Output 75 watts, 7.5 volts, with midtap at 3.75 volts. The capacity of this transformer will supply filament current to four RADIOTRONS UV-202 (5 watt tubes).

KENOTRON Filament Winding: Output 75 watts, 7.5 volts with midtap at 3.75 volts. Windings insulated for 1,100 volts. The capacity of this transformer will supply current for four KENOTRONS UV-216.

Primary Winding: For operation from a 50/60 cycle supply with voltage from 102.5 to 115 volts. Provision is made for voltage adjustment in steps of 2.5 volts between 102.5 and 115 volts. This is accomplished by means of taps brought out from the primary winding of the transformer to studs on a dial switch. This feature eliminates the need of filament rheostats, since it provides filament voltage adjustment in steps of approximately 2.5 volts.



MODEL UP-1016

Plate Winding: Output 450 watts, 3,000 volts between outer wires with midtap at 1,500 volts.

RADIOTRON Filament Winding: Output 140 watts, 10.5 volts between outer wires with midtap at 5.25 volts. The capacity of this transformer will supply current for two RADIOTRONS UV-203 (50-watt tube).

KENOTRON Filament Winding: Output 140 watts, 10.5 volts between outer wires with midtap at 5.25 volts. The capacity of this transformer will supply filament current for two KENOTRONS UV-217.

Primary Winding: Operation from a 50/60-cycle supply at a voltage from 102.5 to 115 volts. Provision is made for voltage adjustment in steps of 2.5 volts between 102.5 and 115 volts, eliminating the need of separate rheostats.

A complete rectifier set for tube operation consists of the following:

- (1) Power Transformer
 - (a) 325 watt, Model UP-1368
 - (b) 750 watt, Model UP-1016
- (2) Tube Sockets
- (3) KENOTRON Valves
- (4) Filter Reactor
- (5) Filter Condensers

POWER TRANSFORMER, UP-1368 325 WATTS\$25.00

Dimensions: 9 3/64 in. x 5 11/12 in. x 4 1/4 in.
Shipping weight: 15 lbs.

POWER TRANSFORMER, UP-1016 750 WATTS\$38.50

Dimensions: 9 27/32 in. x 7 3/8 in. x 6 in.
Shipping weight: 30 lbs.

FILTER REACTORS, UP-1653 AND UP-1654

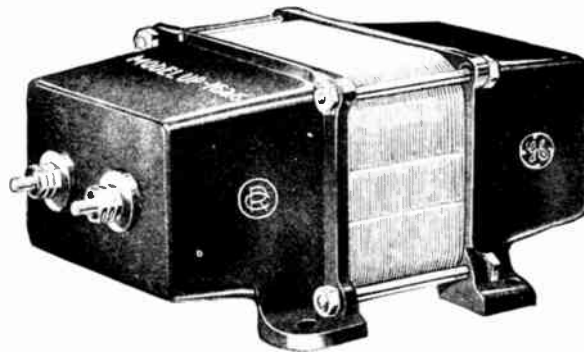

UP-1653
160 Milliamperes

UP-1654
300 Milliamperes

WHEN the plate circuit of a valve transmitting set is energized by a high voltage rectified A. C., using the Radio Corporation's KENOTRON valves and power transformers, a suitable filter unit, to smooth out the rectified pulses must be provided. It has been customary heretofore to provide a relatively small inductance unit in combination with a group of condensers of rather large capacity. It is more economical, however, to provide a large inductance unit and a relatively small group of condensers, and as a consequence the two special reactors here listed have been specially developed for the purpose.

These filter reactors are of the "iron clad type," designed for use with the Radio Corporation's KENOTRON rectifier sets. Liberal copper allowance insures the minimum of losses and no change in value through use. Particular attention has been given to its insulation.

Model UP-1653, 160 milliamperes is designed to operate with any circuit, either A. C. or D. C., employing from one to four 5-watt power tubes, RADIOTRON UV-202. It can be used in connection with either UC-1631 or UC-1632 filter condensers, on any kind of a circuit within the specified voltage and power rating.

Model UP-1654, 300 milliamperes, is designed to operate on any circuit, either A. C. or D. C., employing from one to two 50-watt power tubes, RADIOTRON UV-203. It can be used in connection with either of the models UC-1634 or UC-1635 filter condensers on any kind of a circuit within its voltage and power rating. UP-1654 may also be used as a "smoothing-out" reactance. For 50-watt tubes, one will suffice; for 250-watt tubes, two in series should be employed.

MODEL UP-1653—160 MILLIAMPERES \$12.50
Dimensions: 7 31/32 in. x 5 1/16 in. x 4 1/16 in. Shipping weight: 10 lbs.

MODEL UP-1654—300 MILLIAMPERES 18.00
Dimensions: 9 7/32 in. x 5 11/16 in. x 4 15/16 in. Shipping weight: 18 lbs.

FILTER CONDENSERS

THESE Filter Condensers are manufactured especially for the Radio Corporation of America's KENOTRON rectifier sets. They are intended for use with the REACTORS Model UP-1653 and UP-1654, described above.

Transmitting circuits, Figs. 1 to 9, in preceding pages, show the manner in which the Filter Reactors and Condensers are connected in rectifying tube sets. The number of condensers required depends upon the type of circuit employed. This is fully explained in the data given under the circuit diagrams.

UC-487—750 Volts . . . \$1.40
Capacity 0.5 MFD.

UC-489—1750 Volts . . . \$1.60
Capacity 0.5 MFD.

UC-488—750 Volts . . . 2.25
Capacity 1.0 MFD.

UC-490—1750 Volts . . . 2.50
Capacity 1.0 MFD.

PLATE CIRCUIT REACTOR, UP-415

STANDARD radio telephone circuits using one or more tubes as oscillators and one or more additional tubes as modulators require a reactor in series to the plate circuit to maintain the D. C. supply voltage to the plate at constant value, even though the output of the set is modulated at audible frequencies.

REACTOR UP-415 was designed for this purpose and for circuits using 5-watt RADIOTRONS. The reactor, in general, is built on the same lines as MICROPHONE TRANSFORMER UP-414. It is intended primarily for use in the common positive plate lead to the oscillating and modulating tubes, and as stated above provides a constant current system of modulation. This unit has an inductance of 1 henry at audio frequencies. The D. C. resistance is approximately 64 ohms. It is well insulated between layers.



DIMENSIONS

Net Weight	1 lb. 3 1/2 oz.	Overall Height	2 3/4 inches
Shipping Weight	1 lb. 6 oz.	Area of Base of Mounting	2 inches x 2 3/4 inches
Overall Length	3 7/8 inches	Test Voltage between Winding and Core	1300 volts at 60 cycles

PLATE REACTOR, UP-415.....\$5.75

SENDING KEY, UQ-809



THIS key is especially serviceable for C. W. transmitting sets. The contacts are made of 1/8-inch sterling silver and, besides being interchangeable, are easily replaced. The lever arm is both light and durable and is designed to permit an operator to secure the utmost speed possible. The frame and other metal parts are brass, finely lacquered.

SENDING KEY, UQ-809.....\$3.00

Dimensions: 5 in. x 2 3/4 in. Shipping Weight: 1 lb.

MICROPHONE TRANSFORMER, UP-414

ALTHOUGH the Radio Corporation has developed a magnetic device for modulating the output of vacuum tube transmitters, many amateurs prefer to use prior methods of modulation where one or more bulbs are employed to modulate the plate circuit energy of the oscillating tubes; but, in order to obtain efficient modulation from such circuits, it is necessary to couple the grid circuit of the modulating tube to the microphone through the medium of a voltage amplifying transformer. The turn-ratio of the microphone transformer has been selected to give the most effective excitation of the grid of the modulator tubes based upon the characteristics of RADIOTRONS, when used as modulators. They are exactly the same type as used in the Radio Corporation's commercial sets.

The characteristics of the transformer are such that with a suitable microphone and a battery of four dry cells connected in series with the primary coil, a secondary voltage is obtained which will provide effective control of the radiated energy. The transformer is also provided with a side tone winding, which may be connected to the telephone of a receiving set during the periods of speech transmission, thus enabling the operator to check the operation of his microphone.

Model UP-414 has the same appearance and dimensions as the Radio Corporation's INTERVALVE AMPLIFYING TRANSFORMER, UV-712.

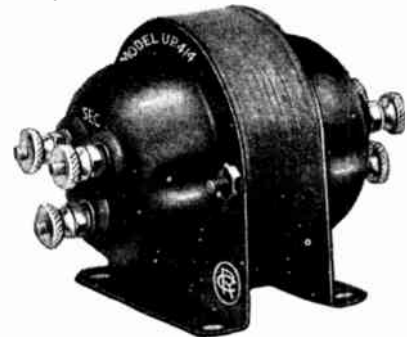

MICROPHONE TRANSFORMER WITH SIDE TONE WINDING, UP-414.....\$7.25

Dimensions: 2 3/4 in. x 3 3/8 in. x 2 in. Shipping Weight: 1 lb. 7 oz.

MOTOR-DRIVEN CHOPPER, PX-1638

For C. W. Vacuum Tube Transmitters

LONG experience in the use of audio frequency buzzers to modulate the output of a tube set to produce damped wave trains has proven that this method is not entirely satisfactory, principally for the reasons that the operation of the buzzer is not constant, necessitating frequent adjustment, and that great care is required in adjusting the circuit to obtain 100 per cent. modulation.

The ROTARY CHOPPER PX-1638 has been developed primarily to overcome the above objections. It may, however, be used in numerous circuits for this or other purposes where an interrupter is required. When used to secure I. C. W. telegraphy, the motor-driven interrupter, or rotary grid chopper, has the following inherent advantages over the other methods:

(a) Gives positive interruption requiring no adjustments. The note obtained can be varied to any desired pitch by changing the driving motor speed.

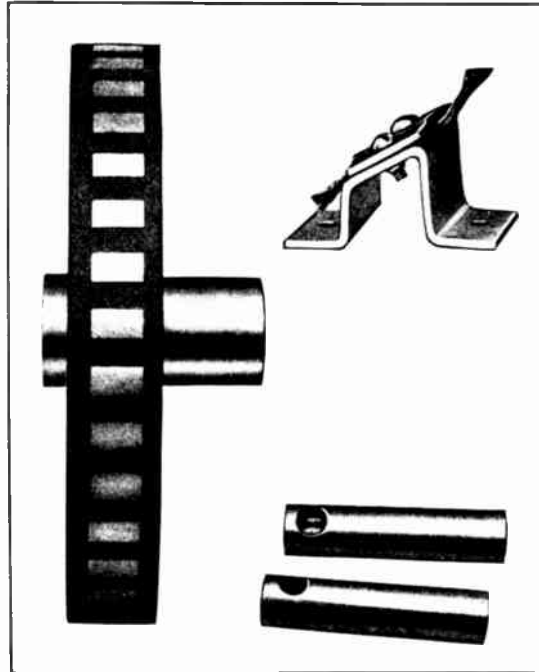

- (b) This system of securing damped wave trains does not require modulating tubes, the interrupter being used in series with the transmitting key.
- (c) The system inherently gives 100 per cent modulation, since oscillations can be completely started and stopped at audio frequencies.
- (d) The output obtained from a given number of oscillators is in general greater than if some of the tubes are used as modulators.

The equipment includes the following parts:

- (a) Interrupter Wheel, Model PX-1638.
- (b) 2 Bushings, so that the wheel may be mounted on motor shafts 1/4 in., 5/16 in., or 3/8 in. diameter.
- (c) Brush Holder and Brush.

The interrupter wheel is built with 34 conducting and 34 insulating segments, making 34 interruptions per revolution. The insulating segments are molded in a single piece.

MOTOR DRIVEN CHOPPER, PX-1638 \$7.25
 Dimensions: 4 in. x 1 3/4 in. Shipping weight: 3 lbs.

SHAFT BUSHINGS, Model PX-1640, for 5/16 in. or PX-1641, 1/4 in. Motor Shaft . . . each .20



RADIO FREQUENCY CHOKE, UL-1655

This is a universal radio frequency choke designed for use in conjunction with the types of transmitting circuits illustrated in this book. Because of its special characteristics, it may be employed in a number of places where, heretofore, it has been necessary to employ radio frequency chokes of different values.

Radio Frequency Choke, Model UL-1655 \$3.85

Dimensions—3 1/4 in. x 3 in.

Weights—Net, 10 oz.; Shipping, 1 lb.

MAGNETIC MODULATORS FOR RADIO TELEPHONY

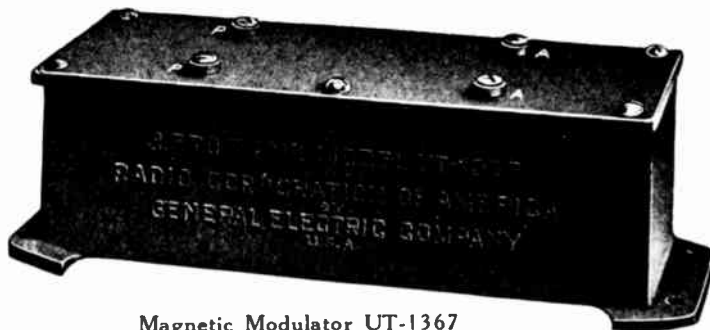

Magnetic Modulator UT-1367

ONE of the most important inventions brought forth in the field of amateur radio telephony during the past year is the MAGNETIC MODULATOR. This development has resulted from the Radio Corporation's experiments with the Alexanderson Magnetic Amplifier, a device which is used at all its high-power transoceanic stations to control the output of 200-KW radio frequency alternators. The same fundamental principle has been adopted in the three magnetic modulators herewith described, and for the first time the amateur experimenter has at his disposal a simple yet thoroughly reliable means of modulating the antenna oscillations of any low-power vacuum tube radio telephone set.

Require No Adjustment

Once connected to a radio telephone set, these modulators positively require no further adjustment or attention. This assures the experimenter that at all times he is obtaining the best possible results from his apparatus. It makes possible practical and reliable radio telephone transmission from a tube transmitter even on the part of an experimenter having a very limited knowledge of radio telephony.

The Radio Corporation's MAGNETIC MODULATOR is a device which utilizes the properties of iron at radio frequencies to control or modulate the output of an oscillating vacuum tube or any other undamped wave generator. It is the result of a number of years of research and development work both by the Radio Corporation and the General Electric Company. The device is extremely simple in nature as well as in operation. It simply acts as a variable resistance connected in series with the antenna circuit of any high frequency oscillating system.

Ideal for Radiotron Telephone Operation

The great advantage of the MAGNETIC MODULATOR over other methods of modulation is that it gives the best and only non-distorting method of controlling the output of a single tube for radio telephony. Furthermore, it permits the parallel use of a number of tubes as oscillators and thus eliminates the use of special modulator tubes with their necessary additional accessories and critical adjustments.

The MAGNETIC MODULATOR is designed specially for the amateur to fill the long desired place for a simple non-destructive and fool-proof device to make a C. W. set into a radiophone set without the use of more tubes or other delicate or costly apparatus.

Three modulators of different current carrying capacity are supplied. The precaution should be taken to select the type of modulator possessing a current carrying capacity within the range of the average antenna current to be expected from a given radiophone transmitter.

Model UT-1643 is designed for antenna currents varying between $\frac{1}{2}$ to $1\frac{1}{2}$ amperes; UT-1357 for antenna currents between $1\frac{1}{2}$ and $3\frac{1}{2}$ amperes; UT-1367 for antenna currents of $3\frac{1}{2}$ to 5 amperes.

Model UT-1643 and UT-1357 are, therefore, applicable to tube transmitters giving outputs of 5 to 50 watts. In general, Model UT-1367 should be employed with a tube transmitter equipped with two 50 watt Radiotrons UV-203.

For antenna outputs in excess of 5 amperes, two or more of Model UT-1367 may be used in parallel.

Practical Uses of the Magnetic Modulator

In general the magnetic modulator functions most satisfactorily in an antenna circuit of less than 15 ohms resistance. It should be connected on the low potential side of a tube transmitter, in the ground lead and as near to the actual earth connection as possible.

In order to obtain an antenna resistance of less than 15 ohms, it is usually necessary to employ an insulated counterpoise and to eliminate the earth ground. The counterpoise should be swung underneath the aerial and in general it should extend a few feet beyond the end of the flat top portion of the antenna.

Control Current

The normal microphone control current, when the microphone is idle, should not exceed 500 milliamperes. It should preferably have an average value of 300 milliamperes. When the microphone is spoken into, the control current may vary from 100 to 650 milliamperes.

Tuning

During the initial installation of a tube transmitter, the transmitting set should be first tuned for a maximum antenna current with the secondary terminals of the magnetic modulator on short circuit. Then the speech microphone and microphone battery should be connected in the primary circuit, and the secondary terminals of the modulator connected in series with the earth wire. Next, the short circuit on

the modulator should be removed and the transmitting set retuned for resonance, with normal current flowing through the microphone-control circuit. Generally, the antenna current should be somewhat less with the modulator in the circuit (25 to 30 per cent. of the normal value when it is not in the circuit) as it introduces an additional series antenna resistance. When the microphone is spoken into, the antenna resistance is varied according to the inflections of the human voice and the wave emission varies in amplitude accordingly.

I. C. W. Transmission

Telegraph transmission by modulated waves (I. C. W.) can be obtained with the modulator by substituting a small buzzer for the microphone. In general, the battery and buzzer should pass an average value of 1 to 1½ amperes through the control circuit of the modulator. The buzzer can be replaced by a rotary grid chopper, provided a regulating resistance is placed in series with the central coil so that the average value of 1½ amperes is not exceeded.

C. W. Transmission With the Modulator

It is possible to control the output of a tube set and to transmit by C. W. telegraphy, by sending a direct current, controlled by a telegraph key, through the primary circuit. The control current should not exceed two amperes. With this method double wave emission will be obtained, one wavelength being radiated with the telegraph key in the "open" position and the other when the key is closed. If then the receiving operator tunes his apparatus to the wave radiated when the key is closed, proper telegraph transmission will result.

Trap Circuit

It is often possible to secure more effective modulation from the magnetic modulator by placing a variable condenser across the antenna terminals. This condenser should have a maximum capacity of .003 mfd. With the condenser set at the zero position and with normal current flowing through the microphone and the primary winding of the modulator, the antenna circuit should be tuned for maximum current. While the transmitter is in operation the capacity of the condenser connected across the secondary should be gradually increased

until the antenna current is reduced to ½ or possibly ¼ of its normal value. The secondary of the modulator and the shunt condenser then constitute a "trap" circuit which filters out a portion of the antenna circuit. Then when the microphone is spoken into, the impedance of the "trap" circuit varies according to the vibrations of the human voice and therefore, the antenna current varies proportionately.

Filtering Features

This circuit will also be found to eliminate to a marked extent the "A. C. hum" generated by tube transmitters excited by rectified alternating current and which are perhaps not provided with the proper "filter" system.

In the use of this special "trap" circuit, care should be taken not to "filter" out too much of the antenna current, as otherwise distortion of the voice will result.

Reduces Distortion

Experiments have shown that the modulator provides less distortion of the human voice than any other form of modulation. This coupled with its simplicity of operation and stability makes it the ideal device for amateur stations.

With an antenna of proper design and of minimum resistance energized by a transmitter using two 50 watt tubes as oscillators, the modulator has given a fluctuation of the antenna current of 2 amperes while the microphone is spoken into.

The degree of modulation can often be increased by shifting the position of the grid tap of the oscillator tube on the oscillation transformer.



Magnetic Modulator UT-1643

MAGNETIC MODULATOR, UT-1643—½ to 1½ AMPERES.....\$9.50
 Dimensions: 4¾ in. x 2⅞ in. x 3⅛ in. Shipping weight: 2 lbs.

MAGNETIC MODULATOR, UT-1357—1½ to 3½ AMPERES.....12.00
 Dimensions: 5⅛ in. x 3⅛ in. x 3⅝ in. Shipping weight: 3 lbs.

MAGNETIC MODULATOR, UT-1367—3½ to 5 AMPERES.....17.00
 Dimensions: 8¾ in. x 3⅛ in. x 3⅝ in. Shipping weight: 5 lbs.

CONDENSERS FOR C. W. TRANSMITTING SETS



Model UC-1803

FARADONS FOR
Better C. W.
Transmission

Highest Grade Con-
densers Available for
Amateur Work

Designed Especially for
Radiotron Power
Tubes

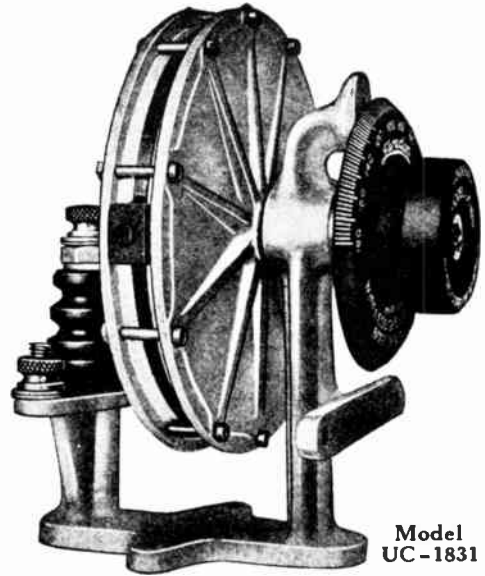

Model UC-1831

THE use of RADIOTRONS as generators of radio frequency oscillators in radio telegraphy and telephony has brought about the need for comparatively small transmitting condensers, which will stand continuous operation with the voltages used on such tube sets.

Due to the far greater effectiveness of C. W. over spark methods of transmission, ampere for ampere in the antenna, ranges are obtainable with RADIOTRON Transmitters equal to those of spark sets of considerably higher power.

There has been developed for the Radio Corporation a series of the FARADON type of condensers which have been especially designed to fit the circuits illustrated in this book, and which will be found the best condensers of their type on the market today.

SIX TYPES ARE NOW AVAILABLE

Model UC-1014, rated at 3,000 volts effective, has a capacity of .002 mfd. This condenser was developed primarily for use as a grid condenser, radio frequency by-pass condenser or blocking condenser for circuits utilizing RADIOTRONS UV-202 and UV-203.

Model UC-1015, rated at 3,000 volts effective, has three capacities, .0003, .0004 and .0005 mfd., and a current-carrying capacity of 4 amperes at 200 meters maximum. At lower or higher frequencies the current-carrying capacity is greater or less, respectively. This condenser is applicable as a series antenna condenser and an intermediate circuit condenser in circuits using RADIOTRONS UV-202 or UV-203.

Both of the above condensers find numerous other applications in the great number of circuits available for C. W. transmission. Their capacities are exact within 2 per cent. and their losses are negligible. They are built with mica dielectric and include the most recent developments in high voltage condenser design.

Model UC-1803 is intended for use as a blocking or coupling condenser, as shown in the various diagrams shown in this book. It is rated at 10,000 volts and has a capacity of .000025 mfd. It is the only compact condenser on the market satisfactory for these purposes.

Model UC-1806, rated at 6,000 volts effective, has a capacity of .002 mfd, and is intended for use as a by-pass condenser in circuits in which the voltages rise to 6,000 volts.



Model UC-1015



Model UC-1806

Model UC-1831 is a variable type condenser, essential for tuning of CW transmitters. Designed as a series antenna condenser and will stand five amperes of CW at its maximum capacity setting. Will vary the radiated wave length by 50 to 100 meters. Minimum .0001 mfd, maximum, .0012 mfd. This condenser is rated at 400 volts.

Model UC-1846 is a special antenna coupling condenser permitting a selection of three capacities, viz., .000018, .000037 and .000075 mfd. It is tested to 10,000 volts. This con-

denser allows more accurate adjustment of the antenna circuit than is possible with the Model UC-1803. A full description of the use of Model UC-1846 is shown below.

All of the above condensers may be employed in radio receiving circuits as well as in transmission circuits, although they were primarily designed for use with RADIOTRON transmitter tube sets. Experimenters should bear in mind that the break-down voltages of all condensers listed herein are considerably greater than the voltage at which they are rated.

FARADON SPECIAL ANTENNA COUPLING CONDENSER

FOR closer regulation of the antenna circuit than is possible with the 1803 antenna coupling condensers, the use of the UC-1846 is recommended. As may be seen from the accompanying diagram, this condenser permits the

the points C or B. Where connection is made to the point B, both condensers are in series, and the resultant capacity is .000018. Where connection is made to the point C, one-half of the condenser is employed, having a capacity

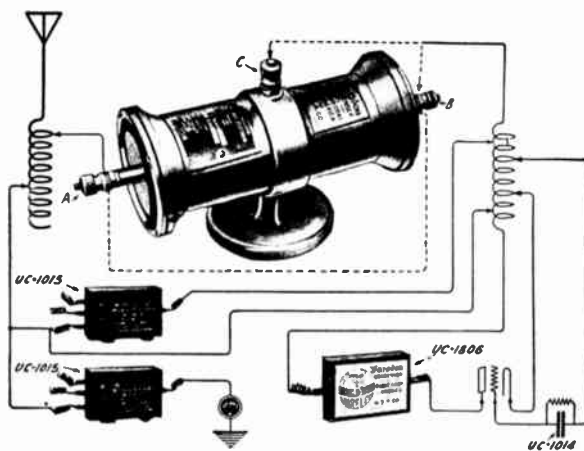

Illustrating a constant frequency vacuum tube transmitter circuit employing the Faradon special antenna coupling condenser UC-1846

use of three distinct capacities, viz., .000018, .000037 and .000075 mfd.

In order to obtain these values, the connections are made as follows: The point A is permanently connected to one adjustable clip of the antenna inductance, while a lead from one end of the oscillating inductance is attached to a two point switch, permitting connection to

of .000037. The third possible capacity combination is formed by connecting to the point C, and placing a shunt around the points A B, as indicated by the dotted lines in the diagram with a resultant capacity of .000075 mfd. By this arrangement both halves of the unit are therefore connected in parallel.

Specifications and Prices

MODELS	CAPACITY	VOLTAGE	DIMENSIONS	SHIPPING WEIGHT	PRICES
UC-1014	.002 mfd.	3,000 Volts	2¼ in. x 1½ in. x 7⁄8 in.	1 lb.	\$2.50
UC-1015	.0003, .0004, .0005 mfd.	7,500 Volts	2¼ in. x 1½ in. x 7⁄8 in.	1 lb.	5.75
UC-1803	.000025 mfd.	10,000 Volts	3 in. x 3 in. x 4 in.	1½ lbs.	5.00
UC-1806	.002 mfd.	6,000 Volts	2¼ in. x 1½ in. x 7⁄8 in.	1 lb.	7.00
UC-1831	.001-.0012 Variable	4,000 Volts	5½ in. x 5¼ in. x 4½ in.	2 lb.	9.00
UC-1846	.000018, .000037, .000075 mfd.	10,000 Volts	27⁄8 in. x 4¼ in. x 8½ in.	5 lb.	10.00

NOTE: Model UC-1014 bears the same size and appearance as Model UC-1806.

WESTINGHOUSE 20-WATT V. T. TRANSMITTER, MODEL TF

A Complete Vacuum Tube Radio Telephone and Radio Telegraph Transmitter Especially Designed for the Amateur

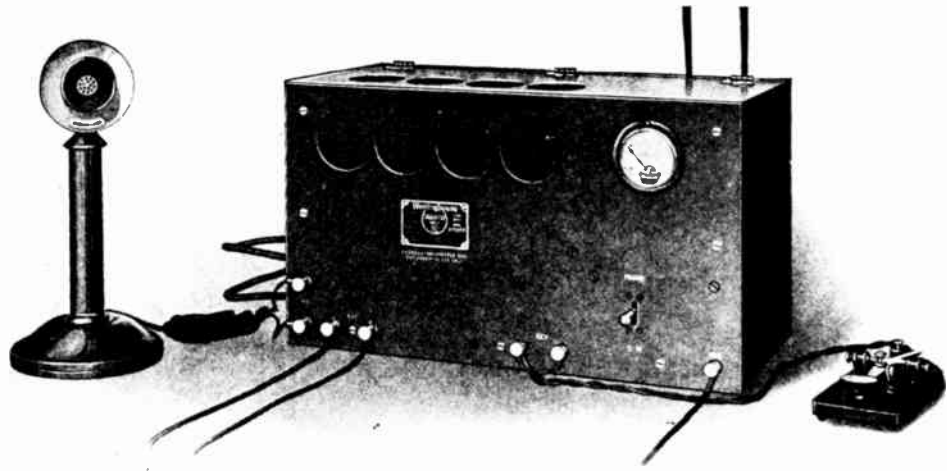

VACUUM tube transmitter set, Model TF, is designed for radio telephony and continuous wave telegraphy, a switch on the front of the panel permitting the use of either at will. When used for continuous wave telegraphy, four 5-watt oscillating tubes supplying approximately 20 watts of oscillating energy are used whereas when used for telephony, two of the tubes are connected as oscillators and two as modulators.

Simple But Effective Circuit Employed

All of the mechanism of the transmitter proper is contained within a highly polished mahogany cabinet 19 inches long, 8 inches high, and 8 inches wide, provided with a Micarta panel. All of the parts are attached to this panel and may be removed from the cabinet as a unit. The top of the cabinet is hinged to facilitate insertion of tubes and adjustment of tuning.

The circuit that is used is extremely simple and at the same time effective. There is only one inductance to which the connected antenna, counterpoise, ground, and the plates, grids and filaments of the modulator and oscillating tubes are connected. Using an antenna 60 to 80 feet long and 25 to 50 feet high, the transmitter can be tuned to any wave length between 180 and 230 meters. When the installation is made the entire tuning operation is accomplished by adjusting clips on the inductance.

The filaments are supplied with alternating current from a transformer contained within the cabinet. The primary of the transformer is wound for alternating current of sixty cycles and will accommodate 105 to 115 volts.

The plate voltage is furnished by a motor generator operated from a 110-volt, 60-cycle AC lighting circuit. The generator is arranged to furnish voltages of 350 or 500 volts. A block of resistance is connected in series with the generator field, two wires being connected to either side of this resistance and brought outside of the machine. By connecting these two wires together, the block of resistance is short circuited and the machine will furnish 500 volts. By disconnecting these two wires the resistance is connected in the field circuit and the machine will then furnish 350 volts. The two voltages that are thus available make it possible to adjust the transmitter to the range desired. For short distances the 350 volt connection is used and for greater distances 500 volts may be used if desired.

Works Best With Counterpoise

With each transmitting set there is furnished a microphone mounted on a desk stand and also a telegraph key. The microphone circuit and the key relay circuit require six volts direct current which may be furnished from the six-volt storage battery used to supply the filaments of the receiving tubes or five cells of dry battery connected in series may be used.

The transmitter is provided with a connection for using a counterpoise. A counterpoise is strongly recommended in all cases where it can conveniently be erected as the output and resultant range of the transmitter is considerably increased.

Although it is extremely difficult to make any statements regarding transmitting range, under reasonably good conditions a range of fifteen miles with telephony and one hundred miles continuous wave telegraphy may be obtained.

Complete Amateur Radio Telephone and Telegraph Transmitting Set, Model TF, including four 5-watt Radiotron vacuum tubes, one desk microphone, one telegraph key and 100-watt motor-generator unit \$305.00

G. E. 20-WATT V. T. TRANSMITTER, MODEL ET-3619

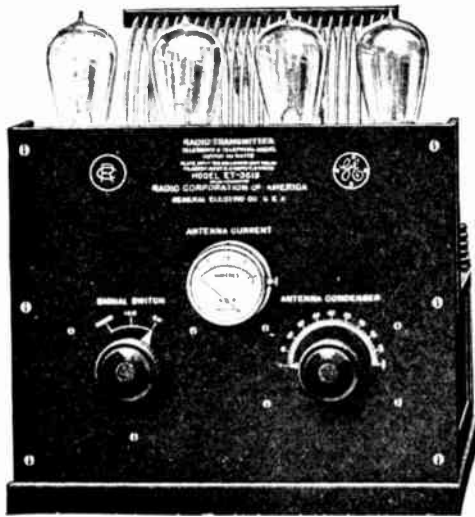

To the left is the Radiotron Transmitter Unit; to the right the Kenotron Rectifier Unit

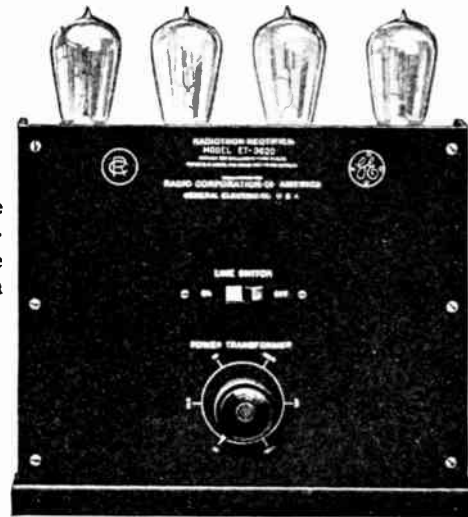

THIS radio telephone and telegraph transmitting outfit has been designed for use in conjunction with the Kenotron Rectifier unit described below. This transmitter, however, may be used with direct current where a motor generator set is available.

With the exception of the power supply everything necessary for a 20-watt transmitter is mounted on a sturdy panel and base made of heavy diletco, artistically engraved, as may be seen from the accompanying photograph. The 20-watt rate on this equipment is based on the same consideration as commercial wireless telephone transmitters, that is, four Model UV-202 5-watt Radiotons are used as oscillators.

Designed for Radiotron Vacuum Tubes

The transmitter is built for operation on telephone, continuous wave (C.W.) telegraphy or interrupted continuous wave (I. C. W.) telegraphy. The method of signalling is controlled by a rotary switch having three positions.

This transmitter requires the following supply for operation at full output: .160 amperes at 350 volts D. C. for the plate supply, and 10 amperes at 8 volts A. C. for the filament supply.

Model ET-3619 transmitter is entirely self-contained with the exception of the following units, which may be connected externally:

- (a) Send-receive Switch; (b) Telegraph Key; (c) Microphone Transmitter and Desk stand; (d) Motor Battery. (Not supplied as part of this transmitter.) (e) Microphone Battery.

Substantial terminals are provided for connecting the above units in circuit. All these terminals are numbered to agree with the connections indicated in the diagrams which accompany the book of instructions supplied.

Terminals are also provided so that the units not supplied with this transmitter may also be connected in circuit: such as—

- (a) Magnetically controlled Send-Receive Switch; (b) Control button for the above switch; (c) Magnetically controlled "Break In" Key; (d) Chopper for obtaining I. C. W. transmission.

Wave length control is obtained by means of a variable condenser in series with the antenna circuit adjusted by a control on the panel.

**KENOTRON RECTIFIER UNIT
MODEL ET-3620**

This equipment has been designed to operate in connection with the above 20-watt transmitter, or as a separate unit for other transmitting circuits. It is designed to give full wave rectification from a 110-volt, 50 or 60 cycles A. C. supply. It utilizes four Model UV-216 Kenotron Rectifier Tubes. The unit contains suitable filter condensers and reactor, so that the rectified A. C. is smoothed out for satisfactory telephone transmission.

This unit also contains a combined plate and filament transformer for supplying power at the proper voltage for heating all the vacuum tube filaments and furnishing the necessary plate potential for the transmitter.

G. E. 20-Watt Telephone and Telegraph Transmitter, Model ET-3619 including Transmitting Panel, 4 Radiotrons UV-202, Telegraph Key UQ-809, Send-Receive Switch, W. E. Desk Stand with Microphone 284W and 4 dry cell microphone battery	\$235.00
G. E. Kenotron Rectifier Unit, Model ET-3620, including 4 Kenotrons UV-216	\$150.00
Complete Transmitter and Rectifier as Above	\$385.00
Dimensions of each unit: Height, 14 in.; Width, 12½ in.; Depth, 11½ in.	

PART FOUR

Information

The Amateur Station

Radio Laws of the U. S.

National Electric Code Rules

Vacuum Tube Precautions

Radio Dictionary

Complete R. C. A. Price List

Radio Man's Bookshelf

Useful Data

A SCIENTIFICALLY CONSTRUCTED AMATEUR STATION

Too little attention has been paid by amateurs to the ground wire system of their radio stations. Amateurs whose stations are located appropriately should give attention to the interesting series of experiments described below, conducted by a Special Engineer of the Radio Corporation's High Power Receiving Research Staff, who has found time to apply the principles utilized in high-power commercial radio stations to amateur stations. By following his advice any amateur can duplicate the results he has obtained. He has analyzed and placed before amateurs the "crux" of a successful tube transmitting station.

MANY amateurs have considerable difficulty in getting a low antenna resistance, particularly in locations where the soil is sandy. Under these conditions, a counterpoise must generally be used to get the antenna resistance down to a reasonable figure. In many cases, however, it is possible to combine a ground connection with a counterpoise, in such a manner as to still further reduce the antenna resistance by a large amount.

An article in the "General Electric Review" for October, 1920, describes the Alexanderson system for Radio communication. It shows how Mr. Alexanderson has combined a buried wire ground with a capacity ground for more uniformly distributing the earth currents. In Figure 1, the inductance of the helix below the ground tap tunes the capacity ground, while the inductance between the ground tap and the antenna tunes the antenna circuit. The section of the helix above the ground connection may be considered positive with respect to ground, and the section of the helix below the ground connection may be considered negative with respect to ground. By suitable tuning, the total antenna current may be distributed between the capacity ground and the buried wire ground in any desired ratio.

In the case of Station "2BML," at Riverhead, L. I., the soil consists mainly of dry sand under the antenna. There is a small pond near the antenna, but not under it. A good ground was obtained in this pond by running several hundred feet of wire into it. The antenna resistance using this ground was very high, between sixty and seventy ohms at 200 to 300 meters. The writer decided that since the soil under the antenna was sandy, the high antenna resistance was due to the fact that the antenna flux was forced to travel through very high resistance soil for a considerable distance before reaching the low resistance ground wires.

A counterpoise of four No. 14 B. & S. copper wires running parallel with the antenna flat top and directly beneath the antenna was put up, the parallel wires being four feet apart and carefully insulated. The counterpoise extended several feet beyond the antenna at both ends. When the counterpoise was substituted for the ground, the antenna resistance was low-

ered from about sixty ohms to ten ohms. By combining the ground with the counterpoise as shown in Figure 2, the antenna resistance was still further reduced to about four ohms. The resistance of the helix used to tune this antenna was about three ohms, making a total antenna resistance of seven ohms. The above resistance values were taken at 280 meters wave length.

When the circuits are properly adjusted, removing either the ground connection or the counterpoise connection will not change the antenna wave length, but will change the antenna resistance only. The easiest way to tune up the counterpoise and ground is to first tune to the desired wave length, using the counterpoise alone, then try the ground clip on different turns until the point is found where the wave length is the same as with the counterpoise alone. The ground clip should be adjusted to within a half turn on a large diameter helix. When the ground clip is at the neutral point, the inductive impedance of the helix below the ground point tunes the capacity impedance of the counterpoise, forming a series-tuned circuit of comparatively low resistance. The total antenna current divides between the ground and the counterpoise inversely proportional to the effective resistances of the ground and counterpoise circuits.

With the counterpoise on the bottom of the helix and no ground connection, the wave length is 336 meters and the effective resistance is about nine ohms. When the ground clip is put on turn No. 1, the total current divides in inverse proportion to the ground resistance and the counterpoise reactance, and, obviously, most of the current will flow in the ground lead. Since the counterpoise has little effect, the wave length is practically determined by the antenna capacity and the helix inductance between the ground clip and the antenna clip. As the ground clip is moved up nearer the neutral point, the wave length becomes shorter, due to the decrease in inductance between the ground and antenna clips, and the counterpoise reactance is partly tuned out by inductance of the helix between the ground and counterpoise clips. The effective resistance decreases as the ground clip is moved up, be-

cause the counterpoise is taking a greater and greater portion of the antenna current. When the neutral point is reached, the counterpoise reactance is entirely tuned out, and the counterpoise takes most of the antenna current.

In the case of Station "2BML," the counterpoise capacity was .0007 M.F.D., and the antenna capacity was .0005 M.F.D. When the ground clip was properly adjusted, about 75 per cent. of the total antenna current flowed in the counterpoise lead and the other 25 per cent. in the ground lead. With this combination the antenna resistance was only about 40 per cent. of the value obtained with the counterpoise alone.

Many amateurs already have a counterpoise, and the writer believes if these amateurs will combine their counterpoise with a ground connection as described, their radiation will, in many cases, be doubled, especially in cases

The antenna current is six to eight amperes, depending upon the voltage of the local 60-cycle supply. The plate voltage is 2,000, using full wave rectification with two KENOTRONS. The smoothing condenser is 1 1/3 M.F.D., but is not large enough to smooth out the 60-cycle ripple, so the modulation is not particularly good and is seldom used, although it has been heard over distances of 300 to 400 miles several times. The RADIOTRONS draw 600 watts or more from the condensers, so a very large condenser would be required to smooth out the 60-cycle hum completely. The maximum input in the antenna with a single tube varies from 250 to 450 watts without overheating the tube, and doubtless more energy could be put in by using a higher plate voltage.

The helix consists of a power line lightning arrester choke coil made of 21 turns of 3/8-inch

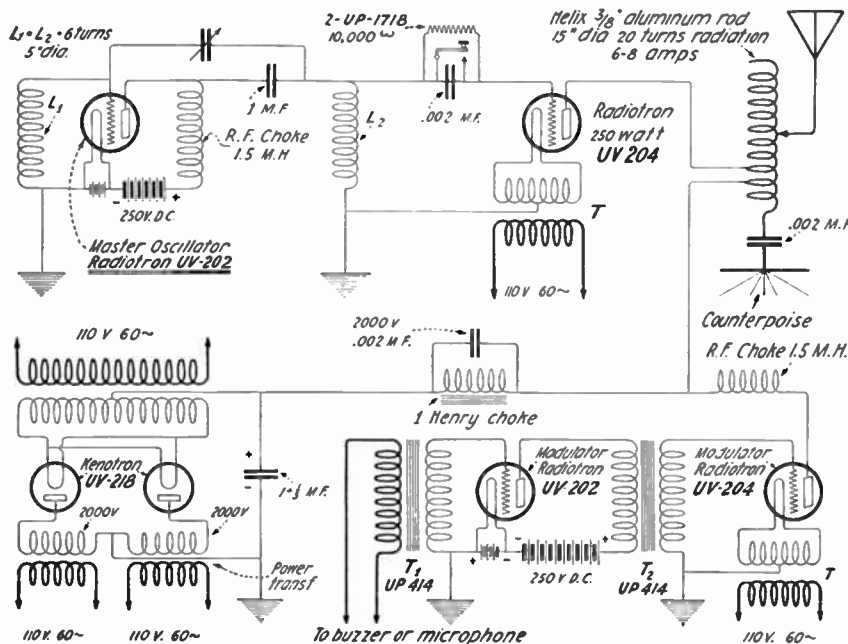

FIGURE 1

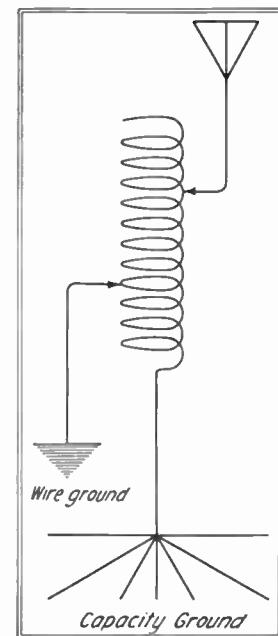

FIGURE 2

where a good ground connection is available. Very good results should be obtained even if the ground system is not directly under the antenna, as for example a water-main ground.

Figure 1 is a diagram of connections of the apparatus used at the above station. There are no special features excepting the combination of counterpoise and ground described above. A master oscillator is used to keep the frequency as constant as possible. It is essential to make the condensers in the ground and counterpoise leads large in comparison with the counterpoise and antenna capacities. The condenser in the counterpoise lead is simply a stopping condenser to keep the plate voltage off the counterpoise. Two 250-watt, type UV-204 RADIOTRONS are used. One tube is used as the oscillator and the other as the modulator.

aluminum rod wound in cylindrical form, 15 inches in diameter. Two old 2,000-volt transformers are used for supplying voltage to the KENOTRON rectifiers. One is a five K. W. 133-cycle power transformer, while the other is a 250-watt potential transformer, both having a 20 to 1 ratio and both delivering the same watts to the rectifiers.

The antenna is also a make-shift affair consisting of a small horizontal cage of three No. 14 wires about forty feet high and eighty feet long.

The station has now been in operation for a number of months, and like many other C. W. stations, the radiation was about one-half ampere at first, but was gradually increased by experimentation until eight amperes was finally reached. Half-wave self-rectification was also tried with both 60 and 300 cycles. The

300-cycle source gave an exceedingly pure, musical note and was very successful, but the available generator was small and the antenna current was only about three amperes with

full load on the 300-cycle generator. The C. W. signals from "2BML" have been reported QSA on many occasions from stations within a 1,000 mile radius.

GENERAL INFORMATION FOR THE AMATEUR

THERE are at the present time approximately 35,000 amateur radio transmitting stations in the United States, and probably twenty-five receiving stations to every transmitting station, making a total of 875,000 amateur stations. The large majority of these stations use only a small amount of power for transmitting; consequently, their range is small. There are organizations of amateurs which include primarily those who are interested in the relaying of messages from one station to another, and during the cooler months of the year, when the air is clear of static, it is frequently possible to relay messages through such stations across the continent within a few hours. As a general rule such messages are relayed over fairly well established lines of communication, including the most efficient stations operated by the best amateur operators of the country. The "National Amateur Wireless Association," which includes in its membership most of the leading amateurs of the country, is one of the organizations which maintains a national traffic organization and relays messages to all points of the country without charge. The stations which are a part of this relay system of the "National Amateur Wireless Association" include many of the

leading amateur stations which employ tube transmitters, and, because they use C. W. transmitters, exceptional results are obtained, the range of these tube stations frequently exceeding 1,000 miles. During the warm months of the year, when there is considerable disturbance from atmospheric electricity due to thunderstorms, repeated tests have proved that tube transmitters can work successfully through heavy static caused by thunder showers, while spark stations of the same power could not be heard.

One of the problems of amateur activities is that of interference between stations. This is largely the result of the use of spark transmitters which radiate their energy over a wide band of wave lengths. In the case of continuous wave transmission the energy is radiated on substantially one wave length, thereby eliminating to a great degree the objectionable interference caused by spark stations. The character of transmitted energy is such that the effect at the distant receiver is much greater, power for power, than a spark set, principally for the reason that the undamped wave transmitter permits the use of highly refined and efficient methods of reception.

RADIO LAWS AND REGULATIONS OF THE UNITED STATES

THE owner of an amateur radio transmitting station must obtain a station license before it can be operated if the signals radiated therefrom can be heard in another state; and also if such a station is of sufficient power to cause interference with neighboring licensed stations in the receipt of signals from transmitting stations outside the state. These regulations cover the operation of radio-telephone stations as well as radio-telegraph stations.

Station licenses can be issued only to citizens of the United States, its territories and dependencies.

Transmitting stations must be operated under the supervision of a person holding an Operator's License and the party in whose name the station is licensed is responsible for its activities.

The Government licenses granted for amateur stations are divided into three classes as follows:

Special Amateur Stations known as the "Z" class of stations are usually permitted to transmit on wave lengths up to approximately 375 meters.

General Amateur Stations which are not within five miles of a Government Radio Station and are permitted to use a power input of 1 kilowatt and which cannot use a wave length in excess of 200 meters.

Restricted Amateur Stations are those located within five nautical miles of Government radio stations, and are restricted to $\frac{1}{2}$ kilowatt input. These stations also cannot transmit on wave lengths in excess of 200 meters.

Experimental stations, known as the "X" class, and school and university radio stations, known as the "Y" class, are usually allowed greater power and also allowed the use of longer wave lengths at the discretion of the Department of Commerce.

All stations are required to use the minimum amount of power necessary to carry on successful communication. This means that while an amateur station is permitted to use, when the circumstances require, an input of 1 kilowatt, this input should be reduced or other means provided for lowering the antenna energy when communicating with near-by stations in which case full power is not required.

Malicious or wilful interference on the part of any radio station, or the transmission of any false or fraudulent distress signal or call is prohibited. Severe penalties are provided for violation of these provisions.

Special amateur stations may be licensed at the discretion of the Secretary of Commerce to use a longer wave length and higher power than general amateur stations. Applicants for special amateur station licenses must have had two years' experience in actual radio communication. A special license will then be granted by the Secretary of Commerce only if some substantial benefit to the science of radio communication or to commerce seems probable. Special amateur station licenses are not issued where individual amusement is the chief reason for which the application is made. Special

amateur stations located on or near the sea coast must be operated by a person holding a commercial license. Amateur station licenses are issued to clubs if they are incorporated, or if any member holding an amateur operator's license will accept the responsibility for the operation of the apparatus.

Applications for operator's and station licenses of all classes should be addressed to the Radio Inspector of the district in which the applicant or station is located. Radio Inspectors' offices are located in the following places:

First District.....Boston, Mass.
 Second District.....New York City
 Third District.....Baltimore, Md.
 Fourth District.....Norfolk, Va.
 Fifth District.....New Orleans, La.
 Sixth District.....San Francisco, Cal.
 Seventh District.....Seattle, Wash.
 Eighth District.....Detroit, Mich.
 Ninth District.....Chicago, Ill.

No license is required for the operation of a receiving station, but all persons are required by law to maintain secrecy in regard to any messages which may be overheard.

There is no fee or charge for either an operator's license or a station license.

C. W. TRANSMISSION AT AMATEUR WAVE LENGTHS

A GREAT many amateur operators have applied to the Radio Inspectors of the different districts for special amateur licenses, giving as a reason that they wish to use tube transmitters which would not operate properly on 200 meters, the regular amateur wave length. This belief is entirely wrong. Tube sets will generate power on 200 meters, as well as on any other wave length, providing the antenna is of proper size for 200-meter work.

Some experiments with tube sets on wave lengths below 200 meters were made at "2ZL" Station, Valley Stream, L. I., where a separate antenna, considerably smaller than the main antenna regularly used, was employed for this short wave work. This smaller antenna was about 60 feet long over all, and consisted of four wires. It was found possible to do successful work on this antenna using wave lengths between 140 and 200 meters. Considerable work was done on 175 meters, the antenna current on this wave length being two amperes with two RADIOTRONS UV-203. One hundred miles in daylight could be covered readily on this wave length and with the current mentioned.

When the transmitter was adjusted to a

wave length of 175 meters it was found, in at least three instances, that the receiving operators had to adjust their secondary circuit variometers at zero in order to hear the signals. This indicates that many amateur receiving sets will not operate efficiently on wave lengths below 200 meters. After the communication had been carried on for some time on 175 meters, considerable comment was made by other amateur stations on the desirability of working on that wave length in that there was no interference at that wave length. Atmospheric disturbances gave little or no trouble, whereas on wave lengths above 200 meters the interference from this source was very pronounced.

It is entirely possible to work on 175 meters with tube transmitters or on any lower wave length, without trouble, provided the antenna system is of the proper size of that wave length. The belief that tubes will not operate and generate power on 200 meters or below, has evidently arisen through lack of experience. Tubes will oscillate on short wave lengths just as well as on long wave lengths. At "2ZL" Station a 50-watt RADIOTRON UV-203 was made to oscillate and generate power in a small antenna circuit with a period of only 50 meters.

RADIO RULES—NATIONAL ELECTRIC CODE

The following requirements governing the installation of radio receiving and transmitting apparatus were placed in effect on April 29, 1922.

The rules are given out by the Electrical Committee of the National Fire Protection Association, and will appear in the next issue of the National Electric Code, 1923 edition, as Rule No. 86, Radio Equipment.

FOR RECEIVING STATIONS ONLY

Antenna:—

a. Antennas outside of buildings shall not cross over or under electric light or power wires of any circuit of more than six hundred (600) volts or railway trolley or feeder wires nor shall it be so located that a failure of either antenna or of the above mentioned electric light or power wires can result in a contact between the antenna and such electric light or power wires.

Antennas shall be constructed and installed in a strong and durable manner and shall be so located as to prevent accidental contact with light and power wires by sagging or swinging.

Splices and joints in the antenna span, unless made with approved clamps or splicing devices, shall be soldered.

Antennas installed inside of buildings are not covered by the above specifications.

Lead-in Wires:—

b. Lead-in wires shall be of copper, approved copper-clad steel or other approved metal which will not corrode excessively and in no case shall they be smaller than No. 14 B. & S. gage except that approved copper-clad steel not less than No. 17 B. & S. gage may be used.

Lead-in wires on the outside of buildings shall not come nearer than four (4) inches to electric light and power wires unless separated therefrom by a continuous and firmly fixed non-conductor that will maintain permanent separation. The non-conductor shall be in addition to any insulation on the wire.

Lead-in wires shall enter buildings through a non-combustible, non-absorptive insulating bushing.

Protective Device:—

c. Each lead-in wire shall be provided with an approved protective device properly connected and located (inside or outside the building) as near as practicable to the point where the wire enters the building. The protector shall not be placed in the immediate vicinity of easily ignitable stuff, or where exposed to inflammable gases or dust or flyings of combustible materials.

The protective device shall be an approved lightning arrester which will operate at a potential of five hundred (500) volts or less.

The use of an antenna grounding switch is desirable, but does not obviate the necessity

for the approved protective device required in this section. The antenna grounding switch if installed shall, in its closed position, form a shunt around the protective device.

Protective Ground Wire:—

d. The ground wire may be bare or insulated and shall be of copper or approved copper-clad steel. If of copper the ground wire shall not be smaller than No. 14 B. & S. gage, and if of approved copper-clad steel, it shall not be smaller than No. 17 B. & S. gage. The ground wire shall be run in as straight a line as possible to a good permanent ground. Preference shall be given to water piping. Gas piping shall not be used for grounding protective devices. Other permissible grounds are grounded steel frames of buildings or other grounded metallic work in the building and artificial grounds such as driven pipes, plates, cones, etc.

The ground wire shall be protected against mechanical injury. An approved ground clamp shall be used wherever the ground wire is connected to pipes or piping.

Wires Inside Buildings:—

e. Wires inside buildings shall be securely fastened in a workmanlike manner and shall not come nearer than two (2) inches to any electric light or power wire unless separated therefrom by some continuous and firmly fixed non-conductor making a permanent separation. This non-conductor shall be in addition to any regular insulation on the wire. Porcelain tubing or approved flexible tubing may be used for encasing wires to comply with this rule.

Receiving Equipment Ground Wire:—

f. The ground conductor may be bare or insulated and shall be of copper, approved copper-clad steel or other approved metal which will not corrode excessively under existing conditions and in no case shall the ground wire be less than No. 14 B. & S. gage except that approved copper-clad steel not less than No. 17 B. & S. gage may be used.

The ground wire may be run inside or outside of building. When receiving equipment ground wire is run in full compliance with rules for Protective Ground Wire, in Section d, it may be used as the ground conductor for the protective device.

FOR TRANSMITTING STATIONS

Antenna:—

g. Antennas outside of buildings shall not cross over or under electric light or power wires of any circuit of more than six hundred (600) volts or railway trolley, or feeder wires, nor shall it be so located that a failure of either the antenna or of the above mentioned electric light or power wires can result in a contact between the antenna and such electric light or power wires.

Antennas shall be constructed and installed in a strong and durable manner and shall be so located as to prevent accidental contact with light and power wires by sagging or swinging.

Splices and joints in the antenna span shall, unless made with approved clamps or splicing devices, be soldered.

Lead-in Wires:—

h. Lead-in wires shall be of copper, approved copper-clad steel or other metal which will not corrode excessively and in no case shall they be smaller than No. 14 B. & S. gage.

Antenna and counterpoise conductors and wires leading therefrom to ground switch, where attached to buildings, must be firmly mounted five (5) inches clear of the surface of the building, on non-absorptive insulating supports such as treated wood pins or brackets equipped with insulators having not less than five (5) inch creepage and air-gap distance to inflammable or conducting material. Where desired approved suspension type insulators may be used.

i. In passing the antenna or counterpoise lead-in into the building a tube or bushing of non-absorptive insulating material shall be installed so as to have a creepage and air-gap distance of at least five (5) inches to any extraneous body. If porcelain or other fragile material is used it shall be installed so as to be protected from mechanical injury. A drilled window pane may be used in place of bushing provided five (5) inch creepage and air-gap distance is maintained.

Protective Grounding Switch:—

j. A double-throw knife switch having a break distance of four (4) inches and a blade not less than one-eighth ($\frac{1}{8}$) inch by one-half ($\frac{1}{2}$) inch shall be used to join the antenna and counterpoise lead-ins to the ground conductor. The switch may be located inside or outside the building. The base of the switch shall be of non-absorptive insulating material. Slate base switches are not recommended. This switch must be so mounted that its current-carrying parts will be at least five (5) inches clear of the building wall or other conductors and located preferably in the most direct line between the lead-in conductors and the point

where ground connection is made. The conductor from grounding switch to ground connection must be securely supported.

Protective Ground Wire:—

k. Antenna and counterpoise conductors must be effectively and permanently grounded at all times when station is not in actual operation (unattended) by a conductor at least as large as the lead-in and in no case shall it be smaller than No. 14 B. & S. gage copper or approved copper-clad steel. This ground wire need not be insulated or mounted on insulating supports. The ground wire shall be run in as straight a line as possible to a good permanent ground. Preference shall be given to water piping. Gas piping shall not be used for the ground connection. Other permissible grounds are the grounded steel frames of buildings and other grounded metal work in buildings and artificial grounding devices such as driven pipes, plates, cones, etc. The ground wire shall be protected against mechanical injury. An approved ground clamp shall be used wherever the ground wire is connected to pipes or piping.

Operating Ground Wire:—

l. The radio operating ground conductor shall be of copper strip not less than three-eighths ($\frac{3}{8}$) inch wide by one sixty-fourth ($\frac{1}{64}$) inch thick, or of copper or approved copper-clad steel having a periphery, or girth (around the outside) of at least three-quarters ($\frac{3}{4}$) inch (for example a No. 2 B. & S. gage wire) and shall be firmly secured in place throughout its length. The radio operating ground conductor shall be protected and supported similar to the lead-in conductors.

Operating Ground:—

m. The operating ground conductor shall be connected to a good permanent ground. Preference shall be given to water piping. Gas piping shall not be used for ground connections. Other permissible grounds are grounded steel frames of buildings or other grounded metal work in the building and artificial grounding devices such as driven pipes, plates, cones, etc.

Power from Street Mains:—

n. When the current supply is obtained directly from the street mains, the circuit shall be installed in approved metal conduit, armored cable or metal raceways.

If lead covered wire is used it shall be protected throughout its length in approved metal conduit or metal raceways.

FOR TRANSMITTING STATIONS (*Continued*)*Protection from Surges, etc:—*

o. In order to protect the supply system from high-potential surges and kick-backs there must be installed in the supply line as near as possible to each radio-transformer, rotary spark gap, motor in generator sets and other auxiliary apparatus, one of the following:

1. Two condensers (each of not less than one-half ($1/2$) microfarad capacity and capable of withstanding six hundred (600) volt test) in series across the line and mid-point between condensers grounded; across (in parallel with) each of these condensers shall be connected a shunting fixed spark-gap capable of not more than one-thirty-second ($1/32$) inch separation.
2. Two vacuum tube type protectors in series across the line with the mid-point grounded.

3. Non-inductively wound resistors connected across the line with mid-point grounded.
4. Electrolytic lightning arresters such as the aluminum coil type.

In no case shall the ground wire of surge and kick-back protective devices be run in parallel with the operating ground wire when within a distance of thirty (30) feet.

The ground wire of the surge and kick-back protective devices shall not be connected to the operating ground or ground wire.

Suitable Devices:—

p. Transformers, voltage reducers, keys, and other devices employed shall be of types suitable for radio operation.

NOTE ON THE CARE OF MINERALS

In receiving outfits employing crystal detectors, the effective range depends a great deal upon the sensitivity of the crystal. Some crystals are naturally more sensitive than others, but even a sensitive crystal may be ruined by improper care. The action of the air on these crystals sometimes oxidizes their surface and

prevents them from functioning properly, but a more serious trouble is caused by touching the surface of the crystal with the fingers. Where this has been done and the surface of the crystal is found to be less sensitive after continued use, it should be scraped lightly with a pen-knife.

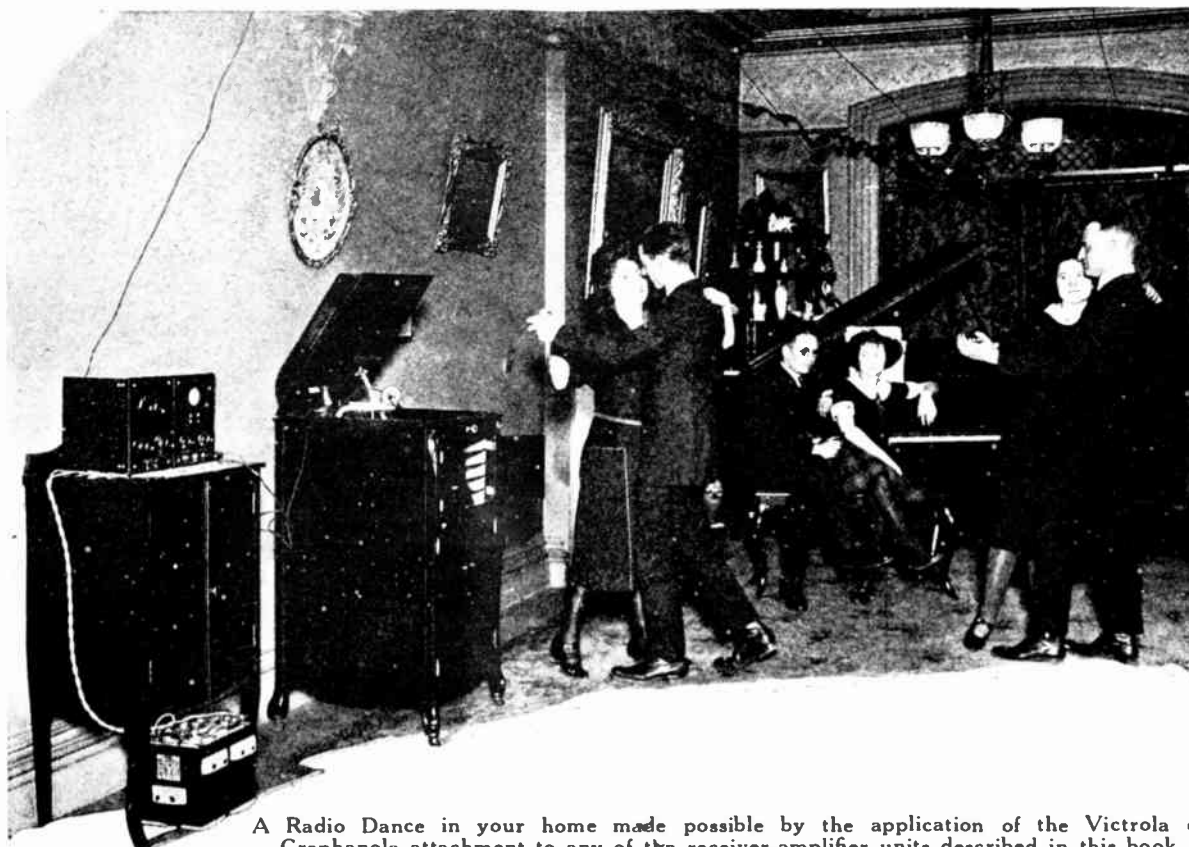

A Radio Dance in your home made possible by the application of the Victrola or Graphanola attachment to any of the receiver-amplifier units described in this book.

VACUUM TUBE PRECAUTIONS

- DON'T** handle vacuum tubes roughly or elements may be injured.
- DON'T** burn vacuum tube filaments above rated amperage and voltage.
- DON'T** rely solely on an ammeter for proper current consumption—filaments should be burned at constant voltage rather than constant amperage.
- DON'T** insert vacuum tubes in sockets unless absolutely certain rheostats are turned off or at the proper setting for normal operation.
- DON'T** make the drastic error of connecting the plate battery to the filament terminals—watch all battery connections.
- DON'T** use more than one standard block plate battery (22.5 volts) on the plate of Radiotron detector tube UV-200.
- DON'T** use more than from 60 to 80 volts on the plates of Radiotron amplifier tubes UV-201—60 volts will be found quite sufficient.
- DON'T** underestimate the value of "A" battery potentiometer PR-536 in connection with Radiotron detector tube UV-200 if you wish to secure maximum signal strength.
- DON'T** burn out a vacuum tube through carelessness and expect your dealer to exchange it for another.
- DON'T** use excessive plate voltage on power tubes if you want long life.
- DON'T** energize the filaments of all the tubes in a cascade circuit at once, unless the circuit has been used before.
- DON'T** take one tube out of a cascade circuit in which the filaments are in parallel—it causes a rise in current in the remaining filaments and may burn them out. Cut off all the power first.
- DON'T** make any alterations in your wiring while vacuum tubes are in their sockets. It is quite a common thing for 40 or 60 volts to become twisted up in the filament circuit as a result of this practice. High voltage for the filament spells disaster for your tube.
- DON'T** expect a continued increase in signal strength as your filament temperature increases beyond normal. You will only reduce the life of your tube. Tubes function best at one particular point—when you increase their filament current beyond this point you do the signal no good and the tube great harm.
- DON'T** forget that necessary filament current may frequently be greatly reduced by proper manipulation of the tuner circuits, especially the tickler or regenerative circuit.
- DON'T** expect to have a loud speaker operate from a detector tube—you'll be disappointed. At least one stage of audio-frequency amplification is generally necessary.
- DON'T** forget that vacuum tubes cost from twenty to thirty times as much as ordinary incandescent lamps—they deserve a little respect.
- DON'T** expect to get the best results if you use an amplifier tube for a detector, or vice versa.
- DON'T** be anxious to produce sound with very great volume—it isn't necessary.
- DON'T** expect your loud speaker to work properly if you have a pair of phones connected to your detector circuit.
- DON'T** try to use Radio Corporation radio frequency intervalve transformers with other tubes than Radiotrons—you may not be able to make them function properly.

NOTE ON CONTROL OF REGENERATION

In vacuum tube receiving circuits employing regeneration, some means is generally provided for controlling this action. If the circuit is adjusted to a point where its action is too great, telephone signals will be distorted by oscillations set up in the detector tube itself. When this happens, it is merely necessary to alter the position of the regeneration control member.

Regeneration, when properly employed, has the effect of amplifying incoming signals many times and the best results may be obtained by bringing the regenerator control up to a point just before oscillation starts, or by bringing it to an oscillating point and then reducing it

slightly. The point of oscillation may be recognized by a peculiar continuous mushy sound in the telephone receivers and a sharp click may be heard when oscillation starts or stops. Too great a degree of regeneration also has the effect of producing whistling noises.

The regenerative feature in receiving sets when properly employed is of great value, but improperly employed it is not conducive to the best operation. Great care should therefore be taken in employing regeneration, otherwise radio telephone speech and music may become distorted.

TECHNICAL TERMS USED IN RADIO

- Aerial**—One or more wires insulated from, and suspended at a certain height above the ground, and used to radiate energy in the form of ether waves produced by a transmitter. When used for receiving purposes the correct name is antenna though both terms are used for either reception or transmission.
- Alternating Current, (Abbreviated A. C.)**—An electrical current flowing through a wire which has the direction of its flow periodically changed. Thus when we speak of a 60-cycle alternating current, we mean one that completely reverses its direction of flow sixty times per second. Alternating current plays a prominent part in practically every part of the radio circuit.
- Ammeter**—An instrument used for measuring the flow of current in amperes through a given circuit. An ammeter is invariably connected in series with a given circuit.
- Ampere**—The standard electrical unit of current flow.
- Amplifier**—This term is used in referring to either an amplifier tube or an amplifier receiving unit. See vacuum tube.
- Amplitude**—In radio work, this refers to the highest point reached by a wave or oscillation, i. e., the crest of each wave. A wave may, therefore, have a high or low amplitude according to the initial energy which created it.
- Antenna**—See aerial.
- Armstrong Circuit**—See Regeneration Circuit.
- Atmospherics**—Also known as static, strays, X's. "The noises of space." Natural electrical discharges occurring in the ether and in reality miniature lightning storms. Since these discharges travel through the same medium as radio waves, they are readily picked up by receivers and prove very troublesome at times. It is comparatively difficult to tune out these disturbances, for they have no definite wave length.
- Audio Frequencies**—Frequencies corresponding to vibrations which are normally audible to the human ear. All frequencies below 10,000 cycles per second are termed audio frequencies. See radio frequencies.
- Broadcasting**—As applied to radio work, the sending of intelligence either by radio telegraphy or telephony from a given central point for the benefit of a great number of receiving stations located within the broadcasting station's range.
- Capacity, (Abbreviated C.)**—Capacity is the property of a device to store energy in electro-static form. Capacity, as well as inductance, governs the frequency and wave-length of a circuit. The unit is the Farad, but on account of its size, the micro-farad (M. F.) is used. A micro-farad is one millionth part of a farad.
- Cascade Amplification**—This refers to high amplification of received radio signals where several vacuum tubes are employed in cascade fashion. Thus, we may speak of a three-step (cascade) amplifier.
- Choke Coil**—A coil wound so as to have great self-induction. This choking action introduced in a radio circuit is called impedance.
- Circuit**—In radio and electrical work the path in which an electric current flows from the source, and returns to it, is called a circuit. A circuit may be either open, closed or oscillating.
- Close Coupling**—A tuning coil, or coils, or transformer are said to be close coupled when the primary and the secondary are very close together, thereby causing large values of mutual inductance.
- Condenser**—Two or more sheets of metal separated by an insulator called the dielectric. A condenser is used in radio work for storing electrical energy and for bringing circuits into resonance or tuning them.
- Counterpoise**—One or more wires stretched immediately above the earth, but insulated from it, usually directly beneath the regular aerial and employed in transmission and reception instead of, or in connection with, a "ground."
- Continuous Wave, (Abbreviated C.W.)**—A form of electro magnetic wave used extensively in radio work having a constant amplitude and no damping, as distinguished from the older form of discontinuous, highly damped wave. C. W. makes possible long distance amateur radio telegraphy and telephony.
- Crystal Detector**—Certain metallic crystals when introduced in a radio receiving circuit have the property of rectifying the incoming signal oscillations so that the resultant intermittent direct current will operate a sensitive telephone receiver.
- Detector**—Any apparatus which transforms the oscillations received by the antenna into a form of current which will operate a telephone or other recording device.
- Direct Current, (Abbreviated D. C.)**—An electric current flowing continuously in one direction. In a two-wire circuit, for example, direct current always flows from the positive source to the negative return. Therefore, direct current always has a readily determinable polarity, while alternating current (A. C.), which is periodically reversing its polarity while flowing through a circuit, and has no apparent polarity.

TECHNICAL TERMS USED IN RADIO (*Continued*)

- Electron**—The final sign of negative electricity. An Atom combined with an Electron is a negative ion; an Atom minus an Electron is a positive ion.
- E. M. F.**—Electromotive force, the unit of which is the volt.
- Ether**—A medium of great elasticity and extreme minuteness, supposed to pervade all space as well as the interior of solid bodies and is the medium through which light, heat and radio waves are transmitted.
- Flat-Top Aerial**—One whose suspended wires are stretched in a plane parallel to the surface of the earth.
- Frequency**—In alternating currents, the number of complete cycles of reversal of current through a circuit per second. Thus, we speak of a 60-cycle current as one which has sixty complete reversals per second. See Alternating Current and Audio and Radio Frequencies.
- Grid Leak**—A very high, non-inductive, resistance connected across the grid condenser or between the grid and the filament of a vacuum tube to permit excessive electrical charges to leak off to an external source, thus furnishing stable control under all operating conditions, and governing the action of the grid.
- Ground, or Earth**—In radio work the ground is the low potential end of the circuit and functions in connection with the aerial or antenna of most sending and receiving systems. The term "ground" is used in any connection to earth, river or sea. See Counterpoise.
- Harmonics**—In radio, harmonics refer to the incidental waves mostly noticeable in undamped wave operation. These harmonics differ in length and frequency from the true and original operative wave of such transmitters. At times, amateurs will hear the harmonics of high power long wave stations while their tuners are set for much shorter waves.
- Henry**—The unit of inductance.
- Hertzian Waves**—Electro-magnetic waves named after their discovery by Prof. Heinrich Hertz, in 1887.
- Hot Wire Ammeter**—An instrument used in radio transmission work which measures current in amperes by means of a wire expanding in proportion to the heat generated by the passing current.
- Impedance**—The combination of resistance and retarding action offered by a coil of wire to a varying current on account of the back e.m.f. produced by the varying lines of force, see also Reactance.
- Inductance, (Abbreviated L)**—Inductance, like capacity, plays a very prominent part in radio circuits. It is the property of a coil of wire which tends to prevent any change in the value of current following through it. It governs the frequency and therefore the wavelength of a circuit. The unit of inductance is the Henry. In radio work the millihenry and the microhenry are the more practical terms used.
- Induction**—The transference of energy from one circuit to another by means of electromagnetic phenomena.
- Insulator**—A non-conductive material and one through which electricity will not pass.
- Kilowatt, (Abbreviated K. W.)**, meaning one thousand watts.
- Loop Antenna**—A small frame antenna used for indoor reception thus eliminating both outdoor aeriels and ground connections. It gives very marked directional effects.
- Loudspeaker**—Any receiving device designed to reproduce signals or speech loud enough to be heard without individual use of the conventional telephone receivers.
- Megohm**—One million ohms.
- Microfarad, (Abbreviated M. F.)**—One millionth part of a Farad and the practical unit of capacity.
- Microphone**—A sound magnifier or an instrument used in both wire and radio telephony to vary the current in circuit by means of speech.
- Miliampere, (Abbreviated M. A.)**—The thousandth part of one ampere.
- Ohm**—The unit of electrical resistance.
- Ohm's Law**—The fundamental law of electricity. It is that the current in amperes flowing through a circuit is equal to the pressure in volts divided by the resistance in Ohms.
- Oscillations**—Alternating currents of very high frequencies are called electrical oscillations. If the amplitude of a series of oscillations is constant, they are called continuous or undamped waves, but if the amplitude is not constant, as in the spark method, they are called damped waves.
- Potential**—Referring to electrical pressure. See E.M.F and Volt.
- Radiation**—The transmission of energy through space in the form of electromagnetic waves.
- Radio Frequencies**—Frequencies corresponding to vibrations not normally audible to the human ear. All frequencies above 10,000 cycles per second are termed radio frequencies. See Audio Frequencies.
- Reactance**—Opposition offered to the flow of a varying current by a condenser (capacity reactance), or an inductance (inductive reactance).
- Rectifier**—An apparatus which converts alternating current (A. C.) into pulses of direct current (D. C.). Tungar, Rectigon and Kenotron apparatus are employed for rectifying purposes. Certain metallic crystals also have rectifying action when used as detectors in radio reception.

TECHNICAL TERMS USED IN RADIO (*Concluded*)

Regenerative Circuit, (also known as the Armstrong circuit)—A radio circuit comprising a vacuum tube so connected that after detection, the signal introduced in the plate circuit is led back to or caused to react upon the grid circuit, thereby increasing the original energy of the signal received by the grid and greatly amplifying the response to weak signals. In reception, the leading back of plate energy to the grid for further strengthening is usually accomplished by means of a small coil placed close to the secondary of the receiving tuner. This small coil is frequently called the "tickler."

Resistance—Opposition to the flow of an electric current through a conducting medium. All metals have more or less electrical resistance. Copper is used universally for both electrical and radio work on account of minimum resistance, comparative low cost and ready availability. The unit of resistance is the Ohm.

Resonance—A very important function of radio circuits. Resonance in a given circuit is said to exist when its natural frequency has the same value as the frequency of the alternating electromotive force introduced in it. The current is then in tune with the natural period of vibration of the circuit. The theory of electrical resonance is the same as that of acoustics, readily demonstrated by the tuning forks, when one tuning fork will not respond to another unless it is of the same key or pitch.

Rheostat—A variable resistance usually employed to control or regulate current flow.

Selectivity—In radio work, the power of being able to select any particular wave length to the exclusion of others.

Sharp Tuning—Where a very slight change of a tuner or tuning system will produce a marked effect in the strength of signals.

Static—See Atmospherics.

Transformer—Any device used in electrical and radio work for the transference of energy from one state to another. Thus we have Power Transformers, Amplifying Transformers, Telephone Transformers, Oscillation Transformers, Tuning Transformers.

Tuning—The act of altering capacity or inductive values in a radio circuit so as to bring the circuit into resonance with an external source of similar character. In radio receiving, the

greatest signal strength is possible only when the product of the inductance — capacity value of the receiver matches that of the transmitter.

Undamped—A train of high frequency oscillations of constant amplitude such as continuous waves or C. W.

Vacuum Tube, (Abbreviated V. T.)—In radio work applies to a glass tube exhausted of air and containing essentially a filament for the creation of electrons, a plate positively charged and to which the electrons are attracted, and a grid, inserted between the filament and the plate, for controlling the amount of electronic flow. This action of the vacuum tube plays three leading functions in radio work, i. e., detection, amplification and generation of high frequency electro-magnetic waves.

Velocity of Waves—Radio, electric and light waves travel through space at the speed of 186,000 miles per second, or 300,000 kilometers per second.

Volt, (Abbreviated V)—The unit of electric pressure.

Voltmeter—An instrument for measuring the voltage across an electric circuit.

Watt, (Abbreviated W.)—The unit of electric power. To find power in Watts multiply voltage by amperage. 746 Watts equal one horsepower. 1,000 Watts equal one kilowatt (K. W.).

Wave Length—Radio waves in their passage through the ether, travel in undulating wave form similar to the waves at a seashore. When the wind is blowing hard and steady the distance between each wave crest is comparatively long, while if the wind is blowing more mildly and in short spurts, the distance between wave crests is accordingly shorter and we have short waves. In radio substitute the wind for the transmitter and you have the same action so to speak. Wave length is therefore, closely allied with frequency, i. e., long wave lengths have low natural frequencies while short wave lengths have greater natural frequencies. In general, short wave lengths are used for short distance low power work, while long wave lengths are employed for long distance high power work, although there is no relation between wave—length and transmitting range.

NOTE ON FILAMENT REGULATION

As a general rule most experimenters are tempted to have the filaments of vacuum tubes burn too brightly. The proper brilliancy is the lowest one at which signals are good. Increasing the filament current beyond this point does not increase the signal strength, but does lessen the life of the tubes considerably. A good general rule to follow is that of keeping

the filament as low as possible, consistent with good reception.

Moreover, certain types of vacuum tubes operate at very low filament temperatures. It is therefore best for the novice to follow closely the directions furnished with each vacuum tube receiver.

PRICE LIST OF RADIO APPARATUS

EFFECTIVE JUNE 1st, 1922

Supersedes all Previous Lists

RECEIVERS AND AMPLIFIERS FOR RADIO BROADCASTING RECEPTION

Item No.	Type	Description	List Price
1	AR-1300	G. E. Combined Crystal Radiophone Receiver and Regenerative Tuner 175-700 meters	\$50.00
2	AA-1400	G. E. Detector-2-stage Amplifier for use with AR-1300 Tuner; less tubes	75.00
3	ER-753	G. E. Crystal Radiophone Receiver, 175-700 meters, with Telephones....	18.00
4	RG	Westinghouse Aeriola Grand Receiver, 150-550 meters, comprising one Aeriotron Detector, three Aeriotron Amplifiers, four Ballast Vacuum Tubes and four "B" Batteries.....	325.00
5	RF	Westinghouse Aeriola Sr., 190-500 meters, with Brandes Telephones and one WD-11-D Aeriola Sr. Dry Battery Detector Tube.....	65.00
6	RE	Westinghouse Aeriola Jr., 190-500 meters, with Brandes Telephones and Spare Crystals	25.00
7	RC	Westinghouse Short Wave Regenerative Receiver, 180-700 meters, less tubes	132.50
8	RA	Westinghouse Short Wave Regenerative Tuner, 180-700 meters.....	68.00
9	DA	Westinghouse Detector-2-stage Amplifier, for use with RA Tuner, less tubes	70.00
10	AR-1375	Wireless Specialty Crystal Receiver, 170-2650 meters, with Telephones..	40.00

BROADCASTING RECEIVER SPECIALTIES AND ACCESSORIES

11	DB	Crystal Detector, complete.....	6.50
12	DE	Spare Crystals (Pressure Type).....	1.00
13	DD	Spare Crystals (Cat Whisker).....	1.00
14	CB	Load Coil for Type RC Receiver.....	6.00
15	LS	Victrola Reproducing Loud Speaker Attachment.....	18.00
16	LS	Grafanola Reproducing Loud Speaker Attachment.....	18.00
17	LV	Vocarola (Loud Speaker).....	30.00
18	AD	Receiving Antenna Equipment (W).....	7.50
18-a	AG-788	Receiving Antenna Equipment (G. E.).....	7.50
19	PA	Receiving Antenna Protector (W).....	2.00
19-a	UQ-1310	Receiving Antenna Protector (G. E.).....	2.50
20	IA	Receiving Antenna Insulator50
21	IA	Transmitting Antenna Insulator	2.00
22	SA	Transmitting Antenna Ground Switch.....	5.00

VACUUM TUBES FOR DETECTION, AMPLIFICATION AND AMATEUR OR EXPERIMENTAL TRANSMISSION

23	UV-200	Radiotron Detector Tube.....	5.00
24	UV-201	Radiotron Amplifier Tube	6.50
25	UV-202	Radiotron 5-watt Transmitter Tube.....	8.00
26	UV-203	Radiotron 50-watt Transmitter Tube.....	30.00
27	UV-204	Radiotron 250-watt Transmitter Tube.....	110.00
28	WD-11	Aeriotron Detector Renewal Tube, for Aeriola Sr. Receiver.....	8.00
29	WR-21-D	Aeriotron Detector Renewal Tube, for Aeriola Grand Receiver.....	7.50
30	WR-21-A	Aeriotron Amplifier Renewal Tube, for Aeriola Grand Receiver.....	7.50
31	WB-800	Aeriotron Ballast Renewal Tube, for Aeriola Grand Filament Circuit..	3.50
32	UV-216	Kenotron 20-watt Rectifier Tube, for 5-watt Radiotrons.....	7.50
33	UV-217	Kenotron 150-watt Rectifier Tube, for 50-watt Radiotrons.....	26.50

VACUUM TUBE SOCKETS AND MOUNTINGS

34	UR-542	Porcelain Socket, for Detector, Amplifier, 5-watt Radiotron and 20-watt Kenotron	1.00
35	UT-541	Porcelain Socket, for 50-watt Radiotron and 150-watt Kenotron.....	2.50
36	UP-552	Bakelite Socket, for Detector, Amplifier, 5-watt Radiotron and 20-watt Kenotron	1.50
37	{ UT-501 }	End Mountings, for 250-watt Radiotron, per pair.....	2.00
	{ UT-502 }		

VACUUM TUBE DETECTOR AND AMPLIFIER ACCESSORIES

Item No.	Type	Description	List Price
38	UV-712	Audio Frequency Interval Amplifying Transformer.....	7.00
39	UV-1714	Radio Frequency Interval Amplifying Transformer, 200-5000 meters..	6.50
40	UV-1716	Radio Frequency Interval Amplifying Transformer, 5000-25000 meters	8.50
41	PQ-1743	Wave-changing Switch for Radio Frequency Transformer UV-1714.....	.45
42	PR-536	"A" Battery Potentiometer	2.00
43	UD-486	Four-Point special Telephone Jack.....	7.25
44	UD-824	Single Telephone Plug	1.75
45	UD-825	Double Telephone Plug	2.60
46	UC-567	Tubular Grid and Plate Condenser, .00025 mfd.....	1.20
47	UC-568	Tubular Grid and Plate Condenser, .0005 mfd.....	1.35
48	UC-569	Tubular Grid and Plate Condenser, .001 mfd.....	1.50
49	UC-570	Tubular Grid and Plate Condenser, .0025 mfd.....	2.00
50	UX-543	Tubular Condenser Mounting.....	.50
51	UP-509 to UP-527	Grid Leaks for Receiving Units, 50,000 Ohms to 5 Megohms.....	.75
52	UX-543	Grid Leak Mounting.....	.50

VARIABLE CONDENSERS FOR RECEIVING CIRCUITS

53	UC-1819	Faradon Variable Mica Condenser, .0001-.005 mfd.....	8.75
54	UC-1820	Faradon Precision Variable Air Condenser, .00004-.0006 mfd.....	7.50

SPECIAL AMPLIFIER UNIT

55	AA-484	Wireless Specialty 2-Stage Component Part Audio Frequency Amplifier, mounted, less tubes.....	45.00
----	--------	---	-------

STORAGE BATTERIES

56-a	3LXL-5	Exide, 6 volts 40 ampere hours.....	17.50
56-b	3LXL-9	Exide, 6 volts, 80 ampere hours.....	23.00
56-c	3LXL-13	Exide, 6 volts, 120 ampere hours.....	30.00
56-d	6HR-5	Westinghouse-Union, 6 volts, 50 ampere hours.....	18.00
56-e	6HR-9	Westinghouse-Union, 6 volts, 100 ampere hours.....	24.00
56-f	6HR-13	Westinghouse-Union, 6 volts, 150 ampere hours.....	33.50

BATTERY CHARGERS

57	195529	Tungar Charger, 2-ampere size.....	18.00
58	219865	Tungar Charger, 5-ampere size.....	28.00
59	195528	Tungar Renewal Bulb, 2-ampere size.....	4.00
60	189048	Tungar Renewal Bulb, 5-ampere size.....	8.00
61	282395	Rectigon Charger, 2½-ampere size.....	18.00
62	285168	Rectigon Charger, 6-ampere size.....	28.00
63	277681	Rectigon Renewal Bulb, 2½-ampere size.....	4.00
64	289414	Rectigon Renewal Bulb, 6-ampere size.....	8.00

COMPLETE AMATEUR RADIO TELEPHONE TRANSMITTING SETS

65	TF	Westinghouse Radio Telephone and Telegraph Transmitter, 20-watts, including four 5-watt Radiotrons, Desk Microphone 284-W, Telegraph Key UQ-809 and 100-watt Motor Generator Unit.....	305.00
65-a	ET-3619	G. E. Radio Telephone and Telegraph Transmitter, 20-watts with 4-UV-202 Radiotrons, Send-Receive Switch UQ-809 Key, Desk Microphone, 284-W, and 4 Dry Cells (Microphone Battery).....	235.00
65-b	ET-3620	G. E. Rectifier for V. T. Transmission, 20-watts, with 4 Kenotrons UV-216	150.00

MOTOR-GENERATOR UNITS FOR VACUUM TUBE TRANSMITTERS

66	ME	Motor-Generator, 100-watts, 500-volts D.C., 110-volt 60-cycle single phase Motor, complete	85.00
67	MH	Motor-Generator, 250-watts, 1000-volts D.C., 110-volt 60-cycle single phase Motor, complete	170.00

POWER TRANSFORMERS FOR C. W. TRANSMITTING SETS

68	UP-1368	C. W. Transformer, 325-watts	25.00
69	UP-1016	C. W. Transformer, 750-watts	38.50

C. W. TRANSMITTER COMPONENT PARTS AND ACCESSORIES

70	UL-1008	Oscillation Transformer	11.00
71	UT-1643	Magnetic Modulator, ½ to 1½ amperes.....	9.50
72	UT-1357	Magnetic Modulator, 1½ to 3½ amperes.....	12.00
73	UT-1367	Magnetic Modulator, 3½ to 5 amperes.....	17.00
74	UP-1653	Filter Reactor, 5-20 watt Tube Transmitter.....	12.50
75	UP-1654	Filter Reactor, 50-100 watt Tube Transmitter.....	18.00
76	UP-415	Plate Reactor, 5-20 watt Tube Telephone Transmitter.....	5.75
77	UC-487	Filter Condenser, 750-volts, ½ mfd.....	1.40

R A D I O C O R P O R A T I O N O F A M E R I C A

C. W. TRANSMITTER COMPONENT PARTS AND ACCESSORIES—(Continued)

Item No.	Type	Description	List Price
78	UC-488	Filter Condenser, 750-volts, 1 mfd.....	\$2.25
79	UC-489	Filter Condenser, 1750-volts, 1/2 mfd.....	1.60
80	UC-490	Filter Condenser, 1750-volts, 1 mfd.....	2.50
81	UP-1718	Transmitter Grid Leak, for 50-watt Radiotron.....	1.65
82	UP-1719	Transmitter Grid Leak, for 5-watt Radiotron.....	1.10
83	UM-530	Antenna Ammeter, 0-2.5 amperes.....	6.00
84	UM-533	Antenna Ammeter, 0-5.0 amperes.....	6.25
85	UQ-809	Telegraph Key.....	3.00
86	UP-414	Microphone Transformer.....	7.25
87	PR-535	Filament Rheostat, for Detector, Amplifier, 5-watt Radiotron and 20-watt Kenotron.....	3.00
88	PT-537	Filament Rheostat, for 50-watt Radiotron, 250-watt Radiotron and 150-watt Kenotron.....	10.00
89	PX-1638	Rotary Grid Chopper, including wheel and brush.....	7.25
90	PX-1640	Rotary Grid Chopper Shaft Bushings, 5/16 in. (PX-1640) or 1/4 in. (PX-1641), each.....	.20
90-a	PX-1641		
90-b	UL-1655	Radio Frequency Choke.....	3.85

SPECIAL CONDENSERS FOR C. W. TRANSMITTING SETS

91	UC-1015	Faradon Antenna Series Condenser (.0003, .0004, .0005 mfd. 7500 v.).....	5.75
92	UC-1014	Faradon Plate and Grid Condenser (.002 mfd., 3000 volts).....	2.50
93	UC-1803	Faradon Antenna Coupling Condenser (.000025 mfd., 10,000 volts).....	5.00
94	UC-1806	Faradon Special Grid and Plate Condenser .002 mfd., 6000 volts).....	7.00
95	UC-1846	Faradon Special Coupling Condenser (.000075, .000037, .000018 mfd., 10,000 volts).....	10.00
96	UC-1831	Faradon Variable Mica Transmitting Condenser (.0001 to .0012 mfd., 4000 volts).....	9.00

SPECIAL HIGH GRADE RECEIVING APPARATUS

97	IP-500	Wireless Specialty Radio Receiver, 300-6800 meters, with Crystal Detector, less Telephone Receivers.....	595.00
98	IP-501	Wireless Specialty Vacuum Tube Radio Receiver, 300-7500 meters, with Crystal Detectors, less Telephone Receivers.....	550.00
99	Triode A	Wireless Specialty Vacuum Tube Control Unit, including Detector and 1-step Amplifier, less tubes.....	190.00
100	Triode B	Wireless Specialty Two-Step Tone Frequency Amplifier, less tubes.....	95.00
101	IP-306	Wireless Specialty Audibility Meter.....	135.00
102	Load Coil, 30 Milihenries.....	10.00
103	Load Coil, 50 Milihenries.....	15.50
104	Load Coil, 100 Milihenries.....	21.50

PRECISION VARIABLE AIR CONDENSERS

105	IP-300	Wireless Specialty Variable Air Condenser .005 mfd., max.....	90.00
106	IP-301	Wireless Specialty Variable Air Condenser, .003 mfd., max.....	72.00
107	IP-302	Wireless Specialty Variable Air Condenser, .0015 mfd., max.....	45.00
108	IP-303	Wireless Specialty Variable Air Condenser, .0007 mfd., max.....	41.50

COMPLETE RADIO TELEPHONE RECEIVER SETS

Westinghouse Aeriola Grand Combination No. 1

109	RG	Aeriola Grand Receiver, 150-550 meters, comprising one Aeriotron Detector, three Aeriotron Amplifiers, four Ballast Vacuum Tubes, and four "B" Batteries, with stand.....	350.00
	6HR-9	Storage Battery, 6 volts, 100 ampere hours.....	24.00
	AD	Receiving Antenna Equipment.....	7.50
	285168	Rectigon Battery Charger, 6 amperes.....	28.00
Total.....			\$409.50

R A D I O C O R P O R A T I O N O F A M E R I C A

Westinghouse Aeriola Sr., Combination No. 2

Item No.	Type	Description	List Price
110	RF	Aeriola Sr., Receiver, 190-500 meters, with Brandes Telephones and one WD-11 Aeriotron Detector Tube.....	65.00
	One Dry Cell for Aeriotron Filament.....	.40
	One "B" Battery, 22.5 volts.....	3.00
	AD	Receiving Antenna Equipment	7.50
Total.....			\$75.90

Westinghouse Aeriola Jr., Combination No. 3

111	RE	Aeriola Jr., Receiver, 150-700 meters, with Brandes Telephones and Spare Crystals	25.00
	AD	Receiving Antenna Equipment.....	7.50
Total.....			\$32.50

Westinghouse Regenerative-Vacuum Tube Receiver Combination No. 4

112	RC	Short Wave Regenerative Receiver, 170-700 meters, less tubes.....	132.50
	CB	Load Coil	6.00
	UV-200	One Radiotron Detector Tube.....	5.00
	UV-201	Two Radiotron Amplifier Tubes.....	13.00
	6HR-9	Storage Battery, 6 volts, 100 ampere hours.....	24.00
	UD-790	Brandes Telephone Receivers.....	8.00
	UD-824	Telephone Plug	1.75
	Two "B" Batteries.....	6.00
	AD	Receiving Antenna Equipment.....	7.50
	LV	Vocarola (Loud Speaker).....	30.00
	285168	Rectigon Battery Charger, 5 amperes.....	28.00
Total.....			\$261.75

Westinghouse Crystal Receiver Combination No. 5

113	RA	Short Wave (Regenerative) Tuner, 170-700 meters.....	68.00
	DB	Crystal Detector, complete.....	6.50
	UD-790	Brandes Telephone Receivers.....	8.00
	AD	Receiving Antenna Equipment.....	7.50
Total.....			\$90.00

General Electric Regenerative-Vacuum Tube Receiver Combination No. 1

114	AR-1300	Radiophone Receiver, 170-700 meters.....	50.00
	AA-1400	Detector 2-Stage Amplifier, less Tubes.....	75.00
	UV-200	One Radiotron Detector Tube.....	5.00
	UV-201	Two Audiotron Amplifier Tubes.....	13.00
	UD-790	Brandes Telephone Receivers.....	8.00
	3LXL-9	Storage Battery, 6 volts, 80 ampere hours.....	23.00
	2156	Three "B" Batteries each 22.5 volts.....	9.00
	LV	Vocarola (Loud Speaker)	30.00
	219865	Tungar Battery Charger, 5 amperes.....	28.00
	UD-824	One Telephone Plug.....	1.75
	AG-788	Receiving Antenna Equipment.....	7.50
Total.....			\$250.25

General Electric Crystal Receiver Combination No. 2

115	AR-1300	Crystal Radiophone Receiver, 170-700 meters, complete.....	50.00
	UD-790	Brandes Telephone Receivers.....	8.00
	AG-788	Receiving Antenna Equipment.....	7.50
Total.....			\$65.50

General Electric Crystal Receiver Combination No. 3

116	ER-753	Crystal Radiophone Receiver, 300-700 meters, with Telephone Receivers	18.00
	AG-788	Receiving Antenna Equipment.....	7.50
Total.....			\$25.50

Wireless Specialty Crystal Receiver Combination No. 1

117	AR-1375	Crystal Radiophone Receiver, 170-2650 meters, with Telephone Receivers	40.00
		Receiving Antenna Equipment.....	7.50
Total.....			\$47.50

Price Changes:

All prices listed in this catalogue are subject to change without notice.

Quotations:

Quotations:—F.O.B. Warehouse, 326 Broadway, New York City, factories, or other points to be designated later.

NOTICE TO PURCHASERS

THE radio products of the Radio Corporation of America are distributed to the trade through its specially selected wholesale distributors located throughout the United States and its possessions. These distributors generally carry a complete line of Radio Corporation apparatus. Broadcast enthusiasts and experimenters are urged to place their orders with the dealers of these accredited representatives rather than through the General Offices of the Corporation. By placing orders with these dealers, the purchaser not only buys in the most economical way and reduces the time of delivery but he also assists the dealer to keep his shelves stocked with up-to-date radio apparatus.

The Radio Corporation of America's wholesale distributors and retail dealers have been selected after a careful investigation of their methods and practices. Consideration has been given to those who give quick service and are able, in addition to effecting radio sales, to assist experimenters in solving their technical problems.

Purchasers are requested to investigate our faith in these supply houses and to place their orders with them directly. If the purchaser is located so far from any of the Corporation's wholesale distributors and their dealers that he cannot conveniently deal with them direct, the Corporation will be pleased to give him counsel and advice, and to point out the type of equipment which it deems most suitable for the purchaser's requirements.



The Wireless Man's BOOKSHELF



TITLE	AUTHOR	PRICE
Practical Wireless Telegraphy.....	Elmer E. Bucher	\$2.25
Vacuum Tubes in Wireless Communication.....	Elmer E. Bucher	2.25
Wireless Experimenter's Manual.....	Elmer E. Bucher	2.25
How to Pass U. S. Govt. Wireless License Examinations.....	Elmer E. Bucher	.75
How to Conduct a Radio Club.....	Elmer E. Bucher	.75
The Alexanderson System for Radio Telegraph and Radio Telephone Transmission.....	Elmer E. Bucher	1.25
Practical Amateur Wireless Stations.....	Compiled by J. Andrew White, Editor of Wireless Age	.75
Radio Telephony.....	Alfred N. Goldsmith, Ph.D.	2.50
Prepared Radio Measurements with Self-Computing Charts.....	Ralph R. Batcher	2.00
Radio Instruments and Measurements.....		1.75
Acquiring the Code.....	E. P. Gordon	.50
Sound Method of Learning the Code.....		.50
Elementary Principles of Wireless Telegraphy (in two volumes).....	R. D. Bangay	
Volume 1.....		1.75
Volume 2.....		1.75
Practical Aviation (including Construction and Operation).....	Major J. Andrew White	2.25
Military Signal Corps Manual.....	Major J. Andrew White	2.25
"What You Want to Say and How to Say It".....	W. J. Hernan	
In French, or Spanish, or Italian or German.....		.25
In Russian.....		.50
Continuous Wave Telegraphy. Part I.....	W. H. Eccles	8.00
Thermionic Tubes in Wireless Telegraphy and Telephony.....	J. Scott-Taggart	8.00
Radio Communication.....	J. H. Morecraft	7.50
Thermionic Vacuum Tubes.....	Van der Bijl	5.00
Principles of Radio Engineering.....	Lauer and Brown	3.50
Spanish Edition, Elementary Principles of Wireless Telegraphy (complete).....	R. D. Bangay	3.25
Thermionic Valve and Its Development in Radio Telegraphy and Telephony.....	J. A. Fleming	5.00
The Oscillation Valve, The Elementary Principles of Its Application to Wireless Telegraphy.....	R. D. Bangay	2.75
Telephony Without Wires.....	Philip R. Coursey	5.00
The Wireless Telegraphist's Pocketbook of Notes, Formulae and Calculations.....	J. A. Fleming	3.50
Wireless Telegraphy and Telephony—First Principles, Present Practice and Testing.....	H. M. Dowsett	3.50
Handbook of Technical Instructions for Wireless Telegraphists.....	J. C. Hawkhead and H. M. Dowsett	2.50
Spanish Edition Handbook of Technical Instructions.....	Hawkhead and Dowsett	3.00
Standard Tables and Equations in Radio Telegraphy.....	Bertram Hoyle	3.25
Wireless Transmission of Photographs.....	Marcus J. Martin	2.00
Calculation and Measurement of Inductance and Capacity.....	W. H. Nottage	1.75
Short Course in Elementary Mathematics and Their Application to Wireless Telegraphy.....	S. J. Willis	1.75
Selected Studies in Elementary Physics (A Handbook for the Wireless Student and Amateurs).....	E. Blake	2.00
Magnetism and Electricity for Home Study.....	H. E. Penrose	2.25
Alternating Current Work (An Outline for Students of Wireless Telegraphy).....	A. M. Shore	2.00
Pocket Dictionary of Technical Terms Used in Wireless Telegraphy.....	Harold Ward	1.00
Useful Notes on Wireless Telegraphy (set of five books), (paper).....	H. E. Penrose	2.00
Book No. 1—Direct Current, 67 pages.....		.50
Book No. 2—Alternating Current, 50 pages.....		.50
Book No. 3—High Frequency Current and Wave Production, 65 pages.....		.50
Book No. 4—1½ Kw. Ship Set, 76 pages.....		.50
Book No. 5—The Oscillation Valve, 52 pages.....		.50
My Electrical Workshop.....	Frank T. Addyman	2.50
Experimental Wireless Stations.....	P. E. Edelman	3.00
High Frequency Apparatus, Design, Construction and Practical Application.....	T. S. Curtis	3.00
Textbook on Wireless Telegraphy.....	Rupert Stanley	
Volume 1—General Theory and Practice.....		5.00
Volume 2—Valves and Valve Apparatus.....		5.00
How to Make a Transformer for High Pressure.....	F. E. Austin	.75
How to Make a Transformer for Low Pressure.....	F. E. Austin	.75
The Operation of Wireless Telegraphy Apparatus.....	A. B. Cole	.35
Wireless Construction and Installation for Beginners.....	A. P. Morgan	.35
Lessons in Wireless Telegraphy.....	A. P. Morgan	.35
Experimental Wireless Construction.....	A. P. Morgan	.35
Home Made Toy Motors.....	A. P. Morgan	.35
Hawkins' Practical Library of Electricity. 10 volumes.....	Per volume	1.00
Hawkins' Electrical Dictionary.....		2.00
Marconi-Victor Records—6 Records—12 Lessons—For Learning Code Quickly.....		6.00
The Wireless Age—America's Foremost Radiophone review—\$2.50 per year, outside U. S. \$.50 extra postage		

THE WIRELESS PRESS, Inc.

ROOM 310

326 BROADWAY

NEW YORK

STATIONS HEARD

Call Letters	Date	Location	Distance	Wave Length	Receiver Adjustments

DEPARTMENT OF COMMERCE
BUREAU OF NAVIGATION
RADIO SERVICE

INTERNATIONAL RADIOTELEGRAPHIC CONVENTION
LIST OF ABBREVIATIONS TO BE USED IN RADIO COMMUNICATION

ABBREVIATION	QUESTION	ANSWER OR NOTICE
PRB	Do you wish to communicate by means of the International Signal Code?	I wish to communicate by means of the International Signal Code.
QRA	What ship or coast station is that?	This is
QRB	What is your distance?	My distance is
QRC	What is your true bearing?	My true bearing is degrees.
QRD	Where are you bound for?	I am bound for
QRF	Where are you bound from?	I am bound from
QRG	What line do you belong to?	I belong to the Line.
QRH	What is your wave length in meters?	My wave length is meters.
QRJ	How many words have you to send?	I have words to send.
QRK	How do you receive me?	I am receiving well.
QRL	Are you receiving badly? Shall I send 20?	I am receiving badly. Please send 20.
	for adjustment?	for adjustment.
QRM	Are you being interfered with?	I am being interfered with.
QRN	Are the atmospherics strong?	Atmospherics are very strong.
QRO	Shall I increase power?	Increase power.
QRP	Shall I decrease power?	Decrease power.
QRQ	Shall I send faster?	Send faster.
QRS	Shall I send slower?	Send slower.
QRT	Shall I stop sending?	Stop sending.
QRU	Have you anything for me?	I have nothing for you.
QRV	Are you ready?	I am ready. All right now.
QRW	Are you busy?	I am busy (or: I am busy with.....). Please do not interfere.
QRX	Shall I stand by?	Stand by. I will call you when required.
QRY	When will be my turn?	Your turn will be No.
QRZ	Are my signals weak?	Your signals are weak.
QSA	Are my signals strong?	Your signals are strong.
QSB	Is my tone bad?	The tone is bad.
QSC	Is my spark bad?	The spark is bad.
QSD	Is my spacing bad?	Your spacing is bad.
QSE	What is your time?	My time is
QSF	Is transmission to be in alternate order or in series?	Transmission will be in alternate order.
QSG	Transmission will be in series of 5 messages.
QSH	Transmission will be in series of 10 messages.
QSI	What rate shall I collect for?	Collect
QSK	Is the last radiogram canceled?	The last radiogram is canceled.
QSL	Did you get my receipt?	Please acknowledge.
QSM	What is your true course?	My true course is degrees.
QSN	Are you in communication with land?	I am not in communication with land.
QSO	Are you in communication with any ship or station (or: with.....)?	I am in communication with..... (through.....).
QSP	Shall I inform.....that you are calling him?	Inform.....that I am calling him.
QSQ	Is.....calling me?	You are being called by.....
QSK	Will you forward the radiogram?	I will forward the radiogram.
QST	Have you received the general call?	General call to all stations.
QSU	Please call me when you have finished (or: at.....o'clock)?	Will call when I have finished.
*QSV	Is public correspondence being handled?	Public correspondence is being handled. Please do not interfere.
QSW	Shall I increase my spark frequency?	Increase your spark frequency.
QSX	Shall I decrease my spark frequency?	Decrease your spark frequency.
QSY	Shall I send on a wave length of..... meters?	Let us change to the wave length of..... meters.
QSZ	Send each word twice. I have difficulty in receiving you.
QTA	Repeat the last radiogram.
QTE	What is my true bearing?	Your true bearing is degrees from
QTF	What is my position?	Your position is latitude longitude.

*Public correspondence is any radio work, official or private, handled on commercial wave lengths.

When an abbreviation is followed by a mark of interrogation, it refers to the question indicated for that abbreviation.

DEPARTMENT OF COMMERCE
BUREAU OF NAVIGATION
RADIO SERVICE

INTERNATIONAL MORSE CODE AND CONVENTIONAL SIGNALS

TO BE USED FOR ALL GENERAL PUBLIC SERVICE RADIO COMMUNICATION

1. A dash is equal to three dots.
2. The space between parts of the same letter is equal to one dot.
3. The space between two letters is equal to three dots.
4. The space between two words is equal to five dots.

A	—
B	—
C	— . — . .
D	— . . .
E	.
F	. . — . .
G	— — . .
H
I	. .
J	. — — — —
K	— . — .
L	. — . . .
M	— —
N	— .
O	— — — —
P	. — — . .
Q	— — . — .
R	. — . .
S
T	—
U	. . — .
V	. . . — .
W	. — — .
X	— . . — .
Y	— . — — .
Z	— — . . .

Ä (German)	. — . . .
Á or À (Spanish-Scandinavian)	. — — . . .
CH (German-Spanish)	— — — —
É (French)	. . —
Ñ (Spanish)	— — . — — .
Ö (German)	— — — . .
Û (German)	. . — — .

1	. — — — —
2	. . — — — .
3	. . . — — .
4 — .
5
6	—
7	— —
8	— — —
9	— — — — . . .
0	— — — — — . .

Period
Semicolon	. — . — . — .
Comma	. — . — . — . — .
Colon	— — — —
Interrogation	. . — —
Exclamation point	— — . . — — . — .
Apostrophe	. — — —
Hyphen	— —
Bar indicating fraction	. —
Parenthesis	. — — — . — . — . — .
Inverted commas	. —
Underline	. . — — . — . — . — .
Double dash — — .
Distress Call	. . . — — —
Attention call to precede every transmission	. . . — — . — . — . — .
General inquiry call	. . — . . — — — . — . — . — .
From (de)
Invitation to transmit (go ahead)	. . . — . — .
Warning—high power	. — — — . — — — . — — — .
Question (please repeat after) — interrupting long messages	. . . — —
Wait
Break (Bk.) (double dash) — — .
Understand
Error
Received (O. K.)	. —
Position report (to precede all position messages)	. . . — — . — . — . — .
End of each message (cross) — — .
Transmission finished (end of work) (conclusion of correspondence) — — .

ADDITIONAL CIRCUIT DIAGRAMS

ADDITIONAL CIRCUIT DIAGRAMS

MEMORANDA

PATENT LICENSE

(1) Purchasers of tubes, grid leaks, transformers, condensers, or other parts, or of sets are not licensed by the Radio Corporation of America under any patents owned by the Radio Corporation of America, or under which it is licensed to use the same for commercial purposes. The sole license the purchaser of any such part or set obtains by the purchase thereof is to use it for amateur and experimental radio use involving no business feature and including broadcast reception of news and music and other entertainments but not broadcast transmission.

(2) Purchasers of parts are given no license either express or implied by reason of such purchase to assemble or make up sets or parts of sets which sets or parts of sets (as distinguished from the separate parts) infringe patents under which the Radio Corporation of America holds rights. The purchaser of a part is licensed by such purchase to use such part only and is not licensed under any patent covering a combination or organization composed of such part and other parts. The right under any patents relating to such a combination or organization to assemble parts into complete sets or to assemble in part such sets is reserved by the Radio Corporation of America, except to the extent that it from time to time permits amateurs to assemble sets under certain conditions as provided below.

(3) To meet and develop the interest of amateurs in the radio art, such amateurs are, until further notice, authorized under the patents under which the Radio Corporation of America has the right to grant licenses, to assemble and use sets (but only for amateur and experimental radio purposes as above defined in section (1)), provided the tubes forming elements of, or used with, such sets have been sold by the Radio Corporation of America or such other persons, if any, as have been authorized by it to manufacture and sell the same for use in the United States of America, and provided that such amateur does not use any assembled or partially assembled set, but himself assembles the various distinct parts.

(4) No license under any such patent covering a combination or organization of elements is granted to replace any tubes in any set sold by the Radio Corporation of America or assembled under license from it, with other tubes not sold by the Radio Corporation of America.



ERRATA

Page 13—Second column, first line, should read "adjustment rotate tuning handle (7) slowly." This refers to bottom figure on diagram. Other (6) and (7) in diagram irrelative to text.

Page 20—Second column, last two lines, "Note" refers to connection from ground clamp on pipe, to protective device.

Page 34—Collapsible Loop Antenna Model No. should be AG-1380.

Page 45—Caption for Fig. 3, correct as follows: (right hand column)
 R1, R2, R3, R4, Standard Filament Rheostats PR-535.
 R5, R6 Standard "A" Battery Potentiometer PR-536.
 R7, Standard grid leak 5 to 2 Megohms UP 516, 519 or 523 with UX 543 mounting.

Pages 52 and 112—Two stage component part audio amplifier discontinued.

Page 53—Bakelite Socket UP-552, discontinued.

Page 62—Ratings of Rectigon Battery Chargers should be 2 amperes and 5 amperes respectively.

Page 73—Description of circuit No. 9 should read "Figure 9 shows a radio telegraph transmitting circuit for two Radiotrons UV-204. The energy supply for the plate circuit must be D. C. An individual transformer on A. C. for filament heating supply being used. A circuit of this character may be employed to communicate over long distances by continuous wave telegraphy."

Page 82—Delete the words "Self-Rectifying" from caption for Fig. 9.

MEMORANDA

MEMORANDA

MEMORANDA

THE SILENCE OF THE SEA IS BROKEN

IT happens to each of us, at some time or other, that a friend or loved one must leave our midst and voyage to a distant land. In years gone by, the last good-bye was said before the ship carried its passengers out into the silent deep. No after thought, no last good wish, was then possible.

Today we thrill at the thought that we are no longer out of touch with our friends at sea, for at our command stands Radio, the ever-willing genie, whose long arm reaches to the furthest waters of the oceans.

Many of the larger liners may be reached direct from R C A Marine coastal stations up to the fifth day of their voyage. Others may be reached almost as readily by relay from ship to ship, until the message overtakes the vessel of its destination.

Sending a Radiogram Via R C A is a simple matter. In New York City, San Francisco or Washington, D. C., it is necessary only to telephone the nearest R C A Office, and a messenger will call for it within a few minutes. Or, as in other cities, the message may be filed at any telegraph office.

The small cost of Radiograms renders them useful to every one. Eighteen cents a word, plus the telegraph charges from your city to the nearest R C A coastal station, is indeed a modest charge for service of this character.

We have prepared a handy little booklet, "How to Send a Radiogram Via R C A." A post card will bring a copy to your home.

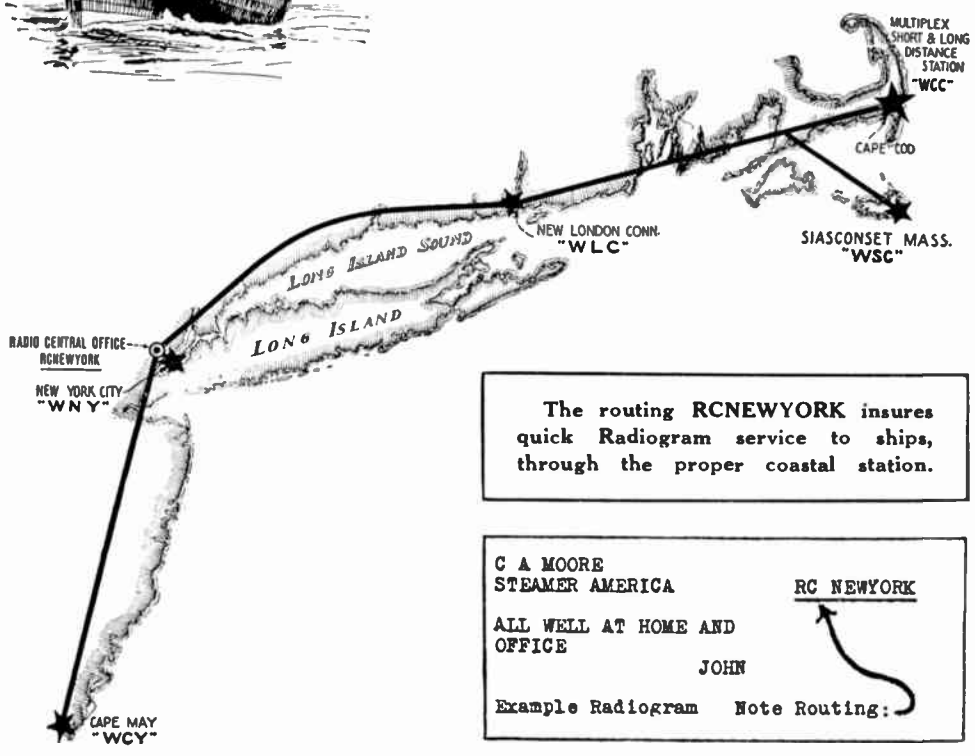
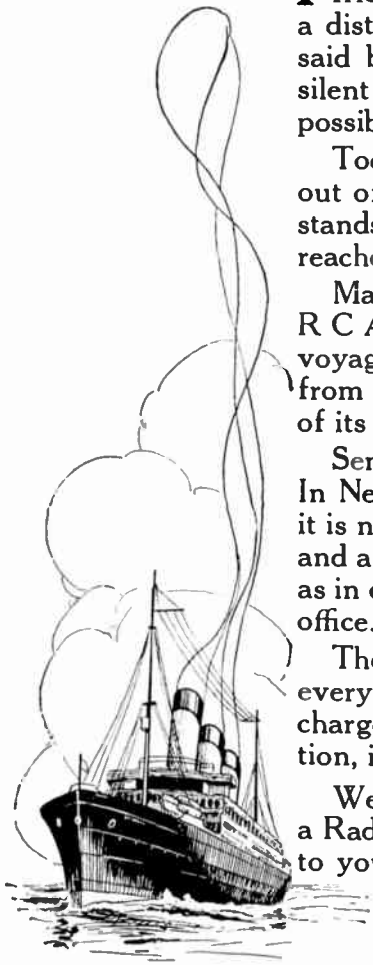

The routing RCNEWYORK insures quick Radiogram service to ships, through the proper coastal station.

C A MOORE
STEAMER AMERICA
ALL WELL AT HOME AND OFFICE
JOHN
Example Radiogram Note Routing:

LINKING THE OLD WORLD WITH THE NEW

A VERY important activity of the Radio Corporation of America, for the past two years, has been the maintenance of high powered, transoceanic radio stations for the transmission of Radiograms to Europe and the Far East.

The pioneer in this thoroughly American Service, inaugurated at the request of the United States Government, this Company has provided American Business with an accurate, speedy and economical means for their transoceanic message traffic. Today more than twenty per cent of the international communications of this Country are routed "Via R C A"

The Radio Corporation of America now spans the Atlantic and Pacific, with direct radio circuits to England, France, Germany, Norway, Japan and Hawaii. Additional special traffic arrangements render almost every corner of the world accessible "Via R C A"

American business men find this means of communication reliable and accurate in the conduct of communications involving commercial transactions. The service is just as satisfactory for the person who may wish to dispatch an occasional message to friends or relatives in other countries. And the low rates place it well within the reach of every one who may find it useful. An interesting booklet, "How to Send a Radiogram Via R C A" will be sent you, on request.

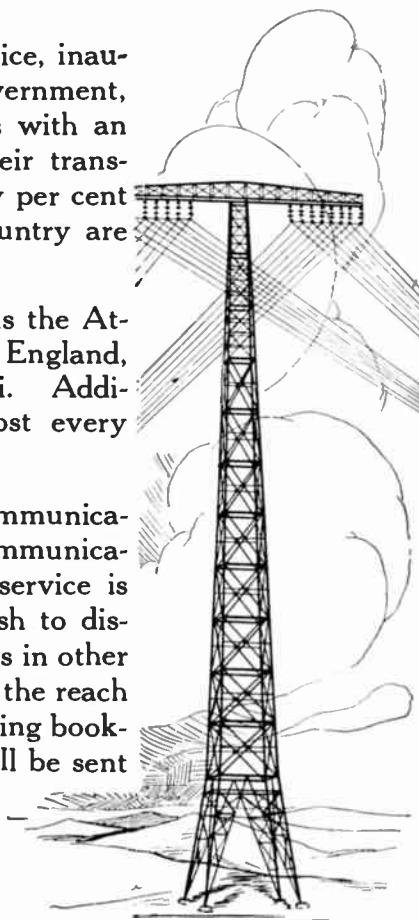

NEW YORK CITY OFFICES

ALWAYS OPEN. 64 Broad Street Tel. Broad 5100

8 A. M. to 8 P. M. { 19 Spruce Street Tel. Beekman 8220
 { 105 Hudson Street Tel. Canal 9477
 { 933 Broadway Tel. Ashland 7314
 { 1329 Third Avenue Tel. Rhineland 9257

8 A. M. to Midnight. . 51 East 42nd Street Tel. Murray Hill 4996

WASHINGTON, D. C. OFFICE

8.30 A. M. to Midnight. 1110 Connecticut Avenue Tel. Main 7400

SAN FRANCISCO OFFICE

ALWAYS OPEN. 300 California Street Tel. Douglas 3030



RCA SERVICE SAFEGUARDS LIVES AT SEA

THE success of any business is governed largely by the effectiveness of machinery or apparatus employed in its conduct. Nowhere is this fact emphasized so strongly as in Radio Communication; unquestionably it accounts in large measure for the present day efficiency of the Marine Radio Service.

This Marine Radio Equipment, with its servicing and operating facilities, represents the development and engineering skill which comes of matured experience in the conduct of a radio communication business.

Competent operators, standing guard with Radio Corporation of America's apparatus, have made incalculable contribution to the safety of those who sail the seven seas. Repeatedly has this apparatus met the test of the crisis. Hourly it demonstrates, in the handling of message traffic over long distances, the sound engineering judgment with which it has been constructed.

Today the stamp R C A on ship radio equipment is the mark of service and reliability to steamship companies whose liners and freight vessels ply their way to every corner of the world.

The nearest R C A Marine Branch Office will be glad to furnish information on ship radio equipment, its maintenance and service.

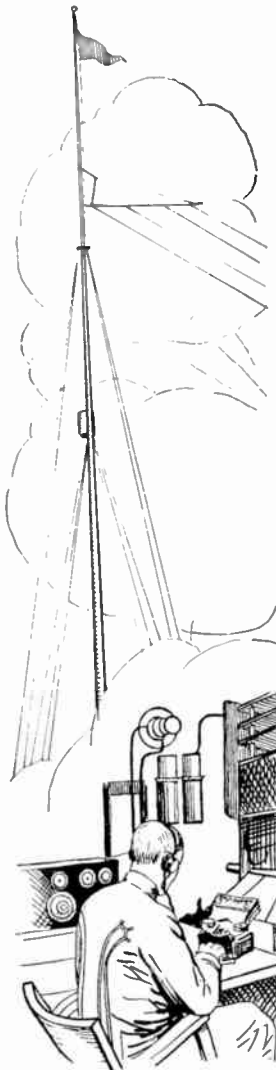

MARINE BRANCH OFFICES

Boston, Mass.
Philadelphia, Pa.
Norfolk, Va.
Port Arthur, Tex.

Chicago, Ill.
Seattle, Wash.
New York, N. Y.
Baltimore, Md.
Honolulu, T. H.

New Orleans, La.
Cleveland, Ohio
San Francisco, Cal.
Los Angeles, Cal.

Radio  **Corporation**
of America
WORLDWORTH BUILDING ~ NEW YORK CITY
(EXECUTIVE OFFICES)

Radio Enters the Home

*How to enjoy popular
Radio Broadcasting
Complete instructions and
description of apparatus*

The Policy of the **Radio Corporation of America**

THE sense of responsibility to the public, which in response to the suggestion of representatives of the United States Government brought the Radio Corporation of America into the field of international communication, also guides the Corporation's sales policy. This policy is one of frankness with the public.

The art of radio is still in the development stage. It has the touch of magic. Its achievements have been amazing, its possibilities unlimited. But, for the present at least, radio, and everything manufactured in the name of radio, has limitations. We urge our distributors and dealers to explain these limitations openly and accurately. The simple assurance can be given to every customer that the symbols of the Radio Corporation of America — R. C. A. — on any set, or any piece of apparatus, mean the highest standard of science and workmanship, of quality and economy, possible at the present time in a rapidly changing art.

Back of the Radio Corporation of America stand the splendid research facilities of its associates in the field of electricity; the General Electric Company, the American Telephone and Telegraph Company, the Western Electric Company, the Westinghouse Electric and Manufacturing Company and the Wireless Specialty Apparatus Company. These companies lend every electrical development which can be advantageously applied to modern radio practice. It is confidently expected that the products of the Radio Corporation will always be regarded as the highest expressions of the advancing art.

*For those who desire to be entertained
with concerts, lectures, dance music —
as well as for the Radio amateur*

Radio  **Corporation**
of America

SALES DEPARTMENT
WOOLWORTH BUILDING NEW YORK