

Taylor

CUSTOM
BUILT

Tubes

1937-1938
CATALOG and MANUAL



Taylor Tubes, Inc.

2341-43 WABANSIA AVENUE
CHICAGO, ILLINOIS

TAYLOR TUBES ARE SOLD THROUGH DISTRIBUTORS

There are TAYLOR TUBE Distributors in every logical distribution point throughout the U. S. and many foreign countries. We have attempted to see that all amateur and Broadcast Engineers could easily obtain TAYLOR TUBES when desired; and at the same time, tried to limit the distribution so that each Distributor would have a market large enough to afford carrying the complete line of TAYLOR TUBES.

All TAYLOR TUBE Distributors have been selected

with full consideration of their ability to serve and their reputation for fair dealing. We are extremely proud of the fact that Distributors not only sell TAYLOR TUBES—they RECOMMEND THEM above all others. We feel Radio Amateurs generally should recognize that the Radio Parts Distributors are their Best Friends—anxious at all times to extend the greatest possible cooperation on every transaction.

THERE IS A TAYLOR TUBE DISTRIBUTOR NEAR YOU.

TAYLOR TUBE RATINGS HAVE F. C. C. APPROVAL

INDEX

	Page		Page
General Information	2	872 Characteristics	17
T20 Characteristics	3-4	Curves	18
TZ20 "	3-4	Calculating Bias	18
T55 "	5-6	General Tube Information.....	19
T125 "	7-8	Circuit Information	20
T200 "	9	Transmitter Considerations	20
822 "	10	Crystal Osc. Circuit.....	21
203Z "	11	Buffers and Doublers.....	22
203B "	11	Insulation and Ant. Coupling.....	22
814 "	12	L/C Ratio Data.....	23
845 "	13	Tube Installation Hints.....	23
203A "	13	A Complete Taylor Tube Xmtr.....	24, 25, 26
211 "	13	A 3 Stage All Band Xmtr.....	27, 28, 33
211C "	13	112 to 450 Watt Xmtr.....	29, 30
756 "	14	5 and 10 Meter Xmtr.....	31, 32
825 "	14	Push-Pull T55 Amp.....	33, 34
841A "	14	T125 Amplifier	35, 36
841SW "	14	Modulation	36
HD203C "	15	Ohm's Law	36
HD203A "	15	T200 Amplifier	37
HD211C "	15	Class B Audio Design.....	38, 39, 40
204A "	15	Capacity Chart.....	41
866 "	16	General Trans. Information.....	42 & 43
866JR "	17	Short Wave Therapy.....	43
866B "	17	Power Supply Circuits.....	44



WARREN G. TAYLOR
President

DISTRIBUTED BY
RADIO-ELECTRIC SUPPLY CO.
FORT DODGE, IOWA
YOUNG'S RADIO SERVICE
108-110 South Seventh St.
Fort Dodge, Iowa



FRANK J. HAJEK (W9ECA)
Sec. & Treas.

THANK YOU

Ever since its inception, TAYLOR TUBES, INC., has faithfully lived up to its motto, "MORE WATTS PER DOLLAR."

That you appreciate these efforts and realize the merits of our products is indicated by our increased sales.

Today TAYLOR TUBES are not only used by thousands of Amateurs, but have found a distinctive place in the commercial radio and industrial field.

With the introduction of this, our new 1937-1938 Catalog and Manual, we again dedicate ourselves to your service. If you find the information herein of value, we feel that our efforts have been rewarded.

May we continue to have the privilege of serving you?

TAYLOR TUBES, INC.

WARREN G. TAYLOR

FRANK J. HAJEK (W9ECA)



JOSEPH F. HAJEK
Vice Pres.



YOUNG'S RADIO SERVICE
REX L. MUNGER (W9ED)
Sales Manager
108-110 South Seventh St.
Fort Dodge, Ia

A SECTION OF OUR TRANSMITTER TESTING LABORATORY

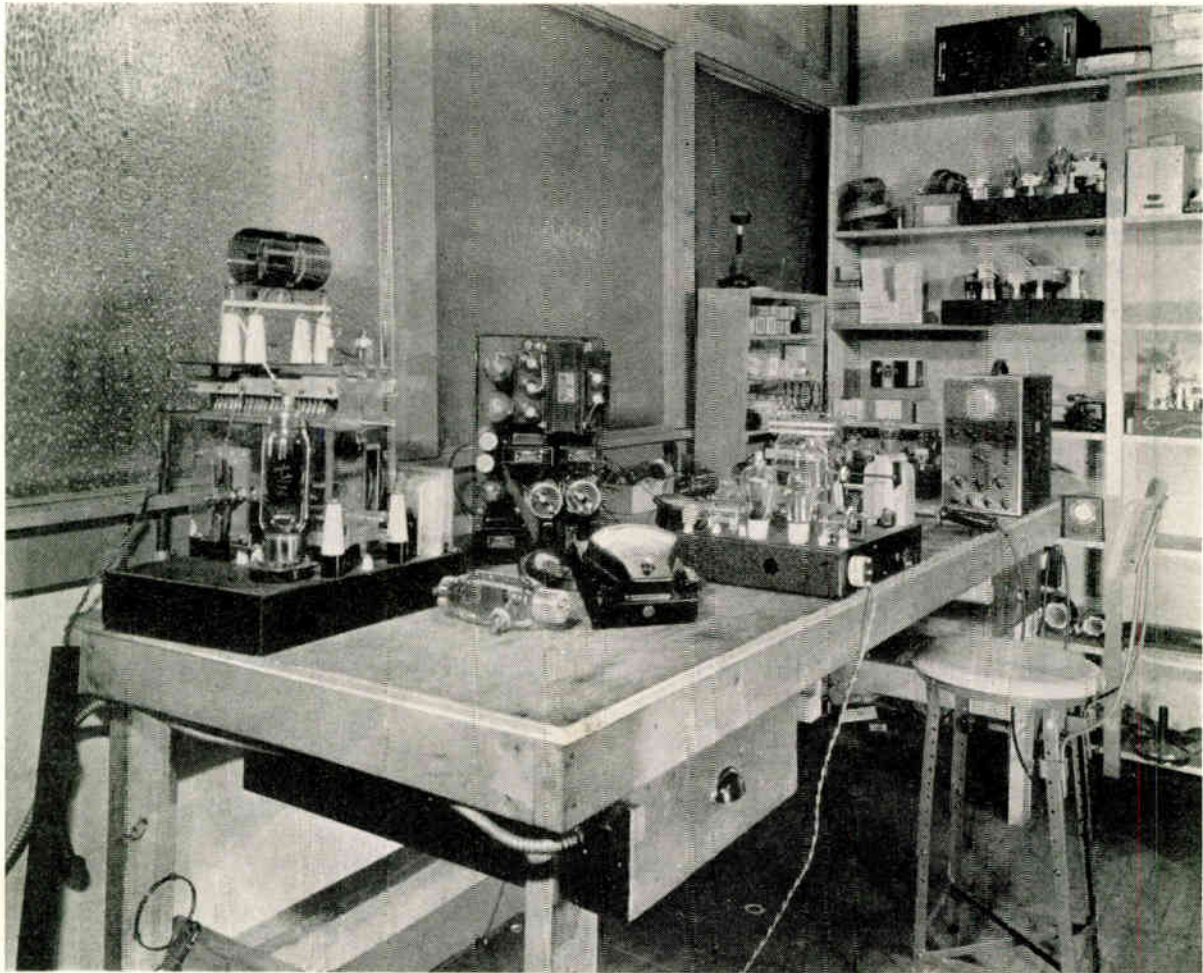

GENERAL INFORMATION

HEAVY DUTY CONSTRUCTION

When building radio transmitters or any other apparatus which incorporates the use of vacuum tubes, it is well to remember that the tube is the most important component of the circuit in which it is used. Our engineers realize this fact and designed our tubes accordingly. In the old days when tubes were as delicate as they were high-priced, the construction was such that they had to be handled very carefully as the slightest jar might be injurious. This is not the case with the present day TAYLOR Carbon Anode Tubes. The Radio field requires tubes of heavy duty construction. The tubes used in portable medical apparatus which is moved about in hospitals and doctors' offices, in mobile equipment such as police cars and boats and in airplane transmitters, must be built to pass severe tests for vibration and shock. Elements must be rigid and braced to withstand shocks which would otherwise throw them out of alignment. The filament, which is inherently brittle, must be correctly suspended by springs so that vibrations will not shatter it. Many manufacturers have chosen TAYLOR TUBES for the above mentioned uses because they meet these requirements.

NOTE

TAYLOR CARBON ANODES CAN BE RUN AT A RED HEAT WITHOUT INJURING THE FILAMENT EMISSION OF THE TUBE.

FLOATING ANODES

All Taylor Tubes having a plate dissipation rating of 50 watts or more, whether the plate lead is brought out thru the base or top of envelope, have the **Floating Anode**.

With this Taylor feature, (patent applied for) and distinctive design, punctures in the stem are eliminated and dielectric losses are reduced, because the structural supports and collar are not at plate potential.

CARBON ANODES

1. Radiate heat four times as fast as bright metals.
2. Do not expand when heated as do metal anodes, and therefore characteristics of Carbon Anode tubes do not vary.
3. Carbon Anodes are machined from a solid block of chemically pure carbon and do not have high resistance contact points as do metal anodes with welded seams.
4. Because Carbon Anodes dissipate heat evenly over their entire surface, hot spots are eliminated.

FUNDAMENTALS OF RATINGS

Remember, a vacuum tube does not amplify power. The power comes from the light line. The tube merely acts as a valve that enables you to control this power and change its form. The tube in changing the D.C. power to Radio Frequency power, wastes some of the energy just as a motor generator does in performing the same function. This wasted energy in a vacuum tube is known as plate dissipation. The watts dissipation is the difference between the watts input and watts output.

T-20 * \$2.45

20 WATTS PLATE
DISSIPATION

A general purpose Triode, offering outstanding value to the amateurs. The T20 has established itself as an extremely fine amplifier on all frequencies up to and including 56 mc., efficient as a doubler or buffer. The T20 is recommended for Class C amplifier purposes.

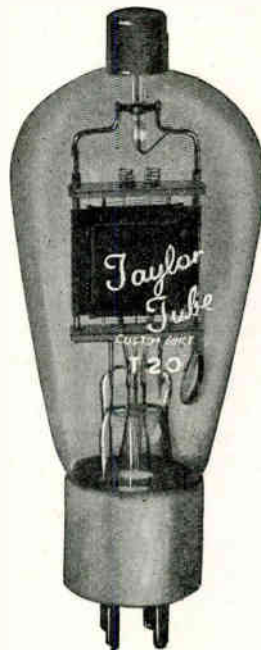

The New TZ-20 *

20 WATTS PLATE DISSIPATION
METAL PLATE
ZERO BIAS TUBE

\$2.45

A High-Mu Triode designed for Zero Bias Class B Audio operation and for efficient frequency multiplying performance. The regular T20 is recommended for all Class C Amplifier purposes.

GENERAL CHARACTERISTICS

TYPE T-20

Filament Voltage, volts.....	7.50
Filament Current, amps.....	1.75
Plate Resistance, ohms.....	8000
Mutual Conductance, uMhos.....	2500
Amplification Factor	20

PHYSICAL CHARACTERISTICS

Max. Length, inches.....	6 1/2
Max. Diameter, inches.....	2 1/2

UX Ceramic Base

INTERELECTRODE CAPACITIES

Plate to Grid, mmf.....	4
-------------------------	---

CLASS "C" AMPLIFIER

Max. Operating Plate Volts	
Unmodulated DC, volts.....	750
Modulated DC, volts.....	750
Max. DC Plate Current, mls.....	75
Max. DC Grid Current, mls.....	25
Max. Plate Dissipation, watts.....	20
Max. RF Grid Current, amps.....	2.5
RF Output, watts.....	42
Percentage of Efficiency.....	75%

NORMAL OPERATION

$E_p = 750$	$E_G = -100$	$E_f = 7.5$
-------------	--------------	-------------

TYPICAL OPERATING CONDITIONS

CLASS "B" A.F. MODULATOR

Push Pull Operation

DC Plate Voltage.....	800	600
Grid Voltage Approx.....	-40	-30
Load Resistance P-P.....	12,000	8100
AV DC Plate Current per tube.....	68	70
Static Plate Current.....	10	10
Power Output, Watts (2 tubes).....	70	50

GENERAL CHARACTERISTICS

TZ-20

The electrical characteristics of the TZ20 are the same as the regular T20 except as follows:

Plate resistance, ohms.....	26,700
Mutual conductance, uMhos.....	2,320
Amplification factor, mu.....	62

TYPICAL OPERATING CONDITIONS

CLASS "B" A.F. MODULATOR

Push Pull Operation

DC Plate Voltage.....	800	600
Grid Voltage Approx.....	-400	-300
Load Resistance P-P.....	12,000	8100
AV DC Plate Current per tube.....	68	70
Static Plate Current per tube.....	20	14
Power Output, Watts (2 tubes).....	70	50

The TZ20 is primarily designed for zero bias Class B audio operation and no bias is required for such operation at voltages up to 800. It is the ideal Class B audio tube for outputs up to 70 watts and 4 of them push pull parallel will form a most economical 140 watt modulator. For pushpull parallel operation the reflected load impedance will be half and the output twice that for two tubes. The Class B operating conditions for the T20 and TZ20 are identical but the TZ20 avoid the necessity for a source of grid bias with good voltage regulation. At 800 volts the no-signal plate current to a pair of TZ20's will be approximately 25 to 30MA. About 35 volts of bias is required with the T20 to limit the plate current to the same value. The audio quality should be the same with either type of tube.

If the TZ20 is used as an RF amplifier the information on the T20 above will apply except that somewhat less bias is necessary. For one TZ20 the bias resistor should be 4000 ohms. Half that value or 2000 ohms would be correct for two tubes push pull or parallel.

The TZ20 is a more efficient doubler than the T20 and is recommended for this purpose. As a doubler the bias resistor should be 6000 ohms or higher if sufficient excitation is available to permit normal grid current with higher values. Efficient doubler operation requires large amounts of grid drive.

Taylor



Tubes

OPERATING DATA ON THE T-20

The T-20 is the latest in the Taylor Series of easy to drive tubes. It thrives on a minimum amount of excitation and its ratings are conservative. At the rated input, no color whatever will show on the plate. While the rated plate dissipation is 20 watts, no color shows on the plate until the dissipation amounts to approximately 32 watts and it takes about 45 watts to cause a cherry red spot in the center of the plate. Any color whatever showing on the plate means that the rated plate dissipation is being exceeded. If the input is not so great that such dissipation may be expected, it is a definite indication that the circuit is less efficient than it should be. To obtain best efficiency with a minimum of harmonics, we recommend that certain values of capacities be used in the plate tank and of course the tank coils should be proportioned accordingly to hit resonance at the operating frequencies with that amount of tuning capacity across the circuit. These capacities should be the actual amount of tank condenser in the circuit across the entire plate tank. A higher value of C will result in lower tank impedance and lower efficiency. Lower values of C will result in slightly higher efficiency, but this will be offset by increased harmonic content as well as poor linearity if the stage is modulated for fone. These values will hold for both single ended and push-pull amplifiers.

1715 KC — 160 MMFD 14000 KC — 20 MMFD
 3500 KC — 80 MMFD 28000 KC — 10 MMFD
 7000 KC — 40 MMFD 56000 KC — 5 MMFD

Under these conditions with an input of 750 volts 75 MA per tube the efficiency should be approximately 75% and the output 42 watts per tube. For one tube, the recommended grid bias resistor would be 6000

ohms. Half that value or 3000 ohms would be correct for two tubes, parallel or push-pull. For CW or buffer operation, the DC grid current should be 12 MA or more and for phone operation should be 17 MA or more per tube. Under no conditions should the DC grid current per tube, exceed the rated value of 25 MA. Expressed in terms of power approximately 2.5 watts of drive are required for CW or buffer operation or 5 watts for fone operation. This of course, means that the tube may be driven to full output directly from the crystal oscillator stage. The tube has several advantages over others in its size class. The interelectrode capacities are lower, making possible satisfactory operation on frequencies as high as 56 MC. The amplification factor is higher, making less grid drive necessary and simplifying the bias requirements. Bringing the plate lead out of the top of the bulb greatly reduces the possibilities of voltage breakdowns. In addition to its RF capabilities it is an excellent Class B Modulator tube.

CAUTION: These tubes have metal plates and do not have the carbon anode which is characteristic of all other TAYLOR Transmitting Tubes. This does not mean that they will be any less efficient but it does mean that they will not stand as much abuse. The plate voltage should be reduced while making adjustments to prevent excessive heating. Properly handled, the efficiency of these tubes will be as great as though they had carbon anodes and their life will be equally as long.

It is well to remember that it requires 4 to 6 times the power to show color on a black anode than it does on a molybdenum or tantalum anode of the same size.

CLASS B AUDIO DATA - - - TZ-20 - - - T-20

The chart at right gives proper Class B Audio operating conditions for various outputs at different plate voltages. The most important value is the reflected load impedance which is given for the entire primary or plate to plate. The current value is the maximum average value as would be indicated on the plate current meter with sine wave input. For the same peak output with voice input the maximum average plate current will be approximately 50% to 60% of this value. The correct bias for the T-20 will limit the no-signal plate current to between 10 and 15 MA per tube.

D.C. Plate Voltage ↓	30	40	50	60	70	←Audio Watts Output
800	59MA 28,000	78MA 21,000	98MA 17,000	117MA 14,000	137MA 12,000	←Max. Av. Ip ←Load Impedance plate to plate
700	69MA 20,000	92MA 15,000	115MA 12,000	140MA 10,000		←Max. Av. Ip ←Load Impedance plate to plate
600	85MA 13,500	113MA 10,200	140MA 8,100			←Max. Av. Ip ←Load Impedance plate to plate
500	109MA 8,200	145MA 6,100				←Max. Av. Ip ←Load Impedance plate to plate

Taylor



Tubes

T-55

55 WATTS PLATE DISSIPATION

Carbon Anode

The TAYLOR T-55 is a tube of medium power capable of efficient power output at frequencies as high as 120 megacycles yet it operates at reasonable values of plate voltage and plate current. Its medium low inter-electrode capacities and efficient flat form of construction result in low losses across the elements avoiding the necessity for high voltages for good efficiency and reducing the grid drive requirements. The T-55 will give more power output for a given amount of grid drive than any other high frequency tube of the same comparative class. The unique design of this tube permits use of ceramic internal insulators. The misalignment of elements (which so often develop in tubes with self-supporting elements) is impossible in the T-55.

GENERAL CHARACTERISTICS

Filament Voltage, volts.....	7.5
Filament Current, amps.....	2.75
Plate Resistance, ohms.....	9000
Mutual Conductance, uMhos.....	2200
Amplification Factor (Mu).....	20

OVERALL DIMENSIONS

Maximum Length, inches.....	7
Maximum Diameter, inches.....	2 5/8

INTERELECTRODE CAPACITIES

Plate to Grid, mmf.....	3.75
Grid to Filament, mmf.....	4.0
Plate to Filament, mmf.....	1.5

CLASS "C" OSC AND POWER AMP

Max. Operating Plate Volts	Class C	OSC.
Unmodulated DC, volts.....	1500	1250
Modulated DC, volts.....	1500	1000
Max. DC Plate Current, mils.....	150	125
Max. DC Grid Current, mils.....	40	40
Max. Plate Dissipation, watts.....	55	55
Max. RF Grid Current, amps.....	5	5
RF Output, watts.....	168	66
Percentage of Efficiency.....	75%	40%

NORMAL OPERATION—Class C

$E_p = 1500$ v.	$E_g = -200$ v.	$E_f = 7.5$
$I_p = 150$ MA	$I_g = 25$ MA	

The improved T-55 may be used interchangeably with previous T-55's in all applications.

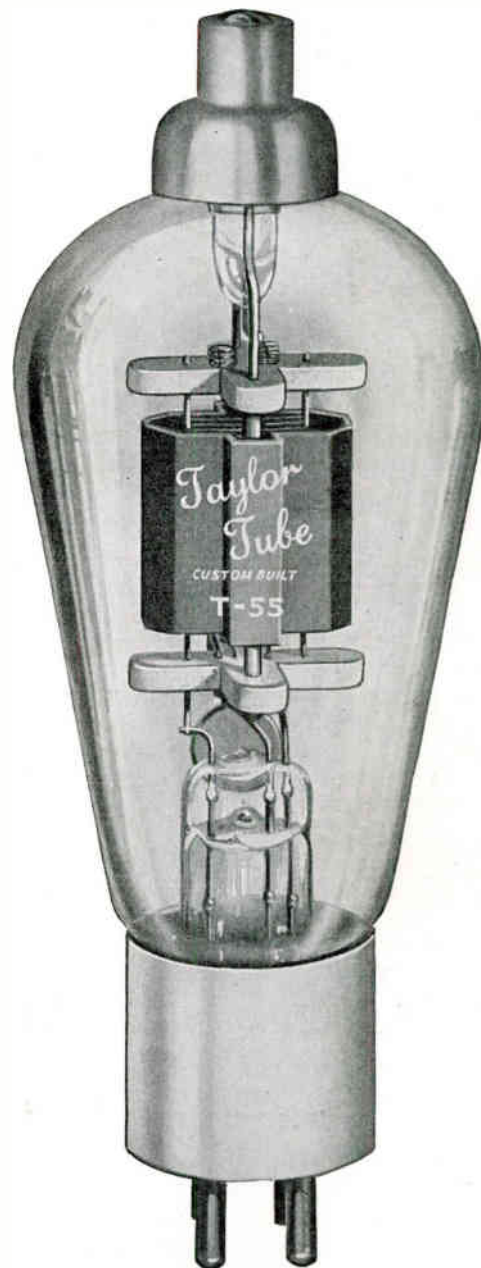

T-55

AMATEUR'S FAVORITE TUBE!
OVER 7000 IN USE!

Improved

~~\$8.00~~

Now the T-55 has been further improved. No basic changes have been made but small improvements have resulted in superior characteristics, which even more than in the past, will make the T-55 stand head and shoulders above others in its price range. Throughout the world, many commercial companies, as well as amateurs, acclaim the T-55 as "the champion" of all transmitting tubes.

Taylor



Tubes

OPERATING DATA ON THE T-55

The T-55 is the fastest selling transmitting tube of reasonable size because it is designed to permit efficient operation at the highest frequencies used by Amateurs—because the rating of 55 watts plate dissipation is conservative—and because the tube will operate at normal efficiency with a minimum of grid drive. Its low price, of course, fulfills the TAYLOR slogan, "More Watts Per Dollar."

At the rated input and normal efficiency, no color will show on the plate. While the rated plate dissipation is 55 watts, no color shows until the dissipation amounts to 75 watts and then it is noticeable only if the filament is turned off. Color becomes noticeable with the filament on at about 85 watts. If the type of operation or input are not such as to result in excessive dissipation, color showing on the plate may be taken as a definite indication that the circuit is less efficient than it should be. To obtain best efficiency with a minimum of harmonic content, we recommend that certain values of capacity be used in the plate tank and, of course, the tank coils should be proportioned accordingly to hit resonance at the operating frequency with the proper amount of capacity in the circuit. These capacities should be the actual amount of tank condenser in the circuit across the entire plate tank. A higher value of C will result in lower tank impedance and lower efficiency. A lower value of C will result in slightly higher efficiency, but this will be offset by increased harmonic content as well as poor linearity when the stage is modulated. These values will hold for both plate neutralized single ended and push pull amplifiers operated at the rating of 1500 volts 150 MA per tube. (Single ended 1500 volts 150 MA—push pull 1500 volts 300 MA.) For operation at other values of voltage or current, the optimum value will be different but may be calculated easily because it will vary inversely as frequency and applied voltage and directly as the plate current.

1715 KC—160 Mmfd 14000 KC—20 Mmfd
 3500 KC—80 Mmfd 28000 KC—10 Mmfd
 7000 KC—40 Mmfd 56000 KC—5 Mmfd

Under these conditions with an input of 1500 volts 150 MA per tube, the efficiency should be approximately 75% and the output approximately 170 watts per tube. For one tube the recommended grid bias resistor would be 8000 ohms. Half that value or 4000 ohms would be correct for two tubes parallel or push pull. For CW or buffer operation the rectified grid current should be 17 MA or more and for phone operation should be 25 MA or more per tube. Under no conditions should the rectified grid current exceed the rated value of 40 MA. Expressed in terms of power approximately 7.5 watts of drive are required for efficient CW or buffer operation or 15 watts for phone operation. Large outputs may be obtained with lesser amounts of grid drive but the plate efficiency may be expected to be less with reduced excitation and the power gain will increase.

IMPORTANT:

Good efficiency at the higher frequencies with a minimum of operating difficulties necessitates the use of tubes with low interelectrode capacities. The T-55 features as low inter-electrode capacities as are consistent with good plate efficiency at reasonable voltages and at reasonable values of grid drive. Low capacities in a tube are achieved partly by isolating the leads from each other as by bringing the plate lead out of the top but principally by making the elements smaller and spacing them farther apart. Because the T-55 grid is comparatively small and placed at some distance from its heat radiator, the plate, the grid must operate at and is designed for higher temperatures than in more conventional tubes. Under normal operating conditions the grid will operate at a dull red. Dangerous grid temperatures are not reached until the grid supports appear to show red above the upper lava supports with the filament lit and in normal light. Such dangerous temperatures will not be reached unless the rectified grid current exceeds the maximum rated value or parasitic oscillations are present. If grid and/or plate leads show color (indicating extremely high circulating R. F. current) or if the grid supports are hotter than the grid wires, it is safe to assume parasitics are present although parasitics may be present with no visible indication in the tube.

CLASS B AUDIO DATA

The chart at right gives proper Class B Audio operating conditions for various outputs at different plate voltages. The most important value is the reflected load impedance which is given for the entire primary or plate to plate. The current value is the maximum average value as would be indicated on the plate current meter with sine wave input. For the same peak output with voice input the maximum average plate current will be approximately 50% to 60% of this value. The correct bias will limit the no signal plate current to 20 MA per tube and will be approximately the plate voltage divided by the Mu.

We do not recommend the T-55 or any of our low C tubes for Class B audio. The operating data is furnished for those who might prefer to use them for Class B audio because of their interchangeability with the RF tubes. This is no reflection on the T-55 but no low C tube is as good a modulator as higher C tubes such as the T-20, 756, 203-B, 203-A or 822 because these tubes will provide higher efficiency at a given plate voltage with less grid drive.

Supply Voltage	100	150	200	250	←Audio Watts Output
1500	100MA 32,000	150MA 21,800	200MA 16,000	248MA 13,000	←Max Av. Ip ←Load Impedance plate to plate
1250	124MA 21,000	185MA 14,000	248MA 10,000		←Max Av. Ip ←Load Impedance plate to plate
1000	164MA 12,000	245MA 8,000			←Max Av. Ip ←Load Impedance plate to plate
800	220MA 6,600				←Max Av. Ip ←Load Impedance plate to plate

Taylor



Tubes

T-125

**125 WATTS PLATE DISSIPATION
CARBON-TANTALUM ANODE**

The T125 is the tube amateurs have demanded to fill the gap between the T55 and T200. It's a man-sized tube at low cost and it features a new **TAYLOR invention (patent applied for)** making possible high efficiency at low plate voltages and with low interelectrode capacities. Rated conservatively, one tube will handle a full 400 watts input at the maximum ratings of 2000 volts, 200MA. The interelectrode capacities are low, making possible efficient operation on even the highest amateur frequencies—but the use of **tantalum fins** increases the inherent efficiency of the tube, making it far more efficient than others with comparative interelectrode capacities. Tantalum is used because it will operate satisfactorily at high temperatures but other materials such as carbon might have been used for the fins. These fins projecting inward toward the grid and filament effectively produce the very desirable characteristics of higher C tubes without greatly increasing the capacities. Thus this tube is truly unique in that it possesses the **advantages of a low C tube together with the advantages of a higher C tube**—without the disadvantages of either. In addition, combining a carbon anode and tantalum fins makes it possible to realize the full advantages of both types of plate materials without the disadvantages of either. It is truly a remarkable tube and is a revolutionary step forward in tube design.

GENERAL CHARACTERISTICS

Filament Voltage, volts.....	10
Filament Current, amps.....	3.85
Plate Resistance, ohms.....	5700
Mutual Conductance, uMhos.....	4400
Amplification Factor (Mu).....	25
Thorated Tungsten Filament	

OVERALL DIMENSIONS

Maximum Length, inches.....	8¼
Maximum Diameter, inches.....	3

INTERELECTRODE CAPACITIES

Plate to Grid, mmf.....	4.5
-------------------------	-----

CLASS "C" AMPLIFIER

Max. Operating Plate Volts	
Unmodulated DC, volts.....	2000
Modulated DC, volts.....	2000
Max. DC Plate Current, mils.....	200
Max. DC Grid Current, mils.....	60
Max. RF Grid Current, amps.....	10
RF Output, watts.....	300
Percentage of Efficiency.....	75%

NORMAL OPERATION—Class C

$E_p = 2000v.$	$E_g = -200v.$	$E_f = 10$
$I_p = 200MA$	$I_g = 50MA$	

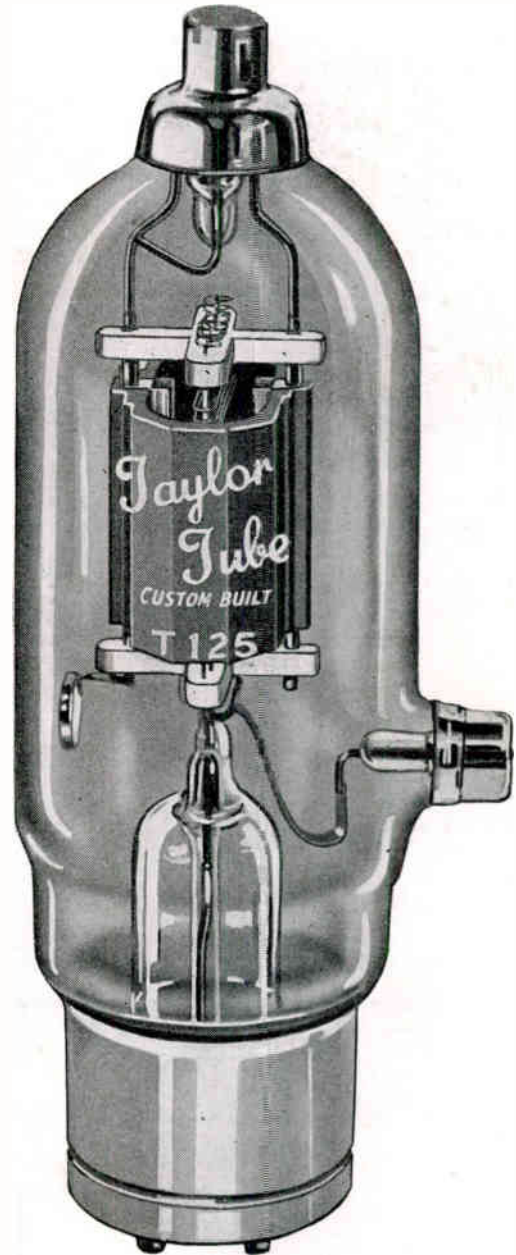

T-125

CARBON-TANTALUM ANODE

\$13.50

Taylor



Tubes

OPERATING DATA — T125

At the rated plate dissipation of 125 watts the carbon plate shows no color but the tantalum fins operate at a bright orange color. If the type of operation or input are not such as to result in excessive dissipation, color showing on the plate may be taken as a definite indication that the circuit is less efficient than it should be. To obtain best efficiency with a minimum of harmonic content, we recommend that certain values of capacity be used in the plate tank and, of course, the tank coils should be proportioned accordingly to hit resonance at the operating frequency with the proper amount of capacity in the circuit. These capacities should be the actual amount of tank condenser in the circuit across the entire plate tank. A higher value of C will result in lower tank impedance and slightly lower efficiency but the harmonic content will also be less and the linearity better if the stage is modulated. A lower value of C will result in slightly better plate efficiency but the fundamental output will not increase appreciably. The harmonic content will be higher and the linearity will be poor if the stage is modulated. These values will hold for both plate neutralized single ended and push-pull amplifiers operated at the rating of 2000 volts 200MA per tube. (Single ended 2000 volts 200MA — push-pull 2000 volts 400MA.) For operation at other values of voltage or current the optimum value will be different but may be calculated easily because it will vary inversely as frequency and applied voltage and directly as the plate current.

1900KC—137 Mmfd.	14,200KC—18 Mmfd.
3750KC— 70 Mmfd.	28,500KC— 9 Mmfd.
7150KC— 36 Mmfd.	58,000KC— 5 Mmfd.

Under these conditions with an input of 2000 volts 200MA per tube, the efficiency should be approxi-

mately 75% and the output about 300 watts per tube. For one tube the recommended grid bias resistor would be 4000 ohms. Half that value, or 2000 ohms, would be correct for 2 tubes parallel or push-pull. For CW or buffer operation, the rectified grid current should be 30MA or more and for plate modulated phone operation should be 50MA or more per tube. Under no conditions should the rectified grid current exceed the rated value of 60MA. Expressed in terms of power approximately 10 watts of grid drive are necessary for efficient CW or buffer operation or 20 watts for phone operation. Large outputs may be obtained with lesser amounts of grid drive but the plate efficiency may be expected to be less with lesser amounts of grid excitation though the power gain will increase.

For some time there has been a need for a high frequency tube to replace tubes of the 203A type with the absolute minimum of changes in the transmitter. The T125 fills the need in a most satisfactory manner. Because of the exclusive TAYLOR carbon-tantalum construction, efficiencies on the order of those obtained with 03A's are possible at the same plate voltages and with the same low grid drive requirements. In addition the plate dissipation is greater than that of an 03A and the plate current rating greater making it possible to increase the power at the same Plate voltage as well as gaining the advantages of low C tube operation at the higher frequencies. In order to replace an 03A type of tube with the T125 it will be necessary only to change the grid and plate connections and to re-neutralize. If the minimum capacity of the neutralizing condenser is too high, plates may be removed. No circuit or bias changes are necessary because the Mu of the T125 is the same as that of an 03A.

T-155

155 WATTS PLATE DISSIPATION
CARBON ANODE

\$19.50

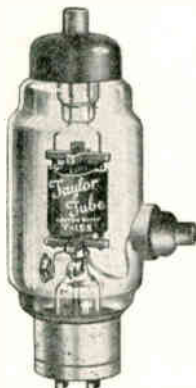

The Taylor T155 is a high voltage low current tube of the same general character as our T55 excepting its size and power rating which is three times that of the T55. The T155 is recommended for use as a Class C Amplifier on High Frequencies. The unique design of this tube permits the use of high resistance internal insulators which prevent the misalignment of elements (which so often develops in tubes with self-supporting elements).

GENERAL CHARACTERISTICS TYPE T-155

Filament Voltage, volts.....	10
Filament Current, amps.....	4
Plate Resistance, ohms.....	5700
Mutual Conductance, uMhos.....	3500
Amplification Factor.....	20
Thoriated Tungsten Filament.	

OVERALL DIMENSIONS

Length	9"
Width	4 1/8"

INTERELECTRODE CAPACITIES

Plate to Grid, mmf.....	3
-------------------------	---

CLASS "C" OSC AND POWER AMP

Max. Operating Plate Volts.....	*3000
Max. DC Plate Current, mls.....	* 200
Max. DC Grid Current, mls.....	60
Power Output, watts.....	450
*These maximum ratings to be applied where efficiency of Class "C" amplifier is 75% or better.	

NORMAL OPERATION

Ep = 2500	Eg = — 250	Ef = 10
-----------	------------	---------

Taylor



Tubes

T-200

The T-200 has often been called "The Amateur's Power House Tube." At the maximum plate modulated rating a single tube will handle 700 watts of input, 2000 volts at 350 MA. For CW operation the plate voltage may be increased to 2500 volts for an input of 875 watts to a single tube. A pair of these tubes push-pull will loaf along at far below the ratings with 1 kw input on any frequency from 30 to 1.7MC. This tube in common with all Taylor tubes uses the most efficient flat form of construction and the inter-electrode capacities represent the best possible combination of inter-electrode capacities and other characteristics for best efficiency at moderate plate voltages with minimum grid drive requirements. The inter-electrode capacities are low enough for ease of neutralization even at the highest amateur frequencies yet are not so low that the characteristics of the tube are adversely affected.

For best efficiency with minimum harmonic content, certain L/C ratios which are a function of the type of operation, frequency, plate voltage and plate current are recommended. These optimum ratios may be found for any amateur band and any reasonable values of input in the L/C ratio chart on page —.

Under proper operating conditions with an input of 2000 volts 350MA the efficiency should be approximately 75% and the output approximately 525 watts per tube. For one tube the recommended grid bias resistor would be 5000 ohms. Half that value or 2500 ohms would be correct for 2 tubes parallel or push-pull. For CW or buffer operation the rectified grid current should be 35MA or more and for phone operation should be 60MA or more per tube. Under no conditions should the rectified grid current exceed the maximum rated value of 80MA per tube. Expressed in terms of power, approximately 20 Watts of grid drive are required for efficient CW or buffer operation or 35 watts for phone operation. Large outputs may be obtained with lesser amounts of grid drive but the plate efficiency may be expected to be less with reduced excitation though the power gain will increase.

The T200 is widely used in Diathermy equipment. This type of service is particularly hard on Tubes and the general acceptance of the T200 by many leading manufacturers of Diathermy equipment is convincing proof of the T200's rugged construction and conservative rating. Do not confuse the T200 with smaller tubes bearing the same type number. Compare the size of its Super Carbon Anode with tubes of similar ratings.

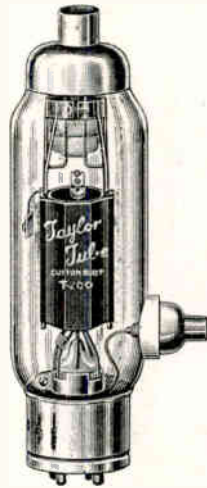

T-200

200 WATTS PLATE DISSIPATION

\$21.50

AMATEUR'S POWER HOUSE TUBE

SUPER CARBON ANODE

LENGTH 2½ in.

WIDTH 1⅝ in.

GENERAL CHARACTERISTICS

Type T-200

Filament Voltage	10-11
Filament Current, amps.....	4
Plate Resistance, ohms.....	3400
Mutual Conductance, uMhos.....	4800
Amplification Factor	16.6

OVERALL DIMENSIONS

Maximum Length, inches	9½
Maximum Width, Including Grid Cap, inches.....	3¾

INTERELECTRODE CAPACITIES

Plate to Grid, mmf.....	7
Grid to Filament, mmf.....	5
Plate to Filament, mmf.....	3

CLASS "C" OSC. AND POWER AMP.

Max. Operating Plate Volts	
Unmodulated D.C., volts.....	2500
Modulated, volts	2000
Max. D.C. Plate Current, mls.....	350
Max. D.C. Grid Current, mls.....	80
Max. Plate Dissipation, watts.....	200
Max. R.F. Grid Current, amps.....	15
R.F. Output, watts.....	500

NORMAL OPERATION

$E_p = 2500$	$E_g = -300$	$E_f = 10-11$
--------------	--------------	---------------

T-200 POPULARITY

SOME OF THE BEST HAM PHONE STATIONS USE TAYLOR T200'S. W9EDW, W9UAQ, W9KYM, W9VXZ, W9JDO, W8JOE, W8BWH, W9IPS, W9ORA, W7CEO, W9NLP, W8CKC, W3EOZ, W3DQ, W9PZ, W8UD, W9LIP, W9ECA AND MANY OTHERS ARE T-200 USERS.

Taylor



Tubes

822

200 WATTS PLATE DISSIPATION

CARBON ANODE

\$18.50

500 WATTS

AUDIO OUTPUT

in

PUSH-PULL CLASS "B" AUDIO

GENERAL CHARACTERISTICS

Type 822

Filament Voltage, volts.....	10
Filament Current, amps.....	4
Plate Resistance, ohms.....	5200
Mutual Conductance, uMhos.....	5400
Amplification Factor	27
Thoriated Tungsten Filament	

OVERALL DIMENSIONS

Maximum Length, inches	9½
Maximum Diameter, inches.....	2½

INTERELECTRODE CAPACITIES

Plate to Grid, mmf.....	14
Grid to Filament, mmf.....	8
Plate to Filament, mmf.....	6

CLASS "C" AMPLIFIER

Max. Operating Plate Volts	
Unmodulated D.C., volts.....	2500
Modulated D.C., volts.....	2000
Max. D.C. Plate Current, mls.....	300
Max. D.C. Grid Current, mls.....	60
Max. Plate Dissipation, watts.....	200
Max. R.F. Grid Current, amps.....	7.5
R.F. Output, watts.....	400

NORMAL OPERATION

$E_p = 2000$ $E_g = -220$ $E_f = 10$

CLASS "B" AS MODULATOR

Push Pull Operation

Filament, volts	10
D.C. Plate Voltage, volts.....	2000
Grid Voltage, appr. volts.....	-90
Load Resistance (plt. to plt.), ohms.....	9000
Av. D.C. Plate Current (2 tubes), mls.....	450
Static Plate Current (per tube), mls.....	25
Power Output, (2 tubes), watts.....	500



The 822 is an unusually efficient tube. Its high efficiency is combined with extreme ruggedness and an ability to stand up under tremendous abuse. Its large carbon plate is rated at 200 watts dissipation. We recommend it highly for class B audio use in large amateur and broadcast transmitters and for RF work on all but the highest amateur frequencies. This tube is the most popular in our line for both RF and audio use in broadcast transmitters. It's a large tube at a small tube price and it is almost immune from voltage breakdowns because the plate lead is brought out the top.

For RF operation the 822 is at its best on frequencies below 8MC. On higher frequencies the interelectrode capacities are great enough to place the tube at some disadvantage compared with the T200 although the overall efficiency of a stage using 822's would be about the same as one using T200's at 14MC. The 822 will operate satisfactorily at frequencies as high as 30MC but at this frequency the T200 will prove superior and is recommended.

All ratings on the 822 are exceedingly conservative. The maximum rated plate current is 300MA and maximum modulated plate voltage 2000 allowing an input of 600 watts per tube. For unmodulated operation the maximum plate voltage rating is 2500 volts permitting input of 750 watts.

Under the above conditions the recommended grid bias resistor would be 4000 ohms. Half that value, or 2000 ohms, would be correct for 2 tubes push-pull or parallel. For CW or buffer operation the rectified grid current should be 40MA or more and for phone operation should be 55MA or more per tube. Under no conditions should the rectified grid current exceed the maximum rated value of 80MA. Expressed in terms of power approximately 20 watts of grid drive are required for CW or buffer operation or 30 watts for phone operation.

The 822 is the finest tube of its size for Class B audio. The maximum output shown on the chart is 500 watts because amateurs cannot use more audio power. At that output under the conditions indicated with sine wave input the average plate dissipation will be only 150 watts. The ratio of minimum plate voltage to maximum grid voltage is high making the tube extremely easy to drive. A pair of 2A3's or 6A3's are recommended as drivers and will furnish more than enough grid driving power with good voltage regulation.

822 CLASS B AUDIO DATA

Supply Voltage ↓	300	400	500	←Audio Watts Output
2,000	.240 17,000	.320 12,500	.400 10,000	←Max. Av. Ip ←Load Impedance plate to plate
1,750	.275 13,000	.365 10,000	.455 7,800	←Max. Av. Ip ←Load Impedance plate to plate
1,500	.315 9,600	.405 7,600		←Max. Av. Ip ←Load Impedance plate to plate

The chart above gives proper Class B Audio operating conditions for various outputs at different plate voltages. The most important value is the reflected load impedance which is given for the entire primary or plate to plate. The current value is the maximum average value as would be indicated on the plate current meter with sine wave input. For the same peak output with voice input the maximum average plate current will be approximately 50% to 60% of this value. The correct bias will limit the no signal plate current to 25MA per tube.

SUPER CARBON ANODE

Length	2½ inches
Width	1½ inches

CARBON ANODES

PRODUCE

More Watts Per Dollar

Taylor



Tubes

203-Z

ZERO BIAS TUBE

The 203Z is an improved high mu zero bias version of the 203A and 203B. It has all the desirable characteristics of these tubes with two additional features of great merit; the amplification factor of the tube is high enough for zero bias class B operation at voltages up to 1250 and the plate lead is brought out the top greatly minimizing the chances of voltage breakdowns.

The 203Z is specifically designed for class B audio. Its characteristics and its low price will make it the most popular tube for this purpose. In practical application of class B audio the average plate dissipation is low compared with the peak output and advantage of this fact has been taken to produce a tube of large capabilities at a low price. The conservative plate dissipation ratings of the tube is 65 watts. As this dissipation the tube shows no color whatever and under normal operating conditions the average plate dissipation will be less than this value under the maximum rated conditions so no color should show on the plate. If the tubes do show color it is an indication that the circuit is less efficient than it should be unless the input or type of operation are such as to result in excessive plate dissipation.

The no-signal or static plate current is about 35MA per tube at 1000 volts and about 45MA per tube at 1250 volts. Because the 203Z is a zero bias tube the grid starts to draw current as soon as excitation is applied the input transformer design requirements are less involved and excellent frequency response with minimum distortion is easily realized. The maximum average grid driving power is approximately 7 watts. Low impedance triodes such as 2A3's or 6A3's should be used in the driver stage.

The 203Z is also suited for RF operation on frequencies below 15MC. At the maximum ratings of 1250 volts 175MA the input would be 219 watts, the output approximately 165 watts per tube, and the plate dissipation 55 watts per tube. For one tube the recommended bias resistor would be 2500 ohms. Half that value or 1250 ohms, would be correct for 2 tubes parallel or push-pull. For CW or buffer operation the rectified grid current should be 30MA or more and for phone operation should be 50MA or more. Under no conditions should the rectified grid current exceed the maximum rated value of 60MA. Expressed in terms of power, approximately 8 watts of grid drive are required for efficient CW or buffer operation or 15 watts for phone operation.

Regular Class B input and output transformers as manufactured for type 203A tubes by Thordarson, Utah, Jefferson, General, Stancor, United, Kenyon, Inca, etc., may be used with the 203Z tubes.

203Z CLASS B AUDIO DATA

Supply Voltage ↓	150	200	260	300	←Audio Watts Output
1250	.175 15,800	.233 11,800	.306 9,000	.350 7,900	←Max. Av. Ip ←Load Impedance plate to plate
1100	.204 11,600	.272 8,750	.352 6,700		←Max. Av. Ip ←Load Impedance plate to plate
1000	.228 9,300	.306 6,900			Max. Av. Ip ←Load Impedance plate to plate
900	.259 7,200	.345 5,400			←Max. Av. Ip ←Load Impedance plate to plate

The chart above gives proper Class B Audio operating conditions for various outputs at different plate voltages. The most important value is the reflected load impedance which is given for the entire primary or plate to plate. The current value is the maximum average value as would be indicated on the plate current meter with sine wave input. For the same peak output with voice input the maximum average plate current will be approximately 50% to 60% of this value.



203-Z

65 WATTS PLATE DISSIPATION

METAL PLATE

\$8.50

ZERO BIAS

GENERAL CHARACTERISTICS

Type 203Z

Filament Voltage, volts.....	10
Filament Current, amps.....	3.85
Plate Resistance, ohms.....	16,700
Mutual Conductance, uMhos.....	5,900
Amplification Factor.....	85
Thoriated Tungsten Filament	

GENERAL DIMENSIONS

Maximum Length, inches.....	8¼
Maximum Diameter, inches.....	2½

CLASS "B" AS MODULATOR

Push Pull Operation

D.C. Plate Voltage, volts max.....	1250
Grid Voltage.....	0
Load Resistance (plt. to plt.), ohms.....	7900
Av. D.C. Plate current (2 tubes), mills.....	350
Static Plate Current (per tube), mills.....	45
Power Output (2 tubes), watts.....	300

CAUTION: These tubes have metal plates and do not have the carbon anode which is characteristic of all other TAYLOR Transmitting Tubes. This does not mean that they will be any less efficient but it does mean that they will not stand as much abuse. The plate voltage should be reduced while making adjustments to prevent excessive heating. Properly handled, the efficiency of these tubes will be as great as though they had carbon anodes and their life will be equally as long.

203B—\$7.50

The 203B was brought out to make available a tube of 203A characteristics and capabilities at a lower price. For class C, RF and Class B audio operation the 100 watt plate dissipation of the 03A is rather high in proportion to the other capabilities of the tube. In other words, at the maximum ratings of the 03A the plate dissipation will probably be far below 100 watts. This made it possible to develop the 203B with a less expensive plate capable of dissipating 65 watts with all other characteristics identical with the 203A. The 203B may be used in place of the 203A in all applications where the plate dissipation will not exceed 65 watts. This should include all Class B audio and class C RF applications.

Taylor



Tubes

814

200 WATTS PLATE DISSIPATION
CARBON ANODE

\$18.50

ESPECIALLY RECOMMENDED
for
GRID MODULATED
or
CLASS B LINEAR
PHONE TRANSMITTERS



The 814 is identical with the 822 except for the Mu or amplification factor and is intended for those applications where a tube of lower mu is desired. The mu of 12 is about optimum for grid modulated and class B linear R.F. operation. We recommend the 814 for efficiency modulated amplifiers. In addition, some manufacturers of diathermy equipment prefer a low mu tube. Both the 814 and 822 are widely used in diathermy equipment on frequencies as high as 27MC. Their rugged construction and conservative ratings provide the ample safety factor necessary in high frequency self excited oscillators. High frequency diathermy is harder on tubes than any other form of operation and these tubes are built to stand it.

A class B linear or grid modulated amplifier should be biased to approximately cut off. For an 814 operating at 200 volts the correct bias voltage would be approximately $\frac{2000}{12}$ or 165 volts. This bias must be furnished from a source with good regulation such as batteries or a good rectified AC bias eliminator. The coupling to the antenna must be very tight. The excitation should be adjusted until grid current just begins to flow on excitation peaks. While very little RF grid drive is required for an efficiency modulated stage the ratio of driver output to excitation required must be large to provide good driver regulation. This excess excitation should be dissipated in a resistive load such as resistors or lamps. The circuit diagram for an efficiency modulated amplifier is the same as that for a class C amplifier.

Because the plate efficiency of efficiency modulated amplifiers is low, usually about 33%, the input to and output from, such a stage will necessarily be much less than with the same tube operating class C. Assuming an efficiency of 33% the maximum permissible input to an 814 would be 300 watts, 200 of which would be dissipated on the plate and 100 watts delivered to the output circuit. This low plate efficiency is at least partially offset by the inexpensive modulation equipment necessary. The usual class B driver stage may be used to plate modulate the preceding stage for class B linear operation or to grid modulate the final.

An interesting article containing more complete information on grid modulation and describing a Transmitter using an 814 will be found on pages 154-155 in the January 1937 Radio.

For class C operation the optimum value of bias resistor for one 814 would be 8,000 ohms. Half that value, or 4000 ohms, would be correct for 2 tubes parallel or push-pull. For CW or buffer operation the rectified grid current should be 30MA or more and for phone operation should be 55MA per tube. Under no conditions should the rectified grid current exceed the maximum rating of 80MA per tube. Expressed in terms of power approximately 25 watts of grid drive are required for efficient CW operation or 35 watts for phone operation.

GENERAL CHARACTERISTICS

Type 814

Filament Voltage, volts.....	10
Filament Current, amps.....	4
Plate Resistance, ohms.....	2400
Mutual Conductance, uMhos.....	5000
Amplification Factor.....	12

OVERALL DIMENSIONS

Maximum Length, inches.....	9½
Maximum Diameter, inches.....	2¼

INTERELECTRODE CAPACITIES

Plate to Grid, mmf.....	13
Grid to Filament, mmf.....	7
Plate to Filament, mmf.....	5.5

CLASS "C" OSC. AND POWER AMP.

Max. Operating Plate Volts	
Unmodulated, D.C., volts.....	2500
Modulated, D.C., volts.....	2000
Max. D.C. Plate Current, mls.....	300
Max. D.C. Grid Current, mls.....	75
Max. Plate Dissipation, watts.....	200
Max. R.F. Grid Current, amps.....	8
Max. R.F. Output, watts.....	400

NORMAL OPERATION

$E_p = 2000$	$E_g = -400$	$E_f = 10$
--------------	--------------	------------

TAYLOR TUBES
ARE RECOMMENDED AND SOLD
by
ALL LEADING
RADIO PARTS DISTRIBUTORS

There is a Taylor Tube Distributor in every important distribution center throughout the world

203-A

100 WATTS PLATE DISSIPATION
CARBON ANODE

\$12.50

GENERAL CHARACTERISTICS
TYPE 203-A

Filament Voltage, volts.....	10
Filament Current, amps.....	3.85
Plate Resistance, ohms.....	6000
Mutual Conductance, uMhos.....	4200
Amplification Factor.....	25
Thoriated Tungsten Filament	

OVERALL DIMENSIONS

Maximum Length, inches.....	7½
Maximum Diameter, inches.....	2⅝

INTERELECTRODE CAPACITIES

Plate to Grid, mmf.....	14
Grid to Filament, mmf.....	8
Plate to Filament, mmf.....	7

CLASS "C" OSC. AND POWER AMP.

Max. Operating Plate Volts	
Unmodulated D.C., volts.....	1500
Modulated D.C., volts.....	1250
Max. D.C. Plate Current, amps.....	.175
Max. D.C. Grid Current, amps.....	.060
Max. Plate Dissipation, watts.....	100
Max. R.F. Grid Current, amps.....	7.5
Max. R.F. Output, watts.....	160

211-C

100 WATTS PLATE DISSIPATION
CARBON ANODE
LOW INTERELECTRODE CAPACITIES

\$12.50

GENERAL CHARACTERISTICS
Type 211-C

Filament Voltage, volts.....	10
Filament Current, amps.....	3.85
Plate Resistance, ohms.....	2800
Mutual Conductance, uMhos.....	4500
Amplification Factor.....	12.5
Thoriated Tungsten Filament	

OVERALL DIMENSIONS

Maximum Length, inches.....	7½
Maximum Diameter, inches.....	2⅝

INTERELECTRODE CAPACITIES

Plate to Grid, mmf.....	9
Grid to Filament, mmf.....	6
Plate to Filament, mmf.....	6.5

CLASS "C" OSC. AND POWER AMP.

Max. Operating Plate Volts	
Unmodulated D.C., volts.....	1500
Modulated D.C., volts.....	1250
Max. D.C. Plate Current, amps.....	.175 .175
Max. D.C. Grid Current, amps.....	.060 .060
Max. Plate Dissipation, watts.....	100 100
Max. R.F. Grid Current, amps.....	7.5 7.5
Max. R.F. Output, watts.....	100 130



211

100 WATTS PLATE DISSIPATION
CARBON ANODE

\$12.50

GENERAL CHARACTERISTICS
TYPE 211

Filament Voltage, volts.....	10
Filament Current, amps.....	3.85
Plate Resistance, ohms.....	3400
Mutual Conductance, uMhos.....	3530
Amplification Factor.....	12
Thoriated Tungsten Filament	

OVERALL DIMENSIONS

Maximum Length, inches.....	7½
Maximum Diameter, inches.....	2⅝

INTERELECTRODE CAPACITIES

Plate to Grid, mmf.....	14
Grid to Filament, mmf.....	7
Plate to Filament, mmf.....	6

CLASS "C" OSC. AND POWER AMP.

Max. Operating Plate Volts	
Unmodulated D.C., volts.....	1500
Modulated D.C., volts.....	1250
Max. D.C. Plate Current, amps.....	.175
Max. DC Grid Current, amps.....	.050
Max. Plate Dissipation, watts.....	100
Max. R.F. Grid Current, amps.....	7
Max. R.F. Output, watts.....	100

845

75 WATTS PLATE DISSIPATION
CARBON ANODE

\$12.50

CLASS "A" AUDIO TUBE

GENERAL CHARACTERISTICS
TYPE 845

Filament Voltage.....	10
Filament Current.....	3.85
Plate Resistance, ohms.....	2100
Mutual Conductance, uMhos.....	3000
Amplification Factor.....	5
Thoriated Tungsten Filament	

OVERALL DIMENSIONS

Maximum Length.....	7½
Maximum Diameter.....	2⅝

INTERELECTRODE CAPACITIES

Plate to Grid, mmf.....	14
Grid to Filament, mmf.....	6.5
Plate to Filament.....	6

CLASS "A" AF AMP. AND MODULATOR

Max. Operating Plate Volts, volts.....	1000	1250
Max. DC Plate Current, mls.....	75	65
Peak Grid Swing, volts.....	150	205
Max. Plate Dissipation, watts.....	75	75
Max. Audio Output, watts.....	22	28

756

40 WATTS PLATE DISSIPATION
CARBON ANODE

\$4.95

100 WATTS AUDIO OUTPUT
In Class B

GENERAL CHARACTERISTICS
Type 756

Filament Voltage, volts.....	7.5
Filament Current, amps.....	2
Plate Resistance, ohms.....	15000
Mutual Conductance, uMhos.....	1600
Amplification Factor.....	25
Thoriated Tungsten Filament	

OVERALL DIMENSIONS

Maximum Length, inches.....	5 5/8
Maximum Diameter, inches.....	2 1/4

CLASS "C" AMPLIFIER

Max. Operating Plate Volts	
Unmodulated D.C., volts.....	850
Modulated D.C., volts.....	750
Max. D.C. Plate Current, mils.....	110
Max. D.C. Grid Current, mils.....	20

CLASS "B" A.F. MODULATOR

Push Pull Operation

Grid Voltage, appr. volts.....	30
Load Resistance (plt. to plt.) ohms.....	6750
Av. D.C. Plate Current (2 tubes), mils.....	225
Static Plate Current (per tube), mils.....	10
Power Output (2 tubes), watts.....	100

841-A

50 WATTS PLATE DISSIPATION

CARBON ANODE

\$7.00

GENERAL CHARACTERISTICS
Type 841A

Filament Voltage, volts.....	10
Filament Current, amps.....	2
Plate Resistance, ohms.....	3600
Mutual Conductance, uMhos.....	4000
Amplification Factor,	14.6
Thoriated Tungsten Filament	

OVERALL DIMENSIONS

Maximum Length, inches.....	6 1/4
Maximum Diameter, inches.....	2 5/8
Plate to Grid, mmr.....	5

CLASS "C" OSC AND POWER AMP

Max. Operating Plate Volts	
Unmodulated D.C., volts.....	1250
Modulated D.C., volts.....	1000
Max. D.C. Plate Current, mils.....	150
Max. D.C. Grid Current, mils.....	30
Max. Plate Dissipation, watts.....	50
Max. RF Grid Current, amps.....	5



825

40 WATTS PLATE DISSIPATION

CARBON ANODE

\$4.95

GENERAL CHARACTERISTICS
Type 825

Filament Voltage, volts.....	7.5
Filament Current, amps.....	2
Plate Resistance, ohms.....	2800
Mutual Conductance, uMhos.....	2500
Amplification Factor.....	8
Thoriated Tungsten Filament	

OVERALL DIMENSIONS

Maximum Length, inches.....	5 5/8
Maximum Diameter, inches.....	2 1/4

INTERELECTRODE CAPACITIES

Plate to Grid, mmf.....	7
Grid to Filament, mmf.....	3
Plate to Filament, mmf.....	2.7

CLASS "C" OSC. AND POWER AMP.

Max. Operating Plate Volts	
Unmodulated D.C., volts.....	850
Modulated D.C., volts.....	750
Max. D.C. Plate Current, mils.....	110
Max. D.C. Grid Current, mils.....	25
Max. Plate Dissipation, watts.....	40
Max. R.F. Grid Current, amps.....	3
Max. R.F. Output, watts.....	50

841SW

This tube is identical in characteristics with our regular 841A with the exception that the glass envelope and stem are Nonex glass and all leads are Tungsten. The base of the 841SW is Isolantite. A very efficient tube for 7 1/2 to 160 meter operation as either an oscillator or amplifier. This tube was especially designed for use in Portable Diathermy apparatus and has been adopted by many leading manufacturers. A pair in the push-pull oscillatory circuit will give 100 watts output.

Price on request

DATA ON THE 756

The Taylor 756 is an extremely efficient tube for use in Class B modulator circuits. At 750DC plate volts, a pair will deliver up to 100 watts of audio power output. Because of its high amplification factor and its ability to produce strong harmonics, the tube is ideal for use as a frequency multiplier.

Taylor



Tubes

TUBES FOR DIATHERMY APPARATUS

HD 203-C

\$17.50

Widely used in many standard Diathermy machines. Has same general specifications as the HD 203A except the interelectrode capacities are lower. Grid to plate capacity is 9 mmf.

HD 211-C

\$17.50

Also on accepted tube in the Diathermy apparatus field. The HD 211C is the same as the 203C except it is a low Mu tube having an amplification factor of 12.

204-A

250 WATTS PLATE DISSIPATION

CARBON ANODE

\$90.00

The Taylor 204A is a three element air cooled power tube designed for use in transmitters as an oscillator, Radio Frequency Amplifier, and Class "B" Audio modulator. A Super Heavy Duty Carbon Anode is used which enables the tube to withstand overloads and still maintain stable characteristics. Because of its heavy duty construction and long life this tube is highly recommended for use in Broadcast transmitters where uninterrupted service is very essential. The characteristics of the Taylor 204A are standard. Detailed data will be supplied on request.



PERFORMANCE CURVE OF THE
TAYLOR 204-A
WILL BE SUPPLIED ON REQUEST

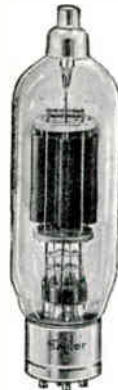

HD 203-A

150 WATTS PLATE DISSIPATION

CARBON ANODE

New Low Price!

Now— **\$14.50**

The Heavy Duty 203A is truly a heavy duty tube and was the first tube designed with the floating anode. The anode is suspended from a stem sealed in the top of the envelope and is not connected electrically to any part of the tube assembly other than the top stem and plate lead. Before the introduction of the HD 203A punctures and flashing over in the stems of the standard 203A were very common especially in Class B audio circuits. These faults have been entirely eliminated in the construction of the HD 203A. The HD 203A is a general purpose tube and is used in circuits built for 203A tubes where more power is desired. A pair of these tubes will furnish 400 watts of audio in a Class B audio circuit. Now more than ever an outstanding value!

GENERAL CHARACTERISTICS

Type HD 203A

Filament Voltage, volts.....	10
Filament Current, amps.....	4
Plate Resistance, ohms.....	5600
Mutual Conductance, uMhos.....	4800
Amplification Factor.....	25
Plate to Grid, mmf.....	12
Thoriated Tungsten Filament	

OVERALL DIMENSIONS

Maximum Length, inches.....	9½
Maximum Diameter, inches.....	2½

CLASS "C" AMPLIFIER

Max. Operating Plate Volts		
Unmodulated D.C., volts.....	1500	2000
Modulated D.C., volts.....	1500	1750
Max. D.C. Plate Current, mls.....	250	250
Max. D.C. Grid Current, mls.....	60	60

CLASS "B" A.F. MODULATOR

Push Pull Operation

D.C. Plate Voltage, volts.....	1500	1750
Grid Voltage, appr. volts.....	-45	-67.5
Load Resistance (plt. to plt.) ohms.....	9600	10,000
Max. D.C. Plate Current (2 tubes), mls.....	315	365
Static Plate Current, per tube, mls.....	18	18
Power Output (2 tubes), watts.....	300	400

Supply Voltage ↓	200	250	300	400	←Audio Watts Output
1750	.180 20,000	.225 16,000	.275 13,000	.365 10,000	←Max. Av. Ip. ←Load Impedance plate to plate
1500	.210 14,500	.265 11,500	.315 9,600		←Max. Av. Ip. ←Load Impedance plate to plate
1250	.255 10,000	.320 8,000	.380 6,900		←Max. Av. Ip. ←Load Impedance plate to plate

Taylor



Tubes

TAYLOR 866

The multistrand filament used in TAYLOR 866 Rectifiers has twice the emitting surface of the nickel alloy ribbon type filaments used in ordinary 866's. This multistrand filament together with the exclusive TAYLOR method of applying the oxide coating results in the coating adhering to the filament more closely. You have probably noticed how the oxide flakes off of ribbon type filaments—this cannot happen with the TAYLOR multistrand filament construction. The result is longer tube life. The greater filament area in the TAYLOR 866 gives increased ability to withstand heavier current overloads.

For over three years the TAYLOR 866's have been made with a Svea Metal Anode (chemically pure iron). Svea Metal does not amalgamate with mercury.

When back emission occurs in a Rectifier using a carbonized anode, small particles of carbon adhere to the filament ruining the filament emission. This condition cannot take place in a TAYLOR 866 Rectifier which has a Svea Metal Anode.

GENERAL CHARACTERISTICS

866

Filament Voltage, volts.....	2.5
Filament Current, amps.....	5.0
Inverse Peak Voltage, volts.....	7500
Peak Current, amps.....	.600
Appr. Voltage Drop per tube, volts.....	15
Multistrand Filament	
Svea Metal Anode	

WARNING: Do not use condenser input where the output voltage exceeds 1000 if the current is 200 milliamperes or more. Condenser input permissible at higher voltages at low current values.

We recommend choke input in all cases as it insures much longer tube life.

SPECIAL NOTE

In transit mercury in tube splatters over filament—therefore when first placing this tube into operation filament should be lighted for fully 15 minutes to allow mercury to condense to bottom of bulb.

THE WORLD'S FASTEST SELLING 866



TAYLOR 866

HALF-WAVE MERCURY VAPOR
RECTIFIER TUBE

\$1.65

THERE ARE OVER 25,000 TAYLOR 866's IN USE IN COMMERCIAL, BROADCAST AND AMATEUR RADIO TRANSMITTERS. TAYLOR 866's ARE KNOWN THE WORLD OVER TO BE THE LONGEST LIVED AND MOST TROUBLE-FREE 866's EVER MADE. "WHEN YOU BUY 866's—SAY 'TAYLOR 866's' AND YOU'LL GET THE BEST."



The New 866 JR. \$1.00

**HALF-WAVE
MERCURY VAPOR RECTIFIER**

The 866 Jrs. will fill a real need for intermediate power requirements. They are intended to be used as rectifiers in power supplies of from 600 to 1000 volts D.C. where the receiving type full-wave rectifiers will not stand up and where the power capabilities of the Heavy Duty 866's are not necessary. The smaller size of the 866 Jrs. is another feature that will prove to be of great advantage in the layout of compact power supplies.

866 JR.

GENERAL CHARACTERISTICS

Fil. Volts	2.5V
Fil. Current	2.5A
Max. RMS A.C. Volts	1250
Max. D.C. Current per pair (Choke input)	250 M.A.

PHYSICAL CHARACTERISTICS

Max. Length, Inches	5¼
Max. Diameter, Inches	2¼
UX Ceramic Base	

Connect Plate Terminal to Usual Position Standard On All UX Bases

866 JR.

The 866 Jr. uses the multi-strand filament introduced by TAYLOR TUBES. The multi-strand filament construction used in TAYLOR rectifiers has twice the emitting surface of the nickel alloy ribbon type filaments used in ordinary 866's. The longer life secured with TAYLOR heavy duty 866's has proven that the use of the multi-strand filament and of a svea metal anode results in better rectifiers.

SPECIAL NOTE

In transit mercury in tube splatters over filament—therefore when first placing this tube into operation filament should be lighted for fully 15 minutes to allow mercury to condense to bottom of bulb.



872

**HALF-WAVE
MERCURY VAPOR
RECTIFIER TUBE
New Low Price!**

\$9.00

The 872 is a Half Wave Mercury Vapor Rectifier for use in higher voltage and current power supplies capable of delivering a uniform supply of D. C. Voltages.

CHARACTERISTICS

Filament Voltage, volts	5
Filament Current, amps	10
Inverse Peak Voltage, volts	10000
Peak Current, amps.....	2.5
Bulb (50 Watt).....	T-18
Base—Standard 50 Watt, prongs.....	4
Appr. Voltage Drop per Tube, volts.....	15
Multistrand Filament	
Svea Metal Anode	

866-B

**HALF-WAVE MERCURY VAPOR
RECTIFIER TUBE**

\$3.00

CHARACTERISTICS

Filament Voltage, volts.....	5
Filament Current, amps.....	5
Inverse Peak Voltage, volts.....	8500
Peak Current, amp.....	1

**RECTIFIER CIRCUIT INFORMATION
ON PAGE 44**

**TAYLOR RECTIFIERS
LOWEST COST—
LONGEST LIFE!**

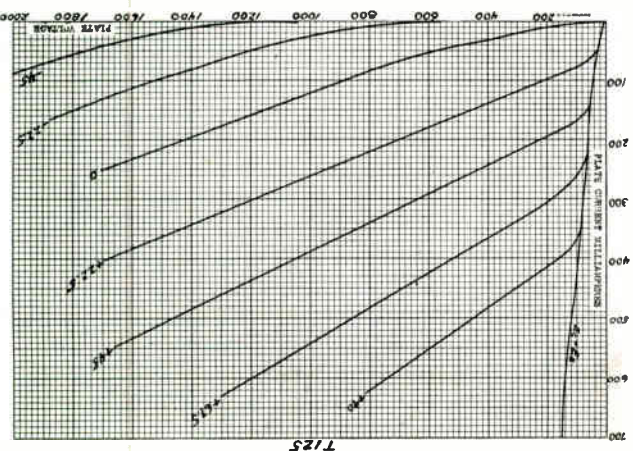
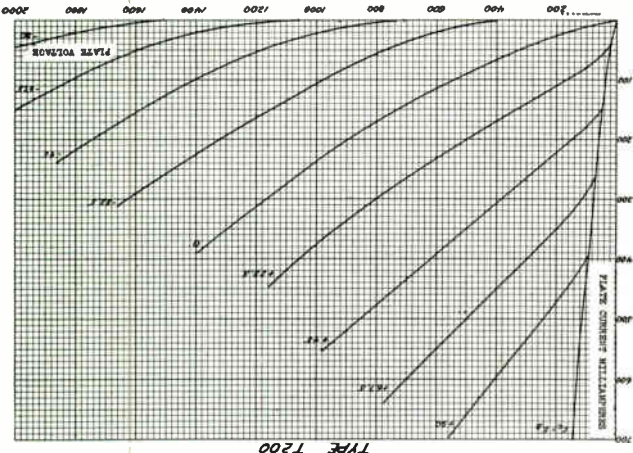
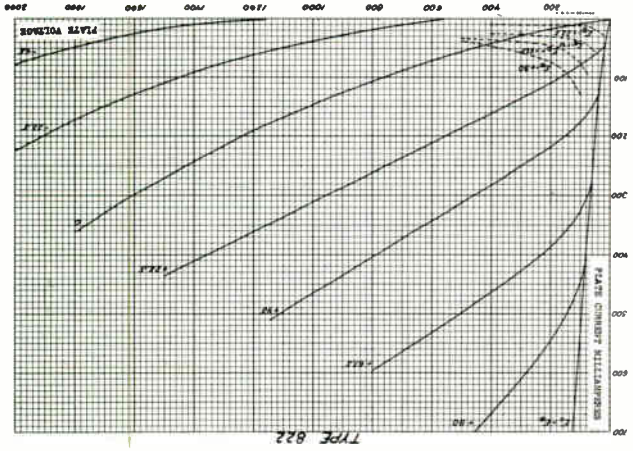
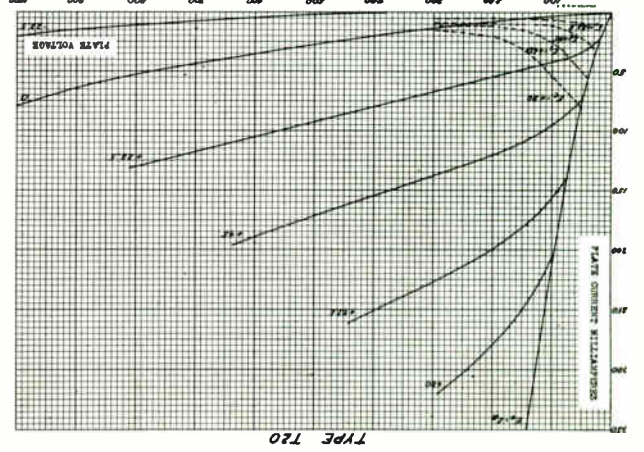
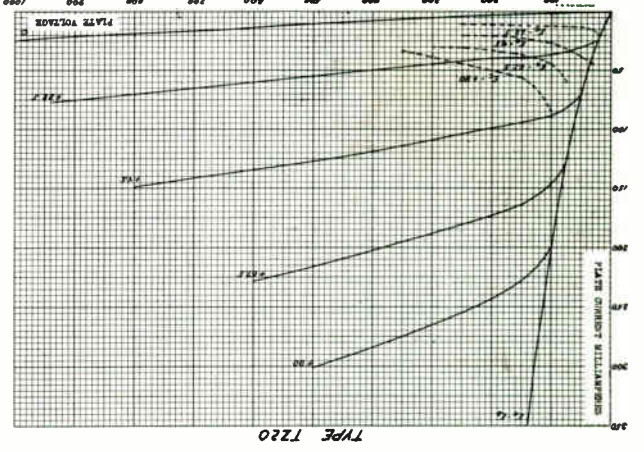
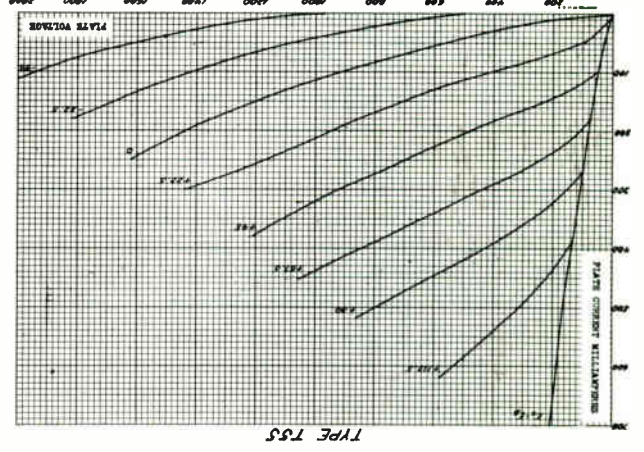
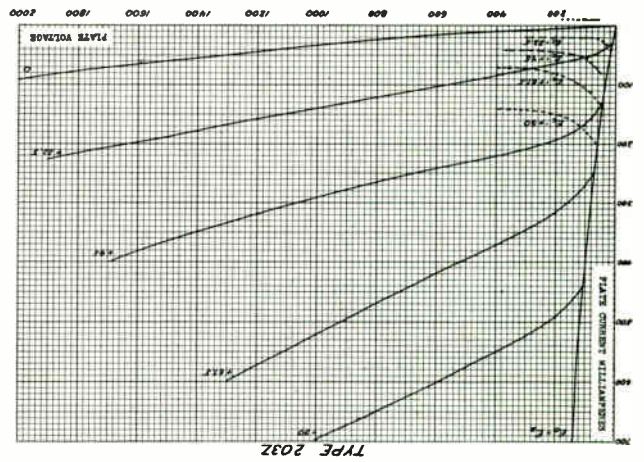

CALCULATING BIAS

To calculate necessary bias for a Class "C" stage (any type tube) divide the plate voltage by the amplification factor and multiply by two for approximate double cutoff. For higher efficiency add at least 40% more to this figure. For C. W. Class "C" or buffer stages, multiply by 1.5.

For example take a 203A tube which is to be used as an amplifier with 1000 volts on the plate. This tube has an amplification factor of 25

$$\frac{1000}{25} = 40 \times 2 = 80 + 32 (40\%) = 112 \text{ volts}$$

necessary for double cutoff plus 40% for phone operation.

$$\frac{1000}{25} = 40 \times 1.5 = 60 \text{ volts}$$

For CW

GENERAL TUBE INFORMATION

In all Radio circuits the tubes are the most important factor and the choice of tubes should be given the fullest consideration before attempting to build up any apparatus.

SELECTING TUBES

In selecting the proper tube for the particular purpose for which it is to be used, the first consideration would be that of power rating and plate dissipation. It is sound economy to purchase tubes that will give the desired amount of power within the ratings since the overloading of tubes results in shortened tube life.

Attempting to operate tubes and circuits at higher than normal efficiencies is false economy. 75% efficiency in Class C is considered normal and can be easily obtained with TAYLOR TUBES at reasonable values of plate voltage, excitation, bias and L/C tank circuit ratios. In order to realize abnormally high efficiencies, all of these conditions must be changed. The excitation must be increased by several times which means that a larger driver tube must be used and perhaps another stage added. The bias must be increased to several times cutoff. The plate voltage must be increased to 1.5 times normal. The L/C ratio must be extremely high because the tank impedance has to be as high as possible and the tank and condenser losses reduced to a minimum. The entire process is very expensive and the result is an improvement of 5% to 15% (maximum) in efficiency. The plate current must not exceed the rated value, the increase in input being gained by increasing the plate voltage. Raising the excitation, bias and L/C ratio inevitably result in excessive harmonic content, a condition which is very undesirable.

INTER-ELECTRODE CAPACITIES:

The next consideration should be that of inter-electrode capacities. If the transmitter is to be used on more than one frequency, your selection should be a tube whose capacities will permit efficient operation on the highest frequency to be used. The tube will then operate on all lower frequencies with equal efficiency.

Because of the great interest in high frequency operation most of the newer tubes have featured low interelectrode capacities. There are two reasons why this type of tube is better for the higher frequencies. The first is the fact that the RF current through a given capacity is proportional to frequency if the voltage is constant. This refers to the RF current which flows in the Grid and Plate leads and not to the direct current which you read on your meters and is the current that often causes the failure of medium C tubes at the very high frequencies. Reducing the inter-electrode capacities allows operation on a proportionally higher frequency for a given safe amount of RF current. You, no doubt, have noticed that where medium C tube operation on high frequencies is specified, the permissible maximum safe applied input becomes less as the frequency becomes greater because lower applied voltages mean proportionally less RF current; therefore, the plate input must be limited to the point where excessive current cannot flow. Excessive RF current will burn off grid or plate leads or cause punctures in the tubes where the leads enter the glass envelope.

The second reason for the use of low C tubes at the high frequencies, is the fact that the tube capacities themselves may be high enough to prevent a suitable L/C ratio in the tank circuit making it impossible to use a tank circuit with enough impedance to permit efficient operation.

Low C in a tube is obtained partially by isolating the grid, plate and filament leads from each other, but most of the capacity reduction is accomplished by using comparatively small elements and

increasing the separation between them. However, increased spacing between elements leads to a disadvantage as well as the advantage gained. This increased spacing means that for a given plate current the voltage drop across the tube will be higher. Low C tubes because of their high voltage drop require a higher plate voltage than medium C tubes in order to realize the same efficiency. The amount of RF grid drive required for the low C tube will be greater than required for the medium C tube assuming, of course, that the tube is used at a frequency where it will operate efficiently.

AMPLIFICATION FACTOR:

The amplification factor is the ratio of change in plate volts to change in grid volts necessary to maintain a constant plate current, and can be simply described as the increase in plate volts required to keep the plate current unchanged when the grid bias is increased one volt.

To calculate the amplification factor of any tube, using a Class A circuit, apply a plate voltage with a set bias and note the plate current value. Next, increase bias one volt and then increase plate voltage until the plate current value is brought up to the original value, since an increase in bias will decrease the plate current. The number of plate volts required to bring the current value back to original reading will be the amplification factor.

From this it might seem that the tube with the highest amplification factor would be the best and easiest to excite. However, it is an unfortunate fact that (other conditions being equal) increasing amplification factor also increases the plate resistance. Since low plate resistance is desired along with a high amplification factor, a happy medium must be decided upon. From our tests and experiments we find a tube with a mu of 15 to 25 is best adapted for all around amateur use.

MUTUAL CONDUCTANCE:

Mutual conductance has some relationship to amplification factor or Mu since it also involves plate current change by grid voltage change over a small range and is expressed in mhos which is the inverse of ohms. The mutual conductance of a tube in micro mhos is the ratio of amperes plate current change to volts grid voltage change $\times 1,000,000$. For example, a tube whose plate current changed 5 MA with a grid voltage change of 2 volts would have a mutual conductance of:

$$.005/2 \times 1,000,000 = .0025 \times 1,000,000 = 2500 \text{ micro mhos}$$

Another way to calculate mutual conductance is to divide the plate resistance of the tube by the amplification factor.

PLATE RESISTANCE:

The plate resistance of a tube is the ratio between a small plate voltage change to the plate current change it effects. Assuming that in a given tube a change in plate voltage of 50 volts caused a change in plate current of 5 MA, its plate resistance would be:

$$50 \div .005 = 10,000 \text{ ohms}$$

Taylor Tubes are evacuated to the highest degree. There is no danger of gas being released from the **TAYLOR CARBON ANODES** when the Anode shows a red color during operation.

Each and every **TAYLOR CARBON ANODE** tube is checked for emission while the Anode is white hot at 60% of the tube's rated filament voltage.

Leading manufacturers of Therapeutic Apparatus have chosen **TAYLOR CARBON ANODE** tubes, because they can stand generous overloads and have a high plate dissipation rating which is so desirable in this type of apparatus.

TRANSMITTERS

The principle aim of the Taylor Tubes, Inc., has been to manufacture for the Amateur transmitting tubes that will deliver More Watts Per Dollar. With this in mind, our engineering staff has developed the following line of transmitters so that the Amateur may obtain More Output Watts Per Dollar from his transmitter as well as from his choice of Taylor Tubes.

Whether you desire low, medium or high power, on any amateur band you will find herein a circuit to fill your requirements.

Each and every transmitter was built and put into actual operation. In some instances, models were demonstrated at Conventions and Hamfests. From the comments noted, we sincerely feel that these transmitters have the stamp of approval of the Amateur.

Circuit simplicity, Efficiency, Eye Appeal, Ease of Operation and construction, Quality of all components, along with getting the Most Watts Output for every dollar spent, were given the utmost consideration.

TRANSMITTER CONSIDERATIONS

A transmitter which presents a neat and workmanlike appearance is a great source of satisfaction when visitors drop in. Not only is neat appearance desired, but stability, in the sense of reliability, dependability and consistency, is a very important requisite.

Transmitters which fail to function properly when line voltage drops and whose adjustments change as the stages warm up, are provoking. The maximum amount of operating pleasure can only be obtained from a transmitter that works perfectly every time the switch is thrown.

A dependable and stable transmitter is not difficult to construct; the use of good components and good design are the major requirements. Each stage must function properly with no interaction between it and other stages and should be free of spurious or parasitic oscillations or regeneration except in the case of a frequency doubler where regeneration is important and almost indispensable. The transmitter must have a sufficient number of stages so that more excitation is present at the grid of each tube than is actually required. This point is of particular importance yet there should not be more stages than are necessary to accomplish a reasonable surplus of excitation. It is almost mandatory that trick circuits be avoided since they usually involve critical adjustments.

Each layout which we recommend fulfills the foregoing requirements. If the layouts are duplicated no spurious or parasitic oscillations should be present, no regeneration is used except where desirable or necessary, and the amount of excitation available at any given point is about twice the amount used or required at that point. In some cases this means that one stage might be eliminated, at least on some bands, without appreciable reduction in output; but doing so might not permit the smooth stable operation which is so important.

In general, for transmitter use, Taylor triodes combine low cost, efficient operation, ease of adjustment, and ruggedness to an extent which must make them the Amateur's choice to the exclusion of tubes having a larger number of elements. There is one exception:—for crystal oscillator stages, pentodes or tubes with pentode characteristics have advantages which dictate their being used for this purpose in preference to triodes.

CIRCUITS

Basically, the requirements for a triode amplifier are an input circuit capable of being tuned to the desired operating frequency, an output circuit capable of being tuned to the same frequency, a source of RF voltage of opposite phase for neutralization, and suitable sources of filament, plate, grid and excitation voltages.

Starting with the grid circuit, the plate circuit of the preceding stage may also act as the grid coil for the amplifier under consideration. See Figure 1. This is the case when capacity coupling is used. The advantages of this system are its low cost and simplicity. If the impedance of the grid circuit is approximately the same as that of the driver plate circuit this coupling system is equally as efficient as any other, at least on the three lowest frequency bands. On 20 meters and higher frequencies the com-

binated input and output capacities plus the capacities of associated equipment to ground may be high enough to prohibit the use of enough inductance in the circuit and the plate efficiency of the driver stage may become poor. If the grid impedance of the driven stage is lower than the plate impedance of the driver stage maximum efficiency may be obtained by tapping down on the plate tank at a point which gives maximum grid drive at minimum plate current to the driver stage. Such an arrangement will provide maximum power efficiency but it is not commonly used since it usually creates new circuits which invite oscillation at parasitic frequencies.

In cases when the grid impedance of the driver stage is sufficiently different from the plate impedance of the driven stage to prohibit using the same tuned circuit for both or where the capacities resulting from this connection would be too great it is common practice to use a separate tuned circuit for the plate of the driver stage and the grid of the driven stage. The coil may be placed in the field of the driver plate coil or it may be placed out of the direct field of the plate coil and coupled thru a low impedance line. This latter method is usually called link coupling. See Figure 2. Inductive coupling in one of its forms is usually of greatest advantage at the higher frequencies and when working from a single ended stage to a pushpull stage and from a push-pull stage to a single ended one and when the driven grid impedance is widely different from the driver plate impedance. A further advantage is the elimination of or minimization of the importance of RF chokes. The disadvantages are higher cost because of more parts, greater space requirements, and more tuning adjustments and coils to change when shifting bands.

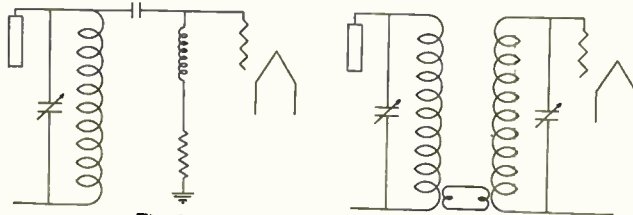

Fig. 1

Fig. 2

Your choice of an input circuit will depend upon all of the considerations previously mentioned and when not duplicating a complete unit already designed the various factors should be weighed carefully that an intelligent selection may be made. The present trend toward link coupling is probably due to the fact that with it best results may be obtained under most any conditions even tho the cost is higher and the complexities greater.

Your plate circuit considerations are quite well determined for you in advance. The important considerations are the L/C ratio to provide maximum unloaded tank impedance consistent with minimum harmonic content and if tunc is used to have sufficient capacity in the circuit to provide for linear action under modulation. All of the necessary calculations have been made for you in the L/C charts.

Neutralization also ties in with grid circuit and plate circuit design, except in the case of push-pull. With push-pull the fundamental circuit arrangement is identical whether the stage is a tuned grid tuned plate oscillator or a neutralized amplifier. The only practical method of neutralizing a push-pull stage is the so-called cross neutralizing method employing two neutralizing condensers, each connected from one grid to the plate of the other tube. See Figure 3.

However in a single ended stage either of two methods may be used. With grid neutralization the center of the grid coil is at ground RF potential. See Figure 4. One end of the coil goes to

the grid of the driver tube and the other end to one side of the neutralizing condenser. Grid neutralization will usually operate satisfactorily and may be of advantage if an unbalanced output stage is desirable as in our all-band 3 stage job using a 6L6G-T20-T55. However, the grid of the tube puts a resistive load across half of the input coil resulting in the opposite end of the coil being other than 180° out of phase if the coupling in the grid coil is less than unity. Unity coupling is never realized in practice at radio frequencies but satisfactory neutralization may usually be realized if the turns of the grid coil are wound as close together as possible. If difficulty is experienced it will usually be at the higher frequencies.

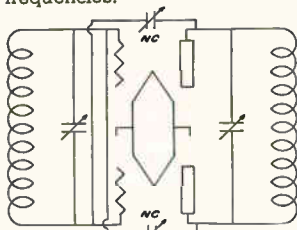

Fig. 3

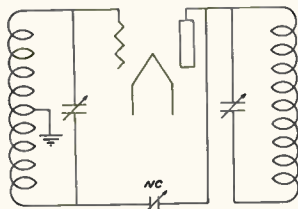

Fig. 4

Plate neutralization of a single ended amplifier necessitates operating the center of the plate coil at ground RF potential. One side of the neutralizing condenser is connected to the opposite end of the plate coil to which the plate of the tube is connected and the other side of the neutralizing condenser goes to grid. See Figure 5.

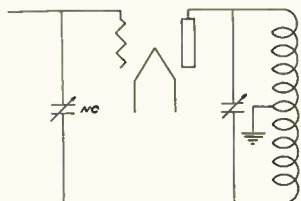

Fig. 5

Our L/C ratio calculations are based on the plate neutralized type circuit because it seems more or less the standard practice in amateur transmitters.

For maximum power gain with reasonable efficiency the bias should be approximately cutoff and the grid current the normal recommended value. An amplifier of this type is suited for use as an intermediate or buffer stage or as the final stage in a CW transmitter.

Class C operation requires somewhat greater than twice cutoff bias with normal recommended grid current. This stage would be characterized by slightly better plate efficiency than the one previously described and would be suitable for intermediate or buffer stage, final stage CW, or plate modulated phone.

Another type of Class C operation would require bias of several times cutoff with normal grid current flowing. With the plate circuit tuned to the same frequency as the grid circuit and with a high impedance plate tank, higher voltages may be applied and higher plate efficiencies, over 75% obtained. However, the harmonic content will be high and unusual precautions to prevent harmonics being radiated by the antenna must be taken. This grid bias and excitation condition is also ideal for the operation of a doubler stage with the plate circuit tuned to twice the frequency of the grid circuit. Reasonable efficiency may be obtained from a doubler if the bias and excitations are high.

The Class B linear of grid modulated amplifier requires approximately cut off bias and little or no grid current. The unmodulated efficiency will be low, varying between approximately 25% and 35%. This type of operation necessitates the use of fixed voltage bias sources. The voltage must remain constant regardless of current variations. Batteries are probably the most satisfactory source because the smaller types may be used and the life will be long.

For all other types of operation it makes little or no difference how the necessary bias is obtained. The simplest and cheapest method is the use of a resistor in the grid return circuit. This arrangement is entirely satisfactory in every respect except that no protection is afforded the tubes in the event the excitation fails or is removed while the plate voltage is on. Batteries are frequently used and they make an excellent bias source from every standpoint except that of cost, life, and in some cases, size. The same amount of power which would be dissipated in a resistor in the same circuit is dissipated in the batteries. This heat dries out the batteries so rapidly where any great amount of grid current is present that the use of batteries can become very expensive.

Bias supplies of one type or another are becoming more common. A discussion of the units would be too involved and lengthy for the space available. Let it suffice to say that even the simplest types should prove entirely satisfactory for RF stage bias since regulation, except in the case of efficiency modulated amplifiers, is not a factor.

Cathode bias also is used. It consists of a resistor between filament center tap and ground. It must be capable of carrying the total grid and plate current and as the plate current is increased the bias also increases. If the stage is modulated the

(Con't. on Page 34)

CRYSTAL OSCILLATOR

Because no triode can provide the versatile crystal oscillator operation obtainable with tetrodes and pentodes, we do not recommend triodes as crystal oscillator tubes in amateur transmitters. Any time our tubes are not the best for a certain purpose we will not hesitate to recommend others.

In selecting a crystal oscillator circuit we had 5 requirements in mind.

1. High output on fundamental and second harmonic frequencies.
2. Minimum number of coils to wind and change.
3. Minimum number of tuning controls.
4. Lowest current thru crystal for best frequency stability and crystal safety.
5. Lowest cost consistent with maximum performance.

Every popular crystal circuit was set up for comparison. The one selected using a 6L6G was first popularized by Jones of Radio Handbook. It fulfills the first, third and fifth requirements perfectly and to a greater degree than any other circuit. It has only one tuning adjustment and one coil to change. The tri-tet its nearest competitor, has two coils to change and two tuning adjustments. The only bad feature, which is the fault of the 6L6 and not of the circuit, is that when working straight thru on the fundamental frequency with a 20 or 40 meter crystal the RF current thru the crystal is too high. When doubling in the oscillator the crystal RF current is extremely low—about 10 to 20MA. A type 6F6G in the same circuit provides satisfactory fundamental operation with safe RF crystal current with all crystals including 20 and 40 meter ones but when doubling the output is only a small fraction of that obtained with a 6L6G. As a result we use a 6L6G with an 8 prong ceramic base when doubling in the oscillator and replace it with a 6F6G when working straight thru. Both tubes fit the same socket and no circuit changes are necessary. Merely place the 6L6G in the socket when the output of the oscillator stage is twice the crystal frequency and the 6F6G when the oscillator stage output frequency is the same as the crystal. With a 40, 80, or 160 meter crystal working straight thru the oscillator output will be about 15 watts. With a 20 meter crystal it will be about 10 to 12 watts. The 40 meter output from an 80 meter crystal will be about 12 watts and the 20 meter output from a 40 meter crystal will be 6 to 9 watts.

While even badly cracked crystals will operate on their fundamental in this circuit a good crystal is required for harmonic output. It must not only be active but must have only one frequency. 20 meter crystals will be very satisfactory in this circuit for straight thru operation but do not provide satisfactory 10 meter output. Most 20 meter crystals are 60 meter crystals operating on their 3rd harmonic. In this circuit the 10 meter output is apparently the 6th harmonic of 60 rather than the second harmonic of 20.

When not oscillating the 6L6 will draw about 140MA. With the crystal oscillating and the plate circuit off resonance the current will be about 100MA. When the plate circuit is brought into resonance on the fundamental or harmonic frequency a very pronounced dip in plate current will be noticed.

With the 6F6G, the non-oscillating plate current will be about 80MA and will dip in the conventional manner near resonance.

The fact that we prefer this crystal circuit does not mean that it has to be used. There is probably more difference of opinion concerning which is the "best" crystal oscillator arrangement than there is concerning any other unit in the transmitter. If you prefer

the tri-tet because it works best for you, by all means use it. However, the circuit as shown delivers 20 to 25MA of grid current to the following stage even on 20 from a 40 meter crystal and the circuit used should do equally as well if equivalent results are expected. The only fault that we can find with the circuit we recommend is that an occasional 40 meter crystal which will double with the tri-tet will not double in this circuit. However, all crystals of reputable manufacture tested in this circuit doubled excellently. In addition some badly cracked crystals which would not operate at all in other circuits worked excellently straight thru on the fundamental frequency.

BUFFER DOUBLER 1

In all of the units we show a T20 or T55 as a buffer. At the maximum ratings of 750V and 75MA input, a T20 will deliver about 40 watts of output. At frequencies lower than 15MC where circuit losses may be kept at a reasonable value and practically the whole 40 watts delivered to the final stage, a T20 will furnish sufficient grid drive for a plate modulated final stage with an input of approximately 500 watts or less. For cw only the T20 will probably drive a 700 watt stage. No definite statement on this subject can be made because the amount of grid drive required can vary over wide limits in different transmitters.

A T20 as a straight buffer on 10 meters may be expected to adequately drive a 250 to 300 watt final stage.

As a doubler to 10 from 20 the efficiency will vary greatly with the excitation, the bias and the L/C ratio but 15 watts of output should be obtained under average conditions without any color showing on the plate. This excitation would permit an input of about 150 watts to the final stage.

For those applications where the T20 does not have sufficient output a T55 may be substituted. The grid drive from the oscillator shown is sufficient for full rated input to the T55. 150 to 170 watts of output may be obtained which will be far more excitation than is required for a 1 Kw final stage. No changes need be made in the circuit when replacing the T20 with a T55 except to use components with adequate voltage ratings so that breakdowns will not be experienced if higher voltages are applied to the T55 than to the T20.

The first two stages, a 6L6 and T20 or T55, will make an excellent 2 stage all band transmitter, and would be ideal for portable operation. The excitation on all bands from 40 to 160 is sufficient for plate modulation with full input. On 20 the excitation is adequate for plate modulation with 100 to 150 watts of input. If operating 20 meter phone with two stages a 40 meter crystal should be used. The 6L6 operates as an oscillator and doubler and apparently the isolation on 20 is adequate to keep frequency modulation to a negligible amount.

DOUBLERS

A doubler is used to obtain an output frequency of twice the input frequency and one or more of these stages are usually necessary when working on the higher frequency bands. Because the plate circuit is not tuned to the same frequency as the grid circuit, neutralization is not necessary to prevent oscillation. However, the efficiency of a doubler may be improved greatly if regeneration is added. The circuit for a regenerative doubler is exactly the same as for a neutralized amplifier so the same stage may be used for either purpose by merely changing the plate coil. The neutralizing circuit provides regeneration when doubling.

As a doubler the plate efficiency of a stage will be much less than when working as a straight amplifier. Consequently for a given plate dissipation the output must be much less. More grid drive is required also so the power gain will be less. The grid bias should be several times that for straight thru operation. The L/C ratio should be as high as possible.

If a stage is used for both straight thru and doubler operation it may be neutralized and the neutralizing condenser setting left the same for doubler operation. If it is used for doubler operation

only, the neutralizing condenser adjustment should be for maximum efficiency without oscillation.

INSULATION

If you are going to operate on the lower frequencies only insulation is no great problem. Below about 8MC bakelite or most any of the various commonly used types of insulation are sufficiently good. About the only important consideration is that it be able to stand the voltages involved without breaking down.

Above 8MC the situation is much different and at 28 and 56MC only the very best insulation is good enough. (At these higher frequencies the amount of grid drive required by a tube does not increase greatly but circuit losses increase tremendously making tubes appear to require more grid drive.) If sufficient grid drive is to be had at the higher frequencies and if reasonable efficiency is to be experienced insulation should be used only where necessary and it should be the best available.

Sockets and condenser insulation should be of ceramic or Mycalex. Wherever possible the inductances should be self supporting with no foreign objects in their field.

ANTENNA COUPLING

The method of coupling the transmitter to the antenna will depend upon the type of feeder system used and the characteristics of the antenna coil will depend upon the impedance of the feeders at the transmitter. Because there are so many variables we cannot provide any quantitative data. In the case of untuned transmission lines the correct number of turns in the pick up coil will be the number which will load the final to the desired input. With tuned feeders the characteristics of the antenna coil will depend upon the amount of inductance necessary to tune the antenna system to resonance. With single wire fed or end fed antenna systems, a separately tuned circuit coupled to the final tank is probably advisable because of the lack of harmonic discrimination with these antennas. If the L/C ratio in the final stage is low enough for reasonable harmonic suppression the L/C ratio of the separately tuned coil may be very high.

Any pick up coil coupled to a tank circuit should be placed at the point of minimum RF voltage to minimize capacity coupling. In the case of a balanced output tank as with push pull or a plate neutralized single ended stage the coupling coil should be at the center of the output tank. With a grid neutralized single ended final stage the coupling coil should be at the cold end of the tank coil.

A faraday screen between tank and pickup coil is usually very helpful in preventing even harmonic radiation but sometime presents mechanical difficulties if the coils are changed for multi-band operation. Grounding the center of the pick up coil to the final stage filament or ground circuit is usually equally effective and far more simple mechanically.

With transmission lines it is legal to tap the feeders, single or double wire, directly onto the final tank but this is likely to result in high mutual impedance between plate circuit and radiating system at the harmonic frequency. It is almost impossible for this condition to exist with a two wire line and a pick up coil whose center is grounded so it would be wise to avoid direct coupling and to use a two wire line to keep harmonic radiation at a minimum.

SPECIAL OFFER

ALL TAYLOR TUBE distributors have competent men who are acquainted with these units and transmitters and will assist you with any problems that may pertain to these units.

Visit these men, they offer this service to you FREE.

L/C RATIOS

Your tank circuits are worth your careful consideration for they will greatly influence the operation of your transmitter. As far as the tubes are concerned the inductance and capacity in the circuit when tuned to resonance are a resistance as shown in Fig. 1. With no load coupled to the tank, the impedance (AC resistance) should be high and its value will be proportional to $\frac{L}{CR}$ where L is the amount of inductance, C the amount of capacity, and R the resistance. When you couple a load to the tank you have the situation shown in Fig. 2. R_{p1} is the unloaded impedance of the tank circuit. R_{p2} is the load impedance reflected across R_{p1} , and the

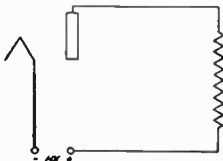

Fig. 1

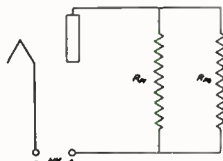

Fig. 2

power developed across R_{p2} will be delivered to the load or antenna. It is useful output. However, the power developed across R_{p1} is power wasted in the tank circuit and shows up in the form of heat. It may easily be seen that as the ratio of R_{p1} to R_{p2} is raised less power will be wasted and more will be delivered to the load. Because R_{p1} is the unloaded tank impedance it can be seen why, as the impedance of the tank circuit is raised less power will be wasted in the tank and more delivered to the load. As shown from the formula L/CR the impedance may be increased by increasing the amount of L and reducing the amount of C. If efficient coils and condensers are used it probably would not be practical to attempt to reduce R but if C were reduced to $\frac{1}{2}$ its former value, L would have to be doubled to hit resonance at the same frequency so the impedance would have increased to four times its former value. Actually, it would not be four times because R would increase slightly with an increase in L but the gain in impedance would approach four.

From the foregoing it would seem advisable to use as much inductance and as little condenser as possible. From a plate efficiency standpoint only this is more or less true, however, after a certain value of tank impedance is reached the efficiency increases only very slightly, yet the driver power required continues to increase and from an over-all efficiency standpoint there might be no improvement.

However, increasing the L/C ratio leads to one disadvantage for CW operation and an additional disadvantage for fone operation.

As the L/C ratio is increased the harmonic content is also increased. If these harmonics reach the antenna, and it is sometimes difficult to prevent them from doing so, they will be radiated and may cause interference to other services. Consequently it is necessary to select an L/C ratio which must necessarily be a compromise between plate efficiency and harmonic content. Fortunately, a ratio may be selected which does not result in appreciably lower efficiency yet the harmonic content is kept at a reasonably low value. In fact measurements seem to indicate that excessively high L/C ratios do not result in increased fundamental or useful output. The increase seems to be composed entirely of harmonics which are not useful and are to be avoided.

For phone operation a certain amount of capacity is necessary if the amplifier is to be linear. Less than this minimum of capacity will result in distortion and carrier shift. This amount of capacity is usually somewhat greater than the amount required to reduce harmonics to a satisfactory value and for this reason different L/C ratios have sometimes been specified for CW and phone operation. However, the permissible L/C ratio for fone is high enough that increasing it to the permissible CW value for that type of operation results in so small an increase in efficiency that it seems desirable to specify L/C ratios for all forms of operation which are capable

of linear phone operation to permit modulation if desired and to obtain greater harmonic suppression. However, if only CW operation is contemplated the L/C ratio may be quadrupled by using about half as much capacity and twice as much inductance as would be required for phone. Twice as much inductance may be obtained with about 41% more turns.

Correct L/C ratios become the greatest problems on the highest and lowest frequencies when all band operation is desired. For example, any condenser with enough capacity to provide a reasonable ratio on 160 meters would undoubtedly have a minimum capacity so high that efficient operation would be impossible on 10 whereas a condenser with suitable capacities for 10 meters would have so low a maximum capacity that poor linearity and high harmonic content must necessarily be present on 160 even though the efficiency would be good on both bands. Probably the most satisfactory answer to this problem would be to build the circuit for the highest frequency to be used and connect another condenser in parallel with the HF tuning condenser for low frequency operation.

If your L/C ratios are correct you will obtain maximum fundamental frequency output with minimum harmonic content and minimum distortion if modulated. If your L/C ratios are not correct you will sacrifice one or more of these desirable characteristics.

In general if your L/C ratios are right the minimum plate current with no load coupled to the output circuit will be about 10 to 20% of the loaded value. Minimum plate currents in excess of 25% of the loaded value are usually an indication that circuit losses are higher than they should be. However, tank circuit losses drop rapidly as the loading is increased so minimum plate currents unless greatly excessive need not be taken too seriously.

Optimum L/C ratios are not directly a function of the type of tube or tubes used. The factors used in the calculations are plate voltage, plate current, frequency, and the type of operation.

TUBE INSTALLATION HINTS

To obtain efficient performance from any radio circuits where tubes are used great care should be exercised in the installation of tubes in these circuits.

The heart of a vacuum tube is its filament. Improper operation of the filament will shorten its life.

Although small variations in filament voltage are compensated for in the designing of our tubes, most satisfactory results are obtained when filaments are operated at their rated voltage. Lower voltage limits the electron emission of the filament and generally results in the over heating of the tube, while higher voltage will rapidly dissipate the supply of thorium in the filament.

Use sockets with large sweeping contacts. Poor contact between socket springs and tube prongs will cause a drop in filament voltage. Heavy well soldered leads are very essential. Light tube at rated filament voltage for ten minutes before applying plate voltage for the first time. Preheating of filament after first installation is not necessary.

The ground return should be connected to center tap of the filament. Where the ground is returned to one side of the filament, connections should be reversed at intervals of 100 hours. Using one side of the filament for ground return causes the opposite side of the filament to function harder. Where D.C. is used on filaments, connect grid and plate returns to negative side of the filament.

All connections in the plate tank circuit should be heavy enough to stand the circulating R.F. current. At frequencies higher than 14,000 k.c. bolted connections are recommended as the heat at these frequencies will melt ordinary solder.

In testing out circuits do not apply full rated plate voltage. It is best to cut plate voltage down to at least one half. After proper adjustments are made, then apply full voltage. At no time should full input be applied to a Class "C" stage with no load coupled to it. Do not key or try to modulate a final stage unless an antenna or dummy load is coupled to this stage.

When operating two or more tubes in parallel insert a non-inductive 100 ohm resistor in the grid leads right at the grid terminal on the tube socket to prevent parasitic oscillations.

When it becomes necessary to operate a tube in a horizontal position, place the tube so that the grid turns are in a vertical position, otherwise the expansion of the filament when heated causes the filament to sag and short against the grid.

A TAYLOR TUBE TRANSMITTER

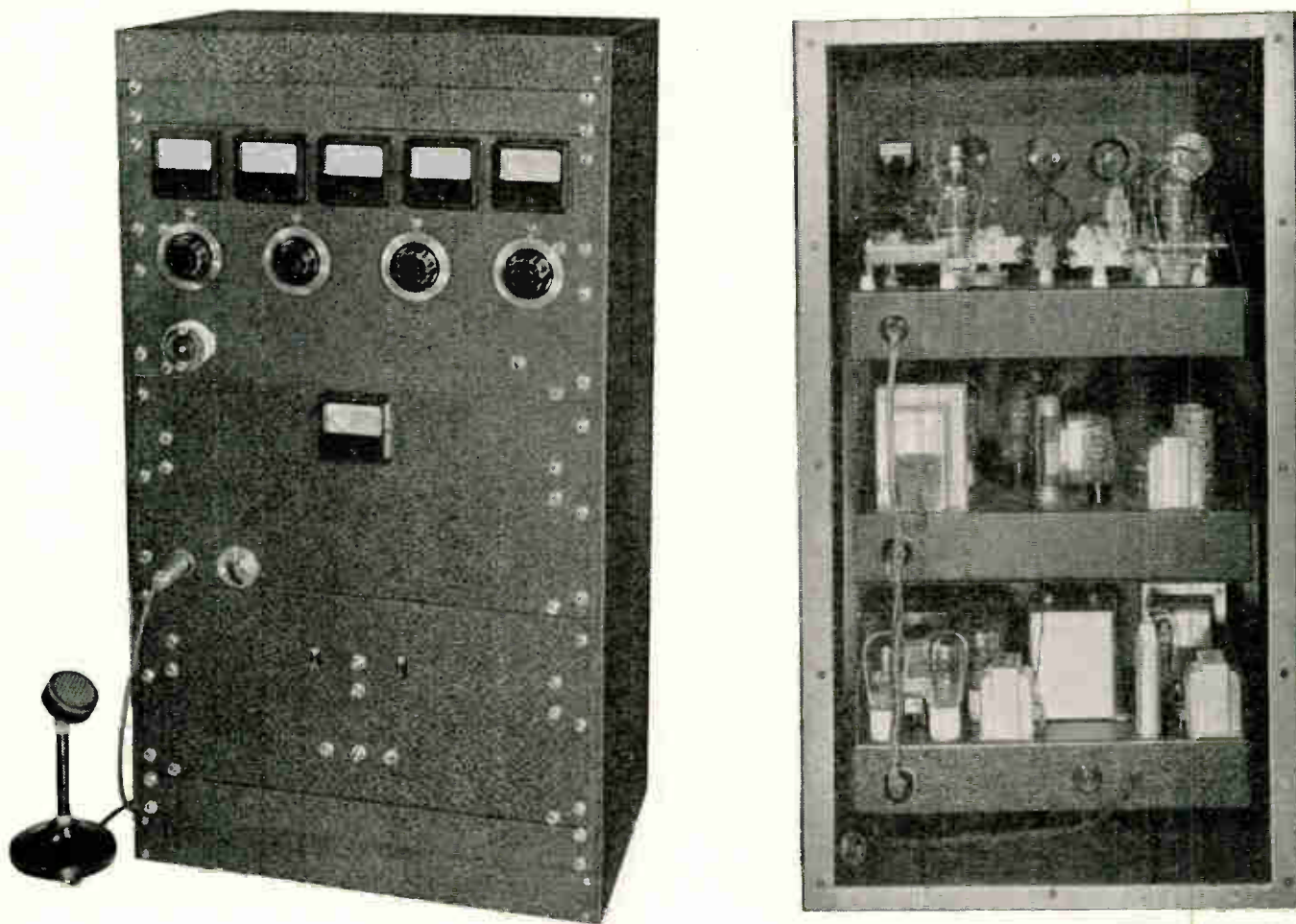

A Complete Taylor Tube Transmitter

This transmitter was built up as a complete unit to illustrate how well any of the RF units described will work into a complete transmitter with a finished and commercial appearance. It was made as small and compact as possible to facilitate carrying or shipping it to conventions and hamfests so you may be able to see and operate it. All of the RF units are designed for equally successful relay rack or cabinet mounting.

It was originally mounted in a Bud No. 1249 32-inch Midget Relay Rack but was remounted in the No. 1262 Bud Cabinet Relay Rack to afford the equipment better protection when being transported. In addition the cabinet rack has $3\frac{1}{2}$ inches more panel space allowing more leeway in power supply parts selection if desired. The finished appearance is somewhat better also.

The panels on the power supply and modulator are $8\frac{3}{4}$ x 19 inch Bud Relay Rack panels. The power supply chassis is set down 2 inches below the lower edge of the panel and the modulator chassis is set down 1 inch below the lower edge of the panel to take advantage of all the space available in the smaller rack. The RF panel measures $12\frac{1}{4}$ x 19". The small $1\frac{3}{4}$ x 19" panels at top and bottom fill in the addition space in the larger rack.

The meters are the new Triplett Series mounting in a $2\frac{1}{4}$ -inch hole but having the same scale length as a 3-inch meter. From left to right, the meters are oscillator plate, buffer plate, buffer or final grid, final plate, and RF feeder current. The toggle switch in the lower right hand corner of the RF panel is the DPDT switch shown in the RF diagram for reading grid current on either the buffer or final with only one meter. The meter in the audio panel is in the Class B plate circuit.

The Turner crystal microphone shown is one of the new VT73 communication type. Its high output level simplifies greatly the problems of hum and RF feedback so often encountered in amateur transmitters.

A 10 TO 160 METER TRANSMITTER

6L6G - T20 - T55 — 150 WATTS — PHONE and C.W.

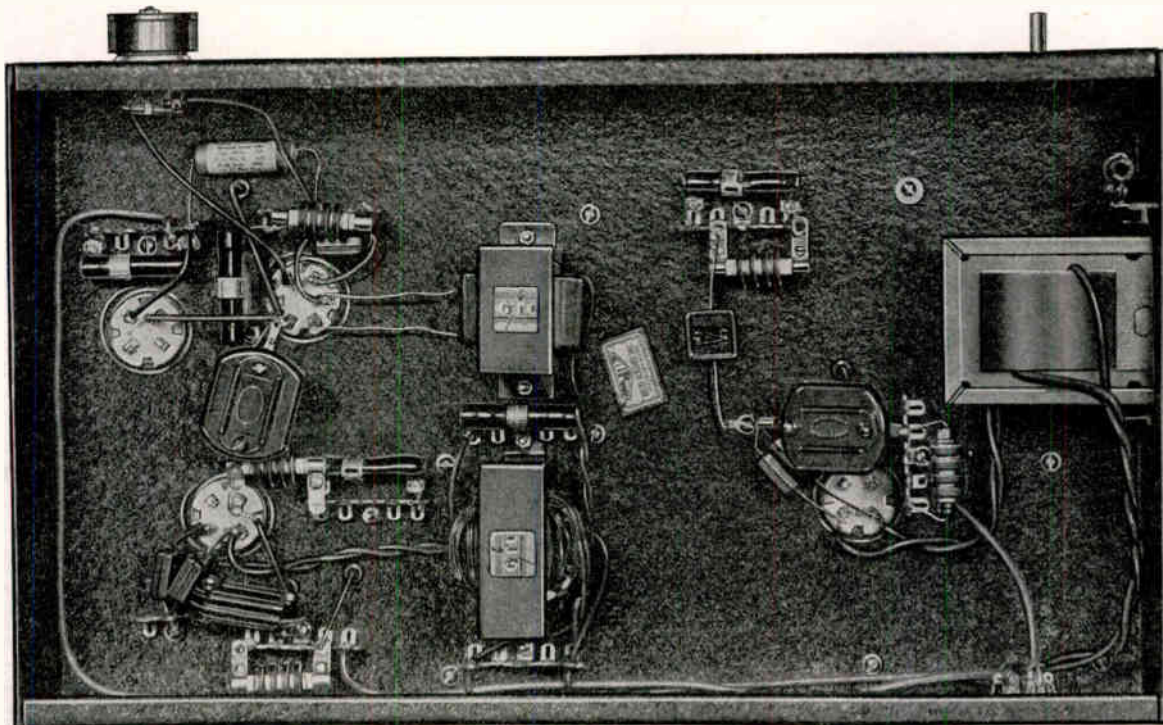
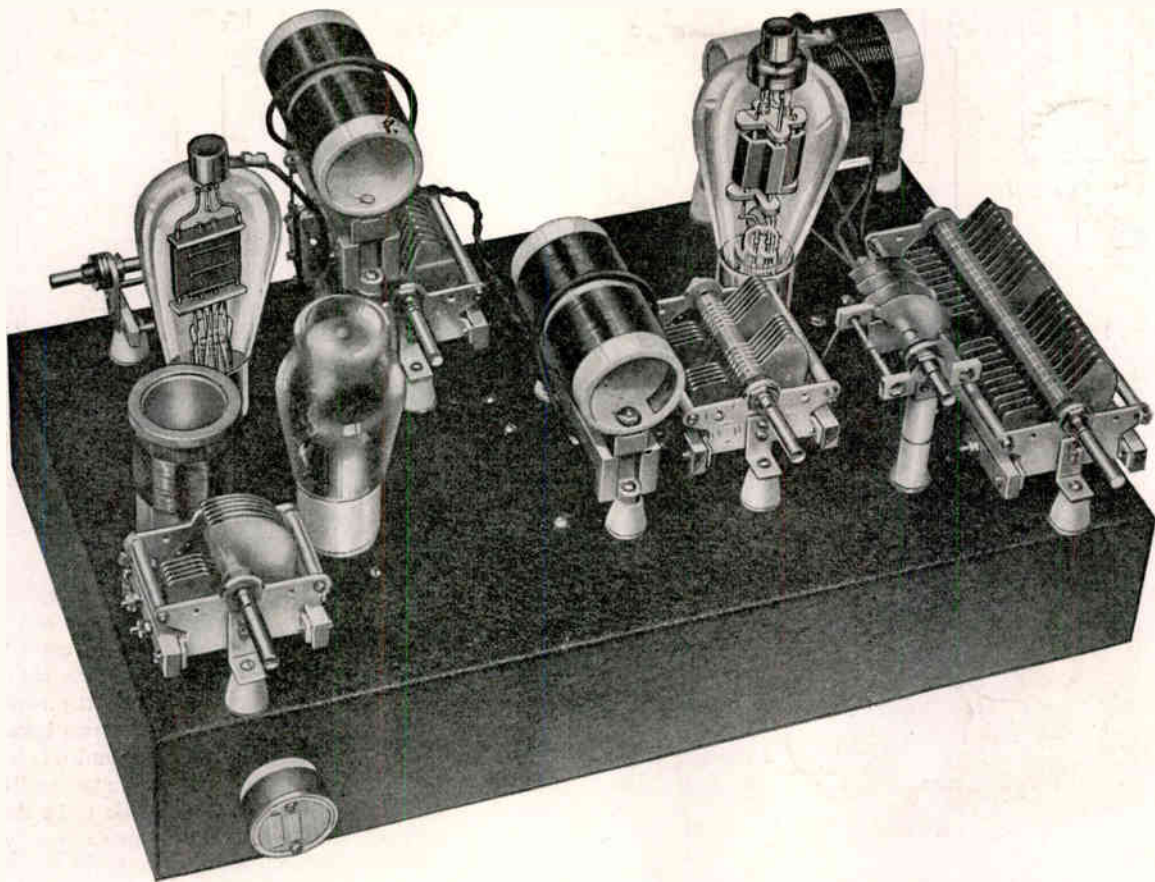

CONSTRUCTIONAL DATA

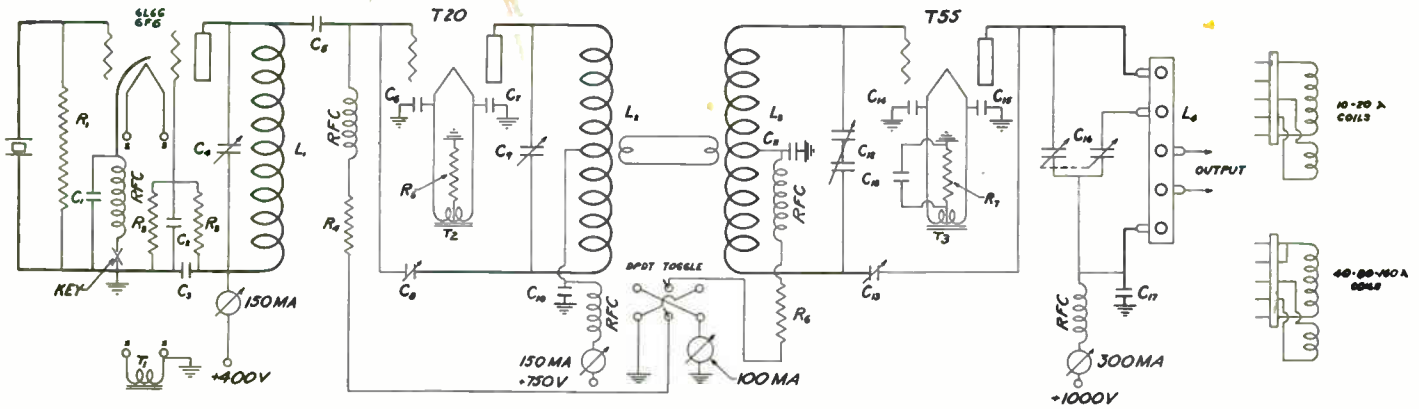

6L6-T20-T55

- R₁—100,000 ohm 1 watt.
- R₂—35,000 ohm 2 watt Ohmite.
- R₃-R₄—10,000 ohm 10 watt Ohmite.
- R₅—400 ohm 10 watt Ohmite.
- R₆—5000 ohm 10 watt Ohmite.
- R₇—400 ohm 10 watt Omite.
- C₁—.00015 mica 600V.
- C₂-C₃—.01 paper 600V.
- C₄—.0001 Cardwell Mr-105-BS.
- C₅—.0001 mica 2500V.

- C₆-C₇—.006 mica 600V.
- C₈—8 mmfd. max with one stator plate removed Bud 564.
- C₉—100 mmfd. Cardwell MT-100-GS.
- C₁₀—.002 mica 2500V.
- C₁₁—.002 mica 600V.
- C₁₂—Double section 100 mmfd. Cardwell MR-100-BD.
- C₁₃—8 mmfd. max. 2 outside stator plates removed Bud 564.
- C₁₄-C₁₅—.006 mica 600V.

- C₁₆—Double section 100 mmfd. Cardwell MT-100-GD.
- C₁₇—.002 mica 5000V.
- C₁₈—8 mfd. 450V electrolytic.
- RFC—2.5 mr. RF chokes Bud.
- T₁—6.3V General 1052, Stancor XP-4019, Thordarson T-61F85.
- T₂—7.5V General 8008, Stancor XP-3022, Thordarson T-16F13.
- T₃—7.5V General 8009, Stancor XP-4018, Thordarson T-16F14.

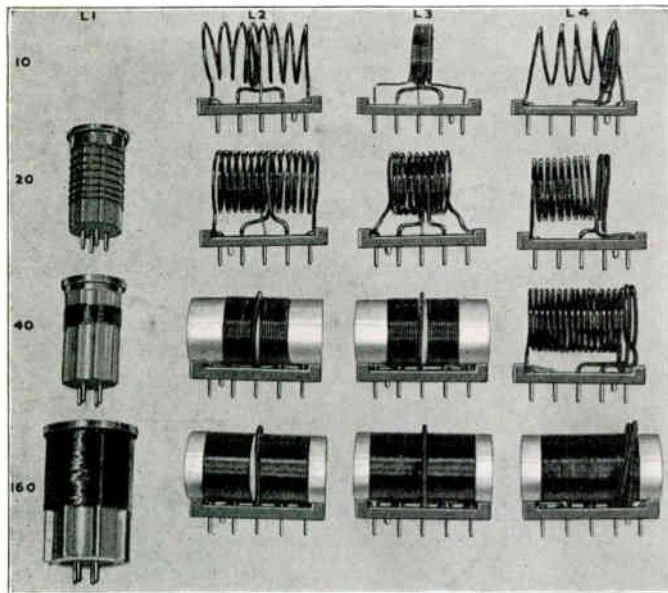

COIL DATA

Band	L ₁	L ₂	L ₃	L ₄
1.75 Mc.	45 t. No. 18 2 1/4" dia. close wound	72 t. No. 20 1 3/4" dia. close wound	78 t. No. 20 1 3/4" dia. close wound	46 t. No. 16 1 3/4" dia. close wound
3.5 Mc.	26 t. No. 18 1 1/2" dia. close wound	36 t. No. 14 1 3/4" dia. close wound	44 t. No. 16 1 3/4" dia. close wound	19 t. No. 14 1 3/4" dia. close wound
7 Mc.	12 t. No. 18 1 1/2" dia. close wound	22 t. No. 14 1 3/4" dia. close wound	24 t. No. 14 1 3/4" dia. close wound	16 t. No. 10 1 3/4" dia. 2 1/2" long
14 Mc.	8 t. No. 18 1 1/2" dia. 1 3/4" long	14 t. No. 10 1 3/4" dia. 2 3/4" long	10 t. No. 10 1 3/4" dia. short as possible	10 t. No. 10 1 3/4" dia. 1 7/8" long
28 Mc.		8 t. No. 10 1 3/4" dia. Approx. 3" long	6 t. No. 14 1 3/4" dia. short as possible	5 t. No. 10 3 3/4" dia. 2 3/4" long

A THREE STAGE TRANSMITTER UNIT FOR 1.75 to 30MC OUTPUT

By far the greatest problem in the design of an all-band amateur transmitter is that of maintaining suitable L/C ratios in the final stage. Insufficient capacity results in high harmonic content and poor linearity if modulated. Too much capacity results in poor efficiency. Because most transmitting condensers have a capacity ratio of about 4-to-1, a maximum of 3 adjacent bands may be covered with proper ratios. Operation on any other bands will leave a great deal to be desired. The transmitter to be described approaches the ideal condition over the full range from 1.75 to 30MC. Actually, the L/C ratio on 30Mc. is slightly lower than the optimum value but the performance should be entirely satisfactory. On 1.75 Mc. the L/C ratio is slightly higher than is desirable for 'phone operation but is adequate for reasonable harmonic suppression.

Only 3 stages are used, a 6L6G or 6F6, a T20 and a T55. Using a 20 or 40-meter crystal more than enough excitation to the final may be obtained on 30MC and on the lower frequencies the T20 loads along delivering only about 1/4 of full output when exciting the T55.

In order to obtain the necessary high capacity ratio, grid neutralization, permitting an unbalanced output circuit, is used in the final stage. The plate tuning condenser is a Cardwell MT-100-GD selected because of its high maximum to minimum capacity ratio (100mmfd. maximum, 13 mmfd. minimum per section). By using only one section or both sections in parallel, the ratio is 15.4 to 1. The final stage voltage and current were then selected to fit the L/C ratios available and the condenser spacing. The T55 should be operated at a 1000 volts and 150MA or less. Operation over so wide a range cannot be achieved without some compromises. One section of the condenser is used on 28 and 14MC and both in parallel on 7, 3.5 and 1.75 mega cycles.

In one respect grid neutralization is rather a bad actor at the higher frequencies. The grid of the tube puts a resistive load across half of the input coil which results in the opposite end of the coil being other than 180° out of phase, the condition necessary for neutralization, if the coupling is less than unity. Unity coupling is never realized in actual practice but satisfactory results are obtained if the coil is made as short as possible with the minimum spacing between turns. The best cure, that of putting a resistor across the neutralizing half of the coil equal to the grid of the tube, wastes too much driver power on 10 meters but could be used on the lower frequencies if desired. The 10 and 20 meter grid coils

CONSTRUCTIONAL DATA—6L6G—T20—T55 TRANSMITTER

should be wound as shown with the turns as close together as possible. If this is done no difficulty will be experienced. The neutralization will hold from 20 to 160 meters and only a slight re-adjustment need be made for 10 meters. The neutralization seems to be better with the center of the coil grounded as shown than with the condenser rotor grounded.

The T55 stage operates normally with grid currents of 20MA or more. In no event should the rectified grid current exceed the maximum rated value of 40MA. No improvement in performance is noted if the grid current exceeds 25MA and it is recommended that the stage be operated with 25MA of grid current under load. Condenser C14 may be used as the excitation control. If tuned to exact resonance, particularly on the lower frequencies, the grid current may be as high as 80MA. C14 should be tuned on the low frequency or high capacity side of resonance until the 25MA optimum value of excitation is obtained. Operation on the high capacity side of resonance is advantageous because it helps to make the driving voltage more sinusoidal.

The unit is very flexible and may be used in 4 different combinations on 20, 40, 80 and 160 meters, and in two combinations on 10 meters.

1. The unit may be operated straight through on the crystal frequency. A 6F6G should be used in place of the 6L6G on 20 and 40.

2. The crystal may be one half the output frequency, doubling in the crystal oscillator and working straight through in the buffer and final. This is recommended for 20 and 40.

3. The crystal may be one fourth the output frequency, doubling in the crystal stage and again in the T20 stage.

4. The crystal may be one half the output frequency, working straight through in the crystal stage and doubling in the T20 stage. The 6F6G should be used in place of 6L6G when using 20 and 40 meter crystals.

Combination 3 or 4 is necessary for ten meter operation, 3 with a 40 meter crystal and 4 with a 20 meter crystal. It was not found feasible to use a 20 meter crystal and double to 10 in the crystal stage with this oscillator circuit because the 20 meter crystal appeared to be a 60 meter fundamental type which operated on its third harmonic. With this circuit, the 10 meter output apparently was the sixth harmonic of 60, and was too low to be usable.

For c.w. operation the transmitter may be keyed in the cathode of the crystal stage or in any other conventional manner. If keyed in the crystal stage, the key should be in series with the r.f. choke and the following stages should be biased to cut-off with some source of fixed bias.

The 10-meter T20 and T55 plate coils should be wound as shown. The inductance of each should then be varied by compressing or expanding the coils (reducing or increasing the spacing between turns) until resonance is achieved with the minimum amount of capacity in the circuit which will permit proper tuning. In other words, the highest L/C ratios possible are necessary for best efficiency. The coils for all other bands will be correct if duplicated mechanically.

All of the grounds for each stage should connect together and to the chassis at a common point near the mechanical center for that stage to make all leads as short as possible. The chassis measures 10 by 17 by 3 inches and the layout should follow that illustrated as closely as possible.

The number of turns in the output coil coupled to L4 will depend upon the impedance of the feeders and the coupling method used. Coupling should always be to the cold end of the coil. All link coils coupled to L2 and L3 are one turn each.

The first two stages, the 6L6 and T20, make a satisfactory lower-power transmitter with an output of 40 to 45 watts from 20 to 160 meters and 15 to 20 watts output on 10. With suitable power supplies this would make an excellent portable transmitter. For phone work, the excitation to the T20 is sufficient for plate modulation.

AUDIO

This speech amplifier was designed to have sufficient gain for any of the crystal microphones commonly used by amateurs and to have enough power output to drive any of the class B tubes we manufacture. In addition the cost was kept as low as possible consistent with good performance and all fancy circuit arrangements were avoided to assure best results with a minimum of complications.

6A3's were selected for use in the class B driver stage because low impedance triodes make the best class B drivers. Incidentally pentodes and tubes with pentode characteristics such as 6L6's make the poorest class B drivers. The ideal Class B driver tube would be a constant voltage tube. The 2A3 or 6A3 is the closest approach to a constant voltage tube available to the amateur today. On the other hand tubes with pentode characteristics are substantially constant current tubes and are just exactly the opposite of what is necessary for best results. Where tubes of this type are used as drivers it is common practice to load the driver tubes with resistance to improve the regulation. Such resistance, if used to improve voltage regulation, should be across the **primary** of the input transformer and not across the secondary. We recommend using tubes with the correct characteristics for the job rather than using tubes with inferior characteristics and attempting to compensate for these deficiencies with degeneration or other methods.

Cathode bias is used, since the output is adequate with the tubes operating class A, and therefore fixed bias is not necessary.

It was decided to use a push-pull 76 stage and a low ratio transformer ahead of the 6A3's so that if under unusual conditions the grids of the driver stage were driven positive the resulting distortion would be limited to that caused by bias shift only, instead of the far more serious distortion which would result if a high impedance class A input circuit were used.

The 6C6 and 76 furnish the desired amount of voltage gain. The filter choke, decoupling resistors, and by pass condensers filter the plate supply so that even a fairly high percentage of ripple in the power supply will not introduce hum in the amplifier.

The power supply voltage must be equal to the desired plate voltage plus the bias voltage. A supply voltage of approximately 350 should be adequate.

The RF choke and C₁ are a filter to prevent RF from reaching the first grid. It invariably does so to an entirely satisfactory degree. Although a crystal microphone has high internal impedance the .0001 condenser does not have any appreciable effect on frequency response because of the characteristics of the microphone. If RF is still present another .0001 condenser from grid to ground of the second stage may help.

The speech amplifier-driver was built up as shown on the same chassis as a TZ20 class B stage for the complete Taylor transmitter. The 6A3's are capable of far more output than is necessary to drive a pair of TZ20's but a large ratio of available power to required power is desirable for best results.

Many amateurs are under the impression that a low impedance line is necessary between the class B driver and the modulator if they are some distance apart. Actually class B grids are of low impedance and the grid leads may be extended the necessary distance in shielded wire. A properly designed class B input transformer will be built so that the coupling between windings will be as tight as possible to keep leakage reactance at the absolute minimum. This is extremely important. If two transformers are used with a low impedance line connecting them the leakage reactance must necessarily be higher than if only one transformer of equal quality is used. Consequently the use of a low impedance line may result in inferior results. If the use of a low impedance line is essential best design would be to put at least the driver stage with the modulator and use the line where the design requirements are not as stringent.

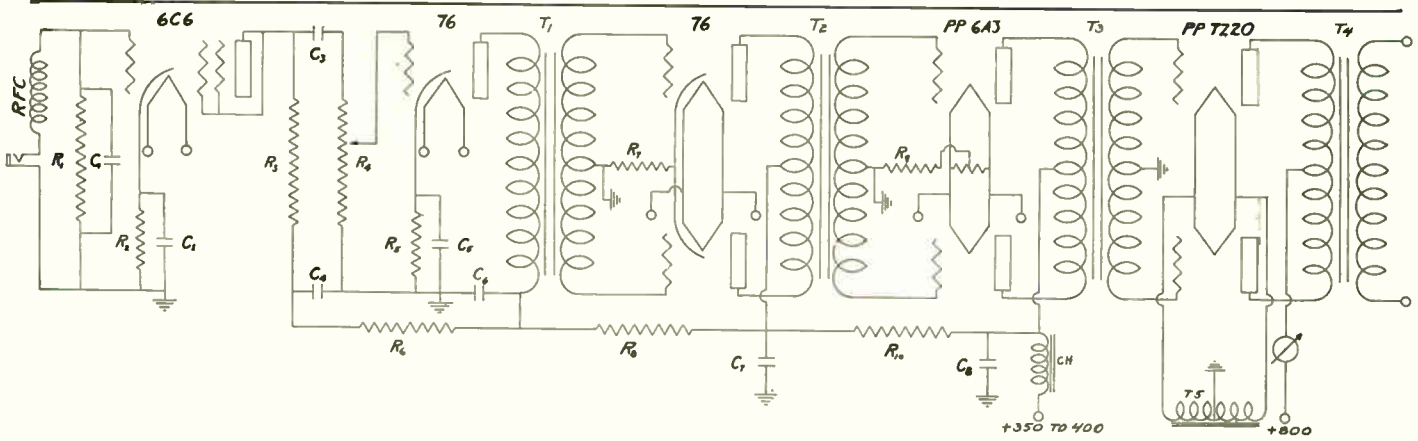

TAYLOR AUDIO FREQUENCY UNIT SCHEMATIC

PARTS LIST

- R₁—5 meg. 1 watt.
- R₂—2500 ohm 1 watt.
- R₃—250,000 ohm 1 watt.
- R₄—250,000 ohm variable.
- R₅—2500 ohm 1 watt.
- R₆—50,000 ohm 1 watt.
- R₇—1500 ohm 1 watt.
- R₈—20,000 ohm 1 watt.
- R₉—800 ohm 10 watt Ohmite.
- R₁₀—10,000 ohm 10 watt Ohmite.
- C₁—.0001 mica C-D.

- C₂—10 mfd. 25V electrolytic C-D.
- C₃—.01 600V paper C-D.
- C₄—2 mfd. 450V electrolytic C-D.
- C₅—10 mfd. 25V electrolytic C-D.
- C₆—2 mfd. 450V electrolytic C-D.
- C₇—8 mfd. 450V electrolytic.
- T₁—Single plate to pushpull class A grids.
Stancor XA-4206, General 2210, Thordarson T-13A34, Utah 7814.
- T₂—Pushpull 76s to class A prime 6A3s.
Stancor XA-4208, General 2294, Thordarson T-74D32, Utah 7815.

- T₃—Class B input.
Douglas D-101, Thordarson T-15D79,
Stancor XA-4212, General 3273.
- T₄—Class B output.
Douglas D-100, Thordarson T-11N75,
Stancor XA-2908, General 3330.
- CH—30 hy. 100MA filter choke.
General 1125, Stancor XC-1001, Thordarson T-13C30, Utah 4508.
- RFC—Bud 2.5 mh RF coke.

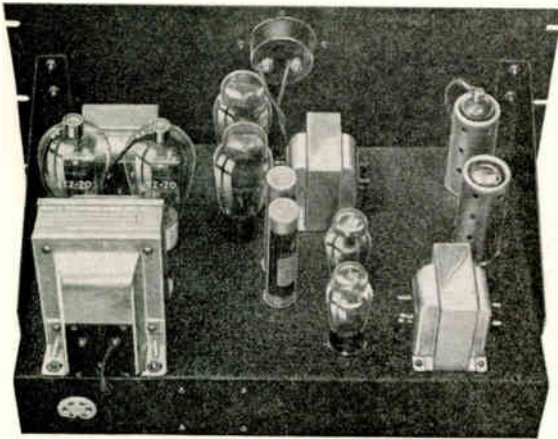

AUDIO EQUIPMENT

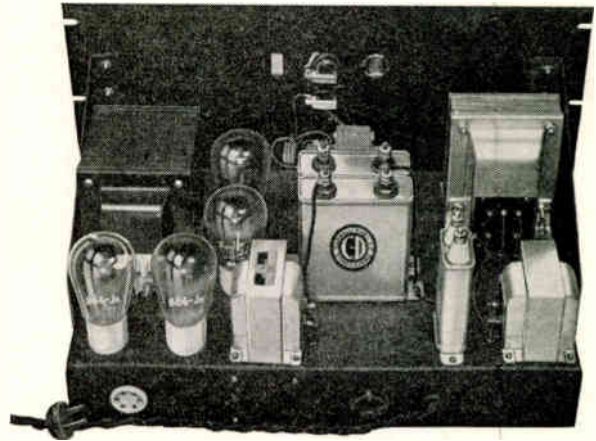

POWER SUPPLY

- T₁—400V DC after filter 150MA or more.
Stancor XP-3010, General 2814, Thordarson T-5303, Utah 1800.
- T₂—1000V and 750V DC after filter 250MA or more.
Stancor P-4030, General 2819.
- T₃—5V 3A Stancor XP3026, General 2095, Thordarson T-16F11.
- CH—Swinging input choke 150MA or more.
Stancor C1400, General 2157, Thordarson T-6405, Utah 4500.
- C₁—4 mfd. 600V Cornell Dubilier.
- C₂—mfd. 1500V Cornell Dubilier.
- X₁, X₂, X₃, X₄, X₅, toggle switches.

POWER SUPPLY

For the RF and modulator units 3 different voltages are necessary, 400 volts, 750 volts, and 1000 volts. The audio amplifier and crystal oscillator operate from the same 400 volt supply. Both the T20 buffer and T220 Class B stage operate at 750 volts and the final stage at 1000 volts. In the smaller rack in which the transmitter was mounted originally, space was at a premium and the largest chassis which could be accommodated was 10 x 17 inches. In addition, the height of the unit had to be kept to the absolute minimum. The 400 volt transformer is tapped for 400 or 500 volts at 175MA. The total drain for both speech amplifier and crystal stage is a maximum of about 150MA.

For the modulator, buffer, and final stage one power transformer designed to deliver 750 and 1000 volts from the filter with choke input at a total of 250MA is used to obtain both voltages. The final operates at 150MA and the buffer at about 50MA. The no-signal

(Continued on Page 34)

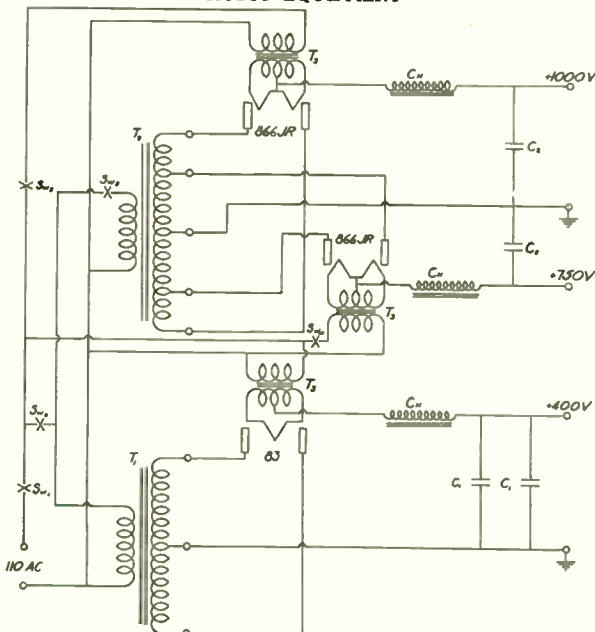

POWER SUPPLY CIRCUIT

825

756

211c

211

~~203~~

845

~~203~~

203 ✓

822 ✓
TW 150 ✓

200 ✓

155 ✓
T100 ✓

125 ✓
T60 ✓

55 ✓

110 ✓
T240 ✓

T220 ✓

T20 ✓

T24 ✓

841A

✓ 866

✓ 866 Jr

866B

872

74 D 203-C DIA

H D 211 C

204A

203A

⊕ - 1000 ✓
MIL

1 amp -
✓ plane

A 110 TO 450 WATT TRANSMITTER

6L6G — T-20 — P.P.T-20
T-55 — P.P.T-55

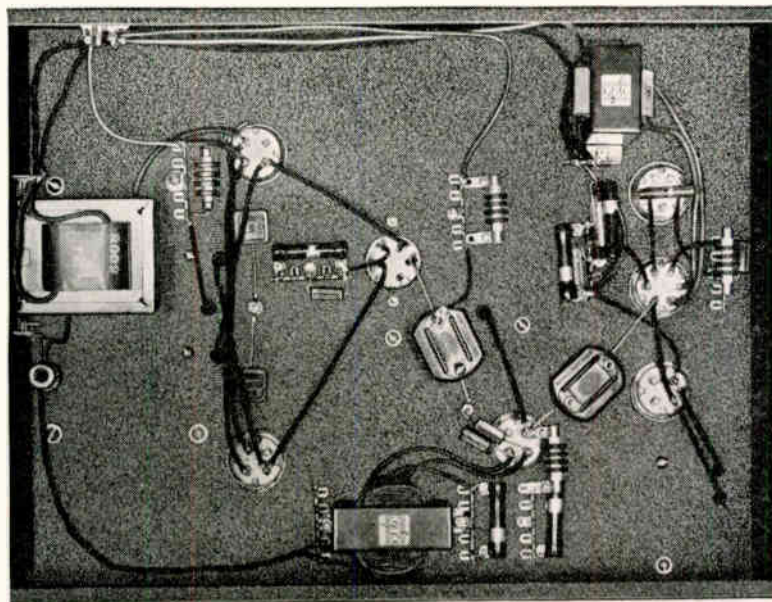
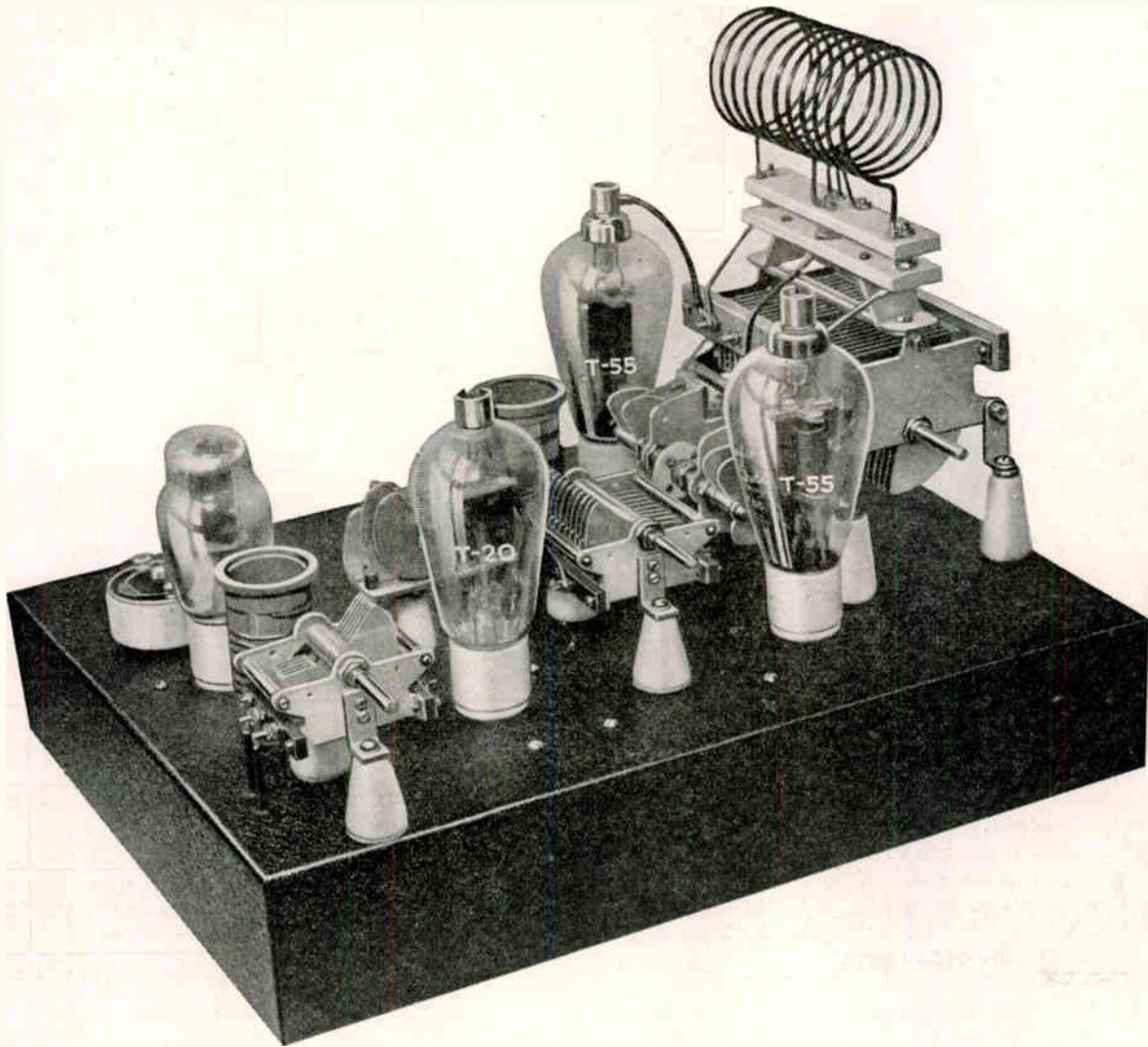

A 110 TO 450 WATT TRANSMITTER

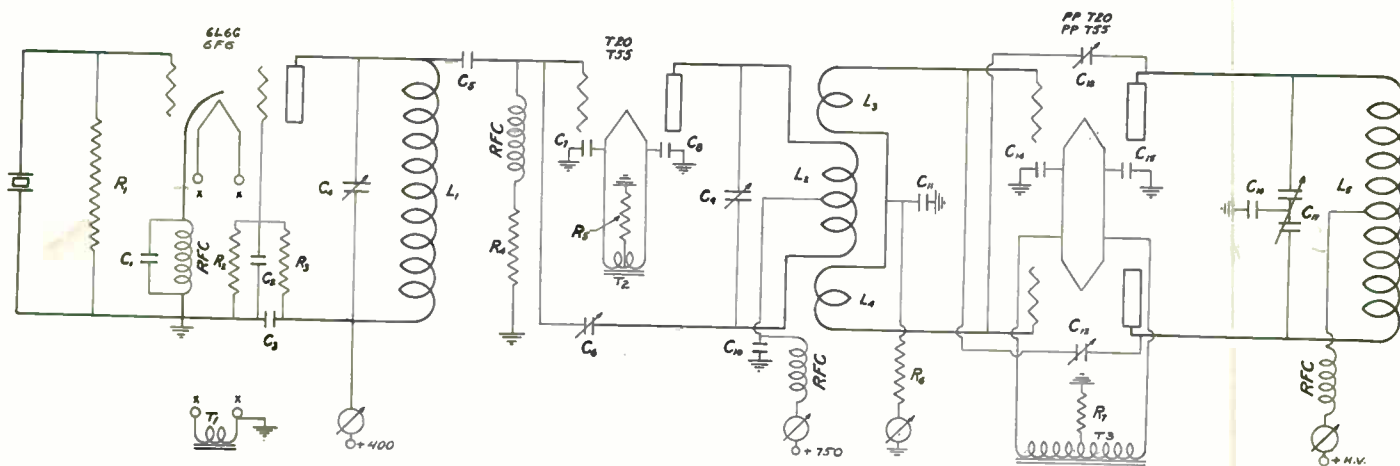

CIRCUIT DIAGRAM

PARTS LIST

- R₁—100,000 ohm 1 watt.
- R₂—35,000 ohm 2 watt Ohmite.
- R₃—10,000 ohm 10 watt Ohmite.
- R₄—5000 ohm 10 watt Ohmite.
- R₅—400 ohm 10 watt Ohmite.
- R₆—5000 ohm 10 watt Ohmite.
- R₇—200 ohm 20 watt Ohmite.

- C₁—.00015 mica 600V C-D.
- C₂-C₅—.01 paper 600V C-D.
- C₄—.0001 Cardwell MR-105-B5.
- C₅—.0001 mica 2500V.
- C₆—Cardwell NA-6-NS.
- C₇-C₉—.006 mica 600V C-D.
- C₁₀—.0001 Cardwell MT-100-GS.
- C₁₀—.002 mica 2500V.
- C₁₁—.002 mica 600V C-D.
- C₁₂-C₁₈—Cardwell NA-6-NS.

- C₁₄-C₁₈—.006 mica 600V C-D.
- C₁₆—.002 mica 5000V.
- C₁₇—Cardwell XT-210-PD.
- RFC—2.5 mh. RF chokes Bud.
- T₁—6.3V General 1052, Stancor XP-4019, Thordarson T-61F85.
- T₂—7.5V General 8008, Stancor XP-3022, Thordarson T-16F13.
- T₃—7.5V General 8009, Stancor XP-4018, Thordarson T-16F14.

6L6—T20—PP T55

This unit is intended for use with either T20's or T55's in the final stage. No change need be made to adapt it to either type of tube. With T20's in the final stage the maximum input would be expected to be somewhat less, about 60 to 75 watts. This unit also makes an excellent exciter unit for higher power transmitters.

With T55's in the final the maximum input would be 1500V 300MA or 450 watts. On all bands from 20 to 160 meters the output should be approximately 340 watts. The T20 buffer will furnish adequate excitation to the final stage.

The coupling between the T20 buffer and the final stage is inductive. This results in one less plug in coil to wind and change and one less tuning condenser to adjust when changing bands. But it also results in more work on the buffer coil because the excitation to the final stage must be adjusted experimentally. With excessive coupling the input to the buffer and the excitation to the final will be too high. With insufficient coupling the grid drive to the final will be too low. The coupling is adjusted by changing the number of turns on the grid windings and by changing the spacing between the grid coils and the buffer plate coil. The number of turns on each grid coil and the spacing between each plate coil must be the same. If the coils are built according to specifications probably only the spacing need be adjusted but it might be well to wind 2 or 3 extra turns on each grid coil and then remove them one at a time until the proper amount of excitation to the final is achieved. With T20's in the final the rectified grid current should be 35MA and with T55's 50MA with plate voltage applied and the antenna coupled to the final stage.

The performance of this unit leaves little to be desired on the 14MC and lower frequency bands. When operating on 10 the buffer must be used as a doubler. Because the grid windings place a considerable amount of capacity across the plate coil the high L/C ratio desirable for most efficient doubler operation cannot be obtained. The T20 or T20Z as a doubler will furnish enough excitation for a pair of T20's in the final. If T55's are used in the final a T55 should be used in the doubler to permit increased dissipation and output to obtain sufficient grid drive to the final.

Band	L ₁	L ₂	L ₃ & L ₄ on each side of and on same form as L ₃	L ₅
160	45 t. No. 18 2 1/4" dia. close wound	42 t. No. 18 2 1/4" dia. close wound	Each 17 t. No. 24 wire close wound 1/4" from L ₂ on each side	46 t. No. 12 3" dia. 4" long
80	26 t. No. 18 1 1/2" dia. close wound	30 t. No. 18 1 1/2" dia. close wound	Each 10 t. No. 24 wire close wound 1/4" from L ₂ on each side	26 t. No. 10 2 1/2" dia. 4" long
40	12 t. No. 18 1 1/2" dia. close wound	16 t. No. 18 1 1/2" dia. close wound	Each 6 t. No. 22 wire close wound 1/4" from L ₂ on each side	20 t. No. 10 2 1/2" dia. 4" long
20	8 t. No. 18 1 1/2" dia. 1 3/4" long	10 t. No. 18 1 1/2" dia. 1" long	Each 4 t. No. 22 wire close wound 1/2" from L ₂ on each side	22 t. No. 10 2 1/2" dia. 4" long
10		4 t. No. 18 1 1/2" dia. 1" long	Each 3 t. No. 22 wire close wound 1/2" from L ₂ on each side	6 t. No. 10 2 1/2" dia. 4" long

TAYLOR TUBES' RADIO LADY

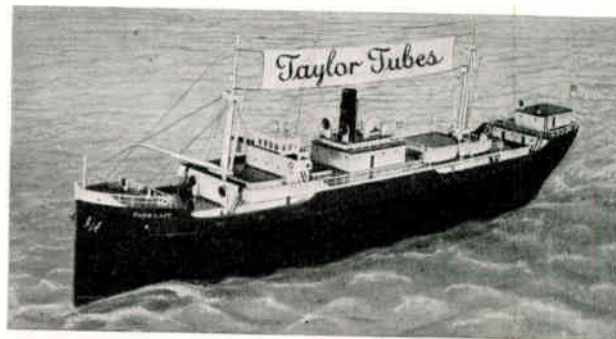

This electrically driven 6 ft. model of an Ocean Freighter was built for Taylor Tubes, Inc., by Felix La Valle, W9GZP, of Hugo, Minn. It is controlled from shore by a 5 meter transmitter.

5 AND 10

METER
TRANSMITTER
(112 WATTS
INPUT)

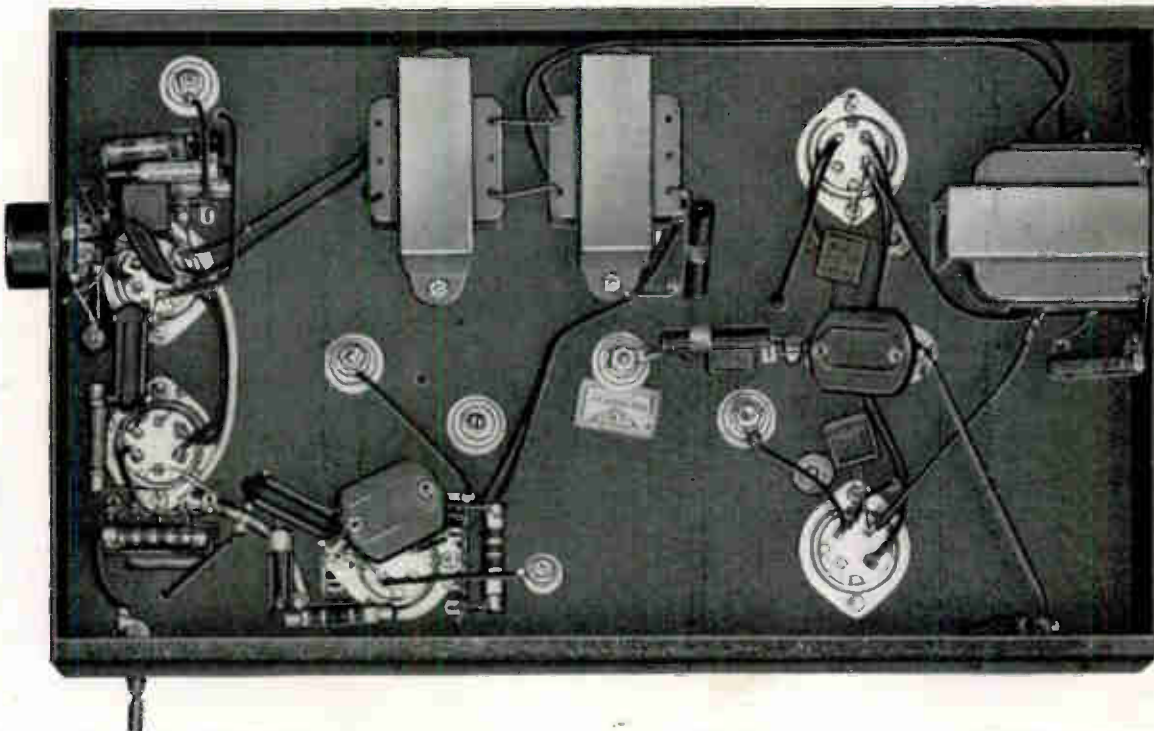
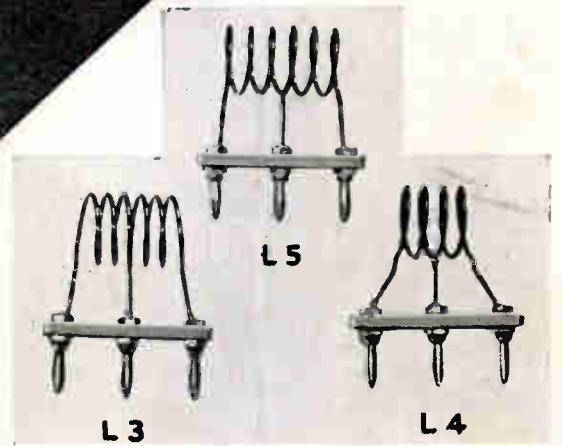
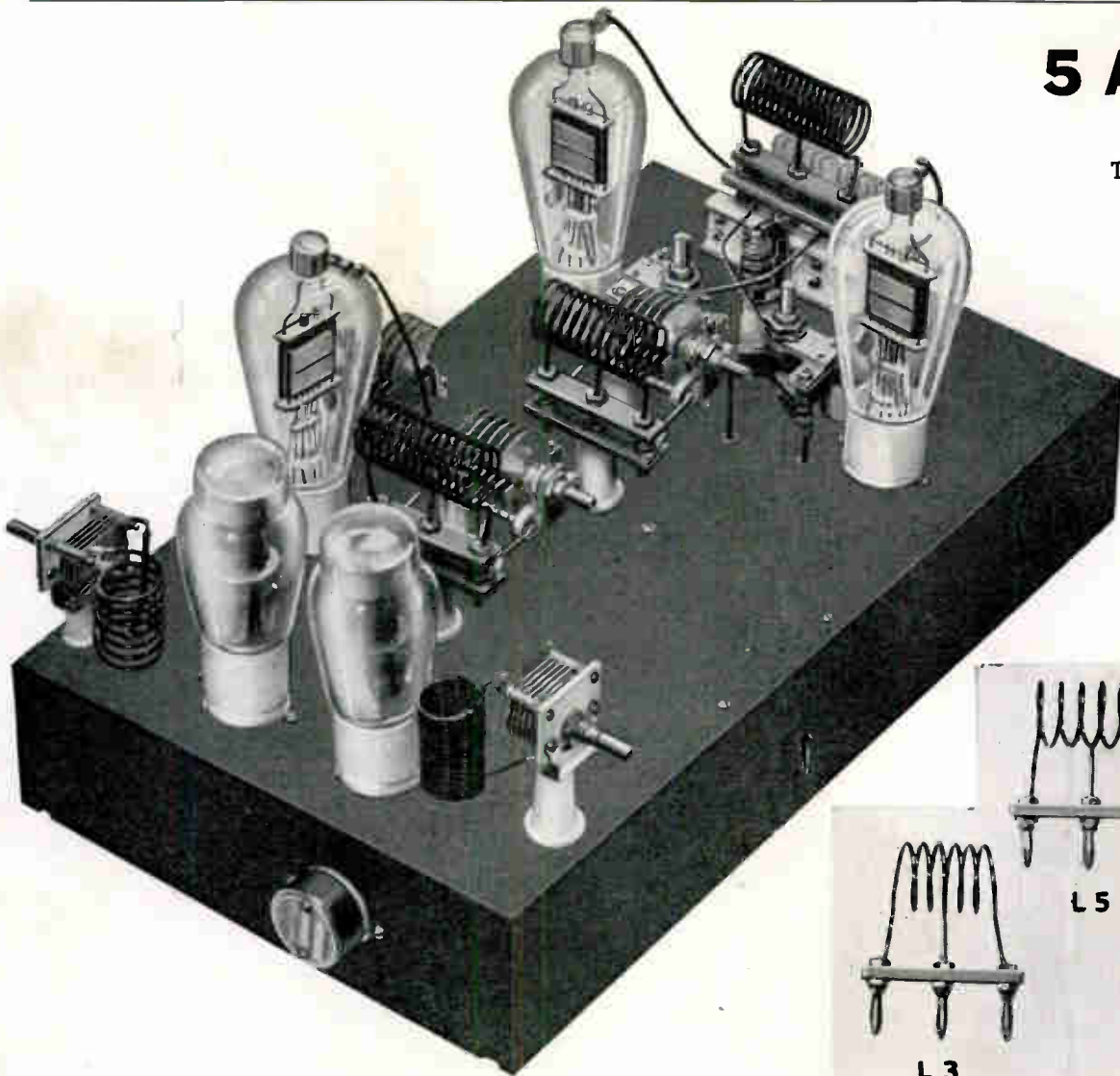

112 WATTS ON 5 AND 10 METERS

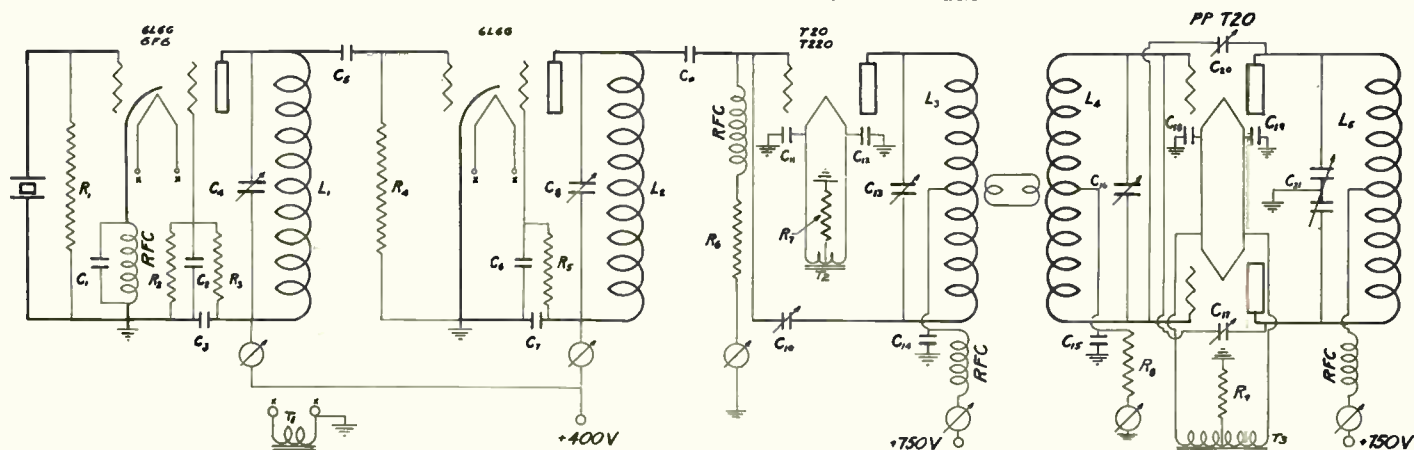

CIRCUIT DIAGRAM

PARTS LIST

- R₁—100,000 ohm 1 watt.
- R₂—35,000 ohm 2 watt Ohmite.
- R₃—10,000 ohm 10 watt Ohmite.
- R₄—50,000 ohm 1 watt.
- R₅—25,000 ohm 10 watt Ohmite.
- R₆—5000 ohm 10 watt Ohmite.
- R₇—400 ohm 10 watt Ohmite.
- R₈—2500 ohm 10 watt Ohmite.
- R₉—200 ohm 10 watt Ohmite.
- C₁—0.0015 mica 600V C-D.

- C₂—C₅—.01 paper 600V C-D.
- C₆—.000035 Cardwell ZR-35-AS.
- C₇—.0001 mica 2500V.
- C₈—C₇—.01 paper 600V C-D.
- C₉—.000035 Cardwell ZR-35-AS.
- C₁₀—.0001 mica 2500V.
- C₁₀—National STN.
- C₁₁—C₁₂—.002 mica 600V C-D.
- C₁₃—.000035 Hammerlund MC-35-MX.
- C₁₄—.002 mica 2500V C-D.
- C₁₅—.002 mica 600V C-D.

- C₁₆—.000035 Hammerlund MC-35-MX.
- C₁₇—C₂₁—National STN.
- C₁₈—C₁₉—.002 mica 600V C-D.
- C₂₁—Double section Hammarlund MCD-35-MX.
- RFC—2.5 mh. RF chokes Bud.
- T₁—6.3V Stancor XP4019, General 1052, Thordarson T61F85.
- T₂—7.5V Stancor XP3022, General 8008, Thordarson T16F13.
- T₃—7.5V Stancor XP4018, General 8009, Thordarson T16F14.

COIL CHART—10 METER JOB

Band	L ₃	L ₄	L ₆
10	14 t. No. 10 1" dia. 2 3/8" long	12 t. No. 10 1" dia. 2 1/4" long	16 t. No. 10 1" dia. 2 3/8" long
5	6 t. No. 10 1" dia. 1 3/4" long	4 t. No. 10 1" dia. 1" long	6 t. No. 10 1" dia. 1 1/2" long
L ₁	16T #14	1" dia	1 5/8" long
L ₂	7T #10	1" dia	1 1/2" long

The circuit shown above was designed for efficient operation on 5 and 10 meters. Many requests have been received asking for this particular tube line-up. Without doubt it will work on 20 meters with suitable coils.

The T-20's in the final stage may be operated at the full rated input of 750V, 75MA per tube, an input of 112.5 watts and because the L/C ratios are correct and insulation losses are at a minimum the efficiency will be about the same as that realized on the lower frequencies. Because most transmitters have condensers with enough capacity for operation on the lower frequencies, the minimum capacities are so high that results on 10 with them are disappointing. This unit uses inexpensive tubes and components throughout and may be built so reasonably that most amateurs can easily afford it in addition to their low frequency transmitters.

Four stages are used. The 6L6G doubler stage could have been omitted for 10 meter operation by using the single T20 or TZ20 as a doubler to drive the final but the excitation would have been just barely adequate and it was felt that the small additional expense was justified because it makes a more satisfactory and stable unit and allows 5 meter operation if desired.

If a 40 meter crystal is used, the 6 prong ceramic base 6L6G oscillator tube doubles to 20. If a 20 meter crystal is used the 6L6G should be replaced with a 6F6G. This excites the 6L6G doubler which drives the T20 or TZ20 buffer on 10. The T20 or

TZ20 operates efficiently because it receives approximately 25MA of rectified grid current from the 6L6G. If a lower powered transmitter is desired construction may be stopped at this point because the excitation to the T20 is adequate for plate modulation. The maximum input would be 750V 75MA or about 56 watts and the output 35 to 40 watts.

The T20 or TZ20 buffer furnishes more than enough grid drive to the final. In fact, if more than 112 watts input is desired the PP T20's may be replaced with T55's with inputs up to 300 or 400 watts, but the plate tuning and neutralizing condensers must be replaced with units having greater spacing to handle the increased plate voltage with T55's.

The coils should be wound as shown. As each stage is placed in operation the inductance of each coil should be adjusted by compressing or expanding it until resonance is reached with each condenser as close to minimum capacity as will permit tuning of the circuit. This will assure maximum efficiency.

If 5 meter operation is contemplated a TZ20 should be used in the driver stage instead of a T20 to permit more efficient doubling to 5. For 10 meter operation only either may be used. Again the inductances must be adjusted until they tune with a minimum amount of capacity. With the TZ20 doubler operating at 750V 75MA no color will show on the plate and the grid current to the final will be about 40MA—sufficient for plate modulation of the PP T-20's with full input. On 5 meters with 112 watts input to the final stage the output was about 60 watts.

The plug-in terminals are made of mycalex insulation and banana plugs and jacks. The jacks and plugs are spaced 1" apart on centers. No suitable units were commercially available so it was necessary to make them up. Strip or sheet mycalex is available from most jobbers and it may be sawed and drilled like bakelite. Bakelite will not do because its losses are too high at these frequencies. If only one band operation is contemplated the inductances may be soldered to the condensers as are the oscillator and doubler inductances which need not be changed for 5 or 10 meter operation.

A PUSH-PULL T-55 AMPLIFIER

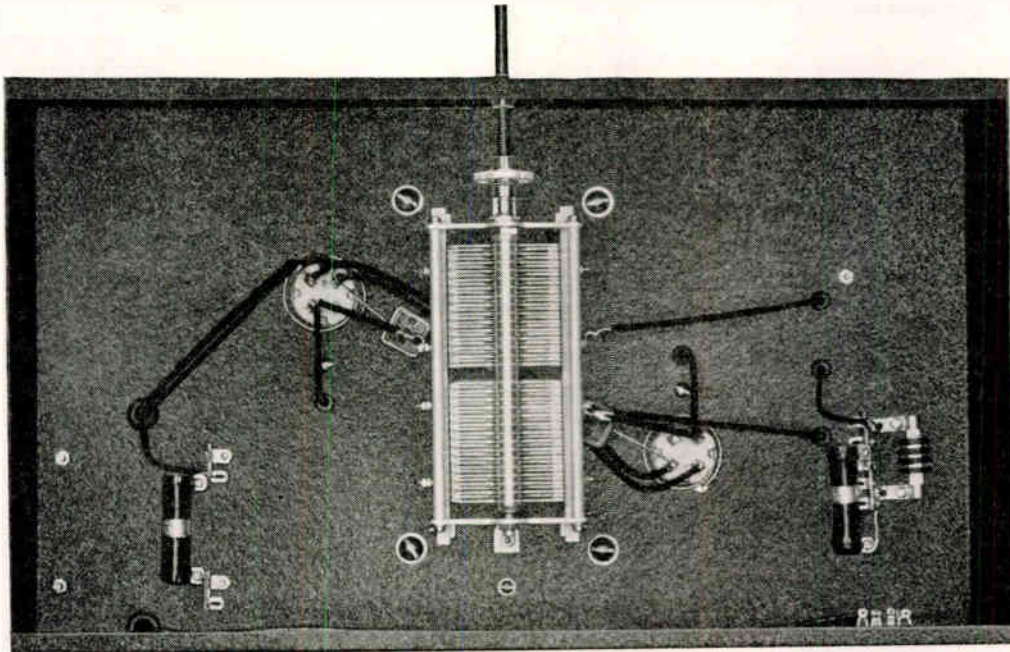
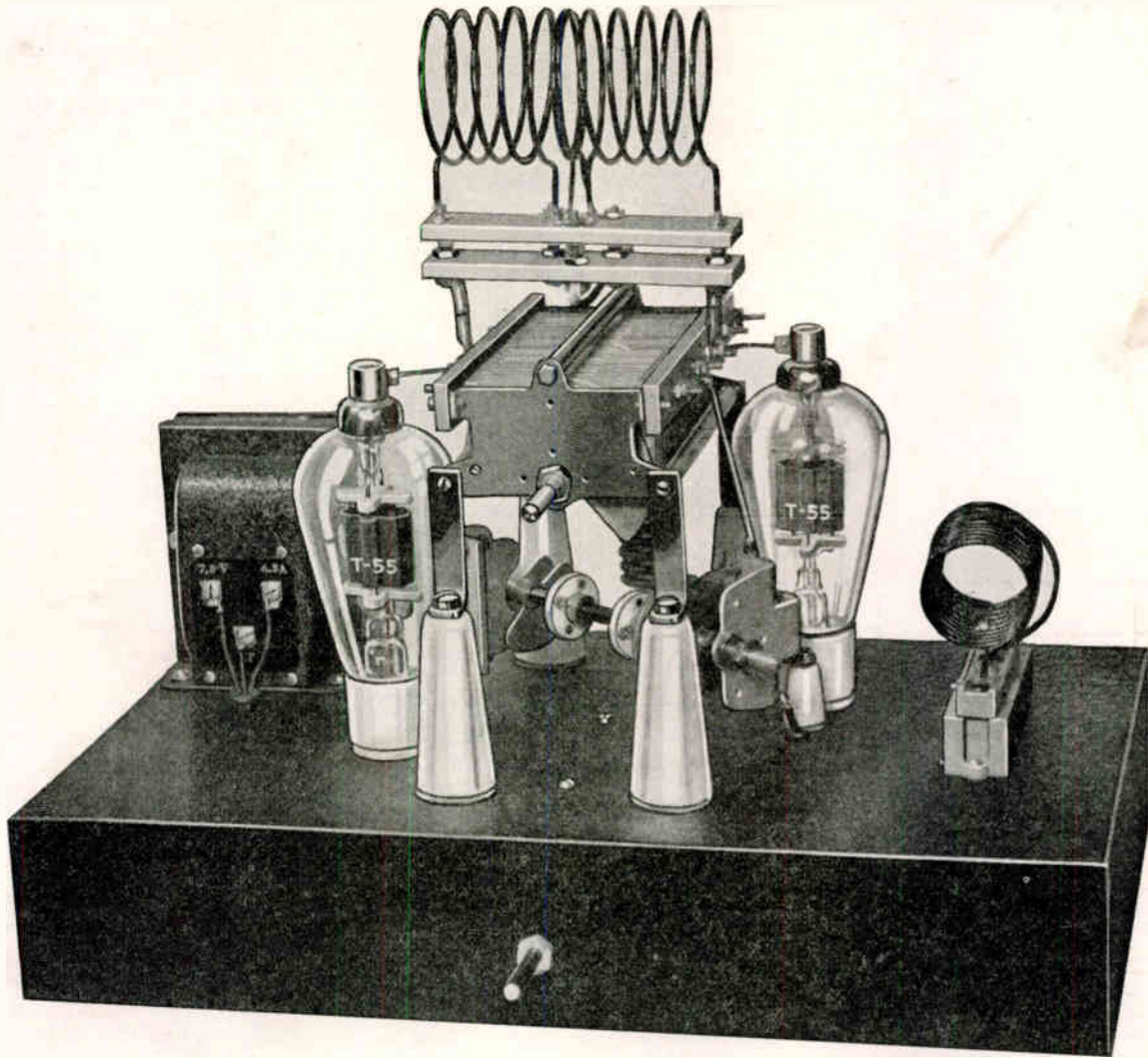

A PUSH-PULL T-55 AMPLIFIER

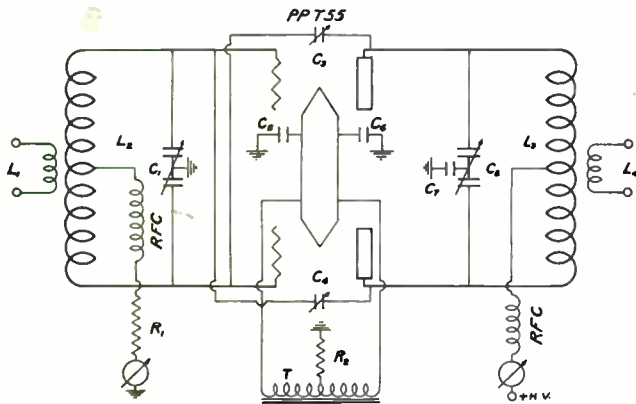

PP T55s

- R₁—2500 ohm 20 watt Ohmite.
- R₂—200 ohm 20 watt Ohmite.
- C₁—180 mmfd. per section
Cardwell Mo.-180-BD.
- C₂—165 mmfd. per section
Cardwell XP-165-KD.
- C₃-C₄—Cardwell NA-6-NS.
- C₅-C₆—.006 mica 600V C-D.
- C₇—.002 mica 5000V.
- T—7.5V6.5A Utah 1819, Thor-
derson T-64F35, Gen-
eral 4019, Stancor
XP-4018.

COIL CHART PP T55

Band	L ₂	L ₃
160	68 t. No. 20 1 3/4" dia. close wound	46 t. No. 12 3" dia. 4" long
80	36 t. No. 14 1 3/4" dia. close wound	26 t. No. 10 2 1/2" dia. 4" long
40	20 t. No. 14 1 3/4" dia. close wound	20 t. No. 10 2 1/2" dia. 4" long
20	14 t. No. 10 1 3/4" dia. 2" long	12 t. No. 10 2 1/2" dia. 4" long
10	8 t. No. 10 1 3/4" dia. 2" long	6 t. No. 10 2 1/2" dia. 4" long

- L₁—One or two turns at center of coil to be determined experimentally.
- L₄—One or more turns at center of coil depending upon impedance of antenna system.

PP T20's OR T55's

This final stage arrangement features perfect symmetry both electrically and mechanically. In addition, all leads which are important are extremely short. The result is a unit which performs beautifully and holds neutralization from 10 to 160 meters. The neutralizing condensers are ganged to afford the last word in neutralizing convenience.

The grid tuning condenser is a Cardwell MO-180-PD and is mounted under the center of the chassis with Cardwell midway mounting brackets. The spacers furnished with the condenser for panel mounting are used to space the condenser from the chassis. The condenser frame is at ground potential and is grounded through the mountings. All other grounds connect to a common point in the center of the chassis.

The plate tuning condenser is a Cardwell XP-165-KD with a maximum capacity of 165MMFD and a minimum of 23MMFD per section, permitting optimum L/C ratios on 20, 40 and 80 meters. If the 10 meter inductance is adjusted so resonance is reached with the condenser at approximately minimum capacity, the L/C ratio will be only slightly lower than the optimum value. The maximum capacity is only about half that desired for 160 meter operation. On 160 the plate current may be reduced to half, 150MA for a pair of T55's at 1500 volts or 75MA for a pair of T20's at 750 volts or the unit may be built with a larger plate tuning condenser. The large stand-offs supporting the plate tuning condenser are Birnbach type 433 which measure 2 3/4" high. The brackets are of 1/2 x 1/8" steel

and raise the condenser another 1 3/8". The neutralizing condensers are Cardwell NA6NS and are supported by 1" Birnbach insulators.

The grid coil assembly is a National XB5 base—PB5 plug assembly. The 10 and 20 meter coils are self supporting but the lower frequency coils are wound on the ceramic forms which may be purchased for the purpose.

The plate coil mounting base is a National PB15 and is mounted directly to the terminals on the condenser. The 10 and 20 meter plate coils are self supporting. The lower frequency coils are wound on National XR10A coil forms. The center turns of the 10 and 20 meter plate coils are spaced about 3/4 inches to permit the 2 turn link coil to be swung in and out to vary the coupling. On the lower frequencies it will be necessary to trim the pick up coils till the proper input is achieved or purchase manufactured coils featuring a variable pick up coil. Variable coupling between final stage and antenna is extremely worth while and various manufacturers are making such units available to the amateur.

POWER SUPPLY—(Con't from Page 28)

plate current to the modulators is about 25MA and swings to 60 or 70MA for 100% modulation so the average drain is about the maximum rating of the transformer. The buffer could be operated from the 750 volt supply with the modulator or from the 1000 volt supply thru a dropping resistor. It was not operated from the 750 volt supply because of the inevitable fluctuation of voltage with change in modulator plate current. In the average amateur transmitter the meters from the only method of checking performance so the change in meter readings under modulation is extremely undesirable. As a result the T20 buffer is operated from the 1000 volt final stage supply thru a 5000 ohm 20 watt resistor. As a result all of the meters except those in the modulator plate and feeder stand still as they should under modulation. Wherever possible, the Class B modulator power supply should not furnish power to any RF stage. If the same transformer is used for modulator and RF it is advisable to use separate filters for each. The same mercury vapor rectifier tubes may be used for both.

At the time this unit was built, no transformers to deliver 2 1/2V at 5A for a pair of 866 Jr. were available. Because 5V 3A transformers for 83's are more reasonable than 2 1/2V 10A transformers for 866's, they were used. The 866 Jr. filaments are connected in series. This is entirely permissible if the center tap of the winding is connected to the common connection between the two tubes.

CIRCUITS—(Con't. from Page 20)

resistor must be by-passed with a large condenser in addition to the RF by-pass which is required anyway. The principal use for this type of bias is to protect the tubes in case of excitation failure. Without excitation cutoff bias can never be reached. The drop across the resistor must be subtracted from the supply voltage to give the actual plate voltage.

The most common arrangement which takes advantage of the best features of each type of bias supply is usually enough pack or battery bias to provide cutoff with no excitation and the balance by resistors. It is particularly important in a CW transmitter to have all stages following the keyed stage biased to cutoff. In the phone transmitter where the plate voltage is off during standby periods enough cathode bias to limit the plate current to a reasonable value plus resistor bias for the balance makes an excellent arrangement.

Grid current should never be permitted to exceed the maximum rated value. If high drive is required or desired the bias should be increased to the maximum which will allow normal recommended grid current to flow. In this manner you may increase grid excitation without greatly effecting tube life.

If any type or combination of types of bias are used they may be measured by connecting a voltmeter from the filament center tap to the grid side of the last source of bias in the circuit. The measurement should of course be made with plate voltage applied to the stage and everything operating under normal conditions. If the rectified grid current and the value of the resistance in the circuit are known the bias will be the product of the two. If any cathode bias is used due allowance should be made for the plate current thru the amount of cathode resistance used.

A T-125 AMPLIFIER

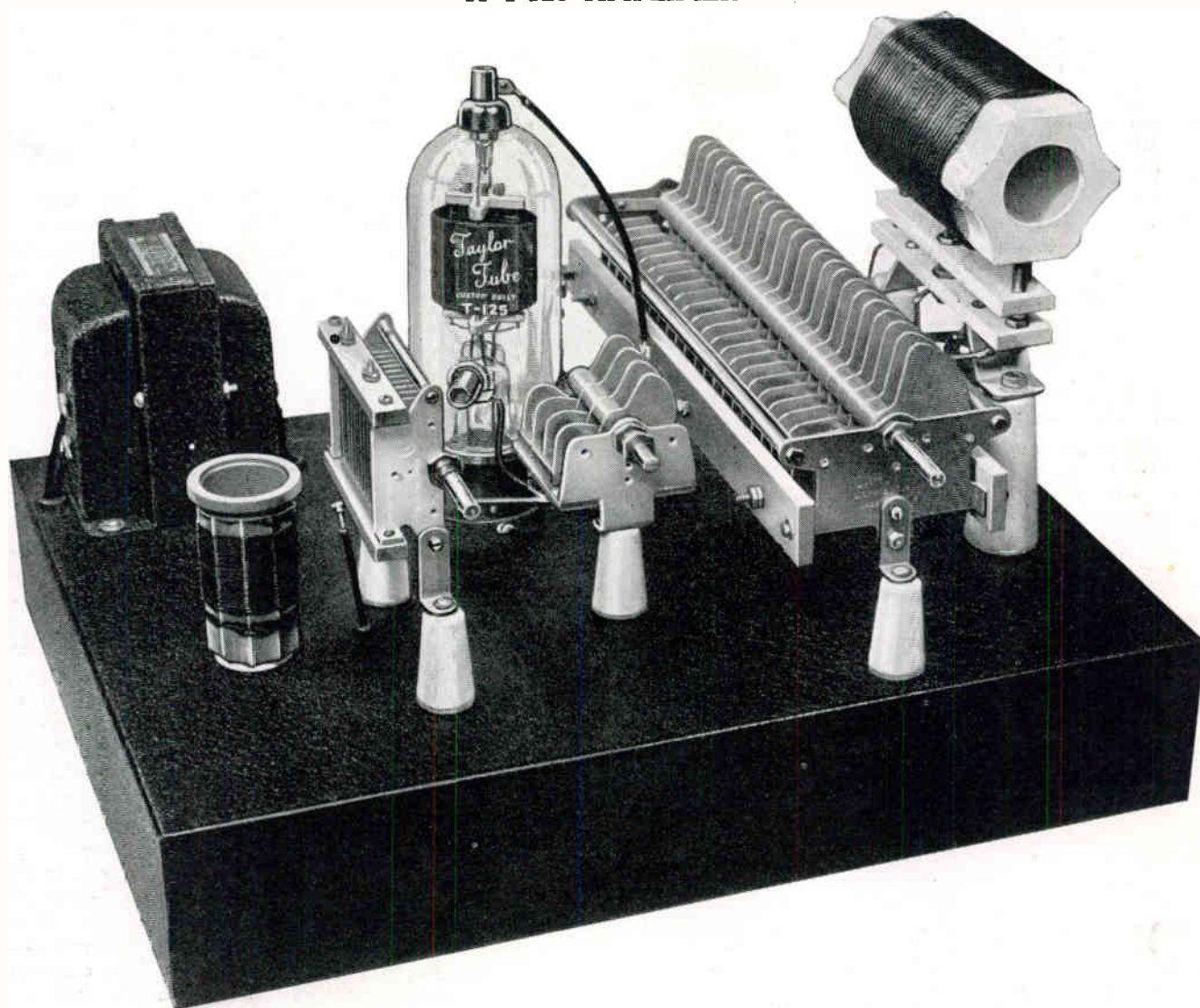

T125

- | | |
|--|--|
| <p>R_1—4000 ohm 20 watt Ohmite.
 R_2—200 ohm 20 watt Ohmite.
 C_1—100 mmfd. Cardwell MT-100-GS.
 C_2—110 mmfd. per section Cardwell XG-110-KD.
 C_3—.002 mica 600V C-D.</p> | <p>C_4—Cardwell NA-16-NS.
 C_5-C_6—.006 mica 600V C-D.
 C_7—.002 mica 500OV C-D.
 RFC—Bud 500MA RF choke.
 T—10V 6.5A Utah 1817, Thor-darson T6414, Stancor XP-3021, General 4021.</p> |
|--|--|

COIL CHART T125

Band	L ₂	L ₃
160	46 t. No. 18 2 1/4" dia. close wound	60 t. No. 12 3" dia. 5" long
80	26 t. No. 18 1 1/2" dia. close wound	30 t. No. 10 3" dia. 4" long
40	12 t. No. 18 1 1/2" dia. close wound	20 t. No. 10 2 1/2" dia. 4 1/2" long
20	8 t. No. 18 1 1/2" dia. 1 3/4" long	12 t. No. 10 2 1/2" dia. 4 1/2" long
10	6 t. No. 14 1 1/2" dia. 1 3/4" long	6 t. No. 10 2 1/2" dia. 4" long

L_1 —One or two turns at cold end of coil to be determined experimentally.

L_2 —One or more turns at center of coil depending upon impedance of antenna system.

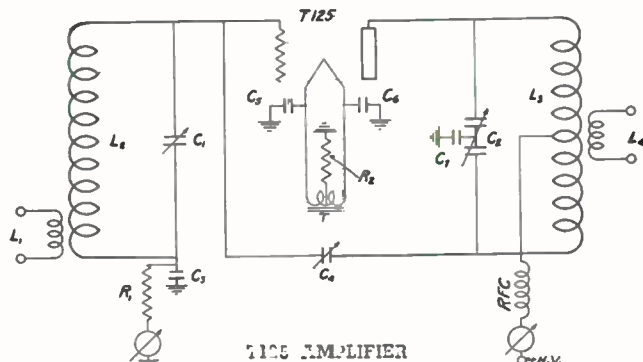

T125 AMPLIFIER

This unit shows a typical single ended stage using a T125. The same type of construction is suited to all types of tubes with only minor variations such as bias resistor, neutralizing condenser, etc. With only such minor changes the stage may be adapted to use a single T55, T200, or 822.

A single ended amplifier is not inherently a balanced circuit as is a push-pull stage. It does not have the even harmonic cancellation properties of the push-pull amplifier nor does it usually hold neutralization quite as well over a wide range of frequencies. Yet it is often more economical to use one large tube than two smaller ones. In addition a single ended stage is less likely to develop parasitics. (Continued on Page 36)

T125 AMPLIFIER

(Con't. from Page 35)

The stage is as symmetrical as possible mechanically and electrically. It holds neutralization extremely well over a wide range of frequencies. The symmetrical mechanical arrangement results in a finished appearance for the completed unit because the dials will be on the same level and uniformly spaced on the panel. The matter of symmetrical panel lay out was an important consideration in the design of all units shown in this catalog. No matter how well a job performs it leaves something to be desired if it does not present a finished appearance.

The grid tuning condenser is a Cardwell MT100GS mounted with Cardwell brackets on a Birnbach No. 432, 1½-inch stand off. The neutralizing and plate condensers are also mounted on the same size insulators.

The neutralizing condenser shown is a Cardwell NA16NS. The T125 neutralizes with the condenser at minimum capacity. An NA10NS is recommended for use with the T125 or T200. If a T55 is used an NA6NS is recommended.

The plate tuning condenser is a Cardwell XG110KD with a maximum of 110 MMFD and a minimum of 27 MMFD per section. Because the sections are in series the range is from 14 to 55MMFD. The stage was intended for operation at 2000 volts 250MA on 10, 20, 40, and 80.

Because the maximum to minimum capacity ratio of tuning condensers large enough to handle the voltages involved is rather small, 55 to 14 or approximately 4 to 1 in this case, it was necessary to compromise somewhat on the L/C ratios at both ends. The L/C ratio on 80 is somewhat higher than the optimum value for good linearity and on 10 is somewhat lower than the optimum value for best efficiency. We selected what we thought to be the best compromise value and satisfactory results should be obtained if resonance is reached on 80 with the condenser as close to maximum capacity as will permit proper tuning. On 10 the inductance should be adjusted to reach resonance with the capacity as close to minimum as possible.

The National XB15 jack base for the plate circuit is supported on Birnbach No. 433 2¾-inch standoff insulators. The entire assembly is mounted on a Bud 17 x 13 x 3 chassis. All grounds return to a common point centrally located next to the tube socket. The hole for the socket is drilled with a 2-inch circulator saw. Mounting the socket below the chassis improves the appearance greatly and shortens the plate lead somewhat.

OHMS LAWS

The relationship between voltage, current, and resistance in a circuit is known as Ohms Law. If any two of the quantities are known the other may be easily calculated. It is included here together with the power formula because of its great importance.

$$R = \frac{E}{I} \quad I = \frac{E}{R} \quad E = IR$$

$$P = I^2R$$

$$P = EI$$

Where:

E = voltage

I = current in amperes

R = resistance in ohms

P = Power

As a practical application assume a 3000 ohm bias resistor with 25MA of grid current. What would the voltage be?

$$E = 3000 \times .025 \\ = 75 \text{ volts}$$

Suppose 100 volts of bias were required at a grid current of 20MA. What value of resistor would be required.

$$R = \frac{100}{.020} \\ 5000 \text{ Ohms}$$

MODULATION

A carrier is modulated by varying its amplitude. Frequency modulation is illegal, and in a properly designed transmitter there must be adequate isolation between the modulated and frequency control stages to prevent any frequency modulation caused by interaction between them. One intermediate or buffer stage with separate power supplies for modulated and oscillator stages usually provides sufficient isolation to reduce frequency modulation to a negligible value.

Amplitude modulation may be accomplished by varying the efficiency of an amplifier as with grid modulation or class B linear operation. It may also be accomplished by varying the DC input. This is usually called plate modulation.

For 100% undistorted amplitude modulation, it must be possible to vary the carrier voltage and current between zero and twice the carrier value. Twice the voltage and current results in peaks which are 4 times the carrier value and the average power output with sine wave input will be 50% greater under 100% modulation conditions than with the carrier only. With input wave forms other than sine waves the instantaneous peak power will still be 4 times the carrier value but the average power may be other than 50% greater. With speech wave forms the average increase in power is usually about 25%.

With efficiency modulated amplifiers the input remains constant under modulation. So if the peak output is to be 4 times the average or carrier value the stage must be operating at low efficiency when unmodulated. Under modulation the average output increases while the DC input remains constant so the plate dissipation decreases.

Efficiency modulated amplifiers are of two general types. With one type the excitation remains constant and the grid bias is varied. This is usually called grid modulation. With the other type, class B linear operation, the bias is held constant and the excitation varied by modulating the previous stage. Under normal conditions the maximum carrier efficiency with low distortion is about 33%. A tube with a plate dissipation of 200 watts would permit an input of 300 watts and a carrier of 100 watts. Comparatively large tubes are required for a given output but comparatively little audio equipment is required.

With plate modulated amplifiers enough audio power is superimposed on the DC supply to swing the plate voltage from zero to twice the unmodulated value. This power is developed by the modulator and added to the DC input. With sine wave input to the speech equipment the average power required is equal to 50% of the DC input. With speech input the average power is about 25% of the DC input but in either case the instantaneous peak power is the same as in the case of efficiency modulated amplifiers and the peak output is equal to 4 times the carrier power. The tubes in the modulated amplifier operate at high efficiency—normally about 75%. A tube with a plate dissipation of 200 watts would permit about 800 watts of input and 600 watts of output or about 6 times the carrier with the same tube as in an efficiency modulated stage. A modulator that is capable of delivering 50% as much power with sine wave input must be used but even so such an installation, if Class B modulators are used, should cost less originally and less to maintain than one using efficiency modulation. For this reason plate modulation is used almost to the exclusion of other methods. In addition it is easier to get working and requires less critical adjustment. As mentioned previously the efficiency of efficiency modulated amplifiers increases during modulation reducing plate dissipation. With voice input the average reduction in dissipation over a reasonable period of time is not great enough to permit increasing unmodulated dissipation. Conversely with plate modulated amplifiers the average increase in plate dissipation with voice input over a period of time is not great enough to necessitate allowing for it, especially with Taylor Carbon anode tubes whose dissipation ratings are exceedingly conservative.

A ONE KILOWATT AMPLIFIER

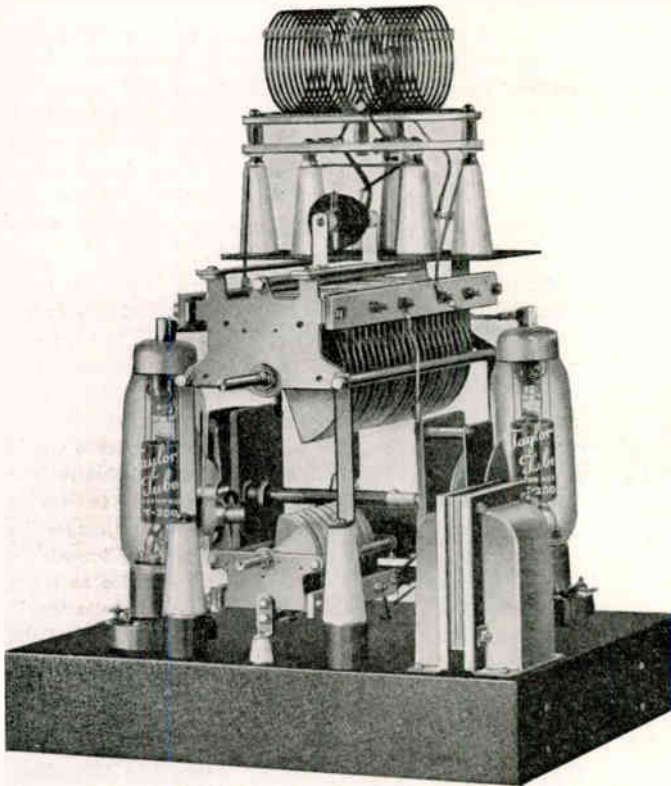

- C1—Cardwell TJ200UD
 C2—Cardwell XC65XS
 C3—002 Mica Cornell-Dubilier
 C4—002 Mica 5000V Cornell-Dubilier
 C5-C6—006 Mica Cornell-Dubilier
 C7—8MFD 450V (For Phone) Cornell-Dubilier
 NC—Cardwell VZ10RS
 R1—2000 ohms 50 watts (Ohmite)
 R2—300 ohms 200 watt (Ohmite)
 RFC—500MA RF Choke (Bud)
 Plate Tank Coil—Barker-Williamson Swinging Link Coils
 Grid Coils—Same as for PPT55 Stage (Page 34)
 Fil. Trans.—Stanco RXP3021, General 4021, Thordarson T6414, Utah 1830.

Efficient high frequency operation with large tubes offers problems which are not encountered with smaller tubes. With the large tubes all of the components as well as the tubes are larger making it difficult to keep leads short. If the unit is used over a wide range of frequencies it often happens that it must be re-neutralized for each band.

Inability to hold neutralization over wide range of frequencies is invariably due to one or both of two reasons—lack of symmetry and long neutralizing leads.

The unit shown overcomes all of these disadvantages in an entirely satisfactory manner. It is symmetrical electrically and mechanically and the leads are as short as it is possible to make them with the large components necessary for plate modulation with 1 Kw input.

The tubes are T200's. These tubes feature high efficiency at moderate plate voltages with low grid drive requirements. The interelectrode capacities are low enough to permit efficient operation on frequencies as high as 60 MC yet not so low that any great amount of efficiency has been sacrificed. In addition its construction is the most efficient known.

It is not generally realized that low C tubes are inherently less efficient than higher C tubes. As a result higher plate voltages and

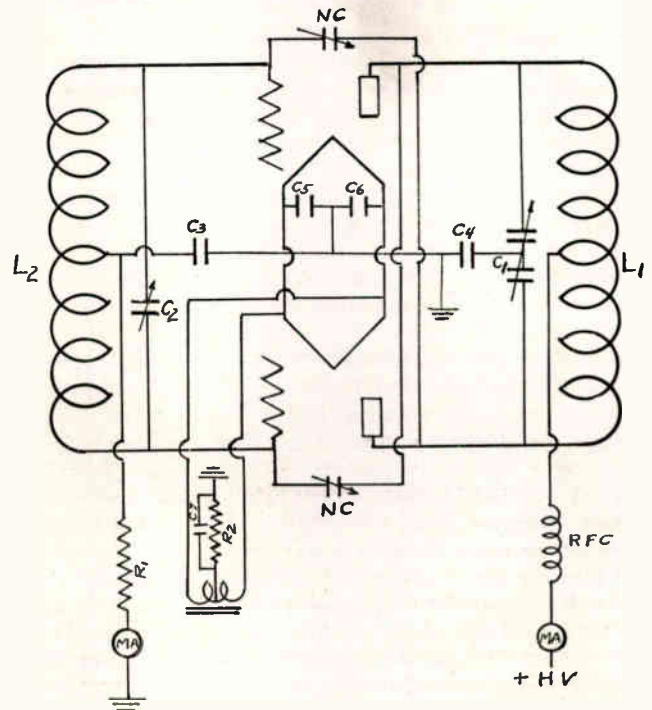

more grid drive must be applied to a low C tube than to those of more normal characteristics. The T200 represents the best compromise between the conflicting requirements of high efficiency at moderate plate voltages and minimum grid drive requirements together with efficient performance at the high frequencies.

It is impossible to accurately predict grid drive requirements because they may vary widely in various transmitters but about 80 watts of drive at the grids of the T200's should be adequate for plate modulation of a full Kw input. On the higher frequencies where circuit losses are considerably higher more buffer output must be available to compensate for these losses.

The entire assembly is mounted on a 13x17x3 inch chassis. The plate tuning condenser is a Cardwell TJ-200-UD and the grid condenser a Cardwell XC-65-XS. The neutralizing condensers are Cardwell VZ-10-RS. Mycalex insulation is used on all of these condensers. Good insulation is exceedingly important on the higher frequencies. The filament transformer is a Stanco P-3021 designed to deliver 10 volts at 6.5 amperes. The T200's require 4 amperes each at 10 volts but the transformer does not seem to heat excessively under the load.

The neutralizing condensers are ganged for ease of neutralization with a piece of 3/8" diameter fiber.

The maximum capacity per section of the TJ-200-UD is 200 MMFD per section giving 100 MMFD with the two sections in series. The minimum capacity is about 20 MMFD. This permits efficient operation with correct L/C ratios on the 20, 40, and 80 meter bands. With an input of 2000 volts, 500 MA the capacity in the circuit should be 11 MMFD on 10, 22 MMFD on 20, 45 MMFD on 40, 85 MMFD on 80 and 170 MMFD on 160 for best efficiency with good linearity for phone and minimum harmonic content. If 10 meter operation is desired a condenser with a lower minimum should be used and a higher capacity condenser would be required for 160 meter operation:

The bias is furnished partially by the cathode resistor and the balance by the grid resistor. This saves the cost of a bias supply because the plate current will drop to a safe value if the excitation fails or is removed. The cathode resistor should be bypassed with an 8 MFD electrolytic condenser if the stage is modulated.

814's, 822's or T125's may also be used in this unit. (Change neutralizing condensers for 814's and 822's.)

Class-B Audio Design

A Simplified Method for Determining Correct Operating Conditions By Earl I. Anderson, W8UD

A review of the principles involved in Class-B operation seems to be in order because a knowledge of the fundamental principles is essential if proper operation is to be realized. This is particularly true if the voltages or tubes, or both, are not the ones specified in the operating data furnished with the transformers. The amateur is usually forced to use as much of the equipment at hand as possible when changes are made. He can not always, for example, purchase new power supplies if the ones at hand deliver voltages slightly higher or lower than the optimum values, nor does he wish to purchase new Class-B transformers when he replaces his modulator tubes with other types, if it is at all possible to use the ones he has.

On the other hand, it is extremely important to have the audio equipment working properly. Harmonic content or distortion must be kept at the absolute minimum. Every one wishes flat frequency response, yet frequency response from an amateur standpoint should be a secondary consideration to low harmonic content. A signal with low harmonic content, whether it has wide-range frequency response or not, will occupy only the minimum amount of territory necessary for voice communication, but a station with high harmonic content will spread and splash into adjacent channels and unnecessarily interfere with other signals. Even if an amateur did not care particularly how good his quality might be, he would owe it to other amateurs to keep his signal as clean as possible—and any improvement in this respect will necessarily improve the quality.

In speaking of distortion, we do not refer to frequency discrimination but to distortion of the wave form. Such distortion results in the generation of frequencies which are harmonics or multiples of the input frequency. Harmonics may be kept at a minimum if all of the tubes in the speech equipment are operating under proper conditions. They may originate in the low-level speech equipment as well as in the modulator stage, but improperly-operated modulators—and this applies to Class-A as well as Class-B—are chiefly responsible in so great a proportion of the cases that the factors involved are worthy of the consideration of every amateur.

TRANSFORMER OPERATION

Except for over-modulation, the commonest source of distortion is an overloaded modulator or one where the reflected load impedance is incorrect. Many amateurs seem to have a mistaken conception of the operation of an audio transformer. Audio transformers act exactly as do power transformers. The principles are exactly the same although, of course, the requirements are different. Perhaps this fact has been overlooked because power transformers are rated in terms of voltage and current while audio transformers are spoken of in terms of impedance or impedance ratios. It is sometimes assumed that if the secondary of an output transformer is marked 2500, 5000, 10,000 ohms or some other value, that the secondary is of that definite value regardless of any other considerations; and that if that secondary is terminated in a load of any other resistance or impedance, there will be a loss in power or fidelity. In other words, there will be a mismatch between secondary and load. Such is not the case. There is never any mismatch between secondary and load nor without any other qualifications is the impedance of the secondary the value marked on the secondary. If the primary is open and the secondary impedance measured, it should theoretically be infinity, and in any event will be many times the value marked on it. What the transformer manufacturer is trying to say is that with the specified modulator tubes, operating at the specified voltage, the secondary should be terminated in a load whose resistance or impedance is the value stamped on the secondary. If the modulator plate voltage is higher or lower, or if more or less output is required, the value probably would be different.

The purpose of a Class-B output transformer is to take the power developed by the modulators which has a certain ratio of voltage to current, and change it to the ratio of voltage and current required at the secondary. If this ratio is correct it is said that the impedances are properly matched, because the ratios are expressed in terms of impedance. Under these conditions the power efficiency of the modulator will be the maximum obtainable with low distortion. If the ratios are not correct, one or more undesirable effects which will be discussed later will be evident.

The primary reflected load impedance depends upon the turns ratio of the transformer and the value of the impedance or resistance in which the secondary is terminated. If we had a transformer with the same number of turns on both primary and secondary, the turns ratio would be 1 to 1 and the impedance ratio would also be 1 to 1. If we were to measure the impedance of either winding with the other winding open, the impedance would be some very high value; but if we connected a 5000-ohm resistor across the secondary and then measured the primary impedance we would find it to be 5000 ohms also. If the resistor across the secondary were changed to 2500 ohms, the primary impedance would also be 2500 ohms. If the transformer had twice as many turns on the secondary as on the primary, the turns ratio would be 2/1, or 2, and since the impedance ratio is the square of the turns ratio, the impedance ratio would be the square of 2, or 4. In this case, if we put a 5000-ohm resistor across the secondary and measured the primary impedance it would be one-fourth of 5000 or 1250 ohms. Similarly, if we put a 10,000-ohm resistor across the secondary, the primary impedance would be 2500 ohms. We are assuming that there are no losses in the transformer, a permissible assumption because in well-designed units the losses are small enough to be ignored in making the necessary calculations.

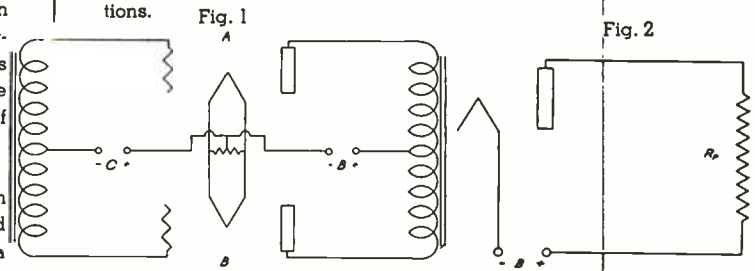

FIG. 1—THE ESSENTIAL CLASS-B AUDIO CIRCUIT
FIG. 2 EQUIVALENT CIRCUIT OF ONE CLASS-B TUBE
The load resistance, R_p , is one-fourth the plate-to-plate

THE CLASS-B PLATE CIRCUIT

The circuit of Fig. 1 is the circuit for all Class-B tubes. The components and operating potentials are varied to suit the tubes, but the circuit stays the same. The tubes are biased to cutoff, or nearly so. So far as audio is concerned, the centers of both input and output transformers are at ground potential. If a.c. is applied to the primary of the input transformer, at any given moment the phase of the voltage applied to tube A will be opposite to that applied to tube B. For instance, when tube A is being driven positive, tube B is being biased further negative and being cut off entirely. On the other half of the cycle, tube B is driven positive and tube A is cut off entirely. From this it may be seen that only one tube need be considered when making the necessary calculations.

So far as the tube is concerned the primary of the output transformer is a resistance, so the circuit for one tube might be drawn as shown in Fig. 2. A certain proportion of the supply voltage may be developed across R_p . It is impossible to develop all of the supply voltage across R_p , because some voltage is required at the plate of the tube to attract enough electrons from the filament to

permit the necessary plate current to flow. Also, the grid must never become positive with respect to the plate. In general, approximately 80 per cent of the applied voltage may be developed across R_p . The power developed will depend upon the current as well as the voltage and may be calculated by

$$\frac{(I_{pmax})^2 \times R}{2}$$

where I_{pmax} = peak plate current to one tube.

R = reflected load impedance to one tube (one-fourth plate-to-plate value)

We can also calculate according to the following expression, substituting E_R (peak developed voltage) for R

$$\frac{(I_{pmax}) \times (E_R)}{2}$$

Let us assume that the plate-supply voltage is 1000 and that the drop across the tube is 200 volts. This would permit us to develop 800 volts peak across R_p . Let us also assume that the maximum recommended peak plate current is 0.5 ampere. $800/0.5 = 1600$ ohms reflected load impedance for one tube. The correct plate-to-plate load would be four times that value, or 6400 ohms. The audio output would be

$$\frac{0.5^2 \times 1600}{2} = 200 \text{ watts}$$

Now let us assume that the wrong value of load impedance had been used, say 2500 ohms per tube instead of 1600. With 800 volts across 2500 ohms, the peak plate current would be $800/2500$ or 0.320 amp.

$$\text{Power} = \frac{0.320^2 \times 2500}{2} = 128 \text{ watts audio output.}$$

From this it should be obvious that if the reflected load impedance is too high, the amount of power obtainable without distortion will be reduced.

On the other hand, suppose the reflected load impedance is lower than the optimum value of 1600 ohms—say 1200 ohms—and we require 200 watts of audio. Using the formula and solving for the unknown, we have

$$\frac{(I_{pmax})^2 \times 1200}{2} = 200 \text{ watts}$$

$$(I_{pmax})^2 = \frac{200}{600}$$

$$(I_{pmax})^2 = 0.333$$

$$I_{pmax} = 0.577 \text{ amp.}$$

With the correct value of reflected load impedance the peak plate current was only 0.5 amp., but now 0.577 amp. is necessary for the same output. As we mentioned previously, the recommended maximum peak plate current for this hypothetical tube was 0.5. The extra 77 ma. of peak plate current may introduce distortion and shorten tube life. In addition, the plate dissipation will be increased. In the previous case, with 800 volts developed across the plate load and a peak current of 0.5 amp., the plate dissipation at peak plate current would be 200×0.5 or 100 watts. In the second case, we are developing $0.577 \times 1200 = 692$ volts and the plate dissipation at peak plate current would be $308 \times 0.577 = 178$ watts. If plate dissipation is one of the limiting factors the tube will be badly overloaded.

THE IMPORTANCE OF IMPEDANCE MATCHING

This should answer the often-asked question of how important it is to match impedances. The situation may be summarized by saying that if the reflected load impedance is too high, the maximum power output without distortion will be reduced, although the efficiency will be good and the harmonic content low. If an attempt is made to obtain more power with excessive drive to the grids, the distortion will increase tremendously. The peak output, which is the important consideration in modulation, will not increase greatly but the average power may be increased consider-

ably because of alteration of the wave form. For this reason, even though it may be impossible to obtain enough peak power to modulate 100 per cent, it may appear from the action of the meters that the capabilities of the modulators exceed 100 per cent modulation if no facilities are available for examining the waveform. The spurious frequencies due to the distortion will also make it appear at a receiving point as though the signal were overmodulated when, in fact, the voltage output from the modulator is insufficient to swing the carrier from zero to twice its unmodulated value—the requirement for complete modulation.

When the reflected load impedance is too low the situation is about as bad. The power efficiency of the modulator stage is reduced and the plate dissipation increased. If, in attempting to develop the necessary power and voltage, it is necessary to drive the plate current of the tube to a point where the filament emission is exceeded, the distortion will be high and tube life will be shortened. The effects of the distortion will be the same as if the reflected load impedance were too high, and it may or may not be possible to modulate 100 per cent.

In general, a variation of approximately 10 per cent from the optimum value is about the maximum permissible if best performance in all respects is to be obtained.

It is important to remember that the optimum value of reflected load impedance varies with the output desired and the applied voltage. For example, for an audio output of 200 watts from a pair of 203-A's with 1000 volts on the plates, optimum performance would be secured with a plate-to-plate load of 6900 ohms. If only 100 watts of audio were required, the optimum plate-to-plate load would be twice that value or 13,800 ohms. If 200 watts were desired and the plate voltage were 1250, the optimum value of reflected load impedance would be 11,800 ohms. Because there are so many variables and because the consequences of improper operation are so serious in our crowded bands, it is extremely important that each amateur be able to make the necessary calculations. Fortunately these are easily made with the simplest of mathematics. Knowing the optimum value of reflected load impedance for the available plate voltage and desired output, as well as the impedance ratio of the output transformer, it becomes a matter of simple ratios. Assume the optimum value is 10,000 ohms and the transformer is marked 8000 ohms on the primary and 5000 on the secondary. The ratio would be

$$\begin{aligned} 10,000/X &= 8/5 \\ 8/X &= 50,000 \\ X &= 6250 \end{aligned}$$

Thus the load resistance of the modulated amplifier should be 6250 ohms. The plate input to the modulated amplifier should be twice the audio output of the modulator.

DETERMINATION OPERATING CONDITIONS

TAYLOR TUBES, INC., is publishing complete class B data for various outputs at various plate voltages for each type of tube recommended for class B operation but common practice is to provide only one or possibly two ratings for each tube, usually the maximum values. With TAYLOR TUBES all of the figuring has been done except that of calculating the load impedance of the modulated amplifier from the impedance ratio of the transformer, as previously explained. With other tubes it will be necessary to calculate the proper conditions. Let us use the hypothetical tube which we previously used in examples. The manufacturer's ratings probably would look like this:

CLASS-B A.F. MODULATOR

Power output (2 tubes).....	1000 volts
D.c. plate voltage.....	6400 ohms
Load resistance (plate-to-plate).....	317 ma.
Max. av. d.c. plate current (2 tubes).....	200 watts

From this information we wish to get two figures of vital importance which are not given. We want the recommended peak plate current and the drop across the tube at that current. With that information we can calculate the maximum output obtainable at the plate voltage available, together with the optimum reflected

load impedance; or, if that output is greater than is necessary, the proper operating conditions for the required output may be obtained.

The peak plate current to one tube may be obtained by dividing the maximum average plate current with sine wave input to both tubes by 0.636. $317/0.636 = 0.5$ ampere. This value should never be exceeded.

The drop across the tube is obtained indirectly by subtracting the voltage developed across R_p from the supply voltage. With a plate-to-plate load of 6400 ohms the reflected load impedance to one tube would be $6400/4$ or 1600 ohms. With a peak plate current of 0.5 ampere, the peak developed voltage would be 0.5×1600 , or 800 volts. With a supply voltage of 1000, the drop across the tube therefore must be 200 volts. The following formula should be used:

$$\text{U.P.O.} = \frac{(I_{p\max}) \times E_{T_p}}{2}$$

Suppose the power supply available for the modulators delivers only 900 volts.

$$\begin{aligned} \text{(Case 1) U.P.O.} &= \frac{0.5 \times (900-200)}{2} \\ \text{U.P.O.} &= \frac{0.5 \times 700}{2} = 175 \text{ watts} \end{aligned}$$

The optimum value of reflected load impedance would be $700/0.5 = 1400$ ohms for one tube, or 5600 ohms plate-to-plate.

If the power supply delivered 1100 volts, the calculations would be

$$\begin{aligned} \text{(Case 2) U.P.O.} &= \frac{0.5 \times (1100-200)}{2} \\ &= \frac{0.5 \times 900}{2} = 225 \text{ watts} \end{aligned}$$

The optimum value of reflected load impedance would be $900/0.5 = 1800$ ohms for one tube, or 7200 ohms plate-to-plate.

Suppose we had 250 watts input to the modulated amplifier, in which case we would require only 125 watts from the modulator. Assuming a modulator plate voltage of 1050

$$\begin{aligned} \text{(Case 3) } 125 &= \frac{I_{p\max} \times (1050-200)}{2} \\ 125 &= \frac{850 \times I_{p\max}}{2} \\ I_{p\max} &= \frac{250}{850} = 0.294 \text{ amp. peak plate current} \end{aligned}$$

$850/0.294 = 2900$ ohms R_p or 11,600 ohms plate-to-plate.

If the turns ratio of the transformer is known, the calculations need not be made in terms of impedance but may be made directly in terms of voltage ratios. The turns ratio may be taken directly from the impedance ratio and is the square root of the impedance ratio. A transformer with an impedance ratio from secondary to total primary of $\frac{1}{4}$ would have a turns ratio of $\sqrt{\frac{1}{4}} = \sqrt{0.625} = 0.79$. This ratio is for the whole primary; the ratio from secondary to one-half primary would be 2×0.79 or 1.58.

In Case 1, we were able to develop 700 volts across R_p , which is half the primary, so the peak voltage across the secondary will be $700 \times 1.58 = 1106$ volts. The modulated amplifier plate voltage will always work out to be 1106 volts so long as the modulator plate voltage is 900 and the same transformer ratio and modulator tubes are used. The modulator will deliver 175 watts of audio so the input to the modulated amplifier could be a maximum of 350 watts. At 1106 volts, the plate current to the modulated amplifier should be $350/1106 = 316$ ma.

In Case 2, we were able to develop 900 volts across R_p , or one-half primary. $900 \times 1.58 = 1422$ volts across the secondary. The audio output is 225 watts, so the input to the modulated amplifier may be a maximum of 450 watts. $450/1422 = 316$ ma. modulated amplifier plate current.

In making the calculations only one precaution need be observed, namely that the input to the modulated amplifier must not

exceed twice the audio output of the modulator. If more input is applied to the modulated amplifier, the plate voltage and current should be increased in proportion. Of course, 100 per cent modulation without distortion cannot be realized with appreciably greater inputs. If less input is desired the plate voltage should be maintained at the calculated value but the plate current may be decreased. This will increase the modulated-amplifier load impedance and also the reflected load impedance to the modulators. However, as the input to the amplifier is reduced less audio is required, and under these conditions the reflected load impedance should be increased, and it will increase in exactly the correct proportion. Perhaps this will be more readily understood if one considers that for a given tube and value of plate voltage, the developed voltage across R_p will be approximately the same for all values of current below filament saturation, and if the ratio of the transformer is not changed the voltage across the secondary will be the same. This is not strictly true because at lower values of plate current the drop across the tube will be slightly less. The difference is small and need not be taken into consideration for amateur applications.

GENERAL CONSIDERATIONS

One of the commonest questions asked is "What should the meter read?" The question has no definite answer when voice input is used. The current value we have been dealing with in making calculations is a peak value which never shows up on any meter. In setting the ratings for Class-B audio, an average value is stated. This is what the meter would read with sine-wave input, and is determined by multiplying the peak value by 0.636. In other words, the average value with sine wave input for two tubes is 0.636 of the peak value for one tube. However, with voice input, because of the difference in wave form the same peak output and peak plate current are realized at much lower average values of plate current. Usually the average plate current with voice input is approximately 50 per cent of the value for sine wave input at the same peak output. Only an oscilloscope will give a correct answer to the question, "What should the meter read?"

In calculating operating conditions, the information presented herewith must be tempered with good judgment. From the figures only it might seem possible to take a pair of 10's and transformers designed for use with them and by raising the plate voltage high enough modulate a kilowatt. However, it cannot be done.

The peak voltage from plate to filament will be the applied voltage plus the developed voltage. For instance, if the applied voltage is 1000 and the developed voltage 800, the peak voltage from plate to filament would be 1800 volts. The voltage from plate to grid would be greater by the amount of the peak grid voltage plus the bias, which would be approximately the drop across the tube, say 200 volts. Thus the peak voltage from plate to grid would be about twice the supply voltage. Consequently, the applied voltages should be in line with the maximum voltage ratings of the tubes or breakdown may be experienced.

Best transformer design involves the use of as small a core window as possible to accommodate the required amount of insulation and wire, and the minimum amount of insulation should be used to permit the tightest possible coupling between windings. For this reason, audio transformers use the least amount of insulation which will provide a reasonable safety factor. Consequently, if the voltages across the transformer are increased above the values for which it was designed, the safety factor will be reduced. Increasing the voltage across the windings also adversely affects the low frequency response, though this is a less important consideration because the low-frequency cut off for most transformers is below the lowest frequencies obtained with voice input. The amount of d.c. through the secondary should not exceed the maximum rated value because it may result in core saturation, which necessarily must cause high harmonic content. In general, for safe operation, the voltages across and the currents through the windings of the transformer should be in line with those at which the transformer was intended to operate.

FREQUENCY →		1900		3750		7150		14,200		28,500		58,000	
← Supply Voltage	Plate ← Current	Single Ended	Push Pull	Single Ended	Push Pull	Single Ended	Push Pull	Single Ended	Push Pull	Single Ended	Push Pull	Single Ended	Push Pull
		500	75	205	102	104	52	54	27	28	14	14	7
	100	275	137	140	70	73	36	37	18	18	9	9	5
	150	410	205	208	104	108	54	56	28	28	14	14	7
750	75	137	68	70	35	36	18	18	9	9	5	5	2.5
	100	182	91	92	46	48	24	24	12	12	6	6	3
	150	274	137	140	70	72	36	36	18	18	9	9	5
	200	365	167	185	92	96	48	48	24	24	12	12	6
	250	456	228	230	115	120	60	61	30	30	15	15	7
1000	75	105	52	52	26	27	13	14	7	7	4	4	2
	100	137	68	70	35	36	18	18	9	9	5	5	3
	150	205	102	104	52	54	27	27	13	14	7	7	4
	200	274	137	140	70	72	36	36	18	18	9	9	5
	300	410	205	208	104	108	54	54	27	8.7	13	13	6
	400	525	262	280	140	144	72	72	36	36	18	18	9
	500	685	342	348	174	182	91	92	46	46	23	22	11
1250	100	110	55	55	27	29	14	14	7	7	4	4	2
	150	164	82	82	41	44	22	22	11	11	6	6	3
	200	218	109	110	55	58	29	30	15	14	7	7	4
	300	328	164	165	82	87	43	44	22	22	11	11	5
	400	437	218	220	110	116	58	58	29	29	14	14	7
	500	550	275	276	138	146	73	73	36	36	18	18	9
1500	100	92	46	46	23	24	12	12	6	6	3	3	1.5
	150	137	68	70	35	36	18	18	9	9	5	5	3
	200	182	91	92	46	48	24	24	12	12	6	6	3
	300	274	137	140	70	72	36	36	18	18	9	9	5
	400	365	182	185	92	96	48	48	24	24	12	12	6
	500	456	228	230	115	120	60	60	30	30	15	15	7
1750	100	78	39	40	20	21	10	10	5	5	3	3	1.5
	150	117	58	60	30	31	15	15	7	8	4	4	2
	200	156	78	80	40	41	20	20	10	10	5	5	3
	300	234	117	120	60	62	31	30	15	15	8	8	4
	400	312	156	160	80	83	41	40	20	21	10	10	5
	500	390	195	200	100	104	52	50	25	26	13	13	6
2000	150	103	51	52	26	27	13	14	7	7	4	4	2
	200	137	68	70	35	36	18	18	9	9	5	5	3
	300	205	102	104	52	54	27	27	13	14	7	7	4
	400	274	137	140	70	72	36	36	18	18	9	9	5
	500	342	171	173	86	90	45	45	22	23	12	12	6
3000	100	46	23	23	12	12	6	6	3	3	1.5		
	200	92	46	46	23	24	12	12	6	6	3		
	300	137	68	70	35	36	18	18	9	9	5		

CAPACITY RECOMMENDATIONS FOR ALL BANDS

Single ended refers to one tube or two or more tubes in parallel plate neutralized with a balanced output circuit. If grid neutralization with an unbalanced output circuit is used, twice as much capacity is required for equivalent operation.

This chart is intended as a guide to the amount of capacity required across an inductance at various frequencies and values of plate voltage and plate current for good efficiency, reasonable

harmonic content, and linear action of the stage under modulation. It reflects our experience with amplifiers operating under the specified conditions measuring up to our standards of performance in these respects. Because the optimum L/C ratio must necessary be a compromise between plate efficiency and other desirable characteristics some variation of opinion may be expected to exist which may result in some difference in recommendations.

GENERAL TRANSMITTER INFORMATION

NEUTRALIZING NOTES

When the stage is perfectly neutralized Maximum DC grid current and minimum plate current occur at the same time. If it is impossible to adjust the neutralizing condensers to obtain this condition, it is necessary to look through the stage for trouble. Check all soldered connections. Poor connections are of high resistance. Look for shorted turns in inductances. If link coupled reduce numbers of turns in link. In push pull stages be sure the center top is at the electrical center of coils. Use Split Stator tank condensers wherever possible. Be sure the grid coil CT is bypassed to ground right at the coil if a split stator condenser is not used. Long leads from CT of coil to by-pass condenser have a tendency to pick up RF.

Check plate leads—they should be as short as possible. If possible place a shield between the grid coil and plate coil. Use the highest C advisable.

Should you get an indication of RF when condenser is set at minimum RF and cannot be eliminated, magnetic or capacity coupling is causing this situation. Placing inductances at right angles, shielding stages where necessary, shortening leads to neutralizing condenser, or inserting RF choke coils in the grid or plate leads, will eliminate this magnetic or capacity coupling which can be detected by removing tube from socket in that particular stage and checking tank for RF while swinging tank condenser through resonance.

On practically all tuning condensers there are terminals on each side to be used for connections to stator plates. The plate lead to neutralizing condenser must be connected to same terminal where the plate lead to tank condenser is connected. If connections are made at opposite sides of the tank condensers the resistance of the plates causes a voltage change and stage will slide out of neutralization when resetting the tank condenser.

In multi-stage transmitters consisting of two or more triode stages, which must be neutralized and which are supplied with plate voltage from a common supply, it is conventional practice to place a switch in the + B supply lead to each of these stages so that plate voltage may be removed from the stage when being neutralized.

However, in a transmitter in which one of the stages (usually the final amplifier) is supplied with voltage from a separate supply, many amateurs remove plate voltage from this amplifier stage, when neutralizing, simply by opening a switch in the primary of the plate supply transformer.

With this arrangement, especially in medium to high power transmitters, it seems impossible to effect complete neutralization. Although complete neutralization may be obtained, a small light bulb in a pick up loop, coupled to the plate tank coil will light up brightly when the tank is turned to resonance.

This condition is possible when stray RF is in-

duced in the leads and is applied to the anodes of the rectifier. This stray RF is then rectified and finds its way to the plates of the amplifier tubes.

A switch to completely remove all plate voltage from the stage being neutralized, should be connected in the + B supply lead to the stage, or it may be connected in the center-tap lead of the H.V. transformer secondary.

LACK OF EXCITATION—CAUSES

1. Low filament emission.
2. Bias voltage too high.
3. Stage not neutralized properly.
4. Improper coupling between stages.

READING D.C. GRID MILS

To read D.C. Grid mils insert D.C. milliammeter in between proper negative bias voltage tap and grid of tube. If resistor bias is used, insert milliammeter between ground and resistor. Where stages are link coupled and battery bias is used, put meter in lead from battery to grid coil.

CAUSES OF BROAD SIGNALS IN PHONE OPERATION

1. Final amplifier not neutralized properly.
2. Regeneration in final stage.
3. Improper L/C ratio.
4. Class "B" audio tubes oscillating on peaks of modulation. (This can be stopped by using resistors in plate or grid leads with a value of 50 to 100 ohms.)
5. **Over modulation.**

THE CONDENSER ARCING

Continuous arcing over of the tank condenser in the final amplifier may be caused by the following:

1. Break down voltage of condenser too low.
2. Wrong L C Ratio.
3. Improper antenna coupling.
4. Regeneration or overmodulation in phone transmitters.
5. Excessive audio peaks from oscillating audio stages.
6. Poorly designed audio equipment.
7. Stage improperly neutralized.
8. Poor regulation in Power Supply in CW transmitters.

QUESTIONS AND ANSWERS

(The following questions and answers are a few of the many found in the 1937 Edition of Jones' Amateur Radiotelephony book.)

Explain the action of a quartz crystal oscillator. Why is its use desirable?

The quartz crystal acts as a tuned circuit, due to its piezo-electric properties, and it has an extremely high degree of stability since it is nearly mechanically resonant to the electrical frequency of oscillation. The tuned plate causes the RF energy to be fed back into the grid circuit, which includes the quartz crystal. The feed-back causes oscillation of the frequency determined by the physical dimensions of the quartz crystal, and power can be taken from the plate circuit.

The quartz crystal is mechanically resistant to changes in physical dimensions, with the result that the frequency of oscillation is very constant.

How is a plate modulated transmitter properly adjusted with a Class-C Amplifier?

The Class-C Amplifier is operated with normal plate voltage, and grid bias of at least twice cut-off. It is neutralized, unless a screen-grid tube is used. The antenna loading is adjusted until normal plate current loads the modulator tube to the proper value for correct impedance matching. All circuits are tuned to exact resonance. The audio gain control should be set below the point where sound input to the microphone causes fluctuation of the Class-C amplifier plate current, or where overmodulation is shown by an overmodulation indicator.

How is a grid-modulated transmitter adjusted?

The negative grid bias of the RF modulated stage is adjusted to approximately 1½ times cut-off for ordinary grid-bias modulation. RF excitation is increased until DC grid current starts to flow. Antenna coupling is increased until the antenna RF current begins to decrease. The audio input is increased until grid current in the modulated stage is indicated during peaks of modulation. In case of excessive plate dissipation, under these conditions, less plate voltage and RF grid excitation will be needed.

Describe the effects of overmodulation. What is the cure?

Overmodulation causes the radiation of a broad interfering wave. Another effect is audio distortion at the receiving end. Overmodulation can be eliminated by using the correct value of grid excitation, correct DC grid bias, well-regulated power supplies, correct amount of audio-frequency output from the modulator, and proper degree of antenna coupling.

Name three or more causes of frequency modulation.

(1) Variation in oscillator plate voltage. (2) Vibration of the oscillator. (3) Reaction of the modulated stage upon the oscillator due to lack of a buffer amplifier. (4) Improper neutralization of an amplifier. (5) Modulated RF feed-back to the oscillator.

How can frequency modulation be eliminated?

By the use of a well-regulated power supply for the oscillator and separate power supplies for the remainder of the transmitter. A buffer-amplifier or doubler and a stable oscillator should also be used. The RF amplifier should be correctly neutralized, and the crystal oscillator should be shielded from the remainder of the set.

What is the proper adjustment for a frequency doubler amplifier?

High RF grid excitation is necessary, and the grid bias should be from 3 to 6 times cut-off. High L-to-C ratio is also desirable in order to give a high impedance to the harmonic frequency.

Explain how to eliminate parasitic oscillations from the various stages of a radio transmitter.

Use shorter leads in the grid and neutralizing circuits, or use small parasitic chokes, shunted by a 200 ohm resistor, in the grid circuits adjacent to the grid terminals. Low-frequency parasitics can be prevented by eliminating the grid RF choke, or by using one with very much less inductance than that used in the plate circuit of a RF amplifier. Parasitics in a Class-B audio amplifier can be eliminated by shunting .0005 mfd. or .001 mfd. condensers from grid to filament, and by inserting 40 ohm resistors in the plate leads to the output transformer. Parasitics are undesirable because they will introduce distortion in Class-B audio circuits. In RF circuits, parasitics will cause excessive tube heating, radiation of undesired frequencies, and instability in neutralized RF amplifiers.

(Courtesy of Frank C. Jones)

SHORT WAVE THERAPY

The oscillating tubes are, necessarily, the most important component of Short Wave Therapy Apparatus and are subject to more abuse than any other part. There are two basic reasons for tube failure in this class of work; either the tubes are not of sufficient size or rating to deliver the power required, or the circuit is poorly designed so that the tubes cannot function as efficient oscillators under varying load conditions.

Improvements in tube design have helped to reduce the number of failures due to punctures from the excessive high frequency voltages encountered.

We wish to point out that in the present state of the Art, the high efficiency obtainable in radio transmitters is impossible in Short Wave Therapy. High efficiency can be obtained experimentally by properly coupling a resistive load, such as a bank of electric lamps of the correct impedance, and adjusting excitation, bias, etc., until maximum output with minimum input is obtained. It is obvious that these ideal conditions are rarely encountered in practical application, as the human body offers resistance varying over a wide range. For example, a treatment from shoulder to foot may offer 20 or 30 times the resistance of a treatment through chest or abdomen. It is necessary then to compromise, sacrificing efficiency in order to obtain Radio Frequency output of sufficient power to heat various parts of the body to a useful degree. From these undeniable facts, it can be readily seen that the selection of oscillator tubes for therapy equipment is of utmost importance.

IT IS NOT THE POLICY OF TAYLOR TUBES, INC., to furnish circuit diagrams for Short Wave Therapy to the casual experimenter; however, bona-fide manufacturers will find our engineers willing and anxious to offer suggestions for bettering the performance of their equipment.

Amateur Radio Operators have, for several years, obtained MORE WATTS PER DOLLAR from the use of TAYLOR TUBES in their transmitters; likewise Short Wave Therapy manufacturers using TAYLOR TUBES in their equipment are reaping the same benefit.

We cannot emphasize too strongly the necessity for careful, conservative engineering and exhaustive tests, as it has been our experience that this is the only procedure that will give satisfaction to both manufacturer and user.

STANDARD RECTIFIER CIRCUITS

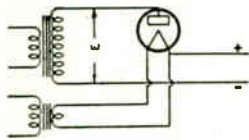

FIG. 1

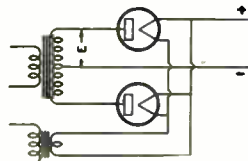

FIG. 2

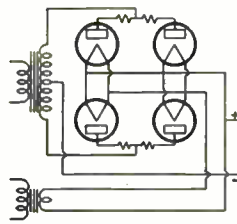

FIG. 3

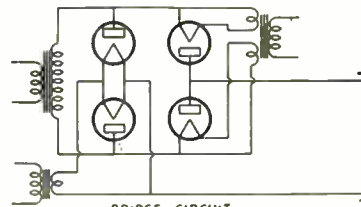

FIG. 4

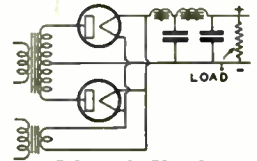

FIG. 7

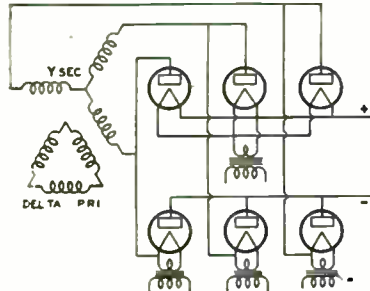

FIG. 6

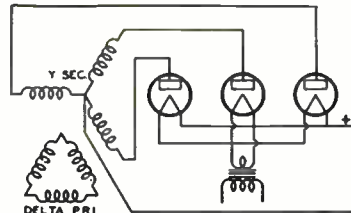

FIG. 5

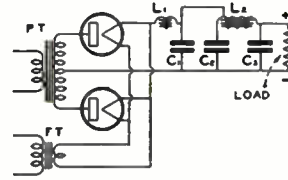

FIG. 9

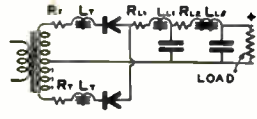

FIG. 8

Figure No.	Transformer Volts E	DC Output Volts at Input to Filter	DC Output Current In Amperes
1	.7 x Inv. Pk. Vtg.	.45 x E	.33 x Pk. Plate
2	.35 x Inv. Pk. Vtg.	.9 x E	.66 x Pk. Plate
3	.35 x Inv. Pk. Vtg.	.9 x E	1.32 x Pk. Plate
4	.7 x Inv. Pk. Vtg.	.9 x E	.66 x Pk. Plate
5	.43 x Inv. Pk. Vtg.	1.12 x E	.83 x Pk. Plate
6	.54 x Inv. Pk. Vtg.	2.25 x E	1.0 x Pk. Plate

Figures 1 to 6 illustrate typical rectifier circuits applicable to amateur use. The single-phase half-wave circuit of Figure 1 is not very popular due to the fact that the ripple is of greater magnitude and being of lower frequency than other systems is more difficult to filter. With choke input, the DC voltage will be approximately .45 that of the r.m.s. voltage E. Figure 2 illustrates the full-wave single-phase circuit which every amateur is familiar with. Figure 3 is identical in nature with Figure 2, except that four tubes (more if desired) are used to obtain higher current output. The resistors shown in the plate circuits of these tubes are very essential, otherwise one tube will generally take most of the load with the natural result that the tube life is greatly decreased; a drop of about six volts across these resistors will insure stability. Figure 4 shows a bridge circuit with four tubes, its advantage is that high DC voltages can be secured without expensive (high peak inverse voltage) tubes and with low voltage transformers. For full-wave rectification the DC voltage can be increased by using the entire secondary output of the plate transformer, in fact, the voltage will be exactly doubled; of course, this halves the current output due to the transformer current carrying limitations. Figures 5 and 6 are similar to that of Figure 2, except that they apply to three-phase circuits. In the circuit of Figure 5, each tube carries current for one-third cycle. The circuit of Figure 6 is very commonly employed in high power transmitters where three-phase power is available due to the high DC output voltage attained. This circuit has the added advantage that the ripple frequency is high, being six times the supply frequency, allowing simple filtering.

THIS ENTIRE PAGE FROM "THE RADIO HANDBOOK"

Courtesy Pacific Radio Publishing Co.

WE wish to sincerely thank these manufacturers who have so generously co-operated with our Engineering Staff in the building of the transmitters described in this manual. We have found their products to be of the best quality and recommend their use very highly.

American Phenolic Co.

Barker-Williamson

Bud Radio, Inc.

Birnback Radio Co.

Allen D. Cardwell

Cornell-Dubilier

General Transformer Corp.

E. F. Johnson Co.

Lenz Electric Mfg. Co.

Ohmite

Stancor

Thordarson

Turner Microphones

Triplett

Utah Radio Products

Vesel's Crystals

Other Circuits using Taylor Tubes can be found in the following publications:

814 Grid Mod. 100 watt Xmtr—Jan. 1937 Radio.

T20's 3 Band Xmtr—Mar. 1937 Radio.

350 Watt Progressive Xmtr—June 1937 Radio.

T55 Xmtr—Jan. 1937 QST.

10 to 160 meter Xmtr—June 1937 QST.

T55 Transmitters—May and June 1937 All Wave Radio.

TAYLOR TUBES, Inc.

2341-43 Wabansia Avenue - Chicago

Foreign Representative

ROYAL NATIONAL CO.

Cable **NATVARNCO**

16 W. 61st St.

New York City

Canadian Representative

ATLAS RADIO CORP.

500 King St., West

Toronto, Ontario

Canada

**DISTRIBUTED BY
RADIO-ELECTRIC SUPPLY CO
FORT DODGE, IOWA**

TUBES WITH A REAL GUARANTEE

PRINTED IN U. S. A.



GENTRY PRINTING COMPANY

DISTRIBUTED BY
RADIO-ELECTRIC SUPPLY CO.
FORT DODGE, IOWA

RECOMMENDED AND DISTRIBUTED BY

Taylor
with
Tubes



Dollar⁹⁹

Per

Watts

More