

JANUARY, 1923

Price 20c

PEANUT TUBE HOOK-UPS

VOL. I

NUMBER
IX

E-Z RADIO

THE ONLY REAL

Table Contents #13

RADIO

PRIMER

FOR THE NOVICE

By Henry M. Neely

E-Z COMPANY, Inc.

614 ARCH STREET
PHILADELPHIA

E-Z RADIO

CLASSIFIED ADVERTISEMENTS

Radio Clippings and diagrams. Tell me what you want and send as many old ones and 5c. Exchange Bureau, R. D. Perry, R. D. 5, Harrisburg, Pa.

For Sale:—3000 Meter Loose Coupler. Brings in Arlington direct on crystal. Good as new. Will sell for \$15.00; cost \$35. A. B. Lawrence, Riverside, N. J.

For Sale:—Atwater Kent tuned coupler, detector and amplifier, and 2 step amplifier, mounted on rubber panel and base board, completely wired, brand new, cost \$48.10. Sell for \$40.00. Have installed short wave regenerative set and will not use this one. Box 4, E-Z Radio, 614 Arch St., Philadelphia, Pa.

Simplex Set—One step radio frequency, detector and two steps audio frequency. Cost \$110. Sale for \$90.00. Has been used only for demonstrating to customers. Practically new. Box 5, E-Z Radio, 614 Arch Street, Philadelphia.

Wanted:—Transmitting Apparatus. I need C. W. Inductance, transformer for 110 A. C. and Microphone. Will exchange almost any type of receiving apparatus. Box 2, E-Z Radio, 614 Arch St., Philadelphia.

Music Master Horn for sale. Slightly used but in perfect condition. Cost \$30.00. Will sell for \$20.00. Box 6, E-Z Radio, 614 Arch St., Philadelphia.

Wanted:—Motor-Dynamo to run on 110-volt A. C. and delivering 350 volts D. C. State condition and lowest price in first letter. Box 3, E-Z Radio, 614 Arch St., Philadelphia.

Receiving Set: Single circuit, detector and two step amplifier; best material. Mounted on rubber panel and in good cabinet. Brand new. Price \$50.00. Box 4, E-Z Radio.

For Sale:—\$18.00 Gould A Battery \$9.00, 1UV. 200, \$2.50. 2 UV. 201, \$6.00, 2647 So. Juniper St., Philadelphia, Pa.

Start your *E-Z Radio* with the **New Year** **SUBSCRIBE NOW!**

CUT HERE

To E-Z CO., Inc., Publishers, E-Z RADIO
614 ARCH STREET PHILADELPHIA

P. _____ Ex. _____
**SUBSCRIPTION
BLANK**

Gentlemen: Date _____ 192____
Kindly enter my subscription to E-Z RADIO, for _____ Year,
commencing with the _____ Issue. Omit _____

Enclosed find Cash, Check or Money Order for \$ _____

We can furnish all back numbers, from May, 1922. Any 6 back numbers for \$1.00. Subscription Price, \$2.00 per Year. Postage Prepaid.

Name _____
Address _____
City _____ State _____

E-Z RADIO

BY

HENRY M. NEELY

VOL. I.

JANUARY, 1923

NO. 9

Entered as second class matter May 26th, 1922, at the Post Office,
Philadelphia, Pennsylvania, under the act of March 3rd, 1879

Copyright 1922 by The E-Z Company, Inc.

CONTENTS

Don't Be Too Ambitious.....	3
About Armstrong's Super-Regeneration.....	4
Making Your Own Aerial Masts.....	5
Another Home-Made Aerial Mast.....	7
The Single-Wire Aerial.....	8
A Home-Made Sending Key.....	9
A Home-Made Practice Buzzer.....	10
A Simple Regenerative Set.....	12
Hooking-Up the Set.....	14
Mounting the Set.....	15
The Peanut Tube For All Sets.....	16
Peanut Tube Hook-Ups.	
1—The Single-Slide Tuner.....	18
2—The Two-Slide Tuner.....	19
3—Simple Double Circuit.....	21
4—Another Loose-Coupler Circuit.....	22
5—Tuning With a Variocoupler.....	23
6—Try a Plate Variometer.....	25
7—Spider Webs.....	26
8—Two Spider Web Tuners.....	28
9—One Step of Amplification.....	29
10—Two Steps of Amplification.....	30
Connections for Spider Web Coils.....	32
Simpler Tapping of Spider Webs.....	33
Storage B Batteries.....	34
Take Care of Your Storage Battery.....	35
An Easy Set to Build.....	36
How Do We Measure Wave Length?.....	38
Switching Out Radio Frequency.....	39

E-Z RADIO

Published monthly by the E-Z Company, Inc., 614 Arch Street, Philadelphia.
Henry M. Neely, President; H. N. Rudley, Secretary and Treasurer;

E-Z RADIO is sold at 20 cents per copy at all news stands, Radio shops and book stores. Subscription in the United States and Canada, \$2.00 per year.

TAKE CARE OF YOUR STORAGE BATTERY

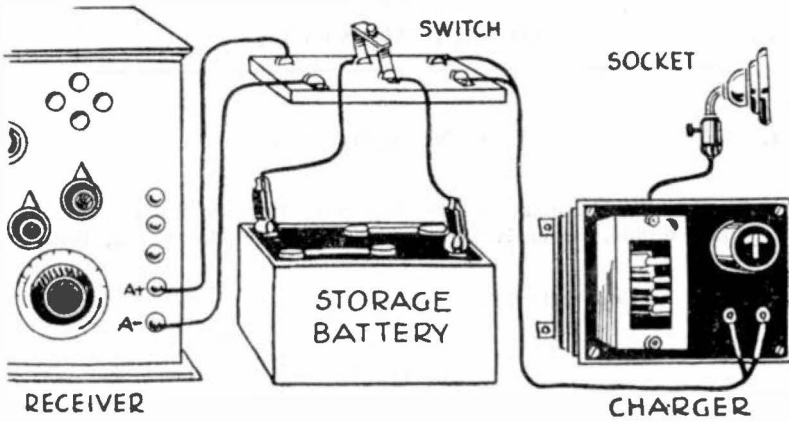

This double pole double throw switch is the handiest arrangement for permanently connecting the home charger, the battery and the receiving set. The article on Page 35 tells about it.

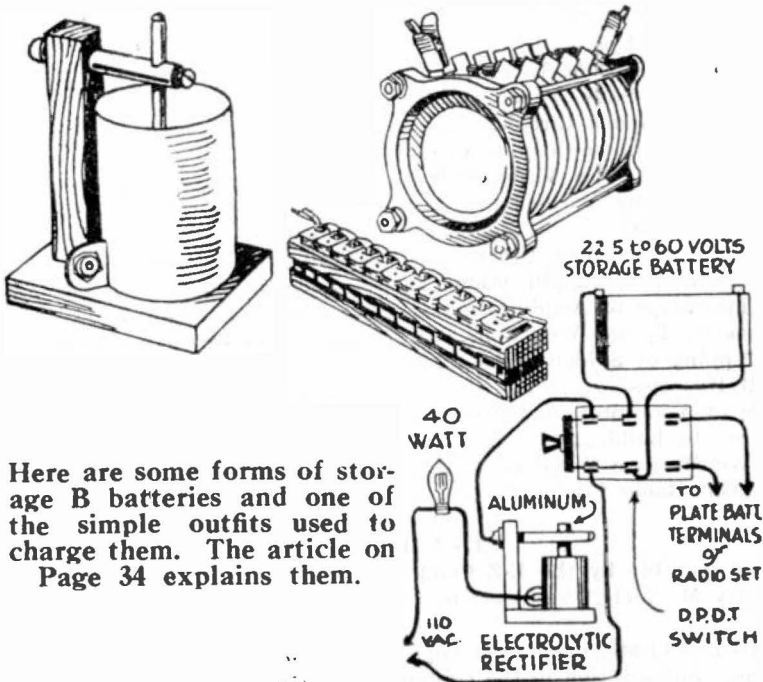

Here are some forms of storage B batteries and one of the simple outfits used to charge them. The article on Page 34 explains them.

DON'T BE TOO AMBITIOUS

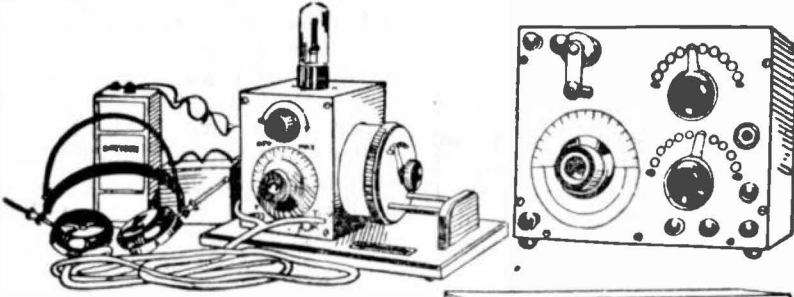

The beginner should start with some such set as we show here. The man with the broadcasting station nearby should begin with a crystal. The man farther away should begin with the little peanut tube or, at most, a single-circuit set

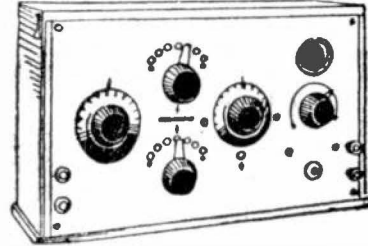

If the radio dealers in this country would only get together and sign an agreement not to sell any beginner any set more complicated than a simple crystal or a single circuit regenerative one tube set, they might do a little less business this year, but they would do more to build up a steady and permanent trade, than by any other method that I know of.

It is simply astonishing to me to get in my mail so many diagrams from beginners showing that they have bought and mounted on panels the most elaborate kinds of apparatus and yet do not know enough about radio to wire the stuff together.

I often wonder how they expect to get any results with sets as complicated as this, even after they do get it wired up.

One man came in to see me the other day and at once started the conversation by asserting that he had been convinced that radio was a fake and that he had just

bought a lot more phonograph records so that he could have some real music in his home.

"I have spent more than \$350 on radio," he said, "and I believe that the whole thing is a swindle."

"What kind of apparatus have you got?" I said.

"Well," he said, "my panel contains two variable condensers, two variometers, a variocoupler, two potentiometers, a B battery tap switch, a series parallel switch, the rheostats for two radio frequency tubes, one for the detector and three for three stages of audio frequency amplification. Then I have a loud speaker with three power tubes and yet with all of that stuff I cannot get a thing that is satisfactory."

"Would you," I asked, "after watching a man run a three-horse power motor boat, undertake to ship as chief engineer on an ocean liner?"

"No," he said, "I would not. I would have to have an engineer's license."

"Yes," I answered, "and you ought to have a radio engineer's license to run that outfit you have bought. I have been in the radio game ever since it started and yet I am not sure that I would care to tackle your set myself if there were any one there waiting for a demonstration."

I wish that every radio magazine would spread throughout its pages some such warning as this in big black type:

"To beginners: Do not let the salesman sell you a variometer. If you are within twenty-five miles of a good broadcasting station and do not know anything about radio, don't buy a tube set;

start with a crystal. If you are too far away for a crystal, get a set using only one tube and do not attempt any kind of amplification until you have mastered this. Do not get any set that has more than two dials to adjust. Get one of the sets employing the standard single-circuit hook-up and you will then have only one variable condenser and the rotor of your variocoupler to bother with."

Later you can gradually build up to the more elaborate sets, but you will get far more satisfaction from radio and find it far more interesting and much less discouraging than if you attempted to start at once with the kind of set that even an expert hesitates to handle.

ABOUT ARMSTRONG'S SUPER-REGENERATION

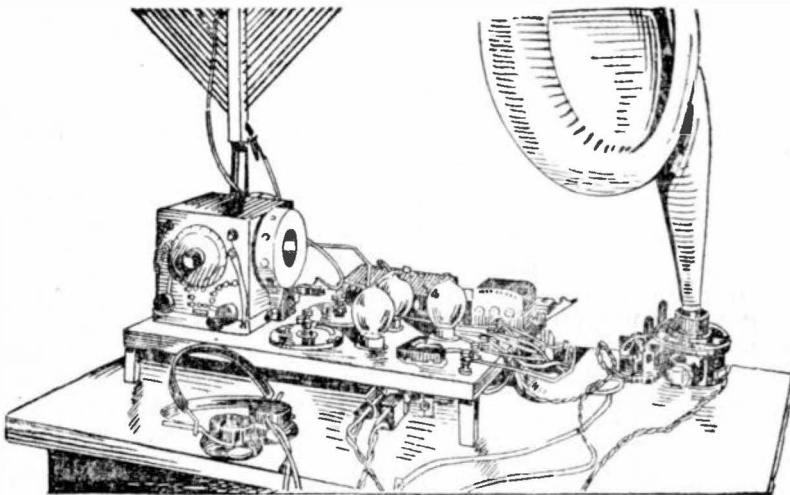

This shows the Armstrong super-regenerative circuit in the form adopted by the inventor himself

"What about the Armstrong super-regenerative hook-up?" many fans are demanding to know. This circuit and its many

modifications have been before the public for a long time now, but I have purposely refrained from dealing with them because,

frankly, I have never yet found one of these circuits which I could operate satisfactorily, and I therefore do not care to advise beginners to attempt it.

Naturally it is impossible to try out all of the various hook-ups that have been developed since Major Armstrong announced his principle. It may be that in the hands of experts these circuits are accomplishing wonders. I know that the audience which heard Armstrong's personal demonstration when he first announced his new idea was astonished at the result.

It seems to me that the best answer to all of the beginners who are demanding instruction in this new circuit is to ask them how many of them see these circuits being demonstrated in radio stores. Personally I do not know of a single instance. It is therefore equally logical, it seems to me, to draw the conclusion that the circuit is too difficult to be put before the general public at the present time.

Some time ago I received through a friend of mine a diagram of the real three-tube circuit direct from Major Armstrong's laboratories. I found in

the first place that the mere wiring up of this circuit was far beyond the ability of beginners.

Even with the circuit wired up correctly I have never been able to get rid of a constant whistle in the phones that becomes a positive nuisance in a loud speaker.

Several experts who are among my acquaintances have invited me to listen to their Armstrong hook-ups, and I have found this same whistle always present, even when the experts themselves tuned in the signals to the best of their ability.

This circuit undoubtedly points the way to a tremendous advance in radio reception. The time will come when its complications will be removed and its annoyances eliminated, and then we can talk about it for the general public.

At this time I feel very strongly that to give any of the hook-ups of this circuit which I have tried would only be to invite disaster to the reader, and would add another doubting Thomas to the already large ranks of those who are attempting more in radio than their knowledge can accomplish.

MAKING YOUR OWN AERIAL MASTS

Any radio man taking a trip through any city at the present time will get one main impression from the aerials which he sees on the roofs of hundreds of homes. This impression will be one of astonishment at the sloppy looking aerial masts which hold the antenna of eight out of ten of the sets, and which just barely hold them, and certainly

would not stand up in any kind of rough weather.

It is undoubtedly difficult for a man in the city to buy a good mast, and therefore he uses anything he can get hold of from a broomstick to a crooked young tree cut down on some Sunday excursion into the country. Yet it is the easiest thing in the world for an amateur to build a very

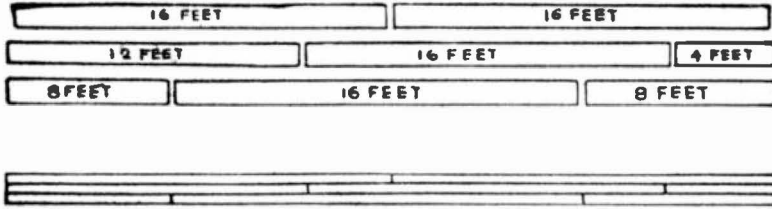

This is a method by which a fine aerial mast can be built from ordinary boards

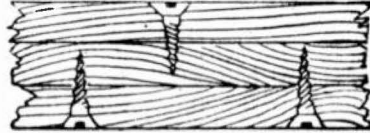

good and extremely durable mast thirty or forty feet high. I want to give two methods of doing this, one of them my own, and the other suggested in a book called "Radio Simplified," by Kendall and Koehler.

The latter one requires less lumber and is perhaps the easiest to build, so I will give it first, but I am inclined to think that my own method is probably stronger. For the mast advocated by Kendall and Koehler they use three layers of board, the boards being ordinary sixteen-foot pieces of lumber one inch thick and three inches wide.

They are put together in what is known as "laminations"—that is, the mast is made up of three layers of these boards screwed together. The illustration shows the method by which this is done without having any two joints come close together. In making up the mast it is wise to nail the boards together with light nails first and then to screw them with strong brass screws which will not rust and then to draw out the nails to prevent rust eating into the wood at this point.

It is also wise to give all of the boards a good coat of paint be-

fore putting them together, as this will make them last indefinitely in any kind of weather.

These boards should be fastened by strong screws about one foot apart, and it is wise to use a short piece of aerial wire to lash them together wherever a joint comes.

A mast of this kind should be stood up with the edges of the boards turned in the direction of the pulling strain of the aerial. They should be guyed at the middle and at the top, and each guy wire should have a strain insulator about the middle of it. It is also wise to have a turn buckle at the lower end, so as to take up any slack that may develop and keep the mast guyed so tightly that there will be no tendency to swing in a wind.

Built in this way this method gives you a solid pole three inches by three inches and you can make it anything from twenty-five to forty feet in height, cutting your boards to suit.

It will not make much difference what length you cut them, as long as you avoid bringing any two joints within about two feet of each other.

ANOTHER HOME-MADE AERIAL MAST

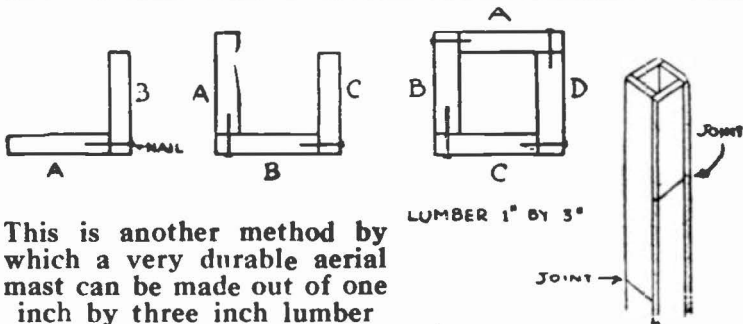
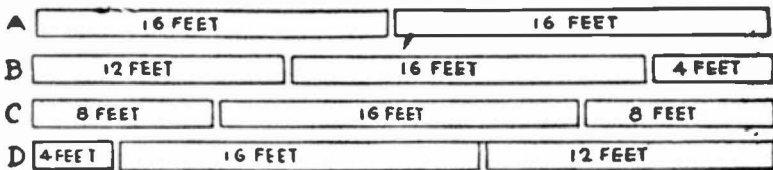

This is another method by which a very durable aerial mast can be made out of one inch by three inch lumber

By means of a "square" method of construction it is possible to build an aerial mast bigger and somewhat stronger than the one dealt with in the last article, while still using ordinary one by three inch lumber.

The first method, joining these boards in layers or "laminations," results in a mast three inches by three inches, but this method, using the same lumber but two extra boards, gives a mast four inches by four inches. I have used a mast of this kind for over a year now and find it as strong as the day I put it up. Personally I find this hollow mast even easier to build than the laminated one, but this is entirely a matter of individual taste, and I can assure the amateur that he will get perfect satisfaction whichever type he uses.

In building this hollow mast it is essential to figure out the length of the boards just as you would with the laminated mast with the object of preventing any two joints coming together.

In the case of my own mast I got boards sixteen feet long and laid two of them full length on the ground to act as one side. This gave a mast thirty-two feet high.

I then took another of the sixteen-foot boards and cut it into two pieces, one twelve feet long and the other four feet. I put the twelve-foot board edgewise up against the first length on the group and nailed it fast with plenty of galvanized nails. Next came a sixteen-foot length nailed edgewise in the same way and then a four-foot length.

In order to make this perfectly clear let me call the first side, consisting of the two sixteen-foot lengths, A. We can then say that A was lying on the ground while we nailed the second side, or B, consisting of lengths twelve feet, sixteen feet and four feet, to it.

I then turned the structure over so that the B side was lying on the ground and the A side was standing in the air. The third side, or C, was made of three

pieces, eight feet, sixteen feet and eight feet, respectively, nailed into the side of B. I then once more turned the whole thing over so that C side was underneath, B side was upright and A side was horizontal, hanging over C, and the mast was finished by inserting D, consisting of lengths four feet, sixteen feet and twelve feet, nailing through them into the edge of C and clinching the whole

thing by nailing down through A into the edge of D.

This mast should be guyed the same as the one described in the last article. It can also be strengthened if, when three sides are fixed together, you insert several short pieces of 3 by 3 inch lumber and nail all the boards solidly to them. These pieces should be about one foot long each and they should be inserted about six or eight feet apart.

THE SINGLE-WIRE AERIAL

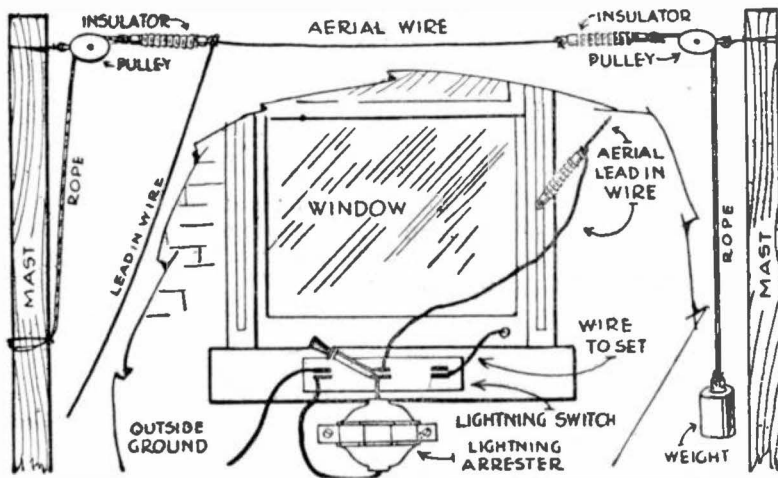

These details will be useful to the novice who is putting up a single-wire aerial

While we are on the subject of aerial masts, it will probably be well to summarize for the beginner the main points in the putting up of an ordinary single wire aerial. This is an article intended strictly for the new convert to radio and can be skipped by those who have been in the game for some time.

To get down to fundamentals then:

If you have a stretch of space between your masts seventy-five feet or more, the single wire aer-

ial will be all that you require. If you have between fifty and seventy-five feet, you should use a two-wire aerial, and if you have less than fifty feet, you should have four or six wires.

Even the single-wire aerial should be so erected that you can take it down at any time. For this purpose the first thing to do is to lash a pulley to the top of each of your masts.

You should then run a rope through the pulley, and by means of this rope you can pull your

aerial up or let it down. This rope can be ordinary clothes line, though it is wise to spend a little extra money and get the more durable window-sash cord.

We will assume that you are going to take your lead in from the near end of your aerial. Therefore, we will begin by describing the arrangement at the far end.

Pass the rope through the pulley and tie an aerial insulator to the rope, making the end of your aerial wire fast through the other hole in your insulator. You should then measure your aerial so as to have it two or three feet shorter at each end than the actual space between masts to allow for expansion and shrinking of the rope.

At the top of the mast at the near end you pass your rope through the pulley in the same way and tie a similar insulator to the end of it. Then you pass the end of your aerial wire through the other hole in this insulator

and twist it around itself in the form of a knot, leaving a long free end of the wire to act as a lead in.

This done, you hoist your aerial by means of your ropes, tying the rope fast at one end but attaching at the other end a weight heavy enough to keep the aerial wire taut. This weight can be a brick or a heavy stone or anything of that kind. The object is to allow a certain amount of play when a wind is blowing or when a coat of sleet forms on the wire in the winter time. This method permits the rope at one end to slide up and down through the pulley and protects the wire against so much strain that it would break.

Another insulator should be arranged just outside your window to which you can tie your lead in wire to keep it as taut as possible, and from this last insulator to your set the wire can be loose.

Details of lightning arrestor and switch are shown in the accompanying illustrations.

A HOME-MADE SENDING KEY

The price of keys for sending the wireless dot and dash code seems unwilling to drop and so I am showing here a very efficient key which any novice can make out of the junk usually found around the house.

The pictures explain themselves and it is only necessary for me to give a few of the details from the particular key from which the illustrations were made and its dimensions, though the amateur can make his from any material or any size that he desires.

The base board of this one was made from a piece of wood taken from an old packing box and cut

5½ inches long and 2¼ inches wide. The key itself was cut from the same piece of board, but is only 4¼ inches long and is cut square.

The uprights which hold the pivot upon which the key swings are two pieces of tin cut from an empty can, ¾ inch wide and 1½ inches long and bent at right angles. There is a hole punched in each to receive the screws which fasten it to the base and other holes punched in the upright portions to take the bolt which acts as a pivot.

The finger-grip is a wooden tin pot knob bought at a hardware store for one cent. It might just

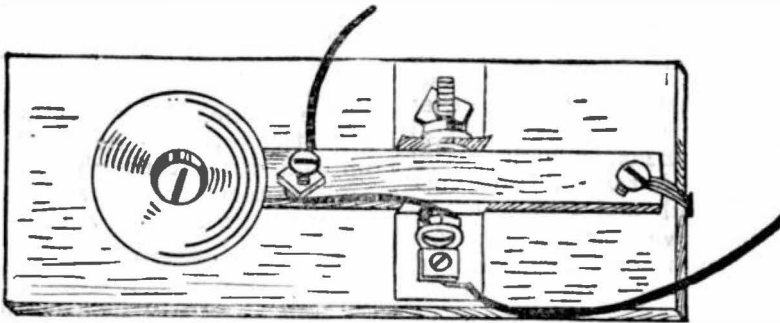
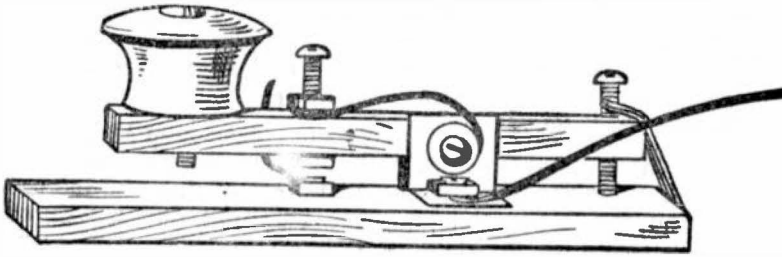

Here is a home-made sending key which any amateur can build at no cost whatever

as well have been a big button or a poker chip or anything that would give the fingers a good grip when sending.

The adjustments are made by means of two small bolts screwed in through holes in the lever and the tension on the key is made by placing a rubber band from the end bolt to a tack driven into the base board.

One wire from your battery

connects to the screw which holds down one of your tin uprights, another wire goes from that same screw or else from the pivot bolt on that side to the adjusting bolt nearest the finger grip and another wire goes from the screw which is set in the base board directly under this adjusting screw, so that when the key is pressed down the two make contact and permit the current to flow.

A HOME-MADE PRACTICE BUZZER

If you are going to learn the fascinating dot and dash code which you hear so often in your radio receiving set while tuning in to find a concert, there is no better practice than a little buzzer worked by a dry battery and a key.

Of course it is best to buy these things already made, but if you

have spent so much on your receiving set that you are doing without lunch in the middle of the day, as many of us are, you can construct quite a satisfactory little practice buzzer out of the junk which you have around the house. The only thing that you need to buy is the battery. I am showing in the picture the type

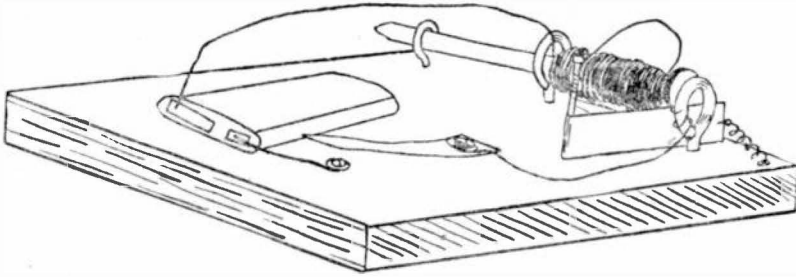

Here is an easily made buzzer for practicing dots and dashes

that I happened to have when I built this buzzer, but any of the little pocket flashlight batteries will do.

The other material required is simply a lot of insulated wire of almost any size from No. 32 to No. 22, a big bolt or iron nail, three screw eyes and two strips of tin cut from an old tin can. No definite instructions are necessary as to the number of turns of wire which you wrap around the nail. I need only say that the more turns you give it the more efficient your buzzer will be.

The first end of the coil of wire, as you see, is fastened to one side of the battery, and the other end is twisted around the nail which holds the strip of tin which we call the vibrator. This vibrator is merely a small piece of tin about a half inch wide and an inch and one-half long, with one end bent around this nail so that it acts as a hinge, but do not bend it too tight because the vibrator must have absolutely free play when it is in operation.

If you have mounted the nail, with the wire wound around it, fastening it as the picture shows, or by any other method that strikes your fancy, put a screw eye in the board at one end of the

head of the nail, spacing it just so that it will scrape the head of the nail as you turn it.

Then you bend the other strip of tin upward and punch a hole in one end just big enough to admit a small screw. This small piece of tin will be the key by which you will make your dots and dashes. Cut a small piece of wire long enough to go from the screw eye to the screw which holds the key down. Scrape the insulation off both ends of the wire, twist one end around the screw eye, put a small washer over the screw and screw the other end down tight over the "fixed" end of the key. Then press the key down and mark the place where it touches the board. Turn the key aside and drive another small screw into the board at this mark, putting a washer over the screw and putting another short piece of wire under it to lead to the other side of the battery.

There is then only one more thing to do and that is to arrange it in such manner as to have the vibrator kept back against the screw eye when the key is not pressed down.

The screw eye should be turned just enough to leave a space for

the vibrator to play back and forth between it and the head of the nail and this space will depend upon the number of turns of wire you have wrapped around the nail. The more turns of wire you used the bigger the space can be and the louder the sound of the buzzer will be. You can, if you like, stand your buzzer up on its edge so that the vibrator will naturally fall back upon the screw eye. If, however, you prefer to have it lie flat, you will have to attach a thin rubber band or a very small spring to the free end of the vibrator, but do not use anything with too strong a pull to it.

Let us now see what happens when we use this outfit.

When we press the key down upon the screw beneath it we provide a path for the electric current to flow from one side of the battery around the coil, thence to the nail that holds the vibrator and along the vibrator to the screw eye, and then along the short wire from the screw eye over the key and so back to the battery.

But we have already learned that when we suddenly send a current of electricity around a coil we make a magnet of it. So

when we press this key the electricity magnetizes the nail the moment the current starts to flow and this magnetism attracts the vibrator away from the screw eye. This breaks the circuit and stops the flow of electricity, but the rubber or spring immediately pulls the vibrator back against the screw eye, the circuit is re-started, the nail attracts the vibrator again and so the little strip of tin keeps buzzing back and forth between the nail head and the screw eye, and gives out the sound by which we can spell the words of the wireless code.

Most beginners make the mistake of not winding enough wire around the nail and so not creating sufficient magnetism to attract the vibrator very far. In this case the screw eye must be turned around until there is a very slight space to play in and the sound that it gives out will not be loud.

This little practice set can also be used as a test buzzer for a crystal receiver. Simply twist another piece of wire around the screw eye and run it to the ground binding post of your set and you can use it exactly as one of the regular test buzzers which you buy in the stores.

A SIMPLE REGENERATIVE SET

Everybody who dreams of an audion bulb receiver wants what is called a regenerative set and dreams of the advantages of having a tickler on his apparatus; but most young fellows who are not very expert are afraid to tackle the job of wiring up and connecting a rotor which must be accurately placed so that it can turn around on a shaft.

For the benefit of these novices I am going to describe a really

regenerative set, using a tickler but doing away with a rotor altogether. This set is about as easy to build as anything I know and it is capable of getting quite surprising results when connected either with the standard audion bulb or one of those little peanut tubes which burn on an ordinary dry cell and which can be set into any standard socket by means of an "adapter."

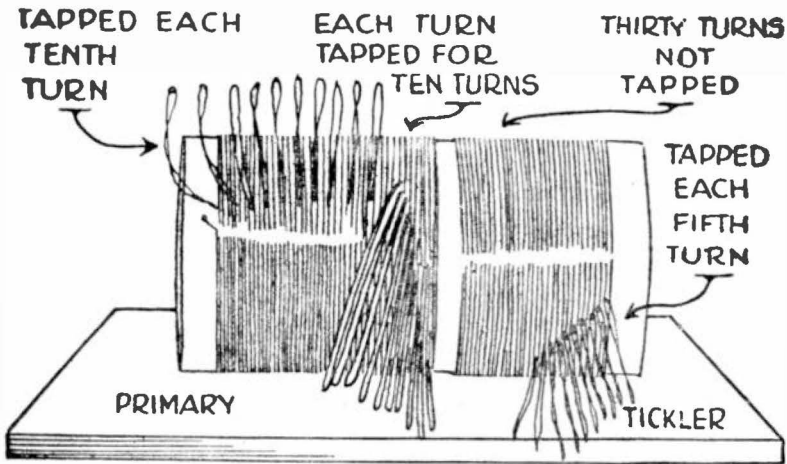

This picture shows how to wind an easy kind of coil for making a regenerative set

The material necessary for making this tuner is a tube of some kind, which may be anything from two and one-half to four inches in diameter; three switch blades and thirty contact points. This tube should, of course, be made of one of the standard insulating materials, but it can just as well be a salt box or an oatmeal box.

You must also get a spool of insulated wire for winding. This wire can be cotton-covered, silk-covered or enameled, and any size from No. 22 to No. 30, though I recommend either No. 22 or No. 24, and my preference is first for the silk-covered, next for the cotton and lastly the enameled. This preference is governed entirely by ease in handling, and you will get the same results no matter what kind you use.

You must have your tube long enough to wind on two sections of wire, each one of which must consist of from 80 to 100 turns. These two sections are to be separated in the middle by a space

of about one-half inch. Both of the windings, by the way, must go in the same direction.

It is best to start winding your coil by marking off this half-inch space in the center and then punch two holes in the left-hand side so that you can tie in one end of your wire.

Then you start winding the left hand or primary coil from the center and for each one of the first ten turns you twist a loose loop about two inches long in the wire and go on winding. These loops are left loose so that later you can attach them to the contact points.

The first ten turns give you ten loops. Then you go on winding and bring out loops each tenth turn thereafter until you have wound on as much wire as that half of the tube will hold.

You wind the right-hand or tickler coil in the same way only here it is not necessary to bring out so many loops. Put on thirty turns at once, bringing a loop out at the thirty-fifth, fortieth, forty-

fifth, fiftieth, fifty-fifth, sixtieth, sixty-fifth, seventieth, seventy-fifth and eightieth turns.

Your eightieth tap can be the last end of the wire, as you will

not need more than eighty turns on the tickler for broadcast work.

I will describe the hook-up and use of this coil in the next article.

HOOKING UP THE TWO-WINDING COIL

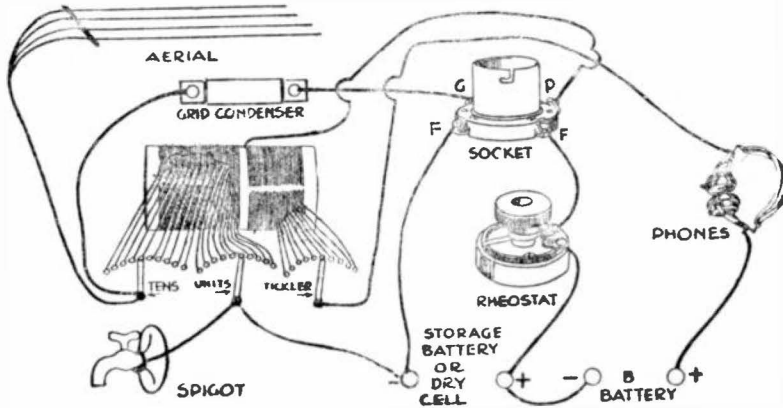

This hook-up for connecting the two-winding coil will be found very easy and very efficient

It is a very simple matter to hook up the two-winding coil described in the least article. I am giving here the diagram of connections and the same diagram can be used whether you are going to have a standard audion bulb burning on a six-volt battery or a peanut tube.

You can use the peanut tube in any standard socket by buying an "adapter" for \$1.25, and then you simply use a dry cell in the place marked for the storage battery in this diagram.

And, by the way, do not forget if you are making your own socket or mount for the peanut tube, that the connections on it are arranged differently from those on the standard socket. On the peanut tube, the thickest prong on the base goes to the plate and the one opposite goes to the grid. The other two which are opposite

each other are the two filament connections, and it does not matter which you use for plus and which you use for minus.

I am showing here the three circles of switch points necessary for the taps of your coil and you can place them in any position that you wish on the panel. All that I am trying to do in the diagram is to make clear how the various wires are connected. The hook-up is virtually the same as the famous single-circuit regenerative hook-up used with a vario-coupler, but the tickler in this case is varied by means of a switch blade and the taps instead of with the more complicated rotor of the vario-coupler. While this arrangement is not quite so delicate in tuning as the rotor, it will be found quite satisfactory for beginners to use. The check-up list of wiring follows:

Your aerial lead-in goes to the tens switch blade of the coil.

That same switch blade is wired to one side of the grid condenser and the other side of the grid condenser is wired to the grid connection on the socket.

The units switch blade on the primary coil is wired to the ground binding post and is also wired to the minus binding post of the storage battery or dry cell.

The minus and plus binding posts of the storage battery or dry cell are wired to the two filament connections on the bulb socket, a rheostat of course being put in the plus line as shown here.

The plus side of the storage battery or dry cell is wired to the minus binding post of the B battery.

The plus of the B battery is wired to one side of the phones and the other side of the phones is wired to the switch blade of the tickler coil.

The wire which connects to the first turn of wires nearest the primary coil is wired to the plate connection of the socket.

This same plate connection on the socket may be wired to one side of a phone condenser (.001 mfd.) and the other side of this condenser is wired to the minus side of the B battery.

You should use a 22½-volt B battery whether you are using a standard bulb or a peanut bulb.

If you fail to get results this way, try reversing the wires to the switch blade and the end of the tickler coil.

TO MOUNT THE TWO-WINDING COIL

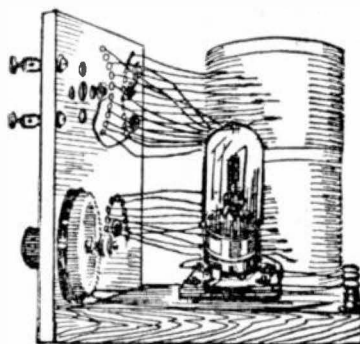
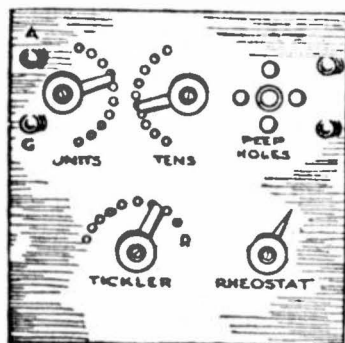

This shows the connections and the way to mount the two-winding coil which was described in the last two articles

As there are no rotors to be turned in the two-winding coil which I have been describing, it is a simple matter to mount the whole apparatus in a very small space.

I find it best to stand the coil upright and thus have the three circles of contact points for taps

all on the left-hand side of the panel, and then on the right hand side you have the peep-holes for your bulb and the dial for the rheostat.

The simplest way of doing this is to mount the cylinder with the tickler coil at the bottom and the primary coil at the top.

This is done because the primary coil require two circles of points, one on each side, and if you have that at the bottom you will have to extend the size of your panel to avoid running the switch points up against the rheostat.

Mounted in my way you have only one circle of switch taps at the bottom, and that gives you plenty of room for the rheostat and the two arcs of switch points at the top, one for the units and the other for the tens taps.

On the upper left-hand side of your panel you put two binding posts, the upper one for the aerial and the lower one for the ground, and next to them come the units and tens taps of the primary. The aerial binding post is wired to the shaft of the tens switch blade and another wire goes from the aerial binding post to the grid condenser.

The ground binding post is wired to the shaft of the units switch blade and another wire goes from the ground binding post to the binding post for the minus wire of your storage bat-

tery or the dry cell, if you are using a peanut tube.

In the upper right-hand corner of the panel you place two more binding posts and these are for the phones. They may also be used later for one or two stages of audio frequency amplification if you care to. The lower binding post of this part is wired to the binding post for the plus side of the B battery and the upper binding post is wired to the switch-blade of the tickler taps.

I advise that all of the binding posts for the batteries be placed on the back of the base board on which the panel is mounted, and with this hook-up you can get along with only three binding posts.

One of these is for the minus side of the storage battery or dry cell. The center one receives both the plus side of the storage battery and the minus side of the B battery and the other one is for the plus side of the B battery.

You may get better signals by changing the wire from the upper phone binding post to the plate screw on the socket and putting the plate wire on the upper phone binding post. Try it and see.

THE PEANUT TUBE FOR ALL SETS

If it had not been for the expense of buying and the trouble of maintaining a storage battery, the number of radio fans who are now enjoying the advantages of audion bulb receiving sets would probably have been doubled in the last year.

Everybody knows that there has been on the market a receiving set using a little bulb popularly known as the "pickle" or "peanut" tube, burning on an ordinary dry cell and giving virtu-

ally the same results as the larger tubes which require a storage battery. But this little tube has only recently been made available to the general market and even then it was not adaptable for general use because, in the first place, it was too small for the standard socket and in the second place its connections were entirely different. Even taking care of this difference in connection meant rewiring a good deal of the set and few fans wanted to go to that trouble.

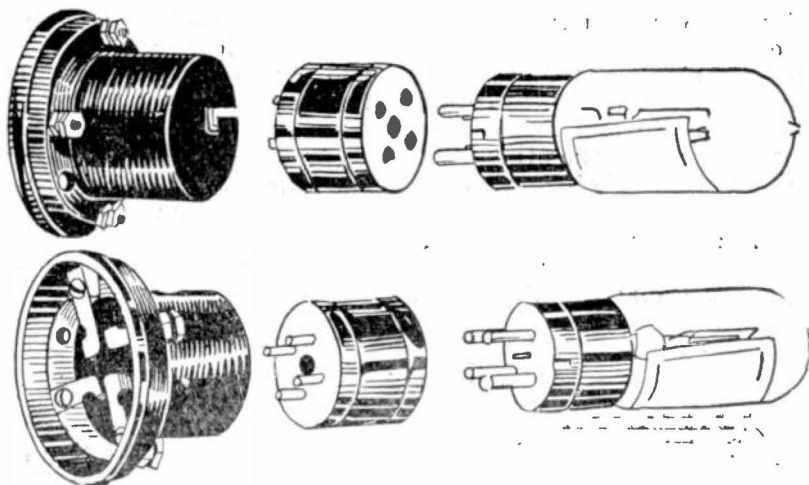

This adapter now makes it possible to use the peanut tube in a standard six-volt tube socket and the difference in connections is taken care of by the wiring concealed inside the adapter

There have been two recent strokes of good fortune for radio enthusiasts, however. One of these is that the price of the peanut tube has come down to the price of the ordinary amplifying tube and the other is that there are on the market from several different factories "adapters" which generally sell for \$1.25 and which now make it possible to plug the peanut tube into any circuit that you have been using or hoping to use with an audion bulb and thus do away entirely with the storage battery.

In many cities, it is possible now to buy sockets especially made for the peanut tube. On the market, this tube is known as WD11.

It is also found that this peanut tube makes an excellent amplifier when used with certain types of transformers and this will also be a blessing to many fans whose pocketbooks can not stand the strain of the size storage battery

desirable for working more than one tube.

Used as amplifiers, it is best to have a separate dry cell for each of the peanut tubes in the circuit, but few beginners use more than one detector and two amplifiers and so this means only three dry cells at 40 cents each.

On all standard sockets for the six-volt type the plate and grid connections are next to each other and the two filament connections are also next to each other on the other side of the socket.

With the peanut tube, however, the plate and grid are opposite each other and the two filament connections are opposite each other.

These adapters look like the bases of regular tubes sawed off where the bulb would join them. They have the same prongs at the bottom and the same little catch sticking out at the side, so as to go into the slot in the barrel of the socket. In the top of the

adapter there are four holes for the peanut tube and there is no chance of getting the tube in wrong because the thickest prong is for the plate and is so much bigger than any of the others that it will fit into only one of these holes.

The fan can now simply plug his peanut tube into the adapter and plug the adapter into a stan-

dard size socket and use this handy little peanut tube in any hook-up which I have given in these articles or in any that he may see in any magazine.

He simply substitutes the dry cell for the storage battery, remembering that the center connection on the dry cell is positive and the side one is negative.

PEANUT TUBE HOOK-UPS 1—Single Slide Tuner

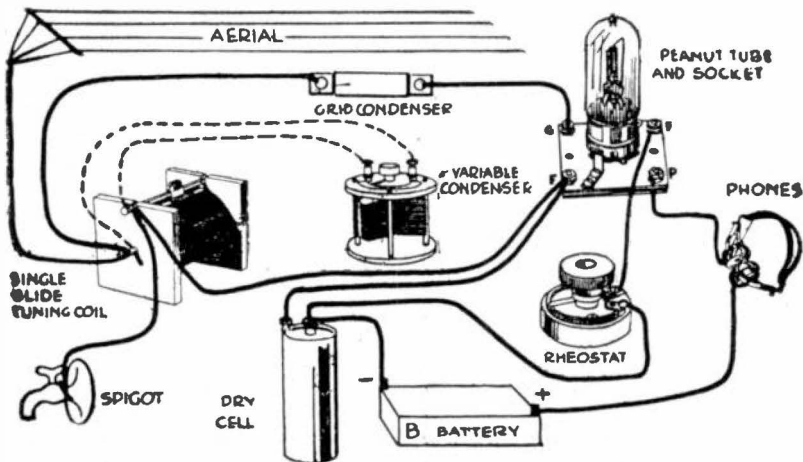

This hook-up shows the best method of using a peanut tube with a single slide tuner. The variable condenser shown in the dotted lines is not essential but it does make tuning sharper.

The advent of the little peanut tube, which burns on a dry cell and requires no storage battery, has proved such a blessing to radio fans with limited pocketbooks that I think it will be well at this time to summarize the various hook-ups in which I have found this extremely handy little detector bulb to work satisfactorily.

All of these hook-ups have been given before for the regular standard-size tube burning on a storage battery, and if you have

started one of these hook-ups already you can still use the little peanut tube by buying one of the different makes of adapters that are on the market and plugging it into your standard-size socket. If, however, you have been hoping for a bulb set and have not seen your way clear to getting it on account of the expense of a storage battery, you can get any one of the dozen different makes of sockets that have just sprung up, especially for this tube, and you will find in this series a hook-

up to suit any kind of tuning apparatus which you may have bought or which you intend to buy or to make.

The prongs on the peanut tube are arranged differently from the prongs on the ordinary tube and that is the reason you cannot use the standard socket for this detector without an adapter.

On the standard socket, reading around the base, the prongs are for grid, next plate, next plus filament and then the minus filament. For the peanut tube, however, they read first grid, then one of the filament connections, then the plate and then the other filament connection.

There are now plenty of sockets for the peanut tube, however, and the connections are plainly marked upon them. As a beginning in this series I am giving here the hook-up using the single slide coil for the tuning arrangement.

Let me observe here in answer to the many letters from beginners, that it is not at all surprising to find that you get stronger signals with either the single slide or double slide tuning coil than

you do with the variocoupler or loose coupler or any combination of two coils. You must remember that whenever you use a coupler or any kind of coupled coils, your signals go directly from the aerial through one of these coils to the ground and the current that you get in the second coil is merely the result of magnetism thrown out from the first coil, which causes a transfer of the energy from one coil to the other, though the two coils are not connected together.

In this transfer there is bound to be some loss of energy, but this loss is compensated for by a greater ability to get sharp tuning and cut out interference. In the single or double slide coil you utilize the full strength of the current which comes from the aerial and thus you get louder signals, though you pay for them in lack of ability to tune out interference.

In this hook-up use a grid condenser of .00025 mfd., an ordinary dry cell, a twenty-two and one-half-volt B battery, and if you use the variable condenser shown in the dotted lines it should be the twenty-three-plate kind.

PEANUT TUBE HOOK-UPS 2—Two-Slide Tuner

Of all of the hook-ups using the little peanut tube as a detector I think, if I were just starting my radio experience, I should install the one using the two-slide tuner and one twenty-three plate variable condenser.

This set is in the fullest sense a "regenerative" outfit. The famous "short wave regenerative" set which uses a variocoupler and two variometers is extremely selective and can tune out interference because it offers separate tuning adjustments for the aerial

circuit, the grid circuit which includes the grid of the bulb and the circuit which includes the plate of the bulb. With all of these three circuits adjusted you have just about as complete control of your tuning as it is possible for the novice to manipulate.

This two-slide hook-up also gives tuning control of these three circuits. The slider which is connected to the ground gives you accurate tuning of the aerial circuit. The slider which is connected to the minus filament con-

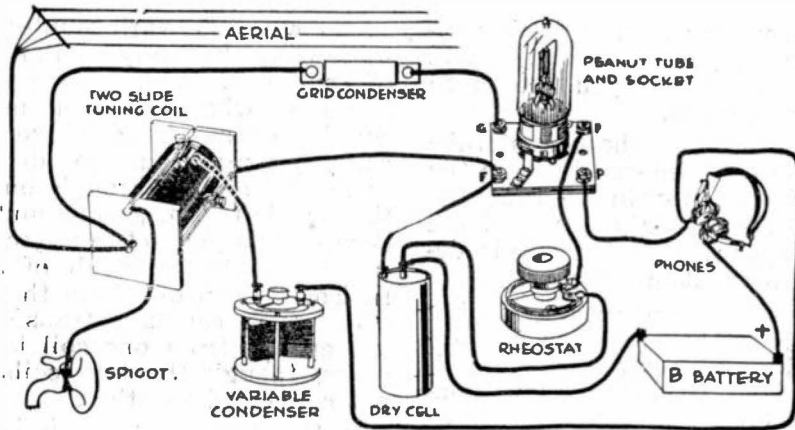

This hook-up shows perhaps the best method of using the little peanut tube without an expensive tuning outfit

nection on the bulb socket gives you accurate adjustment of the grid circuit. The variable condenser which is attached to one end of your coil gives you accurate adjustment of your plate circuit. This variable condenser, by the way, is absolutely necessary not only for tuning but to prevent the two batteries from short-circuiting themselves as they would do if the actual current of electricity were permitted to flow through at this place. The dotted line crossing the coil indicates that this wire from the variable condenser is connected to the last winding of the coil which is usually attached to a binding post on the backboard.

The tuning of this set is not at all difficult once you get the hang of it. In my own case I usually start by setting the variable condenser at about twenty on the scale, then, taking one slider with my left hand and starting to move it up close to the aerial connection, I gradually draw it down toward the other end while at the same time, with my right hand, moving the other slider back and forth between the first slider and the far end of the coil!

If this fails to bring in a signal, I change the setting of the variable condenser to about forty and repeat the process. If this fails to give results I set the condenser at about sixty and go through it again.

On one of these trials I am fairly certain to hear something and as soon as I do I hold both sliders perfectly still. If I have lost the signals when I do this, I move one of the sliders slowly back and forth until I get a suggestion of sound, keep moving it until that sound becomes as loud as possible and then move the other slider back and forth until I have found the loudest point on it.

Then the two sliders are left alone and I carefully turn the dial of my variable condenser back and forth until it, too, gives me the loudest signals and then a slight readjustment of the two sliders brings the whole thing up to its best.

The grid condenser in this hook-up should be a .00025 mfd., the dry cell one and one-half volts, and the B battery should be 22½ volts.

PEANUT TUBE HOOK-UPS 3—The Simple Double Circuit

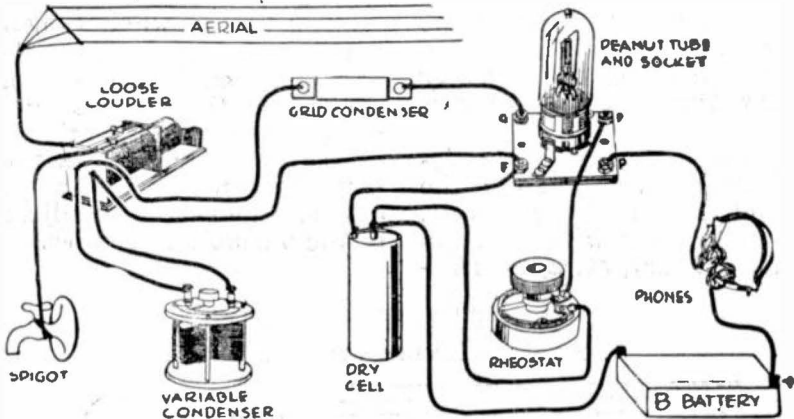

This is the simplest form of circuit for the peanut tube and loose coupler but it is not "regenerative"

There were many thousands of loose couplers left over from the early days of wireless and they are now being used by those who inherited them, or if they are not being used, their owners are wondering whether it would not be well to hook them up and try to get some of the broadcast concerts with them.

There are two ways of using a loose coupler and both of them are very well adapted to the little peanut tube.

The first one, which is the "simple double circuit" hook-up and which is not "regenerative," is probably the easiest to handle, though it will not give concerts or phone stuff nearly so well as the second method.

It is, however, especially good for dots and dashes, and for anybody who wants to go into the fascinating code work and try to translate some of the messages that can always be snatched out of the air, this first hook-up will give plenty of enjoyment.

In its essentials this is the same hook-up that is used when a crys-

tal is employed with the loose coupler, the grid and plate of the bulb taking the place of the crystal detector and the battery and the filament connections of the bulb being inserted in, the line from the other side of the phones.

If the secondary coil of your loose coupler is provided with a switch blade and contact points—and almost all of them are so arranged—you can get the spark signals with perfect satisfaction without using a variable condenser. But if you want to get the continuous wave signals and the broadcast concerts this variable condenser is absolutely necessary for sharp enough tuning to prevent distortion of the sounds.

A variable condenser used in this way should be of the twenty-three-plate type. If you already have a forty-three-plate condenser, you can use it here, but there will be times when it will not give you such exact control as is desirable.

In tuning this set the first thing to do is to set the sliders on the primary—or else the taps, if it

has taps—at about one-half of the total value and then, using the first tap of your secondary, draw the sliding coil in and out of the other and at the same time move one of the sliders up and down or else vary the taps on the primary.

If this does not bring in the signals set the secondary tap on the next point and repeat the process. Do the same thing with each tap of your secondary, always contin-

uing to pull the secondary out or push it in the primary and also moving the slider or the primary tap through its whole range.

This will soon give you the signals and then it will be a matter of getting them perfectly sharp on the primary and on the setting of the secondary coil in the correct position inside of the outer one, and getting nice adjustment of the variable condenser.

PEANUT TUBE HOOK-UPS 4—Another Loose-Coupler Circuit

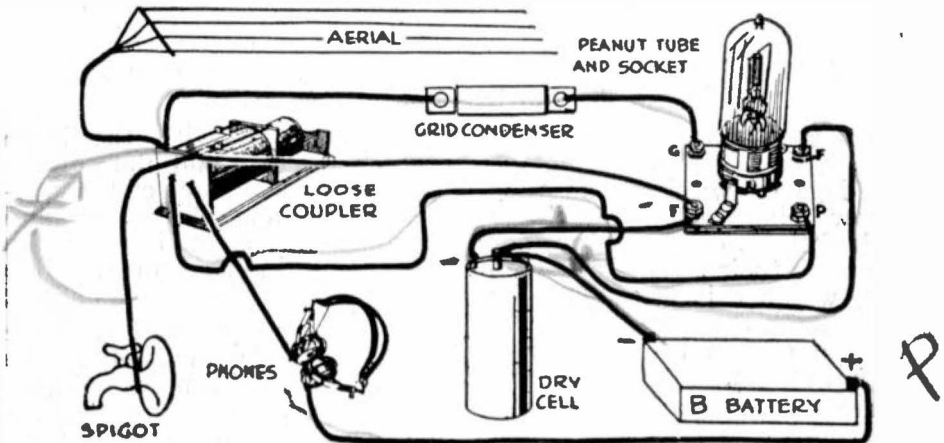

This diagram shows the little peanut tube and a loose coupler connected in the circuit known as the "single circuit regenerative" hook-up

Owners of loose couplers who want to use this instrument and a peanut tube without the necessity of buying a variable condenser can hook the instrument up in what is known as the "single circuit regenerative" set and will find this an excellent arrangement for receiving broadcast concerts at very little expense.

This arrangement is entirely different from the one given in the last article and is a genuine "regenerative" circuit with all the advantages of what is known as

the "feed back." Hooked up in this way the inside coil of the loose coupler is not used as a "secondary," as it was in the last article, but is used as a "tickler" and is directly connected through the telephones with the plus side of the B battery.

By means of this connection the strong currents of the 22½ volt B battery are sent through the coil, pulsating in unison with the incoming signals and these strong currents throw out a field of magnetism which cuts through the in-

sulation on the wires of the primary coil and boosts up the weak signals coming in from the aerial.

This primary coil, as will be seen, is directly connected to the grid condenser and when the incoming signals are boosted up by the tickler this additional energy is added to the energy of the signals and the two together have a much greater effect on the grid and consequently on the resulting impulses released through the plate and the telephones and the sounds we hear are much louder than we would get by a method not employing this feed-back system.

If you already have a variable condenser, whether it be the 23 or 43 plate kind, you can use it to good advantage in this hook-up.

In the one given in the last article the variable condenser was connected to the secondary coil, but in this case we would use a different arrangement. You will see that the minus connection on the bulb socket and one of the leads from the coupler are both connected to the ground binding post. This ground binding post is then connected directly to the cold water spigot or whatever you are using for a ground.

When inserting a variable condenser, you do not make the connection directly to the ground but put the variable condenser in what we call "series" with it. This is done by running a wire from the ground binding post to one binding post of the variable condenser and running another wire from the other binding post of the variable condenser to the ground. The variable condenser then gives you a very quick and easy way of changing wave length to get exact tuning with the incoming signals.

Virtually this same result can be achieved without the variable condenser, but there is no question that it is well worth while having and that you can get much sharper tuning with it.

In using this circuit, you will find that the adjustment of the number of turns of wire used on the inside coil is not so critical as it was in the last circuit, but that you must get a very exact setting of your coil inside of the first one—that is, the "coupling" between the two coils must be accurate to prevent distortion of signals or whistling or howling in the phones.

PEANUT TUBE HOOK-UPS 5—Tuning With a Variocoupler

For the man who wants to have his radio set mounted in a neat cabinet, with a good-looking panel in front and all of the usual knobs and switch points that look so attractive, the tuning apparatus that has already been described in this series on the peanut tube will not do. Slider tuners and loose couplers do not lend themselves well to cabinet mounting without involving rather complicated workmanship, which in-

cludes the use of sprocket wheels and other devices which are beyond the ability of the average amateur. But the variocoupler does not present such difficulties and is an ideal instrument for mounting on a panel.

The standard size variocoupler as built makes it an especially fine instrument for use with the little peanut tube connected in the "single circuit regenerative" hook-up which we gave in the

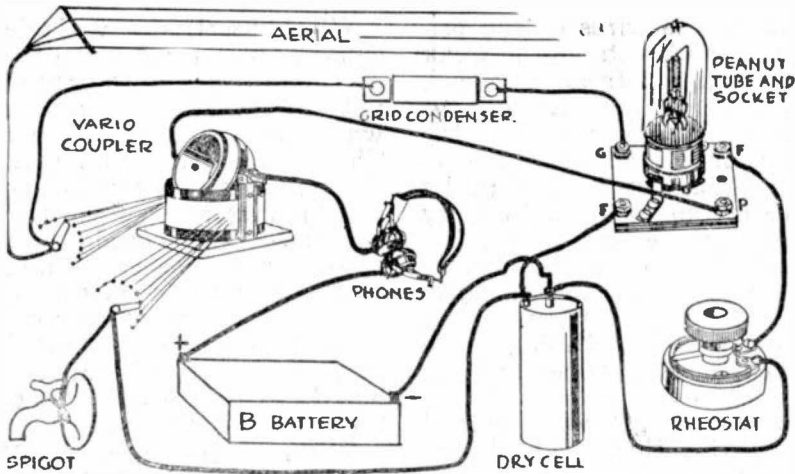

For the man who wants to use a peanut tube on a panel mounted in a cabinet the variocoupler in this hook-up makes a very efficient arrangement

last article for a loose coupler.

Here the windings of wire around the ball-shaped form or rotor take the place of the inside coil of the loose coupler, but there is no method of varying the "feed back" effect except by means of turning the rotor on its axis by the dial and knob which you mount on the panel.

This offers a sufficiently wide range of tuning to give the average man all the signals that he wants and a properly constructed variocoupler should enable him to get very good reception of amateur signals on 200 meters or broadcast concerts on 360 and 400 or crop and weather reports on 485, and all of the commercial dot and dash stations on 600 meters.

There are very few beginners who require more than this, and so for them the hook-up given in the illustration with this article will be found most satisfactory.

I am not including in the hook-up a variable condenser, but, while the variocoupler can be

used without it, I advise its inclusion in the set.

If, however, you cannot afford this instrument, you can do quite well by connecting the blade of the tens taps switch directly to the cold water spigot or whatever ground you use, as shown here.

If you want to include the variable condenser, you should insert it in the line from the tens tap switch to the spigot. Run a wire from the switch to one binding post on the condenser and another wire from the other post on the condenser to the spigot or other ground.

With most amateur aerials the concerts will come in with the rotor form of the variocoupler set with its windings parallel and as close as possible to the windings on the outer tube of the coupler.

I find that usually the 360-meter concerts come in using about three-fifths of the rough adjustment taps, and getting finer tuning with the units switch, and the longer waves come in using all of the rough adjustment taps

der web coils of about fifty turns each hooked up "in series." That is to say, the inside wire of one connects over to the phones, the outside turn of that one connects to the inside turn of the next one and the outside turn of the second coil goes to the plate connection on the socket.

These two spider webs can be attached by hinges and their coupling can be varied by opening and closing them like the leaves of a book or else you can make one spoke of the coil a little longer than the others and pivot them together by means of a short machine screw and varying their coupling like a fan. I prefer the latter method.

Two honeycomb coils of twenty-five or thirty-five turns can also be used in the same way with the connections the same as the one described for the spider web coils. The honeycomb coils can

then be laid on a table one on top of the other with the upper one resting on a piece of pasteboard, and then by means of raising or lowering this pasteboard or moving it to one side the coils can be separated or brought together and thus the coupling between them can be varied, and the amount of regeneration can be controlled.

I have found the addition of such a piece of apparatus as this in the plate circuit to be generally a very great advantage when using a peanut tube, and yet I have two friends who tell me that it seems to weaken the signals for them.

It is a matter that can only be decided by experiment, but if you have a variometer or a couple of honeycomb coils or want to make spider web coils it is well worth trying.

PEANUT TUBE HOOK-UPS

7—Spider Webs and the Peanut Tube

Home wound spider web coils make about as efficient a tuning apparatus for the peanut tube as anything that the commercial market can furnish. These coils are so very easily made and mounted and they can be used in such a great variety of experiments in all sorts of receiving hook-ups that a beginner who is considering installing a cheap tube set and who is fond of doing a lot of the work himself might find it to advantage to try a pair of these inductances before deciding on a permanent form for his receiving apparatus.

In the past I have given very full directions for the making of these coils and it will be remem-

bered that I said at that time that they are simply flat-wound around a card board form with spokes cut in it and the number of spokes does not matter so long as it is an uneven number and not an even number. The inside hub of the card board should be two inches in diameter and a form with a total outside diameter of six inches will answer all amateur purposes.

Number 28 or 26 or 24 cotton covered wire is the best to use and the wire is simply wound in and out around the form like basket weaving. Do not forget, however, in counting your turns that when you have counted five turns on one side there are also

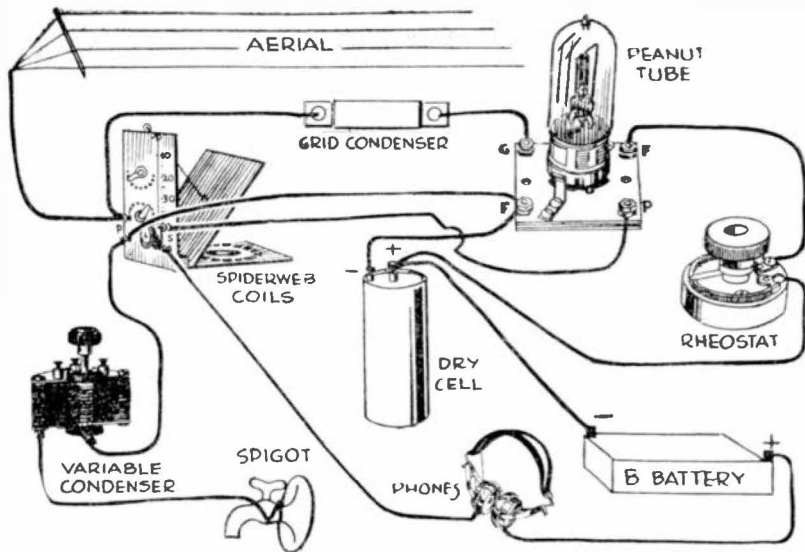

Two home wound spider web coils make a fine tuning arrangement for the peanut tube

five turns on the other side and you then have a total of ten turns. For best results with this peanut tube using only two of these coils, the "single circuit regenerative" hook-up as adapted to them will be found very efficient.

Both coils should be wound with 70 turns and the primary should be tapped at 50, 55, 60, 65 and 70, and the other coil should be tapped at 35, 40, 45, 50, 55, 60, 65 and 70. This other coil is used as a "tickler" in this circuit and varying the number of turns by fives is sufficient for sharp tuning.

With the primary, however, it will be necessary to use a 23 plate condenser in the place shown in the diagram although any other size variable condenser will answer the purpose perfectly well. In fact one of the home-made forms that I have described in the

past made from an envelope or a phonograph record will answer the purpose very well temporarily.

With most amateur aerials, it will be necessary to have more turns on this primary coil than on the other. In fact, it would be a good idea to put 100 turns on it and tap each tenth turn after the 50th.

I am showing in the illustration the standard form of mount which I use for spider web coils in which a thread brought up over the top of a panel and down to a knob on the front pulls the upper coil away from or brings it down upon the lower coil, thus varying the coupling.

The setting of this coupling must be quite accurate with these spider web coils as they require very sharp tuning.

PEANUT TUBE HOOK-UPS 8—Two Spider Web Tuners

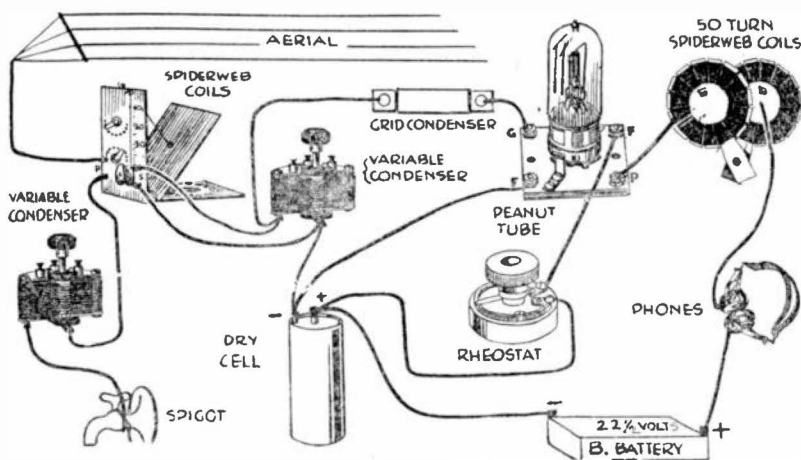

Two pairs of home wound spider web coils give remarkable results when used with a peanut tube in this hook-up

All the advantages of an expensive variocoupler and variometer set can be gained with home-wound spider web coils providing the user does not insist on having a set that he can mount on a panel to look like a factory product.

I am showing here a hook-up that any boy of 12 ought to be able to build and I can guarantee that so far as fine tuning is concerned and strong signals it will not be surpassed by even the most elaborate looking apparatus using the same hook-up. This arrangement is virtually the double circuit hook-up with the plate variometer that I have already spoken of but I am showing it here in the best form for the man or boy who wants to make his own.

The two coils which are used here are exactly the same as the two described in the last article in this series and are tapped in

the same way. It is perfectly possible, however, by using the two variable condensers as shown in the illustration to get the broadcast stations without tapping either of the two coils.

For this purpose make both of the coils in the first mount 70 turns each. Whether you tap them or not you must use the two variable condensers shown. If you are buying them new you should have a 43 plate condenser connected to the cold water spigot or whatever ground you use and a 23 plate condenser in the other position.

The two spider web coils that are connected between the phones and the plate screw on the socket should be of 50 turns each and no tapping is necessary. The phones should be connected to the inside winding on one coil. The outside winding of that coil should be connected to the inside winding of the other coil and the outside

winding of the second coil should go to the plate connection on the socket.

These two coils should be made on forms which have one spoke longer than the others and a pivot should be passed through these spokes so that they can be

opened and closed like a fan. This makes them perform exactly the same work as a variometer and opening and closing them tunes the plate circuit just as turning the inside ball of a variometer would do in the same position.

PEANUT TUBE HOOK-UPS 9—Amplifying the Peanut Tube

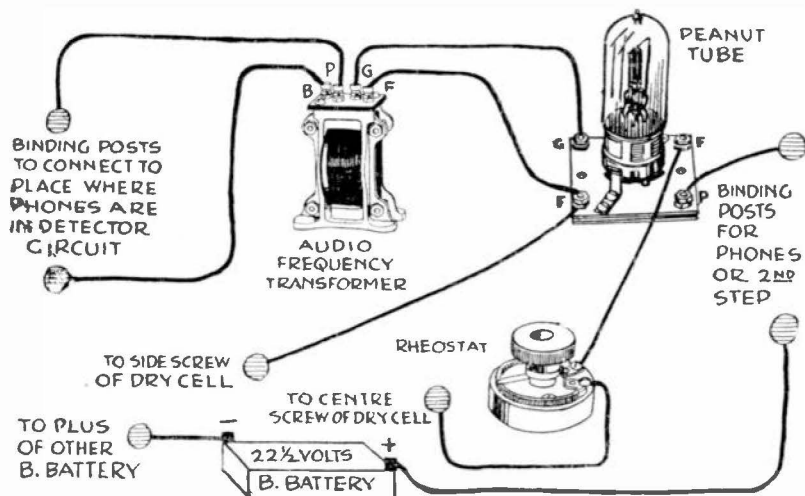

Here is a hook-up by which another peanut tube can be used in one step of amplification with any of the hook-ups that I have given in this series

The little peanut tube has been used very successfully for amplifying and it is quite possible for those who live within a reasonable distance of a good broadcasting station to use one of these tubes as a detector, two more as amplifiers, and put the concerts on a loud speaking horn.

Not all amplifying transformers will function well with this tube, however, and it is a difficult matter to decide just which make to use. I have tried a dozen of the standard makes of transform-

ers and out of that number have had satisfaction with about three or four. It just happens that all of the satisfactory ones have had small windings and it may be that this has something to do with the way the tube operates on them. The hook-up for using these tubes as amplifiers is essentially the same as the one for the standard tube except that in the case of the peanut tube you must use a dry cell for each tube that you have. This does not mean necessarily that each tube must

be wired separately to its dry cell. If you already have an amplifying circuit which you built for standard sized tubes and are using peanut tubes with adapters you can hook up your dry cells in parallel—that is, connect all of the plus posts together and all of the minus posts together—and they can then be put in the regular place of the storage battery.

It is also possible to have your dry cells separated and to connect one to each tube but I believe that the first method is much better.

As a matter of fact even if you are using only one of these tubes as a detector you will find that it will pay you to get two dry cells, connect the two center binding posts to each other and the two side binding posts to each other and hook them up in the regular way.

This will just double the life of your battery and will give

much smoother operation over a longer period of time.

This one step of amplification will require the addition of another 22½ volt B battery and I am showing the plus side of the second B battery connected to a binding post. The other binding post in the same place goes to the plate connection on the socket.

These two binding posts are for your head phones if you are going to use only your one step and if you add a second step later you can take your phones away from that place and hook the next step up right to these binding posts.

The two binding posts on the left of this hook-up enable you to use this diagram with any of the tuning arrangements which I have given in this series. Merely remove the phones from the place where they now are connected on your detector and run those same two connections to these binding posts.

PEANUT TUBE HOOK-UPS

10—A Peanut Tube Two Step

If you are adding your amplification with peanut tubes one step at a time the hook-up given in the last article can be used until you have saved up enough money for your second step and you will then simply need to repeat that same hook-up when you are ready for it.

If, however, you want to put both steps on at once, it will be well to use the arrangement given with this article.

This diagram will apply to any of the tuning arrangements which I have given for the peanut tube. The detector bulb shown here simply takes the place of the detector bulb in any of those hook-

ups and the connections to the tuning apparatus are made as shown in those diagrams.

This illustration shows the method by which the three dry cells are connected in parallel for lighting the bulb. It also shows three B batteries connected in series. The difference is easily seen. When we connect in parallel we connect all of the positive posts together and all of the negative posts together. When we connect in series we connect a positive to a negative. If you will follow the dry cells and the B batteries you will find that the dry cells are connected in parallel with each other but the B batter-

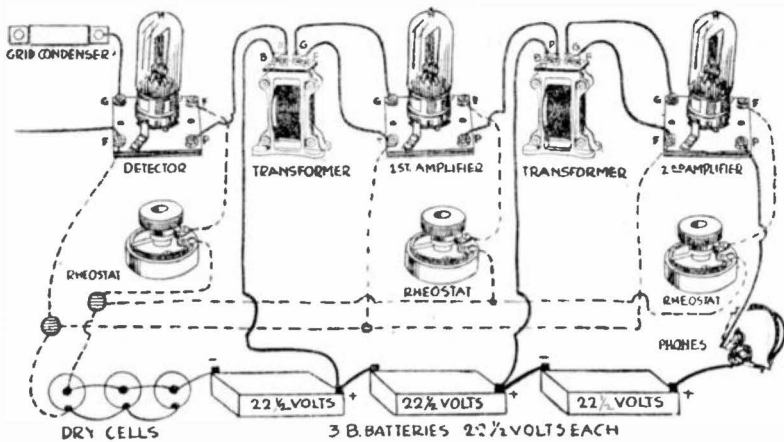

This is the best method of hooking-up apparatus for using the peanut tube with two stages of amplification

ies are connected in series with themselves and also in series with the dry cells.

I am showing three B batteries of $22\frac{1}{2}$ volts each but it is possible to use any number of B batteries whose voltage will add up to make something from 60 to 90 as a total. In this arrangement we connect the first transformer to the $22\frac{1}{2}$ volt tap, the second transformer to a 45 volt tap and the last step including the phones to the full voltage which may be anything from 60 to 90.

This progressive increase of voltage for each step is usually an advantage although many hook-ups use $22\frac{1}{2}$ volts for the detector bulb and then put the full voltage of the B battery on all of the amplifiers.

Just a word of explanation as to why we hook these batteries up in different ways. The dry cells have a potential or force of one and one-half volts and that is what is needed to light the bulb. These cells have a capacity or an amount of current of 30 amperes. When we hook up in

parallel we do not increase the voltage but we do add together the total amount of current in each cell. In other words hooked up as shown the three dry cells still have only one and one-half volts but they have 90 amperes which means that the amount of current that can be taken from them in this way is three times the amount that is in one cell. The drain on these dry cells is mostly on the amperage and that is why we have to provide for three tubes just three times what we would have to for one tube.

The plates of the tubes, however, take an extremely small quantity of amperage but require a very high voltage. We therefore connect the three batteries in series which adds their voltage but does not increase their amperage.

In other words it gives us three times the amount of force or punch the battery can give but does not increase the amount of time over which they can give this force.

THE CONNECTIONS FOR TWO SPIDER WEBS

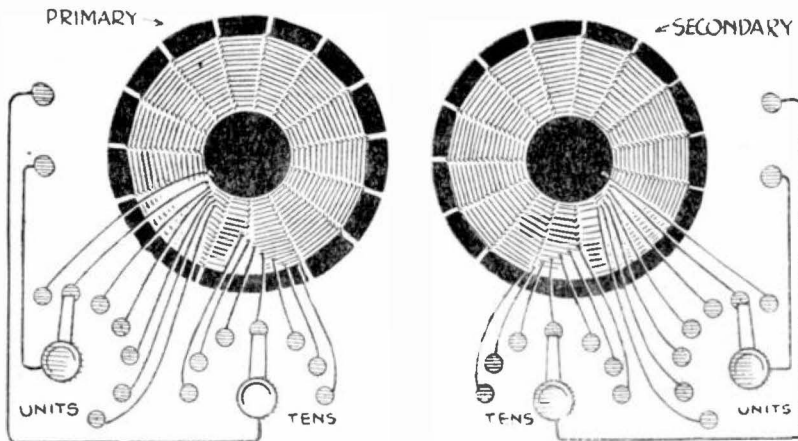

This is the cheapest method of tapping and connecting spider web coils but it requires considerable work

There still seems to be some confusion in the minds of readers of these articles as to exactly how to connect spider web coils in building tuning apparatus. I think it will be well to dispose of this matter as fully as possible now because these coils are so efficient and so easy to make that we are likely to refer to them a good many times. There are two principal ways of tapping and connecting spider web coils. By one way it is not necessary to use variable condensers but it is necessary to do more than twice as much tapping and as tapping is a great deal of trouble this method will be used only by those who do not care to spend four or five dollars for variable condensers.

Personally I strongly advocate the use of condensers as every tap that you make on a coil adds to the possibility of trouble with the set later besides doubling the

trouble of construction. The variable condenser also gives a much more convenient method of adjustment and provides sharpness of tuning that is even better than the taps. For those who do not care to use the condensers, however, I am giving here the connections for two spider web coils, separating the coils so that the connections will be perfectly clear but reminding you that in use the two coils must be hinged together in some way so that they can be moved gradually apart or else brought gradually together so that one is directly upon the other. In this method it is necessary to use two circles of switch points and two switch blades for each coil.

One of these circles of contact points is wired to the eight or ten inside windings of the coil. We call this the "units" switch. In practice it is really not necessary to tap each of these inside

windings because they are so small. Every other winding will do perfectly well.

There should be eight or ten of these taps on the inside of the coil and then you can allow about 30 turns without any taps at all.

After that you should tap the coil by sections of eight or ten turns each and lead these taps out to the circle of contact points which we call the "tens" switch.

The tens switch then gives you a rough adjustment and the units switch gives you a fine adjustment. This must be done on the secondary coil as well as on the primary coil. For broadcast concerts it is not necessary to have a total of more than 100 turns of number 28, 26 or 24 cotton or silk covered wire on each coil. The number of spokes is not important so long as it is an odd number and not an even one.

SIMPLER TAPPING OF SPIDER WEBS

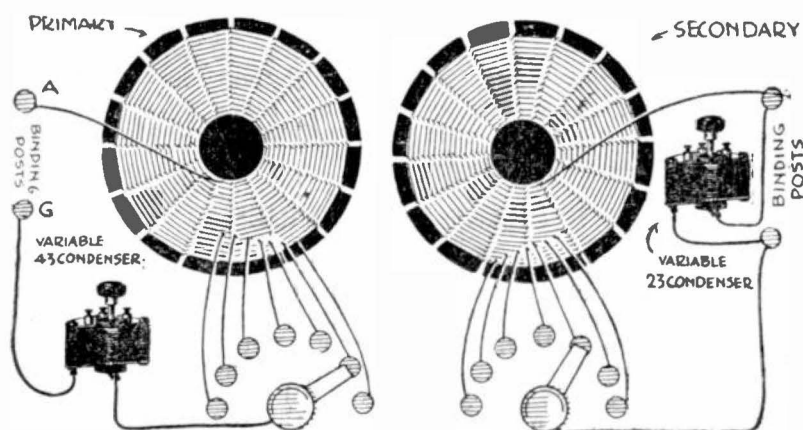

This is a much easier method of tapping spider web coils and the variable condensers give sharper and more flexible tuning

With the price of fairly good variable condensers dropping steadily to the point where almost anybody can afford to buy them it is really not good judgment for any radio fan to go to all of the trouble to make all of the taps described in the last article on spider web coils.

One variable condenser of 43 plates and one of 23 plates will save a lot of work in construction, reduce the probability of trouble in operation and vastly increase the flexibility of tuning.

In this arrangement I am showing in the illustration the coils and condensers connected to the usual binding posts which are put upon panels. The upper binding post on the left is the one to which you attach your aerial lead-in and that binding post is wired directly to the inside winding of the first spider web coil. This coil is not tapped at all for the first 50 turns but is tapped at the 50th turn and each tenth turn outside of that.

The secondary coil is treated in

the same way with the inside turn which is the beginning of the wire attached to the upper binding post on the right. Here too we have 50 turns without any taps but the 50th turn is tapped to a contact point and the same thing is done to each tenth turn outside of that. With the first coil we hook a 43 plate condenser in what we call series. A wire is run from the shaft of the switch blade to one binding post on the variable condenser and the other binding post on the variable condenser is connected to the ground binding post.

The second coil is hooked up in what we call parallel with the variable condenser. That means that the inside turn of the coil and the switch blade are wired to

the two binding posts on the right and the two binding posts of the condenser are also wired to these same binding posts.

Let me caution you again in counting the turns on the spider web coil, to remember that when you have counted five wires on one side you also have five wires on the other side which makes a total of ten wires. So for counting your wires for taps you count five on one side of the coil and tap there, knowing that there are ten wires in the circuit.

This same thing applies to the winding of the coil and when you can count 50 wires on one side you will then know that your coil has 100 turns on it and this will be sufficient for all broadcasting stations.

STORAGE B BATTERIES

It always happens that nothing goes wrong with your radio set when you are listening in to concerts by yourself, but call in some friends to hear the wonders you are so enthusiastic about and you are then in danger of running into one of those snarls that are a part of the fascinating game of radio.

This does not mean that radio has any more difficulties than any other hobby, for the same thing happens with motorboats and automobiles and any other form of human endeavor that depends upon an amateur to operate the mechanism.

One of the greatest annoyances of radio is to have the concerts coming with excellent modulation and apparently full strength, but everything marred by a constant and violent frying or crackling or pounding in the phones or loud speaker.

In nine cases out of ten this means that your B battery is giving its dying gasps. There is still enough voltage left to give your signals strength, but it is coming from all of the nooks and corners inside the battery and apparently arriving in bunches.

The B battery has been a serious problem with manufacturers ever since the advent of the radio craze. They have undoubtedly improved their product wonderfully, but it still remains a fact that even fresh dry batteries will sometimes be noisy, and dry batteries that are nearing the end of their life always will be. The worst of it is that there is nothing to be done about it but throw the battery away and get a new one.

Several battery manufacturers have now developed and put on the market a form of very small storage battery with enough cells

inclosed in a frame to make up the standard twenty-two-volt B battery. These storage batteries cost about twice the price of the dry-cell type of the same voltage, but, if taken care of by the user, will outlast a dozen of the other kind.

At first it was a problem of how to charge these storage B batteries from an alternating current house supply, but now this problem, too, is solved, and there are on the market several types of chargers selling for less than \$2, which make the whole matter very cheap and simple.

These chargers usually take the form of a lead cup with an aluminum rod suspended in the center. The cup is filled with water in which several spoonful of ordinary borax have been dissolved,

and this arrangement has the property of passing an electric current in one direction only. In other words, these instruments are "rectifiers."

To charge the battery an ordinary forty-watt lamp is connected in series with the lead plate and the aluminum rod is connected to the plus side of the storage battery. The other line from your electric light switch goes directly to the minus side of your storage battery.

Turning the current on for a few hours a week will keep your storage B battery always fresh, and with this kind of care they should last for several years.

The apparatus and some of the types of storage B batteries are shown in the lower picture on Page 2.

TAKE CARE OF YOUR STORAGE BATTERY

Neglected storage batteries probably cause more bad radio reception than any other feature of the hobby. There are a number of things about storage batteries that the average fan does not seem to understand, or even if he does understand them, he seems to think that their importance is exaggerated and that he can get along without them.

But he cannot. The man who neglects his storage battery will never have satisfactory concerts, and it will be a question of only a short time when his battery will go all to pieces and he will either have to spend a lot of money for another one or else give up radio. The man who takes care of his storage battery can depend upon it lasting him for four or five years under ordinary conditions, even though the manufacturers' guarantee seldom exceeds two years.

First let us consider the size storage battery that is necessary for good radio reception. All storage batteries sold for radio work are of the six-volt type, the difference in size being rated according to their "ampere hour capacity." The average audion detector bulb consumes just about one ampere an hour. Therefore a storage battery which has a forty-ampere hour capacity will, theoretically, light your bulb for forty hours.

In practice this cannot be done. If you use up all of the capacity in your storage battery you will ruin it. The only way to keep up the efficiency of this valuable piece of apparatus is to see to it that it is never discharged more than one-third or one-half its total capacity, and if you have discharged it this far you should boost it up again to full capacity.

It is also important not to use

the electricity from a storage battery faster than a certain ratio of discharge, and this rate will vary with the ampere hour capacity of your battery.

If you have a forty-ampere hour battery, that will be sufficient, if you are using only one bulb. It might even do if you are using two bulbs, but if you use them both for three hours every night it is absolutely essential that you boost your battery frequently.

I should say that as a general rule a forty-ampere hour battery should not be used with more than one bulb. If you intend to go into a more elaborate set later you can get another forty-ampere hour battery and hook the two batteries in parallel—that is connect the two plus terminals and also connect the two minus terminals—and then you have an eighty-ampere hour battery which will be sufficient for a three or four-bulb set.

The more ampere hours you have in your battery the better.

AN EASY SET TO BUILD

Next time mother or the cook breaks a handle off the rolling pin do not let her throw the pin away. You can use it to make quite an efficient radio receiver. Even if there are not any broken rolling pins about the house, a piece of curtain pole about a foot long or a heavy cardboard mailing tube will do just as well and about fifteen cents' worth of No. 24 cotton or silk covered wire will start you on the way as a radio fan, providing you live within twenty or twenty-five miles of a good broadcasting station.

This proviso is inserted because,

But no matter what you have, you must take frequent tests of the solution by means of your hydrometer, and you should never let this solution drop below a reading of 1225 or 1200 as an extreme.

There are a dozen different makes of home chargers on the market averaging about \$18.50 in price. You would save the price of one of these in six months and would be absolutely sure of doubling the life of your storage battery, and therefore they are very economical.

I advise connecting the charger, the battery and the set by means of the double pole double throw switch shown in the diagram in the upper illustration on Page 2. Then, once a week, when you are done using the set, throw the switch to the right, turn on the electricity and let your battery charge over night.

Throwing the switch to the left disconnects the charger and connects the battery to the receiving set.

in the hook-up I am giving here, a crystal detector is used, but it is a perfectly simple matter to use this same outfit with a standard vacuum tube if you can afford a storage battery or with one of those little peanut tubes if you want to use a dry-cell for lighting it.

I call this set the easiest one to make because, while it is really only an adaptation of the single slide tuning coil, five beginners out of ten find it impossible to wind a coil smoothly and tightly enough to get good results with a slider. With the rolling pin or

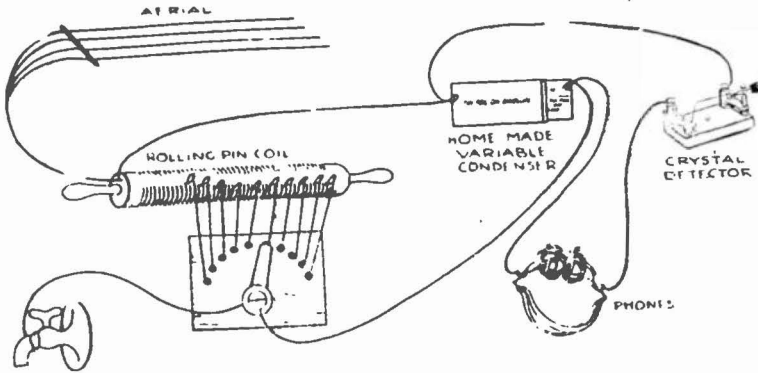

You can make a perfectly good receiving set out of an old rolling pin and a home-made variable condenser

mailing tube or curtain pole, you should wind the wire just as smooth and as tight as you can, but it need not worry you if it shows a little unevenness here and there.

You start off by fastening the beginning of the wire with a tack leaving a loose end for connection to your set, and you go on winding for about four inches, and then you twist a little loop in the wire and from that point on you twist the loop every ten turns until you have about ten loops. These loops are then connected by separate wires to contact points over which a switch blade can be revolved and then, with any of the three or four home-made variable condensers which I have described, your tuning set is complete.

With this apparatus you will find that the home-made variable condenser will be quite efficient in spite of the fact that it has only a small capacity and you will be able to get sharp enough tuning with the condenser made of a phonograph record or a big envelope or a cigar box to have

very fine results in your phones. The hook-up for this set is very simple and can easily be understood from the diagram I am giving here.

A friend of mine built one just like this and mounted it in one of those long card board boxes that soda crackers come in, putting his switch blade and his crystal detector on the top, and he had a set which could easily be tucked out of the way when he was done using it.

The best part about this set is that your only expense is for telephones and a crystal detector because, even if you have not a dollar to spend on an aerial outfit, you will have enough of the wire left to stretch from 75 to 100 feet from your house to a tree or to the house of a neighbor and, while this will not be the ideal aerial by any means, you will at least hear the broadcasts until the insulation gets wet or worn off. Even then you can make insulators out of the tops of bottles or the broken-off handle of a water pitcher or anything that is made of glass, porcelain or hard rubber.

HOW DO WE MEASURE WAVE LENGTH?

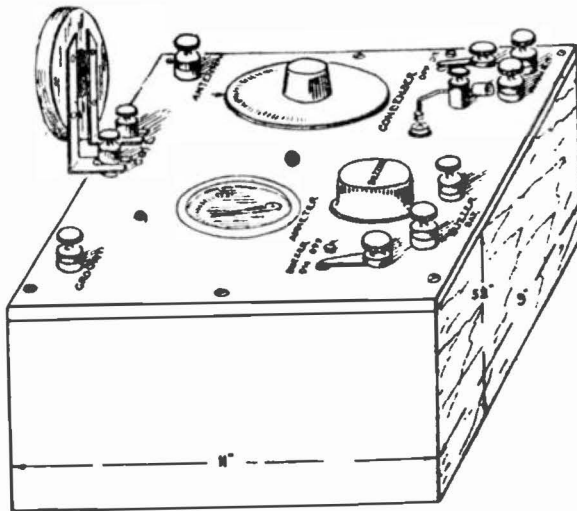

This simple but very ingenious instrument known as a "wave meter" measures exactly the length of the waves in the ether caused by the sending station

Wave length seems to be one of the mysteries which is most puzzling to the beginner in radio, and even after you have explained to him just what it is he seems unable to comprehend how it is possible to make a machine which will actually measure the distance between the crests of two waves in the invisible ether. Yet it is really a very simple matter, and we have in radio instruments which we call "wave meters," that are just as accurate as gas meters or electric meters or speedometers.

The fundamental thing to bear in mind is the fact that the terms "wave length" and "frequency" refer to virtually the same thing.

Suppose you were standing on the end of a long pier running out into the ocean. Suppose you counted the waves as they passed you, all the time holding in your hand a watch. You find that ten

crests pass you a second. You can say then that the frequency of those waves is ten a second.

Now, after you know at exactly what speed those waves are traveling, it is a simple matter to calculate the distance from one crest to the other. If you know that their speed is 100 feet a second, and ten of them pass you in a second, it must necessarily follow that the length of the waves is one hundred divided by ten or ten feet.

Now in radio the speed of the waves in the ether is always the same—300,000,000 meters a second. Consequently if we know the frequency with which the waves strike our aerial a simple problem in division will tell us how many meters there are from crest to crest. Or, if we know the wave length, we can easily calculate how many of those waves will pass our station in a second. A

wave meter is thus a frequency meter.

Just as any scientist can calculate how often a pendulum will tick by knowing the length of the pendulum and its mass, so we can calculate in radio the frequency or wave length of a signal by knowing to just what combination of coil and condenser it will tune sharpest.

Coils of wire make what we call "inductance," and condensers make what we call "capacity," and inductance and capacity together create radio waves at the sending station and tune in those same waves at the receiving station.

Knowing these calculations, it is not difficult to build an instrument which can have a fixed capacity and a variable inductance, or which can have a variable capacity and a fixed inductance, and by means of changing whichever element is variable and noting at which value it gives us the best tuning, it is a mere matter of mathematics to know just

what the frequency of the wave is, and therefore its wave length.

In practice the wave meters use a fixed coil usually of the honeycomb variety because coils wound in other ways have a certain amount of capacity of their own which would affect the measurements.

We therefore use a honeycomb coil whose exact inductance is known and we use a variable condenser which has been put through a series of tests that have shown its exact capacity at every setting.

When we put this coil in such a position in the receiving set that it responds to the incoming signals, we turn the condenser around slowly until we get maximum response in the phones or in an ammeter, and then, knowing the exact values of inductance and capacity that respond best to that signal, we can look up a table and get the wave length or else the wave length will be marked on the scale of the condenser.

SWITCHING OUT YOUR RADIO FREQUENCY

The most remarkable feature of the spread of radio this winter has been the astonishing number of amateurs who have gone into the elaborate and complicated questions of both radio frequency and audio frequency amplification.

No one who was in the business last year expected such a widespread adoption of these two expensive but undoubtedly efficient aids to the general enjoyment of the broadcast concerts.

The fans seemed first to adopt one or two or even three stages of audio frequency amplification so that they could put the concerts, on a loud speaking horn and enable the family and all of the

neighbors to enjoy them.

Then came the lure of long-distance work and people who last year did not know the difference between a transformer and a vacuum cleaner unhesitatingly took a bold leap and put two or three stages of radio frequency ahead of the detector so that they could also get the far distant stations on a loud-speaking horn.

There now seems to be a general demand for a switching arrangement that will enable these enthusiasts to use their detector and their audio frequency for the stations fairly near to them and to save the amount of battery current that would be consumed

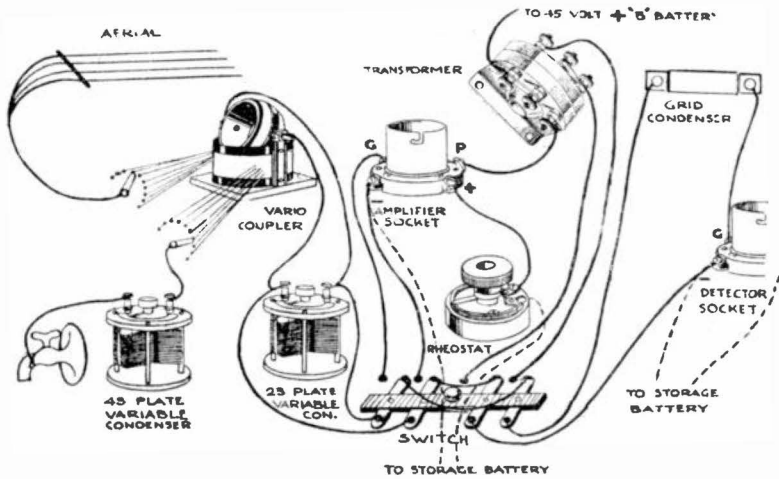

This four-bladed switch will enable you to cut out all of your radio frequency amplification and save battery current when you wish to listen to nearby signals

by the radio frequency amplifiers. Indeed, in most cases, radio frequency seems to have the effect of decreasing the strength of nearby signals and I can understand why it is that these amateurs have asked me for such an arrangement.

The trick can be accomplished by means of a switch having four blades, each blade passing over two contact points such as are used for tapping your coupler. I have described this method of making a switch before and the picture in the illustration will show it more clearly.

In the diagram I am assuming that you have only one stage of radio frequency amplification, but the same scheme will be feasible, no matter how many stages you have.

You simply connect the leads from the secondary of your coupler to the shafts of the first two blades and connect the grid and minus filament screws on your detector socket to the shafts of the other two blades.

Then the two left-hand contacts of the first two blades connect to the grid and minus filament screws of the socket of your first radio frequency amplifying bulb and the left-hand contacts of the second two blades connect to the two binding posts on the secondary of the last radio frequency transformer no matter how many steps of radio frequency you have.

You then wire the first right-hand contact point to the last right-hand contact point and wire the second right-hand contact point to the third right-hand contact point as shown.

Then, when your switch blades are all shoved over to the left-hand contact points you are receiving with all of your radio frequency steps in circuit and will thus get the distant stations.

When all of the switch blades are shoved over to the right-hand contact points all of your radio frequency is cut out of the circuit entirely and you are going directly from your coupler and variable condenser to your detector tube.

E-Z RADIO

A RADIO EDUCATION

ANY ONE CAN UNDERSTAND

The past seven issues of E-Z RADIO make the most valuable volume on the subject that any beginner can have. There is virtually no question that arises in the mind of the novice that is not answered in some one of our past issues in a way so simple and clear that there is not the slightest difficulty of its easy comprehension.

We are giving below, an index by subjects, showing the contents of our previous issues. The beginner can not do better than look over this list, see which issues answer the questions which are uppermost in his mind and send to us for the copies that he wants.

The price is twenty cents per copy or any six copies for one dollar.

THEORY.

	Mo.	Page
What's all this craze about?.....	May	4
How much radio do I have to know?.....	May	5
Don't the signals get all mixed up?.....	May	7
Can I always get the broadcasts?.....	May	11
What we mean by tapping coils.....	May	28
What makes wave length?.....	June	5
The primary and secondary circuits.....	June	7
You can prove induction yourself.....	June	8
You tap your house plumbing supply.....	June	12
The condenser is a fast little worker.....	July	3
What is a condenser?.....	June	29
We live in a vibrating world.....	Aug.	3
Down the scale of wave length.....	Aug.	5
What we mean by resonance.....	Aug.	7
Getting used to radio symbols.....	Sept.	27
The symbols for the coupler.....	Sept.	28
The symbol for the audion bulb.....	Sept.	30
The symbols for a modern hook-up.....	Sept.	32
The symbols for a two slide tuner.....	Sept.	34
A glossary of symbols.....	Sept.	37
Does electricity flow?.....	Oct.	3
What is regeneration?.....	Oct.	5
Waves and what they do.....	Oct.	6
What we mean by heterodyne.....	Oct.	9
Marvels of the radio compass.....	Oct.	11

THE AUDION BULB.

1. Edison effect.....	July	14
2. The Fleming bulb.....	July	16
3. DeForest's grid.....	July	18
4. How the bulb builds up signals.....	July	20
5. The grid condenser and leak.....	July	22
6. How the amplifying bulb works.....	July	24

COST.

What will it cost for a set?.....	May	9
Cost of an ideal aerial.....	Aug.	11
Two stages of radio frequency.....	Oct.	26

Mo. Page

One stage of audio frequency.....	Oct.	28
Second stage of audio frequency.....	Oct.	29
Cheapest tube set.....	Nov.	25

PARTS OF APPARATUS.

What is a detector?.....	May	13
The variometer and variocoupler.....	May	27
Variometers are delicate instruments.....	July	8
What the underwriters require.....	Aug.	14
How plugs and jacks are used.....	Aug.	27
The storage and B batteries.....	Sept.	3
How to use storage and B batteries.....	Sept.	4
The storage battery needs attention.....	Sept.	6
The use of a potentiometer.....	Oct.	14
A home-mounted peanut tube.....	Oct.	17
How a phone plug is connected.....	Nov.	10

HOW TO BUILD.

Be careful how you connect your wires.....	May	15
How to wind and tap a coil.....	May	30
Your panels need not cost a fortune.....	June	10
A few hints on soldering.....	June	14
A panel for your audion bulb.....	June	24
What the bulb control panel is.....	June	26
The best way to handle a B battery.....	June	28
Some ways of using condensers.....	July	4
A salt box variometer.....	July	6
How to build a two slide tuner.....	July	39
Condensers in series and parallel.....	Aug.	22
An easy wave length changer.....	Aug.	24
Series parallel switch on a panel.....	Aug.	26
An envelope variable condenser.....	Sept.	21
Another home made variable.....	Sept.	22
A home made potentiometer.....	Oct.	12
A phonograph record variable.....	Oct.	16
Dials for your receiving set.....	Oct.	36
Spider webs with Gibbons hook-up.....	Nov.	23 to 27
A dandy set for the beginner.....	Nov.	36 to 40

E-Z RADIO

THE AERIAL.

The bugbear of radio—the aerial.....	May 16
How to rig up your aerial.....	May 18
Some hints on putting up aerials.....	May 10
The use of indoor aerials.....	July 22
The best aerial spreader.....	Aug. 2
The ideal amateur aerial.....	Aug. 9
Can you mouse a guy?.....	Aug. 11
Some pointers on the aerial.....	Aug. 13
Is lightning a danger?.....	Aug. 17
The wave length of your aerial.....	Sept. 14
Protect your aerial against wind.....	Sept. 16

CRYSTAL HOOK-UPS.

The loose coupler and the crystal.....	May 21
The test buzzer is important.....	May 22
Two slide tuner.....	July 37
Some points on crystal detectors.....	Sept. 17
Using a variometer with a crystal.....	Sept. 19
Single slider with crystal and bulb.....	Nov. 8

SIX STANDARD CRYSTAL HOOK-UPS.

1. Single slide tuner.....	Nov. 27
2. Two slide tuner.....	Nov. 29
3. The variometer and loading coil.....	Nov. 30
4. The loose coupler.....	Nov. 33
5. The variocoupler.....	Nov. 33
6. The spider web coils.....	Nov. 35

SPIDER WEB COILS.

How to wind spider web coils.....	June 16
Tapping spider web coils.....	June 17
Spider web coil taps and switches.....	June 22
Spider webs in single circuit regenerative hook-up.....	July 2
Spider webs without taps.....	Aug. 19
Demountable spider web outfit.....	Aug. 20
Condensers and the spider webs.....	Aug. 22
Spider webs as variometers.....	Nov. 23
Spider webs in cheapest tube sets.....	Nov. 24

HINTS ON OPERATING.

How to handle the single circuit.....	May 25
Test your condensers for shorts.....	June 31
What we mean by resonance.....	Aug. 7
Those queer code noises you hear.....	Aug. 34
Operating the honeycomb coil set.....	Nov. 15

REGENERATIVE HOOK-UPS.

The Single-Circuit Set.....	May 24
The short wave regenerative set.....	July 10

Putting the units together.....	July 12
Another regenerative hook-up.....	Sept. 13

AMPLIFICATION.

How the amplifying bulb works.....	July 24
There are two kinds of amplification.....	July 26
What an amplifying transformer is.....	July 28
Get ready for your amplifier.....	Sept. 24
Wiring up your transformer.....	Sept. 25
One stage of radio frequency.....	Oct. 24
Two stages of radio frequency.....	Oct. 26
One stage of audio frequency.....	Oct. 27
Second stage of audio frequency.....	Oct. 29
A good amplifying arrangement.....	Oct. 32
Three radio and one audio.....	Oct. 34

LOOPS AND LOOP HOOK-UPS.

A hook-up for the indoor loop.....	July 31
Some ideas on loop aerials.....	Sept. 2
A loop aerial is easy to make.....	Sept. 9
A hook-up for the loop.....	Sept. 10
Hints on loop aerials.....	Sept. 11
More data on loops.....	Oct. 2
Figuring loop aerials.....	Oct. 19
How to mount a loop.....	Oct. 20
A hook-up for a patient man.....	Oct. 22
Loops with radio and audio frequency.....	Oct. 24-31

SLIDER TUNERS.

The two slide tuner with a bulb.....	July 36
The two slide tuner with a crystal.....	July 37
How to build a two slide tuner.....	July 39
The single slide tuner.....	Nov. 3
The single slide tuner with a crystal.....	Nov. 5
The single slide tuner with a bulb.....	Nov. 7
Switching from crystal to bulb.....	Nov. 8

LEARNING THE CODE.

The dot-dash is easy to learn.....	Aug. 36
Good code practice.....	Aug. 38

HONEY COMBS AND DUO-LATERALS.

Winding duo-lateral coils.....	Oct. 37 to 40
A talk on honeycomb coils.....	Nov. 11
The use of honeycomb coils.....	Nov. 13
The three honeycomb coil hook-up.....	Nov. 14
Operating the honeycomb coil set.....	Nov. 15
Amplifiers for the honeycombs.....	Nov. 17

GOOD SETS TO MAKE.

The Gibbons freak hook-up.....	Nov. 19 to 27
The Lindh hook-up.....	Nov. 36 to 40

E-Z COMPANY, Inc., Publishers, E-Z RADIO
614 ARCH STREET : : PHILADELPHIA