



*A Publication for the
Radio Amateur Worldwide*

*Especially Covering VHF, UHF
and Microwaves*

VHF COMMUNICATIONS

Volume No.26 . Spring . 1/1994 . £4.00

Lightning and Overvoltage Protection for Radio Equipment

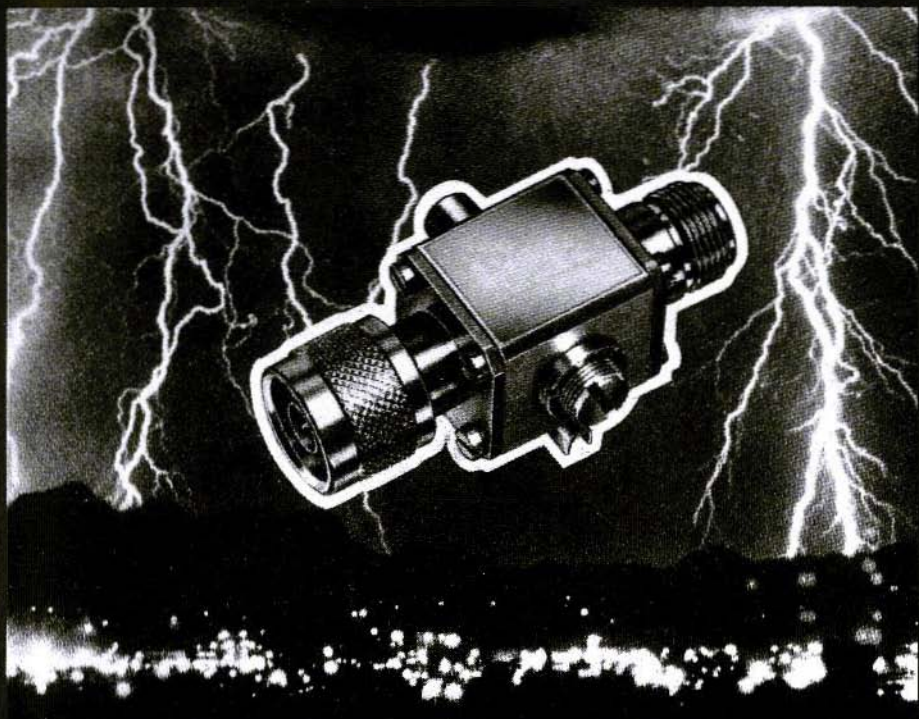

Klaus-Peter Muller



VHF COMMUNICATIONS

A Publication for the Radio Amateur Worldwide

Especially Covering VHF, UHF and Microwaves

Volume No. 26 . Spring . Edition 1/1994

Published by: KM PUBLICATIONS,
5 Ware Orchard, Barby, Nr.Rugby,
CV23 8UF, United Kingdom.

Publishers: KM PUBLICATIONS

Editors: Mike Wooding G6IQM
Krystyna Wooding

Advertising Manager: Mike Wooding G6IQM

VHF
COMMUNICATIONS

The international edition of the German publication UKW-Berichte is a quarterly amateur radio magazine especially catering for the VHF/UHF/SHF technology. It is owned and published in the United Kingdom in Spring, Summer, Autumn and Winter by KM PUBLICATIONS.

The 1994 subscription price is £15.00, or national equivalent. Individual copies are available at £4.00, or national equivalent each. Subscriptions and orders of individual copies of the magazine should be addressed to the national representative, or - if not possible - directly to the publishers. All other enquiries should be addressed directly to the publishers.

Back issues, kits, as well as the blue plastic binders are obtainable from your national representative or direct from KM Publications.

© KM
PUBLICATIONS

All rights reserved, reprints, translations, or extracts only with the written approval of the publishers.

Translated by: Inter-Ling Services Ltd., 16 Naseby Road, Rugby, CV22 5NH, U.K.

Printed in the United Kingdom by Cramphorn Colour Printers Ltd., 15c Paynes Lane, Rugby.

Please address your orders or enquiries to your country representative, whose address is shown in the adjacent column.

AUSTRIA - Verlag UKW-BERICHTE, Terry D. Bittan, POB 80, D-91081 BAIERSDORF, Germany. Telephone: (9133) 47-0. Telex: 629 887. Postgiro Nbg: 30455-858. Fax: 09733 4747.

AUSTRALIA - W.J.A., P.O. Box 300, SOUTH CAULFIELD, 3162 VIC, Australia. Telephone: 528 5962.

BELGIUM - UKW-BERICHTE, P.O. Box 80, D-91081, BAIERSDORF, Germany. Tel: 09133 47 0. Postgiro Nbg: 30455-858 ; Fax: 09133-4747

DENMARK - KM PUBLICATIONS, 5 Ware Orchard, Barby, Nr.RUGBY, CV23 8UF, U.K. Tel: +44 788 890365. Fax: +44 788 891883.

FRANCE - Christianne Michel F5SM, SM ELECTRONIC, 20 bis Avenue des Clairions, F-89000 AUXIERRE, France. Telephone: (86) 46 96 59

FINLAND - PETER LYTZ OH2AVP, Yläkartanonkuja 5 A 9, SF-02360 ESPOO, Finland

- SRAT, pl 44, SF-00441 HELSINKI, Finland. Telephone: 358(0)5625973.

GERMANY - UKW-BERICHTE, P.O. Box 80, D 91081 BAIERSDORF, Germany. Tel: 09133-7798-0. Postgiro: 30455-858

GREECE - CIA ELECTRONIC, P.O. Box 25070, ATHENS 100 26, Greece. Telephone: 01 52 42 867. Fax: 01 52 42 537.

HOLLAND - KM PUBLICATIONS, 5 Ware Orchard, Barby, Nr.RUGBY, CV23 8UF, U.K. Telephone: +44 788 890365. Fax: +44 788 891883

ITALY - ADB ELETTRONICA di Luchesi Fabrizio IW5ADB, Via del Cantone 714, 55100 ANTRACCOLI (LUCCA), Italy. Telephone: 0583-952612.

NEW ZEALAND - Peter Mott, AUCKLAND VHF GROUP Inc., P.O. Box 10 138, AUCKLAND 1030, New Zealand. Telephone: 0-9-480-1556

NORWAY - HENNING THEG RADIO COMMUNICATION LA4YG, Kjølavveien 30, 1370 ASKER, Norway. Postgirokonto: 3 16 00 09

POLAND - Z.Bienkowski SP6LB, ul. Staszica 14/2, 58 500 JELENIA GÓRA 9, Poland. Tel: 514 80

SOUTH AFRICA - HI TECH BOOKS, P.O. Box 1142, RANDBURG, Transvaal 2125, South Africa. Tel: (011) 886-2020.

SPAIN & PORTUGAL - JULIO A. PRIETO ALONSO EA4CJ, Douso Cortés 58 5º-B, MADRID-15, Spain. Telephone: 543.83.84

SWEDEN - LARS PETTERSON SM4IVE, Pl. 1254, Smögården, Talby, S-17500 ODENSBÄCKEN, Sweden. Telephone: 19-50223

SWITZERLAND - TERRY BITTAN, PSchKto, ZÜRICH, Switzerland.

UNITED KINGDOM - KM PUBLICATIONS, 5 Ware Orchard, Barby, Nr.RUGBY, CV23 8UF, U.K. Telephone: 0788 890365; Fax: 0788 891883.

U.S.A. - WYMAN RESEARCH Inc., RR#1 Box 95, WALDRON, Indiana 46182, U.S.A. Telephone: (317) 525 6452.

- Henry Ruh, ATVQ MAGAZINE, 1545 Lee Street, Suite 73, Des Plaines, IL60018, U.S.A. Tel: (708) 298 2269. Fax: (708) 291 1644

ELSEWHERE - KM PUBLICATIONS, address as for the U.K.

ISSN 0177-7505



Contents

Detlef Burchard	DIY Gain Blocks	2 - 11
Dr.Ing.Jochen Jirmann	Intermodulation Properties of Switching Diodes	12 - 18
Richard A. Formato	Maximum Bandwidth Monopole Antennas	19 - 23
Dipl.-Ing.(FH) Klaus-Peter Müller	Lightning and Overvoltage Protection for Radio Equipment	24 - 30
Index to Volume 25 (1993)		31 - 34
Matjaz Vidmar S5 3MV (ex YU3MV, YT3MV)	A DIY Receiver for GPS and GLONASS Satellites	35 - 44
Eugen Berberich DL8ZX	Suppression of Interference to 70cm ATV by using a Highly Selective Notch Filter	45 - 55
Wolfgang Schneider DJ8ES	A Hybrid Power Amplifier for 144 MHz	56 - 61

The Editors wish to apologise for the poor printing quality of some of the copies of issue 4/1993 of the magazine. This was due to circumstances beyond our control, in that the printing house failed to produce the magazine to the high standard required and enjoyed in the past. The matter has now been reconciled and we have retained a new printing house for future work. Again, many apologies to those of you who had inferior quality copies, we sincerely hope that it did not detract too much from your enjoyment of the magazine.

Krystyna and Mike - KM Publications



KM Publications, 5 Ware Orchard, Barby, Rugby, CV23 8UF, UK

Telephone: 0788 890365; INT: +44 788 890 365; FAX: 0788 891883



Detlef Burchard, Dipl.-Ing., Box 14426, Nairobi, Kenya

DIY Gain-Blocks

The division of a high-frequency circuit into blocks which display a uniform system resistance Z_o at their inputs and outputs, has many advantages. The blocks can be connected to one another by cables of almost any length with the same system resistance without any change in the characteristics of the overall pattern. Individual blocks can be replaced by others with different characteristics to improve specific characteristics of the overall pattern, and all of them can be individually measured in an uncomplicated way, using measuring equipment with the system resistance.

1. INTRODUCTION

Gain-blocks are usually supplied for a system resistance of 50Ω and for the amplification of UHF frequencies. The

advantages of block assembly can also be made use of in any other frequency range, and thus even for low frequency with $Z_o = 600\Omega$, carrier frequency with $Z_o = 150\Omega$ and for TV/video with $Z_o = 75\Omega$. The observations below also permit the dimensioning of gain-blocks for values of Z_o which deviate from 50Ω , a field which is not covered by commercially available MMIC's. It is even possible to match many characteristics to the application, within specific limits, such as lack of noise, freedom from distortion, lack of feedback and output.

2. COMMERCIALY AVAILABLE GAIN-BLOCKS

Fig.1 shows some internal circuits. They can be relatively simple, or even complicated. One or more active elements are present, which are recipro-

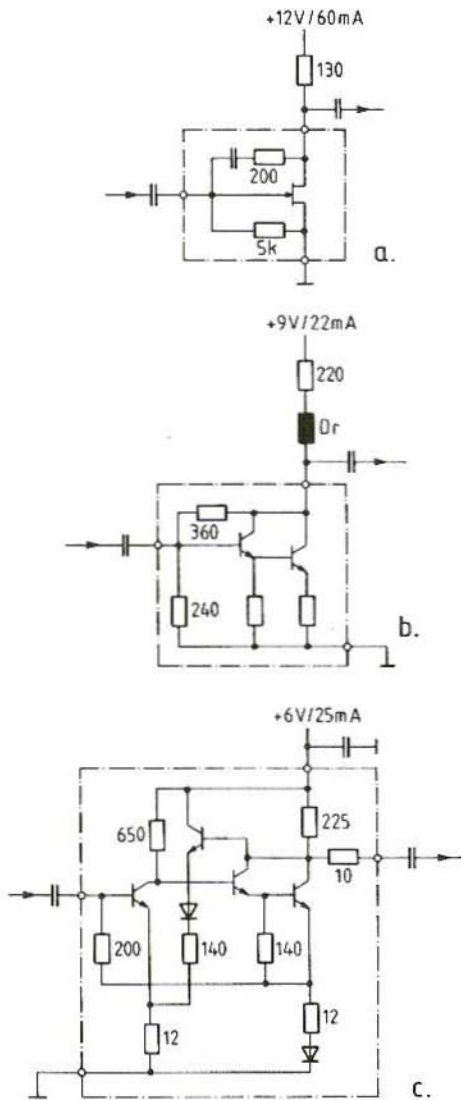

Fig.1: Some commercially available Gain-Blocks
 a. Siemens CGY 40; $V=2.8$;
 0.8-1.8 GHz - 1dB
 b. Avantek MSA 07; $V=4.7$;
 0.1-0.75 GHz - 1dB
 c. Signetics 5205; $V=8.9$;
 0.1-500 MHz - 1dB

cally linked in such a way that stable amplification occurs over a wide frequency range, with matching to Z_o at both gates. Resistance values shown in Fig.1 stem in part from the corresponding publications by the author (4...7) or were measured on specimens, as far as this can be done from outside. The diagram also shows the minimum circuit required: coupling and decoupling capacitors, sometimes resistances for power supply and setting the point of operation. For higher demands, chokes, Zener diodes, transistors and additional resistances also become necessary, in accordance with (4). Commercially available gain-blocks are thus in no way free from peripherals.

3. SEMI-CONDUCTORS FOR DIY GAIN-BLOCKS

An individual transistor with a reciprocally coupled resistance forms a gain-block in itself, which needs no more peripherals than a purchased unit. I shall try to restrict myself in what follows to layouts using only a single transistor, because otherwise the advantage over purchased equipment of having a single housing is lost and the calculations become very complicated.

Bipolars in an emitter circuit or FET's in a source circuit can be used as the transistors. Without reciprocal coupling, their amplification at low frequencies in a system using Z_o , without taking all higher-order terms into account, will be:

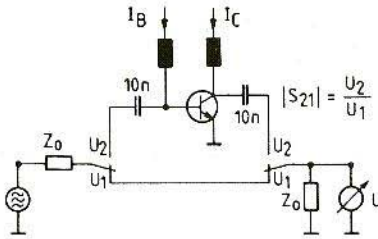

Fig.2: Circuit for measurement of S_{21}

$$V_{bip} = - \frac{2 \cdot \beta \cdot I_c \cdot Z_o}{Z_o \cdot I_c + \beta \cdot U_T} \quad (1a)$$

for bipolar transistors and

$$V_{fet} = - 2 \cdot S \cdot Z_o \quad (1b)$$

for FET's.

In the equations, U_T stands for the temperature voltage (0.028V) and S for the steepness. V is always negative, because the amplifiers invert. With a bipolar transistor any strong dependence on the collector current I_c disappears. The amplification calculated in this way is the maximum available and corresponds roughly to the scatter parameter, S_{21} . For many high-frequency transistors, you will find lists in the data sheets from which S_{21} can be read off. In all cases, you can measure the scatter parameter yourself in a measurement circuit - Fig.2. It stands to reason that a gain-block will always have less amplification than the maximum available. The reverse feedback to be attached will sap a good part of it, though this is repaid by an increase in the frequency range and an improvement in the balancing at the input and output.

At high frequencies, the maximum amplification available also decreases. For a bipolar transistor, we can distinguish several limiting frequencies:

- f_s with regulated base voltage, and
- f_β with regulated base current.

Both apply for any load resistor, however small (here Z_o). If the load resistance is high, then a third limiting

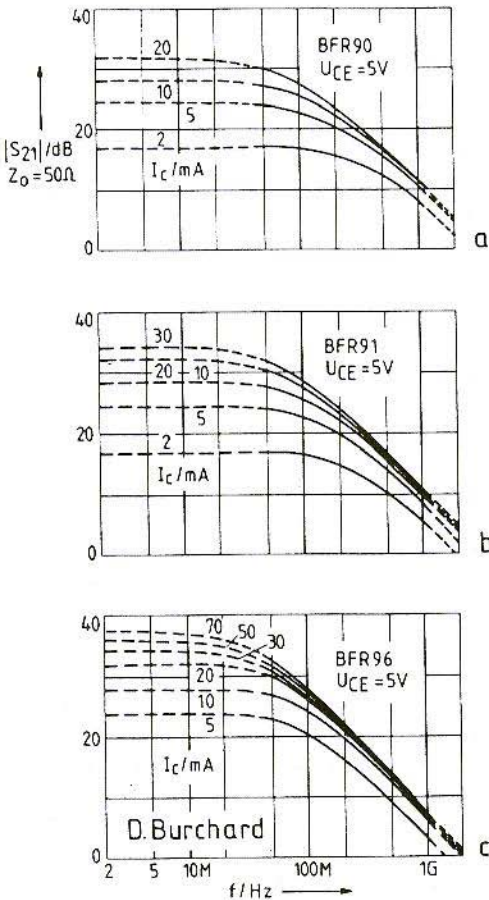

Fig.3: Scatter parameters S_{21} of some Bipolar Transistors



frequency must be taken into consideration, which is calculated from the load resistor and the output capacitance. It depends on the collector current of the transistor whether f_s or f_β determines the reduction in amplification. The transition from impressed base voltage to impressed base current takes place at $Z_o \cdot I_c = \beta \cdot U_T$. The input resistance R_{BE} of the transistor then has precisely the value of Z_o . For R_{BE} :

$$R_{BE} = \beta \cdot \frac{U_T}{I_c} \quad (2)$$

Several limiting frequencies also become effective with an FET:

- f_s for decrease of 3dB in steepness
- f_c from source resistance and input capacitance (including Miller capacitance)
- f_a from load resistor and output capacitance.

It is much easier to look at the S_{21} curve than to calculate the limiting frequencies. For several popular high-frequency transistors and some FET's, these are as shown in Figs. 3 and 4. The dotted curves in Fig.3 are extrapolations corresponding to theoretical considerations. Solid sections of the curve correspond to the published S_{21} lists. The curve for CFY 19 in Fig.4 corresponds to the published values. The power FET curves were taken from a circuit like Fig.2. They serve a similar purpose here to those for the open-loop amplifier. It can be seen at a glance how far the amplification should be reduced to obtain a specific frequency

range, and how much reserve amplification the circuit has in a reciprocally linked condition. It can be seen immediately from Fig.3 that the BFR 90 is the best of the three transistors shown for all currents below 20mA. The BFR 91 is more favourable only in a narrow current range from 20 to 30mA, and the BFR 96 offers greater amplification only below 100 MHz at still higher current levels. Below 45°, there is a decrease as the frequency increases, which indicates, as with operational amplifiers, that reverse feedback of any strength is possible without instability.

The high-frequency reduction in amplification for the FET's in Fig.4 is variable. The curve at 10 GHz stops at CFY 19, so no more precise information can be obtained. This transistor is not suitable for gain-blocks, because it offers too little reserve amplification.

As we shall see later, only 12dB is lost through the matching requirement, so that useful amplification can be supplied in a 50Ω system.

The curves for U 244 and VN 10 KM occupy almost the same space. They have a smooth 1/f reduction, and are therefore suitable for reverse feedback of any strength. But this does not apply to the VMP 1! This is being operated here with a power loss amounting to 12W. The TO-3 housing has to be mounted on a cooling surface, with a mica disc as an intermediate layer, for heat extraction purposes. The resultant capacitance of approximately 150pF brings about a reduction of 2 degrees, so that the transistor will oscillate if the reverse feedback is too strong.

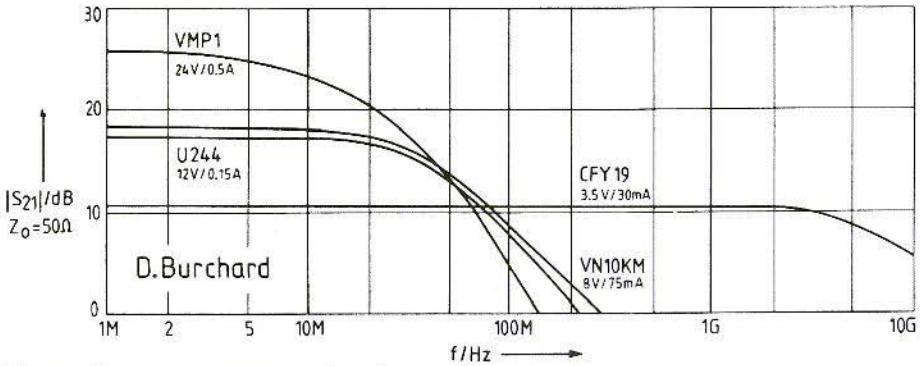

Fig.4: Scatter parameters S_{21} of some Field Effect Transistors

The S_{21} curves shown naturally have tolerances, but they are not defined further, even in the published lists. With the power FET's it is thoroughly established that the measured amplification is considerably smaller than that given in the data sheet. This is due to the fact that the steepness given there, measured using current pulses at 25° C., falls to under a half of the rated value if the crystal temperature rises by 100° K.

It can also be seen from the curves that the bipolar transistors are good for gain-blocks with an amplification of 20dB for a few tens of MHz's and for amplifications of 10dB for a few hundred MHz's. This is due to the fact that the transistors shown here have f_T at 5 GHz, whereas MMIC's contain transistors which are sometimes five times faster.

The power FET's provide gain-blocks which can be used above the limit of the high-frequency range (30 MHz).

4. CIRCUITS OF DIY GAIN-BLOCKS

A broad-band shortwave high-level stage as per (2) is also a gain-block, but one with a rather complicated internal

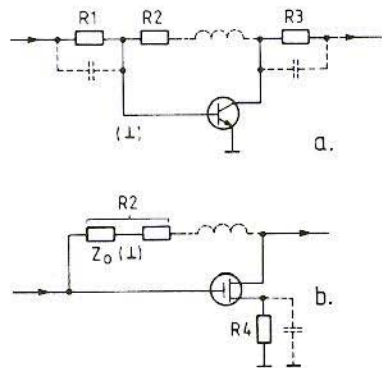

Fig.5: DIY Gain-Block circuit without components for setting the operating point. Components shown by dotted lines; improvement in upper frequency limit
a. with voltage feedback
b. with combined voltage and negative current feedback



circuit. If the idea is to create something which can compete with MMIC's, then only very simple circuits like those shown in Fig.5 come into question. Circuit 5a is particularly simple and the dimensions can be estimated. Circuit 5b gives better results in many cases. All components involved in the operating point setting have been omitted in the diagram, and we have also ignored the components shown by dotted lines to improve behaviour at high frequencies. Such improvements would not be possible with purchased gain-blocks.

Calculation bases for circuit 5a can be found, for example, in (3).

But things can be made even simpler! The transistor can be understood as being an inverting operational amplifier. A virtual zero point, (), forms at the base, due to the reciprocal coupling, R_2 , and the output resistance becomes low. Preceding or succeeding resistances R_1 and R_3 , with an order of magnitude of Z_o , match the system resistance. Now, the individual transistor is not as good an operational amplifier as you might wish. Its amplification reserve is rather small, its input resistance as per equation (2) is not high, and its output resistance is not low. The resistances, R_1 to R_3 , must be corrected if we really want to obtain the desired amplification and the correct matching. The equations for this are given here, without any further explanation of how they are derived:

$$R_1 = Z_o - (1 - V) \frac{U_T}{I_c} \quad (3)$$

$$R_2 = -2 \cdot V \cdot Z_o + (1 - V) \frac{U_T}{I_c} \quad (4)$$

$$R_3 = Z_o - (1 - 2V) \frac{U_T}{I_c} \quad (5)$$

Since the amplifier inverts, V should always be set negative. The first term after the equals sign is always the value for an internal amplification of any size, while the second is the corrective factor referred to above.

The calculation for the circuit as per Fig.5b can be found, for example, in (1). Here the transistor is operated with an emitter resistance, R_4 , which lowers its steepness, S , to S_{red} .

$$S = I_c / U_T \quad (6)$$

$$S_{red} = \frac{1}{R_4 + \frac{U_T}{I_c}} \quad (7)$$

Many power transistors with multiple emitters already have built-in series resistances, which are primarily there to ensure that the current distribution is more uniform, but which also cause a reduction in steepness. They must be taken into consideration in this calculation. FET's, by their very nature, already have low steepness, and a reduction through R_4 is usually unnecessary. For every reduced steepness value, there is only one quite specific reciprocal coupling resistance, R_2 , and thus also only one specific amplification, if the matching condition is to be fulfilled. The equations run as follows:

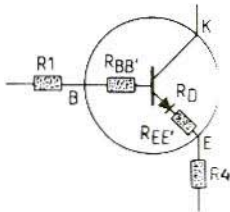

Fig.6: Noise sources in a Gain-Block

$$R_2 = S_{\text{red}} \cdot Z_o^2 = (1 - V)Z_o \quad (8)$$

$$V = 1 - S_{\text{red}} \cdot Z_o = 1 - \frac{R_2}{Z_o} \quad (9)$$

CFY 19 in Fig.4 has $S = 33\text{mS}$. Its amplification during matching is only -0.65 . VN 10 KM has $S = 75\text{mS}$, and under the same conditions $V = -2.75$. Bipolar transistors have high steepness values, even when the collector current is low. If you wish to avoid having an external resistance, R_4 , because then the emitter can be directly earthed, you must reduce the collector current until the desired degree of steepness is obtained. The condition required for this can be found by converting equation (6): $I_c = S \cdot UT$.

5. NOISE

In a DIY gain-block, noise comes not only from the semi-conductors but also from the resistances of the circuit, with one exception: resistance R_2 in Fig.5b does not contribute to the noise. This can be explained by the fact that a virtual zero point forms there. As pointed out in Fig.5, it can also be

thought of as two individual resistances, Z_o and the remainder, put together. Both partial resistances make noise in a correlated way. The fraction from the left-hand partial resistance is amplified in the transistor and reversed in the phase, and then meets the noise fraction of the right-hand partial resistance at the collector, which brings about a nullification. The circuit is thus suitable for low-noise gain-blocks. Other noise sources are indicated in Fig.6. Apart from the resistances in the circuit, R_1 and R_4 , these are the internal base feed resistance $R_{BB'}$ of the transistor, the internal emitter feed resistance $R_{EE'}$ and the differential conducting-state DC resistance of the BE-Diode R_D which is also the reciprocal value of the steepness:

$$R_D = \frac{1}{I_c} = \frac{U_T}{I_c} \quad (10)$$

There is usually nothing in the data sheets about the sizes of $R_{BB'}$ and $R_{EE'}$. In GHz transistors, they are kept as small as possible, in order to improve the high-frequency behaviour. This leads to the curious result that many high-frequency transistors generate less noise in the low-frequency range than specially provided low-noise low-frequency transistors. On top of that, they are especially well suited to oscillator circuits, if low sideband noise values are required.

It can be demonstrated, from calculations and observations, that R_D makes half-thermal noise, and so its noise voltage is only as big as that of an ohmic resistance of half the value.



From all of that, we obtain, for the noise dimension of a gain-block with a bipolar transistor:

$$F/dB = 10 \lg \left(1 + \frac{R_1 + R_{BB'} + 1/2R_D + R_{EE'} + R_4}{Z_o} \right) \quad (11)$$

A relationship as easy to monitor as this can not be laid down for amplifiers with FET's.

6. DISTORTION

When collector or drain currents are low, both bipolar and field effect transistors display an exponential transfer characteristic, i.e. a relationship between the output current and the input voltage, which can be expressed through an e-function. Bipolar transistors are often used in this range, but not usually FET's, and the former are no longer voltage-controlled when the collector current increases, because the input resistance falls.

From a limit which can be calculated using equation (2), with $R_{BE} = Z_o$, current source driving, which has a linearising effect, is increasingly present. At still higher current levels, β is reduced and the characteristic curves in the opposite direction. Thus for many transistors there is an optimal collector current at which distortion values are low even without reciprocal coupling. This is the case, for example, for BFR 96 between 60 and 80mA.

The FET's used here work partly on a linear characteristic section (VMP1) or in a transitional area between this and the e-function area. U244 and VN 10 KM certainly have very attractive linear characteristics at higher current levels, but their limited lost heat extraction does not allow them to be continuously operated in these conditions.

It is very commonly said that distortion arising through reciprocal coupling can be traced back to a factor which corresponds to the amplification reserve. At low frequencies, this factor is naturally greater than the S_{21} curves of Figs. 3 and 4 show. The effect of this is that the values for the third-order intercept point (IM3) and for the 1dB compression point (P-1dB) are monotonically reduced at higher frequencies. This is just the same for purchased MMIC's, but is often not mentioned in data sheets.

If the active component is operating with a characteristic which can be described by an e-function, then there are specific natural relationships which it is worth remembering. We are not going to go through the derivation here, but rather give a short description of the approach. IM3 points and P-1dB points are connected to the third derivative of the characteristic. Using Taylor's method to develop the range, we obtain the coefficients of all mixed products during control using two frequencies. We can now preset the products which should appear at the output, and calculate the input voltage for them. Then, irrespective of the operating point selected on the e-function, we always get -25dBm for the P_{-1dB} point,

i.e. an input voltage of 12.5mV. Whereas the IM3 point always turns out to be -7dBm, which means an input voltage of 100mV. Thus $IM3 = P_{1dB} + 18$ dB is valid all the way through. For BFR 90/91/96 high-frequency transistors, all of which have a typical current amplification β of 50, $R_{BE} = Z_o = 50\Omega$ when $I_c = 28$ mA. If the collector current is lower than this, then without reverse feedback the gain-block will have the points calculated as characterising the distortion. With reverse feedback, they will lie higher, by the extent of the amplifier reserve.

The actual input power is not given only by the P_{1dB} point at the input, but also by the modulation capability at the output. Not all the power generated goes into the load. A good part is destroyed in R2. The operating current and operating voltage must thus match one another and must be selected to be high enough for the output not to generate distortion at the input.

7. SOME PROVEN CIRCUITS

The isolating amplifier in Fig.7 is based on the circuit principle from Fig.5a. Good reverse damping is obtained by the virtual zero point at the base and the low output resistance at the collector. Since the amount of amplification is equal to 1, the output power to operate a pre-scaler can be low and the transistor also still operates very well at a collector voltage of 0.75V, the resulting circuit was simple. A few readings are also given.

The circuit as per Fig.8 certainly appears similar, but operates on the principle of Fig.5b. The collector current is selected in such a way that R4 can be dispensed with. It therefore does not contribute to the noise. The BFR 90 generates its minimum noise at a current level of 2mA. This circuit has the smallest noise dimension that can be obtained overall by this transistor in a 50Ω system. The only way to improve on it is to make the transition into a system with a Z_o which corresponds to the optimum generator resistance for this transistor.

Fig.9 shows a few more amplifiers. They all provide about 10dB amplification, but with widely varying output levels. At even higher power levels, chokes become necessary in the current supply, as is also required for many MMIC's, and more components are needed to set the operating point.

All the circuits illustrated will register a

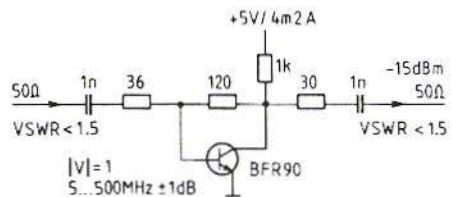

Fig.7: Isolating amplifier with $V = 1$ and particularly high isolation

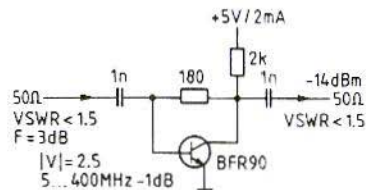

Fig.8: Low-noise small-signal amplifier with $V = 2.5$

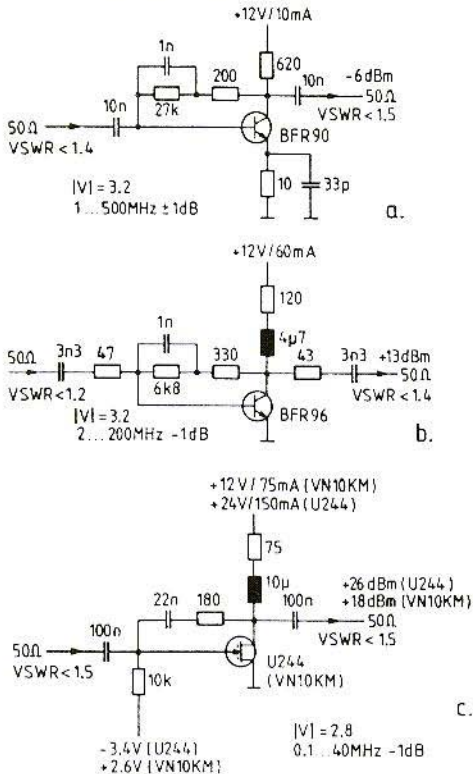

Fig.9: Gain-blocks with approximately 10dB amplification and greatly varying outputs:

- a. with combined reverse feedback, bipolar
- b. with voltage feedback, bipolar
- c. with power FET's

more or less steep reduction in amplification as frequencies get higher. The reduction can be compensated for by one or more of the components shown by dotted lines in Fig.5 (then becoming all the steeper above). It is thus possible, with the transistors used here, to construct aerial amplifiers going right up to the top end of the television band V (800 MHz). But that is outside the scope of this article.

Dimensioning the compensation measures in Fig.5, which would generally not be possible with MMIC's, is best done empirically. At high frequencies, much is dependent on the location of the component. The inductance in series with R2 can simply consist of rather long connecting wires. The parallel capacitor at R4 is also dependent on whether the feed inductance to the emitter plays a role. In many applications it can be convenient to use transistors with two emitter connections. The capacitors lying parallel to R1 and R3 improve matching at high frequencies. Their value will lie between 10 and 33pF, if they are provided at all.

In principle, these amplifiers are stable with any reverse feedback. However, they often oscillate. Factors are involved which are not shown in the wiring diagram - increased switching capacity from base or collector to earth, resistances with excessive inductances (coiled formats) or excessive capacities to earth, and perhaps also too long an emitter supply line.

Dr. Ing. Jochen Jirmann, DB 1 NV

Intermodulation Properties of Switching Diodes

Some attempts to improve the intermodulation properties of short-wave receivers were described in (1). It was demonstrated there that the main reason for the moderate intermodulation properties of many short-wave receivers should be looked for in the use of unsuitable switching diodes for the switching of the input band pass filters. Following numerous enquiries, the intermodulation behav-

our of commercially available high-frequency switching diodes was measured in a second investigation. The results were obtained using resources which were still almost on an amateur level, and should thus not be put down to the "dB scales". The comparison between the various diode types is actually more important than the absolute values.

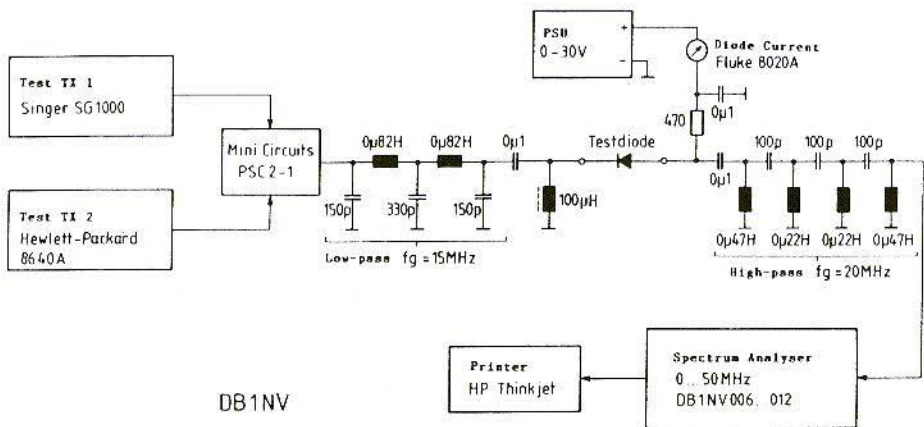

Fig.1: Measuring Rig for the measurement of the Intermodulation Characteristics of Switching Diodes



Spektralanalysator DB 1 NV, Version 1.18 vom 01.02.92
Grafikdruck HP Thinkjet mit 132 Pixel/Zoll

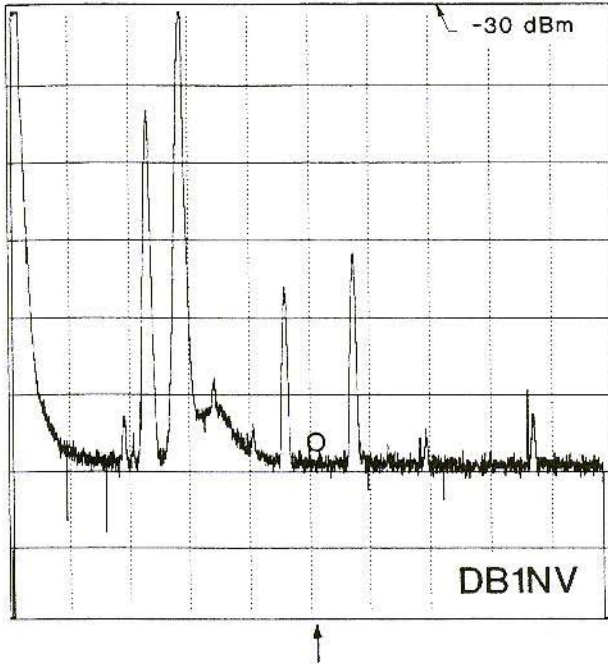

Fig.2:
Measurement Curve
without Diode (IM2
measurement).
Circle shows location
of Intermodulation
Product
SA: centre 25 MHz;
5 MHz/div

1. THE MEASURING RIG

The previous experiments, using an IC765 from OM Hercher, DL8MX, had demonstrated that the critical level above which audible intermodulations arise should be sought at an aerial voltage of about 100mV. This corresponds to an output of -6dBm. By definition, an S1 signal has a level of -121dBm, so that the measuring rig must process a dynamic range of 115dB to detect weak IM products. This is just about possible using commercial measuring technology of the most expensive kind. In order to obtain usable results with amateur resources, measurements were carried out only at selected fixed

frequencies, and the frequency diagram was drawn up in such a way that harmonics from the test transmitter can be separated from the IM products sought. With some filters, a measurement dynamic range could be usable at about 90dB. The measuring rig is sketched in Fig.1.

Two test transmitters act as signal sources, a Singer SG 1000 and a Hewlett-Packard 8640A, the outputs of which are combined by means of a power adder (Mini Circuits PSC2-1). The test transmitter power is 1mW or 0dBm. A simple low-pass filter made of proprietary chokes (Siemens MCC, 0.82 *H) with a limiting frequency of 15 MHz reduces the inherent intermodulation of the test transmitter to below -100dBm. The low-pass filter is fol-

Spektralanalysator DB 1 NV, Version 1.18 vom 01.02.92
Grafikdruck: HP Thinkjet mit 192 Pixel/Zoll

Fig.3:
Measurement Curve:
IM2 Spectrum of a
BA379 with 2mA Diode
Current

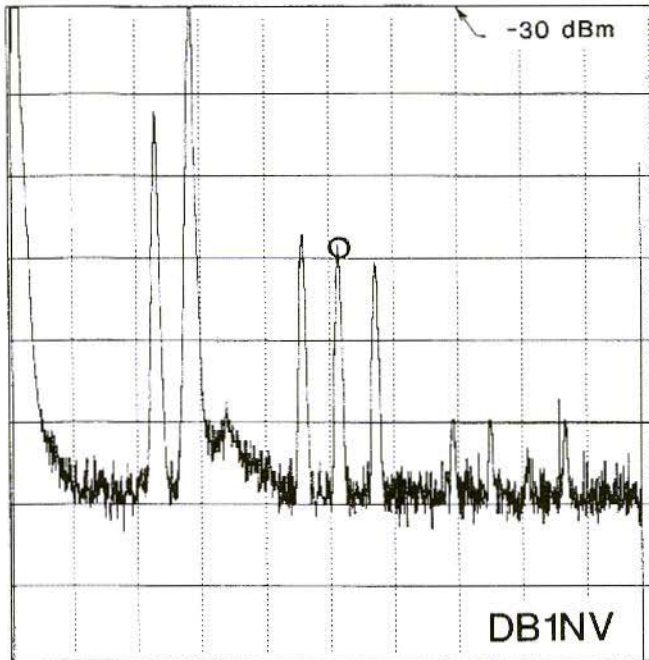

lowed by the test diode, which is biased with adjustable DC. A high-pass with a limiting frequency of 20 MHz relieves the spectrum analyser (home-made by the author) of the strong carrier wave signals from the test transmitter. The analyser was set to an average frequency of app. 25 MHz and to 5 MHz/div.

For the measurement of total frequencies (second-order intermodulation), the test transmitters operated at 15 and 12 MHz. The second-order mixed product at 27 MHz can thus easily be separated from the test transmitter harmonics at 24 and 30 MHz.

To measure third-order intermodulation, the test transmitters were set to 15.5 Hz and 6 MHz and the mixed product was measured at 25 MHz.

To check the measuring rig, the diode was short-circuited. Fig.2 shows the analyser screen print-out. The two test transmitter signals can be recognised (here 12 MHz and 15 MHz), together with their harmonics at 24, 30, 36 and 45 MHz. The reference level at the top edge of the screen was -30dBm here, so that the reduction of inherent intermodulation products could be estimated at better than 85dB. A circle marks the position of the IM product to be expected.

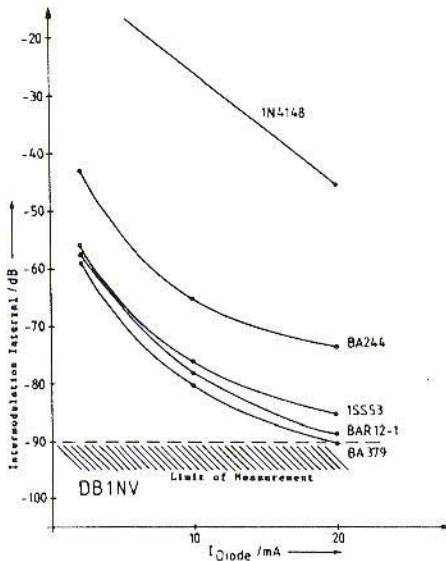

Fig.4: Second-order Intermodulation Products plotted against Diode Current

2. SECOND-ORDER INTERMODULATION

In this range, measuring frequencies of 12 and 15 MHz were used. The diode DC was varied from 2mA to 20mA. The test diodes used were a 1N4148, a 1SS53 (from an IC765), a BA379, a BAR12-1 and a BA244. A typical IM spectrum can be seen in Fig.3. Here a BA379 was operated at a low current of 2mA. The intermodulation signal can be clearly recognised at 27 MHz, with a level of -60dBm between the first harmonics of the test transmitter. The intermodulation intervals measured for

various diodes are plotted against the diode DC in Fig.4. As can be seen, the first round in the IM contest goes to the BA379 from Siemens, followed by the BAR12-1 and the 1SS53. The good cut-off results from the 1SS53 universal diode are surprising. But since the diodes removed from the IC765 carried no type description, it might perhaps be conceivable that ICOM had secretly used improved diodes here. It isn't clear from the parts list. It can clearly be seen how important a sufficiently high level of DC through the diodes is, since at current levels below 10mA the intermodulation products increase greatly.

3. THIRD-ORDER INTERMODULATION

In this measurement range, the test transmitters were tuned to 6 and 15.5 MHz and the IM product was evaluated at 25 MHz. The diode DC was altered here at only two values, 2mA and 5mA, and the same diodes were used as in Section 2. Fig.5 shows the inherent interference spectrum for the measuring rig, Fig.6 the IM spectrum for a 1N4148 misused as a switching diode with a diode current of 5mA. The reference line is at -10dBm and the IM interval for third-order products is about 20dB! Fig.7 further shows the intermodulation intervals measured for the various diodes. As can be seen, the BA379 gives the best results here too, followed by the BAR12-1, whereas the 1SS53 falls off markedly.



Spektralanalysator DB 1 NW, Version 1.18 vom 01.02.92
Grafikdruck HP Thinkjet mit 192 Pixel/Zoll

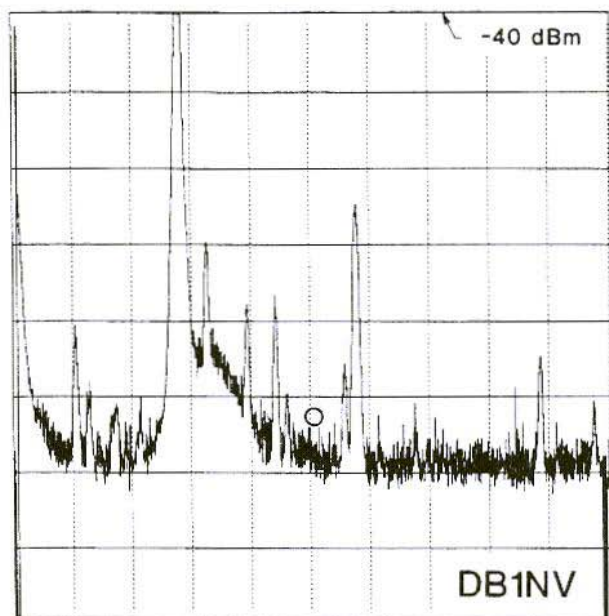

Fig.5:
Measurement Curve
without Diode (IM3
measurement).
Circle shows location of
Intermodulation
Product

4. SUMMARY OF RESULTS SO FAR

The measurement results listed essentially show four things:

- Good, repeatable intermodulation intervals can be obtained only through the use of "correct" PIN diodes, but they have their price. Miniature relays are even better, but more expensive and bigger.
- Universal diodes misused as high-frequency switches can yield very good results (1SS53) or catastrophically poor results (1N4148). Moreover, it can not be calculated what effect variations in the manufacturing parameters will have (different production lines, different production methods).
- The relatively good cut-off results obtained in practise from the apparatus fitted with tuner switching diodes is not consistent with the poor measurement results from the BA244.
- The existing apparatus should also be improved or re-constructed in order to check whether sufficient DC is flowing through the diodes. An attempt should be made to set a value of about 20mA by altering the protective resistors. It can be concluded from the results that the main cause of intermodulation interference in short-wave amateur receivers should be sought in the area of the high-frequency input switching diodes.



Spektralanalysator DB 1 NV, Version 1.18 vom 01.02.92
Grafikdruck HP Thinkjet mit 192 Pixel/Zoll

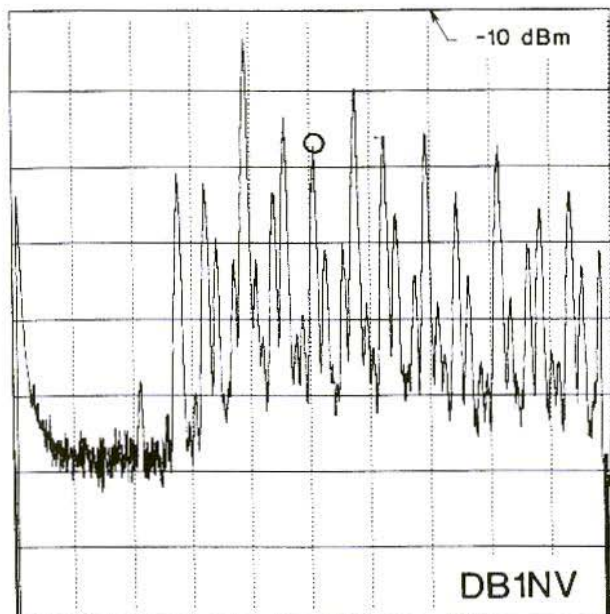

Fig.6:
Measurement Curve:
IM3 Spectrum of a
1N4148 with 5mA
Diode Current

But since over-modulated coils with ferromagnetic cores can also generate intermodulation effects, the same measuring rig was used to classify inductive components.

5. INTERMODULATIONS IN INDUCTANCES

Here both the aperiodic case (coil as choke) and the resonance case were investigated. In the latter case, the coil was brought into series resonance with a high-quality foil trimmer at 15 MHz and subjected to 12 and 15 MHz measurement frequencies. Coils or series resonance circuits were inserted into the measurement circuit instead of the diodes. The following observations were made here:

- With a choke effect, intermodulation products above -110dBm were not detected either for rod core microchokes from the Siemens MCC range or for Neosid and TOKO ready-made coils selected at random. Only the "VK200" six-bore core choke from Valvo or Philips Components, a favourite with VHF Communications readers, yielded an IM level of between 85 and 95dBm, depending on the ferrite material. A DC level of 50mA did not influence the readings for any choke.
- In resonance mode, the Neosid and TOKO ready-made coils, together with some very small ferrite ring cores, came up with IM levels of -100 to -105dBm. The Siemens chokes stayed the course amazingly well. Their intermodulation could be placed at around -110dBm. Some

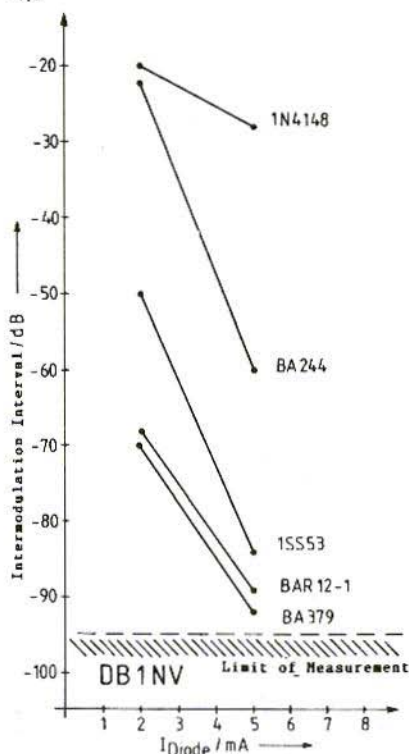

Fig. 7: Third-order Intermodulation Products plotted against 2mA and 5mA Diode Currents

Amidon ring cores, suitable for short-wave use and of various sizes, were practically free from intermodulation.

The following design tips can thus be derived, some of which are in any case not new, but which have probably fallen into oblivion in Japan:

1. Input filters effectively resistant to IM can be produced only using sufficiently large iron powder ring cores as inductances. They offer the best compromise between the space requirement and the level controllability.

2. In compact rigs, rod core chokes, such as the Siemens MCC, can be considered as alternatives.
3. Chokes in the filter structure, e.g. on the operating voltage feed, are largely uncritical, as long as they do not resonate.

In this connection, we might recall the band-pass filters with ring core coils publicised many years ago by VE3TP, which were not exactly cheap to construct, but on the other hand have solved every receiver IM problem so far. This statement shows that, in spite of statements to the contrary from the industry and from a few, probably unqualified, "specialists", it is possible to produce receiver input components which can meet today's requirements in relation to sensitivity and high-level signal strength. Since in our hobby we don't need to worry about tenths of a penny, like industrial manufacturers, we can obtain results which are some orders of magnitude better for a slightly increased cost!

The author hopes that this account of his measurements will start people thinking about experiments of their own, and would be pleased to receive reports of their experiences.

6. LITERATURE

- (1) Dr. Ing. J. Jirmann, DB1NV
Wilfried Hercher, DL8MX:
Improvement in Intermodulation Behaviour of Modern Short-wave Amateur Receivers
VHF Comm, 1/1993 pp. 38 - 43



Richard A. Formato, Ph.D., K1POO

Maximum Bandwidth Monopole Antennas

The monopole on a ground plane is a simple and versatile antenna. One of its most attractive features is the exceptional bandwidth it is capable of providing - up to 50% of the 1/4-wave frequency. This article describes how the monopole's bandwidth behaves and how to maximise it.

1.

THE BASE-FED MONOPOLE

The base-fed monopole on a ground plane is shown schematically in Fig.1. The radiating element is a conducting cylinder of height L and diameter D . The bottom of the element is insulated from the ground plane by a base insulator, and the RF source (transmitter) is connected between the

bottom of the antenna and ground. In theory, the source is a "delta function" generator, which means that the base insulator is infinitely thin. In practice, the insulator should not be too thick. Coaxial cable is usually used to feed the antenna, with the centre conductor connected to the monopole and the shield to the ground plane.

The antenna's bandwidth is determined by the " L/D ratio", which is computed by dividing the element length, L , by its diameter, D , in consistent units. Dimensions specified in different units (feet and inches, for example) must be converted to the same unit before calculating this ratio. The term *bandwidth* (BW) means impedance bandwidth, defined here as the range of frequencies where the antenna's input VSWR is 2.5:1 or less. VSWR thresholds other than 2.5 can be used,

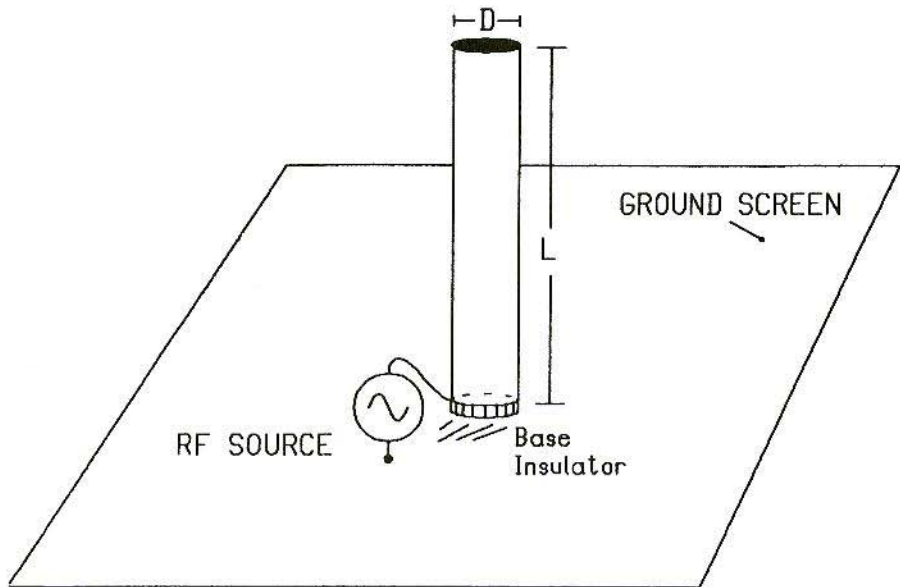

Fig.1: The Base-Fed Monopole on a Ground Screen

but this value is a good compromise for antennas used for both transmitting and receiving.

Fig.2 plots the monopole VSWR relative to 50Ω vs frequency for several L/D ratios. The abscissa is the ratio F/F_0 in percent, where F_0 in MHz is given by:

$$299.8 / (4L)$$

Note that L is in meters and F_0 is the frequency at which L is a quarter-wavelength in free space.

For example, if $L = 2.5$ meters, the free-space wavelength is:

$$4(2.5) = 10 \text{ meters}$$

and the corresponding frequency F_0 is:

$$299.8/10 = 29.98 \text{ MHz}$$

Many readers will recognise this as the formula:

$$f(\text{MHz}) = 300/\text{wavelength}(\text{m})$$

with the more accurate value of 299.8 replacing 300. Note that F_0 is not the monopole's resonant frequency, which is slightly lower than F_0 .

Fig.2 includes curves for L/D ratios ranging from 2500 to 3.125. The narrowest BW is slightly less than 15% of F_0 and corresponds to the highest L/D ratio of 2500. At $L/D = 12.5$, the BW increases to nearly 35%. When $L/D=5$, the BW reaches its maximum value of about 50% of F_0 , which is very large for a simple radiating element without any broadbanding components. As L/D falls below 5, the BW decreases. At $L/D= 3.125$, for example, it is about 38%.

Fig.2 also reveals an interesting distribution of bandwidth with frequency when $L/D = 5$. Slightly less



1/4-Wave Monopole on Gnd Plane

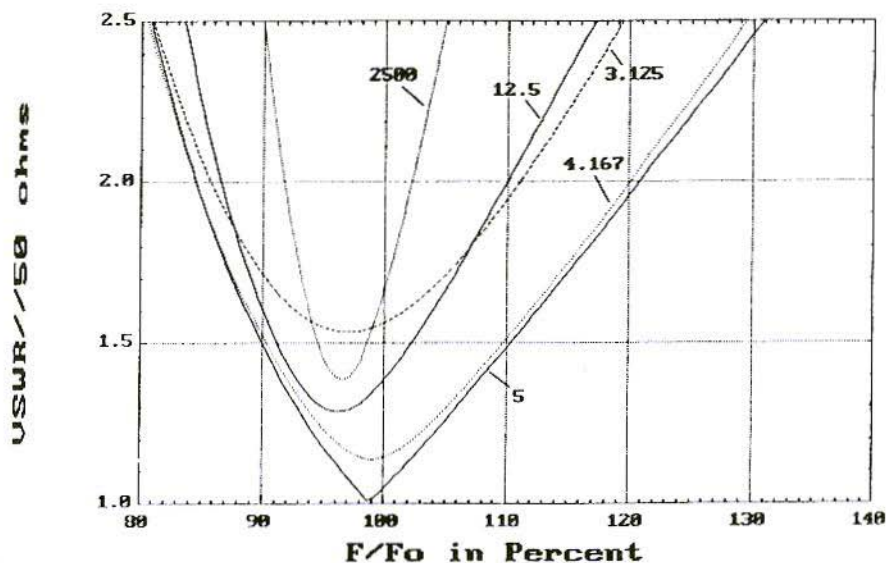

Fig.2: The Monopole's VSWR Characteristics

than $2/3$ of the available BW is above F_0 , and slightly more than $1/3$ below it. The lowest frequency where the VSWR is 2.5:1 is about $0.808F_0$, the highest $1.31F_0$, and the frequency for VSWR minimum is about $0.987F_0$.

These observations provide some simple, easy to remember and use rules for computing maximum monopole bandwidth (50Ω characteristic impedance, $VSWR < 2.5:1$):

- maximum BW occurs when the ratio of monopole length to diameter (L/D) is 5.
- the maximum BW is about 50% of the frequency at which the monopole is $1/4$ -wave long.

(c) the frequency of minimum VSWR is about 1.3% less than the $1/4$ -wave frequency.

(d) approximately $2/3$ of the BW is above the $1/4$ -wave frequency, and about $1/3$ is below it.

(e) the VSWR minimum is a near-perfect 1.009:1

As an example, a monopole 43cm long and 8.65cm in diameter will cover the frequency range 140.84 to 228.34 MHz (2 and 1.25 meter bands) with a $VSWR < 2.5$. Its $1/4$ -wave frequency is 174.3 MHz.

At HF, a monopole 4.35m long and 87cm in diameter will cover 13.92 to 22.57 MHz (20, 17 and 15 meter bands).

Monopole Input Impedance 1/4-wave, gnd plane

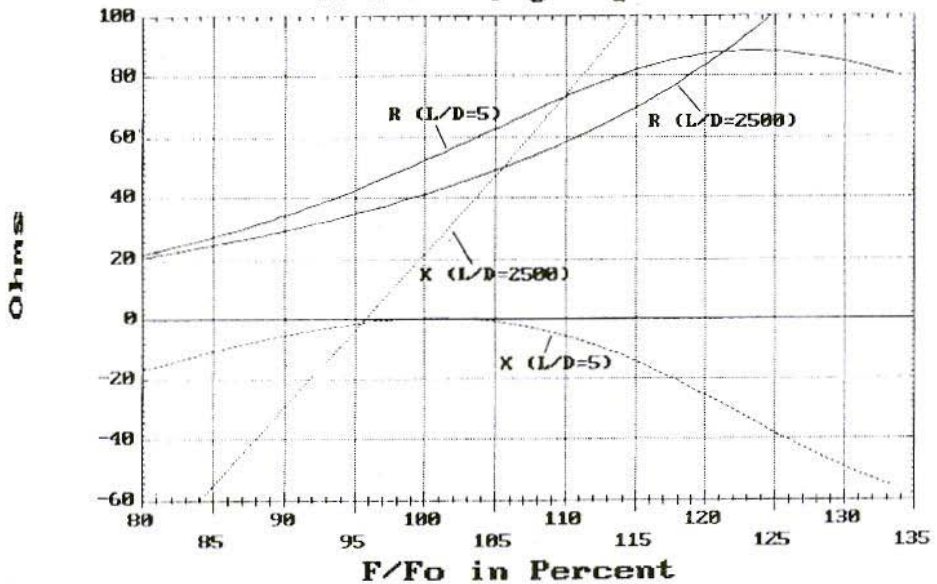

Fig.3: The Monopole's Input Impedance Characteristics

Other frequency ranges can be covered by varying the radiating element length and applying the rules above. Why the monopole's BW behaves this way can be understood by referring to Fig.3. The curves plot the input impedance (resistance R , reactance X) vs frequency for L/D ratios of 2500 ("thin" antenna) and 5 ("fat" antenna).

The resistance variation is similar for both antennas. R is comparable at most frequencies and gradually increases with increasing frequency, but when the frequency exceeds 120% of F_0 , the behaviour changes. The input resistance of the thin antenna increases quickly above $1.2F_0$, while the fat monopole's flattens out, then starts to decrease.

The input reactance behaves much differently. For the thin antenna, X increases almost linearly with

frequency, varying from -60Ω (capacitive) at $0.84F_0$ to $+100\Omega$ (inductive) at $1.15F_0$. The thin antenna is resonant ($X = 0$) at only one frequency near $0.96F_0$. In marked contrast, the fat monopole's reactance varies much more slowly over the entire range 80% to 133% of F_0 . While it is essentially capacitive (-16.5 to -55.5Ω), the antenna is actually resonant at two frequencies, approximately 99.87% and 101.67% of F_0 (not easily discerned in the plot).

Because the resistance and reactance, especially X , fluctuate more for the thin antenna, its VSWR increases more quickly with frequency than the fat monopole's. The gradual variation of input reactance when $L/D = 5$ is primarily responsible for the fat antenna's large impedance bandwidth.



Building fat monopoles at HF may require special construction techniques because the element diameter is large. Instead of a continuous conducting cylinder as the radiator (a former covered by metal foil, for example), an acceptable, easy-to-build alternative consists of wires parallel to the cylinder axis equally spaced around its circumference. This configuration is sometimes referred to as a "cage monopole", apparently because of the resemblance to a bird cage. The greater the number of wires, the better the approximation to a continuous conductor. As a rule-of-thumb, at least 8 wires should be used.

Another consideration in building any kind of monopole is the size of the ground plane. Theoretically, it should extend indefinitely in all directions; but, as a practical matter, a circular ground plane of a few wavelengths radius usually works well. Just as the cylindrical radiating element should be a continuous conducting metallic surface, the ground plane should also be continuous, but in many cases this is not practical. Ground planes of wire mesh or radial wires are frequently used, and they provide good performance if properly constructed. Mesh openings should be a small fraction of a wavelength, typically 1/8-wave or less. If radials are used, a large number is required, at least 16, preferably more.

The predicted monopole bandwidth performance has been verified experimentally, with theoretical and measured data showing excellent agreement, typically within 5%.

The measured BW for a 476 MHz antenna was actually somewhat greater than predicted. Of course, actual and computed performance will not agree well if modelling assumptions are violated. For example, if the ground plane is too small, or if continuous metallic surfaces are poorly approximated by wire structures, then the agreement between measured and theoretical data will be degraded.

Another potential source of error is making measurements through a long coaxial cable. Resistive losses artificially reduce the VSWR and increase the bandwidth at the cable input by dissipating some of the reflected power in an unmatched system. The VSWR reference point in this article is the monopole input, so that only data measured at the monopole's base can be compared directly.

These simple design rules should encourage experimentation with broadband monopoles throughout the amateur bands. Multiband or single band antennas are easy to design and build, and can be fed directly with 50Ω coax without an antenna tuner or matching network. This article also emphasises the importance of the L/D ratio in determining the bandwidth of wire radiators generally. Similar considerations apply to other wire antennas, such as dipoles, parasitic arrays like Yagis, or active arrays. Even though the monopole design rules are not directly applicable, paying attention to L/D should be a design consideration for any wire antenna, because selecting the right value may result in significantly improved bandwidth.



Dipl.-Ing. (FH) Klaus-Peter Müller

Lightning and Overvoltage Protection for Radio Equipment

Overvoltages caused by switching processes, atmospheric discharges and electrostatic discharges are amongst the most frequent causes of failures of highly sensitive electrical installations (which also include professional and amateur radio installations).

This danger can be forestalled by means of special protective measures and the purposeful use of overvoltage protection equipment.

1. MAIN STRUCTURE OF A RADIO INSTALLATION

Every radio installation consists of the radio equipment, perhaps connected up to a control unit (CPU) for rotator control, power amplifiers and/or reception amplifiers, and the actual aerial installation. We make a distinction here between the aerial tower on the roof of a building (Fig.1) and a free-standing

aerial tower (Fig.2). It is unimportant what kind of aerials are mounted on the aerial tower and how many there are.

2. EARTHING OF AN AERIAL INSTALLATION

DIN VDE 0855, Part 1 /1, 2/ requires the aerial support structure to be connected to the earthing installation through an earthing line made of copper, with a 16mm² cross-section (Fig.3). This measure is exclusively an earthing measure and offers no protection to people or property against the effects of lightning.

2.1. Earthing an aerial installation on a building

Should the aerial installation be on a building with no external lightning protection, it is advantageous to lead the earth connection away from the



Fig.1:
Lightning Protection for a Transmitter/ Receiver Installation and Ground-Mounted Aerial Tower

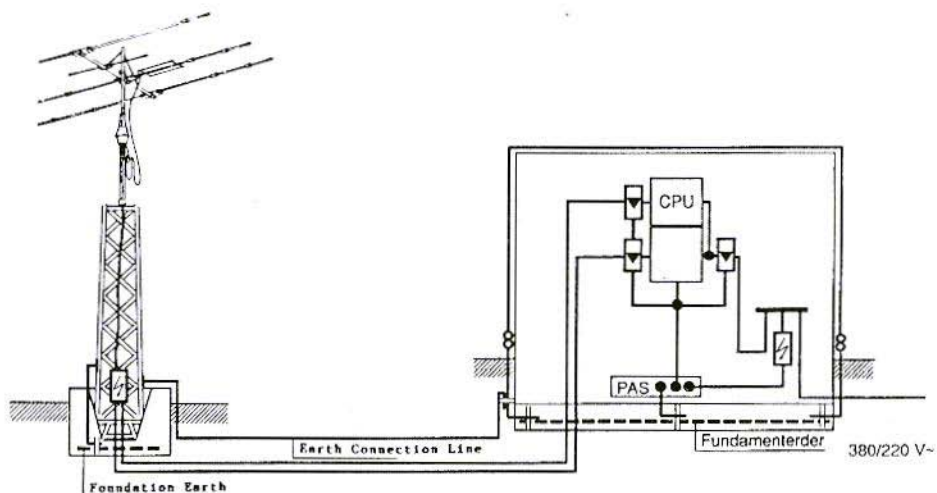
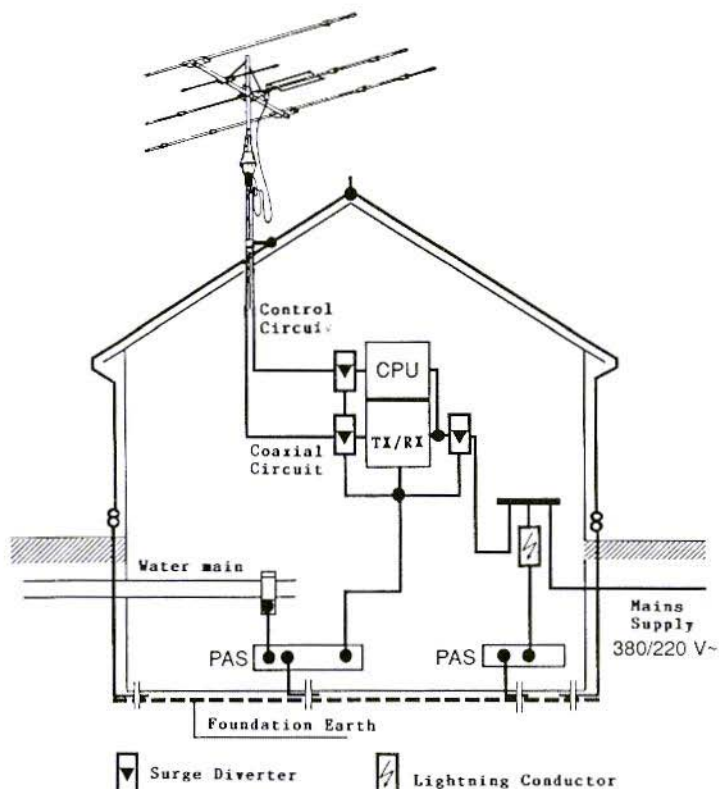

Fig.2: **Lightning Protection for a Transmitter/Receiver Installation and Ground-Mounted Aerial Tower**

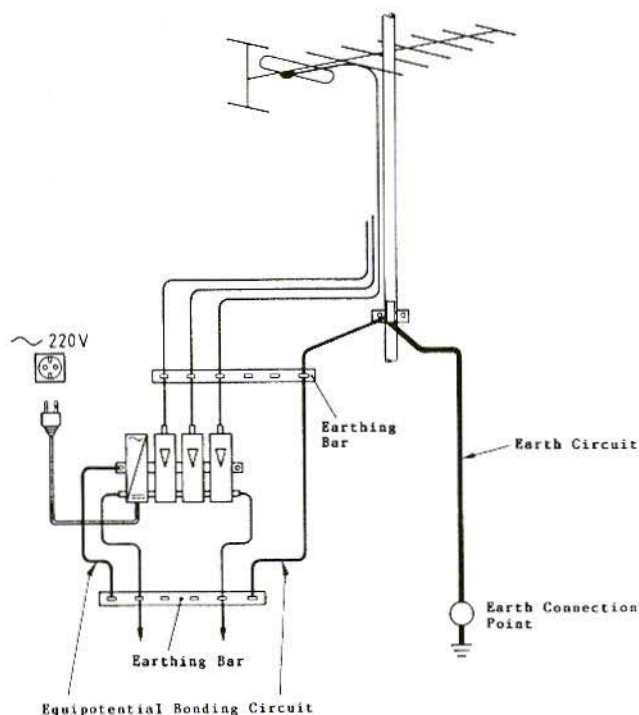

Fig.3:
Earth Balancing
and Equipotential
Bonding of Aerials
with Amplifier
Installations

aerial support structure over the roof and the external wall, and to connect it at ground level to an earthing rod (minimum length, 1.5m), a strip earth connection (minimum length 3m) or, if available, the lead-through terminal lug of the foundation earth connection.

Should external lightning protection be present on the building, in accordance with DIN VDE 0185 (3), then the aerial support structure should be connected to the existing interceptor equipment / lightning conductor by the shortest path. The normal 8mm diameter lightning conductor wires, made of steel, copper or aluminium, are to be used as a cross-section.

2.2. Earthing the aerial with a free-standing aerial tower

There are aerial tower masts made of wood, steel (tubular or latticework) and reinforced steel. As a rule, it can be assumed that the tip of the mast is fitted with a metal aerial tower unit construction. This Cartowerit construction simultaneously acts as an interceptor device for lightning, and must be connected to the earthing installation through a lightning conductor. In the case of a steel mast, the conductor is superfluous, but a connection with the earthing installation should be provided at the base of the mast. If aerial towers made of fibreglass-reinforced plastic (FRP) are used, a lightning conductor should be laid parallel to the FRP mast



3. PROTECTION CONCEPT

from the aerial tower to the earthing installation, in order to discharge the lightning component current from the coaxial screen.

For aerial installations mounted so that they can rotate, the aerial rotator should be flexibly bridged. Make sure that the rotary movement is not impaired mechanically.

Even if the aerial installation is earthed according to the guidelines, there is no protection against overvoltages in the case of a direct lightning strike or a near miss. The rapidly changing magnetic field of the lightning current induces overvoltages in all conductor loops. Such loops arise, for example, from the interaction of the aerial earthing circuit, the aerial feed, the rotator control and the mains circuit.

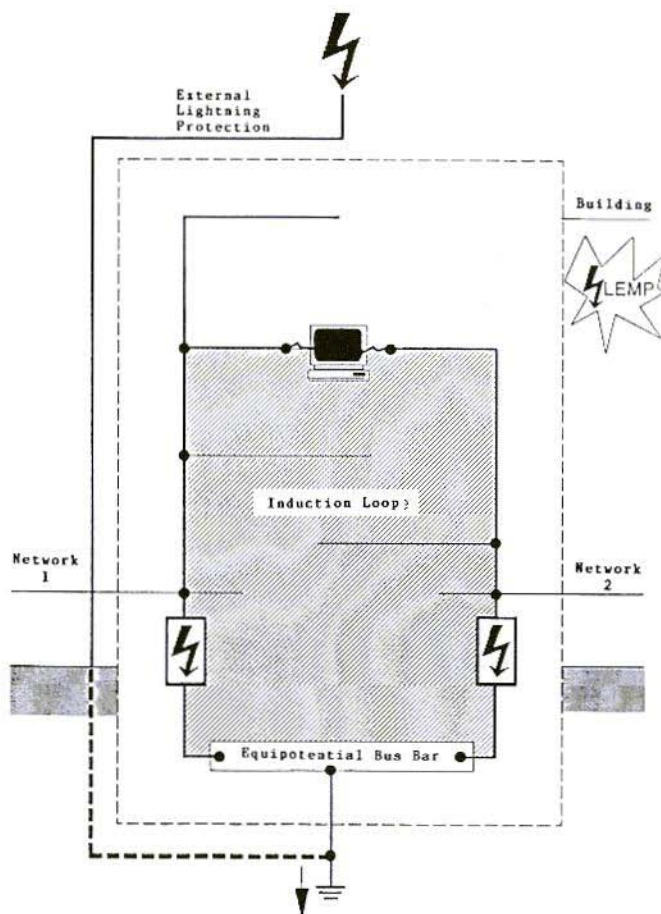

Fig.4:
Loop Formation
using Separated
Networks

Fig.5:
Dehnventil type VGA
280/4 4-pole
Lightning Conductor

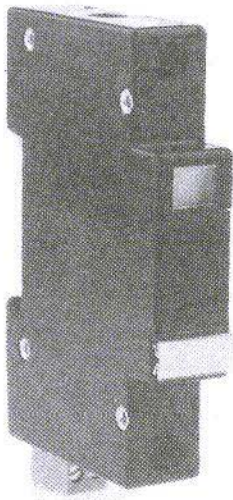
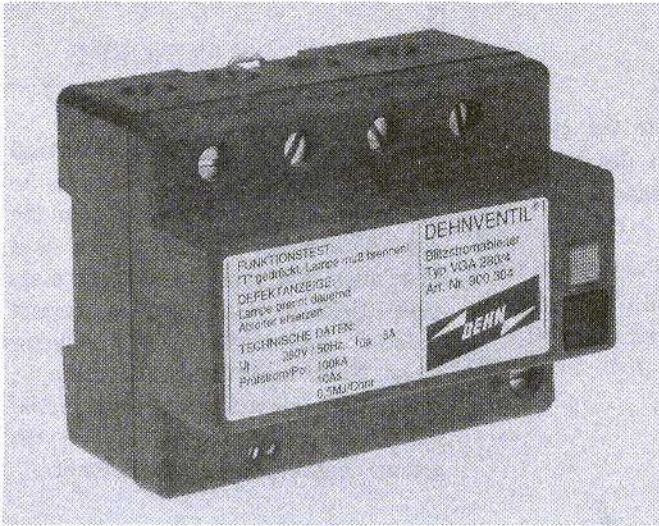

Fig.6: Type VM280FM Module
 Width Surge Diverter, with
 Telecomms Contact

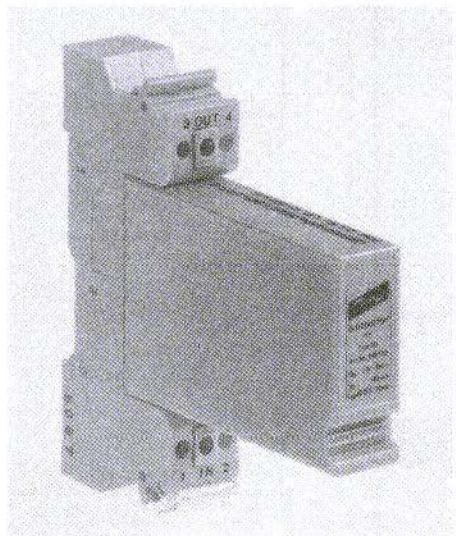

Fig.7: Type LD KT Blitzductor, for
 Rotator Control Circuit

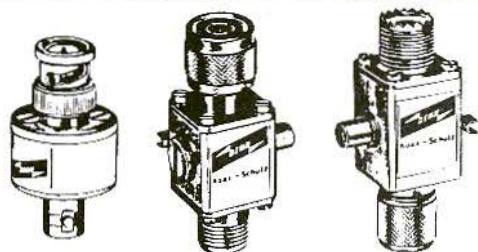

Fig.8:
Overvoltage Units for
50Ω Coaxial Cable

Formats and Technical Data

Daten :

Connectors	BNC	N	UHF
Protection Level	ca. 2 kV	ca. 600 V	
Rated Surge Current	15 kA	5 kA	
Max. Frequency	800 MHz	1,5 GHz	800 MHz
Max. Power	5000 W	2000 W	
Return Loss	≥ 20 dB		
Additional Damping	< 0,5 dB		

As we look outwards from a radio set, the aerial and network connections lie at the end of an open induction loop, which can occupy an area of many square metres (Fig.4). Should there be a direct strike, or even a lightning strike close by, overvoltages of several tens of thousands of volts, or some hundreds of thousands of volts, are induced in these loops, leading to the destruction of the radio equipment and/or the ancillary equipment.

The protection concept which protects radio equipment even if the aerial is directly hit by lightning provides the following measures (Figs. 1 and 2).

- * The support structure of the roof aerial or, on a free-standing aerial tower, the metallic latticework con-

struction, must be connected to the equipotential bus bar or the earthing installation by a connection which can carry a lightning current. A 16mm² copper cross-section is to be used.

- * The protective conductor of the network (PE) must be connected to the equipotential bus bar or the earthing installation in accordance with DIN VDE 0100 and DIN VDE 0800, Part 2 /4, 5/.
- * Overvoltage protection devices are used (6) which connect the weak current and mains networks transiently in the event of a parasitic coupling (protection bypass), and also provide a brief connection to the earthing installation.

The rise in the radio installation voltage as a consequence of a coupled-in lightning current can basically not be prevented, but excessively high potential differences can be avoided by the purposeful use of protective devices.

The following protective devices can be used here:

- Use a lightning conductor at the point where the mains circuit enters the building, or in the distribution of the power engineering network (e.g. Dehnventil, VGA 280) - Fig.5 (7)
- Surge diverter inserted directly into the network feed before the radio installation to be protected (e.g. VM 280 protector NSM or even S protector) - Fig.6 (7)
- Overvoltage protective device, inserted directly into the rotator control circuit before the control unit (CPU) (e.g. Blitzductor KT) - Fig.7 (7)
- Overvoltage protective device inserted directly into the coaxial circuit on radio equipment (e.g. LPN, LPU, LPB or ÜGK) (7)
- The choice here depends on the corresponding connection standard, type BNC, N or UHF (Fig.8). The protective devices can be remote-powered to some extent.
- Should the distance between the radio equipment and the free-standing aerial installation be rather large, additional protective devices should also be inserted into the circuits on the free-standing aerial carrier.

4. SUMMARY

The lightning and overvoltage protection concept presented here makes it possible to protect radio installations effectively, even from direct lightning strikes, distant lightning strikes and electromagnetically coupled-in overvoltages.

5. LITERATURE

- (1) DIN VDE 0855,
Part 1: Earthing Aerial Installations
VDE-Verlag GmbH, Berlin
- (2) Booklet no. 307: Earthing Aerial
Installations as per DIN VDE 0855
/ Part 1; Dehn + Söhne, Neumarkt
- (3) DIN VDE 0185, Part 1: Lightning
Protection Installations
DIN VDE 0185, Part 100 / Draft
10.87: Guidelines for Protecting
Buildings against Lightning
General Principles
VDE-Verlag GmbH, Berlin
- (4) DIN VDE 0100, Parts 540 and 410:
Earth Connections, Protective
Conductors, Equipotential Bonding
and General Protective Measures
VDE-Verlag GmbH, Berlin
- (5) DIN VDE 0800, Part 2: Earthing
and Equipotential Bonding
VDE-Verlag GmbH, Berlin
- (6) DIN VDE 0845, Part 1: Measures
against Overvoltages
VDE-Verlag GmbH, Berlin



Index of Volume 25 (1993)

Article	Author	Edition	Pages
ANTENNA TECHNOLOGY			
Doppler Direction Finder with Improved Characteristics	Detlef Burchard	1993/1	2 - 18
An Antenna for all Meteors	Richard A. Formato K1POO	1993/4	227 - 230
AMATEUR TELEVISION			
Addenda and Comments on the Article: A 10 GHz FM-ATV	Guenter Sattler DJ4LB	1993/4	237 - 240
Transmitter with Dielectric Resonator (Issue 1992/2)			
DSP TECHNIQUES			
Programming the DSP Computer	Gunther Hofmann DK2TX	1993/3	178 - 180

**WEATHER SATELLITE RECEPTION**

A simple Panorama add-on for
Weather Satellite Receivers

Dr. Freek M. Schimmel 1993/2 74 - 79

Observation of Scintillations
while Receiving Meteosat

Detlef Burchard 1993/4 231 - 236

6m BAND

SSB Transceiver for 50 MHz using
50Ω Modules
Part-2

Wolfgang Schneider
DJ8ES 1993/1 48 - 57

SSB Transceiver for 50 MHz using
50Ω Modules
Part-3 (Conclusion)

Wolfgang Schneider
DJ8ES 1993/2 101 - 108

2m BAND

28/144 MHz Transverter

Wolfgang Schneider
DJ8ES 1993/4 221 - 226

MEASURING TECHNOLOGY

A Digital Framestore for the
Spectrum Analyser;
alterations and additions

Dr-Ing. Jochen Jirmann
DB1NV 1993/1 44 - 47

A Simple dB-Linear S-Meter
for Microwave Applications

Erich Zimmermann
HB9MIN 1993/2 117 - 119



MEASURING TECHNOLOGY (Cont)

Measurement Aids for the UHF Amateur	Michael Kuhne DB6NT Dr.J.Jirmann DB1NV	1993/4	207 - 213
---	---	--------	-----------

Assembly Instructions and Experiences with the DB1NV Spectrum Analyser Design	Joachim Danz DL5UL	1993/4	241 - 250
---	-----------------------	--------	-----------

FUNDAMENTALS * NEW TECHNOLOGY

Improvement of the Intermodulation Performance of modern Amateur HF Receivers	Dr.-Ing Jochen Jirmann DB1NV Wilfried Hercher DL8MX	1993/1	38 - 43
---	--	--------	---------

MES-FETishism III	Detlef Burchard	1993/2	66 - 72
-------------------	-----------------	--------	---------

Theory and Practice of the Frequency Synthesiser Part-1	Dr.-Ing Jochen Jirmann DB1NV	1993/2	80 - 100
---	---------------------------------	--------	----------

Output Wiring of GaAsFET Amplifiers	Eugen Berberich DL8ZX	1993/1	120 - 122
--	--------------------------	--------	-----------

Carrier Suppression in the Ring Mixer	Dipl.-Ing J.v.Parpart	1993/3	130 - 138
--	-----------------------	--------	-----------

Theory and Practice of the Frequency Synthesiser Part-2	Dr.-Ing Jochen Jirmann DB1NV	1993/3	139 - 157
---	---------------------------------	--------	-----------

**FUNDAMENTALS * NEW TECHNOLOGY (Cont.)**

EMC - and its consequences
Part-1 Dipl.Phys. Northart Rhode 1993/3 181 - 188

EMC - and its consequences
Part-2 Dipl.Phys. Northart Rhode 1993/4 214 - 220

MISCELLANEOUS

High stability, Low-Noise
Power Supply Volker Espel 1993/1 19 - 37

Poor man's CAE 1 & 2
Public Domain Software
Development Programs for the
IBM PC The Editors 1993/1 58 - 60

The Pont PSA-100 FFT
Spectrum Analyser (Review) Mike Wooding 1993/2 123 - 124
G6IQM

CW Call Sign Transmitter Wolfgang Schneider 1993/3 181 - 188
DJ8ES

Power Supply Unit for
Travelling-Wave Tubes Andreas Schaumburg 1993/4 194 - 206
DF7ZW

The British Amateur Television Club

The foremost association in the world, for anyone anywhere in the world, who is interested in Amateur Television.

CQ-TV the quarterly journal of the BATC is recognised as the most professionally produced amateur publication of its kind.

Join the BATC and receive *YOUR* copy of CQ-TV

Membership is *only* £9.00 per year. Send your Sterling cheque or credit card details (non-UK only) to:

BATC, Grenehurst, Pinewood Road, High Wycombe, HP12 4DD, UK



Matjaz Vidmar, S5 3MV (ex YU 3 UMV, YT 3 MV)

A DIY Receiver for GPS and GLONASS Satellites

Part-1

1. BACKGROUND INFORMATION ON GPS AND GLONASS

Next to the amateur radio satellites, the most interesting satellites are weather satellites. Radio amateurs have already succeeded in building equipment to receive images from all known weather satellites and for all transmission standards in use, and it was also radio amateurs who were the first to receive TV satellite signals, using particularly small aerials, some time before these became mass-produced articles.

It is already more than 30 years since the first navigation satellites were launched into the cosmos. But it is only in the last few years that satellite navigation and positioning have

become really popular, with the introduction of more reliable, more accurate and more user-friendly systems, such as the American Global Positioning System (GPS) and the Russian GLObal Navigation Satellite System (GLONASS).

Each system will eventually replace a whole range of ground-supported navigational aids. As a useful by-product, they give anyone with the right equipment a very precise time base (100ns) and a very accurate frequency (10^{-12}).

Originally both systems, GPS and GLONASS, were designed for military purposes. But since then there have been considerably more civilian than military users.

GPS navigation receivers (soon to be joined by combined GPS/GLONASS receivers) can be manufactured to be as handy, user-friendly and favourably



priced as modern portable radio sets.

These pieces of equipment can measure their three-dimensional position with an accuracy of app. 50 metres at any point on the Earth's surface. So these sets are of interest, not only to leisure-time pilots, lorry drivers or mountaineers, but to radio amateurs too!

Apart from the challenge of building your own satellite receiver, radio amateurs can also put GPS and GLONASS signals to other uses. Probably the simplest application for a GPS or GLONASS receiver is to use it as a high-precision frequency source. Exact timing and synchronisation can be used, for example, for modern transmission techniques, or for precise experiments concerning the propagation path and the propagation mechanisms of radio waves.

Finally, this system can also be of use in the positioning and alignment of high-gain microwave aerials.

This article will be split into several parts: I shall begin by describing the satellites themselves and their radio signals. Next will come a description of the way a GPS or GLONASS receiver works. This will be followed by assembly instructions for a DIY GPS or GLONASS receiver, together with an explanation of the operational software.

These receivers can be built in two versions - as independent portable receivers with a small keyboard and a liquid crystal display screen, or as add-ons with plug-in modules for the DSP computer (1) (2).

2.

DESCRIPTION OF GPS & GLONASS SYSTEMS

2.1. Radio navigation background

Like all areas of electronics and radio engineering, radio navigation is developing very fast.

The basis on which all radio navigation systems operate is that extensive research has been done into the propagation mechanisms of radio waves, and that the propagation speed of radio waves is normally close to the speed of light in free space. Systems working with radio waves normally have a sufficiently extensive range to make it meaningful to use them for determining locations, speeds and positions.

In the end, all measurements involving radio waves, whether we're talking about position finding, and therefore directional search, measuring running time, phase measurement or the measurement of the Doppler frequency shift, can be carried out - on the user's side, at least - using simple and reasonably-priced technical aids.

Earlier radio navigation systems made use of the directional effect of the receiver aerial, the transmitter aerial, or both. In both kinds of system, the main cause of measurement errors was the lack of precision in the alignment characteristic of the aerial. Since the measured variable consists of an angle, the positional error increases linearly with the distance of the user from the position of the navigational reference. These systems are therefore very much

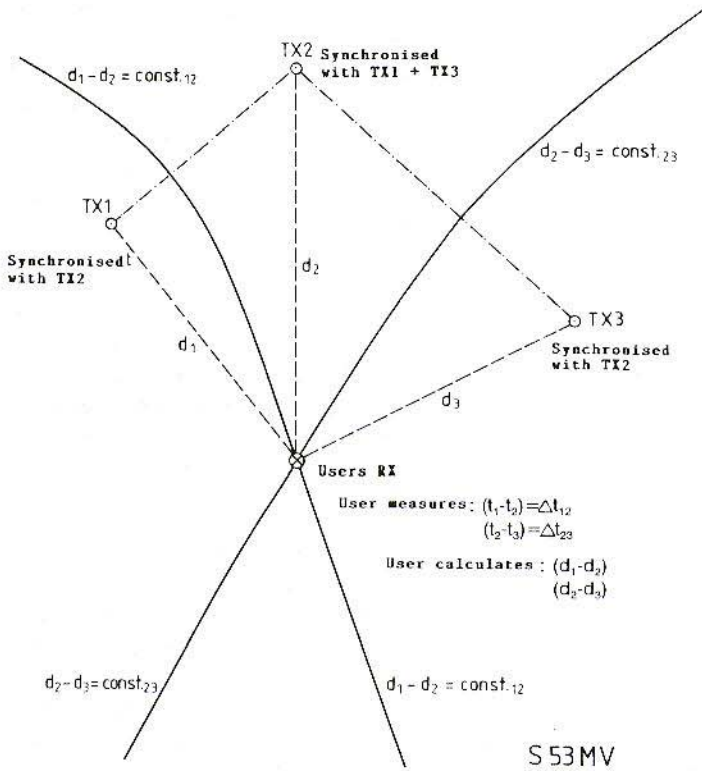

Fig.1: The Principle of Hyperbolic Navigation

limited with regard to their capability of use - in their range or precision, so to speak. They are, of course, outstandingly suitable for one application - getting the user to a specific point, for example guiding an aircraft onto the runway by means of an instrument landing system (ILS).

Time and frequency are definitely the physical variables which can be measured with the greatest accuracy. If the propagation speed and propagation conditions of specific radio waves are known, the distance can be calculated in the simplest way by measuring the

running time. The absolute precision of such distance measurements just does not depend on the order of magnitude of the distance to be measured, irrespective of the uncertainties of the propagation speed of the radio waves used on this path.

For this reason, all high-precision radio navigation systems which are suitable for long distances are based on measurements of running time or path difference and/or on the derivatives of these variables in relation to time, also known as the Doppler frequency shift.



The simplest way to determine the distance to a known location is to install a converter there, transmit a signal and measure the running time until the response signal is received. Although systems of this kind are indeed in use (e.g. DME for civil aircraft), they do have their limitations, since each user has to have a transmitter as well as a receiver.

In the civilian sector, this system has the additional disadvantage that the equipment has to be licensed, and the military try and avoid transmission as much as possible, so as not to give away their position, which must be kept secret. But the biggest handicap is that only a limited number of people can use this system, for the simple reason that they can only use it one at a time.

As regards the user side, we could do without the transmission equipment if we could use some other means to achieve and maintain the synchronisation of the two sides.

For example, both sides, the user and the navigation transmitter, could be equipped with high-precision time standards, e.g. an atomic clock. The user would merely have to synchronise his or her clock at a known location, and then take this clock to the unknown location as an aid to measuring the running time.

But since atomic clocks are a little clumsy and expensive, we need to find a considerably simpler solution, which needs nothing but a receiver.

Such a system must consist of a whole series of synchronised transmitters, as shown in Fig.1.

However, since the precise time is not known on the receiver side, we can not measure either the delays or the distances d_1 , d_2 , d_3 , etc. to the transmitters TX1, TX2, TX3, etc. directly. We can measure only the varying arrival times of the different transmission signals. These time differences directly correspond to the differences in distance.

The multitude of points for a given distance difference for two preset points produce a hyperbola (looked at in two dimensions) or a hyperboloid (looked at in three dimensions). Here the two transmitters are in the foci of the hyperbola (or the hyperboloid).

For two-dimensional navigation (location-finding), signals must be received from at least three synchronised transmitters. For example, the hyperbola $d_1 - d_2 = \text{const. } 12$ can be plotted directly on a map from the difference in the running times measured for TX1 and TX2. The hyperbola $d_2 - d_3 = \text{const. } 23$ can be plotted correspondingly on the map from the difference in the running times measured for TX2 and TX3. The intersection point of the two hyperbolas is the unknown location of the user!

For three-dimensional navigation, signals must be received from at least four synchronised transmitters. The three different running time differences then give three hyperboloids. The surfaces of two hyperboloids intersect in a curved line, which intersects with the surface of the third hyperboloid at a single point. This corresponds to the three-dimensional position of the user.



Should even more transmitters be available, we can seek out the three or four transmitters which give hyperbolas (hyperboloids) which intersect almost at right angles. The remaining transmitters can then be brought in to check for possible errors or ambiguous solutions, since curved lines and surfaces can produce more than one point of intersection.

Hyperbolic navigation systems were originally structured as ground-supported systems in the medium and long-wave ranges, e.g. Loran, Decca or Omega. But since these systems operate from the ground upwards, no three-dimensional position-finding can be carried out - only a reliable determination of geographical latitude and longitude. For it to be possible to measure the height as well, a transmitter must be as far above or below the receiver as possible, or at least outside the horizontal plane of the user.

Radio navigation systems installed on the ground use relatively low frequencies of the radio spectrum to obtain as wide a range as possible, and simultaneously to avoid undefined propagation through space waves. For example, Omega uses a frequency range between 10 and 14 kHz, and thus, using only eight transmitters, covers the entire surface of the Earth!

Longwave navigation systems were developed at a time when digital computers were not easily available. And navigation on two planes, using transmitters at fixed locations, requires only a minimum of calculation from the user. Moreover, the multiplicity of

hyperbolas for each transmitter pair, including the necessary corrections for propagation anomalies, can be plotted directly for use on corresponding maps.

One of the first applications for artificial satellites was radio navigation. Naturally, for their part, artificial satellites needed radio navigation too, in order to estimate the power of the carrier rockets and determine the satellite's final orbit. Moreover, space is an ideal location for navigational transmitters - firstly, an enormous range is available for VHF and for the higher frequencies, and secondly the propagation of the radio waves is calculable and the influence of the continuously changing ionosphere is insignificant. Finally, the locations of the navigation transmitters in space can be selected in such a way that three-dimensional position-finding is possible all over the world.

Since originally satellites could be used only in near-Earth orbits, the first navigation satellites, such as the American Transit satellites or their Soviet counterpart, Cicada, were launched into low Polar orbits (about 1,000 km. up). Since a satellite in a near-Earth orbit travels along its path very quickly, even a single satellite can be made use of for position-finding. The accuracy of a quartz watch is sufficient to measure the few minutes required by a satellite for an overflight. The change in the satellite's position roughly corresponds to a quantity of transmitters at various points along its flight path.

In practise, we measure the Doppler shift of the satellite signal for a certain time and then use the satellite path data



The most serious disadvantage of navigation satellites in low orbit is the fact that we have to wait for a satellite to fly over, and we then need several minutes for the measurement. Finally, our own speed and course must be known precisely, so that they can be taken into account in determining our position. Several satellites are needed for a position to be determined very rapidly. If at least four satellites are visible at various points in the sky, our own location can be determined immediately as regards longitude, latitude and height, without having to wait for the satellites to move through the sky.

To keep the number of satellites required as low as possible, they must be put into higher orbits. The American GPS satellite navigation system and the Soviet GLONASS system are intended eventually to cover the entire surface of the Earth, each having 24 satellites, including reserve satellites in space. At least four of the satellites from either system should be visible anywhere on Earth, distributed over the sky in such a way as to make three-dimensional navigation possible.

Nor should we forget the enormous amount of calculations required to carry out three-dimensional position-finding using satellites. The fact that the satellite's position is constantly changing means a computer must be used.

Perhaps this explains why satellite navigation is only now becoming popular. Suitable satellites have indeed been available for thirty years - but reasonably priced computers have not.

2.2. Equations for satellite navigation

In order to understand satellite navigation systems (SNSs), we must first look at the mathematical background to satellite navigation. First we must define a co-ordination system. Most satellite navigation systems operate by means of a right-handed Cartesian co-ordinate system, like the one shown in Fig.2. The co-ordinate system is rigidly connected to the Earth and is thus a rotating co-ordinate system, and thus deviates from the inertia co-ordinate system for Kepler elements used for most satellites.

The zero point of the co-ordination system normally lies in the centre of the Earth. The Z axis corresponds to the rotational axis of the Earth and points to the North. The X and Y axes are in the plane of the Equator, with the Z axis pointing in the direction of the Greenwich meridian, whilst the Y axis is orientated in such a way that a right-handed orthogonal co-ordinate system is produced.

Naturally it is also possible to convert the data into a more popular co-ordinate system, e.g. into degrees of latitude and longitude, plus height above sea level (height above surface of an ellipsoid). These conversion procedures are always based on the final result, since most of the calculations required for position-determining in navigation receivers can be carried out considerably more easily in a Cartesian co-ordinate system.

Finally, we should not leave out of our reckoning the fact that there are various co-ordinate systems in use with the same basic definition. Meanwhile, SNSs

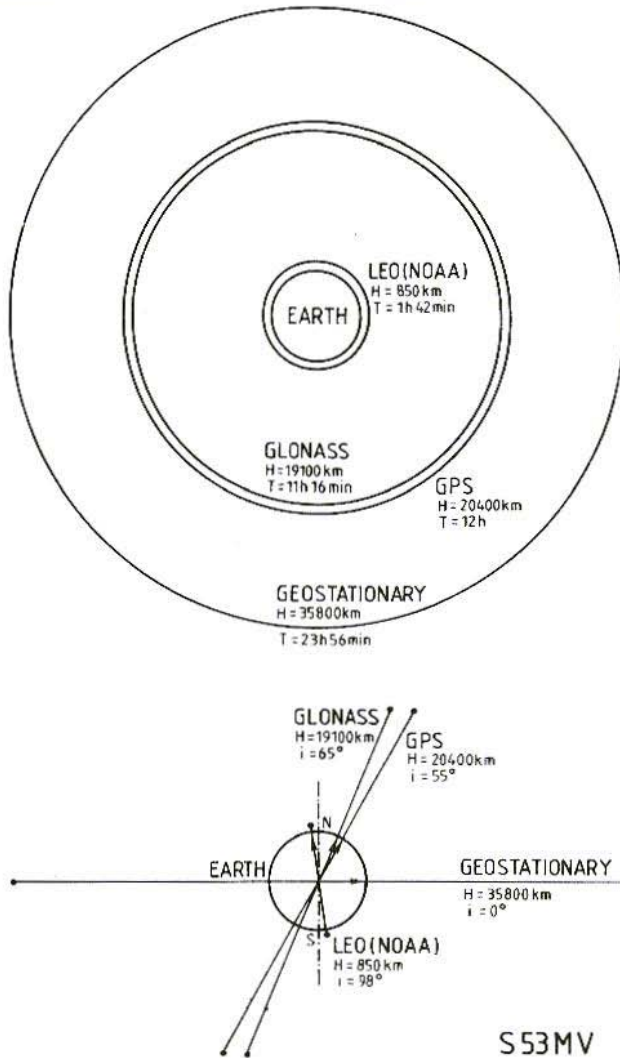

Fig.3: Height and Angle of Inclination of Orbits of GPS and GLONASS Satellites

have improved the absolute positioning accuracy until it is now within one metre, as a result of which the small discrepancies in the different local geographical co-ordinate systems become noticeable. Thus GPS uses the WGS-84 co-ordinate system and

GLONASS uses SGS-85. The differences between the two systems add up to a difference in position of about 10 m. in the East-West direction and the same in the North-South direction for the author's location in Central Europe.



If we use a vector representation, navigational equations can be expressed much more simply. Using a three-dimensional Cartesian co-ordinate system, it can easily be understood that an individual vector describes three independent variables.

The navigational equation for differences in running time consists merely of the area vectors which give the positions of the transmitters (satellites) and the receivers (users). The differences between users and satellites are calculated as absolute values from the area vector differences. On the other side of the equation stands the difference in running time measured, multiplied by the speed of propagation of radio waves (c).

If the user's location is unknown, which means the area vector is too, three variables of the scale are missing, and three independent running time difference equations have to be solved to calculate them. At least four transmitters (and thus four visible satellites) are needed to solve these three equations. The absolute value of a vector is a non-linear function, which is determined by calculating squares and roots. These equations are thus solved, either by numerical iteration or analytically (3).

A navigation equation for calculating the Doppler shift differential contains both area vectors and speed vectors. The speed differential for the Doppler frequency shift must be calculated first, so that the projection of the speed differential vector onto the direction of propagation of the radio waves can then be calculated. Vector projections are

calculated by determining the scalar product of two vectors.

On the other side of the equation, we have the Doppler frequency shift as a dependent variable, the absolute value of which is obtained by dividing by the carrier frequency f_0 . The relative frequency differential can then be converted into speed values by multiplying the variable by the speed of propagation (c).

The Doppler frequency shift navigation equations contain both the positional vector and the speed vector of the user. This can mean up to six unknown scalars. But since we normally do not have six independent equations, the following route can be taken:

1. If the location is already known from the equations for calculating the running time difference, the user's speed vector can be determined using three independent equations to calculate the Doppler frequency shift.
2. If the user's speed vector is known, or if the user's speed is zero (in stationary operation), then the location can be determined using three independent equations for calculating the Doppler frequency shift.
3. Various combinations of the equations for running time difference and Doppler frequency shifts are possible.

Apart from the visibility problem, the navigation equations impose additional restrictions and requirements on the orbital paths of the navigation satellites. The accuracy with which the location

or speed is finally determined depends on the construction of the equation system.

If the equation system is badly selected, every measurement error appears enlarged even in the final result. In terms of geometry, a badly selected equation system is tantamount to having intersections of lines and surfaces at very shallow angles.

The impairment of accuracy due to an unsuitable equation system is referred to as GDOP (geometrical dilution of precision). Naturally, satellite orbits must be selected in such a way that the GDOP is as small as possible for the biggest possible number of users. But since we are dealing with non-linear equations, the GDOP alters with the location of the user. Users must therefore select four satellites which are favourable for them. It is certainly absolutely possible that several satellites will be "visible", possibly even at a rather high elevation, which also increases the GDOP.

The most remarkable case of a large GDOP when running time difference equations are used occurs when two navigation satellites are close to each other in the sky. A more common case is when all four satellites are in almost the same plane. For the same reason, a geostationary orbit is also unfavourable for navigation satellites. A further disadvantage would seem to be the low relative speed of the satellite, since the

equations for calculating the Doppler frequency shifts are not designed for cases where the positional vector is multiplied by very small numbers.

2.3. The GPS & GLONASS satellite systems

GPS and GLONASS are the first satellite systems which require the simultaneous operation of several satellites. Other systems are already operating with one satellite, and each one improves the system further.

In the GPS and GLONASS systems, the satellites have to be synchronised and can in all cases operate only in sets of at least four satellites visible to the user. The requirements for a low GDOP should not be forgotten here.

GPS and GLONASS satellites have been put into similar orbits. Fig.3 compares the orbits of GPS and GLONASS satellites with other known satellite orbits, such as the geostationary or near-Earth contra-rotating Sun-synchronised orbits.

GPS and GLONASS satellites have circular orbits, with an inclination of 55 - 65 degrees and an orbital period in the order of 12 hours, which corresponds to a height of app. 20,000 km. (about 1½ Earth diameters).

(To be continued)



Eugen Berberich, DL 8 ZX

Suppression of Interference to 70cm ATV by using a Highly Selective Notch Filter

In the 70cm band, ATV operation is scarcely possible any longer without interference from other stations. Sources of radio noise with fixed

frequencies can be tuned out in the intermediate frequency stages using highly selective notch filters.

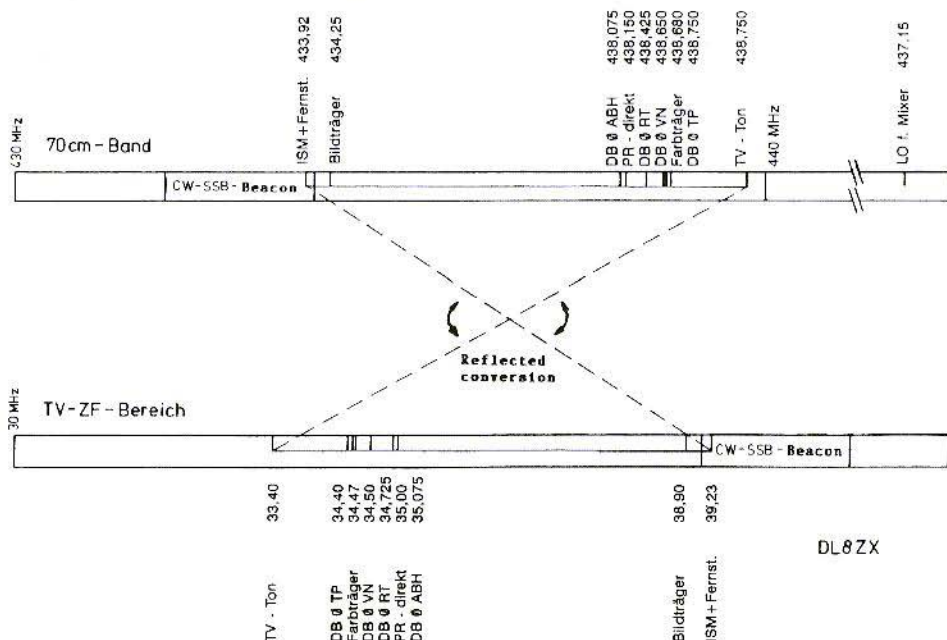

DL8ZX

Fig.1: 70cm Band converted to TV IF



1. INTRODUCTION

With the 70cm band covered with transmissions, interference-free ATV operation is scarcely possible in built-up areas. Interference from packet radio and relay stations operating in the ATV range is unavoidable (Fig.1).

These interfering carriers can not be tuned out directly on the UHF frequency! If we presuppose an input section which can resist saturation, such as frequency-stable oscillators, then the annoying moiré effect and the blocking up of the TV receiver can be suppressed in the intermediate-frequency stages using active notch filters and passive crystal stop filters.

The removal of frequency fractions in the intermediate frequency stages naturally reaches its limits when the in-

terference frequencies fall in the image, sound, or colour carrier range. The effective suppression of unwanted signals is directly dependent on the notch depth and notch width of the filter. Narrow-band signals without modulation can be efficiently filtered out using crystal notch filters of the type described below. For modulated signals, these filters are too narrow, and band filter formats are required.

Particularly persistent sources of radio noise are, for example, packet radio stations, since these are frequently very widely modulated (TTL signals without low pass filtering of the modulation input of the transmitter).

The immediate cause of the development work described here is, indeed, such a station. It was, in fact, the DBOABH digipeater, which was only about 300m away from my QTH (Fig.2).

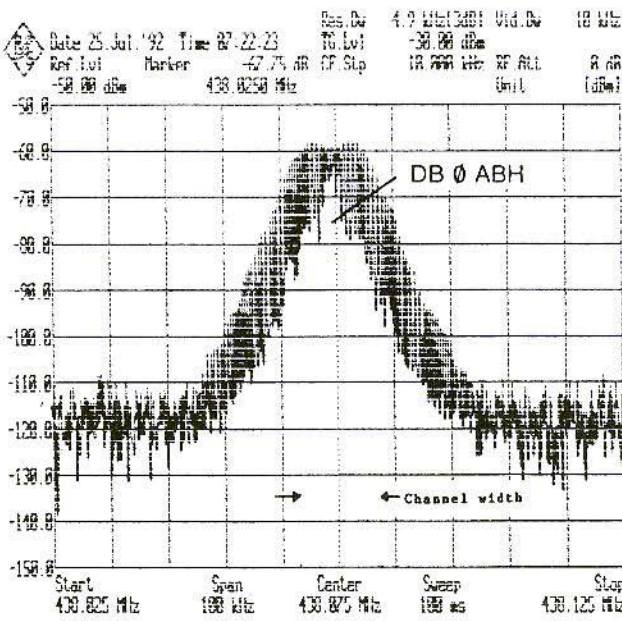

Fig.2: Spectrum of Digipeater DBOABH

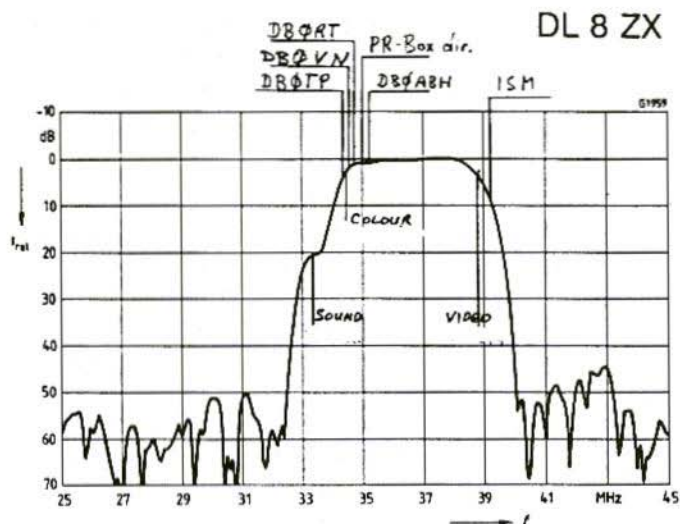

Fig.3:
IF position of
Jamming Transmitter

The high field strength of this station at my QTH put a stop to any kind of ATV activities in the 70cm band. FM relay stations, by contrast, could be efficiently suppressed using a crystal stop filter with a band filter curve form, due to their low field strength and the fact that they were modulated within a narrower band. Interference by ISM equipment at 433.92 MHz can be damped by about 10dB, even using the intermediate frequency filter (Fig.3).

As already mentioned above, stable oscillations are a precondition for the use of the notch filters described. This applies to the TV receiver (TV-RX) as well as to the "jamming transmitter".

It was for this reason also that converter operation was not selected. Instead, there is direct conversion to the usual TV intermediate frequency using a crystal oscillator, so that fewer oscillators are involved.

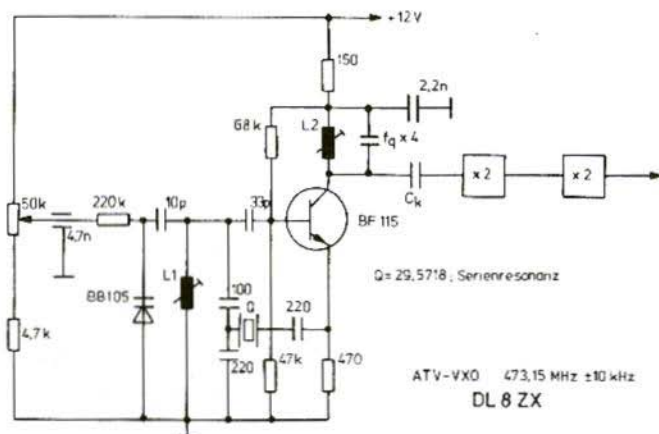

Fig.4:
Circuit Diagram of
an extendable
Converter Oscillator

Since now every oscillator is subjected to frequency oscillations, including from the "jamming transmitter", the converter oscillator was made with a variation range of ± 10 kHz (Fig.4); this makes optimum levelling possible.

If several unwanted signals are present at the location, you have to insist on the operator's keeping to as precise a frequency for the source of radio noise as possible, since the crystal notch locations can only be moved jointly through the converter oscillator.

The quality of TV transmission is not influenced by the slight frequency displacement.

2. THE CIRCUIT DESIGN

Coupling the intermediate frequency signal into a normal TV-RX requires a modification in the intermediate frequency section of the TV receiver. The

basic requirement applying is that the TV chassis must be free of mains potential (isolation transformer or TV with appropriate switch-mode power pack).

If this requirement is met, a 75Ω intermediate frequency input can be created. The driver amplifier of an OFW filter is suitable for this. As a rule, it consists of a broad-band, stabilised feedback transistor amplifier (previously there was very little selection available), the input for which has been established at 75Ω by negative feedback (Fig.5).

It is possible to switch between the two signal sources, the TV tuner and the ATV signal, using a suitable high-frequency relay. When the relay is at rest, the TV RX operates normally. The turn-on voltage goes from the ATV converter along the coax cable to the relay, through a high-frequency/DC shunt. This switches on the ATV input as soon as the converter is switched on (Fig.5).

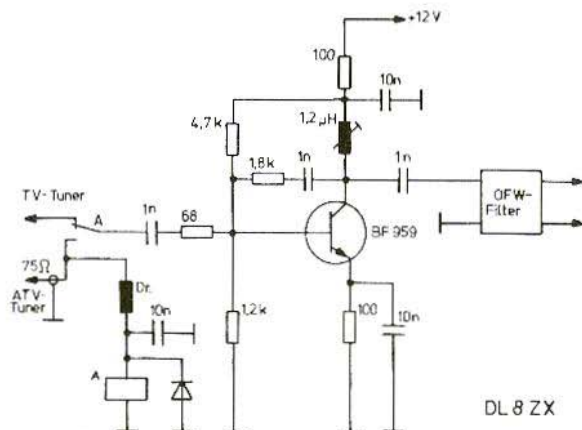

DL 8 ZX

Fig.5:
Modifications to the
IF stages of a TV
Receiver

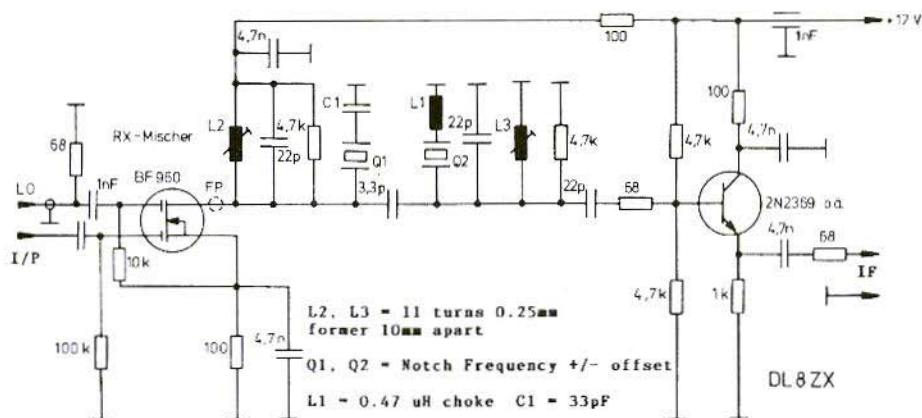

Fig.6: Notch Filter with 2 Crystals, wired downstream from the Receive Mixer

3. VARIOUS NOTCH FILTERS

Three different types of filter are described below, two of which are capable of tuning out most interference from a strong, wide source of radio noise - in the author's case, the PR digipeater referred to above.

3.1. Filter "A"

This crystal stop filter can be relatively simply built into any ATV tuner, even on converter levels (band-1). Standard tuner outputs (mixer stages) are matched to the intermediate-frequency amplifier using LC matching elements.

Previously, in my DIY converter, I was already using a band filter matched to the IF with a corresponding bandwidth, which was obtained through damping, followed by a buffer stage leading into a collector circuit. This creates a low-feedback 75Ω output, so that I can work with cables of any length.

The LC band filter referred to is outstandingly suited to the incorporation of one or two crystal stops for the absorption of unwanted frequencies in the intermediate frequency range.

The circuit described below can also be used with other converters, e.g. to suppress signals from public or private mobile radios or Euro-beeps (Paggers?).

It is well known that crystals have a series resonance and a parallel resonance. Notch filters use the series resonance, at which the crystal has a very low loss resistance, within a range of between 10 and 100Ω, depending on quality and frequency. The holder capacitance of app. 6pF is wired in parallel to this.

If we now add one crystal into the resonant circuit at the mixer output of the band filter described (Fig.6) in each case, then the holder capacitance increases from 6pF to the resonant circuit section capacitance. The resonant circuit capacitor required must be reduced

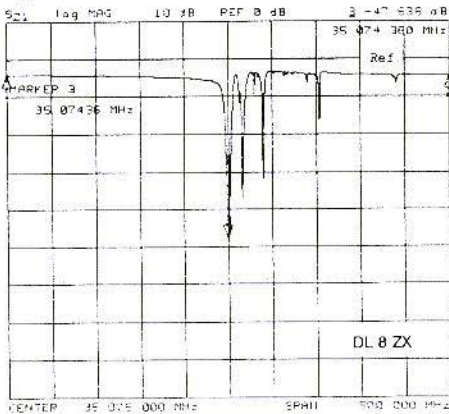

Fig.7: Transmission Curve with one Crystal

by this value. The resonant circuit present would thus be in resonance as before, up to the series resonance range of the crystal introduced.

Here a tremendous drop takes place in the transmission curve, which becomes visible only with good spectra, using slow sweep speeds and with low interference dispersion!

As is well known, voltages behave like resistances. Here the dampened circuit resistance of the band filter lies in the $k\Omega$ range (app. $2k\Omega$), and the series resistance of the crystal at app. 20Ω .

This gives us the following damping at the notch point:

$$a = 20 \log (Z \text{ band filter} / R_s \text{ Crystal})$$

$$= 20 \log (2k\Omega / 20\Omega)$$

A reduction of 40dB is thus brought about at the notch point (Fig.7).

If the crystal in the second circuit works on the same frequency, then a notch depth of 80dB can be obtained (Fig.8). This high damping level can be obtained because of the looser coupling

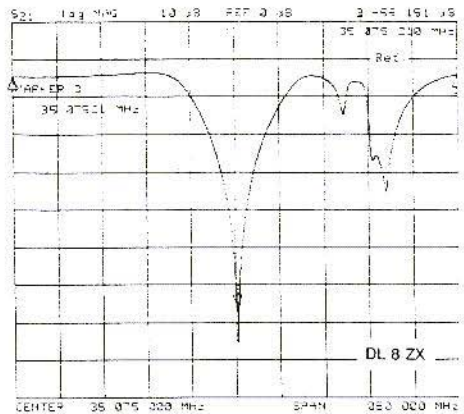

Fig.8: Filter "A" with two Crystals of the same Frequency

of the crystal, as against filter "B". The notch obtained is very narrow in this form. However, with large jamming transmitter modulation, the side bands are outside the notch frequency and the interference is again present.

The notch point has therefore been formed like a super-critically coupled band filter (Fig.9). True, this reduces the notch depth, and the filter becomes

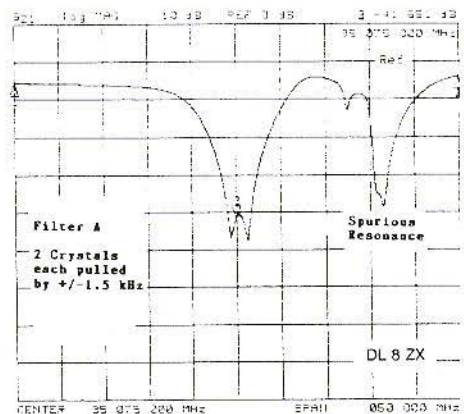

Fig.9: Wide Transmission Curve, as for a Super-Critically Coupled Band Filter



wider, but more effective for the case in point, and the interference is largely suppressed.

Two crystals with the same frequency were used for the experiments, with the band filter form being created by pulling one crystal downwards and the other upwards. When the crystals were purchased, specimens with a symmetrical offset to the average frequency had to be ordered (app. ± 3 kHz).

One unpleasant secondary effect which can not be overlooked is the appearance of spurious crystal resonances in a range between + 10 kHz and 150 kHz, based on the rated resonance frequency. When ordering, you should bear in mind that these are damped by more than 20dB, as against the main resonance (this value depends on the manufacturer). At these spurious resonances, notch points also arise, the depths of which depend simply on the distance from the main resonance (Fig.9).

3.2. Filter "B"

Filter "B" is provided for retrofitting into existing designs of receiver - on condition, of course, that there is a 50 Ω

or a 75 Ω impedance at the output of the receive mixer. If you use the technology described under "A", you have to provide a band filter with damping (TV band width) and a standard impedance at the input or output. This provides for damping of the wanted signal and de-tuning of the circuit in case of any mismatch at the connections.

But there is another solution:

A notch filter has little effect with a 75 Ω line impedance:

$$\begin{aligned} a &= 20 \log (\text{Circuit } Z / \text{Crystal } R_s) \\ &= 20 \log (75\Omega / 20\Omega) = 11.4\text{dB} \end{aligned}$$

This gives a value of app. 11dB, i.e. hardly any reduction. So a higher source impedance has to be selected for the entire transmission range. Frequency response and phase error should be avoided as far as possible, even if the latter can scarcely be measured using amateur equipment.

The components industry (MCL) can offer high-frequency mini-transformers for wide frequency ranges, which can be used right up into the VHF range. A type with a $Z1/Z2$ value of 16 was selected for the application in question. This increases the impedance from 75

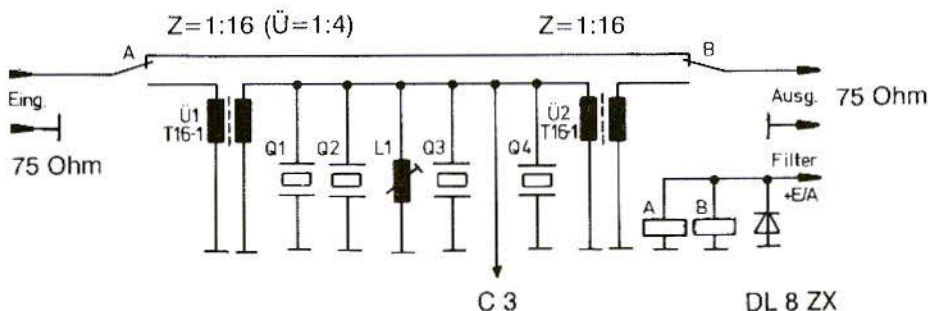

Fig.10: Filter Circuit with Input-Output Transformers

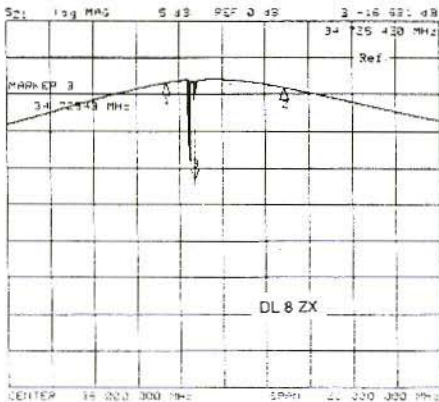

Fig.11: Complete Transmission Curve of Filter "B"

to 1,200Ω. So a usable damping path (notch) can be obtained at the series resonance frequency again in this way. At the output, a second transformer brings about a transformation back to 75Ω. The parallel circuit formed by Z_e'

and Z_a' acts as a source resistance, since these are actually applied jointly (Fig.10).

For impedances of several hundred Ohms, the unwanted holder capacitances of crystals can no longer be disregarded. Coil L1 is provided to compensate for them, and must be dimensioned in accordance with the number of crystals.

Several notch points can be provided on the high-ohmic side. Two crystals with the same frequency, wired in parallel at this point, increase the damping at the notch point by only 6dB. A band filter form can be obtained using staggered frequencies. The resonant circuit consisting of L1 and the crystal holder capacitance does not display any clear resonance at the acting frequency (Fig.11).

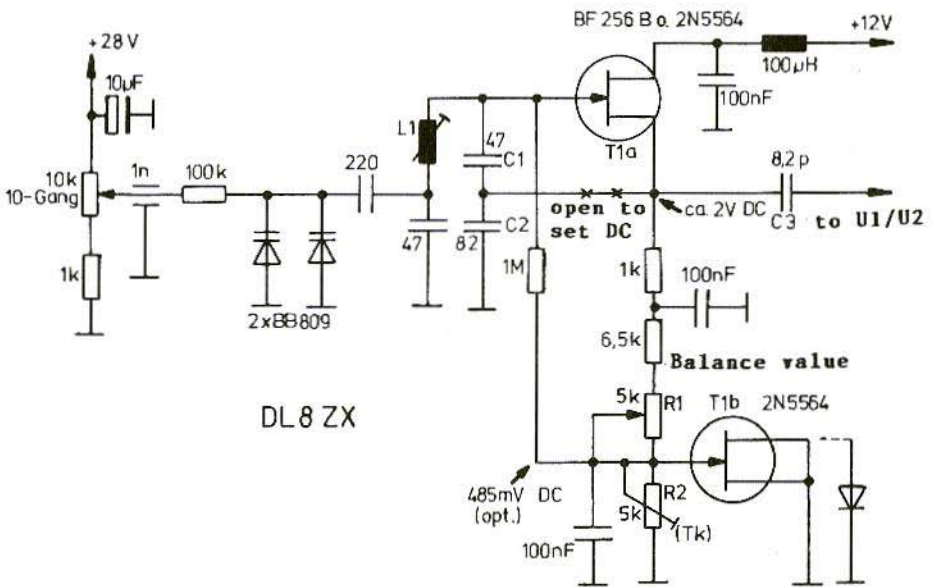
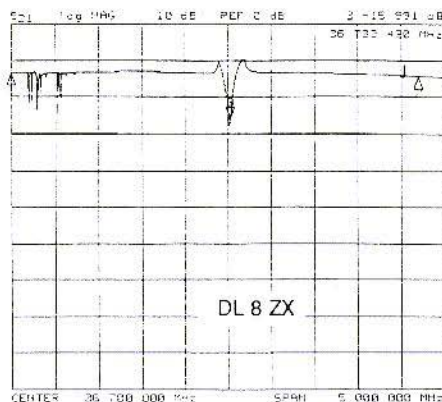
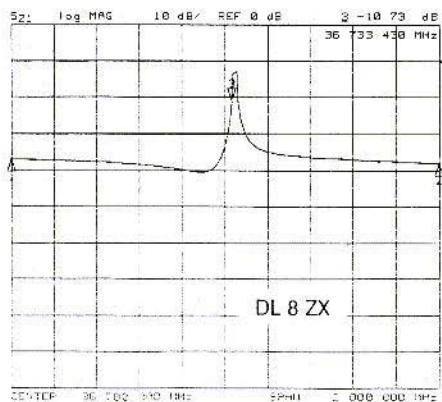

Fig.12: Active Notch Filter for TV IF with Temperature Compensation



Fig's:13 & 14 A Source resistance which is too low causes the Circuit to Oscillate

Many radio amateurs are not keen on dimensioning single-layer high-frequency coils. It's very easy to do, using a rough and ready formula (from DK1FE).

If you're using Vogt spools with a diameter of 4.3mm, you can determine the number of turns very easily by means of the following formula:

$$n = \sqrt{L} * 13,000$$

with a wire thickness of approximately 0.25mm, L in Henries, and a core which is half screwed in. Filter "B" can be looped into the intermediate-frequency path by means of a high-frequency relay, to allow for operation with or without a filter.

In the intermediate frequency the transmission damping, apart from the notch points, lies at about 3dB and is thus negligible. You should draw up a residual frequency chart like Fig.1, bearing in mind that notch points are not set on image, sound or colour carriers.

3.3. Filter "C"

The notch filter described below has a variable frequency, so that the notch depth and notch width can be adjusted within certain limits.

Like all active high-frequency notch filters, it is based on the principal circuit of an oscillator. Such notch filters are described only for the intermediate frequency range (460 kHz) in the literature. After completing this article, I chanced across a publication on this subject in an old DL-QTC (2). A Clapp oscillator, which is certainly known to be very stable, is used as the principal circuit (Fig.12).

The observation that the coil Q of the resonant circuit just before the oscillator is very high can lead to its being used as a notch filter. As with crystal notch filters, in this case too the notch is obtained through absorption (connection to $Z = 600\Omega$) (C3). The stability of the operating point is of great importance in keeping the effect stable. The resonant circuit values must likewise be

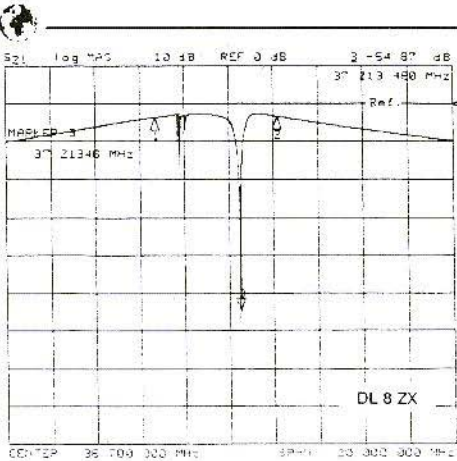

Fig.15: Active Notch Filter "C" and Crystal Notch "B" at different frequencies

stable. Varying temperature coefficients for the partial capacitances of the resonant circuit alter the feedback and thus the stability.

An attempt was made, using a thermally coupled Si diode or using a dual FET as diode, to keep the DC operating point constant over a wider temperature range.

The notch frequency is set by means of a Varicap, roughly above the coil core. The notch depth is set using the source resistance, R1. The protective resistor, R1 (app. 6.5kΩ) restricts the balancing range of R1. Using R2, balancing is carried out with the best DC voltage stability, with an open bridge at source as per C1, C2; the temperature stability can be checked using a cold spray or a hair-dryer.

If the source resistance is too low, the circuit will oscillate (Figs. 13 and 14).

4. THE TUNING PROCESS

Balancing the operating point is very important. A temperature-dependent operating point is set using R2, and alters the source resistance, 1, in such a way that the set-up does not oscillate, and thus maximum notch depths are obtained. An alteration to R1 can now

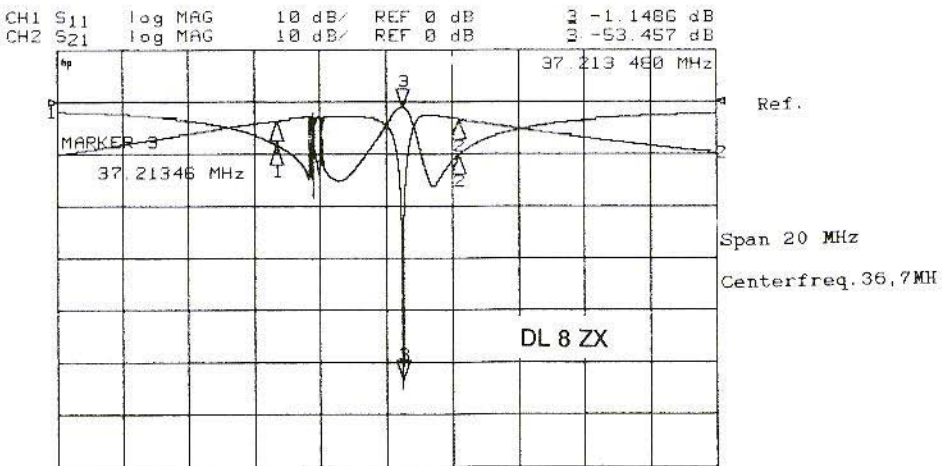

Fig.16: Examples of Notch Depths Attainable



be used for fine balancing of the maximum damping value.

If no suitable signal is available for experiments, a signal generator or a walkie-talkie can be of further help. A packet radio signal is not suitable for balancing purposes, as it usually consists only of short pulses. An attempt can now be made, by displacing the frequency and the notch depth, to suppress the unwanted signal.

Tuning with filter "A" provides for maximum suppression of the fixed source of radio noise. Filter "C" is switched off here, and only the TV receiver VXO is tuned.

Filter "C" is then switched on. The potentiometer is used to set the "notch frequency" and the source resistance, R1, to set an optimum reduction level (Fig.15).

As Fig.16 shows, enormous notch depths can be obtained. There is a multitude of conceivable applications. Thus, for example, crystal notch "A" can be used at a local relay frequency and the variable notch can be set to another source of radio noise. With filters "A" and "C" it has proved possible to tune the PR source of radio noise out completely. Of course, this needs fine fingertip control during balancing.

5. LITERATURE

- (1) VHF Conference Proceedings, Weinheim 1992, p. 79 ff.
- (2) DL-QTC, no. 11, 1964

now available - second edition

GPS THEORY AND PRACTICE

B.Hofman-Wellenhof, H.Lichtenegger & J.Collins

326 pages detailing all you need to know about how the satellite Global Positioning System works. Using GPS for precise measurements, as well as attitude and navigation determination is discussed in detail. Full mathematical analysis, data reduction and coordinate computation are provided.

£39.95

Shipping: UK £2.00; Overseas £3.50; Airmail £7.00

KM Publications, 5 Ware Orchard, Barby, Rugby, CV23 8UF

Tel: 0788 890365

Fax: 0788 891883



Wolfgang Schneider, DJ 8 ES

A Hybrid Power Amplifier for 144 MHz

The following article describes a modern type of power amplifier suitable for the 28/144 MHz transverter described in issue 4/93 of VHF Communications. The amplifier raises the transverter's output signal to 20W and thus makes radio

operation possible at a somewhat higher power level in the 2m band.

The entire amplifier has only a few external structural elements, with a Mitsubishi hybrid module forming its basis. A low-pass filter takes care of the harmonic filtration required.

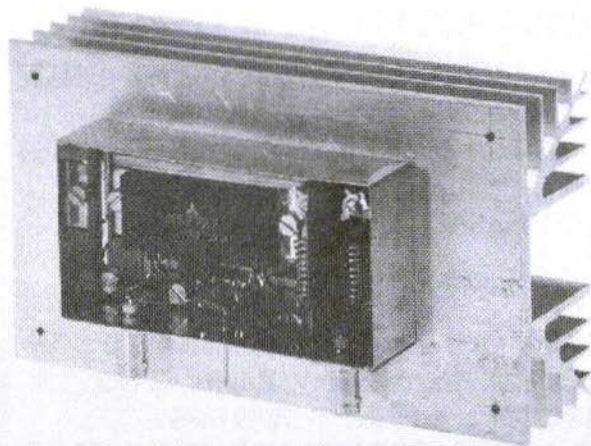
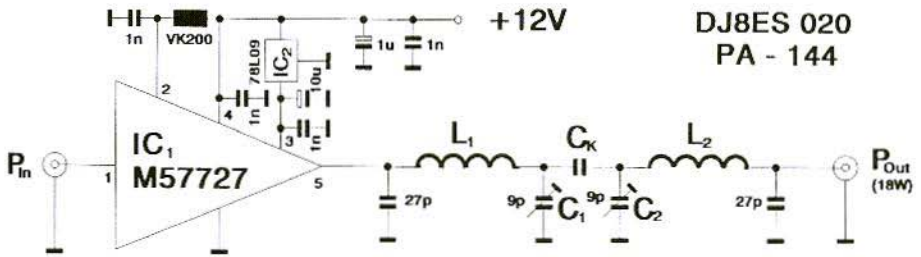

Fig.1:
Prototype Hybrid
Amplifier with
Heat Sink



DJ8ES 020
PA - 144

Fig.2: Circuit Diagram of the 144 MHz Hybrid Amplifier

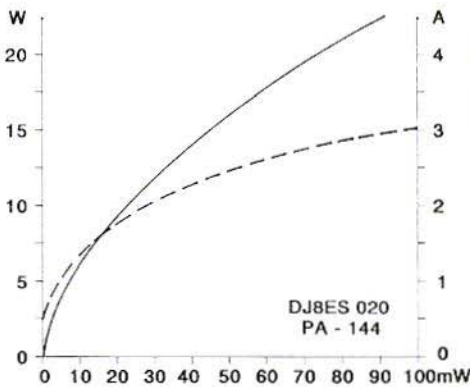

Fig.3:
The Power Output is directly
proportional to the Current
consumption

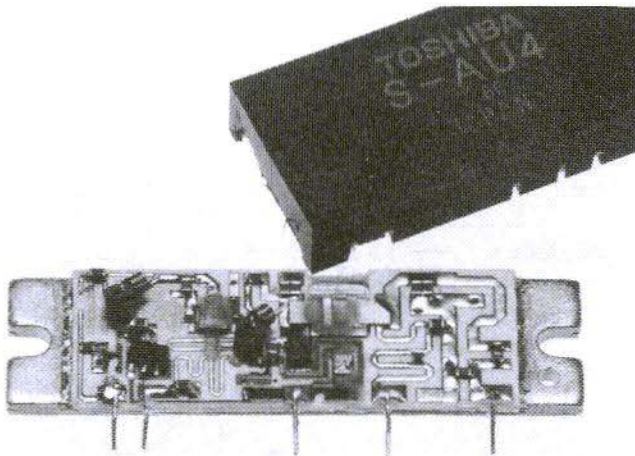

Fig.4:
The internal
structure of the
Hybrid Module

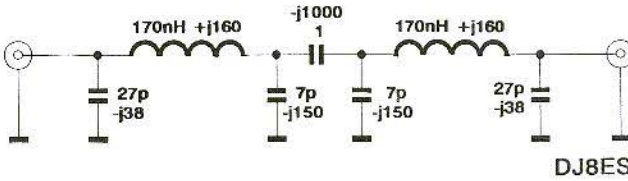

Fig.5:
The Peaked LowPass Filter

DJ8ES

1. DESCRIPTION OF CIRCUIT

Fig.2 shows the relatively simple circuit for the 144 MHz power amplifier. The core of the circuit is a Mitsubishi M57727 hybrid module (IC1). This module operates at a working voltage of 12 Volts. With exactly 27dB amplification, the transverter signal is raised to an output voltage of 20W. The output power to input power ratio is shown in Fig.3. The current consumption of the module is also directly proportional to this ratio.

Such amplifier modules are structured using thick film technology. The system is specially laid out for the 144 - 148 MHz frequency range, and the amplification level in question is reached in two stages.

Fig.4 shows what such a module looks like from the inside. The matching circuits for the impedance matching at 50Ω for the input and output are clearly visible here.

A downstream low-pass filter takes care of the harmonic reduction required. This is a peaked low-pass unit.

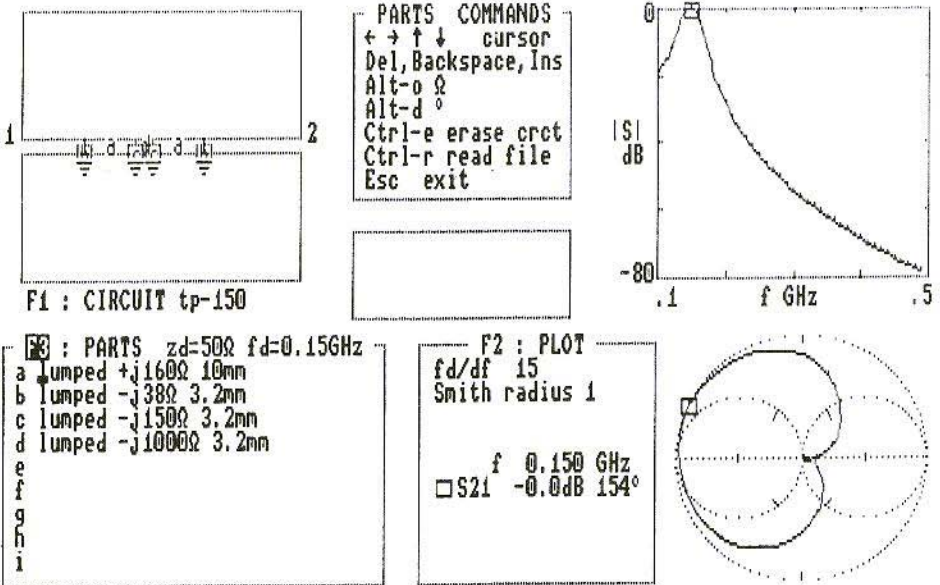

Fig.6: Screen Print-out of Filter Characteristics using PUFF CAD program

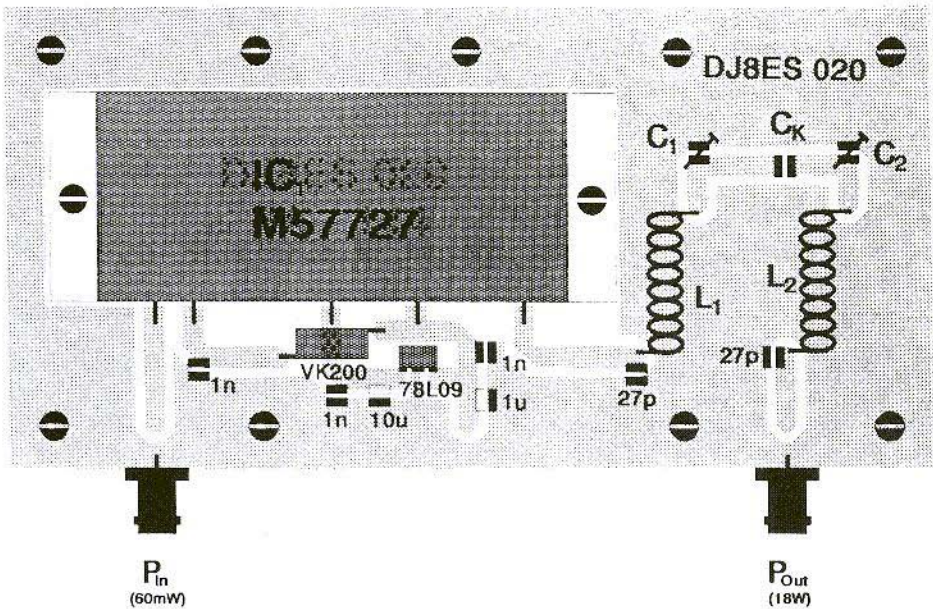

Fig.7: Hybrid Amplifier Component Layout

Amazing values are obtained using only two PI filters wired together. Fig.6 gives a graphic representation of the damping procedure of the filter as a computer simulation.

2. ASSEMBLY INSTRUCTIONS

The 144 MHz hybrid amplifier is assembled on a double-sided coated epoxy printed circuit board measuring 54mm x 108mm. The board can thus fit into a standard tinplate housing (55.5mm x 111mm x 30mm).

A hole of suitable dimensions is sawn out for the hybrid module. Fastening holes are bored along the edge as per Fig.7. No further preparatory work is

required for the board. In contrast to what is otherwise normal procedure, the board is not sprayed with solderable lacquer! Good earth connections are decisive for the satisfactory functioning of the circuit. The necessary through-contacts are provided by means of M3 screws, so that the assembly is screwed to the heat sink at the same time.

The BNC jacks are to be positioned at suitable points in the side wall of the housing. The feed-through capacitor for the power supply is also positioned in the side wall from outside and soldered in. The components are not actually inserted until the board has been soldered to the side surfaces of the housing. The board should now fit precisely against the side-pieces, so that later it will lie flat on the cooling surface.



You will have to make the two coils (L1, L2) and the coupling capacitor, CK, yourself, as they are special components. The coils each consist of 8.5 turns of silvered copper wire with a diameter of 1 mm.. The wire is wound around a 6mm mandrel (e.g. a 6mm auger shank) and finally soldered on with a 1mm base clearance.

The coupling capacitor, CK, is made from a 1 cm. long piece of coaxial cable (RG174). The length is derived from the required capacity of 1pF. A standard chip capacitor can not be used here, due to the relatively high power level. A thin copper plate is soldered between the two PI filters for screening purposes. As can be seen from Fig.1, it is appropriately cut and inserted.

Finally, the components are inserted into the hybrid module. It is screwed directly onto the cooling surface using two M4 screws. Of course, the necessary heat conducting paste must be applied first.

2.1. Component list

IC1	M57727 (Mitsubishi)
IC2	TA78L09F voltage regulator (SMD)
L1, L2, CK	see text
C1, C2	9 pF Trimmer with soldering lug
1 x	VK200 UKW broad-band choke
1 x	1nF feed-through capacitor, solderable
2 x	BNC flanged bush (UG-290 A/U)
1 x	Tinplate housing 55.5 x 111 x 30 mm

All other components in SMD format:

1 x	1 μ F/20 V tantalum
1 x	10 μ F/20 V tantalum
2 x	27pF, ATC chip
3 x	1nF, ceramic capacitor

3.

PUTTING INTO OPERATION

A power meter and a multimeter are required for putting the equipment into operation and for the subsequent calibration.

The ambient current drawn by the unit is of the order of 400mA, which rises to around 2.5A under full drive with an input power of 60mW. This gives an output power of the order of 18W.

Only the low-pass filter (C1, C2) requires tuning in the hybrid amplifier. The trimmers are normally screwed about half way in when the unit is correctly tuned.

In order not to endanger the module, carry out this tuning procedure with only a low drive power level (max. 10mW). There can thus be no damage, even if the hybrid module is briefly mismatched.

4.

CONCLUDING REMARKS

The high-level stage described here has been operating with the transverter for some time and is extremely satisfactory. The author also uses amplifier stages for 70cm and 23cm



mat. As you can see, these modules make a simple construction possible, using only a few external components. This gives you values which correspond to those from commercial products.

Finally, I would just like to express my sincere thanks to an OM, Wilhelm Schürings (DK4TJ), for his energetic support in carrying out the calculations for the low-pass filter and in constructing it.

5. LITERATURE

- (1) Wolfgang Schneider, DJ 8 ES:
28/144 MHz Transverter
VHF Communications, 4/93
- (2) Harald Braubach, DL 1 GBH:
Measuring Aids and a Harmonic
Filter for the VMOS Transistor
100W Power Amplifier for 2m
VHF Communications, 4/83
- (3) Mitsubishi: Data Sheet M57727
Mitsubishi RF Power Modules

The VHF Communications

Disc of the Quarter

RFD.exe

This program was a runner-up in the second RF Design Awards PC Software Contest. The menu-driven collection of small programs covers a wide range of RF design problems, from filter design to bipolar transistor biasing.

Supplied on a 1.44 M 3.25" disc with a copy of the original RF Design article

£10.00 including shipping

**KM Publications, 5 Ware Orchard, Barby, Nr.Rugby,
CV23 8UF. Tel: 0788 890365; Fax: 0788 891883**

Pseudomorphic HEMT GaAs FET amplifier

Camtech's *LNA2001* masthead amplifier uses the very latest Pseudomorphic HEMT technology to give an outstanding performance. The design incorporates an ultra low noise (0.17dB noise figure) PHEMT GaAs FET followed by a microstrip bandpass filter and MMIC amplifier. The amplifier is also designed to meet environmental protection to IP65 in accordance with DIN40050.

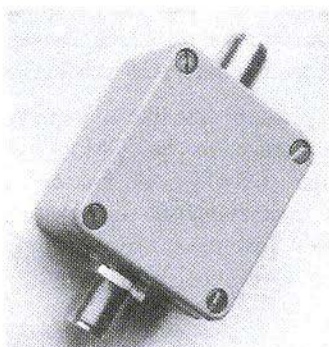

Three models are available.

SPECIFICATION

Frequency	890 - 950 MHz (American Amateur market) 1240 - 1320 MHz (European Amateur market) 1500 - 1600 MHz (Inmarsat and GPS) #
Gain	24dB Nominal
Composite noise figure	0.7dB
Supply voltage	12V DC @ 50mA *
Connections	50 Ohm 'N' Female sockets.
Size H x W x L	37 x 58 x 65 mm Excluding connectors.

* DC power feed via coaxial cable, other supply voltages to order (6VDC Min.)

Price £ 110.50 + 3.00 postage and VAT @ 17.5%. (# Inmarsat / GPS P.O.A.)

ACCESS/VISA/EUROCARD/MASTERCARD facilities available.

Mail or phone to CAMTECH ELECTRONICS, 21 GOLDINGS CLOSE, HAVERHILL, SUFFOLK, CB9 0EQ ENGLAND. Tel INT+44 (0)440 62779, Fax INT+44 (0)440 714147.

KM Publications - Software List

'PUFF' with Handbook (Caltech)	£ 18.50
Motorola/SM6MOM-W6 PUFF supplement	£ 11.00
Siemens S-parameters	£ 9.50
Philips S-parameters	£ 14.50
HP AppCAD/HP	£ 16.50
Post & packing an above £1.50 for UK, £3.00 for Overseas, £7.50 for Airmail	
CAE No.1 collection (VHF Comm 1/93, pp 58-60)	£ 70.00
CAE No.2 collection (VHF Comm 1/93, pp 58-60)	£ 70.00
Post & packing on above £5.00 for UK, £7.50 for Overseas, £10.00 for Airmail	

KM PUBLICATIONS, 5 WARE ORCHARD, BARBY, Nr. RUGBY, CV23 8UF.

Phone: 0788 890365 Fax: 0788 891883



EASY-PC PCB and Circuit Diagram CAD

Forget using tapes and lightbox! Create your Circuit Boards using CAD - like the professionals.

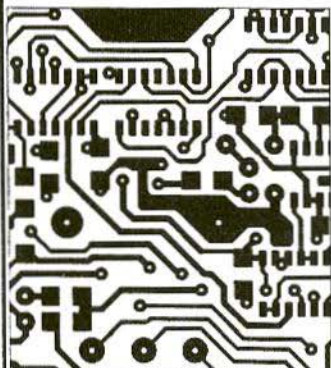

- Runs on PC/XT/AT etc. with Hercules, CGA, EGA or VGA display and many DOS emulations.
- Design Schematics Single and Double sided and Multilayer boards including Surface Mount.
- Standard output includes Dot Matrix / Laser / Inkjet Printer, Pen Plotter, Photo-plotter and N.C. Drill.
- Extremely powerful.
- Very easy to use.

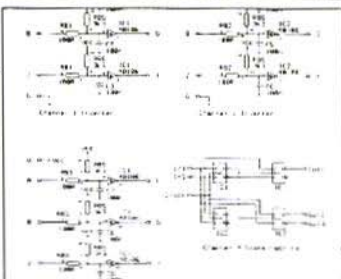

EASY-PC

Technical support is free, for life!

Only
£98.00!

Plus P&H+VAT

Over 18,000 Installations in 80 Countries Worldwide!

Options: -500 piece Surface Mount Symbol Library £48, 1000 piece Symbol Library £38, Gerber Import facility £98.

**DIGITAL
SIMULATION from £98**

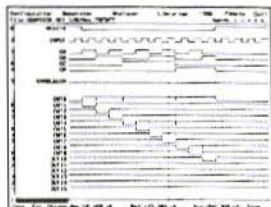

- At last! A full featured Digital Circuit Simulator for less than £1000!
- PULSAR allows you to test your designs without the need for expensive test equipment.
- Catch glitches down to a pico second per week!
- Includes 4000 Series CMOS and 74LS Libraries. 74HC/HCT libraries only £48.00 each.
- Runs on PC/XT/AT/286/386/486 with EGA or VGA.

**ANALOGUE
SIMULATION from £98**

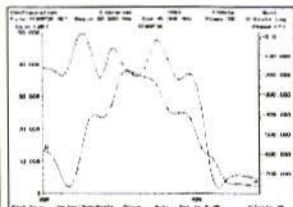

- NEW powerful ANALYSER III has full graphical output.
- Handles R's, L's, C's, Bipolar Transistors, FET's, OP-amp's, Tapped and Untapped Transformers, and Microstrip and Co-axial Transmission Lines.
- Plots Input / Output Impedance, Gain, Phase & Group Delay.
- Covers 0.001 Hz to >10GHz
- For PC/XT/AT/286/386/486 with EGA or VGA.
- Very fast computation.

**SMITH CHART CAD
from £195**

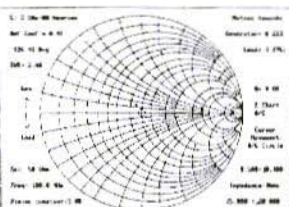

- Z-MATCH II simplifies RF matching and includes many more features than the standard Smith Chart.
- Handles transmission line transformers, stubs, discrete components, S Parameters etc.
- Supplied with many worked examples.
- Superbly easy to learn and use.
- Runs on IBM PC/XT/AT/386/486, CGA, EGA, VGA.
- Ideal for Education and Industry.

For full information, Write, Phone or Fax:-

Number One Systems Ltd.

Ref: VHF, HARDING WAY, ST.IVES, HUNTINGDON, CAMBS, ENGLAND, PE17 4WR.

Telephone: 0480 461778 (7 lines) Fax: 0480 494042

International: +44-480-461778, Fax: +44-480-494042 ACCESS, AMEX, MASTERCARD, VISA Welcome.

- Technical Support free for life!
- Programs Not Copy Protected
- Special Prices for Education



PRINTED CIRCUIT BOARDS - KITS - COMPONENTS

for projects featured in VHF Communications

DB6NT	Measuring Aids for UHF Amateurs		Art No.	Ed.4/1993
PCB	DB6NT 001	RT-Duroid, 0.5mm	06379	DM 36.00
Kit	DB6NT 001	PCB, components, housing and SMA jacks	06382	DM 125.00

Special components sold individually:

INA-03184	IC amplifier	10106	DM 21.00
INA-10368	IC amplifier	10107	DM 22.00
UA 78L12	Voltage controller	10109	DM 1.80
BA 595	SMD Diode	10113	DM 3.50
Housing	74 x 37 x 30	09495	DM 3.80
SMA-Pr-Bu	SMA PCB jacks	00449	DM 13.00

DB6NT	Frequency Divider		Art No.	Ed.4/1993
PCB	DB6NT 002	RT-Duroid, 0.5mm	06381	DM 36.00
Kit	DB6NT 002	PCB, components, housing and SMA jacks	06383	DM 208.00

Special components sold individually:

INA-03184	IC amplifier	10106	DM 21.00
SP 89103	Plessey IC	10108	DM 113.00
UA 7810	10V voltage regulator	10110	DM 2.00
78L05	5V SMD voltage regulator	10111	DM 1.80
BA 595	SMD Diode	10113	DM 3.50
Housing	74 x 37 x 30	09495	DM 3.80
SMA-Pr-Bu	SMA PCB jacks	00449	DM 13.00

DJ8ES	28/144 MHz Transverter		Art No.	ED. 4/1993
PCB	DJ8ES 019	Epoxy, double-sided	06384	DM 36.00
Kit	DJ8ES 019	PCB, housing, BNC jacks, semiconductors and SMD components	06385	DM 229.00

Note: minimum order value DM 35.00

To obtain supplies of the above or any PCB's, kits, components, etc., previously advertised in VHF Communications, please contact KM Publications for Sterling prices, etc., at the address shown on the inside front cover of this magazine.

Publications:

UHF Compendium Pts.1 & 2; <i>K.L.Weiner DJ9HO</i>	£27.50
UHF Compendium Pts.3 & 4; <i>K.L.Weiner DJ9HO</i>	£27.50
Post & packing: UK +£2.50; Overseas +£5.00; Airmail +£10.00	
An Introduction to Amateur Television; <i>Mike Wooding G6IQM</i>	£ 5.00
Slow Scan Television Explained; <i>Mike Wooding G6IQM</i>	£ 5.00
The ATV Compendium; <i>Mike Wooding G6IQM</i>	£ 3.50
TV Secrets Volume I; <i>ATVQ Magazine</i>	£ 7.50
TV Secrets Volume II; <i>ATVQ Magazine</i>	£17.95
A Guide to 23cm Television; <i>Severnside TV Group</i>	£ 3.50
Just a Few Lines (<i>a history of the birth of the BBC</i>)	£ 5.00
Post & packing per book: UK +£0.80; Overseas +£1.25; Airmail +£2.75	

VHF Communications:

1994 Subscription, Volume 26	£15.00
	by credit card £15.75
1993 Volume 25	£13.50
	by credit card £14.20
1993 per single issue	£ 3.75
	by credit card £ 4.00
1980 to 1992 per full volume (4 issues)	£13.00
	by credit card £ 13.60
Any single issue before 1993	£ 3.50
	by credit card £ 3.70
Post & packing per issue: UK +£0.30; Overseas +£0.50; Airmail +£1.25	
Post & packing per volume: UK +£0.80; Overseas +£1.50; Airmail +£4.00	
Binders to hold 3 Volumes	£ 5.50
	by credit card £ 5.80
Post & packing per binder: UK +£0.75; Overseas +£1.25; Airmail +£3.00	

KM Publications, 5 Ware Orchard, Barby, Nr.Rugby, CV23 8UF

Tel: 0788 890365;

Int: +44 788 890 365

Fax: 0788 891883;

Int: +44 788 891 883

Pasokon TV - *the* PC based SSTV system

Pasokon TV is a fully-featured, low-cost alternative to conventional single-mode Slow Scan Television transmit and receive converters. The whole system is on a single card which slots into your PC.

© Send and Receive all popular modes:

Robot Colour: 12, 24, 36, 72 sec

AVT: 24, 90, 94, 188 sec

Scottie: S1, S2, S3, S4

Robot B&W: 8, 12, 24, 36 sec

Martin: M1, M2, M3, M4

Wraase SC-1: 24, 48, 96 sec

- © Interface fits inside computer - no external hardware or power supply needed
- © Graphical User Interface with Mouse support
- © On-screen tuning indicator - colour pictures real-time during receive
- © Full-screen images on standard VGA with 320x200 256 colour mode
- © Read and write popular file formats GIF, PCX, TGA, etc.

£180.00 +£5.00 UK or +£10.00 Overseas Shipping

SSTV Explorer

the receive-only version of Pasokon

The receive-only version of Pasokon. No internal card, requires a spare serial port. The interface is housed in a 25-Way D-connector and a 9-25 way 'gender-bender' is supplied as well, in case your serial port has a 9-way connector. Powered from the serial port. Specifications as for Pasokon excepting no AVT mode

£85.00 +£2.00 UK or +£3.50 Overseas shipping

KM Publications, 5 Ware Orchard, Barby, Nr. Rugby, CV23 8UF, UK

Tel: 0788 890365

Fax: 0788 891883

Int Tel: +44 788 890 365

Int Fax: +44 788 891 883