

OA5H
November 1957
50 Cents
55¢ in Canada

devoted entirely to amateur radio

du (sv) PJ2ME ET 2 US
FRANCE
F3AT
Late Info on
C5R
Satellite Sputnik!
CR7B



RME Dual Conversion 4350A Receiver With 100 KC Crystal Calibrator

4301 Sideband Selector.
\$75, Amateur Net

4302 Matching Speaker.
\$17.50 Amateur Net



Passes Every Ham Comparison Test!

You get everything you want and need in the RME 4350A Receiver! Dual Conversion, two-speed tuning for easy, smooth operation, high selectivity and rejectivity, 100 kc crystal calibrator. Designed for hams by hams, it is laboratory-engineered for maximum performance on SSB, CW and Phone, ideal for contests and DX under *all* receiving conditions. YET IT'S YOURS FOR JUST \$249, Amateur Net! (Listed in Federal Civil Defense Equipment Catalog, Item #R-12.)

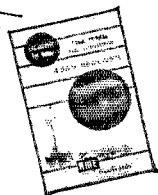

GET THE FACTS about RME—the respected name in communications. Write Dept. Q79 for Bulletin 244. See your RME-Electro-Voice Dealer!



RADIO MANUFACTURING ENGINEERS, INC.

DIVISION OF ELECTRO-VOICE, INC., BUCHANAN, MICHIGAN

The New Ideas in communications are born at hallicrafters

Brilliant performance! The SX-99 receiver features broadcast coverage 540-1680 kc plus three S/W bands, 1680 kc—34 mc. Bandsread calibrated over 10, 11, 15, 20, 40, 80 meter amateur bands. Antenna trimmer, "S" meter, crystal filter. Seven tubes plus rectifier. Black cabinet, silver trim, piano hinge top. **Model SX-99—\$149.95**

Incomparable value! SX-100 Selectable Sideband Receiver proved best for your money by far in its field. "Tee-Notch" filter provides stable non-regenerative system for rejection of unwanted heterodyne. Notch depth control; antenna trimmer; 100 kc quartz crystal calibrator. Logging dials for both tuning controls. Freq. range: 538-1580 kc; 1720 kc—34 mc. **Model SX-100—\$295.00**

New heavyweight champion! Rugged is the word for the SX-101 receiver—and it's all amateur. Heaviest chassis in the industry. Full gear drive. Complete coverage of 7 bands: 160, 80, 40, 20, 15, 11-10 meters. Special 10 mc. pos. for WWV. Tee-notch filter. S-meter functions with A.V.C. off. Selectable side band. **Model SX-101—\$395.00**

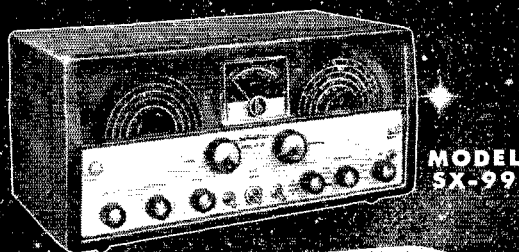

**MODEL
SX-99**



**MODEL
SX-100**

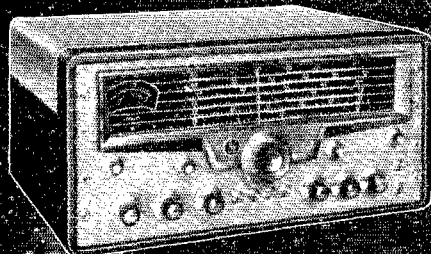

**MODEL
SX-101**



**MODEL
HT-32**

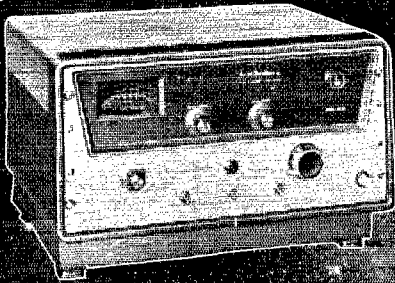

**MODEL
HT-33**

Cleanest signal on the air! Hallicrafters new HT-32 transmitter brings you a new standard of clarity with two exclusive features: (1) 5.0 mc quartz crystal filter—cuts unwanted sideband 50 db. or more; (2) new bridged-tee modulator, temp.-stabilized and compensated network provides carrier suppression in excess of 50 db. SSB, AM or CW output on 80, 40, 20, 15, 11-10 meter bands. High-stability gear-driven V.F.O. 144 watts peak input. Ideal CW keying and break-in operation. **Model HT-32—\$675.00**

New ceramic tubes! Ultra-compact new HT-33 kilowatt amplifier accents performance and dependability with costlier ceramic tubes—another Hallicrafters first. 100 watts greater plate dissipation. Greater overload safety. Unsurpassed ruggedness. *More features:* six amateur bands, 80, 40, 20, 15, 11-10 meters; simplified tuning; low drive requirement; quieter operation from low speed blower. All control leads filtered. **Model HT-33—\$775.00**

The hallicrafters Company

Chicago 24, Ill.

Available on convenient terms
from your radio parts distributor

Export Sales: International Operations
Raytheon Manufacturing Co.
Waltham, Massachusetts

BIG AND CLEAN SSB SIGNALS

There is pride in the ownership of a strong signal and every courteous amateur is equally proud of a clean signal — a signal that a neighboring amateur friend can work close to.

Three kc is enough spectrum space for good SSB voice communication and more just annoys or robs a friend of a contact near your frequency. The Collins filter system, using a Collins Mechanical Filter with steep skirts on both sides, strictly limits the band width. Uses only the amount of spectrum space absolutely necessary.

Once a clean and narrow SSB signal is generated, it must be converted to the desired carrier frequency and raised to the desired power level. Properly designed low level amplifiers and mixers have low distortion, but in the driver and final power amplifier the amount of distortion generated is of concern. Rather severe distortion may not degrade the quality of your signal to the fellow you are working but another amateur near you on the band knows it.

Most PA tubes can be operated with acceptably low distortion, but this is far below their maximum power capabilities. Some compromise between power output and distortion must be made in tube operation. But Collins engineering makes it possible to have your cake and eat it too.

Collins uses RF feedback — an exclusive feature of the KWS-1 and KWM-1 — to get maximum tube output and efficiency and still keep a clean signal. The energy in the distortion products is less than one-tenth with feedback than it otherwise would be.

Any linear amplifier will distort badly when heavily overdriven. Collins equipment uses automatic load control to keep speech peaks within the capabilities of the amplifier and to keep the average level high.

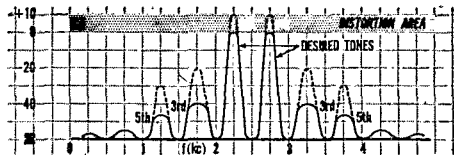

The ALC maintains the signal peaks just within the non-distortion level.

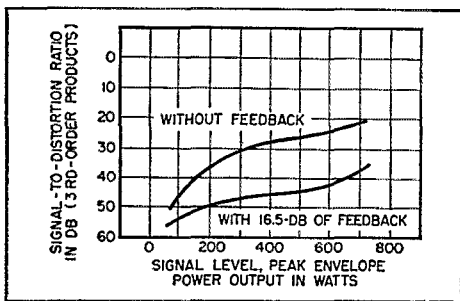

With RF feedback, distortion products are reduced and allow a more efficient amplifier.

It feels good to own a big and a clean SSB signal — the kind the Collins KWS-1 and KWM-1 put out. Collins KWS and KWM are the only amateur transmitters with these features.

Walter B. Bruene

W. B. Bruene — WØTTK

Collins Communication Engineering Division Technical Consultant

Collins

CREATIVE LEADER IN COMMUNICATION

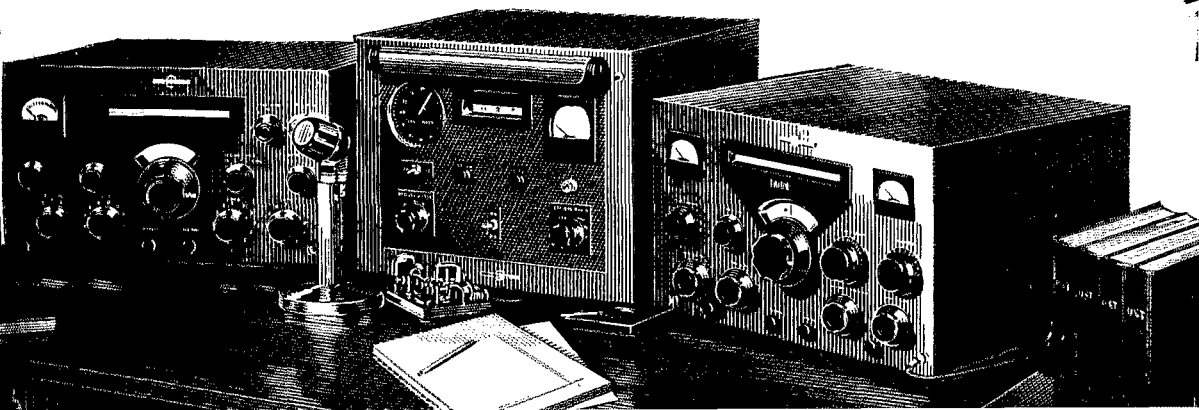

QST

NOVEMBER 1957

VOLUME XLI NUMBER 11

PUBLISHED MONTHLY, AS ITS OFFICIAL ORGAN, BY THE AMERICAN RADIO RELAY LEAGUE, INC., WEST HARTFORD, CONN., U. S. A.; OFFICIAL ORGAN OF THE INTERNATIONAL AMATEUR RADIO UNION

STAFF

A. L. BUDLONG, WIBUD
Editor

RICHARD L. BALDWIN, WIKE
Managing Editor

GEORGE GRAMMER, WIDF
Technical Editor

DONALD H. MIX, WITS
BYRON GOODMAN, WIDX
Assistant Technical Editors

EDWARD P. TILTON, WIHDQ
V.H.F. Editor

C. VERNON CHAMBERS, WIJEQ
LEWIS G. MCCOY, WIICP
E. LAIRD CAMPBELL, WICUT
Technical Assistants

ROD NEWKIRK, W9BRD
Contributing Editor, DX

ELEANOR WILSON, WIQON
Contributing Editor, YLs

NANCY A. ACKERMAN
Production Assistant

LORENTZ A. MORROW, W1VG
Advertising Manager

EDGAR D. COLLINS
Advertising Assistant

Chris Dunkle and Associates
740 S. Western Ave.
Los Angeles 5
California Representative

DAVID H. HOUGHTON
Circulation Manager

J. A. MOSKEY, WIJMY
Assistant Circulation Manager

OFFICES

38 La Salle Road
West Hartford 7, Connecticut
TEL.: ADams 5-2535 TWX: HF 88

Subscription rate in United States and Possessions, \$4.00 per year, postpaid; \$4.25 in the Dominion of Canada, \$5.00 in all other countries. Single copies, 50 cents. Foreign remittances should be by international postal or express money order or bank draft negotiable in the U. S. and for an equivalent amount in U. S. funds. Entered as second-class matter May 29, 1919, at the post office at Hartford, Connecticut, under the Act of March 3, 1879. Acceptance for mailing at special rate of postage provided for in section 1102, Act of October 3, 1917, authorized September 9, 1922. Addition entry at Concord, N. H., authorized February 21, 1929, under the Act of February 28, 1925. Copyright 1957 by the American Radio Relay League, Inc. Title registered at U. S. Patent Office. International copyright secured. All rights reserved. *Quedan reservados todos los derechos.* Printed in U. S. A.

INDEXED BY
INDUSTRIAL ARTS INDEX
Library of Congress Catalog
Card No.: 21-9421

-CONTENTS-

TECHNICAL —

Compact AB ₁ Kilowatt... <i>Raymond F. Rinaudo, W6KEV</i>	11
Project Moonbeam..... <i>W. H. Pickering</i>	15
QRM or Cockpit Trouble?... <i>Steven J. Takacs, K6VYV</i>	21
Artificial Earth Satellites..... <i>V. Vakhnin</i>	22
Technical Correspondence:	
Predetection Band Width..... <i>F. W. Brown, W6HPH</i>	25
Abnormal Propagation	
<i>J. Gregg Stephenson, W2OBX</i>	25
Project Perseids—1957... <i>Walter J. Morrison, W2CXY</i>	26
Improved Control Circuit for Regulated Power Supplies	
<i>George W. Jones, W1PLJ</i>	30
Transistorized Meter Sensitizer	
<i>E. Laird Campbell, WICUT</i>	34
Beam Support for Old Men	
<i>Gordon E. Beeman, W9RCS</i>	36
Recent Equipment:	
The Drake 1-A Sideband Receiver.....	38
A Matching System for a Three-Band Beam	
<i>Lewis G. McCoy, WIICP</i>	40
Tape Recording the Mark II Minitrack Signals	
<i>V. R. Simas and W. B. Moriarty</i>	42

MOBILE—

New Approach to Mobile Converter Design	
<i>C. Vernon Chambers, WIJEQ</i>	16

BEGINNER—

How to Adjust a Key — And Send Good Code	
<i>Lewis G. McCoy, WIICP</i>	28

OPERATING —

1957 Sweepstakes Rules.....	46
How to Handle a Message..... <i>George Hart, WINJM</i>	48
Final Results, 23rd ARRL International DX Competition	
<i>Ellen White, W1YYM and Phil Simmons, WIZDP</i>	50

GENERAL —

Radio Propagation and Atomic Bomb Tests.....	10
Amateurs Assist in Determining Russian Satellite Orbit.	45
Operation Alert, 1957..... <i>George Hart, WINJM</i>	64

"It Seems to Us —".....	9	YL News and Views.....	77
Hamfest Calendar.....	10	The World Above 50 Mc.....	81
A.R.R.L. Far Eastern Pacific		Hints and Kinks.....	87
Division Convention.....	10	Correspondence from Members	90
Our Cover.....	10	Operating News.....	91
Silent Keys.....	63	With the AREC.....	95
In QST 25 Years Ago.....	63	Station Activities.....	102
Quist Quiz.....	63	WWV Schedule.....	190
Happenings of the Month.....	68	A.R.R.L. QSL Bureau.....	192
How's DX?.....	71		

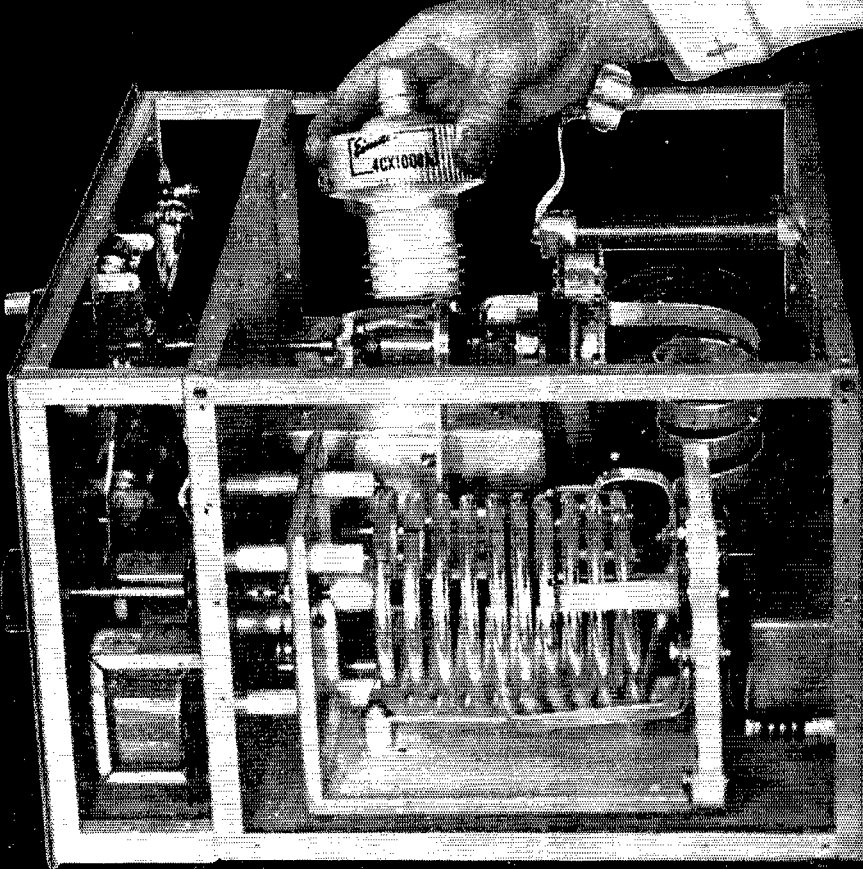

The Eimac Ceramic 4CX1000A "Casual Kilowatt"

This compact SSB final amplifier, designed and built by Ray Rinaudo, W6KEV, was made possible by the rugged, new Eimac 4CX1000A. Only $4\frac{3}{4}$ inches high and $3\frac{3}{8}$ inches in diameter, the ceramic-metal 4CX1000A is capable of dissipating 1000 watts with only 35 cfm of cooling air. This low-voltage, high-current tube is designed to give exceptionally good linearity in Class AB₁ RF amplifiers. Maximum rated output power is achieved without driving the grid into the positive region, thus eliminating the need for a heavily-regulated driver stage.

In the above amplifier the tuned grid circuit has been eliminated. A 100 watt, 100 ohm non-inductive resistor is used, minimizing feedback and elimi-

nating grid circuit tuning problems.

Eimac stacked ceramic design gives the 4CX1000A excellent immunity to damage by mechanical and thermal shock. Electrical stability and long life are assured by internal ceramic support of the tube electrodes and clean internal design. The Eimac SK-800 Air System Socket provides efficient, trouble-free, breechlock socketing.

Running at legal input, the 4CX1000A will last for years — truly a "casual kilowatt". For full details, write our Amateur Service Department.

EITEL-McCULLOUGH, INC.
SAN BRUNO · CALIFORNIA
Eimac First with ceramic tubes that can take it



4CX1000A MAXIMUM RATINGS SSB

DC Plate Volts	3000 Volts	Plate Dissipation	1000 Watts
DC Screen Volts	350 Volts	Screen Dissipation	12 Watts
DC Plate Current	1 Amp	Grid Dissipation	0 Watts

There's a PR for every Service!

AMATEUR

40, 80 and 160 Meters, PR Type Z-2

Rugged. Low drift, fundamental oscillators. High activity and power output. Stands up under maximum crystal currents. Stable, long-lasting, permanently sealed.....\$2.95 Net

20 Meters, PR Type Z-3

Harmonic oscillator. Low drift. High activity. Can be keyed in most circuits. Stable as fundamental oscillators. Fine for doubling to 10 and 11 meters or "straight through" 20 meter operation.....\$3.95 Net

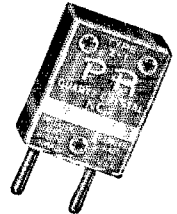
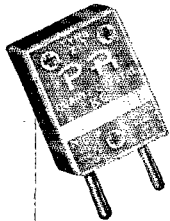
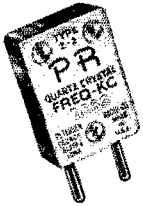

COMMERCIAL

COMMERCIAL, PR Type Z-1

Designed for rigors of all types of commercial service. Calibrated .005 per cent of specified frequency. Weight less than 3/4 ounce. Sealed against moisture and contamination. Meets FCC requirements for all types of service.

SPECIAL TYPES

Type Z-1, AIRCRAFT

3023.5 Kc., .005%.....\$3.45 Net

Type Z-1, MARS and CAP

Official assigned transmitter frequencies in the range. Calibrated to .005%. 1500 to 10000 Kc. \$3.45 Net

Type Z-6A FREQUENCY STANDARD

To determine band-edge. To keep the VFO and receiver properly calibrated.

100 Kc. \$6.95 Net



PR PRINTED OSCILLATOR KIT

Has many uses—

- As 100 Kc. Marker
- As 1000 Kc. Marker for Check Points up to 54 Mc.
- As Foundation Circuit for Low Frequency SSB Crystals

Assembled in minutes. Kit contains everything but 6BA6 oscillator tube and crystal.

Each \$4.50 Net

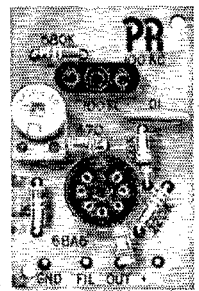

Type 2XP

Suitable for converters, experimental, etc. Same holder dimensions as Type Z-2.

1600 to 12000 Kc. (Fund.) ± 5 Kc. . . . \$3.45 Net

12001 to 25000 Kc. (3d Mode) ± 10 Kc. . . . \$4.45 Net



VHF Type Z-9R

For Lear, Narco and similar equipment operating in the 121 Mc. region, requiring crystals in 30 Mc. range.

Each \$4.95 Net

Type Z-9A RADIO CONTROLLED OBJECTS

27.255 Mc., .04% . . . \$3.95 Net



Type Z-1 TV Marker Crystals

Channels 2 through

13 \$6.45 Net

3100 Kc. . . \$2.95 Net

4100 Kc. . . \$2.95 Net

4.5 Mc. Intercarrier, .01% . . . 2.95 Net

5.0 Mc. Sig. Generator, .01% 2.95 Net

10.7 Mc. FM. IF. .01% . . . 2.95 Net

ALL PR CRYSTALS ARE UNCONDITIONALLY GUARANTEED. ORDER FROM YOUR JOBBER.

PETERSEN RADIO COMPANY, INC.

2800 W. BROADWAY • COUNCIL BLUFFS, IOWA

EXPORT SALES: Royal National Corporation, 250 W. 57th Street, New York 19, N. Y., U. S. A.

Section Communications Managers of the ARRL Communications Department

Reports Invited. All amateurs, especially League members, are invited to report station activities on the first of each month (for preceding month) direct to the SCM, the administrative ARRL official elected by members in each Section. Radio club reports are also desired by SCMs for inclusion in QST. **ARRL Field Organization station appointments** are available in the areas shown to qualified League members. These include ORS, OES, OPS, OO and OBS. SCMs also desire applications for SEC, EC, RM and PAM where vacancies exist. *All amateurs* in the United States and Canada are invited to join the Amateur Radio Emergency Corps (ask for Form 7).

ATLANTIC DIVISION			
Eastern Pennsylvania	W3JNO	Richard B. Mesirov	1372 W. Indian Creek Dr., Philadelphia 41
Maryland-Delaware-D. C.	W3UCR	Louis T. Cronberger	9904 Gardiner Ave., Silver Spring, Md.
Southern New Jersey	K2BG	Herbert C. Brooks	800 Lincoln Ave., Palmyra
Western New York	K2HUK	Charles T. Hansen	211 Rosemont Drive, Buffalo 26
Western Pennsylvania	W3GJY	John F. Woitkiewicz	434 Glenwood Drive, Cambridge
CENTRAL DIVISION			
Illinois	W9YIX	George Schreiber	239 S. Scoville Ave., Oak Park
Indiana	W9TQC	Arthur G. Evans	823 North Bosart, Indianapolis
Wisconsin	W9KQB	George Wolda	2103 South 9 St., Manitowoc
DAKOTA DIVISION			
North Dakota	W8KTZ	Elmer J. Gabel	Hankinson
South Dakota	W8FLP	Les Price	Hermosa
Minnesota	W8KLG	Robert Nelson	Dassel
DELTA DIVISION			
Arkansas	WSZZY	Ulmon M. Gougas	P.O. Box 207, Osceola
Louisiana	WSFMO	Thomas J. Morgavi	3409 Beaulieu St., Metairie
Mississippi	W5EHH	John Adrian Houston, sr.	114 North First Ave., Cleveland
Tennessee	W4SCF	Harry C. Simpson	P.O. Box 10104, Memphis
GREAT LAKES DIVISION			
Kentucky	W4KFW	Albert M. Barnes	830 Third Ave., Dayton
Michigan	W8RAE	Thomas G. Mitchell	409 Liberty, Buchanan
Ohio	W8AL	Wilson E. Weckel	2118 Tuscarawas St., W. Canton 8
HUDSON DIVISION			
Eastern New York	W2EFU	George W. Tracy	1138 North Country Club Drive, Schenectady
N. Y. C. & Long Island	W2TUK	Harry J. Dannels	139 East Zoranne Drive, Farmingdale, L. I.
Northern New Jersey	W2VQR	Lloyd H. Manamon	709 Seventh Ave., Asbury Park
MIDWEST DIVISION			
Iowa	W8BDR	Russell B. Margus	807 North Fifth Ave., Marshalltown
Kansas	W8ICV	Earl N. Johnston	1100 Crest Drive, Topeka
Missouri	W8GEP	James W. Hoover	15 Sandringham Lane, Ferguson 21
Nebraska	W8EXP	Charles E. McNeel	Route 3, RFD, North Platte
NEW ENGLAND DIVISION			
Connecticut	W1TVO	Victor L. Crawford	RFD 5, Stadel Rough Rd., Danbury
Maine	W1LKP	John Fearon	RFD, Wells Beach
Eastern Massachusetts	W1ALP	Frank L. Baker, jr.	91 Atlantic St., North Quincy 71
Western Massachusetts	W1HRV	Osborne R. McKeraghan	22 Mutter St., Easthampton
New Hampshire	W1A1J	John Arthur Knapp	15 North State St., Concord
Rhode Island	W1VXC	Mrs. June R. Burkett	24 Roger Williams Ave., Rumford 16
Vermont	W1OAK	Mrs. Ann L. Chandler	RFD 2, Barre
NORTHWESTERN DIVISION			
Alaska	KL7AGU	Dave A. Fulton	1016 Barron, Anchorage
Idaho	W7RKI	Rev. Francis A. Peterson	Box 66, Preston
Montana	W7NPV/WX1	Vernon L. Phillips	Box 971, Harlowton
Oregon	W7JDX	Hubert R. McNally	11908 S.E. Madison St., Portland 16
Washington	W7FJX	Victor S. Gish	511 East 71st St., Seattle 5
PACIFIC DIVISION			
Hawaii	KH6AED	Samuel H. Lewhel	P.O. Box 3564, Honolulu
Nevada	W7TLV	Albert R. Chin	P.O. Box 14, Reno
Santa Clara Valley	W6VHM	G. Donald Eberlein	P.O. Box 372, Los Gatos
East Bay	W6FDJ	Roger L. Wixson	3018 Berlin Way, Oakland 2
San Francisco	W6OPL	Fred H. Laubscher	655 Wakerobin Lane, San Rafael
Sacramento Valley	K6CFP	LeVaughn Shipley	3005 Maison Way, Sacramento 25
San Joaquin Valley	W6JPU	Ralph Saroyan	3639 Mono St., Fresno
ROANOKE DIVISION			
North Carolina	W4RRH	B. Riley Fowler	Box 143, Morgantown
South Carolina	W4HMG	Bryson L. McGraw	227 Kalmia Road, Columbia
Virginia	W4KX	John Carl Morgan	c/o Radio Station WFVA, Box 269, Fredericksburg
West Virginia	W8PQQ	Albert H. Hix	1013 Belmont St., Forest Hills, Charleston 4
ROCKY MOUNTAIN DIVISION			
Colorado	W8DML	B. Eugene Spagonemore	224 Carlile Ave., Pueblo
Utah*	W7OCX	Col. John H. Sampson, jr.	3618 Mt. Ogden Drive, Ogden
New Mexico	W5OZ	Ray Birch	Route 1, Box 700, Albuquerque
Wyoming	W7PSO	James A. Masterson	851 Bon Ave., Casper
SOUTHEASTERN DIVISION			
Alabama	W4MI	Joe A. Shannon	6890 S.W. 51st St., Cottontale
Eastern Florida	W4KGJ	John F. Porter	1003 E. Blount St., Miami 55
Western Florida	W4MS	Edward J. Collins	359 Fairway Hill Drive, S.E., Pensacola
Georgia	W4CFJ	William F. Kennedy	563 Ramon Lovet, Atlanta
West Indies (Cuba-P.R.-V.I.)	KP4DJ	William Werner	563 Ramon Lovet, Urb. Truman
Canal Zone	KZ5WA	P. A. White	Box 82, Rio Piedras, P. R. Gamboa
SOUTHWESTERN DIVISION			
Los Angeles	W6JOB	Albert F. Hill Jr.	801 No. Millard Ave., Rialto
Arizona	W7OIF	Cameron A. Allen	100 East Maryland Ave., Phoenix
San Diego	W6LRU	Don Stansifer	4427 Pescadero, San Diego 7
Santa Barbara	W6REF	Mrs. Dorothy E. Wilson	Rte. 1, 75 Vista Del Mar, Ventura
WEST GULF DIVISION			
Northern Texas	W5TFP	Ray A. Thacker	4700 West Hanover, Dallas
Oklahoma	W5FEC	Richard L. Hawkins	1408 Bell Ave., Lawton
Southern Texas	W5QEM	Roy K. Eggleston	1109 Vernon Drive, Corpus Christi
CANADIAN DIVISION			
Maritime	VE1WB	D. E. Weeks	R. R. 3, St. Stephen, N. B.
Ontario	VE3NG	Richard W. Roberts	170 Norton Ave., Willowdale, Toronto, Ont.
Quebec	VE2GL	Gordon A. Lynn	R.R. No. 1, Ste. Genevieve de Pierrefonds, P. Q.
Alberta	VE6MJ	Sydney T. Jones	10707-57th Ave., Edmonton, Alta.
British Columbia	VE7JT	Peter M. McIntyre	981 West 26th Ave., Vancouver, B. C.
Yukon	VE4IF	James A. Elliott	190 Oakdean Blvd., St. James, Winnipeg 12
Manitoba	VE5LU	Lionel O'Byrne	Rowatt

*Official appointed to act temporarily in the absence of a regular official.

MALLORY HAM BULLETIN

for Wire Wound Controls — Depend on Mallory

... the standard of precision and quality,
for amateur or professional use in—

bias control
voltage dividers
excitation level control
"S" meter circuits
voltage regulators

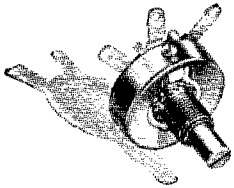

"C" Type 2-Watt Control

one of the smallest rated at 2 watts dissipation; only $1\frac{1}{16}$ " in diameter. Handy for many low voltage spots where size is a factor ... such as bias control, "S" meters. Grounded rotor arm, screw-driver-slotted shaft, 266° electrical rotation. 6 to 15,000 ohms.

"R" Type 2-Watt Control

especially designed for use in high voltage circuits. Insulation between shaft and resistance element rated at 1500 volts AC; dust-proof phenolic case. Shaft is thumb knurled, screw-driver-slotted stub, $\frac{1}{4}$ " in diameter—takes $3/4$ " extension shaft where desired. 2 to 20,000 ohms.

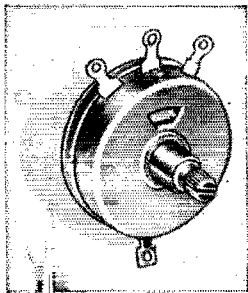
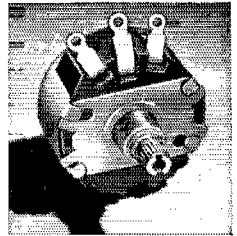

"M" Type 4-Watt Control

the old stand-by, used by more amateurs than any other. Universally accepted for voltage dividers, bias control, test instrument circuits. Resistance values from 0.5 to 100,000 ohms.

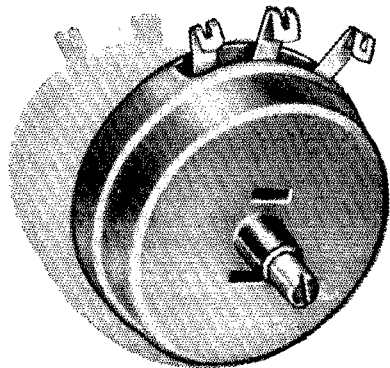

"E" Type 7-Watt Control

fills the gap between relatively low power "C", "R" and "M" controls and 25-watt and up rheostats. Particularly well suited for screen grid and similar voltage divider or voltage adjustment circuits. In nine values from 5,000 to 150,000 ohms.

In addition, Mallory supplies amateur experimenters with a diversified line of "T" and "L" pad attenuators, and center-tapped wound controls. For full information and prompt service, see your local Mallory distributor.

P. R. MALLORY & CO. INC.
P.O. Box 1558
INDIANAPOLIS 6, INDIANA

P. R. MALLORY & CO. Inc.
MALLORY

THE AMERICAN RADIO RELAY LEAGUE, INC.,

is a noncommercial association of radio amateurs, bonded for the promotion of interest in amateur radio communication and experimentation, for the relaying of messages by radio, for the advancement of the radio art and of the public welfare, for the representation of the radio amateur in legislative matters, and for the maintenance of fraternalism and a high standard of conduct.

It is an incorporated association without capital stock, chartered under the laws of Connecticut. Its affairs are governed by a Board of Directors, elected every two years by the general membership. The officers are elected or appointed by the Directors. The League is noncommercial and no one commercially engaged in the manufacture, sale or rental of radio apparatus is eligible to membership on its board.

"Of, by and for the amateur," it numbers within its ranks practically every worth-while amateur in the nation and has a history of glorious achievement as the standard-bearer in amateur affairs.

Inquiries regarding membership are solicited. A bona fide interest in amateur radio is the only essential qualification; ownership of a transmitting station and knowledge of the code are not prerequisite, although full voting membership is granted only to licensed amateurs.

All general correspondence should be addressed to the administrative headquarters at West Hartford, Connecticut.



Past Presidents

HIRAM PERCY MAXIM, W1AW, 1914-1936
EUGENE C. WOODRUFF, W8CMP, 1936-1940
GEORGE W. BAILEY, W2KH, 1940-1952

Officers

President GOODWIN L. DOSLAND, W0TSN
Moorhead, Minnesota

First Vice-President WAYLAND M. GROVES, W5NW
P.O. Box 586, Odessa, Texas

Vice-President FRANCIS E. HANDY, W1BDI
38 La Salle Road, West Hartford, Connecticut

Vice-President PERCY C. NOBLE, W1BVR
37 Broad St., Westfield, Massachusetts

Secretary A. L. RUDLONG, W1BUD
38 La Salle Road, West Hartford, Connecticut

Treasurer DAVID H. HOUGHTON
38 La Salle Road, West Hartford, Connecticut

.

General Manager A. L. RUDLONG, W1BUD

Communications Manager FRANCIS E. HANDY, W1BDI

Technical Director GEORGE GRAMMER, W1DF

Assistant General Manager JOHN HUNTOON, W1LVQ

Assistant Secretary PERRY F. WILLIAMS, W1UED
38 La Salle Road, West Hartford, Connecticut

.

General Counsel PAUL M. SEGAL
816 Connecticut Ave., Washington 6, D. C.

DIRECTORS

Canada

ALEX REID, VE2BE
240 Logan Ave., St. Lambert, P. Q.
Vice-Director: William R. Savage, VE6EO
833 10th St. N., Lethbridge, Alta.

Atlantic Division

GILBERT L. CROSSLEY, W3YA
Dept. of E. E., Penna. State University
State College, Pa.
Vice-Director: Charles O. Badgett, W3LVP
725 Garden Road, Glenside, Pa.

Central Division

JOHN G. DOYLE, W0GPI
4331 N. Wildwood Ave., Milwaukee 11, Wis.
Vice-Director: George E. Keith, W9QLZ
RFD 2, Box 22-A, Utica, Ill.

Dakota Division

ALFRED M. GOWAN, W0PHR
1012 South Willow Ave., Sioux Falls, S. D.
Vice-Director: Forrest Bryant, W0FDS
6840 Harriet Ave., Minneapolis, Minn.

Delta Division

VICTOR CANFIELD, W5BSR
Box 965, Lake Charles, La.
Vice-Director: Milton W. Kirkpatrick, W5KYC
4914 Floydell Dr., Baton Rouge, La.

Great Lakes Division

JOHN H. BRABB, W8SPF
708 Ford Bldg., Detroit 26, Mich.
Vice-Director: Robert L. Davis, W8EYE
247 Highland Ave., Salem, Ohio

Hudson Division

GEORGE V. COOKE, JR., W20BU
3 Daisy Lane
Carmaxek, L. I., N. Y.
Vice-Director: Lloyd H. Manamon, W2VQR
709 Seventh Ave., Asbury Park, N. J.

Midwest Division

ROBERT W. DENNERTON, W0NWX
Box 631, Newton, Iowa
Vice-Director: Sumner H. Foster, W0GQ
2315 Linden Dr., S.E., Cedar Rapids, Iowa

New England Division

MILTON E. CHAFFER, W1EFW
53 Hometown Ave., Southington, Conn.
Vice-Director: Frank L. Baker, Jr., W1ALP
91 Atlantic St., N. Quincy 71, Mass.

Northwestern Division

R. REX ROBERTS, W7CPY
837 Park Hill Drive, Billings, Mont.
Vice-Director: Howard S. Pyle, W7OE
3434 74th Ave., S.E., Mercer Island, Wash.

Pacific Division

HARRY M. ENGWICHT, W6HC
770 Chapman, San Jose 26, Calif.
Vice-Director: Harold L. Lucero, W6JDN
1113 Illinois Ave., Dunsmuir, Calif.

Roanoke Division

P. LANIER ANDERSON, JR., W4MWH
428 Maple Lane, Danville, Va.
Vice-Director: Thomas H. Wood, W4ANK
1702 N. Rhett Ave., North Charleston, S. C.

Rocky Mountain Division

CLAUDE M. MAER, JR., W0IC
740 Lafayette St., Denver, Colo.
Vice-Director: Carl L. Smith, W0BWJ
1070 Locust St., Denver 20, Colo.

Southeastern Division

JAMES P. BORN, JR., W4ZD
25 First Ave., N.E., Atlanta, Ga.
Vice-Director: Thomas M. Moss, W4HYW
P.O. Box 644, Municipal Airport Branch,
Atlanta, Ga.

Southwestern Division

WALTER R. JOOS, W6EKM
1315 N. Overhill Drive, Inglewood 3, Calif.
Vice-Director: Virgil Talbott, W6GTE
9226 Alexander Ave., South Gate, Calif.

West Gulf Division

GRADY A. PAYNE, W5ETA
4103 Linden St., Bellaire, Texas
Vice-Director: Carl C. Drumeller, W5EHC
3824 N.W. 58th St., Oklahoma City 12, Okla.

"It Seems to Us..."

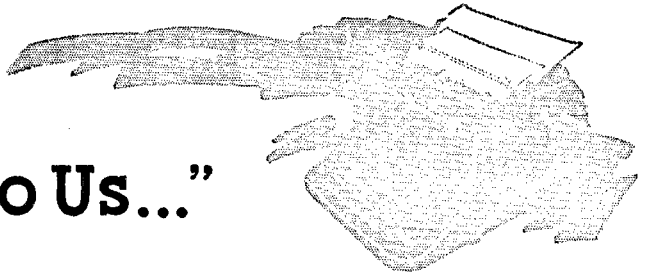

CALL LETTER LICENSE PLATES

Back in 1939, the Great Lakes Amateur Radiophone Association of Detroit thought it would be quite an accomplishment if hams in Michigan could get their call letters on automobile license plates in lieu of the prosaic numbers usually assigned. Not content only to dream, the club, under the leadership of W8NFR, submitted to the Secretary of State a list of some 400 amateurs interested in such plates. Surprisingly enough, the request was granted with no official act of the legislature involved, and the plates were issued. Unfortunately, after the first year officials felt the system was administratively unworkable, and so the privilege was withdrawn. The subject of call plates lay dormant for a decade.

In 1949, Florida State Senator Lloyd F. Boyle, W4IMJ, introduced a license-plate bill in his legislature; the wording itself was a testimonial to all amateurs, and its passage even more of a tribute. We quote some portions:

WHEREAS . . . the amateur radio operator has proven his worth in time of disaster and widespread danger to the people . . . has been directly instrumental by the dissemination of information in saving life and property at times when regular communications facilities were disrupted . . . services in locating travelers and persons whose whereabouts are unknown, and in numerous instances when disaster and storm have threatened, he has been a boon to mankind . . . there are approximately fifteen hundred licensed amateur radio stations in Florida ready and alert, equipped at their own expense and prepared for any emergency . . .

The ball began rolling. In 1950, amateurs in the Canal Zone and the states of Mississippi and Louisiana took Florida's cue and got similar bills through their governing bodies. The next year, ten more states followed suit. The box score today: thirty-eight states, three territories and several Canadian provinces have recognized hams by granting the privilege of automobile license plates carrying their call signs.

This, it seems to us, is a mighty remarkable achievement. It is a tribute to amateur radio — not only as an institution, but to many of our state and regional leaders. It requires

capable, mature, and respected individuals to frame such legislation and guide it through complex legislative processes.

Alabama	New Hampshire
Arizona	New Mexico
Arkansas	North Carolina
California	North Dakota
Colorado	Ohio
Connecticut	Oklahoma
Delaware	Oregon
Florida	Pennsylvania
Georgia	South Carolina
Idaho	South Dakota
Illinois	Tennessee
Indiana	Texas *
Kansas	Utah
Louisiana	Virginia *
Maryland *	Washington
Michigan	Wisconsin
Minnesota	Canal Zone
Mississippi	Hawaii
Missouri	Alaska
Montana	New Brunswick *
Nebraska	Quebec
Nevada	*Mobile units only

We hope that amateur groups in the remaining states, where in many cases equally capable people have made the attempts but run into so far insurmountable difficulty, will soon be able to make the box score a full 48.

SS

Comes again the time of the glass arm, laryngitis, the twelve-cup coffee pot, the sleepless nights, and the full ash-trays: Sweepstakes time is here again. The dyed-in-the-wool contest men are well aware of it, of course; for them this is the high point of the year. They have a pile of log forms in hand, plenty of "dupe sheets" (ARRL Operating Aid No. 6, for keeping track of stations worked to prevent duplication), lots of sharpened pencils and scratch paper. The beam bearings have been greased; an s.w.r. bridge has been used to be sure every last bit of juice can be squirted out the antenna. The receiver has been checked over, and the filaments left on for the last three weeks to make sure it doesn't drift when the contest starts. All is in readiness.

(Continued next page)

Many hams are more casual in their approach to the SS, of course. But nearly everybody who has tried it thinks it's great — whether they are entering wholeheartedly, sharp-shooting to fill gaps in their WAS or WAVE totals, or simply enjoying an hour or two of snappy operating.

For you who have never operated in the Sweepstakes, we want to encourage you to try. Although a lot of operators buzz right along, speed is not necessarily important. Most good operators will answer you at your own speed. A glance at the rules on page 46, and a quick listen to the gang will tell you all you need to know about entering. Have fun, and BCNU in the Contest.



Nebraska — The Pioneer Radio Club will sponsor an all-day hamfest in Fremont at the Hotel Pathfinder on Sunday, November 3. A day of activities for OMs and XYs will be wound up with an evening banquet. For further info, write to Tom Morris, W0VUO, 134 East 4th St., Fremont.

A.R.R.L. FAR EASTERN PACIFIC DIVISION CONVENTION

Agana, Guam — November 9-11, 1957

The Marianas Amateur Radio Club is sponsoring the second ARRL Convention to be held on Guam Island November 9 to 11. The Convention has been approved by the Chief of Naval Operations, and all military commands — Navy, Air Force, Marine, and Army — have been urged to cooperate. In conjunction with the Convention, the Governor of Guam has proclaimed the week of November 3-10 as Radio Amateur Week. The program will include talks, papers, and discussions on technical subjects relative to electronics. Well-known hams including Pacific Division Director Engwicht, ARRL General Manager Budlong, John Reinartz, Paul Fenner and others are on the program. Civilians not on the program must make their own arrangements for travel. Only American citizens are allowed to attend. Registration fee is \$10.00. Further details may be had from the Marianas Amateur Radio Club, P. O. Box 145, Agana, Guam, or any ham station on Guam.

OUR COVER

This month's cover is simply a display of some of the QSLs that came through as a result of last spring's ARRL DX contest. You'll find full details of the contest starting on page 50 of this issue. Lots of pictures, too!



KN5MIS is a gal.

One day recently *QST's* v.h.f. editor, W1HDQ, answered a Technical Information Service inquiry from K4EUS. That night, hearing the 2-meter band wide open to the south, he called "CQ W4" and was answered by none other than K4EUS!

W6QYT reports that the first rocket of the "Smokepuff" series reached the desired altitude but because of a failure in the radio control mechanism the gas cloud could not be released until the rocket had virtually returned to earth. The U. S. Air Force extends warm thanks to all who participated in this first test, and reports that there will be additional tests in October and November which may produce ionization. However, the next all-out attempt to produce an ion cloud is now scheduled for March, 1958.

K2SST lays claim to having sent the largest QSL card in the world. Measuring 3 x 4 feet, it was sent to W2FVB by truck. Any challengers?

KH6CU spotted a newspaper account of W6UOU's recent DXpedition to KS6 which reported that W6UOU used "a new development known as a 'single sideboard transmitter' which enables him to reach great distances with little power." Drunk with power, or powered with drink?

There are a number of good books on the technical aspect of radio available from the Government Printing Office at reasonable prices. Write to the Superintendent of Documents, GPO, Washington 25, D. C., and ask for catalog PL82. — *M. D. Bedrossyan.*

Radio Propagation and Atomic Bomb Tests Amateur Observations Wanted

In the course of the current series of atomic bomb tests at the Nevada Proving Grounds, many reports of peculiar radio propagation effects have come to ARRL. Some appear to be mere coincidence, but others indicate that there may be definite effects on wave propagation, particularly on paths that cross the area of the tests. If such effects exist, we'd like to know more about them, and so would a number of physicists work-

ing in the wave propagation field.

We ask, therefore, that amateurs noting unusual propagation, radio noise, or other effects that might be associated with bomb explosions, report their observations in detail to ARRL. We will see to it that the reports reach the people who are interested in studying them. Simply send such information to the Technical Department, ARRL, West Hartford 7, Conn.

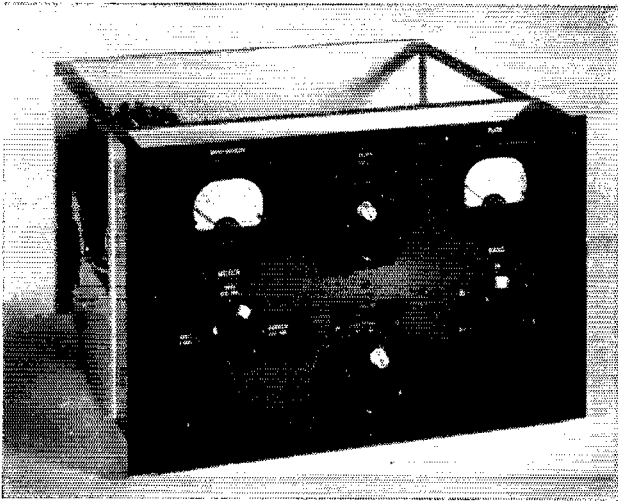

There is a pleasing symmetry to the control layout on the 10 × 15½-inch panel. The grid circuit is untuned, so the only r.f. controls are the band switch, plate tuning, and loading. Separate meters are provided for plate and screen currents, with the screen meter also used as a grid-current monitor. The amplifier, 15 inches deep, contains filament transformer and cooling fan in addition to the r.f. circuits.

Compact AB₁ Kilowatt

Single-tube amplifier runs 1000 watts input on s.s.b., c.w. or a.m. as a linear amplifier with no grid current. A new high-power tube designed specifically for AB₁ operation makes it possible.

BY RAYMOND F. RINAUDO,* W6KEV

BECAUSE IT IS the almost universal practice to generate an s.s.b. signal at a low level and then amplify it to the required output with one or more linear amplifiers operating Class A, AB₁, AB₂ or B, the linearity of the amplifying stages is all important. The stages following the best s.s.b. generator can turn a clean signal into one which is distorted and unnecessarily broad. Thus the need for truly linear amplifiers.

While the individual designer has his choice as to the class of operation in which the amplifier will run, Class AB₁ has several desirable characteristics. Because the control grid is never driven positive the very serious problem of adequate driver regulation never has to be faced, as it does if the mode of operation is AB₂ or Class B. In addition, no driving power is required for the tube: only the grid circuit losses must be supplied.

It should be pointed out that most tetrodes and many triodes appear as a resistance of 200 to 500 ohms from grid to cathode when the grid is positive. During the part of the r.f. cycle when the grid is negative the resistance is infinite. A driving source that can supply either an infinite resistance or a load of a few hundred ohms, with-

out distortion of the voltage wave form in either case, would have to have very low internal resistance. A working approximation is usually achieved by making the tuned grid circuits of r.f. amplifiers extremely high *Q*. In audio amplifiers it is obtained by using low-plate-resistance driver tubes plus a step-down transformer.

Class AB₁ amplifiers compare very favorably in efficiency with AB₂ and Class B. In fact, overall amplifier efficiencies, which take into account the losses in the tube and the circuit, are usually of the order of 55 to 65 per cent. It is only when compared with Class C operation that AB₁ represents a significant lowering of efficiency.

It is for this reason that some of the older tube types do not look particularly attractive in s.s.b. service. In the past almost all transmitting types were designed for optimum service in Class C amplifiers. This optimum provided a balance between plate current and plate dissipation; the higher efficiency realized required less plate dissipation capability for a given input power. In contrast, a tube designed especially for AB₁ application would be expected, for a given output, to have a higher plate-dissipation rating than we have become accustomed to.

* c/o Eitel-McCullough, Inc., San Bruno, Calif.

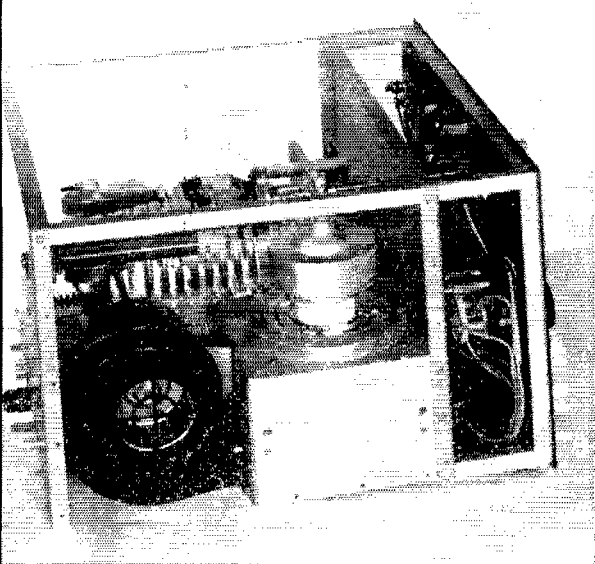

Vertical chassis construction is used, as this view from the tube side shows. The air-system socket is mounted on the 6 by 6-inch top of an aluminum enclosure 4 inches high, with the chassis pan forming one wall. When the bottom plate is in place this forms a pressurized area for forcing air from the blower through the socket. The socket chimney has been removed in this photograph to show the 4CX1000A tube.

The 4CX1000A Tetrode

A tube designed to have exceptionally good linearity in Class AB₁ r.f. amplifiers is the newly announced Eimac 4CX1000A. It is a power tetrode of all ceramic and metal construction having an external anode capable of dissipating 1000 watts with 35 cubic feet of air per minute blown through the cooling fins. The filament requires 6.0 volts at 12.5 amperes to heat the oxide coated cathode. With the usual tetrode connection having the cathode and screen at r.f. ground, the grid-to-cathode capacitance is 85 $\mu\text{mf.}$, plate-to-ground is 12 $\mu\text{mf.}$, and grid-to-plate is 0.02 $\mu\text{mf.}$ In spite of the low feed-back capacitance, the very high transconductance of 37,000 micromhos makes neutralization necessary if a tuned grid circuit is used. The maximum ratings are: plate voltage, 3000; plate current, 1 ampere; screen dissipation, 12 watts; control grid dissipation, zero watts.

The power output will vary with the type of service for which the tube is used. For single side band suppressed carrier single tone, the output

is 1680 watts for 2700 watts input at the maximum plate voltage of 3000. If the driving signal is an amplitude-modulated carrier, either single or double side band, a carrier output of about 300 watts can be expected from a kilowatt input. If a c.w. signal is being amplified then the output power would be approximately 600 watts. Since for a.m. phone or for c.w. the carrier or key-down conditions apply in measuring power input, it is the legal power-input limit that largely determines the output power. In commercial service the capability is considerably greater.

The connection to each element is made by means of three metal tabs or ears which protrude through the side of the envelope at 120-degree intervals around the circumference. The screen tabs are nearest the anode; the control grid, cathode plus one side of the heater, and heater follow in order to the bottom. Ham ingenuity will make it possible for some to build their own sockets but most will use the Eimac SK-800 which has a built-in screen by-pass capacitor. The height of the tube is just under 4 $\frac{3}{4}$ inches, and the diameter approximately 3 $\frac{3}{8}$ inches.

The use of ceramics instead of the usual glass for the envelope makes the 4CX1000A much more rugged mechanically and makes possible a higher operating temperature. The first feature is very handy for the time the prized bottle rolls off the table onto the floor!

It will be noted above that the control grid is rated at zero dissipation. In designing the tube for AB₁ operation the location and number of grid wires was not hampered by compromises such as would be necessary if the grid were called upon to handle power. Consequently, a large number of fine wires were closely spaced to the cathode to give an unusually sharp-cutoff grid

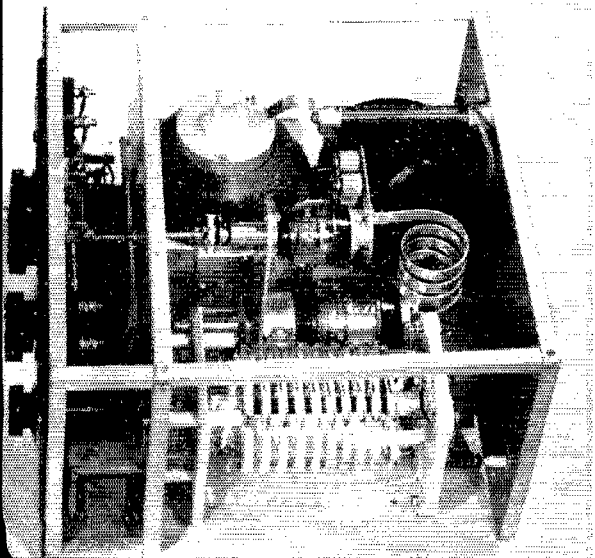

This view from the tank-circuit side shows the tapped pi-network coil and the vacuum input and output capacitors. The capacitors are mounted on an aluminum bracket fastened to the tube compartment. The plate blocking capacitor—four units in parallel—mounts on a plate fastened to the hot terminal of the input tuning capacitor. The plate choke is mounted on the rear wall. The chimney is around the tube in this photograph.

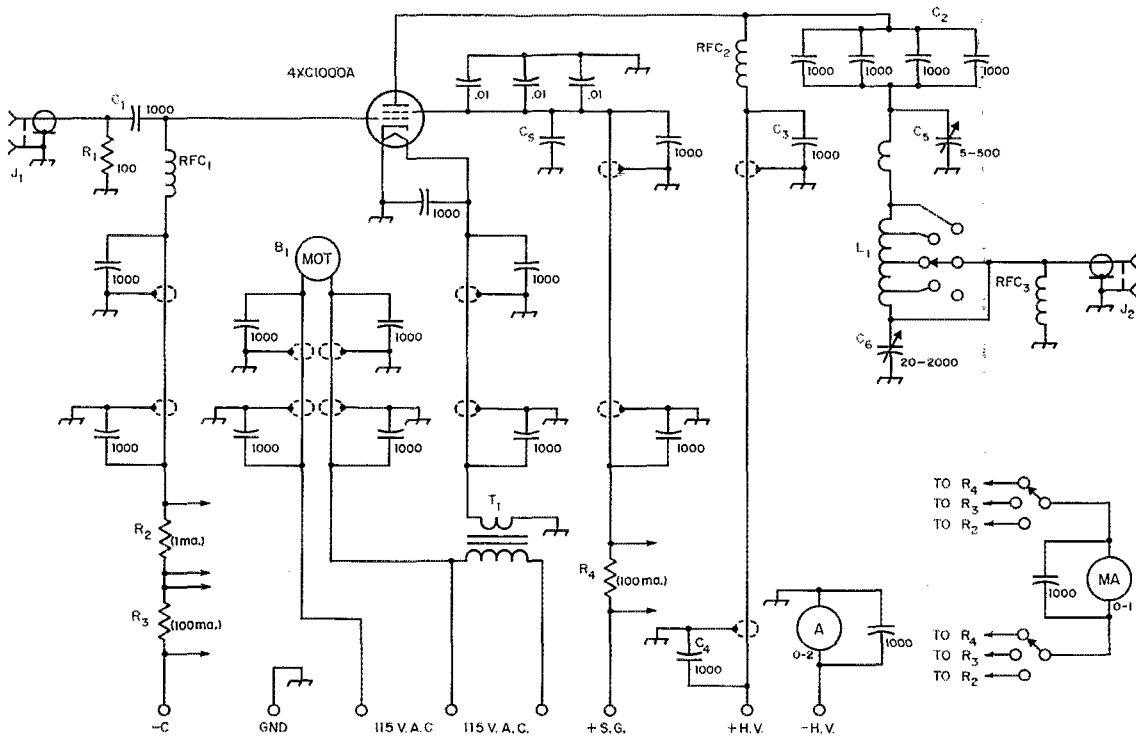

Note: Power lead for blower motor is brought out separately for resistance control of speed during stand-by.

Fig. 1—Circuit diagram of the amplifier. Unless otherwise indicated, capacitances are in $\mu\text{mf.}$, resistances are in ohms. Capacitors not listed below are 600-volt disk ceramic.

B₁—Blower motor.

C₁—1000- $\mu\text{mf.}$ mica.

C₂—Four 1000- $\mu\text{mf.}$ ceramic in parallel, 5000-volt rating (Centralab 858).

C₃, C₄—1000- $\mu\text{mf.}$ ceramic, 5000 volts (Centralab 858).

C₅—5-500- $\mu\text{mf.}$ vacuum variable (Jennings UCSL 500 3KV).

C₆—20-2000- $\mu\text{mf.}$ vacuum variable (Jennings UCSL 2000 2KV).

C₈—Built-in socket bypass, 1450 $\mu\text{mf.}$

J₁, J₂—Coax receptacles, chassis mounting.

L₁—Pi-network tank assembly (B & W 852).

R₁—100 ohms, noninductive, to dissipate at least 15 watts (see text). Can be assembled from 2-watt composition resistors in parallel or series-parallel.

R₂—Approx. 1000 ohms (should be 20 or more times meter resistance).

R₃, R₄—Adjusted to shunt 1-ma. meter for 100 ma. full scale; approx. 0.5 ohm in average case.

RFC₁, RFC₃—2.5-mh. r.f. choke.

RFC₂—Solenoid choke, 500 ma. (B & W 800).

T₁—Two 6.3-volt, 6-amp. transformers paralleled.

voltage-plate current characteristic. Thus linearity is maintained near cutoff.

While the tube is capable of powers in excess of the legal amateur limit it is quite legal to have peak inputs in amateur service well in excess of a kilowatt if the average power does not exceed that figure. (If there are doubters, please read the excellent article by Byron Goodman, "Linear Amplifiers and Power Ratings," in August 1957 *QST*.) In such cases the tube cathode is asked to supply quite high currents and must be capable of such operation if linearity is to be maintained.

A Compact Amplifier

The tube is a relative midget in size and the challenge to design a small amplifier of high power capability could not be resisted. So the amplifier shown in the photos, contained in a package

measuring 10 inches high by 15½ inches wide by 15 inches deep, came into being. The r.f.-tight enclosure is 12 inches front to back, with a 3-inch space between the front panel and shielded box. Not shown in the photographs are the perforated aluminum U-shaped cover, which forms the top and two sides, or the solid sheet of aluminum that completes the shielding on the bottom. The space between the front panel and the main shielded enclosure is out of the r.f. field and so was not made r.f. tight. In spite of the compactness there is no crowding of parts.

The plate circuit is a conventional pi network. However, some of the components do represent a departure from those usually seen in high-power amplifiers. The blocking capacitor is made up of four 1000- $\mu\text{mf.}$ ceramic units in parallel, resulting in a capacitance about double that normally used.

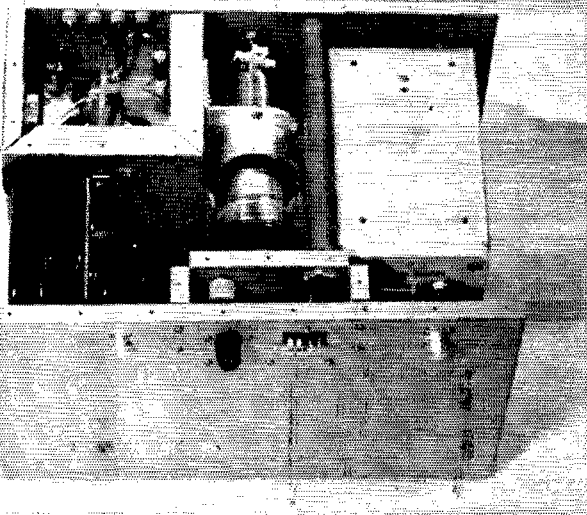

This bottom view gives a glimpse inside the grid compartment, upper left. R.f. input is through the coax connector on the rear wall and a short length of coax into the shield box. Power leads come in through the socket and high-voltage connector at the center, where they are enclosed by a small aluminum shield mounted on the rear wall. All except the high-voltage lead and leads to the blower motor go through the conduit (running alongside the bottom of the tank coil assembly) to the front of the unit. The high-voltage lead goes through shielded wire to the plate choke. Those to the blower are also shielded.

This was done because of the low impedances involved in the low-voltage high-current application. The plate tank inductor has much less inductance than the standard B & W 850A although physically the same size. The unit used was designed specifically for this low impedance application by Barker & Williamson, and it is understood that it is now available, carrying the number 852. The plate choke is the recently announced B & W 800. The Jennings variable vacuum capacitors contributed immeasurably to the compact construction, and here again the 500- μ fd. input capacitor is higher in capacitance than usually expected. The high C is necessary at 3.5 Mc. to maintain the operating Q of the circuit. The low inductance of these capacitors helps considerably in the elimination of parasitic oscillations.

The grid circuit represents a departure from the usual practice by having no tuned circuits. As was mentioned previously, AB_1 operation precludes driving the grid positive and so the voltage stabilizing influence of a high- C circuit is not needed. Instead, a 100-ohm resistor is used in the r.f. circuit between grid and cathode. This also represents very heavy loading of the grid and makes neutralization unnecessary. When using the grid bias indicated for typical operating conditions, -55 volts, the power lost in the resistor is 15.1 watts and is the total required driving power. For those who would like to terminate the transmission line from the driver in a 50-ohm resistor, the driving power would be 30.3 watts. The photograph of the under side of the unit shows two noninductive wire-wound resistors which make up the 100-ohm load; these have since been replaced by a bank of carbon resistors.

If the driving power requirement of this untuned arrangement can not be tolerated, a tuned circuit can be added. In such case the only power needed is that required to supply the tuned-circuit loss. Neutralization, of course, would become necessary, and the usual bridge circuit is the logical choice.

The front panel shows that two meters are used, though one is dual purpose. The plate current meter has a full-scale reading of two amperes; however, the maximum plate current that can be drawn is 1 ampere using the single tone test (into a dummy load). The dual-purpose meter is one milliamperes full scale and is used in combination with a switch and shunts to read grid current at 1 ma. full scale, grid current at 100 ma. full scale, or screen current at 100 ma. full scale. The one-milliamperes scale is used to monitor s.s.b. AB_1 operation so as never to drive into grid current. The 100-ma. grid current scale seems to be (and is) in direct contradiction to the statement that the control grid can dissipate no power. The truth is that from $\frac{1}{2}$ to 1 watt can be handled, but this leaves no margin of safety. The rating of zero dissipation still stands.

Although AB_1 operation minimizes the generation of harmonics, standard TVI-proofing techniques are used throughout. All leads leaving the shield enclosure not normally carrying r.f. are shielded and bypassed at both ends. Leads to the front panel from the compartment that shields the power-input socket are carried through the r.f. enclosure in a length of $\frac{1}{2}$ -inch conduit.

Two filament transformers in parallel are used to supply heater power. This was done because no single transformer of suitable capacity was available to fit into the space allotted. The transformers have a total capacity of 12 amperes to supply a heater requiring 12.5 amperes. However, the overloading is considered negligible.

In operation the amplifier has proved to be quite stable. The 100-ohm resistor between grid and ground undoubtedly contributes a great deal to this stability. However, a change in layout, even though minor, could alter the picture. As always, each new design must be checked for parasitics and be debugged if necessary. Slight changes in an old design in effect make it a new one.

The author wishes to thank Vern Olsen, W6INJ, for the use of the photographs which show the construction of the very neat amplifier built by him.

Project Moonbeam

The Radio Amateur and the IGY Satellite

BY W. H. PICKERING*

Over the past year and a half, *QST* has carried a number of articles describing various sections of the Minitrack system of satellite tracking as developed at the Naval Research Laboratory. The NRL activity is part of the work of a special group in the U. S. National Committee for the IGY. Dr. Pickering, head of this Working Group on Tracking Computation, issues here an official invitation to qualified amateur groups to participate in the volunteer satellite-tracking program — now known as "Project Moonbeam."

THE EARTH SATELLITE project of the IGY is perhaps the most significant scientific experiment of the whole program. Both the U.S.A. and Russia have announced that they are building satellite rockets and within a very few months one or both countries may be expected to be conducting satellite flights. These tiny satellite objects, circling the earth every hour and a half, offer a unique opportunity to observers all over the earth to participate in a fascinating scientific adventure, the beginning of the exploration of space.

The satellite will carry a low-power radio transmitter so that scientific measurements made with instruments aboard the satellite can be transmitted to the earth, to be recorded and analyzed. The transmitter will also be a radio beacon for tracking the satellite as it flashes across the sky. With accurate direction finding it becomes possible to measure the path of the object and therefore to predict its future motion and also to use its motion to provide new information on the exact shape and size of the earth.

Radio amateurs and volunteers from various scientific groups are invited to join in making these observations. The volunteer radio observing program has been given the name "Project Moonbeam." In order to be a part of this project individual amateurs or amateur clubs will need technical competence of a high order. Worthwhile observations can only be made by careful experimenters who understand the significance of all the factors affecting their measurements.

The technical problem of observing the satellite is principally that of building a very sensitive

receiver to operate on 108 Mc. for reception of the Minitrack signal transmitted from the U. S. satellite. The Russians have indicated that they will conduct an ionospheric experiment using satellite transmitters at 20 Mc. and 40 Mc. The transmitted power in the case of the U. S. satellite will be between 10 and 100 milliwatts. The Russian transmitter may be as high as 1 watt. These low powers are a consequence of the problem of power supply for a transmitter which will operate continuously for several weeks, but which will be limited in weight to that which can be carried on the satellite.

Receiving equipment suitable for the satellite experiment has been developed in two places: the Naval Research Laboratory and the Jet Propulsion Laboratory. The systems are known as Minitrack and Microlock, respectively. Articles on Minitrack have already appeared in *QST*¹⁻⁵. It is anticipated that a description of the Microlock station will be published shortly in *QST*.

Amateur groups wishing to join Project Moonbeam should notify the Satellite Office, Committee of the National Academy of Sciences, Washington, D. C. Requests for further information and assistance should also be directed to this office or to ARRL in West Hartford, Connecticut.

Data obtained from the Moonbeam network will be sent to the Naval Research Laboratory in Washington where a computer will analyze all of the radio observations to calculate the orbit of the satellite and to predict its future motion. An "almanac" of satellite positions will then be published so that observers all over the world may know when to watch for the object.

The Naval Research Laboratory in Washington, D. C., in the eastern part of the U. S. and the Jet Propulsion Laboratory in Pasadena, California, in the western part of the U. S., will serve as information centers for the Moonbeam network.

Arrangements for relaying results of observations of amateur stations belonging to the Moonbeam network will be made through ARRL Headquarters in West Hartford.

A similar volunteer observing program, Project Moonwatch, has been established among amateur astronomers. Over 100 observing teams have been

(Continued on page 182)

¹ Easton, "Radio Tracking of the Earth Satellite," *QST*, July, 1956, p. 38.

² Simas, "A Low-Noise Preamplifier for Satellite Tracking," *QST*, Dec., 1956, p. 42.

³ Easton, "Calibration of the Mark II Minitrack," *QST*, Apr., 1957, p. 42.

⁴ Easton, "Mark II Minitrack Base-Line Components," *QST*, Sept., 1957, p. 37.

⁵ Simas-Moriarty, "Tape Recording the Mark II Minitrack Signals," this issue, p. 42.

*Chairman of the Working Group on Tracking and Computation, Technical Panel for the Earth Satellite Program, U. S. National Committee for the IGY; also Director of the Jet Propulsion Laboratory, California Institute of Technology, Pasadena, Calif.

Mobile Converter Construction

Plug-In Coil Assemblies for the Crystal-Controlled High-Frequency Converter

BY C. VERNON CHAMBERS,* WIJEQ

car broadcast receiver following the converter, the i.f. range will be from approximately 550 to 1550 kc. Since the tunable i.f. range is thus limited to a band 1000 kc. wide, the tuning range of the system with any single crystal will be restricted to 1 Mc. This is sufficient for all except the 28-Mc. band. Two crystals are required to cover the entire 10-meter band. The first of these gives a tuning range of 28 to 28.9 Mc. and the second permits tuning 28.8 to 29.7 Mc. An accompanying frequency chart lists the crystal frequencies and the ranges over which the broadcast receiver must be tuned to cover the amateur bands.

It will be noticed that the frequency chart does not take into account the upper and lower

50-kc. segments of the broadcast receiver coverage. Usually, the tuning-dial calibration and band spread at the high-frequency end of the broadcast band leave something to be desired. However, if maximum coverage of the 28-Mc. band with one crystal is of chief concern, the 28.5 to 29.5 portion of the band may be covered by using a 27.95-Mc. crystal and then tuning the receiver between 550 and 1550 kc.

Construction

The input-tuning capacitor, C_1 , the pilot lamp and the switch are in line across the panel of the converter as shown in the front view. Each of these components is centered $\frac{3}{4}$ inch down from the top of the case and each is separated from the other in the horizontal plane by $1\frac{3}{4}$ inches. The male plugs for the grid, plate and oscillator coils

*Technical Assistant, QST

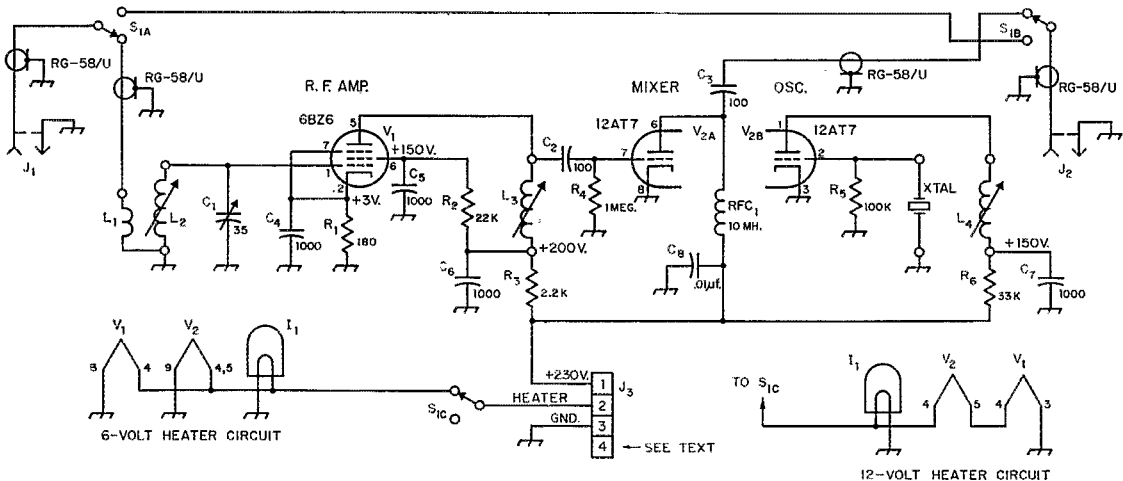
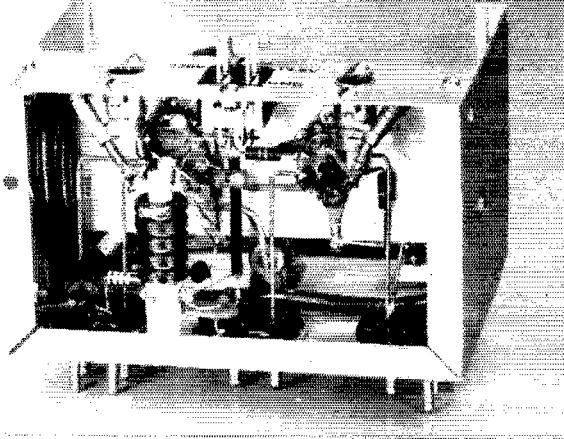

Fig. 1—Circuit diagram of the crystal-controlled mobile converter. Unless otherwise indicated, capacitances are in $\mu\text{mf.}$, resistances are in ohms, resistors are $\frac{1}{2}$ watt.

C_1 —35- $\mu\text{mf.}$ midget variable (Hammarlund MAPC-35-B).
 C_2, C_3 —100- $\mu\text{mf.}$ ceramic tubular.
 C_4, C_5, C_6, C_7 —1000- $\mu\text{mf.}$ disk ceramic.
 C_x —0.01- $\mu\text{f.}$ disk ceramic.
 I_1 —Pilot-light assembly [Johnson 147-503 with No. 44 (6-volt) or No. 1815 (12-volt) lamp].
 J_1, J_2 —Motorola-type shielded jack (ICA 2378).
 J_3 —4-prong male chassis connector (Cinch-Jones P-304-AB).
 L_1, L_2, L_3, L_4 —See coil chart.
 R_1 —180 ohms, $\frac{1}{2}$ watt.

R_2 —22,000 ohms, $\frac{1}{2}$ watt.
 R_3 —2200 ohms, $\frac{1}{2}$ watt.
 R_4 —1 megohm, $\frac{1}{2}$ watt.
 R_5 —0.1 megohm, $\frac{1}{2}$ watt.
 R_6 —33,000 ohms, $\frac{1}{2}$ watt.
 RFC_1 —10-mh. r.f. choke (National R-100S).
 S_1 —3-pole 3-position (used as 3 p.d.t.) selector switch (Centralab PA-1007).
 V_1 —See text and frequency chart (International Crystal type FA-9).



A bottom view of the mobile converter. The amplifier tube socket at the right is mounted with Pin 7 facing toward the rear wall of the chassis. R_1 and R_2 are to the right and left of the socket, respectively. The socket for V_2 is mounted with Pins 4 and 5 facing toward the rear of the unit. C_2 is to the lower left of R_2 , and RFC_1 is mounted on the front wall of the housing. C_7 and R_4 are to the left of the base of the choke. C_6 , C_8 and R_3 are to the right of RFC_1 . The output coupling capacitor C_3 is supported between Terminal 4 of J_3 and Pin 6 of the socket for V_2 . R_4 and R_5 are partially visible to the right and left, respectively, of the V_2 socket.

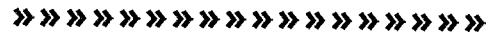

are below C_1 , I_1 and S_1 in that order. Each plug is centered $1\frac{1}{8}$ inches up from the bottom of the cabinet. It is a good idea to make a metal template for marking guide holes for the centers of the holes which must be punched for the plugs. Later on, use of this template for marking the locations of socket holes at the rear of the coil compartments will assure perfect alignment of the plugs and the sockets which must mate.

The chassis, shown in the rear view, may be made of thin aluminum sheet and should be fastened to the side walls of the cabinet with homemade brackets, or angle stock. The sockets for V_1 (at the right as seen in the rear view) and V_2 are centered $1\frac{5}{8}$ inches in from the right and left edges of the chassis, respectively. J_3 is centered on the rear wall of the chassis with J_1 and J_2 to the right and left.

A bottom view of the converter clearly shows the components mounted below deck. Wiring between the coil sockets and the tube sockets, and the lead to the stator terminal of C_1 , is done with No. 16 tinned copper wire. About two feet of RG-58/U will be required for the leads made with coaxial cable (see Fig. 1).

After the wiring of the coil plugs has been completed, it is advisable to clip off the unused prongs on the grid- and plate-coil plugs as shown in the front view of the converter. Less force is required when attaching or removing a plug-in

coil assembly if the extra prongs are removed.

The interior and the exterior of the coil box are shown in the front and rear views of the converter. Remember to use the template when marking the positions of the MIP sockets which support the coils. Wind the antenna coupling coils, L_1 in Fig. 1, around the ground ends of the grid coils before the latter are soldered in place. Wind the coupling coils rather snugly but not so tightly as to prevent adjustment of the coupling to L_2 during testing of the converter.

Prongs removed from an octal socket make ideal clips for connecting to the pins of the crystal sockets. When mounting a crystal, solder one of the clips directly to a socket terminal, and then return the socket terminal to ground with the shortest possible lead. The grid side of the crystal should be connected and supported by a heavy lead running to the MIP socket.

The tuning slugs of the coils may be allowed to protrude through rubber grommets as shown in the front view of the converter. After the coils have been peaked, the slug-adjusting screws may be clipped off, since replacing the cover after the coils have been resonated does not affect the adjustments.

Testing

An a.c. transformer may be used for the filaments while testing the converter. The plate sup-

COIL CHART FOR THE MOBILE CONVERTER

Band Mc.	Turns L_1	Ind. Range, $\mu h.$			Type No.		
		L_2	L_3	L_4	L_2	L_3	L_4
3.5-4	14	36-64	64-105	105-200	120-F	120-G	120-H
7-7.3	7	9-18	18-36	36-64	120-D	120-E	120-F
14-14.35	4	3-5	5-9	9-18	120-B	120-C	120-D
21-21.45	3	2-3	3-5	3-5	120-A	120-B	120-B
26.96-27.23	3	1-1.6	1.6-2.7	2.7-4.5	1000-A	1000-B	1000-C
28-28.9	3	1-1.6	1.6-2.7	2.7-4.5	1000-A	1000-B	1000-C
28.8-29.7	3	1-1.6	1.6-2.7	2.7-4.5	1000-A	1000-B	1000-C

Note: L_1 is wound with No. 28 d.c.c. wire at grounded end of L_2 . L_2 , L_3 and L_4 are slug-tuned coils manufactured by North Hills Electric Co., Inc., Mineola, N. Y.

ply should deliver 20 milliamperes at 200 to 250 volts. A modulated-signal generator covering the bands for which the converter has been constructed is extremely helpful. To be most effective, the generator should have a 50-ohm output termination; otherwise the coupling between L_1 and L_2 cannot be best adjusted for matching the low impedance normally found at the base of a mobile whip. A grid-dip meter for preliminary adjustment of the slug-tuned coils is useful, but not essential to alignment. If at all possible, the car receiver that is to be used as the tunable i.f. should be used during the testing.

Provided that the grid-dipper and the signal generator are available, the following procedure will assure rapid and accurate alignment of the converter:

Using coaxial-cable leads, connect the signal generator and the broadcast receiver to J_1 and J_2 , respectively. Switch S_1 to the ham-band position, and apply heater power. The receiver need not be turned on at this time, and plate power for the converter does not have to be applied. Now, rotate C_1 to approximately half capacitance and then adjust L_2 to resonance (use the grid-dip meter as the indicator) at the low end of the band. Move the grid-dipper over to the plate circuit of the amplifier and peak L_3 at the center of the band. Next, couple the meter to L_4 of the oscillator and tune the coil to the frequency of the crystal in use.

After these initial adjustments, plate power may be applied to the converter and a frequency-indicating device used to detect oscillation of V_{2B} . If the grid-dip meter is the self-rectifying

type it may be used for the check. An absorption-type wave meter with indicator or a receiver tuned to the crystal frequency (with the b.f.o. on) may also be used for the purpose. In any event, L_4 should be tuned through resonance to the high-frequency side of the crystal frequency until the crystal oscillates reliably as indicated by rapid starting when plate power is turned on. Flip the power on-off switch a few times to make sure the crystal will start oscillating immediately.

With the converter and the i.f. amplifier both turned on, and with the signal generator tuned to the center of the band, tune the receiver until the test signal is heard. Peak L_3 and L_4 for best response and then peak L_2 with C_1 set at half capacitance. The coupling between L_1 and L_2 may now be adjusted for optimum performance.

If the aforementioned test equipment is not available, the converter may be aligned while using a strong local of known frequency as the signal source. Of course, the signal frequency must be in the band for which the converter is to be aligned. In using this system, first set the broadcast receiver as closely as possible to the proper i.f. frequency (see the frequency chart) and then tune L_4 until the crystal oscillates. It is advisable to tune the receiver through a narrow range as the oscillator coil is being adjusted to assure that the test signal will be heard as soon as the crystal breaks into oscillation. After the signal is detected, the grid, plate and oscillator circuits may be adjusted for maximum over-all gain.

Operators who confine their operation to phone work should align the converter with the aid of test signals falling in the centers of the

The homemade L-shaped chassis, mounted on small brackets fastened to the side walls of the converter housing is 4 15/16 inches long, 2 inches wide and 1 1/2 inches deep. V_1 is mounted on the chassis to the right of V_2 as seen in this rear view. J_1 , J_3 and J_2 are in line in that order from left to right across the rear wall of the chassis. An interior view of a coil compartment is shown in the foreground. Terminals of the coils are soldered directly to the socket terminals. Notice that the crystal for the oscillator is mounted adjacent to L_4 .

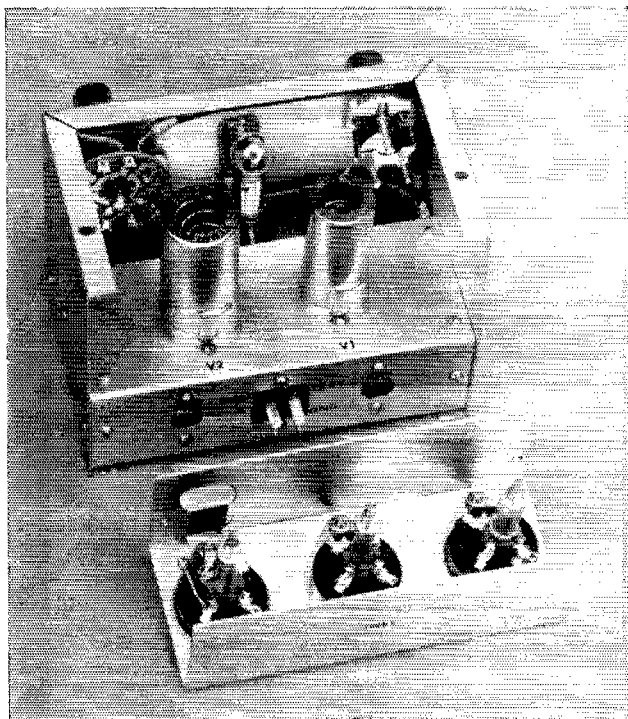

phone bands. A c.w. man may peak the converter circuits for his favorite spots in the more-frequently-used A1 sections of the bands.

Voltage readings that indicate normal operation of the converter are shown in the circuit

FREQUENCY CHART FOR THE MOBILE CONVERTER		
Band Mc.	Crystal Freq., Mc.	I.F. Range Kc.
3.5-4	2.9	650-1100
7-7.3	6.4	600-900
14-14.35	13.4	600-950
21-21.45	20.4	600-1050
26.96-27.23	26.3	660-930
28-28.9	27.4	600-1500
28.8-29.7	28.2	600-1500

Note: I.f. range indicates broadcast receiver tuning range necessary for covering the associated amateur frequencies.

diagram. These measurements were made with a v.t.v.m. and with the converter powered by a supply delivering approximately 230 volts under load.

Antenna, Antenna Coupling and Interference

A previous article¹ explains in detail why the mobile antenna should be resonant and tightly coupled. The article also suggests a method of minimizing interference caused by strong local broadcast signals that feed in through the converter to the tunable i.f. Traps for suppressing this type of interference have not been included in the plug-in-coil converter because the need for them will be entirely dependent on local broadcast-station power and frequency assignments.

Cost

When constructed for one band, the cost of parts for the converter (including tubes, knobs, metal boxes and crystal) is approximately \$20.00. The cabinet, coils, sockets and crystal for each additional band will run another \$7.50 or so.

Strays



K6AXS sent us some interesting pictures and a description of British Field Day exercises which he attended this summer. Those of you who are red hot Field Day enthusiasts will enjoy comparing the differences in rules. For instance, in Britain the maximum power that may be used on Field Day is 10 watts input, transmissions are restricted to c.w., and all operation must be from tents. Only two stations are allowed to operate from any one site, and each individual station may operate only one transmitter and one receiver at a time. Spare equipment is permitted, but cannot be connected. Antennas are limited to four per station, but the wire size is specified, and the maximum height that may be utilized is 45 feet. An official observer from the Radio Society of Great Britain was present at each site to make sure that the rules were enforced. K6AXS reports that none of the equipment he saw was standard commercial gear—it all being either surplus or home-brewed. Yes, they do things a little differently!

IT SEEMS like every time I'm at a ham meeting and single side band is mentioned a barrage of comments follows that reminds me of the little shepherd who cried "Wolf!" And I've been with mobileers who switch to BC reception when a side-band station in some other part of the band comes blasting through his receiver.

Perhaps the owner of a low-priced mobile converter must be saved from ridicule just a little bit (could it be because I'm in the same category?), but phooey on the guy who cries "wolf" when he's sitting there with a home receiver that has oodles of dials and knobs.

QRM is undesired stuff that comes through the receiver when you're trying to copy a particular station. When the signal you want and the signal (or signals) you don't want are on the same frequency you have to make up your mind that you're going to listen to the loudest one. It's the QRM kilocycles away that bothers the wolf-criers; they aren't used to it on a.m. and can't understand why they should get it from side band. In the case of some converters, the QRM may originate 100 kc. away, even though the receiver's i.f. stages are only supposed to pass about 10 kc. To understand the reason for the QRM, you have to understand the action of a receiver.



In a receiving system with no manual r.f. gain control, as is the case of a converter working into a car radio, the entire front end and the i.f. amplifier stages are running wide open when there is no signal present. Any signal that reaches the a.v.c. rectifier will act to reduce the gain of the receiver and prevent overload. An operator used to a.m. reception with the manual gain control "wide open" and dependent entirely upon a.v.c. action probably never realized that

• The author says "This article is intended to enlighten the Novice and remind the old-timer of a few receiver principles he may be prone to forget, especially in the handling of a.m. in the presence of side-band signals." Read it; it may help you.

QRM

or

Cockpit

Trouble?

Correcting Receiver Troubles at the Source

BY STEVEN J. TAKACS,*
K6VYV, EX-W8FBG

the a.v.c. (and S meter) action is often controlled by signals he can't hear because they are too far away (in kc.). The effects of these strong signals are felt at the a.v.c. rectifier because the "skirt selectivity" of the r.f. and i.f. stages is insufficient to reject the signals completely. The a.v.c., by reducing the gain of the receiver, prevents any noticeable overload.

But when the nearby signal is varying rapidly in amplitude, as in the case of side band, the a.v.c. cannot follow fast enough to avoid overloading the receiver. The a.m. case is noticeable only at the instant the carrier is switched on and off, and only a very observant operator is conscious of the action.

Where does cockpit trouble enter the picture? Well, instead of cussing the QRM in the home receiver, simply reach over and turn the r.f. gain way down and the audio gain up to maximum, turn off the a.v.c. and use only the r.f. gain control to vary the receiver volume. You will usually discover that the old "wolf" has disappeared, and signals that were formerly broad as barn doors with the a.v.c. on are now just as narrow as other signals. In fact, the side-band stations of equal volume are almost hard to locate now. In two seconds you have increased the effective selectivity of your receiver by quite a bit.

QRM from strong a.m. stations may have had control of your a.v.c. system for years without being noticed by you (simply because their steady carriers didn't make your "S" meter jump), but as soon as a side-band signal gets anywhere near your receiving frequency you can't help but notice the effects (if the r.f. and i.f. stages are running wide open). In the first place,

(Continued on page 186)

* 3713 David Drive, North Highlands, Calif.

Artificial Earth Satellites

By V. VAKHNIN

This condensation of an article that appeared in the June, 1957, issue of the U. S. S. R. publication *Radio* is timely in view of the wide interest expressed by amateurs in picking up the signals from the first satellite. It covers the general aspects of satellite travel and offers suggestions for participation by radio amateurs in the experiment. The translation is one distributed to members of the IGY technical panel on ionospheric physics.

During the International Geophysical Year the U. S. S. R. proposes to launch several artificial Earth satellites equipped with radio transmitting apparatus. Radio observation of the signals of these satellites will make it possible to obtain new data on the structure of the ionosphere, to establish with precision the size, shape, and position of the satellite's orbit, and to obtain information on the processes taking place in the satellite during its flight. Since radio amateur observations will be of a mass character they can secure extremely important data on the satellite's flight and the state of ionosphere.

The success of radio amateur observations and the value of the data they obtain will depend largely on how well the amateurs take into consideration those characteristics of reception which are associated with the unusually high

altitude, unusually high speed, and other characteristics of the flight of a satellite.

Orbits of Artificial Earth Satellites

The artificial Earth satellite will be launched with the aid of rockets which will raise it to an altitude of several hundred kilometers and then accelerate it in the horizontal direction to a speed of about 8000 m/sec. (Fig. 1), after which the rocket motors will cut off, the satellite will be separated from the rocket, and the former will move around the Earth, making one revo-

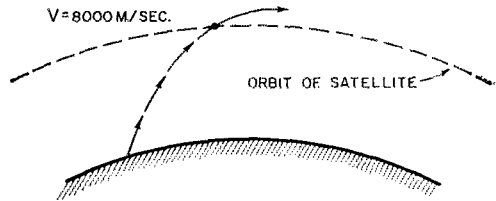

Fig. 1—Diagram of satellite launching.

lution in approximately one hour and a half. The satellite's orbit will be approximately elliptical in shape; the center of the Earth will be the position of one of the foci of the ellipse (Fig. 2).

After launching, the satellite will experience a slight braking action due to friction in the upper atmosphere and, as a result, its flight speed will gradually decrease; thus the flight altitude will also decrease. After several days or weeks the flight altitude will be so reduced that the satellite will enter the denser layers of the atmosphere, be greatly slowed down, and

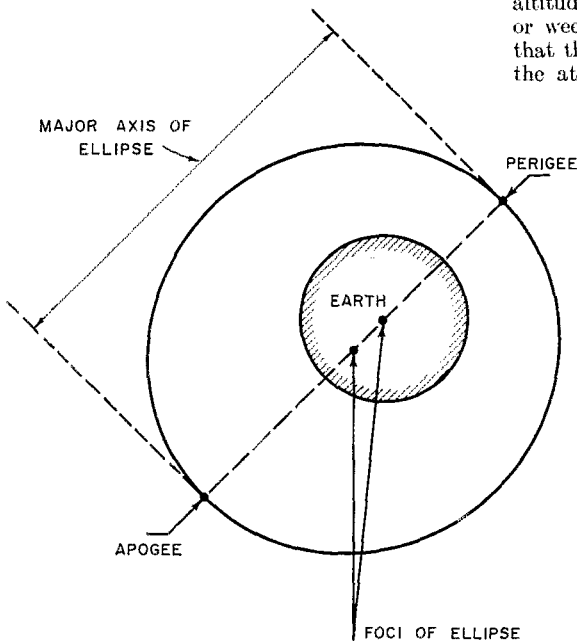

Fig. 2—Orbit of satellite.

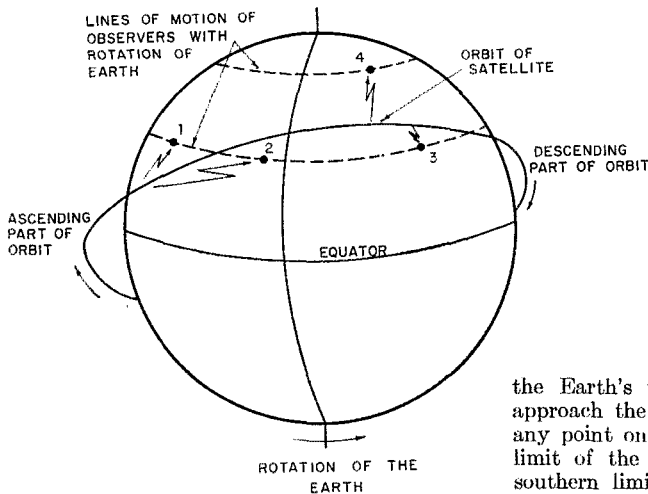

Fig. 3—Motion of satellite and observers. 1—Position of observer during radio pickup of rising part of orbit, 2—position of observer during second pick-up period (on ascending part of next orbit), 3—position of observer during pickup PXX on descending part of orbit, 4—observer located close to northern limit of observation.

be heated by friction with the atmosphere and burn up. The braking force and, consequently, the length of the life of the satellite will depend on the density of the upper layers of the atmosphere, which is known only in the most approximate terms at the present time; therefore the data on how rapidly the satellite is braked and burns up are of considerable scientific interest.

Of particularly high value will be amateur observations at the end of the satellite's flight, to the extent that the process of entry of the satellite into the denser layers of the atmosphere may take place in regions where there are no professional receiving sets.

Region of Observations of the Artificial Satellite

The diagram of the relative motion of the satellite and observers is shown in Fig. 3. The plane of the satellite's orbit does not participate in the rotation of the Earth, while observers on the Earth's surface move with the earth's rotation from west to east on lines shown in Fig. 3 by dotted lines. During one revolution of the satellite (approximately 1.5 hours) an observer on the equator has moved 2500 km. to the east, an observer at 45° latitude has moved 1760 km. and one at 60° latitude has moved 1000 km. The northern and southern limits of observation are determined by the inclination of the orbit; the more steeply the orbital plane is inclined, the further north and south the satellite will pass in its motion. In 24 hours the satellite will make a full 16 revolutions,¹ as a result of which the Earth's surface will have been covered with an almost uniform "grid." A satellite launched in the U. S. S. R. will in its flight cover practically all the populated area of the Earth.

Any observer located between the northern and southern limits of the region of observation will be able to observe the satellite, no matter what the longitude of his position; as a result of

the Earth's rotation he will sooner or later approach the orbit and intersect its plane. At any point on the Earth south of the northern limit of the "orbital grid" and north of its southern limit the satellite will be observable twice in twenty-four hours: On the "rising" and "declining" branches of the orbit (Fig. 3). In the most northern and southern regions both observations will be combined into one.

The time during which the radio signal will be audible on one revolution will be determined by the speed of the satellite (8 km./sec), the range of the radio facilities, and the distance of the path of the given revolution of the orbit from the observation point (Fig. 4). The average duration of one reception period will be several minutes.

Rotational Motion of a Satellite and Its Influence on Radio Reception

The highest rate of rotation of the satellite will not exceed several turns per minute. The influence of rotational motion of the satellite on radio reception is determined first of all by the design of the satellite's antennas: Sufficiently low fading results if the antenna on the satellite is so constructed that it radiates a wave with circular polarization while the antenna of the ground station is designed for reception of linear polarization. In this case reception of signals is guaranteed for almost any rotation of the satellite.

The occurrence of strong signal fading ac-

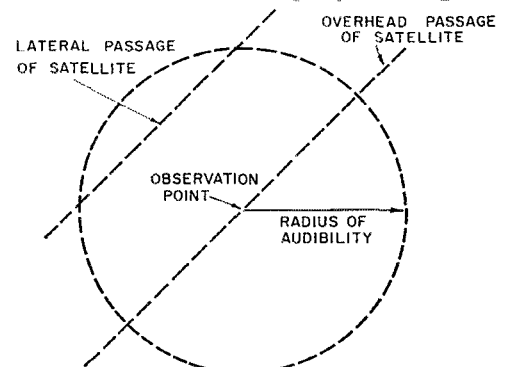

Fig. 4—Duration of audibility of satellite during overhead and lateral passages.

¹ The actual figure for the first satellite turned out to be almost exactly 15, the period being a few seconds over 96 minutes. — Editor.

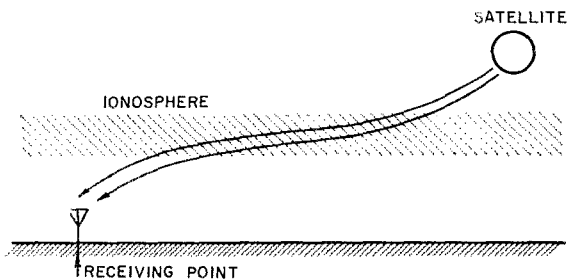

Fig. 5—Passage of signals from satellite.

accompanying the rotation of the satellite is of low probability; more probable are some (moderate) fluctuations of the signal strength.

Radio Signal Fading

In addition to the above described phenomena associated with rotation of the satellite, there may occur ordinary signal fading caused by the addition of radio waves arriving at the receiving antenna by different paths (Fig. 5).

The character of fading can be somewhat unusual: Since the satellite moves at a high speed, the path followed by radio waves will change rapidly. Therefore the moments when waves passing from different directions cancel each other out and the moments when the waves are additive can alternate extremely rapidly, thus fading will not be the slow oscillations in signal strength to which radio amateurs are accustomed, but instead rapid modulation of the signal with a frequency of tens or even hundreds of cycles per second.²

Doppler Effect

The Doppler effect is such that in the case when the radio receiver and transmitter are moved closer together or farther apart the frequency of the signal arriving at the radio re-

ceiver varies in proportion to the rate of movement together or apart.

When the movement is together the frequency of the signal increases, and when apart the frequency decreases. An approximate graph of the variation of the radio signal frequency with time is shown in Fig. 6.

The rate or variation of the frequency in the period of flight past the receiving point depends on the distance at which the satellite passes; the closer the satellite approaches the receiver, the more rapidly the frequency varies from maximum to minimum (see curves in Fig. 6).

The whole period of frequency variation occupies only two or three minutes; if the heterodyne of the receiver is sufficiently stable³ and during the time of reception does not become detuned, the Doppler effect can be easily detected and recorded. This provides important data on the position of the orbit relative to the receiving point. At the beginning of reception of radio signals from the satellite the heterodyne must be tuned so as to take into account the fact that the frequency of the tone at the middle of the reception period varies by approximately 2000 c.p.s. (for 40 Mc.) and approximately 1000 c.p.s. (for 20 Mc.); subsequently, during the remainder of the listening period the tuning of the heterodyne should not be changed. (Note: It should be remembered that, if the heterodyne is tuned below the carrier frequency, then the frequency of the audible tone will be decreased while, if the heterodyne is tuned above the carrier frequency, the frequency of the tone will rise).

(Continued on page 188)

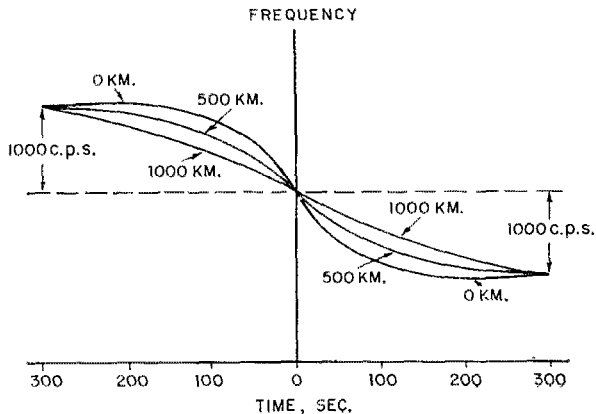

Fig. 6—Graph of frequency variation (Doppler effect) depending on distance along Earth's surface between observation point and plane of orbit.

² A type of fading similar to that known to amateurs as "auroral flutter" when associated with v.h.f. auroral propagation and, on lower frequencies, magnetic disturbances. — Editor.

³ I.e., over-all stability of the order of 10 cycles or less during the period while the signal is audible. Crystal-controlled oscillators are desirable. — Editor.

PREDETECTION BAND WIDTH

1221 East Cota St.
Santa Barbara, Calif.

Technical Editor, *QST*:

Apparently some amateurs have come to believe that predetection band width is an important factor in the performance of v.h.f. receivers. That this assumption is largely erroneous I will attempt to show in this letter.

It is well known that the amplitude of random noise is proportional to band width. However, in an a.m. receiver this is true only so long as no signal is being received. As soon as there is a carrier in the receiver pass band the simple proportionality between predetection band width and receiver output noise no longer holds true.

A precise mathematical solution to this problem is quite difficult but a superficial understanding of what happens can be had by considering the following situation: A carrier very much stronger than the noise level is present at a frequency f_c in the center of the i.f. pass band of an a.m. receiver. The linear second detector now acts to a good approximation as a product detector and hence the output is essentially that of the noise in the i.f. pass band beating with the carrier. If the audio-frequency response of the receiver is limited to a maximum frequency f_1 , only the noise in the i.f. pass band between the frequencies $(f_c + f_1)$ and $(f_c - f_1)$ contributes significantly to the output. In other words, the output is just what it would be if the i.f. were limited to a band width of $2f_1$. This holds true no matter how wide the i.f. pass band actually is.

In the case of c.w. or s.s.b. reception there is no denying that elimination of the audio image will improve the signal-to-noise ratio 3 db., but aside from this the signal-to-noise ratio will depend only upon the frequency response of the receiver's audio amplifier, the loudspeaker, and the listener's ear. This is true because a very strong carrier (the receiver's h.f.o.) is always present when receiving c.w. or s.s.b.¹

In the case of a.m. reception the carrier is not always very strong. However, to produce a readable output the carrier must exceed the noise level by about 8 db., and for signals this strong a majority of the noise output is still caused by the i.f. noise heterodyning with the carrier. Of course, when the predetection band width is increased to something of the order of one megacycle this reasoning will no longer hold.

A very interesting empirical study of this problem was made about a decade ago by Messrs. Cunningham, Goffard and Licklider.² Their study showed by subjective tests that the difference between a 5.2-kc. pass band and a 52-kc. band was only significant for carrier-to-noise ratios below about 8 db. For signals this weak the word articulation was below 50 per cent, which may be construed to be an unreadable signal.

To avoid misunderstanding, it should be pointed out that what is meant here is that (under the assumed conditions) postdetection selectivity, of whatever kind, is equally as effective as predetection selectivity in establishing the signal-to-noise ratio. — *Editor*.

¹ W. J. Cunningham, S. J. Goffard, and J. C. Licklider, "The Influence of Amplitude Limiting and Frequency Selectivity Upon the Performance of Radio Receivers in Noise," *Proc. IRE*, Oct., 1947.

There are a number of advantages to a wide i.f. band for v.h.f. receiver use. One of these is the ease which impulse noise can be suppressed. This was clearly demonstrated in the above-mentioned paper. Another advantage lies in the fact that the local oscillator stability requirements are less stringent.

I think that this analysis accounts for the relative success of broad receivers such as the Gonset "Communicator" and the various surplus receivers currently in use on the v.h.f. bands.

— F. W. Brown, W6HPII

ABNORMAL PROPAGATION

82 Prospect St.
Huntington, L. I., N. Y.

Technical Editor, *QST*:

I should like to report a recent instance of apparent non-great-circle path propagation on 21 Mc. for which a good explanation would be welcomed. I would tend to disbelieve the evidence except for the fact that it was checked at both ends of the path with directional antennas of known characteristics, and there was no doubt as to the optimum azimuths.

On Sept. 8, 1957, at 1245 GMT, I heard VK3KF working European stations on 21-Mc. e.w. The signal from the Melbourne station was steady at RST 449, and my quad beam antenna was pointed directly north at the time. I rotated the beam to the short path (azimuth 265 degrees) expecting to bring the signal up considerably. Instead, it almost disappeared. I then tried the long path (azimuth 85 degrees) but, as expected, the signal dropped out. A few minutes later I called and raised VK3KF with my beam pointed north, my signal also being reported RST 449. His beam, it turned out, was pointed northwest on the great-circle path to Europe from Melbourne. We then checked the azimuths for optimum signal strength, first from Long Island, then from Melbourne, by rotating the transmitting antennas. For any headings other than due north from W2 and northwest from VK3, signals were down by at least 15 or 20 db. and unreadable.

The CRPL predictions indicate that the short path (via great circle) could have been open on 21 Mc. at this time, while absorption would have been excessive on the long path at 1300 GMT. However, the optimum path was clearly not a great-circle one, and no satisfactory explanation has been found. Cases of scattering from areas off great-circle paths have been reported, and ionospheric tilts have been held responsible at times for rather small deviations from great-circle azimuths. In this case the departure is so drastic that an unusual explanation seems necessary. Could there have been a strong scattering area where the two beams illuminated, presumably, a common volume? The indeterminacy of azimuth sometimes noted on signals from West Australia (VK6) closer to the antipode have never been observed here on stations in Victoria. VK3 signals at all other times have clearly peaked at azimuths corresponding to either the short or long great-circle paths. I would be most interested in hearing of similar observations and in an explanation of this phenomenon.

— J. Gregg Stephenson, W2OBX

Strays

A worried-looking motorist pulled up alongside K2JNX and asked directions to the Pennsylvania Station. After receiving them, he pulled ahead. K2JNX was working K2UHF who was up ahead a quarter mile or so, and he reported the conversation and the motorist's description to K2UHF, "just for the heck of it." A few minutes later the same motorist pulled up alongside

K2UHF and before he could say a word K2UHF called out, "Yes, this is the way to Penn station." The look on the motorist's face showed that he was completely mystified!

A flyer from one of the surplus houses recently offered a special deal on a 28 v. inventor.
— W0OHI.

Project Perseids—1957

Some Results Achieved and Observations Made During the August Meteor Shower

BY WALTER J. MORRISON,* W2CXY

If you can't work them during the Perseids of August, you may never work them at all.

THIS conclusion has been reached by most of the really serious 144-Mc. meteor-scatter enthusiasts. The other showers¹ have their points, and they give you more time to work at this fascinating aspect of 144-Mc. DX, but the Perseids have everything. With this in mind, schedules were firmed at W2CXY with several stations around and beyond the 1000-mile mark for the period Aug. 9 through 14. Attempts were also made to line up tests at transcontinental distances, but for one reason or another all bogged down.

Equipment at this end consisted of a pair of 4-125As, driven by a modified 522. The power input, 1000 watts, delivered about 500 watts to the antenna, with the balance serving to keep moisture out of the equipment and to heat the basement. The antenna has 4 10-element Yagis, each 16 feet long, in a 12 × 12-foot square, fed with 7/8-inch Styroflex coax. The receiver is a W2AZL converter working into the 14-Mc. range of a 75A4 receiver, equipped with a Heath Q Multiplier and a Panadaptor. Power at other stations ranged from 80 to 1000 watts. Antennas were both multiple Yagi and collinear types, with 16- and 32-element collinears predominating.

The adding of new states being a prime objective, the following stations were lined up for schedules: W0YSJ, North Dakota; W0BJV, South Dakota; W0LAY, with alternates W0WRT and W0EMS, Nebraska; W0IHD, with alternates W0s RUF LFE TGC and K0DOK, Missouri; W0ZJB, Kansas; W5JWL, Arkansas; W5AJG and W5IRP, Texas; W5FAG, New Mexico; and W7FGG, Arizona. Results were as follows:

Aug. 9 W5FAG, 0700-0730 — 3 very short no-intelligence (n.i.) bursts heard.

Aug. 10 W0YSJ, W0BJV, W0IAY, W0IHD, W5JWL, W5FAG. Due to error in time each station was called one hour ahead of schedule. Results nil! Suggestion: Adopt a standard time for all meteor-scatter skeds. [Amen! W2CXY was not the only one who did some calling and listening at wrong times. You can be awfully foggy at 0400EST! — Ed.]

This error at least allowed time for cooperating stations to zero in on the frequency, but imagine the confusion that could occur if skeds are kept at wrong times and the sending station uses only

his own call, as has been done by some. Suggestion: Every transmission, at least until identification is made both ways, should include both the call of the sending station and that of the station with whom the schedule is kept. [Editor's note — An absolute must; identification both ways, always difficult enough, is impossible without this. Furthermore, it's illegal not to send both calls at least once every 10 minutes.]

Error in time discovered after 4 hours and 40 minutes, and sked with W5JWL was kept, 0640 to 0700; several n.i. only heard. W5FAG, 0700-0830; W7FGG, 0830-0900; W5AJG, 0900-0930; W7FGG, 1000-1030; all nil heard. Reports from the other ends: W0IAY, W0WRT and W7FAG, nil. W0IHD had receiver trouble; alternate W0LFE heard 15 bursts, longest 8 seconds. W5JWL heard the wrong-time transmissions, logging W2CXY as calling W5FAG during W5JWL sked time. W5AJG — few n.i.

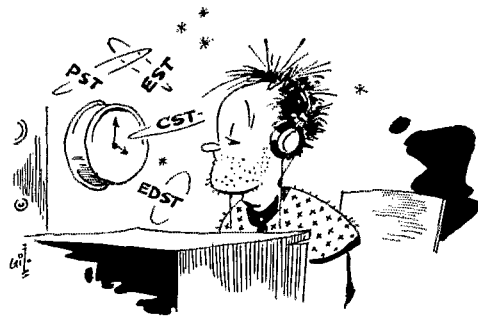

Aug. 11 W0YSJ, 0000-0100 — several n.i. W0BJV, 0100-0200 — 4 n.i. W0LAY, 0200-0310 — nil. W0IHD, 0400-0505 — heard complete call group loud and clear. Recorder tape fouled and broken; no record for posterity. Also heard key-down burst 3 minutes after conclusion of sked. W5JWL, 0505-0545 — several exchanges of calls, reports and R's for QSO. Jay had listened to earlier skeds and heard many good bursts, so was ready. Reception at W2CXY included more than 15 bursts, longest 25 seconds. W5FAG, 0600-0730 — several n.i. W7FGG, 0730-0800 — nil. W5AJG, 0800-0830 — several n.i., plus one 12-second screamer, believed to have been from W5FAG.

W0IAY reports no results, but did hear W2ORI. W0IHD says nil. W0LFE heard 33

* 229 Longwood Ave., Chatham, N. J.

¹ For a schedule of meteor showers see W4LTU'S article, "V.H.F. Meteor-Scatter Propagation," April, 1957, QST.

bursts, best being 10, 15, 22 and 40 seconds. W5AJG heard few n.i., but worked W2ORI, and heard W8PT, the latter with first doppler frequency shift heard by W5AJG. W7FGG nil.

Aug. 12 W0YSJ, 0000-0100 — exchanged complete call groups, reports and strings of R's for first N. Dak.-N. J. 14-Mc. QSO. W0YSJ reports no success with W2NLY on preceding schedule. Question: with W2NLY having what is probably the world's largest 2-meter beam, does this mean that a very large and sharp array can be a liability in m.s. work? K2GQI, with only two Yagis, was heard by W0YSJ, even without schedule. W0BJV, 0110-0215 — complete exchange for first S. Dak.-N. J. QSO. Best bursts heard from W0BJV were two of 10 and 31 seconds duration. W0IAY not heard, 0215-0300. W0IHD, 0400-0500 — exchange could have been completed in 20 minutes or less, but held back on "R" in order to further tape Charles' signal. Some 24 bursts were heard, longest 15 seconds, but much information copied, due to excellent keying at 25 to 30 w.p.m. by W0IHD. Clean and fairly high-speed keying definitely an asset in m.s. work. W5FAG, 0600-0730, and W7FGG, 0730-0755 — nil.

At 0755 observed 85 pips on Panadaptor at 144.005 and 144.052. These turned out to be W5DFU and W9ZIH, latter remaining for 2 minutes. W0YSJ reports W2NLY heard 1b. W9WOK says W2CXY was heard too much during his skeds. W9WOK worked W4AIB, Aiken, S. C., and W7JRG, Billings, Mont., however, a nice spread.

Aug. 13 W5IRP, 0030-0200 — several n.i.; QRN from power line. W0IAY, 0200-0300 — one n.i. No skeds 0300-0345; called CQ last 30 seconds of each minute with no response. W0TGC 0355-0430 — several parts of calls; sked might have worked if for longer period. K0DOK, 0430-0500 — nil. W5IRP, 0500-0600 — few n.i. W5FAG, 0600-0645 — 2 n.i. W7FGG, 0730-0800; W5AJG, 0800-0835; W7FGG, 0900-0930 — all nil.



W5IRP reports 3 S7 bursts, 5 to 10 seconds. W0TGC heard nothing. K0DOK heard several n.i. on the W0TGC sked, but none on his. He also heard several 2- to 3-second bursts nearly

every minute of W2CXY-W5IRP sked, 0530 to 0600, when the W2CXY beam was well off the line to Missouri. W5IRP heard nothing. W5AJG heard one complete set of calls, strength weak.

Aug. 14 W5IRP, 0030-0200 — nil. W0IAY, 0200-0300 — heard "W2" and a few n.i. W0TGC, 0345-0430 — parts of calls and many n.i. K0DOK, 0430-0500, W5IRP, 0500-0615, W0ZJB, 0700-0730, and W5AJG, 0755-0835 — all nil.

W5IRP heard nothing on either sked. W0IAY also heard nothing. W0TGC identified W2CXY immediately and received both calls and reports later. He also copied W2CXY for 20 seconds solid during the K0DOK sked. W0ZJB and W5AJG both heard nothing.

In summary, successful contacts were made with W0YSJ, 1200 miles, 100 watts, 32-el. beam; W0BJV, 1180 miles, 100 watts, 16-el.; W0IHD, 880 miles, 80 watts, 32-el.; and W5JWL, 1150 miles, 450 watts, 16-el. W5FAG, 1800 miles, was heard. All contacts were tape recorded, and copies of the tapes are available to anyone.

As with the 1956 Perseids, the maximum distance seems to exceed the maximum aurora distance by some 300 miles. Contacts at 900 to 1200 miles seem similar to single-hop sporadic-E. The margin of the signal over the noise is often good, and such contacts can be made with medium power and moderately-sized beams, with some perseverance and prior scheduling. High power, and antenna systems having a *real* gain of 17 to 18 db, or more are a considerable help, even when such equipment is used at only one end of the path. The higher-powered end of the circuit will then drive through more consistently, and the operator can get more information across to help the other fellow. If procedure follows exactly the method firmed for the schedule, the lower-powered station will then be able to interpret the needs of the higher for completion of the contact.

Work at 1400 miles is undoubtedly possible, but just a little improbable when running schedules of one hour or less. Contacts may be possible at 1800 miles or more, but they are unlikely because of their dependence on rare high-velocity burnouts that occur at heights of 300 km. or greater. Extensive checks with well-equipped stations at these distances bear this out. In 1956 W7LEE had a 48-element array. W7FGG has a 64-element at 85 feet and 4 5-element Yagis at 45 feet. W5FAG has a 16-db, tiltable array and a 48-element collinear.

Conditions are often good enough during the Perseids and possibly other major showers so that contacts should be possible without prior scheduling, if some standard calling systems could be agreed upon. During nonschedule periods, for example, stations west of the Mississippi might call CQ during the first 30 seconds of each minute and listen for replies from east of the Mississippi, or for CQs from that half of the country, during the second half of each minute. The best-equipped stations might stand a fair

(Continued on page 174)

How To Adjust a Key — And Send Good Code

BY LEWIS G. MCCOY,* W1ICP

HOW IMPORTANT is it to be able to send good code? For the answer to that, just ask yourself how important it is for you to be understood by the person you are communicating with. If you cannot send good code, then the operator trying to copy you will have just one comment: "Another lid!"

Being able to send readable code is not difficult, but it does take a certain amount of know-how and practice. This article has two purposes: first, to show the reader how to adjust a key for the best possible code and second, how to send.

Strange as it seems, and contrary to the beliefs of most beginners, the secret of sending good code is learning good code. Most new code men think their primary objective is to increase their speed, when actually it should be to learn the correct code. By correct code we mean the one that's printed in any book¹ on the subject, in contrast to the 5700 varieties one hears on the air. Where does one learn the "correct" code? Easy. By listening to the tape transmissions of W1AW and other stations using tape transmissions, or by listening to the tape transmissions found on the phonograph records offered for learning the code. The correct code, sent by machine or a good operator, has a beautiful basic rhythm that is a far cry from the stumbling, bumbling odd-ball stuff to be found occasionally in the ham bands

|||||

Many amateurs miss a lot of fun in ham radio by not knowing the code and how to send it. Sure, they know the code well enough to pass the exam and work a few fellows, but they have never really become operators. Much as we would like to have some magical short cuts to offer you, we can't; we can only present a few basic principles that have been found to be effective.

|||||

(and a few other services we can mention). Once you have learned the code from a machine and have acquired a feeling for the basic rhythm, you are on your way toward acquiring a "fist like a tape," because you will be aware of the slightest departures from the correct code. But if you don't know what the code should sound like, you can never hope to pick up your own minor variations and correct them.

The Key

A typical straight key is shown in the accompanying photograph. A telegraph key is simply a lever-type switch that is used to turn the transmitter on and off. When the lever is depressed

*Technical Assistant, QST.

¹The reader who is seriously interested in developing his code ability to the highest proficiency will do well to study *Learning the Radiotelegraph Code*, a booklet published by the ARRL.

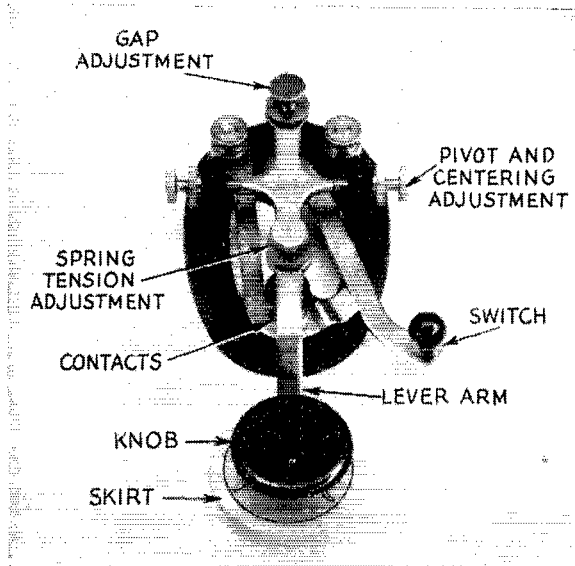

Most U. S. straight keys are built like this, although some omit the shorting switch. Note the lock nuts at each adjustment. The skirt at the knob is not standard with this key; it was made by drilling a poker chip.

The generally-accepted way to hold a key for minimum fatigue. The wrist is well off the table, and only the forearm near the elbow rests on the table. The finger grip will vary slightly with the length of the fingers and the type of key knob.

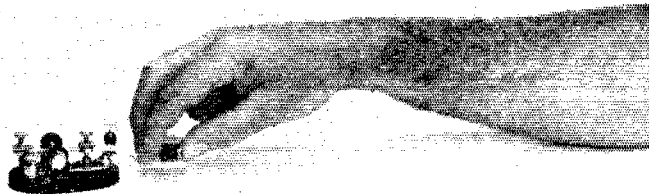

the contacts close, turning on the transmitter. When the lever is released, the contacts open, turning off the rig.

The first step in setting up the key is to align the contact points laterally on the lever and base. This is accomplished by setting the pivot adjustment. First, release the lock nuts on the screws and then bring the contact points into alignment. Don't make the screws too tight; allow a slight amount of play to permit the lever arm to work freely. When the screws are properly adjusted, tighten the lock nuts.

The amount of lever travel is a matter of personal preference. However, a good rule of thumb for lever travel is about one-sixteenth inch, measured at the knob of the key. If the travel is less than a sixteenth of an inch it may be hard to control the spacing between and the length of characters. Operators often feel that they can send faster with short lever-travel distances, and in some cases this is true. But it is true only of the operator who sends 25 or 30 words per minute on a straight key, not of the beginner learning the code and not yet able to copy a solid 15 w.p.m. Once you know the code and can handle 15 to 20 w.p.m. easily you can start looking for a magic key adjustment that will catapult you into the 30-w.p.m. bracket, but we'll warn you now that the answer isn't in the key adjustment.

The gap adjustment setting determines the lever travel, and the spring tension screw controls the lever tension. If you set the spring tension too heavy your sending is inclined to become "choppy." Similarly, if the tension is too light you are likely to run the characters together, so a little experimenting should be done to find the correct tension. You'll probably find that a lever action on the heavy side will permit you to make more accurate dots. With experience, you'll soon

find the correct key adjustments to suit your tastes.

How To Send

Every effort should be made to learn how to send correctly at the very beginning of your amateur career. It is just as easy to acquire good operating techniques as it is to learn bad habits — and habits are very hard to break.

The key knob should be mounted approximately eighteen inches from the edge of the table. By "mounted" we mean screwed down to the table or to a thin board about six inches wide and two feet long. Either system will prevent the key from "traveling." The correct posture for sending is to sit upright in your chair and square with the operating table. Your right arm should be in a line with the key (of course, if you are a south-paw then make it the left arm), and your elbow should rest on the table. The key knob is held on the left side by the thumb, the index finger is on top of the knob and the second finger is on the right side of the key. The two remaining fingers are curled (not clinched!) toward the palm. This method of holding the key is shown in a photograph. Notice that the wrist is not resting on the table, and only the forearm near the elbow rests on the table. The entire attitude should be a relaxed one and the grip should not be tense.

If the table is too high, a sore shoulder may develop in a short time, and a seat cushion would be desirable.

You are now ready to send. First try sending long strings of dits (dots), about ten or more at a time. They should be evenly spaced and should flow smoothly from your key. Once you feel that you've developed a smooth rhythm, try adding dahs (dashes) to your sending. A dah is three

(Continued on page 184)

A common error is to rest the entire forearm on the table. This results in rapid fatigue and a glass arm (loss of proper muscle coordination) at an early age.

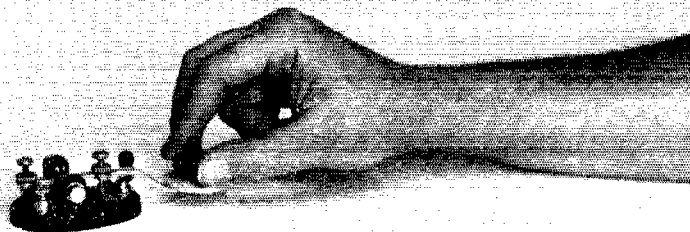

Improved Control Circuit for Regulated

A REGULATED power supply has three parts: first, an unregulated supply whose voltage is higher than that required; second, a series tube or several tubes in parallel which act as a variable resistance in series with the unregulated voltage to cut it down to the desired value; and third, a control stage which compares the actual output voltage with a fixed reference voltage and then changes the resistance of the series tube(s) in such a way as to bring the output voltage as close as possible to the desired value.

Fig. 1 is a simplified diagram of a conventional power-supply regulator circuit. The output volt-

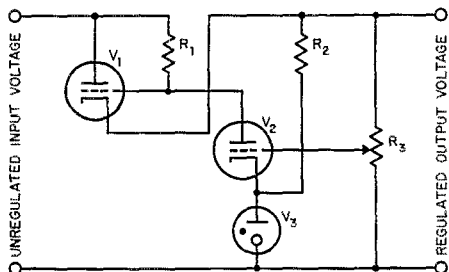

Fig. 1—Conventional electronic voltage regulator for power supplies.

age will be equal to the unregulated input voltage minus the drop across the series tube V_1 . For a given load current there are two limitations on the drop across V_1 . The upper limit is the voltage at which the rated plate dissipation of the tube is reached and is a property of the tube used. If this limit is reached, more output current can be obtained either by using two tubes in parallel or by lowering the unregulated voltage. The lower limit is the plate-to-cathode voltage at the time when the grid voltage, normally negative with respect to cathode, becomes zero. At zero grid voltage the resistance of the series tube is as low as it is going to get, and for that value of load current we will not be able to get any more output voltage unless more tubes are added in parallel with V_1 or the unregulated supply voltage is

By inserting a cathode follower between the control tube and the regulator tube in an electronic voltage regulator, the regulator tube can be driven into the positive-grid region to increase the current range over which regulation can be maintained. The article also describes a novel power supply circuit in which the regulator tubes are the rectifiers.

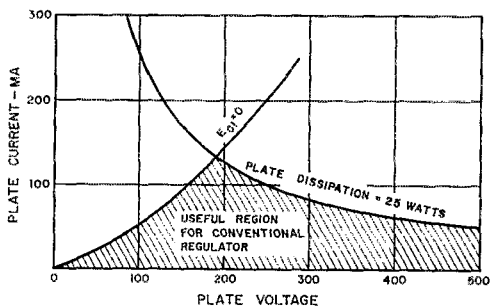

Fig. 2—Static characteristics of the 1625, triode connected. In a conventional regulator, only the region below $E_{c1} = 0$ and below plate dissipation = 25 watts (30 watts ICAS) can be used. This means that current is limited to a maximum of 130 ma. per tube.

increased. This limitation is not the fault of the series tube, V_1 , but of the control stage, which cannot supply appreciable grid current to V_1 . The load resistance, R_1 , for the control tube, V_2 , is made high so that the gain of the control stage will be high, thus giving a higher degree of regulation. This essentially limits the operation of V_1 to the negative grid region since grid current for

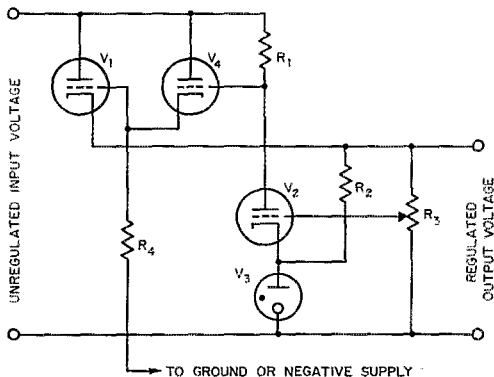

Fig. 3—Regulator circuit using a cathode follower, V_4 , to supply grid current to the series regulator tube, V_1 .

V_1 must flow through R_1 , not through V_2 .

These two limitations can be plotted on the static characteristics of the series tube as shown in Fig. 2. It can be seen that as the load current is increased, the range of permissible voltage drop across the tube is decreased. There is also a current limit above which one or both of the two limitations will be exceeded. If we feel compelled to operate the tube in the negative grid region, the only way to go above this maximum current is to add more tubes in parallel with V_1 .

Cathode-Follower Drive

It isn't really essential to operate the series

Power Supplies

Using a Cathode Follower To Increase Control Range

BY GEORGE W. JONES,* W1PLJ

tube in the negative grid region. To supply grid current to V_1 we must provide a path from the positive side of the unregulated supply to the grid of V_1 . R_1 provides this path but to supply appreciable grid current its value must be made low, which will reduce the gain of V_2 and impair the regulation. A more satisfactory approach is shown in Fig. 3. A cathode follower, V_4 , which in most cases can be a 6C4, reproduces the voltage appearing at the plate of V_2 but in addition supplies grid current to V_1 when needed. R_4 provides a load for V_4 when grid current is not needed for V_1 . Its value is not critical; 1 megohm seems convenient. Incidentally, this stage — consisting of three junk-box type components, a tube, a socket, and a small resistor — can be added to almost any existing regulated power supply to increase the voltage available at higher current or the current available at higher voltages, however you want to look at it. The extra tube can be supplied from the same heater transformer as the series tubes without danger of heater to cathode breakdown. If possible, it should not be supplied from a heater winding which is grounded.¹

Regulators as Rectifiers

Like any circuit using a vacuum tube, the regulators shown in Figs. 1 and 3 act as rectifiers as well as performing their regular function. We can take advantage of this by replacing the unregulated d.c. source with an a.c. source. In this case, V_1 will conduct over the part of the cycle when its plate is positive with respect to its cathode. If the a.c. voltage is great enough and the load current small enough, V_1 will act as a regulator over part of the a.c. cycle and will limit the output voltage to a value dependent on the setting of R_3 . During the part of the cycle when

* 12 Trull St., Cambridge 38, Mass.

¹ If this modification is to be made on W2VQL's power supply ("Really Regulated," March, 1955, *CQ*), resistor R_4 must be returned to the negative bias supply (Pins 2, 4, and 7 of the OB2), not to ground. To modify a Heathkit or other supply using 1619 series tubes, a 2.5-volt heater tube is needed unless another heater transformer is added. The 2BN4 seems to be the only miniature tube suitable here and a $\frac{1}{2}$ -ohm dropping resistor will be needed for the heater. Again resistor R_4 goes to the negative bias supply.

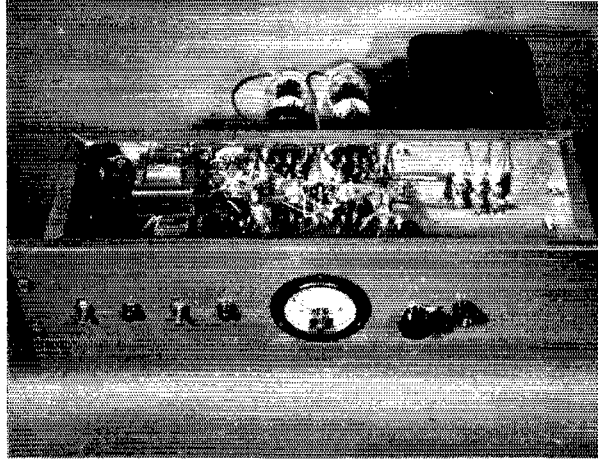

W1PLJ's regulated supply uses dish-type rack construction with a formed panel. The power transformer and tubes are on the rear chassis wall.

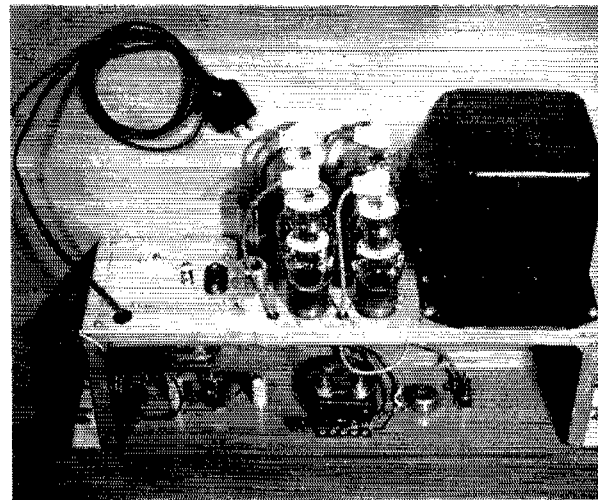

Looking inside the chassis of the power supply from the rear. This assembly includes everything except the filter capacitor, which is external. The power transformer shown is a surplus unit.

the input voltage is great enough for rectifying action but not great enough for regulating action, V_2 will be cut off, V_1 will act as a straight rectifier and V_4 will connect the grid of V_1 to the input voltage to improve the rectifying action. Here the cathode follower, V_4 , not only allows more current to be delivered for the reasons explained previously but it also allows V_1 to act as a regulator over a greater fraction of the a.c. cycle. This makes the output easier to filter, as will be shown.

To make a practical power supply, two of the regulators shown in Fig. 3 would be connected to provide full-wave rectification. This is shown in Fig. 4. Only one reference source, V_7 , and control potentiometer, R_3 , are needed but the control amplifier and cathode follower are duplicated and are supplied from the transformer directly to avoid the need for a separate d.c. supply for them.

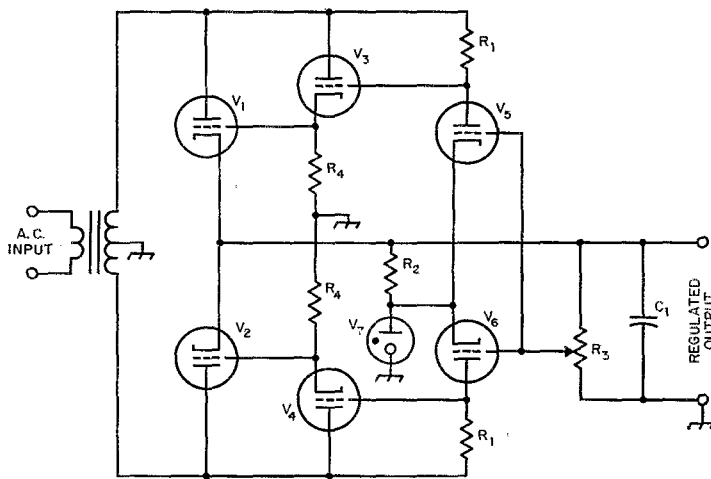

Fig. 4—Using two regulator circuits for the dual function of full-wave rectification and voltage regulation.

In this way each control amplifier and cathode follower receives positive plate voltage only on the half of the cycle when it is needed, and the series tubes do not draw grid current on the half of the cycle when they are not conducting plate current.

If no filtering is provided, the output will be "flat" over part of the cycle with a dip over the part when the series tubes lose regulation. The filter capacitor shown in Fig. 4 fills in this "dip" and the larger it is the purer the d.c. output. The ripple percentage can also be reduced by increasing the length of time the series tubes regulate as well as rectify. This is done by supplying a higher a.c. voltage from the transformer, setting the control for a lower output voltage, or adding more tubes in parallel with the series tubes. It would be nice if three-phase power could be obtained in

the ham shack because three regulator circuits could be used and at least one of them would be conducting at any given time, so there would be no loss of regulation over any part of the cycle. With proper design little or no filtering would be needed.

Practical Power Supply for an S.S.B. Linear

The power supply shown in Fig. 5 and in the photographs was built for a Class AB₁ linear amplifier using two 6146s in parallel. It will deliver 630 volts at 250 ma. with a change of only 15 volts from no load to full load, a degree of regulation better than is needed for the amplifier which it powers.

A neon bulb is used as a reference source and is supplied from the output through a 2.2-megohm

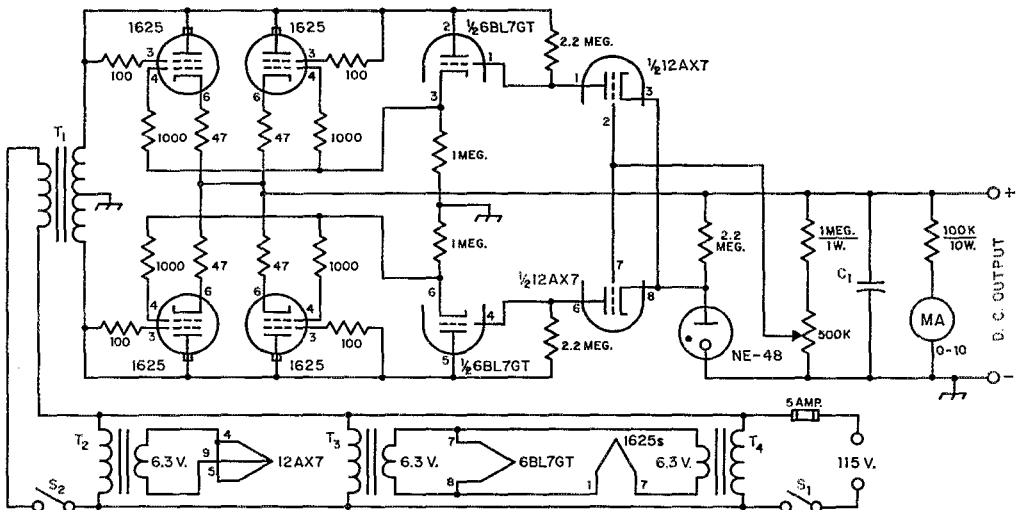

Fig. 5—Practical circuit for a regulated supply capable of delivering up to 250 ma. at 600 volts. Resistors are 1/2 watt unless otherwise specified.

C₁—30 μf. or more, 1000 volts (see text).

T₁—Power transformer, approx. 700 volts each side c.t., 250 ma.

T₂—Filament transformer, 6.3 volts, 1 amp.

T₃, T₄—Filament transformer, 6.3 volts, 3 amp.

resistor. A 12AX7 is used for both control amplifiers, with reference voltage applied to both cathodes and a fraction of the output voltage applied to both grids. A 6BL7 serves as a dual cathode follower and performs somewhat better than a 12AU7 or 6SN7 (which could also be used) because it will conduct more current at low plate voltage, thereby supplying more grid current to the 1625s and permitting them to act as regulators over a greater part of the cycle. The 47-ohm cathode resistors tend to divide the load equally between the 1625s as well as to prevent parasitic oscillations. It is important for the two sides of the circuit to be fairly closely balanced, because otherwise the ripple will contain a 60-cycle component which will not be filtered as effectively. The use of regular 10 per cent tolerance resistors of the same marked value for each function will make the balance close enough for all practical purposes. Pilot lamps (not shown in the diagram) are included in each 1625 plate lead to indicate relative balance and to act as fuses if a tube should short out.

As in any power supply, the layout is not critical. At W1PLJ a Bud CB-1372 panel chassis was used with a Par-Metal P-602 formed panel. With this type of construction the tubes are available from the rear and the wiring can be reached from the front by removing the front

panel without removing the chassis or disconnecting any leads. The filter capacitors are mounted on a separate chassis to make the main chassis easier to handle if changes are to be made.

Performance

The power supply shown will deliver any voltage from 300 to 630 volts at 250 ma. and up to 900 volts at lower currents. Higher voltage could have been obtained with a higher voltage transformer. With a 30- μ f. filter capacitor ripple was 2 per cent at 600 volts and 250 ma. Ripple decreases with decreased load current and increases somewhat when the output voltage is reduced to 300 or 400 volts at 250 ma. With a 60- μ f. filter capacitor, ripple is 1 per cent at 600 volts and 250 ma. Dynamic regulation is excellent — no transient oscillations occur when the load is suddenly applied or removed. This is one of the difficulties with a choke-input power supply having insufficient inductance or insufficient output capacitance.²

Last but not least, this supply has the advantage that the voltage can be varied at the twist of a knob for tune-up or experimental uses.

² *GE Ham News*, "About Power Supplies," January-February, 1954; "More about Power Supplies," March-April, 1954. (See also, Geiser, "The Effect of Capacitance on Power-Supply Filter Bounce," *QST*, September, 1957. — Ed.)

Strays

Further re c.w.-to-s.s.b., K6KSA worked VS6BE and VS2DB on 20 meters way back on Oct. 8, 1956. He was on c.w. and the VS boys were on s.s.b.

Re the c.w.-to-s.s.b. Stray on p. 37 of July *QST* — KN2UXX reports that he worked W2TVS on Feb. 18, 1957, on 40 meters, c.w. to s.s.b.

A Scout Communications Center for the use of Explorer scouts has been dedicated at the WFIL transmitter building in Whitmarsh, Pa. Prior to the ceremony, dedication messages were exchanged via ham radio between Dr. Arthur Shuck, Chief Executive of the Boy Scouts of America, and Dr. Paul A. Siple, Chief Deputy to the Officer in Charge of the U. S. expedition to the Antarctic. Dr. Siple accompanied Rear Admiral Richard E. Byrd to Little America as an Explorer scout almost thirty years ago.

Explorer scouts are groups of boys aged 14 to 19 years who, in addition to their regular scouting activities, work on vocational community service projects at an adult level. It is said that establishment of this new communications center marks the first activity of Explorer Scouts in the field of radio communications.

With the management of WFIL contributing the space and the Mt. Airy V.H.F. Radio Club supplying volunteer instructors, the scouts will be well-equipped for advancement in scouting and ham radio.

The accompanying photo shows (left to right) W3FOZ; W3FSC; W3SAO; W3CPT; Mr. George Koehler, manager of station WFIL; some unidentified scouts; and W3OZP.



Transistorized Meter Sensitizer

E. LAIRD CAMPBELL, * W1CUT

A Current Amplifier to Increase Sensitivity

• Maybe the gimmick you want to build calls for a low-range microammeter instead of the 1-mil meter you've got on hand. If so, you don't need to lay out a good chunk of cash for a new meter. For about a quarter of the cost and very little effort you can convert the old meter into one of more than adequate sensitivity.

Except for variable resistor and switch, all components including the battery are mounted on terminal strips.

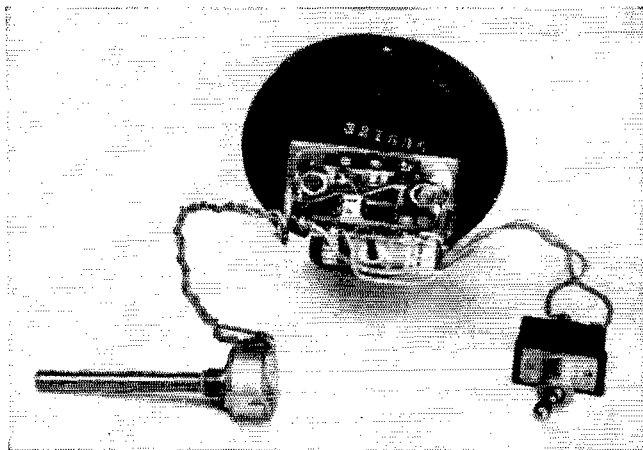

WHEN USING some of the popular instruments — such as the Monimatch¹, field-strength meters, or antenna bridges that use crystal rectifiers — it is sometimes impossible to get meter readings toward the full-scale end even when using relatively sensitive d.c. meters. Many measurements are made with these instruments at very low r.f. levels, using a grid-dip meter to furnish the power, and at such levels it is imperative that a meter of high sensitivity be used. Low-range microammeters are available but are comparatively expensive, and often just can't take the knocking around that a portable instrument is subjected to.

An easy solution is to use a less sensitive but more rugged meter and increase its sensitivity by means of an inexpensive transistor d.c. amplifier. The circuit shown in Fig. 1 is a common-emitter d.c. amplifier using a junction transistor. The common-emitter circuit is superior for current amplification as compared with other transistor configurations, and with available transistors current gains of 10 to 50 are possible. While the amplifier can be used to increase the sensitivity of any low-range milliammeter, it is a natural for use with the popular 0-1 ma. instrument — which is rugged, relatively cheap, and when used with the amplifier will end up with a sensitivity of 50 or 100 μ a. full scale.

Note that the transistor is operated without any base bias. This is necessary since a voltage source cannot be introduced in the base-emitter circuit without also affecting the amplitude of the current to be measured. However, with this arrangement there is a small residual current flowing in the collector circuit. By using variable resistance R_3 and a balancing network R_1R_2 this current can be balanced out in the meter. Since the residual current varies from one transistor to another and will change slightly with temperature, the "zero adjust" control should be in an accessible spot so the meter can be zeroed before each measurement.

When the amplifier is connected into a d.c. circuit properly, current flowing in the base-emitter (input) circuit represents a controlling bias and the collector-emitter circuit will conduct. The collector current will vary in accordance with the controlling bias but will be much greater than the base current because of the current amplification in the transistor.

Circuit Characteristics

Values for resistors R_1 and R_2

* Technical Assistant, QST.

¹ McCoy, "Monimatch Mark II", QST, February, 1957

in the balanced bridge circuit can be chosen so as to act as current-limiting resistors and protect the basic movement of the meter. For all practical

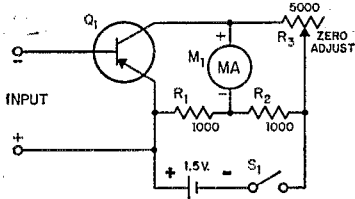

Fig. 1 — Circuit of the transistor d.c. amplifier.
 M_1 — 0-1 ma. (see text)
 Q_1 — 2N107, CK722, GT222 (see text).
 R_1, R_2 — 1000 ohms, $\frac{1}{2}$ watt (see text).
 R_3 — 5,000-ohm potentiometer.
 S_1 — S.p.s.t. switch.

purposes the resistance can be considered to be in series with the battery and meter, so if a 1.5-volt battery is used along with 1000-ohm resistors, the current through the meter cannot exceed 1.5 ma. — hardly enough to damage the instrument. For meter movements other than 1 ma. and for other battery voltages, appropriate values of resistance can easily be calculated.

A typical plot showing input vs. output current of the amplifier is shown in Fig. 2. The curve is reasonably linear at the low and medium end of the scale but begins to taper off at the upper end of the scale. The taper is caused by the current-limiting action of the series resistance in the circuit. It can be straightened out by lowering the series resistance, but doing this means sacrificing meter protection and putting more of a load on the battery.

The nonlinearity will present no problem when the instrument is used for relative measurements. However, for quantitative measurement a cali-

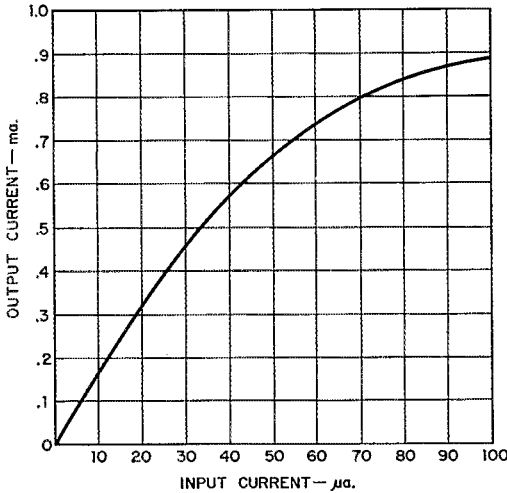

Fig. 2 — Calibration curve for a typical transistor.

bration chart such as the one shown in Fig. 2 can be made. By connecting a 0-100 microammeter in a circuit as shown in Fig. 3A, the input and output current can be measured to produce a curve such as is shown in Fig. 2. If a microam-

meter is not available, a variable resistor, battery, vacuum-tube voltmeter and a known resistance can be connected as shown in Fig. 3B. The input current in the circuit can be calculated from the measured voltage drop across the known resistor. In both Figs. 3A and 3B the setting of the variable resistor can be varied to give different input and output currents. These are plotted on graph paper as points which when connected show the calibration curve.

Assembly and Use

Construction of the amplifier is simple, and the entire project can probably be completed in less than hour. Use a small piece of insulating material such as plastic, bakelite or thin wood as a base to mount the components. Drill two holes in the base material to accommodate the meter terminals, which are used for securing the base to the meter. Mount two terminal strips on the

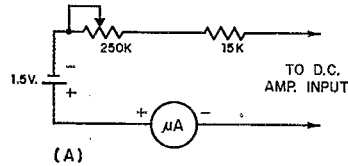

(A)

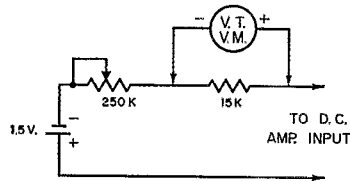

(B)

Fig. 3 — Circuits used for calibrating the amplifier. The value of fixed resistance should be chosen so that the current will not exceed 100 microamperes; that is, 15,000 ohms for a 1.5-volt dry cell.

It is advisable to choose the resistance so that the v.t.v.m. will read full scale on 100 μ a. when using Fig. 3B; the values given above are for a 1.5-volt scale. Thus when the v.t.v.m. indicates 1.5 volts, the input current is 100 μ a., an indication of 0.15 volts is 10 μ a., and so on. For a v.t.v.m. having a 3-volt scale the battery may be increased to 3 volts and all resistance values should be doubled.

base and solder the remaining components to them. Connections to the circuit being measured are made to the terminal strip.

Practically any type of transistor can be used in the circuit. Some of the suitable inexpensive types are the 2N107, CK722, and GT222. All of these are PNP transistors. NPN types can also be used if the battery, meter and input polarities are reversed. Some typical NPN types are the 2N35, 2N170 and 2N169.

To use the amplifier turn S_1 on, set the meter reading to zero with R_3 , and connect the input terminals to the circuit being measured. The reader can use the completed meter in any way that best suits his requirements. It can be mounted in a box with external leads and used as a portable meter or be fixed permanently along with other equipment.

Most beam antennas require work on them from time to time, and my three-band quad is no exception. Having an aversion to doing the necessary work while balancing on top of a pole, I devised my own version of the tilt-over principle. It requires a wooden pole (although the side of a two-story house might do) to serve as a support for a pipe mast. A sketch of the arrangement is shown in Fig. 1. With two people hauling on the rope and with me guiding the bottom of the pipe, it isn't too difficult to

If you have a hankering to work on an antenna but you don't like the climbing involved in getting to the top of a tower, here's a version of the tip-over mast that may solve your problem. W9RCS uses it to support a 3-band quad.

drop in or lift out the bearing collars to or from the bearing plates. The rope can be snubbed around the cleat on the pole if anyone wants to rest during the operation.

For me the installation started with the installation of bearing plate A on the top of the pole. (The pole was on the ground.) The $\frac{1}{4}$ -inch thick steel bearing plates were cut with a cutting torch; bearing plate A was held in place with angle iron as shown in Fig. 1. The pulley block was installed and the $\frac{1}{2}$ -inch rope was threaded through. I set the pole in the ground because I don't want concrete around the pole, although some may prefer to use concrete.

* East First St., Loogootee, Ind.

Close-up view of the base of the pole, showing the rotator and the cleat where the hoisting rope is stored.



This antenna mast uses $\frac{1}{2}$ -inch pipe to rotate a 3-band quad antenna; the rotator is at the bottom of the pole.

Beam Support for Old Men

*A Tilt-Over Support
for Antennas*

BY GORDON E. BEEMAN,* W9RCS



Fig. 1—Details of the tilt-over beam mast. It is made of two 21-foot lengths of 1½-inch i.d. galvanized pipe held together by a pipe coupling. The mast is raised and lowered by the rope and plenty of muscle, but when raised it is held in place by the collars that drop into the bearing plates. The main bearing collar at the top of the mast serves as a thrust bearing to take weight off the TV rotator; the collar at plate B has no shoulder and serves only as a radial bearing. The rope runs over a pulley at the top of the wooden pole and makes up to bar C; bar C rides freely 3 feet below A between two collars held in place by setscrews.

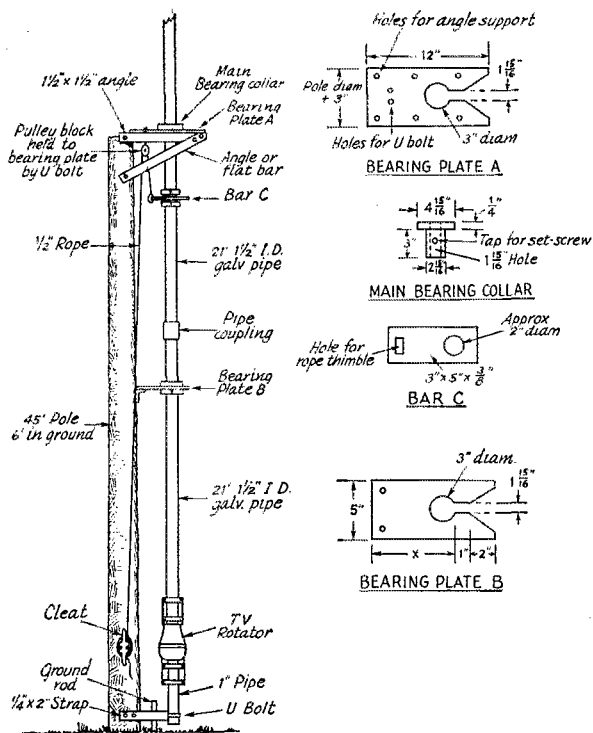

The two lengths of 1½-inch pipe were then fastened together with a pipe coupling, and the bar C was slipped over the pipe and held loosely with two collars fastened with setscrews. These collars are about ¾ inch thick; they have an i.d. of 1 15/16 and an o.d. of 2 1/2 inches. The main bearing collar (see Fig. 1 for dimensions) was put in place, and the 2½-inch long steel collar for bearing plate B was installed. This latter collar has an o.d. of 2 15/16 inches.

The mast can now be hoisted into place by pulling on the rope until the pipe can swing in through bearing plate A. Slacking off on the rope then allows the collar to drop into the 3-inch hole of bearing plate A. The collar holds the top of mast, and the bottom should be secured temporarily after the mast has been made plumb. If the wooden pole had been straight I could have installed bearing plate B before setting the pole. However, the pole was crooked, and I had to do it the hard way by fitting plate B with the pole and mast in position. That is why one dimension on plate B is shown as "x" in Fig. 1. An extension ladder would make installing plate B a simple matter, but I don't have a ladder. Instead, I had attached a piece of clothesline to the rope above bar C; this allowed me to drag down the ½-inch rope and attach a homemade "bosun's chair," and the boy and XYL pulled me up the pole.

With the bearing plates aligned, the next step is to attach the TV rotator and a length of 1-inch pipe; the pipe is clamped to the metal strap as

shown in Fig. 1. A ground rod was attached. To bring the mast down, it is only necessary to remove the clamps at the top of the rotator, pull on the rope enough to lift the mast 3 or 4 inches, and have one person lift the bottom of the mast as one or two others on the rope lower the mast until the top is at a convenient height for installing or working on the beam. The rope can be snubbed on the cleat at any time.

Install the beam or make your adjustments, but before raising the mast apply some grease to the main bearing collar, flat bar C and the collar for bearing plate B. Incidentally, let the main bearing collar take all the weight; don't try to let the rotator take the weight unless you have something other than the small strap at the bottom. Leave some slack in the hoist rope, otherwise it will try to lift the mast out when it shrinks. Originally I used 1¾-inch o.d. steel tubing for the mast, but it bent in the wind and so I installed 1½-inch pipe, which should be adequate for most conditions.

I bring the rotator line from a point about 10 feet above ground at the house over to a point about 10 feet above ground on the pole, then down the pole, along the strap and up the pipe to the rotator motor. I bring the coaxial-cable feed line from the same point at the house over to an exhaust-pipe clamp on the pole halfway between C and A. A loop of coax is left hanging between here and the point on the mast 1½ feet above plate A where it is clamped again. The coax line then runs on up to the beam.

• Recent Equipment —

The Drake 1-A Sideband Receiver

FROM time to time we receive letters from cautious amateurs contemplating the purchase of new equipment, but first they want to check with us and find out if we think "side band is here to stay." These cautious contemplators, and a lot of other hams, will be interested in the approach taken by the R. L. Drake Company in the design of its new receiver. Feeling that side band is the mode of the present and of the future, and that receivers are needlessly expensive because they continue to include features used only in a.m. reception, Drake has built a receiver for side-band phone reception only. Of course, it can be used for code reception, but it has no b.f.o. switch, and if you want to listen to a.m. you have to zero-beat the carrier. It adds up to an entirely new concept in receiver design, and it will be interesting to see what its acceptance is in the amateur market.

Once you start thinking along these lines you realize that a lot of possibilities present themselves. In the 1-A Drake has concentrated on frequency stability, suitable tuning rate, instantaneous muting and recovery, good a.v.c. action and correct response characteristics for side-band signals. A glance at Fig. 1, a block diagram of the receiver, will show how some of these objectives have been obtained. The basic tuning range of the 1-A is 600 kc.; the receiver tunes 600 kc. in any position of the band switch. On 28 Mc. this means the band is covered in three jumps. There is no provision for tuning 160 meters. This 600-kc. tuning range is obtained by tuning the 6BQ7A oscillator stage only; it tunes 4.0 to 4.6 Mc. and feeds a 6BY6 mixer that has a bandpass (2.9 to 3.5 Mc.) input circuit. The reasoning here is that not ganging the oscillator tuning to anything else makes for maximum stability and ease of tuning. Twenty revolutions of the tuning knob cover the 600 kc.

Bearing in mind that the second conversion of the receiver involves a tunable oscillator and a bandpass mixer input, let's get back to the front end of the receiver. Here an "antenna trimmer" tunes the sharp input stage, while fixed-tuned interstage coupling between r.f. and mixer is used, and the high-frequency oscillator is crystal-controlled. The designers took advantage of the harmonic relation of the amateur bands, and only four crystals are required for the seven tuning ranges. Harmonics of the crystals are used where possible, and spurious signals are held to a minimum by switching in circuits tuned to the proper crystal harmonics. For the reader who is thinking that the tunable input circuit and the tunable second oscillator make this a "two-handed" receiver, it should be pointed out that side-band operation normally involves only a small portion

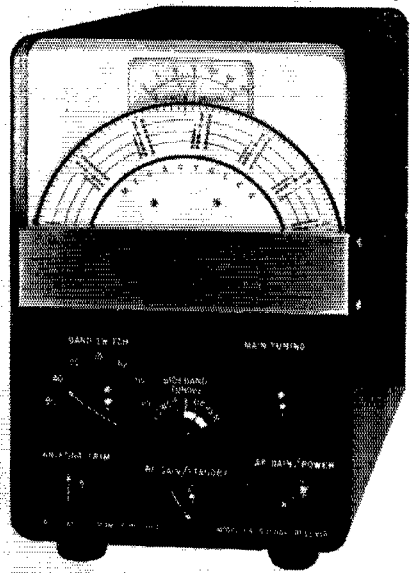

The front panel of the 1-A is unusual in its small size and simplicity, but all of the necessary (and none of the unnecessary) controls are there.

of a band at any time, and it is perfectly normal to "peak up" the antenna circuit after a small frequency excursion.

The output of the second mixer is at 1100 kc., and this feeds a converter with an output frequency of 50 kc. There is a *tunable* 50-kc. filter between the converter and a product detector, and we will have more to say about that in a minute. The signal is sampled at the output of the 50-kc. filter for a.v.c. purposes, and the output of the product detector passes through an audio filter and two stages of audio amplification. To raise the low-frequency response in the audio and give better balance between highs and lows, about 10 db. of negative feedback is provided by connecting the voice coil back to the 12AU7 cathode through a suitable network. The audio filter selectivity supplements the side-band selectivity of the 50-kc. stage.

There is no panel control for the b.f.o.; the b.f.o. remains on its factory-adjusted frequency. This means that there is no problem in reading from the tuning dial the frequency of an incoming signal; if you have it tuned in so that the voice is recognizable the dial is indicating the frequency of the (suppressed) carrier of the signal. The side-band tuning knob that you diddle to throw out

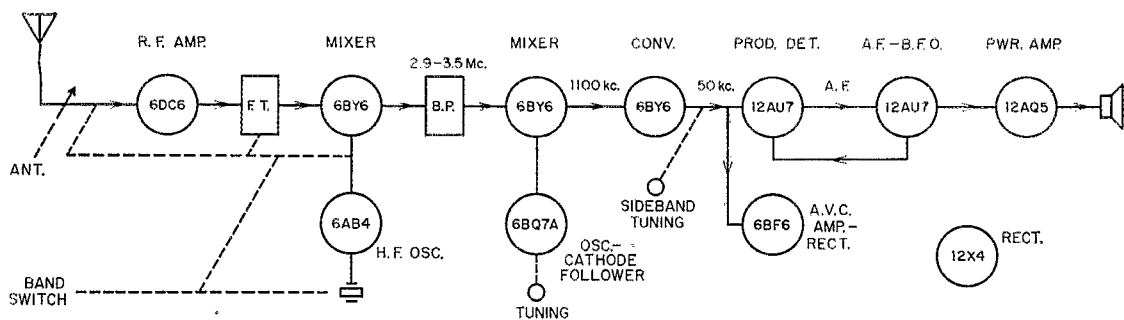

Fig. 1—Block diagram of the Drake 1-A Sideband Receiver.

interference and get the best-sounding reception will have no effect on the way you read the frequency from the dial. The sharp filter at 50 kc. is obtained through the use of four high-Q tuned circuits, gang-tuned. The band width is 2.3 kc. at 6 db. down and less than 7.5 kc. at -60 db. The panel control (side-band tuning) for this filter gives a tuning range of 3 kc., sufficient to move the filter characteristic to one side or the other of the b.f.o. frequency.

If you are beginning to get the feel of the circuit and how different in concept it is from other receivers, you will be interested in one more point. Two tuned circuits are used in the 2.9- to 3.5-Mc. bandpass filter. Overcoupled, they give the usual double-humped characteristic. The fixed-tuned single circuit between the r.f. amplifier and the first mixer is peaked to compensate for the "valley" in the double-humped characteristic. Thus through the two stages the response is practically flat over the 600 kc. of any range.

The tunable oscillator in the 1-A has been designed with maximum stability in mind. To this end a resistance-stabilized Hartley circuit is used, with the grid tapped down on the tank circuit for further isolation. One triode of the 6BQ7A is used for the oscillator, and the other triode serves as a cathode follower to drive the cathode of the 6BY6 mixer. Tests by the manufacturer show a warm-up drift from a cold start of only 240 cycles in the first hour, with half of the drift taking place in the first 15 minutes. As can be seen from the block diagram, no voltage-regulator tube is included, but the inherent stability of the oscillator provides good insensitivity to voltage changes; a shift in line voltage from 90 to 130 volts moves the oscillator frequency only 48 cycles.

Gain control is applied to the first four stages of the receiver. Instead of the usual cathode-circuit manual gain and grid-circuit a.g.c., the 1-A uses a combined manual and a.g.c. in the grid circuits; the a.g.c. has a fast attack and a slow release (about 1 second), of the type that has been found desirable in sideband work. A secondary circuit of fast attack and fast release clips noise pulses and adds a noise-reduction feature to the receiver.

And, last but not least among the new concepts you have to get used to in the 1-A, there is the matter of the packaging. Instead of following the conventional big-panel type of receiver construction, the 1-A has a panel 6¾ inches wide

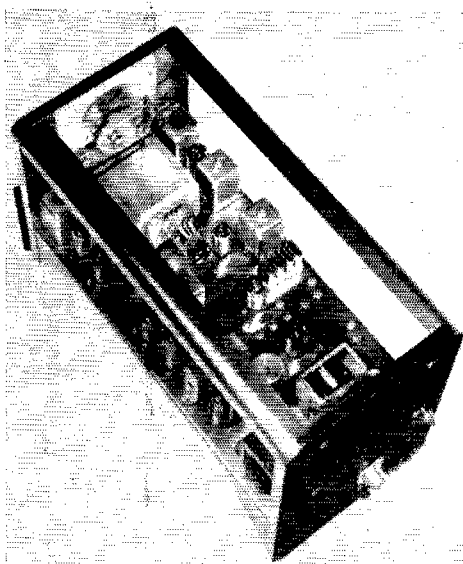

The built-in loudspeaker works out the rear of the receiver where the headphone jack and S-meter adjustment are. The terminal strip is for connecting into the VOX and muting circuits of a transmitter. To minimize temperature rise and consequent drift, the oscillator tube projects horizontally out of the high-frequency tunable oscillator assembly (under the S meter).

and 11 inches high! The chassis is only 15 inches deep, which means that this uniquely shaped receiver occupies about half the desk space of the more usual receiver. Total weight is 17½ pounds and the power consumption is 45 watts.

As mentioned earlier, it will be interesting to see if a streamlined approach like this will catch on, or if no one is truly convinced that "side band is here to stay."

— B. G.

A Matching System for a Three-Band Beam

A RECENT ARTICLE by W6DOB¹ describing a method for using a gamma match on a commercial tri-band beam prompted the author to try a similar installation on his to determine if the standing-wave ratio could be reduced on the three bands. At W11CP, operation is divided between phone and c.w., which, of course, means operating over a large portion of each band. Any reduction in s.w.r. and consequent increase in efficiency is very desirable.

Prior to installing the gamma match on the beam the s.w.r. on 15 and 10 varied considerably over the frequencies on which the antenna was used. Twenty meters did not have s.w.r. variations to the extent of the higher bands but it could still be improved on. A graph of the s.w.r. on the three bands before and after the installation is shown in Fig. 1. Just how much improvement was obtained is quite apparent. If the reader decides to make the installation to be described here, it is suggested that he make a similar check before and after the installation, to satisfy himself on the degree of improvement.

The Gamma Unit

The matching unit is shown in Fig. 2. In our installation the three variable capacitors were housed in a 5 x 6 x 9-inch metal box. However, any box of adequate size can be used. The three capacitors were mounted on standoff insulators, to insulate both the stators and rotors from the box, as the box itself would be connected to the center of the driven element and the antenna boom. W6DOB used variable capacitors from BC-375 tuning units which were already mounted on ceramic insulators.

Insulated shaft couplers were used on the capacitors to bring the rotor controls outside the

¹Jones, "Gamma Match Feeding the Tri-Band Beam," *West Coast Ham Ads*, June, 1957.

Using the Gamma Match for S.W.R. Reduction

BY LEWIS G. MCCOY,* W1ICP

.....
● Multiband beams using the "trap" principle have become quite popular, but the s.w.r. on the feedline has left something to be desired in most cases. In this article a 3-band gamma match is described that permits adjustment to a very low s.w.r. at one point in the band. As a consequence, the band width with an acceptable s.w.r. is increased.
.....

box for adjustment. Three feedthrough insulators were mounted on the box for the gamma line connections to the stators of the capacitors. A chassis mounting coax receptacle (SO-239) was installed on the box for the feedline connection.

Installation and Adjustment

One of the advantages in using a gamma match is that the antenna can be connected to the boom. Having a steel tower which supports the antenna, it was felt that the additional lightning protection offered by using a grounded system made this type of installation worth while. The driven element was connected to the boom with a short

* Technical Assistant, QST.

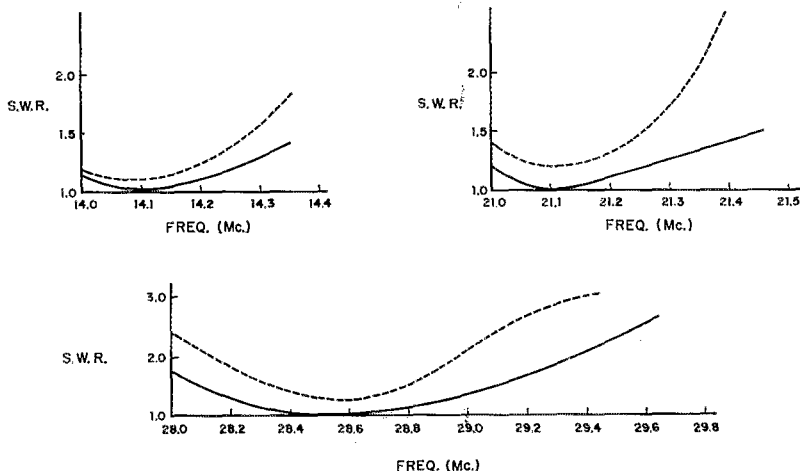
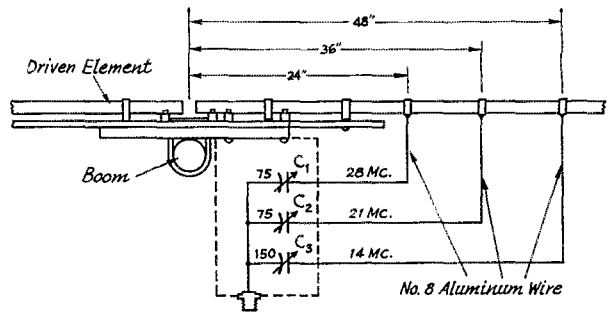

Fig. 1—The charts show the before and after readings of the standing-wave ratios for the three bands. The dotted lines are the before readings and the solid lines, the results after installation of the gamma unit.

Fig. 2—This drawing shows the mounting and connections for the gamma unit. For power inputs under a few hundred watts the plate spacing on C_1 , C_2 and C_3 should be at least 0.030, and it should be at least 0.070 inch for inputs up to a kilowatt. The three gamma wires were made 24, 36 and 48 inches long, respectively. Spacing of the three lines from the box to the element did not appear to be critical.



length of No. 8 aluminum wire. We had a supply of aluminum grounding wire on hand and it was used for the gamma lines and also for "jumping" the former antenna feed point and connecting the element to the boom. Grounding the element to the boom was accomplished by loosening the U-bolt nuts and running the wire under the nuts and to each side of the element.

The box containing the gamma unit was mounted under the steel bracket that supports the element. Four two-inch long screws were used to hold the box in place. Garden-hose clamps were used for the gamma line connections on the antenna. Spacing of the clamps was as follows: 28 Mc.: 24 inches; 21 Mc.: 36 inches; 14 Mc.: 48 inches. All dimensions were measured from the

center of the driven element.

Adjustment of the system is very simple. Start on 20 meters, with the transmitter on or near the frequency about which you center your operating. With the antenna in the air and an s.w.r. bridge in the line, turn on the rig and adjust the 150- μ mf. capacitor for minimum s.w.r. At WIICP the writer monitored the rig and the s.w.r. bridge while the helper adjusted the gamma up on the mast. After matching on 20, the rig was flipped to 15 meters and C_2 was adjusted, and then C_1 was trimmed on 10 meters. We were prepared for some "interlocking" of the adjustments and several checks were made on each band, but it was found that the adjustments were substantially independent.

Strays

W3BFW sends in the following daffinitions:

- Ohm — an H'englishman's castle
- Pentode — Convict frog
- 6N7 — Thirteen
- Square wave — sophisticated member of the Navy
- Amplifier — Device for making noise louder
- Dipole — What Stronganoff said as he shot Czernizowski
- Yagi — Hindu holy man
- Sync — What is done to a ship to get rid of the rats
- Kilocyte — Dangerous two-wheel vehicle

Do you ground your antennas during a lightning storm? KN2YTK thought his 18'-high antenna was protected because it was shadowed by higher TV antennas, power lines, trees and a receiving antenna. But, nonetheless, his DX-35 got sadly mauled by a bolt of electricity. Do you ground your antennas?

A Novice-Technician c.w. net is being organized for First Army MARS members. You can get further info by writing to WIWLP, 50 Trident Ave., Winthrop 52, Mass.

W0YOZ recently worked W1AUT and W3AUT practically simultaneously on 21 Mc.

Six Meter Sonnet

Thou studious type, with every moment spent in concentration
 Aloof from wife and home, happy though introverted;
 Whose last earned penny is to radio parts converted,
 To make the most of freakish propagation!
 What have you spent in dollars and in time
 To work six meters in the boundaries of your city?
 Would it not be best to utilize land-line
 And relieve your offspring of the neighbors' pity?

— K6KWM

W3HQJ sends us an excerpt from the *Journal of the American Medical Association*. Discussing morale in "Medical Notes on a Greenland Ice Cap Expedition", the researchers reported that "morale was lowest when activities and demands on the individual were least; it was improved by radio contacts with the outside world."

VE1WI took a trip to NYC and decided to visit a cousin whom he had not seen since childhood. Reaching the general neighborhood, he pulled over to the curb and asked a passing pedestrian for street directions. He finally reached the proper address, and when he knocked at the door, lo and behold the door was opened by that random passing pedestrian, who turned out to be none other than the cousin!

Tape Recording the Mark II Minitrack Signals

An Inexpensive Recording Method for Amateur Tracking Stations

BY V. R. SIMAS AND W. B. MORIARTY *

● This description of a low-cost recording system for satellite tracking completes the main items of equipment, of a nonstandard nature, that will be needed for the project. Tape recording can be sent to NRL for transcription on paper with an ink recorder. The system has been thoroughly tested and found to be capable of the required accuracy. The work described here was done under the direction of Roger L. Easton.

IN THE ORIGINAL ARTICLE describing the Mark II Minitrack (July, 1956 *QST*) it was suggested that the most satisfactory type of recorder is the high-frequency direct-writing type. In view of the high cost of such an instrument the possibility of using a tape recorder as a substitute has been investigated.

The results of this investigation have shown that, although a visual recorder is preferred, the information can be stored on tape and transferred to a visual recording. Equipment for transferring the information will be available at the Vanguard Control Center at the Naval Research Laboratory.

Fig. 1 shows in block form the equipment needed for tape recording the output of the Mark II system. All of the equipment used previous to detection has been described earlier¹ so this paper will be restricted to the circuits needed to record the information on tape (Fig. 2) and the circuits needed to take the information off the tape (Figs. 5 and 6).

It should be mentioned here that the first tape-recording system investigated involved recording the intermediate-frequency signal directly. However, the required i.f. band width of the system permits a great deal of system noise to overwhelm the signals at low signal levels. This system was not successful because of the excessive noise present at the intermediate-frequency amplifier output terminals and the limited dynamic range of the recording medium.

The signals at the detector output of the Minitrack system have frequencies between 0.1 and 3 cycles per second. Information having frequencies in this range cannot be recorded on tape directly. These low-frequency signals can, however, modulate audio-frequency carrier signals having frequencies in the range that can be recorded. In addition, because the range of signal frequencies is small, the side bands associated with such a carrier occupy very little band width, so several signals can be recorded on the

same tape simultaneously by spacing the frequencies of the carriers appropriately. In the Mark II system there are three signals which should be recorded: the timing signal and the two interferometer outputs. The time signal, if obtained from a WWV receiver, is 5 cycles of a 1000-c.p.s. tone, which can be recorded directly. In order to permit the separation of the three signals the three a.f. carriers should be spaced reasonably far apart without, of course, exceeding the frequency response of the recorder.

The carrier frequencies selected for this system have a spacing factor of about 2.5, starting with 1000 c.p.s. A top frequency of 6.18 kc. was chosen instead of 6.25 kc. because standard components in the filters resonate at this frequency. At a speed of 7.5 inches per second, magnetic tape characteristics are such that all these frequencies are well up on the response curves of commercial recorders. By this selection of carrier frequencies the deterioration due to tape noise is minimized.

Circuit Factors

Fig. 2 is the schematic of the prerecording circuitry. The receiver outputs are at a low impedance and a fairly high level of voltage so the

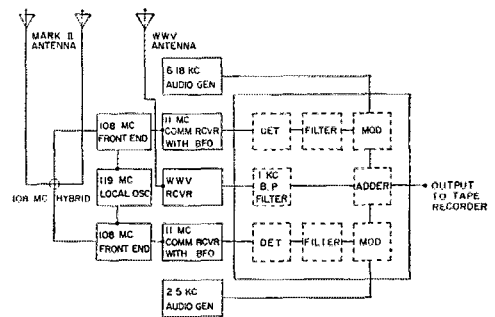
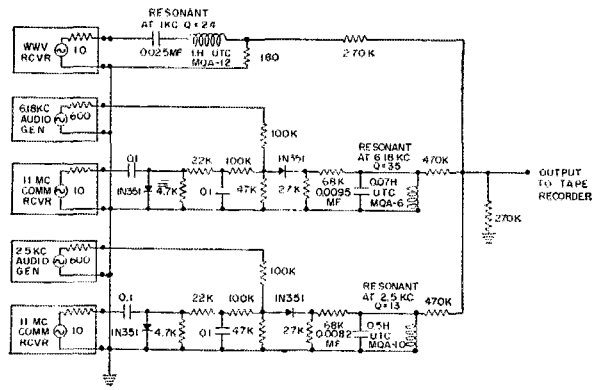

Fig. 1—Block diagram of the receiving setup for using an ordinary tape recorder for recording the satellite signals.

* Naval Research Laboratory, Washington 25, D. C.

Fig. 2—Circuits for using the rectified and filtered audio output of the receiver for modulating 2500- and 6180-cycle carriers. The modulated a.f. carriers, plus the time tick from WWV, are then combined and applied to the tape-recorder input circuit.



demodulation and filtering can all be accomplished without amplification. Basically, the signals required from the receivers are at an intermediate frequency. Most receivers cannot supply the required signal amplitude at this frequency; therefore the v.f.o. is utilized to effectively translate the normal intermediate frequency to a new i.f. frequency in the audio range which, when amplified by the audio stages, becomes a suitable signal for input to the recording system.

In Fig. 2 these signals from the communications receiver are first detected in the shunt detector consisting of the 0.1- μ f. coupling capacitor and the 1N351 crystal diode. The low source impedance permits a circuit loading of 4700 ohms with little loss in signal voltage. The resulting low-frequency signal is then filtered by a low-pass filter consisting of the 22K resistor and the 0.1- μ f. capacitor. This filter has a cut-off frequency of about 72 c.p.s. resulting in the removal of the a.f. carrier and some of the noise from the detected signal.

This detected signal amplitude modulates one of the carriers obtained from the audio generators — either 6.18 kc. or 2.5 kc. The second 1N351 crystal is the nonlinear element necessary for the modulation process involving the two signals combined in the resistor adding circuit. The a.f. carrier signal applied to this modulator

must have an amplitude of at least 1 volt if reasonable modulation percentages are to be obtained.

Unwanted modulation products are removed by the band-pass filter tuned to the 6.18-kc. or 2.5-kc. carrier. The Q s of these filters are set at the proper values to maintain a band width of approximately 180 cycles.

The WWV receiver has a high signal output at a low impedance making it possible to use a series-resonant 1000-c.p.s. filter of the type shown in the schematic. The 180 ohms output resistance is essentially the sole damping resistance seen by the LC filter. A Q of 24 is used to remove as much noise and voice modulation as possible from the time-tick signal without undue decrease in the signal amplitude.

Initial Adjustment

The signals from the two interferometer receivers and the WWV receiver are mixed by the network of resistors shown and then recorded. It is necessary that the signal levels from the receivers and audio signal generators be set to fairly good precision for proper circuit operation.

These controls can be set in the following manner for the case of a weak received signal (-120 dbm.):

- 1) Disconnect the transmission lines from the hybrid, making certain that the connectors are

Fig. 3—Ink recording transcribed from a tape recording made by the system shown in Fig. 2. In this recording the timing pulses, at one-second intervals, have been superimposed on the upper channel only. The r.f. signal in this case was approaching the minimum usable strength.

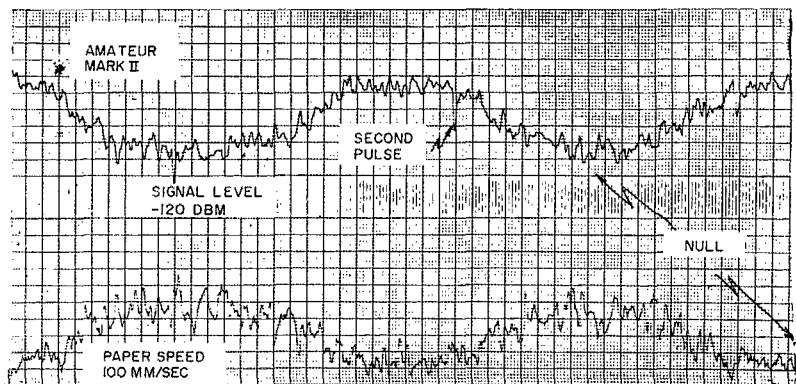
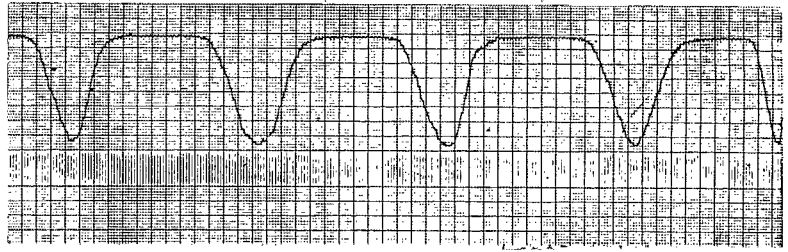

Fig. 4—A stronger r.f. signal makes the nulls more sharply defined, as shown by this recording of a signal 20 db. stronger (100 db. below 1 milliwatt or -100 dbm.) than the one used for the recording of Fig. 3.



coded so the lines can be replaced correctly.

2) Terminate one hybrid transmission-line terminal with its characteristic impedance.

3) Connect a signal generator with an output of -120 dbm. (0.22 μ v. in 50 ohms) to the other terminal.

4) Set the audio and r.f. gains controls on the receivers (with the b.f.o. on) to give 20 volts peak to peak at the speaker terminals.

5) Adjust the audio generator outputs at 6.18 kc. and 2.5 kc. to 15 volts peak to peak.

6) The signal wave-form patterns at the modulator tank circuits should be monitored with an oscilloscope and the relative levels of the input signal and carrier signal adjusted to provide a modulation percentage of about 75 per cent at a receiver input level of about -120 dbm. The input signal generator should be 100 per cent amplitude modulated at the rate of about 1 cycle per second.

7) The WWV receiver output should be adjusted so that the one-second timing bursts in the combined signal are at an amplitude of 15 volts peak to peak.

Playback System

Fig. 3 shows a visual record obtained by recording a -120 dbm. signal on tape and then transferring this signal to a visual recorder. Since the visual recorder had only two channels the one-second ticks were mixed with the information in the upper ticks channel. Higher signal levels will make the nulls appear sharp on the recorded channel. Fig. 4 shows -100 dbm. signals recorded on a setup adjusted for -115 dbm. signals.

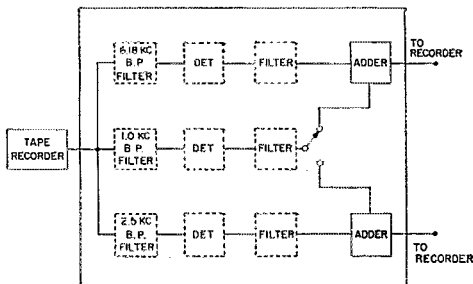

Fig. 5 shows the block diagram of the playback circuitry. The output of the tape recorder is connected to the three selective filters which separate the three signals present on the tape. These signals are detected and filtered separately, then alternately mixed with the timing signal and recorded on a visual recorder. To prevent cross-talk between the two channels the timing pulse may be connected first to one channel which is recorded and then, after rewinding, to the other channel which is recorded.

In the schematic of Fig. 6 all the playback networks are seen to be nonamplifying, which was also the case with the prerecording circuitry. Again this is possible because the tape recorder used in this experiment has a low output impedance (600 ohms) yet provides considerable voltage amplitude.

The output impedance of the recorder was reduced to approximately 300 ohms by means of the 620-ohm resistor across its output terminals. This equivalent source impedance together with the 330-ohm filter terminating impedances provides the damping resistance necessary to establish the required system Q .

The band widths of the filters in the two tracking-signal channels are designed to be 200 c.p.s. wide which requires a Q of approximately 30 at 6.18 kc. and 12 at 2.5 kc. The L/C ratio of each of these circuits was chosen to provide the proper filter characteristics with the parameters involved. The separated information is detected by means of the 1N351 crystals together with the 27K resistor and the 0.1- μ f. carrier bypass capacitance. The impedance at this point is

Fig. 5—Block diagram of the transcribing system, for reducing the tape-recorded information to ink recordings of the type shown in Figs. 3 and 4.

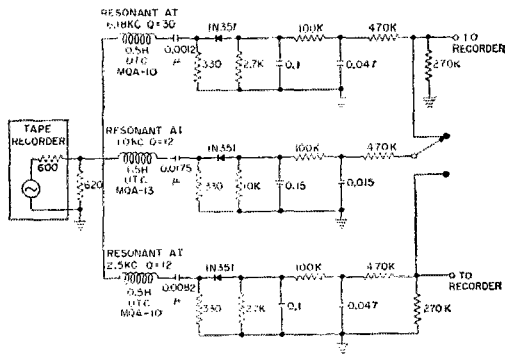

Fig. 6—Practical circuits corresponding to the block diagram of Fig. 5.

sufficiently low so that a filter consisting of the 100K resistor and the 0.047- μ f. capacitance can be connected across these terminals without undue loading. This filter has a cut-off frequency of approximately 30 c.p.s., which is the main post-detection band width limitation. At the signal rates involved, 3 c.p.s. or less, the phase shift, hence tracking accuracy, due to this filter is small and may be compensated for, if desired.

The resulting signals at the output terminals of the low-pass filters in the two interferometer channels are identical with the detected receiver output signals except for any distortion encountered in the recording process. The WWV time tick is converted from 5 cycles of the 1000 c.p.s. tone to a video pulse resulting from the tick being detected and integrated. These three signals are now composed of frequency components which are low enough to be recorded on almost any standard visual recorder.

The reader is cautioned that the exclusive use of passive networks employed in the above-described circuitry is the fortuitous result of having available commercial receivers and signal generators with more or less ideal characteristics for this use. In the event that the available equipment falls short of particular requirements it may be necessary to deviate from the schematics shown in Figs. 2 and 6, perhaps by the addition of one or more amplifiers. There are, of course, a great many variations to the circuitry that can be used to accomplish the desired performance.

Recording the Mark II Minitrack signals directly on a visual direct-writing recorder is certainly preferable to recording on magnetic tape, and every opportunity should be exploited in favor of the visual system. However, the results of our investigation show that tape recording of these signals is certainly feasible and desirable where the budget will not support the relatively high cost of a visual recorder.

Amateurs Assist in Determining Russian Satellite Orbit

The sudden announcement by the U. S. S. R. that an Earth satellite had been launched on the evening of October 4 caught the scientific world without the equipment needed to begin immediate radio tracking. In order to get an approximate orbit while the accurate equipment built for 108 mc. was hurriedly modified for 20 and 40 mc., amateurs were asked to rush observations on the time of appearance and disappearance of the satellite signals to the Naval Research Laboratory. A broadcast to this effect went out from WIAW Friday night and was continued through the next two days.

By Monday, the 7th, NRL's Minitrack Stations had been converted and there was no longer need for the necessarily rough observations obtainable with ordinary receiving equipment. As *QST* goes to press no statistics on amateur reports are available. That these observations had been useful is confirmed by the following message received from NRL on Octo-

ber 7: "Due to increasing number of Minitrack fixes on U. S. S. R. satellite readings by amateur and volunteer observers are no longer required. The U. S. Naval Research Laboratory expresses its thanks for the splendid cooperation provided by these amateur and volunteer observers."

Early information on the satellite amounted to little more than that contained in Dr. Pickering's article (which was received for publication several weeks before the flight of the Russian bird) elsewhere in this issue. The frequencies were placed at 20,005 and 40,010 kc. and the transmissions, at least initially, consisted of a series of pulses on each frequency.

If you kept a log of the satellite's signals, hold on to it for the present. Although the time has been too short for formulating definite plans for making use of such material, data on 20-mc. propagation should have interest for ionospheric physicists in view of the fact that the signal source was on the outer side of the ionosphere.

24th ARRL Sweepstakes: November 9-11 and 16-18

*Certificates to C.W. and Phone Leaders in Each Section
and to Club Winners; Special Novice Awards*

CONTEST PERIODS

<i>Time</i>	<i>Start</i>	<i>End</i>
	Nov. 9 & 16	Nov. 11 & 18
EST	6:00 P.M.	3:01 A.M.
CST	5:00 P.M.	2:01 A.M.
MST	4:00 P.M.	1:01 A.M.
PST	3:00 P.M.	12:01 A.M.

DO YOU LACK some QSLs for WAS, WAVE, Worked All New England and other awards? Can you and your station stand the gaff of 30 or 40 hours of concentrated operating? Can you roll up 50 or 500 or 1000 contacts in two week ends? Can you work all states or all 73 sections in 40 hours? Can you beat out the local competition in your ARRL Section and win an award, and maybe even lead your call area in the bargain? Think you can trounce such seasoned gladiators as W2IOP, K2AAA, W3BES, W4KFC, W4KVN, W6AM, and W7KVU? If you can reply in the affirmative to one or more of those questions, you'd better finalize your SS plans now!

The rules are the same as those of last year, thus following the pattern which has been so highly successful in the past. The contest runs over two consecutive week-end periods, with a maximum allowable total operating time of 40 out of a possible 66 hours for each entry. You may take part on both phone and c.w.; if you do, however, please file separate logs for each mode.

The SS is open to all amateurs located in the ARRL field organization, as shown on page six of this *QST*. Certificates will be awarded to the c.w. and phone winner in each of the 73 ARRL Sections. Within a club, single-operator stations may compete for certificates given to the club's top scorer on both phone and c.w. A corobolo gavel, engraved with the name of the winning club, will be offered to the group whose members run up the highest aggregate score. A certificate also goes to the leading Novice in sections in which there are three or more such entries.

To get in on the fun, just call CQ SS or answer such a call, exchange preambles in the form shown on the facing page and keep a neat, accurate log. ARRL will be glad to send along contest forms free on request, or you can draft your entry in accordance with the sample.

For purposes of this contest, all VE8s may be considered attached to Yukon. Similarly, VO8 count as Maritime and Cuba as West Indies.

Read over previous Sweepstakes results (May and June *QSTs*) for ideas on which bands to

work, operating procedures and short cuts, methods of log keeping and avoiding duplicate QSOs, and other useful data. Then scan the rules below and QRX for two November week ends jam-packed with operating enjoyment!

Rules

1) *Eligibility*: The contest is open to all radio amateurs in (or officially attached to) sections listed on page 6 of this issue of *QST*.

2) *Time*: All contacts must be made during the contest periods indicated elsewhere in this announcement. Time may be divided between week ends as desired, but a total of 40 hours must not be exceeded for each entry. Time spent in listening counts as operating time.

3) *QSOs*: Contacts must include certain information sent in the form of a standard message preamble, as shown in the example. C.w. stations work only c.w. stations and phone stations only other phones. Valid points can be scored by contacting stations not working in the contest, upon acceptance of your preamble and/or receipt of a preamble.

4) *Scoring*: Each preamble sent and acknowledged counts one point. Each preamble received counts one point. Only two points can be earned by contacting any one station, regardless of the frequency band. The total number of ARRL sections (see p. 6) worked during the contest is the "sections multiplier." It is not necessary for preambles to be sent both ways before a contact may count, but one must be received, or sent and acknowledged, before credit is claimed for either point(s) or multiplier. Apply a "power multiplier" of 1.25 to c.w. entries and 1.5 to phone entries if the input power to the transmitter output stage is 150 watts or less at all times during contest operation.

The final score equals the total "points" × the "sections multiplier" × the "power multiplier."

5) *Reporting*: Contest work must be reported as shown in the sample form. Printed contest forms will be sent free on request. Indicate starting and ending times for each period on the air. All Sweepstakes reports become the property of ARRL and none can be returned.

There are no objections to one's obtaining assistance from logging, "spotting" or relief operators, but their use places the entrant in the multiple-operator class, and it must be so reported.

A single-operator station is one manned by an individual amateur who receives no assistance from other persons during the contest periods. He may not have assistance in any manner in keeping the station log and records, or in spotting stations during a contest period. The operation of two or more transmitters simultaneously is not allowed. Contest reports must be postmarked no later than December 4, 1957, to insure eligibility for *QST* listing and awards.

6) *Awards*: Certificates will be awarded to the highest

HOW TO SCORE

Each preamble sent and acknowledged counts one point.

Each preamble received counts one point.

Only two points can be earned by contacting any one station, regardless of the frequency band used.

For final score: Multiply totaled points by the number of *different* ARRL sections worked; that is, the number in which at least one bona fide SS point has been made. Multiply c.w. scores by 1.25 and phone scores by 1.5 if you used 150-watts-or-less transmitter input at all times during the contest.

EXPLANATION OF "SS" CONTEST EXCHANGES

<i>Send Like a Standard Msg. Preamble, the NR</i>		<i>Call</i>	<i>CK</i>	<i>Place</i>	<i>Time</i>	<i>Date</i>
<i>Exchanges</i>	Contest serial numbers, 1, 2, 3, etc., for each station worked	Send your own call	CK (RST report of station worked)	Your ARRL section	Send time of transmitting this NR	Send date of QSO
<i>Sample</i>	NR 1	W1AW	589	CONN	1812	NOV 9

c.w. scorer and to the highest phone scorer in each ARRL section. A c.w. certificate will also be awarded to the highest scoring Novice or Technician in each section where at least three such licenses submit c.w. logs; similarly, a phone certificate will be earned by a Novice or Technician in each section where a total of three such licenses submit phone logs. Only single-operator stations are eligible for certificate awards. Multiple-operator scores will receive separate *QST* listing in the final results.

A gavel will be awarded to the highest club entry. The aggregate scores of phone and c.w. reported by club secretaries and confirmed by the receipt at ARRL of contest logs constitute a club entry. Segregate club entries into phone and c.w. totals. Both single- and multiple-operator scores

may be counted, but only the score of a bona fide club member, operating a station in local club territory, may be included in club entries.

The highest single-operator c.w. score and the highest single-operator phone score in any club entry will be rewarded with a "club" certificate where at least three single-operator phone and/or three single-operator c.w. scores are submitted.

7) *Disqualification*: Failure to comply with the contest rules or FCC regulations or the necessity for avoiding interference with channels handling amateur emergency communication shall constitute grounds for disqualification. In all cases of question, the decisions of the ARRL Contest Committee are final.

Sample of report form that must be used by contestants

LOG, 24th A.R.R.L. SWEEPSTAKES

Station..... C.W. or Phone..... Section.....

Freq. Band (Mc.)	Time On or Off Air	Sent (1 point)						Received (1 point)						Number of Each Different New Section as Worked	Points
		NR	Stn.	CK-RST	Section	Time	Date (Nov.)	NR	Stn.	CK-RST	Section	Time	Date (Nov.)		
3.5	On 1810	1	W1AW	589	Conn.	1812	9	7	W3JNQ	589	E. Pa.	1814	9	1	2
"	"	2	"	589	"	1815	"	6	W4KFC	599	Va.	1817	"	2	2
"	"	3	"	579	"	1820	"	6	W1TYQ	579	Conn.	1821	"	3	2
7	"	"	"	"	"	"	"	21	W5BYJ	479	Ark.	2005	"	4	1
"	"	4	"	479	"	2115	"	38	KN6SXA	579	Sac. V.	1815	"	5	2
"	"	5	"	579	"	2128	"	45	W6BIP	479	S. F.	1820	"	6	2
"	"	6	"	589	"	2133	"	9	W3CPS	589	E. Pa.	2134	"	..	2
"	Off 2135 Time: 3 hrs. 25 min. On 1845														
14	"	7	"	569	"	1915	10	94	KH6MG	569	Hawaii	1418	10	7	2
"	"	8	"	569	"	1925	"	127	W7KVU	569	Mont.	1728	"	8	2
"	"	9	"	469	"	1935	"	114	W7TML	569	Ore.	1630	"	9	2
3.5	"	10	"	579	"	2110	"	130	K6CNC	579	N. D.	2005	"	10	2
"	"	11	"	589	"	2112	"		W5BYJ		Ark.				1

Total Operating Time: 5 hrs. 55 min.

3.5, 7 and 14 Mc. used.

10 Sec., 22 Pts.

145 Watts Maximum Power Input

Assisting person(s), name(s) and call(s)

Claimed score: 22 points \times 10 sections = 220 \times 1.25 (145 watts input) = 275

Type transmitter (tube line-up if home-built)

Receiver

Antennas

Participation for Club Award in the

(Name of Club)

I have observed all competition rules as well as all regulations established for amateur radio in my country. My report is correct and true to the best of my knowledge.

Signature

Number different stations worked

Address

How to Handle a Message

Getting Your Feet Wet in the Traffic Game

BY GEORGE HART,* WINJMJ

LET'S ASSUME that you're an "average" amateur — whatever that is. You've had your ticket only a couple of years, and although you've heard that amateurs are allowed to handle messages, you've never done it (or thought of doing it), never heard it done, and don't know anybody who does it. What's more, this doesn't bother you, particularly. You do some phone yakking, chase a little DX, play around with v.h.f., are signed up in your local AREC and RACES units, and that's about the extent of your amateur operating activities.

The fact that you know nothing about messages doesn't bother you. That is, until some guy calls you on the telephone and tells you he heard you were an amateur and could originate a message to his son, who is stationed in Alaska. Then what do you do? Oh, you could squirm out of it, all right, if you want to be chicken. Let's assume that you're a proud, upstanding amateur who is convinced that, once challenged, he can do anything. You tell the guy *sure* you'll handle his message.



But how do you do it? The League sent you a little complimentary operating booklet once, when you joined, but you don't remember where you put that. Let's see, didn't some article in *QST* not so long ago describe how to handle a message? After searching a while, you finally come across it. Well, I'll be darned! The first three paragraphs describe your exact situation.

The Form of a Message

Every message has, or should have, four parts. They are called the preamble, the address, the text and the signature. The preamble is the trickiest part, but is necessary so that relaying or handling stations will know how to refer to it, what station originated it, how many words it's supposed to contain, where it came from and how old it is. Thus the preamble consists of a

*National Emergency Coordinator, ARRL.

number, station of origin, check, place of origin, filing time and date. The number is any number you want to pick out of a hat, but why not start with number one, since this is the first message you ever handled. The station of origin is your station call. The check is the number of words in the text. The place of origin is the name of the town or city in which the message originated. The filing time is the time the guy called you and gave you the message; most of us use 24-hour time because it's easier to send and avoids the A.M.-P.M. tangle, but that's up to you. That date is, of course, that date that corresponds with the filing time.

The address is easy, because its form is something with which you're familiar. But be careful to separate the parts of the address. A good way to do this is by putting them on three separate lines, the way you would on an envelope. Then leave a space before you start the text underneath.

In the text, avoid punctuation if you can, or spell it out if you can't. ARRL recommends the use of the word "stop" in place of a period or semicolon, but most traffic handlers nowadays just use the letter X, borrowed from the military. The signature of course follows at the bottom of the message — enough said about that.

Message blanks? Oh yes, we have them¹, but any plain piece of paper will do just as well².

Sending the Message

Now you've got the message written and you're sitting there admiring it. What are you going to do with it? Alaska is a long way off. Should you get on 20 or 15 and call "CQ Alaska"? That might work, but more likely it won't — and even if it does, or even if you find an Alaskan station by other methods, he might suddenly develop a bad case of QRM when you ask him to handle a message. That happens! The same thing might happen if you try to peddle the message to anyone else, as happened to our misguided (or unguided) friend W0GYZ³. No, what you ought to have is a net directory⁴ so you can look up the time and frequency of your local net and put the message into it. Since you probably don't have one, and never noticed that *QST* carries net lists from time to time, the next best thing is to do some listening on 75-meter phone or 80-meter c.w. and find a net (most any net) that is handling traffic. Listen a while so you have some idea of their procedure, then report in and tell them your troubles. Chances are,

¹ *Business Mgr's note*: 35¢ per pad.

² *General Mgr's note*: You're fired!

³ Brawley, "Anyway It's Free," *QST*, May, 1956, p. 80.

⁴ Free on request from ARRL Communications Dept.

they'll take the message off your hands. If not, they'll at least tell you the time and frequency of a net that *will* handle it. If they don't, ask them; someone in the net will have a net directory, that's for sure — otherwise it's a pretty raunchy net and you'd best find another one. There are lots of them operating early in the evening.

Okay, you've found a net that will take your message. The net control tells you to stand by, and after a while he calls you and tells you to send the message to W-so-and-so. If W-so-and-so isn't in the direction of Alaska, don't argue! You're getting the message started, aren't you? And it's being sent to someone who knows what he's doing, which is more than you do at this point. The question is, how do you send it without completely exhausting the patience of the receiving operator?

Well, there's nothing difficult about it, but the exact procedure will depend pretty much on whether you're doing it on phone or c.w. Either way, you first call the station you're told to send it to (a one-by one call is enough) and make sure he's getting you O.K.; then you're ready to begin. If you're on c.w., start out with NR (number) and reel off the preamble in the order we gave you above. It's customary to put the letters CK in front of the word count (check). After the preamble go right into the address without stopping. Use the signal "didahdidah" to separate the parts of the address (name, street, city, state) and at the end of the address send a double dash (dahdidididah) to indicate you're about to start the text. After the text, another double dash will indicate the signature is coming, and if the signature has an address use the separation signs (· - - ·) there, too. Don't send SIG before the signature; it isn't necessary and may confuse the receiving operator. After the signature, send AR (didahdidahdit) to indicate the end of the message, then stand by. As an example, your message should have been sent something like this: NR1 W1NJM CK14 NEWINGTON CONN 1900 JULY 23 PFC JOE DOAKS RA573128 AA 87TH FIELD ARTILLERY BATTALION AA APO 564 AA CARE POSTMASTER SEATTLE WASH BT RECEIVED YOUR LETTER STOP EVERYTHING FINE AT HOME STOP WRITING STOP ALL OUR LOVE BT MOM AND DAD AR.

If your sending was decent, chances are he'll acknowledge your message as received (R). If not, you're in trouble because he'll have to ask for "fills" of missing parts. He might ask for AA (all after), AB (all before), WA (word after), WB (word before), or ?BN (what's between?). Or he might just send a word from the message, a question mark, then another word to indicate he missed the part in between. Good thing you read this article before handling that message or you wouldn't know what he was talking about! After you've cleared your message, wait for the net control to excuse you (QNX). If he should

ask you to take a message for your town, be a sport and take it. Chances are he'll excuse you right away to get rid of you.

On phone the procedure is different because you don't have to use a lot of abbreviations; you can say what you mean. This isn't saying that it's easier to handle traffic on phone (*i.e.*, assuming you know the code) — not by a long shot. Unless you're careful to spell unusual or difficult words phonetically with the utmost care, F's become S's and M's become N's (*vice versa*). B's, C's, D's, E's, G's, P's, T's, V's and Z's all sound alike. QRM is terrific. If you know the code well enough to say so, our advice is to stick to c.w. If you do go on phone, dig out that old phonetic list you used when you were in the service (the military don't use it any more, but most amateur nets still do) and use it liberally but not unnecessarily in sending your message.⁵ If you don't have any phonetic list, make one up for the occasion. This last will not especially endear you to the hearts of the phone traffic men, but it will do the job. Geographical names are best in this case: A for Alabama, B for Boston, C for Chicago, etc. One advantage of phone over c.w. is that the net control can tell you what to do without throwing a lot of procedure signals at you.

Your message is now on its way, in the hands of capable, experienced operators who know what to do with it. If the net you gave it to was part of the ARRL National Traffic System, it will follow a systematic route to its destination.⁶

Servicing the Message

After sending the message, indicate at the bottom to whom it was sent, the date and the time. Stick it in your log, or keep it somewhere handy in the shack for a year. This is an FCC requirement. If you'd rather, you can copy it in one of the back pages of your log book.



Restrictions

Wasn't that fun? Maybe you enjoyed it so much you'd like to handle a little more traffic.

(Continued on page 184)

⁵ Copy of the ARRL standard phonetics list available on request.

⁶ Hart, "Handling Traffic by System," *QST*, Feb. 1957, p. 50.

Final Results, 23rd ARRL International DX Competition

BY ELLEN WHITE,* WIYYM, AND PHIL SIMMONS,** WIZDP

THE FIGURES and facts to follow will surely speak for themselves. *This was the year!* Conditions (with few exceptions) superb, competition keen, operating outstanding, and results remarkable! For the sixth successive year entries climbed, reaching the figure of 1781, up 8.1 per cent over the previous year.

Certificates of performance will go to 340 participants in their respective sections and countries, as shown in the following breakdown.

	c.w.	phone
Single-operator, W/VE.....	69	61
Multioperator, W/VE.....	8	3
Single-operator, non-W/VE.....	95	56
Multioperator, non-W/VE.....	2	0
Club.....	30	16

But for the real heart of the DX Competition, read on!

C. W. Highlights

In just one decade, the DX specialist has increased his ability to a degree that was undreamed of by the avid DXer of 1947. In fact, the W/VE leader of today corners a higher multiplier figure than the top contact figures of ten years ago!

In 1947, W2GWE walked away with W-honors by earning 153,450 points with a multiplier of 165 on 310 QSOs. This year, the redoubtable W4KFC keyed his way to a masterful 961,425 total on 882 two-ways and a mighty multiplier of 364. The top Canadian contestant of '47, VE3KE, added a score of 54,384 on 176 contacts and multiplier of 103. This year, VE1PQ did almost five times as well with an end result of 233,320-190-410.

A highlight of the 1947 competition was the

From a modest start in 1953 as 13-year-old KN6BFC, KH6CBP has progressed to amazing c.w. form. Proof of this is evident in his acquisition of 968,691 points for the Oceania lead and 2nd world-high score. Now back in the States attending college, Bill plans to be active as a W9, but has left behind him a record to remember in future DX Competitions.

performance of XE1A as he staggered the stands with his half-million-plus mark. In this, the 23rd DX Test, Juan returned as XF1A to demonstrate once again his mastery of DX competitions. Juan not only exceeded the million mark but did it by an impressive margin. Final results: 1,281,702-114-3757! Most QSOs on 20 meters (1122), then 10 meters (1096) and 15 (869 contacts). Even 160 payed off to the tune of a multiplier of 10!

Last year's W3DGM/3 record was surpassed by 6 U.S.A. operators *par excellence*. The W/VE champ eyed the million mark and came close. W4KFC established the new line to toe as outlined above. Following Vic were W3LOE 913,230, W3ECR (keyed by W3MFW) 913,060, W3GRF 878,240, W3MSK 874,245, W3JTK 820,456.

C. W. Call-Area Leaders

Single-Operator

W1BIH.....	509,456	VE1PQ.....	233,320
W2IOP.....	725,286	VE2APH.....	30,654
W3LOE.....	913,230	VE3DT.....	37,488
W4KFC.....	961,425	VE4RO.....	103,125
W5CKY.....	313,272	VE5OC.....	23,450
W6ITA.....	645,946	VE6NX.....	33,726
W7QGF.....	276,012	VE7ZM.....	141,858
W8FGX.....	757,435	VE8OW.....	56,604
W9LNM.....	611,010	VO1AQ.....	30,954
W0QDF.....	313,686		

Other tremendous scores were posted by: W8FGX 757,435, W3BVN 753,675, W2IOP 725,286, W2WZ 691,742, W3EIV 660,011, W6ITA 645,946, W6YMD 641,520, W9LNM 611,010, W9FJB 594,425, W4RQR 563,456,

* Asst. Communications Mgr., Phone, ARRL.

** Asst. Communications Mgr., C.W., ARRL.

XE1A, Sr. Juan Lobo y Lobo and "maestro of the million mark," led Mexico, North America and the world with an unprecedented 1,281,702 points and a record of 3757 QSOs. Juan's best hour brought 100 exchanges and he maintained an average of 63 contacts per hour, sometimes working five stations per minute! Hats off to XF1A for a superb performance!



Bob Shank, W5CKY, led the 5th call area code-wise, once again reaping Mississippi honors. His big signal led to an impressive 229 multiplier and his 7th Section award.

W9HUZ 559,800, W2AGW 537,588, W3ALB 533,680, W6IBD 533,676, W3GHS 509,751, W1BIH 509,456.

On the more-than-one operator side of the picture W6RW's 1956 record was shattered by both himself and W3CTJ as follows: W3CTJ 867,888-328-882; W6RW 804,436-332-811. Seven other groups topped the 500-K level: W2AIW 763,686, W3VKD 721,935, W0SQO 700,181, W6BXL 613,914, W4KXV 573,196, W6VSS 560,616, W1ICP 559,872. The crew at W6RW tallied 128 different countries in the process and the following boys didn't do badly either: W3CTJ 126, W6BXL 122, W1ICP 121, W0SQO 118, W6TPJ 115, W6PYH 114.

Returning to the single ops, Larry LeKashman (back at W2IOP) topped the different-countries category with a nifty 130, followed by these old reliables: W3JTK 128, W8FGX 126, W3LOE 125, W2AGW 122, W4KFC 121, W3ECR 117, W2WZ 116, W2PRN 114, W4YHD 114, W3ALB 113.

Many a DX station overcame the 100-K hump. For instance: CE3AG DJ1BZ DJ3JZ DL1JW DL4PN DL7AH DU7SV EA1AB EA1BC EA6AF EI9J F3AT F8VJ F9MS FK8AL FS7RT G2HPF G2QT G4CP G5RI HH2DX I1AMO I1NT IT1TAI JA1VX JA3BB KH6AYG KH6CBP KH6LJ KH6MG KH6PM KL7AIZ KL7PIV KL7WAF W9KLD/KL7 KP4ADS KP4DH OK1KI OK1MB OK3DG OZ1W OZ7BG PA0EP PA0RE PA0VB PJ2AJ PJ2AV PY7AN SV1AB SV0WP VK2GW VK2GW VK2QL VK7KM VK9XK VP2LU VP5BH VP7NM XF1A ZE5JA ZL1MQ ZP9AY. Checking into the W/V/E c.w. tabulation if you've a steady eye and strong arm you'll note a total of 182 scores that top 100,000.

Among the many interesting feats and firsts was one by DX-contest "pro" KH6LJ. Katashi scored a 50-Mc. multiplier by QSOing two W7s in Arizona!

Surprisingly enough, at least to your reporters, the boys who brought in the biggest over-all scores are also the ones who brought in big single-band scores. Somehow, it just seemed to us that single-band concentration would prove out in single-band scores. Alphabetically and by band, let's look at single-op calls, multipliers and QSOs. **3.5 Mc:** W3BVN 25-50, W3ECR 27-42, W3EIS 28-48, W3GRF 33-61, W3JTK 27-46, W3LOE 27-43, W3MSK 28-43, W4KFC 33-59, W4YHD 26-43. **7 Mc:** W2IOP 53-110, W3BVN 66-136, W3ECR 57-123, W3EIV 56-107, W3GRF 55-105, W3LOE 62-123, W4BGO 52-91, W4KFC 58-127, W4YHD 59-118, W8FGX 50-95. **14 Mc:** W1TW 110-115, W2AGW 113-304, W2IOP 119-294, W2PRN 105-222, W2WZ 110-268, W2ZGB 107-175, K2GFQ 104-195, W3ECR 108-279, W3GRF 109-281, W3JTK 113-267, W3LOE 116-286,

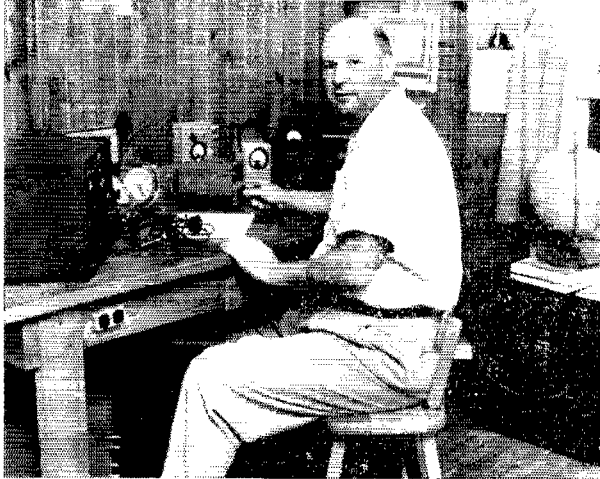

W3MSK 105-276, W4KFC 111-282, W6IBD 105-263, W6ITA 106-286, W6NZW 102-242, W6VUP 100-233, W6YMD 116-318, W8FGX 105-237, W8UPN 100-231, W9VIN 104-305. **21 Mc:** W3ECR 86-220, W3JTK 60-196, W3MSK 82-206, W4YHD 84-223, W9LNM 80-186. **27 Mc:** W3MSK 14-21, W9PKW 14-22. **28 Mc:** W3JTK 71-179, W3MSK 70-174, W9FJB 71-167.

Phone Highlights

W2ATE, new phone record-holder, bettered the 1956 record set by W2SKE/2 by over 200-thousand points. Chad talked up 892 contacts with an impressive 312 multiplier. A rugged 93 hours of vocalizing led to 115 different countries worked.

Reaching the 200-thousand stratum were: W2ATE 833,664, K2AAA 702,452, W6YY 422,304, W3MSK 398,286, W8BKP 322,875, W4OM 304,200, W3ECR 294,360, W9EWC 286,650, W3DHM¹ 270,848, W6VSS¹ 269,418, W8NGO¹ 268,488, W8NWO 232,245, W0EDX 229,104, W4KWY 219,600, W8NXF 216,594, W4DQH 213,120, W3WQN¹ 206,006, W8ZOK 200,725.

Phone Call-Area Leaders

Single-Operator

W1ONK.....175,050	VE1YB.....9800
W2ATE.....833,664	VE2JR.....45,500
W3MSK.....398,286	VE3BNY.....18,800
W4OM.....304,200	VE4RO.....157,209
W5KC.....74,295	VE5VL.....66,096
W6YY.....422,304	VE6NX.....10,062
W7DAA.....28,782	VE7ZM.....15,219
W8BKP.....322,875	VE8AB.....3354
W9EWC.....286,650	VO6U.....26,102
W0EDX.....229,104	

Single-band multiplier highs form an interesting pattern of what happened on the individual phone frequencies. For instance: *75 mc's:* W2ATE 25, K2AAA 16, W6VSS 9, W8AJW 9, W8NXF 9, W9NZM 9. *40 meters:* W3ECR 31, W2ATE 26, K2AAA 22, W4KWY 21, W9NZM 15. *20 meters:* K2AAA 93, W2ATE 90, W8BKP 85, W6YY 78, W4OM 74, W3MSK 71, W4DQH

¹ Multiple-operator station.

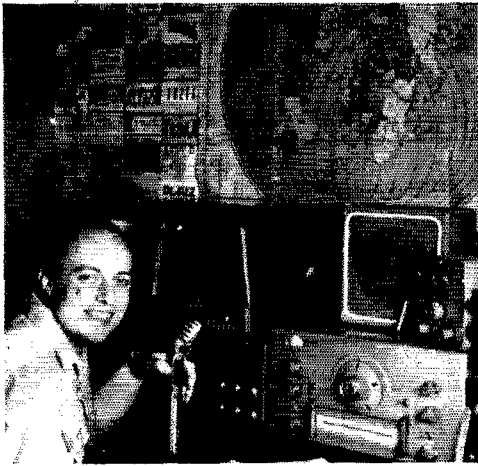

Second to F8PI in continental oral honors, ON4OC tallied 106,062 points in a 5-band effort. Ray's HRO-7 and SX-43 were bolstered by 100 watts input to a 276-foot radiator.

70. 15 meters: K2AAA 83, W2ATE 76, W3MSK 65, W8NGO 61, W3DHM 60. 11 meters: W2ATE 21, W8NGO 19, W8NWO 19, W8NXF 19. 10 meters: K2AAA 81, W2ATE 74, W0GEK 67, W5ALB 66, W1ONK 63, W3DQH 60, W8SDD 60.

DX leaders in number of phone contacts were: KH6CBP 2017, KH6IJ 1918, OA5H 1631, KH6AYG 1075, F8PI 865, VP9L 839, HH2RM 769, VP2VG 756, VK3ATN 727, EA3JE 692, OE5CK 662, KH6MG 624, ZS9G 618, ZS5JY 559, ON4OC 537, G3DO 515, KL7AZN 496, OK1MB 477, YN4CB 423.

DXers prominent in collecting call-areas were: KH6IJ 81, OA5H 81, VK3ATN 81, YN4CB 73, KH6CBP 72, VP2VG 72, OK1MB 71, ON4OC 66, KH6MG 60, HH2RM 57, F8PI 56, ZS5JY 54, G3DO 52, VP9L 50.

Among the interesting competing prefixes *not* to be found in the following c.w. tabulation are: CN2 CR4 HC PJ2M VP2 (Leewards) VP5 (Turks) VP9 VQ3 VR2 YN ZB1 ZB2 ZS9. For the boys keeping track of number of *different* countries worked, this would have meant an additional 13.

Club Scores

The year 1957, one to be remembered for many DX "firsts," brings to the Potomac Valley Radio Club their first DX Test gavel award. Thirty-five of the PVRC brethren made a concerted effort (averaging 285,617 points apiece) and accumulated an amazing aggregate score just short of the ten-million mark. The Southern California DX club and the Frankford Radio Club vied closely for "place" and "show." Altogether 38 clubs are shown in the club tabulation, a 15 per cent increase over last year's listing. Special certificates are being awarded to the leading phone and c.w. operators in each club that submitted the minimum number of entries required by the rules. Congratulations to the winners!

Disqualifications

The following are deemed ineligible for score listings or awards. In each case disqualification under contest rule 14 was in view of non-observance of FCC rules as reported by at least two accredited Official Observers, as confirmed by a single FCC citation, or on report of rule-breaking by a participant himself. Such violations as off-frequency work, contact with countries on the FCC-prohibited list, etc. were the criteria for these disqualifications: C.w. — W1BDI, W5GAI, W8SPO; Phone — W1MXX, W1QWI, W3FYS, W3GRF, KH6MG.

Sidelights

"Went into the contest with a hope of making a Utah contact to complete my WAS, but no dice. And what happened to all the VE stations." — ZS6AJQ. . . . "Conditions were relatively good and I used 21 and 28 Mc. for the first time. Made my highest score ever, either as YA1AM, YI2AM or OD5AX." — YA1AM. . . . "Worked about 200 stations in six continents on 14, 21 and 28 Mc. with beam rotator stuck in northeast position!" — W3WPG. . . . "With merely 90 watts it was tough going to fight European QRM. Watch out next year as am planning a beam to get solidly into the USA!" — 4X4CJ. . . . "Worked the following on 10-11-15-20-40 and 80 meters. K2AAA W4KWY W6VUP and W8LKH." — OA5H. . . . "Band conditions very poor second weekend." — VO8N. . . . "Made better than three times last year's score." — W4CYA. . . . "What a contest, what bedlam, what juicy rare ones. Wish I could have hooked some!" — W4JIT. . . . "Never ever hear any Vermont stations. Better license a few more new ones, the old chaps must be gone, hi!" — YK5JT. . . . "Had an unscheduled stopover on Canton while piloting for Pan American. Considering the size of the pile-up, there was very little difficulty with stations calling while I was trying to copy, etc. The participants are to be commended for good operating manners." — W6YKE/KB6. . . . "Anybody over 21 that enters DX contests has



F8PI, top phone European and first-time contest man, farms crops as well as three-element beams and long wires. The bookcase houses a DX100 and AR88 in the living-room station. Paul's best band proved to be 28 Mc., good for 510 two-ways.

loose guy wires. Must be getting old, hi!" — W3ECR. . . . "Many stations still fail to use GMT when QSLing, making it very difficult to verify contact." — KA5ZS. . . . "DX moving into American phone band on 10 and 15 helped reduce calling time." — W0EDX. . . . "Now that I have a farm and space for antennas, I couldn't find time to get them all up." — W3ALB. . . . "I sure wish the phone DX would announce what frequencies they are listening on." — W3VTH. . . . "Hope I set a new record for a 17 year old operator." — KH6CBP [968,691 points worth, wow! — Ed.]. . . . "My highest score ever; 21, 27 and 28 Mc. never really shut to the states. Who ever dreamed of working a W

in past competitions, George Morrow, W8BKP, has often represented Ohio in a big way via both modes. This year George talked his way to the top W8-spot with 322,875 points, and displayed the 3rd highest 20-meter multiplier (85 countries).



on 27 Mc. at 1330 GMT! My contest #101 post war; such tests keep my gear and me up to scratch." — ZLIMQ. . . . "Was surprised to work VP2VG and HH2RM on 40 phone with a folded dipole only five feet off the ground." — K2OPJ. . . . "Expect to be a VP6 for the phone section of the '58 DX Test." — W2DJT. . . . "More effort should be made to have DX stations sign the call of the station (c.w.) they're working *after* giving the number. It'll save time." — W6ITA. . . . "Ten was totally useless here the 2nd weekend due to aurora effect." — W9KLD/KL7. . . . "Any of my QSOs can be confirmed by writing P. O. Box 4, Bluefields, Nicaragua." — YN4CB. . . . "KH6IJ was worked on six bands (phone) first weekend, ditto HP3FL and VP2LU second weekend. Worked the following on five bands: ON4OC G3COJ VK3ATN VP2VG YN4CB SV9WT and KZ5CS." — W2ATE. . . . "Gets tougher every year!" — W5MTL. . . . "Station closed down March 23 due to tidal wave. No damage to my station." — KH6AYG. . . . "Always enjoy the contest, although the XYL says if I ever have the gear and antennas all working at one time she'll give me a medal!" — W8BTI. . . . "Suggest that stations in rare countries submit logs so that we W and VEs can receive credit for DXCC, particularly if they're unable to QSL 100%." — W5ZWR. . . . "Worked KH6IJ on 5 bands." — VE2APH. . . . "Maybe I'm getting mellow but it seemed to me that signals were cleaner and operating practices more mature than in previous contests." — W6VUP. . . . "Managed to get in a little time despite power failure during first half and arrival of new jr op in middle of the second half." — KL7PIV. . . . "Noticed a shortage of easy ones on 20, such as CX CP HC HP VP1

DX Continental Champions

C.w.		Phone		
CR6AL.....	285,136	Africa	ZS5JY.....	90,180
JA1VX....	342,967	Asia	KA2FQ....	28,866
OK1MB....	373,326	Europe	F8PI.....	144,480
XF1A.....	1,281,702	No. America	VP9L....	201,360
KH6CBP...	998,691	Oceania	KH6IJ...	466,074
PJ2AV....	248,490	So. America	HC2BH....	108,228

CLUB SCORES

	Score	C. W. Winner	Phone Winner
Potomac Valley Radio Club.....	9,996,385	W4KFC	W3M8K
Southern California DX Club.....	7,528,490	W6ITA	W6Y Y
Frankford Radio Club.....	7,134,550	W3ECR ¹	W3ECR
Ohio Valley Amateur Radio Assn.....	2,439,337	W8FGX	W8SDD
Northern California DX Club.....	2,013,371	W6LDD	W68IA
Maui Amateur Radio Club.....	1,373,513	KH6MG
The DX Club (Pa.).....	1,167,948	W3GHS	W3GHS
Connecticut Wireless Assn.....	1,014,281	W1BIH
San Diego DX Club.....	988,888	W6KSM
Order of Boiled Owls (N. Y.).....	900,458	W2PRN
Niles Amateur Radio Club (Mich.).....	833,773
Four Lakes Amateur Radio Club (Wis.).....	710,160	W9LNM	W9RBI
El-Ray Amateur Radio Club (Mass.).....	670,513	W1BOD
Rochester DX Assn.....	632,005	W2FBA	W2TQR
Central Michigan Amateur Radio Club.....	621,732
Hampden County Radio Assn. (Mass.).....	549,698
Greater St. Louis DX Club.....	509,466	W0QDF
South Jersey Radio Assn.....	476,473	W2TE	W2DMR
Milwaukee Radio Amateurs' Club.....	452,976	W9GIL	W9GIL
Westpark Radiops (Ohio).....	416,762	W8AJW	W8BF
Ridgewood Amateur Radio Club (N. J.).....	411,423	W2EQS
Willamette Valley DX Club (Ore.).....	318,570	W7DAA
Morris Radio Club (N. J.).....	281,625	W2YTH	W2WKL
Palo Alto Amateur Radio Assn.....	182,439
Hampsters Radio Club (Ill.).....	133,224
Citrus Belt Amateur Radio Club.....	85,356	W6HAL	W6IIM
Springfield Amateur Radio Club (Ohio).....	85,266	W8OKB
Atlanta Radio Club.....	118,500	W4ZKU
Chicago Suburban Radio Assn.....	66,601	W9FVU	W9FVU
Columbus Amateur Radio Assn.....	50,376	W8QDH
Central High Radio Club (Iowa).....	44,406	W0DSP
Minneapolis Radio Club.....	41,943	W0IFW
Goose Bay Amateur Radio Club.....	38,579
Tri-State Amateur Radio Society (Ind.).....	31,473
Blue Ridge Amateur Radio Society (Virginia).....	15,690	K4DKA/4	K4ETQ
Lake Success Radio Club (N. Y.).....	13,140	W2CMO
Suffolk County Radio Club (N. Y.).....	10,254	W2PZE
Montrose County Amateur Radio Club (Colo.).....	10,047	W0WME

¹ W3MFW, opr.

VP3 CO PZ HK VP8, etc." — *K6EIV*. . . . "Only state I didn't work was North Dakota." — *V77NM*. . . . "Noticed good tendency of phone DX to transmit in the W band when conditions were right. Works fine!" — *W0IUB*. . . . "The most interesting thing I found was that of the 56 contacts I made, 32 replied on my first transmission. It looks like ultra modulation packs a punch!" — *W1DJS*. . . . "Watch for a high score next year, with a kw. on all bands less 160 and rhombics for the east coast, midwest and west coast." — *KL7BZ*. . . . "My first DX test and regret I couldn't work 160 and didn't break 500,000 points." — *VP2LU* [He came pretty close though, 499,359! — *Ed.*] "ZC5AL and CT3AB new countries for me." — *W6UQQ*. . . . "I still enjoy the contest, even after 32 years of hamming. Picked up seven new ones on phone for a grand total of about 150 postwar." — *W1RF*. . . . "Worked JA1EF on 40, the first and only Japanese phone station I've heard on that band." — *W4KWFY*. . . . "My first contest and really enjoyed it. After 26 years, I finally caught the bug!" — *W6ZMX*. . . . "It took 58 hours to make 1457 contacts and 12 to type the log. However, it was a lot of fun and I hope to be able to better my score next year. Generally conditions were very good here and operation was smooth and A-1 from 99.99% of the W/VE stations worked." — *OZ7BG*. . . . "Couldn't get Oregon, the only state I need for WAS." — *G3JHI*. . . . "Enjoyed the 28 Mc. QSO with JA1AA when he was running 4 watts." — *W6ACL*. . . . "Took a vacation from the ARRL DX Contests for the first time in about 31 years." — *W6AM*. . . . "No Russians heard on phone." — *W4HKJ*. . . . "Please remember that our phone bands are 3.6-3.8 and 7.05-7.15 Mc. Why don't the W/K/VE/VO group listen there?" — *P9TV*. . . . "Swell phone contest but an earthquake recalled me to duty." — *NV0WT*. . . . "Worked both KH6s IJ and PM on six bands, and OA5H on five phone bands." — *W6ILM*. . . . "To add to everything else, kids with chickenpox, me with mumps, and power transformers blowing up, the pen runs out of ink while signing my entry!" — *W6LWY*. . . . "It was a pleasure to work so many with such good operating standards." — *G2HPF*. . . . "Put up a new three-band beam for the second week end and it blew down 12 hours before the opening of the 2nd half" — *W6ID*. . . . "Those KII6s were sure trying. Guess I could have filled two quotas of them." — *K6DLY*. . . . "Nearly 200 contacts more than last year." — *F8VJ*. . . . "Lost both rhombics in rainstorm the first weekend; the storm also froze all three rotary beams." — *W6AGO*. . . . "This was my first year from the new location and everything seemed to work pretty well. Next time I expect to have better antennas for 10 and 80." — *W3GRF*. . . . "Worked a novice on Guam for a 15-meter multiplier!" — *W3MSK*. . . . "My best average was 41 QSOs/hour and that was on 20, Feb. 24." — *DL7AH*. . . . "My first contest and worked my last state for WAS, Nevada." — *DL7DF*. . . . "Very few lids noticed; only heard one W calling CQ-SS!" — *W2FBA*. . . . "Score 40 per cent better than last year with same power, same time of operation. In general, conditions were very good." — *W2QJM*. . . . "This was the best ever, conditions were fabulous, swell to have the Russians on. I'm so tired of beating my head against the brick wall of the big W3s that I'm going to DL4-land next year. When I'm back I'm going to buy an antenna farm; a measly 1/2 acre is just too small!" — *W3EIV*. . . . "Good conditions and best score ever, although the need for better antennas was frequently demonstrated!" — *W3EIS*. . . . "American amateurs are the best in the world. Not a bad operator or poor practice in 937 contacts." — *11AMO*. . .

"Better than doubled last year's score. After running between their legs and riding their coat tails, my biggest kick was coming up with ones like CR9AH ET2RH 4X4BX. Made WAC on 28 Mc. with an indoor dipole! Brought 7-Mc. countries total up to 116, 21 Mc. score to 113. Worked V77NM on 6 bands." — *K2CPR*. . . . "Only signal heard on 160 was XF1A." — *W3VKD*. . . . "Best contest I've worked in. Would like to suggest that the DX stations sign the call of the station being worked at the end of the QSO to preclude confusion and repeat QSOs." — *W9FJV*. . . . "We should drag out the Wouff Hong for the lids that persist in long testing even during a DX contest." — *W9V7L*. . . . "My first contest in 25 years of hamming. Great sport. Conditions were excellent. The ethics and consideration displayed by the entire group were generally outstanding and reflected credit on all hams and ARRL. A well-organized and well-conducted contest." — *W0VBK*. . . . "Worked KL7AIZ on five different bands the first weekend." — *W0ZKE*. . . . "Sickness the first weekend and a blizzard the second, that's the story of my life." — *W0BUR*. . . . "Got 599 reports from five continents." — *W9FYM*. . . . "Thought last year's score was best ever that could be made from Wisconsin, but learned differently — made 611,010 this year. Dreaming up improvements for 1958 already!" — *W9LNM*. . . . "Although conditions were not of the best in the first period, I enjoyed my first DX contest and hope to be in many more. Still need Utah and Wyoming for WAS." — *LA2F*. . . . "Conditions were ideal. My 509-456-point score obtained in spite of burning out a high-voltage transformer a few hours after the start of the first week end and running the exciter at 180 watts for the rest of the first period." — *W1BTH*. . . . "One new one for me, FK8AL and worked him on four bands to make sure. Noted decreased participation from Central and South America. Ended up tired but happy as usual." — *W1ODW*. . . . "Disgusted with tail-ending." — *W1TX*. . . . "Compliments to VP5BH on the signal quality and operating." — *W0JSN*. . . . "Picked up my WAC on 7 Mc." — *K5DGI*. . . . "Doubled last year's score. Best conditions yet on 10. My 4th year of participation and enjoy the rough competition." — *W5PYU*. . . . "Didn't do as well as I did at W3DCIM last year, but real proud of my low-power score." — *K4LPW* [On 100 watts input. Mel ran up a tidy 309,063-point sum — *Ed.*] "Score about 50 per cent higher than last year while my operating time was about 45 per cent less." — *CT1CO*. . . . "Picked up four new countries and countless gray hairs." — *W4JBQ*. . . . "Checked back in the records and found this was my 18th ARRL DX Contest, first as W1RY and now as W8RQ. In my first in 1928-1 made 35 contacts in nine countries on four continents. Finished in 40th position using a UV202 in the transmitter, an OV2 receiver, and an end-fed zepp." — *W8RQ*. . . . "For the 3rd year in a row I lost my 20-meter beam." — *W8HMI*. . . . "Increased my score by over 50,000 points. Ten meter conditions were FB this year." — *E11AB*. . . . "Able to gross an additional 40,000 points over 1956 due to better antennas and conditions, and with 20 hours less operating time." — *W1AXA*. . . . "Best experience; made WAC in 16 minutes. Worst experience: A two-hour traffic jam in front of the house when 28 Mc. was hot. The ignition noise was a steady roar." — *W1BOD*. . . . "Worked the Ohio Valley Amateur Radio Assn.'s foreign representative, VP5BH, on five bands." — *W8EV*. . . . "I had plenty of fun and felt I'd accomplished more with lower power than when I used to run the rock crusher and beam." — *W6LV*. . . . "Best conditions I've ever heard during the 2nd week end. Europe stopped coming in only because the contest ended." — *W6LDD*. . . . "Even with a rather mediocre setup had one swell time and picked up five new ones. I had to drive 600 miles on a week-end 3-day pass and it was well worth the lost sleep. Spent the 2nd c.w. period listening from DL4-land. Quite a revelation!" — *W1UGW*. . . . "After winning last year's contest for Germany as DL4ZC, I had high hopes of doing the same in the East Bay Section but found competition much keener." — *W6KG*. . . . "Finally worked a new country in a DX contest (Aden) after ten years of contesting. This made nr. 230 worked." — *W6CTL*.



The big signal out of Europe in the c.w. portion originated with these three boys at DJ3JZ: DL1CR, DL3AO, DJ3JZ. Excellent teamwork led to 1323 contacts and top Europe multi-op position.

QST for

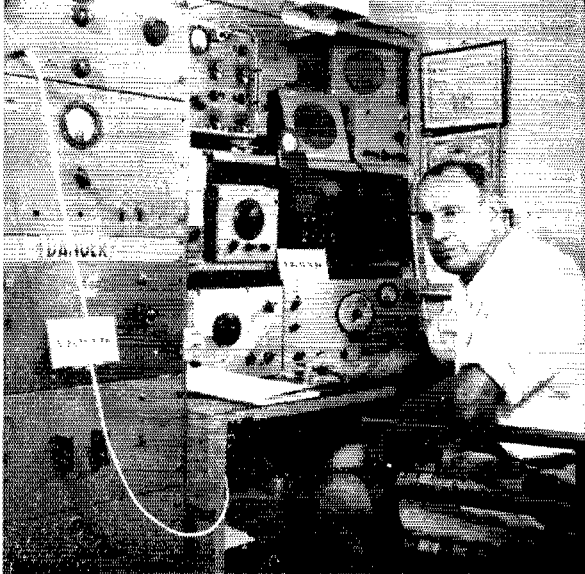

VK9XK ably represented Papua by key through 1125 QSOs in all states but Rhode Island. The rack on the left houses his all-band home-built transmitter while desk equipment includes home-brew dual-conversion receivers, pre-selector, S-27 and frequency meter. Russ reports use of both a 136' long wire and BJK.

... "Enjoyed the contest very much this year. It's always a pleasure to be in a contest with the W/Ks and their fine operating practices." — *HB9QQ*. . . . "As for conditions, no doubt the W6s in Hollywood have a word for it. Stupendous-colossal-magnificent!" — *GW3BQY*. . . . "Spent part of 1st Saturday in hospital and operated entire first week end with arm bound out straight and couldn't put elbow on operating table. Somewhat cumbersome. Conditions certainly wonderful, but I couldn't seem to take very good advantage of them." — *W4RQR* [Now this is a matter of opinion; Bob made considerably more than the half-million mark! — *Ed.*]. . . . "Two weeks after the contest ended I finished getting up a 3-element beam. Seems like I do everything the hard way." — *K2OPJ*. . . . "Conditions were superb, activity the greatest ever. What a paper storm West Hartford is in for." — *W4KFC*. . . . "My quad antenna worked like a charm." — *K4GMX*.

While the crew at 38 La Salle Road thankfully wraps up the colossal '57 contest by preparing section, club and country awards, you're urged to ready the gear and mark the calendar for these dates in '58: Phone — Feb. 7-9 and March 7-9; c.w. — Feb. 21-23 and March 21-23.

C. W. SCORES

Twenty-Third International DX Competition

Operator of the station first-listed in each section and country is winner for that area. . . . The multiplier used by each station in determining score is given with the score — in the case of U. S.-Canada this is the total of the countries worked on each frequency-band used; in the case of non-W/K/VE/VO entries it is the total of the U. S.-Canada districts worked on each band. . . . The total number of contacts is listed next. . . . The letters A, B, and C approximate the input to the final stage at each station; A indicates power up to and including 150 watts; B indicates over 150 watts, up to and including 500 watts; C indicates over 500 watts. . . . The total operating time to the nearest hour is given for each station and is the last figure following the score. . . . Example of listings: W3ECR 913,060-355-858-C-90, or final score 913,060; multiplier 355; 858 contacts; power over 500 watts; total operating time 90 hours. . . . Stations manned by more than one operator

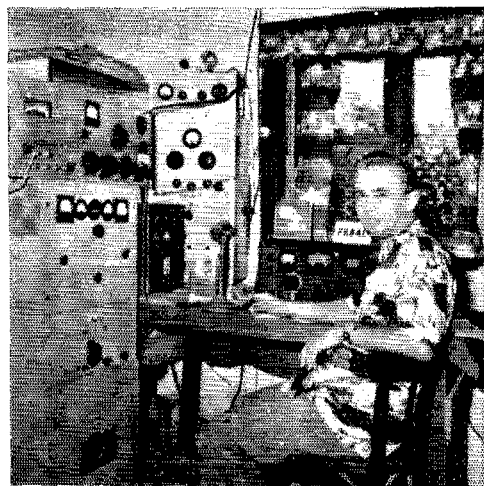

A country that always creates a pileup is New Caledonia and FK8AL was no exception. John reports good c.w. conditions on 20 and above, evident in a respectable 222,768-point figure. His big band was 20, good for 604 QSOs.

are grouped in order of score following single-operator listings in each section or country tabulation; calls of participants at multi-operator stations are listed in parentheses. . . . In sections or countries where three or more multiple-operator entries appear, the top-scoring station is being awarded a certificate.

ATLANTIC DIVISION

Eastern Pennsylvania		W3EQA (W3s DQG EQA)	272,620-215-429	C-60
		W3MDE (W3s MDE SOH)	178,080-160-371-	B-65
W3ECR	913,060-355-858-C-90	<i>Md.-Del.-D. C.</i>		
W3ALB	533,680-280-638-C-70	W3LOE	913,230-365-834	C-89
W3GHS	509,751-271-627-B-71	W3GRF	878,230-352-833	C-90
W3NGV	251,490-202-415-C-68	W3MSK	874,245-349-835	C-90
W3WPG	215,962-176-409-B-88	W3JTK	820,156-343-798	C-85
W3LEZ	146,454-154-317-C-31	W3EIV	753,675-325-773	C-85
W3DBX	124,785-411-295-A-	W3EIV	660,011-319-691	C-85
W3IMV	104,247-117-297-B-10	W3MFS	458,948-259-592	C-74
W3GHD	77,631-113-229-B-	W3WOS	394,500-250-526	A-C-65
W3ARK	71,904-112-214-B-32	W3MSR	378,392-233-542	C-84
W3MLW	49,868-91-184-B-60	W3EKN	365,800-236-519	BC-74
W3ALX	44,838-106-141-C-12	W3EIV	343,980-234-400	C-61
W3HUS	44,838-94-159-C-20	W3KDP	301,968-216-466	C-62
W3BIP	41,719-89-157-A-45	W3ELI	282,528-216-436	C-66
W3DAO	37,800-72-175-B-48	W3DRD	266,684-209-426	BC-59
W3ZLU	29,718-78-127-AB-25	W3ZQ	243,264-192-423	C-82
W3DYU	27,117-69-131-C-27	W3EPR	246,206-102-151	C-27
W3VDV	20,944-68-103-C-25	W3HYM	26,354-83-146	A-22
W3EYW	18,762-59-106-C-17	W3GRS	16,653-61-91	A-9
W3ADZ	18,483-61-101-C-7	W3HXA	17,574-58-101	B-53
W3GRS	16,653-61-91-A-9	W3PSP	21,105-67-105	A-30
W3RFG	15,147-51-89-B-17	W3HXA	17,574-58-101	B-53
W3OCU	13,083-49-89-C-14	W3KLA	11,850-50-79	A-17
W3DQG	12,096-48-84-A-	W3BKE	10,584-49-72	B-24
W3QMZ	12,012-44-91-C-34	W3DVO	9360-40-78	C-43
W3QLW	11,997-43-93-A-33	W3VKI	7920-44-60	A-18
W3CHH	10,902-46-79-B-	W3MCG	6510-35-62	A-
W3ANZ	9933-43-77-B-35	W3VTH	5134-34-51	A-60
W3BYX	8541-39-73-F-40	W3VRJ	5049-33-51	C-16
W3ITP	7080-40-59-C-25	W3KCA	3276-26-42	B-13
W3HTF	4902-38-43-A-7	W3VQZ	3267-33-33	B-8
W3NM	3666-26-48-A-15	W3CQR	507-13-13	B-10
W3NDV	2574-22-39-A-13	W3MET	108-6-6	B-7
W3EAN	2046-22-31-C-6	W3BYO	48-4-4	B-4
W3MOY	1620-18-30-C-8	W3PZW (W3s PZW W)	399,635-249-535	BC-80
W3IYP	1620-18-30-A-18	W3TMZ (W3s TMZ ZAL)	377,224-244-516	C-73
W3SOH	772-14-16-A-1	W3FYS (W3FYS, W6HOH)	341,530-238-479	C-90
W3CTJ (W3s CTJ NOH)	867,888-228-882	W3CPB (W3s CPB WFO)	166,200-163-340	B-55
W3GEM (W3s GEM KDF)	497,859-263-631	<i>Southern New Jersey</i>		
W3EBG (W3s BES DMQ EBG)	418,417-251-557	W2TE	266,140-205-436	B-70
W3KT (W3s JNQ KT)	332,688-228-478	W2GCL	229,874-202-379	BC-67
W3KFP (W3s KFP QK QD)	288,684-198-484	W2SDB	86,304-124-232	AC-48
W3CGS (W3s CGS WJD YIK)	277,704-203-456	K2CPR	67,275-115-195	A-80

W2ILN . . . 32,412-73-148- B-26	W9IVB . . . 96-4-8-A-3	K4DTI . . . 11,907-49-81- B-14	W8BUM . . . 3255-31-35- B-8
W2UA . . . 29,748-74-134- B-20	K9EWB . . . 3-1-1-A-1	W4SUD . . . 546-13-14- A-2	W8GMK . . . 3024-21-48- A-21
W2QKJ . . . 28,728-63-152- B-	W9IRH (W9s FVT IRH, K9IBU)		W8FDC . . . 2160-20-36- A-12
K28WZ . . . 27,612-78-118- A-60	119,190-145-274-ABC-75		W8BSR . . . 1881-19-33- B-30
W2QDY . . . 17,100-60-95- A-20	W9OFR (8 oprs.)		W8FIT . . . 1500-20-25- A-20
K2MIO . . . 11,481-44-87- C-8	28,350-70-135- B-77		W8DFQ . . . 1440-20-24- A-4
K2OBA . . . 10,455-41-85- A-20			W8FDN . . . 1404-18-26- A-5
W2BUT . . . 7068-38-62- B-12			W8CSK . . . 1550-18-25- A-21
W2DAJ . . . 6216-37-56- B-18	Indiana		W8VZE . . . 1298-18-24- B-6
W2PAU . . . 5100-36-50- B-7	K9CLO . . . 135,864-153-296- C-75		W8WOG . . . 900-15-22-AB-3
W2VUM . . . 2460-20-41- A-13	W9POC . . . 66,738-98-227- C-80		W8YGR . . . 594-11-18- A-
W2BQ . . . 363-11-11- A-5	W9UYG . . . 51,408-102-168-AB-		W8W8S . . . 576-12-16- A-7
W2SZP . . . 351-9-13- A-5	W9BYN . . . 31,257-69-151- A-38		W8BOS . . . 300-9-10- A-3
K2CMN . . . 144-6-8- A-3	W9CWO . . . 30,225-75-135- B-36		W8RTF . . . 108-4-9- C-3
W2BLV . . . 30-2-5- A-2	W9UC . . . 22,644-64-117- B-20		
	W9ESK . . . 21,576-62-116- B-32		
	W9SFR . . . 16,884-67-84- C-19		
	W9NH . . . 10,192-49-70- B-		
	W9FGX . . . 10,011-47-71- A-20		
	W9FYM . . . 4500-34-45- B-20		
	W9MUR . . . 1455-33-45- B-15		
	W9NXU . . . 3780-35-36- B-19		
	W9DGA . . . 38-4-4- -		
	W9ZTD (W9ZTD, K9ADJ)		
	111,150-130-285- C-55		
	Wisconsin		
	W9LNM . . . 611,010-310-657- C-82		
	W9GIL . . . 256,878-213-402- C-70		
	W9WJH . . . 141,192-159-296- C-50		
	W9DYG . . . 44,175-95-155- B-50		
	W9KXK . . . 38,800-81-160- B-54		
	W9RKP . . . 25,200-60-140- B-40		
	W9QNO . . . 18,876-52-121- C-25		
	W9RBI . . . 18,328-74-83- -15		
	W9PQA . . . 16,380-60-91- A-29		
	W9PDX . . . 14,400-50-98- C-		
	W9VZP . . . 8532-36-79- A-15		
	W9QGR . . . 3744-26-48- A-8		
	W9NLJ . . . 2376-24-33- A-5		
	W9CHD . . . 1980-22-30- B-		
	W9KQD . . . 1767-19-31- A-11		
	W9MDG . . . 1392-16-29- -		
	K9RCA . . . 189-7-9- A-2		
	W9LKB . . . 180-6-10- B-7		
	W9UDE . . . 168-7-8- -		
	DAKOTA DIVISION		
	North Dakota		
	W8CAQ . . . 27-3-3- A-4		
	K9CNC . . . 27-3-3- A-		
	South Dakota		
	W8BLZ . . . 95,250-127-250- B-35		
	Minnesota		
	W8MPW . . . 154,524-158-326- C-		
	W9YCR . . . 30,360-120-251-BC-10		
	W8WSN . . . 82,677-127-171- B-50		
	W9TFW . . . 37,800-84-150- B-48		
	W9GNC . . . 8256-32-86- B-		
	K8BIT . . . 2376-24-33- B-10		
	W9PPW . . . 1767-19-31- A-7		
	K9ALL . . . 510-10-17- A-2		
	DELTA DIVISION		
	Arkansas		
	W5MY . . . 49,990-98-170- B-30		
	W5ING . . . 4544-32-48- A-8		
	W4SAS/5 . . . 72-4-6- A-2		
	Louisiana		
	W5KC . . . 169,338-169-334- A-50		
	K5DGI . . . 58,275-105-185- A-50		
	W5PYU . . . 46,920-92-170-AB-50		
	W5CEW . . . 8364-41-68- C-6		
	Mississippi		
	W5CKY . . . 313,272-229-456- C-54		
	W5GIF . . . 612-12-17- A-7		
	Tennessee		
	W4DQH . . . 323,610-230-469- C-65		
	K4LFP . . . 309,063-213-485- A-75		
	W4FKA . . . 41,328-82-168- C-60		
	W4IV . . . 25,152-64-131- C-22		
	K4APN . . . 960-16-20- A-11		
	W4VOS . . . 828-12-23- A-10		
	W4EFP (W4s EMU HVV IAS)		
	9360-39-80- A-34		
	GREAT LAKES DIVISION		
	Kentucky		
	W4KVX . . . 223,440-196-380- C-30		
	W4JBQ . . . 121,245-137-295-AC-50		
	W4OMW . . . 17,820-66-90- B-23		
	Michigan		
	W8UPN . . . 396,435-247-535- C-74		
	W8DUS . . . 353,906-238-497- C-65		
	W8RQ . . . 309,837-229-451- B-63		
	W8HMI . . . 226,083-187-403- C-39		
	W8UVZ . . . 33,966-74-153- A-40		
	W8WVU . . . 30,351-67-151- A-50		
	W8ONA . . . 25,560-60-142- B-36		
	W8KPL . . . 19,008-66-96- B-15		
	W8LWG . . . 16,038-54-99- C-26		
	W8LQS . . . 15,900-53-109-AB-20		
	W8WPQ . . . 13,851-57-81- A-		
	W8SS . . . 11,322-51-74- A-25		
	W8LZS . . . 3150-25-42- A-21		
	W8OOR . . . 1410-20-24- B-33		
	W8SSC . . . 810-15-18- B-19		
	W8YCT . . . 507-13-13- B-18		
	W8OCK (W8s DJN OCK)		
	285,795-219-435-AB-65		
	W8TWO (W8TWO, KH6ALN)		
	199,056-174-582-BC-33		
	W8VPC (W8s TJQ VPC, KH6-ALN)		
	114,168-134-284- B-80		
	HUDSON DIVISION		
	Eastern New York		
	W2IOP . . . 725,286-327-742- C-70		
	W2PBV . . . 309,618-206-501- B-80		
	W2BYP . . . 222,006-194-385- C-70		
	W8HSZ . . . 179,744-164-366- B-60		
	W2HFO . . . 171,765-166-347-AB-67		
	W2AWF . . . 148,617-147-337-ABC-61		
	W2FBS . . . 82,044-106-258-ABC-44		
	W2CJM . . . 73,485-115-213- B-38		

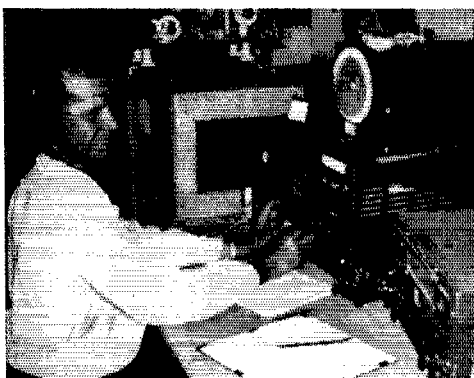

Manned by W6s LDR MBA NUJ RW and K6s DDO LGF, W6RW counted up c.w. points and came up with 804,436, top W6 multioperator tab. A total of 128 different countries were worked is reason enough for that smile on W6RW, shown at the 3.5 and 28 Mc. position.

Ohio	W8PFG . . . 757,435-335-755- C-75	W8GFX . . . 60,632-104-195- B-31
	W8BTL . . . 337,464-218-516- C-55	W2NCI . . . 11,016-54-68- B-25
	W8EY . . . 320,142-229-468-BC-60	KN2UPD . . . 3591-27-45- A-12
	W8TIM . . . 133,846-154-333- C-60	K2SOV . . . 3036-23-44- A-27
	W8PUD . . . 142,778-146-332- C-83	W2BXC . . . 2940-20-49- A-18
	W8BOJ . . . 88,320-138-340- C-23	K2BE . . . 2484-23-36- B-8
	W8CEG . . . 71,910-141-170- C-19	KN2UTC . . . 2457-21-39- A-39
	W8SSD . . . 66,690-117-490- A-40	W2IP . . . 810-15-18- A-14
	W8AJW . . . 62,118-102-203- A-33	<i>N. Y. C. — L. I.</i>
	W8YPT . . . 57,474-103-186- A-35	W2WZ . . . 691,742-314-735-RC-73
	W8OKB . . . 44,073-83-177- C-35	W2PRN . . . 372,033-243-511-BC-51
	W8CDD . . . 39,783-89-149- A-25	K2BSM . . . 156,816-144-368- C-50
	W8SWZ . . . 35,607-83-143- B-28	K2CF . . . 148,044-146-338- B-63
	W8QDH . . . 29,968-71-136- B-17	W2AZS . . . 114,615-135-283- C-41
	W8MQR . . . 26,996-69-128- C-26	W2UMU . . . 108,129-133-271- A-35
	W8ZJM . . . 22,713-67-113- B-19	W2OBX . . . 94,830-145-218- A-38
	W8NDU . . . 21,087-71-99- C-17	W2AYJ . . . 67,671-103-219- A-36
	W8KXV . . . 18,816-56-112- B-20	W2HJM . . . 50,196-94-178- C-
	K8BFX . . . 18,180-56-110- B-	K2OPJ . . . 47,334-98-161- A-38
	W8HZR . . . 18,360-60-102-AB-25	W2EEN . . . 35,235-81-45-AB-20
	W8EEL . . . 18,000-60-100- B-33	W2HQL . . . 34,560-96-120-AB-16
	W8STL . . . 17,466-71-82- C-20	W2BRV . . . 29,388-79-124- B-20
	W8KC . . . 17,050-50-114- B-30	W2KGN . . . 21,888-64-114- B-15
	W8IBX . . . 15,447-57-91- A-36	W2YDT . . . 19,494-57-114- C-20
	W8NWR . . . 13,536-48-94- A-21	K2OIL . . . 18,333-63-99- A-
	W8KMF . . . 10,845-45-81- A-28	W2BOT . . . 11,868-46-86- A-12
	W8LOF . . . 10,437-49-71- A-15	K2PHC . . . 9585-45-71- B-32
	W8NPN . . . 10,164-44-77- B-16	W2CMV . . . 9417-43-73- B-
	W8JQA . . . 9810-41-80- A-19	K2YOR . . . 8274-42-67- B-
	W8DQC . . . 9702-49-66- A-10	W2CUQ . . . 7128-44-54- B-7
	W8UMA . . . 8103-37-73-AC-28	W2PZE . . . 5670-35-54- A-4
	W8TTN . . . 7956-39-68- A-16	W2JB . . . 4830-35-46- B-13
	W8PCS . . . 6688-41-56- B-9	W2DUS . . . 4488-34-44- A-18
	W8BF . . . 4935-35-47- C-	W2MZB . . . 3240-27-40- B-6
	W8DWP . . . 4263-29-49- A-38	K2BTT . . . 1344-16-28- A-5
	K8CFB . . . 4224-32-44-BC-8	K2CMV . . . 1224-17-24- B-
	W8AL . . . 4134-26-53- A-13	W2LRJ . . . 675-15-15- B-16
	W8MFW . . . 3906-31-42- A-	K2DEM . . . 504-12-14- A-2

K2MDL.....396-11-12-A-4
 K2QBG.....210-7-10-A-5
 K2QBW.....168-7-8-A-6
 K2JYH (K2s JYH OPJ)
 116,178-134-289-A-45
 K2YRM (W2ELZ, K2s OWE
 SLM).....3915-27-49-A-17

Northern New Jersey

W2AGW...537,588-274-654-C-83
 K2DCA...421,005-255-555-C-89
 W2BOK...276,135-204-449-A-53
 W2EQS...229,743-201-381-B-90
 W2JTB...220,300-188-409-C-54
 W2GNQ...181,104-176-343-B-55
 W2YTH...155,109-149-347-B-56
 W2GSN...132,399-141-313-C-24
 W2CWX...124,074-183-226-B-35
 K2JLQ...90,145-121-249-AB-60
 W2ZGB...56,175-107-175-B-45
 W2AQT...49,389-101-163-B-58
 W2CYS...48,822-79-203-A-20
 K2KDW...34,572-86-134-C-0
 W2GJD...33,930-65-174-B-61
 K2BJA...30,429-69-147-A-80
 W2BYN...23,115-67-115-A-4
 K2KFP...22,020-60-89-A-22
 K2GLQ...20,010-58-115-B-15
 W2OZU...17,649-53-111-A-0
 W2VJN...15,840-60-88-A-13
 W2DJT...14,249-51-93-A-16
 W2HTX...7876-44-60-B-24
 W2WOS...7752-38-68-A-4
 W2EKN...7120-40-60-A-16
 W2EHN...6952-32-62-AB-25
 K2IYC...5580-31-60-A-10
 K2TML...4704-32-49-A-30
 K2CSC...4080-34-40-A-12
 K2MPB...3325-25-45-AB-10
 W2CVW...2880-30-32-A-11
 W2KKR...1725-23-25-A-3
 W2AEB...1254-19-22-A-3
 W2HMN...1008-14-21-B-13
 W2FKZ...648-12-18-A-6
 W2FMP...288-8-12-C-0
 W2CJG...240-8-10-C-2
 W2DZD...240-8-10-B-4
 W2AIW (W2s AIW GUM OMS)
 763,686-319-800-C-90

MIDWEST DIVISION

Iowa

W0NWX...260,652-203-431-BC-77
 W0DPS...32,175-75-43-B-51
 W0REP...21,624-68-106-C-19
 K0DQP...3350-25-45-A-23
 W0USF...918-17-18-A-11
 K0BMF...714-14-17-B-15
 W0GXQ...450-10-15-B-10
 W0SQU (W0s NCS RT RYJ
 SQU, K0DZX)
 700,181-313-749-C-80
 W0NTA (W0s NTA NUC PKH)
 312,806-227-460-C-93
 W0WDK (W0s WDK YSE,
 K0CZC).....8541-39-73-AB-60
 W0LNT (7 ops).....
 3240-27-40-B-20

Kansas

W0DAE...82,530-131-210-C-25
 K0BSL...61,506-102-301-B-68
 W0YBQ...39,060-84-155-BC-19
 W0IUB...32,706-79-138-B-22
 W0BYV...13,617-51-89-B-31
 W0BCI...6519-41-53-A-40
 K0DRR...3075-25-41-B-20
 W0GAX...2829-23-41-A-8
 W0VFE...1653-19-29-A-8
 W0VBK (W0s BAH VBK)
 65,670-110-199-C-61

Missouri

W0QDF...313,686-222-471-C-74
 W0BPA...135,564-158-286-B-78
 W0BMM (W0s 85,323-119-239-B-55
 W0ZKE...75,114-117-214-B-80
 W0PGI...59,697-99-201-B-47
 W0ANF...57,855-95-203-C-30

W0DU...39,114-82-159-B-33
 W0GVU...18,180-60-101-B-28
 W0RSZ...13,771-47-98-B-27
 W0ETV...6270-38-55-A-28
 W0ZSL...5406-34-53-B-26
 K0ARS...2100-20-35-A-16
 W0WVJ...1008-14-24-A-9
 K0EMK...630-14-15-A-9

Nebraska

W0DW...1500-20-25-AB-15
 W0BUR...135-5-9-A-3

NEW ENGLAND DIVISION

Connecticut

W1BTH...509,456-272-625-BC-63
 W1NMP...413,280-246-560-C-62
 W1VGP...342,720-224-510-A-55
 W1ODW...326,151-217-501-AC-68
 W1PTX...228,501-189-403-BC-52
 W1NWL...202,708-187-362-C-64
 W1OJR...168,760-168-315-B-55
 W1ZDP...134,547-149-302-A-46
 W1PVP...131,418-147-298-B-65
 W1QVQ...117,360-163-240-C-24
 W1IOB...98,568-148-222-B-35
 W1WJO...55,386-102-181-A-10
 W1FEA...51,606-94-183-AB-9
 W1WSC...32,802-77-142-B-47
 W1RWS...24,708-71-116-B-15
 W1WY...20,085-65-103-A-15
 W1WAW...18,900-63-100-C-12
 W1LVQ...8673-49-59-A-12
 W1NLM...3276-28-39-B-9
 W1NJM...2625-25-35-B-5
 W1ICP (W1s ICP WPO)
 559,872-288-648-C-90

Maine

W1DLC...216,220-190-382-C-75
 K1AHS...112,684-43-266-C-67
 W1MFK...12,768-56-76-A-20

Eastern Massachusetts

W1AXA...343,959-231-497-C-65
 W1BOD...308,310-215-479-C-66
 W1JEL...306,432-228-450-C-70
 W1OGU...169,692-158-358-B-60
 W1LEZ...70,632-109-216-AC-49
 W1PEG...58,562-94-213-ABC-61
 W1TW...37,950-110-115-C-20
 W1PWK...27,612-78-118-B-22
 W1AQE...27,432-72-127-A-17
 W1NS...26,270-74-119-AB-26
 W1QOM...21,978-66-111-AB-25
 W1BQL...17,700-59-100-A-34
 W1DDO...13,446-54-83-A-22
 W1JSM...10,350-46-75-A-14
 W1MLG...8967-49-61-A-20
 W1CTW...7980-38-70-C-9
 W1CJP...7686-42-61-A-18
 W1HPI...3840-32-40-B-20
 W1BPW...1560-20-26-A-8
 W1LQO...1479-17-29-A-3
 W1DYY...630-14-15-C-9
 W1MKW...561-11-17-B-5
 W1PLJ...84-4-7-A-16
 W1MXX...12-2-2-C-1
 W1MX (W1YFM, W2LSJ,
 K2DXV).....
 311,156-214-488-C-76

Western Massachusetts

W1JYH...306,450-227-450-BC-65
 W1EOB...241,664-236-342-C-49
 W1RB...59,340-92-215-C-59
 W1EFQ...23,490-58-135-C-24
 W1WEP...819-13-21-AB-3
 W1FSJ...48-4-4-A-3

New Hampshire

W1FZ...220,599-193-381-C-6
 W1GET...151,844-154-332-C-63
 W1ASZ...6888-41-56-B-9

W1TRM...4002-29-46-A-15
 W1JZY...3042-26-39-AB-15
 W1QVZ...1782-18-33-A-5

Rhode Island

W1CJH...241,233-191-421-C-60
 W1PPN...33,462-78-143-AB-31
 W1AWE...20,184-58-116-0
 W1DBA...6018-34-59-A-40
 W1LQA...2079-21-32-A-8
 W1BBN...1122-17-23-A-10

Vermont

W1QMM...45,900-90-170-B-40
 W1UGW...24,480-68-120-AB-22

NORTHWESTERN DIVISION

Idaho

W7WMO...2100-20-35-A-10

Montana

W7CJB...17,493-49-119-AB-50
 W9MLO/7...7326-33-74-B-24
 W7JLD...1938-19-34-A-12

Oregon

W7DAA...147,510-149-330-C-62
 W7FB...65,400-109-200-C-57
 W7OCL...61,692-97-212-B-22
 W7GHB...51,744-98-176-B-47
 W7WJC...29,949-67-149-A-64
 W7MQY...26,784-72-124-A-50
 W7PJC...23,718-59-135-B-33
 W7AC...15,810-62-85-B-20
 W7ENW...9324-42-74-C-15

Washington

W7QGF...276,012-204-451-C-80
 W7PQE...254,200-200-425-C-65
 W7BGH...153,567-158-234-C-64
 W7HJC...74,025-105-235-C-54
 W7JC...30,208-64-158-B-40
 W7CMO...17,160-52-110-A-42
 W7YAO...8058-34-79-A-14
 W7AEA...6498-38-57-A-10
 W7FZB...4860-27-60-A-19
 W7CAB...792-12-22-B-16

PACIFIC DIVISION

Nevada

W7KEV...49,680-90-184-B-32
 K2GUR/7...11,640-40-97-A-28
 W7YNO...6685-29-65-B-16
 W7VIU...3168-22-48-B-6
 W7TFV...1672-19-30-A-10

Santa Clara Valley

W6SR...188,916-173-364-BC-40
 W6HOC...174,033-183-317-C-60
 W6JWT...168,453-153-367-B-66
 W6EFR...68,343-109-209-C-44
 W6LV...20,520-72-95-A-23
 W6KJK...18,270-58-105-A-28
 W6KNM...10,584-42-84-A-12
 W6QDE...9120-40-76-BC-18
 W6ZZ...6240-32-65-A-42
 W6CFK...2373-21-40-B-51
 W6CLZ...2109-19-37-B-22
 W6RLP...108-6-6-B-2

East Bay

W6LDD...353,440-235-502-C-85
 W6KG...224,664-184-407-C-88

W6KEK...78,288-112-233-BC-40
 W6CTL...45,696-78-194-C-40
 W6MPZ...37,848-76-166-C-21
 W6TI...36,750-75-164-C-38
 W6FLT...35,490-70-169-C-48
 W6WLI...31,968-72-148-C-32
 W6ASH...20,832-62-112-A-30
 K6QXF...12,825-45-95-AC-30
 W6OVO...10,120-40-85-C-9
 W6LPH...7854-34-77-B-17
 W6MBN...5236-26-67-A-21
 W6EJA...3300-22-50-B-4
 W6SSA...2880-20-48-A-30
 W6PYH (W6s GLZ PYH)
 458,832-264-580-C-80

K6LZI (W6LJC, K6LZI)
 4500-30-50-C-8

San Francisco

W6ATO...137,025-145-315-C-70
 W6GWQ...70,110-114-205-C-58
 K6POI...30,879-73-141-A-36
 W6YC...19,032-52-123-A-35
 W6MUF...11,466-42-91-10
 W6RZS...3672-24-51-B-16
 K6LRN...600-10-20-A-6

Sacramento Valley

K6EDE...126,054-141-298-B-78
 W6SIA...96,375-125-257-C-52
 W6QNZ...91,560-120-255-C-59
 W6HHR...35,040-80-146-C-12
 W6DBP...13,944-56-83-AC-12
 W6BRL...6084-39-52-C-35
 K6SXA...243-9-9-A-4
 W6MBY...240-8-10-0
 K6LBU (K6s DPs HDP ILB)
 12,900-43-100-A-60

San Joaquin Valley

W6EYF...40,194-77-174-C-24
 W6BYH...29,184-76-128-C-13
 K6AYH...23,170-66-145-C-30
 W6KEV...21,376-64-112-C-15
 K6HFA...11,046-42-88-B-23
 W6BTM...10,320-43-80-C-10
 K6HTM...84-4-7-C-2

ROANOKE DIVISION

North Carolina

W4RQR...563,456-284-662-BC-57
 W4LZF...437,310-258-565-C-61
 W4CBN...438,615-285-513-C-50
 W4GXB...188,964-174-362-C-33
 W4ISP...44,496-92-161-A-41
 W4DTI...9588-47-68-A-15
 W4GYM...2064-24-37-B-9
 W4OPI...490-12-14-A-4
 W4AH (W4AH, W7ROM)
 262,010-190-461-C-55

South Carolina

W4AIS...65,322-114-191-B-32
 K4AVU...7650-34-75-B-12

Virginia

W4KFC...961,425-364-882-AC-85
 W4YHD...770,472-328-783-BC-83
 W4QM...353,124-226-492-C-55
 W4PNK...229,330-190-403-C-55
 W4JAT...206,816-184-376-B-72
 K4BZL...156,780-156-335-AC-59
 K4GMX...121,716-147-276-C-59
 W4CFP...62,328-106-196-B-26
 W4PRO...49,179-97-169-A-48

Casper Jordan, ZE5JA, captured c.w. laurels for Southern Rhodesia and placed 2nd in Africa with 100 watts to parallel 807s. The handsome home-brew v.f.o. rig is used in conjunction with a much-modified RBJ4 receiver and Q-multiplier.



November 1957

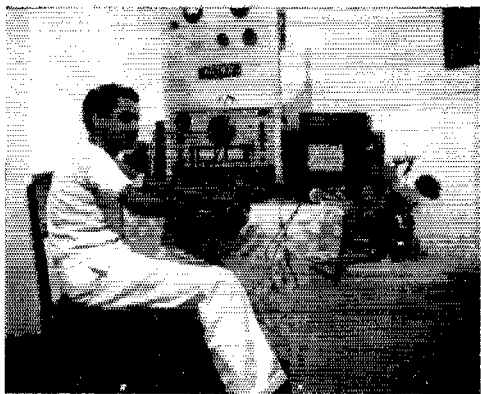

Surmounting various receiver difficulties, 457WP managed to QSO 254 of the boys with just 17 watts input. "Shantii" feeds two 20-meter dipoles simultaneously, one over the short path and one for the long way 'round.

W4WBC.....17.877- 59-101- B-20	W4FNR.....1587- 23- 23- A-13
W4CQI.....11.808- 48- 82- B-22	W4RWA.....1080- 15- 24- B- 4
W4FRO.....11.163- 48- 61-BC-16	K4DRO.....798- 14- 19- A- 3
K4DKA/4.....5460- 35- 52- A-22	W4EEO.....144- 6- 8- - -
W4KMS.....4920- 40- 41- B-25	
W4UBE.....4158- 33- 42- A-39	
K4KES.....3884- 28- 46- -17	W4BGO.....439,008-269-544- C-80
K4HKF.....3321- 27- 41- A- 9	W4WEQ.....32,631- 73-149- C-30
W4WSP.....2376- 22- 36- A- 6	W4HLZ.....23,430- 71-110- B-33
W4ZPR.....798- 14- 19- A- 9	W4LCY.....816- 16- 17- B-15
K4EJG.....637- 13- 17- A- -	
K4EJL.....147- 7- 7- A-11	
K4JKK.....90- 5- 6- A- 4	W4CYA.....283,500-230-411- B-75
W4KXV (W4s KXV TKR, K0AZJ) 573,196-292-655- C-96	W4BBP.....134,964-163-276- B-40
W4NPT (W4s NUS SJB WVN, K4HTD) 98,892-134-246- B- -	K4BAL.....64,176-112-191-BC-40
W4ZZV (W4ZZV, K4GWO) 594- 11- 18- A-15	W4YK.....45,087-113-133- C-23
	W4BFR.....40,495-89-153- B-39
	W4JIT.....35,100- 75-156- B-24
	K4GSS.....20,007- 57-117- A-30
	W4HYW.....9366- 42- 75- C-18
	W4LDD.....4650- 31- 50- A-25
	K4HIG.....75- 5- 5- A- 7

West Virginia

W8UMR.....61.692-106-194- A-23
W8LSJ.....6549- 37- 59- A-19
W8AVW.....1323- 16- 21- A- 5

ROCKY MOUNTAIN DIVISION

Colorado

W08BE.....81,780-116-235- A-68
W0AZT.....41,652- 89-156- C- -
W0COP.....33,810- 80-141- A-31
K0EPK.....24,924- 67-124- A-30
W0WME.....5643- 33- 57- B-31
K0EDK.....2490- 20- 41- A-25
K0EDH.....1944- 18- 36- A-25
W08GH.....1674- 18- 31- A- 7

Utah

W7NMK4.....24,900- 70-119- A-20
W7BOD.....84- 1- 7- A- 3

Wyoming

W7PSP.....432- 9- 16- B- 2

SOUTHEASTERN DIVISION

Alabama

W4DS.....12,852- 36-119- - -
W4WOG.....2208- 23- 32- A-12
K4XCX.....546- 13- 14- A- 2

Eastern Florida

W4LVV.....312,180-220-477- C-80
K4CTU.....241,773-203-397- B-56
W4IEH.....140,600-182-309- C-66
W4AZK.....111,735-145-257-AC-68
W4WHK.....55,277-113-163- B-60
K4HOI.....23,476- 84-113- A-20
W4FZV.....22,836- 66-116- A-40
W4DXL.....15,544- 58- 90- B-24
W4DRK.....2625- 25- 35- A-10
K4GOZ.....2604- 28- 31- B- 3
W4ZKQ.....2046- 22- 32- A-24
KN4KKQ.....1767- 19- 31- A- 4

SOUTHWESTERN DIVISION

Los Angeles

W6FTA.....645,946-301-716- C-85
W6YMD.....641,520-297-720- C-90
W6IBD.....533,676-286-622- C-80
W6BPD.....456,448-256-602- C-82
W6VUP.....408,126-271-502- C-76
K6EWL.....407,077-253-537- C-85
W6NZW.....348,270-235-494- C- -
W6PSJ.....308,880-220-468- C- -
W6OYD.....160,356-161-332- C-36
K6VTQ.....91,800-120-255-BC-36
K6EIV.....82,818-107-258-AC- -
K6CEF.....49,725- 85-195- B- -
W6UOQ.....39,852- 82-162-AC-29
W6SUQ.....39,105- 79-165- C-50
K6IJJ.....38,637- 81-159- B-55
W6SWG.....36,735- 79-155- C-21
W6NIX.....35,424- 82-144- B-40
W6CIS.....32,625- 75-145- B- -
W6LWY.....32,499- 69-157- B-66
W6BUD.....31,590- 65-162- C-24
W6CYV.....24,768- 72-116- C-20
W6HAL.....22,743- 57-133- B-43
K6GLC.....22,680- 56-135- A-29
W6FJF.....21,594- 59-122- A- -
W6KEV.....18,141- 56-108- C-30
W6JST.....12,267- 47- 87- B-40
W6ETJ.....11,439- 41- 91- B-25
W6YV.....11,214- 42- 89- C-10
K6PDA.....9246- 46- 67- B-21
W6APH.....6588- 36- 61- C-22
W6MJP.....4653- 33- 47- A-10
W6ACL.....3687- 23- 53- A-24
K6IBK.....3450- 23- 50- C-16
W6UYW.....2904- 23- 44- C- 8
K6KYH.....2772- 21- 44- B-19
K6DDO.....2508- 22- 38- A- 7
W6HPB.....2376- 24- 35- B-10
K6UFX.....2220- 20- 37- A-15

W6LER.....1734- 17- 34- C-14	W5RKS.....3948- 28- 47- A-21
K6LCS.....1395- 15- 31- A- 4	W2DKS/5.....3906- 31- 42- A-10
W6AM.....1134- 18- 21- C- 2	W5ECP.....2450- 18- 45- A-25
W6IIM.....1050- 14- 25- B-10	W5CA.....550- 10- 19- - -
W6ID.....969- 17- 19- C- 4	
K6DLY.....680- 10- 22- A- 6	CANADIAN DIVISION
W6NVAI.....510- 10- 18- A- 8	<i>Maritime</i>
W6RW (6 oprs.) 804,436-332-811- C-94	VE1PQ.....233,320-190-410- B-69
W6BXL (8 oprs.) 613,914-311-658-BC-84	VO1AQ.....30,954- 67-154- A-40
W6VSS (W6s UFD VSS, K6s CZY FVR) 580,616-284-658- C-90	VE1EK.....23,499- 63-125- A-30
W6TFJ (W6s NNV TPJ) 474,744-282-604- C-96	VE1ZL.....21,774- 57-130- B-36
K6CYX (K6s CYX IBE) 14,787- 53- 93- B-25	VO6N.....9213- 37- 83- B-30
K6ELX (W6UKB, K6s BYB ELX) 12,540- 44- 95- C-70	VE2RS.....3978- 26- 51- A-15
K6IDA (K6s CEO IDA) 10,626- 42- 85- C-35	VE1CU.....468- 12- 13- A- 5
	VO6U.....297- 9- 11- A- 2
	<i>Quebec</i>
	VE2APH.....30,654- 78-131- A-20
	VE2YU.....17,085- 67- 85- A-20
	VE2AVC.....3564- 27- 44- A-10
	<i>Ontario</i>
W7CJZ.....96,348-124-259- C-63	VE3DT.....37,188- 88-142- B-60
W7BSP.....61,464-104-197- A-89	VE3BMB.....26,520- 68-130- A-35
W7ENA.....32,856- 74-148- A-64	VE3HB.....10,086- 41- 82- B-21
W7BAL.....432- 12- 13- B-14	VE3DIF.....9201- 52- 59- B-33
W7ATV (W7s ATV UMS) 146,010-155-314- C-95	VE3IR.....7452- 46- 54- B-19
	VE3PE.....1944- 24- 27- B- 8
	VE3DH.....9000- 15- 20- B- 5
	VE3RN.....440- 12- 15- A- 5
	VE3YV.....562- 11- 14- B- -
	<i>Manitoba</i>
	VE4RO.....103,125-125-275- C-52
	<i>Saskatchewan</i>
W6KSM.....194,877-177-367-BC-63	VE5OC.....23,450- 67-118- B- -
W6LRU.....164,328-167-328- A-60	VE5PM.....12,549- 47- 89- AB-35
W6BZE.....134,904-146-308- C-54	VE5FL.....5220- 36- 51- B-30
W6CHV.....92,202-127-242- B-54	VE5RU.....330- 10- 11- B- 1
W6KYG.....71,595-111-215- C-35	
W6JVA.....69,834-103-226- B-55	
W6RAN.....49,806- 99-198- C-18	
W6OME.....50,828- 85-197- C-30	
W6CAE.....47,770- 85-188- C-29	
W6PLK.....47,595- 95-167- C-30	
K6EBH.....34,932- 71-164- A-60	
W6AMO.....31,671-69-153- A-50	
K6BHM.....20,358- 58-117- A-36	
W6MCY.....15,900- 53-100- A-17	
K6LIV.....7992- 37- 72- A-28	
W6LSQ/6.....1035- 15- 23- A- -	
W6WSV.....480- 10- 16- A- -	
W6WSW.....72- 3- 6- A-12	
W6MGT (W6s BGX MGT) 23,580- 60-131- B-18	
	<i>Santa Barbara</i>
W6ALQ.....70,263-111-211- C-35	
W6GTI (W6s CEM GTI RRR ULS) 480,180-265-604- C-86	
W6AGO (W6s AGO MSG) 278,527-223-417- C-44	
W6PYW (W6s FYW TPO) 54- 3- 6- A- 8	
	WEST GULF DIVISION
	<i>Northern Texas</i>
W5KJN.....56,385-105-179-AB-68	
W5QF.....53,865- 95-189- A-30	
W5DXW.....45,728- 88-177- A-38	
W5OLG.....12,264- 46- 73- B-15	
W5OC.....12,096- 48- 84- A- 8	
W5MTL.....8316- 42- 66- A-31	
W5GSE.....5952- 32- 62- A-21	
W5AWT.....4392- 24- 61- B-16	
W5FTD (W5s FTD HDD) 20,220- 60-112- A- -	
W5VKB (W5VKB, K5AKW) 11,880- 45- 88- B-66	
	<i>Oklahoma</i>
W5ALB.....6588- 36- 61- A-10	
K5BKG.....648- 12- 18- A- -	
	<i>Southern Texas</i>
W5ZD.....238,200-200-397- C-80	
W5LUU.....149,730-161-310- C-36	
K5WAC.....97,092-124-261- C-90	
W5BRR.....79,326-113-234-AC-40	
W5MCO.....63,798- 98-217- A-68	
W5LBC.....44,280- 90-164- B-40	
W5OEN.....31,671-69-153- A-38	
W5BTS.....16,874- 59- 96- C-39	
W5ZWR.....6688- 38- 59- A-14	
K2IVN/5.....4410- 30- 50- A-20	
W5JPC.....2583- 21- 41- B- 5	
	<i>New Mexico</i>
K5CAW.....70,800-118-200- A-38	
W5FJE.....59,600-100-200- A-59	
W5GCT.....48,267- 93-173- A-50	
W5FTP.....25,600- 71-120- B-27	
	<i>Belgian Congo</i>
OU5GU.....169,668- 54-1050- A- -	
	<i>Canary Islands</i>
EA8BE.....218,304- 64-1137- A-54	
EA8BK.....8873- 19-159- A-29	
	<i>Eritrea</i>
ET2RH.....84,123- 39-719- A-37	
	<i>French Equatorial Africa</i>
FQ8AF.....32,982- 23-478- A- -	
	<i>French Morocco</i>
CN8FD.....16,653- 21-269- A-10	
	<i>French Somaliland</i>
FT8AB.....1071- 7- 51- A- -	
	<i>French West Africa</i>
FF8AJ.....20,493- 27-253- A- -	
	<i>Kenya</i>
VQ4CC.....15,180- 20-254- A-12	
VQ4KPB.....12,024- 24-168- A-12	
	<i>Madeira</i>
CT3AB.....64,680- 44-490- A-20	
	<i>Mauritius</i>
VQ8AB.....918- 9- 34- A- -	
	<i>Mozambique</i>
CR7LU.....39,351- 39-374- A-29	
	<i>Northern Rhodesia</i>
VQ2GW.....23,064- 31-248- A-12	

VQ2RG...12,840-20-221- A-10

Southern Rhodesia

ZE5JA...168,903-49-1140- A-64
ZE6JX...35,802-34-351- A-36
ZE2JS...33,561-33-341- A-34
ZE5JE...3708-18-69- A-4
ZE5JY...648-8-27- A-5

Southeast Africa

ZS3Q...10 803-13-277- A-11

Spanish Morocco

EA9AP...65,475-45-185- A-23

Union of South Africa

ZS1FS...37,913-31-419- A-56
ZS6AJ0...33,024-32-344- A-25
ZS10...2472-24-37- A-33

EUROPE

Island Islands

OH2AA/Ø (OH2s KH LP) 17,825-25-238- A--
OH1NA/Ø (OH1s SS ST) 1440-12-40- A--

Austria

OE3VP...86,976-48-619- A-65
OE3ED...50,442-42-401- A-38
OE3SE...58,658-34-379- A-15
OE5SD...30,876-31-332- A-44
OE8SH...7935-15-178- A-16
OE5BW...84-4-7- B--

Azores Islands

CT2BO...14,304-24-199- A-23

G4CP (2 oprs.)

168,675-65-865- A-47

European Russia

UA1CB...4017-13-103- A--

Faeroes

OY7ML...63-3-7- A--

Finland

OH2HK...69,762-42-555- A-46
OH6OB...61,681-37-560- A-72
OH2LA...51,936-32-541- A--
OH3OD...32,610-32-335- A-40
OH2KQ...29,736-36-276- A-17
OH2HG...17,276-28-209- A-28
OH1TI...13,755-15-306- A-4
OH13TH...13,416-26-172- A--
OH7NW...11,748-22-180- A-26
OH7OU...10,741-23-157- A-16
OH3RA...10,469-29-121- A-6
OH2XX...3984-16-83- A--
OH5NJ...3315-13-85- A-7
OH3TU...3276-18-61- A-8
OH2LU...3078-19-54- A-8
OH2RW...2847-13-73- A-18
OH9RD...2640-16-55- A-4
OH2LO...1524-12-43- A-12
OH2XK...742-14-18- B-2
OH9QL...741-13-19- A-4
OH5QV...696-8-29- A-4
OH2VZ...405-9-15- A-4
OH9OB...352-8-15- A-9
OH3TK...288-8-12- A-4
OH9PF...189-7-9- A-11
OH3RU...180-6-10- A-4
OH2KG...75-5-5- A-2
OH5PG...12-2-2- A--
OH1ST...3-1-1- --

DJ1BZ (DJ1BZ, DL3GZ)

248,004-66-1253- A-70
DL1PN (W1TR, DL1PN) 133,630-46-979- B-51

Greece

SV1AB...160,539-59-907- A--
SV0WA...116,064-52-744- A-39
SV0WR...15,660-20-261-AB-10

Hungary

HA5BW...34,353-33-347- A-30
HA5BL...18,180-30-208- A-31
HA5BO...3564-11-108- A-14
HA5BU...1808-16-38- A-11
HA5AM...330-5-22- A-3
HA5KAG...216-6-12- A-8

Iceland

TF3KG...54,020-37-493- A-29
TF3AB...40,641-31-437- A--

Ireland

E19J...235,867-69-1381- A-45
E16D...36,660-26-473- A-13
E19P...26,880-35-256- A-16
E15G...25,024-32-265- A-16
E19F...1593-9-59- A-8

Italy

I1NT...164,781-51-1077- B-55
I1AMO...168,175-57-937- A-51
I1PTAI...122,745-49-835- A-49
I1ZCN...31,317-33-323- A-60
I1FT...840-14-20- A-7
I1ER...637-7-31- A-12

Lithuania

UP2AS...10,281-23-149- A-30

France

F9MS...257,796-66-1302- A-65
F8VJ...146,276-58-844- A-16
F8AT...141,069-59-797- A--
F8TQ...65,200-50-369- A--
F8ZF...33,744-48-244- A-62
F9TV...20,760-40-173- A--
F9OQ...16,646-29-158- A--
F9HB...15,687-21-249- A-19
F8TM...13,545-35-129- A-10
F9NL...7104-24-100- A--
F9CI...4326-14-103- A--
F3II...3320-12-120- A-18
F3CT...3648-16-76- A--
F9DW...3384-24-47- A-13
F8HO...436-9-18- A--
F8DF...432-8-18- A--

Netherlands

P9RE...251,049-67-1249- A-76
P9EP...190,848-64-1002- A-88
P9VB...145,116-58-834- A-85
P9BW...99,309-51-458- A--
P9NV...46,515-35-449- A-33
P9GJ...33,417-47-297- A-50
P9LQ...19,760-19-353- A-60
P9BK...10,900-40-90- A--
P9LV...10,396-23-156- A--
P9CE...4300-20-72- A-10
P9VP...3264-17-64- A-6
P9BX...1910-10-64- A--
P9TA...108-6-6- A-3
P9WAC...104-4-9- A--

Northern Ireland

GI3GAL...36,024-38-316- A-14
GI5UR...6000-20-100- A-18

Germany

DL1JW...259,558-67-1302- B--
DL7AH...207,232-64-1081- A-75
DL1BR...38,502-46-279- A--
DL7CW...34,440-40-287- B-33
DL7AD...33,480-40-279- R-30
DL8DU...28,337-43-220-AB--
DL7DF...11,730-34-115- A-38
DL9PJ...4329-13-111- B--
DJ1VL...2601-17-51- A--
DL1EA...1708-14-41- A--
DJ1IL...132-4-11- A-2
DJ3JZ (DJs 1BP 3JZ, DLs 1CR 3AO)...261,954-66-1323-AB-87

Norway

LA5B...51,240-35-488- A-36
LA2HC...32,046-34-323- A--
LA4K...24,582-34-241- A-46
LA2Q...17,184-32-179- A-30
LA7X...14,904-27-184- A--
LA2TF...13,392-27-166- A-15
LA3RC...11,388-26-146- A-25
LA4ZB...5502-21-90- A-16
LA8MC...3081-13-79- A-8
LA1WF...2142-14-51- A-11
LAGU...1807-13-47- A--

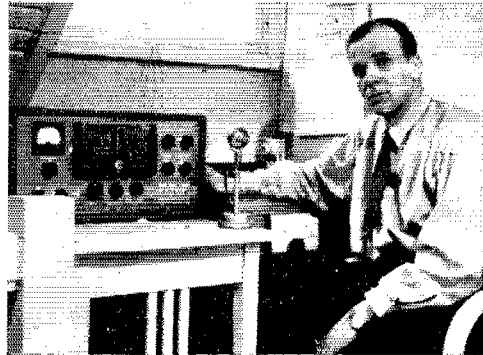

In spite of poor end-of-contest conditions, OH5QN talked his way to Finland's top post and resultant certificate of performance. Basic facts: 100 watts, Geloso receiver, G4ZU beam.

ASIA

Afghanistan

YA1AM...35,743-31-387- B-33

Ceylon

487WP...11,430-15-254- A-26
487MR...8190-13-210- A--

Formosa

BV1US (K2MZM, W4DKD, W7VHR, WSUKU) 6478-11-166-AB--

Hong Kong

VS6AE...1312-8-55- A--
VS6DN (VS6s CO DN) 12,870-22-195- A-17

India

VU2RM...10,780-28-129- A-15
4X4CJ...10,968-24-154- A-8

Japan

JA1VX...342,967-59-1944- C-72
JA3BB...230,956-58-1331- B-77
JA1QI...33,504-32-349- B-23
JA8AA...26,010-17-510- H-26
JA8AQ...12,740-14-304- A-17
JA2JV...10,140-26-130- A-17
JA3JM...9309-29-108- A--
JA3AZ...6832-28-82- A-7
JA1ACA...5265-15-118- A--
JA1AA...3444-14-83- A-28
JA1AB...3120-12-87- A-9
JA1AL...2772-11-84- A--

Lebanon

OD5LX...18,150-25-242- A-13

Macau

CR9AH...58,695-35-559- A--

Pakistan

AP2RH...2910-10-97- A--

Kyukyu Islands

KR6BF...22,854-26-294- A-39

Balearic Islands

EA6AF...208,986-61-1142- A-69

Belgium

ON4HB...76,650-50-511- A--
ON4DB...4956-11-117- A-17

Channel Islands

GC2FZC...3996-18-76- A--

Czechoslovakia

OK1MB...373,326-88-1459- A-60
OK3DG...238,420-65-1225- A-75
OK1FF...162,666-63-864- A--
OK1XQ...75,525-53-475- A--
OK1ASF...13,888-28-168- A-25
OK1JX...59,416-56-362- A--
OK1AEH...46,150-50-308- A-40
OK3EE...37,138-31-400- A-37
OK1LM...14,553-27-181- A--
OK3MM...11,100-20-185- A-9
OK1AJB...3104-16-65- A--
OK1EB...2052-19-36- A-15
OK1KTI (2 oprs.) 165,816-56-987- A-80
OK2KBE (- oprs.) 80,605-49-550- A-64
OK1KDR (- oprs.) 10,872-24-151- A-21

Denmark

OZ7BG...305,830-70-1457- B-58
OZ1W...304,788-66-1541- A-82
OZ4IM...29,874-26-383- A-45
OZ5KQ...1045-11-33- B--

England

G5RI...216,612-69-1094- A-65
G2HPF...148,890-70-709- A--
G2QT...141,292-58-858- A-55
G3HJJ...98,898-53-627- A-64
G2MI...92,288-56-550- A-51
G3EYN...44,100-50-294- A-46
G3JKF...30,459-33-308- A-20
G3JWZ...28,188-36-261- A-25
G5MP...17,982-37-162- A-30
G2AJB...12,609-27-159- A-18
G3JUL...4968-12-138- A-7
G21CH...168-7-8- A-2

One-week-end operation of HH2RM by W2LEJ elicited the 2nd high North American voice total. A small 65 watts and big 500-foot long wire led to a significant 769 QSOs and 131,328 points.

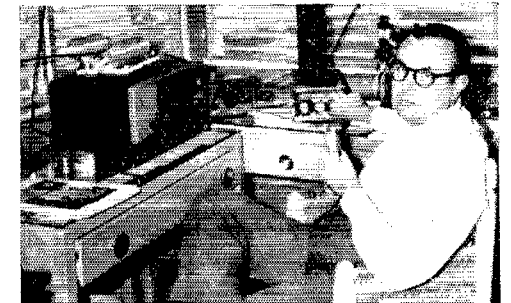

LA3UF.....1512-12-42-A-9	KL7BZA.....7062-22-107-A-8	ZL1MT.....36,371-37-328-A-21	British Guiana
LA3HA.....1500-10-50-A-	KL7AIZ (W3s FY KZQ).....455,139-81-1873-C-69	ZL1APM.....32,340-33-328-A-23	VP3AD.....1810-10-62-A-3
LA9XB.....1460-10-49-A-5	KL7WAF (K2TGL, KL7BZA).....135,168-48-90-AB-42	ZL3OB.....29,715-35-283-A-12	Chile
LA6CF.....1305-9-49-A-28	Bahamas	ZL1TB.....4485-13-115-A-12	CE3AG.....134,940-65-692-B-21
LA9T.....610-10-21-A-5	VP7NM.....693,864-92-2516-A-90	Papua	French Guiana
LA5UF.....105-5-7-A-1	Barbados	VK9XK.....178,716-53-1125-A-50	FY7YE.....15,275-13-396-A--
LA1K (LAs 2LD 2MB 3HF 6GF 6MF).....64,072-40-546-A-70	VP6AF.....15,687-21-249-A-24	Philippine Islands	Netherlands West Indies
Poland	VP6DG.....10,097-23-142-A--	DU7SV.....144,000-45-1067-B--	PJ2AV.....248,490-66-1255-A-65
SP8CK.....34,656-32-361-B-31	Canal Zone	SOUTH AMERICA	PJ2AJ.....105,258-53-662-A-36
SP2SJ.....27-3-3-A--	KZ5EK.....82,521-53-519-A--	Argentina	Paraguay
SPIKAA (6 oprs.).....79,866-34-783-A-96	Cayman Is.	LUSFBH.....59,211-27-731-B-	ZP9AY.....191,723-61-1066-A-80
Portugal	VP5BH (W3s KVX OMW, W8EZF, VP5BH).....569,985-79-2405-A-48	LU9DL.....7182-14-171-A-10	Peru
CT1CO.....65,640-40-553-B-26	Costa Rica	LU7CW.....1350-9-50-B-3	OA4BP.....79,976-52-522-A-41
Roumania	TI2RO.....3000-10-100-A-4	Brazil	OA4FT.....54,050-34-534-A-13
YO3GY.....18,000-20-300-A--	Cuba	PY7AN.....184,509-57-1079-B-51	OA3J.....6633-11-201-B--
YO3RF.....12,762-26-164-A-15	CM8EM.....42,273-33-429-A-11	PY1ANR.....58,490-40-489-A-30	Paraguay
YO3FT.....4380-10-150-A-18	Dominican Republic	PY1ADA.....55,692-42-442-B-17	ZP9AY.....191,723-61-1066-A-80
Saar	HI8BE.....58,050-43-450-A-10	PY7AFK.....9324-14-222-A-18	Venezuela
9S4AX.....22,715-35-219-A--	Greenland	PY1BDU.....8964-27-111-A--	CX2FD.....1140-10-38-A--
9S4CM.....13,464-24-189-A--	KG1KK.....97,088-64-510-AB-27	PY4AO.....4532-11-138-B--	YV5BJ.....1200-8-50-A-2
Scotland	OX3LD.....13,650-25-182-A--	PY4CY.....810-10-27-B--	
GM3EOJ.....45,591-39-394-A-20	Haiti	PY2AQL.....594-9-22-B-2	
GM8SQ.....4095-15-91-A--	HH2DX.....141,372-66-714-A-29	PHONE SCORES	
Spain	Mexico	ATLANTIC DIVISION	
EA1AB.....193,314-58-1111-A-51	XF1A.....1,281,702-114-3757-C-60	Eastern Pennsylvania	K2CPR.....3480-29-40-A-14
EA1BC.....147,312-62-792-A-37	Puerto Rico	W3ECR.....294,360-220-446-C-69	K2CMN.....3366-22-51-A-16
EA1CP.....93,060-47-600-B-42	KP4ADS.856,340-94-3050-C-84	W3GHS.....178,840-170-352-B-54	K2MIO.....1950-25-28-C-5
EA3KT.....28,644-33-292-A-44	KP4DH.809,600-92-2988-B-80	W3ALB.....128,660-140-307-C-39	K2AIM.....969-17-19-A-18
EA4CE.....22,533-29-259-A-25	St. Martin, French	W3HIX.....116,983-131-299-B-61	W2SDB.....686-14-17-AC-5
EA5FI.....20,358-27-255-A-21	FSTRT.....150,993-57-883-AB-33	W3IMV.....45,018-82-183-B-32	K2HDX.....540-9-20-A-4
EA4FU.....13,377-21-214-A-20	Windward Is.	W3RPG.....24,363-71-116-B-31	K2KTS.....300-10-10-A-26
EA2CR.....1080-8-45-A--	VP2LU.....499,359-79-2107-A--	W3NGV.....23,625-75-105-C-33	W2BUI.....45-3-5-A-1
Sweden	OCEANIA	W3KFP.....20,223-63-107-A-36	Western New York
SM3AZV.....82,579-47-593-B--	Australia	W3ZSS.....18,050-51-118-C-40	W2TQR.....52,552-72-197-A-40
SM4DN.....54,264-34-532-AB--	VK2GW.....331,425-75-1473-A-61	W3DQG.....11,144-44-92-A-6	W2PUN.....34,656-76-152-A-40
SM5ANY.....47,040-40-392-B-14	VK2QL.....222,345-61-1215-A--	W3GRS.....5880-35-56-A-6	W2ROM.....23,532-74-100-B-30
SM3AXN.....33,690-30-378-A--	VK7KM.....170,676-66-868-A-26	W3MDE.....5508-36-51-A-6	W2TRX.....17,820-55-108-B-25
SM5AOL.....32,079-37-289-A-4	VK5HO.....70,272-36-653-A-60	W3CGS.....3936-32-41-A-24	W2RWN.....14,120-40-119-B-22
SM6ID.....31,824-34-312-A-41	VK5WO.....37,800-35-364-A-22	W3ORU.....3048-24-43-B-1	K2GVR.....5850-25-78-A-23
SM7BPO.....26,796-29-320-AB-48	VK5JT.....24,668-32-258-A--	W3NM.....2040-20-34-B-14	K2BHP.....1826-38-43-C--
SM5LZ.....24,021-17-471-B-20	VK3PG.....14,697-23-213-A-7	W3DBX.....1767-19-31-A-10	W2CZT.....3321-27-41-C-14
SM2AQ.....23,004-36-214-A-20	VK3ZC.....9200-25-123-A-6	W3TJW.....819-13-21-B-10	W2BYY.....3096-24-43-B-6
SM7MS.....22,260-28-265-B-34	VK3RX.....5076-12-141-A-10	W3LEZ/3.....585-13-15-A-6	W2UFI.....2730-26-35-B-8
SM5ARR.....22,221-27-276-A--	VK3PN.....3906-18-73-A-6	W3GHD.....360-10-12-B-1	W2BSJ.....2375-25-33-B-21
SM5OCE.....13,920-20-232-A-25	British North Borneo	W3QLW.....210-7-10-A-4	W2IOK.....1782-23-27-C-4
SM1CBC.....13,702-26-179-A--	ZC5AL.....8370-15-186-A-26	W3EAN.....147-7-7-C-1	K2JZT.....3-1-1--
SM4BFP.....12,060-20-201-A-1	Canton Island	W3SOU.....147-7-7-A-1	Western Pennsylvania
SM5BCE.....11,180-43-87-B--	W6YKE/KB6.....1089-11-33-A-2	W3SHH.....27-3-3--	W3WZV.....11,286-38-99-A-25
SM6BDS.....10,850-31-118-A-17	Fanning Island	W3DHM (W3s DHM IYE MQC).....270,848-184-492-C-65	W3VEK.....9462-38-83-A-24
SM7EH.....5796-14-138-A--	VR3B.....1152-8-48-A--	W3EBG (W3s BES EBG GXP).....143,264-148-324-C-65	W3LXE.....6960-40-58-A-12
SM5TL.....4998-14-119-B--	Hawaii	W3EQA (W3s EQA LEZ).....104,020-140-249-C-60	W3ABW.....4692-34-46-A-16
SM16V.....3995-17-79-A-8	KH6CBP.968,691-101-3197-C-82	W3KT (W3s GHD KT).....77,436-108-239-C--	W3KPI.....1440-20-24-14
SM5BZ.....3021-19-53-A-1	KH6JL.....965,400-100-3215-C-77	W3CUB (W3s CGS CGN NTP).....51,597-91-189-C-38	W3ZKB.....1404-18-26-A-4
SM6BGJ.....1620-12-45-A--	KH6MG.....721,355-95-2531-C-86	W3VHV (W3s DVY VHV).....780-13-20-A-4	CENTRAL DIVISION
SM5KB.....1560-15-35-A-6	KH6PM.....534,338-88-2024-B-54	W3DRD.....72,102-122-197-B-36	Illinois
SM5ATK.....1452-11-44-A-4	KH6VW.....5502-14-131-B-4	W3IYE.....34,958-77-153-C-36	W9NZM.....187,312-184-340-AC-76
SM5UU.....1302-14-31-B--	KH6AYG (KH6s AYG BCM BLH).....661,028-86-2566-C-70	W3HVM.....1152-16-24-A-6	W9WKT.....70,966-117-204-C-56
SM2CSA.....561-11-17-A--	Marianas Is.	W3VAM.....897-13-23-B-3	W9MID.....13,035-55-79-AB-21
SM2CAA.....552-8-23-A--	KH6AIK/KG6.....25,704-21-408-A-18	W3MSR.....765-15-17-B-6	W9WMO.....10,560-44-80-B-28
SM5CXF.....288-8-12-B--	W6NTJ/KG6 9204-13-237-A-14	W3NAX.....612-12-17-A-16	W9RIH.....9189-49-67-AC-28
SM5AHK.....252-7-12-A--	New Caledonia	W3ZQ.....588-14-14-C-3	W9RKM.....7020-36-65-A-15
SM1ASJ.....195-5-13-A--	FK8AL.....222,768-56-1326-A-81	W3VTH.....297-9-11-A-20	W9YUJ.....5814-38-51-A-11
SM3BCZ.....3-1-1-A--	Switzerland	W3BVO.....114-6-7-B-10	W9YKJ.....3006-31-42-A-6
HB9QO.....72,618-49-496-A-50	HB99U.....33,966-34-333-B-17	W3VQZ.....3-1-1-A-2	W9EUF.....3600-30-41-C-8
HB9GX.....54,972-36-509-A-24	HB9TE.....2456-18-64-A--	W3WQN (W3s EAR WQN ZEQ).....206,006-146-471-C-96	W9LQF.....2337-19-41-A-14
HB9DU.....33,966-34-333-B-17	Trieste	W3TMZ (W3s FYS TMZ).....206,006-146-471-C-96	W9LVB.....1920-20-32-A-12
HB9TU.....2456-18-64-A--	IB8NU.....85,600-50-575-A-47	W6HOH) 32,879-77-143-C-29	W9WFS.....1404-18-26-B-6
IB8LU.....41,820-34-410-A-25	IB8LH.....41,820-34-410-A-25	W2ATE.....833,664-312-892-B-93	W9WNC.....1207-12-24-A-22
IB8VU.....2800-10-94-A-11	IB8LH.....41,820-34-410-A-25	W2DMR.....32,913-69-159-C-40	W9WND.....785-15-17-C-4
Wales	IB8VU.....2800-10-94-A-11	K2BQW.....14,784-44-112-B-64	W9WNE.....675-15-15-B-8
GW3ZV.....73,278-46-531-A-24	IB8VU.....2800-10-94-A-11	W2ESG.....13,161-41-119-B-30	W9WNF.....432-12-12--
GW3BQY.....58,056-41-472-A-33	IB8VU.....2800-10-94-A-11	W2SZP.....9009-39-77-A-52	W9WNG.....297-9-11-A-10
NORTH AMERICA	IB8VU.....2800-10-94-A-11	W2TLN.....4488-33-46-A-13	W9WVX.....75-5-5-C-2
Alaska	IB8VU.....2800-10-94-A-11	W2ZXX.....4366-37-40-C-9	W9WVX.....3-1-1--
KL7PIV.....291,816-63-1544-C-50	IB8VU.....2800-10-94-A-11	Indiana	W9JJP.....72,360-120-201-C-47
W9KLD/KL7.....201,564-66-1019-C-41	IB8VU.....2800-10-94-A-11	W9JYU.....51,510-101-170-B-42	W9RKE.....12,320-44-94-A-36
KL7BPK.....64,170-46-465-A-25	IB8VU.....2800-10-94-A-11	W9RKM.....7020-36-65-A-15	W9PLB.....324-9-12-A-10
KL7BSW.....40,365-39-345-B-16	IB8VU.....2800-10-94-A-11	W9YUJ.....5814-38-51-A-11	W9UKG.....75-5-5-C-2
KL7BND.....26,320-28-316-A-29	IB8VU.....2800-10-94-A-11	W9WFS.....1404-18-26-B-6	W9RFX.....12-2-2--

¹ W3MFW, opr. ² Hq. staff -- not eligible for award. ³ W1WPR, opr. ⁴ W9AZT, opr. ⁵ W6HQN, opr.

W9ZTD (W9ZTD, K9ADJ) 22,466-58-129- C-36 Wisconsin	W8RTF.....1350-18-25- C-6 W8FDN.....1260-15-28- A-5 W8LOF.....1122-17-22- A-5 W8GRG.....672-14-16- A-13 W8TJM.....612-12-17- C-9 W8BPE.....390-10-14- A-3 W8MFW.....363-11-11- A-9 W8PCS.....297-9-11- B-2 W8OMY.....240-8-10- B-4 W8YPT.....216-8-9- A-7 W8RNB.....40-4-4- C-3	W1MX (6 oprs.) 13,400-50-90- C-27 Western Massachusetts	W4ZZV (W4ZZV, K4GE0) 351-9-13- A-12 West Virginia
W9EWC.....286 650-182-527- C-75 W9GIL.....63,630-101-210- C-9 K9EWL.....46,740-76-205- C-65 W9RBI.....40,548-109-124- C-30 W9MBF.....32,472-82-132- A-4 W9VZP.....29,700-66-160- A-37 W9PQA.....16,020-60-89- A-30 W9LKB.....6120-30-68- B-24 W9VQG.....5652-36-63- B-42 W9FDX.....5394-31-58- C-9 W9NLJ.....5328-37-48- A-13 W9OMZ.....1260-20-21- C-9 W9GSS.....988-13-26- A-8 W9R9.....810-15-18- C-9 W9VOD.....611-13-16- B-2 W9QGR.....75-5-5- A-2 W9RKP.....18-2-3- B-9 W9UDK.....3-1-1- -	W8UMR.....6000-40-50- A-9 K8DDB.....3244-38-48- A-41	ROCKY MOUNTAIN DIVISION Colorado W8SBE.....15,600-52-100- A-55 W9CDP.....3306-29-38- A-16 Utah W7ACR.....252-7-12- A-4	
DAKOTA DIVISION South Dakota W9BLZ.....1914-22-29- B-4 K9GWJ.....33-3-4- A-4 Minnesota W9EDX.....229,104-172-444- C-59 W9CSU.....37,584-87-144- B-72 W9MPW.....16,166-59-92- C-12 W9ZZT.....4452-28-53- A-9 K9ALL.....840-14-20- A-3 W9VAF.....147-7-7- A-8	HUDSON DIVISION Eastern New York W2VRE.....28,689-73-131- B-25 N.Y.C.-L.I. K2AAA.....702,452-302-772- C-93 W9WZV.....25,822-66-129- C-20 K20PI.....6120-40-51- A-38 W9MCO.....3534-31-38- A-19 W9BRV.....2958-29-34- B-6 K9GKU.....1564-23-23- A-12 K2DEM.....216-8-9- A-2 K2DZU.....96-6-6- A-8 W9GSN.....90-5-6- - K9CMV.....12-2-2- B-1 W2IID (W2IID, K2PTZ) 4770-30-53- A-21 Northern New Jersey K2MPB.....19,096-62-104-AB-28 W2CYS.....8750-35-84- - W2WKL.....8036-41-66- B-27 K2JLQ.....7740-43-62- A-20 W2DJT.....7503-41-61- A-15 K2KFP.....1104-16-23- A-4 W2IUV.....1083-19-19- B-8 W2IDZ.....270-9-10- B-4 W2YTH.....75-5-5- B-2 W2EQS.....48-4-4- A-2 W2AEB.....12-2-2- A-1	NORTHWESTERN DIVISION Montana W7FIN.....1536-16-32- A-24 Oregon W7DAA.....28,782-78-123- C-9 Washington W7HRH.....17,490-53-112- C-25 W7GDS.....8748-36-81- A-25 W7HJC.....1764-21-28-BC-11 Nevada W7VII.....1734-17-34- B-9 W7YNO.....912-16-19- B-10 K2GUR/7.....459-9-17- A-8 Santa Clara Valley W6ZZ.....2166-19-38- A-40 K6UXV.....1890-21-30- A-24 W6LJK.....858-13-22- A-5 W6LDD/6.....567-9-21- A-6 East Bay W6WLL.....9389-41-77- C-24 W6LDD.....6327-37-57-AC-24 W6KGG.....2331-21-37- C-9 San Francisco K6OPI.....1998-18-37- A-12 Sacramento Valley W6SIA.....28,046-74-127- C-45 W6GVM.....14,508-52-93- C-7 W6BIL.....351-9-13- C-8 K6LLB (K6s DPS LLB) 4950-30-55- A-8	SOUTHEASTERN DIVISION Alabama W4NZM.....23,166-66-117- C-38 W4HA.....9283-43-72- C-15 W4DS.....1200-16-25- - Eastern Florida K4CTU.....100,817-119-281- B-34 W4HKJ.....22,692-61-124- B-27 W4APY.....1020-17-20- A-12 W4IDL.....918-17-20- B-13 W4DRK.....672-14-16- A-6 W4BEO.....585-13-15- B-10 Western Florida W4HIZ.....8448-44-64- B-35 Georgia K4GRR.....60-5-4- A-9 Los Angeles W6YTH.....422,304-212-664- C-92 W6IIM.....34,410-74-155- A-80 W6PKK.....11,280-40-94- C-38 W6BUD.....7560-40-63- C-8 W6KRV.....6732-33-68- C-15 W6HAL.....3384-24-47- A-27 K6IYJ.....3042-26-39- B-15 K6EIV.....1638-21-26- C-9 W6LWY.....1377-17-27- A-16 W6ZMG.....1368-19-24- B-12 K6GLC.....1089-11-33- A-10 W6YQQ.....880-16-19- A-9 W6S9Y.....612-12-17- C-4 K6PDA.....612-12-17- C-14 W6NZW.....540-12-15- C-2 W6HNG.....60-4-5- A-9 K6ICS.....27-3-3- A-1 W6VSS (W6s UFD VSS, K6s CZY EVR).....269,418-166-545- C-90 W6VUP (W6s FUE OCA SWG VUP).....105,903-123-287-BC-90 K6EXO (K6s EXO LGT) 38,640-80-161- A-79
DELTA DIVISION Louisiana W5KC.....74,295-117-213- A-43 Tennessee W4DQH.....213,120-180-396- C-65 K4LPW.....82,215-105-261- A-58 W4FKA.....64,974-92-221- C-80 W4CGW.....105-5-7- A-3	MIDWEST DIVISION Iowa W7DIB.....8505-45-63- B-34 Kansas K6DRR.....28,379-59-162- B-9 W6VBQ.....6600-40-55-BC-18 W6QMS.....5115-31-55- A-18 W6TUB.....1566-18-29- B-9 W6VFE.....1248-16-26- A-8 W6QFQ (W6s DYN QFQ) 19,470-59-110- B-54 Missouri W6GUV.....33,615-83-135- B-96 W6GEG.....32,160-67-160- C-44 W6MCC.....13,803-43-107- C-31 K6DXM.....3186-27-40- A-15 W6ZVM.....2520-21-40- A-8 W6ETV.....1725-23-25- A-19 W6EDH.....1254-19-22- C-5 Nebraska W6BBS.....7722-39-66- C-19 W60MH.....5472-32-57- A-21 W6BUR/0.....48-4-4- A-1	PACIFIC DIVISION Newada W7VII.....1734-17-34- B-9 W7YNO.....912-16-19- B-10 K2GUR/7.....459-9-17- A-8 Santa Clara Valley W6ZZ.....2166-19-38- A-40 K6UXV.....1890-21-30- A-24 W6LJK.....858-13-22- A-5 W6LDD/6.....567-9-21- A-6 East Bay W6WLL.....9389-41-77- C-24 W6LDD.....6327-37-57-AC-24 W6KGG.....2331-21-37- C-9 San Francisco K6OPI.....1998-18-37- A-12 Sacramento Valley W6SIA.....28,046-74-127- C-45 W6GVM.....14,508-52-93- C-7 W6BIL.....351-9-13- C-8 K6LLB (K6s DPS LLB) 4950-30-55- A-8 North Carolina K4RZJ.....23,364-59-132- A-30 W4NYN.....14,256-48-99- A-9 W4CVX.....8541-39-73- A-15 W4EFX.....4340-35-42- B-20 K4HNY (W4s WMP YQY ZLB, K4s CRF CIW) 10,605-35-103- A-36 South Carolina W4EPL.....507-13-13- A-7 Virginia W4OM.....304,200-200-507- C-9 W4KWY.....219,600-200-366- C-9 W4LIM.....28,644-77-124- B-9 W4GRP.....7280-44-55- B-18 K4EYE.....6039-33-61- B-38 W4PTA.....1547-17-31- A-20 W4KMX.....1440-20-24- 9 W4DRW.....1197-19-21- A-10 W4UBE.....1080-18-20- A-36 K4ETQ.....1008-16-21- 6 W4KXY.....900-15-20- C-8 K4EEF.....702-13-18- 7 W4WSF.....588-14-14- A-5 K4LUA.....297-9-11- 4 K4KH.....147-7-7- A-3 K4IKF/4.....3-1-1- A-1 W4YHD (W3s EIV GRF, W4s RVE YHD) 92,008-124-248-BC-40 W4NPT (W4s NUS WVN, K4HTD) 12,876-58-74- B-35	SOUTHWESTERN DIVISION Los Angeles W6YTH.....422,304-212-664- C-92 W6IIM.....34,410-74-155- A-80 W6PKK.....11,280-40-94- C-38 W6BUD.....7560-40-63- C-8 W6KRV.....6732-33-68- C-15 W6HAL.....3384-24-47- A-27 K6IYJ.....3042-26-39- B-15 K6EIV.....1638-21-26- C-9 W6LWY.....1377-17-27- A-16 W6ZMG.....1368-19-24- B-12 K6GLC.....1089-11-33- A-10 W6YQQ.....880-16-19- A-9 W6S9Y.....612-12-17- C-4 K6PDA.....612-12-17- C-14 W6NZW.....540-12-15- C-2 W6HNG.....60-4-5- A-9 K6ICS.....27-3-3- A-1 W6VSS (W6s UFD VSS, K6s CZY EVR).....269,418-166-545- C-90 W6VUP (W6s FUE OCA SWG VUP).....105,903-123-287-BC-90 K6EXO (K6s EXO LGT) 38,640-80-161- A-79 Arizona W7ENA.....8400-40-70- A-32 W7UXS.....294-7-14- A-13 W7BSP.....286-6-16- A-8 San Diego W6CHV.....30,960-80-129- B-43 W6CTP.....24,723-67-123- C-35 W6JVA.....12,948-52-83- A-30 Santa Barbara W6AGO.....46,008-108-142- C-36 K6QBF.....19,947-61-109- C-51 W6ALQ.....1152-16-24- A-8 WEST GULF DIVISION Northern Texas W5QF.....6552-39-56- A-15 W5ITC.....1620-20-27- B-24 W5DXW.....1350-18-25- A-7 W5OC.....1104-16-23- A-9 K5CNO.....812-14-20- A-15 Oklahoma W5ALB.....52,398-71-246-AB-45 W5MCF.....3510-30-39-AB-12 Southern Texas K5EXZ.....26,199-71-123- C-51
GREAT LAKES DIVISION Kentucky W4KZF.....6480-45-48- B-14 Michigan W8NWO.....232,245-195-397- B-90 W8DUS.....93,432-136-229- C-60 W8NOB.....22,932-78-98- B-21 W9VPT.....10,682-43-78- A-32 W8FIC.....4680-30-52- B-24 W8SS.....3567-29-41- A-23 W8WOL.....624-13-16- A-6 W8PWQ.....297-9-11- A-9 W8UJH.....147-7-7- A-6 W8NGO (W8s CLR MZA NGO ONA).....268,488-198-452- B-94 W8OCK (W8s DJN TIQ) 22,713-67-113-BC-35 Ohio W8BKP.....322,875-205-525- C-76 W8NXF.....218,594-191-378- B-66 W8ZOK.....200,725-155-433- B-72 W8LKH.....192,996-174-378- C-72 W8BPF.....160,344-161-332- C-50 W8AJW.....79,443-117-227- A-42 W8SDD.....50,490-99-170- A-34 W8BTU.....45,300-100-151- C-40 W8QAD.....30,441-73-130- C-34 W8BPM.....21,870-64-135- B-48 W8HQX.....15,120-54-94- A-9 K8BFX.....12,833-41-105- B-19 W8AJH.....10,680-40-89- B-9 W8ELB.....10,074-46-73- R-30 W8NDJ.....9159-43-71- A-40 W8UYJ.....6324-34-62- B-23 W8GIZ.....4640-32-49- A-25 W8HYZ.....4257-33-43- B-9 W8KC.....4140-30-46- B-16 W8BOJ.....3321-27-41- C-5 W8OG.....3300-25-44- B-9 W8FBZ.....3120-26-40- - W8MWE.....3105-23-45- A-9 W8MOW.....2880-24-40- A-11 W8QXW.....2346-23-34-AB-9 W8AET.....2001-23-29- C-8 W8MZF.....1512-18-28- A-10 W8FFN.....1350-18-25- B-7	NEW ENGLAND DIVISION Connecticut W1BTH.....114,432-128-300- A-53 W1ODW.....19,836-58-114- A-24 W1MRJ.....10,707-43-83- B-25 W1QFQ.....2346-23-34- A-9 W1FFY.....1122-17-22- A-16 W1AW ²918-17-18-AC-6 W1BD ²12-2-2- - Maine W1DLC.....35,728-88-136- C-40 W1PCD.....8316-36-77-ABC-21 W1DIS.....2360-20-56- B-12 Eastern Massachusetts W1ONK.....175,050-150-389-AB-64 W1PST.....131,616-144-306- C-79 W1OGU.....31,947-69-155- B-35 W1OHA.....5730-30-65- A-26 W1MGP.....4288-32-46- A-24 W1LQO.....3999-31-43- A-6 W1MKV.....1824-19-32- B-5		

W5GAH	13,864	50-80	A-35
W5IBC	5868	36-55	A-21
W5EDX	5508	34-54	B-15
W5BVX	663	13-17	B-20
W5SU	585	13-19	A-10

New Mexico

W5GCI	18,540	60-103	A-45
W5FTP	5811	39-50	B-13
W2DKS/5	3159	27-39	A-12

CANADIAN DIVISION

Maritime

VO6U	26,102	62-141	A-45
W4FOW/VO4	17,756	46-130	B-27
VE1YB	9800	40-82	B-16
VO6N	2967	23-43	B-13

Quebec

VE2JR	45,500	91-168	A-65
VE2ATD	22,825	55-141	A-20
VE2APH	14,784	44-112	A-15
VE2AXC	11,064	36-108	B-29
W1EXZ/VE2	11,685	16-25	A-13
VE2ADX	624	13-16	A-20

Ontario

VE3HNY	18,800	50-126	A-32
VE3BDB	7296	38-64	B-35
VE3BMB	6720	40-56	A-32
VE3FB	5304	34-52	B-14
VE3PPE	684	12-19	B-8
VE3BTR	60	4-5	B-3
VE3DMT (VE3s DMT MB)	84,448	104-272	B-79

Manitoba

VE4RO	157,209	139-377	C-50
-------	---------	---------	------

Saskatchewan

VE5VL	66,096	102-221	B-40
VE5RU	58,600	100-196	A-40
VE5ZM	5130	30-59	A-24
VE5EX	4050	30-45	A-4

Alberta

VE6NX	10,062	39-88	B-23
VE6IN	1350	15-30	A-14
VE6MI	1083	19-19	B-10
VE6GS (2 oprs.)	1248	16-26	A-18

British Columbia

VE7ZM	15,219	87-89	A-22
-------	--------	-------	------

Yukon-N.W.T.

VE8AB	3354	26-43	A-15
VE8MA (4 oprs.)	29,607	71-139	A-30

AFRICA

Bechuanaland

ZS9G	88,992	48-618	A-60
------	--------	--------	------

Cunary Islands

EA8CF	34,055	35-328	A-32
-------	--------	--------	------

Cape Verde

CR4AS	5640	20-94	A-14
-------	------	-------	------

Eritrea

BT2US (W3GZ), W511H, W8GTC	2310	10-77	A-4
----------------------------	------	-------	-----

Kenya

VQ4KPB	1026	9-38	A-5
--------	------	------	-----

Southern Rhodesia

ZE2KR	39,780	39-340	A-40
-------	--------	--------	------

Tanganyika

VQ3ES	11,088	21-176	A-30
-------	--------	--------	------

Tangier Zone

CN2AK	2352	8-98	A-4
-------	------	------	-----

Union of South Africa

ZS6JY	90,180	54-559	A-4
ZS8NQ	35,520	40-296	A-25
ZS8QA	22,770	30-253	A-26
ZS6JO	1596	14-38	A-5

ASIA

Formosa

BV1US (K2MZUW, W4DKD, W7HVR, W8UKU)	17,028	26-226	AB-4
-------------------------------------	--------	--------	------

Hong Kong

VS6AE	36	6-6	A-4
-------	----	-----	-----

Japan

KA2FQ	28,856	34-283	A-41
KA5ZS	14,850	22-225	B-4
JA3BB	4960	20-83	B-10
JA8AA	1680	10-56	B-9
JA1EF	1416	8-50	B-4
JA1CF	162	3-18	A-4
JA2AH	3	1-1	A-1

EUROPE

Austria

OE5CK	87,384	44-662	A-40
-------	--------	--------	------

Belgium

ON40C	106,062	66-537	A-65
ON4DG	3591	21-57	A-4
ON4DB	2079	9-77	A-18

Czechoslovakia

OK1MB	100,110	71-477	A-52
-------	---------	--------	------

Denmark

OZ3TH	42,237	39-362	A-60
OZ4FA	29,760	24-414	A-4
OZ7BF	16,275	35-155	A-9
OZ1JG	11,232	24-160	A-4
OZ5KQ	3542	14-85	B-13
OZ7FG	768	8-32	A-4
OZ1HM	90	5-6	A-4

England

G3DO	80,288	52-515	A-50
G3HJJ	51,948	52-334	A-56
G5HZ	45,012	44-341	A-4
G3COJ	22,788	54-141	A-31
G2DYV	21,204	38-186	A-37
G3JHL	9792	17-197	A-30
G3HFZ	5400	25-72	A-26
G5MP	5229	21-83	A-28
G4BSM (G3s JUL KAB, G5CS)	10,710	15-238	A-18

Finland

OH5QN	40,188	34-394	A-24
OH3RA	23,040	40-192	A-19
OH3NY	210	8-10	A-4
OH2UV	36	3-4	A-1
OH2LU	3	1-1	A-4

France

F8PL	144,480	56-865	A-4
F8LE	16,380	26-210	A-27
F9RM	21,630	35-206	A-4
F8XP	10,920	26-140	A-4
F9TV	5911	23-86	A-7
F9NL	2709	21-43	A-4
F9GL	1848	14-44	A-4
F9PU	621	9-23	A-6

Germany

DL4SK	30,090	34-297	AB-46
DJ2YL	29,280	32-305	A-30
DL9MZ	24,428	31-265	B-14
DL9XR	15,656	19-276	A-18
DL9SN	10,902	23-158	A-4
DJ2RE	4995	15-111	A-4
DL7AD	1107	9-41	B-4
DL9BJ	595	9-22	B-4
DL4ASA (DL4s CU EAL JEM)	17,560	40-399	AB-4

Gibraltar

ZB2I	1087	11-33	A-5
------	------	-------	-----

Greece

SV9WT	61,236	63-324	A-4
-------	--------	--------	-----

Ireland

EI5I	81,796	52-527	A-36
------	--------	--------	------

Italy

I1ASM	47,799	47-339	A-25
I1CHJ	44,694	39-382	A-40
I1AMU	30,960	40-256	A-21
I1CCO	12,798	27-158	A-6
I1AHW	7848	24-109	A-10
I1FT	2350	10-79	A-4
I1ZCN	759	11-23	A-11

Malta

ZB1CA	1078	11-34	A-5
-------	------	-------	-----

Netherlands

PA0NV	19,008	36-176	A-30
PA0VB	10,830	30-121	A-18
PA0QX	6327	19-111	A-15
PA0XX	1302	7-62	A-7
PA0DOK	1089	9-41	A-6
PA0HW	528	11-16	A-4

Northern Ireland

G13GL	5355	21-85	A-9
G13KVQ	3536	17-70	A-16

Norway

LA8WE	10,143	23-147	A-28
LA1ZE	6705	15-149	A-4
LA2AD	560	8-24	A-6
LA9T	288	6-16	A-4
LA7RE	270	9-15	A-5
LA2HC	27	3-3	A-4
LA3RC	3	1-1	A-4
LA1K (LAs 3HF 6HF 7DF)	8710	20-114	A-35

Poland

SP8CK	1887	17-34	B-4
-------	------	-------	-----

Portugal

CT1PK	94,464	64-492	B-24
-------	--------	--------	------

Scotland

GM3BCL	6489	21-103	A-13
--------	------	--------	------

Spain

EA3TE	98,112	48-692	A-68
EA4EP	19,050	25-254	A-26
EA3LL	12,975	25-173	A-26
EA3FQ	1930	10-66	A-4
EA3JJ	888	8-37	B-4
EA1GG	27	3-3	A-8

Sweden

SM5WE	36,143	47-257	B-4
SM3EP	22,755	41-185	A-4
SM5XP	20,775	25-277	A-4
SM5LL	18,315	33-185	A-4
SM2AKA	16,905	35-161	A-32
SM5AI	16,870	35-162	B-19
SM5BIZ	16,065	35-153	A-4
SM6RTT	13,392	27-166	A-40
SM3RNL	4278	31-46	B-13
SM5BFR	2268	14-54	A-4
SM5WC	1755	9-65	A-4

Switzerland

HB9RG	13,536	32-141	A-28
-------	--------	--------	------

NORTH AMERICA

Alaska

KL7AZN ³	63,726	43-496	A-39
W9KLD/KL7	2385	15-53	A-3
KL7AIZ (W3s FY KZQ)	31,824	34-312	B-33

Bermuda

VP0L	201,360	80-839	A-45
------	---------	--------	------

Costa Rica

TI2RO	1188	11-36	A-2
-------	------	-------	-----

Cuba

CO2HB	26,130	26-338	A-18
CO2KV	3498	11-106	A-4

Dominican Republic

HI8SKE	40,128	44-304	A-10
--------	--------	--------	------

Haiti

HH2RM ⁴	131,328	57-769	A-38
--------------------	---------	--------	------

Leeward Islands

VP2VG (W2CAA, KP4DE, KV4BB)	163,296	72-756	A-27
-----------------------------	---------	--------	------

Mexico

XE1RE	40,071	37-361	A-33
XE1QB	17,472	25-210	A-4
XE1PAD/XE2 (K6s DDO ELN)	5544	21-77	A-8

Nicaragua

YN4CB	92,637	73-423	AB-4
-------	--------	--------	------

Puerto Rico

KP4DH	21,582	33-222	A-12
-------	--------	--------	------

St. Martin, Dutch

PJ2MC	10,788	31-116	A-14
-------	--------	--------	------

St. Martin, French

F87RT	5994	18-111	A-11
-------	------	--------	------

Turks and Caicos

VP5DS	10,560	30-455	A-10
-------	--------	--------	------

OCEANIA

Australia

VK3ATN	176,418	81-727	A-39
VK5LQ	35,732	37-324	A-41
VK3G	6390	20-106	A-10
VK7KM	1004	22-61	A-8

November 1932

... An inexpensive crystal-controlled transmitter for the beginner, an all-wave midget receiver, better efficiency in the final amplifier, a condenser microphone — those were the main constructional articles twenty-five years ago.

... WITS pointed out that we could well adopt some of the protective devices used by commercials to protect our gear from accidental overloads.

... The Third All-Section Sweepstakes was announced, it then being a contest nine full days long. No time limit!

... Station descriptions of W9DCX, W5FB, and K7ANQ — say, all the receivers and transmitters were home-built!

... In a letter to the editor, W6EIJ signs for the good old days when receivers weren't so darned complicated as they turn out to be in 1932.

... Leeds carried an ad for copper tubing (for inductances, naturally), while over in the Ham-Ads W9ARA announced that he was out of MIT and in business as Henry's Radio Shop.

Silent Keys

IT IS with deep regret that we record the passing of these amateurs:

- W1DR, Stuart M. Briggs, Fairhaven, Mass.
- W1LF, Charles J. Keenan, Colchester, Conn.
- W1UNH, Leon W. Hamlin, Gardiner, Me.
- K2PQQ, Gail G. Trautmann, Huntington, N. Y.
- W3JPE, Fred J. Boeser, Hatboro, Pa.
- W5BYE, Andreas Buchmaier, El Paso, Tex.
- W5CDD, James S. Lunn, Galveston, Tex.
- W5KRY, Charles W. Urquhart, Orange, Tex.
- W5NMC, James D. McNair, Tylertown, Miss.
- W5ODA, William A. Couse, El Paso, Tex.
- W6DEK, Alfred H. Havens, Milbrae, Calif.
- W6HIR, Richard A. Gandy, Del Paso Heights, Calif.
- W6MLU, George P. Kraft, Altoona, Pa.
- W7DKH, Frank F. Deane, Anacortes, Wash.
- W7EHB, Armand W. Blenner, Spokane, Wash.
- WN7HEY, Lawson L. Brammer, jr., Richland, Wash.
- W7JYA, Bernard L. Dellevolt, Sparks, Nev.
- K8AHO, Clarence W. Scott, jr., Cleveland, Ohio
- W8BID, John S. Hutchison, Spring Lake, Mich.
- W8HSG, Cosmo G. Calkins, Lansing, Mich.
- W8RII, William T. Toman, Cuyahoga Falls, Ohio
- W9AA, Cyrus T. Read, Chicago, Ill.
- W9GTT, George C. Hume, Chilton, Wis.
- W9IBN, Paul W. Barger, Decatur, Ill.
- K0EKS, Frank J. Heini, St. Paul, Minn.
- W0FDI, Ray S. Wilfrey, Haddam, Kans.
- W0GVO, Thomas O. Hall, St. Paul, Minn.
- W0MUH, James A. Ewalt, Northwoods, Mo.
- VE3NI, Earl B. Kimble, London, Ontario
- ZL3JA, Harold J. Rowe, Christchurch, N. Z.

MEMBERSHIP CHANGES OF ADDRESS

Four week's notice is required to effect change of address. When notifying, please give old as well as new address. Advise promptly so that you will receive every issue of *QST* without interruption.

Quiz Quiz

Faithful followers of this department should by now be experts at solving resistance-network problems. Just to check you, old-timer Ken Redick, ex-IDY of Newington, Conn., wants you to find the net resistance between points A and B in the circuit below:

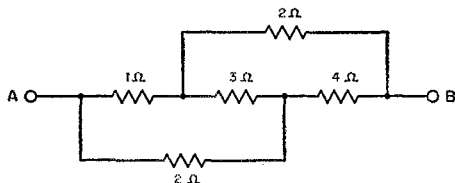

In the "perfect" series circuit shown last month, the initial charges on the capacitors are there only to confuse you. When the current stops flowing around the circuit, the total charges across the capacitors will equal 100 volts, and the charges will be in inverse proportion to the capacitances. Thus the 1- μ f. capacitor will be at 57.1 volts, the 2- μ f. at 28.6 volts, and the 4- μ f. at 14.3 volts.

Strays



Mobile operation sometimes has to be tailored to fit the vehicle. Here we see a couple of different installations. W7TCQ should be quite free of ignition noise, while KN1AAQ rides a different sort of a steed.

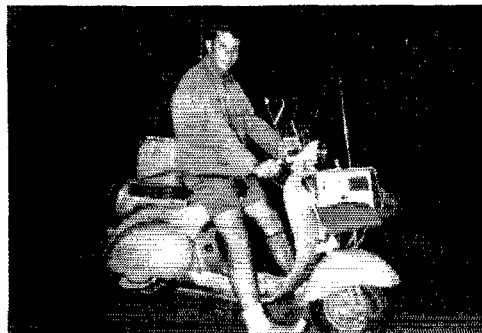

OPERATION ALERT, 1957

Amateurs in 25 States Report the Results of Their Participation

BY GEORGE HART* WINJM

IN AN ATTEMPT to make Operation Alert more realistic, FCDA this year issued no detailed advance "scenario" giving the exact time, location and size of attacks on the various target areas. Various cities affected were on their own, details being released by local civil defense directors only as the exercise unfolded. Likewise, this information, which included the time each city was hit and the exact hypothetical situation, was made available to federal departments only when it was reported from the field. In other words, local civil defense directors alone knew what was going to happen, and for the most part they weren't telling. The result was a much closer simulation of an actual attack throughout all levels — community, state, federal regional and federal headquarters.

Amateurs participated through their RACES organizations, as usual. The exercise was divided into three parts: From July 8 to July 12 the public participated in rehearsing evacuation plans, civil defense service activities and other readiness procedures. From July 12 to July 14 was the period of attack and immediate survival and support actions; this is the period in which local emergency communication was most needed and in which amateur/RACES groups participated. The July 15-19 period was for federal evaluation of the situation and development of hypothetical measures connected with survival and recovery.

So we're mainly concerned with the July 12-14 period immediately prior, during and immediately after the simulated attack. Reports were received from RACES and AREC/RACES organizers in 25 states and two FCDA regions. We have no other statistics, since ECs were asked to drop us an informal writeup of what went on in their bailiwicks — and this is just as well, because statistics in a situation like this are of little value. We summarize herewith the reports received.

*National Emergency Coordinator, ARRL.

Alabama

A clipping from the *Florence Times*, sent in by EC W4WAZ, says that "if a real enemy with real bombs were hovering over the U. S. instead of the mock atomic attack they would find only the hams on the alert in Muscle Shoals." Members of the Muscle Shoals Amateur Radio Club manned their station all night on July 12 and July 13 while Birmingham, Mobile, and Phenix City were being bombed.

California

By means of 2, 75 and 160 meters, amateurs of the Citrus Belt Amateur Radio Club maintained communication with other cities throughout the San Bernardino area. Eleven mobiles were standing by for dispatch to disaster areas throughout the country. The San Mateo County RACES station was on the air from 1800 until midnight, maintaining contact with cities in the county on 2, 6 and 160 meters (DCS), with a separate 6-meter link to Region 2 headquarters. W6QIE took part from South San Francisco by working through San Bruno, which operated on six meters. Millbrae had seven amateurs participating on 2 and 6 meters. EC W6VCZ says San Mateo was "wiped out," so they had no participation, making their part of the drill a "great success." Both the Red Cross and c.d. stations were active in Menlo Park, on 2 and 6 meters. Redwood City's new c.d. setup gave a good account of itself, operating through the South County Amateur Radio Society on six meters under the direction of K6IEE.

Two 6-meter positions were established at Napa C.D. Headquarters, and six and two meter links were also established for the Red Cross. Four mobiles were active, with four more held in readiness if needed. Unlike last year, when they were buried, this year EC W6CAN lined up plenty of facilities and was able to handle the full load without difficulty, this despite the fact that



The Farmington, N. M., RACES Net Control Station W5CIN in action during Operation Alert. Left to right are W5LYT, W5CIN (EC) and W5VDY.

QST for

local c.d. officials handled all traffic by radio, forgetting the telephone.

Colorado

The state RACES net was in operation 48 hours with contact to nine out of ten areas. Six operators were used at the state control center with 93 operators participating throughout the state. A total of 425 messages were handled, this constituting a great majority of all messages handled by radio and telephone.

Connecticut

EC W1WX of Fairfield reports headquarters station manned by six operators for the entire alert from Friday noon to Saturday noon, also manning the remote location for part of the drill. Three mobiles worked on two meters. Contact with Area in Ridgefield was maintained perfectly on six meters.

Area 3 conducted its usual extensive operation with over 20 towns reporting into the area net on 10 and 2 meters. Towns within the area conducted their own local exercises, coordinated into the area and state plans, mostly on 2 meters. Surprise simulated unexploded bombs were uncovered by the military in Burlington and Newington to add some unexpected excitement on Sunday.

Florida

After the simulated attack, c.d. directors flooded the amateur network on 7006.6 kc. with long reports on evacuations, estimated dead, fall-out information, weather reports, medical requests, damage reports, etc. The net was manned statewide by stations in Tallahassee, Pensacola, Orlando, Tampa, St. Petersburg, Miami, Naples, Fort Lauderdale, Key West, Okeechobee and Melbourne. State NCS was W4UHY in Jacksonville, where the state c.d. office is located. Many counties participated at local levels, handling hundreds of messages between zone commanders and MTA coordinators.

The Eglin Amateur Radio Society of Fort Walton Beach, Fla., furnished communications to c.d. directors in all major population centers of Okaloosa Co. All operation was on 29,560 kc. Seven mobiles operating in four cities and Eglin AFB, and five fixed stations operated by a staff of nine operators constituted the setup. Traffic

was principally from the county c.d. director's office in Crestview to other towns and areas, and return.

Illinois

EC W9KMN of McHenry County says the c.d. director there is not interested, but his group cooperated with the c.d. director of Woodstock on Friday. W9IET/m accompanied the fire truck and relayed a message to the c.d. director via W9KMN and K9CCO. This group looks to more active participation in future drills. Amateurs in Rock Island were active in the Test, but no details were given.

Indiana

SEC W9QYQ reports that Indiana state RACES set up with 6 meters links to Frankfurt and Indianapolis where communication was established with Area 1, Area 7 and Area 6 via single side band. The c.w. link maintained contact with FCDA Area 4 as well as most support areas and adjoining states. One of the features was the establishment of RTTY links from Ft. Wayne and South Bend which handled some 60 messages the first day. The operation was complicated by messages from Area 1 concerned with an actual natural disaster caused by floods in that area. Participation by other than target area counties was light. About 75% of the traffic was handled by RACES.

Iowa

In Cedar Rapids, RO W0GQ reports 46 amateurs participating during Operation Alert. Both the City Hall and an alternate control station were equipped to operate on 2, 6 and 75-80 meters after W0LBK worked all Friday evening to get the equipment set up. Local thunderstorms produced a realistic effect (and plenty of QRN!) during the operation.

In Muscatine, most of the amateur work was done on 75 and 80 meters, with the c.w. net on 3560 far outperforming the phone net on 3970 according to EC W0FDL. Thunderstorms and QRN greatly hampered the operation on 75. An attempt to raise Rock Island on 6 meters was fruitless, but Des Moines and Davenport were contacted readily on 80 c.w.

Davenport had some activity, we understand,

Radio Officer W7JIE (r.) and Assistant R.O. W7KKZ of Kings County (Wash.) RACES take a food break during Operation Alert. On July 14 these officers of the Central Area RACES group moved a complete area control center into Paradise Lake Reception Area to furnish a communications link to the King County control center.

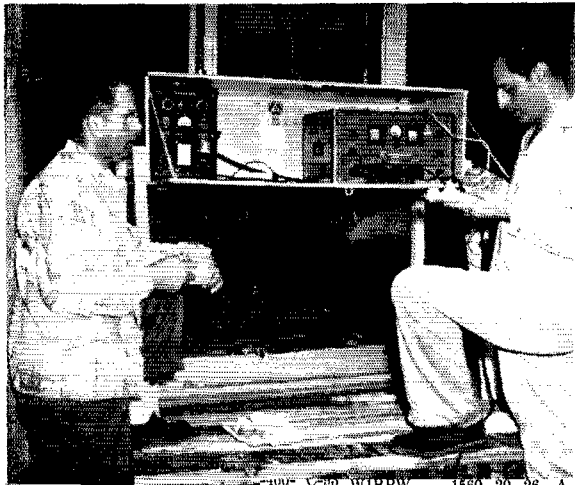



EC and RO for Washtenaw Co., Mich., W8JYJ, balefully contemplates the gear installed in the c.d. communications bus used as an auxiliary control station. This RACES group found a new lease on life with change of c.d. directors.

but except for mention in a newspaper clipping received, details are lacking.

Kansas

Five stations operated at state headquarters, using 35 operators. A total of 821 messages were handled. All seven of the state area stations were in operation using an estimated 50 operators, while local stations reporting to state area stations had an additional 150 operators on duty. W0WBX estimates a total of 235 operators participating in the exercise. W0UOL operated Area III RACES station for 17 hours, handled two messages.

Kentucky

The Kentucky C.D. Director of Communications was very complimentary of communications during Operation Alert, according to SEC W4JSH. At state level, 199 messages were sent and 198 received by radio, about two thirds of the total traffic in each case. In Glasgow, EC W4TQD and his crew monitored and operated on both 3993 and 3940 during the test, handling 22 c.d. messages. In Louisville, most operation was on six meters with some on ten, the only problem being a contact between Third Mobile Group and state headquarters located nearby. C.D. officials said they were satisfied with the communications, but EC W4BAZ felt the amateurs could have been more widely used.

Massachusetts

According to Cambridge EC W1COL, Massachusetts participated only from state c.d. headquarters, the statewide Operation Alert having been held in May when, she reports, the Cambridge control station was in operation all three days of the test, four operators doing the bulk of the work. The c.d. director was greatly pleased with the performance of the RACES group.

Michigan

Ypsilanti was active on 2, 10 and 75 meters, maintaining contact throughout the test with Ann Arbor, Lansing and Detroit. They had a very successful drill under their new c.d. director, although there was some interference between operating positions that needs correcting. Twenty amateurs participated, even though the drill was held Friday during business hours. EC W8JYJ says that the c.d. director used RACES first, telephones as a last resort.

Ottawa County control K8DAA was opened at 0915 Friday and checked into the area and state net on 80 c.w. Local and county nets were activated on six meters. One of the participants in this drill was Mother Nature, who caused a real tornado alert to be called Friday afternoon; but seeing the nets already in operation, she subsided and there were no tornadoes. QRN practically eliminated the net on 80 c.w., but the six meter operations were able to continue. Thanks to EC W8GEH for this report.

Minnesota

The state RACES net was in operation along with five area nets and two "unicom" nets. Waseca County EC W0TCK reports operating MSU5, covering 22 counties in southwest Minnesota. Operation was on 3850 kc. for state net and seven other MSU nets on separate 75-meter frequencies, operating phone when practical, going to c.w. for weak signals. About 10% of the traffic was handled by the RACES group. The high point of the day was when commercial communications failed and the amateurs had to handle all the traffic for a short time — which they did with efficiency and dispatch.

Missouri

An excellent turnout of RACES personnel in the joint St. Louis-St. Louis County RACES organization is reported by RO W0WPS, but operation has hampered by lack of other c.d.



The fire chief of Woodstock, Ill., reports to the c.d. director through RACES mobile W9IET. The Woodstock group is sponsored by the Southern Wisconsin and Northern Illinois Amateur Radio Club.

personnel to originate and receive traffic. All c.d. posts in the area were manned 100% by RACES by 1100, Friday, when the exercise was scheduled to start, but many found themselves alone and eventually secured early. Nevertheless, W6WPS indicates that 243 incoming messages and 170 outgoing messages were handled. The main control was activated in eight hour shifts by some 20 operators. Over-all, more than 100 operators participated out of the 150 assigned — a good turnout for RACES.

Nebraska

Approximately 25 RACES stations were in operation throughout the state with about 40 operators. Contact was maintained direct from state headquarters to five area stations, which in turn handled intra-area traffic. Atmospheric conditions made transmission difficult at times.

Sidney was one of the places on which the simulated bomb dropped. W0AFG, deputy director for communications, placed a receiver in the sheriff's office, then went to the evacuation site with his mobile rig. W0QKR served as the link between W0AFG/m and the sheriff's office. During the day communications were lost, but regained again after W0DQN and W0PUT came on to relay. Says W0QKR, "We learned a lot about emergency communications and also how much more we need to learn. . . ."

New Jersey

One brief report, from old stand-by W2COT. It appears that Essex County RACES has been without an authorized call for several months, so participation in Maplewood was as individual amateurs. Bruce says "The local alert was quite successful and our men performed such services as were required."

New Mexico

Farmington served as an evacuation center for the Albuquerque-Sandia Base area. The control station was activated by W5LYT, W5CIN (EC) and W5VDY.

Amateurs in Los Alamos were very active with mobile units and control stations as a simulated 60-kiloton bomb was dropped in the area. Mobiles were stationed in Las Vegas, Farmington, Pargosa Springs, Eagles Nest and a fixed station was established at Santa Fe for areawide and state-

wide contact. The Los Alamos Amateur Radio Club is the principal implementing organization in this area.

New York

The control station for Schenectady County was activated Friday noon on 6 and 2 meters and contacts made with support areas to the north. A 2 meter net was set up on two channels with portable gear located in cars at Duaneburg, Mariaville, Burnt Hills and Ballston Spa, to test evacuation control points, with good success. W2EFU made liaison with the state command net on 6 and 80 meters. A total of 20 operators participated.

North Dakota

Ten stations were active in state net operation, with 44 messages handled. No additional details available.

South Dakota

The test was conducted on a statewide basis, starting at 0800 July 12 and continuing to 1825 July 13, plus a short session on Sunday. Frequencies used were 3870 and 7225 kc. Traffic was concentrated mainly around target cities, as was to be expected, but this left some outlying stations with little to do. State control center handled 115 messages and 385 were handled by state area nets. Forty of 62 authorized stations were active, averaging three operators per station for a total of 120 operators. Both the state c.d. director and state RO W00XC declared the operation a "tremendous success."

Tennessee

C.D. headquarters station at Oak Ridge was activated at 1100 Friday as W4CXV1, while K4KYL set up to relay to Knoxville and W4CXV and K4MYI set up at the Oak Ridge relocation center at Rockwood. State control at Nashville, operating on 75 meter phone, could not be contacted, and they had no station on 80 e.w. or 6 meters. At 1700 Friday the entire personnel returned to Oak Ridge, where contact was made with Nashville from W4KAMH, who relayed to c.d. headquarters which in turn relayed to Knoxville. Contact with Knoxville was also maintained on six meters. The state net operated on

(Continued on page 176)

The Zone 3 and 4 Control Center at the Town Hall in Miami Springs, Fla. This unit operated under the call K4OSQ on two meters to the main c.d. control center and on ten meters to mobile and fixed stations within the zone. Shown at the operating position (l. to r.) are W4YHW, W4GGQ, K4PAE and ARRL SEC W4IYT (standing).



Happenings of the Month

ELECTION RESULTS

In three of the eight ARRL divisions currently holding elections, incumbent directors have been returned to office without opposition, remaining on the job for another two-year term. They are Canadian Director **Alex Reid, VE2BE** (starting his 29th year!), Dakota Director **Alfred M. Gowan, W0PHR**, and Southeastern Director **James P. Born, jr., W4ZD**.

Similarly without opposition, **Sumner H. Foster, W0GQ**, continues as Vice-Director, Midwest Division. The Delta Division has a new Vice-Director beginning January 1st, the lone nominee being **Sanford B. DeHart, W4RRV**. At the Oak Ridge National Laboratory (Tennessee), **W4RRV** has charge of all p.a., projection and closed-circuit TV gear. Hamwise, he's been licensed for thirty years, having **W9BLQ** and **K5AC** as former calls. He is currently president of the Oak Ridge Radio Operators Club, and SEC of the Tennessee section with particular interest in a section-wide 50-Mc. emergency net recently set up.

All other offices are contested, and ballots have been sent to Full Members of the divisions concerned.

STAFF NOTES

Twenty members of the Hq. Ten-Year Club held a dinner meeting in July to welcome into membership **Miriam Y. Knapp**, secretary to the Technical Director, and as a testimonial to Chief Accountant **Alice V. Scanlan**, now retiring.

Miriam Knapp joined *QST*'s staff as a proof-reader in the production department, shortly thereafter transferring to the Technical Department as secretary-steno. Aside from routine correspondence and putting a considerable volume of *QST* technical copy into form for the printer, **MYK** has charge of the ARRL Library and of the ordering and billing processes in purchase of gear for the lab. A couple of years ago she joined a study group of Hq. gals aiming at Novice tickets, and is one of the few who progressed to General Class. Limited space in a small apart-

ment cramps her operating ambitions at the moment, but she hopes to make **W1ZIM** a better-known call on the air before long.

Words are inadequate to express the gratitude the League owes to **Alice V. Scanlan**, for 28 years chief accountant at Hq. **AVS** is a most meticulous person, which reflects itself in the accuracy and quality of ARRL bookkeeping systems and procedures. One anecdote might help us make the point: Last year a U. S. Air Force auditor visited us, expecting to spend a full day, or more, checking our accounting system for approval in advance of awarding ARRL the government IGY propagation contract; in less than an hour, he gave unqualified endorsement!

We weren't really surprised. One comes to expect that sort of testimonial to a very capable and charming lady whose devotion to the League and its progress is without peer. She has seen the League's membership quadruple, its Hq. staff grow nearly three times, and its gross business increase nearly tenfold — in all of which she has played an important part. **Miss Scanlan** is now on a well-earned vacation trip to Europe. The first Hq. employee to retire under the League pension plan, her coming years will be kept occupied with activity in her church and in organizations such as the Business & Professional Women's Club, in which she is prominent in Hartford.

FCC PROPOSES RULES CHANGE

The Federal Communications Commission has issued a Notice of Proposed Rule Making which would make certain changes in the notification procedure required for amateur operation away from the authorized home location. Comment may be filed up to November 22, 1957.

Notice to the district FCC engineer of portable or mobile operation, required when more than 48 hours of such operation is contemplated, is valid for only thirty days under present regulations, with additional monthly notices required for extended periods. FCC now proposes to make such notices good for a period up to one year, so long as the indicated particulars, such as dates and



K2KGJ, a 16-year-old high-school student, was one of those receiving a special citation from the General Electric Company in connection with its fifth Edison Award. This special citation to **Julius Madey** was for providing communications between Operation Deep Freeze personnel at the South Pole and their families in the States. In this photo **K2KGJ** is receiving the plaque from **G. R. Rahmes**, G.E. district representative, while **Mayor J. A. Stemmer**, of **Clark, N. J.**, looks on.

QST for

location (or itinerary) of operation are observed; any change requires a new notice. The Commission proposes to add two safeguards: (1) the amateur must furnish an address at or through which he may be readily reached, and (2) in the case of mobile operation he must indicate the license number of the automobile (or other vehicle registry). The proposed rule would also drop the present requirement of monthly notices for those amateurs living "temporarily" at fixed locations other than shown on their licenses, and for maritime-mobile operators on ships plying repetitive routes.

An examination of this proposal, looking toward the establishment of an official ARRL view, will be made by the Executive Committee. We publish herewith the text of the notice:

**Before the
FEDERAL COMMUNICATIONS COMMISSION
Washington 25, D. C.**

In the Matter of
Amendment of Part 12 of the Commission's Rules Governing the Amateur Radio Service, Sections 12.90, 12.91 and 12.93, in regard to operation away from authorized locations. } Docket No. 12160

NOTICE OF PROPOSED RULE MAKING

1. Notice is hereby given of Proposed Rule Making the above-entitled matter.

2. The Commission has before it for consideration a petition filed by *Malcolm A. Hormats seeking amendment of Sections 12.91 and 12.93 of its Rules Governing the Amateur Radio Service* so as to provide that only one notice be required in the case of operation away from the authorized location, provided, that an additional notice will be required each time there is any change in the information supplied in the original notice. The Commission is also in receipt of a letter submitted on behalf of the Maritime Mobile Amateur Radio Club requesting that only one notice be required in the case of operation aboard ships, making repeated voyages over the same routes so long as "significant particulars" of such operation remain unchanged.

3. Sections 12.91 and 12.93 of the Commission's rules presently provide, among other things, that an amateur station may be operated away from the fixed transmitter location specified in the license for periods in excess of 48

hours only after written notice, containing specified information, has been given to the Commission of the intention to so operate. If such operation continues for a period in excess of one month, additional notices must be given for each month that such operation continues. An exception is made if the operation away from the authorized location occurs outside the continental limits of the United States, its territories, or possessions. In this instance only one notice is required "during any one continued absence".

4. The petitioner, *Malcolm A. Hormats*, contends that the monthly notices required by Sections 12.91 and 12.93 are of little or no value to the Commission in those instances where the operation of the station is merely being continued in accordance with the information supplied in the original notice, but that the requirement of such notices is unduly burdensome upon the involved amateurs. The letter filed on behalf of the Maritime Mobile Amateur Radio Club, likewise contends that amateurs operating "mobile" aboard ships which make recurrent voyages over the same general routes should not be required to submit a new notice each time the ships return to a United States port unless there is some change in the information supplied in the original notice because "strict compliance with this provision is sometimes exceedingly difficult of accomplishment due to the peculiarities of the movement of ships in which, frequently, there is insufficient time to properly notify the Commission at the conclusion of one voyage and the commencement of a second voyage."

Both petitioner *Hormats* and the Maritime Mobile Amateur Radio Club contend that the changes requested would benefit not only the amateur licensees but would also benefit the Commission because, in their view, such changes in the Rules involved would result in a reduction in the administrative work of field offices "with no relaxation of the Commission's requirements."

5. The Commission, believing that its rules applicable to operation of amateur radio station away from authorized transmitter locations should be revised, proposes to amend Part 12 of its Rules by adding a new Section 12.90, and amending Sections 12.91 and 12.93. The principal effects of such proposed amendment are:

(a) To consolidate within one section all notice requirements, other than designation of the Commission office or offices to be notified in specific instances, when an amateur station is to be operated away from the authorized transmitter location,

(b) To provide that only one notice of operation away from the authorized transmitter location be required for periods not exceeding one year upon the condition that additional notices will be required whenever there is a change in the information contained in the previous notice; and

(c) To provide that the notice required when an amateur station is to be operated away from the authorized location contain the following specific information in addi-

Amateur radio was well represented at the XII General Assembly of the International Scientific Radio Union (URSI) held at the University of Colorado Aug. 22 — Sept. 5. This group, in front of the University Memorial Center in Boulder, includes, left to right, Tilton, ARRL, W1HDQ; Dickson, USA Signal Propagation Agency, Ft. Monmouth, N. J., K2HJU; Booker, K2SKB, son of Dr. Booker of Cornell; Dieminger, Max-Planck Institut for Physik des Ionosphere, DL6DS; Burbank, USN Electronics Lab., San Diego, W6CDF; Moore, Univ. of N. Mex., W5WBZ; Dinger, NRL, W3KH; Peterson, Stanford, W6POH; Menzel, URSIGRAM Committee, Geneva, Switz., DL1UR; Seddon, National Academy of Science, Wash., D. C., W4SBQ; (kneeling) Silberstein, NBS, Boulder, WØYBF; Herbstreit, NBS, Boulder, WØlln; Johnson, Dartmouth, W1FGO; deBettencourt, Pickard and Burns, Inc., W1CXJ.

Other amateur delegates to the Assembly, not present for the picture, included Dyce, Stanford, W2TTU/6; Carpenter, NBS, Wash., D. C., W30TC; Cumming, Wilton, Conn., W1FB; Kirby, NBS, Boulder, WØLCT; Menzel, Harvard, W1JEX; Rohdin, Royal Board of Telecommunications, Stockholm, SM5FD; Swenson, Univ. of Illinois, K9ESK; Morgan, Dartmouth, W1HDA.

Seven of the above are QST authors.

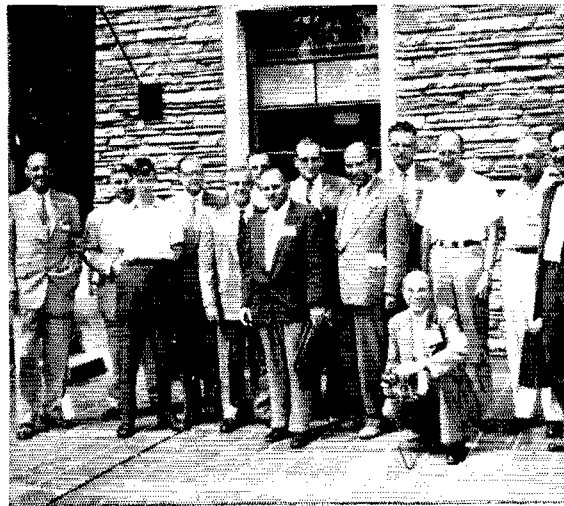

tion to that presently required; The address at which, or through which, the licensee may be readily reached while operating away from the authorized transmitter location, and when operating as a mobile station, the official name registry number or license number of the aircraft, vessel or land vehicle from which the station will be operated.

6. The proposed amendments, authority for which is contained in Sections 4(i) and 303 of the Communications Act of 1934, as amended, are attached hereto as an Appendix.

7. Any interested party who is of the opinion that the proposed amendments should not be adopted, or should not be adopted in the form set forth herein, may file with the Commission on or before November 22, 1957, a written statement or brief setting forth his comments. Comments in support of the proposed amendments may also be filed on or before the same date. Comments or briefs in reply to original comments may be filed within ten days from the last day for filing original comments or briefs. No additional comments may be filed unless (1) specifically requested by the Commission, or (2) a good cause for the filing of such additional comments is established. The Commission will consider all such comments that are submitted before taking action in these matters and, if any comments appear to warrant the holding of a hearing or oral argument, a notice of the time and place of such hearing or oral argument will be given.

8. In accordance with the provisions of Section 1.764 of the Commission's Rules and Regulations, an original and three copies of all statements, briefs, or comments shall be furnished the Commission.

FEDERAL COMMUNICATIONS COMMISSION

EVELYN F. EPPLEY
Acting Secretary

Attachment
Appendix

Adopted: September 5, 1957
Released: September 10, 1957

APPENDIX

IT IS PROPOSED TO AMEND PART 12 OF THE COMMISSION'S RULES GOVERNING THE AMATEUR RADIO SERVICE IN THE FOLLOWING PARTICULARS:

- Delete the text of the subtitle which presently appears immediately following Section 12.82 and substitute the following language:
STATION OPERATION AWAY FROM AUTHORIZED LOCATION.
- Add a new Section 12.90 to read as follows:
12.90 *Requirements for portable and mobile operation:*
(a) Within the continental limits of the United States, its territories, or possessions, an amateur station may be operated as either a portable or a mobile station on any frequency authorized and available for the amateur radio service. Notice of such operation in accordance with the provisions of Section 12.91 shall be given to the Engineers in Charge of the radio district in which operation is intended.
(b) When outside the continental limits of the United States, its territories, or possessions, an amateur radio station may be operated as portable or mobile only under the following conditions:
(1) Operation may not be conducted within the jurisdiction of a foreign government except pursuant to, and in accordance with, expressed authority granted to the licensee by such foreign government. When a foreign government permits Commission licensees to operate within its territory, the amateur frequency bands which may be used shall be as prescribed or limited by that government. (See Appendix 4 of this Part for the text of treaties or agreements between the United States and foreign governments relative to reciprocal amateur radio operation.)
(2) When outside the jurisdiction of a foreign government, operation may be conducted only in the amateur frequency bands 21.00 to 21.45 and 28.0 to 29.7 Mc.
(3) Notice of such operation, in accordance with the provisions of Section 19.91, shall be given to the Engi-

(Continued on page 180)

WHAT BANDS AVAILABLE?

Below is a summary of the U. S. amateur bands on which operation is permitted as of November 1st. Changes will, as usual, be announced by WIAW bulletins. Figures are megacycles. A0 means an unmodulated carrier; A1 means c.w. telegraphy; A2 is m.c.w.; A3 is a.m. phone (n.f.m. may also be used in such bands); A4 is facsimile; A5 is television; F1 is frequency-shift keying; and f.m. means frequency modulation, phone (including n.f.m.) or telegraphy.

3,500-4,000	— A1	14,200-14,300	— A3
3,500-3,800	— F1	14,300-14,350	— F1
3,800-4,000	— A3	21,000-21,450	— A1
7,000-7,300	— A1	21,000-21,250	— F1
7,000-7,200	— F1	21,250-21,450	— A3
7,200-7,300	— A3	28,000-29,700	— A1
14,000-14,350	— A1	28,500-29,700	— A3
14,000-14,200	— F1	29,000-29,700	— f.m.
50-54	— A1, A2, A3, A4		
51-54	— A0		
52.5-54	— f.m.		
144-148	} A0, A1, A2, A4, A3, f.m.		
220-225			
420-450 ¹	} A0, A1, A2, A3, A4, A5, f.m.		
1,215-1,300			
2,300-2,450			
3,300-3,500			
5,650-5,925	} A0, A1, A2, A3, A4, A5, f.m., pulse		
10,000-10,500			
21,000-22,000			
All above 30,000			

¹ Plate input power must not exceed 50 watts.

Also, shared use of 26.96-27.23 Mc. with A0, A1, A2, A3, A4, f.m. In addition, A1 and A3 (but not n.f.m.) on portions of 1,800-2,000 as follows:

Area	Bands, ke	Input power		
		Day	Night	
Minn., Iowa, Wis., Mich., Pa., Md., Del., and states to the north including District of Columbia	1800-1825 1875-1900	500	200	
N. D., S. D., Nebr., Colo., N. Mex., and states to the west including Hawaiian Islands.	1900-1925 1975-2000	500*	200*	
Okla., Kans., Mo., Ark., Ill., Ind., Ky., Tenn., Ohio, W. Va., Va., N. C., S. C., Tex. (West of 99° W or North of 32° N)	1800-1825 1875-1900	200	50	
Tex. (East of 99° W and South of 32° N), La., Miss., Ala., Ga., Fla., Puerto Rico, Virgin Islands, Alas., Guam, and other Territories and Possessions of the U. S. not listed above.	None	No	No	Opera- tion

* Except in State of Washington where daytime power limited to 200 watts and nighttime power to 50 watts.

Novice licensees may use the following frequencies, transmitters to be crystal-controlled with a maximum power input of 75 watts.

3,760-3,750 A1	21,100-21,250 A1
7,150-7,200 A1	145-147 A1, A2, A3, f.m.

Technician licensees are permitted all amateur privileges in 50-54 Mc. and in the bands 220 Mc. and above.



CONDUCTED BY ROD NEWKIRK,* W9BRD

Who?

Hey, you WN/KNs—and overseas WP4s, WL7s, WH6s, etc., for that matter—here's your chance. Outside of an interplanetary QSO, the biggest unattained "first" in DX history is up for grabs. We mean a Novice DXCC membership. Can it be won? Of course. But, excluding the help-from-daddy approach, this feat will require a very favorable conjunction of key factors. (Pun intended.)

A Novice, you know, has no more than twelve months to pull it off. So he or she will have to be a fairly sharp DXer from the start. A code-wise ex-SWL with a fresh tyro ticket, a lad who already knows the 15-meter DX ropes, would fill the bill. Perhaps he'll be an ex-GI hot on c.w. and light on theory, a fellow well up the WIAW Code Proficiency Program ladder. It seems doubtful that he'll be of school age, for 21-Mc. hot seasons, unhappily coincide with the annual Battle of the Books. And he'll probably have a nighttime job which will permit him full access to week-day 15-meter openings.

He'll commence operations with a solid DX layout too, we think. A handful of crystals, a potent rotary array and a full Novice "gallon." Because the period of his license will include only one ARRL DX Contest he certainly will have to be up for this one! Above all, the stunt will have to be pulled off during a stretch of high sunspot activity—around now, for instance. This because 40 meters is so unfavorable for multi-country Novice DX pursuit; the proving ground must be 15 meters.

Yes, why not now? Propagation conditions are fine on 21 Mc. and can't ever be much better. A year or so ago K2CPR, one of the smoothest ops in the business to be sure, set out to work 100 countries in 100 days on 15-meter c.w. running 100 watts without a beam. He made it with days to spare, reaching the century mark in three months. And we've heard of Novice DX countries totals running as high as 80 or 85 in the past. So near and yet so far!

Now where's that savvy know-how Novice who will put the term to shame? He'll make some splash when he appears in *QST*'s DXCC Awards listings! Who—and when?

Which reminds us of another "first" yet to be claimed by a W/K/VE/VO DXer: the "DXCC 2" trick broached on page 59 of April 1957 *QST*. DL4ZC (now W6KG) did it conveniently with the evidence featured in this year's June issue. Admittedly it's tougher from

the Stateside angle, and the largest W/K collection of different-country DXCC-member QSLs so far called to our attention is around eighty. How do you stand on this one?



What:

As fine fall conditions moved into our north temperate scene an amazing *ad hoc* outfit suddenly muscled in on 14 Mc. with a haunting hue and cry. It was the JCA—the JT1AA-Callers of America—and their raucous caucus was a wonder to behold. Short calls, long calls, longer calls, loud calls, weak calls, chirpy calls, rough calls, cicky calls, mushy calls, slow calls, fast calls, drifty calls, stable calls . . . name it, brother, you heard it. Those of you who by now have devised foot-actuated JT1AA calling-wheels will be able to thumb through this month's *QST* DX diary with a minimum of inconvenience. . . .

20 c.w. was a noncompetitive happy hunting ground for the few DXers who disregarded the JT1AA and CR8AC serenading choruses. Here's how things shape up in alphabetical style, led off by W1DBA: DM2AJG, HA7KLZ (14,060) 23-0 GMT, HK3JC (40) 3, KM6AX (30) 3, LX11DF (30) 0, SPs 2AP 8KBM 9KAO, UAs 1DZ 2KAA 2KAW 3KAF 3MIR, UB5s BW KBV LG, UO2KAR (20) 4, VPs 3AD (60) 2, 6PJ (40) 19, 8AT (15) 2, VU2JG (15) 1, YO6XU, ZC4IC (30) 3, ZE5JA (60) 18, 4X4CF (5) 3, now at 118/85 and closing in on DXCC. W1ETV, EA9EH, HA5s AM BW, IT1AL, LZ1DX, OA7I, OD5AV, PJ2ME, SPs 3PL 6EG, UAs 10E 1UA 8AA, ZBs IDC 2V, 954s AX BW CM, 4X4s IR IB. W7LZY: HA2MF, VPs 2VB 9Y, YV5ABD, YUs, has new Extended Double-Zepp, W7LEO: LZ1K5Z, YV5GY, Leewards. W1MBX: GT1TT, DM2ADL, OK2KBA, YU1MV, heard OB9EJ, likes his Vee beam. W2DGB: GR7DQ (71) 12, DU7SV (80) 10, FF8BF (41) 22, FO8AQ (25) 8, KC4USV (50) 9, KP6AL (35) 5, LX1JW (34) 22, SV1CV (33) 0, UA0s FC (40) 10, KKB (48) 9, UC2AR (30) 3, UPOLE (35) 10, VO2s GR (36) 23, RG (40) 13, VQ4AQ (58) 12, VR3B (33) 10, VU2 K56, three HBs in Liechtenstein. W2GTZ: reached 221, 203 on LA2JE P (20) 1 of Hope Isle, UM8AA (56) 0, K56, added VU2SX (54) 0, W2HMT: EA0AB (16) 19-20, KB6BC (64) 11, KJ6BH (64) 3, KW6CA (40) 11, OY1R (30) 11, UH8BA (07) 21-22, U8KAA (95) 2-3, UL7s DA (48) 2-3, KAA (67) 2, VK9AD (59) 12 of Norfolk

*4822 West Berteau Avenue, Chicago 41, Ill.

Island, ZD2WCP (63) 23-0, ZK1BS (50) 3, plus brand new K86AD, VR6TC, added fresh QSLs from FB8XX, UL7KAA, K2BZT; FP8AS, KP6AB (45) 0, SV0s WE WP both 22-0, UA9C'C (48) 2, U18KAE (90) 22, UJ8AF (45) 0, UN1AE (87) 0, VP8s AI (50) 0, AO (30) 0 who said W/Ks have been blacked out since May, VS9AI (21) 0, YA1AM (25) 22 either n.g. or new licensee, ZC4BN(72) 0, 4X4s IL (32) 0 JH (21) 0, ZD2. *K2ECL*: CR6CK (30) 23-0, EA6AW (40) 22, FY7YF (40) 10, K9GIT, KG6 (40) 11-12, KA6SC (8) 11, OQ5GU (30) 23, VK9VM (15) 11, VP2LU (70) 23, VO4GP (90) 23, DU KC4 OY, warns of false VP2AH activity. *K2GMF*: FS7RT, HK3AE, KG1HL, OE6BN, K2IKS: IT1ZND, LZ1s AH KPC, SP5GX, UB5UA, VP7NB, knocked off for school. *K2QBW*: HH2CL (79) 1 for No. 69. *K2QXG*: OX3DL, stalks CE9AH (75) 8-9, VR2DD (10) 9, ZM6AS (40) 8. *K2RUR*: FP8AP, HA3MA, KV4AA (80) 20-23, OE5BG, Liechtenstein, YU UA2 on 60 watts. *W3IZI*: DJ0AD, more Europeans on 30 watts. *W4GRP*: K86, OH3QC/B, enjoys private DX contest with W4VYP. *W4GSP*: now 70/41 via FA30A, GC2CNC, KG6AAY, HK5CR, SP9EC, T12PZ, YV4AU, FP8 KV4 VP2, readying two-band quad. *W4HKJ*: JA6MW, KC4USB (80) 5, UAs 3KAW 6KVB 6UL, UB5s KAB VU, UQ2AH, ZK2AD. *W4UKA*: first reporter of JT1AA (65) 10. *K4DRO*: #9QV, FG, HA8CG, OE6HV, VP2 a la Leewards. *K4GWO*: H1ADW/MI, YU1AG, Liechtenstein, made it 38/15. *K4HIG*: LA2FP. *K4IEX*: GB3SP at British exhibition. *K6BKK*: CE3DZ (50) 4, HB4FE (80) 6 of Swiss military, JA5AL, VP7NB (90) 3 on 70-watt 807. *K5DZE*: Leewards VP2. *W6KG*: HA8WS (90) 6, OK6TJF (30) 7 at Czech engineering exhibition. *PZ1AM* (65) 5, SPs 5AA (65) 3, 9KAS (80) 2, UA0KCA (20) 5, UB5s 1B KCB, VP9BN (20) 5-6, XZ2s GM (58) 17, TH (30) 17, ZD4CM (25) 6, UN1. *W6RLP*: CE0AC (now reported closed), EL2L (49) 8, F8BRJ, FP8AC (79) 8, HSIWR (72) 14, VO4DS (40) 15, VU2RM (50) 15, XZ2AD (55) 15, ZB21 (72) 9, ZD2DPC (51) 7, 4X4s FA (82) 15, JS (67) 14, XW8, ZK1, Norfolk Isle, now 142/110 awaiting DXCC credentials. *W6UQF*: JAs 1AJQ 4AO 9LM, KA2s KS SH USA all 10-14, W6ID/KG6 9, UA0LC at key of UA0KKB, DU, all on 30 watts and doublet. *W6YF*: notes activity by FL8AC (35), VO6s AB AC. *W6ZEN*: FP8 PX1 for 221. *W6ZZ*: hit 20 hard for GE3s QW RE, FP8CA, JAs 1EH 3ZP 8AA 0AQ 1, KA1TF, OH8QA, UA0s FB GF, UO2AB to reach 172. *K6TCS*: VS6AE, ZC5RF, *K6LEB*: Y03ZA, *K6LZI*: HB1MQ/PL made it 103/74. *K6OFF*: CE2DH, FO8AC (325) 7, ZK2. *K6QHC*: CR7AH, HA8WK, KA4, *K6SHJ*: CE1AD, CX1BO, OQ5PB (40) 14, UA1BS, UA0IG (60) 10, UN1AA (50) 8, that UO16 feller, DU, *W7DJU*: JAs 1AHC 3AAK, K6TFSQ, KG6, UA3KAF, *W7GYR*: JAs 1BIO 3TT, TF3AB, UAs 1BQ 3DA, VS1s HU JF, ZC3AL, ZSs in number, likes new RME-4350. *W7DSZ*: CN8FW, JA8AL, UA0KJA, *W8GKB*: YV5GO, Liechtenstein. *W8TBY*: UA1HC, DU EL KV4 UB5, up to 80/57. *W9MAK*: CE1AD, OA4FM, OK1KCF, DM2, more Euros. *W9NDN*: LZ1KAW (35) 5, UG6AB (35) 4, P.E.I. rarity VE1NQ (44) 1, VP9DDD (6) 11, YU3JC, 4X4BX (34) 4, EL. *W9UBI*: YU1DP, UN1. *W0QGI*: UAs 9CM 0SK, UJ8 for 192 on more 2E26. *W0VBK*: VR2DD (15) 13, VE1PQ: KW6CM (20) 11, UD6KAB (90) 0, VS9AD (20) 21, ZC4CB (70) 21, San Marino, Liechtenstein, Alands, K86 VP2, VS1 ZK2, ZMIG, now 198/170 after bravely scratching three, has QSL from ZD8JP, runs skeds with roving VE0NE, says friend VE1EP has worked 150 countries in '57, still chases FB8ZZ, UO5PK, VK0AB, *VE3DGG*: LZ1KQZ, T12VA, Y08CF on DX-35 and 18-ft-high dipole. *VE80A*: GD3UB, hears HL2AM consistently (see "Whence?"), KG4USN, KW6CA, UA6OM, VP8EO, UL7A, UO17, OX3WE, now 75/39. *KH6CM*: JAs 1AC 7AZ 8AZ, UA0, *KL7BPK*: JA1PS (38) 19, UA0s, VK 7L ZS, *KL7CDF*: BV1US, CRs 6A1 6DA 7AD 7AG, DUs 10V 81V, FB8s BC XX, FK8AK, ZJ0PB, KC6UZ, OD5LX, OQ6VN, UD6KAB, UP6s AB FF KAC, UJ8AG, UR2s AK KAA, VXs 2AB 4FM 4KRL, VR2s DC CV, VSs 1GL IHC 1JX 4JT, ZC4JX, ZE1JK, 3V8AB, 5A5TH and many previously mentioned — wow! *KL7MF*: intrigued by C5CG at 17-18 who "stated he had received license two days before and was first 'C' station relicensed." *HR1JH*: JA5AA, OA4FT, ZB2Z, *OA1K7T*: JABCG, KA1AS, clinched W4JD and nearly WFKAS. *4X4CJ*: mentions Sunday activity by VO9AIIY (310) 16.

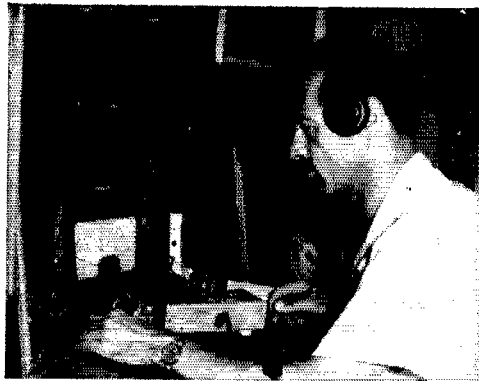

Tel-Aviv's avid 4X4CJ, breaking in a smooth new 615-5763-5763-829B bandswitching 150-watter and multi-band vertical, pursues North Dakota to complete WAS requirements. Zeroes concerned can find Bob on 14,010 kc. almost daily between 0230 and 0330 GMT. Eighty-meter DX is another popular pastime at 4X4CJ.

20 phone received the attention of *W1LEO*: TF2WBG, *K2BZT*: KJ6BU (230) 10, SP5KAB (180) 4, VP5WS (266) 0, VO6ST (160) 4, *W4HKJ*: KP6AL (222) 6, VK9YT (180) 13. *K4IEX*: VP9DC (180) 16. *W6RLP*: KG4AO (236) 8. *W6YF*: notes the availability of ET3PRS, Anjou Island's FB8CD, FL8AB, 15FL, VS4BA, XZ2s GM TH, ZD2DPC, *K6TCS*: BV1US, *K6SHJ*: OA1K (180) 6, *W8DSZ*: KX6AF, ZD4CB, KG4. *W9NDN*: s.s.b. sport with G5US (315) 6, FS7RT (303) 4, KG1HL (287) 3, KV4AA (287) 3, XE1IG (310) 3. *W9UR1*: more s.s.b. with HB90J, KG1. *K0TEL*: CN2AK, HG1LD, HH2s JK R Z, HKs 1DZ 3DB, HP1LB, HHs 1EZ 3HH, KG6AAAY, OA5N, YF2WBU, TI2s AJ JS LDT, VE80F, VP4 4TK 7NP 9HH, TN1MAC, YV5BY, ZK2AB, ZSs in quantity, uses 600 watts to 813 plus 3-el. beam. *KL7CDF*: KC6UZ, KH6BZZ, KJ6, VO4KRL, *HK7LX*: moving up fast with 75-60 and KW6CJ (200), LA7Y (190), OE8JM (190), OH7NV (180), YV9AH, *HP1RB*: recounts September DX round table featuring DL4GLM, G2MF, GW3EHN, KC4USH, KG6NAC, KM6AX, PY2JU, TI2HP, W6s LZE UXY, all single side band. *HR1JH*: HK4DP, SV0FR (155), YS1MS: K4s DRO HIG.

15 c.w. battles OM Twenty to a standoff in its better moods but the competition grows fierce. Those fast 807-and-dipole WACs no longer abound among W.Ks — a beam's the thing. Here's *W1BDI*: GD3UB (68), heard neighbor GD4VH (45). *W1CTW*: YL LUSDEL, UA0GF, WP4AIU, GD, has 133 on 21-Mc. c.w. *W2DGW*: EA8BF (20) 20, KA8RA (80) 0, PJ2ME (70) 22, 3V8AO (40) 21, 4X4DR (45) 21, Leewards VP2. *K2GMF*: SP3PL, *K2IKS*: SP8CK, UO5AA, Y0BMS, *K2TCD*: CN8JW (120) 23, DU7SV (100) 16, FA8JO (60) 21, HA5BW, UA9MI (50) 14, UB5KBV (50) 20, VS1B (80) 18, XW8AG (100) 16, 4X4IV (80) 23, YO, Sint Maarten, *W3LAX*: 9S4CH, hears new French F2s. *W4GRP*: reached 152 on 9FQV/FC (45) 1. *W4GSP*: F2AN, OE8KI, SPs IAP 5GX, UA1DH, UB5UW, 3V8. *W4HKJ*: UB5KQB, VE8NS of Ellesmere Island. *K4DRO*: SP5AR, WP4AHQ, UA1, Alands, *K4LEB*: SP and dozens of Europeans on 28-watter. *K4GWO*: DM2RK, OH5NF, HA 3V8 PJ2. *K4HIG*: OE3FS, SP2BK, UB5, *K4IEX*: WP4AKU (125), *K5DKL*: OA7I, ZS3AG, *W6HPB*: plagued by noises but managed UC2CB, VPs 7NM 9BV/9, *W6ZZ*: XW8 for No. 136 on 15 meters. *K6TCS*: FO8AC, HP1LO, SP *K6LEB*: GP1CJ, FA30A, FO8AK, HA5AP, HC1RY, KG4AI, KW6CA, KX6AF, UB5s FO UW, VK9XK, VR2DD, one ZD9AU, ZD9JII,



HZ1AB has been an Arabian ornament in our DX scene for more than a decade — current operator Carl appears here. The station's new Dhahran installation contrasts with the semiportable layout last pictured in December 1955 QST. At present you'll find HZ1AB's a.m. and s.s.b. signals regularly audible in the vicinity of 21,425 kc. (Photo via W0QGI)

QST for

EAS GD UC2 VP2, now 98/57. **K6QHC: EA9BF, SP6KBE**, UAs 2AW/MM 1GQ, UB5AO, UJ8AF, UQ2AS, 954CM, FC EA8 HA UC2 8V8 for 79/38. **K6SXA: CE2CC**, KH8CV/KW6. **KP6AL, OA4EY, OK1MB, W03WL**, DU SP. **K6TXA**: HAs 1KSA 5DU, JA7AD, UB5AQ, VSIHU, YU3EU, ZC5RF, EA8 OA UC2, made it 84/31. **W7BGU: OE5GD, W7GYE**: Europeans galore. **W8CSK**: approached the half-century with **HA8WS, OA4V, OE5 6LW, 8KI, OZ4F** of exclusive Bornholm Island, **VE8MX, VA3WJ, HA PJ2 SP UG5, W8DSZ: CR7s BN 1U, FA9VJ, HO2TY, GC2CNC, LZIU, SP9DO, SV9WS, UA9CR, UQ2AS, YO3s PD VU** for 109 worked, heard **VO6ST, VRIA (40), ZC4NS (80)**. **W7TBX: LA8ZC, W9MAK, VP2VB** of the Leewards, **W9NDN**: aforesaid VP2, **OH3RU, K9DDC, CN2AQ, OE5KG, SP1KAA, VE8FG, VP5BL, XE1PJ, ZD6RM, EA8, Sint Maarten**, has 46 countries with DX-20 and long-wire. **K9HCP: WH6CKK, WL7CEB (105)**. **W0QGI: IS1CXF** for No. 193. **KL7BPK: JA6PA**, tough-path LU9DL, **ON4KT**: Leewards, Dutch St. Martin, heard one 4W2RP of "Royal Palace, Taiz, Yemen." **TX4CJ**: spotted **ZC5AL (40)** almost daily around 1500 GMT, Friend Bob of Ft. Worth neglected to include his call with his report but scored well on **FF8BZ, UA4IF, CN2 FC FO8 FFS** and **ZD6** targets.

15 phone fans fare well in the fall propagational fling. The tonnage take at **K2RUR: HC6GT, TF2WCC, TG7CD, VPs 1MM 62X, YN4CB, ZP5KQ, K2TCD: CNs 2AK (230) 16, 8FY (220) 23, G3DGMH (230) 21, HI7LS (180) 23, SP6CK (220) 19, TG9JM (220) 2, VP1EE (230) 2, XE1AX (200) 5, YN1AT (230) 16, 4X4s BL (230) 20, FK (250) 16** on new Valiant and heightened 2-el. spinner. **W3DDV: FS7RT, KG6AG, PJ2ME, UA4IF, VR2BC, 3V8AO** for 110/104. **W4GRP: VE3AHU/SU (210) 23, W4HKJ: LX1DC, OQ5EU, W4ZMC**: finds s.s.b. just the thing for **CE2HV, CN8MM, EL4A, KA2MA, KC4s USA, USK, TG9AD, VP2AZ, YU1AD, ZB1CZ, ZEGJB, ZS6KD, F87**, many more Euros, uses 10-B driving four grounded-grid 837s plus 3-element homespun rotary. **K4DRO**: Leewards, **K4HIG: XE2WA, EA, K4IEY: KL7s AIR FAR, K5DZE: CT1BT, EL2D, HR1EZ, KA8RA, OA4s BP EE, EW, TI2PD, VP7NV, YN1MF, YS1MS, YV5BX** via DX-35. **W6ZZ: KA2AL, TI2BX, VK3AHF, ZLs 1BE 2ADG 2AOH 2AX 2BX 3BK 3CD, K86, K61CS: KB6BE, TF2WBZ, YN1BS, 5A2TZ, CN8 KC4 K86, W7BGU**: gave Nevada to **W0MGG/KL7, W8DSZ**: fine haul in **CN8GS, CR4AD, ET3XY, FM7WQ, GB3SP, KG1HL, PJ2MC, TI2PP, VPs 4LR 6LT, ZB1BQ, ZL3BL, 4X4BO, 5As 2TY 3TM, F87 HI KC4 TF VP2** on DX-100, SX-96 and 4-band cube quad. **W9WHM: FE8AK (245), LZ1KPZ (220), UB5s FG (220), WF (240), UO5AA (300), VO6ST (120)**, Alands, Egypt. **KL7CDF: JZ0PB, VS4JT, ON4KT**: heard **ZD1EO's** 30-watter, **SWL W. Steuart: OY4T (265) 21, ZD4BR (230) 22** heard. **R. Rumer**: logged **KG1JA (W3JAK)** who was favoring W/K solicitations.

15 Novice negotiations are brisk. Representatively we find at **KN2UTC**: out-of-the-ordinary Swede **SL7BC**, 53 countries worked on Adventurer and Windom, accumulated WAC and WAS evidence. **KN4MGP: FA8CR, HH2JR, IT1AL, KL7BPK, LA8LF, OE1NV, VE8TD, VS1HU, WP4s AIT AJS**, numerous additional Europeans via Knightkit 50-watter, S-40A, long-wire, awaiting his General ducat. **KN4OAG: DM2AMN, F2AN** (just France), **GM3FFQ, G13JFX, LA4LE, OK1KDC, SP1KAA, TI2EA, VO2AG, TI2EA**, oodles of Gs, DJ/DLs, employs Globe Chief, SX-96A, 3-el. twirler. **KN6IQ: WH6CKK** for No. 3. **KN6KBH/s: CE3DH, LU7DEJ, OA4BP, SM7EH, VK3s AHL AXX TX VJ, WP4s AIL AKI, WH6CCL, ZLs 1APM 1LZ 3DT 4BO 4MK**, likes new Hy-Gain 3-el. beam. **KN6KIZ: WP4AKU, XE1BI**, installs a 2-element rotary. **KN6KPE: KL7FZ, ZLs 1LR 2GS** on DX-35. **KN9HCP: KH6AHQ, KL7CDW, PA8SA**, is now **K9HCP, KN0JJP: KH6AHQ, WP4, KN0LXR**: bagged a ZL1 on second day of Novicehood. . . . **KNs 4011 4PYW 9IWY** and **0JPN** made the grade with **ON4KT**. Also logged in Belgium: **KN1s ALV BDU BHB, KN2s VUA YVJ ZCF ZGM ZHY ZMQ, WN2TKZ, KN3s AHK ARV, KN4s OEF 4 OGT OKA PHY QHG QIE RID, KN5s HUG KFR, KN6ZJV, WN7HYK, KN8s CVQ EAG EEW RHD GAZ GHG HFO, KN9s GAY GBI HSS HTK IAX IGS JDK, KN0s IIS IVP JFN, WL7CEB, WP4s AHQ and AKJ**.

40 c.w. conditions build up to a breathtaking bravura only to collapse repeatedly under Old Sol's speckled spells. Gleaned by **W2JBL: CT1NT (4)**, the fighting 4-watter of **G3BQR, OE6KZ**, heard **ZS5BL, K2GMF: OK1AJE, K2PPT**: left off 7-Mc. rag-chewing for a few evenings and surprised himself with **FP8AY, SP3CU, Y06KEA (15) 2, YU8RM (33) 23**, more Europeans, uses DX-100 and ancient HRO. **W3LAX: EI9V, GM3s ITN K5J, TI2VA (35) 1, VP9MM (40) 0, XE1UO, WH6CEA (164) 10**, sundry P77s on 80 watts and S-53A. **W6UQF: KR6AK 12, UA0UJ 9, XE8RD** on 30 watts and long-wire. **K6DV: JA8AE, VSIHU (10) 14, K6ERT: DU7SV, JAs 1AEA 1EF 8AR, KM6AX, KR6 UA0**, uses 90 watts and ground-plane. **K6QHC: JAs IASO 1DY 1MQ 4HM,**

ZS6CH, DU VKs, K8RGO: JA1s MQ QN, UA0, K6SRZ: JAs 1AAx 3CK, WH6CCL, XE2FB, DU VK ZL on 65: watts. **W7DJU, VK8XK, other VKs: ZLZL, W91YJ: KG1JA, OK1MB, SPs 3AB 61R, TI2VA, YU3DDE, Pys** in quantity. **K9DHH**: several KH0s. **KH6CMM**: many JAs, W/Ks.

10 phone, hitting its full fall stride as this goes to press, shows promise in preliminary reports. **K2BZT: UA1KBB (58) 18, YO2BN (58) 17, ZD6RM 19, ZS3W (820) 16, 5As 1TN 14, 3TH 15, K2CMN: CXs 1AK 1KB 8BM 8CD, HKs 4DF 7LX, HPIAB, K6IWG/HG6, YN1MAC, YV5ABH, ZP5MC, ZS1W, LU5 PUs, swears by 32V-3 and Telrex. **W3LNE: HK1IDZ, PJ2AP, YNs 1LR 4AT, ZL2BL, LUs** in number. **W6ZZ: KW6CM, VK3AHO, ZL3BL, W8DSZ: CR7DS, KA7LB, KB6BC, PJ2AO, VQ4DT, ZP5IB ZS3VC, chases ZD6JS (350), W7TBX: ZS4PB**, advises. "ZS6ANN says too many State-siders crowd into the lower 60 kc. of the U. S. phone band," to which Jeeves might add that too many DX stations commence their tuning from 28,500 kc. upward. **W9NDN: CT1HE, CX3ZBH, XE1H, LU0DAB/MM.****

160 c.w. is back in these rubrics to stay awhile if **WAs 1BB 1LYV 1PPN 3RGQ and 8ANO** have anything to say about it. Those 1.8-Mc. veterans worked **FP8AS (W2EQS)** on 160 in September—**W1s BB and LYV** even switched to phone with success. **FP8AS** sported 50-watts and a grounded quarter-wave radiator. . . . **W3RGQ** advises DX stations to use the 1825-1835-kc. slot for U. S. East Coast contacts. Shely now has 29 countries on the band. . . . **OA5G**, who already has clicked with **W1BB**, will keep his p.p.-250/7Hs kilowatt primed for the 1.8-Mc. hunt this season. **VR3A**, newly returned to Fanning Island, also plans an extensive 160-meter offensive in the 1957-'58 season and this should allow the West Coast gang to crash the act in the "firsts" department. Keep an ear on the 1.8-Mc. range during week-end wee hours from now on!



TF3KG is a Reykjavik regular verging on DXCC membership with a 108/96 record. **Kristinn** runs eighty watts to 807s on 7 through 28 Mc., receives with a Super Pro and AR77-E, and his favorite antenna is a 200-foot-per-leg **Ve0** 40 feet high. Accelerated action during this year's **ARRL DX Test** clinched a hard-earned **WAs** for **TF3KG**.

Where:

Asia—"A 100-per-cent QSL policy will be followed for **JT1AA**. I will store them for him and, in regular skeds, will give him current lists of all cards received. Then **JT1AA**, after checking his log, will send his return cards direct or via bureau from **M.P.R.**" This from **OK1JX**; more **JT1AA** details in "Whence". . . . **NNRC** learns that **F9IL** holds **WS8AG's** loggers for the period June 18 to July 1, 1957, and offers QSL assistance for pertinent QSOs. . . . From **W0UWL, ex-KA5ZS**: "As a **KA5 I** mailed out 1500 QSLs and received some 600 in return, about 40 per cent. And I'm still receiving cards, especially from some of the distant and more isolated areas, and from those stations who must depend entirely on the bureaus, so the percentage will rise. . . . I still have **KA5ZS** QSLs for those contacts deserving." **Zane** touches on the crucial time factor in current QSL habits. In pre-WW-II lazy days a **DXer** was satisfied to see a rare QSL show up in two or three years. Nowadays if he hasn't received his QSL within two or three months he begins to panic.

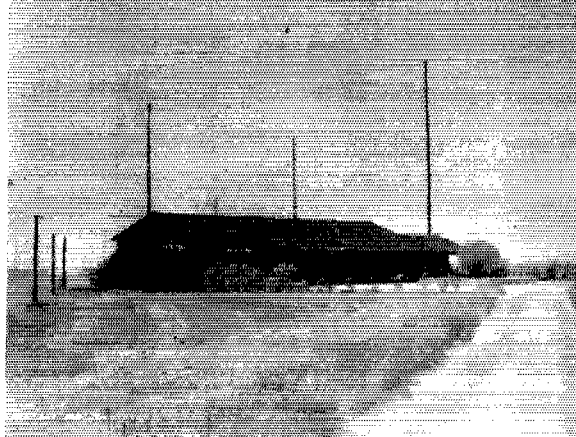
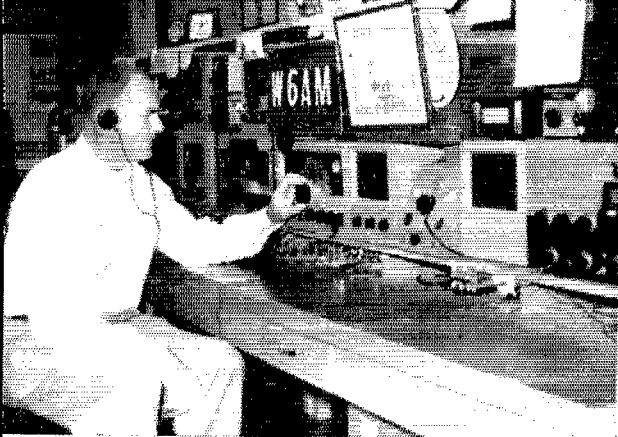

W6AM, stanch contender for top spot in ARRL DXCC Awards monthly listings, rocks the pile-ups from this Rolling Hills environment. Don's shack roosts atop a cape 1200 feet over the Pacific some twenty miles southwest at Los Angeles and ten miles from his Long Beach home. Out of view, six finials at the kilowatt level provide ample flexibility for the contest wars. A few of W6AM's three dozen 70'-to 100-foot antenna poles, a cross-hatched forest which supports 45 miles of wire in twelve reversible rhombic arrays, are visible at right. The unquenchable Wallace enthusiasm for amateur radio, now mainly concentrated in the DX field, is further reflected in other ARRL-activity performances and QST contributions down through the years. (Photos via W8HGW)

Africa — From Comoros customer FB8CD: "I have requested ZS6ANE in Johannesburg to be my manager for receiving and sending QSL cards." Bryan will be a busy one. . . . Ex-FT3AO is back in Germany awaiting a DJ-DL call. "Some of my QSOs are unfortunately not yet confirmed due to lack of QSL cards, but the OMs who are QRX for their ET3AO QSLs will get them, be sure of that! Many illegal stations are using the ET3 prefix now." . . . "FF8AC will QSL 100 per cent but only via bureau because so many U. S. stations are worked. For those who would like direct airmail it is necessary to send me two IRCs; my return will be made upon receipt." Yvon's wife, an ever philatelist, assists with FF8AC QSL duties. . . . CRAH is another stamp fan, says NCDXC's DXer, so keep your commemoratives handy. . . . From ZD1FG via W1VG: "I QSL 100 per cent upon receipt of cards but the fellows must exercise a little patience. . . . IRCs are most welcome with QSLs and I think this goes for all ZD1 amateurs. ZD1EO just purchased twenty dollars worth of stamps and he's out of them already." . . . ZD4CM submits evidence that South African authorities went and did it — licensed a legitimate ZD9AF. SARL says the real one is Dave Watt on Tristan da Cunha. The next mailbox to ZD9 is scheduled for January.

Oceania — W2HWA relays word from VK3KB: "VK0AS QSLs can be sent via bureau or to VK3KB direct. They will be acknowledged on Sandy's return from Mawson Base in March, 1958." . . . FK8AS has worked over a thousand Yanks and is hard put to keep up with his QSLing. W3SOH shipped him some stock and rubber stamp gimmicks which should help him write off the debit.

Europe — From SV0WP (W3JTC): "I've been working on the Signal Officer here to change the issuing of calls. Believe this will be done, and soon SV0WAA, SV0WAB, etc., will be issued." Good — now if only we can get KG1, DL1, VPS, and other licensing authorities to see the light. Larry also points out that he and a few other SV0s have had their APO number switched from 206 to 223. . . . HB1 stations with FL appendages are not operating portable in French Somaliland, fellows. It's a devastatingly ambiguous designator for Swiss visitors to Liechtenstein. . . . W6AWT assists with QSL chores resulting from August 11ADW-M1 activity. . . . After diligent search W2QHH has given up attempts to pin down former SV0WN operator Alac, W1TYW. Howy had offered to handle QSL matters for the fellow but never received logs for the purpose.

Hereabouts — EDR (Denmark) knows naught of the present whereabouts of OX3s AW BD BQ BT CC FD GG IE LX OX4s AB GB and OX5OK and is unable to deliver QSLs on hand. ARRL Assistant Secretary WTUED points out that some of these calls were signed as far back as 1951. He'd appreciate hearing from the operators concerned. . . . HC8GI assures W7DJU and other unfortunates that he has never been on c.w., darn it. . . . W1BDI emphasizes that the listed Call Book address is okay for Antarctica-KC4 QSLs. . . . "Formerly HR2RF, I am recently licensed as H1RB. I find that QSL cards are not arriving, so some of the boys are missing their two-way s.s.b. confirmations." Reach Dick at the address to follow. . . . W9CPT regretfully signs off as ARRL W9 K9 QSL Manager after years at a job well done — vocational pressures too severe. W9DSO rolls up his sleeves to take

over. . . . Each of the following data is necessarily neither accurate nor "official" and is offered in the hope that somebody's QSL problems may be solved or expedited thereby. If you should encounter previously unpublished addresses of active or imminently active DX stations send 'em along, just as did W1s UED WPO, W2s DGW HML, K2s BZT DCA ECL RYK TCD, W3s LNE SOH TZN, W4s HKJ UKA, K4s GWO IEX, W6s KG RLP, W8IBX, W9s CFT NDN RAR, W0VBK, K17CDF, ON4KT, ZD4CM, ZS1MU, Wm. Stewart, International Short Wave League, Japan DX Radio Club, Newark News Radio Club, Northern California DX Club, Ohio Valley Amateur Radio Association, Southern California DX Club, West Gulf DX Club and Willamette Valley DX Club in the instances of the following:

- CE3TH, Rev. A. Hanehak, Box 1479, Santiago, Chile
- CN8HN (via W6AWB)
- CR7s DQ LU, Box 875, Beira, Mozambique
- CX3ZBH (to CX3BH)
- DL4AAP (to W6GHH)
- ex-DL4SK, I. B. White, W4BGP, Rm. 31, Sultan Hall 80A, Ft. Belvoir, Va.
- EL2P, S. Watkins, Liberian Radio Soc., Monrovia, Liberia
- ex-ET3AO, T. Frendeborz, Wolfsburgstrasse 6, Ithringen-hausen bei Kassel, Germany
- FB8GD (via ZS6ANE)
- F8BAK, J. S. Chapman, ex-ZD4BZ, Box 202, Yaounde, French Cameroons
- FF8CA, P. O. Box 971, Dakar, French West Africa
- FP8AR (to W2HTI)
- FP8AS (to W2EQS)
- FP8AX (to VO1BF)
- FP8AY (to VO1BF)
- HA5BW, F. Tevesz, Szabadka 4.19, Budapest 19, Hungary
- HA8WS, T. Hidvegi, St. Istvan UT 2 NR, Mezobereny, Hungary
- HH2DB, c/o U. S. Embassy, Port-au-Prince, Haiti
- HK3KG, A. G. Herreros, P. O. Box 3009, Bogota, Colombia
- HK7AB (to HK3AB)
- HL2AM (banned, at writing — mail via K0CSW)
- HP1AB, H. Arengo, P. O. Box 846, Panama City, R. P.
- HP1RB, R. Bennett, ex-HR2RF, P. O. Box 1773, Panama City, R. P.
- HR1JH, M/Sgt. J. Hathaway, USAF Mission to Honduras, c/o U. S. Embassy, Tegucigalpa, D. C., Honduras
- ex-HR2RF (to HP1RB)
- JT1AA, c/o Jan Sima, OK1JX, CRC, Box 69, Praha I, Czechoslovakia
- KA3JL (via W5JTS)
- ex-KA5ZS, Capt. Zane Sprague, W6UWL, 831 Joyce Dr. Port Hueneme, Calif.
- KA6SC, Stan Chase, APO 815, San Francisco, Calif.
- KH6BZZ/KJ6, APO 105, San Francisco, Calif.
- KV4BZ, D. F. Henry, Box 748, St. Thomas, V. I.
- LU2DJO (via LU2DAS)
- LZ1AH, Box 520, Sofia, Bulgaria
- ex-MP4BBF, N. Wilkinson, c/o Caltex Refining, Visakhapatnam, Andhra, India
- OA4GW, P. O. Box 3190, Lima, Peru
- OO5BM, A. Bogaerts, Box 170, Luluabourg, Belgian Congo
- OO5HP, P. Heurekaerts, Box 910, Stanleyville, Belgian Congo
- OY4T (via EDR)

ex-PA0ULA, J. A. Bloemen, 52 High St., Brookline 46, Mass.
 PY1GJ, R. de Souza, Box 4022, Rio de Janeiro, Brazil
 PY1NG, L. M. Frietas, rua Gov. Portela, 157, Barra do Pirai, Rio de Janeiro, Brazil
 PY4AK, P. O. Box 11, Rio Grande, Minas Gerais, Brazil
 PY4FQ, R. Thielmann, rue Dr. Joao Pinheiro, 163, Juiz de Fora, Minas Gerais, Brazil
 PZ1AM, A. Meubelman, Box 12, Paramaribo, Surinam
 PZ1AO, L. Henning, P. O. Box 494, Paramaribo, Surinam
 SV1CV, Box 89, Athens, Greece
 SV0WN, APO 291, New York, N. Y.
 SV0WP, L. Eisler (W3JTC), USASG, APO 223, New York, N. Y.
 SV0WR, H. Olson, USASG, APO 223, New York, N. Y.
 TI2IO, E. V. Hernandez, rua 4155, San Jose, C. R.
 TI2VA, Box 411, San Juan, C. R.
 T17DB (via RCCR)
 UB5KIA, Polytechnical School of Communications, Kiev, Ukrainian S.S.R.
 VK9NM, c/o RTC, Lae, T. N. G.
 VK9NT, WIA VK9 Division, Box 201 Port Moresby, P. T.
 VK0AS (via VK3KB)
 VK0CJ (via VK38L)
 VP1GLG, P. O. Box 19, Stann Creek, British Honduras
 VP2AZ, P. O. Box 10, Antigua, B. W. I.
 VP4LD, F. Thomas, c/o Govt. Wireless Stn., Piarco, Trinidad
 VP4MM, J. M. MacDonald, 13 Gordon St., Curepe, Trinidad
 ex-VP8CL, A. M. Carroll, c/o 16 Gosling Close, Northolt, Greenford, Middlesex, England
 VR2DD (via VR2AS)
 VS1JF, RAF, Changi, Singapore
 VS6DR, B. C. Fisk, Radio Stn., Chatham Rd., Kowloon, Hong Kong
 WG6AHH, J. P. Babas, Stn. 8, Agaña, Guam, M. I.
 WP4AKU, Box 235, Guaynabo, P. R.
 YK1AT, Box 2249, Damascus, Syria
 Y0SKAD, Radio Club Central, P. O. Box 12, Baia-Mare, Roumania
 YV4AU, D. S. Baldi, Box 4573, Maracay, Venezuela
 YV5HS, P. R. Leon (via RCV)
 YV9AH, D. Pardo, Apartado 2285, Caracas, Venezuela
 ZB1CP, A. A. Milham, Flat 16, 2 St. Mary St., Tizne, Sliema, Malta
 ZB1CR, C. K. Burchall, Officers Mess, RAF Luqa, Malta, B. F. P. O. 51
 ZB1DC, J. Tyrrell, R.N.W.T. Stn., Dingli, Malta
 ZC4CN, A. B. Woolford, RAF Akrotiri, Cyprus
 ex-ZD4BZ (to F8EAK)
 ZD9AF, D. Watt, Tristan da Cunha, via GPO, Cape Town, South Africa (or via SARL)
 ZM6AS, Civil Aeronautics, Western Samoa
 5A1FB (via REF)
 5A5TM, J. O. Merritt, Box 638, Tripoli, Libya

Whence:

Asia — JT1AA almost fractured the grapevine when he spectacularly put the Mongolian People's Republic on ham bands for the first time September 3rd. Op Ludvik, a former OK1KAA staffer, was heretofore a v.h.f. and 80-meter man so he's learning DX ropes the hard way. OK1S CX III JX and MB prepared the way for this one, and OK1JX warns: "Blacklisting of all stations calling on JT1AA's frequency and breaking into unfinished QSOs, etc., will be strictly followed. Heeding Ludvik's instructions of calling procedure is a must." The call JT1AA was selected for this operation primarily because it goes so well with Ludvik's electronic-bug list. . . . OK1JX also points out that YK1AT is another Czech DX fan who expects to remain in Syria for the next year or so. . . . K6CSW keeps a BC-610 warm in Korea as HL2AM, operating c.w. and phone on 7065 and 14,130 kc. with official permission. Paradoxically Korea still is on the ITU-FCC Ban List, so we can't touch him with a ten-meter dipole. It will be recalled that similar HS1 incongruities occurred just before Thailand removed itself from banned status, so perhaps the proper wheels are about to whir. HL2AM's ticket is good until July of '58. . . . W3TZN passes along the current BVIUS schedule which excludes 40-meter work. The South Taiwan gang uses the

call on Tuesdays, Thursdays and even-date Saturdays and Sundays; North Taiwan garrison takes over on Mondays, Wednesdays, Fridays and odd-date Saturdays and Sundays. The boys are most active on 14,163-ke. phone. . . . "JA1JH of Tokyo enjoyed a summer vacation at Karuzawa. On return home he fired up his *Ianuki* (transmitter) but no loadie. After much shouting of trouble, Hide made sad discovery: Antenna stolen." This No drama courtesy K6DV. . . . UP2AS and RAEM intend Tannu Tuva work as UA0s KOJ and ON sometime this fall, says W6YU. . . . W3SOH learns that Ed Foley of defunct TA3US still hopes to return to the air. New Turkey regulations closed the station in March. . . . MP4BBE runs 50 watts to 807s on 7 through 28 Mc. using dipole antennas and receiving with an SX-28. He tells W3SOH of an insufferable noise level which occasionally keeps him QRT. Other active Bahreiners: MP4Bs BC BL and BW. Kuwait MP4Ks available: AA AM and DS. . . . "KA5ZS is now secured. Had a very fine time during my year in Japan and was glad to give so many boys a new country. Krist of KA5MC also has returned Stateside (to W6KTE) as a club enterprise." This from good-to-be-home W6UWL. . . . NNRC sleuths mention possible VU2AX activity as AC1AX.

Africa — FF8AC, in lines conveniently translated by W1UED, pleads for a South Dakota contact to finish his WAS. Yvon claims he's the only French Guinea station now available — DUF-certification seekers take note. FF8AC haunts 11,080 kc. almost daily between 0500 and 0730 GMT. . . . Via W1VG: ZD1FG's hamming energies have been diverted while setting up school station ZD1PW. "The rig and receiver were mine but I gave them to the school so that the boys may have experience operating the equipment and receive the benefit of overseas contact with the ham fraternity." Art and family will pass through the States next month en route New Zealand for annual leave. . . . "Active ET3s include AF LF and S," informs ex-ET3AO, newly returned to Europe. "ET3s Q and R are club stations rarely used." . . . K2TCD and HI7LS report ex-HI7GB on duty at Ascension Island and expecting to dent 20 with a ZD8 tag around this time. . . . Ghanaite gleanings via W1BD1: ZD4CM will be remembered by the old DX school as prewar G2DT and G5BH1. Mike has been in Africa for eight years and now is principal of St. Francis College's teacher training corps at Hohoe, about 140 miles northeast of Accra in what formerly was called British Togoland. "My wife is anxious for me to earn awards but I personally prefer to chat at length when a channel is clear. Have sixty-five countries now and am up on the way to WAS." . . . Ghana will shed the ZD4 prefix in favor of something like 2G1, according to W6YY's advice. . . . With improving conditions W3SOH expects ZD9AF to become more workable around 2100-2200 GMT. Don's phone is a favorite target for 20-meter W6/K6s. . . . WGDXC understands that VQ4EO, F8RQ and other adventurers plan a 10,000-mile two-month auto safari through a dozen African localities. A 150-watt s.s.b. rig will go along. . . . NNRC reports W7GFM visiting in Uganda with gear in tow.

Oceania — Via W6YY's DX news center: VR3A (VK2ANB-VK3AFB) married and returned to Fanning, intending all-band phone and c.w. operation with a more potent punch now that a rotary-converter outfit emancipates him from battery QRP. VR3A's dad, VK3AOM, has a fresh 100-watt job rolling on 7 and 14 Mc. these days. . . . KH6CMM (ex-W4DNU-KA5CL) switched DXpeditionary objectives from Palmyra to Johnston Island and trusts to be dispensing KH6CMM, KJ6 QSOs ore long and popular on. . . . Via W3SOH: VK7KM, VK9, quite popular on 20 c.w., keeps his junkbox-derived rig in a footlocker. He's QRL installing a cosmic ray observatory at Lae as part of Australia's IGY effort, so must take his hamming in relatively small doses. VK7KM, VK9 runs 20 watts to an 807, receives with a BC-348, and does his radiating with a three-wavelength wire. . . . WGDXC reports that W6UOU scored over 1400 QSOs during his August American Samoa DXtravaganza.

Europe — The second annual RSGB 21- and 28-Mc. Phone DX Test beckons this month, scheduled to run from 0700 GMT on the 23rd to 1900, the 24th. Non-Britishers are invited to work as many United Kingdom stations as possible during this affair and the exchange will be the

OA5G made 160-meter history in August and September by thrice working W1BB, reviving a 1.8-Mc. interest first developed before the war as W9FCJ. W1BB reports that TF2WCC heard both ends of the August 18th OA5G-W1BB contact, a fact auguring well for a lively 1957-58 DX season on 160. Other views of OA5G and his Peruvian surroundings appear in your November 1955 QST.

November 1957

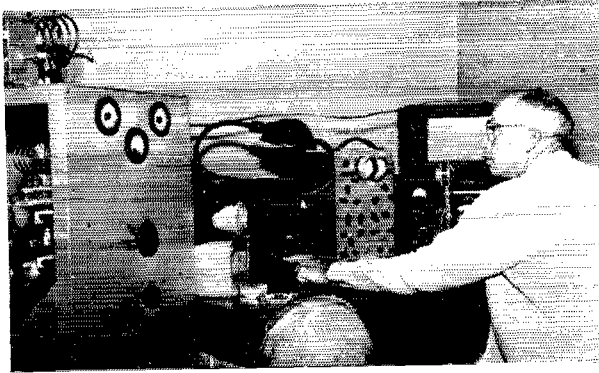

normal RS001, RS002, etc., series. Each station can be worked once per band at 5 points a contact; 50-point bonus credit goes with each different "country-numerical prefix" worked. A hatful of G-stations to you—file your results with RSGB. . . . Luxembourg lament from ON4CC: "After weeks of preparation and hard labor I was informed by the LX PTT (your FCC) that a temporary license could not be granted for my DXpedition. In the future aliens must reside or have a permanent address in Luxembourg and, furthermore, a reciprocal agreement must exist between countries concerned." . . . K2GFQ understands that Russian quarters soon will be the source of a W150C (Worked 150 Countries) certification to be available world wide. One cute condition: All QSLs submitted must bear authentic QSL bureau surcharges—no direct-route confirmations allowed. It's still in the planning stage, anyway.

Through K2RYK, OK2WL reminds us of a Czechoslovakian DX Contest slated to run from 0000 to 1200 GMT on December 8th. For this shortie the regular RST001, RST002, etc., exchange will suffice. You might also check Czech society CAV for information on their OK-100 certification. . . . OK1CG is gunning for WACC but is annoyed by the fact that 90 per cent of all W6/K6s hail from Los Angeles, San Francisco or San Diego counties. He'd like to swap mail with Yank hams of Czech descent. . . . TF3KG notifies that Icelanders now have a spot frequency at 35,020 kc. but so far not many TFs have gotten around to giving it a go. . . . W1BDI learns that the subtle LA2JE/P 20-watter likes 14,030 kc. on Fridays around 1700 GMT. . . . W2HMJ and others have it that W2IOP prevailed upon Vatican authorities to permit a DXpeditionary visit immediately if not sooner. . . . W1WBM returned from Continental wanderings much impressed by ham hospitality "over there." Stops at RSGB and ON4IZ were especially pleasant. ON4IZ, incidentally, knocks off nice DX with a sporting five watts. . . . W6GHH (DL4AAP) talked of Crete and/or Rhodes DXpeditionary possibilities with Ws 1ARR and 4HKJ. . . . W9RAR advises that DJ1WQ will sample DX life as a YN before long.



XZ2TH bolsters the Burma DX front with phone and code activity from Rangoon. Tun appears to specialize in U. S. Sixes and is most available Thursdays and Saturdays around 1200 GMT on 14,050-kc. c.w. (Photo via W6YY)

Hereabouts — The picturesque islands of St. Pierre and Miquelon retain their summertime DXcurseionary appeal. An August onslaught by VO1BD as FP8AY was followed by the sprightly September sortie of W2s EQS and HTI as FP8s AS and AR. . . . HC8GI tells W7DJU to keep an ear out for HC8GI/MM on 15 and 20 meters aboard Bud's seagoing *Symbol*. . . . HP1RB, ex-HR2RF, seeks old buddies on phone around 14,310 and 21,430 kc., s.s.b. preferred, at 1 p.m., 6 p.m. and midnight EST. . . . W9PNE's 12-year-old chip-off-the-block, K9DCF, writes: "Dad and I can operate at the same time so long as we're on different bands. We sit back to back in our small shack." A regular DX factory. . . . W1PNR climbed to 121 confirmed while business-tripping and vacationing in SM, HB, I, LA and UA areas. Now Mack is back on the bands to prime that QSL pump some more. . . . K2BZT observations: T12BX returns to Washington, D. C., after a half dozen years down south. . . . PJ2ME's new re-

ceiver was clobbered in transit. . . . W0VZB volunteers North Dakota QSOs on 20 c.w. around 2300 GMT. . . . HR1JH, lately W9LMC and K8CTI, says: "This is the DX life—pile-ups every time I go on 10, 15 and 20 phone!" . . . W3DDV will sign W3DDV/1 while deer-hunting near Grafton, Vt., from November 9th through 24th. Bill will man a Ranger and RME-4350 on 15, 40 and 160 meters, phone and c.w. . . . W1EYP continues a QRP DX career in Lynn, Mass., using 30 watts of c.w. and 25 watts on phone for a 130/125 tally. A bent center-fed 66-foot wire does Paul's radiating with surprising efficiency. . . . W4UMO/5 contributed phone QSO No. 1 to KC4USK. . . . K6RGO offers Lake County to WACC aspirants on 14,100 kc. at the conclusion of W1AW's late bulletin run. . . . From ex-DL4SK, now W4BGP: "Back in the States now and my mobile rig is operating like a charm. No fixed station yet but mobile WAS, WAC, etc., present a challenge." Which reminds us—what became of the mobile DX fever so rampant a few years back? With improved 28- and 21-Mc. prop conditions we should be hearing from some of you DXers-on-wheels. Or has everybody gone back to the attic? . . . Regarding Novice operating procedures, ON4KT writes: "This 'BK TO YOU' business is sending me gray before my time. Every time I QSO a Novice who suddenly comes up with 'BK . . . I jump for the send-recvie switch, wondering why on earth he wants to work break-in at 8 w.p.m., and then he goes on with ' . . . TO YOU.' It's *unnering!*" Hi-hi! . . . VES0J valiantly fights to pierce frequent N.W.T. ionospheric blackouts for a crack at Maine and Wyoming, holdouts on his WAS check-off sheet. . . . W2HMJ wants EP2BU of yore to give him a sign, while K6DEX is perplexed by lack of QSL response on the parts of HZ1AB and LU3ZS.

Ten Years Ago in "How's DX?" — The November, 1947, opening paragraphs discuss curses and blessings of that hardy chestnut, the use of "CQ DX". . . . The firing line finds the 14-Mc. c.w. gang aiming r.f. at AR1YL, Cs 1DK 7US, EPs 1AL 2DS 3D, EQ2L, ET1s IR JJ, FT4s AE AN, HS1SS, HZ2FL, 16s USA ZJ, Js 2ACW 2EAR 2IMR 2ICQ 3AAD 3GW 4AAO 5AAJ 8AAA 8ACS 9CIP 9SIR, K6SCJ/KP6, KA1ABT, LI2JC, MD1E, PKs 3CK 3JF 3PL 6HA 6TE, RAEM, TA8 1AD 3SO, UH8s AA AF, UI8s AA AB, VR5IP, VS7RL, VU7s AB JU, roving Ws 2WMV/C9 6NQG/KM6 6VTO 'C1 6WSC' KW6 9TKK/VK9, YO5J and ZC6AA. . . . Twenty-phone specialists specialize in HZ1AB, Sardinia's 11AHL, Js 2AAO 2A1A 2CAL 2EVT 2VFW 3WGT 5AAD 8AAB 9ABE 9CRP, KH6KH/KB6, LX1JW, VR3A, W6s WCN/Saipan YOT/C6 and XAMC/Trieste. . . . Eighty- and ten-meter reports are absent in large numbers but 7-Mc. faithfuls mention skirmishes with HK5CR, HR1JB, OX3BG, UA3KAE and ZD3B. . . . Preliminary announcement appears concerning next month's New Zealand DX Test. . . . "How's" conductor W1CH regretfully finds it necessary to terminate his monthly contributions with this issue of *QST*. Joe's successor is unspecified.

All W2/K2 hams are asked to note change of QSL bureau address listed on page 192, this issue.

Strays

"A golfer who can't break a hundred has no business playing golf. A golfer who breaks 70 has no business." I'm sure there is an awful similarity in working 200 countries! — W4UKA

W1HUR called "CQ California" and was answered by W6HUR.

The MARS Technical Net (1400 Sundays, 3295-7540-15,715 kc.) will feature nuclear science during November.

The Navy reports that an additional ham station — KC4USC — should be on the air by the time this appears in print. KC4USC will be operated by the Navy CB Recon unit. The exact location is not known at this time.

WN9HXT and W9AOI shared a locker at school; the serial number on the lock was 7388!

YL News and Views

BY ELEANOR WILSON,* W1QON

Time: August 30, 31 and September 1—*viz.* Labor Day week end 1957 A.D.

Place: The Palmer House, Chicago, Illinois.

Out-of-staters had been counseled by well-wishers at home to expect 100 degree temperatures; the Chicago weather bureau did its best to provide mercury readings in the 80s and 90s only and fought creditably to keep the humidity just under 100%.

Occasion: The Ninth National American Radio Relay League Convention and the Second International Convention of the Young Ladies Radio League.

A double feature with an event-packed program. Those drawn and drooping conventionaires still plodding around the morning after the convention was over confessed to a congenital bent to get their money's worth and had taken in *all* of the events.

Registration: Ninety YLs represented 23 states and two countries

Specifically: W1s CEW, HOY, QON, SCS, TRE; K2s AUE, LOR; W2s EEO, OWL; W3s BIW, CAI, CDQ, DUR, OQF/Ø, PVH, URU, VLX, ZUF; K4s AML, LMB; W4s BAV, DEE, TDK, UDI, UDQ, VCB/3, VKL/9; K5BNQ; KN5HFO; W5s DUR, RZJ; K6s ENK, KUP; W6s CEE, NZP, QGX, WRT; W7s GLK, LXQ; K8SCHL; KN8GLF; W8s ATB, FPT, LIV, SPU, UFZ; K9s AMD, AXS, BUS, BWJ, CCO,

*YL Editor, QST. Please send all news notes to W1QON's home address: 318 Fisher St., Walpole, Mass.

CZQ, EMP, FMS, GXX; W9s CTM, GME, HIX, LDK, LOY, LYU, QV, QXI, RTH, RTQ, RUJ, SJR, STR, UON, USR, WYJ, YWH; KN9s CMZ, ESB, GNQ, GUB, IEM, IXO; KØs BFS, BJZ, BRZ, JAS, KPB; KNØs JHG, JJW, KEN OFM; WØs IBG, MRJ, QXA, QXF; XE1MM.

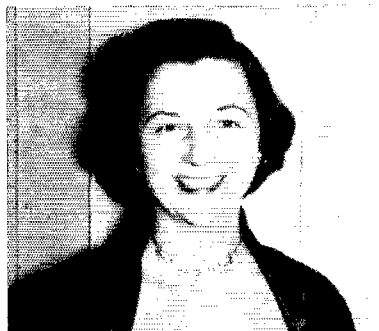

Cris Bowlin, W9LOY, Chairman of YL Activities for the Ninth National ARRL Convention and the Second International Convention of the YLRL. Cris was president of the YLRL in 1956 and was one of the founders and past presidents of the Ladies Amateur Radio Klub of Chicago. An active YL net member, she operates 40 and 75 phone. Her OM is W9RQF.

First Day: YLRL Headquarters was the Crystal Room of the Palmer House—a haven for strictly YL talk. All day YLs filtered in, delight-

The highlight of the entire YL program—Luncheon and Forum on Saturday. Ninety YLs were glad they got together!





A popular mother-and-daughter duo at the convention were Eleanora and Ann Hammonds, W3CAI and W3BIW. Just before the picture was taken W1WPO of ARRL Headquarters informed Eleanora that she was the first W3 YL to achieve DXCC (phone)—hence, the happy smiles.



W1NJM of ARRL headquarters gets K4AML's undivided attention as he explains the standing wave ratio demonstration to Vonda at the ARRL booth in Exhibition Hall. An antique auto enthusiast, Vonda Freyer drove up to take in both the convention and a classic auto show.



The six YLs in the photo learned during the convention that they had been elected officers of the YLRL for the 1958 term (see convention text). Seated l. to r.: W9STR and K5BNQ; standing: W9YWH, W1CEW, W9RUJ and W6QGK.



Connie Kalinowski, W9UON, of Chicago, gladly accepts an ARRL Handbook and gift certificate from Cris Bowlin, W9LOY, while Adeline Weiland, W9LDK, looks on at the Friday night Spaghetti Supper.



Five YLRL members look over the club photograph album which was on display at YL headquarters in the Crystal Room. Left to right: Dolly Maher, K9BUS; Naomi Spence, W4TDK; Liz Zandonini, W3CDQ; Ethel Smith, K4LMB; and Laura Stegner, K0JAS.



W9LOY yields the gavel at the YL Luncheon and Forum. Head table speakers were, left to right, W1QON; Mae Burke, W3CUL, 1956 Edison Award Winner; W9LOY; Betty Frederick, W3PVH, YLRL President; and Louisa Sando, W5RZJ, YL Editor of CQ. (W3CUL's Edison cup is shown at the center of the table.)

ed that after much counting of pennies and juggling of complicated baby-sitting arrangements back home (the convention also provided a nursery and baby-tending service), they had finally made the big ham get-together of the year. And, as always, it was, to say the very least, a revelation to meet the calls we had long worked on the air.

The Spaghetti Supper in the early evening was courtesy of the convention committee — a pleasant social abetted by good food and conversation, games and gifts.

Second Day: In the morning a YL had only to make up her mind whether to view the exhibits, take in a talk or forum, shop, sight-see, or get ready for the high light of the YL program: the YL Luncheon and Forum. Cris Bowlin, W9LOY, Chairman of YL activities for the convention, conducted the program and presented to Betty Frederick, W3PVH, a plaque for Betty's "unselfish service and conscientious duty" to the YLRL as President in 1957. Betty in turn presented W9LOY with a similar plaque for Cris' service to the YLRL as President in 1956. (The plaques were beautifully executed by Viola Grossman, W2JZX.) Talks were given by W3PVH; Mae Burke, W3CUL, 1956 Edison Award winner; Louisa Sando, W5RZJ, of CQ magazine, and W1QON. W5RZJ showed interesting colored slides of life among the Indians of New Mexico. Each U. S. call area was represented for the first time at a YLRL convention and four ex-presidents of the club were present: Ethel Smith, K4LMB, founder; Elizabeth Zandonini, W3CDQ; Vada

Letcher, W6CEE; and W9LOY. Prizes and souvenirs were distributed, and the conclusion seemed unanimous that the luncheon was a well-organized success.

Later, dinner in Chinatown, arranged by Evelyn Tibbits, W9YWH, provided a gourmet's array of Chinese dishes and an opportunity to purchase "trinklets" in Chinese shops, as colloquially suggested by the bus driver of the conducted tour.

From ten until almost twelve an excellent program by professional entertainers was relished by a large audience in the Grand Ballroom of the hotel, and at midnight the mysterious ritual of the Royal Order of the Wouff Hong lured the uninitiated.

Third Day: The stalwart bounced back early Sunday morning and went to church or saw more of Chicago. The exhausted slept until time for a boat trip around Chicago harbor, courtesy of the Newark Electric Company. It was hazy, but cameras clicked continuously for views of the Windy City from the water.

At eight P.M. sharp the Grand Banquet commenced in the Grand Ballroom, and when it was over everyone seemed to have had a thoroughly grand time. The speakers were interesting, the dinner excelled normal banquet fare, and the prize drawing was efficiently dispatched.

Conclusions: As someone said it is difficult, if not impossible, to compare conventions. What appeals to or impresses one does not likewise affect another, so superlatives should be used with restraint. But perhaps the foremost con-



All dressed up, awaiting the start of the Grand Banquet, four foot-weary YLs enjoy a sedentary rag-chew. Left to right: Marge Schum, K9EMP; Jackie Batchelor, W4VKL; Bernice Schmidt, W9SJR; Ruth Ferguson, W1TSCS.

clusion to be drawn about this convention is that from start to finish it brilliantly showed months and months of extensive, exacting organization by the convention manager, chairmen, and committees. To all involved, a salute for an affair which will be long remembered.

To Cris Bowlin, W9LOY, chairman of activities for licensed YLs, a special bouquet for providing such a fine YL program for three days. The birth of her second son on May 28 did not impede Cris from attending countless organizational meetings all winter and spring and from overseeing YL doings constantly during the entire convention period.

A deep thank-you to W9LOY, her committee, and the general convention committee, for the many kindnesses extended to a visiting YL editor, and for a thoroughly enjoyable affair all around.

Addenda: Marie McKissick, the XYL of W9LCA, was chairman of the Ladies Program. XYL activities included tours of various places of interest in Chicago, luncheons, and a SWOOP initiation. And to echo a statement made by one of the banquet speakers, it was gratifying to see so many XYLS present with their OMs at this convention.

YLRL ELECTION RESULTS

The results of the election of officers for the Young Ladies Radio League for the 1958 term were announced for the first time at the Second International Convention of the YLRL in Chicago, Labor Day week end. Outgoing Secretary Lolly Keller, W3VLX, made the announcements at the YL Luncheon, at which six of the newly-

elected officers were present (see photo). The new officers who will serve for a one year term, commencing January 1, 1958, are as follows:

President — Beth Taylor, W7NJS
Manzanita, Oregon

Vice President — Kay Anderson, W4BLR
Richmond, Virginia

Secretary — Betty Rogers, W0TYB
Denver, Colorado

Treasurer — Harryette Barker, W6QGX
La Puente, California

Publicity Chairman — Mary Meyer, W9RUJ
Brookfield, Wisconsin

HARMONICS Editor — Betty Sandberg, W0STR
Chicago, Illinois

District Chairmen: Mary Hinterland, W1CEW, Cranston, R. I.; Eve Reid, K2DXD, Central Square, N. Y.; Florence Collins, W3DBN, Landenburg, Pa.; Claire Bardon, W4TVT, Vienna, Va.; Doris Anderson, K5BNQ, Broken Arrow, Okla.; Irma Weber, K6KCI, Santa Barbara, Calif.; Marjorie Frazier, W7GXI, Oroville, Wash.; Mary Frost, W8VRH, Lake Orion, Mich.; Evelyn Tibbits, W9YWH, Western Springs, Ill.; Kay Barclay, K0BTY, Boulder, Colo.; Della O'Shea, VE3DMX, Fort William, Ontario; Geraldine Nichols, KL7ALZ, Spenard, Alaska; Dotty James, KH6AUJ, Honolulu, Hawaiian Islands.

WAC/YL

Applications for the Worked All Continents YL award may now be sent to Custodian Barbara Houston, W3OQF, at her new address: 1385 Northview Drive, Marion, Iowa.

Strays

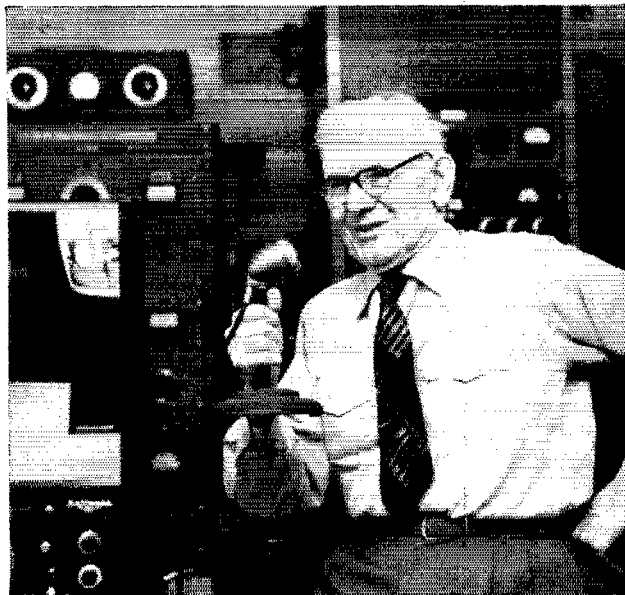

Henry P. Broughton, K2AE, has a good claim to the title of Oldest Active Amateur. Hale, hearty and 92 years young, Henry is a member of the Professional Loafers Club, Schenectady County Emergency Net, Schenectady Amateur Radio Association, and half of the only father-and-son team in the Old, Old-Timers Club (the other half is William, W2IR). First licensed in 1915 (though his interest in radio dates back to 1893, when he assisted Nikola Tesla in lectures at St. Louis) Henry has since filled up 58 log books, and worn out the calls 9SD, 9JM, 8NJ, W9SD, and W2OIV.



CONDUCTED BY EDWARD P. TILTON,* W1HDO

FOR AN ART that has been known only about four years, v.h.f. meteor-scatter communication has come a long way. When the sharp "ping" of meteor signals was first observed on 144 Mc. back in 1953, many people refused to believe that meteors stirred up enough ionization to reflect signals at so high a frequency. That these were, in fact, signals of meteoric origin took some demonstrating. The work of W4AO, W4HHK, W2UK and other pioneers in this field is a chapter in the history of amateur radio in which we may all take pride.

Here was propagation via the ionosphere at frequencies appreciably higher than any previously observed, but at first only a handful of amateurs sensed that the signals could be used to advantage. Recording them seemed to be simon-pure scientific investigation, with little worth for such typical amateur pursuits as collecting new states or setting new DX records. But it wasn't long before the early birds showed that not all meteor returns were pings, by any means. If two operators separated by 600 to 1300 miles bore down at the right time, and with sufficient patience and skill, they were rewarded with bursts of signal long enough to convey useful information, provided that c.w. and fairly high keying speeds were used.

This led to prearranged timing, automatic keying and tape recording, the last having the obvious advantage of playing back at slower speeds
*V.H.F. Editor, *QST*.

in order to study the nature of the meteor signal in greater detail. The first all-meteor QSO was made by W2UK and W4HHK with the aid of timed transmissions and frequent insertion of "BK" — the idea being that eventually one or the other would send the break signal during a useful burst. If you've done much meteor work on 144 Mc. you have some idea of the odds against that happening often!

But it did happen, and W4HHK not only worked W2UK that way, but he managed contacts with W2NLY and W2AZL, during the 1954 Perseids. Your conductor was in there, too, but getting nowhere. Time and again we heard W4HHK tell us to break, and we broke, but to no avail. We recorded several examples with that much evidence, and now and then a signal report, but no complete QSOs.

In desperation W4HHK called your conductor on the telephone. With that conversation was born the idea of breaking down the attempt into short, precisely-timed one-minute sequences of information, repeating over and over. No attempt was to be made to break, or exchange information at random. The system clicked right away, and within a half hour complete information and acknowledgments were exchanged.

Methods have been revised in many ways since, but the basic idea remains the same. March *QST*, page 55, tells how it's done, if you're new to the game. Identification and information ex-

Largest 50-Mc. array? This giant was built on a hilltop near Collierville, Tenn., by W4HHK and W4GYS. Cottage to house equipment was also built especially for the project, and much credit for the job goes to the wives for their cooperation. Array is a 24-element collinear, mounted on two 100-foot Alprodcoc towers. Twelve half waves are fed in phase, using a vertical spacing of about $\frac{3}{4}$ wave length. Parasitic elements are adjusted to make the array bidirectional. Built especially for IGY experimentation, the big array provides consistent communication with well-equipped 50-Mc. stations in Northeastern U. S.

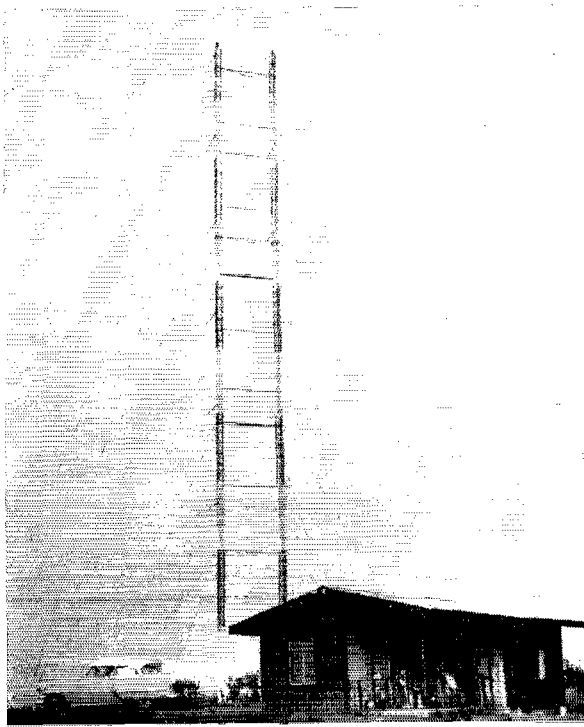

change are the bare essentials. You may have more, but a QSO can hardly be claimed on less. The 1957 meteor DX season, centering on the August Perseids Shower, saw some "contacts" being made under conditions that stir a measure of doubt as to their authenticity. Conscientious meteor DX enthusiasts have expressed concern over this, asking for clarification of what constitutes an acceptable QSO under meteor-scatter conditions.

What was said in March *QST* need not be repeated here, and we see no reason to change it. The question is how can we be sure that we have completed a QO in the true sense of the term? Here's how.

We must have positive identification *both ways*. Just signing one's own call during the initial phases of the schedule is not enough. Each participant must log *two* calls — his own and the other fellow's — before he starts sending signal reports. Sending of the signal report should be evidence that identification has been positively made.

When signal reports are being sent, nothing else other than the two calls is in order. If you send "R R R R S2 S2 S2 S2" for example, your man may get only the "R" and take it that the QSO is over.

How far can we go by automatic methods? To this writer, the automatically sent "S2" so often heard in meteor work has a slightly phony ring, even though it is probably acceptable as evidence. But use of tape recordings to determine whether or not a QSO has taken place *except while the attempt is actually going on* is definitely beyond the realm of reason. "I couldn't be sure if it was a QSO or not until I checked my tapes" is solid evidence that you have not made it. Recording at high speed and playing back at slower rate may be a fundamental part of commercial and military attempts to use marginal forms of v.h.f. communication, but it is legitimate in amateur work only if employed solely while the work is going on. An amateur QSO is an *exchange* of information. How can you reply, if you have not copied what the other fellow sent?

One of these days we're going to be checking an application for a 144-Mc. WAS. The man who makes the first one will have done a tremendous job of utilizing all his skills in a way that should reflect great credit on amateur radio. The award will eclipse all others as evidence of the time and effort invested in our hobby. Let's be sure that we do not mar its significance in any way; that any contacts we claim, by meteor scatter or other marginal forms of communication, are true two-way exchanges of information — not merely flashes of signal caught on a tape recorder!

Aurora Moves South

If the current sunspot cycle does nothing more, it may cause us to rewrite the book on aurora. (And while we're about it, in view of the KH6UK-W6NLZ work across the Pacific, we'd better do some revision on the tropospheric propagation chapter, too!) Call it improved equipment, bigger antennas, sharper operating, hotter conditions — or a combination of all these factors — the fact remains that

2-METER STANDINGS

U.S.		U.S.			
States	Miles	States	Miles		
W1REZ	28 8	1050	W5NDP	8 3	520
W1FZ	21 6	1120	W6PZ	8 3	530
W1KCS	21 7	1150	W5PEK	8 3	580
W1RFU	21 7	1120	W5VY	7 3	1200
W1HDF	20 6	1020			
W1AJR	20 6	810	W6NLZ	9 3	2540
W1AZK	20 6	1160	W6PFG	7 3	1030
W1OAN	19 6	800	W6WSQ	7 3	1360
W1MMN	17 6	800	W6AJE	5 2	340
W1IYZ	17 6	750	W6RRZ	4 2	360
W1UIZ	17 5	680	W6PJA	1 3	1390
W1BCN	16 5	650	W6ZL	3 2	1400
W1KHL	16 5	540	W6BAZ	3 2	400
W1AFO	16 5	810	W6MIU	3 2	388
			W6ORS	3 2	365
			W6LSB	2 2	360
W2CXY	34 8	1200			
W2NLY	33 8	1300	W7VMP	11 5	1280
W2ORI	33 8	1200	W7LEJ	6 3	1020
W2AZL	28 8	1050	W7JRG	6 3	1010
W2BLY	23 7	1020	W7LHL	4 2	1050
K2GJQ	23 6	935	W7JLP	4 2	900
K2IEJ	22 7	1025	W7JL	4 2	353
W2KIR	21 7	880	W7YZU	3 2	240
W2DWJ	21 6	720			
K2CEH	21 8	910	W8KAY	36 8	1020
W2AOC	21 7	700	W8XVY	33 8	1200
W2OPQ	20 6	970	W8RMH	29 8	800
W2AMJ	20 6	960	W8PT	28 8	985
W2PAU	20 6	880	W8LFC	27 8	1050
W2CBB	20 6	740	W8SRW	27 8	850
W2UTH	19 7	890	W8SFG	26 7	850
W2AZP	19 7	650	W8LLC	25 8	800
K2INJ	19 6	925	W8LPD	25 8	750
W2R9V	19 6	720	W8DX	25 8	720
W2LHI	18 7	620	W8WRN	24 8	680
W2SHT	16 6	650	W8AS	24 8	675
W2PCQ	16 5	650	W8SVI	22 8	725
			W8JWV	22 8	710
W3RUE	29 8	950	W8LCY	18 7	810
W3BGT	28 8	740	W8EP	18 7	800
W3TDF	27 8	880	W8ZCV	17 7	970
W3SQA	26 6	550	W8RWV	17 7	930
W3GKP	25 7	825			
W3IBH	23 7	650	W9KLR	35 8	950
W3PH	21 8	800	W9WOK	32 9	1050
W3KCA	21 7	800	W9BGM	27 8	850
W3LZD	20 7	700	W9VJ	26 8	850
W3KWL	19 7	740	W9EQC	26 8	820
W3NKL	19 8	660	W9ZHL	25 8	760
W3BNC	18 7	750	W9GAB	21 7	1100
W3LNA	16 7	720	W9AAG	24 7	850
			W9ZTH	24 8	850
W4HHK	33 9	1280	W9BTV	23 7	1000
W4HJQ	30 8	825	W9UUC	22 8	750
W4AO	26 7	950	W9UED	22 7	960
W4LTC	24 8	1160	W9KPS	21 7	890
W4MKJ	24 8	725	W9AUD	19 7	640
W4JJC	22 6	660	W9LFC	19 6	600
W4UMF	22 6	720	W9ALU	18 7	800
W4DWU	20 6	675	W9JGA	18 6	720
W4OLK	19 6	720	W9MBL	16 7	660
W4TLY	18 7	1000	W9IDG	16 6	700
W4JFV	18 7	850	W9LY	15 7	560
W4IKZ	18 6	720	W9LFE	15 6	720
W4VLA	17 7	825	W9DSP	15 6	760
W4WNH	17 7	750			
W4ZLY	15 5	720	W0HHD	27 7	890
W4ZBU	14 5	800	W0GUD	25 7	1065
W4AIB	14 5	705	K0DOK	22 8	930
W4TCR	14 5	720	W0TGC	20 7	860
W4TCR	13 5	—	W0INI	19 6	830
W4SOP	13 5	680	W0UOP	18 6	—
W4CPZ	12 5	650	W0ONG	17 6	1000
W4DDQ	11 5	850	W0SMJ	16 6	1000
W4NDA	11 5	860	W0USQ	14 6	750
W4KQC	10 4	860	W0IFS	14 5	—
W4LNG	9 4	800	W0OAC	14 5	725
W4GIB	9 2	335	W0MVG	13 5	700
			W0TJF	13 4	—
W5RCI	30 9	1215	W0ZJB	11 4	650
W5DFU	24 9	1300			
W5AJB	19 8	1280	VE3DIR	26 8	915
W5EHL	15 7	830	VE3BQ	26 8	910
W5JWL	14 6	1150	VE3BQN	17 7	790
W5MMW	14 5	700	VE3LRE	16 7	820
W5BQ	13 5	1390	VE3BPP	13 6	715
W5ABN	12 5	780	VE2AOK	12 5	550
W5QNL	10 5	1400	VE3AQG	11 7	800
W5CVW	10 5	1180	VE1QY	11 4	900
W5SWL	10 3	600	VE7FJ	2 1	365
W5MLT	9 3	700			

2-meter DX has expanded on all fronts in the past few months.

The aurora openings of September were caught by 144-Mc. men farther south in the country than ever before. Distances covered also beat anything previously seen in the buzz department. Thanks to conscientious reporting by many of you, we have literally hundreds of contacts on record. They cannot all be detailed here, but let's have a look at some of the high points. Perhaps the best aurora DX on record was the Sept. 13 QSO between W1KCS, Providence, R. I., and W5RCI, Marks, Miss., 1170 miles. AI

also worked W4HHK, both contacts coming around 0500 EST. Needless to say, they are firsts between the states on 144 Mc. W5RCI worked WIREZ, Fairfield, Conn., for the first Connecticut-Mississippi 144-Mc. contact, at 0410 EST the 13th. W1HDQ, having been alerted courtesy of WIREZ and W3TDF, heard, but (alas!) was unable to work W5RCI and W4HHK. These were the most distant and southerly 144-Mc. signals ever heard via aurora in W1.

WIREZ worked W4MBR, Augusta, Ga., another first, at 0350. W41HK at 0430, and K0DOK, Afton, Mo., first W1-Missouri, at 0510. The DX continued to buzz into W1 long after daylight, the last signals being heard around 0730 EST. These four net states, plus W4EQM, Langdale, Ala., worked via meteor scatter in August, gave WIREZ every state east of the Mississippi, and leadership in W1 by a 7-state margin. Ray's fine station, shown in one of our photographs, runs a pair of 4X250Bs in the final stage, feeding a 4R-element 4-Yagi array.

For many years most 2-meter men have considered that auroral propagation was of only limited value in providing contacts with states that could not be worked by other forms of propagation on 144 Mc. The Sept. 1, 4, 13 and 21-22 auroras certainly dispelled that notion, and the best evidence lies in the status-worked box this month. There are over 50 changes in the 2-meter box alone. Better check your listing — and please let us know if it is wrong or out of date.

The farthest-south 144-Mc. penetration of the Sept. 13 aurora is reported by W5AJG, Dallas, Texas. Leroy has been watching for aurora signals for many years. He'd heard them only on tape recordings heretofore, but he knew what to look for. Alerted at 0400 CST by a call from W8KAY, who was hearing stations as far south as W5RCI, Leroy went to work at once. He worked W6QDH, Kansas, and W8TGC, Missouri, and heard W4HHK, K0DOK and W5RCI.

Visible aurora was reported in the Los Angeles area, a very rare event. The farthest south report we have from the West Coast is from K6GOX, Fresno, who worked W7VPT, Vancouver, Wash. on 50 Mc. Sept. 4. Clem had to leave home shortly after, but operation of his station was taken over by K6EDX, who worked W7ZKH, W7UIF and VE7AIZ.

Remember, it is *geomagnetic* rather than geographic latitude that determines how often aurora will be encountered in a given section of the country. Geomagnetic latitude lines slant upward as they run across the country from east to west, so the southwestern part of the country sees fewest auroras. Our September experience shows, however, that there is no corner of the country that is completely out of the aurora picture.

Southeastern 2-meter operators who have done right well by the northern state hunters of late include W4AIB, Aiken, S. C., W4CPZ, Caffney, S. C., W4MBR, Augusta, Ga., W4EQM, Langdale, Ala., W4HHK, W5RCI and many others — all farther south than what we once thought of

as the southerly limit of auroral propagation. On 50 Mc. the line is still farther down. W4RMI, near Jacksonville, Fla., had his second auroral experience Sept. 4. He first heard W3IU, Washington, D. C., at 1944 EST, and worked him soon after. At 2330, Allen worked W4ARI, Chattanooga, Tenn.

Aurora slipping in and out several times over the week-end of Sept. 21-22 turned the fall V.H.F. Party into one of the wildest scrambles in v.h.f. contest history. We won't attempt to deal with it at this juncture, except to say that it "separated the men from the boys" in no uncertain terms. The first really good aurora in all the years since we've had such contests, it bolstered section multipliers for many operators in areas where multipliers are often hard to come by. Just one example: W4HHK got Ontario, Northern New Jersey, Connecticut and New Mexico in the closing hours of the contest. New Mexico from Tennessee is an aurora first, and possibly the first time that aurora work has been done from as far into the Southwest as Albuquerque.

And from W4LTU, Orlando, Fla., comes still another record. Late Sunday night Walt heard his first aurora since he left Ithaca, N. Y., where he used to work the buzz as W2WFB. At about 2300 on the 22nd, W4LTU heard South Carolina stations (via tropo, off the backs of their beams) beginning to call for auroral contacts. At 2352 the first aurora signal appeared on 144 Mc. Following that K4EYE, W4AO, W4CVQ, W4HHK and W4CPZ were heard, in that order. Walt was able to see the aurora, and has reports that it was visible as far south as Miami! This is the first 144-Mc. aurora reception ever reported from Florida, and by about 2 degrees the lowest latitude at which v.h.f. auroral effects have ever been observed.

In the tropospheric propagation department, things have been better than for many years. Greater distances and higher signal levels have been reported than at any time since 1951. Does the peak of solar activity have anything to do with this? Could KH6UK have worked W6NLZ in 1954? You tell us!

50-Mc. DX News

The list of countries available for two-way 50-Mc. DX work this fall is still growing, and the CRPL Predictions for November and December indicate that we should be able to take advantage of the DX interest. The charts show slightly lower m.u.f. across the North Atlantic than for the same period in 1956, but the band should be open to Europe on the better days, at least. Optimum time would appear to be around 1100 EST, though this may extend two to three hours in either direction on peak days.

Best tip-off on European possibilities is obtained from monitoring their TV channels. BBC TV frequencies: Channel 1 — sound on 41.5; video 45 Mc. Channel 2 — sound 48.25 Mc.; video 51.75 Mc. Channel 3 — sound on 53.25 Mc. Experience in 1956 showed that if the Channel 2 video

This neat station helped WIREZ, Fairfield, Conn., to achieve leadership in the 144-Mc. states-worked department in W1 by a wide margin. Final amplifier runs up to 1 kw. to a pair of 4X250Bs.

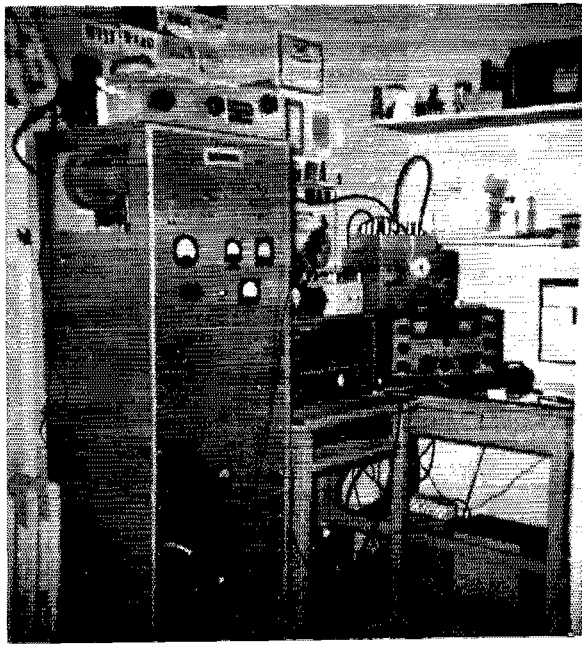

(51.75 Mc.) was in strongly Europeans could hear American 50-Mc. stations. The high power of the TV station makes it an excellent beacon signal, as it begins to be heard well before there is much chance of amateur power levels putting a signal across the Atlantic. The relative signal strengths of the Channel 2 sound and video also show the m.u.f. up clearly.

A list of European assignments in the 50- and 70-Mc. regions follows:

- Eire — 70.575 to 70.775 Mc. (see below)
- France — 72.0 to 72.8 Mc.
- Finland — 70.2 to 70.3 Mc.
- Germany — 70.3 to 70.4 Mc.
- Great Britain — 70.2 to 70.4 Mc.
- Holland — 70.3 to 70.4 Mc.
- Norway — 50 to 54 Mc., 70.6 and 72.0 Mc.
- Poland — 50 to 54 Mc.
- Sweden — 50 to 50.5 Mc.
- Yugoslavia — 72.0 to 72.8 Mc.

Portugal, Azores and Madeira Islands — 50 to 54 Mc.

Most of the above information comes from the IARU Region 1 News. Since it appeared we have received word from EI2W that he has a temporary authorization for 50-Mc. work from October through the end of January. Harry will be on 50.016 Mc., and on 70.662 Mc. when conditions warrant, from 1200 to 1600 GMT daily. Interest in cross-band work, 28 to 50 Mc. is coming along well. In the past month we have received assurances of cooperation in cross-band work from HB9QQ, Zurich, Switzerland, and G2BVN and G5KW.

G5KW has a superb v.h.f. location and all the facilities for DX work on 50, 70 or 144 Mc., and will cooperate in DX schedules or tests on any of these frequencies. He is the operator of the high-powered RSGB IGY station previously mentioned, GB3IGY, which will be running special tests on 145.5 Mc. Ken is the holder of the current record for the new 70-Mc. band, and is hopeful that 70-50 work may be possible across the Atlantic this fall.

In the two-way 50-Mc. department, we have confirmation of the special 50-Mc. authorization available to Norwegian amateurs from LA6QB, who wrote us in behalf of the IARU society in his country, NRRL. The LAs may operate on 50 to 54 Mc. between the hours of 0500 and 1900 GMT, using c.w. or voice. Their assignments at 70.6 and 72.0 Mc. are spot frequencies available for the duration of the IGY.

Most recent word from Poland is from SP6XA, who is on 50-Mc. c.w., along with SP2DX, previously reported. Ted has 40 watts input, and a 3-element 50-Mc. beam, ready for work across the Atlantic.

Transequatorial DX is in evidence, but somewhat below 1956, thus far. The paths across the Pacific should repeat last year's many contacts between our West Coast states and Hawaii and Japan. The important thing is that nobody knows for sure just how things will go. Careful daily monitoring, with transmitting tests at frequent intervals whenever there appears to be the slightest chance of DX, has paid off handsomely before. It is likely to do so again this fall. Try anything!

The farthest-south sporadic-E work reported during the 1957 summer season involved TG9JW, Guatemala, reported worked on July 26 by K4HTO, Middleboro, Ky., W8HXT and K8DKO, Mansfield, Ohio, and W5FXN, Austin, Texas. He was heard by K5DCQ, K8DKK, W8CMS, W8NQD, W9YIL and W0SMJ. Spot these on the map and you pretty well pin this down as multiple-hop sporadic-E, even without the mass of other evidence contained in the Es reports within the country for the same period, around noon and slightly after on the 26th.

The first North-South F₂-layer DX from this country came on the morning of Sept. 5, W5PDE, Shepherd, Texas, worked LU9MA, LU2DGW and LU1ABF, W5FDB, Cleveland, K5AJJ, Conroe, and several Houston stations were also in on this one, which lasted from 0830 to 0930 CST. W6ABN, Long Beach, Cal., reports LU7DDG, LU3EX, LU5CK, LU8AE and CE3CC working into Southern California between 1715 and 1900 PST Sept. 12. The South Americans were working W4, 9 and 7 as well as W6. Both openings were associated with major auroral sessions in this country.

1957 Perseids Summary

A preliminary summary of results achieved during the August Perseids Shower was prepared just prior to your



1 W0ZJB	8 W0INI	15 W0WKB	22 W5SFW
2 W0BJV	9 W1HDQ	16 W0BSMJ	23 W0ORE
3 W0CJS	10 W5MJD	17 W0OGW	24 W9ALU
4 W5AJG	11 W2IDZ	18 W7ERA	25 W8CMS
5 W9ZHL	12 W1LLL	19 W3OJU	26 W0MVG
6 W9OCA	13 W0DZM	20 W0TMI	27 W0CNM
7 W6OB	14 W0HVW	21 K6EDX	28 W1VNH

W1CLS	47	W4LNG	45	W6ANN	45	W9MHP	43
W1CGY	46	W1CPZ	45	W6NDP	45	W9JCI	42
W1LSN	46	W4UCH	45	K6GTC	41	W9MPH	42
W1AEP	46	W4IKK	44	W6GCC	43	W9SWH	42
W1RFU	44	W4QN	44	K6HYI	43	K9EID	41
W1SUF	44	W4FLW	43	W6ABN	43	W9EPT	41
W1FOS	44	W4RFK	42	W6NIT	42	W9IMG	40
W1KHL	42	W4OXC	41	W16WS	41	W9KLR	36
W1EPL	41	W4MS	42	W6CAN	40		
W1MFM	39	W4ZBU	41	W6BWG	39	W9QIN	47
W1SPX	36	W4FNR	40	K6RNQ	38	W9NFM	47
W1UHE	35	W4AYV	38	W6ERG	38	W9TKX	47
W1FMK	34	W4HJJ	38	W6GJF	31	W9KYF	47
W1LGE	33	W4YRM	38			K9GGQ	47
W1FVZ	32	K4DNG	37	W7FFE	48	W9JOL	46
W1FTF	31	W1HHK	37	W7HEA	47	W9USQ	45
W1WAS	31	W4AKX	36	W7BQX	47	W9FKY	45
		W4GJO	35	W7FDJ	46	W9PPP	45
W2MEU	47	W4ZD	35	W7DYD	47	W9QVZ	45
W2RGV	47	K4AGM	35	W7ACD	46	W9OPZ	44
W2AMJ	46	W4HZG	34	W7JRG	44	W9YJF	44
W2BYM	46			W7LNK	44	W9URQ	44
W2FJH	45	W5VY	48	W7BOC	42	W9JHS	43
K2ITP	43	W5LQO	47	W7JPA	42	W9IPI	43
K2ITQ	43	W5GNQ	46	W7PIV	41	W9WNU	42
W2SHV	43	W5FSC	45	W7CAM	40	K9DXS	42
K2JNS	42	W5ONS	45	W7QDI	34	K9GKR	41
K2AXQ	42	W5JLY	45	W7UFB	33	W9PKD	41
W2QYV	40	W5MLL	44			W9ZTW	41
K2HPN	39	W5EXZ	43	W8QJN	46	W9YZZ	38
W2ORA	39	W5JME	42	W8SQU	46	W9ZKD	37
W2QVH	38	W5VV	43	W8HXT	46	W9VIK	36
K2HRB	37	W5FXN	43	W8NQD	45	K9BPM	35
K2LTV	37	W5CVW	41	W8U7	45	K9CLJ	35
K2YWH	34	W5FAL	41	W8RFW	45	W9LJR	35
		W5BZA	41	W8LJD	44		
W3TFP	47	W5BXA	41	W8HJR	43	VE3AET	46
W3KKN	45	K5ABW	40	W8WPD	43	VE1EF	37
W3KMY	44	W5EXZ	38	K8ACC	43	VE3AH	37
W3RUE	42	W5EUQ	38	K8CIC	42	VE3BBX	33
W3NKN	41	K5ABW	38	W8EVH	42	VE1QY	32
W3MQU	41	W5HFF	38	W8YLS	41	VE2AM	31
W3MXW	41	K5CYK	38	W8NCS	40	VE3DER	31
W3OTC	41	W5FRK	38	W8PCK	38	VE3HHQ	30
W3PFH	40	W5NSJ	36	W8NOH	34	VE1GE	27
W3LFC	40	W5WZF	33			O2ZX	24
W3AMO	36	K5AJW	33	W9BRN	48	VE1PQ	23
W3TDF	36	W5ZUL	33	W8ZHB	18	VE3QJ	22
W3UQU	32	K5EWB	32	W9QUV	18	VE1WL	21
		W5ZVF	31	W9VZP	47	O6BW	21
W4EQM	47	W5LVM	26	W9RQM	47	VE4HS	20
W4FBH	46			W9QKM	47	LU9MA	16
K4DJO	46			W9JFP	47	PZ1AE	15
W4UMF	46	W6WNN	48	W9AAC	46	K17VT	9
W4EQR	45	W6UXN	48	W9UTA	45	JAI1UH	5
W4AZC	45	W6B31	45	W9UNS	45	VQ2PL	5

Calls in bold face are holders of special 50 Mc. WAS certificates listed in order of award numbers. Others are based on unverified reports.

conductor's western trip in August, but due to a lapse by the writer the day of departure the copy never got to the printer. Perhaps it's just as well, for the record is more complete now. Here's the story, pieced together from numerous reports. It supplements the report by W2CXY appearing elsewhere in this issue.

If you've looked over W2CXY's story you know that the enterprising meteor-scatter enthusiast can't afford much time out for sleep during the Perseids. W4ITU, Orlando, Fla., ran a total of 49 hours of schedules with 20 different stations, and was on the job continuously through the night several times. Net result: complete QSOs with W2OPQ, Amsterdam, N. Y., 8/11, 1000 EST; K2GQI, Keyport, N. J., 8/11, 1100 EST; K0EMQ, Cedar Rapids, Iowa,

8/11, 2100 EST; W1AZK, Chichester, N. H., 8/12, 0800 EST; W0THD, Overland, Mo., 8/13, 0300 EST; W5JWL, Gurdon, Ark., 8/13, 0600 EST. These 6 QSOs accounted for four new states for W4LTU. Positively identified, but not worked were W1RFU, W1HDQ, W0IFS, W0LAY, W8BKI, W1MIN and W5FSC. Pings, presumably from K6QPT and W7GRA, were heard. No results were had with W0ZBJ, W4HHK, W7VMP and W5FAG.

A new stunt in meteor-scatter was an attempt at voice work by W4LTU and W3TDF, Langhorn, Pa. About all this netted was numerous "bumps" — the voice equivalent of pings on c.w., but Walt did get identifiable voice sounds at times, including a "W3."

All across the country skeds were being kept this time, starting with the Aquarids shower, July 26. This one was good enough for W5JWL and W2NLY, who made it in a long session between 2230 and 0130. Many short bursts kept both boys trying until complete information was finally exchanged, after nearly four hours! This was another first: New Jersey — Arkansas.

W6NLZ racked up some new states that would be tough from California by any other means. John worked W5VWU, Albuquerque, N. Mex., on a 2½-minute S9 burst Aug. 12, and W7JRG, Billings, Mont., the same morning, between 0500 and 0600 PST. W5FAG of Albuquerque was worked for a second time, and W6LIT/5, Silver City, N. Mex., was heard. Finally, W5DFU, Tulsa, Okla., was worked with very weak signals on the 13th. More firsts — Montana and Oklahoma, from California.

W7VMP/7, Phoenix, Ariz., came up with W5DFU on the 10th, W5RCI, Marks, Miss., on the 12th, W7JRG on the 13th and W7LHL, Kirkland, Wash., on the 14th, the first two being firsts from Arizona. Bob, W7VMQ, comments that the shower seemed to be marked by long bursts, with few of the shorter variety and almost no pings; quite a different matter from the Perseids of 1955, when W7VMP worked W4HHK. At W1HDQ we got the same impression. We heard some good ones from W4LTU, W4EQM and W4LNG, but they were very much farther apart than when we were working the meteor racket with W4HHK, back in 1954. Pings were almost nonexistent.

W4HHK, Collierville, Tenn., had partial QSOs with W3GKP, Spencerville, Md., on the 4th and 11th, and a good one with W5VWU on the 10th, 0115 to 0215 CST. He heard, but was not able to work, W1KCS, Providence, R. I.

W5JWL, Gurdon, Ark., worked W2NLY, as already noted, and W2CXCY, Chatham, N. J., 8/11, at 0445 CST.

W7LHL, Kirkland, Wash., worked W6DNG, Compton, Cal., on the 11th and heard W6WSQ. W7VMP was worked on the 14th.

W7JRG put Montana on the 2-meter map for the first time, with his contacts with W6NLZ, W7VMP and W9WOK, the last just after midnight Aug. 12.

W9KLR caught some good ones with W2BHS/4 in South Carolina, for state No. 35 during the Aquarids shower, July 28.

WIREZ made the first Alabama-Connecticut with W4EQM, and was doing well with W4LNG, Atlanta, Ga., the morning of the 17th. W4LNG was putting in some of the best stuff heard at W1HDQ at that time, though presumably the peak of the shower had passed.

W5DFU, Tulsa, Okla., was really dragging after Aug. 16, having gotten up for skeds beginning at 0345 CST every morning for a week. Warren was of the opinion that the Perseids ran out along about 0430 on the 13th, but before that he was doing well: W7VMP, for the first Okla. — Ariz.; W4ZXL, Greensboro, N. C., for the first to that state on the 11th; W7LEE, Parker, Ariz., on the 12th; and W6NLZ on the 13th, also a first. The W6NLZ contact probably marks the first instance of one station working both coasts on 144 Mc. Stop us if we're wrong on this one.

Warren also feels that the signals were mainly long bursts, with very few pings. W7LEE, writing W5DFU, says that visual counts were far below normal. But the Perseids were good to W5DFU — he now has 24 states, and is in the exclusive circle of those who have only one call area to go. Being in the middle had its bad points, however, and W5DFU is one of those pulling for more frequency spread by the meteor enthusiasts another time.

W8KAY, Akron, Ohio, knocked off W0YSJ, Fargo, N. Dak., for State No. 35 at 0150 on the 12th. No results with W7JRG, W7GRA and W5SNX. Art got No. 36 by working W0QDH, Kansas, during the Sept. 13 aurora.

W2ORL, Lockport, N. Y., caught W5AJG, Dallas, Texas,

at 0720 EST on the 11th, W0YSJ, 0105, 8/12, and W0IAY, Pawnee City, Neb., 0202, 8/14. More firsts, New York to Texas, North Dakota and Nebraska!

W2NLY, Metuchen, N. J., picked up W0IFS, Minnesota, and W0YSJ, North Dakota, to bring his states total up to 32. Jim had skeds with W0IAY, W0ZBJ, W0BJV, K6QF1 and W7GRA, but only W0IAY and W0BJV, of these, were heard.

W7JIP, McMinnville, Ore., ran tests daily with W6AJF, Sonoma, Cal., with short bursts heard regularly for about a month prior to Aug. 7. On that date the effects of the Perseids Shower were in evidence and their first contact was made successfully. It is of interest to note that both had their antennas tilted upward 10 degrees, this being a hop of only 510 miles, one of the shortest yet negotiated via 2-meter meteor scatter. Len also worked W7LEE, Parker, Ariz., for a new state, and W6DNG, Compton, Cal. W7JIP made some Esterline-Angus recordings of W6AJF, the first such visual record of amateur meteor signals we've seen.

W9WOK's Perseids QSO with W7JRG, Billings, Mont., covered a path never before bridged on 144 Mc. John also worked W4CPZ, and heard W5DFU and W2CXCY, the latter much of the time too often for comfort. Meteor-scatter QRM is the worst kind; let's spread out!

W1AZK, Chichester, N. H., comments on the long spaces between bursts, sometimes running 10 to 15 minutes, and the almost complete absence of short pings. Don was able to identify W4LTU on several of Walt's skeds with other W1s and 2s. Their QSO was made on a long overdrive burst, beginning at 0824 EST Aug. 12. Don is available for m.s. skeds at any time. Need New Hampshire? His 4-125As and 64-element beam make W1AZK the state's best bet.

W5RCI had nightly skeds with W4AIB and W2BHS/4 in South Carolina for a month before making contact with both the night of Aug. 7. Bursts had been heard frequently before, but not enough for a QSO. These may be even closer than the W7JIP-W6AJF contact reported above. Rex also worked with W7VMP, Phoenix, Ariz., Aug. 10 through 14. Contacts were made on the 12th and 13th, with bursts of 20 to 30 seconds duration. Another interstate first.

W7GRA, Benson, Ariz., ex W3QKI and W6QKI, was able to complete no contacts. Herb heard K6CQI on some good bursts, but had no schedule. He reports that W6LIT/5, 120 miles to the east, worked W6WSQ in Pasadena, and heard W6NLZ and W6AJF.

V.H.F. Man-of-the-Year

A feature of the v.h.f. meeting held at the ARRL National Convention in Chicago was the presentation of a V.H.F. Man-of-the-Year Award, by the Midwest V.H.F. Club. Though the recipient was not present, all the 2-meter operators on hand agreed with the choice: Art Paradis, W8KAY, of Akron, Ohio.

Art is the No. 1 man in the country in states worked on 144 Mc., having gone three-fourths of the way to a 2-meter WAS just recently, with his contact with W0QDH. But that was not the prime reason for his receiving the award. Two-meter men for hundreds of miles around W8KAY don't need to be told the reason. They have listened many times to Art's QSTs, given in the midst of scores of auroral and tropospheric openings. They are well acquainted with the many ways in which he has helped others to enjoy the thrills of 2-meter DX.

The Midwest V.H.F. Club couldn't have picked a better candidate for the award. Art's unselfish expenditure of time and effort in behalf of others sets an example of amateur spirit that is woefully lacking in some other fields of ham operating!

Club and Net Doings

The Six-Meter Club of Chicago, officially organized in July, is off to a flying start. The main purposes of the club are to foster more and better v.h.f. activity, and to contribute to the advancement of amateur radio in general. Two projects were undertaken immediately. A c.w. practice net, headed by W9ZKQ, was put into operation on 50 Mc. nightly at 2000 to 2200 CST, and a TVI Committee that will specialize in the handling of 50-Mc. problems was organized.

Club officers are President: Bob Hodge, K9GHS; Vice President: Al Seymour, W9NYO; Secretary: Lorraine Seymour, K9AZE; Treasurer: Ben Hall, W9OVL; Technical

Advisor: Milton Davis, W9IMG. Anyone interested in further details can write the secretary, or call into the club net on or near 50.4 Mc. Secretary's address: 430 163rd Place, Calumet City, Ill. A QSL Bureau (addresses are sometimes hard to come by as so many of the 6-meter fraternity are newcomers to the game) is being handled by Lee Lawson, K9JFN, Box 173, Cicero, Ill. She will provide mailing addresses wherever possible.

Two club certificates are being made ready for awarding to anyone who works 10 members of the club. One is for any type of emission, the other for 10 contacts on c.w. These are handled by the secretary.

Two other v.h.f. certificates are announced this month. A group of 10 San Diego amateurs, not a formal club group, has a beautiful certificate available for 50-Mc. work in three different categories. Residents of San Diego County qualify by working 20 San Diego stations. California residents outside San Diego County need work only 15. Five 50-Mc. contacts with San Diego from outside the State of California will get you the award. Send QSLs to K6UJL, 4215 54th St., of K6OBS, 2668 Deerpark, San Diego.

The Central Ohio Radio Club announces what should be a real tough one: WOACO (Worked Ohio, All Counties) on 50 Mc. There are 88 counties. All contacts must be made from within one Ohio county, or from inside a 25-mile radius if you are not an Ohio resident. Application forms from Box 23, Delaware, Ohio.

K6JQB announces the formation of the Southern California V.h.f. Club. Meetings are held the second Friday of each month, at the Los Alisos School, Norwalk, Cal., at 8 p.m. Visitors always welcome. About 40 members are on the rolls at present. Officers are President: K6JQB, Vice President: K6JDN, Treasurer: K6RMT, Directors: W6MIT, K6TGH, W6ALJH, K6IIV and K6GYF.

Also from K6JQB: The 6-meter division of the 2-4-6 Net checks in at 1900 Monday through Friday on 50.4 Mc., with K6UOD as Division Control. Traffic is handled to all points, with the total running some 300 to 400 pieces monthly.

The Windblowers of Northern New Jersey announce the 1957 "Big Blow" which will take a different form this year. Participants must look for four member stations on 144 Mc., all using different forms of emission. Work all four for handsome certificate award. Date: Oct. 25, 1400 to 2200 local time.

The Antique Wireless Association, Rochester, N. Y. is making up slide show, to be titled "The World Above 50 Mc." Format to follow the "First Thirty Years of Amateur Radio" presentation used so effectively at conventions and hamfests the country over. Hank Blodgett, W2UTH, in charge of the project, would like to borrow slides and photographs of old or significant v.h.f. gear, or the equipment itself, for photographing. Antennas, stations, particularly with operators included, most desirable picture subjects. Photos or equipment loaned will be returned. Write W2UTH, 515 Victor-Holcomb Road, Victor, N. Y.

The Brown Sugar Net, Dayton Area operates nightly on 50 Mc., 2200 local time. First session in July brought out 18 participants. Code-practice sessions and other activities planned. Info from W8RHR.

220 and 420

Things are really popping on 220 these days. The fine tropospheric opening of Sept. 17-18 saw plenty of work being done on 220, as well as on 144 Mc. This netted a small extension of the 220-Mc. record, when W2DWJ, Elizabeth, N. J., worked W9EQC, Aurora, Ill., 740 miles. This could have been run a few miles further, at least, for W2AOC, Brooklyn, N. Y., 750 miles, was hearing W9EQC for several hours. W9EQC also worked W3ARW, Old Forge, Pa., and heard W3LZD, Dunmore, Pa. The latter was S5 on voice. W2DWJ and W2AOC both worked W8IJG, West Richfield, Ohio.

W2DWJ describes a "220-Mc. Garbage Disposal Unit" that has worked out well for the gang around the New York area who are plagued with spurious responses to the high-band TV signals that abound in that region. With Channels 7, 9, 11 and 13 all running full schedules, keeping their signals out of a 220-Mc. receiver is a must, if any serious work is to be done. Bill uses a 220-Mc. version of a 3-section filter originally described for 2-meter RTTY use in the August, 1955, issue of CQ.

Three rectangular "coaxial" lines are used. They are made of flashing copper, each being 1 $\frac{1}{16}$ inches square and

6.5 inches long. Inner conductors are 5 $\frac{1}{4}$ inches long, $\frac{1}{4}$ -inch copper tubing, tuned with Johnson 11MB11 miniature variables. The three lines are connected in series, and are mounted adjacent to one another. The assembly can be made in the form of a copper box 3 $\frac{9}{16}$ by 1 $\frac{3}{16}$ by 6 $\frac{1}{2}$ inches in size, with two partitions. Coupling loops between the lines are merely hairpins about 1 $\frac{3}{4}$ inches long that run from the end of one compartment, through a hole in the partition, to the end of the adjacent compartment. Coupling into and out of the 3-section filter is done coaxial fittings and conventional coupling loops.

A list of 420-Mc. stations was recently received from W3RQT, including W1s, 2s, 3s and 4s known to be active with most-used frequency, power output, antenna type and receiver details. The list now includes 3 W1s, 14 W2s, 16 W3s, 1 W4, 16 W8s and 1 W9. More information is wanted for future listings. Send information on your setup, if you are active on 420 Mc., to Glenn Skinner, W3RQT, 74 Amatel Ave., Newark, Del., or Lewis Lee, W3GGR, RFD 3, Elkton, Md.

On the air with 420-Mc. TV: W8RAIH, Pontiac, Mich. Ed's r.f. unit has a 4X150A amplifier, feeding a 24-element array. Modulator is a surplus ATJ unit, and the camera is a vidicon in a "peepee-creepee" design, patterned after industrial type cameras, with 350-line resolution. Sound is transmitted on the video carrier by narrow-band f.m.

W8RAIH stresses the importance of low-noise r.f. amplifiers for amateur TV reception. Converted u.h.f. TV converters simply do not "have it" for anything other than purely local work, unless topped up by the use of a really good r.f. amplifier. Ed's TV DX is W8ARR, 20 miles distant.

Also from Michigan, W8PT, Benton Harbor, wants it known that he is ready for 220-Mc. DX, either two-way on 220, or crossband to 144. Jack has a 5894 amplifier, feeding two 8-element stacked Yagis.

Another 220 plug comes from K6GKK, Long Beach, Cal. Ralph says that the 220 population of the Los Angeles area has now reached about 60 stations. A 220-Mc. net operates Mondays and Wednesdays at 1930 PDT.

OES Notes

K1BWX, N. Providence, R. I. — New 5-over-5 for 50 Mc., 85 feet up, has made marked improvement in both transmitting and receiving results.

W1UHF, N. Tiverton, R. I. — Fine tropospheric conditions Aug. 23-24 netted many 220-Mc. contacts with W2, 3 and 4. Best DX: W4UMF, Falls Church, Va. QRAM at low end of 220 now on good nights!

W2LXE, Tonawanda, N. Y. — Converting surplus camera for 420-Mc. TV.

W3WZ, Glenshaw, Pa. — Activity and interest in 420-Mc. work definitely on the way up in Allegheny County. Would like to hear from other W. Pa. u.h.f. enthusiasts, and will take on job of organizing a u.h.f. club, if interest warrants.

W4FEC, Auburn, Ala. — Experiments with high power to 826s on 144 Mc. indicate that at 1900 volts on the plates 700 watts is maximum useful input; c.w. of course.

W4HHK, Collierville, Tenn. — September auroras brought in signals from greater distances, and from farther south than any previously experienced. Sept. 4 session's best DX was W1REZ, most southerly station W4EQM, most westerly W5DFU. All signs peaked north or east of north. Turning to west produced no signals not audible on other headings.

K5DCQ, Irving, Texas — Have completed beacon transmitter for 50 Mc. and endless tape setup for A3 transmissions. Will send AGI World Warning information and make tests for propagation observations. Frequencies: 50.16, 59.225 or 53.34 Mc. Would appreciate heard reports.

W6LWT, San Diego, Cal. — Substitution of 6BS8 for the 6BQ7 in Communicator netted 2-dB. improvement in noise figure. Slight retuning necessary for optimum results.

Polarization tests made with W6KUG indicate better signal-to-noise ratio with horizontal. Large variation in signal levels noted during summer inversion season, with best signals around sundown.

W7BDE, Seattle, Wash. — Cooperative project with W7PUA, W7JIP, K6AXN and K6BAT directed toward the development of stable and effective gear for 1296 Mc.

W9GAB, Beloit, Wis. — Will run 144-Mc. m.s. skeds with any station interested. Recently completed high-stability high-accuracy tunable i.f. for use with crystal-controlled converters.

(Continued on page 176)



Hints and Kinks

For the Experimenter



AUDIBLE CONELRAD WARNING

THE CIRCUIT shown in Fig. 1 provides conelrad monitoring by mixing the output of a broadcast receiver with that of a ham-band communications receiver. The "background" signal caused by the broadcast audio will provide continuous monitoring as long as both receivers — and a broadcast station — are in operation. Amplitude of the background or warning level may be controlled by the volume control for the broadcast receiver. Although the system is simpler and less expensive than most of the a.v.c.

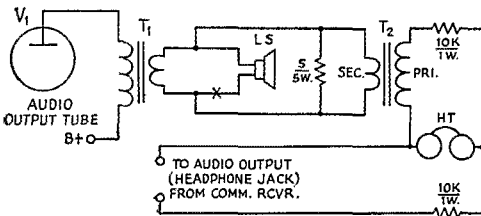

Fig. 1 — Circuit of the audible conelrad monitoring arrangement submitted by W1ZEO.

triggered arrangements, it may be used with any broadcast signal that *can be heard*. And in most cases, signals that can *just be heard* are ones having insufficient strength to operate reliably an a.v.c. controlled alarm.

LS, T₁ and V₁ in Fig. 1 are the loud-speaker, output transformer and audio-output tube, respectively, of a small broadcast receiver. T₂ is a transformer of either the filament or output type and must be connected with the secondary winding in parallel with the low-impedance side of T₁. The values of resistance shown in the schematic work well with headphones of 2000- to 8000-ohm impedance.

A s.p.s.t. toggle switch may be inserted at point X to disable the broadcast receiver loud-speaker if desirable.

— David T. Geiser, W1ZEO

MODIFYING 1625s FOR GROUNDED-GRID OPERATION

IN QST, June, 1955, W9MOW and W9SAR called attention to the desirability of providing a direct ground for the beam-forming plates of the type 1625 when the tube is used in grounded-grid applications. Although the previous modification instructions work well in practice, there is a simple method of providing the separate ground that does not require removing the original base and replacing it with a 6-prong type. At least, the method under consideration can be applied to Ken-Rad (GE), Canadian GE, and some unknown brands that come in Sky-tron cartons.

To get *into* the base of a tube, support it horizontally in a cradle such as a vise with Pins 5 and 6 at the top. Then, use either a rat-tail file or a jeweler's saw to cut a slot in the base directly above Pins 5 and 6. Make the slot about 1/4 inch wide and long enough to permit working around the two pins with a small tool such as a soldering aid. Now, apply heat from a soldering iron to the cathode pin, slip the beam-forming lead out of position, and insert it in Pin 5. Solder where needed, and the tube is ready for use.

— Harry W. Land, W5ZBF

Editor's Notes:

1) Cdr. Jesse F. Adams, MC, USN, KA7JA/W6FNT, also submitted the above hint for modifying type 1625s after he had picked the idea up from W6ESE. And he also reminds us that tubes made by National Union and Raytheon have the beam-forming lead brought out of the glass envelope (to Pin 6) where it is accessible after cutting into the base.

2) W. E. Howard, W8PWS, pulls the beam-forming and cathode leads *out* through a 1/4-inch hole drilled in the side of the base in between Pins 5 and 6. The hole is centered 1/4 inch above the bottom of the base and is drilled with care to prevent shattering of the glass stem at the center of the base. After the leads have been identified by means of an emission test, they are passed down over the *outside* of the base to Pins 5 and 6, and soldered. A few drops of Duco cement secure the leads to the side of the base.

3) Our own interest in modified 1625s led us down to the lab, the tube bin and then to the workbench. We not only found out that the above suggestions are indeed effective, but that the RCA 1625s — the ones we happen to have the most of — do not have the separate leads for the beam-forming and cathode elements. So here is one brand that there is no need for hacking into "just to find out."

A SIMPLE ANTENNA-SWITCHING ACCESSORY

THE need for a convenient method of quickly connecting either a receiver or transmitter to any one of four coaxial feed lines led to the development of the simple switching circuit shown in Fig. 2. The impedance characteristics of this inexpensive system may not be 100 per cent perfect, but the average amateur, operating on frequencies below 30 Mc., can usually tolerate a slight *bump* in the transmission line in exchange for a *dip* in cost.

Connectors J₁ through J₄ of Fig. 2 provide for inside-the-shack termination of four coaxial feed lines. S₁ is a selector switch used to connect any one of the lines to the antenna change-over relay, K₁. The normally-closed contact of K₁ is connected to the receiver jack, J₆, and the normally-open contact of the relay is connected through the r.f. ammeter to the transmitter jack, J₅. The control switch for the relay may be remotely located at the operating position. The ammeter is not a necessary component to the circuit (con-

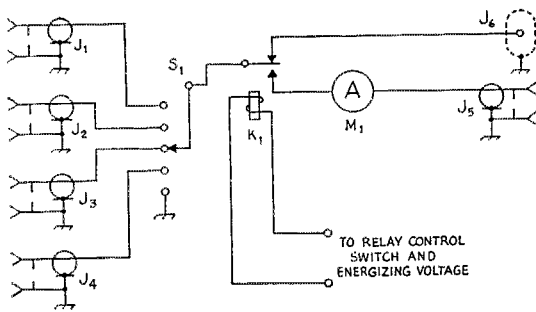

Fig. 2 — Circuit of the simple antenna-switching accessory used by W2EEJ.
 J₁-J₄, J₆ — Coaxial receptacle (SO-239).
 J₆ — Phono jack.
 K₁ — S.p.s.t. normally-open antenna relay.
 M₁ — R.f. ammeter; see text.

nect the relay directly to J₅ if the meter is not used), but it is well worth including.

An ordinary type of selector switch, preferably ceramic, may be used in the circuit for handling the output of low- and medium-power transmitters. If the transmitter used with the accessory is a high-power affair, it is advisable to use a heavy-duty switch such as that found in a surplus BC-365 tuning unit.

Any available metal box large enough to accommodate the jacks, meter, relay and switch may be used as a housing for the circuit. J₁ through J₆ may be mounted on the rear wall of the box and the other components should be arranged to provide for the shortest possible leads throughout the circuit. Use fairly stiff wire for all connections and avoid loops or wire *dress* that will increase stray capacitance or result in shorting. To prevent inadvertent connection of the transmitter to the normally-closed contacts of K₁, use a phono jack (J₆) for the connections to the receiver.

If a low-pass filter for TVI suppression is to be used, it should be installed between the transmitter and the antenna switch in normal fashion. It is advisable to label or otherwise mark the various feed lines and the jacks with which they mate to avoid confusion or improper connection.

The r.f. ammeter serves as a handy indicator for tuning and as a continuous check of the efficiency of the transmitter, particularly if original readings are noted for future reference. It will probably be observed that maximum output occurs with the final tuned slightly off the plate-current *dip*, and optimum grid drive and plate-loading conditions can be quickly determined by observing the meter. Naturally, the meter range — full-scale reading in amperes — required will be determined by the transmitter power-output level.

In use, an additional convenience is the ability to change antennas while receiving, resulting in a modified diversity type of reception which often helps to overcome fading. *Caution:* Remember to reset the switch before transmitting to avoid operating the final without a load.

— Herbert Greenberg, W2EEJ

ANOTHER USE FOR ALUMINUM FOIL

HERE IS AN IDEA which I found in the September, 1955, issue of the *P. F. Reporter*.

When doing touch-up painting or some similar small job, press some aluminum foil (such as Reynolds Wrap) into a cup or container and

paint from this. When finished, the excess paint can be poured back, and the foil thrown away, leaving a clean container and much less mess. It also works when cleaning brushes.

— R. L. Ellis

CUTTING COIL STOCK

THE USE of a small saw to cut Miniductor or Air-Dux is not very satisfactory because a considerable length of the coil is damaged. A hot razor blade may be used to cut even the smallest coils with no damage to adjacent turns. A single-edged blade is clamped in a bench vise. Paper or tape should be used to reduce heat loss to the vise. The tip of a soldering gun or iron is applied to the side of the razor blade while one of the plastic rods of the coil is pressed gently against the cutting edge. After cutting through all of the support bars, the two parts of the coil can be separated far enough to cut the wire with diagonal pliers.

— E. P. Smith, W3JYY

— • • • —

Close-spaced commercial coil stock can be cut without damaging adjacent turns by simply using a length of fine wire, a soldering iron, and a pair of long-nose pliers.

The wire used should be smaller in diameter than the spacing between turns. Loop it around a support bar as shown in Fig. 3 and then twist

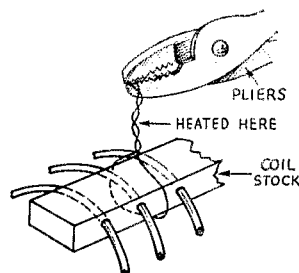

Fig. 3 — Sketch of W7WFC's "hot wire" method of cutting coil stock. Heat from a soldering iron is applied to the pigtail as indicated.

the ends into a pigtail. Grasp the free end with a pair of long-nose pliers and apply heat from a soldering gun at the point indicated. Pull the heated wire through the melted support bar, and then repeat the operation on the other three supports. Clip the two sections apart with a pair of cutters and the job is finished without strain.

— Dale E. Miller, W7WFC

RE THE 4X150A

WE have found that some 4X150As "go west" due to a short between control grid and screen grid. If a d.c. potential of 1800 to 2000 volts is impressed across these grids, the short is vaporized, and in many cases, the tube is returned to operative condition.

Any good v.t.v.m. may be used to check the circuit to show the high-resistance short. Naturally, infinite resistance will appear between grids of a good tube.

— *Dwight B. Olson, W9EAM, DL4GF*

ANOTHER ANTI-SKID TREATMENT FOR BUGS

DURING a three-week hiking expedition I came across the ultimate answer to the problem of sliding bugs. Dr. Scholl's Adhesive Foam, used to prevent blisters, is available from most drugstores at low cost. These foam-rubber pads are $\frac{3}{16}$ -inch thick by 6 inches square and have a layer of adhesive on one side, and a protective gauze covering on the other side.

The foam is cut into $\frac{3}{4}$ -inch squares, the protective gauze removed, and pressed onto the rubber mounting feet of the bug. The feet (of the bug, of course) should be free of dirt and perhaps roughly filed to make a better sticking surface for the Adhesive Foam. The foam pads will hold best on a smooth hard surface such as a table top.

— *Alex Goetz, DJ3BW, K6AGR*

COMPRESSION RING FOR OSCILLOSCOPE GRID SCREENS

HERE is an idea that will prevent celluloid grid screens from warping, falling out, or rotating around the face of an oscilloscope tube.

Cut a section from a black wire coat hanger, bend it into a circle having a diameter somewhat larger than that of the mounting ring at the front of the tube, and then insert it inside the ring against the celluloid scale. When the wire ring is released, the pressure between it and the tube ring will hold the scale in place.

The wire may now be removed and the length reduced so that there will be no overlap when the circle is again formed. A piece of black spaghetti may be slipped over the wire ends to give the loop a finished appearance.

— *Gordon A. Greene, W3VDD*

Fig. 1—Front view of the "A.C. Vari-volter." The bakelite binding post must be well insulated from the panel.

THE JOHNSON RANGER AS A 50-MC. EXCITER

OWNERS of the Johnson Ranger transmitter may obtain 25-Mc. output for driving a 50-Mc. doubler in the following way:

Using the v.f.o., tune up the transmitter in the normal way with the band switch in the 11-meter position and the v.f.o. at the low edge of the band. Now switch to an 8-Mc. crystal and retune the buffer and final for resonance points nearer maximum capacitance (toward the 0 end of the dials). With the usual surplus type crystals, it is possible to develop nearly maximum grid drive. Keying ranges from fair to very good, depending on the crystal. The audio output of the Ranger is available at the accessory socket for use in such an application.

The rabid 50-Mc. man may decide to pad the 11-meter position of the v.f.o. to obtain v.f.o. control at the above frequencies. I have not tried this and therefore cannot vouch for the idea.

— *Otto Woolley, W0SSG*

THE "A.C. VARIVOLTER"

MOST experimentally-inclined hams will agree that the compact type 10 Powerstat (Superior Electric Co.) variable autotransformer, which gives a range of voltages all the way from 0 to 132 volts, is a mighty handy device to have around. As purchased, however, it is unmounted, which makes it rather awkward to use. Maximum convenience, as well as maximum performance of the unit, may be easily obtained by mounting the Powerstat in a $4 \times 5 \times 6$ -inch aluminum box with an ON-OFF switch, a 0-150 a.c. voltmeter, a chassis type outlet and a pair of binding posts.

An assembly as described is shown in Fig. 1. Decals are used to label the controls, and the handle at the top of the box is an ordinary screen-door pull.

— *Frank H. Tooker*





Correspondence From Members -

The publishers of *QST* assume no responsibility for statements made herein by correspondents.

ONE LESS WYOMING

Box 670
Worland, Wyoming

Editor, *QST*:

You should have published my ltr earlier (Sept. *QST*, p. 59). Sudden change of plans and I am moving the QTH to Washington State. Have received numerous requests for skeds and have tried to make as many contacts as possible before leaving. Have enlisted the help of KN7AHO and W7DTD who will attempt to handle any more traffic that comes in. Want to thank all the ops who have written. If you don't get a card for a while, just hang on. My mail will be forwarded and I'll have to reroute it back to Wyoming before AHO or DTD can make a sked. Am very sad I won't be able to work the skeds as the response has been terrific. Will miss being so popular but hope someone will give me a shout when I get the rig on the air again.

— Bob De Vries, W7HAL

SAFETY

Route 2 — Box 755
Benton, Arkansas

Editor, *QST*:

Your September editorial regarding safety reminds me of a frequently-overlooked source of danger in both amateur and commercial equipment. The capacitors so frequently used to bypass the 115- or 230-volt power line, if shorted to the chassis, place the operator in a precarious position if the grounding system fails to take care of the short circuit. Particularly where units of equipment have been removed from racks or cabinets, a chassis at line potential can be a lethal weapon. The fact that most bypassing of power lines is done immediately after the lines enter the chassis and before they go through switches means that such a dangerous condition may exist even if all switches are in the "off" position. In this case complacency is a good companion to shock.

The writer vividly remembers what happened when resting one hand on a chassis while dropping a temporary antenna over a steel easement window!

— Dale Woosley, W5KYQ

CURSES!

P. O. Box 1202
Florence, S. C.

Editor, *QST*:

"Tail ending" is a curse second only to swishing the v.f.o. with the final on. If the procedure of "tail ending" indicates a "sharp guy" then put me down for remaining with the "Squares"!

As a sequel to the article appearing on page 59 of the August, '57 issue of *QST* please have the boys in the technical department run an article on how to build a "Tail ending QRM filter" before the next DX Contest.

— John N. Ellis, W4AUL

HAPPY

Rt. 1 — Box 1273
Auburn, Calif.

Editor, *QST*:

Just a note to let you know that I think the one-element beam as shown and described in your *ARRL Antenna Book* does a very good job for me on 15 meters.

Have been on the air since May 28 and have 32 states confirmed along with WL7, KH6 and DU5. Yesterday was a field day: worked a VE3, KH6, WL7, FK8AH, and VK3TX along with W1s, W4s and way points!

I built the antenna for about \$7, excluding a TV rotor, put it up with approximately 88 feet of coax lead and it's still there — no fuss, no mess.

I am not a stayer-upper. I usually work from 8 to 10 P.M. and off and on Sunday when the band is in. There are others who probably do better but I still have fun.

— F. L. Toune, KN6ZZB

ROTTEN QRM

1360 S. Curson Ave.
Los Angeles, Calif.

Editor, *QST*:

Here on the West Coast many of us take the code practice from K6USN four nights a week at 1830 PDT. I have had the feeling for a long time that other stations unintentionally interfered with the practice because it was not given enough publicity.

Now my opinion has changed. After trying to copy W1AW during the code-proficiency program of August 19, it is plain that there are some amateurs who have no regard for fellow hams. Is there any code program anywhere that is more widely known than the code-proficiency program of W1AW? A person who would QRM a program that raises the standard of operation on our bands isn't the kind of person that belongs in our hobby.

— Barry Taylor, K6SQR

ALL DRESSED UP

354 Osage
Park Forest, Ill.

Editor, *QST*:

Congratulations on your new make-up! The new borders on your boxes are very attractive, and the use of several styles breaks up the monotony of an unvarying page style. Laurels to you also on the new caption type; it's clean, crisp, and highly legible. In my opinion, it's going to make a lot of hams a little bit happier to open their issues every month and no longer see the stiff, stylized, and over-formal format which has been discarded.

Enclosed find a check for the renewal of my subscription and membership. I had no doubts over the question of renewal before your changeover, but now it's almost as if I'm getting a bonus for renewing!

— Frank Joseph, W9AOI

2840 Catherine St.
Dallas 11, Texas

Editor, *QST*:

Your new layout sure is handsome.

— Tom Coates, W5ZJB

RESEMBLANCE

333 N. Meramec
Clayton 5, Mo.

Editor, *QST*:

September issue arrived. I looked at the cover. I looked at my rig. W9UQ will be silent until alterations are completed: the similarity was appalling.

— Bob Leary, W9UQ

RED RADIO

5624-67th Avenue
East Riverdale, Md.

Editor, *QST*:

It's not often I put my general coverage receiver to work on anything other than the ham bands but tonight things were a bit dead and I decided to see how the other half lives (Continued on page 176)



Operating News



F. E. HANDY, W1BDI, Communications Mgr.
GEORGE HART, WINJM, Natl. Emerg. Coordinator
PHIL SIMMONS, W1ZDP, Asst. Comm. Mgr., C.W.

ROBERT L. WHITE, WIWPO, DXCC Awards
LILLIAN M. SALTER, W1ZJE, Administrative Aide
ELLEN WHITE, WIYYM, Asst. Comm. Mgr., Phone

Are You in RACES? As of August 15 there are officially on file some 916 plans for operation under the *Radio Amateur Civil Emergency Service*. The FCDA list includes at least one plan in each of the 48 states, the number varying from state to state and in the several FCDA regions, the Dist. of Columbia, Alaska, and Hawaii.

This progress invites attention of all amateurs to the fact that about forty per cent of our amateur service regulations (see License Manual) deal with the special RACES provisions. Every one of us FCC-licensed amateurs who has a station license and is other than Novice or Technician class operator is eligible for a RACES station authorization provided (a) he is certified by the appropriate civil defense radio officer (on FCC form 481-1) as enrolled in the civil defense organization serving his area, and (b) the amateur station is approved to be a unit of a c.d. network in accord with the particular c.d. communications plan.

Operator requirements in view of the extensive needs for personnel in this service are even broader and provide a place for the Technician or Novice class also. All classes of amateur operators may be enrolled and certified for operation under RACES. The scope of participation of course is according to individual license qualifications. Technician and Novice may not handle RACES radiotelegraph manually-keyed circuits, or the Novice perform technical adjustments or servicing of transmitters. These new figures demonstrate the steady progress of the *Radio Amateur Civil Emergency Service* since its inception in 1952. RACES offers the way for definite application of our skill as communicating amateurs and for the continuation of amateur work in the public interest on earmarked RACES frequencies for civil defense in the event of national emergency . . . such as might once again suspend other amateur privileges.

We mention all this to ask, "Are you in RACES?" Advance inquiry, your suggestions to further filing of local c.d. communications plans, and your certification as an operator or station taking part in tests under RACES will take only a little of your time. If not already RACES authorized, you will find it highly rewarding as a citizen and amateur to be signed up in RACES. Try it?

Ideas for Contest Changes Welcomed With Operating Contest Reports. Contest rules and organizational patterns have been progressively changed through the years. Such adjustments usually become of smaller magnitude as the best forms are evolved. But change is part of living and the policy of constant review of our forms has been helpful to their betterment. Evolutionary change has proved better than the radical changes that have sometimes been put forward by those with special axes to grind.

More widespread understanding of the rules in our activities comes from keeping them fairly constant. Operational improvement should be an aim beyond mere popularity and participation. While evolutionary progress may not satisfy all who would want to remake the world overnight,

there is a better assimilation of change where it is a gradual adjustment to keep techniques to the fore. Change is not desirable for the sake of change itself, but only where the advantages really outweigh the disadvantages. In the SS and other choice activities, please send any ideas and comments along with your participation report so they can be staff-reviewed in planning for the future.

What Disasters Prove. Traffic Netters should all be registered in our ARRL Emergency Corps, and ARRL-RACES folks, above and beyond registering their interest, should handle some traffic right along. ARRL has long advocated combining the traffic know-how and contact with the jobs of highest importance that we may tackle. Our more cynical readers may think these statements just some rather trite pronouncements (!). But *Pacific Area Net News* also has something to say on this subject, so it's just possible there's something in it:

"This has been a bad summer for a lot of nets have been finding themselves called upon to aid in many disaster-stricken areas. One big fault with the average "emergency" net is that it is not used to handling traffic and when an emergency actually comes around some of the traffic takes on a weird appearance. And very few of our traffickers are members of their local ARRL *which all of them should be*. At least they should be registered with the EC so he will know *who* handles traffic for *where*. Only when disaster strikes does the average emergency net find a main function to handle traffic and a whole flock of it, all at once. To the average trafficker this is no problem, but to the non-trafficker who finds himself with a flood of messages, and all of them of a RUSH nature, it is sometimes perplexing. Wouldn't a little planning help on this — a few instructions in how to make up a message, and perhaps a little traffic handling on the emergency nets (even if only of a drill nature) — at least the group would be given some idea of what to do and when."

Whenever stand-by communications are called for, traffic know-how and the emergency organization are coupled in a common destiny. To have a chance to do *best* service, the trafficker should be welcomed by ECs and ROs into their organization; and emergency-dedicated groups should have concrete communications plans and run some traffic in their tests. And while talking about traffic here's another point on message-check, substantially as it appeared in PANN (W7FIX):

"Why a Check on Traffic? Traffic handling is not at all complicated. There is a standard form for a message. The sender gives you the address and text, and the general idea is to get that text to the addressee without any words missing or added. But you can't deliver a complete message without a 'CK'. Without checking you don't know if the words are all there! Of course every amateur knows the simple formula for getting a word count. This is just the count of the words in the text 'as sent.' If the originating station does not give you a check, tell him what it is, and get his OK for it in the preamble."

The 24th ARRL Sweepstakes! A nationwide operating event, the SS is always tops, so don't miss this chance to give your station a real work-out. For Nov. 9-10 and 16-17 you can choose your mode and take part using phone or c.w., just as you like. The Sweepstakes, more than most any contest, builds operating ability of a high order. QSO results are assured with low as well as high power, probably one of the reasons for its high popularity.

In the last SS thirty-five fellows worked all 73 Sections, many more than this got all states, and an untold multitude found missing states for WAS. As stations in different sections are worked

(see list page 6) these multipliers can be checked off in the front of QST. There are certificates for all winners at Section level, and to leaders in club groups, bona fide members taking part in the club's local area submit at least three contest entries in the same mode, thus making the minimum level of competition. The highest Novice or Technician score may likewise be certified by the League where there are three competing logs.

There's a limit of 40 hours total operating time as defined in the detailed rules. Study those as they appear elsewhere in this QST. The two week-ends minimize the chance of a spell of poor radio conditions spoiling our fun. If you have to be away one week end, it's possible to have a good operating time the other week. If new to the SS, you will find that just a few minutes will suffice to get the hang of making the exchange. Note that it's as fast and more definite to send NOV 9 instead of the word "date" and much clearer where your signal straddles a time zone. We honestly think the SS one of the year's most inviting chances to see what your station can do. We hope you get in it and like it. Get our SS reporting forms free on request or just follow the sample with the announcement. Good luck!

— F. E. H.

DX CENTURY CLUB AWARDS

HONOR ROLL			HONOR ROLL			HONOR ROLL		
W1FHL.....273	W6MX.....268	W6CUN.....265	W7IQI.....190	E43KB.....159	OH2VZ.....132	W9KXK.....190	K6ENL.....156	G3HCL.....131
W6AM.....272	PY2CK.....268	KV4AA.....265	OH3RA.....186	G3BNC.....154	W0YFG.....130	ZL2HP.....185	W0PGT.....153	HR2NU.....130
W8HGW.....271	W8NBK.....267	W3KT.....265	W9YEX.....184	G2SX.....152	G3HLJ.....128	W9YEX.....184	G2SX.....152	G3HLJ.....128
W6LNV.....270	W6DZZ.....266	ZL2GX.....264	G8KS.....181	W1NLM.....151	W9POB.....122	W1BGA.....180	K5ABW.....151	W4BEY.....121
W8NDA.....269	W08YG.....266	W6TT.....264	W1BGA.....180	K5ABW.....151	W4BEY.....121	W6GMF.....180	W2YTH.....150	W5GAI.....121
W3CHD.....269	W6BRA.....266	W7AMX.....264	W7DA.....180	W3KDF.....150	W6JL.....121	W7EA.....180	W9HQP.....150	SM5CB.....121
	W6RW.....265		W7EA.....180	W9HQP.....150	SM5CB.....121	IT1TAI.....179	EA4BH.....150	W1PS.....120
			W5RIO.....174	G3ESY.....150	K5DGH.....120	W2TWC.....171	VE7MD.....150	W0JFI.....120
			W2TWC.....171	VE7MD.....150	W0JFI.....120	F8LJ.....171	W2ROM.....148	G3IOR.....120
			VE6NN.....171	W61PH.....148	T1NT.....120	W1ODW.....170	W3EBG.....143	W5NG.....117
			W2CWX.....170	DL3SZ.....143	W4YZZ.....116	W6GMC.....170	W5MCO.....142	W4BWP.....115
			CR6BX.....170	VE1BK.....142	KL7PIV.....114	W2DEC.....166	PA0RLP.....141	G3GNM.....113
			W2DEC.....166	PA0RLP.....141	G3GNM.....113	G6RC.....163	W1PFA.....140	W2JGM.....112
			W9TZ8.....162	W2BUI.....140	W0YUC.....111	W9DYG.....161	W3KFK.....140	VE2APH.....111
			F3FA.....161	W4CYR.....140	W2AWH.....110	W1QMM.....160	W8PCS.....140	W2NTN.....110
			W7AUS.....160	W0BPA.....140	W4YGZ.....110	W7AUS.....160	W0BPA.....140	W4YGZ.....110
			K9BVB.....160	W3BYL.....138	K6KJR.....110			

From August 15, to September 15, 1957, DXCC certificates and endorsements based on postwar contacts with 100-or-more countries have been issued by the ARRL Communications Department to the amateurs listed below.

NEW MEMBERS

LA5YE.....191	GA4ED.....106	OE5BW.....102	W6GVM.....208	HB9ET.....168	EA3GL.....136
FA2CB.....141	OH2HK.....106	W3HVM.....101	PY4CB.....203	W2EOH.....164	HR9NU.....127
K6AYA.....138	SM7AUG.....106	K9DDO.....101	G3FNC.....200	W2YJ.....160	W8CYL.....126
W8OKB.....123	W2QO.....104	F8R.....101	W9WFM.....192	CR6BX.....157	W1PNE.....122
G3JKP.....121	DL1SE.....104	GW2TW.....101	W0GKL.....191	W8ZOK.....156	W8TUA.....122
ZD6RM.....121	OA4C.....104	VK1EG.....101	W5KBU.....190	W8MRC.....150	W8WJ.....120
SP8CK.....113	SM5OW.....104	W2BAMK.....100	W5KBU.....190	G3RNC.....145	W8ZET.....120
K4LPW.....112	YV4AU.....104	W3WJD.....100	LA5YE.....190	EA3KB.....143	W4BWP.....113
W1JSS.....111	W4LCY.....103	K4AL.....100	YV5AB.....190	CT1MB.....141	W5NGN.....111
FA3IKL.....111	W4RCG.....103	K4BL.....100	W4NYN.....183	CE3DY.....140	W5MZF.....110
JA3BP.....111	W6OKD.....103	K5BGB.....100		EA2CB.....140	W0GPR.....110
SM5RC.....111	HB9TT.....103	W5FDL.....100			
UZ2AA.....110	SM5AFT.....103	K6HFB.....100			
L1ZKPZ.....108	VE5KG.....103	W6GSL.....100			
CT1CB.....107	DL1UR.....102	W7TMF.....100			
G3GWO.....106	F8JB.....102	W9LSV.....100			

Radiotelephone

W0DST.....114	W3QMG.....102	W8CSN.....100	W2ACW.....263	VE9WW.....192	VE8AW.....191
W1JSS.....111	W6JFI.....101	CR6AG.....100	W4TM.....255	VE3QD.....210	VO6EP.....190
W6DLN.....110	W0BYY.....100	DL1WP.....100	W5AQ.....262	VE4XO.....118	Z66BW.....255
W3ZQ.....105	W3ZKM.....100	LU9FAY.....100	W0AIW.....252	VE5ZQ.....140	4X4RE.....222

ENDORSEMENTS

W6TS.....260	W3GRF.....219	W7FB.....201	VE1PQ.....170	VE7ZM.....228
W8DMD.....260	W1AR.....212	W6PH.....200		
W5ADZ.....259	W2UFT.....212	W8GLK.....200		
W5KC.....242	W8EV.....212	G3FKM.....200		
W1JYH.....240	W7ENW.....211	W6EPR.....184		
W8FRC.....240	W5PCN.....210	W8QNA.....193		
W2TQC.....230	K6ENX.....210	W7EJD.....192		
W4HA.....230	G3FNB.....203	K6EWL.....191		
G3YF.....227	W6FOZ.....202	CN8MI.....191		
W5OLG.....221	HB9ET.....202	W6ATO.....190		

Radiotelephone

W6GVM.....208	HB9ET.....168	EA3GL.....136
PY4CB.....203	W2EOH.....164	HR9NU.....127
G3FNC.....200	W2YJ.....160	W8CYL.....126
W9WFM.....192	CR6BX.....157	W1PNE.....122
W0GKL.....191	W8ZOK.....156	W8TUA.....122
W5KBU.....190	W8MRC.....150	W8WJ.....120
LA5YE.....190	G3RNC.....145	W8ZET.....120
YV5AB.....190	EA3KB.....143	W4BWP.....113
W4NYN.....183	CT1MB.....141	W5NGN.....111
	CE3DY.....140	W5MZF.....110
	EA2CB.....140	W0GPR.....110

W/VE/VO Call Area and Continental Leaders

W2ACW.....263	VE9WW.....192	VE8AW.....191
W4TM.....255	VE3QD.....210	VO6EP.....190
W5AQ.....262	VE4XO.....118	Z66BW.....255
W0AIW.....252	VE5ZQ.....140	4X4RE.....222
VE1PQ.....170	VE6VK.....173	G2PL.....263
	VE7ZM.....228	

Radiotelephone

W2RKA.....207	VE1CR.....122	VE7ZM.....185
W4HA.....212	VE2GQ.....130	ZL2GX.....230
W5BCP.....224	VE3KF.....163	ODSAB.....180
W7HIA.....190	VE5RU.....116	EA2CQ.....230
W0AIW.....231	VE6NX.....106	

IDEAS TO PROMOTE EFFICIENT NET OPERATIONS

For the last several years more and more net registrations have been recorded — the main purpose stated as traffic handling and for emergency. It is ARRL policy to encourage each state or Section to have one or more nets, tied together by daily radio connections (liaison stations) between them. Section net certificates are issued by or under the jurisdiction of Section Communications Managers to net members who earn them by regular attendance and appropriate connections for moving traffic in and out of the Section areas to all points. There are c.w., phone, and v.h.f. nets; just about all bands are represented. Recognition is granted all nets that register their information in the *ARRL Net Directory*, a printed net list that becomes available on request toward the end of each year.

The booklet *Operating an Amateur Radio Station* contains our basic information on starting a net, network operation and the functions of net control.

This month it is our pleasure to present the best current practical data on Net Operation from some of the going nets, with credit to the various sources of information. Almost without exception any active amateur operator in a section has merely to report in on the net frequency of a given net in that section to be welcomed. Route Managers and Phone Activities Managers can tell you about their nets and the NCS without exception can tell you who they are. Your SCM (see address and invitation page 6 of each *QST*) welcomes all monthly reports of station activities, and also holds out station recognition in appointments as Official Relay Station, Official Phone Station, Official Experimental Station, etc., to those members who qualify by demonstrating interest and activity and report their work through the SCM. To help you understand how nets work, and so you can hook up smoothly with these commendable organized groups doing so much in amateur radio, we're happy to present the following notes.

Net Procedures

The purpose of a set net procedure is to avoid wasting time and to insure that all net members know what is going on. While a uniform and standardized procedure is highly desirable, it varies according to the class of net and whether voice or c.w. operation is used. The use of "QN" and "Q" Signals is required, and a list of these should be on hand for reference on c.w. nets. But the use of Q sigs on voice nets is not recommended unless phonetics are used. This actually

serves no purpose as plain English is more easily transmitted and understood.

Methods used by the NCS to determine who is present and the traffic they have vary greatly, running from a direct roll call on a c.w. section net and a roll call by cities on a section phone net to the general calling used on regional and area nets. Yet all serve the same purpose.

The following general rules are applicable to all nets:

(A) Transmit *only* when invited to do so by the NCS, even though you only wish to "help."

(B) Report into the net promptly at the appointed time.

(C) Copy all net transmissions, whether or not they are addressed to your station.

(D) Answer promptly when the NCS calls you and DO NOT LEAVE THE NET without first notifying the NCS that you are doing so.

(E) In phone operation, use recommended phonetics in spelling.

(F) If directed to go off the net frequency to handle net traffic, return to and report back into the net as soon as you have finished. Do NOT start a ragchew session off side. Save remarks and conversation *until the net is free*.

(G) Send your SCM your Station Activity Report on the first of each month.

Much more can be learned about net operation and procedure than can be put into print if you will copy all transmissions and pay particular attention to instructions of the NCS.

Repeating: the purpose of a set procedure in net operations is to save time, to enable the NCS to say in a few words what he desires done, and to have these instructions understood by all net members. Any time you waste on the net is time wasted for every net member present. — *Pacific Area Net News*.

Phone Net Operations

As an assist to those forming new section phone nets this season, we're presenting some comments and ideas received from seven or eight of the most successful phone nets in the business. This material has been distributed in mid-'57 to ARRL Phone Activities Managers (through ARRL Phone Bulletin No. 11) to assist in their organization efforts.

On Keeping NCS Records. "For keeping track of our stations, we use small index cards kept in a file box, the card (for each net station) is stamped or dated each time that station answers; if after calls on three different net sessions he fails to answer he is dropped but given a chance to renew at any time. We have a mimeo form worked up in columns which goes: date, station with traffic, traffic for, QSO, and two other columns for listing newcomers or what have you." — *WØFNS*.

Ideas From The Alabama Phone Emergency Net. "Our members are each urged to have means for determining their percentage of modulation, thus avoiding questions of "How is my modulation?" They're also urged to use break-to-talk provisions. When drafting messages,

unusual words should be avoided in the interest of accuracy. Member stations agree not to use Q signals in the phone bands. They say, "interference" not QRM or "stand by" not QRX, etc. The word roger is used as a general signal of understanding on receipt." — *W4TKL*.

Virginia Fone Net Practice. "Here are some points which help to keep our net one of the most outstanding phone nets from a performance and traffic standpoint:

1. NCS will call net promptly at 1900. All stations should be *on time* and *on frequency*.
2. NCS will list traffic only. Priority traffic will be handled at once, at the NCS' discretion.
3. Roll call. No breaking stations will be recognized.
4. Standby for mobile stations.
5. Traffic will be handled at this time.
6. Standby for late comers and new members. If we are late, we should be willing to wait until called.
7. Round-table session, one minute each and perhaps go around more than once if traffic is light.
8. Sign net clear.

"In reporting on the net do not say "break break," just give your call. The NCS will get you faster that way. When called during roll call, just give your call and your location. It will save a lot of time and help others to know where you are located. Net operation is time consuming, and we can cut down the time if we become better operators. Do your best to cooperate with your NCS each session. A good net operator is a patient listener." — *K4AET*.

South Dakota Phone Net. "To facilitate traffic exchanges and not promote unneeded calls, we recommend that our netters say "by for check," or "break" and then after a pause go ahead. If stations are copying each other well, it is only necessary for the sending station to break his carrier to listen momentarily. Only the receiving station that requires a fill or repeat or more time needs to turn his carrier on. If that carrier is not heard, the sending station continues the message. For our netters we recommend the "2 in 1" Rand-McNally pocket map and road map. Its index lists every named place in our state." — *W0SCT*.

Nebraska 75-Meter Phone Net Tip. In our experience good zero-beating can make the difference between a smooth-working session and one that is somewhat messed up. It will have the same effect at times as increasing your signal many times in strength. It's one of the differences between a good operator and a lesser one.

Routing Guide Assists Net Operations. The Conn. PAM, W1YBH, prepared a mimeographed list of all CPN stations operating within different Connecticut telephone areas, indicating stations within the areas as well as those having free phone service into the different areas. This has proved a ready help for fast routing of any and all messages to the areas in which fast and economical delivery of traffic can be made. We suggest that all PAMs, net managers and

NCS obtain from their telephone company the comparable state-wide information to have on tap to assist net operations this season.

Indiana Fone Net. "At a meeting in Ft. Wayne, a plan was set up for promotion of good relations between a.m. and s.s.b. operators. We will have an educational program one night a week just before net time, conducted by an outstanding sideband station. After a few sessions of this type we plan to have an s.s.b. station take NCS one night a week. More ideas or suggestions along this line will be appreciated." — *W9NTA*

NATIONAL RTTY CALLING AND WORKING FREQUENCIES

3620 kc. 7140 kc.

These frequencies are employed throughout the United States by amateurs using radioteletype.

HURRICANE AUDREY

Lest those who submitted information on Hurricane Audrey not mentioned in the October *QST* article feel that they have been slighted, we hasten (?) to prepare this supplement to that article telling of the things that went on elsewhere in connection with the antics of this cantankerous female. The disconnection between the two pieces of information arose because your NEC took a vacation (as he always does when an emergency is coming up) and the W5SKW-W5BSR article was rushed into print in his absence. We don't want to omit anybody, so:

K5BJU, in HARC (Houston Amateur Radio Club) News, mentions several stations who have not received previous mention. It seems that Audrey created a little ruckus elsewhere than in the Lake Charles, Cameron vicinity. K5ALF and W5SDA teamed up to start a net which operated continuously until Audrey had moved from Port Arthur to Lake Charles and east to the Mississippi Valley. Other stations participating in this net included W5s ZPD RGD AVW EYE ZIN MON CRH BNI and SYL. K5FFB was also heard dispatching emergency traffic. Along with W5CCD in another net were W5s NSI HIIT MIWE DKU and FYZ.

W5OPJ of Port Arthur also did considerable work in keeping frequencies clear and relaying traffic for lower-powered traffic. Among other Port Arthur stations active during the emergency were W5s UV CCT EEW AEK AWZ EHK, K5V5s JFM IBN and W5ZBU of Lake Charles.

We think that W4SUD should get a mention for his attempts to be of service in handling welfare traffic, most of which the already-established nets were under the necessity of refusing. Sent to Eunice, La., on company business as a result of the hurricane, he found everything under control and set out to ascertain how his mobile communications facilities could help. At Red Cross headquarters he was told that there was no room for an amateur station. At the courthouse he found amateur stations already in operation, but no room for another one. Joining a Salvation Army caravan to Cameron, he found two amateur stations already in operation there at the courthouse, but again no room for another one. He set up at Salvation Army headquarters, using the tail gate of his station wagon for an operating position, but the 75 and 40 meter channels were crowded beyond capacity, so he reported into a MARS net and was able to handle considerable welfare traffic until ordered to leave because of possible contamination from dead cattle.

W5CCD received a personal letter from the Mayor of New Iberia, La., for his efficient handling of welfare traffic at Lake Charles from W5DKU. Mentioned as having been particularly outstanding by SEC and state radio officer K5BES in the emergency were W5s CCD SKW BSR CTQ HIIT and K5BQT.

We also have a report from an anonymous source in Dickinson, Texas, which credits three local amateurs with repairing a blown-down antenna tower at the fire station at considerable risk to themselves during the height of the storm. They are K5DER, K5DGW and KN5IHS.



A number of SECs have complained to us recently that they cannot get their ECs to report on Form 5 (or any other way, for that matter) and therefore don't see much point in making their monthly report on Form 8. Some SECs have even supplied their ECs with return-addressed and stamped Form 5 cards, at our suggestion, without much better success. A few "test" inquiries have revealed several reasons for delinquency in reporting, among them the following: (1) No activity, so nothing to report. (2) Didn't know they were supposed to report. (3) Don't have any of the forms. (4) Can't remember it. (5) Don't see any sense in it, reports don't mean a thing. (6) All civil defense, so no AREC activity. (7) Don't like the SEC. (8) Inactive EC, not really interested but holding down the appointment on paper.

None of these reasons is prevalent, but all added together they spell an uncomfortable amount of indifference, either on the part of the EC, his AREC organization, or both. In either case, there is a remedy. If the indifference is on the part of the EC, a new EC might add some much-needed life to the organization. If the EC is active but the AREC members lax, interest can be stirred up and new AREC members recruited by sponsorship of more activities. In other words, if there is no life, create some. If most civic organizations or agencies are cool to the use of amateur radio for emergency communications, *show* them what you can do, don't just tell them and complain about lack of cooperation, lack of equipment or lack of facilities.

As for reporting: the SEC cannot know what you are doing, or even that you are doing nothing, unless you tell him. A report of no activity is better than no report, because at least it tells him that you are still around, still interested, and willing, if not able, to do your job. *Every* EC should report his monthly status to his SEC, no matter what it is. And if you get tired of making negative reports, maybe rather than stopping the reports you will do something to make them positive.

Still some unfinished business on the Kansas City tornado. Oregon SCM W7JDX informs us that one of his boys played an important part in the emergency, but apparently no prior mention has been made of it. Driving through Kansas on his vacation, W7KEN happened into Ruskin Heights just the day after the big tornado, May 21. From his mobile rig, he was instrumental in finding lost relatives, getting traffic out of the area, and locating shelters for homeless persons.

About 0200 June 15 the St. Clair County (Ill.) area was struck by a flash flood caused by rainfall of 13 inches in six hours! W9BA, the EC, discovered on arising at 0530 that the water was 10 to 12 feet deep on the streets, houses were flooded, and things in general were a mess. Unable to raise anyone on 29,640 kc., he made contact with Scott Air Force Base and Mascoutah on MARS frequencies. Belleville was severed in two by the overflowing of Richland Creek and the breaking of the St. Clair dam. W9BA acted as NCS and after getting in contact with W9UOR/m and W9NXY/m had them alternate as NCS at the temporary c.d. headquarters. Later in the afternoon W9JAY moved his station into the temporary c.d. headquarters and he and K9BLY operated until 0130 next day, after which time amateur communications were no longer needed. W9TCX operated a hand-carried unit in this emergency, performing some valuable communications for the Illinois Light and Power Company, whose radio circuit was out, with the aid of W9KNX and W9BMV. Other mobiles on the job were W9QDM/m and W9RQR/m. Other amateurs participating were W9s ATU EWU END and K9CNM. — W9BA, EC St. Clair Co., Ill.

Supplementing the Fargo, N. Dak., tornado writeup in October QST, we should add the calls W0RRW and K0IYI to the list of amateurs participating. W0RRW was one of the mobiles initially dispersed to operate in the area under

NCS W0QWZ. K0IYI, with superior receiving conditions to those at W0QWZ, assisted in relaying some traffic to the NCS.

On June 25 at 1205 the Red Cross of St. Paul, Minn., called W0PDN, trustee of club station W0DKI, to ask for communications between the chapter house and two Army amphibious units evacuating people, animals and household goods from the Mississippi River flooded area. W0PDN contacted W0IPN, who was able to activate some c.d. units and a number of AREC amateurs. W0DKI was set up in the chapter house and conducted emergency communications from June 25 through June 29, in continuous operation except for short periods during the night when operations in the flood area were halted temporarily. Communications were conducted on 29,520, but could just as easily have been done on 6 meters, because the units used had been constructed by local amateurs to utilize either band. Admittedly, says W0PDN to whom we are indebted for this report, more pigs were saved than people, but the communications to save the pigs were just as vital to the success of the operation. Other amateurs participating: W0s SXU YHF EXC DNO SEC HAFK THY ULU PZV REA WJW UMK ZTX TPO VAF, K0s GIZ ERP GFL AXA AIN.

During Hurricane Bertha a c.w. net was set up on 7115 kc. on Aug. 9 at 1425 CST to help support the already-set-up phone net. This net was in operation until 2400. Net controls were K5s EAW DNQ and DDII with W5BVG assisting in the afternoon. Other stations taking part included K5s HSW EVG BJQ AGJ AOK ADE DOM LPA, W5s NXL WMT EGD ADP QQM VLW, K4OOR, W4WSP 5 and W4HIA. — K5DNQ.

The SCM and SEC of Indiana, W9NTA and W9QYQ respectively, decided to make a barnstorming trip throughout the state to visit the various FD installations operating during that memorable week end in June. After operating an hour and a half from the Hoosier Hills Ham Club, W9QYQ took off with W9ZSX as co-pilot, picked up W9NTA at Martinsville and off they went. From what we could gather out of W9QYQ's rambling account of the rambling journey, they visited 11 club groups, spending a little time at each and contacting most of them from the mobile rig on 2, 6 or 75 meters before, during or after each visit. Whom did they visit? Gosh, we don't know. From Frank's account, we get that they visited the MARC, the IRC, the WEARC, the Cass. Co. Radio Club, and unnamed club groups at Anderson, Muncie, Marion, Logansport, Lafayette and Frankfort, and at least a couple of others. By the time they got back home Sunday, they probably didn't know whom they had visited or why. But Frank says it was a whale of a lot of fun, and made a lot of good personal contacts as well as running up a score for W9QYQ. Incidentally, Frank, W9QYQ, received a plaque as the Outstanding Hoosier Amateur for 1957, awarded by the Indiana Radio Club Council for his work in AREC and RACES. He's a real ball of fire, and you hoosiers are lucky to have him as SEC.

W5UMY reports the results of "Operation Rebound," an operation to test the usefulness of PCDA emergency hospital units throughout Southern Texas. The drill started on March 29 at 1400 CST and concluded the next day at 0600. The Brazoria County Amateur Radio Club set up and operated five stations on 80-meter phone and c.w. and on 144 Mc. to assist in the operation. Results indicated, W5UMY reports, that the effectiveness of communications on 75-meter phone is very doubtful when compared to 80 c.w. and v.h.f., mostly because of QRM and changing skip. Considerable trouble was experienced on 75, none at all on 80, and Charley recommends more use of c.w. for emergency purposes. Traffic handled averaged about 14 per hour, with 37 operators active or assisting. The test was considered a great success, largely because of the many lessons learned.

In Harris County, a portable rig was set up at Baylor Medical School and manned by three medical students: W5GFX, K5JHW and K5HVN. They made contact with W5BVU at M. D. Anderson Hospital in Houston, with W5JNE and W5BRM relaying as required.

On March 31, a mass Salk Vaccination program was given in Harris County (Texas) at 22 clinics and hospitals.

W5DPA set up at inoculation headquarters and about 40 members of the Houston Amateur Radio Club, the Channel Communications Club and the Houston Mobile Dragnet participated. Mobiles and portables at hospitals and clinics relayed reports, requests for serum and supplies as well as general communications. Without amateur communication, the telephone circuits would have been overloaded. Dr. Harrington, in charge of all facilities, complimented the amateurs on the wonderful job they did in adverse conditions, such as in a thunderstorm. — *W7QKP, SEC Southern Texas.*

A highly successful simulated emergency exercise was held on April 27 by the Aiken (S. C.) Amateur Radio Club. Net control station K4JY was manned at club headquarters in the Aiken Municipal Building, directing the activities of three mobile teams using numerical grid coordinates as location references. Specified locations were searched, on foot, for a small card bearing a mission number which then had to be transmitted accurately via radio to the control station before instructions for the next assignment were given. This provided valuable experience which could be effectively used during actual communications emergency conditions.

AREC members of Connecticut participated in a statewide civil defense drill on May 19, under the direction of SEC W1EOR. The problem was to provide communications for various fire companies with all apparatus, operating all

difficulty was experienced on 2 meters. W1ZKE and W1VWL were sent to the top of the base's diving tower to relay reports from 2-meter units.

Communications went off like clockwork on 3880. Seven fixed stations reported in to assist in relaying from mobiles to the base station, but in most cases this was not necessary, all mobiles putting good signals into the control set up at Groton. Over fifty amateurs participated altogether, making the operation one of the most successful ever held in the state. — *W1EOR, SEC Connecticut.*

Eighteen SECS reported July activities on behalf of 4897 AREC members, a decided drop from the nineteen and 5503 reported for July last year. However, this is the first month this year we have not shown an increase over the same month in 1956. Sections reporting: Wis., Ga., Ky., W. N. Y., E. Fla., Santa Barbara, Maritime, Ala., San Joaquin Valley, Colo., N. Mex., Santa Clara Valley, Mont., Wash., NYC-LI, Nebr., Md.-Del.-D. C., W. Va.

RACES News

W1BB sent us a blurb which he entitled "RACES at the Races." Seems as though he is RO for Winthrop RACES and his group actually did participate in the 33rd Atlantic Coast Star Challenge Cup Series Races held off Winthrop and Nahant, Mass., on Aug. 16-17. Messages with regard to position of the starting line, "stake" boats, order of rounding markers, and transfer of passengers and race officials between DE boats and CPYC were handled. (You boat-racing fans will understand all these terms; others will be in the same boat with me.) In one instance, 20 passengers were stranded on a whale boat which broke its rudder and became helpless; the RACES group were of assistance in rescue operations. On the whole, sez W1BB, communications went very well, although some difficulties were encountered and valuable lessons learned for this type of mobile marine operation not hitherto contemplated by the C-D Net. Those members participating are to be complimented for their quick adaptation to this new situation, making instant radio contact available between all boats to handle routine matters and any unexpected emergencies. — *W1BB, RACES Radio Officer, Winthrop, Mass.*



TRAFFIC TOPICS

Ever hear of Ben White, W4PL? Of course you have — that is, if you've been handling traffic very long. Ben is the dean of all traffic men, having been in the traffic game since before many of us were born, and certainly since most of us were in knee pants; and what's more significant, he's been handling traffic ever since, steadily except for an occasional short layoff to QTA an illness. Add to this the fact that he's a real swell guy, even if he doesn't subscribe to NTS, and you have a combination that cannot but bring forth a certain amount of veneration for a gent who has been with us a long time and, we hope, will continue to be with us much longer.

W4IA's Traffic Hounds Morning Watch, a fraternal-type traffic net operating in the early morning (always Ben's favorite time for brasspounding), pulled a surprise party for Ben on the occasion of his 73rd (sic!) birthday. And when we say surprise, we do mean surprise. On August 17, with W4PL as NCS, 52 stations reported into the MW, a new record for the net. All of them had traffic for W4PL.

NATIONAL CALLING AND EMERGENCY FREQUENCIES (Kc.)

C.W.	PHONE		
3550	3875	7100	7250
14,050	14,225	21,050	21,400
28,100	29,640	50,550	145,350

During periods of communications emergency these channels will be monitored for emergency traffic. At other times, these frequencies can be used as general calling frequencies to expedite general traffic movement between amateur stations. Emergency traffic has precedence. After contact has been made the frequency should be vacated immediately to accommodate other callers.

The following are the National Calling and Emergency Frequencies for Canada: c.w. — 3535, 7050, 14,060; phone — 3765, 14,160, 28,250 kc.

over the eastern part of the state and finally converging on the Submarine Base at Groton, Conn. To make sure that communications could be provided all the way and from all points, two kilowatt net control stations were set up, one midway in the eastern part of the state and one at the sub base. The Connecticut Phone Net frequency of 3880 was used for the operation. Twelve mobiles were used, one assigned to each team, for the longer distances, and a group of two-meter mobiles was used for communications in the area of the base. Net control at the beginning of the test was W1EOR, later shifting to the portable kilowatt station set up in the Manchester (Conn.) C.D. bus (W1EKJ's equipment). W1PWQ was NCS for the two-meter gang On Sunday, May 19, W1EOR took the air at 0600 and started checking in the gang. By 0815, W1EOR/1 was on the air from the sub base on both 2 and 75 meters. When

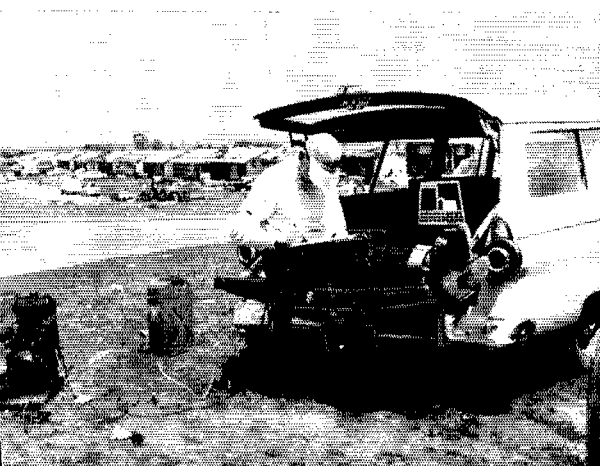

After the big Kansas City tornado in May, K0AFW was the first mobile to go into action in devastated Hickman Mills. Facilities being somewhat limited, his operating position was the tailgate of his station wagon. Some of the tornado destruction can be seen in the background.

QST for

After receiving the first few, Ben said "I begin to smell a conspiracy." But it was only the beginning. It was three hours and ten minutes later when Ben copied the last message, totalling 63 in all from 22 states, D. C., Alaska, Quebec and Ontario. Many other stations were on with additional messages of greetings, but couldn't get through the QRM. As one of the ARF'ers said, "Sounds like a DX pile-up." VE2DR's message was a 73-word poem which we wish we had room to quote. VE3BUR expressed the sentiments of all with such phrases as "... may the ensuing years bring much good health, contentment and peace of mind to a grand old fellow."

Ben responded in typical fashion in a letter which was printed in W4A's FB Morning Watch Bulletin. "Any verbal felicity that I thought I had seems to have deserted me just when I need it most," he said. "I can only say to those who planned this, to those who called in, to those who tried to call, to all who kept the secret, my heartfelt thanks and warm appreciation. Hans is fine people, and the very finest of them are those who handle traffic."

With the joyous comes the sad. As mentioned once before, we don't make a practice of running obituaries in this column, but occasionally find it fitting to take notice of the passing of a very prominent personage in the traffic-handling field. Such a person was Horace Hiddy, W5MIN, himself a very old timer in the traffic field. "Silent Keys" is an appropriate phrase to use in connection with W5MIN, whose key will be greatly missed by us traffic men.

Sorry you didn't get to the National Convention, OMI — or did you? There were plenty of traffic men there, and a room especially set aside for them during the entire convention period. At the traffic meeting on Saturday (Aug. 31) the room was bulging, and we were sorry to have had to divide our time between this meeting and the AREC-RACES meeting which was running concurrently in an adjoining room. Anyway, if you missed it you missed one of the greatest conventions ever. Hope to see you next year in Washington.

Miscellaneous August Net Reports. Dragg Net listed 1890 messages with 680 check-ins in 22 sessions. Early Bird Transcontinental Net handled 251 messages. Interstate Sideband Net handled 658, averaging 37 stations participating at 110 minutes per session. Transcontinental Phone Net traffic total was 3922, made up of 1800 for the first call area, 1289 for second call area and 833 for the fourth, ninth and tenth call areas. North Texas/Oklahoma Traffic Net conducted 31 sessions, had 972 check-ins and a traffic total of 286. Eastern States Net handled 1433 messages in 28 sessions with 82 different stations participating.

National Traffic System. There has been a lot of talk about traffic "misrouting." This is a term that needs special definition as it applies to amateur traffic. Traffic routing, in its greatest simplicity, is best accomplished by sending a message ever closer to its destination until it arrives thereat, and any message that takes a detour is "misrouted." If we apply that definition strictly, it is easy to see that much traffic on NTS is "misrouted," because NTS is not set up to make provisions for the routing of any specific message, but to give systematic routings to all messages. It has to be that way. No one will argue that in specific cases a specific message might arrive at its destination more quickly if NTS channels are bypassed; also, no one will contest the right of any particular station to bypass the channels if he feels he can accomplish quicker message delivery. That's why NTS nets are "open" to any station with traffic for the area covered by that net (provided the reporting station knows the procedure and does not otherwise hold up the net's operation). But if you think a little and study NTS routings you will see that if the system is properly implemented the traffic, even in obviously-roundabout routings, will get there almost as fast via the system.

Let's take an extreme example. Let's say W4KIX in Montgomery has a message he wants to get to Atlanta. Now here are two points not far apart that are separated by a time zone boundary, and therefore one is in RN5 and the other in 4RN. Obviously, the best thing for Bud to do is QNI the Georgia State Net at 1900 EST and get rid of his message. But suppose, for reasons best known to him, he can't QNI at this time — after all, it's only 1800

his time, and he can't get on the air until 1900. He can QNI the Fourth Regional Net, maybe, at 1945 EST, and give the message to the Ga. station, who may be close enough to deliver it but who more likely will have to hold it for the Georgia Net the next day. So instead, he decides to put it into AENB and let it go via the whole NTS route. Trusting soul!

So then the message goes to RN5 and to CAN where it winds up in the hands of a TCC man not later than 2130 CST. If GSN had a late session, this TCC station might still be able to get it into GSN, but GSN has no late session, so he has to hold it over night. The next day, if conditions are decent, he can put the message directly into GSN, in which case it will get there and probably be delivered the day after it was originated. If GSN isn't audible from his QTH, or he can't get on that early either, he might give it to the Georgia station on 4RN, 45 minutes later. If the worst happens, he can still give it to the 4RN station on EAN at 2030 EST, in which case it would probably take an extra day to get to its destination. Okay, two days from Alabama to Georgia isn't such good time, and chances are W4KIX could do better bypassing. But don't forget that the same routing would be followed from Texas to Maine, or from North Dakota to Florida, and the same time would be made from California to Nova Scotia, in which case two days, while still not good, is, shall we say, less bad.

No doubt you will be able to dig up instances in which a message routed by NTS took an inordinate length of time to get delivered. We dare say that such instances are much more notable than those in which the traffic made good time, but far less numerous. Most of them are caused by inability of net managers to fill all liaison assignments, because no one is around to take them. If you had made yourself available, instead of bypassing, your traffic would have made good enough time, considering its probable importance, and so would that of a lot of other people through your efforts.

August reports:

Net	Sessions	Traffic	Rate ²	Average	Representation (%)
1RN	27	356	...	13.2	82.0 ¹
2RN	52	426	.315	8.2	87.9
3RN	44	331	.289	7.5	90.2
4RN	44	343	...	7.7	44.4
RN5	49	608	.373	12.4	81.0
8RN	42	203	...	4.8	86.5
9RN	45	835	.401	18.5	79.4
TEN	93	1762	.459	19.0	53.0
ECN	18	102	...	5.1	75.9 ¹
EAN	21	787	.718	37.5	93.7
CAN	30	1120	.700	37.3	100.0
PAN	30	909	.305	30.3	98.3
Sections ³	579	4711		8.1	
TCC Eastern	38 ⁴	98			
TCC Central		1682			
TCC Pacific	80 ⁴	1004			

Summary Record	1074	15277	EAN	11.6	CAN
	1074	15277	.718	14.8	100.0

Late Reports (July):

Sections ⁵	261	1448
-----------------------	-----	------

¹ Regional net representation based on one session per day. Others are based on two or more sessions.

² New method of calculating rate: total traffic divided by total time in session.

³ Section nets reporting: NJN (N. J.); ILN (Ill.); SCN (Calif.); Iowa 75 Phone; SCN (S. C.); So. Dak. 75 Phone & So. Dak. 40 Phone; NTX (N. Tex.); OSN-PQN (Ont.-Que.); KYN & KPN (Ky.); TLCN (Iowa); WSN (Wash.); AENB, AENP, AENP (Morn.) & AENT (Ala.); GSN (Ga.); WVN (W. Va.); CN & CPN (Conn.); MSN (Minn.); QKS, QKS SS & QKN (Kans.).

⁴ TCC functions reported, not counted as net sessions.

⁵ Following sections reported July activities too late for Oct. QST copy: WVN (W. Va.); QMN (Mich.); WSN (Wash.); Tenn. CW; AENB, AENP, AENP (Morn.) and AENT (Ala.); OSN-PQN (Ont.-Que.); ILN (Ill.). Next year we won't take a vacation (Oh, yeah?).

It never rains but what it pours. This month we received three resignations from regional net managers, all within a day or two of one another. But we are grateful for one thing:



At the Dayton (Ohio) Hamvention last April, some of the traffic men got together for this photo. Meet (l. to r., standing): W8s UPB (SEC), FYO, OPU, RLR, SZU. Seated, W8s CGF AL (SCM), AXX, VTP, HXB. Most of these amateurs are ORS and can be heard on the Ohio Buckeye Net (BN) on 3580 kc.

that each of them waited until the end of the summer instead of dropping out in May or June when the replacement situation was rough. Come to think of it, we're grateful for another thing — that two of the three gave us some advance notice so there won't be a break in the managership resulting in no reports for a time.

W1FMG did a fine job as IRN acting manager while W1BVR took a vacation. W2ZRC announces that 2RN will return to 3600 kc. the end of October; they have been operating on 7100 for the early session, with good results. W3WHK has received his 3RN certificate and a commendation from manager W3UE, who says this is the principal reason for E. Pa.'s improvement in representation; the W. Pa. situation is looking up, too. W5RCF is no longer acting manager of RN5; he has accepted appointment officially and has gone right to work. W6ZRJ has resigned as RN6 manager and the Pacific Area NTS Staff will recommend a replacement; W4KKW notes that the 9RN 1945 session fell off during the summer, but expects it will pick up with better conditions. TEN manager W0KJZ gives notice of her resignation December 31; now that's what I call giving notice! VE3GI also signifies his intention to resign effective October 1. K6DYX has issued a PAN certificate to W6EOT.

Transcontinental Corps: Things have been going along about as usual. We're sorry to hear that Irene, W0KQD, has been ill, but note that a complete report was forthcoming just the same. W0SCA also has had a session in the hospital. W0BDR takes over from W0SCA as Central Area TCC Director Oct. 1.

Area	Functions	% Successful	Traffic	Out-of-Net Traffic
Eastern	38	86.8	797	98
Pacific	89	78.7	1984	1004

The roster: Eastern Area — W1s AW BDI NJM EMG TYQ, W2s HDW ZRC, W3s COK WG, W4ZDB, W8ELW, W9s CXY DO, Central Area — W0s CXY DO, W0s BDR LGG SCA, Pacific Area — W0s ADB VZT EOT RPT HC IPW PLG ZRJ, K6s DYX GZ ORT, W7s GMC XZ YKT, W0KQD.

NET DIRECTORY

This list includes all nets registered up to and including Sept. 19, 1957. Registrations received after that date will be included in the January QST listing if received prior to November 15. If you have not yet registered your net for the 1957-58 season, please send us the data requested on page 79, Sept. QST.

Nets are registered in the ARRL Net Directory on request, and upon receipt of the minimum basic information given below. The complete cross-indexed directory will be available in late November.

IMPORTANT NOTE: QST net listings are for information only. Insofar as possible, net information is listed exactly as received, with certain common abbreviations used to save QST space. Listing in QST or the annual cross-indexed net directory does not signify necessarily that nets listed have any official status, does not entitle them to exclusive or prior right to the frequency or frequencies on which they are registered, and is in no sense a form of copyright. We are glad to include information on nets received,

but ARRL cannot guarantee any net the exclusive right to its frequency, its name or any facet of its operation.

Name of Net	Freq.	Time	Days
AENI (Valley Amateur Radio Club)	3885	1330 CST	Sun.
After-the-Net Net	3910	1900 CST	Tue.
Ala. Emerg. Net B (AENB)	3575	1900 CST	Daily
Ala. Emerg. Net P (AENP)	3955	1800 CST	Daily
		0830 CST	Mon.-Sat.
		0800 CST	Sun.
Ala. Teen Age Net (AENT)	3905	1630 CST	Daily
		0800 CST	Sat.
All Service Net	7270	1400 EST	Sun.
American Red Cross Amateur (Comms. Service) (Fla.)	29,600	1930 EST	3rd Mon.
Antietam Radio Assn. Net (Md.)	3827	1900 EST	1/3 Tue.
	29,530		
Antilles Amateur Weather Net	3815	0700 AST	Daily
		1730 AST	
Arkansas CW Net (OZK)	3790	1700 CST	Mon.-Fri.
Ark. Emerg. Phone Net	3885	0600 CST	Mon.-Fri.
Atlanta Ten Meter Phone Net	29,600	2200 EST	Sun.
Atlantic Teen Age Net (ATAN)	3910	0700 EST	Mon.-Fri.
Baldy Amateur Radio Net	28,700	1800 PST	Mon.
Barnyard Net	3924	0700 EST	Mon.-Sat.
Black Hawk Net (Wis.)	3955	1000 CST	Sun.
Blackstone Valley Radio Net (R. I.)	29,000	1900 EST	Mon.
The Breakfast Club	3838	0700 MST	Mon.-Sat.
Breezeshooter's Net, Inc. (Pa.)	29,000	2000 EST	Mon.
Buzzards Bay, Cape Cod & Islands Emerg. Net (Mass.)	145,260	1900 EST	Mon.
Calumet Area (Phone) Net (CAEN) (Ill.)	1805	1900 CST	Mon.-Fri.
Cape Breton A.R.E.C. Net (N. S.)	3750	1600 AST	Sun.
Capitol Area Radio Emerg. Net	145,350	1500 EST	Sun.
Central Ill. Emerg. Net (CTN)	1815	0830 CST	Sun.
Central Texas Emerg. Net (CENTEXEN)	3870	0830 CST	Sun.
Chattahoochee Valley Emerg. Network (AEND)	3885	1330 CST	Sun.
Chicago Two Meter RACES Net	145,200	2000 CST	Thu.
Colo. Emerg. Phone Net (CPN)	3890	0800 MST	Sun.
Colo. Slow Speed Net (CSSN)	3570	1700 MST	Mon.-Sat.
Colo. Weather Net (CWN)	3945	0800 MST	Mon.-Sat.
Conn. Nutmeg Net (CN)	3610	1745 EST	Mon.-Sat.
		2100 EST	
Conn. Phone Net (CPN)	3880	1800 EST	Mon.-Sat.
Conn. Training Net (CTN)	3640	0800 EST	Sun.
Dade Emerg. Net (Fla.) (DEN)	29,500	1930 EST	1/2-4 Mon.
Doghouse Net (Ohio)	3890	1800 EST	Mon.-Fri.
Dragnet	14,280	0830 CST	Mon.-Fri.
Early Bird Transcon Net (EB)	3845	0400 CST	Daily
Early Morning Net (Calif.) (FRUGLE)	3711	2200 PST	Mon.-Fri.
		2712	
East Tenn. Net (Phone)	3980	0645 EST	Mon.-Fri.
Eastern Area Net (EAN)	3670	2030 EST	Mon.-Sat.
Eastern Pa. CW Net (EPA)	3610	1830 EST	Mon.-Fri.
Eastern States Net (ESN)	7080	1730 EST	Daily

The EC (Echo Charley) Net (N. M.)	3980	1730 MST	Sun.	Lancaster Emerg. Net (Pa.)	146,800	2200 EST	Mon.
Eglin (AFB) Emerg. Net (Fla.) (HAIR)	29,560	1900 CST	Mon.	Linn Co. C.D. Net (Iowa)	50,400	2000 CST	Mon., Wed.
Eighth Regional Net (8RN)	3530	1945 EST	Mon.-Sat.	Linn Co. Emerg. Net (Iowa)	3915	1300 CST	Sun.
El Paso Ten Meter Emerg. Net	29,640	2130 EST	Mon.	Long Beach C.D. Net (Calif.)	29,560	2015 PST	Mon.
Empire Slow Speed Net	3590	1800 EST	Daily		147,300	2030 PST	Mon.
FARM Net	3935	1900 MST	Mon.-Fri.	Long Island Novice Net (LINN)	3745	1700 EST	Mon.-Sat.
Federal Civil Defense Region 6 RACES Net (FCDR6)	3510	1930 MST	Tue.	Lorain County Net (Ohio)	1820	1300 EST	Sun.
	3665	1930 MST	Tue.	Mahoning Valley Emerg. Net (Ohio)	29,500	1900 EST	Mon.
		2030 MST			50,500	1845 EST	Mon.
		2030 MST		Md.-Del. and DC Net	3650	1915 EST	Mon.-Sat.
		2030 MST		Md. Emerg. Phone Net (MEPN)	3820	1830 EST	Mon., Wed., Fri.
		2030 MST	Sun.			1300 EST	Sat., Sun.
		2030 MST	Tue., Thu.	Mayaguez Dist. Emerg. Net (P. R.)	3980	1900 AST	Tue.
		2030 MST	Tue.		7225		
	7120	2030 MST	Tue.	Medford C.D. Net (Mass.)	29,520	1900 EST	Mon.
	14,040	0900 MST	Sun.	Medina Co. Net (Ohio)	1805	1300 EST	Sun.
Fifty Point Seven Net	50,700	1900 EST	Wed.	Memphis Six Meter Net	50,500	2000 CST	Mon.
		1900 EST	Sun.	Memphis Ten Meter Mobile Emergency Net	29,627	1900 CST	Mon., Fri.
First Regional Net (CW) (1RN)	3605	1930 EST	Mon.-Sat.	Memphis Two Meter FM Net	145,500	1930 CST	Mon.
Flamingo Net (Fla.)	29,044	1930 EST	Fri.	Mid-Continent Sideband Net	7206	1800 CST	Daily
Fla. Emerg. Phone Net (FEPN)	3910	1900 EST	Tue.	Midwest Novice Net (MNN)	7152	0730 CST	Daily
	7210			Military Civilian Affiliate Net (MCANT7)	7207	1230 PST	2030
Fla. Hurricane Net (HN)	3695	0700 EST	Sun.				
Fla. Midday Traffic Net	7230	1200 EST	Mon.-Sat.	Mission Trail Net, Inc. (MTN)	3854	1900 PST	0300
Fla. Net (ex-Palmetto) (FN)	3675	1830 EST	Mon.-Fri.	Mo. Emerg. (Phone) Net (MEN)	3900	1800 CST	Mon., Wed., Fri.
Fla. Phone Traffic Net (FPTN)	3945	0700 EST	Mon.-Sat.	Montana Phone Net	3910	1800 MST	Mon., Wed., Fri.
Florida Slow Net (FSN)	3675	1900 EST	Mon.-Fri.				
Forty New Jersey Net (FNJ)	7105	1715 EST	Mon.-Fri.	Morning Conn. Net (MCN)	3640	0945 EST	Mon.-Fri.
Four Corners Net	3885	0700 MST	Daily	Mt. Diablo Amateur Radio Nets (Calif.)	50,680	2000 PST	Mon.
Fourth Regional Net (4RN)	3547	1945 EST	Mon.-Fri.		145,290		
Fulton Co. (Ohio) Net	1885	2000 EST	Wed.	Muskegon Net	3755	1915 EST	Mon.-Fri.
Ga. Peach YL Net (GPN)	3985	0900 EST	Thu.	Nassau Co. 10 Meter Net (N. Y.)	23,720	2000 EST	Thu.
Garfield Co. Emerg. Net (GEN)	3825	0900 CST	Sun.		28,680		
Georgia State Net (GSN)	3595	1900 EST	Mon.-Fri.	Nebr. Morning Phone Net	3983	0730 CST	Daily
Golden Gate Net (Calif.)	28,700	2030 PST	Tue.	Nebraska Phone Net	3983	1330 CST	Daily
Granite State Phone Net (U.S.P.N.)	3842	1900 EST	Mon.-Fri.	The New Brunswick Amateur Radio Assn. Net	3790	1000 AST	Sun.
Grey Bruce Net (GBN) (Ont.)	3645	1830 EST	Mon., Wed., Fri.	New Brunswick AREC Net	3790	1830 AST	Wed.
Hair Net	3875	0800 EST	Sun.	The New England Weather Net	3900	0630 EST	Mon.-Sat.
Hawkeye Emerg. Net (HEN) (Iowa)	29,600	1930 CST	Mon., Thu.	New Jersey Net (NJN)	3695	1900 EST	Mon.-Sat.
Hayseed Fone Net	7273	1530 CST	Tue., Wed., Thu.	N. Mex. Emerg. Phone Net	3838	0730 MST	Sun.
						1800 MST	Tue., Thu.
Hi Noon Net (HNN)	7240	1200 MST	Mon.-Sat.		7272		
Howard Co. (Ind.) C.D. & Emerg. Net	3920	1400 CST	Sun.	N. Y. C.-L. I. AREC Phone Net	3908	1400 EST	Sun.
Illinois CW Net (ILN)	50,700	1930 CST	Tue.	N. J. Phone & Traffic Net	3900	1800 EST	Mon.-Sat.
Ill. RACES-Target City Net	3515	1900 CST	Mon.-Sat.			0900 EST	Sun.
	3503.5	1900 CST	2/1 Thu.	N. Mex. Assistant Director's Net	3838	2030 MST	1st Sat.
	3997	1900 CST	1/3 Thu.	N. Y. C.-L. I. Phone Net	3908	1730 EST	Mon.-Sat.
Indiana CW Net (QIN)	3656	1900 EST	Daily	N. Y. State Phone Traffic and Emerg. Net	3925	1800 EST	Daily
Indiana Fone Net (IFN)	3910	0900 CST	Daily	Newport Co. Emerg. Net (R. I.)	29,530	1000 EST	Sun.
		1830 CST	Mon.-Fri.	Ninth Region Net (9RN)	3640	1630 CST	Daily
Inter-County Net (Dade Co., Fla.)	29,600	1930 EST	3rd Mon.			1945 CST	
Iowa-Des Moines Emerg. Net (IDM)	7130	1730 CST	Mon.-Fri.	Nite-Owl Net (Chicago)	29,640	2230 CST	Thu.
Iowa 75 Meter Phone Net	3970	1230 CST	Mon.-Sat.	NLI Net (N. Y.)	3630	1930 EST	Mon.-Fri.
Kankakee Area AREC Noon Net (Ill.)	3920	1200 CST	Daily			1915 EST	Sat.
Kankakee Area 2 Meter AREC Net (Ill.)	145,800	2100 CST	Sat.	N. Central Phone Net (NCPN)	3915	0800 CST	Mon.-Sat.
Kankakee Area 10 Meter Net (Ill.)	29,620	2100 CST	Thu.	N. Texas Novice Net (NTNN)	7180	0700 CST	Sun., Hol.
Kansas CW Net (QKS)	3610	1830 CST	Mon.-Fri.	N. Texas-Okla. Traffic Net (NTO)	3960	1730 CST	Daily
	1888			Northeast Area Barnyard Net	3960	0800 EST	Mon.-Sat.
Kansas Novice Net (QKN)	3755	1730 CST	Mon., Wed., Fri.	Novice Hurricane Net (NHN) (Fla.)	3725	0800 EST	Sun.
		1700 CST	Sun.	Oak Ridge and Vicinity Traffic Net (ORVTN)	50,700	1900 EST	Mon.-Sat.
Kans. Slow Speed Net (QKS SS)	3610	1830 CST	Sat., Sun.	Oak Ridge RACES Net	50,700	1845 EST	Thu.
	1888			The Ohio Mich. Ind. & Ky. Electronic & Comm. Assn. Net	3820	1000 EST	Sun.
Kaw Blue Radio Club Net	3920	1330 CST	Sun.	Ohio Buckeye (CW) Net (BN)	3580	1900 EST	Mon.-Sat.
Kentucky CW Net (KYN)	3600	1800 CST	Daily	Ohio Emerg. Net (CW) (OEC)	3580	1900 EST	Sat.
Ky., Ohio., Ind. Novice Net (KQIN)	3730	1900 EST	Fri., Sat.	Ohio Emerg. Net (Phone) (OEN)	3880	1800 EST	Thu.
Kings Co. RACES-AREC 6 Meter Net (N. Y.)	50,280	2100 EST	Mon.	Ohio Phone Net	3890	1700 EST	Mon.-Sat.
Kings Co. RACES-AREC 10 Meter Net (N. Y.)	29,640	2100 EST	1/3 Mon.	Okla. Phone Emerg. Net (OPEN)	3860	0800 CST	Sun.
Kings Co. RACES-AREC 2 Meter Net (N. Y.)	145,260	2045 EST	Mon.	Okla. Traffic Net (OLZ)	3682.5	1900 CST	Mon.-Sat.
Labrador Net	3780	2130 GMT	Daily	Ontario Phone Net (OPN)	3770	1300 EST	Mon.-Sat.
Lake Erie Emerg. Net	29,150	2000 EST	Sun.	The O.A.R.S. Net (Ore.)	29,200	1930 PST	Daily
				Oregon Emerg. Net (OEN)	3840	1800 PST	Daily
						1900 PST	

Oregon State Net (OSN)	3585	1830 PST	Mon.-Fri.
Pacific Area Net (PAN)	3675	2030 PST	Daily
Penna. Fone Net (PFN)	3850	1800 EST	Mon.-Fri.
Phil-Mout Mobile Net (Pa.)	29,493	0700 EST	Daily
Post Road Emerg. Net	29,480	1900 EST	Mon.
P. R. Amateur Emerg. Net	3925	1900 AST	Wed.
Putnam Co. A.R.E.C. Net (N. Y.)	3890	1930 EST	Sun.
Red Cross Net (Calif.)	3885	1000 PST	Sun.
River Forecast Net (RFN)	3856	0700 CST	Sun.
San Antonio Radio Club Emerg. Net	3855	1800 CST	Thu.
San Juan Dist. Emerg. Net	3885	1800 AST	Tue.
Sea Gull Net (Me.)	3940	1700 EST	Mon.-Sat.
Sector I-B Stoughton, Mass., Net	29,490	1930 EST	Mon.
Seymour Amateur Radio Club Net (Ind.)	147,300	1700 CST	Sun.
The Short Skip Net (Pa.)	28,800	2330 EST	Sat.
Sooner Traffic Net (STN) (Okla.)	3850	1800 CST	Mon.-Sat.
South Carolina Net (CW) (SCN)	3795	1900 EST	Mon.-Fri.
S. Dak. 40 Meter ("emergency") fone Net	7225	1215 CST	Mon.-Sat.
S. Dak. 75 meter ("emergency") fone Net	3870	1830 CST	Mon.-Sat.
S. Dak. Weather Net	3870	0730 MST	Mon.-Sat.
South Texas CW Net	3790	1800 CST	Mon.-Sat.
South Texas Emerg. Net (CW)	3790	1830 CST	Mon.
South Texas Emerg. Net (S)	3860	1815 CST	Mon.
S. Texas Emerg. Net (SSB)	3805	1815 CST	Mon.
S. Tex. Emerg. Net (Zone 1)	3860	0730 CST	Sun.
S. Tex. Emerg. Net (Zone 2)	3860	1815 CST	Mon., Thu.
S. Tex. Emerg. Net (Zone 3)	3860	1815 CST	Mon., Wed.
S. Tex. Emerg. Net (Zone 4)	3860	1400 CST	Sun.
S. Tex. Emerg. Net (Zone 5)	3860	1815 CST	Mon., Tue.
Southern Calif. Net (SCN)	3600	1930 PST	Mon.-Fri.
So. Calif. 220 mc. Net	222,100	1930 PST	Mon., Wed.
So. New England 6 Meter Emerg. Net	50,700	1900 EST	Wed.
Southtown AREC & RACES Net (Chicago)	29,640	1930 CST	Mon.
Sunrise Radio Club Net (N. Y.)	3950	1000 EST	Sun.
Tarrant Co. Disaster Control Net (TCDCN) (Tex.)	3970	1300 CST	Sun.
Tennessee CW Net (TN/TENN)	3635	1900 CST	Mon.-Sat.
Tenn. 160 Meter Net	1818	2000 CST	Sun.
Tenn. 6 Meter Emerg. Net (T6N)	50,500	2000 EST	Fri.
Third Regional Net (3RN)	3590	1845 EST	Mon.-Fri.
Traffic Hounds Morning Watch	7080	0700 EST	Mon.-Sat.
Transcontinental Phone Net (TCPN)	3970	1700 EST	Daily
Trans Continental Relay Net (TCRN)	7042	0215 GMT	Daily
		0615 GMT	
		1600 GMT	
		2300 GMT	
Tri States Six Meter Net	50,100	0800 CST	Sun.
Tropical Phone Traffic Net (TPTN)	3945	1730 EST	Daily
Tu-Boro Radio Club Net (N. Y.)	29,520	1200 EST	Sun.
United Trunk Line (UTL) (Central)	7125	2030 CST	Daily
	3565	2030 CST	
		2130 CST	
Virginia Net (VN)	3680	1900 EST	Mon.-Fri.
Va. Overflow Net (VON)	29,100	2000 EST	Mon.-Fri.
Virginia Slow Net (VSN)	3680	1830 EST	Mon.-Fri.
Washington Section Net (WSN)	3575	1900 PST	Mon.-Fri.
West. Mass. CW Net (WMN)	3560	1900 EST	Mon.-Sat.
West Va. CW Net (WVN)	3570	1900 EST	Mon.-Sat.
West Va. Phone Net	3890	1830 EST	Mon.-Fri.
Western Mass. Phone Net	3870	1800 EST	Mon., Wed., Fri.
Western Nebr. Net	3850	0700 MST	Mon.-Sat.
Western Pa. Traffic Net	3585	1900 EST	Mon.-Fri.
Wheat Belt Net (WBN)	3825	1230 CST	Sat.
Windblowers VHF Society (N. J.)	144,900	2100 EST	Fri.
Winston-Salem Civil Defense Two-Meter Network	147,150	2000 EST	Tue., Thu.

Wisconsin CW Net (WIN) 3535 1915 CST Daily
YO Net (Wyo.) 3610 1830 MST Mon., Wed., Fri.
York (Pa.) Emerg. Net 145,620 2200 EST Mon.
Mistakes? *Of course* there are mistakes. Let us know how we loused up your net listing and we'll do better in the January issue.

BRASS POUNDERS LEAGUE

Winners of BPL Certificates for August traffic:

Call	Orig.	Recd.	Rel.	Del.	Total
W7BA	23	1309	1258	48	2638
W2KEB	88	1064	810	173	2135
W3CUL	146	1036	653	264	2099
W6PZO	12	947	922	16	1897
W6BDR	30	928	871	21	1850
W4PL	7	996	817	6	1826
W9NZZ	322	564	0	563	1449
W4PFC	142	612	547	65	1366
W6CP	9	665	552	113	1330
W6SCA	4	567	506	1	1338
W9DO	136	364	288	92	1040
W3ZRX	214	442	331	31	1018
W9CXY	3	503	486	17	1009
W0LGG	189	406	354	24	973
W5RCF	5	469	411	52	937
W6GYH	378	139	144	8	869
W0BJP	10	406	387	9	822
W4IA	17	412	364	13	806
W7PGY	29	378	281	93	781
W1UFG	3	379	342	40	764
W8ELW	11	374	359	10	754
K4EZL	108	340	261	14	723
W1TYQ	67	336	307	6	716
K0CLS	69	320	292	20	701
W8UPH	9	347	287	56	699
W8CSK	61	278	219	56	614
K9GDF	487	73	18	36	614
W0KQD	29	282	282	74	587
W1FJ	74	217	275	14	581
K6DYX	3	272	275	20	570
K2MFF	30	272	216	38	556
W1ARR	38	259	244	12	553
W0CZ	8	271	241	30	550
W1FJ	72	240	194	25	551
W9JOZ	7	245	249	10	511
W0GAR	15	240	251	4	510
K68XA	49	231	118	109	507
K6QD	26	244	181	54	505
Late Report:					
W7TLC (July)	103	261	161	93	618

More-Than-One-Operator Stations

Call	Orig.	Recd.	Rel.	Del.	Total
W6IAB	63	1367	1148	220	2798
K9UBN	465	324	280	9	1078
KGIDT	485	271	4	252	1012
K6MCA	237	350	406	0	993
K4MCL	51	356	338	13	758
K7ABR	108	298	240	58	704
W3PQT	19	264	240	53	576

BPL for 100 or more originations-plus-deliveries

K6GZ	219	W4PVA	123	K2ECY	162
K2MMM	205	W9UBI	123	W3YDX	161
W4BXV	201	K3WBJ	118	K0CVD	161
W3CVE	179	W1YBH	114	VE2AWK	160
K4DSD	178	K4GJF	109	Late Reports:	
W6NTY	143	W2JGV	108	W6ZJB	
W4BZE	142	K2WAO	108	(July)	
W8FWQ	137	W0KTK	106	VE2ATL	129
W9ETM	132	W2QYI	105	(July)	
W9JYO	131	K6UOD	103		

More-Than-One-Operator Stations

K0HEA/ø 425 W6TCS 200 W1AW 100
BPL medallions (see Aug. 1954 QST, p. 64) have been awarded to the following amateurs since last month's listing: K2PHE, K4EZL, W5RCF, K6GZ.

The BPL is open to all amateurs in the United States, Canada, Cuba and U. S. possessions who report to their SGM a message total of 500 or more, or 100 or more originations-plus-deliveries for any calendar month. All messages must be handled on amateur frequencies within 48 hours of receipt, in standard ARRL form.

CODE PROFICIENCY PROGRAM

Twice each month special transmissions are made to enable you to qualify for the ARRL Code Proficiency Certificate. The next qualifying run from W1AW will be made on November 14 at 2130 Eastern Standard Time. Identical texts will be sent simultaneously by automatic transmitters on 1885, 3555, 7080, 14,100, 21,010, 28,060, 50,900 and 145,600 kc. The next qualifying run from W6WPF only will be transmitted on November 7 at 2100 PST on 3590 and 7128 kc.

Any person can apply. Neither ARRL membership nor an amateur license is required. Send copies of all qualifying runs to ARRL for grading, stating the call of the station

you copied. If you qualify at one of the six speeds transmitted, 10 through 35 w.p.m., you will receive a certificate. If your initial qualification is for a speed below 35 w.p.m., you may try later for endorsement stickers.

Code-practice transmissions are made from WIAW each evening at 2130 EST. Approximately 10 minutes' practice is given at each speed. References to texts used on several of the transmissions are given below. These make it possible to check your copy. For practice purposes, the order of words in each line of QST text sometimes is reversed.

- Date** Subject of Practice Text from September QST
 Nov. 5: *The Third Method of S.S.B.*, p. 11
 Nov. 8: *V.F.O. Control* . . . , p. 16
 Nov. 11: *Transistors in Speech Equipment*, p. 19
 Nov. 13: *The "Spacistor"* . . . , p. 23
 Nov. 19: *Greater Selectivity* . . . , p. 24
 Nov. 21: *How's Your Soldering?*, p. 48
 Nov. 26: *June V.H.F. Party Summary*, p. 56.

WIAW OPERATING SCHEDULE

(Effective October 27, 1957)
 (All times given are Eastern Standard Time)

WIAW will return to its Fall-Winter operating schedule with the return to Standard Time. General operation covers all amateur bands on which WIAW has equipment. Novice periods include operation on 3.5, 7 and 21 Mc. (see Footnote 2 in box). Master schedules showing complete WIAW operation in EST, CST or PST will be sent to anyone on request.

Operating-Visiting Hours:

Monday through Friday: 1500-0300 (following day).
 Saturday: 1900-0230 (Sunday).
 Sunday: 1500-2230.

Exceptions: WIAW will be closed from 0300 Nov. 28 to 1500 Nov. 29 in observance of Thanksgiving Day, and from 0300 Dec. 25 to 1500 Dec. 26 in observance of Christmas.

General Operation: Use the chart below for determining times during which WIAW engages in general operation on various frequencies, 'phone and c.w. Note that since the schedule is organized in EST, certain morning operating periods may fall on the evening of the previous days in western time zones. WIAW will participate in all official ARRL operating activities, using scheduled general operating periods for this purpose if necessary.

Official ARRL Bulletin Schedule: Bulletins containing latest information on matters of general amateur interest are transmitted on regular schedules:

Frequencies (kc.):

C.w.: 1885, 3555, 7080, 14,100, 21,010, 28,060, 50,900, 145,600.

Phone: 1885, 3945, 7255, 14,280, 21,330, 29,000, 50,900, 145,600.

Frequencies may vary slightly from round figures given; they are to assist in finding the WIAW signal, not for exact calibration purposes.

Times:

Sunday through Friday: 2000 by c.w., 2100 by 'phone.

Monday through Saturday: 2330 by 'phone, 2400 by c.w.

Code Proficiency Program: Practice transmissions are made on the above listed c.w. frequencies, starting at 2130

daily. Speeds are 15, 20, 25, 30 and 35 w.p.m. on Monday, Wednesday and Friday, and 5, 7½, 10 and 13 w.p.m. on Sunday, Tuesday, Thursday and Saturday. Approximately ten minutes of practice is given at each speed. **Exceptions:** On Nov. 12 WIAW will transmit a special Frequency Measuring Test and on Nov. 14 and Dec. 20 WIAW will transmit ARRL Code Proficiency Qualifying Runs instead of the regular code practice.

A.R.R.L. ACTIVITIES CALENDAR

- Oct. 26-27: CD QSO Party (phone)
 Nov. 7: CP Qualifying Run — W6OWP
 Nov. 9-10: 16-17: Sweepstakes
 Nov. 14: CP Qualifying Run — WIAW
 Dec. 4: CP Qualifying Run — W6OWP
 Dec. 20: CP Qualifying Run — WIAW
 Jan. 2: CP Qualifying Run — W6OWP
 Jan. 4-5: V.H.F. Sweepstakes
 Jan. 11-12: CD QSO Party (c.w.)
 Jan. 18-19: CD QSO Party (phone)
 Jan. 20: CP Qualifying Run — WIAW
 Feb. 1-16: Novice Round-up
 Feb. 5: CP Qualifying Run — W6OWP
 Feb. 7-9: DX Competition (phone)
 Feb. 14: Frequency Measuring Test
 Feb. 18: CP Qualifying Run — WIAW
 Feb. 21-23: DX Competition (c.w.)
 Mar. 6: CP Qualifying Run — W6OWP
 Mar. 7-9: DX Competition (phone)
 Mar. 19: CP Qualifying Run — WIAW
 Mar. 21-23: DX Competition (c.w.)

OTHER ACTIVITIES

The following lists date, name, sponsor, and page reference of QST issue in which more details appear.

Nov. 1-2: RTTY Sweepstakes, RTTY Society of Southern California (page 101, last month's issue).

Nov. 6-7: YLRL Anniversary Party (phone), YLRL (page 80, last month's issue).

Nov. 13-14: YLRL Anniversary Party (c.w.), YLRL (page 80, last month's issue).

Nov. 23-24: 21/28 Mc. Telephony Contest, RSCB (page 75, this issue).

Dec. 8: Wisconsin QSO Party, Milwaukee Radio Amateurs' Club (details next month).

WIAW GENERAL-CONTACT SCHEDULE

(Effective October 27, 1957)

WIAW welcomes calls from any amateur station. Starting October 27, WIAW will listen for calls in accordance with the following time-frequency chart:

EST	Sunday	Monday	Tuesday	Wednesday	Thursday	Friday	Saturday
0020-0100 ¹	3555 ²	7255	3555	7080 ²	3945
0100-0200	3945	3555	7080
0200-0300	7255	3945	7080	3945	7255
1500-1600	14,280	21/28 Mc. ³	14,100
1600-1700	14,280	21/28 Mc. ³	14,100	21/28 Mc. ³	21,330
1700-1800	14,100	14,280	21,010 ²	14,280	14,100
1930-2000	7255	7080	7255
2020-2100 ¹	7080	3555	7080 ²	3555 ²	7080
2110-2130 ¹	3945	50.9 Mc.	145.6 Mc.	3945	3945
2230-2330	3555	3945	7080	1885	3555
2340-2400 ¹	3945	1885	3945	1885	3945

¹ General-contact period on stated frequency begins immediately following transmission of Official Bulletin which begins at 0000 and 2000 on c.w. and at 2100 and 2330 on 'phone. Starting time is approximate.

² WIAW will listen for Novices (on Novice band indicated) before looking over the band for other contacts.

³ Operation will be conducted on one of the following frequencies: 21,010; 21,330; 28,060; 29,000 kc.

• All operating amateurs are invited to report to the SCM on the first of each month, covering station activities for the preceding month. Radio Club news is also desired by SCMs for inclusion in these columns. The addresses of all SCMs will be found on page 6.

ATLANTIC DIVISION

EASTERN PENNSYLVANIA—Richard R. Mesirov, W3JNQ—SEC: NNT, RM: YAZ, PAM; TEJ. Frequencies: 3610, 3850 and 3997 kc. New appointments for the month: AXA (a return to the fold!), JBC and ZSX as OOs. GYP applied for ORS appointment and reported a traffic total of 129. On Aug. 8 a \$400,000 fire broke out in Norristown and Montgomery Co. EC ZXY was at the scene and within 30 minutes BFM, CNO, DLB, EQZ, FUS, GWH, KAA, OHY and TWQ were on the 10-meter net to offer assistance. Well done. CUL went to the ARRL Convention in Chicago. LEZ worked KSS, VS1 and VR6 for 3 new ones. YAZ and KN3ALL are helping a blind man get his license and will provide him with gear when he has passed the test. ALB is rebuilding and will be dangerous when all is completed. DVB and ZJD have a three-element beam on 20 and a ground-plane on 10 meters at the new QTH. AAC set up communications for the Powder Puff Derby, with operators supplied by the Short Skip and Penn-Jersey YL Radio Clubs. Section Net certificates were awarded to FAW and KFI, TEJ, BNR, AMC and FCI attended the Trans-Con Phone Net gathering in Toledo. Frankford Radio Club members CHH, GHD and 8JSU attended the ARRL Convention in Chicago and managed to get a receiver for ZC3AC, which will make DXers happy. YDX announces plans to originate approximately 200 messages a month. Congratulations to Philco Employees on birthdays and on their 5th, 7th and 10th anniversaries with their Techrep Division. As a start, YDX made the BPL on originations. ZSX steals the SCM's racket by announcing that school and girls will curtail his operating; he also announces that the ESN meets at 7080 kc. at 1730 EDT. BES rearranged and refinished his shack for the fall activities and expects to have a new kw. final for the DX Test. JBC has a ground plane on 20 meters and is working DX after a long layoff; he was visited for three weeks by VQ3/VQ4/W3KLF, who is now on the beach after a long stay at sea. BNR transmits Official Bulletins on 3,850 and 145.8 Mc. simultaneously at 1245 EDT. Traffic: (Aug.) W3CUL 2099, ZSX 1018, TEJ 215, GYP 129, YDX 104, BFF 69, YAZ 42, OGD 23, EPL 19, TSY 19, NOB 16, BNR 13, DJL 10, FVT 8, KFI 8, PVS 5, JNQ 4, LEZ 4, BES 1, DUI 1, (July) W3YDX 91, (June) W3YDX 53, (May) W3YDX 95.

MARYLAND-DELAWARE-DISTRICT OF COLUMBIA—SCM, Louis T. Cronberger, W3UCR—Asst. SCM Delaware: Philip R. de Courville, 3DQZ. SEC: PKC. MDD meets on 3650 kc. M-S at 1915 EST; MIEPN, on 3820 kc. M-W-F at 1830. SS at 1300 EDST. New appointments: HOW as EC for Worchester co., PZW as RM. The Foundation of Radio Amateur Clubs installed ECP as president. The trustees selected QPL/W4AHG as the 1958 ARRL National Convention (Aug. 15, 16 and 17) General Manager. The convention key chairmen are presently being selected. Mr. Paul Seward, Director of Civil Defense, Harford Co., addressed the ICARA on organization of the County Civil Defense at the Aug. 14 meeting. RE disassembled and reassembled both the Communicator III and the Gonset Model 312, fixed frequency c.d. 220 Mc. transmitter-receiver, at the RCARA on Aug. 10. On Aug. 24 RCARA's program was conducted by WZN, assisted by YAG and two "experts," AIR and RE, who identified "Radio Sounds" along with those present. The ICARA has been donated an acre lot for a club house and station. HZT also has loaned them a small building until they can build their own. The MIEPN and the Anne Arundel ARC have joined the

Foundation of Amateur Radio Clubs, the first groups out of the immediate Washington Area to do so. Other groups who are considering joining and desire information should contact ECP or 4ZM, secy. The Antietam RC had a booth at the Hagerstown Fair. ZGN, who is going to U. of Md. now, maintained the station and c.w. traffic schedules. LII was elected treasurer to fill Dick's term. WAIRC (BPE in charge) under the sponsorship of the Foundation, manned a demonstration station and static display for the premier of the French movie based on amateur radio, "If All the Guys in the World," in the lobby of the Du Pont, Members of Montgomery Co. RACES and RCARA manned a demonstration booth at the Montgomery Co. Fair, supplied by the Gaithersburg Businessmen, where many messages were originated and many made acquaintance with ham radio for the first time. WV, in addition to receiving the NRL IAI 40-year pin, also was recipient of a letter of commendation from the Secretary of the Navy. GCO, with IDF and DWU, went mobile on 6 meters on the Wilson Line ship *Mt. Vernon* to Marshall Hall and back. PPY now is in Washington. Congratulations to members of the MDD and others on the FB traffic-handling at the Montgomery County Fair. BUD is looking for late evening skeels (after 10:30) for delivery of traffic to MDD on 160, 80, and 40 meters. PQ took part in the birthday party for 4PL on the Morning Watch Net. KN3AIC is net manager of the Novice P1-Net. JJI has moved to Grafton, W. Va. KN3ANA passed the General Class exam. PQT is continuing phone-patch traffic to the Antarctic and Newfoundland. K3ACA (1VYI's OM) is back on the air in Baltimore and reporting into TCPN after 20 years of inactivity. QKC, Harford EC, is the new CDRO. HIZ is representing Baltimore in the MDD. PAQ and eleven from Cumberland visited LQS for a week-end of fishing and hamming. Traffic: W3PQT 576, CVE 385, IVE 321, PZW 310, PQ 248, K3WBJ 164, W3CGN 153, TN 132, HIZ 112, BUD 76, COK 71, UCR 50, WV 41, RV 36, AHQ 30, WN3MTA 30, W3CQS 10, JZY 8, KA 6, OYX 5, BKE 3.

SOUTHERN NEW JERSEY—SCM, Herbert C. Brooks, K2BG—SEC: YRW, PAM: ZL. The traffic-handlers are doing a swell job, with RG leading the pack. K2WAO, Fort Dix, made BPL this month originating over one hundred servicemen messages. K2PGC, Trenton, has joined MARS. George expects to return to Bucknell U. and will be heard from 3RPB, K2SOX, Lumberton, soon will be an ORS. K2OOK is back on ESN. BZL, Pennington, had lightning trouble resulting in a burnt-out receiver transformer and damaged antenna. ZI, Trenton, reports that the Jersey Phone and Traffic Net now has 50 members. QCWA (Delaware Valley Chapter) held its first annual picnic at Pakim Pond. K2PPT, Burlington, is handling traffic on 40 meters in addition to working lots of DX on that band. K2HPV, Penns Grove, is adding new gear to add to his station efficiency. K2CPR, Merchantville, expects to be on soon from his new QTH. K2DSL, is increasing power and expects to have a new vertical on 80 meters soon. EZM, Maple Shade, enjoyed his visits this summer to the following DX lands: HH, CM, VP5, PJ2 and HI. K2KEW's XYL has dropped the "N" and is now K2ULP. Welcome to a newcomer in Brigantine, KN2SXV. K2ERC and K2PDR were roommates in the Burlington Co. hospital, TBD (SIRA pres.), GQO, REB and their XYLs, also K2HOB, K2CTQ, W2JAV and K2BG attended the National Convention in Chicago. EBW and EVR are making plans for radio-tracking of the earth satellite, UA and daughter K2INQ plan to visit Europe this fall. MX has been issued to the Maple Shade C.D. Hq. They feel quite honored to use this call that belonged to an old friend who has joined Silent Keys. Traffic: (Aug.) W2RG 298, K2JGU 146, WAO 124, W2HDW 119, K2PGC 93, SOX 54, OOK 48, W2BZK 40, K2SOL 40, W2ZI 27, K2PPT 23, DSL 11. (July) K2PGC 94.

WESTERN NEW YORK—SCM, Charles T. Hansen, K2HUK—SEC: UTH/PRL. RMs: RUF and ZRC. PAMs: TEP and NAL. NYS C.W. meets on 3615 kc. at 1800, ESS on 3590 kc. at 1800. NYS Phone on 3925 kc. at 1800. TAR on 3570 kc. at 1700. NYS C.D. on 3509.5 and 3993 kc. at 0900 Sun.. TCPN 2nd Call Area on 3970 kc. at 1900. SRPN on 3980 kc. at 1000. LSN on 3970 kc. at 1600. K2KIR reports that ESS again is on daily schedule

(Continued on page 120)

BANDWIDTH IN PHONE OPERATION

ONCE upon a time it was the dream of every phone operator to have "broadcast quality." As more was learned about the characteristics of speech it became apparent that this was not the way to get the most communication from a limited amount of power.

IT is well known nowadays that the low voice frequencies contain lots of power but little of the intelligence. So, why not eliminate the lows? There are good electrical reasons for doing so; in sideband transmitters it simplifies the design of the sideband-selecting networks used, while in AM the transformers, bypass capacitors, etc., in the audio system can be smaller.

IF THE low-frequency cutoff (half-voltage or 6db point) is placed around 500 to 600 cycles, naturalness of the speech is affected, but not too much if the slope below 500 cycles is gradual rather than abrupt. The armed services carry this still further in some equipment, placing the lower cutoff as high as 750 cycles. They are not concerned at all with fidelity, but only with getting messages through.

THE high-frequency situation is not so simple. Frequencies as high as 4000 cycles contribute substantially to the intelligibility of speech, but contain little average power, though occasional high-energy peaks occur even out to 8000 cycles.

IF WE reduce the upper cutoff frequency at the transmitter to 2500 or even 2000 cycles to try to get a "sharp" signal we sacrifice considerable intelligibility but save practically no power. If, on the other hand, we transmit up to 3500 or 4000 cycles the intelligibility is good, while the interference to stations near the frequency is very little increased because of the small average power. (Overmodulation and overdriven linear amplifiers cause most of the trouble.)

AT THE receiving end it is nice to be able to adjust the upper cutoff; there are situations when cutting the bandwidth to 2500 or 2000 cycles helps, because the interference and noise are reduced more than the signal. The receiving operator is better able to adjust bandwidth to suit the conditions than the transmitter operator is.

THE audio response of our transmitters is chosen with the above considerations in mind. The HT-32, for instance, has its cutoff points at about 550 and 3500 cycles. Attention to details of this sort is helping to make it one of the most talked-about rigs on the air.

— J. M. LOMASNEY, W9LZV

Buel Halligan Jr.

W. J. Halligan W9AC

for **hallicrafters**

CIRCUIT BY

GATES

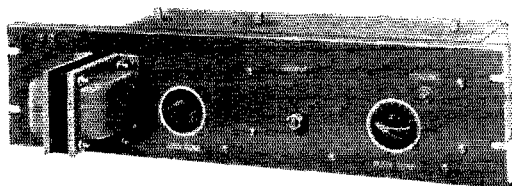
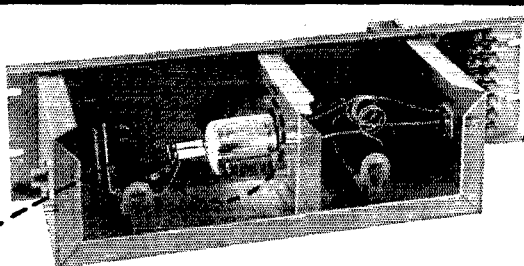
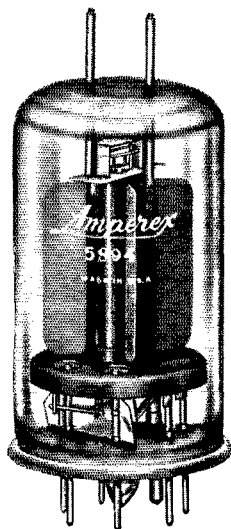

Amperex
Type 5894
twin tetrode

50-watt VHF amplifier manu-
factured by the Gates Radio
Company, Quincy, Illinois

POWER BY **Amperex**[®]

There are good reasons why the VHF amplifiers built by the Gates Radio Company, now celebrating its 35th anniversary, are outstanding for their design efficiency and trouble-free operation. One such reason is the Amperex Type 5894 twin tetrode, used in the output stage of the 50-watt Gates amplifier shown here. Internal neutralization in the Amperex 5894, combined with the wide strap for connecting leads and isolation between the grid and plate circuits, makes neutralization in the amplifier unnecessary. With the grid drive and output load connection removed, there are absolutely no "birdies" as the plate and grid tune controls are varied. Tuning range is from 125 to 185 Mc, with other frequency ranges easily available by changing only the grid and plate tank coils. Required driving power is of the order of 3 watts. Efficiency approaches 65%, and up to 60 watts output power may be obtained with 600 plate volts.



ask **Amperex**

about tubes for communications applications

AMPEREX ELECTRONIC CORP., 230 Duffy Avenue, Hicksville, L. I., N. Y.

In Canada: Rogers Electronic Tubes & Components, 11-19 Brentcliffe Road, Leaside, Toronto 17, Ont.

HERE IT IS!

**THE VIKING "COURIER"
500 WATT LINEAR AMPLIFIER**

Continuous coverage 3.5 to 30 megacycles . . . instant bandswitching 80 through 10 meters!



The new Viking "Courier" delivers full communication power — rated a solid one-half kilowatt P.E.P.* input as a class B linear amplifier; one-half kilowatt input on CW or 200 watts in AM linear mode; in a completely self-contained desk-top package. The Viking "Courier" may be driven by the Viking "Navigator," "Ranger," "Pacemaker" or other unit of comparable output. Drive requirements are 5 to 35 watts depending upon the mode and frequency desired. The linear amplifier employs two Type 811A triode tubes in parallel. Pi-network output circuit is designed to match nominal 40 to 600 ohm antenna loads and will tune out large amounts of load reactance as well. Continuous coverage 3.5 to 30 megacycles (bandswitched) — high efficiency, pi-network output circuit. Fully TVI suppressed and filtered; completely self-contained with built-in power supply.

\$244⁵⁰

Cat. No. 240-352-1 Viking "Courier" Kit with tubes

AMATEUR NET

Cat. No. 240-352-2 Viking "Courier" wired and tested with tubes

\$289.50

Amateur Net

*With an auxiliary SSB exciter.

*Proper wave shaping of the keyed signal, producing a clean, crisp CW note free of clicks and chirps, is essential in high-power operation. Information necessary to modify units without the famous Johnson Timed Sequence Keying System will be made available upon request.

"COURIER" POWER GAIN		
Driver*		Power increase-times
Adventurer	CW	10.0
Navigator	CW	12.5
Ranger	CW	6.6
Ranger	AM	2.5
Viking I & II	CW	2.8
Pacemaker	SSB & CW	5.5
Pacemaker	AM	5.0

See your authorized Johnson distributor for easy payment terms!



E. F. Johnson Company

2824 SECOND AVENUE S.W.

WASECA, MINNESOTA

Your best

Johnson Amateur Equipment for full communication **POWER!**

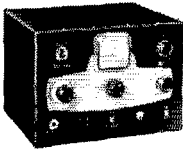

VIKING "ADVENTURER" 50 WATT TRANSMITTER—Used to earn first Novice WAC! (Worked All Continents). Self-contained, effectively TVI suppressed, instant bandswitching 80, 40, 20, 15, 11, and 10 meters. Operates by crystal or external VFO. An octal power receptacle located on the rear apron provides full 450 VDC at 150 ma. and 6.3 VAC at 2 amp. output of supply to power auxiliary equipment such as a VFO, signal monitor, or modulator for phone operation. This receptacle also permits using the full output of the supply to power other equipment when the transmitter is not operating. Wide range pi-network output handles virtually any antenna without separate antenna tuner. Break-in keying is clean and crisp. Designed for easy assembly. With tubes, less crystals and key.

Cat. No. 240-181-1 Kit.....Amateur Net \$54.95

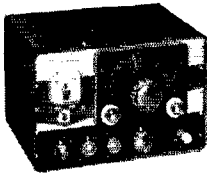

VIKING "NAVIGATOR" TRANSMITTER/EXCITER—This splendid new 40 watt CW transmitter/exciter is designed for the discriminating CW operator who desires a compact, flexible CW transmitter with enough RF power to excite most high powered final amplifiers on CW or AM. Bandswitching 160 through 10 meters. Highly stable, built-in VFO is temperature compensated and voltage regulated—unit may also be operated by crystal control. Electronic timed sequence keying applies wave shaping to the keyed amplifier stages for "make" or "break" on your keyed signal. Fully TVI suppressed and filtered—wide range pi-network output will match transmission line impedances from 40 to 600 ohms. Completely self-contained with built-in power supply.

Cat. No. 240-126-1 Viking "Navigator" Kit with tubes, less crystals and key.....Amateur Net \$149.50

Cat. No. 240-126-2 Viking "Navigator" wired and tested with tubes, less crystals and key.....Amateur Net \$199.50

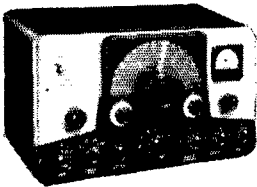

VIKING "RANGER" TRANSMITTER—This outstanding amateur transmitter will also serve as an RF and audio exciter for high power equipment. As an exciter, it will drive any of the popular kilowatt level tubes. No internal changes necessary to switch from transmitter to exciter operation. Self-contained, 75 watts CW or 65 watts phone input . . . instant bandswitching 160, 80, 40, 20, 15, 11, and 10 meters. Extremely stable, built-in VFO or crystal control—effectively TVI suppressed—high gain audio—timed sequence (break-in) keying—adjustable wave shaping. Pi-network antenna load matching from 50 to 500 ohms. Easily assembled—with tubes, less crystals, key and microphone.

Cat. No. 240-161-1 Kit.....Amateur Net \$229.50

Cat. No. 240-161-2 Wired and tested.....Amateur Net \$329.50



VIKING "VALIANT" TRANSMITTER—Designed for outstanding flexibility and performance. 275 watts input on CW and SSB (P.E.P. input with auxiliary exciter), 200 watts A.M. Instant bandswitching 160 through 10 meters—operates by built-in VFO or crystal control. Pi-network tank circuit will match antenna loads from 50 to 600 ohms—final tank coil is silver-plated. Other features: TVI suppressed—timed sequence (break-in) keying—high gain push-to-talk audio system—low level audio clipping—built-in low pass audio filter—self-contained power supplies. With tubes, less crystals, key, microphone.

Cat. No. 240-104-1 Kit.....Amateur Net \$349.50

Cat. No. 240-104-2 Wired and tested.....Amateur Net \$439.50

VIKING "PACEMAKER" TRANSMITTER — This exciting transmitter offers you the ultimate in single sideband . . . 90 watts SSB P.E.P. input . . . 35 watts AM. Self-contained — effectively TVI suppressed. Instant bandswitching on 80, 40, 20, 15, and 10 meters. Excellent stability and suppression. Temperature compensated built-in VFO . . . separate crystal control provided for each band. VOX and anti-trip circuits provide virtually "fool-proof" voice controlled operation. Pi-network output matches antenna loads from 50 to 600 ohms. More than enough power to drive the Viking Kilowatt or grounded-grid kilowatt amplifiers. (Requires use of Cat. No. 250-34 Power Divider when used with Viking Kilowatt.) With tubes and crystals, less key and microphone.

Cat. No. 240-301-2 Wired and tested. Amateur Net \$495.00

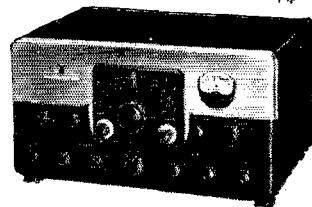

THE VIKING "THUNDERBOLT" — The hottest linear amplifier on the market, the Viking "Thunderbolt" delivers solid communication power — over 2000 watts P.E.P.* input; 1000 watts CW; 750 watts AM linear; in a completely self-contained desk-top package. Continuous coverage 3.5 to 30 megacycles — instant bandswitching. The "Thunderbolt" may be driven by the Viking "Navigator," "Ranger," "Pacemaker," or other unit of comparable output. Drive requirements: approximately 10 watts in Class A₂ linear, 20 watts Class C continuous wave.

Cat. No. 240-353-1 Kit with tubes. Amateur Net \$450.00†

Cat. No. 240-353-2 Wired and tested with tubes . . . Amateur Net \$525.00†

†Prices subject to revision. November 1957 delivery anticipated.

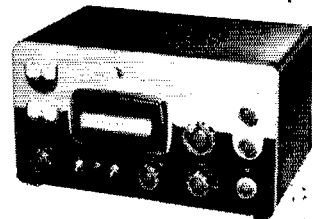

VIKING "FIVE HUNDRED" TRANSMITTER — Rated a full 600 watts CW . . . 500 watts phone and SSB (P.E.P. input with auxiliary exciter). All exciter stages ganged to VFO tuning. Two compact units: RF unit small enough to place on your operating desk beside receiver — power supply/modulator unit may be placed in any convenient location. Crystal or built-in VFO control — instant bandswitching 80 through 10 meters — TVI suppressed — high gain push-to-talk audio system — low level audio clipping. Pi-network output circuit with silver-plated final tank coil will load virtually any antenna system. With tubes, less crystals, key and microphone.

Cat. No. 240-500-1 Kit. Amateur Net \$749.50

Cat. No. 240-500-2 Wired and tested. Amateur Net \$949.50

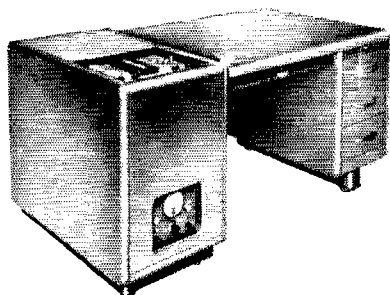
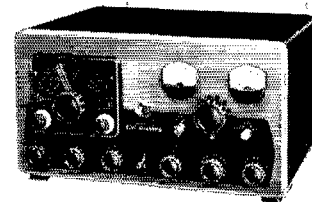

VIKING "KILOWATT" AMPLIFIER — Boldly styled, effectively TVI suppressed — contains every conceivable feature for safety, operating convenience, and peak performance. Full 2000 watts P.E.P. on SSB or low power AM, CW, or SSB with the flip of a switch. Continuous tuning 3.5 to 30 mc. — no coil change necessary. Compact pedestal contains complete kilowatt — rolls out for adjustment or maintenance. Excitation requirements: 30 watts RF and 10 watts audio for AM; 2-3 watts peak for SSB. Completely wired and tested with tubes.

Cat. No. 240-1000 Wired and tested. Amateur Net \$1595.00

Cat. No. 251-101-1 Matching accessory desk, top, back and three drawer pedestal. F.O.B. Cory, Pa. \$132.00

*The F.C.C. permits a maximum one kilowatt average power input for the amateur service. In SSB operation under normal conditions this results in peak envelope power inputs of 2000 watts or more depending upon individual voice characteristics.

Something new in accessories!

PLUG-IN MODULATOR FOR THE VIKING "ADVENTURER"

SPEECH AMPLIFIER/MODULATOR — This compact speech amplifier/screen modulator is designed to provide phone operation for the Viking "Adventurer." High gain — may be used with either crystal or dynamic microphones. Installation is simple, and only minor wiring changes are necessary in the "Adventurer" to use the 250-40. Power is obtained from the "Adventurer" — Speech amplifier/modulator plugs directly into the rear socket on the "Adventurer" chassis. Tube complement: 12AX7 dual triode cascade speech amplifier; 12AU7 dual triode, paralleled, modulator.

Cat. No. 250-40 Speech Amplifier/Modulator Kit with tubes. . . Amateur Net \$12.25

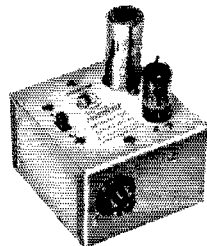

E. F. Johnson Company

2825 SECOND AVENUE S.W.

WASECA, MINNESOTA

Gateway

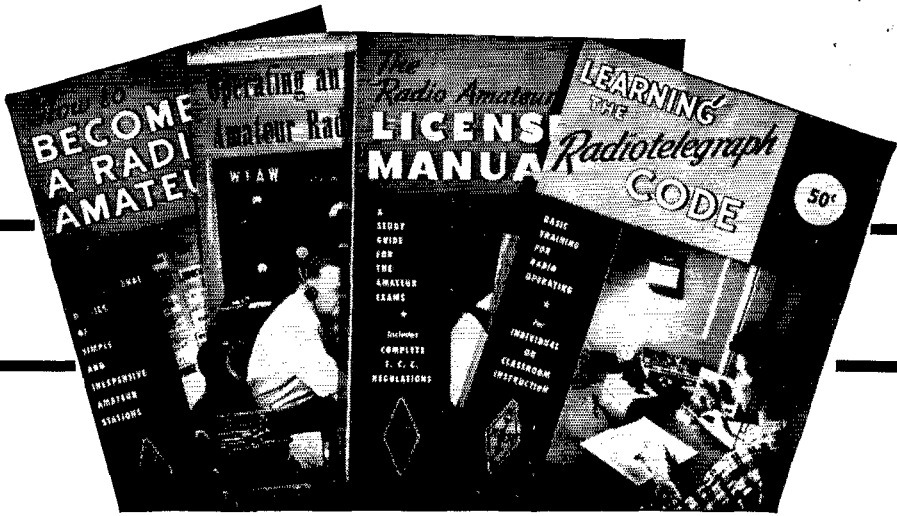

to Amateur Radio!

- ★ HOW TO BECOME A RADIO AMATEUR
- ★ THE RADIO AMATEUR'S LICENSE MANUAL
- ★ LEARNING THE RADIO TELEGRAPH CODE
- ★ OPERATING AN AMATEUR RADIO STATION

Anyone starting out in amateur radio will find these publications a necessary part of his reading and studying for the coveted amateur radio operator's ticket. Written in clear, concise language, they help point the way for the beginner. Tried and proven by thousands upon thousands of amateurs, these ARRL publications are truly the "Gateway to Amateur Radio."

\$1.50

POSTPAID

The American Radio Relay League, Inc.—West Hartford, Connecticut

HEATHKITS®

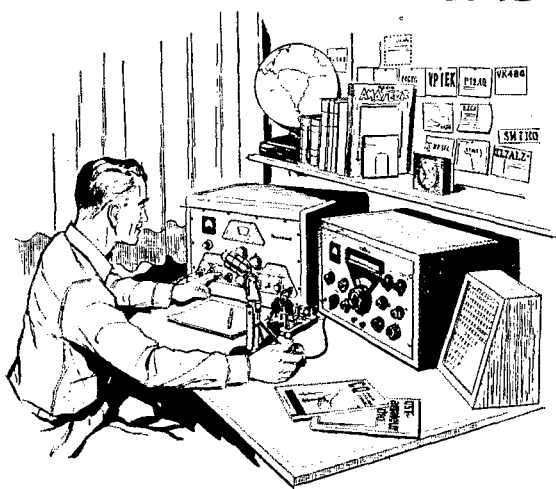

*Top quality
ham equipment
in kit form . . .
designed especially to
meet your requirements!*

Heath amateur radio gear is designed by hams—for hams, to insure maximum "on the air" enjoyment. Good design and top-quality components guarantee reliability. Heathkits are easy to build and are easy on your budget! You save by dealing direct, and you may use the Heath Time Payment Plan on orders totaling \$90.00 or more. Write for complete details.

HEATHKIT

DX-100

TRANSMITTER KIT

PHONE
AND CW

- ▶ Phone or CW—160 through 10 meters.
- ▶ 100 watts RF on phone—120 watts CW—parallel 6146 final.
- ▶ Built-in VFO—pi network output circuit.
- ▶ Easy to build—TVI suppressed



MODEL DX-100

\$189⁵⁰

\$18.95 dwn., \$15.92 mo.

Shpg. Wt. 107 Lbs.

Shipped motor freight unless otherwise specified.

\$50.00 deposit required on c.o.d. orders.

The Heathkit DX-100 phone-CW transmitter offers features far beyond those normally received at this price level. It has a built-in VFO, built-in modulator, and built-in power supplies. It is TVI suppressed, and uses pi network interstage coupling and output coupling. Matches antenna impedances from approximately 50 to 600 ohms. Provides a clean strong signal on either phone or CW, with RF output in excess of 100 watts on phone, and 120 watts on CW. Completely bandswitching from 160 through 10 meters. A pair of 1625 tubes are used in push-pull for the modulator, and the final consists of a pair of 6146 tubes in parallel. VFO dial and meter face are illuminated. High-quality components throughout! The DX-100 is very easy to build, even for a beginner, and is a proven, trouble-free rig that will insure many hours of enjoyment in your ham shack.



HEATH COMPANY BENTON HARBOR 9, MICHIGAN

A Subsidiary of Daystrom, Inc.

HEATHKIT **DX-35** TRANSMITTER KIT

PHONE AND CW

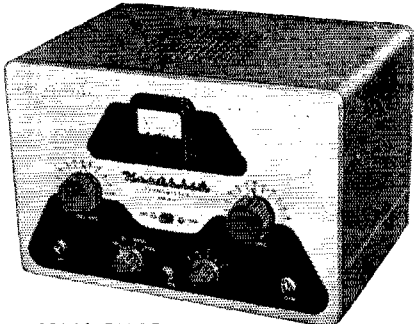

MODEL DX-35
\$56⁹⁵ Shpg. Wt.
24 lbs.
\$5.70 dwn., \$4.78 mo.

This transmitter features a 6146 final amplifier to provide 65 watt plate power input on CW, with controlled-carrier modulation peaks up to 50 watts on phone. Modulator and power supplies are built in, and the rig covers 80, 40, 20, 15, 11 and 10 meters with a single band-change switch. Pi network output coupling provides for matching various antenna impedances. Employs 12BY7 oscillator, 12BY7 buffer and 6146 final. Speech amplifier is a 12AX7, and a 12AU7 is employed as modulator. Panel control provides switch selection of three different crystals, reached through access door at rear. Panel meter indicates final grid current or final plate current. A perfect low-power transmitter both for the novice or the more experienced amateur. A remarkable power package for the price. The price includes tubes, and all other parts necessary for construction. Comprehensive instruction manual insures successful assembly.

- ▶ Phone or CW—80 through 10 meters.
- ▶ 65 watts CW—50 watts peak on phone—6146 final amplifier.
- ▶ Pi network output to match various antenna impedances.
- ▶ Tremendous dollar value—easy to build.

BRAND NEW

HEATHKIT **DX-20** CW TRANSMITTER KIT

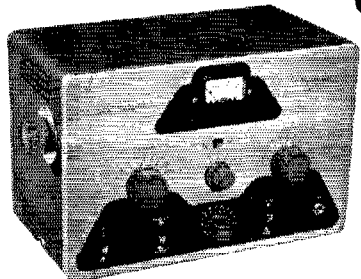

MODEL DX-20
\$35⁹⁵
\$3.60 dwn., \$3.02 mo.
Shpg. Wt. 18 lbs.

- ▶ Designed exclusively for CW work.
- ▶ 50 watts plate power input—80 through 10 meters.
- ▶ Pi network output circuit to match various antenna impedances.
- ▶ Attractive and functional styling—easy to build.

Here is a straight-CW transmitter that is one of the most efficient rigs available today. It is ideal for the novice, and even for the advanced-class CW operator. This 50 watt transmitter employs a 6DQ6A final amplifier, a 6CL6 oscillator, a 5U4GB rectifier and features one-knob bandswitching to cover 80, 40, 20, 15, 11 and 10 meters. It is designed for crystal excitation, but may be excited by an external VFO. A pi network output circuit is employed to match antenna impedances between 50 and 1000 ohms. Employs top-quality parts throughout, including "potted" transformers, etc. If you appreciate a good signal on the CW bands, this is the transmitter for you!



HEATH COMPANY BENTON HARBOR 9, MICHIGAN

A Subsidiary of Daystrom, Inc.

HEATHKIT

COMMUNICATIONS-TYPE, ALL BAND

RECEIVER KIT

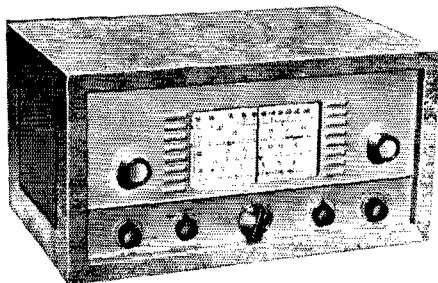

This receiver covers 550 kc to 30 mc in four bands, and is ideal for the short wave listener or beginning amateur. It provides good sensitivity and selectivity, combined with fine image rejection. Amateur bands are clearly marked on the illuminated dial scale. Features transformer-type power supply—electrical band spread—antenna trimmer—separate RF and AF gain controls—noise limiter—headphone jack—and AGC. Has built-in BFO for CW reception.

MODEL AR-3

\$29⁹⁵

incl. excise tax
(less cabinet)

\$3.00 dwn., \$2.52 mo.

Shpg. Wt. 12 Lbs.

CABINET: Fabric covered cabinet with aluminum panel as shown, Part 91-15A. Shipping Wt. 5 Lbs. \$1.50 dwn., \$1.42 mo. \$4.95

(A) HEATHKIT VFO KIT MODEL VF-1

Covers 160, 80, 40, 20, 15, 11 and 10 meters with three basic oscillator frequencies. Better than 10 volt average RF output on fundamentals. Requires 250 VDC at 15 to 20 ma, and 6.3 VAC at 0.45A. Incorporates regulator tube for stability and illuminated frequency dial. Shpg. wt. 7 lbs. \$1.95 dwn., \$1.64 mo. **\$19.50**

(B) HEATHKIT GRID DIP METER KIT MODEL GD-1B

Continuous coverage from 2 mc to 250 mc with prewound coils. 500 ua panel meter for indication. Use to locate parasitics, for neutralizing, determining resonant frequencies, etc. Will double as absorption-type wavemeter. Shpg. wt. 4 lbs. \$2.00 dwn., \$1.68 mo. **\$19.95**

(C) HEATHKIT ANTENNA IMPEDANCE METER KIT MODEL AM-1

The AM-1 covers 0 to 600 ohms for RF tests. Functions up to 150 mc. Used in conjunction with a signal source, will determine antenna resistance and resonance, match transmission lines for minimum SWR, determine input impedance, etc. Shpg. wt. 2 lbs. \$1.45 dwn., \$1.22 mo. **\$14.50**

(D) HEATHKIT "Q" MULTIPLIER KIT MODEL QF-1

Functions with any receiver having IF frequency between 450 and 460 kc that is not AC DC type. Operates from receiver power supply, requiring only 6.3 volts AC at 300 ma (or 12.6 vac at 150 ma), and 150 to 250 vdc at 2 ma. Simple to connect with cable and plugs supplied. Provides extra selectivity for separating signals, or will reject one signal to eliminate heterodyne. Effective Q of approximately 4000. Shpg. wt. 3 lbs. \$1.00 dwn., \$.84 mo. **\$9.95**

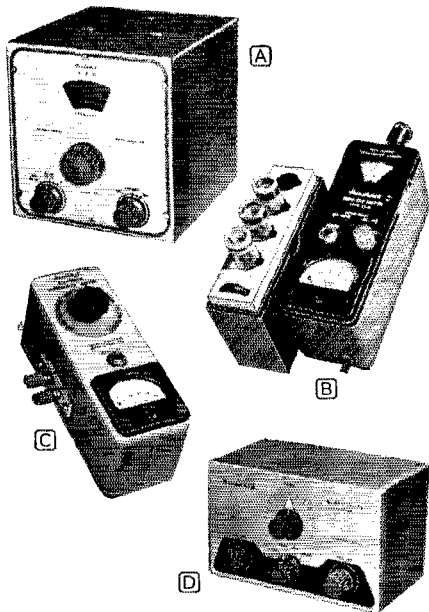

HOW TO ORDER...

It's simple—just identify the kit you desire by its model number and send your order to the address listed below. Or, if you would rather budget your purchase, send for details of the Heath Time Payment Plan for orders totaling \$90.00 or more.



HEATH COMPANY BENTON HARBOR 9, MICHIGAN

A Subsidiary of Daystrom, Inc.



"I am now using the Gotham V80 vertical antenna with only 55 watts, and I am getting fantastic reports from all over the world". VP1SD

ALL-BAND VERTICAL ANTENNAS

GOTHAM'S sensational new vertical antennas give unsurpassed multi-band performance. Each antenna can be assembled in

less than two minutes, and requires no special tools or electronic equipment. In the V160, resonance in the 160, 80, 75, and 40 meter bands is secured through use of the proper portion of the loading coil. Yet, when the coil is eliminated or bypassed, the V160 will operate on 20, 15, 10 and 6 meters! The same idea applies to our V80 and V40 multi-band verticals. No guy wires needed; rugged, occupies little space, proven and tested.

I USE MY GOTHAM ALL BAND VERTICAL ON 6, 10, 15 AND 20

ME TOO, TOM-AND LAST NIGHT I SWITCHED TO 40, 80, AND 160. WORKED SOME REAL DX!



Simple design and superior materials give all-band operation, and effective, omni-directional radiation. Gotham verticals are rugged, with low initial cost and no maintenance. Guaranteed Gotham quality at low Gotham prices. Perfect for the novice with five watts or the expert with a kilowatt.

QUALITY MATERIAL

Brand new mill stock aluminum alloy tubing with Aluminite finish for protection against corrosion. Loading coils made by Barker & Williamson.

ALL-BAND OPERATION

Switch from one band to another. Operate anywhere from 6 to 160 meters. Work the DX on whatever band is open.

EASY ASSEMBLY

Less than two minutes is all you need to put your vertical together. No special tools or electronic equipment required. Full instructions given.

SIMPLE INSTALLATION

Goes almost anywhere. On the ground, on the roof, or outside your window. No trick fittings or castings needed.

AMAZING PERFORMANCE

Hundreds of reports of exceptional DX operation on both low and high power. You will work wonders with a Gotham vertical.

NO GUY WIRES

Our design eliminates unsightly guy wires. You save time, trouble, space and money by avoiding guy wires.

PROVEN DESIGN

Over a thousand Gotham verticals are on the air — working the world and proving the superiority of Gotham design.

AND THE PRICE IS RIGHT!

"I worked LU3ZS on Half Moon Island in Antarctica on Dec. 26 at 21150 Kc. I was using my Gotham V80 vertical antenna and only 35 watts." KN5GLI



Airmail Order Today — We Ship Tomorrow

GOTHAM Dept. QST
1805 PURDY AVE., MIAMI BEACH, FLA.

Enclosed find check or money-order for:

- V40 vertical for 40, 20, 15, 10, 6 meters.....\$14.95
- V80 vertical for 80, 75, 40, 20, 15, 10, 6 meters.....\$16.95
- V160 vertical for 160, 80, 75, 40, 20, 15, 10, 6 meters.....\$18.95

Name.....

Address.....

City.....Zone.....State.....

WORK THE WORLD



How to order
Send check or money order directly to Gotham or visit your local distributor. Immediate shipment by Railway Express, charges collect. Foreign orders accepted.

GOTHAM 1805 PURDY AVENUE
MIAMI BEACH 39, FLA.

YOU COULD WORK WONDERS IF YOU HAD A GOTHAM BEAM!

Study these specifications—compare them—and you too will agree, along with thousands of hams, that **GOTHAM beams are best!**

TYPE OF BEAM. All Gotham beams are of the full half-wave plumber's delight type; i.e., all metal and grounded at the center. No wood, tuning stubs, baluns, coils, or any other devices are used.

MORE DX CONTACTS

GAIN. Gotham beams give the maximum gain obtainable. Our 2-element beams give a power gain of four (equivalent to 6 db.); our 3-element beams give a power gain of seven (8.1 db.); and our 4-element beams give a power gain of nine (9.6 db.).

THE DESIGN IS PROVEN

FRONT-TO-BACK RATIO. We guarantee a minimum F/B Ratio of 19 db. for any of our 2-element beams; 29 db. for any of our 3-element beams; 35 db. for 4-element beams.

THOUSANDS IN DAILY USE

MATCHING. Matching of the transmission line to the beam is extremely simple and quick. No electronic equipment or measuring devices are required.

ALCOA QUALITY ALUMINUM

ASSEMBLY AND INSTALLATION. No special tools are required for assembly and installation. Entire job can be done by one man in less than an hour. Full instructions are included with each beam.

CONSISTENT PERFORMANCE

MAST. Any Gotham beam can be mounted on a simple pipe mast. Diameter of the pipe should be between $\frac{3}{4}$ " and $1\frac{1}{8}$ ".

YOU WILL WORK THE WORLD

STANDARD AND DELUXE BEAMS. Standard beams in the 6, 10 and 15 meter bands use $\frac{3}{8}$ " and $\frac{3}{4}$ " tubing elements; the deluxe models for these bands use $\frac{1}{2}$ " and 1". In 20 meter beams, the standard has a single boom, while the deluxe uses twin booms.

TRIBANDER BEAMS

6-10-15 TRIBANDER.....\$39.95
10-15-20 TRIBANDER..... 49.95

Do not confuse these full-size tribander beams with so-called midgets. The Tribander has individually fed (52 or 72 ohm coax) elements and is not frequency sensitive, nor does it have baluns, coils, traps, or other devices intended to take the place of aluminum tubing. The way to work multi-band and get gain is to use a Gotham Tribander Beam.

TWO BANDER BEAMS

6-10 TWO BANDER.....\$29.95
10-15 TWO BANDER..... 34.95
10-20 TWO BANDER..... 36.95
15-20 TWO BANDER..... 38.95

Each Two Bander has twin 12' booms, and full-size half-wave elements. $\frac{7}{8}$ " and 1" aluminum alloy tubing, all castings and fittings are supplied. Assembly is easy. No traps, coils, baluns or stubs are used. All dimensions furnished, all machining done for you. Satisfaction guaranteed. Send for free literature.

You could work KC4USA in the Antarctica with only 90 watts on 15 meters, as W4SK did.

You could work over 100 countries with a three element 10 meter beam, and be a top man on the frequency, like WøDEL.

You could work terrific skip and DX with reports of 20 over 9, with as little as 36 watts input on 20 meters, as W. E. Woods did.

You could work 29 states in three months on six meters, with low power, as K2LHP did.

HI JIM, HEARD YOU WORKING THAT DX STATION. HOW DO YOU DO IT ON THE LOW POWER YOU RUN?



EASY BILL. I'VE GOT A GOTHAM BEAM. I'M WORKING STATIONS I NEVER HEARD BEFORE. DX IS A CINCH NOW.



Airmail Order Today — We Ship Tomorrow

GOTHAM Dept. QST

1805 PURDY AVE., MIAMI BEACH, FLA.

Enclosed find check or money-order for:

TRIBANDER

6-10-15

\$39.95

10-15-20

\$49.95

6 METER BEAMS

Std. 3-El Gamma match 12.95

Deluxe 3-El Gamma match 21.95

Std. 4-El Gamma match 16.95

Deluxe 4-El Gamma match 25.95

T match 14.95

T match 24.95

T match 19.95

T match 28.95

10 METER BEAMS

Std. 2-El Gamma match 11.95

Deluxe 2-El Gamma match 18.95

Std. 3-El Gamma match 16.95

Deluxe 3-El Gamma match 22.95

Std. 4-El Gamma match 21.95

Deluxe 4-El Gamma match 27.95

T match 14.95

T match 21.95

T match 18.95

T match 25.95

T match 24.95

T match 30.95

15 METER BEAMS

Std. 2-El Gamma match 19.95

Deluxe 2-El Gamma match 29.95

Std. 3-El Gamma match 26.95

Deluxe 3-El Gamma match 36.95

T match 22.95

T match 32.95

T match 29.95

T match 39.95

20 METER BEAMS

Std. 2-El Gamma match 21.95

Deluxe 2-El Gamma match 31.95

Std. 3-El Gamma match 34.95

Deluxe 3-El Gamma match 46.95

T match 24.95

T match 34.95

T match 37.95

T match 49.95

(Note: Gamma-match beams use 52 or 72 ohm coax.

T-match beams use 300 ohm line.)

NEW! RUGGEDIZED HI-GAIN 6, 10, 15 METER BEAMS

Each has a TWIN boom, extra heavy beam mount castings, extra hardware and everything needed. Guaranteed high gain, simple installation and all-weather resistant. For 52, 72 or 300 ohm transmission line. Specify which transmission line you will use.

Beam #R6 (6 Meters, 4-El).....\$38.95

Beam #R10 (10 Meters, 4-El)..... 40.95

Beam #R15 (15 Meters, 3-El)..... 49.95



Name.....

Address.....

City.....Zone.....State.....

A M O D E R N

Illustrated below is a new "helicopt-hut" installation complete with SSB and RTTY transmitting and receiving terminal equipment.

The "helicopt-hut" as designed and manufactured by Craig Systems, Inc., of Danvers, Mass., is easily transported by helicopter and other prime movers.

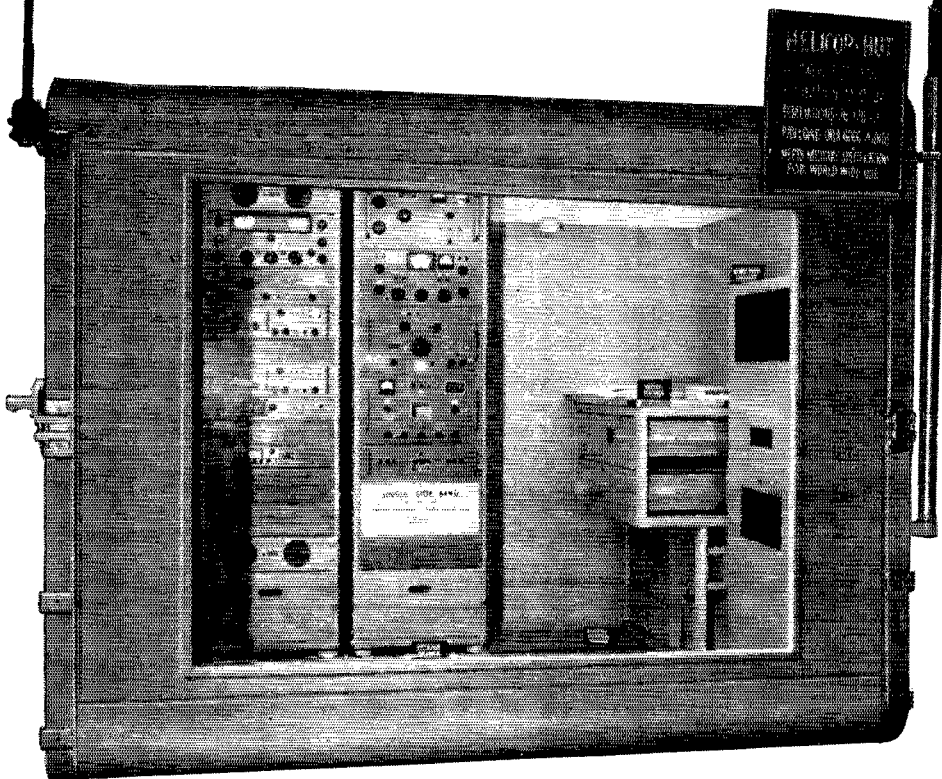

It is interesting to note the number of TMC commercial products which bear armed services nomenclature in this installation such as—

GPR-90	Receiver	R-825/URR
MSR	Mode selector	CV-591/URR
FFR	Receiver (fix tune)	AN/FRR-49(v)
SBE-1	Sideband Exciter	AN/URA-23
PMO	Variable precision Oscillator	O-459/URT

YOU CAN DEPEND ON IT! TMC MEETS ITS PUBLISHED SPECIFICATIONS.

SKYHOOK!

Or...
just
another
way to
deliver
a
TMC
STATION
anywhere
in the world!!!



The Series 5800 Station shown below can also be easily transported by helicopter in crated form.

Provides a complete SSB, AM, CW, MCW and FS Transmitting and Receiving facility. Continuous frequency coverage 2 to 32 mcs band-switched. Up to 1100 watts output CCS.

Modes of operation: Single Sideband, Two Independent Sidebands, Double Sideband (all with adjustable carrier insertion), Conventional AM, Moduplex, FM, CW, MCW and Diversity Frequency Shift RTTY.

COMPLETE BULLETINS
AVAILABLE ON REQUEST

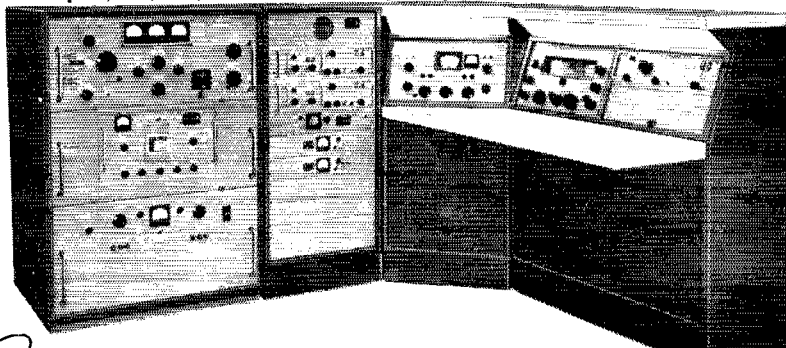

The TECHNICAL MATERIEL CORPORATION

IN CANADA

TMC Canada Ltd., Ottawa, Ontario

Main Office: MAMARONECK
NEW YORK

Across the United States the World Famous

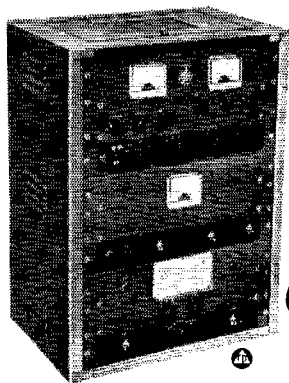

Globe King 500B

A handswitching transmitter for 540 watts on fone and CW; 750 watts on SSB (P.E.P.), with 10W external exciter.

Outperforming any rig in its price and wattage range the King bandswitches 10-160M in a 31x22x14 3/4" handsome cabinet, especially designed for TVI-suppression. The Transmitter is relay controlled; includes a built-in antenna relay; built-in VFO; and separate power supply for modulator section, allowing better overall voltage regulation... Commercial-type compression circuit keeps modulation at high level. King features grid-block keying for signal clarity. Pi-network matches most antennas, 52-600 ohms... Provisions for crystal operation.

Wired & Tested..... \$725.00

 FCDA Certified on factory wired and tested models for crystal controlled operation.

All WRL Electronics Transmitters operate on most CAP and MARS frequencies.

Globe Champion 300

A handswitching, 10-160M Transmitter for 350 watts CW, 275 watts fone, and 500 watts SSB (P.E.P.), with any 10W external exciter.

The single-switch handswitching Champion is extensively TVI-suppressed, filtered and bypassed. High level Class "B" modulation is sustained without usual clipping distortion through use of a new commercial type compression circuit. Pi-network output circuit, 48-700 ohms, built-in VFO, push-to-talk, antenna changeover relay, and improved Time Sequence keying are all features. Final tubes of 400 watt power handling capacity are forced air cooled. Only 12x21 1/2x17" in size, self-contained.

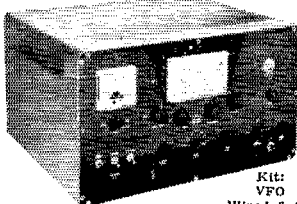

Kit: with wired VFO \$375.00
Wired & Tested .. \$449.00

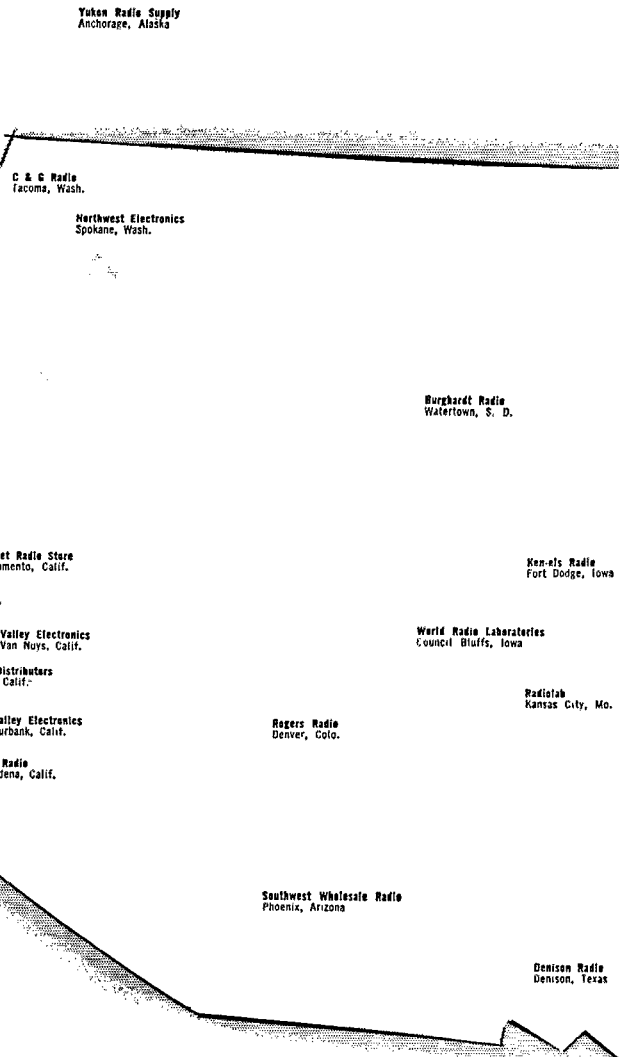

Globe Scout 680

65 watts CW; 50 watts on fone, plate modulated.

A compact, self-contained, handswitching transmitter for operation of the 6 through 80 meter bands, with built-in power supply. High level modulation is maintained. TVI-suppressed cabinet. Pi-network output on 10-80M; link-coupled on 6M, matching into low impedance beams. New type, shielded meter. Globe Scout 66 is identical, except bandswitching 10-160M. Size: 8x14x8".

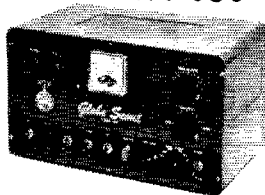

Model 680
Kit..... \$89.95
Wired & Tested... \$109.95
Model 66
Wired only..... \$99.95

these Distributors Stock WRL Electronics Line!

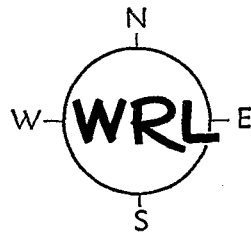

See them for Complete Details

OR WRITE TO

WRL Electronics

34th & BROADWAY
COUNCIL BLUFFS
IOWA

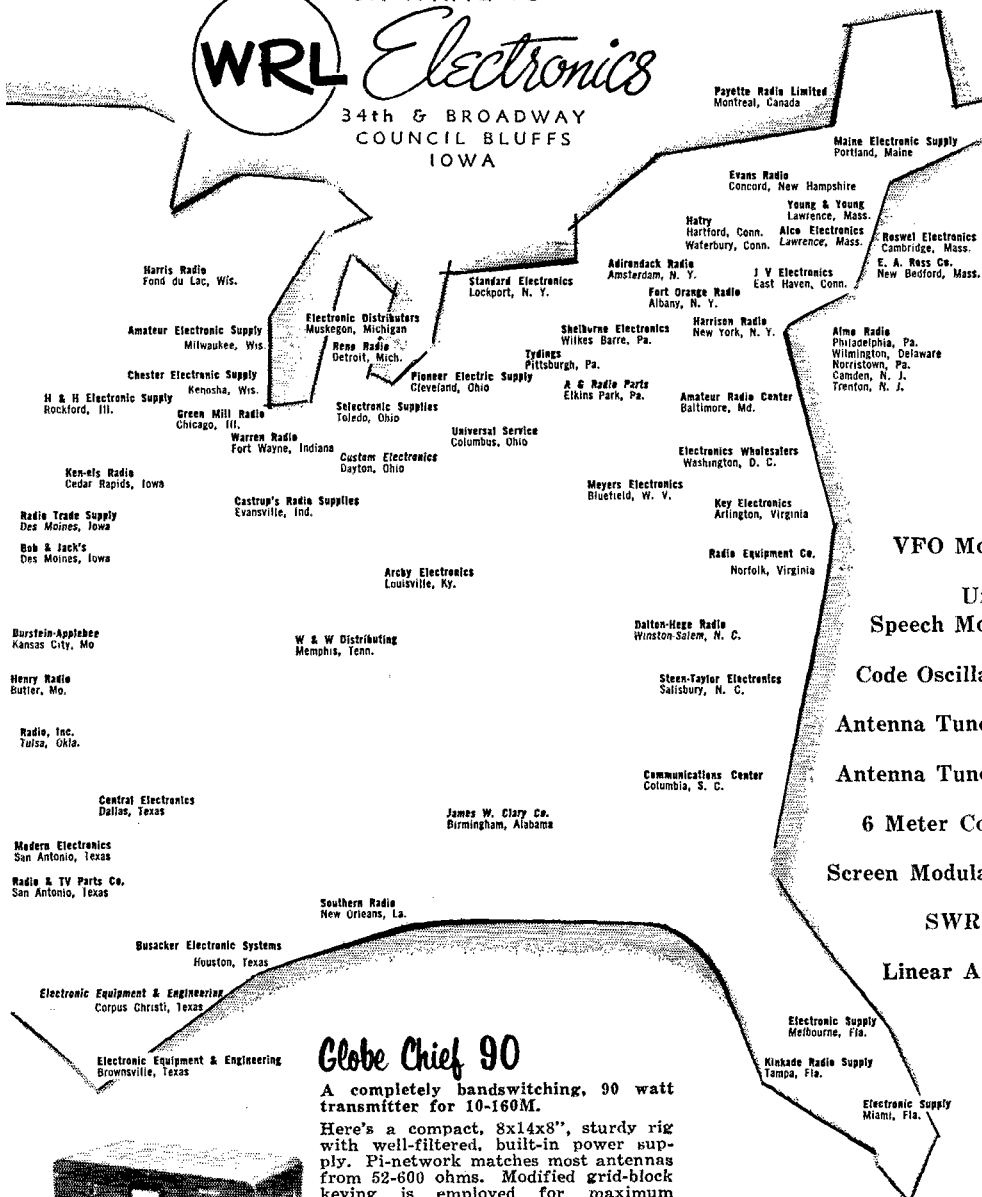

Globe Chief 90

A completely bandswitching, 90 watt transmitter for 10-160M.

Here's a compact, 8x14x8", sturdy rig with well-filtered, built-in power supply. Pi-network matches most antennas from 52-600 ohms. Modified grid-block keying is employed for maximum safety. Has provisions for VFO input and operation. Kit form includes complete manual and all tubes and parts. Meter and cabinet carefully shielded for reduction of unwanted TVI.

Kit.....\$54.95
Wired & Tested.....\$67.50

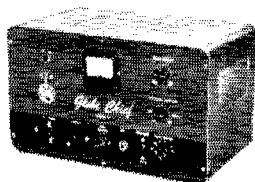

These National Distributors Are Participating in the "Old Receiver Round-Up":

- Alabama**
James W. Clary Co.
Birmingham
- California**
California Radio & TV Supply Co.
N. Sacramento
Elmar Electronics, Inc.
Oakland 7
Henry Radio
Los Angeles 64
Market Radio Store
Sacramento
Northern California Amateur Supply
San Francisco
Frank Quement, Inc.
San Jose
Radio Products Sales
Los Angeles
Sacramento Amateur Radio &
TV Supply, Sacramento
San Francisco Radio Co.
San Francisco
Universal Distributors, Inc.
Inglewood-Los Angeles
Valley Electronic Supply
Burbank
Western Radio & TV Supply Co.
San Diego 1
H. W. Wright Co.
Costa Mesa
Zack Radio
Palo Alto-San Francisco
- Colorado**
Radio Products Sales Co.
Denver
Roger Radio Co.
Denver 2
- Connecticut**
Aikins Electronic Supply Co.
New London
Hatry of Hartford, Inc.
Hartford 3
Radio Shack
New Haven
- D. C.**
Electronic Wholesalers, Inc.
Washington
Sun Parts Distributing Ltd.
Washington
- Delaware**
Almo Radio Co.
Wilmington
Delaware Electronic Supply Co.
Wilmington
Radio Electric Service Co.
Wilmington
Willard S. Wilson
Wilmington
- Florida**
Electronic Supply
Melbourne-Miami
Kinkade Radio Supply, Inc.
Tampa
Peard Electronic Supply Co., Inc.
Jacksonville
Walder Radio & Appliance Co.
Miami
- Georgia**
Yancy Co., Inc.
Atlanta
- Hawaii**
Kaimuki Radio Co., Inc.
Honolulu 16
- Idaho**
United Electronics Wholesale
Twin Falls
- Illinois**
Allied Radio Corp.
Chicago 80
H & H Electronic Supply, Inc.
Rockford
Newark Radio
Chicago
- Indiana**
Brown Distributing Co.
Indianapolis
- M. H. Dossett Co.**
Frankfort
Graham Electronic Supply
Indianapolis
Radio Distributing Co.
South Bend 24
Shaw Electronic Co.
Angola
Warren Radio Co.
Fort Wayne
- Iowa**
Bob & Jack's Store for Hams
Des Moines 14
Ken Els Radio Supply Co.
Cedar Rapids-Fort Dodge
Radio Trade Supply Co.
Des Moines
T. C. R. Distributors
Davenport
World Radio Laboratories, Inc.
Council Bluffs
- Kansas**
Amateur Radio Equipment Co.
Wichita
Norman Electronic Supply Co.
Coffeyville
- Kentucky**
Universal Radio Supply
Louisville
- Louisiana**
Central Radio Supply
Alexandria
Koelemy Sales Co., Inc.
Shreveport
- Maryland**
Almo Radio Co.
Salisbury
Amateur Radio Center
Baltimore
Emco Electronic Wholesalers
Silver Springs
Kann-Ellert Electronics, Inc.
Baltimore
Radio Electric Service Co.
Baltimore
Uncle George's Ham Shack
Silverspring
- Massachusetts**
Aico Electronics
Lawrence
Cramer Electronics, Inc.
Boston 16
DeMambro Radio
Boston
Radio Electronic Sales Co.
Worcester
Radio Shack
Boston 8
Young & Young
Lawrence
- Michigan**
N. M. Duffy & Co., Inc.
Detroit
Purchase Radio Supply
Ann Arbor
Reno Radio Co.
Detroit 26
- Minnesota**
Electronic Center, Inc.
Minneapolis 1
Elliott & Hanson Co.
Rochester
Gopher Electronics Co.
St. Paul
Hall Electric Co.
St. Paul 2
Northwest Radio
Duluth 2
- Missouri**
Associated Electronic
Supply Co., Kansas City
- Henry Radio**
Butler
Norman Electronic Supply Co.
Joplin
Radiolab Inc.
Kansas City
- Montana**
Modern Equipment Co.
Great Falls
- New Hampshire**
Evans Radio, Inc.
Concord
- New Jersey**
Allen & Hurley
Trenton
Almo Radio Co.
Camden-Atlantic City
Federated Purchaser
Mountainside
General Radio Supply Co.
Camden
Hudson Radio & TV Corp.
Newark
N. R. M. Wholesale Radio, Inc.
Ridgefield Park
Radio Electric Service Co.
Camden
Variety Electronics Corp.
Bloomfield
- New Mexico**
Electronic Parts Co.
Albuquerque
- New York**
Adirondack Radio Supply
Amsterdam
Arrow Electronics, Inc.
Mineola-New York
Fort Orange Radio
Distributing Co., Albany
Harrison Radio Corp.
New York 7
Harvey Radio
New York 36
Hudson Radio & TV Corp.
New York & Branches
Morris Distributing Co.
Syracuse
Rochester Radio Supply Co., Inc.
Rochester 5
- North Carolina**
Dalton-Hege Radio Supply
Winston-Salem
Freck Radio & Supply Co., Inc.
Asheville
- Ohio**
Pioneer Electronic Supply
Cleveland
Progress Radio Supply Co.
Cleveland
Richard J. Sauer
Dayton 9
- Oklahoma**
Norman Electronic Supply Co.
Bartlesville
Radio Inc.
Tulsa
- Oregon**
Portland Radio Supply Co.
Portland 5
United Radio Supply, Inc.
Eugene-Medford-Portland-Salem
Verl G. Walker Co.
Medford
- Pennsylvania**
A. C. Radio Supply Co.
Chester-Philadelphia
A. G. Radio Parts Co.
Elkins Park
- Almo Radio Co.**
Norristown-Philadelphia
George D. Barbey Co.
Lancaster-Lebanon-Pottstown-
Reading
Consolidated Radio Co.
Philadelphia
D & H Distributing Co.
Harrisburg
General Radio Supply Co.
Norristown
Lelectronic Distributing Co.
Philadelphia
Radio Distributing Co.
Harrisburg
Radio Electric Service Co.
Allentown-Camden-Easton-
Philadelphia-Willow Grove-York
- Rhode Island**
DeMambro Radio
Providence
W. H. Edwards Co.
Providence
- South Carolina**
Communications Center
Columbia
- South Dakota**
Burghardt Radio Supply Co.
Aberdeen-Rapid City-Sioux City-
Watertown
- Tennessee**
Curle Radio Supply
Chattanooga
Electra Distributing
Nashville 4
L. K. Rush Co.
Jackson
- Texas**
Central Electronics
Dallas
Crabtree's Wholesale
Dallas
Robert Franklin
Houston
Hargis-Austin, Inc.
Austin
Lavender Radio & TV
Supply, Inc., Texarkana
R. C. & L. F. Hall, Inc.
Houston
Jay R. Huckabee Co.
Snyder
Modern Electronic Co.
San Antonio
Radio & TV Parts
San Antonio
- Utah**
Standard Supply Co.
Salt Lake City
- Virginia**
Radio Equipment Co., Inc.
Norfolk
- Washington**
C & G Radio Supply Co.
Tacoma
Pacific Electronic Sales Co.
Seattle
Pringle Radio Wholesale Co.
Everett
Seattle Radio Supply Co.
Seattle
- Wisconsin**
Amateur Electronic Supply
Milwaukee
Harris Radio Corp.
Fond du Lac
Satterfield Electronics, Inc.
Madison

Before buying any receiver...

YOU SHOULD KNOW THE ANSWERS TO THESE NC-300 QUESTIONS

Do you know the answers to these important NC-300 Questions?

What special features make the NC-300 "tops" in effortless single side band reception?

Why does the NC-300 cover only the amateur bands?

National's NC-300 has great sensitivity! Equals or exceeds that of any amateur receiver today. Why?

Why is the NC-300 the most stable receiver in its price class... equaling or exceeding the stability of even the most expensive receivers?

What are the advantages contributed by the NC-300's foot-long slide rule dial?

Why does the NC-300 use 2215 kc as the 1st conversion frequency?

What is the NC-300's tube line-up?

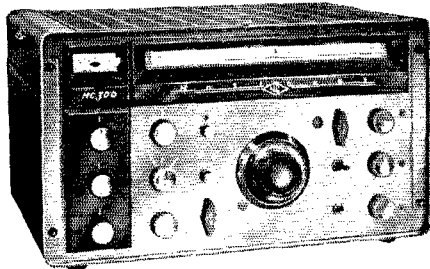

World famous NC-300. Thousands now in use. Suggested price, without trade in: \$399.00* — \$39.90 down, at most National distributors.

*Slightly higher west of the Rockies

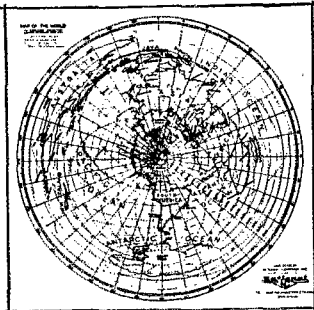

tuned to tomorrow

since 1914 **National**  Company, Inc. Malden 48, Mass.

It's National "Old Receiver Round-Up Time"



BURTON BROWNE / New York

How many times have you wished your old receiver was a bright, new NC-300? Now, make this dream come true — and save money too.

BIGGEST TRADE-IN Allowances in history! Most National distributors are offering top deals for your old receiver, regardless of age, toward National's famous NC-300.

NO CASH DOWN in most instances where old receiver covers down payment, up to 20 months to pay balance.

FREE NC-300 for nation's oldest receiver accepted in trade.

FREE FROM NATIONAL: MAIL COUPON NOW

This is what you get! Free 19" x 20" 360° Azimuthal world map. (Use it to aim your beam!) Full information on the National "Old Receiver Round-Up" plus the answers to important questions on the NC-300.

National Company, Inc.
Dept. 300, 61 Sherman Street, Malden 48, Mass.

Please send me my FREE Azimuthal map and full information on National's "Old Receiver Round-Up" plus detailed facts on the NC-300.

Name _____ Call _____

Address _____

City _____ Zone _____ State _____

VALLEY ELECTRONIC SUPPLY CO.

"Final Word" for all
amateur equipment in the West

WRL



WRL Globe Chief 90. Xmtr kit.
90 watts (75 Novice). 160-10 meters.
Amateur net: **\$57.70**

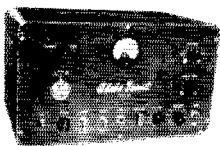

WRL Globe Scout 680. Xmtr kit.
65 watts CW, 50 fone. 6-80 meters.
Amateur net: **\$94.45**

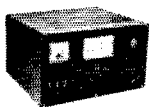

WRL Globe Champion 300. Xmtr kit.
300 watts SSB PEP (with ex. exciter).
Amateur net: **\$393.75** (less exciter)

VALLEY ELECTRONIC SUPPLY CO.

1302 W. Magnolia, Burbank, Calif.
Victoria 9-4641

17647 Sherman Way, Van Nuys, Calif.
Dickens 2-5143

Some prices slightly higher west of the Rockies

(Continued from page 109)

(including Sun.) at 1800. This net is for training beginners at 8 to 18 w.p.m. K2RTN has a new Valiant and SX-101. The Jericho ARC was formed with the call TFP and J.R.J. pres.: K2RTN, trustee, K2QPC has a new five-element beam on 6 meters. RQF is building a linear for his 10B. K2ECL has been knocking the rare ones off on 20-meter DX with his new two-element beam. TKO is working on a fabulous antenna farm which includes beams on 20, 15, 10, 6 and 2, vertical arrays on 20, 40, and 15 and phased arrays on 80 and 40 meters. TKO is most active on RTTY. The Erie County Emergency Net, which meets on 3915 kc. at 1230 Sun. held its first annual picnic. PVI is Net Manager. K2KTK wants to hear from those interested in a W.N.Y. QSO Party. K2CUQ has been spending most of her time on 8 meters. KMW still is working on a new receiver and 20-meter DX. K2ECL now has two finals: P.p. 812A (500 watts) on 40 and 304TL (650 watts) on 20 meters. He also has a two-element beam on 20 meters and recently received an A1-Operator Club certificate and completed WAS, WVT and WNH. MVT spoke on transistor application at the Sept. RAWNY meeting. K2UZJ got his General Class license and is trying to finish off WAS with his AT-1 and SX-99. K2UZJ is 13 years old and is a typical example of the young fellows who are discovering that amateur radio is one of the finest hobbies there is. PVC, EC for Herkimer County, reports that his new trap antenna and 20-watt phone rig does almost as well as his 200-watt rig. QQ has a new beam on top of a 50-ft. telephone pole. The AWA had the honor of being the only club on the National ARRL Convention program from an outside area. ICE reports that "The Story of DX" was presented twice to capacity audiences. Appointments: MTA as OBS, K2RRT as OBS and OPS, EWO as OO Class II, renewals: TVO as Cayuga Co. EC, GIU as Jefferson Co. EC, PVC as Herkimer Co. EC, K2KIR as OBS and COU as OBS. NYSPTEN certificates go to K2s: AIDP, DUB, IJJ, QIX, SQG, SIQ, UTI and W2s: AIG and TBY. Traffic: (Aug.) K2DNV 334, IYF 277, W2RUF 212, ZRC 211, FEB 104, K2GWN 45, GQU 38, BBJ 17, KTK 9, W2RQF 6, K2HUK 5, KIR 2, (July) K2DXU 160, RYH 39, W2RQF 35, K2GQU 13, W2BLO 4.

WESTERN PENNSYLVANIA—SCM, John F. Wojtkiewicz, W3GJY—SEC, OMA, RMs: UFN, NUG and GEG. The WPA Traffic Net meets nightly except Sat. and Sun. on 3585 kc. at 7 p.m. WIQ took a much-needed vacation from traffic. Members of the Allegheny-Kiski ARC enjoyed movies of the past Field Day and a local hamfest held several years ago. TO promote better public relations the AKARA sponsored a float depicting amateur radio in the Port Crawford Day Parade held at New Kensington on Sept. 10. Actual contacts were established with mobiles in the vicinity from a station on the float powered by the club's gasoline generator while the parade was in progress. WGS now locates at Glenshaw. An interesting visit was made by the membership of the Etna Radio Club to the site of KDKA's transmitters and antennas. MVQ was a visitor at a recent meeting. TOC now holds Mobileer and B.S.N. certificates. RIQ is QRL on 6 meters and HSW is QRL with c.d. operations. TOC, IMB and SIR, who are sightless, can be heard daily on 23,744 kc. around 11 a.m. The Mobileers Net meets each Wed. on 29,360 kc. at 8 p.m. JWZ is looking for 420-Mc. enthusiasts in the Pittsburgh Area with a view to organizing a u.h.f. club. Interested persons should contact him at 502 Glenn Ave., Glenshaw, Pa. GXL puts out a nice signal with his new transmitter. Ditto DWO with his new DX-100. GCB and ERJ were visitors at MWJ's shack. JLZ runs a Globe Scout 680 on 6 meters with an SX-100 inverter. ZHQ is a newly-appointed OO at Johnstown. AGF is a new OBS. ZFB proudly displays her newly-acquired OPS and Public Service certificates. The Steel City ARC has virtually completed its new club house. EOR is back at work after a siege in the hospital. RSL has left for a teaching position in New Jersey. RXT got his 40-ft. tower ready for the v.h.f. tests. NKM has been snagging elusive DX on 14-Mc. c.w. and s.s.b. with his KWS-1. OKU is working 40 meters with an HT-32. DQR took "top" prize at the SHBPM Hamfest, a Viking II. ZPZ has increased power with his new Johnson mobile rig. UHM is eyeing a new 75A-4 receiver. AAN acquired a new QTH. ZDW added a prop-pitch motor to his 45-ft. tower. APN has a new Johnson Matchstick. SIQ, ZUZ, TOB, DQR and DVP are attending college. Novice ARV dropped the "N." BSF and CRA took in the National Convention at Chicago. RTB bemoans the lack of DX QSLs. Reports from up Erie way are that the hamfest held at Lake LeBoeuf was a huge success with NXX taking the main prize. The 6-Meter RACES Net is functioning smoothly with JTF, CSM, POS, UCZ and VQS in charge of operations. MS holds DX round tables using an HT-32. QZE has moved to Flor-

(Continued on page 124)

**BOXED,
WRAPPED
and
DELIVERED!**

**IDEAL
CHRISTMAS GIFTS**

for HAMS!

Last year we contributed to the happiness of many a Ham Radio Shack, sending International units made to exacting standards, to a great number of people as Christmas Gifts. Now, as an early gift suggestion, we offer the following:

**T-12 TRANSMITTER 3500-4000 KC
7000-7300 KC**

Only 3 1/2" x 6" x 3 1/4" . . . makes many DX contacts with careful operation under good conditions. Pi-network output enables operator to couple into almost any type antenna. Low drive oscillator with International FA or F-6 crystals; may be used in close tolerance applications. 12BH7 Oscillator-buffer and 5763 final. Power requirements! filaments 6.3 VAC @ 1.35 amp. Plate supply 350 volts dc @ 50 mils. Separate B+ input connection to final for addition of modulation. Crystal frequency same as output frequency; uses straight through operation!

T-12 Wired with tubes and one 80 or 40 meter crystal (Specify) KC \$15.95
(Kits for assembly also available)

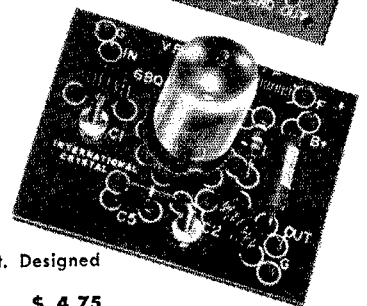
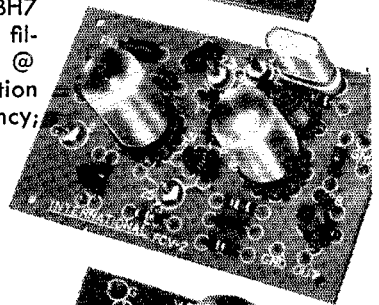
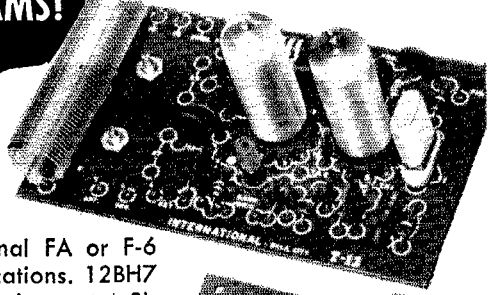

**FCV-2 CONVERTER 2 METERS
6 METERS**
• Model 50 - 6 Meters • Model 144 - 2 Meters

A 6U8 tube is used as oscillator-mixer. Cascode r-f amplifier using 6BQ7A. IF outputs available from broadcast band through 30MC. Designed to mount in a standard 3 x 4 x 5-inch minibox.

Kit with crystal (less tubes).....\$12.95
Wired with crystal and tubes..... 17.95

VFA-1 CASCODE PRE-AMPLIFIER

For 2 Meters and 6 Meters, using the 6BQ7A in a low noise circuit. Designed to mount in a standard 3 x 4 x 5-inch minibox.

Kit, less tubes.....\$ 4.75
Wired, with tubes..... 6.95

IFA-10 I.F. AMPLIFIER

For use between converter and receiver. Uses 6AH6 type tube. Available for I-F ranges from broadcast band through 30MC. Designed to mount in a standard 3 x 4 x 5-inch minibox.

Kit, less tube.....\$ 5.75
Wired, with tube..... 8.50

HOW TO ORDER: Please furnish name (or names) and address of those to receive gifts. Send your Gift Card for each gift-wrapped unit, and state shipping time desired. International will then handle as indicated. (Check or money order must accompany your order).

**International
CRYSTAL MFG. CO., INC.**

18 N. LEE PHONE FO 5-1165 OKLAHOMA CITY, OKLA.

Efficient Multi - Band Operation

the *Hy-gain* Tri-Bander Beams

The Standard of Comparison for 3-Band Antennas

The only factory pre-tuned, pre-matched and pre-adjusted 3-band antennas: may be erected in extremely short time. One beam, one feedline, three bands (10, 15 & 20M). Will outperform any multi-band parasitic or stacked arrays because interaction and detuning effects have been eliminated. Three active elements on each band. SWR less than 1.65 to 1 or better. Rugged construction used throughout. Antennas will handle full KW on all bands. Guaranteed for one year against any defects in material or workmanship. 1-element rotatable dipole trap tribander, \$39.95; 2-element space saver trap tribander, \$69.50; (3-element standard trap tribander shown); 5-element Champion trap tribander, \$395.00.

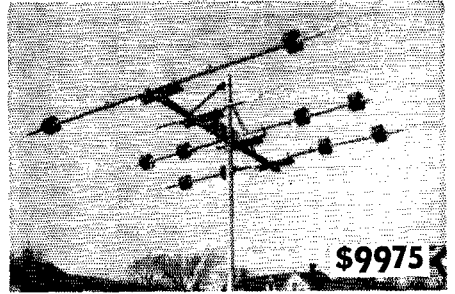

the *Hy-gain* Trap Verticals

Factory Pre-Tuned and Pre-Adjusted

Three of the great new hy-gain self-supporting Trap Verticals, the 12-AV for 10, 15 & 20M, the 14-AV for 10-40M, and the 18-AV for 10-80M, each using the sensational Insu-traps to isolate the various sections of the Verticals and develop $\frac{1}{4}$ -wave resonance (18-AV develops $\frac{1}{4}$ -wave on 20, 40 & 80M bands; $\frac{3}{4}$ -wave resonance on the 10 & 15M bands). 14 & 18-AV use Capacity Hat principal. All utilize new-style Base Insulator & Mount, weatherproofed, for self-support (18-AV self-supporting above 18 ft.) Less than 2:1 SWR on all bands. Mount kits available for 12-AV (\$8.95) and 14-AV (\$9.95).

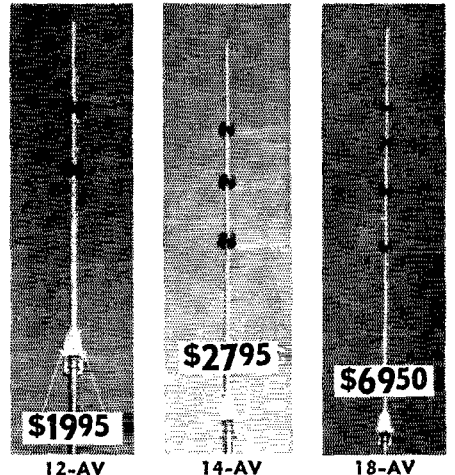

the *Hy-gain* Wonder Doublet & Doublet Coils

The Only Tunable, Completely Weatherproof Trap Circuits

Doublet Coils: Adjustable capacitor color coded for Fone or CW. Hi-Q coils. Pressure clamps supplied with Insu-trap assembly, eliminate messy solder joints and increase mechanical strength, while separating mechanical and electrical connections. Detailed instructions for constructing your own 5-Band Doublet. Insu-traps for 10-80 meters, coils only, per pair: \$12.50.

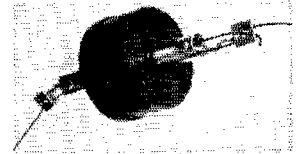

Wonder Doublet Kit: When used with Insu-traps, is resonant and maintains low impedance current feed on all bands. Includes 88 ft. KW Amphenol Twin-Lead, 110 ft. No. 14 Copper Clad Steel Antenna wire, 7" porcelain end insulators, pressure clamps and all instructions. Doublet kit, for use with coils (not including coils): \$12.00.

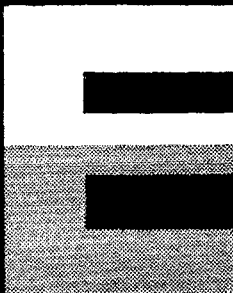

ELECTRONIC SUPPLY

61 N.E. 9th STREET • MIAMI 32, FLA. • Phone FRanklin 9-4512

ELECTRONIC SUPPLY

913 MORNINGSIDE DRIVE • MELBOURNE, FLA. • Phone 1735

ELECTRONIC WHOLESALERS, INC.

2345 SHERMAN AVE., N.W. • WASHINGTON 1, D.C. • Phone HUDson 3-5200

with the **Hy-Gain** Insu-Traps

THE AUTOMATIC ELECTRONIC SWITCH

The Insu-trap is the heart of the Hy-Gain trap tribanders and trap verticals and makes possible for the first time a really efficient multi-band antenna system. It acts as an insulator at its resonant frequency but allows radio energies of other frequencies to pass freely. This automatic switch action isolates various sections of the antenna to make it the proper length for each band. The Hy-Gain Insu-trap is an entirely new concept in parallel resonant trap circuits. It obsoletes old fashioned open type traps and is much superior to the inefficient small diameter, non-adjustable trap circuits. The Hy-Gain Insu-trap is completely mechanically and electrically stable. The Hy-Gain Insu-trap is the only parallel resonant trap which conforms to the moisture resistance requirements of military specifications Mil-C-5015C. This moisture and humidity test is equivalent to the most severe tropical atmosphere.



POLYETHYLENE WEATHERPROOF COVER

Entire trap circuit is enclosed in a carbon activated polyethylene cover and cap. This polyethylene is virtually unaffected by sunlight and is guaranteed for the life of the antenna. The unique cover and cap design uses a neoprene gasket to affect a perfect weather seal. The Insu-trap is not only weatherproof and moisture proof, but completely airtight as well. Two grams of silica gel are enclosed to absorb any condensation. Cap may be removed and resealed in the event trap frequency is to be changed.

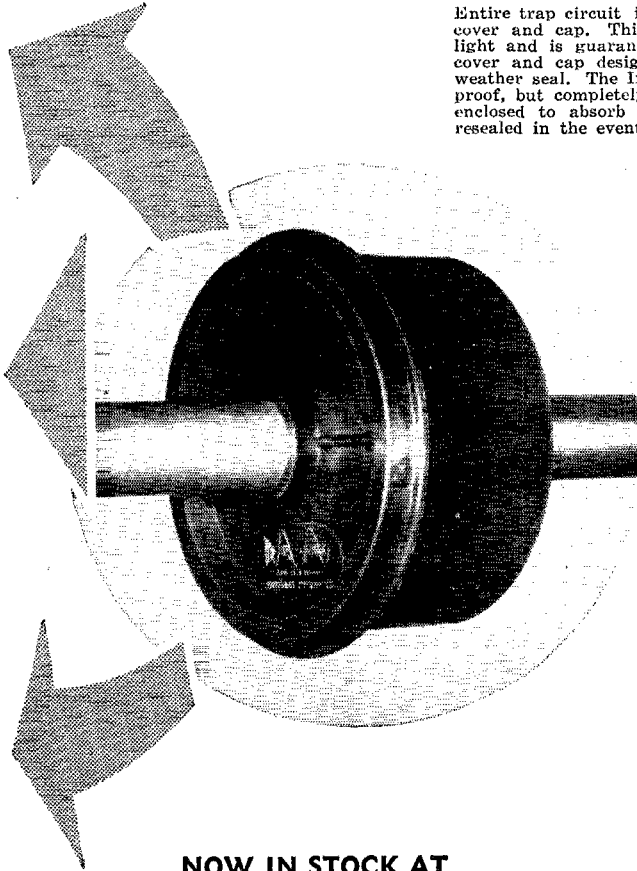

NOW IN STOCK AT
ELECTRONIC SUPPLY in FLORIDA
AND
ELECTRONIC WHOLESALERS
IN WASHINGTON, D.C.

*Your Ham Headquarters
 from
 Washington to Florida!*

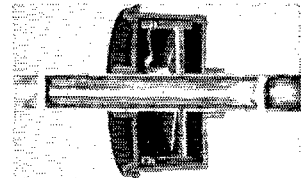

CUTAWAY OF INSU-TRAP

Cutaway shows heavy brass tube which is molded as an integral part of the styron sleeve connecting element ends. This insulating connection is much stronger than the tubing itself. Coil form and capacitor mounting sections are in no way depended upon to maintain mechanical rigidity. Entire form is single piece molded of high impact, low power factor Dow styron plastic.

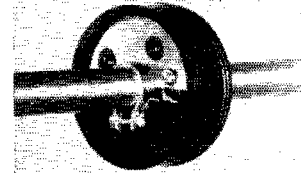

STYRON COIL FORM

Coil is space wound on threaded heavy styron form. Tremendous mechanical stability prevents any change in inductive values. Wire is solid copper for highest Q and lowest circuit resistance. High impact styron plastic form is 3 1/2 inches in diameter and coil is well separated from concentrically running tubing and other metal parts which would reduce efficiency.



ADJUSTABLE CAPACITOR PLATES

Adjustable condenser plates are color coded for maximum performance on phone or CW. May be easily adjusted for lowest swr on any spot frequency and traps are effective over entire band at any setting. Capacitor dielectric is solid styron plastic. No air dielectric is involved and capacity is extremely stable.

KEN-ELS

RADIO SUPPLY

features the newest
from *Collins*



COLLINS 75A-4 This SSB Receiver offers all the proven Collins features — excellent image rejection through double conversion, precise dial calibration and high stability of Collins VFO and crystal controlled first injection oscillator, and the ideal selectivity of Collins Mechanical Filter in the IF strip.
Net Price -----\$695.00

COLLINS KWS-1

Companion transmitter to the 75A-4. Unmatched performance in minimum space for a kilowatt. Extremely accurate 70E VFO, Pi-L output network and Mechanical Filter.
Net price -----\$2,095.00.

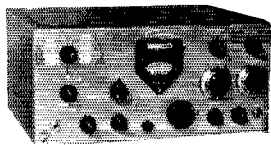

COLLINS KWM-1

The first mobile SSB transceiver in the Amateur field — 175 watts PEP, 14-30 mc. Fixed station use without modification.
Net price -----\$770.00

10% down — 24 months to pay. Your trade-in may cover down payment. Export business welcomed.

KEN-ELS RADIO SUPPLY

428 Central Ave.
Fort Dodge, Iowa
Phone 5-2451

67 16th Ave. S.W.
Cedar Rapids, Iowa
Phone EM 4-1172

ida, AGD, AGF and Novice KJE, along with 9AIIH, were recent club visitors. KNQ and QPP are interested in astronomy. VNB now locates at Pepperell AFB, St. John, Newfoundland. The following have deserted 28 Mc. for the 6-meter band: BFB, VKD, KLD and YWL. Novice newcomers: KN3AFO, BLK, BLJ, BLY, BOQ, BOZ and BLZ. BPE is a new Novice licensee in the Pittsburgh Area. ASD is on 80 meters with a five-watt and an NC-125. Traffic: W3W1Q 384, GJY 50, LSS 26, UHN 14, ACH 13, JWZ 11.

CENTRAL DIVISION

ILLINOIS—SCM, George T. Schreiber, W9YIX—Asst. SCM: Grace V. Ryden, 9GME. SEC: HOA, RM: MAK. Cook County EC: HPG. K9GJR, Asst. RM, has resigned because of ill health. KJ now has a 72-ft. mast in the back yard, but is plagued with drive to his 4-125s in the kw. amplifier. SKR reports that DFS has joined the Silent Keys. The NCPN had a traffic total of 730 messages for August while ILN, in 20 sessions in the same period, had a total of 157. UBI now runs a cool half kw. with which he made WAS and WAC on c.w. and has 30 more to go for DXCC. SXL reports that the Bloomington gang has great sport with "fox and hounds" on 160-meter mobile. New calls in the section are K2MUE/9 and KN9JHC, of Dundee and Oak Park, respectively. K9GHP had the pleasure of seeing his transmitter exhibited at the Cumberland County Fair. It aroused great interest in the crowds. NIU reports the Central Illinois gang is getting a kick out of MARS nets at 9 p.m. on 2258 kc. K9YDT has a "Wonderbar" for 20 meters and likes the reports he gets. He also enjoys traffic-handling on ILN. K4AWV/9 reports he never had so much rig trouble since moving to Illinois, but is working on it. GDI still is "rassling" with his quad but is starting to see a glimmer of hope. New Springfield calls are 6SAK and 6ZOL, who recently moved into the section from Missouri and hope to join the traffic nets soon. K9RIV, the EC for McDonough and Schuyler Counties, reports that he has contacted all amateurs in McDonough, but has not yet heard from any amateurs in Schuyler. Are there any? The Streator Radio Club, K9CAU, handled the p.a. system for the Labor Day celebration. Other news reported from that territory: ENO and family returned from Oregon and California; GTV and family visited a son in Texas; DFK and family visited Upper Michigan; PFV spent his holiday at the Chain-of-Lakes. LFY and his XYL toured Illinois and KN9HCY spent some time in the Northwest. KN9HWQ has entered college and doubts if he will have time for amateur radio. To those of you interested in the AREC, please send your applications to the SEC or the Cook County EC. It will accelerate the issuance of your card. By the time you read this the traffic nets will be in full swing. If you want a new thrill out of amateur radio, join your section net. Get in touch with Route Manager IAK at Lansing, Ill. He will welcome you. A vote of thanks should go from the section gang to the Chicago Area Radio Club Council, which sponsored the 9th Annual Convention of AKRL, to the untiring committee chairmen and the members of their committees (too numerous to mention here), and especially to General Manager QKE and Program Chairman HPG as well as LOY, in charge of YL activities. There never was a dull moment. Traffic: (Aug.) K91SN 1078, W9DO 1040, IAK 309, UBI 249, FAW 206, VVY 192, IDA 160, SXL 115, CSW 88, YYG 64, K9IFB 44, YDT 37, W9YIX 33, K2MUE/9 15, K9AXL 10, W9SKR 2. (July) W9DO 1222.

INDIANA—SCM, Seth Lew Baker, W9NTA—Asst. SCM: George H. Graue, 9BKJ. SEC: QVQ. RMs: DGA, TQC and TT. PAMs: CMT, KOY, SWD and UXX. Our new SCM as of Oct. 14, is Arthur G. Evans, TQC, 823 N. Bosart St., Indianapolis. Please send all October reports to him. Art has been very active as RM for RFN and QIN and also on 1FN and MARS. I hope you will all give him the same splendid cooperation you have accorded to me the past two years. It made it a pleasure to serve you. I especially wish to thank all the LOs who served with me and did such a fine job; also all the clubs for sending their club papers. New appointments: ZSK as EC for Morgan County; CYZ, EJC and GUX as OPSS. MJN won the SX-100 at the Kokomo Hamfest. There is a Howard County C.D. Net on 3910 kc. Sun. at 1400 and Tue. on 50.7 Mc. at 1930. CC has a new Valiant on the air using an EJC TR switch that works fine. HXR received a BPL Medalion. In order to obtain your call letter license plates promptly send the form with \$2.00 before Dec. 1 to Cliff Bemish, Director Special Sales, Bureau of Motor Vehicles, State of Indiana, State House, Indianapolis 4, Ind. Blanks may be obtained from him. LQE is moving to Washington, Ind. New in Culver is KN9JHU. HEN is now in the Navy. BKJ is back at Ft. Wayne after a summer in Wisconsin. He and his team con-

(Continued on page 126)

NEW!

TMS-500 Coaxial Switch Makes Easy Change From Cable Video to Air Reception!



PROVIDES HIGH DEGREE OF ISOLATION!

The New TMS-500 Coaxial Switch, for Cable Video or Air Reception to a Single Television Receiver, provides an exceptionally high degree of isolation with no interaction between two incoming signals . . . makes for precise switching of either of two RF signals to a common output. (Now being installed as part of the "World's First Telemovie" service, bringing the theatre's finest, first-run movies into the home via television).

DATA

Nominal Impedance.....	75 Ohms
VSWR.....	Less than 1.2
Response.....	Flat .0 to 250 MC
Insertion Loss.....	Less than 0.5 DB
Isolation.....	Cable to Cable, at least 80 DB.
	Either Cable to Set, from Open Position, at least 65 DB.
Connections.....	Coaxial Cable RG-59/U Solderless
Mounting.....	Two Single Hole Clip Brackets
TMS-500 Coaxial Switch.....	\$9.50

**LOW COST UNIT
WIDE BAND, LOW VSWR
VERSATILE APPLICATION**

TWO MATCHING TRANSFORMERS for TMS 500

TMT-400 Twin Lead Pigtail.....	2.10
TMT-700 Screw Terminals.....	2.50
Band Pass.....	20 MC to 250 MC
Impedance.....	75 Ohm Cable/300 Ohm Set
VSWR.....	Less than 1.2
Fittings.....	RG-59/U Solderless Connectors
Transformer Dimensions.....	1" dia. x 1 1/4" long

HOW TO ORDER: Electronics Coaxial Switches, Cable Taps, Printed Circuit Units, etc. are sold direct for fastest service . . . shipped prepaid when cash accompanies order. Otherwise C.O.D.



- Manufacturing A COMPLETE LINE of**
- Printed Circuit Units
 - Complete Line Frequency Test Instruments
 - Cable Taps
 - Sub-Channel Converters
 - Video and Sound Modulators

Electronics International, Inc.
SUBSIDIARY OF
International Crystal Mfg. Co., Inc.

18 N. LEE PHONE FO 5-1165 OKLAHOMA CITY, OKLA.



IN NEW YORK STATE

SEE

WARD, W2FEU

FOR THE HY-GAIN

VHF BEAMS!

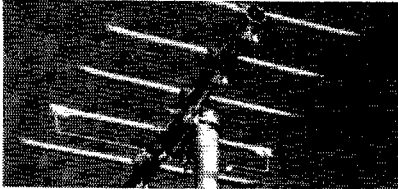

Low cost, light weight, easy to install. Elements snap into position for immediate use. Cut for the middle of the band; covers entire 2M band with excellent gain. Folded ratio dipole, nom. impedance 300 ohms. Low SWR for 300 ohm balanced line or 72 ohm coax thru 1/2 wave balun. Stacking bars provide full wave length spacing and perfect match for balanced line or coax thru 1/2 wave balun; \$3.95.

Only
\$795

2

METERS

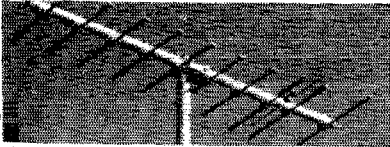

Only
\$995

2

METERS

Highest possible gain per dollar per foot, pre-assembled and pre-cut. Middle of the band, covers entire 2M band with excellent gain and operating characteristics. Folded ratio dipole, nom. impedance 300 ohms. Low SWR for 300 ohm line or 72 ohm coax thru 1/2 wave balun. Stacking bars: provide full wave length spacing and perfect match for balanced line or coax thru 1/2 wave balun; \$3.95.

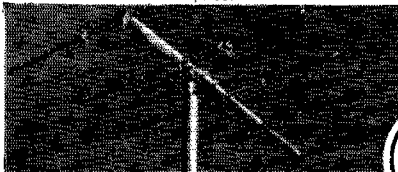

Factory pre-assembled, with elements adjustable over entire 6M band. T or gamma match for balanced or coax line feed. Add'l. gain through stacking. Stacking bars: provide 1/2 wave length spacing and perfect match for balanced line or coax thru 1/2 wave balun; — \$3.95.

Only
\$1495

6

METERS

ADIRONDACK RADIO SUPPLY
185-191 W. MAIN • AMSTERDAM, N. Y.
CALL VICTOR 2-8350

Enclosed is my Check, Money Order
For the 2M, 5E; 2M, 10E; 6M, 5E Beam

Name: Address:

City and State:

ducted the Royal Order of Wouff-Hong initiation at the Chicago National Convention. Those making BPL in August were NZZ, JOZ, ETM and JYO. SWD reports 1FN Evening traffic as 238 and Morning as 112, total 350. QIN, as reported by TQC, had 236: TT gives RFN as 61 and UTL as 1314. KOY reports Interstate S.S.B. as 658. Let's make courtesy on the air a Hoosier habit. Traffic: (Aug.) W9NZZ 1449, JOZ 511, EHZ 355, VAY 240, TT 269, TQC 236, ETM 213, JYO 196, EQO 180, ZYK 130, KOY 88, UQP 84, EJW 79, SWD 70, NTA 68, LDB 57, BKJ 51, SVL 45, WUH 35, AB 32, VPJ 30, VNY 29, HRW 28, QYQ 28, WAU 28, AICN 22, PQZ 19, QR 19, WEL 18, CC 17, HUF 17, DGA 14, ENJ 14, BDP 13, WBA 12, JBQ 11, YXX 11, BUQ 10, GUS 10, IMU 10, EJC 8, SYM 8, AMW 7, DOK 7, SNQ 7, CDW 6, CMT 6, HXR 6, K9AZK 4, W9MAY 3. (July) W9VNV 42, ENU 13, DZC 6, UXK 5, CTF 4.

WISCONSIN—SCM, George Wolda, W9KQB—SEC: EIZ. PAMs: NRP and AJU. RMs: KJJ and K9AEQ. Nets: WIN, 3535 kc, 7:00 p.m. CDT daily; BEN, 3950 kc, 6:00 p.m. CDT daily. New appointees include LVC as OES and VZK as OBS on 10 meters. BPL certificates were earned by CXY and K9GDF. PJT has a new Wonderbar antenna up for 14 Mc. KN9IAY is a new member in the RCC. There is a new Globe Scout 680 at K9CAH. RTP is attending the U. of Wisconsin. K9BELT now is giving WIN its Madison outlet. Phil uses a Globe Chief and an SX-28. SAA remodeled with a new 500B Globe King, 75A-4 and Mosley Tri-Bander. Congrats to KXA, who was married Aug. 31, and to DTV, who tied the knot Aug. 22. GYA is working DX with a new folded dipole. YQH had a full house when Wisconsin appointees held a pre-convention meeting at his home. Chicago floods brought EFC back to the Wisconsin section. K9ERO and K9GOZ dropped the "N" from their calls. MCK ZAV and K9AIF are back at St. Francis Seminary in Milwaukee. IDTM:9 is looking for 2-meter contacts. New in Milwaukee is KN9JFJ, the father of K9GDF. QYW has a new home-spun tri-bander up. The Milwaukee Club now meets at the Milwaukee Public Library, 9th and Wisconsin Ave. K9BEL is in charge of the club's code class. Congrats to OMZ, Jeanne, Wisconsin's first fairer-sex member of the DXCC. A new amateur radio club was formed at Whitewater with UCL, pres.; YBA, vice-pres.; K9DSV, secy.-treas. Madison amateurs had 15 minutes of a one-hour c.d. show on 1V. Field day and mobile pictures were shown. CBE received a certificate from the Defense Dept. for his copy of NSS on Armed Forces Day. CXY's increased antenna height has helped his signal reliability for TCC work. Evidence: Jim's traffic total. UEB and his XYL received a Viking II as an anniversary gift. VCH is operating KAAS at Kyoto, Japan, and will sked W9s on 20 meters. Traffic: (Aug.) W9CXY 1009, K9GDF 614, AEQ 226, W9KJJ 220, KQB 132, SAA 80, K9CAH 43, BLT 42, W9SZR 27, QJW 24, PJT 12, RTP 6, KWJ 4, SIZ 4. (July) W9SIZ 13, KWJ 10, JEF 1.

DAKOTA DIVISION

SOUTH DAKOTA—SCM, Les Price, W6FLP—Asst. SCM, Gerald F. Lee, 0YKY. SCM assistants: SCT and NEO. SECs: YOB and GDE. PAM: ULV. The S.D. 75-Meter Net reports 30 sessions, 29 reports: GQH 5, SCT 24; QNI 538, high 29, low 8, average 18.55; traffic 44, high 7, low 0 (11 times), average 1.5; informals 39, high 5, low 0, average 1.344. The S.D. 40-Meter Phone Net reports 27 sessions: K9FEJ (K9KKA operator) 3, YXY 12, EXX 3, LXP 3, SCT 4; QNT 388, high 18, (3 times), low 8, average 14.37; traffic 36, high 10, low 0 (twice), average 3.185; informals 38, high 3 (twice), low 0 (4 times), average 1.4. RRN reports the Sioux Falls ARC had a picnic Aug. 29 with 71 persons attending. Norman Kahler, a blind man who is a cousin of TLO, copies 7-8 w.p.m. with no difficulty at all. Some new Novices are KN0KJT. Our only active woman ham in town, KN0KLM and KN0KXQ. SVI and K9ARF hosted 14 members of the BHARC and XYL Clubs in August to visit with 7BFC and 7BFE, formerly of Rapid City. The Signal Hill ARC, Lead, had a picnic supper Aug. 5. Ex-0AEN, now K9RXXO, a former member and first president, and his family were guests. On Aug. 2 and 3, six of the members, APL (operated one day by K9DXO), Ed Fredric, sr., DQK, DVB, K9DTL and KN0IRN, helped out with communications for the Days of 76 Parade in Deadwood. Ed Freeman, ex-9AYW of 1919, joined the Prairie Dog ARC. Ed is installing operating benches and additional electrical outlets in the PDARC communications truck. Another new address: Lt. George W. Olsen, FAETU-LANT Det. 3, NAS Quonset Point, Rhode Island. George writes that LXP has received his 2nd-class commercial license. He also says he had a nice visit with Marv Voskia, formerly of Gregory, visiting HYQ mobile in the airforce plane at 8000 ft. over Western

(Continued on page 130)



COMMUNICATOR

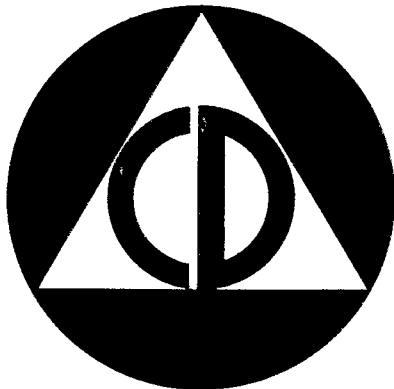

Proved . . . again and again . . . under the most severe operating conditions. In so many disasters . . . floods, hurricanes, fires . . . Gonset Communicators have provided the aid-summoning voice to "outside."

Now . . . a completely, brilliantly new model, Communicator III, C-D. It assures you the dependability of a proved-without-question design, adds, for even better performance, many new features and refinements. Operation has been simplified, made more convenient.

Communicator III, C-D models for 2 and 6 meters are FCDA certified under U-16 and U-14 respectively. New, matching RF linear amplifiers to increase output power up to ten times are also available.

Communicators have always fully met C-D and emergency communications requirements. These new Model III's will do the same . . . but better.

GONSET
BURBANK, CALIFORNIA

DIVISION OF L. A. YOUNG SPRING & WIRE CORPORATION



HARRISON IS HEADQUARTERS

FOR  EQUIPMENT!

Here, at Ham Headquarters, USA, you can actually see every World famous transmitter—

from the Globe Chief up thru the powerful new Globe King—to make a side-by-side comparison of all their features. Then, you can select your choice from the tremendous Harrison inventory of only the very newest and best—and take it safely home with you.

TECHNICIANS!

Here's an FB phone xmitter for the

SIX METER BAND

(also covers 10, 11, 15, 20, 40, and 80!) Full 55 watts talk power (high level plate modulated) phone, 65 watts CW. Completely band-switching, with built-in AC power supply, in compact TVI-shielded cabinet 8"x14"x8" Top value for your money! Factory wired and tested. Model 680 — \$109.95. Complete Kit. 680-K — \$89.95. For 10 thru 160 meter bands, order Model 66 — Factory wired only—\$99.95.



Globe Scout

NOVICES!

Here's the famous 90 watt, 10 thru 160 meter bandswitching transmitter that gives you more real dependable results and service than anything in its price class! Has 75 watt calibration for maximum Novice input. Complete, in TVI-shielded cabinet 8"x14"x8". Factory wired, tested, and guaranteed ready to "fire-up"! Model 90 — \$67.50. Complete KIT, 90-K, only \$54.95. MODULATION KIT for phone operation of Chief, Adventurer, AT-1, etc. Complete—\$11.95



Globe Chief

YOU CAN BE ENJOYING THIS

Globe King

WHILE PAYING ONLY \$34 A MONTH!

(Even less, if your trade-in or down payment is more than \$84 and low carrying cost.)

Ask the Hams who have them! And, this new improved model is much better.

Now with heavy duty 4-400A final, DC relay for quiet, dependable operation, etc.

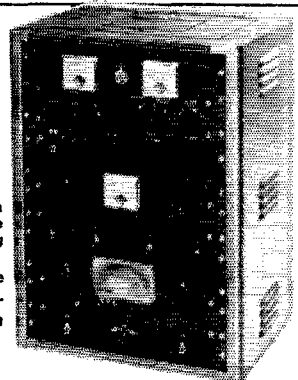

Excellent value at \$725, complete, Factory wired.

\$10.00 CAN BRING YOU any Chief, Scout, Antenna Tuner, etc., etc. Put the balance on Automatic Revolving Credit with your Harrison Charge Account, and you can pay it off with as little as 1/10 of each monthly statement. You can add on more charge purchases any time you want. It's the greatest shopping convenience, ever! Send your order, today! Give employment and credit references, and include deposit.

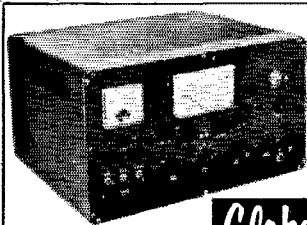

ONLY \$22 A MONTH BRINGS YOU THIS FB NEW

Globe Champion

Complete KIT, with factory assembled VFO. \$375

HARRISON has the new, and improved, model with all the plus features! 350 watts of real power, truly bargain priced. Factory wired, tested, and fully guaranteed — \$449

All WRL wired transmitters are fully covered by their UNCONDITIONAL ONE YEAR GUARANTEE!

BUILD, AND SAVE \$\$\$

It's easy, with any WRL Kit! The big multi-page manual clearly explains every detail step-by-step, and gives you every bit of information for successful construction, installation, and operation. Kits include all parts, tubes, cabinet, and chassis. (no holes to drill!)

FREE LITERATURE ON ANY HAM GEAR

HARRISON

Ham Headquarters Since 1925

225 GREENWICH STREET
NEW YORK 7, N.Y.

PHONE ORDERS - BARCLAY 7-7777
LONG ISLAND - 144.24 Hillside Ave., Jamaica

SEE, BEFORE YOU BUY!

If you can't come to Ham Headquarters, USA, send 50c and we'll mail you any WRL Instruction Manual (Regular Price \$1.00), together with a credit good for the 50c toward any WRL Transmitter, Kit or Wired. I want you to see for yourself how complete and simple it is!

WELCOME . . . to the HARRISON YF NOOK.

Settle your lady in this comfortable corner of the store, for a smoke or a coke, and feminine magazines to read, while you feast your eyes around HAM PARADISE!
OPEN 8:30 TO 6:15
MONDAY THRU SATURDAY

HARRISON

IS HEADQUARTERS

for Collins

the Cadillac of Hamdom!

It actually costs less per year to own the best, especially when you get it from Harrison.

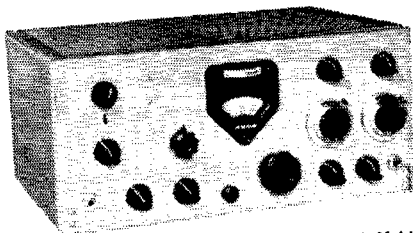

You can be enjoying this new Collins KWM-1 Mobile/Fixed Trans-Receiver while paying as little as

\$39 A MONTH!

(Even less, if your trade-in and down payment come to more than \$68 and the low carrying cost.) You always get the best deal from Harrison!

FOR QUICKEST DELIVERY—

send me your order right now! A deposit of only \$5 (returnable any time you say) will start fast action. If you have a trade-in, tell me all about it so I can give you the very highest allowance. Mention the approximate terms you would like, and give employment and credit references.

Prompt, safe shipment to most anywhere in the world, or, you can "Come and get it!" and take it safely home with you.



No question about it! You're just not getting the most operating fun per hour unless your receiver is a new Collins 75A-4! With almost any kind of a trade-in as down payment, we'll surprise you with how little a month it takes for you to have the pleasure of using the best!

WANT TO STUDY IT? You can have the complete big illustrated instruction and Service Manual for any model, just by sending a \$5 returnable deposit. Or, we'll gladly send you FREE literature.

Our big Jamaica Store is Ham Headquarters for ALL LONG ISLAND!

Conveniently located on Hillside Ave. at 145 Street. Easy parking.

Open Friday nites 'til 9.
RRepublic 9-4102

HARRISON

Ham Headquarters Since 1925

225 GREENWICH STREET
NEW YORK 7, N.Y.

PHONE ORDERS - BARCLAY 7-7777
LONG ISLAND - 144-24 Hillside Ave., Jamaica

ALL ROADS LEAD TO HAM HEADQUARTERS, U.S.A.!

because here, in the World's largest trading center, you can get more for your money. Our tremendous volume gives you the benefit of truly lowest overhead per transaction. You get the greatest values, the latest improved equipment, the lowest prices, the easiest terms, the "hottest" trade-in deals, all with the friendliest personal and helpful Service.

Hurry on in! With the new highways, it really isn't much of a drive, from even Maine, Ohio, or Virginia! Easy parking. Bring along your old gear, for my tip-top allowance. I guarantee you'll go home delighted.

73, Bil Harrison, W2AVA

From South and West: Thru New Jersey, leave Holland Tunnel in "Downtown" exit lane, continue straight down for 12 blocks.

From North: Thruway exit 7, Saw Mill River Parkway, (or George Washington Bridge), down Henry Hudson Parkway and West Side Highway. Exit at Chambers St., left on Chambers 3 blocks to West Broadway, right 4 blocks.

From New England: Merritt Parkway, to West Side New York via Henry Hudson and West Side Highways. (See "From North")

From Long Island: Via Brooklyn-Battery Tunnel, right on West St. 9 blocks to Vesey St., right 2 blocks to Greenwich St., left 1/2 block.

Via Tri-Boro, Queensboro, or Midtown Tunnel: East River (F.D.R.) Drive downtown, and around thru underpass tunnel to Brooklyn Tunnel entrance, but continue straight up West St. 9 blocks to Vesey St., right 2 blocks to Greenwich St., left 1/2 block.

All New York SUBWAYS can bring you to Ham Headquarters, U.S.A.!

IRT, Lexington Ave. Express to Fulton Street station, up Broadway to Barclay St., left 2 blocks.

IRT, 7th Ave. Express to Chambers Street station, down West Broadway 4 blocks.

IND: Take A, AA, CC, or D train to Hudson Terminal (Chambers St.), one block west on Barclay St.

BMT 4th Ave. line to City Hall Station, walk two blocks west on Barclay St.

It's even easy by TRAIN!—
Penn Station: Take IRT Subway Express downtown 2 stops to Chambers St.

Grand Central Station: Take IRT Express downtown 3 stops to Fulton St.

Hudson Terminal: Fulton St. exit, left 1 block to Greenwich St., right 1 1/2 blocks.

Barclay St. Ferry: 2 blocks east to Greenwich St.

KWS-1 SSB/CW/AM TRANSMITTER. The favorite with thousands of discriminating Hams who take pride in owning the very finest!

You can get yours, a latest improved production model, from Harrison for

ONLY \$79 A MONTH.

(Your trade-in and down payment totalling more than \$199 and the low finance charge will make the monthly payments even smaller!) Let's talk it over, now, so you can start living it up, while you're still young enough to enjoy it!

The world-famous
HARRISON
TRADE-IN CENTER

is the greatest! Come, pick your choice from the hundreds of like-new trade-ins, all money-saving bargain price tagged! Easy terms, trades.

QUALITY CUT QUARTZ FOR EVERY SERVICE



All crystals made from Grade "A" imported quartz — ground and etched to exact frequencies. Unconditionally guaranteed! Supplied in:

FT-243 holders
pin spacing 1/2"
pin diameter .093

DC-34 holders
pin spacing 3/4"
pin diameter .156

MC-7 holders
pin spacing 3/4"
pin diameter .125

FT-171 holders
pin spacing 3/4"
banana pins

MADE TO ORDER CRYSTALS

1001 KC to 2500 KC:	
.01% Tolerance.....	\$1.75
.005% Tolerance.....	\$2.50
2501 KC to 9000 KC:	
.01% Tolerance.....	\$1.50
.005% Tolerance.....	\$2.50

Specify holder wanted.

ANY AMATEUR BAND CRYSTAL

.05% Tolerance

NOVICE BAND CRYSTALS

80 meters 3701-3749 KC
40 meters 7152-7198 KC
15 meters 7034-7082 KC

99¢ ea.

6 METER TECHNICIAN BAND CRYSTALS

SEALED OVERTONE CRYSTALS supplied in metal HC/6U holders — pin spacing .486, diameter .050.

10 to 30 MC .005 tolerance.....	\$3.85 ea.
30 to 54 MC .005 tolerance.....	\$4.10 ea.
55 to 75 MC .005 tolerance.....	\$4.25 ea.
75 to 90 MC .005 tolerance.....	\$5.50 ea.

STOCK OVERTONE CRYSTALS in FT-243 holders \$1.00

Frequencies listed in megacycles:

15.01	16.7	17.15	18.225
15.11	16.8	17.16	18.325
16.335	16.9	18.025	18.475
16.435	17.0	18.125	18.925

MARINE FREQUENCY CRYSTALS • All marine frequencies from 2000-3200 KC .005 tolerance..... **\$2.50**
(Supplied in either FT-243, MC-7, or FT-171 holders.)

RADIO CONTROL CRYSTALS • 27,255 MC sealed crystals. **\$2.50 ea.**

Stock crystals in FT-243 holders from 5675 KC to 8650 KC in 25 KC steps..... **50¢**

FT-241 lattice crystals in all frequencies from 370 KC to 540 KC.

Matched pairs = 25 cycles **\$2.50** per pair. **50¢**

200 KC Crystals, **\$2.00**; 455 KC Crystals, **\$1.00**; 500 KC Crystals, **\$1.00**; 1000 KC Frequency Standard Crystals, **\$3.50**; Dual Socket for FT-243 Crystals, **15¢**; Ceramic socket HC/6U Crystals, **15¢**.

ASK YOUR LOCAL PARTS DISTRIBUTOR FOR TEXAS CRYSTALS... LOOK FOR THE YELLOW AND RED DISPLAY BOARD.

(Add 5¢ per crystal for postage and handling)

WRITE FOR CATALOG AND QUANTITY PRICES

Texas Crystals

The Biggest Buy in the U.S.

8538 W. GRAND AVENUE • RIVER GROVE, ILL.

ALL PHONES — GLADSTONE 3-3555

Terms: All items subject to prior sale and change of price without notice. All crystal orders MUST be accompanied by check, cash or M.O. WITH PAYMENT IN FULL. No C.O.D.s. Postpaid shipments made in U.S. and possessions only. Add 5¢ per crystal for postage and handling charge.

South Dakota and Nebraska, en route home to Colorado Springs from Minneapolis. It has been reported that PRL, formerly of Gregory, has accepted a position in the leadership of the South Dakota Republican organization and will live in Pierre. RRN recently spoke on ham radio to the Rotary Club at Canton and on Aug. 8 was interviewed on KELO-TV about ham radio and club work. He has received his new HQ-110 receiver. A Silent Key in Sioux Falls is N. H. Jensen, ex-91D, a pioneer in amateur radio and one of the founders of the South Falls ARC. GWS is back in Mitchell for a couple of months and is reporting into both South Dakota nets, 75- and 40-meter phone. Mr. and Mrs. YOB and son Doug vacationed in Boulder, Colo., in August but the vacation was cut a bit short when Doug had to have his appendix removed. K8GGB has moved to 1014-3rd Ave., W. Grand Rapids, Minn. PHR, Dakota Division Director, is in two of the four Board Meeting photos used in the July ARRL CT Bulletin. Cora, K8CDO, sends along the new Kielhorn address: 412 S. Pierre, Pierre. She says now Woody, QEK, has a place for his rig, too. A new ham at Flandreau is K8IEI. It has been years since IEL at Aberdeen, has been heard. K8BXO, of Normall, Ill., visited the Deadwood-Lead Area, where he formerly had the call AEN. BJV took the family on a 30-day 7000-mile whirl through Montana, Alberta, British Columbia, Idaho, Washington, California, Nevada, Utah, Colorado, Wyoming, a corner of the Nebraska Black Hills and back home. RTD's new address is Pvt. Eldon Lindquist, RA 17494614, Co. 1, U. S. Army, Sig. Sch., Mez. Ft. Monmouth, N. J. BLZ has a new HT-32 s.s.b. transmitter. SVI received a model 20-A s.s.b. exciter for his birthday. OII has his 2nd-class commercial license. 9K LZ, Cincinnati, Ohio, visited K8BMQ in Millboro on July 12. QEK and K8CDO spent the week end of Aug. 24-25 in Danbury, Nehr., visiting Cora's brother, K8DGB. K8BMQ reports a QSO with KN4MHB, Lowery AFB, Aurora, Colo., who was transferred to Ellsworth AFB Sept. 20. GDE swapped in the Tri-pacer on a red and white Beachcraft Bonanza. 9LCB, Rt. 2, Freeport, Ill., would like to have a sked with a station in or near Clark and Willow Lake, S.D. Can anyone help him out? MMQ and family vacationed in the Black Hills and adjoining 7-Land. K8CFX and family went on vacation to the same areas. YVF, of Redfield, is wondering if there are any other towns of only 2600 population that can beat its record of hams. Redfield boasts of 9 hams within the city limits and has another studying directly for the General Class license. K8EWJ obtained a used Viking II transmitter recently which works fine. KN0DII left Fr. Morocco Aug. 18 and was home in Lead Aug. 20 at 0845 for about a month's leave before going to Japan. On Aug. 3 TYSE and Mrs. Jones had supper with BQV and DVB at Lead. On Aug. 9 70A of Boise, Idaho, visited them, CTD and family vacationed in Yellowstone Park. K8TRN now has his General Class license and K8DTI is waiting for his Conditional Class. ZIO, Bob Bogar, 220 Lurray Ave., Johnstown, Pa., wants a sked to complete his WAS. He needs only South Dakota. Traffic: W8SCT 317, SIR 31, K8BMQ 25, W8BQS 10, N1K 7, K8LNZ 2, BQR 1, E1WJ 1.

MINNESOTA—SCM, Robert M. Nelson, W8KLG—Asst. SCM; Robert W. Schoening, 8TKX, SEC; WYO, RMs; DQL and RQJ, PAMS; JIE and LUX, Thanks to TKX, Asst. SCM, for taking over last month while we were on vacation enjoying a trip through all the W8 and W7 states, plus Colorado and the Dakotas. Eighteen new Novice operators were added to the Mankato Area upon completion of a course offered by the M.A.R.C. AGO has a new station set-up, including an HT-33 KW Linear Final and a three-element beam 75 feet up on 10 meters. He has the WAC, DXCC, BERTA and WBE awards (phone) and has worked 149 countries. K8I1Z received his Technician Class license and hopes to be on 6 meters soon. KN8JE has a new Globe Scout transmitter. K8CYD qualifies for the BPI Medalion, the first K8 in Minnesota to do so. PBI worked 4X4, UAI and SV8 for 3 more countries. TJI is being relocated at Minneapolis-Honeywell's new plant in Texas. K8HCC got his General Class license. KOW has a new 10-meter beam. KN8LBA and LBC are new Novices at Dassel. K8BUD is going to further his education at the U. of Minn. and will live at St. Louis Park in a radio-less shack. K8GCN has a new five-band doublet. AAU and NDV are going mobile. K8GCY is attending the U. of Minn. New ECs are as follows: K8BNU for Wadena County, TBX for Suburban Hennepin County and WMA for Metropolitan Minneapolis. New OCs are K8IOE and WMA. K8GVX has a new Ranger. K8AEF musically entertained the gang at Camp Courage, located near Amundale. The St. Paul Mobile Radio Club is the recipient of about 20 v.h.f. 1m. mobile units from the Northwestern Bell Telephone Company. The Mobile Amateur Radio Corps of Henne-

(Continued on page 132)

Well pleased with it

Very fine recvr.

LOOKS REAL GOOD!

PERFORMS WELL!

VERY FINE BUS. FB rig

VERY FINE WORKMANSHIP — AMAZING COMPACTNESS

LIKE IT OK!

WONDERFUL

I'm glad I waited for it!

A LOT FOR \$229*

LIKE ITS SELECTIVITY

Sounds terrific on SSB

WORKS 100%

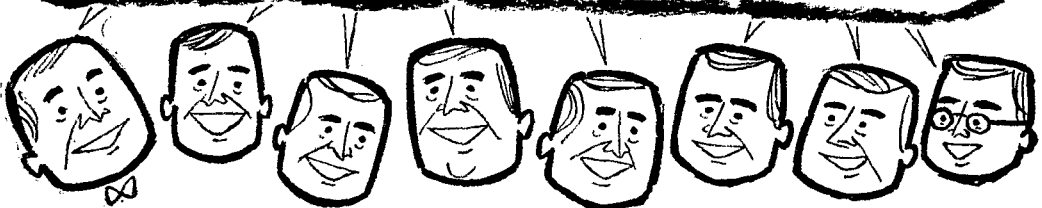

WHAT MORE CAN WE SAY, EXCEPT—



Get yourself an
HQ-110
as soon as
possible!

*Telechron clock-timer,
\$10 extra.

• Send for complete details. Ask for Bulletin Q1157.

HAMMARLUND

HAMMARLUND MANUFACTURING COMPANY, INC., 460 W. 34th ST., N. Y. 1, N. Y.

Export: Rocke International, 13 E. 40th St., N. Y. 16, N. Y. Canada: White Radio, Ltd., 41 West Ave. N., Hamilton, Can.



Electronic Center inc.



for the top
performing
Amateur
kilowatt...

Collins
KWS-1

Unmatched performance, accuracy and stability characterize the Collins KWS-1 in SSB, AM or CW operation. Extremely accurate 70E VFO. Pi-L output network. Collins Mechanical Filter. See us about generous trade-in allowance and time payment terms. KWS-1 kilowatt Transmitter,

Net Price\$2,095.00

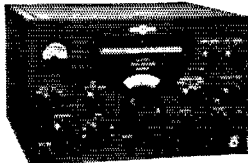

75A-4
SSB
Receiver

Designed expressly for operation on the 7 HF Amateur bands. Features AVC on SSB and CW, separate detectors for AM and SSB, passband tuning, rejection tuning, Gear Reduction Tuning Knob, superior selectivity and many other time-proven Collins features. 75A-4 Receiver, Net Price\$695.00

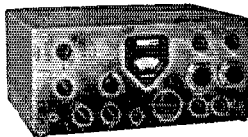

KWM-1
SSB
Mobile Transceiver

First mobile transceiver in the Amateur field — 175 watts PEP input, 14-30 mc. Use for mobile or fixed station without modification.

KWM-1 Transceiver, Net Price\$770.00

For complete information, accessories, terms, trade-ins, write:

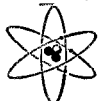

Electronic Center inc.

107 3rd Avenue North, Minneapolis 1, Minn.

pin County received a like number of units for operation in the 6-meter band. The two-way units come through civil defense channels and are for RACFCS use in the Uniform I and II areas. Traffic: (Aug.) W0KJZ 274, WVO 159, K0GCN 92, W0RQJ 43, WMA 43, FGP 26, K0CYD 23, W0IRF 19, VJS 18, QVR 17, UMX 16, BUO 15, KLG 15, QVQ 15, K0BTE 14, GUJ 14, W0UCV 14, K0GKI 9, BUD 8, W0HEN 6, K0HZD 1. (July) K0CYD 197, W0FGP 6. (June) K0GCN 27.

DELTA DIVISION

ARKANSAS—SCM, Ulmon M. Goings, W5ZZY—PAM: DYLL, RM: CAF. It is with much regret that we report that DAG has left Arkansas and now is located at Whitesboro, Tex. We all appreciate the fine work Mac did for amateur radio while he was with us. A new club, the Jonesboro Amateur Radio Club, has been organized in Jonesboro. Officers are VTZ, pres.; RWJ, vice-pres.; VZC, secy.-treas.; K5EED, pub. mgr. The hams of Jonesboro are to be commended for the fine work they have done in the past in emergency communications. Our best wishes for the success of their new club. BLP is now on the air in Russellville. The club at Pine Bluff now has an emergency-power generator. It is reported that K5CRK has it purring like a kitten. We had a very nice time recently when we visited the club in Pine Bluff. The Arkansas Emergency Phone Net still is meeting each morning at 0600 on 3885 kc. Mon. through Fri. The OZK C.W. Net meets each evening at 1800 on 3790 kc. The reports on this net look very good. We want to encourage more stations in Arkansas and neighboring states to make use of these nets for traffic-handling. WSM, of Russellville, and K5HYD, of West Memphis, were visitors in Osceola recently. Traffic: K5HYD 24, HSO 8, W5ZZY 4.

LOUISIANA—SCM, Thomas J. Morgavi, W5FMO—The Baton Rouge Amateur Radio Club had a fine hamfest on Aug. 25 with about 250 persons attending. BSR, Delta Division Director, and FMO, Louisiana SCM, together with K5BES, Louisiana SEC and c.d. Radio Officer, were in attendance affording many a chance to present their problems and ideas in person. The New Orleans ARC has a 6-meter project which is really getting the fellows out. About 25 6-meter rigs are being built with the club buying the parts and the hams reimbursing the club as they go along. The idea for the project and the planning and engineering is the work of QKQ, EB, now out of the hospital and recuperating at home, keeps a daily sked with KR6AF. EA is giving d.s.s.b. some serious thought. CEZ, busy with traffic on RN5, asks that a Louisiana c.w. net be organized. It is suggested that all interested contact EA, Route Manager. K5DDH boasts of a new home-brew phone patch. JPV has moved again. NDV has been endorsed as ORS. K5GAB has been keeping up his OBS skeds. VAR works 2 meters at night and 40 meters during the day. HKZ, FKA and K5CWQ attended the West Gulf Convention at San Antonio. FKA has the mobile back in operation and with HKZ has about finished their s.s.b. rig. FKA has been ill but is getting along fine now and recently was reappointed OPS. JAW has been active on 40 meters with a new rig. KSL is pounding brass for the Border Patrol. Please mail your reports in early. Write the SCM about ARRL appointments. Traffic: W5CEZ 357, JAW 61, JPV 32, NDV 20.

MISSISSIPPI—SCM, John Adrian Houston, sr., W5EHH—Activity is at a high point on the Gulf Coast with the inauguration of the Mississippi V.H.F. Net in Gulfport. GUU is holding regular schedules with K17-Land since erecting a new tri-band beam. K5BKK is working many DX stations with 20 watts and a ground-plane antenna on 20 meters. Your SCM met with the Tupelo Club and found it to be a very active organization. The annual Jackson Picnic-Hamfest was well attended. K5IUE and LEA are new additions to the phone bands, having recently graduated from the Novice ranks. K5AJR's new QTH is the U. S. Air Force. TJU has moved to Cleveland from New Orleans. WZY has moved to the new QTH in Greenville and is heard regularly on 75-meter phone. Traffic: W5JHS 46, JBS 31, EHH 16, K5BKK 12, W5RIM 10.

TENNESSEE—SCM, Harry C. Simpson, W4SCT—SEC: RRV, PAM: PQP, RM: JV. PL explains the fact that he received 996 and relayed only 817! On Aug. 17, our Ben was just 73 years young! The Morning Watch Net held a surprise birthday party for Ben, with 52 stations actually reporting in. Ben says, "After a man passes the Biblical three score and ten he doesn't welcome birthdays, but my 73rd was different. I doubt if any ham ever had one like it—or ever will!" Most messages were numbered "73," and VE2DR's message went further—it was a poem, with a check of "73"! His
(Continued on page 134)

PRE-TUNED FOR OPTIMUM PERFORMANCE

F A M O U S

Telrex

COMMERCIAL- GRADE ARRAYS

-at
amateur
prices!

HIGHEST
SIGNAL-TO-NOISE,
SIGNAL-TO-
INTERFERENCE
RATIO EVER!

- Gusset plate mounting
- Hair-pin resonated
- Wind drag reduced 55%
- Rugged, lightweight aluminum construction
- All stainless steel hardware

ASK THE AMATEUR WHO OWNS ONE!

Whether you are limited for space or money, or whether money is no problem, Telrex has the best suitable array for you. Every Telrex array is fully integrated mechanically and electrically to provide outstanding performance per element. The unsurpassed superiority of Telrex arrays is why the most outstanding radio amateurs, including the world's champion DX'er, use Telrex.

In service in all 48 states, on every continent and 78 foreign countries! Call or write for new illustrated bulletins



Telrex LABS.
TV & COMMUNICATION
ANTENNAS

EXCLUSIVE
TELREX TAPER
SWAGED ELEMENTS



MINIMUM WIND DRAG
AND NOISE

SPECIAL MOLDED
CYCLOAC INSULATORS

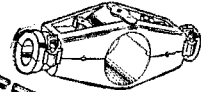

LUG CONNECTORS AT DIPOLE, NO CONNECTOR TROUBLES, MUCH HIGHER POWER CAPACITY

NOW! Telrex features the best arrays ever produced, and new lower cost models designed to do the job.

All Telrex arrays are precision tuned and matched for optimum results per element at your site without experimentation or cut and try.

All models supplied with a coaxial halfwave "balun" for balanced pattern and minimum TVI and BCI.

Super De-Luxe models employ all stainless steel hardware, lower cost models employ heavy cadmium plated hardware. A heavy-duty gusset plate mast fastener supplied with every array.

A model to fit every purse or requirement from 1/4 thru 40 meters.

Write our engineering department for assistance in laying out an antenna system whether you intend to be represented on the frequency or whether you intend to dominate the frequency!

ASBURY PARK 44
NEW JERSEY, U.S.A.
Telephone: PRespect 5-7252

ORIGINATORS AND MANUFACTURERS OF THE WORLD'S FINEST TV AND COMMUNICATION ANTENNAS

*Crystals! Guaranteed!!
We Got 'Em!*

3005 3300	4800	5875 5	6350	6973 7350	7520	7640	7860	8300	8560
3010 3885	4930	5875	6362	6973 7358	7525	7641	7866	8310	8566
3015 3953	4950	5880	6373	7000 7366	7530	7650	7870	8100	8306
3020 3960	4960	5892	6375	7006 7373	7533	7658	7873	8106	8310
3025 3990	4985	5900	6385	7025 7385	7540	7660	7875	8110	8316
3030 3990	5030	5906	6395	7040 7383	7541	7666	7880	8110	8320
3035 4035	5035	5915	6405	7073 7406	7550	7670	7883	8116	8325
3040 4045	5050	5907	6406	7050 7400	7550	7670	7883	8116	8325
3045 4080	5127	5940	6440	7050 7400	7550	7670	7883	8116	8325
3050 4095	5165	5950	6450	7075 7425	7560	7680	7900	8120	8330
3055 4110	5205	5955	6473	7100 7408	7567	7680	7906	8123	8336
3060 4120	5235	5973	6475	7100 7408	7567	7680	7900	8140	8375
3065 4165	5245	5975	6500	7106 7416	7570	7683	7906	8143	8386
3070 4175	5327	5995	6526	7100	7570	7916	8150	8400	8610
3075 4190	5385	6000	6526	7106 7416	7570	7916	8150	8406	8620
3085 4215	5387	6015	6550	7106 7416	7570	7916	8150	8406	8620
3100 4230	5435	6025	6550	7110	7570	8163	8410	8630	8640
3110 4255	5437	6040	6573	7116 7933	7573	8166	8420	8633	8640
3120 4260	5485	6050	6580	7120 7940	7570	8160	8420	8633	8640
3130 4295	5500	6050	6600	7170	7941	8173	8430	8641	8647
3145 4300	5545	6075	6606	7173 7950	7941	8175	8433	8650	8650
3150 4330	5582	6075	6606	7175 7958	7941	8180	8440	8650	8653
3155 4340	5587	6100	6640	7175 7960	8183	8441	8650	8656	8660
3160 4395	5645	6106	6640	7175 7960	8183	8441	8650	8656	8660
3165 4397	5660	6125	6640	7173 7970	8181	8458	8660	8672	8673
3170 4445	5675	6140	6675	7176 7975	8206	8470	8670	8675	8680
3175 4490	5687	6142	6700	7176 7975	8206	8470	8670	8675	8680
3202 4486	5700	6150	6706	7180 7993	8210	8475	8683	8683	8683
3205 4535	5706	6173	6725	7181 7995	8216	8475	8683	8683	8683
3210 4680	5725	6182	6740	7180 7993	8220	8483	8693	8693	8693
3220 4680	5730	6185	6750	7180 7993	8220	8480	8700	8700	8700
3225 4730	5740	6200	6773	7125 7425	7573	7763	8000	8225	8490
3230 4820	5750	6210	6775	7140 7433	7575	7766	8010	8230	8500
3235 4830	5760	6230	6800	7140 7440	7580	7781	8020	8240	8500
3240 4840	5770	6250	6806	7200 7441	7583	7800	8023	8241	8506
3245 4895	5775	6250	6810	7206 7450	7590	7806	8030	8250	8508
3250 4915	5785	6250	6820	7205 7448	7589	7805	8033	8253	8510
3310 4710	5890	6250	6825	7205 7448	7589	7805	8033	8253	8510
3315 4735	5925	6273	6840	7240 7466	7600	7810	8040	8260	8516
3320 4750	5950	6275	6850	7240 7466	7600	7810	8041	8266	8517
3410 4780	5800	6275	6873	7273 7475	7608	7825	8050	8270	8525
3420 4785	5806	6275	6873	7273 7475	7608	7825	8050	8270	8525
3435 4815	5850	6295	6910	7273 7475	7608	7825	8050	8270	8525
3445 4820	5825	6306	6900	7300 7500	7611	7833	8067	8277	8533
3525 4840	5840	6315	6906	7306 7506	7620	7840	8073	8280	8540
3535 4845	5855	6315	6906	7315 7510	7623	7841	8075	8283	8541
3540 4850	5862	6333	6940	7325 7510	7630	7850	8080	8290	8550
3740 4832	5852	6340	6950	7316 7633	7853	8083	8291	8558	8563

**SPECIAL
FT-243
FUND. FREQ.
59¢
each**

FT-243 2-3 Meg. in steps of 5 KC \$1.49

2015 2080	2320	2430	2480	2530	2590	2705	2775	2845	2890	2930
2017 2105	2350	2440	2485	2535	2595	2710	2780	2850	2895	2945
2020 2125	2375	2460	2505	2555	2615	2730	2800	2870	2915	2965
2025 2130	2380	2450	2495	2545	2605	2720	2790	2860	2905	2955
2035 2135	2385	2455	2500	2550	2610	2730	2800	2870	2915	2960
2040 2140	2390	2460	2505	2555	2615	2730	2800	2870	2915	2960
2055 2195	2425	2485	2535	2595	2710	2780	2850	2905	2955	2995
2060 2200	2430	2470	2520	2580	2700	2770	2840	2895	2945	2995
2065 2205	2435	2475	2525	2585	2705	2775	2845	2895	2945	2995

NOVICE BAND FT-243 FUNDAMENTAL OR DC-34 FREQUENCIES **99c**

- Your Choice—Guaranteed for Accuracy & Activity
- 80 METERS** 3701 through 3748 in steps of 1 KC. FT-243 or DC-34.
 - 40 METERS** 7150 through 7198 in steps of 1 KC. FT-243 only.
 - DOUBLING TO 40 METERS** 3576 through 3599 in steps of 1 KC. FT-243 or DC-34.
 - 15 METERS** 5276 through 5312 in steps of 1 KC. FT-243 or DC-34.

- FT-241 SSB. Matched Pairs.....pr. \$1.95
- FT-241 Single Side Band low frequency Crystals—370 KC to 540 KC.....ea. 49c
- DC 34/35 from 1690 to 4440 KC.....ea. 75¢
- AN/TRC-1 FT-241 holders from 729 to 1040 KC—1000 KC excluded.....ea. 75¢
- FT-241 200 KC or 500 KC.....ea. \$1.00
- CR18/U 1000 KC Std Herm. Sealed.....ea. \$2.95
- 100 KC FT-249 RCA VC-5.....ea. 4.95
- 160 Meter—FT243 1005 to 1999 KC.....ea. \$1.99

1000 KC-DC9-LM-BC 221 Std.....\$6.25

Marine and C.A.P.
ALL FREQUENCIES AVAILABLE NOW!
2009—2182—2637 etc. Tol. .005%.....ea. \$2.99

OTHER FREQUENCIES AVAILABLE—SEND FOR CATALOG

Include 5c per crystal for postage and insurance. Calif. add 4% Tax. No. C.O.D.'S. Prices subject to change. Ind. 2nd choice; substitution may be necessary. **Min. Order \$2.50.**

U. S. CRYSTALS, INC.

1342 So. La Brea Ave., Los Angeles 19, Calif.

many friends anticipate a similar party on Ben's 88th birthday! TDZ reports that IKK, TDZ, TDW, FLW, HHK, YGK, JG, ZBQ and ZZ have received an IGY ARRL Consistent Reporting Award. JVM reports the Chattanooga 10-Meter Net has been changed to 8 p.m. EST Thurs. on 28.6 Mc. At the Memphis Club, SCF spoke on Tennessee communications, GVS demonstrated hi-fi recording and playback equipment and APB played a tape of South Pole contacts. Tex Beneke, KØHWY, and his XYL, ØHRH, were visitors at many Memphis shacks. VZU and YMB took a BC-669 on vacation and had fine results. BAO is working on a water-ski portable! BAQ, HHK, UDI and UDQ attended the ARRL Convention, where HHK addressed the v.h.f. group. Congratulations to K4LPW on making DXCC. YRM is now running 180 watts on 6 meters. K4ONQ and K4KTN are new General Class licensees. OGG, retired RN5 manager, vacationed and visited many RN5 members, including W5s WZ, RNB, JHS, W4s KIX, EJZ, BVE and COU. 5BFC, acting RN5 mgr, earns a BPL medalion. Congratulations to TDZ on the new male harmonic. Traffic: W4PL 1828, W5RCF 937, W4PQP 85, VJ 72, UVL 63, IV 60, SCF 50, OGG 39, EWC 23, BQ 19, GFL 14, BMI 13, YRM 9, ONQ 8, PAH 8, H8X 5, HUT 5, LPU 4, TDZ 4, KTN 1, PVD 1.

GREAT LAKES DIVISION

KENTUCKY—SCM, Albert M. Barnes, W4KKW—SEC: JSH, PAMs: SUD and VJV, RM: QCD. SCD reports KPN cleared 97 messages in 31 sessions averaging 3.1 per session. Net control stations are K4BPX, K4ECJ, SBI, HJI, K4HBF, WNF and YZE. Liaison through KYN to 9th Regional is via K4DLG, K4JGN, K4KHE, K4QKQ and YZE. VJV may be inactive for some time because of illness in his family. RM QCD reports 268 messages cleared on KYN with 30 sessions held, averaging 8.9 per session. Net control stations are K4KIN, K4KIO, JSH, MWX, SUD and ZDB. Liaison to 9RN is via K4KIO, KKW, QCD and ZDB. New stations are 4OAH, LVL and OGY. ZDB is high traffic man again. Everyone who attended the Cherokee Park Picnic said they had a fine time. CDA, our hard-working editor of the bulletin, reports he has an untried 250-watt final for 40 meters and no time to work it. NVE, formerly of Vine Grove, now is located in Danville. KKG is keeping those W6 skeds through the summer on 21.4 Mc. MWX is NCSing KNN (Ky. Novice Net) every Tue. on 3735 kc. at 2030 CST. N4Z and YYI have been doing a fine job on KPN. SZL says Glasgow ham club activity is "popping." RHZ's son was selected the best trainee at Ft. Knox. JUI has \$15,000 worth of frequency-measuring equipment. K4JGN worked HB9UL. K4CHK has moved to North Carolina. New ORSs are K4CSH and K4DLG. K4DYR is a new OBS. Your SCM talked to Ed Handy and George Hart at the Chicago Convention and met the SCMs of Illinois, Indiana, Wisconsin, Iowa, Connecticut, West Virginia and Alabama. BZY now is studying at Stanford U. in California and hopes to work 6XN, the university station. Listen for him. Traffic: W4ZDE 422, KKW 138, QCD 93, K4KIO 92, W4BAZ 90, JSH 83, RFP 81, K4CSH 64, KIN 64, AXE 39, AIS 38, W4CDA 37, K4OAH 37, W4KKG 28, MWX 23, NIZ 13, K4MMW 9, W4HJ1 8, H8T 8, K4F4PGR 7, W4RHZ 5, SZL 5, JUI 4.

MICHIGAN—SCM, Thomas G. Mitchell, W8RAE—The passing of our honored and good friend Cosmo G. Calkins, W8HSG/MEX, on Aug. 23 marked the end of his active career, but his work will long be remembered by all of us. In his official capacity as Legislative Technician he was ever on the alert to influence favorable legislation on our behalf. His willingness to foster such legislation as the License Plate Bill and the more recent modification of the Michigan Public Acts (to legalize mobile radio installations) are lasting evidence of his efforts. Despite his illness Cos maintained his usual enthusiasm for our hobby which he enjoyed so much. Thanks for the many notes and clippings. I shall see that Mrs. Calkins is made cognizant of our sentiments. Cos was a fine example to all the fraternity, and especially to us in Michigan. P.L.P. EQK, GHP, CPV, DOI and KWO were Honorary bearers at the services for HSG. There are no new developments in the RACES program to report as of this time, but RDN is very active and getting much done toward implementing the program during this fall and winter. Now is the time to apply for station appointments and we need more active appointees. Read over the qualifications and let me know what you are interested in. With the serious operating season upon us, let's concentrate on sharpening up our techniques and abilities. There's no better event to prove our ability than the Sweepstakes Contest in November. Let's have a better representation from Michigan this year. We all can't win awards, but the experience and challenge that SS operating affords can

(Continued on page 138)

B&W TRANSMITTER GROWS WITH THE RADIO AMATEUR



5100-B

◀ Start with basic Transmitter

Ideal for the oldtimer and beginner alike. It's a complete medium powered transmitter as it is . . . over 140 watts AM phone . . . 180 watts CW. Completely self-contained including power supply, VFO, and integral band-switching. Covers all ham bands 80 through 10 meters. YOU CAN ADD SSB AND A 1 KW FINAL TO THE 5100-B AT ANY TIME. **Net Price . . . \$525.00**

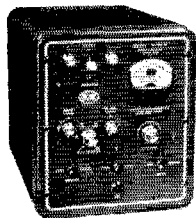

51SB-B

*If you have a Viking I or II, Collins 32 V series, or other commercial or composite home-built rig, get the Model 51SB. It's similar to the 51SB-B, but contains a power supply which you'll need with transmitters other than the 5100-B.

Net Price . . . \$279.50

◀ Add SSB Generator

If you want to enjoy top quality single sideband, just plug the 51SB-B into the back of the 5100-B transmitter* and you're on the air with a commanding signal. The many features of the 51SB-B include voice-operated control, selectable sideband with a flip of the switch, speaker deactivating circuit, and TVI suppression.

Net Price . . . \$265.00

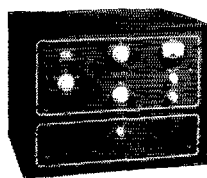

L-1000-A

All these B&W units are housed in attractive cabinets with a blue-grey wrinkle finish. Panels are finished in the distinctive B&W rich semi-gloss grey, with white lettering and border stripes. They're expertly engineered to assure you of long, trouble-free operation as well as ease of control and tuning.

Prices subject to change without notice

◀ and then tie in 1 KW Final

When you're ready to go the limit—1 kilowatt of power—all you need to do is to add the L-1000-A. This grounded grid linear amplifier will stand out in signal eloquence whenever the going gets rough. The pi-network output gives you precise adjustment of tuning and loading from 80 to 10 meters. It's rated at 1000 watts peak envelope power SSB, 875 watts CW, and 375 watts linear AM phone.

Net Price . . . \$495.00

B & W

BARKER & WILLIAMSON, INC.

Bristol, Pennsylvania

VALLEY ELECTRONIC SUPPLY CO.

"Final Word" for all
amateur equipment
in the West

HALLICRAFTERS

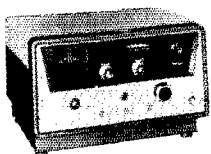

Hallicrafters HT-33. New Ampl.
1 KW SSB Ampl. CW-AM. 80-10 meters.
Amateur net: **\$775.00**



Hallicrafters HT-32. New Xmtr.
AM-CW-SSB. 5.0 mc quartz xtal.
Amateur net: **\$675.00**

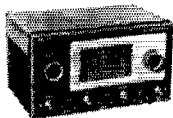

Hallicrafters S-53A. New Rcvr.
Bdctf. & 4 SW bands.
Amateur net: **\$89.95**

VALLEY ELECTRONIC SUPPLY CO.

1302 W. Magnolia, Burbank, Calif.
Victoria 9-4641
17647 Sherman Way, Van Nuys, Calif.
Dickens 2-5143

Some prices slightly higher west of the Rockies

benefit all of us. Please note in the following traffic report that ELW and FWQ made the BPL list again this month. It makes the 13th consecutive monthly award to ELW. Congrats to both. Traffic: (Aug.) W8ELW 754, FWQ 214, ILP 134, YAN 70, DAP 58, FX 57, NAW 35, WNO 35, NOH 26, PXA 22, OGY 15, DSE 14, OCC 14, AUD 8, SCW 8, HKT 4, MSK 4, TIN 4, EGI 2, TIC 2, (July) W8NTC 43, OCC 11, PXA 12, DKV 10, SCW 8, MSK 5, (June) W8DRV 49, MSK 4.

OHIO—SCM, Wil-on E. Weekel, W8AL—Asst. SCM; J. C. Erickson, 8DAE, SEC; UPB, RMs; DAE and FYO, PAMs; FNN, HPP, HUX and HZI, CSK and UPH made BPL in August. AQ is on 6 meters. BUM spent a month in W6- and W7-Land. 1BPA (ex-ENQ) is back in Ohio waiting for a W8 call. FFK spent his vacation in Michigan. ZWX, who graduated from U. of Mich. law school, was admitted to the bar in Ohio. IX has a Viking II and a quad for 10, 15 and 20 meters. UWM and K8AHO have joined the Silent Keys. FFK's daughter is KN8HKU. KN8GZT is a new ham in Massillon. Springfield ARC's Q-3 reports that during the c.d. alert DCJ and WNG worked a total of 52 hours. UPB sent me his copy of *Mike and Key*, the first I've received, which states that ELB had a hip operation. MXY has a new 20-meter beam. NDU has joined the Silent Keys and the Greater Cincinnati ARA has a new meeting hall at 1325 California Ave., Bond Hill. A v.h.f. club was formed in Canton with GNO, pres.; and ULY, vice-pres. K8AII is mobile with a Halo antenna. Your SCM attended the following ham picnics in August: First, the Canton ARC's Picnic at Lake O'Springs attended by 36 amateurs and their families with IKM winning a D-104 mike, AL a Turner dynamic mike and TTJ a Morrow Conrad receiver, which he donated to the club station. Second, the Buckeye Shortwave RA's Hamfest-Picnic attended by 177 amateurs and their families with MIB winning a Viking Ranger, KN8DBU a D-104 mike and DQG a sixteen-element 2-meter beam. Third, the Buckeye Net Picnic at Newark attended by AL, CGF, CSK, DSX, HXB, OPU, VDA, VTP, VVX, WE, K8BPX and K8DDG, plus visitors ATK, EHE, OEQ, OPV, OTK and TND, and the fathers, sons, brothers and XYLs of the net members, KN8s EUT and EUZ are new hams. PBX received V-A-JF certificate No. 212. New appointments are EIL, EPJ and WRT as EC's, K8COI as OPS, K8AEC as OPS, K8CAG as OO, HXB is fighting a bad local line noise, K8AEC worked KC4USK on 40-meter s.s.b. phone, which he believes is the first 40-meter phone QSO with the South Pole. The fine paper, *Shark Gossip*, from Toledo, is published by two gals, IIA and MBI. This bulletin is not sponsored by any club, but is financed by sales tax stamps and donations. They honor me by naming me their Ham of the Month. Yes, gals. I am still OCARC's treasurer, another honor given me. K8EUC received his General Class ticket, GDE and MGB bought an airplane. HRS's sons are KN8s GQR and GQY. IZQ has a new Globe Champion. CLX spent a week in Canada. KPJ has a new baby girl. The EC for Lucas County is RYA. *R-E Carrier*, of the Dayton ARA, reports that both WJL and K8CON have their General Class tickets. ILC has a new car with a complete Gouset mobile installation and CCD, K8BOX, KN8s CTS and DVK are working DX. CLV, DPW, VFD, K8s DLM and GDY are on 6 meters. WJK was overseas most of the summer. GQ was on a 7400-mile vacation trip. Dayton placed five stations in the June V.H.F. Party. BMO, LOF, NAF, NEE and PLQ. SZU spent a week end fishing in Canada. STR worked ZM6AB on 40 meters. LMB operated from Northern Michigan while on vacation. K8EWA has a new Viking Valiant. K8DOU is on 6 meters. ODO and KN8HAX are new hams in Hamilton. The v.h.f. group of the Columbus ARA elected NVI, pres.; LGI, vice-pres.; THU, secy.; HOF, treas.; and WRN and BAX, trustees. WRN worked Minnesota for a new state on 2 meters. A sort of Field Day was held in the Hoeking Valley hills by 10 hams from Pennsylvania, 3 from Michigan, 1 from Virginia and 3 from Ohio, and their XYLs, using AAU as the call. Worked Ohio All Counties On Six (WOACOS) is a new certificate awarded by the Central Ohio Radio Club, Box 23, Delaware, Ohio. KN8EKQ worked WAS in five months, as well as Hawaii and a VK3. K8BPX new/ Nevada for WAS and has WAC on c.w. both as a Novice and as a General Class licensee. NAF has 23 states confirmed on 50 Mc. and a new five-element 20-Mc. beam. Traffic: (Aug.) W8UPH 699, CSK 614, CGF 482, K8AEC 479, W8DAE 159, HXB 147, K8BPX 141, W8SZU 89, YDA 84, OPU 78, K8DDG 38, W8GQD 37, C7Z 34, SYD 33, IBX 29, AL 26, WE 26, LZE 20, CQP 15, FFK 12, KN8HKU 12, W8LMB 10, JMD 9, STB 6, DSQ 4, USU 4, WF 3, EEQ 2, HZJ 2, JHH 2, PLQ 2, K8CCZ 1, W8DDW 1, (July) W8PBX 9, FFK 7, WN6BZF/8 4, W8JHH 3, PLQ 3.

(Continued on page 138)

CUSH CRAFT . . . NOW OFFERS YOU A COMPLETE LINE OF VERTICAL GROUND PLANE ANTENNAS FOR HAMS!!

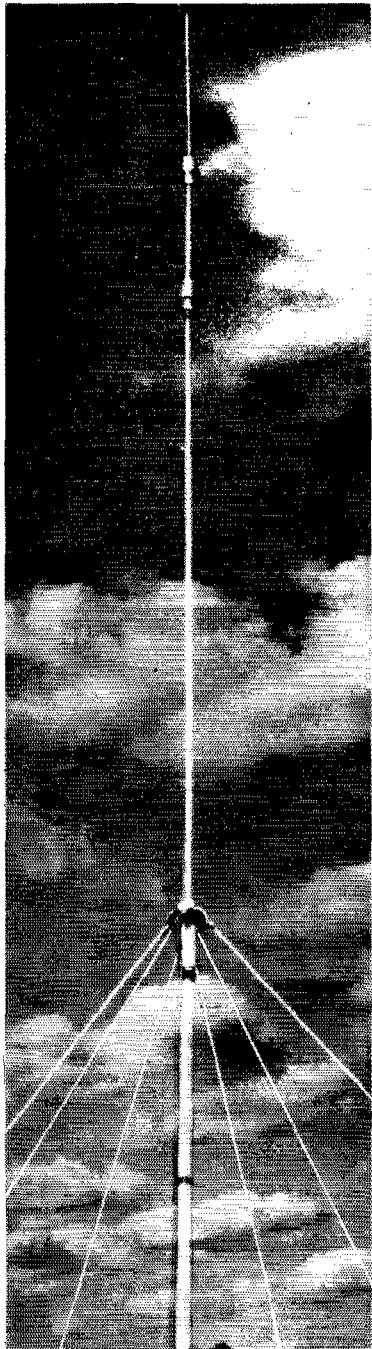

CUSH CRAFT Ground Plane Antennas for Hams are space-savers with a low angle of radiation for ultimate performance and are ideal for DX work or local "rag chew." Greater heights can be achieved with these antennas where bulky beams might be hampered by trees, etc.

CUSH CRAFT Ground Plane Verticals should not be confused with regular verticals which depend on ground conditions for performance and generally have a low feed impedance; making a matching network or loading coil necessary.

ALL CUSH CRAFT Vertical Ground Planes are direct 52 ohm feed — requiring no matching network or tuning.

ATGP-6 - 6 METERS

Model No. ATGP-6 (as illustrated less "Traps") is factory pre-tuned but can be adjusted.

S/W/R (not over) . . . 1.3-1

Shipping Wt. 4 lbs.

Radiator Length (Adj.): 2' 9"-4' 10"

Radial Length 4' 8"

Price \$10.50

ATGP-10 - 10 METERS

Model No. ATGP-10 (as illustrated less "Traps") is factory pre-tuned but can be adjusted.

S/W/R (not over) . . . 1.2-1

Shipping Wt. 5 lbs.

Radiator Length (Adj.): 3' 3½"-8' 8"

Radial Length 8' 4"

Price \$13.50

ATGP-15 - 15 METERS

Model No. ATGP-15 (as illustrated less "Traps") is factory pre-tuned but can be adjusted.

S/W/R (not over) . . . 1.1-1

Shipping Wt. 6 lbs.

Radiator Length (Adj.): 4' 10"-11' 6"

Radial Length 11'

Price \$14.75

ATGP-20 - 20 METERS

Model No. ATGP-20 (as illustrated less "Traps") is factory pre-tuned but can be adjusted.

S W R (not over) . . . 1.1-1

Shipping Wt. 7 lbs.

Radiator Length (Adj.): 7' 4"-17' 6"

Radial Length 16' 7"

Price \$16.50

ATGP-3 - 10-15-20 METERS

Model No. ATGP-3 Tri-Band Trapped Vertical Antenna (as illustrated) for 10, 15 and 20 Meter Bands eliminates switching and tuning—the "Traps," do the switching and tuning for you. This model is pre-tuned but can be adjusted.

S/W/R on 10 Meters (not over) 1.65-1 —

S/W/R on 15 Meters (not over) 1.5-1

S/W/R on 20 Meters (not over) 1.1-1

Shipping Wt. 9½ lbs.

Radiator length 13' 8½"

Radial Lengths 8' 4", 11' and 16' 7"

Price \$28.50

SPECIFICATIONS

FEED LINE one 52 ohm cable

VERTICAL ELEMENT telescoping 61ST6 .058 wall aluminum tubing

TRAPS rigid air wound self supporting coils of 3/16" aluminum rod.

CONDENSER aluminum tubing insulated with phenolite.

SUPPORT heavy wall pipe with set screw to lock mast, which may be any pipe or pole up to 1½" diameter

RADIALS of heavy stranded aluminum wire with strain insulator at the end of each radial, radials act as guy wires for the antenna

COMPLETE ASSEMBLY ready to install (less feed line) with radials and insulators attached

Ask Your Distributor
for CUSHCRAFT !

Cush
Craft

621 HAYWARD STREET
MANCHESTER, N. H.

HUDSON DIVISION

EASTERN NEW YORK—SCM, George W. Tracy, W2EFC—SEC; KGC, RM; BXP, P.A.M.s; IJG and NOC. Section nets: NYS on 3615 kc. at 1900 EST. NYSPTEN on 3925 kc. at 1800 EST, SRPN on 3980 kc. Mon. through Sat. at 1030 EST, IPN on 3970 kc. Mon. through Sat. at 1530 EST. We welcome the E.N.Y. AREC Net on 145.35 Mc. the first Mon. of each month at 2130 EST. The charter members include K2GCH, ICM, W2HIP, KGC, PEH, HZZ, SUL, RTE, K2LWI, MBF, PRB, UKE, VRS, YIF and YOU. All 2-meter stations in the section are invited to join. K2DEM reports one Novice ticket, four crystal sets and 25 one-tube receivers resulted from his counseling at youth camp in Peeks-kill during the summer. A new Novice in Yonkers, sponsored by PHX, is KN2BIG. K2TCD has a new Valiant and worked 14 new countries on 21 Mc. using a two-element beam. The 50.7-Mc. Net has been organized in the Tri-City Area and meets Wed. at 1900 EST and Sun. at 1500 EST. Officers include K2RYG, mgr.; K2TOR, asst. mgr.; K2QVA, secy.; and K2YWH, primary NCS. With large beams, 18 elements at K2CBA and 10 elements at K2YWH, these 50-Mc. stations reach out during band openings. August found several openings on 6 meters and aurora kept the c.w. boys busy. A new modulator is under construction at K2YTD. A cross-country run in Fishkill was given radio coverage by K2GCH, HJX, W2KGC and SU/L. KN2ZDA, a high school teacher in Ellenville, is on the air in Napanoch with a DX-20 rig. Radio vacations using battery power were enjoyed by AWF and GTC. CYW was heard well in the Capitol District while operating 75-meter mobile in Wells Beach, Me. Traffic: K2EJU 272, W2PHX 181, K2UYK 144, HPQ 130, W2EFU 117, K2LKI 73, VTW 25, W2ATA 22, GDD 19, K2YTD 19, BAB 11, HJX 6, RKY 6.

NEW YORK CITY AND LONG ISLAND—SCM, Harry J. Dannals, W2TUK—SEC; ADO, PAM; OBW, RM; WFL. Section nets: NLI, 3630 kc. nightly at 1930 EST and Sat. at 1915 EST; NYC-LIPN, 3908 kc. Mon. through Sat. from 1730 to 1830 EST; NYC-LI AREC, 3908 kc. Sun. at 1400 EST. BPL cards go to KEB, K2ECY and JGV. The NYC-LIPN had 198 call-ins handling 628 messages for a fine month. When monitoring our section nets it would appear that this is a Long Island Section only. Please remember that this is the NYC and LI section and that representatives from the five boroughs comprising New York City are needed. Many times it has been necessary to mail traffic for Manhattan, Brooklyn, Bronx, Queens and Staten Island from Nassau and Suffolk relay points. Stations in the five boroughs are requested to participate in our section nets as often as possible. K2PAM has been doing a fine job as NCS on NYC-LIPN. K2ECY installed a phone patch and VOX facilities in his station. K2LTC joined the Navy. JGV wishes to inform everyone that he is not a bootlegger—his call was inadvertently left out of several issues of the Call Book. K2s DEM and OOG will be heard from Cornell U., CXM, during the college year. A lightning surge damaged JBQ's receiver and 2-meter antennas and equipment, but Joe is back in business. K2EOF joined the group at AEE. TUK finally became DX-minded and completed WAC and is awaiting the QSL cards. UGF kept skeds on 21 Mc. with W2BTP/nun on the *Stormy Petrel* on its trip to Bermuda and return. BTP and OBW obtained the calls VP9PQ and BR, respectively, while there. ZUM and K2RJO had fine signals on 75-meter phone as heard in Hamilton, Bermuda, by the boys. LKG calls attention to the poor operating techniques and careless talk locally on 10 meters. K2KXZ is on 2 meters with the 2E26 *Handbook* rig. AZA is enjoying a DX-35. LGG returned to Purdue for his junior year. K2MYW just completed his WAS. PF is looking forward to seeing more s.s.b. nets formed this season. BQM received a visit from HZ1TA, Prince Talal, the brother of King Saud of Saudi Arabia. K2CF moved to New Mexico and PRN to W4-Land. PZE put up a new multi-band trap antenna for the coming SS. CSZ reports that his son soon will be signing W2URX/KG1 from Thule AFB, Greenland. Your SCM logged a visit from K2CVJ on leave from the Air Force in Florida. Clay is looking for contacts from his 10-meter mobile. K2DNL worked NLI and OTA on 432 Mc. K2QDD has a crystal converter for 50 Mc. and is building a 35-watt rig for that band. K2QFV is building an 8-Mc. v.f.o. for his 6-meter rig. K2SEK is adding a Heath v.f.o. to his DX-35. Ex-DLO, who signs K4NG from Florida, will be happy to make skeds for 2 and 6 meters. K2SIF has a DX-100 and HQ-129X; he received his WAS and is awaiting QSL cards to confirm WAC. K2QYU is now on 6 meters. KN2s UDT, UFS and UPQ passed their Technician Class exams. K2JWT reports that the 2-meter boys he works in Maine, New Hampshire, Ver-

(Continued on page 140)

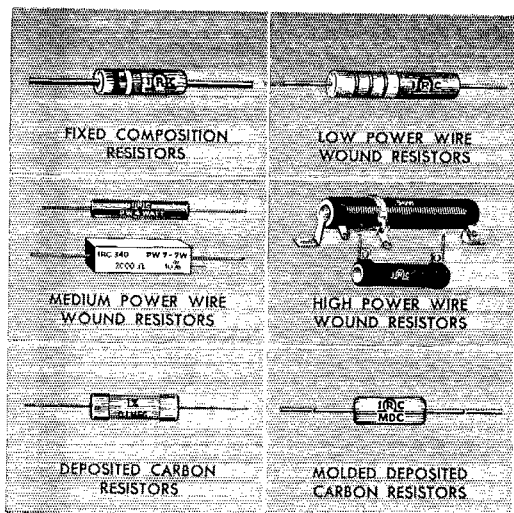

IRC Components make good rigs better

When a resistance component "goes", any replacement will get your rig operating again. But with IRC components your rig will pull in signals farther and clearer than before. And fortunately, you can get superior IRC performance in just about every resistance component you need. See your IRC Distributor. He has them all.



INTERNATIONAL RESISTANCE CO.

Dept. 434, 401 N. Broad St., Philadelphia 8, Pa.
In Canada: International Resistance Co., Ltd., Toronto, Licensee

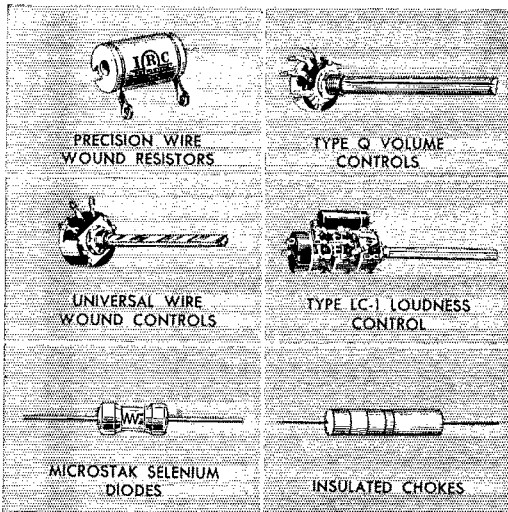

NEW

PLANT



NEW

ADDRESS

29-01 Borden Avenue - Long Island City 1, N. Y.

... and the **NEW** est
in SSB equipment ...

Two superb transmitters, Model SSB-100F basic exciter/transmitter and Model SSB-1000 P.A. Both designed for outstanding performance on all modes of transmission — SSB, AM, CW — with every operating convenience for amateurs concentrating in any phase of ham radio. Now to see at your local distributor ... to command your frequency on the air!

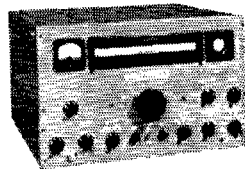
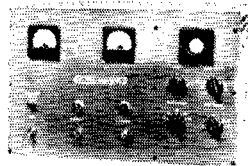

ELDICO
ELECTRONICS

Write W2BFY for additional details
if your distributor can't assist you.

29-01 BORDEN AVENUE, LONG ISLAND CITY, NEW YORK

A Division of Radio Engineering Laboratories, Inc.

NORTHWEST ELECTRONICS

features the newest
from *Collins*



COLLINS 75A-4 This SSB Receiver offers all the proven Collins features — excellent image rejection through double conversion, precise dial calibration and high stability of Collins VFO and crystal controlled first injection oscillator, and the ideal selectivity of Collins Mechanical Filter in the IF strip.
Net Price -----\$695.00

COLLINS KWS-1
Companion transmitter to the 75A-4. Unmatched performance in minimum space for a kilowatt. Extremely accurate 70E VFO, Pi-L output network and Mechanical Filter.
Net price -----\$2,095.00.

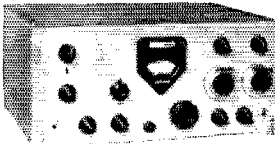

COLLINS KWM-1
The first mobile SSB transceiver in the Amateur world — 175 watts PEP, 14-30 mc. Fixed station use without modification.
Net price -----\$770.00



Buy your Collins equipment on our time payment plan. Trade in allowances will probably handle the down payment. Contact us now for complete information.

NORTHWEST ELECTRONICS, INC.

East 730 First Avenue
Spokane, Washington

mont and Nova Scotia would appreciate it if we would look Northeast more often. WN2TNP has an 807 rig on 15 meters and is building a 7-tube receiver. KN4OKV/2 is on duty at the Brooklyn Navy Yard. A new 75A-4 has been added to the station at JTZ, Chaminade H. S. HQD's XYL now signs KN2AIU. K2OQL has a new rig on 40 meters. RZH is putting the finishing touches on his homebrew receiver. The Nassau RC sponsored a Mobileer's Steeplechase complete with mileage rules, hidden transmitter and treasure hunts. K2VZB is on 50 Mc. with a converted 522. K2ACD now has 42 states on 6 meters and hopes the new 500-watter will complete WAS. All appointees are urged to check expiration dates of their appointments. Traffic: W2KEB 2135, K2ECY 463, W2JGV 240, K2DEM 132, SEK 80, LUM 73, TSE 66, PMI 64, W2JBO 61, OME 58, AEE 54, K2KSP 48, KQG 46, RJO 37, W2THK 32, UGF 21, K2MEM 20, W2LKG 12, K2EQH 8, MYW 8, W2HAE 4, PF 4, JCA 1.

NORTHERN NEW JERSEY—SCM, Lloyd H. Mannion, W2VQR—SEC: IUN, PAM; VDE, RMs: BRC, NKD and CGG. K2MFF has just received a WAS certificate. VCZ is back from vacation. K2AJV is back at school. K2SYB has a DX-35 and an HQ-100 receiver and needs only two more states for WAS. WN2FJC and JRT are new Novices. KN2YUE is working good DX on 40 meters running 13 watts. KN2YUQ has moved to VE3-Land. K2YNT has a new HQ-150 installed at the Metuchen YMCA Club. K2MFF made BPL again. The GSARA held a picnic on Sept. 8. GUM has a new tilt-over tower. PZY is building a new house and a new boat. The GSARA meets the 2nd Wed. of each month at 2000, Red Cross Hq. Bldg., Shrewsbury. Hams stationed at nearby Ft. Monmouth are invited to drop in on meeting nights and meet the gang. NIY visited KN2BXE while on vacation. K2YBM, a new General Class licensee, has a new DX-100. K2GPB was home on leave from the U. S. Naval Academy. K2DOX spent the summer taking courses at New York City colleges, and now has headed back to the U. of Detroit for the school season. WN2TKZ is a new ham in Teaneck. K2QYI made BPL this month. New section appointments are as follows: K2PIM and IKZ as OOs, K2PBP as OES. K2QYI has a new Ranger transmitter. Regular meetings of the Watchung Radio Club resumed on Sept. 6. EWZ met K4DTP, KIN and K6AMI while operating 40YL at the U. S. Naval Amphibious Base at Little Creek, Va. RXL has a new WRL v.f.o. and has rearranged his station for the coming operating season. EBG is a new ORS. K2QYI has been appointed OO. LRO has been painting and repairing his house so has been inactive. K2VAB and SBT received their General Class licenses recently. WN2MRV is going up for his Technician Class license. Bob has been on the air with a borrowed transmitter belonging to K2RSC and TSH, a father-and-son team in the Roselle Park Area. CVW has 69 countries toward DXCC. Ed has added a CM-1 Conelrad monitor to his shack. KN2VZJ has passed his General Class exam at the age of 12 years. Congrats also to K2TVY; a new General Class operator. NJN report for August is as follows: Sessions 27, attendees 327 and traffic 435. K2OBJ has a terrific RTTY set-up at his shack. The TCRA traveled to Red Bank en masse to attend the GSARA picnic. We hope that with the loss of K2AJV to FNJ the net will continue to have the same drive it has had in the past. We hope also that someone will take over the publication of the net's fine monthly paper that K2AJV so ably edited and published. The Penn-Jersey AREC operated at the civil defense booth during the Warren County Farmers' Fair. A total of 147 messages was relayed from the fairgrounds via this station. K2RJD is back from a summer vacation in VE-Land. K2OAM continues to do a fine job as NCS for TCPN. VDE has purchased a new home and will move to the new QTH soon. GVU has his s.s.b. rig off the air for repairs. The Monmouth County RACES group, under the leadership of K2DHE, performed a real public service over the Labor Day week end. The group took advantage of the mass exodus of summer visitors from the Jersey Shore Area, and in cooperation with civil defense officials made use of the severe traffic congestion in the shore area as a basis for an evacuation study in which RACES communications played an important part. The local broadcast station covered the problem, thus affording excellent publicity for amateur radio in civil defense. Traffic: K2MFF 556, MIMI 355, W2MLW 236, K2BHQ 235, W2KFR 212, RXL 212, QYI 148, K2OAM 110, W2BRC 96, K2AJV 71, W2EWZ 55, ZVW 54, OXL 48, K2MFX 41, PYL 41, BWQ 39, W2EBG 35, K2SYB 31, EMJ 20, GIF 14, W2VDE 7, WOJ 7, CVW 5.

MIDWEST DIVISION

IOWA—SCM, Russell B. Marquis, W0DBR—The Iowa 75-Meter Phone Net Picnic held Aug. 18 in Os-
(Continued on page 142)

Advancement

**of these Raytheon men
opens new opportunities in
FIELD ENGINEERING
WITH A FUTURE!**

The ten former field engineers pictured here have been promoted to executive and administrative positions at Raytheon. They join a large group of Raytheon executives whose backgrounds include field engineering.

The positions they vacated are now open for men who have had previous field experience plus an E.E. degree or the equivalent in practical experience with radar, missiles or other associated areas.

As a Raytheon field engineer, you enjoy an attractive salary, assistance in relocating, insurance, educational programs and other special benefits.

Interviews in most U.S. cities and overseas. Please write G. E. Dodge for details.

RAYTHEON MANUFACTURING COMPANY
Government Service Department
100 River Street, Waltham 54, Massachusetts



Excellence in Electronics



Victor Battani
K1AMT
Supv., Factory Service
Govt. Service Dept.



T. Brice Gaither
Field Project Manager
Hawk Program



Raymond C. Remington
W1SBP
Field Project Manager
Hustler Program



Fred Browning
K4GHC
Field Project Manager
Marine Corps



William T. Comisky
Field Project Manager
Army Signal Corps



Robert K. Dixon
W1DYD
Exec. Asst. to Manager
Govt. Requirements Dept.



Arno W. King
ex W1FIQ
Supervisor of Training
Govt. Service Dept.



Warren Thornley
Proj. Engineer
Airborne Systems
Wayland Laboratory



Joseph A. Strong
ex W600T
Product Manager
Radar
Govt. Requirements Dept.

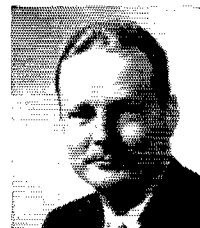

Robert D. Williams
ex W1HDI
Tech. Asst. Mgr.
Ordnance Radar Branch
Wayland Laboratory

New & Different!

the **Mosley**

TRAP

MASTER

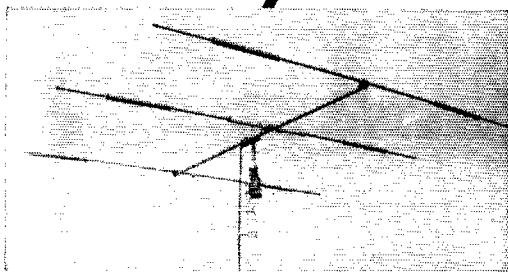

3 Bands ... 10, 15 & 20!

Model TA-33 \$99.75

it's the design ...

New! Different! And, we might add, — Better!

From the exclusive MOSLEY trap design—that defies rain, dust and time, to the sturdy, all-aluminum construction that needs no help from clothes-line or other boom-supporting devices; the MOSLEY "TRAP-MASTER" Beam reflects typical MOSLEY Value, Quality and Workmanship!

Performance? Up to 8db forward gain on each band with 25db, or better, front-to-back. SWR, 1.5/1 at resonant frequencies.

Write for Specification Sheet, No. TR-1, and read the complete story of the MOSLEY 3-Band "TRAP-MASTER". Get set for Fall and Winter DX fun—order your "TRAP-MASTER" Beam from your favorite Ham Dealer ... Today!

You can't go wrong — it's MOSLEY!

Mosley Electronics, Inc.

8622 ST. CHARLES ROCK ROAD, ST. LOUIS 14, MISSOURI

Exp. Dept.: 15 Moore St., New York 4, N.Y.

142

kaloosa was attended by 119 licensed amateurs and their families. NVX and BDR gave short talks. LGG, with the help of her OM EFL, operated a successful booth at the Central Iowa Fair. Another fair booth was operated by the Des Moines Club using KØHEA. Appointments: MFL and EEG as new OPSS. KØAVM and NRQ renewed their EC appointments. LGG renewed as ORS. FBI, KØHAN and KØHLB are new TLCN members. NGS is sporting a Johnson 500 and BXO on the air with a Viking II. UHO vacationed in Florida. The Cedar Valley Club held a mobile picnic in Maquoketa State Park Aug. 25 and the Creston Club held its annual picnic Aug. 4. Congratulations to OLY on making WAS on 6 meters. KØGEY made WAS before dropping the "N." The Council Bluffs Club held a picnic in August. TLCN will miss the services of KVJ since his working hours have been changed. The Burlington Club now operates KØKDN. KVJ and GXQ have received 2500 Traffickers Club certificates. Traffic: (Aug.) WØPZO 1897, BDR 1850, SCA 1138, LGG 973, BJP 822, KØCLS 701, WØCZ 550, KØHEA/Ø 425, WØLXC 358, GXQ 306, BLH 145, KØEJZ 134, WØUTD 117, QVA 101, SLC 57, KVJ 49, NGS 49, IUY 46, KØCBF 33, WØLJW 32, FMZ 29, KØGBD 23, WØVWF 20, PTL 16, REM 14, MEL 11, KØBRE 10, AVZ 8, WØFDM 6, KØCYF 5, WØIHC 5, NYX 5, KØAAH 4, WØADB 4, EEG 3, COD 2, KØEXN/Ø 2, BPE 1. (July) KØEXN/Ø 6.

KANSAS—SCM, Earl N. Johnston, WØICV—SEC: PAH, RM; QGG, PAM; LEW. Most of you are ready for a little activity after summer chores. Some of you will be rebuilding, some ratchewing, and some might want to do a bit of traffic-handling. You can do your bit by reporting in on as many nets as you can because your activity may get an overseas message delivered just that much faster. Here are the nets most active in this section: QKS on 3610 kc, Mon, through Fri, at 1830; KPN on 3920 kc, Sun, at 0800, Tue, at 1230, Wed, at 0630 and Fri, at 1230; the Ham Butchers Net on 7180 Tue, and Thurs, at 1230. The Kansas-Nebraska Hamfest held Aug. 18 at Belleville was well attended, attracting OMs from four states. VZG, of Leavenworth, has a new KWS-1 and a 75A-4. KØHYD has a new HyGain beam. OAQ has his DXCC certificate. KØDFK has a WAC certificate. The following new calls are the results of the ACARA (Air Capital Amateur Radio Association) of Wichita Novice class held last spring: KNØs LFR, LGW, LEV, LEG, LEH, LEJ, LFG and LEB. Congratulations, folks. IEL, of Oswego, an old-timer from way back, is moving to Vinita, Okla. Harold now holds DXCC, WAC, WAS, CP-35 and OTC certificates. Traffic: (Aug.) WØBLI 44, NIX 298, TOT 264, PMS 229, QGG 217, KØBXF 183, BLX 133, HVG 65, WØABJ 54, UOL 41, KØHSE 36, WØMXG 24, IGV 30, KNØKDY 27, WØFDJ 13, FCE 10, IFR 7, LEW 6, DEL 3, WWR 3, ASY 2, IHN 2, UAT 1. (July) WØAQ 40, IHN 16.

MISSOURI—SCM, James W. Hoover, WØGEP—KØHQ has returned from vacationing in Florida. He reports the reception of a number of Missouri Emergency Net stations from the mobile in Southern Mississippi. KØEET is operating 40-meter mobile. KUC is back on 75 meters after an absence of two months. KØDEX is attending the University of Missouri and can be found operating the club station, ZLN. JHY, who is now in the Navy, is operating from K5NRL. PSP has applied for MARS authorization and will be the first YL or XYL on Missouri Army MARS. Columbia's civil defense van was exhibited at the Boone County and Missouri State Fairs. Equipment includes a Viking II and a 75A-3. SAK has moved to Springfield, Ill., but will be attending Central College in Fayette, Mo. KØEQW has a new UX-100. EPI was off the air during August while on a Navy cruise and later for the arrival of a new YL jr. operator. KØLFC has a new 40-watt 6-meter mobile. Officers of the Heart of America Radio Club are KØAEU, pres.; RDI, vice-pres.; UHB, treas.; TFQ, secy. Six-meter stations are invited to listen for and report reception to WEQ, St. Louis, on 50.25 Mc, at 6:30 to 7:30 p.m. CST, Mon, through Fri. WQJ and KLQ, Jefferson City, are available for those wanting test schedules on 6 meters. The Bandhoppers Radio Club's exhibit of ten 6-meter stations, which were built as a club project, won first prize at the ARRL National Convention in the competition for promoting v.h.f. activity. Traffic: (Aug.) WØCPI 1339, GAR 510, KIK 209, OUD 202, VPQ 124, CKQ 68, YVM 53, WYJ 48, EBE 45, BUL 43, KØHQ 37, WØVWF 32, ECE 24, MIZ 24, OVV 20, KØEWD 17, IFM 13, WØHR 10, KØDEX 7, WØPSP 7, GBJ 4, KØHY 4, WØBVL 3, KNØPJ 1, WØSAK 1, VJD 1. (July) WØVZB 14, EPI 13.

NEBRASKA—SCM, Charles E. McNeel, WØEXP—SEC: JDJ, PAM; MAO. The Nebraska 75-Meter Phone Net, on 3983 kc, daily at 1230 CST, had as of Sept. 1st

(Continued on page 144)

Introducing

BRAND NEW
WRL PRODUCTS

THE WRL - GROUNDED GRID Linear Amplifier LA-1

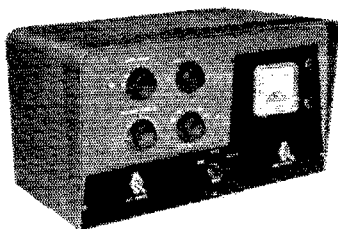

Wired & Tested: **\$124.50**
Kit: **\$99.50**

Complete with
well-filtered power supply

First available amplifier operating either Class B or Class C; with Grounded-Grid Final. Capable of 200 watts input operated AM Class B linear. 420 P.E.P. input. Class B linear SSB or DSB. Requires 15 watts RF driving power. 300 watts Class C, for CW, with 18 watts RF driving power. Pi Net output circuit covers all amateur bands, 80-10M; matches output loads 30-150 ohms. 52 ohm Pi Link coupled output on 6M. Meter for monitoring final plate currents also indicates approx. RF output voltage enabling operator to tune for max. efficiency and output. Extensively bypassed, filtered and shielded for TVI. Housed in attractive 8" x 8" x 14" steel cabinet.

THE WRL Universal Modulator UM-1

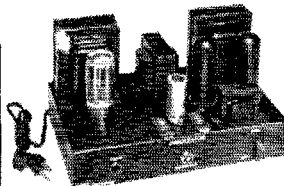

Wired & Tested: **\$49.95**
Kit (less tubes): **\$32.50**

Supplies 10-45 watts audio output depending on tube types and class of operation. May be used as Class A or B modulator to modulate RF inputs 8-100 watts, or as driver for higher power modulator, or as PA amplifier. Output matching impedances from 500-20,000 ohms. Carbon or crystal mike may be used; provisions for addition of external meter for monitoring modulator cathode currents; for remote control of modulator. Dual purpose 6U8 speech tube. 6F6, 6K6, 6V6, 6L6 or 5X81 may be used as modulators. Perforated steel top cover available as accessory, \$3.00 extra. Wired model, complete with 6U8, 5U4GB and two 6L6 tubes. Size with cover: 6x7x11".

THE WRL Globe Matcher Sr. ANTENNA TUNER AT-4



Wired & Tested: **\$79.50**
Kit: **\$69.50**

Handles up to 600 watts RF input from any RF amplifier. Covers amateur bands 10-80M. Max. harmonic attenuation through use of fixed link coupling in output circuit. Coax input and two wire balanced output. Built-in switch allows by-passing of tuner circuits for coax input and output. Built-in VSWR Bridge (in circuit constantly) indicates reflected voltage SWR on specially calibrated panel meter for monitoring actual SWR. Vernier dial for ease of tuning and maximum reset. RF-shielded steel cabinet, 8x8x14".

THE WRL Globe Matcher Jr. ANTENNA TUNER AT-3

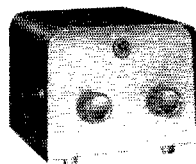

Wired & Tested: **\$15.95**
Kit: **\$11.95**

Antenna tuner will operate with any Xmtr. with power input of 100 watts or less. Provides substantial amount of second harmonic attenuation when properly tuned. Materially aids matching Xmtr. output to various types of antennas. Unbalanced output. Completely self-contained in modern, steel cabinet for TVI-suppression. Size: 5x4x4".

AVAILABLE AT LEADING DISTRIBUTORS . . .

Everywhere!

WRL *Electronics*
34th & BROADWAY
COUNCIL BLUFFS
IOWA

HARRIS RADIO

289 North Main, Fond Du Lac, Wis.

AND AMATEUR ELECTRONIC SUPPLY

3217 West North Avenue, Milwaukee, Wis.

feature the newest
from *Collins*

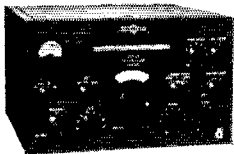

COLLINS 75A-4 This SSB Receiver offers all the proven Collins features — excellent image rejection through double conversion, precise dial calibration and high stability of Collins VFO and crystal controlled first injection oscillator, and the ideal selectivity of Collins Mechanical Filter in the IF strip. Net Price -----\$695.00

COLLINS KWS-1
Companion transmitter to the 75A-4. Unmatched performance in minimum space for a kilowatt. Extremely accurate 70E VFO, Pi-L output network and Mechanical Filter. Net price -----\$2,095.00.

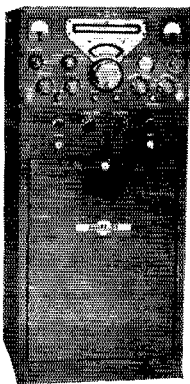
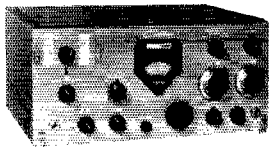

COLLINS KWM-1
The first mobile SSB transmitter in the Amateur field — 175 watts PEP, 14-30 mc. Fixed station use without modification. Net price -----\$770.00

Buy your Collins equipment on our time payment plan. Trade in allowances will probably handle the down payment. Contact us now for complete information.

WRITE "TERRY" W9DIA

HARRIS RADIO

289 North Main, Fond Du Lac, Wis.

AMATEUR ELECTRONIC SUPPLY

3217 West North Avenue, Milwaukee, Wis.

33 stations on roll-call with the report for August being QNT 541 and QTC 85. The Nebraska Slow-Speed Net, on 3750 kc. at 1700 CST, had on Sept. 1st 16 stations on roll-call and the report for August was QNT 212 and QTC 47. The Nebraska C.W. Net is off to a fine start with DDT as net manager on 3525 kc. at 1900 CST. The Western Nebraska Net is going strong on 3850 kc. at 0700 MST with NIK as manager. Our SEC, JDJ, is doing a fine job and is planning a 2- and 6-meter net to cover Nebraska. At present he has it fairly well organized so any one interested, please contact Fran. BTG reports having confirmed 40 stations worked on 6 meters in Nebraska so let's get things going and help this net off to a good start. Our old friend FQB reports that he will be back on 75 meters for the net activity soon. Welcome, Art. The North Platte Picnic was a success with over 100 in attendance. The boys hope to make it an annual event, so plan on it for next year. Traffic: W0DDT 222, M1AO 185, K0EPI 132, W0EGQ 118, ZWG 80, K0BRQ 41, W0NIK 28, HK1 24, SPK 24, ZOU 17, PDJ 16, BOQ 14, ZWF 14, KDW 12, OCU 12, BRS 11, BTG 8, FTQ 6, LJO 4, LEF 3, VGH 3, YCY 3, ZNI 3, HOP 2, NHS 2.

NEW ENGLAND DIVISION

CONNECTICUT—SCM, Victor L. Crawford, W1TYQ —SEC: EOR, RM: KYQ, PAM: YBH. Traffic nets: MCN, Mon.-Fri. at 0645 on 3640 kc.; CPN, Mon.-Sat. at 1800, Sun. at 1000 on 3880 kc.; CN, Mon.-Sat. at 1845 and 2200 on 3640 kc.; CTN, Sun. at 0900 on 3640 kc. The Connecticut state mobile support frequency 29,580 kc. is monitored 24 hours a day. Congratulations to AW and YBH who, along with TYQ, made BPL. FHP reports the CQ Radio Club meets each Tue. on 145.67 Mc. at 1900. DHP is busy with school and Sat. NCS duties on Dragnet. 5YAT, I is active from Fairfield with an HT-32 and an SX-101. KYQ reports CN held 27 sessions handling 365 messages. Average attendance was 10 stations per session. High QNI goes to GVK and KAM. MQQ is busy working DX on 15 meters. WLL is active on the Graveyard Net. KNICBV has worked 39 states. MDB has dropped the "N" from her call. YBH reports CPN met 31 times handling 223 messages, with a daily average of 30 stations. High QNI goes to YBH, 31; VYI 30; DHP and VQH 23. BDI has added a 10-meter element to his beam. KNICTB is a new Novice in Portland. FEA is busy working on his beams for winter. Father-and-son combinations are IOV and KNIDAY in Stamford, ADW and KNICSB in Danbury. Net certificates were issued to EKJ and VQH for activity on CPN. KNIDDE and KNIDDB are new Novices in Bristol. KNICOT is a new Novice in East Haddam. The Middlesex Radio Amateur Society held its summer outing at Cedar Lake, Chester and elected QMB, pres.; WRO, vice-pres.; KNICBV, secy.-treas. JSQ, LKF, OKY, WGJ, WPR and ZTT attended the monthly meeting of the Newington gang at the Nutmegger House. New appointments: EFW and FYF as OOs, KAM as ORS, FYF as OBS. Appointments renewed: AW, CUH and UED as ORS; AW and YBH as OPSs; AW and YBH as OBSs; FVV as OES; EOR as SEC. An OES report was received from FVV and an OO report was received from ECH. KAM has joined MARS. KNIBDL has dropped the "N." WLL reports that the Hunden Club is running code and theory classes again this year. KIBFJ has a new v.f.o. New stations on CPN are LRC, NQL, OQC, WZJ/L, K1BJF and K1AQE. Traffic: W1TYQ 716, EFW 453, YBH 383, AW 203, KYQ 192, GVK 97, ULY 72, MQT 62, CUH 52, BDI 47, FYF 47, RGB 46, VYI 38, RFJ 33, YNC 30, EBW 27, DHP 22, KIBFJ 21, WIFHP 17, KAM 15, NQL 15, YOG 11, VOV 9.

MAINE—SCM, John Ferron, W1KLP—PAM: VYA/BPL, RM: EFR. Traffic nets: Sea Gull Net, 3940 kc., Mon.-Sat. at 1700; Pine Tree Net, 3596 kc., Mon.-Fri. at 1900. I am pleased to be your SCM for the next two years. I'll try to write an interesting column but I'll need monthly reports from all who can send them. The banquet at Dexter was well attended, with more than 200 present, and many new acquaintances were made. DVJ has assembled a Viking "500" and is putting out an FB signal on 75-, 20- and 15-meter phone. IZK has improved his signal greatly since raising his antenna at the center. ZEM and RCJ spent three weeks at York Beach. CAO is NCS for the c.d. drill each Wed. at 8-9 p.m. KIAKC is a new ham at Old Orchard Beach. Ruby, the XYL of PTL, is recuperating nicely after surgery. 3QKW operated portable at the N.E. Music Camp at Oakland. It's nice to hear DAY on 75-meter phone with a Ranger after so many years on 10 and 20 meters. Who remembers the Keenebunk Hamfests? BDV spent the summer at York Beach operating low power. BWT also has a new Viking "500" with an excellent signal on 75 meters. RUD puts out a nice mobile signal from the north country. QUA was on 6 meters

(Continued on page 146)

go mobile with Master Mobile

NEW! . . . SILVER-PLATED ROLLER WITH POSITIVE ACTION, STAY-PUT CONTACT ANTENNA COILS

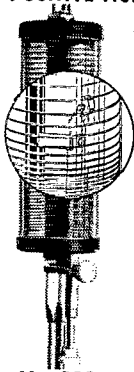

MASTER DELUXE ALL-BANDER
No. 750

HY "Q" construction with wider spacing of turns for high frequency bands. Use as center or base loaded antenna with 60" whip.

- Covers 10 thru 75 and all intermediate frequencies.
- Silverplated single turn contact, positive spring.
- Eccentric cam contact, easy selection of turn.
- Automatic lock prevents damage to coil.

Amateur net. **\$14.95**

No. 333

MASTER MIGHTY MIDGET

. . . engineered to provide the highest "Q" consistent with good design. Compact, extremely rugged, yet lightweight, its operation assures precision tuning with the new adjustable silver-plated roller that stays put! Perfect for 40-20-15-11-10 meters. "Get 5 Bands Plus on 1 Coil." **\$9.95**

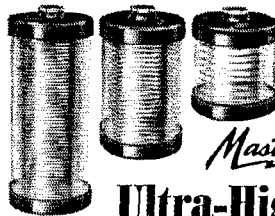
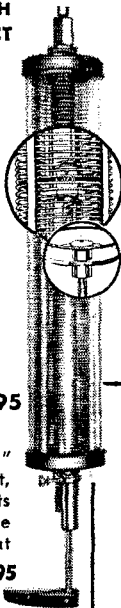

- Ruggedized construction
- Greater efficiency
- Precision made
- 2 3/4" Diameter

Master

Ultra-High "Q" COILS

For 80-40-20 & 15 Meters

After many years of experimentation, here is the coil with the highest "Q" ever obtained. Tested and found to have a "Q" of well over 515. **\$5.25 ea.**
Use with 36" base section, 60" whip.

W6EFX—Says!

"I would not be without a Master Matcher on my mobile rig... I can QSY on any band at the same time peak my antenna to the operating frequency for *maximum output*. It makes a mobile like a home station!"

W. B.

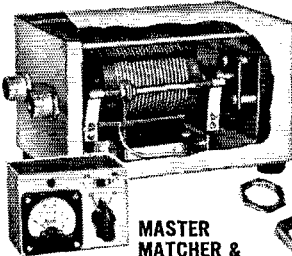

MASTER MATCHER & FIELD STRENGTH METER

Automatically tunes the entire band from the driver's seat! 6 or 12 volt models **\$24.95**

MICRO-Z-MATCH
Matches Trans. Line



Complete with Kit **\$7.95**

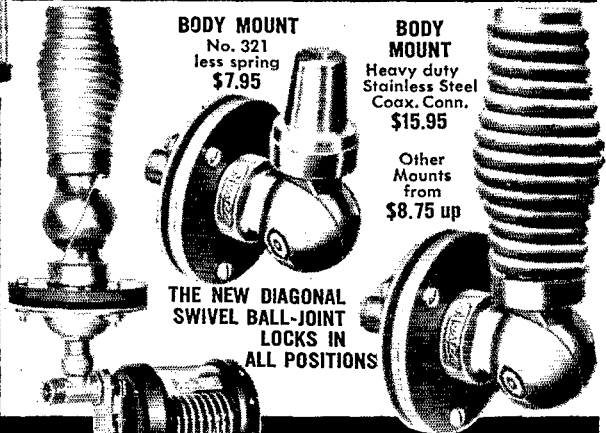

BODY MOUNT

No. 321
less spring **\$7.95**

BODY MOUNT

Heavy duty
Stainless Steel
Coax. Conn.
\$15.95

Other
Mounts
from
\$8.75 up

THE NEW DIAGONAL SWIVEL BALL-JOINT LOCKS IN ALL POSITIONS

Leaders in the Design
and Manufacturing of

mobile equipment

AT LEADING RADIO JOBBERS EVERYWHERE.

Master Mobile Mounts, Inc.

1306 BOND STREET · LOS ANGELES 36, CALIFORNIA

BUMPER MOUNTS WITH NEW X-HEAVY DUTY CHAINS

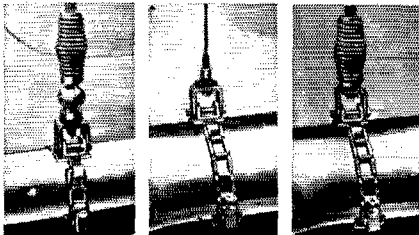

No.444 **\$17.80** No.445 **\$7.95** No.446 **\$13.45**

Adjustable to any bumper. No holes to drill, easy to attach. High-polished Chrome Plated 3/8" - 24 thread, to fit all antennas. Precision engineered.

GROUND PLANE ANTENNA

Outperforms any type mobile vertical dipole, "Drooping" type. Gives a low angle of radiation for general coverage. Ideal for CD, defense nets, Amateur, Broad Band. Matches 52 ohm coax cable. Adjustable radials. For medium or low-powered trans.

Model 300

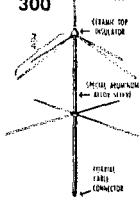

Net \$12.95

NEW NOISE-FREE

E-Z-OFF
ANTENNA CONNECTOR

Connect or remove your loading coils, whips or mounts in a jiffy. No wrenches, pliers or screwdrivers needed. High-grade stainless steel throughout.

- Precision made
- Maximum efficiency
- Positive lock—will not corrode



AMATEUR NET **\$2.95**

Radio Electric

SERVICE CO. OF PENNA., INC.

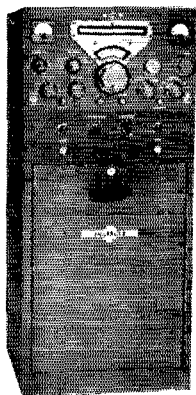

for the top performing Amateur kilowatt...

Collins
KWS-1

Unmatched performance, accuracy and stability characterize the Collins KWS-1 in SSB, AM or CW operation. Extremely accurate 70E VFO. Pi-L output network. Collins Mechanical Filter.

KWS-1 kilowatt Transmitter, Net Price\$2,095.00



75A-4
SSB
Receiver

Designed expressly for operation on the 7 HF Amateur bands. Features AVC on SSB and CW, separate detectors for AM and SSB, passband tuning, rejection tuning, Gear Reduction Tuning Knob, superior selectivity and many other time-proven Collins features.

75A-4 Receiver, Net Price\$645.00

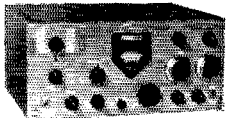

KWM-1
SSB
Mobile Transceiver

First mobile transceiver in the Amateur field — 175 watts PEP input, 14-30 mc. Use for mobile or fixed station without modification.

KWM-1 Transceiver, Net Price\$770.00

Write or see about trade-ins or time payment terms.

Radio Electric

SERVICE CO. OF PENNA., INC.

7TH & ARCH STS. • PHILA. 6, PA.

Phone WAInut 5-5840

Branches in Easton, Allentown and Willow Grove

from York during the summer months. Traffic: WILKP 123, EFR 43, CEV 36, VYA 24, OTQ 18, RJE 10, IZK 4.

EASTERN MASSACHUSETTS—SCM, Frunk L. Baker, Jr., W1ALP—New appointments: RK Reading and CZW, New Bedford as ECs; SAD, K1HVQ and NNS as OOs; K1HVQ as ORS; SAD as RM for 20-meter c.w. Appointments endorsed: MKW Dennis as EC; MEG as OES; GDY as OPS; EEB, WU, HWE and BY as ORSs. K1DBS is new in Lynn. JMS, Hyannis, is on several bands. K1CUW, Malden, is on 6 meters with a Gonset. The Quincy C.D. group has three new Gonsets for 2 and two for 6 meters. The Hi-Q Radio Club has a net on 75 meters on Sun, A.M. NEW is NCS. Heard on 75 meters: ZKO, MIQ and BIA/1 Brewster, ZYA, Danvers, TFI, K1AAX. Heard on 2 meters: YVB, BST, YRD, JTV, YZG, ZHX and LDI and KN1s CPF, BSM and BIO. WU likes his new place in Lakeville near the junction of Routes 18 and 105. CZW is the new R.O. for New Bedford. EEB is at Fort Dix, N. J., until mid-October with the N.G. Div. The T-9 Radio Club met at TJP's QTH. AJU/4 writes from Orlando, Fla., and is mobile on 10 meters. WFQ is out of the Army and working at M.I.T. KN1s CJM and CRP are on 80-meter c.w. in So. Boston. SAD, chairman of the TVI Committee, says he needs some investigators for Somerville, Cambridge and Arlington. Call him at UN 4-8880. He and his XYL COL are on 20-meter c.w. COL, EC for Cambridge, has a net on 10 meters for c.d. work. FMW and HIT are very regular. Dot, K1BUP, is new in Somerville and is on 10- and 80-meter c.w. and our Eastern Mass. Net on 3660 kc. GLW and K2OBP/1 are on 2 meters. SXD has a Valiant transmitter. PIW moved back home. EK is working on his house. RM is trustee for Newton C.D. MJA visited Florida. NWP is building a receiver for 2 and 6 meters. K1AIO has gone back to school. TNA has an M.R. car. LAU is back on 10 meters. VE1BY visited in this section. K1BCS is keeping the E.M.N. busy. ETH is back in Brookline. New General Class licensees in New Bedford are K1AMA, AYH, BBE and BBF. BBE and BBF are OM and XYL UQH is going to Texas. DIY is working VK- and ZL-Lands with an AT-1. K1ACJ is General Class and has worked 31 states and 11 countries. HWE is about the same physically. UE visited ERW, TY, FJJ, EMG, ATX, DIY, DTB, BPW, IBE, BRH and SMO are active in the Eastern Mass. Net on 3660 kc. KCR has a new transmitter. The Braintree Amateur Radio Club held a meeting. MRQ is now with WHDH-TV in Boston. LAV got on 75 meters and will be on 2 and 6 and other bands. GDY visited KOC in New Hampshire. LQQ added 8 countries. Hamilton has a RACES plan and is awaiting c.d. gear. He has WANE, WVT, WAM and WNH. BDW is R.O. for Bellingham. Hams in Bellingham: DUU, HGN, HGO, IRQ, LSE, ZAO, ZAR, KN1s AFK, BIR, K1s AUL, AXF, BFL, BYV and CPY. KN1CZQ and CWE are on 2 meters. Is anyone interested in starting up a traffic net on 2 meters to speed up traffic direct to any town? Let's hear from you. KN1s AYW, AYI and BAU are new in Lynn and on 80, 40 and 15 meters. AYI worked UA1BE on 15 meters. FJJ has a three-element beam for 15 meters. K1AUL passed the General Class exam and is putting up a 50-ft. tower. EMG is working days now. BAE worked Delaware on 2 meters while mobile in Stoughton with a Halo antenna and Gonset. RCQ has DXCC. AYG has a 304TH grounded grid final for a.m./s.s.b. working and was mobile while on a trip to Kankakee, Ill. ZNG is in the hospital with a heart attack. FJJ made BPL. KCR has a Gonset for 6 meters, made a two-element portable beam and went to the hamfest in Vermont. K1CLO passed the General and Technician Class exam and will be on 15 meters. TZ has the rig in the car and is taking a month's trip to Michigan. HHG is working DX on 20-meter c.w. CTW has a place in New Hampshire under the call IQD on the v.h.f. bands and is on 15 meters at home. Traffic: (Aug.) W1FJJ 531, EMG 421, EAE 83, AUQ 60, ETH 49, DIY 33, IBE 31, KN1AYW 26, W1CZW 26, KN1AYI 16, W1ZEN 16, KN1BAU 14, W1ATX 12, TZ 10, UKO 9, AOG 7, BPW 6, HHG 6, K1BUP 5, W1SMO 4, TY 4, K1ACJ 3, W1HWE 3, K1BRH 2, W1DTH 2, RCQ 2. (July) W1AKN 9, K1HVQ 2. (June) W1AKN 10.

WESTERN MASSACHUSETTS—SCM, Osborne R. McKernghan, W1HRV—SEC: RRR, RM: BYR, PAM; MNG, The West Mass. C.W. Net needs representatives from the Worcester and Pittsfield Areas. The West Mass. Phone Net now operates three nights a week with increasing traffic and coverage. The C.W. Net meets Mon. through Sat. on 3660 kc. at 1900 EST. The Phone Net meets Mon., Wed. and Fri. at 1800 EST on 3870 kc. UEQ has been appointed OPS and made BPL again this month. DVW did a fine job as Acting RM during July and August. The Mountausset Club held its annual corn and chowder feed at the QTH of K1AVO

(Continued on page 148)

TENNALAB PLYTUBULAR BEAMS

All Over the World -

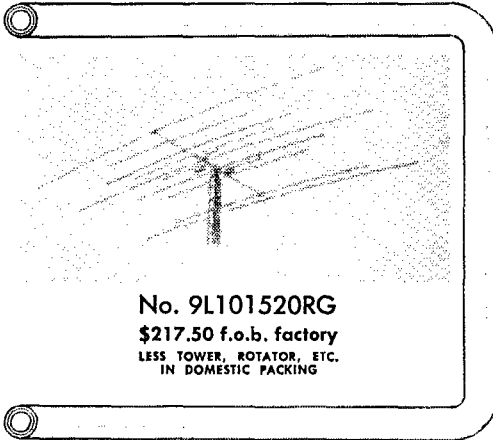

No. 9L101520RG
\$217.50 f.o.b. factory
LESS TOWER, ROTATOR, ETC.
IN DOMESTIC PACKING

*In the Arctic, the Antarctic,
the Far East and in the
Western Hemisphere it's
Tennialab Plytubular Beams
for the
Deans of Communication!*



PLYTUBULAR CONSTRUCTION is a shop process developed by TENNALAB whereby close tolerance 61ST aluminum tubing of telescoping sizes are fabricated together into booms and elements having multi-ply walls for greater strength and less vibration.

TENNALAB PLYTUBULAR BEAMS HAVE BEEN SELECTED BY A NUMBER OF UNIVERSITIES AND FOREIGN GOVERNMENTS FOR A VERY IMPORTANT ROLE IN CONNECTION WITH INTERNATIONAL GEOPHYSICAL YEAR AND OTHER POINT TO POINT COMMUNICATION SERVICES ALL OVER THE WORLD — A HIGH TRIBUTE TO THE STRENGTH AND DURABILITY OF PLYTUBULAR CONSTRUCTION!

The TENNALAB 9L-101520RG THREE-BAND BEAM is better in performance than separate beams, closely spaced vertically or crowded on an average city lot. We build separate single band beams too—so, this is straight dope!

The 9L-101520RG:

Bridge Tuned SWR

Taken at 40 feet
with 72 ohm line

14400	1.5 : 1
14200	unity
14000	1.1 : 1
21450	1.1 : 1
21250	unity
21000	1.2 : 1
29700	1.7 : 1
28500	unity
28000	3 : 1

Boom Length—17' 1/2"

Turning Radius—19' 8"

Weight—67 lbs.

Mast Clamp—Universal

For 1 1/2" to 2" OD mast,ing,
or up to 2 5/8" by purchas-
ing longer 1/2" bolts locally.

- HAS NO DUAL PURPOSE ELEMENTS TO ACCENT THE TRANSMISSION OF HARMONICS. ALL ELEMENTS ARE FACTORY TUNED AND FULL SIZE, FOR BETTER GAIN, PATTERN AND FRONT TO BACK.
- HAS NO EXCESSIVE SWR RISE AT BAND EDGE TO OVERLOAD MODERN PI-NETWORKS. MATCH IS FACTORY TUNED, BUT FOR UNITY MATCH, USE A 52 OR 72 OHM BRIDGE. ALL THREE TUNERS CAN BE REACHED FROM THE TOWER. USE THREE SEPARATE COAX LINES.
- HAS NO LOADING COILS OR OTHER EXTRA GADGETS EXPOSED TO WEATHER FOR FREQUENCY SHIFT IN RAIN, SNOW, OR ICE.
- HAS NO UNGROUNDED SEGMENTS THUS PROVIDING GREATER LIGHTNING PROTECTION TO SHACK AND EQUIPMENT WHEN INSTALLED ON A GROUNDED TOWER.
- HAS NO WEAK WOODEN OR PLASTIC SECTIONS IN THE STRUCTURAL DESIGN TO CRACK OR BREAK IN SERVICE.
- HAS NO EXTREMELY LARGE DIAMETER BOOMS OR ELEMENTS TO CAUSE EXCESSIVE ICE LOADING OR WINDTHRUST.
- HAS NO LARGE HOLES IN EITHER BOOMS OR ELEMENTS TO WEAKEN THE STRUCTURE.
- HAS NO SEVERE INHERENT VIBRATION, AS BOTH BOOMS AND ELEMENTS ARE OF PLYTUBULAR DESIGN, TO DAMPEN VIBRATION. THIS FEATURE ALSO LESSENS THE GUST-SHOCK IMPOSED UPON THE TOWER AND ROTATOR DURING HIGH WINDS.
- HAS NO EXCESSIVE WEIGHT AT POINTS WHERE WEIGHT REDUCTION IS PERMISSIBLE. SUCH REDUCTION WITHOUT A SACRIFICE OF STRENGTH IS POSSIBLE ONLY IN PLYTUBULAR CONSTRUCTION. MANY OWNERS USE TR-2, TR-4, OR SIMILAR ROTATORS AS PER ILLUSTRATION ABOVE.
- HAS NO ASSOCIATED RATINGS OF PERFORMANCE ARRIVED AT BY SPECIAL METHODS FOR THE PURPOSE OF PRESENTING HIGHER CLAIMS OF PERFORMANCE. SEE EXPLANATION BELOW.

PERFORMANCE RATINGS OF BEAMS WHICH WE CONSIDER ACCURATE CANNOT BE OBTAINED EXCEPT BY DESIGNING SIMILAR BEAMS IN MINIATURE, AT 100 MC OR SMALLER. IT WOULD BE IMPOSSIBLE TO DESIGN AN ACCURATE MINIATURE OF THE 9L-101520RG AND MANY TIMES MORE DIFFICULT TO DESIGN A MINIATURE OF NUMEROUS OTHER TYPES OF MULTI-BAND BEAMS. IN VIEW OF THIS WE PUBLISH NO SUPPOSEDLY EXACT PERFORMANCE RATINGS ON MULTI-BAND BEAMS.

FOR A COMPLETE CATALOG OF OTHER INTERLACED AND SINGLE BAND MODELS SEE PAGE 109 NOVEMBER 1956 QST

TENNALAB - QUINCY, ILL.

IT IS FAR CHEAPER TO BUY THE RIGHT BEAM FIRST, INSTEAD OF LATER

by TEST or TESTIMONIAL

the finest transmitter

in its price & wattage range

W50PJ

Wednesday night, June 26; - I was on the air with your Globe King 500B, charting course of Hurricane Audrey by staying in contact with coastal cities from New Orleans to Mobile. Thursday morning, I carried my family to a spare building. Winds and rain were heavy. I called in two more amateurs and they brought with them a Globe Scout. When we lost commercial power at height of storm, we used the Scout with a gasoline generator, continuing to pass messages to other areas. We continued using the Scout until power was restored, then switched back to the King until regular communications had been restored. Thanks to members of the Port Arthur Club, and to the WRL Globe King and Scout, necessary communications were maintained throughout the hurricane.

W. S. Terry, W50PJ
848 Stilwell Blvd.
Port Arthur, Texas

THE WRL Globe King 500B

\$40⁶⁰
per mo.
Just \$72.50 Down

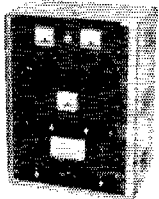

Wired & Tested: \$725.00

Bandswitching, 10-160M Transmitter for 540W on fone & CW; 540W on SSB (P. E. P.), with any external exciter of 10-15W.

Outperforming any rig in its price and wattage range, the King is housed in a handsome 31x22x14 3/4" cabinet, specially designed for TVI-suppression. Relay controlled; includes a built-in antenna relay; built-in VFO; separate power supply for modulator section, allowing better overall voltage regulation. Commercial type compression circuit keeps modulation at high level. Features grid-block keying for signal clarity. Pi-net matches most antennas, 52-600 ohms. Provisions for crystal operation. New 4-400A Final Amplifier tube used for increased safety factor.

And the World-Famous

Globe Chief 90 \$ 67.50; \$ 5.47 per mo.
Globe Champ 300 \$449.00; \$25.14 per mo.
Globe Scout 680 \$ 109.95; \$ 8.91 per mo.

SEND FOR COMPLETE BROCHURE!

WORLD RADIO LABORATORIES



3415 W. BROADWAY
COUNCIL BLUFFS, IOWA

Please send me your free catalog and info on:
 Globe Chief, Globe Scout, Globe Champ,
 Globe King.

Name:

Address:

City & State:

and an FB time was had by all. The Hampden County Club enjoyed a talk on atomic radiation by Harold Minor of West Springfield, an authority on the subject and pioneer in the development of teaching atomic energy in high schools. New officers of the BCARA are UDT, pres.; HJL, vice-pres.; UEY, secy.; and COL, treas. The Hoosac Valley Club gave five exams as a result of its summer Novice course. KIAEH and HIB are new recruits for the 6-meter band in Adams. DGL, DZY and KGJ recently enjoyed a visit to ARRL. BVR lost his favorite antenna mast to Dutch Elm disease and had to build one up in a hurry. FZY has a new Globe Scout and Windom antenna. A West. Mass. C.W. and Phone Net Picnic was held Sept. 15 in the Quabbin Area. DVW, BVR and MXG worked out the details. FGV has a new Valiant. BKG has been working KC4USK regularly via s.s.b. ZEW has moved to Pittsfield from Vermont. New Novices are KNIS CSI, CPG, DAK and DAB in the Pittsfield Area and CZZ and CZY in Wilbraham. Worthington and Ware are now on the air with 6-meter gear in C.D. Sector 4C and several other towns are expected to join the net soon. Weekly drills are held on Mon. nights to train new operators and get procedure down pat. Traffic: (Aug.) W1UEQ 764, DGL 46, DVW 19, TAY 12, BVR 11, HRV 7, FZY 4. (July) WITAY 10.

NEW HAMPSHIRE—SCM, John A. Knapp, W1AJJ —SEC: BXU, RMIs: CRW and COC. PAM: CDX. NH/RACES Net meets Sun. at 1300 on 3850 kc.; GSPN meets Mon. through Fri. at 1900 on 3842 kc. and Sun. at 0900; the NTN (traffic net) meets Mon. through Sat. at 1900 on 3685 kc. The Nashua Mike and Key Club held an outing at OLMZ's camp on Aug. 18. Mobilers were in full swing to and from the outing. Welcome home to WBMI who, during his European jaunt, visited many hams and attended an RSGB luncheon and meeting for visiting hams. KIBCS reports participation in handling a "once in a lifetime" message for urgently-needed medicine from Boston to Baffin Island, via VERMX and UTL. ARR has added FFSAP to his DXCC list. Further reports from ARR advise that he expects an NHN (traffic net) monthly bulletin to be underway by Nov. 10. Congrats to GVL and MTX on acquiring their General Class tickets. KYG is a new OBS. KIAHE did an FB job of keeping his station on during the summer RACES test for nineteen hours continuous operation. GSPN certifies go to FBZ, NZZ, HUR, YNP, CEV, PFA, TTM, BST, WUB, CCE, 2JXN and K2TZM. Traffic: W1ARR 553, K1BCS 120, W1QGU 101, 1IQ 27, ENM 17, CDX 6.

RHODE ISLAND—SCM, Mrs. June R. Burkett, W1VXC—SEC: PAZ, PAM: YNE, RMIs: BBN and BTY. Word comes from K1NAP, the Seabee station at Davisville, that the first successful contact between KC4USA and the U.S. on 10 meters was made by them on Aug. 9. Since that date, several other Rhode Island stations have been welcomed into the tests with a report of successful two-way contacts between KC4USA and ZPG, CEW, CMH, TAT and HJB. ZGH, now in the Air Force, is stationed in the Philippines. BIL has just returned from a trip to California. CPV is a new member of the Quarter Century Wireless Assn. BGA is nearing the 200 mark on DXCC. HKN is installing a Conset mobile unit in the car for all bands. AQ has rigs on 80, 40 and 2 meters. Anyone interested in participating in the Johnston c.d. unit should contact YKQ. HFC, ex-2UZN, is building a 6-meter converter. GR expects to be on 6 and 2 meters shortly. QR has installed a transmitter and PAIR-7 for 10-meter mobile operation and has plans for a 15-meter beam for his home station. JXD finds 15-meter phone tops for working DX. VWR has been endorsed as an OPS. UHE reports 10 states worked on 220 Mc. K1ABR and his XYL have a new YL jr. operator. K1BWX reports exceptional results on 6 meters with his new 5-over-5 beam which is 85 feet above ground. FII left with his family for Spain in August and will spend about a year there. K1CHI is on the air with a DX-100 and an 8-38. Traffic: (Aug.) W1YKQ 21, TGD 20, JJW 18, WED 14, YRC 11, HKN 10, QJR 6. (July) W1HTQ 138.

VERMONT—SCM, Mrs. Ann L. Chandler, W1OAK —SEC: SIO, RAL; BNV, PAM: SEO. New appointment: FAK as OES. All League appointees whose certificates have expired, please send them to your SCM for endorsement. On Sun. Aug. 25, at Branbury State Park, Lake Dunmore, the Annual Vt. Phone/C.W. Picnic was attended by approximately 35 amateurs with their families. K1WBL, the 294th Ord. Co., Vt. National Guard, while on a recruiting drive, offered a mobile unit with operators DBF, HRG and HIN. The transmitter runs a pair of 807s, 90 watts input and a BC-569 receiver. The VTN started Sept. 16. WOA has returned home from the Veterans Hospital. W1LJG has passed his Conditional Class exam and is stationed on the U.S.S.

(Continued on page 150)

new, improved

PIERSON KE-93

communications receiver

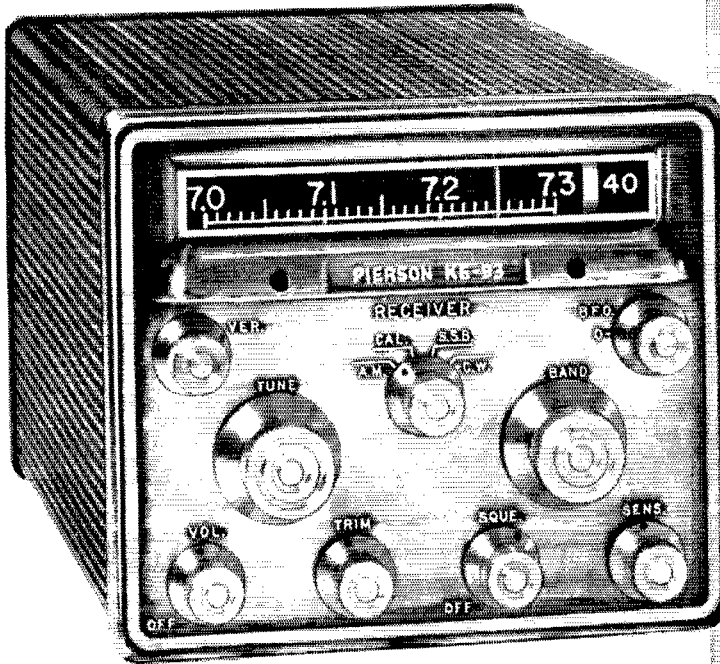

A Full-Fledged 12-Tube All-Band Communications Receiver In A Small, Mobile Package!

Built to outperform existing mobile receivers, the Pierson KE-93 equals and surpasses many receivers of the large-console variety.

Extremely small and compact, the KE-93 Receiver is designed for either mobile or fixed station operation. It delivers high over-all performance on seven bands; 10, 15, 20, 40, 80, 160 meters, and broadcast band. In addition, it features a new functional design and simplified control operation. Best of all, it bears the name of Pierson, whose more than 25 years of radio-engineering know-how have produced many outstanding receivers familiar to veteran hams the world over.

- Dual conversion, crystal second mixer, virtually eliminates image responses
- Dial displays only the band in use. Indirect lighting provides non-glare readability of large legible lettering.
- Plated satin finished panel styled to match the most luxurious car interior.
- Each ham band spread over entire length of dial.
- Extreme selectivity and sensitivity.
- Size: 6" wide, 5" high, 9" deep.
- Rigid construction, die cast panel and turret housing.
- Highly effective noise silencer and squelch circuits of new design.
- Provisions for external S meter.
- Controls in most practical and convenient operating panel position for mobile operation.
- Function switch provides ideal settings for A.M., C.W. and S. S. B. operation. Excellent S. S. B. reception even in "mobile in motion" operation.
- Versatile, 7 position turret band switching.
- 6 or 12 V.D.C. or 110 V.A.C. power packs permit mobile, fixed, or portable operation.
- Competitively priced.



AUTOMATION ELECTRONICS, INC.

1500 West Verdugo Avenue, Burbank, California

**WRITE TODAY
FOR COMPLETE DETAILED
INFORMATION**

Receive "Ham" signals
anywhere, on any set with
Model ATC-1 Transistorized
Amateur Band Converter by

Regency®

WORLD'S
ONLY
SPECIALIST
IN
TRANSISTORIZED
EQUIPMENT

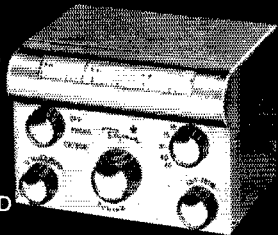

ARE YOU MOBILE?

Model ATC-1 is Self-Powered (3 penlight batteries, shelf life expectancy); simple to connect—one connection to antenna, other to receiver antenna input; only 4 3/4" x 3 1/4" x 4 1/8" — 30 ounces — small and light enough to be carried easily, mounted in any convenient spot in car; adaptable to any receiver—receives AM, CW and SSB on the 80, 40, 20, 15 and 10 meter amateur bands; a natural for new cars using 12 volt tube and/or transistor receivers; the answer to mobile SSB listening—built in BFO plus a high degree of stability make the tuning of SSB, DSB, or CW signals a pleasure; provided with outstanding selectivity on AM phone by the modified "Q" multiplier circuit. **Model ATC-1, \$79.50**

See your Electronic Parts Distributor for full information on Transistor complement, Diode clamp protection, Controls, Sensitivity, etc., or write

Burton Browne Advertising

Regency

Division I.D.E.A., Inc.
7900 Pendleton Pike
Indianapolis 26, Ind.

Burton Island AGB-1 Navy Ice Breaker, the first Navy ship to have a ham station authorized. Look for the call W4WEL from 14-Mc. phone this winter as the ship will be in Antarctica. Also aboard is 9HJM, KCR, from Milton, Mass., operated portable on 50 Mc. from Island Pond. CCS is FMK's XYL. LJA has dropped the "N" and is heard on 7 and 14 Mc. BWZ is now K9HHJ. KN1AQ has dropped the "N." A new AREC member is KN1CY. KN1SCD has passed his General Class exam. ENZ is keeping nightly skeds with QIG in Maine on 50 Mc. ENZ and FMK are having good luck with their skeds. Delaware and North Carolina are two new states for MMN on 14 Mc., making 17. ELJ worked ex-NDB (now K6GMI on 14-Mc. s.s.b. AC has a new Hallcrafters 101-X. EIC has made some good contacts on 15 meters using a 40-meter dipole. HFS is heard on 7-Mc. phone daily and has made a mobile antenna. KJG was visited by K1AUE. VMC enjoyed a few weeks vacation and is back to his duties at Holy Angels' Rectory in St. Albans. Calls added to Brattleboro's 6 x 6 Net are PPS, JEV, TRZ (club's call), TDG and K1s APA and CWS. Visitors at MMN and OAK were NOM, SEO, VE2s AGN, APC and ATT. Attention all Vermonters: The following came through the W1 QSL bureau from CX2AM (CX QSL Manager): "Wanted, dead or alive, W1-Vermont for my WAS, c.w. in 21 Mc. between 24 to 2 GMT. Phone, cable or wire." Traffic: W1AVP 76, OAK 69, ELJ 21, KJG 20.

NORTHWESTERN DIVISION

IDAHO—SCM, Rev. Francis A. Peterson, W7RKI—The Idaho C.D. Director is making much surplus material available for RACES members. The Boise Club got an Army truck for a mobile c.d. unit and ran an FB rummage sale to pay for its delivery. The FARM Net is increasing in efficiency and planning elections soon. ZRC broke his leg but is recovering. DV, Rosie, now is on s.s.b. GCO is sending code practice on 80 meters for Novices. The Pocatello Club is planning a big exhibit for the county fair. New clubs are being formed at Idaho Falls and Twin Falls. Two amateur TV stations are planned for Preston. Send your RACES applications to OCR in Boise. Each town and club should have an Official Observer to help the surrounding amateurs. If news from your area is not listed, it is because YOU forgot to send it in. Send to your SCM on the first of each month, together with the amount of traffic you handled. Traffic: W7RKI 6, DLA 2.

MONTANA—SCM, Vernon L. Phillips, W7NPV/WX1—SEC: KUH, PAM; EOI, RM; KGJ. The Electric City Radio Club had a booth at the North Montana Fair in Great Falls Aug. 5-10. Radio contacts were made with stations at both the North and South Poles. The Yellowstone Radio Club had a booth at the Midland Empire Fair in Billings Aug. 12-17. RTTY was the main feature. The Electric City Radio Club had its annual picnic on King's Hill Aug. 18. Great Falls amateurs supplied communications for the annual Fish Derby on the Missouri River Aug. 25. New calls: KN7AJ and KN7AJP in Billings, and KN7AZH in Harlowton. K7AET received her Conditional Class license. ZPT got married. SVF is in the Navy at Great Lakes. Recent moves: RZY from Livingston to Harlowton; SPH from Billings to Buffalo, Wyo.; SUO from Billings to Minnesota; and TRB from Billings to Great Falls. WQDP operated portable at Darby during July and August. JRG went to Oklahoma City for 14 weeks of CAA training. EPZ has 24 states on 6 meters. Recent appointment: EPZ as OES. Traffic: W7QDP/7 23, W7OIP 10, OOG 3, NPV 2.

OREGON—SCM, Hubert R. McNally, W7JDX—Present lineup in the section is: QYS as SEC; HHH, ADX, TBG, AHH, RCL, BLC, ZQM, UZU, NGW, ZQB, TMF, PFG, SO, BLN, ISP, KL, UQI, HCE, AWI and TUW as ECs; AJN as RM; UJL, OMO, TLC, YUY, WJ, QYS, APF, LT, BVH, ABJ, VIL, AII, AJN, ESJ, ZPH and YKT as ORSs; GNJ, UJL, TLC, QYS, ATQ, TMF, WFW, FY, LVN, HDN, BLN, APF, SPB, AHX, QKU, GUR, THX, AII, VIL, QWE, HAZ, OLU and NJS as OPSs; HAZ, ZUD, TLC, QWE, YG, OFC, AJN, WLL, QNI and OLU as OBSs; WNV, UJ, PQJ and WLL as OOs; DIS and VPH as OESs. We have no PAM so far. The SCM would very much like to hear from anyone interested in making application for OO and OES appointments. LT is busy on three nets now. QWE has a swell new Minibeam on 15 meters. JCJ is sporting a new '57 Plymouth. OLU is building a new 500-watt rig. QNI has a new Viking Yaliant. DEM is all excited over a contact with HZ1TA. The Tillamook-Astoria Clubs had a swell picnic but the SCM got lost! We understand TMF has finally made DXCC. The three big nets in Oregon, OEN on 3840 kc., OARS on 29.2 Mc. and OSN on 3585 kc., are going

(Continued on page 152)

HARVEY ALWAYS HAS IT...IN STOCK For IMMEDIATE DELIVERY

Cesco

STANDING WAVE REFLECTOMETER

FOR 52 -OHM COAX

Here's a high quality device for continuous measurement of standing waves on transmission lines. Suitable for frequency range from 3 to 200 mc. See the article in the QST June '57 issue, page 43, for complete details on the unit

FEATURES: Uses sensitive 0-100 microamp meter • For continuous line insertion • Power to 1000 watts and over • Prevents false loading from antenna tuner, match box, PI network • SWR observed immediately at all times without adjustment • Makes possible increased radiated power by reduction of line reflection • Simplifies adjustments of various antenna networks. "T," Gamma, Balun, Delta, etc. • Any change or defect in antenna immediately noticeable • No balancing adjustments • Housed in one unit 5" x 3" x 2 1/4"



Complete,
with
instructions
\$29⁹⁵

A VACUUM RELAY

designed, built and tested
by the Harvey Radio Company

Here's a unit that will handle up to 5 KW of RF without humming, buzzing or sticking. It is a must for SSB operation where a rapid acting quiet coax relay is wanted.

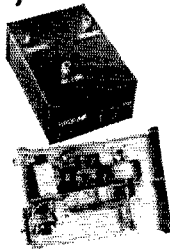

CHECK THESE FEATURES:

- Coax Vacuum Antenna Relay plus a self-contained double pole-double throw relay for receiver muting, etc.
- Built-in power supply for actuation of vacuum relay solenoid.
- No floating 115 volt A.C. . . . unit may be grounded directly.
- Uses transformer power supply for solenoid.
- No insertion loss—with SWR ratio superior to any other.
- Operates on 115 V.—A.C.

The unit is ideally suited for any Ham Transmitter running up to and well above the legal limits. Its compact design and thoroughness of manufacture assure you of the finest, most trouble-free Vacuum Relay. Specify if to be used with KWS-1 or any other transmitter.

Price . . . KIT **\$6450**
Wired & Tested **\$7950**

THE W3DZZ ANTENNA

Model FT-200 SET OF TRAPS For 5-Band Wire Antenna

10, 15, 20, 40 and 75/80 Meters • 75 Ohm Twin-Lead or Coax Feed Line • Concentric Coil and Capacitor Completely Potted in Polyester Resin • High-Voltage Polystyrene Insulation on Concentric Capacitor.
Pair\$12.50

ANTENNA KIT for FT-200 Traps

150' #12 Copper-Weld Wire • Special Center Insulator • 2 End Insulators • 2 additional Egg-Type Insulators\$6.90
RG11/U Coax\$0.14 per ft.
RG59/U Coax\$0.07 per ft.
72 ohm Kilowatt twin lead\$0.06 per ft.

Model FT-100 BEAM ANTENNA

3-Band Parasitic Array for 10, 15 & 20 Meters
Light weight — only 55 lbs. • Total length of elements less than 28 ft. • Clean design with shortened elements gives low wind resistance • Uses RG8U as feed line • Trap capacitor insulation of highest quality polystyrene.
Complete\$225.00

COMMUNI-Q-BOOSTER

Utilizes the Q multiplier principle to increase the gain and selectivity of the GONSET Communicator. Operates with 6-mc if. Reduces interference...Improves reception. Available for 6 or 12-V power supply. (Specify which). **\$25⁹⁵**



TELECOM TRANSISTOR MOBILE POWER SUPPLY

12 VDC input—500 VDC Output @ 200 ma
—250 VDC Output @ 100 ma
(Simultaneous continuous duty)

For operating transmitters such as:

El-mac • Gonset • Morrow
Harvey Wells • Palco • etc. PRICE:

Also **\$68⁵⁰**
Receivers • Converters
Low-powered transmitters

Harvey has the complete Line of all
New Johnson Components in Stock.
We're Generous on Trade-Ins
If You Want to Talk SWAPS and DEALS
write . . . or call **W2DIO**



Harvey ships all over the world—known by Hams everywhere as a reliable source of supply. Whatever your Ham needs, shop Harvey's first. All orders are shipped same day received.

Harvey RADIO CO., INC.
103 W. 43rd St., New York 36, N.Y. • JUdson 2-1500
Established 1927

GET YOUR

Hy-gain

ANTENNA

at DeMambo

IMMEDIATE DELIVERY
ALL MODELS

**NEW SELF-SUPPORTING
TRAP VERTICAL SERIES
FACTORY PRE-TUNED & PRE-ADJUSTED**

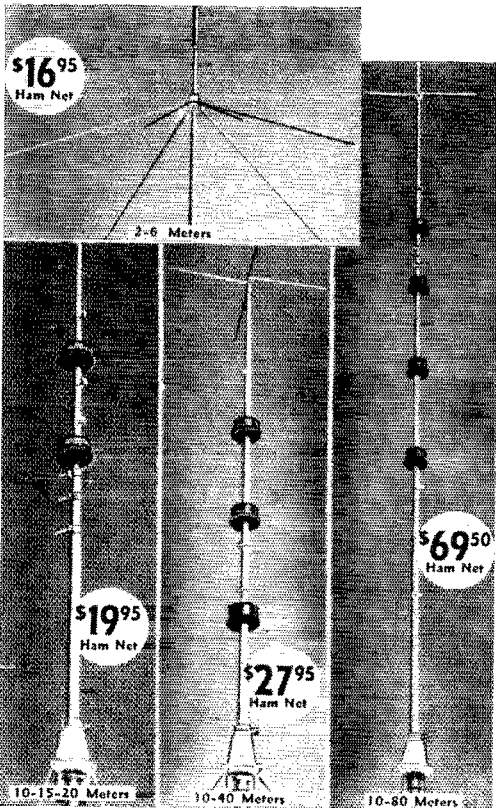

DeMambo

RADIO SUPPLY COMPANY, INC.

SIX STORES TO SERVE YOU

Worcester, Mass. Providence, R.I. Manchester, N.H.
Keene, N.H. Brockton, Mass. Lawrence, Mass.

All with TELETYPE CONNECTION to MAIN STORE
1095 Commonwealth Ave. Boston 15, Mass.

Write, wire or phone ERNIE BONO (W1QBP) for immediate service
BETTER STILL, COME IN—PLENTY OF PARKING SPACE

strong as the traffic total will show. Planning work on the new Council of Radio Clubs around Portland is making progress. Also the more than 100 mobile folks are trying to band together to offer better emergency services to anyone needing them. Traffic: (Aug.) W7YKT 145, CUW 92, OLC 70, LT 59, JDX 37, ENU 30, GUR 27, ZBO 24, AJN 19, DEAI 17, QWE 12, SPB 10, ZFH 9, QMO 7, ESJ 5, (July) W7TLC 618, WALE 17, QWE 14, GUR 10, ZUD 7, ESJ 4.

WASHINGTON—SCM, Victor S. Gish, W7FTX—SEC: PQT, RM: AIB, PAM: PGY, QCWA Nets—7125 kc, at 1500 PST Sun., 3950 kc, at 1530 PST Sun, NTN, 3920 kc, at 0600 and 1730 PST Mon.-Fri, WSN, 3575 kc, at 1900 PST Mon.-Fri, WQD is QRL the MARKS nets. The Walla Walla Valley Radio Amateur Club had an FB hamfest and picnic Sept. 3 at Wildwood Park. The Valley Amateur Radio Club held its annual picnic at Point Ohop Aug. 18. The 30-Mc. group in the Seattle Area did a fine job of radio communication during Seattle's "Gold Cup" unlimited hydro races and in "Seafair" Parades. JBY visited OE in August. VI and PGY poured bases for new towers. DZO is working on 6-meter rhombics with his old pal RT. PCY is home from Peru with many tall 15-meter tales. LYB reports TTV, appliance QRM and fishing interfere with hamming. KEG no longer is at K7WAT, the new operator is K7AKL. AIB has a new operating desk and test bench installed in the super-duper shack; he also has a new HQ-150, which gives him two operating positions. UQY reports that EQK is rebuilding and EQL is building a John-on 500. JNC made DXCC 100; BA has 94 confirmed, which he gets between breaks in traffic. PZQ NCSed WSN for the first time. PHO still is chasing DX. JNC is becoming interested in s.s.b. EHHI is going back on ALN when W6 goes back on Standard Time. Traffic: W7BA 2638, PGY 781, K7FAE 704, WAT 454, W7FRU 291, WAH 102, PZQ 60, APS 59, ALB 51, WQD 48, AMC 33, USO 24, EHHI 21, JEY 20, GVV 16, LYB 5, EVW 3, JC 1.

PACIFIC DIVISION

HAWAII—SCM, Samuel H. Lewbel, KH6AED—II is the latest convert to s.s.b. He is now on the air with a new HT-32. By the way, Nose works into Honolulu on 2 meters any time he so wishes. He is using a 4N2 transmitter. ARE is now on double side-band, KS has abandoned grounded-grid in his new linear final, W6UOU and W6HS attended the monthly single-sideband dinner. KH6CEN and his NYL, CRO (Kayla) have put up a new tower and tri-bander beam, ABQ, AEN (Al and Jeanette DeLong) have moved to Wahiawa, thereby joining WU/ACD (Charlie and Ernestine Yee) in an area rapidly filling up with hams. RU finally got his tower and W3DZZ tri-bander up in the air and can be heard on the s.s.b. portion of 20 meters any evening when there are no ships in port. ASV and his NYL are touring the States. Note: Only one station reported traffic this month. Traffic: KH6AJF 247.

NEVADA—SCM, Albert R. Chin, W7JLY—SEC: JU, New EC for Boulder City: HJ. New hams for Reno are WN7JKT and WN7JKS, the NYL and NYL of ZVN for a 100 per cent ham family; also WN7JDI and K7ANK, for a father-and-son team. A newcomer to Reno is Jeanne, INFA, who is looking for 6-meter contacts. Congrats and welcome. If you have ham plates at the assessor's office, please pick them up. Has anyone figured out the plate LIHQ is sporting on his new Cad? It sounds like some high-powered mobiles are in prospect with new station wagons—for OYQ a Mercury and for MAH a Chevie. ZLQ is building a 1-watt s.s.b. rig. GVA worked Europe with an assist from YKQ. JU attended the Southwestern Division Convention and brought back a Gonset "Big Bertha" and Johnson "8N2" for some 144-Mc. activities. New jr. operators: Baby girls for the TNP, and the Doug Webbs. It is with regret that we report JYA, of Sparks, as a Silent Key.

SANTA CLARA VALLEY—SCM, G. Donald Eberlein, W6YEM—SEC: NVO, RM: ZRJ, PAMs: OFJ and WGO. K6UWM is a new OES and sends in a nice report of work with power supplies for microwave work. K6DHO is installing a Gonset rig in the car for mobile. WNT is building a kw. in a 7-ft. rack. K6CGA traded his Ranger for a new Valiant and reports working several Europeans. ZLO and K6DYX report on MBRC activity at the Monterey Bay County Fair. The club had a booth at the fair handling a total of 200 messages directly from the booth. Only traffic for out-of-state delivery was handled. SHK loaned his NC-183D receiver and 20-A exciter with the B&W 500-watt final. UJA directed the flow of traffic, with K6RWJ taking care of the operators' work schedules. PHN has 76 countries confirmed, all worked on 15 meters. K6RWJ

(Continued on page 154)

Of Course It's In Stock At WORLD RADIO . . .

the *Hy-gain* 2-Element Tri-Bander

ONE FEEDLINE - THREE BANDS (10, 15 & 20M)

There Are More hy-gain Tri-Banders In Use Than All Other 3-Band Beams Combined!

2 Active Elements on Each Band!

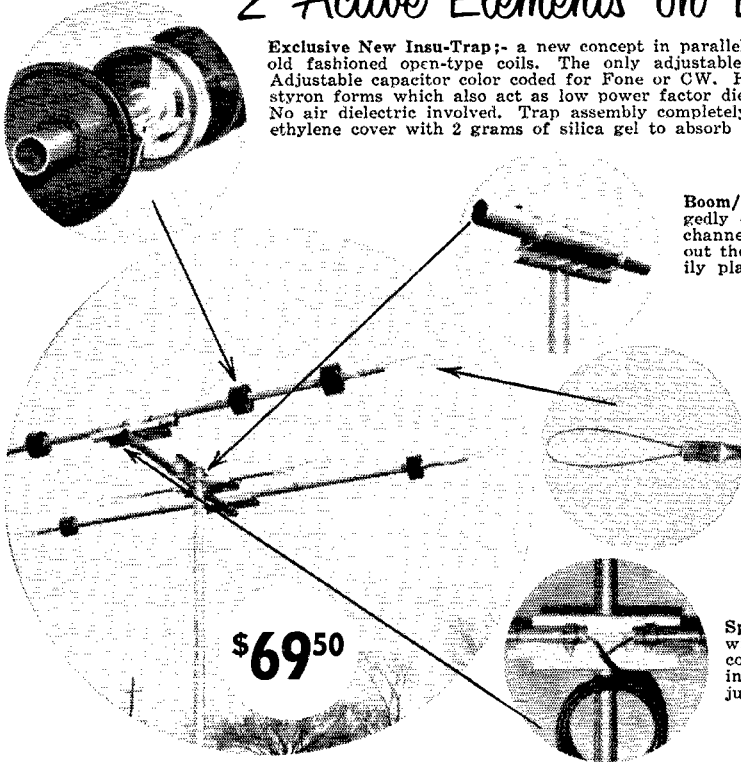

Exclusive New Insu-Trap;- a new concept in parallel resonant trap circuits obsoletes old fashioned open-type coils. The only adjustable, completely weatherproof trap. Adjustable capacitor color coded for Fone or CW. Hi-Q coils wound on high impact styron forms which also act as low power factor dielectric for adjustable capacitors. No air dielectric involved. Trap assembly completely enclosed in weatherproof polyethylene cover with 2 grams of silica gel to absorb condensation.

Boom/Mast and Element Clamp;- ruggedly designed 12 Ga. galvanized steel channel for positive grip. Used throughout the entire Tri-Bander Series. Heavily plated and serrated 5/16" U-Bolts.

The "Carpet Beater" Ends;- employed on all Tri-Banders, specially designed of aluminum wire to reduce fatigue caused by vibration, increase the broad band characters of the beam, and to reduce element sag to a minimum.

Split Insulated Dipole;- fed directly with RG-8U ohm coaxial cable and coaxial line balancing choke results in low SWR on all bands. No adjustment necessary.

All specifications furnished from experimentally derived data. These figures will maintain in most installations if antenna is relatively in the clear.

	Model No.	Gain in DB Over Dipole	F/B Ratio In DB	SWR	Max. Power	Horizontal Beam Width	Boom Length	Boom Diameter	Element Diameter	Element Wall	Element Alloy	Longest Element	Approx. Net Wt.
2 Element	152T-2	5.8 Aver.	18 Aver.	Less Than 1.5:1	1 Kw	68°	72"	1 1/2" Hot Dip Galv. Steel	1 1/8, 1 3/4	.058, .049, .035	6061ST6 Ant. 41	29'	36#

The standard of comparison for three band antenna systems, the hy-gain Tri-Bander is factory pre-tuned, pre-matched and pre-adjusted and may be erected in an extremely short time with no test equipment and no further adjustment necessary. Guaranteed to outperform stacked

arrays, because interaction and detuning effects have been eliminated. All hardware hot dip galvanized steel for maximum weather ability. Injection molded polyethylene, styron and cyclocac plastic used throughout. Complete assembly and installation instructions furnished.

PLUS THESE OTHER TOP HY-GAIN TRI-BANDERS:

LOW COST, 1-ELEMENT: \$39.95 STANDARD 3-ELEMENT: \$99.75 CHAMPION 5-ELEMENT: \$395.00

at the "World's Largest Distributor of Amateur Radio Equipment!"



Guaranteed for One Year . . .

SEND FOR INFO ON THE WORLD FAMOUS

Globe King 500B • Globe Chief 90
Globe Champ 300 • Globe Scout 680

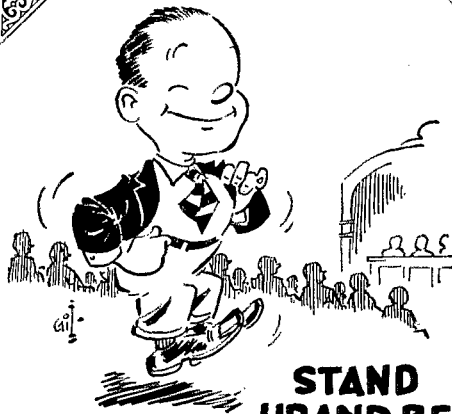

STAND UP AND BE COUNTED!

In 1959 the governments of the world will meet, in another International Radio Conference, to make frequency and band assignments for all radio communications services. The decisions of this conference will determine what frequency bands will be available to amateurs, and others, in ensuing years.

During the past twelve months, under sponsorship of the Department of State, representatives of the numerous U. S. radio services — military, commercial, and private — have held a series of conference-preparatory meetings in Washington. These meetings will continue as long as necessary to establish our government's position toward future frequency assignments. Officials of ARRL have been, and will continue to be, in attendance at such meetings to speak for the amateur service when pertinent matters are brought up for discussion.

As an individual amateur, none of us could carry much weight at these meetings or conferences. Together we can do far more. Let your voice be heard — stand up and be counted as a fully-active, well-informed and interested member of the League.

QST and ARRL Membership

\$4 in the USA \$4.25 in Canada

\$5 elsewhere

**THE AMERICAN
RADIO RELAY LEAGUE
WEST HARTFORD 7, CONNECTICUT**

is installing a mobile rig in the new car. GBC moved to a new QTH in Carinel Valley. EFR, PH, NAD and WJM are reported to have worked OH3UI/8 with the Aland Island Expedition. K6JAW moved to a new QTH in the country. K6BBD has been QRL with summer school at State College. Dick has been keeping UW, at the Red Cross, open on Thurs. nights. Please get your reports in the mail by the fourth of the month. The traffic season will be in full swing by the time you read this. Are you active? Your help is needed to keep the record of the section up to standard. If you wish information, drop me a card. Traffic: (Aug.) K6DYX 570, W6BPT 454, K6GZ 390, W6PLG 250, UCS 212, HC 82, ZLO 56, AIT 55, K6HGV 45, W6YBV 25, (July) W6PLG 206, K6DHO 25.

EAST BAY—SCM, Roger L. Wixson, W6FDJ—We have received a letter from K6EHW and her OM, W4GMX, from Somerset, Bermuda, dated Aug. 29 with text in part as follows: "Just a short note to let you know we are enjoying East Bay news every month in QST over here in Bermuda. Give our 73 to all the fellows in the club. We have been listening for W6s on 10, 15 and 20 but as yet haven't heard too many. Awful lot of European stations on, they really put a good signal in here. There is no 2- or 6-meter interest in Bermuda, the VP fellows stick mostly to 15 and 20." Ruth goes on to say that they are trying to get a VP9 call as the local government won't allow them to work using portable VP9. I'm sure Ruth and Jan would like to hear from the gang so here is their address: Jan C. Terry, ET3, Navy Facility, Navy #138, c/o FPO, N.Y.C., N. Y. Another line letter was received from CAN, our SEC. Wayne is doing a fine job up Napa way and it looks like we have a new EC for Lake County. IUZ, K6BYQ is interested in carrying on EC work in Napa County. The 6-meter gang has signed up ten or twelve in AREC work and has had some worthwhile drills. At the moment they are in the process of developing a simple but effective antenna for 6 meters which is compact, light, but good. The little 4-tube 6-meter rig went commercial, although YSD (the one behind the project) is not satisfied with the commercial version. Around the clubs in the East Bay, Headlining club activities was the WESCON RTTY Dinner held in San Francisco. The meeting was held in honor of Bruce Rowlings, ZL1WB, from Onerahi, New Zealand. Bruce has been with the CAA and is visiting here for a few months. He is very active on RTTY and is real DX. Through the efforts of AEE and others Bruce obtained a Mod. 26 machine and got it going. It turns out that ZL-Land is using 50 cycles and Bruce had to use a belt and pulley set-up to get his RTTY machine to work. Among the notables at the RTTY dinner were Merrill Swan and his XYL from Arcadia, VR2AC from the Fiji Islands, W9NOE from Chicago, who was the lucky winner of a Mod. 26 machine, and IZJ and CQI from Sonora. Guest speaker for the evening was VE2AGE/8, who is now with Eimac. His topic was "Operation Polevault" which had to do with installation of communications in the Far North. The SARO enjoyed a fine dinner at the Bow and Bell here in Oakland and some excellent movies supplied by the telephone company, entitled "Mr. Hemo." According to the *Carrier*, the Mt. Diablo Club heard a talk given by IIF, factory representative for Hickock Instr. The topic of Mr. Boring's talk was "Test Equipment." Harold Mumford's son, KN6AKN, is now on a trip through Europe and Russia. Traffic: W6VPC 75.

SAN FRANCISCO—SCM, Walter A. Bueklev, W6GGC—May I take this opportunity to thank all the ARRL members in my section and also the clubs in the section for the wonderful cooperation they gave me while I held office as their Section Communications Manager. It has been a great pleasure to have met some wonderful fellows and ladies in the field of amateur radio and I hope our friendship will continue for many years to come. As a last request to all in the San Francisco section may I ask that you continue to send club activity reports and all data for QST to the new SCM, Fred Laubscher, W6OPL, 655 Wakerobin Lane, San Rafael. Your SCM can only make up his report to ARRL when he receives the news from the individuals and clubs in the section which he governs. HJP is signing KR6RX on Okinawa and is using a 4-1000A tube in the final amplifier. He hopes to be back in the U. S. in '58. CBE has moved to the Santa Clara Valley section without getting Delaware for WAS. PKH spent his vacation in the High Sierras working the Bay Area boys with "put-put" power. TLN was very kind and put GQA's antenna back up when the "string broke." K6EKC, act. mgr. for the Far West Radio Club, mobilized to Minnesota and attended the hamfest at St. Cloud, Minn. He won a *Handbook* for coming the longest distance (2200 miles). WN6WIA and WN6YOM are new Novices in the Far West Club.

(Continued on page 156)

Arrow! ... Supplier Of All NAME BRAND Ham Equipment!

**National
NC-300**



National's famous "Dream Receiver". An extremely sensitive, highly stable receiver with exceptional calibration accuracy. Has eight electrical bands, 160 thru 10 meters, plus a special 20-35 mc range used as a tunable IF for 6, 2, and 1 1/4 meters.

Amateur Net\$399.00

**Hallicrafters
SX-101**

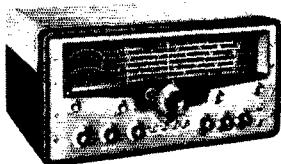

New heavyweight champion! Rugged is the word for the SX-101 receiver—and it's all amateur. Heaviest chassis in the industry. Full gear drive. Complete coverage of 7 bands: 160, 80, 40, 20, 15, 11 & 10 meters. Special 10 mc. pos. for WWV. Tee-notch filter. S-meter functions with A.V.C. off. Selectable side band.

Amateur Net \$395.00

**Hammarlund
HQ-110**



Amateur Communications Receiver — Dual conversion superheterodyne with automatic noise limiter. Covers 6, 10, 15, 20, 40, 80 and 160 meter amateur bands. Separate SSB linear detector. Q-Multiplier. Crystal calibrator. Separate stabilized BFO. Crystal control. Auto-response. Clock \$10 extra.

Amateur Net \$229.00

FREE!

With any purchase from Arrow. Amateur band frequency allocation chart in color.

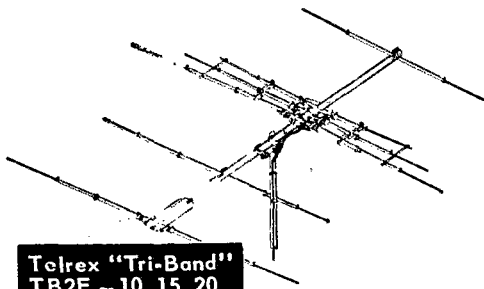

**Telrex "Tri-Band"
TB2E - 10, 15, 20**

Full size — no compromise! Three-band one transmission line array. Telrex tuned, matched and calibrated for easy assembly (without formulas or traps to break down) to provide outstanding performance on 3-bands with a practical long-lasting structure incorporating the finest of materials. Install a Telrex tri-band today for full size 2-element performance (gain 5.5db) F/B 18db — and enjoy your hobby to the fullest!

Amateur Net \$158.00

52 Ohm Coax



100-ft. roll RG-8U, 52 ohm coax. Complete with two PL-259 connectors.

Special Price\$3.95
(Please include shpg. charges for 8 lbs.)

"Wonder Bar" 10 Meter Antenna

As featured in Nov. 1956 QST. Complete with B&W 3013 Miniductor. Only 8 feet long for 10 meters.

Net\$6.95



6 Volt Dynamotor



Rated output: 425 V. DC at 375 ma. High efficiency, compact. 4" diameter, 7 1/2" long. Shpg. wt. 13 lbs. Worth 2 to 3 times this low price..... **\$12.95**

**MAIL ORDERS PROMPTLY PROCESSED
SAME DAY SHIPMENT FROM STOCK**

ALL PRICES F.O.B. N. Y. C.

Arrow's Export Dept. Ships To All Parts Of The World!

ARROW ELECTRONICS, INC.

65 Cortlandt St., New York 7, N. Y. • DIgby 9-3790
525 Jericho Turnpike, Mineola, N. Y. • Pioneer 6-8686

BUD "Mighty-Mite"

NEW! LOW COST!

C.P.O. and MONITOR

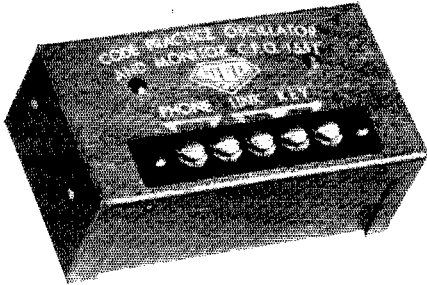

LOOK AT THESE OUTSTANDING FEATURES:

- Small size—only 1½" x 2¼" x 4 ¼"
- Completely transistorized
- Can be converted from Oscillator to Monitor without any internal changes by user.
- Sturdy aluminum case with grey hammer tone finish.

Here is the first low cost, combination Code Practice Oscillator and Monitor. It's small, lightweight and operates entirely on transistors, not on tubes. Works indoors or outdoors, since it requires no separate power supply. Uses pen-light batteries. Earphone model only. Not a gadget... its performance will compare favorably with higher priced earphone models. Ideal for Novices, Cub Scouts, Boy Scouts and others. Full instructions furnished for operating and converting from C.P.O. to Monitor.

Catalog No. Amateur Net \$5.88
C.P.O. 155-T (less batteries)

See and try the new BUD "Mighty-Mite" at your distributor's showroom now or write for literature.



**BUD
RADIO CORP.**

2118 East 55th Street
Dept. Q Cleveland 3, Ohio

The club has started a Novice c.w. net on 3720 kc. W6FXX, now W7FXX, was in San Francisco and attended the Central California Radio Council at GGC's QTH. All the gang was happy to see Joe once more. Congratulations to K6CXB on the new YL and K6DGA on the new boy jr. operator. Both K6CXB and K6DGA are members of the Humboldt Radio Club. AHII acted as hidden transmitter official for the 29ers hunt. Had the pleasure of taking in the ARRL Southwestern Division Convention and had a fine time. The weather in Long Beach was perfect. The San Francisco Naval Shipyard Club had a good turnout for its annual picnic, this time held in San Mateo Memorial Park. The HAMS (Red Cross) has a new generator all set up for any emergency. JWF and GGC worked one Saturday to set up the generator, with the assistance of KZF, IVLH, Mason Southworth, gave a very interesting talk on ARRL-IGY Propagation Research to the San Francisco Radio Club. The San Francisco Radio Club Picnic was a huge success with a big turnout. The members are glad that BZG again is able to make it to meetings. K6TYN came in the monthly 6-meter hidden transmitter hunt. RTTY had a special dinner at "Westlake Joe's." Bruce Rowlings, ZLIWB of Onerahi, New Zealand, was a special guest. Bruce got permission to operate the first radioteletype amateur set-up in his country. Thanks to AEE and CQI, who guaranteed Bruce's expenses, he will be able to stay in the United States for 90 days instead of 26 days. We all enjoyed meeting him at the dinner. K6GYA hopes to be aeronautical-mobile soon, for the last time and again thanks, gang, for the help rendered me during the past four years as your SCM. Traffic: W6GGC 28, GCV 16, GHI 14, BIP 10, JWF 8, GQA 2.

SACRAMENTO VALLEY—SCM, LeVaughn Ship-lay, K6CFF—May I urge that all amateurs in the section submit regular reports to the SCM prior to the 4th day of each month. Reports of club activities are particularly solicited. If such reports are not received you may be "stuck" with no report for our section in QST or even worse some ridiculous effort toward poetry or prose. C.d. activity is booming in Sacramento. Often the check-ins on 2 meters exceed those on 75! Two-meter check-ins on Tuesdays have been more than 40 during recent weeks. The New North Hills Club at Fair Oaks is becoming very cal.-minded and is standardizing on a 6-meter transceiver which many of the fellows already have on the air. Watch for forthcoming 2-meter activity from the Aerojet Club. K6SXA asks for support on the Frugal Net at 2200 PST, Mon-Fri. on 3711 kc. CMA is looking forward to more help on the Central Valleys Net this fall. Your SCM has net directories and traffic information for anyone who is interested. Don't forget the traffic roundtable on Sun. at 9 a.m. on 3820 kc., phone or c.w. The Tehama County Radio Club in Red Bluff put on an FB exhibit at the County Fair in August. No club activities took place at the California State Fair this year. Traffic: K6SXA 507, W6CMA 78.

SAN JOAQUIN VALLEY—SCM, Ralph Saroyan, W6JPU—Eleven members of the Turlock Amateur Radio Club supplied communications with excellent results for a controlled burn. Those participating were GIW, SQR, K6RPL, K6SWW, K6PFA, HAB, SKII, K6CME, GYN, K6SNA and K6BXE. They used walkie-talkies on 2 meters. OEM has a new DX-100. K6HFA is now DXCC with 103 countries. K6PFB is heard on 75 meters with a pair of 807s. K6HTM is having s.s.b. problems. K6KLE bought a new SX-101. PXP, JPU, PSQ, UBK and K6GTI attended the Wescon show in San Francisco. KN6VLG has an SX-25. K2QNZ/6 is heard on 6 meters. K6HWS is now running a Pacemaker. DVI is operating 40-meter c.w. KN6NKZ has a jumping 183. Gremlins probably. On Aug. 20, 1957, #PB operated on the top of Mt. Whitney using 20 watts. He heard lots of fellows on 3995 kc. from down Los Angeles but they were too busy racing to listen for a "pioneer" on 3995 kc. ZKP finally saved the day for him on 3920 kc. This was the only contact from the top of Mt. Whitney. As far as I know, this is the only time anyone has operated from this point. K6LLF has a new 6-meter Gonset. PSQ is building a tri-band 10-15-20-meter beam. K6GTI also is building a 10-15-20-meter beam. Don't forget to check into your local c.d. nets. The Tulare County Radio Club meets the first Wed. of each month. Traffic: W6ADB 164, EBL 26, ARE 11.

ROANOKE DIVISION

NORTH CAROLINA—SCM, B. Riley Fowler, W4RRH—SEC: ZG. PAM: DRG. North Carolina now has the most counties in RACES of any state in the United States. This is based upon the report of the

(Continued on page 158)

Let me put **YOU** in this *Collins* Picture!



"In the many hours my Collins 75A-4 and KWS-1 have been on the air in the last two years, they have always exceeded my expectations. They truly represent amateur communication equipment at its finest."

TED HENRY

The Operating Position at W6UOU showing Ted Henry and his Collins 75A-4 and KWS-1.

Collins KWS-1 SSB Transmitter, Net Price	\$2,095.00
Collins 75A-4 SSB Receiver, Net Price.....	\$695.00
Collins KWM-1 SSB Mobile Transceiver, Net Price.....	\$770.00

HENRY HAS ALL

Collins SSB EQUIPMENT
for immediate delivery

Top trades . . . 90 days open account or only 10% down—up to 20 months . . . Personal Service . . . Fast Delivery. Henry has ALL the New Equipment.

Write, wire, phone or visit either store today.

We are proud to have helped hundreds of fellow amateurs enjoy the thrill of operating these superb Collins transmitters and receivers. Our liberal trade policy and easy terms puts them within YOUR reach.

Butler 1, Missouri
Phone 395



Bob Henry,
W6ARA
Butler, Mo.

Henry Radio Stores

GRanite 7-6701

11240 West Olympic Blvd Los Angeles 64



Ted Henry,
W6UOU
Los Angeles



"World's Largest Distributors of Short Wave Receivers."

New LOW Prices for CBS Power Transistors

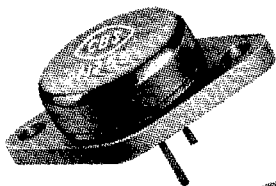

2N255
\$1.35

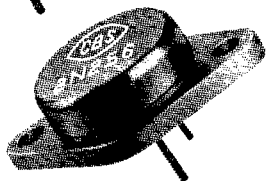

2N256
\$1.50

Stepped-up sales and production made them possible. The savings go to you. Your net prices for the CBS 2N255 and 2N256 are cut in half!

Now radio amateurs and experimenters can build a variety of economical transistorized equipment, fixed or mobile, capable of real power output:

- Ten-watt mobile modulator
- Mobile power inverters
- Six-watt hi-fi amplifier
- Code practice oscillator
- Compact mobile p-a system
- Portable phono amplifier
- Sensitive relay circuit
- D-c voltage multiplier
- Regulated power supply



Write for Bulletin PA-16, CBS Power Transistor Applications, giving complete details. Or pick it up along with your low-cost 2N255 and 2N256 transistors at your CBS Tube distributor's.

CBS-HYTRON

Semiconductor Operations, Lowell, Mass.
A Division of
Columbia Broadcasting System, Inc.

State Radio Officer, CVQ. Forty-one counties are now covered by RACES Plans. Congratulations to those persons responsible for seeing these plans through. In most cases these persons are actually the Emergency Coordinators. In the few counties where the EC is not the Radio Officer he was very instrumental in getting the plan written and approved. This surely does speak well of the type amateur selected to serve as EC. I have had no actual report of the AREC in some time, but in talking with the ECs on the air and by letter I am reasonably sure we are nearing 600 registered amateurs in the AREC. An excellent report was received from TQU, who has a splendid plan. I know that over 93 per cent of the ECs have AREC plans and are drilling their nets and I surely would like to receive any information you might have in this regard. All concerned are very pleased to note the amount of funds you have been able to get in matching funds to purchase equipment. North Carolina is predominately a phone state. We haven't forgotten you. The A-1 Operator certificate is equally available for phone or c.w. Official appointees, please send me your activity report so that I will receive it by the third of the month. Traffic-handlers, also note.

SOUTH CAROLINA—SCM, Bryson L. McGraw W4HAIG—Many thanks to the Charleston Club for being such a fine host to me during my visit, and especially thanks to FFH, EAR and AVG. NTO now works for CAA, BPN finally kicked a bad by-pass and is full blast again. PHS puts out a fine wallop with a custom de luse 6146 mc. K4WU/4 has moved to Columbia and is making many new friends. ERG is a med. student in Charleston. LHC works out fine now, thanks to the new antenna coupler and good operating via CSP. K4GGP is the proud owner of a new 2½-kw. gas job. YAA is now K8HID in West Virginia and asks the gang to look for him. K4KWL is going steady on 20 meters with a new ticket. 2BHIS/4 is going great on 2 meters with 14 States confirmed. Congrats to K4EJR on being an A-1 operator. K4DWJ took a flyer to 75 meters but gave up quickly and headed back to 20 meters. K4HDJ is doing a nice job as NCS of the New Piedmont local area net on 3920 kc. Mon. through Fri. at 1830. This net makes a nice traffic outlet for Spartanburg and the general area. K4OBH is doing a nice job with a barefoot IOB on s.s.b. FAY is back on a.m. after giving s.s.b. the old college try. There is much interest in the coming SCM election and several good men are interested. ANK and FFH are doing nice jobs as MARS NCS stations. If you wish to be certified as a RACES operator write K4AIL, AKC, our RM announces a new plan for the c.w. boys. The State is now zoned into 10 areas for faster traffic-handling in emergency. BVX is currently NCS for the C.W. Net. FFH, at Charleston Hts., reports an unusual QSO, when on Aug. 7 he was requested by WPZ to contact a party on the USS *Markeral*—this fish on dry land (dry dock) at the Naval Shipyard. Join "YOUR" ARRL. Do it today. Traffic: W4ANK 70.

VIRGINIA—SCM, John Carl Morgan, W4KX—SEC: PAK. Va. Nets: VN, 3680 kc. M-F 1900 EST; VSN, 3680 kc. M-F 1830; VFN, 3835 kc. 1500 daily. Dig those crazy traffic totals below! Six made BPL, and while we don't have totals for all previous years, the grand total of 4681 for the month could be an all-time State record. And there must be many more not reported to the SCM. You are urged to report your traffic, no matter how small. PVA made BPL with his one-man set-up at Prince Wm. Fair. He also got valuable AREC publicity. K4BYS reports the Old Dominion ARC held its Aug. 12th meeting on the air with satisfactory results. The Bristol Club (K4QJW) is getting code and theory classes underway for some 20 beginners. The Fairfax High and Peninsula Clubs are back in the swim. K4OQR is now out of the service and back to Iowa and K8AZJ. College will take its toll of our younger traffic men. Sophomore CXQ will have help from Freshmen K4BU1 and K4KWW in trying to get club station K4KDJ on the air at V.P.I.; K4DWP is M.I.T.-bound, and AAD and K4BUG start at N.C. State. K4BUG, incidentally, has moved to Danville. JUJ received a 130 sticker on DXCC with 140 QSOed. Charlie says 242 VA-JF certificates have been issued to date. SVG assisted with Hurricane Bertha traffic at home and at the Navy Yard Club station. RSS, K4LEF made General Class, while KN4RJQ is a new ham in Bedford. K4JKK is doing a swell job as VN/VFN liaison. K4DPX finished wiring his new DX-100 and now is setting up an AREC plan for Giles County. Should you tune to 3680 kc. and hear "omk" don't assume the pigs are out. That's the new rallying call of VN! Traffic: (Aug.) W4PFC 1366, IA 806, K4EZZL 723, DSD 344, W4QDY 260, SHJ 244, PVA 188, BZE 167, K4JKK 107, JLO 86, ELG 62, W4KX 59, PLX 40, RHA 32, AAD 28, CFV 27, K4MEV 27, BYS 19, W4LW 19, K4BU1 17, W4TFX 13.

(Continued on page 160)

Always...the latest
 equipment
 on **ELMAR**
 stock shelves

...for example Communicator III series

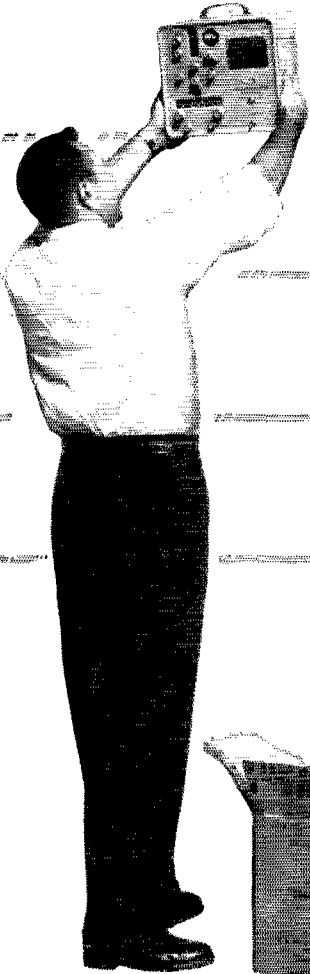

Communicator III highlights:

- 6V DC and 12V DC and 115V AC. All three. One vibrator. Simple inside strapping changes voltages.
- Full press-to-talk operation. (Actuated by button on microphone) Transmit-receive switch on panel can be used if desired.
- Receiver: New low-noise X155 RF tube in sensitive "Cascode" with AVC to avoid blocking tendency from very strong locals. Special gang-tuned circuits provide new high order of image rejection. Improved I-F selectivity. Gonset noise limiter. Adjustable squelch. Earphone provisions.
- Transmitter: All tunable circuits now have panel knobs. New gang-tuned circuits reduce spurious responses to negligible values. New 6L6GB modulator tube gives heavier modulation.
- Panel meter replaces "Green eye." Meter switches to exciter or RF output or to receiver for indication of relative signal level.
- Provision for 6 crystals with panel selector switch. (Also operation with external VFO.)

Look to Elmar for all of these fine new models which include those for amateur 2 and 6 meters... airports... industrial... emergency... Civil Defense. They'll be on the shelves.

- 2 meter Communicator III (6-12V DC, 115V AC)
 #3133 Net..269.50
- 6 meter Communicator III (6-12V DC, 115V AC)
 #3136 Net..269.50

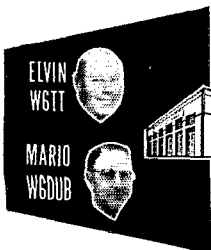
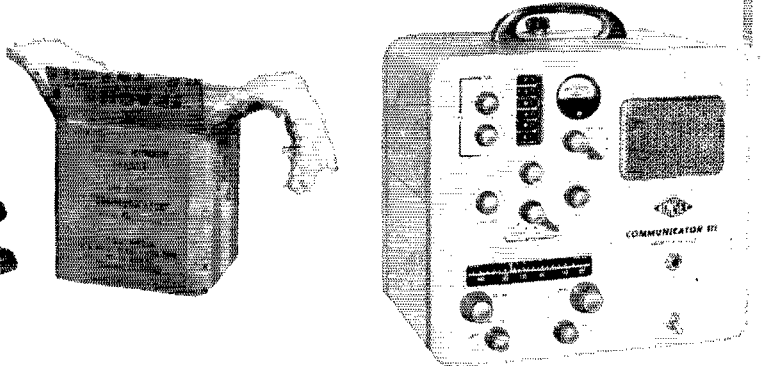

ELMAR ELECTRONICS

Serving the entire Western Region...

140 Eleventh Street, Oakland 7, California.

Alaska.. and the Pacific Area

"Phasemaster II-A"

IMPROVED AND ADVANCED OPERATING FEATURES

- SSB or DSB suppressed carrier or with carrier, PM and CW.
- 6146 power amplifier delivers 65 PEP watts output, giving sufficient power to drive nearly all types of linear amplifiers INCLUDING grounded grid finals.
- Calibrate control allows variable control of signal for zero beating VFO to receiver frequency or TOF (talk on frequency.)
- Voltage Regulation of 6146 Screen and 9MC OSC.
- Temperature compensating condensers in critical 9MC circuit for improved stability.

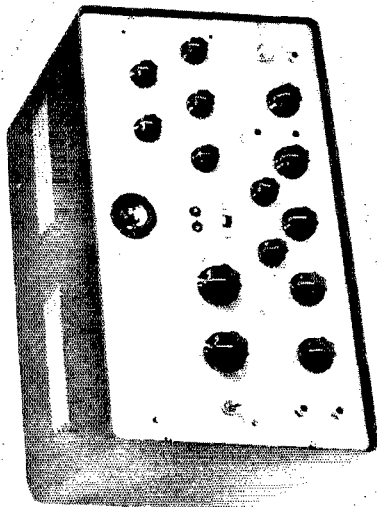

ALL BAND OPERATION

FRONT PANEL OPERATING CONTROLS

Emission switch with 5 positions for selecting CW
PM — AM or DSB — Sideband 1 — Sideband 2

Indicator Switch —

Position 1. Tuning eye indicates R.F. output.

Position 2. Tuning eye indicates when flattopping occurs.

Valuable aid for tuning up on AM and as a Distortion indicator for SSB.

"Phasemaster II-A" complete \$329.50

"Bandhopper" VFO complete \$139.50

P-400 Grounded Grid Linear Amplifier \$269.50

Price and design subject to change without notice.

See Your Dealer or Write Today

Lakeshore INDUSTRIES

MANITOWOC, WISCONSIN

MANUFACTURERS OF PRECISION ELECTRONIC EQUIPMENT

K4EAS 12, IIP 7, OYS 7, W4THM 6, BRG 5, ZM 4, K4DKA 3, ATF 1, W4SVG 1, (July) W4PVA 51, K4EAS 10.

WEST VIRGINIA—SCM, Albert H. Hix, W8PQQ, Asst. SCM: Festus R. Greenhouse, 8PZT SEC: KXD, PAM: FGL, RMs: DFC, GBF, HZA and PBO. K8EMO is working lots of states for WAS, Ex-W4YYA is now K8LID and is a new OBS, AKQ, GBF, PQQ and PZT attended the National Convention in Chicago. The Parkersburg and Charleston Clubs had good turn-outs at their picnics. 4WTFQ is now permanently located in Charleston. ESH is one of the most active 6-meter stations in West Virginia. He renewed his OES appointment. K8CGS is doing a good job of OO work and is Asst. EC for Kanawha County. Bill also is OBS. He visited K9HBK while on vacation, PQQ attended the Chattanooga, Tenn., Hamfest and visited 4QT while on vacation. K8DDH is building a TR switch. He will be on 75 meters soon. NYH is a new EC. Frank replaced the tubes in all his ham equipment recently. IHY is attending college in Baltimore. K8DIT is back on active duty in the Navy and is at sea. FNI is doing a bang-up traffic job, as is PBO. KN8GGG is a new Novice in Charleston. He is on 40 meters. KN8HAI (XYL Gloria) and KN8IEEX (OM Jim) operate a family station on 40-meter c.w. Gloria worked over 15 states in only 3 weeks' operation. K8CNB is very active in traffic work. Traffic: W8FNI 302, PBO 283, HZA 26, BWK 41, K8LID 26, W8GBF 25, NYH 20, SNP 18, K8CNB 6.

ROCKY MOUNTAIN DIVISION

COLORADO—SCM, B. Eugene Spoonemore, W8DAIL, SEC: NIT, PAM: IUF, OBS: K8BTU, OOS: OTR and RRV, OES: K8CLL, K8DCC is confining his activities to police radio; he says nearly 30 years of meeting deadlines is enough. We have 207 AREC members, 39 mobile and 9 emergency nets. If you have not signed with AREC, please contact your local EC. The *Spatter Chatter* states that those who leave their area wind up a MUQ—K4MUG, Vic, and W8MUG, Trapper. KN8JSQ has a new Globe Scout, K8DTEK has a new Mon-Key, K6s UYD and UYE, Floyd and Virginia, were visitors in this area. IHDC, Ed Tilton, V.H.F., Editor, spoke to the Boulder group Aug. 23. WVV has a new G-66 receiver, NIT, VLS, NCB, SKB and Betsy made a trip to the Western Slope stopping off at Montrose, Grand Junction and Fruita. K8CEN says the new home on Bates looks more and more like an antenna farm. K8AYK has a new AF-67. TDG is recuperating slowly but surely since his recent operation. The v.h.f. gang, IJR, TH and K8CLJ, have been making consistent two-way A-3 contacts nightly with K8IEC, 7 atop Black Hall Mountain near Encampment, Wyo. Jim is running a Gonset Communicator. TH and IC are proud owners of the new IGY Observer's certificates. Also TH was the top Technician Class licensee in the ARRL June V.H.F. QSO Party. QOT has no claim as the best fisherman in the family any more. Traffic: W8KQD 587, K8DCW 109, W8QOT 91, K8DCC 72, DXF 72, CEN 35.

UTAH—Acting SCM, Col. John H. Sampson, jr., W7OCX—SEC: GPN, PAM: DTB. The Ogden City-Weber County Emergency Net meets each Thurs. at 2000 MST on 29.510 Mc. Check-ins are welcome. Lately the NCS of this net has been using the civil defense truck and radio gear for the net meetings. GPI has donated an electric heater for cold-weather use in the truck. The Ogden Amateur Radio Club again has been asked to furnish radio communications for the NCAA Ski Meet at Snow Basin this winter. To reduce back-packing of radio gear on snow shoes in heavy snow, the group plans to build light battery-operated, portable 6-meter and 420-Mc. equipment. LQE, former SCM, paid us a surprise visit. He is now mobile with a Viking. NIA sold his small foreign-make car and got a new Ford in order to be mobile. Ogden is being considered as the location for the next Rocky Mountain Division Convention. YDZ has lost the big "N" in his call. Traffic: W7OCX 2.

NEW MEXICO—SCM, Ray Bueh, W5OZ—SEC: K5DAA, PAM: DVA. The Four Corners Net can be heard daily on 3885 kc. at 0700 to 0800 MST. This net will help you with traffic for Arizona, Utah, Colorado, the Four Corners Area and New Mexico. The wheels are CIN, POL, 7TCN and 4QBP. K5DIZ, UVZ, GOT, W5LEF and WBG (mobilers) were once again thanked for the part they played in helping the Sheriff's Dept. when recent flash floods hit Albuquerque. FPB reports that a loud "kaput" from his h-i, transmitter has kept him off the airlines. The Pecos Valley Radio Amateur Club can now be recognized by its new call, K5FWI. New calls around Gallup are K5LFE, LOU and LOV. K5LOV is the only XYL in that area actually on the air. CIN is the proud possessor of a new all-band

(Continued on page 162)

WE TRADE HIGHER!

Howdoody...

This picture shows me, Jack S., spendin' a quiet evenin' in my own cozy little well-upholstered apartment after a hard day at the office as evaluator of trade-ins at Walter Ashe Radio Co. They immigrated me here from the Ozarks and I don't get to fraternize with the natives none.

The Boss says he's afraid they'll spoil my natural big-hearted stupidity and imbue (whatever that is) me with something he calls the profit motive. He says if I ever get the trade-in dept. out of the red he'll trade ME IN.....on an imbecile!.....or less!! I think he's red-herringing me though; I called the F.B.I. and they don't even have a file on a soul in the place!

So just write and tell me what old obsolete gear you want to trade in and I'll whip out my crazy mixed-up marking chalk and whomp up a price for so high you'll swear I'm as buggy as an August Picnic. I shouldn't have said "Obsolete Gear". It can't be older than 1945. I found that out last week when I took in a gross of TV Kits, brand new, in original factory cartons with pre-ferred scannin-discs!

Write your lonesome fren.

Jack S.



IT'S EASY TO DO BUSINESS WITH WALTER ASHE!

1. Just tell us what factory-built gear (made since 1945) you have to trade, and what new gear you wish to purchase. You'll get our top dollar quote by return mail.

2. When the deal is made, you ship your equipment to us by prepaid express or, if express is not available, by prepaid truck. We check it at once and, in most cases, your new gear is on its way to you within 24 hours after we receive your trade-in.

3. We will ship your new gear to you via express in most instances. Where express is not available, or not practical, we will ship by truck.

LOOK! FOUR BRAND NEW MODELS!

CON SET

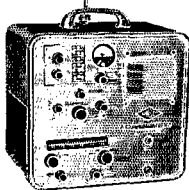

COMMUNICATOR 111
2 or 6 Meters.....\$269.50

JOHNSON

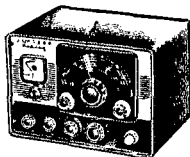

NAVIGATOR KIT \$149.50
Wired & Tested.....199.50

JOHNSON



COURIER KIT.... \$244.50
Wired & Tested..... 289.50

JOHNSON

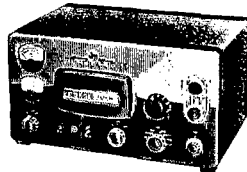

THUNDERBOLT KIT \$450.00
Wired & Tested..... 525.00

DO YOU HAVE OUR 1958 CATALOG? IT'S FREE!

WRITE FOR FULL DETAILS ABOUT OUR TIME PAYMENT PLAN

All prices f. o. b. St. Louis • Phone CHestnut 1-1125

Walter Ashe
RADIO CO.
1125 PINE ST. • ST. LOUIS 1, MO.

WALTER ASHE RADIO COMPANY
1125 Pine Street, St. Louis, Mo.

OUR 36TH YEAR

Rush "Surprise" Trade-In Offer on my.....
for.....
(show make and model of new equipment desired) Q-11-57

Send new FREE Walter Ashe catalog.

Name.....
Address.....
City..... Zone..... State.....

by TEST or TESTIMONIAL

the finest transmitter

in its price & wattage range

K4EJQ

I thought I'd drop you a line to tell you how much I like the Globe Scout. I bought the Scout second-hand from a ham who bought it factory wired and have now had it in operation for 9 months. In that time I have worked all states, all continents, 21 zones and 87 different countries. My antenna is a long wire 136' long and 40' off the ground. The Scout loads on all bands perfectly. I have not had one complaint about TVI. I think that the Globe Scout is the best low powered transmitter on the market today. By the way, it works just as fine on phone as well as CW.

James Botts, K4EJQ
Route 2, Box 545
Bristol, Tennessee

THE WRL Globe Scout 680

\$891
per mo.
Just \$11.00 Down



Wired & Tested: \$109.95

Kit Price: \$89.95

A compact, self-contained, bandswitching transmitter for 6-80M, with built-in power supply, 50W fone, 65W CW. High level modulation. Cabinet shielded for TVI-suppression. Pi-net output on 10-80M; link-coupled output on 6M, matching into low impedance beams. New type shielded, full-range meter. Adaptable for Mobile. Best by any test. Try it!

And the World-Famous

Globe Chief 90 \$ 67.50; \$ 5.47 per mo.
Globe Champ 300 \$449.00; \$25.14 per mo.
Globe King 500B \$725.00; \$40.60 per mo.

SEND FOR COMPLETE BROCHURE!

WORLD RADIO LABORATORIES



3415 W. BROADWAY
COUNCIL BLUFFS, IOWA

Please send me your free catalog and info on:
 Globe Chief, Globe Scout, Globe Champ,
 Globe King.

Name:

Address:

City & State:

doublet antenna. FHL welcomes all helpers with his new "shack building." The New Mexico AREC now has 68 members. Traffic: K5DAA 20, W3ZU 16, LPK 8, CIN 7.

WYOMING—SCM, James A. Masterson, W7PSO—SEC: MNW. RM: BHH. The Pony Express Net meets Sun. at 0830 on 3920 kc., AMU and MWS alternating as NCS. The YO Net meets Mon., Wed. and Fri. at 1830 on 3610 kc., BHH, DXV and NMW alternating as NCS. NMW reports that N7AUP is signed up as a supporting member of the AREC. Harry also advises us that the new Call Book lists 253 amateurs in the State of Wyoming and asks what it would be like if they were all active on the air. BHH reports that the YO Net still is plugging along with hopes of having more check-ins as conditions become better. UFB operated mobile and portable on 6 meters from the Black Hills while on his vacation. PNO received a commendation letter for his participation in the RTTY phase of the Armed Forces Day Program. MZW has a new 75A-4 and Central Electronics 20A. If you do not see any of your station's activities listed in this column, it is because you do not notify your SCM. Reports are solicited from all Wyoming amateurs. Traffic: W7BHH 6, NMW 3.

SOUTHEASTERN DIVISION

ALABAMA—SCM, Joe A. Shannon, W4MI—SEC: TKL. PAM: K4AOZ. RM: KIX. K4AOZ and W4HKK now have A-1 Operator certificates and K4ANB is displaying a 30-w.p.m. sticker on his CP certificate. ANB also reports a new "V" beam on 15 meters is knocking 'em off! K4KJZ is now WAS. K4KZQ is trying out a trap antenna. K4JVK is a "hundred percent" in attendance on AENT. K4ELM rebuilt the antenna system and added push to talk. K4BFL comes up with a trapped dipole with 18 watts into it. FEC is active on 2 meters and reports installation of a pole pig in the new power supply. Joe has a near gallon on 2 meters! K4KID celebrated the obtaining of his General Class license with WAS and operates full break-in. K4IOX installed push to talk and is playing with s.s.b. A most hearty welcome to the following newcomers: K4RFX, Opelika, and KN4QMM, Alex City. IAX and AAN are drooling over a new grandson. K4EEH and his XYL have a brand-new son. The Mobile Club is sponsoring an assembly-line production of 6-meter transmitters and converters. Traffic: (Aug.) W4RLG 203, HIKK 199, K4AOZ 153, EOG 115, W4KIX 80, K4EOH 76, BTO 69, KJZ 56, ANB 51, W4ZSQ 45, USM 41, K4AJG 40, OCV 34, KZQ 31, W4WOG 28, K4LOE 27, KJP 26, HJM 25, JVK 25, W4DGH 24, K4BFL 19, W4CEF 18, K4KJD 15, W4CIU 14, K4JWB 14, W4WHW 12, MI 11, YRO 11, RTQ 10, CRY 6, FEC 5, K4DDC 4, W4TOI 4, K4KID 2, IOX 1. (July) K4ANB 28, IPP 11, W4PHY 2.

EASTERN FLORIDA—SCM, John F. Porter, W4KJG—SEC: IYT. RM: LAP. PAMs: TAS and JQ. We have several good section nets in operation. Pick out the one of your choice and join up. The big news in Dade County these days is that amateurs can now put up poles and towers in their back as well as front yards with the blessings of the County Commissioners. The new ordinance was passed unanimously on Aug. 15. The WPBRC has a new emergency net on 28,980 kc. K4DAS is whooping it up in the CD Parties. KN4MZL has a new beam. The LARS is starting classes for General Class licenses. HCQ is running a full kw. to his new transmitter. Sarasota: New in the 2-meter group are K4QBQ, OHV and KN4QHN. We worked QHN on 2 meters while mobiling in Bradenton. GJO is working the Miami gang nightly on 2 meters. K4KZG has a new Valiant. Orange County CD now has its new panel truck and the Gosnet 86s and 77s to go in it. The Orlando Club meets the second Tue. of the month at 8 p.m. at the Red Cross Building. K4IRE has moved to Orlando. Any YLs visiting or passing through St. Petersburg are asked to contact some member of the SPARCYS. BIL, TDK and BAY are at home evenings. DQA is back from Swan Island. The Daytona Beach Amateur Radio Assn. is holding regular hurricane drills. K4PFN is the club call. The Fort Lauderdale Club is running weekly code and theory classes each Tue. night at the C.D. Building. The DEN held an informal dinner Aug. 13 at Del Monico's. The 2-meter section of the net is shifting to 147 Mc. NYE net controls for the Flamingo's 2-meter section. K4OSQ is equipped with a CD Communicator now. K4BNE is now acting net manager of FMTN. Traffic: (Aug.) W4PIU 324, DVR 257, PZT 128, EHW 105, IYT 90, K4AKQ 86, BNE 71, W4AHZ 58, TAS 55, K4DRO 45, W4LMT 45, K4KDN 32, W4DTV 30, K4OSQ 28, W4SMK 28, K4CJE 23, IWT 23, MTP 23, W4RKK 18, K4AEE 16, AHW 11, W4BWR 11, K4LB 8, AZM 7, W4GGQ 7, BJI 2. (July) W4HCQ 96, QCP 7, K4DAS 3.

(Continued on page 164)

RADIO SHACK CORP. SUPER HAM VALUES!

SKILLMAN Deluxe HIGH SPEED KEY

- Solid Polished Brass Base
- Solid Silver Contacts
- Quadruple Ball-Bearing Pivots
- With Circuit Closing Switch

BRASS POUNDER'S SPECIAL!
Reg. \$6.85 Net Value! **\$2.95**

You've never seen a key value as *Sensational* as this one . . . even in the "good old surplus days". In addition to the features listed above the SKILLMAN HIGH SPEED KEY is fully adjustable for proper spacing and spring tension. Chrome-plated brass binding posts. Really a Wow of a buy . . . makes a handsome addition to any man's shack. Ship. wt. 1½ lbs.

Order No. R-1206Q\$2.95

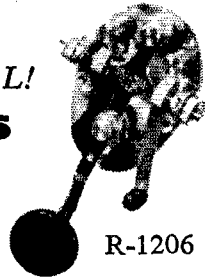

R-1206

Skillman Semi-Automatic Key

\$11.95 R-7902

The "Bug" to end all "Bugs" . . . priced so low it makes your mouth water! Has 8 separate tension and speed adjustment knobs to personalize for your own fist. Adjusts easily from 10 WPM to any speed desired. Precision tooled brass parts. Easily equals any \$20.00 bug made! Imported and protected by RADIO SHACK'S Money back guarantee! Complete with cord and wedge. Ship. wt. 5 lbs.

Order No. R-7902Q\$11.95

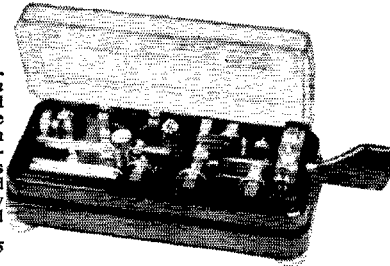

Telephone Lineman's Handset

- + CARBON BUTTON MICROPHONE
- + 1000 OHM MAGNETIC EARPIECE

\$9.50 Value



\$2.98

Makes ideal mobile telephone or multi-station intercom system when used with 4½ volt battery. Sturdily constructed to U.S. Govt. military specifications. Complete with 5 ft. cord and alligator clips. Wt. 3 lbs.
Order No. R-900Q\$2.98

#1625 12v Version of 807

Q-31625

3 for \$1

**RCA 1616 Half-Wave
Q-1616
10 for \$5.95
69c Rect.**



WORTH OVER \$1. High vacuum, coated filament type rectifier. Medium 4-pin bayonet base, medium cap. 2V @ 5A. Max. inverse peak 6000V. Peak plate 800 Ma. DC output current 130 Ma. 6¼x2½".

Magnetic Headset

MONITOR QUALITY — 50-14,000 CPS



\$3.98

Worth \$8.67

NOW! . . . for the first time anywhere —! A true high fidelity stethoscope-style magnetic headset at less than the going price for the bulky old ear-busters! Lightweight! Less than 1 oz. Response actually better than 50 to 14,000 cps! Impedance is 10 ohms at 1 KC. Fits comfortably into ears and held securely by feather-light spring tension. Would cost at least twice our price if made in U.S.A. Ship. wt. ¼ lb. Order No. R-6601Q\$3.98

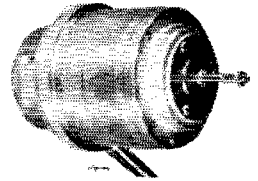

BRAND NEW

2/\$24.50

BRAND NEW in original Govt. packaging. 110 VAC 60 cycle. Type 11-1, Phase — 1 Synchronous Repeaters Part No. C-44968. Ideal for hams . . . can be used to rotate a 2 or 6 meter beam, or as an indicator for 10 meter beam. Enclosed brass casing 5½" x 4" dia. Shaft ½" dia. x 1½" long. 3 removable screws permit easy front panel mounting. With 5 coded 5 ft. leads and wiring diagram. Ship. wt. 42 lbs. per pair. Shipped by EXPRESS ONLY.
Order No. R-6000Q
per pair \$24.50

Radio Shack Corp.

167 Washington St., Boston

PLEASE SEND 224 Pg. 1958 CATALOG

Name _____

Address _____

City _____ State _____

Wow! 110 VAC Selsyn Motors

- ★ MADE BY BENDIX-DIEHL
- ★ EXTRA HEAVY DUTY
- ★ ROTATES HAM BEAMS

RADIO SHACK CORP.

167 Washington St., Boston, Mass. 230 Crown St., New Haven, Conn.

IN HONOLULU

write or see **KH6BM**

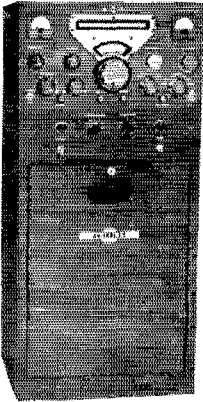

for the
Collins
KWS-1

Unmatched performance, accuracy and stability characterize the Collins KWS-1 in SSB, AM or CW operation. Extremely accurate 70E VFO. Pi-L output network. Collins Mechanical Filter. See us about generous trade-in allowance and time payment terms. KWS-1 kilowatt Transmitter,

Net Price\$2,095.00

75A-4 SSB Receiver



Designed expressly for operation on the 7 HF Amateur bands. Features AVC on SSB and CW, separate detectors for AM and SSB, passband tuning, rejection tuning, Gear Reduction Tuning Knob, superior selectivity and many other time-proven Collins features. 75A-4 Receiver, Net Price\$695.00

KWM-1 SSB Mobile Transceiver



First mobile transceiver in the Amateur field — 175 watts PEP input, 14-30 mc. Use for mobile or fixed station without modification.

KWM-1 Transceiver, Net Price\$770.00

10% down payment, balance 18 months.
Trade-ins. Write today to:

KAIMUKI RADIO CO., LTD.

3620 Waiialae Avenue
Honolulu 16, Hawaii

WESTERN FLORIDA—SCM, Edward J. Collins, W4M8/RF—SEC: HIZ, EC: MFY, RMs: AXP Escambia, BVE Okaloosa, EQR is the proud owner of a new self-supporting tower. K4QQO is building a new 6-meter beam. K4AGM now has 35 states confirmed on 6 meters and is attending Fla. State U. RKH makes the rounds of the various hamfests. K4OXB sticks to vertical on 6 meters, K4KLF wants more power. UUF is planning a kw. which should bring the Tennessee Valley Indians out of the reservation again. MS and K4AGM returned from the ARRL National Convention in time to QSO LU9MA on 6 meters. K4IYQ has the best-sounding mobile rig in the area. K4ECP has a DX-35 going on 6 meters. K4IYJ hopes to be home from the Army by Christmas. K4GXV has returned from Pennsylvania after a summer job on a farm. The recent Operation Alert in Tallahassee was handled by YUU, CHZ, BKV and K4JMN. K4APE is doing an FB job as OO. K4JMN has the DX bug. New hams at Tally are KN4MZT and KN4PVU. The Leon High Radio Club will become active with the opening of school and extends an invitation to all hams at Florida State U. to visit the club. ACB and CCY are QRL work. GMS is fighting beams and measuring equipment. HBK has at last worked 100 countries. FHQ is enjoying the Viking KW. QK meets the Gulf Hurricane Net regularly. VR prefers 40 meters. AXP is busy giving Novice exams and QSOing them to help their code. ZFL has entered F.S.U. AYS left for school, too. OOW still runs low power on 10 meters. K4OWW will be on 6 meters shortly. PQW has licked his TVL. PAA still hunts DX. W4BGG is at F.S.U. HIZ works 75 and 6 meters with a big signal. K4IVD works 6 meters, mobile and fixed. K4PJC is steadily improving his signal on 6 meters. DAO-DEF still helps Novices. UYS returned to Georgia Tech. K4BH is looking for power transformers to increase power. KN4RIV is pounding brass to increase code speed. K4AH stays with low-power c.w. KN4PMP keeps 3.7 Mc. warn. RZV has come to life again. We would like to hear from new W4s in the area. I'd appreciate more reports.

GEORGIA—SCM, William P. Kennedy, W4CFJ—SEC: K4AUM. PAMs: LXE and ACH. RM: PIM. GCEN meets on 3995 kc. at 1830 EST Tue. and Thurs., 0800 on Sun.; ATLCW on 7150 kc. at 2100 EST Sun.; GSN Mon. through Fri. at 1900 EST on 3995 kc. with PIM as NC; 75-Meter Mobile Phone Net each Sun. at 1330 EST on 3995 kc. with UUH as NC; Atlanta Ten-Meter Phone Net each Sun. at 2200 EST on 29.6 Mc. with VHW as NC.; Ga. Teen-Age Net each Mon. and Thurs. at 4:30 p.m. on 3810 kc. with K4HVK and K4IOV as NCs. K4HMB is secy.-treas. of the GTAN. The Georgia Peach YL Net meets each Thurs. at 0900 EST on 3985 kc. with UMM as NC. The Middle Georgia Radio Club has been organized at Macon with K4GGD, pres.; K4IGS, vice-pres.; RZX, secy.; K4GQQ, treas.; and K4ICT, act. mgr. The Atl. Teen Age Radio Club has K4IOV, pres.; K4QQR, vice-pres.; K4JSQ, secy.; and WKP, act. mgr. K4PKL now has his General Class license. The Atlanta Radio Club had a wonderful picnic at Chastain Park Sept. 8. CFJ received a QSL card from NT in August although it was only 24 years late. K4HAV, of Tifton, is sending in FB information of the club. KN4MGP passed his Conditional Class exam. K4GQN is attending Emory U. K4HAV is going to North Ga. College. K4MCL had a good traffic report this month with 748 messages. K4BQF made his first BPL this month, and then joined the Navy. FGH now has his 40- and 20-meter beams both 50 ft. plus in the air. ETD has doubled his station-room size. K4LVE might have had something to do with it. PBK has his Class C power supply fixed. K4APC has a three-element beam on 15 meters. OQY has his General Class license. IMQ was paid a visit by CNZ and RLL from North Ga. The Tifton Amateur Radio Club's new officers are K4BMD, pres.; KN4MGP, vice-pres.; ENC, secy.; KN4MSA, treas.; K4LAX, pub. chairman. ECs, get your reports in on time to your SEC. K4AUM. Traffic: K4MCL 748, W4BQF 581, K4LVE 309, W4BXV 244, PIM 134, ETD 125, PBK 33, K4DWF 12, W4ZD 12, K4KIV 11, W4CFJ 8, K4APC 7, GNO 6, BAI 4.

WEST INDIES—SCM, William Werner, KP4DJ—SEC: AAA. KD has a daily sked with son KN4PUJ on 21,135 kc. New next-door neighbors of KD are WP4ALC and his XYL WP4ALE with a DX-20 on 3.7 Mc. ADX transferred to Winston-Salem. AHV transferred to Washington, D. C. with the USWB. YT has new tower and beams. DH is returning to the States. KD and ZK have been made honorary life members of Old Old Timers Club. AIS is a new station on 3925 kc. using a Viking II. JZ bought a Viking II and kw. final and is heard on 3925 kc. every evening. ACF reports to the 3925-kc. Net since he put up the new antenna for his Viking II. QM reports to the 3925-kc. Net from mobile in Mayaguez on the other side of the Island. HG, secy. of Mayaguez

(Continued on page 166)

FREE! LAFAYETTE CATALOG



JUST OFF THE PRESS!
NEW 180 PAGE ELECTRONIC CATALOG FEATURING THE BEST BUYS IN THE BUSINESS

The newest and largest assortment of Electronic, Radio and TV parts, Hi-Fi and Public Address Components and systems, Test Equipment, tubes, Transistor Kits and miniaturized components for transistor circuitry, Ham Equipment, Builders Kits, Tools, Books, Microscopes, Binoculars, Telescopes, Cameras, and Drafting Equipment.—**ALL AT LOWEST PRICES**—Catering to the economy minded dealer, serviceman, engineer, technician, experimenter and hobbyist. **GRAMMED FULL OF MONEY SAVING BUYS. SEND FOR YOUR FREE COPY TODAY.**

LAFAYETTE SMASH HAM CLEARANCE DEMONSTRATOR CLOSEOUTS PRACTICALLY AT COST! ALL NEW AND IN PERFECT SHAPE! QUANTITY LIMITED! SUBJECT TO PRIOR SALE

- 1 B&W MATCHMASTER NO. 851... 35.63
- 1 DRAKE TVS2-40LP Low Pass Filter 8.95
- 1 GONSET NO. 3041 SUPER-CEIVER 95.60
- 2 HALLICRAFTERS S102 2 Meter Revr. 44.95
- 1 HAMMARLUND HQ-140X Revr. 175.00
- 2 HARVEY WELLS VFO (Band-master) 34.95
- 2 KRECO CO-6 6 Meter Cox. Antenna 18.75
- 1 LYSCO A129 10 Meter Mobile Xmt. 29.50
- 1 LYSCO A178T Xmt. 25.15
- 2 LYSCO 310 (10 meter ground plane) 14.95
- 1 LYSCO 315 (15 meter ground plane) 17.25
- 2 LYSCO 316 (20 meter ground plane) 26.25
- 2 LYSCO No. 402 Modulator 29.95
- 1 LYSCO No. 401 Modulator 14.95

- 1 LYSCO 800S Xmt. 142.45
- 1 MORROW Fixed Tuned Revr. #1059 96.30
- 2 MORROW Top Hats 1.95
- 1 MOSLEY YP20-3 Antenna 49.75
- 1 MOSLEY YP20-2 Antenna 11.25
- 1 MOSLEY YP20-3 Antenna 17.25
- 1 MOSLEY YP-105-5 Loading Coils 17.22
- 2 NATIONAL PB-1 Revr. Tilt Bottoms 4.95
- 1 NATIONAL PB-3 Revr. Tilt Bottoms 4.95
- 2 NATIONAL NC300 Receiver 299.50
- 1 SONAR MB-26 2 Meter Xmt. 59.95
- 1 SONAR SRT-120P Xmt. w/Pwr. Supply 209.50
- 1 SONAR SRT-120P Kit 148.85
- 1 SONAR C-120 Mobile Case for SRT-120 7.50

MENTION THIS AD IN YOUR ORDER

Lafayette's Radio-Control Specialties

R/C ELECTRIC SERVO MECHANISM

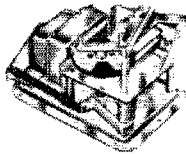

• **DESIGNED AND PRICED FOR HOBBYISTS**

New, powerful, motor driven R/C actuator. Delivers positive, instantaneous action. Provides selective steering and electronic, automatic return to neutral: Extremely efficient when used with model boats and land vehicles. Only 2 1/2" x 2" x 1 1/4". Includes instructions and linkage. **F-327 Net 5.95**

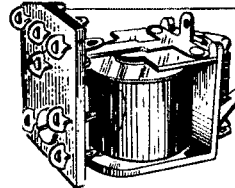

LITTLE "JEWEL" R/C RELAY

The Mighty Mite of the R/C field. Weighs less than 1/2 oz.! Only 3/4" H x 17/32" W x 1-1/16" L. Highly sensitive—extremely rugged. Pulls at 1.4 Ma—drops out 1.2 Ma D.C. S.P.D.T. 5000 ohm coil. **F-260 Net 2.75**

LAFAYETTE SPECIAL R/C RECEIVER

Completely wired and assembled, with tube, ready to operate on exam free 27.255 MC remote control band. Size: 1 3/4" x 1-15/16" x 3". Weight 3.3 oz. Uses one 1.5 volt and one 4.5 volt battery. Less batteries. Shpg. wt., 6 oz. **F-208 Net 8.95**

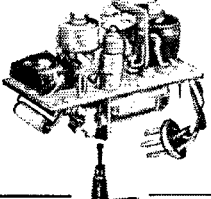

LAFAYETTE SPECIAL RADIO CONTROL TRANSMITTER

Completely assembled—tested—and guaranteed R/C transmitter: Includes tube and 27.255 MC crystal, 6 sect. telescoping antenna. Size: 4" x 4" x 12". Approx. 1 mile range. Shpg. wt., 3 lbs. Less batteries. **F-249 Net 14.95**

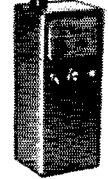

TRANSISTOR CODE PRACTICE OSCILLATOR KIT

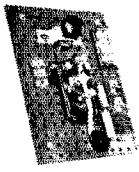

For those interested in mastering the international code, an audio tone oscillator is essential. The circuit of this transistorized feedback oscillator has the simplicity of the neon glow, the signal strength of the vacuum tube, and requires only two penlite cells for weeks of service. It may be used for solo practice, or two may send and receive with the same unit. Kit comes complete with Transistor, Telegraph Key, Resistors, Condensers, Masonite Board, etc., and Schematic Diagram. **KT-72 Net 2.99**
Canon EC1—Single Headset Net 1.13

NEW! HIGH SENSITIVITY POCKET MULTITESTER 20,000 OHMS PER VOLT DC — 10,000 OHMS PER VOLT AC



A terrific buy in a convenient accurate, completely wired instrument. Has a 3" 36 μ A meter, 1% precision resistors and efficient single selector switch. Scales: Volts DC and AC; 0-10-50-250-500-1000 Ohms; 0-50K-500K-5 Mega; DC current; 0-50 μ A-1MA-25MA-500MA: Decibels; —20 to +22, +20 to 36. Attractive plastic front in rugged shielding metal case. Imported to save you money. Size: 3-5/8 x 5 1/4 x 1-5/8". Complete with batteries and test leads. Shpg. wt., 3 1/2 lbs. **RW-50 Net 14.50**

3 TRANSISTOR SUPERHET POCKET RADIO KIT

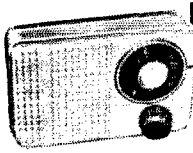

• A TRUE POCKET SUPERHET RECEIVER—NO EXTERNAL ANTENNA • NO EXTERNAL GROUND

A remarkable sensitive, super-selective pocket superhet receiver with astonishing performance over the complete broadcast band. Uses 2 high-frequency and one audio transistor plus efficient diode detector and features 2 specially matched IF transformers for maximum power transfer. The components are housed in a professional looking beige plastic case. The receiver's appearance enhanced by attractive maroon and silver station dial. Sensitive built-in ferrite antenna eliminates need for external antenna. A designer's dream in a true pocket superhet receiver! Complete with all parts, transistors, battery, case, dial and easy to follow step-by-step instructions. 4 1/4" x 2 1/4" x 1-1/16". Shpg. wt., 1 lb. **KT-116—Complete Kit, less earphone..... Net 16.95**
MS-260—Super Power Dynamic Earphone..... Net 3.95

NEW "DYNA-SLIM" MICROPHONE

• HIGH IMPEDANCE — 50,000 OHMS
 • ON-OFF SWITCH • "QUICK-SLIP" ADAPTER

New dynamic, high output microphone with all the features of "mikes" costing 3 times Lafayette's price! Output level —55 db. Smooth response from 60 to 10,000 cycles. Omnidirectional head. External on-off switch. Slips on or off stand adapter in a wink. Standard 5/8" — 27 adapter permits tilting mike for multi-angle use. Satin black and chrome finish. Complete with detachable cable and connector. 8" long, 1 1/2" max. dia. tapered panel. Shpg. wt., 2 lbs. **PA-43 Net 6.95**



Lafayette Radio
 Dept. V K

165-08 Liberty Ave.
 JAMAICA 33. N. Y.

100 SIXTH AVE. NEW YORK, N. Y.
 PLAINFIELD, N. J., 139 W. Second St. BOSTON 10, MASS., 110 Federal St.
 BROXN 58, N. Y., 542 E. Fordham Rd. NEWARK 2, N. J., 24 Central Ave.
 Include postage with order.

TRANSFORMER NEWS

FROM TRIAD

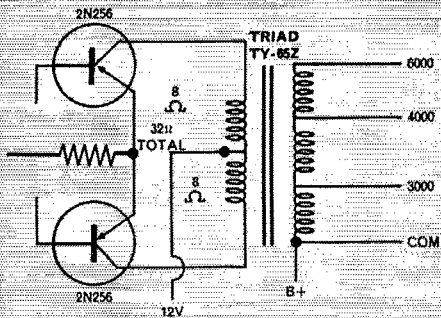

All-transistor modulator circuit for low-power mobile transmitters. Triad TY-65Z Transformer is used in conjunction with the new 10-watt transistor (CBS Hytron 2N256).

TRANSISTOR TRANSFORMER for the advanced amateur

Ourexperience in building miniature transformers for military use led to the development of this new transistor transformer for you. The Triad TY-65Z is designed especially for amateur use. See your distributor, or write to us.



PRIMARY IMPEDANCE 32 CT. (575 Ma.)	SECONDARY IMPEDANCE			
	6000	4000	3000	
MAXIMUM LEVEL 10W	DIMENSIONS, INCHES			
	H	W	D	MW
WEIGHT, OUNCES 20	2-5/16	2-7/8	2	2-3/8
4055 REDWOOD AVENUE, VENICE, CALIFORNIA 312 E. STATE STREET, HUNTINGTON, INDIANA				

A SUBSIDIARY OF LITTON INDUSTRIES

ARC, signed up AGO, ADY, AIT, TIN, MR, A1U, QM, AFK and HG in the AREC. RM is awaiting new TZ40 modulator tubes. MP is sticking to 75 meters since there is no TVI when using the kw. transmitter at the new QTH in Reparto Metropolitano. AAM repaired the v.f.o. in the DX-100 and is active on all bands. AAA put up a 20-ft. steel tower and Hy-Lite 10- and 20-meter beams. AEF has ordered a Hy-Gain Triple Globe Spanner. AZ is using a vertical antenna on 80, 40 and 20 meters while installing beams on 60-ft. towers (2). AAA has a new mobile antenna. DW is using Taylor Supermodulation with 807s for 120-watt carrier and 240-watt peak power. KV4BY is a new station on 3925 kc. from St. Croix. W3SAE/KP4 returned to the States. VP4LF, of Trinidad, visited KP4-Land for five days en route from New York to Trinidad. W2DIN, ex-KP4RL, keeps in touch with Puerto Rico via KP4GN, ES and DJ. PRARC has 16" X 10" charts of the world centered on P.R. for beam directions available for one dollar. Send to the Secretary, P. O. Box 3533, San Juan, P. R. The PRARC Picnic at Luquillo Beach was attended by 25 hams and their families. ACH took more than 300 feet of moving pictures at the picnic which were shown at a general meeting held in C.A.P. headquarters at Isla Grande Airport. PRARC's anniversary is Oct. 12. KD submitted cards for WPR-425 and WPRN-60!! AEB joined the AREC. ADR has a new QTH on the Caguas Road. DP maintains a sked with KC4USA for a doctor assigned to the base and his parents. DP has 2-meter mobile and fixed stations. Traffic: KP4KD 2.

CANAL ZONE—SCM, P. A. White, KZ5WA—RU has been appointed EC on the Pacific Side of the Isthmus. TG has been appointed Assistant EC to help KT, the Atlantic-side EC. News was received from W5COB that Andy Becker, ex-PB has taken a bride. They are now living in New Jersey while he attends RCA school. JS has a rig on 2 meters now and is looking for contacts on that band. CC was issued his ticket in August, making all the adult male members of the Howe family amateur operators. The others are K4AEE, KZ5RM and K4GYE. Dwight Nichols, W5AAE, and his XYL, Dorothy, while on a visit here from Eureka Springs, Ark., gave a nice talk and showed a sound movie of travels in Costa Rica at the August meeting of the CZARA. New operators: CC, Charlie Howe; CT, Charles Tyrill; FG, Fred Gruette; HJ, James Harris; HP, Clarence Peters; JQ, John Quaranta; OG, Orin McKinney; PY, Harold Hyson; TL, Tony Lopez; TW, Tom Walker; UB, Urda Barrett; JJ, James Hagen; WM, William Malone; CAN, Daniel Caffery; LF, Lee Boynton. Traffic: KZ5VR 93, 1F 31, WA 22, QA 21.

SOUTHWESTERN DIVISION

LOS ANGELES—SCM, Albert F. Hill, jr., W6JQB—SEC: LIP, RMs: BHG and GJF. PAMs: K6BWD and ORS. BFL this month went to GYH, K6OQD, and K6MCA. Congrats on a wonderful job. LVQ is taking a well-deserved vacation. NUJ is planning a trip to Navassa Islands, KC4, next June. K6OZJ received a BPL Medallion. Congrats, Jack, K6CSR is trying for more and better skyhooks. K6UYK set up at El Mirage Airport for the West Coast Soaring Contest. SRE is back in harness after a summer at the beach. K6COP is arranging traffic skeds with KC4USA. K6IXJ worked 3 new countries with a DX-100. K6DDO received WAS. K6MON got married Sept. 1. Congrats. Bud! New officers of the So. Calif. V.H.F. Club are K6JQB, pres.; K6JDN, vice-pres.; K6RMT, treas. K6QPG received CP-30 endorsement. Nice going, Mary. K6TBC received his General Class license. K6GGS set up gear for the Antique Car Club meet in Redlands. Riverside County Amateur Radio Assn. members completed a very successful expedition to Mt. Whitney. Novices, join the Frugle Net on 3711 kc. Contact HJY. AM is now tied for first place on the DXCC roster. Support your section net. SCN, on 3600 kc. at 1930 PDT nightly. Traffic: (Aug.) K6MCA 993, W6GYH 869, K6OQD 505, MON 374, OZJ 360, W6HJY 197, BHG 158, ZJB 135, K6JQB 105, W6QLM 89, USY 82, K6EYPY 60, GUZ 43, EA 41, QMK 40, W6VSH 28, K6COP 20, W6BUK 14, K6DDO 13, W6YSK 13, K6HOV 10, W6AM 7, K6UYK 6, 1YJ 4. (July) W6ZJB 219, K6GOK 72, KN6ZDL 28, W6GJP 2.

ARIZONA—SCM, Cameron A. Allen, W7OIF—SEC: YWF. The Arizona Emergency Net meets Mon. through Fri. at 1930 MST on 3865 kc. with ASI as PAM. The Grand Canyon Net meets Sun. at 0900 on 7210 kc. with LUJ as PAM. Phoenix and Maricopa County have at last received their RACES license. UVR/M is active again working DX and as OO and OBS. He will be on s.r.b. mobile soon again. The hamfest at Ft. Huachuca was the largest and best they have had. Many new faces showed up as well as the regular gang. Traffic: W7FKK 55, YWF 17, OIF 8, CAF 2.

(Continued on page 168)

For a Limited Time Only!

FROM THE "WORLD'S LARGEST DISTRIBUTOR OF AMATEUR RADIO EQUIPMENT"

- Compact, portable, fixed frequency 2-way crystal controlled transmitter-receiver
- Communicate up to several miles under average conditions
- Guaranteed 100% satisfactory operation; all fresh batteries

For fun, for emergency, for point-to-point communication, every ham should own a pair of these compact, portable, fixed frequency 2-way crystal controlled Walkie Talkies. Made for the U. S. Navy by Communications Company of Coral Gables, Florida, these units are new. But because they have been warehoused for several years, each one has been carefully tested and operated to guarantee 100% satisfactory operation. All batteries are new. Applications are unlimited; — short-haul point-to-point communication, amateur field day service, marine mobile service, etc. (subject to the usual FCC regulations). Both transmitter and receiver are crystal controlled and designed to cover pre-set frequencies in the range 2.3 to 4.5 MC. When ordering, specify frequency: 3865 or 3995 KC. Crystals for additional frequencies available at \$6.95 per set. Receiver Tube Line-Up: 1R5 Crystal Oscillator Mixer, 1T4 IF amplifier, 1S5 Detector, 1st Audio, 3S4 Audio Output. Transmitter Tube Line-Up: 1T4 Crystal Oscillator, 3S4 RF Amplifier and 3S4 Modulator. Size: 7½x10x3-9/16". Shpg. wt.: 32 lbs.

WALKIE TALKIES



Just \$850 Down

And \$689 per mo.

Originally priced at Approx.
\$400 per pair

Only \$85⁰⁰ per pair

OR \$49.50 PER UNIT!

- Includes press-to-talk mike, separate whip antenna (closed: 15¼", opens to 85"), headphones, battery pack, crystals (specify frequency: 3865 or 3995 KC.), all tubes and complete instruction manual.
- Fully waterproof
- Covers 2.3-4.5 MC; mobile marine, CAP, MARS and 80M amateur phone band. Crystals for special frequencies available on order.

**First Come . . . First Served
As Long as They Last**

**Get Your Order In
TODAY!**

GENTLEMEN: Please rush immediately . . . One Walkie Talkie . . . A pair of Walkie Talkies to address below! I am enclosing my check for _____ in payment! Include crystals for 3865 Kc., or 3995 Kc.



NAME: _____
ADDRESS: _____
CITY & STATE: _____

Now In Stock In

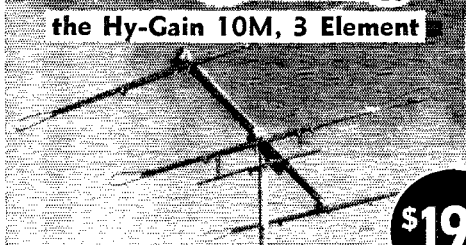

the Hy-Gain 10M, 3 Element

\$19⁹⁵

Small enough to be rotated by any TV rotator. Elements adjustable for max. gain over entire 10M band. Factory pre-tuned, pre-adjusted and pre-matched. Easy to assemble. No further adjustments necessary. Only 18 lbs. wt.

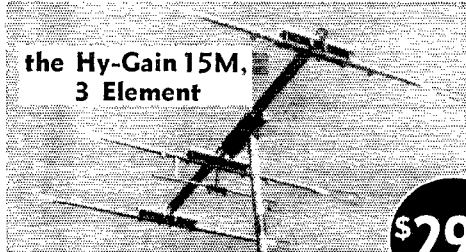

the Hy-Gain 15M, 3 Element

\$29⁹⁵

Ruggedly built, yet small enough to be rotated by heavy duty TV rotator. Adjustable over entire 15M band. T or Gamma match for any line balanced or coax 52-450 ohms. Simple to put up and into operation.

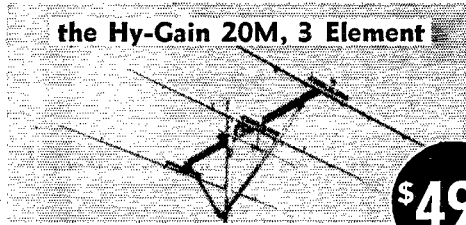

the Hy-Gain 20M, 3 Element

\$49⁹⁵

Heavy duty, full-sized 20M array; built to take it! Elements adjustable over the entire 20M band and are telescoped three times to minimize element sag. Combination T or Gamma match for any line balanced or coax 52-450 ohms.

and the complete line of **the Hy-Gain** ANTENNA PRODUCTS!

PLEASE SEND ME THE HY-GAIN BEAM CHECKED. MY CHECK OR MONEY-ORDER IS ENCLOSED.

10M 15M 20M

NAME:

ADDRESS:

CITY & STATE:

WESTERN RADIO 1415 INDIA ST. SAN DIEGO 1, CALIF.

SAN DIEGO—SCM, Don Stansifer, W6LRU—Your SCM is happy to report that he was renominated and automatically reelected for another two-year term while on vacation. K6UJL is now an OES and is very active on 6 meters. UQF, in Escondido, is now an ORS. Twenty-two active stations in North San Diego County report in on 8825 kc. at 0900 Sun. mornings to EC FVA for the AREC Net. K6s MYV and VYA now have AFS-13 on the air. A new Novice in National City is WN6NFO. A new club, the South Bay, has been formed. All are ARRL members. Officers are K6UMA, pres.; Carl Anderson, vice-pres.; KN6UUC, secy.-treas. They are holding classes for Novices and Generals. MIT is now teaching at La Jolla High School after graduating from San Diego State. K6E and K6DZ were authors of an electricity book recently published by the American Technical Society. FWF is now mobile in his new car. K6DVF is attending San Diego State while K6HKY is attending the Junior College. New secretary of the North Shores Club is ZBE. Ex-KN6ZDQ has passed his General Class exam. Well-known San Diego phone DXer and antenna expert ZWK has moved to the Los Angeles Area. CAE is up to 226 countries worked. CGQ again is active from San Diego after buying a new home. The Helix Club enjoyed a ladies' night dinner in September. The Upper-Ten Annual Picnic was, as usual, a success. K6UOD, in Orange County, is NCS for the 2-4-6 Traffic Net. His wife is K6ZEE, and their son is K6SEK. Traffic: W6LAB 2798, EOT 406, K6UOD 257, UJL 7.

SANTA BARBARA—SCM, Dorothy E. Wilson, W6REF—Asst. SCM: Bill Farwell, 6QIW. SEC: K6CVR. The Fiesta Day Parade of Santa Barbara Aug. 8 ran smoothly because of the help of the mobile and fixed stations manned by AMD, DOB, JRB, HUT, ELR and K6EGQ, CRJ, EAQ, DXW, UEC, LUA, ODE and EGR. Publicity in the Santa Barbara newspapers was written by K6ATX, YCF, Arroyo Grande and QIW. Oakview, were active in the CD Party. K6AEZ, Camarillo, is slowly recovering from a hip operation. Ex-VE3DDB now is a Santa Barbara resident. Traffic: W6REF 62.

WEST GULF DIVISION

NORTHERN TEXAS—SCM, Ray A. Thacker, W5TFP—Asst. SCM: Bruce Craig, 5JQD. SEC: BNG. PAMs: K5AEX and IWQ. RM: AHC. Once again the Waco hams came through with a bang-up job on their annual hamfest held in Cameron Park with congenial company, beautiful scenery, speeches to a minimum and "gobs" of prizes! LGY now is sporting a new 10-meter beam. The new officers of the Pampa ARC are JQJ, pres.; IWQ, vice-pres.; JHA, secy. KN5ULA is now on the air from Cowtown. She is the XYL of UXY. KN5LQB also is new to the hobby and lives in Sherman. FYL is the newly-elected NCS of the NWTEN and has named NEX, AVG, NFO and SHN as ANCSs. We hear that OCV and NFO recently endured a stint in Lubbock hospitals. I would like to take up the balance of our allotted space to bring to your attention the matter of official appointments. All holders of such appointments as ORS and OPS are required, by rules and regulation, to forward their certificates to their SCM for endorsement. This should be done on the anniversary date of the certificate. OO and OES appointees should, in addition to getting annual endorsement, agree to forward a monthly report of their activities in order to retain their appointments. I am sorry to say that my records reflect a failure on the part of too many appointees in this section in complying with this requirement! How about it? Traffic: W5ACK 341, AIIC 139, K5EMR 86, HAY 38, HTH 34, W5CRP 32, BOO 31, BKH 30, TFP 28, LGY 9, K5HWE 1.

OKLAHOMA—SCM, Richard L. Hawkins, W5FEC—Asst. SCM: James R. Booker, 5ADC. SEC: LXL. PAMs: EJK and MFX. RM: JXM. MFX is doing a fine job with our nets. Let's give him all our cooperation and thanks. 01EL/5 is now 5KG. KN5KWI moved to Pawhuska. DFF is studying Pre-Med, at Houston. K5DVE shorted her modulation transformer. K5KFS is a new OO. JKR is growing an antenna farm. CBY and CCK joined the ACARC. EIU has a new HQ-129X. ERV, K5TEC and HWP also are attending college this year. KN5HMY recently removed the "N" from his call. LTB and K5DJA visited the SCM. Come again, fellows. K5KTW has a new Valiant and HQ-110. K5EGS is the new EC for Comanche County. K5KTW is a new OPS. K5JEA, IYU and JSP are working DX. ESB received a BPI Medallion for outstanding traffic work. Congratulations. Bill, K5EJC's contact with KC4USK received nice publicity in the local paper. New calls in Bartleville are K5KHL, K5GQE and KN5LDP. Operating conditions are improving and traffic-handling is increasing. How about swamping me next month with activity reports.

(Continued on page 170)

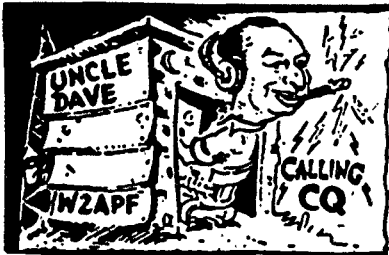

FORT ORANGE

Radio Distributing Co. INC

904 BROADWAY, ALBANY 4, N Y U S A
AMATEUR HEADQUARTERS

Call Albany 5-1594

Cable address "Uncledave"

Nites—Albany 2-7729

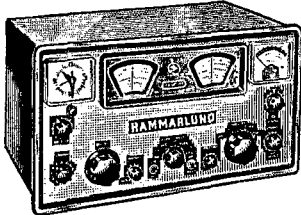

HAMMARLUND
HQ110 **\$229**

160-6 mtrs. Xtal calibrator built in.
Db11 conv. SSB. Speaker extra.

3-PART COMBINATION

for the CW BUG

**JOHNSON
MATCHBOX** **54⁹⁵**

**JOHNSON
NAVIGATOR** **149⁵⁰**
KIT

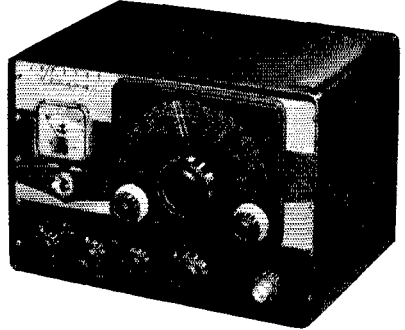

40 watt CW xmtr. 160-10 meters. Self contained power supply. Kit, 149.50 w/t, 199.50. Get all 3 pieces. Use our time pay plan.

NOW IN STOCK
JOHNSON THUNDERBOLT
2000 w P.E.P. input
wired and tested **\$525**

QSU
for best trades
for easy terms
for fast service
for largest stock

TAPETONE
XC144 2 mtr **84⁹⁵**
converter
XC50 6 mtr **64⁹⁵**
converter

WRL XMTRS

Globe Chief... kit 54.95, w/t..... 67.50
Globe Scout, 680, kit 89.95, w/t....109.95

IN STOCK RIGHT NOW
Full line of Cushcraft antennas, including

PRETUNED VERTICAL **28.50**
Triband trapped. 10, 15, 20 meters.

PANDA BEAMS **99.50**
Famous G4ZU pretuned 3 band minibeam single
feeder. Fits any 2" pole.

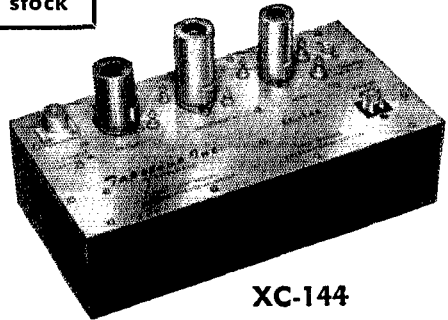

XC-144

QSU for TOP USED EQUIPMENT

TRANSMITTERS

Tecraft 2 mtr, TR144	\$ 44.95
Sonar 120, fone, CW (new).....	125.00
Elmac AF67, like new	149.95
Collins 32V3, xInt.....	595.00
Johnson Viking I, scratched.....	174.50
Eldico TR75, shopworn.....	29.50
Millen VFO, Mod. 90711.....	74.50
Eldico VFO	24.95

RECEIVERS

Collins 75A2, xtal cal.....	\$310.00
Hallcrafters SX42	165.00
Hallcrafters S38A	34.95
National HR05, complete	149.95
RME 84, 80-10 meters	69.95
Echophone, 80-10 meters	19.95
Elmac PMR6A, w. 6 volt sup.....	79.50
... and many, many others	

Write Uncledave
W2APF
with your needs
and problems.

FREE! CONELRAD CHARTS
NEW CATALOGUE

WE SPECIALIZE IN FOREIGN TRADE

TIME PAYMENTS
18 Months to pay, life
insurance at no extra cost

24 HR. SERVICE
on stock items

THE

Collins KWM-1

first mobile SSB
first mobile
transceiver

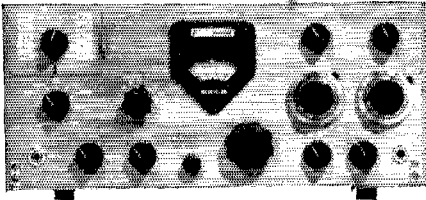

Use it for mobile. Use it for fixed station. No modification necessary in this 14-30 mc 175 watt PEP input transceiver. It's new, revolutionary, and we have it for immediate delivery!

Utilization of common components in both transmitting and receiving functions results in a saving of both space and cost and, in the case of frequency-determining components, assures exact coincidence of transmitted and received signals. Frequency stability and readability is comparable to that of the KWS-1/75A-4. The panel meter serves as an S-meter during receive and multimeter during transmit. Break-in CW using VOX circuits is built-in, as is a side tone for monitoring CW. Ten 100 kc bands are available anywhere in the 14-30 mc range.

NET PRICES

KWM-1 Transceiver	\$770.00
516E-1 12 vdc Power Supply	248.00
516F-1 115 vac Power Supply	103.00
312B-2 Speaker Console with directional wattmeter	146.00
312B-1 Speaker in cabinet	25.00
351D-1 Mobile Mounting Tray	TBA

Write us for complete information and details of our unusual Time Payment Plan. We feature a complete line of Collins equipment and accessories.

KINKADE RADIO SUPPLY INC.

1707 Grand Central Ave., Tampa 6, Florida

Traffic: (Aug.) W5ESB 317, DRZ 306, K5CAY 127, W5EJK 96, K5EGS 95, W5QVV 52, K5DVE 37, W5CCK 33, F5C 33, GOL 21, K5DJA 19, KTW 19, W5MPX 18, K5CBA 15, W5BBA 12, K5KFS 12, W5PNG 11, K5HIV 9, W5IER 2, (July) W5IER 4.

SOUTHERN TEXAS—SCM, Roy K. Eggleston, W5QEM—SEC: QKF, RM: FCX, ESZ has a new shack. MLV has a new QTH. FCX is the RM for South Texas. He has started the badly-needed South Texas C.W. Traffic Net at 3790 kc. at 1800 CST each evening Mon. through Sat. The fellows will welcome anyone with traffic or who wish to check in and join them. Mildred, YLRL vice-pres., ex-3YTM, now K5LIU, is living in Houston. Her OM is 3RRL. ZIN is manager of the 7290 Yankee Traffic Net, with BTH as assistant. ABY has 223 countries confirmed. K5EHA, EFB and ECB are new on 6 meters in Houston. New officers of the Brazoria County Radio Club are K5BYV, pres.; YXW, vice-pres.; BD, corr. secy.; UMY, secy.-treas.; WFO, pub. rel. off. URW has a new Matchstick antenna and says it works good with the DX-100. QKF and QEM have new Tri-band antennas. The Corpus Christi Amateur Radio Club has code classes each Thurs. at 7 p.m. from 5 w.p.m. up. LMU and his XYL have been vacationing in Colorado. DTJ has 200 Texas counties confirmed with only 54 more to go. DKK is leaving for Japan. He will be missed in Southern Texas. Traffic: W5EGD 210, FCX 158, DTJ 39, URW 31, KN5KVC 4, K5JGU 1.

CANADIAN DIVISION

MARITIME—SCM, D. E. Weeks, VE1WB—Asst. SCM; Aaron Solomon, IOC, SEC: FH. Congratulations to all members of the Keith Rogers Memorial Club on their fine performance in sponsoring the Charlottetown Convention. Some hamfest highlights: The GR Memorial Trophy for meritorious service was awarded to FQ. EK won the Brown-Holder DX Trophy. VE2AYA won the hidden transmitter contest, with VE1FS a close second. WINB won the prize for the best mobile installation. Newly-elected officers of the NSARA are VN, pres.; GA, 1st vice-pres.; FR, 2nd vice-pres.; AO, secy.-treas. AG has been transferred to the VE7 district. New appointments include AV, Official Observer, W1QCC/VE1. Official Experimental Station. EK has received word that he is the first Canadian to win the Swiss (H22) "Worked at Cantons" Award. VO2AT is active with a DX-35 transmitter. VO2TA has received a promotion and transfer to Montreal. VO2AD has moved to Ontario. VO2NA reports that he has been accepted into the "Tops C.W. Club" of England. Jack is the first VO to receive this honor. VO2AB was first in the low-power class for the district in the BERU Contest. Traffic: VOIEK 49, VU 2.

ONTARIO—SCM, Richard W. Roberts, VE3NG—RH reports the SWAP Club of Ontario is turning out successfully. It meets Tue. nights after the Ontario Phone Net on 3770 kc. We regret to announce the passing of Earl Kimble, VE3NI, of London, who was a very popular member of our fraternity. We will miss his portable at Rayfield, EBE, at Peterboro, has his Valiant perking. CE has a new HQ-110. DUU was made a grandpappy twice in one week. The Hamilton Radio Club held a very PB picnic at Aldershot. BBH won the hidden transmitter mobile hunt. LY will be heard from Lake Mazinaw on 75 meters soon. DSM, BUT, MF, RU, CO, NG, BIA, YD, DXNT and ADA assisted the committee in the running of the Governor General's Cup Race by providing communications for the course. The Toronto Flying Club passes its appreciation to all. The Air-Show at Toronto C.N.E. was the occasion. GJ is active from Orillia. GH and NG were guests of AJA at Meaford for the Rainbow fishing at Thanksgiving. NF was a visitor to the Exhibition at Toronto. Ontario hams are after their call letter plates for autos. Send QSLs or letters to the SCM stating that you are in favor of same. AJR, BBH, NG, DZA, DGV, DQG, BFQ, AQB and AZX were some of the visitors at the Hamilton Picnic. The Niagara group held a very successful Weiner Roast at TW's at Port Weller. VM is ill in St. Catherine's Hospital. DYJ has applied for his WAS. BXI has an HRO. DPG prints the paper for the Thumb Area group in Sarnia. DEY, DNJ and GI were FX hunting in Algonquin Park. Results? A few small fish. The antenna was a fish pole. GI, after 28 years, finally hooked 4X4 for his WAC. GI has resigned as manager of ECN. DNT has his flying ticket. DLIJZ is now a resident of Ontario and soon will be heard with a VE3 call. Plans are under way by the North Bay group for a moonlight hidden transmitter hunt for the hamfest to be held in the summer of '58. FGG has acquired a new SX-100. BUR was fishing in Connecticut and bumped into WIFYG; he also had an eyeball QSO with WIFFW. Traffic: VE3BUR 314, NO 101, GI 97, OD 70, DEX 62, NG 60, AUU 59, AML 58, LPO 47, EAU 40, DTB 39, AJR 37, (Continued on page 172)



RIDER BOOKS THE EASY WAY TO MORE ELECTRONIC KNOWLEDGE

for Career Advancement—More Successful Ham Operation

READ THESE NEW RIDER BOOKS

STEREOPHONIC SOUND by Norman H. Crowhurst

World famous audio authority, Norman H. Crowhurst's new book, is the first true assessment of this exciting new medium for realistic sound. It covers the theory of stereophonic sound; the differences that it can make in reproduction; what goes into making it successful; and what is needed to bring out the best in systems available, or likely to be available. It applies all this information to selecting the proper loudspeakers and components for the best stereo reproduction. Also covers stereo systems and techniques used for motion pictures. No. 209, soft cover, 128 pp.\$2.25

HOW TO READ SCHEMATIC DIAGRAMS by David Mark

Covering the symbols and abbreviations used in schematic diagrams related to the electronics field, this book starts with individual components and carries through to receivers and similar equipment. Components and circuits are identified and explained. No. 208, soft cover, approx. 170 pp.\$3.50

REPAIRING HI-FI SYSTEMS by David Fidelman

Deals with finding the troubles and repairing faults in hi-fi equipment with no test instruments—with simple equipment—and with elaborate equipment. Encompasses pre-amps, amplifiers, AM-FM tuners, loudspeakers, record players, changers and tape recorders. Shows how to analyze and repair typical troubles through a system of logical steps. No. 205, soft cover, 170 pp.\$3.90

GETTING STARTED IN AMATEUR RADIO by Julius Berens W2PK

For the individual who wants to get a license to own and operate his own amateur radio transmitter. Explains the license classes and requirements for each. Fundamentals of electricity and electronics explained in easy-to-understand language. Sample transmitting circuits. Stress placed on learning the International Morse Code, with a diagram of a code oscillator, and code memorization techniques. Numerous questions and answers for license examinations. Explanation of the FCC regulations. No. 199, soft cover, 140 pp.\$2.40

BASIC SERIES by Van Valkenburgh, Nooger & Neville, Inc.

The fabulous picture-text books, that teach faster and easier! The theory, principles and practice of electricity, electronics, synchros and servos, are here presented in a manner which permits a rapid grasp of the fundamentals of these vitally important subjects. Over 2,000 specially prepared illustrations present, explain and make every topic discussed picture clear.

- BASIC ELECTRICITY**, #169, soft cover, 5 volumes, 624 pp., \$10.00 per set. #169H, cloth bound in single binding, \$11.50
- BASIC ELECTRONICS**, #170, soft cover, 5 volumes, 550 pp., \$10.00 per set. #170H, cloth bound in single binding, \$11.50
- BASIC SYNCHROS & SERVOMECHANISMS**, #180, soft cover, 2 volumes, 270 pp., \$5.50 per set. #180H, cloth bound in a single binding, \$6.95

BASIC TELEVISION

by Dr. Alexander Schure

The whole world of black and white television is before you for only \$10.00.

New 5-volume Rider "picture book" course by Dr. Alexander Schure teaches the complete basic principles and practices of black and white television easily, quickly and understandably. You can master the basics of television easily, rapidly and thoroughly with this "learn by pictures" training course.

It's so easy to learn

Here's how this easy, illustrated course works. Every page covers one complete idea! There's at least one big illustration on that same page to explain it! What's more, an imaginary instructor stands figuratively at your elbow, doing "demonstrations" that make the theory easy for you to follow and understand. Then, at the end of every section, you'll find a review that highlights the important topics you've just covered. You build a thorough, step-by-step knowledge at your own pace—as fast as you yourself want to go.

5 complete volumes

It starts with the transmitter and discusses in detail the following subjects: Volume 1 deals with the transmitter; the handling and the operation of the camera; formation of the picture signal and the general content of the transmitter. Volume 2 covers the organization of the entire TV receiver treating each section individually from antenna to picture tube. Volumes 3, 4 and 5 contain the TV receiver circuit explanations. Each volume covers a specific number of sections in the receiver. In effect, the presentation is like a spiral—first an overall view of the whole, and then the detailed explanation of each part. The most perfect modern teaching technique. The result—maximum understanding.

No. 198, soft cover, 5 volumes, \$10.00 per set; No. 198-H, cloth bound in a single binding, \$11.50.

ADVANCE YOUR CAREER WITH THESE BOOKS

- INTRODUCTION TO PRINTED CIRCUITS** by Robert L. Swiggett, #185, soft cover, 112 pp., \$2.70
- HOW TO USE TEST PROBES** by A. Ghiradi & R. Middleton, #165, soft cover, 176 pp., \$2.90
- UNDERSTANDING VECTORS & PHASE** by Rider & Usian, #103, soft cover, 160 pp., \$3.99
- HOW TO USE METERS** by John F. Rider, #144, soft cover, 144 pp., \$2.40
- FUNDAMENTALS OF TRANSISTORS** by Leonard Krugman, #160, soft cover, \$2.70
- INTRODUCTION TO COLOR TV** (2nd Edition) by Kaufman & Thomas, #156 soft cover, 160 pp., \$2.70
- HOW TO SELECT AND USE YOUR TAPE RECORDER** by David Mark, #179, soft cover, 148 pp., \$2.95
- OBTAINING & INTERPRETING TEST SCOPE TRACES** by John F. Rider, #146, soft cover, 190 pp., \$2.40
- TELEVISION—HOW IT WORKS** (2nd Edition) by J. Richard Johnson, #101, leather finish MARCO, 352 pp., \$4.60. #101-H, cloth bound, \$5.50
- REPAIRING TELEVISION RECEIVERS** by Cyrus Glickstein, #191, soft cover, 212 pp., \$4.40
- FM TRANSMISSION & RECEPTION** (2nd Edition) by Rider & Usian, #102, cloth bound, 460 pp., \$4.95
- CLOSED CIRCUIT TV SYSTEM PLANNING** by M. A. Mayers & R. D. Chipp, #203, cloth bound 8 1/2 x 11", approx. 250 pp., \$10.00
- HOW TO INSTALL & SERVICE INTERCOMMUNICATION SYSTEMS** by Jack Darr, #189, soft cover 152 pp., \$3.00
- TRANSISTOR ENGINEERING REFERENCE HANDBOOK** by H. E. Marrows, #193, cloth bound, 9x12" 288 pp., \$9.95
- BASICS OF PHOTOTUBES & PHOTOCELLS** by David Mark, #184, soft cover, 136 pp., \$2.90

ELECTRONICS TECHNOLOGY SERIES edited by Alex. Schure, Ph.D., Ed.D.

- #166 RC & RL Time Constant.....Only \$.90
- #166-2 FM Limiters & Detectors.....Only \$.90
- #166-3 Frequency Modulation.....Only \$.90
- #166-4 Crystal Oscillators.....Only \$1.25
- #166-5 A-M Detectors.....Only \$1.25
- #166-6 Limiters & Clippers.....Only \$1.25
- #166-7 Multivibrators.....Only \$.90
- #166-8 R-F Transmission Lines.....Only \$1.25
- #166-9 Amplitude Modulation.....Only \$1.25
- #166-10 Blocking Oscillators.....Only \$1.25
- #166-11 Wave Propagation.....Only \$1.25
- #166-12 Superheterodyne Converters & I-F Amplifiers.....Only \$.90
- #166-13 L-C Oscillators.....Only \$1.25
- #166-14 Antennas.....Only \$1.50
- #166-15 Inverse Feedback.....Only \$.90
- #166-16 Resonant Circuits.....Only \$1.25
- #166-18 DC Circuit Analysis.....Only \$1.35



W2RID

RIDER BOOKS

FREE! FREE! Handsome genuine leather, gold stamped bookmark—lasts a lifetime — if you write today for FREE 1957 Summer-Fall Catalog Q-11 of all RIDER Books.

JOHN F. RIDER PUBLISHER, INC. 116 West 14th Street, New York 11, N. Y.

In Canada: Charles W. Pointon, Ltd. 6 Alcina Ave., Toronto, Ontario

LEARN CODE and Theory



50¢ UP

SIMPLE, FAST, HOME STUDY

78 or 45 r.p.m. Unbreakable Phonograph Records & Easy-To-Understand Books. **PASS COMMERCIAL AND AMATEUR CODE & THEORY EXAMS, FOR YOUR FCC LICENSE!**



AMECO Courses & Books Available:

No. 1 — NOVICE CODE COURSE. You get and keep 10 recordings (alphabet through 8 W.P.M.). Includes typical FCC type code exams. Free instruction book on learning how to send and receive code the simplest, fastest way; plus charts to check your receiving accuracy; plus an album; all for the low price of only: 45 r.p.m. **\$6.95** 78 r.p.m. **\$7.95**

No. 2 — SENIOR CODE COURSE. You get and keep everything given in the Novice Course except that you get 22 recordings (alphabet through 18 W.P.M.), plus typical FCC type code exams for General class and 2nd class commercial telegraph licenses. All this for only: 45 rpm **\$11.95** 78 rpm **\$12.95**

No. 3 — NEW ADVANCED COURSE. Prepares Novice operators for the amateur general class and second class commercial license tests. Contains 12 recordings (8 through 18 W.P.M.) PLUS the complete code book — PLUS typical F.C.C. code examinations for general and commercial tests. ALL for only: 45 r.p.m. **\$3.95** 78 r.p.m. **\$6.95**

No. 4 — COMPLETE RADIO THEORY COURSE. A complete, simplified home study theory course in radio covering the Novice, Technician, Conditional and General classes — all under one cover — with nearly four hundred typical FCC type questions to prepare you for license exam. No technical background required. You also get, FREE, a guide to setting up your own Ham station. All for the amazing low, low price of . . . **\$3.95**

No. 5 — RADIO AMATEUR QUESTIONS & ANSWERS LICENSE GUIDE. A "must" if preparing for Novice, Technician or general class exams. Approx. 200 questions & answers (most multiple choice type) similar to ones given on F.C.C. exams. Has 2 typical F.C.C. type exams. Other questions by subjects, easier to study. Low, low price of **50¢**

No. 6-01 — MASTERING THE MORSE CODE. This book gives the fastest, up-to-date method for learning how to send and receive International Morse Code. It describes the code alphabet and give practice study lessons for the exam. Also discusses construction and hook-up of a code practice oscillator. Only **50¢**

No. 8-01 — THE COMMERCIAL RADIO OPERATOR'S QUESTION AND ANSWER LICENSE GUIDE — Elements 1 and 2. This book contains the questions and clear, simplified answers for elements 1 and 2. In addition it contains sample FCC-type practice exams using multiple choice questions. Elements 1 and 2 are required for all FCC commercial exams). Only **75¢**

No. 9-01 — THE COMMERCIAL RADIO OPERATOR'S QUESTION AND ANSWER LICENSE GUIDE — Element 3. Contains questions and answers and sample FCC-type practice exam for element 3. Complete preparation for 2d class Radio Telephone license. Only **\$1.75**

FREE LITERATURE AVAILABLE Sold at leading distributors everywhere or write to Dept. Q11

AMERICAN ELECTRONICS CO.
1203 Bryant Ave., New York 59, N.Y.

See Page 108

QUEBEC—SCM, Gordon A. Lynn, VE2GL—BR has resigned as SEC and Felix Edge, QN, 2604 de la Falaise, Sillery, Que., has been appointed to take his place. ECs are requested to send their reports to him. EC skeds AEM daily at 0830 and APP Sun. at 1315 and KJ daily at 1300, and reports into the Quebec Net if any traffic is offered. AGL mobile, handled traffic from the Boy Scout Camp at Lake Souris. AGN is working on a new rig but continues to handle considerable traffic on various skeds. ATL also handles traffic on skeds. AWK likewise handles traffic on skeds and this month makes BPL on originations and deliveries. DR and CP are holding up the Quebec end of PQN/OSN. Traffic: (Aug.) VE2AGN 230, ATL 125, AWK 124, DR 116, EC 43, GL 14. (July) VE2ATL 137.

ALBERTA—SCM, Sydney T. Jones, VE6MJ—PAM: OD. MQ has moved his QTH to Ottawa and is active from the new location on 14 Mc. Congratulations to NX, IC and KC on their recent fine showing in making the first 144-Mc. contact between Edmonton and Calgary. Using i.m. equipment, with 40 watts at the Calgary end and 60 watts at the Edmonton end, plus eight-element beams, contact was established on Sept. 2. This is the best distance worked to date, and while it is not a record from an international point it is a record in these parts. Nice going, boys. Can Calgary top this one? DZ and his XYL have returned from a vacation trip to W6-Land. IC has completed a 420-Mc. beam. SF is a newcomer and sports an FB signal from Barhead. WG is active on 7-Mc. c.w. and is a new ORS. CP was a recent Edmonton visitor. ED was a vacation visitor to Jasper, from which point he made his usual check-ins on the Alberta Net. Traffic: VE6HM 193, MJ 8, TT 6, BL 4.

BRITISH COLUMBIA—SCM, Peter M. McIntyre, VE7JT—Asst. SCM: Vic Waters, 7ALR. With an assist from stormy Sol, members of the British Columbia DX Club enter their season dedicated to the Promotion of Interest in DX affairs' in Canada's far-west province. Charter members include GH, with a total of 243 captured and 233 confirmed, as prey; YR, 204/189 as secy.; and QL, a former DXCC holder from Ontario under the call 3TB, as treas. Other founders include DXCC members VC, 197/182; MD, 173/151; and ZK near 200. Within four or five confirmations of the elusive parchment are ALR, JY, BV, AMI, KJ, AHG, DT, HV and VO, 200 plus. With club stimulus, many members who enrolled with totals of around 30 or 40 have garnered 100 to 125 countries and lurk behind the drapes daily watching for the postman. The club contains its own TVI and technical committees to assist membership. Highlight of last season's social activity was a trip to Centralia, Wash., to meet and exchange dope with members of the Seattle and Williamette Valley Clubs. Seattle plans to be host city this year with Vancouver hosting in '58. Besides rigs and 'hooks for the regular bands, all club members operate 50-watt 2-meter rigs for liaison purposes. The club welcomes DX visitors regularly and arranges reports and demonstrations on new apparatus for further interest. New members with DX leanings are welcome. Contact the secretary, YR. Traffic: KG1DT 1012.

MANITOBA—SCM, James A. Elliott, VE4IF—LO is back to work from Gull Lake. He works mobile now and then and the home station is back in operation at Charleswood. HB has returned from a very fine vacation in California. He had a mobile rig in the car but didn't have too many QSOs. JW's car broke down on his trip to Togo, Sask., and had to be towed back. SR has been operating fixed portable at Lake Breerton in the Whiteshell. The rig is a DX-35 working all bands. CU has been working fixed portable at Falcon Lake. The rig is a Globe Scout and a National 46 receiver working 20 and 75 meters. ER will be off work for some time yet. The doctors are trying bone graft on his leg. ARLM Hamfest Highlights: The winner of the NC-300 was Robert Hall. Yep, you guessed it. He is not a ham! XZ was first in the hidden transmitter hunt, EG first in the mobile contest, and the c.w. contest was won by MM. Our many thanks to all those who helped to make this event so successful. AU and family arrived back from a month's vacation in Eastern Canada. TB and Alma are back to work after a trip to Clear Lake and Pin Flon. We are very happy to report a new XYL licensee. Fran Gingles, SQ. Traffic: VE4GE 17, IF 8, JY 8, AN 6, HL 4, KN 4.

SASKATCHEWAN—SCM, Lionel O'Byrne, VE5LU—GQ has moved from Saskatoon to Regina and is on 10 meters. HN is going to the States. CW has a new QTH. The RARA gave XX and his XYL, YY, a farewell party and presented them with a gift. They are

(Continued on page 174)

don't settle for less than *Collins* from **ACK** RADIO SUPPLY CO.

CALL "ACK"
W4ECI

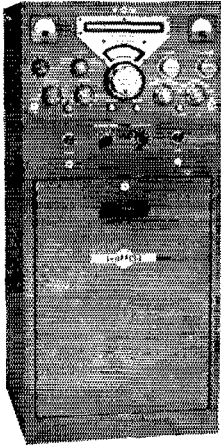

KWS-1

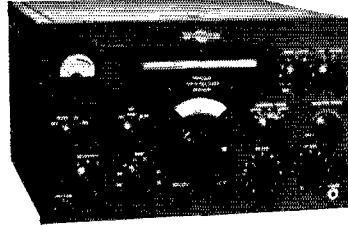

75A-4

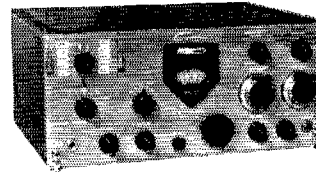

KWM-1

KWS-1

POWER AMPLIFIER INPUT — 1 kw peak envelope power SSB, 1 kw CW operation. Equivalent to 1 kw on AM when using narrow bandwidth receiver.

R-F OUTPUT IMPEDANCE — 52 ohms.

FREQUENCY BANDS — 80, 40, 20, 15, 11, 10 meters.

EMISSION — SSB, AM carrier plus one sideband, CW, HARMONIC AND SPURIOUS RADIATION — (Other than 3rd order distortion products.) Intra-channel radiation is at least 50 db down. All spurious radiation at least 40 db down at output of exciter. Second harmonic at least 40 db down; all other harmonics at least 60 db down.

DISTORTION — SSB, 3rd order products approximately 35 db down at 1 kw PEP.

FREQUENCY STABILITY — After 15 minutes warmup, within 300 cps of starting frequency. Dial accuracy: 350 cps after calibration.

AUDIO CHARACTERISTICS — Response: ± 3 db, 200 to 3,000 cps. Noise and hum: 40 db or more below reference output level. Input: .01 volts for rated power output.

MICROPHONE INPUT — Will match high impedance dynamic or crystal.

WEIGHT — 210 pounds.

SIZE — (Both Units) — 40 1/2" high, 17 1/4" wide, 15 1/2" deep.

RACK MOUNTING — Angle brackets kits available for RF Unit and power supply.

Net Price -----\$2,095.00

75A-4

FREQUENCY BANDS — 160, 80, 40, 20, 15, 11, 10 meters. **SIZE** — 10 1/2" high, 17 1/4" wide, 15 1/2" deep.

WEIGHT — 35 pounds.

RACK MOUNTING — Angle mounting kit available.

NUMBER OF TUBES — 22, including rectifiers.

SENSITIVITY — 1.0 microvolt for 6 db signal-to-noise ratio with 3 kc bandwidth.

AVC CHARACTERISTICS — Audio rise less than 3 db for inputs of 5 to 200,000 uv.

IMAGE AND IF REJECTION — Image ratio at center of each band 50 db or better. IF rejection at center of each band 70 db or better.

AUDIO CHARACTERISTICS — Output — .75 watts with a 3.0 uv signal, 30% modulated. Output impedance — 500 ohms, 4 ohms. Response of audio circuits — ± 3 db 100 cps to 5,000 cps. Distortion — Less than 10%.

MUTING — Provisions for muting the Receiver during key-down operation are provided. A muting voltage of +20 volts must be supplied by transmitter.

FREQUENCY STABILITY (at 14 mc) — Temperature — Less than 1200 cycles drift from 0 to $\pm 60^\circ$ C. Warmup drift — Less than 300 cycles after 15 minutes operation. Line voltage — Less than 100 cycles for $\pm 10\%$ change. Dial accuracy — 350 cycles after calibration.

Net Price -----\$695.00

KWM-1

Use it for mobile. Use it for fixed station. No modification necessary in this 14-30 mc 175 watt PEP input transceiver. It's new, revolutionary, and we have it for immediate delivery!

Utilization of common components in both transmitting and receiving functions results in a saving of both space and cost and, in the case of frequency-determining components, assures exact coincidence of transmitted and received signals. Frequency stability and readability is comparable to that of the KWS-1/75A-4. The panel meter serves as an S-meter during receive and multi-meter during transmit. Break-in CW using VOX circuits is built-in, as is a side tone for monitoring CW. Ten 100 kc bands are available anywhere in the 14-30 mc range. Size: 6 1/4" H x 14" W x 10" D.

NET PRICES

KWM-1 Transceiver	\$770.00
516E-1 12 vdc Power Supply	248.00
516E-1 115 vac Power Supply	103.00
312B-2 Speaker Console with directional wattmeter	146.00
312B-1 Speaker in cabinet	25.00
351D-1 Mobile Mounting Tray	TBA



**RADIO
SUPPLY
COMPANY**

Wholesale Electronics
3101 FOURTH AVE. SO.
BIRMINGHAM 5, ALA.
TELEPHONE 4-0588

**24 MONTHS
TO PAY!
TRADE-IN
ALLOWANCES!**

the Collins KWM-1

SSB Mobile Transceiver

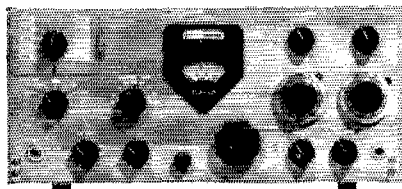

FIRST Mobile SSB Transceiver — 175 watts PEP input, 14-30 mc. Excellent frequency stability. Use as mobile or fixed station without modification. Break-in CW using VOX circuits, side tone for monitoring CW. Ten 100 kc. bands available anywhere in the 14-30 mc range. 6¼" H x 14" W x 10" D. Net price -----\$770.00

Write or see us about trade-ins,
time payment terms.

ELMAR ELECTRONICS

140 Eleventh Street

Oakland 7, California

NOW AVAILABLE...



Just released by the Philco Technological Center . . . gives comprehensive coverage of the Concepts of SSB . . . Transmitter and Receiver Theory . . . Transmitter and Receiver Maintenance Techniques.

140 pages—easy to read and easy to understand with **Only \$300**
127 illustrations. Postage Prepaid

Send check or money order to:

PHILCO TECHNOLOGICAL CENTER

PHILCO TECHREP DIVISION
22nd & Lehigh Avenue, Dept. TC-2
Philadelphia 32, Pa.

leaving for Weyburn where XX will manage new station CFSL. The Moose Jaw Club has purchased a trailer for the AREC and is installing the club transmitter. The RARA set up club station NN at the exhibition and reports 18 applications for code classes. Send your reports and letters to me at Rowatt. My telephone number is Lakeside 7-4714.

Project Perseids — 1957

(Continued from page 37)

chance of making random contacts in this way. Once calls were exchanged, the balance of the QSO could be carried out in the more-or-less standard meteor-scatter routine.²

A Panadaptor is a great help in the hand-scanning that must be done to take advantage of such a calling system. The method at W2CXY is to scan from 144.0 up to 144.5 and back, using a 50-kc. sweepwidth. Any promising pips can be zeroed in at once, and then all the operator has to do is wait for the next burst.

Best direction from W2CXY appears to be a few degrees south of west, though no obstructions interfere in other directions. A virtual meteor pipeline is in evidence to Missouri and Oklahoma. Anyone in doubt can see for himself; there are plenty of fellows in those states who want schedules in the future. Intensive use of meteor-scatter techniques should make a practical maximum of 37 states workable from the East Coast. For a strategically-located W5, W9 or W0, a 144-Mc. WAS is not beyond the realm of possibility, and 40 or more are well within the reach of many others.

A comparison of DX possibilities of meteor scatter and aurora is of interest, in view of recent auroral DX of record proportions. W4LNG, Georgia, at 700 miles, has yet to be worked via meteors, but W4MBR, running only 50 watts in the same state, was worked via aurora Sept. 4 and 13. K0DOK, not even heard via m.s., and W0TGC, both 900 miles with whom we couldn't quite make it during the Perseids, were both worked via aurora on the 13th. Conversely, stations at greater distances, such as W5AJC, W5DFU and W5JWL, all active during the big auroras recently, were not heard here except by meteor skeds during the Perseids. At the moment it appears that for extreme DX meteor scatter is one's best bet, but for ranges out to a maximum of perhaps 1000 miles, and with stations in the higher geomagnetic latitudes, auroral reflection may provide the best chance for solid contact.

That tropospheric openings have a potential for extreme DX is proven by the KH6UK — W6NLZ work on 144 Mc. And the tropospheric session of Sept. 17 provided a chance to work out almost to the distances thus far covered only by m.s. Perhaps consistent effort on all three fronts will someday help us to reach that numerically not-too-distant goal of a 144-Mc. WAS!

² "World Above 50 Mc.," March, 1957, QST.

MM-1 + Receiver Monitoring = MM-2

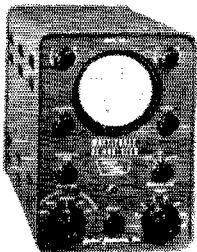

All the transmit features of the MM-1 *plus* RECEIVER MONITORING are presented in the new MULTIPHASE RF ANALYZER MM-2.

For use on SSB, DSB, AM, PM and CW.

RECEIVER MONITORING — use with any receiver.

Look at received signals. Give reports of Overmodulation, Flat-topping, Parasitics Key waveshape, etc. Simple connections, no holes to drill, plug-in IF unit. New features asked for in your letters.

New variable sweep control with improved speech locking for transmit and receive.

TRANSMITTER MONITORING — NO TUNING, BROADBAND response flat from 1 MC to 55 MC at power levels of 5 watts to 5 KW. Useful indications to 200 MC. For use in "series" with 52-72 ohm coaxial lines. A short pickup antenna is recommended for other systems. RF attenuator controls height of pattern in 3 db steps. Function selector for envelope, trapezoid or bow tie patterns. Built-in 1 KC oscillator.

Silent, Automatic, Electronic switching between RECV and XMIT triggered by transmit RF.

Model MM-2 wired, less IF Adapter \$129.50 Kit . . . \$99.50

Plug-in IF Adaptors — Model RM-50 for 50 KC IF, Model RM-80 for 80 KC IF,

Model RM-455 for 450 to 500 KC IF \$9.95

Watch for early announcement of our new Model 100V Broadband Exciter-Transmitter with built-in Linear VFO. It will be advertised when it is in stock at your distributor.

WRITE FOR INFORMATION



Central Electronics, Inc.

1247 W. Belmont Ave. • Chicago 13, Illinois

THE C & G 7-BAND ANTENNA SYSTEM IS PROVING ITSELF!

CAN CHANGE BANDS QUICKLY!

Roy Devish, W7AZI, says:

"I didn't know how much fun being a ham really is until I got my Model 200. I can change bands quickly with no tower climbing nor elaborate switching."

Send for FREE BROCHURE

C & G RADIO SUPPLY CO

2502 JEFFERSON

Phone

TACOMA 2, WASH.

BR 3181

DEPEND
ON...

PREMAX

FOR POSITIVE UHF RECEPTION

CAR-TOP and MOBILE ANTENNAS

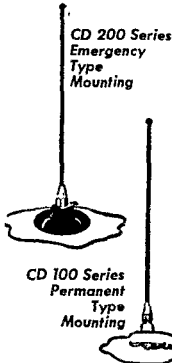

Sharpen all UHF radio signal reception with Premax Car-Top Antennas. Heavily plated, tempered spring steel with well-insulated mountings for 108 to 120 Mc., 144 Mc. and 152 to 162 Mc. reception. Permanent type mounts easily through a single hole. Emergency type attaches with single suction cup fitting.

SEE YOUR DEALER, OR WRITE

PREMAX PRODUCTS

Div. Chisholm-Ryder Co., Inc.

5735 Highland Ave.

Niagara Falls, N. Y.

Correspondence

(Continued from page 90)

on the air waves. While tuning around the 15-Mc band I bumped into Radio Moscow just in time to catch the program "Moscow Mailbag" beamed to the U. S. It seems several listeners in this country evince quite an interest in what goes on in Russia, but especially what gives with the Russian ham. Of a total of eight questions fired in by SWLs in the U. S., five were questions on the activities of Russian hams and SWLs.

I copied down the answers to a portion of the questions as follows: SWLs, to obtain a license, must demonstrate their ability to copy 50 "signs" per minute, and know how to operate a receiver. "Beginners" are limited to 10 watts c.w. on the 80- and 160-meter bands and must be able to copy 60 "signs" per minute. To obtain a Second Class license one must build his own transmitter, be able to copy 80 "signs" per minute and is limited to 40 watts c.w. on 160, 80, 40, and 20 meter bands. The First Class operator must be able to build a "complicated transmitter," copy 120 "signs" per minute and can operate c.w./phone on all the above bands plus 20 and 15 meters.

Things are tough all over, ain't they? And just think, they don't have the equivalent of Heathkit and Co., over there.

—H. M. Austin, W3IPO

... DE ... DE ...

542 So. Irving Blvd.
Los Angeles, Calif.

Editor, QST:

Why is it that most of the newcomers think that their calls include DE on the front end? Heard a KA4 sending "CQ NNQ TENMA DEKA4. DEKA4. DEKA4." Enough has been said in the past about this. Before it becomes international, can't some law be passed that only one DE be used between calls? It would be interesting to discover just how all this got a toe hold in the game.

—Dave Atkins, W6YX

EDITOR'S NOTE: The correct use of DE, and lots more hints on good operating can be found in W6DTY's article, "Your Novice Accent," November, 1956. Reprints are available from Hq. on receipt of self-addressed, stamped envelope.

World Above 50 Mc.

(Continued from page 86)

W9KLR, Rensselaer, Ind. — QRM in low part of the 2-meter band is a limiting factor in DX work during wide-spread openings. Many good signals heard from points beyond 1000 miles during summer sessions, but seldom can get through, even with high power and 64-element array. Too many operators are fascinated by hearing strong signals on voice, at distances of 500 miles or so, and they fail to listen carefully for c.w. signals from much greater distances.

W6WEG, Normandy, Mo. — Would like to hear from individuals or groups interested in establishing cross-country 50-Mc. net. Aim would be consistent coverage, ultimately for traffic purposes, regardless of conditions.

Operation Alert

(Continued from page 67)

3980 kc. Operations were resumed on Sunday, after a five-hour layoff during the period from 0300 to 0800. About 150 messages were moved, most of them with long and difficult text. The Oak Ridge net operated on 50.7 Mc. and maintained contacts with several outlying points. W4CXY summarizes difficulties as follows: (1) Unsatisfactory operation of the Knoxville mutual aid headquarters. (2) Failure to utilize frequencies specified in the RACES plan. (3) Insufficient

(Continued on page 178)

NEW

series 7000 sub-miniature rotary switch

OFFERING
UP TO TWELVE
POSITIONS
PER DECK
AND THREE DECKS

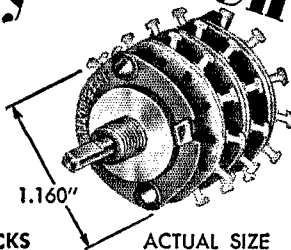

Maximum versatility, 1 to 3 decks, wide range of contact arrangements. Specially impregnated glass melamine wafer. Solder type lugs. Positive indexing.

Write FOR ENGINEERING DATA SHEETS ON ROTARY SWITCH AND:

1½" Ruggedized Meters; 1" and 1½" Panel Meters; 1½" VU, Db and Illuminated Meters; Miniature Multitesters; and Side Indicators.

international instruments, inc.

P.O. BOX 2954, NEW HAVEN 15, CONN.
Cable "INTERINST"



Quality Built
2 & 6 METER CONVERTERS

XC-144

Two Meter grounded grid 417A Crystal Controlled Converter. 2.8 db Noise figure, 33 db Power gain, 60 db Image rejection, 80 db I.F. rejection and 80 db down on all other spurious responses. XC-144 output 14 to 18 mc. Other models — XC-144-C output 26 to 30 mc, and XC-144-N output 30 to 34 mc. Price \$84.95

Special DOUBLE CRYSTAL Converters Available for COLLINS 75A4 receiver
XC-144-C4 \$89.95 XC-50-C4 \$69.95

New Regulated Power Supply Model PSR-150 available . . . price 49.95



- UNIFORM RESPONSE
- LOW NOISE FACTOR
- HIGH OFF-BEAM SIGNAL REJECTION
- TOP NOTCH RECEPTION

XC-50 — Six Meter Double Cascode Crystal Controlled Converter. 4 db Noise figure, 33 db Power gain, 90 db Image rejection, 80 db I.F. rejection and 80 db down on all other spurious responses. XC-50 output 14 to 18 mc. Other models — XC-51 output 10 to 14 mc, XC-50-C output 26 to 30 mc, and XC-50-N output 30 to 34 mc. Price \$64.95

Ask your dealer or write to

TAPETONE, INC.
10 ARDLOCK PLACE, WEBSTER, MASS.

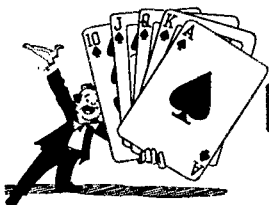

for the
BEST DEAL
try

BOB and JACK'S
WØAUL WØPRF

STORE FOR HAMS

- ✓ **THE NAMES YOU KNOW**—B & W, Gonset, Hallicrafters, Hammarlund, Hy-Gain, Johnson, Mosley, National, RME and WRL.
- ✓ **PRICES YOU CAN AFFORD**—Easy terms. 10% down—18 months to pay.
- ✓ **MONEY SAVING TRADE-INS**—Top trade-in allowances cut the amount you pay.
- ✓ **GUARANTEED USED GEAR** — We won't sell it unless it works.
- ✓ **HELPFUL SERVICE** — We'll take time to personally help you. Ham radio is our only business.
- ✓ **CENTRAL LOCATION—FAST DELIVERY**—We're as near as your mailbox or telephone . . . as fast as the trains.

SEE OR WRITE US WHATEVER YOUR NEEDS

BOB and JACK'S
STORE FOR HAMS

611 FOREST AVENUE
DES MOINES, IOWA

the *Collins* KWM-1 SSB Mobile Transceiver

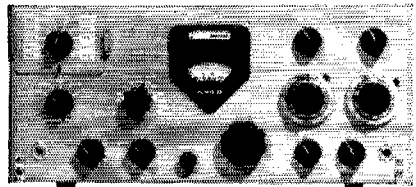

FIRST Mobile SSB Transceiver — 175 watts PEP input, 14-30 mc. Excellent frequency stability. Use as mobile or fixed station without modification. Break-in CW using VOX circuits, side tone for monitoring CW. Ten 100 kc. bands available anywhere in the 14-30 mc range. 6 1/4" H x 14" W x 10" D. Net price -----\$770.00

Write or see us about trade-ins, time payment terms.

GRAHAM
ELECTRONICS SUPPLY, INC.
102 So. Pennsylvania St.
Indianapolis, Indiana

1 of 4 **NEW**

Self-Supporting

(Above 18 ft.)
TRAP VERTICAL
Antennas
from
hu-gain

THE
18
AV

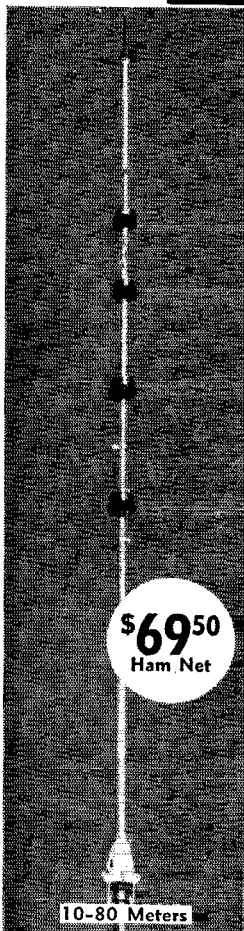

\$69.50
Ham Net

10-80 Meters

Trap Vertical for automatic coverage of 10-80M bands. Insu-Traps isolate sections of Vertical; develop 3/4-wave resonance on 10 & 15M, and 1/4-wave resonance on 20, 40 & 80M. 52 ohm coax feed. Less than 2:1 SWR all bands. Incl. side-mount kit for use at 18' height; self-supporting above. Height: 38'. Detailed instructions.

NOW IN STOCK

Write for Brochure

World Radio
LABORATORIES

3415 W. Broadway
Council Bluffs, Iowa

178

use of 6 meters and 80 meter c.w. for statewide coverage. Nineteen amateurs participated in the alert from Oak Ridge and did a magnificent job.

In Memphis, local activity commenced at 1000 CST on Friday, using portable, mobile and fixed stations for point-to-point service within the city. At headquarters, transmitters were in operation on 2, 6, 10 and 75 meters, the latter for maintaining contact with Nashville. About 75 messages were handled on the state net, some of them as long as 230 words. For the most part, traffic was handled without delay, and the c.d. director commended the amateurs on their performance. Over 40 amateurs participated.

Virginia

Hampton EC W4AJA, although declining to speak officially for RACES, informs us that operation in the Hampton-Newport News-Warwick area was on a limited basis with activation of key personnel only. Operation was on 3997 only. W4AJA activated the Tri-Cities Emergency Net on 10 meters at 0930 Friday until 1030 Saturday, making contact with Norfolk city and county nets. Seven stations acted as net control during this time, with six others participating.

Washington

We don't have much information on Kings County RACES participation in Operation Alert, but we do know they were active and did a good job by the copy of a press release we received. It seems that operating procedures, message center and around-the-clock operations were all thoroughly tested, and the mayor of Seattle was pleased to the point of issuing a public statement praising the RACES group. Fifty-five mobile units participated.

West Virginia

State Radio Officer W8HZA and SEC W8KXD both submitted summaries on the statewide operation. All three target cities (Wheeling, Huntington and Charleston) had a good amateur representation. Twelve operators took the 24-hour period of operation from the control station in South Charleston. Twenty operators were used at Wheeling to maintain the state-to-county circuit and provide 10 and 6 meter links between county c.d. headquarters and the remote RACES station. About 40 operators were used throughout the state. All statewide traffic was handled on 3502 kc.; little use was made of 3997 except to confirm previous observations that it was useless for practical message handling. A total operating time of 15 hours, 45 minutes was logged, with 58 messages handled. W8HZA acknowledges the enthusiastic support of the AREC in West Virginia.

Wyoming

State control center operated six RACES stations with six operators 44 out of 56 hours, handling a total of 60 messages. No detail of local operation available.

(Continued on page 180)

1 of 4 **NEW**

Self-Supporting

TRAP VERTICAL
Antennas
from
hu-gain

THE
14
AV

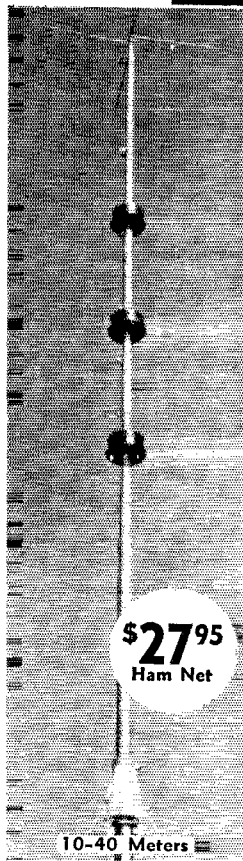

\$27.95
Ham Net

10-40 Meters

Trap Vertical for automatic coverage of 10, 15, 20 & 40 meters. Insu-Traps isolate sections of the Vertical; develop 3/4-wave resonance on all bands. "Capacity Hat" included. Height: 21'. 52 ohm coax feed. Less than 2:1 SWR all bands.

Model 14-RMK: Combination Radial & Guy Wire Mount Kit for 14-AV Vertical. Incl. 5' of 1 1/2" steel mast, pre-cut radials acting as guy wires, hardware and base mount: \$9.95.

NOW IN STOCK

Write for Brochure

World Radio
LABORATORIES

3415 W. Broadway
Council Bluffs, Iowa

The Following Popular Lines Are Available For . . .
IMMEDIATE DELIVERY FROM STOCK! . . . Plus The Best Stock

NEW EQUIPMENT

CUSHCRAFT ANTENNAS

HY-GAIN

WRL TRANSMITTERS

Globe Scout

Globe Chief

Globe Champion

AUTENNA - MOBILE ANTENNAS

BELL MICROPHONES

LYNMAR BALUNS

VOCALINE RADIO TRANSCEIVERS

These And Many Other Popular Lines
 Are Available At All Times.



And Selection Of . . .

GUARANTEED USED EQUIPMENT

USED TRANSMITTERS

Collins — 32V2	\$395.00
Collins — 32V3	\$495.00
Hallicrafters — HT-31 (Inventory Closeout)	\$299.95
Johnson VIK II — (Like New)	\$249.95
Johnson 6 N 2	\$149.95

USED RECEIVERS

Hammarlund — SP-400X	\$229.95
National NC-125	\$139.95
Gonset Communicators	\$159.95 Up
Hallicrafters — SX-62	\$225.00

Terms can be arranged on both new and used equipment. Write W1BFT for credit application form and an explanation of our terms and Used Equipment List.

Evans RADIO

P.O. BOX 312

CONCORD, N. H.

GET INTO ELECTRONICS

Train for best technical positions in a Top-flight school. Specialize in missiles, computers, radar, communications, industrial electronics, color TV, automation. Excellent program in theory, laboratory, mathematics. Major firms select our graduates as Tech. reps., field engineers, specialists. Associate degree granted. 21 months' program. High school or equivalent required. Write for catalog.

VALPARAISO TECHNICAL INSTITUTE
 Dept. TW Valparaiso, Indiana

Sending is so much easier with

The FAMOUS
 SEMI-AUTOMATIC

VIBROPLEX

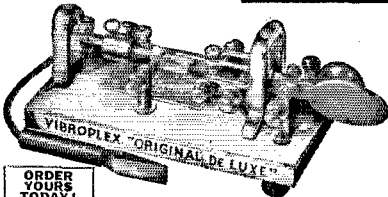

Ends
 Sending
 Fatigue
 Forever

ORDER
 YOURS
 TODAY!

That's because its semi-automatic action performs all the tiring arm work for you. No special skill necessary. It is free of nervous and muscular tension common to old-fashioned keys, and it's trouble proof. Adjustable to any desired speed — fast or slow always under perfect control, and the signals are strong, clean and easy to read. Touch control provides the touch you like for best work. Vibroplex is precision built for long life and rough usage. Gives years of the finest, easiest sending service. Take the advice of the world's finest operators and get your Vibroplex today — its easy operation will amaze you.

Choice of five models standard or deluxe, priced from \$15.95 to \$29.95. Left-hand models, \$2.50 more. Carrying case, \$6.75. Order yours today. At dealers or direct.

THE VIBROPLEX CO., INC.

833 Broadway

New York 3, N. Y.

why wait?

Radio Products Sales'
easy time payment
plan makes Collins
SSB equipment yours now!

A down payment of as little as \$95.00 can put a Collins 75A-4 in your shack now. Take 20 months to pay the balance in monthly installments of \$36.00. Contact us now for easy payment terms on any Collins equipment. We have the complete line.

Collins 75A-4 SSB Receiver	\$ 645.00
Collins KWS-1 SSB Transmitter	\$2,095.00
Collins KWM-1 SSB Mobile/Fixed Station Transceiver	\$ 770.00

Radio Products Sales Company

1237 Sixteenth Street
 Denver 2, Colorado

1 of 4 NEW

Self-Supporting

TRAP VERTICAL
Antennas
from
Hy-gain

THE
12
AV



10-15-20 Meters

Trap Vertical for automatic coverage of 10, 15 & 20 meters. Insu-Traps isolate sections of the Vertical; develop $\frac{1}{4}$ -wave resonance each band. 52 ohm coax feed. Less than 2:1 SWR all bands. Height: 14'. Complete instructions.

Model 12-RMK: Combination Radial & Guy Wire Mount Kit for 12-AV Vertical. Incl. 5' of $1\frac{1}{2}$ " steel mast, pre-cut radials acting as guy wires, hardware and base mount: \$8.95.

NOW IN STOCK

Write for Brochure

World Radio
LABORATORIES

3415 W. Broadway
Council Bluffs, Iowa

FCDA Region 6

The regional headquarters station and stations in 8 states were activated for a 24-hour period, handling 112 messages. Assistant regional communications officer W0WBC says that from six to eight times more traffic could have been handled with ease. Contact with the Kansas, Minnesota and South Dakota stations was made and maintained with good efficiency using RTTY, the rest by c.w. An additional RTTY link was established between the regional RACES station and the fifth Army.

FCDA Region 7

During the alert, station K6HA at regional headquarters in Santa Rosa, Calif., established contact with each of the eight states in FCDA Region 7, plus FCDA headquarters in Battle Creek. Hawaii and Guam were also contacted. All states except Oregon were contacted on 3.5 Mc. Oregon and several other states were contacted on 7 mc. and Guam and FCDA on 14 mc. Weekly schedules have been arranged to continue these schedules after a successful Operation Alert test.

* * *

And so another Operation Alert is history. We regret more reports were not received, but we know that in this exclusively civil defense test many more amateurs participated than are indicated above. Amateurs in RACES remain an important phase of civil defense communications and become more so as time passes. We urge all to get signed up in their local RACES and become a part of this national trend in preparedness.

Happenings

(Continued from page 70)

neer in Charge of the district having jurisdiction of the authorized fixed transmitter location.

- 3. Delete the text of Section 12.91 and insert the following language:

12.91 Notice of operation. Whenever an amateur station is, or is likely to be, operated for a period in excess of 48 hours away from the fixed transmitter location specified on the station license without return-thereto, the licensee shall give advance written notice of such operation to the Commission office or offices specified in Section 12.90 or 12.93. A new notice is required whenever there is any change in the particulars of a previous notice or whenever operation away from the authorized station continues for a period in excess of one year. The notice required by this section shall contain the following specific information:

- (a) Name of licensee.
- (b) Station call sign.
- (c) Authorized fixed transmitter location.
- (d) Portable location(s), or mobile itinerary as specifically as possible, or temporary fixed transmitter location, or new permanent fixed transmitter location.
- (e) The dates of the beginning and end of each period of operation away from the location specified in the station license.
- (f) The address at which, or through which, the licensee can be readily reached.
- (g) In the case of mobile operation, the official name, registry number or license number (including the name of the issuing state or territory, if any) of the aircraft, vessel, or land vehicle.

(Continued on page 182)

1 of 4 NEW

Self-Supporting

TRAP VERTICAL
Antennas
from
Hy-gain

THE
26
AV



2-6 Meters

Hy-gain's automatic Vertical for 2 & 6 meters, with new "sleeve decoupling" principle. Complete with ground plane. Height of Vertical & length of ground plane: 5'. Less than 2:1 SWR both bands. 52 ohm coax feed. Complete instructions.

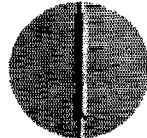

Decoupling Sleeve isolates various sections of 26-AV; develops $\frac{1}{4}$ -wave resonance each band. Ground plane dual resonant both bands. Unaffected by weather; efficient at high frequencies.

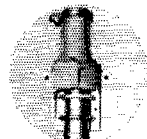

Base Insulator & Mount makes possible self-support of all Trap Verticals. Heavy-duty cast aluminum bracket adjustable various size masts. Weather protected. Electrical connections factory sealed.

NOW IN STOCK

Write for Brochure

World Radio
LABORATORIES

3415 W. Broadway
Council Bluffs, Iowa

FOR YOUR TRANSMITTER —

NOW—

JUNIOR BALUNS

150 Watts—1.5 to 30 mc
Specifically Designed For
Transmitters of 200 Watts or Less Input

Low cost, conservatively rated, broadband baluns which may be used with B & W 5100—Collins 32-V—Heath DX-100 and other similar transmitters.

These units require no tuning, no switches . . . weatherproof for outdoor mounting; small enough for mounting in transmitter. These baluns are indispensable when connecting coaxial cable to a balanced line as in feeding dipoles, folded dipoles, trap antennas, beams, etc.

BALUNS NOW IN PRODUCTION

		Price
TB-2J	75 ohms unbalanced to 300 ohms balanced	\$9.95
TB-4J	75 ohms unbalanced to 75 ohms balanced	\$9.95

Also In Production—RF TRANSFORMER

T-1J	75 ohms unbalanced to 50 ohms unbalanced	\$9.95
------	--	---------------

Specifications: Overall length 4½", height 2", width 2¼", weight 1-lb.



it's Here!

**AN ELECTRONIC
T-R SWITCH
THAT REALLY
WORKS!**



FEATHERWEIGHT • MIDGET-SIZE • UPS EFFICIENCY

Don't confuse this great, new electronic Transmitter-Receiver Switch with anything similar you've ever known! Here is a truly effective, efficient and practical replacement for that time-worn coax relay. The Lynmar TRS-1 Switch is designed for any amateur transmitter, home-made or commercial. Wonderfully tiny, it hides away inside most transmitters (1½ x 1½ x 2¼, weighs approx. 4-oz.), does not add any TVI and makes most receivers perform better. Under test, receiver sensitivity increased up to 15db when used with transmitters of 150-watts or less . . . uses negligible power for operation and takes 6.3 volts filament and 150 volts @ 13 mils for plate of type 6AH6 tube, ordinarily supplied by transmitter. This switch is a must for every Ham rig!

PRICE \$11.95
(with tube)

LYNMAR ENGINEERS, INC.

1432 N. CARLISLE STREET • PHILADELPHIA 21, PA.

Consultants and Manufacturers

ELECTRICAL - MECHANICAL - ELECTRONIC

**SALES MANAGER
WANTED**

*H*ighly successful manufacturer. Recognized leader in field. Needs experienced merchandiser, familiar with communications equipment, ham merchandise, and component sales through distributor trade. Must have EE degree or equivalent. Salary high. Once-in-a-lifetime opportunity for right man. Send resume . . . all inquiries kept confidential.

Write BOX 181

QST

38 LaSalle Rd.

West Hartford 7, Conn.

IN THE MIDWEST AREA
RADIO TRADE SUPPLY

IS THE PLACE TO BUY

Collins **EQUIPMENT**

KWS-1

1 kilowatt Transmitter

w/Power Supply\$2,095.00

75A-4 SSB Receiver\$695.00

KWM-1 SSB

Mobile/Fixed Station
Transceiver\$770.00

and a complete stock
of all Collins accessories.

Liberal trade-in allowance.
Convenient Time Payment Plan.

write Vince WONTA

RADIO TRADE SUPPLY

1224 Grand Ave.

Des Moines 9, Iowa

MAKE DOW RADIO, INC.

YOUR SOURCE FOR *Collins* EQUIPMENT

We have the complete line of world famous Collins Amateur equipment, outstanding for SSB, AM or CW operation. And, we carry all Collins accessory items in stock. Write, call or come in for more information on whatever you need.

Collins KWS-1 SSB Transmitter, Net Price	\$2,095.00
Collins 75A-4 SSB Receiver, Net Price	695.00
Collins KWM-1 SSB Mobile Trans- ceiver, Net Price	770.00

DOW RADIO, INC.

1759 E. Colorado St., Pasadena, Calif.



TRYLON

Engineered

ANTENNA SYSTEMS

From the unique broadband curtain antenna shown below and difficult microwave and television installations involving rigid sway and twist limits, to lightweight towers for amateur beams — Trylon's sound engineering approach to every phase of antenna design pays important performance dividends.

FIRST SUCCESSFUL Broadband CURTAIN ANTENNA



Designed, built and installed by Trylon, these two broadsides give 5% to 10% more reliable long-distance communications than comparable rhombics — and with a bandwidth of $\pm 15\%$ of center frequency at 1.5 VSWR.

WIND TURBINE COMPANY, West Chester, Pa.

In Canada: The Wind Turbine Company of Canada, Ltd., Toronto 9.

ele in which the mobile station is installed and operated.

4. Delete the text of Section 12.93 and insert the following language:

12.93 *Special requirements for non-portable stations.*

(a) An amateur station that has been moved from the authorized permanent location to another permanent location may be operated for a period not exceeding four consecutive months at the latter location, but in no event beyond the expiration of the license unless timely application for renewal thereof has been filed in accordance with the provisions of Section 12.67 under the following conditions:

(1) Advance notice, in accordance with the provisions of Section 12.91, shall be given to the Engineer in Charge of the radio district in which operation is intended; and

(2) formal application for modification to change the permanent location shall be filed with the Commission within the above specified four month period.

(b) The licensee of an amateur station who changes residence temporarily, but retains a permanent residence associated with the fixed transmitter location designated in the station license, and moves his amateur station to a temporary location associated with his temporary residence, or the licensee-trustee for an amateur radio society which changes the normal location of its amateur station to a different and temporary location, may operate the station at such temporary location under the condition that: Notice, in accordance with the provisions of Section 12.91, shall be given to the Commission in Washington 25, D. C., and to the Engineer in Charge of the radio district in which temporary operation is intended.

(c) When the station is operated under the provisions of this section, the portable identification procedures specified in Section 12.82 shall be used.

Project Moonbeam

(Continued from page 15)

organized within the U. S. and abroad. It is hoped that in many cases Moonbeam stations will be able to work closely with Moonwatch teams, relaying information and results.

The IGY satellite panel has expressed great confidence in the ability of the radio amateurs to contribute to the project. In addition, the American Radio Relay League is aiding the establishment of the Moonbeam program and the dissemination of technical information. This is an opportunity to prove once again that the amateur fraternity is able to add to our scientific knowledge in a new field of endeavor.

SWITCH TO SAFETY!



RADIO-TV ELECTRONICS

FREE 172 PAGE 1958 B-A CATALOG

Complete guide to Everything in Radio, TV and Electronics for Dealers, Servicemen, Schools, Amateurs, Broadcasters, Public Utilities, Engineers, Experimenters, Factories and Laboratories.

BURSTEIN-APPLEBEE CO., 1012 McGEE ST., KANSAS CITY, MO.

QST BINDERS

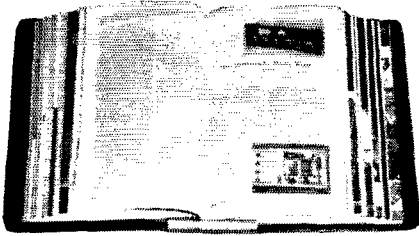

Price **\$3.00** postpaid

Available only in the United States and Possessions

As QSTs get older, they become more valuable. Are your 1957 copies scattered sloppily about the shack? If so, it's time to store them neatly as the year end approaches — and the best way to accomplish this is to file them in QST Binders.

- Holds 12 issues of QST
- Opens to any page and lies flat
- Protects and preserves your copies
- QSTs always available for reference

The AMERICAN RADIO RELAY LEAGUE, Inc.

WEST HARTFORD 7, CONN.

ATTENTION MOBILEERS

Positive band change in an instant
with *Antenna!*

See Page 138, September 1957 QST

**RAFRED
ENTERPRISES**

Box 47725, Wagner Station
Los Angeles 47, California



Founded in 1909

RADIO TELEPHONY RADIO TELEGRAPHY RADAR & TELEVISION

Courses ranging in length from 7 to 12 months. Dormitory room and board on campus for \$48.00 a month. The college owns KPAC, 5 KW broadcast station with studios located on campus. New students accepted monthly. If interested in radio training necessary to pass F.C.C. examinations for first-class telephone and second-class telegraph licenses, write for details. New: Advanced TV Engineering Course.

PORT ARTHUR COLLEGE PORT ARTHUR
TEXAS

Approved for G. I. training

NEW!

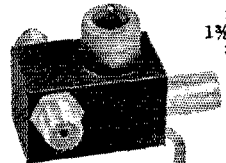

SIZE:
1 1/2" x 1 1/2"
x 2 3/4"

with a performance rating never before possible.

DOW-KEY

ANTENNA SWITCH

MODEL DKC-TR

Operates in frequency range of 0db at 60 mc to -6db at 3.5 mc. Can be close-coupled to the transmitter for easy, compact installation with a Dow DKF-2 connector. Instantaneous recovery, powered from transmitter accessory terminal. No TVI, no SWR in transmitter circuit — 52 to 72 ohm impedance. Handles one KW with ease.
POWER SPECS: B plus 125-150 volts, consumption at 125 volts, 6.2 mils; .450 amps at 6.3 volts; uses 6AH6 tube.

GUARANTEED! Fully backed by factory warranty for unit replacement.

DOUBLE MALE-CONNECTOR (DKF2) for mounting relay directly onto output of transmitter.

See your local electronics dealer or write direct for complete specifications.

PRICE, \$12.50
(price subject to change without notice)



DOW KEY CO., INC.
WARREN, MINNESOTA

Own this Popular
WRL
Globe Champion 300

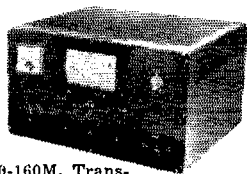

A bandswitching, 10-160M, Transmitter for 350 watts CW, 275 watts fone, and 300 watts SSB (P.E.P.), with any 10W external exciter.

The single-switch bandswitching Champion is extensively TVI-suppressed, filtered and bypassed. High level Class "B" modulation is sustained without usual clipping distortion through use of a new commercial type compression circuit. Pi-network output circuit, 48-700 ohms, built-in VFO, push-to-talk, antenna changeover relay, and improved Time Sequence keying are all features. 1000 volt plate capacity of Final tubes offer 33 1/3% safety factor. Only 12x21 3/4x17" in size, self-contained.

Net: \$449.00; Kit: \$375.00

TIME
PAYMENTS
AND
LAY-A-WAY
PLAN

IN STOCK! SEND FOR DETAILED BROCHURE!

All Amateur Lines Carried In Stock!

WE TAKE TRADE-INS ALL
AMATEUR EQUIPMENT, ALSO SURPLUS GEAR

UNIVERSAL DISTRIBUTORS, INC.

4642 WEST CENTURY BLVD.
INGLEWOOD 2, CALIF.

ELECTRONICS • RADIO • 36 Years of Successful
RADAR • TELEVISION • Training in Electronics

COMMERCIAL RADIO INSTITUTE

Approved by Maryland Board of Education

38 West Biddle St. Baltimore 1, Md.
Write for Free Catalog • Tel. LE 9-3342

CALLING ALL HAMS!

Individualized with your own call letters

Personalized hand made accessories for
the ham who displays his call with pride.

A quality line of jewelry made of precious metals



TIE CLIP
Sterling silver or
1/20 12K gold filled \$7.50
Solid 14K gold \$45

CUFF LINKS

Sterling silver or
1/20 12K gold filled \$16



An ideal gift to give or receive

WILLMART JEWELRY CO.

4278 Bedford Ave.

Brooklyn, N. Y.

Message Handling

(Continued from page 49)

If so, we can help you, but don't get carried away. Amateurs in most countries aren't so fortunate as we in being allowed this privilege, and international regulations forbid it *between* countries except by specific treaty. We have such treaties in effect *only* with the following countries: Canada, Chile, Costa Rica, Cuba, Ecuador, Liberia, Nicaragua, Panama, and Peru. Of course you can handle traffic with any U. S. possession, too; they're not classed as foreign countries for this type of activity.

Receiving and Relaying

What you just did was to *originate* a message. If you receive one from another station and send it to still another station, you are *receiving* and *relaying*. If you receive one for your town and deliver it by telephone, in person or by mail, you are *receiving* and *delivering*. Perform 500 or more of these operations in a month (or 100 or more originations-plus-deliveries), report it to your SCM (see p. 6) and he'll send you a pretty little card that says BPL (Brasspounders League) on it in big red letters. Collect three of these cards and we'll send you a little engraved medallion as a memento.

Before you know it, you'll be a seasoned traffic man and writing letters to headquarters telling us what's wrong with the way traffic is being handled.

Key and Code

(Continued from page 29)

times as long as a dit and the time interval between dits and dahs is the same as a dit. Your sending should be almost entirely a wrist action — not fingers or arm, just the wrist. Try to relax and not tense up as you send.

When you find that you can send dits and dahs smoothly you are ready to send characters. One of the easiest and surest methods of sending good code is to say the character as you send it. For example, if you are sending the letter F then say, "di-di-dah-dit" as you send it. You'll be surprised how smoothly you send characters when you do this. The interval between characters is the same as a dah and between words the space is approximately two dahs. A common trouble with newcomers (and many oldtimers are guilty, too) is not leaving enough space between characters and words. Remember that you are attempting to communicate with another party. If you

(Continued on page 186)

WANTED • Aircraft radio man for installation and service to corporation aircraft. Modern, fully equipped shop in East. Excellent living and working conditions. All replies confidential.

PAGE AIRWAYS, Inc.

Rochester Airport, Rochester, N. Y.

QST ADVERTISERS

"Advertising is accepted only from firms who, in the publisher's opinion, are of established integrity and whose products secure the approval of the technical staff of the American Radio Relay League."

Quoted from QST's advertising rate card

Amateurs and Electronic Engineers: Practically everything you need can be supplied by the advertisers in QST. And you will know the product has the approval of the League's technical staff.

ONLY
\$78.00

plus 10%
Fed. Tax

24-HOUR DIAL ELECTRIC CLOCK

Big 15" illuminated dial for easy reading. Handsome and durable with glass crystal, aluminum case and stainless steel bezel. Ideal as a gift.

SEND CHECK OR MONEY ORDER TO:

SCIENTIFIC INDUSTRIES, Inc.

23 Park Street, Springfield 3, Massachusetts
or write for Free Literature

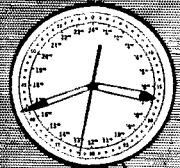

NOW HAM RADIO IS PAYING ME!



Over the years I've invested considerable money in this wonderful hobby. Been worth it, too, for I've had lots of fun—and learned a lot about radio. Just last year while in QSO a ham upstate told me about the boom in commercial and public-safety 2-way radio. He said he was cashing in on his ham radio experience by doing regular maintenance and FCC checks on commercial rigs.

After pulling the big switch I started reading QST—and saw Lampkin Laboratories' ad for their free booklet "HOW TO MAKE MONEY IN MOBILE-RADIO MAINTENANCE." I sent in the coupon . . . and learned how easy it is to get into 2-way radio maintenance. Now I have a high-paying business in my own shack!

The same coupon is at the bottom of this ad—and it can lead to the same results for you.
BETTER MAIL IT TODAY—WHILE IT'S FRESH IN YOUR MIND!



LAMPKIN TYPE 205-A
MODULATION METER
Range 25 to 500 MC
Price \$240.00 net



LAMPKIN TYPE 105-B
FREQUENCY METER
Range 0.1 to 175 MC and up
Price \$220.00 net

THESE ARE THE TEST INSTRUMENTS USED BY THOUSANDS OF 2-WAY ENGINEERS:

TIME PAYMENT PLAN AVAILABLE!

LAMPKIN LABORATORIES, INC.
Mfg. DIVISION, BRADENTON, FLA.

At no obligation to me, please send free booklet and dope on time-payment plan.

Name _____

Address _____

City _____ State _____

LAMPKIN LABORATORIES INC., BRADENTON, FLA.

LET A HINT
STRAIGHTEN OUT A
Kink!



Confused over something? Let the latest edition, Volume Five, of ARRL "Hints & Kinks" give you a helping hand and save you grief and time. You'd be surprised at the shortcuts and tips listed in this book.

As its cover says, it is a symposium of 333 practical ideas for the station and workshop, and the Ready-Reference Index, a new feature, will help you find information quickly and easily.

\$1.00

U. S. A. Proper — Elsewhere, \$1.25

The American Radio Relay League
West Hartford 7, Conn.

OVERSEAS

Career opportunity with MAJOR OIL PIPE LINE for Technicians with several years maintenance experience on VHF, FM, Mobile and Point-to-Point systems. Instrumentation experience valuable, but not essential. High net earnings and liberal employee benefits.

TRANS-ARABIAN PIPE LINE CO.
505 PARK AVENUE
NEW YORK 22, NEW YORK

run characters and words together he'll never know what you are trying to say.

The only way to know how correctly formed code sounds is by listening to stations that send good code. There are many stations on the air that use automatic transmitters where the code is run on tapes, meaning of course, perfect code is transmitted. If you are interested in hearing such stations, the Communications Department of ARRL has available a mimeographed list of stations, times, and frequencies. This list includes press, Naval, and amateur stations. The amateur stations listed transmit code practice and while they are usually not taped transmissions, the operators send excellent code. If you want the list, write to the ARRL Communications Department, and ask for form CD-139 and a WIAW operating schedule. Our Headquarters station, WIAW, transmits code practice daily. An excellent method of learning to send good code is to send in unison with WIAW. To do this, you must, of course, know what WIAW is going to send. Every month in *QST* the material to be sent via WIAW is listed in the Operating News section. This material is taken from previous *QST*'s.

Remember: Don't tense up, develop a smooth rhythm, watch your spacing, and you'll have the satisfaction of hearing hams tell you they like your "fist".

QRM?

(Continued from page 21)

your a.v.c. system is operated by steady r.f. signals, not at a syllabic rate, hence the s.s.b. or voice-controlled signals will come through the receiver just as though there were no a.v.c. circuit whatsoever. What you have done by using your r.f. gain control is to permit equal amplification of all signals with the same peak power, hence the side-band stations no longer appear to be stronger than the a.m. stations.

To further narrow the i.f. pass band, crystal filters or Q multipliers can be used, or the coils in the i.f. cans can be spaced further apart (which will also reduce the over-all gain). In the case of mobile converters, one must install an r.f. gain control in the cathodes of his r.f. amplifiers, or otherwise control the gain of his first two tubes. Utilizing a weak signal to peak all tuned circuits in the receiver is also a must for best results. With these mobile precautions, it will be almost impossible for another mobile to block your receiver again, and DX will suddenly become possible.

The above method of operating a receiver is also necessary to properly understand and tune
(Continued on page 188)

RADIO COURSES

Radio Operating • Code •
Radio Servicing • Television Servicing •

Preparation for Civilian, Maritime,
Army and Navy License requirements

Write for information on these courses to:

BROOKLYN Y.M.C.A. TRADE SCHOOL

1115-1119 Bedford Ave., Brooklyn 16, New York

XMTRS FOR 160 TO 2 METERS
TECHNICIAN - NOVICE - GENERAL
 or Special Freq. 500 KC. to 160 MC.

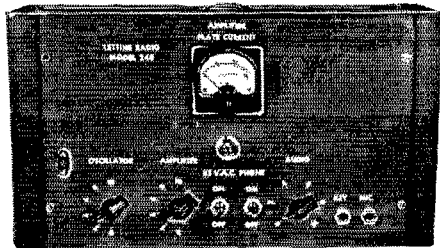

LETTINE MODEL 240 TRANSMITTER WITH MOBILE CONNECTIONS AND A.C. POWER SUPPLY

This outstanding transmitter has been acclaimed a great performer throughout the world. Air wound plug-in coils used for high efficiency. Takes any freq. from 1.6 to 30 mc. Ideal for General Class, Novice, CAP, CD, Industrial. Sold direct from our factory, ready to operate, 40 to 50 watts input, Phone CW. Complete with 8 x 14 x 8 cabinet, 40 meter coils, xtal, tubes: 6V6 osc., 807 final, 5014G rect., 6S17 xtal mike amp., 6N7 phase inv., 2-6L6's PP mod. Wt. 30 lbs. \$79.95. 80, 20, 10 meter coils \$2.91 per band. 160 meter coils \$3.60.

MODEL 130 FOR 120 TO 130 WATTS — \$199.50

MODEL 242 FOR 6 METERS OR 2 METERS — 45 WATTS INPUT — 6146 FINAL. Complete with mobile connections, A.C. power supply, tubes, xtal. Xtal mike input. Uses 8 mc. xtal or Lettine VFO. Swinging link matches 52 — 400 ohm antennas. Same cab. as 240. \$89.95.

VFO—\$49.95 — ANT. TUNER \$20.00 LESS COILS
 Send full amount or \$25 with order — balance C.O.D.

LETTINE RADIO MFG. CO.

62 Berkeley St.

Valley Stream, N. Y.

EASY TO LEARN CODE

It is easy and pleasant to learn or increase speed the modern way — with an **Instructograph Code Teacher**. Excellent for the beginner or advanced student. A quick, practical and dependable method. Available tapes from beginner's alphabet to typical messages on all subjects. Speed range 5 to 40 WPM. Always ready, no QRM, beats having someone send to you.

ENDORSED BY THOUSANDS!

The **Instructograph Code Teacher** literally takes the place of an operator-instructor and enables anyone to learn and master code without further assistance. Thousands of successful operators have "acquired the code" with the **Instructograph System**. Write today for full particulars and convenient rental plans.



INSTRUCTOGRAPH COMPANY

4709 SHERIDAN ROAD CHICAGO 40, ILLINOIS

HAMS! Here is
Everything you need
 in Amateur Equipment.

FREE! 360 pages of the
Newest in

ELECTRONICS
 HIGH FIDELITY • RADIO • TV



NEW **CATALOG** **1958**

Offers you a fast, efficient, dependable way of selecting the finest components in the field at the lowest prices.



Write Dept. T-11

223 W. Madison St. • Chicago 6, Illinois
 4736 W. Century Blvd. • Inglewood, Calif.

IN THE LEXINGTON AREA

Radio Equipment Co.

is the place to buy

Collins **Equipment**

KWS-1 1 kilowatt Transmitter w/Power Supply \$2,095.00
 75A-4 SSB Receiver ... \$ 695.00
 KWM-1 SSB Mobile/Fixed Station Transceiver ... \$ 770.00
 and a complete stock of all Collins accessories.

RADIO EQUIPMENT CO.

480 Skain Avenue
 Lexington, Kentucky

V.H.F. RECEIVERS

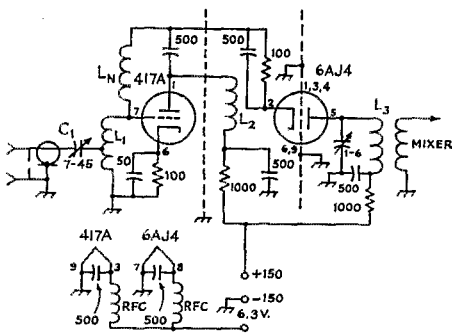

Fig. 16-2—Circuit of the cascode r.f. amplifier. Coupling capacitor, C_1 , may be omitted if spurious receiver responses are not a problem . . .

This circuit is just one of many discussed in the V.H.F. Receiver Chapter of the 1957 Radio Amateur's Handbook. Whether you're seeking information on v.h.f., u.h.f. or the lower frequencies, transmitters, receivers, antennas, a.m., s.s.b., keying or whatever, you'll find plenty of dope in the Handbook: 756 pages, plus hundreds of photos, diagrams and drawings.

RADIO AMATEUR'S HANDBOOK

\$3.50

\$4.00 U. S. Possessions and Canada, \$4.50 elsewhere

THE AMERICAN RADIO RELAY LEAGUE, INC.

West Hartford 7, Connecticut

LMB PRESENTS "SAL-MET"

FREE 1957 CATALOG covering the full precision engineered line of original box chassis as manufactured by LMB including new Miniature, new Jiffy, new T.F., new Utility Boxes. Eleven different types, 160 different shapes and sizes. A ready reference for engineers, experimenters or anyone using metal boxes. Send for your FREE CATALOG now!

"SAL-MET" Non-corrosive Flux—solders copper to aluminum, aluminum to aluminum, any metal to any metal using conventional solder and regular soldering methods. Send for both LMB and "SAL-MET" Catalogs.

LMB

1011 Venice Boulevard
Los Angeles 15, California

in side-band stations. With the receiver b.f.o. (or transmitter v.f.o.) turned on, the side-band signal must be reduced in volume (by use of the r.f. gain) until it no longer overrides your oscillator amplitude, nor affects your a.v.c. circuit.

It must be realized that the r.f. gain control will have to be readjusted for signals of greatly differing amplitudes, but you will find this to be preferable to complaining about QRM.

Artificial Earth Satellites

(Continued from page 24)

Use of Radio Amateur Observations for Precise Establishment of the Orbit

The task of precise determination of the orbit is distinguished from the task of determining the trajectory of an aircraft by radar, for example, principally the fact that in our case we know ahead of time that the satellite is unable to perform arbitrary motions in space, and for given initial data it can move only along a completely predictable trajectory. This circumstance permits the use of more simple measurements than in the case of radar. For example, if the position of the satellite has been accurately found by bearings from five or six points and the accurate time of these bearings has been established then the position of this orbit can be calculated with an accuracy sufficient for practical purposes.

For determination of the orbit, Doppler effect recordings can also be used (Fig. 6). With these it is possible to determine the distance at which the satellite passes and the moment of time when it is at the minimum distance.⁴

Therefore, in order to use radio amateur observations, it is extremely important to have recordings of signals on magnetic tape which can be used for, in the first place, measurement of the Doppler effect and, in the second place, "tying down" of the recording obtained to the exact time. From the duration of tones and pauses information can also be obtained on some processes taking place in the satellite itself.

Highly qualified radio amateurs and radio clubs can also build apparatus with which to take direction bearings on the satellite. The moment of direction finding also must be "tied down" to the exact time.

It must be noted that, in order to check the orbit, the signal with the frequency of 40 mc. is of greatest value, since it is less distorted by passing through the ionosphere.

⁴ For additional discussion on Doppler effect see letter from Paul E. Wilkins, W4SBA, in "Technical Correspondence," *QST*, October, 1956, page 46. — Editor.



Be a Radio Ham or Commercial Operator. Pass FCC code test in few weeks. Fascinating hobby. Good pay, interesting work in Commercial field. Same system used by radiotelegraph specialists. FREE book explains how Amateurs and Operators learn code and develop amazing skill and speed. Candler System Co., Dept. 4-M, Box 928, Denver 1, Colo., U.S.A. and 52b, Abingdon Rd., Kensington High St., London W.8, England

SILENT Coaxial Relay

DOW-KEY

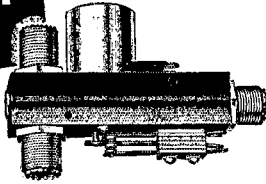

MODEL
DKC-GE

**TESTED AND PROVEN
BY AMATEURS AND INDUSTRIALS**

New magnet principle makes high-contact pressures possible — gives a new concept of low-contact resistance. Free of AC hum or chatter, available with special receiver protecting connector and heavy-duty, external SPDT switch.

One-million operations completed in life test with no apparent deterioration. Power consumption, AC models approx. four watts; DC models three watts. V.S.W.R. at 150 mc 1.1 and 1.2 at 300 mc. Coil voltages: AC 6, 12, 24, 110 and 220; DC 6, 12, 24, 48, 110 and 220. Special coil voltages available.

GUARANTEED! Fully backed by factory warranty for unit replacement.

DOUBLE MALE-CONNECTOR (DKF2) for mounting relay directly onto output of transmitter.

See your local electronic parts dealer or write direct for complete specifications.

Price, \$10.90 to \$15.60



DOW KEY CO., Inc.
WARREN, MINNESOTA

CHECK Your QSLS

with **DXERAMA**

Second Edition

So Many Hams Have DX Operating Awards
Earned **AND DO NOT KNOW IT!**

Nearly 50 DX Awards with up-to-date rules and regulations as offered by Ham Radio Organizations in all six continents; fully spread in log form, well indexed, 8½" x 11", 72 pages. Compiled by W3AXT.

\$1.60 U.S.A. & Possessions

\$1.85 Foreign

Order from your Distributor or direct from

DXERAMA 1101 Farmingdale Rd., Lancaster, Penna.

Printed Circuit



Series 31
Jacks



Plastic
Sleeves
for Jacks

- For printed circuit test points—AF, RF and pulse signals
- Accommodates std. phone tip plugs—.081" to .0825" dia.
- Rivets to board—rivet dia. .114"

Write for Bulletin M-200



Telephone Fleetwood 4-1040

513 Hillgrove Avenue
La Grange, Illinois

**T
e
s
t
J
a
c
k
s**

IN THE ILLINOIS AREA

Klaus Radio & Electric Co.

is the place to buy

Collins **Equipment**

KWS-1 1 kilowatt Transmitter w/Power Supply \$2,095.00
75A-4 SSB Receiver ----\$ 695.00
KWM-1 SSB Mobile/Fixed Station Transceiver ---\$ 770.00
and a complete stock of all Collins accessories.

*Liberal trade-in allowances.
Convenient Time Payment Plan.*

Klaus Radio & Electric Co.
103 E. Lake Street Peoria, Illinois
Phone 8-3401

QTC?

Whether you are a dyed-in-the-wool traffic man or just an occasional trafficker, your sense of good public relations tells you that ARRL Radiogram forms are a must in your station. Attractively printed on a new high grade paper, message blanks add that final touch to this important public service.

OFFICIAL RADIOGRAM FORM

Pad (70 blanks) 35¢
 Message Delivery Cards
 each 2¢ plain, 4¢ stamped

The American Radio Relay League

West Hartford 7, Connecticut

WWV-WVVH SCHEDULES

For the benefit of amateurs and other interested groups, the National Bureau of Standards maintains a service of technical radio broadcasts over WWV, Beltsville, Md., and WVVH, Maui, Territory of Hawaii.

The services from WWV include (1) standard radio frequencies of 2.5, 5, 10, 15, 20 and 25 Mc., (2) time announcements at 5-minute intervals by voice and International Morse code, (3) standard time intervals of 1 second, and 1, 3 and 5 minutes, (4) standard audio frequencies of 440 cycles (the standard musical pitch A above middle C) and 600 cycles, (5) radio propagation disturbance warnings by International Morse code consisting of the letters W, U or N, together with digits from 1 through 9, indicating present North Atlantic path conditions and conditions to be anticipated. (See ARRL *Handbook* for details on interpretation of forecast symbols.)

The audio frequencies are interrupted at precisely two minutes before the hour and are resumed precisely on the hour and each five minutes thereafter. Code announcements are in Universal Time using the 24-hour system beginning with 0000 at midnight; voice announcements are in EST. The audio frequencies are transmitted alternately: The 600-cycle tone starts precisely on the hour and every 10 minutes thereafter, continuing for 3 minutes; the 440-cycle tone starts precisely five minutes after the hour and every 10 minutes thereafter, continuing for 3 minutes. The fourth minute of each 5-minute period is silent, and voice announcements are made during the fifth minute. The one-second intervals are heard as a clock-like tick; the tick at the beginning of the last second of each minute is omitted.



"Mags" Magers
 W0OJI, President

FOR ONLY 3c
 YOU CAN LEARN
 ABOUT VESTO'S
NEW
 Hurricane-Proof*
 Self-Supporting
TOWER

Vesto's New Tower Is Ready Now!
 A Galvanized Tower that will last a lifetime.
 Available in ten sizes, 22 ft. to 100 ft. As low as \$104.

VESTO TOWERS HAVE: No guy wires! No cables! No moving parts!

VESTO TOWERS OFFER YOU:

- 4-leg construction for better balance—greater strength
- Safe, steel ladder from ground to platform near top
- Safety platform with metal railing and trap door

PLUS VESTO'S NEW Geared Crank-Over Antenna Head

Now! Tilt antenna for easy accessibility! Tilts heaviest antennas! Holds in any position!

* NO VESTO TOWER HAS EVER BEEN DAMAGED BY HURRICANE

Invest 3 cents!
 Write today for
 complete
 FREE information

VESTO CO., INC.
 20th & Clay St.
 North Kansas City, Mo.

IS YOURS ON FILE WITH YOUR QSL MGR?

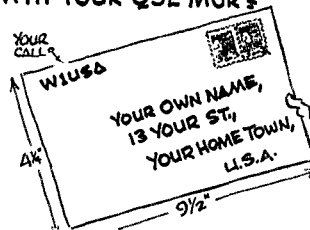

(See page 192 this issue)

For the Finest in Ham Equipment
VARIETY ELECTRONICS CORP.
 Bloomfield Ave. & State St.
 Bloomfield, N. J.
 Open Mon., Wed. and Fri. to 9 P. M.

Try It! . . . Buy It!

THE RELIABLE, COMPACT Globe Scout 680

Bandswitching 6-80 M

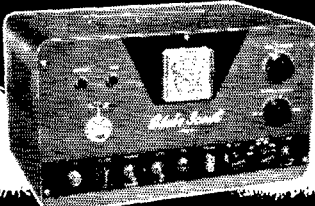

Only
\$109⁹⁵

KIT: \$89.95

Compact, completely bandswitching transmitter for 6-80 Meters; allows operation of 6 M band by technicians, novice CW bands, or use by advanced ham without becoming obsolete. Completely self-contained with built-in power supply, for 65 watts CW, 50 watts phone. High level modulation. TVI-shielded cabinet. Pi-Net output on 10-80M; link-coupled output on 6 M, matching into low impedance beams. New-type shielded, full-range plastic meter for better readability. Adaptable for Mobile Operation.

Globe Scout 66, 10-160M, Wired, Only \$99.95

SEND FOR COMPLETE BROCHURE!

CURLE RADIO SUPPLY
439 BROAD STREET
CHATTANOOGA, TENNESSEE

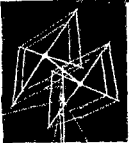

GIVE YOUR SIGNAL a
"SHOT IN THE ARM"
WITH A
CUBEX—10-15 MTR DUAL BAND
CUBICAL QUAD

FREE BROCHURE FROM ONLY

CUBEX COMPANY

3322 TONIA AVE., ALTADENA, CAL.

\$34⁹⁵

F08

NEW! . . . 60-ft. 4-BAND ANTENNA TUNES 40-20-15-10 METERS



Same Hi-power design except 4 bands in 60' ft. over all. Tested at 10,000 KV RF. Will handle 2 KW of well over-modulated AM. Only coils guaranteed to take a KW on the market.

Available for immediate delivery

40M-C 4 band KW coils \$14.95
40M-A 4 band KW antenna \$24.50

All antennas have 88 ft. KW twinlead, heavy duty insulators, copperweld wire.

FIVE BAND ANTENNAS STILL AVAILABLE:

HC-F 5 band KW coils \$19.95
HA-F 5 band KW antenna \$33.95

Improved quarter KW 5 band models:

5 BC-F phone coils; 5BC-C CW coils \$12.50
5BA-F phone; 5BA-C CW antennas \$27.50

Postpaid in U.S.A.

MONEY BACK GUARANTEE

GENERAL CRYSTAL COMPANY, INC.
372 Wilmot Ave., Burlington, Wis.

PORTABLE POWER PLANTS

Push Button Start—115 V AC (& 12 V DC) Always available.

Be prepared with reliable emergency power, designed for use with radio gear, etc. Only unit at these low factory prices, fully shielded and filtered for radio, and individually checked by scope. Not surplus, but brand new 4 cycle, easy starting, cast iron cylinder engines, fiber glass insulated generators, and control boxes with voltmeter and controls. Conservatively rated. Just the generator for C.D., Field Day, Camping and Boats. Complete line. Fully guaranteed.

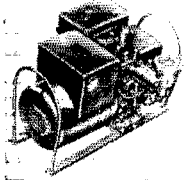

700 watt (A712) Shpg. wt. 77 lbs. \$143.50
1000 watt (A1012) Shpg. wt. 90 lbs. \$195.50
Sizes to 3500 watts. Dual voltage models, automatic controls, etc., available. Write:

GENERAL ELECTRONIC SERVICE CO.
P. O. Box 9 R0ckwell 3-2425 Burlington, Wisconsin

HAM REGISTER 1958

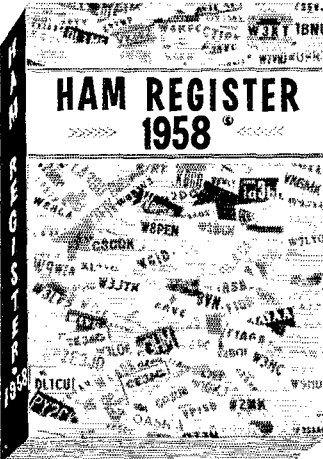

Clip Coupon &
Mail Today!

NOW AVAILABLE

Two years in the making. 500 pages. Handbook size. For those interested in knowing about those they hear on the bands. Locates others with interests common to yours. Helps you remember. 1,000 uses.

HAM REGISTER

37 S. 6th St.
Indiana, Pa., U. S. A.

(C.O.D. only in U. S. and Pos.)

Please fill my order for () copies of H. R. at \$5.00 each. () Pmt. herewith, () Send C. O. D. I must be pleased or book will be returned in 10 days for refund of purchase price.

Name _____

Address _____

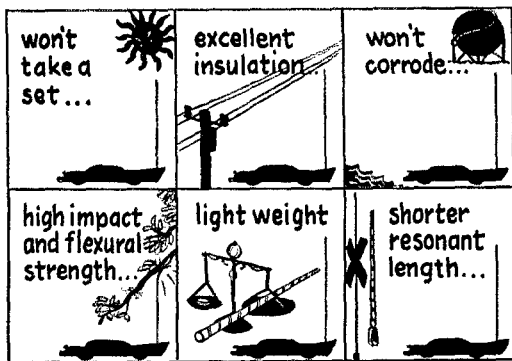

PAT. APPLIED FOR
Shakespeare WONDEROD

Fiberglass Whip Antenna

- made by the pioneer manufacturer of fiberglass fishing rods
 - industrial applications solicited
 - standard whips — 54" to 60", \$5.75
61" to 90", \$6.95
- base extensions with .500" dia. —
18", \$4.80; 27", \$5.48; 36", \$5.82
3/8" — 24 thd. base fittings

— prices amateur net

COLUMBIA PRODUCTS CO.
Subsidiary of Shakespeare Co.
P. O. BOX 5207, COLUMBIA, S. C.

CANADIANS! We have large stocks of nationally advertised Ham parts. Write for Free catalog.

THE CRAWFORD RADIO

VE3YR 119-121 JOHN ST., N. VE3JU
"Geo" HAMILTON, ONT. "Bill"

GET YOUR COMMERCIAL TICKET EASIER WITH ...

Kaufman's RADIO OPERATOR'S LICENSE Q AND A MANUAL

now available 6th EDITION up to the minute

The BEST book for FCC License Preparation
Covers elements 1 thru 8.

The only book with complete discussion of answers to every technical question in the FCC Study Guide. Makes it very easy to answer multiple choice questions. Used by leading schools and industry. Only \$6.60 at jobbers, bookstores or direct from:

JOHN F. RIDER PUBLISHER, INC.
116 West 14th Street, New York 11, N. Y.

A.R.R.L. QSL BUREAU

The function of the ARRL QSL Bureau system is to facilitate delivery to amateurs in the United States, its possessions, and Canada of those QSL cards which arrive from amateur stations in other parts of the world. Its operation is made possible by volunteer managers in each W, K and VE call area. All you have to do is send your QSL manager (see list below) a stamped self-addressed envelope about 4 1/4 by 9 1/2 inches in size, with your name and address in the usual place on the front of the envelope and your call printed in capital letters in the upper left-hand corner.

- W1, K1 — D. W. Waterman, W1IPQ, 99 Flat Rock Rd., Easton, Conn.
W2, K2 — E. F. Huberman, W2JIL, Box 746, GPO Brooklyn 1, New York.
W3, K3 — Jesse Bieberman, W3KT, P.O. Box 400, Bala-Cynwyd, Pa.
W4, K4 — Thomas M. Moss, W4HYW, Box 644, Municipal Airport Branch, Atlanta, Ga.
W5, K5 — Robert Stark, W5OLG, P.O. Box 261, Grapevine, Texas.
W6, K6 — Horace R. Greer, W6TI, 414 Fairmount St., Oakland, Calif.

IS YOURS ON FILE WITH YOUR QSL MGR?

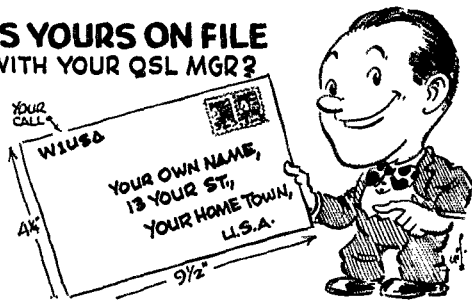

- W7, K7 — Joseph P. Vogt, W7ASG, P.O. Box 88, John Day, Oregon.
W8, K8 — Walter E. Musgrave, W8NGW, 1245 E. 187th St., Cleveland 10, Ohio.
W9, K9 — J. F. Oberg, W9DNO, 2601 Gordon Drive, Flossmoor, Ill.
W0, K0 — Alva A. Smith, W0DMA, 238 East Main St., Caledonia, Minn.
VE1 — L. F. Fader, VE1FQ, 125 Henry St., Halifax, N. S.
VE2 — George C. Goode, VE2YA, 188 Lakeview Ave., Pointe Claire, Montreal 33, Que.
VE3 — Leslie A. Whetham, VE3QE, 32 Sylvia Crescent, Hamilton, Ont
VE4 — Len Cuff, VE4LC, 286 Rutland St., St. James, Man.
VE5 — Fred Ward, VE5OP, 899 Connaught Ave., Moose Jaw, Sask.
VE6 — W. R. Savage, VE6EO, 883 10th St. N., North Lethbridge, Alta.
VE7 — H. R. Hough, VE7HR, 1684 Freeman Rd., Victoria, B. C.
VE8 — W. L. Geary, VE8AW, Box 534, Whitehorse, Y. T.
VO — Ernest Ash, VO1AA, P.O. Box 8, St. John's, Newfoundland.
KP4 — E. W. Mayer, KP4KD, Box 1061, San Juan, P. R.
KH6 — Andy H. Fuchikami, KH6BA, 2543 Naumau Dr., Honolulu, T. H.
KL7 — KL7CP, 310 — 10th Ave., Anchorage, Alaska.
KZ5 — Catherine Howe, KZ5KA, Box 407, Balboa, C. Z.

HAM-ADS

(1) Advertising shall pertain to radio and shall be of nature of interest to radio amateurs or experimenters in their pursuit of the art.

(2) No display of any character will be accepted, nor can any special typographical arrangement, such as all or part capital letters be used which would tend to make one advertisement stand out from the others. No Box Reply Service can be maintained in these columns nor may commercial type copy be signed solely with amateur call letters.

(3) The Ham-Ad rate is 30¢ per word, except as noted in paragraph (4) below.

(4) Remittance in full must accompany copy, since Ham-Ads are not carried on our books. No cash or contract discount or agency commission will be allowed.

(5) Closing date for Ham-Ads is the 20th of the second month preceding publication date.

(6) A special rate of 7¢ per word will apply to advertising which, in our judgment, is obviously non-commercial in nature. Thus, advertising of bona fide surplus equipment owned, used and for sale by an individual or apparatus offered for exchange or advertising inquiring for special equipment, takes the 7¢ rate. Address and signatures are charged for. An attempt to deal in apparatus in quantity for profit, even if by an individual, is commercial and all advertising so classified takes the 30¢ rate. Provisions of paragraphs (1), (2) and (5), apply to all advertising in this column regardless of which rate may apply.

(7) Because error is more easily avoided, it is requested signature and address be printed plainly. Typewritten copy preferred but handwritten signature must accompany all authorized insertions.

(8) No advertiser may use more than 100 words in any one issue nor more than one ad in one issue.

Having made no investigation of the advertisers in the classified columns except those obviously commercial in character, the publishers of QST are unable to vouch for their integrity or for the grade or character of the products or services advertised.

QUARTZ—Direct importers from Brazil of best quality pure quartz suitable for making piezo-electric crystals. Diamond Drill Carbon Co., 248 Madison Ave., New York City 16.

MOTOROLA used FM communication equipment bought and sold. W5BCO, Ralph Hicks, 204 E. Fairview, Tulsa, Okla.

WANTED: Cash or trade, fixed frequency receivers 28/42 Mc. W9YIY, Troy, Ill.

MICHIGAN Hams! Amateur supplies, standard brands. Store hours 0830 to 1730 Monday through Saturday. Roy J. Purchase, W8RIP, Purchase Radio Supply, 357 E. Hoover St., Ann Arbor, Michigan, Tel. NOrmandy 8-8262.

WANTED: Early wireless gear, books, magazines, catalogs before 1922. Send description and prices. W6GHI, 1010 Monte Dr., Santa Barbara, Calif.

WANTED: All types aircraft & ground transmitters, receivers ART-13, RT/ARC1, R5/ARN7, BC610E, ARN6, BC788C, ARC3, BC342. Highest prices possible paid. Dames, W2KUW, 308 Hickory St., Arlington, N. J.

ATTENTION Mobilists! Leuce-Neville 6 volt 100 amp. system alternator, regulator & rectifier, \$45.00. Also Leuce-Neville 12-volt 100 amp. system, alternator, regulator & rectifier, \$85.00. Good condition. H. A. Zimmerman Jr., K2PAT, 115 Willow St., Brooklyn 1, N. Y. U1ster 2-3472.

CASH for your gear. We buy as well as sell. Write for cash offer or trade. We stock Elmac, Gonset, Hallcrafters, Hammarlund, Johnson, Lyco Master Mobile, Morrow, National and other ham gear. E & H Electronic Supply, Inc., 506 Kishwaukee St., Rockford, Ill.

WANTED: Receiver R5/ARN-7, MN-62A transceivers, RT18/ARC-1, AN/ARC-3, BC788C, I-152C, Collins, Bendix equipment, test sets, dynamometers, inverters. We pay highest prices. Advise quantity condition, price in first letter. Aircraft Radio Industries, Inc., 15 East 40th St., New York City, Tel. Lexington 2-6254.

DX'ERS Notice! Save money? Save Time? Free info. DX QST, Coop, Box 5938, Kansas City 11, Mo.

MULTI-BAND Antenna, 80-40-20-15-10, \$19.95. Patented. Send stamp for information. Latin Radio Laboratories, Owensboro, Ky.

SAN FRANCISCO and vicinity. Communication receivers repaired and realigned. Guaranteed work. Factory methods. Special problems invited any equipment. Associated Electronics, 58 South P St., Livermore, Calif. W6KFP, Skipper.

RECEIVERS: Repaired and aligned by competent engineers, using factory standard instruments. Authorized Factory Service Station for Collins, Hallcrafters, Hammarlund, National. Our twenty-first year. Douglas Instrument Laboratory, 176 Norfolk Ave., Boston 19, Mass.

RADIO magazines. Buy, sell or trade. Bob Farmer, Plainview, Texas
HALLCRAFTERS, Central Electronics ham gear—others. Swartzlander Radio Limited, Fremont, Ohio. Call Jerry, W8EPI or write.

TECHNICAL Manuals TM11-273, 120 pages covering BC-312 receivers and BC-191 transmitters, \$2.50, 1D-60/APA-10 Pan-adaptor maintenance manuals, \$2.75. Both postpaid in U.S.A. Electroncraft, Bronxville, N. Y.

"PIG-In-A-Poke?" Not if you visit Ham Headquarters, USA, and take your choice from the hundreds of "Like New" bargains in the world-famous Harrison Trade-In Center! (See photographs, p. 137, March QST and p. 133 April QST). Greater values, because tremendous turnover means lower overhead! Terms, Trades, BCNU, Bill Harrison, W2VA, 225 Greenwich St., New York City.

SHAW Electronic Supply has new and used ham gear. Clyde, W9KLF, Darling at Gale, Angola, Ind.

QSL'S? SWL'S? Finest and largest variety samples 25¢ (refunded). Catalogs (latest) \$4.50. "Rus" Sakers, W8PFD, P.O. Box 210, Holland, Mich.

QSL'S, Taprint, Union, Miss.

DELUXE QSL'S—Petty, W2HAZ, Box 27, Trenton, N. J. Samples 10¢.

QSL'S "Brownie," W3CJI, 3110 Lehigh, Allentown, Penna. Samples 10¢; with catalogue, 25¢.

QSL'S-SWL'S, Samples 10¢. Malgo Press, 1937 Glendale Ave., Toledo 14, Ohio.

QSL'S-SWL'S, 100, \$2.35 up. Samples 10¢. Griffith, W3FSW, 1012 Pine Heights Ave., Baltimore, Md.

SWL'S, Twenty exclusive designs in 3 colors. Rush \$3 for 100 or \$5 for 200 and get surprise of your life. 48 hour service. Satisfaction guaranteed. Constantine Press, Bladensburg, Md.

QSL Samples. Dime, refundable. Roy Gale, W1BD, Box 154, Waterford, Conn.

QSL'S, Neat, Attractive. Samples 10¢. Woody's, Box 164, Asher Sta., Little Rock, Ark.

QSL'S, Sharp! 200 one color, glossy, \$4.75; Multi-color samples dime. K9DAS QSL Factory, Edward Green & Sons, Box 197, Frankfurt, Ind.

QSL'S, Reasonable, 3 Week Delivery. Samples dime (coin). Dick, K6GJM, Box 294, Temple City, Calif.

QSL'S samples, dime. Gay Krenz, Fall Creek, Wis.

QSL'S, Reasonable. Nice designs. Samples free. Stan, W2DJH, 10 Elm St., Warrensburg, N. Y.

QSL'S-SWL'S, Samples free. Bartnoski, W2CVF Press, Williams-town, N. J.

QSL'S-SWL'S, High quality. Reasonable prices. Samples. Bob Teachout, W1FSV, 204 Adams St., Rutland, Vt.

QSL'S: Glossy. Samples 10¢. WIOLU Press, 30 Magoun, Medford, Mass.

QSL'S of distinction! Three colors and up, 10¢ brings you samples of distinction. Uncle Fred, Meshoppen, Pa.

SEND \$3.00 for 200 2-color QSL'S-SWL'S. Fast service. Samples 25¢. Bolles, W5OWC, Box 9007, Austin 17, Texas.

CREATIVE QSL and SWL Cards. Are you proud of your card? If not, let us print your next order. Write for free samples and booklet. Personal attention given to all requests. Bob Wilkins, Jr. KN6ZMT, Creative Printing, P.O. Box 1064-C, Atascadero, Calif.

QSL'S-SWL'S that bring returns! Samples 25¢ (deductible). C. Fritz, 1213 Briargate, Joliet, Ill.

QSL Special. Free sample. Nat. Stinnette, W4AYV, Umatilla, Fla.

QSL'S Samples, dime. Printer, Corwith, Iowa.

QSL'S, glossy, colors, samples 10¢ (refunded). 200, \$3.75 up. Zone 1, postpaid. W1GKH Press, Danbury 18, Conn.

QSL'S Plain and fancy samples 10¢. Fred Leyden, WINZJ, 451 Proctor Ave., Revere 51, Mass.

BACKUS Press QSL'S-SWL'S. Samples Free. 703 Cumberland St., Richmond, Va.

QSL'S samples, Eddie W. Scott, W3CSX, Fairplay, Md.

QSL'S: Cartoons, colors, something different! Samples 15¢. Chris, W9PPA, 365 Terra Cotta, Crystal Lake, Ill.

RUBBER Stamps for QSL'S, sample impressions. W9UNY, C. W. Hamm, 542 North 93rd St., Milwaukee, Wis.

QSL'S-SWL'S; 1¢ each. Samples 10¢. Rusprint, Box 7507, Kansas City 16, Mo.

QSL'S-SWL'S, Meade, W0KXL, 1607 Central Ave., Kansas City, Kans.

CODE Course Supreme, on magnetic recording tape. Results guaranteed. Novice tape, basic instruction, practice material to 8 WPM, \$6.50; advanced tape—practice material 9 to 18 WPM, \$5.50. Combined, \$11.00. 7" dual track, 3 1/2 IPS. Tapedcode, Box 31-B, Langhorne, Penna.

WANT For Cash: Instruction manual for HRO50T1, coils, 50XCU, Have Heath V6, tubes and small parts for sale or for trade, stamp brings list. M. Marshall, 455 Washington Ave., Dumont, N. J.

CASH Paid for BC-342, BC-312, BC-610E/UP, BC-611E/UP, BC-639, BC-221, JB-70, BC-60; also TTY equipment and parts for TG-7, model 15, etc. RM-39 remote control, AN/TRC-7 receiver, surplus test equipment. Freight paid. Amber Industrial Corp., 75 Varick St., N. Y. 13, N. Y. Tel. CANal 6-7455.

SELL: BC779A revv and power supply unit, \$125; transformer 1.5 KVA at 500 mhz. One amp Class B xfrm, matches Class B 810's to Elmac 250T's or similar load. Also chokes, filter condx, plate xfrms, filament strms, all from one Klowatt, plus rig of Ex-W2JY. Two-cent post card of inquiry for items too numerous to list to W2LXL, 57 Hoover Ave., Bloomfield, N. J.

SIDEBAND and High Power operators: End antenna relay problems with our vacuum coaxial relay. Send for dope sheet. South Bay Electronics, 3125 Barney, Menlo Park, Calif.

FOR Sale: Collins 30K1 400 watt transmitter, like new condx. W8VYE, Orville Wood, Camden, Ohio, Tel. 243.

ETCHED—Circuit material, supplies, instructions, free catalog. Etched circuit, P.O. Box 2582, South Bend 14, Ind.

DELTA-TENNA ground planes, commercial quality 2 mtr., \$19.95, 6 mtr., \$24.95; 10 mtr., \$29.95. Also cut to any commercial frequency 450-20 Mc. Western Gear, Dept. Q, 132 W. Colorado, Pasadena, Calif.

WANTED: Used receivers and transmitters. Will pay cash or trade. 10% down with up to 24 months to pay. In stock: New 75A4's KW5-18, KVM-1 883B mobile transceiver, Johnson, E&W National, Hallcrafters, Elmac, Hammarlund, Gonset, Central Electronics, Mosley, Hi-Gain and Gotham Beams. Write for list of bargains in reconditioned receivers and transmitters with new guarantee. Shipped on approval. Write Ken, W0ZCN, or Glen, W0ZKD for your best deal. Ken-Fis Radio Supply Co., 428 Central Ave., Ft. Dodge, Iowa.

SSB Transformers identical to those used in W2BWV exciter (see QST March 1956). brand new, 3 for \$4; Eimac 32 kV vacuum condensers 12 grid and 30 grid, brand new \$5.50 ea., 2 for \$10.50; brand new full-wave bridge selenium rectifiers 30 VAC to 24 VDC at 500 Ma, perfect for surplus gear, \$1; 4 for \$3.50; brand new Ouncer xfrms, 1000 to 1 imp. ratio eliminates one voltage amp. stage, ideal for portable and/or mobile \$1.95 ea., 2 for \$3. All post-paid except condensers. No C.O.D. please, S. Tucker, W2LLT, Rt-10 Little Neck Pkwy, Little Neck 62, N. Y.

HIGH Band Motorola, Link GE, 2-way FM equipment, \$40 per unit up; 6V dynamo dynamotors, 600V at 170 Ma., \$7.50 each. Some low ball-throw and Link equipment. Dave Graves, W4LR1, Barnesville, Ohio.

GPR-90 and matching speaker, brand new, guarantee. Will accept reasonable offer. G. F. Gulter, Traller Haven, Melbourne, Fla. Telephone 1255-J.

WANTED: Highest prices paid for ART-13, ARC-1, BC788, BC610, BC348, ARC-3, BC312, BC342 and other military or aeronautical surplus. Name your price. We pay freight and C.O.D. James S. Spivey, Inc., 4908 Hampden Lane, Bethesda, Md.

WANT For Cash: Instruction manual for H1050T1, coils, 50XCXU, brings Hist. V6, tubes and small parts for sale or for trade, stamp prices list. M. J. Marshall, 455 Washington Ave., Dumont, N. J.

HAMMARLUND HQ140A receiver, like new condx, \$175; also Hallcrafters 844 very gud condx, \$45. Gerst, 2674 West 25th St., Cleveland, O. Want: RME-45, Calomatie.

WANTED — "Two Hundred Meters & Down" by Clifton DeSoto, Hill Halligan, W9AC.

RECORDING & Brochure: Limited Edition. A tribute to Radio and Morse operators. "The Saga of Telegraphy" is a historical story of communications men and their progress since 1844. It highlights courageous deeds performed by them. Available in two parts: 33 1/2 record, playing time 45 minutes, includes narration and code. Brochure is the written & illustrated story. Special price to amateurs: Brochure, \$1.00; Recording, \$3.00 or both for \$3.75. J. R. Graham, W4RJD, P. O. Box 1556, Arlington 3, Va.

CASH Paid! Sell your surplus electronic tubes. Want unused, clean transmitting, special purpose, receiving, TV types, magnetrons, klystrons, broadcast, etc. Also want military, and commercial lab test and communications gear. We swap, too, for tubes or choice equipment. Send specific details in first letter. For a fair deal write, wire or telephone: Barry Electronics, 512 Broadway, New York 12, N. Y. Tel. Walker 5-7000.

SELL Johnson Matchbox practically brand new, and SWR bridge, \$40 F.o.b. 84 Mt. timer D. Solomon, 41 Westbrook Lane, Koozebun, N. Y. K2AN VFO.

SELL: Heath 0-8 scope, \$25; PP 812 amplifier, \$12.50; antenna coupler, \$7.50; 1000 volt 200 Ma. power supply, \$12.50; 2 KVA variac, \$10. Molyneux, 2101 Oakmont Ave., Anniston, Ala.

WANTED: BC1004, CW-3 receivers; FM signal generator covering 144 to 148; #14 teletype repeformer; uncalibrated LM; M209 converter; inductance bridge; books on telephony, acoustics, noise and sound. John Longley, W2ANB, Slicerlands, N. Y.

NC-10KRB in 21 x 25 rack, \$75; RAX-1 naval aircraft (G.E.) B8east revr 110V/AC, \$40; Stromberg-Carlson AU-32 amplifier, \$40. All exc. oper condx and near-new appearance; HFS and pwr supp. \$30. Shipping extra. L. G. Barrett, EX1NP, 1916, 31, S. Park, Hanover, N. H.

SX-71, late model, extra. R46 speaker, \$15; 2 meter Communicator, \$140. W3YPL, 104 Johns Ave., Gettysburg, Penna.

SELLING RME HF-10-20 converter. Excellent condx, \$40; also Gotham 4-el. T-match beam with improved hoo, \$20. Make offer. William Ellis, K6UES, 338 McKendry Dr., Menlo Park, Calif.

TRANSMITTER for sale: 75 w. CW rig, xcelnt on 80, 40, 20 M. \$35. Don Uver, W1FGW, 132 Woodbridge St., South Hadley, Mass.

TABLETOP 600 watt G.G. linear, including supply, pi net output. TVI suppressed, \$100; 4X150A, \$8 each, 2 for \$15; Eimac air system sockets, \$3 each, 2 for \$5; 701A, \$3 each, 2 for \$5; 701A filament transformer, \$5; Johnson Matchbox, \$35; new ID60 Panadaptor with operating manual, \$30. W9ONO, George McKinley, 6149 N. Clark Ave., Chicago 31, Ill.

NC300: XCU calibrator, speaker, like new, will ship: \$375 or best offer. K4BYC, P. O. Box 546, Paducah, Ky.

PRESERVE those prized QSLs in laminated plastic, 50¢ each. Also photos, licenses, etc. Write for prices. VanArtsdalen, W3AXA, Box 73, Jacobus, Penna.

FOR Sale: Deluxe KW, TVI suppressed fone and CW, 4-250As, final, pr. 100THS, modulator; power supplies variac controlled. Racks 42 in. high with dollies. Iack #1 final power supply with 872As and variac, 4 meters, antenna tuner, rack #2 final stage, Millen 90901 exciter and regulated screen supply with variac, 5 meters and grid band stretching; rack #3 modulator stage, power supply with 872As, variac control, Millen 90902 oscilloscope. Excellent shielding and final coils for 40-20-15-10 meters. Eimac vacuum variable in final. Cannot ship very easily. Price complete, \$695. Parts alone cost \$1400. W9THB, 2422 Grand Ave., Granite City, Ill. Phone TR4ange 6-1879.

FOR Sale: Hallcrafters SX-28, \$25; Heathkit DX-100, \$195; DX-35, \$55; MA-1, Multiplier, \$25. Gene Tomlinson, W1QCQ, South Windsor, Conn.

10 Meter 12 w. mobile xmitr, \$12.50; 15 mtr. 30 w. CW xmitr, \$15; 10 or 15 w. Deluxe Preselector, \$4.50; 10 mtr. converter, \$3.50; 10 mtr. 250 w. Deluxe VFO phone xmitr, \$125. F.o.b. W6RET, Box 2121, Oxnard, Calif.

SELL: BW5100-B transmitter, \$400; NC900 with speaker, xtal cal. \$340; both in new condition, ideal for complete C.I. radio control center. Prefer Conn. sale. Miller, W1AMJ, 53 South View St., Waterbury, Conn. Tel. PLaza 6-5056 after six.

AUSET Sell immediately: Heath DX-35; Heath VFO; Precision sig. gen. series E-200; Pentron tape recorder model HT-225; SX-99 new; DX-100 new; Heath "G" multiplier; Heath ant. coupler AC-1; Superior multimeter model 870-A; Eico multimeter, model 536; Barker & Williamson balun coil, mod. 713 40 meter 1 KW; all equipment in gud condx, ready to use. Make me an offer. Ed, K4MIQE, Muldraugh, Ky.

HEATH Equipment: 0-11 scope, TS-4A generator, V7-A VTVM, C-3, T3, TC2P tube checker. All probes. Best offer takes one or all, Bob Oakes, 371 N.E. 13th St., Homestead, Fla.

WANTED: 3 phase 12 volt alternator with rectifier and regulator. Clyde Salford, Chief, Police Dept., Westfield, Penna.

FOR Sale: KW-1 with RF section factory-wired for ssb, 75A-2 w/ mech. filter, Multiphase 10A exciter, P. W. May, W9WRR.

FOR Sale: Johnson Viking II with Johnson VFO. Excellent condx, \$230. W0AZZ, Kenneth Ames, Box 290, Afton, Iowa.

FOR Sale: Complete station for \$300 or separately: DX-100 with coaxial relay; NC-88 revr with Heath "Q" Multiplier. Want: 10A or 10B exciter. Lee Owen, W8KKG, R.D. #1, Ravenna, Ohio.

SSB: B.W. 5100 with 51B8 slide band generator installed, \$450; NC900 with xtal calibrator and speaker, \$325.00. Will not ship. Frank Platner, W8FQV, tel. TE 6-3728, Afton, Ohio.

SELL: BC348P, \$65; 10M converter, \$15; Johnson Signal Sentry, \$12.00; Matchbox, \$30; High power gear, transformers, etc. All in exc. condx. W2LVE, 39, 17th Ave., East Paterson, N. J.

RECEIVERS: Transmitters; transformers; tubes, resistors, coils, condensers, relays, dynamotors, motors, microphones, etc. Large collection of meters, crystals and parts of all kinds. Write for list. Will ship anywhere in the U. S. R. E. Woods, W6KEG, 2142 Parkway Dr., El Monte, Calif.

FOR Sale: BC639A VU receiver 100 Mc-155 Mc less power supply, excellent, \$95; SCR522A, reconditioned, \$55; SCR24N plug, 75¢ each; BC348, volume control, \$1.95; MC12A, right angle geared drive for Command receivers, 75¢. Long Island Radio Co., 3309 Lockhead St., Houston 17, Texas.

FOR Sale: Home brew kilowatt, AM-FM-CW. Pair of 818s in a 3 ft. cabinet. Beautiful construction. In perfect working order. Must sell, \$200.00 including all coils. All BC348, \$60; RME VHF 152A, \$45.00; Lettine 6 mtr. xmittr with 3 xials like new, \$70; Tecraft 6 mtr. converter like new, \$27.50; Telrex 6 mtr. beam with Alliance rotor (heavy duty), like new, \$30; ARC-5 VFO with power supply, \$10. All equipment in excellent working order, K2UHN, Arthur Kieghaupt, 223 Stephen St., Levittown, N. Y. Tel. Wells 5-2667.

HQ140X. In original carton with manual, used only 10 hours, \$200. Ted Beseparis, Frackville, Pa.

HARVEY-WELLS T90 with AP8-90 power supply, in like-new condx. Both are in original cartons with instruction manual: \$185. Edwin Harvey, W3DIB, Frostburg, Md.

WANTED: S88D receiver. State price and condition. David Stanley, Route 4, Vienna, Va.

SELL, NC-57B, in gud condx, \$35.00. Pnl, 206 E. Jackson, Harlingen, Texas.

FOR Sale: BC610D with speech amp., ARC5 VFO, tuning units and B+W 3400 coils for 80 through 20 meters, spare tubes, and technical manuals included, \$360.00. Local disposal preferred. Will deliver within 100 miles. Dave DeArmond, W6MSD, 1708 1/2 Whipple, Redwood City, Calif.

GOLLINS 32V9 for sale, W9OF0, 6733 No. Loron, Chicago, Ill. Tel: KOdaer 3-4733

SX96 Revr, \$165.00; Hickok 191X signal generator, \$55; Eico #360 sweep sig. gen, \$20; all in A-1 condx. Cash & carry deal Philly. W3VXE, Tel. VI 8-2249.

SELL: Ranger, perfect operx, condx, \$190; 75 watt 40-80 meter CW xmitr, \$27; UTC-8-50 6000V CT 300 Ma., \$25; UTC-8-46 2000V CT 300 Ma., \$13; 5V-20A, \$7.50; two 44d 4000V, \$6 each. All are in excellent condx. New 4-250A with used space, \$18. Band edge crystal 7011.25, \$1.50. Need: 4X150A sockets, 110V blower. Ray Jones, W2AEV, 111 Hillside Road, Farmingdale, L. I., N. Y.

FOR Sale: DX-100, A-1 shape, break-in & antenna relay, \$175; Viking I with Meissner BX Signal Shifter \$175; 6-100T F1 tubes, new \$7.50 ea., 8-4X250A, new, \$20.00 ea., 3-4X150 tubes, new, \$20.00 ea.; BC348Q, unmodified, \$35.00; GR-358 absorption wavemeter, \$15.00; Philco panel mount 100 watt 2-meter transmitter 4MC xtl, 829 in final, \$30 with tubes, 1-140A freq. meter 2.6 KMC to 3.0 KMC, caliber dial and cavity control, \$30.00. Want: Gud 500 watt modulator, same also 1000 watt or lower modulation xmitr, 10 type preferred. W8BHV, P. O. Box 722, York, Penna. Phone 2-6037.

FOR Sale: Collins 70E-S VFO complete w/dial. Never used. Sonar SR175 comprising VFX-680 and 75 watt final. Narrow band modulated or provision for attaching separate modulator. Coils for 80-40-20-15 and 10. What's your offer? W1DIS, James F. Hartley, Raymond, Me.

GOLLINS Receiver, 75A4 in original unopened crate; \$595; 32V1 transmitter, \$255. 300 watt modulator, \$35, crystals for 2 and 6 meters, 6 for \$1. W6IMC, 405 Alden Road, Hayward, Calif.

SELL: BC603D FM revr 25-38 Mc., \$65 with heavy duty 110V AC power supply, \$80. Johnny Gammon, W5VVY, 515 East 12th St., Bonham, Texas.

SALE: S83A ES 8-METER, QF1 ES power supply, xtal calibr., pre-selector, \$100. KN4PLZ, Cooper, 318 Hemlock, West Palm Beach, Fla.

SELL: Central Electronics, Q-Multiplier, \$20; RME HF 10-20 converter, \$50. K2PHP, RFD 2, Westwood, N. J.

SELL: 8 new plate modulators with speech for DX-20, Knight Adventure, and other transmitters, \$20 each. New #13 socket, 10 volt transformer, Johnson 200DD45 variable condenser, all \$20. 5 new AT-1 modulators, \$8 each. New supplies: 750v./250 Ma., 6.3V, 1.5, 800v./250 Ma., \$13. 500v./300 Ma., — 6.3V, \$10. Dual: 900v./250 Ma., —400v./125 Ma., \$20. 400v./100 Ma., \$7. many others. 10 good used 2D218, \$5. 48 Olds, \$0 (conv.), 50 Hudson radios, \$6 each. 6V, —400v./75 Ma. Vibration, \$5. W8KQU, 2748 Meade St., Detroit 12, Mich.

WANTED: Bound volume Number One of General Electric "Ham News". Will pay any reasonable price. W1DBS, John Savonis, 11 Dwight Court, New Britain, Conn.

S40B recently aligned by Hallcrafters factory with Heathkit Q multiplier, \$70. Bill King, 204 Lagoon, Northfield, Ill.

SELL: 32V3 with spare 4D32 \$450; 75A-1 with mech. filter and spr. \$310. Virgil Schaffer, 3165 Grove Court S.E., Cedar Rapids, Iowa.

SELL: Top condition NC-173, \$120, no sprk. Precision E200-C signal generator, \$35. K2LUF.

RARE Opportunity! Bound volumes QST complete, Vols. I through 31 (1915-1947 inclusive). Includes Special QST Bulletin issued after end World War One. Excellent condition. Best offer. Write to Mrs. K. B. Warner, 73 Mohawk Dr., West Hartford, Conn.

FOR Sale: Precision EV10A VFTM \$20; Instructograph \$10; Dow coax relay, \$3.00; Telex Twinset \$2.00; RMEAMB3 Monitor, \$5.00; 160 powerstat, \$5.00; Premax 40 meter vertical, \$5.00; UTC components, \$31; 32, 45, 57, 61, \$1.50 each. \$45. \$4.00; two CD 44d, 1000 v. \$1.00 each. R. Coklin, 2202 St. Elmo, Canton, Ohio.

FOR Sale: Collins 75A1 receiver. Just realigned. Guarantee excellent condition. \$225. Model A Signal Slicer, \$25. Steve Cerwin, 4 Longfellow Rd., Mill Valley, Calif.

FOR Sale: Complete 10 meter mobile rig for 6 volt automobile, incl. Stancor ST-203 xmtr, Palco 500V, 200 Ma., Vibrapack; Gonset 10-11 converter, complete Master Mobile Mount antenna—all working, with tubes, vibrator, \$45. J. B. Bullock, 412A Whitman Dr., Haddonfield, N. J.

SELL Complete station Viking II and VFO, SX-28 with Q Multiplier and Panoramic, 40 meter Amphenol diode, baluns, antenna relay; JT-31 mike with deluxe metal stand; \$400. Sell; 32V-3, \$555.00 or take factory-wired Ranger in trade. Need pair 4-250A also pair 810's. Lewis West, W9AIO, 3414 West St. Louis, Wichita 12, Kans.

SWAP: A 27 year collection of 78 RPM pop records, 2400, all in sleeves, and listed in catalog, for ham reg. equivalent in value. Call or write T. R. Adams, W2PFF, Middle Island R.F.D. L. 1, N. Y. Phone SElden, 2-3894.

IMMEDIATE answer to your request for new listings of reconditioned equipment and our new complete amateur catalog. We give you a realistic deal! always on all brands, new or used. Check our offer first. We deal quickly, easily and on a personal basis. Our terms tailored-made to your budget. Stan Burghardt, W9BJV, Burghardt Radio Supply, Watertown, So. Dak.

WANTED: Used Johnson Matchbox. WN6WEB, Box 594, Sonora, Calif.

SELL Complete station Viking II with all modifications, Johnson low pass filter, Vikings VFO, balun box, antenna relay, NC57 receiver with TMS and 8-meter, plus KIM 2 meter converter, T-23 ARC-turret tuned 2 meter transmitter, modulator, power supply in 3 ft. enclosed cabinet; 6 element Workshop beam, Alliance rotator, Vibroplex bug, T-3 Grip talk, Astatic crystal mike. Best offer over \$400 takes all. Local deal preferred. Milton Cohen, W10KK, 3 Millbrook Rd., Natick, Mass.

NR1 Receiver and TV course complete, \$40 postpaid to sender if first check. Warren Smith, KH6WW, 445 Lauone St., Wailuku, Maui, T. H.

NOVICES! Hallier-Smith S-38D receiver. Like new cond! \$35. W2BAC, 8 Jeff Baker, 4 Bayard St., Larchmont, N. Y.

SELL: Transmitter, pair 813's, conservative 350 watts output; Voltage regulating transformer for filament supply; keying tube, built by Federal. Used by K6AF. Best offer. South 1212 Monroe St., Spokane 4, Washington.

WANTED: Coils, buffer and antenna. For Collins transmitter 32RA7. Dave Goggio, 2671 Barron Road, Memphis, Tenn. W40CG.

WANTED: Instruction manual for Hickok signal generator Model 292X, Ser. #28-22. Give price. John J. Sullivan, 99 Aldrich St., Roslindale, Mass.

NEED 78 backdated magazines: QST; March 1951, July thru December 1951; CQ; January 1950, March, 1950, July thru December 1950; September and October 1955, June and July 1956; Radio & TV News; July through December 1953; July thru December 1953; July thru December 1954; June thru December 1956; January thru April 1957; Radio-Electronics, January thru June 1956; July thru December 1954; Sept. 1955; January 1956, June thru December 1956; January thru July 1957. W9PVR, Box 1, State Teachers College, Minot, North Dakota.

MORROW 5BR-2 mobile converter in original carton and book and cond. list \$50. You pay shipping. Bob Davy, Harvard, Ill.

SWAP—Radio course plus set repair booklets for Heath GDO. K4ALY, 701 Farmdale, Ferndale, Michigan.

FOR Sale: BC-610G, excellent condx. Melsner EX shifter. Both for \$350 or 10 letters answered. Price F.o.b. Salt Lake City. W7CTI, 2756 Adams St.

SALE or trade: 500 watt 813 mod. xfrmr RCA 901769-501, never used. Want xfrmr 550 Ma. 2500-0-2500 or larger. F. Osier, W9CPC, Fairfield, Ia.

SALE: DX-100 like new, used 5 hours, wired by Radio Engineer, \$185; Gonset II, 12v in exc. condx, w/xtal, \$175; coax 110v, relay, \$8; balun coils mounted on chassis with all connectors; \$6; McElroy code oscillator, \$5; Smith-Corona Skyriter mill, exc. condx, \$40. Herbert Holzberg, 125 Hobart Ave., Rutherford, N. J. Tel. WEbster 9-9456.

BC-603 10-tube Superhet, brand new, perf. condx. Covers 21 to 28 Mc. Squelch circuit, \$39.50. Jerry Ronkin, KN7AFH, 403 E. 84th St., Seattle 15, Wash.

SELL: B&W 51-SB SSB generator, \$200; Viking I, TVI suppr. and B&W SSB kits installed, 175-200 watts AM, C.W., SSB with spare 1032, \$175; PE-103A, \$15. Webster Bandsparner mobile antenna, \$15. F.o.b. Oak Lawn, Ill. Dr. J. R. Perciful, W4PDC/9, 11624 Joyce Dr.

FOR Sale: Hammarlund HQ-150; Heathkit DX-100; VOM, Grid Dip meter; microphone, headphones and antennas. All like new. Everything for \$500. Must sacrifice this fine rig to pay school expenses. Grady Chick, Jr., K5DZJ, Rte. 1, Dike, Texas.

FOR Sale: C-D HF-60 capacitor checker. Range-1 up to 240 ohms. Like-new condx. Precision 612 portable tube tester. Used very little. Each one \$25.00. Cecil Baumgartner, Box 343, Milton, Penna.

FOR Sale: RME-45, VHF-152, Q-5'er. \$110 takes all. L. S. Eberhardt, K2C2VT, 9 Ranger Rd., Milltown, N. J.

TRADE: Have Super-Pro Mod. ASP-SX, 1250 Kc. to 40 Mc. continuous coverage, new tubes, original separate power supply and speaker, factory circuit is unchanged, clean. Trade for 75A-2 unchanged and pay difference. W5IPH, Box 364, Natchez, Miss.

NATIONAL SW3 coils wanted for frequencies between 300 and 500 Kcs. J. Armstrong, W3FXR, 7 Long Lane, Malvern, Penna.

SELL: Elmac AF67, Elmac PMR6A, Elmac 12 V. Vibrator supply, PE103 dynamotor, Johnson almbred antenna coil, bumper mount and 8 ft. whip, \$225 F.o.b. Ft. Wayne, Ind. J. D. Leavy, W9OTR, 5118 Northeast Dr., Ft. Wayne, Ind.

SELL: SX99 and matching sprk used less than 50 hours; \$115. Chester Carter, W9NJP, Richmond, Mo.

NFRMR, power—input 115V/60v; output 1120v/0.6 amp et; 6.3v/3A at 0.3A; 5v/7A at 2A, \$7.50. S. S. Brody, 211-10 73rd Ave., Flushing 64, L. I., N. Y.

FOR Sale: SCR522A reconditioned, \$55; SCR522 plugs, \$1.00 each; SCR274N plugs, 75¢ ea.; BC348 volume control, \$1.95; MC211A right angle geared drive for Command receivers, 75¢. L. I. Radio Co., 8309 Lockheed St., Houston 17, Texas.

FOR Sale: 32V2, \$325; Temco 75GA, \$100; SX-88 w/sprk, \$349; SX-101, \$315.00. All in excellent condition. Bill Harper, W9BWM, 4037 Eddy St., Chicago 41, Ill.

SELL Or swap: Condensers: 200 ufd, 3000v dc, \$40; 2 ufd 3000v dc, \$5; 2 ufd 4000v dc, \$6; 2 ufd 5000v dc, \$7; 4 ufd 2500v dc, \$9; 2 1/2". Speed Graphic trade: GR100-Q Variac, \$22; 2450v dc 500 Ma., supply, \$50; 3000v dc 500 Ma. transformer, \$50; 650 Ma. choke \$10. Want: Modified BC-291 or LA-7 and Heath 9-11 oscilloscope. Perry Valente, W1G0L, 5 Summit Terr., Peabody, Mass.

WANTED: Six meter Gonset Communicator No. 2, 12 volt. State price and condition. Prompt cash for a good buy. Hosking, W2ADI, Flinders, N. J.

SELL: SX-71, \$140, handled like a baby. W3NKK, Pittsburgh, Penna. Carnegie Inst. of Technology, Carnegie Tech Radio Club.

SELL: Elmac A54H, good condition. First check over \$60 takes it. K8CSG, 88 Riverside Dr., So. Charleston, W. Va.

FOR Sale: One only, BC7M1 McElroy inking code tape recorder with MC310 tape puller, \$35; PE103 with all cables, \$25; 3 high vacuum HK253 rectifiers with Johnson sockets, \$10. Everything unused. Want electronic keyer. W9TE, Ben Woodruff, 6140 N. Harding, Chicago 45, Ill.

FOR Sale: SX-71 and R46 speaker, \$150. Reynolds, K5JGF, 2520 East 23rd St., Tulsa 14, Okla.

FOR Sale: HQ-150 receiver and speaker. Just like new. Modified 6 meter 20 tubes, earphones and key. \$40. Paul Nyitrai, 7057 Elmwood, Toledo 18, Ohio.

10A with BC458 VFO, \$90; NC125, \$100; HRO7, \$125; BC221, \$50; Astatic 75 microphone with G stand, \$15; BC610 plate xfrmr, \$90.00 dc at 500 Ma. CWS, \$40; Gonset 100 miles radius. Carl Willis, K8DKO, 464 Forest St., Mansfield, Ohio.

ATTENTION Novices! Used Instructograph, in excellent condition, with 20 tapes, earphones and key. \$40. Paul Nyitrai, 7057 Elmwood, Toledo 18, Ohio.

WANTED: Collins 32V3 in gud condx and reasonably priced. New York City vicinity. Tel. WAtkins 4-7983, 460 West 24th St., N. Y. 11, N. Y.

SALE: NC-300 and BW-5100B brand new, used only 20 hours. Must sell. Sacrifice: \$695.00 Write Ernie Hoffman, W7RJH, P.O. Box 511, Tucson, Arizona.

FOR Sale: Brand new Johnson Matchstick, \$100. F.o.b. Chicago, Ill. One brand new 20-meter 3-el. Telrex, \$150. F.o.b. Chicago, W. A. Kuehl, W9E2N, Drake, 3654-56 Lincoln Ave.

CANADIAN Amateurs! 600 watt bandswitching transmitter, Collins PTO, completely shielded, phone c.w./RTTY with Hammond power supply delivering zero to 5000 volts at 1500 mills, Variac controlled, \$500; Model 12 teletype, \$40; Model 26 teletype \$75; E9'er, \$10; Collins 75A3 like new, speaker, calibrator, NBFM discriminator, filters, complete. Want or sell trade for general coverage HRO60 complete, like new. New PE103 dynamotor, \$30; RCA Mod. TE-497-E radio teletype keying unit, xtal oven, etc., like new, complete, \$50; W9PAT teletype converter, \$50; Presto professional Mod. K8 record circuit, \$75; Need: Ampex tape recorder. R. E. Hadfield, VE3CH, 14 Sunnyside Ave. East, Toronto 18, Ont.

VIKING Vallant and Globe Champion-300. Schematics 18" x 24", \$1.25 postpaid. Am cleaning house, surplus equipment, transformers, condensers, variacs, bargains. Send for list. W8FNS.

HARVEY-WELLS TBS-50C Bandmaster, Sr. transmitter with carbon mike; in excellent condx; Bandmaster VFO, APS-50AC power supply; 1 Johnson Key speed X 114-320 and 2 Amphenol 150-010; 150-020, all never used; 1 Shure 101C carbon mike; Mobile Mounts antenna 80 m., xtal; control box and all cable for mobile rig. Best offer. J. B. Kambourian, Jr., 49 Fay Lane, Needham, Mass.

SELL: Heathkit DX-35, excellent condx, \$45. Paul Makowski, K2EYG, 338 Elmwood Ave., New Providence, N. J.

FOR Sale: Complete 500w. SSB station: Collins 75A4 revr with matching low speaker; Globe King 400 converted for sideband with electronic regulated grid supply; 20A exciter with Elicdo U.F.O.; FT18 U.F.O. for use on A.M.; xtal mike and earphones and prop pitch changemotor. All of above are in perfect operating condition as the station has recently been dismantled due to moving. Total price: \$1100. May consider separate sale of items. W. Sinsheimer, W2NRE, 30 Herkimer Rd., Searsdale, N. Y.

SELL: AT-1, AC-1, both for \$30. K9GUB, Conrad, Iowa.

BARGAINS: WITH NEW GUARANTEE: HQ-100C \$145.00; HT-20 xmtr, \$249.00; Collins 32V3 \$495.00; SX-100 \$229.00; TBS-50C \$69.00; TBS-50D \$69.00; APS-50 p.s. \$29.50; TBS VFO \$35.00; Lysec 382 VFO \$19.95; Lysec 600 \$69.00; Elicdo TB-75TV \$25.00; B&W 5100 \$299.00; Adventurer \$34.50; Knight CW xmtr, \$34.50; Gonset #302 VFO \$45.00; Norel SRT-120P \$129.00; Globe Trotter \$29.50; Globe King 500A \$495.00; Globe King 275 \$199.00; Globe King 400B \$275.00; Scout 65A \$69.00; Scout 65B \$75.00; Globe King 400C TVT \$299.00; Globe King 500B \$599.00. Free trial, terms, write Leo, W9GPG for best deals. World Radio Laboratories, 3415 West Broadway, Council Bluffs, Iowa.

SELL: HQ129X, Viking II and Viking VFO. All in operating condx; don't use it enough to justify owning. Frederiek Ostlund, W9PVL, Clyde, Kans.

SELL Super Pro Model 1004 like new. \$3 to 20 Mc. rack mounted in deluxe enclosed cabinet 22 x 17 x 48 on casters with metal operating desk, 8" PM speaker, technical manuals, \$195 complete or swap for B & B sideband generator. W2DTE, 29-29 213 St., Bayville, L. I., N. Y.

FOR Sale: 300 watt c.w. xmtr, TVI suppressed, \$100; Stancor 2000 volt 5000 Ma. pwr supply, \$100; RF meter, \$5 each 0-150 Ma.; 0-1.5 amp; 0-8 amp. Other parts cheap. W4ALL, 109 Lindsey Court, Haleah, Fla.

FOR Sale: Complete SSB station 10A, deluxe 458 VFO, PA400, Elenco 450 watt final, \$195. Can be heard nightly on high end of 75. K2HPX, Box 103, Pomona, N. J.

WANTED: Cheap A.C. Instructograph with oscillator. J. H. Pruet, 2635 W-21 Pl., Chicago 8, Ill.

PRESLECTOR Model RME DB23, three tubes, 35 DB boost in signal received, \$28.50; Elco model 232 VTFM peak to peak w/probe, \$27.50. Iollicarn 152 Mc. \$22.50. Charles Kunde, R.F.D. #1, Roselle, Ill.

WANTED: To buy, Lampkin type .105B micrometer frequency meter. State condition and price. E. Raymond, Bunker Hill, Ill.

LINEAR amp, Gonset 500-W, \$225; C15 20A 888 exciter, \$210; C16 VFO, converted BC458, \$39; Elmec 67A mobile transmitter \$140; Sonar MR3 80-40-20 mobile revr, \$39; Hallcrafters BX-42, \$175; 1750v. 500 Ma. PS UTC parts, \$35. A. Dayes, 29 Charles, Merrick, N. Y.

FOR Sale: TV Camera, Model CRV-59, complete and ready to go on the air (less power supply) with complete instructions. Price, \$99 plus shipping charges. Other ham and surplus equipment. Write for list, W4ZEM, Moate, 18152 Sunburst St., Northridge, Calif.

SELL: Navy ARB receiver with 110 ac pwr supply; 15 watt mobile transmitter, Alenco 35w. amplifier, 500v. and 300v. power supplies. Many other parts. Write for list, B. G. Shickman, W0YJB, 512 Lucas Ave., St. Louis 1, Mo.

TRADE Collins ART-13 (used) and/or Bendix ATD (new), for ham receiver or converter. Fred Marco W9ZA, Des Plaines, Ill.

SELL: Hallcrafters HT-19, TVI suppressed with add'l new 4-65A. National NC-173 in gud condx. Best offer takes both or either. XYL says go. W0LFR/4, 2231 Martin Blvd., Prattville, Ala.

WANTED: ART-13, BC-610E, BC-614E, BC-939, JH-70 junction box; BC-312, BC-342 and other military surplus. Advise what you have, condition and price. W4VEG, Ritter, Box 6878, Bethesda, Md.

SELL: Collins KWI transmitter, factory adapted for Central Electronics, Inc., Multiphase exciters 10E or 20A, excellent condition, \$1,900.00 cash. F.o.b. Trenton, Michigan. E. V. Rieder, 2210 Ruskin Rd., Trenton, Mich.

FOR Sale: Precision 954 tube and set tester, \$65; Precision E-200-C signal generator, \$35; Heathkit 425 scope, \$25; HQ129X Communications receiver, \$100. All above in very gud condx. phone JA 1-7661. Write Mr. Vasallo, 99 Greenpoint Ave., Brooklyn, N. Y.

SELL: Modulator and speech amplifier for 500 watt final, \$45.00; RME-45 Calumet dial model receiver, \$40; Western Electric 500 watt mobile xmtr, complete, \$40. H. K. MacLeod, W2CIT, 3919 William St., Seaford, N. Y.

Hq-140-X revr, used three months, like new condition, with Johnson xtal calibrator, \$20. Best offer F.o.b. Pittsburgh, Penna. M. J. Gray, 61, K6DAE, Rm 5259, Bancroft Hall, U. S. Naval Academy, Annapolis, Md.

FOR Sale: Two (2) Vocaline transceivers used very little, in good condition. Complete with inside and one outside antenna, microphones, \$100. Ron Jones, 518 Polk, Topeka, Kans.

SELL: RME-45 with speaker, \$75; Heathkit AR-3 receiver, \$24; Knight 50-watt transmitter, \$30; Elco brand-new RT-75 VFO transmitter, \$35; wanted: HRO-7 in excellent condition. John Bradley, General Delivery, Montclair, N. J.

HC-342-J, \$40. Jack Mackowiak, National Co., Inc., Malden, Mass. Call Boston ME 4-6330.

HEATH DX35 with Heath VFO, like new, \$75; Gonset 12 volt Communicator II, 2 meters with 6-el. Telrex beam and 6 xtals, like new, \$185. K1BL1, Don Grimme, 54 Seminole Rd., West Acton, Mass.

WANTED: One 8X-28, AR-88, NC-173 or NC-183-D in perfect condition. Top set gets top price. Advise condition and price desired. N. Fotladi, F9AB, 37 Cottage Place, Long Branch, N. J.

DOES it quicker, does it better: DiAxial Antenna Connector. Newest and easiest, no soldering with this connector. This is it for centered antennas using coaxial transmission lines. \$4.75 net. Lakeland Electronics, 1327 Leonard Ave., Muskegon, Mich.

FOR Sale: Complete 12 volt mobile rig; Elmec AP67 xmtrr, \$130; PMR64 revr, TNS, Vibrapak, \$110; 600 volt Dynamotor, relays and filter base, \$15; Ext. 8 Meter for PMR64, \$6; Drake Q Mult., \$15; Advance coax relay, \$5; Mallard 75 meter loading coil, \$5; 117B mike with T-1 button, \$3; Elmec 6 volt vibrator xmtrr to convert Vibrapak to 6 volts, \$4. Best offer over \$250 takes all with all interconnecting cables and manuals. Will consider selling units separately. Bob Christen, W2EPE, 2443 East 22nd St., Bklyn, N. Y. Tel. Nighthengale 6-8972.

COLLINS 2A47 for sale, all coils and mic. pickup, \$70. Berman, W2JJY, 3311 Halsey Rd., Fairlawn, N. J. Tel. Fairlawn 4-3102.

SELL Collins 75-A4, \$500. Will have reconditioned. Sell BC-698 and power supply, \$25 and ID-59/ AFA-11 scope. James Quinby, W2EVZ, Copake, N. Y.

SWAP Gonset II, 6 volt; Stancor 203A, 10 meters; PE-103, Gonset 10-11 converter; Micro-Match for Model A Ford roadster or Phaeton, complete and not rodded. W2GND.

XMITTR: "Hart 75", 125 watt, all band, pi-net, Also Meissner signal shifter. Sell both for \$80. Robert Jordan, 202k West Scheunz Ave., Dayton, Ohio.

FOR Sale: HY-9 transmitter with coils, excellent condx, \$100. Prefer a local sale. PE-103, brand new, \$25. Henry Garon, Donaldsonville, La.

WANTED To Buy: Elmec AF-67 transmitter, A-54, etc. Mobile equipment. Also high power transmitter, tape recorder, radio supplies. Al Haberman, 129 Morgan St., Holyoke, Mass.

SELLING out: NC300 revr, xtal calibrator National speaker, just completely aligned by National, \$330; B&W 5100 B with Dow Co. AX relay, perfect, \$350; Johnson Match-box, \$32.50; new Elmec PMR7 revr, 60 watt power supply, never used, \$135. K1AHO, 101 Woodchester Dr., Weston, Mass.

NATIONAL NC-98 with speaker and manual, new condition, \$95. K5GHN, 6824 Latta, Dallas 27, Texas.

ARC-5 VHF xmtrr, \$5.00; SCR552 xmtrr, \$5.00; 25 cycle xmtrrs for sale. Box 391, Ft. Wayne, Ind.

ADVENTURER, \$30; Master Mobile 10-75M loading coil, new, \$10; Sonar MR-4 mobile receiver, \$40; swap 35mm enlarger w/lens, (\$7.00 value); Need Matchbox, K2DQD, Box 27, Wall St. Sta., N. Y. C. 5.

WANTED: Teletype equipment, ART-13, BC-342, BC-312, BC-348, APN-9, ARC-3, AR-8, BC-610, BC-221, amateur receivers, transmitters, etc., in trade for new Johnson Ranger, Courier, Thunderbolt, Vallant, Five Hundred, Hallcrafters, National, Hammarlund, B&W, Telrex, Gonset, Elmec, Fisher Lt-F1, Gonset or other, Write Tom, W1AFP, Altrionics-Howard Co., Box 19, Boston 1, Mass.

S-76 Hallcrafters receiver for sale. Clean, sensitive, selective, \$99.50. F.o.b. Maplewood, N. J. H. C. Vance, Sr., K2FF, 33 Oakview Ave., Maplewood, N. J.

BC-454, BC-455, \$8 each. Heathkit Communications receiver Model AR-2 with cabinet, \$29. Modulation transformers for 807's, \$2.50 each. W8GUJ, 18944 Sorrento, Detroit, Mich.

FOR Sale: Viking I xmtrr, mod. 200 watts, extra audio stage, TVI-suppressed, etc. In excellent condition. Viking VFO. Bud low pass filter, Hallcrafters BX28 rec with speaker, 3 el. Telrex beam with motor and CDR rotor for 10 meters. Also Lettine 10 to 80 meter xmtrr TVI-suppressed, 60 watts with Lyco VFO and power supply complete. Going to electronics school and need the money. No time for fun radio at present. Prefer local deal. W2KNG, Charlie, 68-164th Ave., Paterson, N. J. Call Lambert 3-1250 or Swarthmore 6-5683 between 5 and 6 p.m. or write, Salvatore La Cava, 68-16th Ave.

LATE Model Johnson Viking II and VFO, factory-wired, excellent condition, \$225; Hallcrafters receiver SX100, less than 1 year old \$200, w/spkr. F.o.b. Hamden, Conn. Raymond H. Zeek, WITNG, 314 Shepard Ave.

RTTY Equipment wanted. Desire teleprinter or tape enter and transmitting distributor. Send description with model number and condx. Write to: W4JON/K1CJ, H. C. Caldwell, Comservpac, C.O.M., Box 28, c/o FPO, San Francisco, Calif.

RICHLEU, W8JSB, the flying saucer man from Mocking Bird Hill solicits your vote for Director, Great Lakes Division. Be sure to vote. CALL Letters on black background, beautiful tie or lapel pin made in Holland, \$1.50 postpaid. K9EPK, De Wall, 4900 E. Kansas Dr., Denver, Colo.

WANTED: W2EWL exciter, Ernest Bergman, 640 Riverside Dr., New York 31, N. Y.

GENERATOR Set: 1 Kw. factory new, not surplus, \$167. Stephen Grossman, W2YZA, Clinton Corners, N. Y.

FOR Sale: Viking II, Viking VFO, Viking SWR/Bridge, low pass filter, Matchbox, NC-125, Dispatcher mike. Write for details. W1WNB, Jeffrey McKeuzie, 1339 Yale Station, New Haven, Conn.

SALE: 75 watt Eldico transmitter with low pass filter, D.P.D.T. relay and crystal. In perfect condx. F.o.b. \$50. Want: Harvey-Wellis Z-Match, 15 and 20 meter beams, K2ZVA, Paul Kroll, 3527-203 St., Bayside 61, L. I., N. Y.

MORROW 2BR converter with fixed tuned receiver and 8 meter. Jig plus in; excellent condx, \$65; RME 1B20 Presetor, \$25; TC58 xmtrr and K1C pwr sup. \$45; Elmec 4X150A tube, new, \$12.50; RME69 revr, beautiful, \$75. M. D. Welch, W7WOG, 637-49th S.W., Seattle 16, Wn.

75AH, never used, with 800 and 3.1 filters, \$575. Pair of BC611 Handie Talkies, \$150. Custom-built liner amplifier using 4-1000A per Radio Handbook, \$400. Power supply 4000 volts, home-built available slightly extra cost. Contact Box 575, Church St. Station, N. Y. N. Y.

FOR Sale: New factory-wired Johnson GN2. Used only 10 hrs: \$119.95. Also have 12 volt deluxe II Communicator, in perf. condx. \$160. H. Barrett, W8OQY, Whitehall, Mich.

SELL: Viking II, factory wired, \$175; Johnson Matchbox, \$35; New Gonset Super-8, \$35; 40 watt modulator, \$20; 125 watt modulator, \$35; 811 tubes, new, \$2; slightly used 4-125A, 9, 35; 35T, new, \$3; 26 in. cabinet, \$12; back issues of QST, CQ and Radio, 25¢. Hecht, W5WVI, Junction, Texas.

COLLINS 75A2 with speaker, \$250, F.o.b. Baltimore. No space here. Must sell. Art Andersen, K2DNG, c/o Tektronix, 8118 Hartford Rd., Baltimore 14, Md.

SELL Heath 57' 06 oscilloscope. New CRT. In exc. condx. \$30 or best offer. W2NTD, 931-76th St., Brooklyn 9, N. Y.

SX-71 in exc. condx: \$143. James Devlin, West Mountain, Ridgefield, Conn.

NEED Cash, Selling out. Complete 400 watt SSB rig, BC458 VFO, 20A, Iay linear PP 811A final, 200V0 5000 V 500 mill power supply, complete, \$275. New SX-101 receiver, \$315. M. P. Howell, 417 Heradson, Corpus Christi, Texas.

COMPLETE transmitting section, 200 watt max. less power supply for final, FB VFO, SM-90 screen modulator on Heath AT-1, 813 final with PI network and clamper. First \$100 takes. Bob Crawford, K6SNB, 1322 Edgebrook Dr., Modesto, Calif.

SELLING Globe King 500, like new, on the air only 46 hours. First offer of \$465 takes it. Phone HE-3-4428, K2KBU, Brooklyn, N. Y.

PROSPECTIVE mobileers drive and mobile free of battery troubles with 6V Leeco-Neville system, \$40 F.o.b. Martin, Topeka, Kansas. W9MNXG, 1268 College Ave.

HC-610E: A Headquaters station souped-up to a cool galton; only \$1,000 (cash or part mchise); Modified for 10 & (VFO) 20; its kilowatt has worked world-wide. Includes: BC-614 speech amp., coils, mic. manual, and 2 spare 250THT bottles. R. D. Wessburne, 750-CI E. Front St., Plainfield, N. J.

SWAP - New Minifon pocket-size wire recorder, cost \$380, and SX-100, cost \$295. Will trade both for good 75A4, W. Abbott, 173 Del Mar, Costa Mesa, Calif.

WANTED: Used transmitters and receivers, modulators, power supplies, analyzers, exciters, and VFO. Price and description in first letter. Ward L. Lantis (W4LE), 3935 Skyline Dr., Kingsport, Tenn.

TELETEXT 10M-56-59 beam, new, in factory carton: \$64.90; new 10-96 receiver, unused, \$125.00; NC-98, used only 6 mos., \$95. W4AVU, Box 1189, Charlottesville, Va.

Designed for

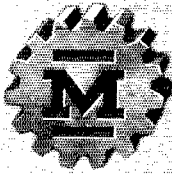

Application

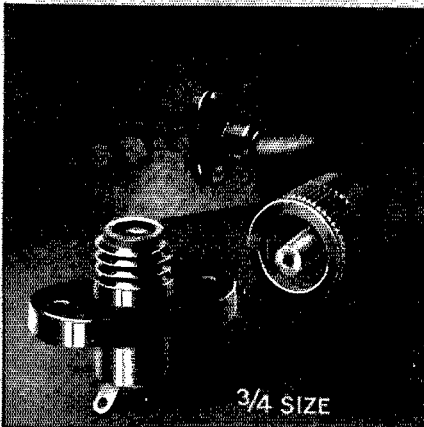

3/4 SIZE

THE NO. 37001 SAFETY TERMINAL

An old favorite in the line of exclusive Millen "Designed for Application" products. Combination high voltage terminal and thru-bushing. Tapered contact pin fits firmly into conical socket providing large area, low resistance connection. Pin is swivel mounted in cap to prevent twisting of lead wire. Easy to use. 1/4" o.d. insulation high voltage cable fits into opening in cap. Bared conductor passes thru pin for easy soldering to pre-finned tip of contact plug.

Standard 37001 available in either black or red bakelite. No. 37501 is low loss mica filled yellow bakelite for R.F. applications.

JAMES MILLEN MFG. CO., INC.

MAIN OFFICE AND FACTORY
MALDEN
MASSACHUSETTS



Index of Advertisers

Ack Radio Supply Co.	173
Adirondack Radio Supply	226
Allied Radio Corp.	210
American Electronics Co.	172
American Radio Releay League	
<i>QST Advertising Policy</i>	185
<i>QST Gateway</i>	154
<i>Handbook</i>	108
<i>Radiograms</i>	188
<i>Hints & Kinks</i>	190
<i>Binders</i>	186
Amperex Electronic Corp.	183
Arrow Electronics, Inc.	104
Ashe Radio Co., Walter	155
Automation Electronics, Inc.	161
Barker & Williamson, Inc.	149
Bob & Jack's	135
Box 181	177
Brooklyn YMCA Trade School	181
Bud Radio, Inc.	186
Burghardt Radio Supply, Inc.	156
Burstein-Applebee Co.	193
Candler System Co.	182
CBS-Hytron	198
Central Electronics, Inc.	158
C & G Radio Supply Co.	175
Collins Radio Co.	175
Columbia Products Co.	2
Columbia Products Co.	192
Commercial Radio Institute	184
Crawford Radio, The	182
Cubex Co.	182
Curl Radio Supply	191
Cushman Products	137
DeMambro Radio Supply Co.	152
Dow Radio, Inc.	182
Dow-Key Co., Inc. The	183, 189
D'Kerama	189
Eitel-McCullough Inc.	4
Eldico Electronics	139
Electronic Center	132
Electronic Supply Co.	122, 123
Electro-Voice, Inc.	Cov. 11
Elmar Electronics	159, 174
Equipment Crafters, Inc. The	199
Evans Radio	179
Fort Orange Radio Distributing Co., Inc.	169
General Crystal Co., Inc.	191
General Electronic Service	127
Gonset Div.	191
Gotham	112, 113
Graham Electronics Supply, Inc.	177
Grayhill, Inc.	189
Hallerafters Co., The	1, 103
Ham Register	191
Hammarlund Mfg. Co., Inc.	131
Harrison Radio Corp.	128, 129
Harris Radio-Amateur Electronic Supply	144
Harvey Radio Co., Inc.	151
Heath Co., The	109, 110, 111
Henry Radio Stores	157
Instructograph Co., Inc.	187
International Crystal Mfg. Co., Inc.	121, 125
International Instruments, Inc.	176
International Resistance Co.	138
Johnson Co. B. E.	105, 106, 107
Kalmuki Radio Co., Ltd.	164
Ken-Els Radio Supply	124
Kinkade Radio Supply Co.	170
Klaus Radio & Electric Co.	189
Lafayette Radio	165
Lakeshore Industries	180
Lumpkin Labs, Inc.	185
Lettine Radio Mfg. Co.	187
LMB	188
Lynnmar Engineers, Inc.	181
Mallory & Co., Inc. P. R.	7
Master Mobile Mounts, Inc.	148
Millen Mfg. Co., Inc. James	195
Mosley Electronics, Inc.	142
National Co., Inc.	118, 119, Cov. III
Newark Electric Co.	187
Northwest Electronics, Inc.	140
Page Airways, Inc.	184
Petersen Radio Co.	5
Phileo TechRep.	174
Port Arthur College	183
Premax Products Co., Inc.	176
Ruffed Enterprises	183
Radio Electric Service Co. of Pa., Inc.	146
Radio Equipment Co. (Lexington, Ky.)	187
Radio Products Sales Co. (Denver)	179
Radio Shack Corp.	163
Radio Trade Supply	181
Raytheon Mfg. Co.	141
RCA Electron Tube Div.	Cov. IV
Regency Div. of I.D.E.A., Inc.	150
Rider Publisher, Inc., John E.	171, 192
Scientific Industries, Inc.	185
Tapetone, Inc.	177
Technical Material Corp.	114, 115
Telrex, Inc.	133
Tennalab	147
Texas Crystals	130
Trans-Arabian Pipe Line Co.	186
Triad Transformer Corp.	166
Universal Distributors	184
U. S. Crystals, Inc.	134
Valley Electronic Supply Co.	120, 136
Valparaiso Technical Institute	179
Variety Electronics Corp.	190
Vesto Co., Inc.	190
Vibroplex Co., Inc., The	179
Western Radio	168
Willmart Jewelry Co.	184
Wind Turbine Co.	182
World Radio Labs	148, 153, 162, 167, 178, 180
WRL Electronics Products	116, 117, 143

CRYSTAL CONTROLLED CASCODE CONVERTERS

AVAILABLE FOR AMATEUR, COMMERCIAL, CIVIL DEFENSE-CAP AND SPECIAL SERVICES—
USE WITH ANY COMMUNICATIONS RECEIVER

These **NEW** converters by Tecraft fill a need for quality equipment which will allow your present communications receiver to function on the VHF and UHF bands.

A Tecraft converter, connected to the antenna terminals of such a receiver, provides the finest reception and control of the signals. The resulting receiving system is ideal from the point of view of **LOW NOISE, EXTREME SENSITIVITY, HIGH GAIN** and **MAXIMUM STABILITY**. Virtually any make or model of receiver, including broadcast type or short wave receivers, can be used, since Tecraft Converters may be had in a wide choice of I.F. output frequencies—to suit the tuning range of the receiver.

FEATURES

- A Precision crystal oscillator assures freedom from mechanical modulation and drift and gives completely stable CW or Phone reception.
- The input circuitry allows use of co-axial feed lines of from 52 to 72 ohms impedance. 300 ohm balanced feed line may also be used as per instructions supplied.
- Power Supply requirements are small and in many instances may be obtained from the companion receiver, transmitter, or an independent power supply (our model P 1) may be employed.
- Case and Chassis are beautifully finished in hammer-tone, which is baked for durability. The chassis is also copper plated to minimize circulating chassis current and to provide low impedance RF returns.

The **ULTIMATE** for high sensitivity—for use where top performance is a **MUST!** CAP, Police and Fire Departments, CD and Amateurs interested in optimum reception have proved this design on every communications band in the range from 50 to 220 mc.

SPECIFICATIONS CC-144

LOW NOISE FIGURE: Approximately 4 db. 1 microvolt of signal will provide better than 20 db. thermal noise quieting.

SENSITIVITY: Approximately 1/10 microvolt input will provide a signal 6 db. over noise level. Gain: Better than 30 db.

VARIABLE RF GAIN CONTROL: to minimize cross-modulation.

PASS BAND: 6 mc at 6 db down points. May be peaked to favor any portion of the band.

TUBES AND ACCESSORIES: 1 6BZ7 (or 6BQ7) 2 6CB6, 1 6J6, — Input, output, power plugs, and crystal are supplied.

POWER INPUT: Filament, 6.3 V AC, @ 2.4 amps, and 150 to 250 V DC at .043 amps at maximum voltage.

SIZE: 9½" x 3" x 4½" (Less tubes). Use in any position.

I.F. output frequency should be chosen to suit the tuning range of receiver you employ.

For use with General Coverage receivers, such as HQ 129X-140X, BC 348, BC 321, GPR 90, Hallicrafters, etc., choose 6-10,7-11, 8-12, 10-14, 12-16, 14-18 mc.

With Collins 75A4 use 28-30. With 75A1 etc. use 26-30 mc.

With National HRO 50-60, use 7-11. With NC 300, use 30-35 mc. CC220 (1¼ meters), available only in 14-18 mc and with 1F to suit Collins and National. (as above).

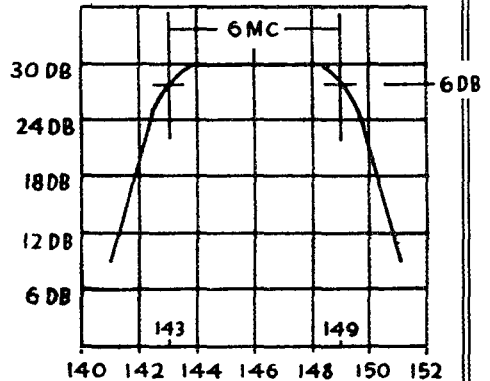

The pass band is essentially flat, as shown by this idealized curve of the Model CC-144.

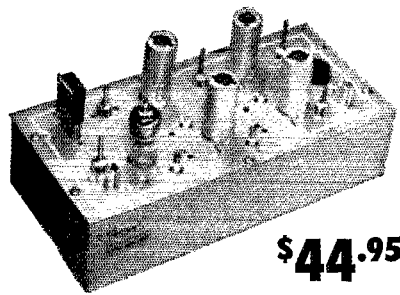

\$44.95

- Model CC- 50* 50-54 mc—6 meters
- CC-108 108 mc
- CC-120 CAP intercom, etc.
- CC-144* 144-148 mc—2 meters
- CC-148* CAP intercom, etc.
- CC-220 220-225 mc—1¼ meters

*AVAILABLE IN KIT FORM
SPECIFY I.F. FREQUENCY



WRITE
The Equipment Crafters Inc.

OR SEE YOUR DISTRIBUTOR.
523 WINNE AVENUE

RIVER EDGE, NEW JERSEY
COllfax 2-0159

we're trading *high* at ALLIED

Try us for the highest trades. Write today—describe your equipment—and see what a sweet deal we'll give you on the new gear you want.

Select your new equipment from our complete offering of all the famous brands and get a "King-Size" trade-in on your old equipment.

easiest terms:

Only 10% down, or your trade-in as down payment—up to 18 months to pay. Fast handling—no red tape.

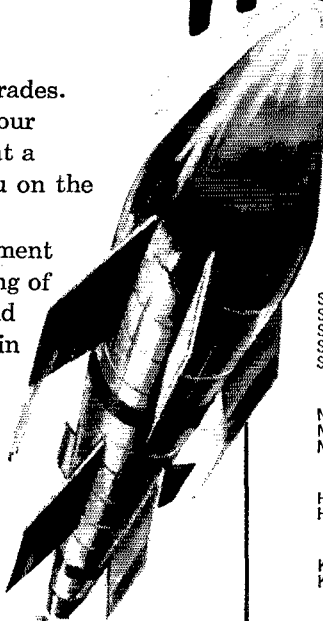

**TRADE
HIGHEST
AT ALLIED**

write us today for
the best deal
anywhere

Our 37th year



ALL FAMOUS BRANDS ALWAYS IN STOCK

HALLICRAFTERS

S-38E (NEW)	HT-32 (NEW)
S-53A	HT-33 (NEW)
SX-62A	SX-101
SX-99	SX-100
S-85	



NATIONAL

NC-66	NC-188
NC-109 (NEW)	HRO-60
NC-300	NC-183D



HAMMARLUND

HQ-100	HQ-150
HQ-110 (NEW)	HQ-140XA



COLLINS

KWM-1 (NEW)	75A4
KWS-1	



JOHNSON

Ranger	500
Pacemaker	Navigator (NEW)
Valiant	Kilowatt
6N2	



CENTRAL ELECTRONICS

100V (NEW)	600L
20A	GC-1



BARKER & WILLIAMSON

L-1000A	5100B
51SB-B	

GONSET

G-66	Communicator III
G-77	(NEW)

RME 4350A (NEW)

plus the famous products of:
MULTI-ELMAC • LAKE SHORE
MORROW • TMC • TELREX
SONAR and others

FREE 404-PAGE CATALOG!

It's packed with the largest selections of station gear—it's your complete Buying Guide to everything in Electronics. If you haven't a copy, write for it today.

ALLIED RADIO

100 NORTH WESTERN AVENUE
CHICAGO 80, ILLINOIS

FINEST AMATEUR RECEIVER IN ITS PRICE CLASS



NC-109

FEATURES:

- ★ Calibrated bandsread for 10, 11, 15, 20, 40 and 80 meter amateur bands. Separate tuning capacitors, knobs, and scales for general coverage and bandsread.
- ★ Large 12 inch indirectly-lighted lucite slide rule dial.
- ★ Adequate over-all selectivity with eleven miniature tubes including rectifier and voltage regulator.
- ★ Has exclusive "microtome" crystal filter providing five degrees of sharp selectivity in addition to normal bandwidth for voice, has sharp phasing notch over 60 db deep for interference rejection.
- ★ Separate product detector for excellent reception of CW and SSB Signals.
- ★ Has "S" meter on front panel for signal strength indication and more accurate tuning.
- ★ Accessory socket for external adaptors, and other accessory devices including phono input or crystal calibrator.
- ★ Has gang-tuned RF amplifier stage, two IF and two AF stages.
- ★ Has separate antenna trimmer and tone control on front panel.
- ★ Separate high frequency oscillator tube increases stability. Has ceramic oscillator coil forms and is temperature compensated for exceptional stability.
- ★ Separate RF and AF gain controls.
- ★ Series type automatic noise limiter.
- ★ Conelrad (CD) frequencies clearly marked on dial.
- ★ Mode selector switch for ANL, AM, CW, SSB and accessories.
- ★ Smartly designed two-tone cabinet.

COVERAGE:

BAND	GENERAL COVERAGE	BANDSPREAD
A	.54-1.6 mc	—
B	1.6-4.7 mc	3.5-4.0 mc (80 meters)
C	4.7-15.0 mc	6.9-7.3 mc (40 meters)
D	14.0-40 mc	14-14.35 mc (20 meters) 20.4-21.5 mc (15 meters) 27-30 mc (10/11 meters)

TUNING SYSTEM: Separate general coverage and bandsread tuning capacitors connected in parallel on all bands. Bandsread, used primarily for tuning the amateur bands, can be used as a vernier for general coverage use. Antenna trimmer is on the front panel.

The accent is on value . . . with features found only in more expensive receivers.

The lowest-priced general coverage receiver available today with exclusive "Microtome" crystal filter, separate product detector for CW and SSB reception. Has big "S" meter. Covers 540 kc to 40 mc in four bands including broadcast band. Voice, CW or SSB. Features smart, new styling.

AUDIO SYSTEM: Two-stage audio amplifier with single 6AQ5 output tube provides 1.5 watts at less than 10% distortion. A handsomely styled accessory speaker is available. Output impedance 3.2 ohms. Has phone jack.

DRIFT: .01% or less.

SENSITIVITY: Under 1-2 microvolts (10 db signal/noise ratio).

SELECTIVITY: 6 Positions. Constant Gain.

	NORMAL	SHARP
6 db	5.2 kc	200 cycles
60 db	29.5 kc	10 kc

plus four additional intermediate degrees of sharpness.

CONTROLS: Main tuning; bandsread tuning; antenna trimmer; band selector switch; RF gain control; AC ON/OFF and AF gain control; stand-by switch; mode selector switch for ANL, AM, CW, SSB and ACC; tone control switch; BFO pitch control; selectivity control; phasing control.

TUBE COMPLEMENT:

RF Amp.	6BA6	AF Output	6AQ5
Freq. Conv.	6BE6	Rectifier	5Y3GT
HF Osc.	6C4	Voltage Regulator	0B2
1st IF Amp.	6BA6	Product detector	6BE6
2nd IF Amp.	6BA6	Det, AVC and ANL	6AL5
1st AF and BFO/S meter amp.	12AT7		

OTHER SPECIFICATIONS:

Antenna Input: 50-300 ohms, balanced or unbalanced.

Size: 16 13/16" Wide x 10" High x 10 7/8" Deep.

Finish: Handsome Two-tone gray wrinkle finish.

Shipping Weight: Approx. 35 lbs.

Optional Accessories: Matching Speaker, XTAL calibrator.

Only \$19.95* down

Up to 20 months to pay at most Receiver Distributors.

*Suggested Price: \$199.95**

**Prices slightly higher west of Rockies and outside U.S.A.

Eight out of 10 U.S. Navy ships use National receivers

Since 1914

National COMPANY, INC.,
Malden 48, Mass.

tuned to tomorrow

NEW VIKING "NAVIGATOR"

Close-up view of the final
in the Viking Navigator—
showing the Beam Power
Tube RCA-6146 ready to go.

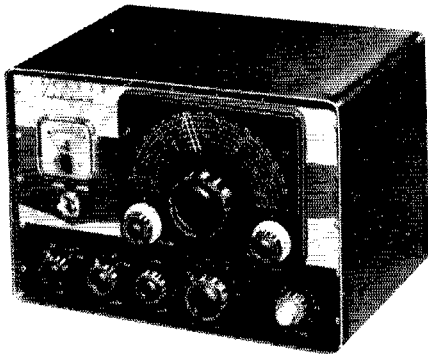

Viking Navigator—
Johnson's all-new
40-watt transmitter-
exciter for CW men.

Designed for rapid QSY, all-band switching, and a clean keyed signal—Johnson's 40-watt Navigator is becoming new conversation among CW men everywhere. RCA is proud that Johnson engineers specified the RCA-6146 beam power tube in this "pro" rig.

Why the outstanding acceptance of RCA power tubes by transmitter designers?

RCA power tubes are conservatively rated—can give you maximum on-the-air hours per tube dollar invested. RCA power tubes are built with a big reserve of cathode emission—an important advantage when peak loads run high. And many RCA power tubes are high-perveance design—a feature permitting full power output at relatively low plate voltages.

For maximum performance in that new rig you're considering make sure those tubes in the sockets—are RCA! Available in a comprehensive line at your RCA Tube Distributor.



TUBES FOR AMATEURS
RADIO CORPORATION OF AMERICA
Electron Tube Division, Harrison, N. J.