

QST

March, 1950

40 Cents

45c in Canada

devoted entirely to

amateur radio

AMATEUR
RADIO STATION
VQ7AA

CALL BOOKS HANDBOOKS SAD LETTERS REAL SAD LETTERS
HEADBREAK LETTERS REPLY COUPONS CRYSTALS SO-METER CRYSTALS

MARCH-1950
MON TUES WED
5 6 7
2 (13)
97



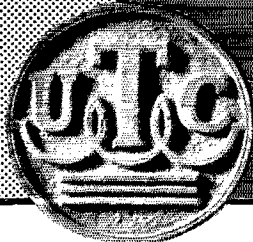

...SPECIAL SERIES

The most popular ham line for a decade

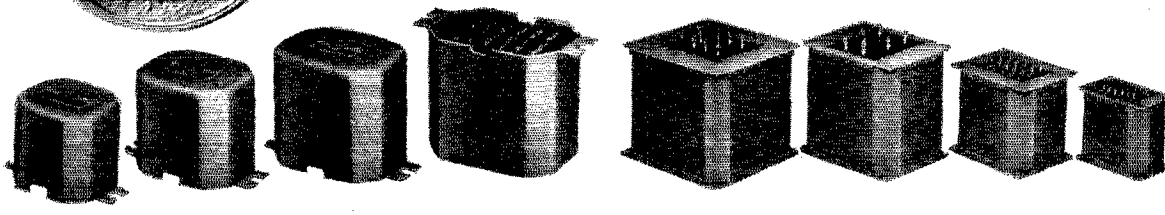

UTC Special Series transformers are specifically designed for amateur and popular priced PA service. Both small units (in drawn steel cases), and large units (in formed steel cases) provide for chassis or above chassis wiring. These units are ruggedly constructed . . . vacuum impregnated . . . compound filled . . . to assure dependability under the varied operating conditions of amateur service. Universal windings are provided on driver, matching and output transformers to assure maximum flexibility.

TYPICAL AUDIO COMPONENTS

CLASS A INPUT TRANSFORMERS

Type No.	Application	Ratio	Net Price
S-2	1 plate* to 2 grids	2:1 4:1	\$3.80
S-5	Single or double button mike or line to 1 grid hum-bucking type	16:1	4.25
S-6	Single or double button mike or line to 1 grid, compact type	16:1	3.10

UNIVERSAL DRIVER TRANSFORMERS

Type No.	Application	Net Price
S-9	Pushpull driver plates to grids of class B tubes up to 400 watts output	\$5.20
S-10	Pushpull 56, 6C6 triode, 6CS, or similar plates to 45's, 2A3's or 6L6's, self of fixed bias.	4.70

UNIVERSAL MODULATION TRANSFORMERS

Secondary carries class C current
Any modulator tubes to any RF load.

Type No.	Audio Power	Net Price
S-18	12 watts	\$ 5.00
S-19	30 watts	7.50
S-20	55 watts	11.00
S-21	110 watts	15.50
S-22	250 watts	24.00

UNIVERSAL OUTPUT TRANSFORMERS TO LINE AND VOICE COIL

(Secondary Impedances: 500, 15, 8, 2 ohms)

Type No	Primary Impedance	Typical Tubes	Net Price
S-14 10 W.	Single Tubes: 2500 ohms	2A3, 6A3, 6A5, 6B4, 6L6, 6Y6, 25L6, 35L6	\$4.50
	4000 ohms	31, 43, 45, 48, 6V6, 12A5, 12A6	
	7000 ohms	33, 47, 42, 47, 59, 89, 2A5, 6AC5, 6F6, 6K6, 6N6, 7B5	
	10,000 ohms	37, 38, 41, 1G5, 3C5, 6A4, 6N7	
S-15 12 W.	P. P. Tubes: 4000 ohms	6Y6, 25L6	4.70
	5000 ohms	45, 2A3, 6A3, 6A5, 6B4	
	10,000 ohms	30, 1H4, 6AC5G, 6B5, 19, 49, 53, 79, 89, 6A6, 6N6, 6N7, 6Y7	
S-16 30 W.	3000 ohms	45, 48, 2A3, 6A3, 6A5, 6B4, 25L6	6.20
	6000 ohms	42, 2A5, 6F6 triodes	
S-17 55 W.	9000/10000 ohms	48, 59, Parallel 53, 6A6, 6N7	7.50
	3800 ohms	42, 45, 2A5, 6AC5, 6B5, 6F6, 6L6, 6V6	
	4500/5000 ohms	6L6's 4-6L6's 46, 1608, 809	

TYPICAL POWER COMPONENTS

PLATE AND FILAMENT TRANSFORMERS

Primary 115 V. — 50/60 Cycles

Type No.	Voltage	D.C. Voltages*	Rectifier Fil.	Fil. No. 1	Fil. No. 2	Net Price
S-40	525-425-0-425-525 250 Ma.	400/310	5 V.-3A	6.3 V.C.T. -3A	6.3 V.C.T. 3A	\$10.5
S-41	600-0-600 200 Ma.	475	5 V.-3A	7.5 V. tapped 6.3 V.-3A	6.3 V.C.T. 2A	9.5

PLATE TRANSFORMERS

Primary 115 V. — 50/60 Cycles

Type No.	High Voltage	DC Voltages*	DC Current	Net Price
S-47	1500-1250-1000-0-1000-1250-1500	1275/1050/825	300 Ma.	\$19.00
S-48	1500-1250-1000-0-1000-1250-1500	1300/1075/850	500 Ma.	28.00
S-49	2100-1800-1500-0-1500-1800-2100	1815/1510/1275	300 Ma.	26.50
S-50	3000-2500-0-2500 3000	2625/2175	300 Ma.	37.00

FILAMENT TRANSFORMERS

Primary Tapped 105, 115 Volts — 50/60 Cycles

Type No.	Secondary Volts	Secondary Current	Insulation	Net Price	
S-53	2.5 VCT	10 A.	1500 V.	\$3.20	
S-54	5 VCT	4 A.	2500 V.	3.2	
S-55	6.3 VCT	3 A.	1500 V.	3.2	
S-57	2.5 VCT	10 A.	10,000 V.	4.5	
S-59	5 to 5.25 VCT	13 A.	5000 V.	4.5	
S-62	10 VCT	10 A	3000 V.	5.5	
No.	Fil. 1.	Fil. 2	Fil. 3	Insulation	Net Price
S-65	2.5 VCT-5A	5 VCT-4A	6.3 VCT-3A	3000 V.	5.5
S-67	5 VCT-6A	6.3 VCT-5A		3000 V.	5.5
S-70	6.3 VCT-5A	6.3 VCT-5A		3000 V.	6.00

FILTER AND SWINGING CHOKES

Type No.	Service	Inductance	Current	Resistance	Insulation	Net Price
S-26	Filter	15 Hy.	60 Ma.	230 ohms	1500 V.	\$ 3.1
S-27	Filter	30 Hy.	75 Ma.	350 ohms	1500 V.	3.8
S-28	Filter	20 Hy.	100 Ma.	350 ohms	1500 V.	3.8
S-29	Filter	10 Hy.	175 Ma.	95 ohms	1500 V.	3.8
S-31	Filter	20 Hy.	225 Ma.	120 ohms	2700 V.	5.0
S-32	Swinging	5/25 Hy.	225 Ma.	120 ohms	2700 V.	5.0
S-33	Filter	20 Hy.	300 Ma.	90 ohms	4000 V.	7.0
S-34	Swinging	5/25 Hy.	300 Ma.	90 ohms	4000 V.	7.0
S-37	Filter	20 Hy.	550 Ma.	60 ohms	6000 V.	14.0
S-38	Swinging	5/25 Hy.	550 Ma.	60 ohms	6000 V.	14.0

Write for our
Catalog NO.500

United Transformer Co.
150 VARICK STREET NEW YORK 13, N. Y.
EXPORT DIVISION: 13 EAST 40th STREET, NEW YORK 16, N. Y. CABLES: "ARLAB"



SUPERIOR SHIELDING

here... and elsewhere
MARKS G.E.'S GREAT GL-813



GL-813 BEAM POWER TETRODE

Filament voltage	10 v
current	5 amp
Max plate voltage	2,500 v
current	225 ma
Frequency at max ratings	30 mc

TAKE care, when you install a GL-813 as replacement for another-make tube of the same type—*neutralizing no longer may be needed!* In which case, to simplify your circuit becomes a “must”, and a welcome one.

A prime example of the tube's superior shielding, is the large ground-plane barrier. By adding to a GL-813 the customary short external base shield, you have as fine all-around protection from feedback as may be obtained. Consequently, the need to neutralize disappears in most cases.

And what a miser for drive this high-gain G-E tube is! Using only .35 w of driving power, a pair of GL-813's in Class A₂ modulator service will deliver 650 w of audio.

Quality where quality counts, has been the creed in every detail of the tube's design, at every stage of its manufacture and testing. See the GL-813 at your nearby General Electric tube distributor! Study its many features that are *better . . .* giving you *better* performance in all the ham applications which the GL-813's famed versatility makes possible! *Electronics Department, General Electric Co., Schenectady 5, N. Y.*

Series 8 in a listing, by areas, of tube distributors who can supply you with Ham News, G.E.'s bi-monthly magazine:

- Arlene, Tex.: R. and R. Electronics Co.
- Albuquerque, N. M.: Electric Supply Co.
- Amarillo, Tex.: R. and R. Electronics Co.
- Austin, Tex.: Hargis Co.
- Billings, Mont.: General Electric Supply Corp.
- Boise, Idaho: Craddock's Radio Supply; General Electric Supply Corp.
- Brownwood, Tex.: Central Supply Co.
- Butte, Mont.: General Electric Supply Corp.
- Corpus Christi, Tex.: Wicks DeVilbiss Co.
- Dallas, Tex.: Crabtree Wholesale Radio Co.; General Electric Supply Corp.
- El Paso, Tex.: Mr. C. C. McNichol; Reeves-Radio Supply; Triangle Electric Supply Co.
- Fargo, N. D.: Dakota Electric Supply.
- Fort Worth, Tex.: Fort Worth Radio Supply Co.; Scooter's Radio Supply.
- Houston, Tex.: General Electric Supply Corp.; Hall, Inc.; Lenert Co.
- Lubbock, Tex.: R. and R. Parts and Supply Co., Inc.
- McAlister, Okla.: Southeast Oklahoma Radio Supply.
- Oklahoma City, Okla.: Radio Supply Co., Inc.; Wolfe Distributors.
- Omaha, Neb.: General Electric Supply Corp.; Omaha Appliance Co.; Radio Equipment Co.
- Phoenix, Ariz.: Radio Specialties and Appliance Corp.
- Salt Lake City, Utah: General Electric Supply Corp.; O'Laughlin's Radio Supply Co.; Radio Supply Co.; S. R. Ross, Inc.
- San Antonio, Tex.: Modern Radio Supply, Inc.; WSHJY Radio Supply.
- Topeka, Kan.: Acme Radio Supply.
- Tucson, Ariz.: Elliott Electronics.
- Tulsa, Okla.: Radio, Inc.; S. and S. Radio Supply.
- Tyler, Tex.: Lavender Radio Supply Co., Inc.
- Waco, Tex.: Hargis Co.
- Wichita, Kan.: Interstate Distributors, Inc.

(List as of Dec. 27, 1949)

ELECTRONIC TUBES OF ALL TYPES FOR THE RADIO AMATEUR

GENERAL ELECTRIC



32V-2 Transmitter

It all adds up to **SATISFACTION**

HERE ARE some of the reasons why owners get so much unalloyed pleasure in the use of their Collins 32V-2 transmitters:

1. Complete in one cabinet.
2. Compact. Same size as the 75A-1 receiver.
3. Exceptional stability.
4. Very accurate dial calibration.
5. All controls conveniently located on front panel.
6. Both coarse and fine antenna loading controls actuated by the same dial.
7. Push-to-talk switch on mike, key, or a separate switch.
8. Provision for disabling receiver when 32V-2 is in SEND position.
9. Grid block keying on 3 stages following the VFO.
10. Keying very clean; no chirp or clicks.
11. Keyer circuit includes side tone oscillator, used as a c-w keying monitor.
12. Fine audio contributes to good voice understandability.
13. TVI avoidance through improved exciter and output design of the 32V-2, and through Collins engineered accessories, if necessary, at extra cost.
14. The 32V-2 covers the 80, 40, 20, 15, 11 and 10 meter bands. Conservatively rated at 150 watts input on c-w, 120 watts on phone.

See this fine ham transmitter at your Collins dealer's. The price is \$575.

FOR SUCCESS IN AMATEUR RADIO, IT'S . . .

COLLINS RADIO COMPANY, Cedar Rapids, Iowa

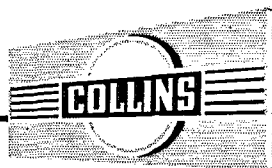

11 West 42nd Street, NEW YORK 18

2700 West Olive Avenue, BURBANK

PUBLISHED, MONTHLY, AS ITS OFFICIAL ORGAN, BY THE AMERICAN RADIO RELAY LEAGUE, INC., AT WEST HARTFORD, CONN., U. S. A.; OFFICIAL ORGAN OF THE INTERNATIONAL AMATEUR RADIO UNION

STAFF

Editorial
A. L. BUDLONG, W1BUD
Editor
HAROLD M. McKEAN, W1CEG
Managing Editor
GEORGE GRAMMER, W1DF
Technical Editor
DONALD H. MIX, W1TS
BYRON GOODMAN, W1DX
Assistant Technical Editors
EDWARD P. TILTON, W1HDQ
V.H.F. Editor
RICHARD M. SMITH, W1TX
C. VERNON CHAMBERS, W1JEQ
Technical Assistants
ROD NEWKIRK, W9BRD
DX Editor
WALTER E. BRADLEY, W1FWH
Technical Information Service
Production
RALPH T. BEAUDIN, W1BAW
Production Manager
NANCY A. PRICE
Assistant
Advertising
F. CHEYNEY BEEKLEY, W1GS
LORENTZ A. MORROW, W1VG
EDGAR D. COLLINS
Circulation
DAVID H. HOUGHTON
Circulation Manager
RALPH T. BEAUDIN, W1BAW
Assistant Circulation Manager

OFFICES

38 La Salle Road
West Hartford 7, Connecticut

Subscription rate in United States and Possessions, \$4.00 per year, postpaid; \$4.50 in the Dominion of Canada, \$5.00 in all other countries. Single copies, 40 cents. Foreign remittances should be by international postal or express money order or bank draft negotiable in the U. S. and for an equivalent amount in U. S. funds.

Entered as second-class matter May 29, 1919, at the post office at Hartford, Connecticut, under the Act of March 3, 1879. Acceptance for mailing at special rate of postage provided for in section 1103, Act of October 3, 1917, authorized September 9, 1922. Additional entry at Concord, N. H., authorized February 21, 1929, under the Act of February 28, 1925.

Copyright 1950 by the American Radio Relay League, Inc. Title registered at U. S. Patent Office.

INDEXED BY
INDUSTRIAL ARTS INDEX

—CONTENTS—

"It Seems to Us . . ."	9
A Beginner's Four-Tube Superhet Receiver <i>Donald H. Mix, W1TS</i>	11
In QST 25 Years Ago This Month	17
Incandescent Light Flicker . <i>Robert E. Shank, W5CKY</i>	18
Eliminating TVI with Low-Pass Filters — <i>Part II</i> <i>George Grammer, W1DF</i>	20
Simulated Emergency Test — 1949 <i>George Hart, W1NJM</i>	26
Crystal-Controlled Oscillators <i>C. Vernon Chambers, W1JEQ</i>	28
A 2-Meter Station for the Novice — <i>Part II</i> <i>Edward P. Tilton, W1HDQ</i>	34
Book Review	38
Happenings of the Month	39
Calibrating a BC-221 Frequency Meter . <i>Beverly Dudley</i>	40
On the Air with Single Sideband	44
I.A.R.U. News	45
Technical Topics — "Clamp-Tube Modulation"	46
The Difficult Takes a Long Time <i>Keith S. Williams, W6DTY</i>	48
Adjusting Antenna Coupling in V.H.F. Receivers <i>Henry H. Cross, W1OOP</i>	50
Silent Keys	51
Hints and Kinks	52
TVI Tips — Junk-Box TVI Checker	54
How's DX?	55
The World Above 50 Mc.	58
United States Naval Reserve	61
Hamfest Calendar	61
Military Amateur Radio System	62
Correspondence from Members	63
Operating News	64
With the AEC	66
Station Activities	71
ARRL QSL Bureau	122

no other set gives you so much

HAM PERFORMANCE

so economically as the new... **SX-71**

\$179⁵⁰



Check These Features Before You Buy!

DOUBLE CONVERSION — images practically eliminated. First i-f 2075 kc.

SELECTIVITY — plenty of it. 11 tuned circuits, one r-f, two conversion, and 3 i-f stages. $2\frac{1}{2}$ kc "nose" selectivity.

BUILT-IN NBFM — controllable from front panel. Increasingly important as more hams switch to NBFM to avoid TVI and BCI. Sensitivity approximately 1 microvolt at 28 Mc for 500 milliwatts output.

AVC — essentially flat—far surpassing comparable sets now on the market.

TEMPERATURE COMPENSATION — it's good! Ceramic coil forms—wound in Hallicrafters own coil plant. Special band switch insulation, special trimmers.

SIGNAL TO NOISE RATIO — Amazingly high, almost twice as good as the SX-28.

TUNING — Calibrated Bandsread—Parallel drive dial pointers. Logging scales on both dials.

OTHER FEATURES — 11 tubes plus Regulator and Rectifier. Range 538 kc to 35 Mc and 46-56 Mc. Crystal filter. "S" meter.

hallicrafters
"The Radio Man's Radio"

See it at your Parts Distributor
or write direct to us for a spec sheet

4401 W. FIFTH AVE., CHICAGO 24, ILL.

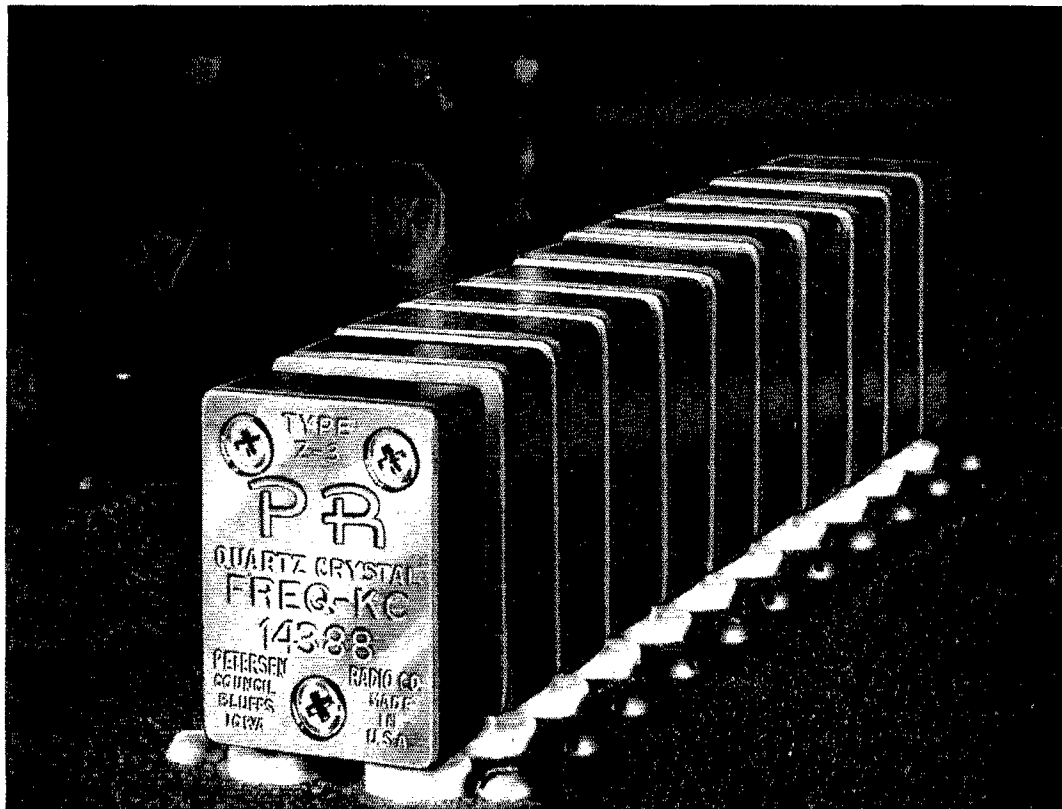

**CRYSTAL CONTROLLED
BUT NOT
"ROCK BOUND"**

Skip around as your heart desires... be a bandhopper with a vengeance... and yet retain the priceless advantages of crystal control. All you need is a half-dozen or more PRs. Multiple crystal operation is the answer to today's maddening QRM problems on phone or CW. It's most economical, too. See your jobber and select low-cost PRs from his all-frequencies stock. Be a gypsy on the band.

• 20 METERS, Type Z-3, \$3.75 • 40, 80 & 160 METERS, Type Z-2, \$2.75

PR

Crystals



Since 1934

USE **PR** AND **KNOW** WHERE YOU ARE

PETERSEN RADIO COMPANY, INC.
2800 W. BROADWAY • COUNCIL BLUFFS, IOWA

Section Communications Managers of the ARRL Communications Department

Reports Invited. All amateurs, especially League members, are invited to report station activities on the first of each month (for preceding month) direct to the SCM, the administrative ARRL official elected by members in each Section. Radio Club reports are also desired by SCMs for inclusion in QST. All ARRL Field Organization appointments are now available to League members. These include ORS, OES, OPS, OO and OBS. Also, where vacancies exist SCMs desire applications for SEC, EC, RM, and PAM. In addition to station and leadership appointments for Members, *all amateurs* are invited to join the ARRL Emergency Corps (ask for Form 7).

ATLANTIC DIVISION			
Eastern Pennsylvania	W3BES	Jerry Mathis	617 Crescent Ave.
Maryland-Delaware-D.C.	W3BWT	Erpa W. Darne	132 Tennessee Ave., N.E.
Southern New Jersey	W2ASC	Dr. Luther M. Mkitarian	500 Warwick Road
Western New York	W2PGT	Harding A. Clark	RFD 2
Western Pennsylvania	W3KWL	Ernest J. Hineky	509 Beechwood Ave.
CENTRAL DIVISION			
Illinois	W9EVI	Lloyd E. Hopkins	27 Lynch St.
Indiana*	W9RE	W. E. Monigan	1504 East Ewing
Wisconsin	W9RQM	Reno W. Goetsch	929 S. 7th Ave.
DAKOTA DIVISION			
North Dakota	W0JWY	Rev. Lawrence C. Strandenaes	St. Andrew's Church
South Dakota	W0NGM	J. S. Roasberg	509 Idaho Ave., S.E.
Minnesota	W0RA	John B. Morgan	1411 Summit Ave.
DELTA DIVISION			
Arkansas	W5JIC	Marshall Riggs	
Louisiana	W5VT	W. J. Wilkinson, jr.	Room 313, Jefferson Hotel
Mississippi	W5DLA	J. C. Wicks	2406 Kelly St.
Tennessee	W4QT	Ward Buhrman	1000 Overlook Ave.
GREAT LAKES DIVISION			
Kentucky	W4KWO	Dr. Asa W. Adkins	Box 240, Woodland Park
Michigan	W8AQA	Robert B. Cooper	132 Guild St., N.E.
Ohio	W8WZ	Dr. Harold E. Stricker	247 W. 5th St.
HUDSON DIVISION			
Eastern New York	W2EQD	Fred Skinner	500 Wolfs Lane
N. Y. C. & Long Island	W2OBU	George V. Cooke	88-31 239th St.
Northern New Jersey	W2ANW	Thomas J. Lydon	190 Mortimer
MIDWEST DIVISION			
Iowa	W0PP	William G. Davis	373 St.
Kansas	W0ICV	Earl N. Johnston	624 Roosevelt
Missouri	W0ICD	Ben H. Wendt	RFD 8
Nebraska	W0OED	Scott E. Davison	433 North Nye Ave.
NEW ENGLAND DIVISION			
Connecticut	W1VB	Walter L. Glover	Glover Ave.
Maine	W1VW	Manley W. Haskell	15 Hemlock St.
Eastern Massachusetts	W1ALP	Frank L. Baker, jr.	91 Atlantic St.
Western Massachusetts	W1AZW	Prentiss M. Bailey	62 Dexter St.
New Hampshire*	W1CRW	Clifton R. Wilkinson	
Rhode Island	W1CJH	Roy B. Fuller	17 Ledge Road
Vermont	W1NLO	Burtis W. Dean	P. O. Box 81
NORTHWESTERN DIVISION			
Alaska	KL7IG	Charles M. Gray	Box 1237
Idaho	W7IWI	Alan K. Ross	2105 Irene St.
Montana	W7EGN	Fred B. Tintinger	328 Central
Oregon	W7MQ	J. E. Roden	519 N.W. Ninth
Washington	W7ACF	Clifford Cavanaugh	Route 1
PACIFIC DIVISION			
Hawaii	KH6HJ	Dr. Robert Katsuki	1817 Wilbelmina Rise
Nevada	W7CN	N. Arthur Sowle	Box 2025
Santa Clara Valley	W6BPT	Roy E. Pinkham	1061 Fremont St.
East Bay	W6TT	Horace R. Greer	414 Fairmont Ave.
San Francisco	W6NLT	Samuel C. Van Liew	215 Knowles Ave.
Sacramento Valley	W6ZF	Ronald G. Martin	2648 13th St.
San Joaquin Valley	W6FKL	Ted R. Souza	3515 Home Ave.
ROANOKE DIVISION			
North Carolina	W4CYB	W. J. Wortman	c/o Duke Power Co.
South Carolina	W4AZT	Wade H. Holland	P. O. Box 116
Virginia	W4KFC	Victor C. Clark	Box 73
West Virginia	W8JM	Donald B. Morris	303 Home St.
ROCKY MOUNTAIN DIVISION			
Colorado	W6IQZ	M. W. Mitchell	1959 Uinta St.
Utah	W7SP	Leonard P. Zimmerman	House 4
Wyoming	W7KFV	Marion R. Neary	Box 215
SOUTHEASTERN DIVISION			
Alabama	W4VE	Leland W. Smith	615 Southmont Drive
Eastern Florida	W4FWB	John W. Hollister	3809 Springfield Blvd.
Western Florida	W4ACB	S. M. Douglas, jr.	P. O. Box 3
Georgia	W4DXI	Clay Griffin	1557 Athens Ave., S.W.
West Indies (Cuba-P.R.-V.I.)	KF4KD	Everett Mayer	P. O. Box 1061
Canal Zone	KZ5AW	Everett R. Kimmel	Box 264
SOUTHWESTERN DIVISION			
Los Angeles	W6VIM	Virge A. Gentry, jr.	2156 W. 10th St.
Arizona	W7MLL	Gladden C. Elliott	39 North Metwood
San Diego	W6BWO	Dale S. Bose	12851 E. California St.
WEST GULF DIVISION			
Northern Texas	W5CDU	Joe G. Buch	5234 Vickery Boulevard
Oklahoma	W5AHT/AST	Frank E. Fisher	104 East 11th St.
Southern Texas	W5BDI	Ammon O. Young	4803 Eli St.
New Mexico	W5SDA	Lawrence R. Walsh	2100A 35th Street
MARITIME DIVISION			
Maritime (Nfld. & Labr. att.)	VE1MQ	A. M. Crowell	69 Dublin St.
ONTARIO DIVISION			
Ontario	VE3CP	Thomas Hunter, jr.	1920 Elrose Ave.
QUEBEC DIVISION			
Quebec	VE2GL	Gordon A. Lynn	R. R. No. 1
VANALTA DIVISION			
Alberta	VE6MI	Sydney T. Jones	P. O. Box 373
British Columbia	VE7FB	Ernest Savage	4553 West 12th Ave.
Yukon	VE8AK	W. R. Williamson	P. O. Box 534
PRAIRIE DIVISION			
Manitoba	VE4AM	A. W. Morley	26 Lennox Ave.
Saskatchewan	VE5DW	J. H. Goodridge	c/o Canadian Pacific Air Lines
			St. Vital
			Regina

* Officials appointed to act temporarily in the absence of a regular official.

hallicrafters

portable is ALREADY going places!

Amazing new all-purpose portable receiver

Extra sensitivity for weak signal areas . . . extra performance for good Ham operation.

One r-f, two i-f stages. Separate 3-gang bandspread tuning. Two built-in antennas—62-in. collapsible whip for short-wave plus loop for broadcast. 540 kc to 31 Mc in 4 bands. 8 tubes, plus rectifier. Space for 'phones. AC, DC, or battery pack.

NEW LONG-WAVE VERSION S-72L

Covers airways, ranges, control towers, marine beacons. 175-420 kc, 540 kc to 12.5 Mc. All other features of the S-72. **\$99.95**

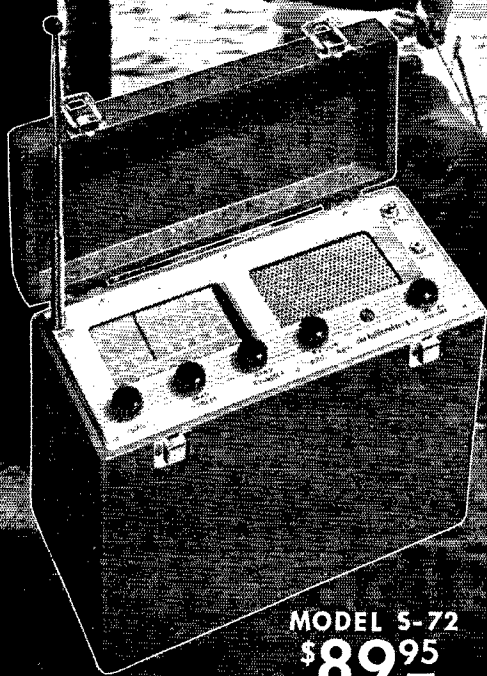

MODEL S-72
\$89⁹⁵

hallicrafters
"The Radio Man's Radio"

4401 W. Fifth Avenue, Chicago 24, Illinois

THE AMERICAN RADIO RELAY LEAGUE, INC.

is a noncommercial association of radio amateurs, bonded for the promotion of interest in amateur radio communication and experimentation, for the relaying of messages by radio, for the advancement of the radio art and of the public welfare, and for the representation of the radio amateur in legislative matters, and for the maintenance of fraternalism and a high standard of conduct.

It is an incorporated association without capital stock, chartered under the laws of Connecticut. Its affairs are governed by a Board of Directors, elected every two years by the general membership. The officers are elected or appointed by the Directors. The League is noncommercial and no one commercially engaged in the manufacture, sale or rental of radio apparatus is eligible to membership on its board.

"Of, by and for the amateur," it numbers within its ranks practically every worth-while amateur in the nation and has a history of glorious achievement as the standard-bearer in amateur affairs.

Inquiries regarding membership are solicited. A bona fide interest in amateur radio is the only essential qualification; ownership of a transmitting station and knowledge of the code are not prerequisite, although full voting membership is granted only to licensed amateurs.

All general correspondence should be addressed to the Secretary at the administrative headquarters at West Hartford, Connecticut.



Past Presidents

HIRAM PERCY MAXIM, W1AW, 1914-1936
EUGENE C. WOODRUFF, W8CMP, 1936-1940

• • • • •

Officers

President GEORGE W. BAILEY, W2KH
New York, N. Y.

Vice-President J. LINCOLN MCCARGAR, W6EY
Oakland, California

Secretary A. L. BUDLONG, W1BUD
West Hartford, Connecticut

Communications Manager FRANCIS E. HANDY, W1BDI
West Hartford, Connecticut

Treasurer DAVID H. HOUGHTON
West Hartford, Connecticut

• • • • •

General Counsel PAUL M. SEGAL
816 Connecticut Ave., Washington 6, D. C.

Assistant Secretaries JOHN HUNTOON, W1LVG
RICHARD L. BALDWIN, W1IKE
West Hartford, Connecticut

DIRECTORS

President
GEORGE W. BAILEY W2KH
1 East 79th St., New York 21, N. Y.

Vice-President
J. LINCOLN MCCARGAR W6EY
86 Hamilton Place, Oakland 12, Calif.

Canadian General Manager
ALEX REID VE2BE
240 Logan Ave., St. Lambert, P. Q.
Alternate: William W. Butchart VE6LQ
10740 107 St., Edmonton, Alta.

Atlantic Division
WALTER BRADLEY MARTIN W3QV
1033 Arbuta Rd., Abington, Pa.
Alternate: Henry W. Wickensher, Jr. W3KWA
1112 State Ave., Coraopolis, Pa.

Central Division
JOHN G. DOYLE W9GPI
4331 N. Wildwood Ave., Milwaukee 11, Wis.
Alternate: Wesley E. Marriner W9AND
624 College Ave., Dixon, Ill.

Dakota Division
GOODWIN L. DOSLAND W0TSN
Moorhead, Minn.
Alternate: Robert A. Kimber W0BLK
Canyon Lake Rd., Rapid City, S. D.

Delta Division
VICTOR CANFIELD W5BSR
P. O. Box 965, Lake Charles, La.
Alternate: George S. Acton W5BMM
Plain Dealing, La.

Great Lakes Division
JOHN H. BRABB W8SPF
417 Ford Bldg., Detroit 26, Mich.
Alternate: Harold E. Stricker W8WZ
247 W. 5th St., Marysville, Ohio

Hudson Division
JOSEPH M. JOHNSTON W2SOX
423 Monmouth Ave., Bradley Beach, N. J.
Alternate: Gay E. Mills, Jr. W2NJJ
170 Broadway, New York 7, N. Y.

Midwest Division
LEONARD COLLETT W0DEA
Civil Aeronautics Administration
Box 776, Joplin, Mo.
Alternate: Alvin G. Keyes W0KTK
1201 Merchants Nat'l Bank Bldg., Cedar Rapids, Ia.

New England Division
PERCY C. NOBLE W1BVR
37 Broad St., Westfield, Mass.
Alternate: Clayton C. Gordon W1HRC
70 Columbia Ave., Providence 5, R. I.

Northwestern Division
R. REX ROBERTS W7CPY
110 W. Brennan St., Glendive, Mont.
Alternate: Allan D. Gunston W7GP
1033 Salem Ave., Apt. 4, Dayton 6, Ohio

Pacific Division
KENNETH E. HUGHES W6CTS
810 W. Orange Ave., So. San Francisco, Calif.
Alternate: C. Porter Evans W6BF
134 Dracena Ave., Piedmont 11, Calif.

Roanoke Division
J. FRANK KEY W4ZA
Box 707, Buena Vista, Va.
Alternate:

Rocky Mountain Division
FRANKLIN K. MATEJKA W0DD
P. O. Box 212, Estes Park, Colo.
Alternate: William R. White W0PDA
1263 Pearl St., Denver 3, Colo.

Southeastern Division
LAMAR HILL W4RO1
104 Myrtle Cochran, Ga.
Alternate: William P. Sides W4AUP
Fleming Road, Montgomery, Ala.

Southwestern Division
JOHN R. GRIGGS W6KW
3212 Grape St., San Diego 2, Calif.
Alternate: John E. Bleckel W6NY
14820 E. Whittier Blvd., Whittier, Calif.

West Gulf Division
WAYLAND M. GROVES W5NW
P. O. Box 586, Odessa, Texas
(W5NW at Humble Pipe Line Camp, Odessa)
Alternate: David H. Calk W5BHO
7730 Joplin St., Houston 17, Texas

"It Seems to Us..."

ARRL COMMENTS ON AMENDED F.C.C. PROPOSALS

On November 16, 1949, FCC issued a revised set of proposals in its Docket 9295 for amendment of the amateur rules, and requested comment by interested parties. To a considerable extent these proposals embodied the views set forth in the League's presentation at the informal conference held in Washington last October, reported in substance in December *QST* beginning on page 27. However, as set forth on this page last month, the Commission in its November proposals returned to some of its original thinking, particularly in connection with Section 12.0, and the Amateur Extra Class license. After careful consideration, the League's Board of Directors felt that in these and several minor respects it could not agree, and it directed the League's Secretary and its General Counsel to file comment in opposition. The complete text of our filing, representing the latest development in this long-drawn-out proceeding, is printed herewith for the information of the membership and radio amateurs generally.

Simultaneously with ARRL's filing, comments were submitted by both NARC and SARA; their comments are summarized in the "Happenings" section of this issue.

FEDERAL COMMUNICATIONS COMMISSION

In the matter of
Amendments to Part 12 of the
Rules and Regulations

Docket 9295

COMMENTS OF THE AMERICAN RADIO RELAY LEAGUE ON THE FURTHER NOTICE HEREIN

American Radio Relay League, Inc., makes these comments on the further notice of rule making of November 16, 1949, herein:

A. Adherence to Request for Oral Argument.

Heretofore the American Radio Relay League has requested oral argument, particularly with regard to § 12.0 of the proposed amendments. The notice of November 16th announces an intention to hear such oral argument should the League still desire it. The League does so desire.

B. Comments with Respect to Proposed § 12.0.

1. Proposed § 12.0 is not in fact a statement of the basis and purpose of the amendments

a. Section 4(b) of the Administrative Procedure Act is the section upon which the staff of the Commission has based its contention that language such as that contained in proposed § 12.0 of the Rules and Regulations is required.

b. The Attorney General's Manual on the Administrative Procedure Act at Page 32 has the following to say with regard to the relevant language of Section 4(b):

"Section 4(b) provides that upon the completion of public rule making proceedings 'after consideration of all relevant matter presented, the agency shall incorporate in any rules adopted a concise general statement of their basis and purpose'. The required statement will be important in that the courts and the public may be expected to use such statements in the interpretation of the agency's rules. The statement is to be 'concise' and 'general'. Except as required by statutes providing for 'formal' rule making procedure, findings of fact and conclusions of law are not necessary. Nor is there required an elaborate analysis of the rules or of the considerations upon which the rules were issued. Rather, the statement is intended to advise the public of the general basis and purpose of the rules."

c. The Rules and Regulations governing the amateur service antedate the Administrative Procedure Act. They were first adopted by the Federal Radio Commission and were re-adopted as modified and have been amended from time to time over a period of years. The last official revision was published in the Federal Register (11 F.R. 4241), effective April 1, 1946. The last official printing of the Rules by the Government Printing Office comprised a revision to November 18, 1948, and was printed in 1949.

d. The present rule-making procedure proposes certain changes in these Rules and Regulations which are not extensive in scope and which do not alter the basic philosophy of regulation.

e. Any requirement of § 4(b) of the Administrative Procedure Act for a statement of basis and purpose would apply only to the basis and purpose of the particular amendments now proposed. It would have no connection whatsoever with the broad and extensive proposed § 12.0, the character of which is to recapitulate the entire amateur service from its very inception and to postulate a direction of the development of the amateur service.

f. There is no occasion at this juncture for any re-evaluation of the amateur service, and such is not germane to the present proceeding.

2. *The statement of basis and purpose is not correct.*

a. In an effort to obviate further controversy concerning proposed § 12.0, representatives of the American Radio Relay League, at a conference held October 10 and 11, 1949, with the Commission staff, suggested a compromise phrasing of a possible § 12.0 and committed themselves to the extent that they would not oppose the adoption of the language suggested by them.

b. However, the language now proposed differs from the compromise suggestion and, through the insertion of a specified philosophy of regulation, reverts to the original proposal of the Commission as made April 20, 1949, and published April 21st.

c. The League has heretofore and on July 19, 1949, filed its written statement of comment on that original philosophy; it persists in that statement and desires the opportunity to present its views orally.

C. *Comments with Respect to Provisions for an Amateur Extra Class License and Elimination of the Class A License.*

1. In §§ 12.20 (and footnote), 12.21, 12.23, 12.29 and 12.43 of the proposed amendments, the effect of certain provisions would (1) stop further issuance of the present Class A amateur license after December 31, 1951 and (2) create a new class of license, to become available after January 1, 1951, to be known as the Amateur Extra Class license. Thus, after December 31, 1951, the Amateur Extra Class license would be the only one available to new applicants for advanced amateur privileges.

2. The League, at the conference with the Commission staff on October 10 and 11, 1949, rejected certain proposals then made by the Commission for such a new class of license, and gave its reasons therefor, as well as its reasons for believing that the present Class A license should be continued unchanged. Our conclusions in this respect were concurred in by every other participant in the meeting. Nevertheless, the Commission in its modified amendments still proposes to stop issuance of the Class A license and to substitute therefor a new class. While some

changes have been made from the previous proposals, no change has been made in the major aspects which the League previously found objectionable. The League, therefore, finds itself still obliged to object to the amendments as they accomplish the Commission's aims in these respects. We reiterate our feeling that creation of the Amateur Extra Class license is unnecessary and undesirable, and renew our request that the Class A license be continued in the amateur rules under the same conditions and carrying the same privileges as at present, without change.

3. The only privilege now enjoyed by holders of the advanced class (Class A) license is permission to operate in the 3.5- and 14-mc. radiotelephone sub-bands. In its proposals, the Commission indicates an intention of making additional privileges available to holders of the new Amateur Extra Class license and it outlines the general scope of the examination for such license. However, no specific additional privileges are described. The League feels it is illogical to create a license and outline its examination elements before the privileges to be enjoyed under it are known.

4. The present Class A examination is designed to ensure an applicant's familiarity with radiotelephone techniques, a proper objective in view of the operating privileges available to those who possess the license. In general, the elements of the Class A examination appear to be satisfactory for their purpose, but in any event could be revised at any time the state of the art required. The League does not feel, however, that a higher code speed requirement than is normally required for amateur operation, or familiarity with radio control of remote objects, transmissions of energy for measurements and observations applied to propagation, etc., are pertinent to qualification for the only advanced privileges available to amateurs under the rules.

5. In the absence of any need for an Amateur Extra Class license on the terms indicated by the Commission, and considering that the present Class A license and examination appear satisfactory for the purpose, the League is obliged still to express opposition to the proposals for an Amateur Extra Class license and repeat the request that the provisions in the rules for issuance of a Class A license, and the privileges enjoyed by holders thereof, be continued without change.

6. No objection is seen to the change of name of this class to Advanced Class.

D. *Comments with Respect to Proposed Amendment to § 12.44(b).*

1. In § 12.44(b) it is proposed by the Commission that the holder of a Technician or Novice Class license, obtained on the basis of a mail examination, be exempted from the usual requirement of taking an examination again before

(Continued on page 10B)

A Beginner's Four-Tube Superhet Receiver

Multiband Operation Without Coil Changing

BY DONALD H. MIX, * WITS

WHEN it comes to the receiver these days, the newcomer to amateur radio — especially the youngster who may be as short on cash as he is on experience — is faced with a choice not too easy to make. For many years the building of his own receiver served as almost every ham's teething ring. While it was a matter of necessity at one time, even in later years it was recommended as an invaluable aid in acquiring experience in the construction and wiring of equipment and in getting first-hand acquaintance with simple circuits and their adjustment. When the job was finished, it could immediately be put to practical use as the station receiver.

But a receiver considered satisfactory at that time was comparatively easy and inexpensive to construct and any youngster was thrilled if he heard anything resembling a signal when he finally hooked on the antenna. Today's would-be hams have grown up taking for granted the sort of signals that blare from the b.c. set loudspeaker. In fact, a lot of them have become interested in the ham game through the SWL route alone. It is natural that many may be disappointed at the way the old simple two-tube regenerative receiver falls short of meeting present minimum requirements for a satisfactory station receiver.

* Assistant Technical Editor, QST.

On the other hand, when anything more ambitious is contemplated, we are faced with the fact that the cost for parts may approach the price for which one of the cheaper manufactured communications receivers may be purchased. It is not surprising, therefore, that the decision so often is in favor of the dealer's counter. Thus we have a host of hams growing up who may know their transmitters from A to Z and yet who are afraid to do more than change a tube in the receiver, not appreciating the fact that they are missing half of the fun in the game. Even though the cost and time required for building a satisfactory beginner's receiver are greater these days, there is still much to be said in favor of it.

Unfortunately the word superheterodyne in itself often is enough to dissipate any initial enthusiasm the average beginner may work up toward building his own. If that doesn't do it, a glance at the wiring diagram will! However, taken section by section, a superhet breaks down into a collection of simple circuits, each one of which is much more readily tamed for proper performance than the old unpredictable regenerative receiver. Building and adjusting a simple superhet can be a most interesting as well as instructive project, once the initial unfounded fear of tackling the job has been dispelled.

A four-tube superhet receiver covering the 3.5- and 7-Mc. bands as well as spots in the commercial point-to-point and short-wave broadcast bands with a single pair of coils.

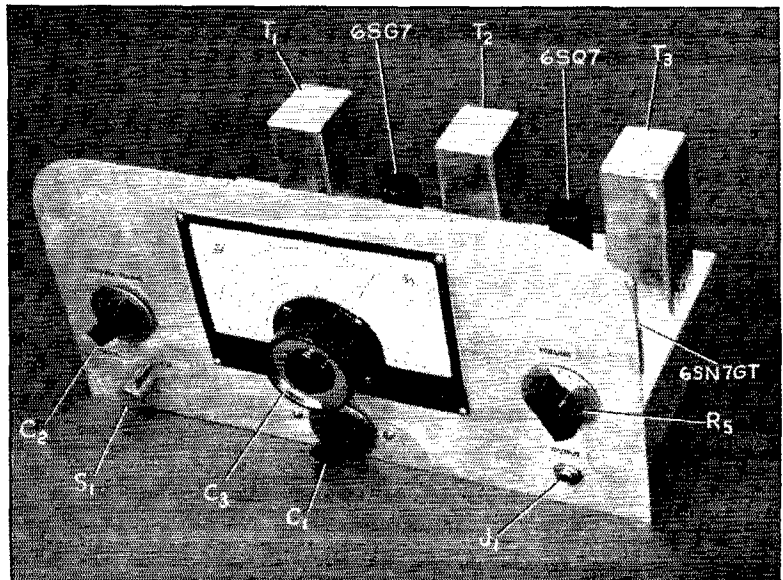

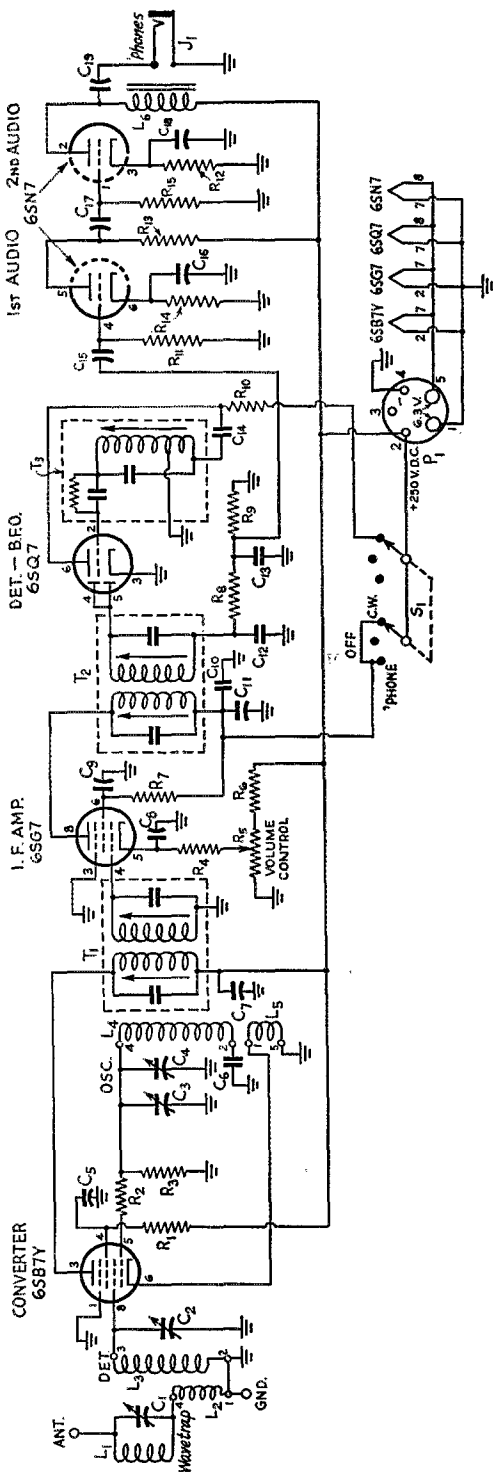

Fig. 1—Circuit diagram of the beginner's four-tube superhet receiver.

- C₁, C₂ — 335- μ fd. variable (National STH-335).
- C₃ — 50- μ fd. variable (National ST-50).
- C₄ — 150- μ fd. mica trimmer (Johnson 1672A).
- C₅, C₆, C₉ — 0.1- μ fd. 150-volt paper.
- C₆, C₁₄ — 0.001- μ fd. disk ceramic (Sprague).
- C₇, C₁₁, C₁₉ — 0.1- μ fd. 600-volt tubular.
- C₁₀ — 0.01- μ fd. disk ceramic (Sprague).
- C₁₂, C₁₈ — 100- μ fd. mica.
- C₁₅, C₁₇ — 0.01- μ fd. paper.
- C₁₆, C₁₈ — 10- μ fd. 25-volt electrolytic.
- R₁ — 12,000 ohms, $\frac{1}{2}$ watt.
- R₂ — 47 ohms, $\frac{1}{2}$ watt.
- R₃ — 22,000 ohms, $\frac{1}{2}$ watt.
- R₄ — 220 ohms, $\frac{1}{2}$ watt.
- R₅ — 5000-ohm volume control.
- R₆ — 82,000 ohms, 1 watt.
- R₇, R₁₀, R₁₃ — 47,000 ohms, 1 watt.
- R₈ — 47,000 ohms, $\frac{1}{2}$ watt.
- R₉ — 0.33 megohm, $\frac{1}{2}$ watt.
- R₁₁, R₁₅ — 0.22 megohm, $\frac{1}{2}$ watt.
- R₁₂, R₁₄ — 1500 ohms, 1 watt.
- L₁ — 24 turns No. 20 wire, 1-inch diameter, 1 $\frac{1}{2}$ inches long (B & W 3015 Miniductor).
- L₂ — 6 $\frac{1}{4}$ turns No. 22 d.s.c. wire, 1-inch diameter, turns close-wound (see text).
- L₃ — 14 $\frac{1}{2}$ turns No. 22 d.s.c. wire, 1-inch diameter, close-wound (see text).
- L₄ — 16 $\frac{1}{2}$ turns No. 22 d.s.c. wire, 1-inch diameter, close-wound (see text).
- L₅ — 3 $\frac{1}{4}$ turns No. 22 d.s.c. wire, 1-inch diameter, close-wound (see text).
- L₆ — 20-h. 15-ma. filter choke (Stancor C-1515).
- J₁ — Open-circuit 'phone jack.
- S₁ — Double-pole triple-throw rotary switch (Mallory 3123J).
- T₁, T₂ — Interstage i.f. transformer (Millen 64161).
- T₃ — B.f.o. unit (Millen 65163).

The Circuit

The circuit of Fig. 1 shows the diagram of a four-tube superhet. It is particularly well adapted to the beginner. While it is not as pretentious as any of the manufactured jobs, it contains all of the fundamental elements necessary to demonstrate superhet action clearly. Furthermore, the finished receiver is suitable for station use and on all counts will run rings around any regenerative receiver ever built. Two of the tubes each serve double functions for which separate tubes are commonly employed, so that the receiver is really a six-tuber. By taking advantage of certain characteristics of superhet action not normally used, it is possible with one pair of coils to cover both the 80- and 40-meter ham bands as well as ranges where commercial point-to-point c.w. and short-wave broadcast signals may be found. Headphone strength on average signals commonly exceeds that of any of the manufactured jobs.

The first section of the circuit, from L₂ to T₁ — the converter — is the important part. L₂ is the antenna coupling coil, while C₂ and L₃ comprise the input circuit which is tuned to the frequency of the incoming signal. This signal is fed to the control grid (Pin 8) of the 6SB7Y. L₄, L₅, C₃ and C₄ make up the essentials of a high-frequency oscillator circuit. The screen of the 6SB7Y serves as the plate of the oscillator section of the tube. L₅ provides the necessary feed-back for oscillation.

With the oscillator circuit tuned to some selected frequency, the superhet can be made to respond to any antenna signal whose frequency differs from the oscillator frequency by the frequency to which the intermediate amplifier (T_1 and T_2) is tuned. This means that there are two frequencies to which the receiver will respond for each setting of the oscillator frequency — the oscillator frequency *plus* the intermediate frequency and the oscillator frequency *minus* the i.f. Thus, if the oscillator is tuned to 5000 kc., and the i.f. amplifier is set at 1500 kc., the system will respond to signals at 5000 plus 1500 = 6500 kc. and at 5000 minus 1500 = 3500 kc. Either of these two signals may be selected by tuning the input circuit L_3C_2 . If the input circuit is tuned to 3500 kc., the signal at 6500 kc. is called the i.f. image; if the input circuit is tuned to receive the 6500-kc. signal, the 3500-kc. signal is the image. The degree to which the input circuit can discriminate against the unwanted signal (the image) is called the image rejection.

From the above, it is seen that with a single range of oscillator frequencies, the receiver can be made to respond to two signal-frequency ranges. All that is necessary is to have an input circuit capable of being tuned across both ranges. If a proper intermediate frequency is chosen, a rather unique possibility is presented. Suppose we tune the i.f. amplifier to 1500 kc. Then we adjust the oscillator circuit $C_3C_4L_4$ to cover the range of 5000 to 5800 kc. Now, when we subtract the 1500-kc. i.f., we find that the signal range is 3500 to 4300 kc. and when we *add* the i.f., the signal range becomes 6500 to 7300 kc. Thus, with

the oscillator tuning over the single range of 5000 to 5800 kc., we can receive in either the 80-meter band or the 40-meter band at will, simply shifting the tuning of the input circuit by adjusting C_2 to cover either range. It will further be observed that the width of each of the above ranges is 800 kc., and that 7300 kc. appears at one end of the tuning dial and 3500 kc. comes at the other end. Therefore we have a tuning system which, by proper shifting of C_2 , will cover the 7-Mc. band for the first 300 kc. and the 3.5-Mc. band for the last 500 kc. — all on the same dial range!

This arrangement not only provides an interesting point, but it has a practical function as well. The single tuned input circuit cannot be expected to provide too much selectivity. Even the high intermediate frequency, which increases the frequency gap between the desired signal and its image, does not result in sufficient separation to take care of a strong image from a local ham station. With the tuning range selected, it will be noted that the images of each of the two ham bands fall outside the other. Therefore a strong local ham signal in one band will not cause interference in the other. Except for those hams living close to commercial stations operating on certain frequencies, images from the latter will not be so severe because of the distance involved. When they do occur in objectionable strength, the wave-trap, L_1C_1 , provided in the antenna circuit, will do a good job of wiping them out when the trap is tuned to the frequency of the offending station.

In this receiver advantage also may be taken of another characteristic that is usually treated as a defect in more advanced superhet design.

Rear top view of the beginner's superhet receiver showing the placement of parts on top of the chassis.

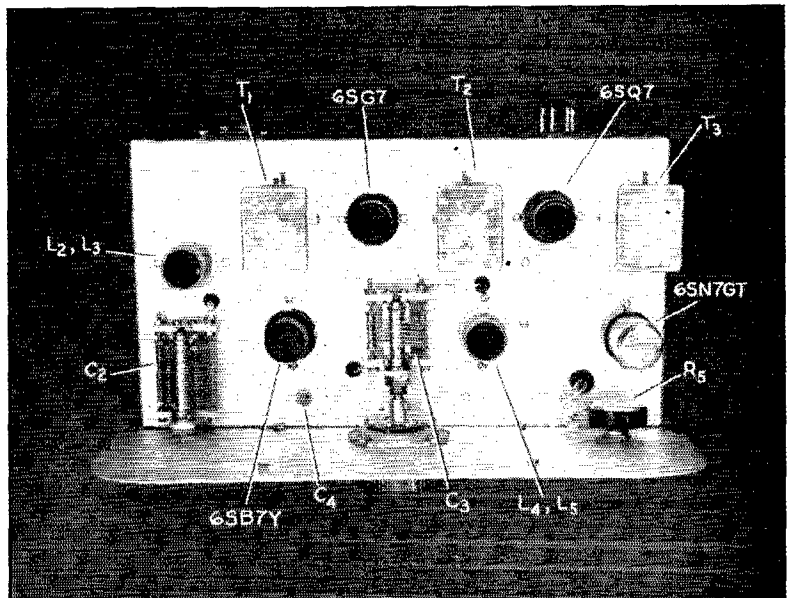

The second harmonic of the oscillator may be used to provide still another pair of ranges. With the fundamental oscillator range at 5000 to 5800 kc., the second-harmonic range will be twice this, or 10,000 to 11,600 kc. When we add and subtract the i.f. of 1500 kc., we get the signal ranges of 11,500 to 13,100 kc. and 8500 to 10,100 kc. respectively. These, together with the nonamateur portions of the two fundamental ranges give the beginner a fair sampling of the high-frequency spectrum with a single set of coils. The fact that WWV's 10-Mc. signal appears at one end of one range is useful in adjusting the oscillator accurately to the proper tuning range.

The remainder of the circuit of Fig. 1 is quite simple. Following the converter is a single stage of i.f. tuned to 1500 kc. This feeds into the diode-detector section of a 6SQ7. The triode section of this tube is used for the beat-frequency oscillator required in c.w. reception. The output of the diode is fed into a two-stage resistance-coupled audio amplifier in which a single 6SN7 dual triode is used. The headphones are choke-capacitance coupled to the output to isolate the 'phones from the d.c. plate supply.

The volume control, R_5 , adjusts the gain in the i.f. amplifier. The switch, S_1 , cuts the B supply to the b.f.o. when it is set for 'phone reception, cuts the B supply from the i.f. amplifier in the central stand-by position while transmitting, and turns the b.f.o. on in the c.w. position.

Construction

If you decide to build this receiver, don't try to complete the job on a Saturday afternoon. Take your time and do a careful job. By this we don't mean that the mechanical workmanship must be perfect. Simply make sure that the parts are securely mounted and that the wiring doesn't end up in a rat's nest. It will pay you in results.

The unit is assembled on a standard chassis 7 by 13 by 2 inches. Aluminum is much easier to work with than steel — particularly with simple tools — and the cost is about the same. The panel is cut from a sheet of $\frac{1}{16}$ -inch aluminum $7\frac{1}{2}$ inches high and 14 inches long. If it is desired to put the receiver in a cabinet, the panel furnished with the cabinet may be substituted.

In laying out the chassis, the first thing to do is to spot the centers for the components on top of the chassis. The exact placement is not at all critical. To provide for a good-looking arrangement of controls on the panel, the tuning condenser, C_3 , should come at the center and the input tuning condenser, C_2 , should be placed at the left-hand end of the chassis where its shaft will balance the shaft of the volume control on the right. C_3 will have to be elevated about $\frac{1}{4}$ inch on metal spacers so that the National SCN dial mechanism can clear the chassis. The socket for the input coil (L_2L_3) should be near C_2 and the socket for the oscillator coil (L_4L_5) should be fairly close to

C_3 . The 6SB7Y socket should be about midway between the two variable condensers. The i.f. transformers and the i.f. and detector-b.f.o. tubes are lined up along the back, with the adjusting screws of the transformers toward the rear. The 6SN7 is placed in front of the b.f.o. can (T_3) in line with the oscillator coil socket and the 6SB7Y.

Socket holes are best cut with a socket punch, although the aluminum is not difficult to cut with a circle cutter in a carpenter's brace, or by drilling and chipping out with a hand drill and cold chisel. A $1\frac{1}{8}$ -inch punch is required for the Amphenol MIP bakelite octal sockets for the 6SG7, 6SQ7 and 6SN7, while a $1\frac{1}{4}$ -inch punch is needed for the Millen ceramic sockets for the 6SB7Y and the two coil forms. The $1\frac{1}{4}$ -inch punch is used also for the power plug at the rear. A similar hole should be punched in the middle of the front edge of the chassis with its center $\frac{3}{8}$ inch above the bottom edge. You will also need a hole for adjusting the trimmer C_4 located near the 6SB7Y, and clearance holes for connections to the stator terminals of C_2 , C_3 , and the volume control, as well as a hole under the center of each of the i.f. cans for the transformer leads. A cut-out is required in the rear edge near the left-hand end for the antenna terminal strip, and shaft holes must be cut in the front edge for the switch and headphone jack. The latter two should be placed at either end to balance.

C_1 is mounted under the chassis, insulated by fastening it to the center of a piece of $\frac{1}{8}$ -inch polystyrene sheet 3 inches long and $1\frac{3}{4}$ inches high. The insulating strip is then fastened with 6-32 screws against the inside front edge of the chassis so that the shaft of C_1 will be central in the large punched hole. C_1 is mounted with its ceramic stator bars running vertically to provide access to the mounting screws for C_2 . The choke, L_6 , is fastened under the chassis, next to C_1 .

Before the switch, the jack and C_1 are mounted, the panel should be placed against the front edge of the chassis with the bottom edges even and the panel centered. Then the mounting holes should be transferred to the panel by marking with a scriber from the rear. The centers for the shaft holes for C_2 , C_3 and the volume control should then be measured out and marked. A $1\frac{1}{2}$ -inch hole is needed for the mechanism of the main tuning dial.

Wiring

Time will be saved if a soldering lug is placed under each of the socket-mounting nuts when the sockets are fastened in place. They will be needed for ground connections to the chassis. Fiber lug strips fastened to the chassis by the mounting screws of the i.f. cans will provide convenient insulated anchorages for condenser and resistor terminals that should not be grounded. As the bottom view shows, a separately-mounted lug

strip is used for mounting the i.f. filter in the diode detector. This filter is made up of C_{12} , C_{13} , and R_8 and is placed immediately in front of the 6SQ7 socket.

The filament wiring should be done first, keeping the wiring down close against the chassis. The two wires of the circuit should run parallel and close together wherever possible. They may be bound together with bits of Scotch tape to keep them from spreading. Next, resistors and by-pass condensers which connect directly to tube-socket terminals should be placed, and the insulating lug strips installed wherever the free ends of the resistors and condensers must be kept away from contact with the chassis. Then the wiring for the plus-B circuit should be laid in, keeping the wiring bunched and close to the chassis. The leads furnished with the i.f. transformers should be long enough to reach the proper tube-socket terminals or a ground lug as required, but the red leads to the plus-B line should be anchored at an insulating lug-strip terminal and the wiring extended from there.

Very little r.f. wiring is required. This is the wiring between the stator terminals of C_2 and C_3 and the coils and tube terminals. No. 14 tinned

antenna wire should be used and the wiring should be kept well spaced from the chassis and other components wherever possible. A small cone insulator threaded onto the rear mounting screw of the 6SB7Y socket will serve as an anchorage for the wire running from L_3 to Terminal 8 of the 6SB7Y. A lead from the front stator terminal of C_3 (a lug will have to be added at this terminal) passes down through a clearance hole in the chassis to R_2 which is soldered to Terminal 5 on the 6SB7Y socket. One terminal of C_4 is connected to this wire; the other terminal of C_4 is grounded. The Johnson trimmer can be supported by its connecting leads. A wire from the rear stator terminal of C_3 runs to the right and then through a hole in the chassis close to the rear of the oscillator coil socket where it is connected to Pin 4. The long wire connecting Terminal 6 of the 6SB7Y socket to Pin 1 of the coil socket is insulated with a sleeve of spaghetti and run under C_1 (in the bottom view). L_1 is cut from a section of Barker and Williamson "Miniductor" and this coil is mounted directly across the rear terminals of C_1 on short lengths of No. 14 wire. Check the wiring as you proceed and go over it again after the job is completed to make sure that there

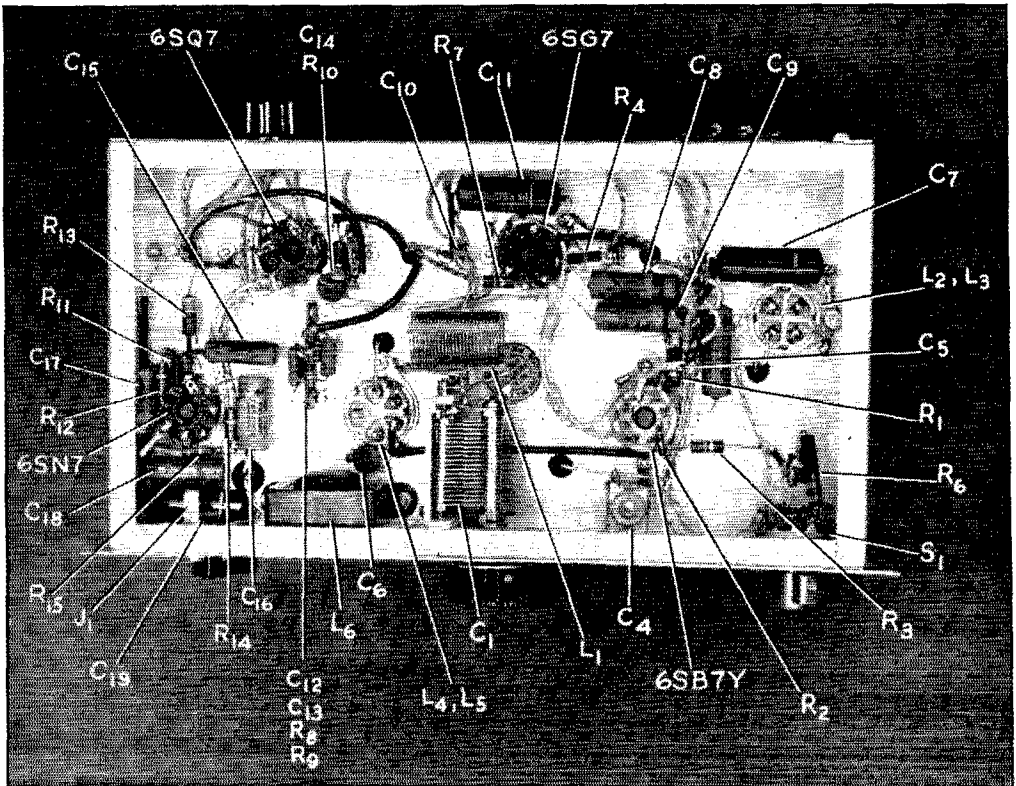

Bottom view of the simple superhet receiver. Components in the circuit diagram are identified by the arrows.

are no mistakes or accidental short circuits to the chassis or other parts.

Coil Winding

In winding the coils, be sure that No. 22 d.s.c. wire is used and that the turns are tight and wound snugly together. The proper frequency range depends on this. Both oscillator and input coils are wound on National or Millen plastic forms 1 inch in diameter. The form for the input coil has 4 pins, while the oscillator form has 5 pins for identification. In winding L_2 and L_3 , measure up on the form $\frac{1}{4}$ inch directly above Pin 4. At this point drill a small hole to pass the No. 22 wire. Next, measure up $\frac{7}{16}$ inch directly above Pin 1 and drill another hole. Starting with the wire at the hole above Pin 4, wind $6\frac{1}{4}$ turns in a clockwise direction with the pins facing you. This should bring you out at the second hole. Now drill a hole $\frac{1}{2}$ inch above Pin 2 and another $\frac{7}{8}$ inch above Pin 3. Starting with a new piece of wire at the lower of these two holes, wind $14\frac{1}{4}$ turns in a clockwise direction as the pins face you. This should bring you out at the top hole. The windings may be cemented in place with Duco cement or coil dope.

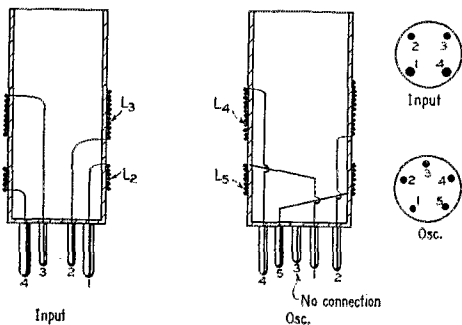

Fig. 2—Sketch showing pin connections in coil forms. Figures at right are bottom views of the coil-form bases.

Special care should be used in winding the oscillator coil. Both windings *must* be wound in the same direction. Drill holes $\frac{1}{4}$ inch above Pin 5, $\frac{3}{8}$ inch above Pin 1, $\frac{7}{16}$ inch above Pin 2 and $1\frac{5}{16}$ inch above Pin 4. Starting at the bottom hole, wind $3\frac{1}{4}$ turns in a clockwise direction, with the pins facing you. This should come out at the second hole. Then starting at the third hole, wind $16\frac{1}{2}$ turns in the same direction. This should bring you out at the top hole. The ends of the wire should be scraped and fed through the proper pins, as shown in Fig. 2, and soldered. Be sure that you have followed the pin numbering shown for the coil sockets in Fig. 1. *The receiver will not work if connections to coil pins are switched or if the oscillator coils are wound in opposite directions.*

Adjustment

The receiver is designed to work from any small receiver power supply delivering 250 volts at 50 ma. or more.

The receiver can be adjusted quite readily with the help of almost any superhet broadcast receiver. The Millen transformers are pretuned to 1600 kc. so must be readjusted for 1500 kc. First the b.f.o. is turned on by throwing S_1 to the c.w. position. The b.c. receiver, placed close to the ham receiver, is tuned as accurately as possible to 1500 kc. Then the slug in the b.f.o. can (T_3) is adjusted until the swish of the b.f.o. is heard in the b.c. speaker. The b.f.o. is now set at approximately 1500 kc. Next, wind several turns of hook-up wire around two or three fingers. Twist one end of the wire around the turns to hold the coil in shape and leave a lead of three or four feet at the other end. Make sure that the ends of the wire are not bare (if necessary cover them with Scotch tape) and insert the bunched wire into the back of the b.c. receiver somewhere near the tuning-condenser gang. Now put the end of the free lead into the hole in the side of the second i.f. transformer can (T_2). If the can has no hole, push the end of the wire up into the can from the bottom. Now tune the b.c. set until a whistle is heard in the headphones. It may be weak at first, so listen carefully. The whistle should be heard when the b.c. receiver is tuned to approximately 1045-kc. if the b.c. receiver has the usual 456-kc. i.f. Starting with the second i.f. transformer, T_2 , adjust first the bottom slug screw and then the top screw for maximum signal in the headphones. Now transfer the lead wire to the first i.f. transformer, T_1 , and adjust similarly for maximum response. Remove the test lead and turn off the b.c. receiver. The i.f. amplifier should now be tuned up at approximately 1500 kc.

Next, turn off the b.f.o. (switch in 'phone position) and set C_1 at minimum capacitance and C_2 and C_3 at maximum capacitance. Connect the antenna and adjust C_4 with a screwdriver until the background noise comes up to a maximum. By this time you should be hearing outside signals. Now set the main tuning dial at 50 and adjust C_2 for maximum background noise. Adjust C_4 very carefully until 75-meter 'phones are heard. Note by listening where the high-frequency end of the 'phone band stops, and trim C_4 slightly until 4000 kc. falls at about 50 on the dial. Pick out a reasonably steady 'phone signal and go back and trim up the i.f. tuning for maximum signal (or you can use background noise). Now tune in a 'phone signal as closely as possible on the nose. Then switch on the b.f.o. and, without additional touching of the main tuning dial, readjust the b.f.o. (T_3) to bring the beat note to the desired pitch.

If the oscillator coil has been wound carefully to dimensions, the receiver should now be tuned

up to cover the 3500-to-4300-kc. range. In covering this band, it will be necessary to keep C_2 tuned for maximum signal strength. In practice, signal strength will remain quite satisfactory if C_2 is reset only two or three times across the band, although a more accurate setting may be necessary for maximum selectivity.

To cover the 6500-to-7300-kc. range, all that is required is to set C_1 at maximum capacitance and readjust C_2 lower in capacitance until a second peak in background noise is heard. Then signals in and around the 7-Mc. band should be heard. Similarly, to tune to the 8500-to-10,000-kc. and 11,500-to-13,100-kc. ranges, tune C_2 still lower in capacitance to find two more respective points where the background noise comes up. This must be done carefully for the latter two bands, since the maximum response points come quite close together near the minimum capacitance of the condenser.

The Wavetrap

In case an image signal from one of the bands not in use causes interference, it can be wiped out

almost completely by accurately tuning C_2 for maximum response of the desired signal and tuning the wavetrap to the frequency of the interfering image. If you suspect that the interfering signal is an image, simply tune C_1 until the interfering signal becomes weaker or disappears altogether. If the *desired* signal and the interfering signal disappear together, the interfering signal isn't an image! If the desired signal becomes weaker without affecting the strength of the interfering signal, the wavetrap is tuned to the wrong frequency and a search should be made for the proper spot. The only thing to watch out for is that the trap isn't left tuned to the portion of the band where you want to listen. That is the reason for the preceding instructions regarding the preliminary setting of C_1 at minimum and maximum — to keep the trap tuned away from the band where you're listening.

If things have progressed as they should, we don't think you'll be complaining about signal strength when the job is finished. On the contrary, you'll be reaching for the gain control to save your ears on the louder ones!



March, 1925

... Daylight transcontinental communication becomes a reality as 1XAM and 6TS work regularly on 20 meters. 6TS is also partner to another amateur first, an early-evening transcon QSO with 2MU on 40 meters.

... Secretary Warner announces preparations for ARRL participation in the first congress of IARU, to be held in Paris in April.

... Two dozen amateurs have heeded the call to become ARRL Official Wavelength Stations, thereby expediting the work of calibrating wavemeters and tuners to the new short-wave bands. Don C. Wallace and C. M. Jansky, jr. are in charge of the program.

... The signal QRR has been adopted as the League's "land SOS" to facilitate emergency work with railroads.

... Technical Editor Kruse tells how to build and adjust the new McCaa anti-static devices.

... A low interelectrode-capacity vacuum tube for short-wave receivers is announced by the Magnavox Co.

... A. L. Budlong of the ARRL Experimenters Section appraises present-day receiver circuitry.

... The "Deresnadyné" — a receiver employing r.f. transformer coupling controls known as "deresonators" — is described by its inventors, E. F. Andrews and E. A. Beane.

... With emphasis on accuracy and ruggedness, John M. Clayton and L. W. Hatry of the Hq. staff have designed and built what is considered the last word in wavemeters.

... A tunable audio transformer for c.w. reception, featuring a sliding core, has been developed by R. A. Braden of the ARRL Experimenters Section.

... The Hq. staff is saddened by the untimely passing of Miss Margaret M. King, assistant treasurer and chief accountant.

... The newsstand price of *QST* has been raised to 25 cents — no increase to members.

... 6DD, Grass Valley, Calif., 9BMX, St. Paul, Minn., British 2SZ, London, and Canadian 1EB, Halifax, are worthy subjects of the month's station descriptions section.

Strays

Need a set of book ends for the shack library? W9IEU recommends using a pair of *QST* binders to do the job. Ben finds the large-area bottoms and weight of the binders (when filled) make them ideal for this purpose.

A nine-year-old Milwaukeean, Armand Schultz, victim of leukemia, has received more than 10,000 QSLs and postcards from hams throughout the world as a result of nightly appeals inaugurated by Harry Rex, WIQLL, Nantucket, Mass. and carried on by other amateurs. WIQLL started the chain of cards coming after reading about Armand's serious condition and his desire to receive mail. The Milwaukee Radio Amateurs Club has made Armand an associate member, presenting him with an appropriate certificate at ceremonies presided over by Vice-President Fred Zolin, W9ONY.

QST is soon to be available on microfilm. Primarily for libraries, University Microfilms will produce positive microfilm copies of each volume of *QST* at a cost comparable with that of binding the same material in a conventional library binding, assuming an edition of 30 or more. Sales are restricted to those subscribing to the paper edition, and the film copy is distributed only at the end of the volume year. Interested parties should write University Microfilms, 313 N. First St., Ann Arbor, Michigan.

Incandescent Light Flicker

A Recommended Solution for Amateurs

BY ROBERT E. SHANK,* W5CKY

ONE of the problems encountered by amateurs using a medium- or high-powered transmitter is that of the house lights flickering as the transmitter is keyed or modulated. Although the FCC is little interested in this aspect of radio operation, others more closely associated with the operator usually are. After the complaint that the household b.c. set has clicks, the amateur is next requested to stop the lights from jumping. As an aid in the solution of this problem, this article presents a time-tested means for reducing lamp flicker caused by transmitter operation.

Power Company Service Voltages

The power company furnishes a.c. voltages in the ranges of 110 to 130 or 220 to 260. The frequency is 60 cycles, with a few scattered 50- and 25-cycle systems. The secondary winding of the pole transformers is in the range of 220 to 260 volts, with the center tap of the winding grounded in order to obtain the 110- to 130-volt range. If

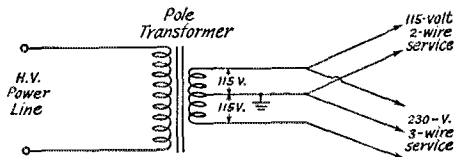

Fig. 1 — A power company pole transformer with 2- and 3-wire customer service drops.

you have two wires running from your house to the pole, you are served in the 110- to 130-volt range. If there are three wires, you have the 220- to 260-volt service. The company has fixed voltages for delivery to its customers, usually 115 volts and 230 volts. These fixed voltages will vary slightly in different power systems. Should you check your own lighting voltage, you will probably find it in the range of 112 to 122 volts. This range of primary voltage is satisfactory for the operation of all your equipment. Fig. 1 is the conventional arrangement of a power company pole transformer with a 2- and a 3-wire service to customers.

Causes of Light Flicker

If your house lights flicker when the transmitter is operated, the principal reason is that the transmitter suddenly takes a heavy current from

the power (a.c.) lines. This in turn causes the a.c. voltage to drop from its former value when the transmitter key was open and the final was not drawing power. This rise in current multiplied by the impedance of your house wiring and the power-system lines from the transmitter to the power-system substation is the change in line voltage that occurs at the plate transformer of the transmitter. This change in power-line voltage can be measured by placing a 0-150 a.c. voltmeter on the line feeding the plate transformer and reading the primary voltages when the transmitter key is open and closed. The resulting drop in line voltage occurs mostly in the house wires, the service wires between the house and pole, and the pole transformer.

Another type of light flicker is caused by r.f. being induced in the house wires. This flicker can be cured by placing a condenser across the a.c. lines where the r.f. is apparent. A 0.1- μ fd. condenser of 1000 volts d.c. rating is usually sufficient, but care in installation should be taken to avoid a fire hazard. In extreme cases, r.f. chokes may also be required in series with each wire of the a.c. lines.

The change in the a.c. line voltage is directly proportional to the plate power input to the transmitter. In other words, if an input of 100 watts to the plates caused a drop of 1 volt in the lines, then 200 watts input would cause a 2-volt drop. The change in the line voltage at the transmitter causes a change in the rest of the house wiring. This causes the lights on the house wiring to change in brightness.

The graph, shown in Fig. 2, is a plot of flicker volts *vs.* flicker frequency voltage variation, for a 115-volt line. When used for a 230-volt line, the voltage scale should be doubled. The curves in the graph show the areas that represent imperceptible, perceptible, and objectionable flicker. The borderline areas represent flicker objectionable to some people, while not to others. You will note that the frequency of flicker has considerable bearing upon the degree of flicker volts in the objectionable area.

The frequency of voltage dips attributable to the operation of an amateur transmitter varies from 3 to 15 per second. These are the worst limits from the standpoint of light flicker. As an example in the use of Fig. 2, assume you operate a transmitter with 350 watts input to the final stage. The primary side of the plate transformer is 115 volts a.c. Placing a 0-150 a.c. voltmeter

* % Ebasco Services, Inc., New York, N. Y.

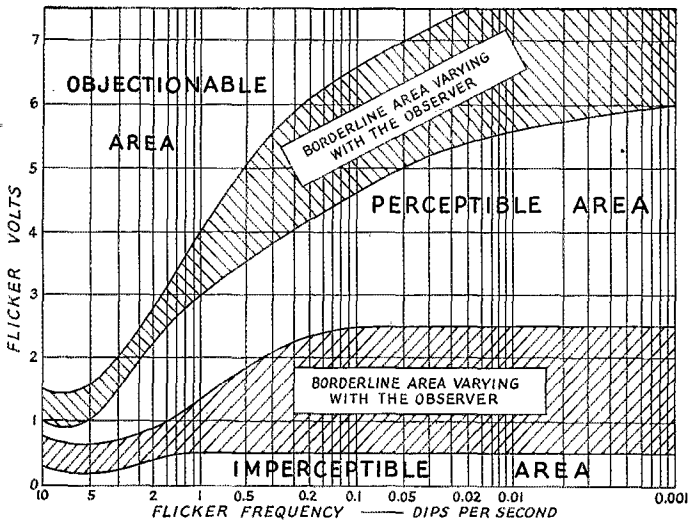

Fig. 2 — A plot of line-flicker volts vs. flicker frequency. Flicker frequency can be approximated by taking $\frac{1}{2}$ of the code speed. On voice, the average is around 10 dips per second.

across the primary, you measure 118 volts. Closing the key to the transmitter you measure 116 volts. The dip or flicker voltage is thus 2 volts. If you key the transmitter at 15 words per minute, the flicker dips average about 5 per second. Now using Fig. 2, locate 5 dips per second on the bottom line. Follow up this line until it intersects 2 volts on the flicker volts line. This intersection falls in the objectionable area, and some correction is in order. Amateurs using A-3 can determine their flicker rating in the same manner as with c.w., by assuming a modulation dip rate of 10 per second.

Curing Flicker

The large majority of objectionable light flicker is caused by transmitter plate transformers being operated on 115 volts. The most practical method of curing this flicker is to use 230 volts to supply the plate transformers. If your house is already supplied with 230 volts a.c., all that is required is a 230-volt circuit from the house switch to the transmitter and an autotransformer. Three No. 12 wires are sufficient for the circuit, and the autotransformer should be one-half the capacity of the plate transformer or larger. If the plate transformer has a 230-volt primary winding, the autotransformer is not required. The connections of the 230-volt line, autotransformer, and plate transformer are shown in Fig. 3.

If the house has only a 115-volt 2-wire service, the power company should be asked to replace it with a 230-volt 3-wire service. Most companies will do this free of charge to the customers. The old main switch will have to be replaced with a

3-wire switch suitable for the new service. From this switch a 230-volt circuit can then be run to the transmitter. The writer installed a new main power switch and a 230-volt circuit at a cost of \$9.00. The six hours of labor was charged to amateur radio.¹

By using 230 volts at the plate transformer in place of 115 volts, the dip in line voltage or flicker volts is reduced to one-quarter of the previous amount. Going back to our example of the transmitter running 350 watts, we will now have a $\frac{1}{2}$ -volt dip instead of the original 2 volts. Again referring to the graph in Fig. 2, we find that the flicker is in the borderline between imperceptible and perceptible.

You can use this graph to determine how much plate power you can run without causing a flicker in the objectionable area. In our example we now have $\frac{1}{2}$ -volt flicker with an input of 350 watts. If we raised the input to 700 watts, the flicker voltage would become 1 volt, which is not objectionable.

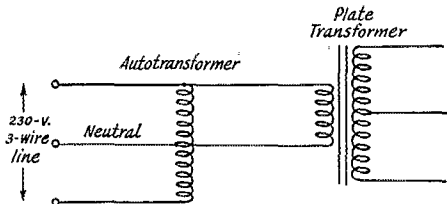

Fig. 3 — An autotransformer can be used between a 230-volt line and a 115-volt transformer to improve the regulation. The autotransformer must have a power rating equal to at least half the rating of the plate transformer.

Should the flicker voltage enter the objectionable area of the graph when the transmitter is supplied by 230 volts, the power company should be consulted about increasing the size of their service and secondary wires and of their pole transformer. An overloaded pole transformer creates a large voltage drop, as do long runs of secondary and service wires.

Line-voltage flicker is one of the little annoyances that creep into amateur radio operating. Curing it doesn't help you to get out any better, but it will probably help you to get along better with your family and the neighbors, and it might even cut down some of that chirp.

¹ There are many communities where all house wiring must be done by a licensed electrician. This should be investigated before undertaking the wiring job yourself. — Ed.

Eliminating TVI with Low-Pass Filters

Part II † — Filter Operating Characteristics and Attenuation in Relation to the TVI Problem

BY GEORGE GRAMMER,* W1DF

ONE of the essentials in getting the most out of a filter — aside from giving it a fair chance, as discussed in the first part of this article — is to have a working knowledge of its operation. Because of the similarity of some of the terms used in connection with both filters and transmission lines, it is easy to acquire some misconceptions of filter operation.

Attenuation is an example. In a line it is expressed as a power loss in some given distance, usually in decibels per hundred feet. It does not

through it there is never any power loss in it. Hence there cannot under any circumstance be a power loss in a filter composed of such reactances. Any power that enters the filter either has to leave by the output terminals or be returned back to the source through the input terminals.

It is the power returned to the source that accounts for the attenuation in a filter. In the attenuation band the filter hands back a part of the power that enters. The greater the proportion handed back the greater the attenuation. This is the same as saying that the filter refuses to accept power from the source in greater or lesser degree. Such power as it does accept is passed on to the load, not used up in the filter itself.

Those who know their decibels will immediately question the legitimacy of expressing filter attenuation in db. In the ideal filter the ratio of power output to input is always unity, hence the attenuation is always zero db. because by definition the decibel expresses a power ratio. As used in evaluating filter performance, the decibel is simply a measure of a current or voltage ratio, with no reference at all to power. In practical applications of filters the voltage and current may not be attenuated in the same ratio, which is, to say the least, confusing. However, there is one special case in which the current and voltage ratios are the same — the case where the load on the filter has an impedance equal to the characteristic impedance of the filter itself. Filter attenuation formulas are based on this condition, because then the formulas assume their simplest possible form. The condition can be met to a good approximation over part of the passband, but is seldom even approximated in the attenuation or stop band. This point can stand a little elaboration.

Impedance Characteristics

Suppose that a variable impedance, Z_R , is connected to the output terminals of a filter, as shown in Fig. 8. While Z_R is varied from zero to infinity the impedance Z_S looking into the input

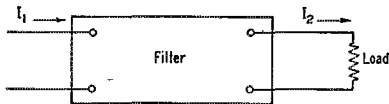

Fig. 7 — Attenuation in a filter is the ratio of output current to input current. It can also be expressed as the ratio of output voltage to input voltage. The two ratios are not the same except when the filter is terminated in a load equal to its characteristic impedance.

have the same meaning when applied to filters. If a filter is connected between a source of power and a load, as in Fig. 7, the attenuation of the filter is simply I_2/I_1 , the ratio of the current flowing out of the filter to the current flowing into it. This definition of attenuation says nothing about any power loss. In fact, there is theoretically no power loss even when the attenuation is infinitely large.

If you have had the idea that a TVI filter works by "dissipating" your harmonics, you will be wondering where the harmonic power goes. But first let's see why there should be no power dissipation in a filter. In the interests of simplification, filter design is based on the assumption that the coils and condensers used in them are perfect — pure inductance and pure capacitance, no resistance of any kind. Hence an "ideal" filter is composed of pure reactances — which, incidentally, would give better performance than can be obtained with practical coils and condensers. The better the coils and condensers used in filters — i.e., the lower their resistance — the more nearly can ideal performance be approached. Now it is characteristic of a pure reactance that no matter what the value of the current flowing



Fig. 8 — Illustrating the experimental method of determining characteristic impedance.

* Technical Editor, QST.

† Part I of this article appeared in Feb. QST, p. 19.

terminals is simultaneously measured. If certain conditions are fulfilled there will be one value of Z_R that will "repeat" at the input terminals; that is, Z_S will be equal to Z_R . At all other values of Z_R , Z_S will not be equal to Z_R . The value of Z_R that causes Z_S to equal Z_R is the characteristic or image impedance of the filter. Unlike the characteristic impedance of a transmission line, which is substantially resistive and independent of frequency, the magnitude of the image impedance of a filter can vary violently with frequency. Furthermore, in a perfect filter it is a pure resistance in the passband and a pure reactance in the stop band.

In many filter applications this variation in image impedance, particularly in the passband, is an undesirable feature. Consequently, a good deal of attention is paid in design to minimizing the image impedance variations throughout the passband. However, it should be kept in mind that the effect of a mismatch between the load and the filter is chiefly to cause the impedance

looking into the filter to be different from that of the load. The desired amount of power can always be put into the load by proper adjustment of the coupling between the transmitter and the filter.¹⁰ Of course, practical filter components are never free from resistance, so there is a small power loss even with perfect matching. This loss increases when there is a mismatch because the effect of mismatching is to increase the current circulating through some of the filter components, but in many cases the increased power loss is negligible.

Image Impedance in the Passband

As an illustration of the variation in image impedance, the performance in the passband of constant- k T and π sections is shown by the curves of Fig. 10. Note that the image impedance of the π section is always higher than the design value, R , and is theoretically infinite at the cut-off frequency. The T-section image impedance is always lower than R and is theoretically zero at cut-off.

The cut-off frequency is obviously the worst condition, so it is of interest to see what will happen at this frequency when a filter section is terminated in a resistive load equal to R . Our notions of transmission line behavior would lead us to expect something horrible, but as shown by Fig. 11 the actual conditions are not so bad. With the T section the input and output voltages are the same, but the input current is a bit more than twice the load current. With the π section the input current is equal to the load current but the input voltage is high.¹¹ Assuming that all the resistance in a practical filter is in the coils, the power lost in the filter at cut-off is of the order of twice what it would be at some very low frequency where the image impedance and R are practically equal. However, the power loss in the latter case should be so small, with reasonably good coils, that doubling it still should make no appreciable difference in the over-all efficiency.

It must be pointed out that the situation will be worsened if two or more constant- k sections are connected in cascade and operated at the cut-off frequency. In contrast, at frequencies below cut-off the over-all performance will be improved by using more than one section.

The variation in image impedance with frequency in an m -derived section depends on the type of section used. A series m -derived T section

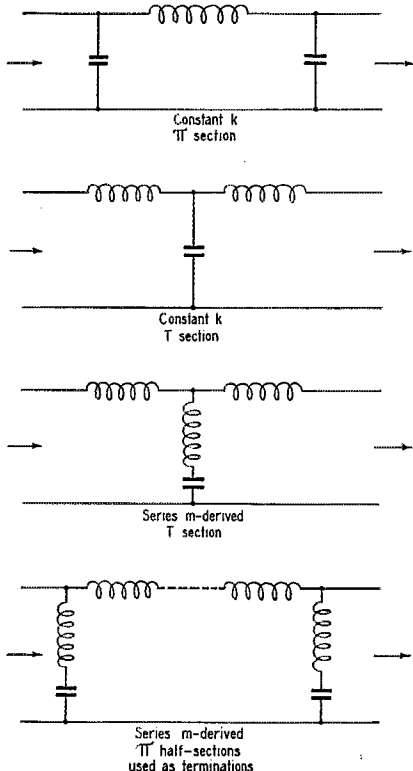

Fig. 9—Types of filter sections discussed in the text. In the lowest drawing, the dashed line between the two coils indicates that additional filter sections may be inserted. In case only one section is desired the two half-sections are simply connected together. The two coils may then be combined into one having twice the inductance of either.

¹⁰ The case is parallel to that of coupling to a transmission line when the s.w.r. is greater than 1. The latter case is discussed in some detail in *The A.R.R.L. Antenna Book*, 1949 edition, page 79.

¹¹ This illustrates the point, made earlier, that the voltage and current attenuation are not the same unless the filter is terminated in its image impedance. With the T section the voltage attenuation is zero db, but the current attenuation is 7 db. With the π section the current attenuation is 0 and the voltage attenuation 7 db. In neither case is there any attenuation of the actual power because the filter components were assumed to be loss-free.

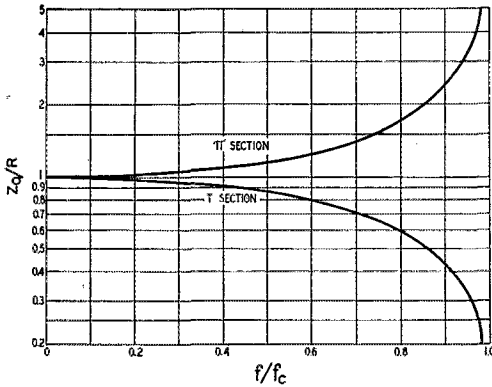

Fig. 10 — Variation in image impedance of constant- k T and π low-pass sections in the passband. Horizontal axis: ratio of applied frequency, f , to cut-off frequency, f_c ; vertical axis: ratio of actual image impedance, Z_0 , to nominal or "design" impedance. The latter is usually designated by the letter R in filter formulas.

shows exactly the same image-impedance variations as a constant- k T section. However, series m -derived π half-sections will have greatly improved image-impedance characteristics if m is equal to 0.6. With this type of section the image impedance will stay within 10 per cent of the nominal value at all frequencies up to nine-tenths of the cut-off frequency. When used as terminations at both ends of a filter having intermediate T sections, such half-sections with $m = 0.6$ will similarly improve the characteristics of the filter as a whole, which is the reason why they so frequently appear in filter designs. However, the selection of the value of m is another point that should be considered in relation to the particular problem at hand — in this case the TVI filter.

The Stop Band

In the stop band the image impedance is always variable; matching in this region is never attempted and would not be particularly helpful if it were. The actual attenuation of the filter depends not only on its design but on the conditions that exist at its input and output terminals,¹² and is practically independent of whether or not a match exists at the frequency that is being passed. In other words, the harmonic attenuation of a TVI filter will not be improved by perfect matching at the fundamental frequency, unless by chance the steps taken to bring about a match also make a favorable change in the conditions existing at the harmonic frequencies.

In this band the point of chief interest is what the filter can be expected to do in the way of suppressing harmonics. The question of attenuation cannot very well be approached without

¹² This point was discussed in the first part of this article.

reiterating the fact that the theoretical attenuation of filters is based on assumed conditions that will exist only by extreme coincidence in an actual installation, and then probably at only one frequency in the stop band. This does not mean, necessarily, that the actual performance of the filter will differ very greatly from the theoretical. It can, but probably won't, except for the terminating effects discussed in the first part of this article. The greater the number of sections used in the filter the more independent the attenuation becomes of what is connected to the input and output terminals.

At any rate, we have to use the theoretical attenuation because there is no other basis for discussion. The curves of Fig. 12 can be used for estimating the attenuation of filters designed for TVI reduction. They show the theoretical attenuation of full sections for selected values of m , together with the attenuation of a constant- k section.

Below the frequency f_∞ at which the attenuation of an m -derived section is theoretically infinite, the attenuation is always greater than that of a constant- k section. Above f_∞ the attenuation decreases and approaches a limiting value which depends on the value of m . At frequencies high enough so that the capacitive reactance in the shunt arm (in the m -derived T section shown

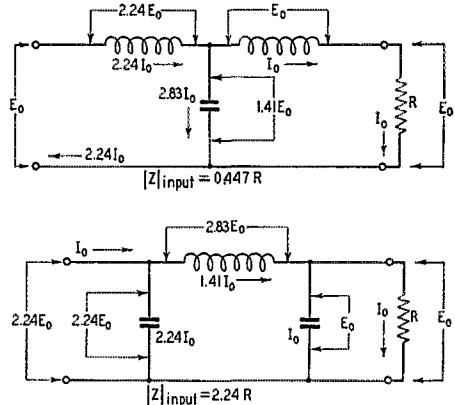

Fig. 11 — Voltages and currents in constant- k and π sections at the cut-off frequency, when terminated in the nominal characteristic impedance, R .

in Fig. 9) is negligible compared with the inductive reactance the network becomes a simple voltage divider composed entirely of inductances, and hence the attenuation levels off at a practically constant value.

Figs. 13 and 14 will be of assistance in estimating the attenuation curves for values of m not shown in Fig. 12. Fig. 13 shows the frequency of infinite attenuation, f_∞ , in terms of the chosen cut-off frequency, and so locates one point in Fig. 12. Fig. 14 gives the limiting value of at-

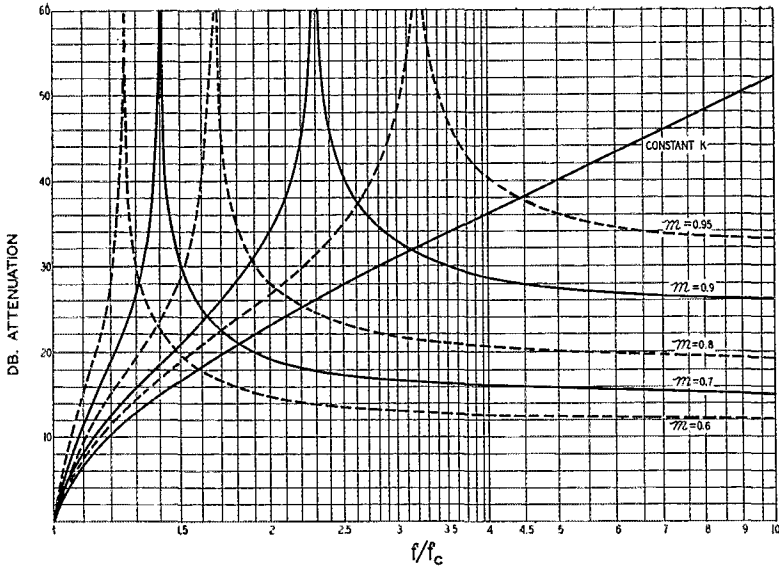

Fig. 12 — Theoretical attenuation, in the stop band, of single filter sections. (Two half sections, as shown in the lowest drawing of Fig. 9, count as one section.) The horizontal axis is in terms of the ratio of the applied frequency, f , to the cut-off frequency, f_c .

tenuation for various values of m . So long as m is below 0.95 this point can be located on the ordinate representing 10 times the cut-off frequency in Fig. 12. Because of the family resemblance between the curves for various values of m , locating these two points on Fig. 12 will permit sketching the attenuation curve for any selected value of m with an accuracy that is entirely adequate for our purposes.

The range of m values shown in Fig. 12 is sufficient for most TVI filters. There is no point in using a lower value than 0.6, because the lowest frequency at which high attenuation is required will always be at least twice the operating frequency. Consequently the sharp cut-off that can be obtained with lower m values is not needed. On the other hand, a filter that is to pass all frequencies below 30 Mc. is not likely to require an f_∞ greater than three times the minimum usable cut-off frequency, so $m = 0.95$ is about as high as we need to go.¹³

An interesting feature of the curves of the m -derived sections is that the width of the rejection notch becomes greater for larger values of m . This means that a single filter section of this type will give high attenuation over a whole TV channel if m can be made large enough. The curves also show that an m -derived section cuts off less sharply as m is increased, and (this is also shown in Fig. 14) the attenuation above f_∞ is improved.

¹³ For still higher values (which might be used if the cut-off frequency is chosen below 30 Mc.) the error will not be consequential if the section is designed on a constant- k basis and a small inductance is inserted in series with C (in the T section, Fig. 9) to resonate with C at the desired f_∞ .

Combining Filter Sections

Assuming that the sections are properly designed,¹⁴ the attenuation of a filter composed of a number of sections will be the sum of the attenuations (in decibels) of the individual sections as shown in Fig. 12. As an illustration, suppose we have a filter with one constant- k section, one m -derived section with $m = 0.6$, and one m -derived section with $m = 0.8$. Adding the atten-

¹⁴ Methods of design were covered in the excellent article by Mack Seybold, "The Design of Low-Pass Filters," in December, 1949, *QST*. A chief point is that all sections must be calculated for the same value of R .

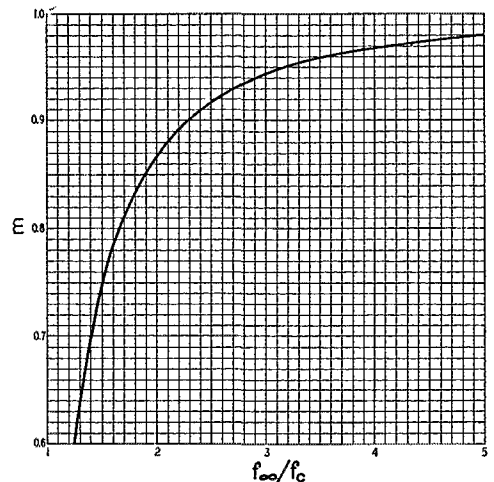

Fig. 13 — Value of m as a function of the ratio between the frequency, f_∞ , at which maximum attenuation is desired and the cut-off frequency, f_c .

uations of the appropriate curves of Fig. 12 gives the complete curve of Fig. 15. The arrangement of these sections in the actual filter will not affect the attenuation, but will have a pronounced effect on the impedance characteristics in the passband. As pointed out by Seybold,¹⁴ full T sections are to be preferred to π sections in a filter for use with coax line, so the most satisfactory arrangement would be as shown in Fig. 16. The upper drawing shows the individual sections, while the lower drawing shows the filter as it would be constructed with the separate inductances between each pair of shunt arms combined into one coil. Since the impedance looking into the filter is the same in either direction (the same is true of the attenuation) it does not matter which pair of terminals is used for the input.

How Much Attenuation?

There is no open-and-shut method for deciding how much filter attenuation is needed for eliminating TVI. The question itself is meaningless unless

1) The transmitter causes no interference when operated at full power into a shielded dummy antenna.

2) The TV receiver has been protected, if necessary, from fundamental overload by the installation of traps, filters, shielding and the like to the extent required.

Once these preliminary requirements are satisfied, the filter attenuation needed will be greater if

1) The TV receiver and your transmitter are close together.

2) The TV signal is weak.

3) A low-order harmonic falls in a TV channel that is receivable in your locality.

4) You use high power.

The last is not as important as might be thought. There is only a 10-db. difference between 100 watts and a kilowatt, and assuming that the harmonics are in proportion, the difference between the two power levels is less than the attenuation afforded by a simple constant- k section.

If the transmitter has been treated to prevent stray radiation and the receiver is protected against the fundamental, the chances are that the battle is already half won. In regions where the TV signal strength is high this (plus an antenna coupler) should have reduced the interference to the point where even the low-order harmonics (from 28 Mc., for example) do not greatly exceed the strength of the TV picture carrier at a near-by receiver. As a rough guide, when the two are approximately equal the cross-hatching produced by carrier interference will have about the same contrast as the desired picture. That is, the black part of the crosshatching will just reach pure black at its darkest part,

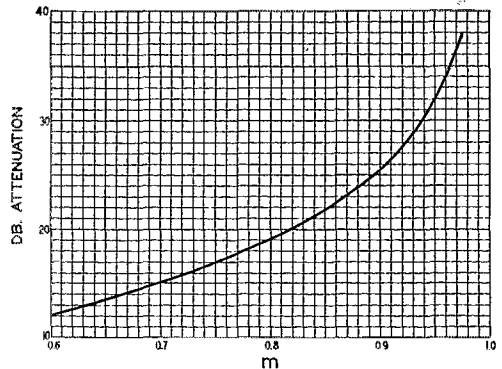

Fig. 14 — Attenuation in an m -derived full section, at frequencies far above f_{∞} . The curve theoretically represents a limit approached as the applied frequency approaches infinity, but for practical purposes the attenuation can be considered to be constant at these values for all frequencies above about four times f_{∞} .

and the white part will similarly just reach pure white. The picture itself will be easily visible through interference of this strength. If the black and white crosshatching bars wash out the picture the interference is considerably stronger than the carrier. On the other hand, if the crosshatching shows up as medium gray bars the harmonic is not as strong as the TV carrier. These effects depend on the exact frequency of the interfering harmonic.¹⁵ An alternative check can be made on the sound channel, if it is possible to put the harmonic on that frequency. If the harmonic suppresses the sound completely, it is stronger than the sound carrier by a margin of at least 6 db., and vice versa.

An interfering signal near the picture carrier must be at least 40 db. below the latter for the interference to be tolerable. Thus if the harmonic and the TV carrier are approximately the same strength, the filter should have an attenuation of at least 40 db. for that harmonic. More, possibly much more, will be needed if the crosshatching wipes out the picture entirely. It is readily possible to secure attenuations in excess of 60 db., which should take care of a harmonic ten times as strong as the desired signal. If a filter having such theoretical capabilities does not seem to do what it should, the probable reasons are (1) that it was improperly designed and constructed, or (2) that the harmonic is leaking past it by one means or another. The higher the filter attenuation the more important the latter point becomes, because a small amount of leakage places a ceiling on the over-all attenuation.

The Local Situation

The TV channel assignment for populous centers follows, in general, definite patterns. In the low group of channels — 2 through 6, the most

¹⁵ "TVI Tips," *QST*, June, 1949.

important group from the TVI standpoint — Channels 2, 4 and 5 will be assigned to one area while Channels 3 and 6 will be assigned in others. There is no particular point in providing attenuation in frequency regions where you have no harmonics. If you are, for example, concerned only with operating 10-meter 'phone you will have either Channel 2 or Channel 6 to worry about, but in most cases not both of them. (This ignores those beyond-the-fringe-area television DX-ers who try to get stations the allocation plan never intended them to get.) In such a case the filter can be built to provide the maximum attenuation where it will do the most good, even though it may not have high attenuation outside the channel that is being protected.

As an illustration, suppose that the transmitter operation centers around 29 Mc. and that Channel 2 is to be protected. To see what a single m -derived section will do, let us assume that the rejection frequency, f_∞ , is to be placed at 58 Mc., the second harmonic. From the earlier discussion we know that it is desirable to have m as large as possible, which means that the cut-off frequency should be as low as possible. In view of the earlier discussion of image impedance, let us assume that the highest operating frequency, 29.7 Mc., should not exceed 0.9 times the cut-off frequency of 34.7 Mc. so that m will be 0.8 ($f_\infty/f_c = 1.67$ from Fig. 13). The harmonic "shadow" of the 10-meter 'phone band is 57 to 59.4 Mc. The cor-

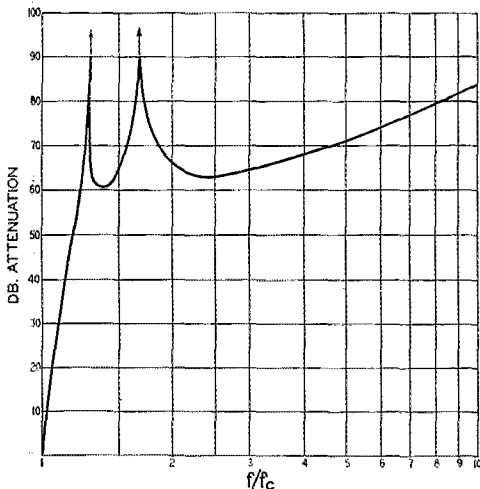

Fig. 15 — Theoretical attenuation of the three-section filter used as an example in the text. The circuit is shown in Fig. 16.

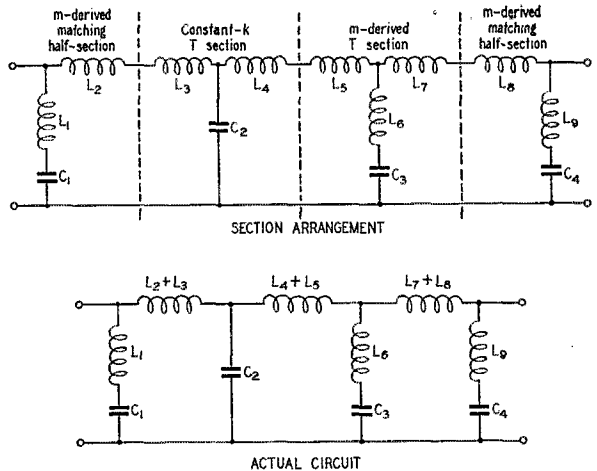

Fig. 16 — Development of the filter circuit used as an example in the text.

responding ratios to the cut-off frequency are $57/34.7 = 1.64$ and $59.4/34.7 = 1.71$. From Fig. 12 the attenuation will range from 48 db. at 57 Mc. through infinity (theoretically) at 58 Mc. and back to 42 db. at 59.4 Mc.

Where Channel 6 is the only concern somewhat more favorable results can be obtained from a single section. In this case we are mainly concerned with the harmonic shadow that falls below 88 Mc., the upper limit of the TV channel. Since the third harmonic of 28.5 Mc. falls at 85.5 Mc., the rejection point can be placed midway between 85 and 88, at 86.5 Mc. The cut-off frequency should not be lower than $29.7/0.9 = 33$ Mc. Using this figure, the ratio $f_\infty/f_c = 86.5/33 = 2.62$, and from Fig. 13 this corresponds to $m = 0.925$. The curve can be sketched on Fig. 12 as previously described. Proceeding as before, it is found that the attenuation anywhere between 85.5 and 88 Mc. exceeds 50 db.

It can be seen, therefore, that a single m -derived T section is theoretically capable of protecting a given channel when the strength of the harmonic does not exceed the strength of the TV picture carrier. In the ten-meter case the next harmonic that can interfere with television is the sixth, which can fall in Channel 7 (174–180 Mc.). Using 34.7 Mc. as the cut-off frequency, the frequency ratio is $174/34.7 = 5$. From Fig. 12 this ratio would give an attenuation close to 20 db. when $m = 0.8$. With the Channel 6 filter the attenuation is about 30 db. These attenuations could be adequate, in view of the frequency of the harmonic as well as its high order. The v.h.f. resonances that occur in the tank circuits of transmitters¹⁶ working at 28 Mc. and below

(Continued on page 104)

¹⁶ "TVI Tips," QST, Oct., 1949.

Simulated Emergency Test - 1949

Nationwide Test of Emergency Plans and Facilities Demonstrates Preparedness of AEC Groups

BY GEORGE HART,* WINJMJ

THE Simulated Emergency Test gets bigger every year. A total of 127 AEC groups reported activity in the 1949 test as compared with 93 in 1948 and 54 in 1947. Reports were received from most states, a few Canadian provinces and groups in Canal Zone and Puerto Rico. Each group represents many (in some cases hundreds) of amateurs who devoted time during the week end of October 15th and 16th preparing themselves to serve their community in time of direst need. The year-to-year improvement is an indication of the increasing emergency-consciousness of amateur radio clubs and community groups.

Readers are invited to look at the listing of participating groups. Is your community represented? Are *you* represented? Of course you will be on hand in the event of a *real* emergency to help wherever you can; we all know that. But don't kid yourself into thinking you will be *ready*. For a small amount of your time, why not become an integral part of your local AEC group to be *ready in fact* when the need arises? Why not hold an Emergency Corps card and lend the weight of your example to the showing for the amateur service?

The list of group participants which follows is in order of their "scores," but these are not meant to be competitive. The circumstances of the different groups involved are at such wide variance that there can be no basis for competition. The scores are simply an indication of the "antenna current" of each group. The fact that one antenna shows more antenna current at its feed point than another does not necessarily mean that it is better than the other; but when a change in loading (or power) shows a higher an-

tenna current with the same antenna, it is an indication of improvement. Your score should be compared with that of previous years rather than with that of other groups.

Appleton, Wis.....	100	Winthrop, Mass.....	100
Bangor, Me.....	100	San Fernando Valley, Calif.....	97
Bergen & Passaic Co., N. J.....	100	Jefferson Co., N. Y.....	94
Big Spring, Texas.....	100	Davison Co., S. Dak.....	92.5
Billings, Mont.....	100	Western Los Angeles, Calif.....	92
Bismarck-Mandan, S. Dak.....	100	New London, Conn.....	90.8
Boone Co., Ark.....	100	Dade Co., Fla.....	90
Calgary, Alta.....	100	Isabella Co., Mich.....	90
Ceas Bay, Ore.....	100	Peoria, Ill.....	90
Cullman Co., Ala.....	100	Memphis, Tenn.....	89.5
Cuyahoga Co., Ohio.....	100	Morris Co., N. J.....	89.1
Danbury, Conn.....	100	Albany Co., N. Y.....	88
Dedham, Mass.....	100	Everett, Wash.....	88
Dresden, Tenn.....	100	Grand Rapids, Mich.....	88
Elko, Co., Nev.....	100	Nassau Co., N. Y.....	88
Fort Smith, Ark.....	100	Portland, Ore.....	88
Granite City, Ill.....	100	Racine, Wis.....	88
Green Co., Ill.....	100	Long Beach, Calif.....	86
Groveland, Mass.....	100	St. Paul, Minn.....	86
Huron & Sanilac Co., Mich.....	100	Bloomfield, Conn.....	85
Lewiston & Auburn, Me.....	100	Springfield & Clark Co., Ohio.....	85
Madison, Wis.....	100	Mercer Co., Pa.....	84
Massena, N. Y.....	100	Wausau, Wis.....	84
McKean Co., Penna.....	100	Santa Clara Co., Calif.....	83.6
Milwaukee Co., Wis.....	100	Hamilton, Ont.....	82.9
Muskegon, Mich.....	100	Colo. Springs, Colo.....	82
New Castle, Ind.....	100	San Juan, P.R.....	82
New Port Richey, Fla.....	100	Aberdeen, S. Dak.....	80
Oklahoma Co., Okla.....	100	Augusta, Me.....	80
Ottumwa, Iowa.....	100	Burlington, Vt.....	80
Phoenix, Ariz.....	100	Kansas City, Mo.....	80
Pike Co., Ohio.....	100	Windsor, Ont.....	80
Quebec, Que.....	100	Kingsport, Tenn.....	79
Roswell, N. M.....	100	Toledo, Ohio.....	78.18
San Bernardino, Calif.....	100	Genesee Co., Mich.....	77.17
Southbridge, Mass.....	100	Canal Zone, Pacific Side.....	77
Stevens Point, Wis.....	100	Haverhill, Mass.....	76
Stratford, Conn.....	100	Akron, Ohio.....	75.55
Sudbury, Ont.....	100	Iroquois Co., Ill.....	73.33
Washington Co., Okla.....	100	Richmond Co., Ga.....	73

* National Emergency Coördinator, ARRL.



W6CXO, sponsored by the American Red Cross under the auspices and trusteeship of the San Francisco Naval Shipyard Amateur Radio Club, had a busy time of it during the SET. Two main operating positions were in action, plus auxiliary 2-meter and portable set-ups. A third operating position to the left, out of the picture, has four crystal-controlled receivers permanently tuned to the National Emergency Frequencies of 3550, 3875, 7100 and 14,050 kc. Operators shown are, left to right, W6BWL, W6BYS (San Francisco EC) and W6NL (San Francisco SCM).

QST for

WIQHT kibitzes as WIJEN operates while taking part in the annual Simulated Emergency Test. This field unit was part of the Burlington (Vt.) Emergency Corps set-up and used completely independent power sources.



Dorchester, Mass.	71	Erie Co., Pa.	64
Butte, Mont.	70	Mansfield, Ohio.	64
Clinton, Ill.	70	Eureka, Calif.	63
Crawford Co., Ohio.	70	Hartford, Conn.	60
Green Bay, Wis.	70	Marinette, Wis.	60
Joplin, Mo.	70	Hartford Co., Conn.	59.2
Pittsfield, Mass.	70	Cincinnati, Ohio.	52.75
Toronto, Ont.	70	Oneida Co., N. Y.	52
Kitsap Co., Wash.	69	Norwalk, Conn.	48
Chattanooga, Tenn.	67.3	Plainfield, N. J.	48
Monroe Co., N. Y.	67	Portland, Me.	46
Onondaga Co., N. Y.	67	Torrington, Conn.	44
Schenectady, N. Y.	66	Minneapolis, Minn.	43.6
Columbus, Ohio.	65	San Diego Section, Calif.	43
Muscatine, Iowa.	65	Crescent Bay Area, Calif.	42.16
Pittsburgh, Pa.	65	S.E. Portland, Ore.	30
Tuscaloosa, Ala.	65	Pendleton, Ore.	8.6
Eau Claire, Wis.	64		

No Scores Reported

Greene Co., N. Y.	Des Moines, Iowa
Danville, Ark.	Fall River, Mass.
Piqua, Ohio	Marietta, Ohio
New York Co., N. Y.	Portsmouth, Ohio
Canal Zone, Atlantic Side	Chillicothe, Ohio
Zanesville, Ohio	Steubenville, Ohio
Erie Co., N. Y.	Wilmington, Ohio

Traffic Routings

The SET traffic started to pile up at centralizing points on Saturday night and roll eastward to ARRL Headquarters or to Red Cross stations K3NRW (now W3PZA), W6CXO and W9DUA, but the going started to get really rough for the traffickers on Sunday night. On Monday the regular traffic nets took over. By Tuesday the large volume of traffic had all been delivered; on Wednesday and Thursday it had stopped except for an occasional sporadic message. Most emergency groups designated one or two stations specifically for the purpose of handling long-haul traffic. It was then centralized by areas and relayed in bulk toward or directly to its destination. The handlers did an admirable job considering the fact that most traffic nets do not operate week ends. The list of stations who sent messages to Headquarters is too long to reproduce here, but the number of messages received runs into four figures. Connecticut amateurs and those at Red Cross centers were kept busy both during the week end and for one or two days afterward.

Publicity

The Simulated Emergency Test is valuable as an "opener" for the fall season; it puts emergency coordinators to work on a practical, down-to-earth basis for overhauling of old plans or development of new ones, in accordance with changing personnel and requirements; it instills the confidence and feeling of usefulness necessary for continued interest of each AEC member.

But aside from these important interior organizational matters, it also brings our activities and organizations emphatically to the attention of the public and the agencies and local authorities we are dedicated to serve; and although this represents an entirely different phase of emergency-preparedness from the operating phase, it is every bit as important to the welfare and reputation of amateur radio.

The annual test of amateur facilities first of all provides an opportunity for ECs to renew their contacts with the several local officials and agencies and serves notice upon them that their community amateurs are still organized and ready to go into action at a moment's notice. During last October's test many public officials came forward as observers or even participants in the test, and copies of official sentiments of pleasure and congratulations signed by mayors, Red Cross disaster chairmen, chiefs of police and other dignitaries have crossed our desk by the score. Secondly, the local newspapers did a marvelous job in covering some of the tests and cooperated at numerous points in giving readers something of the excellent story of amateur radio's practical organization for emergencies. Practically every report of participation was accompanied by a newspaper clipping, many of them complete with photographs, from front-page spreads to rear-page features. The availability of amateur facilities for emergency communication is always of interest to community officials; the *proof* of what it can do as demonstrated by the annual Simulated Emergency Test is *news*. The prestige of clubs, AEC groups and individuals was thus enhanced as a result, in addition to the substantial improvement of our practical AEC plans and progress, emergency-wise, in all these communities.

Comments

There is more to the story than just this. Each EC who had a group in the field and sent in a report of activities had his own detailed report on

(Continued on page 108)

Crystal-Controlled Oscillators

A Review of Modern Crystals, Circuits and Tubes

BY C. VERNON CHAMBERS,* WIJEQ

A PERIODIC survey of the behavior of crystal-oscillator circuits is desirable because of the new types of crystals and tubes that appear over a period of time. Previous examinations of crystal-oscillator circuits by Lamb¹ and Goodman² resulted in much useful data pertaining to crystals and tubes of prewar design. Although the oscillator-tube complement has not grown appreciably since the time of the work by Goodman, considerable development was done in the crystal field during the years of wartime research. The crystals now commonly available on the regular and the surplus markets are smaller and therefore cannot handle as much power as those produced in the past and, as a result, the operating conditions of an oscillator circuit are now more critical.

The object of this latest investigation was the determination of optimum operating conditions for three popular oscillator circuits using the new type of crystals in conjunction with any one of four popular oscillator tubes. The circuits tested were the grid-plate, the Tri-tet, and the modified Pierce and the tubes were the Types 6AG7, 6F6, 6V6GT and 6L6. The operating characteristics sought after were good keying, low crystal current, reduction in the frequency shift normally caused by tuning of the plate circuit, and moderate power output at the fundamental and the harmonic frequencies.

For clarification it should be stated that good keying in this instance means a keyed signal free from chirp and that power output does not mean maximum obtainable power. In these tests power output was secondary to keying and frequency shift, and no attempt was made to generate more power than would be required to drive another receiving-type tube or a low-power transmitting tube such as the 807. During the test the 6L6 was operated at a higher input than the other three types of tubes but this was done to permit study of the crystals in a power circuit — not as an attempt to increase output.

The Test Equipment

The test equipment consisted of d.c. meters for measuring power input and oscillator output, two

* Technical Assistant, *QST*.

¹ Lamb, "A Practical Survey of Pentode and Beam Tube Crystal Oscillators for Fundamental and Second Harmonic Output," *QST*, April, 1937.

² Goodman, "Keying the Crystal Oscillator," *QST*, May, 1941.

receivers, a frequency standard, an audio oscillator, an oscilloscope and, last but not least, a pair of 60-ma. pilot lamps. One of the receivers was used for monitoring the output signal of the oscillator and the second receiver was used in conjunction with the 'scope, the audio oscillator and the frequency standard to provide means of measuring the frequency shift. One pilot lamp, connected as shown in Fig. 1, was used to measure crystal current. During test runs, the brilliance of this lamp was compared with that of the second lamp which was in turn connected in a circuit consisting of a battery, a meter and a potentiometer. Inasmuch as the filaments of 60-ma. bulbs do not become incandescent with a current of less than 30 ma., the performance curves of the oscillators do not show crystal currents less than this value. Fortunately, these unmeasurable currents are *safe* currents.

The Test Unit

In the test unit all values of C , R and L were made variable so that optimum circuit values could be readily determined. A Type 807, connected as shown in Fig. 1A, was used as the oscillator load. The tube load allowed study of the keying and the other characteristics of the oscillators under normal working conditions. Incidentally, output data for the oscillators are expressed in terms of rectified current measured at the grid of the 807. Dials for the feed-back condensers were calibrated in terms of capacitance and the plate-circuit control was calibrated in terms of frequency. These calibrations permitted rapid logging of the circuit values for different sets of operating adjustments.

Input to the Types 6AG7, 6F6 and 6V6GT was approximately 5 watts in all cases and the input to the 6L6 was around 10 watts. The output of the plate supply was controlled by a Variac and the screen voltage for the tubes was held constant by a VR-150 regulator tube.

It was decided at an early stage of the game to make the keying, frequency-shift, crystal-current and power-output measurements with 7-Mc. crystals providing the fundamental frequencies. It was felt that the 7-Mc. crystals might be a little more tricky to handle than the 3.5-Mc. crystals and we wanted to make the tests as conclusive as possible. However, 3.5-Mc. crystals were used for obtaining the harmonic data because more reliable checks could be made in the

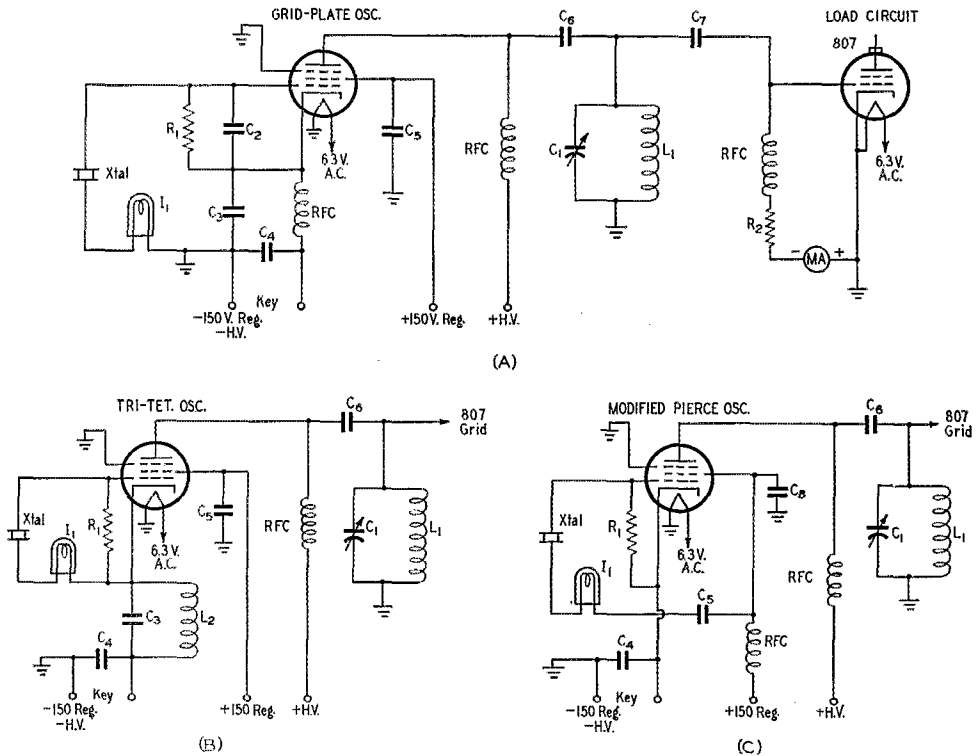

Fig. 1 — Circuit diagrams of the crystal oscillators.

- C₁ — 250- μ fd. variable.
- C₂, C₃, C₅ — Feed-back control condensers (see text and Figs. 2, 3, 4 and 5).
- C₄, C₅, C₆ — 0.005 mica.
- C₇ — 100- μ fd. mica.
- R₁ — 0.1 megohm, $\frac{1}{2}$ watt.
- R₂ — 15,000 ohms, 10 watts.

- L₁, C₁ — Tuned to crystal frequency or desired harmonic.
- L₂, C₃ — Tuned above crystal frequency (see text).
- I₁ — 60-ma. pilot lamp.
- MA — Grid-current milliammeter.
- RFC — 2.5-mh. r.f. choke.

range up to 14 Mc. than could be made if the range extended up to 28 Mc.

As work progressed a set of fixed circuit values was arrived at and these values appear in the parts list of Fig. 1. The values apply to all three circuits and are optimum for good keying, minimum frequency shift and output at the fundamental and the harmonic frequencies. Circuit values that apply to a single circuit are listed along with the performance curves of Figs. 2, 3, 4 and 5.

General Conclusions

The results of the oscillator tests are best presented by the curves of Figs. 2 to 5, inclusive. However, additional data of a general nature apply to all three circuits and this material will be covered before the individual circuits are discussed.

The circuit diagrams of Fig. 1 show the use of regulated screen voltage. (Actually, it might be more correct to say regulated plate voltage be-

cause the screen grid serves as the oscillator plate in each of the circuits shown.) The value of this voltage, 150 volts, was determined by the oscillator output when a 250-volt plate supply was used. Lower screen voltages reduced the output and higher voltages contributed nothing more than an increase in crystal current. The regulated screen voltage has two desirable effects: it provides a noticeable improvement in keying and makes the power output of the oscillator more independent of plate voltage. Cathode current of a screen-grid tube is largely controlled by the screen voltage, and with this voltage held constant there is less change in plate current as the plate voltage is swung around a given value. With the test circuits shown it was possible, by means of the Variac, to swing the plate voltage approximately 100 volts above and below the regular value without affecting keying, frequency shift or output to any significant extent.

The output from each of the circuits was greatest when a low-C plate tank was used. This fea-

ture is of particular interest when harmonic output has importance. Usually, it is desirable to obtain nearly equal output at the fundamental and the second-harmonic frequencies and this condition cannot be obtained with a low- C tank circuit at both frequencies. However, a single tank circuit that can be tuned over two bands will give the desired effect, because the resulting high- C at the fundamental reduces the output at that frequency, a condition that usually can be tolerated. In one series of tests, when separate plate coils were used for each band, oscillator output at the fundamental frequency was nearly twice that obtained at the second harmonic. Changing over to a two-band tank lowered the output (expressed in terms of 807 grid current) from 12 to 9.8 ma. at the fundamental but in-

creased the second-harmonic output from 6.3 to 8.2 ma.

A high value of grid-leak resistance was selected for the following reasons: (1) better keying as indicated by less chirp, (2) less crystal current, (3) a reduction in d.c. input (less cathode current) without affecting plate-circuit output, (4) it eliminated the need for the customary grid-circuit r.f. choke. The resistance can be lowered to approximately 50,000 ohms before grid loading becomes great enough to warrant use of a choke.

Plate-circuit keying of the oscillators proved to be slightly less chirpy than did straight cathode keying. Plate-circuit keying is accomplished by returning the grid leak to cathode rather than to ground. This arrangement has one disadvantage in that the key is hot with $B+$ when the circuit is open. Anyone interested in experimenting with other types of oscillator keying should study the article by Goodman.²

Although a lamp bulb connected as shown in Fig. 1 serves well as a crystal-current indicating device, it should not be used as a permanent part of a keyed oscillator circuit. The resistance of a lamp varies as the current through the lamp is increased or decreased by, for instance, keying. This variable resistance affects the activity of the crystal as indicated by a chirp that can be eliminated only by removing the bulb from the circuit.

The Grid-Plate Oscillator

Circuit A of Fig. 1 is different from the grid-plate circuit shown in the *Handbook* only in that it includes an external feed-back condenser, C_2 , between the grid and the cathode of the tube. This condenser and C_3 form a voltage divider across the crystal and by adjusting the ratio of the two capacitances it is possible to control the feed-back.

Operation of a circuit with both optimum and improper feed-back is shown by the curves of Figs. 2 and 3. Fig. 2, showing optimum operation, indicates that low crystal current, minimum frequency shift and maximum output are obtained with a low value of C_2 and a fairly large value of C_3 . This same capacity ratio results in maximum harmonic output and clean keying.

With a really active crystal working along with a Type 6AG7 tube, it is possible to depend on the grid-cathode capacitance of the tube as the grid-cathode section of the feed-back divider. However, an external condenser—a 15- $\mu\text{fd.}$ variable would be best—will permit optimum adjustment for all grades of crystals.

Study of Fig. 2 will show that the Types 6F6, 6V6GT and 6L6—all popular oscillator tubes—do not compare favorably with the 6AG7. It will be noticed that the feed-back requirements (a lower ratio between C_2 and C_3) are greater, that the crystal current is higher and that the tubes oscillate only when the plate circuit is tuned

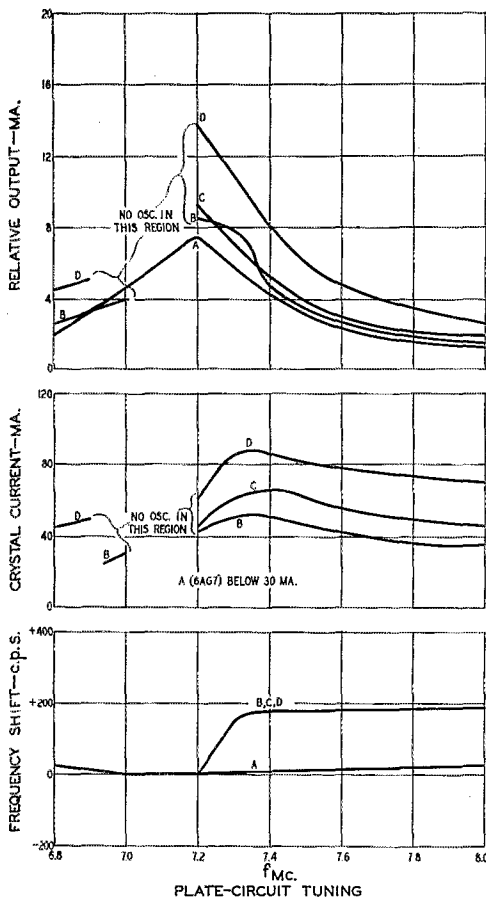

Fig. 2—Showing crystal current, relative output and frequency shift of the grid-plate oscillator when optimum circuit adjustments are made. Curves A, B, C and D are for the Types 6AG7, 6F6, 6V6GT and 6L6, respectively. Critical circuit values for the 6AG7 are: $C_2 = 10 \mu\text{fd.}$; $C_3 = 220 \mu\text{fd.}$ C_2 and C_3 for the other tubes are 25 and 100 $\mu\text{fd.}$, respectively.

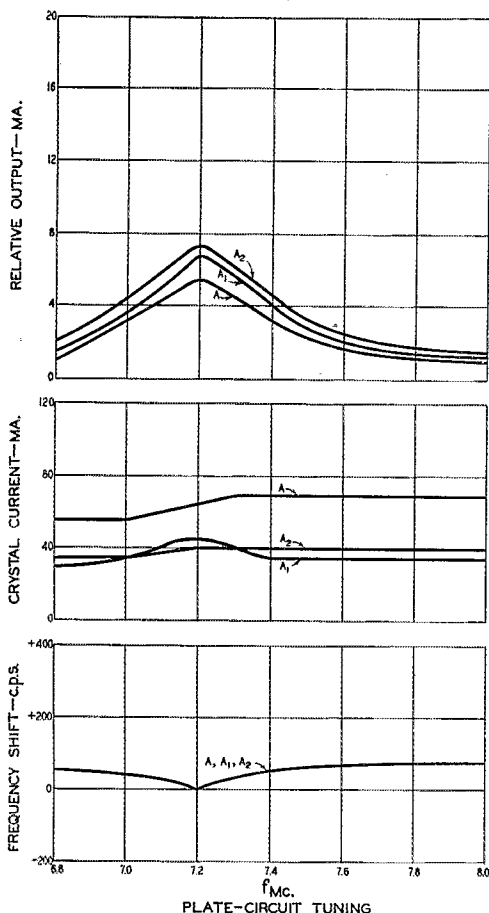

Fig. 3 — Curves showing the effect on the operating characteristics of a 6AG7 grid-plate oscillator when the feedback is not optimum. The excessive crystal current and increased frequency shift also occur in the other circuits under similar conditions. Feed-back capacitance values associated with the three curves are:

- A — $C_2 = 75 \mu\text{fd.}; C_3 = 10 \mu\text{fd.}$
- A₁ — $C_2 = 75 \mu\text{fd.}; C_3 = 220 \mu\text{fd.}$
- A₂ — $C_2 = 10 \mu\text{fd.}; C_3 = 10 \mu\text{fd.}$

to the high side of resonance. Furthermore, as shown by Fig. 2, the plate-circuit tuning has considerable control over crystal current, frequency shift and, naturally, power output. All of this means that tuning to the high side of resonance gets to be a delicate operation.

The curves of Fig. 2, by showing how the frequency is pulled as the plate tanks for the various tubes are tuned through resonance, clearly demonstrates the superior isolation qualities of the 6AG7 as compared with that of the other three tubes.

The harmonic-generating capabilities of the grid-plate oscillator are listed with those of the Tri-tet and the modified Pierce in Table I.

By using optimum feed-back along with a 6AG7, it is possible to obtain good keying of the grid-plate oscillator when the plate circuit is tuned to resonance (maximum output) at either the fundamental or the harmonic frequencies of the crystal. The Types 6F6 and 6V6GT can be made to key well only by careful adjustment of the feed-back condensers and, because of its part in feed-back control, the plate circuit. No set of operating conditions which permitted good keying of the Type 6L6 in a high-power set-up could be found and there is no reason to believe that this tube can be made to key any better than the Types 6F6 and 6V6GT even when the input is reduced to a lower level.

The Tri-Tet Oscillator

The circuit diagram of the Tri-tet oscillator appears as section B of Fig. 1. The general performance of the Tri-tet, shown by the curves of Fig. 4, is quite similar to that of the grid-plate circuit. The Tri-tet does offer slightly more output at the fundamental and the second-harmonic frequencies. The power-output chart shows that the Tri-tet gives more third-harmonic output than does the grid-plate circuit when Type 6AG7 or 6L6 tubes are used. Regardless of the tube used (any one of the four tested) the Tri-tet does the best job at the fourth harmonic.

A comparison of the curves of Figs. 2 and 4 is interesting because it shows that although the output of the Tri-tet is greater than that of the grid-plate circuit, the crystal current is lower. The one exception to this rule is caused by the use of a Type 6AG7 in which case the Tri-tet still gives the most output but at a higher crystal current than the other circuit.

Considerable time was spent working with the cathode circuit of the Tri-tet oscillator and the conclusions reached are as follows: (1) A high-C circuit is best from the standpoint of both crystal current and output. (2) The circuit should be tuned to a frequency somewhere between the

TABLE I

Harmonic	Relative Harmonic Output — Ma.			Tube
	Grid-Plate	Tri-Tet	Mod. Pierce	
2nd	5.6	8.2	6.6	6AG7
3rd	3.2	4.3	4.1	
4th	1.3	2.0	1.2	
2nd	6.6	8.5	see text	6F6
3rd	3.0	2.3		
4th	0.	1.2		
2nd	7.0	8.2	see text	6V6GT
3rd	2.8	2.6		
4th	1.2	1.5		
2nd	12.5	16.0	see text	6L6
3rd	5.5	13.4		
4th	2.8	6.0		

fundamental and the second-harmonic frequencies. (3) A fixed tuned circuit is a practical as well as a convenient arrangement to use for output at both the fundamental and the harmonic frequencies.

By a high- C circuit we mean one that employs approximately 250 $\mu\text{fd.}$ when tuned for operation with 3.5-Mc. crystals. A value of 150 $\mu\text{fd.}$ is suitable for use with 7-Mc. crystals.

The frequency at which the cathode circuit should be tuned was determined by a series of test runs made while using a variable-frequency circuit. These tests seemed to indicate that with some tubes it is advisable to tune the cathode slightly above the crystal frequency and that other tubes operate best with the cathode tuned to the second or even the third harmonic. However, an r.f. indicator coupled to the plate tank showed that maximum output at the fundamental and the harmonic frequencies was ob-

tained with the cathode tuned approximately midway between the fundamental and the second-harmonic frequencies. Output at the crystal frequency will have high harmonic content if the cathode is tuned near any one of the harmonics. When the plate tank was adjusted to a harmonic frequency, it was not possible to increase output by retuning the cathode to a higher frequency nor did the r.f. indicator show an excessive amount of fundamental present in the output.

There does not appear to be a *spot* frequency (for a particular crystal) to which the cathode must be tuned. If, however, the circuit is made variable to facilitate maximum power output over a wide range of crystal frequencies, it should not be capable of tuning down to the crystal frequency. This adjustment results in excessive feed-back which, in turn, causes dangerously high crystal current, frequency creeping and reduced output. Tubes other than the Type 6AG7 won't even start to oscillate consistently with the cathode set too close to the crystal frequency.

Tuning of the plate circuit of the Tri-tet oscillator using a Type 6AG7 tube causes slightly less frequency shift than does the tuning of a grid-plate circuit using the same tube. A comparison of Figs. 2 and 4 proves this point and also shows equivalent frequency-shift curves for the two circuits when the Types 6F6, 6V6GT and 6L6 are employed. Also pointed out by Fig. 4 is the fact that the plate circuit of the Tri-tet must be tuned to the high side of resonance when tubes other than the 6AG7 are used. From these curves it is also obvious that plate-tank tuning has an effect on feed-back.

Some frequency shift does occur when the cathode circuit of a Tri-tet is tuned in the vicinity of the fundamental or the harmonic frequencies. This information is not presented in curve form because it represents an improper circuit adjustment which should be avoided.

Use of the Type 6AG7 tube in a Tri-tet oscillator assures keying free from chirp even when the plate tank is adjusted for maximum output, and frequency shift is almost negligible with this arrangement. Types 6F6 and 6V6GT key well only at the expense of reduced output, because of the necessity for tuning the plate tank off resonance. There is no set of circuit adjustments which permits chirp-free keying of the high-power 6L6 circuit.

The Modified-Pierce Oscillator

The circuit diagram of the modified-Pierce oscillator is given in Fig. 1C. Ordinarily, variation in screen voltage provides the primary means of adjusting feed-back in this circuit. However, if regulated screen voltage is to be employed in the interests of good keying, it is necessary to find another method of regulating the feed-back. This can be accomplished by adding a fixed capacity, C_3 of Fig. 1C, between screen grid and ground.

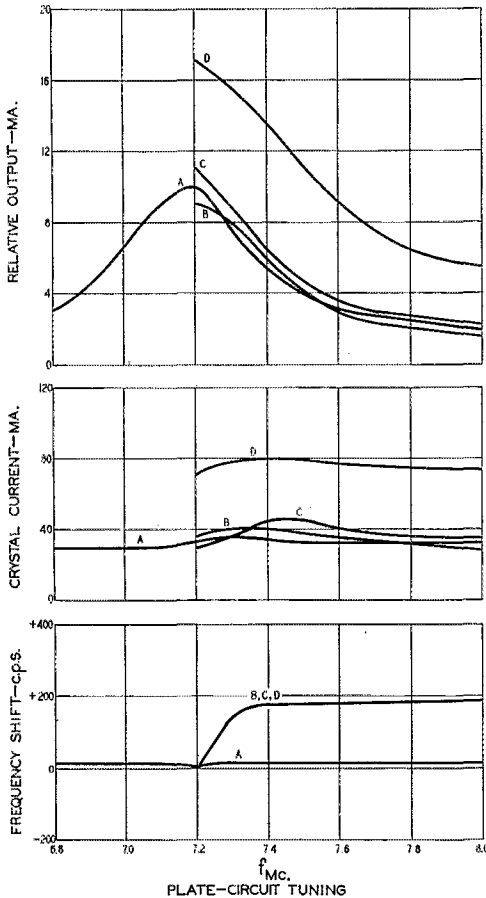

Fig. 4— Performance curves for the Tri-tet oscillator. See text for critical circuit values. A, B, C and D refer to the 6AG7, 6F6, 6V6GT and 6L6, respectively.

Each type of tube requires a fairly critical value of external feed-back capacitance, and optimum values for the four tubes tested are listed under the performance curves for the oscillator.

Addition of the external feed-back control to a 6AG7 modified-Pierce circuit raised the relative output at the fundamental from 6.4 to 9.8 ma. without making any measurable increase in crystal current or without increasing the frequency shift caused by plate tank tuning.

Curves of the relative output and of the frequency shift caused by plate-circuit adjustment are given in Fig. 5. Crystal current curves are missing in this case because they were always below the measurable value of 30 ma.

The operational curves show an interesting trait of the modified-Pierce oscillator. Although the 6AG7 reacts to plate circuit tuning just as it does in the other two circuits, the other three tubes require that the plate tank be adjusted to the *low-frequency* side of resonance when 7-Mc. crystals are used. Not shown by the curves is the fact that these same tubes require a plate-circuit adjustment on the high side of resonance when 3.5-Mc. crystals are used. This is possibly due to a change in feed-back conditions as the frequency of operation is increased. In any event, we have learned that the plate-tank of the Pierce circuit requires the same careful tuning as the plate circuit of the other oscillators.

Harmonic output data for the Type 6AG7 tube operated in the Pierce circuit are listed in Table I. Harmonic output delivered by the other three tubes was so low as to be of no practical use and, as a result, the output figures are not listed. As a matter of fact, some of the tubes would not oscillate when the plate tank was tuned very far off the fundamental frequency.

In conclusion, we can say that the modified-Pierce oscillator is a simple, practical circuit so long as the Type 6AG7 tube is used. With this tube, it will key well when adjusted for maximum output and the harmonic output capabilities are comparable with the other two circuits. Use of the modified-Pierce in conjunction with Types 6F6, 6V6GT and 6L6 is not recommended if either good keying or harmonic output are design considerations.

Summary

In summary, the following should be considered in the selection of any one of the three circuits discussed above:

- 1) Regardless of the circuit selection, use regulated screen voltage if good keying is desired.
- 2) Of the four tubes tested, the 6AG7 is by far the best from every standpoint.
- 3) The Tri-tet oscillator gives the most output (at both the fundamental and harmonic frequencies). The modified Pierce is second in this respect, so long as a Type 6AG7 tube is used.
- 4) The modified-Pierce circuit is easiest on the

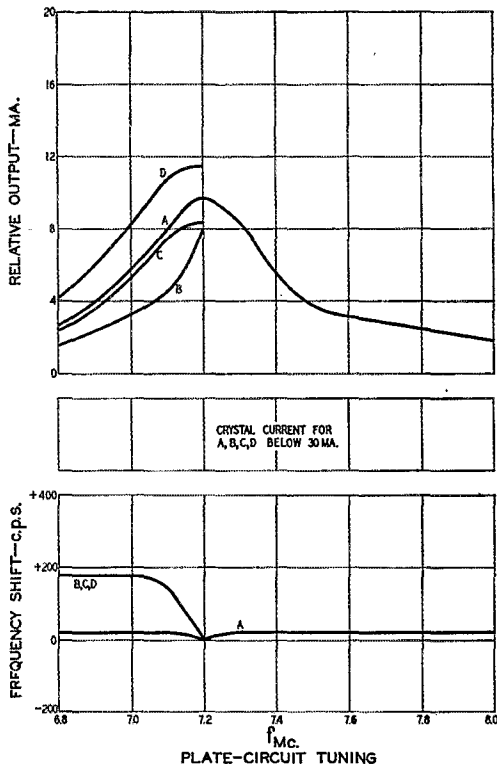

Fig. 5 — Crystal-current, frequency-shift and output data for the modified-Pierce oscillator. Feed-back capacitances (C_s) for the various tubes are: 6AG7 = 220 $\mu\text{fd.}$; 6F6 = 40 $\mu\text{fd.}$; 6V6GT = 50 $\mu\text{fd.}$; 6L6 = 60 $\mu\text{fd.}$

crystals and, except when a 6AG7 is used, the grid-plate oscillator operates with the highest crystal current.

5) With a tube other than the 6AG7 in use, it is not advisable to tune any of the oscillators for maximum output because a slight change in circuit conditions may cause frequency shift.

6) Plate-circuit keying of the circuits results in less chirp than does the use of straight cathode keying.

7) Remember — the use of a crystal doesn't automatically assure a good sounding note. But the crystal is willing to do its part — if you'll give it the chance.



W1AGM and W4GJW report that their directory of doctor and dentist radio amateurs is rapidly taking shape. If you are a U. S. or foreign amateur engaged in these professions and haven't already done so, you are requested to communicate with W4GJW, Dr. Arthur W. Woods, Woodward Building, Birmingham, Ala., before the directory's deadline of May 1st.

A 2-Meter Station for the Novice

Part II—The Transmitter R.F. Section

BY EDWARD P. TILTON,* WIHDQ

[This is the second in a series of three articles describing a 2-meter station especially for the beginner. The receiving equipment, Part I, appeared in February QST. The concluding installment, dealing with the modulator, power supply, and control circuits, will appear in a subsequent issue.]

WHEN the 144-Mc. band was released for amateur occupancy in the fall of 1945, replacing the former assignment at 112 Mc., most of the early activity in the new band was carried on with simple equipment of the modulated-oscillator variety left over from the prewar period. When equipment such as the SCR-522, the ARC-5, and other wartime communications gear appeared on the surplus market soon after, it afforded an excellent opportunity to make the change from the simple but inefficient equipment of the prewar era to the crystal-control and superhet-receiver techniques now employed for practically all 2-meter work.

The war-surplus gear was available in tremendous quantities at ridiculously low prices, and literally hundreds of v.h.f. beginners cut their 2-meter teeth on the 522. Having thus standardized on improved techniques the way was opened for a considerable expansion of 2-meter operating ranges and an elevation of the 2-meter band to the status of a major amateur operating field.

Though there are still countless surplus rigs on the air on 144 Mc., the supply of them for sale

* V. H. F. Editor, QST.

has been largely exhausted, and today's beginner in the 2-meter field will very likely find it advantageous, if not absolutely necessary, to build his own. Useful though it was, the surplus gear is not the most efficient means of generating a 2-meter signal, and duplication of it, with other than surplus components, would be an extremely expensive undertaking. Thus there is a considerable need for a 2-meter design that will provide a stable signal with a minimum of complication. The transmitter described herewith was built with these considerations in mind. It is capable of about the same power output as the 522 and other war-surplus rigs, yet it is much simpler in design and lower in duplication cost. A single low-cost tube type, the 6J6, is used throughout, and the components are all standard parts that should be obtainable readily in almost any location. The circuit is straightforward and adjustments are not particularly difficult.

Electrical and Mechanical Details

As is often the case with such equipment, the circuit diagram, Fig. 3, looks more complicated than does the equipment itself, but if we take it stage by stage we should not find it hard to follow. The first 6J6 is used as a combination of crystal oscillator and frequency doubler. The first triode section is a regenerative crystal oscillator of noncritical design, the regeneration being added to insure quick crystal starting and adequate power output from the oscillator sec-

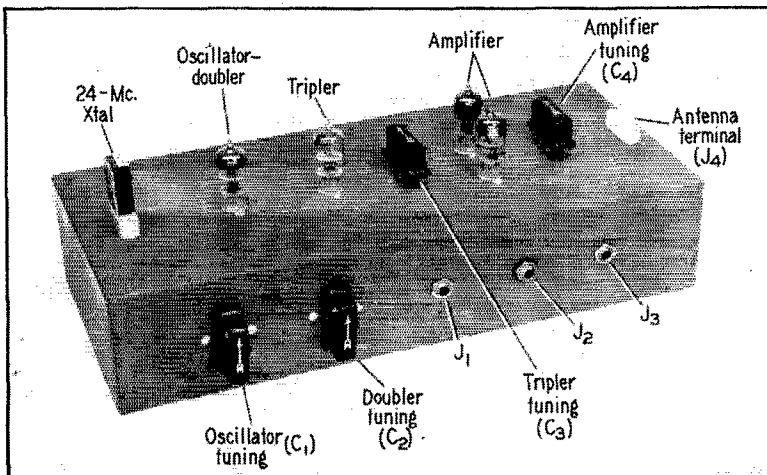

◆
Top view of the 2-meter transmitter. 6J6 tubes are used throughout, the two in the output stage being connected in push-pull-parallel.
◆

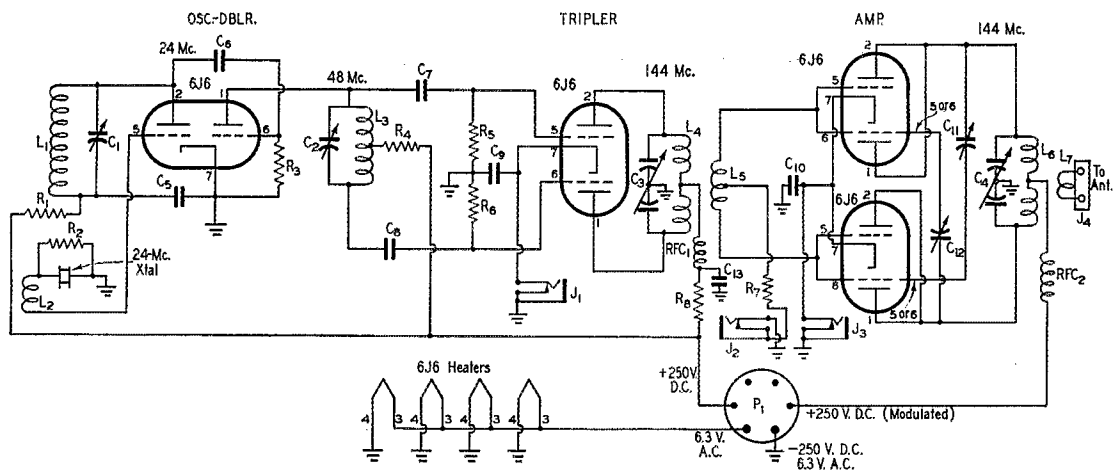

Fig. 3 — Wiring diagram of the 2-meter r.f. unit.

- C₁ — 50- μ fd. midget variable (Millen 20050).
- C₂ — 15- μ fd. midget variable (Millen 20015).
- C₃, C₄ — 6- μ fd. butterfly-type variable (Cardwell ER-6-BFS).
- C₅, C₉, C₁₀, C₁₃ — 0.005- μ fd. disc-type ceramic (Sprague 29C-4).
- C₆ — 27- μ fd. ceramic or mica.
- C₇, C₈ — 47- μ fd. ceramic or mica.
- C₁₁, C₁₂ — 3-30 μ fd. mica trimmer (Millen 40001-2).
- R₁ — 3300 ohms, 1 watt.
- R₂, R₃ — 6800 ohms, $\frac{1}{2}$ watt.
- R₄ — 2200 ohms, 1 watt.
- R₅, R₆ — 33,000 ohms, $\frac{1}{2}$ watt.
- R₇ — 2700 ohms, $\frac{1}{2}$ watt.
- R₈ — 1000 ohms, 1 watt.
- L₁ — 18 turns B & W Miniductor No. 3003.
- L₂ — 3 turns of above. L₁ and L₂ made from a single coil — see text and photograph.

- L₃ — 15 turns B & W Miniductor No. 3003, center-tapped.
- L₄ — 3 turns each side of center tap, No. 14 enamel, $\frac{1}{2}$ -inch inside diameter, turns spaced half wire diameter. Leave $\frac{3}{8}$ -inch space at center for L₅.
- L₅ — 3 turns No. 18 enamel, $\frac{1}{2}$ -inch diameter, spaced wire diameter, center-tapped.
- L₆ — One turn each side of center, $\frac{7}{8}$ -inch diameter, No. 14 enamel. Leave $\frac{3}{8}$ -inch space at center for L₇.
- L₇ — 2 turns No. 14 enamel, $\frac{7}{8}$ -inch diameter, spaced wire diameter.
- J₁, J₂, J₃ — Closed-circuit jack. (J₂ insulated from chassis.)
- J₄ — Antenna terminal — crystal socket (Millen 33102).
- P₁ — 6-prong retainer-ring plug (Amphenol 86-CP-6).
- RFC₁, RFC₂ — No. 24 enameled wire close-wound on 1-watt resistor, or Ohmite Z-14 r.f. choke.

tion.¹ The crystal is a 24-Mc. harmonic-type unit. Output is capacity coupled into the second section, which acts as a doubler to 48 Mc.

The second plate circuit is double-ended, permitting the use of capacity coupling to the grids of a second 6J6 operating as a push-pull tripler to 144 Mc. The output of the tripler is inductively coupled to the grids of a pair of 6J6s connected in push-pull-parallel and operating as a neutralized amplifier on 144 Mc. A single 6J6 could be used, but the arrangement shown gives somewhat more output and results in longer tube life than would be the case if a single tube were used and run at maximum ratings. Closed-circuit jacks are included in the cathode circuits of the tripler and final stages and in the grid circuit of the final, to permit metering these stages during the adjustment process. Note that J₂ (final grid current) is insulated from the chassis by bakelite washers. This is done to avoid the necessity for reversing meter connections.

Looking at the front-view photograph we see the crystal at the left, followed by the oscillator-

doubler, tripler, and final tubes, in that order. The two knobs on the front wall of the chassis are the controls for the oscillator and doubler plate tuning condensers, C₁ and C₂. The knobs on the top of the chassis are on the shafts of the tripler plate condenser, C₃, and the final tuning condenser, C₄. The jacks are spaced along the front wall, and the antenna terminal (a standard crystal socket) is at the far right. Identification of the components in the bottom view follows in the same order, and the arrangement of the coils and other smaller parts is fairly obvious.

Detailed layout drawings are given so that the constructor can make an exact duplicate if he wishes to do so, provided he has parts that are the same as those used in the original. Much of the construction is not critical, however, and parts that are not mechanical duplicates of the original can be used with good results. Lead lengths are important in the 144-Mc. circuits, however, and the general arrangement of the parts in the tripler and final circuits should be followed closely. The chassis used is larger than is really necessary, but it gives plenty of room to work and results in a neat-looking and accessible layout.

¹ For an explanation of the operation of the regenerative crystal-oscillator circuit used, see "V.H.F. Crystal Oscillators," Sells, Nov., 1947, QST, p. 44.

Coil leads and other r.f.-carrying wires should be as short and direct as possible. Other wiring (power leads) may be arranged to suit one's fancy. Ready-wound coils made from B & W Miniductor are used for L_1 , L_2 and L_3 . The others are wound by hand, of enameled wire. L_1 and L_2 are made from a single piece of Miniductor having 23 turns, with about two inches left at each end for leads. The wire is then cut at the fourth turn in from the end, and one turn is unwound in each direction from the cut. This leaves 18 turns for L_1 and 3 turns for L_2 , and takes care of the proper spacing between the two windings. This spacing is fairly critical, as it controls the amount of regeneration,⁴ but the correct adjustment is assured if the method of making L_1 and L_2 outlined above is followed.

Spacing between the tripler plate coil, L_4 , and the amplifier grid coil, L_5 , is also important, and L_5 should be mounted so that it may be moved into or out of the space at the center of L_4 , as explained in the adjustment procedure. The same is true of L_6 and L_7 .

Variable condensers C_1 and C_2 are mounted on half-inch spacers, to bring their terminals out toward the middle of the chassis and reduce lead length. The rotors are ungrounded, so care should be taken in mounting the condensers to see that there is adequate clearance around the shafts. Also, it should be noted in this connection that

knobs made of insulating material should be used, as there is B-plus on the rotors. The butterfly-type variables used in the tripler and final plate circuits have their rotors grounded to the chassis.

Adjustment and Testing

The power supply to be used for testing the transmitter unit should be capable of delivering 150 to 250 volts d.c. at 100 ma. or more, and 6.3 volts a.c. at about 2 amperes. A power supply capable of handling the transmitter, receiver and modulator unit will be described in a subsequent issue, but for test purposes almost anything that delivers 250 volts or less may be used. Initial checks may be made with 150 volts without worrying about harming the tubes if adjustments are not made correctly, so it may be desirable to connect a 2000-ohm 10-watt resistor in series with the plate supply, if 250 volts is used. This may be shorted out when the adjustments are completed or when a check under full voltage is desired.

Throughout the test procedure the 6J6 plates should be watched closely for signs of overheating. If there is any tendency to show red on the plates the equipment should be turned off at once, as the 6J6s will not stand excessive plate dissipation for long. Reduce the plate voltage, if necessary, before continuing. This may be done

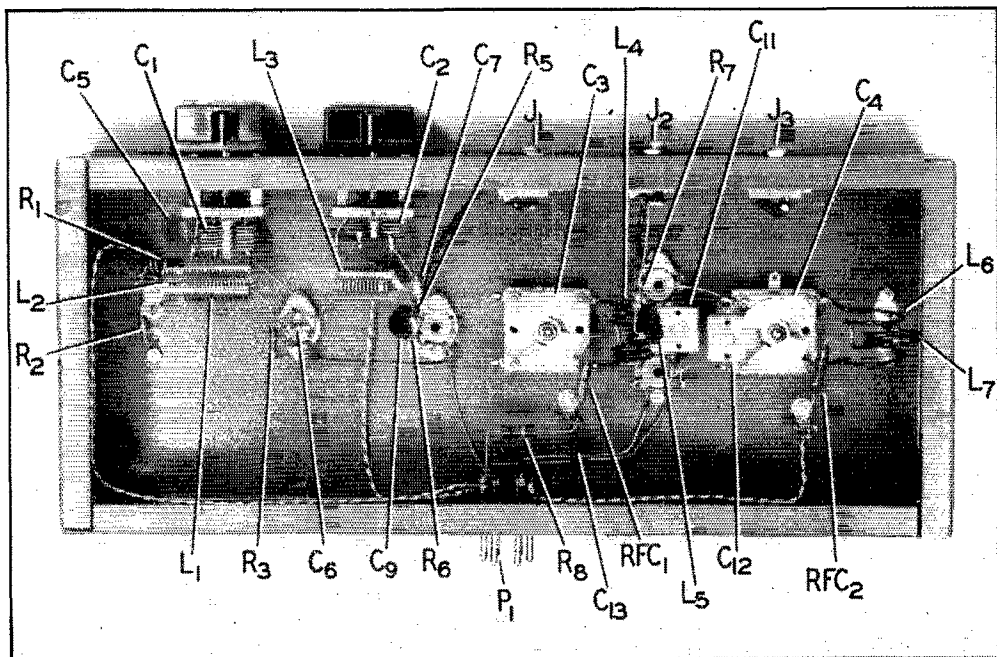

Under the chassis of the simple 2-meter transmitter. Components are spaced out for easy assembly and adjustment. Two parts do not show in the photograph. They are C_8 and R_4 , out of sight under the doubler plate coil, L_4 .

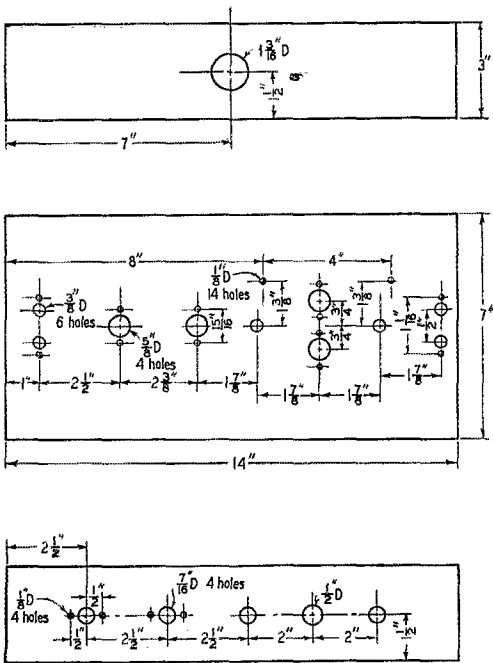

Fig. 4 — Layout drawing of the chassis for the 2-meter transmitter. The large view is looking down at the top of the chassis, with the front wall below and the rear wall above.

by using a series resistor larger than 2000 ohms in the power lead. Do *not* apply heater and plate voltages simultaneously; it will ruin the 6J6s in short order. Be sure that the tubes are fully warmed up before applying plate voltage.

Operation of the oscillator should be checked first, and this may be done by applying plate voltage to the first 6J6 section only, at R_1 , disconnecting the other B-plus leads. Connect a meter (0-50 or 0-100 ma.) in series with R_1 , and rotate C_1 with plate voltage applied. If the oscillator works correctly there will be a dip in plate current as the oscillator starts, with maximum output occurring near the point where the current is lowest. If a calibrated receiver capable of tuning to 24, 48 or 144 Mc. is available, listen to the quality of the oscillator note with the receiver b.f.o. on. It should be a clear, musical note, and the frequency should change only slightly as C_1 is adjusted. If there is a continuous change in frequency, or if the note is rough, the oscillation is probably not being controlled by the crystal. There should be no trouble on this score if the details given for layout and coil dimensions are followed closely. Monitoring may be done with the converter described in Part I of this series.

The crystal should be for a frequency between 24 and 24.66 Mc., for operation between 144 and 148 Mc. Harmonic- or overtone-type crystals

in this range are now available from most crystal manufacturers. The one used in the original model is a Valpey CM-5. Another is the Bliley AX-3. These crystals, and recent products of other manufacturers, are quite stable. Some harmonic-type crystals made prior to 1948 may, however, be rather unstable, particularly if the crystal current is high. Otherwise they should work about the same as the newer types in this circuit.

Some sort of r.f. output indicator will be needed from here on. The simplest is made by soldering a one- or two-turn loop of insulated wire to the terminals of a 2-volt 60-ma. pilot lamp. When this loop is held close to a circuit carrying r.f. the lamp will glow. With 150 volts applied to the stages in this transmitter it should be possible to get some visible indication when the circuits are properly tuned. With higher voltages care should be used in coupling the loop to circuits, as the 60-ma. bulb can be burned out very quickly if it is lighted to more than normal brilliance.

Maximum output will also be nearly coincidental with minimum plate current, but maximum grid current in the stage following the one under test is the best indication. The pilot lamp method may detune the stage somewhat so it is useful principally as a check to see if the stage is working, rather than as an exact indicator of resonance. If a low-range milliammeter (0-10 ma. or so) is available, it may be connected between R_3 and ground, to measure the grid current in the second 6J6 triode section to check the tuning of C_1 .

When the oscillator is working properly, apply plate voltage to the doubler, through R_4 , and adjust C_2 for maximum output as indicated in the 6J6 tripler stage. This can be measured in J_1 , if *no plate voltage* is applied to the stage through R_5C_1 . Next apply plate voltage to the tripler, through the r.f. choke, and adjust C_3 for maximum output, as indicated by the pilot lamp coupled to L_4 . The bulb should glow brightly if 200 volts or more is used on the plates of the tripler stage.

Now plug a milliammeter (0 to 10, or more) into J_2 and check the grid current to the final stage. Adjust the position of L_5 with respect to L_4 , retuning C_3 carefully each time the coupling between these coils is changed. The position of L_5 will be found to be quite critical, and it should be set at the point that gives maximum grid current in the final stage, though the exact position need not be found at this stage of the game.

Before plate voltage is applied to the final stage, it must be neutralized. Because it is a triode amplifier there is sufficient feed-back through the grid-plate capacitance of the tubes so that the stage will oscillate unless this grid-plate feed-back is neutralized. So, we feed some voltage of opposite phase back from plate to

grid, through the neutralizing condensers, C_{11} and C_{12} . These are the small mica or ceramic trimmers that can be seen in the bottom-view photograph, between the tube sockets and the final tuning condenser.

If mica padders are used, as in the original, they should be screwed down tight and then opened slowly, an equal amount on each side, until turning C_4 produces no change in grid current as the circuit is tuned through resonance. This check is made *without* plate voltage on the final. If the stage is not correctly neutralized there will be a sharp downward dip in the grid current as resonance is reached. There may be just a perceptible rise in grid current at resonance, but there should be no downward dip whatever.

When this condition is obtained plate voltage may be applied and C_4 tuned for maximum output, as indicated by a lamp connected across the antenna terminals. Two short pieces of wire can be soldered to the terminals of a 10- or 15-watt lamp, and this used as a dummy load by plugging into J_4 . With full voltage (250 volts) a 10-watt lamp should show nearly full brilliance, and a 15-watt bulb will glow a bright yellow.

Thus far we have purposely said nothing about the current values that should be obtained in the various stages, as it has been assumed that the tests outlined would be conducted with voltages somewhat below normal, in the interest of safety, in case some portion of the rig might not be working correctly. Now we are ready for a final adjustment, for normal operating conditions. A maximum of 250 volts should be used for all stages and the adjustments checked to see that they are at optimum all the way along the line. If everything is working correctly the readings should be something like this: oscillator plate current 12 ma., measured in series with R_1 ; doubler plate current 16 ma., measured in series with R_4 ; tripler cathode current 30 ma., measured in J_1 ; final grid current 12 ma., measured in J_2 ; final cathode current 55 ma., measured in J_3 . Of this final cathode current, only 43 ma. (cathode current minus grid current) is plate current, and that figure multiplied by the plate voltage gives the final-stage input. It should be around 10 watts, with the power supply to be described in Part III, and not more than 15 watts under any condition. This is well within the ratings for the 6J6s, yet is enough power to have a lot of fun on 144 Mc. The output will be about equal to that of most war-surplus rigs that take a lot more power supply, and the signal will be stable and of good quality.

Better still, the unit we've just described is fine for use as an exciter for another amplifier, if you decide to go to higher power later on. With 200 volts or so on the plates, and a total drain of less than 100 ma., the output will be more than enough to drive an 829 amplifier capable of an

input of 100 watts or so. We will have found out more about how transmitters operate than could have been learned with a piece of converted surplus, or a ready-made commercial rig, and we won't have wasted a penny when the time comes to increase power later on.

Let no one think that a rig of such power is incapable of working out. During the Third Annual V.H.F. Sweepstakes the complete station (see the composite photograph in Part I) was given an intensive workout by WIICP, West Hartford. Though only a temporary indoor folded-dipole antenna was used, 33 stations were worked on 144 Mc., with good reports being received at distances of 40 miles or more.

BOOK REVIEW

Reference Data for Radio Engineers, third edition, by members of the staff of the Federal Telephone and Radio Corporation and associates, edited by F. J. Mann. 640 pages plus index, $5\frac{1}{2} \times 8\frac{1}{2}$ inches. Published 1949 by the Federal Telephone and Radio Corp., 67 Broad St., New York 4, N. Y. Price \$3.00.

The new edition of *Reference Data* has almost exactly twice the number of pages contained in its predecessor — a fact which, as much as anything could, indicates the wealth of new material that has been added. There is hardly a subject that has not had its share of revision and expansion. Of those treated in earlier editions, the most comprehensive changes have been made to the sections on transient phenomena, electric filters, iron-core transformer design, vacuum tubes, amplifier and oscillator circuits for special purposes such as differentiation, integration, and generation of nonsinusoidal waveshapes, waveform analysis, transmission lines and wave guides, electroacoustics (in preceding editions only room acoustics were treated) and the section on mathematical formulas.

New subjects introduced in this edition include chapters on bridges and impedance measurements, radar, broadcasting (standards and coverage data), servomechanisms, and Maxwell's equations. In the course of editorial rearrangement of the book a new chapter also has been added on modulation, combining and enlarging material formerly scattered through the book. There is also a new chapter on radio noise, a much enlarged treatment over that formerly included in the "propagation and noise" chapter.

This recital of the changes in the new edition almost, but not quite, gives those who are not familiar with the preceding editions an idea of the complete contents. The subjects not singled out above include much useful information on materials used in radio, general physical data, circuits, wire transmission and the like.

The "Federal Handbook," as it is often called, is a unique publication in the technical radio field. Not a handbook in the usual sense, it is exactly what its title implies — a collection of all sorts of data and formulas that are constantly needed by those engaged professionally in radio. Although the book is intended primarily for engineers, amateurs will find a great deal of data in it that will be directly useful. Maxwell's equations and the color code may be worlds apart, but *Reference Data* encompasses both extremes. — G. G.

Happenings of the Month

DOCKET 9295

As this department goes to press, the latest developments in Docket 9295 are the filing of comments by interested parties on the Commission's modified proposals of last November.

The text of ARRL's filing appears on the editorial page of this issue. Both the "National Amateur Radio Council" and "Society of American Radio Amateurs" also filed comment, in each case abandoning at least in part the recommendations they supported at the October conference. SARA's brief comment "strongly and enthusiastically endorses the philosophy and detail" embodied in FCC's proposals, stating that such proposals, if carried into the rules, would provide the first tangible postwar progress in a "dormant and moribund¹ service" (that's our amateur radio they're talking about, gang!); they suggest that FCC now simply announce a decision without any further proceedings, which they think unnecessary, but say that if any formal hearing should be held they want to be a party. NARC's filing, after pirating some of the language in the ARRL's original July filing for its introduction, devotes most of the remainder of its six-page document to an attack on the League; aside from this, it expresses itself "in general agreement with the broad outline of the philosophy of regulation" of FCC, states it finds the "petulant" action of the League's Board in opposing such a philosophy to be "unwarranted, unreasonable, harmful and arbitrary"; it thinks a full formal hearing should be held, and asks for it; it comments on FCC's other proposals only in a concluding paragraph which states it has no position on the Amateur Extra Class license and so suggests that the Commission poll each amateur licensee on that question and on acceptance of § 12.0.

¹ *Moribund*: In a dying state; near death.—Webster.

Flown in from all sections of the country for a surprise broadcast, friends and kin of Robert Gunderson, W2JIO, participated in a tribute to him and to amateur radio on the Philip Morris program, "This Is Your Life," aired over NBC on January 4th. In foreground: MC Ralph Edwards, Bob, and his mother. In rear: Martin Bannister, W6CDY, of FCC's Los Angeles office; Bob's wife, Lillian; Joe Grumick of Alamogordo, N.M.; W. C. Ommen, W6STX; Don Wallace, W6AM; and Mrs. Alvina Gunther of Louisville, who paid particular tribute to amateur work in the 1937 Ohio River floods. ARRL Communications Manager Handy added his commendation via tape recording. Born without sight, and now an instructor for the blind as well as an inventor in the electronic field, Bob can now realize one lifelong ambition—the program sponsor is financing the first edition of his proposed new magazine for the blind: the *Braille Technical Press*.

ROANOKE SPECIAL ELECTION

Responsive to call for nominations in December and January QST, members in the Roanoke Division have named three candidates to fill the alternate director vacancy for the term expiring at the end of the year: Gus Browning, W4BPD, Victor Clark, W4KFC, and Walter Walker, W4AKN. Balloting is now in progress; ballots must be returned to Hq. for counting before noon of March 20th.

F.C.C. DISCIPLINARY ACTIONS

Several recent actions of FCC in amateur matters give adequate evidence of the extent to which the Commission carefully carries out and enforces the requirements in its rules.

The amateur operator license of George B. Ellis, W5NAV, El Paso, Texas, was suspended for eighteen months, after it was shown that Ellis had appeared before an FCC examiner and taken a Class B exam in the name of a friend.

An application by John B. Moreno, Los Angeles, for an amateur operator license was denied after it was determined that Moreno had been operating on amateur bands without a license and persisted in doing so even after receiving a warning from FCC monitors.

In an initial decision (i.e., subject to appeal), the Commission suspended the amateur operator license of William R. Fuller, Little Rock, Ark., for operating on the 75-meter radiotelephone band with only a Class B license.

420-MC. SHARING

The amateur band 420–450 Mc. is temporarily shared with aircraft altimeters under an FCC rule due to expire February 15th. Because new equipment for a higher band is not yet ready, FCC now plans to extend the sharing arrangement until 1953, including the 50-watt peak antenna power limitation on amateurs.



Calibrating a BC-221 Frequency Meter

How To Use Harmonics for Freqmeter Calibration

BY BEVERLY DUDLEY *

THE BC-221 heterodyne frequency meters, available as war-surplus material, probably offer the amateur the best value in a precise frequency meter he has ever had. Provided they are in good condition when purchased and are, of course, supplied with proper calibration book and accurate 1000-kc. crystal, these instruments can provide exceedingly precise frequency measurements in the hands of a careful and skilled operator. In the past, most BC-221 frequency meters were available as complete units, but of late some meters are being advertised without calibration books and crystals. With a little expense and some careful effort, such incomplete equipment will serve the amateur exceedingly well if the meter is otherwise in good electrical and mechanical condition, since the instrument contains means for providing its own calibration.

It is recommended that the user of such a meter obtain a copy of the War Department's technical manual, TM11-300, entitled *Frequency Meter Sets, SCR-211*, with supplements, available from the Government Printing Office, Washington, D. C. This booklet describes the different models of these heterodyne frequency meters in detail, and includes data on the proper operation and maintenance of these instruments.

As usually purchased, BC-221 frequency meters have no batteries or other power supply. The convenience of these instruments is greatly increased by building a suitable power supply in the lower compartment so that the meter may be operated from the 115-volt a.c. line. The usual transformer-and-rectifier arrangements, supplying 6.3 volts at about 1 ampere and 150 volts at about 25 milliamperes, will be ample. It is recommended that the plate supply be regulated by using a VR-150. With such regulation the frequency will probably not vary more than a few cycles at most, even during its initial warm-up. With battery supply these instruments are designed to have no more than 100 cycles change during warm-up and no more than 325 cycles change for a 10 per cent change in the supply voltage.

The success of the BC-221 frequency meters depends upon (1) a precisely-adjusted 1000-kc. crystal in the crystal-controlled oscillator and (2) an extensive and highly-accurate calibration of the variable, or interpolating, oscillator. A frequency meter lacking these two units can still be turned to good account, however, if it is other-

wise in good condition, by supplying the instrument with its own quartz crystal and using harmonics of the crystal-controlled and interpolating oscillators to calibrate the instrument.

The 1000-Kc. Crystal

Originally the BC-221 frequency meters were supplied with a 1000-kc. crystal with octal socket and mounting resembling a metal tube (DC-9 mounting). However, other 1000-kc. crystals will make quite satisfactory substitutes. When FT-243 mountings are used it may be necessary to provide a jumper connection between certain socket terminals. The fixed oscillator should be adjusted precisely to 1000 kc. by beating its appropriate harmonic with the standard-frequency signals from WWV, after the instrument has had an initial warm-up of at least 10 minutes. The crystal frequency can be varied by screwdriver adjustment of the small adjustable capacitor

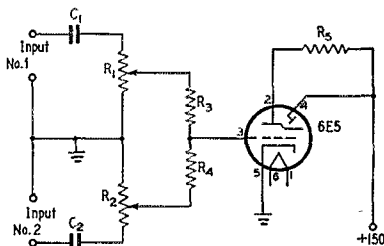

Fig. 1 — A visual zero-beat indicator circuit.

C₁, C₂ — 0.1- μ fd. paper.

R₁, R₂ — 0.5-megohm volume control.

R₃, R₄ — 0.22 megohm.

R₅ — 1.0 megohm.

located near the crystal. Ordinarily this adjustment cannot be made with the frequency meter in its cabinet, but making a flexible cable to supply power from the power-supply unit to the frequency meter will permit working on the unit when it is removed from the case.

It is well to note the temperature at which this adjustment is made, for changes in temperature can cause slight deviations from the standard frequency. The careful operator may wish to mount a thermometer on the front panel of the frequency meter, since a change of 5° C may cause an error of as much as 325 cycles.

For making precise zero-beat determinations, a 6E5 zero-beat visual indicator will be found use-

*22 Temple Street, Belmont 78, Mass.

ful. Aural indications by means of a headset or loudspeaker are usually possible even to very low audio frequencies, but the visual indicator has definite advantages for beats of 5 per second and less. The circuit for a suitable beat indicator is shown in Fig. 1.

The VFO

The calibration of the variable-frequency oscillator, as given in the calibration chart book, may be relied upon to be accurate to within 500 cycles, provided the instrument has reached thermal equilibrium after a 10-minute warm-up and provided also that adjustment of the variable-frequency oscillator is checked and adjusted to zero beat against the (precisely-adjusted) crystal oscillator at the nearest crystal check point. Such adjustment should be made before each frequency measurement. The frequency of the variable-frequency oscillator is brought to its proper value by turning the "Corrector" knob for zero beat, with the variable oscillator set to the dial reading corresponding to the crystal check point, as given in the calibration table.

Although the "Corrector" knob can usually be set without difficulty to obtain a very low-frequency beat, it is difficult to get and maintain a true zero beat with the bar knob usually supplied. A gear-reduction unit attached to the corrector shaft and driven by a large, circular knob will facilitate zero-beat adjustments.

Calibration

Assuming the crystal-controlled oscillator is adjusted exactly to 1000 kc., the precision of the BC-221 depends upon the accuracy of calibration. The calibration supplied with the instrument can be checked, or a completely new calibration can be made (if the instrument is not provided with a calibration chart) by making use of harmonics of the crystal-controlled and interpolating oscillators. The procedure is essentially the same in either case, so it will be described for the more difficult case of providing a completely new calibration. Blank calibration books (MC-177) have been available as surplus material and the use of such a book, if available, is more convenient than a homemade table or graph, although the latter is quite adequate if carefully made.

A zero beat will be found for those conditions for which

$$n_v f_v = n_c f_c \quad \dots\dots(1)$$

where n_v = the order of the harmonic of the variable-frequency oscillator,

n_c = the order of the harmonic of the crystal-controlled oscillator,

f_v = the fundamental frequency of the variable-frequency oscillator, and

f_c = the fundamental frequency of the crystal oscillator.

Thus the frequency of the variable, or interpolating, oscillator is

$$f_v = f_c \frac{n_c}{n_v}$$

Since $f_c = 1000$ kc., it follows that

$$f_v = 1000 n_c/n_v \quad \dots\dots(2)$$

where f_v is expressed in kc. Thus it is possible to determine precisely the value of f_v every time a zero beat is heard in the headset for, under these conditions, n_c and n_v will both have integral values. The difficulty, of course, with this procedure is primarily that of determining the integral values for n_c and n_v for those dial settings where zero beats are obtained. The difficulty is not by any means insurmountable, however, so long as the problem is tackled systematically and the work carefully carried out.

The lower-order harmonics (those for which n_c and n_v are small integers) will produce the loudest beat notes and this fact facilitates the original rough calibration. First make an approximate frequency calibration for each range, on suitable graph paper. Since the dials of the BC-221 meters have 5000 units (and may be read to 0.1 unit) the abscissa (horizontal scale) should, preferably, be marked in multiples or submultiples of 5000 units. The ordinate (vertical scale) should be scaled to cover 125 to 250 kc. and 2000 to 4000 kc., the two fundamental ranges.

Let the instrument warm up for about ten minutes and check the crystal oscillator against WWV. Then, beginning with the dial set at 0000.0, sweep through the frequency band, noting precisely the dial settings each time a zero beat is obtained. At first, only loud beats should be used. Try to locate about a dozen strong beats more or less uniformly distributed between 0100.0 and 4900.0 on the dial. To assist the reader the following table is given for both frequency bands, showing the approximate dial setting for the loudest beat notes. The frequencies given are those whose harmonics are likely to produce the loudest sounds, but the dial settings as given here should be used merely as a guide in identifying the proper harmonic. The approximate calibration, then, should be something like this:

Low-Frequency Band		High-Frequency Band	
Frequency in Kc.	Approx. Dial Setting	Frequency in Kc.	Approx. Dial Setting
125.000	0200.0	2000.000	0200.0
133.333	0530.0	2166.667	0600.0
142.857	0900.0	2250.000	0800.0
153.857	1300.0	2333.333	1000.0
166.667	1800.0	2500.000	1400.0
176.471	2150.0	2666.667	1800.0
181.818	2350.0	2750.000	2000.0
200.000	3000.0	2800.000	2100.0
214.286	3480.0	3000.000	2500.0
222.222	3750.0	3250.000	3100.0
230.769	4050.0	3333.333	3250.0
250.000	4700.0	3500.000	3600.0
		3666.667	4000.0
		3750.000	4150.0
		4000.000	4700.0

The frequencies given here represent the lowest-order harmonics and the beat notes near these frequencies should be fairly strong on any instrument. The frequencies presented are calculated to the nearest cycle, but such precision is not required in making the preliminary or approximate calibration. These frequencies, and the corresponding dial settings (those actually determined on any instrument, not the rough settings indicated earlier) should then be plotted on fairly large graph paper. The resultant curves should be similar to those given on page 14, War Dept. technical manual TM11-300. Once this graph is constructed, an approximate calibration is available for any fundamental frequency within the range of the meter. The corrector knob should be at, or very near, the center of its scale when the data are taken.

With an approximate calibration, as determined above, the meter should be calibrated more precisely using other and additional beat notes not previously used for calibration. Until the meter is quite accurately calibrated throughout its full range, only the stronger beat notes should be used. Usually there will not be much difficulty in hearing the beat notes or in determining the zero beat. The problem is rather one of determining the order of the harmonics of the two oscillators, in any particular case. Unfortunately this is pretty much a matter of trial-and-error. However, the lower-order harmonics (2nd, 3rd, 4th, 5th, etc.) will produce much louder beat notes than the higher-order harmonics (15th, 23rd, 38th, etc.) and they are more widely distributed throughout the dial readings; it is not difficult, therefore, to determine these settings once an approximate calibration is at hand. In fact, for the lower-order harmonics, the proper harmonics of the two beating oscillators can often be found with the use of a slide rule when the approximate frequency is known. This is done by setting the index (sliding scale) to the approximate frequency at which zero beat occurs (stationary scale). Then, on these same two scales, note which set of *integers* coincides. An example should help clarify the procedure.

Suppose, for example, that the zero for a loud beat occurs when the variable-frequency oscillator is set at about 3670 kc. Set the index (1) of the C scale of the slide rule opposite 3670 on the D scale. Then, with the sliding glass, run over the C and D scales until a low-order integer (small whole number) on one scale coincides (or nearly coincides) with an integer on the other scale. For the case in question this occurs when 3 on the C scale is very nearly opposite 11 on the D scale. Hence, the third harmonic of the variable-frequency oscillator is beating with the 11th harmonic of the crystal oscillator. Using equation (2), we find the exact frequency at which zero beat occurs to be

$$f_r = (1000 \times 11)/3 = 3666.667 \text{ kc.}$$

instead of 3670 kc. as given by the approximate calibration.

Using the technique outlined above, the author has checked the calibration of two BC-221 frequency meters. One of these was an early model in which only the lower-order harmonics could be easily heard, but the other was a later model in which check points up to the 10th harmonic of the crystal oscillator for the low-frequency range, and up to at least the 16th harmonic of the variable-frequency oscillator for the high-frequency range, were identified. This provides about 125 check points for the low-frequency range and about 200 check points for the high-frequency range, all highly accurate.

On the basis of such work, two tables are attached that should assist amateurs in the calibration of their instruments, or should aid in checking the calibration. Table I gives the exact frequency and the harmonic ratios for a variety of check points in both high- and low-frequency

TABLE I

Frequencies and Harmonic Ratios for High- and Low-Frequency Bands of the BC-221 Frequency Meter

Low-Frequency Band			High-Frequency Band		
Frequency in Kc.	Crystal Har-	VFO Har-	Frequency in Kc.	Crystal Harmonic	VFO Har-
	monic	monic		monic	monic
125.000	1	8	2000.000	2	1
133.333	2	15	2086.667	31	15
136.364	3	22	2142.857	15	7
142.857	1	7	2166.667	13	6
148.148	4	27	2200.000	11	5
153.846	2	13	2250.000	9	4
157.895	3	19	2333.333	7	3
160.000	4	25	2375.000	19	8
166.667	1	6	2400.000	12	5
173.913	4	23	2454.545	27	11
176.471	3	17	2500.000	5	2
181.818	2	11	2571.428	18	7
187.500	3	16	2600.000	13	5
190.476	4	21	2666.667	8	3
195.122	8	41	2714.286	19	7
200.000	1	5	2750.000	11	4
208.333	5	24	2800.000	14	5
214.286	3	14	2857.143	20	7
217.391	5	23	2909.091	32	11
222.222	2	9	2950.000	59	20
227.273	5	22	3000.000	3	1
230.769	3	13	3076.154	40	13
235.294	4	17	3125.000	25	8
240.000	5	25	3166.667	19	6
250.000	1	4	3200.000	16	5
			3250.000	13	4
			3333.333	10	3
			3375.000	27	8
			3400.000	17	5
			3454.545	38	11
			3500.000	7	2
			3571.428	25	7
			3600.000	18	5
			3666.667	11	3
			3714.286	26	7
			3750.000	15	4
			3800.000	19	5
			3857.143	27	7
			3900.000	39	10
			4000.000	4	1

TABLE II

Calibration Check Points in the Amateur Bands for Harmonics up to the 20th of the Interpolation Oscillator of the BC-221 Heterodyne Frequency Meter

Frequency in Kc.	Crystal Har- monic	VFO Har- monic	Frequency in Kc.	Crystal Har- monic	VFO Harmonic
3500.000	7	2	3750.000	15	4
3526.316	67	19	3784.706	64	17
3529.412	60	17	3769.231	49	13
3533.333	53	15	3777.778	34	9
3545.454	39	11	3785.714	54	14
3546.154	46	13	3789.421	72	19
3550.000	71	20	3800.000	19	5
3555.555	32	9	3812.500	61	16
3562.500	57	16	3818.182	42	11
3571.428	25	7	3823.529	65	17
3578.632	68	19	3833.333	23	6
3583.333	43	12	3842.105	73	19
3588.235	61	17	3846.154	50	13
3600.000	18	5	3850.000	77	20
3611.111	65	18	3855.143	27	7
3615.387	47	13	3866.667	58	15
3625.000	29	8	3875.000	31	8
3631.579	69	19	3882.362	66	17
3636.364	40	11	3888.889	35	9
3642.857	51	14	3894.738	74	19
3647.059	62	17	3900.000	39	10
3650.000	73	20	3909.091	43	11
3666.667	11	3	3916.667	47	12
3684.210	19	7	3923.769	51	13
3687.500	59	16	3928.571	55	14
3692.308	48	13	3933.333	59	15
3700.000	37	10	3937.500	63	16
3705.882	63	17	3941.177	67	17
3714.286	26	7	3944.444	71	18
3722.222	67	18	3947.368	75	19
3727.273	47	11	3959.000	79	20
3733.333	56	15	4000.000	4	1
3736.842	71	19			

ranges. The exact frequency values selected are, so far as possible, those for which zero beats are produced by low-order harmonics. Also, they have been chosen with such frequency intervals that one check point is provided for each list of frequencies given on a different page of the usual calibration books.

The second table should be particularly useful to radio amateurs, since it contains all check points (up to the 20th harmonic of the variable-frequency oscillator) for the range between 3500 and 4000 kc. In addition to the exact frequency (to nearest cycle) the order of harmonics of the two oscillators is also given, since such information is useful in ascertaining, approximately, the intensity of the different beat notes.

In most calibration books, the standard check points between 3.5 and 4.0 Mc. are given as: 3500, 3667, 3750, and 4000 kc. Between these standard values, the most useful intermediate check points occur at 3600, 3714, and 3857 kc. (Table I). Other useful intermediate check frequencies (selected for approximate uniform distribution throughout the 3.5-4.0-Mc. range, as well as for low harmonic order) are the following:

3533	3688	3800
3555	3700	3833
3571	3727	3875
3615	3733	3889
3625	3769	3900
3636	3778	3929

as listed in Table II.

In addition to these check frequencies, the following check points may be of interest to amateurs because they (or their harmonics) occur at or near the edges of some amateur bands:

3500	3578.6	3850
3550	3600	3900
3562.5	3650	4000

Beats for some of these frequencies may be weak and, on some instruments, unidentifiable.

The BC-221 or other frequency meter may, of course, be calibrated by means of a standard-frequency crystal-controlled oscillator and harmonic generator, or by means of another calibrated variable-frequency oscillator. However, these methods require additional equipment. The purpose here is to explain a method by which the BC-221 meter may be used to provide its own calibration.

Strays



New Key for Hot Man

Tex Bencke, well-known tenor man who took over the former Glenn Miller band, has passed the amateur exam and is now W2CKD. Tex says FCC made him give an encore before they would issue him a ticket. "That's one time you can't improvise," he added. "You copy it the way it's sent or you're not solid." Now, when he's not fingering the keys on his horn he's pushing the key in his dressing room, operating the ten-meter rig in his car, or working someone from home. Swing your beam, gang, and get in the groove for a QSO with a new ham, W2CKD, New York. — (Photo courtesy Samuel Schwartz, Philadelphia)

On the Air with SINGLE SIDEBAND



SOME of the European stations aren't letting any grass grow under their feet in the single-sideband field, and the next few months should see a number of trans-Atlantic s.s.b. QSOs. The first station on in Denmark is OZ7T, Steen Hasselbalch of Hellerup. Steen operates between 3.7 and 3.8 Mc., with occasional excursions into the 14-Mc. band. The transmitter uses audio and r.f. phase-shift networks similar to the W2UNJ exciter, but balanced modulators are not used. Instead, a pair of grid-modulated 6SJ7s is used to generate s.s.b. with carrier, and the carrier is then balanced out by introducing equal-and-opposite carrier through a third 6SJ7. The resultant s.s.b.-suppressed-carrier signal is amplified by an EBL21 (similar to a 6L6). Steen got across the pond with the rig in early December, when he worked VO3X on 80 meters. It is reported that OZ7BO and OZ7HB are building s.s.b. transmitters.

In Bjornstorp, Sweden, Thure-Gabriel Gyllenkrok has had a phasing rig on at SM7HZ since mid-1948. It ends up with a pair of T40s running 200 watts peak, and skeds with OZ7T are kept every Tuesday at 2000 GCT on 3720 kc. The receiver is an SX-42 with a homemade version of the YRS-1 adapter. About the adapter he says, "That's about the best thing I have ever built." His friend SM7PP built a receiving adapter using 1N34s in the balanced demodulator, with a Dome network for the audio shift, all on a 4 x 5 x 2-inch chassis. Summing up his experiences, SM7HZ says about s.s.b.: "No QRM or QSB can hurt your signal, but they won't believe you when you tell them to turn on the beat oscillator!"

Another one in Sweden is SM5QV, Gunnar Petersson in Stockholm. His rig is a phasing job with 6SJ7s and ending with an 807. Peak input on 80 or 20 runs around 50 watts.

If you read the English *Short Wave Magazine* you already know that G2NX, H. C. Woodhead of Salop, is active in G-land. He has had a series of articles describing his equipment and the general principles of s.s.b. His rig is unusual in that it uses a crystal filter at 5.6 Mc. to eliminate the unwanted sideband. The filter uses two crystals collected from BC-733s, and it took quite a bit of search to find two close enough together in frequency. The transmitter runs 20 to 40 db. sideband suppression over the speech passband of 2300 cycles, and the peak power on

80 meters runs 90 watts. He can be found anywhere between 3.6 and 3.73 Mc. from 1900 to 2300 GCT, with 3.73 Mc. the usual frequency. His first QSO with OZ7T was in December.

The first on in France is A. Claudet, F8AJ at Orly. The rig is similar to the W2UNJ design, using 1619s for the balanced modulators, with drive furnished by a 6AG7 crystal oscillator. Although the output is low (2 or 3 watts), locals report the signal equivalent to that from the 20-watt a.m. rig. It took careful selection of the 1619s to get good carrier suppression, and the r.f. phase balance was a bit tricky, but this might be expected on 14 Mc. Operating frequencies are 14,346 and 14,300 kc., with most of the activity on Sundays. F8AJ says, "The stuff is awfully exciting, and I don't remember enjoying such a thrill since my first CQ in 1927."

In Cape Town, H. G. Manchip has ZS1KC on 20-meter s.s.b., running 50 watts to an 807. A filter rig is used, and a fixed beam headed NNW gives the signals a good chance of getting over here and giving the gang its first crack at a two-way s.s.b. contact with Africa.

When Dave Mann, W3MBY, built his first filter rig back in 1948, "Butch" Mason, W3MGG, built one too, and together they explored some of the possibilities of s.s.b. on 20 and 75. When they finished PG school at Annapolis in mid-1949, Dave went to Washington, D. C., and Butch took his rig and his 2½ stripes to Southern California, where he got his old call of W6KAG. It seemed like a good chance to see what s.s.b. could do over a long-haul path, and they started 14-Mc. schedules in late October. Since then they have had more than twenty solid QSOs that average an hour or more (some have lasted two). Analysis shows that three factors determine the length of QSO: "(1) The band folds up. (2) A wife decides it is long past bedtime on the East Coast or long past dinnertime on the West Coast. (3) Everything to be said has been said and then some." The output stage at W6KAG is the 813 in a Meissner 150B, running 400 watts on peaks, and the antenna is a Twin-Lead W8JK 40 feet high. The receiver is a BC-348Q into a BC-453 into a balanced detector (pair of 6L7s) fed by a 6J5 oscillator switchable to either 83.5 or 86.5 kc., followed by a Selectoject. The receiver does a good job of making all 'phone signals s.s.b., and it does a beautiful job on s.s.b.-suppressed-carrier signals. Butch says KH6CT has a YRS-1 adapter that he swears by and is planning a phasing rig, while KH6OR is busy collecting filter components for his new job. As one last comment on the long-haul skeds, W6KAG says it is amazing how weak an s.s.b. signal can get and still be solid copy. He and W3MBY often wind up their QSOs and find that the band is dead and has been for some time.

(Continued on page 108)

I.A.R.U. News



DECEMBER CALENDAR

Chronicling I.A.R.U. affairs during 1949, the December Calendar reports the addition of two amateur societies to Union membership: the *Union de Radio Aficionados Espanola* (U.R.E.) was reinstated after a lapse of membership during the war years, and the *Liga Panamena de Radio Aficionados* (L.P.R.A.) was granted new membership. Membership in the I.A.R.U. now totals 40, and thus represents nearly 120,000 amateurs on all continents.

During 1949 the Headquarters issued 1030 WAC certificates, 397 of these being for work exclusively on radiotelephony. These figures compare with an issuance of 1112 certificates during the previous year.

As a result of voting during the latter half of the year, members of the Union have agreed to give consideration to a universal numbering system for DX contests and to a universal phonetic alphabet for radiotelephony use.

Other matters covered by the I.A.R.U. Calendar included the I.A.R.U. Paris Congress (see below), international amateur communications (see Dec., 1949, *QST*, p. 30), the *Radio Club Argentino* trophy (see Oct., 1949, *QST*, p. 10), and the Voice of America broadcasts (see Jan., 1950, *QST*, p. 29).

I.A.R.U. CONGRESS

Tentative plans are being formulated by the R.E.F. for an I.A.R.U. Congress to be held in conjunction with the Paris Fair in May. The purpose of the Congress is to celebrate the 25th anniversary of the founding of the I.A.R.U. and to discuss matters of mutual interest. Several societies are already making plans to send delegates.

BRAZIL'S WAA AWARD

The *Liga de Amadores Brasileiros de Radio Emissoa* has instituted an award known as the WAA — "Worked All America." It will be issued to any amateur who can submit proof of contact

with 45 or more countries in the American area. Confirmations must be forwarded directly by registered mail to L.A.B.R.E. Headquarters, P.O. Box 2353, Rio de Janeiro, Brazil, with sufficient postage for their return.

The various rules providing that contacts must be only with "land" stations, all QSOs from same call area, all QSOs postwar, etc., are quite similar to DXCC requirements. A minimum readability report of 3 and a minimum tone report of 8 are necessary.

ARRL's official Country List (see p. 40, Feb., 1950, *QST*) shows 57 countries in the American area, which includes the continents of North and South America.

SOUTH AMERICA

The *Primer Concurso Bolivariano de Radio Aficionados*, sponsored by *The Radio Club Peruano* last May, was a contest between hams in South American countries that owe their national independence to Simon Bolivar. High score was submitted by HP1LA, who was rewarded with a handsome silver cup. First-place winners in their respective countries were YV5ABQ, OA4AO, HK4JO, HP1HB, HC2AF and CP1AY. Second-place winners were YV5AU, OA4AV, HP1LB, HK6JH, HC2GRC and CP1JK. It is expected that the *Concurso Bolivariano* will be held annually.

QSL BUREAU CHANGES

The last complete listing of foreign QSL bureaus was contained on page 61 of Dec., 1949, *QST*. The following changes to that list are noted:

Belgian Congo: U.C.A.R., P.O. Box 271, Leopoldville

Roumania: A.A.U.S.R., Box 95, Bucharest

Venezuela: R.C.V., P.O. Box 2285, Caracas

NEW ZEALAND DX CONTEST

To celebrate the centennial of the province of Canterbury in New Zealand, the N.Z.A.R.T. is sponsoring the Canterbury Centennial DX Con-

(Continued on page 110)

Reported elsewhere on this page is the readmission of the *Union de Radio Aficionados Espanola* to membership in the I.A.R.U. This group comprises U.R.E.'s governing board. *L. to r.*, sitting: EA7BZ, EA4FC (vice-pres.), EA4AD (pres.), EA5BE, EA4LQ; standing: EA4BV, EA4LA, EA1AW, EA7AV.

March 1950



• Technical Topics —

“Clamp-Tube Modulation”

AMONG the various topics of discussion in the A'phone bands these days is the possibility of using the screen-circuit “clamp tube” to modulate an amplifier. It is a convenient method for some transmitters and is well worth digging into.

The “clamp-tube” circuit, shown in Fig. 1, is usually incorporated in a screen-grid amplifier stage to avoid the necessity for protective control-grid bias. With no excitation to the stage, the clamp tube draws current through the screen

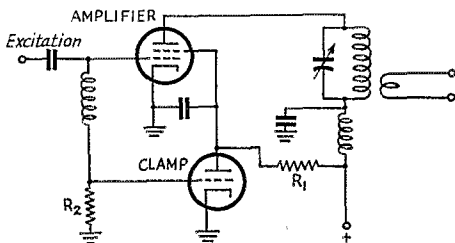

Fig. 1 — The clamp-tube circuit eliminates the need for protective fixed bias in a screen-grid amplifier by reducing the screen voltage when there is no excitation.

resistor, R_1 , and drops the screen voltage to a low value. This in turn holds the plate current down to a reasonable level. When excitation is applied, the clamp tube is cut off by the bias developed across the grid leak, R_2 , and the screen voltage rises to its normal value. Obviously the clamp tube at zero grid volts must be capable of handling more current than is drawn by the screen of the amplifier under normal conditions, and the most popular clamp tubes are the 6Y6 and the 6L6, triode-connected. The choice of tube depends upon the screen current and the normally developed grid bias of the amplifier — the bias must be enough to cut off the clamp tube. The 6L6 is good for a pair of 807s, and the 6Y6 is more often used with larger tubes.

A screen-grid amplifier can be modulated in the screen circuit, of course, by varying the screen voltage, and the method has been kicked around since the first tetrode was introduced. As a first approximation you would set the screen voltage at half its normal value and swing it about this point. With a perfectly-linear screen characteristic (and complete cut-off at 0 volts), 100 per cent modulation would be obtained when the voltage swing on the screen was from 0 to normal operating value. Screen-grid tubes aren't this ideal, however, but some aren't too bad. Most

screen-modulated amplifiers have used a transformer in the screen lead, but it can also be done quite handily with the clamp tube, with no modulation transformer.

A practical circuit is shown in Fig. 2. It differs from Fig. 1 only in the addition of a bias source for the clamp tube, an extra dropping resistor and audio by-pass condenser and, of course, the source of audio signal (speech-amplifier output). Some may wonder at the need for the dropping resistor, R_3 , and the audio by-pass, C_1 , but it will be obvious to anyone who recalls the old days of Heising modulation and the need for a dropping resistor from the modulator tube to the r.f. amplifier, if full modulation was to be obtained. The circuit under discussion is the same thing slightly disguised — the clamp tube is the Class A modulator tube, the amplifier screen circuit is the load, and the audio impedance is R_1 instead of the familiar choke coil. The dropping resistor, R_3 (by-passed for audio by C_1), allows the modulator tube to operate at a higher voltage than the screen and thus maintain linearity over the required voltage range.

Don't let all this big talk frighten you, however — the thing is easy to set up. Assuming that you have an 807 amplifier using a clamp tube, first make a note of the normal plate current and screen voltage. Then add a cathode bias resistor and condenser to the clamp tube and the other components shown in Fig. 2. The voltage between cathode and plate of the clamp tube should be 20 or 30 volts higher than the normal amplifier screen voltage, and can be adjusted by changing the value of R_5 . The voltage between the ampli-

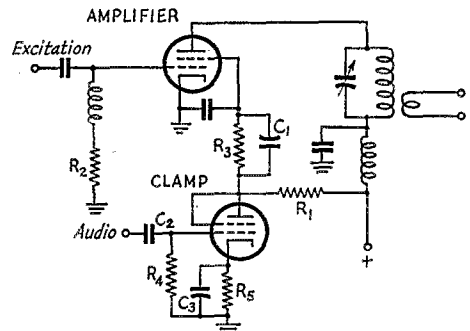

Fig. 2 — The clamp tube can be used to screen-modulate the amplifier stage. Component values for an 807 amplifier are given in Fig. 3.

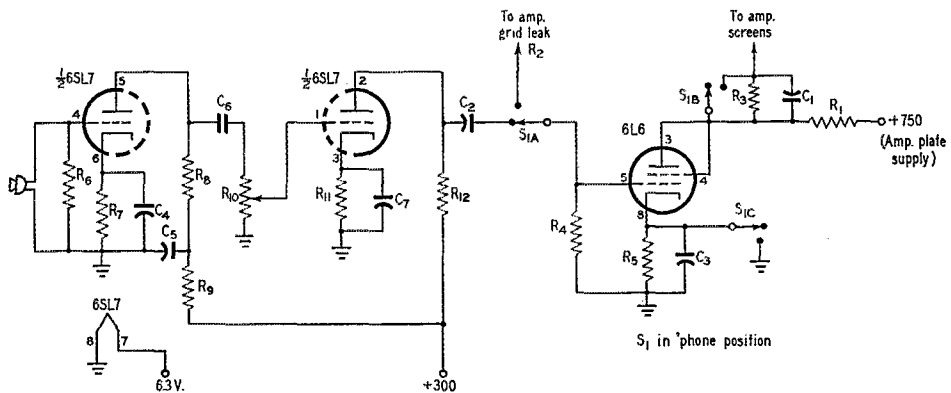

Fig. 3 — Circuit for screen modulating two 807s with screen protective tube, with provision for switching from 'phone to c.w. Lead from microphone to grid of first 6SL7 section, as well as leads to and from the gain control, should be shielded to prevent hum pick-up. A tube shield around the 6SL7 may be required, to reduce hum.

- C₁ — 1 μ fd. or more, 250 volts.
- C₂ — 0.01- μ fd. paper or ceramic.
- C₃ — 10- μ fd. 50-volt electrolytic.
- C₄, C₇ — 10- μ fd. 25-volt electrolytic.
- C₅ — 8- μ fd. 450-volt electrolytic.
- C₆ — 0.0022- μ fd. mica or ceramic.
- R₁ — 30,000 ohms, 25 watts.
- R₂ — Transmitter grid leak.
- R₃ — 20,000 ohms, 1 watt.
- R₄, R₁₂ — 0.1 megohm, $\frac{1}{2}$ watt.
- R₅ — 2000 ohms, 1 watt. (Adjust to 25 volts drop.)

- R₆ — 4.7 megohms, $\frac{1}{2}$ watt.
- R₇ — 6800 ohms, $\frac{1}{2}$ watt.
- R₈ — 0.47 megohm, $\frac{1}{2}$ watt.
- R₉ — 10,000 ohms, $\frac{1}{2}$ watt.
- R₁₀ — 1-megohm volume control.
- R₁₁ — 1500 ohms, $\frac{1}{2}$ watt.
- S₁ — 3-pole 2-position switch.

NOTE: The 6SL7 plate-current drain is negligible. Plate voltage may be taken from any convenient supply having good filtering.

fier screen and ground should be approximately one-half the normal operating voltage — it can be changed by varying the value of R_3 . At this value of one-half normal screen voltage, the plate current should be one-half its normal value (if there is no change in plate voltage). With audio applied to the grid of the clamp tube, no change in amplifier plate current should occur before 100 per cent modulation is obtained. Within the proper operating limits of the clamp tube, no change in cathode voltage should be noticed with varying amounts of audio signal, as in any Class A amplifier.

This isn't any radical modulation system, and it isn't a something-for-nothing deal. The peak output is equal to the normal c.w. output, and so the unmodulated-carrier output is one-fourth this value. It is, however, a convenient system for the casual 'phone operator who isn't interested in investing in high-powered modulation equipment. A three-pole two-position ceramic switch will change your rig from c.w. to 'phone and back, by switching the clamp-tube grid lead from R_2 to C_2 and opening a short across R_5 and another across R_3 .

The system was checked in the laboratory on a rig using a pair of 807s running 785 volts on the plates. With a 6Y6 clamp tube, typical conditions were 280 volts from plate to cathode on the 6Y6, 135 volts from screen to ground on the 807s, and 48 volts bias on the 6Y6. With a 6L6

clamp tube operating with 25 volts bias, the plate-to-cathode voltage was 250 and the 807 screens showed 140 volts. The value of R_1 and R_3 was 30,000 ohms in both cases, and C_1 was 1 μ fd. Grid current to the 807s was 7 ma., with a 6800-ohm grid leak. It will be noticed that the above conditions are not the usual ones for Class A operation of triode-connected 6L6s or 6Y6s, but the audio power demand is so slight that some variation from optimum conditions can be tolerated. The load for the audio (clamp) tube is the screen resistance of the modulated tubes in parallel with R_1 . If the power demand on the tube were greater, as would be the case with larger tubes drawing more screen current, more careful choice of clamp-tube operating conditions would be required. The 6L6 makes a better clamp tube for the 807s than does the 6Y6 (because it cuts off at a lower grid voltage) and would be the logical choice. If a single 807 is to be modulated, the value given in Fig. 3 for R_3 should be doubled, and R_1 should be adjusted to give 250 volts plate-to-cathode on the 6L6.

Fortunately or unfortunately (depending upon what you have in your rig), there is no assurance that every tetrode can be screen-modulated satisfactorily by this method or any other method. The 807 is well-suited to this method of modulation because it can be modulated close to 100 per

(Continued on page 110)

The Difficult Takes a Long Time

(The Impossible We Never Do)

BY KEITH S. WILLIAMS,* W6DTY

NOW AND THEN a letter in *QST*'s correspondence section reminds me that there is a constant supply of would-be hams and new hams (God bless them all!) who arrive at the stage wherein the complexities of electronics in this day and age seem insurmountable. I can well understand and readily sympathize. Modern radio is pretty complicated and all of us at times wonder if we can possibly keep up. But, on the other hand, it isn't so bad after all. In spite of the cries of anguish one hears, it's really much simpler now than it was a good many years ago because detailed information is so plentiful. No matter what your interest, you can find step-by-step instructions on building most anything your heart desires . . . right down to the dope on which hand is best for holding the soldering iron.

For the benefit of those who are weeping bitter tears because of the complications of present-day radio gear, let me light up a big, black cigar and try to recall a typical set of instructions for building a ham station back in the days when radio was "simple."

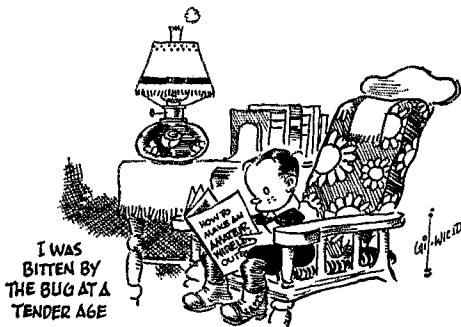

At a tender age I was bitten by the Bug. Determined to join the ranks of the ether-busters (we used the ether then; who ever heard of the ionosphere?), I obtained a set of instructions entitled, "How to Make an Amateur Wireless Outfit." It contained no pictures, no drawings, no diagrams and mighty little reading and writing and went somewhat as follows:

"There are three parts to every wireless set: (1) the aerial system, (2) a sending set, and (3) a receiving set. You can purchase these complete, ready to put up, or if you have some tools you can build all of them yourself. You may have to

buy the head telephone receivers as they are very difficult to make.

"The aerial is formed of two or three (four to six might be better) stranded copper wires stretched as high above the ground as you can get them. These wires must be insulated from the poles, and for this you will need some porcelain insulators and some strain insulators. Each wire should be as long as possible, but not less than forty feet long, and the wires are attached to wooden spreaders by means of the insulators. Keep in mind that the longer the wires and the higher the aerial the greater the distance to which messages can be sent.

"The next important item is the *ground* and you can obtain a good ground in several ways. One way is to solder a No. 6 bare copper wire to a water pipe. Or you can drive a piece of pipe into the earth far enough to reach moisture. The best method is to dig a hole about ten feet deep and put a sheet of zinc in the bottom of the hole and solder a piece of No. 6 wire to the zinc. Then cover the zinc with earth. Also important is the grounding switch. Obtain a heavy copper knife switch and mount it outside the window near the aerial wire so the aerial can be grounded during lightning storms.

"To send out messages you will need the following: (1) an induction coil, (2) a telegraph key, (3) a spark gap, (4) a battery, (5) a tuning coil, and (6) a condenser. [What could be simpler, eh fellers?] The induction coil will change the direct current from the battery into high-pressure alternating current. [Maybe you think *this* technical detail didn't have me stopped!] The purpose of the telegraph key is to break up the battery current into dots and dashes which represent the International Morse code. [Not much change here; keying is still supposed to represent the Morse code, although sometimes one wonders.]

"Next is the spark gap. This is a pair of brass rods fitted with brass balls. The rods should be equipped with handles so that you may slide them back and forth through a pair of brass standards for adjusting the length of the gap. The standards should be bolted to a marble base. Connect the spark gap to the terminals of the induction coil. [Note how precise these instructions are! You can't begin to imagine what a foggy notion I had of how to go about making a spark gap. Where should one put the balls and how big should they be? How long is the gap supposed to be? Which terminals on the induction coil?

*244 Magnolia Ave., Oxnard, Calif.

Where in tarnation to find marble for the base? I am still amazed to think that this monstrosity was actually built.]

"The tuning coil is very simple. It consists of a coil of heavy copper wire, about one quarter inch in diameter, wound in a helix around a wooden frame. The tuning coil will give the electric waves you send out a certain length. The tuning coil is connected in a circuit with the



spark gap and the condenser. [Good Lord! You fellows who are groaning about present-day difficulties take a look at that last item again. How many turns? What diameter? What length? And what kind of a circuit with spark gap and condenser?]

"The high-pressure condenser can be made of a number of sheets of glass covered with tinfoil. The size of the condenser must be appropriate to the size of the tuning coil and the larger it is the shorter and fatter will be the spark. The shorter and fatter the spark the stronger the waves sent out by the aerial. [That's fine, that stuff about the waves being stronger. But doggone it, how many sheets of glass and how much tinfoil? How big should the sheets be? How do you mount it all together to make a condenser? Note how "simple" radio was in those days!]

"When you have made all these pieces of the sending set, connect them up with No. 14 copper wire. The primary of the induction coil, the battery, and the key are connected in series. The spark gap, the tuning coil, and the condenser are connected in series. Connect the aerial wire to one end of the tuning coil and the ground wire to the other end. Sometimes it is helpful to put a heavy clip on the ground wire and try clipping it on to different parts of the tuning coil.

"Of course, before you send messages with this sending set you must have a government license. [Oh! Oh! I *knew* there'd be a catch!] Send fifteen cents to the Superintendent of Documents, Washington, D. C., for the pamphlet entitled, 'Radio Communication Laws of the United States.' You must be able to send International Morse code at least five words per minute before you can obtain a license. [How do you like that! I remember thinking that it was a horrible situation. Five

words per minute, no less! What would those termites in Washington think of next?]

"The receiver consists of: (1) a crystal detector, (2) a tuning coil, (3) a variable condenser and (4) a set of head telephone receivers. It is worth while to mention that if you cannot have a sending set or cannot learn the Morse code sufficiently well to obtain a government license you may operate a receiving station. No matter where you live you are almost sure to be within signaling range of a sending station. [Ha!] It will be best to buy the crystal detector, complete with cat whisker and mounting. The tuning coil is made by winding a single layer of No. 20 insulated copper wire on a cylinder of wood or other material. The insulation is scraped off in two parallel lines the length of the coil and two springs, sliding on brass rods, make contact with the wire. The tuner, as it is called, is for the purpose of adjusting the receiving set to the wavelength of the sending station and helps to make the received message ring loud and clear in the head telephone receivers. [Pretty good dope, don't you think? How many turns? What diameter? How long should the cylinder be? What's the dope on the two springs? Of course, the invention of rolled oats contributed its share to the progress of the wireless art.]

"The best kind of a receiving condenser is the variable condenser. It consists of a set of fixed plates and a set of movable plates. The movable plates can be turned by means of a knob attached to a shaft and provides very sharp tuning when used in conjunction with the tuning coil. [Not bad. I had been wondering about that variable condenser.]

"You are advised to buy the head telephone receivers. They are very difficult to build yourself. [Who bought head telephone receivers? The telephone company may have suffered a little inconvenience, but it was all in the interest of science.]



A receiver wound to 500 ohms resistance is satisfactory for short-distance work but if you wish to receive messages from as far as 100 miles you should obtain receivers wound to at least 1000 ohms. Be sure to buy receivers wound with copper

(Continued on page 112)

Adjusting Antenna Coupling in V.H.F. Receivers

Lower Noise Figures Without a Noise Generator

BY HENRY H. CROSS,* W1OOP

THE following comments grew out of attempts to help out fellow 2-meter enthusiasts in the adjustment of antenna coupling on their cascode-front-end receivers. Perhaps other workers will find the technique useful in their search for better v.h.f. reception.

When a receiver or converter is placed in service on the v.h.f. bands it is desirable to adjust the antenna coupling so as to obtain the lowest-possible noise figure. If the impedance presented to the receiver by the antenna system is known, and if one has a suitable noise generator available,¹ this is not hard to do. However, if one does not have access to a noise generator, or if there is some doubt as to the actual impedance of the antenna system (not all "300-ohm line" antennas look like 300 ohms to the receiver input!) some other method must be employed. Signals alone will *not* do, even if they are suitably weak and yet steady, but in many instances the receiver's own noise may be used, once the method is understood.

All electrical conductors contain free electrons that are in continuous random motion, resulting in a voltage that varies in a random manner across the terminals of the conductor. This voltage represents noise energy distributed throughout the frequency spectrum, and known as *thermal-agitation noise*. The noise output of receivers for low and medium frequencies comes largely from this source. In v.h.f. receivers, however, the noise is produced almost entirely by the tubes; the first tube, in well-designed receivers. In a perfect receiver the thermal-agitation noise in the antenna would be the only noise in the receiver output. Thus the ratio of the total noise power to the antenna noise power, or *noise figure*, is used to express the merit of an actual receiver, without regard to its total gain or selectivity.

At frequencies lower than our 10-meter band, the static and other *external* noise picked up by a good antenna will be great enough to override the thermal-agitation noise of the antenna by 6 to 10 db.; thus a perfect receiver is of little or no advantage for these frequencies, as compared with a receiver that has three or four times as

much noise. On the other hand, in the v.h.f. range and higher there is no such noise pick-up by the antenna in a *quiet* location, so it is to our advantage to see that the noise generated within the receiver itself is held to the lowest possible value, and that the energy our antenna collects is fed to the receiver with the highest possible efficiency.

It has been demonstrated² that the noise figure of a single amplifier stage is lowest (best) when the amplified induced-grid (transit-time) noise is equal to the noise due to the plate current (shot noise). The balance of the noise is assumed to be thermal-agitation noise, and if all the resistance in the input circuit is supplied by the antenna, it will be antenna thermal noise.

If the noise figure is 10 db. the thermal noise is but one-tenth of the whole; if the noise figure is 5 db. the thermal noise will be one-third, with shot and induced-grid noise making up the other two thirds, providing that 5 db. is the best noise figure that can be obtained with the particular tube employed in the stage. Shorting the grid to ground will reduce all but the shot noise to zero, and the noise will drop by 5 db. Thus it can be seen that the change in noise output when the grid is shorted to ground may be used to check input coupling. Obviously, this does not apply in grounded-grid r.f. amplifiers, where the grid is already shorted to ground. It is also inapplicable to receivers where the input circuit is in the mixer grid.

First, a value for the best noise figure obtainable with the particular tube in use must be assumed. If this figure is unduly optimistic the adjustment will be in error, and the result will be several times worse than the best possible. On the other hand, if the estimate is on the pessimistic side the most that can be lost is 3 db. A conserva-

TABLE I

Noise Figure (db.)	Power Ratio	Noise Increase db.	Voltage Ratio
20	100	3	1.4
10	10	3½	1.5
7	5	4	1.6
5	3	5	1.75
3	2	6	2.0

* 70 Symphony Road, Boston 15, Mass.

¹ Tilton, "Noise-Generator Technique for the V.H.F. Man," Aug., 1949, *QST*, p. 20.

² Wallman, Macnee and Gadsen, "A Low-Noise Amplifier," *Proc. IRE*, June, 1948, p. 702

tive guess is thus in order. In a very poor receiver, where tube noise is more than 90 per cent of the total, the figure is easy to remember: set the antenna coupling so that, in the absence of external noise, and with the input circuit tuned, shorting the grid to ground drops the noise by 3 db. For other noise figures the information in Table I applies. The noise reading should be taken with a db. or output meter or a.c. voltmeter connected to the loudspeaker terminals.

A few probable values for noise figure that can be obtained with various tubes commonly used in v.h.f. receiver work are given in Table II. These are merely estimated values for use in the adjustment procedure outlined above. They are not intended to prove anything else.

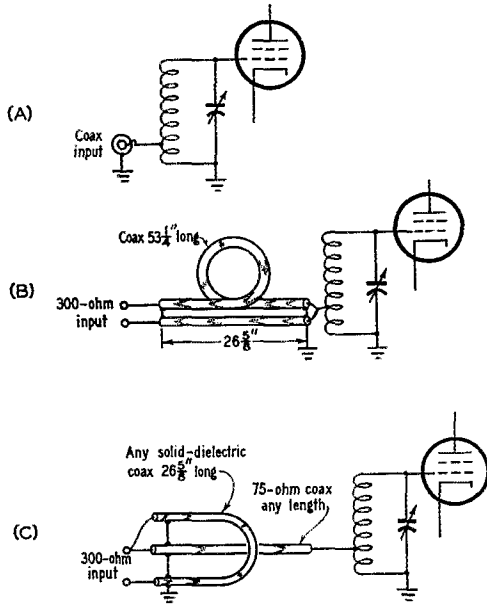

Fig. 1 — Recommended methods of coupling to the antenna in v.h.f. receivers. When coaxial line is used, best coupling is obtained with the inner conductor tapped directly on the coil, as shown at A. The position of the tap is critical, and may be adjusted by the method outlined by the author.

Optimum coupling for balanced lines is attained through the use of a "balun" as shown at B or C. In B two pieces of RG-59/U or other solid-dielectric coaxial line are used, one a half wave longer than the other. Outer conductors are connected together and grounded. In C the coax feeding the input circuit may be any length. Dimensions given are for 146 Mc.

A small fixed condenser may be inserted between the line and the grid coil, if it is desired to avoid a direct d.c. path from antenna to grid.

In some cases it may be found that, because of poor over-all performance, the peak of noise at resonance may not be enough to permit employing this method. This may also result from degeneration caused by cathode-lead inductance. In this instance merely adjusting the antenna coupling for maximum signal will probably produce the

TABLE II

Probable noise figures for types of r.f. amplifiers commonly used in v.h.f. receivers

Tube	Noise Figure at 290 Mc.	144 Mc.	50 Mc.	30 Mc.
6AK5 cascode	10 db.	6 db.	3 db.	2 db.
6AK5 pentode	15	10	4	3
954 pentode	20	12	7	5
6AC7 & 1851	—	—	6	4
6K7, 6SG7, 6BA6, etc.	—	20	10	7

best results. The loading is not solely or even mostly supplied by the signal source, and thus the above analysis does not apply.

Using this technique on several converters for the v.h.f. bands, including one recently described by the writer in *QST*,³ results have come so close to those obtained when a noise generator is employed that there is no measurable difference. In the case of the 2-meter cascode converter referred to above this means adjusting the position of a tap on the grid coil for a 4- to 5-db. rise in noise when the ground is removed from the grid. Readers of the *QST* story may recall that a series-tuned antenna coil was shown for use with coaxial-line antenna systems, but it was later found that a slightly lower noise figure could be obtained when the coaxial line was tapped directly on the grid coil, rather than using inductive coupling. Using a moderately high-Q input circuit, with the coaxial line tapped on the grid coil, it has been possible to get a noise figure of 4.8 db. at 146 Mc.

For 300-ohm input the only way that has been found to get really adequate coupling is the use of a balun of the half-wave type, as shown at B or C in Fig. 1, giving balanced-to-unbalanced input. With the customary inductive coupling the best that could be done was a noise figure of about 5.5 db. The tapped-coil method is quite critical in adjustment, and its success depends on reasonably-constant antenna impedance over the band, but when these conditions are satisfied it is the best system yet tried. The connection to the coil may be made through a small fixed condenser if desired, to prevent direct d.c. connection between the antenna system and the r.f. grid.

³ Cross, "A Cascode Converter for 144 Mc.," Oct., 1949, *QST*, p. 11.

Silent Keys

IT IS with deep regret that we record the passing of these amateurs:

- W2ADW, Maurice G. Carter, E. Quogue, L. I., N. Y.
- W2COJ, Dale M. Fravel, sr., Rochester, N. Y.
- W4DON, Hugh B. White, Chattanooga, Tenn.
- W5CMJ, Osborne C. Palmer, Tyler, Texas
- ex-9AIM-9AJ, Harry A. Mackley; Peoria, Ill.
- W0BZE, Dr. Lothrop Smith, Iowa City, Iowa
- W0EKT, ex-W9EKT, Francis H. Parker, Chancellor, S. D.
- VE3NN, Peter V. Swan, Cobourg, Ont.



Hints and Kinks

For the Experimenter



TWO IMPROVEMENTS IN ALL-METAL BEAM CONSTRUCTION

ANYONE who has made an all-metal rotary array by running the elements through a boom made of dural tubing knows that this method leaves a lot to be desired. The elements vibrate in the wind and soon wear themselves loose, even if they were originally driven into the holes in the boom. Worse, the abrasive effect of aluminum and its alloys soon wears the elements thin enough at the points of contact so that they break under wind or ice loading.

This is easily corrected by the use of simple "U"-shaped clamps that can be cut from ordinary soft sheet aluminum. Where thin-wall conduit is used for elements these may be the pipe clamps used for mounting the conduit when it is used for electrical work. Two of the size that fits the elements are used at either side of the boom, with two more that fit the boom running over the top of it, as shown in Fig. 1.

The clamps may be made from strips of aluminum $\frac{3}{4}$ inch or more in width. Make them such a length that they do not quite meet when mounted in place. Pulling up on the screws then results in a

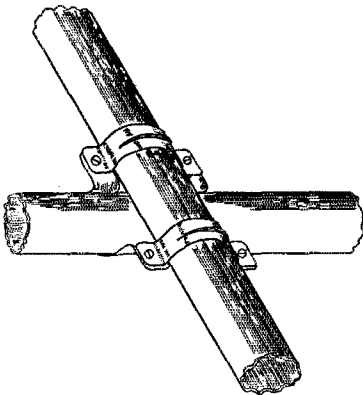

Fig. 1 — A really rugged method of fastening beam elements to a boom in an all-metal array. Pairs of pipe clamps back-to-back do the job. (Suggested by W2AOE.)

very strong and absolutely rigid joint. An easy way to judge the right size is to cut samples from thin soft sheet metal such as copper, then make them to size from the sample. Laying out all of them side by side on a single sheet of aluminum and drilling the holes before cutting and bending

simplifies the operation. Credit for the above ideas goes to W2AOE and W1JEQ.

If you haven't already put up your all-metal job you may prefer the system used by W5KQD. George uses a short length of 24ST channel stock as a cradle, bolting the elements to this, and attaching the channel to the boom by means of "U" bolts as shown in Fig. 2. The "U" bolts or clamps

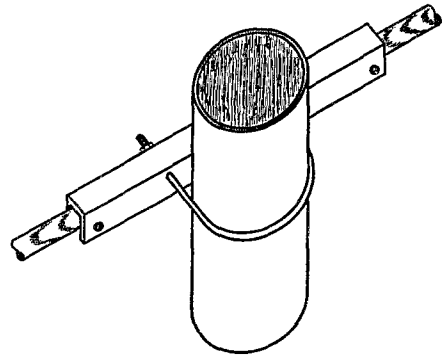

Fig. 2 — Another method of mounting the beam elements. Aluminum channel brackets and "U" bolts are used in a neat and rigid assembly. (W5KQD).

may be bought in various forms in hardware or auto-accessory stores. This system has two advantages over the through-the-boom method. It leaves the boom at full strength, and it permits adjustment of the spacing. The elements, of course, may be mounted above or below the boom. — W1HDQ

SIMPLIFIED LC CALCULATIONS

A RECENT letter that appeared in "Correspondence From Members" ¹ urged me to dust off a formula I've used for several years to determine the number of turns required for a coil of given inductance. It originated from the formula given in Circular 74 of the Bureau of Standards. Converting the published formula to inches, and assuming a coil length equal to the coil diameter, the following simple expression results:

$$N = 7.6 \sqrt{L/D}$$

where N = number of turns required,
 L = inductance in microhenrys, and
 D = diameter of coil in inches.

For example: Assume that a coil of 0.119 μ h. is

¹QST, Nov., 1949, p. 57.

required. Its diameter is to be $\frac{1}{2}$ inch, and length the same.

$$N = 7.6\sqrt{0.119 \times 0.5} = 3.7 \text{ turns}$$

The formula may also be modified for use in cases where the diameter is one-half the length of the coil. It then becomes $N = 10\sqrt{L/D}$. For coils in which the length is to be half the diameter, $N = 6.2\sqrt{L/D}$. — *Keith Rhodes, P.E.*

CODE-PRACTICE OSCILLATOR

AN AUDIO SIGNAL for code practice may be obtained by owners of National receivers that are equipped with accessory sockets by using the circuit shown in Fig. 3. The parts for the oscillator are small, so all may be built into the top of an octal multiwire plug such as the Amphenol 86-PM8. Two leads for connecting the key are brought through the top of the plug.

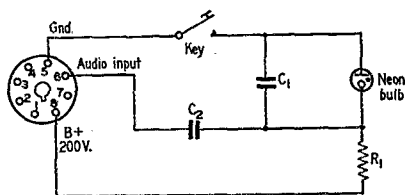

Fig. 3 — Circuit for an audio oscillator that can be connected to the accessory socket of receivers such as the National NC-173. The neon bulb is a Type NE-2.

- C_1 — 0.001- μ fd. mica.
- C_2 — 100- μ fd. mica.
- R_1 — 6000 ohms, $\frac{1}{2}$ watt.

The oscillator frequency may be varied by changing the size of either C_1 or R_1 , or the applied voltage. Any voltage between 100 and 350 should be suitable, and the current drain is so little that the unit may be connected to any of the voltages available at the accessory socket without fear of either overloading the supply or impairing receiver operation. — *A. D. M. Lewis, W8LOT*

SIMPLE BCI CURE

OPERATING a kilowatt 'phone rig in the same house with an a.c.-d.c. midget radio usually spells BCI. In some cases rather drastic measures are needed to clear the interference, but the simple dodge described here may do the trick. If the transmitter is operating in the 10-meter band, add a 6-foot extension cord to the a.c. power cord of the midget. Wind the extension cord around a $\frac{1}{2}$ -inch diameter form. When you get the right number of turns, the interference should disappear.

For 20-meter operation, a 12-foot extension cord wound in a hank (just as they come from the store!) was added, and now everyone is happy. It's so simple that it's worth a try. — *William Hall, W5ASG*

PRESERVATIVE FOR WOODEN MASTS

A VERY CONVENIENT, effective, and easy way to "seal" and waterproof a telephone pole or other wooden mast that is to be set in the ground is to paint it with automobile chassis black. This paint has a very high percentage of asphalt, and after the job has been completed the brush can be cleaned with kerosene.

This paint can be obtained from almost any auto supply store for about \$1.75 per gallon. A more expensive grade is also available, but for this purpose the cheaper variety is good enough. — *W. E. McCormick, W5KMA*

DIRECT-READING DIAL FOR THE HRO

MANY HAMS find it inconvenient to have to refer to the calibration charts supplied with the coils of the HRO receiver. Shown in Fig. 4 is a method of applying a direct-reading calibrated scale to the flange of the HRO dial.

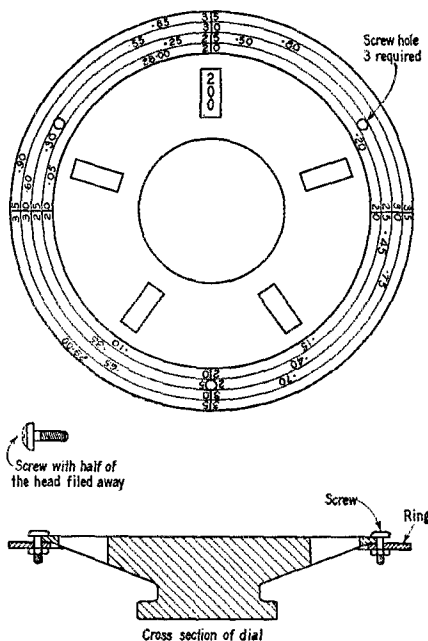

Fig. 4 — Novel direct-reading calibrated scale for attachment to the HRO dial.

A cardboard or Lucite circle, slightly larger than the dial, is pierced with a hole that is just slightly less in diameter than the dial. Four concentric circles are then scribed as shown in the drawing. It usually takes about four complete revolutions of the dial to cover a given amateur band with this receiver, thus one circle is available to carry the calibration for each revolution.

Key figures to indicate which of the various circles applies for a given dial setting are lettered

(Continued on page 108)

TVI Tips

JUNK-BOX TVI CHECKER

By far the best way to check TVI is on a television receiver in your own house. But if you don't yet have a TV receiver, it isn't necessary to go entirely without a means for checking. A regular converter, for use with your communications receiver, can be built up,¹ but if that seems like too much trouble there is an even simpler way. Simpler, that is, if you own — and

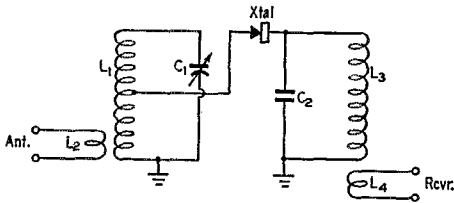

Fig. 1 — Circuit diagram of the crystal mixer.

- C₁ — 50- μ fd. midget variable.
- C₂ — 47- μ fd. mica.
- L₁ — 5 turns No. 14, inside diameter $\frac{1}{2}$ inch, length $\frac{3}{4}$ inch; crystal tapped on at center.
- L₂ — 1 turn No. 14, inside diameter $\frac{3}{4}$ inch.
- L₃ — 8 turns No. 22, diameter 1 inch, length $\frac{1}{2}$ inch.
- L₄ — App. 3 turns No. 22 at ground end of L₃.
- Xtal — 1N51 or 1N34.

you should — a grid-dip meter covering the TVI range. All you need to do is to use the grid-dip meter to supply the local-oscillator voltage for conversion, and then build a very simple mixing circuit using a crystal detector.

Fig. 1 is a suitable circuit, and the photograph shows how such a gadget can be constructed. The parts required can be found in almost any junk box. Essentially, the device is nothing more than two tuned circuits and a crystal detector. One circuit tunes over the low group of TV channels; the other has its tuning fixed at a selected intermediate frequency. C₂ in Fig. 1 is both a by-pass for the signal frequency and the tank condenser for the intermediate frequency. The i.f. output is taken from a small coil and fed to the antenna terminals of a communications receiver.

You can select practically any intermediate frequency that is convenient. The constants in Fig. 1 put the i.f. at about 16 Mc., a frequency that is covered by most communications receivers and which is far enough from the signal frequency to put the oscillator frequency at a spot where it isn't likely to cause too much interference in some other channel than the one being tuned in.

¹ For example, see *QST* for April, 1949, p. 17. A suitable oscillator is described in the Nov., 1949, issue, p. 29.

The sensitivity of a device of this sort is quite adequate if the TV signal strength is enough to give good pictures on regular TV receivers. The grid-dip meter can be used for setting it up. Tune the signal circuit to the TV picture carrier frequency by resonating with the grid-dip meter, and then set the meter 16 Mc. (if that is your i.f.) higher, coupling as tightly as possible. Searching with the communications receiver around the i.f. should bring in the picture carrier, which can easily be identified because it sounds like particularly harsh diathermy with a series of satellite carriers spaced about 16 kc. on either side. Note the S-meter reading, and then compare the S-meter readings of your harmonics in that channel. If the harmonic strength is 40 db. or so below the picture carrier you should have no harmonic TVI. The best way to carry out a test of this sort is to put up a dipole cut for the TV band, turning it to give maximum picture signal.

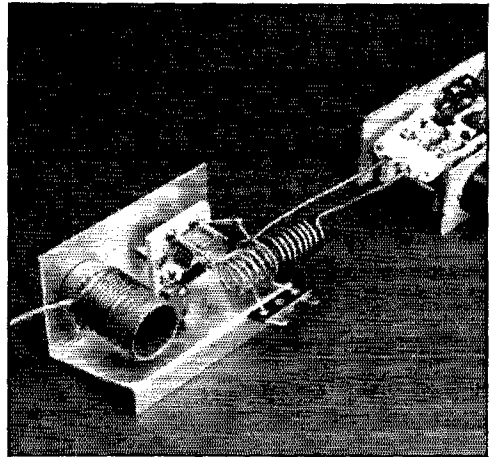

Simple crystal mixer for the 50-100 Mc. range, showing how the grid-dip meter is coupled.

A simple mixer like this has about all the faults that any mixing system can have — although because of the tuned circuit it will respond less to your fundamental than most TV receivers. But its tuning is somewhat cantankerous, it will radiate every bit as well as the worst TV receiver, the mixer pulls the oscillator, and it will give spurious beats. Its virtues are cheapness and ease of construction. Operated with reasonable intelligence, it will give the answers you need in TVI work.

— G. G.

How's DX?

CONDUCTED BY ROD NEWKIRK,* W9BRD

How:

Despite scattered occurrences during the DX Test now in full swing, the fact remains that we haven't been strongly called upon to fling diarrhea and boiling midnight oil on the heads of the DX Hog menagerie for quite some time.

Jeeves, cynic and pessimist that he is and will always be, offers the unsolicited opinion that everyone has merely grown accustomed to the situation. Undoubtedly a happier view should be taken.

The fat mailbag indicates that more DX is being worked these days than ever before and thus gives us better reason to believe that the postwar DX rush with spiked elbows and stilettos flashing has definitely passed its peak.

It is apparent to many that even the most antsy-panted individuals have come to realize that they'll all live long enough to paper their walls with Asian QSLs and that, after all, such fancy accumulations of wallpaper aren't really worth the reeking reputations possibly built up in the process of QSOs at any cost.

Being no more than rank laymen in the castuistic field we'll have to let it go at that and continue to hope and work for the best.

If you've finished totaling up your multipliers for the opening sessions of the 16th ARRL DX Competition you may have time to digest, or at least masticate, a few of the items to follow. . . .

What:

The region around 1800 kc. has been sounding like 14,000 kc. at about midnight and later EST. The following *one-sixty* DX has been getting across the pond in our direction: Gs 2PL, 2YS, 3PU, 5JU, 6BQ, 8NF; GD3UB; GM8UM; FASBG. W1s BB, OE, W4NNN and VE1EA were the principal participants in festivities on this end. Up through January 15th, VE1EA had knocked off seven European QSOs with six stations including two GD3UB contacts while W1BB has hit S9 peaks at G2PL. For best results, G2PL recommends that Ws transmit just above 1800 kc., listening in the spectrum 1780-1800 for foreigners; the latter, to minimize interference, should operate vice versa.

On *eighty*, W8GZ has been working JA2AZ (3851) on 'phone and c.w. from 0600-0800 EST. VE7JT and W5KMZ were fortunate to grab the Asian, too. . . . W4BRB came down with mumps and that gave him time to catch up with YO3RI (3512), MI3SC (3510), SV9WH (3533), CT3AB (3518) and SP1CM (3535) and that makes 75 countries worked for Gene on 80. Also in the W4BRB log are KL7OK (3547), OH2NB (3512), HA4SA (3515), ZLs IHM (3520), 2ACV (3523), FA9RZ (3518), ZS5YF (VFO), EI9J (3515) and OZ7BO (3515). Not bad for a non-DX band (as some have had the gall to term 80 meters!) W2QHH now has 62 3.5-Mc. countries, his 35-watter recently adding SP1CM, CT1BV (3562), TA3GVU (3505), OH2NB, FA8IH (3500), VP5BD (3503), EK1AO, VK5KO,

CT3AB and SM4AEE (3505) W9AND made it 32 countries with PY7WS and VP5BF while W1QIQ got behind the key at W1YA to knock off SV9WH, EI9J, KZ5DR (3550) and a hatful of Gs and DLs ZS5YF, who tries to hit 80 twice weekly, lists among his QSOs W4s BRB, DXI, KFC, W2PEO, W6ZAT, G6QB, VE1BV and VE3AGX.

Forty takes on more of the characteristics of 20 meters day by day. W2FXN works VK5KO, ZS2A and various Europeans around 1300 EST. Australia at high noon on 7 Mc. with solid signals is DX not to be sneezed at. While this long-path stuff is rare, regular skip is entertaining enough W7MQY has things under control out west with KG4AK (7071), VS6BK, KG6GM (7040), VS1BX (7040), PK5WB (7039) and UA0KFD plus a logful of more common Pacificans. . . . W6FNJ has some of these and adds UA0FB (7010) while W2KIR returned to the air in time to swipe EA6AI, EA8BC and VR2AS for new ones. FK8AA has been heard but AI's 25# 211 hasn't yet made the grade on that one. . . . W9NN said farewell to the old QTH with I1AOH, OK3AL and FA8DA and W4QQH thought Pensacola ought to have a plug because of UB5DC, HB9X, DL5AA, OH6NR and VK2AJG W1QMJ was particularly intrigued by calls like LZ2DC and ZC2OT while working CT1AL, MD7DC, HA4SA, PY2AC, UB6BK, FA8RJ and sundry others Recommended by W5LAK are CN8BI (7014), HA4SB (7004) and HR2HZ (7004), and W4CJS, formerly W3CJS, found the new QTH just right for YO2BU, FA9VN, HA5C and LX1BO, W4CJS, by the way, uses one of those invisible antennae of No. 26 wire. . . . At W2EQS we have FA9RZ, MD2PJ, HA5K, CT2JL, YO3RI and LA6U. Charles was informed by the RSGB that VP7RL, a 7-Mc. QSO, must be a pirate; no such animal licensed. . . . W7GVH, 69 years young, has his 100-watter fired up on 7045 for some of this DX he's been reading about on these pages. He opines that Jeeves deserves a toupee!

By the time this appears in print *twenty* will probably be hotter than a two-bit 6L6 all around the clock but right now there are varied viewpoints. The fellows who can get on in the daytime think conditions have been superb but



*DX Editor, QST. Please mail reports of DX activity to W9BRD's home QTH: 1517 Fargo Ave., Chicago 26, Ill.

the chaps stuck with nighttime operating hours — we dassn't quote them! KH6PM must have been in the first category, having snaffled QSOs with C3MY (14,125 t6), FF8MH (14,120), FE8AD (14,135), HC2GRC, HR2RF (14,080 t7), KX6BA (14,067), OQ5CH (14,030), PJSRE (14,010 t7), TF3ZM (14,005), TG9FU (14,085 t3), UD6AH (14,060), VK9RH on Norfolk (14,050), VP3TY (14,070), VP6CDI (14,000), VQ3KIF (14,045), VR2BU (14,070), VS6JH (14,100), VU2BY (14,000) and XZ2EM (14,000). Fred has been chasing HLIUS (14,070), TA3FAS (14,080) and VR1AR (14,095) but no luck to date During a week's school vacation, WØEYR hauled in FY8AA (14,002), KC6WB (14,039), 4X4CJ (14,040), UP6KAF (14,010), SP1CM (14,083), FN8AD (14,013), UJ8KAA (14,032) and AP2N (14,080) In another good week's work W9TQL, with leg in cast, knocked off 72 countries including EA6AF, ZD2FAR, CR4AE, UO5KAA, UP2KBC and UN1AB The QRP at W2QHH eked out GC2FMV (14,036), VS6BO (14,083), UAØAA (14,018) and ZD8B (14,019) while W8BZX is rather curious about a DI2BC heard around 14,000 kc. An interesting one at W6EYR is XA1A (14,020), "QSL to Box 18, Cairo, Egypt," and W4MR collected EP2A, VS9AL, F9QV/Corsica, VQ8AX (14,080) plus several UAs Nebraska can't be such a tough QTH inasmuch as WØFWW has contacts with UL7AB (14,060), UA9s KCC (14,010), KOH (14,026), FE8AB (14,060), EL5B (14,140), EL7A (14,070), VQ4HJP (14,068), VU2AT (14,056), MI3GH (14,020), YS1ZG (14,052), HA5B (14,094), ZB1AY (14,042), CT3AV (14,020), CN8BQ (14,015) and 4X4BM (14,068) entered in the log WØWFP and others are intrigued by LUØDAG (14,051 t4) and W2ICO is headscratching about AC4D (14,089), "Box 7, Lhasa, Tibet." W5JUF tried some c.w. before changing QTH. John is thinking of trying for an HR call after verifying 91 out of 117 in a short while on 'phone Close to his DXCC, W5LAK lists chats with SP5AC (14,028), VK9GW (14,008), VQ4KRL (14,022), ZS3B (14,048), ZS9D (14,075) and TF3SF (14,058) and W2EQS caught up with ZD4AM, MD7DC, TF3AB and TA3AA CR4AF (14,042) could use a filter condenser and 14-Mc. crystal as mentioned to W2WZ. Al also swapped salutations with VQ4BB (14,011), KP6AB/KM6 (14,004), FY8AA (now signing FY7YA), CR6AW (14,030), MD7XP (14,034) and FQ8CH (14,058 t8). Checking with his rotary, W2WZ found much DX coming in on the short and long hop simultaneously, morning and afternoon.

On 'phone, W4IUO found fishing well worth while: KB6AJ (14,214), HR2RF (14,320), HZ1KE (14,355), MID (14,315), MI3US (14,340), ZS3s G (14,318), M (14,311), Z (14,320), ZS8A (14,312), CR5UP (14,130), CP1AD (14,287), EA8CO (14,300), 9AI (14,320), FA9WD (14,315), OQ5CF (14,312). GD3UB (14,360), ZD1FB (14,178), YKs

IAA (14,307), 1AC (14,312), AR8BC (14,310) and KR6BM (14,163). Jim is still stalking VK1ADS (14,370), W6COI/-KB6 (14,285) and ZC2AL (14,187) TG5DM tells W5ISF that prefix TG5 is given to portables in Guatemala. TG5DM changes QTH so regularly that he wound up with such a call and vows 100% QSL WØEYR adds some more nice voicers to look for, working XZ2SY (14,313), VS7s GR (VFO), SV (14,377), YO7WL (14,360) and VU2s DU, DY and ET VS6BE (14,303), VU2s DH and GB were welcomed at W5JUF and John still seeks contact with VU7AH and ZC1AR.

W1EKU continues to capture nice stuff on ten but still can't get a QSL from Pakistan. AP2G, SVØWB, SVØWF, EQ8SAM, FF8PG, ST2KR, ZS3G, ZS9F, ZB1H, EK1AD, HZ1AB, MD7HV and 3V8AP now no longer need Vermont for WAS Forsaking v.h.f. temporarily, W1EIO exchanged words with T2s SA, VO, 4X4AD, HH2W and EL9A while W2VRE specifies P1WS (28,335), ZD4AU (28,295), EK1CH (28,073) and ZC6UNJ (28,140) MD7HV tells W8GZ that he's the only Cyprus feller active on ten (28,240) and S. C. listener L. G. Brazell thinks the boys ought to know about DU1s VVS (28,380), FH (28,175), PK3SJ (28,250), YO7WL (28,370), ZD2S (28,375), ZK1BA (28,200) and AP2G (28,600). He's particularly curious about a ZC3TA heard rolling through during the a.m. In Grand Rapids, W8NOH's antenna fell down, giving him a chance to drop us a line, but before succumbing to sleet the wire raised KR6AS, KR6CG, MF2AA, GC2RC, FF8AH, GD6IA and OQ5AO W2ZVS adds CR6AI, ZD1FB, ZD1PW, TA3GVU, IS1RPA, 4X4AD, TF3MB and ZD4AU to his collection while W4QT wonders why he didn't try 10 'phone a long time ago, now being mighty close to that diploma.

C.w. plays second fiddle on this band but the Ontario boys don't much mind. VE3AFY nailed GC3EUB, GC2AAO, UB5BY, CN8BQ, YO3RD and SP5ZPZ while neighbor VE3DBF was bagging FE8AB, CN8MR, TA3FAS, CX6BT and FA3RR W9AND finds that CE6AB (28,033) is looking for Delaware and Vermont. Wes also hooked CR4AF (28,012), YO3RI (28,048), MI3SC and GD3FOC while W2QHH was busy with San Marino in the person of IIAHV/M1 (28,007).

Where:

We are informed that any Guantanamo (KG4) station may be QSLd via FPO, Navy 115, New York, N. Y., and any DL5 can be reached through the REF. The URE (Spain) asserted to W9TRD that EA stations will soon be on in droves and that all will receive cards through the URE bureau, Box 220, Madrid. Also note the following:

C3MY	P. O. Box 34, Taichung, Formosa
CT2JL	James Leal, Santa Maria Airport, Azores
EL9A	Bishops House, Monrovia, Liberia
FF8AH	Box 566, Dakar, French West Africa
FQ8AA	SCKN, Brazzaville, French Equatorial Africa
HH2W	Box 117, Port-au-Prince, Haiti
HR2RF	Tela RRCC, Lalima, Honduras
IS1RPA	Merello 67, Cagliari, Sardinia, Italy
KR6CG	1962 AACs Sqdn., APO 239, % PM, San Francisco, Calif.
KR6CI	Lt. C. Engle, 13th Comm. Sqdn., APO 239, % PM, San Francisco, Calif.
MI3DX	Box 880, Asmara, Eritrea
MI3SC	AP0 843, % PM, New York, N. Y.
OE7FR	(via W1LSZ)
PK1RI	Palmenlaan Nr. 8, Djakarta, Indonesia
PK3MR	M. R. la Cotey, P. O. Box 222, Soerabaja, Java, N. E. I.
PK4KS	Tan Koon San, Pangkalpinang, Banka Island Indonesia
SP5ZPZ	% PZK, Box 320, Warsaw, Poland

These boys passed out 340 Liechtenstein contacts during their recent expedition to the principality. L. to r.: HE1s HK, JJ, EL and JZ. They also hold HB9 calls to match.

QST for

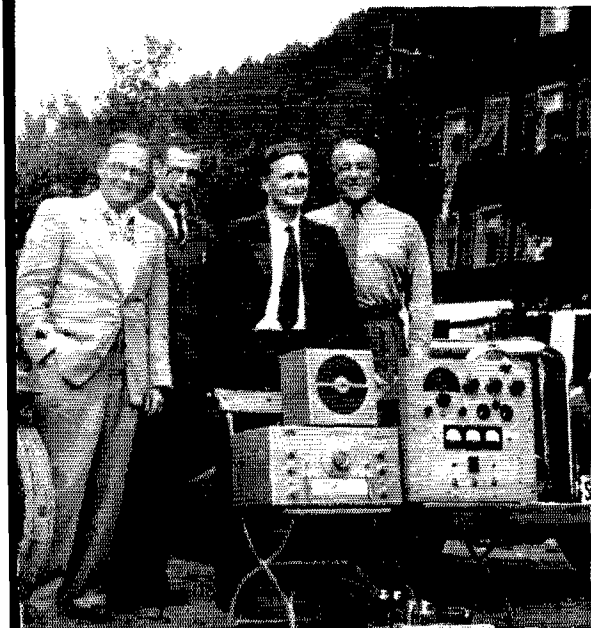



The well-engineered installation at ZS6Q, Johannesburg, operated by Harry Chemik. The gear features such items as a BC-221 VFO with slug-retuned exciter, separate finals for four bands, and rigidly-monitored modulation. Antennae include close-spaced and Lazy H beams plus 40- and 80-meter folded dipoles.

- SV0WI QSL Bureau, 17-a Bucharest Street, Athens, Greece
- TG5DM Inter-American Geological Survey, % U. S. Embassy, Guatemala City, Guatemala
- TI2SA P. O. Box 1266, San José, Costa Rica
- TI2VO Ed Myers, % U. S. Embassy, San José, Costa Rica
- ex-VO2RF Ray Forrester, W3STT, 516 Morgan Ave., SE, Washington 20, D. C.
- VQ3KIF R. Stephenson, RSEA, P. O. Box 1313, Nairobi, Kenya, B. E. A.
- VQ4BB Box 20, Nanyuki, Tanganyika, B. E. A.
- VR2BU (via VR2AS)
- VU2BY % IRAL, Box 5588, Bombay, India
- VU2RX % IRAL, Box 5588, Bombay, India
- YS10 Box 329, San Salvador, Salvador
- ZD2FAR % Post and Telegraphs, Lagos, Nigeria
- ZD2TBS % A. T. & P., Ltd., Sapele, Nigeria
- 4X4AD Box 2713, Tel-aviv, Israel

W1s GD EIO NLM ODW, W2s ADP CJX EQS SUO ZVS, W3s KB VES, W4IUO, W5ISF, W6s ALQ CTL, W7s AYJ EK, W8s NOH OCA, W9s AND CFT LI MDG TQL, KH6PM and the No. Calif. DX Club's *The DXer* all spent postage to pass along the preceding information.

Tidbits:

We unwittingly opened a session of "Can You Top This?" with that OA4DO Tidbit a while back. W8NOH states that CPIAM, attached to the U. S. Embassy at La Paz, is at least a thousand feet higher and usually augments his radio equipment during extensive operating periods with a cylinder of oxygen. CPIAM comes from



W2WMV/C9 was quite in demand for a considerable period of time on 10 and 20 meters. Here is a shot of his neat set-up in Manchuria where various types of beam antennae were tried with considerable success. (Photo courtesy W1PDF)

March 1950

W9-land and has a hundred watts of 'phone perched on 28,400 kc. Also, Ed strives for a 100% pasteboard policy . . . ON4QF shipped out 750 LX1QF QSLs, according to W9TQL, and is making plans for that future Monaco trip. Mick wants to make sure that worth-while conditions will prevail before he knocks himself out in this next venture. Meanwhile, ZS5YF hears that DL4ND will try to hit the air during a vacation in Monaco due shortly. ZS5YF, himself, will be returning to G3BYF before long and F8AB will take up his old concession at F3AT shortly . . . If you've been wondering about an overdue OE7FR QSL, you may now take your troubles to W1LSZ who is taking over as his Stateside liaison. W1LSZ's address: Les C. Halliwell, Box 177, Barre Plains, Mass. . . . W6CG passed word through W9WEA to the effect that MP4BAD has now closed down for a return to England. There he will become active under a G call and wishes to thank all Ws for fine cooperation during the past eleven months. For QSL purposes Ken may be reached via RSCB . . . Though KX6BA is still being operated, "Cliff" of that station may now be reached through W6CTL . . . Wool ZS8A told W4IUO that a diminishing supply of petrol for his generator is going to curtail his operating hours. [Too bad he can't turn the thing on some of your hot air, Boss. -- Jeeves] . . . KL7ACI mentioned to W9AND that the station was located next to The Valley of Ten Thousand Snakes. What a place to go on a bender! . . . We've heard much pro and con on EQ3SAM and wish someone would settle the question once and for all. KR6CI vehemently takes the affirmative. Too bad most of us have to be such skeptics but we hope it turns out that way, anyhow . . . Add possible new prefixes: The boys have been chasing an LUØ from somewhere and W9AND tripped across VEØAA on Ellesmere Island, 20 meters . . . ZS6DO will try some portable-ZS7 work soon says ZS5YF and ZS2X notes that FY8AA is now signing FY7YA at the same old stand . . . Quoting W9TRD, who should know, the present legit Cyprus licensees are MD7s DC, GR, HV and WE. U. S. Air Force men MD7BL and MD7TJ are QRT and presumably back in Germany . . . The latest in the certificate department comes from the Argentine. The periodical *Radio-Onda* offers to any local or foreign amateur a sheepskin upon working 50 or more countries over the range 7 through 30 Mc. QSLs are not necessary; a list of QSOs "legalized by a Radio Club or responsible entity of radio amateurs" may be submitted to DX Editor LU8BF, L. M. Moreno Quintana (h.), Cerrito 1222, Buenos Aires, Argentina, with specifications as to whether the QSOs were all c.w., all 'phone, or both. The ARRL Countries List may be referred to. W9WXT forwards this info and the line forms on the left and right . . . If the U. S. S. R. doesn't lead the world in the number of amateurs they are certainly holding their own in the SWL field, judging from W4MR's collection of reports. Al is rolling up sleeves for a rebuilding job that should permit him to jump hands with the greatest of ease . . . VP5BD cards began coming through with a rush accompanied by yelps of joy throughout the country. That was one well worth waiting for . . . Attention, all former KA/DU station operators who have operated from the Philippines since 1944, whether undercover or not: There is an accumulation of QSL cards, some possibly for you, in the hands of Sgt. (Continued on page 114)

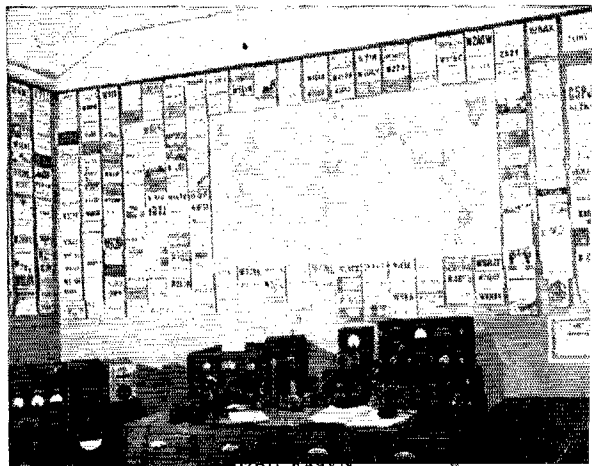



The World Above 50 Mc.



CONDUCTED BY E. P. TILTON,* W1HDO

THE DEADLINE for reporting in the 3rd Annual V.H.F. Sweepstakes is still several days away as we write, and though a goodly number of logs are already in the contest file it is too early to have much indication of the scoring. We promise you the complete story next month, but right now, while the memory of the contest is still fresh in our minds, is perhaps as good a time as any to consider the long-term effects of such operating activities.

Several objectives are kept in mind when the ARRL program of v.h.f. activities for the year is formulated. V.h.f. contests are not quite like those sponsored primarily for lower bands. They have some common purposes, of course. Certainly one of these is to provide a period of intense but friendly competition, with all the fun and excitement that such rivalry brings out. Another is to furnish a test of equipment — who doesn't see ways to improve his layout during one of these workouts? But the v.h.f. program has some specialized aims. Since it seems that we never have enough stations on the v.h.f. bands and too many on our lower frequencies, a primary purpose of a v.h.f. contest should be to entice a few recruits away from lower and more crowded bands. In the same vein, it is hoped that periodic contests encourage those who already have v.h.f. gear to use it oftener.

How well our present program serves these aims is the subject of some differences of opinion. A v.h.f. contest has been likened to a terrific binge, with similar hangover effects. If it is true that, after a week end of concentrated operating, the wornout contestant wants no part of 50 or 144 Mc. for weeks or months to come, then the contest idea is wrong in principle, and it should be discontinued forthwith, or at least be changed radically in form.

Let us take a careful look at our contest forms as they stand at present. The V.H.F. Sweepstakes pays off on *operating*. Club awards spur participation, bringing out some of the country's crack operators, some of them for their first try at v.h.f. Versatility, as shown by the ability to work more than one band, helps to boost the scores, but it is not a dominant factor. The same station worked on two bands counts as two contacts (the only essential change from the regular SS rules) but only the total number of ARRL

sections is used as the multiplier. No extra credit is given for use of 220 Mc. and higher. The V.H.F. SS is scheduled each year in January, normally the low point of the year in v.h.f. interest. Its most important function is to thaw out activity on 6 and 2 that would otherwise be lost from November to April.

In the spring and fall contests the accent is on versatility. There is little need for a pure activity incentive in June, for instance, when propagation is at its peak and enthusiasm is riding high. So the V.H.F. Party rules are changed to promote use of the higher frequencies, and to encourage participants to use both of the major v.h.f. bands. We want to draw operators from the low frequencies, of course, but we want them to try all the bands, and provide at least a beginning of amateur utilization of our higher-frequency allocations.

These, then, are some of the objectives. Are they well served by the contest forms presently used? There is bound to be some weakness in any contest set-up — but would anyone want to see the contests discontinued entirely? Is there a form that would work out better, than the ones we now follow? Remember, these operating activities are sponsored for your enjoyment; if you see any special way in which they can be improved, we at ARRL Headquarters want to know about it.

Let's take 50-Mc. activity in Hartford County as a typical example of the ends a contest may serve. During the V.H.F. Sweepstakes there were eleven stations on 50 Mc. in Hartford County. Of these, only five had worked on 6 meters with any degree of regularity heretofore. Three had never been on the band, and three others were giving it a real try for the first time. For all these fellows the band was on trial — and several of them liked what they found there so well that they are taking up permanent residence. They'd been talking about trying six for a long time, but it was the prospect of contest activity led them to take the hurdle. Now that they're on, they like it, and what's more important, they are trying to talk others into getting on the band, too. Isn't this just what we're after? In the evenings since the contest there has been much more doing on 50 Mc. than would normally be expected at this time of year. If this be a "hangover" let's have more binges!

* V.H.F. Editor, QST.

Horizontal-Vertical, De Luxe Version

When W3RE decided to compare horizontal and vertical polarization on 144 Mc., he went about it with characteristic thoroughness. He realized that the test array would have to be both big and symmetrical; the photograph reproduced herewith shows how both these objectives were attained. Two 32-element arrays were mounted back to back, one horizontal and one vertical. Tuned circuits in waterproof containers at the center of each array are linked to the feed lines of 52-ohm coaxial line. This eliminated pick-up on the feeders, helping to reduce the cross-polarization components, and also provided an all-weather feed system.

There is a slight vertical component in the horizontal system, and vice versa, but it is a minor factor. Both beams show a gain between 16 and 18 db., and the patterns are practically the equivalent of a single 32-element job. Robbie aims to improve the isolation between the arrays, come spring, by the installation of a screen reflector between the driven-element curtains. His experience with the arrays as pictured agrees closely with the results reported by your conductor, and he arrives at the same conclusion: horizontal preferred by a slight margin.

Here and There on the V.H.F. Bands

Except for the preparations for and the recuperation after the V.H.F. SS, January was a quiet month for the most part. There were few 50-Mc. openings in this country, though our friends in South America were finding that the band was coming to life somewhat after its December lethargy. HC2OT, Guayaquil, Ecuador, worked W5ONS, Victoria, Texas, at 10:20 A.M. on the 8th, and on the evening of the 26th there was a good opening to YV5BX, YV5AE, and YV5AC. This session started as early as 7:50 P.M. EST for YV5AC, and Jerry worked LU6DO, LU6DR, LU9AS, LU1BW, OA4AE, and OA4BG, as well as HC2OT. The band was still open at 10:30 when they called it a night. HC2OT heard Texas stations briefly on the 5th and 10th.

LU9EV reports that 50 Mc. was open in the Buenos Aires area on the 13th, 14th, 15th, 21st, and 26th. Venezuela stations were worked on these occasions, and OA4AE came though on the 15th and 26th. Colin also passes along the information that CM9AC is now all set on 50 Mc.

Looking for ideas for radio club meetings? How about a v.h.f. night? Round up all the club members who are interested in v.h.f. and get them to display their wares and discuss the phases of v.h.f. work in which they are specialists. If there is an authority on v.h.f. in the locality get him for a speaker, but such a formal speech is not necessary to the success of a club v.h.f. night. Member participation is much more important, and the more fellows who take part the better. In many localities there is considerable latent interest in v.h.f., with potential converts just waiting for a little incentive to get started. The radio club can be an excellent medium for developing this interest into a concrete program. Has your club tried it?

The Schenectady Amateur Radio Association tried it on Jan. 9th, with George Tracy, W2EFU, L. F. Jeffrey, W2GYV, George Floyd, W2RYT, and Dallas Hurd, W2PFU, as speakers. There was a display of v.h.f. gear. The region around Schenectady and Albany is not ideally suited to v.h.f. activity promotion, being a difficult area to work out of to any distant point, but a fairly high level of activity is maintained on 144 Mc. regardless. The 2-meter band is included in emergency plans for the area, the 2-meter net tying in with nets on 3.5-Mc. c.w. and 75-meter phone each Thursday at 7 P.M.

Probably a record for number of elements, the 2-meter array of W3RE, Washington, D. C., combines two 32-element arrays, one horizontal and one vertical, on a single support. Both systems are terminated in tuned circuits at the center of the structure, and fed with coaxial line. The midget at the top is a 4-element job for 220 Mc.

Eindhoven, The Netherlands — It may be a little late for use in m.u.f. checking, but 50-Mc. enthusiasts will be glad to have the news from PA8UN that a television station is now in operation on 49 Mc. The sound channel is on 54 Mc. Any one want to bet that they don't get heard on this side of the Atlantic one day before long?

Collierville, Tenn. — The unprecedented ice storm that hit the Memphis area on the night of January 4th gave W4HHK a fine opportunity to demonstrate the emergency possibilities of the 2-meter band. How constant contact was maintained between Memphis and Collierville is detailed elsewhere in this issue. This work was done with a single dipole antenna, the 18-element job at W4HHK having been an ice casualty. To get back in business with his Mississippi pals, W5JTI, W5NYH and W5NLP, Paul put up a 4-element horizontal on the 60-foot tower where the big array had been in order to make a few points in the V.H.F. SS. So far the circuit to the W5s has been working out OK with the small beam, and even W5MKP in Baton Rouge, La., has been worked, a distance of some 330 miles.

Columbus, Ohio — A 100-mile 2-meter teletype circuit is reported by W8WRN. Ken says that K8NAC, Port Columbus, has worked W8WJC at Everett, on at least two occasions.

Johnstown, Penna. — A 2-meter traffic circuit all the way to Beaumont, Texas, was in operation in time to handle greetings addressed to your conductor and signed by W5SM, W5MKP, W5JTI, W4HHK, W9FVJ, W9HKQ, W9DHI, W9NW, W9TKL, W9UCH, W8BFQ, W3LNA, W3KWE, and W3KWH. When it came to W3TIF Doc could not get it across the mountains to the East, so he forwarded it by mail. This still looks like pretty good relaying for the 2-meter band in winter!

Downers Grove, Ill. — A somewhat less heroic effort was involved in a message to your conductor, from W9PK, as follows:

GREETINGS STOP THIS MESSAGE CAME ALL THE WAY ON
80 STOP HI STOP DONT ASK ME WHAT IM DOING THERE
STOP

We could never guess, Jack!

Ashland, Ohio — TVI has not yet become a serious problem to the 50-Mc. gang in the north-central part of Ohio, according to W8NQG. Tom says that W8ECU has no TVI at all, with only 15 feet separating his 50-Mc. array

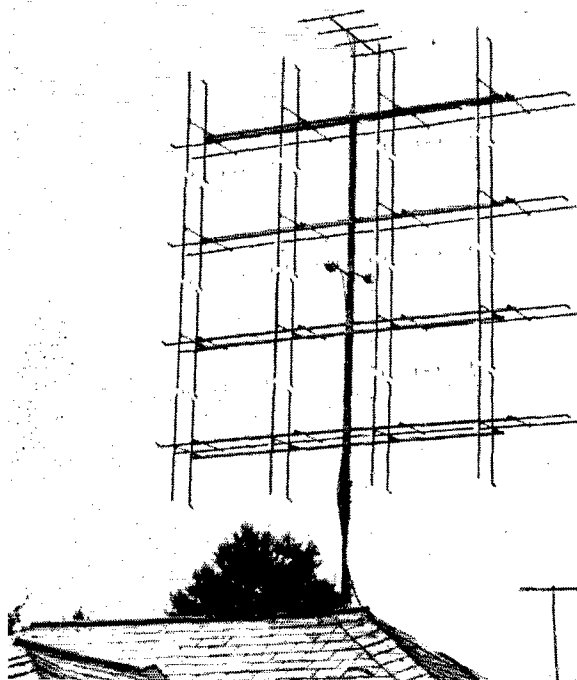

and the TV antenna. Channels 4, 5 and 9 are in use in the area. This rig is a shielded version of the 6AG7-829B rig designed by WICTW and described in August, 1949, *QST*. Tom adds that his experience with this arrangement (and he has built several of them) indicates that better stability in the oscillator results when the 6AG7 suppressor is tied directly to ground, rather than to the cathode, as shown in the *QST* diagram.

Kitchener, Ontario — The first 2-meter activity in the Kitchener-Waterloo area began in December, when VE3-ANU and VE3DPB pooled their equipment and got on using the latter's call. The first successful contact was made on Jan. 5th with VE3AIB of Toronto. Horizontal polarization is used and frequencies are 144.6 and 146.3. VE3ANU will soon be on as a separate station. The boys are on almost every evening from 6 to 9 P.M.

They should have no lack of contacts, if the 144-Mc. activity report of VE3EAH in Toronto is any indication. He has worked 45 VE3s, 26 W2s, and 5 each of W3 and W8.

St. Albans, N. Y. — A 2-meter net for the express purpose of exchanging information relating to 420-Mc. work is reported by W2DKH. Each Saturday morning at 10:30 A.M. W2s OTA, JTV, ZPG, EK, and DKH congregate on 145.3 Mc. to talk over their 420-Mc. problems and arrange tests on the higher band.

On Tripling to 420 Mc.

From time to time your conductor receives letters from 420-Mc. enthusiasts taking us to task for not running more material on stabilized transmitters for 420 Mc. They feel that we are letting the brethren down by not furnishing more information on the operation of various readily-available tubes in frequency multipliers and amplifiers for 420. Actually, we'd like nothing better than to have some nice articles on this subject in *QST*, but the facts are that satisfactory amounts of stable power are not generated easily or inexpensively at this frequency.

There are a few tubes that are capable of working after a fashion, of course. Several low-cost triodes (low cost on the surplus market, that is) are built compactly enough so that it is possible to develop some output with them as oscillators on 420. The 316A, 15E, 24G, and 826 are in this category. But what happens when you try to make them triple?

First you need an inordinate amount of driving power, and very high bias. Then, if you do manage to hit resonance in the plate circuit (a half-wave line may help) the output is apt to be dismally low. Also don't be too sure that the r.f. you do get is all 420-Mc. stuff. Examination of the output power may show a considerable proportion of 140 and 280 Mc. as well. Perhaps you can get rid of the unwanted fundamental and second-harmonic frequencies with some sort of antenna coupler, but it isn't easy, and 420-Mc. circuits radiate with so little excuse that your 420-Mc. micro-watts may be largely lost before they get up to that 48-element beam.

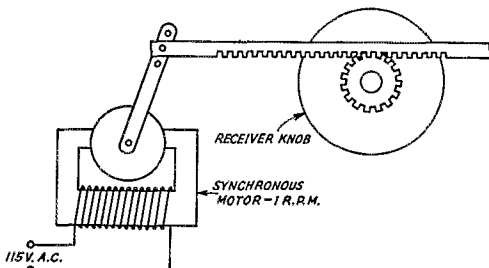

The automatic band-scanning device used by W0ZHL. A low-torque synchronous motor is geared to his converter knob. Revolving at one r.p.m., this rack-and-pinion arrangement scans 50.0 to 50.3 Mc. in 30 seconds, returning to 50.0 in the following 30 seconds. With the b.f.o. on and the audio turned low, enough sound is made to attract attention when signals appear.

2-METER STANDINGS

Call			Call		
States	Areas	Miles	States	Areas	Miles
WIPIV	13 5	550	W4JHC	8 4	500
WIHDQ	13 5	480	W4OXC	8 4	470
W1BCN	12 4	500	W4AJA	8 4	—
WICTW	12 4	500	W4NRB	8 4	—
WIREZ	11 4	—	W4PWH	7	—
WIJSM	10 3	—	W4PQI	6	—
WIJGO	10 3	—	W4KKG	5	—
WIJMU	9 3	—	W4LNG	4 2	—
W10OP	9 3	—			
W1QXE	9 3	—	W5JTI	9 5	660
WIMBS	8 2	275	W5ML	2 1	425
WIAW	5 2	—	W5AJG	2 1	400
			W5LRP	2 1	365
W2BAV	14 5	430	W5FSC	2 1	250
W2NLY	13 5	515	W5JLY	1 1	1000*
W2NGA	13 5	—			
W2DFV	13 5	350	W6ZEM/6	1 1	415
W2CET	12 5	405			
W2WLS	12 4	—	W8UKS	18 7	720
W2DPB	12 5	500	W8WJC	18 7	700
W2QNZ	11 5	—	W8BFQ	15 6	600
W2NPN	11 5	500	W8WSE	14 6	620
W2PJA	10 4	—	W8WRN	13 5	—
W2PLX	9 4	—	W8CYE	12 6	—
W2WGH	9 4	—	W8CPA	12	— 650
W2BNX	7 4	300	W8BA	9	—
W2FHJ	7 3	—	W8DJV	8 4	—
W2RPO	5 4	—	W8RDZ	8 4	340
W2UTH	5 4	—	W8BKI	7 4	—
W2UXP	4 4	—	W8WAB	4 4	—
W3RUE	15 7	760	W9FVJ	13 6	680
W3KBA	13 6	—	W9JMS	13 6	600
W30WW	13 6	600	W9PK	10 5	—
W3GKP	13 5	610	W9GLY	10 5	525
W3KUX	12 5	575	W9OBW	8 4	—
W3PGV	12 5	—	W9KFK	8 4	410
W3KWH	11 6	—	W9GJE	6 3	—
W3BLE	10 6	—	W9UIA	5 3	205
W3KWL	10 5	—			
W3GV	9 5	660	W0NFM	14 7	660
W2HB	9 5	—	W0EMS	13 5	830
W3LMC	9 4	—	W0WGZ	10 4	760
W3KWU	8 3	—	W0TFB	9 6	—
W3VVS	7 4	430	W0EIAQ	8 4	—
			W0DEN	7 4	520
			W0ZJB	6 3	—
			W0GOK	6	—
W4IKZ	13 5	500	W0LXY	5 2	—
W4CLY	12 5	500	W0JHS	4 2	—
W4FJ	12 5	450			
W4FBJ	11 5	—	VE1QY	9 3	650
W4JDN	11 5	—	VE3AIB	8 5	520
W4MKJ	10 5	475	VE3BPB	6 4	—
W4HHK	10 5	650	VE3ANY	4	—
W4JFV	9 5	830	VE3EAH	3 3	230
W4OLK	9 4	500			
W4ODG	9 4	500			

Of course, the right way to do it is to use some of the coaxial-electrode types of tubes that are designed specifically for operation at 500 Mc. and higher. A number of these are available that are capable of multiplier or amplifier service at frequencies up to the thousands of megacycles, with reasonable efficiency. The catch is that they are too expensive to be of much interest to those of us who have to come by them honestly. And coaxial tank circuits are not the easiest thing in the world for the kitchen-table mechanics.

All of which boils down to the tetrodes. We've already seen that the 832A will deliver power at 420 Mc.¹ By smacking it hard enough we can get up to about two watts on 420

(Continued on page 118)

¹ Brannin, "Tripling to 420," June, 1948, *QST*, p. 52.



United States Naval Reserve



THE FOLLOWING radio amateur members of the Naval Reserve have been assigned Naval Reserve call signs for participation in drills on Naval Reserve frequencies from their individual stations:

W1s: AKE AMI BGQ BIG BIY BKR BMS BNN BOD
CBF CMB COM DNP DPH EFQ EHF EOB ERG FI
FWS GHG GPU GQQ GTS GVI GYZ IAE ICN IOK
IPU IVI IVZ KG KLY KTI KTU KUC LIV LQQ LZS
MBV MNK MOG MPS MQR MQV MXJ MYR NK
NS NGD NGV NHC NKB NRL NWG NWQ OGC
OHP OHW OKC OKD OOK OSG OUG PAL PCZ PGZ
PHE PHS PIE PJA PLE PNE POW PSG PTB PUN
PYD PZT QAU QCI QDH QFP QFW QIB QIK QJM
QKA QKW QKY QMK QNA QPQ QVP QWZ QYE
QZL RH RK RBN RCW REC RHW RJF RQQ RXS
WN W3VAL/1

W2s: AA ABI ADL AGE AWQ BPJ BZJ CIT EQF
FBS FCR FFL FYQ GWY HXJ IWH JJT JLT JYL
KEL KGO KMQ KTX LA LC LRI LZS MLZ MMY
MZB NGJ NJF NKJ NVH OFB OYV PNQ PPY QLN
QUH QXV RCQ RJQ RPZ RSE SHM SJC SNP TGB
TMA TSD TXU UPU USH UVT VDE VDR VVV
VVY VZM WJL WLI WVJ WVT WXU YEC YGW
YHO YJP YLP YMI YSH ZFK ZGE ZNE ZRZ ZUT
WABSE/2 W4BYK/2

W3s: AJZ AKY ATM CH DMW DOM DUI DUZ
EBO ELI EW FDH FDQ FWX GA GD GUF HJL HQL
HSZ IJ IME JBG KIP KLE KVM KWA LP LMH
LOY LQM MBB MCG MPB MQC MRP MSU MYM
NAR NIH NKA NNW NOW NRQ NUL OCQ OGE OIU
OOL OPJ OSI OVS OWV PGB QL QV SDS WB K2AT

W4s: AAY AGR ANK BL BGA BIH BNL BRK
BWB BZX CH CQ CJE CQF CRP DAW DFC DHY
DQO DRH EF EAS EBA ECW EFA EFT EGT EHD
EIZ EJY ELL ENI FAV FEH FIL FJO FLF FSN FXG
GY GBA GCS GCV GMM GWF HGQ HDM HDN HJR
HTR HYP HYV ICW IHN IJM ILD IQR IWA IWX
IYA IYR IYV JB JH JRL KT KGQ KKO KMG KRI
KUA KYD KYP LBH LHR LQW LRI LVT LWN
MQ MDA MDL MEM MEV MFK MHE MIA MIC
MKR MPF MQE MSS MWH MXT MYK MYV MYX
NV NBP NDS NRW NHY NJB NOU NRO NSB NTQ
NVG NZX ODA OFE OHO OHZ OMX ONF ORA ORD
OTA OXY PI PAS PDG QEL QU QV VY W4LLA/3

W5s: ABE ABN AIA AXS BAM BAR BQT BRR BUK
BUX CLD CLR CPT DKA DXQ ECB EGX EUS
EXI EZC FH FJ FBL FIV FJE FNS FOG FPX FZU
GCJ GKC GRG GRY GXU HDX HEF HFX HGC
HKP HOT HTI HYD HZW IBL ICS IGL INC INL
IQJ IRP JET JFO JKC JKT JOS JPY JSW KAO KHB
KHH KJD KMI KMN KNM KQT KPC KRL KUC
KXD KXX KYQ LAK LCT LCU LIZ LLO LMI LNU
LPG LQO LQV LRA LSA LVM LXZ LZR MAV MCZ
MED MEJ MFD MFS MGM MIG MPB MPD MPI
MPV MPY MQR MRB MRN MUP MVA MWT MXN
MZE NAL NAV NAY NBR NCN NCR NCS NEL
NGA NJY NLU NMY NOA NOS NPC NQM NSG
NSW NTS NTT NXM NXZ NYP NYV OJ OM OAI
OAU OBJ OCK ODO OEH OGG OHD OJJ OJV OOZ
OQL OQM OQS ORV OSW OTH OTO OXL OXT OXQ
OYE PCL PFO PEP PLQ POC POT PQQ PVE PVG
PYU QFU QMC RY UPC K5QKF KL7LB/5 W1PPS/5
W3KMD/5 W4SQ/5

W6s: ACB ADF AFC AFY AGQ AHO ARB BEU
BFS BHC BHR BJM BNO BSY BVD BVH BVY CMY
CWR CXG DAD DBZ EMX EUG FCX FDR FNZ
FWK GBW GNV GUV GYH HDU HTY IZ ICU JDU
JFX JSF JUW KQK LGO LRU LTE MKH MMZ MSG
NTS NYR OFS ONL OSK PQ QL QVZ RAS RCD
RHB SRU TWT UPL UVX UWL YER VGJ VJK VRK
VRM VSU VWF VZU WDD WEZ WGL WIH WQU
WUB WXU YCO YLD YLE YMK YQC YQS YUV
ZAB ZCF ZGZ ZPM ZQY

W7s: APK APT BCV BKW BML BWC CQK DET
DNG DPU EHB EDP EYD FBO FFZ FHM FIN FZZ
GEV GHW HJ HVD IDU IQV JCU JDB JEC JGT
JPM JWT KX KBY KHO KKR KQD KYY LGP LGS
LHS LKX LLE LNW LOJ LOK LVG LWV LYU MP
MAR MOI MQM MVC NAK NBK NCI NGW NLR
NSE OVQ SJ TH

W8s: AD ABT ALN ALW ANJ AXT BAH BXA
CAL CDB CHT CJV CLP DGE DHX DIT DLM DSD
EIV EMT PDT FOR FRY GWS HKT LBI LZO MTC
PWI PYZ RKY TCO UDT UFG VZ WV WYP YDF
YHB YIP YMN YPX ZBO ZBV ZDC ZDJ ZHM ZJT
ZJY ZOH ZOY W8KOX/4

W9s: AL AKP AMT ANA ART AUB BWI CA CGY
CHV CHK CND DW DTK DTO DXI ECI EIZ FDC
GMI GYP HF HN HCR HEZ ICC IDY IML LOG
LOL MTU NGM OQY OSV OUY PEH RKV RZW SO
SGU TEG VUD ZRF ZYL K9AAD

W9s: ADN AJS AMH AOK BP BBL BCT BJG BPS
BRA BSL BYL CFL COA CQK CRY CTM CWM DJE
DKJ ER ELS FA GBG GLI HT HED HEY HJW HKM
HOC ILS IZH JRN KBT KDY KNR LQW MDJ MFH
NPW NZQ PVJ RKS SHI SKF SQF TSN UJU UNW
VNA YZX ZIQ

KH6s: BE BF CT DA FW JB LM

It is hoped that the above list will assist Naval Reservists in spotting one another for rag chews on the ham bands. Any non-Reservist can obtain information on the interesting activities available in the Naval Reserve by contacting any of the amateurs listed.

HAMFEST CALENDAR

NEW JERSEY — Saturday, April 15th, in the Terrace Room, Hotel Stacy-Trent, in downtown Trenton: Sixth Annual Old Timers' Nite and Round-Up sponsored by the Delaware Valley Radio Assn. Starts promptly at 6:30 p.m. Banquet, famous speakers of the pioneer days of radio, entertainment, awards to oldest-licensed amateurs and commercials, exhibit of W2ZI's ancient wireless gear. Reservations for this stag affair are \$5.00 per man and must be made by April 8th through General Chairman Ed G. Raser, W2ZI, 315 Beechwood Ave., Trenton 8, N. J. Tickets purchased at the door will be \$6.00.

Strays

W50LU, whose regular QTH is Sacramento Peak, N. M., elevation 9200 feet, wonders if any other permanently-established W amateur station can top this location.

Military Amateur Radio System

THE FIRST MARS station ever to operate in the Middle Eastern republic of Turkey went on the air recently at Ankara, as a quasi-official communications outlet of the American Mission for Aid to Turkey. Because Turkish law always has restricted the use of radio equipment in the fear that enemy agents could employ radio as an espionage tool, delicate negotiations had to be conducted with the Turks to permit establishment of the precedent-breaking MARS outlet, a licensed amateur station with the call AE3US.

Operated by Lieutenant Colonel Fred J. Elser, well-known DX-er and ham of 30 years' standing (he holds FCC Class A and commercial licenses), AE3US maintains scheduled contact

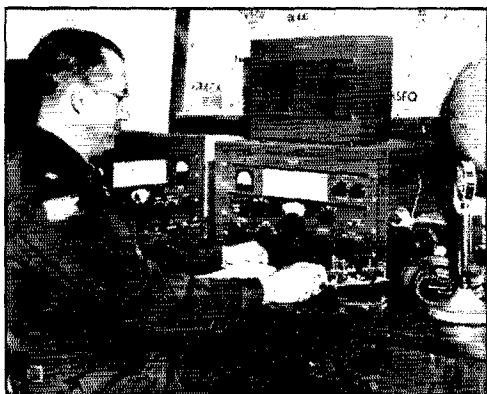

Lt. Col. Fred J. Elser operating AE3US at Ankara.

with the Pentagon MARS station in Washington to transmit unofficial and quasi-official traffic.

(The Air Force group now has an MARS station on the air too, operated by Master Sergeant J. D. Frye, jr. This latest station in Turkey signs the Air Force MARS call AJ3F.)

Colonel Elser, signal officer for the Army group of the American Mission for Aid to Turkey, uses his own equipment which he brought from the States, borrowing only an Army line transformer to convert the local 220 voltage. His 100-watt transmitter is a Collins 32V-1 and the receiver is a Collins 75A-1 plus Q5-er. He uses a close-spaced three-element rotary beam on 10 meters.

Mail service is slow and cablegrams are luxuriously expensive (there is no telephone link between Turkey and the Western Hemisphere) so AE3US looms as an important factor in morale. The station offers the fastest direct contact with friends and family in the States. When time and atmospheric permit, Colonel Elser makes voice

(Continued on page 120)

Strays

The Office of Technical Services has announced the issuance of Volumes I and II of a new publication to be known as *Schematic Manual for Surplus Electronic Equipment*. The series provides basic circuit diagrams, parts lists, and operating voltages and currents of the more common types of war-surplus equipment. The first volumes are described as follows:

Vol. I, PB No. 98487: 44 pages; includes ARC-4 transmitter-receiver, ARC-5 aircraft equipment, BC-191 transmitter, BC-222 receiver and transmitter, BC-223 transmitter, BC-312 receiver, BC-314 receiver, BC-610 transmitter, BC-614 speech amplifier, SCR-177-B radio set.

Vol. II, PB No. 98539: 43 pages; includes BC-474 receiver and transmitter, BC-652-A receiver, BC-653-A transmitter, BC-654 receiver and transmitter, BC-1306 receiver and transmitter, SCR-274-N Command set.

Copies of either volume are available from the Office of Technical Services, U. S. Department of Commerce, Washington 25, D. C., at \$1.00 (send only check or money order payable to the Treasurer of the United States). Be sure to include the PB number of the volume you desire.

National Boys' Club Week, March 20-26th, prompts us to remind amateurs and amateur clubs with a particular interest in promoting our hobby among youth that here, just as in the Boy Scouts, is an excellent field of prospects. If there is a Boys' Club in your town, why not see one of the counselors about a possible instruction program on ham radio?

A well-known radio amateur and electrical engineer, Robert C. Cheek, W3LOE, has received the Eta Kappa Nu Association award as the "Outstanding Young Electrical Engineer of 1949." The award is made annually by the national honorary electrical-engineering fraternity and stresses personal and community leadership as well as professional achievement. A graduate of Georgia Tech and the University of Pittsburgh, the 32-year-old award winner is employed as a central station engineer by Westinghouse. Mr. Cheek has 25 recognized inventions in the radio and power fields to his credit, is the author of numerous articles appearing in the technical press, and has presented scientific papers to engineering societies on nine occasions. W3LOE is perhaps best known in the ham bands as a DX-er, with over 200 countries worked to his credit. He is a member of ARRL and holder of a 35-w.p.m. Code Proficiency certificate.

Toggle-switch contact resistance can be minimized by agitating the switch in carbon tetrachloride for a short time. — W1LOP



Correspondence From Members -

The Publishers of *QST* assume no responsibility for statements made herein by correspondents.

NEW PROPOSALS

Box 718, Lovington, N. M.

Editor, *QST*:

I am unhappy over the continued proposals of the FCC to change amateur rules. To be specific, what is the justification for an Extra Class license? The present Element 4 for Class A is an advanced technical examination and additional pertinent questions covering recent developments could be added at any time. About the only significant innovation is the 20-w.p.m. test, appropriate enough for an advanced c.w. license if there were one, but about as logical for restricted 'phone operation as forcing children to memorize poetry; it usually causes them to hate poetry.

The vague indeterminate language makes me nervous. For example, in Section 12.23, what are to be the authorized special privileges for Extra Class? Section 12.27(f) adds to the feeling of insecurity. Who knows what the rules may be when it comes time to renew?

— T. M. Blackmon, W5ETM

Bangor, Me.

Editor, *QST*:

I think the League did a good job in fighting those regulations that were issued by the FCC but I am not satisfied with those that they issued in their place. I am still against this 20 words and the new class of license. I don't get what it is all about.

— P. L. Sprague, W1UP

P.O. Box 251, Pawnee City, Nebr.

Editor, *QST*:

. . . I am opposed to an Amateur Extra Class as proposed by the FCC . . .

— Loren M. Greiner, W0GTW

Box 1314, Chadron, Nebr.

Editor, *QST*:

. . . I am personally opposed to the revisions . . .

— Philip E. J. Brooks, W0HBJ

Forrest City, Ark.

Editor, *QST*:

Please impress upon the FCC that television and b.c. interference is much more important for prospective Class A hams than a stiff 20-w.p.m. code test.

Don't give up the fight for more reasonable requirements for Class A.

— Charles S. Fleming, W5DYL

WHAT! NO RELAYS?

10 North 10th Ave., Mount Vernon, N. Y.

Editor, *QST*:

Thanks for the wonderfully informative article by Dallas T. Hurd, W2PFU, in January's *QST*. This article has shed more light on a controversial subject than all of the claims that I have heard in many years — claims from both sides of the fence, too.

However, I have encountered a few advantages in c.w. operating that I don't think Mr. Hurd mentioned. Perhaps he's never encountered them. For instance, when I quit

the night's work at the local TV-sender and come home past twelve, I often fire up the rig for a contact or two. With c.w., I can have my cake, and listen, too (to paraphrase an old adage). Coffee and cake sit on the operating table, and the OM eats while conversing, via c.w.

Furthermore, you can send c.w. without waking up the guy in the next apartment after midnight. Try doing this on 'phone without a soundproofing job!

— Neil A. Johnson, W2OLU

THE GOLDEN RULE

224 South Aurora St., Collinsville, Ill.

Editor, *QST*:

I am trying to learn the code that I might take the exam and become a ham. To improve my receiving I make a vain effort three times a week to listen to W1AW but some kilowatt-crazy maniac invariably will pick out the same frequency as W1AW.

I don't know how to solve the problem of listening to W1AW without QRM but I do feel that some of these high-power rigs could be soft-pedaled for at least one half hour, three times a week, without hurting anyone's feelings.

— A. W. MacDonald

IT'S YOUR LEAGUE

12031 Wagner St., Culver City, Calif.

Editor, *QST*:

The demonstration of the matter of FCC Docket 9295 is an excellent example of the reasons for supporting ARRL regardless of personal agreement or disagreement with some minor items. As concerns the major items our democratic system of electing directors is the members' method of controlling the Board. Since in a true democratic spirit, the majority vote controls, if one is overruled, he should have the plain old "guts" to take it.

— Cary R. Mangum, W6WFW

NOSTALGIA

920 Alpha St., Inglewood, Calif.

Editor, *QST*:

Can anyone tell me what has become of the hams who were code-conscious? They have certainly departed from Los Angeles County.

Many hams have their call letters displayed on the backs of their cars but it's been years since I found one who would recognize a "Hi" blown on my horn. Instead they turn around and glare at me as much as to say, "Wot ails you, Brother, I'm in my own traffic lane!"

The old Hollywood gang had auto QSOs down to a science long before the FCC licensed us for portable-mobile work. 6C7O had the horn on his Model T muted with a piece of inner tube so the law wouldn't run him in for disturbing the peace. He would tow down the highway happily answering all calls. 6CPG installed a telegraph key on his steering column to facilitate such contacts. Then there was 6BVS who had a bigger swing than Recreation Park. But by golly "Bivis" knew the code and if you blew a "Hi" at him his face would light up like the filament of his 203!

I hope there's an explanation and these guys aren't really tin-eared lids!

— George Dery, W6HG

(Continued on page 120)



Operating News



F. E. HANDY, WIBDI, Communications Mgr.
JOHN E. CANN, WIRWS, Asst. Comm. Mgr., C.W.
GEORGE HART, WINJM, Natl. Emerg. Coördinator

J. A. MOSKEY, WIJMY, Deputy Comm. Mgr.
L. G. McCOY, WIICP, Asst. Comm. Mgr., 'Phone
LILLIAN M. SALTER, Administrative Aide

FD Rules. All affiliated radio clubs have now received the usual advance review of June FD plans by way of the annual-survey bulletin. For the most part rules committee correspondence reviewed pertained to the general subject of "why a multiplier" for the West Coast. Agreed that this might have been desirable to encourage FD activity at one time, the facts reviewed caused the committee to arrive at the conclusion that for fairness and simplicity's sake, there should be no multipliers on geographical grounds for this year's FD. That, coupled with the decision to show results under the transmitter classifications "by licensing areas," makes the major change in this year's rules. The full announcement of FD rules will appear in June, 1950, *QST*. That issue for 1949 may be consulted to get an idea of the specific plan for the activity bearing in mind that there will be no 1.5 or other geographical multiplier this year. A few extra copies of the affiliated club bulletin which contains FD data are available for other clubs with FD interest who may wish to send a radiogram for a copy.

The Individual Emergency Power Source. Potentially the ability of the amateur to serve in key spots where communications are required in disaster is as great as our geographical distribution as amateurs. This statement has to be qualified in practice, to show the interested governmental agencies (a) how many amateurs are registered in the full and supporting divisions of the ARRL Emergency Corps; (b) how many of these are equipped for work on *emergency power*, how many have mobility, and how many are part of community plans under an EC. Main purpose of this item is to give out with a tip on a cheap power source. However, in passing let us again urge every individual amateur to lend his support to our public service work by filling out a registration of availability and interest in the AEC. Belong to the "supporting division" if tied down so you cannot be active on tests as a "full" member.

Don't deny yourself any longer the pleasures of mobile work (160 to 2 meters for practical car installations) for vacation and FD and possible 1950 emergency utilization! Only the club perchance can afford a big gas-electric power supply. Of course we're for that wherever we have clubs

— but for cashing in on the geographical spread of amateur and public service capabilities the whole nation over, we simply *must* have *individual* emergency-capable transmitters. These must have emergency power. Ordinarily this power source is thought of as "just as near as the nearest automobile battery." Cheap dynamotors and Vibrapacks are still available on the surplus mart but some have deferred the purchase, feeling that an extra storage battery was worth a young fortune these days. This is not strictly so! In trying to practice what we preach and maintain a home emergency station as well as one in the car, WIBDI has found that the nearest gas station handling batteries has the cheap source. Turn-ins of car batteries with one bad and two good cells, husky trucks bats too, can be got at the junk dealer's price, a dollar only, often less, at the service station. Merely short the bad cell and form your banks of 12 v. or 24 v. good for many months or even years of service — free battery exchange for a similar, or your "junk price" back in cash for the lead if and when another cell cashes in its chips! A small selenium rectifier unit can keep your cells all charged at slight cost. A fuse should be put in each bank of cells as a safety measure against possible shorts.

From the operating standpoint, and we write only from that view, there are numerous advantages in having an independent small rig around the station. This makes it possible to leave the lower-powered set on the section net frequency for a fast QNI; the regular transmitter can be kept free for DX or 'phone or any other-than-scheduled operation or experimentation.

Send Complete QSLs. The value of any QSL or other written confirmation of a QSO for awards purposes depends on the completeness of its information. WIRWS found one in a stack the other day that didn't even confirm a QSO! Sometimes QSLs have to be sent without full data at hand. Those with partial information are better than none since they convey the fraternal spirit. However, if the written card *you* supply doesn't give frequency, or show the difference by reports or otherwise for 'phone or c.w., it's not likely to be held as such a prize by the sincere amateur worker who receives it for a given objective. Some amateurs are working for a WAS, others for DXCC, and still others for special achievements

where the *date, band or mode* may be vital. An amateur who is working for written proofs that he did all the work for a particular award on 6, 10 or 40 meters isn't exactly happy when the hard-to-get card from the Dakotas or Nevada or Little Rhody doesn't show the frequency band! So in sending QSLs let's each try to make them decently complete.

DX Test in Progress. There are two week-end periods of the 16th ARRL International DX Competition coming up in March. Give one or both these a whirl, if you haven't already tried your hand at the DX opportunities of the year! March 10th to 12th are the week-end dates for c.w. work in this contest, March 17th to 19th for putting the finishing touches on those 'phone logs. For full details of this leading activity for February and March see the announcement that appeared on page 17 of January, 1950, *QST*. All scores and reports will be welcomed by ARRL. See if you can add some good new countries to the list of those already worked!

— F. E. H.

BRIEF

The Montreal Amateur Radio Club, sponsor of the annual VE/W Contest, recently awarded miniature loving cups to be held as the permanent possessions of each United States and Canadian national winner in the VE/W contests held since 1939. Recipients of the awards in the U. S. were W2IOP for his high scores in the 1939 and 1947 contests, W1BFT the 1948 winner, and W3GYV, top-scoring W in the 1949 contest. The two large MARC trophies, which are competed for annually, are still in circulation and will be offered to the winners in the 1950 VE/W contest, scheduled for the week end of April 29th-30th.

CODE-PROFICIENCY PROGRAM

Twice each month special transmissions are made to enable you to qualify for the ARRL Code Proficiency Certificate. The next qualifying run from W1AW/WØTQD will be made on March 17th at 2130 EST. Identical texts will be sent simultaneously by automatic transmitters. Frequencies of transmission from W1AW will be 1887, 3555, 7215, 14,100, 28,060, 52,000 and 146,000 kc. WØTQD will transmit on 3534 kc. The next qualifying run from W6OWP only will be transmitted on March 5th at 2100 PST on 3590 and 7248 kc.

Any person may apply; neither ARRL membership nor an amateur license is required. Send copies of all qualifying runs to ARRL for grading, stating the call of the station you copied. If you qualify at one of the five speeds transmitted, 15 through 35 w.p.m., you will receive a certificate. If your initial qualification is for a speed below 35 w.p.m., you may try later for endorsement stickers.

Code-practice transmissions are made from W1AW each evening, Monday through Friday, at 2130 EST. References to texts used on several of the transmissions are given below. These make it possible to check your copy.

Date	Subject of Practice Text from January <i>QST</i>
Mar. 3rd:	A High-Attenuation Filter . . . , p. 11
Mar. 5th:	Qualifying Run, 2100 PST, from W6OWP only
Mar. 7th:	Antenna Polarization on 144 Mc., p. 15
Mar. 9th:	A One-Tube VFO Amplifier, p. 20
Mar. 13th:	Folded Elements . . . , p. 22
Mar. 15th:	An RC-Type Audio Signal Generator, p. 32
Mar. 17th:	Qualifying Run, 2130 EST, W1AW, WØTQD
Mar. 21st:	On the Air with Single Sideband, p. 38
Mar. 23rd:	Audio Phase-Shift Networks, p. 42
Mar. 27th:	Debugging the Electronic Bug, p. 48
Mar. 29th:	Answering the Beginner's Question . . . , p. 50

A.R.R.L. ACTIVITIES CALENDAR

Mar. 5th: CP Qualifying Run — W6OWP
 Mar. 10th-13th: DX Competition (c.w.)
 Mar. 17th-20th: DX Competition ('phone)
 Mar. 17th: CP Qualifying Run — W1AW, WØTQD
 April 1st: CP Qualifying Run — W6OWP
 April 15th-16th: CD QSO Party (c.w.)
 April 19th: CP Qualifying Run — W1AW, WØTQD
 April 22nd-23rd: CD QSO Party ('phone)
 May 5th: CP Qualifying Run — W6OWP
 May 16th: CP Qualifying Run — W1AW, WØTQD
 June 3rd: V.H.F. Contest
 June 4th: CP Qualifying Run — W6OWP
 June 15th: CP Qualifying Run — W1AW, WØTQD
 June 24th-25th: ARRL Field Day
 July 7th: CP Qualifying Run — W6OWP
 July 17th: CP Qualifying Run — W1AW, WØTQD
 July 22nd-23rd: CD QSO Party
 Aug. 4th: CP Qualifying Run — W6OWP
 Aug. 18th: CP Qualifying Run — W1AW, WØTQD



A display board, such as the one above used at the Topsfield, Mass., State Fair last fall, can go a long way toward attracting public interest to the doings at the amateur radio booth, and save booth personnel a lot of verbal explanation over the counter. The above chart shows that messages go from the Fair to W1NVB, thence to W1OTA, W1WITY or into ARRL's National Traffic System networks for systematic routing toward their destinations. Such a display quickly dispels, at a glance, the notion held by many that amateurs are a disorganized bunch of hobbyists "playing" at radio communication. The display board can be lighted with bulbs controlled from the operating position showing when the transmitter is in operation and with whom contact is being made. A really worth-while project in preparation for an exhibit, and something for our more active clubs to think about!



Not a great deal of room for small talk this month, fellows. There are quite a few pieces of emergency communication to report, and we only hope that we can get them all covered to everybody's satisfaction. The fact that these emergencies occurred over a widespread area makes them scattered in substance but unifying in effect. Preparedness is the watchword — spring is a favorite season for Old Man Disaster. Better get your emergency gear out and dust it off, and get the rest of the gang to do likewise. You can never tell when you will need it.

Montana SCM W7EGN calls our attention to emergency work performed by amateurs on November 27th last when heavy wind and rain disrupted railroad communications between Whitefish and Spokane. Details are reported in the Montana Section report in February QST.

In British Columbia in late January, AEC members were instrumental in carrying on badly-disrupted communications for the PGE railway during heavy snows. VE7s AY, BC, FB and QV were among those who took part in this operation.

Interest of railroads in developing auxiliary communication by means of amateur radio is not new, but appears to be on the upsurge. For example, the Santa Fe Railroad has recently published a directory of amateurs in Illinois, Iowa, Kansas, Missouri and Oklahoma who have offered their services to the railroad in time of communications need. ECs in making their plans should not overlook the railroads as one of the agencies to be served.

A recent disaster in Norwalk, Conn., demonstrated how amateur emergency preparation can result in effective service even when normal communications channels are not impaired. The occasion was a factory fire of tremendous proportions for which every piece of apparatus in the area was called out, and the American Red Cross set up first-aid stations and canteens for the firemen. The Amateur Radio Emergency Corps of Norwalk promptly set up communication from Red Cross Headquarters to the scene of the fire. The Red Cross station, W1SGZ, maintained contact with mobile W1DBM at the scene of the fire for three hours. W1RKA and W1MGX operated W1SGZ. W1QOO, W1MRP and W1SLB stood by in case they were needed. Operation was on 27 and 29 Mc. Needless to say, the Red Cross people were very pleased with their "private telephone line to the fire."

The Tennessee Emergency Net was alerted on December 26, 1949, to assist in the search for a missing private aircraft supposed to be lost between Houston, Texas, and Bristol, Tenn. The alert was instigated by W4IYI, who was in touch with the brother of the missing flyer, and contact was maintained with W4NJE in Louisburg, Tenn. Civil Air Patrol and Tennessee State Highway Patrol officials were contacted and kept supplied with information gathered by some 62 amateurs in the area who were participating in the net. The missing flyer was eventually found frozen to death a mile from his plane, which had crashed near Crossville, Tenn. Description of the aircraft and other data through the use of amateur radio was a great help to CAP and the Tenn. Highway Patrol.

On January 1st another missing aircraft search was instigated by W4LRE of Laurenceburg, Tenn., who contacted W4BAQ in Memphis concerning the whereabouts of a plane leaving Memphis with four hours' fuel and headed for Tulsa, Okla. This plane was found to have refueled and returned to Memphis. Meanwhile, W4IVC in Montgomery

called in concerning a missing plane crashed near Hernando, Miss. W4BAQ was just about to leave Memphis for Hernando with mobile equipment when word came through that the second missing plane, an Army P-47 from Maxwell AFB, Ala., had been found. The following stations participated in this operation: W4s BAQ, FCC, FDF, HQM, HXC, IKG, IVC, KOY, LCB, LRE; W5s DSW, GG, GWT, LNN.

Northern Mississippi was struck by floods and freezing weather on January 6th, causing disruption of communications lines, interrupting traffic and virtually isolating at least one community. Mississippi's Magnolia Net was alerted by SEC W5MUG assisted by W5FFF and W5KYC. The Illinois Central Railroad requested W4BAQ to link Memphis and Jackson for traffic. Assistance was obtained at the Memphis end from W4FCC, W4FCF and W4GXO. W5MZV handled the Jackson end with the assistance of W4EOC/5 and W5s ITL, JIP, NLP, NRW, PCD, PFC, PNA, PRB and QXK. Relay stations W5HDN and W5IGW were also used. The Magnolia Net passed light traffic during the emergency period from 1100 to 1830. W5PAF at Columbia, who received a weather report transmitted through W5FFF at Jackson, was invited to the local broadcast station to deliver the message personally to the listeners, and was thereby enabled to put in a valuable plug for amateur radio.

In Memphis, large parts of the city were without power, and the Mid-South Amateur Radio Club established emergency equipment in the home of W4BAQ. Later, when the cable between Memphis and Collierville went out, along with all long-distance lines, W4HHK in Collierville, with the assistance of W4FCU, installed a gasoline-driven generator, put up a dipole and maintained solid communication with W4DI in Memphis on two meters for the rest of the day. Messages were handled for the railroad, power company and local citizens. W4DI also was the only communication between the studios of station WMC and their transmitter several miles out in the country for many hours.

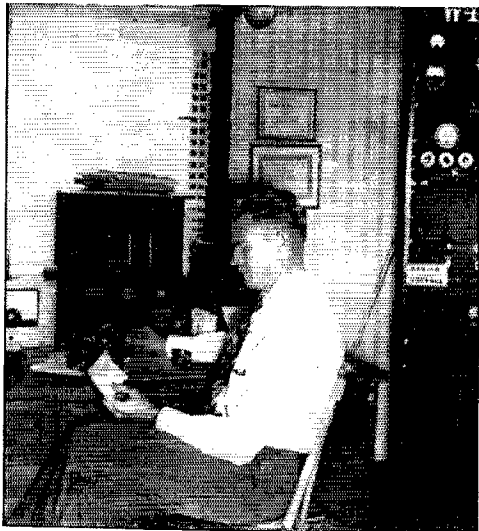

Walter Mewborn, W4BAQ, EC for Memphis, Tenn., at his operating position. This station, with additional operators, averaged 16 hours of operation each day for over three days during the January Mid-South ice-storm emergency. Eighty and 40 c.w. and 75- and 2-meter 'phone were used. Emergency power was in use for 41 hours and was supplied by the gasoline-driven generator owned by the Mid-South Amateur Radio Association. Relief operators and assistants included W4BAO, W4HCU, W4HHK, W4IYI, W4IRI, W4MHN and W4MRD.

W8WZ, Ohio SCM, and W8UPB, Ohio SEC, call our attention to the fact that many registrants in the AEC are forwarding their completed Forms 7A direct to the SCM or the SEC instead of to the local emergency coordinator. Your local EC (the local club can give you his name) is the one who needs and can make best use of the information supplied by this form, and it is he who issues the AEC identification card. When the form is sent to the SCM or SEC, it has to be remailed to the EC in charge of your area, and you can save them some time and postage by doing this yourself in the first place. Only when there is no local EC (or you can't find out who he is) should the form go directly to the SEC (see p. 64, Oct., 1949, *QST*), and only when both EC and SEC are missing should the form go to the SCM. This is a minor matter, but it can be the cause of a lot of extra trouble to hardworking SCMs and SECs.

ILLINOIS-MISSOURI ICE STORM

On the morning of December 10, 1949, rain started falling over Illinois and Missouri which developed into one of the most damaging ice storms in their histories. Before it was over, dozens of towns in both states were affected, a few completely isolated, and amateur radio had chalked up another "well done" for its part in maintaining badly-disrupted communications lines. Illinois and Missouri emergency and traffic nets swung into action as the probable need for their services became apparent, and community AEC organizations began to mobilize to perform the tasks for which they had been preparing for many months.

As ice accumulated on trees and wires, communications lines started to go out, one by one. Western Union appealed to local amateurs for help, and in most cases got it promptly — the boys were there waiting. Urgent communications continued to flow through the wires where they were still up, by amateur radio where wires were down. Commercial power was strictly not available in many communities, but this did not daunt the AEC boys; they started up their gasoline generators or hooked their equipment to Vibrapacks or dynamotors and kept the circuits open.

During the emergency period, liaison was maintained between the Illinois and Missouri groups at all times so that good contact was maintained across the river with the effect that the whole operation was conducted in unified fashion. Reports of this operation have reached us from two main sources, however, and we therefore treat each separately herewith.

Illinois

The emergency work in Illinois centered about Quincy, where W9AEX held forth as the key station with the assistance of W9BIG, W9BIQ, W9GEB, W9GQK, W9HQW, W9LHU, W9MTO and W9WWO, all members of the Western Illinois Amateur Radio Club. W9AEX reports that icing conditions in Quincy first began to get bad about 1000 on December 21st. At noon on that date, W9AEX came on the air to handle emergency traffic for the telephone and power companies. At 1230 his power went off (lines were coming down many places in the state either due to falling trees or the weight of the ice itself) and for the next 55 hours communication was maintained by means of a gasoline-driven generator made available through the cooperation of the local Naval Reserve training center and W9WWO, a member of the USNR. Within three hours of the time AEX went on the air to contact the main offices of the telephone and power companies in Springfield truckloads of material and personnel were on their way to the Quincy area to attempt to maintain and restore service.

As the afternoon progressed and icing conditions continued to grow worse, the Illinois Emergency Net on 3940 kc. swung into full action and handled emergency communications throughout the state and in some cases over state borders for numerous commercial and civic agencies, among them the Illinois Bell Telephone Company; The Central Illinois Public Service Company; The Chicago, Burlington and Quincy Railroad; Western Union; City of Quincy; Illinois Police Dept.; radio stations WGEM and WTAD; U. S. Weather Bureau; CAA at Baldwin Field; and the Quincy *Herald-Whig* when the AP and UP wires went out.

Francis Wentura, W9AEX, has come in for a big share of the praise for his diligent and efficient emergency communication work during the storm. It was primarily due to his ability to line up assistance on the Illinois Emergency Net and elsewhere that amateur radio again was able to rise to the situation to be of service to utilities, industries, services and the general public. W9AEX sent approximately 200 messages out of Quincy and handled about 175 incoming messages.

W9RNM, of Homewood, Illinois, also deserves a special pat on the back for his effective work in clearing 3940 kc. of QRM. In this connection, it should also be observed that "they also served" who so willingly shifted to another frequency or stood by when asked to do so.

The following stations are known to have taken active part in the emergency work in Illinois, aside from those already mentioned: W9BCQ, FNE, JNF, KCX, KQL, RPL, TUC, UQT; W9AFQ, BAF, CJH, QVA.

Missouri

About twenty towns were affected by the storm in Missouri, the worst of which were Hannibal and Sedalia. The Missouri Emergency Net was in operation with W0EBE, W0ECA and W0HUI acting as net control stations. W0ROB also assisted in the NCS spot at times when other stations could not be on, neglecting his business in doing so but being instrumental in relaying a great number of Western Union messages. W0AZL, W0TTZ and W0ZFN succeeded in setting up emergency communications facilities in the former's place of business and handled nearly 200 messages, most of which were Western Union. This operation started Thursday morning and lasted until Saturday noon when regular wire service was restored.

W0RB and W0FGS of Windsor, Mo., also hard hit by the storm, were active. Forty-three messages, most of them Western Union, were handled by the former. W0CJH carried the brunt of the load from Hannibal. Other stations handling Western Union traffic in volume were W0GCT, W0UID and W0FXW of Kansas City who handled traffic for Warrensburg via W0DSO and Sedalia via W0AZL and W0TTZ. The following is an additional list of stations involved: W9AEX, AHE; W0BRN, BQL, CKR, RMF, RUV, TGG, VER. W9RNM and W5JIC are to be commended on their efforts to keep the frequency (3905 kc.) clear of QRM so that the task could proceed unhampered.

A.E.C TIP-OF-THE-MONTH

AEC members whose mobile or emergency-power plans are held up for lack of funds should consider this: Any garage dealing in storage batteries usually has a large accumulation of defunct batteries awaiting the junk man. Many of these batteries have only one defective cell, the other two perfectly good. By shorting out the defective cell, you have a perfectly good 4-volt battery, and it can be picked up for the salvage price, usually not over a dollar. See "Operating News" lead in this issue for full details. — *W1BDI*

BRIEF

January 5th saw the revival of an International QSO Party, an annual round table including Canadian and U. S. amateurs that enjoyed great popularity prior to 1940. More than 50 Ws and VEs took part and made the party a real success. Russ Brackett, W1PTL, acted as control station and many well known amateurs took part. A message of greetings from President Bailey was delivered to the round table from W1AW. Alex Reid, VE2BE, ARRL Canadian general manager, Ed Handy, W1BDI, and other members of the Headquarters staff were present and called into the party. Ed Hudon, W1LYK, did the organizational work and was on hand to see that everything went off as planned.

TRAFFIC TOPICS

W2UWK calls our attention to the fact that many stations are confused about how to "check" a message containing an "ARL" text. The answer is simple: the same as any other message, by the actual number of words in the transmitted text. The symbol ARL in the preamble simply indicates that an ARL text-number is included in the text. It does not indicate which text or how many texts are included. Thus, if the ARL texts Nos. 50 and 8 were intended, the transmitted text would read "FIFTY STOP EIGHT" (not "Fifty eight") and the check would be ARL 3. If the person originating the message wants to add a personal word he can do so and it is added to the transmitted text of the message and the check, and ARL remains in the preamble to indicate that an ARL text number is included. Thus an ARL message text transmitted as "FIFTY FIVE STOP SAY HELLO TO EVERYBODY" would contain the check ARL 7. Okay?

Speaking of ARL texts, WØTLY tells us of an incident in which a message containing ARL text number fifty was delivered as the word "filthy." We'll bet the addressee was considerably more perplexed than amused!

The Transcontinental Phone Net (3970 kc.) is looking for recruits to fill some holes on the eastern end. The western end is perking fine and much traffic is being handled, but organizational difficulty is being experienced back East. Any 'phone traffickers interested in TCPN should contact W2LMB or WØUHC.

W7CKT, in his Washington Amateur Radio Traffic System bulletin "The Parasite" suggests that holiday traffic be originated well in advance of the holiday with the word "hold" appearing in the preamble, after the check, to indicate that the message should be held until the holiday for delivery. This, he says, may help to alleviate the terrific flood of traffic that immediately precedes the Christmas and New Year's holidays and results in some of it reaching its destination too late. The same device could be used for birthdays, anniversaries and similar occasions by inserting a date after the word "hold" so that the message will be held by the delivering station for delivery on that date. What do you fellows think of this idea?

It is sometimes hard to know what to do when a regular outlet for traffic to a certain point or area refuses to accept a message because of some defect. Every amateur has the right to accept or refuse any message which for one reason or another he does not wish to handle. In most cases, however, when this occurs, you are putting some innocent relay station on the spot, which is simply relaying the message as he received it, and wasting time in a net. Why not QSL the message and then send a service message to the originating station asking for clarification, or authority to make correction or cancel? This is the logical thing to do. It saves network time, and doesn't cost you any traffic points (on the contrary, you gain some).

Some of the best traffic men are still counting their traffic totals incorrectly. Please, fellows, go over the details of the new traffic-counting system in September, 1949, QST, page 66, and make sure you are doing it right. We

realize when you've become so used to a system it's hard to change over, but now that we've definitely changed over let's do it right. If your total number of *relayed* points is higher than your total number of *received* points, chances are that you have not counted your traffic properly. Let's get together on this, shall we?

Well gang, 1949 is over and done with, and it has been the best traffic year since the war. 1950 is going to be even better. In next month's QST we hope to get together a traffic summary of the year's work, including recognition of the outstanding traffickers of the year and of the post-war period. This will take some paper-and-pencil work and we have not yet even started it, so we don't know what the outcome will be. Place your bets now.

The test of all traffic nets is made during the pre-Christmas and pre-New Year's periods when greetings are flowing thick and fast. This season we had the customary rush of traffic, picking up suddenly about two weeks before Christmas and continuing unabated through the first of the year. The NTS nets performed admirably, but were overloaded like all nets, and a fine exhibition of internet cooperation and coordination resulted in better speed of delivery than has generally been the custom in the past. We take off our hats to those traffic stalwarts who carried the brunt of the load by spending long hours, often late into the night, to move the traffic along as quickly as possible and establish ham radio message service high in the eyes of the public, many of whom file messages with their tongues in their cheeks. Whatever else we derived from the experience, the Christmas rush certainly pinpointed the glaring deficiencies of each net. Next season, with increased traffic participation by all amateurs, we shall do even better.

NET DIRECTORY CHANGES AND ADDITIONS

This listing can be used to make corrections in and additions to previous listings in November QST (p. 63) and January QST (p. 66-67). This will correct your net list to January 15, 1950. Since some of the information listed herein is later than those of the cross-indexed mimeographed net directory (available upon request), operators using that directory should make changes as appropriate herefrom. An asterisk indicates a change from a previous listing either in November or January QST.

Name of Net	Freq.	Time	Days
Arizona Phone Net	3865	1900 MST	Tue.
Badger Emerg. Net (Wis.)*	3950	1800 CST	Mon.-Sat.
California Slow Speed Net	3705	2030 PST	Mon.-Fri.
Central Radio Amateur Club Net (Mo.)*	7225	2100 CST	Tue., Thu., Sat.
Coastal Emerg. Radio Net	146,800	1400 CST	Sat.
Conn. Phone Net	3880	1830 EST	Mon.-Fri.
		1000 EST	Sun.
Cracker Emerg. Net (Ga.)*	3995	0830 EST	Sun.
Dog House Net	3860	1700 CST	Mon.
Early Bird Transcontinental Net	3860	0445 CST	Mon., Wed., Fri.
Eastern Penna. Net*	3610	1830 EST	Mon.-Fri.
Eastern Shuttle Net*	7120	1030 EST	Daily
		1900 EST	Mon.-Fri.

If you have handled much traffic, you probably know this fellow. It's W6FDR at his operating position, doing what has made him one of the outstanding traffic men in the country, and landed him in the BPL ten times in 1949. RM and ORS in the East Bay Section, Bill is manager of Pioneer Net, is a member of the A-1 Operator's Club and holder of a 35-w.p.m. Code Proficiency certificate. In prewar days, as W5FDR, he once put down 65 w.p.m. in an AARS code speed contest, so don't be afraid of going too fast for him. Give W6FDR a call for any traffic and it will receive prompt handling. (Photo courtesy of W6DDE)

QST for



Golden State Emergency Net (Calif.)	3965	1930 PST	Mon. & Wed. Sun.
Hamden (Conn.) Emergency 80-Meter CW Net	3550	0930 EST	Sun.
Hit & Bounce Net	7200	0030 CST	Daily
Indiana Phone Net*	3905	1830 CST	Mon.-Fri. Sun.
Interstate Utility Net (Colo.)*	3540	1900 MST	Mon.-Fri
Iowa 75 Phone Net	3970	1230 CST	Mon.-Sat.
Kansas Net	3610	1845 CST	Mon., Wed., Fri.
Kansas 75 Phone Net	3920	1230 CST	Tues., Fri. Sun.
		0800 CST	Sun.
		1645 CST	Tue.
Kansas Slow Speed Net	3610	1845 CST	Tue., Thu.
Kentucky Net*	3600	1900 CST	Mon.-Sat.
		7200	0900 CST
		3760	1900 CST
		3625	0900 EST
Manitoba Phone Net* McKean County (Pa.)	3625	0900 EST	Sun.
Emergency Net			
Minnesota State CW Net*	3795	1900 CST	Mon.-Sat.
Montana Phone Net	3995	1900 MST	Mon., Wed., Fri.
Morris County (N. J.) Emergency Net	147,000	2000 EST	2nd & 4th Wed.
Mountain Area Net*	3540	0330 MST	Mon.-Fri.
NYC-LI Emergency Net*	3710	2000 EST	Fri.
New York State Net*	3720	1900 EST	Mon.-Fri.
		2200 EST	
N. Y. State Slow Speed Net*	3720	2030 EST	Mon.-Fri.
Newport (R. I.) Emerg. Net	28,900	2000 EST	Thu.
North Central Texas Emergency Net	3930	0800 CST	Sun.
North East Texas Emergency Net	3940	0800 CST	Sun.
North Texas Emerg. Net	3930	0800 CST	Sun.
N. Texas Section CW Net	3657	1900 CST	Mon., Wed., Fri.
North West Texas CW Net	3830	1930 CST	Sun.
North West Texas Emergency Net	3950	0800 CST	Sun.
Ohio Emergency Net	3860	1830 EST	Thu.
Ohio River Valley Net	3860	0800 EST	Sun.
Ontario Phone Net	3815	1900 EST	Mon.-Thu.
Oranoke Co. (N. Y.) Net	146,250	0900 EST	Mon., Tue.
Oregon Slow Speed Net*	3595	1930 PST	Daily
	7170	1400 PST	Sun. & Holidays
Pioneer Net*	3725	1900 PST	Mon.-Fri.
		2200 PST	
Pony Express Net (Wyo.)	3920	0930 MST	Sun.
Potomac-Rappahannock Valley Net	3935	0900 EST	Sun.
	146,800		
Rhode Island Net	3540	1900 EST	Mon.-Fri.
Saskatchewan Phone Net	3830	2030 MST	Daily
Second Regional Net*	3690	1945 EST	Mon.-Fri.
	3730	2115 EST	
Sixth Regional Net*	3725	1945 PST	Mon.-Fri.
		2115 PST	
South East British Columbia AEC Net	3755	1730 PST	Mon., Wed., Fri.
Southern Calif. Net*	3765	1900 PST	Mon.-Fri.
		2200 PST	
Susquehanna Emergency Net	3910	0800 EST	2nd & 4th Sun.
Trunk Line C*	3775	1900 EST	Mon.-Fri.
Valley Net (Calif.)*	29,280	2200 PST	Mon., Wed., Fri.
	3775	1900 PST	Mon.-Fri.
		2200 PST	Mon.-Fri.
Virginia Phone Net	3880	1930 EST	Mon.-Fri.

A-1 OPERATOR CLUB

We are pleased to announce the following additions to the ARRL A-1 Operator Club roster: W1BUD KJF RHU. W2CLL EGM OUS PWP QHH RDK RPH RTZ RUF URX VNJ VSU. W3ELI HRD MAL MHE NHI NRE NUG QEW WTS YDJ. W4BLE IYT NUL W5CEW. W6CUU MUR TY. W7BVZ. W8AUT AVB DAW GAV HSW TRN TZO YFJ. W9DXL KFO KOK LFK. W0AY IQZ. VE2TA 3AZZ 3IA 3SR 3TF 7HC. P8EO G2LB Z2C 3LP 5LI 5PS 6AY JA3AA OZ1W ZBO PA0IF TA3GVU Z8GOS.

The A-1 Operator Club was designed to recognize and promote good operating in the amateur bands. To become

a member one must be nominated for membership by at least two operators who already belong. An attractive certificate is awarded to each amateur who qualifies for membership. Every amateur should strive to make his operating merit nomination by following standard operating practice, by observing the rules of good phone operating, and by making his sending as clean and accurate as possible. Members should nominate every deserving operator after careful observation of his operating habits. The complete A-1 Operator Club rules may be found in the booklet *Operating an Amateur Radio Station* (sent gratis to League members upon request).

BRASS POUNDERS LEAGUE

Winners of BPL Certificates for December traffic:

Call	Orig.	Recd.	Rel.	Del.	Total
W6CE	351	2375	2267	63	5056
W7CZY	63	2176	2092	30	4361
W3CUL	98	1658	1417	204	3377
W6FDR	187	1581	1127	428	3323
W0ZJO	56	998	928	58	2040
W5GZU	7	848	732	110	1697
W4PYV	18	643	623	20	1304
W2TYU	10	653	575	50	1288
W2BO	6	572	500	49	1127
W0HMM	6	566	542	10	1124
W4KVM	95	494	380	108	1077
W5LSN	15	482	386	96	979
W3NRE	17	454	459	10	940
W0CBE	10	427	381	40	858
W4BAQ	19	54	708	47	828
W7JWJ*	740	13	11	2	766
W7IOQ	0	346	340	45	731
W0GMZ	6	355	350	16	727
W7ESJ	245	282	68	107	702
W4PL	2	370	290	37	699
W7KCU	560	82	2	44	688
VE3IA	97	274	300	15	686
W7GWE	48	278	278	62	666
W2CLL	52	325	256	18	651
W2PRE	33	315	278	10	636
W5DRW	8	301	297	9	615
W8TRN	47	295	213	58	613
W6DDE	81	256	79	185	601
W7ZU	50	274	163	99	586
W0NIY	33	249	218	82	582
W0RVG	4	289	271	18	582
W8GBF	53	279	217	28	577
W3UF	50	260	200	60	570
W0ESJ	20	273	192	82	567
W3GEG	21	278	252	14	565
W3ABT	546	8	0	7	561
W0QXO	14	274	228	40	556
W7JJK	101	223	193	35	552
W6YLZ	8	271	126	145	550
W0FQB	38	255	227	20	540
W0SUF	10	263	233	8	534
W4IQV	105	207	185	41	518
W8RJC	12	250	230	14	506
W5MN	11	248	110	135	504
W7JWJ	441	33	20	8	502

* August traffic

The following made the BPL for deliveries:

W6NW	107	W4MLH	73	W0KIK	62
W7FIX	95	W0CMC	71	W0LDI	60
W1AW	88	W7JZR	70	W8NOH	59
W4ANK	78	W9SXL	67	W0IC	58
W0CMN	78	W8SCW	66	W0GWB	55
W9CBA	77	W1BTY	62	KH6UL	54
W1EMG	76	W6LXH	62	W1PYM	53
W3GJY	75	W8SJF	62	W7DRA	51

A message total of 500 or more or 50 or more deliveries will put you in line for a place in the BPL. The Brass Pounders League is open to all operators who qualify for this monthly listing.

DX CENTURY CLUB AWARDS

HONOR ROLL

W1FH.....228	G2PL.....218	W3GAU....209
W6VFR....225	W3BES....218	W0YXO....209
W6EBG....220	W2BXA....216	G6ZO.....208
	W8HGW....214	

RADIOTELEPHONE

W1FH.....184	W2BXA....160	W4CYU....158
W6VFR....172	W8HGW....159	G2PL.....156
W6DI.....170	W1JCX....158	W1NWO....154
VQ4ERE...162	W9RBI....154	

From December 15, 1949, to January 15, 1950, DXCC certificates and endorsements based on postwar contacts with 100-or-more countries have been issued to the amateurs listed below.

NEW MEMBERS

VK3BZ....178	W1ATE....105	W2MYV....102
PA6MZ....118	SM6AWE...103	W7TAJ....101
VK4RC....114	W2UPH....103	IS1AHK...101
V87NX....109	GW3AHN...102	VE5JV....101
SM6DN....106	ON4FQ....102	HP1BR....100
G3DCU....105	W5DGV....102	W8AJW....100
	W1NLM....102	

RADIOTELEPHONE

VK3BZ....119	W1MMV....104	W1ATE....101
ZS6DW....107	ZS6Q.....103	W3BYL....100
W9IOD....105	HB9J.....101	W6OZE....100
W7HIA....104	W2PRF....101	W6NIG....100
	W8NML....101	

ENDORSEMENTS

W3CPV....203	W1AB.....160	ZS2AG....131
W2QKS....200	KP4KD....160	W1LKE....130
W8NBK....200	W6JZP....152	KH6CD....130
W6AM....190	W2TXB....151	W8ZMC....130
W6OMC....190	W1KFY....150	W6JK....130
W2QHH....180	PY2CK....150	W7KTN....130
W6SYG....180	W9IOD....150	W9UX....123
W9UOX....180	W4LZF....146	VK6KO....121
W1BHH....180	W2DSB....142	W4RBQ....120
W6ANN....172	G2ML....142	IE5F....119
G3DO....164	W1DQH....140	W2GTL....112
W7GUV....161	W3HRD....140	W7DET....110
ON4QF....161	VK4EL....132	ZL4GA....110
LA7Y....161	W8GLE....131	W3MLW....110

RADIOTELEPHONE

G3DO....143	G6RRH....141	HC2JR....113
PY2CK....142	W8KML....141	IA5M....112
	HB9DS....133	

COUNTRIES LIST POLICY

Ever wonder why some suggested additions to the Post-war Countries List never make the grade, or why those which make the grade aren't added overnight? On the surface, it would appear a simple matter to act immediately on every proposed new country, but there's more to it than meets the eye. ARRL has never considered itself the final authority on what constitutes a country for DX purposes, especially since the geographical and political implications are often far-reaching. A tiny island out in the middle of nowhere, one that seems destined at the beginning to find a place on the Countries List, may never make the printed page because of some political oddity. Some candidates for the Countries List can be settled one way or the other in short order when their political and geographical make-ups are so obvious as to be beyond dispute. However, in most cases, ARRL goes to the outside for information and advice. Recognized authorities on the political and geographical status of any country or area in the world are consulted.

In turn, the information received from these authorities is passed along to a group charged with deciding whether or not a certain proposed country should be added to the Countries List in view of all the available data. This group also includes men outside of ARRL, and consists of those who are in a position to know what's going on in the DX world through their operating and their work. The vote is cast, and the majority rules in each case. Geographical separation from the mainland often serves to swing an area into a place on the Countries List even when the political set-up alone apparently doesn't warrant it, and likewise form of government often turns the tide in making two countries out of one island. Many details enter into the workings of the Countries List, and in the final analysis when a new country is added to the List or an old one deleted, there's a good reason for the change after the matter has been considered from every angle.

BRIEFS

Morrie Morris, VK3BZ, recently submitted 178 confirmations in application for postwar DXCC. This in itself might not seem too impressive but 120 of the confirmations were for 'phone, and all contacts were made using 40 watts input! Can any DXer top this low-power 'phone record?

In the results of the 1949 DX Contest published in September, 1949, QST, W2DS was listed among these amateurs whose entries were disqualified for off-frequency operation as confirmed by a single FCC citation. Upon corresponding with the Commission, W2DS was able to show that his station had not in fact operated off frequency and subsequently FCC withdrew the citation. ARRL has retracted the disqualification and is pleased to announce that the score of W2DS, 92,430 points, earned from 237 contacts and a multiplier of 130, is officially the fourth-highest valid score entered by participants in the Western New York section.

W1AW OPERATING SCHEDULE

(All Times Given Are Eastern Standard Time)

Operating-Visiting Hours:
 Monday through Friday: 1130-0600 (following day)
 Saturday: 1900-0230 (Sunday)
 Sunday: 1600-2200

General Operation: Refer to page 64, September, 1949, QST, for a chart showing W1AW general operation. This schedule is still in effect and is not reproduced herewith for space considerations. Mimeographed complete master schedules of all W1AW operation in EST, CST, MST, PST or GCT are available upon request.

On Saturdays and Sundays during which official ARRL activities are being conducted, W1AW will forego general-contact schedules in favor of participation in the activity concerned.

Official ARRL Bulletin Schedule: Bulletins containing latest information on matters of general amateur interest are transmitted on regular schedules:

Frequencies:
 C.W. — 1887, 3555, 7215, 14,100, 28,060, 52,000, 146,000 kc.
 'Phone — 1887, 3950, 14,280, 29,000, 52,000, 146,000 kc.

Times:
 Sunday through Friday, 2000 by c.w., 2100 by 'phone.
 Monday through Saturday, 2330 by 'phone, 2400 by c.w.

Code-Proficiency Program: Practice transmissions are made on the above-listed c.w. frequencies, starting at 2130, Monday through Friday. Speeds are 9, 13, 18, 25 and 35 w.p.m. on Monday, Wednesday and Friday, and 15, 20, 25, 30 and 35 w.p.m. on Tuesday and Thursday. Approximately ten minutes of practice is given at each speed. Next certificate qualifying run from W1AW and W9TQD is scheduled for Mar. 17th; from W6OWP, Mar. 5th.

The station staff:
 T. F. McMullen, W1QVF, "fm"
 R. N. Eidel, W1RUP, "re"
 R. E. Morrison, W1RXL, "lr"

SCM ← AEC ← ORS ← CP ← SEC ← OBS ← TJS ← OO
Station Activities
 OES ← AIOPR ← EC ← DXCG ← CLUBS ← RM ← OPS ← RCC

• All operating amateurs are invited to report to the SCM on the first of each month, covering station activities for the preceding month. Radio Club news is also desired by SCMs for inclusion in these columns. The addresses of all SCMs will be found on page 6.

ATLANTIC DIVISION

EASTERN PENNSYLVANIA — SCM, Jerry Mathis, K1W3BES — NHI has a new NC-173 (won at a raffle) and a Collins 32V-2. 1QNU has been assigned duty at Johnsville. ASW reports a novel triplex method of QSO with s.s.c. on 3999.5 kc. by using voice-operated transmitter control. Look at that BPL total of CUL's. She operated ten hours per day to do it! New officers of the Car-Le Radio Club are TCC, pres.; HA, vice-pres.; AIW, secy-treas.; OP, act. mgr. For the York Road Radio Club we have LVF, pres.; KFK, vice-pres.; ALB, treas.; UKI and MQU, secys. HVB was appointed to represent the YRRC in promoting the Philadelphia Area Council of Radio Clubs. Clubs, get behind this project for the benefit of all the hams in the territory. The Atlantic 6-meter Net operates at 10:30 P.M. Thursdays on 50.4 Mc. MFY is Net Control and runs 700 watts to a five-element wide-spaced beam. Traffic is solicited from Long Island to Pleasant Hill, Md., as these areas are worked regularly. W8s, W4s, and HC2OT have been worked by Philadelphia stations. The 6-meter fraternity urges more activity on that band. Members to date are MFY, OQS, OWY, MXW, GGR, UKI, FZQ, OAS, 2BAY, and PAU. Five states are worked regularly on ground wave. MFY has a clean bill from the FCC for TVI and has been authorized to go back to full-time operating. Our new SEC, ISE, is working hard reorganizing the AEC in Eastern Pennsylvania. Traffic: W3CUL 3377, ABT 561, NHI 138, PMG 102, EAN 94, PDJ 87, WTS 73, NTD 63, ELI 31, QEW 12, OML 7, EU 2.

MARYLAND-DELAWARE-DISTRICT OF COLUMBIA — SCM, Eppa W. Darne, W3BWT — At the Washington Radio Club's first December meeting, the new Articles of Incorporation were discussed and voted on, the membership being in favor of same. Brad Martin, QV, Atlantic Division Director, as guest speaker talked on the proposed new regulations for amateur radio and answered questions pertaining to them. Director Martin also presented the ARRL TVI film to complete an extremely interesting meeting. The Club held its annual Christmas Party on Dec. 17th, with games, entertainment, grab bag, and eats, which were enjoyed by all present. The Baltimore Amateur Radio Communications Society held its first Hidden Transmitter Hunt on Dec. 11th. Suitable prizes were awarded the winners. HJY, KDV, and MWY composed the committee in charge of the hunt. Details were outlined at the Dec. 5th meeting, which also featured a talk on "GM curves" by Dr. Heats Pullen of the Ballistics Research Labs at Aberdeen, Md. Code practice continues on 28 Mc. from PSG, Monday through Friday, 9:00 to 7:30 P.M. Feature of the Chesapeake Amateur Radio Club's Dec. 6th meeting was a discussion, the subject being "Vacuum Tube Mixers in Superheterodyne Receivers" by NVL. At the Dec. 20th meeting, LXX gave a talk on "Amateur Applications of the Cathode Ray Oscilloscope." The regular meeting of the Rock Creek Amateur Assn. on Dec. 9th featured a talk on "Test Instruments and Their Construction." The Potomac-Rappahannock Valley Emergency Net continues its regular drills on 3.85-Mc. 'phone and on 144 Mc. Field drills by the 144-Mc. section, with simulated emergency conditions, have been very successful. The University of Maryland Amateur Radio Assn. now is an ARRL affiliated club. EQK is very active in his OO work. Shirley Dobos, XYL of JCL, now has her own call, QBG, and her own rig. She was active in WERS during the last war, and now puts out a nice signal on 28-, 14-, and 7-Mc. c.w., as well as 28- and 14-Mc. 'phone. CG has been transferred to California. FQZ is newly-appointed ORS in the Washington area. UF is newly-appointed Official Bulletin

Station. IL is active on 7- and 14-Mc. c.w. from his new radio shack, which is one of the most beautiful and well-laid-out the SCM has ever seen. FQZ has almost licked his TVI problem, and uses input of 700 watts on 3.5 Mc. MCG is building new exciter. Ethel, MSU, joined the WAVES in the Naval Reserve so she also could join the MARS. She is the second YL member of MARS. EUQ frequently is heard on 3.5 Mc. and is active in M.D.D. Net. ECP's XYL presented him with a shiny new Vibroplex for Christmas. Traffic: W3UF 570, PTZ 234, ECP 190, LFG 129, MCG 91, EAX 73, FWP 68, CIQ 60, QL 44, AKB 43, NNX 26, BWT 13, JHW 7, CJ 6, IL 6, NB 6, AKR 5, FQZ 3.

SOUTHERN NEW JERSEY — SCM, Dr. Luther M. Mkitarian, W2ASG — SJRA officers for 1950 are RE, pres.; OQN, vice-pres.; PNA, corr. secy.; PFQ, rec. secy.; QKO, treas.; and UCV, QQQ, SDO, PFT, ADA, and YRW, directors. CRC officers for the new year are JAV, pres.; CEU, vice-pres.; PFQ, corr. secy.; SPN, rec. secy.; RUX, treas. The DVRA-sponsored 6th Annual Old Timer's Nite will take place at Stacy-Trent Hotel on Saturday evening, April 15th. Young and old let us go! General Chairman ZI has all the information. Contact him. RFF still is on the sick list. UCV has a new metal tower and a new beam for 144 Mc. ZI has a brand-new antenna. K2AZ "reports" hearing JA2AZ on 52 Mc. BV, PAU, PEN, FTX, REB, and JAV have high-power finals on 144 Mc. BEI had 1000 QSOs with G6BY. PPT is a new ORS. Please drop a postal to your SCM with all the news. Traffic: W2RFH 219, ORS 44, PFT 18, RG 18, ZI 15, ZYX 10, ASG 6.

WESTERN PENNSYLVANIA — SCM, Ernest J. Hlinsky, W3KWL — We offer our congratulations to our Three Musketeers of the traffic nets, GEG, GJY, and NRE. They now are members of "Ye Ole Brass Pounders League," with a grand total of 1795 messages handled between them. My humblest apologies to the boys up Bradford way, for failing to mention their splendid club work and their participation in the recent emergency drills. From up Erie way, your SCM gets a nice big blue envelope each month with clippings from the local paper by TFX. The Erie Radio Club Old Timers' Nite was a big success. SILC was honored as the organizer of the first radio club in 1922. It is with regret we learn of the passing of ROP. ZTU is a newcomer to Erie. NGB and NLU are recruiting stations for 420 Mc. OIE, OIN, and PSI were heard on short skip working the Wis. The Horseshoe Radio Club of Altoona sends along its *Hamateur News* and says that QGH is a newcomer. BWL is a new DX man with 89 countries. LIV is on with 812 final. LJQ and POZ can be heard on 160 meters. The Steel City Amateur Radio Club with its club paper *Kilowatt Harmonics* finds its editorial staff with DND, LBE, RIK, NRQ, and MPO constantly on the spot. RXT is urging everyone to be on 50 and 144 Mc. and the high frequencies. The SCARC Net got off to a surprise opening with LOR, MTP, UUG, PAS, NRQ, LEG, OKU, and two visitors stirring up the fire. At State College NGZ renewed his station ORS appointment and says the gang is QRL with traffic and DX hunting. UVD is finding 7-Mc. DX to his liking with GW and a couple of Gs his latest. Up Titusville way, PAI uses only 6 watts and his DX is VO1, TF3, KV4, and KP4. FYR is building a new VFO. Up Sharon way KUR found Santa Claus good to him with a new Collins 32V-2 transmitter. PMB has another swell 28-Mc. rig going. NCD finds traffic-handling a lot of fun. The Mercer County Radio Assn. is making great plans for the coming Field Day. Traffic: (Dec.) W3NRE 940, GEG 565, GJY 348, NCD 73, LIW 52, YDJ 44, KWL 33, PAB 33, DNO 24, LSS 22, AER 14, LOD 9. (Nov.) W3NCD 37, LIW 26.

CENTRAL DIVISION

ILLINOIS — SCM, Lloyd E. Hopkins, W9EVJ — Section I Nets: ILN 3765 kc. and IEN 3940 kc. SEC: QJLZ, PAM; UQT, RMs: SXL and SYZ. Orchids to AEX and his crew of Quincy hams who did such a wonderful job during the recent severe ice storm there. Our c.w. net began publication of *ILNus* this month through the efforts of JMG. The Tri-Town Radio Amateur Club of Chicago came out with the first postwar issue of *The Oscillator*, a swell club paper. EWE recently suffered severe burns after contact with high voltage at WBBM transmitter, but is recovering satisfactorily. JNC is kept busy with contests and experimenting. JMG has new keying filter. UBF is laying plans for higher power and new HRO. ASN is doing a nice job on ILN. LNI is trying

to get out of the back yard. EBX has recovered from his recent illness and is ready for action. The Cahokia Amateur Radio Club meets the second Wednesday of each month. CKM sends first report and is active on 7-Mc. c.w. and 28-Mc. 'phone. CBZ is fighting TVI. AAH is spending his time on 144 Mc. BON is building mobile rig, FKG is vacationing in Florida. KCX was ably assisted during the ice storm and reports IEN made headlines in the Springfield papers. New officers of the Central Illinois Radio Club are SXL, pres.; JRX, vice-pres.; CFV, secy.-treas. The Starved Rock Radio Club elected ATA, pres.; DKW, vice-pres.; QLZ, secy.-treas.; IDA, editor of *Static*, the club paper. NOO purchased 'phone rig with 813 final. YNE is the proud owner of instruction book for 32V-2! TLC is taking a fling at 160-meter 'phone. PHB recently was married. MZW snagged QSLs from OQ5, SM5, and ZP9. BRX is nearing the end of his antenna construction. FFR completed new 300-watt final and can be found on 7 Mc. BIN reports emergency equipment ready for any need. NN is preparing to move into new home and shooting for DXCC on 7 Mc. WEA is pounding away on 14-Mc. c.w. NGG has 50 watts on 3.85-Mc. 'phone. JAU is recovering at home from recent auto accident injuries. DKW spent most of the month in the East on business. ZEN was home for the holidays and helped the local post office carry the mail. QLZ received two 36" cabinets as a birthday present. IDA can't seem to get rid of his job of putting out the club scandal sheet. EVJ did a quick rebuilding job over the New Year week end and now has everything lined up in new steel rack. Attention members of IEN: We have only 13 Official Phone Stations in our section. Certainly many of you fellows are eligible to hold this appointment. Write your SCM for information. Let's keep our rigs in operating order at all times for possible emergency use. Plan your changes and rebuilding so that you will not be off the air a single day. It may be important to you and your city. Your SCM thanks you for the many Christmas cards and wishes you all the success in the world for 1950. Traffic: W9EVJ 459, SXL 346, CMC 260, CBA 232, DUA 191, FLQ 166, CMU 88, FFR 79, UBP 71, BUK 70, IIZ 69, MRQ 66, KCX 62, ASN 42, FRP 41, JMG 35, LIN 31, FKI 20, PEK 15, ZPC 12, JNC 10, FFD 6, CKM 5, SYZ 4, EBX 2.

INDIANA — SCM, W. E. Monigan, W9RE — EF and WAY are new stations in Crown Point. KQV is back on the air after two years. GHK remodeled the rig and is active in QIN and MARS. WRH is new MARS in South Bend. Louise Beringer, ex-WPTQ, has old call, 9JTX, reassigned. DGA and QLW have DXCC certificates. TT works G6GM with 40 watts input. GFO has new QTH with space for antennas. 8STK/9 now is in Evansville. KTX says SWLs are PB; one gave him a clock for Christmas. New officers of the Michiana Amateur Radio Club are WRH, pres.; YME, vice-pres.; PDF, secy.; BYY, treas. An interesting program has been set up for 1950, based on self-improvement of the members and to develop more interest in contests and traffic handling. Emergency operation also is stressed. The Club is sponsoring a "Civ. Educ. Program," which gives non-technical talks to the local service and civic clubs and local organizations. These include lectures on amateur radio, plus a demonstration of 28-Mc. amateur operation. Equipment is set up in the hall to communicate with the mobile stations of cooperating amateurs. INV and IFN are new stations in Gary. New officers of the Lake County Amateur Radio Club are GQJ, pres.; WIB, secy.-treas. SNF has new rig with VT127As in the final. RJU has returned to Ohio to live. TV listeners claim to see the shadow of EGQ's beam on their tubes even if the transmitter is discontinued. GNR is new monitor station for the Gary Area emergency. Frequency 29.276 Mc. QOU also is MARS ANC and sends code practice on 3750 kc. each Wednesday at 2000 CST. Are you interested in c.w. nets? Contact RCB on 3656 kc. 'Phone? BKJ on 3905 kc. Emergency? PRO on 3905 kc. or by mail. Traffic: W9TT 224, DKV 182, BKJ 118, QLW 85, DHJ 75, JTX 40, RCB 33, DGA 34, DOK 24, RE 24, HUV 23, SNO 17, KTX 14, GHK 3.

WISCONSIN — SCM, Reno W. Goetsch, W9RQM — Congrats to CBE with a traffic total of 858, as well as ESJ with 567 and SUF with 534. AEY will be on WIN as soon as the Clapp WFO is finished. SUF, new ORS, says that he modulates the bed spring next door when he goes on 'phone! ESJ says traffic is moving nicely on 'phone with good cooperation from stations in neighboring states. LFK has a new mill and as soon as it has been TVI-cured, he will have the big rig back on. SZL renewed RM appointment. HDZ, now ORS and OBS, has new 24-hour clock as a result of Christmas. FXA worked his first ZS, and now is ORS. ANM has been providing traffic liaison between BEN and WIN. According to SFL, LaCrosse activity is on the upswing with GCT, ZSO, and GPU taking care of the BEN, and SFL and GPU on the WIN. UIT, as OBS on 3855 kc. at 0100 daily, has heard reports from all parts of U. S. and Canada. YCV now boasts a Q5-e which works fine. KXK's DX now totals 94 countries. ESJ renewed OPS and OBS appointments. BZU has new 3.5 to 28 Mc. 100-watt rig with MB150 final tank under construction. CXY received 35-w.p.m. Code Proficiency award. LLR christened his new 28-Mc. beam by working OZ2M right after putting it up. IWT qualified as Class I OO in the Frequency Measuring Tests. DJV provided an interesting traffic summary in the December *WIN Bulletin*. VHA, ZTO, EWM, FYP, FXA, CTD, CFT, JBF,

RQM, and HEE were active in the 10-meter WAS Contest. YYY discussed emergency organization at WVRA and Rock River Club meetings. A new HFS receiver is keeping RLB occupied. VHA worked a JA to complete WAC. Plan now to attend the WVRA annual banquet at Wausau, Apr. 15th. CBE finally made WAS. Traffic: W9CBE 858, ESJ 567, SUF 534, AEY 327, LFK 179, DND 97, SZL 93, HDZ 68, ANM 62, FXA 62, YCV 59, CWZ 57, SFL 56, RQM 54, UIT 40, MUM 36, BZU 5.

DAKOTA DIVISION

SOUTH DAKOTA — SCM, J. S. Foasberg, W0NGM — The Huron Radio Club and the Navy Electronics Unit have a new joint room to be used for operating. The equipment now on hand and on the air includes a BC-610, a TDE, a TCS and two National receivers. The new room is in addition to the regular classroom and workshop. The club call is QDN and the site is the American Legion Building, with shop and classrooms in the basement and operating room on the second floor. OXC is setting up amateur operators in all the State stations with the equipment to operate on 40, 80, and 160 meters. He has found that a vertical cage type of antenna loads up and works out fine on all these frequencies. UVL now has his kw. on the air and it works FB. Now is the time to plan for a bang-up State convention this summer or fall. VT is rebuilding his 14-Mc. transmitter and it will be somewhat lower power than the kw. Traffic: W0GCP 75.

MINNESOTA — SCM, John B. Morgan, W0RA — KGG has a swell new QTH with lots of room for rhombics. YTL has a mobile in his new car. The St. Paul Radio Club heard an interesting talk by Craige Schemsted, of the Physics Department of the University of Minnesota, on the mathematical solution of switching problems in transmitters. BHY and SMT have their new exciters working. HQW is in the V. A. Hospital in Minneapolis and requests calls from local c.w. men. KYE is back home from a hospital sojourn and working 7-Mc. c.w. EA, GHN, EHO, LDI, PNQ, and RXL are new ORS. DX-er PNQ is breaking in on 3.5 and 7 Mc. for a change. GHN has rebuilt his antenna tuner, VFO, and exciter and is back on 3.5 Mc. with 600 watts. RXL suggests that NCS use more brevity in lining up traffic when nets start so that stations not needed may be excused promptly. This applies to both c.w. and 'phone nets. SMT won the Hidden Transmitter Hunt on Dec. 30th. BOL has broken into c.w., and now works traffic on both c.w. and 'phone nets, as well as his test schedules with his EC group. All ECs are requested to send in their certificates for endorsement when due. RA's 32V-1 is back after having various bugs and birdies suitably trapped. BGY, LDI, and RLF have been doing heroic service as NCS of the Minnesota State Net, and checking into the Tenth Regional Net. IXR has a new electronic key. UME, Mrs. Eva Cross, is on 28 Mc. in St. Paul with 1 watt, and is doing OK. Minnesota mobile spot frequency is 29.640 kc. There is nearly always someone listening there. Traffic: W0ORJ 212, LDI 191, BGY 103, BOL 76, KXG 74, RXL 64, IXR 58, FID 50, GHN 38, LIL 32, UCY 18, BBN 4, EG 3.

DELTA DIVISION

ARKANSAS — SCM, Marshall Riggs, W5JIC — NTV is attending college at Russellville and is running 25 watts on 3.5-Mc. c.w. DRW has mobile rigs on 3.85, 14, and 28 Mc. working out fine on all bands. PYY has EB emergency set-up at Canton. Let us hear more from you, Bill. NTV has a pair of V70Ds on 7, 14, and 28 Mc. OQS is running 250 watts p.p. 24Gs on 7, 14, and 28-Mc. 'phone and c.w. and is doing OK on DX, too. OXL is in Air Cadet Training and is QRT at present. OCO is running 160 watts from Magnolia using 837s as modulators. QQM is a new call in Little Rock. JIC had visitors from Texas, California, Missouri, Oklahoma, and Kansas, and also Ft. Smith and Horatio. He was active in clearing the frequency for a girl hunt in Washington. Don't miss the big meeting of the renowned Chickenhouse gang, the Pole Cat gang, the Arkansas Catfish Club, and the Losey Operators Net which will meet here the early part of June. Traffic: (Dec.) W5DRW 615, FMP 272, LUX 117, OXU 62, MRD 53, JIC 43. (Nov.) W5DRW 576, FMP 258.

LOUISIANA — SCM, W. J. Wilkinson, jr., W5VT — Back again after a layoff of a couple of months and we are in hopes that business in this department will pick up more than just a little. Reports have been very few and far between in this corner for quite a spell now. Let's hear from more of you during 1950. CEW still is trying to work a new country occasionally and at the same time is PAM. KTE, I understand from several sources, is active although there has been no dope from him in several months. OWY has applied for membership in the Emergency Corps and FTU has been transferred to Japan, so look out for him with a new JA2 call. NGN reports traffic regularly. GHF has had his appointments renewed so he must be on the active list. LQY has been travelling around the section lately so there is not too much activity from that quarter. VT still is QRL but has high hopes of hitting the ether in the very near future. Boy, will I be glad to get with you fellows again. Traffic: (Dec.) W5NGN 17. (Nov.) W5NGN 161. (Oct.) W5NGN 50.

(Continued on page 74)



This time of the year finds us reviewing equipments and components manufactured during the past year and selecting certain of our products considered to be of general interest to the radio industry for display at the annual Institute of Radio Engineers Trade Show. Following the pattern of past years we know we can anticipate a busy four days. Nevertheless, the opportunity of seeing and chatting with many of our friends in the industry is always a stimulating experience. This is the occasion when we meet users of our products face-to-face. It is here that we find out why some particular gadget we brought out during the past year may have missed the boat; some small detail may have been overlooked when the final application was considered. The detail will be explained and all future production of the item will benefit. This is what we are constantly striving for — improvement of our products. Likewise, new devices will be suggested for consideration and possible future development. This is what you are looking for — new products.

In addition to new transmitters and receivers developed and manufactured for commercial and government applications during the past year, there will be new components on display that were often developed as a necessity to produce the equipments. Of course, we will have the new HRO-50 in evidence. (Though we had the best of intentions of having the HRO-50 available for the tough workout during the DX contest this year, we found that new procurement of materials and new tooling required to manufacture this set delayed us about 45 days. We now expect to start deliveries to distributors during the first part of March.)

Characteristically, all of our newest developments will not be on display as military restrictions or classification will apply in some instances to keep products under wraps for the time being. One receiving equipment which we consider of interest is the URR-9 receiver, which is a super-duper 10-channel or variable frequency receiver, operating from 200–400 mc. with a projection type dial with frequency read directly. This receiver was built for the Navy Department, Bureau of Ships and will be on display at the Navy Department's exhibit.

Incidentally, we have had a preview of the Navy's exhibit and can say without reservation this will probably be one of the Navy's finest.

The entire Navy show is planned to be of dynamic nature. The Navy indicates that wheels will spin and sparks will jump. This show will be unique in that the audience may participate in the majority of the exhibits. Among some of the interesting exhibits are an electronic Radio-Sonar locator which is used for rescue of personnel at sea, the UHF exhibit showing the latest trends in UHF communications, (this is the portion where the URR-9 is featured), the electronics multiplex system devised by the Navy, and many other interesting devices.

Before it's all over, we hope to have the pleasure of seeing you at our exhibit, Booth No. 14, main floor, Grand Central Palace, New York City, March 6–9, 1950.

W. A. Ready



MISSISSIPPI — SCM, J. C. Wallis, W5DLA — Are you emergency-minded? If so, let the SEC, MUG, put you in the files as an EC or AEC member. QMQ has joined the Magnolia Net, Kessler Club, and GCARC. LAK has two generators available for use in event of emergency. CKY has new 14-Mc. beam. BK logs 14-Mc. DX. IGW is back in the Rebel Net. MNR is on 14-Mc. c.w. JHS is a new ORS. OZV is new EC. DOL and MUG have new NC-183s. OKQ is very active on 28.5 Mc. DEJ is active in RN5 and Magnolia Nets. LPL is back on 28.5 and 7 Mc. FGE, new OB8, has schedules Mon., Tue., Wed. at 1900, on 3975 kc. WZ is busy with traffic schedules. JJA and BEV are working on CAP gear. PDM is on 14-Mc. 'phone. LN is Manager and NCS of the Magnolia Net, with FFF 1st ANCS and ANP 2nd ANCS. Correction in October traffic: JHS should be 113, WZ should be 43. Traffic: W5WZ 86, JHS 82, DEJ 45, KYC 34, DOL 20, DLA 17, ANP 12, MUG 9, LPL 7, QDL 5, LAK 4, QMQ 2.

TENNESSEE — SCM, Ward Buhrman, W4QT — AYE is operating MM on a freighter running between N.Y.C. and various ports in the Orient and South Pacific. He maintains contact with MKB to handle traffic with the home folks in Nashville. PSB (age 13) has received his 20-w.p.m. Code Proficiency endorsement. MKB has his second DXCC endorsement. He is No. 159, all on 28-Mc. 'phone. Search for a lost private plane occupied the 'phone net (3980 kc.) for several days. NJE displayed excellent ability as NCS. Use of amateur facilities narrowed the search and saved time in checking private landing fields. PL is convalescing; he should be back on the air by the time this is printed. LHQ put up new 80-meter wire to work West Virginia. 'The boys up there had difficulty hearing him, but he worked EK1AO and ZS5YF. Traffic: W4BAQ 828, PL 699, LNN 326, APC 296, ETN 284, CZL 125, NNJ 104, AEE 35, FCU 35, LHQ 32, QT 30, LNF 18, ONX 10, PMR 8, NPS 1.

GREAT LAKES DIVISION

KENTUCKY — SCM, W. C. Alcock, W4CDA — This is my final report. The new SCM is Doc Adkins, KWO, Hazard, Ky. Send all traffic and activity reports to him. We extend thanks to the gang for the swell support given us the last two years. JQY says the KYB Net (Dec.) had 28 stations report in 124 times with 73 messages handled. Write Mac for details of KYB Net work on 3890 kc. ERP is working DX on 7 Mc. with an old 8141 ALB runs radio patch shop. NIX works traffic nets on 7 Mc. WYW has new portable rig to use at school. OGB is working on converted Link mobile rig for his "buggy." NUQ is conducting classes for would-be hams. MWX says Henderson is to get a few new amateurs soon — if they pass! JSH and KFA keep Lexington on KYN Net schedules. BXU has rebuilt his homemade bug. JCN is doing over the house so his rig has to wait. NZH puts a nice signal on the Net from Paducah. FKM had receiver trouble but it's fixed now. VD is in the throes of rebuilding. VP is Class I Official Observer and lined up several other Louisville stations as Observers. Nice work. Doc! KKG has the power but no time to operate. LDW/4, with a converted BC-459A, is new at Lexington. For net work, report your schedules every month to BAZ or JQY, listing towns and states you cover. Traffic: W4BAZ 305, YPR 274, JQY 157, NIX 134, MWX 73, NBY 54, CDA 36, JSH 23, BXU 21, JCN 21, NZH 20, KFA 12, FKM 5.

MICHIGAN — SCM, Robert B. Cooper, W8AQA — Asst. SCM: T.P.P., Arthur P. Kohn, STTY, Asst. SCM c.w., Joseph R. Beljan, SCW, SEC: GJH, RM/QMN; TRN and UKV, RM/8RN; NOE, PAM; YNG. The intensive efforts on the part of TTY have finally culminated in an Upper Peninsula Net on 3930 kc. The "UP" Net meets at 10 a.m. Sunday, with CSI and TTY sharing the NCS duties. WNT had the honor of running the organizational roll call and had 15 stations reporting. New appointment this month is a Class I endorsement for AYY as OO. TRN is the high traffic man this month. RJC also made BPL. SCW and NOH make BPL by deliveries. DOI is a new NCS for the QMN, and UTH with TQP serve as alternates for the BR. ELW asks for a standby Q signal less confusing than QRX. Are there any suggestions? CLP is working into the QMN via SH while at East Lansing. FOV reports for ACW and also reports into the TCGN. CRH is working DX with a new 10-meter beam. YMO and WXO are using a new electronic keyer. DeD can be found on 28 Mc. and does report into the Holland Emergency Net. New officers of the DARA are RX, pres.; HP, vice-pres.; FX, financial sec.; SCW, recording sec.; BHL reports new officers of the Adrian Club are Hall, pres.; PUF, vice-pres.; BHL, sec. Lake Superior Club officers are ERE, pres.; ZNM, vice-pres.; HPH, treas.; TTY, sec. FLA lists the Allegan officers as EH, pres.; Collick, vice-pres.; FLA, sec.; COM, treas.; ZQZ, act. mgr. DSE reports TBP is the trustee for the 350-watt rig at Red Cross Headquarters. NDC is using a new Meissner Signal Shifter on 14 Mc. GJH reports new officers of the Flint Club are HRL, pres.; ILG, 1st vice-pres.; BCC, tech. vice-pres.; AMT, program vice-pres.; GXA, secy.-treas. New hams in the Copper Country are EYK and EYO, while DAS, CVE, ZKV, HYQ, and EVL are Class A. ZUJ, better known as 9GPM, has joined the ranks of Silent Keys. ENT has a new half-wave dipole for 3.5 Mc. EXZ reports into the QIN for Michigan traffic. TNO, with a TVI-proof exciter, will be back on QMN. RTN is working M.A.R.S. for traffic. Traffic:

W8TRN 613, RJC 506, SCW 465, NOH 291, ZWM 202, UKV 194, URM 128, AQA 97, WXO 97, YNG 63, UGD 59, YMO 59, TQP 47, DSE 45, IV 41, YGS 39, CRH 37, ATB 31, LR 30, TBP 24, Bvy 21, ACW 20, DED 19, ELW 19, FX 18, DLZ 17, DOI 17, WV 16, ZBT 16, ZDF 16, RTN 10, ALN 9, CLP 9, MHH 9, ERT 6, EXZ 6, OAF 6, EBF 6, UHF 5, DPE 4, ENT 4, TNO 4, EJD 2, NKK 2.

OHIO — SCM, Dr. Harold E. Stricker, W8WZ — Asst. SCMs, C. D. Hall, 8PUN, and Charles Lohner, 8RN, SEC: UPB, RM: PMJ, PAM: PUN. The Ohio Council of Clubs met in Columbus Jan. 14th at the YMCA. Both the Director and Alternate Director were present. EYE was chairman of the meeting and 17 clubs were represented. The following were present: YFJ, WAB, WXG, ELN, HRN, VZE, BMC, QA, AXN, TAJ, KUW, UJN, WRL, EQN, RJD, ARP, WPK, CPM, UGE, ENH, ZJM, EYE, CPA, CUO, BLS, UPB, AL, AIM, OKB, YYH, TND, and QQ. UPB, WAB, and EYE gave short talks which were recorded for the "Voice of America" program. The Ohio River Forecast Center, located in Cincinnati, contacted UPB to set up nets around the main centers or observing centers. This was done and the nets have functioned three times so far. Please look at your certificates and if they are due or overdue for endorsement, send them to me. I would appreciate more OO reports. To the OOs, I get your station activity report but no OO report. We need more ORS and OPS in some of the larger cities. I failed to give credit for a good emergency operation that was simulated in Bucyrus. The information was mislaid and just found. An imaginary tornado hit the locality and the emergency was well handled under the direction of ICD, the EC for that area. He was assisted by BHE, ICC, VTB, and members of the C.A.P. At the last meeting of the GCARA rotary beams were discussed for members contemplating building them. Various members entered in the discussion, and from the DX records of that area the issue was capably discussed. Since JIN put up his new beam he certainly has moved up the DX ladder. The Cleveland Area Council of Amateur Radio Clubs is arranging a hamfest. The members of GORC are sponsoring a code class for Boy Scouts. From the Q-5 of Springfield: The Navy Electronic Warfare Unit is assured for Springfield and VKV is the local commander. From the DARA: ZJM spoke at the last club meeting on "Methods for matching the transmission line to the antenna." The reporting staff for the DARA is AUN, OUL, ZQU, ZJM, KKH, CEA, ACE, ZOK, YCP, NNS, and ZFO. From the ARC OVER (Air Material Command Amateur Radio Club): Thirty are enrolled in the code class, with ABL in charge. ZAU spoke on net procedures. The president of the club is DLK and the secretary is ABL, assisted by DZX. From the CARA: BYE spoke at the last meeting on "Super-Modulation." From the Voice-Cod: New officers of the MVARA are PWH, pres.; CHN, vice-pres.; CUI, secy.; DPK, treas. The January meeting was held at DKP's. YKK lost parts of his rig because of fire. FRY still is editing the Voice-Cod and doing a swell job. ECJ has moved from Niles to Warren. The MVARA will sponsor a ground-wave contest in February. IOO has new 75A. ZJM is only keeping traffic schedules as he is building a broad-band exciter. TAO can work single- or multiple-band operation. RN has been under the weather and his activity has been curtailed. SJF again leads the pack in traffic and she made BPL this month. DAE is very active on BN, ESN, and RN. PUN is rounding up the 'phone boys and they are handling more traffic. CBI has new transmitter. UW has left for San Juan and will be on the lookout on the low end of 3.5, 7, and 14 Mc. VZ has new 65-ft. beam. WRN states that 144-Mc. activity was low but that several 144-Mc. teletype contacts were made. Traffic: W8SJJ 487, DAE 211, UPB 190, EIU 104, PMJ 79, CBI 72, ZJM 58, PUN 38, RN 33, EQN 19, DXO 16, QIE 12, YCP 10, YFJ 10, VZ 9, ZOF 8, BZX 7, WAB 7, FNX 6, TAO 6, DZO 5, UW 5, LBH 4, LCY 4, TRX 4, BUM 3, IVC 3, OUR 2, PNJ 2.

HUDSON DIVISION

EASTERN NEW YORK — SCM, Fred Skinner, W2EQD — SEC: CLL, LDS has been appointed EC for Dutchess County. ZDE resigned as EC of Rockland County. CJP received postwar ORS appointment #14 as a renewal of prewar ORS. Endorsements: GYV as OES, EQD as ORS. IXK is doing a fine job pushing traffic in Poughkeepsie and as OES is working on a means of getting v.h.f. output from oscillators using MF crystals. GYV reports the following 1950 officers for SARA: FZW, pres.; VUI, vice-pres.; GYV, secy.; PFU, treas.; GTC, UKA, JZX, and EFU, directors. CLL made the BPL again. Our apologies to TYC for neglecting to mention last month that he made BPL on deliveries. That's about the fourth time for him during the year. Don't the rest of you fellows want one of those fine-looking BPL certificates? Traffic: W2CLL 651, TYC 258, PHO 165, CJP 99, EQD 39, BSH 37, GCL 13, IXC 12, WIK 4.

NEW YORK CITY AND LONG ISLAND — SCM, George V. Cooke, W2OBU — SEC: BYF, RM: TYU, KTF and NZJ, Nassau and Southern Queens ECs, were the only ones sending AEC reports this month. KTF states most of the AEC members show interest in a weekly drill on 3600 kc. Fridays at 8:00 p.m. NZJ is endeavoring to get the Southern Queens group going and to recruit members of the UHF

(Continued on page 78)

MALLOBY HAM BULLETIN

Important Announcement! 4-GANG INDUCTUNER* AVAILABLE

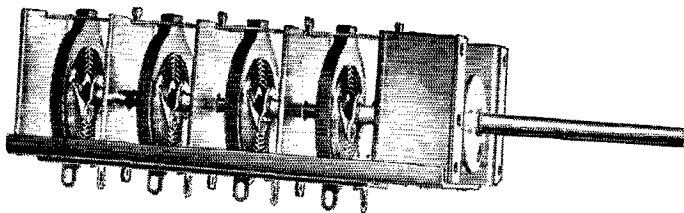

In the December 1949 issue of the Mallory Ham Bulletin the new Mallory 3-gang Spiral Inductuner, variable inductance tuning device, was announced to the amateur designer for use in the construction of VHF converters and TV receiver front-ends.

The 3-gang Inductuner with its 3 variable coils has done an admirable job of providing reliable and efficient superheterodyne tuning over the entire 52 to 216 megacycle VHF spectrum without the use of variable tuning condensers, bandswitches, plug-in coils or turret coil assemblies.

Experience has shown that for all ordinary VHF front-end tuning requirements, 3 tuned circuits are entirely adequate.

However, under certain receiving conditions, it has been known that 4 tuned circuits would provide more consistent and reliable reception than would 3. The number of boosters and RF pre-amplifiers sold to owners of TV sets verify this thought, since, basically, the average booster adds little more to the normal VHF receiver than another tuned state of RF amplification. As a result, we have decided to make available to the amateur a special Inductuner equipped with 4 variable coils, instead of the standard 3.

By using this new, special 4-gang Inductuner in the construction of a VHF tuner, the amateur can now have an additional tuned circuit as an integral part of his set without the fuss and bother of separate tuning controls, he can avoid the long interconnecting leads ordinarily required when a booster is used, and he can increase the efficiency of his set by locating all tuned circuits precisely where they will operate best.

With the exception of its overall case length, which has been increased to $5\frac{1}{8}$ " to accommodate the extra coil, the 4-gang Inductuner is identical in appearance to the 3-gang. Both models are equipped with automatic rotation limit-stops, both are well shielded between circuits as well as overall, and both feature the precision construction for which all Inductuners are noted.

The 3- and 4-gang Inductuners are available from your Mallory Distributor who will be pleased to give you more details concerning their operation. Why don't you drop in and see these new Inductuners today?

In the meantime don't forget those other fine Mallory parts your Mallory Distributor stocks for you. They include ham band switches, controls, rheostats, potentiometers, pads, tubular capacitors, transmitting capacitors, dry electrolytics, dry disc rectifiers, resistors, vibrators and vibrator power supplies.

*Registered trademark of P. R. Mallory & Co., Inc., for inductance tuning devices covered by Mallory-Ware patents.

P. R. MALLORY & CO., Inc.
INDIANAPOLIS 6 INDIANA

P. R. MALLORY & CO. Inc.
MALLORY

Club 2-meter net into AEC drills; so far OTA, ZPG, DKH, TYA, OZA, ZXQ, CCM, and OKX have come on the drills. WHB reports that PKV has been appointed Asst. EC for Manhattan and the Bronx and is getting a 10-meter AEC group started and requests more stations to contact him. The frequency will be set when the response is sufficient. Emergency power is not required. The NLI Traffic Net, 3710 kc., 7:00 p.m. Mon.-Fri. with TYU as RM, has had 11 new stations showing up regularly. PRE, RM for the 2nd Regional Net, reports the net has grown in popularity and now has 100 per cent attendance by W2 sections. MPL, Class I OO, received many grateful letters from unsuspecting offenders and is glad to help those who have trouble with their signals. WFL finally got on again after rebuilding. KVV now is in Arlington Va., and contacts NLI Net regularly. ESO is using fire-escape for antenna and his 10 watts does a good job. The Tu-Boro Club has its own net on 29.6 Mc. daily at 1900 with IAG, JSV, IRJ, KGP, LLR, and UMD holding the fort. LG is very active on 3.5 and 7 Mc. The Tu-Boro 2-meter group consists of JSV, AVI, LJP, and LGK. DAV is a new licensee in L. I. City. BZQ and BID are new OES in Laurelton. Anyone desiring to increase code speed and learn traffic-handling procedure with the aim of joining the faster speed nets is invited to contact PHO, RM for the New York State Slow-speed Net, on 3720 kc., at 2030 daily. The first edition of the Knickerbocker Radio Club's bulletin, QRN, is at hand and marks the first anniversary of the Club; KRC's anniversary party was a great success. G2AAU is a new member of KARC. DRM is a member of MARS with the call A2DRM. GUB, UYR, VVP, and 8WYP got the 4D32 rig going for KARC. PJH acquired an XYL, PL, OBB, and GUB have a grand total of 100 years in radio. NJF and OBB are helping to fight juvenile delinquency via radio classes in key points throughout the city. The 1950 officers of the Jamaica UHF Club are DKH, pres.; ZEO, vice-pres.; ZPG, treas.; ZQP, secy.; CIC, rec. secy.; ZEO, TZU, and ZPG, delegates. A new club, the Inner Sanctum Radio Club, has been formed in the Bronx; the following are charter members: BGO, AFO, MMY, PIQ, ODO, TSD, APG, KLD, KOD, MXG, CZF, RRR, and CYH. After 20 years CJI, CUE, and PT have resumed a weekly schedule as run back in '30. BO took over 4PL's traffic schedules and spent 7 hours a day clearing enough traffic to make BPL. TUK/GG is enjoying 144-Mc. mobile operation with a 522. Santa braver LGK a new Sky Champion. Late flash: The 80-meter c.w. AEC Net meets Fridays on 3710 kc. at 2030 to avoid QRM from other nets on 3600 kc. WHB is NCS, ZDE alternate. The Tu-Boro Radio Club officers for 1950 are: LGK, pres.; LLR, vice-pres.; BOT, secy.; HVD, treas. MHE asks for information on 420 Mc. receiver circuits. The passing of ADW in December brought to a close a lifetime devoted to radio communication. Nick started his career as an amateur in 1906. He operated for many years on the mailbox, *President*. At the time of his death he was employed as a skilled technician in the RCA Communications receiving station at Riverhead, L. I. A leader in emergency work, he was first on the scene at Westhampton, L. I., in the 1938 hurricane, setting up his emergency equipment and operating all night by the aid of an oil lantern. As president of the Suffolk Amateur Radio Club for many years, he was the natural leader of the amateurs on Eastern L. I., and the moving spirit behind the annual Field Day activity. In addition, he was an active member of the Suffolk County Radio Club. Amateur radio has lost one of its pioneers and most active members. Traffic: W2TYU 1288, BO 1127, PRE 636, WNI 254, EC 123, OUT 119, OBU 117, JBQ 105, SJC 82, TUK 52, WHB 30, BGO 29, LGK 3, RQJ 8.

NORTHERN NEW JERSEY — SCM, Thomas J. Lydon, W2ANW — The N. N. J. c.w. net meets Monday through Saturday at 7 p.m. on 3630 kc. The 'phone net meets every Sunday at 9 a.m. on 3900 kc. LMB has been appointed key station for area 9 of the transcontinental 'phone net. OUS has installed TVI filter. ZT has moved to Mahwah. New Ridgewood Radio Club officers are ZT, pres.; JGJ vice-pres.; IVO, treas.; GNG, secy.; KRO, ATE, and IHP, trustees. YOB, BFP, and VYB are working hard for WAS. ZEP is active on 28 Mc. and has 8 new countries. BZJ is using low-powered battery rig on 3.5 Mc. DAY is the new Red Cross station in Englewood. It is being operated by NNJRA. EWZ is on with a pair of 812s. CWK has removed those TVI bugs. CVW is a new ham in South River. LTP has completed a major overhaul of kw. rig. He now has a total of 134 countries. Traffic: W2CUI 144, LMB 111, KUS 74, NKD 58, NCY 56, OXL 54, DRV 48, NOZ 29, NIY 16, ZEP 16, BZJ 7, CJX 2.

MIDWEST DIVISION

IOWA — SCM, William G. Davis, W0PP — The Sioux City Club was called on to furnish communications from the Swift Company plant after the explosion which wrecked the building and took out the telephone circuits. Wally Leonard had his 75-meter mobile rig at the scene of the disaster, assisted by MCU, AZR, and Bob McKelvey, who set up a Mark II, YNW, UHC, VRU, ENS, and YMH were at Red Cross Headquarters, which was set up in Naval Reserve Training center. QAO is new to 3.5 Mc. and TLGN. The Sioux City club has organized an anti-TV committee. A new ham at Stewart is 9NTF/9. HMM makes BPL again.

OHO has added a 75-A to his shack. ZFO is new member of TLGN. VRA is president of the Northeast Iowa Radio Amateur Assn. AYC's New Year's resolution is to report to the SCM regularly. AXE is the only club secretary sending in a report. BEN has new tower and ten-meter beam. POY has his half-gallon back on and gets his best reports from TV sets. YNW wants to get a gang on 160 meters, TVI you know! MCU is working on a new speech compressor. UFL has new mast. AZR and UHC are on transcontinental 'phone net. GQE has swell low-power set-up. MBW is going to 160 meters. YMH, ZLD, and VRU really are enjoying local ground-wave contacts. Warren Sladky, W8CTZ and W0ZYX, has been named manager of KMRA, new campus radio station at Iowa State College, Ames. Traffic: W0HMM 1124, SCA 283, SQQ 175, QVA 154, WMU 139, NYX 116, AUL 114, YDN 68, QAO 62, VCM 58, SRR 50, JAD 23.

KANSAS — SCM, Earl N. Johnston, W0CV — Greetings to the High Plains Net, which operates Mon., Wed., and Fri. at 1830 on 1995 kc. While listening Jan. 5th FDJ, of Linn, heard EJQ, of Atwood, the NCS, call the roll. Practically all stations in Kansas were S9 and the stations in neighboring states S5. The Wichita Amateur Radio Club elected CQC, pres.; BVU, vice-pres.; RC, secy.; GAV, treas.; DEB, publicity director; and Jim Madden, associate representative. The KVRG of Topeka held annual banquet and square dance, and elected UYU, pres.; ICV, vice-pres. and treas.; and SSB, secy. BNU, Chanute, reports a homecoming hamfest for FLZ, who has returned from vacation. FLZ, NXJ, WPL, IFR, W6ECH, 5EAK, NSO, and BNU were present. FER is enjoying his net work and traffic-handling but deplores the tuning up on a net frequency. IZJ, on 7 Mc., and OOU, of Emporia, on 3.85 Mc. were heard here. Two of our section boys were made officers of the Heart of America Club of Kansas City. KXL/NY is elected president and OOT sgt. at arms. CAG, of Kansas City, now is instructor in radio school in San Antonio. CLX replaced his SX-25 with an RME-69. 6QKS/KL7UB was home for the holidays and is leaving for Scott Field, Ill. PBX, of Miltonvale, is on 160 and 75 meters. ABY, of Beloit, is back on 3.5 and 3.85 Mc. UKH, of Wilson, is active on QKS. VBQ has temporarily deserted traffic for DX using a pair of 807s. Traffic: W0NYI 582, KXL 357, FER 222, YOS 77, FDJ 68, UKH 13, BNU 10, ICV 8, LIX 3, VBQ 2.

MISSOURI — SCM, Ben H. Wendt, W0ICD — TVI seems to be giving several of the hams in the section a hard time. The FCC release, FCC 48-1803, 24809, probably would be of great aid. The ARRL release entitled "Television Interference Remedies" also may prove to be of great value. An early season ice storm struck Missouri towns Dec. 21st. The locations most severely affected were Hannibal and Sedalia. Amateurs were on the ball keeping Western Union traffic moving when no other means of communication were available. The Missouri Emergency Net was active, with special mention going to AZL, ZFN, and TTZ. The SCMs of the Midwest Division have been appointed secretaries of the Section Federation of Radio Clubs by Director Collett. The HARC selected the following new officers: NIY, pres.; SSG, vice-pres.; GCT, activities chairman, BQU, corr. secy.; IFQ, rec. secy.; VRF, treas.; OOT, sgt. at arms; NNU, technical chairman; VOP, publicity chairman; UID, membership chairman; BXB, legal officer. CGZ is successfully using the electronic keyer built from the circuit in Jan. QST. ARH has added San Marino and Eritrea, to bring his total of countries worked to 103. Thanks to WIS for assisting WAP as NCS for the Show Me Net; also to HUI for assisting AZL as NCS for the Missouri Emergency Net. The Show Me Net boasts 16 regular members. 6GUN, formerly 9HWL, is back working from Denver and wishes to contact old pals. YYI is a new ham in Cape Girardeau. AIQ and AIP are new hams at Marionville. GCL is receiving better reports because of a new 3/4-wave antenna. INK is welcomed back to Poplar Bluff. GNX is on 160 meters with 75 watts. Traffic: W0RVP 582, QNX 556, AZL 370, KTK 136, CGZ 123, PHO 112, WAP 109, SKA 66, RB 43, OUD 40, ICD 24, JAP 14, QMF 13, SOM 13, PTG 12, NNH 11, PMT 8, DEA 6, GBJ 6, ARH 2.

NEBRASKA — SCM, Scott E. Davison, W0EOD — The SENRC now is the proud owner of the club station under the call RUJ, which call formerly was held by one of the club members who died in World War II. VOI is trustee. LAA has new Hammarlund 420 on 28 Mc. ADW and AGZ are new calls in Milford. QAN is back on the air on 7 Mc. RQK reports emergency nets well organized for 1950. EIE has moved to Shenandoah. GMZ and FQB made BPL. AY is on 7 Mc. MUQ is active in High Plain Net. UIV/9 can be heard regularly on 160 meters. GBH has new high power on 3.85 Mc. IEO is snagging DX. DMY is trying 3.85-Mc. 'phone along with net work. GPX is new president of North Platte club; ZOQ is secretary. LKE is on 28 Mc. KJP is new SNCS for the 3.85-Mc. 'phone net. ZAA is new call at Ogalala. The c.w. net has held simulated emergencies which have worked smoothly. DNW has ART-13 working 160 through 10 meters. AGE is active in Chappell. New officers of the Ak-Sar-Ben Radio Club are 6AID/9, pres.; IOS, vice-pres.; QHG, secy.; and EAO, treas. QXR has an 80-ft. tower supporting his 2-meter beam. FQB is busy taking part in four nets. The following have been issued c.w. net certificates: CXT, DMY, EDI, YDE, VOI, KON, FAM, FHA.

(Continued on page 78)

Follow the Leaders to

Eimac
TUBES

The Power for R-F

ABRACADABRA

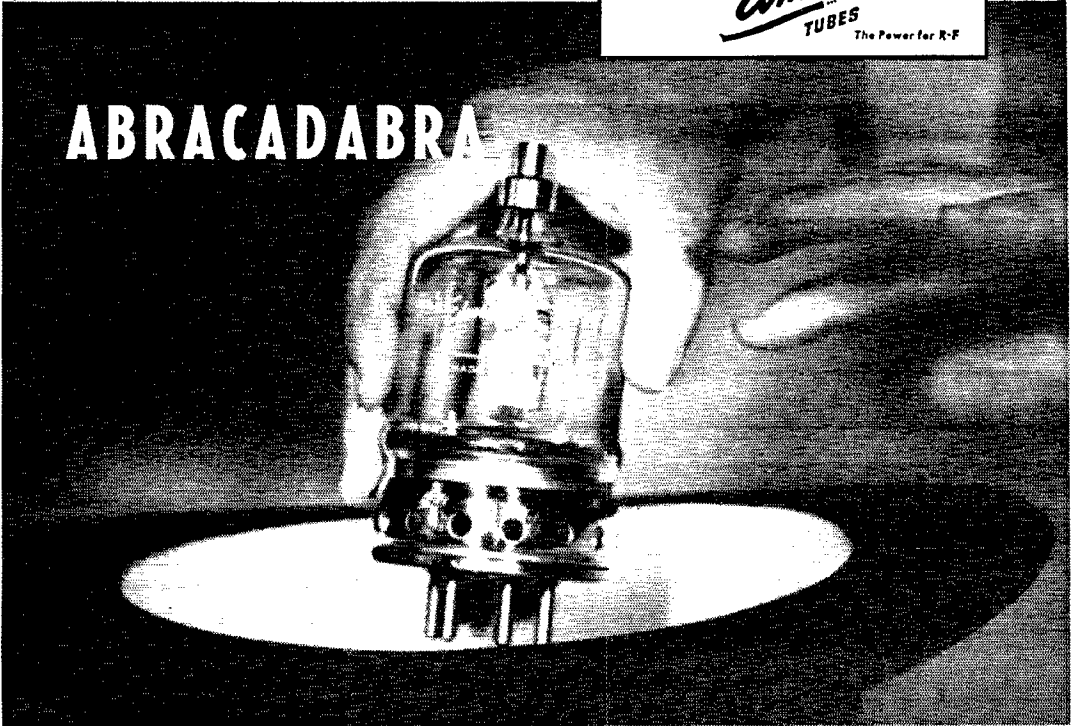

No, we don't pull them out of a hat. Nor is there any magic about the Eimac 4-125A tetrode. To make one you need only the tried and proven Eimac design, first-rate materials, painstaking workmanship, plenty of know-how, and Eimac processing.

But some of the tricks you can do with this versatile tube may seem like magic if you haven't yet had the experience of putting one through its paces. From audio frequencies to UHF, the Eimac 4-125A offers real advantages over old-fashioned tubes.

Your dealer will be glad to show you this tube that has revolutionized transmitter design. After you cradle one of these beauties in your hand, you'll find it hard to leave without taking it along. If you like to look twice before you leap, write the Eimac Field Engineering Department for free complete characteristics and operational data on the 4-125A.

GENERAL CHARACTERISTICS

ELECTRICAL

Filament: Thoriated tungsten	
Voltage	5.0 volts
Current	6.5 amperes
Grid-Screen Amplification Factor (Average)	6.2
Direct Interelectrode Capacitances (Average)	
Grid-Plate (without shielding, base grounded)	0.05 μ fd.
Input	10.8 μ fd.
Output	3.1 μ fd.
Transconductance ($i_b = 50$ ma., $E_b = 2500$ v., $E_{c2} = 400$ v.)	2450 μ mhos

RADIO FREQUENCY POWER

AMPLIFIER AND OSCILLATOR	
Class-C Telegraphy or FM Telephony (Key-down conditions 1 tube)	
MAXIMUM RATINGS	
D-C Plate Voltage	3000 Max. Volts
D-C Screen Voltage	400 Max. Volts
D-C Grid Voltage	500 Max. Volts
D-C Plate Current	225 Max. Ma.
Plate Dissipation	125 Max. Watts
Screen Dissipation	20 Max. Watts
Grid Dissipation	5 Max. Watts

248

EITEL - McCULLOUGH, INC.

San Bruno, California

Export Agents: Frazer & Hansen, 301 Clay Street, San Francisco, California

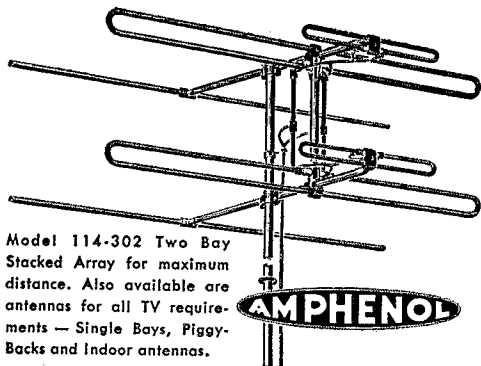

Model 114-302 Two Bay Stacked Array for maximum distance. Also available are antennas for all TV requirements — Single Bays, Piggy-Backs and Indoor antennas.

TV and FM ANTENNAS

All Amphenol antennas are engineered and perfected in our Development Laboratories. They will provide unsurpassed reception of FM and TV signals and assure long, trouble-free service.

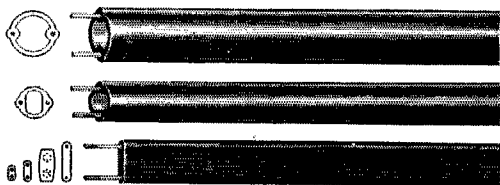

TWIN-LEAD TRANSMISSION LINES

Amphenol Twin-Lead is the ideal means of transmitting signals with minimum losses. Durable polyethylene dielectric resists weather, acids, alkalis, and oils. Remains flexible at -70°C . For standard FM and TV receiver installations use Receiving Twin-Lead — No. 14-271 for deluxe installations.

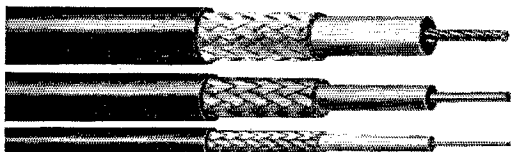

COAXIAL CABLES

Amphenol Coaxial "RG" cables are produced to standards that surpass Army-Navy specifications. Charts showing characteristics and dimensions are available upon request.

RADIO SOCKETS AND CONNECTORS AN CONNECTORS RF CONNECTORS

Catalogs of Amphenol products will be mailed upon request. Be sure your name is on the mailing list to receive our monthly magazine, The Amphenol Engineering News.



AMPHENOL

AMERICAN PHENOLIC CORPORATION

1830 SO. 54TH AVENUE
CHICAGO 50, ILLINOIS

FMW, FQB, THF, GMZ, HSO, HYR, IXL, JDJ, KPA, KJP, LJO, and SAI. RCH has rebuilt to all-band rig. FDG has new shack and rig on all bands. Traffic: W0GMZ 727, FQB 540, FAM 372, KJP 240, HSO 169, KON 40, FMW 36, IXL 31, SAI 27, DDJ 26, DLX 18, CBH 17, LJO 7, AY 4.

NEW ENGLAND DIVISION

CONNECTICUT — SCM, Walter L. Glover, W1VB — BVB is back on 3.5 Mc. after a long bout with TVI. RMU has the car all rigged up for 3.5- and 7-Mc. c.w. and 28-Mc. 'phone. EFW has been working hard on CAP nets and reports they could use more hams in that activity. Anyone interested get in touch with Milt. CGD uses 3880 kc. for OBS at 6:45 p.m. Mon. through Fri. AW has new 14-Mc. transmitter and Dick reports he is chasing down TVI troubles. The AEC of Bridgeport, as reported by LIG, operates in the Stratford Net. BDI lost one element of his 50-Mc. beam. HYF also has the car fixed up with a 10-watt and Gon-Set. The Connecticut 'Phone Net is operating on 3880 kc. at 6:30 p.m. nightly and Sundays at 10 a.m. VW, our PAM, reports a good attendance. Any 'phone stations interested, just jump in, as all stations in the section are welcome. HYF, our CN scribe, is currently listing monthly station attendance in the CN Net in his bulletin. It seems to be causing a little competition for top honors. Maybe we ought to have a prize. Anyway attendance and interest seem to be at an all-time high, at least in the SCM's experience. Traffic: WINJM 431, DAV 244, AW 207, KUO 197, HYF 188, KV 127, HUM 80, BDI 76, BIH 73, QIS 71, ORP 70, CTI 49, LKF 46, ADW 42, LV 23, BVB 26, EFW 25, JTD 18, SJ 16, VW 13, CGD 12, RMU 7, GVK 6, QAK 2, LIG 1.

MAINE — SCM, Manley W. Haskell, W1VV — Pine Tree Net: RM NXX, 2550 kc., 1900, Mon. through Fri. Sea Gull Net: PAM FBJ, 3961 kc., 1700, Mon. through Fri. RJQ is new OBS. His final of 125 watts will be on the job sending bulletins of interest to all amateurs. A new modulator for 28-Mc. 'phone is in the making. RJE has his new rig on the same band and is DX happy. A prospective ORS is K1NRM, USNR Communications Unit at Augusta under Frederick Best. New officers of the Portland Amateur Wireless Assn. are: QUI, pres.; ITU, vice-pres.; RSX, secy.; IRS, treas.; LNI, chief operator. KVL, the club station, will be on 3.5-Mc. c.w. soon with 200 watts. A W/VE QSO Party was held Jan. 5th at 1930 EST on 3961 kc. PTL, the control station, did an outstanding job with 125 watts input. VE2BE, Canadian General Manager, spoke for the boys over the border and assisted PTL. AW came on to greet all hands and brief words from President Bailey were read. AW's operators had a word and both NJF, the NEC, and BDI, the CM, were there to extend greetings for the New Year. 3BFZ kept the frequency clear down south and ZE dusted off the northern end when required. It is estimated that stations in the U. S. and Canada participated. It was the third such party that has been arranged and promoted by LYK, of Lewiston. Traffic: W1LKP 300, NXX 179, NGV 159, KLH 124, YA 67, VV 63, LBJ 30, FBJ 29, OTM 25, AWN 23, EFR 22, JAS 19, K1NRM 17, WIIGW 15, QDO 15, APT 12, PTL 11, FV 9, KDE 8, JTH 7, RJQ 7, AEK 5, QUA 5, GE 3, GMD 3, COV 2, AMR 1.

EASTERN MASSACHUSETTS — SCM, Frank L. Baker, jr., W1ALP — The following renewed their appointments: MRQ as ORS/OPS; HIL as OES, OPS, and EC; UE as EC. RXT now is an ORS. The Quannapowitt Radio Assn. elected OEX, pres.; CTS, vice-pres.; JBI, secy.; KXU, treas.; AAE, HXN, HIL, GAG, and PRQ, directors. Doc Piccard gave a talk on radio forecasting with slides. BGW has mobile schedule with FH and is working DX on 3.5 Mc. The Eastern Mass. Club had a business meeting and a discussion on power supplies. The South Shore Radio Club had a talk by Byron Goodman, DX, on "Single Sideband." QE and ADL are on 3.5-Mc. c.w. SNK is a new ham in Cohasset and is on 144 Mc. CTR has a new crystal rig on 144 Mc. at his portable QTH. HIL says his work is keeping him very busy and he is not on the air much. RXT is trying to get his 813 exciter going. ILN is busy at his job. PYM has a 522 on 50 Mc. RUD is on 28 Mc. from a new QTH in Newton Center. WC works his son in Texas on 28 Mc. ZR is on the air at her QTH in Boston with a BC-457. DMS rebuilt his VFO. QJB kept 32 traffic schedules. TY was tie-in for I Hobby Show at Marblehead High School. SJX is having trouble with his RME-45. KKK has schedule from MPP to PS. HWE is able to get on 29 Mc. now. The Southeastern Radio Club of New Bedford elected the following: LAZ, pres.; WU, vice-pres.; QUE, secy. BB has remote-controlled receiver in mobile station. I wish that all of you that hold appointments in this section would be a little more cooperative in sending me your certificates for the annual endorsement. Remember these have to be endorsed once a year to keep them in force and I don't think I should have to notify you two or three times about it. Thanks for the many Season's Greeting cards received. MX is going to tie in with Eastern Mass. Net when open house is held in April. Attention all hams in Massachusetts: The South Shore Amateur Radio Club, P. O. Box 8, Quincy, Mass., is sponsoring a bill, known as Senate Bill #229, to get license plates for your cars with your call on it. Kindly talk this matter up and

(Continued on page 80)

The FAMOUS GENUINE
JENSEN MODEL 510
COAXIAL SPEAKER

BEST AT ANY PRICE - - -

Comparative tests with the most expensive types of two-way speakers will prove that the Jensen Model 510 is the best regardless of price.

The new, wide-angle acoustic lens of the "510" is an example of Jensen leadership in loudspeaker engineering. By adapting optical principles to acoustics, this lens acts in conjunction with the h-f horn to distribute h-f radiation uniformly over a wide angle. This insures constant balance and high quality reproduction throughout the whole room.

Whether the "510" is used for broadcast monitoring, professional sound reproduction, or for home entertainment systems, the advanced Jensen electroacoustic design assures the finest performance.

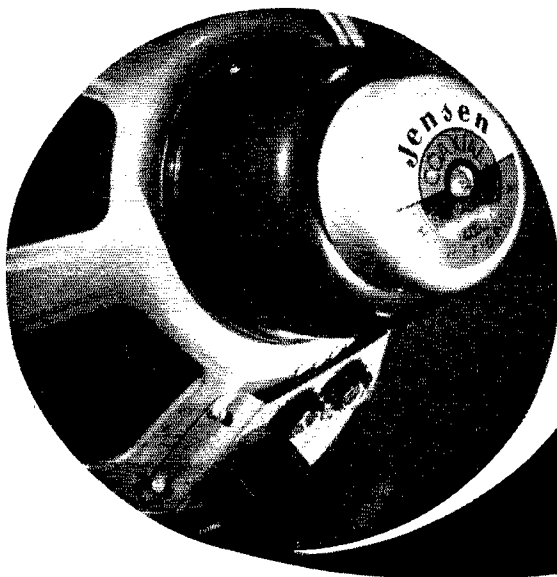
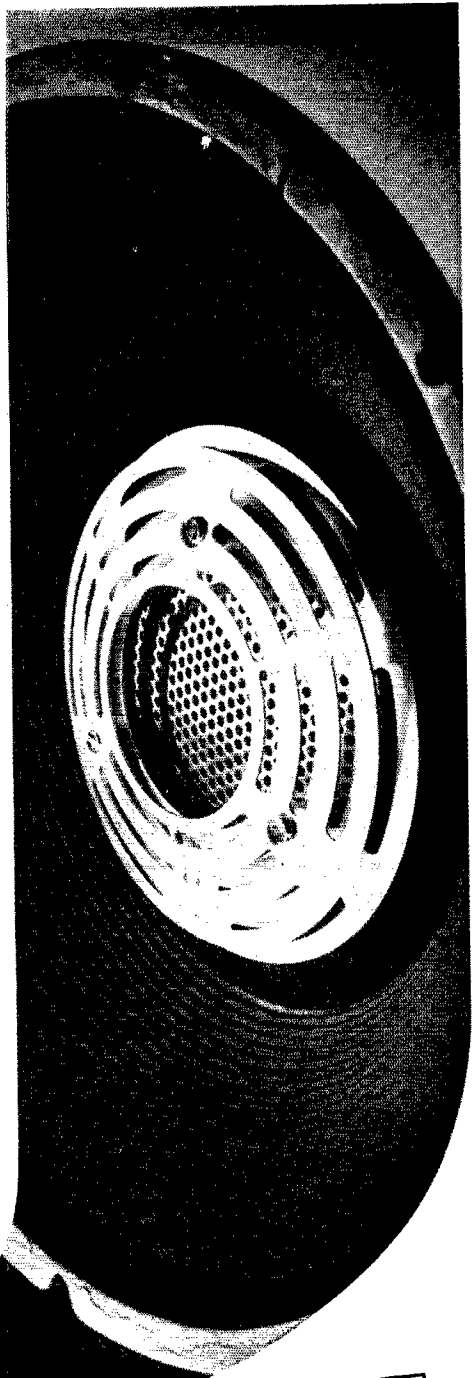

JENSEN MANUFACTURING COMPANY DIVISION OF THE MUTER COMPANY
6611 South Laramie Avenue, Chicago 38, Illinois • In Canada: Copper Wire Products, Ltd., 351 Carlaw, Toronto

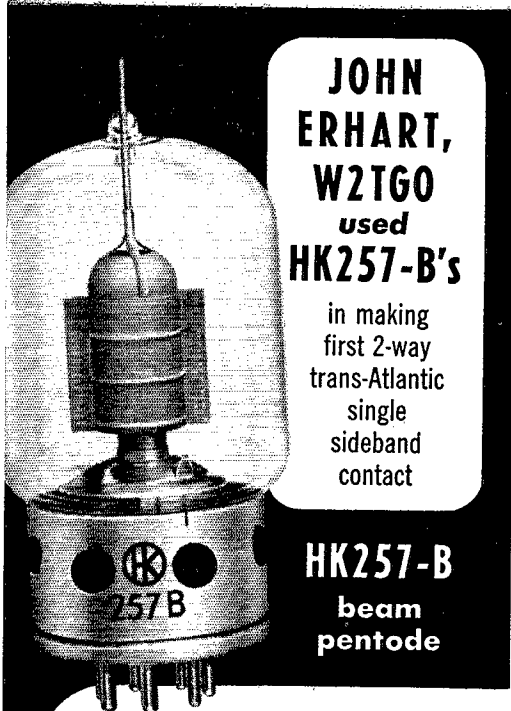

**JOHN
ERHART,
W2TGO
used
HK257-B's**

**in making
first 2-way
trans-Atlantic
single
sideband
contact**

**HK257-B
beam
pentode**

A natural for

SINGLE SIDEBAND

Amplifiers!

Two Tubes in Push-Pull, Class B, RF Service

Plate volts	2000
Screen grid volts	750
Control grid bias	-160 (Note 1.)
Suppressor grid bias	0
RF grid voltage swing	320
Zero signal plate current	35 ma. per tube, 70 ma. 2 tubes
Maximum signal plate current	200 ma. per tube, 400 ma. 2 tubes

Note 1. Adjust control grid bias until each tube draws 35 ma. static plate current.

Note 2. Plate load impedance must be adjusted for peak output conditions without introducing distortion.

THE ROBERT DOLLAR CO.
HEINTZ and KAUFMAN
Redwood City DIVISION California

Export Agent:

M. SIMONS & SON • 23-25 Warren Street • New York City

Note new factory address

see if we can get this put through. Every ham and radio club will be contacted by mail. Traffic: (Dec.) WILM 414, QMJ 353, EMG 269, PYM 201, TY 181, RXT 132, QZS 86, KKJ 72, ZR 55, DMS 50, QJB 37, PU 27, BB 22, WU 19, SJX 10, HWE 6. (Nov.) WILM 18. (Oct.) WIRKT 6.

WESTERN MASSACHUSETTS — SCM, Prentiss M. Bailey, W1AZW — SEC: UD, RM: BVR. Net frequency 3725 kc. 7 and 10 p.m. Monday through Friday. BVR has been appointed a member of the ARRL Communications Dept. Committee. EOB leads the section in traffic this month and had time to work seven new countries for a total of 114. Santa left him a new Vibroplex. RHH has rig trouble again. RDB has a rig at school now but doesn't plan to let it interfere with studies. GZ has a rig on 7, 14 and 28 Mc. now with plans for 3.5 Mc. COI still is working on TVI. GVJ is experimenting with wire recorder. Jerry records f.m. programs for later use in classrooms. MUN still hits the top in FMT measurements. UD is busy chasing images and streaks on TV screens around Springfield. It looks like JYH had the high total for Western Massachusetts for SS Contest. CJK probably takes first honors for 'phone. The Hampden County Radio Club had a total of 473,105 points. Traffic was heavy on WMN and IRN during December. EOB, BVR, and AZW, as controls, handled the bulk of the traffic. However, RHH, RZG, IHI, and others handled plenty. 8VCW/1 is the proud papa this month. Congratulations, Don. AZW completed 3.5-Mc. WAC by working ZL1CI. Traffic: (Dec.) WIOB 467, BVR 272, AZW 212, GZ 126, RDD 48, RHH 42, RDB 34, MOK 18, GVJ 12. (Nov.) WIGVJ 21.

NEW HAMPSHIRE — Acting SCM, Clifton R. Wilkinson, WICRW — RM: CRW. Bill Joyce, SLA, is a new ham in Chester. He passed the exam at the Manchester Hamfest, and is Civil Service Radio Repairman now at Otis AFB on the Cape. MGP, who was at Grenier Field, now is at Shaw AFB, S. C. He is working 28-Mc. mobile and is watching for the gang. RVG, running about ten watts and operating on 14 Mc., has worked 5, 6, 7, and a G. He expects to have 50- or 75-watt final soon. RFP, new ORS, reports in NHN three nights a week. He also does some 28-Mc. 'phone work. On the morning of Dec. 8th, "Sherb" Hall, ex-GKE, formerly of Concord and later of Manchester and Goffstown, passed away. POK operates mostly on 7 Mc. Watch for him and he will tell you exactly what your signal sounds like, a good OO-4. QJX is a regular member of the NHN and reports almost every night. There are two things that New Hampshire needs. More reports for this column and more originating of traffic. What say, gang. Remember to renew your ORS certificates on time. Traffic: (Dec.) WICRW 396, SAL 94, MXP 63, PFU 57, QJX 28, ATJ 17, EWF 2. (Nov.) WIMXP 34.

RHODE ISLAND — SCM, Roy B. Fuller, WICJH — RM: BTY. PAM: BFB. Rhode Island Net (RIN) meets Monday through Friday at 7 and 10 p.m. on 3540 kc. Net stalwarts BTY, BBN, QR, ODJ, and HLY had a rough but enjoyable time during the Christmas season, handling around 800 messages during December. NAARO's annual Christmas Party was held on December 16th with about 40 persons enjoying the event. Two more mobile rigs to add to the emergency set-up will be MJL and LWA. PRA's TVI Committee, comprising QLD, MJJ, and RAY, have been active by actually checking at TV locations the harmonics of ham transmitters and has helped many hams in the Providence area. PRA held its annual Christmas Party Dec. 20th and it was well attended by members and their friends. Presents were exchanged and refreshments served. Two clubs, PRA and NAARO, have set up TVI committees to help you fellows with problems, so consult them if you have something that is hard to lick. Traffic: WIBBN 357, BTY 158, QR 153, CJH 115, ODJ 22.

VERMONT — SCM, Burtis W. Dean, W1NLO — KRV is the lucky winner of a BPL certificate for handling 615 messages during December. New hams in the State are SIO, Brattleboro; SNI, Middlebury; BRO, Middlebury; SOV, Burlington; and SPK, Middlebury. BRO, IDM, LTW, LYD, OKH, QXZ, and RNZ are on 160-meter 'phone. SPK is OBS and also EC for Addison County. MMV and NDL are new OOs. KRV and PZX are to be congratulated on the FB job they are doing with the Vt. nets. NDL and OKH lost beams in the big blow. PTP has 29-Mc. 'phone rig in his truck. LYD and QXZ have Viking I transmitters. QQN has a new Globe King. SEL is on 29-Mc. 'phone with 500 watts to a pair of 812Hs. QVS is busy getting TVI out of his transmitter. NLO recently visited PAL, KRV, FN, SPK, PSD, BLC, EBU, and CUN. Traffic: (Dec.) WIKRV 615, AXN 34, OAK 32, PZX 22, JEN 20, RNA 3. (Nov.) WIKRV 232, PZX 45, AXN 32, AVP 10, ELJ 6. (Oct.) WIKRV 178.

NORTHWESTERN DIVISION

ALASKA — SCM, Charles M. Gray, KL7IG — After ten years of faithful service as QSL Manager of Alaska, CK is turning the job over to FM. CK deserves a vote of thanks for his fine service. FM has been assigning CK for the past year and is well qualified for the job. Word from Nome has it that only SF and ABU are on steady but four others plan activity soon. Ex-SZEF, of Nome, got the last two-letter call, ZZ; AAA, also of Nome, got the first three-letter call. (Continued on page 82)



The CARDAX

World's favorite premium crystal mike—the only high level crystal cardioid with dual frequency response. Lists at \$38.50.



The "630" DYNAMIC

Very popular super-dynamic. Ideal frequency response. High output. Acoustalloy diaphragm. Lists at \$36.50.

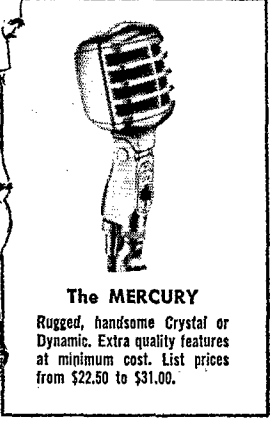

The MERCURY

Rugged, handsome Crystal or Dynamic. Extra quality features at minimum cost. List prices from \$22.50 to \$31.00.

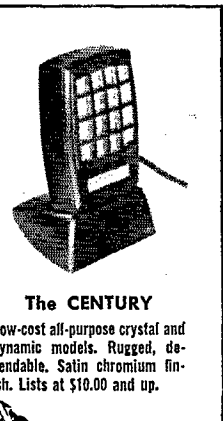

The CENTURY

Low-cost all-purpose crystal and dynamic models. Rugged, dependable. Satin chromium finish. Lists at \$10.00 and up.



TOUCH-TO-TALK

First to fit any mike with $\frac{5}{8}$ "-27 stand coupler. Finger-tip relay operation or microphone "On-Off." With or without mike.

A roll call of Hams proves the popularity of E-V mikes. That's because E-V engineered response assures *clear, exact* voice reproduction...E-V high output provides more power! There's a model made for you in the complete E-V line—with all the *extra* quality, *extra* features, *extra* value you want! Ask your E-V Distributor or write for Bulletin No. 104.

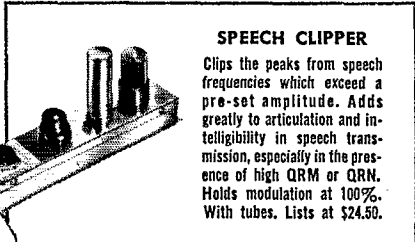

SPEECH CLIPPER

Clips the peaks from speech frequencies which exceed a pre-set amplitude. Adds greatly to articulation and intelligibility in speech transmission, especially in the presence of high QRM or QRN. Holds modulation at 100%. With tubes. Lists at \$24.50.

FAVORITES for Clear QSO's

NO FINER CHOICE THAN
Electro-Voice

ELECTRO-VOICE, INC., BUCHANAN, MICH.
Export: 13 East 40th St., New York 16, N. Y.
Cables: Arlab



**FIELD DAY...
EVERY DAY!**

PRECISION Series 85

AC-DC Circuit Tester
(20,000 Ohms per Volt)

**will help YOU to
STAY on the AIR**

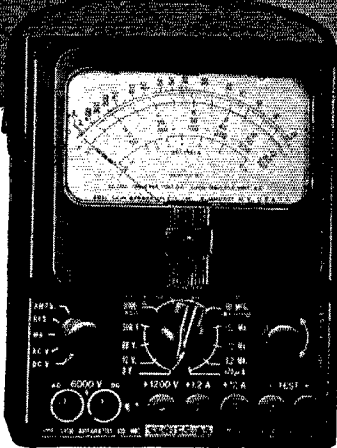

**Self-Contained to
6000 volts, 60 Megohms, 12 Amperes, +70DB**

A compact, laboratory type, high sensitivity test set indispensable for test and maintenance of modern amateur communications equipment.

20,000 Ohms per Volt D.C. — 1000 Ohms per Volt A.C.

VOLTAGE RANGES: 0-3-12-60-300-1200-6000 A.C. & D.C.

CURRENT RANGES: 0-120 microamps; 0-1.2-12-120-MA;
0-1.2-12 Amps D.C.

RESISTANCE RANGES: 0-6000-600,000 Ohms 0-6-60 Megohms.

DECIBEL RANGES: From -26 to +70DB.

Complete with batteries and test leads..... **\$3875**

PLUS superior physical features:

- ★ 4 1/2", 50 microamps, Easy Reading Meter.
- ★ Heavy duty bakelite case 5 1/2 x 7 1/8 x 3".
- ★ Deep etched, anodized aluminum panel.
- ★ Recessed 6000 volt safety jacks.
- ★ Only two pin jacks for all standard ranges.

LC-1 LEATHER CARRYING CASE—Custom designed, top-grain cowhide case with tool and test lead compartment. **\$8.75**
See Series 85 and other famous "Precision" instruments, on display at leading radio parts and ham equipment distributors. Write for latest catalog.

Precision Apparatus Co., Inc.

92-27 Horace Harding Blvd., Elmhurst 13, N. Y.

Export: 458 B'way, N. Y. City, U.S.A. Cables: MORHANEX
In Canada: Atlas Radio Corp. Ltd., Toronto, Ontario

ZM is on at Fairbanks with 300 watts to p.p. 5514s on 14 Mc. LV is on the air from Gambell and is with the C.A.A. Traffic: KL7GP 20.

MONTANA—SCM, Fred B. Tintinger, W7EGN—Darby, population of 500, has six hams and two of them are YLs. The Gallatin Amateur Radio Club includes Livingston, Bozeman, Belgrade, and Manhattan, and its nightly ten-meter "Jim Bridger Net" works FB between these cities as well as working into Butte 95 miles away. MYF worked a G3 and a KH6 on 28-Mc. mobile. ED is new EC for Gallatin Valley. The Billings SMARA code classes are held at the Naval Reserve Armory Mon., Tue., and Fri. from 7 P.M. to 8 P.M., and on the air code broadcasts on 28.1 Mc. every Wed., Thurs., and Sat. from 7 P.M. to 8 P.M. SMARA AEC drills are held the 2nd Sunday of every month at 2 P.M. on 3655 kc. and 28-Mc. 'phone. The Glacier Radio Club put on a surprise party for IWC, who is leaving for new position in Ranier (National Park. At Lewistown, KL7SF visited home, GFT moved to new home, and FTO visited BXL. AFM handled emergency train orders for GNR the same day that BNU and EGN did but didn't report in time for last QST report. HDM is moving to Puget Sound area. KOG is going to attend school in California. Traffic: W7KGJ 235, EGN 185, CT 62, FGB 37, COH 29, LEQ 29, BNU 27, IWC 21, FTO 16.

OREGON—SCM, J. E. Roden, W7MQ—Albany: SO reports MNS, OU, LEX, CN, and MIIT are all mobile and holding AEC drills. Baker: HAZ is new OBS. Baker Club sent some unusual Christmas cards to other Oregon clubs. Bend: GNJ is NCS one night a week on OEN 'phone, and once a week as NCS on OSN c.w. JOP made 20-w.p.m. certificate in CP run. Klamath Falls: MYI is new ORS. JRU also is NCS one night a week on OEN and OSN. La-Grande: NOB, the XYL of MEZ, is new ORS. MUY now is located here and HBO might be able to get a little help in his AEC program here. Lakeview: EJL, after 15 years off the air, is back to hamdom. He is a district ranger located at Bear Springs. JVO and MLJ also are active on Oregon Nets. Medford: GEU is a welcome addition to Oregon. Pendleton: BDN is rebuilding his entire station and will announce his grand opening when completed. KR has trouble keeping his Collins signals out of local Police Radio System during the wet weather. Prineville: CNA is doing a swell job as NCS on OEN. Portland: ESJ makes BPL DIS reports activity on the new Snakeye 2-meter net, with a number of stations holding AEC drills Tuesday through Saturday from 2000 to 2300 PST. AIZ did a grand job originating 435 messages from Veterans' Hospitals in Portland and Vancouver during the holiday season and received fine cooperation from the OEN. Sweet Home: GWE, the new OEN 3600-kc. net manager, made BPL this month. Traffic: W7ESJ 702, GWE 666, AIZ 492, APF 356, HDN 338, JRU 181, HLF 162, MW 158, GNJ 118, AJN 115, GXO 71, KL 65, ACZ 62, FRT 41, FY 41, NOB 35, LT 31, MYI 30, NNE 30, HVD 27, DIS 23, AUH 21, BDN 20, JOP 17, NQD 15, JGH 13, KZI 13, MBI 13, HDY 10, KHV 10, NGG 7.

WASHINGTON—SCM, Clifford Cavanaugh, W7ACF—SEC: KAA, RM: CZY, PAM: CKT. HGK received some nice radio gear for Christmas. JZR is going to fire up a couple of 304TLs just to heat up his shack. KAA is turning out volumes of ABC material for the use of state ECs. FRU doesn't like the skip. AXT reports that the c.w. gang is too poky for him and he now is 100 per cent 'phone where traffic can be handled with a little speed. HWK still is taking things easy after his trip to the hospital. The Walla Walla Valley Radio Club had another big meeting on December 26th with a fine Christmas tree and presents for all the gang. Even the club's RME-99 receiver turned up. It had been borrowed by one of the boys until Santa arrived with the one he had ordered. FWR, the new QSL manager, reports a new OBS service—each Saturday at 7 P.M. PST on 3697 kc. she will send a list of stations having six or more QSL cards for which there are no self-addressed stamped envelopes on file with the QSL Bureau. FIX reports PAV News going over fine. He mailed out 200 copies of the last issue. ETO is having fun on 28-Mc. 'phone but moves his traffic on c.w. JJK is handling lots of traffic and is putting up new antenna so he can be heard in Seattle on 2200 schedule. CZY certainly has a record—his traffic total for the year is 26,183, or 2181 per month, or 71 per day, all done by pounding a key. KCU also has a record. She originated 3373 messages during 1949 and finished the year by making the BPL with 560 organizations. NUN wants OBS job. APS is trying out antennas. ZU says he is going to take it easy this year. We wonder. LVB says too much Christmas. Wonder what he got. DRA now has a 35-w.p.m. Code Proficiency certificate. CWN visited the SCM. LJM is off the air because of TVI trouble. The following made the BPL for December: FIX, JJK, IOQ, KCU, DRA, ZU, CZY, and JZR. JER is experimenting with underground antennas. He claims good results. EPW is keeping Bremerton in the traffic game. EYN is new ORS. Traffic: (Dec.) W7CZY 4361, IOQ 731, KCU 688, ZU 586, JJK 552, JZW 502, FIX 462, JZR 260, QGN 244, KAA 183, FRU 120, BX 119, HWK 119, ACF 112, DRA 108, FWT 83, KTL 69, EAU 44, LVB 42, ETO 33, EPW 26, AXT 24, APS 10, CWN 5. (Nov.) W7AXT 6. (Aug.) W7JWJ 766.

(Continued on page 84)

★ TO A MAN INTERESTED IN ★ A Better Paying Job in Television

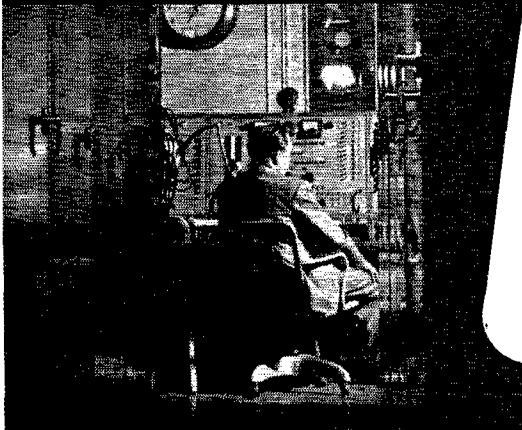

ASK YOURSELF THESE QUESTIONS:

1. Are new men—with less experience than yourself—passing you by?
2. Has it been "too long" since you have received a satisfactory raise?
3. Are you tied down to a routine, production-line job?
4. Does your future seem limited to small stations and small salaries?
5. DO YOU GENERALLY FINISH WHAT YOU START?

If your answer is **YES** to most of these questions, **CREI'S Home Study Course** can help you get a **BETTER JOB** in Television

WHAT YOU DO to keep abreast of new developments is what counts toward advancement in television. Obviously, everyone cannot qualify. *Those who do are well rewarded.* The television industry offers almost unlimited opportunity to trained engineers and technicians. CREI training helps all levels, from novice to experienced engineer, because its specialized individual instruction brings out the best in a man and takes him as far as his own aptitude and effort will let him go.

CREI is an accredited technical institute founded in 1927. Its home study graduates fill important jobs throughout the radio, television and electronics industries. Leading industrial firms — RCA Victor, Pan Ameri-

can Airways, United Air Lines, to name only a few — have CREI group training programs now in operation. Industry welcomes CREI grads — CREI training is recognized as a respected reference.

Make your own opportunity in television! Add CREI technical training to your present experience — start either at the beginning or at an advanced stage. Get yourself a better TV job — make more money — enjoy increased security. The next two years can be the most important of your lifetime. Write today for complete information. The cost is popular, the terms easy.

(Veterans: CREI training is available under the G.I. Bill. For most veterans, July 25, 1951 is the deadline—act now!)

FREE SAMPLE LESSON

● Send for "The Orthicon and Image Orthicon" which describes the development, theory and operation of the orthicon and image orthicon TV camera tubes.

THE THREE BASIC CREI COURSES:

- ★ **PRACTICAL RADIO ENGINEERING**
Fundamental course in all phases of radio-electronics
- ★ **PRACTICAL TELEVISION ENGINEERING**
Specialized training for professional radiomen
- ★ **TELEVISION AND FM SERVICING**
Streamlined course for men in "top-third" of field

Also available in Residence School courses
An Accredited Technical Institute Founded in 1927

CAPITOL RADIO ENGINEERING INSTITUTE

Dept. 163B, 16th Street & Park Road, N. W.
Washington 10, D. C.

Branch Offices:

New York (7) 170 Broadway • San Francisco (2) 760 Market St.

Capitol Radio Engineering Institute

Dept. 163B 16th & Park Rd., N.W. Washington 10, D. C.

Gentlemen: Send me **FREE SAMPLE LESSON** and booklet, "Your Future in the New World of Electronics," together with details of your home study training, CREI self-improvement program and outline of course. I am attaching a brief resume of my experience, education and present position.

CHECK FIELD OF GREATEST INTEREST

<input type="checkbox"/>	PRACTICAL TELEVISION ENGINEERING
<input type="checkbox"/>	PRACTICAL RADIO ENGINEERING
<input type="checkbox"/>	TV, FM & ADVANCED AM SERVICING
<input type="checkbox"/>	AERONAUTICAL RADIO ENGINEERING
<input type="checkbox"/>	BROADCAST RADIO ENGINEERING (AM, FM, TV)
<input type="checkbox"/>	RADIO-ELECTRONICS IN INDUSTRY

Send Details on Residence School

NAME..... AGE.....

ADDRESS.....

CITY..... ZONE..... STATE.....

I AM ENTITLED TO TRAINING UNDER G.I. BILL.

Bliley

... OF COURSE!

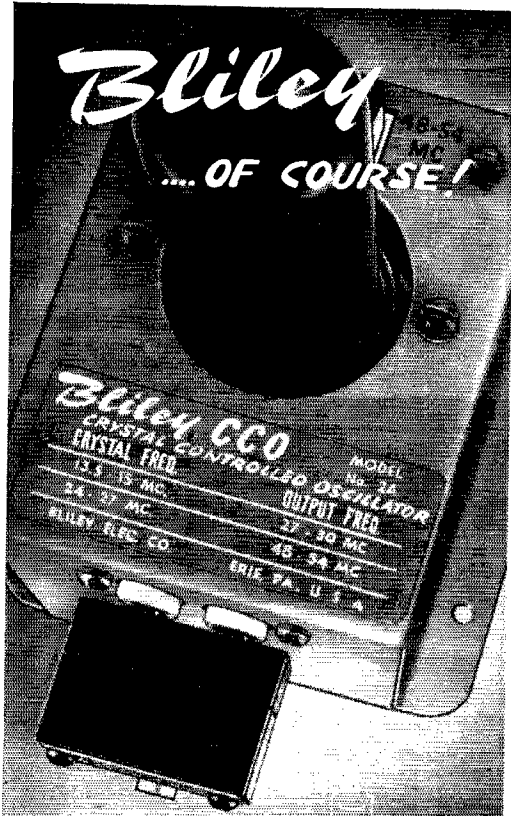

TEAMWORK!

High output at less cost with the Bliley CCO-2A Oscillator. Ample drive for VHF medium power tubes. Designed especially for use with Bliley types AX2 and AX3 crystal units on the 2, 6, 10 and 11 meter ham bands.

- CCO - 2A Oscillator \$9.95
- AX2 Crystal \$3.95
- AX3 Crystal \$3.95

EXPERIENCED AMATEURS know they can rely upon Bliley craftsmanship for superior crystal performance on all ham bands! When you need precision, accuracy, and dependability... IT'S BILEY... OF COURSE!

Bliley

CRYSTALS

BLILEY ELECTRIC COMPANY
UNION STATION BUILDING
ERIE, PA.

PACIFIC DIVISION

HAWAII — SCM, Dr. Robert Katsuki, KH6HJ — The Pineapple Net (Hawaii Regional Net) has seen varied activity. BW is RM and NCS. UL and PL have been our chief mainland outlets. C.w. traffic men seem to be awfully scarce. The "49th State Phone Net" has had better luck and all major Islands, including Molokai, still are tied in. Net night is Tuesday at 8 p.m. on 3.85 Mc. BW reports trans-Pacific contacts on 3.85 Mc. with 60 watts. UL, which has been struggling with only one operator to handle a rather heavy traffic schedule, has two operators again. AS reports a total of 19 members in the 28-Mc. mobile group which constitutes our AEC. Drills are held Tuesdays at 7 p.m. A trailer is being equipped with transmitter, receiver, and gasoline-powered generator. QH reports his kw. rig "blew up," but he's back full-power again. HJ is rebuilding his 10-20 combination around a 257B. Traffic: KH6UL 270, PX 54, BW 51, HJ 50.

SANTA CLARA VALLEY — SCM, Roy E. Pinkham, W6BPT — The Palo Alto Club held its first meeting of 1950 with WB giving a talk on TVI. The meeting was attended by WGO and HC from San Jose. VIQ reports working Italy on 14-Mc. 'phone. Buck remodeled his ten-meter beam, making a two-element for 14 Mc. ZRJ is building new rig using 304-TL in final. VZT was heard on 3.85-Mc. 'phone during the holiday vacation while home from U. C. YQN and GFJ were in an auto accident while coming home from Santa Cruz. At last word Clayton was confined to bed but YQN was up and around. PVV reports that she is well on the way to a membership in DXCC with 84 countries worked on 28-Mc. 'phone. CFK received FB 16mm. movie camera from Santa Claus. NW made BPL again for the month of December with 107 deliveries. WGO moved his rig into the house from the garage during the cool weather so has made it look pretty and is back on MTN. JSB is using a small GF-11 since he sold his BC-610. Hurry, Cecil, and get the new rig built so you can get back into NCS on MTN. NX has rearranged his store by making more counter space. SCCARA's Christmas party was well attended. Several of the gang from outside San Jose were down to enjoy the fun. Well, gang, it will not be long before you will be choosing your SCM for the next two years, so keep watch for the call for nominating petitions in QST. Traffic: W6BPT 439, NW 430, MMG 5.

EAST BAY — SCM, Horace R. Greer, W6TI — Asst. SCM, Charles P. Henry, 6EJA. SEC: OBJ, RMs: FDR, ZM. ECs: AKB, EHS, NNS, IT, IDY, QDE, WCM. The following new officers of the SARO have been elected for 1950: K6AY, pres.; DDO, vice-pres.; CMZ, secy.; QWX, treas.; CML, communications mgr. On Dec. 15th the following new officers were elected by the Oakland Radio Club: MFZ, pres.; DBM, vice-pres.; ZZT, secy.; KZN, treas.; OBJ, director at large; YDP, chief op.; JYR, public relations; HOR, agt. at arms; VE4VD, asst. ITH still is experimenting with radioteletype. KV4AF/6 is a new ORS. Ted expects to be around for six months or so. DQL has gear working on 160 meters. VDR needs 7-Mc. contact with Delaware for WAS. OT has schedules and operating times all set for 1950, thanks to the hard work of DYP. The Richmond Radio Club meets the 1st and 3rd Fridays of each month in Red Cross Bldg. YDI claims things are a little on the quiet side. FDR turned in a total of 3323 messages handled for December. WII is plugging along. LDD is putting up two-element 10-meter beam. IKQ is rebuilding his 20-meter beam. Phil's tower is sporting a new paint job and it is only 70 feet high at that. Anyone wanting a first-class paint job should get in touch with Mr. Caldera. On Jan. 28th the Northern California DX Club and the Southern California DX Club held a special dinner meeting in Fresno. More than 50 DX men from the two organizations were present. DX, contests, etc., were discussed. It was voted to make this an annual event. PB likes his new Plumber's Delight Submarine 20-meter beam. MHB has a big job ahead on his antenna farm. BUY is QRL work but snags a new one now and then. AED likes the country QTH; no noise. ELW now has more time for radio. OBJ is active again on all bands. In December the ORC had a swell dinner dance with more than fifty present. CTL, KEK, and JK are keeping El Cerrito on the map. EY is using 150 watts with key clicks and all. YDI wins the Hammond Memorial Traffic Trophy for the last six-month period. This will be the second time Bland has had his call inscribed on the bug. Remember, gang, this is a swell trophy to win. Nobody can win it twice in a row without a break of six months. The Vallejo gang is going strong. KZF has retired from wire records. Traffic: (Dec.) W6PDR 3323, OT 243, IXH 237, KV4AF/6 60, W6DQL 58, YDI 25, ITH 20, VDR 16, WII 6, TI 2. (Nov.) KV4AF/6 6.

SACRAMENTO VALLEY — SCM, Ronald G. Martin, W6ZF — Asst. SCMs: Northern Area, 8YNM; Central Area, 6CKV; Southern Area, 6SUP. SEC: KME. ECs: Met. Sac., BVK; Walnut Grove, AYZ; Dunsmuir, JDN; Chico Area, HBM; Roseville, GHP. RM: PIV. OBS: AF, BTY. OES: PIV, GHE. OO: ZYV, BTY, GDO, YV. OPS: JDN. Sac. Emer. Net (City) NCS AUO. Section Traffic Net, 29.4 Mc., NCS ZYV. Asst. NCS BTY. Please have your reports in the hands of the SCM by the 2nd of each month. Northern Area:

(Continued on page 86)

HAVE YOU A COPY OF

The 1950 RADIO AMATEUR'S HANDBOOK

JUST OUT!

Continues the lively, refreshing style of presentation as well as the breadth of content which has made it world famous, and which makes each new edition so eagerly sought. This acceptance (to the tune of more than 2,000,000 copies since the first edition) is based on the *Handbook's* practical utility, its treatment of radio communication problems in terms of how-to-do-it, and its long-established policy of presenting the soundest and best aspects of current practice rather than merely the new and novel.

NEW CONTENT

The current edition reflects the changes that have taken place in technical practices during the past year. Of major concern in practically all the larger centers of population is the problem of interference with television reception, a subject that is treated extensively in this edition. Equipment that is designed to be as harmonic-free as possible is featured in the chapter on construction of transmitters, and new material on harmonic reduction has been included in the antenna chapter. The growing importance of single-sideband telephony has resulted in an increase in the space devoted to this subject. The chapter on measuring equipment has been expanded. New equipment is incorporated in the chapters covering the very-high and ultra-high frequencies. And as always, the tube tables have been revised to incorporate the new tubes that have appeared during the year.

FOR THOSE WHO WANT TO KNOW HOW AND WHY!

\$2.00 U.S.A. proper • \$2.25 U. S. Possessions and Canada • Elsewhere \$2.50
Buckram Bound Edition \$3.00 U.S.A. proper • Elsewhere \$4.00

AMERICAN RADIO RELAY LEAGUE, INC.

WEST HARTFORD, CONNECTICUT, U.S.A.

Become an ELECTRICAL ENGINEER

B.S. Degree in 36 Months

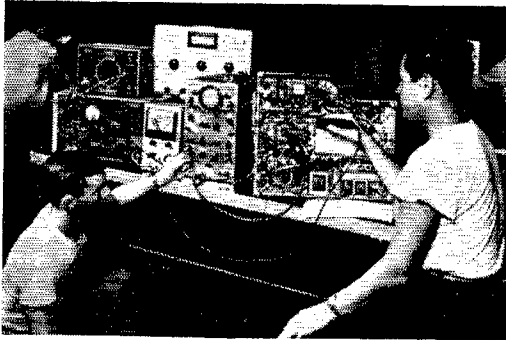

MAJOR IN ELECTRONICS

Important advantages are yours at this nonprofit Technical Institute and College. A valuable year is saved by gaining your B.S. degree in 36 months of continuous study. You get both practical, specialized training in well-equipped laboratories — and a solid education in Electrical Engineering and related arts.

You Become an **ELECTRONIC TECHNICIAN** after 12 months study in the Electrical Engineering Course. Electronics is of tremendous growing importance in broadcasting, radio-television, high frequency heating, air conditioning and other fields.

The **Radio-Television Technician's** certificate can be yours in 18 months. You are then equipped for specific positions in receiver and transmitter testing, servicing, sales and production. This course will be credited toward your B.S. degree in Electrical Engineering.

Military, Academic or Practical Training is evaluated for advanced credit. Preparatory courses are also available.



Faculty of 85 specialists. 1555 currently enrolled from 48 states and 35,000 alumni. Terms open April, July, Oct., Jan.

MILWAUKEE SCHOOL OF ENGINEERING

Founded 1903 by Oscar Werwath

Write for free 110-page catalog and 48-page pictorial booklet, "Your Career."

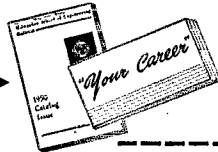

MILWAUKEE SCHOOL OF ENGINEERING

Dept. Q-350, 1020 N. Broadway, Milwaukee, Wis.

Without obligation, send me the 110-page catalog and 48-page "Your Career" booklet.

I am interested in course.

NAME AGE

ADDRESS

CITY ZONE STATE

Check if World War II Veteran

Mt. Shasta Amateur Radio Club met Dec. 7th and 21st and discussed plans for ham shack. HPL is newcomer to area. JDN is giving tests for ham tickets at Dunsuir. *Central Area:* SLY has new converter and sixteen-element beam on 144 Mc. HBM is Chico's outlet through Section Net into NTS. QEE has new beam. LYQ is back on 144 Mc. TTD is using screen-grid modulation on 3.85-Mc. 'phone. GERC 1950 officers are TKE, pres.; CKV, vice-pres.; GUV, secy-treas. The club now holds meetings twice monthly. *Southern Area:* RMP has new 10-20 beam. GDO's mother received call HTS and his dad HSB. HOP has new Collins exciter. GDE conducts code class Mon., Wed., Fri., 8 p.m. PST on 29 Mc. Placer Radio Club 1950 officers are OXG, pres.; SUP, vice-pres.; Mr. Amtek, secy-treas. Meetings are held 1st and 3rd Fridays of the month. KKL has two-element 10 and 20 beams to insure sked with KL7NWH. OXG is on 420 Mc. CTH worked TI2TG and VK2MI on 28-Mc. 'phone with 30-watt mobile rig. GHP is on 160 for first time since the war. ASE has 659A mobile on 28 Mc. ZYV is planning section nets on all bands. AK finished kw. final. ZF redesigned final for 10 to 80 continuous coverage. KME is back to 3.5-Mc. traffic. Traffic: W6PIV 407, ZYV 154, KRX 62, JDN 46, ZF 19, CTH 12, UNT 8, ASE 3, PFM 1.

SAN JOAQUIN VALLEY — SCM, Ted R. Souza, W6FKL — Asst. SCM, James F. Wakefield, 6PSQ. SEC: JPS. ECs: PHL, WBZ, AJE, PJF is busy on the San Joaquin Valley Emergency Net. EXH has been keeping twice-daily schedules on 144 Mc. with the Bay Area. GQZ is active on 3.5 Mc. after an absence of several years. WBZ and VKD have been busy with portable gear for emergency work. QUE again is active on 144 Mc. DVS is working some fine DX on 28 Mc. BRE has some new beams on a 60-ft. stick. QER has a new ham shack and workshop. INP has been trying out some new gear. FYM has been very busy but soon will be on the air more. CUE is on 3.85-Mc. 'phone. AJE also is active on 3.85 Mc. OHB now is on 144 Mc. EPQ was a visitor at the antenna farm of EXH. VPF has been doing some fine work on his 28-Mc. mobile. UWY likes to build and try out new circuits. DWH is out of the hospital and recovering nicely. PRJ and his father, QQS, hold weekly schedules on 3.5 Mc. The following are heard regularly on 7 Mc.: EGX, DBH, AZX, FGJ, GNU, and ADB. MDQ still is trying to get into his new home. LVR has a new rig and is active on 28 Mc. GRB is building a new rig — capacity, one gallon. A c.w. traffic net is urgently needed on 3.5 Mc. for this section. A station in each town would be swell but we'll take what we can get. How about it, fellows? Drop me a line for more information. OHT has been busy keeping law and order in Tulare. WC still is among the sage brush and jack rabbits at KTKR in Taft. Traffic: W6GRO 111.

ROANOKE DIVISION

NORTH CAROLINA — SCM, W. J. Wortman, W4CYB — The Greensboro Club has been combining operating activities with fish fries, oyster roasts, etc., thus making with the social activities as well as ham radio. New officers for 1950 are BHA, pres.; GS, vice-pres.; AGD, treas.; HEH, secy.; KYB, dir. Plans have been approved to increase the size of the club building with a rather elaborate lay-out for operating, etc. FB, gang. TVI isn't bothering MR — he lets TV take the consequences when a new DX station comes along. Thanks to Ed Haden, secretary of the Salisbury-Spencer area, Piedmont Amateur Radio Club, for the dope on the gang in that area. NTW is rebuilding with a pair of 100THs. BIU has forsaken c.w. and now may be heard on 28-Mc. 'phone. EAM is letting LSB do most of the operating in that OM-XYL combination. FXU has his hands full, and lost out on an antenna, too. Try a new rope, Bob. KJS is feeling mighty low because of lack of interest in traffic on 3.5 Mc. and EC organization. If any of the gang have any ideas that will help, pass them on to Charlie. NXS still is kicking on 3.5 Mc. and helping to hold the fort. The Kinston Amateur Radio Society is going in for re-organization and more and better work. Congrats, gang. The Mecklenburg Amateur Radio Society elected officers and installed them at a ladies' night dinner, Jan. 6th. FXU is president, NHV vice-president, CFL secretary, and CAY treasurer.

SOUTH CAROLINA — SCM, Wade H. Holland, W4AZP — Our SEC, ANK, Route 8, Box 690, Naval Base, S. C., writes as follows: "The Emergency Plans for South Carolina call for the appointment of an Emergency Coordinator in each of the 46 counties for work with the County Red Cross Chapters. If your county does not have an EC make application to the SEC of SCM. Every amateur should be a member of the AEC. If you are not a member or your card has not been endorsed, see your local EC or send your card to the SEC for renewal. Both 'phone and c.w. nets will be used in an emergency and the South Carolina Plans call for liaison between the nets. Copies of the Plan are available from the SEC on request. Join the S. C. Emergency Corps now!" DX says no more TVI as he sold TV set. He sends in the following information: WJRA Engineers are planning ham stations in Myrtle Beach. KTI is on 14 Mc. working DX. HXZ sends this information: PST acquired an XYL recently; ODU is mobile on 3.85 (Continued on page 88)

Belden
CHICAGO

WIRES

CORDS

100 FT.
8401
SINGLE CONDUCTOR
MICROPHONE CABLE
MADE IN U. S. A.

**MORE
HOURS
OF
SERVICE
•
MICROPHONE
CABLES**

Every Type for Every Service

Belden
Radio WIRE

MOBILE RIG?

Master Mobile MOUNTS

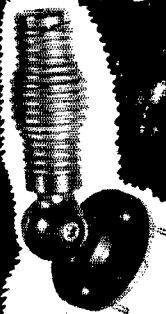

MASTER MOUNTS

● Hefty shock absorbing springs. Two types, straight and double tapered. Body Mounts fit any body contour. Bumper Mounts clamp to bumper in few seconds. Cad plated. Heavy bakelite or mica insulation.

● **Model 132—Body Mount.** Shipping weight 3½ lbs.

Net price **\$7.95**

● **Model 140—Bumper Mount.** Shipping weight: 3½ lbs Net Price **\$5.95**

● **Model 142—Bumper Mount.** Less spring insulated for direct mounting for Series 100 antenna. Shipping weight 2 lbs.

Net Price **\$2.95**

BODY MOUNT
MOD 132
\$7.95
NET

BUMPER MOUNT
MOD. 140
\$5.95
NET

MASTER WHIP ANTENNAS

● One piece stainless steel designed and tapered to prevent excessive swinging.

● **Series 100** in stainless steel with ¾" stud fitting. Screws directly into mount. Available in 72", 78", 86", 90" and 96" length. Postage rate 10 lbs. min.

Net Price **\$4.77**

● **Series 106** in stainless steel—same as series 100. Has plain end. Fits **Model 92** extension.—Available in 72", 78", 86", 90" and 96" length. Postage rate 10 lbs. min.

Net Price **\$4.11**

MASTER EXTENSION

● **Model 92.** Chrome plated. Provides for additional 18" adjustment for Series 106 Antenna.—Shipping weight 14 ounces.

Net Price **\$2.95**

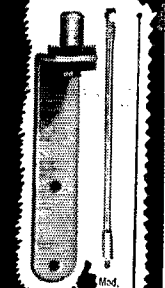

BUMPER MOUNT
Mod. 142
\$2.95
NET

MASTER ALL BAND ANTENNA

- CENTER-LOADED—20-40 OR 75 METERS**
- Antennas come with one coil—20, 40 or 75 meters.
 - Change coils to any band 80 through 20.
 - **10 meter operation**—short out coil in use.
 - Fits any Master Mount or ¾ SAE thrd.
 - Chrome-plated.
 - Length: 8' 10" overall. Wt.: 28 oz. Shpg. wt. 3 lbs. Antenna (Specify coil desired). Net... **\$7.95** Extra coils, 20, 40 or 75 M. Each. **\$2.95**

Master products guaranteed for one year against defective materials or workmanship.

REP. and DEALER INQUIRIES INVITED

Order from your dealer or write:

MASTER MOBILE MOUNTS, INC.
5200 Wilshire Blvd., Los Angeles 36, Calif.

Gen. Sales Agent: Harry Appleton Co.
311 W. Pico Blvd., Los Angeles 15, Calif.

Mc. with 30 watts. HXZ has plate modulator again. (His listeners wish to take this opportunity to thank him for this consideration of their ears.) NKA is on 28 Mc. and JSM on 3.85 Mc. in Anderson. ANK makes BPL this month. Traffic: W4ANK 461, AZT 37, DX 7.

VIRGINIA—SCM, Victor C. Clark, W4KFC—Asst. SCM, Elias Etheridge, Jr., 4KYD. Statistics furnished by RM IA and VFN NCS IWA show that 108 different Virginia hams have reported on VFN (3680 kc.) and VFN (3880 kc.) so far this season. PYV, KVM, and MLH made BPL during December. Just look at those traffic reports! IWA has accepted appointment as Virginia's new SEC. All those interested in building up a first-rate Emergency Corps in Virginia are urged to contact IWA, 707 Maple Ave., Richmond 26. New officers of Ocean View Club are DHZ, pres.; OHZ, vice-pres.; MAY, secy. New ORS: MWH, NQV, PAS, PED, PYN, PYV. NNN worked AC4RF for first Zone 23 QSO. NQV is working DX on 28 Mc. with new three-element beam and five watts. Santa brought IWA a new Collins 75A-1 receiver and 32V-2 transmitter. MLE reports as follows on Wm. & Mary College Club members: 2BWL/4 has 28-Mc. 'phone in Phi Alpha lodge. 4JGW is DXing on 28-Mc. 'phone. #WJG/4 has an AR85 and 30-watt 28-Mc. 'phone. 2CKM/4 made Phi Beta Kappa with 2nd highest scholastic record in college! 3PZD/4, 4MLE, NRO, and NHX keep PYN (club station) going on traffic schedules. MLE's mother is working for ham ticket! PED reports new Lynchburg Club members working up a local 50-Mc. net for on-the-air meetings; he also is teaching code to several prospective hams. Lynchburg Club members made the local paper with an article on ham activities and pictures. CFV and CLD, both in post office work, are relaxing after the Christmas rush. PAS, IA, and KFC visited the Winchester Radio Club. BZE is raising antennas at new QTH. IWO is busy de-TVing and reports progress. NAD landed JA2AZ, KS4AC, and SV0WF on 28-Mc. 'phone for new countries. MLH reports receiving 50 cards from 60 DX stations worked! LAP vacationed in Florida during January. EYG is en route to Japan with the AACs and will be looking for Virginia QSOs on 28-Mc. 'phone and c.w. on all bands. NJV likes new Select-o-ject he built. OZA, with new p.p. 813 final, reports DX good. KVM has a ½-kw. rig in the works. PED is QRL exams. FV gleefully reports TVI practically whipped. There was a new all-band National tuner in KYD's Christmas stocking. MWH has new break-in system working. KXW now is ½ in Schenectady with G.E. and hopes to be back in Virginia soon. NBA and ISE qualified for VFN certificates; IQR, PED, PYN, PYV, PAS, and NQV qualified for VN certificates. PVA joined the AEC. CVO joined the VFN in December. NXN is back on 7 Mc. after an extended absence. Traffic: (Dec.) W4PYV 1304, KVM 1077, LAP 370, MLH 310, PYN 142, FF 120, KFC 97, FV 74, IA 40, NRO 39, KFT 28, NAD 25, IPC 24, CLD 22, VEJ 21, ISE 20, CVO 18, IWO 17, PWX 15, NQV 12, KYD 11, NCN 11, NBA 6, OZA 5, PED 3, NJV 2. (Nov.) W4PYV 309, FV 53, LPP 18.

WEST VIRGINIA—SCM, Donald B. Morris, W8JM—GBF again has a swell traffic total. PQQ moved into the house VAN vacated and now has room for more antennas. PZT is building a small rig to operate as BYN in Fairmont.

(Continued on page 90)

6th WEST VIRGINIA QSO PARTY

The Mountaineer Amateur Radio Association will sponsor the 6th West Va. QSO Party starting at 6 P.M. April 1st and ending at 6 P.M. April 10th.

Rules: Open to all West Va. amateurs and to all other amateurs who have at sometime in the past held a call in West Va.

No power limitations. Any and all amateur bands may be used and the same station may be worked on different bands for credit. C.w. and 'phone and c.w.-to-'phone contacts on one band are permissible but cross-band QSOs are not allowed. In working W. Va. stations, score two points for each completed QSO when the following is exchanged: date, time, call, city, county. For contacts with stations working outside W. Va., score four points and exchange the above plus receiving the call the operator held when he was in W. Va. Multiply total QSO points by number of different counties and states worked. Stations outside W. Va. use same method for scoring. All logs must contain complete information. Incomplete and incorrect logs will not be counted. The following frequencies are suggested for finding W. Va. stations: 3770-3780, 3890-3900, and 7100-7110.

To be eligible for prizes, logs must be postmarked not later than April 20th and be sent to Lyle E. Bates, secy. of MARA, 234 Locust Ave., Fairmont, W. Va. Highest scorer in W. Va. will receive a two-year ARRL membership, second an ARRL Handbook. A special prize will be awarded to the highest scorer outside of W. Va.

HOW TO BUILD WAVE TRAPS for TV. I.

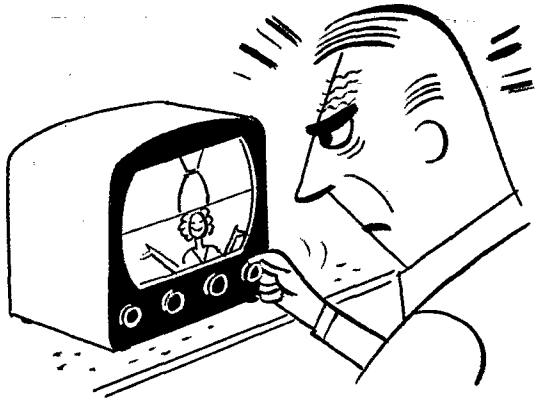

THERE are many cases where the front end of a TV receiver lacks the selectivity required to eliminate very strong 14 or 28 Mc signals. These fundamental frequencies jam through the receiver front end and create many kinds of cross-modulation products which affect the viewed picture (not to mention the set-owner's temper). The only solution: each receiver affected must be treated separately, to prevent such fundamental frequencies from getting in and affecting the TV signal.

Tuned wave traps—either series, parallel, or combination types—are most commonly used to eliminate this trouble. They can be made quite effectively with Ohmite high-Q Chokes, in com-

bination with suitable trimmer capacitors. (See diagrams below.)

Since most receivers have 300-ohm input, that type has been treated here. These designs, however, can be adapted to 72-ohm input as well. Series-tuned traps (A) are connected from the receiver terminals to ground. In some cases, however, two parallel-tuned traps (B) may prove equally satisfactory. The chokes and trimmers can be mounted on a small terminal board with binding posts or clips for easy installation.

Table below shows approximate capacity necessary to resonate OHMITE Frequency-Rated Chokes at various frequencies:

OHMITE CHOKE	mmf at 3.5 Mc	mmf at 7 Mc	mmf at 14 Mc	mmf at 21 Mc	mmf at 28 Mc	mmf at 50 Mc	mmf at 56 Mc
Z-28	98	25	6.2				
Z-50		74	19	8.2	4.6		
Z-144			72	32	18	5.7	4.5
Z-235				6.9	39	12	9.7
Z-460						51	40

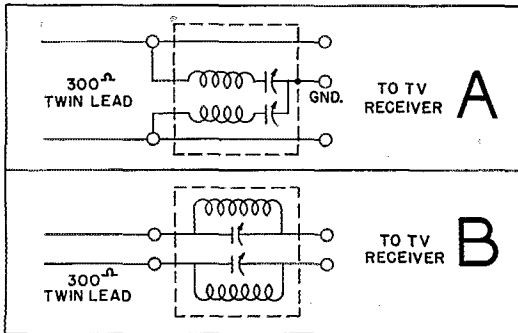

**USE OHMITE
"Frequency-Rated" Chokes**

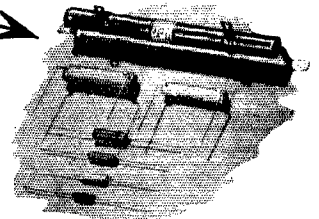

Frequency characteristics accurately predetermined. High "Q" single-layer wound on low power-factor plastic or steatite cores; insulated and protected by moisture-proof coating. Z-14 and Z-28 rated 600 ma; others 1000 ma. Seven sizes—covering range 3 to 520 megacycles.

Write for Bulletin 133
and Catalog 21.

OHMITE MFG. CO., 4865 Flournoy St., Chicago 44, Ill.

Be Right with **OHMITE**

Reg. U. S. Pat. Off.

RHEOSTATS • RESISTORS • TAP SWITCHES

New HAM-R-PRESS

TRADE MARK

by PIONEER

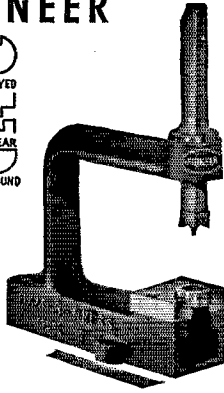
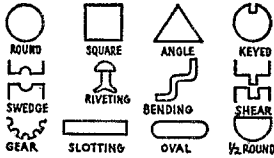

PAT. PENDING

**HAMMER BLOW
POWER
MODEL H75
7 1/2" THROAT
\$16.95 NET
PUNCH AND DIE EXTRA**

NOW chassis punching in almost every size and shape may be done in your own workshop with the unique NEW PIONEER BROACH "HAM-R-PRESS". Punch mounting hole for ANY electronic part. Easily. No drilling. . . Slip punch on ram. Insert die in work table. Lower ram to chassis and strike top of ram with hammer. Hole complete. . . Some of its features: Simple operation—Precision alignment—Deep throat—LOW COST. No Starting Hole Needed.

H50—5" Throat... \$ 9.95 H120—12" Throat... \$24.95
H75—7 1/2" Throat... 16.95 H240—24" Throat... 39.95

ROUNDS	Punches	Dies
1/8, 1/4, 3/8, 1/2	\$.80	\$.65
5/8, 1 1/8, 3/4, 7/8, 1, 1 1/8	1.20	.80
1 1/4, 1 1/2, 1 3/4, 1 7/8, 1 3/4	1.20	.80
SQUARES —3/8, 1 1/8	1.25	1.00
3/4, 7/8	1.50	1.25
KEYED —1 1/4	1.40	1.20
RIVETING SET —Requires Adaptor HAD-5	1.50	
SHEARING SET —(1" length of cut)	3.75	
CABLE SWAGER SET	2.75	
DIE RAISER —3" high	3.95	
HAD-5 ADAPTOR —For 1/2" and under dies	1.00	

PIONEER CHASSIS PUNCHES CUT ROUND-SQUARE-KEYED HOLES

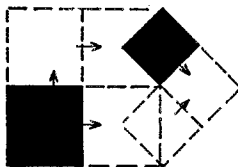

Type CS
Square
Punch
(Right)

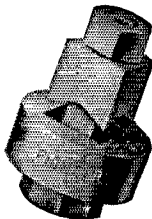

CUTS ANY SIZE HOLE LARGER.
SQUARES: 3/8—\$2.95, 1 1/8—
\$3.25, 3/4—\$3.50, 7/8—\$3.95

ROUNDS: 1/2 to 7/8—\$1.95, 1—\$2.15, 1 1/8 to 1 1/4—\$2.30.
KEYED: 1 1/4—\$3.50. For mounting IP's, Terminal Strips, Sockets, Plugs, Meters, Controls, Xformers, Switches, Panel Lites, Etc. . . SIMPLE HAND WRENCH SCREW ACTION. . . CUTS CLEAN.

Available with Descriptive Literature
"AT YOUR FAVORITE DISTRIBUTOR"

PIONEER BROACH COMPANY
LOS ANGELES 15, CALIF.

BWD has regular schedule with EP on 50 Mc. BNL reports good progress on radio club, AUJ, OXO, DFC, and BWK are quite active in traffic-handling on WVN and TLCS. UHK is back in Weston and CMJ in Elkins after long absence. BWK is clearing property for improved antenna system. FLASHI W. Va. now becomes the 48th state to have an active YL station on the air; EWR, at DuPont City, is secretary of the Charleston Radio Club and operates all bands. KWL is off the air along with FMU on a rebuilding TVI-clearing program. DHI is working Asiatic DX on 28-Mc. phone. 4HLQ, ex-KKG, may be heard on 3.5 Mc. and schedules JRL. MARA's technical board is assisting MIS with his antenna problems. YBQ has new 7-Mc. rig for DX. YGL admits renewed interest in c.w. operation. OIC deserves credit for his regular reports. Be sure to read rules for West Va. 6th Annual QSO Party. Then get rig ready and enter. Traffic: W8GBF 577, OXO 355, AUJ 252, BNL 135, DFC 120, BWK 66, JM 10, CSF 9, BOK 3, VCA 2, AKQ 1, JRL 1.

ROCKY MOUNTAIN DIVISION

COLORADO—SCM, M. W. Mitchell, W0IQZ—Phone East 2038. ECs: KHQ (75), IC (Denver 28 Mc. and all c.w.), RMs: LZY (CSSN), ZJO (UN). ZJO is manager of the Mountain Area Net (MAN). The Colorado Emergency Net meets Sundays at 0830 MST on 3885 kc. DYS is trying out 420 Mc., but sees no future in it because of lack of stations within his range. WVZ would like more traffic outlets. LZY advises CSSN is not going so well but expects things to pick up. IA reports in with a nice traffic total and is new ORS. GUV is new EC in Pueblo and the only one we know of in Pueblo that is on 3.85-Mc. phone. Pueblo is a city of approximately 100,000 and only one ham on 3.85 Mc. What gives?! Report cards were conspicuous by their absence this month. How about a few more reports? The more cards, the more news. ZJO is back in the swing of pounding brass and makes BPL with a total of 20401 IC also makes BPL by the delivery route. Traffic: W8ZJO 2040, IC 373, LZY 71, IA 40, WVZ 7, KHQ 4.

WYOMING—SCM, Marion R. Neary, W7KFV—NOU has 400 watts on 3.85- and 14-Mc. phone. JBI operates on 28-Mc. phone. MFL is on 3.5-, 7-, and 14-Mc. c.w. HNI is handling traffic on 3.5 Mc. and is back on 3.85-Mc. phone. ILL, KRV, and MWD are on 160 meters. JXT is on 3.85-Mc. phone. NKR is DXing on 14 Mc. FCS now has 140 countries. JDB is on 3.5-Mc. c.w. working traffic and DX with 25 watts. The Intermountain 160-meter Net is represented by MWS, ILL, KOF, MWD, and ACC. OBB is the Laramie Club station call. AGC and his XYL IDO have 200 watts on 160 meters to 813s. 9MV177, from Scott Field, now is at Warren Air Base. ECL is on 160- and 28-Mc. phone. GGC is active on 3.5-Mc. c.w. HDS has her SEC hat set out to make Wyoming EC conscious. SQI and CIB are active on c.w. CGK has new versatile all-band c.w. rig. Traffic: W7OWZ 20, HDS 16, JDB 16, KRV 16, HNI 13, HLA 12, GZG 9.

SOUTHEASTERN DIVISION

ALABAMA—SCM, Leland W. Smith, W4YE—GJW went to town with traffic this month. How do you do it, Doc? MVM is active in Chickasaw. The Dothan gang is planning a hamfest for April 30th. HLF has been bitten by the DX bug. HA and BA already have checked out their high-power transmitters for the DX Contest. GBP has new jr. operator and gets on in the wee hours on c.w. DYM is very active as OG. LEO has returned to 14 Mc. PJB can't leave 28 Mc. DX is too hot. MAB still is looking for modulator tubes. QBK is a new ham in Montgomery. KIX finally has finished his all-band exciter. OBV had a bad motorcycle accident but is improving fast. PXO, our Sunshine Girl in Birmingham, is active on 28-Mc. phone. Traffic- or emergency-minded Alabama hams are invited to join the 'phone or c.w. nets on 3955 and 3715 kc. The reports were off this month! Let's hear from you, ARRL member or not. Mail your card or letter by the first of each month. Traffic: W4GJW 201, SLJ 104, OAO 37, KIX 24, YE 22, DYM 3.

EASTERN FLORIDA—SCM, John W. Hollister, W4FWZ—The new ARRL Handbook has more space devoted to equipment by cutting down on space devoted to emergency operations and station operating, as these subjects are covered by special pamphlets which you may obtain from your SCM or ARRL. These pamphlets are worth having, so let me hear from you. It soon will be time for the Gator Net on 7290 kc. to get going on summer schedule. Fast or slow you can qualify, so let me know what nights you can check in. Clearwater: AXX is EC. COB is trying n.f.m. on 14 Mc. Daytona: New hams on 7 Mc. are OAG, PYA, and PYB. OAV has been sending code practice on 28 Mc. for aspirants. Fort Myers: PJG has 813 at 500 watts on c.w. and 450 watts on 'phone with 811 mods. Jax: Congrats to EEW on the JARS Beam. CGY is new EC. JCK made DXCC plus 5. LZM has 105 confirmed. BVX, NFC, and PAE are headed for the Mediterranean. Lake City: It's BPL for IQV again with a traffic total of 518. AI uses a 4-125A on 3.5 Mc. Miami: BYF says PJ5TR is on each night at 8:00 on 14,050 kc. QSL via BYF. VP5BD
(Continued on page 92)

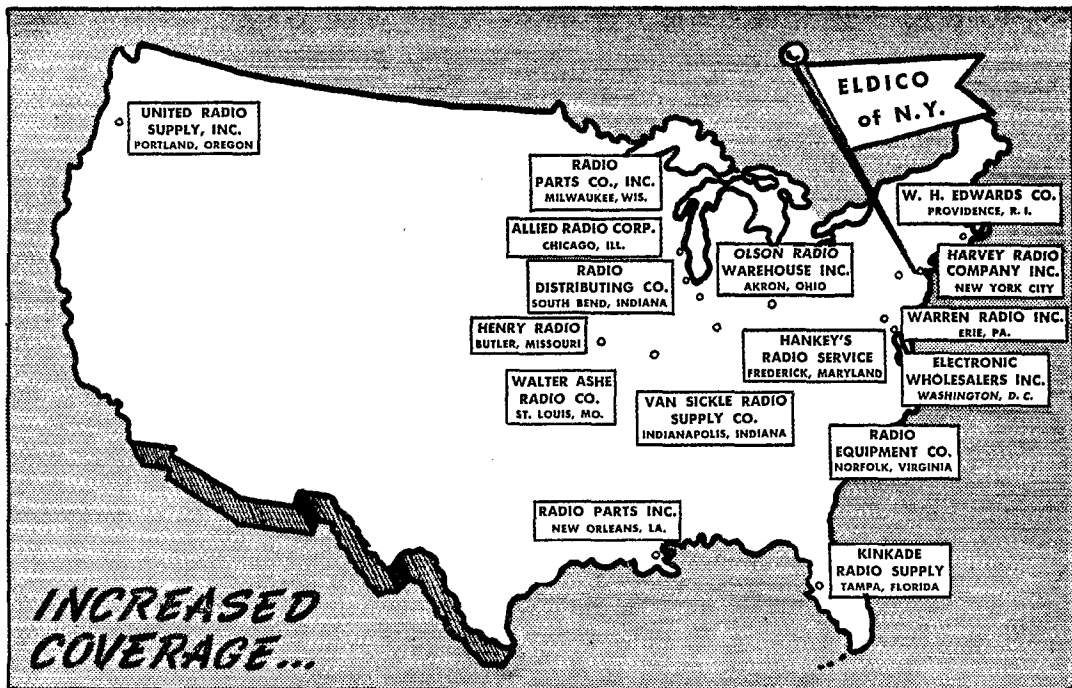

NATIONWIDE FOR YOUR CONVENIENCE

THE COMPLETE ELDICO LINE OF TRANSMITTERS, POWER SUPPLIES, AND TVI FILTERS IS AVAILABLE FOR IMMEDIATE DELIVERY FROM STOCK OF THE ABOVE DISTRIBUTORS, THEREBY SAVING YOU SHIPPING COSTS AND LETTING YOU SEE BEFORE YOU BUY.



TR-1 TRANSMITTER KIT

A conservative 300-Watt phone and c.w. rig 6V6-6V6-6L6-813, Class B 811 modulators. All bands, 80, 40, 20, 15, 11, and 10. Exciter broad band, single control PA tuning. Three power supplies delivering 1500 v.d.c. at 350 ma, 500 v.d.c. at 200 ma, and bias supply. Aluminum chassis, tubes, transformers, capacitors, resistors, antenna changeover relay, meter, wire, hardware and coils included. Electro-Voice 915 high level crystal microphone part of the package. Plug in the crystal and line cord and you're on the air.

Only \$179.50 cash or \$89.50 down payment plus six monthly payments of \$15.75.

ALL ELDICO KITS NOW HAVE PUNCHED CHASSIS

Just mount the parts and wire. Each Kit contains complete instructions, schematic, photographs (top and bottom), complete parts list, Test Voltages and Resistances at all points — alignment and tune-up procedure, step by step. The most complete instruction book ever compiled.

TVI BOOK — Just Hot Off The Press!
Write to your favorite dealer or write direct for your **FREE copy**

MD-40, MD-40P LOW POWER MODULATOR

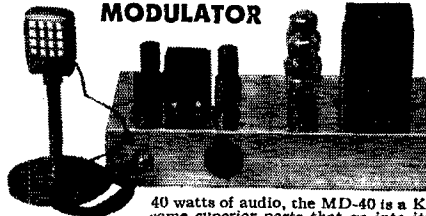

40 watts of audio, the MD-40 is a Kit of the same superior parts that go into its bigger counterpart, the MD-100. The MD-40P is identical to the MD-40 with Power Supply added. In place of the 2807's in the MD-100, a pair of 6L6's are used. Both units are designed to accommodate the Electro Voice Speech Clipper for 14.70 extra. The MD-40 series includes the Electro-Voice No. 915 high level crystal microphone.

MD-40 \$29.95
MD-40P \$39.95



TVD-104 DIAXIAL BAND PASS FILTER

Equivalent of ELDICO'S TVD-62 filter except it is designed for use with a balanced transmission line such as a pair of RG8/U, a pair of RG-58/U or RG57/U (95 ohm Twinax) RG-22/U — or any other approximately 100 ohm impedance line.

GET OUR TVI BOOK FOR COMPLETE KIT LIST BEFORE YOU BUILD

ELDICO OF NEW YORK
INCORPORATED
44-31 DOUGLASTON PARKWAY
DOUGLASTON, L. I., NEW YORK

RADIO SHACK SCOOP! FOR HAMS,
SERVICEMEN, SCHOOLS, LABS!

SENSATIONAL

TEST OSCILLATOR WR-67A

PRICE CUT

Regularly
~~\$950~~

Our
Price **49⁵⁰**



HURRY — LIMITED QUANTITY!

The WR-67A provides speed, accuracy, convenience, and over-all dependability in signal injection and alignment work. A range switch allows the quick selection of three fixed frequencies of 1500, 600, and 455 kc...band-spread dial provides continuously variable fundamental frequencies from 100 kc to 30 Mc, plus useful harmonics out to 90 Mc. Add to this—a temperature compensated oscillator...special signal-injection probe...both step and vernier attenuators...double shielding...six-band drum dial with easy-to-read, four-foot scale spread...scale accuracy of +2%, adjustable modulation level on internal and external modulation positions...power-line filter to minimize rf leakage...and 400-cycle signal source—More features than can be found in most signal generators. Shipping weight, 20 lbs.

• SPECIFICATIONS

Frequency Range: Continuous from 100 kc to 30 Mc
Band A: 100-260 kc; Band B: 260-650 kc; Band C:
635-1600 kc; Band D: 1.6-4.7 Mc; Band E:
4.4-12.8 Mc; Band F: 10.5-30 Mc
Scale Accuracy, +2%
Fixed Frequencies: 455, 600, 1500 kc
Output Voltage (RMS): Continuously variable,
5 μ v to 1 volt
Internal Modulation: 400 cps; adjustable from
0% to 50%
External Modulation: 2 RMS volts req. for 30% mod.
Audio Output: 25 max. RMS volts across 100,000 ohms
RF Output Impedance: 10-1000 ohms
(Varies with attenuator setting)
Dimensions: 10" x 13 1/2" x 7 1/2"

ORDER BY MAIL,
ORDER TODAY!

GUARANTEED!

The RADIO SHACK Corp.

CABLE ADDRESS • RADIOSHACK
167 WASHINGTON ST., BOSTON, MASS., U.S.A.

usually is on 7295 kc. Tampa: ALP reports that a station will be installed at Red Cross Headquarters with tie-ins with local communication systems. Nice going, John, that will be a nice AEC set-up. At this writing the big deal coming up is the Tampa Fair traffic and a hamfest at IJ's with a whole airfield to throw it in! Reports from ARRL on Frequency Measuring Tests reveal that Florida has some fellows that really can check you closely, such as BYF, BT, MVJ, NKD, QN, and AKV. BT missed the exact frequency on 7 Mc. by 1 cycle and on 3.5 Mc. by 5 cycles. BT had an average error of 9.9 parts per million in 4 measurements and BYF not 29.9 p/p/m in 6 measurements. Traffic: W4IQV 518, CZV 173, OAV 115, JEP 102, DES 38, KI 29, RP 27, NAK 23, BYF 3, FWZ 3, AYX 2.

GEORGIA — SCM, Clay Griffin, W4DXI — The Marietta gang organized a club and named it The Kenneshochee Amateur Radio Club. Officers are IDY, pres.; PBW, vice-pres.; MCM, secy.-treas. OFT, MCQ, FHW, and IDL are on 28-Mc. phone. PBW works 28-Mc. phone and 7-Mc. c.w. IDY gets on 7 Mc. occasionally. KXT is on 3.85- and 28-Mc. phone; NEJ is on 14-Mc. phone. FYN works 3.85-Mc. phone. MCM is on all bands now and is up to 70 countries. UR has a 32V-1. The amateurs and SWLs around Cedartown have organized the Cedar Valley Amateur Radio Club. There are 15 members, with IMQ as president. Macon has a new ham on 28 Mc., FZD. PTE is in Augusta attending medical school. BK has a new 14- and 28-Mc. mobile rig. KGP reports the following new officers for the Savannah Club: JCA, pres.; FEH, vice-pres.; PIZ, secy.-treas.; KGP act. mgr. It is expected Chatham Field personnel will increase the club membership. The Georgia Slow Speed Net will welcome more members. Operation is on 3.5 Mc. at about 13 w. p. m. KY has been on 7, 14, and 28 Mc. MA has been on 28 Mc. Traffic: (Dec.) W4KGI 25, DXI 15, MCM 5. (Nov.) W4KGI 34, MCM 15. (Oct.) W4MCM 131.
WEST INDIES — SCM, Everett Mayer, KP4KD — DJ schedules W20BU and W2TYF on 3.5 Mc. W8WVM visited DJ and talked to his XYL at his home station from AZ. AZ and his XYL report a daughter was born Thanksgiving Day. DJ and DV are rebuilding KP4HD all-star rig. AL is on 3559 kc. with 15 watts. W2DD/KP4 is operating 28-Mc. phone and 14-Mc. c.w. KO is on 28.9 Mc. with TBS-50 and three-element beam. IT reports AJ, IP, JL, JO, KM, KP, KY, and LD active at Ramey with IQ and XYL. KQ and KL on leave in the States. JO lost quad in the wind and now has three-element beam. KP has worked all states. BR is new AEC member. KD moved back into town and is on 14 Mc. only for H4ZOL schedules. HU is hearing down on 3.5-Mc. DX. HZ built new Plumber's Delight. RJ is DXing in the wee small hours. JF has new Q5-er. FU is transferring to KW4, as is ex-KP4BJ (W4OLC). KV4AL is transferring to W4 and KV4AJ to KP4. Traffic: KP4KO 6, KD 5, DJ 3.

SOUTHWESTERN DIVISION

LOS ANGELES — SCM, Vincent J. Haggerty, W6IOX — Harold J. Bovee, LDM, met death near Victorville in December when a 70-ton boulder crashed on a picnic party, killing four persons. Our condolences to his family and the Ventura County Amateur Radio Club, of which he was an active member. The Red Cross Headquarters Amateur Radio Station in Los Angeles is HGV; MVK is the EC in charge. Members of the staff include Asst. Ecs BBY (3.5 and 7 Mc.), WKO (29-Mc. phone), and ZUX (144-Mc. phone). The station will be on the air during emergencies for AEC-Red Cross liaison. Since Jan. 15th it has been fully manned on all bands with the above-named operating independently and simultaneously. All amateurs in the section are urged to be on the lookout for HGV. Be prepared for emergency operating by which we may increase the security of our amateur radio privileges. Concerning a recent bazaar by the Two Meter and Down Club, MVK reports that XYLs of the club members furnished the cakes for this successful affair. Congratulations to the Mission Trail Net on its birthday party held on Jan. 20th. MTN is the fine traffic net operating on 3855 kc. at 7:30 p.m. nightly. KGC was guest speaker at the January meeting of the Long Beach Club with "Impedance Matching Without Math" as his subject. Twenty-one traffic reports were received this month and the totals indicate a great volume was handled. Five section members made the BPL. CE admitted that he was just a little bit weary after the holiday rush in which his total for the month surpassed the 5000 level. JQB has almost completed work on a new receiver. LYG continues daily schedules to the South Pacific. IR is active with the American Legion Net on 3975 kc. TFC passes along thanks to CMN and 7ZU for cooperation extended in arranging contact with 7EZA for emergency communications on Dec. 22nd. Notes To You is the title of a two-page bulletin edited by Section Emergency Coordinator ESR and issued to all AEC members. Asst. SCM FYW reports from the northern part of the section that CTJ, YLZ, and MSG are active on 144 Mc. FSA blew a transformer in his big rig. HJL needs Rhode Island to complete his WAS. CFL reports nightly 420-Mc. schedules with NLZ, NNN, GTJ, and FSC. Traffic: W6CE 5056, DDE 601, YLZ 550, GWB 470, JQB 308, CMN 301, LYG 232, ANT 114, BHG 79, IOX 78, (Continued on page 94)

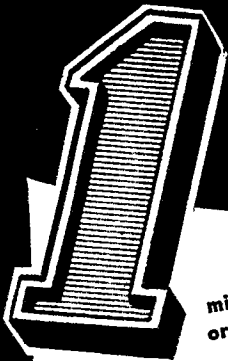

TUBE SALE

THE RADIO SHACK again honors the forgotten penny and the penny-wise gentleman who uses tubes! LIMIT is two tubes per type. Penny-sale ENDS March 24. All tubes brand new, standard makes. Tubes will be shipped by Railway Express only, for your protection. Inspected for mechanical breakage by us before shipping.

minimum order \$2

TYPE	EACH	SALE PRICE
1A3...	.39	2 for .40
2X2...	.40	2 for .41
2E22...	1.50	2 for 1.51
3A4...	.39	2 for .40
3FP7...	2.25	2 for 2.25
6AK6...	.89	2 for .90
7C4...	.35	2 for .36
7E5...	.75	2 for .76
12A6...	.23	2 for .24
12SF7...	.69	2 for .70
15R...	.98	2 for .99
227A...	3.50	2 for 3.51

304TH...	4.50	2 for 4.51
724B...	1.70	2 for 1.71
805...	4.25	2 for 4.26
814...	2.95	2 for 2.96
815...	1.95	2 for 1.96
826...	.49	2 for .50
830B...	3.50	2 for 3.51
838...	2.95	2 for 2.96
872A...	1.15	2 for 1.16
957...	.25	2 for .26
1616...	.60	2 for .61
1626...	.37	2 for .38
9001...	.40	2 for .41
9004...	.30	2 for .31
9006...	.42	2 for .43
FG27A...	5.45	2 for 5.46
RK72...	.75	2 for .76
VR150...	.60	2 for .61

IT'S HERE! \$17.90 DOWN! Hallicrafters SX-71 Receiver DOUBLE CONVERSION Circuit

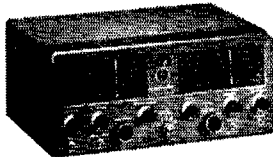

\$179⁵⁰

Extra sensitivity, selectivity and stability! Superior image rejection with double conversion circuit plus built-in NBFM reception! All these and more are what make the new SX-71 a bigger ham value than many receivers priced up to \$100 more. SX-71 features continuous tuning from 538 kc to 35 mc and 46-56 mc; built-in limiter and balanced det. stages for hiss-free NBFM; double conversion gives image rejection of better than 300-1 at 28 mc. One RF, 2 conversion and 3 i.f. stages for sensitivity of 1 microvolt. Five bands — 538-1650 kc, 1600-4800 kc, 4.6-13.5 mc, 12.5-35 mc 46-56 mc.

IT'S COLLINS! IT'S REDUCED! IT'S YOURS IF YOU HURRY!

MODEL 51-Q
RECEIVER
Only \$3495

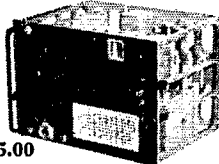

Worth over \$175.00

... beautifully constructed in the famous COLLINS communications manner. Perfect replacement for your SHIPBOARD or SHORE RADIO station, also for HAM communications receiver. Seven tubes — 3 — 12SK7, 2 — 12A6, 12SQ7, 12SA7. Precision tuning in 4 ranges, 1.5 mc to 12 mc. CW pitch control; separate RF and audio gain controls; slug-tuned i.f.'s. Input 12 VDC. Overall 18 1/2 x 10 x 10. Weight 30 lbs. COMPLETE with tubes (uses external power supply). BRAND NEW, and the supply is LIMITED.

with the Drake Low Pass Transmitter Filter

TV-52-40LP for 52-ohm Coax
TV-300LP for 300-ohm
Twin Lead

Either \$12.95 Amateur,
Model Net

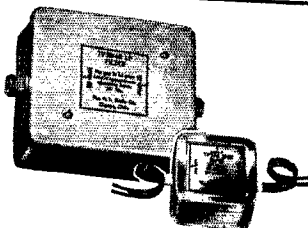

Installed in the transmission line of your transmitter, 30MC and lower, the filter attenuates all antenna and feed system harmonic radiation above 40 MC with no reduction in signal strength at your fundamental frequency. Handles 1 KW on reasonably flat lines. No adjustment required. Once installed it is forgotten and you can QSY and move from band to band at will.

High Pass Filter Amateur Net \$3.57

Installed in antenna input to a TV receiver system. Two types: TV-300 for 300-ohm Twin Lead and TV-72 for small 72-ohm coax.
Net Each ... \$3.57

\$89.50 RCA V.T.V.M. REDUCED TO \$39.50!

Save \$48 (while they last) on RCA's famous battery-operated voltohmmyst. Type WV-65A — compact, portable, electronic voltmeter, ammeter and ohmmeter combined. Power supply four 1 1/2 and two 45 volt batteries, not included. Complete with 2 RCA 1C5GT and 1 G.E.-NE51 tubes, plus a 1 meg shielded signal-tracing probe. Ideal for measuring ac/dc voltage, dc current, resistance, AVC, AFC and FM discriminator voltages; dc supply and bias cell voltages, etc.

Ranges: 0-3/10/30/100/300/1000 volts D.C., constant input resistance 11 meg-ohms for all ranges; 0-10/30/100/300/1000 volts A.C. @ 1,000 ohms per volt; 0-1,000/10,000/100,000/1 meg/10 meg/1,000 megohms; 0-3/10/30/100/300 milliamperes D.C.; 0-10 amperes D.C.
Battery kit \$2.52 extra.



OUR UP-TO-DATE 152-PAGE 1950 CATALOG IS READY!

ARE YOU ON OUR MAILING LIST? If so, your new Radio Shack Catalog is being mailed to you right now!

IF NOT, write today for your copy. Don't miss radio's newest, most up-to-date, complete, authoritative parts catalog!

AND REMEMBER: The Radio Shack stocks complete lines of — Collins, Hallicrafters, National, Millen, Hammarlund, McMurdo-Silver, Johnson, Stancor, Meissner, Lyco, and Harvey Wells equipment. Easy terms: 10% down, 12 months to pay, no interest if paid within 60 days!

FREE SURPLUS BULLETIN

The RADIO SHACK Corp.

CABLE ADDRESS · RADIOSHACK
167 WASHINGTON ST., BOSTON, MASS., U.S.A.

Only

SPRAGUE

Makes

HYPASS CAPACITORS

for TVI

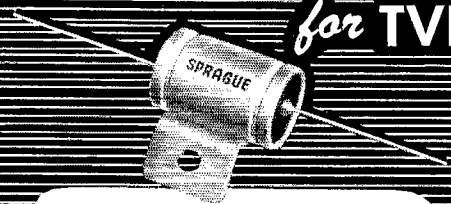

This exclusive Sprague capacitor design is curing TVI problems all over the country. Unlike ordinary capacitors, it is an effective v-h-f filter and bypass unit... ideal for eliminating harmonics in transmitter circuits and for filtering interference on a-c mains and on control circuits. Developed in cooperation with ARRL HQ. See QST for Feb. and Oct. 1949 and CQ for Sept. 1949 for details on how these capacitors solve tough amateur TV interference problems.

Write for bulletin 432 or see your Sprague jobber today.

Catalog Number	Mfd.	Working Voltage	Size Diam. - Length	List Price
48P9*†	.1	250 a-c	11/16 x 1 13/16	\$2.60
46P8	.005	600 d-c	1/4 x 1 5/8	2.15
47P6	.01	600 d-c	7/16 x 1 1/4	2.35
47P12†	.005	1000 d-c	7/16 x 1 1/4	2.40
47P13†	.01	1000 d-c	7/16 x 1 1/2	2.60
47P14†	.005	2500 d-c	1 x 1 9/16	2.90
47P15†	.01	2500 d-c	1 x 1 9/16	3.10
47P16†	.002	5000 d-c	1 x 1 9/16	3.20

*Recommended for power lines, filaments, and control circuits up to 20 amps line current. Often more effective than a choke-capacitor filter. Has female screw terminals.

†Circulating current to ground at 14 and 28 mc should not exceed 2 amps for 47P15 and 47P16, 3 amps for 47P13 and 47P14, 4 amps for 47P12.

SPRAGUE PRODUCTS COMPANY

75 Marshall Street

NORTH ADAMS

MASSACHUSETTS

WMQ 87, FMG 39, VG 37, IR 34, MU 24, K6NRI 24, W6TFC 13, FKO 12, CUF 11, DBY 9, FYW 7, ARIZONA — SCM, Gladden G. Elliott, W7MLL — Congratulations to PBD upon his 1000th QSO with ZL2MQ on December 24th. Not only a nice DX record, Marsh, but a wonderful achievement in cementing two great nations together. New 25 Club officers are JMC, pres.; LVR, vice-pres.; RMB, secy. HDO has 200 watts on 14- and 28-Mc. phone. JIN is running a kw. on 7-Mc. c.w. at Safford. JGZ is on 3.5-Mc. c.w. at Nogales. LSK kw. is operating from Gallup, New Mex. PNJ is running 200 watts on 3.85-Mc. phone at Safford. JMQ has a nice 3.85-Mc. mobile. SBN is reporting good results with a folded 20-meter beam. NUC has a half-kw. on 28-Mc. phone at Safford. 5MMX/7 is on 7-Mc. c.w. at Kingman with 2 watts and is being heard quite well around Arizona. BH is on 7-Mc. c.w. at Mesa. NSJ is working 3.5- and 7-Mc. c.w. in Tucson. OAO is on 28-Mc. phone with a Viking. PZ has a new 10-meter beam. JRK is on 3.85-, 14-, and 28-Mc. phone in Phoenix. 2YZC now is 7YZC and is on 28-Mc. phone in Phoenix. LVR is mobile on 28 Mc. PFL has been transferred to Japan. MAE is handling traffic for Arizona on several nets. Look for Arizona on 3515 and 3895 kc. Traffic: W7MAE 391, MOW 89.

SAN DIEGO — SCM, Dale S. Bose, W6BWO — YXE reports Emergency Corps work is progressing nicely with the AEC council consisting of AMQ, PGO, ERS, KW, MI, NBJ, RMG, SK, VJQ, YXE, and YXI. ELQ is doing very well sparking the Southern Border Net. He turned in the high traffic total for the month. VJQ/6, at the Naval Hospital, with the help of FMZ cleared a lot of holiday traffic for the boys who had to spend the holidays in the hospital. AD says 'TVI is good? The El Centro gang held a special meeting Dec. 15th to discuss the FCC Docket 9295 (revised). The Orange County Club cancelled its December meeting because it was too near to Christmas. Traffic: W6ELQ 238, YYN 111, FMZ 87, BAM 56.

WEST GULF DIVISION

NORTHERN TEXAS — SCM, Joe G. Buch, W5CDU — HOF has resumed activity after a lay-off of one year. EN, of Greenville, makes his first postwar debut on 3.85-Mc. phone. KJB is experimenting with helix-type antennas. City officials of Fort Worth have formed a City Council Emergency Board coordinating all emergency operation. ARK is the radio amateur representative of the new organization. John Edwards, K5WAA, is the newly-elected president of the Dallas Amateur Radio Club with PCY, vice-pres.; FAJ, secy.-treas.; MA, financial director; MHW, technical director; CSU, program director; PED, sgt. at arms; and FDI handling the entertainment for 1950. We're still waiting for that 80-meter QSO promised by AW. Andy is happy to report that the Big Spring Radio Club now is an ARRL affiliate. Congrats. PXR was transferred from Big Spring to Lamesa. GML has increased power to a kw. NGD is getting good results on 160 meters with an input of 5 watts. LGY reports her 12 watts input and folded dipole does a better job on 28 Mc. than the 60-watt rig with doublet antenna. GZU and LSN again make BPL. This is the eleventh consecutive month for GZU. If you don't have time to write and mail items for this column, send them in via radio. It's your column. Traffic: W5GZU 1697, LSN 979, ARK 13, CDT 118, BKK 38, PXX 21, A5S 12, LGY 6.

OKLAHOMA — SCM, Frank E. Fisher, W5AAT, 1ST-SEC.; AGM, RM, MBV, PAM; ATJ, the OCARC, and ACARC of Oklahoma City have joined forces in the publication of a club bulletin, *Short Skip*. HXL is off in W6 Land for a stay of several months. EHC is working hard as EC of Oklahoma County. GVV was appointed EC for Garfield County. NLZ is Assistant EC for v.h.f. in Oklahoma County. We need an EC in every county of the State. Won't some of you fellows help us along? MEN has improved his phone by peak limiter and filter. EEL is operating at KOSO, the State police station. HEV has good luck with single sideband. HXT is trying to cut his big rig down to fit his new home. ELI claims good luck with super modulation. FAB has two nice masts. NQJ fixed his modulation troubles. KVG won a bug at Enid ARS' annual dinner. Herb is wondering what a phone man does with such a thing. HGF is on 160 meters looking for a QSO. NHD has a whole farm of v.h.f. antennas and is promoting 50-Mc. activity in the State. HGC still is trying to convince us that he has quit ham radio. OLZ is badly in need of additional operators and new men and women also are needed in the slow-speed section of OLZ, which meets Mon., Wed., and Fri. at 2000 CST. The slow-speed section works at fifteen w.p.m. or under and offers a good opportunity for the fellow who is not so fast on the key but wishes to indulge in some traffic-handling. Traffic: W5OWV 376, AHT 322, FOM 296, QOD 216, NMM 154, K5NRJ 35, W5FRB 18, EHC 15, NHD 6, ADB 4.

SOUTHERN TEXAS — SCM, Ammon O. Young, W5BDI — HBM is new OPS and had a DX visitor in the person of KP6AA. Traffic totals at MN have picked up the last two months. QLP, the son of MN, is working DX with his dad's rig. NIY is spending what time he has available in rag-chewing and traffic-handling. FI is doing experimental

(Continued on page 96)

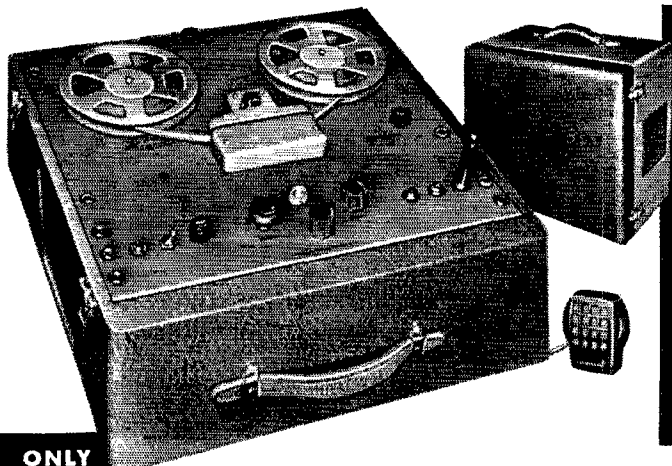

**A QUALITY
NEW MAGNETIC
TAPE RECORDER
AMAZINGLY PRICED**

AT ONLY \$99⁵⁰

**ONLY
\$9⁹⁵
DOWN**

KNIGHT MAGNETIC TAPE RECORDER SUPER-VALUE!

Records from Mike, Radio or Records . . . Has deluxe features heretofore available only in higher-priced models . . . yet it's unbelievably low priced! Buy while they last . . .

COMPACT! LIGHTWEIGHT! SIMPLE! Features easy threading and one-lever operating control, with only 3 positions: "Record-Play, Off, Rewind." Fast rewind—20 times recording speed! Heavy flywheel on capstan drive assures constant tape speed.

Excellent response: ± 6 db, 80-6500 cps. Records for full hour on 1200 foot reel of tape (30 minutes for each half of tape width). Recording speed: $7\frac{1}{2}$ per second. All controls easily accessible. Neon recording level indicator. Efficient high-frequency erase system. Built-in 5 watt amplifier and speaker. Can also be used as P. A. System.

The KNIGHT Magnetic Tape Recorder is supplied complete with tubes, crystal mike and cable, 600-ft. reel of outside coated tape, and take-up reel. In portable two-tone brown leatherette case, 13" wide, 10" high, 14" deep. For 105-125 volts, 60 cycle AC. Shpg. wt., 26 lbs. The best tape recorder value we know of!

96-144. CASH PRICE ONLY \$99.50

Terms: \$9.95 down, \$7.91 monthly for 12 months

Send for the Leading Amateur Buying Guide

You'll find everything you want in receivers, transmitters, instruments, parts and station equipment in our up-to-the-minute 196 page Catalog. Get it today. And get every buying advantage at ALLIED—fast shipment, money-saving values, top-quality equipment, ideal easy-payment terms, square trade-in deals on communications receivers, and down-to-earth help from ALLIED'S old-time Hams. For full satisfaction, get and use the ALLIED Catalog!



**ALLIED
RADIO**

Everything for the Ham

**ALLIED RADIO CORP., D. L. Warner, W9IBC
833 W. Jackson Blvd., Chicago 7, Ill., Dept. 15-C-O**

- Send **FREE** 1960 ALLIED Catalog
- Enter order for *Knigh*t Magnetic Tape Recorder
Enclosed \$..... Full Payment Part Payment (Bal.C.O.D.)
- Send ALLIED Easy Payment details and order blank

FREE

Name

Address

City Zone State

WHAT IS YOUR PROBLEM?

You will find the answer in

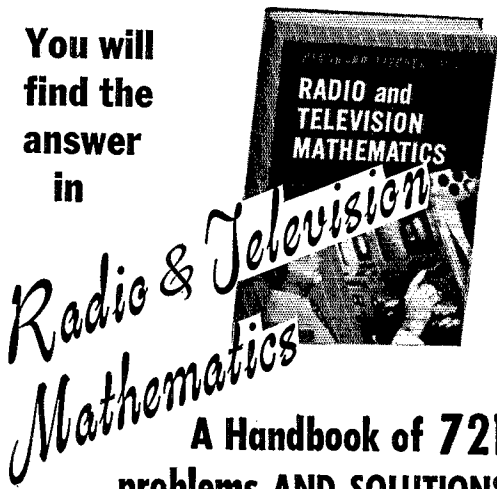

Arranged under radio topics and completely indexed for quick reference, these sample problems show what formulas to use, how they are used, and the step-by-step solutions for every calculation commonly required in work on receivers, power supplies, tubes, transmitters, and all other aspects of radio, television, and industrial electronics. Every problem requiring math in the FCC STUDY GUIDE for all classes is included. This book makes the "hard" part of radio easy. \$6.00

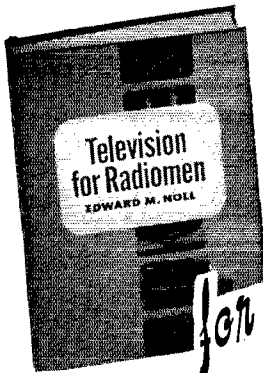

The how's AND WHY'S of Television for Radiomen in the practical

terms of operation and servicing

This book explains the *theory* as well as the techniques of television construction, operation, and servicing. In the clearest, most practical terms it gives the radioman all the basic information he needs to meet the increasing demand for skilled television technicians. It shows *how and why* all modern equipment operates, including all essential mathematics. \$7.00

SEE THEM FREE

The Macmillan Co., 60 Fifth Ave., New York 11

Please send me copies of the books checked. I will remit in full or return the books within ten days.

- Radio & Television Mathematics, \$6.00
 Television for Radiomen, \$7.00

Signed _____

Address _____

work with instantaneous deviation control in connection with n.f.m. NMA is licking TVI by using a Class B linear final on 28-Mc. 'phone. JWM worked some nice DX during the holiday season. Noticed quite a bit of activity in the 10-meter WAS Contest in Houston. Hope they all report. Traffic: W5MN 504, HBM 82, NIY 2.

NEW MEXICO — SCM, Lawrence R. Walsh, W5SMA — SEC: BYX, PAM: BIW, PAM-v.h.f.; FAG, RM; ZU, JXO has organized a net on 144.14 Mc. (8:00 P.M. Tues.) and one on 29.160 Mc. (7:30 P.M. Tues and Thurs.). BYX has appointed the following ECs: CXP, NKG, MJJ, QNQ, NSZ, EUD, and QKJ. JXO has appointed QAG AEC for 2 meters and QDY AEC for 10 meters in Albuquerque. TLS, which meets on 3545 kc. at 2100 EST, desires a N. M. station to handle traffic for New Mexico; if anyone interested, contact me or your RM. HSO has a Trigrinal beam on 28 Mc. NRP is sending c.w. practice on 29 Mc. at 7:00-7:30 P.M. Thurs., and 9:15-9:45 P.M. Tues. CTP is back in Roswell using 14-Mc. n.f.m. PAW is back from the East and on 28-Mc. 'phone. QDY organized a 10-meter net (29.160 Mc.) in Albuquerque which meets Tues. and Thurs. at 8:00 P.M. QAG has a new six-element stacked array on 144 Mc. A new member of the Los Alamos Club is ØHVK/5. DRA took part in recent YLRL Anniversary Contest. CXP is on 144 Mc. with a 522 and four-element beam. MJJ and JXH are on 144 Mc. FAG is building a cascade preamp for his 144-Mc. receiver. AOE and FVY are on 160-meter 'phone. FVY would like anyone with 50- and 144-Mc. gear to contact him by radio or postcard. MYJ has a new 32V-21 PEJ heard BIW on 14-Mc. 'phone and your SCM heard Dick's XYL, DRA, on 28-Mc. 'phone! Traffic: W5ZU 109, NJR 72 ASZU 45, W5NKG 8, SMA 8.

CANADA

MARITIME DIVISION

MARITIME — SCM, A. M. Crowell, VE1DQ — SEC: FQ, MK has been active as Flight Leader in AFARS Net on 4290 kc. Cape Breton members are HY, PZ, YO, and MK. DB spends most of his time rag chewing but gets in a bit of traffic on 14-Mc. c.w. W9TJY/MM, while in port, recently visited DQ and FQ. Look for him on 28-Mc. 'phone. ES has had good luck with his 617-6AK5 converter. QZ worked HC2QA on 50 Mc., and has been putting the new 28-Mc. high-power rig (pr. 813s p.p.) through its paces. OM has been doing well on 14-Mc. 'phone with the "little 2 watter." HC has been putting out with n.f.m. on 3.8 and 14 Mc. PQ also was heard on 14-Mc. n.f.m. FQ did some very fine "phone-patch" work for the VE8 boys in isolation to talk to their XYLS during the Christmas season. Following is from the *LCARC Bulletin*: New HARC president is FQ. PCARC president is TX, and RE and XYL, FP, are doing the editing of the *Bulletin*. TF is SSARC secy.-treas. The St. John High School Club has been organized under FN and has code practice and instruction in theory weekly. HQ got a nice write-up in the *LCARC Bulletin*. ET WACed in seven hours on 28-Mc. 'phone. PF, of Fredericton, is on 7- and 14-Mc. c.w. Traffic: VE1MK 24, DB 8, ES 1.

ONTARIO DIVISION

ONTARIO — SCM, Thomas Hunter, jr., VE3CP — Asst. SCM c.w. M. J. McMonagle, 3AWJ, Asst. SCM 'phone, E. B. Kimble, 3FQ, SEC: KM, RMs: ATR, AWE, BMG, BUR, DU, GI, TM, and WK, PAMs: BSA and DF. My congrats to the gang on the fine traffic scores and especially to IA, who made BPL with 686. BBM is using 814. DU worked a CPl on 3.5 Mc., BUR a VP5, and AHL a DL3. ATR completed his 10,000th QSO. AUG is new president of Frontier Radio Club and BXJ is the new secretary. BHY has new 50-watt all-band rig going. AZN is on 3.8 Mc. with 500 watts. AGB has new QTH in Niagara Falls suburbs. The gang in Kirkland Lake are forming a Northern Ontario 'Phone Net on 3.8 Mc. The Kingston Club puts out a fine bulletin. CAZ controls the Kingston net on 7188 kc. BDA is on 3.5 Mc. CAQ has new rig on 28-Mc. 'phone. BBY has RCC ticket. GI has new VFO. OI and TM are back on after many months. FP has new daughter. BSG is back on 3.8 Mc. with 50 watts. BCZ lost his radio records in a fire. The Hamilton Club had a New Year's Party at the home of AGW. BDA, ATL, CBA, CAQ, and CAV are on 7 Mc. from Kingston. The McMaster Radio Club is on with an AT-3. ABP has WAC on 28 Mc. BNQ has DXCC. AQQ, KM, BOW, BEC, QT, BVN, and AWR are on 144 Mc. regularly from Hamilton. DCA keeps CKOC under control when not on 28 Mc. FT has antennas for 3.5, 7, and 14 Mc. BMG likes the new ARRL Traffic Plan. ABZ seems to spend all his time on mobile on 3.8 Mc. BSA is new PAM and BTI is new EC for St. Catharines. Traffic: VE3IA 686, BUR 394, BBM 203, WK 198, IL 153, GI 141, ATR 131, WY 99, ANO 94, DU 87, NL 83, NI 78, APS 57, CP 57, BNQ 49, BER 48, BTQ 45, AJN 42, BUG 41, RG 38, BUS 36, DF 32, TM 32, BMG 30, BSA 30, FQ 29, YJ 29, ADN 22, HK 21, BQL 20, AOK 16, DH 16, AQB 14, JS 12, AYW 10, AZH 10, DBJ 10, VD 10, AG 8, TO 3, ZE 3.

(Continued on page 98)

HARVEY presents the ELDICO Line

ELDICO TVI FILTERS



TVI Book Now Off Press

Get your free copy of Eldico's new book "TVI Can Be Cured". Just drop us a postcard with your call, name and address and we'll shoot it right to you.

Eldico Transmitter Filters



Dual low-pass, 40 Mc cut-off, over 75 db harmonic attenuation. 52-72 ohm input and output. At other impedances use antenna tuning network. Good for 1 KW input, negligible fundamental attenuation. No effect on antenna performance.

Model TVT-62, \$7.99 kit, \$10.99 wired & tested. Shpg. Wt. 6 Lbs.

Eldico Receiver Filters

Hi-pass, 40 Mc cut-off, no attenuation to sigs above 40 Mc. Efficient on any manufactured set. Will not affect picture, quality or strength. Available for coaxial or twinex.



TVR 300 for Twinex—TVR 62 for Coax Either model \$1.98 in kit form Shpg. Wt. 1 Lb. \$3.98 wired & tested



Brute Force Line Filter

Similar to one on Page 508 ARRL Handbook. Will handle 1 KW. Completely filtered and shielded. \$5.98 in kit form, \$8.98 wired & tested. Shpg. Wt. 6 Lbs.

GDA GRID DIP KIT



The most valuable piece of test equipment in the ham shack is the Grid Dipper. Build one with this kit and save countless hours in building, improving and de-bugging your rig. The GDA Kit builds an exact duplicate of the "Grid Dipper" and includes everything from the special handy case permitting one-hand operation down to a complete application and instruction book. With tube and internal power supply, range 3 Mc to 250 Mc in 6 steps, size 5 1/2" x 2 3/8" x 3". Complete Kit\$21.50 Shpg. Wt. 6 Lbs.

All prices Net, F.O.B., N.Y.C. Include ample postage with your remittance, any excess will be refunded. Prices subject to change without notice.



TVD-104 DIAXIAL COAXIAL FILTER

Matches impedance of pair RG8U or RG58U — or Twinex cables RG22U, RG57U, or any other approx. 100 ohm line. Same characteristics as TVT-62.

TVD-104...Kit Form.....\$14.50
TVD-104...Wired and Tested...\$17.95

R.F. BYPASSES — All AC Leads, power leads, relay and switch leads and every connection between chassis should be bypassed. Use our Hi voltage Ceramic for Hi Voltage, our button or feed thru's for medium and low voltages, our micas for AC, relay and switch leads.

HI VOLTAGE CENTRALAB—7500V working — 50 MMFD. Tapped for 6/32 screws —The best for RF bypassing—\$.89 each.

BUTTON CONDENSERS — available in various ranges and capacities. Automatically grounded through mounting screws 50, 100, 180, 500 MMFDS.

\$.18 each \$1.80 per dozen
2400 MMFD .25 each 2.50 per dozen

FEED THRU CONDENSERS. Just insert in hole in chassis, tighten nut and you have a feed through connection which is automatically bypassed to ground. Available in 50 MMFD with nuts. 15c each — \$1.25 per dozen.

R.F. BYPASSING COMBINATION #1 — Enough to do a thorough job on any amateur transmitter — Contains 6 Hi voltage ceramics, 20 button 30 feed throughs and 20 ceramics. A \$16.00 combination for \$8.95 per kit.

TRANSMITTER FILTER COMBINATION #3 — Contains one TVT-62 Dual Transmitter Filter, two TVR Receiver Filters (Your choice of 300 or 62 ohms) and one Brute Force Line Filter.

A \$17.99 combination for \$14.98 in kit form

A \$27.93 combination for \$22.50 wired and tested



HV-1500 HIGH VOLTAGE POWER SUPPLY KIT

Here is a power supply that is designed to take it. Ultra-conservatively rated, will deliver under continuous service load 1500 v.d.c. at 350 ma. Kit includes plate and filament transformers, two filter capacitors and filter chokes, bleeder, safety plate caps, less 866 rectifier and chassis. The total cost is what you would expect to pay for the transformer alone. Complete kit price.....\$29.50 Shpg. Wt. 50 Lbs.

Telephone: **7** Luxemburg 2-1500

HARVEY
RADIO COMPANY INC.

103 West 43rd St., New York 18, N. Y.



TR-1 TRANSMITTER KIT

A conservative 300-Watt phone and c.w. rig 6V6-6V6-6L6-813, Class B 811 modulators. All bands, 80, 40, 20, 15, 11, and 10. Exciter broad band, single control PA tuning. Three power supplies delivering 1500 v.d.c. at 350 ma, 500 v.d.c. at 200 ma, and bias supply. Punched chassis, hardware, tubes, transformers, capacitors, resistors, antenna changeover relay, meter, included. Shpg. Wt. 125 Lbs.....Only \$179.50

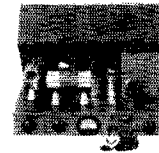

TR-75 TRANSMITTER KIT

Loafing along at 75 watts this is the c.w. man's buy of the year. Simple enough for the beginner to assemble. Punched chassis. Uses the time proven 6L6 oscillator-807 amplifier combination. Pi-network output. Husky power supply delivers 600 volts to the 807. Complete. Shpg. Wt. 50 Lbs.....Only \$34.95



MD-40 LOW POWER MODULATOR

40 watts of audio, the MD-40 is a kit of the same superior parts that go into its bigger counterpart, the MD-100. In place of the 807's, two 6L6s are used. 200 ma. additional power available in MD-40-P. Complete, including the same standard communications Electro-Voice 915 high-level crystal microphone, only \$29.95

MD-40-P with built-in power supply \$39.95
Shpg. Wts.: MD-40—15 Lbs.
MD-40-P—30 Lbs.



MD-100 MEDIUM POWER MODULATOR

100 watts of audio, this AM modulator is designed to be assembled once and put into action...with no maintenance problems. Lineup consists of a 6S7J, 6J5 audio amplifier driving a pair of 6J5s

which drive two 807s. It is an ideal modulator for the quarter kw c.w. rig and is another Eldico complete package with punched chassis. It even includes an Electro-Voice 915 crystal microphone. At the low price of \$44.95 this is the kind of postwar price the hams have been waiting for. Speech clipper, if you want it, \$14.70 additional. Shpg. Wt. 35 Lbs.

JOIN



ARRL, 38 LASALLE ROAD
WEST HARTFORD 7, CONNECTICUT

Enclosed is \$..... (\$4 in the U. S. and possessions; \$4.50, U. S. Funds, in Canada; \$5, U. S. Funds, elsewhere) for ARRL membership dues for one year. Start QST with the..... issue. I prefer a membership certificate card.

Name.....Call.....

Street and Number.....

City.....State.....

QUEBEC DIVISION

QUEBEC—SCM, Gordon A. Lynn, VE2GL—SEC: SA. ECs: BB, TA, ZZ, RMs: BB, GM, PAM: DX, PT now is using n.f.m. to get away from BCL. DX is rebuilding and has new exciter unit, 13 tubes, 80 40 20 15 11 and 10, with n.f.m. all on chassis 14 x 17 with 807s p.p. output on the air pending completion of final. Antennas are 80-20- and 10-meter folded dipoles at his new QTH in Valois. EC reports 144-Mc. net consisting of EV, HZ, GU, RM, ACD, HO, AV, and himself in regular operation. AKJ, in Trois Rivieres, has been handling some traffic and occasionally is heard on PQN. XO worked G2AWA on 3.8-Mc. 'phone. LO reports the entire month's operating devoted to handling Christmas traffic. BB also has been hitting the traffic hard on 7 Mc. XB also handles quite a bit of traffic on 7 Mc. and on the AFARS Net. KG and ZF maintain schedules with VE8MJ. XX is in the process of erecting mast for skywires. PZ has added 'phone to his 14-Mc. rig. LE, in Trois Rivieres, has 19 set operating on 3.5 and 7 Mc. His antenna is end-fed Hertz 136 feet long. SF is on 3.5 Mc. from Seven Islands. TQ is expecting a transfer from Seven Islands to Montreal. RI has been haunting 14 Mc. of late. BV has two-element beam on 14 Mc. XL has three-element beam on 14 Mc. with ART-13 transmitter. NW has about 400 watts on 3.5-Mc. 'phone from Rapide Blanc, about 100 miles north of Three Rivers. TM is back on 3.5-Mc. c.w. from Quebec City. Traffic: VE2BB 299, LO 237, CD 128, GL 52, XB 46, EC 36, KG 14, AKJ 7.

VANALTA DIVISION

ALBERTA—SCM, Sydney T. Jones, VE8MJ—SEC: MJ. AQ reports good DX with low power. MB, Official Bulletin Station at Coronation, now is on 3778 kc. Listen for him Mondays and Fridays. He reports progress in the AEC. OD handled a considerable volume of traffic over the Christmas holiday. ES is confined to the hospital. All the gang wish you a speedy recovery. Hilda, NA is not so active owing to frequent trips to the hospital to visit his XYL. VE6ES. QJ is interested in ORS appointment. NR claims he needs a new receiver and plans to change to 1155. OU has trouble getting the small fry to bed at night. OW says he has the formula but wants too high a price. KN is very much improved after a recent illness and has returned to work. BN again is active after a rebuilding job. JJ visited Edmonton on business. DZ puts out an FB signal on 28 Mc. EF has moved and is busy with varsity. My term as your SCM expires on April 30th. Many thanks to all for the FB spirit of cooperation. I am willing to carry on for another term if you wish. HM, LZ, LQ, and MJ achieved good results in the Frequency Measuring Test. Volunteers are needed for work on Trunk Line "L." Write the SCM. Traffic: VE6OD 110, MJ 87.

BRITISH COLUMBIA—SCM, Ernest Savage, VE7FB—Our new RM is XA. Please support him and your nets by routing your traffic that way. Loran Station at Spring Island is supported by HZ on 7 Mc., KF on 7 Mc., AGJ on 3.5 Mc., RN on 7 Mc., II on 3.85-Mc. 'phone, and AEF (XYL) looking on. QV, AEF, OM, FB, and 6WB handled R.R. traffic for P.G.E., which lost its lines. CB lost his sky wire in snow storm. Emergency Coordinator US requests more interest in stations checking in and joining the S.E. area if they live there. 'phone or c.w. frequency 3755 kc., Mon., Wed., Fri. at 1730 PST. AHX is home again after several months on the Coast. BQ left his appendix in the hospital and is home recovering nicely on 50 Mc. and TV. AOQ is kept busy with 5 O'clock, AEC, and Alta 'Phone Nets. XW is learning motor mechanics through the purchase of a Model A Ford. TF is leading B.C. in c.w. traffic count and now is NCS Regional Net No. 7. BJ is leading for NCS of Five O'clock Net 'phone traffic. ABP, OES, reports little 144-Mc. activity during the Christmas holiday but AEZ, BQ, EN, FN, and APB in Abbotsfords and AIW and JG in Duncan were heard. Schedules are being made with Bellingham, Wash. LK reports his Northern Net is going FB on 3782 kc. at 1930 nightly. Santa delivered an HQ-129X to ZF. FY reports Royal City amateurs very active. You 28-Mc. rag chewers should listen in the evening for outside contacts from Powell River, Sherman, and way points. Traffic: VE7TF 430, BJ 242, AOQ 193, FB 20.

PRAIRIE DIVISION

MANITOBA—SCM, A. W. Morley, VE4AM—A section c.w. net, under the direction of GV, is in the planning stage and will operate on 3.5 Mc. Stations interested are requested to contact GV or AM. The 'phone net now operates on 3760 kc. and has AM, AR, AX, BS, CE, CI, DJ, DN, DQ, DT, FA, FE, FS, GB, GP, GV, HR, HS, IW, JB, JN, JP, LF, LS, NR, and QD reporting in. Connections are maintained to the south through W0JWY and TEN and east and west via TL "I." Any station interested in joining should contact any net member for details. GE and IF pooled their rigs to get on 3.8-Mc. 'phone, and IF is reported on c.w. RO needs Asia for WAC on 3.5 Mc. CE and CI teamed up on a coast-to-coast 75-meter 'phone QSO with VO4AM on the east end and VE7AMC on the west. DN

(Continued on page 100)

BOB HENRY, WØARA, OFFERS YOU:

LOW PRICES: I sell to you as cheap or cheaper than you can buy anywhere.

COMPLETE STOCKS: Collins, Hallicrafters, National, Hammarlund, RME, Millen, Harvey-Wells, Meissner, Gonset, Meck, Johnson, RCA, all other amateur receivers, transmitters, beams, TV, AM-FM, high fidelity amplifiers and speakers, test equipment, tubes, parts, etc. I can supply nearly any equipment shown in any catalog or advertisement and at lowest prices.

BEST TRADE-IN ALLOWANCE: Customers in all parts of the USA trade with me because I allow so much. Tell me what you have to trade and what you want. I also buy equipment.

TIME PAYMENTS: You can order anything on terms. I finance the terms myself to save you time and bother. Customers everywhere in the USA find my terms best. Write for details.

QUICK DELIVERY: Mail, phone, or wire your order. It will be shipped promptly. I can be reached nearly 24 hours a day, 7 days a week.

TEN-DAY TRIAL: Try any communications receiver ten days -- if you return it your only cost is shipping charges.

PERSONAL ATTENTION: The Butler store is run by Bob Henry, WØARA, and the Los Angeles store by Ted Henry, W6UOU. We make the deals ourselves. We finance the time payments ourselves. That way we have the lowest overhead and can do more for you. That's why YOU AND I CAN DO BUSINESS. Write, phone, or visit either store.

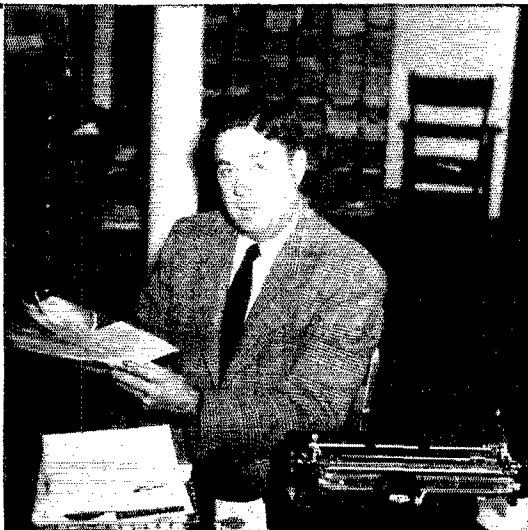

73,
Bob Henry
WØARA

Butler, Missouri

HENRY RADIO STORES

11240 Olympic Blvd.
LOS ANGELES 28
CALIF

'WORLD'S LARGEST DISTRIBUTORS OF SHORT WAVE RECEIVERS'

NEW FOURTH EDITION

The RADIO MANUAL

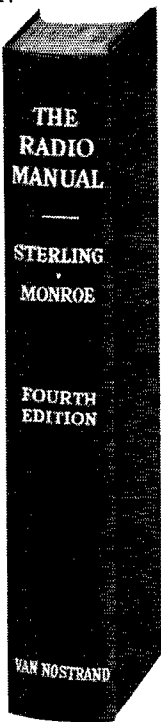

Complete, practical and authoritative, this great new handbook contains up-to-the-minute information on all types of radio equipment.

It explains the operation of communication equipment of all types — receiving, transmitting, broadcasting; for AM, FM, television, radar, and loran; for marine radio, police radio and other specific services. It covers motors, generators, batteries, amplifiers, oscillators, transmitters, antennae, and other specific types of apparatus.

Prepared by Experts

In this brand-new edition the authors, George E. Sterling, Commissioner, Federal Communications Commission, and Robert B. Monroe, Radio Engineer, Columbia Broadcasting System, give you the detailed information you need to qualify for work in government and industry. Basic principles are simple and clearly explained. All necessary computations are illustrated by fully worked examples that require no mathematical knowledge beyond arithmetic. The duties of the operator of any type of installation are set forth explicitly and fully. Hundreds of diagrams, photographs and charts show every detail of construction and wiring. From the first page to the last this brand-new working manual gives the most complete, authoritative information on all up-to-date radio equipment.

Examine This Great Book FREE

MAIL THIS COUPON

D. VAN NOSTRAND COMPANY, Inc.
250 Fourth Avenue
New York 3, N. Y.

QST-350

Please send me a copy of THE RADIO MANUAL for free examination. Within 10 days I will either return the book or send you \$3.00 as first payment and \$3.00 a month thereafter until the total price of \$12.00, plus a few cents postage is paid.

NAME.....

ADDRESS.....

CITY.....ZONE.....STATE.....

(If you send \$12.00 with this coupon we will pay the postage. Same return privilege guaranteed.)

hooked XE1 and VE8. KN is using 8-tube receiver and 6V6-6L6 transmitter on 7 Mc. GQ has been heard on 7 Mc. HG is back using a 6L6 on 3.5 Mc. IPF (ex-LM), in Fredericton, requests you look for him on 7020 or 7070 kc. nightly. DW is new in The Pas and is using 807s and a Super Pro. IB is keeping on 28 Mc. DS has a pair of 813s into a new 14-Mc. beam. HA has new VFO as per March QST. Traffic: VE4AM 231, FA 114, CE 46, DN 12, GV 12, GB 8, HS 5. SASKATCHEWAN — SCM, J. H. Goodridge, VE5DW — SD is on 28-Mc. 'phone. RC is O.K.ed for all 'phone bands. QT is heard on "75" again. PA has new antenna. VB worked Palestine on 14-Mc. 'phone. IC has new rig; FS has his old one. Christmas season produced heavy traffic on the 'phone net. HR has 28-Mc. converter in use and is aiming at DXCC. I.V. again is active after rebuilding the rig. CO built a house and hopes to be active again soon. FV has another surplus rig, JD, now with the RCAF, was home on leave. IL reports success with his cubicle quad. RM is trying n.f.m. MQ gave the Saskatoon Club a lecture on wave propagation at the December meeting. CE has requested cancellation of his OO appointment. AB is active on 28- and 3.8-Mc. 'phone. FY needs Asia for 28-Mc. 'phone WAC. AN broke his wrist cranking the old Chev. DW moved again and is using long wire along the fence until spring. JH is heard occasionally. WK pounds brass on 14-Mc. c.w. UQ is constructing a mobile rig. Traffic: VE5HR 92, BH 59.

NATIONAL CALLING AND EMERGENCY FREQUENCIES

C.W.	'PHONE
7100 kc. (day)	3875 kc.
3550 kc. (night)	14,225 kc.
14,050 kc.	

During periods of communications emergency these channels will be monitored by stations of the National Emergency Net for personal-inquiry traffic. At other times, these frequencies can be used as general calling frequencies to expedite general traffic movement between amateur stations. Emergency traffic has precedence. After contact has been made the frequency should be vacated immediately to accommodate other callers.

If clear of emergency utilization, and if any current amateur calling-and-answering has been completed, a directional CQ or a QSTed "traffic list" should bring results. If you get a reply, tell the station you hook up with what traffic you have and what frequency to go to in order to complete your QSO.

Use the above frequencies for making contact only. Do not tie them up with rag chewing or traffic transmission.

Strays

For several Christmases KL7AN, Fairbanks, has been serving as the Alaskan relay for W amateurs whose kiddies desired to talk with Santa Claus at the "North Pole." This past Yuletide Bill decided to expand his operations to include the youngsters of a number of VE friends. Spinning his VFO to the low edge of the 10-meter 'phone band, Bill handled the VE-NP relay in his usual competent manner. Thrilled young voices told Santa their wants; Santa responded heartily and assuringly.

Came January 15th and Bill was going about the more routine business of rag chewing and DXing when the mail arrived from the States. Lo and behold! — therein were official greetings from FCC: "Santa Claus at the North Pole, KL7AN, was found to be on 28,499.74 kc."

— KL7WC

Price Slashed!
HAMMARLUND
Four-11
MODULATOR KIT



\$19⁹⁵ Complete Kit
 Regularly \$72.50

Terrific Saving on the last few units! Use this modulator with your present transmitter as a high powered speech amplifier. All genuine Hammarlund parts. Complete with schematic, diagram and parts list. The kit includes all necessary parts, cut and punched chassis, cabinet, hardware, tubes and instructions.

- 11 watts audio output • High impedance mike input • 500 ohm output — can be changed for use with class "C" load. • 110 DB gain • Flat in Speech range: 200-3000 cycles • Tubes: 6SL7GT, 6CS, 2-7CSLT, 5U4G. Complete Modulator Kit, 105-120 V, 50/60 cycles. Shpg. Wgt. 41 lbs. No. S-713.....\$19.95

New Low Price!
Famous Make
CRYSTAL MIKE



Brand New—Made by leading mfr. Mike can be removed from base for hand use or on floor stand. For amateur, PA, or recording. High output. Hammerstone finish. 5 lbs. **\$5.45**
 No. S-518

RCA POWER SUPPLY COMPONENTS

Big Bargains! Perfect components for building a rugged power supply for low power xmitters, exciters, amplifiers, etc. Conservatively rated—Built by RCA for continuous operation. **While they Last!**

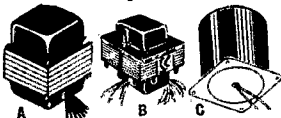

(A) **POWER XFORMER**—Primary: 120 V, tapped @ 110 V, 60 cycles. Secondary: 768 V, CT @ 305 ma, electrostatically shielded. Flush mtg. 4 1/8 x 3 3/8 x 5 1/8" H overall. Shpg. Wt. 12 lbs. **\$2.95**
 No. S-851.....Special

(B) **FILAMENT XFORMER**—Primary: 117 V AC. Secondaries: (1) 5 V @ 6 amp., (2) 6.3 V, CT @ 6 amp., 3 1/8 x 3 3/8 x 3 1/8" H overall. Shpg. Wt. 6 lbs. **\$1.49**
 No. S-852.....Special

(C) **FILTER CHOKE**—4.2 Hy @ 300 Ma. DC Resist. 78 ohms. 2500 V breakdown. 3 1/2" dia. x 4 1/2" H. Base 4" sq. 9 lbs. **\$2.49**
 No. S-853 Special

For The First Time Anywhere....
Famous NORELCO "PROTELGRAM"
12 x 16" SCREEN PROJECTION
TELEVISION SYSTEM

NORELCO PROJECTION TV SYSTEM consists of 3NP4 Projection Tube, Yoke and Focus Coil Assembly, Schmidt Optical System, 12 1/2 x 16 1/2" Ground Glass Screen, 14 x 14" Mirror, Diagram for Protective Circuit, Detailed Operation Guide. Total Wgt. 42 lbs.

No. S-1296
\$49⁵⁰

LESS HV SUPPLY

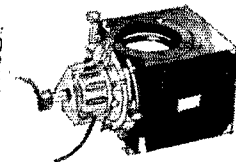
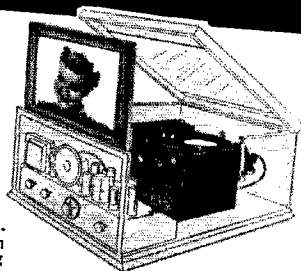

This Sensational offer makes Television History! The original North American Philips "Norelco Protelgram" Projection electro-magnetic deflection, to a Life Size television set, square inches. The screen measures 12" x 16", has square corners and is designed for wide-angle visibility. This is the same system used by the country's leading makers of TV receivers. ALL BRAND NEW... GUARANTEED PERFECT... at a price far below MANUFACTURER'S COST!

ALL ORIGINAL NORELCO "Protelgram" COMPONENTS
SCHMIDT-TYPE OPTICAL SYSTEM—Contains 3 optical elements: Aspherical Corrector Lens 4 1/2" dia., and (3) Plane Mirror to at the factory and provide 8.6 linear magnification and a numerical aperture of 0.62. Completely dustproof. Black crackle finish. 8 1/2 x 8 1/2 x 9".

ALIGNMENT ASSEMBLY—Mounts 3NP4 Tube into Optical System, with Focus and Deflection Coils. 9 x 9 x 8".

3NP4 MAGNETIC PROJECTION TRIODE—2 1/2" dia., 2nd Anode Contact is surrounded by a glass cup to prevent arc-over. Focusing and Deflection are possible, using only the excitation required to deflect a 10BP4 or other direct-view tube. 10 1/2" long, neck 7".

MIRROR—Highly polished and specially silvered on both sides. Mounted at a 45° angle to corrector lens. 14" x 14".

SCREEN—Ground optical glass, 12 1/2" x 16 1/2".

Essential Protective Circuit Kit—Simple to build, and recommended to prevent 3NP4 screen from burning in the event of sweep failure. No. S-1300.....**Net \$2.57**

THIS "NORELCO" PROJECTION TV SYSTEM REQUIRES A HIGH VOLTAGE POWER SUPPLY THAT WILL DELIVER 25 KV AT 150 MICRO-AMPERES.

LEACH DPDT RELAY

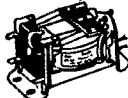

Dependable control for transmitter power circuits. Built for industrial use. 3/16" silver contacts. DPDT—coil operates on 115 V, 60 cycles. Metal base—no circuit grounded to frame. No. S-876 **\$1.39**
 Bargain.....

AC VOLTMETER



A fine meter, bargain priced! Ideal for use in protecting your emitting tubes from excess filament voltage. 3" round, 0-8 volts DC. Weston type 476, with built-in rectifier. Brand new. While They Last! No. S-614.....**\$2.49**

0-1 RF AMMETER—3" square, with built-in thermocouple. 0-1 scale. Use in antenna circuit—easily shunted if antenna current is over 1 amp. No. S-616 Special **\$3.95**

WIRED POWER SUPPLY

for Tuners, Low Power Amplifiers, Test Equipment, etc.

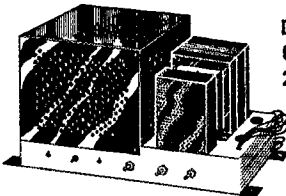

Delivers 400 VDC @ 225 Ma., 6.3 V @ 7.5 Amps., 5 V @ 2 Amps., 5 V @ 3 Amps.

\$12⁹⁵

A compact unit which provides 400 volts B supply, 6.3VAC filament supply and two 5VAC filament supplies. Includes 6BG6 Horizontal Amp and 5V4G Damper. Horizontal and Vertical Deflection Coil, and Focus Coil Currents and Controls are available directly from this supply, as well as Horizontal and Linearity Controls, if desired. Designed for use with "Norelco" Projection Equipment. Can be converted to make a complete High and Low Voltage Power Supply for any TV receiver. 15 x 5 3/4 x 8" H. For 115 V, 50/60 cps. No. S-1297 Shpg. Wt. 25 lbs.....Special **\$12.95**

3 GREAT STORES! Uptown at 115 West 45th Street and Downtown at 212 Fulton Street in NEW YORK
 323 West Madison Street in the heart of CHICAGO

MAIL ORDER DIVISIONS: 242 West 55th St., N. Y. 19 and 323 West Madison Street, Chicago 6, Illinois

Include Postage
 All Prices F.O.B. New York or Chicago
 Enclose 20% Deposit with C.O.D. Orders

NEWARK
 for
RADIO & TELEVISION
 NEWARK ELECTRIC CO., INC.

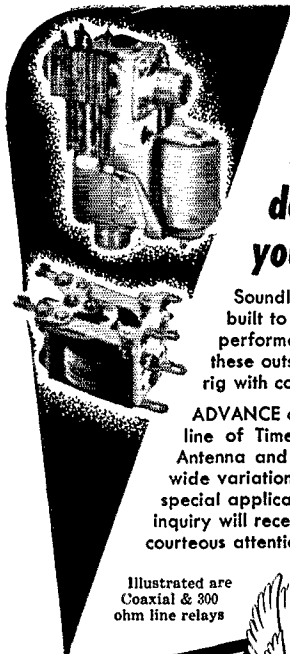

ADVANCE RELAYS

designed for
your application

Soundly engineered and built to famous standards of performance—you can install these outstanding relays in your rig with complete confidence.

ADVANCE offers a complete line of Time Delay, Overload, Antenna and Keying Relays with wide variations of types for special applications. Your inquiry will receive prompt and courteous attention.

Illustrated are
Coaxial & 300
ohm line relays



ADVANCE ELECTRIC & RELAY CO.
1260 WEST SECOND STREET * LOS ANGELES 26, CALIFORNIA



HERE'S A TIP FOR YOU
FELLOW "HAMS" FROM M.B. "Mager"
Magers — WFOJL (Ex-K6OJL)

How You Can Get
MORE SIGNALS PER DOLLAR
With An Amazing Low-Cost VESTO

Self-Supporting, 4-Post
STEEL TOWER

AT A PRICE YOU CAN AFFORD

22'—\$73.50	33'—\$109.75	44'—\$149.75
28'—\$92.25	39'—\$129.75	50'—\$175.00
61'—\$239.75	100'—\$846.50	

EASY MONTHLY PAYMENTS

You can have up to 12 Vesto Towers. Only 1/2 down.
months to pay for any Write for free details.

NO GUY WIRES!

Vesto Towers are giving fine satisfaction all over the world. They are famous for their sturdy 4-post construction. They are popular because they are extra easy to erect or take down and move. Vesto Towers require no expensive foundation. Your tower comes complete — ready to assemble. Order today. Prices shown F. O. B. Kansas City, Mo. Shipped to your home 4th class freight.

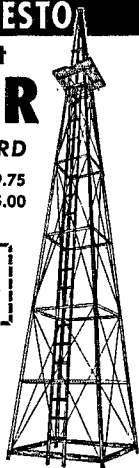

Width at Base
Equals 1/2 Height

WRITE TODAY FOR FREE INFORMATION!
VESTO COMPANY, Inc., 101 Main St., Parkville, Mo.

"It Seems to Us . . ."

(Continued from page 10)

a Commission examining officer when he changes residence to within 125 miles of a regular examining point, or when the Commission establishes a new regular examining point within 125 miles of the said licensee.

2. Because the Novice Class license is proposed on a one-year nonrenewable basis, the League perceives that no useful or practical purpose is served by requiring the licensee to be examined again under such conditions. The League therefore endorses this aspect of the proposal.

3. However, the League does not believe it is necessary or desirable to exempt the Technician Class licensee from this requirement. The Technician Class is proposed as part of the permanent licensing structure in the amateur service. It is a renewable license. The League believes that the holder of such a license issued on the basis of a mail examination should be subject to the usual provisions for re-examination if he finds himself within the 125-mile distance from a regular examining point, and so recommends.

4. The proposed amendments provide, also, that licenses of the Technician and Novice classes will be issued after January 1, 1951. It is requested that earlier provision be made for these classes if at all feasible.

E. Comments with Respect to Proposed Amendment of §12.27(a), Concerning Renewal of License.

1. In the conference with the Commission staff on October 10 and 11, 1949, the League expressed its opposition to proposals then advanced by the Commission for amendment of §12.27, concerning conditions for renewal of license, and advanced its reasons therefor. It is noted in the present proposed amendment the Commission has acted to take into account some of the specific objections we expressed at the October conference. The League has carefully examined the proposed modifications. After study, however, and since the Commission's proposal does not indicate any substantial reasons for amending the existing rules in this respect, it is our conclusion that existing §12.27 as it stands is satisfactory so far as the provisions for terms of renewal are concerned. We agree with the proposed amendment for §12.27(b), (c), (d), (e) and (f).

AMERICAN RADIO RELAY LEAGUE, INC.

By: PAUL M. SEGAL
General Counsel
A. L. BUDLONG
Secretary

January 16, 1950

SWITCH TO SAFETY!



DEPEND ON WHOLESALE RADIO OF BALTIMORE

FOR HIGHEST QUALITY, LOWEST PRICES ON AMATEUR, RADIO & T.V. NEEDS

COLLINS & WHOLESALE RADIO

Bring You the Newest in Communication Equipment

32V-2 TRANSMITTER

With TVI Reduction Circuit



148B-1 Narrow Band Adapter
For use with 32V-1 or 32V-2 transmitters. For FM operation on all bands.....\$31.75

VFO controlled bandswitching, gang-tuned amateur transmitter, conservatively rated at 150 watts input on cw and 120 watts on phone. Covers the 30, 40, 20, 15, 11 and 10 meter bands. The frequency range of the 70E-8A permeability tuned oscillator is 1600-2000 kc., covered in 16 turns of the vernier dial. Has TVI reduction circuits. Power source 115, 50/60 cycles, 2 1/2" wide, 12 7/16" high, 1 3/4" deep. Shipping Wt. 128 lbs. Complete with instructions and instruction book. Price shown is net domestic **\$575**

35C-1 Low Pass Filter

52 Ohm three section filter App. 0.2 db insertion loss below 29.7 mc provides app. 75 db attenuation of harmonic emissions at TV frequencies.....\$40

NOW—RECORD YOUR QSO's With Bell Hi-Fidelity Tape Recorder RECORD-O-fone

Reproduces any audible sound with remarkable clarity and fidelity. Tape can be played back immediately. Can be erased and used again and again. Tape can be played back thousands of times. One 7" reel records for full hour. Complete with crystal mike with desk-type stand, 6 ft. cable, full 5" reel of tape, 1 empty 5" reel and instruction manual.
Model RT-50



\$86.50

Hi-Fidelity FM Tuners Approved FM-AM TUNER

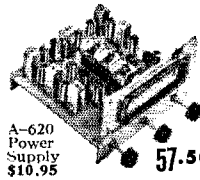

A-620 Power Supply **\$10.95**

57.50

Hi-Fidelity! 12 Tubes! Lowest price custom built tuner available. Drift-free, realistic hi-fidelity reception. Perfect for the amateur, custom builder, experimenter and serviceman. Chassis complete with 12 miniature tubes, tuning scale, escutcheon plate, operating instructions and circuit diagram. Air tested and aligned. Less power supply.

MEISSNER 8C FM TUNER

Range — 88 to 108 mc. Audio fidelity flat within 2 db. from 50 to 15,000 cps. Will also add full coverage to obsolete AM-FM sets.



Model 8C Complete with cabinet \$38.33
Model 8C Chassis pre-assembled 34.40
Model 8CK Kit (Less cab.)..... 29.97

TV INTERFERENCE FILTER FOR TV RECEIVERS DRAKE HIGH-PASS FILTER

Attenuates all unwanted signals from zero to 50 mc. No insertion loss of TV signal. Order model TV-72-50HP for 300 ohm twin-lead cable. Order model TV-72-50Co for 72 ohm coaxial cable..... **\$3.57**

For Transmitters

DRAKE LOW-PASS FILTER

Used on 10 to 160 meters. Attenuates all antenna and feed system harmonic radiation above 30 mc. TV-52-40LP..... **\$12.95**

Hi-Fidelity Record Amplification

GE PHONO PRE-AMP

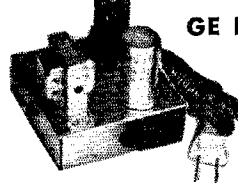

Has built-in power supply for 117 v. 60 cycles. For use with GE variable reluctance cartridge.

Model UPX-003..... **\$9.57**

Low Prices On BUD ALUMINUM CHASSIS

Cat.No.	Depth	Width	Ht.	Gauge	Cost	Cat.No.	Depth	Width	Ht.	Gauge	Cost
AC402	5"	7"	2"	18	\$.69	AC425	8"	17"	3"	16	\$1.52
AC403	5"	9 1/2"	2"	18	.81	AC412	8"	17"	3"	16	1.77
AC404	5"	9 1/2"	3"	18	.89	AC413	10"	12"	3"	16	1.44
AC405	5"	10"	3"	18	.99	AC414	10"	14"	3"	16	1.92
AC422	5"	13"	3"	18	.98	AC415	10"	17"	2"	16	1.80
AC406	7"	7"	2"	18	.81	AC416	10"	17"	3"	16	2.04
AC406	7"	9"	2"	18	.90	AC426	11"	17"	2"	14	1.89
AC407	7"	11"	2"	18	.96	AC417	11"	17"	3"	14	2.40
AC408	7"	12"	3"	18	1.14	AC418	11"	17"	3"	14	2.52
AC409	7"	13"	3"	18	1.02	AC419	11"	17"	2"	14	2.25
AC411	7"	15"	3"	16	1.68	AC420	13"	17"	3"	14	2.67
AC423	7"	17"	3"	16	1.43	AC427	10"	17"	4"	14	2.36
AC424	8"	12"	3"	16	1.38	AC428	13"	17"	4"	14	3.05

For More DX ALLIANCE TENNA ROTOR WITH DIAL INDICATOR

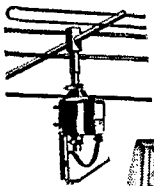

Rotate your antenna for wider range. Get stations you never got before. The rotor is sturdy, water tight and metal housed. The control box with Dial Indicator plugs into any 110 v. 60 cycle outlet. You get antenna rotator and control case with Dial Indicator. Max. allowable ant. wt. 20 lbs. Order model DIR..... **\$29.95**

ALLIANCE THRUST BEARING — Should be used on installations where antenna weighs over 20 lbs..... **\$4.77**

CABLE FOR TENNA ROTOR — Flat four conductor, interconnecting cable. (3¢ per ft.) 100 ft..... **\$2.75**

GE TRIPLE PLAY CARTRIDGE

Variable Reluctance



Plays all 3 speeds, 33 1/3 — 45 — 78 rpm. Dual stylus. Order model RPN 050.

\$8.37

Solve Hi-Fidelity Problems

UNIVERSITY DUAL TWEETERS

Reproduces to 15,000 cycles Crossover at 2000 cps. Handles 12 watts. Model 4402. \$24



HIGH PASS FILTER, Model 4405. \$6

Just Plug In and Spray

No Motor! No Compressor

New Burgess

VIBRO SPRAYER

Handles enamel, lacquer, varnish, shellac and light oils. Wt. 2 1/2 lbs. Complete with 25 oz. jar and 8 ft. cord.

\$9.75



BELL 2122 HI-FIDELITY

RADIO PHONO AMPLIFIER

Frequency response: 4db. 50 to 15,000 cycles with controls set for flat response. Four input — radio, crystal and two magnetic pick-ups. Built-in pre-amplifier for each magnetic input. Bass and treble boost with attenuation. Output 10 watts. Power 117 v.; 60 cycles. 7 1/2" deep, 6" high, 11 1/2" long.



\$41.70

WRITE FOR FREE "FYI" BULLETIN

Address orders to Dept. QR 22 Or Phone: MULberry 2134

WHOLESALE RADIO PARTS CO., Inc.
311 W. Baltimore St.
BALTIMORE 1, MD.

A NEW APPROACH!

RIDER'S Bigger and Better book for the

- ★ COMMERCIAL RADIO OPERATOR
- ★ BROADCAST STATION OPERATOR
- ★ TELEVISION STATION OPERATOR
- ★ The STUDENT who wants to get his COMMERCIAL TICKET
- ★ The INDIVIDUAL who wants his AMATEUR RADIO LICENSE

Kaufman's

RADIO OPERATOR'S LICENSE Q and A MANUAL

Is more than a presentation of the questions and answers for FCC examinations. The "follow-through" discussions, a new feature of great value, give the answers infinitely more meaning and serve as refreshers of pertinent radio theory. Useful appendices, which include Small Vessel Direction Finders and Automatic Alarm, not ordinarily found in a book of this type, provide other valuable extras.

608 Pages. 193 Explanatory Diagrams... \$6.00

The New — Revised

RADIO AMATEUR BEAM POINTER GUIDE and FACT BOOK

Complete with Latest Prefixes

By John F. Rider (W2RID)

By merely consulting the charts of this book you can point your beam accurately to any country or island in the world (containing amateur prefix listing) and radiate the maximum amount of energy in the proper direction for an R9 report. The book contains a country-prefix list, a cross index of prefixes and countries... and also gives highly valuable data about ham beams.

32 Pages. 8½" x 11".....\$1.00

MAIL THIS COUPON NOW!

JOHN F. RIDER PUBLISHER, INC.
480 Canal Street, New York 13, N. Y.

Please send me the following RIDER BOOKS:

- Radio Operator's License Q and A Manual, \$6.00
- Radio Amateur's Beam Pointer Guide... \$1.00

Name.....

Address.....

City.....Zone.....State.....

Check M.O. C.O.D.

NOTE: We pay postage if you send remittance with order.
Slight postage charge on C.O.D.'s

Low-Pass Filters

(Continued from page 26)

usually fall in the region 50-160 Mc., depending on the construction, and are probably less of a factor in building up harmonic output in the high group of TV channels.

Numerous examples of this same general nature could be worked out, but the preceding ones should serve to point up the value of selecting your filter in the light of local requirements. Of course, it does no harm to build in more attenuation than is necessary. Also, the greater the number of bands you use the greater the TV frequency range that it is necessary to cover with high attenuation. A 14-Mc. transmitter, for example, will have harmonics in both Channels 2 and 4, covering two out of three in the 2-4-5 group. It will hit only Channel 6 in the 3-6 configuration, however. Transmitters on 3.5 and 7 Mc. will have harmonics in all channels, but they are of high order and should not be too strong unless built up by a tank-circuit resonance. Where the TV signal strength is adequate for noise-free reception these cases usually can be handled by a filter consisting of two *m*-derived sections.¹⁷ In the 2-4-5 areas the *m* values should be chosen to give maximum attenuation in Channels 2 and 4, and in the 3-6 areas the rejection points should be placed in Channels 3 and 6.

If the intensity of your TVI indicates that a single-section filter ought to be sufficient, you have your choice of the lower two circuit arrangements shown in Fig. 9. The T section has the advantage of requiring only one condenser, but will have an impedance characteristic like that shown in Fig. 10. If the filter is to be used on only one band, the characteristic impedance can be chosen to fit. In the 10-meter example above where $f_c = 34.7$ Mc., the average ratio f/f_c is $29/34.7 = 0.84$, approximately. From Fig. 10 the Z_o of a T section is equal to $0.5R$ at this ratio. If the line into which the filter works is 52-ohm coax, the filter should not be designed for a nominal impedance of 52 ohms, but for $52/0.5 = 104$ ohms. Its actual characteristic impedance will then average 52 ohms over the 10-meter band. The π -section arrangement will have good impedance characteristics when designed for the actual line Z_o , but requires two condensers. The attenuation with either circuit is the same.

[NOTE: The third part of this article, to appear in an early issue, will describe simplified graphical methods for designing low-pass TVI filters.]

¹⁷ A filter of this type is shown in Fig. 14 in the article by W2RYI in December QST. Constructional details for similar filters, for both channel allocation patterns, are given in *The Radio Amateur's Handbook*, 1950 ed., p. 336.

SWITCH TO SAFETY!





B&W

FARADAY SHIELDED LINKS

... for reducing TV and BC interference

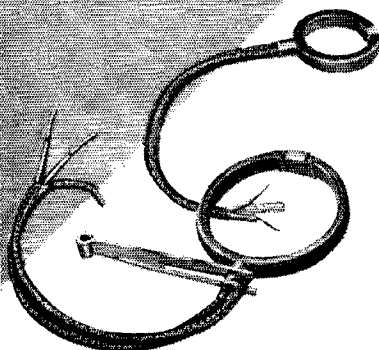

Barker and Williamson offers amateurs an effective method of reducing harmonic or spurious signal radiations, normally transferred by capacity coupling, that are always present with a conventional open wire link.

These shielded links are adaptable to all conventional link-coupled circuits and with external antenna tuning units or, in conjunction with harmonic reduction filters of either the low-pass or band-pass type. Available for B&W HDVL, TVL, TVH and BVL Series.

For sizes available, write for descriptive sheet No. 605 to Dept. Q-30.

BARKER & WILLIAMSON, INC.

237 FAIRFIELD AVE., UPPER DARBY, PA.

LOOK

??WHAT'S THIS??

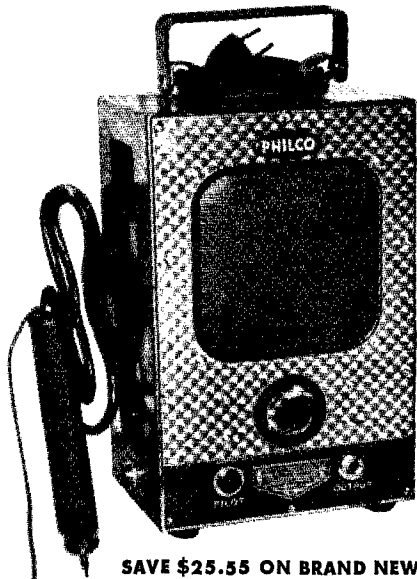

SAVE \$25.55 ON BRAND NEW

PHILCO DYNAMIC TESTER

- PHONE MONITOR
- AUDIO ANALYZER
- SIGNAL TRACER
- MICROPHONE OR PHONO AMPLIFIER

Designed for FAST diagnosis of radio trouble in RF or AUDIO circuits.

Frequency coverage 60 cycles to 100 MC.

Lighted head in probe with 4 input capacities. 5" dynamic speaker and output jack for gain comparisons.

Directly locates sources of distortion or hum. Sensitive phone monitor, no connection to xmtr. required.

Input sensitivity gain 10,000, output 2 watts, variable.

Tubes: 6AQ6, 7L7, 7A5, 7Y4

Dimensions: 10" x 6½" x 4½"

A STEINBERGS EXCLUSIVE

Reg. Dealer **\$26.95**
Net **\$52.50**

Radio Servicing Manual Included

Steinbergs

633 WALNUT STREET • CINCINNATI 2, OHIO

Simulated Emergency Test

(Continued from page 27)

how the test went off, in practically all cases exhibiting a great deal of hard work and time on the part not only of the EC but of the group behind him which made his efforts count and amount to something. It is significant that although most ECs were pleased with their showing, few of them felt that they had reached a peak of efficiency. "We'll do better next year!" was a typical expression on many report forms. Since it is impossible to reproduce all comments, we present a few typical ones:

The QRM on Sunday was terrific on 10 meters. . . . Six meters would be better. All net control stations should use nondirectional antennas (all verticals). — *W1LIIH, EC Bloomfield, Conn.*

I was not completely satisfied the last two years, but this time I can say every one of the fellows . . . did a very nice job. — *W9UFX, EC Madison Co., Wis.*

I submitted a letter, following the form you mailed me, to the Dedham Transcript, and it was published on the front page of the paper, one week in advance of the test date. The Chairman of the Red Cross Disaster Committee 'phoned me and wanted to get together with me, after reading the paper. This we did. — *W1SH, EC Dedham, Mass.*

We should have more emergency tests on a national basis. — *W20EW, EC Morris County, N. J.*

We had a remarkable turnout and a very successful emergency test. — *VE8EUS, EC Sudbury, Ont.*

We considered the test a success. . . . Amateur radio is to have a seat on the disaster committee which it has not had formerly. — *W8AUL, EC Des Moines, Iowa.*

This kind of a test not only shows up our weak spots but is excellent practice for the beginners in AEC. — *W6HKD, EC San Bernardino Area, Calif.*

This was the first simulated test ever held in Billings. The test was very successful but I believe it will be much better next time. — *W7KUH, EC Billings, Mont.*

Bad weather here added a touch of reality to the program. Good test! We will do better next time. — *W4CBU, EC Kingsport, Tenn.*

Next year it'll be better. We intend running a simulated emergency test once every two months from here on in. — *W6HC, EC Santa Clara County, Calif.*

We all had a fine time and the test went very well. It showed us what to do to speed things up. — *W7OIF, EC Phoenix, Ariz.*

The Amateurs of Greater Cleveland were glad to participate in the test and are looking forward to another. Response great. — *W8PBZ, EC Cuyahoga Co., Ohio*

Hints and Kinks

(Continued from page 53)

on the ring in contrasting color Any arbitrary system may be chosen. In the one illustrated, the numbers 20, 25, 30, and 35, lettered at 90-degree intervals around each of the four circles are used. These correspond to dial readings of 200, 250, 300, and 350 respectively.

Thus, in tuning over the range from 28 Mc. to 29.6 Mc., the calibration data are lettered in the first circle until the dial has been turned through 360 degrees. For the second dial revolution, the calibration is lettered in the second circle, and the key figure, obtained from the numerical dial reading at the start of the second revolution is made to correspond. The same process is extended through the entire range.

Separate scales may be made for each amateur band. They are attached to the dial by three screws as shown in the drawings. — *Kenneth M. Sen, LUSEJ*

PLATE TRANSFORMERS

For Small Transmitters, DC Voltage Ratings are Approx. Values Obtained at Output of a 2 section Choke input Filter. Using Mercury Vapor Rectifier Tubes Pri. is for 115 V. 60 cy.

Type No.	Sec. Rms. Volts	DC Volts	DC Sec. MA.	Dimensions H. W. D.	Price Each
P 57	660-660† 550-550	1000*	125	4 3/4 3 1/2 5	8.23
P 58	1080-1080 500-500	400	150	4 3/4 3 1/2 5 1/2	7.94
P 59	900-900 800-800	750	225	5 3/4 6 1/2 4	19.84
P 67	1450-1450 1175-1175	1200	300	5 3/4 6 1/2 4 1/4	24.99
P 68	2100-2100 1800-1800	1750	300		

* For dual operation with simultaneous use of both sec. ratings.
† Has 40-volt bias tap.

MERIT DRIVER TRANSFORMERS!

Type No. A-2022 For a 30 to 50 watt modulator (100 watt transmitter)
Type No. A-3126 For a 175 watt modulator (300 watt transmitter)
Type No. Net Price
A-2922 \$2.35
A-3126 \$3.38

6A6, 6C5, 6N7, 4E
PP2A3, 6L6, 4E,
50V, 6F6

Single Output
6A6, 6N7, Push-Pull 4
PP800, 208A, 811, 812, 812A,
RK18, RK68, T20, T240, T65,
807, 809, 838, 845, 35, 100T8

Type No.	Turn Ratio	Class.	Pri. M.A.	Mtg. A D
A-2922	Pri. to 1/2 Sec. 5:1, 4:1, 3:1, 2.5:1	B-	20	A
A-3126	2:1	B	40	D

MERIT FILAMENT TRANSFORMER for a pair of 811A's or 812A's

Type No. P-2948 Net Price \$3.67 Sec. Volts 6.3 c.t. Sec. Amp. 10 Insulation 2500 Volts Mtg. EV

FILAMENT TRANSFORMERS

Type 940	2.5VCT @ 10 Amps.	7500V Ins.	\$2.79
Type 040	5 VCT @ 3 Amps.	2500V Ins.	\$2.06
Type 941	5 VCT @ 6 Amps.	2500V Ins.	\$2.35
Type 943	5 VCT @ 20 Amps.	2500V Ins.	\$5.29
Type 946	6.3VCT @ 3 Amps.	2500V Ins.	\$1.91
Type 947	6.3VCT @ 6 Amps.	2500V Ins.	\$2.79
Type 948	6.3VCT @ 10 Amps.	2500V Ins.	\$3.67
Type 960	7.5VCT @ 4 Amps.	2500V Ins.	\$2.35
Type 143	7.5VCT @ 8 Amps.	2500V Ins.	\$4.12
Type 146	10 VCT @ 10 Amps.	3000V Ins.	\$4.99
Type 961	Dual 6.3VCT @ 3 Amps.	2500V Ins.	\$3.38
Type 041	5VCT @ 3 Amps.	2500V Ins.	\$3.38
	6.3VCT @ 3.6 Amps.		
Type 930	6.3V @ 1 Amp.		\$0.69



MODEL 51 DYNAMIC
Output—52 DB below 1 volt per bar. Frequency range 60 to 10,000 CPS. Impedance same as Model 55. With 20' two conductor shielded cable .. **\$23.37**

Complete line of Shure Microphones in Stock.



MODEL 737A X-TAL
Frequency response 60 to 10,000 CPS. Output level—53 DB. Can be pointed toward desired sound or upwards for non-directional horizontal plane pickup. Metal Seal X-Tal for long life. Built in cable connector. With 20' cable .. **\$23.37**

MODEL 710A X-TAL
High impedance, high output. diaphragm type unit. Resonance 60-9,000 CPS. Output—50 DB. Die Cast case with stand adapter. 7' shielded cable .. **\$5.88**



LYSCO CONVERTERS MODEL 135
Full calibrated coverage in the 26 to 148 Mc. band and the illuminated dial. Clock type 4". May be operated fixed or mobile. Power requirements A. C. or D. C. @ 25 Ma., 6.3V Complete with tubes .. **\$37.50**

LYSCO MOBILE VFO

Model 381
3-6AK5's Doubler, Oscillator & Buffer. Doubler supplies plenty of drive to replace 3.5Mc. or 7Mc. X-tal. Direct reading illuminated clock dial. Ideal size 3"x4 1/2"x5". Operates on 200 to 400V D.C. @ 25Ma. Complete with tubes .. **\$21.95**

NOW . . . QUICKLY AND EASILY CUT SQUARE & OBLONG OPENINGS IN RADIO CHASSIS
Greenlee No. 731 square punches are time saving tools that pay for themselves.

5/8" square	.. \$2.95	3/4" square	.. \$3.44
1" square	.. \$3.97		
Standard Greenlee No. 730 punches size 1/2" to 3 1/2" diameter, in stock.			
1 1/2", 5/8", 3/4", 7/8"	.. \$1.94	1 3/8"	.. \$2.52
1-1/16", 1 1/8", 1-5/32"	.. \$2.12	1 1/2"	.. \$2.54
1-3/16", 1 1/4"	.. \$2.25	2 1/4"	.. \$5.37

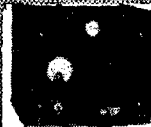

RAPID ELECTRIC SELENIUM RECTIFIER MODEL 507 SPECIFICATION

AC Input—110/120V AC 60 cycle single phase.
DC Output—5 Amperes 0-7 Volts Duty—Continuous

FEATURES:

Accurately calibrated voltmeter—Output current and voltage tapered control affecting smooth variation from zero to maximum—Full wave rectification with capacitor filtering for extra smooth (low ripple) DC power.

SUGGESTED APPLICATIONS:

Battery charging—(from 2 volt to 6 volt cells) at any current up to 5 Amps.—Battery eliminator—substitute for dry or wet cells—Operate and control speed of model locomotive—DC power for hobby plating kits—Portable DC supply for Analytic Chemist to do "on the Spot" analyzing—Ideal for Physic and Chemistry teachers and School Laboratories. **\$19.95**



CHOKES

SMOOTHING TYPE	Hy	SWINGING TYPE	Hy	PRICE EACH
C-80	10	C-87	4-16	MA 150 \$3.09
C-81	10	C-88	4-16	200 \$3.82
C-82	10	C-89	4-16	250 \$5.29
C-83	8	C-90	3-14	300 \$5.59

All above 3000 Volts Insulation

STANDARD STEEL CHASSIS

Black Crackle	
4 x 4 x 2	59c
6 x 14 x 3	\$1.06
10 x 14 x 3	\$1.44
10 x 17 x 3	\$1.44

GRID DIP METER LYSCO "DIPMASTER"

3 Mc to 150 Mc frequency range; calibrated dial. Ideal for Signal generator, 3.4 to 300 Mc range phone monitor, F.S. meter, or absorption wavemeter. Complete power supply and tubes. Really a good buy at **\$32.83**

SUPERIOR POWERSTATS

Smooth, efficient voltage control. 0 to 135V. output from 115V. AC line.
Type 20 (illustrated) 3 amps .. **\$12.50**
116 for table mtg 7.5 amps .. **23.00**
116U for panel mtg 7.5 amps .. **18.00**
1126 15 amps .. **46.00**
1156 45 amps .. **118.00**
Also available for 230 volt input. Write for descriptive literature.

NATIONAL MULTI BAND TANKS

MB—20 10 to 80 meter Multi-Band Tank .. **\$ 9.92**
MB — 150 10 to 80 meter Handles 150 watts .. **18.50**

ALUMINUM CHASSIS

7x5x2	18 gauge	\$0.82
7x7x2	18 gauge	\$0.92
9x7x2	18 gauge	\$1.03
5x10x3	18 gauge	\$1.12
7x11x2	18 gauge	\$1.06
12x10x3	18 gauge	\$1.62
10x14x3	18 gauge	\$2.26
15x7x3	16 gauge	\$1.76
17x10x3	16 gauge	\$2.20
17x18x3	14 gauge	\$2.82
17x18x5	14 gauge	\$3.67

We carry a complete stock of steel & Aluminum Chassis & Panels.

STEEL PANELS

3/8" Thick Black Crackle Finish	93c
3/4"	\$1.17
1"	\$1.32
2 1/4"	\$1.62
4"	\$1.86

If not rated 25% with order, balance C.O.D. All prices F.O.B. our warehouse New York. No order under \$2.00 We ship to any part of the globe.

LEEDS RADIO CO.

75 Vesey Street Dept. QS 3
COrtlandt 7-2612 New York City 7

RAYTHEON VOLTAGE STABILIZERS

Positive Stabilization ± 1/2%
Input 95-130 volts, 60 cycles single phase; output 115 volts stabilized to ± 1/2%. *Output 6.0 or 7.5 volts stabilized ± 1/2%.



Catalog No.	Output Cap. Watts	Net Wt. lbs.	Net Price
VR-6110	15	4	\$15.00
VR-6101*	30	5	\$17.00
VR-6111	30	5	\$17.00
VR-6112	60	8	\$24.00
VR-6113	120	14	\$31.00
VR-6114	250	25	\$48.00
VR-6115	500	45	\$75.00
VR-6116	1000	92	\$125.00

Telex Headsets Keep QSO's Q5

TWINSET*

MONOSET*



Telex Headsets are easy on the ears! No pressure whatsoever, background noise blocked out. They clip sharply at 3000 cps adding another Q5'er to your receiving setup. Mighty relaxin' for hours of traffic, DX, or just plain rag chewing.

The Twinset weighs only 1.6 ounces, the Monoset, 1.3 ounces.

Write for free folder on both headsets today . . . or see your Parts Jobber.

TELEX

Dept. Y-24-3
TELEX PARK
Minneapolis, Minn.

TRADEMARK

IN CANADA, ATLAS RADIO CORP., TORONTO

STANDARD OF THE WORLD FOR QUALITY HEADSETS

EASY TO LEARN CODE

It is easy and pleasant to learn or increase speed the modern way — with an **Instructograph Code Teacher**. Excellent for the beginner or advanced student. A quick, practical and dependable method. Available tapes from beginner's alphabet to typical messages on all subjects. Speed range 3 to 40 WPM. Always ready, no QRM, beats having someone send to you.

ENDORSED BY THOUSANDS!

The **Instructograph Code Teacher** literally takes the place of an operator-instructor and enables anyone to learn and master code without further assistance. Thousands of successful operators have "acquired the code" with the **Instructograph System**. Write today for full particulars and convenient rental plans.



INSTRUCTOGRAPH COMPANY

4709 SHERIDAN ROAD, CHICAGO 40, ILLINOIS

Single Sideband

(Continued from page 44)

Another new one on the Coast is W7LWB, A. Kerzie of Seattle. He uses the "basic 'phone exciter" followed by 6SA7-6AG7-807, the 807 running Class A. A final using a pair of 811s is in the works. Prior to the 807, which is good for 40 watts on s.s.b., the 6AG7 drove an 815 at 12 watts peak input on 20, but with that QRP (and a 3-element beam) the East Coast and KH6 were worked on s.s.b. Commenting on his experiences, W7LWB says, "If the results with the 811s are anything like those obtained with the 815, there will be a good 400-watt conventional a.m. rig for sale or swap. As a matter of fact, it hasn't been used since the first day of s.s.b. operation." The receiver is an HQ-129X with s.s.b. adapter built from the *G.E. Ham News* article. The adapter "was built long before the transmitter, helping a great deal in the construction of the transmitter. The hams are sure missing a good bet for a.m. and c.w. as well as good s.s.b. reception by not using one."

The s.s.b. rig at W9ERN, John Clemens of Evansville, Ind., is built in a Meissner Signal Shifter box. Using ideas from several phasing jobs, the r.f. end is a 6AK6-6AK6 VFO doubling to 75 meters driving a pair of 6SN7 balanced modulators through a low-Q r.f. phase-shift network. The audio end is 6AU6-6BF6 into a Dome network into a pair of 6AQ5s. The output of the 6AQ5s is used to plate-modulate the 6SN7s, and the output drives a Class A 807 to 5 watts peak output. With a 7-Mc. antenna that "shouldn't get out" on 75, John has managed QSOs with Vermont, Minnesota and many of the s.s.b. gang, and a larger s.s.b. rig is already in the works. It took only a little operation to find that the 5 watts of s.s.b. was enough to join the 75-meter battle.

A new one on 28 Mc. is Mark Moynahan of Brooklyn, W2ALJ, ex-KL700. The rig is a phasing job on 4.5 Mc. heterodyned to 28 Mc. and amplified finally by a pair of 5514s running 500 watts. The antenna is a 4-element rotary. All oscillators are crystal-controlled, so the stability will be determined by the receivers in use.

WØTLE finally deserted 10 for 75, where results with a BC-610 on a.m. had never been very good with the low-lying (20-foot high) antenna. However, with 650 watts peak to the pair of 813s operating s.s.b. it is an entirely different story. Ward has worked out all over the place, including about 25 different s.s.b. stations. There are a few operators who appear to be "antagonistic" toward s.s.b., but that seems to be misunderstanding brought about by lack of understanding.

The only dope we have on recent activity at W1SHN is that he worked G6WT on 75 in December, but that is a nice little hop on that band. . . . Ed Flowers, W4OFG of Oakville, Ky., has a W2UNJ exciter on 75, driving a pair of 5D21s to 500 watts.

If you want to see for yourself what s.s.b. can

(Continued on page 110)

SAVE \$ ON SUN SURPLUS AND STANDARD SPECIALS!

CRYSTALS Low Freq.

FT-241A holder 1/2" pin spacing, for ham and general use. Xtal controlled Signal Generators, marked in army Mc harmonic frequencies—Directions for deriving fundamental frequencies enclosed. Listed below by fundamental frequency, fractions omitted.

412	424	437	448	483	495	511	518
413	425	438	462	484	496	512	519
414	426	440	468	485	497	515	522
415	427	441	472	487	498	516	523
416	429	442	473	488	503	each	
418	431	443	474	490	504	49¢	
419	433	444	475	491	506	10 for \$4.50	
420	434	445	477	492	507	each	
422	435	446	479	493	508	39¢	
423	436	447	481	494	509	each	

372	375	377	380	383	386	388	each
374	376	379	381	384	387		39¢

390	393	395	401	403	405	409	each
391	394	397	402	404	408	411	79¢
392	395	400					each

450	464.815	529.166	533.333	538.888	each
452.777	465.277	530.555	536.111		99¢
461.111	526.388	531.944	537.500		

Frequency Standard 98.356 \$3.98
kc 3-prong holder.....

HAM CRYSTALS

FT-243 holders, 1/2" pin spacing, for ham and experimental use. Fractions omitted.

4190	6100	6208	6973	7906	8273	8306	each
5030	6106	6773	7740	7925			49¢
5485	6140	6840	7773	7973			10 for \$4.50
6006	6150	6873	7806	7975			each
6040	6173	6906	7840	8240			99¢
6073	6206	6940	7873				10 for \$9.00
6975							

3735	5773	5925	6450	6740	7540	7673	each
5305	5775	5940	6473	6806	7373	7706	99¢
5675	5806	5973	6475	7306	7606	8173	10 for \$9.00
5677	5825	5975	6506	7340	7640	8340	each
5700	5840	6273	6540	7373			99¢
5706	5850	6340	6573	7406			10 for \$9.00
5725	5873	6373	6606	7440			each
5740	5875	6406	6640	7473			99¢
5750	5900	6425	6673	7506			10 for \$9.00
5760	5906	6440	6706				

SCR-522 CRYSTALS

3910	6470	6547.9	7480	7930	each
6310	6497.9	6610	7580		\$1.29
6450	6522.9	7350	7810		

SPECIAL 200 kc Xtals without holders 21-32"
x 23-32", 69¢ each, 3 for \$2.00

BC-610 CRYSTALS

2045	2258	2360	2545	3222	3550	3945	each
2105	2260	2390	2557	3510	3570	3955	\$1.29
2125	2282	2415	3202	3520	3580	3995	each
2145	2300	2435	3215				99¢
2155	2305	2442	3237				10 for \$9.00
2220	2320	2532	3250				each

Payments must accompany order. Enclose 20¢ for postage and handling. Minimum order \$2.00 plus postage. Crystals shipped packed in cloth bags inasmuch as they are shock mounted. All shipments guaranteed.

PHONO ARMS, for replacements.

ASTATIC-5L—8 or D-9, with 1-26A cartridge. New in original boxes. Original list price \$4.95, reduced to.....\$1.65

PHONO ARMS, less cartridge, with all necessary hardware, straight or curved. Five (5) for.....\$1.95

2-SPEED RECORD PLAYER, in portable carrying case, including 3-tube amplifier, 8" speaker and 3 3/4 & 7 8 rpm Green Flyer motor, 115 volt AC or DC operated. Used, reconditioned. Only...\$12.50

Reduced for Clearance!

USED
19.95

LIKE NEW
29.95

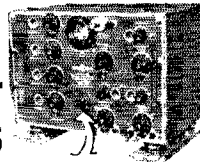

Bendix TA-12 Transmitter, 100 watt.

4 separate ECO's with tubes, 3-807, 4-12SK7. Complete instructions for converting to 10, 20, 40, and 80 meters supplied. Only a few left at this low price!

VARIABLE CONDENSERS, as used in SCR-522, brand new, 2-gang, 220 mmf per section, \$1.29; 3-gang, 220 mmf per section, \$1.59; Variable condenser, 1-gang capacity 14-600 mf., \$5.99

RECORD CHANGERS, single speed automatic, removed from new console combinations, single post, \$9.95; double post, \$14.95; Special Capehart record changers, value \$85.00, reduced to.....\$17.95

FILTER CHOKES, Jefferson Electric 2.2 HY-65 MA, 70 ohms 1500 V, ins. Hermetically sealed.....\$6.69

CARBON MIKES—T-17B, new, \$1.29

BC-728A. Pushbutton Receiver 2-6 mc with tubes and speaker, less batteries, includes conversion instructions for broadcast band.....\$9.95

BC-728A, as above, slightly damaged less one tube, less speaker, as is \$4.95

RCA AVR-20, AIRCRAFT RECEIVER, 2300-6500 kc with tubes, 2 crystal controlled channels plus variable tuning.....\$14.95

TRANSFORMERS
Ham Transformers, Peerless (Altec Lansing) new, not surplus, priced below cost.

Modulation Trans.—20 w. Universal Model No. M-4081Q. List \$9.25—Only.....\$3.70

Modulation Trans.—300 w. Universal Model No. M-2107T. List \$70.00—only.....\$28.00

Plate Trans.—2428 V. CT—300 MA. No. P-3196A. List \$45.00—only.....\$18.00

Fil. Trans.—2.5 v. CT-20 Amp. 4500 v. ins. No. F-8513J. List \$8.00—only.....\$3.20

Driver Trans.—Universal 70 MA. for 15 w. Audio No. A4237Q. List \$10.75—only.....\$4.30

Grid Mod. Trans.—Kenyon.....\$9.99

ARMY HEADPHONE, High Impedance. \$2.49

TUNING UNITS, from BC-375 transmitter, TU-9B, TU-10B. Each.....\$1.89

INTERPHONE AMPLIFIER, AM26, with 4 tubes, 2-12J5, 2-12A6, and dynamotor, new with instructions for conversion to HI-FI mike and phono amplifier.....\$4.95

SPERRY ELEVATOR SERVO AMPLIFIER, Brand new, with tubes and diagram.....\$3.95

METERS:
Weston, 2" round, 500 micro amp movement, with scale calibrated for 0/15/600 volts, D.C.....\$2.97
Triplett, 2" square, 0-40 volt D.C.....\$2.97

TUBES;
MAGNETRONS, 2J38. New.....\$18.95
CATHODE RAY 5BP4. New.....\$3.89
CATHODE RAY 58P1. New.....\$3.89

BC-746 Tuning Units, contains antenna, oscillator coils, 140 mmf midget tuning condenser, double crystal socket, less xtals.....\$5.39
With 2 crystals.....\$9.99
With 2 crystals one in 80 meter band.....\$1.29

PORTABLE WINDUP PHONOGRAPH, Heavy duty spring motor, variable speed, in sturdy carrying case, new.....\$9.95

RADAR TRANSMITTER, BC-1072A, 150-210 mc, 115 v. 60 cy. power supply, contains 11 tubes, GR-1 amp, variac, blower, 0-1 ma, 3" meter, 15 amp. circuit breaker, hi-voltage condensers and many other valuable parts, complete.....\$19.95

TUBE TESTER METER, Foundation meter for building your own mutual conductance tube tester 1.4 MA movement calibrated in Micromhos, with diagram.....\$3.49

TELEPHONE HANDSETS, new TS-13 carbon mike and magnetic head phones with butterfly press-to-talk switch.....\$3.95

FAMOUS MAKE BUTTERFLY TRANSMITTING CONDENSERS SPLIT STATOR

All New—Boxed—Below Cost

.500 sp. cap.	.375 sp. cap.	.250 sp. cap.
96 mmf \$22.15	22 mmf \$9.95	13 mmf \$7.95
115 mmf \$25.20	94 mmf 18.75	30 mmf \$16.80
	106 mmf 20.15	30 mmf \$9.80
	118 mmf 21.60	111 mmf \$16.80
	130 mmf 23.10	141 mmf 24.50
	141 mmf 24.50	159 mmf \$21.00
	153 mmf 25.95	

OSCILLOSCOPE BC-403B, 5" radar 115 v—60 cy. operated, can be converted to laboratory scope, complete with all tubes.....\$64.95

PORTABLE MEGAPHONE. Complete battery operated P.A. system, with tubes, batteries, tripod, carrying case and extra mike.....\$24.95

ANTENNAS for BC-645.....\$9.99

CARBON MICROPHONE, T-17B, push-to-talk switch, new.....\$1.29

WAVEMETER, BC-1073A, 150-210 mc cavity resonator, 115v-60 cy. power supply, less tubes.....\$12.95

VHF TRANSMITTER, 80-105 mc CW, battery operated, uses 2-1G4 tubes, less tubes and batteries.....\$4.95

CALLING "CG" to all HAMS from W3PPQ-Pick and W3MQD—Johnny, we are always ready to help you in obtaining any kind of gear you may need for your rigs. We carry a full line of ham parts of all popular makes and can ship from stock as soon as we receive your order.

SUN RADIO

OF WASHINGTON, D. C.

938 F STREET, N. W. WASH. 4, D. C.

TERMS All items F.O.B., Washington, D. C. All orders \$30.00 or less, cash with order. Above \$30.00, 25 per cent with order, balance C.O.D. Foreign orders cash with orders, plus exchange rate.

Hams everywhere are back on the air

with Drake TVI Filters

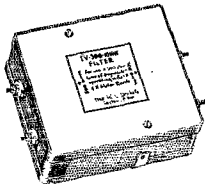

**Drake 10-Meter
Half-Wave
Harmonic Filter**

MODEL TV-300-10HW

\$10.95
Amateur Net

Patterned after the G. E. Harmoniker, the model TV-300-10HW uses specially constructed capacitors with an extremely low inductance for maximum attenuation of high frequency harmonics. Attenuation of 2nd harmonic approx. 30 db, 3rd harmonic 60 db, etc. Balanced construction permits use in 300 ohm twin lead or in open wire transmission lines up to 600 ohms.

The TV-300-10HW is for use in transmitters operating in the 10 and 11 meter bands only. It is rated to handle up to a 1 KW AM modulated phone transmitter.

SEE THIS NEW TVI FILTER AT YOUR DISTRIBUTORS NOW

Models for Other Bands To be Announced Soon

Drake Low Pass Filters—for transmitters up to 1 KW and operating in the low frequency bands, 10 to 160 meters

TV-52-40LP For 52 or 72 ohm Coax
TV-300LP For 300 ohm Twin Lead

Either Model **\$12.95** Amateur Net

Drake High Pass Filters — for use in the TV Receivers transmission line.

TV-300-50HP For 300 ohm Twin Lead
TV-72-50HP For 72 ohm Small Coax

Either Model **\$5.95** list

All Drake Filters are precision engineered, completely assembled and adjusted.

See them at your distributor or write us for details.

The R. L. Drake Co.

11 Longworth St., Dayton 2, Ohio

NEW SUPER DELUXE VIBROPLEX

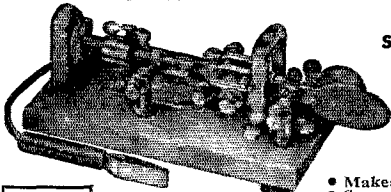

Marvel of Sending Ease

Easy As Pressing A Button

24-K Gold-Plated Base Top \$27.50

"PRESENTATION"

- Makes Sending Easy
- Saves the Arm
- Prevents 'Glass' Arm

A finger-touch on jeweled-lever button—that's all you do. Vibroplex does the rest, **SMOOTHLY! EASILY! PERFECTLY!** No arm fatigue . . . no nerve strain. Has jeweled-lever movement, adjustable main spring and other aids to easier sending. Other models \$9.95 up. Left hand models one dollar more. **FREE** literature. At dealers, or

THE VIBROPLEX CO., Inc., 833 Broadway, N. Y. 3, N. Y.

do, listen to some of the snappy single-frequency duplex and triplex QSOs of W4OLL, W3BOL and W3ASW on 3999 almost any evening. This gang has installed voice-controlled electronic relays that silence their receivers when they are talking and cut off the transmitters when they aren't. It isn't true duplex or triplex, in that they can't hear the other stations *through* their own transmitters, but it is so close in effect that you can hardly notice the difference. It's just about the snappiest operating you will find in any of the 'phone bands.

— B. G.

I.A.R.U.

(Continued from page 45)

test from 0001 hours NZST March 25th to 2359 hours NZST March 26th. Essentially it is a contest between New Zealand and Rarotongan stations *versus* the rest of the world.

'Phone and/or c.w. may be used; operation only on 3.5-, 7-, 14-, and 28-Mc. bands; only single-operator stations; one contact per station per band per mode; serial numbers to consist of 6 (or 5, if 'phone) digits, the first three (or 2, if 'phone) to be the signal report and the last three to be the contest contact number.

Certificates will be awarded as follows:

7 Mc. c.w.

14 Mc. c.w. — 'phone — combined operation

28 Mc. c.w. — 'phone — combined operation

All Band c.w. — 'phone — combined operation

Certificates according to above schedule will be awarded to leading contestants in each country and in each U. S. call area. Complete logs must reach ZL3LL, 4 Mary St., Papanui, Christchurch, New Zealand, by June 19, 1950.

Technical Topics

(Continued from page 47)

cent without serious distortion, but other tubes might be limited to 50 or 60 per cent. The screen current is low in an 807, and consequently the screen resistance is high and the audio power requirements are slight. Further, 807s frequently use screen-dropping resistors to drop the plate voltage to the proper value for the screen, an uneconomical procedure with high-voltage high-screen-current tubes. If screen-grid modulation is applied to tubes using a separate screen supply, it would be advisable to use the usual form of screen modulation, with transformer coupling of the audio power. — B. G.

Strays

A new test clip which should save amateurs much time and wire scraping in their building and testing activities has been announced by the Mueller Electric Co. Known as the 50-C, the clip features a sharp needle in one jaw for piercing the insulation of wires, thereby permitting quick electric contact with the conductor.

SEE LEO FIRST . . . QUIT WORRYING ABOUT TVI— GET A WRL TRANSMITTER . . .

Tests with amateurs living in congested and fringe areas using WRL transmitters have proven to us that we have a XMTR with minimum television interference. Write today for detailed information!

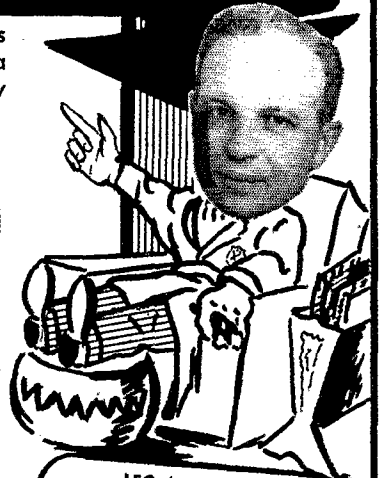

NEW WRL "400"

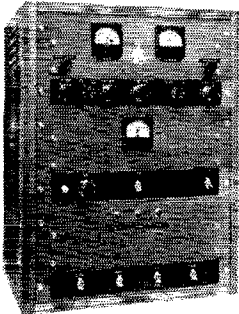

GLOBE KING "More Watts Per Dollar"

A versatile, advance design transmitter that gives efficient performance on all bands—10 to 160 on phone and CW. 350 watt phone—400 watt CW. Provisions for ECO. Complete with one set of coils.

KIT FORM
\$379.45

WIRED-TESTED
\$399.45

Low Down Payment

WRL 175 WATT GLOBE CHAMPION

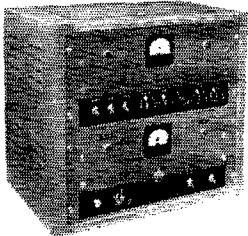

R.F. Section a complete 175 watt XMTR. Provisions for ECO. Automatic fixed bias on Final and Buffer. Class B Speech Modulator—175 watt input—10 thru 160 meter bands. Complete with tubes, meters, and 1 set of coils.

WIRED KIT FORM
\$299.00 \$279.00

Low Down Payments

Write For Detailed Specification Sheet

LEO I. MEYERSON
WØGFC



GIANT RADIO REFERENCE MAPS

Just right for your control room walls. Approximately 28" X 36". Contains time zones, amateur zones, monitoring stations. Mail coupon today and . . .

25c



FREE

Deal with the "World's Most Personalized Radio Supply House". Send for your new complete WRL Catalog containing everything new in radio.

E-Z PAYMENTS

LIBERAL TRADE-INS

PERSONAL SERVICE

"Guaranteed Satisfaction From The World's Largest Distributor Of Amateur Radio Transmitting Equipment."

WRITE - WIRE

PHONE 7795

World Radio
LABORATORIES INCORPORATED
COUNCIL BLUFFS, IOWA



World Radio Laboratories, Inc.
744 West Broadway
Council Bluffs, Iowa

O-3

Please send me:

- Radio Map Globe King Info
 New Catalog Globe Champion Info
 List of Used Equipment

Name _____
Address _____
City _____ State _____

RADAR, COMMUNICATIONS and SONAR TECHNICIANS WANTED

For Overseas Assignments

Technical Qualifications:

1. At least 3 years' practical experience in installation and maintenance.
2. Navy veterans ETM 1/c or higher.
3. Army veterans TECH/SGT or higher.

Personal Qualifications:

1. Age, over 22—must pass physical examination.
2. Ability to assume responsibility.
3. Must stand thorough character investigation.
4. Willing to go overseas for 1 year.

Base pay, bonus, living allowance, vacation add up to \$7,000.00 per year. Permanent connection with company possible.

**Apply by Writing to
C-3, P.O. Box 3552
Philadelphia 22, Pa.**

Men qualified in RADAR, COMMUNICATIONS or SONAR give complete history. Interview will be arranged for successful applicants.

Difficult Takes a Long Time

(Continued from page 49)

wire. German silver wire is not recommended.

"To hook up the receiving set connect one end of the tuning coil to the aerial wire. Connect the ground wire to one of the brass springs. [Aha!] Connect the condenser to the other spring. The other post of the condenser is connected to the detector. The other side of the detector is connected to the ground wire. The telephone receiver is connected around the detector for receiving messages.

"If you are going to send and receive you will need an aerial switch. This is a specially-made switch. When the lever is up the sending set is cut off and the receiving set is ready to receive messages. When the lever is down the receiving set is disconnected and the sending set is ready to operate. [Of course there was no dope on connections or where to obtain such a switch. Probably a very minor matter.]



"The operation of the wireless station is very simple. To receive messages, adjust the cat whisker to a sensitive spot on the crystal and slide the springs back and forth until the received message is loud and clear. To send, push the aerial switch down and press the telegraph key. The electric waves you send out will strike the aerial of a receiving station, if there is one within range of your set, and buzzing sounds will be made which are read by the distant operator (a short buzz is a dot and a long buzz is a dash) and in this way messages in the International code will be transmitted and received. [Seems to me some of this buzzing is still going on, judging by what one hears nowadays on the ham bands!]

Now, friends, wasn't that simple? In a pig's eye it was! Having sweated and struggled with radio all these many years, I am ready and willing to say that I'd much rather be a beginner in 1950 than in the days when the material I've just presented was the latest word on "How to Make an Amateur Wireless Set."

SWITCH TO SAFETY!



WHAT! NO LIGHTS!

Sizes range from small portable 300 Watts to 300 K.W. Mfgs. of Converters, high frequency Generators, Motor Generator sets.

**KATO
ENGINEERING
COMPANY**

1437 First
Avenue

Mankato
Minnesota

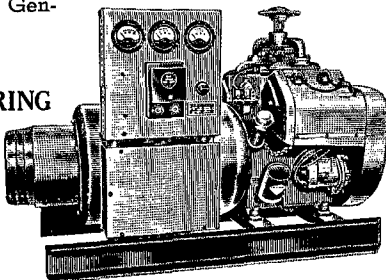

HARRISON IS HAM HEADQUARTERS *for*

TVI ELIMINATION

RECEIVERS AND XMTRS

EVERYTHING FOR THE SHACK

ORDERS SHIPPED WITHIN 4 HOURS

HARRISON HAS IT IN STOCK!

UNBELIEVABLY FAST MAIL ORDER SERVICE

WORLD'S BIGGEST EXCITER BARGAIN!

LYSCO'S AMAZING NEW TVI-LESS BAND SWITCHING VFO TRANSMITTER



Write for descriptive bulletin
 LySCO Transmitter **\$99.50**
 Model 600
 Now in stock for immediate delivery!

- **TVI SUPPRESSED!** - Xmt'r designed with 3-section, low-pass filter incorporated in output - all leads by-passed for RF - most effective shielding - etc., etc.
- **35 WATTS!** - 6AG7 Clapp Oscillator, 6AG7 Buffer Doubler, and 807 Final Amplifier with 35 watts input on 10 bands.
- **VFO CONTROL!** - Calibrated output on 10, 11, 15, 20, 40, 80, and 160 meters. Provision for crystal control, too!
- **CW BREAK-IN!** - Oscillator keying for clean, chirpless, full break-in operation. Built-in key click filter.
- **MODULATION PROVISION!** - Terminals provided for external modulator. Add 15-watt amplifier and enjoy phone operation. (Special 18 Watt Modulator - \$39.95 complete!)
- **FINGER TIP CONTROL!** - Completely band switching! All controls, xtal socket, VFO-xtal selector switch, etc., on front panel. Large illuminated vernier dial.
- **REGULATED SUPPLY!** - Built-in supply uses VR-150 voltage regulator and 5R4GY, high output rectifier!

Excellent as a compact portable or home station transmitter. Coaxial connector output to 50 to 75 ohm cable to feed antenna or high power amplifier. Attractive metal cabinet finished in black crackle with chromium trim - 15" x 9" x 8" deep. Weighs 35 lbs. Supplied complete with all tubes. Nothing more to buy! Simply plug into 115V AC line! Complete installation and operation instructions including antenna data furnished. Operate all bands - QSY at will - eliminate TVI!

A HARRISON EXCLUSIVE! - ONLY HARRISON HAS IT!

"HARMONIKER"

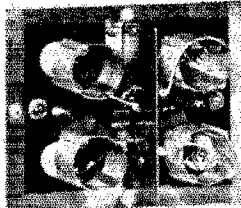

Here's the latest, and most sensational TVI filter - as described in GE Ham News and December QST, page 36. Unlike 40 MC low pass filters, this half-wave filter attenuates ALL harmonics (as much as 110 DB for the TV band harmonics of an 80 meter xmitter!) Negligible insertion loss. For flat, untuned line with low SWR. Simple to construct! Nothing to tune or adjust, when using our factory guaranteed 2% accurate condensers!

Harrison Kits contain the metal box, brass for inter-section shield, B and W Miniductors, (no coils to wind!), ground posts, the indicated condensers, connectors, and complete instructions.

For 50 to 100-ohm coaxial cable (Includes coaxial fittings):
 With 1000 Volt (2000V Test) SILVER MICA condensers for stabilized tuned circuits. Will handle 1 KW CW or 250 W AM Fone RF output.

- | | |
|---|--------------------------|
| 80 Meters - FI-85 \$5.99 | 40 Meters - FI-45 \$4.99 |
| 20 Meters - FI-25 \$4.29 | 10 Meters - FI-15 \$3.79 |
| Same with 2500 Volt (5KV Test), 2% Transmitting Mica Condensers to handle a full KW Fone! | |
| 80 Meters - FI-86 \$9.95 | 40 Meters - FI-46 \$9.41 |
| 20 Meters - FI-26 \$7.21 | 10 Meters - FI-16 \$6.85 |

For 200 to 600-ohm twin lead or spaced open wire, (Includes feed-thru insulators): With 1000 Volt (2000 V Test) SILVER MICA condensers. Will handle 1 KW CW or 250 Watts AM Fone.

- | | |
|--|---------------------------|
| 80 Meters - FI-83 \$6.71 | 20 Meters - FI-23 \$5.87 |
| 40 Meters - FI-43 \$5.47 | 10 Meters - FI-13 \$5.35 |
| Same with 2500 Volt (5KV Test) 2% Transmitting Mica Condensers to handle a full KW Fone. | |
| 80 Meters - FI-84 \$13.25 | 20 Meters - FI-24 \$12.27 |
| 40 Meters - FI-44 \$12.51 | 10 Meters - FI-14 \$11.75 |

Special copper plated utility box provided with all kits
ANY HARMONIKER WIRED AND TESTED - \$3.00 EXTRA
 (Add W to Item Number)

Send for building instructions and complete parts list. A postcard will bring your copy! If you don't have our Holiday Ham-A-Log, let us know and we'll send it along.

Special! Special! Special!
 Copper plated utility boxes 3"x4"x5". Just the thing for those "special" UHF jobs. Excellent ground. Ideal for filters. Special at Harrison's!
 Only 98c

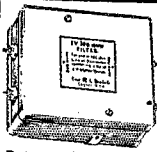

BRAND NEW! Drake 10-Meter Half-Wave Harmonic Filter

Patterned after the G.E. Harmoniker, the TV-300-10HW uses specially constructed capacitors with an extremely low inductance for maximum attenuation of high frequency harmonics. Attenuates everything but the fundamental! Balanced construction for use with 300-ohm twin lead or in open wire transmission lines up to 600 ohms. Rated 1 KW AM phone! For 10-11 meters only!

MODEL TV-300-10HW **\$10.95**
 Amateur Net

DRAKE 1 KW LOW PASS FILTERS - Use on any band from 10 to 160 meters. One filter suffices for ALL bands!
 TV-52-40LP For 52 or 72-ohm Coax EITHER MODEL **\$12.95**
 TV-300LP For 300-ohm Twin Lead

DRAKE HIGH PASS FILTERS - For TV Receiver Load-in
 TV-300-50HP For 300-ohm Twin Lead EITHER MODEL **\$3.57**
 TV-72-50HP For 72-ohm Small Coax



G.E. SENSITIVE RELAYS

Item RL-6 - Only 1.79

COIL - 2000 ohm. Pulls in on 18 milliwatts DC (3 MA) CONTACTS - SPDT, 1/4" diameter, pure silver. Center pivot armature, meter type spring. Sealed in inert gas filled, 2 1/8" diameter, aluminum case. Standard five pin base. Original sealed boxes.

LONG ISLAND HAMS

You'll find a complete stock of Ham parts and equipment at our conveniently located Jamaica Branch - Hillside Avenue at 172 Street. Lots of parking space! Old timer, "Mo" Tepper, W2BQF will help you solve your problems.

HAM HEADQUARTERS
 HARRISON
 EXPORT DEPT.
 "HARRISON"
 NEW YORK 7, N.Y.
225 GREENWICH STREET
 (10 West Broadway, at Barclay St.)
 Barclay 7-7777
 OPEN ALL DAY SATURDAYS

2 METER BEAMS

16 AND 32 ELEMENTS

Horizontal and Vertical Polarization—Pre-tuned, Pre-spaced and Pre-matched

Also

6, 10, and 20 METER

Wide Spaced, High Forward Gain, Parasitic Arrays

U.H.F. RESONATOR COMPANY

(formerly of Rye, N. Y.)

224 SEVENTH ST. RACINE, WISCONSIN

Write for literature

How's DX?

(Continued from page 57)

William Ritter, 14th Communications, APO 74, % PM, San Francisco, Calif., and he would like to clear the stack to rightful owners. Drop a line to the sergeant giving your present mailing address with Philippines call used and the matter will be attended to W6DBZ admits that he has never been seriously attacked by the DX virus but Don recently had such an interesting visitor in the person of PY1JH/PY1MH that he has now resolved to erect that long-dreamed-of beam and get into the swim. Dr. Francisco Pena doesn't do very well through the local QRM around PY1JH but after his return to Brazil he intends to be more active from his mountain hideaway at PY1MH W9EXY would appreciate some word regarding the present address of W6YOT/C6 whom he worked last winter for the purpose of you-know-what The present TA3FAS sets us straight with word to the effect that the only other active Turkish stations are TAs 3GVU, 3AA and 1BS. You may have worked Jim as W5HBQ before he left to take over TA3FAS from Lt. John Odel who has since returned to the U. S. MD7DC wrote to W2QHH that a ZC4NX



H. J. Buckley, ZS5U, needs scant introduction to the DX gang. At this time he happened to be hiding from W/VE QRM behind a few of his contest trophies. You are likely to collide with ZS5U on any band, 3.5 through 50 Mc.

may be heard operating from Cyprus while the latter vacations at intervals from Egypt "ZS6GV and ZS6DO are going to Swaziland for one week in March—exact date unknown. . . . Every effort will be made to work the maximum quota of Ws with simultaneous operation on 14 and 28 Mc." This via W1FH, W1RUP and W1AW from ZS6GV and the boys want cards sent direct to their home QTHs G2MI reports that a flock of VP8AD QSLs fell into his lap with a promise of more to follow ST2TC used to QSL upon contact but his return percentage grew so low that now he slips out cards only upon receipt of same. This from the No. Calif. DX Club's *The DXer* which also has it that ST2TC is scheduled to remain in the Sudan for the greater part of a year longer W5AJG denies knowledge of the BA8AN QSL situation although we had it on good authority that he was doing the job. Crossed wires somewhere but we'll get it straightened out and the cards on their proper way W9DGA claims he is heading for the traffic nets for a while after capturing DXCC No. 786 and W9KOK finds it hard to tear himself away from his new television set long enough to work a new one. Mitch is another who doubts that AC4RF's present location is within Tibetan borders. Older maps place Chiamdo in Tibet but newer ones make it C5. We'll have to huddle over that one W4AZK heard from ST2TC that there are no ST4 calls on the Sudan roster and therefore ST4JX is somebody with an over-fertile imagination Cofounder of the Rochester DX Association, W2UPH, had an interesting chat with CR4AD in his native tongue and offered to assist in fixing up the

(Continued on page 116)

Since the earliest days of Radio...



have been preferred for their absolute uniformity, superior qualities and ultimate economy. Foremost set manufacturers specify CORNISH, because our engineers keep abreast of electronic developments. Let us serve YOU.

Write for catalog #57

"MADE BY ENGINEERS FOR ENGINEERS"

CORNISH WIRE COMPANY, INC.
15 Park Row New York 7, N. Y.

Of Course You don't have to PREFER the ASTATIC D-104 MICROPHONE

Just because the Great Majority of Amateurs do

BUT... Often manufacturers tell you that their product is preferred by most buyers and, therefore, you should prefer it, too. Such reasoning is open for question. It depends upon whether the preference is the result of studious, qualified decisions on the part of buyers or is the result of other factors. Seldom do you find a group of buyers so well informed technically on the products they

buy as among purchasers of equipment for amateur radio rigs. Certainly this gives real weight to the overwhelming popularity of the D-104 Microphone. Astatic feels justified in taking unreserved pride in this "opinion of experts" on the D-104 . . . feels that it merits your consideration.

Astatic Crystal Devices manufactured under Brush Development Co. patents

THE **Astatic** CORPORATION
ASTATIC CORPORATION
CONNEAUT, OHIO
- IN CANADA, CANADIAN ASTATIC LTD. TORONTO, ONTARIO

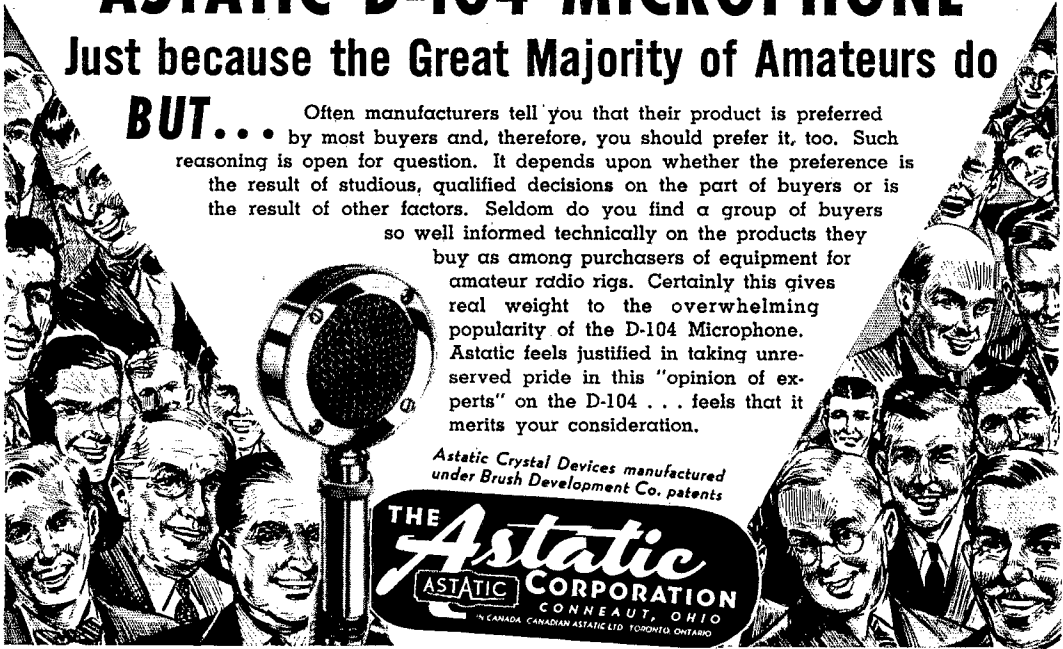

145K MULTI-SIGNAL TRACER KIT \$18.95
Wired \$28.95



320K SIGNAL GENERATOR KIT \$19.95
Wired \$29.95



221K HIGH PRECISION VACUUM TUBE VOLTMETER KIT \$23.95
Wired \$49.95



360K SWEEP SIGNAL GEN'R T'R KIT \$29.95
Wired \$39.95



**SAVE TIME
SAVE MONEY!**

315 DELUXE SIGNAL GENERATOR \$59.95
Wired only



511K POCKET VOLT-OHM-MILLIAMMETER KIT \$14.95
Wired \$17.95



425K 5" PUSH-PULL SCOPE KIT \$39.95
Wired \$69.95



BUILD PRECISION INSTRUMENTS WITH TEICO KITS

Build it yourself and save the assembly labor cost. The schematic and pictorial diagrams enclosed with each EICO Kit are easy to follow, it's no trick at all to complete the job in one evening!

Ideally suited for TV: EICO VTVM goes to 30,000 volts and over 200 Mc with our accessory probes—EICO Sweep Generator has TV channels marked on panel and crystal marker—new EICO 'scope has high sensitivity and Push-pull.

West Coast prices 5% higher.

Write now for our new catalog "Q".

HI-VOLTAGE PROBE
Wired only \$6.95



5 Mc. Crystal \$3.95



HI-FREQ PROBE KIT \$3.75
Wired \$7.50



ELECTRONIC INSTRUMENT CO., INC.
276 Newport Street, Brooklyn 12, N. Y.

EASY - TO - FOLLOW SCHEMATIC & PICTORIAL DIAGRAMS WITH EVERY EICO INSTRUMENT KIT.

ATTENTION

MOBILE HAMS

Complete mobile package — nothing else to buy. Outstanding mobile signals use motorola equipment — backed by years of communication equipment experience — World's largest producer of 2-way mobile equipment.

A mobile transmitter with a double feature FM or AM at flip of the switch, the MOTOROLA FMT-30-DMS (27-30 MC.). **\$130.00**

MOTOROLA P-69-13-ARS receiver with special noise limiter for use with any converter having 1500-3000 KC. **\$60.00**

P-7253 spring base rear — mount antenna **\$22.50**

3-30 famous Gon-set converter complete to connect to the P-69-13-ARS receiver.... **\$39.95**

P-327-E Fire wall loud speaker.... **\$5.00**

The above comes complete with all necessary accessories and mounting hardware. Order direct or through the Motorola National Service Organization member in your area.

For further information write to:

MOTOROLA INC.

Amateur Sales Dept. QST-March
1327 W. Washington Blvd. Chicago 7, Illinois
Attention: Harry Harrison W9LLX
Telephone — Taylor 9-2200 Ext. 161

A COMPLETELY NEW TRYLON MAST

...at a cost within
amateur budgets

The new TRYLON #650 double-welded antenna mast weighs only 2 lbs. per foot; is easy to erect and climb; gives you a mast height of from 10 to 60 feet; and costs little more than \$1 per foot complete with fittings! It is hot-dipped galvanized after fabrication and comes in handy 10 ft. sections. The ideal support for doublet, rhombic or other wire-type antennas; lightweight rotary beams or for portable antennas at field meets! Featured by leading distributors. Write for free folder.

Tower and Antenna Division
WIND TURBINE COMPANY
WEST CHESTER, PENNA.

latter's note after hearing that Brito was using a 6L6 Hartley with 320 volts of unfiltered vibrator output on its plate. The club got on the ball and a box of miscellaneous radio gear is going to make CR4AD pretty happy W6DLY runs into fellows who doubt the veracity of HZ1HZ because of Ahmed's terrific signal. HZ1HZ runs about a half gallon and attempts to QSL 100% from Mecca Hop yourselves up for another fancy one. The Guayaquil Radio Club of Ecuador will operate HC8GRC or HC2GRC/8 from the Galapagos during the latter part of March, to quote HC2JR On a QSL confirming a 7-Mc. contact with WICEG, VS6BK states he is returning to the U. K. We hate to lose this all-band Asian enthusiast, darn it.

In the No. Calif. DX Club's *The DXer* we see that W6TL has done some serious and heavy thinking about the DX situation and sums it up in the following observation:

"A small DX man is said to be a man who knows a great deal about a very little and who goes along knowing more and more about less and less until he practically knows everything about nothing whereas a good DX man on the other hand is a man who knows very little about a great deal and keeps knowing less and less about more and more until he knows practically nothing about everything. So the big DX man starts out knowing practically everything about nothing but ends up knowing nothing about anything due to his association with lids, CQ hounds, bad notes and the overmodulation boys."

As soon as we figure it out we'll either agree or disagree with him!

DX CONTEST NOTE

Following publication of the rules for the 16th ARRL DX Contest in January *QST*, Headquarters received inquiries about the status of Newfoundland and Labrador and whether VO stations would, as in the past, contact W and VE stations or would be classed with the latter and contact stations outside the U. S. and Canada. On April 1, 1949, Newfoundland and Labrador became part of Canada; VO stations therefore come under DX Contest Rule 2 which requires that "Amateurs in continental U. S. and Canada will try to work as many amateur stations in other parts of the world as possible under the rules and during the contest periods." For the benefit of stations outside the U. S. and Canada, we wish to point out also that contact with VO will add another point to their multiplier; foreign participants thus may obtain 9 multiplier points by working all the VE call areas plus VO.

IS YOURS ON FILE WITH YOUR QSL MGR?

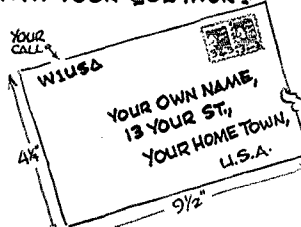

ACCENT

ON COMMERCIAL APPEARANCE & EFFICIENCY

The NEW JOHNSON **VIKING I**
TRANSMITTER KIT ONLY \$209⁵⁰

Amateur Net

150 Watts Input on All Bands

Here's a new transmitter whose superlative performance and operating convenience set new standards for amateur transmitters.

There's a full 100 watts output of AM phone, 115 watts cw on 160, 80, 40, 20, 15 or 10-11 meters at your fingertips.

The pi-section output stage will efficiently load many antennas without external couplers. The final tank coil is a variable inductor with excellent insulation and high Q throughout its range. Plug in coils are completely eliminated.

Novice or oldtimer can obtain brilliant performance from the Viking I. A punched chassis and parts, table cabinet, all parts, wiring harness and carefully detailed instructions furnished with each kit. Tubes, crystals, mike and key not included.

For Complete Information
See Your JOHNSON Jobber or
Write For Your Illustrated Folder Today!

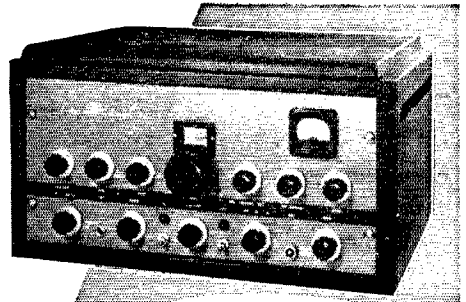

Build It Yourself
In A Few Evenings

features

- Band Switching All Bands
- Continuous Tuning
- Final Tank
- Front Panel Controls
- Unique Pierce Oscillator
- VFO Input Receptacle
- 10 Crystal Positions
- Pi-Network Coupling
- Freedom from Parasitics
- Two Complete Power Supplies
- All Stages Metered
- Desk Cabinet, 11 3/16" x 15" x 21"
- Two-tone Panel

E. F. JOHNSON CO.
Waseca, Minnesota

The EKCO Solder Pencils

Ideal for miniature and sub-miniature equipment, model making, instrument repairs etc. Light, efficient, robust, reliable. Perfect control without fatigue — precision soldering in the most awkward places without risk of damage — operates from car battery, accumulator or mains transformer. Only \$3.00 complete post free! If ordered at same time, spare bits 20c. Spare element wire (for 3 elements) 20c. Payment — banker's check on Wall Street correspondent. Mail coupon with check attached to E. K. Cole Ltd., Export Dept., 5 Vigo Street, London, W.1, England.

- weight complete 2½ oz.
- length 7 ins.
- diameter ⅜ ins.
- solder heat in 50 secs.
- 6, 12 or 24 volts
- consumption 10 watts

\$3.00
POST FREE

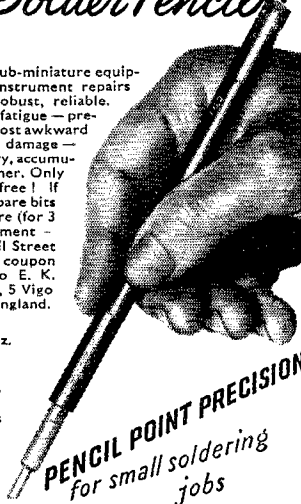

PENCIL POINT PRECISION
for small soldering jobs

Please write clearly

NAME.....

ADDRESS.....

QST 1

SEND . . . Ekco Solder Pencils . . . volt (6, 12 or 24) @ \$3.00 each; . . . spare Bits @ 20c. each; . . . spare cards Element Wire @ 20c. each. Total value \$ Check attached.

To: E. K. COLE Ltd., Export Dept., 5 Vigo St, London, W.1, England

JOBS in TELEVISION

AMERICAN RADIO INSTITUTE

CAN TRAIN YOU FOR THIS JOB

Syracuse, N. Y.
131 Shonnard St.

New York
2010 B'way (68th St.)

Buffalo, N. Y.
640 Main St.

Mount Vernon, N. Y.
174 Gramatan Ave.

FREE EMPLOYMENT SERVICE • GI APPROVED

NOW... Quickly and Easily
cut **SQUARE** and **OBLONG**
openings in radio chassis



**WITH THE GREENLEE No. 731
SQUARE RADIO CHASSIS PUNCH**

Now, in 1½ minutes or less you can do hole-cutting jobs that might take an hour or so with old "drilling and filing" methods. Simply insert GREENLEE Punch and turn with an ordinary wrench; a "clean" square or oblong opening is quickly cut. An indispensable, timesaving tool that pays for itself in a hurry.



In sizes ¼", ⅜" and 1"

Write today for facts and prices on this handy Punch.
Greenlee Tool Co., 1863 Columbia Ave., Rockford, Illinois

HY-LITE'S NEW

SKY-LITE
ALL GROUNDING ARRAY FOR 10-11 METERS

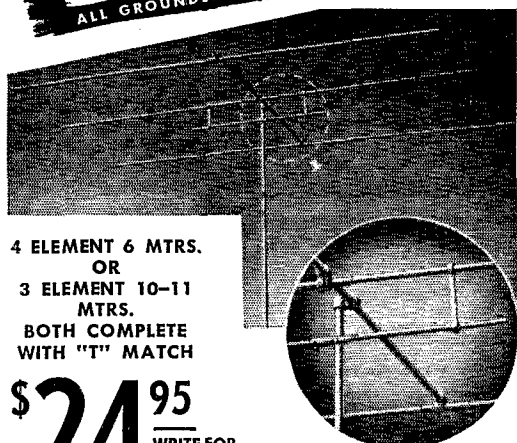

4 ELEMENT 6 MTRS.
OR
3 ELEMENT 10-11
MTRS.
BOTH COMPLETE
WITH "T" MATCH

\$24⁹⁵
WRITE FOR
CATALOG
Q-3

HY-LITE Antennae INC.
Makers of Fine Antennas for **AMATEUR · FM · TELEVISION**
1060 WASHINGTON AVE., BRONX 66, N. Y.

50 Mc.

(Continued from page 60)

out of an 832A, and with some juggling this can be made to drive another 832A as a 420-Mc. amplifier, with an output of perhaps 6 watts or so. This is still a long way from the maximum power limit, and it is apt to be pretty rough on the 832As, too. The important thing seems to be to get really adequate drive on the tripler stage. Don't try to do it with anything less than about 7 or 8 watts output from the driver. And don't run the tripler at more than 300 volts on the plate — they just won't stand more for long.

A new tube that shows some promise for 420-Mc. service is the Amperex AX9903. This dual tetrode has the plate

(Continued on page 120)

50 WAS Mc.

Standings as of January 25th

W9ZHB	48	W5AJG	47	W8QYD	44
W9ZJB	48	W5VY	47	W8CMS	39
W9QUV	48	W5JTI	44	W8NQD	39
W9BJV	48	W5JLY	43	W8YLS	38
W9CJS	48	W5ML	42	W8WSE	36
W6WNN	48	W5VY	42	W8LBH	36
		W5ONS	41	W8RDZ	28
W1CLS	45	W5FSC	41	W8RPF	25
W1CGY	44	W5GNQ	41		
W1LL	43	W5JME	41	W9HGE	47
W1HDQ	42	W5HLD	40	W9ZHL	47
W1KHL	41	W5FRD	38	W9PK	47
W1LSN	41	W5DXB	35	W9ALU	46
W1HMS	38	W5ZZF	34	W9JMS	45
W1GJO	37	W5NHD	33	W9QEM	45
W1EIO	36	W5JBW	32	W9QJM	44
W1RO	36	W5IOP	30	W9UIA	43
W1ELP	36	W5IRP	39	W9UNS	42
W1DJ	36	W5LWG	26		
W1JLK	35			W9USI	47
W1ATP	33	W6UXN	47	W9QIN	47
W1HIL	31	W6OVK	40	W9DZM	47
W1CGX	31	W6IWS	40	W9NFM	47
W1FZ	30	W6ANN	38	W9INI	47
		W6BPT	36	W9KYP	44
W2RLV	45	W6AMD	35	W9JHS	44
W2BYM	42	W6NAW	35	W9PKD	43
W2IDZ	40	W6FPV	34	W9YKK	43
W2AMJ	38	W6BWG	25	W9TKX	43
W2QVH	37	K6BF	17	W9SV	42
W2FHV	33	W6JKN	11	W9HXY	41
				W9IPI	39
W30JU	44	W7HEA	47		
W3OR	35	W7BQX	45	VE3ANY	38
W3RUE	34	W7DYD	45	VE1QZ	32
W3MKL	33	W7ERA	43	VE1QY	28
		W7JRG	40	VE3AET	27
W4FBH	45	W7BOC	40	HC20T	25
W4EQM	44	W7JPA	40	VE4GQ	20
W4QN	43	W7FIV	40	XE1GE	19
W4FWH	42	W7CAM	40	XE2C	14
W4LNG	42	W7KFM	40	VE2GT	14
W4GIY	40	W7FDJ	36	XE1QE	10
W4EID	40	W7FFE	35		
W4EQR	40	W7KAD	35		
W4CPZ	39	W7ACD	32		
W4DRZ	38	W7QAP	32		
W4MS	38	W3CIR/7	32		
W4FQI	34				
W4GMP	34				
W4WMI	33				
W4FNR	33				

Calls in bold-face indicate holders of special 50-Mc. WAS certificates listed in the order of the award numbers. All other listings are based on unverified reports.

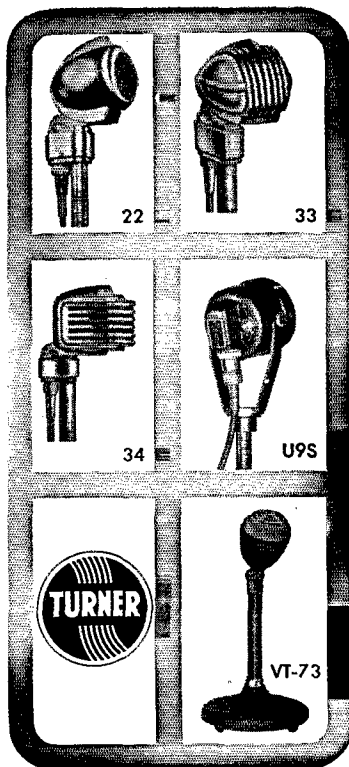

FOR QUALITY AND PERFORMANCE

2653 Inf. 1, M. Nativida
Manila, Philippines
31 August, 1949

I am a user of Turner Microphones and I know just the microphone for me. My job requires rugged performance because the Philippine climate is very rainy at times, then excessively humid, then hot. . . . If a wrong microphone is used it is very sure of not lasting very long.

I have a Turner Model 99 which was caught several times in sudden showers and believe me it is still excellent if not perfect. I recommend Turner Microphones for quality and the best performance. Very truly yours,

TOMAS M. TAGULAO
CO-Owner, Sterling "AA" Sound System

Turner
Model 99

Write for Free Microphone Literature

In Canada: Canadian Marconi Company, Montreal, P. Q.

Export Ad. Auriema, Inc., 89 Broad Street, New York 4, N. Y.

THE TURNER COMPANY

917 17th Street, N. E.

Cedar Rapids, Iowa

Microphones by **TURNER**

Microphones licensed under U. S. patents of the American Telephone and Telegraph Company, and Western Electric Company, Incorporated.
Crystals licensed under patents of the Brush Development Company

LEARN CODE!

SPEED UP Your
RECEIVING
with G-C
Automatic Sender
Type S
\$24.00 Postpaid in
U. S. A.



Housed in Aluminum Case. Black Instrument Finished. Small—Compact—Quiet induction type motor. 110 Volts—60 Cycle A.C.

Adjustable speed control, maintains constant speed at any Setting. Complete with ten rolls of double perforated tape. A wide variety of other practice tapes available at 50c per roll.

GARDINER & COMPANY

STRATFORD

NEW JERSEY

CALL LETTER PLATES

Type A-16 -
For Your Car

W8ENH

A large, sturdy cast aluminum plate with satin-finished letters and border against a black baked enamel background. Red, green, blue and gray -- 50¢ extra. Size - 2½" x 8½" with 1½" letters.

Type A-19 -
For Panel
Mounting

\$2.95 POSTPAID

LAPEL BUTTONS

An attractive metal button with highly polished raised letters against a black background. Other colors 50¢ extra.

W9HKZ

ACTUAL SIZE **\$1.10 POSTPAID**

Type A-26L With Screw Backing
Type A-26P With Pin Backing

SREPCO Inc.
STANDARD RADIO & ELECTRONIC PRODUCTS
135 E. Second St. DAYTON 2, OHIO Tel. FURton 2174

CASH WITH ORDER
Allow 3 weeks for delivery

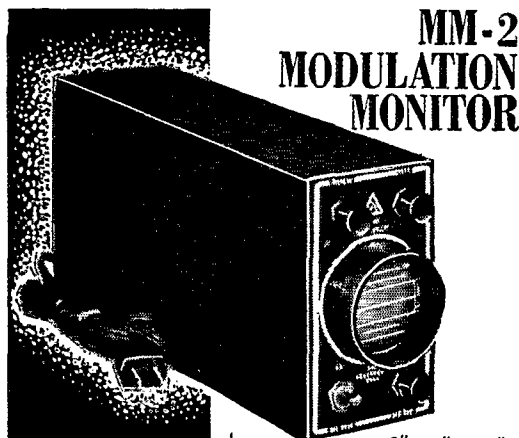

MM-2 MODULATION MONITOR

3" x 5" x 10"

ONLY
\$24.95
COMPLETE WITH TUBES
REVERSIBLE PANEL—CALIBRATED
TRACE INTENSIFIER WINDOW
INSULATION BOX

ADD SIGHT TO YOUR SOUND

with this basic oscilloscope featuring calibrated modulation percentage scale, linear 60 cy sweep with return trace blanking, trace intensifier window, complete controls, reversible panel, rack mounting provisions and many other outstanding features. See the MM-2 at your dealer or write Dept. 3-50.

NOW—ALSO AVAILABLE IN
COMPLETE KIT FORM

FOR ONLY **\$14.95**

Send for Descriptive Literature



LAMBDA ELECTRONICS CORP.

BOX No. 55

CORONA, N. Y.

Learning Telegraphy & Wireless is *EASY*

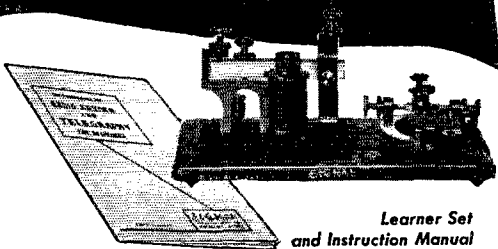

Learner Set
and Instruction Manual

Keying fundamentals, codes—learn it all quickly, easily with Signal's new booklet, "Radio Keying and Telegraphy for Beginners". Performance-proven practice keys and two-way learner sets are also available. Mail 15c (stamps or coin) today for your instruction manual and equipment catalog.

Signal ELECTRIC MANUFACTURING CO.
DEPT. D-2, MENOMINEE, MICHIGAN

TRAIN FOR ALL TYPES FCC (RADIO OPERATOR) LICENSES

Complete Raytheon AM and FM broadcast transmitters and studio control equipment. Also TV camera chain unit. 30th anniversary year. Send for catalog Q.

MASS. RADIO SCHOOL

271 Huntington Avenue Boston 15, Massachusetts
Lic. by Comm. Mass. Dept. Ed.



Founded in 1909

RADIO TELEPHONY RADIO TELEGRAPHY

Courses ranging in length from 7 to 12 months. Dormitory room and board on campus for \$40.00 a month. The college owns KPAC, 5 KW broadcast station with studios located on campus. New students accepted monthly. If interested in radio training necessary to pass F.C.C. examinations for first-class telephone and second-class telegraph licenses, write for details.

PORT ARTHUR COLLEGE PORT ARTHUR TEXAS
Approved for G. I. training

ratings of an 829B, and input and output capacitances lower than an 832A. Though we've not yet had a chance to exploit it fully, we did put one into an experimental set-up as a tripler from 144 to 432 Mc. Using an 832A amplifier on 144, providing 5 ma. grid current through a 50,000-ohm grid resistor, we were pleased to find that the 9903 would deliver up to nearly 10 watts output on 432 Mc., without exceeding the tube's 40-watt plate dissipation. Under these conditions it could be plate modulated successfully.

Latest Propagation Information — Watch WIAW

We know that ionospheric storms are closely allied with DX openings on both 6 and 2 meters. The important thing is to know when they may be expected. To help amateurs everywhere to make the most of propagation vagaries connected with magnetic disturbances, WIAW transmits the latest CRPL information on anticipated ionospheric storm dates nightly. Form the WIAW habit for up-to-the-minute propagation information!

M.A.R.S.

(Continued from page 62)

contact with the Pentagon to allow telephone relay transmission to homes or offices anywhere in the States. However, since he is the only MARS operator in the Army group his time is necessarily limited. The Colonel reports that Mission personnel are conscientious in the use of the amateur facilities, and voluntarily limit their requests for messages to matters which cannot be handled economically through normal channels.

Correspondence

(Continued from page 63)

114-67 223rd St., St. Albans, N. Y.

Editor, QST:

When I passed my 40th birthday, I suddenly felt old. It took me more than 5 years to recuperate — and then out of the blue comes your January issue. Why did you have to depict a 1910 amateur station on the front cover? Have you no mercy on those of us who can remember coherers, electrolytic and crystal detectors of any and all types, tuning coils, variable condensers made of two pieces of wood, some tinfoil and a hinge, Ford spark coils, zinc spark gaps? Did you have to remind me of the special 10¢ crystal detector put out by the old Electric Importing Company of New York? Did you have to bring up long-forgotten memories of a crystal detector, a buzzer to find a sensitive spot and NAH and NAA?

— Old Man Roth, W2DKH

Strays

Electric currents as minute as 100 millionths of a millionth of an ampere can be measured accurately by the Brown electrometer, an instrument specifically designed to detect nuclear-energy rays. The new device is expected to find wide application in recording the output of vacuum phototubes, as in measurement of light intensities for ultraviolet or visible-spectrum analysis.

COMPLETE RADIO TRAINING!

Prepare now to accept a responsible position in Commercial Radio. New developments will demand technicians with thorough basic training, plus a knowledge of new techniques discovered during the war. Training open to high school graduates, or those with high school equivalency. Courses 6 to 18 months' duration in RADIO AND ELECTRONICS. Approved Veteran training in Radio. Write for Particulars.

VALPARAISO TECHNICAL INSTITUTE
DEPT. TN Valparaiso, Ind.

RCA VOLTOHMYST Self-Contained Batteries!

Model WV-65A — RCA Battery Voltohmyst vacuum tube voltmeter and volt-ohm-milliammeter combined! Features self-contained long-life battery power supply. Ranges: 0-3/10/30/100/300/1000 volts D.C.; constant input resistance 11 megohms for all ranges; 0-10/30/100/300/1000 volts A.C. @ 1,000 ohms per volt; 0-1,000/10,000/100,000/1 meg/10 meg/1,000 megohms; 0-3/10/30/100/300 milliamperes D.C.; 0-10 amperes D.C.

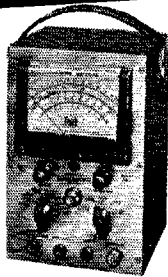

- RCA WV-65A Voltohmyst complete with 1-Meg. D.C. dynamic test probe and test leads, less batteries **39.50**
 BATTERY KIT — Two 45V and four 1½V, factory-fresh! **2.58**
 WG-263 — RCA Crystal Probe, read R.F. voltages flat to 100 megacycles **8.95**
 WG-284 — RCA high-voltage probe, read D.C. volts to 30,000 volts **15.95**

NEW EICO 425-K 5" OSCILLOSCOPE KIT

Improved push-pull circuit for all-around oscilloscope use! Features new tube lineup: three 6SN7, two 6J5 and 5BP1 5" cathode ray. Kit supplied with all tubes, parts, giant power transformer, controls, knobs, handsome case with etched panel, instructions, etc. Nothing else to buy! Your cost, complete..... **39.95**

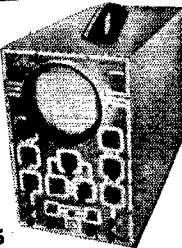

All prices net, F.O.B. New York

TVI BOTHER YOU?

Then bother us — we don't mind!

No kidding, television interference is an annoyance that can be eliminated — easily and cheaply (in most cases) when you know how! Ask our TVI experts — Ed, W20TV and Bob, W2UUE — they know how to clear your TVI woes and will be glad to assist you. We carry all types of filters for suppressing TVI at transmitters and at television receivers.

- G.E. "HARMONIKER" kits for 10, 20, 40 and 80 meters **12.95**
- Drake Low Pass Filters for transmitters, 52 ohm coax or 300 ohm twin-lead. Each **3.57**
- Drake High Pass Filters for TV receivers, 72 ohm coax or 300 ohm twin-lead. Each **3.57**
- Sprague HYPASS Capacitors—all sizes from 250 VAC to 5,000 VDC
- OHMITE power line and plate circuit chokes

TERMINAL RADIO CORPORATION

Distributors of Radio & Electronic Equipment

85 CORTLANDT STREET, NEW YORK 7, N. Y.
 WOrth 4-3311 • Cable: TERMRADIO

Are you . . . ?

AN ACTIVE HAM, with several years of enthusiastic experience? Have you Sales, Technical and/or Advertising background that qualifies you to handle competently, practical, technical selling, correspondence, expedite mail orders, and help with ads, etc.?

IF SO—there's a solid, dependable future for you with the largest and friendliest Distributor of Amateur Equipment in New York City. Please give full resume and happy starting minimum in first letter.

BOX 145 QST

RECEIVING SENDING
CODESPEED *without strain*

CHAMPIONS ENDORSE CANDLER WAY
 Get skill, accuracy, speed with the highly endorsed Candler System. Learn to send and receive by telegraph or radio code. Government service and commerce need thousands of better trained operators. Air commerce, mail, freight, etc., demand expert, reliable operators. (Good pay. Get the Candler System, the maker of champions. It teaches you the "knack" of sound sense, alertness, speedy sending and receiving without strain. Adventure — good pay. Learn at home or wherever you are. Rush name today for free book.)

FREE!

CANDLER SYSTEM CO.

Dept 4-C, Box 928, Denver 1, Colorado, U.S.A.
 and at 121 Kingsway, London, W. C. 2, England

Performance Plus!

with the Peerless hi-quality 18 watt TRIODE output amplifier kit. Heart of this kit is the Peerless S-240-Q output transformer, conclusively proved a superior product in square wave tests. Amplifier's response is flat from 20 to 20,000 cps for radio input. Phono input equalized for variable reluctance pickup. Kit contains all basic components and instructions.

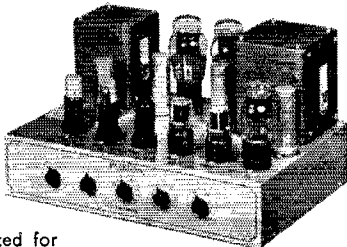

10722
 Triode
 Amplifier
 Kit

PEERLESS Electrical Products Division



1161 N. VINE STREET, HOLLYWOOD 38, CALIFORNIA • 161 SIXTH AVENUE, NEW YORK 13, NEW YORK



NATIONAL

- **Proven**
- **Dependable**
- **Quality**

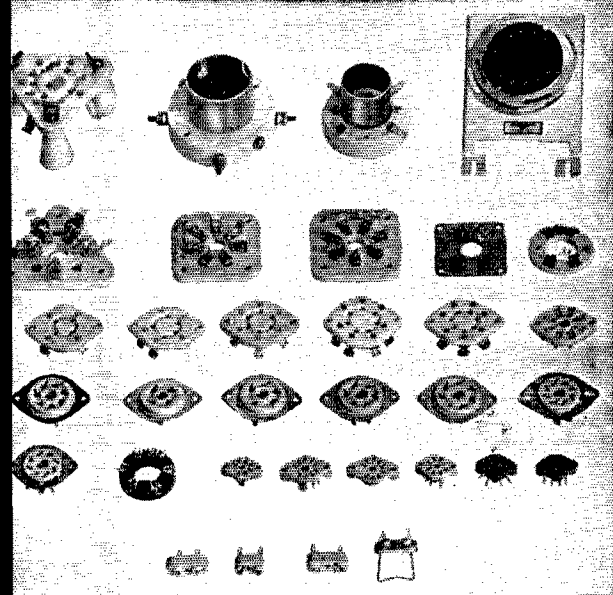

**... A SOCKET
FOR
EVERY PURPOSE**

Write for General Catalog

National



NATIONAL COMPANY, Inc.
MALDEN, MASSACHUSETTS

A.R.R.L. QSL BUREAU

The ARRL maintains a QSL bureau system to make it easy for you to receive your DX QSL cards, but in order for it to function it is necessary that we receive your cooperation. All you have to do is send the QSL manager for your call area a stamped self-addressed envelope of the No. 10 stationer's size (No. 8 post-office size), with your name and address in the customary place and your call letters printed prominently in the upper left-hand corner. When he has an envelope full of cards for you, he'll return the envelope to you. Upon receipt of that envelope, be sure to send him another.

If you've previously held a different call, send an envelope to the manager for that call area. All QSLs for portable operation are routed via the *home district*.

Do not send cards for other W or VE stations for distribution via the QSL bureau; they cannot be accepted. Likewise, do not send cards for distribution to foreign stations via this domestic QSL bureau system. For the addresses of the proper bureaus to which foreign cards may be sent, see page 61 of December, 1949, *QST*.

The bureau handles only incoming DX QSLs.

W1, K1 — Frederick W. Reynolds, W1JNX, 83 Needham St., Dedham, Mass.

W2, K2 — Henry W. Yahnel, W2SN, Lake Ave., Helmetta, N. J.

W3, K3 — Jesse Bieberman, W3KT, Box 34, Philadelphia, Penna.

W4, K4 — Johnny Dortch, W4DDF, 1611 East Cahal Ave., Nashville, Tenn.

W5, K5 — L. W. May, jr., W5AJG, 9428 Hobart St., Dallas 18, Texas

W6, K6 — Horace R. Greer, W6TI, 414 Fairmount St., Oakland, Calif.

W7, K7 — Mary Ann Tatro, W7FWR, 513 N. Central, Olympia, Wash.

W8, K8 — William B. Davis, W8JNF, 4228 W. 217th St., Cleveland 16, Ohio

W9, K9 — John F. Schneider, W9CFT, 311 W. Ross Ave., Wausau, Wis.

W0, K0 — Alva A. Smith, W0DMA, 238 East Main St., Caledonia, Minn.

VE1 — L. J. Fader, VE1FQ, 125 Henry St., Halifax, N. S.

VE2 — Austin A. W. Smith, VE2UW, 6164 Jeanne Mance, Montreal 8, Que.

VE3 — W. Bert Knowles, VE3QB, Lanark, Ont.

VE4 — Len Cuff, VE4LC, 286 Rutland St., St. James, Man.

VE5 — Fred Ward, VE5OP, 899 Connaught Ave., Moose Jaw, Sask.

VE6 — W. R. Savage, VE6EO, 329 15th St., North, Lethbridge, Alta.

VE7 — H. R. Hough, VE7HR, 1785 Emerson St., Victoria, B. C.

VE8 — Jack Spall, VE8AS, P. O. Box 268, Whitehorse, Y. T.

KP4 — E. W. Mayer, KP4KD, P. O. Box 1061, San Juan, P. R.

KZ5 — C.Z.A.R.A., Box 407, Balboa, Canal Zone

KH6 — Andy H. Fuchikami, KH6BA, 2543 Nanau Dr., Honolulu, T. H.



RADIO and TELEVISION

Thorough Training in All
Technical Phases

APPROVED FOR VETERANS

WEEKLY RATES DAYS—EVENINGS

RCA GRADUATES ARE IN DEMAND

For Free Catalog write Dept. ST-50

RCA INSTITUTES, INC.

A Service of Radio Corporation of America
350 WEST 4th ST., NEW YORK 14, N. Y.

Outstanding POWER CONVERSION UNITS

for any Voltage and Amperage Rating

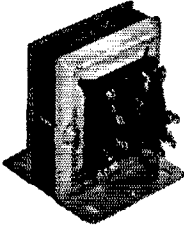

**THERMADOR
TRANSFORMER**

R.P.S. Power Conversion Units specially designed to convert any d-c Receiver, Transmitter, etc., into a-c use. No rewiring necessary; simple, easy, quick installation. No Tubes! Instant Warm-up! Cool Operation! No Maintenance! Low Cost!

Installation Diagram with each unit. When ordering—be sure the input rating of your dynamotor does not exceed the d-c output rating of the rectifier. For

example, 12 V. 2 amp. dynamotors require Rectifier No. S-295A and Transformer RPS-8883.

Weights listed—contact freight agent for cheapest means of shipment and include charge with remittance.

All prices are F.O.B. Los Angeles (California purchasers add 3% sales tax). Include 25% with orders—balance on delivery. Foreign orders cash. Address correspondence Dept. C7.



**VICKERS
SELENIUM
RECTIFIER**

ALL NEW—FULL WAVE VICKERS SELENIUM RECTIFIERS

Code No. Rectifier	d-c Output Volts	Amps.	Ship. Wt. Lbs.	Amateurs Net Pr.
S-295A	14	2	1.25	\$ 6.95
S-458A	14	4.5	1.75	7.25
S-167A	14	10	3.75	10.95
S-292A	14	40	12	29.95
S-296A	28	1.8	1.25	5.75
S-344A	28	5	5.75	11.50
S-172A	28	10	6	16.50
S-291A	28	20	12	29.95
S-297A	28	40	23	52.25

ALL NEW—THERMADOR TRANSFORMERS 50/60 Cyc—117 Volt Primary Rating (For Taps, see Note A)

Code No. Transformer	Secondary Volts	Amps.	Ship. Wt. Lbs.	Amateurs Net Pr.
RPS-8883	18	3	3.5	\$ 3.75
RPS-8884	18	5.2	5.5	4.25
RPS-8885	18	12	12	6.15
RPS-8886	18	46	35	19.65
RPS-8888	36	2	5	4.15
RPS-8889	36	6	12	6.75
RPS-8892	36	12	25	11.65
RPS-8890	36	23	32	19.25
RPS-8891	36	46	78	51.25

NOTE A: All transformers have 3 extra taps—for example: 20, 19, 18, 17 volts and 38, 37, 36, 35 volts.

Distributed Nationally by

RADIO PRODUCTS SALES, INC.

1501 SOUTH HILL STREET • LOS ANGELES 15, CALIFORNIA • PHONE PROSPECT 7471



RADIO COURSES

- RADIO OPERATING
- RADIO SERVICING
- CODE
- FM TELEVISION
- REFRIGERATION SERVICING

Personal Counselling Services for Veterans
Write for Catalog T.O. and Picture Brochure

YMCA

TRADE & TECH. SCHOOL 229 W. 66 St., N. Y. 23
ENdicott 2-8117

COMMERCIAL RADIO INSTITUTE

A RADIO TRAINING CENTER FOR 30 YEARS

Resident Courses Only • Broadcast, Service, Aeronautical, Television, Radar, Preparatory Mathematics, Frequency Modulation and Marine telegraphy. Classes now forming for summer term June 5th. Entrance examination May 22nd.

Literature upon request. Veteran training

Dept. B, 38 West Biddle Street, Baltimore 1, Maryland



*"It's KENYON Transformers For My Rig
Because They Always Put Out!"*

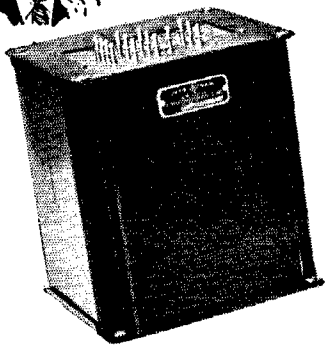

- Hams everywhere specify KENYON "T" Line Transformers! Manufactured under rigid standards, all KENYON transformers are constructed of the finest grades of material plus the skill and long experience of a highly trained competent operating staff.
- All KENYON transformers are checked progressively in the course of manufacture and are laboratory-tested upon completion to insure satisfaction. Yes, KENYON "T" Line Transformers meet the most exacting requirements of critical purchasers. For skillful engineering, progressive design and sound construction—Specify KENYON for top performance in your rig!

KENYON TRANSFORMER CO., Inc.

840 BARRY STREET

NEW YORK, U. S. A.

HAM-ADS

(1) Advertising shall pertain to radio and shall be of nature of interest to radio amateurs or experimenters in their pursuit of the art.

(2) No display of any character will be accepted, nor can any special typographical arrangement, such as all or part capital letters be used which would tend to make one advertisement stand out from the others.

(3) The Ham-Ad rate is 30¢ per word, except as noted in paragraph (6) below.

(4) Remittance in full must accompany copy. No cash or contract discount or agency commission will be allowed.

(5) Closing date for Ham-Ads is the 25th of the second month preceding publication date.

(6) A special rate of 7¢ per word will apply to advertising which, in our judgment, is obviously non-commercial in nature and is placed and signed by a member of the American Radio Relay League. Thus, advertising of bona fide surplus equipment owned, used and for sale by an individual or apparatus offered for exchange or advertising inquiring for special equipment, if by a member of the American Radio Relay League takes the 7¢ rate. An attempt to deal in apparatus in quantity for profit, even if by an individual, is commercial and all advertising by him takes the 30¢ rate. Provisions of paragraphs 2 (1), (2) and (3), apply to all advertising in this column regardless of which rate may apply.

(7) Because error is more easily avoided, it is requested signature and address be printed plainly.

(8) No advertiser may use more than 100 words in any one issue nor more than one ad in one issue.

Having made no investigation of the advertisers in the classified columns, the publishers of QST are unable to vouch for their integrity or for the grade or character of the products or services advertised.

Please note the 7¢ rate on hamads is available to ARRL members only.

QUARTZ — Direct importers from Brazil of best quality pure quartz suitable for making piezo-electric crystals. Diamond Drill Carbon Co., 719 W. 4th St., New York City.

QSLs, 100¢ \$1.25 up. Stamp for samples. Griffith, W3PSW, 1042 Pine Heights Ave., Baltimore 2, Md.

AMATEUR radio licenses. Complete theory preparation for passing amateur radio examinations. Home study and resident courses. American Radio Institute, 101 West 63rd Street, New York City.

QSL's, SWL's. Finest stock. Fastest prices. Faster service. Dossett, W9BVB QSL Factory, 857 Burlington, Frankfort, Ind.

QSLs! Kromkote cards at a fair price. Dauphinee, W1KMP, Box 219, Cambridge 39, Mass.

SUBSCRIPTIONS, Radio publications a specialty. Earl Mead, Huntley, Montana, W7LGM.

DON'S QSL's, "The finest". Samples, 2106 South Sixteenth Avenue, Maywood, Illinois.

QSL's high quality, fair prices. Samples? W7GPP R. D. Dawson, 1308 F Street, The Dalles, Oregon.

10-METER Beams, \$19.50. Send Card for free information, Riverside Tool Co., Box 87, Riverside, Illinois.

UNCLE Fred's QSLs. For Hams of distinction! Three colors and up. Rainbow map QSLs. Special DX QSLs. Samples, 10¢. Uncle Fred, Box 86, Lynn, Penna.

ZIPPO lighter, ARRL insignia and call sign, inlaid enamel, \$5.00. Ideal birthday gift. McCarron, W2BNO, 3050 Decatur Avenue, New York 67, N. Y.

QSL Quality cards, priced right! Samples, Ferris, W9UTJ, 1768 Fruitdale, Indianapolis, Ind.

BARGAINS: New and used transmitters, receivers, parts: Globe King, \$299.00; Meissner 150B, \$295.00; Hallicrafters HT-9, \$295.00; Sonar SRT-75, \$149.00; New 150-watt 'phone, \$199.00; 60-watt 'phone, \$99.00; Globe Trotter, \$57.50; HT-17, \$39.50; new Meissner Signal Calibrators, \$29.95; MB611, \$29.50; HRO 5TA1, \$199.00; HRO complete, \$149.00; SX-43, NC-173, HO-129X, \$139.00; RME-45, SX-25, \$99.00; S-38, \$29.95; S-41, \$22.50; latest signal shifter, \$59.50; DB22A, \$49.00; BC610s, AF100, and many others. Large stock trade-ins. Free trial. Terms financed by Leo, W9CIG. Write for catalog and best deal to World Radio Labs, Council Bluffs, 740-44 West Broadway.

QSL's, SWL's. Samples free. W4HUD, Albertson, Box 322, High Point, N. C.

CRYSTALS: Bassett Type 100A precision low-drift units made to your exact specified frequency within the 80 or 40 or 20 amateur bands, at \$1.50 each, plus postage. Rex Bassett, Inc., Bassett Building, Ft. Lauderdale, Fla.

BC610-E: Complete. Like new and perfect. Converted 10 through 75 meters. Spare 250TH and 100TH's. \$450.00. F.o.b. Will consider trade of smaller rig. Sidney Miller, W2CIW, B540, Apt. 6, Fort Monmouth, N. J.

BARGAINS: New and used reconditioned Collins, Hallicrafters, National, Hammerlund, RME, Millen, Meissner, Sonar, etc. Reconditioned S-38, \$29.00; S-40A, \$59.00; S-53, \$49.00; SX-42, \$129.00; NC-87, \$59.00; NC-173, \$139.00; NC-183, \$199.00; HO-129-X, \$129.00; RME-45, \$89.00; RME-84, \$89.00; DB-22A, HF-10-20, VHF-152A, HO-C, NC-240D, S-47, SX-45, SX-28A, Collins 75A1, \$285.00; BC-610, etc. Shipped on approval. Terms, List free. Henry Radio, Butler, Missouri.

QSLs? SWLs? Modernistic? Cartoons? DeLuxe? Photographic? QSL specialists. Samples, 3¢. Sackers, W9DED, Holland, Michigan. QSLs Made to order. Free estimates given on any special QSL design. Just send sketch, or ideas.

QSLs-SWLs. By WIHJI, Cushing, Samples, Box 32A, Manchester, N. H.

STEEL TV towers, shipped direct from the factory at \$8.50, 10 foot section. Can be erected to 70 ft. Built to order. Write Youngtown Steel Towers, 1316T, Wilson Ave., Youngstown 8, Ohio.

NEW 1-82A eelsyn indicators, \$3.95; new BC-1206C "Lazy O-River", \$5.95; new BC-455, \$6.95; new BC-453B, \$12.95; FL-8A filters, \$1.37; FL-5F filters, \$2.95; Excellent used AN/AP5-13, \$14.95. Guaranteed T-17 mikes, 69¢. Trouble-shooting manuals (includes schematics), BC-348, BC-779, SCR-522, BC-610, \$1.00 each. Add postage. RCA sound powered units, \$2.22 pair. Free catalog. Lectronic Research Laboratories, 1021-Q Callowhill St., Philadelphia 23, Penna.

BC-610E, in excellent condition, extra exciter, extra tubes and crystals, all coils, factory converted for 10-meters, \$555.00. Dr. Ciskowski, 6310 W. Florissant, St. Louis, Missouri.

FOR Sale: 125-watt fone/cw xmitter and power supplies; 6 ft. rack, meters, coils, now in operation. Tunes from 2 meters to 160 meters. Also many extras. \$150.00 takes all. W9WFH, 9736 Reeves St., Franklin Park, Illinois.

MOTOROLA mobile transmitter T-69-20A, 28-30 Mc with matching rcvr. factory re-worked for 10 meters, complete with dash control head, tubes, cables, control box, remote antenna control box, microphone and power supply. Also extra D.C. Car bumper stainless steel 96 inch whip. Also BC-654A complete with rack mounting, including dynamotor, microphone, cables, tubes and speaker. Extra BC-654A used with tubes and new D.C. supply. Best offer takes any part or all. W9CVU, P. O. Box 224, Cedar Rapids, Iowa.

QSLs-SWLs. High quality, reasonable price. Free samples. Write Bob Teachout, W1FSV, 40 Elm Street, Rutland, Vermont.

1000 VA G-E transformers, 1100-2200-4400 each side CT, guaranteed. Fred Dawson, 5740 Woodrow, Detroit 10, Michigan.

WANTED: Instructograph complete, with tapes, in excellent condition. Send description and price. Box 1112, Curundu Post Office, Canal Zone.

I-KW bandswitching transmitter, complete for xtal or shifter on 10-20-30 meter bands. 100% AM or NBFM. Built-in 9 ft. Par-Metal cabinet. Parts alone cost over \$1000.00. Will sell for \$500.00. Also have Model PCA-2T-200 Panadapter and No. 912 Precision tube checker. W3BTY, P. O. Box 994, Lancaster, Penna.

FOR Sale: BC-221 very good condition, original calibration, and xtal, \$48.00. Sonar XE10, new, \$18.00. Wanted: a 3 x 5 printing press. Clyde Keeler, Seward Ave., Port Jervis, N. Y.

BC-610-E for sale. Excellent condition. Previous owner bought new from Hallicrafters Co. on priority in 1947. Need money for my business. \$550.00. Victor Hintzman, W9VDK, 1308 1/2 6th St., Menomonee, Wisconsin.

WANTED: Steel cabinet only and coils for UHX-10 transmitter, WBB.

WANTED: Pre-war National NC-101X receiver. R. H. Dempsey, 1731 N. E. 10th, Portland, Oregon.

SELL Mackay 167BV without power supply, \$250.00. Cash and carry. W2VAF, 22 Clinton Street, Babylon, L. I., N. Y.

\$250.00 takes HQ-129X with speaker A-1 shape, Meissner Model B-signal shifter, Meissner NBFM attachment, JT30 mike, cord and stand; Triplet Model No. H666 tester, 400-watt xmitter, 812A PP in final with spare, BW VAR, Link final coils, Handbook, several years QST and CQ; miscellaneous antenna and parts, all for above price. Reason: TV infested area, doctor's equipment. Write W3BBV, 1357 Hill St., York, Penna.

SELL: SP-400X in excellent condition, \$300.00. AR1-13 fair condition, \$45.00. BC-348, in good condition, unconverted, \$50.00. BC-321, unconverted, in excellent condition, \$80.00. F.o.b. Richmond, Va. W1AQG, 5012 Lakeside Ave., Richmond, Va.

FOR Sale: 522s, \$20.00, converted BC-312, \$50.00; BC-348s, unconverted, \$50.00. C. Gouveia, 3310 63rd St., Sacramento, Calif.

SALE: SCR-522 trans. BC-348, BC-221, W4OEN, P.O. Box 25, Alabama City, Alabama.

"TAB" Bargains! New tuning meter, 5 Ma., 98¢; 6V Magmotors, 400V/150 Ma., \$3.98; 250V/100 Ma., \$4.98. Guaranteed tested tubes: 6AG5, 6AK5, 6BH6, 6J6, 1S5, 7Y4, 12A17, each 39¢. Write for "Free Tabogram". "TAB", 109 Liberty St., New York City, N. Y.

WANTED: QST for February, March, July 1916. I have 500 other copies QST and Radio for trade or sale. W9MXX, 1022 N. Rockhill Rd., Rock Hill, 19, Mo.

SELL complete with schematics following in excellent condition: SCR522 with remote box and dynamotor, \$40.00; Millen 90700 Variarm ECO, \$25.00; DeLuxe Melehan Valiant key, \$20.00 new Sonar XE10 NBFM Exciter, \$30.00. W6NDF, Escondido, Calif.

QSLs: Quality is remembered long after price is forgotten! C. Fritz, 1213 Briargate, Joliet, Illinois.

MOBILE rig, three months old, 3-30 Gon-Set, ST203A, factory wired, tubes, xtal, PE103, mike, antenna, controls, cable, complete, \$95.00. HRO rack mounting power supply, \$10.00. B29 slip-ring mounting, complete, \$10.00. AC operated condenser mike, complete, \$15.00. W9DUD

SELL or trade, half KW xmitter, power supplies modulator, 7 ft. rack Bus 100-watt phone, complete BC-312, 274N units 654 complete, lots of extras. Write for price or trade for Contax camera or other equipment. Prefer deal someone close who can inspect everything and haul it away. Morris Cooper, W8EBK, Box 173, Mason City, Iowa.

SELL new Collins 32V2, 150-watt transmitter, \$475.00. Cost \$575. W5DA, 4425 Bordeaux, Dallas, Texas.

LOS Angeles hams: 400-watt 20-meter phone/cw xmitter 813's, VRO, NC-156 rcvr, LM free, meter, AC power, 100-watt 40-meter xmitter, Q5'er, tube tester, audio oscillator, box of misc. parts, bring truck. All for \$150.00. W9RET, Normandy 6186, 4524 Fountain Ave., Los Angeles 27, Calif.

WANTED: Two KS-9472 input transformers. Sinclair, W2VNO, 19 Olyphant Place, Morristown, New Jersey.

SELL Collins 32V-1. Like new. No time to operate. How about \$375.00? W1GQE/Z, Al Dole, 267 Jewett Ave., Staten Island 2, N. Y.

SCR-522 technical manual, urgently needed. Beg, borrow, steal, even buy! Larky, 223 W. Summit, Somerville, N. J.

FOR Sale: ART-13 complete, 3 power supplies, 28v, 50v, and 1500 v, as per Dec. 1946 Radio Magazine. Excellent condition, not tampered with, \$195.00. W9THB, 1920 Edison, Granite City, Illinois.

FOR Sale: Webster basic unit wire recorder (brand new) amplifier, 1-1 hour spools of wire, \$40.00. Meissner FM tuner, like new, \$25.00. W0 ZXS, Dr. H. A. Hecht, 8444 Lackland, St. Louis 14, Mo.

MUST sell new Harvey-Wells TBS-50A, power supply, 1 N. SX-28A, Gonset 10-11, new PE-103A, oscilloscope, 7X50 Leitz binoculars, photographic equipment. Queries answered. W30VI, 605 Montgomery, Laurel, Maryland.

SALE or swap: SX-23 for Amertran 6200V 700 Ma. W8TSD, Box 94 Oak Harbor, Ohio.

SELLING out: Hallcrafters S-20R, SX-28A, S-36A, SX-42, best offer; two used Mallory Inductors, \$12.50 each; BC-348Q, AC converted; Hickok 288X, 610A, generator, 157 traacometer. Make your offer for any item. C. A. Green, Box 204, Harvey, Illinois.

QSLs. Free samples. Narvestad, Granite Falls, Minnesota.

BEST cash offer takes new Elmac 4-250A, Pilot FM Tuner, 100 watt modulation transformer or what do you need. WIWV, 206 Ledyard, New London, Conn.

SELL: Asst. mica condensers .0002 to .000068 μ fd, 2500 volts working, 25¢ each. W20BH, 78-15, 141st St. Flushing, L.I., N. Y.

BC-610 for sale with speech amplifier, \$400.00, used very little. Several R 4's used, one brand new. Make offer. WISF, Harry Johnson, Bradford, Conn.

QST: Complete issues from January, 1935 to December, 1948, including 1942 Handbook. Also pair of 807's, pair 811's, pair 813's, brand new. Make offers. You pay transportation. Oscar G. Herrick, W3QLW, 1328 Hillside Ave., Honesdale, Penna.

CONVERTED BC-312 receiver, PE-103, DM-36 converter, Q5'er. For sale, best offer. W7MRL, 600 University, Moscow, Idaho.

ART-13, latest model, having vernier VFO, 28V10A, filtered DC supply, cable, connectors, instructions, microfilm of 300-page maintenance manual with 186 pages enlarged for reading; new, used 20 hours, \$235. WIOTU, C. E. McDougall, Druid Lane, Riverside, Conn.

FOR Sale: HQ-129-X, BC-453Q, 400W rig in 6 ft. rack, 41 Meissner shifter, 813 stage, 812's final, 811's mods, 17 watt Pa Masco amplifier. All for \$295.00. W1QEU, 11 Wayne St., Manchester, N. H.

QSLs, Stationery, "etc." Taprint, Sumrall, Mississippi.

DUMONT 57" scope, used 5 hours, \$75.00. Ferret Sig. Gen., used 5 hours, \$35.00. Collins 75A used 20 hours, \$315.00. Two TBV Walkie Talkies, complete ready to go, with antennae, \$40.00. Solar Eclairage, \$60.00. P.P. 813 rig, partly completed. Photo and list. W8CWA.

BC-610. Want cabinet parts, lower panels, skirts, rear covers. Sell exciter, tuning boxes, tank coils, meters, upper panels, handles, hardware, brackets, dial drive parts, speech amplifier, cables, switches. Walt Strasser, W8BLR, 15384 Birwood, Detroit 21, Michigan.

SELL: NC-57, \$75.00. Gardner tape machine, \$20.00. Both in new condition. Sale reason: financial. Marvin J. Hayostek, Lakefield, Minn.

KILOWATT final, \$40.00. Sonar VFX680, \$45.00. W7KRR, 16654 5th Ave. South, Seattle, 8, Washington.

10 and 20 Meter Beams, \$19.25 up. Aluminum tubing, etc. Willard Radcliff, Fostoria, Ohio.

CARBON tetrachloride, cleaner, solvent 27 oz., \$1.50. Polystyrene high frequency coil and splices $\frac{1}{2}$ \$1.00 pint. Special chiron, 65¢ pint. Craft Chemical Lab, 4533 Jape East Exchange St., Akron 4, Ohio.

EXCITER difficulties? Solve them with a Collins 310B-1 from Carl, WIBFT at Evans Radio, Concord, N. H.

SELL: Hallcrafters 7" television receiver, Model #505 complete, \$55.00; also S-29 receiver, \$15.00. Needs slight repair. C. Horn, 325 East 163rd St., New York 56, N. Y.

HALLCRAFTERS SX-42 with Model R-44 speaker, for sale. In good working order. First money-order for \$100.00 takes all. Will ship express collect. Elmer Krute, W5OWL, 2349 Glenwood Drive, Port Arthur, Texas.

SELLING entire station. BC-610E, BC-639, RCA receiver, test equipment, etc. Write for full list. Reason for sale: Can't move it with me. Ex-DL4ZV, W. H. Wernimont, 204 N. Wayne St., Arlington, Va.

QSLs. The finest there are. Samples today will prove it by far. Larry's QSL's. P.O. Box 59, Opportunity, Wash.

FOR Sale: Collins ART 13 Autotune transmitter, 350 watts, covers 75, 40, 20, 10. Built-in precision VFO. Enclosed power supply included. Ready to plug in. Also, Stancor 30 watt mobile rig, power supply for same. Also, 780 volt supply. George Kravitz, 7919 20th Avenue, Brooklyn 14, N. Y.

WANTED: 32V2, Harvey-Wells, TBS50 and it's dynamotor. Box 104, Dyker Station, Brooklyn 28, N. Y.

SELL: Rack-mounted VFO. BC-696 (3-4 Mc) and BC-459 (7-9 Mc) using regulated power supply with 1100 V, 300 Ma, xfrm; pair 200 Ma chokes; 2, 2, two 6A3, 6S17, VR75; two 6.3 V xfrms; extra power xfrm; 6.3 V AC antenna and keying relays; 300 Ma meter; dial lights; and 80-40 meter switch. Handsome wooden cabinet for desk mounting. Wt. 80 lbs. \$55.00 or highest offer. All inquiries answered. W30EK, 1208 Romine Ave., McKeesport, Penna.

COLLINS 30K, complete. A beauty. \$999.00 F.o.b. Little Neck, L. I., N. Y. Brizzolari, W27G, 42-68 247th Street.

1000 Kilocycle crystals (less BC-221 holders) \$1.50 postpaid; mounted in F117B holders, \$2.00 postpaid. 500 kilocycle crystals (in FT-243 holders) \$1.00 postpaid. Frequency modulation discriminator transformers, 450 kilocycles to 470 kilocycles (air-tuned secondary) \$1.00 postpaid. I will sell, in my store (or through it) your excess electronic equipment at your price or no charge. Equipment also bought. Write for details. Ed Engbreitson, W9KRK, KRK Radio Products, 4112 Montrose Ave., Chicago 41, Ill.

WANTED: Job for summer 1950; have Class A, first telephone licenses; second year engineering at Univ. Va. Experienced in swimming. Write: G. P. McCasland, 854 Locust Ave., Charlottesville, Va.

SELL BC-348 with power supply, \$50.00, W5NW, Box 586, Odessa, Texas.

TRE Proceedings, 1946, 1947, 1948, 1949. Make an offer. Sell following locally: 10HP4, \$10, magnifier \$5.00; Melancon, 140-71 Ash Ave., Flushing, L. I., N. Y.

NEW Crystals for all commercial services at economical prices, also commercial regrinding. Over fourteen years of satisfaction and fast service! Edison Electronic Co., Phone 3901, Temple, Texas.

SELL: 450 watt cw xmitter, Pr 812's final, Millen exciter, 400 volt and 1500 volt power supplies, 6 ft. standard oak relay rack, \$125.00 crated for shipment. 450 watt' phone xmitter, Pr. T55s final, Millen exciter, 500 volt and 1800 volt power supplies, 6 ft. standard metal relay rack, Pr. 203Z modulator with 1800 volt power supply, Pr. 2A3 speech amp., \$210.00. Crated for shipment. Lawrence Hokanson, W9FYI, Wheaton, Minnesota.

FOR Sale: Rider Chemanalyst with instruction book, also matching H.F. converter (less H.F. probe). First \$75.00 takes both. Harry Ulyat, 106 Muse, Cambridge, Maryland.

USED relay racks, open welded steel, weighing 110 lbs. accommodations 6 ft. panel space, only \$10.00 F.o.b. Overbrook, Mass. A few 1200-0-1200 1500 Ma plate xfmers left at \$16.00. The Overbrook Company, Overbrook 81, Mass.

FOR Sale: 3' Clough-Brengle oscilloscope, \$25.00. K-35 kodak F3.5, \$25. R. Van Wuyckhuysse, W2CR, 412 Humboldt St., Rochester, N. Y.

SELL: Teletype machine, model 12, complete with table, typing unit, keyboard, paper relay, etc. Converted for Ham use. Also tape equipment consisting of tape transmitter, distributor, and repeater. All in working condition. Best offer. Semel, W2SHE, 111-85 77th Ave., Forest Hills, L. I., N. Y.

SELL: ART-13 converted 110 VAC, complete with all power supplies, ready to go, \$225.00. C. L. Tillotson, W4OIP, 4221 Kecoughtan Road, Hampton, Va.

BEST offer takes 1 Kw 20-meter 'phone transmitter, pair 304TL final modulators, pair 805's, driver ECO to T21-807 to pair 808's. All parts of the best heavy duty power supplies, rack mounted, fully metered. Will work other bands. Also 500-watt 75-meter 'phone, pair 8005's, final pair 811's modulators, rack mounted, complete with ECO ready to operate. Make offer, extra plate transformers, etc. Write for list. W5HXC, P.O. Box 109 Blackwell, Oklahoma.

BC-459 VFO (7-9 Mc) transmitters, excellent, used, with power plug CKT diagram, tested for output and frequency, \$8.75. Two BC-659, 10-meter FM transceivers, with battery case and 6-12-24 volt supply, \$22.00 each. Al Williams, W7HYA, 12015 75th Ave. S., Seattle 88, Wash.

SELL UTC transformers, S-32 \$3.50; S-41, \$7.00; S-19 \$5.50; S-8 \$2.75; W7NGE, 7704 37th SW, Seattle 6, Washington.

SELL: HT-9 new condition, extra 814, coils for 10 and 20 meters, \$150.00. W2MCZ, Kavanagh, 3311 Broadway, New York 31, N. Y.

SELL: Sonar XE-10 NFM exciter, brand new, never used — \$33.00. Will ship C.o.d. F.o.b. Jenkintown, Penna. W3KB, 214 Runnymede.

FOR Sale: Collins 75-A receiver, in excellent condition and A-1 shape. Express prepaid \$300.00. J. A. Selvidge, W9OMG, 1103 Gardner St., Poplar Bluff, Mo.

SELL: BC-348R receiver, A-1 condition. AC converted; mounting base, \$60.00. 300 watt modulation transformer, UTC VM-4, \$15.00. Mark II tank set and accessories, new, \$15.00. W6BEZ, 17 Pacific Ave., Piedmont 11, Calif.

SUPER Skyrider, 13 tubes, speaker, crystal, excellent ham receiver, \$145.00. W9IVN, 1022 Sheridan Road, Evanston, Ill.

FOR Sale: Meck T-60 transmitter, with coils for 40, 20, and 10. \$65.00. Bud VFO-21, 80 and 40-meter output, \$25.00. SCR-522 for 2 meters, with power supply, \$25.00. All in good operating condition. \$109.00 will take all three. W1QWI, 3 Chestnut St., Nantucket Island, Mass.

WE are trying to obtain high quality lab test equipment for cash. Weston Laboratories, Weston 93, Mass.

SELL Stancor ST202A 125-watt transmitter. Brand new shape. Complete with tubes, spare tubes, three 7 and one 3 Mc crystals. Triplett meter, coils for 7 and 14 Mc bands. Express collect or pick up \$85.00. Howard Reffelt, 11 Orchard St., Shelton, Conn.

QSLs: Original designs priced to fit ham's pocketbooks. Stamps for samples. Leonard's Print Shop, 854 View St., Hagerstown, Md.

FOR Sale: Hallcrafters transmitter HT-4B (BC-610) in good condition. Has BC-610E power and modulation transformers. With or without home-made speech amplifier. Has exciter boxes, coils, extra 250TH and two extra 100TH. Asking \$350.00. T. W. Rast, 1695 Union Street, Merced, Calif.

SELL: BC-348Q receiver. Converted. In perfect condx. New speaker. Baffle. \$49.00. Frank Moroney, 1423 Linden St., Des Moines, 14, Iowa.

FOR Sale: NC-100X, complete. In good condition. First offer over \$45.00 takes it. W4KMB, B. Snider, 456 Pochontas St., Naval Base, Norfolk, Va.

SELL: Limited quantity uncased 114 Kva distribution transformer, 120/240 to 7200 VCT with overload relays. \$15.00 each F.o.b. Power Electric Company, Att: J. W. Tucker, Service Div., W5KLG, Jackson, Mississippi.

ELIMINATE TVI. Shield your rig. 26 gauge heavy plated bright steel. Perforated 75 #3 holes per inch. Easily cut forms and soldered. Sheets 29" x 23", two for \$3.00, five for \$6.00 postpaid. Sample dime in stamps. Republic Television, Inc., Dumont, N. J.

COUNCILOR wanted for Maine boys' camp for summer. License required to operate Ham voice station, 20 years minimum age. Healy, 18 Floral, Hastings, N. Y.

SACRIFICE: RME VHF-152 \$50; Meissner VFO Model EX \$40. W1KE, 38 LaSalle Road, West Hartford 7, Conn.

SELL: BC-610 transmitter, complete, factory converted for 10; operating on 10 thru 80 meters; 700 watts tone and c.w.; \$500.00. W5OPQ, C. H. Boyd, 1522 West Fourth St., Freeport, Texas.

Designed for



Application

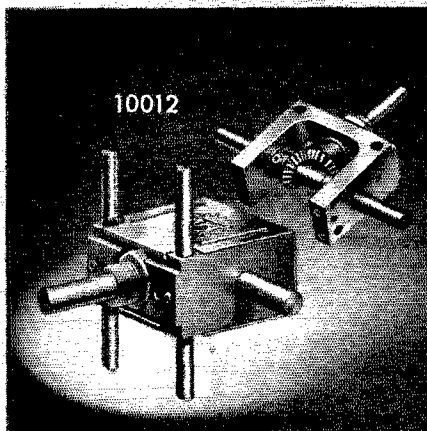

10012

The No. 10012 RIGHT ANGLE DRIVE

"Designed for Application." Extremely compact. Case size is only 1½" x 1½" x ¾". Uses bevel gears. Mounts on adjustable "standoff rods," single hole panel bushing or tapped holes in frame. Ideal for operating switches, potentiometers, etc., that must be located, for short leads, in remote parts of chassis.

JAMES MILLEN MFG. CO., INC.

MAIN OFFICE AND FACTORY
MALDEN
MASSACHUSETTS



Index of Advertisers

Advance Elec. & Relay Co.	102
Allied Radio Corporation	95
Altec-Lansing Corporation	121
American Phenolic Corporation	78
American Radio Institute	117
American Radio Relay League, Inc.	85, 98
Astatic Corporation, The	115
Barker & Williamson, Inc.	105
Belden Manufacturing Co.	87
Bliley Electric Company	84
Candler System Company	121
Capitol Radio Eng. Institute	83
Centralab	127
Cleveland Inst. of Radio Electronics	128
Cole Co., Ltd., E. K.	117
Collins Radio Company	2
Commercial Radio Institute	123
Cornish Wire Company	114
Drake Co., The R. L.	110
Eitel-McCullough, Inc.	77
Eldico of New York	97
Electronic Instrument Co., Inc.	115
Electro-Voice, Inc.	81
Gardiner & Company	119
General Electric Co.	1
Greenlee Tool Company	118
Hallcrafters Co., The	4, 7
Harrison Radio Corporation	113
Harvey Radio Company	97
Helntz & Kaufman, Ltd.	80
Henry Radio Stores	99
Hy-Lite Antennae, Inc.	118
Instructograph Company	108
Jensen Mfg. Co.	79
Johnson Co., E. F.	117
Kato Engineering Company	112
Kenyon Transformer Company	123
Lambda Electronics Corp.	119
Leeds Radio Company	107
Macmillan Co., The	96
Mallory & Co., P. R.	75
Mass. Radio & Teleg. School	120
Master Mobile Mounts, Inc.	88
Millen Mfg. Co., The James	126
Milwaukee School of Engineering	86
Motorola, Inc.	116
National Company, Inc.	73, 122, Cov. III
Newark Electric Company	101
New York YMCA Tr. & Tech. Schools	123
Ohmite Manufacturing Co.	89
Petersen Radio Company	5
Pioneer Broach Co.	90
Port Arthur College	120
Precision Apparatus Company	82
RCA Institutes, Inc.	122
Radio Corporation of America	Cov. IV
Radio Products Sales Inc.	123
Radio Shack Corporation, The	92, 93
Rider Publishers, John	104
Signal Electric Mfg. Co.	120
Sprague Products Company	94
Srepco, Inc.	119
Steinberga	106
Sun Radio of Washington	109
Telex, Inc.	108
Terminal Radio Corp.	121
Turner Co., The	119
U.H.F. Resonator Co.	114
United Transformer Co.	Cov. II
Valparaiso Technical Inst.	120
Van Nostrand Co., Inc., D. H.	103
Vesto Company, The	102
Vibroplex Company, The	110
Wholesale Radio Parts Co.	103
Wind Turbine Company	116
World Radio Laboratories, Inc.	111

You Say Goodbye to Guesswork When You Use Centralab Parts

You Can Rely on CRL Components for Top Quality Performance

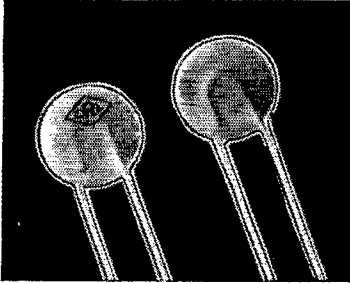

1 **KOLORDISK HI-KAPS** replace old-type by-pass or coupling capacitors in TV, AM, FM, HF, VHF, UHF, AF circuits. Smaller than a dime!

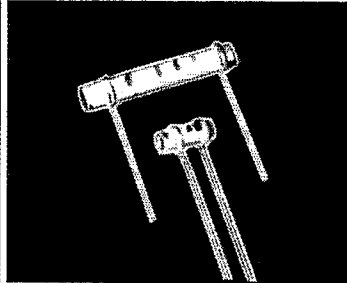

2 **TC, BC TUBULAR HI-KAPS**; Use TC for greater stability in temperature compensation. Use BC for non-resonant, by-pass and coupling circuits.

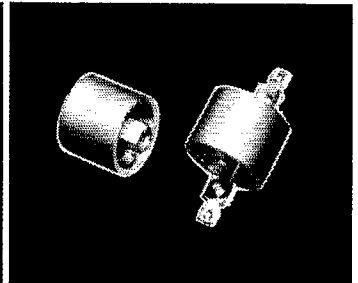

3 **HIGH VOLTAGE CAPACITORS**. These capacitors for transmitter and industrial use afford low power factor, stable retrace characteristics.

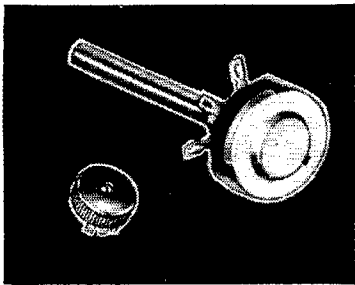

4 **MODEL "I" RADIOHM**, left, for miniature uses such as hearing aid controls. *Model "M"*, right, most popular and versatile of all controls.

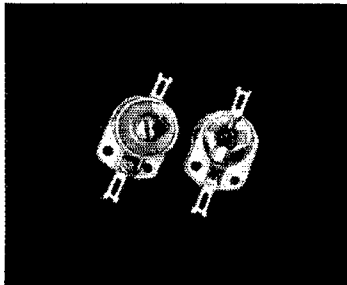

5 **TRIMMERS** for RF, HF circuits. Made with steatite base, burnished silver electrodes for electrical and mechanical dependability.

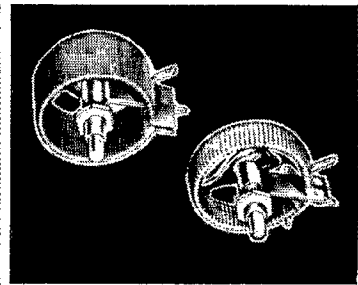

6 **POWER RHEOSTATS** for filament control on transmitters, small motor speed controls, other industrial applications. 25 and 50 watt sizes.

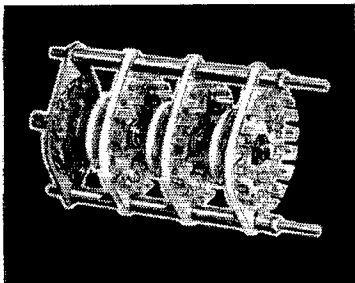

7 **POWER SWITCHES** are designed for transmitters, power supply converters and other applications. Efficient performance to 20 megacycles.

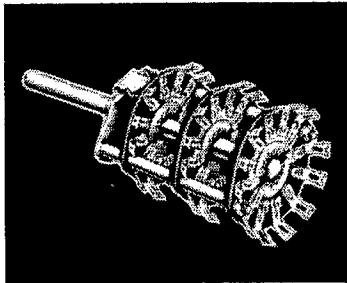

8 **ROTARY BAND SWITCH** is used primarily for band change and general tap switch applications. Made with steatite or phenolic insulation.

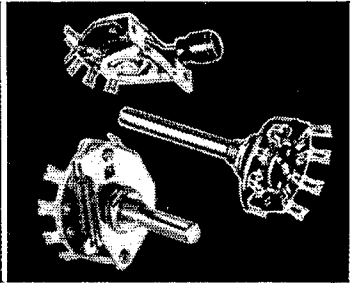

9 **LEVER, SPRING RETURN, TONE SWITCHES**. See your Centralab distributor for complete details on these switches—and all quality CRL parts.

WRITE FOR LITERATURE AND NAME
OF NEAREST CRL DISTRIBUTOR

Centralab

Division of GLOBE-UNION INC., Milwaukee

An FCC COMMERCIAL Radio Operator LICENSE

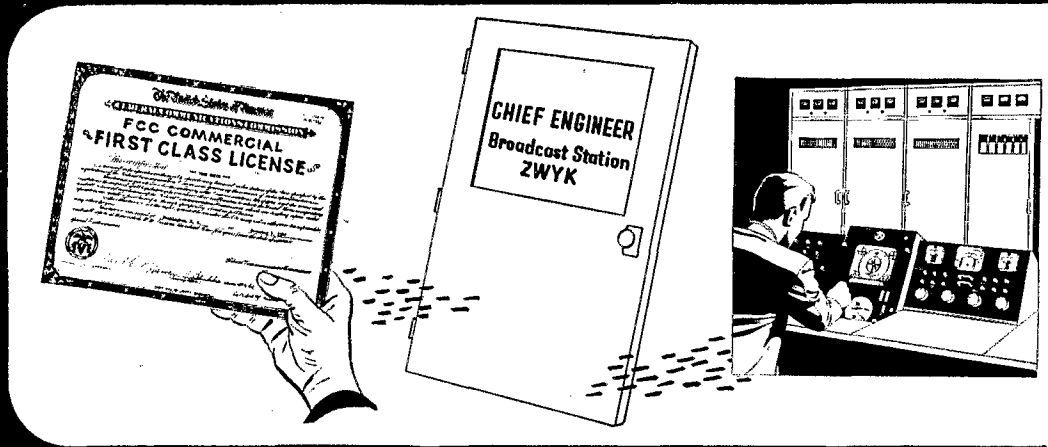

Your DOORWAY TO SUCCESS!

Get your FCC COMMERCIAL Radio Operator LICENSE in a few short weeks ...Then—Use Famous CIRE JOB-FINDING SERVICE

It's EASY if You Use CIRE Simplified Training and Coaching AT HOME in SPARE TIME

Do you know that over 50% of broadcast engineers started as hams. Add technical training to your ham experience now! Get your license easily and quickly and be ready for the jobs open to ticket holders which lead to \$3000 to \$7500 (average pay reported by FCC nationwide survey.) Then CIRE Job-Finding Service helps you get the job a license qualifies you to hold. Your FCC Commercial License is always recognized in all radio fields as proof of your technical ability.

Here's PROOF License Plus CIRE Job-Finding Service Gets Jobs!

"Have found and accepted a position at KWAD, Wadena, Minn. I secured this position through help of CIRE Job-Finding Service. I had six other offers from stations receiving my employment application and CIRE reference."
Student No. 2760 AT

"I have been recently employed at WOC-AM-FM-TV, Davenport, Iowa. Am connected with the Television, and certainly do find the course that I took with you people is helping me out tremendously. If it would not be for taking your course, I would not be where I am today."
Student No. 3451N12

CLEVELAND INSTITUTE OF RADIO ELECTRONICS
Desk QT-15, 4900 Euclid Bldg., Cleveland 3, Ohio
Approved for Veteran Training Under the "G.I. BILL OF RIGHTS"



GET THIS AMAZING FREE BOOKLET

1. Tells of thousands of brand-new, better paying radio jobs now open to FCC License Holders.
2. Tells how we guarantee to train and coach you until you get your FCC License.
3. Tells how our amazing Job-Finding Service helps you get the better paying radio job our training prepares you to hold.

CIRE IS THE ONLY PLANNED COURSE OF COACHING & TRAINING THAT LEADS DIRECT TO YOUR FCC Commercial LICENSE

Get All 3 FREE Send Coupon Now!

CLEVELAND INSTITUTE OF RADIO ELECTRONICS
Desk QT-15 • 4900 Euclid Bldg., Cleveland 3, Ohio
(Address to Desk No. to avoid delay)

I want to know how I can get my FCC Commercial ticket in a few short weeks by training at home in spare time. Send me your FREE booklet, "Money Making FCC License Information," as well as a sample FCC-type exam and free booklet, "How to Pass FCC Commercial License Examinations" (does not cover exams for Amateur License.)

Name.....
Address.....
City..... Zone..... State.....
 Veterans check for enrollment information under G. I. Bill

THE NEW HRO-50

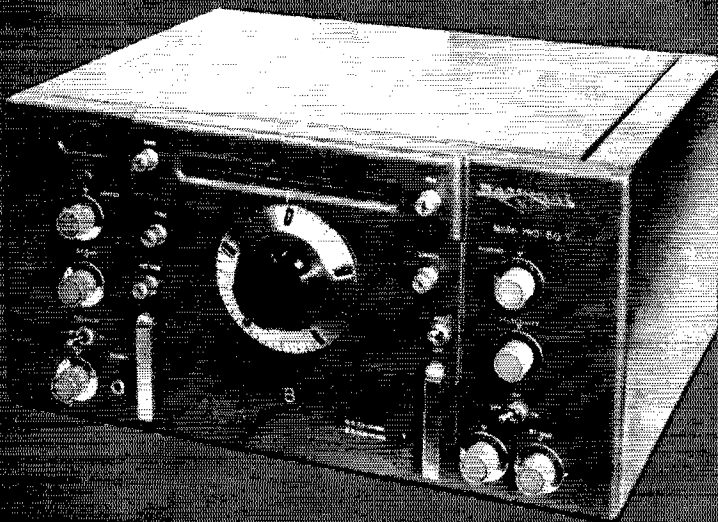

"CHARACTERISTICALLY" SUPERB!

Compare the characteristics of the new HRO-50 and see why, once again, the HRO sets the standard of receiver performance! You'll appreciate the convenience of the new HRO-50, too — the new edge-lighted, direct reading dial and the insulated, heavy-duty, built-in power supply. For thrilling performance, be sure to see and try the new HRO-50 — the receiver of the year!

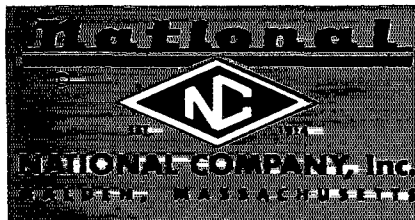

SUMMARY OF CHARACTERISTICS

- Freq. Range:** 50-430 kc., 480 kc. — 35 mc.
Tube Complement: 6BA6, 1st r.f.; 6BA6, 2nd r.f.; 6BE6, mixer; 6C4 h.f. oscillator; 6K7, 1st i.f.; 6K7, 2nd i.f.; 6H6 det. & a.v.c.; 6H6, a.n.l.; 6SJ7, 1st audio; 6SN7, phase splitter and S-meter amp.; 6V6 (2) p.p. audio; 5V4G, rect.; 6J7, b.f.o.; OBZ, volt. reg. **Accessories:** Crystal Calibrator, 6AQ5; NFM Adaptor, 6SK7, i.f. amp., 6H6, ratio det.; Select-o-ject, 12AT7 (2).
- Power Output:** 8 watts undistorted, push-pull amplifier fidelity ± 1 db 50-15,000 cycles.
- Sensitivity:** 1 microvolt or better at 6 db sig./noise.
Selectivity: Variable from 15 kc. overall to about 400 cycles at 40 db.
- Drift:** Negligible after warm-up.
Calibration: Direct frequency reading.
- Shipping Weight:** 100 lbs. incl. spkr. and 4 coils.
Dimensions: 16½" deep x 19¾" wide x 10⅛" high.
Price: \$335.00 (less speaker).
Accessories: 100/1000 kc. calibrator, \$19.95; NFM adaptor \$16.95; SOJ-3, \$24.95.

The Big Three



YOUR SELECTION OF RCA POWER RECTIFIERS

Tube Type	Rectifier	Max. DC Input to Filters	
		Volts	Ma.
RCA-5R4GY	single-tube	750	250
RCA-816	two-tube	950	150
RCA-866-A	two-tube	2390	250
		3180	500

The Fountainhead of Modern Tube Development is RCA

Table-top or kilowatt rig ... — here's dependable power

● Name your power and one of these three time-proved RCA rectifier types will supply it at less cost and over longer trouble-free periods.

RCA 866-A half-wave mercury-vapor rectifier has an edgewise wound filament with an enormous emission reserve—hence, longer life. This tube has the ability to withstand a peak inverse voltage of 10,000 volts at 1000 ma. peak plate current. A pair will deliver a kilowatt of dc at 3000 volts ... with plenty of power to spare.

RCA-816 half-wave mercury-vapor rectifier is also double-ended; therefore its internal high-voltage qualities are not limited by glass electrolysis or by base and socket insulation. A smaller version of the

RCA 866-A, this tube also has an edgewise wound filament and will handle high peak voltages and emission currents. A pair will deliver 550 watts of dc at 2200 volts!

RCA 5R4GY is a full-wave, high-vacuum rectifier with a heavy-duty coated filament. Fitted with a low-leakage Micanol base, this tube can handle peak inverse voltages up to 2800 volts at 650 ma. peak current per plate. A single tube will supply a dc output of over 150 watts at 250 ma.

To get all the rectifier power, performance, and life you pay for ... buy genuine RCA tubes in the familiar red, black, and white cartons from your local RCA tube supplier.



RADIO CORPORATION of AMERICA

ELECTRON TUBES

HARRISON, N. J.