

September, 1947

35 Cents

# QST

devoted entirely to

# amateur radio

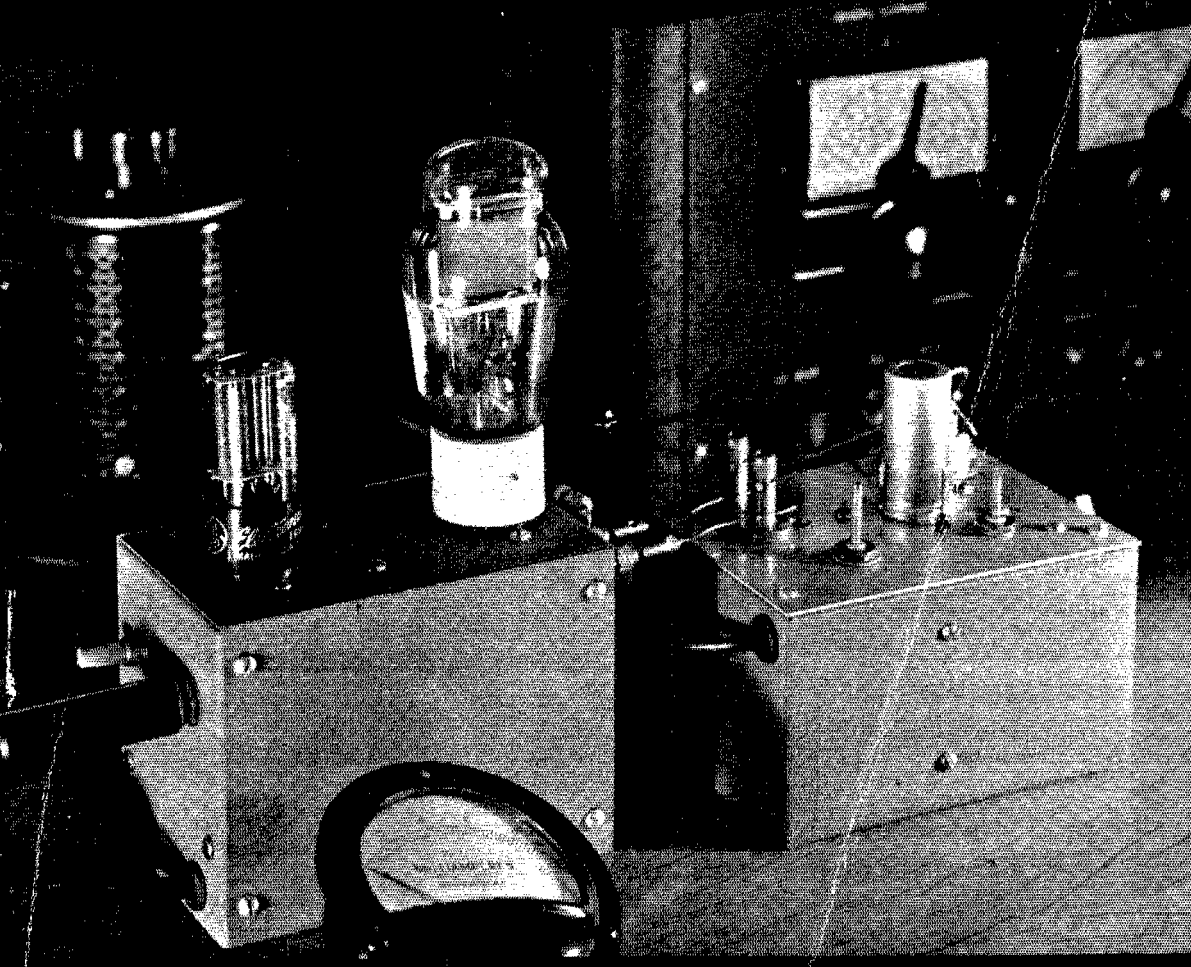

PUBLISHED BY THE AMERICAN RADIO RELAY LEAGUE



# FOR HIGH Q TOROIDS

UTC is known by all who know the value of the toroidal type of coil for each application. The toroidal type of coil is the most efficient and most economical of all coil types. It is the only type of coil that does not radiate energy.

## UTC HIGH Q TOROID COILS

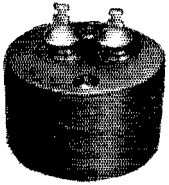

### HQA REACTOR

These reactors are designed for audio frequency operation with high Q and excellent stability. For a typical coil, (.14 Hy.), inductance varies less than 1% from .1 to 25 volts . . . Q is 120 at 5,000 cycles . . . hum pickup is low (toroidal structure), 70 Mv. per gauss at 60 cycles . . . variation in inductance less than 1/3% from -60° C. to +85° C. . . hermetically sealed in drawn case 1-13/16" diameter x 1- 3/16" high . . . weight 5 ounces . . . available in inductance values from 5 Mhys. to 2 Hys.

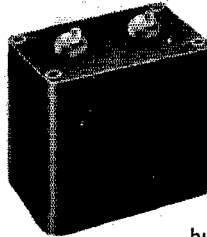

### HQB REACTOR

The HQB reactors are similar to the HQA series, but provide higher Q. For a typical coil, (.45 Hy.), inductance varies less than 1% with applied voltage from .1 to 50 volts . . . hum pickup twice that of HQA . . . variation of inductance less than 1/3% from -50° C. to +85° C. . . Q is 200 at 4000 cycles . . . hermetically sealed in steel case 1 1/4" x 2 1/2" x 2 1/2" high . . . 14 ounces . . . available in any inductance value from 5 Mhys. to 12 Hys.

## UTC TOROID COIL INTERSTAGE FILTERS

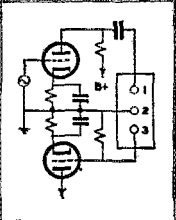

UTC Toroid Coil Interstage Filters are designed to provide the highest quality of filtering for audio frequency applications. The filters are hermetically sealed in drawn cases and are available in a wide range of inductance values. The filters are designed to provide the highest quality of filtering for audio frequency applications. The filters are hermetically sealed in drawn cases and are available in a wide range of inductance values.

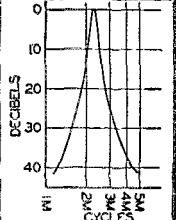

The filters are designed to provide the highest quality of filtering for audio frequency applications. The filters are hermetically sealed in drawn cases and are available in a wide range of inductance values. The filters are designed to provide the highest quality of filtering for audio frequency applications. The filters are hermetically sealed in drawn cases and are available in a wide range of inductance values.

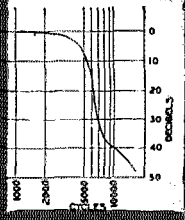
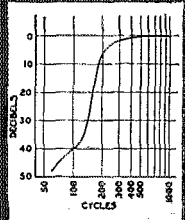

For further details write for Bulletin PS-407

*United Transformer Corp.*  
 1000 W. 10th St., Chicago, Ill. 60607  
 Phone: 312-421-1100

# HAVE A HEART!



**Overworked power-supply rectifier tubes may be trying to send you that message!**



GL-816

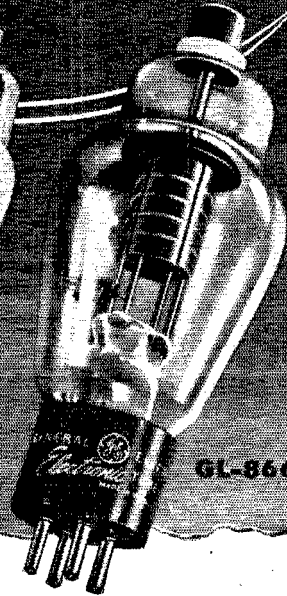

GL-866-A

● Checked your rig's power supply recently? A capacity that was adequate when you first went on the air, may not "fill the bill" today.



New, more powerful postwar transmitting tubes you're using, other steps to modernize your rig on the r-f end—these may overstrain a rectifier tube or pair of tubes that simply isn't up to handling the increased load.

In nine cases out of ten, two GL-816's or GL-866-A's, properly applied, will take care of the situation. Here are some things you may wish to remember in case you re-design your power supply:

*First*, figure the total current needed by the tube or tubes to which you are supplying power. *Second*, add to this the current required by the power-supply

bleeder. *Third*, include a small additional percentage as a safety factor. The sum represents your power-supply current requirement.

If this is under 250 ma, and your d-c voltage needs are no greater than 1,600 v, a pair of GL-816's is your logical choice. Current requirements above 250 ma, or a d-c voltage exceeding 1,600 v, call for two GL-866-A's. (Please bear in mind that the tube ratings given at right are *maximum*—i.e., by operating either type at a lower current, it does not follow that the voltage can be raised above the max figure, or vice versa.)

Prices and further information gladly will be furnished by your G-E tube distributor. Or write *Electronics Dept., General Electric Company, Schenectady 5, N. Y.*

## TYPE GL-816

A pair of these mercury-vapor rectifier tubes delivers 250 ma d-c current (max) at 1,600 v (max), handling up to 350 w transmitter input.

## TYPE GL-866-A

Two of these mercury-vapor rectifier tubes deliver 500 ma d-c current (max) at 3,200 v (max)—enough to supply a kilowatt final and its driver.

● Read Ham News regularly! See your G-E tube distributor for your free copy.

ELECTRONIC TUBES OF ALL TYPES FOR THE RADIO AMATEUR

# GENERAL ELECTRIC

161-F18-8850

# Now... a **7**-inch oscilloscope

## IN THE LOW-PRICE RANGE!

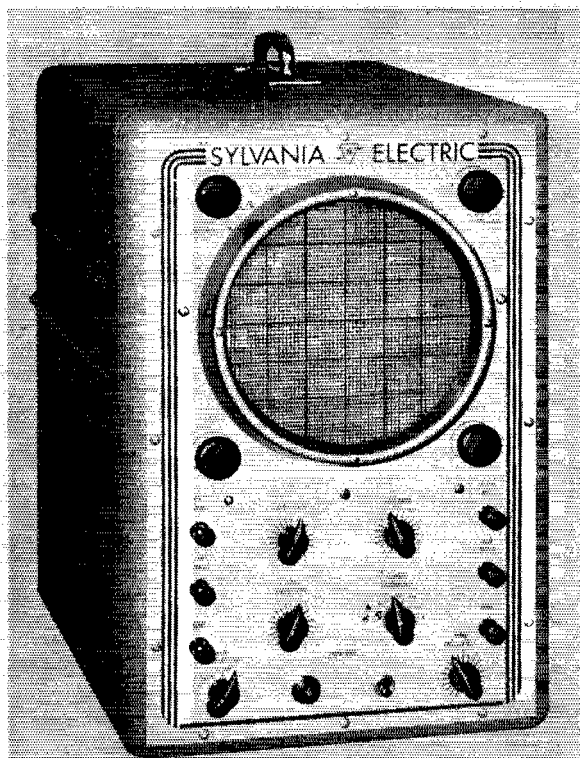

### IDEAL FOR

Wave Form Study

Set Alignment

Audio Circuit Analysis

Transmitter Checking

Filter Circuit and Hum Analysis

# SYLVANIA ELECTRIC

MAKERS OF ELECTRONIC DEVICES, RADIO TUBES, CATHODE RAY TUBES,  
FLUORESCENT LAMPS, FIXTURES, WIRING DEVICES, ELECTRIC LIGHT BULBS

The new Sylvania 7-inch Oscilloscope Type 132 is an AC operated general-purpose cathode ray unit for waveform study and voltage and current measurements. Large 7-inch Sylvania tube and new push-pull amplifier circuit provide "jumbo" patterns with maximum trace sharpness.

Its wide range of applications is still further extended through the added feature of a Z axis input for intensity modulation.

Power consumption is 35 watts, from 105-125 volt, 50-60 cycle supply. Extra-long, heavy-duty line cord furnished.

Type 132 is designed and built to provide the finest instrument in its class. The panel is "efficiency designed" with control size and placement offering time-saving ease of operation.

And . . . it's priced within the range of the average budget!

Product of Sylvania's Electronics Division, sold through the Radio Tube Division, the 7-inch Oscilloscope Type 132 is available through your Sylvania Distributor. Mail coupon for full technical details.

Sylvania Electric Products Inc.,  
Dept. E1309, Electronics Division  
500 Fifth Avenue, New York 18, N. Y.

Gentlemen:

Please send me full information on Oscilloscope Type 132.

Name .....

Street Address .....

City ..... Zone # .....

State .....

PUBLISHED, MONTHLY, AS ITS OFFICIAL ORGAN, BY THE AMERICAN RADIO RELAY LEAGUE, INC., AT WEST HARTFORD, CONN., U. S. A.; OFFICIAL ORGAN OF THE INTERNATIONAL AMATEUR RADIO UNION

## STAFF

### Editorial

KENNETH B. WARNER, W1EH  
(Managing Secretary, ARRL)  
Editor

HAROLD M. MCKEAN, W1CEG  
Assistant Editor

GEORGE GRAMMER, W1DF  
(Technical Director, ARRL)  
Technical Editor

DONALD H. MIX, W1TS  
BYRON GOODMAN, W1DX  
Assistant Technical Editors

EDWARD P. TILTON, W1HDQ  
V.H.F. Editor

RICHARD M. SMITH, W1FTX  
C. VERNON CHAMBERS, W1JEG  
JOHN W. PADDOX, VE3BLZ  
Technical Assistants

JOSEPH E. GRAHN, W1CH  
Contributing Editor, "How's DX?"  
WALTER E. BRADLEY, W1FWH  
Technical Information Service

### Production

RALPH T. BEAUDIN, W1BAW  
Superintendent

NANCY A. PRICE  
Assistant

### Advertising

F. CHEYNEY BEEKLEY, W1GS  
LORENTZ A. MORROW, W1VG  
EDGAR D. COLLINS

### Circulation

DAVID H. HOUGHTON  
Circulation Manager

RALPH T. BEAUDIN, W1BAW  
Assistant Circulation Manager

## OFFICES

38 La Salle Road  
West Hartford 7, Connecticut

Subscription rate in United States and Possessions, \$3.00 per year, postpaid; \$3.50 in the Dominion of Canada, \$4.00 in all other countries. Single copies, 35 cents. Foreign remittances should be by international postal or express money order or bank draft negotiable in the U. S. and for an equivalent amount in U. S. funds.

Entered as second-class matter May 29, 1919, at the post office at Hartford, Connecticut, under the Act of March 3, 1879. Acceptance for mailing at special rate of postage provided for in section 1103, Act of October 3, 1917, authorized September 9, 1922. Additional entry at Concord, N. H., authorized February 21, 1929, under the Act of February 28, 1925.

Copyright 1947 by the American Radio Relay League, Inc. Title registered at U. S. Patent Office.

## — CONTENTS —

"It Seems to Us . . ."	11
Hamfest Calendar . . . . .	12
How Sensitive Is Your Receiver? <i>Byron Goodman, W1DX</i>	13
Revamping the 150-B for 14-Mc. Operation <i>John M. Murray, W1BNN</i>	22
Interference with Television Broadcasting <i>George Grammer, W1DF</i>	24
Silent Keys . . . . .	30
Simple L and C Calculations . . <i>Jack Najork, W2HNN</i>	31
Atlantic City Report . . . . .	32
A Hydraulic Antenna Rotator . <i>Joseph C. Lotter, W9JBU</i>	36
Medium Power — Living-Room Style <i>Leroy T. Waggoner, W1PEK</i>	37
Hudson Division Convention . . . . .	46
Happenings of the Month . . . . .	47
In QST 25 Years Ago This Month . . . . .	49
Wanted — Radiomen for Overseas . . . . .	49
An Antenna That Multiplies by 50 <i>J. A. Kmosko, W2NLY</i>	50
Looking Over the Postwar Receivers . . . . .	54
Painless Reconversion <i>Chester B. Cunningham, W3MHW</i>	56
'Phone-Band Phunnies . . . . . <i>John T. Frye, W9EGV</i>	57
Do It Inductively . . . . . <i>Louis Taich, W3IKX</i>	58
ARRL QSL Bureau . . . . .	62
I.A.R.U. News . . . . .	63
How's DX? . . . . .	64
2, 6, and 10 with Crystal Control <i>James Millen, W1HRX</i>	66
The World above 50 Mc. . . . .	71
Correspondence from Members . . . . .	74
Operating News . . . . .	76
Station Activities . . . . .	84

# Presenting the **NEW MODEL SX-43**



**...to give amateurs:**

## **Built in the Hallicrafters Classic Tradition**

The new SX-43 is built in the Hallicrafters classic tradition: providing custom quality, precision engineering, excellent performance and wide frequency range at a medium price. The SX-43 offers continuous coverage from 540 kc. to 55 Mc. and has an additional band from 88 to 108 Mc. AM reception all bands, CW on four lower bands and FM on frequencies above 44 Mc. In the band 44 to 55 Mc. wide band FM or narrow band AM, just right for narrow band FM reception is provided. This is a big-league, versatile, all-around receiver with the hottest ham performance ever offered at this price.

Added technical details on all these models in Hallicrafters New Catalog, No. 38. Ask your local distributor for a copy.

## **MORE VALUE**

Never before all these features at this price

## **GREATER PERFORMANCE**

AM-FM-CW . . . all essential amateur frequencies from 540 kc. to 108 Mc.

## **LOWER PRICE**

# **\$169<sup>50</sup>**

Sets available after August 1947

*New*

**BETTER QUALITY** **AM**  
**WITH NARROW BAND** **FM**

**Exclusively designed**  
**VARIABLE**  
**MASTER OSCILLATOR**  
**only \$110.00 (amateur net)**

Here is the hottest transmitter item available today. Packed with outstanding features never before available in one low-priced unit. Add to the HT-18 one or two amplifier stages and you have a complete, high quality transmitter permitting operation on phone or CW up to 1 KW. Low frequency drift, low FM distortion, low hum and noise level, dual voltage regulators and low impedance output circuit all contribute to superior performance that only Hallicrafters can provide at this price.

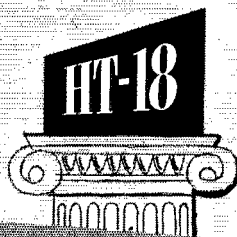

*Narrow band FM . . . direct frequency calibration . . . finger-tip control of entire station . . . full frequency deviation on all ham bands to 29.7 Mc. . . only 1/10 the distortion of comparable units . . . excellent stability . . . clean keying . . .*

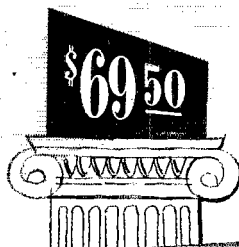

**New** **LOW PRICE** **Transmitter**

**MODEL HT-17**

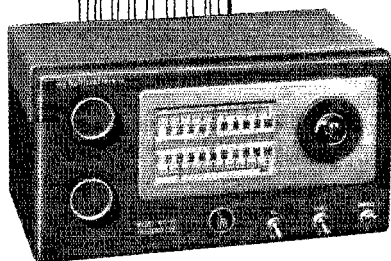

- Ham bands from 3.5 to 30 Mc.
- 15 watts power output on low frequency bands.

Here's real Hallicrafters transmitter performance with maximum convenience and economy. This compact and smartly engineered unit provides an honest 15 watts of crystal-controlled CW output on the amateur bands of 3.5 and 7 Mc. and 10 watts on 14, 21 and 28 Mc. A pi-section matching network, as well as a link, provides coupling to any type of antenna or permits the HT-17 to be used as an exciter for a high power final amplifier. Oscillator stage uses a type 6V6-GT tube and is automatically switched to a Tritet circuit when coils for the 3 higher bands are plugged in. Coil sets extra.

BUILDERS OF

*Skyfone*

AVIATION RADIOTELEPHONE

**hallicrafters RADIO**

**THE HALLICRAFTERS CO., MANUFACTURERS OF RADIO AND ELECTRONIC EQUIPMENT, CHICAGO 16, U. S. A.**

Sole Hallicrafters Representatives in Canada:  
Rogers Majestic Limited, Toronto-Montreal

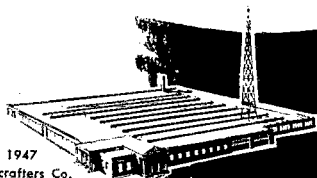

Copyright 1947  
The Hallicrafters Co.

## Section Communications Managers of the ARRL Communications Department

**Reports Invited.** All amateurs, especially League members, are invited to report station activities on the first of each month (for preceding month) direct to the SCM, the administrative ARRL official elected by members in each Section. Radio Club reports are also desired by SCMs for inclusion in *QST*. All **ARRL Field Organization appointments** are now available to League members. These include ORS, QES, OPS, OO, and ORS. Also, where vacancies exist SCMs desire applications for SEG, EC, RM, and PAM. In addition to station and leadership appointments for Members, *all amateurs* are invited to join the ARRL Emergency Corps (ask for Form 7).

ATLANTIC DIVISION				
Eastern Pennsylvania Maryland-Delaware-D.C. Southern New Jersey Western New York Western Pennsylvania	W3BES W3BWT W2OXX W2UPH W3KWL	Jerry Mathis Eppa W. Darne George W. Tunnell Charles I. Otero Ernest J. Hlinsky	623 Crescent Ave. 132 Tennessee Ave., N.E. 22 W. Young Ave. 4158 Ridge Road, West 509 Beechwood Ave.	Glenside Gardens Washington 2, D. C. Audubon Spencerport Farrell
CENTRAL DIVISION				
Illinois Indiana Wisconsin	W9AND W9SWH W9KQM	Wesley E. Marriner Ted K. Clifton Reno W. Goetsch	624 College Ave. 550 Eben St. 929 S. 7th Ave.	Dixon New Haven Wassau
DAKOTA DIVISION				
North Dakota South Dakota Minnesota	W8CZD W8QVY W8CWB	Paul M. Bessoletti P. H. Schultz Walter G. Hasskamp	204 Polk St. 118 N. Vankton Ave. 116 3rd Ave., S.W.	Grand Forks Pierre Crosby
DELTA DIVISION				
Arkansas Louisiana Mississippi Tennessee	W5JIC W5TVC W5IGW W4FLS	Marshall Riggs W. J. Wilkinson, jr. Harold Day James W. Watkins	4405 Howell Ave. Room 313, Jefferson Hotel Route 1, Box 111 220 North Howell St.	Fort Smith Shreveport Greenville Chattanooga 4
GREAT LAKES DIVISION				
Kentucky Michigan Ohio	W5IEZ/4 W8SCW W8PNC	Joseph P. Colvin Joseph R. Beljan, jr. William D. Montgomery	1653 Beechwood Ave. 13959 Tuller Ave. 1290 Coolidge Ave.	Louisville 4 Detroit Cincinnati 30
HUDSON DIVISION				
Eastern New York N. Y. C. & Long Island Northern New Jersey	W2HZL W2KDC W2IIN	Ernest E. George Charles Ham, jr. John J. Vitale	2044 Lexington Parkway 200 Harvard St. 57 Sayre St.	Schenectady 8 Westbury Elizabeth 3
MIDWEST DIVISION				
Iowa Kansas Missouri Nebraska	W8PP W8AWP W8QUD W8RQK	William G. Davis Alvin B. Urath Mrs. Letha A. Dangerfield William T. Gemmer	3rd St. 842 N. Terrace Drive 411 Moffett Ave. 1708 West 6th St.	Mitchellville Wichita 6 Joplin North Platte
NEW ENGLAND DIVISION				
Connecticut Maine Eastern Massachusetts Western Massachusetts New Hampshire Rhode Island Vermont	W1KOY W1GKJ W1ALP W1AZW W1AXL W1HRC W1NDL	Edmund R. Fraser F. Norman Davis Frank L. Baker, jr. Prentiss M. Bailey John H. Stoughton Clayton C. Gordon Gerald Benedict	90 Atwater St. RFD 1 91 Atlantic St. 62 Dexter St. Box 44 70 Columbia Ave., Gaspee 23 Foster St.	West Haven Old Orchard Beach North Quincy 71 Pittsfield Barnstable Plateau, Providence 5 Montpelier
NORTHWESTERN DIVISION				
Alaska Idaho Montana Oregon Washington	K7CBF W71WU W7EQM W7HAZ W7CZY	August G. Hiebert Alan K. Ross Albert Beck Kaleigh A. Munkes Laurence M. Sebring	% KFCAR 1017 East Jefferson St. 2326 Amherst Ave. Box 44 RFD 2	Fairbanks Boise Butte Baker Everett
PACIFIC DIVISION				
Hawaii Nevada Santa Clara Valley East Bay San Francisco Sacramento Valley Philippines* Sau Joaquin Valley	KH6EL W7CX W6BPT W6FTI W6NML W6MGC KA1CB W6PSQ	John Souza N. Arthur Sowle Roy E. Pinkham Horace R. Greer Samuel C. Van Liew John R. Kirby Craig B. Kennedy James F. Wakefield	Box 2025 1061 Fremont St. 414 Fairmount Ave. 534 Knowles Ave. 5240 K St. 25 Roosevelt Road 2940 Adoline Ave.	Wailuku, Maui Reno Santa Clara Oakland 11 Daly City Sacramento 16 San Francisco Del Monte, Quezon Fresno
ROANOKE DIVISION				
North Carolina South Carolina Virginia West Virginia	W4CYB W4BOE/ANG W4HJK W8JMK	W. J. Wortman Ted Ferguson Walter R. Bullington Donald B. Morris	% Duke Power Co. 3422 Rosewood Drive 1740 Oak Hill Lane, Rt. 1 303 Home St.	Charlotte 1 Columbia 25 Richmond 23 Fairmont
ROCKY MOUNTAIN DIVISION				
Colorado Utah-Wyoming	W9QVT W7NPU	Glen Bond Alvin M. Phillips	2550 Kendall 3887 Quincey Ave.	Denver 14 Ogden, Utah
SOUTHEASTERN DIVISION				
Alabama Eastern Florida Western Florida Georgia West Indies* (Cuba-P.R-V.I.)	W4GBV W4FWZ W4DAO W4HYW KP4KD	Lawrence J. Smyth John W. Hollister Luther M. Holt Thomas M. Moss Everett Mayer	808 Winona Ave. 3820 Laurie 223 W. Romana St. 870 Oak Drive P. O. Box 1061	Montgomery Jacksonville Pensacola Hapeville San Juan 5, P. R.
SOUTHWESTERN DIVISION				
Los Angeles Arizona San Diego	W6QWZ W7MLL W6GC	Ben W. Onstent Gladden C. Elliott Irvin L. Emig	9631 3rd Ave. 1408 West Fresno St. 4852 Marlborough Drive	Inglewood Tucson San Diego
WEST GULF DIVISION				
Northern Texas Oklahoma Southern Texas New Mexico	W5DAS W5HNI W5HIF W5HJF	N. C. Settle Bert Weidner Ted Chastain J. C. Hancock	2911 Elm St. Box 14 3037 So. Staples St. 110 S. E. Nevada St.	Dallas Crescent Corpus Christi Portales
MARITIME DIVISION				
Maritime (Nfld. & Labr. att.)	VE1DQ	A. M. Crowell	69 Dublin St.	Halifax, N. S.
ONTARIO DIVISION				
Ontario	VE3DU	David S. Hutchinson	827 Lovett St.	London, Ont.
QUEBEC DIVISION				
Quebec*	VE2GL	Gordon A. Lynn	General Delivery	St. Lambert, Que.
VANALTA DIVISION				
Alberta British Columbia Yukon	VE6LO VE7WS VE8AK	W. W. Butchart W. W. Storey W. R. Williamson	10740-107 St. 3915 W. 32nd Ave. P. O. Box 137	Edmonton, Alta. Vancouver Whithorse, Y. T.
PRAIRIE DIVISION				
Manitoba Saskatchewan	VE4AM VE5CO	A. W. Morley Norman Thompson	26 Lennox St. 1120 7th Ave., N. W.	St. Vital Moose Jaw

\* Officials appointed to act temporarily in the absence of a regular official.



# For Versatility of Application

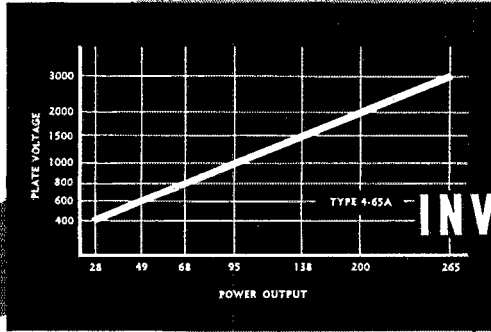

WITHIN THE POWER RANGE

INVESTIGATE THE NEW

**EIMAC 4-65A**

**MORE FOR YOUR VACUUM TUBE DOLLAR**

Conservatively rated at 65 watts plate-dissipation, the 4-65A is physically small and radiation cooled.

Instant heating thoriated tungsten 6.0 volt filament makes the 4-65A ideally suited for mobile application.

Self-supported internal elements. No troublesome insulators.

Direct electron beaming without the use of deflecting hardware.

Low interelectrode capacitances. (Average) Grid-Plate .08  $\mu\text{mf}$ , Input 8.0  $\mu\text{mf}$ , Output 2.1  $\mu\text{mf}$ .

Unique design, shields input output circuits, simplifies neutralization.

Non-emitting processed grid provides stability familiar to all Eimac tetrodes.

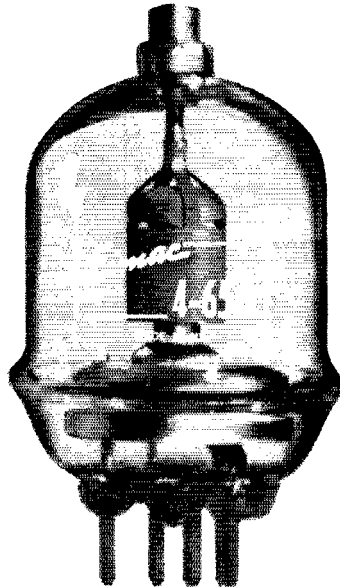

Versatile operation . . . the 4-65A has excellent power characteristics over a plate voltage range from 400 to 3000 volts, as indicated in the above chart.

Base pins fit available commercial sockets.

Low inductance and short direct leads enable operation above 200 mc.

Processed metal plate assures long tube life and can really "take it" during momentary overloads.

Hard glass envelope provides resistance to thermal shock and permits high temperature operation.

Proven design, the 4-65A is a physically smaller version of the 4-125A.

In the 4-65A you get truly "more for your vacuum tube dollar"

**PRICE \$14.50**

**EITEL-McCULLOUGH, Inc.**  
179 San Mateo Ave.,  
San Bruno, California

Write today for additional data.

Follow the Leaders to

**Eimac**  
TUBES

The Power for R-F

EXPORT AGENTS: FRAZAR & HANSEN, 301 CLAY ST., SAN FRANCISCO 11, CALIFORNIA, U.S.A.

# FLAT or RISING RESPONSE

*... as you need it!*

No need to worry about your microphone, or even to install a filter in your speech amp . . . when your choice is the Electro-Voice CARDAX. With dual frequency response and high output in this one microphone, you can use a flat response for clear channel, or rising response to cut thru QRM. Simply adjust the two-position selector switch on rear of case. When in the "out" position, the frequency response curve is wide and flat. Your voice quality is smooth, rounded and full range. In the "in" position, the curve rises 7 db at 4000 c.p.s., and your signal is sharp, clean, brilliant. Model 950 lists at \$37.00.

THE  
*Cardax*  
CARDIOID CRYSTAL MICROPHONE

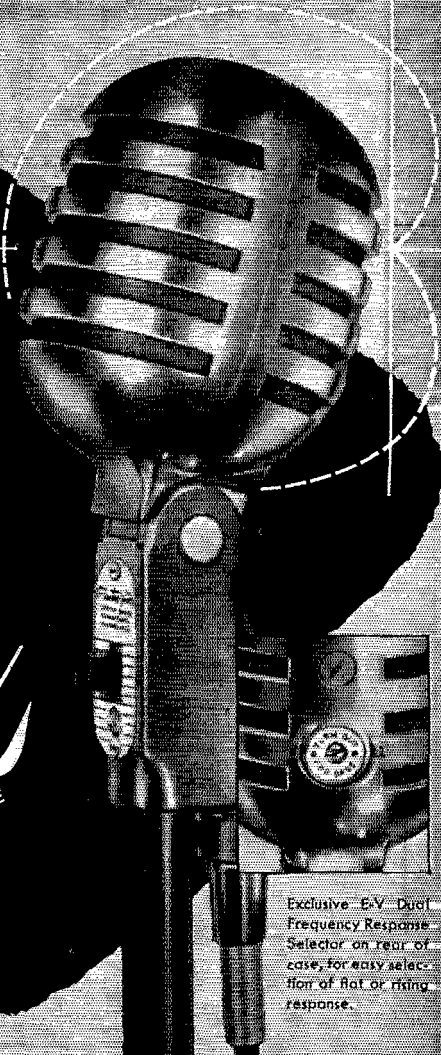

Exclusive E-V Dual Frequency Response Selector on rear of case, for easy selection of flat or rising response.

SEND FOR CATALOG No. 101

\*

Authorized Distributors Everywhere

*Electro-Voice Patent Pend.  
Lombard Auto. Brush Patents*

NO FINER CHOICE THAN

# *Electro-Voice*

ELECTRO-VOICE, INC., BUCHANAN, MICHIGAN

Export Division: 13 East 40th Street, New York 16, N. Y., U. S. A. Cables: Arlab



*Listen*  
...IT'S A  
**Jensen**

**MODEL VH-91**  
*Hypex*<sup>\*</sup> **SPEECHMASTER**

Delivering good quality, intelligible speech with maximum "punch" to override high noise levels, the Model VH-91 Speechmaster is recommended for paging and intercommunication applications. Hypex horn formula gives useful output over a 100° angle.

Especially efficient for voice, the VH-91 has a frequency range of 400-5,000 cycles. Power handling capacity: 15 watts maximum speech signal input. Designed for both inside and out-of-door use, VH-91 will withstand extreme weather conditions, including exposure to salt spray. Nominal voice coil impedance 8 ohms. Transformer number Z-3345, with 5/8" x 5/8" core available for 45-ohm use. Bell diameter, 8 7/8 inches; height, 9-1/16 inches; weight, 4 1/4 pounds.

Universal mounting bracket adjusts projector to any direction, locks securely in position by a single wing nut, has facilities for mounting transformer.

**Jensen VH-91 Speechmaster Projector (ST-171).....\$32.50**  
\*Trade mark registered

**JENSEN MANUFACTURING COMPANY**  
6611 S. LARAMIE AVE., CHICAGO 38, U. S. A.  
In Canada: Copper Wire Products, Ltd., 11 King St., W. Toronto 1

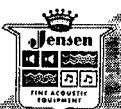

*Designers and Manufacturers  
of Fine Acoustic Equipment*

# THE AMERICAN RADIO RELAY LEAGUE, INC.,

is a noncommercial association of radio amateurs, bonded for the promotion of interest in amateur radio communication and experimentation, for the relaying of messages by radio, for the advancement of the radio art and of the public welfare, for the representation of the radio amateur in legislative matters, and for the maintenance of fraternalism and a high standard of conduct.

It is an incorporated association without capital stock, chartered under the laws of Connecticut. Its affairs are governed by a Board of Directors, elected every two years by the general membership. The officers are elected or appointed by the Directors. The League is noncommercial and no one commercially engaged in the manufacture, sale or rental of radio apparatus is eligible to membership on its board.

"Of, by and for the amateur," it numbers within its ranks practically every worth-while amateur in the nation and has a history of glorious achievement as the standard-bearer in amateur affairs.

Inquiries regarding membership are solicited. A bona fide interest in amateur radio is the only essential qualification; ownership of a transmitting station and knowledge of the code are not prerequisites, although full voting membership is granted only to licensed amateurs.

All general correspondence should be addressed to the Secretary at the administrative headquarters at West Hartford, Connecticut.



## Past Presidents

HIRAM PERCY MAXIM, W1AW, 1914-1936  
EUGENE C. WOODRUFF, W8CMP, 1936-1940

## Officers

President . . . . . GEORGE W. BAILEY, W2KH  
Washington, D. C.  
Vice-President . . . . . J. LINCOLN MCCARGAR, W6EY  
Oakland, California  
Secretary . . . . . KENNETH B. WARNER, W1EH  
West Hartford, Connecticut  
Communications Manager . . . . . FRANCIS E. HANDY, W1BDI  
West Hartford, Connecticut  
Treasurer . . . . . DAVID H. HOUGHTON  
West Hartford, Connecticut  
General Counsel . . . . . PAUL M. SEGAL  
816 Connecticut Ave., Washington 6, D. C.  
Assistant Secretaries . . . . . ARTHUR L. BUDLONG, W1BUD  
JOHN HUNTOON, W1LVQ, LEROY T. WAGGONER, W1PEK  
West Hartford, Connecticut

## DIRECTORS

**President**  
GEORGE W. BAILEY . . . . . W2KH  
921 19th St., N.W., Washington, D. C.

**Vice-President**  
J. LINCOLN MCCARGAR . . . . . W6EY  
86 Hamilton Place, Oakland 12, Calif.

**Canadian General Manager**  
ALEX REID . . . . . VE2BE  
240 Logan Ave., St. Lambert, P. Q.  
Alternate: Leonard W. Mitchell . . . . . VE3AZ  
78 Raglan Ave., Toronto, Ont.

**Atlantic Division**  
EDWARD G. RASER . . . . . W2ZI  
315 Beechwood Ave., Trenton 8, N. J.  
Alternate: J. Victor Brotherson . . . . . W8BH  
1743 Ottawa Drive, Erie, Pa.

**Central Division**  
CLYDE C. RICHELLEU . . . . . W9ARE  
4901 So. 30th St., Milwaukee 14, Wisc.  
Alternate: Harold H. Jansen . . . . . W9DJG  
3519 California Ave., Alton, Ill.

**Dakota Division**  
TOM E. DAVIS . . . . . W9SW, ex-W0VVA  
915 W. Becker Ave., Willmar, Minn.  
Alternate: Harold B. Love . . . . . W0ZRT  
Box 446, Mandan, N. D.

**Delta Division**  
GEORGE S. ACTON . . . . . W5BMM  
Plain Dealing, La.  
Alternate: Eugene H. Treadaway . . . . . W5DKR  
P. O. Box 44, La Place, La.

**Great Lakes Division**  
HAROLD C. BIRD . . . . . W8DPE  
114 Hickory Dr., R.F.D. 2, Pontiac 2, Mich.  
Alternate: John H. Brabb . . . . . W8SPF  
1321 Berkshire Rd., Grosse Pointe Park 30, Mich.

**Hudson Division**  
JOSEPH M. JOHNSTON . . . . . W2SOX  
427 Lincoln Ave., Avon-by-the-Sea, N. J.  
Alternate: Robert A. Kirkman . . . . . W2DSY  
1910 Oak Drive, West Belmar, N. J.

**Midwest Division**  
C. A. COLVIN . . . . . W0VHR  
c/o Omaha & Council Bluffs St. Railway Co.,  
Omaha 2, Nebr.  
Alternate:

**New England Division**  
PERCY C. NOBLE . . . . . W1BVB  
37 Broad St., Westfield, Mass.  
Alternate:

**Northwestern Division**  
HAROLD W. JOHNSTON . . . . . W7DXF  
3727 Belvidere Ave., Seattle 6, Wash.  
Alternate: R. Rex Roberts . . . . . W7CPY  
110 W. Brennan St., Glendive, Mont.

**Pacific Division**  
WILLIAM A. LADLEY . . . . . W6RBQ  
200 Naylor St., San Francisco 12, Calif.  
Alternate: Elbert J. Amarantes . . . . . W6FBW  
1875 Dale Ave., San Jose, Calif.

**Roanoke Division**  
H. L. CAVENESS . . . . . W4DW  
2607 Vanderbilt Ave., Raleigh, N. C.  
Alternate: J. Frank Key . . . . . W3ZA  
Box 707, Buena Vista, Va.

**Rocky Mountain Division**  
FRANKLIN K. MATEJKA . . . . . W0DD  
P. O. Box 212, Estes Park, Colo.  
Alternate: P. Arthur Smoll . . . . . W0KVD  
529 No. Nevada Ave., Colorado Springs, Colo.

**Southeastern Division**  
WILLIAM C. SHELTON . . . . . W4ASR  
527 Reville Blvd., Daytona Beach, Fla.  
Alternate: William P. Sides . . . . . W4AUP  
Fleming Road, Montgomery, Ala.

**Southwestern Division**  
HANS R. JEPSEN . . . . . W6KEI  
6837 Ethel Ave., No. Hollywood, Calif.  
Alternate: Arthur E. Schifferman, sr. . . . . W6CGI  
1445 Raymond Ave., Glendale 1, Calif.

**West Gulf Division**  
WAYLAND M. GROVES . . . . . W5NW  
P. O. Box 585, Odessa, Texas  
W5NW at Humble Pipe Line Camp, Odessa  
Alternate: Jack T. Moore . . . . . W5ALA  
4531 Fairway Ave., Dallas 4, Texas

# "It Seems to Us..."

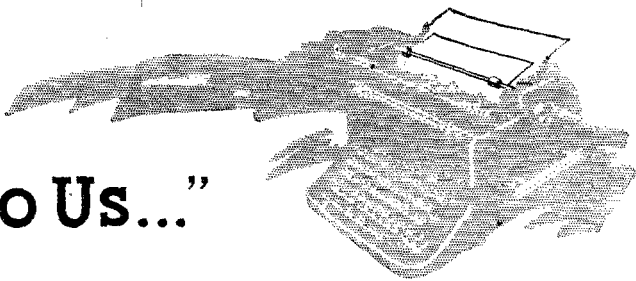

## CHANGE

While the frequency allocations of the Atlantic City meeting will probably be known to most of amateur radio by the time this sees print, at this writing there have been no final conference decisions. That many individuals, committees and working groups have been hard at the job since the middle of May is but further evidence of the magnitude of the problem of fitting all the world's radio needs into one common spectrum.

As we write, things are moving rapidly to a climax and a close. Although we are in constant daily touch with the League's Atlantic City delegation, those of us holding the fort at Hq. find ourselves, along with you, "in the position of the expectant father chewing his nails in the anteroom." While pacing the floor in this brief period of purgatory and wondering exactly what lies ahead, we have been prompted also to look behind.

Does it seem a full two years ago that the atom bombs first fell, Japan surrendered, and amateur radio was reactivated with its first postwar privilege — the  $2\frac{1}{2}$ -meter band? The world has had to make many readjustments since that time, and so have we as amateurs. Witness that we no longer have a  $2\frac{1}{2}$ -meter band as such, it having been shifted to 2 meters. Nor do we have a 5-meter band — it is now "six," with promise of a WAS soon. We have numerous new microwave bands. We have a smaller 10-meter band, a new one at 11 meters. Old 160 is no longer available, at least for the present. We have every prospect of a new and very interesting assignment at 21 Mc.

Change — that's the word. The whole world changes, and we must move with it. Actually amateur radio is composed mostly of changers, men who were not satisfied with the state of the art — technically, theoretically, regulation-wise or from an operating standpoint. And we have moved ahead; change makes progress. Most of us are pioneers in one way or another. One can't be much of an amateur otherwise. If it weren't for changers such as Marconi and Popoff, we'd still be practising American Morse on our back yard telegraph lines.

Yet we've always had a small group of amateurs who didn't want changes. They insisted c.w. would never replace spark, balked at crystal control, fought the d.c. regulations, cried that our 1929 bands would never support amateur radio and therefore predicted its immediate doom. They scoffed at "microwaves" (then almost everything above 14 Mc.) and when the utility of such bands was demonstrated, they were first to protest the outlawing of modulated oscillators there. Who was it said the only difference between a rut and a grave is in the dimensions?

There are certainly going to be some amateur-frequency changes at Atlantic City. For instance, we are virtually assured of one new band. There is always the possibility that some of our other assignments will be shifted, or in some cases partially lost. Assuredly we shall have to readjust our DX procedures when the bands inevitably become narrower in many foreign countries as a result of the attitude of those governments.

We have always had changes, and we always shall. For amateurs at world radio conferences, some of them have been favorable, some of them disheartening. We have had to make readjustments, yes; so has every other service. But the over-all effect has never impeded our net progress. The aim is to look and move ahead. So as we sit here watching for the cloud of the conference to disperse so that we may see a few more years into our future, it strikes us that the really important thing to us as individual amateurs is, rather than precisely what we get, our own ability to make an intelligent and well-planned use of it. And that, friends, is the field in which the amateur has always excelled.

— J. H.

## SUBSTITUTION OF COMPONENTS

During the course of a year there are hundreds of fellows faced with the problem of deciding whether or not the condenser they already have can be substituted for the one specified in a *QST* story, or what changes are necessary to make a *QST* gadget work with a power supply that delivers only 400 volts

instead of 550, and so on. A few of these fellows write in and ask us (and of course we tell them), but many of them prefer to dig a little for the answers. In doing so, they learn something, and we say "more power to them!" It is on just such doing-with-what-you-have that ham radio was founded and developed. But a lot of the fellows put off building a piece of gear, in the hopes that *QST* will come up next month with a construction story *exactly* filling their particular wants. Their chances on being disappointed are very good indeed!

Then how is a guy going to make use of what he has? Well, in the early days when there were few if any standard components, *QST* carried circuits and as much how-many-turns dope as possible — but there was plenty of substituting of parts. There had to be — there was no other way. And the stuff worked! It worked because radio was young, and a lot of the hams in the game knew as much radio theory as did the high-powered engineers. Don't forget that the high-powered engineering consisted of plenty of cut-and-try (and much of it still does). As radio grew up and became more complex, a few fellows dropped by the wayside technically, as could be expected. But those who stayed with it, absorbing new bits of theory as they were published, had no trouble keeping up. They may have longed for the "good old days" when radio was simple (and less effective), but they didn't let it get them down. These fellows have no trouble nowadays in making the same kind of substitutions. They read over a *QST* article, or several treating the same subject, and then add their own ideas as to how the thing should be done. They more or less instinctively pick the right values of by-pass condensers, and they know where to go for information on grid leaks and voltage dividers. They don't mount tank coils smack against a metal panel, and they watch the stray capacities and inductances that have to be built into a unit. They rearrange components to suit their needs, but they avoid all the little jokers that would allow coupling of any kind between the grid and plate circuits of straight-through amplifiers. They avoid similar r.f. chokes in the plate and grid circuits of amplifiers, and they put the low-inductance one in the grid circuit, to avoid low-frequency parasitics. They do all these things and a hundred more because they know what goes on in the piece of gear. Maybe they know it from reading about it, and maybe they know about it from other pieces of gear they built and had trouble with, but they know it. Theory? Sure it is, but it isn't the integral-sign-and-long-equation sort of thing so many fellows associate with theory. It's the practical bedrock stuff that a ham needs to know to make substitutions or alterations in published designs.

It's the theory they dug out for themselves by finding the answers when things didn't work right at one time or another. It's the theoretical background given to them by reading and tinkering and listening to the other fellow's experiences.

Naturally such a road to theory looks rocky to a newcomer to the game. The old hand grew up with it and has had a lot of years to absorb it. But the new fellow has the big advantage that plenty has been written on the subject, and digging back through the books and magazines will give him the background in months that it took the others years to acquire. As a newcomer, once you get into this "practical-theory" business, you'll find it isn't nearly as formidable as it looks from the outside, and you'll get a kick out of knowing why and how your gear works.

Remember that no design is sacred or the last word. *QST* descriptions by staff members or outside contributors represent designs that have been made to work. If another staff member or outside ham were given the same project, he would come up with something that might look entirely different physically, and probably some of the values would be different. The values that differed would represent components whose values weren't critical, or were changed because the approach wasn't the same. It takes some background to decide about these things, but it certainly doesn't take an Act of Congress or a letter from your senator. So don't be afraid to make substitutions. All you need is a soldering iron — and the reason!

— B. G.

#### HAMFEST CALENDAR

OHIO — The Greater Cincinnati Amateur Radio Assn. will hold its annual picnic on Sunday, September 14th, at Ash Grove, Winton Place, Cincinnati. As customary, the affair will be for OMs only. Tickets are \$1.50, which covers all expenses including food. Prizes and a good time for all are promised.

OHIO — The Findlay Radio Club is staging its annual picnic on Sunday, September 7th, at Riverside Park, Findlay. There is no reservation fee for this popular non-profit affair — just bring your own basket lunch. Great Lakes Division Director Bird is expected to attend. The club station, W8FT, will be in operation again this year from the picnic grounds.

**SWITCH  
TO SAFETY!**



# How Sensitive Is Your Receiver?

*The Diode Noise Generator for Testing Receiver Sensitivity*

BY BYRON GOODMAN,\* WIDX

## OUR COVER

this month shows how simple it is to get the cold dope on a receiver or preselector with the "noise generator" described on these pages. Unlike the spark-coil or neon-sign type of noise generator familiar to all amateurs, this one gives a kind and gentle sort of noise that tells how closely your receiver approaches the ideal noise-free set. All it takes is an old tube, a few simple parts, and a milliammeter.

**B**UILDING a converter, preamplifier or even a receiver is a simple job compared with checking its sensitivity. Most amateurs use a no more complicated system than to compare their finished product with someone else's that is presumed to work well. Most hams can tell by the "feel" if a receiver or converter is sensitive at frequencies up to 15 Mc., but above that it is easy to be fooled. Switching two units back and forth on the same antenna is another expedient, but it isn't the most convenient method and it often leads to inconclusive results when the difference is slight. Even if a high-priced signal generator were standard equipment in every ham shack, one would find it difficult to measure the ultimate worth of the receiver or converter, because sensitivity measurements are not easy to make even with a good c.w. or modulated generator.

### Receiver Noise

Before describing a new and simple means for checking receivers, let's review briefly the hows and whys of receiver sensitivity. On frequencies where outside noise is the limiting factor to weak-signal reception; as on the broadcast band and up to 20 or 30 Mc. (depending on location and time), sensitivity is generally defined as the input required to give a specified output. However, this is only a measure of the *gain* of the receiver and

\* Assistant Technical Editor, *QST*.

◆  
A diode noise generator for amateur use. The ceramic-based tube is a diode-connected 801A, and the noise output is taken from the two terminals just beyond the tube. The other tube is a 117Z6 used as a source of d.c. voltage. The d.c. milliammeter used for measuring diode current is plugged into the 'phone jack. The potentiometer shaft is left over from an earlier design.

isn't what the amateur means by sensitivity. He is thinking of "signal-to-noise ratio," and this is an equine of another hue. At the higher frequencies, where atmospheric and other noise can be quite small, the noise generated by the tubes and circuits in the receiver becomes the limiting factor to weak-signal reception. If the stage gain in the front end of the receiver is high, only the noise generated by the first stage is important, because it is amplified by the tube and then masks the noise generated in the following stages. If the gain of the first tube isn't high enough to build up the first-stage noise to a level that will mask subsequent noise, then the first two stages must be considered, and so on. If the gain of the first stage is reduced for gain-control purposes, it is apparent that the signal-to-noise ratio can suffer, because the noise in the system is now contributed by the first and second stages. For this reason, it is advisable to run the first tube of a receiver "wide open" for best weak-signal reception. The first two or three stages might be run at full gain all of the time if it were not for the overloading

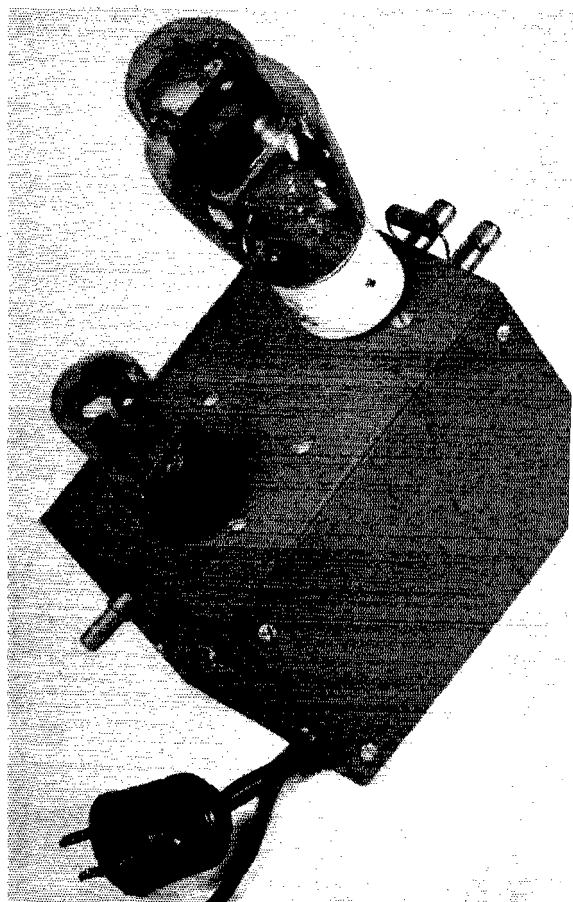

### ACKNOWLEDGMENT

• The new techniques discussed in this article are the result of intensive work at many wartime research laboratories, both in this country and in the British Empire. The practical diode noise generator was developed at the M.I.T. Radiation Laboratory, mainly by E. J. Schremp and C. P. Gadsen. Further details of these developments can be found in the Radiation Laboratory series of books now being published by the McGraw-Hill Book Co. The author wishes to express his thanks to Yardley Beers, W2AWH, ex-W3AWH, formerly of the Radiation Laboratory, for much of the information contained in this article.

and cross-modulation by strong signals that might take place.

### Sources of Noise

Before discussing circuits, we must consider the types of noise that can occur in a receiver. These divide into two groups: the Johnson, or "thermal-agitation," noise, and the "shot" noise.

At any temperature above absolute zero, the conductor electrons in metals are in random motion. At any instant, and quite by chance, more than the average number of electrons are present at one end of the conductor, with a consequent deficiency at the other end. This causes a voltage to exist between the ends of the conductor at that instant. These random voltages we recognize as noise, and thus all ohmic conductors are sources of thermal-agitation noise. Needless to say, the magnitude depends upon the temperature of the resistor, since the motion of the electrons increases with the absolute temperature. This noise is produced over a wide range of frequencies but, of course, any receiving system that follows has a finite bandwidth, and the noise generated at frequencies outside of the passband will not contribute to the noise output of the receiver. Consequently, the equivalent noise voltage produced by the resistor increases with the bandwidth of the receiver (more exactly, it is proportional to the square root of the bandwidth<sup>1</sup>). Incidentally, the people who have developed the theory of this effect use the word "bandwidth" with a very special definition, but for all practical purposes it is the same as the bandwidth at the "half-power," or 3-db., points.

There is one special form of thermal-agitation noise that deserves special mention — the noise generated by the antenna. Yes, even though there is no static or ignition noise being picked up, an antenna is still a source of thermal noise. It has been shown that this noise is exactly the same as

would be generated by a resistor equal to the radiation resistance of the antenna, at a temperature equal to the temperature of the antenna.<sup>2</sup> The practical result of this antenna thermal-agitation noise is that even if one could build a "perfect" receiver with no sources of noise within it, he would still have noise generated by the antenna. This antenna noise sets the ultimate limit upon the weakest possible signal we can hope to detect. It is not possible to build a "perfect" receiver, but it is possible to calculate what its noise level would be. Also, we can measure the noise level of a practical receiver and compare it with this "perfect" receiver. Expressed in proper mathematical language, this ratio is called the "noise figure" or "noise factor" of a receiver, and is an indication of the merit of the receiver.

In our discussion of thermal-agitation noise, we were very careful to use the word "ohmic" when speaking of resistors. Actually not all resistors are "ohmic." Some are what might be called "electronic," such as those produced by vacuum tubes, and are not sources of thermal-agitation noise. For example, the very low input resistance of a grounded-grid amplifier is such a resistance. This resistance is caused by feed-back — the plate current is caused to flow through the input circuit. In general, the feed-back will have little effect on the signal-to-noise ratio, since signal and noise are affected more or less in the same way by the feed-back.

While vacuum tubes are not sources of thermal noise, they are sources of the other type of noise, the "shot" noise. This effect is caused by the random way in which the electrons leave the cathode, and thus the plate current contains random variations. If grid current flows, it also generates noise in the same way.

As a matter of fact, this "shot" noise can be applied to our advantage. Under certain conditions, it is easy to calculate just how much noise is produced by a diode. The gadget to be described later operates on just such a principle. It is connected to the input of the receiver and adjusted to cause the noise power output of the receiver to double.

In multigrad tubes there is an additional type of noise known as "partition" noise. The cathode current, which already contains the ordinary shot effect, must divide between the plate and the screen grid, and the fraction of the current that goes to the plate fluctuates in time, causing larger variations in the plate current than would be produced in comparable triodes. Thus, theoretically triodes are far superior to multigrad tubes, from the standpoint of inherent noise. However,

<sup>2</sup> This effect has been put to practical use at microwaves, where it is possible to build antennas of high directivity. The "noise temperature" of the antenna is then controlled by some object placed along the path of maximum gain. It is possible to detect a lighted cigarette at a few feet by means of the noise at a 1 cm. wavelength.

<sup>1</sup> See Appendix.



as anyone knows, triodes cannot ordinarily be used as r.f. amplifiers without neutralization, which is often impractical or at least very inconvenient. In contrast to triodes, tubes which have relatively-high screen-to-plate-current ratios are unusually bad from a noise standpoint. Tubes like the 6SA7, 6K8 and 6L7, designed for converter use, fall in this category.

The ability of a tube to produce shot (and partition) noise is expressed as an "equivalent noise resistance." This is a hypothetical resistance whose Johnson noise at room temperature would cause the same fluctuation in the plate current of an otherwise noise-free tube as the actual shot effect. If the reader does not care to bother with definitions, he can think of this quantity as a number that expresses the relative noisiness of a tube. The lower the value is, the better the tube is. Table I gives the calculated equivalent noise resistances of most of the common receiving tubes. Note that the triodes have lower values than pentodes, as would be expected from the previous discussion. It will also be seen that there is a tendency for the higher-transconductance tubes to have the lower equivalent noise resistances. When triodes and pentodes are used as converter tubes, the conversion transconductance is usually less than the transconductance of the same tube used as an amplifier by a factor of about 3 or 4. The equivalent noise resistance increases by approximately the same amount. The figures for the converter tubes are quite high, and the moral is obvious: in a superheterodyne with no r.f. stages, multigrid converter tubes should be avoided. The inferiority of converter tubes is caused by the large partition noise, since the screen current generally runs several times higher than the plate current.

While the equivalent noise resistance gives a general idea of the relative merits of the various tubes, it doesn't tell the whole story. In the first place, at high frequencies transit-time effects give rise to additional noise, particularly in tubes not designed for these frequencies. In the second place, a more efficient input circuit can be designed when the input capacity is low. Partly because of its high input capacity, the 6AC7 is not quite as good as the table would indicate. In the third place, grid current may give rise to additional shot noise. Laboratory measurements have indicated that most tubes give slightly worse results than predicted, while the 6AK5, when employed as a triode and as a pentode, gives results that are more closely in agreement with the theoretical.

Hey, wait a minute! Don't go rushing off to slap a triode-connected 6AK5 into the input of your receiver and expect to have the best possible receiver — there is a lot more to the story. In the first place, the table indicates only what is theoretically possible in the way of performance — it doesn't come about automatically. The as-

sociated circuits and the operating voltages of the tube determine how close one can come to the theoretical figure.

A most important consideration is the fact that the adjustment of the input circuit which gives the best signal-to-noise ratio is not the same one that gives the loudest signal. For this reason, special apparatus (such as the noise generator to be described) is very desirable for obtaining the optimum adjustment. Simply adjusting for the loudest signal isn't the whole story, and generally results in something less than best performance. The antenna is, of course, the source of the signal and some thermal-agitation noise. In a perfect receiver there would be no other source of noise. In a well-designed practical receiver there are other sources but they make relatively small contributions. Adjusting the input circuit will affect signal and noise in different ways, because some of the noise is generated in the first tube and its associated circuits; therefore if one varies the adjustment away from the one that gives the loudest signal in the correct direction, it is to be

**TABLE I**  
*Equivalent Noise Resistances of Receiving Tubes*

Tube	$G_m$ ( $\mu$ hos)	Req. (ohms)	$C_{input}$ ( $\mu$ fd.)
<i>Triode Amplifiers</i>			
1LE3	855	2920	
3A5	1800	1390	0.9
6AC7	11,250	220	11.0
6AK5	6670	385	4.0
6C4	2200	1140	1.8
6F4	5800	430	2.0
6J4	12,000	210	2.8
6J5	2600	960	3.4
6J6	5300	470	2.2
6SC7	1325	1840	2.2
6SL7	1600	1560	3.2
6SN7	2600	960	2.4
7F8	5650	440	2.8
9002	2200	1140	1.2
<i>Sharp Cut-Off Pentodes</i>			
1L4	1025	4300	3.6
1LN5	800	3450	3.4
6AC7	9000	720	11.0
6AG5	5000	1640	6.5
6AJ5	2750	2650	4.1
6AK5	5000	1880	4.0
6AS6	3500	4170	4.0
6SH7	4900	2850	8.5
6SJ7	1650	5840	6.0
9001	1400	6600	3.6
<i>Remote Cut-Off Pentodes</i>			
1T4	750	20,000	3.5
6AB7	5000	2440	8.0
6SC7	4700	4000	8.5
6SK7	2000	10,500	6.0
9003	1800	13,000	3.4
<i>Converter Tubes</i>			
1LC6	270	160,000	9.0
1R5	250	160,000	7.0
6SA7	450	250,060	9.5

expected that, for a while, the signal will decrease less rapidly than the noise. If the input circuit involves a transformer, the optimum occurs at somewhat tighter coupling than the loudest signal or, if a single coil with an antenna tap is used, the tap will be closer to the grid end than with the loudest signal.<sup>3</sup> Under these conditions the input circuit will have poor selectivity. Thus if the receiver first stage is designed for optimum signal-to-noise ratio it cannot contribute much to the selectivity, and if high selectivity is desired it will have to be obtained in following stages.

You will recall that the receiver noise power is proportional to the bandwidth, and too often this fact isn't appreciated. In practically all receivers the bandwidth of the receiver is determined by the i.f.- and audio-amplifier characteristics, since the r.f. stages are incapable of any high-order selectivity. Assuming uniform noise over the portion of the spectrum where one is listening, the noise appearing in the output will be proportional to the bandwidth of the receiver, but the amount of signal is constant for any bandwidth in excess of that necessary to pass the signal with good fidelity. It is readily apparent, therefore, that the bandwidth of a receiver should be only enough to pass the signal, and that any greater bandwidth will result in a poorer signal-to-noise ratio.

### Noise Figure

We have already described the noise figure of a receiver as a quantity that expresses the relative merit of a receiver as compared with a "perfect" receiver of the same bandwidth. This quantity may be expressed as a power ratio, but more commonly it is given in decibels. The smaller the number, the better the receiver is. In general, it is more difficult to obtain good noise figures at high frequencies than at low. With the best techniques now available, figures as low as 12 db. are obtained at centimeter wavelengths, 6 db. at 60 Mc., and 2 to 3 db. at 30 Mc. A perfect receiver would have a noise figure of 0 db.

This concept is particularly useful because it allows us to compare various receivers of different bandwidths. Receivers A and B might both have the same noise figure and the same gain. However, A might be only 10 kc. wide, since it is intended for telephony reception, while Receiver B, designed for radar work, might be 2 Mc. wide. Because of its greater bandwidth, Receiver B would have a larger equivalent noise power, but the fact that their noise figures were equal would indicate that in their respective applications they were equally good. If both had noise figures of 2 db., it would be apparent that little further improvement could be obtained by input-circuit refinements.

<sup>3</sup> These statements do not apply to grounded-grid amplifiers.

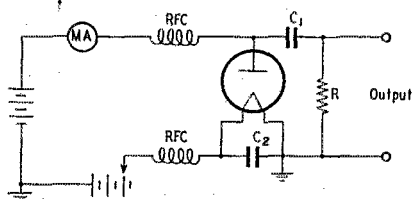

Fig. 1 — The basic circuit of the diode noise generator for measuring receiver sensitivity. By controlling the filament temperature of the diode, the d.c. current through the diode is a direct measure of the noise power developed across R.

### Measurement of Noise Figure

The measurement of noise figure consists of first measuring the equivalent noise power of the receiver and then dividing this by the equivalent noise power of a perfect receiver. To measure the noise of the receiver, a noise generator having an internal impedance equal to that of the antenna is connected to the input. Some sort of device that indicates power is connected to the output. This power-reading device is read with the generator turned off. The generator is then turned on and its output increased until the receiver power output is doubled. Then the power of the generator (more exactly what is called its "available" power — see Appendix) is determined. This is equal to the equivalent "available" noise power of the receiver.

### A Noise Generator

While noise figure can be measured with a c.w. generator, it is quite difficult. Noise figures of 3 to 20 db. correspond roughly to equivalent noise powers of  $10^{-16}$  and  $5 \times 10^{-15}$  watts respectively in good communications receivers with 10-kc. wide i.f. amplifiers. Power can be measured directly only down to about  $10^{-8}$  watts, and hence an attenuator must be used that is accurate over a range of 100 db. The exact determination of the "noise bandwidth" is a nuisance. And, lastly, some devices which might be used to measure output power in the receiver do not respond to noise and c.w. in the same way. On the other hand, noise figure becomes a simple thing to measure with a "noise generator," the war-born development mentioned earlier. Perhaps it would be better to say that it becomes easy to compare performance with a noise generator, since comparative checks will tell in an instant when an improvement in performance has been made in the unit under test. It is difficult to be sure that one's absolute measurements are exact, and great care must be taken with the construction and use of the generator, although the results obtained with the generator to be described have been quite reasonable and probably less than 2 or 3 db. in error from the absolute value. In any event, when the generator is used at one fre-

quency under fixed conditions, the errors in measurement should all be the same, so the comparative checks will be quite good.

A simplified diagram of the noise generator is shown in Fig. 1. A diode is operated in a "temperature-saturated" condition, which means that the anode voltage is high enough so that the diode current is determined by the filament temperature alone. A diode of this type acts as a constant-current generator of noise because of the fluctuations in the number of electrons leaving the cathode (commonly called the "shot" effect). The chokes *RFC* prevent the r.f. components of this noise from flowing back through the batteries, and so they flow through *R*. The condenser *C*<sub>1</sub> prevents a short-circuit of the power supply. The resistor *R* represents the generator impedance, and should be a value equal to the input impedance of the receiver being tested. When the noise generator is connected to the input of the receiver, the temperature of the diode filament is adjusted until the noise output power of the receiver doubles. The noise figure of the receiver expressed as a ratio is then given by <sup>4</sup>

$$F = 20IR \quad (1)$$

where *I* = diode d.c. current in amperes

*R* = resistance of generator (*R* in Fig. 1)

Since the quantities *I* and *R* are readily known, the simplicity of the system is obvious.

Expressed in db., *F* is 10 times the common logarithm of the value given by the equation.

Unfortunately, not all diodes are suitable as noise generators, since the diode should have a pure tungsten or thoriated-tungsten filament. Oxide-coated filaments introduce error because of "flicker" effect; i.e., shifting of the active spots on the cathode, which introduces additional noise not covered by the above relation. One of the best diodes for the purpose is a British tube, the CV172, and the Western Electric 708-A, the Eimac 15E (not the 15R), and the 801A, all seem to be good generators. The time-honored '01A will do in a pinch, if you have one around, but the 801A is in surplus and is the one we finally used. The 801A passes more current and hence can be used over a wider range, but both the 801A and '01A gave the same results.

The noise generator is shown in the photographs, and the actual circuit is given in Fig. 2. The output is brought out to two terminals that also take the resistor *R*<sub>1</sub> (which represents the generator impedance) so that different values can be used without diving into the unit itself. The choke, *RFC*<sub>1</sub>, should be wound to resonate at the

operating frequency with the diode and socket capacities, although the generator can be used for comparison purposes at other frequencies without changing the choke. A voltage-doubling rectifier circuit, using a 117Z6, furnishes enough anode voltage to saturate the tube. The filament is fed through a 6.3-volt transformer (full voltage is not needed, nor would the anode supply stand the drain), and the primary of the filament transformer is connected to *P*<sub>2</sub>. In our tests we controlled this voltage with a Variac, but there is no reason why one of the many 10- and 25-watt rheostats in surplus wouldn't do the job just as well. All that is needed is smooth control of the filament voltage. The plate meter plugs in at *J*<sub>1</sub> — a 0-10 milliammeter will do the trick. Because the meter jack is at plate potential, it must be carefully insulated from the case.

The generator was built in a 3 × 4 × 5-inch box, and a small shield separates the r.f. portion from the power supply. The photographs show how the unit was assembled, and undoubtedly many variations will work as well. It is important to pay attention to the r.f. portion of things — everything to the right of the dotted line in Fig. 2 — and these leads should be kept as short as possible. To obtain absolute results it is necessary to resonate the choke *RFC*<sub>1</sub> with the tube and socket capacities — this was done with a grid-dip meter — but for comparison work we see no reason why one need be fussy. Getting absolute results allows one to compare his results with other amateurs, but we believe the usefulness of

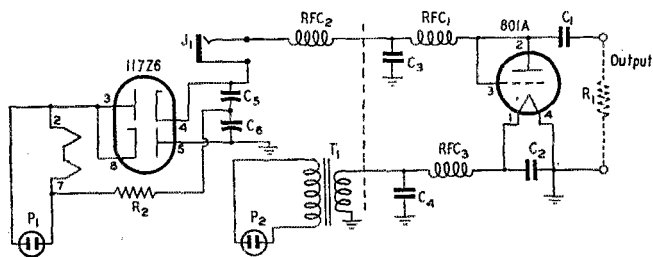

Fig. 2 — A practical circuit for a diode noise generator. The filament temperature is controlled by a Variac or rheostat in series with the a.c. to *P*<sub>2</sub>.

- C*<sub>1</sub>, *C*<sub>2</sub>, *C*<sub>3</sub>, *C*<sub>4</sub> — 0.001-μfd. mica.
- C*<sub>5</sub>, *C*<sub>6</sub> — 16-μfd. electrolytic, 150 volts.
- R*<sub>1</sub> — Generator impedance. See text.
- R*<sub>2</sub> — 1000 ohms, 2-watt composition.
- J*<sub>1</sub> — Open-circuit meter jack, insulated rom case.
- P*<sub>1</sub>, *P*<sub>2</sub> — Male plugs, 115-volt line.
- RFC*<sub>1</sub> — Resonates with tube capacity to signal frequency. For 29 Mc.: 30 turns No. 24 d.c.c. close-wound on 1/4-inch diam. form.
- RFC*<sub>2</sub> — 2.5-mh. r.f. choke.
- RFC*<sub>3</sub> — 38 turns No. 22 d.c.c. close-wound on 1/4-inch diam. form. *RFC*<sub>1</sub> and *RFC*<sub>3</sub> are wound on 1/4-inch diam. carbon resistors. Any value above 10,000 ohms is satisfactory.
- T*<sub>1</sub> — 6.3-volt filament transformer.

<sup>4</sup> See Appendix.

this gadget to the amateur lies primarily in its simplicity and the fact that it tells you at once when you have made an improvement in your receiver front end.

Using the generator is easy. If you are feeding your receiver with a flat line (300-ohm Twin-Lead or 50- or 75-ohm cable), connect a *non-inductive* resistor of this value at  $R_1$  and use short leads to connect the generator to the antenna posts of your receiver. Connect an a.c. voltmeter across the output transformer of your receiver and run up the receiver audio gain until the receiver noise indicates some convenient voltage as read by the a.c. voltmeter. With the diode noise generator turned on, slowly increase the filament voltage of the 801A until the receiver output voltage increases 3 db. (41 per cent). Read the diode current and that's your reference. You can substitute it in the equation  $P = 20IR$  if you have confidence in the noise generator, but we won't guarantee it will be exact. However, you do have a reference from which to work. If you want to see how much of an improvement your preselector gives, connect the noise generator to the preselector and make the same test. If you get a lower diode current with the preselector, the preselector is better than the receiver at that value of line impedance. The tests should be made with the receiver a.v.c. and b.f.o. switched off, and the r.f. gain control should be advanced as far as possible without overloading the receiver with noise. (You can check the latter by increasing the output of the noise generator well above the point that gives a 3-db. increase in receiver output. If the output is still going up fast, it is reasonably safe to assume that the overload point has not been reached.) And if you want to see whether having the input stage peaked at resonance is important, make a measurement with the input stage tuned "on the nose" and one with it detuned. Unless the antenna input circuit is very closely coupled (so that the tuning will have little effect) you will be amazed!

### A Cathode-Coupled Preamplifier

The noise generator has been used on 28 Mc. with several of the receivers around the lab and on two preamplifiers. One of these preamplifiers was the popular "R9-er" which uses a 6AK5 in a broadband amplifier, and the other was a cathode-coupled 6J6 that will be described later. The R9-er showed quite a bit of improvement at 28 Mc. over the receivers (with the single exception of one using a 6AK5 r.f. stage), although a new converter using a 6AK5 r.f. stage and a 6AK5 mixer showed comparable performance. The variations in receiver performance became obvious when using the noise generator. By using different values of resistors at  $R_1$  (Fig. 2), it was possible to see how the performance of the receivers varied with different input impedances, and the value of having the input impedance adjustable, as in the R9-er, became quite apparent. For example, the "hot" receiver with the 6AK5 input stage showed a noise figure of 6 db. with 300 ohms and 9.5 db. with 70 ohms, while the R9-er gave a value of 6 db. with either value of resistor. The receiver in question has no antenna trimmer brought out to the panel, and its incorporation might have helped the situation. However, this receiver was still better than others using regular metal tubes of the 6K7 variety, since their noise figures ran between 12 and 16 db. At several points during the development of the cathode-coupled preamplifier it showed inferior performance compared with the R9-er, although the difference wasn't apparent when listening to signals on the air. It was finally possible to get slightly better performance from the 6J6 job than the R9-er, although the difference was only 1 db. (as indicated by the noise generator). This is not to be interpreted as a boost for the 6J6 over the 6AK5, but only to show the usefulness of the noise generator. If we had spent as much time on the R9-er as on the 6J6 job, it might have turned out the better! We want only to stress

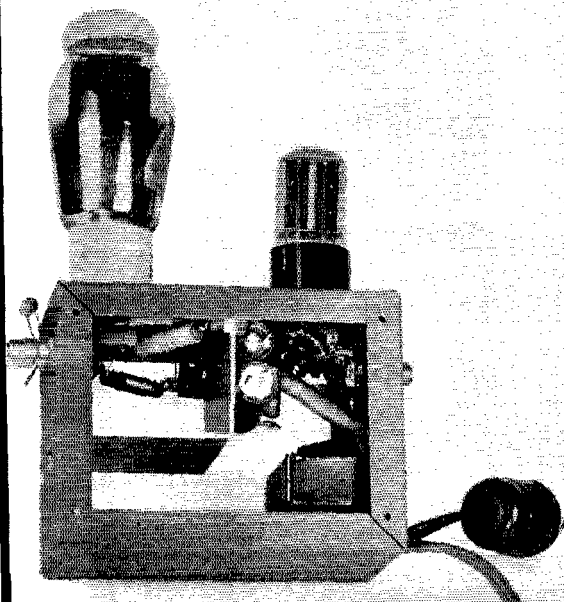

This view of the noise generator shows how the r.f. portion is shielded and filtered. The r.f. choke in the foreground is the filament choke—the resonant plate choke is in the rear.

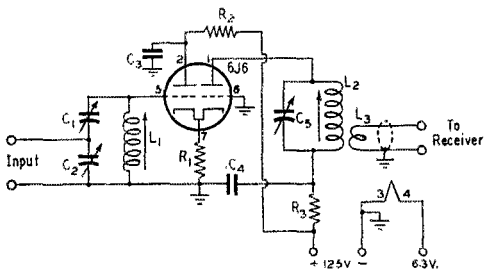

Fig. 3—Circuit diagram of the cathode-coupled preamplifier.

- $C_1, C_2$ —3- to 30- $\mu$ fd. mica trimmer (National M-30).  
 $C_3, C_4$ —0.001- $\mu$ fd. mica, smallest size.  
 $C_5$ —35- $\mu$ fd. midjet variable (Millen 20035).  
 $R_1$ —470 ohms,  $\frac{1}{2}$ -watt carbon.  
 $R_2, R_3$ —1500 ohms,  $\frac{1}{2}$ -watt carbon.  
 $L_1$ —28 Mc.: 17 turns No. 22 d.c.c., close-wound.  
 14 Mc.: 34 turns No. 30 d.c.c., close-wound.  
 $L_2$ —28 Mc.: 10 turns No. 18 enam., space-wound to fill form.  
 14 Mc.: 20 turns No. 22 d.c.c., close-wound.  
 $L_3$ —3 turns No. 18 flexible hook-up wire close-wound over ground end of  $L_2$ .  
 Coils wound on National XR-50 forms.

that the noise generator is a handy tool for the fellow trying to improve his receiver performance at 14, 28 and 50 Mc. At higher frequencies, the inductance of the leads in the 801A would probably enter into the picture too much, and no hope for absolute results could be held, although a comparison could still be made.

Pictures of the preamplifier are shown on these pages, and the circuit diagram is given in Fig. 3. The antenna is coupled in through a reactive network,  $C_1C_2$ . The plate of the input section of the 6J6 is grounded for r.f. through  $C_3$ , and the signal is developed across  $R_1$ . The second half of the 6J6 acts as a grounded-grid amplifier, with the signal coupled in through  $R_1$ . The plate circuit,  $L_2C_5$ , is tuned to the signal, and the condenser shaft of  $C_5$  is brought out to a knob. Thus this condenser is the only tuning adjustment required, once the other constants have been set properly. The input circuit,  $C_1C_2L_1$ , is broad-

banded because it is relatively low- $C$  and is loaded down by the antenna, but the output circuit tunes and hence gives some image rejection. The improvement in image rejection at 28 Mc. is not great, however, and the merit of the preamplifier lies in its improved reception of weak signals. On 14 Mc., the image rejection is slightly better.

The construction of the unit is apparent from the photographs, and no lengthy description is required. With the single exception of the interstage shield, all of the components are mounted on the 4  $\times$  5-inch piece of aluminum used to replace one side of the can. This makes it an easy matter to work on the gadget, since all of the construction work can be done with the chassis removed from the box. The two condensers,  $C_1$  and  $C_2$ , are supported by No. 12 tinned wire soldered to the input terminals (a National FWH assembly) and a lug on a small National GS-10 stand-off insulator. This turns out to be a more rugged assembly than we expected, and nothing to be ashamed of mechanically. The output tuning condenser,  $C_5$ , is mounted on a small aluminum bracket. All r.f.-circuit grounds are brought to a single lug under one of the 6J6 socket mounting screws. The power leads are brought out through a Jones P-303-AB miniature plug, and the lip of the case must be cut out slightly to clear one bracket of this plug. The output cable, a length of RG-58/U, is secured to a small tie-point which also serves as a tie-point for the ends of  $L_3$ . The outer conductor of the cable is grounded by the tie-point mounting bracket.

The interstage shield is fastened to one side of the case only, and it is jugged into place after the chassis is fastened down. The interstage shield has a notch to clear the r.f.-circuit ground lug, and another notch holds the output cable in place. A small hole is necessary to pass the lead from  $L_1$  to the grid of the tube. This grid lead must be connected after the shield is in place, but it is the only connection that can't be made beforehand. The grounded grid lead, from Pin 6, runs across the socket to the socket center shield, and then to Pin 3 and ground.

A cathode-coupled 6J6 preamplifier. The knob at the front tunes the output—the input tuning is fixed-tuned. Note the two holes just in front of the antenna binding posts, for ready access to the input coupling condensers.

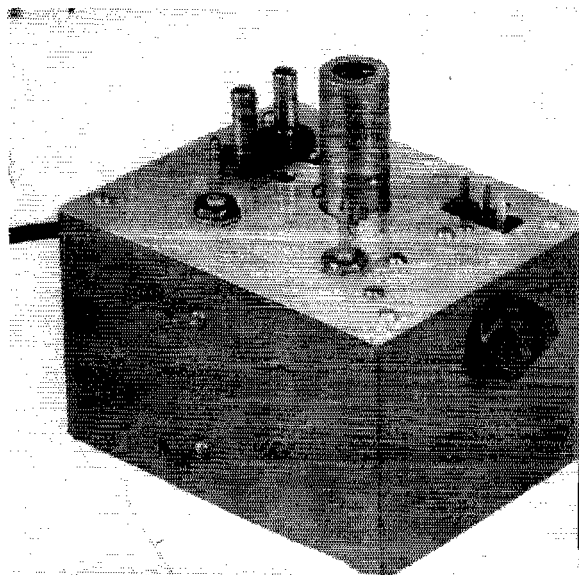

The permeability-tuned coils and the adjustable input condensers make adjusting the preamplifier a fairly easy job. Connecting the amplifier to the receiver,  $C_5$  is set at about half-scale and the core of  $L_2$  adjusted for resonance, as indicated by a slight increase in noise in the receiver. Then different ratios of  $C_1$  and  $C_2$  are tried, resonating the circuit with the slug in  $L_1$ , until best results are obtained. If  $C_1$  is small compared with  $C_2$ , the loading on the input circuit will be light, and if it is too light the amplifier will oscillate. This is remedied by increasing the capacity of  $C_1$  (or decreasing that of  $C_2$ ) and reresonating  $L_1$ . If the receiving antenna uses a tuned line, some combinations may occur where proper loading cannot be obtained, in which case it may be necessary to resort to an external tuned circuit link-coupled to the input of the preamplifier. With a reasonably "flat" line, no difficulty should be encountered.

With the diode noise generator, adjustment of the gadget is quite simple. The correct resistor (corresponding to your line impedance) is connected at  $R_1$  in Fig. 2, and the noise generator is connected as described earlier. The input circuit of the preamplifier is then adjusted for the center of the band, and the performance across the band can be checked by making the same measurement at several frequencies. If the noise figure drops off at the edges, slightly tighter input coupling should clean it up. It will be found that loose coupling to the antenna, which makes for a regenerative condition in the preamplifier, will often give a good noise figure, although the input circuit is too sharply tuned to operate across the band without retuning. Here, however, may be the answer to the success hams have had in years gone by with regenerative preselctors using inductive antenna coupling. It has been found that the best noise figure generally obtains when the antenna coupling to the first tube is slightly more than optimum (which is why it isn't worth while at high frequencies to try to obtain much selectivity in the antenna circuit). In a regenerative preselctor, the negative resistance introduced in the grid circuit rapidly changes the  $Q$  of the circuit as the regeneration is increased. Raising the  $Q$  increases the effective coupling, and so the regenerative preselctor probably adjusts itself more or less automatically to a good operating condition.

In radar work, noise figures at 30 Mc. of less than 3 db. have been obtained with careful techniques. Since amateur antennas vary so widely, it is practically impossible to describe a universal unit that will work at optimum for everyone. However, with a noise generator to check whether or not an improvement has been made, and with the knowledge that "flat" lines can be made to behave more readily than tuned ones, we feel that the few hints given in this story will enable a serious worker to devise and develop his equipment to the point where the maximum performance is obtained with the tubes that are available. The input coupling circuit used in the preamplifier just described is a simple one that will meet a number of conditions, but inductively-coupled circuits, with provision for tuning both primary and secondary, and for changing the coupling, will probably give slightly better results. Higher- $Q$  coils should also give improved performance, since the only desirable resistance ahead of the first grid is that furnished by the antenna itself.

#### Appendix Proof of Equation 1

Electrical generators are generally represented as a source of voltage  $e$  in series with an internal resistance  $R$ . As far as the outside world is concerned, they may also be represented as a constant-current generator,  $i$ , in parallel with  $R$ , where  $e = Ri$ . A third way of describing a generator is in terms of its so-called available power and its internal resistance  $R$ . The available power  $W$  is the maximum power that the generator can supply to an external load, which happens to occur when the external load resistance is equal to  $R$ . When this condition is fulfilled, the voltage across the load is  $\frac{1}{2}e$ . The power dissipated within it is this voltage squared divided by  $R$ . Consequently,

$$W = \frac{e^2}{4R} \quad (2)$$

Also since  $e = Ri$ ,

$$W = \frac{Ri^2}{4} \quad (3)$$

In noise theory, sources of noise and signal are generally described in terms of their available powers.

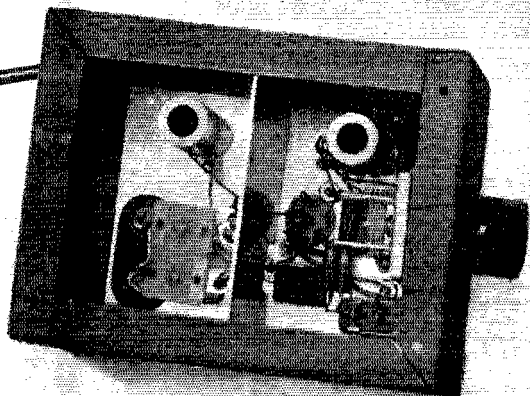

A view of the underside of the preamplifier, showing the shield partition through which the grid lead passes.

**QST** for

The preamplifier chassis can be removed from its case after cutting the grid lead and removing the shield. The coils shown are for 14 Mc. — coil dimensions for 14 and 28 Mc. are given in Fig. 3.

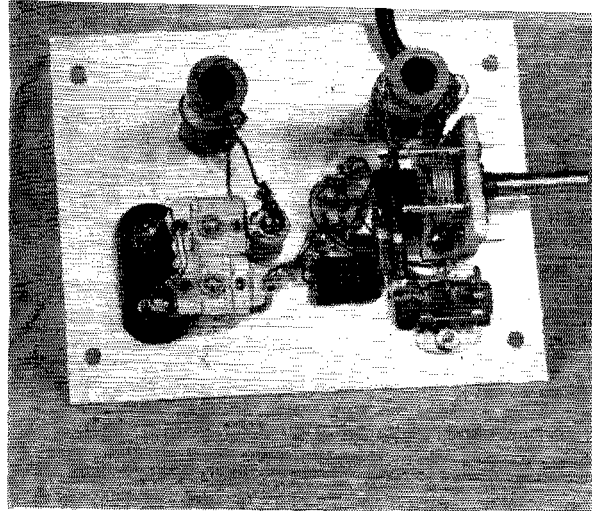

Now we are in a position to give more rigorous definition of noise figure. If we had a "perfect" receiver, there would be sources of noise within it, and the only source of noise would be the thermal-agitation noise of the antenna which has an available power  $N_1$ . With a practical receiver we have additional sources of noise. To get the same noise output from a perfect receiver of the same gain and bandwidth as the actual receiver we would have to place at the input a noise source having an available power  $N_2$  (which is larger than  $N_1$ ). The noise figure  $F$  is then defined by

$$F = \frac{N_2}{N_1} \quad (4)$$

We shall now evaluate  $N_1$  and  $N_2$ .

The theory of thermal-agitation noise shows that  $e$ , the r.m.s. equivalent noise voltage in series with a conductor of resistance  $R$  is given by

$$e^2 = 4kTR\Delta f, \quad (5)$$

wherein  $k$  = Boltzmann's constant,  
 $T$  = absolute temperature,  
 and  $\Delta f$  = noise bandwidth of receiver.

If we substitute the value of  $e$  from Equation 5 into Equation 2, we see that a conductor has an available noise power of

$$W = kT\Delta f, \quad (6)$$

a factor of  $4R$  having canceled out, and thus the available noise power is independent of  $R$ . It is useful to remember that at approximately room temperature (exactly  $292^\circ$  absolute)  $kT\Delta f$  equals  $4 \times 10^{-15}$  watts per Mc. bandwidth.

Since the available noise power at the input of the perfect receiver is that due to the thermal agitation in the antenna,

$$N_1 = kT\Delta f. \quad (7)$$

When we connect the diode noise generator and adjust it to cause the noise output power of the receiver to double, its available power must equal  $N_2$ . The shot noise in a temperature-limited diode can be represented as a current-generator  $i$

connected from cathode to plate, where  $i$  has an r.m.s. value given by

$$i^2 = 2eI\Delta f, \quad (8)$$

wherein  $e$  = charge of electron (which is equal to  $1.6 \times 10^{-19}$  coulombs), and  $I$  = the d.c. plate current.

When a resistance  $R$  equal to the radiation resistance of the antenna is connected in parallel with the diode, the combination has an available power given by substituting the value of  $i$  from Equation 8 into Equation 3. If  $I$  represents the particular value of the d.c. plate current which causes the output to double,

$$N_2 = \frac{\epsilon IR\Delta f}{2} \quad (9)$$

When  $N_1$  from Equation 7 and  $N_2$  from Equation 9 are substituted into Equation 4,

$$F = \frac{\epsilon}{2kT} IR, \quad (10)$$

the bandwidth  $\Delta f$  having conveniently canceled out. At room temperature the constant factor  $\epsilon/2kT$  is very nearly equal to 20, if  $I$  is expressed in amperes and  $R$  is expressed in ohms. Therefore,

$$F = 20 IR. \quad (1)$$

## Strays

It is with heavy heart that we list the late Samuel C. Hitchon, VE4AE, in Silent Keys this month. Mr. Hitchon, a prominent amateur since the early '30s, was accidentally electrocuted on June 22nd. When discovered in his shack, the victim was holding a grounded microphone stand in his right hand and the station transmitter had been pulled from its shelf. It is believed that Mr. Hitchon's left hand came in contact with an exposed plate coil while he was tuning the rig.

*Switch to safety!*

# Revamping the 150-B for 14-Mc. Operation

Another Surplus-Conversion Job for the Ham Bands

BY JOHN M. MURRAY,\* WIBNN, ex-W2AMD

PROMINENT in surplus transmitting gear suitable for ham operation is the Meissner 150-B. This transmitter has an output rating of 150 watts, c.w. or 'phone, and a frequency range of 1500 kc. to 12.6 Mc. It consists of two physical units—an exciter unit which includes a 6F6G VFO and a 6L6G doubler, and an amplifier section which uses a single 813. Plug-in coils are used in all tank circuits except in the grid circuit of the 813, where coils are switched. The amplifier section includes a modulator in which a 6J5GT and push-pull 6VGGTs drive Class B 813s. The speech section is designed for use with a single-button carbon microphone. Complete power-supply equipment is self-contained and since it operates from a 115-volt single-phase 60-cycle supply, it dissipates an S9 headache which must be overcome in many other surplus-conversion jobs.

At this writing, several hundred of these transmitters are already in use on amateur bands.

\*47 Keeney Ave., West Hartford, Conn.

• The 150-B is one of the many surplus transmitters now available. It has a rating of 150 watts, 'phone or c.w., and is perhaps more suitable for ham use than some of the others since it is designed to work from a 115-volt 60-cycle supply. However, because its original frequency range is limited to a maximum of 12 Mc., it must be altered to cover higher frequencies. This article shows one way of getting it to work at 14 Mc.

with varying degrees of success—usually good. It is the purpose of this article to point out merely one simple method of conversion that has brought continued excellent results, particularly with regard to 14-Mc. 'phone and c.w. operation. No alterations at all are necessary for 3.5 and 7 Mc.

## Adding a Doubler Stage

The first consideration was to obtain sufficient excitation to the 813 final amplifier in the 14-Mc. band. Since the circuit was designed to go no higher than 12.6 Mc. the problem resolved itself into a question of whether to make new coils for the exciter unit or to add a doubler stage. The latter appeared most practical, since it involved no tampering with circuit components or recalibration. Therefore, the 72-ohm r.f. line from exciter to final was cut and a link-coupled 6L6GA doubler stage was inserted between the exciter and amplifier units. Fig. 1 shows the circuit of the doubler unit and its associated external power supply, which is quite orthodox. The 6L6GA is connected as a high- $\mu$  triode. These two units on their  $7 \times 7 \times 1\frac{3}{4}$ -inch chassis nicely fill out the space behind the exciter to bring the back of this flush with the rear of the main transmitter frame. Two additional Amphenol male and female plugs in the r.f. exciter line provide entrance and exit from the doubler. For 3.5- and 7-Mc. operation, the r.f. line is removed from the output of the doubler and plugged directly into the exciter.

In case the question arises as to why plate and filament power for the doubler could not have been derived from the power supply in the unit, it will be seen, on reference to the ratings of the two power sources, that they are probably running close to their capacity.

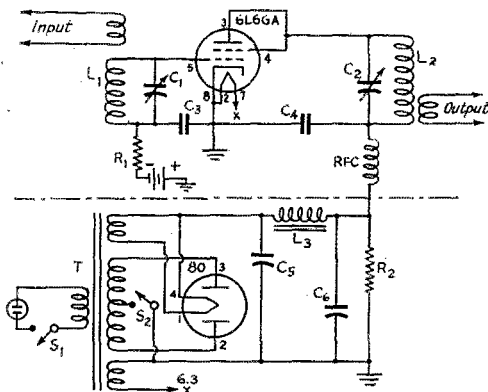

Fig. 1—Circuit diagram of the doubler stage that is added to the 150-B for 14-Mc. operation.

- C<sub>1</sub>—100- $\mu$ fd. midget variable.
- C<sub>2</sub>—50- $\mu$ fd. midget variable.
- C<sub>3</sub>, C<sub>4</sub>—0.0022- $\mu$ fd. mica.
- C<sub>5</sub>, C<sub>6</sub>—8- $\mu$ fd. 450-volt electrolytic.
- R<sub>1</sub>—47,000 ohms, 1 watt.
- R<sub>2</sub>—40,000 ohms, 10 watts.
- L<sub>1</sub>—14 turns No. 22 d.c.c.,  $1\frac{1}{2}$  inches diam., 1 inch long (B & W JEL-10 with 5 turns shorted out).
- L<sub>2</sub>—9 turns No. 22 d.c.c.,  $1\frac{1}{2}$  inches diam., 1 inch long (B & W JEL-20 with 4 turns shorted out).
- L<sub>3</sub>—75-ma. 30-hy. filter choke (Stancor C-1002).
- RFC—2.5-mh. r.f. choke.
- S<sub>1</sub>, S<sub>2</sub>—S.p.s.t. toggle switch.
- T—Power transformer—700 v. c.t., 70 ma., 5 v., 3 a., 6.3 v., 3 a. (Stancor P-4078).



The 14-Mc. doubler and its power supply in place behind the 150-B oscillator cabinet.



### Tuning the Amplifier

In converting the final stage it was necessary only to short out two turns by soldering a piece of No. 12 bus across the bottom of the first two "left-hand" turns of the smallest coil furnished with the unit, the one designated  $L_{203}$ . Readjustment of the grid circuit is unnecessary. Adequate excitation is obtained with the grid-range switch in either the 7.0-8.8-Mc. or 8.8-10.7-Mc. position, although the first provides more drive. With the exciter fundamental set between 7 and 7.2 Mc., the final grid current runs about 6 ma. between 14 and 14.4 Mc., which is quite adequate. Recommended excitation is 5 ma. for normal operation. This may be reduced to as low as 3 ma. without apparent decrease in efficiency.

The output tank circuit is of the pi-section type, designed to couple to an unbalanced antenna system. Since it was desired to feed the output into a two-wire line, this system was discarded in favor of an external link-coupled tuning unit, fed by a piece of Amphenol RGSU coaxial cable with the center conductor connected to the normal output terminal and the outer conductor grounded at the transmitter frame. Its 4-foot length is cut at one point by the antenna change-over relay before it ends up at the two-turn loop around the antenna coil. At this point the sheath is also connected to the center of the antenna coil. To tune to 14 Mc. and match 450-ohm feeders, this coil consists of ten turns of No. 12 wire,  $2\frac{1}{2}$  inches in diameter. A 50- $\mu$ fd. double-spaced variable condenser is shunted across the entire coil, with the feeders clipped on at each end.

### Using a Crystal Microphone

One last alteration rounded out the conversion. To permit the use of a crystal microphone, the

carbon-microphone transformer and gadgets affixed thereto were replaced by a 6SJ7 stage, as shown in Fig. 2. The tube and its associated trappings are easily mounted in the space formerly occupied by the discarded components. In removing the carbon-microphone jack, care should be taken to observe the relation of ring, tip and sleeve contacts. The sleeve is grounded, the ring carries the speech currents, and the tip is in the relay circuit which puts the plate power on and off. In Fig. 2 it will be noted that the external "on-off" switch bears the same relationship to the original circuit. The 6SJ7 picks up its filament and plate power from the nearby 6J5GT/G. Optimum voice-level input is obtained by balancing the new external microphone potentiometer with the old gain control,  $R_{311}$ .

This change is well worth while, considering the tremendously-improved speech quality. It is possible that installation of the crystal microphone may be partial remedy for what seems to be the 150-B's one great weakness — an overrated modulation transformer. A heavy percentage of owners have burned out these transformers. Sudden peaks of great amplitude are normal with the carbon microphone. Using the push-button microphone provided, these peaks are greatly accentuated by a stiffness in the controlling button, causing sharp "cracks" and a resultant violent agitation of the carbon, which frequently generates plate-current surges beyond the recom-

(Continued on page 120)

Fig. 2 — Diagram of speech-amplifier stage added to 150-B modulator to permit use of a crystal microphone.

- $C_1$  — 25- $\mu$ fd. 50-volt electrolytic.
  - $C_2$  — 0.1- $\mu$ fd. 300-volt paper.
  - $C_3$  — 0.01- $\mu$ fd. paper.
  - $R_1$  — 1-megohm variable.
  - $R_2$  — 1500 ohms, 1 watt.
  - $R_3$  — 0.5 megohm, 1 watt.
  - $R_4$  — 2 megohms, 1 watt.
  - $S_1$  — S.p.s.t. toggle or push-button switch.
- Other component labels refer to diagram in 150-B instruction book.

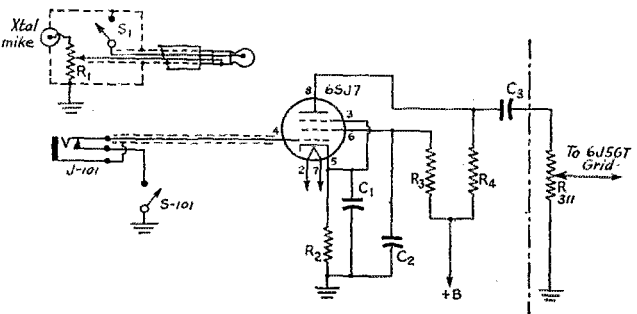

# Interference with Television Broadcasting

## A Survey of the TVI Situation

BY GEORGE GRAMMER,\* WIDF

**A**MATEUR interference with television promises to be principally — but by no means entirely — a question of harmonics from our transmitters. As such it is just one part of the still larger problem of harmonic interference to all services that operate above us in the spectrum. Television, however, appears to have more headaches in store for us than all the other services combined. Those of us who live in regions where there is television broadcasting, therefore, will do well to become familiar with some of the things that can happen in a TV receiver when a nearby ham opens up.

There isn't much of the radio spectrum that a TV receiver misses. To understand why, it is necessary first to take a look at a television channel. Fig. 1 shows the idealized television channel that is the standard toward which TV transmitters work. It is 6 megacycles wide, has the picture carrier placed 1.25 megacycles above the low-frequency edge, and has the sound carrier 5.75 megacycles from the low-frequency edge. For example, Channel No. 2, which runs from 54 to 60 megacycles, has its picture carrier at 55.25 Mc. and its sound carrier at 59.75 Mc. The frequency characteristic of the video transmitter is supposed to drop off rapidly at the low end, starting 500 kc. in from the edge, until the radiated signal is negligible outside the low edge. It is also supposed to be similarly attenuated in the 500-ke. portion just below the sound carrier, to prevent the video signal from appearing in the sound channel. Amplitude modulation is used for the picture signal and f.m. for the sound.

Note that the picture sideband extends 4.5 Mc. from the picture carrier in the high-frequency direction, but only 1.25 Mc. in the low-frequency direction. In ordinary modulation the two sidebands would be equal, but in this case only the upper sideband is completely transmitted; the lower sideband is confined to those components that are within 1.25 Mc. of the carrier. This "vestigial-sideband" transmission — part way toward single-sideband — not only saves spectrum space but also simplifies the technical problems of broad-banding antennas and r.f. circuits.

### Receiver Characteristics

The receiver used for such a signal obviously must have an intermediate-frequency amplifier that will pass the picture carrier with at least its

upper sideband intact, if the received picture is to look like the original. Receiver manufacturers have decided to standardize on placing the receiver's high-frequency oscillator on the h.f. side of the TV channel being received, and to place the i.f. sound channel somewhere between 21.25 and 21.9 Mc. Information to date is that most manufacturers are using 21.9, with a few as low as 21.7. They have all, so far, wisely avoided the 21.25–21.5 region, in part of which, at least, it appears probable that there will soon be an amateur band.

Assuming, for the sake of an example, that the i.f. sound channel in a particular receiver is placed at 21.9, then the 6-Mc. channel converted to intermediate frequency turns out to lie between 21.65 and 27.65 Mc., with the picture carrier at 26.4 Mc. The ideal i.f. characteristic, based on having the sound carrier at 21.9 Mc., is shown in Fig. 2. Starting 750 kc. below the picture carrier,

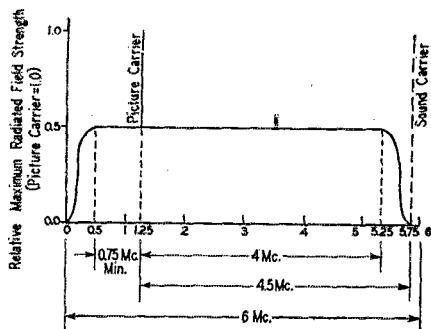

Fig. 1 — The television channel and ideal transmitter frequency characteristic for the picture signal.

the i.f. response should drop off linearly, reaching 50 per cent at the carrier frequency (26.4 Mc.) and zero at 750 kc. above the carrier frequency. This sloping part of the curve has two sidebands to work on, and therefore puts as much sideband energy through the system as the flat part of the curve, which handles only one sideband. The sound signal goes through a separate i.f. centered at 21.9 Mc., and usual practice is to put a trap (tuned to the sound carrier frequency) in the picture i.f. so that the sound-carrier does not go through the picture channel.

The second detector in the picture i.f. channel strips off the video component and the video signal is then given further amplification before

\* Technical Editor, QST.

being applied to the viewing tube. The video channel covers the entire spectrum from the low audio range up to about 4.5 Mc. In addition, of course, there is the usual audio amplifier for the sound that accompanies the picture.

The *intended* coverage of the receiver is therefore from zero frequency to 4.5 Mc. in the video channel, from 21.65 to 27.65 Mc. in the i.f. channel, plus a 6-Mc. signal channel that lies at a number of assigned spots in the spectrum above 44 Mc. If the receiver were perfect, it would respond *only* to signals in an assigned TV channel and nowhere else; the video and i.f. channels would be so well protected that no outside signals could get into them. But no receiver is perfect. An attempt even to approach perfection costs a lot of money. If there is anything certain in this picture it is that the receivers offered to the public will be far short of perfection. They're cheaper that way.

### Back-Door Interference

So let's take a look at the possibilities when receivers aren't perfect. In the first place, there's the video amplifier. It covers everything right up through our 3.5-Mc. band, so a nearby 80-meter transmitter can be expected to cause interference if its signal can somehow get into the video channel. The most likely possibility is that such a signal would be picked up through the power line or directly on the video-circuit wiring, rather than that it would come through the front end of the receiver. So far, there have been only one or two cases of 80-meter interference, and we don't know whether or not it will turn out to be a serious factor. There are a few points in our favor: The video amplifier also will respond to nearby broadcast signals, since the whole broadcast band is in the video range. Therefore shielding is a necessity, from the set manufacturer's standpoint, because there is no locality where that type of interference can be ignored. (Amateurs are relatively few and far between.) Also, the video amplifier usually works at a pretty high signal level, so the signal-to-interference ratio is probably favorable in this case. Nevertheless, those who work "80" in a television region should not be surprised to get complaints from owners of TV receivers in the immediate vicinity.

Next, the intermediate-frequency amplifier. In view of the tolerances established by manufacturers for the i.f. channel, this can range from the 21.65-27.65 channel mentioned above to a channel lying between 21.0 and 27.0 Mc. There is a choice of two evils here with respect to amateur interference at the i.f. The 21.65-27.65 channel includes our (and diathermy's) 27-Mc. band, and 21-27 covers the new band we'll probably get at 21 Mc. That would be bad enough if the i.f. had absolutely no response outside the ostensible channel. However, the i.f. response will be appreciable well beyond the standard limits.

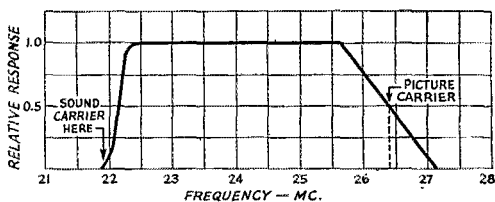

Fig. 2 — Ideal response curve for the receiver picture i.f. channel, for reception of a signal of the type shown in Fig. 1.

The fact that the sound channel is placed at the low-frequency end of the total channel helps us in two respects. The sound trap in the picture i.f. amplifier puts a notch in the selectivity curve and makes the amplifier as a whole cut off rather sharply at the low-frequency end. Second, even if the receiver has a 21-27 Mc. i.f. channel, an amateur signal in a band starting at 21 Mc. not only would fall in the part of the picture channel in which the attenuation is high, but the video frequency it causes after rectification also would fall in a part of the video channel in which the response is dropping off. The interference it would cause also would be of the least objectionable type, because it would put a pattern of extremely fine structure on the screen, a pattern that if visible at all would be about like the "graininess" of a printed half-tone reproduction of a photograph.

A signal in the high-frequency end of the i.f. channel gives a more serious and objectionable type of interference. Here the interfering signal is near the picture carrier, so it represents a comparatively low frequency when rectified by the second detector. Our 27-Mc. band is likely to give plenty of trouble. Also, receivers being what they are, it is a practical certainty that 28-Mc. signals also will interfere. The i.f. response will *not* be zero outside the theoretical channel limits, and if the 28-Mc. signal is strong enough — remember that it is the receiver next door we have to worry about — it will reach the receiver's second detector. Unfortunately the entire 28-Mc. band falls within the picture sideband range, when the picture carrier is placed between 25.75 and 26.4 Mc. Our signals are not likely to be "vestigial" — next door — as the TV transmitter's sideband on that same side of the i.f. picture carrier is supposed to be.

In this connection, the FCC laboratory made some tests on one of the most widely-distributed of current television receivers and determined that a 28-Mc. signal having an intensity of 10,000 microvolts, applied to the antenna input terminals of the receiver, gave a discernible pattern on the screen. No television signal was being received at the time, but it is reasonable to assume that a 28-Mc. signal of this level would at least be detectable in the presence of a marginal television signal. It is not easy to apply such a figure

to the practical case of an amateur transmitter with a television receiver next door. A bit of exposed wiring in the receiver's i.f. amplifier, or a small amount of r.f. getting into the receiver through the power lines, easily could upset any calculations based on possible field strengths near the transmitting antenna. Considering the fact that some sort of beam antenna is becoming customary for TV reception, it may be that the combination of selectivity and directivity in the antenna system will make direct antenna pick-up less bothersome, in some cases, than pick-up on or through the receiver itself. On the other hand, it would certainly be unsafe to assume that the average TV antenna installation is going to be so perfectly balanced that there will be no pick-up on the transmission line, particularly when open lines are used instead of co-ax. It is not at all unusual for foreign high-frequency broadcast stations to get into the i.f. in the prewar television receivers (which used an i.f. that included some of the "hottest" long-distance bands); a fact that gives us no comfort when thinking about the next-door television receiver.

#### Adjacent-Channel QRM

Coming now to the front end of the TV receiver, it can be taken for granted that the selectivity, insofar as the adjacent channel is concerned, will be small. The front end has to be at least 6 megacycles wide just to accommodate a desired signal. Without good preselection — and the cheapest, and therefore most popular, sets won't have it — the receiver has to depend entirely on its i.f. for adjacent-channel selectivity. That the i.f. is not much of a defense is plain to be seen in the present channeling system, which is based on the fact at least 4 megacycles separation is required between television channels to permit satisfactory reception of TV broadcasting from two stations in the same locality. Our 50-Mc. band is between Channels 1 and 2, and the same FCC tests showed that a 50-Mc. signal of only 500 microvolts was enough to cause a discernible pattern with the receiver tuned to Channel 1, and only 300 microvolts when tuned to Channel 2. These signal strengths are of the same order as those from TV transmitters in the outer region of the service area, and are far less than will be produced by a low-power 50-Mc. station nearby.

Interference by 50-Mc. transmitters is likely to be worse on Channel 2, for the reason that the band is closer to the picture carrier on that channel than on Channel 1. It is the i.f. selectivity situation all over again. However, when the interfering signal is strong there are so many possibilities in overloading and cross-modulation effects that there may not be much to choose between the two, in the end. The same cross-modulation effects, incidentally, can lead to plenty of interference from transmitters on other bands, particularly 28 Mc.

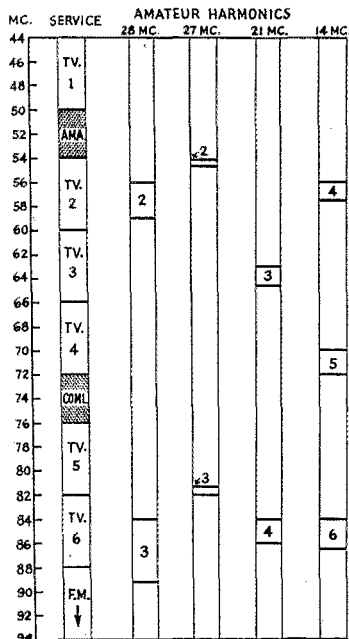

Fig. 3 — The relationship of amateur-band harmonics, 14 to 28 Mc., and frequency assignments in the 44-88 megacycle region.

#### Other Responses

This outline of receiver defects would not be complete without mention of images and spurious responses caused by signals getting mixed with receiver-oscillator harmonics. As might be expected, the ordinary television receiver is not distinguished by exceptionally good image rejection. Fortunately for us, we happen to be out of range in this case; our 144-Mc. band — the nearest one we have above the presently-used television channels — is too high in frequency to put any images in the television channels as now assigned. This does not mean, though, that 144-Mc. is entirely in the clear with respect to television interference. The same FCC tests showed that an 80,000-microvolt 144-Mc. signal, at the receiver antenna terminals, could be seen on the screen. In this case the 144-Mc. signal was mixing with the second harmonic of the receiver oscillator, the receiver being tuned to Channel 2. It remains to be seen how much of this type of interference will occur in practice.

This is a pretty formidable list of possible ways of interfering with television reception. Most of them have turned out to be actualities, not just possibilities, even though our experience with TVI is only just getting started. They are all things we can blame on the receiver, inasmuch as they result from legitimate transmissions on frequencies assigned to amateurs. But interferences of this sort have been relatively minor so far; the really serious interference is that caused by our harmonics.

## Television Channels and Amateur Harmonics

Fig. 3 shows the present television set-up in the 44- to 88-megacycle range, together with the frequencies at which harmonics from four amateur assignments (assuming 21–21.5 as amateur) fall. The fact that no amateur bands lower than 14 Mc. are shown does not mean that our operations on these bands will not cause harmonic interference. On the whole, however, interference from the lower-frequency bands will be less troublesome. As shown by the chart, harmonics from the 14-Mc. band will fall in three television channels. The 28-Mc. band puts harmonics in two.

The channeling system shown was devised so that four channels would be available in metropolitan areas such as New York, Chicago and Los Angeles. In a given area, transmitters cannot be put on adjacent channels because the receivers are not expected to be good enough to separate the signals. The two 4-Mc. "guard bands" — one amateur and the other commercial — provide the necessary separation to permit squeezing in an extra channel in the metropolitan areas. The heart of the channeling plan is that Channels 2 and 4 have to be assigned in such areas, and the chart shows that both these channels are vulnerable to amateur harmonics. So far as harmonics are concerned, we need not worry about Channel 1, which also would be assigned in such areas. The fourth channel to be assigned would be either 5 or 6, one of which — Channel 6 — is wide open to harmonics from three ham bands. Channel 5 is fairly clear and, in the New York area at least, is the one actually assigned.

The experience to date in and around New York consequently may be taken as typical of what we may expect in the population centers. At present there are three television broadcasting stations operating: WCBS-TV on Channel 2, WNBT on Channel 4, and WABD on Channel 5. We have had reports of interference with one or more of these stations from amateur transmitters working on 7, 14 and 28 Mc. The 28-Mc. band is the worst, as is to be expected, because it is nearest to the television assignments. Although 14 Mc. signals will have harmonics in both Channels 2 and 4, these are fourth and fifth harmonics and might be expected to be weaker than a second harmonic. The first harmonic to cause any trouble from 7 Mc. would be the eighth; it should be fairly weak in the ordinary case.

We want here to look at the most unfavorable situation. This occurs when a 28-Mc. transmitter is close to a television receiver at the edge of the service area of the TV transmitter. It is, unfortunately, likely to be a very common situation because it includes many of the suburban areas surrounding large cities. Television requires a stronger signal than does ordinary sound broadcasting to produce a result that is of entertainment quality. Generally speaking, a signal

strength of 500 microvolts per meter is considered to be about the lower limit, making allowance for the probability of noise interference. However, current receivers will produce a usable output from a signal of 100  $\mu\text{v./m.}$  or less in a reasonably quiet location; perhaps not a perfect picture, but one that is acceptable enough — particularly in the early stages when the novelty hasn't worn off.

### Interference Ratios

Just what constitutes objectionable interference in a television picture is bound to be a matter of opinion; furthermore, it depends on the picture subject matter and the form of interference. Estimates run from 20 to 40 db. below the picture signal; in other words, the interfering signal voltage must not exceed 1/10 to 1/100 of the desired signal voltage. In conjunction with the required field strengths mentioned above, this makes a pretty broad range — anywhere from 1 to 50  $\mu\text{v./m.}$ , depending on the frequency relationship between the picture carrier and the interfering signal, and on whether the picture carrier is 100 or 500  $\mu\text{v./m.}$

These figures mean something only to people who are equipped for making field-strength measurements. We are fortunate in having a means for interpreting them. The Central Jersey Radio Club, a group of amateurs located in suburban towns in the Summit-Short Hills region, early ran into television troubles and determined to do something about it. Many of the club members are professional radio engineers and, under the leadership of R. M. Morris, W2LV, set out to determine the causes of the interference in each individual case and, if possible, to find remedies. In the course of the investigation, field-strength measurements were made on both television signals and amateur harmonics from 28-Mc. transmitters.

The situation at W2MYH, Summit, N. J., is of particular interest. This station, owned by Henry O. Pattison, jr., can run a kilowatt on 28 Mc. The antenna is a 4-element beam fed by co-ax, with a line-balancer at the antenna end of the line. The television receiver is in the house next door, the distance between the two antennas being about 150 feet. As the receiver is a prewar model using an 8- to 14- megacycle i.f. the possibility of i.f. response was practically eliminated, leaving an almost clear-cut case of harmonic interference. W2MYH has excellent shop facilities, an ample selection of parts and equipment for experimenting — and a cooperative neighbor. This set-up, in other words, offered an ideal opportunity to see what could be done.

Originally the transmitter was unshielded and had no special means for preventing harmonics from getting into the antenna system. Under these conditions the second harmonic (approximately 58 Mc.) simply wiped off the picture on Channel 2 on the next-door receiver; in fact, its owner at first assumed that the TV transmitter

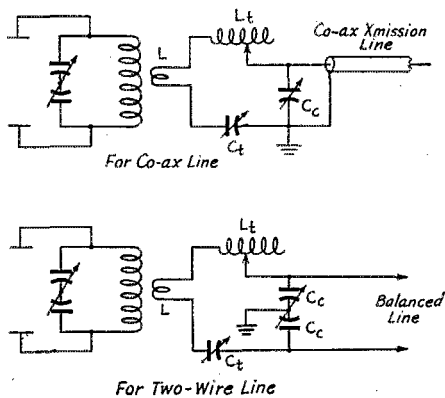

Fig. 4—Harmonic-suppressing circuit for coupling into flat lines.  $L$  is the pick-up link, consisting of one or more turns as required. One-turn links may be constructed as shown in Fig. 6 to reduce coupling through stray capacitance.  $L_t$  and  $C_c$  should be adjusted to resonate the whole circuit, including  $L$  and  $C_c$ , at the operating frequency. Capacitance values in  $\mu\text{fd}$ . for  $C_c$  are as follows:

	28 Mc.	14 Mc.	7 Mc.	3.5 Mc.
<b>Grounded lines:</b>				
50 ohms	100	200	400	800
70 ohms	100	200	400	800
<b>Balanced lines:</b>				
150 ohms	160	320	640	1280
300 ohms	120	240	480	960
500 ohms	92	184	368	736
600 ohms	84	168	336	672

NOTE: In the case of balanced lines the capacitance given is for each section of a split-stator condenser or for each condenser if two separate units are used.

was having trouble and going off the air! Channels 4 and 5 were subject to bad interference, but not wiped out.

At this stage the transmitter was rebuilt in a commercial relay-rack cabinet, completely enclosed. In addition, the harmonic filter shown in Fig. 4 was installed between the final tank and the co-ax feeder. This circuit, which is essentially a low-pass filter, is known locally as the "Smith suppressor," after a club member who worked out the constants. Despite these changes, Channel 2 was still wiped out and the interference on Channels 4 and 5, although reduced considerably, was not negligible. At about this time the club held a meeting to which the local FCC office was invited to send a representative for discussion of the TVI problem. The writer also was invited to sit in, and after the meeting spent several days, at intervals, working with W2MYH in an attempt to effect a further reduction in interference.

The first step was to install a dummy antenna inside the transmitter cabinet, completely disconnecting the antenna cable so that antenna radiation would be out of the picture. So far as could be judged, the interference did not diminish with the antenna disconnected. So a pick-up device of the "Little Gem" type, capable of tuning over the harmonic range, was made up so the spots where the signal was leaking out of the trans-

mitter could be found. This gadget, the circuit diagram of which is shown in Fig. 5, proved to be an invaluable asset in locating the causes of radiation and showing how effective the remedies were. This particular instrument was quite sensitive, inasmuch as the indicator was an 0-20 microammeter which W2MYH was fortunate enough to have found in the surplus market.

To go through all the things that were done in the course of the attempt to cut down direct radiation would be a long story. Suffice to say that the 58-Mc. signal was getting out in both expected and unexpected ways. One of the most potent of the latter turned out to be a glass-covered slot in the panel, behind which was a row of meters. The pick-up device indicated a strong field in the vicinity of this slot, and furthermore pointed out the particular meter that was "hot" — the plate meter in the driver stage, which doubled from 14 to 28 Mc. By-passing that particular meter reduced the field to the same intensity as around the metal cabinet itself. The power-supply cables entering the cabinet were found to be carrying 58-Mc. currents, and this also was true of the outsides of several co-ax cables that carried r.f. into and out of the cabinet. Bonding and grounding the shields of the co-ax lines at strategic points outside the cabinet (these points being determined with the aid of the pick-up device), grounding all shields at the point of entrance to the cabinet and by-passing those leads that could not be directly grounded, together with some bonding and rearrangement of antenna leads inside the cabinet, eventually reduced the r.f. to a point beyond which no further improvement could be effected. The maximum readings on the microammeter were, at this stage, well down on the scale.

It helped. Checking on the receiver showed that the interference on Channels 4 and 5 was eliminated. The interference on Channel 2 was considerably reduced — but only to the extent that the picture did not disappear when the carrier was on; it could be seen, but through interference that made it unusable. There was no marked difference whether the transmitter was working into the dummy antenna or into the regular beam.

Later, the club group took field-strength measurements at the receiving location. With 750 watts input to the transmitter, the 58-Mc. field was 5000  $\mu\text{v./m}$ . At the same point the signal from WCBS-TV on Channel 2 had an intensity of 375  $\mu\text{v./m}$ . The 28-Mc. signal from W2MYH under the same conditions was 1.5 volts per meter — enough to suggest that possibly some of the trouble was receiver overloading. However, a 28-Mc. trap at the receiver input had no effect on the interference, confirming the previous observation that it was direct radiation from the transmitter (power and other wiring included). The fundamental-to-harmonic voltage ratio of

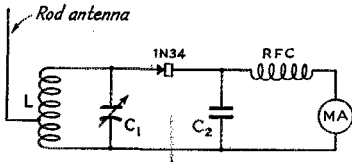

Fig. 5 — Pick-up device for tracing harmonics.  $L$  and  $C_1$  should resonate at the frequency being checked; in the 56-Mc. range suitable values are  $25 \mu\text{fd.}$  (variable) for  $C_1$ ; for  $L$ , 10 turns of No. 14, diameter  $\frac{1}{2}$  inch, turns spaced to make the coil one inch long.  $C_2$  may be  $500 \mu\text{fd.}$  or more;  $\text{RFC}$  a 1-mh. r.f. choke. The meter,  $\text{MA}$ , should be a microammeter if possible; a 0–1 milliammeter may be used, but will be less sensitive. The pick-up antenna, which may be a rod one or two feet long, should be tapped across a few turns; adjust so that the meter indicates on weak signals but without loading the circuit to the extent that the tuning range and selectivity are materially decreased.

300 is equivalent to nearly 50 db. — but the 5000-microvolt harmonic was still 22 db. above the television signal. This, plus another 30 or 40 db., is the *additional* harmonic suppression required to give interference-free reception on Channel 2. In other words, a fundamental-to-harmonic ratio of 100 to 110 db. would be required in a case such as this, where the television signal is marginal and the transmitter is operating near the legal power limit for amateurs.

#### Possibilities in Harmonic Reduction

The point here is this: At W2MYH the orthodox methods of good engineering practice were applied and, while effecting an improvement — a worth-while one, in that interference was confined only to the channel in which the harmonic falls — they fell far short of the mark of completely eliminating *all* interference. As compared to the ordinary amateur installation, with no shielding and with no special attention paid to harmonic reduction, the performance is quite good. Measurements on open transmitters showed a fundamental-to-harmonic ratio (second harmonic from 28 Mc.) of approximately 25 db., average. An exception was the transmitter at W2LV, which, although not shielded, is compactly constructed and is located in the basement of the house. It is more than possible that the basement location accounts for the ratio at W2LV (41 db. at a distance of 30 feet and 52 db. at 300 feet)

because the transmitter is partially shielded by the ground. If so, it is further evidence that our problem is not primarily that of keeping harmonics out of the antenna, but keeping them from being radiated from the transmitter.

If orthodox methods won't solve the problem completely, the question is whether there is any promise in the unorthodox. W2RYI has shown that extraordinary measures can be made to work in the case of a 14-Mc. transmitter.<sup>1</sup> In such a case we are dealing with the fourth and higher harmonics which normally can be expected to be weaker than the second and third. FCC has done design work on a diathermy oscillator in which a 68-db. ratio between fundamental (27 Mc.) and second harmonic was secured. This figure is not directly comparable to the ratios mentioned above because the diathermy machine was not connected to an antenna tuned to the fundamental, as is the case with amateur transmitters. The ratio no doubt would be better if the fundamental power were intentionally radiated. More significant is the fact that the field strength on 54 Mc. at 100 feet was found to be  $172 \mu\text{v./m.}$ , which is far too high to be negligible except in regions where the television signal's field strength can be measured in millivolts.

Complete details on the FCC oscillator are not yet available, but in general it was found necessary to (1) shield the oscillator and then place it and the associated equipment in a metal shield; (2) filter all external leads at the point where they leave the cabinet; (3) use a separate resonant circuit for the load, link-coupled to the oscillator through a shielded link, with the load circuit separately shielded; (4) use high- $C$  tuned circuits. The shielded link circuit, shown in Fig. 6, gets around using a regular Faraday screen to prevent harmonic coupling through stray capacitance between coils. It has been used successfully by a number of amateurs and deserves wider application.

There are probably tricks, aside from tuned traps, that can be used to suppress a particular harmonic in an amplifier. Oddly enough, we were unable to find an indication of a third harmonic around W2MYH's transmitter, although the

<sup>1</sup> Seybold, "Curing Interference to Television Reception," QST, August, 1947.

Fig. 6 — Self-shielded link for reducing capacity coupling between inductively-coupled circuits. It is simply a piece of co-ax cable formed into a single turn, with the inner conductor at the end soldered to the outer shield braid as shown. Its application to a link-coupled antenna tuner is shown in the diagram.

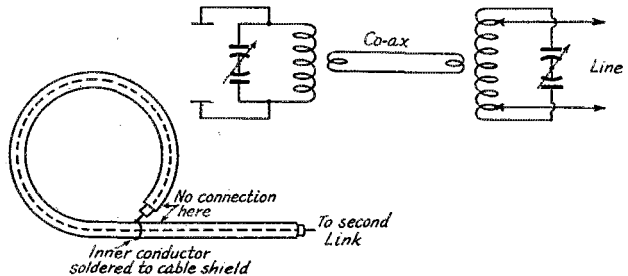

fourth was readily identifiable and the fifth harmonic of the driver also could be detected. No measurements were made near the transmitter on the third harmonic with the field-strength equipment, but at a distance of 1250 feet it could not be heard. At the same distance the second harmonic had a strength of 250  $\mu\text{v./m.}$ , which is a husky signal by ham standards. In comparison, the third harmonic from W2LV was a little stronger than the second at comparable distances. On the other hand, a small portable transmitter owned by W2LV had a very weak second harmonic and a strong third, checked by a pick-up device alongside the transmitter. This set, incidentally, used an 807 final in the usual single-ended circuit. None of this is in line with our ingrained ideas about the harmonics in push-pull and single-ended circuits, and leads to the suspicion that, as a result no doubt of circuit layout, there may readily be a very high degree of suppression for a particular harmonic. If so, we ought to be able to take advantage of it, once the clue is found.

But this is largely speculation. The fact is that in the worst case — where the television signal is weak and the amateur transmitter is quite close to the receiver — it appears to be necessary to have better than a 100-db. ratio between the fundamental and harmonic. For the second harmonic that is an exceedingly tall order. It may be equally difficult for the third harmonic.

A general solution of the TVI problem is not yet in sight. Unquestionably a rearrangement of frequency allocations so that second harmonics from the 28-Mc. band would not fall in a television channel would relieve matters considerably. In the New York area it would practically solve the immediate problem, since it has been demonstrated that good engineering practice will reduce the second harmonic to the point where it will interfere only in the channel in which it falls. There is no present third-harmonic situation in New York because Channel 6 is not assigned there. Any rearrangement of channels, if practicable, probably would involve our moving back to the old 56-60 Mc. band. Under the present channeling system, New York is fortunate in that the third harmonic of the anticipated 21-Mc. band also would fall in an unused channel, but might not be so fortunate should the channels be reshuffled. In fact, since we can't expect to be protected on *all* our harmonics, odd as well as even, the chances are good that any steps taken to clear up one bad spot may simply create another somewhere else.

We aren't the only ones with problems. Every other service in that part of the spectrum — and they are numerous — is up against TVI. FCC is keenly concerned about the whole situation, rea-

lizes that something has to be done if the services provided for under the present allocation set-up are to carry on their operations, and is exploring every possibility that has any promise.

The situation is not hopeless for all of us, of course. In regions where the television signal is strong, good shielding and filtering at the transmitter can keep harmonics at a low-enough level to eliminate much of the interference. Those who can't solve their ten-meter problems still have other bands available to them during the evening hours when television is operating, and it has been demonstrated in practice that interference from lower frequencies can be reduced to the negligible point.

[Identification of various types of television interference and methods for reducing it will be taken up in a subsequent article. —*Editor*]

### Silent Keys

IT is with deep regret that we record the passing of these amateurs:

W1MNH, Harry B. Patten, Beverly, Mass.

W2QGZ, ex-W3AFH, William L. Meade, Trenton, N. J.

W2RGL, Lawrence E. Wilson, Buskirk, N. Y.

W2UBF, Arthur O. Olson, Brooklyn, N. Y.

W3CTB, Henry B. Thompson, Meadowbrook, Pa.

W4BX, Gordon S. Smith, Charlotte, N. C.

W5LEP, Garland A. Langford, Canyon, Texas

W6JKR, Robert H. Smith, Santa Rosa, Calif.

W6NUB, Carlton G. Isham, Oakland, Calif.

Ex-6OU, Captain Lindley Winsor, USNR, Southampton, L. I., N. Y.

W6RVE, Edwin H. Andrus, Ojai, Calif.

W6YLV, Albert H. Ryan, Chula Vista, Calif.

W8IRA, J. Hyatt, Mt. Vernon, Ohio

W0WFK, William C. Cowherd, Monett, Mo.

VE4AE, Samuel C. Hitchon, Winnipeg, Manitoba

**SWITCH  
TO SAFETY!**





# Simple L and C Calculations

## A Useful Formula for Bandsread and Padder Problems

BY JACK NAJORK, \* W2HNN

• This article discusses a well-known but seldom-appreciated simple relationship between frequency and circuit capacitance. It has the advantage over many radio calculations in that it takes less time to work out the formula than it does to arrive at the answer by "cut-and-try" methods.

ONE of the most useful formulas, and at the same time one most neglected by hams who build or alter their own gear, is the simple mathematical relationship between a change in the frequency of a tuned circuit, such as indicated in Fig. 1, and the change in capacitance which causes it. Its most common application is in the determination of capacitance values in bandsread or other tuning-range problems in receivers or VFOs. It shows the frequency range that any variable condenser will cover or, conversely, the variable capacitance necessary to cover a desired frequency range.

The relationship is expressed by

$$\frac{C_{\max}}{C_{\min}} = \left(\frac{f_{\max}}{f_{\min}}\right)^2, \text{ or}$$

$$\frac{f_{\max}}{f_{\min}} = \sqrt{\frac{C_{\max}}{C_{\min}}}$$

Also,

$$C_{\text{var}} = C_{\max} - C_{\min}$$

In other words, it always takes a capacitance ratio of the square of the frequency ratio to cover the desired frequency range. If the frequency ratio, maximum to minimum, is 2 to 1, the required capacitance range to cover it is 4 to 1; if the frequency range is 3 to 1, the capacitance range must be 9 to 1, etc. And, of course, the converse is true — the frequency range that a variable condenser will cover is the square root of the capacitance ratio, i.e., a capacitance range of 4 to 1 produces a frequency change of 2 to 1.

*Example:*

Desired frequency range — 3500 kc. to 4000 kc.  
Minimum circuit capacitance — 30  $\mu\text{fd.}$

$$\text{Frequency ratio} = \frac{4000}{3500} = 1.143$$

$$1.143^2 = 1.3$$

Therefore the capacitance change to tune over this band must be in the ratio of 1.3 to 1. Since the minimum circuit capacitance with the condenser set at zero is given as 30  $\mu\text{fd.}$ , the maximum must be  $(1.3)(30) = 39 \mu\text{fd.}$  The difference between maximum and minimum, 9  $\mu\text{fd.}$ , is the required variation.

The formula can be twisted around, of course, to give any one of the desired values by substituting known values for the other three factors.

$$C_{\text{total}} = C_{\min} \left(\frac{f_{\max}}{f_{\min}}\right)^2$$

$$C_{\min} = C_{\max} \left(\frac{f_{\min}}{f_{\max}}\right)^2$$

$$f_{\max} = f_{\min} \sqrt{\frac{C_{\max}}{C_{\min}}}$$

$$f_{\min} = f_{\max} \sqrt{\frac{C_{\min}}{C_{\max}}}$$

$$C_{\text{var}} = C_{\min} \left(\frac{f_{\max}^2}{f_{\min}^2} - 1\right)$$

$$C_{\min} = \frac{C_{\text{var}}}{\frac{f_{\max}^2}{f_{\min}^2} - 1}$$

In all of the foregoing,  $C_{\min}$  is the minimum circuit capacitance with the variable condenser set at zero,  $C_{\max}$  the total circuit capacitance with

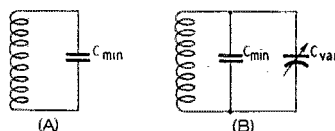
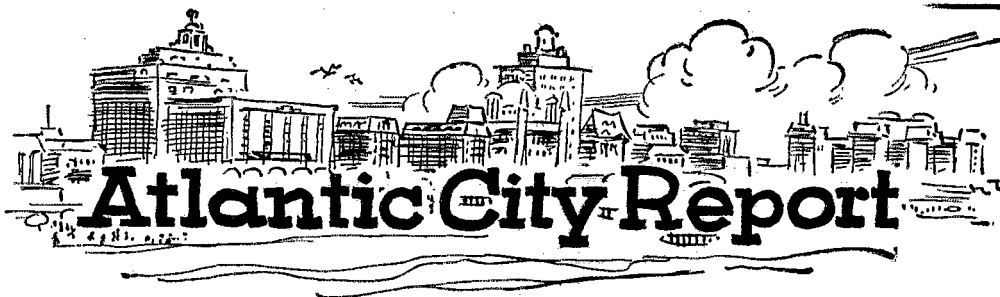

Fig. 1 — A — Circuit for  $f_{\max}$ . B — Circuit for  $f_{\min}$ .  $C_{\min}$  is the total minimum circuit capacitance which includes tube capacitances, minimum capacitance of the tuning condenser and capacitance introduced by sockets and wiring as well as the distributed capacitance of the coil.  $C_{\text{var}}$  is the variable part of the tuning-condenser capacitance (maximum minus minimum).

the variable in full,  $f_{\max}$  and  $f_{\min}$  respectively the highest and lowest frequencies to which the circuit tunes and  $C_{\text{var}}$  the variation in capacitance in the tuning condenser.  $C_{\min}$ , of course, includes any fixed capacitance that may be used in the circuit either for bandsread or to obtain a

(Continued on page 120)

\*110 Merrill St., Syracuse, N. Y.



# Atlantic City Report

## JULY IN REVIEW

What started here in Atlantic City in May was the International Radio Conference, the administrative conference to revise the Cairo regulations, including allocations. On July 2nd the second conference began, the International Telecommunications Conference, the plenipotentiary conference to revise the Madrid convention. Now there are 77 countries represented, with about 800 delegates in attendance, and two sets of meetings are running concurrently. The need of the smaller delegations to divide themselves more thinly over the two conferences has slowed down the work of the radio conference. So, in particular, did a series of plenary sessions of the two conferences, when allocations were forgotten for days and attention went to such questions as admission to the conferences, the procedure for voting and the official languages. Indeed, if the allocation table were the only concern here it is probable the job would have been finished long ago but now there are not only the other regulatory matters but such concerns as the structure of the International Telecommunications Union itself, its relations with United Nations, the creation of the International Frequency Registration Board and the preparation of the new frequency registration list, the revamping of C.C.I.R. as a continuing body, and numerous other such questions of an organizational or political nature.

The general amateur regulations (minus frequencies) have been agreed to in principle in substantially the Cairo language and now await passage by a subcommittee and then by the regulations committee itself. We'll give you the text next month. The minor matters of interest to us have progressed satisfactorily. It is, however, in frequency allocation that we amateurs find our chief interest, so let us proceed to that at once.

The first thing to remark is that, although there have been one or two very unpleasant surprises, the net progress in the month of July has been almost nil so far as the amateur service is concerned, and there are still no decisions to report. When we closed our last report, it will be remembered, the chairman of the allocations committee had discharged his subcommittees and,

taking account of their work, had himself prepared proposed allocation tables representing his analysis of the greatest common factor of agreement to be found in the proposals and discussions to that date. These drafts were then submitted to the discussion of the main allocations committee, the largest and most intense committee of the conference. It was natural that there were many disagreements all up and down the line.

To attempt the resolution of these diverse dissents brought out in discussion, the chairman adopted the novel course of appointing a working group of four internationally known and respected allocations experts, with himself as arbitrator and chairman, to attempt reconciliations. The men of this group, shown and named in our photographs, were chosen not so much as representatives of their countries or areas or points of view as they were on the basis of an international public trust, all being the acknowledgedly-competent spokesmen of major powers at previous conferences. Their duty has been to take into account all available data on a segment of the spectrum — the original proposals, the decisions of the old subcommittees, the chairman's drafts, and the extensive continuing comments in the main committee — and to attempt to forge from them a ladder of recommended assignments that will gain the approval of the conference. In the midst of this work the allocations chairman, Sir Stanley Angwin, was obliged to return to England with his committee work unfinished; and he has been succeeded by Colonel A. H. Read, also of the U.K. delegation. Meanwhile the Working Group has toiled mightily. The last two words deserve a heavy underscoring. While meetings of the main committee QRX'd for them, sometimes for days on end, they worked daily to all hours to find some basis for agreement among the diverging philosophies they each inevitably represented. They have made some reports of agreements and a few reports of utter disagreement. In both cases the allocations committee has chewed upon the report, has found itself too unwieldy to come to agreement itself, and has again sent the fields of disagreement back to the WG for reexamination in the light of the further discussion. Little by little there has been progress, more and more has

been agreed to in the main committee, and now, finally, in the last few days of July, some allocations are being adopted in the I.f. end of the spectrum. At this writing the WG continues to meet daily, indeed in almost continuous session. Almost all of the divergent viewpoints of the 77 countries of the conference here find themselves reflected as the personal opinions of some of these four men closeted in a hotel room. They meet without visitors or observers, in fact without assistants; and their internal discussions are secret and unreported. However, it is obvious that they have had a most difficult time of it and that, despite a month of nearly-daily meetings, there are many problems still unsolved. Yet it is true that the conference is now inescapably rolling into its final weeks, the top management of the conference is calling for decisions, and all hands realize that agreements of some sort must soon be reached.

There are still, we repeat, no amateur frequency decisions to report. They will come more or less in a rush, we think, under the head of August business, to be reported to you next month. Meanwhile, however, we'll give you below the current situation on each of our bands as it appears to us in the closing days of July, asking you to remember that later events may result in changes:

**1.75 Mc.:** There is tentative agreement that in the European region Austria, Ireland, the Netherlands, Switzerland and the United Kingdom may assign to amateurs 200 kc. out of the band 1715-2000 kc., on the conditions that power be limited to 10 watts and that there be no interference to other services. In the other regions of the world, where 1800-2000 kc. will be assigned to loran in two 100-kc. channels, there is tentative agreement that whichever is locally unused for loran may be made available to amateur, fixed or mobile. Loran commonly uses only one of the two channels but in the North American area they are both now in use, so that the provision offers nothing to American and Canadian amateurs. (Anything that we may be able to promote on the basis of geographically sharing with loran will be a private matter between our governments and ourselves, to be arranged later, and not an Atlantic City matter.) Finally, all the foregoing is on a temporary basis, pending the development of a new long-distance navigational aid, and is subject to review in 1949.

In *QST's* articles on international conferences you have read that inevitably, at every conference, the details of frequency allocation are finally worked out by a small group of experts. Here are the men who are making the allocations ladder of Atlantic City, four "men without country" appointed for their individual skill and repute, and their chairman. L. to r., A. H. Mumford (U.K.), Paul D. Miles (U.S.A.), Col. Sir A. Stanley Angwin (chairman of the main allocations committee), Valentin Bragin (U.S.S.R.), and Charles Loven (France).

**3.5 Mc.:** The views of the various regions of the world being so different in this part of the spectrum, the only possible solution is seen to lie in regional assignments, just as at Cairo, Madrid and Washington. A proposal having tentative approval would retain in the American region the assignment of Cairo, namely, 3500-4000 to amateur, fixed and mobile, subject to later regional determination. Two of the Latin-American countries indicated a desire to divert part of the band for other purposes and this prevented the outright assignment of the whole band to amateurs in the American column of the Atlantic City table. (As a side note, Cuba proposed that 3800-4000 be assigned exclusively to tropical broadcasting, but a satisfactory alternative provision for this service seems now to have been made.) For Europe the tentative agreement is to an amateur band of 3500-3800 shared on a mixed basis with fixed, land mobile and maritime mobile. (3800-3900 would be fixed, land mobile and aero mobile, 3900-3950 aero mobile alone, and 3950-4000 broadcasting and fixed.) The proposal also was for other areas of the world to follow Europe but this is still undecided, since both China and New Zealand have indicated that they desire the whole 500 kc. for amateurs.

**7 Mc.:** You will remember, particularly from our notes last month, that this spot has always been a toughie at Atlantic City, the subcommittee on "targets" reporting disagreement. The trouble, of course, has been Europe's wild insistence upon expanding broadcasting in this part of the spectrum. After long talk in committee the matter was referred to the Working Group and the latter produced a compromise proposal that seems to have rather general support at this writing. It recommends that 7000-7300 be exclusively amateur both in the American region and in other areas except Europe, India and Australia (the latter two countries having also expressed the wish to use some of the band for broadcasting). For Europe and those two countries the exclusively-amateur part of the band would be reduced to 7000-7100. Amateurs and broadcasting would share 7100-7150 on the condition of amateurs offering no QRM to broadcasting, while the latter service would enjoy 7150-7300 on an exclusive basis. This proposal is not acceptable to Australia, which wishes to avoid sharing and to



expand the amateur portion somewhat, up to 7175 or possibly 7200 kc. — an angle which is not yet settled, since nearby New Zealand insists upon the entire band for amateurs. The pending proposal is, at best, a sad solution, since this further mutilation of the band not only seriously impairs its usefulness for our purposes on this side but gives foreign amateurs a very poor deal. Admittedly the principle of divergent regional uses of such frequencies is bad engineering, but when Europe insisted upon going its way there was nothing for the other regions to do but to insist upon going their separate ways too if amateurs were to retain the whole width of the band outside Europe.

*14 Mc.:* It is necessary to report that on this band there has been a sudden and unpleasant development which, as of this writing, appears to leave no possibility of worldwide agreement on the maintenance of the whole 400 kc. bandwidth. In Dr. Mao's subcommittee on allocation "targets," whose work we reported last month, this band was examined on at least two occasions, with up to 15 countries participating, and each time was quickly and easily agreed to unanimously in its full width. It was so reported out of subcommittee and it so appeared in the summarizing draft prepared by the chairman of the full committee for study by his group. This draft table covered 6 to 25 Mc. Although this document was the subject, in full committee, of a great deal of discussion of its provisions for broadcasting and the fixed and mobile services, and although several passes were taken at our 7-Mc. band, again everyone took the 14-Mc. amateur band for granted and the discussion did not touch it. After opinions were thoroughly aired the whole h.f. part of the spectrum was turned over to the Working Group for study and report. A week passed and then a development occurred that took the whole conference by surprise — the WG report ap-

peared, with recommended solutions for almost all the problems that had been before the committee, but reporting that no agreement could be reached on the amateur 14-Mc. band! Serious concern had developed over the reductions experienced by the fixed service in making expanded provisions available for broadcasting and in establishing exclusive bands for maritime mobile rather than the shared bands of Cairo. When the WG report was taken up in the committee, France, U.K. and U.S.S.R. suggested that, with every other service feeling the pinch of distress through the insufficiency of the spectrum to meet the world's minimum requirements, it was necessary for the amateur service also to make a contribution to the world's relief by giving over some of this band to the fixed service. Following this suggestion, and spark-plugged by a specific suggestion from Portugal, many countries in Europe and around the Mediterranean Basin that had never thought there was a chance to cut this band arose to propose that amateurs now be assigned only 300 kc. and that 100 kc. be given over to fixed. The entire American region stood firm for 400 kc. for amateurs and was joined by Australia, China, India, New Zealand and the Republic of the Philippines, and in Europe by Switzerland and, in principle, the Netherlands. The United Kingdom said it would settle for any figure between 300 and 400 to which world agreement could be had. U.S.S.R. wanted for amateurs either 300 kc. or a band of 250 kc. worldwide plus another 100 kc. shared with fixed in Russia. After half a day of committee discussion the problem was returned to the WG for further study. Two weeks have passed and now the WG has again reported that it can come to no agreement. There the matter hangs at the moment of writing, awaiting a final threshing out on the floor of the full committee. The four h.f. broadcasting bands between 9 and 18 Mc. have been increased some

This exclusive QST photograph portrays the Working Group of Committee 5 at Atlantic City sitting down to begin its work on compromise allocation plans based on the proposals and arguments of 77 countries and 700 delegates — a small group of experts in a hotel room, the 1947 version of the "teacuppers" of previous radio conferences. L. to r., Captain Miles, Mr. Mumford, Sir Stanley, Lt. Cmdr. de Calan of the French delegation (serving as interpreter), Major Bragin (in far corner), Commander Løyen.



300 kc. over the wishes of the U.S. and many other nations, largely at the expense of the fixed service; and the 14-Mc. amateur matter not only receives pressure from this fact but is heavily involved in the fate of three maritime-mobile bands in this part of the spectrum where the divergent allocation philosophies of the U.S.S.R., with its vast needs for fixed use, have produced a critical impasse between the maritime nations and the non-maritime ones. The WG's latest report says that it seems possible to get worldwide agreement on an amateur allocation only if it is reduced in width, and there are many important countries in agreement that at such frequencies it is essential to have worldwide uniformity. The United States has made the strongest possible defense of the 400-kc. assignment and is joined in its support not only by Canada and all the Latin-American countries but by the other ones mentioned above. The forces for 400 kc. and for 300 kc. were about equal when noses were last counted in the allocations committee, the 400 group having just a bit the better of it. How it will go now nobody knows but it is apparent that the bitterest amateur fight of the conference is on this band. It is also apparent that there is no hope now for world agreement at 400 kc. and that there is widespread feeling that sharing at this higher frequency is impracticable and that the matter must be resolved at some figure on which world agreement can be reached. Every amateur will doubtless know the outcome of this fight before these lines are read but here, for the record, is the story up to this moment.

**21 Mc.:** No developments since our last report. The subcommittee's report, the chairman's initial draft and the WG's report, now pending before the committee, all recommend the opening of a new band from 21,000 to 21,450 kc. but the matter has not yet been examined in the main committee.

**27 Mc.:** Undetermined, awaiting the fixing of a worldwide allocation for industrial, scientific and medical apparatus. Still in the hands of the WG.

**28 Mc.:** The WG recommendation, now before the main committee, is for a world-exclusive assignment of 28 to 29.7 Mc.

**50 Mc. and up:** The study of the higher spectrum has not progressed very far. Except for air-navaids, proposals are vague and a tentative tabulation of them is still under study in the WG. This, however, is a regional problem, generally speaking, and the outlook is that the U.S. amateur assignments will remain unchanged and that the American region generally will follow the same plan. Other regions are much less liberal in their preliminary suggestions, with some tendency to indicate a shared amateur band around 70 Mc. and nothing else below 1215. While China substantially supports the U.S. bands, Australia currently proposes only 50-54 and 166-170, U.K. only 166-168 and 400-415. It will not be possible

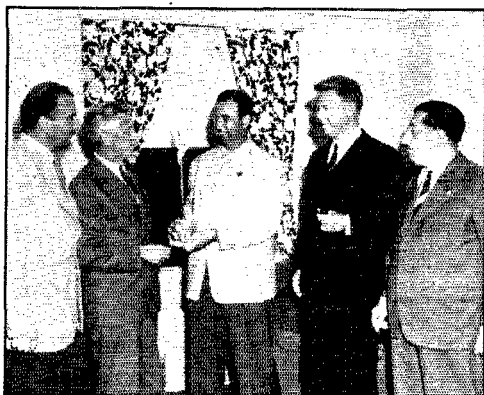

The flag of Argentina comes to ARRL Hq. Centerpiece at a recent banquet of *Radio Club Argentino*, this miniature flagpole and flag were presented to ARRL officials at the Atlantic City conference by members of RCA who are also Argentinian delegates, on behalf of RCA President Osvaldo Risso Peuser, LU7BK. L. to r. Fioravanti Dellamula, LU2CR, delegate of Argentina from the Ministry of the Interior; ARRL Secretary K. B. Warner, W1EH; Juan Antonio Autelli, RCA chief of instruction and spokesman for their president, a technical adviser on the LU delegation; A. L. Budlong, W1BUD, assistant ARRL secretary; Antonio Navatta, LU5AQ, also a delegate from the Ministry of the Interior. The flagpole's onyx pedestal bears the RCA emblem. It will be on display at Hq. after the conference.

to appraise the prospects for amateur radio in these other regions until the WG recommendation emerges.

— — —

Here we leave you until another and the final month's report. With the prospect of early and rapid developments, we hope you will all have followed W1AW for current bulletins but we'll see you on this page next month for a blow-by-blow account of the closing phases of the Atlantic City battle.

## **Strays**

Hams visiting New York City will find it profitable to include in their itinerary a visit to the RCA Exhibition Hall, 36 W. 49th Street. Aptly tagged "The Radio World's Fair," the exposition features the newest television, radar, loran, radiomarine, teletype and electron-microscope equipment in full operation. The showplace, a permanent affair, is open daily.

— — —

Alicia G. Rodriguez, KP4CL, the only active woman amateur in Puerto Rico, has been awarded the Emergency Work Trophy of the Southern Puerto Rico Ham Club, Ponce, for her outstanding operation during the Texas City disaster. E. G. Reed, KP4AJ, another stellar performer, was runner-up for the award.

# A Hydraulic Antenna Rotator

*A Different Method of Turning Directional Arrays*

BY JOSEPH C. LOTTER, \* W9JBU

• Rotation of a remote directional array is always a problem, especially if the mast is high or at a fair distance from the shack. The Lotter brothers, W9JBU and W9DRI, proprietors of a machine shop, have come up with a novel hydraulic system which has a neatness and reliability not always found in motor-driven mechanisms.

**H**YDRAULIC apparatus for the support and rotation of a beam antenna, with the motive power, direction indicator and control unit indoors on the operator's desk, probably sounds like something conjured up by a comic-strip artist. Add to this the fact that no outdoor motors, gears, ropes or wires are necessary and

\*Seymour, Wisconsin.

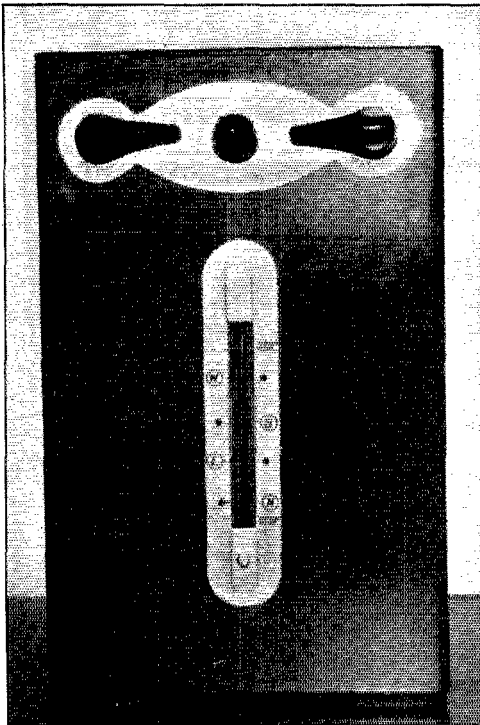

Hydraulic rotator control and direction indicator. The box is 6 x 10 x 11 inches.

you will have a fair picture of the beam rotators used at W9DRI and W9JBU. The system consists of a combination control and power unit housed in a small case on the desk, a weatherproof rotator atop the mast, and a single copper tube which is the only control connection needed between the operating position and the antenna. A 115-volt drop cord attached to the desk unit is the only electrical connection.

The rotator resembles a hydraulic jack in that oil under pressure operates in an enclosed cylinder to drive a piston. The cylinder carries a key which rides in a spiral thread or groove in the piston so that as pressure is applied to the bottom of the piston, the piston will twist as it rises. By this means, the piston, which carries the array, turns through 360 degrees as it rises one foot. Oil is fed to the cylinder through the copper-tubing line which runs from the operating position to the top of the tower. The portion of the line between the station and the bottom of the tower is buried, providing lightning protection.

The top of the piston is fitted with a platform to which the framework carrying the array is fastened. When the oil pressure is released, the piston reverses its direction of rotation as the piston returns to the bottom of its travel under the weight of the antenna. No brake against wind pressure is necessary since the spiral makes the system irreversible and self-locking. The array can turn only upon an increase or decrease in oil pressure against the bottom of the piston. A novel feature of the design is that the saddle or platform on which the array is mounted is attached to a "T"-head piston rod with two bolts in such a manner that removal of one of the bolts allows the beam structure to be tipped ver-

(Continued on page 122)

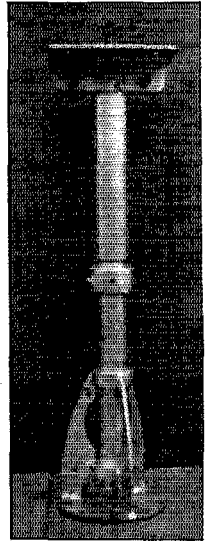

The hydraulic rotator. The saddle at the top which supports the antenna framework can be tilted for adjustment. The over-all length of the rotator is approximately 42 inches.

# Medium Power—Living-Room Style

*A Complete 350-Watt 'Phone-C.W. Transmitter in Seven Cubic Feet*

BY LEROY T. WAGGONER,\* WIPEK

THE transmitter described herein is the result of a decision to build a rig that would be completely enclosed, compact, capable of being changed easily from c.w. to 'phone, band-switching, having at least medium-power output on each of the major bands and, last but not least, safe.

The goal of not more than three feet of panel height was achieved with an inch to spare, but only by dint of considerable experimentation in layout. Space limitations precluded having a separate power supply for each stage so a rather husky high-voltage supply was designed to supply the plates of both the modulator and final-amplifier stages. A 600-volt pack supplies the r.f. exciter and speech amplifier. From purely mechanical considerations, the r.f. exciter and speech-amplifier stages are mounted on the same panel and the final amplifier and modulator stages are similarly grouped. Some care was required in the placing of parts to avoid unwanted interaction between stages.

\* Assistant Secretary, ARRL.

The circuits used are straightforward and quite conventional. Hytron Type 5514 triodes were selected for the final amplifier because their high power sensitivity and zero-bias characteristics fitted so nicely in the limited-space motif. The 807 stage furnishes ample excitation to drive a pair of them to rated input on all bands from 3.5 to 28 Mc. For voice work, the 5514s in the Class B stage can loaf along easily and still deliver plenty of audio power for 100-per-cent modulation with 350 watts input to the final stage.

With 'phone-c.w. changeover made possible by two relays controlled by a single switch, all the operator need do for voice work is to flip a toggle switch and adjust the gain control. Bandswitching for the final plate circuit was considered but the idea was finally discarded because of the desire to stay within the three-foot panel limitation.

A bandswitching medium-power 'phone-c.w. transmitter, completely self-contained and compactly housed in a metal cabinet 36¾ inches high, 21½ inches wide, and 15 inches deep. The panels are standard 19-inch width and total 35 inches in height. The meter at the left in the row at the top of the panel reads filament voltage. The milliammeter on the right measures modulator plate current while that in the center can be switched to read final-amplifier grid current and plate currents in each r.f. stage. The final-amplifier plate-tank tuning control is centrally located in the top panel and the dial in line at the left is for grid-tank tuning. The 'phone-c.w. switch is at the bottom right of the top panel and the bandswitch for the final grid is at the left. The knob in the middle is for the meter switch. The tuning control for the 807 plate is located high on the left of the middle panel under which are controls, left to right, for oscillator, first doubler, second doubler and bandswitch for the 807 output tanks. The crystal-selector switch is at the lower left, with the cathode coil switch at its right. The excitation control next to the right is flanked by the two key jacks. Under the bandswitch for the output tanks is the one for the earlier stages. The audio gain control is on the extreme lower right corner. On the power-supply panel, switches in the a.c. circuits to control filament, 600- and 1250-volt supplies are matched at the top with indicating panel lights.

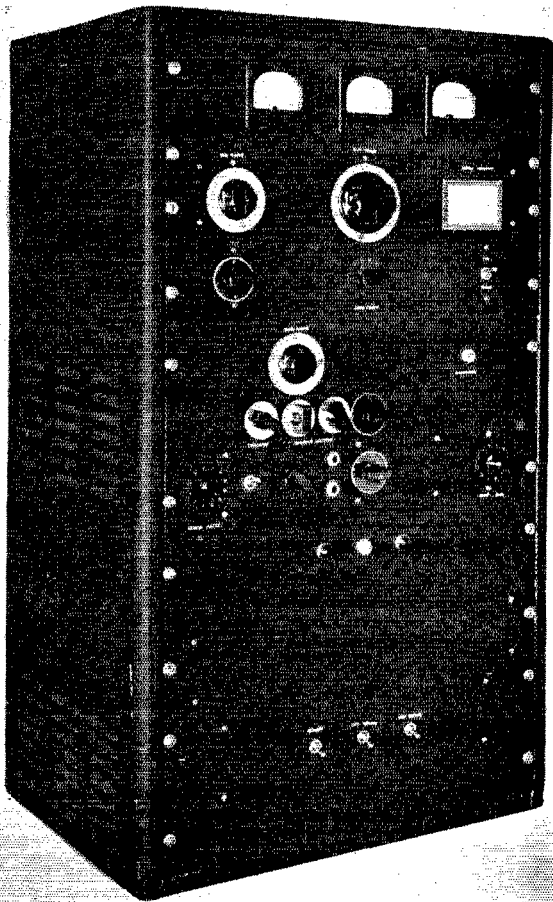

September 1947

The r.f. section consists of an exciter chassis with a 6V6 Tri-tet crystal oscillator giving fundamental or second-harmonic output using 3.5-Mc. crystals or fundamental output using 7-Mc. crystals, a 6N7 dual-triode frequency multiplier with the first section doubling from 7 Mc. to 14 Mc. and the second section doubling from 14 Mc. to 28 Mc., an 807 buffer-amplifier stage and, on a second chassis, push-pull 5514s in the final.

### Bandswitching Exciter

Fig. 1 shows the circuit of the exciter chassis. A 12-position wafer switch  $S_1$  is used to select one of 12 crystal sockets or to switch to external VFO input. The Tri-tet cathode coil may be switched out of the circuit by  $S_4$  to permit straight-through crystal-oscillator operation of the 6V6 with either 3.5-Mc. or 7-Mc. crystals. For 27-Mc. band output, suitable crystals must of course be selected.

Provision is made in the switching circuit, controlled by the 4-section switch  $S_2$ , to disconnect grids of unused triode sections of the 6N7 from the preceding stage and to ground them, thus avoiding applying excitation to idle stages. Both 3.5 Mc. and 7 Mc. are covered with one coil ( $L_1$ ), an extra condenser (air-padder  $C_3$ ) being shunted across the 7-Mc. coil  $L_1$  to extend the tuning range to cover 3.5 Mc.

The output of the 807 is link-coupled to the grid of the final amplifier but all exciter stages are capacitance-coupled. Parallel feed is used in the first three stages so that the tuning condensers,  $C_4$ ,  $C_5$  and  $C_6$ , may be mounted directly on the metal panel. The coupling to the 807 grid is through a tap on each plate coil; this provides proper loading of the various driver stages.  $C_{23}$ , connected across the 3.5-Mc. output link winding, was found necessary to detune the link, which resonated at 28 Mc., absorbing a considerable amount of power when operating in the ten-meter band. Grid-leak bias is used in the 807 stage. Screen voltage for the 807 is obtained from the 600-volt supply through a dropping resistor,  $R_7$ , and approximately 300 volts is applied to the driver plates from a tap on the voltage divider,  $R_{10}R_{11}$ , across the 600-volt supply. Excitation to the 807 may be adjusted by  $R_2$  which varies the oscillator screen voltage.

The d.c. cathode returns of both the oscillator and the 807 stage are connected to closed-circuit jacks offering a choice of keying the 807 stage only, or keying both oscillator and buffer-amplifier stages simultaneously. With no fixed bias on the 807, the oscillator alone may not be keyed since the 807 plate current with the key up would skyrocket without excitation. The 6N7 is protected by cathode bias.

### Exciter Construction

The r.f. exciter unit is built on a  $14 \times 10 \times 3$ -inch chassis and is mounted with the speech-amplifier chassis on a standard rack panel  $8\frac{3}{4}$  inches high. Viewing the unit from the rear, the row of eleven crystal sockets to accommodate new-style crystal holders is mounted along the right-hand edge of the chassis. A spare socket to the front of the others is provided for old-style crystals with  $\frac{3}{4}$ -inch pin spacing and is wired in parallel with the eleventh socket from the panel. The 6.3-volt transformer to supply the heaters in both the r.f. exciter and the speech amplifier is located to the rear of the crystal sockets.

Coils for the crystal-oscillator stage and the first two doublers are wound on Milen 1-inch diameter forms and secured to the chassis with small machine screws. The leads from these coils are fed to the 4-gang bandswitch,  $S_2$ , below, through small insulating bushings immediately in front of the coils. The 6V6 crystal-oscillator tube is slightly to the right of the oscillator coil and the 6N7 is directly to the left.

The tuning condenser for the 807 driver stage is mounted on small ceramic stand-offs on a bracket formed of sheet aluminum, to permit the fiber shaft extension rod to clear the oscillator and doubler coils and condensers. In line with this condenser and immediately to the rear of it is the socket and shield can for the 807. A short length of braid connects the plate cap of the tube to the stator of the condenser.

The coils for the bandswitching assembly for the 807 stage are mounted on small ceramic stand-off insulators and fastened to another sheet-aluminum platform below which is mounted the 2-gang 807-stage bandswitch,  $S_3$ . The wafers of  $S_3$  are spaced about  $2\frac{1}{2}$  inches so that one section is almost directly under the 28-Mc. coil, to permit shortest possible leads to

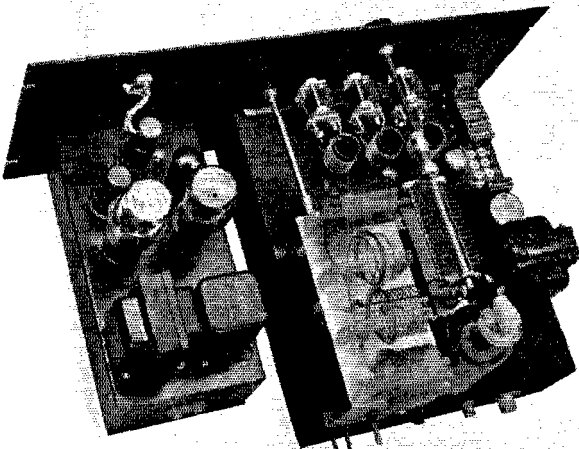

Top view of the speech amplifier-r.f. exciter unit. The speech-amplifier equipment is mounted on the  $3 \times 5 \times 10$ -inch standard chassis to the left. The r.f. unit is spaced two inches from it with interconnections cabled through a grommetted hole in the side of each chassis. The coil assembly for the plate circuit of the 807 stage is mounted on a bracket bent from sheet aluminum. It is  $3\frac{1}{2}$  inches wide,  $6\frac{1}{2}$  inches long, and  $2\frac{1}{2}$  inches high.

**QST** for



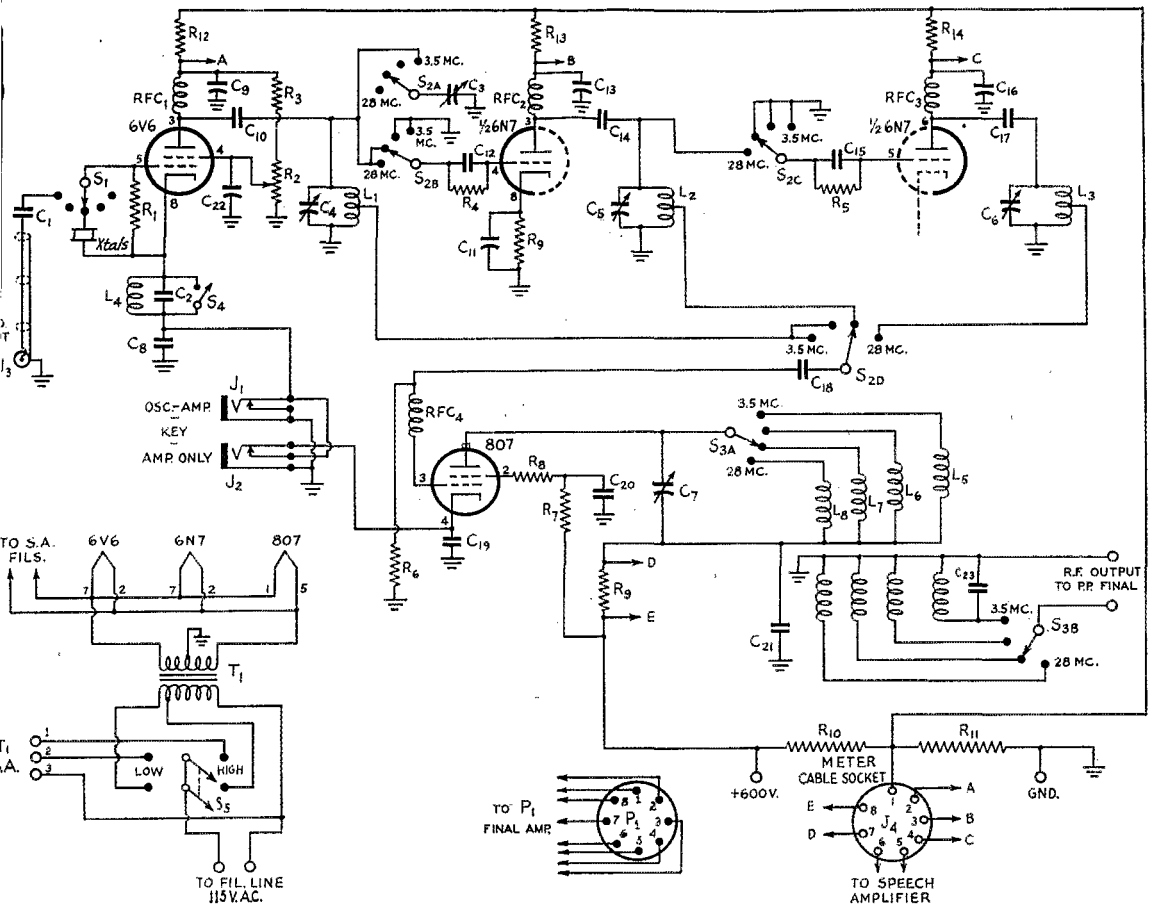

Fig. 1 — Circuit diagram of the r.f. exciter unit.

$C_1, C_{10}, C_{14}, C_{17}$  — 0.0022- $\mu$ fd. mica.  
 $C_2$  — 220- $\mu$ fd. mica.  
 $C_3$  — 140- $\mu$ fd. air padder.  
 $C_4, C_5, C_6$  — 100- $\mu$ fd. variable (National ST-100).  
 $C_7$  — 100- $\mu$ fd. variable (Hammarlund MC-100-SX).  
 $C_8, C_{19}$  — 0.0047- $\mu$ fd. mica.  
 $C_9, C_{11}, C_{13}, C_{16}, C_{22}$  — 0.01- $\mu$ fd. 600-volt paper.  
 $C_{12}, C_{15}, C_{18}$  — 100- $\mu$ fd. mica.  
 $C_{20}$  — 500- $\mu$ fd. 2500-volt mica.  
 $C_{21}$  — 0.002- $\mu$ fd. 2500-volt mica.  
 $C_{22}$  — 22- $\mu$ fd. mica.  
 $R_1$  — 0.1 megohm,  $\frac{1}{2}$  watt.  
 $R_2$  — 50,000-ohm potentiometer, 10 watts.  
 $R_3$  — 47,000 ohms, 1 watt.  
 $R_4$  — 47,000 ohms,  $\frac{1}{2}$  watt.  
 $R_5$  — 22,000 ohms,  $\frac{1}{2}$  watt.  
 $R_6$  — 22,000 ohms, 1 watt.  
 $R_7$  — 50,000 ohms, 10 watts.  
 $R_8$  — 47 ohms (carbon),  $\frac{1}{2}$  watt.  
 $R_9, R_{12}, R_{13}, R_{14}$  — 22 ohms,  $\frac{1}{2}$  watt.  
 $R_{10}$  — 3000 ohms, 50 watts.  
 $R_{11}$  — 15,000 ohms, 25 watts.  
 $L_1$  — 21 turns No. 18 on 1-inch diam. form, length 1 inch, tapped 15 turns from ground.

$L_2$  — 10 turns No. 18 on 1-inch diam. form, length 1 inch, tapped 7 turns from ground.  
 $L_3$  — 5 turns No. 18 on 1-inch diam. form, length 1 inch, tapped 2 turns from ground.  
 $L_4$  — 13 turns No. 18 on 1-inch diameter form, length 1 inch.

Note —  $L_1, L_2, L_3$  and  $L_4$  are wound on Millen Type 45000 forms.

$L_5, L_6, L_7, L_8$  — Millen 43082, 43012, 43022 and 43012.

$J_1, J_2$  — Closed-circuit jack.

$J_3$  — Coaxial-cable socket (Amphenol).

$J_4$  — Octal socket.

$P_1$  — Octal plug.

$RFC_1, RFC_2, RFC_3$  — 2.5-mh. r.f. choke (National R-100U).

$RFC_4$  — 20 turns No. 20 d.c.c. wound on 1-watt resistor (any high value of resistance may be used).

$S_1$  — Single-gang 12-position wafer switch.

$S_2$  — Four-gang four-position ceramic wafer switch.

$S_3$  — Two-gang four-position ceramic wafer switch.

$S_4$  — S.p.s.t. toggle switch.

$S_5$  — D.p.d.t. toggle switch.

$T_1$  — 6.3-volt 4-amp. filament transformer (Stancor P-4019).

that coil. The 14-Mc. coil is placed next in line to the rear and the 7-Mc. coil is farthest to the rear of the subbase. The 3.5-Mc. coil is nearest the panel. The switch section at the front is used to switch the links for the various coils. The National Type FWJ banana-jack terminal for r.f. output is set in the rear end of the coil-supporting subbase.

Looking at the bottom of the exciter, the crystal-selector switch is in the lower right-hand corner below the row of crystal sockets. The voltage-divider resistors,  $R_{10}$  and  $R_{11}$ , are mounted toward the rear of the chassis on angle brackets. The crystal-oscillator tube socket is at right center, with the cathode coil and condenser toward the panel and slightly to the right. The switch to short out the cathode coil is mounted on the panel immediately to the left of the crystal-selector switch. The excitation-control potentiometer,  $R_2$ , is mounted centrally just to the right of the two key jacks. The bandswitch  $S_2$  is at the extreme left-hand front of the chassis with the 3.5-Mc. padding condenser for the plate tank mounted at an angle to the right. The shaft of the latter extends through the chassis for screw-driver adjustment from above.

Associated components are mounted wherever convenient to permit leads to be as short as possible. Much of the non-r.f. wiring, including connections to the speech amplifier, is cabled and placed around the edge of the chassis. The terminal board, mounted on small pillars, facilitates wiring. The parasitic-suppressor choke,  $RFC_4$ , is wound using a 1-watt resistor of 100,000 ohms as a form. The 115-volt male connector at the left of the back side of the chassis is the input terminal for the filament-transformer primaries. The high-low line-voltage switch,  $S_5$ , is next to the right. The Millen safety terminal is for 600-volt supply with a banana-plug jack ground connection next to it. An octal socket at the extreme right rear edge of the chassis is for the cable containing metering leads and other interunit connections. To its left is an Amphenol coaxial connector for VFO input. A length of RG-58/U

cable leads along the lip of the chassis to the blocking condenser,  $C_1$ , soldered to the No. 12 crystal selector-switch lug. A chassis bottom plate, removed for the picture, forms part of the shielding for the unit.

### Final Amplifier & Modulator

The final amplifier shares the top chassis with the modulator. The wiring of this chassis is shown in Fig. 2.

Bandswitching is employed only in the grid circuit of the final amplifier because of the bulk that plate-coil switching would involve. One side of each link joins a common line and the other side is switched in automatically when a band is selected. Both ends of the grid tank coils are switched. The individual 500-ohm resistances at the center-tap of each coil help to isolate unused coils. The common resistor,  $R_5$ , makes up the balance of the grid leak.  $L_5C_1$  and  $L_6C_2$  are trap circuits to suppress v.h.f. parasitic oscillation.

The plate spacing of the plate tank condenser is reduced to a minimum by arranging the circuit so that d.c. and audio voltages do not appear across the condenser section. This requires that the condenser rotor be insulated from the chassis and that the shaft be provided with a high-voltage insulating coupling. The 5514s require no protective bias so they may be operated safely with grid-leak bias only.

Hytron 5514s are used also in the Class B modulator; its circuit is included in Fig. 2. High-frequency response is limited by shunting condensers across the primary and secondary of the modulation transformer. This added capacitance acts in conjunction with the leakage reactance of the transformer windings to form a low-pass filter that fairly effectively attenuates the highs, including those arising because of modulator distortion. Since transformers vary, the proper value of capacitance must be determined experimentally. In this particular set-up, a capacitance of 0.003  $\mu$ fd. was found to result in a rather sharp cut-off for voice frequencies above 3000 cycles.

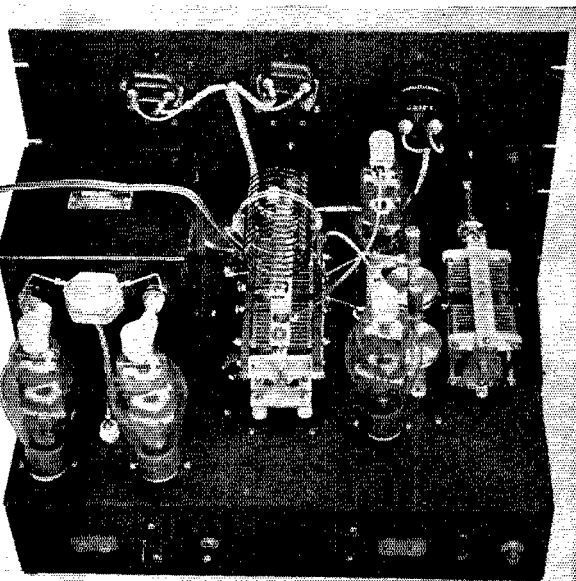

Built on a common chassis, the modulator occupies the left-hand portion while the push-pull final amplifier is to the right.

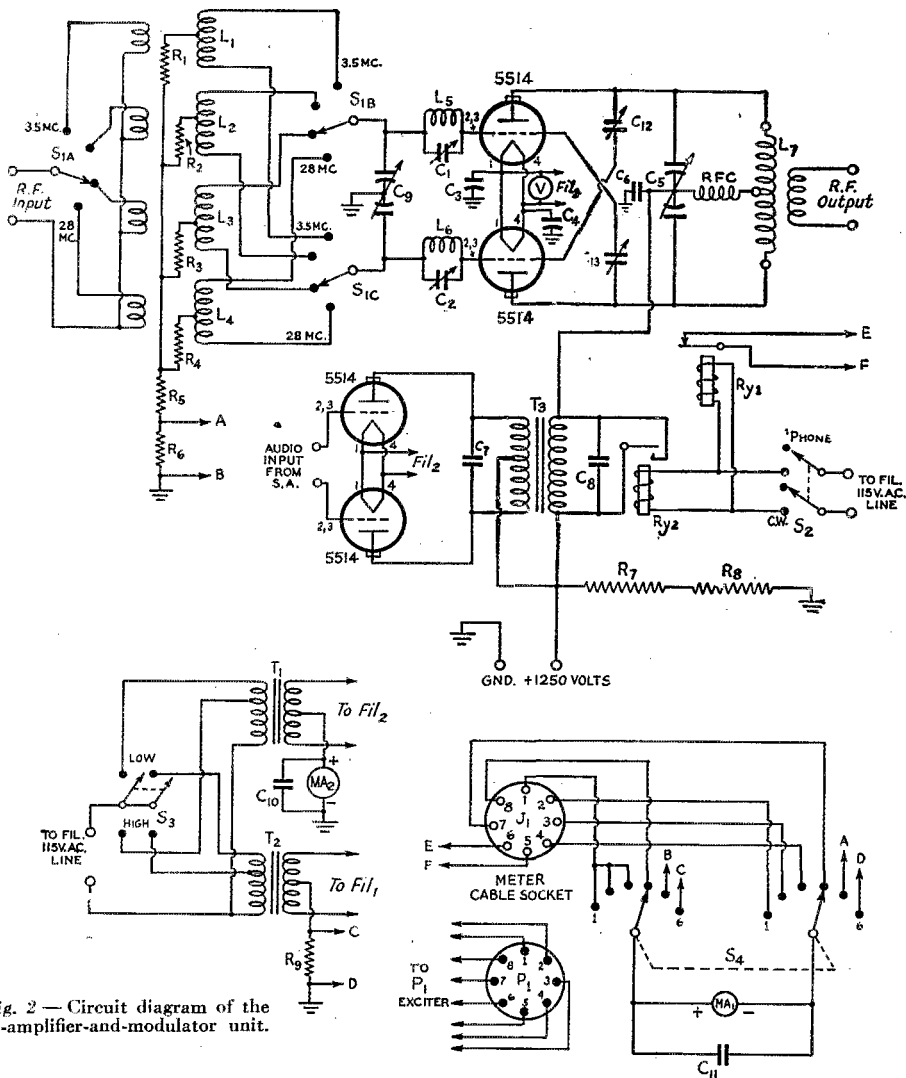
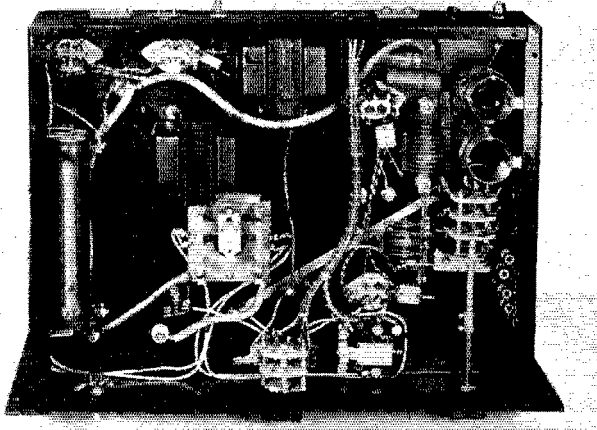

Fig. 2 — Circuit diagram of the final-amplifier-and-modulator unit.

- C<sub>1</sub>, C<sub>2</sub> — 3-30- $\mu$ fd. mica trimmers.
- C<sub>3</sub>, C<sub>4</sub> — 0.01- $\mu$ fd. 600-volt paper.
- C<sub>5</sub> — 100- $\mu$ fd. per-section variable, 0.07-inch spacing (Cardwell PL7030).
- C<sub>6</sub> — 0.02- $\mu$ fd 2500-volt mica.
- C<sub>7</sub>, C<sub>8</sub> — 0.003- $\mu$ fd. 2500-volt mica (see text).
- C<sub>9</sub> — 100- $\mu$ fd. per-section variable, 0.047-inch spacing (National TMK-100D).
- C<sub>10</sub>, C<sub>11</sub> — 0.001- $\mu$ fd. mica.
- C<sub>12</sub>, C<sub>13</sub> — Neutralizing condenser (National NC-800).
- R<sub>1</sub>, R<sub>2</sub>, R<sub>3</sub>, R<sub>4</sub> — 500 ohms, 10 watts.
- R<sub>5</sub> — 1300 ohms, 10 watts.
- R<sub>6</sub> — 22 ohms,  $\frac{1}{2}$  watt.
- R<sub>7</sub>, R<sub>8</sub> — 10,000 ohms, 75 watts.
- R<sub>9</sub> — 22 ohms,  $\frac{1}{2}$  watt, shunted by a length of No. 30 copper wire wound around the resistor. The wire length should be adjusted to make the milliammeter read one-tenth its normal value, increasing the full-scale range to 1,000 ma.
- L<sub>1</sub>, L<sub>2</sub>, L<sub>3</sub>, L<sub>4</sub> — Millen Types 43081, 43041, 43021 and 43011 coils.

- L<sub>5</sub>, L<sub>6</sub> — 5 turns No. 14 bare copper wire,  $\frac{3}{4}$ -inch diameter,  $\frac{3}{4}$  inch long.
- L<sub>7</sub> — B & W BXL series.
- J<sub>1</sub> — Octal socket.
- MA<sub>1</sub> — 0-100 d.c. milliammeter.
- MA<sub>2</sub> — 0-300 d.c. milliammeter.
- P<sub>1</sub> — Octal plug.
- RFC — 1-mh. r.f. choke (National R-300).
- Ry<sub>1</sub> — D.p.d.t. 110-volt coil relay (Ward-Leonard 507-549 used as s.p.s.t.).
- Ry<sub>2</sub> — D.p.d.t. 110-volt coil relay (Ward-Leonard 507-531 used as s.p.s.t.).
- S<sub>1</sub> — 3-gang four-position ceramic wafer switch.
- S<sub>2</sub> — D.p.s.t. toggle switch.
- S<sub>3</sub> — D.p.d.t. toggle switch.
- S<sub>4</sub> — 2-gang 6-position ceramic wafer switch.
- T<sub>1</sub>, T<sub>2</sub> — 7.5-volt 5-amp. filament transformer (Stancor P-4091).
- T<sub>3</sub> — Modulation transformer, 5514s to Class C (Thorndarson T-14M49).
- V — 0-10 a.c. voltmeter.



Under the final amplifier-modulator chassis. The toggle switch controlling the 'phone-c.w. relays is shown in the lower left-hand corner of the chassis.

### Metering System

A single milliammeter and switching system is used to check the plate current of all exciter stages as well as the grid and cathode currents of the final amplifier. The double-gang switch, *S*<sub>1</sub>, Fig. 2, connects the meter *MA*<sub>1</sub> across low-value resistors in each circuit. The resistance of *R*<sub>9</sub>, *R*<sub>12</sub>, *R*<sub>13</sub> and *R*<sub>14</sub>, Fig. 1, and *R*<sub>6</sub> in Fig. 2, is sufficiently high so that it does not affect the reading of the meter. However *R*<sub>9</sub>, Fig. 2, in the filament center-tap of the final amplifier, is a lower-resistance shunt that multiplies the meter-scale

reading by ten. A separate milliammeter, *MA*<sub>2</sub>, is provided for checking modulator cathode current, while the a.c. voltmeter, *V*, Fig. 2, serves as a check on filament voltage.

Switch *S*<sub>2</sub> (Fig. 2) is the 'phone-c.w. switch. When it is closed for c.w. operation, *Ry*<sub>2</sub> short-circuits the output of the modulator and *Ry*<sub>1</sub> opens the high-voltage line to the speech amplifier.

### Building the Final Amplifier

In the top view of the final-amplifier unit, the dual-section variable condenser for the plate

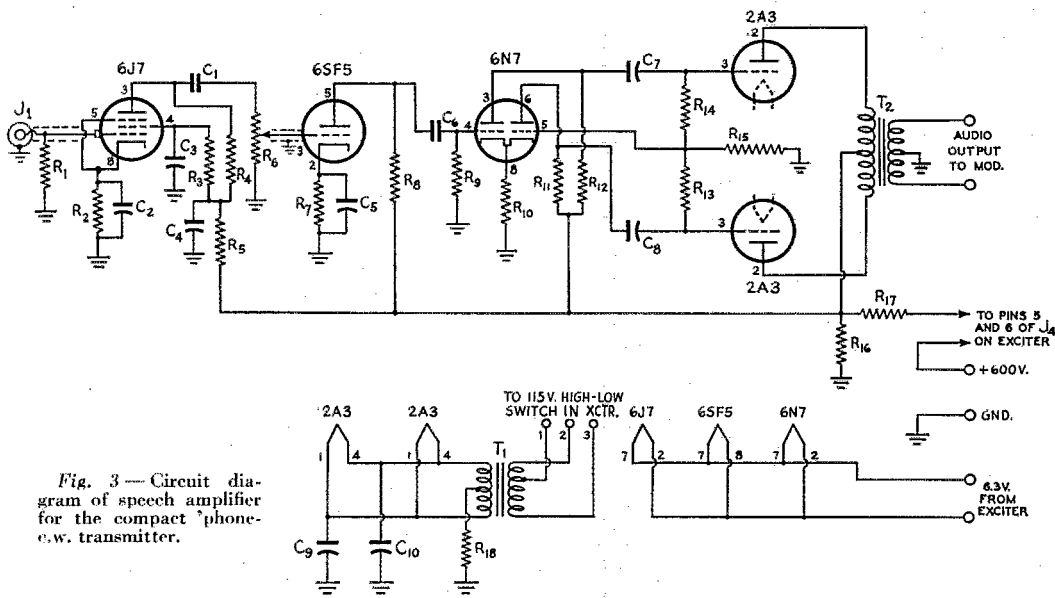
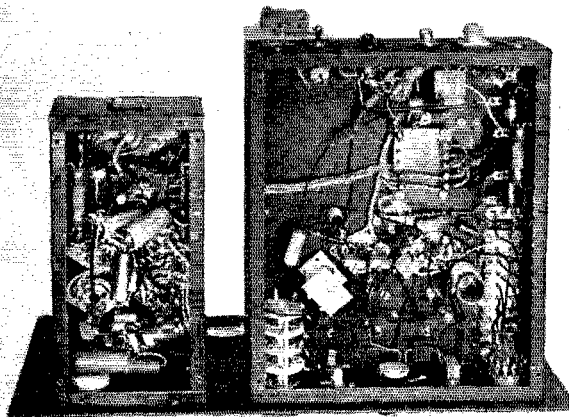

Fig. 3 — Circuit diagram of speech amplifier for the compact 'phone-c.w. transmitter.

- C<sub>1</sub>, C<sub>6</sub> — 0.0047- $\mu$ fd. mica.
- C<sub>2</sub>, C<sub>5</sub> — 25- $\mu$ fd. 50-volt electrolytic.
- C<sub>3</sub>, C<sub>7</sub>, C<sub>8</sub>, C<sub>9</sub>, C<sub>10</sub> — 0.1- $\mu$ fd. 400-volt paper.
- C<sub>4</sub> — 8- $\mu$ fd. 450-volt electrolytic.
- R<sub>1</sub> — 4.7 megohms, 1 watt.
- R<sub>2</sub> — 2200 ohms, 1 watt.
- R<sub>3</sub> — 2.2 megohms, 1 watt.
- R<sub>4</sub>, R<sub>8</sub> — 0.17 megohm, 1 watt.
- R<sub>5</sub> — 47,000 ohms, 1 watt.
- R<sub>6</sub> — 0.5-megohm potentiometer, 1 watt.
- R<sub>7</sub> — 4700 ohms, 1 watt.

- R<sub>9</sub> — 0.17 megohm, 1 watt.
- R<sub>10</sub> — 1500 ohms, 1 watt.
- R<sub>11</sub>, R<sub>12</sub> — 0.1 megohm, 1 watt.
- R<sub>13</sub>, R<sub>14</sub>, R<sub>15</sub> — 0.22 megohm,  $\frac{1}{2}$  watt.
- R<sub>16</sub> — 15,000 ohms, 15 watts.
- R<sub>17</sub> — 4500 ohms, 35 watts.
- R<sub>18</sub> — 750 ohms, 10 watts.
- J<sub>1</sub> — Microphone jack.
- T<sub>1</sub> — Filament transformer, 2.5 volts, 2.5 amperes (Stancor P-4082).
- T<sub>2</sub> — Output transformer to match p.p. 2A3s to Class B grids (Stancor A-4212).

Bottom of the r.f. exciter-speech amplifier unit, with covers removed.



circuit,  $C_5$ , Fig. 2, is mounted centrally on the chassis on small ceramic stand-off insulators. The jack bar for the plug-in plate coils is fastened to the condenser frame with small angle pieces. Sockets for the 5514s are mounted just far enough apart to permit mounting the neutralizing condensers in between, while the grid tank condenser is fastened directly to the chassis at the right. The plate by-pass condenser,  $C_6$ , and r.f. choke are to the left of the plate tuning condenser.

The amplifier grid-tank coils are grouped closely around the triple-gang selector switch,  $S_1$ , shown at the right-hand side in the under-chassis photograph. The switch is mounted on a metal bracket about halfway back to the rear edge. The 7-Mc. and 3.5-Mc. coils are mounted on ceramic stand-off insulators on the side of the chassis and to the rear. The 28-Mc. coil is mounted on small angle brackets just to the left of the bandswitch and the 14-Mc. coil to the rear of the switch. The parasitic-trap circuits,  $L_5C_1$  and  $L_6C_2$ , supported by the grid leads, are placed as close as possible to the grid pins of the tube sockets. The grid resistors are mounted on a terminal board fastened to the side of the chassis, just forward of the coil-selector switch.

The modulator occupies the left-hand side of the chassis as viewed from the rear. The modulation transformer,  $T_3$ , Fig. 2, is placed as close to the edge of the chassis as possible with the two 5514s directly to the rear. Two 0.0015- $\mu$ fd. condensers in parallel make up the required 0.003- $\mu$ fd. capacitors for  $C_7$  and  $C_8$  and these are fastened directly across the transformer input and output terminals. The high-voltage connection is made to the center-tap of the primary of  $T_3$  and fed through a ceramic feed-through insulator in the chassis. The two filament transformers for the 5514s,  $T_1$  and  $T_2$ , and the bleeder resistors for the 1250-volt supply,  $R_7$  and  $R_8$ , Fig. 2, also are mounted underneath the chassis of this unit.

The relay just below the filament transformers is  $Ry_2$ , which short-circuits the modulation trans-

former during c.w. operation. The smaller relay at the bottom is  $Ry_1$ , the supply-voltage control relay for the speech amplifier.

The three meters are mounted above the tuning controls on the final-amplifier panel, while the meter switch,  $S_4$ , is located under the chassis at the center of the front edge of the same unit. Connections between the switch and the exciter unit are made through the cabling system.

Banana-plug jacks for r.f.-link input and audio input to the modulator, a 115-volt line plug for the filament transformers, the high-low filament switch,  $S_3$ , Fig. 2, a Millen safety terminal for the high-voltage connection and another banana-plug jack for ground connection are mounted along the rear edge.

### Speech Amplifier

The speech amplifier is a separate unit built on a 5 × 10 × 3-inch chassis that shares the same panel as the exciter unit. It is designed for use with a crystal microphone but, by altering slightly the circuit shown in Fig. 3, any type of microphone may be used. A 6J7 input stage is followed by a high-gain triode stage with a 6SF5. A 6N7 phase inverter feeds a pair of 2A3s in push-pull which drive the 5514 modulator stage. The gain control is inserted in the grid of the second stage. Low-capacitance coupling condensers are used throughout to reduce low-frequency response.

In the top view of the speech amplifier the 6J7 input tube is at the front, with its input resistor and shielded lead to the microphone terminal. The 6SF5 is located a little to the rear and to the left of the 6N7 phase inverter. The two 2A3 driver tubes occupy the center of the chassis, directly in front of the driver transformer and the 2½-volt transformer for the 2A3 filaments,  $T_1$ , Fig. 3. The National FWJ output terminal is at the center of the back end of the chassis.

Under the chassis, the gain control,  $R_6$ , is at the lower left as viewed from the rear. The voltage-divider resistors,  $R_{16}$  and  $R_{17}$ , are mounted along the left-hand side of the chassis and the internal

terminal strip along the right-hand side. Holes in the rear cut with a socket punch allow entrance of the leads from the two transformers mounted above.

The grid lead of the 6SF5 is run through grounded shielding braid. Connections to the terminal strip are cabled and fed through rubber-grommetted holes in the sides of the chassis to appropriate external terminals. A bottom plate covers the chassis of this unit.

### Power Supplies

Two power supplies provide plate voltage for all tubes in the transmitter. A 600-volt 200-ma. section supplies voltage for the 807 and, through voltage dividers and series voltage-dropping resistors, voltage for the exciter and speech-amplifier tubes as well. A single 1250-volt 550-ma. section provides plate voltage for the four 5514s in the final amplifier and modulator. Both supplies are assembled on a single  $17 \times 13 \times 4$ -inch chassis behind a 14-inch panel that occupies the lower part of the transmitter cabinet.

The circuits are shown in Fig. 4.  $S_1$  and  $S_2$  are interlock switches that operate when the rear door and hinged top lid of the cabinet are opened and closed. The control switches,  $S_3$ ,  $S_4$  and  $S_5$ , are arranged so that neither of the high-voltage transformers can be turned on before the filament

A 1250-volt 550-ma. and 600-volt 200-ma. dual power supply. Components are mounted both above and below the  $17 \times 13 \times 4$ -inch chassis. Close to the panel are the filter choke,  $L_4$ , the filter condensers  $C_1$  and  $C_2$ , and the 1250-volt transformer  $T_1$ . Along the rear are the 866 Jrs., the choke  $L_2$ , and the 866s. The female socket at the left is for the a.c. line to the filament transformers on the other chassis. The toggle switch selects the proper tap on the primaries of the filament transformers to partially compensate for low or high line voltage and the male Amphenol socket is for the a.c. input line from the safety switches on the top and back doors. The Millen safety terminal to the right of the toggle switch is the 600-volt output terminal while the one near the right-hand edge of the chassis is for the high-voltage output. At the extreme right-hand edge of the chassis is the ground connection, a banana jack mounted on a small spacer.

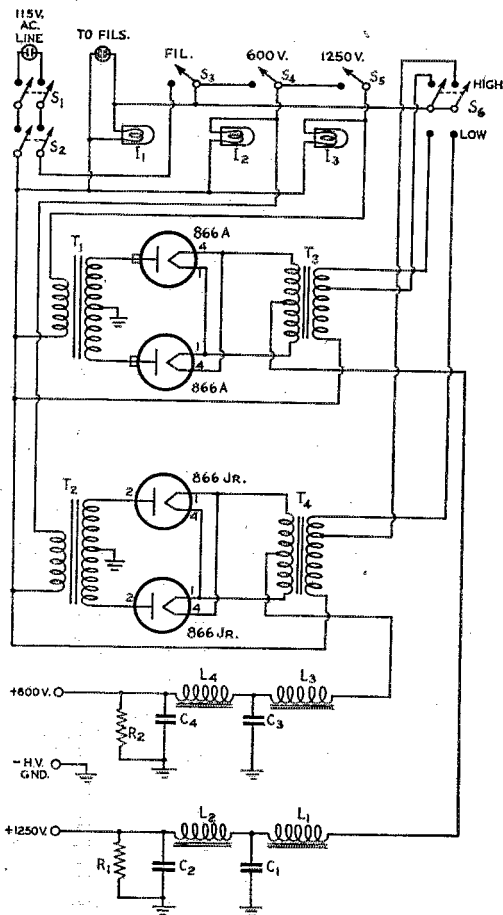
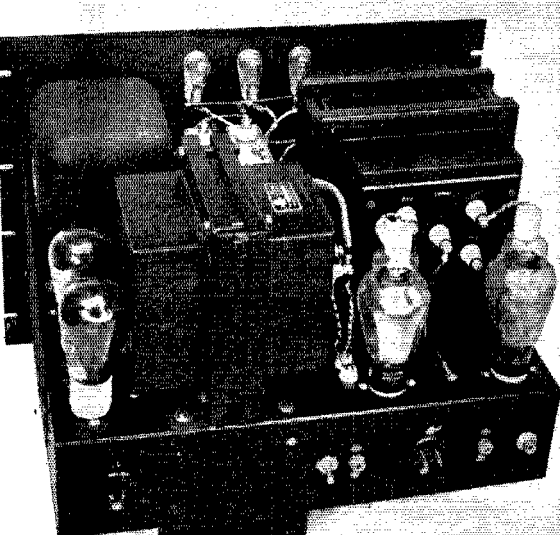
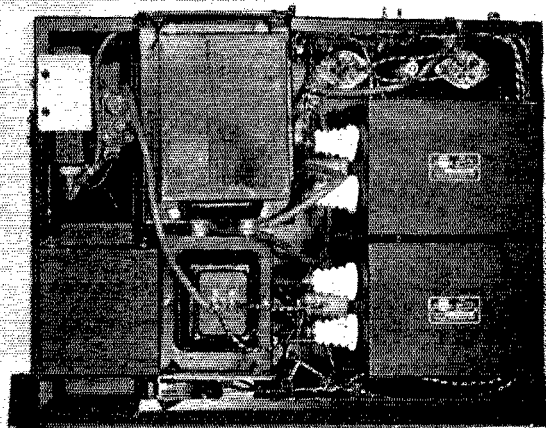

Fig. 4—Circuit diagram of the dual power supply for the medium-power handswitching transmitter, delivering 1250 volts at 550 ma. and 600 volts at 200 ma.

- C<sub>1</sub>, C<sub>2</sub>—4- $\mu$ fd. 2000-volt filter condenser (C-D TJU 20040).
- C<sub>3</sub>—2- $\mu$ fd. 1000-volt filter condenser (C-D TJU 10020).
- C<sub>4</sub>—4- $\mu$ fd. 1000-volt filter condenser (C-D TJU 10040).
- R<sub>1</sub>—0.5 megohm, 5 watts.
- R<sub>2</sub>—0.5 megohm, 2 watts.
- L<sub>1</sub>—Swinging choke, 5–20 hy., 550 ma., 75 ohms (Thordarson T-19C38).
- L<sub>2</sub>—Smoothing choke, 8 hy., 550 ma., 75 ohms (Stancor CI415).
- L<sub>3</sub>—Swinging choke, 6–19 hy., 300 ma., 125 ohms (Thordarson T-19C36).
- L<sub>4</sub>—Smoothing choke, 11 hy., 300 ma., 125 ohms (Thordarson T-15C16).
- I<sub>1</sub>, I<sub>2</sub>, I<sub>3</sub>—115-volt indicator lamps.
- S<sub>1</sub>, S<sub>2</sub>—D.p.s.t. push-button interlock switch.
- S<sub>3</sub>, S<sub>4</sub>, S<sub>5</sub>—S.p.s.t. toggle switch.
- S<sub>6</sub>—D.p.d.t. toggle switch.
- T<sub>1</sub>—Plate transformer, 1250 volts each side of center, 550 ma. (Stancor P8027).
- T<sub>2</sub>—Plate transformer, 600 volts each side of center, 200 ma. (Stancor P8012).
- T<sub>3</sub>, T<sub>4</sub>—Rectifier filament transformer, 2.5 volts, center-tapped, 10 amperes, 10,000-volt insulation (Stancor P3025).



Bottom view of the dual power supply. The two rectifier filament transformers,  $T_3$  and  $T_4$ , are at the right with sockets for the 866As to the rear. The sockets for the 866 Jrs. in the 600-volt supply are located under the filter condensers,  $C_3$  and  $C_4$ , in the upper left-hand corner. Switches for control of the a.c. lines are set in the front edge of the chassis. The lip of the chassis is turned down to make room for mounting of the 600-volt transformer,  $T_2$ , at the lower left. The filter choke for the low-voltage supply,  $L_3$ —lower center—is supported on an aluminum bracket near the panel to allow space for switches and associated wiring. The choke  $L_1$  is immediately above.



switch,  $S_3$ , is closed, nor can the 1250-volt supply be turned on until the 600-volt switch,  $S_4$ , has been thrown. In operation  $S_5$  is closed and then  $S_4$  serves to control both plate supplies simultaneously. Signal lamps  $I_1$ ,  $I_2$  and  $I_3$  are provided for each switch.

The two photographs of the power-supply unit show the general placement of parts, which will probably vary somewhat in individual cases depending upon the available components. The chassis is fastened to the panel 2 inches up from the bottom edge of the panel and large side brackets are used to add strength to the assembly. To provide sufficient room, it may be necessary to cut and bend the chassis lip at certain points so that the unit may be fastened to the edge of the chassis. Wire with high-voltage insulation should be used for all except the primary circuits.

The three pilot lamps are mounted in the upper part of the panel, while the three toggle switches,  $S_3$ ,  $S_4$  and  $S_5$ , are along the bottom edge. Line a.c. input and high-voltage output connections are made at the back, Millen safety terminals being provided for the latter.

### Tuning Procedure

The tuning procedure is quite simple. The 'phone-c.w. switch should be in the c.w. position. With the key connected to the buffer only, set the exciter and final-grid bandswitches for 28-Mc. output. Set the meter switch to read oscillator plate current (Position 1). With a 3.5-Mc. crystal, the cathode-coil switch should be open; for a 7-Mc. crystal, it should be closed. Switch on the 600-volt supply and, *without closing the key*, rotate the oscillator plate tank condenser to resonance as indicated by a dip in plate current. Switch the meter to the first doubler (Position 2) and rotate the first-doubler tank condenser for a similar resonance-indicating dip. Check the 28-Mc. doubler stage in like manner.

With these driver stages tuned to resonance, close the key and rapidly rotate the 807 tank condenser for resonance. Then adjust the grid current to the final amplifier by rotating the

final-amplifier grid condenser. It may be necessary to retune the plate circuit of the 807 to bring it back to resonance after adjusting the final-grid tuning. Grid current to the final should read 80 to 100 ma.

The final amplifier should then be neutralized in the usual manner. After neutralizing, voltage may be applied to the final and the output tank resonated and the amplifier loaded in conventional manner.

### 'Phone Operation

For 'phone operation the plate supplies are switched off, the 'phone-c.w. switch changed to the 'phone position. The key should be closed or the keying plug removed entirely from the jack. First the 600-volt and then the 1250-volt supply should be switched on; then the gain control adjusted to proper level after which the 600-volt supply switch alone may be used to control the transmitter by leaving the high-voltage supply switch in the "on" position.

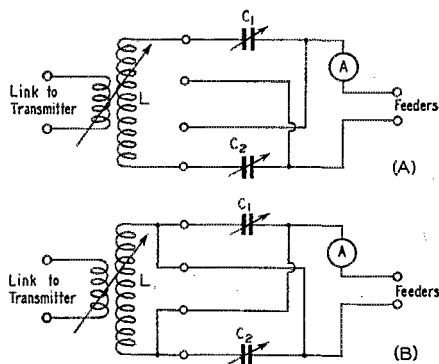
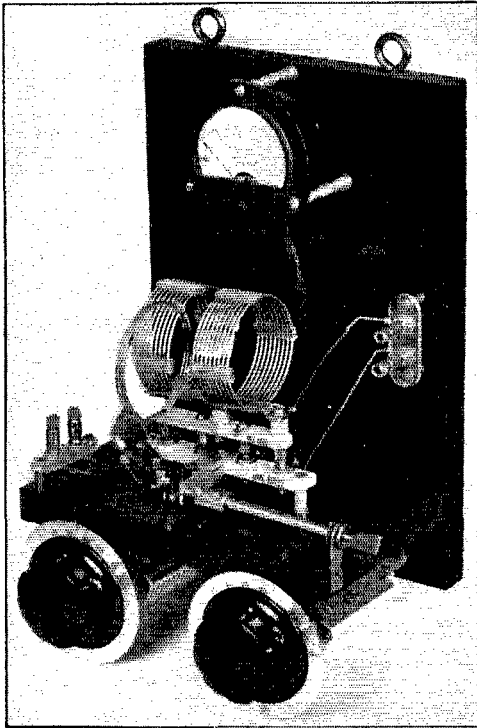

Fig. 5—Circuit diagram of the antenna coupler for use with the compact medium-power transmitter. A—series tuning. B—parallel tuning.

$C_1$ ,  $C_2$ —100- $\mu$ fd. single-section variable, 0.070-inch spacing (Cardwell MT-100-GS).

L—B & W BVL series.

A—0-2.5 thermocouple r.f. ammeter.



A wall-mounting antenna tuner for the medium-power bandswitching transmitter.

### Antenna Tuner

The antenna coupler is an external unit. A separate coil is used for each band and desired connections for series or parallel tuning are made automatically when the coil is plugged in. Coil connections to the pins for alternate circuit arrangements are shown in Fig. 5. The tuning condensers specified, together with a set of standard plug-in transmitting coils, should cover practically all coupling conditions encountered if the feeders terminate reasonably near a voltage or current node. After determining which mode of tuning is to be used, the coil connections may be made permanent.

The entire unit is mounted on an  $8 \times 12 \times \frac{3}{8}$ -inch board for hanging on the wall near the operating position to facilitate tuning and loading adjustments. As pictured, the 2.5-ampere r.f. ammeter is mounted centrally by long wood screws through spacers at the top of the unit. A short length of twisted pair connects it to the thermocouple, secured in a horizontal position at the bottom of the backboard. The tuning condensers are mounted on the underside of a 4-inch shelf extending the width of the unit. Atop the shelf, the jack bar for the coil is supported on

pillars by wood screws. An extension shaft to vary the degree of coupling is supported by a bushing fastened to a short strip of brass at the right of the shelf. A short length of 300-ohm ribbon connects the input terminals to the movable link, while the output terminals are located at the middle right of the backboard. Two screw eyes at the top permit the unit to be hung from screws or nails in the wall.

### Conclusion

The juxtaposition of components involves many problems, both electrical and mechanical. A great deal of experimentation was necessary in arriving at this particular design. In building a similar rig with components other than those specified or with a different layout, it may be necessary to do a bit of mental (and perhaps actual) juggling to fit the required parts into the limited space. The relative positions of circuit components may have to be changed experimentally to avoid unwanted interaction between the various stages. For the amateur who wishes to operate all bands with easy changeovers and who enjoys both voice and c.w. work using moderate input power, but who still wants his station to occupy a minimum of space, the extra labor involved in building this rig is well worth while.

### HUDSON DIVISION CONVENTION Asbury Park, N. J., September 26th-28th

The first Hudson Division Convention in many years is being held September 26th-28th at Asbury Park, N. J., co-sponsored by the Jersey Shore Amateur Radio Association and the Monmouth County Amateur Radio Association. That they are out to make up for lost time is evident from an outline of the program, which includes technical talks and engineering sessions, special meetings for DX, traffic and v.h.f. interests, a visit to the moon-radar installation nearby, amateur station W2HDC on the air, demonstrations of blind-landing equipment, many displays by manufacturers—and, of course, many prizes. For the ladies there will be card parties, a fashion show and parties.

Registration is \$3.50 for the three-day convention and \$4.00 additional for the banquet (limited to the first 500 on advance reservation). Write M. Krause, jr., W2HKY, 135 Bridge St., Red Bank, N. J. See you there!



# Happenings of the Month

## REGULATORY MATTERS

The shooting may have stopped, but many of war's effects are still with us. FCC recently took two actions to liberalize amateur regulations which it believed might deal harshly with some amateurs as a result of wartime dislocations.

Before taking the examination for Class A privileges, it has been necessary for an applicant to have held an amateur operator license for a period of a year or more within the previous five years. Because some long-time amateurs were obliged to let their licenses expire before Pearl Harbor and find themselves now eligible only for Class B privileges until a year of postwar license-holding has been completed, the Commission now feels that the application of this five-year limit is no longer desirable. On July 3rd FCC issued an order amending §12.21 of the rules, concerning eligibility for licenses, to read as follows:

Class A — Any citizen of the United States who at any time prior to receipt of his application by the Commission has held, for a period of a year or more, an amateur operator license issued by the Commission.

The practical effect is that a year's holding of an amateur license subsequent to about 1934, the year that saw FCC's birth, will make an applicant eligible to take the Class A examination.

By its Order 77-H FCC has again suspended, this time until June 30, 1948, the application of its rule requiring "proof of use" as a condition precedent to the renewal of an amateur operator license, "in order to provide a cushion for the full return to normal peacetime procedure." This action postpones for another year the effective date of the requirement to show three c.w. contacts on renewal applications. Meanwhile, the applying portion of the license application form may still be ignored.

## C.A.A. ALASKAN OPENINGS

The Civil Aeronautics Administration has a need for aircraft communicators to man approximately 45 communications stations along Alaskan airways. They want veterans who have had 18 months of military or commercial aeronautical communication experience, single (because of shortage of family housing facilities), in good physical condition, who can handle c.w. at 30 w.p.m. and touch-type at 35. Starting salary is approximately \$3300 per year, with the usual Civil Service provisions for overtime. New employees are given orientation training at Okla-

homa City before being assigned to an airway communications station. Complete details and application forms may be obtained by addressing the Director, CAA Aeronautical Center, Box 1082, Oklahoma City 1, Oklahoma.

## BEADLE RETIRES

To the average person the most famous signature is perhaps that of John Hancock. But to well upward of 100,000 past and present amateurs it certainly is



And why not? It has appeared on practically all ham licenses that FCC has issued in its thirteen-year history. Yet we've never heard him complain of writer's cramp.

Now, after sixteen years of loyal service to FRC and FCC, John Beadle has taken a well-deserved retirement. These many years he has been superlatively fine to amateurs. "Doc" Beadle handled the amateur licensing section as if he himself were each amateur awaiting his renewal or modification, or each would-be amateur eagerly expecting his first ticket. He took a personal interest in the work, an approach we like to call the amateur spirit.

Yet somehow the ham bug never got its teeth in JBB. Perhaps he was steered away by the thought of possibly becoming as fanatic about radio as most of the hams he knew through official correspondence; after all, somebody in the radio game has to stay normal!

So while we can't wish him an S9 report from Tibet nor the first WAC on 50 Mc., we are talking his language when we say, "73, OM, and mni tnx!"

## ELECTION NOTICE

**To All Full Members of the American Radio Relay League Residing in the Atlantic, Dakota, Delta, Great Lakes, Midwest, Pacific and Southeastern Divisions:**

You are hereby notified that, in accordance with the Constitution, an election is about to be held in each of the above-mentioned divisions to elect both a member of the ARRL Board of Directors and an alternate thereto for the 1948-1949 term. Your attention is invited to §1 of Article IV of the Constitution, providing for the government of ARRL by a board of directors; §2 of Article IV, and By-Law 12,

defining their eligibility; and By-Laws 13 to 24, providing for the nomination and election of division directors and their alternates. Copy of the Constitution & By-Laws will be mailed to any member upon request.

Voting will take place between October 1 and November 20, 1947, on ballots that will be mailed from the headquarters office during the first week of October. The ballots for each election will list, in one column, the names of all eligible candidates nominated for the office of director by Full Members of ARRL residing in that division; and, in another column, all those similarly named for the office of alternate. Each Full Member will indicate his choice for each office.

Nomination is by petition. Nominating petitions are hereby solicited. Ten or more Full Members of the League residing in any one of the above-named divisions may join in nominating any eligible Full Member residing in that division as a candidate for director therefrom, or as a candidate for alternate director therefrom. No person may simultaneously be a candidate for both offices. Inasmuch as all the powers of the director are transferred to the alternate in the event of the director's death or inability to perform his duties, it is of great importance to name a candidate for alternate as it is for director. The following form for nomination is suggested:

*Executive Committee*

*The American Radio Relay League  
West Hartford 7, Conn.*

*We, the undersigned Full Members of the ARRL residing in the ..... Division, hereby nominate ..... of ..... as a candidate for director; and we also nominate ..... of ..... as a candidate for alternate director; from this division for the 1948-1949 term.*

*(Signatures and addresses)*

The signers must be Full Members in good standing. The nominee must be a Full Member and must have been both a member of the League and a licensed radio amateur operator for a continuous term of at least four years immediately preceding receipt by the Secretary of his petition of nomination, except that a lapse of not to exceed ninety days in the renewal of the operator's license and a lapse of not to exceed thirty days in the renewal of membership in the League, at any expiration of either during the four-year period, will not disqualify the candidate; provided that if a candidate's membership was interrupted by reason of service in the armed forces of the United States or Canada between September 1, 1939, and May 3, 1947, he shall not be deemed to be disqualified so far as concerns continuity of membership if within those dates he resumed his League membership within the 90 days following his release from active military duty. He must be without commercial radio connections; he may not be commercially engaged in the manufacture, selling or renting of radio apparatus normally capable of being used in radio communication or experimentation, nor commercially engaged in the publication of radio literature intended, in whole or part, for consumption by licensed radio amateurs. Further details concerning eligibility are given in By-Law 12. His complete name and address should be stated. The same requirements obtain for alternate as for director. All such petitions must be filed at the headquarters office of the League in West Hartford, Conn., by noon EDST of the 20th day of September, 1947. There is no limit to the number of petitions that may be

**ARE YOU LICENSED?**

• When joining the League or renewing your membership, it is important that you show whether you have an amateur license, either station or operator. Please state your call and/or the class of operator license held, that we may verify your classification.

**N.B.F.M. AUTHORIZED**

• On August 1st FCC authorized the use of narrow-band frequency modulation in the following band segments:

- 3850-3900 kc.
- 14,200-14,250 kc.
- 28,500-29,000 kc.
- 51,000-52,500 kc.

Usual Class A restrictions apply to the 75- and 20-meter bands. The authorization is on an experimental basis for a period not longer than one year, within which time the matter will be reexamined for a decision whether it should be discontinued or made permanent.

FCC defines amateur use of n.b.f.m. as "a system of frequency modulation wherein the peak deviation is limited to a value equal to or less than the maximum modulation frequency." Put another way, the bandwidth may not exceed that occupied by an amplitude-modulated signal of the same audio characteristics.

filed on behalf of a given candidate but no member shall append his signature to more than one petition for the office of director and one petition for the office of alternate. To be valid, a petition must have the signature of at least ten Full Members in good standing; that is to say, ten or more Full Members must join in executing a single document; a candidate is not nominated by one petition bearing six valid signatures and another bearing four. Petitioners are urged to have an ample number of signatures, since nominators are frequently found not to be Full Members in good standing. It is not necessary that a petition name candidates both for director and for alternate but members are urged to interest themselves equally in the two offices.

League members are classified as Full Members and Associate Members. Only those possessing Full Membership may nominate candidates or stand as candidates; members holding Associate Membership are not eligible to either function.

Present directors and alternates for these divisions are as follows: Atlantic Division: director, Edward G. Raser, W2ZI; alternate, J. Victor Brotherson, W8BHN. Dakota Division: director, Tom E. Davis, W6SW; alternate, Harold B. Love, W0ZRT. Delta Division: director, George S. Acton, W5BMM; alternate, Eugene H. Treadaway, W5DKR. Great Lakes Division: director, Harold C. Bird, W8DPE; alternate, John H. Brabb, W8SPF. Midwest Division: director, C. A. Colvin, W0VHR; alternate, none. Pacific Division: director, William A. Ladley, W6RBQ; alternate, Elbert J. Amarantes, W6FBW. Southeastern Division: director, William C. Shelton, W4ASR; alternate, William P. Sides, W4AUP.

These elections constitute an important part of the machinery of self-government of ARRL. They provide the constitutional opportunity for members to put the direction of their association in the hands of representatives of their own choosing. Full Members are urged to take the initiative and to file nomination petitions immediately.

For the Board of Directors:

K. B. WARNER,  
Secretary

July 1, 1947

**SWITCH  
TO SAFETY!**





AS FAR as the calendarians were concerned, September 1922 was just another 30-day month. However, readers of *QST* for this same month found their favorite magazine bulging just a bit, containing eight extra page 32s — 32A through 32H. The reason: Returning from a vacation spent in pursuit of the finny tribe, the editor found the back of the issue all printed and pagenumbered, an aggressive advertising department having oversold its space allowances. There was only one way to make room to report important summer doings — sandwich in this specially-numbered 8-page section up front!

There's a wealth of receiver-circuit dope crammed into this issue, prompted no doubt by general dissatisfaction with a summer of poor receiving conditions. "Radio-Frequency Amplification at Amateur Wavelengths," by K. B. Warner, provides us with the design data of the new air- and iron-core fixed-tuned r.f. coupling transformers now making their appearance. There is hope that these devices will simplify the operation of amateur receivers, although admittedly the performance of the complex manually-tuned units is superior. Amrad, R.C.A., Radio Instrument Co., Coto-Coil and Mu-Rad are all in the market.

E. H. Armstrong's new superregenerative circuits and theory have been put to acid test by a number of amateurs, returning verdicts hot and cold. In "Notes on the Super-Regenerative Receiver" L. M. Cockaday, 2XK, reports favorably on his working model. Kenneth Harkness gives his impressions of the circuit in "Operating the Super-Regenerator," finding results satisfactory but tuning complicated. In "Progress in Super-Regeneration," a critical appraisal of this new invention, K. B. W. reports the consensus of a number of amateurs — that the circuit is excellent for local 'phone work with strong signals but so far hasn't proved its worth in the reception of c.w. or long-distance stations. Mr. R. B. Bourne, 2BML, reports excellent results with his "superregenerative" Reinartz tuner.

President Maxim tells in this issue of his recent meeting with "The Greatest of All Amateurs" — Senatore Marconi. Through Mr. Maxim and *QST*, the famous Italian inventor pays tribute to amateurs in the following words: "... I wish ... I might convey to them the inspiration they have been to me!"

ARRL members — ten thousand strong — are being encouraged by means of a subscription contest to sign up as League members the many new people now showing interest in radiophone listening. Equipment prizes totaling \$2000 are offered!

C.w. leads again this month in traffic-handling volume, showing 53% of the total. It's still a spark station that cops individual honors, though — 7OT of Boise, Idaho. We're given the sad news that our Daylight Transcons failed because of July QRN; but there's no saying quit — a new attempt is scheduled for Thanksgiving Day. Traffic to Hawaii is moving reliably, we find, President Maxim having made a test of the route from his home station, 1AW. Cliff Dow, 6ZAC, always reliable, held down the Pacific end.

The need for international agreement on the use of special prefixes to eliminate confusion between stations in different countries is rapidly approaching, according to "International Amateur Radio," *QST*'s new department. Already French 8MT has been confused with American 8MT!

We're given introductions to Nicholas H. Jensen, Dakota Division manager, and Major Alfred E. Banks, 6IY, in this month's "Who's Who" section. The prominent Chicago station, 9HY, is featured in the Station Descriptions Department.

Cigar smoke is dense at the *QST* factory nowadays because the Warner household has been blessed with the arrival of Betty Jean, a "superregenerating 8-pounder." Further perusal of Strays divulges more good tidings: Matty of 9ZN is putting in c.w. . . . a pair of 250-watters!

## Wanted — Radiomen for Overseas

A department of the United States Government has need for civilian radio operators and operator-technicians for interesting overseas duty. Men with qualifying experience will be selected to operate and maintain radiotelegraph stations in various parts of the world, qualifying and operating under federal regulations.

The work has particular appeal to radio amateurs, often calling for the special sort of ingenuity with which hams are endowed. The pay is good, ranging from \$2644.80 for communications technicians to \$4149.60 for senior supervisors. In those places where the living costs exceed the current cost of living in the United States, an allowance is paid, designed to meet this differential. There is opportunity for further promotion within the organization to grades paying considerably higher salaries. Transportation, in accordance with U. S. Government travel regulations, is furnished to and from the overseas duty station. It is expected that living quarters and transportation for families will be available at a few locations. Men employed for this work will

(Continued on page 188)

# An Antenna That Multiplies by 50

*A High-Gain 24-Element Array for 144 Mc. or Higher*

BY J. A. K MOSKO,\* W2NLY

ALL of us often dream of having a signal that will really push that S-meter around at the receiving end. To visualize the power increase required to raise the S-meter from S6 to S9, consider that if we double our power the S-meter at the other end will move up only 3 db., or one-half an S-unit. To raise it one S-unit, or 6 db., it is necessary to increase our power four times. To achieve our aim of a rise of three S-units would require a power multiplication of 50 times! One thing is quite obvious: it takes a great increase in power to make a noticeable difference at the receiving end. Not all of us can afford kilowatt rigs, but a great majority can build a good antenna, if we have a little spare time and live in a place where the neighbors are reasonable.

Following is a description of a beam antenna that makes 10 watts output equivalent to an effective radiated power of 500 watts, at a cost of less than 20 dollars. Just think what it would cost to achieve this improvement by increasing transmitter power!

Not only is the effective radiated power increased by better than 50 times along the line of the beam, but the same array ahead of the receiver raises the level of incoming signals in the favored direction by approximately three S-units over that received on a simple dipole. Signals that are inaudible or down in the noise level on a dipole antenna can be copied satisfactorily.

## General Description

The array consists of 12 half-wave elements fed in phase (Fig. 1), six broadside and two high, backed up with 12 reflectors spaced one-quarter wave behind the driven elements. Originally this antenna was fed in the conventional manner as

shown in Fig. 2-A, but unequal current distribution was experienced, limiting the maximum gain to 14.6 db. and showing several extremely-large minor lobes. It was also quite critical in loading with respect to frequency. This trouble was remedied by removing the center matching section and feeding each group of six elements at the center as shown in Fig. 2-B, resulting in an increase of 2.5 db. in forward gain, improving the front-to-back ratio by 4 db., and increasing the main-to-side-lobe ratio considerably.

The impedance of the phasing sections interconnecting the radiators and the two sections of transmission line leading to the matching transformer is about 500 ohms. They are made of No. 14 wire with 2-inch spacing. It will be noted that the two 500-ohm transmission lines (one wavelength long) feeding each half of the beam are fed in parallel by the matching transformer. The impedance at this point is therefore half the value of the lines, or 250 ohms.

The matching transformer was designed to provide an adjustable match between the antenna impedance and transmission lines with characteristic impedances from 52 to 400 ohms. To achieve this match, the transformer characteristic impedance should be equal to the square root of the product of the antenna and transmission-line impedances.

This transformer, Fig. 3, consists of two quarter-wave rods (or Q-bars)  $\frac{1}{2}$  inch in diameter, with one rod mounted stationary and the other adjustable by the use of two slots in the transformer support. This method allows any impedance to be set up by adjusting the center-to-center spacing of the two rods.

Table I is provided to show the approximate transformer spacing for different types of transmission line. This chart holds true for  $\frac{1}{2}$ -inch

\*119 Lakeview Avenue, South Plainfield, N. J.

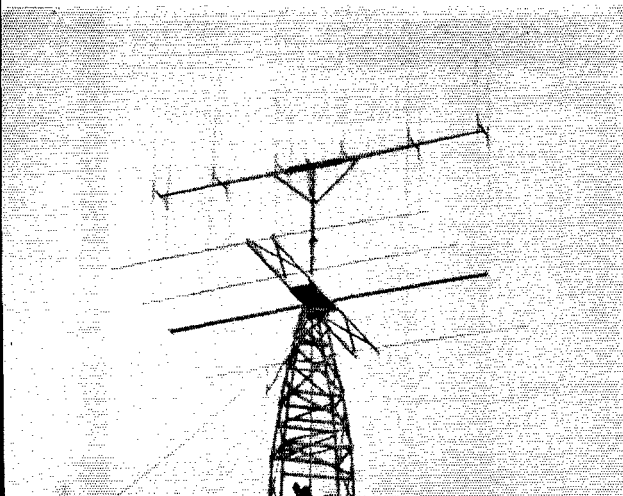

The 24-element array at W2NLY is mounted atop a 4-element 10-meter array.

QST for

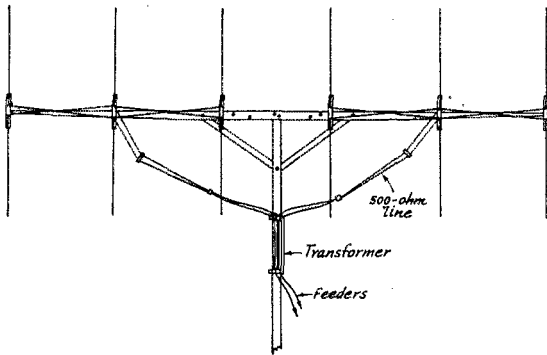

Fig. 1 — Detail drawing of the W2NLY 24-element array.

diameter tubing *only*. If these dimensions are followed, good results can be expected without further adjustments. However, if the transformer is provided with slots as shown in Fig. 3 it will be possible to adjust for the best possible match with any of the available types of line.

If coaxial line is to be used, care should be taken as to the type selected, especially if a long run is necessary. There is quite a quantity of inferior coaxial cable having a very high loss per foot, along with the good cable, now available on the war-surplus market. For best results with coaxial feed, a line balancer should be used, allowing the unbalanced line to feed the balanced antenna system.

### Constructional Details

The main boom (*H* in Fig. 4) consists of two 8-foot 3-inch lengths of  $1\frac{1}{2} \times 3$ -inch seasoned fir, tapered down from 3 inches at  $1\frac{1}{2}$  feet out from the center to  $\frac{3}{4}$  inch at each end. This taper reduces the total boom weight by one-third. The upright (*J*) is a 7-foot length of  $1\frac{1}{2} \times 2\frac{1}{2}$ -inch seasoned fir with two  $1 \times 2$ -inch bracket supports (*I*) approximately 3 feet long to reinforce the boom to the upright. There are six "H" sections, each of which supports four elements, two radiators and two reflectors. One of these is shown in detail in Fig. 5.

TABLE I

Spacing and Transformer Impedance Required To Match Various Lines to a 260-Ohm Terminating Impedance

Transmission-Line Impedance (Ohms)	Transformer Characteristic Impedance (Ohms)	Transformer Spacing Center-to-Center (Inches)
52	114	0.75
72	134	0.85
97	156	1.0
150	194	1.3
300	274	2.5

The insulators are made of  $\frac{1}{2}$ -inch polystyrene rod cut  $1\frac{1}{4}$  inches long, drilled and tapped for 10-24 brass screws. This insulator is considerably lighter than the conventional isolantite type and has a better dielectric constant.

The elements are made of 24ST aluminum alloy  $\frac{3}{8}$ -inch o.d. with a 0.035-inch wall. Approximately 80 feet is needed. The weight of this material (0.045 pound per foot) and its amazing tensile strength make it much better suited for the job than pure aluminum. It was purchased at 12 cents per foot.

Table II gives figures for the 144-Mc. band, for which the beam was designed, as well as the 235- and the 420-Mc. bands. This beam will perform equally well on these higher frequencies if the dimensions given in the table are followed. General mechanical construction could be the same except for boom length and detail *B* of Fig. 5.

### Measurements

A test pattern made of this array is shown in Fig. 6. The beam width is approximately 17 degrees at the half-power points. Forward gain is more than 17 db. over a simple dipole and the front-to-back ratio is 22 db. The gain figures might seem a little high for this combination, but considerable care was taken in making the initial measurements and in the calibration of the field-strength meter, and a different system of measurement was set up to check on the original results.

A half-wave dipole was set up a considerable distance from the array and excited by the trans-

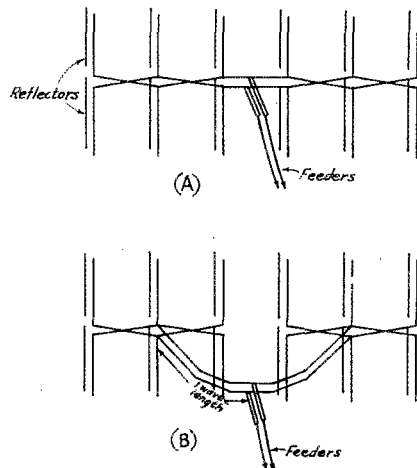

Fig. 2 — The 24-element array was fed originally as shown in A. Unequal current distribution made it necessary to change to the split system shown in B.

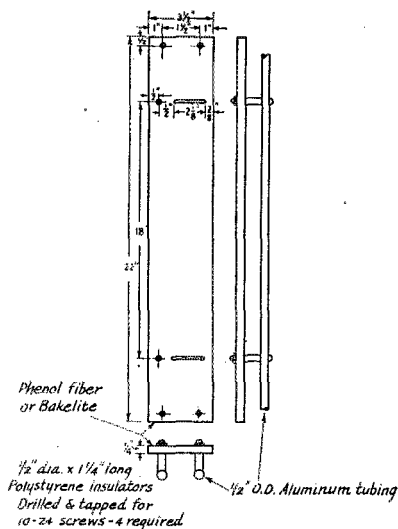

Fig. 3 — Detail drawing of the matching transformer, showing the method used to obtain various impedances.

mitter. The transmission line was disconnected from the beam and in its place, at the bottom of the transformer, a noninductive 300-ohm 1-watt resistor was connected.

An r.f. voltmeter was built up using a 1N34 crystal rectifier, two noninductive multiplier resistors and a 0-200 microammeter. This meter was calibrated in terms of volts, with particular attention being paid to the low end of the scale, where the meter operates on the nonlinear portion of the crystal-rectifier curve. This meter was then connected across the 300-ohm resistor at the bottom end of the transformer. The power input to the transmitter was then checked and recorded.

The beam (on test pole) was then pointed at the transmitting antenna, and rotated for maximum indication on the r.f. voltmeter. The spacing of the Q-bars was changed slightly, the meter dropping off in both directions, indicating that the original transformer setting was satisfactory.

The r.f. voltmeter reading was recorded as 2.90 volts. The power, then, was

$$\frac{2.90^2}{300} = 0.028 \text{ watt}$$

or 28 milliwatts. The r.f. voltmeter and terminating resistor were removed from the transformer and the beam taken off the test pole. In its place the folded dipole (comparison antenna) was substituted with the same 300-ohm terminating resistor and r.f. voltmeter connected in the center.

Frequency (Mc.)	Radiators	Reflectors	Transformer	Spacing between Elements
144	37.9	39.75	18.9	40
146	37.31	39.2	18.6	39.5
148	36.82	38.7	18.4	39
235	23.22	24.4	11.6	24.5
420	12.9	13.6	6.4	13.75

Length of  $\frac{1}{2}$  Wave in Inches =  $\frac{5902 \times K}{\text{Freq. Mc.}}$  ( $K = 0.925$ )

The transmitter power was rechecked and found to be the same. The r.f. voltmeter now read 0.4 volt, or a power of 0.000533 watt. Expressed as a power ratio the gain in db. over the dipole would be 17.19.

This measurement was repeated by replacing the beam on the test pole and reconnecting the measuring equipment. The power input to the transmitter was checked once more. The beam was rotated for maximum signal. This time the meter read 2.95 volts, indicating 0.029 watt of power.

This corresponds to a gain of approximately 17.3 db. over the dipole in comparison with the previous measurement of 17.2 db., and the 17.1 db. obtained with the field-strength meter when the array and the comparison dipole were excited directly.

Convinced that our gain measurements were reasonably correct, thought was given to measuring the terminating impedance of the array. This was done by disconnecting the matching transformer and connecting the value of resistance that gave us the most recovered power using the same measuring equipment and a selection of 1-watt resistors ranging from 200 to 300 ohms, values of which were checked on an impedance bridge and marked on tags attached to the re-

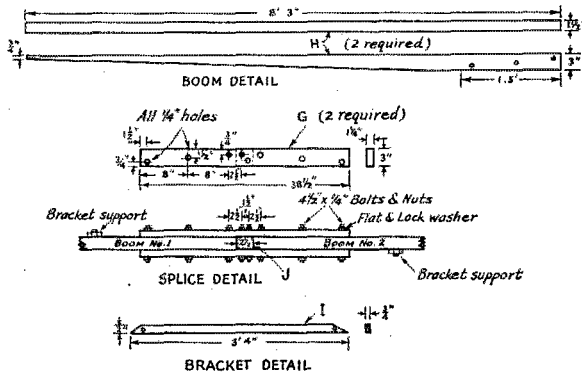

Fig. 4 — Details of the boom, center splice and braces used in the 24-element array.

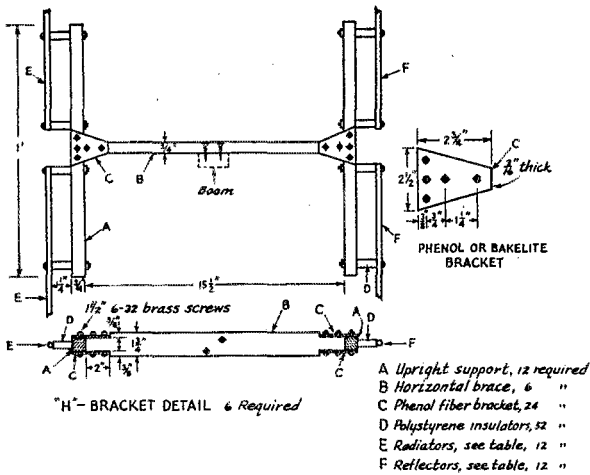

Fig. 5 -- Antenna elements are mounted in six sets of four each (two radiators and two reflectors) on an H-shaped bracket attached to the main boom.

sistors. A value of 246 ohms was arrived at, being very close to the 250-ohm value that we had originally estimated.

Thanks are due Stavid Engineering for their cooperation and the use of their electronic laboratory for the calibration and testing of our measuring equipment.

### Results

Tests at W2NLY have shown this array to outperform anything yet tried on two meters.

We have a very unfavorable geographical location for 144-Mc. work, being surrounded on three sides by hills that are considerably higher than the array. In spite of this, many stations have been worked more than 25 miles beyond these hills under normal operating conditions. Under more favorable conditions contacts up to several hundred miles are usually possible.

On the evening of April 10th, with conditions slightly better than those typical of early spring, six states were worked in less than one hour. Stations contacted included W1NWM, Milford, Conn.; W3BNU, Hatboro, Pa.; W2FQW, East Meadow, L. I.; W2PKF, Runnemede, So. Jersey; W1BJE, Westport Harbor, Mass., and W1JFF, Newport, R. I., who, incidentally, was using the 6-element beam described by the writer in November, 1946, *QST*.

Fig. 6 -- Beam pattern of the W2NLY array. The solid line shows the pattern in terms of power ratio. The small dash-line circle is the pattern of a comparison dipole.

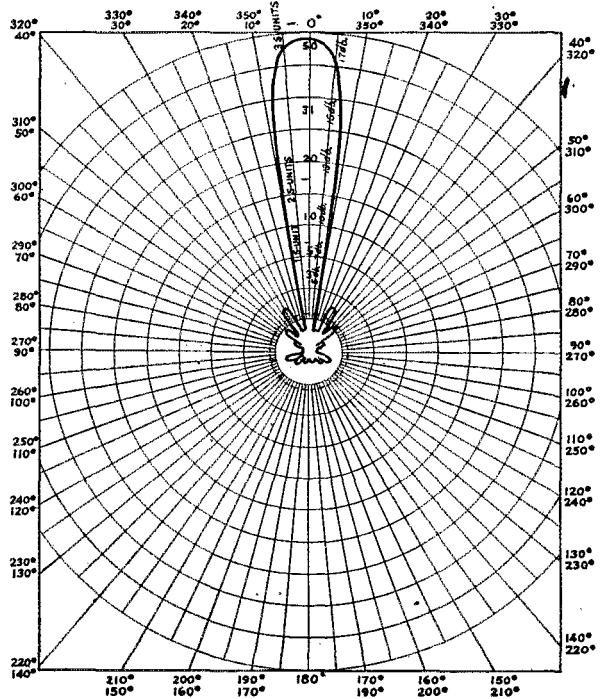

# Looking Over the Postwar Receivers

## The Collins 75A

WE ATTEMPT to write these *QST* reports on the new receivers from an impartial viewpoint, without too many bouquets and brickbats for the receiver under discussion. It is a very difficult thing to do, however, because favorite communications receivers, like neckties and girl friends, depend to a large extent on personal preferences and the state of one's pocketbook.

Take the new Collins 75A receiver, for example. The price puts it out of the reach of the large majority of amateurs at the present — and probably

and still retain its advantages will become apparent when the tuning system is considered.

### The Circuit

The circuit of the 75A is quite different from that of any other receiver on the market. The block diagram of the receiver, Fig. 1, shows how the receiver works. On any range, the signal is amplified by the 6AK5 r.f. stage that feeds the first mixer, a 6SA7. A 6AK5 crystal oscillator (with a different crystal for each band) excites

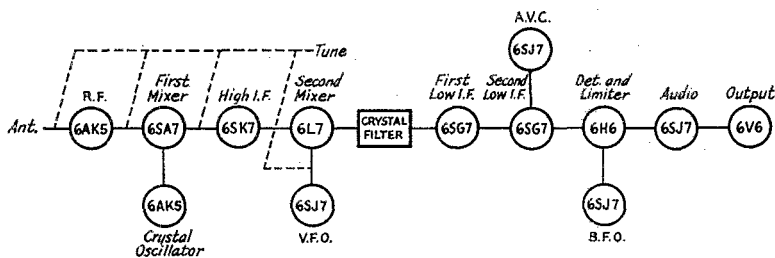

Fig. 1 — Block diagram of the 75A receiver. The high-frequency oscillator is crystal-controlled on all bands, using separate crystals for each band.

the future. It doesn't cover the broadcast band, the 50-Mc. band or the f.m. broadcast bands, and there are doubtless plenty of paying customers who insist on such features in their amateur receivers. If this review were written by such a consumer, it might have a different tone.

But let's forget about the price and whether or not it is a home receiver to cover all frequencies and services, and just see what kind of a job it does in covering the ham bands up to 30 Mc. It has six ranges: 3.2 to 4.2 Mc. (80-meter band), 6.8 to 7.8 Mc. (40-meter band), 14.0 to 15.0 Mc. (20-meter band), 20.8 to 21.8 Mc. (14-meter band), 26.0 to 28.0 Mc. (11-meter band), and 28.0 to 30.0 Mc. (10-meter band). Thus the ham bands are adequately covered, a check-point on WWV is available at 15.0 Mc., and some extra coverage is obtained in most of the ranges. But it isn't an "all-wave" receiver. The reason why it can't be

the 6SA7 mixer, and the resultant beat is amplified in a tunable first i.f.-amplifier channel. The output of the first i.f. channel feeds into a second i.f. channel at 500 kc., and this channel includes the crystal filter. To make a system like this work, of course, it is necessary to gang-tune the r.f., first mixer, first (or high) i.f. and second oscillator (marked "VFO" in the diagram). It is akin to a crystal-controlled converter working into a lower-frequency communications receiver, with the r.f. circuits of the converter gang-tuned with the receiver. In the 75A, it is further complicated by switching the tuning range from 1.0 Mc. on the low frequencies to 2.0 Mc. at 26 and 28 Mc.

A tuning system like this has some nice advantages. Once the second oscillator is calibrated in kilocycles, it is only necessary to select the proper crystal frequencies for the first oscillator and the

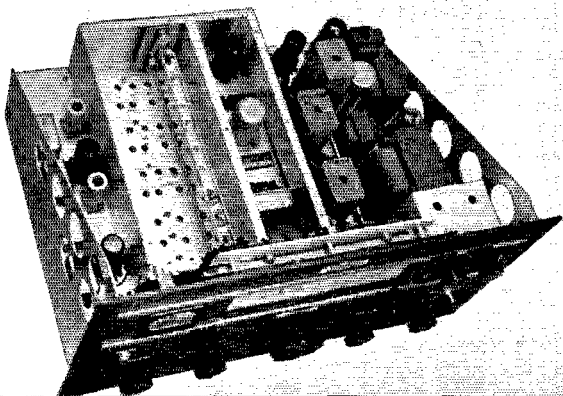

A top view of the Collins receiver with the cover plate removed from the tuning assembly. The many holes are for trimmer adjustments in the r.f. and first i.f. stages — note the movable tuning platform on one side of the compartment.

*QST* for



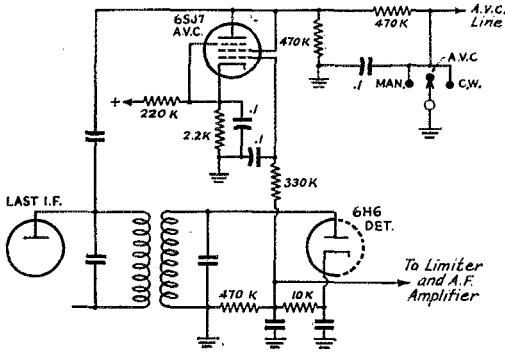

Fig. 2—The a.v.c. system used in the receiver. The 6SJ7 tube picks up the signal from the plate of the last i.f. stage. Delay bias is introduced in the cathode circuit across the 2200-ohm cathode resistor. When a signal develops at the 6H6 detector, some positive voltage is fed back to the grid of the 6SJ7, thus canceling out the delay bias and permitting an a.v.c. voltage to develop. The result is that the S-meter (which is controlled by the a.v.c. voltage) indicates on weaker signals than it would if a more conventional system were used.

receiver will be direct-reading in kilocycles on all of its ranges. The receiver uses the basic v.f.o. unit<sup>1</sup> used in the Collins transmitters, which is set up to be quite linear in its frequency scale. There are two frequency scales on the receiver. One is directly coupled to the tuning knob and is marked in kilocycle divisions. The second is a full-vision dial scale that gives the rough frequency reading. For example, if the pointer on the large scale is between 7.1 and 7.2, and the other scale reads 74, the frequency is 7174 kc. On the full-vision scale, only the tuning range in use is illuminated. On the 10- and 11-meter bands, where the tuning rate is doubled, each division on the vernier scale represents 2 kc., and an auxiliary scale indicates this. Reading the dial is more complicated to describe than it is to do.

With the crystal-controlled oscillator working at the high frequency, and the v.f.o. working at a relatively low frequency, the mechanical and thermal stability of the receiver is outstanding. Tuning c.w. signals on 14 or 28 Mc., they sound just like signals on the lower frequencies, and you don't have to hold your breath or walk on tip-toe after you've found the signal. The high first i.f. makes image response no problem on any range.

The constant tuning rate is a nice deal. It means that signals tune in and out at the same rate on any band, excluding the two highest ranges where the rate is doubled. One can forget all about "bandsread" and talk "tuning rate"

<sup>1</sup> Hunter, "Permeability-Tuned Oscillators," *QST*, August, 1946

after handling the receiver. The 1.0-Mc. range of the receiver (2.0 Mc. on 10 and 11 meters) is covered by ten turns of the tuning knob.

The ganged circuits of the receiver are all permeability-tuned. The tuning knob is coupled directly to the "VFO" and coupled through gears and metal belts to a movable platform that varies the iron cores in the r.f. and first i.f. circuits. To eliminate the need for separate tunable cores on each band, the cores in the lowest-frequency coils only are varied (3.5-Mc. coils in the r.f. and mixer, 2-Mc. coils in the high i.f.). On other frequency ranges, circuits are switched in in parallel to give the necessary range. This is a clever principle that will probably find more application in the future, in both gang-tuned receivers and transmitters. Adjustable ceramic trimmers and adjustable powdered-iron cores are used throughout the receiver for alignment. The antenna circuit is coupled to the 3.5-Mc. coil only.

One interesting circuit trick in the tail end of the receiver (which is otherwise more or less conventional after one gets into the familiar territory of the 500-kc. i.f. amplifier) is the a.v.c. detector, shown in Fig. 2. The a.v.c. voltage comes from a 6SJ7 rectifier tapped off the plate of the last 500-kc. i.f. stage. The 6SJ7 is fixed-biased in the cathode circuit, so that no signal can be rectified until it exceeds this bias, or "delay," voltage. A positive voltage proportional to the signal at the 6H6 detector is fed back to the 6SJ7 grid and bucks the delay bias. The S-meter works

(Continued on page 130)

In this bottom view one gets an idea of the excellent construction of the receiver. A cover plate has been removed from the oscillator and r.f. portions to show the details. Note the bank of six crystals that controls the first oscillator on the various bands.

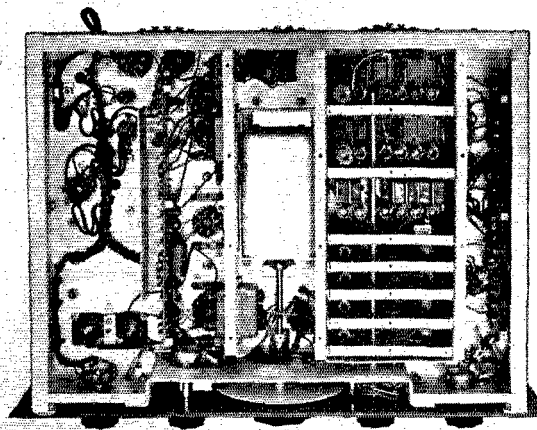

# Painless Reconversion

*Establishing Hobby Relations on a Firm Footing*

BY CHESTER B. CUNNINGHAM, \* W3MHW

**A**RE you a ham . . . and married? Do you even contemplate such a step? If you can answer "Yes" to the above questions, read on, brother!

I, too, am a ham; also happily married. And do I have difficulties with the XYL regarding ham radio? Never! All is sweetness and honey in our little shack. I have half the bedroom devoted to the pursuit of the elusive DX. And when I need a new crystal, the little woman offers to go to town to get same. Naturally, such a pleasant state of affairs did not just happen! It took a little intrigue, plus true ham luck, but I think the results justified the effort. Listen to my story.

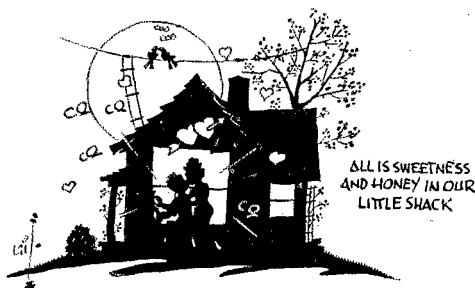

Back in '43 when ham radio was practically extinct (with due apologies to WERS), an acquaintance took me out to the local airport. He was taking flying lessons. Great stuff, this coming age of flying. Besides, there was no gasoline rationing for training planes. Just an instructor's fee for the first eight hours, and then a small rental fee for solo flying. One could be free as a bird. Hot stuff! I made a beeline for the front office.

Taking flying lessons was fine. The instructor and I flew out to Manassas, Va., to a cow pasture, and shot landings. We did stalls. We did spins. (Remember your first QSO? Same feeling!) Then I soloed! Me, I was the hottest thing in the air. Total expenses to date, \$100. Now I had to fly by myself. To take my friends up for a thrill required a "private" license, involving at least 30 hours solo. At seven bucks per hour, \$210. Think of the surplus stuff that much money will buy today! Then this friend and I decided to investigate buying a plane, believing that two could fly as cheaply as one. (An old familiar falsehood!) We looked over the market. The cheapest beat-up

\*2716 Knox Terrace, S.E., Washington 20, D. C.

Cub cost \$1000. Of course we were assured that we could fly it for a year and get our money back, but that still was a lot of money for a Cub. Then we heard about the big Government surplus-plane sale over at another field. We looked at them, turned in a sealed bid, and suddenly owned a plane. We named it, appropriately, *Money Flies!* It was one of those open-cockpit low-wing jobs that required a 1/2-inch gas line from the tanks to the engine! It was guaranteed to hold together through everything but an outside loop! Of course, in an open cockpit, at 5000 feet, it's cold. So I had to have a helmet, goggles, a flying suit, and boots. Nothing but the best for me. And why should I rent an old worn-out parachute for a buck an hour? I bought one for \$75.

Because this was a larger plane, I practically had to learn to fly all over again. More instructors' fees. By this time my investment amounted to about \$700. But I could always get it back. (More hollow laughs!)

First you learn to get the plane off and back on the ground. Then you follow a few simple maneuvers. The instructor showed me just how to spin it. Simple! So I tried it over the airport all by myself. While the little woman watched, I followed his instructions to the letter. Climb to 4000 feet. Fly straight and level, throttle back, stick back, hard right rudder, *whoosh*, and count the number of times a road whirls by . . . one, two, three. Now, hard left rudder, stick forward, and watch the ground come up to meet you. Back on the stick, easy on the throttle, and there's nothing to it. So that's what I did — almost! Fly straight and level at 4000 feet, throttle back, stick back, hard right rudder, and — hey, the book didn't include this! There I was, on my back, flying *upside down*, my head out in

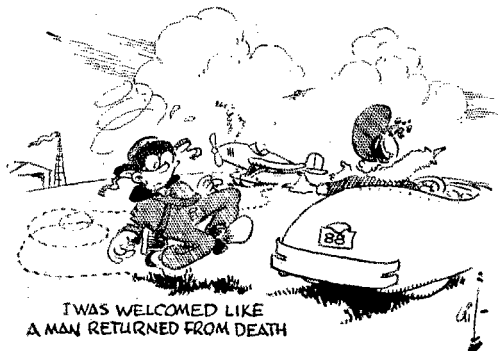

the slip-stream, my feet in the instrument panel, and the safety belt slipping! Brother, the only thing to compare with that feeling is working that first VK! The plane finally fell into a spin, but not until I had lived ten long years in ten seconds! I landed and staggered to the car, to be welcomed like a man returned from death.

Came the great day. I completed my cross-country solo and went up for my ticket. I passed. I was a *pilot*! Now I was permitted to take up passengers. Was I mobbed by friends asking to see Washington from 1500 feet up? Not this ham! Only by trickery just short of kidnaping did anyone ride with me. I got the little woman in the rear cockpit one day. I showed her Mount Vernon, our little shack, and the sights around Washington. When we landed, she sighed "Thank heavens, that's over!" By now I had spent \$1200.

VJ day came and 2½ meters was opened. It was then that I exercised sheer genius. I said, "Honey, a man offered me \$500 for my share of the plane today. Would you let me have a rig in the bedroom?"

I fly no more. I have the bedroom filled with assorted gear dear to the heart of any true ham. I get in from the "radio club" at 2 A.M. and no questions are asked. Occasionally, when there is a slight bit of complaining, I drive the family out to the airport to watch the students shoot landings. I get a dreamy look in my eye. I remark that flying is such a safe and cheap sport! It has worked like a charm.

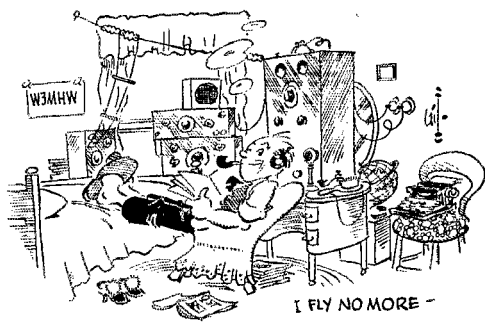

You, too, can have a ham rig. It's simple, though expensive. But it's worth every cent of the cost. Say, I know where you can pick up a plane cheap — my ex-partner wants to be a ham!

## Strays

W2HAQ, who modernized his RME-69 per Bill North's article in April *QST*, enthusiastically recommends the modifications to other RME-69 owners. The 6AK5 oscillated a bit in W2HAQ's conversion, but this was cured by adding a 0.1-µfd. paper capacitor directly from the screen terminal to chassis ground.

# 'Phone-Band Phunnies

## Proud Papa

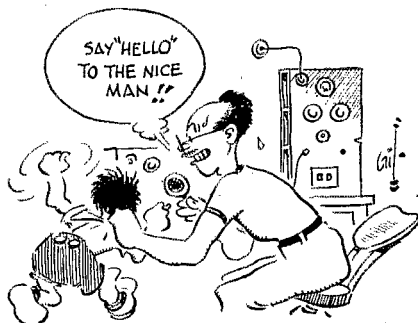

THE proud father who carries around pictures of Little Stinkey and bores everyone he meets to death by showing the pictures and demanding comments on same has long been a subject for derision in story and cartoon, but this character reaches the very acme of obnoxiousness on the amateur 'phone bands. Here he no longer thrusts a shadowy likeness of Little Stinkey upon you; he thrusts Little Stinkey himself!

"Just a minute, OM," Proud Papa will say. "I'll let the junior op say hello to you. Go on, Stinkey; say hello to John."

There are great quantities of what the broadcast men call "dead air."

"Come on now, Stinkey; please say something to the nice man."

Still nothing but an echoing silence.

"Ha, ha! That's the way they are, OM. You can't keep them still when you want things quiet, and then when you want them to talk, they won't say a word. But I think I can persuade him to say something." There is a certain grim, desperate, but determined note in his voice as he says this, and then you hear sounds of a sharp scuffle that create a clear picture of a child's arm being savagely twisted while a bull-whip is brandished over his head. By listening intently, you finally hear a small whimper of anguish.

"There you are, OM!" Proud Papa says with a note of triumph in his voice, although he is still breathing a little hard. "I'll bet that came through all okay. He really loves to talk over the mike when he gets started. Think I'll make a fine business ham out of him, OM?"

It is best not to say what you think.

— John T. Frye, W9EGV

# Do It Inductively

## Design Data for Coupling to Rotatable Arrays

BY LOUIS TAICH,\* W3IKX

A SHORT listen across the 10- or 20-meter bands shows quickly that a greater, far greater, proportion of the brethren are using rotary beams today than in 1941 before the long QRT. Notice, too, that these enterprising lads are the ones who are snagging the DX, and, equally as important, are completing their QSOs.

However, it is not my purpose to sell you on the idea of switching to a rotary — it is generally conceded that the power gain and selective receiving characteristics of a directive array are indeed worth while — but to describe an efficient method of inductively coupling a transmission line to the rotating flat top.

Since the three- or four-element array is usually a low-impedance instrument, and since the antenna must be easily rotatable, the feed system becomes a matter of paramount importance from both a physical and electrical standpoint. As the years have gone by, many good feed systems have been presented and many are being used successfully today.

I have tried and discarded them all in favor of the inductive-coupling method to be described. Let me say, however, that any good system, properly constructed and adjusted, will work. Consider first direct feed. This method will get the r.f. to the flat top, sure enough, but have you ever forgotten the direction the beam was last rotated, and slowly but surely pulled the feeders away from the antenna or — even worse — pulled down the antenna itself after starting the drive

• Inductive coupling to a beam antenna has been used for a number of years, but there has been a dearth of information on how to design it. Here's how, reduced to the simplest possible type of computation.

motor in the wrong direction after the last period of rotation? Brother! Any direct-feed linear transformer, "T"-match, delta match, and so on, has this undesirable feature.

Slip rings avoid tearing feedlines, but rings inevitably become noisy, and often cause power loss and mismatch. The new rotary coaxial joint removes the mismatch hazard but wear and tear, oxidation and noise become factors with time. Mercury pools are quiet, but again there is likelihood of mismatch — and worse, the amalgam formed by mercury with metals is undesirable because of the resulting lowered conductivity and the tendency toward brittleness. Another point to consider is the fact that any system calls for the antenna and feedline to be out in the weather all of the time, year in and year out. Now, when the transmission line terminates in a loop and is coupled to another loop that feeds the driven element, the array can be rotated until the drive-motor bearings melt without worrying about feeders, noise, and so on.

Most antenna calculations can become rather hairy (see most engineering handbooks!) and a great many of the CQ-machine operators haven't the time, inclination or know-how to cope with the problem at hand. Therefore we'll look into the situation practically, with a minimum of mathematics, and leave the differential equations and network and mesh affairs to the boys who didn't QSL.

### Calculate — Then Tune!

First of all, let's recognize that we are operating with a few factors that are not absolute and there-



Rotator assembly with inductive-coupling rings built by the author. The box contains the drive motor, gear train, control relays, and the tuning condenser. The plate at the top is for supporting the boom that holds the beam elements. The short length of cable connects the fixed loop to the tuning condenser.

**QST** for

\* 5709 Ethelbert Ave., Baltimore 15, Md.

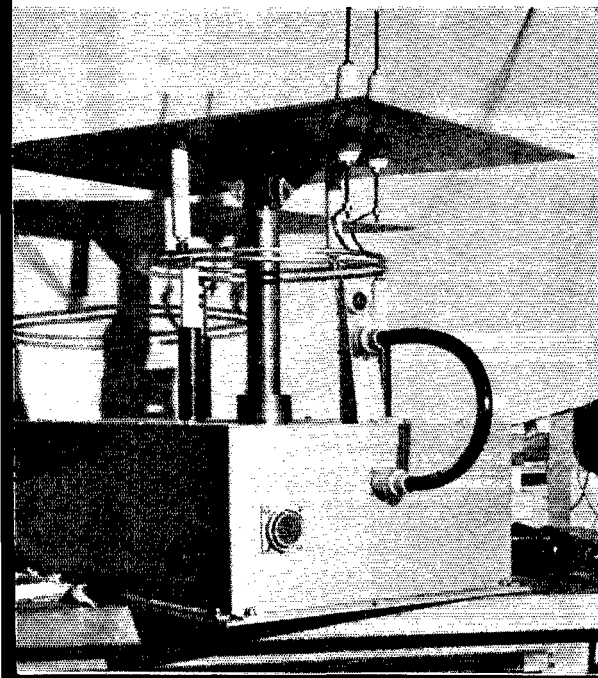

fore must make certain assumptions (these will iron out when the array is finally adjusted). We don't know, absolutely, what the driven element will look like, so far as its impedance is concerned, because this will vary with height above ground, even if we were certain where electrical ground is — and it is usually a bit off the level at which we push the lawn mower about. Then, transmission-line impedance may vary a bit from advertised figures. Surrounding objects will reflect electrically into the array. Element spacing and length interact. In short, we'll build the array around a set of figures that will put the beam in business, but only after adjustment and tuning will the array operate at a good profit; i.e., show advertised power gain and directivity. Don't make the common error of not tuning the beam — a high- $Q$  system calls for adjustment. You peak your i.f.s., don't you? Well, it's equally important to tune the beam. It's well worth the effort involved.

All the math we need can be found in the *Handbook*, and in Terman's *Radio Engineers' Handbook*. An elaboration of the material in the *Engineers' Handbook* can be found in Terman's *Radio Engineering*. Our answers are slide-rule accurate, and if you feel inclined to carry out to umpteenth decimals — remember our little unavoidable assumptions?

Inductive coupling to a rotary beam is by no means new. The *ARRL Handbook* has for years illustrated one method. At least two commercial manufacturers currently employ this means of coupling. During the war the famous SCR-270 radar set used inductive coupling to transfer power to a rather complex antenna. Nevertheless, little if any specific information on how to design such a coupling system seems to have been published.

Actually, inductive coupling to a beam antenna can be treated by the same methods that are used for inductive coupling in other applications. Where it differs from what we are normally accustomed to is in the impedance levels involved. The r.f. line is terminated, at the antenna end, in a parallel-tuned circuit whose coil is inductively coupled to a pick-up coil in the antenna circuit. If the line is to be flat, it must look into an impedance equal to its characteristic impedance; that is, if a 600-ohm line is used, the tuned circuit in which it is terminated must look like 600 ohms, pure resistance, to the line. Getting such a low value of parallel-resonant impedance in a tuned circuit calls for a much higher- $C$  circuit than is customary, particularly as the  $Q$  of the circuit must be of the order of 10 or more for good coupling.

The fact is that the  $L/C$  ratio must be so low that, at 14 and 28 Mc., a single-turn loop has enough inductance. This is a convenience, naturally. Inserting the coupling coil or loop in the antenna circuit adds some loading, which may be canceled out by using series capacitance to re-

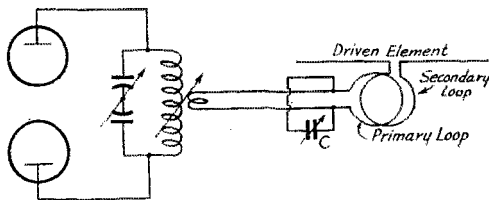

Fig. 1 — Circuit of the coupling system. Primary and secondary loops are identical.  $C$  is the tuning condenser. A 400-ohm open line is used.

sonate the antenna, but this is an added refinement that is not really essential, as the example to follow shows.

Briefly, the system as used here consists of a flat transmission line running from 100 to 400 or even 600 ohms, terminated in a one-turn loop eleven inches in mean diameter. This loop has a variable capacitor across its terminals. The secondary loop is of the same diameter as the line-terminating loop, is also one turn, and goes directly to the driven element. The circuit is shown in Fig. 1.

### A Practical Example

Let's look into a typical case. We have a three-element array with close-spaced director and reflector, to be fed with a 400-ohm open line. Our coupling loops are of  $\frac{1}{4}$ -inch soft-copper tubing having a mean diameter of eleven inches. The loops are circular and are closed to within one inch of being a complete circle. Call the fixed loop the "primary," and the loop that rotates with the array the "secondary." Assume that the array is to be tuned for operation at 14.3 Mc., and that the radiation resistance approximates 8 ohms.

The coupling loops have a self-inductance of 0.73 microhenry. This figure was arrived at by actually placing the loop in a tuned circuit on a  $Q$ -meter (Boonton) of known accuracy. However, many engineering texts contain a simple nomograph from which the inductance of a loop can be determined by simply using a straight edge.<sup>1</sup> At 14.3 Mc., the reactance of an inductance of 0.73 microhenry is

$$\begin{aligned} X_L &= 2\pi fL \\ &= (2) (3.14) (14.3) (0.73) \\ &= 65 \text{ ohms} \end{aligned} \quad (1)$$

This figure should be represented as  $+j65$  to indicate that it is reactive and inductive (positive). Don't let operator  $j$  bother you, though; it is quite harmless and we'll soon leave it by the wayside.

The secondary consists of a series circuit made up of the radiation resistance ( $R_r$ ) of the antenna and the reactance ( $+jX_s$ ) of the coupling loop. Incidentally, don't figure the radiator length to include the length of the coupling loop; let the

<sup>1</sup> Page 52 of Terman's *Radio Engineers' Handbook* contains such a nomograph.

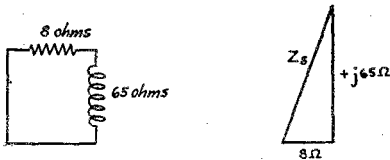

Fig. 2—The secondary circuit and the impedance triangle.

radiator assume its normal length. The secondary circuit is therefore as shown in Fig. 2.

Now we are prepared to determine the impedance of our coupling-system secondary ( $Z_s$ ).

$$\begin{aligned} Z_s &= R_r + jX_s \\ &= 8 + j65 \text{ (a vector sum)} \end{aligned} \quad (2)$$

This sum can be calculated arithmetically by the right-angled triangle rule:

$$Z_s = \sqrt{(8)^2 + (65)^2} = 65.5 \text{ ohms} \quad (3)$$

#### Effect of Coupling

When mutual inductance exists between coils that are in separate circuits, as in the case of our primary and secondary coupling loops, there will be energy transfer between the two circuits. The degree of coupling effected by the mutual inductance of the two coils will determine the operating characteristics of the circuit, and we may have undercoupling, overcoupling or proper coupling. Also, as far as the primary circuit is concerned, the effect of the coupled secondary circuit is to add impedance in series with the primary. Naturally, the closer the two loops are placed with respect to each other, the greater will be the effect of the reflected or coupled impedance from secondary to primary. Conversely, the greater the separation between the two loops, the smaller the degree of coupled impedance. Since the secondary impedance ( $Z_s$ ) is composed of resistance ( $R_r$ ) and reactance ( $X_s$ ), the reflected or coupled impedance is also composed of resistance and reactance. It may be shown as a vector and set up as an impedance triangle like the one we used in determining the impedance of the secondary ( $Z_s$ ).

An important property of this coupled impedance must be emphasized. This is that the reactive component of the reflected impedance changes sign, and when it is positive in the secondary, it appears and acts like negative reactance in the primary; that is, it looks like capacitive reactance. This cancels or neutralizes some of the inductance of the primary loop. The reflected resistive component just rides along as pure resistance and is the load that appears in the primary because of the radiation resistance of the antenna. The residual reactance in the primary can be tuned out with the variable capacitor indicated earlier.

It becomes evident that the degree of mutual coupling ( $k$ ) is important. Undercoupling will prevent efficient power transfer, and overcoupling will produce "double-humped" tuning and increase the probability of standing waves and inefficient power transfer. Experiment has shown that proper coupling runs from  $k = 0.6$  to  $k = 0.85$  and is quite critical.

With a coupling coefficient of  $k = 0.65$

$$\begin{aligned} k &= \frac{M}{\sqrt{L_1 L_2}} = \frac{M}{L} \text{ (since } L_1 \text{ and } L_2 \text{ are identical)} \\ 0.65 &= \frac{M}{L} = \frac{wM}{wL} \text{ and since } wL = 2\pi fL = 65 \\ &\text{ ohms} \\ 0.65 &= \frac{wM}{65} \\ wM &= (65)(0.65) = 42.25 \text{ ohms} \end{aligned} \quad (4)$$

The impedance transferred into the primary ( $Z_t$ ) is easily calculated by the formula

$$\begin{aligned} Z_t &= \frac{(wM)^2}{Z_s} \text{ from (3) and (4)} \\ &= \frac{(42.25)^2}{65.5} = \frac{1785}{65.5} = 27.3 \text{ ohms} \end{aligned} \quad (5)$$

This reflected primary impedance is of course composed of the reflected resistive and reactive components. These components are related to the reflected impedance in the same way that the secondary resistance and reactance are related to the secondary impedance, the reactance being reflected with a change in sign. Therefore

$$R_t = \frac{R_s}{Z_s} Z_t = \left( \frac{8}{65.5} \right) (27.3) = 3.34 \text{ ohms}$$

and

$$X_t = -\frac{X_s}{Z_s} Z_t = \left( -\frac{65}{65.5} \right) (27.3) = -27.1$$

ohms

$$\text{Thus } Z_t = 3.34 - j27.1 \text{ ohms.} \quad (6)$$

To determine the total primary impedance, add the primary reactance, which is closely identical to the secondary reactance since the two loops are the same in dimensions, to the reflected reactive component in (6). We have, then (neglecting any inherent resistance—which should be negligible—in the primary):

$$\begin{aligned} Z &= Z_p + Z_t = 3.34 + j(65 - 27.1) \\ &= 3.34 + j37.9 \text{ ohms} \end{aligned} \quad (7)$$

It is now time to apply a simple test to check our coupling coefficient,  $k = 0.65$ , to check on the power transfer.

Assume a power of 400 watts. (Any power will do but 400 watts makes the arithmetic easy.)

With 400 watts, 400-ohm line,

$$E = \sqrt{PR} = \sqrt{(400)(400)} = 400 \text{ volts}$$

The current in the primary loop is

$$I = \frac{E}{X} = \frac{400}{37.9} = 10.55 \text{ amp.}$$

where  $X$  is the residual reactance from (7).

The theoretically developed power, when  $R$  is the reflected-resistance component from (6), is

$$\begin{aligned} I^2 R &= (10.55)^2 \times 3.34 \\ &= 111.3 \times 3.34 \\ &= 372 \text{ watts} \end{aligned}$$

The theoretically developed power is within 7% of our assumed power of 400 watts. Any figure within 10% of the assumed power can safely be used. Had the developed power fallen more than 10% short of the assumed figure, the coupling coefficient would have to be slightly increased and a new set of calculations made. If the opposite had occurred,  $k$  would have to be decreased.

The residual reactance ( $X$ ) from (7) must be tuned out by the variable capacitor across the primary loop. At 14.3 Mc. a reactance of 37.9 ohms is equivalent to 294  $\mu\text{fd.}$  by the formula<sup>2</sup>

$$\begin{aligned} C &= \frac{51}{2\pi f X} \\ &= \frac{1}{2 \times 3.14 \times 14.3 \times 37.9} \\ &= 294 \mu\text{fd.} \end{aligned}$$

A 350- or 400- $\mu\text{fd.}$  variable would be suitable. The spacing need not be great because the voltage across the circuit is low; 1000-volt spacing will suffice.

The standing-wave ratio on the transmission line is easily calculated. First the  $Q$  of the tuned loop circuit must be determined:

$$Q = \frac{X}{R}$$

where  $X$  = residual loop reactance  
 $R$  = residual resistance

$$Q = \frac{37.9}{3.34} = 11.3$$

The impedance the transmission-line terminals sees is circuit  $Q$  multiplied by residual reactance:

$$\begin{aligned} Z &= QX \\ &= 11.3 \times 37.9 \\ &= 428 \text{ ohms} \end{aligned}$$

<sup>2</sup> The value of capacitance so calculated is sufficiently accurate if the circuit  $Q$  is at least 10. At lower values of  $Q$  considerable error may be introduced. If the  $Q$  turns out to be less than 10 in the calculations outlined above, a new set of conditions may be assumed, or sufficient capacitance range ( $\pm 50\%$  of the calculated value) provided in the variable condenser to compensate for possible error. — Ed.

◆  
 Inside the rotator-assembly box. The tuning condenser is at the right. The pipe support for the boom plate (see other photograph) sets in the socket in the gear-train assembly.

The standing-wave ratio (s.w.r.) is equal to the terminating impedance divided by the characteristic impedance of the line, or

$$\text{s.w.r.} = \frac{428}{400}$$

$$\text{s.w.r.} = 1.07$$

This value of s.w.r. is realized only when the tuned circuit is resonant at the frequency of operation. Resonance can be checked by means of a wavemeter, neon bulb, thermogalvanometer, etc.

The remaining problem is to find the spacing required to give the proper coupling coefficient. Again we resort to Dr. Terman's *Handbook* and consult the section that treats mutual inductance between single-turn coils. This formula is accompanied by a chart and a curve and reproduction here would prove rather bulky. Suffice to say that a loop spacing, center-to-center, of 0.5 inch, will give the desired degree of coupling. Actual adjustment can be carried out experimentally by making provision to vary the spacing between the loops, tuning the variable capacitor at each loop spacing for the maximum power transfer consistent with minimum standing-wave ratio.

#### Pointers in Mounting

In constructing and locating the loops, be sure that they are true round and that the rotating loop turns about a true center with reference to the fixed loop. If the rotating loop has a wobble or changes its vertical or horizontal plane with reference to the fixed loop, the loading on the power amplifier will vary with rotation of the beam and the reflected resistive and reactive components will change. This will change the

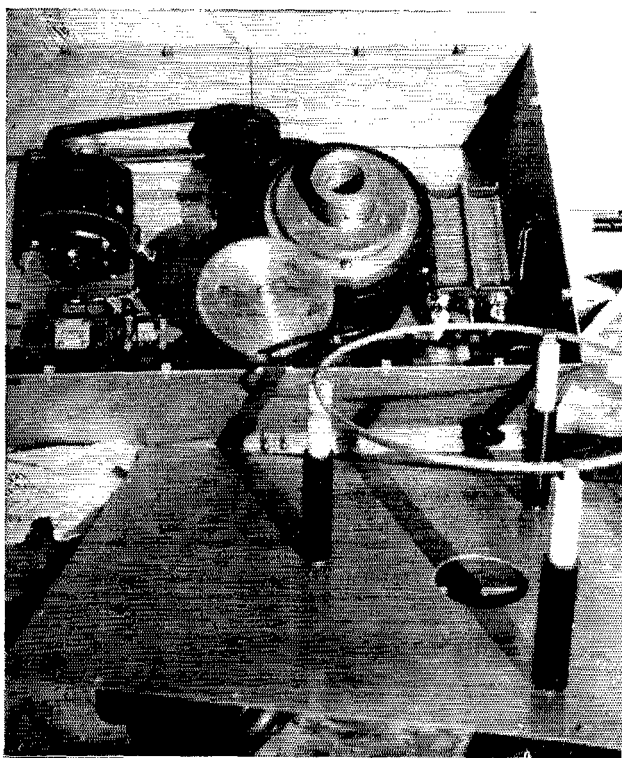

operating characteristics of the array to an appreciable degree.

Of necessity the shaft from the gear train to the metal plate, which supports the boom holding the beam, must go through the fixed and rotating loops. The diameter of this supporting shaft should be as small as is consistent with good mechanical design. The distance between the supporting plate — if a metal one is used — and the loops should be at least half the diameter of the loops. Likewise, the separation between the loops and any bulk of metal, such as the rotator gears or motor, should be at least the same distance. The reason for isolating large bodies of metal is to prevent them from affecting the inductance of the rings and thereby upsetting our calculations to a considerable degree.

It is an excellent idea to weatherproof the tuning capacitor because smoky areas, salt atmosphere or places where high humidity prevail make the capacitor life expectancy shrink to that of a present-day rocket-bomb jockey. The capacitor should be placed as close as possible to the junction of the transmission line and the fixed ring. The photos of the rotator which I have recently completed illustrate the general physical layout of the equipment, but of course this is by no means the only method of construction. "To Each His Own," I believe the song goes.

One point I'd like to dwell on for a moment, while considering the construction of the unit, is weatherproofing. It is very nice to be able to construct a truly weathertight mechanism. The electric drive motor, Autosyn direction indicator, relays, gear train, or whatever electromechanical devices are used will naturally perform better and last longer when they operate in a protected medium. Rubber gaskets may be used very nicely. I used a method of protection that works rather well. Instead of struggling to weatherproof every nook, crack and cranny, I arranged for a water drainage path and applied generously a waterproofing compound (Dow-Corning No. 4 Ignition Sealing Compound) on seams, motor and Autosyn mounts, connectors and plugs. This substance is an excellent water repellent, and does not run in hot weather or set in low temperatures. It is reasonably priced and appears to be a good, protective investment for an instrument that must operate remotely and without attention over extended periods of time. There are very likely many other excellent water repellents that would do the job equally as well.

Finally, a word about tuning the array. The entire tuning procedure is identical with that of any other parasitic close-spaced system except that it is of paramount importance to keep the tuned circuit resonated while making adjustments to the director and reflector. Failure to do this will make the s.w.r. rise and the radiation efficiency decrease, as well as cause misleading results to be read from the field-strength meter.

## A.R.R.L. QSL BUREAU

FOR the convenience of American and Canadian amateurs, the League maintains a QSL-card distributing system which operates through volunteer "District QSL Managers" in each call area. To secure such foreign cards as may be received for you, send your district manager a standard No. 10 stamped self-addressed envelope. If you have reason to expect a considerable number of cards, put on an extra stamp so that it has a total of six cents postage. Your own name and address go in the customary place on the face, and your station call should be printed prominently in the upper left-hand corner. If you have held other calls in previous years, submit an envelope for each such call to the proper manager — there are many thousands of uncalled-for cards in the files. All incoming cards are routed by Hq. to the home district of the call shown in the address. Therefore, cards for portable operation in other districts should be obtained from the home-district manager.

- W1, K1 — Charles Mellen, W1FH, 320 Cornell St., Boston, Mass.
- W2, K2 — Henry W. Yahnel, W2SN, Lake Ave., Helmetta, N. J.
- W3, K3 — Maurice W. Downs, W3WU, 1311 Sheridan St., N. W., Washington 11, D. C.
- W4, K4 — Edward J. Collins, W4MS, 1003 E. Blount St., Pensacola, Fla.
- W5, K5 — L. W. May, jr., W5AJG, 9428 Hobart St., Dallas 18, Texas.
- W6, K6 — Horace R. Greer, W6TI, 414 Fairmount Ave., Oakland, Calif.
- W7, K7 — Frank E. Pratt, W7DXZ, 5023 S. Ferry St., Tacoma, Wash.
- W8, K8 — Fred W. Allen, W8GER, 1959 Riverside Drive, Dayton 5, Ohio.
- W9, K9 — F. Claude Moore, W9HLF, 1024 Henrietta St., Pekin, Ill.
- W0, K0 — Alva A. Smith, W0DMA, 238 East Main St., Caledonia, Minn.
- VE1 — L. J. Fader, VE1FQ, 125 Henry St., Halifax, N. S.
- VE2 — Austin A. W. Smith, VE2UW, 6164 Jeanne Mance, Montreal 8, Que.
- VE3 — W. Bert Knowles, VE3QB, Lanark, Ont.
- VE4 —
- VE5 — Fred Ward, VE5OP, 899 Connaught Ave., Moose Jaw, Sask.
- VE6 — W. R. Savage, VE6EO, 329 15th St. North, Lethbridge, Alta.
- VE7 — H. R. Hough, VE7HR, 1785 Emerson St., Victoria, B. C.
- VE8 — Yukon A. R. C., P. O. Box 268, Whitehorse, Y. T.
- KP4 — E. W. Mayer, KP4KD, P. O. Box 1061, San Juan, P. R.
- KZ5 — Signal Officer, KZ5AA, Quarry Heights, Canal Zone.
- KH6 — Andy H. Fuchikami, KH6BA, 2543 Namaau Dr., Honolulu, T. H.
- KL7 — J. W. McKinley, KL7CK, Box 1533, Juneau, Alaska.



# I.A.R.U. News

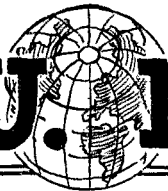

## W.I.A. INTERNATIONAL DX CONTEST

The Australian society announces the rules for the 1947 DX contest to be held over the four week ends of October and invites amateurs all over the world to take part. The contest is open to all licensed transmitting amateurs in any country. Contestants may compete on all authorized amateur bands or on any one or more individual bands by submitting a log for each band used. The contest will begin at 1401 GCT, October 3rd, and will continue until 1359 GCT, October 5th (0001 EST, October 4th, to 2359 EST, October 5th). The same starting and ending times will be used over the following three week ends in October. The first two week ends will be devoted to the 'phone contest while the last two will be for c.w. operation.

Only one licensed amateur is permitted to operate any one station under its owner's call. If there is more than one operator at any one station, each will be considered a competitor and must enter his own call and submit, in his log, the contacts established by him. In other words, all entrants must be licensed amateurs. In the United States, this has the effect of limiting participation in the contest to single-operator stations.

Contest call for VK stations will be CQ DX TEST and that for non-Australians will be CQ VK. The Contest Committee of W.I.A. especially requests c.w. stations to refrain from operating during the 'phone contest and similarly that 'phone stations not be used during the c.w. trials. VK participants will endeavor to contact as many stations in as many countries as possible and overseas stations will try to work a maximum number of VKs in the eight VK districts, VK2 through VK9. Only one contact with a specific station on each of the amateur bands during each week end may be counted, but contacts may be repeated on each of the succeeding week-end

periods. Exchange of serial numbers, hereinafter described, and signal-strength reports including readability, strength and tone, must be effected as a part of each contact. The judges reserve the right to disqualify any contestant whose tone report is consistently less than T8.

Each participating amateur will assign himself a three-figure number between 111 and 999. This number will constitute the first three digits of a six-digit serial number and will remain unchanged throughout the contest. For his first QSO, he will transmit his self-assigned number, plus three zeros; for example, 123 000. In exchange, he will receive a similar number, say 687 989, which shows that station has worked another station before because the three zeros have been replaced by 989. For the second contact, 123 687 would be used as the serial number, and so on throughout the contest, always retaining the first three figures and adding the first three digits of the serial number last received. When two or more operators use the same station, each will assign himself, and use, a separate number.

Three points may be counted for each contact completed with an exchange of serial numbers and signal reports. A VK contestant will multiply his total score by the number of countries worked on each band. A participant outside Australia will multiply the total of 3-points-per-contact by the number of districts worked on each band in Australia.

No prior entry need be made for the contest but each participant must submit his log at the conclusion of the event showing for each contact, the date, time (GCT), frequency band employed, call of station worked, in-and-out serial numbers, in-and-out signal reports and points claimed. A summary of points and multipliers claimed must be shown at the conclusion of the log. Each entry

*(Continued on page 132)*

◆  
Taken at a meeting of V.E.R.O.N. in Utrecht. Left to right: PA0QJ, treasurer of V.E.R.O.N. at Eindhoven. PA0VH, president of Eindhoven V.E.R.O.N., PA0UM (ex-PK4DA.) PA0UN, and PA0GN, traffic manager.



September 1947



# How's DX?



CONDUCTED BY JOSEPH E. GRAHN,\* W1CH

## How:

Returning from our annual ramble to the vacation spots, we found Jeeves with the old Baldwins draped over his head and a grin on his countenance a mile wide. Without saying a word, he handed us the cans and here's what was taking place: There was a four-way QSO cooking on 20 c.w. between two W6s, a W7 and a WØ. The signal reports having been swapped, one of the W6s broke in with "Hey, gang, let's QSY to the h.f. end of the band because this is a bad place for rag-chewing, being a pet DX spot for everyone." Listening on the h.f. end of 20 over an hour later, we heard the same foursome still at it. Why bring this up, you say? Well, it sure is a cheery note after all the griping one hears, both on the air and off, and proves that there still are some real hams and gentlemen left. Now for the meat, such as it is at this time of year.

## What:

Alaska seems to be a good place for several things, including 80-meter DX. Here's what KL7DJ grabbed off: ZL2BE (3938), ZL1KN (3935), ZL4DC (3940), ZL2LM (3930), ZL2DW (3940), ZL1QF (3930), ZL4DU (3866) and ZL4HH (3866). For the summer months, and forty watts on 'phone, it was a nice piece of work.

\* 53 Quinapoxet Lane, Worcester, Mass.



W3DZ, who sticks close to 40, managed to work G3BFC (7055) and KZ5FS (7052) . . . . . VE5QZ snagged W6NQG/KM6, HH2FE, ZL1AE, KP6AB, KM6AA, VR2AM and CO6AJ, plus numerous VKs and ZLs. Forty watts did the job for VE5QZ also . . . . . W6ZGY sneaked in VK3UJ (7172), VK2ALG (7125) and KH6HW (7150 VFO). Thirteen watts did it for Don.

For the DX chasers, 20 is still holding its own. W7FZA is up to 117 postwar, the latest being FT4AN (14,000), UG6AB (14,125), HI6O (14,150), YI7BZ (14,085) and ET1IR (14,130), and he was one of the lucky ones to be in on the AC4YN grab around the first of the month — along with W6OMC, W6WN, W6SC and W6CEM . . . . . KP4KD, with a QRO to 450 watts plus a new 2-element beam, finally reached 100 postwar, some of them being W2WMV/C9, G3BMJ/V57, HS1SS, HZ2TG, UA9CB, UQ2AD, VR5PL, PK6EE, UD6AA, C3YW, UO5AD and YU7LX . . . . . Now up to a total of 145, the newest at W5ASG are ZD6DT, WØTKK/VK9, ZD2KC, HA2IQ, TF3EA, UA4MA and PK3CK . . . . . Best picking at W5LUI includes CN8BK (14,015), VS2AL (14,032), KL7DM (14,100), KS4AC (14,030), RAEM (14,000) and ON4JW (14,115) . . . . . Rebuilding and a new 2-element beam at W9FNR raised his total to 74 postwar, some of them being OK2MM (14,080), UAØKQA (14,035), UA3KAH (14,048), OH2NQ (14,070), UA9CE (14,120), I6USA (14,095), LI2JC (14,075) and EI4B (14,025) . . . . . Finally reaching the 100 postwar mark, W3JTC grabbed off VP1AP, ZB1AF, TA1B, FQ3AT, KG6AQ, LB8B, UO5AD and YV5ACA . . . . . Latest "choice stuff" at W2BRV is UR2KAA, UB5BC, EP2BU, MB9AA, ZK1AK, ZC6SX, ZD4AH and KL7AD . . . . . WØVEE helped himself to CX1DB (14,082), GM8HP (14,062), OA4BG (14,120), SM7PY (14,000), D4AND (14,075), GI5UW (14,080), UA1KEB (14,070), UA3GI (14,070), VP9E (14,030), ZK1AK (14,132), HK1AM (14,120) and PAØRE (14,060), plus his only Asian — HZ1AB . . . . . W1NMP sent in a nice list bringing his total to 111 postwar . . . . . W3BXE has passed the century mark with OY3IGO, ZC6AA, LI2JC, F8EX/FC, UC2AC, OA4U and SU1US. . . . . W5ACL had some pleasant 20 c.w. contacts with J5AAL (14,080), UA1AB (14,040), OK1SV (14,000), PK6SA (14,110), J2AAO (14,125), KH6KL/KS6 (14,110) and UAØKQA (14,070).

A new receiver at W8KPL helped him snag



Here is Bill Wayne, KS4AE, holding up one of the palm trees down on Swan Island. Bill says Swan Island has a population of 10 Americans and 12 natives. The natives harvest coconuts, the Americans check weather and work the radio for CAA. Four of the Americans (with another on the way) have ham tickets, which makes the hams-per-capita ratio on Swan about the highest in the world. Local QRM isn't much of a problem, though, because the transmitter is a community proposition, and only one guy operates at a time. The transmitter runs about 800 watts, and a doublet antenna is used.

Mail is slow getting to and from Swan, but cards for the KS4 gang should be marked "via Tampa, Fla." This reduces by almost 50% the chances of their being lost or of some postman returning your card because "there is no such place as Swan Island." Incidentally, the island is 2 miles long and  $\frac{3}{4}$  mile wide, and is located at 17° 24' N and 83° 56' W, about 90 miles from the Grand Cayman Islands.

MB9AA, GC4LI, ZB1AF, ZK1AA, KS4AE, VP3JM, KG6AQ, UB5KAE, PK6HA, LX1AB and UR2KAA, which are the best of a nice list . . . . . The choice ones at W2RDK are YN1MH, ZB1Q, UJ8AA, KA6FA, ZA1RP, YI2AM and MB7AH, making it 117 . . . . . W7BD, with YV5ABX, VU2PB, FA8IH, VP2AD, FA8BG, PK400 and SU1US, boasts 147 postwar . . . . . The cream from a long list at W6OBD includes D4AUT, ON4SW, PA0VB, GM4RF, OX3GE, ZS4AM, ZS6MP, CR7BC, KZ4AU, PZ1AL, OA4BR, CX1DZ, LU1AA, KA1ABW, W2BXF/-Iwo, PK3FL, HS1LN, W6YAW/Korea, MX2A,

VO6X and C6YZ . . . . . W4JXM kept busy swapping A1 signals with FQ3AT, CT1TT, ZE2JI, UD6BM, KM6AB, VS1AQ, VR2AO, VR5IP, CR7VAL and TF3EA . . . . . Up to June 23rd, VK4GJ and W3JCR have had 100 consecutive contacts; VK4GJ using an 807 with 45 watts and W3JCR 260 watts. Antennas are two half-waves in phase and a 2-element beam respectively . . . . . W0RBA says he is proud of his 80-watter which got through to W2SLW/KL7, UA0KQA, KL7AD, J2AHI, J2AAO, J4AAK, PY1AJ, PY1FM, and three KS4s . . . . . W9IHN is very happy with his five new ones which are KS4AE, RAEM, I1PQ, W6VDG/KW6 and PK6SA . . . . . W2RGV's dream of a DXCC is getting closer to reality with QSOs like CT2AB, SV1RX, ZD4AB, HA4RS, J3AAH, J9CRP, VQ4ERR, ZC6BB, CT1DD, YR5V, VQ3HJP, UB5KAA, VR6AA, VP2GF, OH5NF, VS9AB and KA1AK . . . . . W6OKK, with two doublets, got his share in knuckling into ON4QF, C7XX, VS1PL, ZS6IV, OK2DD, G2DM, ZM6AF, EI9N, KP4DO, VK7NL, F3AI, KZ5AH, GW4CX, G5WB and G4DW, to name the choicest . . . . . W2UFT broke in his new p.p.-810 final by sneaking up on VK9BI, F8GD, ZC6AA and OX3GE . . . . . On the 'phone side of the fence, W1GR celebrated his return to the DX fold by yodeling to VK9BI, G2AIS, J2JCQ, VP3LF, W5GWD and EL5B. Not bad! . . . . . W1BPH got himself YS1JR, YN1LB, O1ZKAJ, EK1AS and MB9AJ . . . . . In the downtown YMCA, Minneapolis, W6HJP/Ø, who has deserted c.w. for the gabby way of doing it, raised WSOK/KG6, J3GNX, KG6AB, VK2TE, LU2DS, CE3AG, VK2ADT, VK2QR, KP6AA, ZS6DW and VK3YH . . . . . On c.w., W3ARK made it 116 postwar, W1ME 140, W1LVH 116. Thanks for the nice info, gang.

Looks like 28 Mc. is beginning to perk up a little already. W6WZL, who thought it might pay off to stick on ten for a while, was rewarded by getting ZS6CZ (28,240), ZS4H (28,280), PZ1A, CO2SE, CX1DB (28,150), VR6AA, ZL2BN, OA4BC, PY1JY, and HR1MB (28,420) . . . . . W4LAP's 75 watts got through to ZD4AB (28,020), CX4CZ, PZ1FM and ZE1JI, all on 28,020; ZE1JU (28,080), and VP4TO (28,020) . . . . . Ten pays off for W4KXF who has been skedding OQ5AE these past thirteen months for

*Continued on page 186)*

◆  
XADW, operated by Major Lee R. Haas (Signal Corps), is located in the center of Rome which, according to the Major, is one of the world's worst receiving spots. The equipment consists of a BC-610 transmitter, RCA 88 and SX-28 receivers. An Italian 10-tube superhet fills in the gaps. On 28 Mc. the antenna is a 5-element ground-plane job and on 14 Mc. a three-element wide-spaced beam.

September 1947

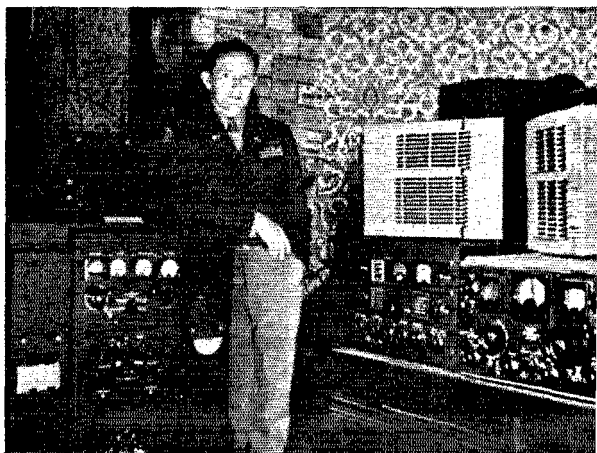

# 2, 6, and 10 with Crystal Control

## A Three-Band Transmitter with 829B Final

BY JAMES MILLEN,\* W1HRX

RECENT developments in crystals, crystal-oscillator circuits and ultrahigh-frequency components make it possible to construct a high-performance compact 10-11-meter transmitter, of 100 watts or so input, that is also capable of quick shift with relatively little decrease in power output to the 2- and 6-meter bands. Also, the availability of 829Bs in the surplus-tube market at this time helps materially in holding down the cost of the tubes needed in the construction of such a transmitter. The transmitter to be described takes advantage of both factors.

### Crystals & Oscillators

The transmitter was designed around the new Bliley Type CCO-2A crystal-oscillator combination, which uses the Type AX2 crystal for 10-11-meter operation and the new Type AX3 crystal, operating on the third "overtone" frequency, for 48- to 54-Mc. output.

The "overtone" type crystals are not nearly so tolerant of circuits and operating conditions as their low-frequency counterparts, and satisfactory performance with respect to efficiency, output and stability depends critically on the use of the right oscillator tube, coil sizes, circuit components and layout. Using the CCO-2A unit and AX3, which are designed to work as a team, assured us optimum performance without the headaches that go with the cut-and-try that is usually necessary to get high-frequency crystals working to complete satisfaction. The oscillator is used either to drive an 829B power amplifier directly, for 6- or 10-meter output, or with additional multiplication through a 2E26 tripler for

• Here's a neat little job incorporating a new unit designed for h.f. crystals and having an output stage using the popular 829B. On 10 and 6 there are only two stages altogether; a tripler is added for 2 meters.

output on the 2-meter band.

The basic circuit of the oscillator unit is the familiar Tri-tet, with sufficient revamping and modification so that the usual problems of self-oscillation and other difficulties are eliminated. In addition, the features needed to obtain the best performance with crystals operating on the third "overtone" frequency are included. One of the difficulties with crystals of this type in the past has been their tendency to fracture when not used in just the proper circuit and under just the right conditions.

The Bliley unit is semienclosed in a small metal case, as shown in the accompanying photograph of the transmitter. A tuning control and a crystal socket are located on the front face. The oscillator tube, a 6AG7, plugs into a recessed socket, mounted below the top surface of the unit. Band-switching is provided by means of a double-pole single-throw switch located on the top of the case; this permits a choice of oscillator output (with the appropriate crystal) on either 10-11 or 6. For final output on 2 meters it is necessary to use frequency tripling from the 6-meter output of the oscillator. The power and output terminals are located on the back of the crystal unit so that short direct leads into the transmitter chassis are possible.

\* % The Millen Mfg. Co., Malden, Mass.

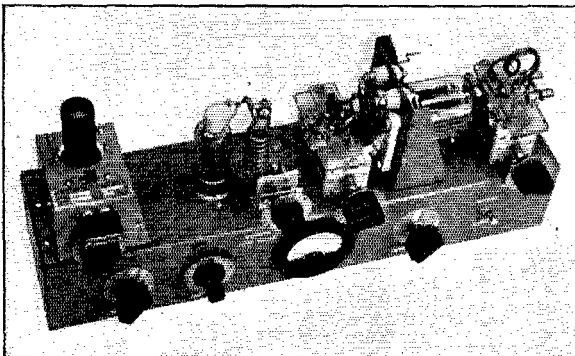

◆  
The transmitter can be used as shown or can be fitted with a panel for relay-rack mounting. There are only three tubes—6AG7, 2E26, and 829B—and the 2E26 is used only when 144-Mc. output is required. This view shows the amplifier 2-meter coils in place.  
◆

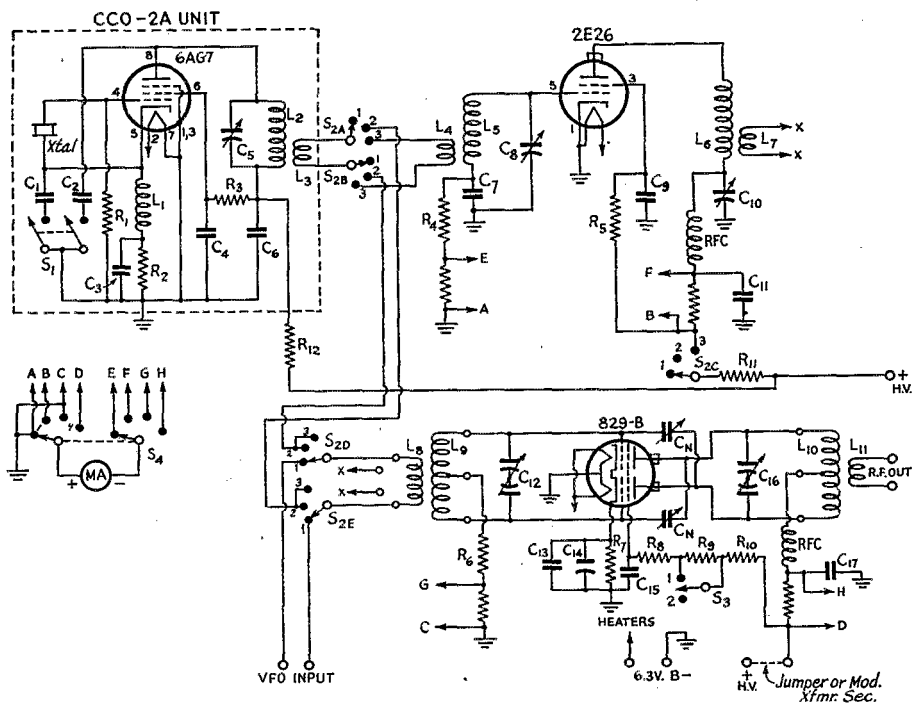

Fig. 1 — Circuit diagram of the 2- to 11-meter transmitter.

- C<sub>1</sub> — 50- $\mu$ fd. Erie Ceramicon.  
 C<sub>2</sub> — 40- $\mu$ fd. Erie Ceramicon.  
 C<sub>3</sub>, C<sub>4</sub>, C<sub>6</sub>, C<sub>7</sub> — 0.0022- $\mu$ fd. mica, 500 volts.  
 C<sub>5</sub> — 25- $\mu$ fd. midget variable (Millen 26025-5).  
 C<sub>8</sub> — 35- $\mu$ fd. midget variable (Millen 20035).  
 C<sub>9</sub>, C<sub>11</sub>, C<sub>13</sub>, C<sub>15</sub>, C<sub>17</sub> — 470- $\mu$ fd. mica, 500 volts.  
 C<sub>10</sub> — 15- $\mu$ fd. midget variable (Millen 20015).  
 C<sub>12</sub>, C<sub>16</sub> — 10- $\mu$ fd. per-section split-stator, double-spaced (Millen 23912A).  
 C<sub>14</sub> — 25- $\mu$ fd. electrolytic, 250 volts d.c.  
 CN — Neutralizing condenser; see text.  
 R<sub>1</sub> — 22,000 ohms, 1/2 watt, carbon.  
 R<sub>2</sub> — 220 ohms, 1 watt, carbon.  
 R<sub>3</sub> — 6000 ohms, 2 watts, carbon.  
 R<sub>4</sub> — 0.1 megohm, 2 watts, carbon.  
 R<sub>5</sub> — 50,000 ohms, 2 watts, carbon.  
 R<sub>6</sub> — 3900 ohms, 1 watt, carbon.  
 R<sub>7</sub> — 50 ohms, 10 watts, wire-wound.  
 R<sub>8</sub> — 5000 ohms, 10 watts, wire-wound.  
 R<sub>9</sub> — 0.1 megohm, 2 watts, carbon.  
 R<sub>10</sub> — 10,000 ohms, 10 watts, wire-wound.  
 R<sub>11</sub> — 5000 ohms, 10 watts, wire-wound.  
 R<sub>12</sub> — 7500 ohms, 10 watts, wire-wound.  
 L<sub>1</sub> — 9 turns No. 14 enam., close-wound, 1/2-inch i.d., air core.  
 L<sub>2</sub> — 8 3/4 turns No. 14 enam., double-spaced, 1/2-inch i.d., air core.  
 L<sub>3</sub> — 2 turns No. 22 double-spaced, 1/2-inch i.d., air core.  
 L<sub>4</sub> — 2 turns No. 18 ins. wire, 5/8-inch diam.  
 L<sub>5</sub> — 8 turns No. 10 bare, 5/8-inch diam., double-spaced.  
 L<sub>6</sub> — 6 turns copper tubing, 1/2-inch diam., double-spaced.  
 L<sub>7</sub> — 2 turns No. 18 insulated, 1/2-inch diam., wound between bottom turns of L<sub>6</sub>.  
 L<sub>8</sub> — 27-30 Mc.: 3 turns 7-22 insulated, 5/8-inch diam., wound between middle turns of L<sub>9</sub>.  
 50 Mc.: 3 turns No. 20 tinned, 5/8-inch diam., interwound with middle turn of L<sub>9</sub>.

- 144 Mc.: 1 turn No. 18 enam., 3/8-inch diam.  
 L<sub>9</sub> — 27-30 Mc.: 12 turns No. 16 tinned, 5/8-inch diam., center-tapped.  
 50 Mc.: 6 turns No. 14 tinned, 5/8-inch diam., center-tapped.  
 144 Mc.: 2 turns 1/2-inch tubing, 3/8-inch diam., spaced 3/16 inch between turns, center-tapped.  
 L<sub>10</sub> — 27-30 Mc.: 2 coils 12 turns each No. 16 tinned, center-tapped, spaced 5/8-inch between coils.  
 50 Mc.: 2 coils, 5 turns per coil, 1/2-inch tubing, 7/8-inch diam., spaced 1/2 inch between coils, center-tapped.  
 144 Mc.: 2 turns 1/2-inch tubing, 3/8-inch diam., spaced 5/8-inch between turns, center-tapped.  
 L<sub>11</sub> — 27-30 Mc.: 6 turns No. 14 tinned, 5/8-inch diam., 1 1/2-inch leads.  
 50 Mc.: 6 turns No. 14 tinned, 5/8-inch diam., 1 1/2-inch leads.  
 144 Mc.: 2 turns 1/2-inch tubing, 3/8-inch diam., spaced 1/16-inch between turns.  
 (NOTE: Grid coils, L<sub>8</sub> and L<sub>9</sub>, mounted on Millen 40407 jack-bar; plate coils, L<sub>10</sub> and L<sub>11</sub>, mounted on 40403 jack-bar except 27-30-Mc. coil, which is on 40203 jack-bar. Complete coils are the 48,000 series.)  
 RFC — 75 turns No. 30 enam., 1/4-inch diam, close-wound on large-value resistor.  
 S<sub>1</sub> — D.p.s.t. toggle.  
 S<sub>2</sub> — 3-pole 3-position ceramic wafer, 2 gang.  
 S<sub>3</sub> — S.p.d.t. toggle.  
 S<sub>4</sub> — 2-pole 4-position ceramic wafer.  
 NOTE: The milliammeter MA used in the unit has a range of 0-50 ma. This range is used for grid-current readings and the range is extended to 0-500 ma. for plate readings. Shunts AE and CG should have negligible effect on the meter readings; values of 120 ohms are used in the unit. Shunts BF and DH must be adjusted for the meter used; they are each 1.5 ohms in the unit.

The 829B tube — readily available now for only a few dollars in the surplus market — is capable of an input of about 100 watts and an output of approximately 70 watts, without forced ventilation. If a blower or other means for air-cooling is available, these excellent high-frequency push-pull p.a. tubes can be forced to even higher outputs. In addition, the 829B is an easy tube to drive, requiring only about 2 grid watts with 100 watts plate input.

The tripler is cut in and out of the circuit by means of a three-pole three-position wafer-type switch that connects the oscillator output link to either the 2E26 or 829B and disconnects the plate and screen voltages from the 2E26 when that tube is not needed. The grid and plate coils of the 829B stage are plug-in, and it will be observed in Fig. 1 that the proper link connections to the grid coil for the different bands are made by using an extra set of contacts on the coil forms and sockets.

Provision is made for driving the 829B on 10-11 meters from a VFO; in the transmitter shown in the illustrations, this was done by running a pair of leads to binding posts on the rear of the chassis, leaving the leads permanently connected to the 829B grid link. An alternative arrangement that permits disconnecting the VFO by using extra switch wafers ganged with  $S_2$  is suggested in the diagram. The simpler arrangement shown in the photographs has no bad effects electrically, but makes it necessary to disconnect the leads from the VFO when crystal control is used.

The milliammeter is switched by means of a two-pole four-position wafer switch and is so shunted as to give readings for tripler grid current, tripler plate current, power-amplifier grid current and power-amplifier plate current. In addition, a toggle switch is provided, as indicated at  $S_3$  in the circuit diagram, for reducing

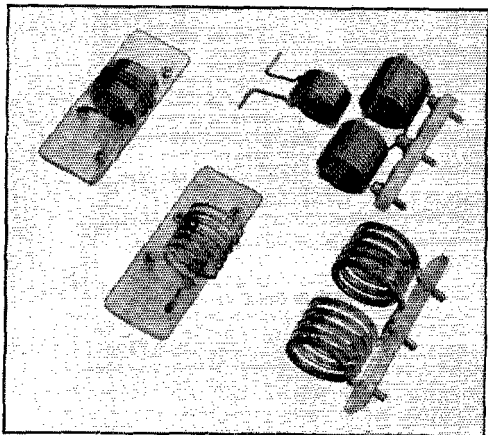

The two coils at the top are the amplifier grid and plate coils for 10-11 meters; the 6-meter coils are at the bottom.

power input during the tuning-up procedure.

### Construction Details

The transmitter was constructed for table-top operation without a panel, and is built on a  $3 \times 3 \times 17$ -inch chassis. Starting with the crystal unit at the left-hand end of the chassis, the components are mechanically laid out in a straight line, directly in sequence according to the circuit. Immediately following the crystal unit is the 2E26 tripler, with its associated tuned grid-input circuit below the chassis and with its plate circuit above. The grid and plate inductors for the tripler are not changed in band-shifting and consequently can be wound to be self-supporting, using heavy bare or enameled wire or copper tubing.

The tripler plate inductor is supported at one end by a polystyrene stand-off to provide an extremely short, flexible lead from the coil to the tube plate connector, and at the same time provide a rigid mounting for that end of the plate inductor. The other end is supported directly on one of the stator terminals of the plate tuning condenser. Plate voltage is fed in at this same point through a v.h.f. r.f. choke that is mounted in a novel manner by passing it through a rubber grommet in the chassis in such a way that the low-potential end of the choke is insulated from the chassis and supported by the grommet while the high-potential end is in the clear. A silvermica by-pass capacitor is placed between the ground terminal on the 2E26 tube socket, the adjacent tie-point on the chassis itself and the low-frequency end of this choke coil.

As shown in the top view, the output of the tripler is link-coupled to two of the prongs on the socket for the 829B grid coil. This is a new polystyrene socket (Millen 41407) having a dual set of link contacts, an arrangement that eliminates the necessity for complicated switching when, as in this case, a multiplier stage must be cut in or out when changing bands. The particular coil plugged in at any time has its link make contact with the directly-associated link socket contacts.

The 829B amplifier occupies the right half of the chassis. The tube is mounted horizontally, with its input and output circuits shielded from each other by means of the socket mounting plate. Even though this "shelf" has side brackets, the aluminum shield furnished for the socket (Millen 33999) should also be used. The top view of the chassis does not show this shield, as it is hidden from view by the mounting shelf. This same socket mounting plate also carries the 829B neutralizing condensers, which are readily constructed from feed-through bushings and adjustable pieces of bus bar, whose position, relative to the tube plates, can be readily adjusted to secure the extremely low neutralizing capacity required for this particular tube. The pieces of bus bar should be bent as shown in the photo-

In this bottom view the 2E26 grid coil is just to the left of the tube socket and below the tuning condenser. Relatively little of the r.f. wiring is below the chassis.

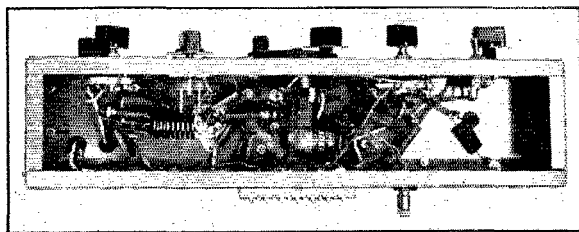

graph so that the free ends can be swung toward or away from the plates of the two sections of the 829B. The over-all length should be such that the straight portions at the ends are opposite the bottoms of the plates, and the length of these portions should be about one-half inch.

The grid tuning condenser for the 829B is mounted so close to the socket that lead lengths of only approximately one-half inch between the two socket grid terminals and the condenser are required. The polystyrene coil socket is mounted directly on the variable condenser by means of small right-angle brackets, thus permitting the socket contact-lug to be soldered directly to the condenser terminals at the exact point at which the leads from the grids are also attached.

On the output side of the 829B, a similarly symmetrical and compact circuit arrangement requires plate leads only one inch in length from the plate connectors to the stator terminals of the dual output condenser. The coil socket is mounted and connections to the condenser made in the same way as in the grid circuit. The center connection of the plate coil is brought directly down to the plate r.f. choke, which is supported by a grommet in the chassis in the same way as the previously-mentioned choke in the tripler circuit. The output plug-in coil socket differs from that used in the 829B grid circuit in that provision has been made for an adjustable link which, when swung to the desired coupling, can be locked into place by means of the knurled locking supports.

On the rear of the chassis is mounted the terminal strip to which connections are made for filament and plate power, and also a pair of binding posts to which VFO input may be fed when it is desired to use the transmitter with an existing 10-11-meter band VFO.

In general, the wiring and mechanical assembly are straightforward and not at all tricky. There are a few points, however, worth special comment. These concern the ground leads, especially around the tripler. One-quarter inch braid is used for essentially all grounding circuits, in order to reduce high-frequency impedance of the ground connections at these points to a minimum. On the tripler socket, Contacts 4, 7, 8 and 1 are tied directly together with a piece of  $\frac{1}{4}$ -inch braid, which in turn continues on to an adjacent contact on the chassis. It is to this particular strap that one of the socket contacts in the silver-mica

by-pass condenser from the plate choke is grounded, as well as the ground or rotor terminals from the 2E26 grid tuning condenser. The grid connection to this input tuned circuit is less than  $\frac{3}{4}$  inch long and there is another piece of braid directly from the No. 5 or grid contact on the socket, down to the stator spindle of the grid tuning condenser.

It is also important in mounting the two high-frequency plate-circuit chokes to see that the cold end is supported by the grommet and *only* the cold end.

The arrangement of the controls is such that should the builder desire to mount the transmitter chassis in a cabinet or on a relay-rack panel, a neat-appearing symmetrical panel arrangement will result. If this is done, a small rectangular hole should be cut in the panel to expose the crystal socket, rather than attempting to remount the crystal socket from the crystal-oscillator unit on the panel itself.

In the initial tests on the transmitter illustrated, an interesting experience was had in connection with link circuits. Stranded wire was used between the 2E26 plate link and its termination on the 829B grid-coil socket. It was found that although the 2E26 was operating normally with adequate power in the plate circuit, yet insufficient grid drive was being obtained on the 829B. The difficulty was discovered to be caused by a single broken strand in the flexible lead wire connecting the two stages! Of course, another piece of wire, with no broken strands, cured the trouble; but perhaps it might be just as well in applications of this kind to use a solid lead covered with varnished cambric. Certainly then there could be no question of a hidden broken strand dissipating the missing power.

The actual connection of the transmitter to the power supply is simplified by the inclusion of divider resistors in the transmitter itself. The negative high-voltage ground and the ground side of the heater are connected to Post 1 on the terminal strip. The other side of the heater is connected to Post 2 and the high voltage is connected to Post 3. For c.w. operation, Posts 4 and 5 are connected by a jumper; on 'phone a Class B modulator is connected between the same two posts.

### Operating Notes

The adjustment and operation of the transmitter are straightforward. Those who have used 829s before do not need to be reminded of the necessity for neutralizing them or told how to do it, but those who have not will find the process very simple. The neutralizing preferably should be done with the amplifier operating on 2 meters, and the transmitter should be tuned as described later but without plate voltage on the 829B (the plate voltage may be disconnected by leaving the modulation-transformer terminals open). The positions of the neutralizing "condensers" — the short lengths of wire mounted on the stand-off insulators as shown in the photograph — are then varied, keeping them symmetrical with respect to the tube, until the 829B grid current remains constant when the plate tank condenser,  $C_{16}$ , is swung through resonance. The adjustment is not too critical.

For 10-11-meter operation the bandswitch is set to Position 2, the crystal oscillator switched to the 10-11 position and the toggle switch,  $S_3$ , to the "tune" position. The meter switch should be set in Position 3, so as to read the 829B grid current. A crystal for the correct frequency (between 13.6 and 13.7 or 14 to 14.85 Mc.) is then plugged into the CCO-2A crystal unit. Final-amplifier grid and plate coils for 10-11-meter operation should be plugged into their respective sockets.

After allowing the heaters to reach operating temperature, the plate voltage is applied and the oscillator tuned for maximum 829B grid current. After that, the 829B grid tank condenser is adjusted for maximum grid current. The meter switch is then set in Position 4 so as to read the 829B plate current. This should be adjusted to minimum by means of  $C_{16}$ . After this has been done, the "tune-transmit" switch should be set in the "transmit" position. The antenna coupling link is then adjusted for maximum output. The 829B grid- and plate-tank adjustments are then corrected to give optimum performance.

The power amplifier can be operated from a VFO by connecting its output to the binding posts on the back of the chassis, switching the band-change switch to Position 1 and following the procedure just outlined, except insofar as the crystal oscillator is concerned.

The procedure on 6 meters is very similar except that a 25- to 27-Mc. crystal is used,  $S_1$  is set for 6-meter output, and the 50-54-Mc. grid and plate coils are plugged in the 829B circuit.

Adjustment on 2 meters is very much the same, and is tabulated below:

- 1) Turn bandswitch to Position 3. Set  $S_1$  in the CCO-2A to the 2-6-meter position.
- 2) Turn toggle-switch  $S_3$  to "tune" position.
- 3) Turn meter switch to Position 1 (reads 2E26 grid current).

- 4) Plug in 24-24.22-Mc. crystal.
- 5) Plug in 144-148-Mc. final-amplifier grid and plate coils.
- 6) Turn on filament voltage.
- 7) Turn on plate voltage after heaters are up to temperature.
- 8) Tune  $C_5$  for maximum grid current.
- 9) Tune 2E26 grid tank condenser,  $C_3$ , for maximum grid current.
- 10) Turn meter switch to Position 2 (reads 2E26 plate current).
- 11) Tune 2E26 plate tank condenser,  $C_{10}$ , for minimum grid current.
- 12) Turn meter switch to Position 3 (reads 829B grid current).
- 13) Tune 829B grid tank condenser,  $C_{12}$ , for maximum current.
- 14) Turn meter switch to Position 4 (reads 829B plate current).
- 15) Tune 829B plate,  $C_{16}$ , for minimum plate current.
- 16) Turn  $S_3$  to "transmit" position.
- 17) Adjust antenna coupling to final amplifier for maximum output.
- 18) Recheck 9, 11, 13 and 15.

The transmitter can be operated from a single 600-volt supply that is capable of delivering 250 ma., or the 600-volt supply may be used for the 829B alone and a separate supply delivering about 300 volts at 100 ma. used for the 6AG7 and 2E26. Under normal operating conditions the 6AG7 plate current is 35 ma. and the 2E26 plate current 75 ma. The plate potential on the 829B can be increased to 750 volts for c.w. operation, with a total plate-and-screen current of 160 ma. On 'phone, the plate-and-screen current should not exceed 150 ma. at 600 volts. However, if forced air-cooling is used the plate current can be increased to 200 ma., at 750 volts for c.w. and 600 volts for 'phone.

### Strays

W6JQV provides his DX contacts with a QSL service de luxe. Recently, while working XU6GRL, "Doc" Stuart requested QSL by mail. "Oh, that won't be necessary," responded Hal, "I'll bring it over." And so he did, W6JQV's ocean-hopping work with the airlines making it an easy matter to deliver the card in person!

-----

We are indebted to W3CPT for bringing to our attention a War Department technical manual entitled "Suppression of Radio Noises — TM11-483," which may be obtained (supply limited) from the Superintendent of Documents, G.P.O., Washington, D. C. The cost is 20¢ in cash, certified check or money order — no stamps. This publication makes an excellent supplement to Harold G. Price's article in May QST, "Eliminating Car Noise in 28-Mc. Mobile Reception."





# The World Above 50 Mc.

CONDUCTED BY E. P. TILTON,\* W1HDO

**M**AY 27th — first W4-W7 contacts on 50 Mc.; June 27th — first W1-W7 contacts; how about July 27th, the traditional date for that "big night," when transcontinental contacts are made in one final blaze of glory marking the passing of the summer v.h.f. DX season? The 50-Mc. gang on both coasts were ready and waiting, and it was no great surprise when the signals of W7DF, Everett, Washington, W7BQX, Port Angeles, Washington, W7FFE and W7FDJ, St. Helens, Oregon, made their appearance on the East Coast at about 9 P.M. They were in for an hour or more, with good enough signals to show well in the midst of the welter of W9 and W0 signals that had been filling the low end for an hour or so earlier. Like other post-deadline openings, this one caused a hasty rewrite of the opening paragraphs of this department. Not enough is known of the accomplishments of the W7s to present a complete report at this writing, but it is known that scores of contacts with W1, 2 and 3 were made by the above W7s and probably others not heard here in Connecticut.

Whether this opening marks the end of the DX season this year is a matter of some conjecture. Even with the limited activity which had developed up to this time last year, there were quite a few good openings during August; now that there are stations just about everywhere in the country, there may still be plenty of sporadic-E left in the 6-meter band's bag of tricks. Not that more is needed to make 1947 a banner year — in a season that has broken all records, sporadic-E skip has been worked almost daily since early May, and contacts beyond the single-hop limit of about 1500 miles have been made so often that they have become almost routine, at least to some of the v.h.f. newcomers who have never had to get them the hard way!

In the past, the removal of the July page from the calendar has heralded the end of the year's activities for the v.h.f. enthusiast who was remote from heavily-populated areas. Though his intentions were good, he often found it hard to stick with the band through the long fall and winter months, when skip contacts became less frequent. He faces a brighter prospect in the fall of 1947, however. This season we are just rolling over the top of the 11-year sunspot cycle, and the possibilities are fully as intriguing as those af-

## 144-MC. RECORD SMASHED! W3EKK/1 and W3KUX Link Maine and Washington, D.C.

*Inland record reaches 400 miles;  
new 420-Mc. mark set in California*

The existing 144-Mc. record of 425 miles was broken by a wide margin early in the morning of Aug. 7th, when W3EKK/1, Mt. Cadillac, near Bar Harbor, Maine, worked W3KUX, Washington, D. C., a distance of 575 miles! The new record was the result of a carefully-planned expedition by W3EKK, W2PAU and W2PFQ, combining efficient gear, DX know-how, a perfect geographical set-up, and a fortunate break in hitting tropospheric conditions right at the summer's peak.

The rig was a converted 522, with an 829 in the final running at 80 watts; the receiver a hopped-up BC-639; and the antenna a vertical full-rhombic, 4 waves on a leg, terminated and aimed at Philadelphia. Scores of stations in W2 and W3 were worked, and the signal was heard by W4FJ, Richmond, Va., 650 miles distant! W2PAU and W2PFQ, each with separate rigs, also worked W3KUX, to share in the record.

Proving that long-haul work on 144 Mc. is not the exclusive property of our coastal areas, a phenomenal inversion made possible contacts from the Cleveland area to Wisconsin and Illinois stations at distances up to 400 miles, on July 31st. W8MLL and W8UKS worked W9ZHB, 400 miles. W8WXV worked W9HEJ, W9ESE (Port Washington, Wis.), W9BBU, W9JPK, W9PZS, W9WWH, W9RIW and W9PK, all well beyond 300 miles. Reports incomplete — more later.

A new 420-Mc. mark of 186 miles was set on July 27th, when W6VLX/6, Mt. Helix, near San Diego, worked W6ZRN/6, Mt. Frazier. Both stations used converted BC-645 rigs and parabolic reflectors. W6IBS/6, Point Loma, also worked W6ZRN/6, 176 miles, and W6DJW and W6WWP, in the Los Angeles area, about 100 miles.

forded by the summer-skip season. In addition, widespread new activity throughout the United States has demonstrated the value of the 50-Mc. band for operation over a radius of 100 miles or more, and many parts of the country will be enjoying such contacts for the first time, filling the in-between periods when no DX work is in prospect. Great strides in extending the reliable range of operation, on both 50 and 144 Mc., have proved that both bands can be employed successfully almost anywhere, and 1947 bids fair to become the first year in which there has been consistent country-wide v.h.f. activity around the calendar.

\* V. H. F. Editor, QST.

And what are the 50-Mc. DX prospects? Many of us like to try our hands at the prediction of sporadic-*E* skip openings, but few have been able to achieve more than occasional success. The opportunities for  $F_2$  DX are, however, laid out for us in black and white by the Central Radio Propagation Laboratory's prediction charts. By a study of these charts, and by careful observation of signals heard in the range between 30 and 50 Mc., one can plot his chances with reasonable certainty, both as to time and date. The predictions show the maximum usable frequency for  $F_2$  propagation rising sharply during September, going over 50 Mc. at several points. From Southern United States to Peru (where OA4AE and others will be on hand) the m.u.f. is up to 50 Mc. in September and October, as compared with only a little over 40 Mc. in the corresponding period last year.

Previous experience indicates that a prediction of 44 Mc. for any month is high enough to present the possibility of a 50-Mc. QSO at the peak period during that month. (The prediction for the North Atlantic path for November, 1946, was 44 Mc.) It should be encouraging to v.h.f. DX aspirants to know that predictions of 44 Mc. or higher are shown for October, 1947, for the following representative paths; the most favorable time for each is indicated:

W4, W5 to OA, 1200-1500 EST; W1 to W6, 1200-1700 EST; W3 to SU, 0930-1230 EST; W6 to J9, 1400 PST.

These are samples wherein the predicted m.u.f. is sufficiently above last year's predictions to warrant tests by interested workers. Many other paths, which were high last year, are as high or

higher in 1947, and with increased interest and activity at most points there is a much better chance for long-distance contacts.

Already, the 28-Mc. band is coming to life (in fact, it never went completely dead this summer) and now is none too soon to be lining up test schedules with interested parties in other countries. As things stand at Atlantic City, this may be the last opportunity for some foreign amateurs, particularly those of Europe, to attempt two-way v.h.f. contacts with other countries. Let's all make the most of it! Crossband tests with foreign stations having 50-Mc. receiving facilities represent what is probably the best means of determining whether a given path is open. Listening in the range just below 50 Mc. for harmonics and fundamental transmissions will show whether such tests are in order. A check on the predictions will show the best time of day. This will be about one to three hours after mid-day for north-south paths, and somewhat before noon at the western end of east-west paths, as a general rule. Obviously, a general-coverage v.h.f. receiver is handy in this work, and the ability to change bands rapidly with both transmitter and receiver is highly advantageous.

#### 50-Mc. WAS in 1947?

Mississippi is on! On the evening of July 10th, 50-Mc. men all through the northeastern part of the country were electrified by the sound of a voice repeating familiar words, which, had they emanated from almost anywhere else, would have gone unregarded. These magic words were "Hello test — W5JTI, Jackson, Mississippi, testing — hello test —" One could almost feel the weight of the receivers leaning on that frequency! Mississippi, at last! Never before had anyone ever heard a single sign of 50-Mc. activity from this, the last state left on the unworked list. Every time the fading carrier left the air there was a roar from W1s, 2s and 3s — "W5JTI, W5JTI —", but Tim wasn't having any right then!

When he finally stood by for calls he had to peel them off in layers. Anxious W1s sighed when they heard that he was using a folded dipole, four feet off the ground — would he give up, and disappear from the band before they had a chance to grab him? They were reassured, however, when the signal of W5JTI appeared again and again, its operator obviously interested in doing a good job on 6, not only when the band is hot with skip, but in promoting use of 50 Mc. for

Second only to the arrays used in early radar-warning service, the 144-Mc. beam at WILKH, Olneyville, R. I., has 48 elements, each of which is adjustable. It consists of 16 half-waves in phase, with reflectors and directors. It has a gain of nearly 20 db.

**QST** for

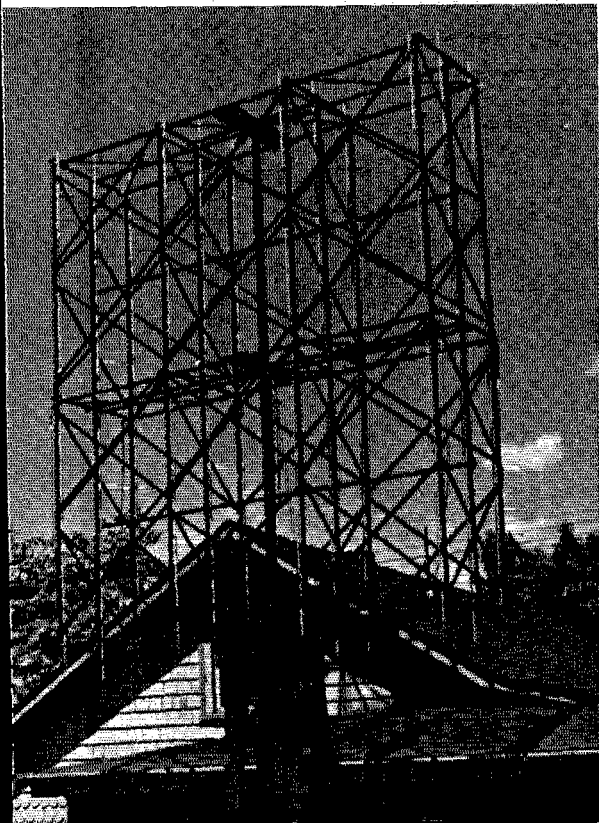

daily contacts within the local range as well. Tim is working on several other fellows in his state, and is hopeful of lining up coöperation with stations in surrounding states, with a view to establishing permanent activity in that area.

The arrival of W5JTI on the 50-Mc. leaves only Vermont and South Carolina without resident activity. Vermont contacts were provided for 57 stations in 14 states by W3CIR/1, operating his mobile rig from Hogback and Equinox Mountains; and South Carolina QSOs have resulted from similar mobile efforts by W4HVV/4 and W5VV/4. So, for the first time, a v.h.f. WAS is at last possible. The experiences of June and July have served to demonstrate that there is no distance within the United States that cannot be covered on 50 Mc. Everyone can work everyone else; the W9s and W0s have an advantage, it's true, but 44 states worked this year by W4GJO, 42 by W3CIR/1 and W1CLS, and 37 by W7BQX show that the WAS race is no walkaway for the Middle West.

A beautiful bronze plaque is being provided by ARRL, to be awarded to the first operator to work them all. The WAS box, appearing for the second time herewith, shows the standings of the known leaders in each call area. To make this list (and to stay on it) send in a postcard or letter listing one station for each state worked, and follow this each month with a list of new states added. The listing is automatic for Marathon participants, of course. The reports should be in the writer's hands by the 25th of each month.

#### Pacific Islands Work on 50 Mc.

Last month we reported, unfortunately in somewhat garbled form, the first two-way work between Tokio and Okinawa, and between Yokohama and Iwo Jima. With apologies to the principals, whose calls were reported incorrectly, we confirm that W5LIV/Iwo worked W2CDJ/J2, at Yokohama, on June 28th, at 0350 GCT. At this time W2CDJ/J2 was hearing J9ACS on Okinawa, and J9ACS was heard later the same day on Iwo. Contact with J9ACS was made by W5LIV/Iwo on July 2nd, and a 4-way QSO involving J9AAO and J9AAI was maintained for 3½ hours. J2AAO, Tokio, and W2CDJ/J2 worked the Okinawa stations on this date also, but no work was possible between the Tokio and Yokohama stations and Iwo. On July 14th, W5LIV/Iwo heard a signal, apparently of U. S. origin, for a brief period, and the automatic transmission of J9ACS was copied again on this date. W5LIV is leaving Iwo in late August, but he writes that W3KXO/Iwo is on 6 and that others are expected to follow.

W2CDJ/J2 reports that the automatic transmission of J9ACS can be copied almost daily, with good strength and little fading. He gives the following frequencies of active stations: J9AAO — 50.02, J9ACS — 50.04, W5LIV/Iwo — 50.4,



#### Standings as of July 30th

W3CIR/1	42	W4AVT	22	W0JMS	32
W1CLS	42			W9ALU	31
W1LLL	40	W5ML	38	W9FKI	26
W1HDQ	39	W5AJG	38	W9HSB	26
W1HMS	32	W5VY	36	W9ULA	27
W1CGY	32	W5FSC	33	W9AB	21
W1JLK	30	W5JLY	29	W9MBL	10
W1AEP	36	W5ZZF	29	W9CZD	11
W1CLH	27	W5ESZ	25		
W1AF	24	W5LTU	22	W0ZJB	43
		W5GNQ	21	W0QIN	43
W2BYM	36			W0TQK	42
W2AMJ	35	W6ANN	28	W0SV	42
W3RLV	33	W6OVK	28	W0DZM	41
W0TDZ	31	W6WNN	24	W0USI	41
W2QVH	31	W6BPT	20	W0CXB	41
W2PWP	29	W6HZ	16	W0HXY	40
		W6BWG	9	W0NI	40
W3RUE	27			W0YUQ	39
W3CGV	25	W7BQX	37	W0JHS	38
W3OR	23	W7PFE	31	W0CJF	36
W3LFT	11	W7QAP	26	W0DKS	36
W1KMZ/3	31	W7ACD	19	W0YKX	36
		W7TXM	17	W0BJV	35
W4GJO	44	W7JPN	12	W0DYG	33
W4QN	40			W0DNG	32
W4GIV	40	W8RFW	33	W0KYT	32
W4DRZ	35	W8TDT	21	W0VTK	20
W4EQR	34	W8QQS	20		
W4EID	33			VE1QY	19
W4FBH	31	W9DWU	45	VE1QZ	19
W4WMI	29	W9PK	43	VE3ANY	16
W4HVV	26	W9ZHB	41	VE2GT	14
W4EMM	25	W9ZHL	39	XE1KE	12

J2AAO — 51.125, and W2CDJ/J2 — 52.2 Mc. There is considerable interest in the fall  $F_2$  prospects, and it is expected that many DX contacts will be made by the Pacific Islands gang this fall and winter.

Down in Australia and New Zealand there are high hopes of DX contacts this year on 6. More stations are active this year, and equipment and antennas are being improved. According to a message received from VK3MJ, the Victorian Division of the WIA has announced a v.h.f. field day on September 7th. All VK states and ZL have been notified, and a majority of their stations will be active between 0200 and 0700 GCT.

Other DX reports this month come from England and Argentina. G5BY now has 10 countries on 58 Mc., including G, GW, F, FA, I, HB, OK, OZ, SM and ZB1. He has been reported heard by PA0PN and has heard ON4IF, both by tropospheric bending of no mean proportions. Work across to the stations on the Continent has become quite common in England, but this is a considerable feat for G5BY, in view of his location on the southwestern coast. Hilton is now using a 58-Mc. version of the 4-element array originally described in these pages last July, and

(Continued on page 140)



# Correspondence From Members -

The Publishers of *QST* assume no responsibility for statements made herein by correspondents.

## "ALL WORK TOGETHER"

Cambridge, N. Y.

Editor, *QST*:

... In June *QST* there is a letter from W0PXH belittling the *License Manual*. I must write in defense. In February I bought this plus *Learning the Code* plus the new *Handbook*. I found that all worked together if one bothered to learn why the answers in the *Manual* are the correct ones.

I am still a beginner, but I dislike seeing my old friend abused. Personally, I am grateful to the League for making this information available to newcomers at such a ridiculously low price.

— H. Herman Hitchcock

## HI

1103 Peachtree St., N. E., Atlanta, Ga.

Editor, *QST*:

What young squirt up there at Hq. had the nerve to take to task the old timers who still use the good old-fashioned amateur term of "aich eye"?

Say, son, it's too bad that the OM is still not with us for if he were, you, who wrote this in "Briefs," would surely be subjected to the torture of the Wouffhong and Retty-smitch. Better be careful how you comment on the likings of the "old timers"; we still like to say "aich eye" and dog-gone it, we're going to keep on saying it as long as we have the old spirit of the OM in our blood.

— Henry L. Reid, W4KU

## THE HAM SPIRIT

[Editor's Note: The following letter was written to an SWL in New York by an amateur who is helping him prepare for the exam. Because of the inspirational message it carries, we have obtained, through W2KDC and W2LAG, permission to publish the letter.]

Ahmeek, Mich.

Dear Johnny:

I was going to write this letter last night but I ran into several old friends on the 10-meter band, and I just couldn't resist calling them. Our QSOs stretched out so long (I'm a terrible gas bag on the air, hi) that I was an hour late for supper and too tired to write to you. So I am writing to you this morning before I turn on the rig. That way it will catch the same mail.

Gee, I sure am having fun on the air, Johnny. My brother-in-law, W8SOX, rebuilt my rig for me so it would be suitable for use now when I am unable to reach over to handle the controls. It now has a full set of relays, all of them activated by the push-to-talk switch on my microphone so that the antenna is automatically switched from receiver to transmitter, receiver plate current is shut off and transmitter plate turned on, etc., when I press the mike switch to talk, and all the operations are reversed and I am ready to receive the moment I release the pressure on the switch. So all I need in bed with me is my mike, and the transmitter is nearby so I can watch the dials on the meters and see that nothing goes wrong. The receiver is on a small roller table right up against the bed so I can tune around easily. Nowadays I work only on 10 and 11 meters. The xmtr can be switched from one frequency to another in about 40 seconds. My wife does the switching.

I broke my back in 1928, Johnny. It got fixed up pretty

well but bothered me a lot after that, so I was stiff and clumsy. In 1933 I was out deer hunting alone. Thought I heard a deer and jumped up on a windfall to see over the surrounding brush. The bark was loose on the old tree and I slipped. Was too stiff to catch my balance and fell with my back across the fallen tree. Broke my back again in the same place. I had to drag myself home to our farm through snow and slush and it took me over 10 hours to make the 2½ miles. I fainted pretty often, I guess. Anyway, everyone was asleep when I got home and I passed out again on the steps and lay there until the folks were up in the morning.

No one knew I had a broken back, and by morning I was unable to talk and tell them. So I was lifted about and moved about more than was good for me, and the doctor treated me for the bronchitis and pneumonia I had developed. By the time I was able to write a note telling about my back several weeks had gone by. They took me to the hospital but could do nothing. They said the damage was too severe. They gave me 6 months to live. I sure felt tough and like the whole world was down on me. I wouldn't talk to anyone, even my best friends. Even turned my face to the wall and stayed that way 4 days without eating or anything. I was about 24 then, Johnny.

A pal of mine brought me a stack of magazines to read. I told him to get the heck out, but he left the magazines. Gee, I was a punk in those days. In the stack of magazines was a copy of *QST*. How it got there I don't know because my pal was not a ham and neither of us had ever heard of ham radio. But it sounded swell to think a fellow could talk to someone else over the air, so when I saw an ad for the *Handbook* and the booklet *How To Become a Radio Amateur*, I borrowed \$1.25 from my kid brother and ordered the books.

In six hours I had doped out what parts I would need for a 2-tube receiver, and my brother ordered the tubes, parts and batteries. We used an old aluminum pot for a rvcr chassis and wound an 80-meter coil, and the darned thing worked the very first time we tested it. That's the only time I've ever had that good luck, hi! We got an old b.c. rvcr from someone and got enough stuff to build a transmitter using a single Type 30 2-volt battery tube. After we got it working we took our rvcr apart to use the parts in building a monitor so we could listen to our signals. Then we used the same parts to build a wavemeter. Then the same parts to build a code oscillator, because by now I was darned sure I wanted to learn the code and get a ham ticket. I learned 10 w.p.m. in about 3 weeks and then studied the regulations and theory some more. I had kept tearing up the rvcrs, monitors, code oscillators, etc. I had built in order to build other circuits shown in the *Handbook* and that kind of made theory a little easier and quicker to learn. For code practice I used the regulations for a text and because I repeated the regulations so often in code they stuck pretty well in my noggin. I had so much pain that I couldn't sleep and so I spent day and night on the ham stuff and a little over 2 months after I had seen my first *QST* I had taken my exam and 2 weeks after that I had my ticket, W9SQB.

After I had that I was willing to let my brother spend more money (about \$20) so I could have tubes, batteries and parts enough to have a rvcr, xmtr, and monitor going all at the same time. My brother would wire in the parts and hold the chassis over me on the bed and hand me the hot soldering iron so I could do the soldering. I still have white scars on my chest and stomach from hot solder that burned through the bed clothes and onto my hide, hi!

I worked 80-meter c.w. and had hundreds of QSOs in 4 years. It was real heaven because here I could talk to

all sorts of fellows and none of them could see that I was crippled. I was pretty sensitive about how I looked, hi!

Well, I didn't die! I am here yet and over 12 years has gone by since the 3 doctors I had gave me that 6 months to live. In fact, 2 of those doctors have since died and I am still very much on deck! I was so darned busy hamming and having so much fun out of it that I didn't have any time for dying. I didn't have time to think how bent and thin I looked or how much hunting, fishing and swimming I was missing. I even had daily skeds with half a dozen fellows, and several of them drove up hundreds of miles to visit me because we had had so much fun on the air. And when they saw I was crippled and couldn't even get out of bed it may have been a surprise, but it didn't bother them any and they didn't think any the less of me, so I got over worrying how I looked.

That first year I ran into W9PCU on the air and learned she was a YL. She lived a couple of hundred miles away from me, so I figured it was okay to rag-chew with her as often as I liked because she would never see me anyway. We had so much fun and our tastes were so much alike that pretty soon we were having a daily sked that often lasted 2 or 3 hours — in fact, sometimes we had *two* skeds in a day. The following spring she told me she was attending the Upper Michigan Hamfest at Marquette and asked if I would be there. I told her I couldn't make it, so she said she would drop in on me on her way to the hamfest.

I was pretty scared, but she was nice. It didn't bother her that I was crippled. She was just tickled pink to meet the guy she had had so many swell QSOs with and who liked so many of the things she did. Johnny, that did it. I fell in love with her right there and I didn't give a damn that I was unable to support a wife or anything like that. In 30 days I could hobble around a little with a short cane. In the summer of 1935 I went to visit her at the tourist resort her dad owned, and by golly, I got a job there as bookkeeper. I held the job until her dad sold the place in 1938.

I went out and got another job, as caseworker at a welfare camp for homeless men, and in 1940 the YL and I were married. Shortly after that I slipped on my crutches and was hurt again. Spent quite a while in a hospital and had to give up my job. But soon as I got out I got another job on a WPA clerical project and in a short time I was county foreman on it, crutches and all. I was appointed a member of our County Rationing Board when the war came, and soon became chairman of it. Also became director of the Civilian Defense Volunteer office in our county. And heck, I was only a hick, a farm boy who had not even completed high school before going to work in the copper mines. Anything I had learned was learned after that first meeting with the YL when I made up my mind I was going to marry her. (She must have had an inkling of how I felt and been all for the deal in order to wait until I felt ready to pop the question, hi!)

That extra war work on top of my regular job was too much for me and my ticker gave out. Doc said no heart could stand all that chasing around on crutches. So I had to quit everything and get into bed in 1943. I had a hobby of cutting and polishing agates and other semiprecious gems, and a little rig I could have shoved to the bedside, so I passed the time on that, seeing that ham radio was out for the duration.

The next year I tried selling some agates (we were on public relief) and sold about \$280 worth. That looked good to me so I spent all that money on better equipment, and by the summer of 1945 I was self-supporting again and able to get off relief. This year our business has expanded enough so that we can afford to hire two employees and were able to buy our own home besides. Only trouble was that we started on such a slender shoestring that we could not afford to hire help at the start, and for the first 18 months I worked 16 to 20 hours a day, every day including Sundays, to get the business going as well as I wanted it to go. So about 2 months ago the old ticker began to get fussy again and I had to drop everything and just plain relax. Doc says I have another 3 or 4 months to go before I can attend to any business again. But what the heck, with 10 meters open that's a pleasure, hi! First chance I've had for hamming since 1939 and I'm like a kid in clover. And I don't have to worry about busi-

ness because my wife is managing it as well as I ever did, and the two men we have working for us are steady and capable.

I sure am lucky, and I owe it all to ham radio. It saved my life back there in '33-'34; it brought me my wife who gave me the courage to go ahead and *live* without feeling I was all washed up; it taught me (through my wife) the gem-cutting hobby that is now supporting us and has given us a new home. I have something that's downright fun to keep me occupied and help pass the hours now while I am temporarily laid up again. We have a beautiful daughter 4½ years old. My wife is the most wonderful companion anyone could possibly have. She says she has never been happier than in the six years she has been married to me. We are happy, Johnny.

And the nicest compliment I've ever heard was from my sister-in-law. She said, "You know, Hank, I can never seem to remember that you are crippled. Every time I come to see you you are busy as can be with something or other and so enthusiastic about some piece of good luck with something you have been doing that I always picture you as bustling around all over the place doing this and that."

And yesterday one of my old high school teachers whom I have known since 1923 came to see me and looked at me for the longest time while I finished a QSO I was in. When I was through he shook his head and said: "Henry, I simply cannot figure you out. In the twenty-something years I have known you I have rushed to a hospital at least a dozen times because I had heard you had a serious accident or were seriously ill. Today I came to see you in a hurry because I heard you had another heart attack yesterday and here you are joking with somebody in Oregon, and right this minute you are grinning at me like you had just got a million dollars. Any time I see you you are grinning about something or other. You just do not make sense to me, Henry."

What could I tell him? Heck, Johnny, I died over 12 years ago and I'm still here. Every day is clear profit. Why cry about it? I've got the world by the tail and by golly I'm going to keep swinging it for a long time to come. It will be a dizzy world before I shuffle off, hi!

So, Johnny, you get after those hams and get them to take you over that theory and 13 w.p.m. code hump so you can get on the air. Let me know what your set-up is and if there is any way I can help you — any books you need or radio parts or equipment.

I know you love ham radio already or you would not be such an enthusiastic SWL. Don't be shy about asking any local hams you know or hear of for help or info. The ham bug is a peculiar insect. When it bites a fellow, not only does he become nuts about the game in his own right but he gets as much fun out of passing the bug on to others who have not yet been bitten. Hams are swell scoundrels, Johnny. I mean that. A ham may not know you from Adam but just call him up and let him know you want to get on the air and want some dope. Watch that guy cling to you like a lost brother until he is sure you are contaminated with the virus hammicus. You've got to get on the air, Johnny. Any way I can help, just let me know.

— Hank, W5YFT

## THE HIGH END OF 6

101 Bay State Rd., Boston, Mass.

Editor, QST:

Since the sporadic-E propagation began some weeks ago, W1BJB, phase-modulated, at 52.68 Mc. has sat in on the great majority of the good openings, as well as many not so good. I hasten to assure you that a mobile unit in what used to be called Chinese Turkestan is not more remote, from the standpoint of sporadic-E, than 52.68 Mc. in Lincoln, Mass. During the course of these numerous openings, W1BJB has called CQ nearly 400 times. The results are difficult to deal with statistically, since no answer has ever been received!

On occasions when some neighboring good Samaritan among the a.m. stations has primed an outlander to look for me, there has never been any difficulty in establishing or maintaining contacts, but aside from W4QN, who heard me

(Continued on page 158)



# Operating News



F. E. HANDY, WIBDI, Communications Mgr.  
J. A. MOSKEY, WIJMY, Asst. Comm. Mgr.

GEORGE HART, WINJM, Communications Asst.  
LILLIAN M. SALTER, Communications Asst.

**Praise for Cleveland.** Mr. George S. Turner, chief of the FCC Field Engineering & Monitoring Division, recently reviewed correspondence received from FCC's Cleveland field office. Mr. Paul Holloway, engineer-in-charge, detailed the constructive accomplishments of Cleveland amateurs in handling their BCI cases:

... Cleveland is particularly fortunate in having very active and efficient Radio Club Interference Committees. The broadcasting stations have been contacted by the clubs and requested to refer BCI complaints to certain amateurs instead of to the FCC office. The newspapers have been furnished with and have printed articles to the effect that because a radio receiver picks up excessive noises and untunable voices, it does not necessarily follow that some amateur is operating improperly. However, in the event interference of some kind is experienced, the listener is requested to call the club's telephone number. He is then advised that the matter will be investigated. One committeeman handled as many as forty cases in one month. He did not call a case closed until after a check-back later to see if the complainant was still satisfied. . . .

**Clubs and BCI.** Establishment of an interference committee within the framework of every amateur radio club is recommended as certain to pay dividends to both the club group and the community, as well as to the amateur service generally.

Standing ARRL policy recommends that as a service to local members, each affiliated radio club organize and maintain interference committees. The typical committee is made up of five members: two broadcast listeners, who may be prominent citizens with suitable interest and inclinations, two technically-skilled amateurs, and one representative of or contact with the local press.

In actual operation, the committee approves data prepared for newspaper publication soliciting interference complaints, explaining the many sources and probable nature of different types of interference. Complaints not relating to amateur radio are referred to the organizations or individuals responsible for operation of the interfering devices. The committee spends its major effort assisting individual amateurs and their neighbors to reach a satisfactory operating situation. A small proportion of the cases is usually identified as of amateur origin. While local policies of interference committees may vary slightly from point to point, the above outline describes the successful approach made by most clubs to this problem.

The ARRL Communications Department publishes two circulars to assist amateurs in their

interference and public relations problems. These are available in reasonable quantities for use by club interference committees; also in single copies on request of ARRL members. A one-page mimeograph explains interference and its many sources in layman terms, offering BCLs a basis for tests to ascertain possible sources of interference. A summary of remedies for reducing and eliminating interference to broadcast receivers by external or internal means is likewise available under the title *Typical Solutions to BCI*. For data in connection with interference to television receivers see W2RYT's article, August *QST*, and George Grammer's article, this issue.

**J Regulations.** Headquarters of the Eighth Army, overseas, has just amended its "Regulations Governing Amateur Radio Operation by Allied Personnel in Japan." Effective June 12, 1947, an additional band, 14,150-14,200 kc., was authorized "for trans-oceanic radio telephone only, subject to the limitation that the band be used exclusively for amateur radio telephone communication to the nations of legal domicile of licensee." The GI amateurs accorded this new operating privilege can, if U. S. citizens, work direct from J with Class A amateurs in the continental U. S. A. using 14,200-14,300-kc. A3 emission, or crossband to other U. S. amateurs. Citizens of the United Kingdom can work A3 with British Isles only and Australian citizens to Australia only on these 50 kc. Any deviation from the highest standards of equipment, emission or operating practice will result in immediate withdrawal of this privilege.

Concerning amateur message traffic, we should again note that the regulations governing GI stations in the Japanese area confine such message traffic strictly to persons in the U. S. military service. There must be no pecuniary interest involved in the subject matter of messages, and traffic to or from Japanese civilians is *strictly prohibited*.

**Implications of Break-In.** BK means "stop whatever you are doing and answer me." Received in the middle of a transmission, or during a message, BK intimates that the communication has been interrupted (1) by a possible interfering station, (2) drop out of a word or more, or (3) by fast-changing propagation conditions. A local caller, family or business emergency, failure of equipment, ringing telephone, etc., can require a

"break." Usually, however, communication can continue without delay. In conversation BK is a way to interject a comment. In traffic it is a way to get the word missed immediately, without later pause for fills. A BK may require QSV or QSY to circumvent interference conditions. Break-in makes it possible to interrupt a contact instead of wasting transmission on deaf ears, and permits immediate attempt to correct the difficulties. Used after calls, BK means to call immediately. We have heard fellows use it and called them, only to find that they didn't "break," or pause in their call to listen. It is strongly urged that no one use BK *unless he is set up to receive immediately once his key or microphone is inactivated*. Break-in of course works in the groups that fully understand its use . . . and between stations equipped for full break-in. Let's talk up push-to-talk and break-in as soon as we have it working so the advantages may be more universally available. Since most amateurs do not have remotely-controlled transmitters, VFO users should be reminded in attempting to "break" stations they call first (as well as in all calling of DX stations) to make their calls at least two to five kc. off the frequency of the station called. Every amateur who does *not* have break-in, please note: When you copy BK it is not necessary for you to have equipment working break-in fashion. You can nevertheless break the man who requests it and enjoy the advantages!

**Cleaning Up Signals.** Right at the start of this new radio season is a good time to check into transmitter performance. Whether you operate in a section traffic net which will now be getting under way, or in DX or casual fraternal work, a check-up is worth while. According to our mail bag, many hams have been cited over the summer period under FCC Rule 12.133 on spurious radiation. BM (W1KKS) remarks, "Phone operators sometimes comment about a station splattering, hoping the guilty party will take the hint. Checking for parasitics and trouble off one's exact frequency is important when using c.w. as well as 'phone. Some keyed VFOs splatter, as anyone can check by listening on 14 Mc. when signals are strong. The trend toward buffer-keyed VFOs is O.K., but to avoid citation fellows should clean these up, and *not* be satisfied with just throwing a band-scooter together." A word to the wise . . .

**On Coöperation.** W2UTF writes ". . . Then there is the fellow who disappears into thin air if you ask him to QRS or take a message. Others promise a QSL and never write it. July QST mentioned long CQs but apparently some amateurs can't read. Two nights ago I heard one operator who yelled CQ for four minutes. Such length of calls is unnecessary even when QRM is bad." Coöperation of all operators in accurate handling and delivery of traffic whenever practicable and faithful performance of promises to send

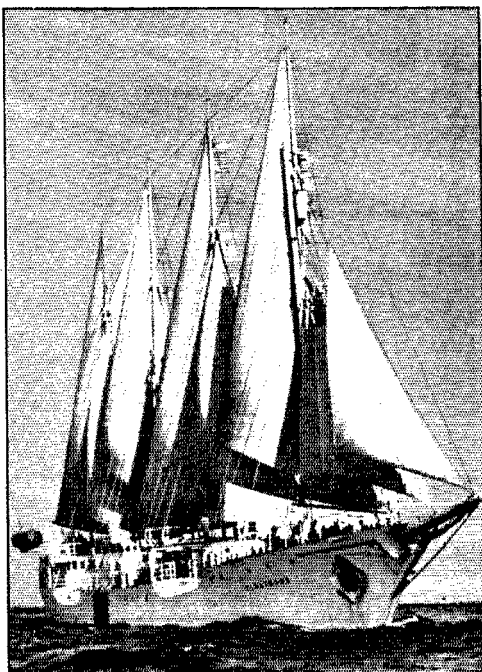

SHFLX, the schooner *Albatross* of the Swedish Round-the-World Deep-Sea Oceanographic Expedition, works on 7024, 14,350 and 28,420 kc. The mobile installation is used for contacting amateurs, and assistance is appreciated in relaying messages to SHF1, which station is located at Chalmers Institute of Technology, Gothenburg, Sweden. The *Albatross*' rig is a 350-watter; a rotary beam is used for 28 Mc. The schooner passed through the Panama Canal about August 18th bound for the Galapagos Islands, Marquesas, Hawaii, the Marshalls, Carolines (due about Christmas time) and the Dutch East Indies. The expedition will return by the summer of 1948 via Ceylon, the Indian Ocean, Suez Canal, Mediterranean and Atlantic. QSLs may be sent to: Professor Hans Pettersson, Director of the Oceanographic Institute, Attn. Viggo Wentzel, Radio Operator, Research Laboratory of Electronics, Gothenburg, Sweden.

acknowledgment cards (or frank reason why this cannot be done in place of promises) should be the policy of all amateurs.

— . . . —

The good fall operating weather should be just around the corner as you receive this QST. Section nets, c.w. and 'phone, will be reopening. ARRL trunk-line posts along 14 north-south east-west routes will be given to sincere traffic men. ORS and those eligible for appointment by having submitted three monthly traffic reports, are invited to apply. We are calling for code-practice stations too. Whatever your interest, get in the swim and enjoy amateur radio operating. Write your SCM (see p. 6) for blanks for ORS, OPS or OES posts. Also, give the FMT (Sept. 19th) a whirl if you can measure frequencies accurately.

— F.E.H.

## HIGH CLAIMED SCORES — 1947 FIELD DAY

Advance indications are that the 1947 ARRL Field Day set many new records for high scores and participation. Logs have been arriving in large volume at Hq. and it will be some time before we are able to analyze the results. The highest claimed scores submitted are listed below. These are subject to checking and grouping according to number of simultaneously-operated transmitters used at each station and are not to be considered a final tally. A complete FD report will be presented in a later issue.

### CLUB GROUPS

(Listing shows club name, call used in FD, claimed score and number of simultaneously-operated transmitters.)

Jersey Shore Amateur Radio Association.....	W2GSA/2	15,724-10
Frankford Radio Club.....	W3FRY/2	13,923-10
Palomar Radio Club.....	W6NWX/6	13,298-11
Tri-County Radio Association.....	W2OM/2	13,149-10
Somerset Hills Radio Club.....	W2ZD/2	10,674-8
Monmouth County Amateur Radio Association.....	W2WK/2	10,422-10
Mountaineers Amateur Radio Association.....	W8JM/8	9891-9
York Road Radio Club.....	W3QV/3	9783-7
Four Lakes Amateur Radio Club.....	W9SWQ/9	8937-5
Minneapolis Radio Club.....	W6KIS/8	8676-6
West Side Radio Club of Toronto.....	VE3JJ/3	8325-6
York Radio Club.....	W9GY/9	8217-4
Wisconsin Valley Radio Association.....	W9RQM/9	8163-2
KBT Radio Club.....	W2CLO/2	8046-5
Central Jersey Radio Club.....	W2AI/2	7968-4
Citrus Belt Amateur Radio Club.....	W6IK/6	7965-6
New Haven Amateur Radio Association.....	W1GB/1	7668-6
Cleveland Brasspounders Association.....	W8ROX/8	7623-3
Concord Brasspounders.....	W1OC/1	7443-3
South Lyme Beer, Chowder and Propagation Society.....	W1EH/1	7380-1
Dayton Amateur Radio Association.....	W8TQ/8	7029-3
Bridgeport Radio Amateurs Club.....	W1NKR/1	6867-4
Pole Cats Emergency Corps of the Hamfesters Radio Club.....	W9DXU/9	6750-4
Schenectady Amateur Radio Association.....	W2NIV/2	6561-3
Lakeland Amateur Radio Association.....	W2VDJ/2	5994-5
Radio Club of Oklahoma A. & M.....	W5YJ/5	5886-3
Woodpeckers, Hamfesters Radio Club.....	W9WEN/9	5634-4
Trenton Radio Society.....	W2RNX/2	5607-4
Racine Megacycle Club.....	W9QC/9	5598-5
Syracuse Amateur Radio Club.....	W2AW/2	5589-4
Delta Radio Club of New Orleans.....	W5BPL/5	5472-8
Candlewood Amateur Radio Association.....	W1VB/1	5319-2
Bloomfield Radio Club.....	W2JC/2	4800-2
Detroit Amateur Radio Association.....	W8NLG/8	4797-2
Yonkers Amateur Radio Club.....	W2NY/2	4797-4
Delaware Valley Radio Association.....	W2ZQ/2	4623-4
Ocean View Amateur Radio Club.....	W4LBG/4	4554-1
Lancaster Radio Transmitting Society.....	W3KBZ/3	4554-3
Manchester Radio Club.....	W1DJC/1	4434-3
Suffolk County Radio Club and Suffolk Amateur Radio Club.....	W2US/2	4407-7
Mercer County Radio Association.....	W3OAJ/8	4059-4
San Antonio Radio Club.....	W5UB/5	3510-3
Electron Club of Denver.....	W6AAB/8	3483-4
Recreation Radio Club.....	W1LXT/1	3465-1

La Crosse Radio Amateur Club.....	W8AKY/9	3303-4
The Horseshoe Radio Club.....	W3QZF/3	3096-2
Winston-Salem Amateur Radio Club.....	W4NC/4	3042-2
Central Ohio Radio Club.....	W8AIC/8	2970-1
Chattanooga Amateur Radio Club.....	W4FLS/4	2610-1
Baltimore Amateur Radio Club Society.....	W3VT/3	2520-5
Cambridge Amateur Radio Club.....	W8HDG/8	2484-1
Kickapoo Radio Operators.....	W9AML/9	2358-2
Skagit Amateur Radio Club.....	W7JKL/7	2340-3
Calgary Amateur Radio Association.....	VE6NQ	2286-3
Queens Radio Amateurs.....	W2TZZ/2	2259-1
Forest Nymphs Radio Society.....	W9BRD/9	2025-1
Utica Amateur Radio Club.....	W2NNK/2	2007-1

### NONCLUB GROUPS & INDIVIDUALS

(Listing shows call used by each group, number of operators, claimed score, and number of simultaneously-operated transmitters.)

W6ERT/6.....	11-6791-6	W6BAM/6.....	2-3307-1
W3AM/4.....	8-6498-3	W2FBA/2.....	2-2970-1
W6EYH/6.....	3-6170-1	W8LCN/8.....	2-2727-1
W3EIS/3.....	12-4677-4	W6NIK/6.....	5-2678-4
W8GW/8.....	10-4626-3	W0DEF/8.....	5-2655-1
W1BDI/1.....	6-4215-1	W7HAZ/7.....	4-2336-1
W7JU/7.....	1-4050-1	W8JTI/8.....	4-2322-2
W4HHU/4.....	6-3728-2	W7RT/7.....	1-2061-1
W8AII/8.....	3-3466-2		

### KX6USN, BIKINI ATOLL

FCC has assigned the prefix KX6 to the Marshall Islands group. This assignment was made at the instigation of the Navy Department, the "X" being taken from Operation Crossroads. Captain Christian Engleman, USN, W3RC, is operating KX6USN, Bikini Atoll, on 14- and 28-Mc. phone and c.w., and is officer-in-charge of the electronics phase of the Bikini Scientific Resurvey Expedition. Suitably autographed photographs of the station will be sent to the first 25 amateurs contacted. The call KX6USN will not be used after September 15, 1947, at which time the Resurvey Expedition is expected to leave the island.

### A.R.R.L. ACTIVITIES CALENDAR

Sept. 18th: CP Qualifying Run  
 Sept. 19th: Frequency-Measuring Test  
 Oct. 17th: CP Qualifying Run  
 Oct. 18th-19th: Emergency Corps Test  
 Oct. 25th-26th: CD QSO Party  
 Nov. 12th: CP Qualifying Run  
 Nov. 14th-16th and 21st-23rd: Sweepstakes Contest  
 Dec. 16th: CP Qualifying Run  
 Jan. 19th: CP Qualifying Run  
 Jan. 24th-25th: ARRL-Member Party

-----

Jan. 16th-Dec. 15th: 1947 V.H.F. Marathon  
 Jan. 1st-Dec. 31st: Most-States V.H.F. Contest  
 First Saturday night each month: ARRL Officials Nite (Get-together for SCMs, RMs, SECs, ECs, PAMs, Hq. Staff, Directors, Alt. and Asst. Dirs.)



## MESSAGE-PUSHERS CLUB PROPOSED

An ARRL "Message Pushers Club" is under consideration. The MPC would require merely proof of know-how and a pledge to do right by all messages — "as they come" — in the future, with token accomplishment in proof of qualifications to join. While a possible stepping-stone toward ORS, section net membership, BPL, TLS, etc., it would *not* compete with those ultimate ARRL objectives for the top men in traffic. This is not an announcement, but a presentation of some proposed rules. Comments and suggestions are requested from *all readers*.

*How to get in:* (1) Report compliance with the membership rules in writing to MPC, ARRL Comm. Dept., West Hartford 7, Conn. (2) Subscribe to the principles and procedures of ARRL traffic handling as set forth in §VII, operating booklet. (3) Pledge the prompt, accurate handling, relaying or delivery of any traffic that may come your way in subsequent casual amateur operating. (4) Show interest and use of the General Traffic Period, thus keeping in touch with MPC members from time to time. (5) Submit proof of handling five\* messages (originated or other) in proper form and showing handling data. (\*At least two messages shall be handled in the General Traffic Period, 6:30-8:30 p.m. local time, on the currently-specified General Traffic Channels: 3575-3600 and 7150-7175 kc.)

*How to get out:* (1) Refuse a message without due cause. (2) Hold a message without action for more than 48 hours or (foreign) more than half the time to reach destination by mail. (3) Use improper, incomplete or faulty procedure or form consistently, or unnecessarily refuse cooperation with other traffic amateurs.

There you have it. The MPC you will note can be likened in form to the Rag Chewers Club. But just as the RCC is dedicated to a good initial workout of rag-chewing that shows the fraternal spirit, the MPC is dedicated to the upbuilding of general knowledge and practice in traffic handling. The value of traffic in building personal operating skill, developing accuracy and "savvy," as well as promoting a high degree of fraternalism, is well known. Traffic men, in the course of their operation, serve the best interest of themselves and fellow amateurs. Tell us frankly what you think of the idea — and give us pros and cons on the above tentative specifications. Let us have your ideas. We want to hear *both* from those within and outside present traffic groups. Drop a line to the ARRL Communications Department to help us decide action on this matter.

## BRIEF

Late summer brings word of many fairs, exhibits, and conventions where ham equipment and techniques are on display, thanks to affiliated radio clubs and members. Amateur radio stations identified with these affairs, usually operating briefly courtesy of notifications (under portable privileges) to FCC, have excited favorable public comment. ARRL Hq. will supply suggestions for public displays of this nature when dates of arrangements are mentioned and such data requested.



Awarding of the Milwaukee Radio Club Cup. Offered in 1936, the trophy remained unclaimed until 1947. Glenn Harman, W4IUJ, of West Palm Beach, Florida, was proclaimed the winner for his two-way 50-Mc. contact last March with O44AE, Lima, Peru. Left, W4IUJ making his speech of acceptance after official presentation by Major Frank R. Maiorana, W9TPT, MRAC representative. The ceremony was performed at the All-Florida Hamfest sponsored by the West Palm Beach Radio Club on June 15th.

## IOWA EMERGENCY

Three days after the ARRL Field Day in June, Muscatine amateurs were alerted for possible emergency communications from Oakville, Iowa. The swollen Mississippi and Iowa rivers were threatening the levee at Oakville. ARRL Emergency Coördinator WØFDL called for volunteers to assist him in setting up communications in the endangered town; WØGPJ and Bradford Crow responded. WØVRD moved his emergency rig to broadcast station KWPC so that faster service on flood evacuation work could be effected. FCC granted KWPC special authorization for full nighttime operation to supplement the efforts of the Muscatine amateurs. WØFDL and his volunteers were assisted by the National Guard in getting their equipment to Oakville where the station was set up in an evacuated garage. Messages then were handled for individuals and the state police. In some instances these were broadcast back to Oakville by KWPC to help in the direction of rescue, relief and evacuation work. All communication was between Oakville and Muscatine, and was conducted on 3.5 Mc. Shortly after midnight, June 19th, the rivers reached their crest and started to recede, whereupon the WØFDL group signed off and returned to Muscatine. The station at Oakville consisted of WØFDL's 814 transmitter, running 80 watts input, and WØGPJ's BC-348 receiver. Power was supplied by a 1-kw. gas-engine-driven generator. Station KWPC and the *Muscatine Journal* gave liberal praise to the radio amateur emergency-communications efforts.



Ready for emergency communications! Part of the gang at W4OM/4, the Norfolk control point set up by hams for the U. S. Engineers. Shown in the photograph, left to right, are some of the leading men aiding on this project: Barnes, McDonough, W4DGG, Priest, W4KWY, Turner, W4IVS, White, W4OM, and Beamon, W4KAN.

## NORFOLK HAMS READY IN EMERGENCY

Radio amateurs who established a network when communications emergency threatened in April, were heartily commended by the U. S. Army Engineers (Norfolk) in charge of flood control in the Virginia area. W4OM was responsible for Norfolk ham operations, and Virginia SCM, W4JHK, arranged coverage at Roanoke (W4KAK, W4BTL), Clarksville (W4WG), Martinsville (W4JAR), Danville (W4JRI), Lynchburg (W4FBR), Richmond (W4CLD, W4LK), Chesapeake Beach (W4IKZ) and Hampton (W4AJA).

Norfolk amateurs manned a station using the call W4OM/4, installed at the Engineers' offices. Collins rigs were obtained from the Naval Base by W4DGG and W4DHZ to facilitate the work. W4KWY and W4CWH arranged to handle Red Cross traffic and members of the Ocean View Amateur Club (W4LBG) assisted by manning another station on 3880-kc. 'phone and 3510-kc. c.w. For the Engineers the over-all plan was to report in twice each day with river-gauge readings from key points on the various rivers of the state, and in the event of flood possibilities, to maintain constant watch and report more often. During April successful drills on 3.9-Mc. 'phone were held. In mid-June Certificates of Commendation were presented by the District Engineer to W4KAK, W4BTL, W4WG, W4JAR, W4JRI, W4FBR, W4CLD, W4LK, W4KWY, W4CWH, W4DHZ, W4DGG, W4IVS, W4KAN, W4IKZ, W4AJA and W4OM. Plans are to reconstitute the network for any future emergency that may arise in the area.

For local requirements the Ocean View Amateur Radio Club operates a 144-Mc. Emergency Net, drilling each Monday at 7.30 p.m.

## BRIEF

An amateur station (VE8MB) will soon be operated at Winter Harbor in northern Canada using 14,120 and 14,380 kc. Like the station (VE8MA) at Eureka Sound, also on "20," this new one is jointly under the auspices of the Canadian Department of Transport, Meteorological Division, and the Arctic Section, U. S. Weather Bureau. Don Meserve, W1FL, consultant for USWB, had a hand in making these arrangements.

## CODE PROFICIENCY AWARDS

Once each month a special W1AW transmission is made to enable you to qualify for a Code Proficiency Certificate, at a speed of 15, 20, 25, 30 or 35 w.p.m. If your initial certificate is for a speed below 35 w.p.m., you may later try for endorsement stickers indicating progress above your first certified speed. See W1AW schedule for details on frequencies used for Code Proficiency transmissions.

The next qualifying run will be on September 18th. The text on that date, received successfully by ear at the highest speed you can copy, should be sent to ARRL for checking. To avoid errors in transcribing, send your original copy. *Attach a statement certifying over your signature that the text submitted is direct copy, made from reception of W1AW by ear, without any kind of assistance, personal or mechanical.* If you qualify, you will receive a certificate, or appropriate endorsement sticker for certificate you already hold.

Do you need practice? If you want to "brush up" before trying the official "qualifying run," use the W1AW practice transmissions Tuesday and Thursday, 10:00 P.M. EST, at speeds of 15, 20, 25, 30 and 35 w.p.m. On Monday, Wednesday and Friday, also at 10:00 P.M., practice transmissions are made at 9, 12, 18, 25 and 35 w.p.m. When you feel qualified for at least 15 w.p.m., make copy of the monthly official run and submit copy. Then work for the endorsement stickers, right up through 35 w.p.m.

QST lists in advance the text to be used on several of the CP schedules. This makes it possible to check your own copy. It also provides a means of obtaining sending practice since it permits direct comparison of one's fist and tape sending. To get sending help hook up your own key and buzzer and attempt to send right in step with the tape transmissions.

Date	Subject of Practice Text from July QST
Sept. 3rd:	<i>Meteor Detection by Amateur Radio</i> , p. 13
Sept. 5th:	<i>A One-Man Skyhook</i> , p. 19
Sept. 9th:	<i>Low-Frequency N.F.M.</i> , p. 21
Sept. 11th:	<i>Atlantic City Report</i> , p. 29
Sept. 15th:	<i>Amateur Radio Operations</i> , p. 35
Sept. 17th:	<i>Amateur Radio Operations</i> , p. 38
Sept. 18th:	Qualifying Run, 10:00 P.M. EST
Sept. 23rd:	<i>A Standing-Wave Meter for Coaxial Lines</i> , p. 41
Sept. 26th:	<i>An All-Metal Array for 6 and 10</i> , p. 52
Sept. 29th:	<i>An Inexpensive Crystal Substitute</i> , p. 56

**A.R.R.L. FREQUENCY-MEASURING TEST**  
**September 19th (Fri.) & 20th (Sat.) —**  
**See W1AW Sked Below**

There was so much general interest in the early 1947 FMT that ARRL is announcing another, open to all radio amateurs. Official observers (Classes I and II) are required to participate in at least two of the four Frequency Measuring Tests run each year to demonstrate their continuing accuracy in measurement. This is a combined chance for OOs to meet such requirements and for all hams to warm up their new and old frequency-measuring gear and see what they can do in the way of utmost accuracy!

Individual reports on results will be sent ARRL members who take part. For highest average accuracy there will be a prize following this run to the League member in the non-Observer group, and an equivalent one in the OO group! Reported readings will be compared with readings submitted by an independent professional frequency-measuring organization. Hq. staff are ineligible for prizes. G.E. Selecto-Switch Model 8H53 electric clocks or equivalent values in radio equipment will be awarded for top results, though no prize will be given based on results of a single reading. Average accuracy requires more than one reading. To be considered for the clock award it is necessary to attach a statement that you alone, as operator, handled your equipment in making the readings submitted to the Communications Department of the League. An award committee will examine results to insure fairness to all, and its decisions shall be final.

When the average accuracy reported shows errors less than 71.43 parts per million, or falling between limits of 71.43 and 357.15 parts per million, the participants, if they own their equipment, will become eligible for appointment by SCMs as Class I or II official observers, respectively. It is only necessary that the individual amateurs have and express the requisite interest and activity for carrying forward in such League organization work. Observers not demonstrating the requisite average accuracy will lose their classifications until they demonstrate the above-stated minimum requirements for Class I and II appointments.

September 19th (Friday) W1AW will transmit the signals on special "different" frequencies for purposes of facilitating measurement. Approximate frequencies to be sent at stated times, to promote successful reception at different points, are as follows:

Sept. 19th, Starting Fri., 9:30 P.M. EST (6:30 P.M. PST) ..... 3565, 7165, 14,105, 28,040  
 Sept. 20th, Starting Sat., 12:30 A.M. EST (9:30 P.M. PST) ..... 3610, 7275, 14,385, 28,130

The signals sent for measurement will be transmitted simultaneously on four frequency bands. Dashes interspersed with station identification will be sent, following a general message (by tape) to enable listeners to find the signal for measure-

ment before dashes start. About 4½ minutes will be allowed for measuring each frequency, the long dashes starting no earlier than six or seven minutes after the indicated time. The signals should be found within 10 kc. of the indicated points. It is suggested that the frequencies be measured *in the order listed*, which is the order to be followed by the official measuring organization. Measurements submitted may be from one or both frequency groups given above. If any difficulty is found on one transmission, it is hoped you will have better success the second time.

Results should be addressed to ARRL Communications Department and postmarked by September 22nd to constitute an FMT entry. Entries from participants outside the U. S. and Canada must reach Hq. no later than October 6th, and should be sent by air mail.

**28-MC. CODE-PRACTICE STATIONS NEEDED**

Do you remember the days when you were learning the code? You do? The code gave you trouble, did it? That's not at all surprising. Most of us found the mysterious dits and dahs exceedingly difficult to master. At times it seemed that these twenty-six letters, ten numerals and a few punctuation marks simply never would be absorbed by our straining gray matter! Many lads who are working toward a ham ticket are having similar trouble learning the code. How about lending them a helping hand?

This fall ARRL will continue its program of on-the-air code practice for beginners. The 28-Mc. band will be used for this worth-while activity. If you are willing to assist, Hq. will send you suggestions on how to conduct code lessons by radio. The schedules of volunteer ARRL Code Practice Stations will be published in *QST*. In addition, Hq. will furnish the schedules in mimeographed form to each would-be amateur requesting same.

It is hoped that the program can get under way by mid-October. If you're interested, send us a postal at once signifying your willingness to cooperate and we'll send further data.

**BRASS POUNDERS LEAGUE**

(June Traffic)

Call	Orig.	Del.	Rel.	Extra Del. Credit	Total
W7JFY/GDF	304	304	-	304	912
W4PL	6	42	636	41	725
W6REB	24	15	500	7	546

The following make the BPL with over 100 "deliveries plus extra delivery credits":

W2OEC 192      W7KXB 130  
 W5GLS 177      W1AW 127

A message total of 500 or more, or 100 "deliveries plus extra delivery credits," will put you in line for a place in the BPL. The Brass Pounders League listing is open to all operators who qualify for this monthly "honor roll."

## MEET THE SCMs

Donald B. Morris, W8JM, West Virginia SCM, needs no introduction to the ham fraternity, having been active in almost every phase of amateur radio since receiving his first license. Born in Monongah, West Virginia, March 13, 1911, he attended Fairmont State College and West Virginia University.

From 1934 to 1941 he was chief engineer of WPHJ, Fairmont Police Department, and to him goes the distinction of having designed and made the original installation of WPHJ. He is employed by the Monongahela Power Company.

Since the receipt of his original license in 1928, he has held the calls W8APN, W8JFV and W8LXD, in addition to his present call. In 1940 he was issued a Code Proficiency Certificate for 25 w.p.m.; he also holds membership in the A-1 Operator Club and the RCC, has made WAS, and has worked all continents except Asia with 50 watts. SCM work is not new to Morris; he was elected to that post in 1930 and held office until



his resignation the following year. Before the war he held appointment as RM, OBS, ORS, OPS, PAM and OO, and is a postwar ORS and OPS. He has been extremely active in Sweepstakes, DX Contests, and W/VE Contests; in 1939 he was West Virginia winner in the W/VE Contest and Mountaineer Amateur Radio Association

winner in the Sweepstakes. Incidentally, he is a charter member of the MARA and was its first president. During the Ohio River floods of 1936-37 he performed notable emergency radio work.

W8JM's radio room is located on the second floor of his house, with the 100-per-cent approval of his XYL. Regular transmitting equipment includes a 6L6-807-812s p.p., running 250 watts on 3770-kc. c.w. and 3875-kc. 'phone; modulators are Class B 811s. A 6L6 transmitter and 6D6-76 receiver, built in a compact unit, are available for portable emergency work. Receiver is a Hammarlund Comet Pro. Antenna is a voltage-fed halfwave. Operation at present is on 3.5-, 7- and 14-Mc. c.w., and 3.85- and 14-Mc. 'phone.

Don collects pictures of railroad engines, enjoys attending football games, and indulges in a little golf, tennis and softball from time to time. He has two junior operators, a boy, three, and a girl, seven, and says his daughter, June Morris, should be a natural to take over his call — W8JM.

SCM Morris has taken a prominent part in amateur radio activities for almost twenty years

without a let-up. He has attended radio conventions from North Carolina to Illinois to New York. Don's untiring efforts and continued interest have made for him many ham friends, and under his direction it is felt that much will be accomplished in the West Virginia section.

## TRAINING AIDS

*Code Training:* At this writing, 62 clubs have returned the postcards attached to our June 11th circular letter to all affiliated clubs. Of these, 38 indicated interest in the loan of tape recorders, 11 in code-practice oscillator and equipment, 28 in tape keyers, and 20 stated they were not interested. This response seems to be sufficient to get the program started, and we have purchased three tape keyers for this purpose. Procurement of recorders seems to be another matter, however, and so far we have only one.

If your club has not sent in this postcard response, we should like to have you do so at once. All you have to do is make a check mark or two, indicating your interest or lack of it.

By the time this reaches print, whatever training equipment we have been able to procure will be available for distribution. We contemplate loan of recorders for one meeting only — tape keyers for one month — to each club interested. Suggestions for conducting a code training program using this equipment will also be drawn up and will accompany the equipment when it is shipped out, or will be sent separately to clubs who have their own equipment. Tapes made from automatic transmission will be available to affiliated clubs for use with TG-keyers or similar photocell keyers, in case your club has a keyer but needs the tapes. This is your chance to bear down on your unlicensed members to get their code speed up to the requirement. Better take advantage of it now.

*Film Library.* With the start of the fall active season, the demand for motion picture films from the ARRL Film Library will be definitely on the upswing. If you expect to use some of the films and have not already put your year-end three-month schedule on our books, there is a good possibility you will not be able to get the films you want. If you *do* want films, and have not already booked them, here is what you should do immediately:

- 1) Decide which of the twenty-odd films in the ARRL Film Library your club could use, and list them in order of preference.

- 2) Decide on which dates you want to show the films, and make a list of these dates, equal in length to the films on the above list.

- 3) Send in *both* lists and wait until you hear from us.

This procedure, if followed, will enable us to make a prompt booking and confirmation, with the least correspondence at both ends. Don't be offended if you get form replies to routine re-

quests. Such short-cuts may become necessary in the near future.

Don't forget that there are also film strips and slide collections, with more to be added to that department in the future. They are *not* inferior to motion picture films as a training medium, but if you prefer motion pictures and cannot get them for every meeting you want them for, try scheduling some of the other visual aids to fill in. There are no special restrictions on film strips and slides, and in most cases we can order additional copies if the demand gets heavy.

### NEBRASKA FLOODS

Flash floods, created by severe storms, caused failure of normal communications and power facilities at several towns in the vicinity of North Platte, Nebraska, in late June.

On Sunday, June 22nd, Cambridge, Nebraska, was isolated by the effects of flood waters. Members of the North Platte Amateur Radio Club gathered together suitable emergency equipment and dispatched it to the stricken town under the charge of WØGPX and WØSAI. After an arduous automobile trip over a devious route of 150 miles, much of it over water-covered roads, these amateurs arrived at Cambridge. A battery-powered station, operated on 3.5-Mc. c.w. under the call WØGPX, was set up and contact established with WØEXP and WØRQK, both in North Platte. A second transmitter, operated under WØSAI's call, was set up for 3.9-Mc. 'phone. Both units handled considerable traffic for the Red Cross until the morning of June 24th when commercial facilities were restored sufficiently to take over the load.

On June 23rd, WØBIW, ERM, OHK and OHU loaded emergency gear into a car and set out for Curtis, Nebraska, another town badly in need of aid. Traveling as far as possible by automobile, the group was finally forced to carry their equipment across a canyon by means of a boat-swain's chair; remainder of the journey was made via wheelbarrow, truck, planking across a washed-out bridge, and pack horses! Upon reaching Curtis after an 8½-hour trip (distance 47 miles!), these hardy amateurs found that communication on 7 Mc. had been established from the town to WØRQK, North Platte, by WØQOW, just one hour earlier. QOW also had emergency circuits to Lincoln, Nebraska and Denver, Colorado. The group that had made its way to Curtis with such difficulty assisted in handling communications until the next morning when they made their way home under less hazardous conditions and using more conventional modes of transportation.

Amateurs who participated in the emergency won glowing tribute from civic officials and the press in several Nebraska cities and towns. The North Platte Amateur Radio Club wishes to thank all operators who helped to make the operations successful.

### WIAW OPERATING SCHEDULE

#### Operating-Visiting Hours

Monday through Friday, 8:30 A.M.—1:00 A.M.

Saturday, 7:00 P.M.—2:30 A.M.

Sunday, 3:00 P.M.—9:00 P.M.

A mimeographed local map showing how to get from main state highways (or from Hq. office) to WIAW will be sent to amateurs advising their intention to visit the station.

**Official ARRL Bulletins** containing latest information on matters of general amateur interest are transmitted on regular schedules:

*Frequencies:* 3555, 7145, 14,150, 28,060 and 52,000 kc. (voice — 3950, 14,280, 52,000 kc.)

*Times:* Monday through Friday, 8:00 and 11:30 P.M. EST (0100 and 0430 GCT, Tuesday through Saturday)

Sunday 1:00 A.M. and 8:00 P.M. EST (0600 Sun. and 0100 Mon., GCT)

Bulletins are sent simultaneously, first at 25 w.p.m. and then repeated at 15 w.p.m., on all frequencies during the early schedule to facilitate code practice. Telegraph bulletins are followed, in turn, by voice transmissions on 3950 kc. and 52,000 kc. simultaneously, and then on 14,280 kc. Any changes from this schedule will be announced.

**Code Proficiency Program:** Practice transmissions at 15, 20, 25, 30 and 35 w.p.m. are made Tuesday and Thursday on the above-listed frequencies, starting at 10:00 P.M. EST, and on Monday, Wednesday and Friday at 9, 12, 18, 25 and 35 w.p.m. Approximately ten minutes practice is given at each speed. Next certificate qualification run is scheduled for Thursday, September 18th.

**General Operation:** WIAW engages in two-way work with amateurs, as follows:

*Monday through Friday, all times EST—*

11:00 A.M.—11:30 A.M. ....	28,060-kc. c.w.
11:30 A.M.—12 noon .....	29,150-kc. voice
3:00 P.M.—3:30 P.M. ....	14,280-kc. voice
3:30 P.M.—4:00 P.M. ....	14,150-kc. c.w.
4:30 P.M.—5:00 P.M. ....	3850-4000-kc. voice
6:00 P.M.—7:00 P.M. ....	7210-kc. c.w.
7:00 P.M.—8:00 P.M. ....	3555-kc. c.w.
9:30 P.M.—10:00 P.M. ....	3555-kc. c.w.
12:15 A.M.—1:00 A.M. (Tues. through Sat.) .....	7210-kc. c.w.

*Saturday and Sunday (excepting dates of official ARRL activities).*

Saturday: Midnight—1:00 A.M. (Sun.) .....
 3555-kc. c.w. |

Sunday: 1:45 A.M.—2:30 A.M. ....
 7210-kc. c.w. |

6:00 P.M.—7:00 P.M. ....
 3850-4000-kc. voice |

7:00 P.M.—8:30 P.M. ....
 7210-kc. c.w. |

The station staff:

John T. Rameika, W1JJR, "JR"

Wm. H. Matchett, W1KKS, "BM"

James E. White, W1PHW, "JE"

WIAW is not open on national holidays.

### BRIEF

On working W9GBB recently, Stan of mobile W6YHR was surprised to be greeted by another Stan. A greater surprise was in store, however . . . on glancing at the *Call Book* he beheld the *identical* name, Stanley L. Pierce.

• All operating amateurs are invited to report to the SCM on the first of each month, covering station activities for the preceding month. Radio Club news is also desired by SCMs for inclusion in these columns. The addresses of all SCMs will be found on page 6.

### ATLANTIC DIVISION

**EASTERN PENNSYLVANIA** — SCM, Jerry Mathis W3BES — W3HRD/J3AAE is on the way home after a long stay in Kyoto. The Delco Radio Club is going full blast now and sends the following information: The club house is located at Front and Providence Rd., Media, Pa. Meetings are held Fridays at 8:30 p.m. Initiation fee \$10.00. The club has a 100-watt 'phone/c.w. rig on 3.5 Mc. Officers are CL, pres.; AIG, vice-pres.; DZ, secy.; PX, treas.; ABN, trustee. The club will soon apply for ARRL affiliation. CL just finished n.f.m. ABN has inherited a pair of 30-foot poles. CAA now has his WAC certificate. BQP and IJJ are chasing DX on 14-Mc. c.w. DZ uses an old 203A on 7 Mc. with excellent results. CGS is on the air again after many years of silence. The Lancaster Radio Transmitting Society placed two groups in the field on Field Day. The club has a new 144-Mc. beam at its headquarters and has applied for a station license, and reports much interest in the transmitter hunts offered by the Harrisburg, Lebanon, York, and Lancaster Clubs. The Susquehanna Valley Club had a rough time on Field Day because of an all-day driving rain during which they erected the tents and antennas. QEW won an SCR-522 in a contest. EU is moving to Wilkes Barre. CAU is faithfully doing his OO duty. QP reports his OA4U and VK6MO schedules are still clicking and he intends to add a trans-Pacific net. The Frankford Club threw a little party for G6CL, who gave us a fine talk, principally on the Atlantic City Conference. Many outstanding DX and contest operators were present. On July 4th the Frankford Club, plus NAD and HMK, provided 144-Mc. communication for the Red Cross in Fairmount Park, Philadelphia. A TR4B was placed in each lost-and-found tent and in a park guard station. Many lost children were returned to their parents quickly despite the crowd, which totaled about 800,000. The Red Cross warmly commended the participants for their performance. Traffic in the section is at a low ebb, DX is at a new high, which accounts for the low totals. Traffic: W3EVW 20, QP 10, OK 8, CAU 7, EU 6, GMK 6, EAN 5, QEW 5, ELI 4.

**MARYLAND-DELAWARE-DISTRICT OF COLUMBIA** — SCM, Eppa W. Darne, W3BWT — The Washington Radio Club held its annual Picnic and "Hamboree" on June 22nd at Palisades Park in Washington. The OMs, XYLs, YLs, and jr. operators greatly enjoyed a full afternoon and evening of outdoor games, hidden transmitter hunt, all the food they could eat, entertainment, and lots of prizes. Approximately 350 were present, including locals and a number of out-of-town hams. The Capitol Suburban Club meeting June 20th featured two movies, "Theory of Transmitted Radio Waves" and "Standing Waves on a Transmission Line," shown by IZL, club president. The club now has a nice orchestra available for club functions. AB is building a new VFO and a kilowatt for 7- and 14-Mc. c.w. BWT has a new half-kw. rig for 3.5, 7, and 14 Mc.; also a new 600-watt gas-engine generator for auxiliary power. IZL has a new VFO; uses drain pipe for antenna. BHV and NB get out nicely on 14-Mc. c.w. EOY is on 14 Mc. and gets out well. BKZ gets excellent results with his new QST "Table-top Kilowatt." EYX worked Wake Island on 14-Mc. 'phone. CDQ is on 14-Mc. c.w. with new antenna. LSX is on 28-Mc. 'phone. ISF will be on 420 Mc. as well as the popular bands in the fall. Dave shut down for the summer to undergo a major operation. CJT is on 3.5, 7, and 14 Mc. with 100

watts c.w. He also pounds brass at BWT mostly late evenings on 3.5 Mc. WU kept schedule with W3EKK/VK9 at Admiralty Island on 14-Mc. c.w. Besides being our QSL Manager, Wilson finds time to do plenty of DX. AKR has a new 8JK two-section antenna. LVY works on Trunk C, the Traffic Outlet Net, and Section Net. GKP has a new 48-foot windmill tower. JJD finally got one rig on 3.5 Mc. despite being very busy with much office work. ECP schedules YA daily to clear Kon Tiki raft traffic. MNA and MHW operate on 144 Mc. "Dawn Patrol," a group that is on an hour and a half after sun-up each morning. KHL runs morning schedules on 7 Mc.; is also on 465 Mc. FYB has a new YL jr. operator. MGM is vacationing in Florida, and has 144-Mc. rig with him. BDU is installing a new floor in his shack. KAM made a new panel assembly for his BC-348. 5LF1/3 is on 28-Mc. 'phone, 25 watts, with a new three-element "Plumber's Delight" beam. Besides 7-Mc. c.w., INX is on 28-Mc. 'phone. LYA has new BC-221 frequency meter. KNU recently received his Class A ticket. KJF has left 3.85-Mc. 'phone in favor of 28 Mc. AHQ made all 19 contacts in his Potomac Valley Emergency Net from his Field Day location on Skyline. MJU gets out FB on 28 Mc. Traffic: W3LVY 70, AKR 34, CJT 17, KHJ 11, AKB 10, ISF 10, JJD 8, ECP 7, BWT 5, WU 5, KBX 2, EYX 1.

**SOUTHERN NEW JERSEY** — SCM, Ray Tomlinson, W2GCU — BAV gave a talk on high-frequency, high-gain antennas at the July meeting of the D.V.R.A. The SJRA held a hidden transmitter hunt on June 29th. That brand-new 1-kw. atom-buster at AQP sure is a honey. LS has worked 65 countries with only 60 watts input on 28-Mc. 'phone. QKJ is knocking 'em off on 28 Mc. with that 813 final. ATV is on 28 Mc. with new beam and 140 watts. CGP is poking holes in the spectrum with his 60-wattter. PQJ has rhombics all over the farm. JBF, commander of local Coast Guard Auxiliary, is organizing a communications group among the hams in his vicinity. UKS has new SX-42 and FB transmitter. BIG can be heard on 3.85 Mc. N.f.m. is one of the new outlets at SAS. The FB 1-kw. signals at AWR are taking care of the Barnegat area along with FLO on 28-, 14- and 3.85-Mc. 'phone. FMQ and TJ are on 3.85 Mc. GCU is on with new line-up of 6L6G-807-811. RDK is sporting new 14-Mc. beam with new tower and rotator. SAI has "V" beams and rhombics. HHH has new Collins VFO exciter. BEI passed his 200th contact with G6BY on daily schedule. RPH is working into the WIPMC net at 9 p.m. Since OUS obtained his ticket early this year he has accomplished 28-Mc. 'phone WAS. The Lakeland Radio Assn. has call VDJ. RGV has 99 countries under new call. The LARA has 200-watt rig on 28 Mc. PFZ finished new 1-kw. crusher. MHX is on 28 Mc. with n.f.m. SIV has 25 watts on 28 Mc. Traffic: W2ZI 16, SXK 12, QCL 10, RDK 8, BEI 5, RPH 5, WI 1.

**WESTERN PENNSYLVANIA** — SCM, Ernest J. Hlinsky, W3KWL — The RAE of Erie held a successful hamfest June 17th at Vets Club with 75 attending. WBM was M.C. BHN, NCJ, VHP, MMI, TFX, and AU spoke briefly. KQB is president and SLC is director of RAE. The Coke Center Radio Club boasts of 29 active members, 19 licensed. Officers are: LBL, pres.; UG, vice-pres.; TTV, treas.; MOK, station mgr.; S. Macrum, secy. The monthly *Hamateur News* of the Horseshoe Radio Club of Altoona is something worth reading, thanks to editor LJQ and publisher LJS. MOT renewed ORS appointment. If interested in appointment as ORS, write your SCM for details. YA, State College, maintains frequent schedules with LI2B. On the station staff for the summer are: MDV, BPA, KXT, MHA, MOD, LMS, OSI, RYB, SHY, JZF, MLN, LFG, KXS, MEM, and 2PAP. This staff also keeps daily schedule with LA1C. LWN is using a quarter-wave vertical on 7 Mc. NCJ completed his p.p. 813 and now is awaiting 2000-volt transformer. 3AER says cutting a section out of the beam improved his DX reports. He also is trying negative coefficient condensers in receiver to secure no drift receiver. RAT says the new 'phone net in Pittsburgh and vicinity is rounding up in good shape. KOB's homemade receiver works like an HRO. PJJ is putting out FB signals on 28 and 14 Mc. with his new beam. LFM is on 144 Mc. GJY can be heard

(Continued on page 80)



THE LENGTH of time a receiver will go without servicing depends upon a great many things including actual operating time, conditions of operation, and the possible abuse to which it has been subjected. Under ordinary conditions a good receiver will go many years without getting seriously out of alignment. However, for top performance, it is generally well to have the receiver realigned periodically.

When the time comes for such realignment or overhaul, the ham usually feels that he cannot spare the receiver any longer than is absolutely necessary. Hardly a day goes by that we do not receive several letters from hams inquiring about the length of time necessary to service their receivers. We have found in most instances that the time consumed in shipping a receiver from various parts of the country to our plant in Malden varies from about one week to four weeks depending upon the method of transportation. Allow the same length of time for the receiver to be returned, and about two weeks for the receiver to clear through our Service Department, and you can understand why a fellow ham sometimes wonders if his receiver has been "lost in the rush."

Until recently we recommended that all repair and modification work on National equipment be done at our plant. However, in view of the above mentioned time element, not to mention the additional transportation charges and greater possibility of damage in shipment, we have carefully selected and established a few Authorized Service Stations throughout the country.

These Authorized Service Stations have been thoroughly investigated, and are equipped with suitable gear manned by responsible technicians who have a satisfactory knowledge of communications equipment. They are kept up to date and supplied by the factory with the latest data and parts for the maintenance and repair of National equipment, and are prepared to turn out work which you will find to be the equivalent of a factory repair job. Give them a chance to prove it!

Any repairs or modifications to be made on your National equipment can now be handled by the nearest Authorized Service Representative. New equipment requiring service during the warranty period should be referred to the dealer from whom it was purchased in order to secure the necessary authorization for such work. We suggest you make a note of the Authorized Service Station nearest you for future reference. Names and addresses are as follows:

MR. W. BEN WIMBERLY  
8114 Knox Avenue  
Skokie, Illinois

MR. GEORGE E. DAMMANN  
15 South Michigan Avenue  
Villa Park, Illinois

ENGINEERING PRODUCTS CO.  
4905 Ross Avenue  
Dallas, Texas

STAFFORD ELECTRONICS  
1423 Curtis Street  
Denver 2, Colorado

RADIO COMMUNICATION LABS.  
P.O. Box 711, Municipal Airport  
Atlanta, Georgia

ELECTRONIC MARKETERS, INC.  
190 Varick Street  
New York 14, N. Y.

UNITED ELECTRIC SERVICE  
1160 John Street  
Seattle 22, Washington

MR. W. O. WATTS  
11th & Highview  
Manhattan Beach, California

WINSBY-FLEMING  
2573 94th Avenue  
Oakland 3, California

ELECTRONIC RADIO LABORATORY  
7555 Emily  
Detroit, Michigan

BEACON RADIO  
142 East 4th Street  
St. Paul 1, Minnesota

EASTERN RADIO CORP.  
637 Main Street  
Clifton, N. J.

Service in the New England area is still handled at the factory, 61 Sherman Street, Malden 48, Massachusetts.

S. W. BATEMAN, W1RX



DXing. Recent graduates of Penn. State are WVN, MTF, LFG, LMS, and MAB. One Romeo who prefers YL to radio is OKP. LIN says his new VFO is FB on 3.5 Mc. UW has moved to another QTH. IWH and NUG paid TVA a visit. The SZHB and 8DIP QTH is in Lewistown, Mich. He is interested in QSOing his W. Pa. pals on 7250 kc. each afternoon. TXQ got his Asian card for WAC. KQD needs Arizona and Delaware for WAS. My sincere apologies if I miss out on any individual in this column. All late reports will be carried over to the following month. This is your activity section, so keep the news coming. All club secretaries are urged to send activity reports on their respective clubs. Traffic: W3YA 95, RAT 18, AER 8, NCJ 2.

### CENTRAL DIVISION

**ILLINOIS** — SCM, Wesley E. Marriner, W9AND — Many of the gang are off the air at this time. Some who are rebuilding are: HON, who also is moving to Western Springs; BON, who is building a 28-Mc. mobile rig; and LNI, who lost his transmitter in an electric storm. FKI worked 14 states on 50 Mc. recently. The Champaign County gang is looking for 50- and 144-Mc. contacts. QBH changed 28-Mc. frequency from 28,744 to 28,640 kc. HVG has 28-Mc. mobile rig and is interested in joining emergency net. SYZ is away on vacation. EVJ enjoyed Field Day with the SRRCC boys near Lowell. FDF is on 14-Mc. c.w. ZPC is putting out a nice signal on 3.5-Mc. c.w. EVJ exchanged 5 messages with WIAW. JMG participated in Field Day Contest from home station. He has opened up a radio service shop on the side. APK is a new ham in Wenona, says DBO, who also had the pleasure of meeting EVJ at Field Day outing. SXL says the Kickapoo Radio Operators are meeting at Forest Park for the summer months. #MIN stopped off on his vacation trip. SXL is building new QTH with plenty of antenna space. EJX is using four-element beam on 28 Mc. and has just returned from two weeks portable W8 operation at Houghton Lake, Mich. SMD has remodeled slightly and boosted the power. He finds DX on 14 Mc. pretty good. An extra edition of *Stork News* is sent by YTV to announce the arrival of a jr. operator, William Ross Brands. The proud parents are Charles and Etta Brands. DX List: GNU 82, AND 82, AWA 79, KMN 67. Send in your DX total each month for Illinois DX country-worked total. EBX is in a slump until September first. VJN has his new 14-Mc. beam up and new NC-173 receiver. GNU plans 144-Mc. operation soon. BUK and VOQ are new ORS. AWA has 7-Mc. portable station in auto. CKM rebuilt exciter stages and schedules EQJ and #BCJ on 7195 kc. AHV has new VX-101 VFO. FUR needs only a receiver and antenna to get on the air. ALW will soon be on 7 Mc. with ARC-5 transmitter. KOK has new 86-ft. windcharger tower with 14-Mc. beam on top. The 14-Mc. band is not very good at D4AON. Traffic: (May) W9YTV 38, AHV 3. (June) W9EVJ 119, FKI 42, SXL 18, DBO 13, SYZ 5, AND 5, D4AON 4, LNI 1, JMG 1.

**INDIANA** — SCM, Ted K. Clifton, W9SWH — SWN is new ham at Evansville. QLW took a message from VK7LJ for WIAW at 0445 on June 3rd on 14-Mc. c.w. Carly relayed it to GFO on 28-Mc. 'phone; at noon he gave it to KZ5AQ who relayed it to WIAW. UNT and TBU won door prizes at the last meeting of the TARS. EGQ has a 522 on the air and can be heard on 3.85-Mc. now. EGV is on 3.85-Mc. New officers of the Muncie DARA are: SQD, pres.; OSA, vice-pres.; Orville Johnson, secy.; EDU, treas.; OMN, act. mgr. TT and KLM made over 60 contacts on Field Day using an antenna only 17 feet high. The DARA worked 32 states on 6 bands and had 129 contacts using less than 30 watts on Field Day. FJI, of Evansville, won first prize at Peoria on June 15th. JDW has moved to a farm near Muncie. The Michiana Amateur Radio Club received a nice write-up in the *South Bend Tribune*, along with a picture of its Field Day set-up. The club made more than 300 contacts. ONB worked WAS in four days on 28-Mc. 'phone. MXU has moved from Mishawaka to Pittsburg. RE has moved to Peru from South Bend. The Michiana Radio Club has announced its affiliation with the ARRL, and has named a QRM committee consisting of KYM, DMH, and NGR. Club speaker on June 25th was NTI from Collins Radio, who gave a talk on, and a wonderful demonstration of, his permeability tuned linear oscillators. All the equipment of the late JPK is for sale. Information on same can be obtained from any member of the Indianapolis Radio Club. The Indiana 'Phone Net, with BKJ as NCS, will continue through the summer months. The QIN C.W. Net, with DHJ, as NCS, and RCB, as ANCS, has closed until September. MOK, who is the new emergency communications commit-

tee chairman of the TARS, is our newest EC. John has assured us that the Ohio River boys will be well represented on the nets this fall. The Fort Wayne Radio Club had a 350-watt a.c. generator stolen within one hour after the start of Field Day activities. Traffic: W9NH 36, BKJ 21, TT 17, EGQ 6, EGV 4, QLW 4, BKH 3, RYJ 1, SWH 1, YDA 1.

**WISCONSIN** — SCM, Reno W. Goetsch, W9RQM — LFK handled less traffic this month because of QRN and rebuilding. CIH schedules J7AAA (W9YMY) daily. MUM reports considerable interest in Eau Claire in forming a local club. YCV and DTE are active in State net. MSJ is active on 3.85 Mc. SBY will be on 28 Mc. with a kw. soon. GYQ is doing FB with his mobile rig. IVE is chief operator at WNAM, Neenah. OUT has B.C.I. trouble. EWC feels fine after recovery from a recent operation. A swell time and FB results in Field Day operation are reported by club groups participating at Madison, LaCrosse, Manitowoc, Racine, and Wausau. FTG moved to Sauk City. AWO does an FB job in reporting activities from the Madison area. OBZ spent several days in Wausau on vacation. The MRAC elected the following officers: DTK, pres.; DWI, vice-pres.; PTE, secy.; RHI, treas. GPI is chairman of committee for National Convention to be held in Milwaukee next year. MRAC meetings will be resumed weekly starting Thursday, Sept. 4th. JPK is doing outstanding work on 144 Mc. in Milwaukee. The RMC annual picnic is scheduled for Aug. 24th at Johnson's Park, Racine. HHM now is Class A and will operate 28-Mc. portable on a month's tour of the West. 144-Mc. activity is brewing in Racine following the purchase of SCR-522a by 14 of the gang there! RQM is on with 30 watts while rebuilding. IJB is working in Washington, D. C. during the summer. WON now is equipped for mobile. RBI is on 50 Mc. with a four-element beam. The Racine Megacycle Club used a VHF set-up in connection with the yachting regatta July 5th. IZL and WWM are on 144 Mc. AJL and ACQ are new calls at Racine. ZCS is on 7-Mc. c.w. LED is planning a new e.c.o. GDD is active on 50 Mc. Traffic: W9YCV 81, LFK 39, CIH 17, DTE 16, MUM 6, RQM 3.

### DAKOTA DIVISION

**SOUTH DAKOTA** — SCM, P. H. Schultz, W0QVY — S VOD has returned to Pierre from the U. of Michigan, where he was taking special courses in Public Health. SDE is one of the engineers at WMHK, new b.c. station at Mitchell. GCP has new Super-Pro and a Bud VFD unit driving a pair of 807s. Bill says response to net activities was practically nil and he is quite disappointed in the showing made so far. WUU has emergency rig with receiver and transmitter on same chassis. ZBU received a reply from the FCC on the petition sent in after the hamfest requesting opening of a small portion of the 160-meter band. FCC will give consideration to said request. However, no action can be taken until present allocation matters are settled. Traffic: W0GCP 4, SDE 1.

**MINNESOTA** — SCM, Walter Hasskamp, W0CWB — ALP, Aurora, was awarded a prize of an 815 for working Duluth on 28-Mc. extended ground wave. The award was made by GKO on behalf of the Arrowhead Radio Amateurs. This type of 28-Mc. communication was instigated by BBN, who with 8BY of Ironwood, Mich., has had consistent communication via 28-Mc. extended ground wave over a distance of 100 to 140 miles for the past six months. The secret lies in good beams and pre-selectors. The Mesabi Range Wireless Club has filed for affiliation with ARRL. LJH and SCZ have converted their YLs to XYLs. 6RHJ/θ is on 28 Mc. with 100 watts from YMCA, Minneapolis. EHO's new QTH is Olivia. RJF is now a member of the Rag Chewers Club; he also renewed his ORS appointment. BBL sent in OPS Nr. 1 for endorsement. BMX is new OBS. OMC has rebuilt his final to TZ40s and renewed his ORS appointment. GKC has a new three-element rotary for 28 Mc. and is building new 200-watt final. ANU's new final has V7ODs. The Jackson County Radio Club has a new field unit for 3.5 Mc. with 25 watts on c.w. and 20 on 'phone. RAJ is back from school and is building a new modulator with 811s, a three-element beam and has a new exciter using the Collins 70E-8 VFO. The Rochester Radio Club has a local net on five nights a week. RPT reports daily into the Iowa Net. FLK is new MSN member, the northern-most in the State so far. ANN is new ham at East Chain. BHY and ZWW visited Fairmont Radio Club and spent a week end with RPT. GKO has eight-element stacked array on 144 Mc. KIG is building new exciter. HQW is building new final with 813. YUU is back on 3.85! MCY has new Class A and is on

(Continued on page 88)



# You're Looking at the Finest—



## —a complete Hammarlund station

An HQ-129-X receiver, the choice of thousands of well-satisfied owners. And a Four-20 Transmitter with its companion Four-11 Modulator, a combination that is getting out all over the world. R9+ reports from China, Argen-

tina, Hawaii, Australia . . . coming in to the many amateurs now using the Four-20 on the air.

You, too, can be in this picture . . . Equip yourself with a complete Hammarlund station.

*There will be no new Hammarlund receiver in the price range of the HQ-129-X until the spring of 1948 at the earliest.*



# HAMMARLUND

THE HAMMARLUND MFG. CO., INC., 460 W. 34<sup>TH</sup> ST., NEW YORK 1, N.Y.  
MANUFACTURERS OF PRECISION COMMUNICATIONS EQUIPMENT

 Write for Descriptive Booklet

3.85 Mc. now. The Minneapolis Club worked Tokyo and New Zealand on 14-Mc. 'phone and Australia on 14-Mc. c.w. for a bit of DX FD. KQA is back on the air. Come fall the Willmar Club plans reorganization. How about it, you boys on 7 Mc.? Care for a state-wide 40-meter net? Drop your SCM a card if interested. Traffic: W5ITQ 58, CWB 34, RPT 24, BBL 19, RJE 18, FLK 5, SW 5, VJH 5.

### DELTA DIVISION

LOUISIANA—SCM, W. J. Wilkinson, jr., W5VT—KTE and KUG are doing FB jobs as SEC and RM respectively. CEW is carrying out PAM duties. Drop a line to them or the SCM if you'd like appointment such as ORS, OBS, OPS, and OES. They tell me that Field Day activities in New Orleans were really the "stuff." BPL has just completed a new final with T55 p.p. taking 300 watts. JPJ worked solid 'phone with 9DPI on 3.85, 14, and 28 Mc. all in one hour between 7 and 8 P.M. CST. FYS is visiting in Washington, D. C. ZBO was on a vacation trip to New Orleans and Shreveport. CGC is putting out a whale of a signal on 14 Mc. c.w. KRX reports little activity and traffic. FMO visited the SCM. ZV is vacationing in New York and Canada. KTD is in Shreveport for a while. IOP still is trying out the 50-Mc. band. Well, the Pelican Network will open on or about September 15th so drop a line to the RM or SCM and make plans now to join the traffic boys on 3550 kc. for lots of activity during the next six months. Also, KTE wants to hear from all the ECs and those interested in emergency operation. No more news this month. How about some from all of you for the next issue? Hope all of you had a big time at the convention. Traffic: W5KUG 71, KRX 29, VT 7.

MISSISSIPPI—SCM, Harold Day, W5IGW—LN is carrying on as Alt. NCS for Delta 75 'Phone Net through the summer. IGW is building a new QTH with his bare hands during hours after work, and week ends. He hopes to be back on the air regularly about October. LAK now has a nice VFO working "bk-in" and enjoying QSOs all over the bands. A nice hand to the gang in Meridian who went in for Field Day in earnest. The boys used a portable rig under the call CUU/5. Those participating were, DNS (EC), DEJ, DNW, DNV, CUU, and 4EDG. The rig was used through the courtesy of DEJ. We need much more of this kind of activity in the State. KUT is new ORS at Vicksburg. Spence is commercial operator on the Mississippi River. Thanks this month to LN and DNS for the dope. Welcome to all the new hams in the State. Don't forget to send in some dope to your SCM. We need your help, and a postal from you is most welcome. Traffic: W5LN 7.

TENNESSEE—SCM, James W. Watkins, W4FLS—3TWI/4 now is 4TWI. HAL is new ORS at Oak Ridge and is active on 3.5-, 7-, 14-, and 28-Mc. 'phone, and c.w. with 300 watts. FQI is doing a good job on 50 Mc. with 100 watts to an 812. BBL is working on a new rig using a pair of 304TLs. BEG is on 28 Mc. with a mobile rig. AFR is on 3.85 Mc. with an Army surplus rig. JAF's house burned to the ground recently and all he managed to salvage was a BC-348 receiver and a BC-221 frequency meter. HHC blew out an 814 buffer and now is rebuilding. ILZ is on 3.85 and 7 Mc. MEQ is new call in Nashville. MP is bedridden with a bad ticker. The Chattanooga Radio Club elected the following new officers: FZ, pres.; DIJ, vice-pres.; PL, secy.; QT, treas.; BD, act. mgr. LHQ is working the DX on 14-Mc. c.w. with relatively low power. PL is running a full line of schedules on 7 Mc. in spite of summer QRN. FEI is new OPS in Nashville. AQR is new OBS in Memphis. BD is new EC for Chattanooga and HHQ is new EC for Knoxville. The MidSouth Amateur Association membership now totals 104 licensed amateurs. AQR, SW, and DQH have all worked VR6AA. CV has new Meissner Signal Shifter. DQS and SW are each building another kw. station. Memphis reports quite a bit of local activity on 144 Mc. LVW, LVH, LWD, and LVI are new calls in Memphis. DJY has an eight-element beam on 144 Mc. LVM is new XYL ham in Memphis and is operating on 7 Mc. FLW worked 13 states on Field Day. Traffic: W4PL 725, LHQ 16.

### GREAT LAKES DIVISION

KENTUCKY—SCM, Joseph P. Colvin, W5IEZ/4—The following report was written by 4BAZ. NEP is working 3.5-Mc. 'phone but not on KYP. KWO has new Super-Pro. FQQ has folded dipole on 14 Mc. LTU works KYN occasionally. KFH has BC-459 for sale cheap. ERP is running 150 watts on 7 Mc. MFH, LVL, and IEZ are

working on 144 Mc. LXP put up 28-Mc. beam. LNJ is working 7- and 28-Mc. at Ft. Knox. MMY is building new rig. MFI worked HH2 for the first DX. LVL heard St. Louis on 144 Mc. KFI needs West Virginia for WAS. KFH is running 812 p.p. on 28 Mc. LEI has pipe beam on 28 Mc. BPE has pair of VT127s on 28 Mc. PN still is hitting DX on 14 Mc. MQ also is doing well on 14 Mc. LXP has an 807 on 3.5-Mc. c.w. The ARTS Field Day outing was very successful and well-attended. JXB is on all bands with 600 watts. ERH and LUB are on 28-Mc. 'phone trying for WAS. KDR is working 7-Mc. c.w. A movement is on foot in Somerset to start a radio club. KRY is getting good results on 50 Mc. SXP is working 28 Mc. YGS is running a kw. on 14 and 28 Mc. CIS is trying 7 Mc. YPR is most consistent on KYN. CDA soon will be on 7 Mc. CMP is alternate NCS on KYF and works all bands. EDV is building 14- and 28-Mc. rig with 813 final. JHU is pouring 150 watts into a 250TH. IXN handled some traffic. KUP is working all bands. NDY is helping the XYL to get her ham ticket. TFK is working Lexington on 50 Mc. UWR plans a 50-Mc. rig. JBU has BCI trouble. KBY has harmonic trouble.

MICHIGAN—SCM, Joseph R. Beljan, jr., W8SCW—SEC: SAY. New appointments: ORS—UKV and YBR. Section Net Certificates were issued to YAO and YBR. The MCRC, using club call MRM/8, once again led the State on Field Day with 481 contacts. The DARA, with club call NLG/8, made 279 contacts. Single station set-ups included PVB/8, 57; MTE/8, 12; DYH/8, 8. Other known Michigan stations operating portable included CSI/8, HDM/8, and SAY/8. The GRARC held a picnic at Dutton Park on June 29th. NCB won the balloon-blowing contest and ZBH was the first to locate the hidden transmitter. Congrats and best wishes to the newly-formed Saginaw Valley Amateur Radio Assn. SWG and YBC are planning on QMN activities in the fall. WO and RWE handled the boat races at Wyandotte using 50-Mc. portable equipment. Doc was in the boat and Gus in the marine barge giving the crowd the information by loud speaker. SWF enjoyed vacation through Canada and New England States and met hams along the way. GJX enjoyed a well-deserved rest and vacation in Florida and New Orleans. NCB won the GRARC contest for working the most stations in Kent County. Ed is also a super-sleuth on the hidden transmitter hunts held by the GR emergency net. 9DMN, ex-8VQY, now is at Syracuse, Ind., and has the rig fired up on 3.85 Mc. looking for the Michigan. 3MHH, ex-WSI, and 9HSK, sends 73 to the gang. Congrats to PYW, who recently tied the knot. YCT is pleased with his new VFO and is taking radio engineering course from CREI. GQZ is trying to decide between frequency or phase modulation for his new 28-Mc. rig. YCB will be back on 3.5 Mc. shortly. GLW is rebuilding and putting up beam for 28 Mc. KPL worked over 70 countries with haywire draped over the roof of the house. KOS is rebuilding and planning on 250 watts. DEN is sailing the lakes as radio operator with D & C. FX keeps QRL with club and QMN work and surplus converting. MGQ is planning on 28-Mc. mobile. Traffic: (May) W8UFR 64, YAO 14, DED 4, (June) W8NOH 115, UKV 90, SCW 33, KPL 31, YJU 12, TRP 8, YDR 8, VPE 7, CLL 5, SWG 3, QF 1, MGQ 1.

OHIO—SCM, William D. Montgomery, W8PNQ—With the summer well under way, reports and traffic have fallen off considerably. The only appointment to announce for June is that of EDX as OO. From RN we learn that the Buckeye Net is operating as a QNF net for the summer months, because of lack of traffic and the high QRN. He further reports the formation in Bedford of a new amateur social club. No further details are available about this club, but we should have more dope next month. Well, we have a few reports from Field Day groups, but the final reporting of that event will be found in special columns of QST. The GCARA Annual Hamfest on Sept. 14th in Cincinnati will feature three prizes—an NC-173 receiver, a VHF-152 converter, and a Collins VF oscillator. Tickets may be obtained from 4HAV, 8ALW, 8BCJ, or 8ODF. From Delaware we see that TZI is operating from a trailer in Larue, Ohio, and that OUR has a new jr. operator. From Cleveland and the CRA Bulletin we see that NV has been forced to resign as CRA director because of pressure of business; that regular CRA meetings are not being held during July and August; that the second meeting of the Cleveland Council of Radio Clubs was held May 21st and UKS was elected chairman; that seven radio clubs were represented; and that nine Cleveland hams attended the Michigan State Hamfest May  
(Continued on page 90)

Where you find  
**HAM RIGS**  
 There you will find  
**THESE ASTATIC  
 MICROPHONES**

KNOWN THE WORLD OVER

**D-104 CRYSTAL MICROPHONE.** Developed in 1933 as a dependable low cost microphone for the "Ham Rig." Changed but little after 14 years, and still a big favorite with Hams.



**CONNAUT—Model G-600 Crystal Microphone.** New Streamlined Model, chrome with plastic grille. Shown mounted on G Stand.

**MODEL JT-40 CRYSTAL MICROPHONE.** Complete with handle and interlocking base. Opalescent gray and bright chrome.

**MODEL DN-HZ-S—Dynamic Microphone** highly favored for general use where temperatures vary or high relative humidity is encountered. Supplied in four models of different output impedance. All models available, if desired, on Grip-to-Talk Desk Stand.

MICROPHONES . PHONOGRAPH  
 PICKUPS . CARTRIDGES

THE *Astatic* CORPORATION  
 CONNEAUT, OHIO  
IN CANADA: CANADIAN ASTATIC LTD., TORONTO, ONTARIO  
 Astatic Crystal Devices Manufactured  
 under Brush Development Co. patents.

18th at Ypsilanti. WXG says there are a bunch of swell fixed-frequency receivers on the surplus market which are ideal for net operations of all types. BUM says his new kw. is working out better than he expected. DAE got his first Panama QSO in 25 years recently — HP4Q on 14 Mc. SDD has an all-band mobile rig ready to throw in his car as soon as the FCC changes the rules. He has one of the new a.c. generators (with rectifier) in the car to keep the battery up. Traffic: W8RN 46, EQN 14, PUN 8, ROX 7, TH 5, ZEI 5, BUM 4, EFW 2.

## HUDSON DIVISION

**N**EW YORK CITY & LONG ISLAND — SCM, Charles Ham, jr., W2KDC — The NYC and LI AEC sponsored a picnic at Bethpage which was so successful that a repeat performance will take place on Sept. 14th in Bethpage at 11 a.m. A hidden 144-Mc. transmitter hunt is one feature and all hams are invited. There are no fees, tickets, or strings attached. Should a heavy dew fall, come out one week later, on Sept. 21st. KDC is ordered to be there by BGO. Those attending and enjoying the June picnic were BTA, OQI, AVC, LFL, AUF, OHE, AES, ADW, OXM, BSP, NLD, FI, RZ, VAF, MBB, UGV, CIQ, UGW, TUK, VKS, UNS, TUX, NRL, MFI, DSY, CET, ADT, and BGO. OQI reports that the Suffolk RC and the Suffolk Amateur RC. joined up for a bang-up Field Day covering all bands except 14 Mc. DOG has the unenviable task of compiling a neat report from dozens of unintelligible log books. UDP, in Riverhead, is using an SCR-522, which means another crystal signal in that area. VPY, in Huntington, Station, ditto except that he uses an ARC-5. JWO, in Patchogue, uses 250 watts to three-element beam on 144 Mc. ADW is getting an SCR-522. OQI is using 522 with NC100A as 12-Mc. i.f. IXT is heading for higher power on 144 Mc. Suffolk County is looking for active stations between Patchogue and the Nassau line. The local YLRL held its 3rd annual luncheon at the Hankow Chinese Restaurant in June and awarded such fascinating gadgets as nylons, tubes, etc. NFR is waiting for her postwar WAC certificate. PBI received a nice batch of QSLs recently. PMA is using a DB20. TU has neon-lighted remote beam indicator. TFO was pleased to work a WI. NQC is on 7-Mc. c.w. Remember the YL round table 'phone on 29.2 Mc. the first of each month. OHE starts his monthly report "Nothing much to report this month" and follows with a full page closely typed. Preliminary plans are under way to form a 28-Mc. AEC net in Brooklyn, frequency to be above 29 Mc. to take in the f.m. gang. LVI is assisting OHE in organization and Leon is scheduled to be control station. NQQ reportedly sold out and is rebuilding for the low frequencies. NXT is searching for a good 100-ke. standard to use on 144 Mc. OHE is tuning up ear and fist by some 7-Mc. c.w. AUF has the reputation of being "the wizard of the 1068A." The U.H.F. Institute is a newly formed group of "experts" who will guide and assist new-comers and old-timers who are having a little trouble on the bands; contact them through any AEC station. SJC is building for 144 Mc. TSA is on 420 Mc., but finds little activity. FEI uses 100-watt bandswitching transmitter and an 8-40 receiver; he also is interested in AEC work. TVE shifted to 7-Mc. c.w. and is now adding a pair of 807s. The Sunrise RC, using the club call SV, set up as usual at Comack for Field Day, concentrating on the lower frequencies. HXT gave up some good DX to answer his old buddy, 6NZ, and a swell rag-chew ensued. LGK is using 6 watts to 2 antennas and working out fine. QMP called "CQ dial phone" during phone strike and some lucky and helpful dial-user came right back and made several calls for Dave. BIV is building an 813 rig on 3.5-Mc. c.w. RQJ travelled during April and May, meeting 4EKA, 5KYK, and 4HOK. OUT is looking for an OO certificate. OBU reports the NYC-LI gang had 7 operators on for Field Day; they also operated mobile/marine on fishing trip July 20th. The 27 stations in the net are on summer schedule Tues. and Fri. PRE finally nabbed Arizona for WAS. Traffic: W2TYU 230, BO 107, OBU 90, SJC 44, BIV 24, HXT 13, RQJ 12, ZBP 5, LGK 3, OUT 2, PRE 2, PWJ 1.

**NORTHERN NEW JERSEY** — SCM, John J. Vitale, W2IIN — On Field Day the SCM and his side, OSQ, made an inspection tour of some of the Field Day club sites, working 144-Mc. mobile en route. The wind and rain storm on Saturday really brought emergency operating conditions. The most spectacular set-up was GSA/2, with its many forms of antennas, operating positions, and methods in teamwork, including 235-Mc. equipment. Unique rotary

"Super" beams were observed at ZD/2. OM/2, with its usual big turnout and equipment, was going right to town. Fast operating and "stations worked" quick reference index were observed at JC/2, at Garret Mountain, WK/2, with its enormous layouts, made the pages of *Life Magazine*. GSX/2 was out as usual combining the affair with a picnic; NVK/2 also was visited. CJX maintains foreign schedules. UWN is on 3.5 Mc. with 40 watts from Livingston. VGW is interested in emergency equipment and operations, also 40 watts c.w. on 3.5. Mc. EGM and QEM are OBS and EC on 3.9 Mc. NJF is on the net. NCY is getting ready for f.m. on the lower frequencies, NKD is summer NCS with LFR for the N.N.J. 3630-ke. net. During the Annual Soap Box Derby in Elizabeth communication between the starting and finish lines was handled by two 144 Mc. portables with IIN in charge and CRW, CQD, UQY, ZF, and PIX assisting. PQS is building a control board for remote operation from his new operator's deck. JYJ, a flying instructor, and JUD are on 144 Mc. from plane to ground. JGP was appointed reporter for Livingston RC and writes that the club has the site and necessary finances to go ahead on the clubhouse. On Field Day, NVK/2 operated on all bands and made 170 contacts for the first time out. Very good results were had with the 500-ft. long wire antenna for 14 Mc. and the beam for 28 Mc. ICA made many of the 28-Mc. contacts. WO is making the set plans for the shack. NAP, the 'phone man, now is c.w. LZW is removing bugs out of his big rig. EWL works 14-Mc. 'phone when not building television receivers. The Hudson Division Convention Committee is getting ready to greet you at Asbury Park on Sept. 26-7-8. If you plan to attend, make arrangements with HKY, 135 Bridge St., Red Bank. TZY has an HT-9 on 28 Mc. with 125 watts and is handling some GI traffic to his son and others. He wants someone to put up a 132-ft. antenna in a 50-ft. space! ANG is going mobile with f.m. 28 Mc. OEC put on a four-day show in Atlantic City at the I.T.C. using call QDU/2. QEM was chief operator, assisted by VPT and 9EHR. BOX is on 14- and 28-Mc. 'phone. If interested in N.J. 75 'Phone Net activities call in on 3.9 Mc. at 9 a.m. Sundays. EGM is acting NCS. Ocean County ARA elected AWR, pres.; MMG, secy.; DYR, treas. The club meets the 3rd Tues. of each month at Bayville Lodge. The Northern N. J. RA held its picnic and FD Party on June 21st. Traffic: W2OEC 428, QDU/2 184, NKD 83, CJX 40, NCV 33, QEM 26, OXL 25, ANG 18, APL 16, IIN 12, VGW 9, PQS 3, NIY 1.

## MIDWEST DIVISION

**I**OWA — SCM, William G. Davis, W0PP — For the second time in two weeks QLP, KZL, DVZ, WLI, and CFB furnished emergency communications in the Ottumwa flood area. WML took his portable from Newton to Ottumwa to assist in the emergency. FP, JDV, TWX, CVU, CPU, and PP handled outgoing traffic from Ottumwa through the Iowa 75 net. LRY was control station in an emergency 28-Mc. mobile net consisting of LRY, MCK, GBB, OLY, and UOP with his fixed station serving the flood in the Des Moines area June 28th. HMM is busy on the Iowa Tall Corn Net, the Atlantic and Pacific Net, the Rebel Net and the QMW Net and schedules 5LSN, all on c.w. HKN, Des Moines, is organizing a c.w. net on 7120 kc. for 18- or 19-year-old hams. He wants to hear from hams in this age group in Iowa who are interested. FP is busy with EC organizational work for Tri-City area. The Iowa 75 'Phone Net meets daily except Sunday on 3970 kc. from 12:30 to 1:00 p.m. YBV is building a real ham shack. FDL, Muscatine EC, with help of GPJ and Bradford Crow, handled lots of traffic during Oakville flood while VRD set up at KWPC. TLL assisted the Naval Reserve in handling traffic during Oakville flood, using Burlington Club BC-654 portable. Let's pep up the reports in the Iowa section. Your SCM is open to constructive suggestions; your cooperation is very much desired. Watch your several appointments and renew promptly. Traffic: W0QLP 300, HMM 126, KZI 120, DVZ 20, CFB 10, HKN 8, GKS 6, FSH 2, PJR 2.

**KANSAS** — SCM, Alvin B. Unruh, W0AWP — KVRG, Topeka, using ICV, and WARC, Wichita, AWP, made good scores in Field Day Contest. BPL has LM7 frequency standard. He keeps daily 3.5-Mc. c.w. schedule with RGC. OAQ has new rig for QKS Net on 3610 kc. ZAT is on 3.9-Mc. 'phone. BQJ made good scores in: CD and ARRL Parties. PKD has 50-Mc. schedules with ZJB, YUQ, and DKS. At Emporia OOU has three-element rotary on 28 Mc

(Continued on page 92)

your  
basic  
**3R's**  
for correct  
current control

Ward Leonard  
**RELAYS**

Ward Leonard  
**RESISTORS**

Ward Leonard  
**RHEOSTATS**

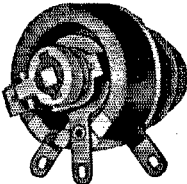
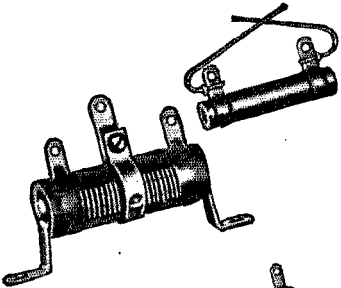
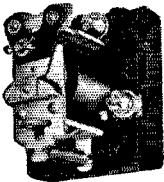

**RELAYS**—provide convenient circuit control, protection, and greater operating efficiency . . . help reduce length of connecting leads. Amateur Relays available from stock: Antenna Change-Over, Antenna Grounding, Keying, Band Switching, RF Break-In, Safety, Overload, Underload, Latch-In, Remote Control, Sensitive, Time Delay. Also Industrial and General-Purpose Relays.

**RESISTORS**—exclusive features of VITROHM wire-wound resistors insure that *extra* performance needed in critical circuits. Fixed type in 8 stock sizes from 5 to 200 watts. Adjustable type in 7 stock sizes from 10 to 200 watts. Wide range of resistance values. Stripohm, Discohm, and Plaque types also available.

**RHEOSTATS**—for fixed or variable close control. Protected by tough, acid resistant, crazeless vitreous enamel. Sizes: 25, 50, 100, and 150 watts, in wide range of resistances.

*Authorized Distributors Everywhere*

**WARD LEONARD ELECTRIC COMPANY**  
Radio and Electronic Distributor Division  
53-B West Jackson Blvd., Chicago 4, U. S. A.

**WARD LEONARD**  
**RELAYS • RESISTORS • RHEOSTATS**

Electric control  devices since 1892



**SEND FOR  
FREE CATALOGS**

Write for Amateur Relay Catalog No. D-111, and for Resistor-Rheostat Catalog No. D-2.

When you need a Ceramic Switch . . . specify Mallory for Dependability

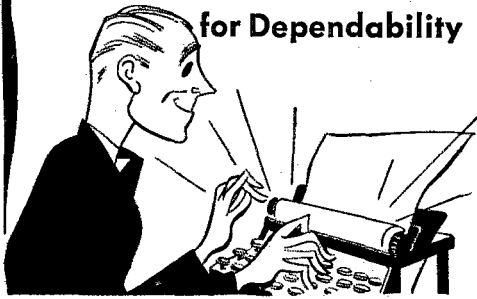

Only Mallory makes "Ham Band Switches"; the famous 90° indexing 4-position ceramic band switches that have won acclaim from engineers—everywhere.

Their 1000 volt DC and 100 watt power rating (they will mount inside a 2" circle) means that you can have band switching in exciter stages of high-powered rigs and complete band switching in medium-powered rigs without excessive size or cost.

Ham Band Switches are swell, too, for receivers, signal generators, monitors, and similar equipment where turret coil placement is desired—and where low losses, positive low resistance contacts and stability of characteristics are important.

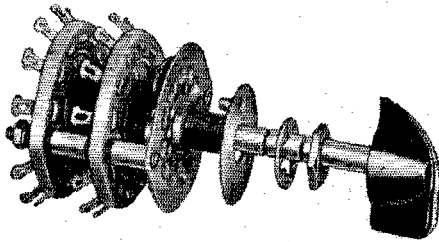

For applications where special high-voltage characteristics and 90° indexing are not required, Mallory makes the low-loss 170C series ceramic section selector switches available in one, two and three gangs, with up to 11 positions with 30° indexing, and with one, two and three circuits per section. Mallory 160C and 170C ceramic switches are available from your authorized Mallory distributor.

P. R. MALLORY & CO., Inc.  
INDIANAPOLIS 6 INDIANA

P. R. MALLORY & CO. Inc.  
**MALLORY**

(Continued from page 90)

IZJ is on 50 Mc. with 807 final and three-element beam. BEV is new Emporia call. DSR, DQP, and GCJ are working 144 Mc. UWN has weekly schedule with 70WZ. The Garden City Radio Club now is affiliated with ARRL. RTZ, secy-treas., has two-element 14-Mc. beam. He reports LNW has a pair of 810s on 3.9- and 14-Mc. 'phone. QLK has a pair of 35Ts. TJQ has 807, 3.5 through 14 Mc., and will add a pair 24Gs. LNW, AVR, and QLK are building 829B rigs. LQS has NC240D receiver. New Topeka calls are ZMC, who is active on 28 Mc., and QV, who was old-timer 9QV. He has an ART-13 on the air. ICV has worked all districts on 50 Mc. and has new NC-173. KRZ has portable-mobile rig in new car. AK is active on 7158 kc. with a 6L6. In Wichita, UUS is active on v.h.f., has new antennas for 144, 50, and 28 Mc. BZX has new rig. GWN has new metal tower and rotary beam. With the coming of fall, the Kansas traffic net will resume activities Mon., Wed., and Fri. on 3610 kc. A 6L6 crystal oscillator will do the job. Traffic: W8OAZ 15, BPL 3, KEI 2, LQS 2, AWP 1.

MISSOURI—SCM, Mrs. Letha A. Dangerfield, W8OUD—The summer slump has set in, but here are the reports that were received and they are pretty good. SKA is keeping his 7-Mc. traffic schedules, having trouble with the 7-Mc. rock and trying to get down on 28 Mc. GCL sent in his ORS certificate for endorsement and has his 813 working very well on 7 Mc. According to TXP there now are the following hams in Willow Springs, all active on 7 and 28 Mc.: ANK, ZFL, CBT, AQP, KGP, KCG, and TXP. DEA has his 100THs on the air and spent most of his vacation working on his two fixed beams and the 3.85-Mc. half-wave. GBJ took part in Field Day Contest. CXE got Class B last fall, and has had 721 QSOs with 372 stations in all districts, and some DX, including about 20 watts and now has 811s with more power—all contacts on 28 Mc. ZZW and GEP are roommates at M.U. and have put up two 35-ft. towers. The Central Missouri Amateur Radio Club had a good turnout for Field Day, using auxiliary power, helium balloons to support a 3.5-Mc. full-wave, and a 28-Mc. antenna with others on trees. Operators were CKS, GEP, KHD, UHR, ROB, RMF, BTW, JHH, YKB, and ZZW. FIR had a new NC-173 and a wish for room for an antenna instead of the gutter and down-spout arrangement which ruined his crystals. ZXS is recruiting new members for the traffic net in the fall. OUD is on 3755 kc. and blames the vines on the antenna for failure to get out—conditions not too bad here though. Remember to send in those certificates for endorsement. QXO received the Missouri Traffic Cup for highest traffic score for the year. We regret to add WFK to the list of Silent Keys. Traffic: W8QXO 73, SKA 10, ZZW 6, ARH 2.

#### NEW ENGLAND DIVISION

CONNECTICUT—SCM, Edmund R. Fraser, W1KQY—We regret the resignation of OGQ, our Nr. 1 EC. Club news—BRAC: The club operated on Field Day under call of NKR at Shelton. Operators were LIG, OKT, RY, JMI, JBK, JVM, NOM, AMQ, OS, MHH, OHI, EHI, NUB, MGS, FSY, ODW, KNY, KQT, and NKR. Karvosky, Lehman, and Sanchione assisted. Four transmitters were used simultaneously running up 379 contacts for 6867 points. On 144 Mc. a sixteen-element beam ran up 34 contacts. TCRC: QDR, chief operator, reports JUD, Trinity College station, on the air with 250 watts to 813 final. BARA: JHT operated on Field Day from Bethel. Prizes are being offered for first VE Award, DXCC, SS 'phone and c.w., as well as all other contests. NHARA: GB spent Field Day at Orange making 408 contacts and 7668 points in six-transmitter class. Power was furnished from 10-kw. gas generator, courtesy of Conn. Refining Co. Three 50-ft. portable masts and a flag pole supported eight transmitting antennas. SARA: AZP, OGQ, PLI, KBZ, ASO, and KUO participated in Red Cross message-handling test. Field Day was spent at Nichols. MCA is a new member. News in general—PHW has VFO driving 810 amplifier. MHF has 40-ft. pole with two-element beam. COB is on 3691 kc. JEY has acorn converter. OND has 14- and 28-Mc. beams atop 50-ft. pole. KIO has p.p. 250TH final. KZ5AH wants to contact Connecticut hams. ORP and HFO operated on Field Day under latter call using former's equipment. BDI/1 was on Field Day. JTD, AFB, AOK, ODY, and JMY were also in the group. BEM has 79 post-war countries with ET3Y, FB3AC, UD6BM, ZD2KC.

(Continued on page 94)

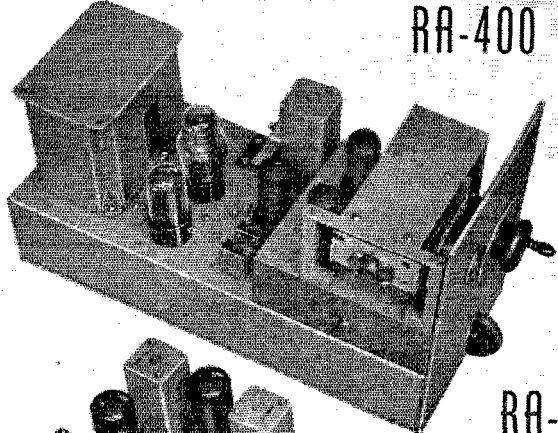
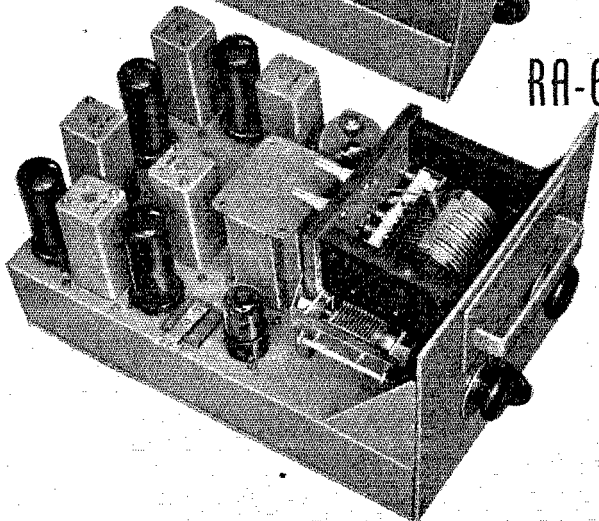
**RA-400****RA-600**

# It's NEW!

## Complete TEMCO 150 WATT

### TWO-UNIT SERIES RA RADIO FREQUENCY PACKAGE

In these RA Basic Chassis Units Temco brings you that rare combination—Revolutionary Flexibility—Mechanical Excellence—Electrical Efficiency and Superb Modern Styling. These two units represent a complete 150 watt R.F. section of a transmitter and may be used as a team for a C.W. Transmitter with addition of proper voltage supply. They can be used by Amateurs to modernize home built equipment or as a complete exciter for 500 and 1000 watt amplifiers. Ask your dealer for complete engineering bulletins.

#### **RA-400 FREQUENCY METER TYPE VFO AND CRYSTAL OSCILLATOR**

This unit consists of a highly stable, temperature compensated Variable Frequency Oscillator followed by a class A isolator and a wide band frequency doubling stage, with complete voltage regulated power supply for all stages. By means of a selector switch, the class A isolator stage functions as a crystal oscillator with provision for two crystals. Approximately 40 volts rms output is obtained from both the VFO and crystal oscillator; more than ample to drive succeeding frequency multipliers. Frequency coverage is continuous from 3.3 to 4.2 mcs. VFO frequency stability is comparable to that obtained from direct crystal control. Resettability is within 100 cycles at the fundamental frequency. Approximately 3000 dial divisions are available for the 500 KC range of the VFO. Plug-in type chassis with all controls mounted on front panel.

#### **RA-600 WIDE BAND MULTIPLIERS AND POWER AMPLIFIER**

The series of amplifiers and frequency multiplier stages preceding the final power amplifier, require no tuning adjustments within a single band of frequencies. Bandpass action is accomplished by coupled circuits, which, once adjusted, require no further tuning. Panel switch for band selection. Final amplifier stage (with either 150 or 250 watt input ratings) employs a panel inserted plug-in inductor. Tuning and vernier loading by panel controls. Frequency range: 3.5-4 mcs, 7.0-7.3 mcs, 14-14.4 mcs, 21-21.5 mcs, 27.1-29.7 mcs. Output impedance range: 50 to 1000 ohms, balanced or unbalanced loads. Those interested in only one or two bands may economize by buying only required sets of coils. Automatic RF input and output connections. All power connections emerge through rear chassis plug.



**TRANSMITTER EQUIPMENT MFG. CO., INC.**  
345 HUDSON STREET • NEW YORK 14, N. Y.

# ARE YOU AWARE OF THESE IMPORTANT ADVANTAGES ?

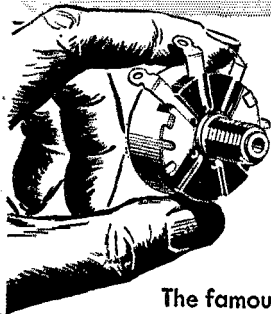

CHECK YOUR  
VOLUME CONTROLS

**NOW!**

① The famous IRC bonded resistance coating assures you the most stable, permanent type of element.

② "Knee-action" five-finger contactor reduces contact noise to a minimum.

③ A simple but unique spiral spring makes a positive electrical connection between rotating contactor and terminal lug.

④ A special steel coil spring washer prevents objectionable shaft wobble and "end play".

Remember these exclusive IRC features when buying volume or tone controls for your set. Say IRC and know that you're getting the best.



Get your copy of the new No. 4 Edition Volume Control Replacement Manual and bring yourself up to date with this amazingly popular and useful handbook. 156 pages. Only 25c at your IRC Distributor.

INTERNATIONAL RESISTANCE COMPANY, Philadelphia 8, Pennsylvania. In Canada: International Resistance Co., Ltd., Toronto, Licensee. I-27

# INTERNATIONAL RESISTANCE COMPANY



(Continued from page 92)

UG6AB, and SU1US as new ones. BGJ handled message from Admiralty Island, delivered and sent reply in fifteen minutes. AMQ is experimenting with 50-ke. multivibrator for frequency checking. IKE is using Meissner Signal Shifter to p.p. 809s with three-element 14-Mc. beam and long wire for low frequencies. EFW is active during the summer on TLC Tuesdays. QAU is operating on 7 Mc. with 6L6-807 rig and BC-348-Q. Traffic: W1AW 216, BDI 84, NJM 78, GB 43, ORP 41, EFW 22, APA 4, BGJ 3, HYF 2.

MAINE—SCM, F. Norman Davis, WIGKJ—SEC: LNI. PAM: FBJ. OHY is on 3963-ke. 'phone and 3764-ke. c.w. LKP is mostly on 3790-ke. c.w. Although the weather was bad during most of the Field Day activities, the groups at Portland and Old Orchard reported having numerous contacts and plenty of fun. The Portland Amateur Wireless Association had a fine write-up of its Field Day set-up in the *Portland Press Herald*. OKU has a four-element beam on 144 Mc. and worked a station on Cape Cod. EFR also reports working Massachusetts stations on 144 Mc. FZ/1 is at Wells Beach. TE and OUN have rigs working on the 144-Mc. band. 2PRW/1, at Pine Point for the summer, is on 28.5-Mc. 'phone. MXT is running 150 watts to a pair of 812s on 3.85-Mc. 'phone. BGZ, now in Baltimore, expects to be back in Maine within a year and gives his regards to the gang in the meantime. Probably the usual summer inactivity accounts for the lack of reports this month, but certainly would like to hear from a lot more of you on the first of the month. Traffic: WINXX 7, EFR 2, OHY 2, PLD 2.

EASTERN MASSACHUSETTS—SCM, Frank L. Baker, jr., W1ALP—We regret to report the deaths of BCF and MNH. LQQ renewed OPS appointment. BHW is Class 1 and 2 OO. FEC and IXI renewed EC appointments. BL renewed SEC appointment. QHC is an OBS and will be on 3528 kc. PUG is on 3.85-Mc. 'phone. QE is on 3.85-Mc. 'phone. RL is on 144 Mc. 3LH/1 is in Boston and on 144 Mc. QA and KPB are on 144 Mc. GGH, RCQ, SH, JHG, ALP, LCF, HJ, PDO, and LLL had 359 contacts for a score of 5877 points on Field Day using LLL's call. BIA will be on 144 Mc. and 3816 kc. from Brewster this summer. PXII and his son won a Collins receiver, BC-625A and a soldering iron at the Framingham Hamfest. To all ECs, don't forget the monthly tests on the last Sunday of each month. Here are the dates for the rest of this year: Aug. 24th, Sept. 28th, Oct. 26th, Nov. 30th, Dec. 28th. The following reported on in the June 29th test: AHP in Fall River; Dedham EC with 11 stations on; MCR, Dorchester; LJT, Brockton, with 8 on; HJ, Wellesley; Newton with 2 on; and 3LH/1 at the Fargo Building in Boston. AYG is on 14-Mc. 'phone and c.w. IVI, FCZ, ERH, and AGC are having a WAS party. NF reports a lot of DX on 50 Mc., he has worked 7 districts and 22 states, has a Workshops three-element beam, and has a television receiver ready. LMB has a tower up. QFR is on 7 Mc. The South Shore Amateur Radio Club held its annual banquet at the Brewster Boat in Quincy with 84 present. The T-9 Club held a meeting at IBF's QTH, and went to Holt's Hill, North Andover on Field Day. DJ is on 50 Mc. The Eastern Mass. ARA held its final meeting for the summer. DKD spoke at the Brockton Club. LQ visited Florida. GEQ is ill at the Cushing General Hospital in Framingham. LVN has five of his fellows with crystals for EMEN on 3745 kc. BDU says the Eastern Mass. Net is fairly active. HJ has an SCR-522 for 144 Mc. WI is modifying Mark II. HUV says that the 50 Mc. Minutemen will be on Sunday mornings during the summer. He had 70 QSOs on 50 Mc. LMU has a six-element beam for 144 Mc. AAA has new Sonar VFX on 28 Mc. BUG also has one for MM work. QDE has one at QTH. PYE is portable on 27 and 28 Mc. at Hull. PNG will be on 27 and 28 Mc. from Tucson, Ariz. LLP has mobile rig on 28 Mc. OGJ is on with Supreme transmitter on 27 and 28 Mc. OEL has new dipole for 27 Mc. AKD, ARN, and EU have n.f.m. on 28 Mc. OJT is quite active on 144 Mc. with a crystal rig. The following have superhets on 144 Mc.: OJT, LJT, PFL, JXM, JPM, and LWI. These chaps have coaxial receivers: HM, MSW, FED, JPM, JQA, LSR, IPE, and HXT. Operators for the Merrimack Valley ARA on Field Day were: BLO, BMO, CBY, CRW, DOO, HGO, IGH, JDU, KNU, KNU, LBE, LEA, LGG, LSX, MCD, MQN, NNG, NON, OHZ, PFA, and PNE. LXQ is on 'phone on 14 and 3.9 Mc. LMU worked 17 stations on Field Day. Members of the South Eastern Massachusetts ARA sent greetings to ARRL from the New Bedford Centennial Exposition. Traffic: W1BDU

(Continued on page 96)



# CONDENSERS...

## ... BASIC TUNING UNITS

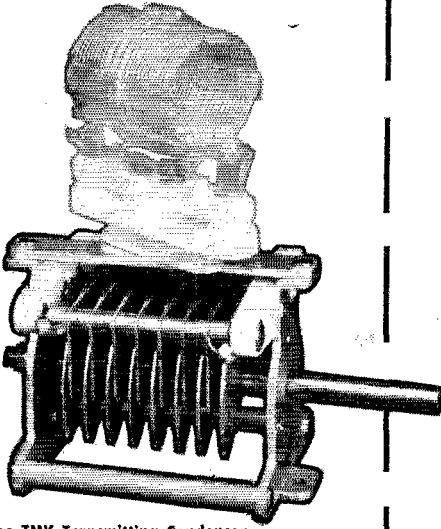

### Type TMK Transmitting Condenser

An ideal condenser for exciters and low power transmitters. Available in single and double stator models. Steatite insulation. Special provision has been made for mounting AR-16 exciter coils in a swivel plug-in mount on either the top or rear of the condenser if desired. Over-all width 2-11/16", height 2-23/32".

Capacity (max.-min.)	Air Gap	Peak Voltage	Length	Catalog
35 mmf.-7.5	.047"	1500v.	2-7/32"	TMK-35
50 -8	.047"	1500v.	2 3/4"	TMK-50
100 -10	.047"	1500v.	3"	TMK-100
DOUBLE STATOR MODELS				
35/35 mmf. 7.5/7.5	.047	1800v.	3"	TMK-35D
100/100-10/10	.047	1500v.	4 1/4"	TMK-100D

Complete List in Catalog

These transmitting condensers should be the basic tuning units of your transmitter designs.

Compact assembly, steatite insulation, sturdy construction, and conservative ratings will enable National condensers to prove their superiority in your transmitter.

Send for your copy of the 1947 National catalog, containing a complete list of variable condensers and some 600 other parts, today.

**National  
Company, Inc.**  
Dept. No. 8  
Malden, Mass.



### Type TMC Transmitting Condenser

Designed for use in the power stages of transmitters where peak voltages do not exceed 3,000. The frame is extremely rigid. Insulation is steatite. The stator in the split stator models is supported at both ends. Over-all width 3-9/16", height 3-5/8".

Capacity (max.-min.)	Air Gap	Peak Volt.	Len.	Cata.
50 mmf.-10	.077"	3000v.	3"	TMC-50
100 -13	.077"	3000v.	3 1/2"	TMC-100
250 -23	.077"	3000v.	6"	TMC-250
DOUBLE STATOR MODELS				
50/50 mmf.-9/9	.077"	3000v.	4 3/4"	TMC-50D
100/100-11/11	.077"	3000v.	6 3/4"	TMC-100D

Complete List in Catalog

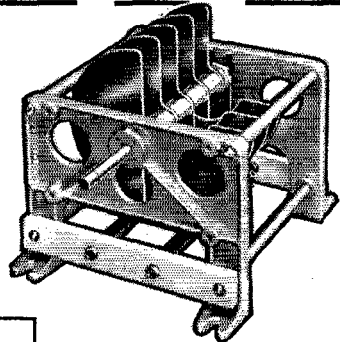

Capacity (max.-min.)	Air Gap	Peak Volt.	Len.	Cata.	
75 mmf.-25	.719"	20,000v.	18 1/4"	TML-75E	
50 -22	.469"	15,000v.	8 3/4"	TML-50D	
500 -55	.219"	7,500v.	18 1/2"	TML-500A	
DOUBLE STATOR MODELS					
30/30 mmf.-12/12	.719"	20,000v.	18 1/4"	TML-30DE	
60/60.	.26/26	.469"	15,000v.	18 1/4"	TML-60DD
100/100.	27/27	.344"	10,000v.	18 1/4"	TML-100DB

Complete List in Catalog

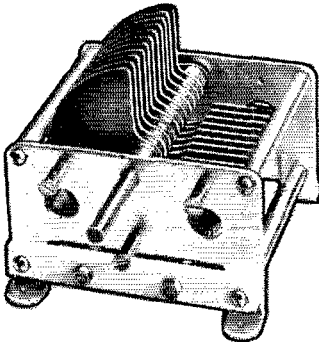

### Type TML Transmitting Condenser

This is a 1 KW job throughout. Special steatite insulators prevent arc-overs. Sturdy cast aluminum end frames and dural tie bars permit an unusually rigid structure. Precision end bearings insure smooth turning and permanent alignment of the rotor. Over-all width 7", height 7-1/8".

MAKERS OF LIFETIME RADIO EQUIPMENT

# Browning Instruments

## New HAM FREQUENCY METER

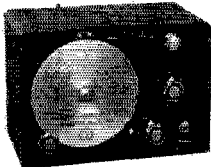

Checks all your operating frequencies with a .05% accuracy. Has direct, frequency-reading dial on seven ham bands. Audio detection of zero beat. Also an accurate ECO with an output comparable to a crystal for driving an exciter. The MJ-9 meter is an essential for your shack.

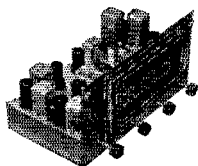

## New BROWNING TUNER FOR FM-AM

Hi-sensitivity unit with Armstrong circuit. Provides distortion-free reception on FM and quality reception on AM. Separate RF and IF systems on both bands. One antenna serves both FM and AM. Tuning eye shows correct tuning.

WRITE FOR DESCRIPTIVE LITERATURE

## OTHER BROWNING INSTRUMENTS

Model RH-10 Frequency Calibrator for full, accurate use of WWV. Model OL-15 Oscilloscope for laboratory work, production testing or research. Model 5-4 Frequency Meter for mobile transmitters.



**BROWNING**  
LABORATORIES, INC.  
WINCHESTER, MASS.

(Continued from page 94)

122, MDU 26, TY 11, PKW 7, WI 7, LM 4, LXQ 2, HJ 1. WESTERN MASSACHUSETTS — SCM, Prentiss M. Bailey, W1AZW — RM: BVR. SEC: UD. BVR attended the State Convention at Framingham. Perce now is fully equipped for emergency power on all bands. BIV has 240 watts c.w. and 'phone and is working out very nicely. COI is operating on 144,045 from his home and occasionally from Greylock. Best DX so far is 75 miles. NKN is on with his super-duper five-band bandswitching exciter. Many attended the State Convention at Framingham. Adams, Pittsfield, Springfield, Fitchburg, and Worcester were all well represented. Field Day was a great day and many in Western Massachusetts participated. The 144 Club of Springfield, at Wilbraham Mountain, ran up a good score and had plenty of fun. The Pittsfield Radio Club on Windsor Mountain doubled its last year's score. 6SRP/1 is the proud papa of a baby girl and EZT is pretty proud of his jr. operator. For you DX boys, the following plea has been issued by Chuck Millen, W1FH, our QSL Manager for the first district. He wants to remind you to send your envelopes to him so he can send out your DX cards. The summer slump has started as is evidenced by the size of this column and traffic total. Hope all of you have a swell time on your vacations. Traffic: W1BVR 32, BIV 6.

RHODE ISLAND — SCM, Clayton C. Gordon, W1HRC — DWO has been DXing on 7 and 14 Mc. AQ says their kw. rig is on the air, a 144-Mc. crystal job and 144-Mc. beam are in the works, and a BC-221 frequency meter has been added, also a new kw. gas-driven generator. Movies of the Field Day activities recently were shown. EJ sits on his screened-in piazza (sans mosquitos) and runs TR-4 with vibrator supply. CPV likes his 6L6-807-PE-103 genemotor FD rig! AOP has an RC-5 7-Mc. FD job. IQJ has 50-Mc. rig mounted on motor block of his Chevie. LAB is on 7 Mc. AWE is DXing on 14 Mc. MNC is mobile on 144 Mc. and ARC-5 c.c. job at home QTH. IFD has new sixteen-element beam. AKA has sixteen-element beam, 400-ft. elevation, but nobody hears him on the air. OPR is on 144 Mc. because of BCI on 28 Mc. BGA is on 144 Mc. with ARC-5 c.c. job. CH came jaunting down from Worcester to help the AQ gang on Field Day, during which they made 140 contacts, had 25 pounds of turkey and all the fixings, 10 gallons of cold milk, five tents, four transmitters, four receivers, six operators, six utility men, one 300-watt, one kw., and one 3-kw. gas-driven generators, at Pascoag Lake. Traffic: W1BTW 22, DWO 11, HRC 5.

VERMONT — SCM, Gerald Benedict, WINDL — Congratulations to all who helped in the Rutland emergency. A very good job was done, typical of ham radio. PYO is new ham in Newport, and has 65 watts to 807 on 3650 kc. CUN has new final on 28 Mc. OAB now is QGF in Burlington and OAB in Chester Depot. 5MKA/1 is in Chester Depot. PAL and NDL report that house-remodeling is bad for ham radio. MCQ and KJG worked from Lake Elmore on Field Day. EKU used his 30-33 and low power 3.85-Mc. 'phone rig. 9WSF/1 now is PJK. QCT is new ham in Stowe area. More Vermont hams are needed for the Vermont Net on 3740 kc. The net will operate at a speed at which all can take part. A flood or other disaster could hit your area. Be ready for it. Have that emergency rig ready. Traffic: W1AAJ 75, MCQ 6, NDL 4, CGV 1, EKU 1.

## NORTHWESTERN DIVISION

ALASKA — SCM, August G. Hiebert, K7CBF — The Arctic Amateur Radio Club, of Fairbanks, voted to cancel meetings until the second week in September. A display and message center will be established at the Tanana Valley Fair as planned, however, with messages relayed. Stateside for interested BCLs. 5KPY/KL7 will be in charge. The Adak Amateur Club has 16 members, and is formulating plans for a 144-Mc. network. W2SLW/KL7 reports 23 Mc. completely dead at Adak. JI just bought a new airplane. Recent visitors at CBF were QT, now back in the Army as a major, and VE5JO, who is on lend lease to AACCS in Alaska. JF is on the air at Waterfall with a pair of 4-250As pumping a lazy kilowatt into a three-element beam on the low end of 14 Mc. CU, plus XYL and two junior YLs, moved bag and baggage to the States, where he hopes to get back his original call, W7EGN. Traffic: KL7BD 46.

IDAHO — SCM, Alan K. Ross, W7IWU — Sandpoint: KDV worked IYG (Nampa) and JJQ (Gooding) on 29-Mc. 'phone. IDA received his Class A ticket. Mountain Home:

(Continued on page 98)

THE NEW

**SHURE**

# "VERSATEX"

## CRYSTAL MICROPHONE



Is Tops Any Way You Use It...

IN YOUR HAND

MODEL 718A

**FOR HOME RECORDING ... COMMUNICATIONS ...  
PAGING SYSTEMS ... LOW COST PUBLIC ADDRESS**

### The Amateurs Want These Features

1. Can be used by itself as a desk stand, on a floor stand, or in your hand.
2. Is the lowest-priced combination microphone—only \$10.00 list.
3. High output. Specially engineered speech response for maximum intelligibility.
4. Has special moisture-proofed crystal.
5. Heavy, rich maroon plastic case—eliminates shock hazard.
6. Contains R-F filter to prevent crystal burnout.
7. The cartridge unit is mounted in rubber to provide mechanical isolation from the case, so that the microphone may be handled or carried about without annoying mechanical noise pickup.

### DELIVERY NOW!

Never before has there been so much microphone value for \$10 list as this.

*Patents applied for by Shure Brothers. Licensed under the Patents of the Brush Development Company*

## SHURE BROTHERS, INC.

Microphones and Acoustic Devices

225 West Huron Street

Chicago 10, Illinois

Cable Address: SHUREMICRO



# Tops for FM

STANDARD BROADCAST  
AND SHORT WAVE

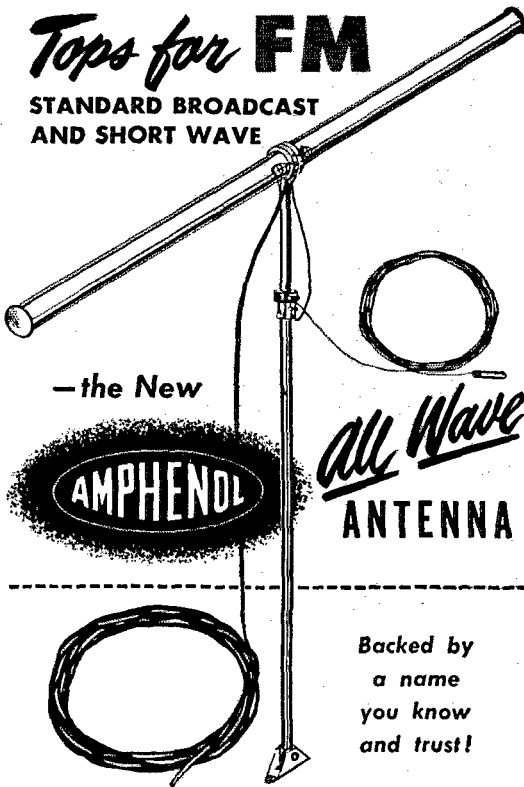

— the New

AMPHENOL

all Wave  
ANTENNA

Backed by  
a name  
you know  
and trust!

- In actual tests, over the 500 kc-108 mc frequency range, the new Amphenol All-Wave Antenna out-gains the best double doublet. It assures interference-free reception, even in areas of low signal strength.
- The All-Wave Antenna combines a horizontally polarized FM dipole with a 65-foot copper wire antenna for standard broadcast and short wave. A special wave filter channels energy to receiver input. A leadin of 52 ohm coaxial transmission line reduces interference to the minimum.
- The All-Wave Antenna is individually packaged for unit sale with installation instructions, all hardware (except guy wires), and a guy wire clamp.

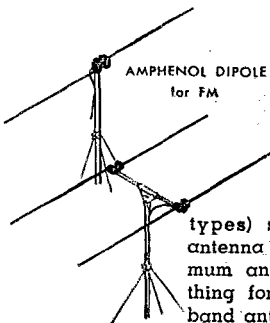

Amphenol Dipole Antennas are available now thru your jobber, or get prices and technical data by writing direct

## AMERICAN PHENOLIC CORPORATION

1830 South 54th Avenue, Chicago 50, Illinois

COAXIAL CABLES AND CONNECTORS • INDUSTRIAL CONNECTORS, FITTINGS AND CONDUIT • ANTENNAS RADIO COMPONENTS • PLASTICS FOR ELECTRONICS

98

(Continued from page 98)

IY/7, as home station, worked eight portable stations during Field Day. Speaking of Field Days, were BDL, HPH, and IWU the only ones out? With fall coming on, we can still get out. Don't overlook the QRP rig on 3.5, 4, or 7 Mc. They really get out OK. Nampa: The Nampa gang was host to Boise at a picnic in the park. Some 144-Mc. activity prevailed between sandwiches. IYG has new 29-Mc. beam, selsyn and motor-controlled, with world globe in shack indicating beam direction. GPM is putting an SCR-522 on 144 Mc. He has a 50-Mc. rig handy, also. Shelley: ACD is going to town on 50 Mc., having worked 19 states and 6 districts. Rig is a BC-625A (transmitter of the SCR-522) with 15 watts to a four-element beam. Traffic: W7EMT 23, IWU 6, BAA 3.

MONTANA — SCM, Albert Beck, W7EQM — SEC: BWH. LCF is back in Lewistown and building a new rig with about 325 watts on c.w. FTO is planning on organizing a radio club in Lewistown this summer. JRM repairs radios in Lewistown. LBK operated portable on 7 and 3.5 Mc. from the Boy Scout Camp on the East Boulder River July 7th to Aug. 7th. FTX and FGR are back in Montana and located at Hamilton. They are working 28 Mc. at the present time and are going to build a new home across the lot from FDG. Les is proud of his new beam antenna. Look for the red and black ring design when in Hamilton. The California fellows are eager for the W7s to create a few more nets so they can have a positive out to rout their traffic this way. There seems to be a bottleneck, especially in Montana. The Butte Club participated in the June Field Day event about seven miles south of the city. Hope to see a lot of the gang at Waterton Lakes.

## PACIFIC DIVISION

HAWAII — SCM, John Souza, KH6EL — The Oahu Radio Club had Lee Dawson, of FCC, as speaker at a big meeting, with LP taking home the crystal mike as one of the seven door prizes. DU completed new 14-Mc. beam. AW's red and white tower spouts dual 10-20. MI is on 14 Mc. with 610. W1QDS/KH6 finally worked Massachusetts. BD schedules GP, at Hilo, from Kaawa on 3.85 Mc. during week ends. GH QSOed W4DQA for two hours solid 89 on 28-Mc. 'phone on July 4th. BX went back to two-element beam on 14 Mc. The 3.85-Mc. gang is very active at about 7 p.m. with all islands represented. FC has double three-element beam on 28 Mc. CY still is feeling lumber shortage on his beam for 28 Mc. BW has modernized prewar receiver with the addition of limiter and 600-ohm audio output. IJ saw his kw. modulation transformer go up in smoke. The Maui Amateur Radio Club had an enjoyable outing on Field Day with 12 members present. Traffic: KH6DF 14.

NEVADA — SCM, N. Arthur Soule, W7CX — Asst. SCM, Carroll Short, jr., 7BVZ. SEC: JU. ECs: OPP, TJJ, KEV, QYK, and JLV. RM: PST. PAM: KHU. OBS: JUO. OES: TJI. 7WVZ, ex-9WVZ, is eager to get lined up in a traffic net. LCK is on 7 and 3.5 Mc. with an 807 and will be on 50-Mc. c.w. from Nevada. BNX has new final with pair of 35Ts. VMP is on 28 Mc. with 30 watts when the band is open. KHU reports lots of traffic. QAY has a BC-221. 6ZTM/7 is new to the Silver State. PWE is active on the Sagebrush and Mission Trail Nets. OPP visited 6GRL, operated by 6HBD while Doc is in XU Land. JUO lost his 14-Mc. beam in a recent wind storm. KJQ is DXing on 14-Mc. c.w. and will be another Nevada 50-Mc. station soon. 7YN had a number of transmitters on for Field Day at 9000-ft. altitude near Reno. JU and KJQ were on Mt. Charleston near Las Vegas. Traffic: W7KHU 146, JU 42, CX 29, OPP 17, KLK 3, KCE 1.

SANTA CLARA VALLEY — SCM, Roy E. Pinkham, W6BPT — Asst. SCM, Geoffrey Almy, 6TBK. RM: CIS. PAM: QLP. The SCCARA has lost another of its officers with the resignation of HGW. Tom has moved to Sacramento. MUR has been appointed to fill out the term as treasurer. CFK and BPT both had their vacations beginning the last week in June. KG now has his micromatch calibrated and is measuring standing waves on his feed line. TBK has a new 28-Mc. beam which is putting a fine signal into KH6 Land. LCF found shorted padder in his HRO. BHH converted his beam using eight wires in the driven section and reports very fine results. JWT has a DM-36 working on 50 Mc. Hope he gets transmitter on to enjoy the skip on the band. WUI is one of the operators at b.c. station KEEN. DZE schedules J3GNX every morning at 2 a.m.

(Continued on page 100)

# REGULATION

§12.136. LOGS. Each licensee of an amateur station shall keep an accurate log of station operation, including the following:

(a) The date and time of each transmission. (The date need only be entered once for each day's operation. The expression "time of each transmission" means the time of making a call and need not be repeated during the sequence of communication which immediately follows; however, an entry shall be made in the log when signing off so as to show the period during which communication was carried on.)

(b) The signature of each licensed operator who manipulates the key of a radiotelegraph transmitter or the signature of each licensed operator who operates a transmitter of any other type and the name of any person not holding an amateur operator license who transmits by voice over a radio-telephone transmitter. The signature of the operator need only be entered once in the log, in those cases when all transmissions are made by or under the supervision of the signatory operator, provided a statement to that effect also is entered. The signature of any other operator who operated the station shall be entered in the proper space for that operator's transmission.

(c) Call of the station called. (This entry need not be repeated for calls made to the

same station during any sequence of communication, provided the time of signing off is given.)

(d) The input power to the oscillator, or to the final amplifier stage where an oscillator-amplifier transmitter is employed. (This need be entered only once, provided the input power is not changed.)

(e) The frequency band used. (This information need be entered only once in the log for all transmission until there is a change in frequency to another amateur band.)

(f) The type of emission used. (This need be entered only once until there is a change in the type of emission.)

(g) The location of the station (or the approximate geographical location of a mobile station) at the time of each transmission. (This need be entered only once provided the location of the station is not changed. However, suitable entry shall be made in the log upon changing the location. Where operating at other than a fixed location, the type and identity of the vehicle or other mobile unit in which the station is operated shall be shown.)

(h) The message traffic handled. (If record communications are handled in regular message form, a copy of each message sent and received shall be entered in the log or retained on file at the station for at least 1 year.)

*The*

Convenient    ∨ ∨ ∨    Complete

## ARRL LOG BOOKS

Regular Log, 8½ x 11 • 50 cents each

Mini-Log, 4 x 6¼ • 25 cents each

*American* RADIO RELAY LEAGUE

WEST HARTFORD, CONNECTICUT, U.S.A.

**SILVER****75 WATTS CW  
30 WATTS AM  
PHONE**

**W2RNB TELLS** the story of Model 701 Transmitter: "I work for Electronic Marketers, Inc., and when the 701s come in I immediately tack one home to test. The results were as follows: With a 40-meter Zepp antenna I worked F8SF, 559; ON4SU, 589; UA3AF, 579; P21AL, 599X. Power input was approximately 45w with 500v on the 807. Freq. 14138."

Only 5" x 5 1/2" x 10", MODEL 701 covers 80, 40, 20, 16, 11, 10, and 6 meter bands . . . hardly drops output at all even when quadrupling xtal frequency. 6AQ5 triode oscillator drives one 807 up to 75 watts CW input. Push-pull 14-watt 6AQ5 modulator gives 100% phone modulation of 28 to 30 watts phone input. Ideal for your main station, perfect for portable, mobile and emergency work, price of this little demon is only \$36.95 less power supply, tubes, xtal . . . with plug-in coils only 50c each.

## "MICROMATCH"

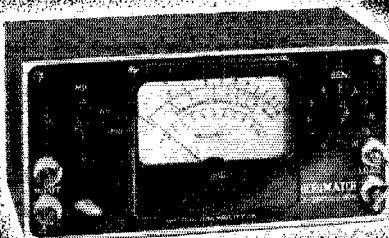

**APRIL, 1946 QST** said of MICROMATCH — "simply astonishing." It's a new meter which, connected in your feeders . . . in any link coupling line . . . measures standing-wave ratio directly. MICROMATCH lets you determine what happens to the power your transmitter generates. It will surprise you by proving how little really gets into your antenna. With MICROMATCH you can probably double, triple, possibly quadruple power into your antenna . . . where it alone does good. Same size as 701 Transmitter, with big 4 1/4" meter, fully tested, range 1 through 1,000 watts, 3 through 30 mc., 50 through 300 ohms impedance, it's the biggest transmitter efficiency guarantee money can buy. Only \$29.90 net.

Mail penny postcard for NEW, 16-page catalog of amateur and measuring equipments.

OVER 36 YEARS OF RADIO ENGINEERING ACHIEVEMENT

*McMundo Silver Co., Inc.*

1249 MAIN ST., HARTFORD 3, CONNECTICUT

(Continued from page 98)

for traffic. Anyone having messages going to Japan can reach Byron at his home QTH, or phone Col. 4115-M. JSB keeps schedule with KALHR for traffic going to the Philippines. Both ZZ and TBK have worked Nevada on 28-Mc. 'phone for their WAS on that band. The following stations in this section have been very active on 50 Mc.: OVK, YX, IWS, GGM, CCJ, and BPT. PBV is mounting his rig in two relay racks so he has been off the air. BO checks into the Mission Trail Net and handles traffic going to the Pacific Islands. Traffic: W6JSB 72, DZE 20, VZE 19, ZZ 3, TBK 2.

EAST BAY — SCM, Horace R. Greer, W6TI — Asst. SCM, C. P. Henry, 6EJA. SEC: OBJ. RM: ZM. EC: QDE. Asst. EC u.h.f.: OJU. UPV and IKQ plan to install Collins ART-13 rigs in their autos. EJA, QDE, and LMZ hold up the Richmond gang with DX on 14-Mc. c.w. MHB worked AC4YN on 14-Mc. c.w. 7HXG/6 now is 6HXG. RM, UZX, WJX, LDD, MBK, MVQ, and IDY are looking for rare DX. TT now has 125 postwar countries, TI 105, and PB 104. BUY worked some of the gang on 3.5-Mc. c.w. from Tahoe while on vacation. ITH is doing all right on 14-Mc. 'phone DX. On June 12th the Northern California DX Club, Inc., elected IKQ, pres.; BUY, vice-pres.; and EJA, secy-treas. The following members of the SARO did a bang-up job on Field Day: 144 Mc. — RBQ, IPK, 60 Mc. — VBJ, 28-Mc. c.w. — EHS, EY, CVL. 3.5-Mc. c.w. — ZA, WTI. 14-Mc. 'phone — HE, CHE, BS. 14-Mc. c.w. — BET, SC, CEO. 40-Mc. c.w. — CFM. GTI. 28-Mc. 'phone — OMC, IVZ. The Mission Trail Net has its stations divided into divisions which seem to be working out. F.B. The Oakland Radio Club, Inc., is planning a big hamfest in September. The Vallejo, Mare Island, and Mt. Diablo Radio Clubs are making good progress. ELW is making plenty of noise on 14-Mc. 'phone with his 250TH final. PZ is knocking over DX on 14-Mc. c.w. QXN won the Hammond Memorial Bug for handling and reporting the most traffic in six-months period from January to June. This award will be made to an East Bay section member each six months. Report your traffic each month, gang. SS is putting up new three-element beam. WP is putting up a new high doublet antenna so he can work something besides Js. EVQ is happy to hear that his PA9 friend is on the air with the equipment he sent to him. OCZ has been operating portable with a GF-11 from Guerneville. ZA is planning to increase power to 200 watts. BGY is on with a GF-11. UMZ is getting ready to install a pair of 257Bs with three-element 28-Mc. beam. UT has new 64-ft. tower. SSN will be on soon with one of his new 1-kw. Winsby-Fleming transmitters. MFZ is getting set with new portable 28-Mc. rig in the car. QBL is back on the air after his illness. CZQ has new QRA and will have new antenna system. OBU is playing with surplus gear. AED had GF-11 on vacation. WCQ now has 39 countries. YDI is building new final with HK257B. KEK is trying new twin-lead beam. Traffic: W6QXN 117, TI 15, YDI 10, EJA 4, KEK 2.

SAN FRANCISCO — SCM, Samuel C. Van Liew, W6NL — Phone JU 7-6457. Asst. SCM, Joseph Horvath 6GPB, RM: RBQ. SEC: PTS. CEC: SRT, KNZ. The Humboldt Amateur Radio Club in Eureka moved to a new location. Membership is growing steadily. The club can be contacted through Julio Sannazzari, CWR, 1336 B Street, Eureka, Calif. CWR has added an 813 to his final. NAO is building new test gear. MHF has been doing fine work on 14-Mc. c.w., having WAC, WAS, and over 100 countries worked since Feb. '47 in spite of low power of 10 watts. He uses a modified eight-element flat top beam. ITA, from Los Angeles, visited RBQ. Apparently good radio conditions and also good weather are again attracting Southern California hams to San Francisco. ZF and ZS, both of Sacramento, visited RBQ and San Francisco. ZF has new 30-watt portable rig. WB still is high DX man in San Francisco area with over 130 countries to his credit. BIP is recovering from a sprained ankle. More reports on Field Day were received from the SARO. Its 144-Mc. rig was furnished by RBQ, also sixteen-element rotary beam. The 144-Mc. operators were RBQ and IPK. 50-Mc. used a three-element rotary beam. VBJ furnishing the equipment and operating. 28-Mc. c.w. used a "J" antenna. Operators were EHS, EY, and CVL. 28-Mc. 'phone used three-element rotary beam. Operators were OMC and IUZ. 14-Mc. c.w. used a doublet antenna with good results. Operators were CEO, BET, and SC. 144-Mc. 'phone used three-element rotary with fine results. CHE, HB, and BS operated. 7 Mc. made use of a "V" beam to build up a nice score. CEM and GTI operated. 3.5-Mc. c.w. used a folded doublet with three-hundred-ohm

(Continued on page 104)

# KENYON T-LINE ADDITIONS

## For Amateur and Industrial Use!



### KEN-O-TAP UNIVERSAL DRIVER TRANSFORMERS

500 Ohm Line to any Class B Grids

Primary to Secondary Ratio Variable from 1:13.3 to 1: .7

Type	Power Rating	Case No.	Weight	List Price
T-261	7 Watts	3A	2¾ lbs.	\$ 9.70
T-262	18 Watts	4A	5¼ lbs.	13.20

Any Line or Single or Push Pull Plates to Class B Grids

Primary to ½ Secondary Ratio Variable from 7.0:1 to 1:9.0

Type	Audio Rating	Case M Size	Max. Pri. D.C.	Max. Sec. D.C.	Weight	List Price
T-264	7 Watts	3A	100 MA	100 MA	2¾ lbs.	\$ 9.95
T-263	18 Watts	4A	200 MA	200 MA	5¾ lbs.	15.25

### FILAMENT TRANSFORMERS

Primary 115 Volts, 50 to 60 Cycles

Type	Sec. Rating	Insul. Test	Case No.	Weight	List Price
T-393	5/5.1/5.25 V. — 26 ACT	2000 V.	5A	9½ lbs.	\$17.30
T-394	5/5.1/5.25 V. — 32 ACT	2000 V.	5A	10½ lbs.	18.65
T-395	6.3 V. — 20 ACT	2000 V.	5A	9 lbs.	15.30
T-396	6.3 V. — 30 ACT	2000 V.	5½A	12 lbs.	21.00
T-397	6.3 V. — 12 ACT	2000 V.	4A	5¾ lbs.	10.90

### PLATE TRANSFORMERS

Primary 115 Volt, 50 to 60 Cycles

Type	Primary Conn.	Secondary Volts		M.A. D.C.	Case No.	Weight	List Price
		D.C.	A.C.				
T-673	High	3000	3400-0-3400	400	10A	82 lbs.	\$110.00
	Low	2500	2840-0-2840	500			
T-674	High	3000	3400-0-3400	800	Special	135 lbs.	155.00
	Low	2500	2840-0-2840	1000	End Castings		

These Units are designed for Continuous Duty on Low Voltage Taps at 85% of D.C. Current Rating.

### REACTORS

Type	Inductance At Rated D.C.	Rated D.C. MA.		D.C. Resistance	Insul. Test	Case No.	Weight	List Price
T-180	10	500 MA.		60	7000 V.	8A	26¼ lbs.	\$43.00
T-181	5	1000 MA.		18	7000 V.	9A	50 lbs.	63.00
T-530	6/20	500/50 MA.		60	7000 V.	8A	26¼ lbs.	43.00
T-531	3/10	1000/100 MA.		18	7000 V.	9A	50 lbs.	63.00

### KEN-O-TAP MODULATION TRANSFORMERS

Type	Audio W. Pri.	Class C W. Sec.	Max. Pri. D.C.	Max. Sec. D.C.	Max. D.C. Voltage	Primary Range Ohms	Sec. Range Ohms	Case No.	Weight	List Price
T-441	125	250	250 MA.	250 MA.	1500	2000-20000	200-20000	6A	15½ lbs.	\$25.20
T-442	600	1200	400 MA.	400 MA.	3000	500-18000	200-19000	9A	45 lbs.	67.50

YOUR INQUIRIES ARE INVITED. WRITE TODAY FOR FURTHER DETAILS.

# KENYON TRANSFORMER CO., Inc.

840 BARRY STREET  
NEW YORK 59, N. Y.

# The New MEISSNER

## ...the outstanding variable

With more amateurs going on the air almost daily, the ability to dodge QRM has become of utmost importance. As the ham bands become increasingly crowded, amateur operators all over the world have come to regard the Meissner Signal Shifter as their most useful single piece of equipment. Built-in band switching, all controls on front panel, crystal control on all bands plus many more new, exclusive features all combine to make this new instrument the finest variable frequency exciter ever offered. At your dealers or write to the address below for full information.

**Meissner Signal Shifter (Model EX), less all coils and less power supply but with aluminum strips attached to turret.**

Amateur Net . . . . . \$66.50

**Power Supply Only (Model PX),**

Amateur Net . . . . . 13.00

**Coils, per set**

Amateur Net . . . . . 4.00

### CHECK THESE FEATURES:

**BAND-SWITCHING** is accomplished by a six position shielded turret.

**CRYSTAL CONTROL.** Not only does the Shifter function as a variable frequency oscillator, but by plugging in a suitable crystal it may be converted into an excellent crystal controlled exciter for any band (especially desirable for net operations).

**TUNING.** Only two controls select any operating frequency; the band selector switch to move coil strip into position and the precision vernier control to rotate the ganged condensers. Illuminated dials for 0-500 calibration. Exceptionally stable.

**KEYING.** Two jacks for CW or phone. May be keyed in oscillator or amplifier circuits. Tuning eye checks keying.

**POWER.** Input 110V 60 cyc. AC. Output in excess of six watts.

**TUBES.** 6V6GT/G oscillator doubler, 807 amplifier-doubler, 2-5Y3 high voltage, 0D3/VR150 osc. voltage reg., 6U5/6G5 tuning eye.

**COUPLING.** Output impedance 300 ohms. Coupling possible into grid circuit of single-ended or push-pull stage of transmitter; into crystal stage with crystal removed; into plate tank of crystal oscillator with tube removed.

**CABINET.** Gray-wrinkle metal, 13 13/16 by 13 1/4 by 8 3/4.

# Meissner

ELECTRONIC DISTRIBUTOR AND  
INDUSTRIAL SALES DEPARTMENT

**MAGUIRE INDUSTRIES, INCORPORATED**

936 NORTH MICHIGAN AVENUE, CHICAGO 11, ILLINOIS



# SIGNAL SHIFTER

*frequency exciter*

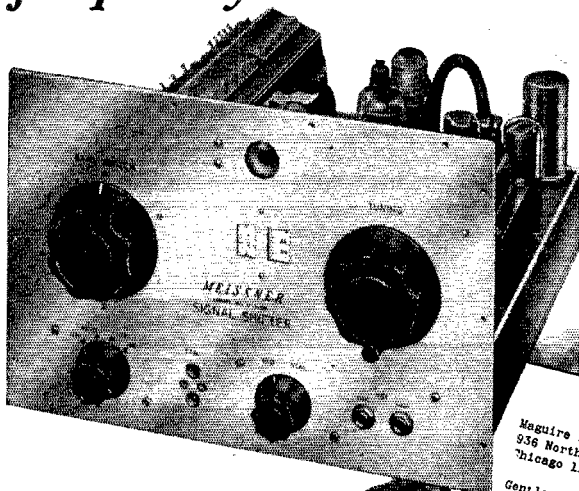

*Plays  
Important Role  
In Texas City  
Disaster*

Maguire Industries, Inc.  
936 North Michigan Ave.  
Chicago 11, Ill.

c/o CAA Box 779  
Galveston Texas  
April 20, 1947  
WSKVM

Gentlemen:

I know you will be interested to learn what an important role your Meissner Signal Shifter has played in the recent Texas City disaster; Three days ago I got delivery on my new Meissner Signal Shifter, #3007, Series 712. I had just about gotten it out of the box and was temporarily checking it into the xtal stage of the xmitter for 75 meter zone work when the shack was rocked by the explosion from the first blast of the Texas City disaster. At first we did not know what had happened except that we could see high flames and black smoke mushrooming like an atomic cloud over Texas City, nine miles away.

Another terrific explosion followed on the heels of the first and we immediately listened in on the BC band. In a few minutes our local radio station here in Galveston advised us that a ship had blown up in Texas City. We immediately got on 75 zone and inquiries started to pour in from Houston Texas, 50 miles away. WSPQQ started out for Texas City and was soon set up over there on 75 zone. At that time I was the only "out" known on 75 zone and 5PQQ the only means of communication into Texas City. Thus, in those first few hours, our two stations were the only means of communication between the stricken city and Galveston.

To make a long story short, your Signal Shifter stayed in operation, in my station WSKVM, for two solid days of continuous operation without "missing a beat". In that time we handled close to 1000 messages and utilized three radio operators, 2 clerks, 1 shorthand company and two others on the special lines that the telephone company ran into WSKVM for us. I don't know what we would have done without the Shifter since, previous to purchasing it, I had always operated xtal control and thus would never have been able to have operated the clear channel of 3860 Kcs assigned to us by the FCC.

Very truly yours,

Julius J. Bamberg WSKVM

EXPORT ADDRESS—SCHEEL INTERNATIONAL INCORPORATED  
4237 NORTH LINCOLN AVENUE, CHICAGO 18, ILLINOIS—CABLE HARSHEEL

# FM MODULATOR EXCITER

MODEL  
FMO-428

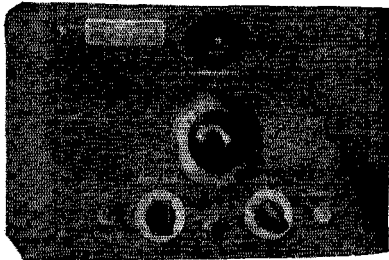

A perfect ECO Exciter for any amateur transmitter. Reactance Modulator for narrow band FM. Output on 80, 40, 20 and 10 meters. Visual indication of frequency deviation. Self contained, regulated power supply. Provision for CW keying. (FM permitted at present on 10 meters and above 29 megacycles.)  
Amateur net price..... \$79.50

# HF CONVERTER

Model HFC 610

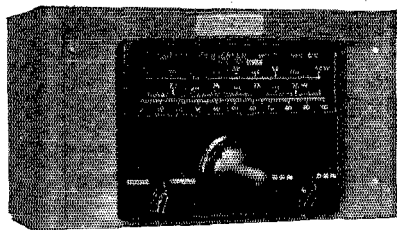

Two ranges: 27 to 30 megacycles and 50 to 54 megacycles. Embodies a 6AK5 high gain RF amplifier stage, a 6AK5 mixer, and a 6C4 stable oscillator. Self-contained, regulated power supply. Provides sharp tuning and separation between stations. Low internal noise. Image-free reception. Smooth tuning, directly calibrated dial.

Amateur net price, complete..... \$79.50

Write for Bulletin Q9 describing high gain 6, 10, and 11 meter Frequency Converters, and also FM Modulator Exciter.

Sold through Leading Jobbers.



**COLUMBUS ELECTRONICS**

229 So. Waverly Street, Yonkers, N. Y.

Designers & Manufacturers of Amateur Equipment

(Continued from page 100)

twin lead. ZA and WTI were operators. 3.85-Mc. phone used an aluminum sky wire, a Collinear two half-waves in phase. Operators were KPO, KQQ, QWX, and NZY. Relief operators were AER, NZY, MUC, DDO, AVX, CBX. Photography was by CBF and CMZ. From all reports received a swell time was had by all clubs and individuals who participated in our recent event. Thanks for all the reports.

SACRAMENTO VALLEY — SCM, John R. Kinney, W6MGC — Asst. SCM, R. G. Martin, 6ZF. SEC: KME. RM: REB, OES: PIV. The Mt. Shasta Radio Club is planning a hamfest on Sept. 27th and 28th to outdo previous hamfests. The activities program will start at 10 A.M. Sunday, the 28th. Opportunities will be had for 50-Mc. v.h.f. records at the 8000-foot level at Panther Meadows, located at Mt. Shasta. Many FB prizes are to be given. OMR, Box 303, Mt. Shasta, Calif., is activities manager. The Golden Empire Radio Club held its first annual hamfest on June 22nd, with the following cities represented: Chico, Corning, Willows, Oroville, Paradise, Butte City, Hamilton City, Mt. Shasta, Redding, Susanville, Burney, Yuba City, Marysville, El Cerito, Sacramento, and San Francisco. Fifty-two licensed hams registered. Prizes were won by all who attended. YQC won a new Meissner Signal Shifter, UIE a Turner mike, WVR and DPL both won 304TLs, ATQ a BC-348A. TUT a crystal kit, LYQ an Eimac 4-250A, 9CEB/6 a 4E27, WCC an auditorium Jensen speaker, GUV an HK-57. There sure was plenty to eat and drink for everybody. Our SEC, KME, tells us that on June 26th the first 50-Mc. Sacramento Valley emergency net was formed and put into operation with the following members: AK, QYQ, MYL, PEI, PIV, GZY, DLB, MIW, UYO, WSI, OVK, TYW, BLP, MYQ, and KME. Drills are held every 4th Thursday. KME is looking for additional ECs and Asst. ECs. Thanks to REB, AF, VDR, OJW, and GUV for reports. Traffic: W6REB 546, VDR 199.

## ROANOKE DIVISION

NORTH CAROLINA — SCM, W. J. Wortman, W4CYB — If you missed the hamfest in Asheville you really did lose out on another "good-un." Good feed and, believe it or not, everyone there received a prize in the drawing, and then enough prizes were available to start out all over again so that several received two. The next one will be the old Floating Club meeting with the Charlotte gang the first Sunday in October. Start making your plans now to attend this one. It seems as if activity really did go down this month. Have heard indirectly that the Greensboro and Winston gangs did some swell work in the Field Day activity. Charlotte was active at the new club house out at Morris Field and made quite a nice record. DSO has been in the hospital, but is up and active on 28 Mc. again. HVV and WMI are going to town on 50 Mc. BYA must be doing swell on 28 Mc. because plenty of fellows are heard calling him, but what happened to that report for this month? DCW/EFE is the proud possessor of an OW. He has just traded his free and easy bachelor's existence for that of an old married man. I know the whole gang will join me in regretting the untimely death of BX. Gordon will be missed by the fellows. If you don't have reports you ramble on a bit, and then stop writing. How about some stuffing for this space? Look at the dates of your official appointments and see how near they are to renewal time. Traffic: W4CAY 12.

SOUTH CAROLINA — SCM, Ted Ferguson, W4BQE/ANG — DPN is to be found on 3.85-Mc. 'phone. FNS has just taken unto himself a wife. Is ham radio out, Hugh? AZT is operating 3.85-, 14-, and 28-Mc. 'phone. BSS reports that he is dividing his time between 3.85 and 14 Mc. To H. A. Morris and Timothy Roper, I am indebted for the following news from Greenville: "FNS got hitched June 14th. IRU is on 28-Mc. 'phone and 14-Mc. c.w. KZ was active in the preparations for 144-Mc. 'phone and Field Day operation in the name of the Greenville Ham Club. IMW is on 3.85- and 28-Mc. 'phone. EMT is on 3.85-Mc. 'phone. There is plenty of 28-Mc. activity here. ILQ, ILY, ITP, KMK, KED, KEC, HWZ, ETC, HGB, JHG, HTT, (XYL), IMW, and 5IQH/4 just finished a club class for beginners with three awaiting licenses. MAF is a new ham on 28 Mc. LPB is home from school. 5IQH/4 and hams at the Greenville Army Air Base pooled field equipment with the Greenville Ham Club for Field Day operations atop Paris Mountain. IPD and CCU are new hams on 28 Mc.

(Continued on page 106)

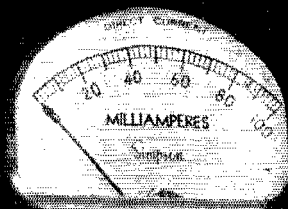

**Here's a new way  
to read meters  
...in the dark!**

How often have you wished for a meter you could see *clearly*—the whole scale of it, wherever you were using it—in the dark, under low lights, or even in the kind of glare that causes reflections on the glass—a really illuminated meter for your transmitter? Well, here it is—the result of a new Simpson patented method of illumination.

On these new Simpson Illuminated Meters (A.C. and D.C. voltmeters; D.C. milliammeters; and Radio Frequency ammeters), every fraction of the dial face is flooded with a full and even radiance—there isn't a spot of shadow.

An ingeniously shaped Lucite cone carries the light from a recessed bulb in the back of the instrument through the front edge that surrounds the entire dial. This makes possible the use of the standard Simpson metal dial. Unlike translucent dials, it cannot fade or discolor so that reading becomes difficult. It cannot warp or buckle, causing the pointer to stick, or distort readings. The bulb recess is neoprene sealed.

Behind this refinement to the basic reason for preferring Simpson instruments—their in-built accuracy. That high quality which is the indispensable component of every Simpson instrument makes sure that the accuracy will *stay* there, year after year.

**ASK YOUR JOBBER**

3" Rectangular Case. Width, 3"; height, 3-1/8". Mounts in round hole. Body diam. 2 3/4".

2" Rectangular Case. 2-3/8" square. Mounts in round hole. Body diameter, 2-3/16".

**SIMPSON ELECTRIC COMPANY**  
5200-5218 West Kinzie St., Chicago 44, Ill.  
In Canada, Bach-Simpson Ltd., London, Ont.

**Simpson**

INSTRUMENTS THAT STAY ACCURATE



**THE NEW SIMPSON  
MODEL 240  
"HAMMETER"**

1947 version of the first self-contained pocket portable instrument built expressly to check high voltage and component parts of transmitters and receivers.

Ranges: 0-15, 150, 750, 3000 A.C. volts; 0-15, 75, 300, 750, 3000 D.C. volts; 0-15, 75, 300, 750 D.C. milliamperes; 0-3000 ohms (center scale 30). 0-300,000 ohms (center scale 3000); 1000 ohms per volt A.C. and D.C.

# New! Munger ELECTRO-BEAM ROTATOR

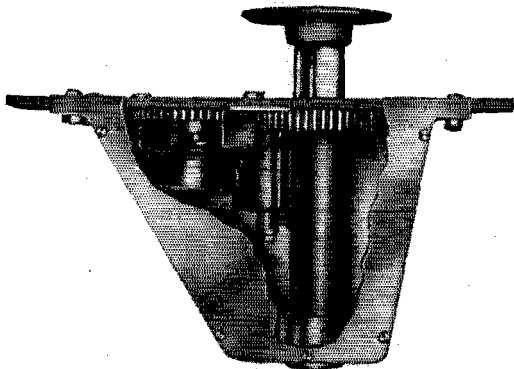

PRICED AT ONLY

**\$69.50**  
COMPLETE

F.O.B. Chicago, Illinois

● Price Includes Reversible Electro-Beam Rotator and Direction Indicator.

● Foolproof Potentiometer and Meter Circuit. Calibrations in Both Degrees and Directions.

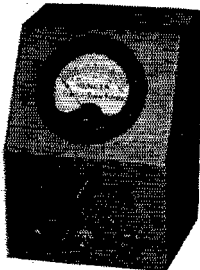

## A BIG VALUE—

### Immediate Delivery if You Order Now!

When you see the many fine features of my new Electro-Beam Rotator, you'll be as pleased as I am. And you'll feel good too, because it's such an honest value—priced low because we kept you in mind constantly through all the stages of design, engineering and testing. Now that it's ready for delivery, you can take my word that it's a real honey. About the specs: 1 R.P.M.—115 volts, 60 cycle operation. Powerful reversible motor drives main shaft through heavy steel gears. Lifetime Oilite bearings. Mechanism is completely weatherproofed—housed in sturdy non-rusting duraluminum case. All parts accessible for easy inspection. Rotator mechanism weighing only 10½ lbs. makes it easy to mount. Top mounting plate 10" x 12".

### 10 Day Free Trial Offer

Send your check for \$69.50 for one Electro-Beam Rotator complete with Direction Indicator. You pay small express charge upon arrival. Try it at my risk for 10 days. If you are not completely satisfied in every way, return the units undamaged in their original carton and your money will be immediately refunded in full. You take no chances. Order your Munger Electro-Beam Rotator today!



W9LUP

Illustrated Bulletin on Request  
**MANUFACTURED AND SOLD  
EXCLUSIVELY BY**

**Rex L. Munger Company**

4701 Sheridan Rd., Chicago 40, Illinois

(Continued from page 104)

KMK is looking for 50- and 144-Mc. contacts. KQV is on 7- and 14-Mc. c.w. LRA and KTS are on 7-Mc. c.w." WEST VIRGINIA — SCM, Donald B. Morris, W8JM — Congratulations to the Charleston (KVARA) Radio Club for a successful hamfest. More than 200 attended and there were prizes for all. V06K attended and was kept busy renewing acquaintances made during the DX Contest. GBF and CSF lined up the 3770-kc. West Virginia Net members with activity starting Oct. 1st. MOL, recovering from illness, has new 3.85-Mc. antenna. AHF is new EC for the Huntington and Cabell County area. While on vacation NY4AC visited JM and arranged schedule for messages home. For those working toward WACWV, ZBK now is active in Wyoming County. It is with regret we record the death of Charles Handy, for many years secretary of the MARA. ATI is a new amateur in Clarksburg. PQQ has new postwar DXCC Certificate obtained with one of those antennas, the exact length of which you like to know. While on MARA Field Day SPY/TDJ worked Texas and Nova Scotia on 50 Mc. YBQ and YBO are rebuilding for fall activity. JLL has 500 watts on 3.85 Mc. after a long layoff. If interested in the EC emergency program, drop me a card and information will be sent you. Traffic: W8GBF 27, OXO 19, JM 9, CSF 5, FMU 2.

### ROCKY MOUNTAIN DIVISION

UTAH-WYOMING — SCM, Alvin M. Phillips, W7NPU — The Shy-Wy Club spent quite a lot of time working out plans for Field Day. KIY has received his A-1 Operator certificate and is handling traffic and rag-chewing on 7060 and 7140 kc. BED is active on 3.5, 7, and 14 Mc., working traffic, rag-chewing, and DXing. He also is working on organization plans for the Utah Net which soon will be in full swing. 4GFC/7 and 7UOM were in charge of electronic equipment at the Western States boat regatta held at Pine View Lake in Ogden July 5th. HDS has made out message forms for the fellows at the Veterans Hospital to use in contacting their loved ones. She has offered to handle all of their messages. DLR has an 815 on 50 and 144 Mc., VFO crystal, n.f.m.-a.m. He has an 813 for 3.5-Mc. c.w. traffic. 4GFC has moved to Clearfield and worked his first J. UOM has 55 countries. Fellows, there are several important appointments to be made in our section. All active and interested members are invited to write to the SCM for information and applications. Traffic: (May) W7KIY 22. (June) W7HDS 18, JHL 14, EVH 6, BED 4.

### SOUTHEASTERN DIVISION

EASTERN FLORIDA — Acting SCM, W. E. MacArthur, W4BYF — SEC: JQ. Asst. SEC: FWZ. RM: BNR. PAM: JQ. HAW's hamfest was one of the best ever. IUJ received the Milwaukee Cup and the Club replaced it with another trophy for WAC above 50 Mc. Election of officers resulted as follows: LXY, pres.; IUJ, vice-pres.; MCJ, secy.; DCF, treas.; KGJ, station engineer. Can anyone beat BRB with 131 countries and 38 zones confirmed? ISF soon will be J2ISF. Congratulations to ISZ and his new XYL. MCJ runs 250 watts on 28 Mc. AGR is back on the air on 28 Mc. New ORS and OO: IQV, BT, IKI. DOO is pushing that big generator with a new governor on the 12-HP Palmer. We will try to do better in answering letters now that the health is improving. CNZ now is BP and happy to be back home in Mt. Dora. The Miami crowd wish you the best, Tiny. Never thought anything would keep DQW off the air but the tarpon fishing got the best of him. HAD and BYR were recent visitors at his shack. BXL is feverishly rebuilding before big wind time comes so that he can use his exciter as an emergency rig. Amateurs in this section should make every effort to get all emergency equipment in top condition and ECs are urged to check AEC membership lists and to conduct drills in anticipation of possible hurricane emergency. Amateurs not enrolled in the AEC should indicate to ECs their willingness to participate in emergency operations. AYV is polishing up the rig for some of the summer contests. That last score was a honey, Nat. BRB has some roses coming, also, for his remarkable showing in recent ARRL contests. BT, one of our old reliable OBS, made RCC. AAR is DXing during the summer traffic slump. LAP sends in a fine DX report. Nice work, Bill. Traffic: W4BT 46, IQV 30, IKI 20, AAR 8, BP 2, DQW 2.

WESTERN FLORIDA — SCM, Lt. Comdr. Edward J.

(Continued on page 108)

# PICK YOUR SPOTS!



## *...Your PR Jobber has them in Stock*

There's a tough winter ahead. All bands—phone and CW—will be screaming with signals. QRM is due for a new high! If you want to enjoy your radio, get set to move on spot frequencies with PR Precision CRYSTALS. PR has made it easy to select the spots you want—for all bands. This summer hundreds of PR Jobbers were supplied with new VISUAL DISPLAY CASES, stocked with all frequencies available to amateurs . . . and kept up to date! This means you can walk into your favorite jobber's store and get PRs for the

EXACT FREQUENCIES (INTEGRAL KILOCYCLE) YOU WANT WITHIN AMATEUR BANDS AT NO EXTRA COST . . . NO PREMIUM . . . NO "PLUS OR MINUS" THE SPOT YOU WANT. If you buy your radio gear at a distance . . . your jobber can supply PRs at exact frequencies by return mail. Get set . . . go PR and KNOW WHERE YOU ARE! — Petersen Radio Company, Inc., 2800 W. Broadway, Council Bluffs, Iowa. (Telephone 2760)

SINCE 1934



# PR Precision CRYSTALS

**10 METERS**  
PR Type Z-5.

Harmonic oscillator. Ideal for "straight through" mobile operation. High activity. Heavy drive without damage in our special circuit . . . \$5.00

**20 METERS**  
PR Type Z-3.

Harmonic oscillator. Low drift. High activity. Can be keyed in most circuits. High power output. Just as stable as fundamental oscillators . . . \$3.50

**40 & 80 METERS**  
PR Type Z-2.

Rugged, low drift fundamental oscillators. High activity and power output with maximum crystal currents. Accurate calibration \$2.65



**WANT YOUR FCC COMMERCIAL LICENSE IN A HURRY? USE CIRE TRAINING AND COACHING SERVICE—AND GET YOUR "TICKET" IN A FEW SHORT WEEKS!**

Thousands of new jobs are opening up—FM, Television, Mobile Communication Systems—These are only a few of the radio fields which require licensed radio technicians and operators.

Get your license without delay—Let Cleveland Institute prepare you to pass FCC commercial license examinations and hold the jobs to which a license entitles you.

Your FCC ticket is recognized in all radio fields as proof of your technical ability. Employers frequently give preference to license holders even if the job does not require a "ticket."

**HUNDREDS OF SATISFIED, SUCCESSFUL STUDENTS**

"I have had my 1st. class radiotelephone license since March of this year, and plan to continue with your course since I find it a great help in studying transmitters."—Student No. 2779N12

**FREE BOOKLET**—Tells you the Government requirements for all classes of FCC commercial licenses. (Does not cover Amateur License examinations). Check coupon below for Booklet "B."

**CLEVELAND INSTITUTE COURSES OFFER COMPLETE RADIO TECHNICAL TRAINING RANGING FROM LOW-LEVEL TO COLLEGE-LEVEL.**

**A. Master Course in Radio Communication.**

Covers complete Preparation for broadcast station employment including preparation for FCC Commercial Operator License Examinations.

**B. Advanced Course in Radio Communication Engineering.**  
A college-level Radio Engineering course.

**C. Specialized Television Engineering.**  
Including post-war Television Techniques.

All Courses include the Remarkable Workbooks of Instructional Aids, prepared by the instructing staff of Cleveland Institute.

Choose the course best suited to your needs—Start with the section you are qualified to enter—Use the economical CIRE "Pay-As-You-Go Plan."

Mail the coupon for Catalog "A," checking course in which training is desired.

**Cleveland Institute of Radio Electronics**

Approved for Training under GI Bill of Rights

QT-9, Terminal Tower

Cleveland 13, Ohio

**Cleveland Institute of Radio Electronics**  
QT-9, Terminal Tower, Cleveland 13, Ohio

Gentlemen: Please send information about your home study courses in Radio Electronics.

If a veteran, check here

Send booklet "B." "How to Pass FCC License Examinations." (Does not cover Amateur License examinations)

Send catalog "A." Check Training Desired A  B  C

Name.....

Address.....

City..... State.....

(Continued from page 108)

Collins, W4MS — EQR is pushing 50 Mc. for a WAS. BFD is holding forth on 7 Mc. MAM and MEN are new hams in Pensy. QK has new beam and puts out a swell 23-Mc. signal. AXP seems to be our principal traffic-handler. LUC is another new-comer. LRC has finished R-9er. JPA has portable-mobile. EQZ and GWY are aiming for perfection. BKQ has swell four-element beam. FHQ wants modulation. LND has new harmonic. DXQ is back on 7 Mc. DZX has almost everything ready for big signal. 5NDB is new-comer to Pensy. KVG sold his HT-9 to GXN. HJA operates all bands and is going mobile. FDL is on 28 Mc. ACB works 14 Mc. but is looking 50 Mc. over. TL, MS, and QK attended convention. HIZ puts out his usual FB signal on 28 Mc. LT holds down 3.85 Mc. over Panama City way. DAO has been elected as your new SCMI. Please give him your support.

GEORGIA — SCM, Thomas M. Moss, W4HYW — The following OBS schedules have been announced: BQU retransmits W1AW bulletins on 28,696 or 28,940 kc., 1400 to 1430 EST Saturdays and Sundays, and on 28,940 kc. 2115 to 2130 EST Mondays. EEE keeps schedule on 14-Mc. 'phone at 1900 EST Tuesdays, Thursdays, and Saturdays, and on 29-Mc. 'phone at 1500 EST Sundays. HWS is our newest OBS. JDR is new OO, Class I. Many other OOs are needed. If you have equipment for exact frequency measurement, or a receiver good for plus and minus 5 kc. at 14 Mc., let us hear from you regarding OO appointment. BOL and BQU, with the Macon gang, promoted a very successful EC drill at Macon working with the Cracker Emergency Net. City officials witnessed the successful demonstration. TO is a member of the A1 Operator Club. We would like to have a complete file of section operators holding RCC, A1 Operator Club, Code Proficiency, WAC, and WAS certificates. How about a card listing those you hold? KGI has new three-element beam on 28 Mc. Traffic activities have been slim with the summer season. Anyone interested in traffic nets for the coming fall and winter season, should get in touch with me or the RMs. JDR took his rig over to Birmingham and heard just about everybody in Atlanta on 28 Mc. FID and FKE are building mobile rigs. Illegal 'phone stations, 28 Mc. or elsewhere, should acquire proper tickets or expect to be reported to FCC for disciplinary action by hams who value and respect their hobby. Traffic: W4JDR 10.

WEST INDIES — Acting SCM, Everett Mayer, KP4KD — AM worked CX1DB on 28-Mc. 'phone for a new country and repeats on OA and XE. He has new 348R converted to AC working with Gon-Set converter on 28 Mc. DV has 800 watts on 14-Mc. c.w. and works OK, G, F, PA, and VR. EN went to his home in Bowie, Texas. BJ has gremlins in the big rig but works some nice DX. DV schedules W3EIV, Washington, D. C. W2KMY/KP4 and KP4EW, ex-W4ETE/KP4, have been transferred to Roosevelt Roads NAS. EP has antenna difficulty. KD's 450 watts got him up to 100 postwar including C9, C3, HS, VR5, 16, UG6, UD6, VST, PK6, HZ, UH8, and UA9. CH, on the air again with 616, has new HQ-129X. WPR certificates were issued to VE3AZI ('phone), W2QHH (c.w.), W2JXH ('phone and c.w.), W30P (c.w.). BY and BL have applied for WPR. DT is working nice DX with QRP. Why not drop me a report of your activities each month, fellows? Traffic: KP4DV 16, KD 2.

**SOUTHWESTERN DIVISION**

LOS ANGELES — SCM, Ben W. Onstenk, W6QWZ — Just had a visit from Santa Claus; he wanted some information on handle-talkies. Probably going to work 144-Mc. MS (mobile sled). Some Field Day scores are: Inglewood Club, 13,030½; Metropolitan, 12,660¼; San Fernando Valley, 11,500. The Inglewood Club worked into Mexico on 144 Mc. with MSO operating. All clubs in the section participated except the Long Beach boys, who say that they will not only be on next year but will lead the section. You can start making plans to attend the Southwestern Division Convention at Phoenix, Ariz., on Oct. 18th and 19th. See you there. FYW reports from Paso Robles that the club now has the call ZOI. The club has a GP7 and a 375E for transmitters. ANN reports that the Long Beach AEC Net, with AOT as EC, is beginning to hold drills on 144.151 Mc. FE will be control. ANN, who is president of the Council of Clubs, says there is wind of an all-club picnic. Long Beach news: SWJ and PWI are on 28-Mc. f.m. ZPE is on 7 Mc., as is XRY, XHL, RSA, WGW, UYW, ZKL, and

(Continued on page 110)

# Five NEW ONES!

HY75A

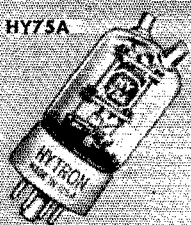

\$3.95

## HY75A IMPROVED VERSION OF HY75 VHF TRIODE

To improve upon the HY75 was not easy. But the new HY75A does the trick. Maximum plate current of the HY75A is increased to 90 ma. Grid-to-plate capacitance is sharply reduced to  $2.6\mu\text{fd}$ . An HY75A substituted for an HY75 in a 144-mc quarter-wave line oscillator raises the resonant frequency by 20-30 mc. Efficiency is up; 25% more useful power output at 144 mc. How was this accomplished? By a shorter mount, smaller elements, special high-voltage processing of the lava insulators, redesigned vertical bar grid, and zirconium-coated graphite anode. All at no extra cost to you. Substituted for the HY75, the HY75A requires only pruning of the tank circuit and a higher value of grid resistor. For replacement or new vhf equipment, the rugged, instant-heating HY75A is your logical choice.

## 5514 ECONOMICAL VERSATILE ZERO-BIAS TRIODE

The new 5514 supplants the HY30Z, HY40, HY40Z, HY51A, HY51B, and HY51Z. Economies of standardization give you the low price of \$3.95. A tube to grow with — the 5514 is efficient at plate potentials from 400-1500 volts. Associated components are economical and still usable as power is increased. At conservative CCS ratings, two 5514's handle 525 watts class C input; deliver 400 watts class B output. One HY69 or 807 can overdrive at maximum input two 5514's in class C. No costly protective fixed bias is needed for this all-purpose, zero-bias 5514. Features: zirconium-coated graphite anode, low-loss lava insulators, dual plate connections, ceramic bushing for plate cap, grid leads to pins 2 and 3, convenient 4-pin medium low-loss base and 7.5-volt filament.

5514



\$3.95

5516



\$3.95

## 5516 INSTANT-HEATING 165-MC BEAM AMPLIFIER

Designed for frequencies beyond the capabilities of the 2E25, the new 5516 plate-modulated delivers useful power outputs of 21, 16, and 12 watts at 75, 125, and 165 mc respectively. No neutralization is needed in properly designed circuits. All electrode potentials may be applied simultaneously for minimum battery drain in mobile and aircraft use. A dish-pan stem gives short leads with low inductance and capacitance. The zirconium-coated plate and specially treated grids permit higher power outputs. Three separate base-pin connections to the filament center tap provide for lowest possible cathode lead inductance. Excellent r-f screening, high power sensitivity, conservative CCS ratings make the 5516 ideal for your mobile equipment.

## 2E30 INSTANT-HEATING VHF MIN. BEAM DRIVER

Fine illustration of the 2E30's versatility is Ed. Tilton's article beginning on page 31 of QST for June, 1946. Mr. Tilton uses the 2E30 as crystal oscillator, frequency multiplier, speech amplifier, and class AB<sub>2</sub> modulator. Primarily for mobile and aircraft vhf equipment, the 2E30 is an excellent driver or final amplifier for h-f or vhf fixed stations. Designed, manufactured, and tested for transmitting, the 2E30 has a husky, instant-heating filament and generous maximum plate dissipation (10 watts). It develops high efficiency at only 250 volts plate and screen. Imagine doubling to 144 mc with 4 watts output and 0.2 watt drive. The miniature bulb is compact, has low base losses, lead inductance, and capacitance. You can find many uses for the economical 2E30 — a peanut for size, a power-house for output.

2E30



\$2.25

HY-Q 75



Unassembled \$9.95  
Assembled \$11.95  
(without tube)

## HY-Q 75 1¼—2 METER VHF VFO

With this HY-Q 75 linear oscillator kit, you can be on 1¼ or 2 meters in an hour. Features are: carefully engineered for easily duplicated results, micro-metric tuning (140-250 mc), silver-plated tank, precision-machined shorting bar, special filament, grid, and plate chokes, non-inductive coaxial plate blocking condenser, quick band changing, chart for frequency determination, peak performance for HY75A or HY75 (useful power output with HY75A is 17.5 w on c-w, 13.5 w on phone), a natural for VFO on VHF.

SEE THESE FIVE NEW HYTRON PRODUCTS AT YOUR JOBBER'S—OR WRITE FOR DATA SHEETS

**HYTRON RADIO & ELECTRONICS CORP.** 76 LAFAYETTE ST. SALEM, MASS.



**\$77.50**

LESS TUBES

SIMPLEST, NEWEST CIRCUIT • EASY TO ASSEMBLE •  
DESIGNED BY TELEVISION SPECIALISTS • PRE-TUNED  
IF COILS • SOUND IS HI FI FM • GUARANTEED  
PERFORMANCE • ONLY 5 CONTROLS.

"Terrific . . . An Amazing Buy!" That's what they're saying about this wonderful Electro-Tech Television Set. Now, practically everyone can afford the luxury of television at home. This Basic Kit contains everything you need, except tubes and cabinet. Thousands of these sets are being enjoyed by both students and experts, who built 'em . . . It's easy\* . . . and so inexpensive! Illustrated and pictorial Instructions and Servicing Manual, with clearly labelled, finest quality parts make step-by-step assembly simple and foolproof. Advanced technical features, designed by outstanding Television Engineers assure Guaranteed Performance. Here's your big chance to have a fine Television Receiver with FM Sound Reception at a Sensationally Low Price—plus the satisfaction of having built it yourself. Don't miss it! Shpg. wgt. 20 lbs.

Only \$15.50 Down —  
\$5.48 Monthly

17 Tubes—1-6J6, 1-5U4G, 1-2X2 (879), 1-6V6, 1-XXFM(7X7), 5-6SN7, 5-6AC7/1852, 1-7GP4 (7" Picture).

Kit of 17 Tubes (as above)..... \$33.42  
Handsome Walnut Cabinet..... \$22.50

\*TELEKIT service stations in all leading cities.

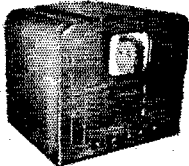

**ELECTRO — TECH 10" TELEKIT**

Similar to above, but large 10" picture and additional refinements in circuit ..... **\$124.50**  
LESS TUBES

Only \$24.90 Down — \$8.80 Monthly  
Complete Kit of 19 Tubes..... \$56.37  
Walnut Cabinet..... \$29.50

Complete line of Television Components in Stock

Use Your CREDIT, Take ONE YEAR to Pay  
20% Down . . . 12 Monthly Payments

SHIPMENTS FOB NEW YORK or CHICAGO  
20% Deposit Required with All COD Orders

NEW YORK  
Offices & Warehouse  
242 W. 55th St. N.Y. 19

**NEWARK** CHICAGO  
ELECTRIC COMPANY, INC. 323 W. Madison St. Chicago 6, Ill

New York City Stores 115-17 W. 45th St & 212 Fulton St.

(Continued from page 108)

CAE are new members of the Associated Radio Amateurs of Long Beach. CMN, RM for the SCN, reports the net now consists of LYF, RAD, YPR, SRI, and WJM. The SCN would like more members in and around Los Angeles, so give CMN a call on 3725 or 3615 kc. and see what's doing. 50 Mc. went to town during June. UXN worked 38 states. Others competing in the race for WAS and WACA on 50 Mc. are: LSN, OB, FPV, AOR, VES, URN, ZJY, AMD, TMI, QFT, ANN, PUZ, VXJ, QUK, NLZ, NAW, NYF, and QWZ. MK news: The MK Club used the club call VB on Field Day, using rotary beams on 144, 50, 28, and 14 Mc. BHA is back on 3.85 Mc. ESR has new 50- and 28-Mc. mobile rig. OHM is on 7 Mc. WOU has new jr. operator. OKL goes to Tokyo twice a month to buy his radio gear cheaper. TVK is on 28-Mc. 'phone, VDE, VIX and ZRN are trying to break 144 Mc. record from Flagstaff, Ariz., to Mt. Frazer. VTX now is 71HL. The MK Club meets every other Thursday at the Dyne Plant, 33rd and Pico, Santa Monica. Santa Monica AEC drills are run by TBS. QJG is Asst. EC. PTR is EC. Inglewood news: WTJ schedules ZK1AA daily at 1 p.m. ZK1AA also sends c.w. signals every half hour for two minutes on 50.040 Mc. VOO is on 50 Mc. QXB is back from mobile on 50 Mc. to Texas. UXN is recovering from a session with the sawbones. VES and URN have new 50-Mc. beams. The Inglewood Club is promoting emergency work by giving a PE103 dynamotor for a door prize at each meeting. HMW is going to handle Inglewood AEC on 28 Mc. New OES is WVM. IWU is active again as OO. YXL is on with a 610. ERT is on 7.1 and 28.8 Mc. WVM has a combination 144- and 235-Mc. antenna. SMI is using a 522 on 144 Mc. JXZ is back on 144 Mc. UFH and DYJ hold regular Burbank to Bakersfield contacts on 144 Mc. KEI reports the Golden State on 3965 kc. is now starting at 8 p.m. Note the FB leading traffic work of IOX, JQB, and CMN. CMN led Los Angeles in the April CD Party. Be sure to get your reports in on the first of the month as otherwise they will be too late. Thanks to those sending in reports. Traffic: W6IOX 409, JQB 220, CMN 128, ERT 9, VAQ 4, AAE 2, MEP 2.

ARIZONA — SCM, Gladden C. Elliott, W7MLL — The Tucson gang enjoyed an FB Field Day on "A" Mt. Layout consisted of 6 rigs, 30 operators, a 10-kw. generator from KVOA, and tents from D-M Field. JXL is making lots of contacts on 50 Mc. with the DHS rig. KAD has a kw. on 50 Mc. TXM and QAP report Mexico City on 50 Mc. UFF made WAC on 14-Mc. 'phone in three weeks. New Tucson calls are: LHI, on 7 Mc.; LHD, on 28 and 144 Mc.; LHH, on 7 and 28 Mc.; LHX, on 7 Mc.; LKF and AWA on 28 Mc.; KUN, on 7 and 14 Mc.; LIB and LFX, on 144 Mc. JIW reports 53 countries. QMG, GMG, and 5NAF are active in Benson. QAP worked FD in Huachuca Mts. TBJ and JMC worked FD from Mt. Lemon. PEY has 87 countries. MDD has a BC-610 rig. TSZ is on 3.5 Mc. at Flagstaff. MAE wants more activity on 3551-kc. net, the new-comers net. JMT has a pair of 813s and a 1700-volt generator at Camp Geronimo for Boy Scout traffic. JPY/GDF and KXB did an FB job on traffic from Mt. Lemon. KGN has a wide-spaced 28-Mc. beam. JMQ and TCQ have their Class A tickets. Plans are completed for the 7th Annual Arizona Hamfest and Southwestern Division Convention to be held at Phoenix Oct. 18-19. Traffic: W7JPY/GDF 912, KXB 345, MAE 245.

SAN DIEGO — SCM, Irvin L. Emig, W6GC — Asst. SCM and SEC, Gordon Brown, 6APG. New ORS; BGF. CHV reports the Palomar Club had 11 transmitters and 35 operators, and made 702 contacts for a score of over 13,000 in Field Day activities. YYW is building new 14-Mc. two-element rotary. DEY schedules 0BDU/5. MKW has 18 watts on 144 Mc. A very active code class in San Diego is being run by VJQ and his wife, YXI. They also have 30-watt mobile rig in car for 50, 28, and 27 Mc. YZD is back on 14 Mc. after a 13-year layoff. BAM reports code practice class being held each Tuesday evening at BWO's house. LRU is overhauling his 28-Mc. beam. MI reports a new breakfast club which meets on 28 Mc. Members are: FEX, RMN, VTS, APG, YXM, JC, IV, and VJQ. LMV moved from S9 QRM. WUW is trying his hand at receivers. FFV is building a 300-watt VFO rig. MWL built an all-band gang-tuned transmitter. FGU is all set for n.f.m. on 14 and 3.85 Mc. CNQ wants schedules with Salt Lake City, Oregon, or Denver. RDI is rebuilding for 28-Mc. 'phone. ZMF is new call on 7-Mc. c.w. and 28-Mc. 'phone. VIX, VDE, and MEP are making plans to bring the 144-Mc. DX record

(Continued on page 118)



Now Available to Amateurs —

# A Line of PLASTICON\* GLASSMIKE RF Transmitting Capacitors

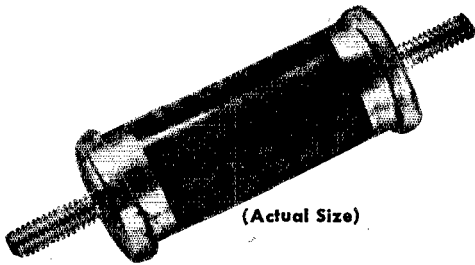

Superior to mica capacitors because:

- Greater safety factor  
(3500VDC Operating; 7500VDC Test)
- Lower RF losses  
(See current ratings below)
- More conveniently mounted
- Less chassis space
- Smaller overall volume
- Impervious to moisture  
(The GLASSMIKE construction is 100%  
sealed)
- Silicone-fluid filled

The above advantages are possible by the use of the Type L film dielectric which has lower losses than mica.

## TYPE LSG — PLASTICON\* GLASSMIKES 3500VDC Operating • 7500VDC Test

Cat. No.	Cap. Mfd.	Dimensions OD Length	Current Rating in RF Amperes				List Price
			100 Kc	300 Kc	1 Mc	3 Mc	
LSG500	.00005	1 <sup>1</sup> / <sub>32</sub> " x 1 <sup>1</sup> / <sub>16</sub> "	.02	.05	.16	.47	\$1.50
LSG101	.0001	1 <sup>1</sup> / <sub>32</sub> " x 1 <sup>1</sup> / <sub>16</sub> "	.03	.09	.31	.94	1.50
LSG251	.00025	1 <sup>1</sup> / <sub>32</sub> " x 1 <sup>1</sup> / <sub>16</sub> "	.05	.25	.5	2.2	1.50
LSG501	.0005	1 <sup>1</sup> / <sub>32</sub> " x 1 <sup>1</sup> / <sub>16</sub> "	.15	.5	1.6	3.0	1.50
LSG102	.001	1 <sup>1</sup> / <sub>32</sub> " x 1 <sup>1</sup> / <sub>16</sub> "	.31	.94	2.5	4.5	1.70
LSG202	.002	3 <sup>1</sup> / <sub>4</sub> " x 1 <sup>1</sup> / <sub>16</sub> "	.62	1.9	4.5	7.0	2.45
LSG502	.005	3 <sup>1</sup> / <sub>4</sub> " x 1 <sup>1</sup> / <sub>16</sub> "	1.6	3.1	6.0	7.0	3.50
LSG602	.006	2 <sup>3</sup> / <sub>32</sub> " x 1 <sup>1</sup> / <sub>16</sub> "	1.9	3.5	6.2	7.0	3.75
LSG103	.01	2 <sup>3</sup> / <sub>32</sub> " x 1 <sup>1</sup> / <sub>16</sub> "	3.1	5.0	7.0	7.0	4.25

\*PLASTICONS — Plastic Film Dielectric Capacitors

**CP** **Condenser Products Company**

1375 NORTH BRANCH STREET • CHICAGO 22, ILLINOIS

# LEEDS *The house you have known for 25 years*

RADIO, TRANSMITTER & RECEIVER APS 13

410-440 mc., light weight, fully enclosed; 30 mc. I.F. complete with 17 tubes, including 5-6J6; 9/6AG5; 2/2D21; 1/VR105. SCHEMATIC supplied with each unit. Only

**\$11.95**



Wire wound general radio type Potentiometer precision made laboratory 25 watt 100,000 ohms. 6" diam Brand new	<b>\$1.95</b>
300 ohm Twin Lead, indoor or outdoor cable, per 100 ft.	<b>\$2.95</b>
52 ohm Coaxial Cable RG/8U outdoor per 100 ft.	<b>\$4.50</b>
0-1 MA 3" D.C. G.E. meter	\$3.50
0-1 AMP 2" R.F. G.E. meter	2.45
500-0-500 microamps 4" W.E.	3.75

### OIL-FILLED CONDENSERS

2 Mfd 1000 VDC	\$ .79	16 Mfd W. E. 400 VDC	\$ .98
8 Mfd 1500 VDC	3.25	3 x 0.2 Mfd 4000 VDC	.98
2 Mfd 2000 VDC	1.75	2 x 0.1 Mfd 600 VDC	.25
0.1 Mfd 7500 VDC	1.50	2 Mfd 600 VDC	.49
2 Mfd 10000 VDC	17.50	10 Mfd 1500 VDC	3.50
.02 Mfd 8000 VDC	.98	7 Mfd 330 VAC	1.25

### LOUDSPEAKER

LS-6-C

Consists of P.M. Speaker, Microphone, Trumpet, with triggered gun grip handle and connecting cable. Brand new.

**\$3.95**

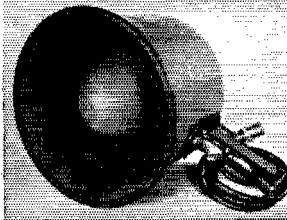

Ohmite 50 watt adj 25 ohm Resistor	\$ .15
10 for	1.25
Ohmite Rheostats 50 Watt 25 ohm	.39
25 Watt 15 ohm	.35
Sigma Relay 2000 plug-in type 4Ma DC	\$ .95
R.F. Oscillator 68-74 MC. with IG68T Tube	.50
Bussman 8 AG 1/100 AMP Instrument Fuses, per doz.	.50

### NEONS — While they last

2 Watt Edison base	\$ .29
1/2 Watt Bay	.20
1/2 Watt Bay or wire leads	.08

### [IN STOCK]

New National H.R.O.-7 and 173-T Receivers.

[Complete stock of parts.]

**SCHWEIN** — Free and Rate Gyro. Operates from 24 V.D.C. Special. **\$5.00**

**BC-645 TRANSCEIVER**; 420-450 MC; complete with 15 tubes including W.E. 316A door knob and conversion diagram. Brand new in original packing. Special. **\$14.95**

### NEW STOCK OF AMERTRAN TRANSFORMERS, POWER TRANSFORMERS

K-606; 117V 60 Cy., 700 V.C.T. 120 MADC; 5V @ 4A; 6.3V @ 4.7A	<b>\$5.46</b>
K-602; 117V 60 Cy., 580 V.C.T. 50 MADC; 5V @ 3A; 6.3V @ 2A	<b>\$3.54</b>
K-604; 117V 60 Cy., 700 V.C.T. 70 MADC; 5V @ 3A; 6.3V @ 2.5A	<b>\$4.08</b>

**FILAMENT TRANSFORMERS** — K-116; 117V 60 cy; 10 V.C.T. @ 8A, 7500 V. test. **\$3.84**  
K-404; 117V 60 cy; 2.5 V.C.T. @ 10A, 7500 V. test. **3.24**

**OUTPUT TRANSFORMER** — K-292; For PP 6L6 ABI PRL-6000 ohm. Sec. 4/8/15/250/500 ohm. 30 watts. **\$6.54**

If not rated 25% with order, balance C.O.D. All prices F.O.B. our warehouse New York. No order under \$2. We ship to any part of the globe

# LEEDS RADIO CO.

75 Vesey Street  
Cortland 7-2612

Dept. Q59  
New York City 7

(Continued from page 110)

back to W6 Land. LZ has SCR-522 on 144 Mc., as has VKA. MIQF is working lots of 14-Mc. DX, VT is on 144 Mc. YJP is on 28 Mc. UJP is heard often on 28 Mc. DX note: 3FAM/6 is active on 144 Mc. at San Nicolas Island with a TR-4. DHP, HWJ, URU, and BWO are on 3.85-Mc. phone often. Our Southwestern Division Director visited the Orange County Club during the July meeting. QG is working hard on 50 Mc. and is considering 144 Mc. LQX has frequency-measuring service at Corona del Mar. The Los Angeles Council of Radio Clubs held a big picnic at Orange County Park. Traffic: W6CHV 36, BGF 13, MI 10, VJQ 8, VCD 5, YTH 5, CNQ 4, GC 4, ZMF 4, DEY 2, YYW 2.

### WEST GULF DIVISION

**NORTHERN TEXAS** — SCM, N. C. Settle, W5DAS/5MNL — Asst. SCM, Joe Bonnett, 5III. SEC: QA. PAM: ECE, RM; GDU, ARV has a new shack with 450 watts. DX includes G, F, KL6, VK, and ZL. ISD reports big doings in the No. Tex. c.w. net. If you like fast c.w. get in touch with CDU. We now have over 400 licensed amateurs in Dallas. Let us know how many you have in your town. GGD is on the 28-Mc. band with 100 watts. He still has to finish the kilowatt which he has under way. FDI is moving into the house and will be on more now. KWC has a Sonar mobile rig and is really working out. IYJ has a broadcast station on 1000 kc. at Henderson. MMR is a new ham in Greggton. MXE is new in Longview. NEK and NFS are new in Dallas. How about you fellows having the new hams in your town send me a card for publication in this spot. GKH passed and received her 35 w.p.m. Code Speed Certificate from ARRL. Looks like the YL hams are about to get ahead of us 15-per boys. Had a nice visit with FAH, who was out at the shack one Saturday night. QA, our SEC, needs more ECs. If interested, drop him a line. Be sure to send AJG, the QSL Manager, an envelope for that DX card. How about some club news? Let us have the regular meeting dates. Would you like to be a guest reporter? Drop me a line and I will send you a form for same. How many YL or XYL operators do we have in the Northern Texas section? Let us know. Traffic: W5JFF 32, ISD 12, DAS 4, ARV 2.

**SOUTHERN TEXAS** — SCM, Ted Chastain, W5HIF — SEC; HQR, PAM; EYV. Capt. C. A. Murgatroyd has resigned as SEC due to transfer out of this section. Henry Binz is new SEC. All ECs, please send reports to 2016 Buford, Corpus Christi. EYV and FZB have new KP-81a. W1PHI/5, ex-NY4AA, would like to know what has happened to the NY4s. He would like a call from any of them. CCD, FH, and HQR were out Field Day with two transmitters and two receivers. Antenna supports were two 90-ft. oil derricks. HZJ has 400 watts to 813. EWZ has Meck T-60. MPE worked a VK2 on 7 Mc. using a vertical indoor wire 9 ft. long with 50 watts input. LFM reports the number of countries worked by stations in San Antonio: LGG-74; LVD-56; GKI-94; BE-116; FNA-112; HHO-40; FZA-57; IFM-34. MAK signed up with the merchant marine.

The San Antonio Club is conducting a three-month DX and WAS Contest for club members. LEM, UB, GKI, LFM, LVD, MIQ, and BE got together on Field Day. AQN has new high-voltage power supply, speech amplifier, and modulator. JPC has Meissner Signal Shifter. MXE is new call in Longview. Active on 50 Mc. in San Antonio are PVJ, ESZ, and AOT. MKL and GEL are members of Rebel Net. HQR, FH, DYV, and CCD, erected station on 7 and 3.5 Mc. at Federal Bldg. in Corpus Christi for U. S. Weather Bureau, made contacts with San Antonio, Refugio, Cuero, and Austin, and tore down all of it in one hour and fifteen minutes. JBZ is editor of *Stenscope*, monthly rag of STEN. He would like to hear from all of you. BVB has been elected chaplain for STEN. IVU is Zone 3 control station. FNY is net control officer for STEN, CIX is alternate. MWN is new call in Rockport. DSU has kilowatt on 3.85 Mc. Traffic: W5GLS 355, GEL 154, MN 136, LEM 17, MSZ 10, JPC 9, CCD 5, MKL 5, HZJ 2.

**NEW MEXICO** — SCM, J. G. Hancock, W5HIF — ZU/ZM is back in Roswell and will resume his duties at N.M.M.I. this September. Clovis is organizing a radio club at the Benson School of Radio with the call MFQ and soon will be on 14-Mc. with 65 watts. The club is supervised by MXE, ex-W9UFZ, who is active on 7- and 3.5-Mc. c.w. at the present time from Santa Fe Heights addition of Clovis. Louis, senior operator at ZA, is in the hospital. The nature of his illness is not known but it is hoped that Eunice won't

(Continued on page 114)

AT LAST

# IT'S HERE

# N B F M ON ALL PHONE BANDS

XE-10 \$39.45

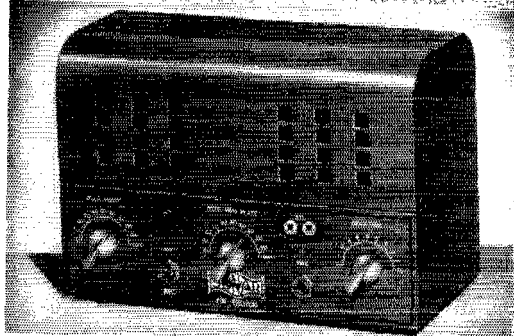

VFX-680 \$87.45

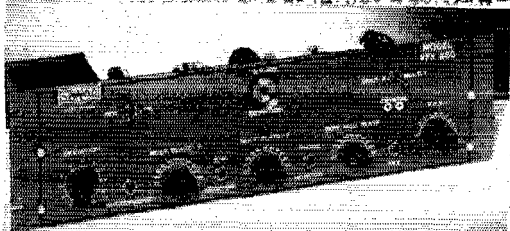

MB-611 \$72.45

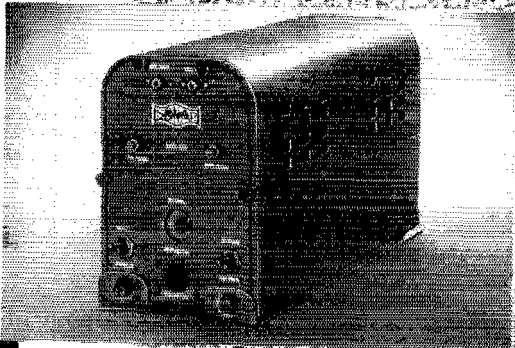

For months, Sonar engineers, in cooperation with well-known hams throughout the country, all using Sonar equipment, conducted exhaustive FCC-authorized tests of NFM transmissions on the 75 & 20 meter bands. Their findings were submitted in a formal report to the FCC. It's no coincidence that NFM use has since been extended, from the original 10 meter allocation, to all phone bands.

## WE'RE READY ARE YOU?

SEE YOUR DEALER OR WRITE US DIRECT



SONAR RADIO CORP.  
Box 445  
BKLYN 1, NEW YORK

**NARROW BAND FM**

Originators of NBFM  
Equipment for the Amateur

**GENERAL ELECTRIC  
UNIMETER UM-3**  
Priced PEERLESS-low

at  
**\$18.95**

Regularly sold at  
\$35.00

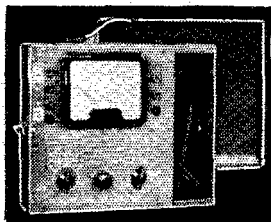

Completely portable all-around utility instrument. Scales marked in red. Ranges: DC VOLTS — 0 to 2 1/2, 10, 50, 250, 1000, 2500, all at 2000 ohms/volt. AC VOLTS — 0 to 2 1/2, 10, 50, 250, 1000, 2500, all at 1500 ohms/volts app. RESISTANCE — 0 to 1000, 100,000 ohms and 1 megohm. MILLIAMMETER RANGE — DC: 0 to 1, 10, 100 milliamps and 0 to 1, 10 amperes. DB RANGE — -12 to +55 in 3 ranges 6 milliwatts into 500 ohms is used as zero reference level. Welded steel case. Supplied with leads. Size: 9 x 10 x 1 1/4" Weight 9 1/4 lbs.

Buy 12 . . . get a BAKER'S DOZEN  
**SYLVANIA CRYSTAL DIODES TYPE 1N-34**



13 for the price  
of 12

Specially developed for H.F. work. Low shunt capacity. Rated for average anode current of 22.5 ma.

**\$1.19 each**  
**\$14.28 for 13**

**BUD**

Two-panel **CABINET RACKS**  
Priced PEERLESS-low

**\$11.75 each** List price \$23.50

Sturdy, inexpensive racks to house low-power transmitters and similar apparatus. Has two panels: one 10 1/2" high and the other 1 1/2" high. Takes chassis up to 8 1/2" deep and 15" wide. Overall size — 18" x 21 1/2" x 10". Rear of cabinet is covered by hinged door with locking device. Sides are louvred. Entire unit formed from black crackle-finish steel.

**MILLEN  
R-9'er**

Engineered by GE and James Milten Co. Automatically boosts any impedance antenna up to 30 db. Broad band r.f. amplifier for additional 30 db. gain. Complete with 10 meter coil, less tube . . . \$24.75 ea. 6 or 20 meter coils. \$3.15 ea. 6AK5 tube . . \$4.49 ea. (if bought with R9'er)

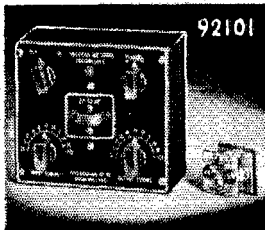

**MILLEN  
50-Watt  
XMITTER  
EXCITER**

For all bands. Uses 6L6 and 807 tubes. Complete with 10-11 meter coils . . \$42.50

**90800**



**NATIONAL  
NC-173**

Powerful, 13-tube superhet receiver. Calibrated amateur band spread on 6, 10-11, 20, 40, and 80 meter bands.

**\$189.50**

All prices F. O. B. Jamaica, New York. Add postage. Write Dept. QS4.

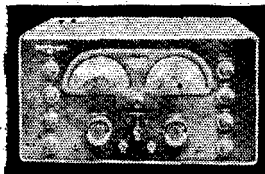

**Peerless**

**RADIO DISTRIBUTORS, INC.**

92-32 Merrick Rd., Jamaica 3, New York  
Branch: 71 Murray St., New York 7, N.Y.

(Continued from page 112)

be doing all the operating at ZA for very long. DER is about to work WAS on 50 Mc. with his new VHF-152/6A6-807 set-up. KCW is trying to get a BC-375E to work on 28 Mc. HJF is trying to get his 3.5-Mc. Zepp to work.

**CANADA**

**MARITIME DIVISION**

**MARITIME** — SCM, A. M. Crowell, VE1DQ — RM: EY, SEC: FQ, HJ tops the traffic list this month, and schedules V06SC, the Dalhousie College Expedition, daily at 7:30 ADT on 7088 kc. V06U, ex-VE4SO, at Goose Bay is relaying from V06SC. OK is using a long "V" beam. EK handles a few and just had the receiver overhauled. DB, EF, FB, FN, and RP have all been heard snagging the elusive DX. BC is putting the new five-element 28 Mc. beam through its paces. The local "phone gang has gone "beam conscious" almost to a man. FQ has changed from a two- to a three-element for 14 Mc. DQ is working on the mismatch in his dual. ET is sporting new 3L for 28 Mc. and MZ has a new 3L for 14 Mc. Highlight of the month was the all-time high in this section piled up by FO, the HARC station, on Field Day. Under the able direction of FB, the club president, and ably assisted by an operating crew of HARC officers and members, FO made an excellent showing with the new emergency lighting plant as power source. Did you send in YOUR station report? Please let's have one for next month so we can make a nice showing. Traffic: VE1HJ 40, EK 6.

**ONTARIO DIVISION**

**ONTARIO** — SCM, David S. Hutchinson, VE3DU — The summer season is with us again. However by the time that this appears in print the gang will be returning from their vacations ready for a busy fall and winter season. HP is doing construction work. FP is busy with f.m. receiver. Glad to welcome ATR back to 3.5 Mc. VD reports things rather slow with no schedules for the summer months. Sorry I did not report the fact that VD got his Code Proficiency Certificate for 25 w.p.m. in February. AWJ is overhauling the rig but will remain on the air with 5-watt rig. MY, AHL, WA, WD, BJP, AWJ, and AXP took part in Field Day at Windsor. The Peterborough Club also took part in Field Day. OI got three-element rotary back up and is busy working such DX as KV4, F9, I, HK, TI, HH, D4, D2, VK6, EL, ON, KS, UA3, CO, KH6 and XE, all on 14 Mc. The Hamilton Club had over 400 contacts on Field Day week end with rigs on 3.5-, 7-, and 14-Mc. c.w. and 3.5-, 28-, 50-, and 144-Mc. "phone, all running simultaneously. Another EC in Hamilton, BQL, is prospective ORS. KM reports good conditions on 50 Mc. in Hamilton, with a six-station net on that frequency. New licensee on in King is AWE on 3.5 Mc. BAJ is working on 807 final rig. AJE puts all his spare moments on 7- and 14-Mc. c.w., as does WP. DU, on 7 Mc., will have a TA12 Bendix transmitter in the fall. The following qualified in May and June CP runs: XI, 15 w.p.m. certificate; YV, 25 w.p.m. endorsement. Walter M. Guillot, of Windsor, 35 w.p.m. endorsement. AOU reports that on May 10th at Kingston ham groups from Brockville, Belleville, Trenton, and Kingston met for a dinner meeting, which was highlighted by an informal talk by Alex Reid, Canadian General Manager. Traffic: VE3ATR 14, OI 9, FP 6, AWJ 3, HP 3, CP 2, KM 2, VD 2, AXQ 1.

**QUEBEC DIVISION**

**QUEBEC** — Acting SCM, Gordon A. Lynn, VE2GL — QSU finds it necessary to resign as SCM and has requested yours truly to carry on pending election of a successor. Highlight of the month was the MARC picnic held on June 28 with over 100 hams, together with their XYs and harmonics, registering. XX now the Army 19 set. W1AR was most distant visitor. ZA now is HH; PZ is GL. BG is building speech clipper and reports hearing W4-9-0 on 50 Mc. UO has 807 on 3.8-Mc. "phone. BB and NR visited W2OUT. BB is rebuilding. BE, BG, DX, and SE report lots of DX on 14 Mc. XX, DX, XD, YA, HH, GL, HE, AI, AV, and ZZ are heard regularly on 3.8 Mc. TH lost a pair of VT127s and is rebuilding rig into FB cabinet with 304TH in final. LP is rebuilding separate finals, one for 50 Mc. and one for lower bands. ER is building new rig with pair 813s

(Continued on page 116)

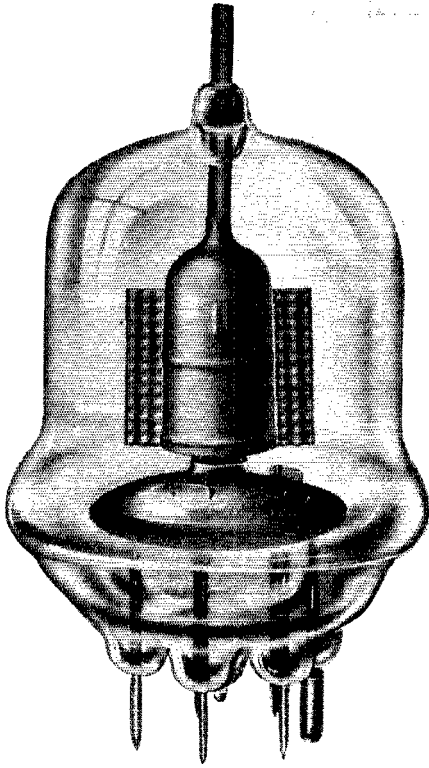

**ANNOUNCING  
THE NEWEST**

*Gammatron*

**HK-57**

**BEAM  
PENTODE**

**MAX. POWER OUTPUT**

Class C R.F. Unmodulated . . . . . 250 Watts

**PLATE DISSIPATION** . . . . . 50 Watts\*

**MAX. SCREEN INPUT** . . . . . 25 Watts

**MAXIMUM RATINGS:**

D.C. Plate Volts . . . . . 3000 Volts

D.C. Plate Current . . . . . 150 MA.

D.C. Screen Voltage . . . . . 500 Volts

D.C. Screen Current . . . . . 20 MA.

D.C. Control Grid Voltage . . . . . 400 Volts

D.C. Control Grid Current . . . . . 15 MA.

D.C. Plate Input . . . . . 300 Watts

**MAX. FREQUENCY** . . . . . 200 Mc.

**INTERELECTRODE CAPACITIES:**

Plate-Grid . . . . . .05 mmfd.

Input Capacity . . . . . 7.29 mmfd.

Output Capacity . . . . . 3.13 mmfd.

**FILAMENT VOLTAGE** . . . . . 5.0 Volts

**FILAMENT CURRENT** . . . . . 5.0 Amps.

\*Continuous rating. Intermittent rating 75 watts.

The HK-57 is a 50-watt\* radiation cooled beam pentode that may be operated even at very high frequencies without neutralization. Its driving power requirements are very low, reducing the number and size of preliminary stages needed.

Tantalum plate and grid elements allow the HK-57 to withstand high plate and screen voltages, and to take large momentary overloads without gassing.

In addition to its exceptional performance as an r.f. power amplifier, the HK-57 makes an excellent high power exciter for amateur service.

Write for data sheet showing characteristics.



**HEINTZ AND KAUFMAN, LTD.**

**Gammatron Tube Division • South San Francisco, Calif.**

Communications Equipment Division • 50 Drumm Street • San Francisco, Calif.

Export Agents: M. Simon & Co., Inc • 25 Warren Street • New York City



## ELECTRONIC MARKETERS

### A Reliable Source of

**EQUIPMENT:** Complete stocks of standard radio communication equipment including NATIONAL, TEMCO, MILLEN, AMERTRAN, CARDWELL, WESTON, E. J. JOHNSON and other well-known makes. Orders for standard stock items are "shipped today."

**PARTS AND MATERIALS:** One call or one letter will fix you up with everything you need for that Fall overhaul. Complete stocks include rotary beams to ground clamps and everything in between. Send in your order with complete confidence of fair prices and right treatment.

**FACTORY SERVICE:** Bring in or ship us that old receiver for reconditioning and precise re-alignment. You will get it back promptly and as nearly new as modern laboratory repair service can make it. Remarkably low charges.

### SOME GOOD BUYS

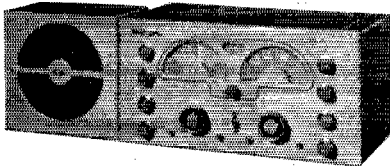

**NATIONAL NC-173:** Price complete with matching speaker each **\$189.50**

**PLATE TRANSFORMER:** Gardner Electric plate transformer. Prim: 110/120 volts 60 cycles. Sec: 3200 volts, 350 mls. Center tapped. ideal for a pair of 812's or 816's. Each..... **\$9.95**

**FILAMENT TRANSFORMER:** Gardner Electric filament transformer. Prim: 110/120 volts 60 cycles. Sec: 2.5 volts, 10 amps.—9000V insulation. Just right for use with 866's. Each..... **\$2.95**

**FREQUENCY METER:** Army BC221 Frequency Meter complete with original crystal and calibration book. Use as frequency meter or as accurate E.C.O. in your xmtr. Price complete, like new... **\$39.50**

Terms: 20% cash with order — balance C.O.D.



## ELECTRONIC MARKETERS, Inc.

CA6-6937 190 VARICK ST., NEW YORK 14, N. Y.

## SPECIAL BARGAINS IN ARMY SURPLUS RADIO GEAR

Send me your current bargain stock list of surplus Transmitters, Receivers, Tubes and Test Equipment.

NAME.....

STREET.....

CITY.....STATE.....

(Continued from page 114)

in final. KG has nice rotary on 28 Mc. SU is continuing as SEC and requests that all AEC members be ready for fall tests. HB reports the following from Quebec: TM visited VT, AB, HB, LZ, and VT, are on 3.8-Mc. 'phone regularly. AB has portable on his yacht. YV is heard on 7 and 28 Mc. MZ and HB are working DX on 14 Mc. HB is using three-element rotary on 14 and four-element on 28 Mc. DF is on 28 and 14 Mc. VO is on 28 Mc. VP is on 28 and 3.8 Mc. NL is on 3.8 Mc. OF has steel towers 60 ft. high. DX, DY, GL, HH, RA, and XX visited Thousand Islands Hamfest and all won prizes. Traffic: VE2BG 23, ZA/HH 15, GL 11.

### VANALTA DIVISION

**ALBERTA** — SCM, W. W. Butchart, VE6LQ — OF has been transferred from Lethbridge to Calgary. RH is moving to Toronto. FO and FB are new Lethbridge calls. EV sold his SX-28A. MN is working lots of DX. OG is president of Canadian Legion at Lethbridge. IC is QRL work these days. EO plans on setting up his QSL Bureau at Edmonton Hamfest. YD, of Medicine Hat, visited former QTH at Peace River. 4AC, Bob Browne, formerly with Winnipeg RCMP, is stationed at Edmonton in charge of radio set-up with the Force. He has FB QTH nearly ready for occupancy. AL has trouble getting 813 tamed down on 28 Mc. AO got room reservation early for Edmonton 'Fest. IG says QSLs being distributed by the Alberta Government are nearly ready. They are FB, no foolin'. EA motored to the Coast on his holidays. WS is visiting the States for his holidays. BD has taken over AFARS set-up in Edmonton. BW reverts to 7-Mc. c.w. and gets a big bang out of it. He suggests more of us try it! HY returned to Army work. He has rig set up on 14-Mc. 'phone. MJ sports fancy new QSL. EF keeps 3.8-Mc. hot in Edmonton. PP, of Lac la Biche, was burned badly when training ship *Essex* blew up at her wharf on the Lake. Traffic: VE6LQ 2.

**BRITISH COLUMBIA** — SCM, W. W. Storey, VE 7WS — During his holidays ABEY visited some of the hams he had worked on 14 and 28 Mc. TQ has decided to put up his 28-Mc. tower which was blown over last winter. The SCM still is looking for monthly reports from all the active clubs in B. C. ZZ is putting up new tower for 28 Mc. The Collingwood Radio Club, DJ, now is on the air with a number of contacts on 3.5-Mc. c.w. and will be heard on unrestricted 'phone soon with the OK of the R.I. AZ is busy on the frequency meter for the club transmitter and also finds time for the odd QSO on 28- and 14-Mc. 'phone. XT is working out on 14-Mc. c.w. with a beam antenna. KK is operating with a nice note on 7- and 3.5-Mc. c.w. UU has rig in console now. ADV was out with mobile rig recently running 15 watts on 28-Mc. 'phone and called CQ like mad but no contacts. Although West Coast hams report they heard him, the last we heard he was mumbling about a 28-Mc. beam on the roof of the Willys. OJ is in new QTH on 49th Ave. East, but the electric company has not put in pole tranny yet, and so with the help of a.c. via extension from next door he is running VFO about 5 watts and working W6s on 7-Mc. c.w. Doug Gordon is doing troubleshooting on club transmitter. DJ will have a new 7-Mc. antenna as soon as BE can talk his neighbor into letting him use his garage as a base for the second antenna pole. LF is on 7-Mc. c.w. with low power. MH, club secretary, is working DX on 14-Mc. c.w.

### PRAIRIE DIVISION

**MANITOBA** — SCM, A. W. Morley, VE4AM — Activity is high on 3.5 Mc. for this time of year. Could a YL have anything to do with it? You can call her Fran, boys. Welcome to ham radio, Fran. New calls heard lately are GL, GC, and EY. All are active on 7 and 3.5 Mc. VO6U, ex-VE4SO, was in Winnipeg visiting, as were VE1LO and W2ANH. W2ANH says all the rumors about NI are wrong — Bill does wear shoes and adds stockings on Sundays. Further there is no hay sticking out of his ears. GQ continues to get out whenever 50 Mc. opens and is also heard testing 3.8 Mc. YW, at Brandon, worked 14 stations on 50 Mc. on June 27th. During the past month we have had several districts flooded and a tornado in southern Manitoba. Fortunately no severe damage was done to communication lines but it has proved that IT CAN HAPPEN HERE. Do you belong to the AEC? If not, why not? Drop me a line for details.

# SAME TRANSMITTER • SAME ANTENNA ... MORE POWER ...



FEATURED IN APRIL QST

## AN INSTRUMENT FOR MEASURING STANDING WAVE RATIO AND RF POWER

### An Indispensable Aid in Such Routine Tasks as:

- Adjusting antenna matching network for maximum efficiency.
- Adjusting directional beam antenna for maximum performance.
- Adjusting interstage coupling networks.
- Measuring RF resistance of unknown load.
- Measuring RF power being fed down a transmission line.
- Measuring standing wave ratio on a transmission line.

### MODEL MM1 FOR OPEN WIRE LINES

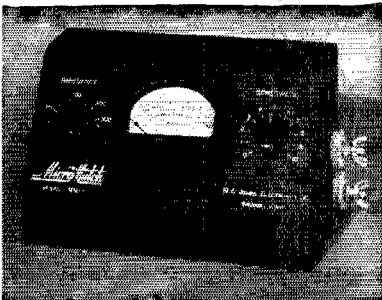

Frequency 3 to 30 MCS  
Power 10 to 1000 watts  
Impedance 70 to 300 ohms

**Complete \$29.50**

Manufactured by . . .

### ANNOUNCEMENT

### The New MODEL MM2 FOR COAXIAL TRANSMISSION LINES

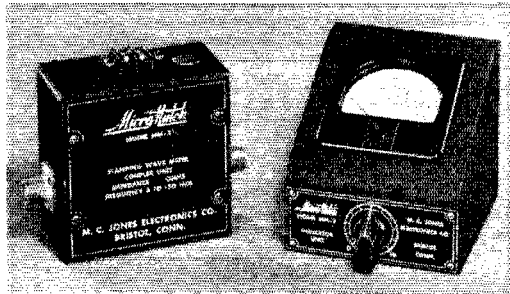

Frequency . . . . . 3 to 162 MCS  
Power . . . . . 10 to 500 watts  
Impedance . . . . . 52 or 72 Ohms  
Connectors . . . . . 83-1R\*

**Coupler \$19.95 • Indicator \$17.50**

### LOW POWER LOSS

- Both models of the MicroMatch are designed to read accurately without absorbing appreciable power from the line.
- The instruments may be left connected to the transmission line to read standing wave ratio and RF power while the transmission line is in use.

CONTACT YOUR LOCAL DISTRIBUTOR

## M. C. JONES ELECTRONICS COMPANY Bristol, Connecticut

Distributed Outside of Continental U. S. A. by RCA International Division, Radio Corporation of America, 745 Fifth Avenue, New York 22, N. Y., U. S. A.

\* Available with Amphenol type 82-24 connectors at slight additional charge

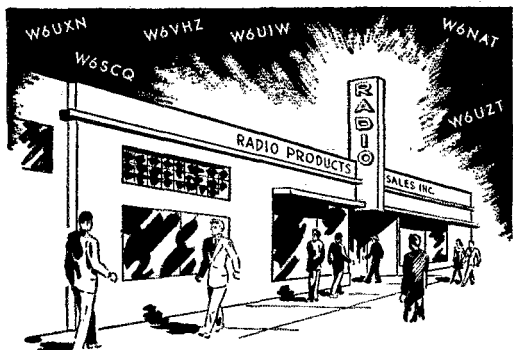

## NEW COAXIAL ANTENNA RELAY

This relay — Advance Electric Type No. 7200 (AC) — 8200 (DC) will eliminate loss in your coaxial transmission line. Relay uses Amphenol 83-1R receptacles, and is designed for use with 52 and 72 ohm line. Contact combination is single pole, double throw with a 10 amp. rating. Available from 1 — 220 Volt AC, or 1 — 220 Volt DC.

Price.....\$7.50

This unit is also available with auxiliary contacts in double pole, double throw with a 5 amp. rating.

Price.....\$9.30

**SPECIAL WHILE THEY LAST!**  
(For those of you who missed our May Advertisement.)

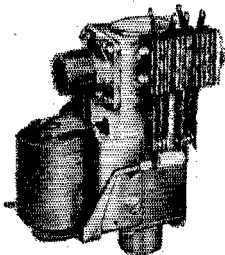

## TRANSMITTER and RECEIVER

### BC 1335 FM Transmitter and Receiver

(Choice of one xtal free with each unit)

Check xtal. desired  29580 KC  29600 KC  29620 KC

Additional above xtals.....\$3.50 Each  
Handset to match.....4.95 Each

Input six or twelve volt DC. Frequency 27 to 38.9 MC. with 2½ w. output. Makes ideal 10 meter mobile transmitter. This has two (2) fixed channels which can be set on any xtal frequency from 27 to 38.9 MC. (Note: The receiver is not tunable.) Sold complete with 27 tubes and vibrators, but less handset and top and bottom covers.

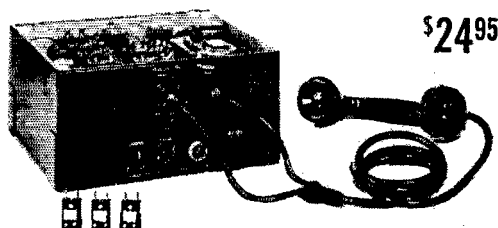

Prices subject to change

All prices F.O.B. Los Angeles (California purchasers add 2½% Sales Tax). Include 25% with order—balance on delivery. Foreign orders cash

Get **YOUR NAME** on our mailing list. We'll keep you posted on merchandise available, new equipment and special bargains. Address correspondence to Dept. QST.

## RADIO PRODUCTS SALES INC.

1501 South Hill Street • Los Angeles 15, Calif  
Phone: PR. 7471 • Cable Address: RAPRODCO

## Strays

Life isn't too dull these days for the boys signing maritime mobile. Recently a juicy five-way QSO on ten 'phone included W4JQT/MM, in Durban Harbor, South Africa, W6NSQ/MM, off the southeast coast of Brazil, W4AYE/MM, in mid-South Atlantic, and W2PFL/MM, 200 miles north of the tip of Brazil. The fifth party to the three-hour rag-chew was a landlubber, CX1DB, Montevideo.

Need strain insulators for that new mast or beam? W9TOO found that electric-fence insulators, available in farm-equipment stores, fill the bill nicely. There's no strain on the pocketbook, either: W9TOO's cost only 2¢ each!

Now that FCC has advised that there is nothing in the law governing radio communications to prevent two licensed amateur radio stations being utilized to consummate a wedding ceremony, W9UKK/8 wants to know how playing the Wedding March would fare under the no-music regulation, §12.104. And will someone also page Mr. Petrillo, please!

W2FMI's XYL is a meticulous housekeeper, and though her cleaning duties are often hamstrung because of her errant choice of a lifetime partner, she has learned during the years to manage every situation in stride. Some time ago, while getting in a few licks on her cleaning chores, Mrs. W2FMI's jaundiced eye spotted an attic mess of wire laying on the floor and hanging on the wall. The OM had been lax again. Duty to home and OM called—the disorderly jumble was filed in a convenient ash can.

W2FMI worked out swell on ten for a whole week — with an occasional report of tinny modulation, perhaps — until he discovered the resting place of his pet folded dipole and feedline!

—W2CSC

Tungsten wire 0.00018 inch in diameter and invisible to the naked eye is now being used in filament applications in certain types of vacuum tubes, according to Ohmite News.

Publications worth space on your bookshelf:

An interestingly-written 24-page booklet, *20 Steps to Perfect Amplification*, by A. C. Shaney, covering the field of audio-amplifier design considerations, may be obtained for a 3¢ stamp from the Amplifier Corporation of America, 398-11 Broadway, New York 13, N. Y.

Copies of Volumes I and II(a) of the new "Index of RCA Technical Papers" may be obtained free of charge from RCA Laboratories Division, Radio Corporation of America, Princeton, N. J. Also available without cost is a revised edition of the RCA "Quick Reference Chart on Miniature Tubes," which provides illustrations, characteristics, fundamental data and socket connections of 48 miniature types. Ask for Form MNT-30A.



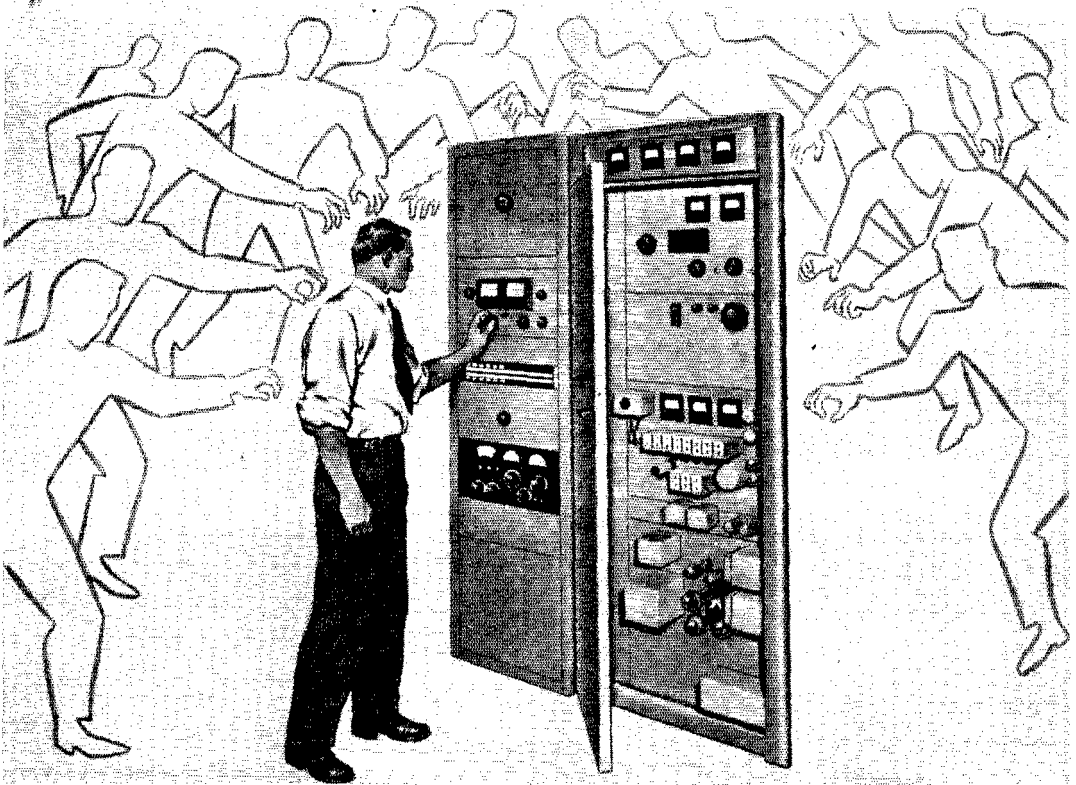

# How Much Competition Have You

... For Your Present Job - For a Better Job ?

Again employers can afford to be "selective", particularly when there are thousands of new, ambitious, young men who have entered the radio industry since the war. This means both you newcomers and "old timers" must improve your technical knowledge not only to qualify for the better job you want, but to hold the job you now occupy.

Your own success in radio depends upon the effort you make now to fortify yourself with modern technical training. You may have "gotten by" up to this point. But, if you are like some radiomen, many wartime and postwar technical advances of the industry have passed you by. If you want to progress with the industry... if you want

an important, good-paying position and future security — you must acquire up-to-date technical training.

We invite you to investigate the CREI proved program for professional self-improvement for which thousands of radiomen have enrolled since 1927. CREI can help you by providing down-to-earth, practical technical training that should equip you to advance to the better-paying radio jobs that offer security and happiness. CREI home study courses are adaptable to the needs of every radioman — for the man who is just beginning or the man who wants advanced engineering training.

The facts about CREI and what it can do for you are interestingly described in our 24-page booklet. It is well worth your reading. *Send for it today.*

## Mail Coupon for FREE BOOKLET

*If you have had professional or amateur radio experience and want to make more money, let us prove to you we have the training you need to qualify for a radio job. To help us intelligently answer your inquiry — in writing, PLEASE STATE BRIEFLY YOUR BACKGROUND OF EXPERIENCE, EDUCATION AND PRESENT POSITION.*



**VETERANS! CREI TRAINING AVAILABLE UNDER THE "G.I." BILL!**

## Capitol Radio Engineering Institute

*An Accredited Technical Institute*

DEPT. Q-9 16TH AND PARK ROAD, N. W., WASHINGTON 10, D. C.  
 Branch Offices: New York (7); 170 Broadway • San Francisco (2); 760 Market St.

**CAPITOL RADIO ENGINEERING INSTITUTE**  
 16th & Park Rd., N. W., Dept. Q-9,  
 Washington 10, D. C.

*Gentlemen:* Please send me your free booklet, "CREI Training for Your Better Job in RADIO-ELECTRONICS," together with full details of your home study training. I am attaching a brief resume of my experience, education and present position.

Check  Practical Radio-Electronics  
 Course  Practical Television

Name.....

Street.....

City.....Zone.....State.....

I am entitled to training under the G.I. Bill.

# COMPLETE STOCK IN OUR HAM DEPT.

Manned by HAMS, our HAM DEPT. is well stocked with all the standard, nationally advertised products of the well-known Manufacturers.

ARROW'S HAM DEPT. stands ready to serve you with prompt, speedy service and guaranteed merchandise.

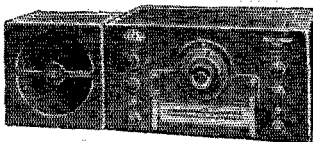

HRO-7T \$311.36 COMPLETE

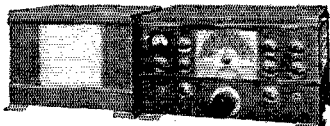

NC2-40-DT \$225.00 Spkr. \$16.44

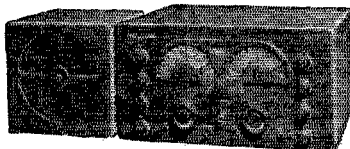

NC173-T \$179.50 Spkr. \$10.00

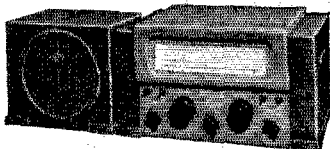

NC46 \$97.50 Spkr. \$9.90

WRITE FOR OUR LIBERAL  
TRADE-IN ALLOWANCE  
AND EASY PAYMENT PLAN

# ARROW

## ELECTRONICS, INC.

82 CORTLANDT ST., N.Y. 7, N.Y.

## Revamping the 150-B

(Continued from page 28)

erate plate-current surges beyond the recommended peak of 220 ma. Such surges may well contribute to the ultimate breakdown in the modulation-transformer winding. Good and sufficient modulation can be achieved with peaks not in excess of 110 ma., and the crystal microphone is, of course, not subject to the sudden handling surges of its cruder brother.

During the past ten months numerous contacts have been made with other amateurs using the 150-B. Exchange of information regarding it discloses the following important points: If you have already blown your modulation transformer, or want a reserve against that sorry day, the UTC VM-3 will make an excellent substitute.

Frequency stability of the VFO is generally excellent, but in locations where the input line voltage varies greatly, it is advisable to check the VR-105 and VR-150 tubes in the exciter to make sure that they are functioning properly. A lowered line voltage will tend to cause drift in frequency which can make Washington unhappy and you very sad if it isn't watched.

When high-frequency coils are used in the VFO exciter, as an alternative to adding the doubler stage, it has been found in several installations that the keying circuit is upset, causing a noticeable "yoop" in 14-Mc. c.w. operation. The chirp is not present so long as the exciter remains on 7 Mc. On any band, it is highly inadvisable to modulate the gear with the main power switch in "tune-up" position. Insufficient load to the final may cause damage to the 811 modulator tubes, the modulation transformer, or both.

A number of the boys have doubled the ante and taken their 150-Bs on down to 10 meters. This not only requires considerable reworking of the final stage—but the addition of another doubler, or a combination of this appendage and a "facial" on the exciter coils. But that is beyond the scope of this article, as the title indicates. Besides, for that maneuver one should have a small-sized railroad crane in the shack to hoist the 150-B's 350 lbs. of steel and wire. You know, just to correct that slight error "way down inside" . . . where you shorted the HV on to the microphone lead.

## Simple Calculations

(Continued from page 31)

high-Q circuit such as in VFOs. Of course  $f_{min}$  and  $f_{max}$ , and  $C_{min}$ ,  $C_{max}$  and  $C_{var}$ , should be in the same units, i.e., kc. or Mc. for  $f$  and  $\mu\text{fd.}$  or  $\mu\text{fd.}$  for  $C$ .

In practical application it should be recognized that the variation in capacitance that may be expected from a variable condenser is not the rated maximum capacitance shown in the catalogues; it is the difference between the condenser's maximum and minimum capacitance. A typical small 100- $\mu\text{fd.}$  variable may have a

(Continued on page 128)

# \$175 AND 25 MONOSETS GIVEN

## To Winners of This

# EASY CONTEST!

### RADIO AMATEURS

*Just write 50 words or less telling us why you like the TELEX MONOSET better than old style earphones.*



WIN:

**\$100**

and a Monoset

**\$50**

and a Monoset

**\$25**

and a Monoset

PLUS

TELEX MONOSETS  
to 22 Runner-ups!

### HERE'S ALL YOU DO:

1. Go to your *parts jobber* and ask him to let you try out the revolutionary under-the-chin TELEX MONOSET.
2. In 5 minutes you'll get at least half a dozen good, WINNING ideas. Be sure to get *all* the facts and an OFFICIAL ENTRY BLANK.
3. Then write 50 words or less telling us "Why the TELEX MONOSET is

Better than Old-Style Earphones." Clearness and sincerity will count most.

4. Print or type your answer on the OFFICIAL ENTRY BLANK your jobber will give you.

Mail direct to: TELEX, INC., Telex Park, Minneapolis 1, Minnesota, before Midnight October 15, 1947.

FIRST PRIZE: \$100.00 cash and a TELEX MONOSET  
SECOND PRIZE: \$ 50.00 cash and a TELEX MONOSET  
THIRD PRIZE: \$ 25.00 cash and a TELEX MONOSET

TELEX MONOSETS to the 22 next best opinions. In case of a tie, *duplicate* prizes will be awarded.

Employees of Telex, Inc. and their advertising agency not eligible to enter this contest.

NO BOX TOPS!  
NO JINGLES!  
Get Entry Blank  
From Your Parts  
Jobber

## CONTEST CLOSES MIDNIGHT OCTOBER 15, 1947!

### TIPS TO GET STARTED WITH:

1. TELEX MONOSET is quickly replacing old-style, cumbersome headsets because you wear it under-the-chin instead of over-the-head.
2. Featherweight: Only 1.2 oz. No ear fatigue.
3. Excellent fidelity. Clear, natural reception of sound.
4. Reliable performance assured by TELEX precision engineering.
5. Exclusive, TELEX designed, volume control—permits individual adjustment of volume.

*Decision of impartial judges will be final. All entries become property of Telex, Inc. Winners will be notified by mail approximately November 1, 1947. Contest subject to all state and federal regulations.*

*Remember, wherever a headset is used—TELEX MONOSET will do the job better.*



HEARING AT ITS BEST

**TELEX INC.**

ELECTRO-ACOUSTIC DIVISION

TELEX PARK  
Minneapolis, Minn.

# QST

## YEARLY BINDERS



### Are We Right?

You should have at least two of them—one for your complete 1946 file of copies, and one for each 1947 issue as published.

With each Binder is furnished a sheet of gold and black gummed labels for years 1928 through 1948. The proper one can be cut from the sheet and pasted in the space provided for it on the back of the binder.

Price **\$2.00** postpaid

Available only in United States and Possessions

**THE AMERICAN RADIO RELAY LEAGUE**  
West Hartford, Connecticut

(Continued from page 180)

minimum capacitance of 10  $\mu\text{fd}$ . making the variation only 90  $\mu\text{fd}$ . This minimum as well as any capacitance introduced by mounting the condenser close to grounded metal must be included in the minimum circuit capacitance,  $C_{\text{min}}$ . This minimum circuit capacitance usually is the only factor that is not readily determined and since it may run as high as 50 to 75  $\mu\text{fd}$ . when capacitance coupling is used between tetrode or pentode stages, especially when the condenser is mounted close to the chassis, it isn't something that can be neglected entirely without introducing considerable error in the calculations. In many cases, however, it is possible to estimate the total minimum capacitance with an accuracy sufficient for the purpose. In the case of capacitance coupling between stages, the output capacitance of the driving tube and the input capacitance of the driven tube are in parallel with the tank coil and therefore form part of the minimum circuit capacitance. The values for any particular combination of tubes may be made up from the information given in tube manuals.<sup>1</sup> Variable-condenser minimum capacitances also are usually shown in the manufacturer's catalogue.

Mounting a midget-type condenser on metal in the usual manner introduces a stray capacitance between stator and ground equivalent to from 2 to 4 times the condenser's rated minimum capacitance. This must be added to the circuit minimum although it does not alter the amount of capacitance variation to any appreciable degree. Socket, wiring, and coil capacitances may add another 10 to 20  $\mu\text{fd}$ . If the circuit minimum is to be held down, the condenser in particular must be well spaced from grounded metal chassis and shields.

The inductance required to go with the condenser may be determined from the following formula:

$$L = \frac{25,330}{(f_{\text{min}})^2 (C_{\text{max}})}$$

where the frequency is in Mc., the capacitance in  $\mu\text{fd}$ . and the inductance in  $\mu\text{h}$ . Coil dimensions to give the calculated inductance may be selected from published tables or the ARRL Lightning Calculator.

<sup>1</sup> See p. 22, February, 1947, QST, for popular audio-receiving-tube capacitances.

### Antenna Rotator

(Continued from page 36)

tically alongside the tower. Removal of four smaller bolts permits turning the assembly on a hub. This makes it possible to reach any part of the beam from the tips of the elements to the hub, for painting the framework or adjusting the elements.

(Continued on page 124)

# HAMS . . . HERE ARE SOME SYLVANIA PRODUCTS OF INTEREST TO YOU

## CRYSTAL DIODE VARISTOR (1N40)



The 1N40 consists of four specially matched germanium crystal diodes. Point contact utilized in these diodes reduces capacitance to the order of a few  $\mu\text{f}$ . As a result the useful frequency range is greatly extended. Stability is improved, and the contact potential effects occurring in

vacuum diodes are practically eliminated.

## GERMANIUM CRYSTALS



1N34  
(DIODE)

1. Small size.
2. Eliminates heater supply and possible source of hum.
3. Pigtail construction — can be soldered into place.

1N35  
(DUO-DIODE)

4. High resistance to vibration and shock.
5. Tested for matched r-f loading in a tuned circuit.
6. Low shunt capacitance.

The 1N34 and 1N35 are ideal for use in lightweight and portable equipment. Fields of application include: field strength meters, detectors, clippers, discriminators, series noise limiters, demodulators, meter rectifiers.

## TECHNICAL MANUAL



You'll surely welcome this handy reference manual, with its important features including: Fundamental Properties of Vacuum Tubes; The Characteristic Curves; General Tube and Circuit Information; Resistance Coupled Amplifier Data—and many more. We urge you to get your copy right away—because we know you'll find this volume invaluable.

See your Sylvania Distributor or order from Sylvania Electric Products Inc., 500 Fifth Avenue, New York 18, N. Y.

# SYLVANIA ELECTRIC

MAKERS OF RADIO TUBES; CATHODE RAY TUBES; ELECTRONIC DEVICES; FLUORESCENT LAMPS, FIXTURES, WIRING DEVICES; ELECTRIC LIGHT BULBS

## TEST PROD OHMMETER

With the Sylvania Pocket Test Prod Ohmmeter in your tool kit, you can locate shorts or open circuits in a jiffy!

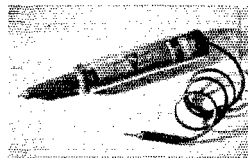

This handy-size meter gives direct readings of resistance from 600 to 10,000 ohms . . . reaches easily into hard-to-get-at corners and awkward spots. Completely self-contained—powered by 1.5 volt "penlight" battery. Only  $5\frac{3}{4}$ " long,  $\frac{7}{8}$ " diameter.

## MODULATION METER

(Model X-7018)



Now you can monitor your modulation percentage and speech quality with the new Sylvania Model X-7018 Modulation Meter. Compactly styled. Economical. Of great assistance in com-

plying with FCC regulations on overmodulation. Helps keep your average percentage up between 60% and 90%. Also indicates carrier shift. Designed for use through the 54 megacycle region.

## TRANSMITTING TUBES

(Type 3D24)



First of Sylvania's new line of transmitting tubes, the 3D24 is a four-electrode amplifier and oscillator with 45 watt anode dissipation. An outstanding development is the electronic graphite anode, which allows high plate dissipation for small area and maintains stable grid-plate and anode characteristics.

# ADVANCE COAXIAL RELAY

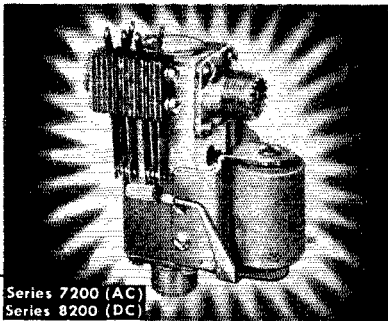

Series 7200 (AC)  
Series 8200 (DC)

**New coax relay for RG-8U cable**  
**Outside contacts for associated circuits**

## New 50 ohm coax relay...

- SPDT SWITCHING OF 50 OHM RG-8U CABLE • STANDING WAVE RATIO OF 1.02
- 1/4" PURE SILVER INTERNAL CONTACTS • INSPECTION PORT NEXT TO INTERNAL CONTACTS • 3/16" PURE SILVER EXTERNAL CONTACTS UP TO DPDT FOR INDICATOR LIGHTS AND OTHER ASSOCIATED CIRCUITS • CONNECTORS ARE AMPHENOL 83-IR OR SIG. CORPS. SO-239
- POLYSTYRENE INSULATED • ANY VOLTAGE UP TO 440 V. A. C. OR 240 V. D. C.

See it at your jobber's today  
PRICE \$7.50 net  
\$9.30 net with aux. contacts



**Advance Relays**

**ADVANCE ELECTRIC & RELAY CO.**  
1260 West 2nd Street, Los Angeles 26, Calif.  
Phone Mlchigan 9331

## ROTATORS SO-1 Radar Type

Plenty husky for any beam antenna a ham can dream up. Built to last a lifetime.

Powerful gear train and motor housed in rugged aluminum pedestal. Speed 2 RPM. Instantaneous reversing. Automatic lock-in prevents drift in strong winds. This is a he-man rotator and not a toy! Ask any navy communicator or radarman about the SO-1.

Price brand new—complete with 110-volt 60-cycle power supply, f.o.b. Tuckahoe..... **\$89.00**

See our advertisement on page 122 in the June issue of "QST"

**ELECTRONICRAFT, Inc.**  
Waverly Place Tuckahoe, N. Y.  
Tel. Tuckahoe 3-0044

(Continued from page 122)

## Direction Indicator & Control Panel

The direction-indicator unit includes a 1/8-hp. motor, cylindrical fluid storage chamber, pump, valves, and the all-important indicator. The motor mounts vertically on rubber in the rear of the box and the storage chamber and pump assembly are placed close to the front panel. A slot milled in the wall of the chamber is sealed by a transparent plastic window. This window is designed so as to protrude through a matching slot in the front panel. The window is grooved at the back to bring the fluid out to the front surface to show the fluid level in the storage chamber. Side grooves permit the attachment of a thin aluminum stamping on which are printed the necessary calibration marks that translate oil level into terms of beam direction. This scale is adjustable and may be quickly corrected at any time by the operator as he remains seated at his desk.

The pump, of single-rotor type, is attached to the base of the storage cylinder and is driven by a vertical shaft protruding through the chamber cover. A "V"-belt couples the motor and pump just under the removable box cover. Three valves are provided—a pump check valve, a by-pass-and-control valve and a ballast valve. These were developed for the special purposes they serve and have proved to be silent and faultless in operation. The control or front panel shows three control knobs. These are, left to right, motor switch, indicator-light switch, and master-control valve.

In operation, the beam is turned counter-clockwise by increasing the pressure in the system by means of the pump and motor. Clockwise rotation is obtained by turning the control-valve knob through limits of one-fourth turn, whether the motor is or is not running. In any case, the return or clockwise rotation is caused by the weight of the beam and associated structure attached to the piston rod. So with the motor operating the beam may be swung back and forth at will by merely opening and closing the control valve. Should the operator forget to stop the beam at the end of the travel with the pump running, the beam stops gently and the fluid is by-passed in the control unit.

The fluid level showing in the plastic window follows most accurately any movement of the beam. It is read like a thermometer to indicate direction. The normal speed of the beam travel is 30 seconds for 360 degrees of rotation. This speed can be controlled at will by the operator who need only watch the direction indicator.

In an earlier model, a hand-operated pump was used for some time by W9JBU. This turned the beam 20 degrees per stroke of the lever. In the present installation at W9JBU 180 feet of copper tubing is used to reach the beam atop a fifty-foot steel tower. W9DRI has his 20-meter beam on a fifty-foot power pole and expects to move it to a 100-foot telescopic tower as soon as materials are obtained to complete fabrication of the top sec-

(Continued on page 128)

# TRULY HERMETICALLY SEALED ... FOR POST-WAR PERFORMANCE

## SEALED LIKE A VACUUM TUBE

100% GUARANTEED



Marion Glass-To-Metal Truly Hermetically Sealed Electrical Indicating Instruments are guaranteed for six months. You get top performance ... critical accuracy ... at a cost no more than that of most competitive unsealed instruments.

Additional economy is offered in Marion's special replacement offer. After the initial six-month guarantee expires, any 2½" and 3¼" type, ranging from 200 microamperes upward, will be replaced, regardless of whether the instrument has been overloaded, burned out, or mistreated ... provided the seal has not been broken, for a flat fee of \$1.50. Instruments with sensitivity greater than 200 microamperes will be replaced for \$2.50.

### MARION "4 FOR 1" FEATURE

Interchangeable Round and Square Colored Flanges ... one instrument can thus fill four different needs:

1. ROUND



2. ROUND FOR STEEL PANEL



3. RECTANGULAR



4. RECTANGULAR FOR STEEL PANEL



Stop in at your nearest radio supply shop today and see the best in electrical indicating instruments ... the Marion line.

**MORE EXTRAS WITH MARION "HERMETICS"**

**DURABLE**

... Unaffected by extremes of heat or cold ... permanently protected against dust, dirt, moisture ... instrument malfunctioning eliminated.

**SHIELDED**

... Heavy steel case gives magnetic and electrostatic shielding so important in modern high frequency equipment.

**INTERCHANGEABLE**

... The Marion case, with its high conductivity plating, eliminates the need for separate shielding and permits interchangeability on any type of panel without affecting calibration.

**DRESSY!**

... Marion "hermetics" are supplied with either round or square flanges in black ... or any one of 12 iridescent colors at no extra cost.



**MARION ELECTRICAL INSTRUMENT CO.**

MANCHESTER, NEW HAMPSHIRE

Export Division 458 Broadway New York 13, U. S. A. Cables: MORHANEX

THE NAME "MARION" MEANS

THE "MOST" IN METERS

IN CANADA: THE ASTRAL ELECTRIC COMPANY, SCARBORO BLUFFS, ONTARIO

Be Bargain wise - Check these Low Prices

offered by the RADIO SHACK

**SCR-522 VHF XMTR-RCVR**  
for 100-156 MC work

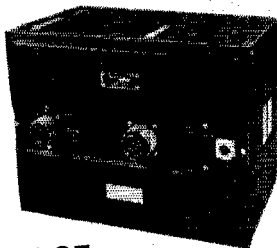

**\$14.95 NEW LOW PRICE**

An amazing value at a new low price. Sensitive receiver combined with 15-watt xmtr as used in AAF and RAF planes. Used, but in good condition, these popular rigs, complete with tubes are yours at only \$14.95.

Speed delivery and save C. O. D. charges — send full amount with order. 50% deposit required on all C. O. D. orders.

**NEW! NAVY AIR-BORNE RCVR Model ARB**  
**\$49.50**

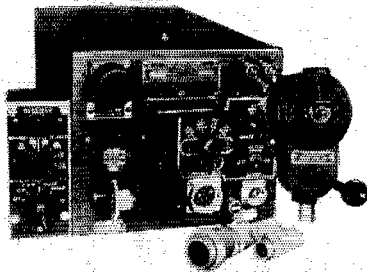

Here's an outfit that you can use for many purposes as its four bands include the broadcast band besides the 195-500 kc and the 1.6-4.5-9.05 mc bands. This 6-tube superhet handles MCW and CW, with MVC and AVC and sharp or broad selectivity. Pilot control box and calibrated tuning head (requires flexible shaft for connection) allow

operation from a distance if desired. Designed for 28-volt d-c use, with manual or electric band switching; readily converted to 110-volt a-c operation with manual switching. Complete with tubes and necessary plugs for connecting cables. An ideal rig for marine, aircraft, or automobile installation; high sensitivity; usable with loop antenna for direction finding.

Complete instruction book furnished.

**COLLINS AN-ART-13 XMTR** **\$7500**



A real bargain — famous Collins quality in a transmitter covering 1500 KC to '18 MC — in A-1 used condition — complete with tubes. Shipping weight, 90 pounds.

**RADIO RECEIVER** **\$4.95**  
**BC-1206-A** with tubes

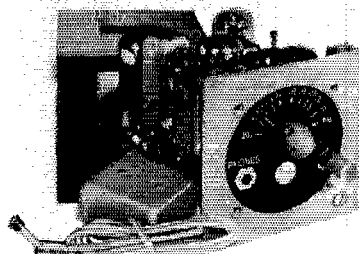

This compact midget superhet is designed to fit a 3-inch meter hole for back-of-panel mounting. Originally used for receiving marker beacons and weather reports, in 200-400 KC band, you'll find it a handy all 'round receiver. Five tubes provide pre-selector, converter, oscillator, 175 KC IF, 2nd detector, and AF. Draws 900 mills at 28 v. d-c. Container in metal case; shielded battery lead passes through RF filter. Can't be told from new.

**PE-103 DYNAMOTOR**  
NEW \$9.00



Brand new, in original Signal Corps packing; delivers 160 mills at 500 volts; operates from 6 or 12 volts d-c; complete shock-mounted assembly includes breakers, switches, relays, filters, and cables.

**BC-221 A K FREQUENCY METER**

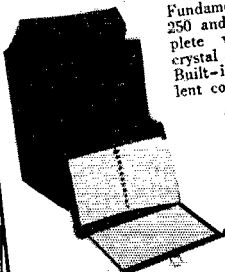

Fundamental ranges are 125-250 and 2000-4000 kc. Complete with tubes, original crystal and calibration charts. Built-in modulation. Excellent condition. Order today!

The BC-221 makes an exceptionally fine VFO — WNU tells how in March QST.

**\$7950**

**CO-AX CABLE SETS**

Fifty-foot RG-8/U co-ax cable with PL-259 connectors **\$1.95** attached each end

One hundred-foot RG-8/U cable comprising two 50-foot **\$3.90** cables coupled with CPH-4919

**XMTG CAPACITORS**

Nationally known, high-voltage, oil xmtg capacitors, all in rectangular cases, with stand-off insulators.

Mfd.	Volts d-c	Net Ea.	Mfd.	Volts d-c	Net Ea.
4	600	\$0.71	2	1500	\$1.20
6	600	.79	8	1000	1.49
8	600	1.19	6	1500	1.79
10	600	1.29	2	2000	2.95
2	1000	.71	8	2000	3.75
4	1000	1.19	2	2500	3.25

\*The one and only original RADIO SHACK is located in Boston and has no branches or affiliates elsewhere.



# You can't beat these Values in NEW UN-USED RADIO EQUIPMENT



**NEW  
AAF XMTR  
BC-375-E  
\$5500**

At last we can offer you brand new BC-375-E's that have never seen prior service. They're complete with five tubes, seven tuning units covering 200 kc to 12 mc (less BC band), antenna tuning unit with variometer and tap switch, and filtered dynamotor.

## NEW! FULL-WAVE RECTIFIER SUPPLY RA-91-A \$49.50

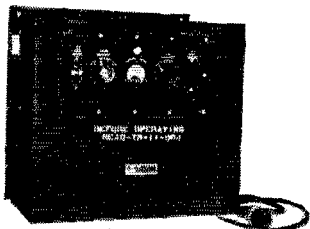

Four selenium rectifier stacks give full-wave rectification; tap switches in transformer circuit afford coarse and fine adjustment of voltage from six to 48 volts d-c at loads up to 15 amperes. Circuit includes filter reactor, so you can make it into a power source for 28-volt d-c equipment by adding a couple of 1000 mfd 50 volt electrolytics. Housed in well-ventilated steel case; control panel has a-c and d-c circuit breakers, tap switches, and 0-15 ampere output meter. Made by Federal Telephone & Radio Corp.

**SUPER SPECIAL  
BRAND NEW 807's**  
Westinghouse  
JAN-inspected  
**70¢ each**  
3 for \$1.95  
6 for \$3.75  
**THE BUY OF A  
LIFETIME**



**NEW! BC-348  
COMMUNICATIONS  
RECEIVER \$6950**

It's the best surplus communications receiver value in the world, in our opinion, and you may never have another opportunity to get a brand new BC-348 at this extremely low price. Guaranteed absolutely new and unused, they are shipped you in the original, unopened, wood cases in which the AAF received them. Complete with built-in dynamotor, crystal filter, full set of tubes, and detailed technical manual . . . at the low price of only \$69.50. Not all with shock-mount.  
**DON'T WAIT—ORDER YOUR BC-348 TODAY!**

Shpg. wt. 61 lbs.; size, packed 3 cu. ft.  
Kit for conversion to 110 volt a-c operation, with full instructions .....\$6.50  
Transformer for 220 volt stepdown to 110 volts, 60 cycles .....\$6.50

## GOVERNMENT SURPLUS TUBES

Type	Net	Type.	Net	Type	Net
2AP1A	\$5.25	801	1.72	957	.75
2C34	1.12	803	9.00	958	.75
2C40	2.62	809	1.79	959	.75
2D21	.60	811	1.95	95A	.75
		813	6.75	955	.75
VR105	.75	814	4.50	9001	1.05
VR150	.75	836	1.50	9002	.90
3B24	3.00	840	2.70	9003	1.05
		866A	.75	9004	.90
		872A	2.25	9006	.60
5CP1	3.37	874	1.95	832	2.25
5CP7	5.25	914	5.62	(VT118)	
3BP1	3.00	860	3.00	826	2.25
5BP4	3.37	923	.45	(VT222)	
6AK5	.90	931A	1.87	2X2A	.90
6C21	13.50	1619	.75	815	2.25
8005	\$3.15	1624	.90	(VT287)	
8000	6.00	1625	.75	3E29	3.00
		1626	.60		
		1651	.75		

**HOT! 3C24 (HK 24G) HOT!  
90c each . . . . 6 for \$4.50**

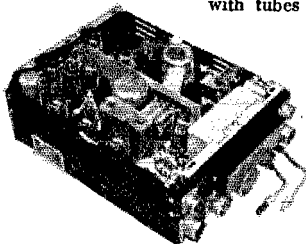

## NEW! BC-645A's for 420 MC \$16.95 with tubes

Easily converted to make a "hot" xmtr-rcvr for phone or ICW (see QST Feb. 1947), these brand new, G.E.-built outfits make it a cinch to get in on the fun to be found on 420. Originally priced in four figures, we offer them at less than the price of the tubes alone. At this low price, be sure to send full amount with your order.

## MIMS-AMPHENOL BEAM ANTENNA

This efficient system for transmitting and receiving is now available at the Radio Shack. Time-payment orders are filled on down payment of 20%; balance on usual Radio Shack terms. Write today for details. Amateur net price of Mims-Amphenol Beam Antenna is \$358.00.

# The RADIO SHACK Corp.

CABLE ADDRESS · RADIOSHACK  
167 WASHINGTON ST., BOSTON, MASS., U.S.A.

**"The ELECT  
In Electronics"  
For Industry • Schools  
And The Amateur**

**Visit Your Nearest  
Friendly**

**H&Y STORE  
Now**

Get acquainted with the  
men who are prepared to  
take care of your needs.

See what we mean by *Friendly*

**REMEMBER — No. 9  
IS AT SPRINGFIELD**



**CONNECTICUT**

HARTFORD  
203 ANN STREET  
BRIDGEPORT  
544 E. MAIN STREET  
NEW HAVEN  
77 BROADWAY

NEW LONDON  
428 BANK STREET  
WATERBURY  
89 CHERRY STREET

STAMFORD  
97 MAIN STREET

**MASSACHUSETTS**

BOSTON  
42-44 CORNHILL  
LAWRENCE  
639 ESSEX STREET

**AND NOW**  
SPRINGFIELD  
169 SPRING STREET

**RECEIVING SENDING  
CODESPEED** *without strain*

**CHAMPIONS ENDORSE CANDLER WAY**

Get skill, accuracy, speed with the highly endorsed Candler System. Learn to send and receive by telegraph or radio code. Government service and commerce need thousands of better trained operators. Air commerce, mail, freight, etc., demand expert, reliable operators. Good pay. Get the Candler System, the maker of champions. It teaches you the "knack" of sound sense, alertness, speedy sending and receiving without strain. Adventure—good pay. Learn at home or wherever you are. Rush name today for free book.

**FREE!**

**CANDLER SYSTEM CO.**  
Dept. 4-K, Box 928, Denver 1, Colorado, U.S.A.  
and at 121 Kingsway, London, W.C. 2, England

(Continued from page 124)

tion. It is planned to rig this tower with indoor control of the height as well as the direction of rotation.

Wisconsin's four seasons, with a temperature variation of 100 above to 25 below zero, succeeded only in bending and breaking antenna elements but did no damage to the hydraulic system.

We shall be happy to receive comments or suggestions on our control system.

**Radiomen Wanted**

(Continued from page 49)

be sent, whenever possible, to a country of their choice. The minimum period of overseas service is twenty-four months.

Requirements range upward from the minimum for communications technicians, a code speed of 18 five-letter random groups per minute, one year's experience in professional, military, or amateur radio, and ability to handle simple maintenance. At the top of the list is senior supervisor, for which applicant must hold, have held, or be able to qualify for, a radiotelegraph 1st- or 2nd-class or radiotelephone 1st-class license; and he must hold, have held, or be able to qualify for, an amateur radio ticket; must be thoroughly familiar with maintenance of communications-type receivers and able to design and construct c.w. transmitters of medium power. He also must be familiar with common models of commercial and military equipment and be well versed in radio propagation, including ability to make practical use of Bureau of Standards publications on that subject. Code-speed requirement is 25 five-letter random code groups per minute (typewriter). He must be able to supervise a large radio station (up to 30 positions). Ratings in between communications technician and senior supervisor require a proportionate amount of experience and operating ability. Any trained radioman should be able to qualify quite easily for one of these ratings, particularly if he has had recent military communications experience.

Qualified operator-technicians who are interested in these positions should write letters setting forth qualifications, particularly with respect to the following:

- 1) Radio-operating and technical experience, including military.
- 2) Present code speed.
- 3) Present license(s) and length of time held.
- 4) Part of the world in which duty is desired.
- 5) Part of the world in which duty is *not* desired.
- 6) Age and marital status, including number of children, if any.
- 7) Specialized training, e.g. teletype maintenance, etc.

Letters should be addressed to: *Box 73, c/o Administrative Headquarters, The American Radio Relay League, West Hartford 7, Connecticut.*

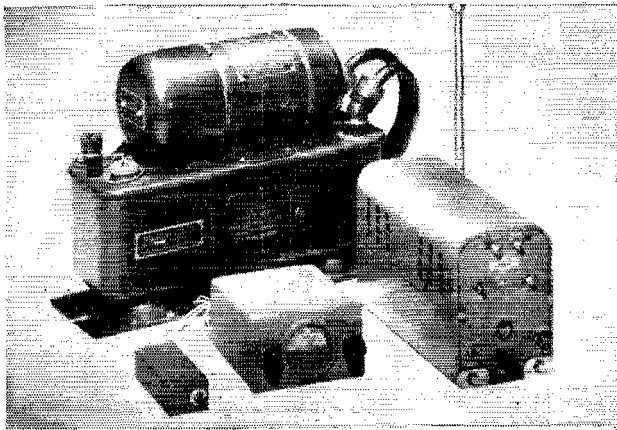

## Let ALLIED Put Your Rig on Wheels!

**NOW—COMPLETE MOBILE OPERATION IN YOUR CAR!**

Here's your chance to have a complete 10 meter mobile set-up in your own car—NOW! ALLIED offers everything you need to put your rig on wheels—to enjoy the thrill of working on the open road, wherever and whenever you want. Join the rapidly growing group of Mobile Hams. A surprisingly modest cost will bring you years of real pleasure on-the-go.

**SONAR MOBILE TRANSMITTER.** Model MB-611 available for immediate delivery. Size: 7" high, 5" wide, 10 1/4" deep. Uses: 1-6SL7 speech amp., 1-6SL7 xtal osc. & phase modulator, 1-6SL7 DC amplifier and Deviation amp., 1-6SK7 1st Freq. multiplier, 1-6SK7 2nd Freq. multiplier, 1-6AF6G dual tuning indicator, 1-2E26 power amplifier. Power output 22.5 watts of Narrow Band FM phone. Input for any crystal or dynamic mike. Requires 6.3 v. at 2.6 a. AC or DC for filament circuit, 450-500 volts DC at 100 ma. for plate supply. Complete with tubes and instructions, less 40 meter crystal and power supply. **\$7245** No. 97-611. NET.

**PE-103 DYNAMOTOR.** Big, husky power unit ideal for use with Sonar transmitter. Operates from either 6 or 12 volt battery. Completely filtered output, all input and output circuits protected by circuit-breakers and safety relay. Battery cables 10' long can be shortened if desired. New units; with circuit diagram; weather-proofed—at a fraction of Gov't cost. **\$785** No. 98-101. NET.

**GON-SET 10-11 METER CONVERTER.** Converts auto radio for 11-10 meter reception. Calibrated bandsread 27 to 30 Mc. In steel case, 3 1/2" x 5 1/2" x 5 1/4"; gray wrinkle finish. With tubes and instructions. No. 84-956. NET. **\$3995**

**GON-SET CLIPPER.** Highly efficient ignition-noise silencer, easily installed. In steel case, 2" x 4" x 1 1/4". With instructions, tubes, cables. No. 60-596. NET. **\$8.25**

**PREMAX MOBILE ANTENNAS.** Solid rod "whip" style made of heat-treated, oil-tempered stainless steel rod. No. 97-403. 90" Rod. NET. **\$3.38**  
Type TA Tripod Mount. No. 97-407. NET. **\$11.76**  
Type K Adjustable Bumper Mount. No. 97-408. NET. **\$5.00**

**WRITE W9IBC FOR DETAILS**

# ALLIED RADIO

*Everything for the HAM*



## YOUR ALLIED CATALOG

The One Complete Guide  
that Fills ALL of Your  
Station Supply Needs

**KEEP YOUR COPY HANDY**

### FIRST WITH THESE NEW Communications Receivers!

National HRO-7 ..... \$299.36  
Hallicrafters SX-43 ..... 169.50  
Hallicrafters S-47 ..... 200.00

### ALSO—FOR IMMEDIATE DELIVERY:

National NC-173 & Spkr.....\$189.50  
National NC-2-40D..... 225.00  
National NC-46 & Spkr..... 107.40  
Hallicrafters SX-42..... 275.00  
Hallicrafters S-38..... 47.50  
Hallicrafters S-40A..... 89.50  
Hammarlund SPC-400X & Spkr. 347.25  
Hammarlund HQ-129X & Spkr. 173.25  
RME-84..... 98.70  
RME-45 & Spkr..... 198.70  
RME VHF-152 Converter..... 86.60  
RME DB-22 Preselector..... 60.00  
Net F.O.B. Chicago. Prices subject to change  
without notice.

### TIME PAYMENTS

Trade-Ins Accepted

Keep This  
Buying Guide  
Handy



ALLIED RADIO CORP., D. L. Warner, W9IBC  
833 W. Jackson Blvd., Dept. 27-J-7  
Chicago 7, Illinois

- Send FREE 164-Page ALLIED Catalog.  
 Enter order for.....  
 Enclosed \$..... Full Payment  Part Payment (Balance C.O.D.)  
 Send Literature on Receivers and Time Payment Plan

Name.....

Address.....

City..... Zone..... State.....



**"BUCK" STRETCHER  
KITS**  
Contain Everything

Only SUN RADIO has 'em!

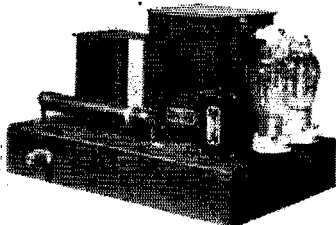

**POWER  
SUPPLY  
KITS**

**from 500 to 2000 Volts**

Everything you need to build your own power supply. All parts are brand new: condensers, tubes, sockets, bleeders, Kenyon transformers, Millen caps and H.V. connectors and special, heavy-duty chassis with bottom plates. All systems have 4 mfd. filtered choke input.

**ORDER NOW!**

Kit #1—500 or 700 Volts DC @ 300 ma. .... **\$39.50**

Kit #2—1000 or 1250 Volts DC @ 300 ma. .... **\$49.50**

Kit #3—1500, 1750 or 2000 Volts DC  
@ 300 ma. .... **\$59.50**

Complete wiring diagram with every kit

**POWER SUPPLY KIT FOR THE BC-221**

Delivers 135 V DC plus 6.3 V AC. Complete set of brand new parts to assemble the kit, including Stancor filament transformer and special schematic featuring prevention of AC line to ground short circuit. **\$595**

**SUN RADIO**  
& ELECTRONICS CO., Inc.  
122-124 DUANE ST. NEW YORK 7, N. Y.  
BARCLAY 7-1840

**ELECTRICITY**

FOR RADIO AND ELECTRONIC APPLICATIONS

ONAN ELECTRIC GENERATING PLANTS supply electric service for electronics applications and general uses, mobile or stationary. Driven by

Onan 4-cycle gasoline engines, they are of single-unit, compact design and sturdy construction.

ONAN Electric Plants are available in many sizes and models. ALTERNATING CURRENT: 350 to 35,000 watts in all standard voltages and frequencies. DIRECT CURRENT: 600 to 10,000 watts, 115 and 230 volts. BATTERY CHARGES: 500 to 3,500 watts; 6, 12, 24 and 32 volts. Write for detailed literature or engineering assistance.

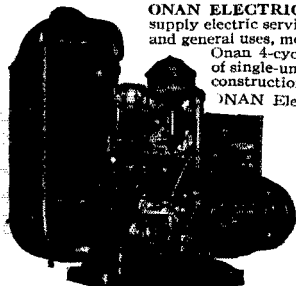

**D. W. ONAN & SONS** 4663 Royalston Ave. Minneapolis 5, Minn.

**Postwar Receivers**

(Continued from page 65)

on the change of cathode current in one of the i.f. tubes controlled by the a.v.c. The effect of the bucking action is to give an S-meter reading on weaker signals than generally affect a meter in more conventional systems. The S-meter has provisions for adjustment of sensitivity and zero-set, to compensate for antenna systems of different gains.

The noise limiter uses the other half of the 6H6 detector in a self-adjusting series-type arrangement. As is true of all of the self-adjusting circuits, the limiter works better on 'phone than on c.w., because the presence of the b.f.o. voltage when receiving code establishes the operating point of the limiter. However, the b.f.o. injection seems to have been held down in the 75A, and the limiter is effective on strong noise during c.w. reception. On 'phone it is quite effective at practically any level of noise.

**Construction**

The Collins 75A receiver is beautifully built. It looks modern and yet it looks like a radio receiver, with no attempts to disguise it as anything else. Looking at any part of the receiver, inside or out, reveals a cleanness of layout and wiring that is unexcelled by any piece of electronic equipment this reviewer has seen. Wherever feasible, components have been mounted on Phenolite terminal boards, further to add to the clean look of the gear.

The controls on the front panel are kept to a minimum. One large tuning knob is used, and the other controls are Audio Gain, R.F. Gain, Crystal Selectivity and Phasing, and BFO Control. In keeping with the accuracy of calibration of the receiver, the b.f.o. control is marked "+1" and "-1," indicating the amount to be added to or subtracted from the tuning-dial reading. Switches on the panel are "Man-AVC-CW," Band Change, Noise Limiter, and "Off-Fil. On-B+ On."

Although not present in the model examined at Headquarters, we have been advised that a movable index, or "fiduciary," has been added to the calibration dial. This allows the operator to set up the receiver exactly on frequency, in the event that drift or aging of components shifts the calibration slightly.

The 75A has incorporated in it some of the things necessary to any receiver that is to be an improvement over present technique. The crystal-controlled high-frequency oscillator, giving practically uniform stability on all bands, makes this a real "c.w. man's receiver." The same high stability makes it a good job for any 'phone operator, and also gives the n.f.m. man a chance to receive n.p.m. signals through the crystal filter, even on 30 Mc. The 500-ke. i.f. channel appears to have about the same order of selectivity that is to be found in contemporary communications receivers, and this reviewer believes it to be inadequate. It doesn't need to be that

(Continued on page 132)

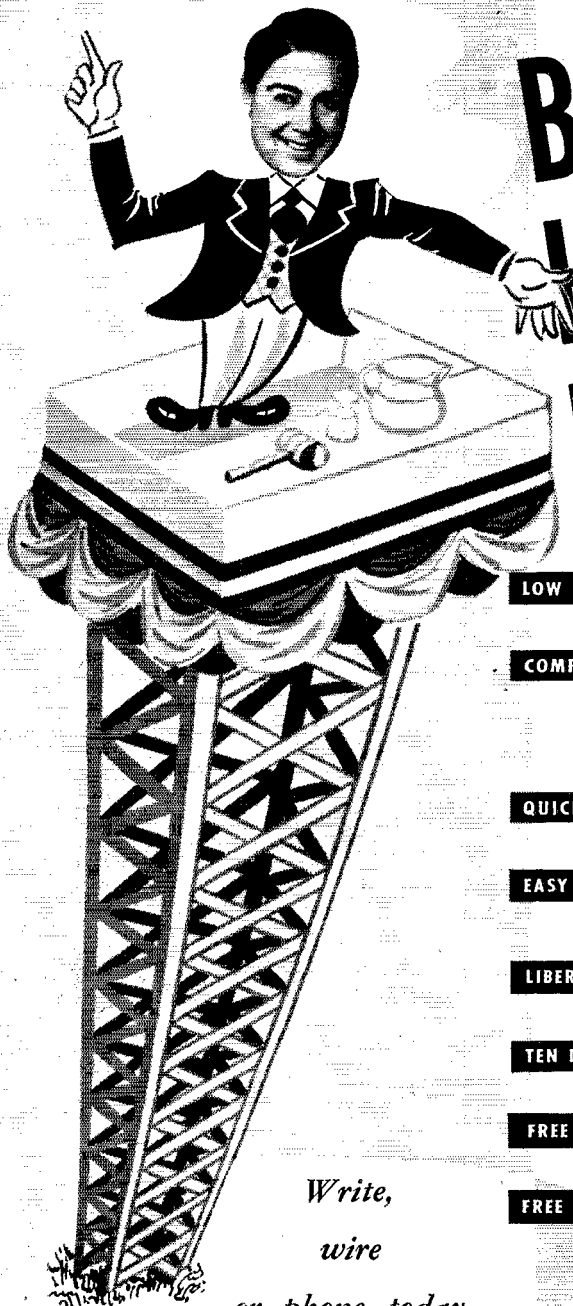

# BOB HENRY'S PLATFORM

## LOW PRICES

I guarantee to sell to you as cheap as you can buy anywhere.

## COMPLETE STOCKS

Hallcrafters, National, Hammarlund, Collins, Millen, RME, Pierson, Temco, Meissner, Supreme Transmitters, Meck, Gordon, Amphenol-Mims, RCA, Vibroplex, Sonar, all other amateur receivers, transmitters, beams, parts, etc. If it is amateur or communications equipment—I can supply it.

## QUICK DELIVERY

Mail, phone, or wire your order. *Shipment within four hours.*

## EASY TERMS

I have the world's best time sale plan because I finance the terms myself. I save you time and money. I cooperate with you. Write for details.

## LIBERAL TRADE-IN ALLOWANCE

Other jobbers say I allow too much. Tell me what you have to trade and what you want.

## TEN DAY FREE TRIAL

Try any receiver ten days, return it for full refund if not satisfied.

## FREE NINETY DAY SERVICE

I service everything I sell free for 90 days. At a reasonable price after 90 days.

## FREE TECHNICAL ADVICE

and personal attention and help on your inquiries and problems.

*Orders from outside continental U.S.A. also welcomed*

Write,  
wire  
or phone today

Butler, Missouri

# HENRY RADIO STORES

Los Angeles 25, Calif.

"WORLD'S LARGEST DISTRIBUTORS OF SHORT WAVE RECEIVERS"

# FS-135-C

FREQUENCY  
STANDARD

Keeps  
you  
"ON  
THE  
BEAM"

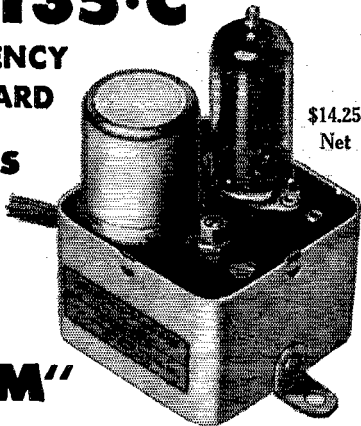

No more "hoping" you're in the band. Mount the FS-135-C Frequency Standard in your receiver, zero beat it with WWV and you'll have a frequency meter that is really accurate.

## HAMMARLUND

THE HAMMARLUND MFG. CO., INC., 460 W. 34TH ST., NEW YORK 1, N.Y.  
MANUFACTURERS OF PRECISION COMMUNICATIONS EQUIPMENT

*Crystals for the Critical*

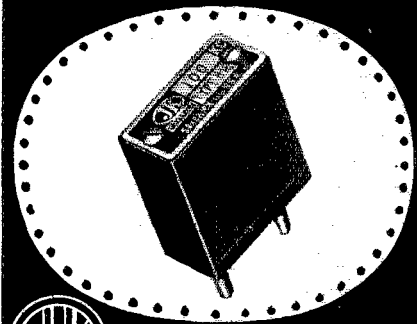

"STABILIZED"

**H16 — 100 KC CRYSTAL**  
**For Only \$6.95**

Here, at last, is a practical and economical 100 KC Crystal for the amateur. It has extremely low drift and the finest techniques known to the industry are employed in its construction. Electrodes are pure silver and mounting wires are soldered directly to the silver plating.

*Write for Illustrated Folder*

**The JAMES KNIGHTS CO.**  
**SANDWICH, ILLINOIS**

*(Continued from page 150)*

broad for usable 'phone reception, and it doesn't do a complete job of backing up the crystal filter. This is no criticism of the receiver design, since it is appreciated that too many operators insist on "fidelity," which can only be obtained at the expense of selectivity. When more operators realize what real selectivity can do for them in helping to get QRM-free contacts, then some manufacturer may take heart, throw caution to the winds, and offer a selective i.f. channel. Only a receiver with the stability of the Collins could make use of such high selectivity, particularly on 21 and 28 Mc., and it would show up "drifting" transmitters fast. But at least the 75A has paved the way. — B. G.

### I.A.R.U. News

*(Continued from page 63)*

must be signed by the contestant as a declaration that he has abided by the rules of the contest. It should be clearly stated whether the contestant wishes to compete for a single band or for the all-band contest. Logs must be mailed so as to reach the *Wireless Institute of Australia*, 191 Queen St., Melbourne, C.I., not later than December 31, 1947. Decisions of the Contest Committee of W.I.A. will be final.

Attractive certificates will be awarded by W.I.A. to the operator getting the highest score in each state of each participating country. Section winners in Australia will receive special prizes in addition to certificates. There will be no world winner for the contest.

### KOREA

Amateurs in the occupying forces in Korea have been accorded operating privileges in a directive issued by the Korean headquarters of the United States Army. Particularly welcome to the many GI hams stationed in that area, this authorization removes the last of the prohibitions of amateur activities for service personnel in occupied territories. Upon application through proper channels, a license valid for amateur operation in Korea will be issued to any serviceman holding a valid FCC amateur ticket or who successfully passes an examination similar to FCC tests. Both Class A and Class B licenses will be issued. Calls assigned will bear a J8 prefix. For c.w. operation, 14,000-14,400 kc. and 28,000-29,700 kc. have been assigned. Class A licenses only may use 'phone in the band 14,150-14,200 kc. only if transmissions are to the United States, and for general operation in the band 14,200-14,300 kc. Class B 'phone operation is limited to the 28,100-29,500-ke. band.

### ICELAND

*Íslenzkir Ráðio Amatörar*, recently organized society of Icelandic radio amateurs, has inquired

*(Continued on page 156)*

# IT'S NEWARK for TOP QUALITY — BEST VALUE

## Sensational Reduction! HALLICRAFTERS SP-44 Panoramic Adaptor

Really Terrific — Look at this Sensational Buy! The famous Panoramic Adaptor, sold everywhere for \$99.50, now reduced at Newark to only \$49.50. The amazing Sky rider — "Seeing Eye of Sending" is a 10 Tube Superhet, electronically — mounted, with self-contained scope — monitor up to 200 kc visually and analyze signal characteristics from your own or other transmitters. Hooks into any rig. No Ham should be without one.

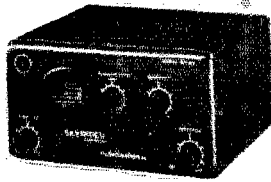

HALLICRAFTERS SP-44, Panoramic Adaptor, complete with tubes and scope, for 115 VAC operation. Shpg. Wgt. 20 lbs. Now **\$49.50**

*While They Last!*  
**NEWARK CRYSTALS**  
6-11-20-40-80 Meters  
Terrific Values! What's left of our famous, accurately calibrated 88c Crystals at this unbelievable price!

Orders filled to within 25 KC of desired frequency in the following groups only. Hurry!

**49¢ EA.**  
3 for \$1.25

A-3800-3956 D-8701-8890  
B-6250-6995 E-9000-9250  
C-7200-7265 F-14065-14220

## SCR-522 TRANSCEIVER

Amazing Bargain — These wonderful Surplus 2-Meter Rigs for practically a song! Receiver and Transmitter, less Power Supply and Control Box. Some have Crystals and Tubes, some may be missing. But the basic unit is there — ready to operate. Can be converted to 110 VAC. Schematic included. Shpg. Wgt. 75 lbs. Limited Quantity at this amazing price. **\$14.95**  
The whole works "AS IS" for only

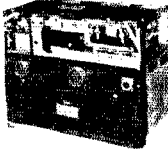

Available FOB New York Only

## GREAT SURPLUS BARGAIN

### 350-PS Universal POWER SUPPLY



Sensational Buy for mobile or fixed operation. Input Voltages, DC: 12, 24, 32, 110, and 110 VAC. Outputs: 110 VAC at 70 w., 300 VDC at 150 Ma, 600 VDC at 300 Ma, 6, 8 or 10 VDC at 1.5 amps. ALL BRAND NEW. Complete with Tubes, Input and Output Cables with Connectors, Shock Mig. Base, Carrying Chest, Instruction Manual. Size: 26x15x13" H. Shpg. Wgt. 26.5 lbs. Complete, Only..... **\$49.50**  
Available FOB Chicago Only

## Save on JOHNSON CONDENSERS

Superior Quality Variables. Single section. Steatite front and end plates, 1/4" double end shaft. Rotor and stator insulated from ground. Aluminum plates. Sturdy Constr.

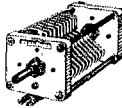

No. S-491-100 mmdf., 21 plates, .030 gap, 17/8" L. **79¢**  
No. S-492-35 mmdf., 8 plates, .030 gap, 1 1/2" L. **69¢**

## New Types - Bigger Values

### Transmitting and Special Purpose TUBES

ALL NEW — GUARANTEED, Great Savings from our Tremendous Stock of Top Grade Gov't. Surplus Tubes. All JAN Approved. Buy Now!

EL148	\$ 2.25	811	1.95
HY65	3.00	813	6.75
HY69	1.65	814	4.50
HY615	1.13	815	2.25
TZ40	1.88	826	1.50
2A1	2.25	832A, 832	2.25
2A1A	5.25	836	1.13
2C26A	.75	837	2.25
2C40	3.00	838	3.75
2C44	1.50	841	1.20
2V3G	1.38	843	.75
2X2-879	.90	845W	3.75
3A1	3.00	865	1.50
3B1	3.00	872A/872	2.25
3C24/24G	.75	874	1.95
3CP1	3.00	884	3.75
3EP1	3.00	922	.68
3E29	3.00	923	.45
3FP7	3.00	931A	1.88
3GP1	3.00	954	.75
5A1	4.50	955	.75
5B1	3.38	956	.75
5CP4	3.38	957	.75
5CP1	3.38	958A	.75
5CP1A	6.00	959	.75
5LP1	9.00	1613	.75
6AK5	.90	1616	3.00
6D4	.45	1619	.75
7B7P	5.25	1624	.80
9F1	2.25	1625	.53
10Y	.75	1626	.60
12DP7	6.00	1629	.27
12GP7	11.25	1641	.90
0C3/VR105	.75	1665/2050	.90
0D3/VR150	.75	1851	.95
211	1.13	2051	.53
30ATL	3.75	7193	.45
318A	3.75	8005	3.15
559	1.13	9001	1.05
801A/801	1.13	9002	.90
803	9.00	9003	1.05
807	.95	9004	.90
809	1.50	9066	.68

## Smashing Value! BC-375-E TRANSMITTER

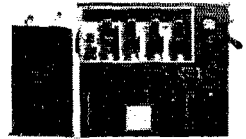

Famous Transmitter complete with 7 Tuning Units, less Tubes and Power Supply. All Brand New Rigs, water-damaged, but due to fungus treatment probably in perfect shape to operate. Can be converted to 110 VAC. Schematic Incl. Superb rig — originally cost \$1800. Shpg. wat. 275 lbs. Yours, "AS IS" for only..... **\$19.95**  
FOB New York Only

BC-375-E Complete with Tubes \$23.45

## MALLORY VIBRAPACK



Mallory vibrator power supply. Efficient, Dependable. Excellent quality. 12 volt DC input. Output: 220-250 volts at 60 ma. Exceptional Buyl Size: 5 1/2" x 2 3/4" x 6" H. No. **\$6.95**  
S-460. Special

**Cornell-Dubilier  
Xmitting Capacitor  
2 Mfd. — 1,000 VDC**  
New, oil-filled, Exceptional Quality. 4 1/2" L x 1 1/2" dia. Solder lug attached. Limited Quantity. No. S-473. Special **49¢**



## PHONES

Terrific Brand New, Guaranteed Army-Navy Phones. 8000 ohms. Rubber covered throughout. Ear Cushions, Cord, PL-54 Plug. Adj. band. No. S-481. Hurry! **99¢**

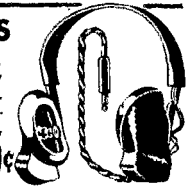

Take ONE YEAR TO PAY! 20% Down — 12 Monthly Payments for any Mdse. \$75 or Over

HAMS — Visit and Chat with Bob Gunderson, W2JIO, at either New York Store EVERY SATURDAY

20% DEPOSIT  
REQUIRED WITH ALL  
C.O.D. ORDERS  
Shipments FOB N.Y. or Chicago  
SEND FULL AMOUNT  
SAVE C.O.D. CHARGES

Prices Subject to Change

Enclose postage with order

**NEW YORK**  
Offices & Warehouse  
242 W. 55th St., N.Y. 19

**NEWARK**  
323 W. Madison St.  
Chicago 6, Ill.  
**ELECTRIC COMPANY, INC.**

SEND ORDERS TO  
242 W. 55th STREET  
NEW YORK 19, N. Y.  
OR  
323 W. MADISON ST.  
CHICAGO 6, ILL.

New York City Stores: 115-17 W. 45th St. & 212 Fulton St.

Head  
Phones

\$1.87



Signal Corp 4000 ohm magnetic headphone. This double headphone set comes complete with phone plug, cord and leather covered headphone band. Brand new. \*Please enclose 30c to cover mailing and handling.

# Hot Radio Values

## AT SUN RADIO

### 100 WATT

**BENDIX TRANSMITTER  
TA12-B**

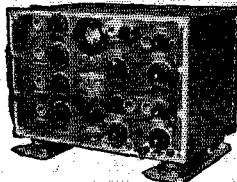

**CHECK THESE VALUES:** Three 807 Tubes, four 12SK7, one 2 inch 5 amp. RF meter, four Separate Master oscillators. (These can be easily changed to cover 20-40-80 meters and by using crystal for the 10 meter band you will have a complete coverage transmitter.)

Four separate output tanks.  
One 4 position selector channel switch having seven sections which changes the ECO, IPA and output tanks simultaneously. All the controls are mounted on the front panel. The housing is cast aluminum; shields and case are sheet aluminum. Dimensions 11 x 12 x 15 inches, weighing 35½ lbs. Complete, simple instructions for conversion furnished. Complete with **\$49.95** tubes.....



**SUPERHETERODYNE RECEIVER:** This crystal fixed frequency receiver comes with full conversion instructions for variable tuning of all ham bands and broadcast. A highly selective superheterodyne receiver, 110 V. A.C. power supply built in. Using the following tubes: 6K7—RF Amplifier; 6K8 Mixer and Oscillator; 6K7 IF Amplifier; 6F7—Detector and A.V.C.; 6CB Output and Noise Suppressor; 80 Rectifier. Dimensions—3½ x 19 x 11½ inches. Comes complete, brand new, with one set of coils **\$16.95** and two sets of tubes.....

Extra set of coils.....**\$2.95**

**MICROPHONE**

Brand new single button carbon hand mike by "Shure" with push to talk switch.

**\$1.79**



**A.C.  
VOLT-  
METER**

**\$3.49**

Brand new G.E. 3" square panel meter 0-150v ideal for checking primary voltage.



**WESTON OHM METER**

No. 689 A beautiful instrument for accurate work. Scale 0-10 ohm and 9-100 ohm scaled to read 1/20 of an ohm with ease. This 2¼" round meter is housed in a black bakelite case 1¾" x 2¾" x 5". Complete with heavy duty felt lined leather case and lock. **\$14.95** Special.....



**5-GANG  
TUNING  
CONDENSER**

Brand new... 5 gang, 365 mmfd. per section... a truly precision built condenser with ceramic insulation. A \$13.50 value in the greatest offering ever made in tuning condensers for only... **\$2.95**

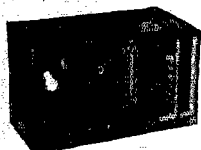

**BC 684 F.M. 35 WATT  
TRANSMITTER**

Brand new, complete with eight tubes, crystal control, 10 channel pushbutton, non-linear modulation coil... less coverplate, crystal and **\$17.95** power supply..



**BC645 UHF RECEIVER  
TRANSMITTER**

"The citizen's Radio" covers 450-500 mc. Consists of complete transmitter, modulator system and receiver, 15 tubes, and simple complete conversion instructions for 420 mc operation.

Brand new **\$15.95**

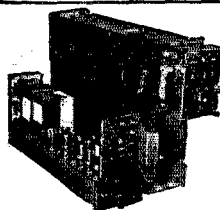

**WAVEMETER** We're closing out the last few of these precision wavemeters which tune from 150-210 mc and which contain a high quality resonant cavity wavemeter, oscillator, heterodyne amplifier, electric tuning eye, complete with 19 tubes, 110 v AC power supply. The tubes alone far exceed your close out costs of **\$17.95** only.....

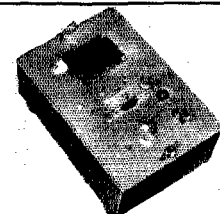

**V.H.F. TRANSMITTER**

Here is one of the greatest offerings in war surplus! Hundreds sold at \$20 and now closed out at an amazingly low price. Brand new. Battery operated (67½ v B and 1½ v A.) Frequency 80 to 105 mc. Complete with 2-1G4 tubes and full instruction manual. Ready to go on the air. **\$6.95** Less Batteries....

**ANTENNAS**

(A) Small four-section telescopic aerial ideal for portable receivers, transceivers or test equipment.

**99¢**

(B) 22' tapered high frequency aerial covering 150 to 200 mc. Complete with coax cable connector.

**\$1.69**

\* All items F.O.B. Washington, D.C. Orders \$30 or less cash with order. Above \$30, 25 per cent with order, balance C.O.D.

# SUN RADIO

OF WASHINGTON, D. C.

938 F STREET, N. W. WASH. 4, D. C



# CRYSTALS

## Sun Radio Completes World's Largest Purchase of Crystals

In the greatest purchase of radio transmitting crystals ever made by one wholesaler in the history of the Radio Parts Industry, Sun Radio acquired title to over a half million dollars (\$500,000.00) of Army Surplus, precision built, exactly tooled crystals in moisture proof holders. Can you visualize the immensity of this stock of ours . . . thousands, or should we say miles, of gleaming BRAND NEW CRYSTALS IN MOISTURE PROOF HOLDERS manufactured by the world's finest

crystal manufacturers (RCA, Bliley, Western Electric, etc.) lying in long rows; lovely to look at but even better to own. We can't claim we can supply every frequency but we do claim that we can supply you with brand new crystals of the below listed frequencies AT THE LOWEST PRICES YOU HAVE EVER SEEN. . . . We say it's Sensational!!! And remember, you may never again see the day that you can buy BRAND NEW CRYSTALS IN MOISTURE PROOF HOLDERS at the prices that we have offered here. . . .

### CRYSTAL FREQUENCY STANDARDS

98.356 Kc.

Alterable to 100 kc Standard. Mounted in low loss 3 prong holder.

**\$4.49**

400kc Standard . . . . . **\$1.95**

BLILEY 186.30kc in type MC 72 Holder **59¢**

### I. F. FREQUENCY STANDARDS

450kc  
451.388kc.  
452.777kc  
454.166kc  
455.556kc.  
459.259kc  
461.111kc  
464.815kc.  
465.277kc.

**99¢**  
EACH

Payment with order. Enclose 20c for postage and handling. Minimum order—\$2.00 plus postage.

Please specify alternate choices or "no substitutes"

### CRYSTALS WITH A MILLION USES

FRACTIONS OMITTED

412kc	429kc	445kc	469kc	490kc	505kc
413	430	446	470	491	506
414	431	447	472	492	507
415	433	448	473	493	508
416	434	451	474	494	509
418	435	453	475	495	511
419	436	456	477	496	512
420	437	457	479	497	515
422	438	458	481	498	516
423	440	459	483	501	518
424	441	462	484	502	519
425	442	463	485	503	522
426	443	466	487	504	523
427	444	468	488		

**49¢**  
EACH

### FOR CRYSTAL CONTROLLED SIGNAL GENERATORS

525kc	533.333kc
526.388	534.722
527.777	536.111
529.166	537.500
530.555	538.888
531.944	

**99¢**

### FOR HAM & GENERAL USE

Fractions Omitted

390kc	402kc
391	403
392	404
393	405
394	406
395	407
396	408
397	409
398	411
401	

**79¢**

### ASSORTED MISCELLANEOUS CRYSTALS

Fractions Omitted

370kc	380kc
372	381
374	383
375	384
376	386
377	387
379	388

Priced at a fraction of the cost of their holders

**39¢**

# SUN RADIO

OF WASHINGTON, D. C.

938 F STREET, N. W. WASH. 4, D. C.



## TRYLON ROTARY BEAM ANTENNA SUPPORT

for 4-element 20-meter array

Quick, easy to install on any tower. Stainless steel, spot-welded construction. 19' 2" long, yet weighs only 30 lbs. Adaptable to either manual or motor drive. Ball bearing design provides full 360° traverse. Support can be tilted in either direction for easy accessibility. Has ample safety margin to withstand severe wind and icing conditions. Write for descriptive circular.

### RADIO TOWERS

Galvanized Steel and Aluminum

Standard and special types for amateur and commercial requirements.



**TRYLON TOWER AND ANTENNA DIVISION**  
Wind Turbine Co., West Chester, Pa.

IT'S

# New

## VALPEY XTALECTOR

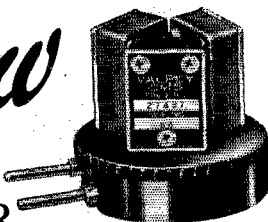

Facilitate rapid QSY from one frequency to another by mounting two or three crystals in a new VALPEY XTALECTOR. Instant QSY from one crystal to the next by a simple turn of the knurled rim. Simplicity of contact design does not add capacity or loading to the crystal. Unused crystals are completely out of the circuit.

Ruggedly constructed of glossy molded Bakelite, it is the handiest little gadget that you can have in your shack. Designed to hold Valpey type CM5 crystals having 1/4" spacing and .094 diameter pins.

Supplied in two types — "X 2" with 1/4" spacing and "X 3" with 3/8" spacing. Your local dealer can supply you with an XTALECTOR from stock.

XTALECTOR to fit 3/8" or 1/2" sockets — ONLY.

**\$1.35 each**

Valpey type CM5 crystals for 80 and 40 meters net \$2.80  
— 20 meters \$3.50  
— 10 meters \$4.50

**Valpey**  
CRYSTALS

**VALPEY CRYSTAL CORP., Holliston, Mass.**

Craftsmanship in Crystals Since 1931

W1ATP W1HVP W1BZJ W1PLX W1ONF

(Continued from page 132)

concerning membership in the Union. Icelandic amateurs are assigned calls with the prefix TF and a numeral from 1 to 6 indicating the district in Iceland, followed by two letters for a fixed station or three for a station in portable status. Maximum input power permitted is 50 watts. Frequency bands assigned for amateur use are: 14,020-14,380 kc., A1 only; 28-29.7 Mc., A1, A2; and 50-54 Mc., 144-148 Mc., 220-225 Mc., and 440-450 Mc., A1, A2 and A3.

The QSL Bureau address for members of the Icelandic society is I.R.A., P.O. Box 1080, Reykjavik.

### SOUTH AFRICA

The name of the S.A.R.R.L. has been changed, in response to a vote by its members, to the *South African Radio League*. Not being permitted to handle third-party message traffic, the members of the League felt it was illogical to include reference to a nonexistent activity in the name.

Officials of S.A.R.L. are keenly interested in promoting reciprocal amateur licensing arrangements with other countries. At the present time, only citizens of the Union and British subjects may apply for amateur licenses in South Africa. The society feels that its own government would not be adverse to such reciprocal arrangements.

### JAPAN

A change in regulations governing amateur radio operation by Allied personnel in Japan authorizes transoceanic 'phone in the frequency band 14,150-14,200 kc., subject to the limitation that this additional band be used exclusively for communication to the nations of legal domicile of the licensee. For example, a U. S. serviceman may operate in this band only to continental United States, citizens of the United Kingdom to British Isles only; Australian service amateurs only to Australia.

Amateurs operating in this band will be required to observe highest standards of equipment, emission and operating practice. Any violation may result in immediate withdrawal of this privilege.

### How's DX?

(Continued from page 86)

170 contacts with only one miss; 40 watts at OQ5AE and 200 watts and a 3-element rotary at W4KXF . . . . . W6ZZ was there at the right time and the dividends are KH6DF, KG6AO, W7EWJ/HK6, KH6IG, ZL1KN, W6OMT/KH6, KH6GN, KH6JE and W6DDR/KH6!

### Where:

W6OJW sends us CIKC, Box 77, Shanghai, China; KZ5GD, George Dunlop, Box 28, Balboa, Canal Zone; C1MG, P.O. Box 409, Shanghai, China; KA1HR, 503rd Signal Service Detachment, APO 613, C/o PM, San Francisco, Calif.

(Continued on page 138)

# Globe Trotter Xmitter Kit

## REALLY WORKS 'EM

Read what Herb Barnes, W1OTO  
Says about this powerful, low cost kit



### WRL Globe Trotter Xmitter Kits

Giving 'round the World performance for amateurs 'round the world.

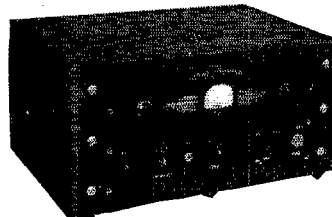

Car. No. 70-300 less tubes.....\$69.95  
Cat. No. 70-312 same as above, wired..... 79.50  
1 set coils, meter tubes, extra..... 17.15

## NO RED TAPE—WE FINANCE OUR OWN PAPER. USE LEO'S EASY PAY PLAN Liberal Trade-ins

Item	Cash Price	Down Payment
Hallcrafters S38.....	\$ 47.50	\$ 9.50
Hallcrafters S40A.....	89.50	17.90
Hallcrafters SP44.....	99.50	19.90
Hallcrafters SX42.....	275.00	55.00
Hallcrafters HT-9.....	356.00	70.00
RME VH-F-152.....	86.60	17.32
RME S4.....	98.70	19.74
RME-45.....	196.70	39.34
Hammarlund HQ 129X.....	161.40	32.28
Hammarlund SPC400X.....	334.05	66.81
National NC46.....	97.50	19.50
National J-10A.....	67.50	13.50
National NC173.....	179.50	35.90
National NC240DT or NC240D R.....	225.00	45.00
National HRO-5TAL or HRO-SRA.....	245.00	49.00
Pierson KP-81.....	367.65	73.53
Gen-Set Converters.....	39.95	7.99
Collins 70E-8.....	40.00	8.00
Bud VFO-21.....	52.50	10.50
Meissner Signal Shifter.....	99.50	19.90
Abbott TR-4B Special.....	45.00	9.00
New Micro-Match Unit.....	29.50	5.90
Millen R-9er.....	24.75	4.95
BB-27 10 meter converter F.B. for 348.....	27.50	5.50
Sonar Mobile MB-611 transmitter.....	72.45	14.49
MB-611 with power supply.....	81.45	16.29
WRL extiter unit wired.....	23.95	4.79
Millen 90800 exciter.....	42.50	8.50
Sonar XE-10 transmitter.....	87.45	17.49
Workshop 28 megacycle beam 3 element.....	39.50	7.90
Workshop 8 element 28 megacycle type.....	100.00	20.00
Workshop 20 meter beam 3 element.....	120.00	24.00
Gordon Rotary Beam.....	225.00	45.00
Direct-O-Beam.....	117.00	23.40
New Beach ECO.....	32.50	7.50

★ 4 Mfd 1500 Volt DC Condenser \$1.29  
0-500 D.C. Mills G.E. 2 1/2" Round Meter 2.95  
0-1 D.C. Mills — 3 1/2" " 3.95 ★

FOR THE BEST DEAL—  
WRITE TO LEO, W0GFQ



Leo (W0GFQ)  
World Radio Labs.  
Council Bluffs, Iowa

June 28, 1947

Hi Leo:

I've been meaning to drop you a line for quite some time now. I ran across your full page ad in the latest "QST" and it reminded me to do it.

Since I got my "Globe Trotter" last fall I've been having myself quite a time! Beside the fact that I'm a bed patient here in this hospital, and I work the 10 Meter Band only, here is a quick list of how the "Globe Trotter" and I have been doing the last 7 months:

Over 650 PB QSO's! (mostly 100% at that!)  
Worked all U.S. Districts.  
Worked 37 of the states (don't worry, I'll get the rest!.)  
Many swell contacts outside the U.S.; including the Hawaiian Islands; Europe; Mexico and Porto Rico!

Thought you might like to have the enclosed photo and QSL. Yep! That mike I'm grabbing, came from you, too!

He? Well, I got banged up in the Navy in 1945, and I've been in hospitals ever since. I figured that ham radio would have to be the thing that would keep me from talking to myself. Your "Globe Trotter" seemed to fill the bill—so I got one, got a ticket, and got on the air! Been having myself a swell time ever since! The little rig sure delivers the goods!

Oh, yeah, Leo. I expect to get out of this place some day, and when I do, I'm going to want a rig with a little more power. Your new 250 watt rig sounds good. If it works out as well as the "Globe Trotter" in relation to its power, it will be something! So, will you please send me the dope on the new rig??

Well, Leo, that seems to be about all on this end, so I'll say 73' to you and

Adios and good luck, from (W1OTO)

Herb Barnes  
Sassaquin Hospital  
New Bedford, Mass

## LEO'S NEW 250 WATT XMITTER KIT

6 meters through 80. Phone—C.W.

Latest design... phone—C.W.... provisions for ECO. Tune 6 meters as well as other bands. RF section has latest 705, two 2E26's, two V70D's in final. A compact, versatile unit to sell for about \$350, completely wired. Comes in streamlined gray crackle finish steel cabinet, 28 3/16" high x 22" wide x 14 3/4" deep. Place your order now for first delivery.

World Radio Laboratories  
Department Q-9  
Council Bluffs, Iowa

Send latest Free Flyer  
 Send data on WRL 250 Watt XMTR  
 Send more data on the Globe Trotter

Send more data on.....

Name.....  
Address.....  
City.....  
Call letters.....  
Zone..... State.....



# ELINCOR ALL ALUMINUM BEAMS

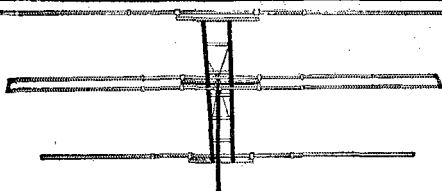

Model 400-EA

Model 400-EA. 3-ELEMENT FOLDED DI-POLE 10 METER BEAM KIT. Feed with RG8/U coaxial cable. Amateur net price. **\$31.20**

Model 400-RA. 3-ELEMENT 10 METER BEAM KIT. Feed with 300 ohm twinax line. Amateur net price. **\$27.00**

Model 400-EA. 2-ELEMENT 10 METER BEAM KIT. Feed with RG8/U coaxial cable. Amateur net price. **\$20.40**

All of the above antennas are furnished complete with all aluminum supporting ladder, 2 1/2" steelite standoff insulators, hardware and instructions. The elements are 3/4" aluminum tubing telescoping to 1/2" and are adjustable over a range of several feet.

Model 200-EA. 5-ELEMENT 2 METER BEAM KIT. Folded di-pole driven element. All aluminum construction. Feed with low impedance coaxial cable. Amateur net price. **\$8.40**

We also manufacture a complete line of FM, Television, Broadcast and shortwave antennas. Send for literature.

Sold through Dealers  
Only



Prices slightly higher  
on West Coast

## ELECTRONIC INDICATOR CORP.

35-44 61st STREET

WOODSIDE, L. I., N. Y.

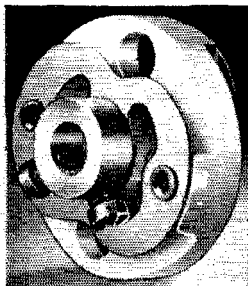

OVERALL DEPTH 1 1/4 INCH  
DIAMETER . . . 1 1/4 INCH  
HUBS DRILLED FOR 1/4 INCH  
SHAFTS

## FC-46-S

### INSULATED FLEXIBLE COUPLING

The FC-46-S is a sturdy flexible coupling which will provide a linkage between angularly misaligned shafts without causing backlash or play.

The forces developed in the coupling are uniform as the shaft is rotated, which gives you that SMOOTH feeling as you turn the shaft.

WRITE FOR FOLDER

# HAMMARLUND

THE HAMMARLUND MFG. CO., INC., 460 W. 34TH ST., NEW YORK 1, N. Y.  
MANUFACTURERS OF PRECISION COMMUNICATIONS EQUIPMENT

(Continued from page 136)

From W3DPA we got: VQ4ASC, P.O. Box 667, Nairobi, Kenya Colony, Africa . . . . . W8KYN helps along with: OX3BD, Glenn Bartoo, USCG Cutter *Storis*, FPO, N.Y.C.; FT4AN, George Solet, Box 72, Tunis, N. Africa . . . . . W4JXM passes along: XAFY, 3196 Signal Service Co., APO 782, C/o PM, N.Y.C.; FQ3AT, Ivan Pastre, Base Aviation, Fort Lamy Tchad, F.E.A. . . . . W1JLT contributes: VE8OG, Cambridge Bay, Victoria Isle, N.W.T., C/o M.P.O. 1315, Edmonton, Alta., Canada; W6YKY/KG6, A. C. Gentry, 147 Atch. Sqdrn., APO 184, C/o PM, San Francisco, Calif. . . . . From W6OBD we have: PK1RX, C/o Radio PTT, Garoot, Java; C1AN, Box 409, Shanghai, China; HK1AM, Anthony Gallen, U. S. Naval Mission, Naval Base, Cartagena, Colombia; VK9BI, Port Moresby Post Office, Papua . . . . . From ZE2JO (ex-VQ4MNS) comes his new QTH: Thistle-Etna Gold Mines, Box 63, Eiffel Flats, Southern Rhodesia . . . . . HZ1AB is now off the air for good, but QSLs for contacts can be obtained by sending a card to J. P. Anderson, jr., W4JMQ, 1130 Leighton Ave., Anniston, Alabama . . . . . ZD6DT says his mailing address is: Royal Signals, Zomba, Nyasaland, Africa . . . . . Cards for J2AJA go to: Clayton Thompson, 1539 AAF BU, APO 226, Handed Army Air Base, C/o PM, San Francisco, Calif. . . . . WØEFK/J2, C/o Northwest Airlines, APO 226, C/o PM, San Francisco, Calif.

### Tidbits:

By the time this is in print OH2NL will be in and around Chicago and Milwaukee and wants the gang out there to be on watch for him . . . . . From Al Tungate, YI2AT, we learn that the YI stations will not be heard from any more, the reason being that the authorities have forbidden service equipment use on the ham bands. Legit calls being effected are YI2CA, YI2AT, YI2AH, YI2KP and YI2JJ. Al further states that he has never operated 20-meter 'phone or c.w., so that let a lot of us out . . . . . Friends of LU3AQ will be interested to learn that he will soon be on the air with a CO2 call. His QTH will be: Martin E. Bortagaray, Secretary of the Argentine Embassy, Havana, Cuba . . . . . From OK3RR, secretary of the S. S. K. A., we learn that OK3AA is another foney. Too bad — he has a nice sig too . . . . . We have another letter from OY3IGO who says he is positively the only licensed ham in the Faroe Islands. He has on hand bunches of cards for the following: OY5GS, OY3G and OY3PL. So, gang, don't QSL OY unless you work OY3IGO . . . . . John L. Mohn (ex-EA1D) says that anyone working EA1D after November 22, 1946, will have to whistle for their cards as far as he is concerned. So-o-o-o . . . . . In the July column we gave credit to W2PUN for a 59-minute WAC; the call should have been W2PTE (ex-W8AHC). Sorry fellows . . . . . G2FFO, who in June wrote us that CR4BQ was

(Continued on page 140)

# If it's Radio... HARVEY has it!

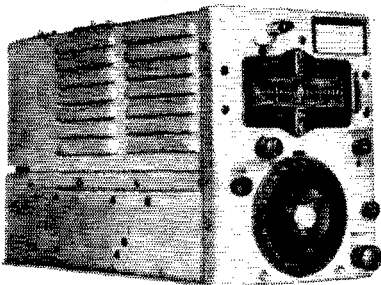

### BC 459A VARIABLE FREQUENCY TRANSMITTER

Frequency range 7 — 9.1 MC. Uses 1626 variable oscillator and parallel 1625's in amplifier. May be used as VFO for all bands from 1 1/4 thru 40 meters with appropriate doublers. Has self contained G.E. hermetically sealed 8 mc crystal oscillator and tuning eye which is used as a check point for dial calibration: Complete with tubes and crystal.

**Special Price . . . . . \$9.95**

### 1616 TUBE

Half wave, high vacuum rectifier. Filament 2.5 volts, 5 amps; peak inverse 5500 volts; peak current .8 amps; surge current 2.5 amps; average plate current .130 amps. List price \$7.50, Harvey special price, while they last . . . . . **95¢**



### HARVEY HAS IN STOCK

#### THE NEW NATIONAL HRO-7 RECEIVER

This new HRO-7 features many new refinements in receiver circuitry and design. A new automatic adjustable threshold coupler, active noise limiter effectively reduces interference by external noise pulses. Two new metal type tubes — a 6C4 high frequency oscillator and OA-2 voltage regulator are employed to give a high order of oscillator stability, thereby assuring a minimum of tuning drift.

The HRO-7 is housed in a new completely restyled cabinet with an attractive gray finish. Coils furnished cover 1700 to 30,000 KC. The receiver, complete with coils and power supply but less speaker, is priced at **\$299.36**

**SCR 522 — RECEIVER AND TRANSMITTER ONLY.** In perfect condition. Complete with all tubes, less generator and control box. Get your order in quickly, supply limited. Special price . . . . . **\$14.75**

#### HARVEY'S HITS OF THE MONTH

Harvey has 20 meter crystals for a buck! Mounted in holder with 1/2" pin spacing. Also 40 and 80 meter and 6 and 13 mc. bands at the same low price. . . . . **\$1.00**  
 Special 8 mc. xtals for 2 meter xtal control, only. . . . . **\$1.50**  
 Also in stock complete line of Bliley AX-2 xtals. Include 10¢ postage with your crystal order.

#### HARVEY'S HAMFESTIVAL OF VALUES

- BC 375 TRANSMITTER** complete with all tubes — 1 type 10 and 4 type 211 — generator, antenna tuning unit and all other tuning units. . . . . **\$35.00**
- HANDY TALKY HT-144** 2 meter band, batteries self contained, one hand control. . . . . **\$34.50**  
Set of tubes. . . . . **\$2.49** Batteries. . . . . **\$2.25**
- SUPREME AF-100 TRANSMITTER.** 100 watts output on CW or phone, 10 to 80 meters, VFO and 2 xtal positions . . . . . **\$550.00**
- MILLEN 90700 VFO** — an extremely stable unit . . . . . **\$42.50**
- MILLEN R9ER** with coil for 10 and 11. . . . . **\$24.75**  
**COIL** for 6 or 20 meters. . . . . **3.15**  
**6AK5** tube for above. . . . . **.95**
- THE NEW SONAR MB-611 MOBILE TRANSMITTER** complete with tubes . . . . . **\$72.45**
- BUD GIMIX** — Five band wave meter — 10 thru 80 meters with band switch, can also be used as phone monitor field strength meter, etc. Complete. . . . . **\$8.30**
- HAMMARLUND 4-11 MODULATOR** — 11 watts audio output — perfect as speech amplifier and modulator for 4-20 or any other transmitter. Complete with tubes . . . . . **\$72.50**

- BC 348 RECEIVER** complete with all tubes and generator. Has two stages of RF and three stages of IF. Approximately 1 watt audio output. Easily changed over for 110 volt AC operation. . . . . **\$49.50**
- BROAD BAND CONVERTERS, C.M.L.** BB-27 for 10-11, BB-50 for 6, BB-144 for 2 meters. Takes power from receiver . . . . . **\$27.50**  
Power supply for above. . . . . **\$19.50**
- JONES MICROMATCH** measures standing wave ratio, RF power . . . . . **\$29.50**
- SONAR XE-10** Narrow band FM exciter complete with tubes . . . . . **\$39.45**
- SONAR VFX-680** with built-in VFO and VFX. Complete with tubes . . . . . **\$87.45**
- THE NEW SYLVANIA MODULATION METER.** Extremely accurate, very attractive . . . . . **\$34.75**
- HAMMARLUND 4-20 TRANSMITTER** — complete CW rig for 10, 11, 20, 40 and 80 meter bands, 20 watts power output, tunes four circuits to four different frequencies with single control. Complete with tubes, less crystal. . . . . **\$120.00**

Telephone: Longacre 3-1800

**NOTE:** All prices are Net, F. O. B. NYC and are subject to change without notice.

# HARVEY

## RADIO COMPANY INC.

103 West 43rd St., New York 18, N. Y.

**Get Your Order  
In Early For Im-  
mediate Delivery.**

# DRAKE RADIO SOLDERING IRONS



600-10—the Drake No. 600-10 is ideal for those all important connections when rewiring your rig. Get back on the air fast. Make good dependable connections with this 100 watt  $\frac{3}{8}$ " tip.



400—the Drake No. 400 is the perfect iron for work in small places. Only 9 inches long, it is especially designed for tight corners and delicate connections. 60 watt,  $\frac{1}{4}$ " tip.



Ask your nearest supplier or write for the name of the distributor nearest you . . . and give yourself the advantages of these superior irons.

**DRAKE ELECTRIC WORKS, INC.**

3656 LINCOLN AVE.

CHICAGO 13, ILL.

## USE SIGNAL WIRELESS AND TELEGRAPH INSTRUMENTS



SEND FOR A  
CATALOG  
SHEET TODAY

Also send for our Booklet on "Radio Keying and Telegraphy for Beginners" —

15¢

POSTPAID  
COIN, OR  
STAMPS

This Booklet gives the fundamentals of keying. . . . It contains codes, and how to learn them.

SIGNAL ELECTRIC MFG. CO., Menominee, Mich.

ESTABLISHED  
1892

**SIGNAL**

(Continued from page 133)

NG, now comes through with the welcome news that CR4BQ is definitely okay and is sending cards. Cards for CR4BQ should go to REP. That's another one for all of us . . . . . W8QBF, who had the misfortune to have his shack destroyed by fire, wants to know if anyone has information as to the whereabouts of the operators of the 1940 Byrd Expedition. His contacts were with KC4USA and KC4USC, and these cards went up in smoke. Please write to J. D. Shirer, Olmstead Falls, Ohio . . . . . The Rochester DX Club has really got under way with W2PUD as chairman, W2DOD as vice-chairman, and W2PYW as secretary-treasurer. Any information regarding the DX Club can be obtained by writing any of the three stations above . . . . . 73.

### 50 Mc.

(Continued from page 73)

finds it fine for long-haul work via tropospheric bending, though his 8-element stacked array is occasionally superior for sporadic-E DX. From Argentina via W9PK and W7EHT, we learn that active stations now include LU9AX, LUSBQ, LU1AM, LU8AT and LU9EV. All have crystal rigs, with which they are making regular c.w. test transmissions, with the hope of working into W on 50 Mc.

### Here and There on 6

50-Mc. business in Canada continues brisk, according to reports from VE3ANY, v.h.f. editor of XTAL, who lists DX worked by VEs for almost every day in June and July. The VE DX record is held by VE3AZV, who worked a W6 on June 1st. VE3BKL heard an XE on the evening of July 12th. This was undoubtedly XE1KE, who has now worked W4, 5, 7, 9 and Ø, for a total of 12 states and 5 call areas, and has heard W2BYM and W8NMU.

The motor-driven tuning mechanism of the ARR/5 (airborne version of the S-36) makes a fine band-scanning device, according to WØTKX/MM, who often uses his in this way while he is busy with his regular duties aboard the S.S. *Fi. Winnebago*. He has heard or worked some DX almost daily, often hearing them when he is unable to work them. With no more than 10 watts to a 7C5 doubler he has worked stations all over the eastern half of the country, from points in the Atlantic, the Gulf of Mexico, and several coastal ports. His contacts within the three-mile limit bring up a point in connection with WAS claims. Because of the difficulty of establishing the exact position of a ship (particularly in state-bounding rivers and bays) it has been decided to rule out contacts with maritime-mobile stations in states-worked lists. This follows the precedent established in the rules for WAC and DXCC claims, in which such stations

(Continued on page 148)

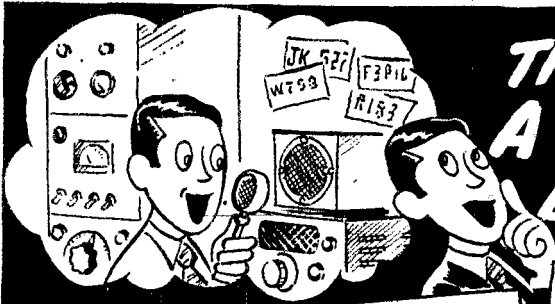

# THINK OF IT... A COMPLETE NEW AMATEUR STATION

CAN NOW BE YOURS AT  
AMAZING SAVINGS!

## HERE'S YOUR DREAM RIG COME TRUE!

NOW... thanks to the extra-liberal trade-in allowances offered by Walter Ashe on your used equipment, you can obtain the rig of your dreams at a real bargain price! Here's how! Select the items of your choice from our complete stocks. Then wire, write or phone for a money-saving deal.

All Prices F.O.B., St. Louis, Mo.

## YOUR FAVORITE BRANDS OF RECEIVERS

National HRO-7 (less power supply and speaker)	\$279.00
National NC-240-D (less speaker)	225.00
National NC-173 (less speaker)	97.50
NC-173 Speaker	179.50
RME-45 (with speaker)	10.00
RME-84	198.70
Hammarlund HC-129X	98.70
Hammarlund SPC-400X (with speaker)	173.25
Hallcrafters SX-40	347.25
Hallcrafters S-42	275.00
Hallcrafters S-38	89.50
	47.50

Prices subject to possible change

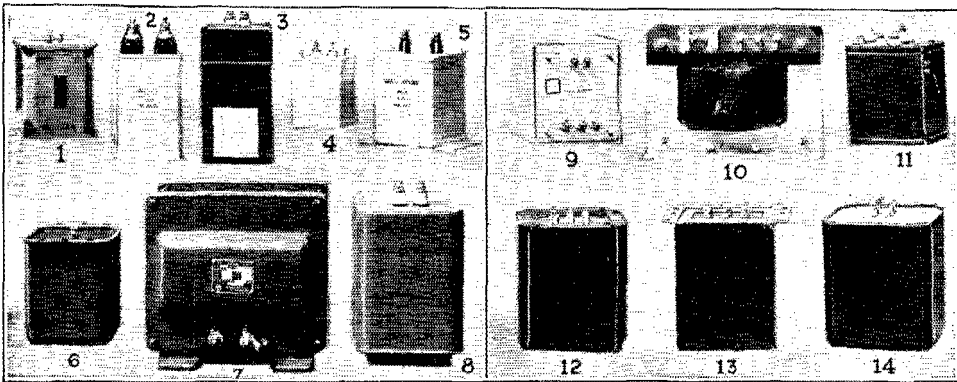

## SURPLUS CHOKES, TRANSFORMERS and CONDENSERS

- 1 FILTER CHOKE**  
12 HV @ 200 MA, 200 ohms DC Res. Steel Case..... **\$3.50**
- 2 TRANSMITTING FILTER CONDENSER**  
2 Mfd. 5000 VDC, Dykanol, regular net price \$29.63. Our low bargain price..... **\$7.51**

**SENSATIONAL NEW HI POWER FOTO FLASH KIT**  
Unit can be fired every 3 seconds if necessary. Complete kit, including AMGLOW tube, carrying case, etc., with simple assembly and operating instructions... **\$77.50**

### ASHE HAS IT!

New Hallcrafters HT-17 Transmitter 3.5 to 30 MC. Minimum output all bands. Pi-section antenna coupling. **\$69.50**

### SELSYN MOTORS

115 VAC 60 CY. Navy Surplus Selsyn Motors. Heavy brass case. Large, continuous duty type. No. 806. per pair..... **\$12.50**

- 3 DUAL CHOKE**  
12 HV @ 200 MA, per section. 150 Ohms DC Res. Steel case with stand-off insulators. No. 2785..... **\$4.95**
- 4 FILTER CHOKE**  
4 1/2 HV, 150 MA, 70 ohms Res. DC. Hermetically sealed in case. Stand-off insulators. No. 5209 **\$1.29**

**5 TRANSMITTING FILTER CONDENSER**  
2 Mfd. 4000 VDC, oil filled regular net price \$25.44. Our give away bargain price..... **\$4.50**

**6 FILTER CHOKE**  
4 HV, 300 MA, 40 ohms DC resistance. Hermetically sealed in case, screw terminals. No. 6317..... **\$4.95**

**7 HIGH VOLTAGE FILTER CHOKE**  
6 HV, at 1.2 Amps., 27 ohms DC resistance, 12500 volt breakdown insulation. Shielded case and standoffs. No. 0813. A super buy at... **\$17.95**

**8 FILTER CHOKE**  
8 HV, at 500 MA, 55 Ohms DC res. Very high quality. Hermetically sealed. No. 8056. Net..... **\$11.85**

- 9 PLATE TRANSFORMER**  
2500 VCT., 150 MA. Pri. 115 VAC. 60 CY. Steel case with standoff insulators. No. 161919..... **\$9.95**
- 10 RCA 1 KW MODULATION TRANSFORMER**  
Primary will match class "B" tubes up to 10000 ohms plate to plate. Secondary No. 1, 450 MA for beam tube plate. Secondary No. 2, 80 MA for screen grid..... **\$14.95**

**11 SCOPE/TELEVISION TRANSFORMER**  
Primary with match class "B" tubes up to 10000 ohms plate to plate. Secondary No. 1, 450 MA for beam tube plate. Secondary No. 2, 80 MA for screen grid..... **\$4.25**

**12 PLATE TRANSFORMER**  
2010 VCT 200 MA. Pri. 105-125 VAC 60 CY. Steel case screw terminals. No. 8275..... **\$9.95**

**13 PLATE TRANSFORMER**  
1400/1200 VCT at 200 MA. Pri. 115 VAC 60 CY. Steel case, screw terminals. No. 4891-N..... **\$7.45**

**14 PLATE TRANSFORMER**  
1400/1200 VCT at 200 MA. Pri. 115 VAC 60 CY. Hermetically sealed steel case, screw terminals. No. 8931..... **\$7.95**

W0JWD • W0ULH • W0WTM • W0NRF • W0IYD • W0PGI • W0QDF

REMEMBER... your Trade-In's worth more at the Walter Ashe Store! Bigger-than-ever trade-in allowances on your used receiver

Coming!

A new, bigger, better Walter Ashe Catalog. Ask to have your name placed on our mailing list.

# Walter Ashe RADIO CO.

1125 PINE ST. • ST. LOUIS, MO.

# CUT HOLES FAST IN RADIO CHASSIS

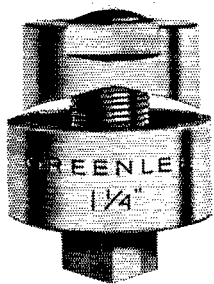

## WITH A GREENLEE RADIO CHASSIS PUNCH

Eliminate tedious reaming and filing. Just turn GREENLEE punch with an ordinary wrench and make clean, accurate holes in a hurry. There's a GREENLEE for each of these sizes:  $\frac{1}{2}$ " ;  $\frac{3}{8}$ " ;  $\frac{3}{4}$ " ;  $\frac{1}{2}$ " ; 1" ;  $1\frac{1}{16}$ " ;  $1\frac{1}{8}$ " ;  $1\frac{1}{4}$ " ;  $1\frac{1}{2}$ " ;  $1\frac{3}{4}$ " ;  $1\frac{1}{2}$ " ;  $2\frac{1}{4}$ ". Also GREENLEE Knockout Punches and Cutters for conduit and meter holes up to  $3\frac{1}{2}$ ". Write for facts. Greenlee Tool Co., 1869 Columbia Avenue, Rockford, Illinois.



## Feather Light MINIATURE Test Meter

Dependable accuracy plus convenient pocket size make these little instruments most useful and popular aids to better amateur station performance. Self contained standard size batteries supply current for resistance readings. Three models are available in this small size: 3 15/16" x 2 7/8" x 2".  
Model 450A Volt-Ohm-Milliammeter

The outstanding value in the test equipment field, D'Arsonval movement. Zero adjustment. Rotary range switch. 1000 Ohms per volt.

Volts DC: 0-10/50/100/500/1000  
Mils DC: 0-1  
Ohms full scale: 5000/50,000/500,000  
Ohms center scale: 30/300/3000

Model 451A AC-DC Volt-Ohmmeter with Output Ranges  
Volts DC: 0-10/50/100/500/1000  
Volts AC and Output: 0-10/50/100/500/1000  
Ohms center scale: 7200 Price only \$14.90

Model 452A High Sensitivity Volt-Ohmmeter  
10,000 Ohms per Volt  
Volts DC: 0-10/50/100/500/1000  
Ohms full scale: 2000/20,000/200,000/2,000,000  
Ohms center scale: 30/300/3000/30,000 Price \$14.90

Ask your Jobber or write direct for circular

America's Pioneer Makers of Pocket Test Equipment

**CHICAGO INDUSTRIAL INSTRUMENT CO.**  
536 West Elm Street - Chicago 10, Illinois

(Continued from page 140)

may not be counted for country or continent claims.

We often wonder whether some of the fellows who are now getting in their first licks on 50 Mc. appreciate the DX opportunities the band now affords, in comparison to the prewar days, when anything outside of purely local contacts was sure to cause a rise in blood pressure. An example: W7ILL, Big Piney, Wyoming, made his first contact on 6 with W4GJO, Orlando, Florida, more than 1700 miles distant! W4GJO reports a phenomenal amount of double-hop contacts this season. Though he was active all through last summer, he made no contacts beyond about 1300 miles, but this summer he has worked no less than 25 W6s alone, and has all the states within the double-hop range except Utah and Nevada.

Along with all the double-hop, there has been a pronounced lengthening of the skip for the average contacts. Notable is the lack of frequent openings between the East and Great Lakes areas. Relatively few W1-W9 contacts have been made, and even less W1-W8 and W2-W9. It appears that ionization sufficient to reflect 50-Mc. signals is now more frequent and widespread, but less dense, than formerly. The predominance of low-angle beam antennas may have something to do with this also. There have been several occasions when the skip has been extremely short, but contacts over less than 500 miles or so are believed to be at least partially the result of sharp-angle reflections, such as are common on 28 Mc.

Being in the middle is not all it's cracked up to be, according to W9IZQ, Wauwatosa, Wis. It's all very well to be within single-hop range, making it seemingly easy to snag all the states, but when the West Coast boys start hearing the East, it's just too bad for the W9s, who are just another contact, then.

To select either horizontal or vertical on 50 Mc., or by a combination of both to effect circular polarization, W1KMMZ/3 mounted two 4-element arrays, one horizontal and one vertical, on a single boom. Element spacing and method of feed are the same as the 4-element described in these pages several times over the past year or so. Separate 300-ohm lines are brought down to a switching arrangement at the operating position. Rick reports that the circular polarization effects a considerable reduction in the violent fading normally associated with sporadic-E skip reception. He has also found that signals radiated by horizontal arrays occasionally are received best on the vertical system.

## A Two-Meter "Beam To End All Beams"

Not so long ago, a 16-element array was something to be proud of, but the two-meter boys are now building arrays that put the 16-element job almost in a class with the folded dipole. This is a logical development, for by no other approach can so much return be had for so little cost as in

(Continued on page 144)



# HARRISON HAS IT!

# HARRISON HAS IT!

**IF** you like friendly helpful service, and want to enjoy that warm feeling of confidence that you are getting a square deal and your full money's worth, every time—  
**THEN I'M YOUR MAN!!**

**I offer you —**

- **COMPLETE STOCKS**  
All the best makes of Receivers, Transmitters, Test Equipment, Parts, etc.—all latest models.
- **LOWEST PRICES**  
always!
- **GUARANTEE**  
Free Service for 90 days.

- **TOP TRADE-IN ALLOWANCE**  
at least 5% more!
- **FREE TRIAL**  
If not satisfied with your new receiver, you may return it for full refund.
- **QUICKER DELIVERY**  
I know how eagerly you look for its arrival!
- **HARRISON EASY PAY PLAN**  
Easiest terms in the country! Tell me what you want, terms desired, and enclose only \$5

AND there's plenty more good reasons for doing business with me. Let's get together—I promise you'll be well satisfied. Drop in, or write to me—NOW!

Tnx es 73, *Bil Harrison*, W2AVA

**NEW ARRIVALS**

- ASK FOR LITERATURE — OR SEND ME YOUR ORDER
- NATIONAL HRO-7. The new streamlined eleven tube version of this world famous receiver. Complete, with speaker. **\$299.31**
  - HALICRAFTERS SX-43 Receiver. More features, more performance, more value! **\$169.50**
  - RME VHF-152-A. New model covers the 11 meter band. **\$86.60**
  - RTL "Handy" Converter. Works with auto, BC, surplus, or regular ham receiver. For 2, 6, or 10-11 meter band. **\$29.95**
  - HALICRAFTERS HT-17. Compact CW transmitter (or exciter) 10 to 15 watts output. Complete with tubes. **\$69.50**  
Coils: 80—\$3.50, 40—\$3.50, 20—\$7.00, 10—\$7.00.
  - AMPHENOL (MIMS) SIGNAL SOURTER BEAMS. Dual 10-20, with indicator, etc. **\$385.00**
  - HAMMARLUND FOUR-20 TRANSMITTER. Band switching, simplified QSV, 20 Watts output, many advanced features. Complete. **\$120.00**
  - FOUR-11 MODULATOR. **\$72.50**
  - SILVER "Micromatch" SWR and RF power output meter. Improved Jones design, large meter. **\$29.90**
  - COLLINS Transmitters and Receiver. *Now in stock — at new lower prices*
  - BEACH Model 1700 VFO. Chirpless keying, stable, compact. **\$31.50**
  - HALICRAFTERS newest production of the FB 100 watt HT-9 Transmitter **350.00**
  - RIBBON TWIN LEAD. Standard 300 ohm. 500 foot spool, **\$10.95**. Per foot **3¢**

(CUL at the ARRL CONVENTION, Asbury Park, Sept. 26-7-8)

**—HARRISON SELECT SURPLUS—  
RELAYS**

**SENSITIVE!** Positive action on less than 1 ma. (10 volts). Balanced armature, vibration-proof. PIVOT DRIVEN. Adjustable 5 bearings. Heavy SPLT to 120 seconds. 15 Ampr. contacts. Coils 10,000 ohms. (Also 2,500 ohm, 2 ma., 5 volt operation) **\$1.19**

**TIME DELAY.** Protect those rectifier tubes! 115 volt, 60 cycle MOTOR DRIVEN. Adjustable 5 contacts. Enclosed, compact, W.E. made for Navy. **\$4.95**

**COAXIAL CABLE (the good kind!)**

New, clean, perfect. Full measure  
RG-8-U, 52 ohm. 6c per foot. . . . **\$4.50** per 100 feet  
RG-11-U, 75 ohm. 7c per foot. . . . **\$5.00** per 100 feet

Abbott BM2 five element, wide spaced, high gain

**HSS TUBES**

All new, perfect, JAN Gov't tested.  
24G Still the favorite compact VHF triode **\$3.98**  
FOUR for. . . **\$3.98**  
2C26 10 watt UHF triode. 6.3 heater, 400 plate. FIVE for. . . **\$1.99**  
for. . . . **\$2.28** each.  
3E29 (829-B) **\$3.97**  
TWO for. . . **\$3.97**

**TWO-METER  
BEAM**

All dural, precision machined — NO TUNING! List Price \$23.50.

HSS SPECIAL... **\$8.82**

**CRYSTAL OSCILLATOR—CALIBRATOR—MONITOR**  
Navy type CGQ-61933. Complete with instructions, diagrams, kit of spare parts and 3A4 tube. Brand new in original sealed cartons. Less crystals and batteries. **\$3.84**

**HAM HEADQUARTERS**  
Since 1925!



**HARRISON RADIO CORPORATION**

12 WEST BROADWAY • NEW YORK CITY 7

PHONE—BArcly 7-9854 • EXPORT DEPT.—CABLE—"HARRISORAD"

JAMAICA BRANCH—172-31 Hillside Ave.—REpublic 9-4102

# The Perfect Table

## FOR THE AMATEUR

One of the greatest developments in utility tables that makes an all-around, all-steel, service table for the radio ham.

• Ham receiver and transmitter table • Ideal utility work table • Storage cabinet for records or supplies • Compact... hinged top swings down—ideal end-table

• Fitted for Pendoflex folders  
• Open: 42" x 24" and 28 $\frac{3}{4}$ " high • Closed: 14" x 24"

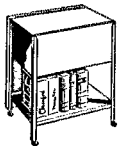

ALSO AVAILABLE IN JUNIOR SIZE  
SIZE 35" x 20" —  
\$14.95 NET.

**\$27.50**  
Net

See your local jobber or order direct.  
25% deposit, balance C.O.D.

**NORMAN** RADIO EQUIPMENT CO.

94-29 MERRICK ROAD

JAMAICA 5, N. Y.



(Continued from page 142)

adding elements to the antenna system. W2NLY jumped to 27 elements, and W1SF, W2ER and W2BAV, to name a few, have gone to 32; each with an improvement in performance sufficient to justify the added effort. Dissatisfied with his results in a poor location, Paul Carignan, W1LKH, Olneyville, R. I., topped them all with the awesome structure shown in the photograph on page 72 — a 48-element array!

Standing 25 feet above the ground and weighing 225 pounds, the W1LKH array is capable of continuous rotation. Performance tests indicate a gain of nearly 20 db., and the array has an 18-degree horizontal and vertical pattern. It has 16 half-waves in phase, with reflectors and directors, and every element is adjustable for length. A 6.3-volt bulb can be lighted at a distance of 150 feet out in front of the antenna. For further information as to whether it works, ask numerous W2s who have heard the signal it puts out, when hooked to the crystal-controlled rig at W1LKH, which runs a pair of HK54s 200 watts on 'phone and 500 watts on c.w., on 144.1 Mc.

Not all the big beams are vertical — W9BBU, Elgin, Ill., has a 30-element horizontal array, with which he has worked W8AKR, W8HDM, W8BTL and W8CVQ.

### Yawn Patrol

The early-morning movement, originated by W2DOG and organized by W3QKI, started out bravely. At least a few stations could be heard just about any morning, and results were encouraging, but not phenomenal. No DX records have been set, or even approached, but signals are generally stronger and steadier than during the evening contacts over medium distances. The signal of W2LKN, Elizabeth, N. J., has been heard with good strength on numerous occasions as far north as Boston, and QSOs with him are reported by W1JMU, W1CTW and W1IZY. W1CTW, Arlington, Mass., reports that the signal of W1SF (that 32-element beam guy) has been S9-plus, on the better mornings, and that the stations within the semilocal range are consistently stronger in the early-morning hours. No phenomenal DX conditions have prevailed at any hour since the early-morning tests began, so no definite conclusions can yet be drawn.

One thing is certain: all the DX records to date have been made in the hours after midnight, and when the gang work until about 2 A.M., not many of them are on deck at 6:30 again the same morning. The night of July 7-8th was the closest approach to ideal conditions experienced during July, and the log of W1CTW shows that the best DX worked was W3JDP, near Wilmington, Del., who was inaudible at 12:30, S3 at 1:30 and S5 at 2 A.M. The distance is about 300 miles, and several other stations beyond 200 miles were worked the same night, all of them increasing in signal strength after midnight. What conditions prevailed on the 6:30 A.M. sked are not recorded!

(Continued on page 146)



**STANCOR**

*First* WITH DISCRIMINATING AMATEURS

**ON STANCOR'S PROGRAM**  
Transformers and Reactors of all types  
... Versatile Line of Transmitter Kits,  
Audio Amplifier Kits, and other  
Electronic Devices to serve the  
Discriminating Amateur.

**STANCOR** STANDARD TRANSFORMER CORP.  
1000 KEDzie AND ADDISON, CHICAGO, ILL.

# IF IT'S IN TELEVISION Resco Has It!

## BUILD YOUR OWN TELEVISION SET

Never before have such fine television receiver kits been offered at such amazing low prices! The Telekit is easy-to-assemble, and GUARANTEED to receive sound and video of superior quality. Complete instruction books with each kit show every step of the way. Photographs and diagrams are included so you cannot make a mistake. Thousands have already been assembled throughout the country.

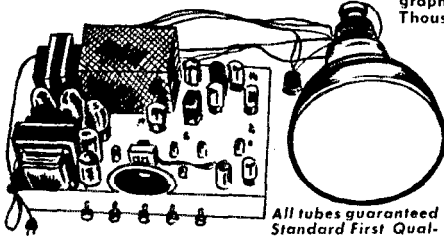

All tubes guaranteed Standard First Quality - No Surplus!

### 7 INCH TELEKIT

The 7" kit uses the simplest, most advanced television circuits; has easy-to-align pre-tuned I.F. coils. Sound reception is high quality F.M.; switching arrangements for three bands. Number 7 Kit is perfect for the television beginner, and brings you better picture reception at less than half the price of commercial receivers. Tubes required: 1-6J6, 1-5U4G, 1-2x2/879, 1-6V6, 1-7X7/XXFM, 6-6SN7, 5-6AC7/1852, and one 7GP4 (7" picture tube).

KIT ..... 77.50  
TUBES—Including Cathode Ray Tube ..... 37.70  
CABINET ..... 24.50

### 10 INCH TELEKIT

The 10" kit features larger picture & Electro-magnetic scanning & focusing. It is the first to use new TTI interlock circuit for horizontal and vertical sync control—holds picture steady even at low signal strength & noisy location. Big 10,000 volt R.F. power supply for 10" picture tube, & 2 separate low power voltage supplies prevent interaction between circuits. High quality F.M. sound reception without distortion. Pre-tuned I.F. coils inc. Switching arrangements for 5 bands. Tubes required: 1-6J6, 1-7X7/XXFM, 1-6V6, 1-6AC7/1852, 5-6SN7, 1-6BG6/807, 4-6AG5, 1-5V4G, 1-1B3GT/8016, 2-5U4G, 1-10BP4 (10" picture tube)

KIT ..... 124.50  
TUBES, including Cathode Ray Tube 62.50 — CABINET 29.50

2X2/879, Sub-Chassis Mounting Socket, excellent up to 10,000 volts ..... 49c

### Television Books You'll Want To Read!

"TELEVISION SIMPLIFIED" by Milton S. Kiver  
The most complete practical description of modern television with the latest diagrams. Last word for radio servicemen, radio workers etc. .... 6.00  
"Design and Construction of a Modern 5- or 7-Inch Television Receiver" ... Detailed sketches, layouts and schematics for the builder. 1.75



## FILTER CAPACITOR SPECIALS

All standard brands, rectangular cans, oil filled.

2 mfd. 600 WVDC	.95
4 mfd. 600 WVDC	1.45
1 mfd. 1000 WVDC	.79
2 mfd. 1000 WVDC	1.95
4 mfd. 1000 WVDC	2.95
8 mfd. 1000 WVDC	3.75
2 mfd. 2000 WVDC	2.95
2 mfd. 4000 WVDC	4.95
.1 mfd. 2000 WVDC	.95
.01 mfd. 6000 WVDC	.95

Round can capacitors with center terminal

.03 mfd. 7500 WVDC	.95
.1 mfd. 7500 WVDC	.95

## MICA CAPACITORS

.056 mfd. 1000 VDC	79c ea.
.024 mfd. 1000 VDC	
.033 mfd. 1500 VDC	

## RCA PARTS & COMPONENTS

Projection Size Control 201R2	1.32
Width Control 201R1	.78
Horizontal Linearity Control 201R3	.84
Video Series-Peaking Coil 203L1	.45
Video Shunt-Peaking Coil 203L2	.45
Video Series-Peaking Coil 203L3	.45
Video Shunt-Peaking Coils 203L4	.45
Sound i-f Transformers 201K1	2.25
First Pix. i-f Transformer 202K2	2.25
Second Pix. i-f Transformer 202K3	2.25
Cathode Trap 202K4	2.25
Detector Transformer 203K1	2.70
Third and Fourth Pix. i-f transformer 202L1	.45
Filament Choke 204L1	.18
Horizontal Sync-Discriminator Transformer 208T8	2.85

Deflection Yoke 201D1	8.25
Deflection Yoke 201D2	8.94
Yoke Mounting Hood 201X1	1.65
Focus Coil 202D1	5.46
Ion-Trap Magnet 203D1	3.90
Transformer—Linear & Undistorted Output 204T1	13.80
Horizontal Output Transformer 204T3	8.73
Horizontal Output Transformer 211T1	10.11
Horizontal Output Transformer 211T2	13.65
Vertical-Output Transformer 204T2	5.40
Horizontal Blocking-Oscillator Transformer 208T1	3.60
Vertical Blocking-Oscillator Transformer 208T2	3.42
Horizontal Blocking-Oscillator Transformer 208T3	2.73

Write for FREE Descriptive Folder and Typical Diagram



## TELEVISION ANTENNAS

RCA Single Dipole #226	6.00
RCA Dipole with Reflector #225	9.00
RCA Universal Mounting Brackets #227	4.50
Shur Dipole with Director #1-62	5.70
Shur Folded Dipole with Director #1D62	7.50
Shur Antenna Mount for any Antenna	5.25
Taco Double-doublet Antenna with Reflector	15.00
Kings Roto-Beam	69.00

## TELEVISION LEAD-IN WIRE

Standard Amphenol 300 Ohm Twin Lead	Ft., 3c
Amphenol 150 Ohm. Ft., 2 1/2c	
Amphenol 75 Ohm. Ft., 2c	
RG59 Co-axial lead, single wire, shielded polyethylene insulated	Ft., 10c

## AMPHENOL POLYSTERENE

12" x 16" Sheets		8" x 4" Sheets	
1/16" thick	1.44	1/16" thick	17c
3/32" thick	2.22	3/32" thick	20c
1/8" thick	2.78	1/8" thick	24c
3/16" thick	4.11	3/16" thick	30c
1/4" thick	5.56	1/4" thick	40c

Tubing—1 Ft. Lengths		Rods — 1 Ft. Lengths	
3/8" O.D.	11c	1/4" diam.	8c
1/2" O.D.	14c	3/8" diam.	17c
5/8" O.D.	19c	1/2" diam.	31c
3/4" O.D.	23c		
1" O.D.	31c		

Write for big Free Bulletin • Include postage with cash orders

## TRANSFORMERS

HIGH-VOLTAGE. T8 —	LOW-VOLTAGE. T9 —
2200 Volt 2 ma. Separate 2.5 Volt 2 Amp. Winding. (2500 VDC at filter)	385-0-385, 200 Ma., Separate 5 Volt 3 Amp., Separate 6.3 Volt 5 Amp., Separate 6.3 Volt 5 Amp.
7.95	8.50

# Radio Electric

## SERVICE CO. OF PENNA., INC.

7TH AND ARCH STREETS, PHILA. 6, PENNA.  
Branches: 5133 Market St. & 3145 N. Broad St., Phila.  
Also in Wilmington, Del., Easton, Pa., Allentown, Pa., Camden, N.J.

**Save-BUY NOW**  
... while present Supply Lasts

**ENCLOSED  
RELAY RACK**

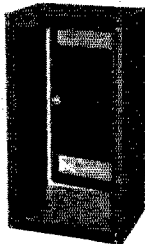

Par-Metal ER-213

Size—16½"x22"x42"

Panel space—19"x36¾"

(Regular List \$47.50) **OUR SPECIAL \$1825**

★ ★ ★

**VT-127A TRANSMITTING TUBE**

★ ★ **SPECIAL \$2.25** ★ ★

Cash with order. Prices F. O. B. Louisville  
Bears our money-back guarantee!



**UNIVERSAL**

**Radio Supply Co., Inc.**

715 So. Seventh St., Louisville 3, Ky.

**Headquarters for Amateur Radio Receivers**

**LEARN  
NAVIGATION**

and fulfill CAA requirements for flight operator or navigator on commercial airlines.

Write today for complete information on our

**HOME STUDY  
&  
RESIDENCE COURSES**

Basic or Advanced Training

**APPROVED under G. I. Bill**

School established 1928



(Continued from page 144)

**RECORDS**

**Two-Way Work**

- 50 Mc.: KH6DD — J9AAK  
4600 Miles — January 25, 1947
- 144 Mc.: W3KUX — W3EKK/1  
575 Miles — August 7, 1947
- 235 Mc.: W6OVK — W9OAW/6  
186 Miles — March 2, 1947
- 420 Mc.: W6VIX/6 — W6ZRN/6  
186 Miles — July 27, 1947
- 1215 Mc.: W1BBM — W1ARC  
3 Miles — April 7, 1947
- 2300 Mc.: W6IFE — W6IFE/6  
24.6 Miles — May 24, 1947
- 3300 Mc.: W6IFE — W6IFE/6  
20.2 Miles — June 5, 1947
- 5250 Mc.: W2LGF/2 — W7PQF/2  
31 Miles — December 2, 1945
- 10,000 Mc.: W4HPJ/3 — W6IFE/3  
7.65 Miles — July 11, 1946
- 21,000 Mc.: W1NVL/2 — W9SAD/2  
800 Feet — May 18, 1946

Down in Richmond, Va., W4FJ reports that signals were good on the dawn schedule, and a number of Washington and Baltimore stations were worked the first few mornings, but little has been heard since. W1SF worked down to Virginia on the first morning of the schedules, contacting W4JAZ at Arlington, a hop of close to 300 miles. This same morning, July 1st, was the best to date for W1CTW, as far as strength of signals was concerned, but no great DX was worked.

**Relay Networks on 2**

One good way of promoting activity and extending operating ranges is to organize relay circuits, attempting to push a message to the farthest possible point. To work out most satisfactorily, this should be tried on a regular schedule, with a certain night set apart each week for such efforts. One aim might well be the lining up of a complete chain of stations the length of the Atlantic Seaboard. The all-California chain mentioned previously is another. A circuit from Chicago to Boston is probably feasible, at the current state of accomplishments on 144 Mc., and this route is being exploited by W9BBU, Elgin, Illinois, who is promoting an attempt at relaying from West of the Mississippi to ARRL. A proposed route would include W0IFB or W0HAQ, for a starter, W9ZHB, W9BHI, W9UDO, W9BBU, W8BTL, W8AKR, W8CVQ, W8HDM, and from here on by whatever route the W8s are able to put across Pennsylvania or New York State. Organizational efforts are being carried on via 75-meter 'phone, each night at 9:55 P.M.

Another form of relaying was tried on 144 Mc. with good results on July 29th, when the first of a series of forum-type discussions of amateur prob-

(Continued on page 148)

# THE RADIO AMATEUR'S LIBRARY

These are the publications which every Amateur needs. They form a complete reference library for the Amateur Radio field; are authoritative, accurate and up to date.



<i>Title</i>	<i>Price</i>
QST.....	\$3.00 per year*
Operating an Amateur Radio Station	
	Free to members; to others 10c
The Radio Amateur's Handbook.....	\$1.25**
The Log.....	50c each
How to Become a Radio Amateur.....	25c
The Radio Amateur's License Manual.....	25c
Hints & Kinks for the Radio Amateur.....	50c
Lightning Calculators:	
a. Radio (Type A).....	\$1.00
b. Ohm's Law (Type B).....	\$1.00
A.R.R.L. Antenna Book.....	50c
The Minilog.....	25c
Learning the Radiotelegraph Code.....	25c
A Course in Radio Fundamentals.....	50c

\*Subscription rate in United States and Possessions, \$3.00 per year, postpaid; \$3.50 in the Dominion of Canada, \$4.00 in all other countries.

\*\* Postpaid in Continental U. S. A. —  
\$2.00, postpaid, elsewhere. (*No stamps, please*)



## THE AMERICAN RADIO RELAY LEAGUE, INC.

WEST HARTFORD 7, CONNECTICUT

# MORE AND MORE HAMS are switching to TERMINAL

*\*There must be a reason!*

## TERMINAL RADIO CORP.

*New York's Leading Radio Supply House*

85 CORTLANDT ST., NEW YORK 7, N.Y.

Phone: WOrth 2-4415

Cable: TERMRADIO



*Scoops Again!*

### 52 OHM COAX CABLE

BRAND NEW 60 Foot COILS  
COMPLETE WITH CONNECTORS. .... **\$1.25**

It's genuine Amphenol RG-5/U—use it in place of RG-8/U. Has smaller diameter (.332), less capacity between center conductor and shield, less weight, easier to handle than RG-8/U. Rated at 1100 watts at 30 Mc. Supplied complete with standard Amphenol 83-1SP-(PL 259) connectors attached at each end.

No. 4A496—60 ft. coil with connectors ..... **\$1.25**

Any number coils connect together with 83-1J connectors (below)



83-1SP

83-1R

83-1AP

83-1J

**Extra  
Connectors**

For use with above  
Choice  
Each. **35c**

### 10 Hy. - 200 Ma.

#### Thordarson Filter Choke

200 ohm D.C. resistance, 2000 V. RMS.  
Size 3 3/8" sq. x 4 3/8" high. Wt. 5 1/2 lbs.  
Has 12" leads at side.

No. 13A266 Special Each... **\$1.88**

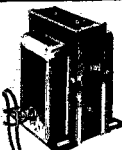

ORDER NOW, from this ad. Add Postage



**BURSTEIN-APPLEBEE**  
1012-14 MCGEE STREET, Company  
KANSAS CITY 6, MISSOURI

(Continued from page 146)

lems was inaugurated by the Midwest V.H.F. Club of Chicago. On alternate Tuesday nights, from 8:30 to 9:30, these meetings are transmitted by W9ENP, whose antenna system atop the 46th floor of a building in the Loop district gives her wide coverage in all directions. Selected relay stations pick up and retransmit the signal, so that coverage is already extended to five states, and more relay stations are being lined up.

The first discussion featured Jack Brown, antenna engineer, and W9MFC, W9NNQ, W9RIL and W9ELV. Relay stations were W9BBU, Elgin, W9IPO, Chicago, and W9GGH, Kenosha, Wis. More relay stations are needed for outlying points, and persons having facilities for retransmission (a selective receiver and two separate antennas will do it) are invited to write the secretary of the Midwest V.H.F. Club, W9WOK, Bensonville, Ill., for further details.

#### First VE1-W QSOs on 144 Mc.

Ever since VE3BLZ has been working at ARRL Headquarters, he has been pining away because he could not get on the v.h.f. bands legally in West Hartford, except by talking over your conductor's microphone. To remedy that, and to try for the first 2-meter contacts with Ws from VE1, he decided to take a trip to Yarmouth, Nova Scotia. This looked like a good choice — Yarmouth is at the tip of the Nova Scotian peninsula, with an all-water path the length of the Atlantic Seaboard. DX signals from W3 and W4 were always heard last at Cape Cod — why not at Yarmouth, some 275 miles farther to the northeast?

So, with two crystal-controlled transmitters, two receivers, and all the materials for a 16-element beam, John was off for Yarmouth on July 13th. But, alas, the next ten days were the occasion of an extended spell of high humidity, blanketing Yarmouth with a pea-soup fog; certainly no weather for 2-meter DX. The prearranged night and morning skeds were kept religiously, but for a solid week nothing was heard of or from VE3BLZ/VE1.

The first break came on July 21st, when the m.c.w. of VE3BLZ/VE1 was heard by W1BDF/1 on Nantucket Island, 25 miles south of the elbow of Cape Cod. First contact between the two was made at about 10:15 EST, when the signals from Yarmouth were heard by W1MNF, East Orleans, and W1BCN, Hyannis, both on Cape Cod, and by W1OSQ, Milford, and W1SE, Branford, in Southern Connecticut, a distance of some 375 miles. The all-water path to Nantucket and the Cape was open again on the following night, but no more contacts were made until the 26th, the last night of John's stay at Yarmouth, when the circuit to Nantucket was open all evening long, with solid S9 signals, and contacts were made with W1MNF, W1BCN and W1IZY, the last mentioned being at East Freetown, Mass. Never was the difference in overwater and overland

(Continued on page 153)

# MR. RADIO RETAILER

A MUST for NOISE-FREE STORE DEMONSTRATION

BRACH

## PURATONE\* SIGNAL BOOSTER

CARRIES AM, FM and TV ANTENNAS ALL ON THE SAME MAST

Increase your radio sales by bringing home-like reception to any AM, FM and TV set in your showroom... eliminating all interference and bothersome noises.

**HERE'S HOW:** The Puratone Signal Booster System is easily installed on the roof of your building. A shielded coaxial cable runs directly from the mast to the concealed amplifier on the display floor.

From the amplifier a radiating wire is placed inconspicuously around the display space. No direct wire connection to radio sets required. One system serves any number of floor models. Dual wave traps in the video-type AM-FM amplifier bring in all stations at an average tone-level. 30-40 DB gain on FM; 40-60 DB gain on AM. Effective for any radio department layout.

Write for illustrated circular.

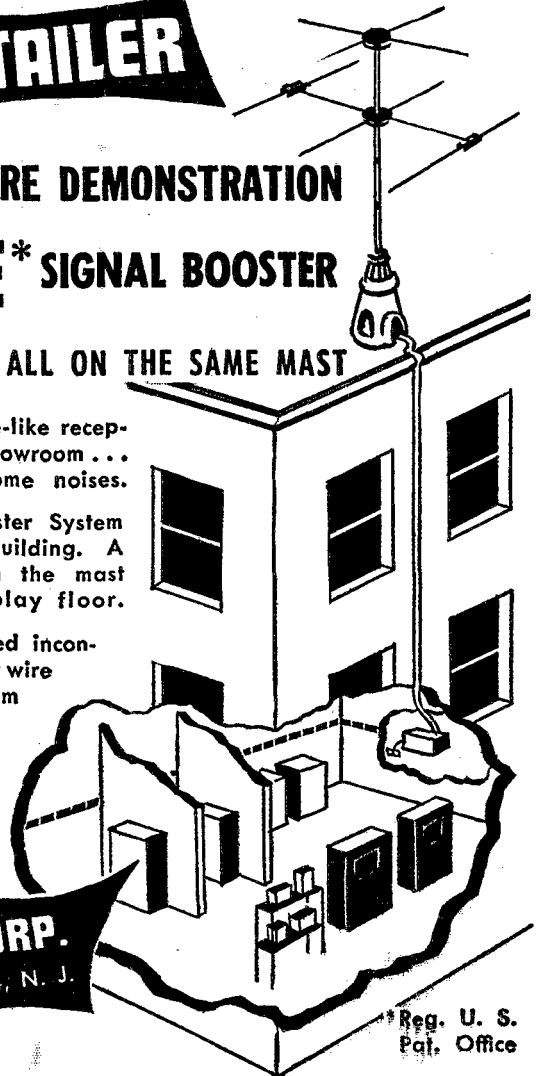

\*Reg. U. S. Pat. Office

**L.S. BRACH MFG. CORP.**  
200 CENTRAL AVE., NEWARK 4, N. J.

WORLD'S OLDEST AND LARGEST MANUFACTURERS OF RADIO ANTENNAS AND ACCESSORIES

PATRONIZE A "HAM" AND "VETERAN"

RME-45

RME-84

VHF-152A

DB-22

FREE FOLDER ON ANY ABOVE SET

HAM PRINT SHOP

QSL PRINTERS • SAMPLES 20c • No cheap trash  
"RUS" SAKKERS, W3DED HOLLAND, MICH.



### RCA INSTITUTES, INC.

Offer thorough training courses in all technical phases of

RADIO and TELEVISION

WEEKLY RATES

DAYS—EVENINGS

**VETERANS:** RCA Institutes is approved under C. I. Bill of Rights

For Free Catalog write Dept. ST-47

RCA INSTITUTES, INC.  
A Service of Radio Corporation of America  
75 Varick Street, New York 13, N. Y.

PROFESSIONAL TRAINING  
IN A MINIMUM OF TIME

## RADIO-ELECTRONICS TELEVISION • BROADCAST ENGINEERING

An Accredited Technical Institute nationally recognized for high calibre training. Prepares high school graduates for technical careers. Classes start every Monday. Comprehensive courses in Radio-Electronics Engineering, Broadcast and Television Engineering, Broadcast and Television Servicing; 2,100 hours classroom and laboratory study. Write today for free informative booklet, "RADIO ENGINEERING AS A CAREER."

**CAPITOL RADIO ENGINEERING INSTITUTE**  
DEPT. QS-9, 16th STREET & PARK ROAD, N. W. • WASHINGTON 10, D. C.



# LOOK

## HALLICRAFTERS S40-A

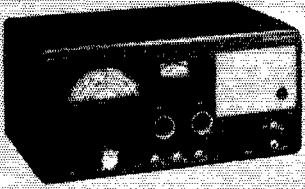

Immediate Delivery from Large Stock:

S40A.....	\$89.50
S38.....	47.50
SX42.....	275.00
NC46 with speaker.....	107.50
NC240 with speaker.....	241.44
NC173 with speaker.....	189.50
HQ-129X with speaker.....	173.25
Super Pro, complete.....	347.25
RME84.....	98.70
RME45 with speaker.....	198.70

Send 20% with COD orders  
73, Jule Burnett W8WHE

### Steinberg's

633 WALNUT STREET • CINCINNATI 2, OHIO

## SELSYN MOTORS



FOR  
ROTARY  
BEAM  
INDICATION

**\$2.95**  
PAIR  
Add 25¢ for Packing  
and Postage

STOCK NO.  
B-407-A

**BRAND NEW - General Railways Signal Co.**  
Selsyn Transmitter and Indicator

- Operate from 115 volt 60 cycle thru a 300 ohm 20 watt resistor or 40 watt lamp. (Diagram furnished)
- $\frac{1}{2}$ " long shaft threaded for 6-40 nuts.
- Quick disconnect plugs.
- Small in size ( $2\frac{1}{2}$ " dia x  $4\frac{1}{2}$ " long) and light in weight (20 oz.).
- Other uses - remote indication of liquid levels in tanks, remote wind direction indicators, remote signaling, etc.

TERMS ... Orders under \$3.00, cash with order; orders over \$3.00 require 20% deposit ... balance C. O. D.

## SREPCO

STANDARD RADIO & ELECTRONIC PRODUCTS CO.  
135 E. SECOND ST DAYTON 2, OHIO.

## V.H.F. MARATHON

Call	Contacts Through July 15th				States in 1947	
	50	144	256	Score	50	144
W1AF	153			1115	24	
W1BGT		175	5	832		6
W1CGY	111			1172	32	
W1CLS	259			3152	41	
W1EH*		31		136		3
W1HDQ*	216	72		2911	35	7
W1HMS	101	8		1077	32	
W1KLR		128		673		4
W1LLL	193			2310	38	
W1LNU		72		302		2
W1MPO		35		227		5
W1PEN		107		922		6
W1PYM		43		154		1
W3CIR/1	245			2832	42	
W2AMJ	224			1973	35	
W2BYM	242			2555	35	
W2CBB		169		720		7
W2COT	59	116		599	9	3
W2DZA		168	11	817		6
W2NLY		282		1788		7
W2PWP	121			942	27	
W2QVH	213	83		1993	31	3
W2RLV	102			1512	33	
W2RSO		115		1316		7
W3AWS		29		138		3
W3CGV	106	30		989	25	5
W3GKP	32	64		711	8	6
W3HWN		150		1255		6
W3MHW		173		956		5
W3MNA		95		597		5
W3RUE	75	50		1367	26	2
W1KMZ/3	99		2	1098	29	
W4AVT		69		811	22	
W4FJ		66	22	1125	24	5
W4HVV	135	2		1816	26	2
W4LNG		8	27	203	3	1
W4WMI	135	2		1772	29	1
W5ESZ		67		866	25	
W5FSC		69		1375	28	
W5ZZF		110		1360	29	
W5LIU		51		536	22	
W6BPT		51		1085	20	
W6BWG		125		742	9	
W6HZ	127	169	1	1374	13	1
W6OVK	100	132	4	2967	27	1
W6WNN	113	5		2080	24	1
W7ACS/KH6		6		123	0	
W7QAP	130			2076	25	
W8QQS		64		825	20	
W8RFW		72		882	23	
W8TDJ		52	1	719	21	1
W8UKS			63	690		4
W9AB		53	6	585	18	1
W9AGV			35	154		2
W9ALU		81	11	673	31	2
W9CZD		32		337	11	
W9JMS		195	2	2717	32	1
W9MBL		37		424	10	
W9PK		230	40	3437	40	2
W9ZHL**		274	4	4232	39	1
W0DNW		150		1708	32	
W0QIN		221		3022	43	
W0VIK		90		917	20	

\* Not eligible for award.

\*\*Sixth-period winner: W0ZHL, Terre Haute, Ind., heading the list with 1671 points, for the second consecutive month!



# BETTER LC RATIOS at high frequencies

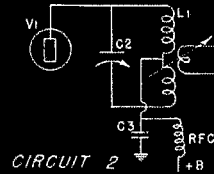
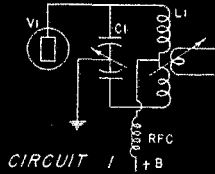
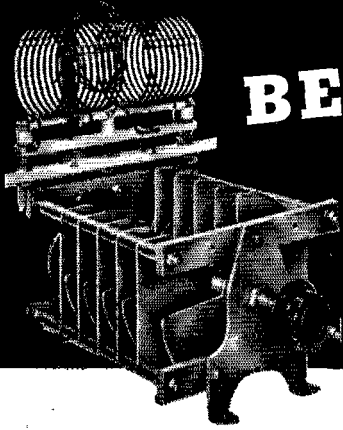

... with beam power tubes

Here is an ideal method for obtaining better LC ratios at high frequencies when using beam power tubes in single ended circuits. By using split coil circuit arrangements as shown, effective tube capacity is reduced 75%. Circulating current and consequently coil losses are reduced to a minimum. Output coupling efficiency is increased.

Conventional B&W fixed or variable center link coils may be used in either circuit. No. 1 employs a split stator condenser; No. 2 a single-ended condenser. Conversion to push-pull operation is a simple matter. All of the beam power tubes from 807 up may be employed—with greater output efficiency and ease of operation.

Write for B&W Bulletin

**BARKER & WILLIAMSON, Inc.**

237 FAIRFIELD AVENUE

UPPER DARBY, PENNA.

Export: Royal National Co., Inc., 75 West St., New York, N. Y.



## RADIO

TECHNICIAN and RADIO SERVICE COURSES  
FM and TELEVISION

Approved under G. I. Bill of Rights

**AMERICAN RADIO INSTITUTE**

101 West 63rd St., New York 23, New York

TEACHING RADIO SINCE 1935

## W8CFK

**Aluminum  
Call Plates**

Your call cast in aluminum with black background and polished 1/4" letters. Plate size 2" by 6 1/2", 3 styles: P for panel mounting, L for car license and D for desk use. \$1.75 each, postpaid.

and polished 1/4" letters. Plate size 2" by 6 1/2", 3 styles: P for panel mounting, L for car license and D for desk use. \$1.75 each, postpaid.

P & H SALES CO.

619 Jasper St.

Kalamazoo 31, Michigan

# New!

Actual  
Size

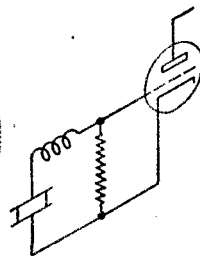
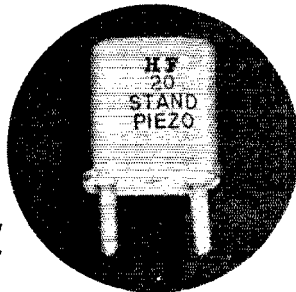

48 mc  
to 54 mc  
CRYSTALS

\$6.95 NET

The new HF-20 does the trick! Eliminates frequency multiplication on 50 mc and necessitates only one tripler on 144 mc. Ideal for that mobile rig. Hermetically sealed—dirt proof—moisture proof. For Commercial Application—100 kc to 100 mc.

# STANDARD PIEZO Co.

Office and Development Laboratory • CARLISLE, PA., P. O. BOX 164

Write W3HWN for catalogue now available

# ★ YOUR FUTURE IN ★ RADIO . . .

May depend on the integrity and ability of your School's Administration. At MELVILLE no effort is spared to provide the best in facilities and service for the serious student of RADIO, TELEVISION, FREQUENCY MODULATION, TELEGRAPHY, SLIP TRANSCRIPTION, RADIO MATHEMATICS, etc.

Approved for Veterans

Licensed by the State of N. Y.  
Write or call today for FREE  
Bulletin B

**MELVILLE  
RADIO INSTITUTE**  
MELVILLE BUILDING  
15 W. 46th St., N. Y. 19, N. Y.  
BRYANT 9-5080  
"Managed by Radio Men"

## MODULATION & DRIVER TRANSFORMERS

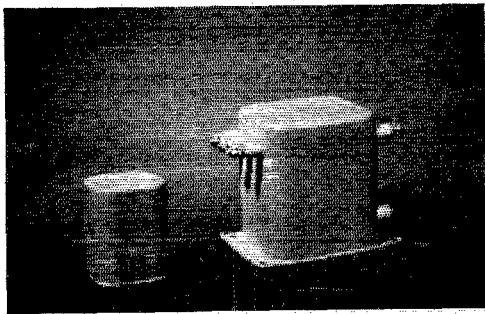

These transformers are suitable for use with type 811, 809, TZ40, TZ20, etc. to modulate either triode or beam tube RF amplifiers. Two secondaries are provided. Impedance ratio primary to secondary number one, 2 to 1. Primary to secondary number two, 16 to 1. Will modulate up to 300 watts input. Modulation transformer, driver transformer, circuit diagrams and other information all for . . . . . \$6.90 Please include 50 cents for postage and handling. Write for latest bargain bulletin listing bargain in filter condensers, chokes, transformers, vacuum condensers, switches and many other items.

**ELECTRONIC NAVIGATION, INC.**  
Box 735, Church Street Station  
New York 8, New York

(Continued from page 148)

paths better demonstrated — the signal from Nova Scotia was S9 at Nantucket Island, when it was not even audible at inland points.

The set-up at VE3BLZ/VE1 was something to behold. Atop Grand Hotel, Yarmouth, in a glass-enclosed cupola that formerly housed a small broadcasting station, John had his 50-watt crystal-controlled transmitter, an ARR/5 receiver, and a t.r.f. superregen. On the roof, at a height of 70 feet above ground, was the 16-element array, erected with the help of VE1QY and a local boatbuilder. The hotel itself was about 70 feet above the water, with a view out over the Atlantic to the southwest, where there was nothing in the way nearer than Cape Cod, 250 miles distant. Everything was right but the weather, and that was just beginning to break when it was time to pull up stakes and head back for West Hartford. The very night that VE3-BLZ/VE1 was dismantled was the first really good one for at least two weeks. The seed of a new record was sown, however. The 16-element array was left with VE1QY, and the interest the expedition germinated is almost certain to produce more VE1-W results before the summer is over.

Here is another fellow with DX aspirations: W7QG will be on 2 and 20 from Point Barrow, Alaska, during August and September.

### 420-Mc. Progress

Another surplus item which has real 420-Mc. possibilities has appeared on the scene. The APS-13 has a complete transmitter and receiver that are readily convertible to amateur use. Units of this type are seeing service at W1JLK and W1NFE, Woods Hole, Mass., and at W1OOP, Boston. W1PRZ, East Milton, is working on a crystal-controlled rig, driven by a tripler from his 2-meter job. His receiver is a 6J6 push-push mixer working into the i.f. of a BC-645. W1PBB, Belmont, Mass., uses a similar mixer working into a double-conversion (26 Mc. to 5 Mc.) set-up employing three stages at the lower frequency. His transmitter is a pair of 6J6s in push-pull parallel. Horizontal polarization is being used. Interested stations are invited to join in a round table that takes place at 7:30 each Wednesday night.

### Correspondence

(Continued from page 75)

working a local, here in the Boston area, and called me "blind" (in a sense) after I had signed off, I have established no DX contacts on n.f.m.

I hope to operate n.f.m. mobile from Vermont a couple of evenings to see if I can give W4QN a reward for vigilance, and make some of the other gentry wonder why their dials won't turn a little farther.

— S. Forrest Martin, W1BJB

P.S.: Flash! On July 13th my CQ marathon ended, when a 52.68-Mc. DX CQ was answered! It was No. 3991 *Sic transit gloria mundi* (and Sunday, too!).

(Continued on page 154)

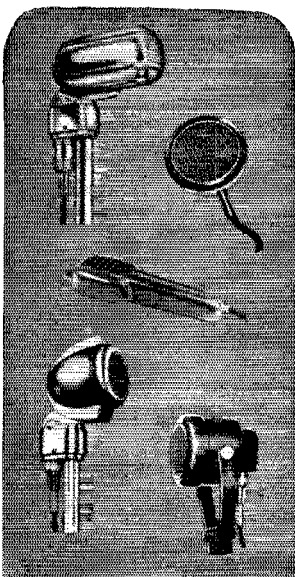

## New TURNER MODEL 20X

A SWEET PERFORMER  
AND LOW PRICED TOO!

Here's a new hand microphone that offers response characteristics usually found in higher priced mikes. The model 20X features a Metalseal crystal which withstands humidity conditions not tolerated by the ordinary crystal. New circuit design results in exceptionally high output level and ideal response for sharp, clear speech reproduction. Range: 50-7000 c.p.s. Level: 54 db below 1 volt/dyne/sq. cm. Natural to hold. Has convenient hook ring for hanging. Weighs only 8 ounces. Finished in rich baked brown enamel. Also available with slidelock switch at extra cost.

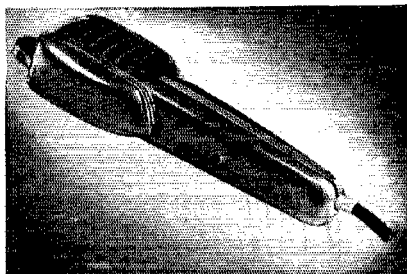

List price only \$12.85

At your dealer or write for Bulletin

## THE TURNER COMPANY

917 72th STREET, N. E. • • • CEDAR RAPIDS, IOWA



# Microphones BY TURNER

Microphones licensed under U. S. patents of the American Telephone and Telegraph Company, and Western Electric Company, Incorporated. Crystals licensed under patents of the Brush Development Company.

## COMMERCIAL RADIO INSTITUTE

A RADIO TRAINING CENTER FOR 27 YEARS

**Resident Courses Only** • Broadcast, Service, Aeronautical, Television, U.H.F., Preparatory Course, Frequency Modulation and Marine telegraphy classes forming for Fall Term Oct. 1. Entrance examination Sept. 15.

Literature upon request. Veteran training

Dept. B, 38 West Biddle Street, Baltimore 1, Maryland

## COMPLETE RADIO TRAINING!

Prepare now to accept a responsible position in Commercial Radio. New developments will demand technicians with thorough basic training, plus a knowledge of new techniques discovered during the war. Training open to high school graduates or those with high school equivalency. Courses 6 to 18 months' duration in RADIO AND ELECTRONICS. Approved Veteran training in Radio. Write for Particulars.

VALPARAISO TECHNICAL INSTITUTE  
Dept. TN Valparaiso, Ind.

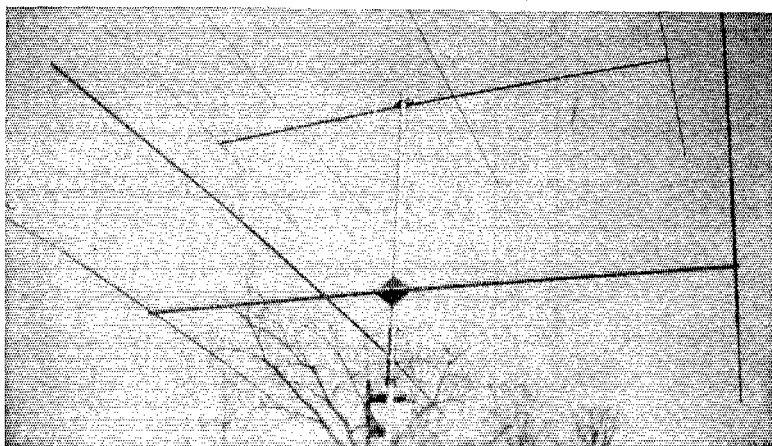

## U. H. F. RESONATOR CO. "TEN-OVER-20"

High-gain beams using *Wide, Maximized, Spacing*, available for 20, 10 and up. Power gain of 15 over folded doublet on ten. Send for literature.

U. H. F. RESONATOR CO. GUION ROAD, RYE, N. Y.  
TEL. RYE 7-2030

**\$194.50**

as shown with two heavy duty bearings. Many other combinations available, including 54-ft. and 72-ft. masts.

# Send the Easier Way . . . . .

WITH THE GENUINE EASY WORKING

Saves the Arm  
and  
Improves Sending

## VIBROPLEX

Reg. Trade Marks: Vibroplex, Lightning Bug, Bug

SEMI-AUTOMATIC  
RADIO KEY

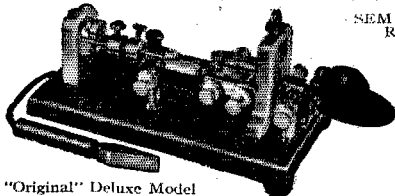

With  
Patented  
Jewel  
Movement  
**\$19.50**

"Original" Deluxe Model

Eliminate forever the nerve-trying and tiresome pounding on the ordinary key. No arm strain. No special skill required. Simply press lever . . . Vibroplex does the rest. Striking design. Polished chromium base and parts. DIE CUT contacts and main spring. Colorful red switch knob, finger and thumb piece. 3/16th contacts. Complete with circuit closer, cord and wedge. Deluxe finish also available in "Blue Racer" and "Lightning Bug" models. Place your order to-day! Money order or registered mail. Immediate shipment. FREE folder.



The "BUG" Trade Mark identifies the Genuine Vibroplex. Accept no substitute

**THE VIBROPLEX CO., Inc.**

833 Broadway NEW YORK 3, N. Y.

## AMATEURS EXPERIMENTERS SUPPLIES & EQUIPMENT

Leading Brands

Headquarters for

**HALLICRAFTERS  
NATIONAL HAMMARLUND  
RADIO PART DISTRIBUTING CO.**

Agents for War Assets Administration

128 W. Olney Road NORFOLK, VA.



Founded in 1909

### RADIO TELEPHONY RADIO TELEGRAPHY

Courses ranging in length from 7 to 12 months. Dormitory accommodations on campus. The college owns KPAC, 5 KW broadcast station with studios located on campus. New students accepted monthly. If interested in radio training necessary to pass F.C.C. examinations for first-class telephone and second-class telegraph licenses, write for details.

**PORT ARTHUR COLLEGE** PORT ARTHUR TEXAS

Approved for G.I. training

(Continued from page 152)

## SUGGESTIONS TO INDUSTRY

954 Farnham St., Elmira, N. Y.

Editor, *QST*:

The article in June *QST* entitled "Why Don't They Build Better Receivers?" covers the situation very well as to superhets. The lowest priced superhet is still above the amount that a lot of us can afford to pay for a receiver so we are using our homemade "junk-box" t.r.f. jobs and hoping some day the price of a decent receiver will come down within the range that we can afford.

If the receiver manufacturers want to cover the market of those of us who are not as flush as some, why don't they put out a good t.r.f. job such as the old SW-3 with a few changes such as front-panel coil changing and using the newer tubes? I'm sure that beginners and those "hams" cramped for space would welcome such a receiver. I sure wish I had the old SW-3 that I sold to begin a series of superhets, the last of which was sold because of lack of space.

— Dransfield Hamilton, W2HQY

Zapata, Texas

Editor, *QST*:

It seems to me that the recent tremendous increase in prices on transmitters and receivers by some of our manufacturers is very ill-advised at this time with buying power drying up, and with most manufacturers trying to "hold the line" on price advances. I feel that it will cost those concerns more in good will than they will affect in pecuniary gain, and sound business logic demands that long-range good will of customers be given deep consideration. . . .

— E. Harvey Cunningham, W5CU

4307 Union Bay Lane, Seattle, Wash.

Editor, *QST*:

The recent trend toward commercially-built equipment in our ham stations began when we demanded bandswitching for our receivers, and now it has spread to the transmitting gear for the same reason. The average ham does not have the time or the mechanical equipment needed to build a bandswitching receiver. It is my thought that if we could purchase a complete bandswitching unit (i.e. r.f., mixer, oscillator coils, trimmers, tuning capacitors, etc., designed to cover the 10-15-, 20-, 40- and 80-meter bands) the problem of building a good ham superhet would be within the scope of the average amateur, and at a price he could afford.

A similar deal for transmitters could be worked out or a roto-coil unit (i.e. a variable inductance, ganged to a variable capacitor so that the inductance and capacity are directly in proportion to maintain a constant Q for the freq. range) supplied in various power ratings would begin to solve this problem for us. . . .

— Alfred Obrist, W2IYR/7

## SENDING SPEEDS

Friendship, Maine

Editor, *QST*:

. . . In 28 years as an amateur and commercial operator I have witnessed but twice any person capable of speeds in excess of 40 w.p.m. without error. Anyone who can transmit 30 w.p.m. for five minutes or longer, without error, is indeed among the top five per cent of all radio operators.

The criterion of good sending is not *who* can copy it, but rather *how many* can do so. New men in our ranks would be so much happier with their ability if they knew that they were not so far from this ideal in their own present, and future, ability after experience and careful practice.

— William L. Hall, W1BMS

**PREMAX**

# Vertical Antennas



*Telescoping, Adjustable Tubular Types That Meet Every Dx Requirement for the Amateur*

WIDELY known and accepted in amateur, commercial and military fields for their dependable performance, Premax Tubular Metal Antennas are available to meet every requirement. Sizes range from 6 feet to 35 feet high and may be had in steel, aluminum or monel . . . with suitable mountings for any installation.

*Ask your Radio Jobber for details and prices of these outstanding Antennas and Mountings*

**Premax Products**

Division Chisholm-Ryder Co., Inc.  
4715 Highland Ave. Niagara Falls, N. Y.

## EASY TO LEARN CODE

It is easy and pleasant to learn or increase speed the modern way — with an Instructograph Code Teacher. Excellent for the beginner or advanced student. A quick, practical and dependable method. Available tapes from beginner's alphabet to typical messages on all subjects. Speed range 5 to 40 W.P.M. Always ready, no QRM, beats having someone send to you.



### ENDORSED BY THOUSANDS!

The Instructograph Code Teacher literally takes the place of an operator-instructor and enables anyone to learn and master code without further assistance. Thousands of successful operators have "acquired the code" with the Instructograph System. Write today for full particulars and convenient rental plans.

## INSTRUCTOGRAPH COMPANY

4709 SHERIDAN ROAD, CHICAGO 40, ILLINOIS

## IN STOCK

**NEW BC348 receivers 24V DC \$49.50.** Terms \$9.90 down and \$41.97 payable \$5.00 a month.

**NEW BC348 receivers 110V AC \$69.50.** Terms \$13.90 and \$58.93 payable \$5.00 a month.

Send \$5.00 and we will ship COD the balance. Or write for details.

## HENRY RADIO STORES

BUTLER, MISSOURI  
and

11240 W. Olympic Blvd., Los Angeles 25, Calif.

## Ham Post!

VHF-152.....	\$86.60	Hammarlund HQ 129X...	\$173.25
Gon-set 10-11.	39.95	RME - 45....	198.70
Sonar MB 611.	72.45	Hallicrafter SX42.....	275.00
Sonar VFX680.	87.45	National NC-2-40-D	240.00



## CONTINENTAL SALES COMPANY

135-137 CENTRAL AVENUE, NEWARK 4, N. J.

## Mass. Radio School

271 Huntington Ave., Boston 15, Mass.

For over 28 years the educational radio center of New England. Prepares for all U. S. Government Radio Operators' Licenses. Also gives Radio Technician Training. Approved courses for Veteran Training under G.I. Bill.

Send for Catalog

Licensed by Commonwealth of Mass.  
Department of Education

# HAM-ADS

(1) Advertising shall pertain to radio and shall be of nature of interest to radio amateurs or experimenters in their pursuit of the art.

(2) No display of any character will be accepted, nor can any special typographical arrangement, such as all or part capital letters be used which would tend to make one advertisement stand out from the others.

(3) The Ham-Ad rate is 30¢ per word, except as noted in paragraph (4) below.

(4) Remittance in full must accompany copy. No cash or contract discount or agency commission will be allowed.

(5) Closing date for Ham-Ads is the 25th of the second month preceding publication date.

(6) A special rate of 7¢ per word will apply to advertising which, in our judgment, is obviously non-commercial in nature and is placed and signed by a member of the American Radio Relay League. Thus, advertising of bona fide surplus equipment owned, used and for sale by an individual or apparatus offered for exchange or advertising inquiring for special equipment if by a member of the American Radio Relay League takes the 7¢ rate. An attempt to deal in apparatus in quantity for profit, even if by an individual, is commercial and all advertising by him takes the 30¢ rate. Provisions of paragraphs (1), (2), (4) and (5), apply to all advertising in this column regardless of which rate may apply.

(7) Because error is more easily avoided, it is requested signature and address be printed plainly.

(8) No advertiser may use more than 75 words in any one issue.

*Having made no investigation of the advertisers in the classified columns, the publishers of QST are unable to vouch for their integrity or for the grade or character of the products or services advertised.*

**QUARTZ** — Direct importers from Brazil of best quality pure quartz suitable for making piezo-electric crystals. Diamond Drill Carbon Co., 719 World Bldg., New York City.

**QSLs in colors.** Stamp for samples. Glenn Griffith, W3FSW, 1042 Pine Heights Ave., Baltimore 29, Md.

**DEKA-XIAL.** New compact 10-crystal unit for standard 5-prong socket. Looks and operates like a dial-knob. Just plug it in and turn to any of 10 frequencies, your selection. Ask your dealer or write us. Also other low TC ham crystals in FT cases to fit octal sockets. 80 and 40 + kc. \$2.65; 20 + 4 kc., \$3.50. Scientific Radio Products Co., 738 1/2 W. Broadway, Council Bluffs, Iowa.

**SURPLUS** bargain catalog. Send for the bargain ham catalog every one is talking about. Surplus Radio, Inc., 30 Munson St., Fort Washington, N. Y.

**QSLs, samples,** Albertson, W4HUD, P.O. Box 322 High Point, N. C.

**AMATEURS,** experimenters, industrials and export accounts. Write for catalog and monthly bulletins. Buy the "TB" guaranteed way and save. I.A.B. Dept. Z, 6 Church St., New York 6, N. Y.

**AMATEUR** radio licenses. Complete code or theory preparations for passing amateur radio examinations. Home study and resident courses. American Radio Institute, 101 West 63rd Street, New York City.

**COMMERCIAL** radio operators examination, questions-and-answers. One dollar per element. G. C. Waller, WSATV, 6540 E. Washington Blvd., Tulsa 15, Okla.

**LATE** radio-television courses, \$50, commercial radio ops sample questions, 40 sets, \$10. Corrected. Used radio, math books, reasonable. W6VTC, Box 1298, Hollywood, Calif.

**QSLs** on kromekote cards. Dauphinee, W1KMP, P. O. Box 219, Cambridge, Mass.

**METER** repair. Braden Engineering, 3317 Kenmore, Dayton, O.

**SELL QSLs:** Aug. 1928, thru 1946. Make offer. J. W. McEwan, W2BPC, 34 Dogwood Drive, West Orange, N. J.

**RECEIVER:** Sell National SW45 comp. with spkr, 6 tubes, and pwr supp. Perfect working order. \$18 f.o.b. Sciencetoday, N. Y. W2RCT, 2205 Dean St.

**SCHEMATIC** diagram BC-453, BC-454, BC-455 rrvs and simple conversion instructions. \$1. C. Reber, 47 W. 58th, Kansas City, Mo.

**WANTED:** Back issues QST: Aug. 1942; February and June, 1943; Jan. 1946. David Causey, University Sta. Box 1, Urbana, Ill.

**COLORTONE QSLs!** New, modernistic designs in distinctive colors. Deluxe! Different! Reasonable! When you send Colortone QSLs, you send the finest! Colortone Press, Tupelo, Miss.

**FOR Sale:** National NC-Y6 rcvr new, still in factory crate, never used. Complete with spkr. \$100. Ward Lantis, 2228 Sherwood, Kingsport, Tenn.

**SELL TR4** complete less pwr supp 6j6 replacing 615 new band, \$35. BC-1068 two meter super het converted 100 Kc L.F.; audio in, etc. \$57.50. W2BNX, 215-1111 Ave., Queens Village, N. Y.

**BC-610E,** factory modified for 10, 20, 40, and 80 for sale at \$500 if called for, crating, shipping extra. C. C. Smith, W3CZW, 587 School Lane, Lancaster, Pa.

**HALLICRAFTERS** SX-24 rcvr for sale. \$55 including speaker. A. Rosenthal, W2UUP, 2685 University Ave., Bronx 63, N. Y. Phone K1-5054.

**KYTOON,** slightly used, guaranteed. Ideal for high vertical antennas, will lift a VHF antenna with amphenol feeder cable. Retail for \$35. My price, \$20. H. W. Wickes, 3749 Jocelyn St., NW, Washington 15, D. C.

**BEST** offer takes FB7XA, coils, 40, 20, 10, pwr pk, peak preselector. J. Davis, W5JKY, RFD 2, Mesquite, Texas.

**LOOKING** for fb QSLs? Stamp brings samples. W7APH, Box 59, Opportunity, Washington.

**FOR Sale:** NC-700 \$90. Millen exciter, \$23. New Millen pwr supp. (700 volts), \$60.70 watt exc. xmtr, \$40 (HK24 final). W1OER, 9 Peters, Cambridge 39, Mass.

**T-350XM** xmtr (Tech Rad Co. SR) 2-30MC; 813a run 700 w; 805 hveval mods; 220 VAC; 5 at post 8 call; oae; Grey steel cab. 39" x 16" x 25"; many spec. features. Instr. books; 600 lbs; OPA said \$1200. First \$75 picks up as is in orig. crates; consider something portable trade. Cdr. W. Hudgins, Electronics Officer, Boston Naval Shipyard, Ph. Chelsea 4127W.

**WANTED:** One BC-221 freq. meter in good condx. Charles C. Hay, Box 1110, Grand Junction, Colo.

**SELL HRO** Sta I, 7 mos. old, complete. 4 sets. BS coils, A-1 condx. C. E. H. Ernsberger, W2VSW, Romulus, N. Y.

**SELL** new Millen exciter coiled for 10, \$35. BW& tank condxer CX78C N3 neutralizer plates TVH coil bar and link, \$25. Want Thordarson T-15D79, W3OKP, 584 Ardmore Blvd., Wilkesburg, Pa. Phone PENhurst 8271.

**HALLICRAFTERS** HT-6 Phone Xmtr, Stancor 10P xmtr; S38 rcvr, New, \$45; handie-talkie wired chassis, \$25 pair; RM7C remote control unit, \$15; LS3 spkr, \$3.50; Readrite #700 set analyzer, tube tester, \$16; Biley 200 Kc. xtals; 5 Kw gasoline generator, \$125. W2OEA, 712 Bergen, Linden, N. J.

**COMPLETE** station, xmtr, superhet rcvr, freq. standard, fone, cv. 17 watts output, 3.8-5.8 mc., 6-v. pwr supp., new, export-packed, all accessories, SCR-284-A, \$62. Meszger, W2BLI, 617 Beverly Rd., Teaneck, N. J.

**FOR Sale:** three Eimac 3C26 tubes, 300 watt, \$12 each. Jan. new. R. S. Daggett, W1OB, ex W1JMJ, Vineyard Haven, Mass.

**SELL:** SZOR, pre-war but in exc. condx. Clipper added. To first offer of \$40. Benjamin Barker, E. Main Road, Portsmouth, R. I.

**FOR Sale:** 50-watt fone/xmtr. Also miscellaneous xmtting parts. Stamp brings list. Ernest Austin, 1445 Ogden Northwest, Washington, D. C.

**AUTOMATIC** dita and dahs with Vallant key. With Bud code oscillator, \$20. W4FIN.

**HALLICRAFTERS** SX-24 with spkr, \$75. SX25 with a matching spkr, \$100. Both rrvs completely lined and new tubes, where needed. Myron Travis, 2117 Marlowe Rd., Toledo 6, Ohio, W8TRF.

**POWER** Supply: 110 volt input, 28 volts, 20 amps output. \$35. Viola, 1963 Hobart, Bronx 61, N. Y.

**FOR Sale:** radio xmtr, complete, unused, 10 to 160 meter operation. 200 watt fone. 40 watt cv. Floyd Barnes, R. 5, St. Johns, Mich.

**FOR Sale:** complete station consisting of Natl. 600 xmtr 10, 11, 20 and 80 meters P. P. 100TH final, Natl. NTE push-button exciter, meter beam with remote indicator, National NC-200 and HQ-120 rcvr, RCA oscilloscope. Spare meters, tubes and components. Transmitter in two 48" rack cabinets with interlocks. Seven crystals and ECO. All equipment highest quality excellent condition. Nine hundred dollars packing, shipping extra. E. L. Schacht, 167-10 Cryders Lane, Beechhurst, L. I., N. Y.

**SELLING out:** HRO, xmtrs, other units, parts. Ends. 181 Carman St., Freeport, N. Y.

**SX-28A** rcvr and 12" spkr, \$180. W2QMD, 218 Main, Binghamton, N. Y.

**SELL** factory-built Utah unit complete. \$40 cash and carry. W6VRH, North Hollywood, Calif.

**QSLs.** Good service. Central Printing Co., Huntington, Ind.

**WANTED:** SX24 or SX25 or equivalent. For sale: Model 560 Vedolyzer. Best price. Robert Kraft, W2LPL, Hicksville, N. Y.

**CONDENSERS:** Mica, Cornell-Dubilier and Sangamot: .022, .0035, .004, .005 pfd, .2500 W.V.D.C., 5000 V. test. .0004, .0005, .0007 and .0010 W.V.D.C., 75¢ ea. postpaid. W6UOU, 63 Westview, San Francisco 12, Calif.

**SACRIFICE:** complete mobile 40-watt AM, 10-11 station, includes new Gen-set and noise limiter, re-built 39 Mc police xmtr with built-in 6v. dynamotor, push to talk relay operated from dash remote control unit 4" square, all coaxial cables for trunk installation, spring mount 1/4 wave commercial mobile antenna, mike tubes, 10-11 meter xtals. \$100. W3WJL, 138 Huron, Mt. Clemens, Mich.

**NEW** or used: all popular brands in stock. Hallcrafters, National, Hamarlund, Collins, RME, Gonset, Milten, Meissner, others. Send deposit for new gear or write for list of used or surplus. Van Sickle Radio Supply, Indianapolis 6, Ind.

**KNOW** more than the next man by subscribing to Practical Wireless, Britain's foremost radio monthly. Only \$2 yearly. Leading technicians give fullest information latest receivers; constructional developments British and European radio-television fields, and statistical details all ham activities. Free advice your knottiest problems. Blue-note rates. Send \$2 to Subscription Dept., P. W. J. Tower House, Southampton St., Strand, London, W. C. 2, England.

**EVERYBODY'S** going. 1946 biggest Hamfest in country. 1947 bigger yet. 10th Annual Boston Hamfest, Oct. 18th.

**HRO.** Fine shape. Seven sets general coverage coils. 190 Kc., 30 Mc. Complete with relay rack, power supply, no spkr. \$175 or best offer. W1OCL, 75 Colt St., New London, Conn.

**BEST** offer within 20 days this ad accepted on HQ-129 X rcvr and spkr, latest model, used 6 hrs. W4CT, Lt. Col. Offringa, 124-A Burns Hampton, Va.

**QSLs.** Good service. Central Printing Co., Huntington, Ind.

**QSLs?** SWLSt Super-gloss stock! No cheap trash! Samples 20¢. W8DED (Sackers), Holland, Mich. Biley crystals? RME-45? VHF-132?

**SX-25** for sale. In excellent condx. First \$37.50 takes it. W0ZJJ, 558 No. 26th St., Lincoln, Nebr.

**CRYSTALS:** Where quality and not price is main consideration, demand Eidsen crystals. Fine commercial units for Aircraft, Police, Marine, Geophysical and other services; commercial crystal re-grinding. Also broadcast station monitor service. Over a decade of satisfaction and fast service! Try us first. Eidsen Electronic Co., Temple, Texas.

**HAMMARLUND** Super-pwr, SP-400-X, excellent condx, \$300. Mr. Horn, 645 Henderson Ave., San Luis Obispo, Calif.

SELL Stancor 60-P Phone Cw xmttr in Deluxe cabinet, good condx, \$85. 1. Navy TBY-4 transceiver 28 to 80 MCS, with calibration charts extra tubes, set portable batteries ready to go. \$45 new condx. T. C. Willis, W4CLA, Blakely, Ga.

SELL 500-watt fone xmttr, 6 ft. relay rack with Kw power and modulation xtrms, \$225. Sell 200-watt Cw xmttr less pwr supp., \$35. W6PS, 251 N. Reese, Burbank, Calif.

NEW sound mirror magnetic wire-recorder, paid \$229.50, sell best offer. Sell or trade the following new equipment: Turner mike, left-handed Champion model Vibroplex, set Signal Corps code learning records, misc. xtrms, xtals, chokes, etc. Blumm, 2661 Dibblee Ave., Columbus 4, Ohio

QSL-SWLS. Meade, W0KXL, 1507 Central Ave., Kansas City, Kans

SELL Hallcrafters HT-9 xmttr complete tubes, 10-meter coils, xtal, Myron Reich, 5801-14th Ave., Brooklyn, N. Y.

RUBBER stamps for QSLs. Emblems, brassards for Ham Clubs. George Wood, 1242 Ontario St., Lynn, Mass.

DON'S QSLs. "Leader in the field." Samples, 2138 So. 16th Ave., Maywood, Ill.

2C22/7193 Gov. surplus. New tubes, 59¢, 2 for \$1. 100, \$30. Filament chokes, 25¢ plate, 10¢ ea. No c.o.d. orders. See April QST for 2-meter diagram and tube. W8NH1, 2047 Navarre Ave., Toledo, Ohio.

[N Stock: new and used Hallcrafters, National, Hammarlund, Collins, Pierson, RME, Millen, Temco, Supreme and all other revrs, xtrms, parts, etc. Lowest prices. World's best terms financed by me. Reconditioned revrs: S-38, \$35; S-20R, \$59; S-40, \$69; SA-42, \$199; RME-69, \$79; RME-45, \$99; SX-24, SX-25, SX-16, SX-17, SX-28, SX-28A, H-7-129-X, SPC 400X, SPC-400SX, HRO, NC-240D, NC-173, others. Terms available. Shipped on approval. Send \$5, pay rest c.o.d. Write for free list and details. Henry Radio, Butler, Mo.

T-3/ARC-5 xmttr coils and diagrams. Many pages for \$1. Radio WIGBY, So. Lincoln, Mass.

QSLs, large type, quality cards. VVS Print, 1704 Hale Ave., Ft. Wayne, Ind.

TRANSMITTER kits, 40 watts, \$69.95. Exciter kit, \$17.95. 175-watt xmttr and mod. All makes and models new and recon'd revrs. Trade-ins accepted low payment plan; terms financed by Leo, W0GFC. Write for specials. World Radio Labs., Council Bluffs, Iowa.

YOUR QSL permanently sealed in plastic, 50¢. Solomson Box 1942, Boston 5, Mass.

SELL complete 100-watt cw rig, 20-40-80 meters, 6V6-6V6 PF 807 in Bud cabinet and also VFO duplicate 1947 Handbook. Want ART-13 or Meissner 150-B. All inquiries ansd. W5HHB, Route 4, Box 278A, Beaumont, Texas.

SALE or trade: nearly new Vomag, crystaliner and Supreme Model 589A tube and battery tester. J. W. Montgomery, W0LGL, Burlington, Kansas.

COD RME 69 with DB 20, \$100; BC0342M, \$50; both in perfect condx. W4LUU, 2 Jefferson Ave., Langley View, Va.

SELLING unused National NC-240C, Scott SLRM 12-tube communications revr, BC375E xmttr, Best offers. W5LIX, Box 582, McAlester, Okla.

BARGAINI BC457 and 458, \$2.50, BC-429 and 430, \$2; BC-37, less coils, \$7.50; 0 to 500 milliammeters, \$1.95; BC-696, \$3; BC-459 \$6.50. R. L. Kalmbach, Lykestand, S. C.

SELL combinational radio, record player, radio recorder, mike recorder. Good condx. \$50. W. Stempel, 396 First St., Brooklyn, N. Y.

SELL brand new Collins 34V xmttr and 75A revr. Bargain. Craig 180 No. Commercial, Salem, Ore.

IRE sell 1927 thru 1931; QST, 1928 thru 1946. Have tube collection with trade duplicates. W3ET, 740 Fairview Rd., Chester Pa.

CRYSTALS: Precision low drift units. Type 100A in 80, 40, and 20 meter bands. Two units plug in one octal socket. Plus or minus 5 Kc. Cost \$1.00 each. Exact frequency, \$1.95 ea. Rex Bassett, Inc., Ft. Lauderdale, Fla.

FACTORY new BC610E (not rebuilt, cost over \$850) with HDVL coil and four Weston 301 meters added. New HRO STA1, both used less than 15 hrs. Both for \$975 or make offer individually. H. E. Housholder, Beloit, Wisc.

FOR Sale: RME-45 and DB20. W1VG, 99 Bentwood Rd., West Hfd., Conn.

SELL 500-watt commercial xmttr, fone & cw, Dual RF channels 80, 40, 20, PF 813s each final. Also brand-new Collins 2 1/2 Kw modulation xtrmr. Best offer, all letters ansd. W6ACD, 2825 Coolidge Ave., Oakland 1, Calif.

WANTED: NC-100XA revr. R. J. Anderson, W8BIE, 17 Lexington Ct., Midland, Mich.

RAS-5 (HRO) or HQ-120-X. Best offer. W0RVS.

FOR Sale: new Hammarlund Super-Pro, SP-400-X complete with pwr supp. and spkr. \$300 or best offer. James Vecchione, W1ERG, East Douglas, Mass.

SWAP new GI-R70L recorder, playback for xmtg parts or Woolley, W0SGG, St. Francis, Colorado Springs, Colo.

FOR Sale: BC-610 xmttr, Four sets coils. Speech ampfr with compressor. Dynamic mike. Fine condition. \$475. Crum, 751 N. Central Ave., Chicago, Ill.

SELL BC-312 revr, purchased new, converted for 110 AC with spkr and husky pwr supply for \$45. 200-ft. length RG-11U, 75 ohm coax for \$12. W1PQC, Box 117, Groton, Conn.

SELL BC-348-H, converted AC. LS-3 spkr matching case, excellent working order, \$75. Cecil Nelin, 1203 N. Walnut, Brady, Texas.

BC-314 and 348 revrs, 150-1500 Kc and 1.5-18 Mc, Govt. cost \$64, best surplus buy yet, never before - never again at \$24 and \$29. Write for bargain bulletins. Lectronic Research, 5832 Hegerman, Phila. 24.

MEISSNER 150-B xmttr, complete. New mod. xmttr installed. Sfr. shifter adapted for portable use. Best offer over \$225. Will deliver within 150 miles. W3DWX, 2001 South, Baltimore 9, Md.

SELL QST May, 1927 through December 1933 for best offer. R. B Sutton, c/o KPQ, Wenatchee, Wash.

RME-45, latest Calomatic model, with spkr. Used one month. Perfect. First \$140 takes it. W4FPS, 106-2nd St., S. W., Roanoke, Va.

SELL Bud VFO-21 with 40 meter coils, \$25. Redford C. Fleming W8OCA, 17172 Santa Barbara, Detroit 21, Mich.

EX-W9LTL, W6UZU, now KH6LV. Desire info or QTH of following hams formerly of Omaha: W9IPZ, W9OUC, and W9DWX. J. F. Reynolds, Hq Oahu Signal Service, APO 958 c/o Postmaster, San Francisco, Calif.

FOR Sale: Strong easily welded or riveted drawn aluminum tubing 3/4" square round corners x .035 wall 8¢ per foot. Excellent corrosion resistance minimum sag. Write or wire Purchasing Agent, Piper Aircraft Corp., Lock Haven, Pa.

QSTs: Aug. 1920 thru April 1940; 229 issues with indices, in good condx; complete except missing October 1923, July 1925, January 1927, April through August 1937. Will sell for best cash offer or swap for good used ham receiver. G. Hall, W2AHE, 104 Hampden Rd., Rochester 10, N. Y.

URGENTLY wanted, to complete my file of QSTs, April, May, June, August, 1916 issues. Bradshaw, W2ELN (Ex-IESP 1916), 89-19, 78th St., Woodhaven 21, N. Y.

SELL: HQ-129-X revr, Kw xmttr complete with ECO. First offer over \$500 takes all. C. B. Jones, 128 George St., Findlay, Ohio.

SELL: 100-watt 5-stage cw xmttr ECO to pair 807s, complete with 2 pwr supplies antenna and King relays. Also cathode modulation xtrmr, \$75 f.o.b. W5IDS, 9373 Palm, New Orleans, La.

FOR Sale: New HQ-129-X complete with matching spkr. Best offer takes it. Silberberg, 2175 Morris Ave., Bronx 53, N. Y.

TOWERS for your rotary beam. Full lattice-work, spruce construction. Priced for the amateur. Write for Bulletin T-101. Sky Lane Products, Ironwood, Mich.

FOR Sale or swap: \$198.70 RME-45 Calomatic revr. Guaranteed to be clean and in like-new condx. \$165. Will swap for good 3 1/2 x 4 1/2 anniversary speed graphic and pay difference if exchange values warrant. W9YVY, 804 W. Daniel, Champaign, Ill.

BEAM-Castings, aluminum, boom supporting type, 10-20 meters or combination. Build your own light weight beam reasonably. W2DIB, 24 Seminole Ave., Dumont, N. J.

SELL Browning Preselector or converter using 1852, 1.7 to 60 Mc. in 5 bands. Black crinkle cabinet. Guaranteed perfect condx. \$20. J. Beavers, Kosciusko, Miss.

COMMERCIAL operators wanted, First or Second Class radiotelegraph, good salary, room and board, bonus for extra work, paid monthly liberty time, paid yearly vacation, steady all year work on board ship. Contact R. K. McKesson, Radio Supervisor, Ann Arbor Railroad, Frankfort, Mich.

TCE-1 xmttrs with tubes and tuning unit, \$20 ea. with ant. tuner. \$22.50. Ray Hiebert, Central Valley, Calif.

QSLs, SWLS. The way you want them. Write Dossett, W9BHV, 857 Burlington, Frankfort, Ind.

BC-312 receiver with crystal filter, AC power supply also FB7 with 6 sets of coils, like new. Also misc. equipment. Write for list, W8GU, 18944 Sorrento, Detroit, Mich.

FOR Sale: SX-25 complete with PM-23 spkr. Excellent condx. Larry Chilton, 1415 Stratton Ave., Nashville 6, Tenn.

PRESS Wireless diversity revr, Model AN/RRR3, good condx, reasonable. Joron's Distributing Co., 209 So. 3rd, Louisville, 2, Ky.

RME-45 for sale, \$150. Kenneth Bishop, 59 Dartmouth Place, Newington, Conn.

WANTED: Two FB-7 10-meter coils. Contact W4KXF, P. O. Box 3105, Daytona Beach, Fla.

FOR Sale: NC-100X communications revr, complete with 12" spkr and metal cabinet. Recently overhauled by National serviceman. Frequency range .54 to 30 Mc. First 150 bucks takes it. W6LHV, Box 79, Independence, Calif.

FOR Sale: Gon-Set, 10-11 meter with silencer, \$37.50. 10-P Stancor xmttr, 12-watts, Phone/cw, Vibropack or AC, complete, mike, tubes, \$39.50. W6NCT/2, 166 Sylvan Ave., Leonia, N. J.

LARGE 42" gray wrinkle relay rack with hinged door in unopened 1 box, \$6 Robert Johnson, R. D. #2, Canton, Ohio.

WANTED: Coto transmitting coil 10-BTYL. W0TDDH, 2823-A Lyon St., St. Louis 18, Mo.

MEISSNER Shifter, coils, 2 sets, 10 and 11-meters. \$2 per set, prepaid. W8KJ, member ARRL.

SELL: New Hammarlund, Super-Pro, 400-X, complete. Bill Robinson, 206 West California St., Pasadena, Calif.

SALE f.o.b. Okla. City, NC-100X used but good, less spkr, \$85. NC-46 complete with speaker used 30 days, \$75. BC-348S converter for 110 V. \$49.50. K. M. Jessup, W5EIO, Box 1963, Ocala, City, Okla.

AMERICAN Radio Home Study amateur course, \$7. Cahn, 4002 No. 38th, Tacoma, Wash.

FOR Sale: propeller pitch-change motors suitable for direction changing beams and antennas. Large stock aluminum tubing for shortwave, FM, and television aerials. Stratford Metal & Rubber Co., 1558 Barnum Ave., Bridgeport, Conn.

MUST sell BC-610. Make reasonable offer. W0LAE.

BEAM rotators, propeller pitch motors, geared one RPM, reversible 25 volts AC, described P. 54 July QST. \$12.50 c.o.d. W5FJE, 214 North Pine, Albuquerque, N. M.

New York City hams. Sell SX-25 complete with tubes and ECO, converted for 20 mtrs. \$250 cash. Wm. Plimpton, W2IXH, RFD Martinsville, N. J.

FOR Sale: one NC-40 revr with spkr, used about 10 hrs. Won at a hamfest. Will sell for \$85. W2RSY, Earl Foster, Russell, N. Y. Box 253.

FOR Sale Meissner 150-B complete with tubes and ECO, converted for 20 mtrs. \$250 cash. Wm. Plimpton, W2IXH, RFD Martinsville, N. J.

Designed for

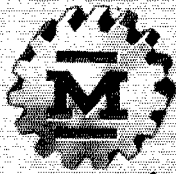

Application

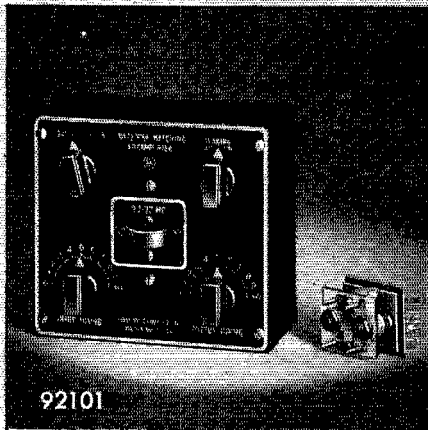

92101

**The No. 92101—Antenna Matching Pre-amplifier**

The Millen 92101 is an electronic impedance matching device and a broad-band pre-amplifier combined into a single unit, designed primarily for operation on 6 and 10 meters. Coils for 20 meter band also available. This unit is the result of combined engineering efforts on the part of General Electric Company and the James Millen Manufacturing Company. The original model was described in G.E. Ham News, November-December, 1946. The No. 92101 is extremely compact, the case measuring only 6 1/4" x 5 3/4" x 3". The band changing inductor unit plugs into the opening in the front of the panel. Plug is provided for securing power requirements for the 6AK5 tube from the receiver. Coaxial connectors are furnished for the antenna and receiver connections.

**JAMES MILLEN  
MFG. CO., INC.**

MAIN OFFICE AND FACTORY

**MALDEN**

**MASSACHUSETTS**



**Index to Advertisers**

	Page
Advance Electric & Relay Co.	124
Allied Radio Corp.	129
American Phenolic Corp.	98
American Radio Institute	151
Arrow Electronics, Inc.	120
Ashe Radio Co., Walter	141
Astatic Corp., The	89
Barker & Williamson	151
Brach Mfg. Co., L. S.	149
Browning Laboratories	96
Burstein-Applebee Co.	148
Candler System Co.	128
Capitol Radio Eng. Institute	119, 149
Chicago Ind. Instrument Co.	142
Cleveland Inst. of Radio Elec.	108
Collins Radio Company	160
Columbus Electronics Corp.	104
Commercial Radio Institute	153
Condenser Products Co.	111
Continental Sales Co.	155
Drake Electric Co.	140
Eitel-McCullough, Inc.	7
Electro-Voice, Inc.	8
Electronic Indicator	138
Electronic Marketers	116
Electronic Navigation	152
Electronicraft, Inc.	124
General Electric Co.	1
Greenlee Tool Co.	142
Hallcrafters Co., Inc.	4, 5
Ham Print Shop	149
Hammarlund Mfg. Co., Inc.	87, 132, 138
Harrison Radio Co.	143
Harvey Radio Co.	139
Hairy & Young	128
Heintz & Kaufman, Ltd.	15
Henry Radio Stores	131, 155
Hytron Radio & Electronics Corp.	109
Instructograph Co., The	155
International Resistance Co.	94
Jensen Mfg. Co.	9
Jones Electronics Co., M. C.	117
Kenyon Transformer Co.	101
Knights Co., James	132
Leeds Radio Co.	112
Maguire Industries	102, 103
Mallory & Co., P. R.	92
Marion Electrical Instr. Co.	125
Mass. Radio & Telegraph School, Inc.	155
Melville Radio Institute	152
Millen Mfg. Co., Inc., James	158
Munger Co., Rex L.	106
National Co., Inc.	85, 95, Cov. III
Newark Electric Co.	110, 133
Norman Radio Equipment	144
Onan & Sons, D. W.	130
Peerless Radio Distributors	114
Petersen Radio Co.	107
P & H Sales Co.	151
Port Arthur College	154
Premax Products Co.	155
Radio Electric Service Co. of Penna.	145
Radio Mfg. Engineers	159
Radio Parts Distributing Co.	154
Radio Product Sales Co.	118
Radio Shack Corp., The	126, 127
RCA Institutes, Inc.	149
RCA Mfg. Co., Inc.	Cov. IV
Shure Brothers	97
Signal Electric Mfg. Co.	140
Silver Co., McMurdo	100
Simpson Electric Co.	108
Sonar Radio Co.	113
Standard Piezo Co.	151
Standard Radio & Elec. Prod.	150
Standard Transformer Corp.	144
Steinberg's	150
Sun Radio Co. of Washington	134, 135
Sun Radio & Electronics Co.	130
Sylvania Electric Prod. Co.	2, 123
Telex, Inc.	121
Terminal Radio Co.	148
Transmitter Equipment Mfg. Co.	93
Turner Co., The	153
U. H. F. Resonator	153
United Transformer Corp.	Cov. II
Universal Radio Supply	146
Valparaiso Technical Inst.	153
Valpey Crystal Corp.	136
Vibroplex Co., The	154
Ward Leonard Electric Co.	91
Weems System of Navigation	146
Wind Turbine Co.	136
World Radio Labs.	137



# FOR AMATEURS

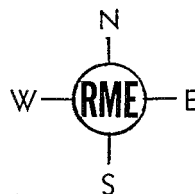

## WITH PROFESSIONAL TASTES

### *The New DB22A Preselector*

Coverage .54 to 44 Mc. — Average Gain 30 DB

Here's the new DB22A completely redesigned for greater efficiency and higher signal to noise ratio. It uses new 6BA6 miniatures. Image ratio is better than 50 DB with a communications receiver having a single stage of RF. It's calibrated, has smooth planetary tuning, self contained power supply, antenna bypass switch, gain control and many other features. Connect the DB22A to your receiver just like an antenna — no wiring — no plug in coils. It's entirely self-contained — entirely in a class by itself!

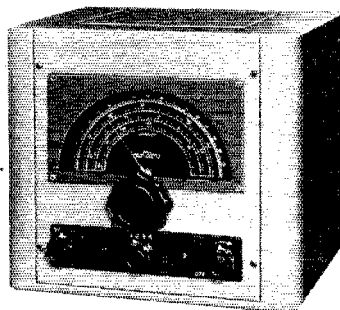

### *The RME 84*

For Home, Portable or Mobile Operation

A quality receiver in the lower price field that will give you the most for your money. Operates from 115 volts AC, batteries or from the VP-2, a six volt power pack, optional with the RME 84. Also optional, and illustrated, is the CM-1 — Carrier Level "S" Meter.

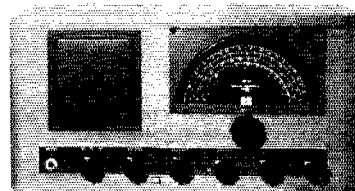
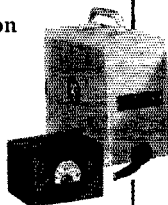

### *The VHF-152 Converter*

For Two, Six, Ten and Eleven Meters

At a cost that an amateur can afford — the new VHF-152 used with a communications receiver will give you peak performance on the very high frequency bands, utilizing an efficient double conversion system. Unit has built in power supply, voltage regulator and temperature stabilized oscillator circuits. Provision is made for connection of 4 separate antennas.

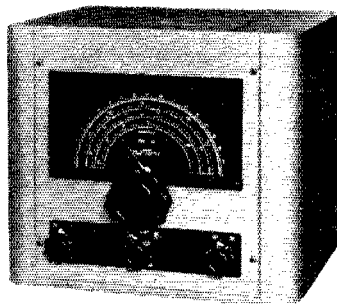

Illustrated  
Folders  
On Request



# RME

FINE COMMUNICATIONS EQUIPMENT

## RADIO MFG. ENGINEERS, INC.

Provia 6, Illinois U. S. A.

Mr. Johnson, Collins 310A exciter on table back of switch, and Collins 30K-1 transmitter in right background.

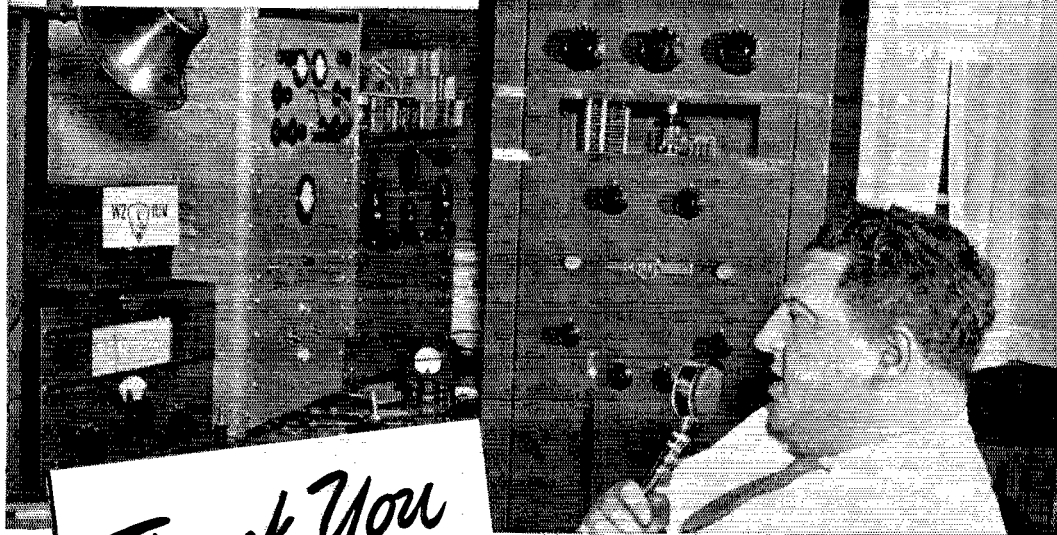

Thank You  
W2IUUV



The following letter from Chas. F. H. Johnson, Jr., is published with his permission:

"I just had to let you know how pleased I am with the 30-K. When those nine big cases arrived last Saturday, I was counting the days when I'd be on the air. You can imagine what a thrill I got when after getting things all lined up and reading the instructions at least nineteen times, I got up enough courage to pull the switch. In true Collins tradition, everything went off beautifully.

"I listened on 20 and heard WØQLX calling CQ. When he got through, I went back at him and much to my surprise, discovered that he was in Cedar Rapids and a member of the Collins family. I know the first QSO in a long time always gives you a big thrill, but that made it doubly exciting. I thought his reports on the rig might be a little bit prejudiced

(Hi), but when I got back later in the evening, I listened around and finally heard VK4BA calling CQ. I went back at him and he came right back. And so No. 2. He gave me a fine report and told me I was the only W2 on the band.

"There remained only one check to make and that was with the neighbors and the family receivers in the rest of the house. As usual, not a bit of QRM from W2IUUV, and I certainly can say that it pays to be right. It gives you a fine feeling of comfort to know that you're enjoying yourself and not bothering anybody else."

Yours sincerely,  
Chas. F. H. Johnson, Jr.

FOR BEST RESULTS IN AMATEUR RADIO, IT'S . . .



**COLLINS RADIO COMPANY, Cedar Rapids, Iowa**

11 West 42nd Street, New York 18, N. Y.

458 South Spring Street, Los Angeles 13, California

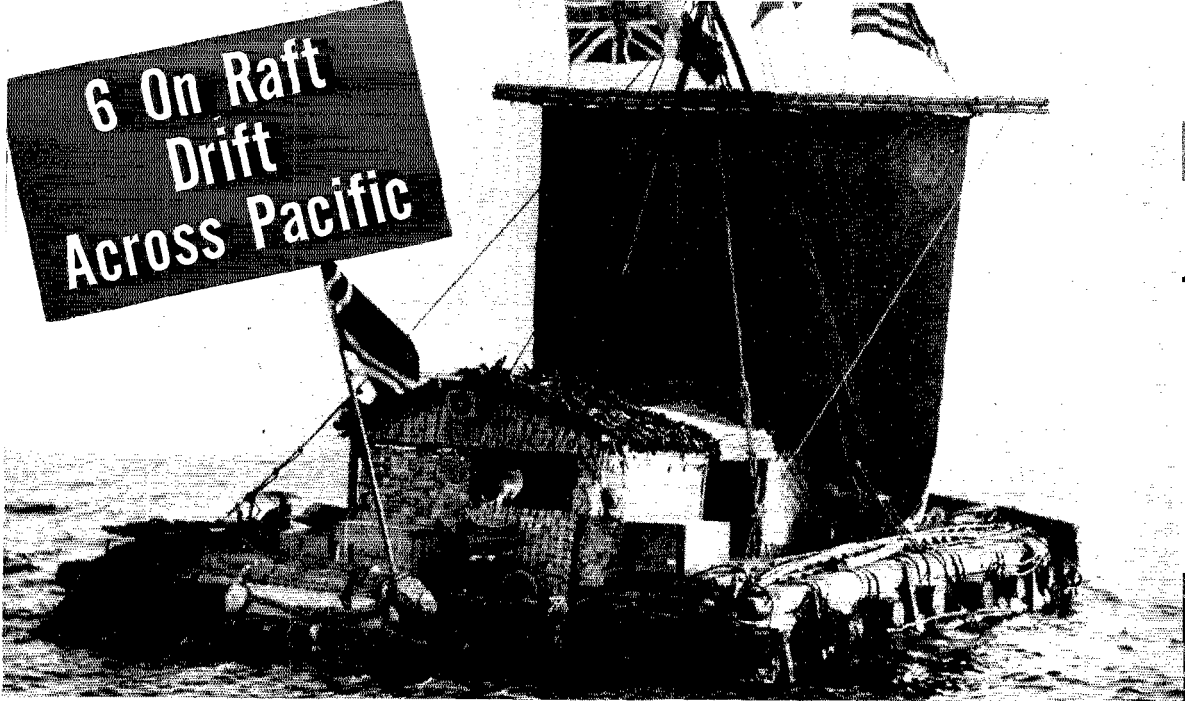

Courtesy of Science Illustrated

# KON-TIKI EXPEDITION PICKS NATIONAL RECEIVERS



Somewhere in the vast loneliness of the Pacific a frail, balsa wood raft is drifting westward, carrying six Norwegian scientists toward the Polynesian Islands. Their mission: to prove that the Polynesians could have been settled by pre-historic Peruvian Indians.

Courage, yes, recklessness, no. These adventurers are scientists, not stunt men. Before setting out from Peru they made sure that they would have the finest radio equipment in the world... National receivers, of course (Models NC-173 and HRO-7).

For safety... to bring in the weakest signal in the worst kind of weather... for science... to exchange vital weather and navigational data with land stations thousands of miles away. Battered by wind and sea for months on end these superb National receivers aboard the Kon-Tiki Expedition raft are still functioning as reliably as ever.

What better testimonial than operator Knut Haugland's cheerful "All's Well" radioed from the Tuamotua Archipelago... 4000 miles across the Pacific, and still going strong.

Congratulations are also in order to W6AOA, W6EVM, and W3YA who have been in regular contact with LI2B. 27.98 and 14.142 megs have been assigned for general contact. Next time you go on the air, why not see if you can contact Haugland and get the Expedition's story first-hand.

**National**  
**Company, Inc.**  
 Malden, Mass.

National Receivers of the Type Selected for the Kon-Tiki Expedition



**HRO-7**

Brand-new successor to the famous HRO used throughout the world. 11 tubes plus a voltage regulator. Frequency coverage from 50 to 430 and 480 to 30,000 kc. Adjustable Threshold Noise Limiter. Streamlined grey cabinet. AM phone and code reception.

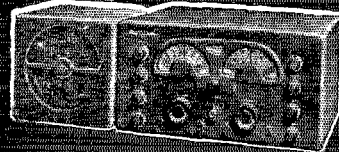

**NC-173**

A new and versatile receiver, popularly priced. Frequency coverage from 540 kc to 31 mc plus the 48-56 mc range. Calibrated amateur band, spread on 6, 10, 11, 20, 40 and 80 meter bands. Phonograph or Microphone pick-up jack.

MAKERS OF LIFETIME RADIO EQUIPMENT



***If grid emission  
is your problem...***

**...solve it simply—with RCA tubes**

• No worry ... and no risk ... with soaring plate current in RCA tubes. No need either to reduce d-c grid current and plate input to halt it.

Why this freedom from grid emission and grid bias cancellation?

Simple enough. RCA power tube grids are made of special materials, such as platinum-clad molybdenum, having very low grid emission. They run cool because they are built with special heat-conducting side rods and because RCA tube plates are large and operate at relatively low temperature.

To get all the tube power you pay for ... and get

**The Fountainhead of Modern Tube Development is RCA**

high-efficiency performance right up to full input, buy RCA tubes. They're available at your local RCA Tube Distributor.

**FREE—RCA Headliners for Hams**

... 4 pages of power tube data charts that quickly tell you the correct voltages, currents, driving power, dissipation, etc., for each tube service. Indispensable to every transmitter man who builds equipment. Ask your RCA Tube Distributor for a copy of Headliners, or write RCA, Commercial Engineering, Section M541, Harrison, New Jersey.

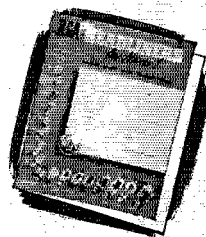

**TUBE DEPARTMENT**

**RADIO CORPORATION of AMERICA**

**HARRISON, N. J.**