

QST

may, 1945

25 cents

35c in Canada

devoted entirely to

amateur radio

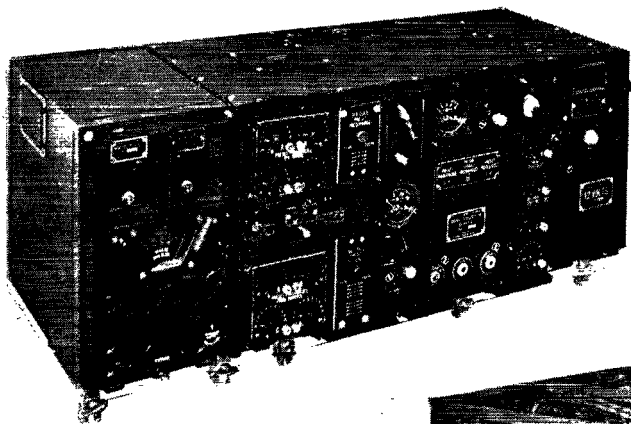

**RADIO SET
SCR-506**

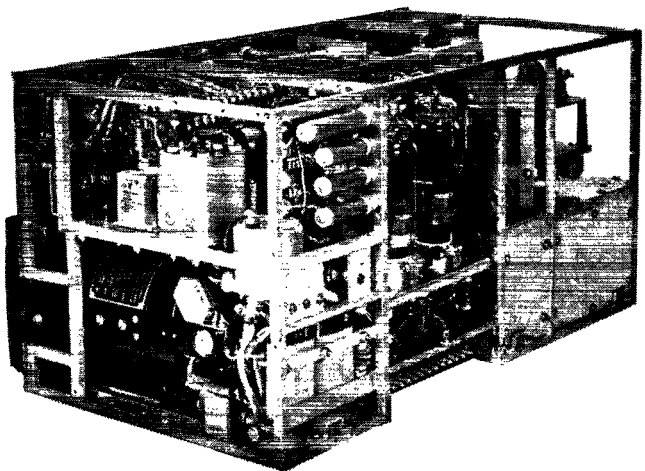

In This Issue:

V. F. O. Stability

Crystal - Controlled Trans-
mitter for V. H. F.

Low - Frequency Aircraft
Transmitter for CAP

Video Amplifier Design II

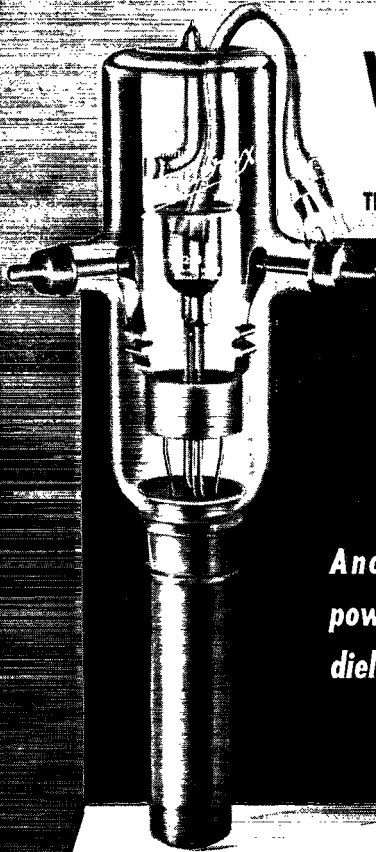

WHY AMPEREX

WATER AND AIR COOLED
TRANSMITTING AND RECTIFYING TUBES

233

*Another new AMPEREX
power tube for induction and
dielectric heating equipment*

The new **Amperex 233** is designed for use as a Class C oscillator or amplifier for generating radio frequency power at frequencies up to 30 megacycles. Two grid arms make neutralization more convenient in the amplifier connection, and also permit cooler operation of the grid when the tube is employed at higher frequencies either in a self-excited oscillator or power amplifier. As do all tubes designed and developed in our laboratory, the 233 incorporates well-known "Amperextras" which make for longer operating efficiency and lower operating costs. **Write for engineering data.**



AMPEREX

... the high performance tube

AMPEREX ELECTRONIC CORPORATION

79 WASHINGTON STREET • • • • • BROOKLYN 1, N. Y.

Expert Division: 13 E. 40th St., New York 16, N. Y., Cables: "Arlab"

GIVE WHAT YOU'VE GOT... DONATE A PINT OF BLOOD TO THE RED CROSS

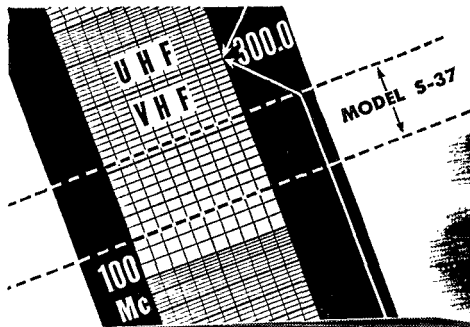

HOW hallicrafters EQUIPMENT COVERS THE SPECTRUM

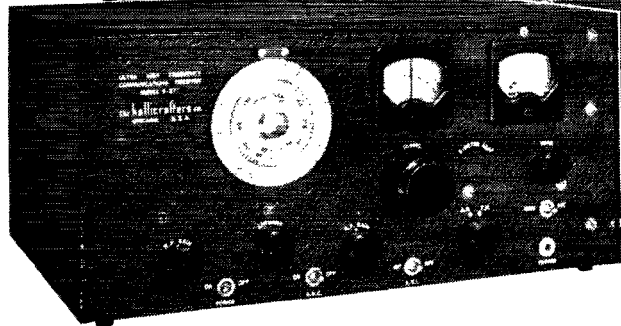

Model S-37

FM-AM

for very high frequency work
130 to 210 Mc.

THE new Model S-37 FM-AM receiver is an outstanding example of Hallicrafters pioneering work in the upper regions of the spectrum. Covering the frequencies between 130 and 210 megacycles, the S-37 provides VHF performance which is in every way comparable to that of the finest communications receivers operating in the medium and high frequency bands. The average over-all sensitivity of the S-37 is approximately 5 microvolts. The image ratio of at least 1000 times is achieved through the use of two pre-selector stages and an intermediate frequency of 16 megacycles. No band switching is necessary and exceptional ease of tuning is provided by mechanical band-spread with 2300 dial divisions between 130 and 210 megacycles. The pre-loaded gear train is completely enclosed and is equipped with a positive stop at each end of the tuning range. Hermetically sealed transformers and capacitors, moisture proof wiring, and extra heavy plating, all contribute to the long life and reliability of the S-37 . . . the only commercially built receiver covering this frequency range.

The amazing performance of the Model S-37 is largely due to the RF section shown at right. It is mounted as a unit on a brass plate $\frac{1}{4}$ inch thick. The two type 954 RF amplifiers and the type 954 mixer are placed in the heavy shields which separate the stages. The type 955 oscillator is mounted directly on its tuning condenser. Exceptional stability is assured by the use of individually selected enclosed ball bearings, extra-heavy end plates, and wide spacing in the oscillator condenser—rigid mounting of all components—and inductances of $\frac{1}{8}$ inch copper tubing wound on polystyrene forms. All conducting parts are heavily silver plated.

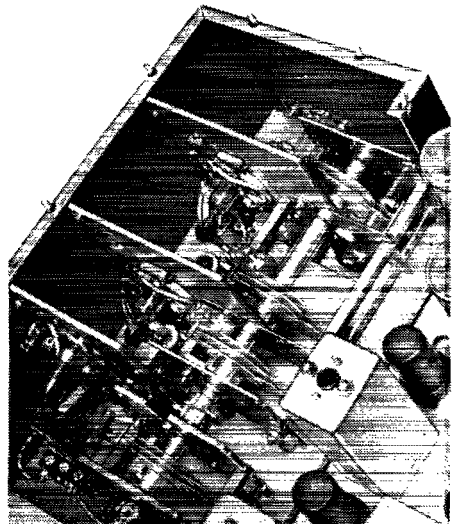

Write for Catalog No. 36A, describing
Hallicrafters complete line of high
frequency receivers and transmitters.



hallicrafters RADIO



BUY A WAR BOND TODAY!

THE HALLCRAFTERS CO., MANUFACTURERS OF RADIO
AND ELECTRONIC EQUIPMENT • CHICAGO 16, U. S. A.

over and above all...

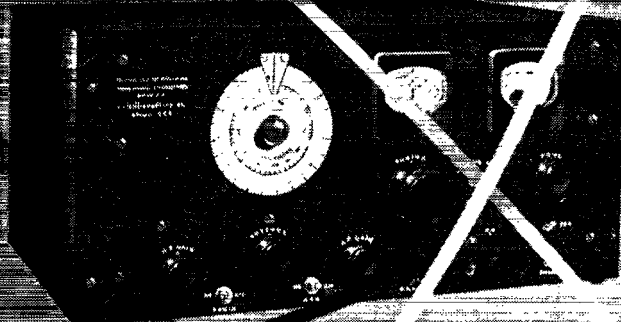

For very high frequency work . . .

Hallicrafters S-37 stands over and above all. Providing both AM and FM reception on all frequencies from 130 to 210 Mc., it covers a higher range than is available in any other commercially built receiver. The development is typical of the ingenuity and resourcefulness that Hallicrafters bring to the ever-new problems in electronics and communications. Forward looking technicians in these fields must look to Hallicrafters for instruments that will chart the new directions.

MODEL S-37 . . . The highest frequency range of any continuous tuning commercial type receiver.



Buy a War



Bond Today!

hallicrafters RADIO

THE HALLICTRAFTERS CO., MANUFACTURERS OF RADIO AND ELECTRONIC EQUIPMENT, CHICAGO 16, U.S.A.

MAY 1945

VOLUME XXIX

NUMBER 5



STAFF

Editorial

KENNETH B. WARNER, W1EH
General Manager of A.R.R.L.
Publications

CLINTON B. DeSoto, W1CBD
Editor

A. DAVID MIDDLETON, W2OEN
Assistant Editor

GEORGE GRAMMER, W1DF*
Technical Editor

DONALD H. MIX, W1TB
Acting Technical Editor

J. VENABLE FITZHUGH, W5VL
BYRON GOODMAN, W1JPE*
Assistant Technical Editors

EDWARD P. TILTON, W1HDQ
Contributing Editor, V.H.F.

WALTER E. BRADLEY, W1FWH
VERNON CHAMBERS, W1JEQ*
Technical Information Service

LOUISA B. DRESSER, 1SPH
Assistant to the Editor

ELSIE C. HOCHMEISTER
Editorial Assistant

JAMES J. LAMB, W1AL*
Research Engineer, A.R.R.L.

Advertising

F. CHEYNEY BEEKLEY, W1GOS
Advertising Manager

Circulation

DAVID H. HOUGHTON
Circulation Manager

RALPH T. BEAUDIN, W1BAW
Asst. Circulation Manager

*On leave of absence



OFFICES

38 La Salle Road
West Hartford 7, Connecticut

Subscription rate in United States and Possessions, \$2.50 per year, postpaid; all other countries, \$3.00 per year, postpaid. Single copies, 25 cents. Foreign remittances should be by international postal or express money order or bank draft negotiable in the U. S. and for an equivalent amount in U. S. funds.

Entered as second-class matter May 29, 1919, at the post office at Hartford, Connecticut, under the Act of March 3, 1879. Acceptance for mailing at special rate of postage provided for in section 1103, Act of October 3, 1917, authorized September 9, 1922. Additional entry at Concord, N. H., authorized February 21, 1929, under the Act of February 23, 1925.

Copyright 1945 by the American Radio Relay League, Inc. Title registered at U. S. Patent Office.

QST

devoted entirely to

AMATEUR RADIO

PUBLISHED, MONTHLY, AS ITS OFFICIAL ORGAN, BY THE AMERICAN RADIO RELAY LEAGUE, INC., AT WEST HARTFORD, CONN., U. S. A.; OFFICIAL ORGAN OF THE INTERNATIONAL AMATEUR RADIO UNION



CONTENTS

It Seems to Us	9
Splatter	10
“Radio Set SCR-506” — A Biography A. David Middleton, W2OEN	11
A Search for V.F.O. Stability Claude L. Robinson, W6KJV	18
Happenings of the Month	22
CARL — The Chinese Amateur Radio League Kung Shao-Hsiung	24
A Crystal-Controlled Transmitter for the V.H.F.s George W. Brooks, W1JNO	25
New Apparatus — Plywood Antenna Masts	27
In the Services	28
Practical Design of Video Amplifiers — Part II Elliott A. Henry, W9FEN	32
In QST 25 Years Ago This Month	39
A Low-Frequency Aircraft Transmitter for CAP George Peterson, jr., W3IOV	40
“Flummajimmery” “Sourdough”	44
Gold Stars — W6SPE, W3IKG, W1MLI	45
Radar Techniques — Part II Clinton B. DeSoto, W1CBD	46
Hams in Combat Hamming on the Road to Berlin Cpl. Guy B. Welsh, W8OWC	50
Hints and Kinks A One-Tube 112-Mc. Converter — A Condenser-Checker Using a 6E5 — Battery-Powered One-Tube 450- and 1500-Kc. Signal Generator — A Time Saving Idea for Coil Constructors — Push-Pull Class-A Without a Phase Inverter — Jig for Centering Holes in Shafts or Screws — A New Source of Aluminum Stock	52
Correspondence from Members	54
Operating News	56
The Month in Canada	59
Amateur Activities	60
Missing in Action	78
Silent Keys	78
Ham-Ads	100
QST's Index of Advertisers	102

Ⓞ All material appearing in QST conforms with the “Code of Wartime Practices for the American Press” of the U. S. Office of Censorship.

Ⓞ All material involving military security has been reviewed by appropriate military, naval or other competent authority.

What type of microphone is best suited for a particular application?

How can I convert the level of a microphone rated on the basis of milliwatts per bar to a level of volts per bar?

What new types of special purpose microphones have been developed for voice and sound transmission?

These and many other answers may be found in the
NEW and COMPLETE *Electro-Voice* CATALOG



More than an exposition of microphone types, the new Electro-Voice Catalog provides a source of valuable information which should be at the fingertips of every sound man. It contains a simplified Reference Level Conversion Chart which marks the first attempt in the history of the industry to standardize microphone ratings. Several pages are devoted to showing basic operating principles of microphones . . . offering a guide to the proper selection of types for specific applications. And, of course, every microphone in the Electro-Voice line is completely described, from applications to specifications.

*Reserve your copy of the new
Electro-Voice Catalog. Write today.*

Electro-Voice MICROPHONES

ELECTRO-VOICE CORPORATION • 125 N. SOUTH BEND AVENUE • SOUTH BEND 24, INDIANA
Export Division: 16 East 20th Street, New York 10, N. Y. • U. S. A. Canada, Africa



These U.S. Navy Planes Carry Collins Autotune Transmitters

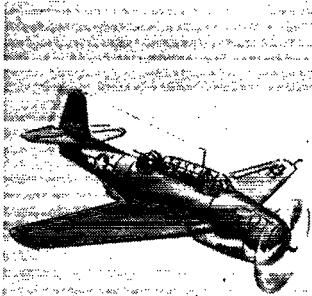

GRUMMAN TBF AVENGER

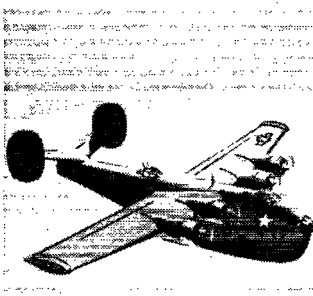

PB2Y-3 CORONADO

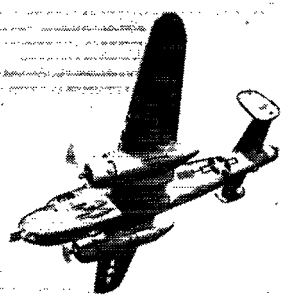

MARINE CORPS PBJ MITCHELL

The voice of thousands of Navy fliers



THE COLLINS ATC Autotune transmitter is regulation equipment for most two-place-and-larger types of Navy aircraft. It is the military successor of Collins airborne Autotune transmitters which were adopted by several of the great commercial airlines years before the war. Since Japan struck, the Navy has ordered many thousands. In advanced design and rugged construction, today's ATC reflects the lessons of war learned in every quarter of the world. It is a foretaste of the reliability and efficiency to be expected of Collins by commercial and private users after victory. Collins Radio Company, Cedar Rapids, Iowa; 11 West 42nd Street, New York 18, N. Y.

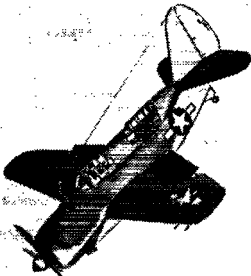

CURTISS SB2C-1 HELLDIVER

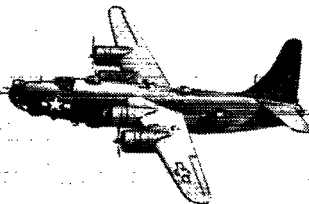

PB4Y-2 PRIVATEER



MARTIN PBM-3D MARINER



IN RADIO COMMUNICATIONS, IT'S...

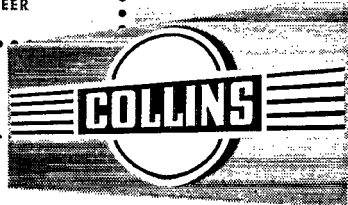

Section Communications Managers of the A.R.R.L. Communications Department

Reports Invited. All amateurs, especially League members, are invited to report communications activities, training plans, code classes, theory-discussion groups, civilian-defense building or planning each mid-month (16th of the month for the last 30 days) direct to the SCM, the administrative official of ARRL elected by members in each Section whose address is given below. Radio Club reports and Emergency Coördinator reports representing community organized work and plans and progress are especially desired by SCMs for inclusion in **QST**. **ARRL Field Organization appointments**, with the exception of the Emergency Coördinator and Emergency Corps posts, are suspended for the present and no new appointments or cancellations, with the exception named, will be made. This is to permit full efforts of all in Emergency Corps plans.

ATLANTIC DIVISION			
Eastern Pennsylvania	W3BES	Jerry Mathis	623 Crescent Ave. 1970 Monroe St. Silver Springs P. O. Linden, Maryland
Maryland-Delaware-District of Columbia	W3CIZ	Hermann E. Hobbs	623 E. Brown St. 186 Dorsey Rd. 703 Broadway Trenton 10 Rochester East McKeesport
Southern New Jersey	W3GCU	Ray Tomlinson	
Western New York	W8MC	William Bellow	
Western Pennsylvania	W8CKO	E. A. Krall	
CENTRAL DIVISION			
Illinois	W9NUX	David E. Blake, II	4501 N. Malden St. 385 Johnson St. 116 N. Longworth Ave. R.F.D. 2, Box 223 122 St. Albert St. 1625 N. 18th St. Chicago 40 Gary Louisville 12 Pontiac 2 St. Bernard 17 Milwaukee 5
Indiana	W9EGG	Herbert S. Brier	
Kentucky	W9ARU	Darrell A. Dowward	
Michigan	W8DPE	Harold C. Bird	
Ohio	W8MFP	Carl F. Wiehe	
Wisconsin	W9RH	Emil Felber, Jr.	
DAKOTA DIVISION			
North Dakota	W9VVF	John W. McBride	620 North Menlo Ave. 118 N. Yankton Ave. 2802 So. Western 608 N. Huron Ave. Sioux Falls, South Dakota Pierre Los Angeles 7, Calif. Spring Valley
South Dakota	W9QVY	P. H. Schultz	
Northern Minnesota	W9FUZ	Armond D. Bratland	
Southern Minnesota	W9YUQ	Millard L. Bender	
DELTA DIVISION			
Arkansas	W5GED	Ed Beck	2503 Bishop St. P. O. Box 44 524 Santini St. R.F.D. 6, Shady Dell Trail Little Rock LaPlace Biloxi Knoxville
Louisiana	W5DKR	Eugene H. Treadaway	
Mississippi	W5HAV	P. W. Clement	
Tennessee	W4SP	James B. Witt	
HUDSON DIVISION			
Eastern New York	W2HZL	Ernest E. George	2044 Lexington Parkway 102 Central Ave. 617 Spruce St. Schenectady 8 Massapequa, L. I. Roselle
N. Y. C. & Long Island	W2AZV	E. L. Baunach	
Northern New Jersey	W2CQD	Winfield G. Beck	
MIDWEST DIVISION			
Iowa	W9FIR	Leslie B. Vennard	2712 Washington St. 1617 S. Seneca St. Box 123 6105 N. 37 St. Burlington Wichita 12 Butler Omaha 11
Kansas	W9AWP	A. B. Unruh	
Missouri	W9OUD	Mrs. Letha A. Dangerfield	
Nebraska	W9FQB	Arthur R. Gaeth	
NEW ENGLAND DIVISION			
Connecticut	W1KOY	Edmund R. Fraser	48 Willow St. 379 No. Main St. 91 Atlantic St. 239 Columbia St. 1435 Snowden Ave. 70 Columbia Ave., Gaspee P. O. Box 81 West Haven 16 Brewer North Quincy 71 Adams Memphis 7, Tennessee Providence 5 Burlington
Maine	W1AOL	G. C. Brown	
Eastern Massachusetts	W1ALP	Frank L. Baker, Jr.	
Western Massachusetts	W1JAF	William J. Barrett	
New Hampshire	W1FTJ/4	Mrs. Dorothy W. Evans	
Rhode Island	W1HRC	Clayton C. Gordon	
Vermont	W1NLO	Burtis W. Dean	
NORTHWESTERN DIVISION			
Alaska	K7GNN	James G. Sherry	
Idaho	W7AVP	Don D. Oberbillig	P. O. Box 486 Boise
Montana	W7CPY	Rex Roberts	Box 1088 Glendive
Oregon	W7GNJ	Carl Austin	1137 Federal Bend
Washington	W7FWD	O. U. Tatro	513 N. Central Olympia
PACIFIC DIVISION			
Hawaii	K6ETF	Francis T. Blatt	837 16th Ave. Honolulu
Nevada	W6WCW	N. Arthur Sowle	Box 2025 Reno
Santa Clara Valley	W6IUZ	Earl F. Sanderson	600 Acacia Ave. San Bruno
East Bay	W6TTI	Horace R. Greer	414 Fairmount Ave. Oakland 11
San Francisco	W6RBQ	William A. Ladley	200 Naylor St. San Francisco 12
Sacramento Valley	W6MDI	Vincent N. Feldhausen	113 South Quincy St. McCleod
Philippines	KA1GR	George L. Rickard	Box 849 Manila
San Joaquin Valley*	W6BXB	Edward H. Noack	811 West Magnolia St. Stockton
ROANOKE DIVISION			
North Carolina	W4CVB	W. J. Wortman	P. O. Box 566 Morganton
South Carolina	W4BQE/ANG	Ted Ferguson	3422 Rosewood Drive Columbia 25
Virginia	W3AKN	Walter G. Walker	217-51 St. Newport News
West Virginia	W8JRL	Kenneth M. Zinn	P. O. Box 132 Clarksburg
ROCKY MOUNTAIN DIVISION			
Colorado	W9VGC	H. F. Hekel	2743 Julian St. Denver 11
Utah-Wyoming	W7DIE	John S. Duffy	P.O. Box 293* Medford, Oregon
SOUTHEASTERN DIVISION			
Alabama	W4GBV	Lawrence J. Smyth	808 Winona Ave. Montgomery
Eastern Florida	W4HP	Robert B. Murphy	3302 S.W. Grapeland Blvd. Miami 33
Western Florida	W4AXP	Oscar Cederstrom	408 S. Pine St. Warrington
Georgia	W4FDJ	Ernest L. Morgan	R.F.D. 2 Lyons
West Indies (Cuba)	CM2OP	Mario de la Torre	Escobar 110 (Altos) Habana, Cuba
(Puerto Rico-Virgin Islands)	K4KD	Everett Mayer	24 Lindberg St. Santurce, P. R.
SOUTHWESTERN DIVISION			
Los Angeles	W6QVV	H. F. Wood	429 So. Fairview Burbank
Arizona	W6RWW	Douglas Aitken	341 S. Mt. Vernon Ave. Prescott
San Diego	W6CHV	Ralph H. Culbertson	1712 Eads St. La Jolla
WEST GULF DIVISION			
Northern Texas	W5ALA	Jack T. Moore	5712 Berkshire Lane Dallas 9
Oklahoma	W5AYL	Ed Oldfield	2141 N.W. 35th St. Oklahoma City 6
Southern Texas	W5JIC	James B. Rives	1721 Kentucky Ave. San Antonio 1
New Mexico	W5HJF	J. G. Hancock	110 S. E. Nevada St. Portales
MARITIME DIVISION			
Maritime	VE1DQ	A. M. Crowell	69 Dublin St. Halifax, N. S.
ONTARIO DIVISION			
Ontario	VE3EF	Wing Commander Donald R. Gunn	c/o Canadian Bank of Commerce New Toronto, Ont.
QUEBEC DIVISION			
Quebec	VE2CO	Lieutenant L. G. Morris	211 Bolton St. Ottawa, Ont.
VANALTA DIVISION			
Alberta	VE4GE	C. S. Jamieson	581 W. Riverside Drive Drumheller, Alta.
British Columbia	VE5DD	C. O. I. Sawyer	2634 West 31st Ave. Vancouver
PRAIRIE DIVISION			
Manitoba	VE4AAW	A. W. Morley	26 Lennox St. St. Vital
Saskatchewan	VE4SY	Arthur Chesworth	1084 Redland Ave. Moose Jaw

*Officials appointed to act temporarily in the absence of a regular official.

Built to take it!

Because they are built to take it
— built to do the job with a wide
margin of safety — Hammarlund
variable condensers are used in
every type of military equip-
ment from planes to battleships.

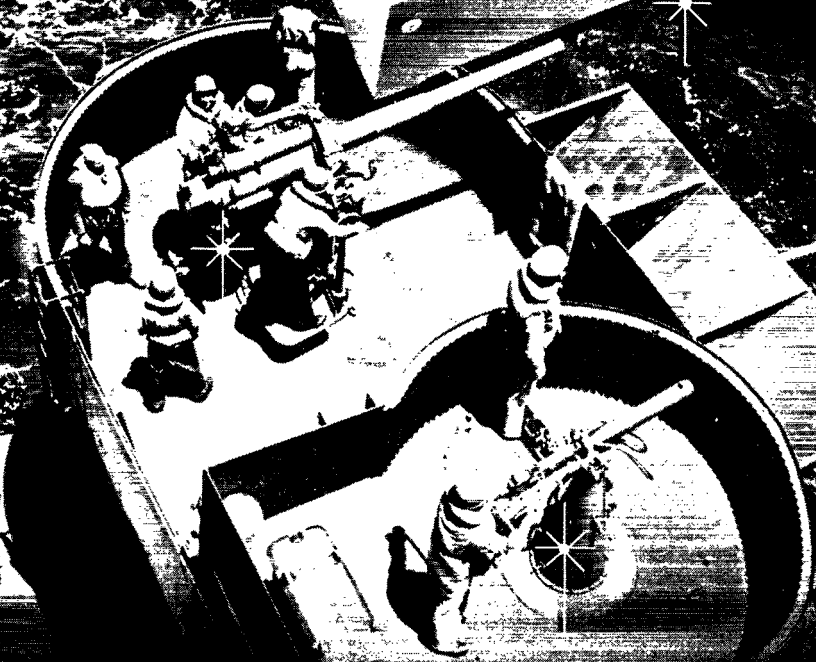
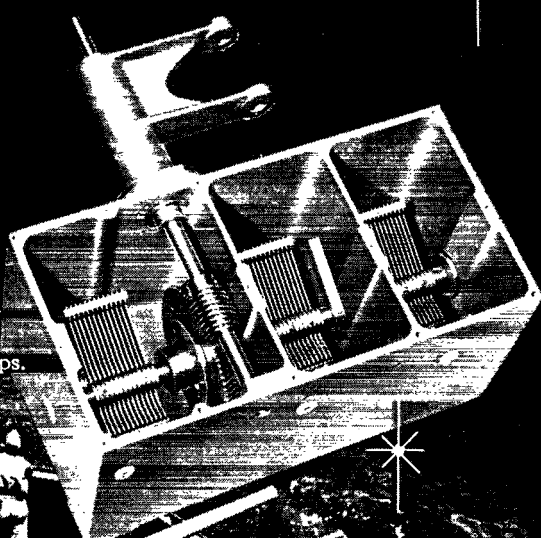

ESTABLISHED 1910

THE HAMMARLUND MFG. CO., INC., 460 W. 34TH ST., N.Y.C.
MANUFACTURERS OF PRECISION COMMUNICATIONS EQUIPMENT

OFFICIAL U. S. NAVY PHOTO

THE AMERICAN RADIO RELAY LEAGUE, INC.,

is a noncommercial association of radio amateurs, bonded for the promotion of interest in amateur radio communication and experimentation, for the relaying of messages by radio, for the advancement of the radio art and of the public welfare, for the representation of the radio amateur in legislative matters, and for the maintenance of fraternalism and a high standard of conduct.

It is an incorporated association without capital stock, chartered under the laws of Connecticut. Its affairs are governed by a Board of Directors, elected every two years by the general membership. The officers are elected or appointed by the Directors. The League is noncommercial and no one commercially engaged in the manufacture, sale or rental of radio apparatus is eligible to membership on its board.

"Of, by and for the amateur," it numbers within its ranks practically every worth-while amateur in the nation and has a history of glorious achievement as the standard-bearer in amateur affairs.

Inquiries regarding membership are solicited. A bona fide interest in amateur radio is the only essential qualification; ownership of a transmitting station and knowledge of the code are not prerequisite, although full voting membership is granted only to licensed amateurs.

All general correspondence should be addressed to the Secretary at the administrative headquarters at West Hartford, Connecticut.



Past Presidents

HIRAM PERCY MAXIM, W1AW, 1914-1936
EUGENE C. WOODRUFF, W8CMP, 1936-1940

Officers

President GEORGE W. BAILEY, W1KH
Washington, D. C.
Vice-President CHARLES E. BLALACK, W6GC
Yuma, Arizona
Secretary KENNETH B. WARNER, W1EH
West Hartford, Connecticut
Communications Manager F. E. HANDY, WIBDI*
Chevy Chase, Maryland
Treasurer DAVID H. HOUGHTON
West Hartford, Connecticut

General Counsel PAUL M. SEGAL
1026 Woodward Building, Washington 5, D. C.

*On leave of absence. Address correspondence to the Acting Communications Manager, Charles A. Service, W4IE, West Hartford 7, Connecticut.

Directors

President
GEORGE W. BAILEY W1KH
1530 P St., N.W., Washington 25, D. C.

Vice-President
CHARLES E. BLALACK W6GC
Box 108, Yuma, Ariz.

Canadian General Manager
ALEX REID VE2BE
240 Logan Ave., St. Lambert, P. Q.
Alternate: Leonard W. Mitchell VE3AZ
78 Raglan Ave., Toronto, Ont.

Atlantic Division
WALTER BRADLEY MARTIN W3QV
25 Arbuth Rd., Abington, Pa.
Alternate: Herbert M. Wallace W8BQ
P. O. Box 18, Drums, Pa.

Central Division
JOHN A. KIENER W8AVH
3462 Edison Rd., Cleveland Heights,
Cleveland 21, Ohio
Alternate: Earl S. Nelson W8DS
22551 Hadden Rd., Euclid 17, Ohio

Dakota Division
TOM E. DAVIS W9VVA
915 W. Becker Ave., Willmar, Minn.
Alternate: Aaron E. Swanberg W9BHY
1487 Breda St., St. Paul 4, Minn.

Delta Division
E. RAY ARLEDGE W58I
340 N.E. 20th Terrace, Apt. 7, Miami 37, Fla.
Alternate: Samuel H. Dowell W5ERV
1057 Mildred St., Shreveport 15, La.

Hudson Division
ROBERT AKERIDGE KIRKMAN W2DSY
Verah Pl., R.F.D. No. 1, Box 61, Long Branch, N. J.
Alternate: George Ruffa, Jr. W2JY
38 Brookwood Drive, Manhasset, L. I., N. Y.

Midwest Division
FLOYD E. NORWINE, JR. W9EFC
7405 Hlawatha Ave., Richmond Heights 17, Mo.
Alternate: C. A. Colvin W9VHR
% Omaha & Council Bluffs St. Railway Co.,
Omaha 2, Nebr.

New England Division
PERCY C. NOBLE W1BVR
37 Broad St., Westfield, Mass.
Alternate: Clayton C. Gordon W1HRC
70 Columbia Ave., Warwick, R. I.

Northwestern Division
KARL W. WEINGARTEN W7BG
3219 N. 24th St., Tacoma 7, Wash.
Alternate: R. Rex Roberts W7CPY
110 W. Brennan St., Glendive, Mont.

Pacific Division
J. L. McCARGAR W6EY
66 Hamilton Pl., Oakland 12, Calif.
Alternate: Elbert J. Amarantes W6FBW
1675 Dale Ave., San Jose, Calif.

Roanoke Division
H. L. CAVENESS W4DW
2607 Vanderbilt Ave., Raleigh, N. C.
Alternate: J. Frank Key W3ZA
Box 707, Buena Vista, Va.

Rocky Mountain Division
C. RAYMOND STEDMAN W9CAA
925 So. Gaylord St., Denver 9, Colo.
Alternate: Howard R. Markwell W9TFP
355 Monroe St., Denver 6, Colo.

Southeastern Division
WILLIAM C. SHELTON W4ASR
527 Revilo Blvd., Daytona Beach, Fla.
Alternate: William P. Sides W4AUP
Fleming Road, Montgomery, Ala.

Southwestern Division
JOHN E. BICKEL W6BKY
1834 E. Whittier Blvd., Whittier, Calif.
Alternate: Eldridge E. Wyatt, Jr. W6GAR
P. O. Box 3597, Long Beach 3, Calif.

West Gulf Division
WAYLAND M. GROVES W5NW
Box 1314, Seagraves, Texas
Alternate: Jennings R. Poston W5AJ
APO 14192, c/o Postmaster, New Orleans, La.

"IT SEEMS TO US—"

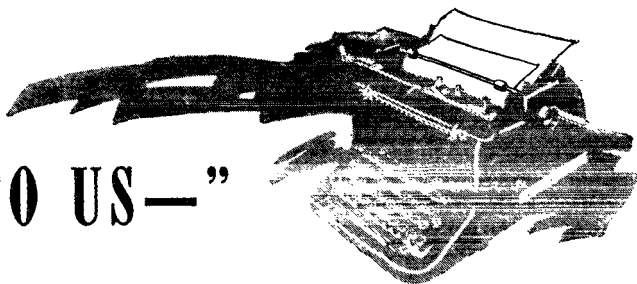

ON BEING AN AMATEUR

WE WISH that the nontechnical press of the country could come to the realization that the expression *radio amateur* is a term of art, specifically defined in international treaty and FCC regulations as comprising a particular class of persons — ourselves — licensed by the Commission to conduct a clearly defined type of radio service. We wish they would stop talking about amateurs when they mean mere listeners-in or other unlicensed classes of people who don't get paid for what they do in radio, and would understand that an amateur in radio is a person of demonstrated proficiency who has been granted licenses to engage in two-way communication over his own station because of his personal interest in the technique of radio.

We have been particularly irked by this confusion in the press in its reporting of the interception of the data on prisoners of war which interlard enemy propaganda broadcasts. Government agencies monitor these broadcasts, sift the data and notify the next-of-kin of these reports. They render a satisfactory service and the only necessary service. But numerous individuals engage in this activity, too, as a hobby and in the hope of helping. There probably are some licensed amateurs who do this, although all the individuals we can remember being identified in the press articles we've read have been SWLs, not hams. The practice is unnecessary but is harmless in itself. However, numerous dirty rackets have arisen during this war, all the way from the petty victimizing of service men to bigtime ration-stamp counterfeiting. One of the most despicable of these rackets is the attempt to extort money from the families of missing service men in return for the prisoner-of-war reports in the enemy broadcasts. It is deplorable but it has happened. Government agencies have promptly stopped the practice and from time to time have announced the facts. The press, reporting the news, has all too frequently fallen into the error of charging the racket to hams, just because it was an "amateur notification system," not an official Government one. Your ARRL has been in touch with press associations and individual newspapers on each of these instances that has come to knowledge. They are sorry when they know the facts and generally they publish a correction, but frequently some damage has been done our reputation. The fact is that these are

not hams. We have verified anew from FCC, no later than this very morning, that *FCC has never had a single report of a licensed amateur engaging in this vile activity*. Will you, brother ham, help to spread this word where our reputation is in doubt? And won't you, Mr. Press, stop saying ham or amateur when you don't mean us?

WE CAN'T be too surprised that such confusion exists in the use of the word *amateur*, since it not only has other legitimate applications but is one of the most misused words in the English language anyway. But we get a distinct shock when other people not only improperly employ *amateur* but ring in the synonym *ham*. To us they mean the same thing but when they're incorrectly used in the first place, *ham* becomes a second-power error of ghastly effect. The result is nothing short of ludicrous when the press, wishing to call an SWL an amateur because he is not a professional, also calls him a ham because he is an amateur. Imagine an SWL being entitled to be called a ham!

But there's that word again. *Ham* is now practically barred by the Radio Society of Great Britain as beneath the dignity of an amateur. Well, we like it. We disagree with those who think it implies a punk or lid and that it's derived in derision from *ham actor*. We won't agree, either, with the rather astounding definition contained in a book called the *Dictionary of American Tramp and Underworld Slang*. You need a laugh today, don't you? Well, read this:

ham. A telegraph operator or radio amateur. Abbreviation for *hammer* because the key operates with an up and down motion similar to a hammer. Applied in a derogatory sense as an amateur does not have a light and gentle touch but hammers the key.

No, those things are not our story, you know. The way we tell it, most of the language of sports derived from Cockney English. *Amateur* was *h'amateur* in Cockney, and when *amateur* was abbreviated to *am* it naturally became *h'am* or *ham* by direct transliteration. In our estimation the words therefore mean precisely the same thing, with *amateur* the formal term and *ham* the affectionate diminutive. For what it's worth from us, we're hams and proud of it. The League, by the way, has suggested to

the staffs of the various American dictionaries the desirability of defining *ham* as a synonym for licensed radio amateur.

We are pleased, too, to see the term coming into use in other fields of activity. There have been several references in the aviation press in the past year or so to *ham pilots*, meaning amateur or sportsmen pilots not flying for hire. And the term *ham photography* seems to be coming into a certain vogue, too. We consider they are on the beam and they can have the use of the term free from us.

WE MIGHT as well take this opportunity to unload another peeve about the recognition of amateurs. The wartime solicitations of the Civil Service, even during the period of most desperate need for Government radio personnel, commonly took no account of amateur training and bluntly stated that no credit whatever would be allowed for amateur experience. In a way this was understandable, because the over-all personnel needs were so huge that examinations were being abandoned and applicants were being rated on their demonstrable schooling and training and their record of paid jobs successfully held. There are many persons of high competency in radio whose only experience has been as an amateur, but what proof is there that a given individual has actually progressed beyond the knowledge required for his initial license?; how can the amateur establish that his personal work has qualified him to hold a Government job?

The obvious answer is tests and examinations, both written and in a practical way at bench and key. Private industry did that, and that was the method of the armed forces — they could quickly tell whether a man had what it took and they didn't care where the

knowledge came from so long as he had it. Also they quickly learned that if he had amateur background he probably possessed resourcefulness and enterprise, on top of knowledge, that made him doubly valuable. The Civil Service had to find literally millions of applicants, in many fields, and with rare exceptions it was not feasible to explore their qualifications by examinations that gave each candidate an opportunity to prove his competency. Instead, they apparently relied on the philosophy that if a man were good enough to earn his living at radio work, that proved something; while amateur experience could not be credited because there was no way to evaluate it. This is largely understandable, we say — but what a pity it is! There are thousands upon thousands of licensed amateurs in radio work under Civil Service appointments, and the bulk of them probably got there because of skill originally acquired as amateurs, but in most cases they got acceptance only because they were also able to point at paid radio experience as professionals. During the time of greatest need, the civilian Governmental services were denied the aid of many additional thousands of persons of comparable abilities because no mechanism could be devised to weigh and judge the competency they had acquired purely as amateurs. It ain't right, McGee.

In many fields of activity, administrative agencies are now reviewing their wartime activities, studying how to do better next time, possibly writing little memos to themselves for future application. We suggest one: that the Civil Service Commission study the possibilities of making a more fruitful employment of the talent of the simon-pure radio amateur in time of national emergency.

K. B. W.

★ SPLATTER ★

OUR COVER

MIGHTY little aid and absolutely no comfort is afforded the enemy by the unveiling of the radio set pictured on the cover this month. Two hundred and twenty-three pounds of fighting radio equipment, the Army's new Radio Set SCR-506, means only bad news to our enemies in the battle of communications.

FOOTNOTES

THREE new *QST* contributors are presented this month. The first on our list, **George W. Brooks, W1JNO** (p. 25), has operated on all bands from 112 Mc. down, starting his ham activity in 1935. A graduate of Eastern Radio Institute, Boston, he put in a couple of years as chief engineer at the Laconia (N. H.) b.c. station, WLNH. He then began a tour of duty with New England Tel. and Tel. which took him to their

station, WOU, and then to W1XUJ, an experimental f.m. station. W1JNO's present assignment is completely obscured by the smoke screen of military security. . . . Two old-timers are on our roster this month, the first being **George Peterson, jr., W3IOV**, who started hamming as 3ANQ after the lifting of the ban following World War I. In 1926 Peterson left the air for nine years during which period he graduated from Yale with an EE. (Ordinarily an EE doesn't take nine years to hatch, but he didn't tell us what else took place in that time!) In 1935 Peterson returned to the air — in two ways — as an amateur radio operator and as an amateur fier. He combined his hobbies and, when CAP was formed, he became Training Officer for the First Group Pennsylvania CAP. Serving now as CAP deputy communications officer and president of the Aero Club of Pennsylvania, Peterson realized a need for, and designed the i.f. equipment described in his current article (p. 40). The regular job of W3IOV is that of plant engineer in the J-P division of a company manufac-

(Continued on page 82)

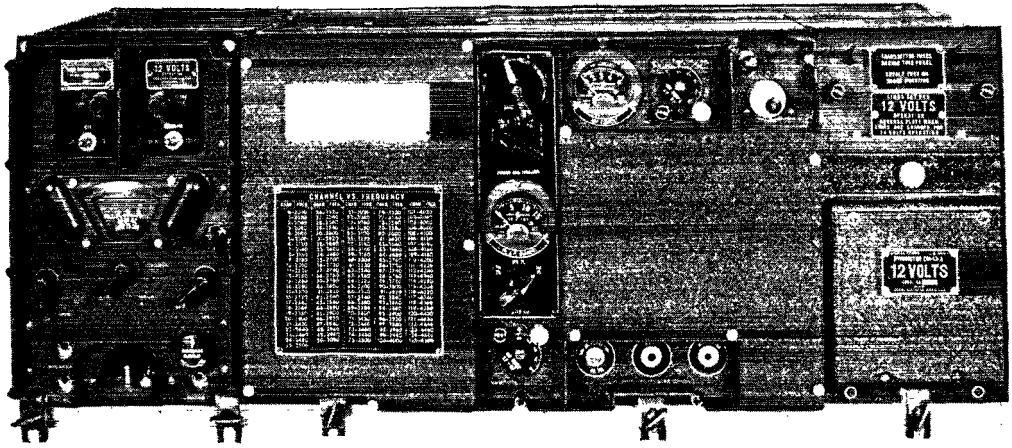

All Official U.S. Army Signal Corps photographs.

“Radio Set SCR-506” — A Biography

The History of the U. S. Army’s Highly Perfected New Medium-Range Mobile Radio Set

BY A. DAVID MIDDLELTON,* W2OEN

IT WAS mid-afternoon of a spring day in 1942. One hundred and twenty miles south of San Antonio, on the road from Laredo, a dusty command car was hitting sixty under the heavy boot of its GI driver. The whip antenna on the side swayed evenly in rhythm with its motion.

Meanwhile, parked in Alamo Heights outside San Antonio, Bill Schwartz, W2AEL, idled away the afternoon near the speaker of his BC-312 receiver. The test schedule for which he was waiting still a couple of hours away, Bill relaxed in his radio truck, gazing off into space.

Riding in the back seat of the speeding command car was Ed Raser, W3ZI, and the writer. On the impulse to see if he could QSO W2AEL on the “fly” and at an unscheduled time, W3ZI threw a switch. He slapped out a terse call on the key strapped to his leg. Following the Army call with a “BK,” he leaned back, listening. There was a moment’s silence. Then from the speaker came the answer. “Are you in motion?” queried W2AEL in San Antonio, surprised at this unscheduled call. “You bet we are!” replied W3ZI.

While the C & R car bounced along at an undiminished pace, a perfect c.w. QSO was maintained on a frequency in the old 80-meter ham band without once touching the receiver in the new military radio set under test — the SCR-506. No repeats, no tuning — good solid signals each way. And when QRM set in on the mobile signal the Alamo Heights station merely broke and said, “Shift to B.” W3ZI keyed “R,” flipped a switch to the point marked “B” — and the QSO continued on a clear channel quite removed from the original frequency.

Later, in 1943, out on the dust-laden prairies that surround Fort Riley, a command car appeared to be wandering aimlessly around. In the front seat were a cavalry test officer and a soldier driver, while a civilian engineer in the back seat operated the set. The GI chauffeur was disgusted. All morning he had been hunting rough terrain on which to bounce that transmitter hard enough to make it break down. Now it was nearly chow time, and still the set refused to give up despite the terrific pounding.

Finally the officer took the wheel, muttering something about finishing off that damned set so they can go back for lunch. The car lurched forward, plunged down a hill, headed cross-country and tried to hurdle a deep ditch. There was a thunderous crash! The rear end failed to clear, and the car smashed into the bank. The GI jumped clear, but the radio operator found himself lying on top of his radio set and the dazed

This article is more than an account of the development and extensive field testing of a military radio set — more, even, than a technical description of one of the Signal Corps’ most modern items of communications equipment. It is also a record of the contribution by radio amateurs to a notable military radio accomplishment — and a personal experience narrative, at that. For Assistant Editor Middeltton, during the hectic days of ’41-’43 an engineer at the Signal Corps Labs, was himself project engineer in charge of the work on the SCR-506.

* Assistant Editor, QST.

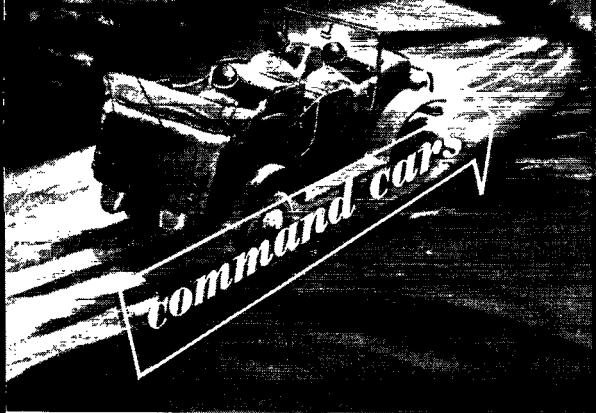

officer climbed out painfully from the vehicle. The rear end of the car was badly disabled — but the radio set was still unhurt. If that C & R car could have registered human emotion, it would surely have looked chagrined. For the radio set, the SCR-506, was not only undamaged but still worked perfectly. Its voice soon was calling for aid in pulling the car out of the ditch. Changed within an hour to another car, the set later reached out 1600 miles on c.w. in keeping an evening schedule on 3610 kc. with Fort Monmouth.

These are but two incidents of the many that occurred during the field testing of a new type of radio set — the U. S. Army's Radio Set SCR-506 — the fightingest high-powered vehicular-mobile radio set in the world. Delivering up to one hundred watts output in the frequency range from 2000 to 4500 kc., with instant selection of any one of *five* completely pretuned frequencies, the 506 has been rightfully called the radio equivalent of the Garand rifle.

Did you say "frequency shift"? Never before has there been such flexibility in a long-range military radio set.

Imagine you are a World War II cavalryman riding in an armored scout car bumping across country on a reconnaissance mission. You are 'way out in front of your own front line. Beside you in the rear seat is a 506. You top a rise — ahead you spot a heavy enemy concentration, apparently well camouflaged against air observation. Its presence must be reported at once! A call must go through for ground-force action with tank destroyers, swift-striking tanks, and men. The word must reach back to the "bomber-demand" group for tactical air support. There is no time to relay the news; you must report it at once to widely scattered command posts, far to your rear — and on different nets. You turn the switch and flash your message to one headquarters. While the acknowledgement is still ringing in your ears you flip the switch again and crash into another net with your important information. You repeat this four — or even five — times. For with you in that car you have the equivalent of five complete transmitters tuned to as many different frequencies, any one of which is available at the flip of a single switch!

What sort of radio set can take that sort of beating and still operate? What kind of a set can stand modern vehicular warfare and still function smoothly and without breakdown? Where did this set come from that can take the worst punishment man can devise and still remain intact, operating perfectly on preset frequencies in spite of wide temperature variation, vibration and mobile conditions?

The Project

This is the story of the SCR-506 — and the radio amateurs who participated so importantly in its design and development, its testing and pro-

These illustrations, taken from the Army's training film on the SCR-506, dramatically depict four of the many types of fighting vehicles equipped with the 506.

duction. It's a story that began long before Pearl Harbor when the Armored Force, the Cavalry and the civilian radio engineers at Fort Monmouth Signal Laboratories realized that a completely new type of radio set was required.

What was needed was a streamlined frequency-shifting transmitter plus an easily operated receiver, all compactly and sturdily built — a radio set designed exclusively for vehicular operation in modern mobile warfare.

Much of the planning and early development of this new set was the work of Wm. S. Marks, jr., chief of the Vehicular Radio section of the Labs under the direction of Lt. Col. Roger B. Colton¹ and Major J. D. O'Connell.

In May, 1941, Quido Shultise, W9NX, one of the VR section radio engineers, turned over a set of prints and a lot of engineering data on the new set to the writer, then a Signal Corps civilian radio engineer likewise working under Bill Marks. Shultise had been closely allied with the development of the new set before he transferred the project to the writer.

Shortly thereafter we went to the Schenectady plant of the General Electric Company to assist in laboratory tests and, what was more important, to meet the boys who had designed and built the original test model and to see the set itself. There we found a crew of highly trained engineers and workmen, putting all they had learned in years of professional and amateur radio experience into its design and fabrication. They were resolved to make it the best piece of vehicular radio equipment that it was possible to build into the limited space allotted. The electrical design and the over-all coordination was in the hands of L. H. Lynn, ex-W9BTY, who combined his GE background with his ham experience to produce a set that would meet military demands and yet include the worth-while features found desirable in amateur practice — notably frequency stability, flexibility, and maximum convenience and simplicity of operation. The mechanical design engineering was coordinated by M. R. Johnson, W2DSB — and his wizardry paid high dividends in 506 operating performance.

Gathered around Lynn and Johnson was all the enormous inventive and productive genius of the entire General Electric organization, with its vast collective resources.

The design engineers and fabricators put all their skill and talent into the design and building of this new type of equipment. Their enthusiasm was reflected by every man and woman who had

¹ The military rank of all officers mentioned is that held at the time of these activities.

contact with what they called "the tank set." Lynn; Johnson; J. D. McLean, W2MSA; P. L. Chamberlain, W8HAU-ex-W9DZY, from the sales department; Don Vroman, who did much of the receiver design, and R. L. Downey, W2-KFN, who designed the 506 v.f.o., nobly assisted by many others had taken "military characteristics" (preliminary specifications) calling for extremely difficult requirements — especially those concerning power output, form factor and space limitations — and had come up with a radio set such as the military world had never seen.

The original AFII (Armored Force Type 2) set was strictly a c.w. job capable of furnishing from 50 to 90 watts output into a 15-foot whip-type vehicular antenna. An eight-tube superheterodyne-type receiver with a built-in crystal calibrator, a quick frequency-shift transmitter (with four preset and one variable frequency), together with their complete power supplies (other than the primary source) — all were contained in a space measuring 14 × 14 × 34 inches. (Early Armored Force plans placed the AFII set in the small space available in the sponson of a light tank.) Forced-air ventilated, shock-mounted, fool-proof and almost crash proof, the equipment was designed to stand up under what was then thought to be the ultimate degree of punishment in military vehicular operation — installation in a tank.

But before the first working model of this set was delivered, the Air Corps dropped a "blockbuster" right into the AFII works! The airmen, with whom the Armored Force maintained liaison for "bomber-demand" and other services, announced that they *must* have voice signals from the ground for use by non-c.w.-trained pilot-operators.

Imagine, if you can, the problem confronting the boys doing the engineering and planning of the 506! Here was a box of tubes, switches, coils, a couple of dynamotors — not to mention lots of other gadgets, such as an elaborate gear-train — all crammed into a framework already full to overflowing. And now there was an unequivocal demand for the addition of a modulator and voice operation. What were the engineers to do? Grid modulation would take little space, but would the Armored Force accept a voice carrier with one-quarter the c.w. power output? They said they would, gladly; so far as they were concerned for they did not need voice anyway. The Air Corps agreed, too, with a stipulation: "If it works okay, we'll take it." So grid-bias modulation was installed, space being made by rearranging some of the components.

Left — A typical 506 installation in a jeep (Truck, ¼ ton, 4 × 4). Right — Installation in a half-track (M2).



Field Trials — Armored Force

Field trials of the service test models began in mid-summer of 1941. Within a few minutes after the first set was received at Fort Monmouth, we had it installed in a GI truck. Accompanied by interested Army personnel, we soon were working with a Laboratories' base station manned by Web. Woolfe, W2MWW.

The tests begun that afternoon continued, in one form or another, for almost three years, taking these sets and a brass-pounding crew into all parts of continental United States and to a few other spots which cannot now be named. Service — and, later, production — models of the 506 were tested in every kind of weather over all types of terrain and in all manner of vehicular and fixed installations. This almost continual handling proved that the SCR-506 had what was required — unyielding electrical and mechanical stability and with unflinching high performance under the severest field conditions.

After the preliminary trial-runs were made, elaborate screen-room and laboratory tests were conducted on the models, to determine if the electrical and mechanical qualities of the equipment met the military characteristics. Participating in the various phases of the laboratory tests were A. H. Ross, W2ODF-ex-W3TA; J. Kravetz, W2OEF-ex-W3BMG; E. Black, W2ESO and L. H. Craig, W2OIZ.

The first formal acceptance tests were conducted for the Armored Force Board by a test crew consisting of J. J. Kelleher, W2DSV; Wm. Schwartz, W2AEL; J. H. Durrer (no license), and the writer, under the official direction of Capt. F. F. Urhane, an ex-K7, at Fort Knox. We made tank and half-track installations, and exhaustive (and exhausting) performance and operational tests were carried out over widely varied terrain simulating typical Armored Force conditions. Just for the record, let us state here that operating

a 506 in a roaring M3 tank being driven over rough, winding back-country Kentucky roads by a wild-eyed mountaineer GI comes strictly under the classification of an "occupational hazard." "Throw me a crash-helmet!" was the first order on each run — and *no fooling!*

A highly specialized installation technique (called the "Brooklyn bend and squat" method in honor of its originator, W2AEL) was developed whereby a heavy brute of a radio set could be squeezed through a hole half as large into an inaccessible spot in a small tank already filled to overflowing with machine guns, "ammo," and other radio sets and interphones — not to mention the tank crew, their bulky helmets, jackets, miscellaneous feet in GI shoes, and a few odd canteens.

During one of the early Fort Knox runs, an event of historic military and amateur importance was duly recorded in the official report. On August 20, 1941, the operator of a 506 in an M3AI scout car operating on 3540 kc. contacted amateur radio station W8OUX in Chillicothe, Ohio. W8OUX reported that the signal strength was fine, but that it sounded like someone was "moving around in the shack." He was almost correct, at that — except for the fact that the *shack was moving around with the set*. It happened that we were going at a good clip along some not-too-smooth Kentucky roads at the time, but since we couldn't very well explain where or what we were doing we had to let W8OUX figure it out for himself.

Field Trials — Air Force

In the fall of 1941 came the voice tests for the Air Corps. Officially, these tests were satisfactory to all concerned. But the writer — who hitherto was a dyed-in-the-wool c.w. man — had a strictly personal beef. Here's what happened when a c.w. man got mixed up with a microphone! We

Left — Right side view of the BC-652 receiver. The top chassis contains the calibrator and receiver power supply. The bottom chassis holds the r.f., i.f. and a.f. components. *Center* — Top view showing the dynamotor, power supply and calibrator components. The dynamotor is fastened by four clips, rubber mounted to eliminate vibration. Dynamotor connections are made by a plug located adjacent to the rear binding posts. Battery connections may be made to these two posts when the receiver is serviced permitting operation without the mounting base. At the top are located, left to right, the crystal, the oscillator tube and the two multivibrator tubes. *Right* — Left side view of the receiver. The plugs at the rear center of the chassis make all connections to the receiver, except antenna and output, when the receiver is in place on Mounting Base FT-253. A fan in the end-bell of the dynamotor draws air through a glass-wool filter in the receiver case. This air, circulated through the receiver, is exhausted through another filter.

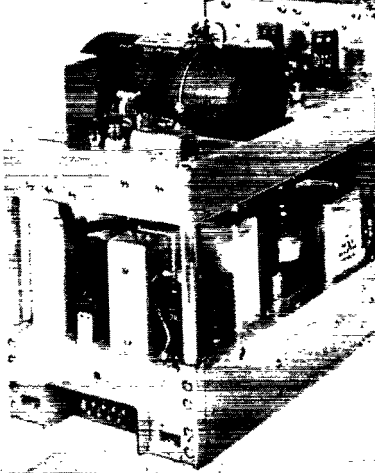
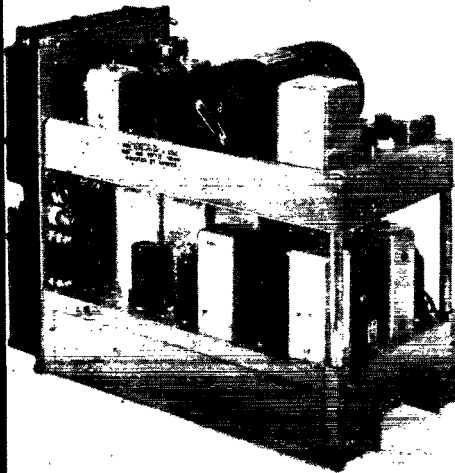
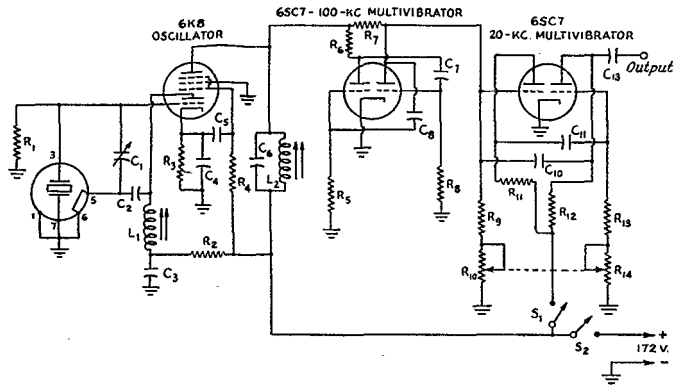

Fig. 1 — Circuit diagram of the crystal calibrator built into the BC-652 receiver. A DC-24 crystal is shown connected to pins 3 and 7. A jumper, located inside the metal tube shell protecting the crystal, connects pins 5 and 6, thus completing the circuit and grounding the junction of C_1 and C_2 . C_1 is adjusted to set the operating frequency exactly on a harmonic of 200 kc. When an FT-241 type crystal is used, it is plugged into Nos. 1 and 3 of the socket. C_1 and C_2 are then in series from grid to plate of the 6K8. C_1 is then adjusted for maximum capacity. The DC-24 crystals used are similar to types generally available.

- C_1 — 50- μ fd. variable.
- C_2 — 225- μ fd. silvered mica.
- C_3, C_4, C_5 — 0.006- μ fd. mica.
- C_6 — 250- μ fd. silvered mica.
- C_7, C_8 — 100- μ fd. mica.
- C_9 — 10- μ fd. mica.
- C_{10} — 5- μ fd. mica.
- C_{11}, C_{12}, C_{13} — 400- μ fd. silvered mica.
- R_1 — 1 megohm, $\frac{1}{2}$ watt.
- R_2 — 10,000 megohms, $\frac{1}{2}$ watt.
- R_3 — 330 ohms, $\frac{1}{2}$ watt.
- R_4 — 15,000 ohms, $\frac{1}{2}$ watt.
- R_5, R_8, R_{11} — 39,000 ohms, 1 watt.
- R_6, R_7, R_9, R_{13} — 15,000-ohm variable, ganged.
- R_{12} — 51,000 ohms, 1 watt.
- L_1, L_2 — Permeability-tuned inductance coil.
- S_1, S_2 — S.p.s.t. switch.



were ordered out to Fort Knox's Godman Field to be ready to test with two planes that would fly down from somewhere up north. This was our big chance, there must be *no* slip up! A listening watch was to be maintained on a certain frequency, and the planes would call us. That, at least, was the *plan*. As happens too often to exact plans, however, something went haywire. The writer guarded the assigned frequency for four hours — in a tank with its engine running (to maintain battery voltage) — listening for a call. At the end of that time we were informed, by

W5GEU, participated actively from both ground and air. W9DCM even did some of the operating in the planes. Extra-curricular work was done using W9TDM's ham rig as a base station, resulting in useful additional range and operating data. During this time another amateur station, W9DGA, Evansville, Ind., was worked on 3900 kc. using voice from an M2 half-track near Fort Knox. Army calls were used, of course, with no locations given. We've often wondered what the gang thought of the infrequent appearances in the ham bands of those queer Army calls during this brief period during which amateurs could legally communicate with Army stations.

Then came Pearl Harbor. Shortly afterward other communication equipment was under test by us at Fort Knox and a new 506 was taken down for use in this work. En route back home, the truck in which the set was installed was side-swiped and ditched. The truck was reduced to junk. When Johnny Cox crawled out of the wreckage his first thought was of his shiny new 506. Cox found the set dangling by the battery leads, but when he turned it on it worked perfectly; except for a dent in the transmitter framework, it had suffered no damage whatsoever. This unfortunate happening proved one thing — the set was practically crash-proof!

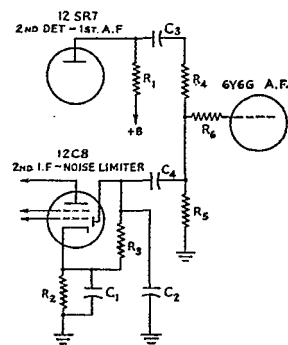

Fig. 2 — The basic circuit of the automatic noise limiter in the BC-652.

- C_1, C_3, C_4 — 0.006- μ fd. mica.
- C_2 — 200- μ fd. mica.
- R_1 — 100,000 ohms, $\frac{1}{2}$ watt.
- R_2 — 330 ohms, $\frac{1}{2}$ watt.
- R_3 — 5.6 megohms, $\frac{1}{2}$ watt.
- R_4 — 680,000 ohms, $\frac{1}{2}$ watt.
- R_5 — 330,000 ohms, $\frac{1}{2}$ watt.
- R_6 — 1000 ohms, $\frac{1}{2}$ watt.

messenger, that the planes had flown over at 15,000 feet, sighted us, called us *once* on another (and different) frequency, and then went off into the "wild blue yonder" leaving us — literally — stewing in our own juice! It has been alleged that the writer blew his safety valve wide open when he finally crawled out of that Armored Force Turkish bath still clutching a microphone! But even the combined heat of the Kentucky sun, the idling engine and a boiling-hot operator hadn't phased the 506! It had forced-air ventilation — even if the boys in the tank did not!

Two more amateurs entered the 506 scene during those ground-air tests. Capt. Webster N. Soules, W9DCM, and Lt. Larry Boyts, W9TDM-

Riding the Range With the TDs

In the spring of 1942 two 506s, converted for narrow-band frequency modulation, were taken to Camp Hood in Texas for tests by the Tank Destroyer Board. The test crew consisted of Schwartz, W2AEL; Frederick Taylor, W1HCU; Ed Raser, W3ZI, and the writer, under the general supervision of Lt. O. D. Perkins, ex-W7MH. We ran through the exhaustive TD tests under the official direction of Capt. Ben Adams, W4EV-W4APU.

These tests made military radio history. The 506s proceeded to run up records in all departments in a series of road and cross-country runs involving operation under the extremely varied

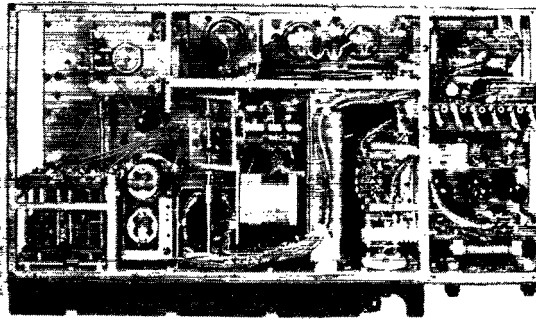
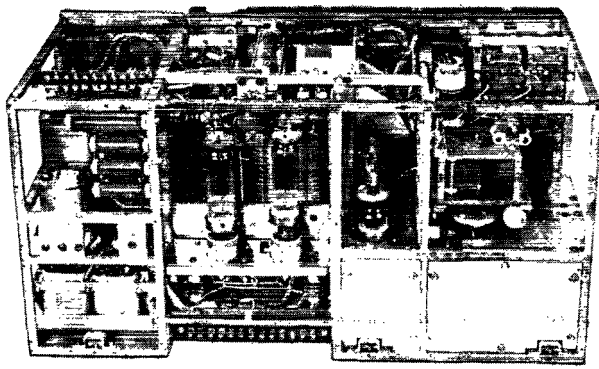

Left — Rear view of the BC-653 transmitter chassis. The two 814 amplifier tubes are located directly behind the final tank coil. The upper portion of the 807 buffer tube is shown protruding from its shielded compartment. The tunable position buffer condenser is visible at the right, with the preset buffer condensers showing directly above. The oscillator components, well shielded, are inside the lower compartment. The transmitter is built in a strong hollow steel tubing framework. The plugs shown at the lower center of the chassis make all the connections to the transmitter when it is in place on the mounting base. The three small devices on the back of the chassis receive projecting hooks on the base, thus relieving the plugs from any mechanical strain. *Right* — Top view of the chassis, starting at the left — Buffer preset tuning condensers, buffer coils, oscillator tube, gear train, antenna loading coil, keying relay, voltage regulator tubes and the modulator tube. Directly behind these tubes are the 12-24-volt links. The wide turned-over metal lip on the front of the transmitter provides adequate protection for the dials and controls.

conditions of rain, mud, sun and dust to be found in the wide open spaces about Camp Hood.

One morning W4EV asked, "How far do you think you can work with the 506?" That was definitely a leading question. So, armed with a gas card and accompanied by two heavy-footed GI drivers and a student GI operator for additional ballast, W3ZI and the writer embarked on an epic journey in a C & R car. The expedition reached Corpus Christi by late afternoon, despite frequent halts for schedules involving W1HCU at Temple and W2AEL at San Antonio. Moving westward past the town of Alice we kept our last evening schedule under the brilliant light of the Texas stars. Our f.m. signals, with a 15-foot whip, were R5-S5 on 4200 kc. so we called it a night and arranged for a schedule the next noon.

That contact found us parked in the native quarter of Laredo, with signals still R5, S5 on voice and a perfect QSO. Only the failure of our

attempt to cross the international bridge into Mexico forestalled ripening plans for continuing the expedition into Central America. Anyway, the GIs had heavy dates back in Temple that night — and it was already noon. (For the benefit of you stay-at-homes we record here that we were in Temple in time for those GI dates. One native is said to have remarked to his little son as we passed, "No, José, that was *not* a P-38. That was merely a 506, flying *very low!*" W3ZI reported, after catching his breath when we landed (sic) in Temple, that he'd counted three times when all four wheels were on the ground at once.)

But that rugged trip paid off in additional performance data, and the Tank Destroyers, advised by W4EV, adopted the set.

And so it went, tests and experiments — and then more tests. . . . Two-way QSOs with W1HCU and W3ZI pounding brass in sub-zero

(Continued on page 84)

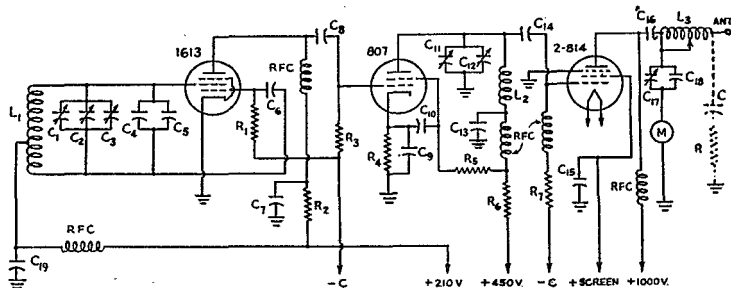

Fig. 3 — Diagram of the basic circuit used in the BC-653 transmitter. No switching circuits are shown. The antenna network is made complete by the addition of the equivalent antenna resistance, *R*, and capacity, *C*.

- C*₁ — Capacity of antenna, lead-in and mast base to ground.
- C*₁ — 4-28- μ fd. variable.
- C*₂ — 280- μ fd. variable.
- C*₃ — 6-45- μ fd. variable.
- C*₄ — 70- μ fd. 750-volt mica.
- C*₅ — 28- μ fd. temperature-compensating condenser
- C*₆ — 500- μ fd. 5000-volt mica.

- C*₇, *C*₈, *C*₁₀, *C*₁₃ — 0.005- μ fd. mica.
- C*₈ — 0.002- μ fd. 1000-volt mica.
- C*₁₁ — 170- μ fd. variable.
- C*₁₂ — 3-9- μ fd. mica trimmer.
- C*₁₄ — 40- μ fd. 600-volt mica.
- C*₁₅, *C*₁₆ — 0.005- μ fd. mica.
- C*₁₇ — 33- μ fd. variable.
- C*₁₈ — 45- μ fd. ceramic padder.
- C*₁₉ — 200- μ fd. 1000-volt mica.

- R* — Antenna resistance.
- R*₁, *R*₃, *R*₅ — 22,000 ohms, 2 watts.
- R*₂ — 8000 ohms, 4 watts.
- R*₄ — 390 ohms, 2 watts.
- R*₆ — 6000 ohms, 20 watts.
- R*₇ — 4000 ohms, 4 watts.
- L*₁ — Oscillator coil.
- L*₂ — Buffer coil.
- L*₃ — Amplifier coil.

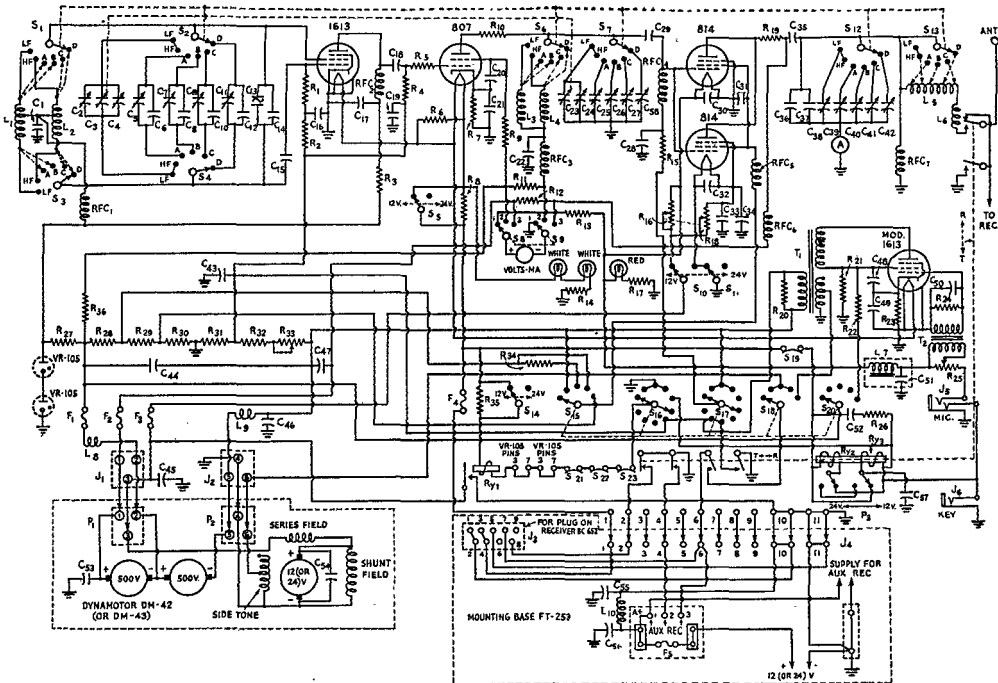

Fig. 4 — Complete diagram of Transmitter BC-653 and Mounting Base FT-253. Operational switch shown in OFF position and frequency selector switch shown in position D. Links are connected for 12-volt operation. The meter switch, consisting of S_8 and S_9 , ganged, measures the 814's filament voltage, the buffer and the final amplifier plate current, respectively. When the circuit of R_{y2} and R_{y3} is completed by the closing of the key in J_6 or by operating the switch on the microphone in J_5 , the movable contacts (shown connected by dotted line) operate. These contacts are shown in the RECEIVE position, and the antenna is connected to the receiver.

- | | | |
|---|--|--|
| C_1 — 200 μ fd. 1000-volt mica. | R_5, R_{10}, R_{19} — 5 ohms, 5 watts. | S_{12} — Amplifier tuning condenser selector switch. |
| C_2 — 4-28- μ fd. variable. | R_6 — 15 ohms, 8 watts. | S_{13} — Amplifier coil selector switch. |
| $C_3, C_5, C_7, C_9, C_{11}$ — 280- μ fd. variable. | R_7 — 390 ohms, 2 watts. | $S_{15}, S_{16}, S_{17}, S_{18}, S_{20}$ — Operational switch. Positions: OFF, CALIBRATE, CW $\frac{1}{4}$, CW FULL, VOICE. |
| C_4 — 6-45- μ fd. variable. | R_8 — 7 ohms, 20 watts. | S_{19} — Interlock in operational switch, to open primary circuit of R_{y2} and R_{y3} . |
| C_6 — $C_8, C_{10}, C_{12}, C_{28}$ — 25- μ fd. mica. | R_{11}, R_{22} — 160 ohms, 1 watt. | S_{21}, S_{22}, S_{23} — Interlock switches; fuse compartment door, buffer coil-link door and amplifier coil door. |
| C_{13} — 28 μ fd. temperature-compensating condenser. | R_{12} — 25 ohms, 8 watts. | T_1 — Modulation transformer. |
| C_{14} — 70 μ fd. 250-volt mica. | R_{13} — 2400 ohms, 1 watt. | T_2 — Microphone transformer. |
| C_{15} — 500 μ fd. 5000-volt mica. | R_{14} — 15 ohms, $\frac{1}{2}$ watt. | F_1, F_2 — 0.5-ampere, 1000-volt fuse. |
| C_{16}, C_{34} — 0.005- μ fd. paper. | R_{15} — 4000 ohms, 4 watts. | F_3, F_4 — 10-ampere fuse. |
| $C_{17}, C_{18}, C_{19}, C_{20}, C_{21}, C_{22}$ — 0.005- μ fd. 1000-volt mica. | R_{16}, R_{18} — 3-ohm, wire-wound variable, ganged. | F_5 — 70-ampere primary line fuse. |
| C_{23} — 170- μ fd. variable. | R_{17} — 39 ohms, 2 watts. | L_1 — Oscillator coil, i.f. band. |
| C_{24} — 3.9- μ fd. mica trimmer. | R_{18} — 2500 ohms, 25 watts. | L_2 — Oscillator coil, h.f. band |
| C_{25}, C_{26}, C_{27} — 180- μ fd. variable. | R_{19} — 2500 ohms, 25 watts. | L_3 — Buffer coil, i.f. band. |
| C_{28} — 500 μ fd. 1000-volt mica. | R_{20} — 2000 ohms, 12 watts. | L_4 — Buffer coil, h.f. band. |
| C_{29} — 40 μ fd. 600-volt mica. | R_{21} — 18,000 ohms, 12 watts. | L_5 — Amplifier coil. |
| C_{30}, C_{32}, C_{37} — 0.005- μ fd. paper. | R_{22} — 2000 ohms, 20 watts. | L_6 — Antenna loading coil. |
| C_{31}, C_{35} — 0.005- μ fd. mica. | R_{23} — 430 ohms, 2 watts. | L_7 — Microphone filter choke. |
| C_{33} — 0.02- μ fd. 600-volt mica. | R_{24} — 0.33 megohms, $\frac{1}{2}$ watt. | L_8, L_9 — Dynamotor line choke. |
| C_{36}, C_{37} — 45- μ fd. ceramic padder. | R_{25} — 200 ohms. | L_{10} — Line filter choke. |
| $C_{38}, C_{39}, C_{40}, C_{41}, C_{42}$ — 33- μ fd. variable. | R_{26} — 4.7 ohms, 1 watt. | J_1, J_2 — Dynamotor terminal jacks. |
| C_{43}, C_{46} — 0.05- μ fd. 400-volt paper. | R_{27}, R_{30} — 5000 ohms, 25 watts. | J_3 — Receiver terminal jacks. |
| C_{44}, C_{47} — 1.0- μ fd. 1200-volt. | R_{28}, R_{29} — 3150 ohms, 25 watts. | J_4 — Transmitter terminal jacks. |
| C_{45} — 0.025- μ fd. 400-volt paper. | R_{31} — 2500 ohms, 25 watts. | J_5 — Microphone jack for plug PL-68. |
| C_{48} — 1.0- μ fd. 500-volt Pyranol. | R_{32} — 225 ohms. | J_6 — Key jack for plug PL-55. |
| $C_{49}, C_{51}, C_{54}, C_{55}$ — 25- μ fd. 50-volt electrolytic. | R_{33} — 225 ohms. | P_1, P_2 — Dynamotor terminal plugs. |
| C_{50} — 100- μ fd. 500-volt mica. | R_{34} — 56,000 ohms, 2 watts. | P_3 — Transmitter terminal plugs. |
| C_{52} — 1.0- μ fd. 600-volt paper. | R_{35} — 16 ohms, 20 watts. | $RFC_1, RFC_2, RFC_3, RFC_4, RFC_5, RFC_6$ — Radio frequency |
| C_{53} — 0.015- μ fd. 2500-volt mica. | R_{36} — 6000 ohms, 20 watts. | RFC_7 — Antenna drain r.f. choke. |
| C_{56} — 0.1- μ fd. 1200-volt Dykanol. | R_{y1} — Dynamotor relay. | |
| C_{58} — 25- μ fd. variable. | R_{y2}, R_{y3} — Keying relay. | |
| R_1, R_4, R_9 — 22,000 ohms, 2 watts. | S_1, S_2 — Oscillator coil selector switch. | |
| R_2 — 4700 ohms, 1 watt. | S_2, S_4 — Oscillator tuning condenser selector switch. | |
| R_3 — 8000 ohms, 4 watts. | $S_5, S_{10}, S_{11}, S_{14}, S_{24}, S_{26}$ — Connecting links, for either 12- or 24-volt operation. | |
| | S_6 — Buffer coil selector switch. | |
| | S_7 — Buffer plate condenser selector switch. | |
| | S_8, S_9 — Meter switches, ganged. | |

A Search for V.F.O. Stability

Some Pointers on Reducing Frequency Drift in Transmitter Oscillators

BY CLAUDE L. ROBINSON,* W6KJV

ALL of the electron-coupled or variable-frequency oscillators tried to date by the writer have had one common failing, frequency drift as a result of the expansion of the tube elements caused by heat from plate dissipation. If the oscillator is made inoperative during receiving periods, the plate cools and the temperature within the tube envelope drops, causing the frequency to drift back to its previous value. Take the case of the v.f.o. described on page 14 of March, 1941, *QST*.¹ The plate input is 3 ma. at 150 volts. This sounds very conservative, yet I measured a temperature rise of 10 degrees Fahrenheit near the top of the tube envelope within 5 minutes after applying plate power. The envelope previously had been allowed to come to a stable temperature by leaving the filament voltage on for an hour. This rise in plate heat was responsible for a drift of at least 150 cycles at 3.5 Mc. At 14 Mc. the drift would have been 600 cycles. This is not too bad; in fact, it compares favorably with the best of other v.f.o. units. Of course, the drift with c.w. operation, where the oscillator is keyed, is less because of the intermittent application of plate power. The above-mentioned oscillator is a splendid one, very straight-forward and easy to adjust. I like it better than any other I have tried thus far, even preferring it to the e.c.o. since it eliminates a couple of tube elements. The e.c.o. circuit requires adjustment of screen voltage and feed-back to get decent keying characteristics.

I had what I thought was a pretty good average e.c.o. in operation before the war. Having a little time for experimenting, I found out just how

* 2345 N. McCall Ave., Selma, Calif.

¹ Goodman, "A Gang-Tuned V.F.O.," *QST*, Mar. 41, p. 14.

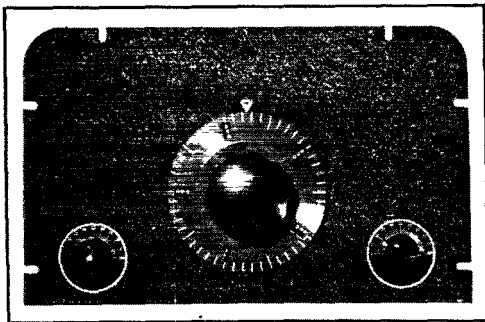

Panel view of W6KJV's v.f.o. exciter. The main tuning dial operates C_1 and C_{14} , setting the frequency and tuning the 1852 plate circuit to resonance. The small knob to the left controls the oscillator trimmer, C_2 , while the one to the right is for C_{10} , the output-stage tank condenser.

awful that unit actually was from the standpoint of frequency stability. The mechanical construction wasn't too bad but, from what I have learned, I know I can do a better job when the proper materials are available once more.

Preliminary Tests

The Perrine² version of the e.c.o. was the last tried before we were taken off the air. The line-up consisted of a 6SK7 oscillator, keyed in the screen lead, a 6V6 Class-A amplifier and a 6L6 output doubler. The measurements referred to in the following were started one minute after turning on the filaments, the key in the screen lead of the oscillator being left open except while checking frequency in the 3.5-Mc. band. A crystal frequency standard set to WWV, was used to check the v.f.o. The S meter on the receiver gave a visual check of the beat much closer than could be distinguished by ear.

When the Perrine unit first was checked, it took eight hours for the unit to approach drift stability; in this period of time the drift was 2400 cycles. After removing all voltage-dropping resistors, a period of six hours was required for the unit to settle down, while drift was reduced to 1800 cycles. I then removed the 200- μ fd. variable padding condenser from the oscillator tank, replacing it with a fixed zero-temperature-coefficient condenser. This time the unit reached stability in three hours and the drift was reduced to 750 cycles. Thinking that the filament current through the winding at the bottom of the oscillator coil might be responsible for some of the drift, I moved the connection directly to the filament lug on the tube socket. Stability was reached in two and a half hours and the drift was reduced to 550 cycles as a result. When the unit reached stability, I closed the key for ten minutes and a further drift of 100 cycles, following the increase in heat within the tube, was observed.

Using the same chassis set-up as was used for the Perrine e.c.o. I changed over to the v.f.o. described in March, 1941, *QST*. The only changes made in the original circuit were to use an 802 in place of the 6L6, because of its greater stability and the fact that neutralization was not needed, to replace C_1 with a 150- μ fd. tuning condenser, and C_2 with a 10- μ fd. trimmer and the balance of the capacity with fixed zero-temperature-coefficient condensers. When the unit was checked, it was found that stability was reached in forty-five minutes. The key was closed for ten minutes. A

² Perrine, "An Answer to the E.C.O. Problem," *QST*, September, 1939, p. 14.

150-cycle drift caused by plate dissipation was observed over and above the 350-cycle warm-up drift. I wasn't satisfied with this state of affairs, so I decided to see what I could do about it. When I reduced the plate power input the frequency drift from plate heat became lower and lower until it was negligible. Now I am using a 22½-volt "B" battery and the plate current to the oscillator is only 0.4 ma. giving a power input of 0.009 watt! I had to wind a few more turns on the grid coil to increase the feed-back.

In order to maintain sufficient driving power to the 802, I installed a Class-A amplifier immediately following the oscillator, using a 6SK7 for that purpose. This stage is a worth-while addition for reasons which I will comment upon later. The grid current of the 802 was now 0.5 ma. using a 20,000-ohm grid resistor and a 1000-ohm cathode-biasing resistor. Wishing to raise the driving power to the 802 to get better efficiency from this stage, I installed an 1853 in the Class-A stage and replaced the 6V6 with an 1852. Lo and behold! The grid current with a 50,000-ohm grid resistor and 1000-ohm cathode resistor now read 2 ma.!

A new test was run on the unit after these changes. Stability again was reached in 45 minutes and the drift was 350 cycles. The key was closed for a period of 15 minutes and at the end of this period no additional drift was observed. In fact, the S-meter needle was swinging back and forth giving visual indication of the beat between the frequency standard and oscillator signals. What could be better?

I feel that I have gone as far as I can at this time with the problem of frequency stability,

One of the problems in the design of a v.f.o. for transmitter frequency control is that of combatting the effects of temperature change upon frequency. In this article W6KJV recounts some experimental work which has resulted in the design of an exciter unit of improved stability.

that is, with the materials to which I am now restricted. After the war we shall be able to obtain better materials than we had before. Intelligent use of them plus never skimping on the quality of parts in the oscillator circuit should give us very stable frequency control.

The use of a small-size 22½-volt "B" battery allows its inclusion in the shield box with the oscillator. The problem of voltage regulation is solved, the key can be placed in the negative lead which will give a better keying characteristic than cathode keying, the life of the battery should be very close to its shelf life, and the arrangement permits a "cold" key. The battery I am using is over a year old and is still going strong. Appears pretty attractive, doesn't it?

The plate tank of the 1852 purposely is manually tuned, instead of being gang-tuned with the oscillator. The tuning of this stage can be off-set to one side of resonance while the grid tank circuit of the driven stage is detuned to the other side of resonance. Thus, the whole 7-Mc. band can be covered without retuning either of these tanks. The maximum drop in grid current any place in the band is one milliampere.

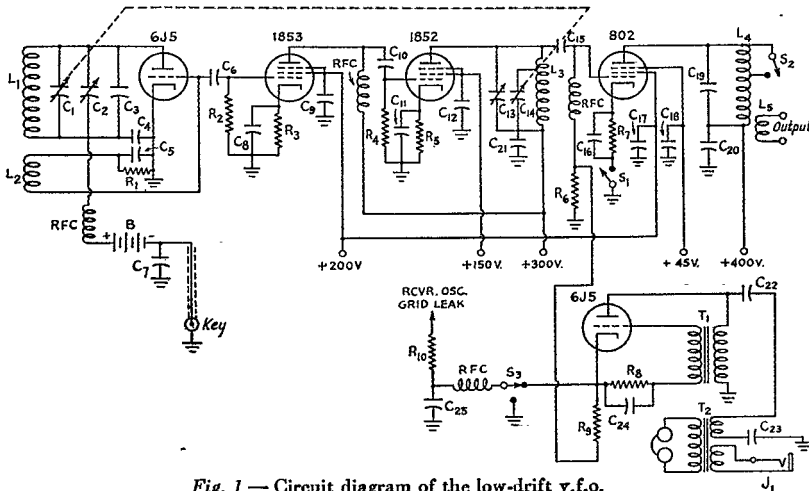

Fig. 1 — Circuit diagram of the low-drift v.f.o.

C₁ — 150- μ fd. variable.

C₂ — 10- μ fd. variable.

C₃ — 400- μ fd. zero-temp.-coefficient fixed.

C₄, C₇, C₈, C₉, C₁₁, C₁₂, C₁₆, C₁₇, C₁₈, C₂₀, C₂₁, C₂₃, C₂₅ — 0.01- μ fd. paper.

C₅ — 250- μ fd. zero-temp.-coefficient fixed.

C₆, C₁₀, C₁₅ — 100- μ fd. mica.

C₁₃, C₁₄, C₁₉ — 50- μ fd. variable.

C₂₂ — 0.02- μ fd. paper.

C₂₄ — 0.006- μ fd. mica for paper.

R₁, R₆ — 50,000 ohms.

R₂, R₄, R₉ — 150,000 ohms.

R₃, R₅ — 500 ohms.

R₇ — 1000 ohms.

R₈ — 5 megohms.

R₁₀ — Receiver oscillator grid leak.

L₁ — 26 turns No. 24 s.c.c. close-wound for 1750-2000 kc.

L₂ — 17 turns No. 28 enam. close-wound, spaced ¼-inch below L₁.

L₃ — 37 turns No. 24 d.s.c. close-wound, tapped at 10 turns from plate end (for 3500 kc.).

L₄ — 38 turns No. 20 enam., close-wound, tapped at 20 turns from plate end for 3500-7000 kc.

L₅ — 4 turns No. 24 s.c.c.

RFC — 2.5-mh. r.f. choke.

T₁, T₂ — Audio transformer.

B — 22.5-volt "B" battery.

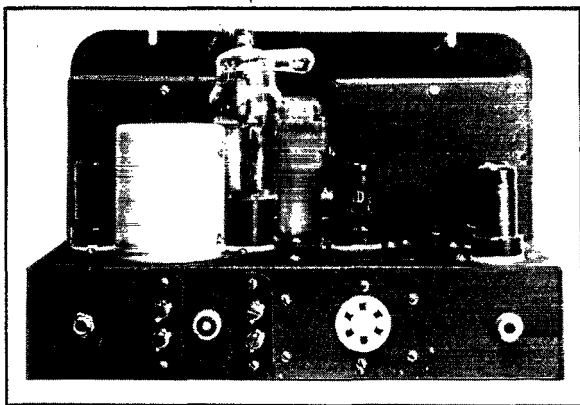

The rear view of the v.f.o. exciter shows the two shielded compartments, close to the panel, containing the oscillator and 1852 tuned circuits. The tubes are mounted externally to provide ventilation. The 6J5 oscillator tube and the 1853 Class-A buffer tube are to the right and the 1852 and 807 are at the center. The tube at the left is in the 6J7 audio-oscillator keying monitor which had not been completed at the time the photographs were taken. The 807 tank coil is contained in the shielding can which is to the left.

Because of the isolation provided by the preceding stages, the 802 plate circuit can be tuned through resonance without affecting the frequency of the oscillator. Try that on *your* unit!

For tuning, I use an HRO PW-0 dial-drive unit. The 3.5-Mc. band is spread from 10 to 495 degrees on the dial, the 7-Mc. band covers 150 degrees and the 14-Mc. band 100 divisions, so there is plenty of bandsread.

Adjusting Feed-back

In making the coil for the oscillator, space the plate and grid coils about $\frac{1}{16}$ -inch and use the same number of turns in each winding. Then remove one turn at a time from the grid end of the grid coil so as not to change the coil spacing. Check the keying characteristics on the 14-Mc. band. Be sure to check the keying at both high- and low-frequency ends of the band because the keying may seem perfect at the low-frequency end of the band while the feed-back may be a little too great and cause a "yoop" at the high-frequency end. Turns should be removed until the keying is good over the entire band. Now check for "squegging." If no frequencies outside the fundamental, harmonics and images are found you are all okay. If you do run into "squegging," reduce the turns until it stops. The idea is to use a lot of feed-back so that the oscillator will slide into oscillation easily at voltages as low as three or four volts, thus improving the keying characteristics. As a check, I reduced turns on the grid coil to 11 and spaced it $\frac{1}{8}$ -inch from the plate coil; the circuit would not oscillate with $22\frac{1}{2}$ volts.

To check the keying, disconnect the oscillator from the Class-A stage. Clip a length of wire onto the grid blocking condenser feeding the Class-A grid to insure getting a signal of sufficient intensity for proper checking. In my case it was necessary to connect the wire directly to the antenna post of the receiver to get an S6 signal on 14 Mc.

Having adjusted the feed-back according to the foregoing paragraph, you are now ready to take measures to reduce the clicks. For a keying choke try the primary or secondary winding of an audio transformer in series with the keying lead. The primary proved to be just right in my case. The signal on "make" should be solid and rather hard but with no trace of click. For the click at "break," try values of fixed condensers varying between 0.01 and 0.1 μ fd. right across the key contacts. One of these values should be just right, giving a signal with a smooth break and no discernible tail. A couple of 2.5-mh. r.f. chokes in series with the key leads right at the key may prove useful also. If you are using a "bug" key, press the dot lever and, if a series of very weak clicks is heard, connect a small fixed condenser of 0.01 μ fd. or so across the stationary dot-contact adjusting screw and the tension-adjusting screw on the frame which adjusts the tension against which the dot lever works. Evidently the connections from the dot contacts to the binding posts are of sufficient length to radiate a little interference. The above remedy should prove a cure.

That is all there is to adjusting the oscillator. Each succeeding stage should be added in turn and checked for stable operation. The signal input to the receiver should remain at about the same level all the way through the checking so that any increase in clicks will be identified as coming from the last stage added and not from increased signal strength. Check the signal with the b.f.o. off, then turn the b.f.o. on to check the note.

Buffer-Stage Stability

In any circuit following the oscillator, the importance of stability, which includes freedom from any tendency toward self-oscillation or parasitics, should be stressed. An unstable amplifier or doubler stage can ruin a perfect signal from the oscillator. Good shielding is indicated. The oscillator circuit especially must be well shielded from feed-back from other stages. An experience of mine will illustrate what I mean. After checking the oscillator and Class-A stage for good keying characteristics, I added the buffer-doubler stage. The plate tank of this stage was under the chassis and about five inches from the oscillator coil with an interstage shield between them, giving what I figured should be satisfactory shielding. After the addition of this stage, a click was noticed on the "break" of the key. It was of high frequency, sounding in the receiver something like the turning off of a light switch. I kept adding capacity across the key contacts and the frequency became lower until it became a sort of "yoop" on the tail of the signal. The frequency at zero beat was stable.

After everything in the book was tried to stabilize an already stable stage, with absolutely no effect, I decided to see what would happen if I

moved the buffer-doubler tank to the top side of the chassis. This gave the required shielding and eliminated the feed-back to the oscillator. The signal immediately cleared up and the oscillator performed as it should. If you cannot find the correct combination for your key-click filter look into this matter of feed-back to the oscillator; it may surprise you. My filter, with the exception of the audio-frequency transformer used as a choke, is mounted right on my "bug" key. The choke is mounted in the shield box with the oscillator and battery. Shielded single-conductor mike cable makes an excellent key lead.

I have not used an oscilloscope to determine the waveform of the keyed signal, but I can assure you that it is beautiful to listen to. There is not a sound in the headphones when the signal is tuned just out of audibility; no clicks or thumps, even when the input signal to the receiver is S9 at 14 Mc., with audio control turned full "on" and the r.f. gain control more than three-quarters advanced. This is the first unit I have had which would stand up to this test. I well remember the racket I used to have when working break-in.

Class-A and Buffer-Doubler Stage

The first buffer, or Class-A stage, should make use of a tube having low grid-to-cathode and grid-to-plate capacitances and high transconductance for the purpose of boosting the signal as much as possible. This is the secret of being able to operate the oscillator at such low-power input, leaving the oscillator only the job of producing a stable signal without making it a workhorse in addition. The plate input to the Class-A stage remains the same with or without excitation, thus maintaining the same plate dissipation. This is important, because part of the interelectrode capacitances are connected effectively across the oscillator circuit. Therefore any change in these capacitances with a rise and fall of heat in the tube envelope is bound to cause a small change in the frequency of the oscillator. This is the reason a Class-A stage should follow the oscillator rather than a buffer-doubler operating under near-Class-C conditions. In the latter case the buffer-doubler plate current would rise and fall, thus causing the input capacity to change. Should a lot of operating be contemplated, the circuit can be wired so that the filaments of the oscillator and Class-A stage run continuously, thus eliminating by far the greater portion of the warm-up drift. I placed a thermometer on top of the oscillator tube and the temperature of the tube envelope rose steadily for forty-five minutes before becoming stable. The 1853 is the best tube I have found thus far for the Class-A stage. It is operated with 300 volts on the

plate, 200 volts on the screen and a plate current of 9 milliamperes.

An 1852 is used in the buffer-doubler and it really does a nice job. With 300 volts on the plate, 150 volts on the screen and a 400-ohm cathode resistor, the plate current is only 5 ma. without excitation. With excitation it increases to 10 ma. This tube replaced a 6V6 which wasn't doing nearly as good a job of exciting the 802 and was running far more plate current in the bargain.

Properly proportioning the plate and screen voltages on the tubes following the oscillator will result in increased output; a little experimenting will surprise you.

Constructional Considerations

Needless to say, mechanical construction should be solid. The oscillator circuit should be protected from heat from outside sources as much as possible. It might be a good idea to insulate the compartment, shielding the oscillator with some good sheet insulating material to prevent sudden temperature changes which will cause a shift in frequency. If you wish to go all the way, you can obtain a good thermostat-and-switch combination very reasonably which will keep the temperature within the shield box constant. Use as little air-paddling condenser as possible. Heat the air close to your oscillator tank condenser and listen to the rapid frequency change. Then, as the air cools to normal, the frequency returns to its former value. Use zero-temperature-coefficient fixed condensers instead, then use a 5- or 10- μ fd. variable air condenser to bring the frequency to zero beat when calibrating. This condenser should be controlled from the front of the panel to keep the calibration right on the nose. Do not use voltage-dropping resistors in the unit; use the

(Continued on page 80)

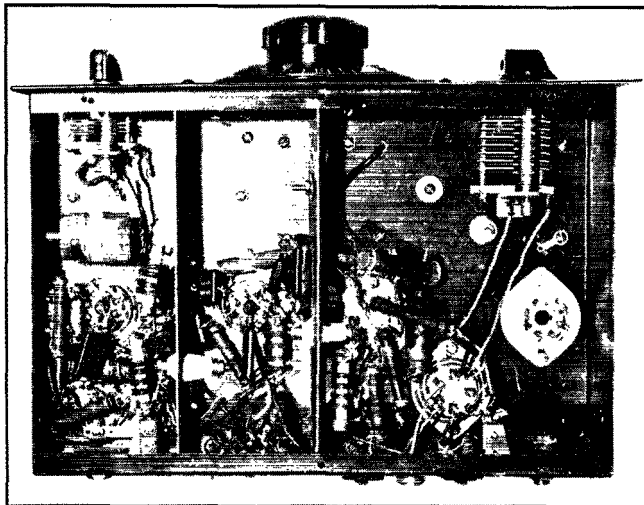

The space below the chassis of the v.f.o. exciter unit is divided into three shielded compartments. Oscillator- and 1853 buffer-circuit components are to the left, those for the 1852 stage are at the center with the output amplifier assembly at the right.

HAPPENINGS OF THE MONTH



ALLOCATION NEWS

ALTHOUGH Government agencies have put in much hard work on allocations the past month, no announcements have been made and there is little to add to the report we gave you in our last issue.

The FCC-IRAC proposal for frequencies below 25 Mc. is expected to appear before middle April. About that same time, or shortly thereafter, the final action of the Commission on frequencies above 25 Mc., taking into account the recent arguments, is also to be expected. The State Department committees and RTPB's Panel 2 will then also be busy on their respective tasks. Very soon there will be much news, as a great deal is cooking behind the scenes, but up to our presstime there had been no announcements.

Allocations above 25 Mc. would be reasonably easy of accomplishment were it not for the f.m. problem. A closed session of the oral argument before FCC was held on March 12th-13th, attended only by "cleared persons," to discuss classified propagation data released for that purpose by the military services. Again f.m. was the major topic. On the amateur side, ARRL was represented by George Grammer, our technical director, who gave further testimony on amateur v.h.f. experiences. A letter from Edward P. Tilton, *QST*'s contributing editor on v.h.f., advocating moving f.m. upward to avoid sporadic E, was read into the record. At the conclusion of that meeting FCC sprang a surprise. Much of the testimony against the proposed move has related to the loss to the public in junking sets for the present f.m. band. George S. Turner, chief of FCC's field division (and onetime ARRL district superintendent for Missouri, in his amateur days), demonstrated a homemade converter for the proposed new band which had been made in his department from parts purchased over the counter at retail stores for \$8.85. Using a Stromberg-

Carlson receiver, he tuned in a low-powered f.m. transmitter on 97 Mc., operating in another part of the building. Testimony was also introduced from The Hallicrafters Co. to show that converters can be built easily and cheaply. Hallicrafters have advised FCC that they can supply tunable 3-tube converters with built-in power supply at a factory net price of \$11, or single-tube fixed-tune wide-band converters at \$5.60.

Meanwhile the Hallicrafters crew have demonstrated their "one-holer" at Chicago and we think it has sufficient interest to be presented at this point. The circuit diagram is shown in Fig. 1.

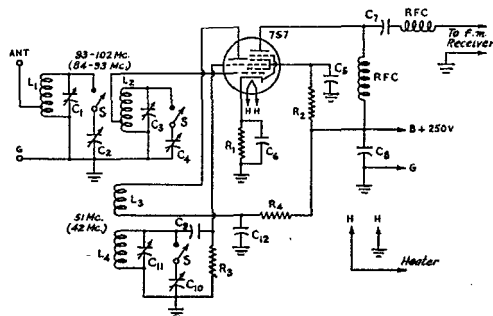
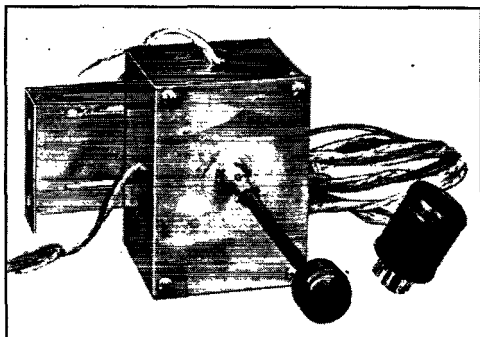

Fig. 1 — Circuit diagram of the one-tube f.m. converter. C₁, C₂, C₃, C₄, C₁₀, C₁₁ — 15- μ fd. mica trimmer. C₅, C₆, C₁₂ — 300- μ fd. mica. C₇ — 500- μ fd. mica. C₈ — 0.01- μ fd. paper. C₉ — 100- μ fd. mica. R₁ — 100 ohms, 1/2 watt. R₂ — 25,000 ohms, 1 watt. R₃ — 50,000 ohms, 1/2 watt. R₄ — 20,000 ohms, 1 watt. L₁ — 3 turns, 1/2 inch diameter, tapped 1 turn from ground end. L₂ — 3 turns, 1/2 inch diameter, tapped at center. L₃ — 2 1/2 turns, 5/8 inch diameter. L₄ — 2 1/2 turns, 5/8 inch diameter. RFC — V.h.f. choke. S — Poles of 3-pole, single-throw switch. L₁ and L₂ are coupled together.



Experimental model of Hallicrafters' one-tube f.m. converter, with universal mounting bracket and plug for taking off power from the receiver.

It uses a single 7S7 tube, its power drawn through an adaptor plug which fits under one of the receiver's output tubes. It mounts in a single hole in the f.m. receiver cabinet, and all tuning is done with the regular receiver dial. This is a fixed-tune device, using the receiver as a variable i.f. Our diagram shows the circuit used in one of the preliminary models. The r.f. input goes to a band-pass filter, while the oscillator section operates at a fixed frequency — or, rather, there are two fixed frequencies so that the proposed new band, 84-102 Mc., is covered in two ranges. The single control is a three-position panel switch, one position permitting normal operation of the receiver while the other two connect in different values of capacitance in the band-pass and oscillator circuits of the converter. This rig would

seem to substantiate the claim made by Cy Read in his original testimony for Hallicrafters that a practicable converter for the new f.m. band can be retailed at less than \$10.

BOARD MEETING

THE ARRL Board of Directors will have its annual meeting in Hartford on May 4th. Members with ideas on their chests for the good of the craft are invited to get in touch with their respective division directors, as listed on page 8. The main items on the Board's agenda of course relate to the continuing effort to assure the restoration of our frequencies and the necessary planning for the resumption of amateur radio after the war. Under the latter head, the Board is expected to examine the problem of assuring an adequate number of station calls in the postwar period, as discussed in our February editorial. A detailed report of the meeting will appear in our July issue.

CANADIAN NOTES

ALEXANDER REID, VE2BE, the ARRL Canadian General Manager, has announced his selection of representatives of the ARRL Canadian Section on the Canadian Radio Technical Planning Board. On Panel A the section will be represented by Mr. Reid himself or, alternatively, by Lt. Comdr. Noel N. Wright, VE2DU, or by Gordon Southam, VE2AX. On Panel B the section will be represented by Roderick D. McDonald, VE2FO (chief of the aircraft division of War Assets Corp.), or by Air Commodore A. H. Keith Russell, VE9AL, who has lately returned to civilian life. Panel C, Leonard Walker, VE3JI, or W. C. J. Meredith, K.C., VE2HM; Panel D, A. H. Dingman, VE2IE, or L. R. C. McAteer, VE2EM; Panel E, O. C. S. Wallace, jr., VE2AL, or J. A. Adam, VE2CM; Panel F, F. W. Heyv-sege, VE2HV, or T. S. Welsman, VE2HW. The CRTPB is expected to be actively at work at panel level by the time this appears in print, making recommendations to the Government for postwar radio matters in the Dominion.

BRITISH NOTES

THE current issue of the *R.S.G.B. Bulletin* carries a statement issued by the Council of the Incorporated Radio Society of Great Britain on postwar license policy, reporting its negotiations with the General Post Office and other government departments on the restoration of amateur facilities after the war. Briefly:

The GPO intends to restore facilities to all prewar fully licensed amateurs who formally apply, re-allocating prewar calls. New licensees probably will receive three-letter calls, e.g., G7ABC. It is believed that the artificial aerial license will be discontinued, prewar holders of same to be given full licenses upon evidence of code proficiency. The examination will have a technical portion and a code test at 12 w.p.m. Applicants who have served in radio in the Army, Navy or Air Force and produce satisfactory proof of proficiency in code or theory may be exempted

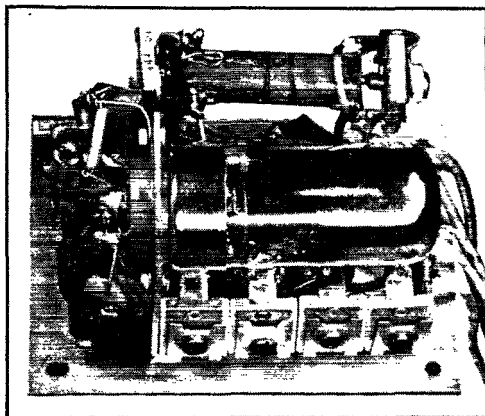

Inside view of the one-tube converter, showing band-pass windings at the left, adjustable condensers at the right. The oscillator coils are below the socket of the 7S7 tube.

from that part of the examination. It is anticipated that there will be three types of license: Class A, 25 watts to new applicants, telegraphy only except on special application; Class B, 150 watts after twelve months' experience, 'phone and c.w.; Class C, high power for a restricted period and under stiff regulations. Power on the 1.7-Mc. band, previously limited to 10 watts, is expected to be set at 25 watts postwar. Guard bands and the old restrictions on sending times are expected to be abolished. Impounded apparatus is to be returned as soon as possible after the cessation of hostilities. The British license is expected to authorize any British amateur to operate any other licensed British amateur station. The operation of portable stations within a radius of ten miles of home is expected to be authorized. RSGB has asked that all frequencies made available to amateurs in the international regulations be assigned to British amateurs. On this point we quote from the article:

"The Society has requested the GPO to make available the following bands of frequencies to amateurs: 1715-2000 kc., 3500-4000 kc., 7000-7300 kc., 14,000-14,400 kc., 28,000-30,000 kc., 56,000-60,000 kc. The GPO has also been asked to support the Society's request for permission to use the band of frequencies 21,000-22,000 kc. and to agree to allocate sample bands of frequency in the v.h.f. region. If it is not possible to continue the harmonic sequence beyond 56-60 Mc., the Society has suggested that a new datum point be assigned say 130 Mc., doubling to 260 Mc., 520 Mc., etc. The importance of amateurs being allotted sample bands throughout the spectrum up to the highest frequencies, is recognized by the GPO.

"Whilst it is not yet possible to state whether the six short-wave bands referred to above will be issued in toto to British amateurs, the Society intends to press for the most liberal treatment, bearing in mind

a) the very valuable service which British amateurs have rendered during the war,

AMATEUR WAR SERVICE RECORD

Name

Call, present or ex; or
grade of op-license only

Present mailing address

SERVICE

Rank or rating

- Army
- Navy
- Coast Guard
- Marine Corps
- Maritime Service
- Merchant Marine
- Civil Service
- Radio industry,
100% war

Branch or bureau: *Signal Corps, AAF, BuShips, WAVES, etc.*
If civilian industry, give title and company.

- b) the substantial increase in the number of licensees which is certain to occur within a few years of facilities being restored,
- c) the educational and scientific value of amateur radio."

WAR SERVICE RECORDS

WE REPORT to you again that at ARRL headquarters we are endeavoring to compile a record of all the U. S. and Canadian amateurs who are employing their radio know-how in the war effort, whether in uniform or in certain essential civilian capacities shown on our form above. This record provides the data to prove the value of amateur radio to the nation and supplies, as well, the information for our "In The Services" column. Although we have worked on this endeavor throughout the war, there are thousands of you whose names we do not have. Won't you do your part by checking in with us? It will take only a moment to clip and fill out the form below — or to reproduce its essentials on a post card if you prefer. It will help the good work along and we'll much appreciate it.

CARL — The Chinese Amateur Radio League

BY KUNG SHAO-HSIUNG*

PRIOR to the Sino-Japanese war the Chinese amateurs had some district organizations, the most notable of which was the Chinese Amateur Radio Club in Hangchow. After the war broke out, most of the Chinese hams in Hangchow and Shanghai went to Nanking and asked the Chinese government for war service. The Chinese Amateur War Service — CAWS — was

then founded in 1937 under the auspices of the Chinese government. It was a nationwide organization through which the efforts of about 200 Chinese hams were activated in different lines.

They had once in a while maintained the radio link between occupied and free China. They had jabbed the Jap's absurd broadcasts and reciprocated with correct conceptions. One of the most interesting things was that they sent messages for the Jap prisoners in China to their homes, told their mothers and wives of the kindness they received from the Chinese government and the new comprehension of the deceit they received from the Japanese government. Those are worthy of mention in the work done by CAWS.

In 1940 the Chinese hams began to look forward to a permanent organization. The CAWS was replaced by the CARL — the Chinese Amateur Radio League. This organization is now considered by the Chinese public to be equal in rank with other technical societies, such as the Chinese Institute of Engineers. Its work extends to new aspects. District branches under the control of the headquarters in Chungking have been set up in big cities and universities. This action aims at membership especially among the college students. It now has twelve city branch and six university branch organizations, with a total membership of 1500. The president now acting is U. T. Hsu, who was the former vice minister of communication. The vice president is K. T. Chu, an OM who designed the first short-wave transmitter in China.

Since its formation, the CARL has published a magazine, *CQ*, issued monthly. Training schools have been erected in Chungking and Kunming to train radio servicemen and operators for government needs. Public lecturing meetings are often held. Chinese hams speak on radio topics to audiences who receive free admittance. War service remains a part of its work.

As most of the amateur stations in different countries are dismantled now, in China there is

(Continued on page 80)

* c/o International Training Administration, 734 15th St., N. W., Washington, D. C.; formerly the manager of the Chungking Branch of CARL and at one time an operator of station XU6KL.

A Crystal-Controlled Transmitter for the V.H.F.s

Three Tubes in a Simple 175-Watt Job

BY GEORGE W. BROOKS,* WIJNO

As the title indicates, this article describes a three-tube crystal-controlled transmitter covering the amateur 14-, 28-, 56- and 112-Mc. bands. Its circuit is straightforward, the construction is simple and the cost of the required parts should be low.

THE year before Pearl Harbor I had the desire to have a simple medium-power rig for the higher-frequency ham bands up to and including 112 Mc. I wanted it to be modern and to put the best possible signal on the air. Since cost entered into the picture, I wanted also to use the same modulator, power supplies and tubes used in my low-frequency transmitter. When it came to additional parts, the junk box would have to furnish as many of them as possible.

Before I started laying out the new rig, several plans were investigated and friends were consulted for suggestions. These ideas had to be balanced against whatever the junk box had to offer. The outcome of the struggle is shown in the accompanying photograph.

The Circuit

To start out, the oscillator circuit should be simple. Since I had several 14- and 28-Mc. crystals, a 6J5GT was chosen as the oscillator tube and the circuit shown in Fig. 1 was designed around it. Included in the circuit is the screen voltage-dropping resistor, R_2 , and the by-pass condenser, C_2 , so that a 6V6GT can be substituted for the 6J5GT and a coil-and-condenser combination substituted for the crystal for use with an f.m. exciter unit. Also, the 6V6GT will furnish more power from 14-Mc. crystals if their use is desired. Grid bias is obtained from the cathode resistor, R_1 , alone. The

values for the plate tank circuit were secured from the Bliley crystal manual and the arrangement works out excellently with a very minimum amount of crystal heating and frequency drift.

The plate circuit of the oscillator is connected to the 807 buffer amplifier or doubler by capacitive coupling. By keeping the capacity of the coupling condenser, C_5 , small, grid loading of the plate circuit of the oscillator isn't excessive and good drive to the 807 is obtained. Originally a grid r.f. choke was tried, but the 75,000-ohm grid resistor, R_4 , by itself permits better excitation and prevents a tendency toward parasitic oscillations in the 807 stage when working "straight through" at 28 Mc. The plate tuning condenser, C_6 , in the buffer-doubler stage originally was a 100- μ fd. unit. All plates were removed except one rotor and two stator plates, although it might be better to leave another rotor and stator plate, especially if 14-Mc. operation is contemplated. This stage and the oscillator are operated from the same power supply, plate voltage to the oscillator being dropped to 250 volts through R_3 .

Inductive coupling is used between the buffer-doubler and the final amplifier. The grid coil, L_3 , is close to self-resonance and is coupled tightly to L_2 so that C_3 tunes the amplifier grid circuit to a certain extent as well as the plate circuit of the 807. To my mind this arrangement is just as efficient as link coupling without the bother of an ad-

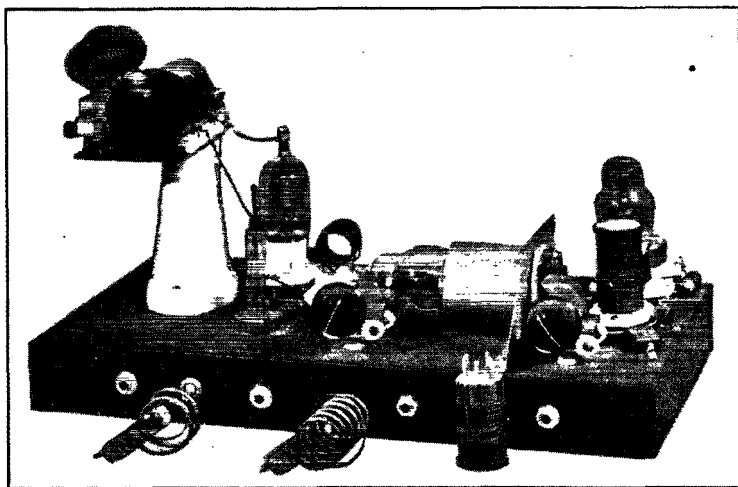

The simple crystal-controlled transmitter for v.h.f. work. The crystal oscillator is to the right, the 807 buffer-doubler in the center and the HK24 final amplifier to the left.

*28 Friendship St., Newport, R. I.

ditional tuned circuit. It is very easily adjusted for maximum transfer of power.

The output amplifier is operated as a frequency doubler at 112 Mc. with a 28-Mc. crystal, or at 56 Mc. with a 14-Mc. crystal.

Almost any of the medium-power, low-capacity, high- μ tubes, such as the 35T or, as in my case, the HK24, may be used with appropriate filament supply. A split-stator neutralizing circuit is used with a Millen low-capacity neutralizing condenser, C_{11} . If a plate voltage higher than 800 is contemplated, the tank condenser, C_{12} , should have greater plate spacing than that specified. The tube is biased to plate-current cut-off by a 45- to 90-volt battery. Additional operating bias is contributed by the grid-leak resistors, R_7 and R_8 . The latter is used to obtain high bias for doubling frequency only and is short-circuited by S_1 when the stage is operating as a straight amplifier. Link coupling is used between the output tank and a separate antenna-tuning unit.

Metering jacks are provided for checking cathode currents of all stages as well as the grid current of the final amplifier.

Construction

The components are mounted in breadboard style on a standard steel chassis $17 \times 9 \times 2\frac{1}{2}$ inches. The oscillator is at the right-hand end of the chassis with the crystal, the 6J5GT, the plate coil, L_1 , and the tuning condenser, C_4 , in line. The condenser is insulated from the chassis by mounting it on "button"-type ceramic feed-through insulators. The oscillator coils are wound on

standard bakelite plug-in forms $1\frac{1}{4}$ inches in diameter.

The 807 is mounted in a horizontal position to permit short leads from the oscillator output circuit to the input of the 807. In fact, the entire grid-lead length is made up of the grid coupling condenser, C_5 . Similarly, the components of the buffer-doubler plate tank circuit are grouped closely around the plate terminal of the 807. The cathode and screen by-pass condensers, C_6 and C_7 , and the grid resistor, R_4 , all are terminated to ground at the same point on the tube socket where the screws holding the socket and bracket shield together meet at the filament pins. Coils L_2 and L_3 are self-supporting and are mounted on a four-prong ceramic plug-in base with the low-potential ends (bottom ends in Fig. 1) coupled tightly.

The HK24 and its neutralizing condenser, C_{11} , are placed close to the socket terminals of L_3 . Short leads to the output tank circuit are made possible by elevating the components on a large stand-off insulator which brings them up near the plate terminal of the tube. A piece of bakelite sheet is used as a base upon which C_{12} and the Millen medium-size coil socket for L_4 are mounted. A hole in the bakelite base is lined up with the mounting hole of the condenser and the hole through the center of the stand-off insulator and a long machine screw is passed through to bolt the assembly together. This screw also serves to bring the high-voltage line up through the insulator to the r.f. choke, RFC_3 , which is mounted between the coil socket and the hole in the con-

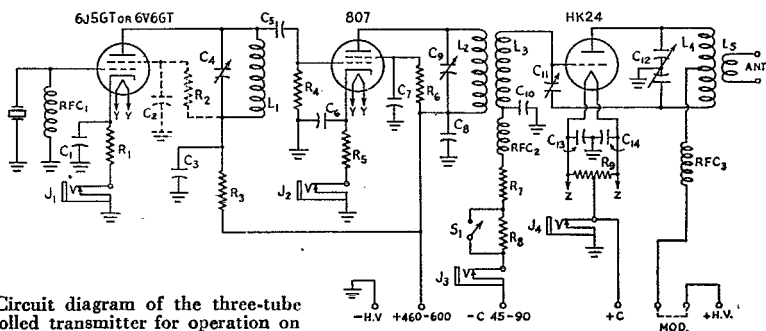

Fig. 1 — Circuit diagram of the three-tube crystal-controlled transmitter for operation on high frequencies.

- $C_1, C_2, C_3, C_6, C_7, C_8, C_{10}, C_{13}, C_{14}$ — 0.002- μ fd. 1000-volt mica.
- C_4 — 100- μ fd. variable.
- C_5 — 75- μ fd. 1000-volt mica.
- C_9 — 20- μ fd. (approx.) midget variable.
- C_{11} — Neutralizing condenser (Millen 15001).
- C_{12} — 35- μ fd. per section, double-spaced midget variable. (Use condenser with greater spacing if plate voltage is over 800.)
- R_1 — 500 ohms, 1 watt.
- R_2 — 50,000 ohms, 2 watts.
- R_3 — 10,000 ohms, 5 watts.
- R_4 — 75,000 ohms, $\frac{1}{2}$ watt.
- R_5 — 500 ohms, 5 watts.
- R_6 — 25,000 ohms, 2 watts.

- R_7 — 5000 ohms, 5 watts.
- R_8 — 25,000 ohms, 5 watts.
- R_9 — 75 ohms, center-tapped, 5 watts.
- L_1 — 9 turns No. 18, $1\frac{1}{4}$ inches diameter, $1\frac{1}{4}$ inches long for 14 Mc.; 4 turns No. 18, $1\frac{1}{4}$ inches diameter, $\frac{3}{4}$ -inch long for 28 Mc.
- L_2 — 11 turns No. 18, $1\frac{1}{4}$ inches diameter, $1\frac{1}{4}$ inches long for 14 Mc.; $5\frac{1}{2}$ turns No. 18, $1\frac{1}{4}$ inches diameter, $1\frac{1}{4}$ inches long for 28 Mc.; 4 turns No. 12, 1 inch diameter, turns spaced wire diameter for 56 Mc.
- L_3 — 15 turns No. 22, $1\frac{1}{4}$ inches diameter, $1\frac{1}{4}$ inches long for 14 Mc.; 7 turns No. 22,

- $1\frac{1}{4}$ inches diameter, 1 inch long for 28 Mc.; $4\frac{1}{2}$ turns No. 12, 1 inch diameter, turns spaced wire diameter for 56 Mc.
- L_4 — 22 turns No. 12, $1\frac{1}{4}$ inches diameter, $2\frac{1}{2}$ inches long for 14 Mc.; 12 turns No. 10, $1\frac{1}{4}$ inches diameter, $2\frac{1}{2}$ inches long for 28 Mc.; 6 turns No. 10, $1\frac{1}{4}$ inches diameter, $2\frac{1}{2}$ inches long for 56 Mc.; 2 turns No. 8, $1\frac{1}{2}$ inches diameter, turns spaced to tune to the band for 112 Mc.
- L_5 — 1 turn No. 14, $1\frac{1}{4}$ inches diameter for 14 Mc., 28 Mc., and 56 Mc.; 1 turn 1 inch diameter for 112 Mc.

denser base. This arrangement provides a very compact and sturdy mounting.

Coils for the final amplifier are self supporting and are mounted on Millen plug-in coil bases. The 112-Mc. coil is wound with wire which is larger than the holes in the pins of the base, so the ends of the coil are filed down to fit and sweated into the pins with solder. This makes an excellent mechanical and electrical connection as witnessed by the fact that the rest of the coil gets hotter than the pins under operation.

Metering jacks and the toggle switch, S_1 , are mounted in holes lined up along the front edge of the chassis.

When the final stage is operated as a straight amplifier, the grid current should run between 22 and 25 ma. with load applied with either the 35T or the HK24. When doubling frequency with the additional grid-leak resistance in the circuit, it should run 12 to 15 ma. This provides sufficient excitation, and the minimum unloaded plate current should not exceed 30 ma. even at 112 Mc. with 1000 volts on the plate. It is, of course, unwise to operate the stage unloaded for any length of time because the circulating currents and voltages developed are quite high.

This transmitter will get up to 112 Mc. in a hurry, has few parts and performs excellently. For any v.h.f. work up to about 175 watts I think that, part for part, it cannot be beaten.

New Apparatus

Plywood Antenna Masts

ANTENNA-MAST problems of the postwar hams will be greatly simplified by the use of lightweight tubular plywood masts whose development and manufacture were recently announced by the Plymold Corporation of Lawrence, Massachusetts. Outstandingly attractive to amateurs is the ease of erection and the simplicity of removal of masts of this type from one location to another. Steel towers embedded in concrete or ladder masts similarly anchored, as well as bulky wood lattice structures, usually are not erected in the first place unless permanency of location is reasonably assured. This no longer need be a factor in deciding to erect a 50-, 55- or 75-foot support for directional systems, simple antennas or even v.h.f. rotatable arrays. These poles are engineered to withstand a horizontal pull of 10,000 pounds and a top load of 300 pounds. Neat-looking tapering masts capable of withstanding wind velocities of 125 miles per hour may well replace the more or less unsightly construction of the prewar era.

New records in v.h.f. DX and favorable progress in u.h.f. experimentation seem inevitable in view of the portability of these masts. The lack of tall trees from which to hang a good antenna or the presence of adjacent buildings or other low obstacles no longer need hamper the choice of an otherwise good location. Nor will the fear of one day having to move elsewhere and having

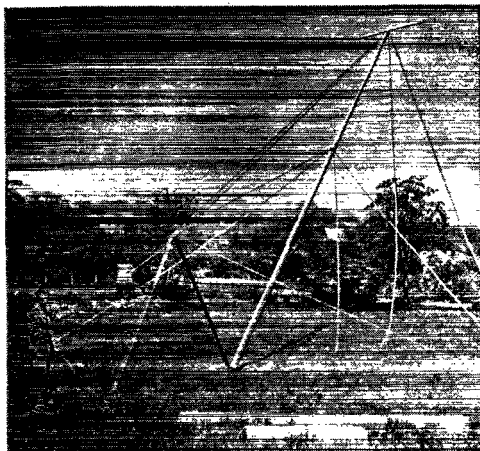

This tubular plywood antenna mast is easily erected by one man.

to tear down or leave behind the old mast stop a ham from putting up a good one. Field Day contests, especially, will take on new aspects of greater and more interesting activity. The hollow sections of these masts when packed in a carrying case are telescoped and no one section is longer than twelve feet. The whole works, mast sections and fittings, can be carried by hand to a choice spot and erected in a few hours by one or two men. The 50- and 55-foot masts can be mastered single handed. Adjustment of element lengths and spacings may be made time and again, for the entire mast may be lowered and raised in a matter of minutes once its guy wires and anchor stakes have been fixed.

Almost any type of v.h.f. array may be mounted on these masts. Special cross arms and fittings are available not only for supporting, but for rotating and tilting the elements as well. This is just the ticket for getting out and working DX on the new amateur-band assignments in the u.h.f. regions.

Equipment for mounting and raising are included with each of the units. The method is straightforward and simple. Mast sections are put together, guy wires fastened on, and anchor posts properly spaced are driven into the ground. As the photograph shows, a hoisting boom, similar in some respects to the familiar gin pole, is fastened to the base of the mast at approximately right angles to it; at the other end guy wires and a block-and-tackle are attached, making everything ready for raising the mast. All guys, except the two that will take up their slack as the mast comes up are made taut. Guy rings are placed at the top and the center. Rounding up the old gang for the "barn raising" ceremonies and getting out the old buggy to "yank 'er up" are things of the past, for masts of this type up to 55 feet in height are one-man propositions.

Undoubtedly, in the postwar amateur activities to come, such masts will play a very important role.

— W. E. B.



REGISTRATIONS for ITS from men in the service are now on the wane, a condition we have been expecting for some time, but we feel there are still many who have not enrolled. As a suggestion to all amateurs in the war effort who are members of a radio club, how about asking the secretary of your club to compile an honor roll and send it to League Headquarters? Several large clubs now send us club bulletins monthly with this information and it is very helpful in swelling our roster. And don't forget to mail the AWSR form on page 24.

ARMY—SIGNAL CORPS

ex-1BND, Nyhen, Major, foreign duty
 1LBQ, Hume, Pfc., foreign duty
 2HVC, Hill, Lt., Kelly Field, Texas
 2HDR, Foster, Lt., foreign duty
 2JMG, Rook, Cpl., foreign duty
 2MDA, Hamilton, 2nd Lt., foreign duty
 2MEV, Lifgren, Sgt., foreign duty
 2MPQ, Barker, Cpl., foreign duty
 3AAL, Summers, T/5, foreign duty
 3IAX, Bilinski, T/3, foreign duty
 3JEG, Buts, S/Sgt., foreign duty
 3JLM, Tanenbaum, T/5, foreign duty
 4FYG, Barton, Lt., foreign duty
 4HIA, Gilliam, Sgt., Jamestown, N. Y.
 4HLW, Pavel, M/Sgt., foreign duty
 5FZM, Saye, 2nd Lt., Ft. Monmouth, N. J.
 5H0J, Bahn, T/3, foreign duty
 5IGG, Keener, T/4, foreign duty
 5IYA, Inabnet, T/5, foreign duty
 6BAQ, Snyder, Capt., Camp Crowder, Mo.
 6EAB, Rice, Major, Camp Crowder, Mo.
 6JYA, Dellevoit, W/O, foreign duty
 6PPO, Spaulding, 2nd Lt., Ft. Monmouth, N. J.
 6QGP, Walther, T/3, foreign duty
 K6QMC, Hosken, Lt. Col., foreign duty
 6SBV, Vieira, Pfc., Ft. Lewis, Wash.
 7JAB, Ellis, T/4, foreign duty
 8AMP, Gardner, T/4, Ft. Hayes, Ohio
 8DIY, Beard, Capt., Ft. Monmouth, N. J.
 8LIO, Rodebaugh, Cpl., Camp Crowder, Mo.
 8NCV, Dettmar, T/5, foreign duty
 8PUJ, Hulbert, S/Sgt., foreign duty
 8RZB, Garard, Pfc., foreign duty
 8TWC, Hanson, Pfc., foreign duty
 8TYX, Mathews, 2nd Lt., Ft. Monmouth, N. J.
 8UUD, Murray, T/5, foreign duty
 9AST, Patchman, T/5, foreign duty
 9HHA, Dwyer, Pvt., foreign duty
 9HWW, Camien, Capt., foreign duty
 9MFB, Hargraves, Pfc., foreign duty
 9OGY, Reynolds, Lt., foreign duty
 9QWU, Bendon, S/Sgt., foreign duty
 9TUL, Cannon, 2nd Lt., Ft. Monmouth, N. J.
 9ULH, Ruzicka, Pvt., Camp Crowder, Mo.

Operator's license only:
 Bates, T/5, foreign duty
 Corathers, T/4, foreign duty
 Corbett, T/Sgt., foreign duty
 Eisenschiml, M/Sgt., foreign duty
 Hill, S/Sgt., foreign duty
 Newstrom, T/5, foreign duty
 Starr, Cpl., foreign duty
 Weinstein, Pvt., Ft. Jackson, S. C.
 Zitzman, Col., foreign duty

NAVY—SPECIAL DUTY

1MYF, Latway, Sic, foreign duty
 2NLI, Moulton, RT3c, Chicago, Ill.
 3JTV, Eskridge, Sic, Great Lakes, Ill.
 6IAP, Thompson, RT1c, Treasure Island, Calif.
 ex-6LNY, Lea, CRT, foreign duty
 6PSY, Shaddock, CRT, Chicago, Ill.
 6QKY, Current, CRT, foreign duty
 6RTR, Seguin, RT1c, Treasure Island, Calif.
 6SSJ, Campbell, RT1c, foreign duty
 6STO, Bryant, RT2c, foreign duty
 6UKG, Beahr, RT3c, Treasure Island, Calif.
 8OKK, Sadd, RT3c, Washington, D. C.
 9HQW, Main, RT1c, foreign duty
 9LWZ, Setzke, RT2c, foreign duty
 9VWF, Mackie, RT3c, Camp Pendleton, Calif.
 9YTF, Jameson, Sic, Lombard, Ill.
 ex-9ZAX, Williamson, CRT, foreign duty

Operator's license only:

Cowell, Sic, Chicago, Ill.
 Grubbs, RT1c, Philadelphia, Pa.
 Slemmer, RT1c, Washington, D. C.
 Thornley, Sic, Great Lakes, Ill.



The fur bearing animal in this photo will be recognized by his many friends as Ralph J. Gibbons, W7KV, now a lt. colonel in the Air Corps, CO for the ATC at a base in the northwestern part of Canada. He was formerly ARRL Northwestern Division director from 1933 to 1942 and a captain for United Air Lines. Called to active duty in 1942, he has been in the North for the past year. Amateur radio still occupies a place in his life as he has had many interesting rag-chews and attended a hamfest in Fairbanks, Alaska.

COAST GUARD

1EXG, Lindsay, RT1c, Gainesville, Ga.
 1MCC, Konos, RM1c, foreign duty
 1MFV, Lowe, CRM, New Orleans, La.
 1MWX, Hemeon, CRM, foreign duty
 3JUV, Thompson, foreign duty
 4SQ, Cunningham, CRT, Coral Gables, Fla.
 5FSA, Hargus, CRM, New Orleans, La.
 5IKV, Feindel, RT1c, Port Arthur, Texas
 7COB, Hart, CRM, Aloha, Oregon
 8GZP, Dohne, Sic, Washington, D. C.
 9KFE, Frayser, RE, foreign duty

Operator's license only:

Prewett, A/S, Brooklyn, N. Y.
 Schmidt, RT1c, Union, N. J.

ARMY—AIR FORCES

2LPB, Silver, Cpl., Camp Ritchie, Md.
 2NBB, Herrmann, Lt., Champaign, Ill.
 2NEF, Kaidler, Pfc., Asheville, N. C.
 2NOS, Rivman, Sgt., foreign duty
 4EAD, Schauer, S/Sgt., Boca Raton Field, Fla.
 4FHC, Hastings, S/Sgt., foreign duty
 5EJF, Wanja, Major, foreign duty
 5FEY, Neidert, Lt., Ellington Field, Texas
 5FEY, Hunt, M/Sgt., foreign duty
 5HMG, Snow, 2nd Lt., foreign duty
 5JWS, Schafer, Pvt., Keesler Field, Miss.
 ex-6LDW, Komer, Sgt., Sioux Falls, S. D.
 6LWL, Shallenberger, S/Sgt., foreign duty
 6NSO, Riesenman, Lt., Baer Field, Ind.
 6RNM, Garner, Pfc., Gowen Field, Idaho
 6TRZ, Harsh, Lt., Chanute Field, Ill.
 ex-8BVA, Jones, Cpl., McCook, Neb.
 8PMT, Siebert, Cpl., Eglin Field, Fla.
 8FOS, Lash, S/Sgt., foreign duty
 8ULP, Vanderjaag, T/Sgt., Dodge City, Kans.
 8WOZ, Casciotti, Lt., foreign duty
 8WSS, Tallero, Cpl., McClellan Field, Calif.
 9BEK, Hill, Sgt., Harvard, Neb.
 9BYN, DeLong, Cpl., Bluetenthal Field, N. C.

9KIU, Chambers, Pvt., Pittsburg, Kans.
 9FDN, Cockrell, Cpl., foreign duty
 9PKD, Addison, Lt., Salina, Kans.
 9QAE, Sarikas, Sgt., foreign duty
 9CVR, Stone, Sgt., foreign duty
 9RDO, Carpenter, T/4, foreign duty
 9WVE, Cidlik, Sgt., foreign duty

Operator's license only:

Holt, Pfc., Morrison Field, Fla.
 Mumz, Pvt., Alamogordo, N. M.
 Nehman, T/Sgt., foreign duty
 Vince, Cpl., foreign duty

NAVY—GENERAL

1AZT, Paskus, CRM, foreign duty
 1IHC, Pechilis, RM3c, foreign duty
 1LHZ, Burgoyne, CRM, Quonset Point, R. I.
 1NHC, Booth, RM2c, foreign duty
 2LQC, Herman, RE, foreign duty
 2LYH, McGraw, RM2c, foreign duty
 2NTF, Wouffe, RM2c, foreign duty
 2ODN, Bestard, RM2c, foreign duty
 2OMC, Hansmann, Mid., Annapolis, Md.
 3EDG, Koontz, Lt. (jg), Bethesda, Md.
 3HAP, Sweeny, Lt. Comdr., foreign duty
 3JCF, Smith, RM3c, foreign duty
 ex-K4AXG, Taylor, WRE, Jacksonville, Fla.
 4FOL, Floyd, RM1c, foreign duty
 5FYX, Briehn, S2c, Beaumont, Calif.
 5IAU, Collins, Sic, Chicago, Ill.
 5KMN, Stephenson, RM2c, foreign duty
 6DPL, Heywood, RM1c, foreign duty
 ex-6ENS, Coggins, Lt., Gainesville, Ga.
 6FNN, Roberson, CEM, foreign duty
 6SJZ, Williams, Lt. (jg), foreign duty
 6TLU, Ballenger, A/S, Berkeley, Calif.
 ex-7AZY, Gilroy, Lt. Comdr., address unknown
 ex-7GI, Barber, Lt., Gainesville, Ga.
 7GUS, Nelson, EM3c, San Diego, Calif.
 7GWK, Brown, CRM, foreign duty
 8BMX, Mueller, Lt., Norfolk, Va.
 8DLJ, Digby, Lt. (jg), Washington, D. C.
 8JGR, Hart, Lt. (jg), Norfolk, Va.
 9AAR, Sodaro, Lt., Gainesville, Ga.
 9BVD, Sullivan, RM3c, Gainesville, Ga.
 ex-9FYA, Jensen, Sic, Gainesville, Ga.
 9SPR, Logan, RM1c, Little Creek, Va.
 9UAD, Robinson, A/S, Lafayette, Ind.
 9YEZ, Klopfenstein, Ens., Brunswick, Me.

Operator's license only:
 Demoris, RM3c, Oceanside, Calif.
 Frank, RM3c, Woodland, Calif.
 Hriczo, RM3c, foreign duty
 Meeks, S2c, Bremerton, Wash.
 Phillips, RM3c, Oceanside, Calif.
 Wisler, CRM, foreign duty

ARMY — GENERAL

1JRD, Bishop, Sgt., foreign duty
1KXU, Walsn, S/Sgt., foreign duty
2CQL, Greyson, Lt., Harrisburg, Pa.
2IJT, Kaiser, S/Sgt., foreign duty
2JUQ, Schwartz, Lt., Ft. Lewis, Wash.
2LRT, Bohn, T/5, Santa Fe, N. M.
2NCL, Molony, T/3, New York, N. Y.
2NGF, Smikle, T/5, Camp Plauche, La.
3AID, Burroughs, Camp Wheeler, Ga.
3HUZ, Duffield, T/5, Camp Croft, S. C.
3ILA, Ruth, Lt., foreign duty
3IMX, King, Lt. Col., Arlington, Va.
4CCJ, Huggins, Capt., Washington, D. C.
4GRR, Beason, T/4, Rome, Ga.
5DNN, Stevenson, Major, foreign duty
6KOW, Atebora, Pvt., Camp Bowie, Texas
6TIA, Nickel, Pvt., Oak Ridge, Tenn.
6UPY, Simpson, Sgt., foreign duty
7BTZ, Mitchell, Pvt., Ft. Lewis, Wash.
ex-7BUU, Jenkins, Pfc., foreign duty
9CJN, Erickson, Sgt., foreign duty
9FAW, Smith, T/5, foreign duty
9CAG, Dumas, T/Sgt., Brooklyn, N. Y.
9QAC, Perry, 2nd Lt., Ft. George G. Meade, Md.
9TJM, Lowell, Pvt., Auburn, Calif.
9UEH, Kittleson, Pvt., address unknown
9VWF, Robinson, T/Sgt., foreign duty

Operator's license only:

Chase, Pvt., foreign duty
Fritz, Pfc., Camp Stewart, Ga.
Haynen, Lt. Col., Dallas, Texas
Petty, Lt., foreign duty

NAVY — AERONAUTICS

2MMY, Ziner, ART1c, Hutchinson, Kans.
4EXK, Comer, ACRT, Gainesville, Ga.
5EJT, Jank, ART1c, Gainesville, Ga.
5OH, Barringer, AEM3c, Terminal Island, Calif.
6BMK, Morrill, Lt. Comdr., Los Alamitos, Calif.
6DIU, Hartley, ACRT, foreign duty
6EAG, Cline, ART1c, Gainesville, Ga.
6SCX, McConnell, ACRM, College Station, Texas
KOSDM, McDonald, ACRM, Gainesville, Ga.
7EXF, Sutherland, ACRM, Lakehurst, N. J.
7LOC, Poole, Ens., Boca Chica, Fla.
8GLQ, Kingsbury, ART1c, Miami, Fla.
8LOE, Monos, ART1c, Gainesville, Ga.
8UHI, Lumney, AEM3c, Jacksonville, Fla.
8VLI, Jones, Lt. (jg), Memphis, Tenn.
9CWF, Christofferson, ART3c, Corpus Christi, Texas
9PWW, Hutchinson, ART2c, Gainesville, Ga.
ex-9YAE, Whitlock, ACRT, foreign duty

MARINE CORPS

1MWQ, Werner, Pvt., Camp Lejeune, N. C.
1NBD, McMaster, Pfc., Camp Lejeune, N. C.
4FJS, Walton, Capt., Kinston, N. C.
4FMJ, Harrell, T/Sgt., Corpus Christi, Texas
4FT, Penney, Sgt., foreign duty
7FNU, Spaugh, MT/Sgt., Camp Miramar, Calif.
8EFW, Ryan, Cpl., foreign duty
8MSG, Shafer, RM1c, foreign duty
9FZL, McGown, W/O, Camp Lejeune, N. C.
ex-9QZK, Malloy, Sgt., foreign duty

Operator's license only:

Andrikopoulos, Pvt., foreign duty
Baker, Pfc., foreign duty

MERCHANT MARINE AND MARITIME SERVICE

1ANB, Curran; 1BIR, Gastonguy; 1FPS, Flood; 2HCW, Tamehin; 2MMN, Ingraham; 2NPF, Hamilton; 2NKL, Mauer; 2OGG, Abel; 3EED, Yoder; 3ISY, Gutke; 3IUQ, Dziubek; 5FZG, Duncan; 7OG, Lundquist; 8TVV, Milazzo; 9ACQ, Ward; ex-9CQW, Maxwell; 9ISS, Feil, and 9NHV, Reutner, Burnett, Carter, Greenlun, McDonough and Smith hold operator's license only.

We take pleasure in presenting a group of radio amateurs who are in the Technical Training Department of the NATTC, Ward Island, Corpus Christi, Texas. *Left to right, front row:* T/Sgt. Gumb, on license only; ART1c Wimberly, W4EPY; ART1c Montgomery, W4DEW, and T/Sgt. Harrell, W4FMJ. *Second row:* RE Horvath, W9SPE; Ens. Schiavone, W3INA; Ens. Lehner, W9VHF; Lt. Dilks, W3AHN; Lt. Snelling, W9PHZ; Lt. Kent, W2JFA; Lt. Cox, W6PHW; Lt. (jg) Brown, W9EPV; Lt. (jg) Pfister, W9IQZ, and Lt. (jg) Sprecher, W6AOU. *Third row:* ACRT Young, W7CIA; ACRT Dotts, W6RCJ; ACRT Kirkpatrick, W6MSL; ACRT Galloway, W6AOK; ACRT Barsumian, W9UPR; ACRT Pulliam, W9LBQ; ACRT Yeoman, W8VHY; ACRT Wedel, W6-MRF; ACRT Stacy, W6DUP; ACRT Leonard, W7DFU; ACRT Mifflin, W7AMB, and ACRT Jennings, W4CTT. *Fourth row:* ACRT Randall, W1KVP; ACRT Webster, W5FBS; ACRT Walker, W7GIV; ACRT Hartley, W1EQG; ACRT Dubler, W6CNB; ACRT Haimbach, W3JKK; ACRT Sappington, W7IJK; ACRT Whitaker, ex-W6PUD; ACRT Morgan, W4WB, and ACRT Schauer, W8OEA. *Fifth row:* ART1c Bergin, W51KS; ART1c Greene, W1KO; ART1c Williams, W4DJJ; ART1c Ketchum, W7IIQ; ART1c Humphreys, W5JYT; ART2c Rakowski, on license only; ART1c Krassner, W9PDU; ART1c Lucy, W9SQL; ART1c Trotter, W9KVO, and ART1c Cook, W9KNT. *Sixth row:* ART1c Bishop, W2NTN; ART2c Turner, W1OCR; ART1c Klar, W1LFI; ART1c Blandor, W7IGN; ART1c Cline, ex-W5IW; ART1c Speer, W5DWJ; RT3c Podwall, W2CVM; ART1c Yerga, W8LOU; ART2c Wiley, W9RAI; ART1c Gillette, ex-W9MWM, and ART1c Engel, W8NKR. *Seventh row:* ART1c Belian, W5DYV; T/Sgt. McCoy, W4GTB; ART2c Gibbs, W4HGJ; ART1c Gullberg, W5GGG; ART1c Stedman, on license only; ART1c Polchow, W5GVG; ART2c Schmuck, W5EBI; ART2c Gray, W9QCA; ART2c Stuckey, W4IHC; ART1c Fischer, W5BRW; Sgt. Motta, PY7CM, and ART1c Smith, W9PAG.



100 PER CENT WAR WORK—INDUSTRY

Pan American Airways:

1HDV, Freeman, GRO, foreign duty
 1LVU, Titus, foreign duty
 2BAN, Griggs, radio mechanic, foreign duty
 2FPX, Masterson, radio technician, foreign duty
 2GQM, Rafford, FRO, Roselle Park, N. J.
 3CM, Stephen, radio mechanic, Miami, Fla.
 4FQZ, Bryant, RO, foreign duty
 4HG7, Whitaker, FRO, Flushing, L. I., N. Y.
 4HMQ, Rhoades, Miami, Fla.
 5FVJ, Johnston, Miami, Fla.
 5GST, Gildersleeve, SFRO, Brownsville, Texas
 5IUB, Spann, FRO, Miami, Fla.
 5JTC, Marshall, FRO, Alameda, Calif.
 5KPI, McClaughey, FRO, Alameda, Calif.
 5KSW, Maring, New Orleans, La.
 6AGS, Callen, radio maintenance, Alameda, Calif.
 ex-6CIC, Williams, FRO, Alameda, Calif.
 6CIT, Elliott, radio maintenance, Alameda, Calif.
 6EBP, Meyer, FRO, Alameda, Calif.
 6FPD, Crawford, FRO, Alameda, Calif.
 6FOF, Penning, SFRO, Oakland, Calif.
 6GSP, Anderson, radio technician, foreign duty
 6HRN, Ross, radio technician, foreign duty
 6ISX, Hogan, FRO, Alameda, Calif.
 ex-6JOE, Morgan, radio maintenance, Alameda, Calif.
 6KMS, Harper, FRO, Alameda, Calif.
 ex-6KZJ, Daily, FRO, Alameda, Calif.
 6MDF, Hurd, FRO, Alameda, Calif.
 6MPC, Hansen, FRO, Alameda, Calif.
 6OCQ, DeCamp, FRO, Alameda, Calif.
 6OEZ, Lillard, FRO, Alameda, Calif.
 6OZL, Fleming, radio maintenance, Alameda, Calif.
 6PIO, Nosek, radio technician, foreign duty
 6PUG, Ray, radio maintenance, Alameda, Calif.
 6PWH, Hatch, radio maintenance, Alameda, Calif.
 6PYR, Senecal, FRO, Hayward, Calif.
 6QLS, Strickland, FRO, Alameda, Calif.
 6QPM, Streib, FRO, Alameda, Calif.
 6QWF, Canham, FRO, Alameda, Calif.
 6RBS, Galli, radio technician, foreign duty
 6RLZ, Hamilton, FRO, Alameda, Calif.
 6RQC, Braccini, radio maintenance, Alameda, Calif.
 6RUC, Price, radio technician, foreign duty
 6RVY, Holzknecht, FRO, Alameda, Calif.

6RWS, Schaffner, FRO, Alameda, Calif.
 6SLD, Knight, radio maintenance, Alameda, Calif.
 KD6SQD, Holliday, FRO, Alameda, Calif.
 6SWR, Cotterill, FRO, Alameda, Calif.
 6THM, Anderson, address unknown
 6TTJ, Gagian, FRO, Alameda, Calif.
 6UAT, Norberg, FRO, Alameda, Calif.
 6UBS, Bautista, FRO, Alameda, Calif.
 6UHM, Struven, FRO, Alameda, Calif.
 6UIR, Carroll, FRO, Alameda, Calif.
 K7BUIK, Multon, radiomaintenance, Alameda, Calif.
 7EAB, Herness, FRO, Alameda, Calif.
 7EJU, Herness, FRO, Alameda, Calif.
 7EPP, Matsun, radio tech., Seattle, Wash.
 7EST, Caughie, WRE, La Guardia Field, N. Y.
 K7ETS, King, FRO, Alameda, Calif.
 K7FGT, Lane, FRO, La Guardia Field, N. Y.
 K7FNE, Lane, FRO, Alameda, Calif.
 8VBL, Weber, Miami, Fla.
 ex-9EEY, Russell, radio technician, Miami, Fla.
 9KPA, Darnell, foreign duty
 9LPZ, Torrence, radio technician, foreign duty
 ex-9PIH, Mackay, FRO, Oakland, Calif.
 9RQW, Hegarty, FRO, Alameda, Calif.
 9VTO, Campbell, FRO, Alameda, Calif.
 9VOY, Hagglund, radio maintenance, Alameda, Calif.
 ex-9ZHT, Woodside, FRO, Alameda, Calif.

Operator's license only:

Collins, RO, foreign duty
 Cook, radio mechanic, foreign duty

CIVIL SERVICE

ex-6IMX, Lambers, SC, inspector, Southgate, Calif.
 6IPA, Huotari, AAF, instructor, San Antonio, Texas
 KF6JEG, Lee, CAA, foreign duty
 6JH, Slocum, Navy Dept., foreman, San Diego, Calif.
 6JJB, Wildschut, War Dept., associate engineer, Berkeley, Calif.
 6KOZ, Buck, CAA, radio elect., Fallon, Nev.
 ex-6KP, Miller, Forestry Dept., engineer, Oregon City, Ore.
 6LFY, Falkenstien, SC, assistant foreman, Los Angeles, Calif.
 ex-6LIS, Garretson, Navy Dept., electrical engineer, Mare Island, Calif.
 ex-6LL, Kendrick, FCC, assistant monitoring officer
 6LMD, Blair, FCC, monitoring officer

6LOZ, Fritze, Navy Dept., San Francisco, Calif.
 ex-6LQP, Owens, radio technician, Camp Beale, Calif.
 6MQN, Middlecoff, Navy Dept., electrical engineer, Washington, D. C.
 6NAH, Jewell, Forestry Dept., radio technician, Arcadia, Calif.
 6NAT, Driml, SC, radio mechanic, Los Angeles, Calif.
 6NAV, Price, electrical engineer, Coronado, Calif.
 6NGV, Ayers, WPB, regional manager, San Francisco, Calif.
 6NJR, Nelles, WPB, consulting engineer, Washington, D. C.
 K6NKL, Gardenhire, Navy Dept., electrical engineer, O'Donnell, Texas
 6OXU, Huff, SC, Seattle, Wash.
 6OZR, Saunders, CAA, aircraft communicator, Elko, Nev.
 6PBL, Settle, Navy Dept., radio inspector, San Diego, Calif.
 6PLS, Mathews, CAA, radio engineer, Brisbane, Calif.
 6QAC, Martin, FCC, monitoring officer
 K6QUD, Firth, SC, electronics inspector, foreign duty
 6QZX, Dunato, CAA, foreign duty
 6RDM, Gibbs, Navy Dept., radio mechanic, San Pedro, Calif.
 6RSR, Hiltabedel, AAF, instructor, San Bernardino, Calif.
 6RTM, Ames, AAF, radio repairer, San Bernardino, Calif.
 6RVV, Miller, CAA, aircraft communicator, Truckee, Calif.
 6SIG, DeVoe, FCC, radio inspector, San Diego, Calif.
 6SLV, Tessier, SC, radar technician, Ordville, Calif.
 6SPX, Onnigian, SC, jr. electrician, Sacramento, Calif.
 6SWU, Ayers, AAF, San Bernardino, Calif.
 6THV, Lombardi, SC, inspector, Stockton, Calif.
 6THW, Miller, SC, radio mechanic, Los Angeles, Calif.
 6TLJ, Luke, SC, electronics tech., foreign duty
 6TLK, Maddox, CAA, foreign duty
 6TOA, Clyne, FCC, radio inspector, Beaumont, Texas
 6TRH, Rinaman, Navy Dept., radio mechanic, San Carlos, Calif.
 6TRM, Keyes, SC, radio mechanic, Ogden, Utah
 6TXI, Magowan, CAA, aircraft communicator, Newhall, Calif.
 6UCR, Benton, Navy Dept., San Diego, Calif.
 6UOQ, Gomes, SC, foreman, San Diego, Calif.
 6VU, Greenleaf, CAA, radio electrician, Ingewood, Calif.
 ex-6ZBE, Smith, AAF, San Bernardino, Calif.
 K7AAN, Miller, USED, electrical foreman, foreign duty
 7AFC, Hensley, CAA, foreign duty
 7AIW, Kellar, Navy Dept., radio inspector, Bremerton, Wash.
 7AJC, Henke, CAA, maintenance supervisor, foreign duty
 7AUH, Bargabus, CAA, aircraft communicator, foreign duty
 7AYQ, James, FCC, radio inspector, Seattle, Wash.
 ex-7AZC, Walker, CAA, foreign duty
 7BCT, Barrows, FCC, monitoring officer
 7CNP, Gordon, SC, instructor, Lexington, Ky.
 7CNG, Folsom, foreign duty
 7CRS, Carr, CAA, radio engineer, Seattle, Wash.
 7CSN, Emerson, Navy Dept., instructor, Moscow, Idaho
 7DQ, Curbow, Mt. Vernon, Wash.
 7DXF, Johnston, CAA, maintenance inspector, Seattle, Wash.
 7EDD, James, FCC, monitoring officer
 7EEL, Jason, FCC, radio operator technician, foreign duty
 7EJU, Bargabus, CAA, aircraft communicator, foreign duty
 7ELN, McGoldrick, SC, radio engineer, Spokane, Wash.
 7EET, Carpenter, AAF, Mountain Home, Idaho
 7GFI, Ells, CAA, radio electrician, Helena, Mont.
 7GVV, Williams, Navy Dept., electrician, Portland, Ore.
 7GWI, Owen, Navy Dept., Bremerton, Wash.



Photographed in late 1944, this group represents a few of the hundred odd amateurs attending the AAF Technical School for radio mechanics at Truax Field, Madison, Wis. *Left to right, standing:* Cpl. Dale, W9JNC; Hume, W9GTT, Civil Service; Cpl. Fesenmeyer, W9DVG, and Sgt. Parke, W9PPT. *Kneeling:* Cpl. Demergian, W9RCW, and Pfc. Cabe, W7IRE.



ARM2c Richard S. Allen, LSPH, has seen much action since he enlisted in 1942. Assigned to the USS *Birmingham*, he took part in the Sicilian invasion and was awarded the DFC for observation flights over enemy territory. On the same vessel he was in air attacks over Formosa and Leyte, and received the Purple Heart for wounds sustained when the damaged aircraft carrier *Princeton* exploded alongside the assisting *Birmingham*. He is now back in the U. S. for further technical training.

7HAG, Holte, SC, radio engineer, Chicago, Ill.
 7HNP, Lein, Navy Dept., electrician, Bremer-
 ton, Wash.
 7HS, Schwartz, SC, radio engineer, Seattle,
 Wash.
 7IAB, Beck, Seattle, Wash.
 7ILN, Crane, SC, radio instructor, Layton,
 Utah
 7IMG, McNichol, CAA, aircraft communica-
 tor, Bozeman, Mont.
 7IMT, Crouch, Navy Dept., foreign duty
 7IXA, Woltz, CTC, foreign duty
 7JCG, James, CAA, aircraft communicator,
 Overton, Neb.
 K7JDK, Spires, CAA, aircraft communicator,
 foreign duty
 7JZD, Hesper, CAA, radio electrician, Bel-
 grade, Mont.
 ex-7PY, Turner, radio operator, foreign duty
 7VX, Rudesill, FCC, Portland, Ore.
 8ABZ, Millich, technician, Glen Burnie, Md.
 8APQ, Croft, CAA, aircraft communicator,
 Martinsburg, Pa.
 ex-8AYI, Hall, SC, radio engineer, Washing-
 ton, D. C.
 8BFN, Jefferies, OWI, foreign duty
 ex-8BLY, Agnew, AAF, chemical engineer,
 Dayton, Ohio
 ex-8BOL, Thompson, AAF, electronics inspec-
 tor, San Bernardino, Calif.
 8BRX, Yopp, SC, radio engineer, Asbury
 Park, N. J.
 8BWA, Carnevale, SC, radio engineer, Ft.
 Monmouth, N. J.
 ex-8CIU, Drew, AAF, radio engineer, Phila-
 delphia, Pa.
 8CLL, Atems, FCC, monitoring officer
 8CTC, Maintz, CAA, aircraft communicator,
 Grand Rapids, Mich.
 8DGT, Stewart, Navy Dept., Norfolk, Va.
 8DHR, Jacobs, Navy Dept., Norfolk, Va.
 8DT, Fitch, AAF, engineer, Washington,
 D. C.
 8DXL, Milde, AAF, electrical engineer, Wright
 Field, Ohio
 8ECN, Scovill, SC, radio mechanic, Selfridge
 Field, Mich.
 8ESY, Webb, SC, radio operator, Chicago, Ill.
 8FLX, Johnson, Navy Dept., radio engineer,
 Brooklyn, N. Y.
 8GEU, Fate, SC, inspector, Chicago, Ill.
 8GRC, Snyder, Navy Dept., Norfolk, Va.
 8GYH, Schmitt, Navy Dept., Norfolk, Va.
 8HDX, Malone, SC, eng., Havre de Grace, Md.
 8HPC, Hartzell, SC, inspector, Chicago, Ill.
 8JCC, Goodman, SC, inspr., Emporium, Pa.
 8KMK, Miller, SC, inspector, Jonesboro, Ind.
 8KWW, Quinn, SC, electrical test inspector,
 Chicago, Ill.
 ex-8LOD, Fisher, SC, radio engineer, Dayton,
 Ohio
 8MML, Feldsteen, SC, inspr., Buffalo, N. Y.
 8NOQ, Beale, CAA, foreign duty
 8NVY, Tonart, AAF, aircraft mechanic, Wilkes-
 Barre, Pa.

8NWD, Bollen, Navy Dept., Norfolk, Va.
 ex-8OBY, DeFriend, CAA, radio electrician,
 Blythe, Calif.
 8PF, Stevenson, Navy Dept., engineer, Wash-
 ington, D. C.
 ex-8PHG, Anderson, Navy Dept., Chicago,
 Ill.
 8RNM, Kean, SC, radio technician, Ft. Hayes,
 Ohio
 8ROV, Slack, SC, engineer, Philadelphia, Pa.
 8SO, McCoppin, SC, radio engineer, Dayton,
 Ohio
 8SUU, Teed, Ogdensburg, N. Y.
 8TDS, Treese, FCC, monitoring officer
 8TKH, Gillespie, Post Office Dept., Arlington
 Heights, Ohio
 8TYH, Carney, CAA, Miami Springs, Fla.
 8UHR, Missick, Navy Dept., Norfolk, Va.
 8UHX, Morrison, War Dept., Washington,
 D. C.
 8UIW, Wright, SC, Chicago, Ill.
 8UJX, O'Dell, Navy Dept., Norfolk, Va.
 8OXD, Souter, Navy Dept., radio inspector,
 Long Beach, Calif.
 8YKF, Bird, CAA, radio electr., Lacombe, La.
 8WKL, Gowen, SC, inspector, Minneapolis,
 Minn.
 8WOM, Magill, Navy Dept., Norfolk, Va.
 9AF, Hansen, Navy Dept., radio mechanic,
 foreign duty
 9AIV, Willoughby, AAF, instructor, Trux
 Field, Wis.
 9AJN, Clegg, foreign duty
 ex-9AMH, Olson, SC, Chicago, Ill.
 ex-9ANR, Williams, SC, inspr., Chicago, Ill.
 9AQO, Cary, SC, radio engr., Philadelphia, Pa.
 9ARD, Powell, SC, Chicago, Ill.
 9ATF, Fallas, SC, radio engineer, Philadel-
 phia, Pa.
 ex-9AZD, Gates, AAF, foreman, San Bernar-
 dino, Calif.
 9BB, Wightman, SC, radio engineer, Phila-
 delphia, Pa.
 9BEK, Jackson, SC, inspector, Chicago, Ill.
 9BSI, Gibbs, SC, associate engineer, Newark,
 N. J.
 9BVO, Luther, SC, radio mechanic, Lowry
 Field, Colo.
 9BXX, Yost, AAF, radio engineer, Wright
 Field, Ohio
 9BZK, King, SC, Chicago, Ill.
 9CCH, Story, SC, inspector, Chicago, Ill.
 9CFM, Brunteardi, SC, radio technician, Day-
 ton, Ohio
 9CGC, Eavenson, AAF, aircraft electrician,
 Tinker Field, Okla.
 9CIW, Hopwood, FCC, monitoring officer
 9CKV, Balderston, AAF, radio mechanic,
 Dodge City, Kansas
 9CLA, Rathjen, CAA, airways engineer,
 Arlington, Va.
 9CQT, Forristal, SC, technical coordinator,
 Kansas City, Mo.
 9DND, Smith, SC, radio op., Chicago, Ill.
 9DQE, McCormick, SC, radio engineer,
 Arlington, Va.
 9DSG, Martino, SC, inspector, Chicago, Ill.
 9DSP, Moulton, SC, radio op., Chicago, Ill.
 ex-9EHG, Gookin, Navy Dept., radar engi-
 neer, foreign duty
 9EWK, Schnedorf, SC, radio engineer, Chi-
 cago, Ill.
 9FAH, Norgaard, CAA, technician, foreign
 duty
 9FE, Heppert, SC, inspector, Bridgeport,
 Conn.
 9FFW, Apperson, SC, inspector, Kokomo, Ind.
 9FJN, Wilpe, SC, radio operator, Chicago, Ill.
 9PLO, Hemen, War Dept., engineer, Igloo,
 S. D.
 9FWY, Johnson, SC, radio engineer, Long
 Branch, N. J.
 ex-9GCI, Evans, SC, instructor, Camp Crow-
 der, Mo.
 9GFY, Hoff, CAA, technician, foreign duty
 9GGC, Hofslund, SC, radio op., Chicago, Ill.
 ex-9GJU, Haueier, AAF, electronics inspector,
 San Bernardino, Calif.
 9GKZ, Thomas, SC, inspector, Chicago, Ill.
 9GLW, Bowman, SC, Chicago, Ill.
 9GNC, Bligh, CAA, aircraft communicator,
 foreign duty
 9GNR, Dale, SC, Chicago, Ill.
 9HEG, Falk, FCC, radio operator, Brainard,
 Neb.
 9HEA, Dwyer, SC, radio op., Chicago, Ill.
 9HFD, Sanders, CAA, radio electrician, for-
 eign duty

9HKT, Arildson, Navy Dept., Kirkland, Wash.
 9HLQ, McCall, SC, inspr., Kansas City, Mo.
 9HZC, Elliott, SC, Los Angeles, Calif.
 9IAN, Glunt, FCC, RID, monitoring officer
 9IVW, Harmon, SC, inspector, Schenectady,
 N. Y.
 9JAP, Hampton, FCC, RID, monitoring officer
 9JFB, Walker, CAA, radio electrician, Rock-
 ford, Ill.
 9JF, Frank, Navy Dept., Chicago, Ill.
 9JVU, Congdon, FCC, RID, monitoring officer
 9JZF, Amelianovich, SC, inspector, Ft. Wayne
 Ind.
 9LFI, Mehler, Navy Dept., inspr., Ottawa, Ill.
 9LRM, Morgan, Navy Dept., inspector, Chi-
 cago, Ill.
 9LWG, Vaughan, AAF, instr., St. Louis, Mo.
 9LYC, Baxter, Immigration Dept., radio op-
 erator, El Paso, Tex.
 9MEO, Riley, SC, radio op., Chicago, Ill.
 9MJB, Brown, SC, inspector, Chicago, Ill.
 9MJP, Eugen, SC, Chicago, Ill.
 9MKO, Amelianovich, SC, inspr., Chicago, Ill.
 9MNR, Zalucha, AAF, radio instructor, Scott
 Field, Ill.
 9MND, Martin, AAF, supervisor, Chanute
 Field, Ill.
 9NIS, Carr, AAF, inspector, Tulsa, Okla.
 9NLM, Firman, AAF, technical advisor, Wic-
 ita, Kan.
 9NTP, Utech, SC, supervisor, Chicago, Ill.
 9NUL, McNally, SC, inspector, Wausau, Wis.
 9ODX, Dolczal, Navy Dept., engineer, Bos-
 ton, Mass.

CANADA

WE REGRET the omission of Canadian amateurs from our ITS list this month but we have received only twenty new registrations in all branches of the service since the March issue, an insufficient number to print. Please, fellows, let us hear from you and make your section truly representative of your country.

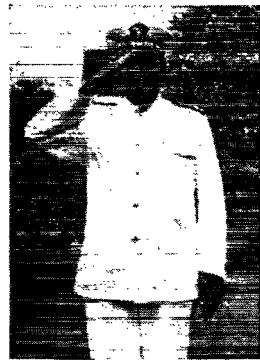

Lt. Comdr. James L. Woods, jr., USNR, ex-9COR, of McGregor, Iowa, has served for the past two years as communications officer in the Southwest Pacific. While still a lieutenant, he was the recipient of a citation from Admiral Nimitz for meritorious and efficient performance of duty as OIC of motor torpedo boat communication units. He established advance radio stations on five Pacific islands, was frequently subjected to night and day enemy attacks, and his leadership and courage contributed largely to the success of motor torpedo boat operations in these areas. 9COR has now returned to the U. S.

Practical Design of Video Amplifiers

Part II—High-Frequency Compensation

BY ELLIOTT A. HENRY,* WOFEN

IN low-frequency compensation discussed in last month's issue it was found necessary to make the plate load impedance, and consequently the voltage gain, rise in proportion to the loss in voltage across the coupling condenser. In high-frequency compensation, however, it is necessary to keep the plate load impedance, and thus the stage gain, constant over the desired frequency range.

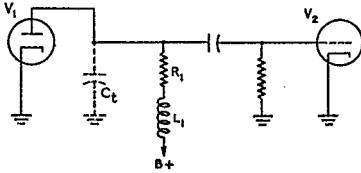

Fig. 6—Shunt-peaked stage.

One way of accomplishing this is to add an inductive reactance to the plate-load network to counteract the effect upon the impedance by the change of capacitive reactance with frequency by the shunt circuit and stray capacities. Such a network is shown in Fig. 7, and its impedance can be made essentially constant, from zero frequency up to any frequency where the network proportions are such that the reactance of C is equal to the resistance of R and twice the reactance of L . The impedance of this network is given by

$$Z = X_C \sqrt{\frac{R^2 + X_L^2}{R^2 + (X_C - X_L)^2}} \quad (14)$$

Actually if a plot of impedance versus frequency is made, using the proportions above, it will be found that the impedance begins to rise at a frequency $0.2f$, where f is the chosen correction frequency, and gradually rises as the frequency is increased to approximately $0.6f$ and then decreases, becoming equal to the low-frequency impedance at f . The magnitude of this increase is about 0.5 per cent at $0.2f$ and 3 per cent at $0.6f$. For example, if f is assumed to be 5 Mc., C to be $31.8 \mu\text{fd.}$, L to be $15.9 \mu\text{h.}$ and R to be 1000 ohms, the impedance, Fig. 7, will be

$$\begin{aligned} \text{At 5 Mc., } X_C &= 1000 \text{ ohms} \\ X_L &= 500 \text{ ohms} \\ Z &= 1000 \sqrt{\frac{10^6 + [(25)(10^4)]}{10^6 + (1000-500)^2}} \\ &= 1000 \sqrt{\frac{(1.25)(10^6)}{(1.25)(10^6)}} = (1000) \sqrt{1} = 1000 \\ &\text{ohms.} \end{aligned}$$

*RCA Victor Division, Radio Corporation of America, Camden, N. J.

$$\begin{aligned} \text{At 4.5 Mc., } X_C &= 1112 \text{ ohms} \\ X_L &= 450 \text{ ohms} \\ Z &= 1112 \sqrt{\frac{10^6 + [(0.2025)(10^6)]}{10^6 + (1112-450)^2}} \\ &= 1112 \sqrt{\frac{(1.2025)(10^6)}{(1.43825)(10^6)}} = 1112 \sqrt{0.834} \\ &= (1112)(0.913) = 1016 \text{ ohms.} \\ \text{At 3 Mc., } X_C &= 1668 \text{ ohms} \\ X_L &= 300 \text{ ohms} \\ Z &= 1668 \sqrt{\frac{10^6 + [(9)(10^4)]}{10^6 + (1668-300)^2}} \\ &= 1668 \sqrt{\frac{(1.09)(10^6)}{(2.87155)(10^6)}} = 1668 \sqrt{0.37966} \\ &= (1668)(0.616165) = 1027 \text{ ohms.} \\ \text{At 1 Mc., } X_C &= 5000 \text{ ohms} \\ X_L &= 100 \text{ ohms} \\ Z &= 5000 \sqrt{\frac{10^6 + 10^4}{10^6 + [(24.01)(10^6)]}} \\ &= 5000 \sqrt{\frac{(1.01)(10^6)}{(25.01)(10^6)}} = 5000 \sqrt{0.040384} \\ &= (5000)(0.201) = 1005 \text{ ohms.} \end{aligned}$$

This plate-load network is a parallel-resonant circuit of very low Q , and the circuit actually is being worked along the resonance curve. By increasing the correction frequency, f , the linearity over a desired frequency range can be made almost perfect at a sacrifice of gain. Design data for this are covered under the section on shunt peaking which follows.

Generally speaking, high-frequency compensation of amplifiers is based upon wave-filter theory, and the more complex the filter used, the higher the gain. The more complex types of filters are usually used where highest possible gain or a very sharp cut-off characteristic is of prime importance. The most widely used types of high-frequency compensation are:

- 1) Shunt peaking.
 - 2) Series peaking.
 - 3) Combination or series-shunt peaking.
- The gain of the different types are in the order listed above, with series peaking giving 50 per cent more gain than shunt peaking and combination peaking giving 80 per cent more gain than shunt peaking. Combination peaking is widely used as the best compromise between maximum gain and simplicity.

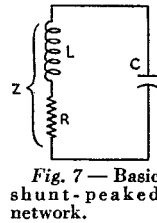

Fig. 7—Basic shunt-peaked network.

Shunt Peaking

Referring to Fig. 6, repeated here for convenience, there are three components of interest in extending the high-frequency range of the stage. These are labeled, C_i , R_1 , and L_1 . C_i can be determined by the methods previously outlined. R_1 is made equal to the reactance of C_i at the highest frequency of correction, f_c .

$$R_1 = X_{C_i} \text{ at } f_c \quad (15)$$

L_1 is such that its reactance at f_c is one-half of X_{C_i} at f_c , or,

$$X_{L_1} = \frac{X_{C_i}}{2} \text{ at } f_c, \text{ or} \quad (16)$$

$$L_1 = \frac{R_1}{4\pi f_c} \quad (17)$$

For example, suppose it is desired to extend the bandwidth of the stage in Fig. 6 to 5 Mc. and C_i is 25 μfd . Then,

$$X_{C_i} = \frac{1}{(6.28)(5)(10^6)(25)(10^{-12})} = \frac{10^6}{785} = 1273 \text{ ohms.}$$

Therefore, $R_1 = 1273$ ohms from equation (15) and

$$L_1 = \frac{1273}{(12.56)(5)(10^6)} = \frac{1273}{(62.8)(10^6)} = (20.3)(10^{-6}) \text{ h.}$$

$$L_1 = 20.3 \mu\text{h.}$$

The stage gain is given by equation (6) repeated below from the first installment.

$$A = G_m Z_p, \quad (6)$$

where A is the stage gain,

G_m is the transconductance in mhos, and Z_p is the plate load impedance.

Assuming V_1 to be an 1852, the gain will be $(1273)(0.009) = 11.45$. Equations (15), (16), and (17) are satisfactory for shunt peaking where only one or two stages are required. Actually the response at f_c , using these formulas, is the same as the low-frequency response, but there is about a 3-per cent rise in output at a frequency somewhat lower than f_c . Shunt peaking can be made nearly perfect if f_c is made about 40 per cent greater than the highest correction frequency desired. Since

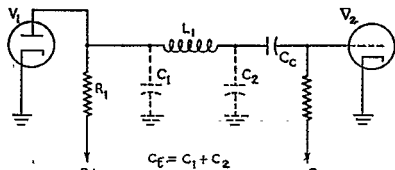

Fig. 8 — Series-peaked stage.

this would result in a reduction in gain of 30 per cent, an accepted compromise is to design for a reduction in gain of 15 per cent.

If a conservative design is desired, or several stages are to be cascaded, the following formulas may be used. Still referring to Fig. 6, equation

(15) may be replaced by

$$R_1 = 0.85 X_{C_i} \text{ at } f_c \quad (18)$$

and equation (17) may be replaced by

$$L_1 = \frac{0.3}{(2\pi f_c)^2 C_i} \quad (19)$$

If the previous example is recalculated,

$$R_1 = (0.85)(1273) = 1000 \text{ ohms (approx.)}$$

$$\begin{aligned} L_1 &= \frac{0.3}{[(6.28)(5)(10^6)]^2 [(25)(10^{-12})]} \\ &= \frac{0.3}{[(3.14)(10^7)]^2 [(25)(10^{-12})]} \\ &= \frac{0.3}{(9.85)(2.5)(10^8)} \\ &= \frac{300}{24.6} = 12.2 \mu\text{h.,} \end{aligned}$$

and the stage gain will be $(0.009)(1000) = 9$.

Series Peaking

The basic circuit of a series-peaked stage is shown in Fig. 8. Here again interest is directed toward three components, L_1 , R_1 and C_i broken down into C_1 and C_2 . C_i can be determined by the methods previously outlined, but in addition to evaluating C_i , a 2-to-1 ratio between C_1 and C_2 , is required, although the ratio may be reversed by moving R_1 to the opposite side of the coil L_1 , Fig. 8. The rule is to keep the load resistor on the low-capacity side of the filter. (See Fig. 9.) Usu-

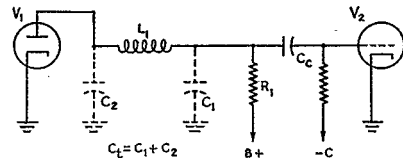

Fig. 9 — Series-peaked stage.

ally, with a bit of juggling, the ratios may be kept close to 2-to-1. For instance, the coupling condenser, C_c , could be moved to the plate side of L_1 , Fig. 8, thus shifting the capacity of C_c to ground from C_1 to C_2 . Referring to Fig. 8 or Fig. 9,

$$C_i = C_{out} \text{ of } V_1 + C_{in} \text{ of } V_2 + C_{stray} = C_1 + C_2 \quad (20)$$

$$C_2 = 2C_1 \quad (21)$$

$$R_1 = (1.5)(X_{C_i} \text{ at } f_c) \quad (22)$$

$$L_1 = \frac{1}{2(2\pi f_c)^2 C_1} = 0.67 C_i R_1^2 \quad (23)$$

In using equation (23), it is suggested that the second expression be used; that is, where C_i is used to determine L_1 , because C_i is more important than the division of C_1 and C_2 in the compensation network and in all probability less error will be made in determining C_i than in calculating C_1 .

For example, let us calculate R_1 , L_1 , and the stage gain of Fig. 8, assuming V_2 to be an 1852, f_c to be 5 Mc., and C_i to be 30 μfd ., with $C_2 = 2C_1$.

Then, from equation (22),

$$R_1 = (1.5) (X_{C_1}) = (1.5) (1060) = 1590 \text{ ohms.}$$

From equation (23),

$$L_1 = (0.67) (30) (10^{-12}) (1590) = (51) (10^{-6}) \text{ h.}$$

$$L_1 = 51 \mu\text{h.}$$

The stage gain will be

$$A = G_m Z_p = (0.009) (1590) = 14.3$$

The series-peaked network is characterized by a sharper cut-off and a more linear phase characteristic than the shunt-peaked network.

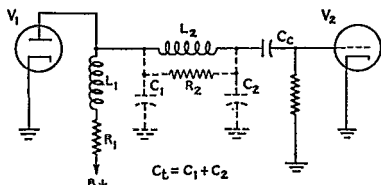

Fig. 10 — Combination-peaked stage.

Series-Shunt or Combination Peaking

Combination peaking, as its name implies, is a combination of shunt and series peaking and has a still sharper cut-off than series peaking. Here again the problem is similar to series peaking in that a 2-to-1 division of the capacity C_1 is required for best performance of the stage. The same rule applies to the location of the load resistor; that is, the load resistor should be placed on the low-capacity side of L_2 . (See Fig. 9 and Fig. 10.) R_1 and L_1 may be reversed, and usually it is desirable to do this since the stray capacity, which composes parts of C_1 and C_2 , will be smaller with a resistor connected to either side of L_2 than if L_1 were so connected (smaller physical size, primarily).

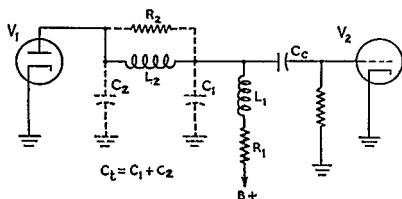

Fig. 11 — Combination-peaked stage.

Referring to Fig. 10 or Fig. 11, the design criteria for combination peaking are:

$$C_t = C_1 + C_2$$

$$C_2 = 2C_1$$

$$L_1 = 0.12 C_1 R_1^2 \quad (24)$$

$$L_2 = 0.52 C_1 R_1^2 \quad (25)$$

$$R_1 = 1.8 X_{C_1} \text{ at } f_c \quad (26)$$

A high distributed capacity in coil L_2 or improper ratio between C_1 and C_2 may cause a rise in response in the higher-frequency portion of the pass-band. This rise usually can be flattened out by the addition of the resistor R_2 , Fig. 10 and Fig. 11, to lower the Q of L_2 . The exact value must be determined by experiment in each case. A good

starting value is about five times the value of the plate load resistor.

As an example, using the same specifications used in the example for series peaking, in calculating L_1 , L_2 and R_1 , Fig. 10,

from equation (26),

$$R_1 = (1.8) (1060) = 1908 \text{ ohms.}$$

From equation (24),

$$L_1 = (0.12) (30) (10^{-12}) (3.64) (10^6)$$

$$= (13.1) (10^{-6}) \text{ h.} = 13.1 \mu\text{h.}$$

From equation (25),

$$L_2 = (0.52) (30) (10^{-12}) (3.64) (10^6)$$

$$= (56.7) (10^{-6}) \text{ h.} = 56.7 \mu\text{h.}$$

The stage gain is

$$A = (0.009) (1908) = 17.17.$$

The "High-Peaker" Stage

One problem usually encountered in transferring the video voltage output of an Iconoscope to the grid of the first amplifier stage is that of getting the maximum signal-to-noise ratio. The most satisfactory method for accomplishing this is to provide the highest possible signal input to

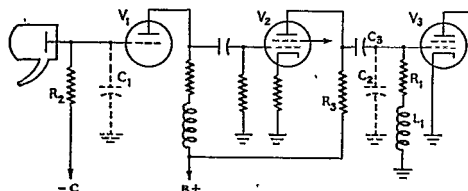

Fig. 12 — "High-peaker" stage.

the grid of the first amplifier stage without regard for frequency distortion, then carefully to preserve this distorted signal while it is being amplified in one or two stages, and finally introducing a complementary network which gives equal and opposite distortion to that generated by the input network. With frequency components from 30 cycles to about 4 Mc. in the output signal of an Iconoscope developed across R_2 in Fig. 12, it is readily seen that the shunt reactance of C_1 will limit severely the high-frequency components.

If the linearity is preserved by compensating as previously outlined between V_1 and V_2 to keep intact this distorted waveform, the network $R_1 L_1$ can be inserted as the load for V_2 . This network is complementary to the network $R_2 C_1$, and it has the opposite impedance and phase characteristic, provided the time constants are equal. The time constants will be equal when

$$R_2 C_1 = \frac{L_1}{R_1}$$

A stage with this type of correction is called a "high-peaker" stage, and the design data are:

C_1 = total circuit and stray capacities (input stage).

C_2 = total circuit and stray capacities ("high-peaker" stage).

$R_2 =$ nominally 100,000 ohms.

$$R_3 > 10 X_{L_1} \text{ at } f. \quad (27)$$

$$X_{C_3} < 0.1 R_3 \text{ at the lowest frequency} \quad (28)$$

$$R_1 = \frac{L_1}{R_2 C_1}, \text{ where } R \text{ is in ohms, } L \text{ is in } \mu\text{h. and } C \text{ is in } \mu\text{fd.} \quad (29)$$

$$L_1 = \frac{(25.33)(10^3)}{(2f)^2(C_2)}, \quad (30)$$

where L is in $\mu\text{h.}$, C is in $\mu\text{fd.}$ and f is in Mc. Thus, with equations (27), (28), (29) and (30), a satisfactory compensating network can be designed. Equation (30) shows that the resonant frequency of $L_1 C_2$ is twice the cut-off frequency, f_c .

For an example let's determine L_1 , R_1 , R_3 , and C_3 of Fig. 12, assuming C_1 to be 12 $\mu\text{fd.}$ and C_2 to be 30 $\mu\text{fd.}$, f_c 5 Mc., and 30 cycles the lowest frequency. From equation (30),

$$L_1 = \frac{(25.33)(10^3)}{(10^2)(30)} = \frac{253.3}{30} = 8.43 \mu\text{h.}$$

From equation (29),

$$R_1 = \frac{L_1}{R_2 C_1} = \frac{8.43}{(10^5)(12)(10^{-6})} = \frac{8.43}{12} = 7.25 \text{ ohms,}$$

From equation (27),

$$R_3 > (10)(6.28)(5)(10^6)(8.43)(10^{-6}) = 2650 \text{ ohms or greater.}$$

From equation (28),

$$X_{C_3} < (0.1)(2650) = 265 \text{ ohms or less.} \\ C_3 = 20 \mu\text{fd. or more.}$$

The stage gain, if V_2 is an 1852, will be

$$A = (0.009)(7.25) = 0.06525.$$

From this it is apparent that the stage is operating at a loss, but the actual over-all voltage output is greater than if a much lower value for R_2 had been used in an attempt to preserve the high-frequency response into V_1 ; also the signal-to-noise ratio is better.

Phase Characteristics

These correction circuits will provide essentially flat frequency response to f_c and a phase shift proportional to frequency; or saying it in another way, the time delay is independent of frequency. Up to now little has been said of the phase characteristic of amplifiers. The phase characteristic is relatively unimportant in amplifiers designed for audio work, since the human ear is very insensitive to phase distortion, but this becomes very important in video work or wherever complex waves are to be amplified without distortion. Without going too deeply into the subject of complex waves, which is beyond the scope of this article, every complex wave is composed of a fundamental frequency and any number of harmonics, having various phase relationships with one another, and whose amplitudes and phases may be expressed by a Fourier Series. To see why it is important that the phase shift be proportional to frequency, that is, the second harmonic should be delayed twice as much as the

fundamental, the third harmonic three times, etc., let's take a look at Fig. 13.

Wave A is a complex wave composed of the fundamental wave, B , and the second harmonic, C , in phase. If the wave A is passed through an amplifier which delays waves B and C the same amount (30 degrees for instance), the wave shape will be shown in Fig. 14.

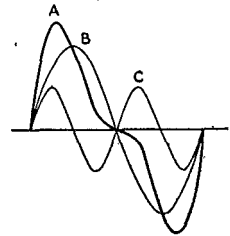

Fig. 13 — Complex wave with components in phase.

Wave C goes through two cycles, 720 electrical degrees, while wave B goes through one cycle, 360 electrical degrees; or to put it another way, with respect to time, wave C is traveling twice as fast as wave B . Therefore, if both waves are delayed 30 degrees, wave C will be ready to repeat its cycle 50 per cent sooner than wave B ; or with respect to wave B , wave C will be advanced in phase. When these two waves are summed up, with the altered phase relationship, wave A in Fig. 14 results. When this is compared with wave A in Fig. 13, it is seen that both are composed of the same two frequencies, only the phase relationship being changed. If the phase characteristic of the amplifier is proportional to frequency, the wave coming out of the amplifier will be of the same shape as the input wave, provided the frequency response is uniform. As a point of interest, the shorter the pulse, the greater the number of harmonics present and the wider the bandwidth of the amplifier required to pass the pulse without distortion. A single impulse of infinitesimal duration contains all frequencies of equal amplitude from zero to infinity.

Cathode Followers

Cathode follower is the name given to a stage when the load is in the cathode circuit instead of in the plate circuit. This type of circuit finds its widest use in video work as an impedance-changing device. Since the output voltage of an amplifier taken from the plate circuit is at a comparatively-high impedance,

unless changed by an impedance-changing device such as a transformer, securing a proper match to a transmission line of nominal impedance is somewhat of a problem. This is especially true in video work where a wide frequency range is encountered, and the design of a transformer with flat response from 30 cycles to 4 or 5 Mc.

presents quite a few difficulties. The simplicity and low cost of the cathode follower is primarily responsible for its popularity. Either pentodes or triodes may be used and a conventional circuit for each is shown in Fig. 15 and Fig. 16, respectively.

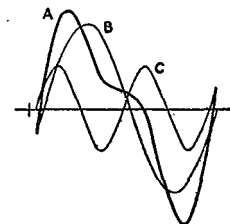

Fig. 14 — Complex wave after both component waves are delayed 30 degrees.

Both the input conductance and the grid-to-cathode capacity of the tube in a cathode-follower stage are modified by the factor

$$\frac{1}{1 + G_m R_k}$$

The pentode cathode-follower stage is used in preference to the triode in applications where a lower input capacity or a higher output voltage is desired. The effective internal impedance of the tube is the reciprocal of the grid-to-plate transconductance in mhos and must be added in parallel with the cathode resistor to determine the output impedance, Z_o , Fig. 15 and Fig. 16.

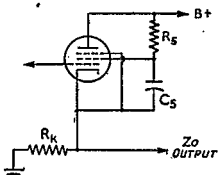

Fig. 15 — Pentode cathode follower.

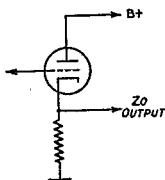

Fig. 16 — Triode cathode follower.

In a triode cathode-follower stage, Fig. 16, the dynamic input capacity is given by

$$C_{eff} = \frac{C_{ok}}{1 + G_m R_k} + C_{cp} \quad (31)$$

and if a pentode is used, as in Fig. 15, the dynamic input capacity will be

$$C_{eff} = \frac{C_{in}}{1 + G_m R_k} \quad (32)$$

The stage gain is given by

$$A = \frac{G_m R_k}{1 + G_m R_k} \quad (33)$$

The effective output impedance, Z_o , is given by

$$Z_o = \frac{\left(\frac{1}{G_m}\right) \left(R_k\right)}{\frac{1}{G_m} + R_k} \quad (34)$$

From equation (33) it can be seen that the stage always operates with a gain of less than 1 and that the higher the value of R_k the closer to unity the gain becomes. The circuit in Fig. 17 is sometimes used to secure higher output voltages. In this circuit, R_k is divided into two parts, R_1 and R_2 , arranged so that the d.c. voltage drop across R_1 is equal to the required grid bias and, since the grid is returned to the junction of R_1 and R_2 , the correct bias will be obtained; the G_m will not change, but R_k will be increased and also the voltage output, from equation (33). Similarly, Z_o will be changed, from equation (34).

For example let's determine the effective input capacity, stage gain, and effective output impedance of an 1852 cathode-follower stage with a 160-ohm cathode resistor. From the tube manual,

C_{in} is 11 $\mu\mu\text{fd.}$ and G_m is 9,000 μmhos (0.009 mho). From equation (31),

$$C_{in} = \frac{11}{1 + [(0.009) (160)]} = \frac{11}{2.44} = 4.52 \mu\mu\text{fd.}$$

From equation (33)

$$A = \frac{(0.009) (160)}{1 + [(0.009) (160)]} = \frac{1.44}{2.44} = 0.59$$

From equation (34)

$$\frac{1}{G_m} = \frac{1}{0.009} = 111; Z_o = \frac{(111) (160)}{271} = 65.7 \text{ ohms.}$$

By using the arrangement shown in Fig. 17, a perfect match into a 72-ohm line can be obtained by making R_1 160 ohms and R_2 45 ohms. The gain, A , then would be

$$A \text{ (unloaded)} = \frac{(0.009) (205)}{1 + [(0.009) (205)]} = \frac{1.845}{2.845} = 0.648.$$

$$A \text{ (loaded)} = \frac{(0.009) \left[\frac{(72) (205)}{72 + 205} \right]}{1 + \left\{ [0.009] \left[\frac{(72) (205)}{72 + 205} \right] \right\}} = \frac{(0.009) (54.7)}{1 + [(0.009) (54.7)]} = \frac{0.492}{1.492} = 0.33.$$

With a normal bias of 3 volts on the grid, the maximum voltage output would be (3) (0.33) = 0.99 peak volts. In terms of peak-to-peak voltage, and assuming a grid swing from 0 to 6 volts, the output would be 1.98 volts peak to peak.

The output impedance will be

$$Z_o = \frac{(111) (205)}{316} = \frac{22755}{316} = 72 \text{ ohms.}$$

Design Hints

It is evident from the foregoing design data that the limiting factor in securing good high-frequency response is the shunt reactance across the plate load resistor and that this shunt reactance has a direct bearing upon the gain of the amplifier. Therefore, good practice demands that every effort be made to keep the stray and circuit capacities at a minimum. A well-designed lay-out and careful planning will pay big dividends.

The practice of placing a small paper or mica condenser across a large electrolytic bypass condenser to by-pass the high frequencies is sometimes dangerous, so far as flat frequency response is concerned. The inductance of the electrolytic together with the paper or mica condenser may form a parallel-resonant circuit, and this may cause either an increase or decrease in the gain

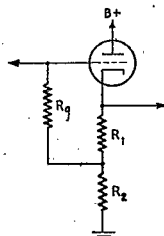

Fig. 17 — Cathode follower with Z_o matched to load.

at its resonant frequency depending upon the location of the network.

Care should be used in selecting resistors since there is a wide variation in high-frequency characteristics between the products of different

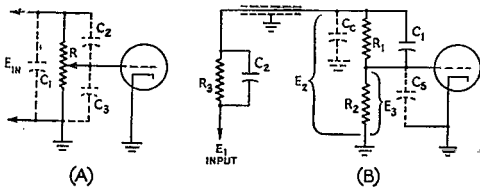

Fig. 18 — Attenuation systems. A — Uncompensated. B — Compensated.

manufacturers. Wire-wound resistors for plate loads should be used with extreme caution. The inductance and distributed capacity may be quite high and upset the network.

When triodes are used in wide-band amplifiers, where the required plate load is usually comparable to the plate resistance of the tube, the plate resistance should be considered in selecting the plate load-resistor value. The plate load resistor should be of such a value that when it is in parallel with the plate resistance of the tube, the resistance of the combination will equal the calculated value. For example, if a 6J5 is used and the calculated load resistance is 1000 ohms, a plate resistor of 1175 ohms would be used.

$$R = \frac{(1000)(6700)}{6700 - 1000} = 1175 \text{ ohms.}$$

In critical applications, generally, the peaking coil is made with a movable high-permeability iron core for adjusting the inductance to take care of unpredictable minor variations in circuit and stray capacities. The gain-frequency characteristic of the amplifier may be checked with a good-grade signal generator supplying the constant-voltage input and a wide-range vacuum-tube volt meter for monitoring the output. The response of the amplifier may be observed visually using a video sweep generator and a wide-range oscilloscope. A standard oscilloscope may be used in place of the wide-range oscilloscope by inserting a linear detector between the amplifier and oscilloscope input and using a sinusoidal voltage equal to the sweep frequency for the time base.

Attenuators

The effects of the circuit and stray capacities, C_1 , C_2 and C_3 in Fig. 18-A, are negligible at audio frequencies but become increasingly important as the frequency is increased. At video frequencies they cause reduced input impedance as well as frequency and phase distortion. The frequency and phase distortion, and to a certain extent the input impedance, will vary with the position of the slider on R . This condition can be remedied by use of a compensated step-type attenuator. Fig. 18-B is a schematic of the basic circuit of an input cable and attenuator system generally used on wide-range oscilloscopes.

Ignoring the input cable for the moment, the ratio of output voltage, E_3 , to the input voltage of the attenuator, E_2 , will be independent of frequency if the time constants of R_1C_1 and R_2C_2 are made equal. Since C_2 is the sum of circuit and stray capacities, and thus fixed, the design procedure is to set the values of R_1 and R_2 for the voltage ratio desired, and then make C_1 such value that

$$TC = R_1C_1 = R_2C_2 \text{ or } C_1 = \frac{R_2C_2}{R_1} \quad (35)$$

This means that a different value of C_1 will be required for each step of the attenuator; and since, as will be explained below, it is desirable to keep the total resistance of R_1 and R_2 constant, these values will have to be changed for each step also.

It is generally desirable to load the circuit supplying the signal voltage as little as possible. Yet, however, means must be provided for making connection to the signal-voltage source. A low-capacity cable with an isolating resistor in the probe is usually satisfactory. Even with so-called low-capacity cable, the capacity of a five-foot section plus fitting and circuit capacities is considerable at video frequencies.

The voltage division can be made independent of frequency in the same manner as outlined for the attenuator; that is, by considering R_1 and R_2 as one resistor and summing up the cable and fitting capacities together with the effective capacities of C_1 and C_2 in series as one capacity,

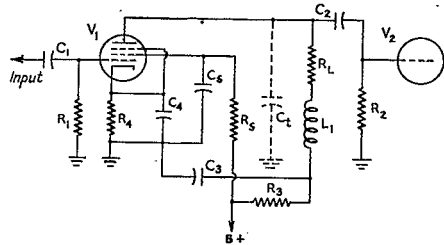

Fig. 19 — Typical shunt-peaking circuit.

Gain = $G_m R_L$
 $C_t = C_{pk} + C_{pk}$ of V_1 and V_2 respectively plus wiring capacity.

f_c = highest frequency of correction

f_1 = lowest frequency of correction

$R_L = X_{C_t}$ at f_c

$L_1 = \frac{R_L}{4\pi f_c}$ } General

$R_L = 0.85 X_{C_t}$ at f_c
 $L_1 = \frac{3}{(2\pi f_c)^2 C_t}$ } Conservative

$X_{C_t} < \frac{2}{G_m}$ at f_1

$R_3 > \frac{3/f}{C_3}$ at f_1

To compensate for R_1C_1 or R_2C_2 :

$$C_3 = \frac{R_2C_2}{R_L}$$

$$R_3 > 20 X_{C_3} \text{ at } f_1$$

To compensate for R_4C_4 :

$$R_4C_4 = R_3C_3 \text{ and } \frac{R_3}{R_4} = \frac{C_4}{C_3} = G_m R_L$$

C_1 , and then adding the capacity C_2 across the isolating resistor R_3 , making its value such that the time constants of $R_3 C_2$ and $(R_1 + R_2) C_1$ are equal. This is the same as equation (35). This will mean, of course, that E_2 will become

$$\left(\frac{R_1 + R_2}{R_1 + R_2 + R_3} \right) E_1$$

but, by making the reduction a factor of 10 and increasing the gain of the amplifier by the same factor, the over-all gain remains the same and a coupling and attenuating system which has a high input impedance and gives minimum distortion of the wave shape of the signal is provided. The effective input impedance will be a resistance equal to $R_1 + R_2 + R_3$ with a parallel capacity equal to C_2 and C_1 in series and may be calculated for any frequency by equation (4) repeated below from the first installment.

$$Z_k = \frac{RXC}{R^2 + XC^2} \quad (4)$$

For example, if we wished to have E_3 , Fig. 18-B, one-tenth of E_2 , and E_2 one-tenth of E_1 , and C_1 is 50 $\mu\mu\text{fd.}$ with C_2 200 $\mu\mu\text{fd.}$, we can proceed with the design by making

$$\begin{aligned} R_1 &= 90,000 \text{ ohms} \\ R_2 &= 10,000 \text{ ohms} \\ R_3 &= 900,000 \text{ ohms} \end{aligned}$$

$$C_1 = \frac{R_2 C_2}{R_1} = \frac{(10^4)(50)}{(9)(10^4)} = \frac{50}{9} = 5.56 \mu\mu\text{fd.}$$

$$C_2 = \frac{10^4 + [(9)(10^4)(200)]}{(9)(10^5)} = \frac{(2)(10^7)}{(9)(10^5)} = \frac{200}{9} = 21.1 \mu\mu\text{fd.}$$

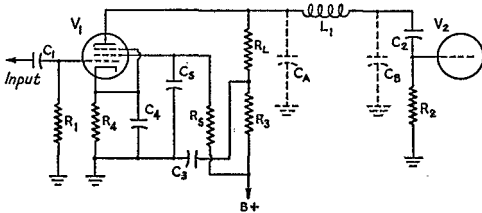

Fig. 20 — Typical series-peaking circuit.

$$\text{Gain} = G_m R_L$$

$$C_1 = C_A + C_B$$

$$C_B = 2C_A$$

$$f_c = \text{highest frequency of correction}$$

$$f_1 = \text{lowest frequency of correction}$$

$$R_L = 1.5 X_{C_1} \text{ at } f_c$$

$$L_1 = 0.67 C_1 R_L^2$$

$$X_{C_1} < \frac{2}{G_m} \text{ at } f_1$$

$$R_4 > \frac{3/f}{C_1} \text{ at } f_1$$

To compensate for $R_1 C_1$ or $R_2 C_2$:

$$C_3 = \frac{R_2 C_2}{R_L}$$

$$R_3 > 20 X_{C_3} \text{ at } f_1$$

To compensate for $R_4 C_4$:

$$R_4 C_4 = R_3 C_3 \text{ and } \frac{R_3}{R_4} = \frac{C_4}{C_3} = G_m R_L$$

The input impedance will be one megohm with 19 $\mu\mu\text{fd.}$ in shunt (21.1 $\mu\mu\text{fd.}$ and 200 $\mu\mu\text{fd.}$ in series). By always keeping the total resistance of R_1 and R_2 equal to 100,000 ohms, one setting of C_2 will be correct for any setting of the attenuator.

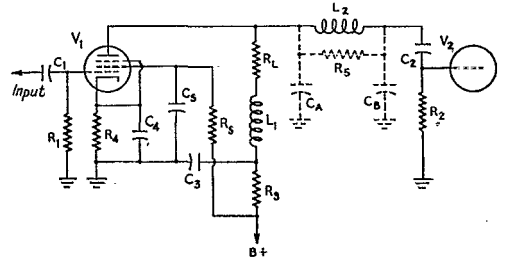

Fig. 21 — Typical combination-peaking circuit.

$$\text{Gain} = G_m R_L$$

$$C_1 = C_A + C_B$$

$$C_B = 2C_A$$

$$f_c = \text{highest frequency of correction}$$

$$f_1 = \text{lowest frequency of correction}$$

$$R_L = 1.8 X_{C_1} \text{ at } f_c$$

$$L_1 = 0.12 C_1 R_L^2$$

$$L_2 = 0.52 C_1 R_L^2$$

$$X_{C_1} < \frac{2}{G_m} \text{ at } f_1$$

$$R_4 > \frac{3/f}{C_1} \text{ at } f_1$$

$$R_3 = 5 R_L \text{ (approx.) by experiment.}$$

To compensate for $R_1 C_1$ or $R_2 C_2$:

$$C_3 = \frac{R_2 C_2}{R_L}$$

$$R_3 > 20 X_{C_3} \text{ at } f_1$$

To compensate for $R_4 C_4$:

$$R_4 C_4 = R_3 C_3 \text{ and } \frac{R_3}{R_4} = \frac{C_4}{C_3} = G_m R_L$$

Summary

As a final summary, the accompanying three design charts have been prepared. Fig. 19 shows a chart for compensated stages using shunt high-frequency peaking; Fig. 20 one for series high-frequency peaking, and Fig. 21 one for combination high-frequency peaking. Low-frequency compensation data are included with each to keep each chart complete in itself.

Of the numerous reference sources used in writing this article, the author desires to give special mention to lecture notes of Mr. T. M. Gluyas of RCA on the subject of "Generation and Application of Non-Sinusoidal Waves."

CIRCULATION STATEMENT

PUBLISHER'S STATEMENT OF CIRCULATION AS GIVEN TO STANDARD RATE AND DATA SERVICE

This is to certify that the average circulation per issue of QST for the six months' period July 1st to and including December 31, 1944, was as follows:

Copies sold.....	54,577
Copies distributed free.....	315
Total.....	54,892

K. B. Warner, Business Manager

D. H. Houghton, Circulation Manager

Subscribed to and sworn before me

on this 13th day of March, 1945

Alice V. Scanlan, Notary Public



25 YEARS AGO THIS MONTH

AS THE end of the radio season approaches, warm weather and consequent QRN causing a shortening of relay ranges, *QST* for May, 1920, comments bitterly on the radio weather we have had to fight this past season. It is enough, the editor says, to make a man murder his grandmother. An epidemic of sunspots is believed responsible. There has been terrible static for weeks at a time when we ought to have had quiet air; signals have faded unmercifully in all kinds of crazy fashions; many localities have had dead periods of days at a stretch when no signals could be heard beyond daylight range. On March 22nd there was the most gorgeous display of aurora seen in this country in many years. Amateur radio was paralyzed, only local signals being heard. There was no static but some southern stations reported queer whistling noises. During most of March, and notably on March 4th, stations in the central states found operation exceedingly difficult in an east-west direction, and sometimes impossible, although southern stations were more numerous and much louder than ever before heard. An attempt has been made to correlate observations with the weather maps of these dates but to no intelligent conclusion. It is recalled that a 1917 transcontinental test failed under the same circumstances, strong north-south signals but complete inability of the necessary stations to engage in their usual east-west interchange. . . . However, we are going to fight fading; we intend to learn some things about it, ascertaining whether a signal fades at the same time at every receiving station, and we hope that something can be found to overcome it. Transmitting stations and receiving observers are being assembled for a double-barreled program, one in collaboration with the radio section of the Bureau of Standards and the other a purely ARRL program. Schedules will be announced soon. So serious has the trouble become from fading that we have had to create a new "Q" signal to deal with it: QSS, meaning "Your signals fade."

The leading technical article describes an experimental tube transmitter using a Colpitts circuit and useful for c.w., i.c.w. or 'phone. . . . For local and other strong signals the amateur should save his tube and batteries by changing over from tube to crystal detector, says Dr. Elliott A. White in "Combination Crystal and V.T. Detectors Without Switches." "Buzzer Transmission" reports recent progress in low-powered transmitters made of buzzers, which are an ideal thing for local work because they eliminate a lot of bothersome QRM. . . . The second part of Clement's article on "The Vacuum Tube as a Detector and Amplifier" is in this issue and we are amazed to discover that some of

the drawings are our own handiwork — tracings of L.M.C.'s drawings, we suppose. . . . The editor points out our need for radio-frequency amplification, it having many advantages over audio amplification, but says that if we have to retune six circuits every time we change from 200 to 210 meters there won't be much traffic handled. "There is an answer, however, and it's Mr. Armstrong's superheterodyne arrangement described in the February *QST*. Better results are had on short-wave work with this than have ever heretofore been possible."

9ZN has been heard in the harbor at Colon, Panama, nearly 2600 miles, and at sea 200 miles south of Balboa. This is the best distance record that we know of for an amateur station. 2AR and 2DA in Poughkeepsie are working voice a half a mile by inserting a telephone microphone in the ground lead of their oscillating audion receivers. "Who's Who" presents A. E. Bessey, the new manager of our Pacific Division, and K. A. Duerk, 8ZY. The station descriptions of the month present 2XX at Ossining, the station of Robert F. Gowan, chief engineer for the de Forest Company, and 2QR at Keyport, N. J., the station of Harold and Hugh Robinson. We're rather heavy on humor this month with "Rotten Booze" by T.O.M., "Whither Are We Whenc-ing?" by Wolfe, and "A Reply From Mars," which still smells of Vermilya.

Messrs. Joseph Stantley and John diBlasi, late of the Mesco stores, take great pleasure in announcing to their many friends that on May 1st they will engage in business for themselves as the Continental Radio & Electric Corp. at 6 Warren Street, New York City. . . . The CRL Paragon regenerative receiver (tuner only, no tubes) is now available at \$55. . . . *QST* has a surplus of back numbers and offers eleven issues of 1916-17 and two in 1919 for a \$1 bill. Rawson, 1RM, who has the finest equipment in the First District, including a Telefunken 500-cycle transmitter, has moved to Chicago to enter the manufacturing business. We shall miss his separate wireless 'phone set which entertained us evenings.

Strays

Late in March, just as a "gag," a GI on Iwo Jima beamed his walkie-talkie toward a buddy in a neighboring foxhole and sent a message saying that Germany had surrendered unconditionally. Something went wrong with the transmitter and the message was picked up on a frequency monitored by the command headquarters receiving center. Jubilation reigned on the island for ten minutes until the GI who played announcer went to his CO and said: "Sir, I think I've done something wrong."

A. Low-Frequency Aircraft Transmitter for CAP

A Two-Band Light-Weight Unit for Small Aircraft

BY GEORGE PETERSON, JR., * W3IOV

IN PRESENT-day aviation a radio receiver has become an almost indispensable accessory. To make the radio installation complete, however, it is highly desirable to provide a transmitter to afford two-way communication. When approaching any of the larger airports, it is extremely advantageous to be able to secure in advance the wind direction and velocity, local traffic, and to be advised whether or not you are cleared to land. When on the field, it is desirable to be in communication with the tower for taxiing and take-off instructions. Also, when flying cross-country there are many times when the weather ahead may be doubtful and it is most comforting to be able to request this information and be informed as to what may be expected.

Two frequencies are assigned for this purpose, 3105 kc. and 6210 kc. Since these two frequencies are in harmonic relationship, only one crystal is needed to cover both.

The transmitter installation in an airplane should be small in size, light in weight, rugged in construction, free from an excessive number of controls to be operated in flight, but powerful enough to provide a reasonable range.

The transmitter and power supply illustrated in the photographs are designed to conform to these specifications. They are the outcome of several prototype models which were tried out under actual operating conditions in the author's Luscombe. The transmitter, which has an output of about 10 watts, weighs only 5 pounds and measures $5 \times 5 \times 6\frac{1}{2}$ inches. It may be mounted on the instrument panel or in any other convenient location. The power supply, which weighs

This article describes the construction of a simple three-tube crystal-controlled transmitter for the CAP frequencies of 3105 and 6210 kc. Since the unit has been designed to keep weight and size at a minimum, by changing the coil dimensions slightly it also should make an excellent postwar portable rig for the 3.5- and 7-Mc. ham bands.

10 pounds, can be installed in the baggage compartment. It is supplied by a 6-volt storage battery which, in turn, is charged by a wind-driven generator. The unit supplies the "B" requirements of both the receiver and transmitter.

Circuit Details

The circuit, shown in Fig. 1, consists of a 6J5 Pierce oscillator controlled by a 3105-kc. crystal. This oscillator drives a 6L6 power amplifier, plate-modulated by another 6L6. In place of the 6L6 tubes, 6V6 tubes can be used and if a 12-volt supply to the filaments is desired, the modulator and output-tube filaments can be connected in series and a 12J5 substituted in the oscillator circuit. The circuit arrangement provides simplicity, reliability and a minimum of controls.

The final tank circuit has a switching provision which permits the power amplifier to operate either at the crystal fundamental frequency or as a doubler at twice the crystal frequency. Although both frequencies are not necessary, it is nevertheless quite desirable to be able to select one or the other. It will be noted that different tuning condensers, C_7 and C_8 , are used for the two frequencies and different antenna taps are provided so that the adjustments for these two frequencies are not interdependent.

The tank coil, L_1 , consists of 30 turns of No. 20 enameled wire, close-wound in two sections of 15 turns each, on a $1\frac{1}{2}$ -inch-diameter form. The two sections are separated about $1/16$ inch, just enough to permit bringing leads out from the ends of the sections. Each turn of both sections is tapped in staggered rows of three by bending out the wire of the turn to be tapped and pushing

*385 South 16th St., Philadelphia 2, Pa.

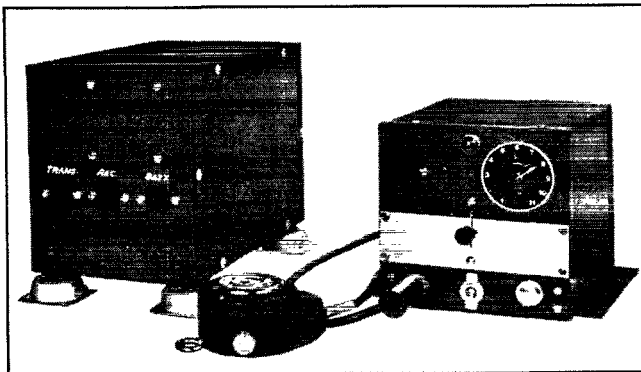

Transmitter (right) and power-supply (left) of the I.f. CAP installation.

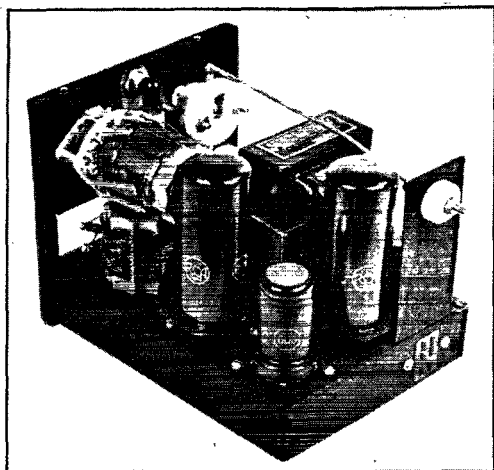

Right-side view showing the two 6L6s, the 6J5, the plate tank coil, L_1 , and the antenna loading coil, L_2 . The latter are mounted at right angles with L_1 below.

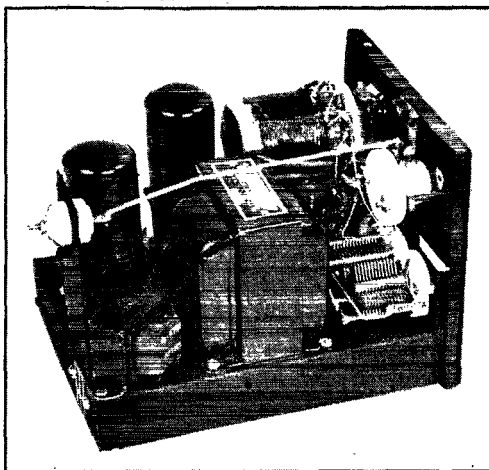

Left-side view showing the tuning condensers and antenna-indicator lamp on the panel. The microphone transformer and modulation choke are in the foreground.

back the adjacent wires. The protruding wire then is scraped clean for the antenna tap.

Parallel feed is used in the plate circuit of the output stage to maintain the condenser rotors at ground potential and keep high voltage off the antenna and the antenna taps. An adjustable antenna-loading coil is provided, since the antenna is reeled in while the plane is on the ground and must be properly loaded to make it take power from the transmitter. This loading coil, L_2 , consists of 36 turns of No. 20 enameled wire close-wound on a $1\frac{1}{2}$ -inch-diameter form. It is tapped at the following turns: 2, 4, 6, 8, 26, 28, 30, 32, 34, 36, and these taps are brought to the eleven-point selector switch, S_4 . The first switch point cuts the coil out entirely.

The "on-off" switch controls the filaments and also energizes the remote-control relay, Ry_1 , in the power supply, Fig. 2, which actually is controlled by the push-to-talk switch, S_1 , on the

200-ohm single-button carbon microphone. The same switch button also completes the microphone circuit which is powered by a $4\frac{1}{2}$ -volt "C" battery located in the power-supply cabinet.

Power Supply

The power supply, the circuit of which is shown in Fig. 2, is remotely controlled and therefore can be located at any convenient place. It should be placed as close as practicable to the storage battery, however. The unit is arranged to provide power to both the receiver and transmitter, and consists of a 300-volt 100-ma. Vibrapak with the necessary additional filters and relays. Jones plugs are used for connecting the battery, transmitter and receiver. The battery connection is a four-prong plug using two contacts in parallel for one lead and two for the other. All six contacts are used for the transmitter. The receiver uses only five of the six contacts originally in the plug. The

Fig. 1 — Circuit diagram of the two-band low-frequency CAP transmitter.

- C_1 — 0.005- μ fd. paper.
- C_2 — 100- μ fd. mica.
- C_3 — 250- μ fd. mica.
- C_4 — 0.1- μ fd. paper.
- C_5, C_6, C_9 — 0.003- μ fd. paper.
- C_7, C_8 — 100- μ fd. variable.
- C_{10} — 10- μ fd. 150-volt electrolytic.
- C_{11} — 8- μ fd. 450-volt electrolytic.
- R_1 — 30,000 ohms, 1 watt.
- R_2 — 100,000 ohms, 1 watt.
- R_3, R_5 — 250 ohms, 10 watts.
- R_4 — 5000 ohms, 10 watts.
- R_6 — 15,000 ohms, 10 watts.
- RFC — 2.5-mh. r.f. choke.
- L_1, L_2 . See text.
- L_3 — Modulation choke 15 h., 100 ma. (Thordarson 4666).
- J_1 — Microphone jack, double-contact, open-circuit.
- J_2 — Metering jack, closed circuit.
- S_1 — Double-contact push-button switch on mike.
- S_2 — S.p.s.t. toggle.

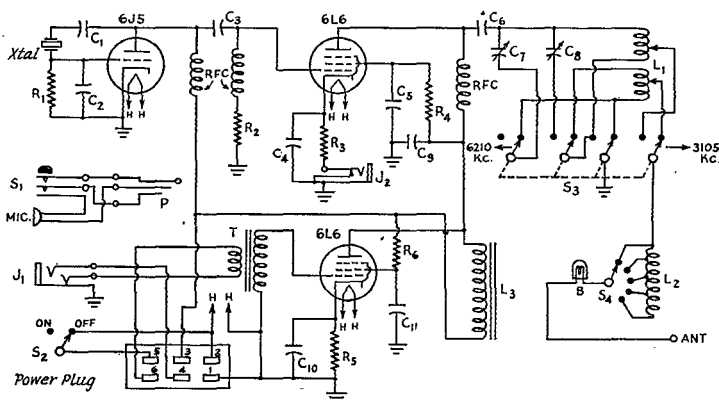

- S_3 — 4 p.d.t. rotary switch.
- S_4 — 11-point rotary tap switch.
- T_1 — Carbon-microphone transformer (Stacor A-4706).

No. 4 contact is removed, the bakelite cut away to enlarge the opening and then another thickness of metal the same width as the prong is soldered to the No. 4 prong, so that this plug will fit only the receiver outlet and cannot be inadvertently put into the transmitter socket.

When the transmitter is in use, the filter choke, *L* in Fig. 2, is left out of the circuit to eliminate the voltage drop across it. The slight hum audible on the carrier is not in the least objectionable and considerable weight is saved, since the choke can be much smaller for the receiver only than if it were used in both circuits. Two dry batteries are incorporated in the power supply, one 4½-volt "C" battery for the microphone and a 1½-volt battery for the receiver filaments. These are used to eliminate "hash" which would be objectionable, because of the characteristics of the Vibrapack, if the 6-volt supply were tapped. However, if 6-volt heater-type tubes are used in the receiver the leads to the 1½-volt battery may be connected to the 6-volt source, thus eliminating the 1½-volt battery.

An "on-off" switch, *S*₁ in Fig. 2, is provided in the receiver. When snapped "on," it actuates the double-pole, single-throw relay, *Ry*₂, which turns on the filaments of the receiver and the vibrator "B" supply. When it is desired to transmit, the switch, *S*₁, is snapped "on." Then when the "push-to-talk" button at the microphone, *S*₁ in Fig. 1, is pressed, the single-pole, double-throw relay, *Ry*₁, is actuated, transferring the "B" supply from the receiver to the transmitter. Shielded cable is used for all leads between the transmitter, receiver, power supply and battery.

If it is desired to power only the transmitter with this supply and to use dry "A" and "B" batteries for the receiver, one relay can be eliminated and the remaining relay, actuated by the button, *S*₁, can be made to turn on the Vibrapack.

Antenna

The transmitting antenna consists of an 80-foot length of phosphor-bronze stranded wire which trails behind in flight. A reel is provided in order that the antenna may be reeled in when landing. It is led out from the top of the fuselage and through a fairlead on the tail of the ship.

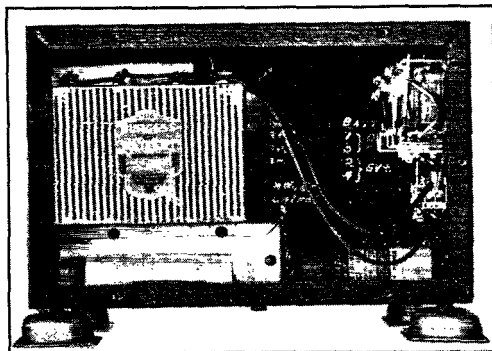

Side view of the power-supply unit in its cabinet showing the mounted relays and microphone battery.

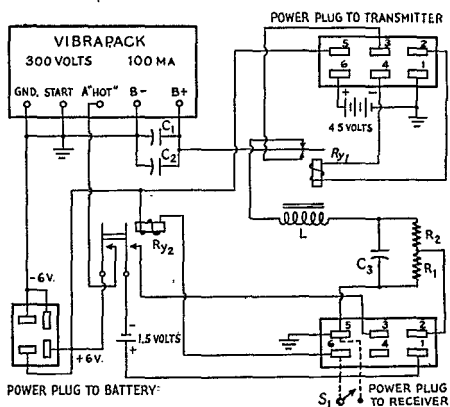

Fig. 2 — Circuit diagram of the power supply used with the low-frequency CAP transmitter.

*C*₁, *C*₂, *C*₃ — 40-μfd. 450-volt electrolytic.

*R*₁ — 5000 ohms, 10 watts.

*R*₂ — 15,000 ohms, 10 watts.

*L*₁ — 10 h., 50 ma.

*Ry*₁ — S.p.d.t. relay.

*Ry*₂ — D.p.s.t. relay.

*S*₁ — S.p.s.t. switch in receiver (see text).

Therefore, when it is reeled in, the length from the front to the tail still is in the clear and by use of the antenna-loading inductance, this portion can be used for communication while on the ground. Reeled out in flight, the antenna on 3105 kc. acts as a quarter-wave antenna against the fuselage to which the transmitter is grounded, and as a half-wave antenna when operating on 6210 kc.

A separate antenna along the belly of the ship is used for receiving, so no transfer of the antenna from receiver to transmitter is necessary.

Transmitter Construction

The chassis and cabinet for the transmitter unit are constructed from 0.032-inch sheet aluminum. The chassis is 4⅞ inches wide, 6½ inches long and 1¼ inches deep. The panel is slightly more than 5 inches square after all four sides have been bent back so that they slide over the 5-inch-square opening of the cabinet. Two openings are cut in the panel, one exposes the screw-driver adjusting points of the tuning condensers, *C*₇ and *C*₈, while the other is for access to the antenna-coupling taps on the amplifier plate-tank coil. These openings are normally covered with an aluminum plate which is slotted to slip over the control knob of the frequency switch, *S*₂, in the center of the panel. The knob in the upper right-hand corner controls the antenna loading-coil switch, *S*₄.

The arrangement of apparatus behind the panel is shown quite clearly in the photographs. On the left side the two tuning condensers, *C*₇ and *C*₈, are mounted on a strip of aluminum, bent at the ends so that the condensers are spaced back from the panel and their shafts do not protrude from the front. The porcelain socket for the antenna-indicator lamp, *B*, is mounted directly above on long spacing screws. On the chassis, behind the tuning condensers, are the modulation choke, *L*₃, and the microphone transformer,

*T*₁. The antenna lead may be seen running from the indicator-lamp socket to the antenna terminal.

On the right side are the coils *L*₁ and *L*₂. Both are wound on sections of ribbed tubing cut from Hammarlund plug-in coil forms. *L*₁ is mounted on the chassis where the clip connections to the antenna-coupling taps may be reached through the opening in the panel. *L*₂ is fastened to the rear of the tap switch, *S*₄, mounted in the upper right-hand corner of the panel.

Directly behind the coils are the 6L6 r.f. amplifier tube and the 6J5 oscillator tube. The 6L6 modulator tube is next to the antenna-terminal mounting strip and the crystal socket is between the modulation choke and the r.f. amplifier tube. Self-tapping screws and "shake-proof" nuts are used throughout.

The cabinet for the transmitter measures 5 × 5 × 6½ inches. At the back an opening is made through which a Jones plug may be inserted for connecting the transmitter to the power supply and another hole is cut through which the antenna terminal may protrude. The cabinet is mounted permanently in the instrument panel of the plane, being supported at the front and back sides of the flange by brackets fitted with Lord rubber shock mountings. The hole in the instrument panel is slightly larger than the cabinet, permitting the set to move slightly in the shock mounts. The transmitter can be inserted or removed without disturbing the mountings.

The power supply is enclosed in a standard 5 × 6 × 9-inch cabinet mounted on shock mounts and provided with Jones socket connections for the receiver, transmitter and storage battery. This cabinet houses the 300-volt, 100-ma. Vibrapack, the relays, filter-circuit components, etc., as shown in the side-view photograph.

Adjustment and Operation

The only controls used by the pilot in flight are the antenna-loading adjustment in the upper

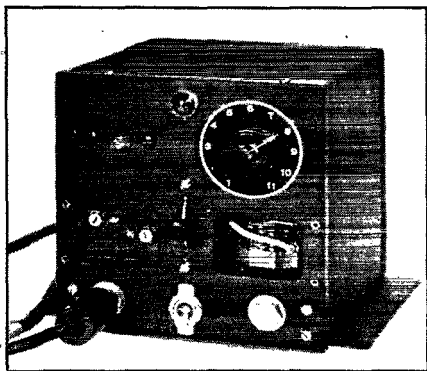

The transmitter with cover plate removed providing access to tuning condensers and amplifier plate-coil taps. The bulb protruding from the panel is the antenna-resonance indicator.

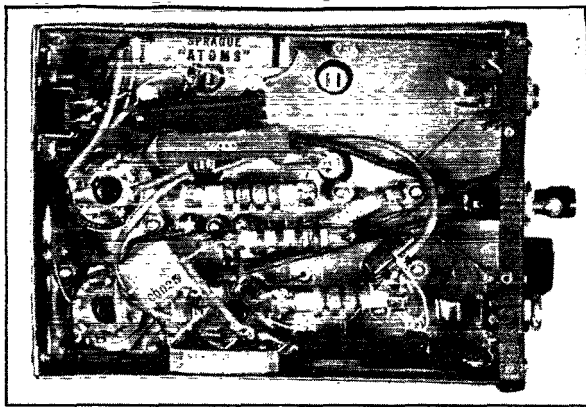

Bottom view of the low-frequency transmitter for CAP.

right-hand corner of the panel and the frequency-change switch in the center. The switch at the bottom center is the "on-off" switch. The pilot light at the top center indicates when the set is "on" or "off." At the bottom left is the microphone jack, *J*₁, and at the bottom right a jack, *J*₂, in the cathode circuit of the 6L6 output tube for a milliammeter for adjustment. This jack normally is covered by a cap to prevent insertion of the mike plug by an unknowing pilot. The cap is easily made by soldering a large thumb tack to a lock nut. Radiation indication is obtained from the bulb sticking through the panel at the upper left. If available, an r.f. ammeter may replace the antenna resonance-indicator bulb, *B*, since sufficient space is provided for this substitution.

With the ship on the ground, the antenna disconnected and a milliammeter plugged in, the frequency-selection switch, *S*₃, is put on 3105 kc. and the condenser, *C*₇, adjusted for minimum plate-current dip. The switch then is changed to 6210 kc. and the condenser *C*₈ adjusted for minimum dip in plate current. Once these settings have been made, further adjustments in flight should be unnecessary. Then, with the antenna connected and reeled out to its full length, the correct location for both the 3105-kc. and 6210-kc. antenna taps on the tank inductance are found. These should be approximately six turns for 3105 kc. and three turns for 6210 kc. It should be remembered that the three turns for 6210 kc. are above the split in the tank coil.

The antenna loading coil can be cut out completely by turning the selector switch, *S*₄, to the first point and the antenna adjusted to optimum length by reeling the antenna in and out until it is properly resonated. Then the number of turns is counted and the antenna reeled out this amount each time. This makes for greatest efficiency. However, it is possible also to cut the antenna slightly shorter than the resonant length and use the first taps on the antenna-loading inductance to tune for maximum antenna current. On the ground, the tank condensers are left unchanged and the antenna load adjusted to secure maximum antenna current as indicated by the bulb in the antenna lead,

"Flummajimmery"

The Polecat County Philosopher Proposes Attenuating the Positive and Eliminating the Negative

BY "SOURDOUGH"

WE SURE had some winter this year. What with cutting pulp for the government and telephone poles for spring delivery and sawing firewood *and* sawing firewood **AND** sawing firewood, a feller don't have much time for writing. Still and all, there's nothing promotes quiet thinking like being on one end of a cross-cut saw. (Promotes a purty good perspiration, too.) Anyway, I had me a chance to think back on recent QSTs and chew things over point by point.



One thing sticks out about a million miles — we gotta do a lot of working-out *now* about how we're going to handle the bands when we get 'em (praying that it will be soon). Now I've heard a pile of stories about them there Noo York subways when folks is going home from work. Seems like folks is wedged in like straws in a baling press. Wal, they'll look like the great wide open spaces compared to what the bands is going to be if we have even part of the growth in the number of hams we expect.

Ain't never been in one of them subways and ain't envious to, neither — but I betcha that, crowded as they are, you don't see one lady stick her umbrella in another lady's eye just to make a little more standing room for herself nor some big feller pick a little guy and throw him outta his seat so the big feller can sidown. Them folks know they gotta get home from work, and the subway is the facility provided — so, crowded as they may be, they have an unwritten set of rules about behavin' so's to make it as workable as they can under the unavoidable conditions.

T'aint only that we *can* do the same — we *gotta!* The native horse sense of the American ham would bring it about in time anyhow. What I claim is that we should ought to thrash this thing out now, so that when the great day comes we'll have at least, the start of a workable plan. What we don't want — especially on 'phone — is to have argymints and bad temper on the air. Little BCLs have big ears, and just when we git a'going t'wouldn't be reasonable nor decent to have our family spats "aired" on the air. There's

plenty of you young fellers, in the service and out, who must have good ideas, if only you'll just send 'em along to West Hartford and let them boys sort 'em out and spread 'em around for everyone to see. Sure, whatever the idea, there'll be argymints over it. Argymints is healthy things. But let's have our argymints right now, so's not to waste time and breath workin' this thing out later on when we get back on the air.

N'ruther thing. Fer years now I been trying to work up gumption enough to speak my two cents worth about these here "high-fidelity" microphones. Never did dare, 'cause I figgered you young squirts would put it down to senile maunderings from an outta date fossil. Now along comes McMurdo Silver, 'n' he ain't so senile or outta date nor has his record ever shown any tendency towards maundering. So, havin' some support at last, guess I'll argify a bit.

The law sez we ain't to broadcast music. What we put on the air is speech (in most cases, anyhow; I've heerd some stuff that sounded more like feeding time at the zoo). The object is to transmit intelligence, meaning so one feller can tell another feller somethin' and the second feller will understand it okay. Maybe some fellers got the idea theirs is the voice beautiful and make like they think they're competing with Gabriel Heater or Gram Swing or something — maybe even working up to being ham-band Sinatras. Well, them fellers using mikes that run flat right up to 15,000 cycles (plus or minus 1½ dbs.) might get heard by an occasional BCL with a hi-fi receiver what would do justice to their dulcet larynxes. But

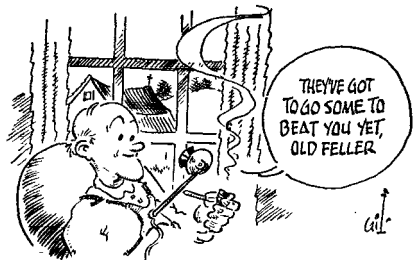

plain Oscar Ham, crouched over a business-like receiver with a corn cob in his jaw, wouldn't hear any difference except maybe in the extra sideband splash.

The telephone companies ain't given to spending money on useless research. Yet they put in years of study to develop the "optimum speech characteristic." That there characteristic was worked out so's the customers could hear each other and understand each other better — and so as many of 'em as possible could be accommo-

dated at one time. Costs a lot of dough to put a trans-Atlantic (or trans-Pacific) circuit in service — and they run at about the same speech characteristic as the telephone set up. What do they use? You know the answer — carbon mikes, and an upper limit under 4000 cycles — and only half that on long distance circuits nowadays.

Fer years I been using an ordinary single carbon mike on a "breast" holder (like the kind you see in telephone exchanges), and never had nobody know the difference or complain about hiss. This riggin' suits me fine 'cause I wear the mike and it moves when I move; it don't keep me hogtied with my grizzled puss the right number of inches from some chromium-plated designer's dream to which I have to spend my time bowing and scraping. Using the "breast set" I can pull the plug and shove it in my pocket if Martha wants me to come down and put another log of wood on the fire. At the operating position it leaves two hands free, and it don't clutter up the operating table either.

With a high-fidelity mike the upper-frequency stuff goes on the air whether anyone hears it or not. You got sidebands stickin' way out to where they get in the next feller's hair. They don't do you any good and they mess him up plenty. Also you're spending power to manufacture modulation energy that ain't no use to you — and that goes for the low-frequency end, too.

O' course, if the neighbors is real impressed by the chromium-plated flummajimmery around the shack ain't no reason in the world why a feller shouldn't derive a little innocent elevation of his ego therefrom — if he can afford it. But for the love of Ariel shove a filter in somewhere that, as the feller says, attenuates the bass below 100 cycles and eliminates the treble above 5000 cycles (that's a maximum limit; t'would be better to chop her off at 3500.)

T'other day I took time off from woodchopping to make a trip to the city. Heerd one feller say to another in a smoking car that there weren't any frontiers any more and nothing left to explore anywhere in the world. It all sounded real doleful 'till another gentleman sitting over in the corner opened up and gave a list of unexplored regions within ten hours of New York by air. The feller shut up quick when the gentleman said he worked for the Geodetic Survey and maybe had some idea of what he was talking about.

Same with ham radio. Through the years I've heerd a lot of fellers wailing about the game getting stale and there not bein' anything new — a good line of unimaginative, defeatist ullaage as ever was. Wal — they sure was wrong! From all I read and from what fellers tell me (some of 'em bright fellers too), there's enough new problems and frequencies and gadgets and aerials and jehosphat knows what to keep them hams as has an exploring turn of a mind busy for the next fifty years. Even them as likes to just operate has got a lot to study up on control methods and procedures. . . .

No, I figger there ain't never been as interesting a time in the handsome history of hamdom as we're going to start on as soon as the lid is off.

★ ★ ★ ★ ★ ★ ★ ★

Gold Stars

CPL. LESLIE E. HAUGHS, W6SPE, died on December 25, 1944, in Belgium as a result of wounds sustained while investigating a disturbance at Mons. He was serving in a military police company at the time.

W6SPE was an active amateur until the outbreak of the war, operating mostly on the 14- and 28-Mc. bands. A graduate of the National Radio Institute, he held a Class A license and had just completed a 1-kw. transmitter at the time of the attack on Pearl Harbor.



PFC. ALVIN T. FRIEND, W3IKG, was killed in action on November 27, 1943, when his transport ship was sunk in the European Theater.

After induction in September, 1942, Alvin received training at Miami Beach, Fla., Scott Field, Ill., and Truax Field, Wis., where he graduated as a radio operator in the AAF. His unit went to Africa in October, 1943.



W3IKG received his amateur license in 1939 and was most active on 56 Mc., taking particular interest in Field Day operation.

A radio serviceman by trade, W3IKG was tireless in his experimenting.

CPL. WALLACE A. COPELAND, W1MLI, died in Hawaii August 30, 1944, from an accident.

From the time he was a young boy, W1MLI was very much interested in radio work. He was a member of his high school radio club and also belonged to an informal club called SPARK (South Providence Amateur Radio Club).

Soon after graduating from high school in 1942, W1MLI enlisted in the Signal Corps and trained at Ft. Monmouth for eight months before going overseas. He served as an instructor and inspector and did radio repair work on planes operating in the Central Pacific.

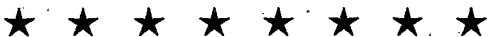
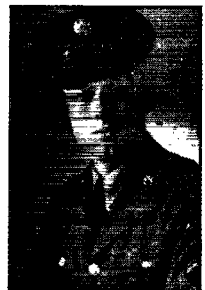

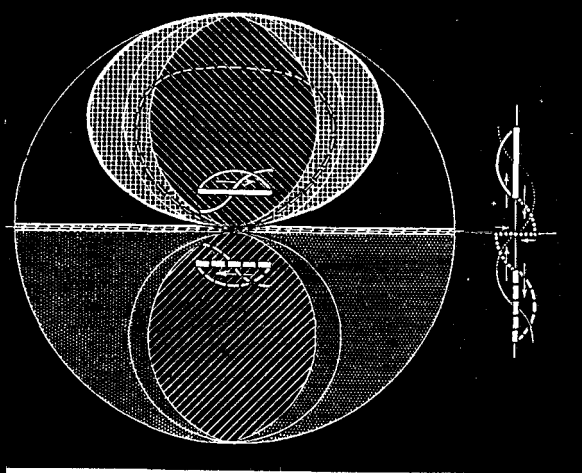

Radar Techniques

II—Simple Analogies

BY CLINTON B. DESOTO,* WICBD

BEFORE delving further into the details of actual radar circuits and components, it seems important to establish a concept of the kinetics of radar, and, in particular, an understanding of the manner in which radio waves are reflected. On the thesis that it is easier to comprehend new ideas by relating them to familiar facts, this discussion will begin with a preliminary examination of obvious analogies from allied fields.

Actually, comparison of radar techniques with older fields of physics is more than merely analogous. The laws of geometrical optics offer the contemplative researcher a fruitful basis for analyzing and predicting radar behavior — being, as it is, only one highly specialized and restricted branch of the fundamental geometry of radiation.

The Why of the Radio Echo

So far we have taken quite for granted the fact that radio waves can be reflected. Since this phenomenon, which makes radar practicable, is highly complex, it merits careful attention.

The laws of reflection are the same for radio waves as for light. It is a fundamental physical principle that reflection is caused wherever a discontinuity or boundary exists between two media. Thus, when a train of radio waves traveling in one medium encounters the boundary of a second medium having different properties, some of the wave energy usually will be turned back or reflected at the interface.

A body illuminated by incident radiation may transmit, reflect or absorb the radiant energy, depending upon the physical characteristics of the body, in terms of *transmissivity*, *reflectivity* and *absorptivity*.

*Editor, QST.

Transmissivity, T , represents the ratio of the proportion of the radiant energy impinging upon a surface to that transmitted through the body. If transmission is complete ($T = 1$), the body is totally transparent. If no radiation leaves the body ($T = 0$), it is totally opaque. Energy which is not transmitted must be either absorbed or reflected. A perfectly absorbing body ($A = 1$) is equivalent to a perfectly matched load impedance, electrically, or to an optical "black body."

Such of the energy as is neither absorbed nor transmitted will be reflected. If, for a given wavelength, a body is totally reflecting ($R = 1$), it is described as a perfect mirror. At angles of incidence above a certain critical value, either a transparent or an opaque body may be totally reflecting.

In the case of a plane conductor normal to the direction of propagation the reflected wave will travel in a direction negative to the incident wave, setting up a system of standing waves as on a transmission line. If the conductivity is high, nearly all the radiant energy in the incident waves will be reflected by re-radiation resulting from the currents set up in the sheet. Such energy as is not reflected will be absorbed; there will be no transmitted wave. The angle made by the incident ray with the normal (perpendicular to the plane of the surface) is the *angle of incidence*, ϕ . The angle made by the reflected ray with the normal is the *angle of reflection*, which is at all times (a) equal to the incident angle, ϕ , and (b) in the same plane perpendicular to the reflecting surface.

When a wave traveling through free space strikes a medium where $R < 1$, it divides into two rays: a reflected ray, and a transmitted ray penetrating the medium in an altered direction. The latter ray is said to be refracted.

Refraction is a deviation in the direction of a ray which results when it passes into a medium wherein the velocity of propagation is different from that of the first medium.

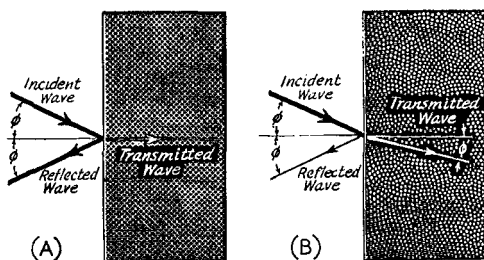

Fig. 1 — Fundamental principles of reflection at a boundary separating media of differing properties of dielectric constant and/or conductivity. A represents practically total reflection above the critical angle ($\cos v/v'$) at the interface of homogeneous isotropic media. A disturbance is created in the second medium but no part of the energy is transmitted. B illustrates partial reflection at the boundary between media having refractive indices (intrinsic impedances) in the ratio of 2:1. The angle of reflection, ϕ' , is determined by the respective velocities of propagation.

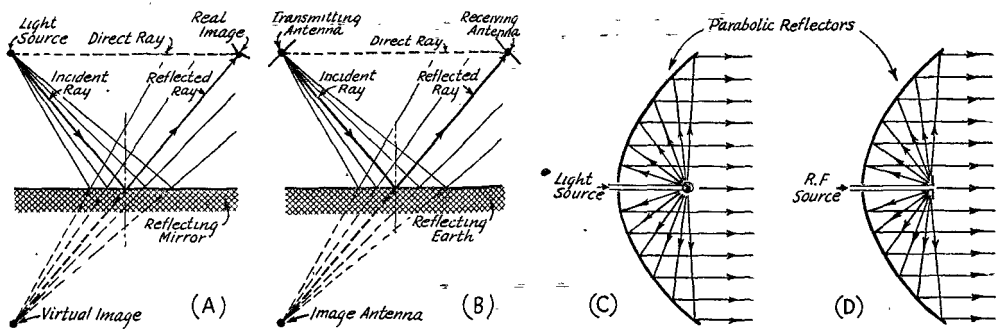

Fig. 2 — The geometry of radiation is equally applicable to light rays and radio waves, provided the unit dimensions involved exceed a wavelength. A and B show the virtual image principle, long used in computing radiation patterns of antenna systems near ground as well as in optics. Parabolic reflectors are equally useful in directing a searchlight beam (C) or a radio beam (D). Any point on the parabola presents an angle such that waves radiated spherically from the point source are reflected as parallel in-phase plane waves.

Reflection and Refraction

According to Fermat's principle, radiation obeys the geometrical law of following the shortest *optical path* between two points. In a given medium this is, of course, a straight line; but where there is a choice between two media having differing velocities of propagation "the long way round" may be, optically, "the shortest way home."

Thus reflection occurs when, as a ray enters a transmission medium of different velocity the entering edge travels faster or slower than the remainder, causing a progressive change in the position of the wave front. If the difference in velocity is sufficiently great and the angle of incidence sufficiently oblique, the entire front will be so rotated that it is turned back and re-emerges from the boundary. At lesser angles some of the energy will be similarly returned, but the remainder will continue into the medium as a transmitted wave. This refracted wave also will have been turned somewhat on entering, and thus will travel in a new direction.

Snell's Law of refraction states that radiation in a medium, incident upon a boundary, will proceed into the second medium with an angle between the normal and the direction of propagation termed the *angle of refraction*, ϕ' . The ratio of the sines of the two angles, ϕ and ϕ' , is the *index of refraction* of the second medium. The density of a substance is equal to the refractive index, which is the same electrically as the intrinsic impedance. The refractive index varies with wavelength but is independent of the angle of incidence.

At oblique angles of incidence, when transmission is from a rarer to a denser medium, the transmitted ray is refracted *toward* the normal; going from a denser to a rarer medium, the ray is bent *away* from the normal.

The interlocking relationships of the quantities involved are shown by the following:

$$\frac{\sin \phi}{\sin \phi'} = \frac{\sqrt{\mu' \kappa'}}{\sqrt{\mu \kappa}} = \frac{v'}{v} = \eta'$$

where μ = permeability; κ = dielectric constant; v = velocity, and η = refractive index.

If the reflecting surface is smooth (i.e., free from irregularities of a size approaching the length of the wave), the reflection will be specular like that of light waves reflected from a mirror, and waves impinging normally on the surface will be regularly reflected back toward the source.

If the surface is not sufficiently smooth, however, reflection will occur at various angles, and the re-radiation will be *diffused*. If the surface is sufficiently rough the incident waves will be scattered; in this case only a portion of the reflected or scattered energy will be returned along the path of the incident waves.

Diffraction is the deviation of a wave because of the finite size of an object, as when the wave is partially cut off by an obstacle or passes near the edge of an opening. *Scattering* is the dispersing of a wave in many directions by an object small compared to the wavelength.

The variation in refractive index of a medium with wavelength results in *dispersion*. A multi-frequency (polychromatic) ray, containing radiation of many wavelengths, can be separated into its monochromatic components by utilizing this dispersive effect. For example, high frequencies (blue light), which travel more slowly than low frequencies (red light), can be separated by glass prisms. *Regular* or *normal dispersion* occurs where the refractive index increases with decreasing wavelength; *anomalous dispersion* is the opposite case.

It is far from superficial to liken radar reflection to a light beam striking a silvered mirror —

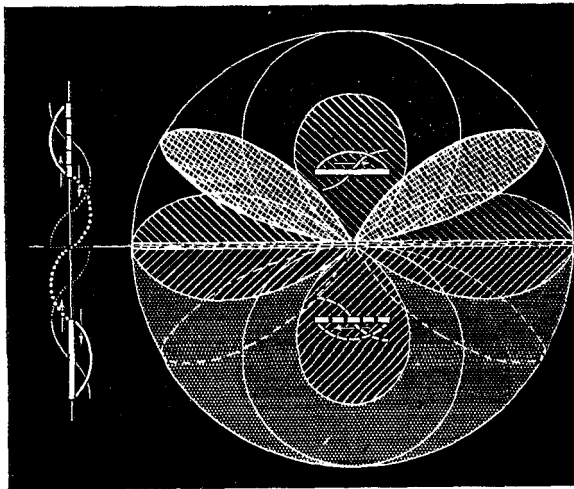

or to compare searchlight reflectors used to concentrate light energy with the directive antenna arrays employed to concentrate r.f. energy, or even to liken the focusing of a cathode-ray beam to the action of an optical lens. We need not draw the analogy solely on the basis of similarity of results. These similarities exist because the respective processes are, inherently, the same; they stem from a common ancestry.

The device of a virtual image, for example, was long hence borrowed from optical science in connection with the construction of antenna radiation patterns—not to mention for such other purposes as the representation of recurrent networks and transmission lines. In every case the

effect involved is that of reflection—the transmission backward toward the source of energy originally propagated down the line but not consumed at the receiving end.

Transmission-Line Analogies

A two-conductor transmission line is the most satisfactory analogy for the radar system as a whole, synthesizing the entire link between the generator—the transmitter—and the receiver.

The term “transmission line” applies to arrangements of every description from a quarter-wave section having the dimensions of a hairpin at radar carrier frequencies to the interstate power transmission and long-distance telephone lines. In the latter the “wavelength” is very long indeed—some three thousand miles in the case of a 60-cycle a.c. line. Even at the higher audio frequencies a wavelength is a distance that—were it not for transmission lines, radio and wire—would require an hour’s drive to span.

A beam of radio waves propagated in space may be visualized as traveling along an unbounded transmission line. If such a line is terminated with an impedance having a value approaching either zero or infinity, complete reflection of the wave train will occur and the familiar phenomenon of standing waves will be set up. Intermediate values of terminating impedance will result in proportionate coefficients of reflection.

The voltage and current distribution along a transmission line of any ratio of length to wavelength and with any value of associated terminating impedance is readily derived from familiar transmission line theory.

To obtain maximum power transfer from source to line, Z_I and Z_0 must be matched. To accomplish this, an intermediate coupling section of transmission line—a matching section—is introduced. This matching section may be a quarter-wave transformer, a linear “step-up” transformer or stub, or a longer length of line with spacing gradually varied so the characteristic impedance changes progressively along its length—a delta or exponential matching line.

So long as this section correctly relates the impedance of the r.f. generator to the characteristic impedance of the long line, the actual length of that line—provided it in turn is properly terminated—does not matter. In fact, the terminating impedance could be moved back to the output terminals of the matching section and the power transfer would not be affected.

The same applies if the output be either open- or short-circuited, moreover. Standing waves similarly would be set up by the combination of incident and reflected traveling waves.

A transmission line may be represented as a form of four-terminal network containing the universal electrical quantities of inductance, capacity, and resistance—and therefore also of reactance, impedance, and leakage conductance. These characteristics are not isolated in readily identified packages but are hidden throughout the system, distributed uniformly in an “infinity of infinitesimals.”

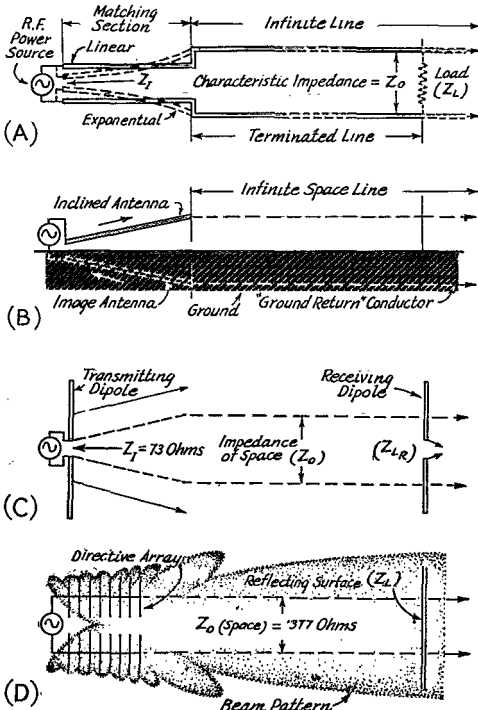

Fig. 3—Development of the “space line” from a parallel-conductor transmission line. The two-wire line (A) has a characteristic impedance, Z_0 , depending on size and spacing of conductors and properties of intervening dielectric. For maximum power transfer from source to line, Z_I and Z_0 must be matched. This is accomplished by a coupling line (matching section).

When one conductor is replaced by a ground return connection (height above ground made equal to one-half initial spacing between conductors), Z_0 is halved. In both line and matching system the second conductor may be replaced by an “image” conductor.

If the two conductors of the matching section are opened out—either by up-ending the inclined conductor at (B) or turning a linear quarter-wave transformer into a half-wave dipole (C)—the matching section will couple the input power to space by radiation. The system remains the equivalent of a transmission line with a matching section. The characteristic impedance of the free-space line is 377 ohms. Performance and general behavior of the space line—shown at D as a beam from a highly directive u.h.f. array—can be predicted as with any other transmission line.

Fig. 4 shows an equivalent circuit for such a line. (Only L and C are indicated, for simplicity; it is understood that a small amount of resistance is associated with each element.) The individual increments of the inductance of the conductors and the capacity between them being arranged in the form of a series of T sections, the performance of the line as a whole can be analyzed on the basis of such a section. By suitably proportioning the physical constants of the line, the equivalent of almost any electrical network — series- or parallel-resonant circuit, low-, high- or band-pass filter, impedance-matching transformer, etc. — can be obtained. Thus this circuit can be used to simulate an equivalent energy path in space — a path in which not only coils and condensers but the line itself is invisible.

Line Experiments

Radar transmission, as explained in Part I, is in the form of spaced short pulses. Electrically, such a pulse can be represented as the unidirectional surge of current obtained by connecting a battery across the input in series with a switch (X) and closing the switch for a brief instant.

1) Removing the load impedance shown, Z_R , will make it an unterminated finite (open) line. If the switch is suddenly closed, a positive pulse of current from the battery will travel down the line. At each section the current wave will pause briefly — delayed first by the retarding action of the inductance, again for the minute interval required to charge the condenser. As rapidly as the current charges each elemental capacity along the conductor in turn it passes on to the succeeding element, its velocity inversely proportional to the square root of the product of L and C .

The current flow continues along the upper (positive) branch until it reaches the end — the terminating LC section. Condenser C thereupon also becomes charged, retaining the charge so long as the applied voltage is maintained.

Since this is a brief — a practically instantaneous — current pulse; by the time C is fully charged it will have received all or nearly all the energy in the circuit. When the charging current ceases, therefore, it will seek to discharge this accumulated energy. Being at the end of the line, C will have to discharge the energy toward the source. Thus the current pulse travels back — a negative wave, this time, 90 degrees out of phase with the initial wave.

That represents reflection. The returned energy constitutes a reflected pulse.

On reaching the point of origin (assuming the voltage source to be disconnected and the resistance in the circuit negligible), the applied charge along the entire line — in both negative and positive branches — will be constant, and a state of equilibrium attained. The energy, now that current flow has ceased and induced magnetic flux is collapsed, exists as voltage across the distributed shunt capacity of the line.

2) Consider, now, the effect if the open end of this charged line is suddenly shorted. Almost immediately condenser C will begin to discharge

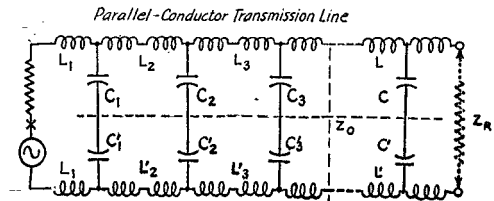

Fig. 4 — Equivalent circuit of an "infinite" transmission line. Distributed capacity and inductance along the conductors constitute a T-section network.

through the short, delayed only by the restraining inductance of L . The preceding sections, too, must give up their energy store; consequently a wave of negative voltage — the potential difference which has been displaced by the short circuit — will start down the line. By the time it reaches the open end, the charge on the line is no longer in equilibrium; all the potential is at the open end. A reflected positive pulse will then rush back as fast as it can — at the velocity permitted by L and C , that is — to restore the balance. This process could continue indefinitely — assuming that leakage conductance, radiation, and other sources of loss were zero.

3) Now reverse the original conditions and, with the output end of the line shorted, close the switch applying the d.c. voltage. Initially the line will be charged in the same manner as before. Once the current wave reaches the terminating section, however, C promptly begins to discharge through the short. Since there can be no potential across the short, a negative voltage wave will travel back toward the source — a reflected wave. At any point the negative voltage in this wave will be equal in amplitude to that of the positive wave from the source. Since it is a reverse-traveling wave, however, the current will be 90 + 90 or 180 degrees out of phase with the current in the positive wave; in other words, at any one instant the negative and positive current waves will be traveling in the same direction, their sum thus becoming the net current in the circuit. With each succeeding cycle — assuming the d.c. input remains connected to provide the necessary energy — the value of current will build up further. Eventually, of course, it could achieve a value of infinity — assuming the battery at the source could stand the load! This part of the experiment we'll defer for the present, however.

4) The remaining experiment is to place a resistive "short" across the line. Actually, there can be two cases — one where the load resistance is high compared to the characteristic impedance of the line; the other where it is low. The results correspond with those described above except that some of the negatively traveling voltage wave will appear across the resistance, and thus is subtracted from the reflected wave. If R_L equals Z_0 , all the voltage will appear across R_L ; where $R_L < Z_0$ the reflected wave will be negative but of lesser amplitude, and where $R_L > Z_0$ the traveling wave will be positive.

This article is Part II of a series. Part III will appear in the June issue of QST.

Hams in Combat



Hamming on the Road to Berlin

BY CPL. GUY B. WELSH,*
W8OWC

AFTER almost losing out by drawing a rejection slip from the Navy in April, 1942, I had better luck with the Army a week later. The recruiting sergeant promised to see that W8OWC got in the Signal Corps — just as *QST* had informed him would happen upon request.

Somehow a slip-up occurred. Less than a week later I was California bound, on my way to becoming a radio mechanic. After six months I decided that was no way for a ham to waste away. The manufacturers who made the radio equipment used in the basic training planes had the problems too well under control. Over ninety per cent of the troubles that arose were so-called "cockpit" difficulties. This left me with nothing to do but make routine frequency checks. Why, there wasn't even any need for keeping spare parts around so I could do some experimenting!

But another spot caught my eye — the control tower. Surely this must be better suited to some excess ham enthusiasm. A CO who was dead set against radio, but willing to help his boys, allowed me to try it. Sure enough, holding a mike regularly (I had spent the last two years on 160-meter 'phone) and having swell receivers to play with eased my mind somewhat.

I soon found that I was the only one who knew how to tune up the transmitter without the help of the instruction book. And, before long, a new antenna was stretched from tower to telephone pole, allowing us to put out a better signal than

*APO 887, c/o Postmaster, New York, N. Y.

We had the time of our lives tearing the abandoned Jerry transmitter apart — though we sweated a little over the possibility of booby traps.

perhaps was desirable. I even helped one of the other boys repair a few radio sets when he got stumped. But here again the lack of spare parts kept experimenting at too low an ebb for happiness. In fact, there was so little to do that I found time to get married!

When the call for men to go overseas became great, I was discovered hiding out in the semi-desert area of Taft, Calif. Almost before I knew it I was heading for England to join the AACCS. Strange as it may seem, I had been unable to get into the AACCS in the States because the CO of our field wouldn't release radio men for transfer!

When I joined my detachment, I wasn't surprised to find that the CO was a ham, Captain Stan Witkowski, ex-W8AUH. Furthermore, he had ideas as well as junk parts to play with, and scavenging hunts were possible in an emergency.

Since our unit was mobile and knowing that France would soon be calling, Captain Witkowski wanted some means of communication between front and rear of possible convoys. With the aid of Sgt. Hall, one of our maintenance boys, the CO and I put together a workable combination and test hopped it in two jeeps the day before we received our traveling orders.

We used conventional v.h.f. circuits with a 9002 as the basis for receiver and transmitter. The leading jeep in the convoy took the receiver, while another jeep at the rear of the convoy carried the transmitter. Lacking two complete units, this system enabled us to keep together as any trouble along the line could be immediately spotted from the rear and passed forward.

The equipment served faithfully on two different occasions, but one evening while we were swimming on the Normandy Beach near our camp the tide very rudely tried to swallow up the CO's jeep — which had been over one hundred feet from the water at the beginning of the evening's events! Be that as it may, our receiver was running no longer, the salt water having proved the master.

It was not long before we made another move to a place near Le Mans. I now was one of the radio operators and, with hand key and bug, I was happy for the first time since entering the service.

Varying reception conditions here shortly convinced the CO that our whip transmitting antenna needed a rest. At this time we were using only one frequency. (For a time three were used, calling for fast band-changing which involved switching final coils and occasionally adding a fixed vacuum condenser. This was right up my alley, but the others weren't sure what it was all about since they were Army-trained radio operators — good ops nonetheless.) An untuned half-wave doublet was cut to exact frequency and we soon had such a signal pounding out that our station had to serve as unofficial net control.

In the meantime, Ish Higginbotham, our power unit mechanic who had a stimulating interest in radio, had been out on a trip looking for parts for some of the equipment — only to run into a Jerry transmitter. He confided in me and we arranged a trip to look it over for possible salvage.

The Jerries must have been in a hurry when they left as they had smashed only the tubes, meters and a few other vital parts. We had the time of our lives tearing it apart — though we sweated a little over the possibility of booby traps.

Two days after our discovery we were on our way again. We set up at a spot that made Paris available to us and in short order an abandoned warehouse was discovered which contained numberless French and Jerry receivers. All were rather badly wrecked, especially such parts as loudspeakers, power transformers and filter condensers. However, enough parts were salvaged to enable me to build a superheterodyne receiver to provide entertainment for the outfit. I gained valuable knowledge from this experience and never would have succeeded without the assistance of a copy of the '44 edition of the *Handbook* one of the boys brought with him from the States.

Using a circuit diagram in the *Handbook* as a basis, I built five superhets out of the salvaged junk. On our second trip to the warehouse we found bandswitching coils, and all but the first set were wired that way. One receiver has provided continuous service during the past several months, with only one night out when our room caught on fire. The receiver had to be smoke-conditioned after that, although it still played on the band on which it was set at the time.

My copies of *QST* didn't catch up with me until a few days before Christmas but the October, November and December issues arrived all in the same week. Before the week was up Ish fell in love with the two-tube regenerative receiver de-

U. S. War Bonds for Stories of War Service

QST wants reports on the experiences of radio hams in active service on the battlefronts — for immediate publication in this section, where feasible, or to be held confidential where security considerations so require.

Do you have a story of war service to tell — either your own or that of someone you know? Then write us a letter giving full details, including photographs, clippings and other substantiating data where available. If your story is published in *QST*, you will receive a \$25 U. S. War Bond. Please indicate clearly on the report if it is available for publication in its entirety, if names, dates or places should be deleted, or if all information must be held confidential.

scribed in the October issue,¹ so nothing would do but that one had to be built. Lacking the usual parts available to the experimenter back home, a b.c.-band coil was doctored up in conjunction with a two-gang b.c. tuning condenser. The receiver was built in and on a "Limey" mess kit Ish had picked up on his boat ride to England, and, supplied with headphones, the set has entertained that Texan in his sack more than once when he otherwise might have been asleep.

Very little has been done here in the way of experimenting with transmitters, but this may come later if the "go" sign comes while I'm still overseas. In the meantime, with another move in the offing, the latest idea is to mount one of the receivers in the truck assigned for our next convoy.

Captain² Witkowski moved higher up several months ago, but two other hams have arrived in the persons of Clifford Proetz, W9PDN, and S/Sgt. W. Hastings, W4FHC, so we still have occasional rag-chews as we sweat it out.

¹Bradley, "A Versatile Two-Tube Regenerative Receiver," *QST*, October, 1944; p. 9.

Using a circuit diagram in the *Handbook* as a basis, I built five superhet receivers out of the salvaged junk.





HINTS AND KINKS FOR THE EXPERIMENTER



A ONE-TUBE 112-Mc. CONVERTER

A novel and inexpensive type of 112-Mc. converter is shown in Fig. 1. The normal primary winding is removed from the antenna coil of the broadcast-band receiver used as an intermediate amplifier and two one-turn coils added. L_5 is link-coupled to the v.h.f. oscillator and L_4 is used as an antenna coil.

The v.h.f. oscillator should be shielded, and insulated couplings used between the variable condensers, C_1 and C_2 , and their dials.

The 6J5 requires about 15 to 20 volts on the plate. The coupling between L_1 and L_2 is adjusted until oscillation is uniform over the range of the tuning condenser, C_2 , with the broadcast receiver dial set on a point where no station is heard.

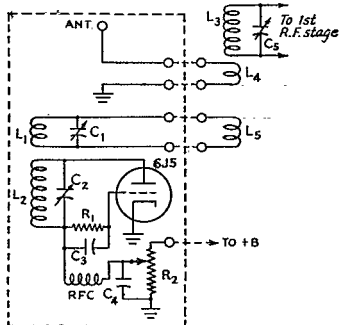

Fig. 1 — A one-tube 112-Mc. converter using a broadcast receiver as the i.f. amplifier.

- | | |
|--|---|
| C_1 — 20- μ fd. variable. | L_1, L_4, L_5 — 1 turn 0.5-inch diameter. |
| C_2 — 15- μ fd. variable. | L_2 — 4 turns 0.5-inch diameter. |
| C_3 — 50- μ fd. mica. | L_3, C_5 — B.c. receiver antenna-coil secondary and tuning condenser. |
| C_4 — 0.05- μ fd. paper. | |
| R_1 — 4 megohms, $\frac{1}{2}$ watt. | |
| R_2 — 250,000-ohm potentiometer. | |

An "on-off" switch in the "B" + lead to the v.h.f. oscillator will permit the use of the broadcast receiver in the normal manner.

A regular half-wave 112-Mc. antenna is used with this converter. — *Oliver Ekstedt, 1512 Illinois Ave., E. St. Louis, Ill.*

A CONDENSER-CHECKER USING A 6E5

THE condenser-checker shown in Fig. 2 has proven extremely handy in GI radio service work. This checker will detect excessive leakage or break-down of either paper or mica condensers. The only part required, other than the 6E5 tube, its socket and the test prods, is a 1-megohm resistor, R_1 . Ample insulation must be provided

on the test leads and around the prods themselves as the unit is extremely sensitive to leakage.

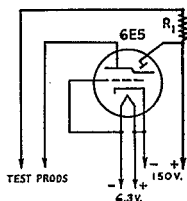

Fig. 2 — A sensitive condenser-checker requiring only one tube (a 6E5) and a 1-megohm resistor, R_1 , in addition to the power supply.

The shadow closes on contact with a shorted condenser. If the condenser is leaking or intermittent, the shadow flickers. — *Pfc. Theibert D. Brown, APO 81, c/o Postmaster, San Francisco, Calif.*

BATTERY-POWERED ONE-TUBE 450- AND 1500-KC. SIGNAL GENERATOR

HERE at our ATC Headquarters, I do the radio servicing work for our Special Service section as well as the majority of the work on the fellows' personal radio sets. I needed a small signal generator and tried out one originally designed by P. W. Winsford, G4DC. After slight modifications the circuit now appears as shown in Fig. 3. The location of the taps on the coils

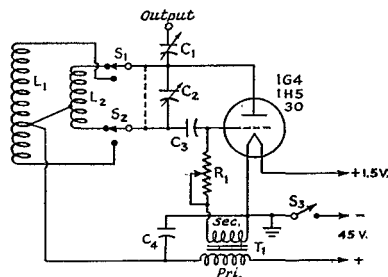

Fig. 3 — A battery-powered signal generator for 450 and 1500 kc.

- | |
|--|
| C_1 — 3-30- μ fd. trimmer. |
| C_2 — 500- μ fd. variable. |
| C_3 — 100- μ fd. mica. |
| C_4 — 0.002- μ fd. mica. |
| R_1 — 1-megohm potentiometer. |
| S_1-S_2 — D.p.d.t. toggle or rotary switch. |
| L_1 — 140 turns, No. 30 d.s.c. or 1/4-in. form (450 kc.). |
| L_2 — 42 turns, No. 20 d.s.c. or enameled wire on 1/4-in. form (1500 kc.). |
| S_3 — S.p.s.t. toggle switch. |

was determined by experiment. The unit was calibrated for 1500 and 450 kc. by checking with a Super-Pro. The signal output is brought out of the cabinet through a three-foot shielded lead. — *Major Joseph D. Andrew, Chaplain, USA, W4EFG.*

A TIME SAVING IDEA FOR COIL CONSTRUCTORS

I HAVE found a simple way to assemble coils or adaptors using coil forms or tube bases. I cut the lead for the No. 1 pin about one inch longer than required, then cut each following lead about one half inch longer than the one preceding it. This makes it easier to assemble the unit. After the wires are put through the pins, they are pulled tight, soldered and then cut off. — *Fred C. Barker, P. O. Box 408, Los Angeles, Calif.*

PUSH-PULL CLASS-A WITHOUT A PHASE INVERTER

SHOWN in Fig. 4 is a push-pull Class-A amplifier that some of the fellows might like to try. Tribute to the development of this circuit should be paid to Du Mont since it was from the sweep circuit of one of their oscilloscopes that we borrowed the main idea. However, I found that it may also be used as an audio amplifier. I constructed such an audio system with 6L6s in the output and found that I had no trouble at all in obtaining 15 watts of undistorted power output.

The beauty of this hook-up appears in the fact that there is no need to use a phase inverter stage or push-pull input transformer. Due to the fact that the cathode resistor is not by-passed a slight amount of inverse feed-back is induced which tends to cancel out the small amount of distortion, if any. The important feature still remains to be the lack of necessity of using a phase inverter.

This circuit was pointed out to me by F. C. Brown, T/1c, USNR, when he noticed the original circuit in the Du Mont instruction book.

In order to more clearly picture the mode of operation involved, follow through one cycle of the input excitation voltage. Beginning with the positive swing of excitation as the voltage on the grid of V_1 goes positive it causes the plate current in V_1 to increase. The increase of current flowing through R_2 (the cathode resistor) causes the voltage drop across R_2 to increase with

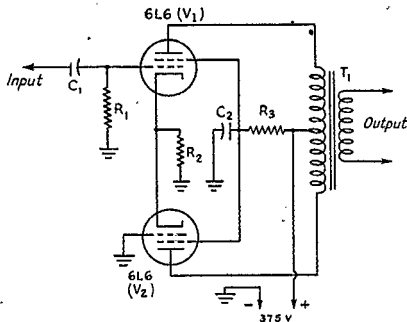

Fig. 4 — Push-pull Class-A amplifier without a phase inverter.

C_1, C_2 — 0.05 μ d.-600 volt paper.
 R_1 — 250,000 ohms, $\frac{1}{2}$ watt.
 R_2 — 300 ohms, 10 watts wire wound.
 R_3 — 200 ohms, 1 watt.

the grounded side of R_2 becoming increasingly negative. (This change is instantaneous since R_2 is un-bypassed.) This voltage also exists between the cathode of V_2 and its grid since the two cathodes are connected together and the grid of V_2 is grounded. Therefore the over-all effect on V_2 is the same as though a negative voltage was being applied on its grid from an external source. The remainder of the cycle may be traced out and in all cases as the grid voltage on V_1 varies the effective grid (bias) voltage on V_2 will vary 180 degrees out of phase with it. This gives true push-pull operation which cannot become unbalanced unless Class-A operation is exceeded and V_1 allowed to draw grid current. — *George H. Taylor, W7ITL.*

JIG FOR CENTERING HOLES IN SHAFTS OR SCREWS

MANY times I have tried to drill a hole in the end of a screw or a volume-control shaft, but I always have had difficulty centering the hole. I finally devised a jig which permits the drilling of an accurately placed centering or starting hole.

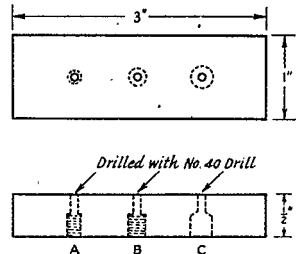

Fig. 5 — A jig for use in drilling a centering-hole in the end of a screw or shaft.

The jig, shown in Fig. 5, consists of a piece of soft iron, or brass, about one by three inches and one-half inch thick. I first drilled three holes clear through the block using a No. 40 drill. One of the holes, A, was then redrilled half-way with a No. 35 drill and tapped for 6-32, B was redrilled half-way with a No. 29 drill and tapped for 8-32 thread. The third hole, C, was redrilled half-way with a $\frac{1}{4}$ -inch drill to accept the standard size shafts of variable controls.

The small holes serve as guides for a small drill which will make a centering or guide hole in the end of the screw or shaft. — *Felix W. Mullings, W5BVF.*

A NEW SOURCE OF ALUMINUM STOCK

HEAVY sheet aluminum may be inexpensively obtained from broadcast studios. Aluminum-base records and transcriptions are usually available at broadcast studios as they clear out their files of old transcriptions regularly.

The acetate or "Q" coating on the aluminum base may be easily removed by boiling the discs in water and peeling off the coating while the discs are still hot.

The 16-inch transcription discs will provide material for many uses around the ham shack. — *Paul M. Bossoletti, W9GZD.*



CORRESPONDENCE FROM MEMBERS

The Publishers of *QST* assume no responsibility for statements made herein by correspondents.

WARTIME RACKETEERS

EDITOR'S NOTE. — Under the above self-explanatory title a book has recently been published by Putnam in which it was incorrectly implied that licensed amateurs had engaged in the racket of exacting money from the relatives of prisoners of war in payment for delivering the data on prisoners contained in enemy broadcasts. As again reported on this month's editorial page, there is no truth to such charges. The League immediately protested to publisher and authors through General Counsel Segal. The publisher investigated at once, quickly found we were correct, and has offered apologies to the League and its members. General Counsel Segal has received the following letter from the authors:

Washington, D. C.

Dear Commander Segal:

Confirming our conversation of yesterday, we take pleasure in clarifying the unfortunate misinterpretation which was placed upon certain passages in the book, "Wartime Racketeers," referring to radio amateurs.

The "amateurs" in question were described as having intercepted enemy broadcasts on American prisoners of war and to have offered information thus intercepted to relatives of the prisoners for monetary return.

We should like to emphasize that in describing the activities of a minute fringe of irresponsible individuals, we did not intend to cast any reflection either upon the licensed amateurs or upon the thousands of members of the American Radio Relay League whose work at home and on the battlefronts has contributed so much to the success of the war effort.

Moreover, this is one instance where authors are glad to admit they have been in error. We have been reliably informed that no licenses were suspended nor were amateurs subjected to disciplinary action, as we related.

We are informed by our publisher that subsequent editions of the book, "Wartime Racketeers," will contain appropriate changes.

— Harry Lever

— Joseph Young

Authors, "Wartime Racketeers"

A DES MOINES DXER PRAISES A.R.R.L.

Somewhere in France

Editor, *QST*:

I must say that the most elated feeling I have experienced in years came from reading in *Newsweek* magazine of Jan. 22, 1945, that the FCC has tentatively provided for wider amateur bands

in postwar allocations. I firmly believe that the credit for that triumph belongs exclusively to the ARRL. Previously I had feared the worst for amateur radio, but now all I want to say is "Praise the ol' ARRL." Keep fighting, gang! I wish I could help but I am not finished over here as yet.

Oh, brother, I can smell the heat from that groanin' kw. on 20-meter c.w.:

— Capt. Gerald C. Corrigan, A.C., W9BBB

PRE-V-J DAY WORK ABOVE 200 MC.?

Navy Radio School, University of Wisconsin, Madison, Wis.

Editor, *QST*:

After thoroughly reading the list of proposed frequency allocations which were published in the March issue of *QST*, I feel that amateur morale should hit a new high. Undoubtedly there were many of the gang who thought that ham radio was a thing of the past when this fracas got under way in December, 1941. But thanks to an alert crew at Headquarters, our little piece was spoken at the FCC hearings. And as the picture looks thus far, I feel that a good job is being done on our behalf. It serves as an indication of our success in retaining most of the amateur bands on the lower frequencies.

The allotment of the many high, ultrahigh and very-high frequency bands will give plenty of room for pioneering and hamdom, in general, will have a hand in this pioneering. A person wonders at a time like this whether it wouldn't be a smart move to open up the bands above 200 Mc. when the situation in Europe is under control and thereby develop equipment and designs for such operation. The hams could go a long way in this respect even before the war was entirely over. Operation above 200 Mc. would not be detrimental to the war effort, inasmuch as this range provides little more than line of sight transmission and reception.

— John P. LaBlonde, W9FZC

HAM GAGETTEERING

236 Fifth St., Ridgefield Park, N. J.

Editor, *QST*:

. . . I don't know what we would do without *QST* in these days of war and strife. It not only keeps us in constant touch with the "noblest of hobbies" in the only way possible for the duration, but it also gives one things to do — things to build and gadgets to try. Hams love that, as you know, and I try lots of them. . . .

— David Carruthers, W2JA

HOSPITALIZATION NO HANDICAP

Olive View Sanitarium, Olive View, Calif.
Editor, *QST*:

Since I'm not working at my regular job of airborne radio and radio maintenance, being in the sanitarium with tuberculosis, I have spent a large part of my time studying amateur radio — and the experience has been most valuable to me.

Using 'phone in nearly all my work, I have never gained enough code speed to pass the amateur examination. But I'm not giving up.

Since I was to be confined to bed for one to two years, I decided to do something constructive with my spare time. Via our sanitarium monthly paper, I issued an invitation to our other boys to correspond with me about amateur radio. To date I have had four answers and we are carrying on QSOs in written code. I have introduced amateur radio to them and they want to become amateurs as soon as they can qualify.

The method of writing code described in the letter by H. A. Frankboner, W9BPS, in the February 1945 issue of *QST*, was at once adopted for our correspondence. As much as we have written code, that method never occurred to us.

Even the shut-ins can still have amateur radio, if only by means of books and written QSOs.

— C. F. LaGreide

ANOTHER METHOD OF WRITING CODE

5430 Arnold Ave., Maspeth, L. I., N. Y.
Editor, *QST*:

... Regarding the letter about writing code from Mr. Frankboner published in the February, 1945, issue of *QST*.

It is true that there are times when one wishes to write code, but I am of the opinion that it should be written so that it can be done either by hand or on a typewriter.

The method that I have been using for the past twenty-five years, and which I believe many amateurs know about, is this:

-. . . / . . . - / - . . . - - / - . . . / - - - / - . . . /
. . . / / . . . - / - . . . / / . . . / - - . . . / . . . / - . . .
/ / . . . - / . . . - . . . / - / - - - / - . . . / - - - / /

— William Schwartz, W2BNK

PROSPECTIVE HAMS AT A.C.T.S.

716 S. Jackson, Belleville, Ill.
Editor, *QST*:

In the past two and one half years I have been teaching radio operating procedure in the Air Corps Technical School and have taught procedure to several thousand men.

I always make it a point to make the last lecture of the course an explanation of the differences between military radio procedure and that used by amateur and commercial operators.

At this time I also give a little sales talk on ham radio, explaining all its pleasures and the possibilities for world-wide friendships. In closing the lecture I always put my call on the blackboard

and invite them to take it down in their notes and I tell them that I expect to see them on the air sometime from somewhere.

This procedure has led to many of the men receiving their ham tickets while they were here at Scott Field.

— Paul M. Cooper, W9TGG

HAMS HELP MAKE WORLD SMALL

107 Parkway, Layton Park, Clearfield, Utah
Editor, *QST*:

I arrived back Stateside last November after two and a half years in China with the China Air Task Force and 14th USAAF. I saw my first copy of *QST* on a newsstand about two weeks later. Boy — was I tickled! I was afraid that the organization had folded for the duration.

During 1940-41, Al Rainous, W9BCK; Tauno Ketonen, W1JKQ, and I, W9NFX, ran a ham station together at Lowry Field, Colo., operating under my call. Naturally, the war broke up the deal. I buzzed off on a ferry trip to Chungking early in 1942, arriving just in time to become a member of the newly minted China Air Task Force under "Pappy" Chennault. After I had been hanging around China for a year then came Ketonen, who had transferred to the Signal Corps. Six months later who should pop up but Al Rainous, a member of the AACCS. Needless to say, we really had a celebration. Who said the world was so big?

— Capt. W. F. Burch, W9NFX

THE NEW HANDBOOK

38 Brookwold Drive, Manhasset, L. I., N. Y.
Editor, *QST*:

The 1945 edition of *The Radio Amateur's Handbook* is a splendid book indeed and, to be frank, I am tickled pink to see so much new material!

This edition should satisfy those amateurs who have heretofore found the *Handbook* little more than a reprint of a previous edition, with a few changes here and there.

I can well imagine the difficulties the staff had in preparing this new book. To them we should extend a vote of thanks for a job well done under trying circumstances.

— George Rulfs, jr., W2CJY,
Alternate Director, Hudson Division

70 Columbia Ave., Gaspee Plateau,
Providence 5, R. I.

Editor, *QST*:

I am extremely pleased with the great amount of new material which I find in the 1945 edition of the *Radio Amateur's Handbook*. . . .

In the past, the changes in the *Handbook* have been just about enough to tempt a fellow to get the new edition, but this time you folks have really produced a *new* book. You can stick your chest out and let the vest buttons fall where they may. Congratulations.

— Clayton C. Gordon, W1HRC



OPERATING NEWS



CHARLES A. SERVICE, W4IE
Acting Communications Manager

LILLIAN M. SALTER
Asst. Communications Manager

WERS Prepared. The month of March saw floods and threats of floods in many communities in the Middle West and East and floods, tornadoes and tidal waves in the Deep South. Although few reports have been received, it is evident that WERS groups in these affected areas were ready if assistance were required. WKHO, Hamilton County, Ohio, was reactivated March 2nd and, until March 6th, handled 485 contacts that could not have been taken care of in any other way. WJKK, Jefferson County, Ky., was on the air from March 6th until March 9th and, when regular communications facilities became overloaded, handled a volume of messages that required swift and urgent attention. WKNQ, Middletown, Conn., stood by until there was no longer danger of a serious flood.

While the flood season has passed, there are many disasters that strike at any time and place and with no advance warning. Therefore, it is imperative that all WERS nets be in a state of perpetual preparedness for any eventuality. Keep your equipment ready for action at any moment; keep your operators in practice so that they will be able to assist whenever called upon.

WERS Write-Ups Solicited. With the January, 1944, issue of *QST* a new column called "WERS of the Month" was instituted. This feature was designed to describe an organization in general, how it came into being, how it was set up and how it operates, or some particular phase of the organization which makes it unique. Although this idea met with lukewarm response, it has been possible to publish write-ups on eleven WERS licensees. We now have reached the bottom of the barrel and urge each radio aide to send in a story on his unit for possible publication under "WERS of the Month."

WERS Standings. A few months ago, when the military situation began to brighten, many local civilian defense offices closed down and it was feared that there would be a considerable lessening of interest in WERS activity. Fortunately, we received only scattered reports of WERS units folding up. Rather the opposite was the case, and, as numerous opportunities were presented to WERS licensees to demonstrate their effectiveness and willingness to cooperate, the number of CD-WERS licensees increased rather than decreased. Lately we have had occasion to gather statistics on WERS and feel that some of these figures will prove interesting to you. Since reports were received from radio aides of only 96 of the 273 CD-WERS licensees, it is not possible to give accurate figures on anything but population coverage.

The following statistics show the population covered by civilian defense regions:

Region	Number of Licensees	Coverage (% population)
I. (New England states)	60	56.5
II. (N. Y., Del., N. J.)	58	66.4
III. (Pa., Md., D. C., Va.)	37	35.4
IV. (Ala., Fla., Ga., Miss., N. C., S. C., Tenn.)	14	10.6
V. (Ind., Ky., Ohio, W. Va.)	37	43.3
VI. (Ill., Mich., Wis.)	20	46.0
VII. (Colo., Iowa, Kans., Minn., Mo., Nebr., N. D., S. D., Wyo.)	18	15.1
VIII. (Ark., La., N. M., Okla., Texas)	7	9.2
IX. (Ariz., Calif., Idaho, Mont., Nev., Ore., Utah, Wash.)	22	52.2

All of these regions show an increase in the number of licensees and population covered with the exception of Region IV, which remains the same. Statistics by states are given as follows:

State	Number of Licensees	Coverage (% population)
1) District of Columbia	1	100.0
2) Maryland	11	83.5
3) New York	22	79.1
4) Connecticut	10	71.6
5) Illinois	11	65.5
6) California	11	58.9
7) Ohio	23	56.4
8) Massachusetts	33	55.3
9) Michigan	7	40.8
10) Arizona	1	37.3
11) Missouri	4	33.8
12) Rhode Island	12	33.4
13) Pennsylvania	22	31.9
14) New Jersey	36	29.9
15) Colorado	2	29.0
16) Indiana	11	29.0
17) Florida	5	27.1
18) Louisiana	3	26.0
19) Washington	6	24.7
20) Alabama	2	21.3
21) Wisconsin	2	19.6
22) Nebraska	5	19.2
23) Kentucky	2	14.8
24) Iowa	3	13.4
25) Georgia	2	11.5
26) West Virginia	1	10.3
27) Texas	4	9.9
28) Wyoming	1	8.8
29) North Carolina	4	6.9
30) Montana	1	5.4
31) Virginia	3	3.9
32) New Hampshire	2	3.3
33) South Dakota	3	3.0
34) Oregon	3	2.5
35) Vermont	1	1.4
36) Maine	2	1.2
37) Tennessee	1	0.5

It will be noted that thirty-six states and the District of Columbia now are licensed for CD-WERS operation. States as yet unlicensed are Arkansas, Delaware, Idaho, Kansas, Minnesota, Mississippi, Nevada, New Mexico, North Dakota, Oklahoma, South Carolina, and Utah. With the recent licensing of Erie County, N. Y., all cities with a population of over 500,000 except one have been licensed, a coverage of 92.9 per cent. Of the cities with over 250,000 population, 60.9 per cent are licensed and 60 per cent of the cities with a population of over 100,000 are licensed. We'd like to request each radio aide to send in a report so that in the future we may include statistics on station units, personnel, etc.

Mutual Assistance Planned at New York City Meeting

ON FEBRUARY 24TH a meeting was held in New York City, attended by WERS representatives from a number of cities and towns in several North Atlantic States. This meeting was called by Vincent T. Kenney, W2BGO, radio aide and director of New York City WERS, to work out a plan whereby units of the WERS in different areas may extend mutual aid in any disaster which disrupts normal communications facilities.

Deputy Chief Police Inspector Arthur W. Wallander, head of New York City's protective services, called the service "a must" and added it had been used to great advantage in several emergencies, including the hurricane of last fall.

All present were in full accord on all subjects discussed, there being no opposition whatever. The group felt that a step toward a better WERS had been taken and was unanimous in the opinion that further meetings should be held.

It is hoped that this initial meeting of radio aides will be copied by other groups of radio aides throughout the country, eventually resulting in close coordination of ideas and purposes of all WERS systems.

Those in attendance were: Lt. Col. Samuel S. Murray, field protection officer, Second Service Command Area;

Lt. Col. Clifford H. Stem, C.E., chief engineer, U. S. Office of Civilian Defense, Washington, D. C.; Arthur Batcheller, inspector in charge, 2nd Radio District, FCC; Louis E. DeLaFleur, acting supervisor, Radio Intelligence Division, FCC, North Atlantic Area; Inspector William Burns, Philadelphia Police Dept.; T. J. Lyden, Rutherford, N. J.; Everett D. Gilk, Malverne, L. I., N. Y.; George Rulffs, borough radio coordinator, WNYJ, Queens, N. Y., and Hudson Division Alternate Director; M. A. McIntire, W2BO, borough radio coordinator, WNYJ, Brooklyn, N. Y.; Harry Gregor, borough radio coordinator, WNYJ, Staten Island, N. Y.; Archie Cooke, supervising operator, WNYJ, City Control; Capt. William K. Allen, Nassau County Police, Mineola, N. Y.; Mrs. Shiverly, representing P. Stanley Case, radio aide of WKXQ, Hillsborough-Branchburg Twp., N. J.; Dr. R. W. Woodward, radio aide, State of Connecticut; Warren Waterman, radio aide of WKJB, Middletown, N. Y.; George Hautenschild, radio aide of WKIB, Philadelphia, Pa.; R. L. Cassell, radio aide of WJMN, Bridge-water Twp., N. J.; F. C. W. Thiede, assistant radio aide of WKLR, Nassau County, N. Y.; R. T. Dalton, radio aide of WJQV, Rutherford, N. J.; H. Dallas Fogg, radio aide, State of New Jersey; Arthur Stuarts, jr., radio aide of WJPD, Troy, N. Y.; Pearce Chauncey, radio aide of WHLH, Millburn Twp., N. J.; Thomas F. McNulty, radio aide, State of Maryland; Victor L. Miller, radio aide of WKLR, Nassau County, N. Y., and Vincent T. Kenney, W2BGO, radio aide of WNYJ, City of New York.

BRIEFS

Oscar Cederstrom, W4AXP, recently paid a visit to the Civil Air Patrol training room at the Pensacola Trade School and interviewed Lt. Darwin E. Walter, the squadron commander. Besides Lt. Walter the staff consists of Lt. J. B. Ward, Lt. Frazie Phelps, Lt. Ed Ellington and Lt. H. Q. Seidel. John Blackman and George Wall are instructors in radio and communication and Carl Rodgers instructs in navigation, meteorology and firefighting. The purpose of the training is for plane emergency rescue work. The student cadets are very enthusiastic about the course and are making fine progress. Thirty cadets have already qualified for and received restricted telephone licenses. Two of the students have obtained 2nd-class telegraph tickets. The boy is now in the merchant marine and the girl is a control tower operator. A transmitter is under construction and, judging from the appearance of the material being used, will be a nice layout when finished. George Wall is putting his radio knowledge to good use on the construction job. Under the able leadership of Lt. Walter and with the cooperation of his fine staff this CAP School will do things in a big way.



These WERS representatives were in attendance at the meeting held in New York City on February 24th. *Left to right, front row:* Vincent T. Kenney, W2BGO; Mrs. Shiverly; Miss Jesse Burns, and Lt. Col. Clifford H. Stem. *Second row:* Louis E. DeLaFleur, Pearce Chauncey, Arthur Batcheller, unidentified, and Warren Waterman. *Third row:* Inspector William Burns, George Hautenschild, and H. Dallas Fogg. *Back row:* Harry Gregor, George Rulffs, Archie Cooke, Thomas F. McNulty, and M. A. McIntire, W2BO.

Photo by John Neva, WNYJ

SARO Mid-Pacific Chapter Organization

IT HAD long been felt by members of the Society of Amateur Radio Operators stationed in the Central Pacific area that a Mid-Pacific chapter of the SARO was very much in order. Consequently, the first meeting of hams at Pearl Harbor was held February 2nd at the Senior Officers' Bachelor Quarters, attended by Al Dodge, W6NZG; Lt. Comdr. N. DeWolfe, W6CBX; Lt. S. Glasson, W6OCZ; Lt. (jg) F. F. Tenhunen, W6FAQ; R. J. Williams, W6LCG; M. W. Peterson, W6PSN, and Ens. R. D. Ogg.

After dinner the group adjourned to the Officers' Lounge, for a business meeting. W6NZG was elected president; W6OCZ, secretary and treasurer, and W6CBX and W6LCG were appointed to the membership committee.

The second meeting was held late in February at the Hotel Halekulani, Honolulu, T. H. Thanks are due W6NZG for making available the facilities for this meeting. The main purpose of the gathering was to bid farewell to Lt. Comdr. N. DeWolfe, W6CBX, who was leaving for duty in the forward area. Needless to say, the affair was put on in the usual SARO style with a pre-dinner social gathering during which the members toured the Halekulani Hotel grounds and adjoining beach areas, viewing the lovely grounds which are planted with Hawaiian flowers of many special varieties and all kinds of tropical plants, bushes and trees. Certain members availed themselves of the excellent swimming and swam out to the coral beds and examined the flora and fauna. W6NZG conducted the swimmers to underwater caverns and spots where strange fish were seen.

The SARO gang then embarked for the Chinese restaurant of P. Y. Chong, famous Hawaiian eating spot. W6CBX reversed the usual procedure and insisted on paying for the meals. The group then adjourned to the Music Room of the Hotel Halekulani which, incidentally, is outdoors on a platform under the stars surrounded by palms and plants about twenty yards from the beach front. A songfest was held during which all the old-time songs were sung.

At 2130 the Pearl Harbor members were driven to the Moana Hotel where they embarked on the Navy bus for Pearl. The following day Norte was escorted to the plane by members of the SARO who bade him Godspeed.

The third meeting of the SARO was held with a much enlarged turnout. The meeting was arranged by W6OCZ at the Senior Officers' Bachelor Quarters. A private bar was set up on the second deck. As the members and guests arrived they were requested to sign the log and were served by the bar boy.

Those present were: Capt. T. M. Dell, USN, Joint Overseas Shipping Control Officer; Comdr. L. M. Hill, W9BNL, Officer in Charge CincPac Communications Office; Lt. Comdr. R. S. Drake, USNR, W7ESK, ComServPac; Lt. Comdr. M. E. Solotar, USNR, W2KC, ComServPac; Lt. Comdr. W. E. Kipp, FMO and ex-RCA; Lt. S. F. Glasson, USNR, W6OCZ, administrative officer, Joint Overseas Shipping Control Office; Al Dodge, W6NZG, BuShips Engineers and President Mid-Pacific Chapter SARO; Lt. (jg) F. F. Tenhunen, W6FAQ; R. F. Williams, W6LCG, WECO eng.; John T. Heineman, W6CZU, eng.; D. Sasstrom, W8MBI, WECO; T. W. Hart, W8RQD; M. W. Peterson, W6PSN, BuShips eng.; W. D. Hase, W7DZA, WECO; W. D. Bailey, W9AQR; Lt. Comdr. T. D. Maybank, USNR, AdComPhibsPac; Ens. D. Ogg, USNR, ComServPac Radio Planning Section; E. Wac, WECO.

After dinner the group adjourned to the Lounge where colored motion pictures were projected. The films viewed were taken by W6PSN and W6OCZ in the Hawaiian area. Discussion centered around the probable ham bands after the war, the opinion being that a great deal of activity will be seen on the ultrahigh frequencies. A good deal of old-time rag-chewing went on as members from the same districts compared calls and DX worked in the past. The SARO, with a majority of its members now engaged in the building, operating or servicing of ultrahigh-frequency equipment, should lead the West Coast again in contacts and Field Day operation after the war. It might be mentioned at this time that the SARO was first on the West Coast and third in the United States in the number of stations contacted in the last Field Day. The meeting adjourned with plans for a future hamfest of islandwide participation with all services being represented plus the civilian hams serving in the various Navy and Army activities.

Other amateur radio operators attached to CincPac or ComServPac staff or in the forward area are: W6HZV, W6ALK, W6UQR, W3ACD, W31WD, W7ALP, W6BNO, W6CBX, W6EC, W6BVD, and W6CGO.



Shown here are those who attended the third meeting of the Mid-Pacific Chapter of the SARO. Left to right, first row: Maybank, W6PSN, W6LCG, W6CZU, W9BNL, and Capt. T. M. Dell, USN, JOSCO. Second row: Ex. W9NX; W9AQR; W7DZA; W2KC; Kipp, RCA; Wac, WECO. Third row: W6NZG, Ogg, W7ESK, W9LC, W8RQD, W8MBI, and W6OCZ.

The Month in Canada

QUEBEC—VE2

From Lt. L. G. Morris, VE2CO:

ERNIE MILLER, 2AF, keeps busy studying and teaching the intricacies of radio to his newly arrived daughter, Maureen. **AF** says he has an occasional rag-chew with Johnny McGrail, 2BP, and Alex Ross, 2PR. Our old SCM, Stan Comach, 2EE, saw Alex Reid, 2BE; Gord Southam, 2AX; Bill Stygall, 2GH; Rod McDonald, 2FO, and Fred Hasell, ex-2FF, on a short trip to Montreal. After having been working in Toronto for the past few years, Val Sharp, 2CR, was all set for a transfer back to Montreal. Unable to find accommodation for his family, Val is back in the Queen city again. Bill Oke, 3AKP, has been posted from Ottawa to Halifax. Joe Kelly, 2DE, called on 2CO while on a brief visit to Ottawa.

ALBERTA—VE4

From W. W. Butchart, VE4LQ:

A LETTER from 4ADW, Jack Goodridge of Edmonton, now with the RCN and taking basic training at Cornwallis, N. S., reveals that he and 4ALP, Johnny Huska of Saskatoon, joined the Navy together in Saskatoon last fall with the idea of becoming radio artificers. Since that time the Navy has decreed that the RA courses are filled up and that Jack and Johnny will become O/Ss instead. While stationed in St. Johns, N. B., the two boys decided to spend their five-day New Year's furlough in New York, Boston and Hartford, but as it finally turned out they spent New Year's Eve in Boston, then went to Hartford to visit ARRL Hq. The Headquarters gang showed our two heroes such a superb time that all ideas of visiting New York were chucked and they rounded out the remainder of their five days in Hartford. Most interesting highlights of their stay: visiting the headquarters of ARRL and the gang and being shown around the airport, broadcasting station WTIC, etc. Biggest disappointment: not seeing W1AW, which has been boarded up for the duration. The sincere thanks of the NARC to ARRL for giving our boys such a swell time. Jack's XYL, Audrey, is still in Saskatoon and, according to Jack, is learning the code. Looks as if we'll be hearing a feminine fist and voice over 4ADW when we again hit the air. As a final note Jack asks to be remembered to all the VE4 gang.

Since last reporting on 4HM's (Chas. Harris of Edmonton) new amplifier, it is learned that he has made more than the odd change in layout, etc., but he says it's working very nicely now and using a bass-treble tone control circuit which 4EA, Roy Usher of Edmonton, has popularized around Edmonton. 4ANS, Cpl. Frank Willan, RCMP, of Ft. Smith, N. W. T., "blew into Edmonton again recently, and before leaving he "robbed" HM and LQ of a gramophone turntable and camera, respectively! He also told us that 4YD, Pete Fair of Peace River, is overseas with the RCAF and now has his commission. We sincerely hope, Pete, that this last bit of news is authentic! Another letter from 4AOZ, Slim Marsden of Milo, tells us that 4AGS, Don C. Fleming of Calgary, is radio officer on a 10,000-ton freighter on the Atlantic convoy run. Don used to be radio instructor at Calgary Tech. before joining up.

BRITISH COLUMBIA—VE5

From Jack Sibson, VE5BQ:

CONGRATULATIONS to Royal City Radio Club on having completed ten years of activity. They are a going outfit compared with the other clubs. They have a new club room now through the generosity of 5FY. Meetings include code practice, technical talks and discussions as well as educational movies from the Extension Dept. of the University of B. C. They also keep in contact with their members who are overseas by sending them packages. They would like to hear from other clubs regarding postwar plans, and would like to get in touch with the VEOPS. Every letter will be answered. Write to Fred Taylor, Sec'y, c/o 1411 London St., New Westminster, B. C. The Totem Club is still holding together. It is made up of a jolly bunch of fellows around 32 years of age who are married and have families. Ted Goode, 5ND, has a new jr. op which makes three now. Tom Hart, 5OE, also has a new jr. op — total two. Len Scott has just one so far. The West End Club members have been scattered over the face of the globe. We are sorry to say that one of its members, Dick Smith, 5RS, is missing. He was with TCA in

a plane which crashed in mid-Atlantic. He sure was one grand fellow. The president, Don Vaughan Smith, 3EP, who was stationed at Victoria for some time, has been posted to a station yet unknown. Gordie Emerson, who is over in Italy, has been collecting parts for his postwar transmitter — queer looking stuff he says. The Point Grey Club members are still around but don't seem to get together for meetings. Was very pleased to meet Eric Risby, 5AJT, from the Langley Clubs. We would like to meet anyone from out of town who would care to come to club meetings. Write to Fred Taylor at Westminster, or John Sibson, 8685 Laurel St., Vancouver, B. C.

MANITOBA—VE4

From A. W. Morley, VE4AAW:

AFTER being overseas with the RCAF for four years, 4ABO has returned. Larry received his commission as a signal officer and has since retired. He is taking up residence in the VE5 district. Mail will reach him at P. O. Box 1086, Kelowna, B. C., and Larry has promised to answer all letters. 4QV writes that he had a visit from 1AX and all they talked about was ham radio. 4ACR and 4WL are still with him working on the same old job. They also have a prospective ham by the name of Meade Wood all lined up. Don has the itch to get on again and, from the sound of things, 4QV will have to be watched. Saw 4VG on the street and, incidentally, Bill, I never got that dope you promised. How about some news, fellows? This column depends on you, so don't blame me for last month's blank report. Would like to hear from 4RO and 4BG. How about it, George and Alex? 73, Art.

ONTARIO—VE1

From L. W. Mitchell, VE3AZ:

ON March 1st a special meeting of radio amateurs in Toronto was held under the auspices of the Wireless Association of Ontario in the Electrical Building, University of Toronto. Guest speakers were Air Commodore Keith Russell, 9AL, and Ralph A. Hackbush, IRE, vice-president and managing director of Stromberg Carlson Company of Canada, Limited. Air Commodore Russell, who is now retired to the Reserve, RCAF, was given a hearty reception. After paying tribute to the hams who had fought and given their lives in the cause of freedom, he gave a brief outline of his work in the RCAF, and expressed his thanks to those hams who had joined the service to become instructors, thus rendering valuable assistance in training men as WAGs and operators. As Keith had a later engagement for the evening he had to leave early but not before he had put the gang in excellent humour with one of his inimitable anecdotes. The second speaker, Ralph Hackbush, who is also vice-chairman of the CRTPB, and chairman of its frequency allocation section, outlined the formation of the Board and its subdivision into thirteen panels each dealing with a different type of work. He discussed the problems being encountered by the different services including FM, television, and facsimile, as well as the amateurs, and spoke highly of the work being done by the ARRL and CGM Alex Reid on behalf of the amateurs. Before closing Mr. Hackbush reviewed the possibilities for the amateur in the region above 100 Mc. and predicted that it might well be a repetition of the old story of the amateur below 200 meters. The next meeting of the Wireless Association of Ontario will be held on May 31st at which the speaker will be Carl Nelson, development engineer of Addison Industries. His paper will cover light beam communications.

2AX, Frank Bowkett, is feeling very proud of his new 30-watt speech amplifier just completed. 3AYJ, Ft. Lt. Alfred Thomas Patterson, has recently been transferred to the RCAF station at Clinton, Ontario, where he is taking a special course. Prior to 1944 Al was stationed at Gander, Newfoundland. Later he established his headquarters at Debert, N. S. Incidentally, Al, who is a member of the Wireless Association, has two fine jr. ops. — his son is now three years old and his daughter four months; both look just like daddy. Clark Pollock, one of the new members of WAOO and ARRL, reports that he is ready for his ham certificate as he can do 25 w.p.m. Good going, Clark. 3IN, J. D. Brown, has just returned home on rotation leave. He informs us that he picked up a German radio set as a souvenir, but it was so heavy he had to give up the idea of bringing it home with him. By the way, he says that just before he joined up he paid \$175 for a new tube checker. Someone borrowed it from his home while he was overseas and he would very

(Continued on page 78)

AMATEUR ACTIVITIES

ATLANTIC DIVISION

EASTERN PENNSYLVANIA — SCM, Jerry Mathis, W3BES — The v.h.f. relay in which WERS stations from Philadelphia to New York took part was reported to be a great success. 3HRE says that the elevating of the Easton WERS headquarters station enables it to work nearly across New Jersey. 2LQP, from Staten Island, is stationed in Philadelphia. 3BVX, former president of the Frankford Radio Club, paid the city a flying visit. He is with Westinghouse in Pittsburgh. 3AQN reported by phonograph records again. 3GHM is in India. 3JBC received the Bronze Star and 3EDC the Silver Star and Purple Heart. 3HFD bought a new QTH in Penn Valley with much more antenna space. 3BXE is working in Washington. 3CHH is going to school in Northern New Jersey. 3DMQ completed his first round trip across the Atlantic on a merchantman. 3AOJ is in the Philippines. 3CXU has been transferred to Philadelphia. 3FLH is out of the hospital and is on the mend. 3GET is looking around Jersey for a new QTH. 3JKC is meeting with much success as radio instructor for the CAP at Pottstown. 3HXA is preparing to go on 'phone when we go back on the air. 3AQN and 3BES are still interested in swapping QSOs via records. 73, Jerry.

MARYLAND-DELAWARE-DISTRICT OF COLUMBIA — SCM, Hermann E. Hobbs, W3CIZ — The WERS gang have done themselves proud in Frederick County. WN is radio aide and I. L. Hankey, Class A but no call, is deputy radio aide. ATQ, JCV, AKX and WN have been active in organizing the gang. Most of the tests have been run from Gambri State Park with successful contacts with WMDD, Montgomery County. WJGS-70, state control, and WMSK-4, using TR-4, were heard by WJYC-5. They also have eight auxiliary operators awaiting arrival of their licenses and WERS permits. They should be able to pick up WMDC on 1500 without any trouble. XU6KL was a recent visitor at the Washington Radio Club meeting.

SOUTHERN NEW JERSEY — SCM, Ray Tomlinson, W3GCU — Asst. SCM, Ed G. Raser, W3ZI. ASQ advises that Watchung Boro has requested his presence at a conference toward the betterment of that organization. Watchung Boro, WJUB, is one of the oldest WERS licensed municipalities in the State and has an efficient organization under the leadership of communications chairman, Edward Jones, and the radio aide, John H. Gullans. ASQ reports progress within the WKPX organization. One new unit containing an r.f. stage on the receiver has been completed by GCU, and will be placed in active service at No. 20. ITS, chairman of maintenance, has ironed the bugs out of his t.r.f. receiver. GCU is preparing for construction of another separate t.r.f. receiver. ASQ has just completed his 9001/9002 t.r.f. receiver and reports excellent reception. The Hamilton Twp. WERS Operators Assn. is functioning nicely; Chairman DeWald of operations has laid out some excellent "incident" drills for future test periods and Fred Muhs, chairman of personnel, is placing operators so that all units are covered on drills and emergencies. ABS, of Hillsboro/Bransburg Twp., reports five more licenses for 3rd-class 'phone operation. WKXQ is heard at WKPX, Hamilton Twp. control, as is WJMN of Bridgewater, Twp. control. CCO, chairman of the DVRA bond drive reports FB progress. This drive is now in its fifth series with the Ladies' Auxiliary team still in the lead. At the March meeting of the DVRA, Oliver Wright, chief engineer for A. T. & T. at Lawrenceville, gave a very instructive talk on u.h.f. antennas. The newly-elected officers of the DVRA are: Ex-BRJ, pres.; ITU, vice-pres.; ZI, secy. and H. L. Yoder, treas. Everett Roberson was appointed business manager of the DVRA News. Another new member, Charles E. Rehman, was added to their roll. Former President EED, who shipped with the merchant marine on Feb. 19th, was present at the March meeting. JAG, chief operator in the merchant marine, enjoyed a short stay at home. GRW is at sea with the merchant marine; Paul is CRO. BAQ is doing special research work at Ft. Monmouth. GNU is instructing in radio at Belmar. Doc, who recently visited AFH, has changed his QTH to 300 Chelsea Ave., Longbranch. M/Sgt.

IOW married a Florida lass while assigned as instructor in radar and has been transferred to duty in California. JXX is residing in New Brunswick; Chick now is in charge of service and maintenance for IBM, Newark area. Steve Czorga, CPO, is doing radar maintenance in Florida, and is working c.c. There are rumors that Jimmy Hassal of the U. S. Air Force, somewhere in England, has bought himself an airplane. BWF is rebuilding his rig into an 812 or 8005 final. FTU did not accept a position as transmitter engineer with local b.c. station; Bill still is teaching radio at Belmar. GCU has joined the ranks of OMS; Ray just had the last eight snags yanked. FMU has been reported as being in the hospital. ARN is teaching radio at Naval Radio labs at Bellevue, Wash. GEO is doing high priority work at Plastic Appliances Corp., Philadelphia. ATF has been transferred to the Marine Corps Air Station, Cherry Point, N.C. It has been reported that IUQ has resigned his position at Eastern Aircraft and has accepted a place on the staff of local b.c. station, WTTM. GHK, on duty in the So. Pacific area, has been promoted to chief warrant officer. LH, professor in electrical labs of Trenton Central High, has acquired a farm just outside of Fallsington, Pa. VE has been reported safe following the big push near the Belgian frontier. HVO has been reappointed district chairman for YLRL. EFM, formerly of Atlantic City, has moved to Plainfield and is with the Western Electric. Many thanks to SJRA for the copy of *SJRA News*. IZP, editor of this paper, deserves much credit. GU, who has a medical discharge, is the first SJRA member to return to the fold. Bill Wescott, who was laid up five months in the hospital, is sailing the So. Pacific. Bob Haworth is now an ART man. Bob Mathieson now is Y1c, Personnel Office, Fort Pierce, Fla. BCC is very ill at his home in Pensgrove. IXZ, ART1c, is stationed at Palau Island. His full QTH may be obtained by contacting this office. New SJRA officers are: GZS, pres.; IAS, vice-pres.; GYM, treas.; IIC, POF, JNZ, AEU, AKI, IZP, directors. EEQ's address is J. Russel Snedaker, jr., APO 500, c/o Postmaster, San Francisco, Calif. Russ is installing and servicing high-speed decoding equipment for IBM. JTR writes that they often grab off German radio equipment.

WESTERN NEW YORK — SCM, William Bellow, W8MC — The Rochester Amateur Radio Association hamfest promises to be a bang-up affair. The three WERS services (CD, CAP and SG) in Rochester are on the air in full swing. The Rochester WHNH group were hosts on March 19th to a delegation from Buffalo and Tonawanda, including the radio aides of WQWT and WKNL. Elmer Sonn is radio aide of the Buffalo unit, WQWT, with Ray Lamey, Henry Kuhn, Carl Bieber, Frank Marks and Norbert Carnath, deputy aides. For those interested in WERS in Erie County, address communications to Elmer Sonn, 695 So. Tiorunda Drive, Buffalo. A lot of credit goes to Ed Graff, radio aide of WKNL, Tonawanda. He and one other ham have trained over fifteen civilian operators, including thirteen YLs and XYLs. RDX is back on the job after several weeks of illness.

WESTERN PENNSYLVANIA — SCM, E. A. Krall, W8CKO — We are indebted to AOE for the following report. MWV, CPO, is reported as being a ship's carpenter aboard a troop carrier transport. OWC, from Reynoldsville, is doing radio operating in France. Your old friend QHS and the rest of the gang send their regards. TNG, USA, was last reported as being in England. OAJ still has not been heard from since he landed in Italy. BVP is doing work as a government radio inspector in Philadelphia. BTU was home on furlough from overseas duty with the Navy. VNL is sporting the neat uniform of the merchant marine, and is reported trying to speak French to some of the girls here in the States. From down in South America TVA took time out to mail in his signature to nominate an SCM. UVD reports he has moved to the country and has an ideal location for u.h.f. work if only he had someone to work with. Walt also does a nice job at cartooning. He reports that VNE is ART2c in French Morocco. Pvt. UHO has a portable b.c. receiver overseas and has to drop down the 220 volts to 110 before he can use it. Many of the gang overseas will remember Edward Banas, who died in a plane crash March 18th. Although not a radio amateur, Edward was interested in radio and copied many code transmissions. WKXV, Mercer County's 2½-meter net, is doing things in grand style. We now have ten active licensed stations, each doing an excellent job. WKXV, Mercer County, and WKML, Mahoning County, Ohio, carry on regular scheduled drills each drill night. Warren is heard in Sharon with strong signals. Gang, let's make the Western Pennsylvania news section the best ever. Thanks, *Ernie*.



LAST MONTH we described the output stage for a high quality phonograph amplifier. This month we will give some attention to the input stages.

Considered strictly as an amplifier, the input stages present few difficulties, as they are conventional resistance-coupled stages. Fig. 1 shows a suitable circuit for one stage, and as many stages as are required may be cascaded. If the frequency compensation circuit is located ahead of the amplifier input (as is usually the case) a simple voltage amplifier is all that is required, but the impedance at the compensating circuit must match the pickup. The recommendations of the pickup manufacturer should be followed.

The circuit below, Fig. 2, shows a compensating circuit located after the first input tube. It is not affected by the pickup impedance. The value of R_1 controls the amount of bass boosting, higher values giving less rise. Similarly, C_1 controls the frequency at which the rise begins. The curve shows the effect when R_1 is 5000 ohms and C_1 is 0.04 μ fd. This carries the boosting down to extremely low frequencies, which in turn requires large coupling and bypass condensers, as shown on the diagram. It is not necessary to carry bass compensation this far, but we wished to show what could be done.

Also in Fig. 2, provision is made for controlling high frequencies. Condenser C_2 serves this office, and its size determines the amount of attenuation.

Reduction in scratch is best controlled by a filter with sharp cut-off. For this reason, and for the reasons given on this page in December *QST*, we strongly advise such a filter. A choice of cut-off frequencies is desirable, but if a fixed frequency is selected, we recommend that it be about 7000 cycles. Commercial filters are made for this purpose, and these are your best bet. Simple filters are not difficult to design or build, but the inductances are apt to be a problem. Iron-core R.F. chokes often work out well, and we have made successful filters with them. If you want to try building your own, you can find plenty of published information in textbooks and handbooks. Terman's *Radio Engineer's Handbook* has a lot of good dope on filters beginning on page 226.

WILLIAM A. READY

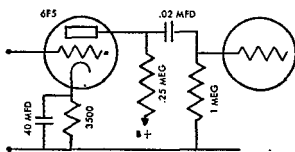

FIG. 1

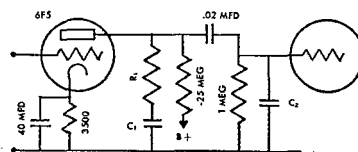
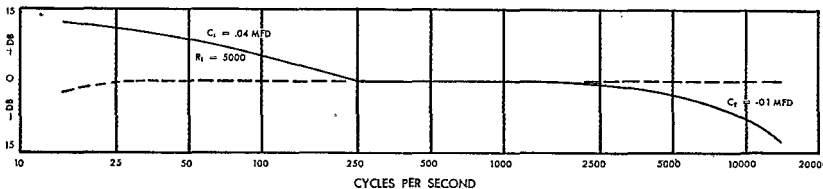

FIG. 2



CENTRAL DIVISION

ILLINOIS — SCM, David E. Blake, II, W9NUX — NGG reports that the Starved Rock Radio Club holds meetings every three months. NGG is pounding brass and barking into the mike for the Illinois State Police at Pontiac on WQPP. NTU recently renewed his contract with the LaSalle County sheriff's office for another two years. QLZ is researching for the General Times Instrument Westclox factory at Peru. ATA is in the lab at Hallcrafters. LIG still is installing radio and intercommunications equipment on LSTs at Seneca Shipyards. QXA is a lt. colonel in the Air Force based in England. NOO is to be inducted soon. QGN is much involved in Navy radar equipment, last address Norfolk. TAY still is making beer bottles (empties) for Libby Owens plant at Streator. SLF is there also. UQT is battling the brass at the Illinois State Police station, WQPS, Springfield. RM1c ZEN, Coast Guard, when last heard of was in the Southwest Pacific. QWN is doing radar work. TLC still is the big shot in the Pontiac Telephone Company with radio service on the side. NGG reports that the 30-40 Mc. f.m. band was plenty hot in March, stations from 900 miles away coming in with good volume. DTZ is busy wiring switchboards on LSTs at the Seneca Shipyards. YBY is busy on his phonograph recording with a new amplifier. IJ is now in Chicago as chief engineer in charge of crystals for a local manufacturing company. ARA, of Quincy, who was with the State Police at Springfield, has been transferred to their station at Chicago. T. M. B. Lowe, who was chief engineer of the State Police system, is now a lt. comdr. in the Navy somewhere in the So. Pacific. Joe Angsten, 4131 W. Monroe St., Chicago, who has worked as radio operator on lake and gulf coast vessels, as broadcast operator and as code instructor in a radio school, now is working as inspector. Hamfeaters new officers are: HXW, pres.; AA, vice-pres.; YES, secy.; DXU, treas.; ABR, sgt.-at-arms. CARCC new officers are: YDV, chairman; MAT, vice-chairman; KBO, secy.; AYL, treas. AA has been made a member of the Veteran Wireless Operators Assn. PNV extends his thanks for the support given in the recent ARRL Central Division election. LLM, Box 363, La Mesa, Calif., wants information on PK. Lt. CZB, APO 230, New York City is keeping up a steady correspondence with YZE, who is somewhere in the Pacific area. CZB wants to get in touch with AGV. M/Sgt. PTQ, APO 650, New York City, sends the following news: "3CSW, from near Baltimore is a radio teletype and switchboard operator in my platoon. While attending a school here last August I found one of the instructors was KEG of Louisville, Ky. I'm in charge of maintenance and operations in our line of work. I now have had twenty-six months of service overseas. I correspond with DBO and JCG regularly and have written to YZE in the Pacific area but have not received an answer as yet. If any of the boys care to write I would certainly appreciate hearing from them. (The SCM has his complete address.) I'm looking for the address of SUV, formerly of Charleston, Arcola, Jacksonville and Chicago. I also hear quite regularly from QAL of Peoria, Philadelphia and San Diego and JTE of Adams, Ind. I worked the Army net in civilian days and would like to see some mention of the old gang, especially ILH, RMN, VS, RLU, Phil Haller, the radio aide, and any of the gang formerly worked on Illinois A, B, C, and D nets. I was the net control station for C and A nets for a couple of years." 73, Dave.

INDIANA — SCM, Herbert S. Brier, W9EGQ — ZNC reports from Germany that it is a job to keep communications in under battle conditions. AB has built a 30- to 300-Mc. frequency-meter oscillator. ZYK has moved near AB. HJW is at Camp Leonard Wood, Mo. SVJ, now a s/sgt., is back in Trinidad after a furlough at home. ONB is getting boot training at Memphis. PQL reports from "somewhere in San Francisco." He and TTY spent an enjoyable afternoon together in Honolulu. EHT, SAD2c, is located in the State of Washington. ILL is studying a correspondence course on plastics to pass the time in the Aleutians. UMK is a navigator with a bombing group in the Philippines. SWH changed companies March 1st but is still a tool engineer. KBL's wife's only knowledge of hams is that the best place for them is a hot oven, after which they should be served with applesauce and yams. NXU is going to U. of Ill., studying radio for the Army. UYP is on his way to India. EBB has hopes of making his annual return to Indiana in June. ABB and AQD are on the same island. ABB thought that when he got married his troubles were over; yet the Navy has him doing his own laundry. DEE has spent most of his Army career in school;

fifteen months studying meteorology, five months studying communications, and five months in radar and electronics. HUV has been active in radio; he fixed two "midgats." WKN is building a 112-Mc. transmitter for WERS using an 815 or 829. MJH has a similar project in the works. MKM is building a 6L6 transmitter as a stopgap rig. DUT, EGQ, MJH, MVZ and WWG are giving technical instruction and code lessons. S/Sgt. FDS is located in Stoatsburg, N. Y. SVH is resting in the hospital and would welcome letters. Send them to: J. P. Gilliam, 422 Goshen Ave., Elkhart. ZYJ, in Belgium, has been "liberating" equipment from telephone exchanges to keep Signal Corps equipment running. DGA, somewhere in the Near East, wants the addresses of QLW and EHU. If you have them, please give them to me for forwarding. UCT is in France wishing he wasn't. WIB has been in Leyte Gulf, Lingayen Gulf and Philippine Islands operations. PUB finds Navy life in Hutchinson, Kans. so tough that he is ready for sea duty again. OKP is on the same ship as 8CCS and 6NFC.

MICHIGAN — SCM, Harold C. Bird, W8DPE — C. B. Skeels sent in the following on the Muskegon gang: PPQ is a medic in the Army. M/Sgt. WAK, Army, is in New Delhi, India. SXD is an instructor for the Navy. QT is in the Navy somewhere in the Pacific area. VHX, Navy, has been in fifteen major battles. BRT, Navy, is at Bishops Point, Hawaii. OQY is an instructor at Ft. Knox. SAY is with FCC in Allegan. VQN is doing radar work for Western Electric. MRK is in Grand Rapids, TWN is at Wright Field. Lt. Comdr. RLB is stationed in Virginia. 9UCD is in Perry, Ohio. BHH is on the road in the USA. Those in Muskegon are ADU, NWU, GSC, BRP, CFN, ex-EXJ OAH, DLX, UBO, UCG/WOG, NZU, DAQ and TBP. WERS there consists of twelve units, operating under WIXC. Tom Rabey is OCD commander; Fred Castenholz, radio supervisor for city police, is WERS engineer; MRK is radio aide. The main control has a closed "J" antenna located in the center of the city. The control consists of an RK3 oscillator modulated by a pair of 2A3s, speech equipment crystal mike. All units except 5 and 10 use HY75 oscillators with one or two 6L6s as modulators. Antenna is six-element beam. Several types of antennas have been tried, such as closed "J," open "J," folded-doublet, pitchfork coaxial whips, two-element whips and vertical stacked beam. Control used National 1-10 receivers. Unit No. 5 used a Meissner converter; unit No. 9 a superhet, composite built; unit No. 2 an Abbot 24. The WERS gang has worked with State Troops on several occasions. Capt. KNP reports he is still battling it out at Tank Destroyer School. VZZ says if we could hook up now both of us would be working extreme DX. UGR reports letters from the boys overseas on some of his stories. SWF says, "Am getting the old 10-meter beam ready to get going this summer, I hope. Will be calling the QMT net together." JZD is very QRL with electrical job in a war plant and installing f.m. in police radio. He reports PYP has been married over two years and expects a jr. operator soon. MCB is working for the Signal Corps with eight or more out-of-state hams. OCC still is on maintenance work doing a variety of electronic jobs. NOH has his hands full as he has all the equipment as well as operating to handle. OPY writes that he still is with the highway department, besides helping the town folks with their radio troubles, acting as scout master and serving on various committees. The DARA had the extreme pleasure of a visit from our old secretary-treasurer, MV, at a recent meeting. Mrs. MV was with him and attended the auxiliary meeting. Two new members were taken into the club. Ken Glass, former DARA director, sent his regards via MV. At a recent meeting the Pontiac WERS club put on a demonstration of electronic equipment. Graphs were drawn on tube operation and the demonstration was enjoyed by all. The superhet v.h.f. receiver is coming along fine.

OHIO — SCM, Carl F. Wiehe, W8MFP — TQS, radio aide for WKHO, Cincinnati, reports Cincinnati's third worst flood found WERS fully prepared. Control station WKHO-3, activated March 2nd, handled 485 contacts that could not have been handled in any other way. Although messages handled were chiefly for the Red Cross many were for flood-isolated suburbs. Even U. S. Army Engineers, stranded on a so-called flood control barrier dam when flood waters went through it, depended on WERS as their only means of communication. Campbell Co., Ky., part of WKHO, headed by 9NRA, bore the brunt of the disaster and came through with flying colors. RRZ reports the following: QUO of Paris Radio was promoted to lieutenant in the field. SNQ, in the Pacific area for 2 1/4 years, is in E.T.O

"SUPER-PROS"



ON THE LINE

Five thousand hours of continuous operation demand good engineering. The "Super-Pro" receivers in the CAA installation at La Guardia Airport have been on duty twenty-four hours a day for over four years.



HAMMARLUND

THE HAMMARLUND MFG. CO., INC., 460 W. 34TH ST., NEW YORK 1, N. Y.
MANUFACTURERS OF PRECISION COMMUNICATIONS EQUIPMENT

in a Long Tom artillery outfit. RQI is also in E.T.O. TXI is back from 2½ years in the Pacific area. RZB is in France. CVV is in Germany. CBI reports that Dayton, WJTW, activity is good and regular Wed. night schedules are held with WKOD, Hamilton, and WKHO, Cincinnati. WHIK, Troy, has also been worked regularly. Plug-in conversion of v.h.f. receivers for f.m. broadcast reception is contemplated. NAF, in RM school at Bainbridge, Md., copying 26 w.p.m., would like to hear from Ohio hams and expects to be shipped soon. NXJ reports increased activity in Canton WERS. The old club headquarters was burned out and the club now meets the first and third Thurs. in the police station assembly room. UYL, an RT in the Navy, has been recommended by his OC. PZA reports that attendance at the CRA March meeting was 75. The club is sponsoring a code and theory class. Prof. Martin, of Case School of Applied Sciences, is giving six three-hour lectures covering everything up to u.h.f. There is no charge to disabled veterans! Larry Diamond, a former active WERS member, was killed in action in Luxemburg. EFW wrote from Hawaii. OFF, in the merchant marine, wrote about the trials of a radio operator during blackouts at sea. QV is keeping the ham spirit alive in Cleveland. AVH has a new QTH on the other side of Cleveland. "Less gas to work," he says, but MFP thinks it's just a better antenna location. 73.

WISCONSIN — SCM, Emil Felber, jr., W9RH — 1st Lt. VKC has been transferred to New Delhi, where he holds down the job of business manager-assistant editor on the staff of *The Roundup*, the official service newspaper of the India Theater of Operations. JFS, ACRM, is in a PAT-SU outfit and had a bull session with Comdr. SO. Ed Thornley, S1c RT, is becoming accustomed to Navy life. Sgt. Jimmy Fischer still is in France. Cpl. Curtis Schultz is in Burma and sends 73 to the gang. Sgt. Bob Keusel is at Assam, India. Capt. Reid Burrows, USMCR, on Palau Island, says the boys there have taken up gardening. If any of you have some spare flower or vegetable seeds, please send them to him via Air Mail. The SCM has his complete address. S1c ROM has been transferred to a light cruiser. Sgt. Gil Rink sends regards to the boys from France. Frank Janearik, RT3c, USCG, has been transferred from Florida to a Coast Guard cutter. T4 ANK is in England. Sgt. Dick Butler is in the Philippines. SYT, dropped us an Air Mail letter from Italy and related how they rigged up a stove on the second floor of a three-story stone building on the side of a mountain. It consisted of a five gallon oil drum, some copper tubing, tile, stovepipe, tin can and a valve. Lt. RRT met up with SYT in Italy and had a pleasant two-hour bull session. Sgt. Bernie Kellner is in Texas. Sgt. John Rashinsky is in Italy. M/Sgt. ULE is in an overseas screening, processing and replacement unit. Lt. ANA, USNR, on Luzon, has collected a lot of radio junk. Pfc. Orrin Loch is in Paris and says that all the stories about "Gay Paree" are true. All the news this month was received from HRM. 73, Emil.

DAKOTA DIVISION

SOUTH DAKOTA — SCM, P. H. Schultz, W9QVY — SOB, now a lieutenant in the Navy, has been at home in Platte after two years of service as radio officer with a submarine patrol. Why not sit down *right now* and send in a few items? Someone is interested in what you are doing, have been doing, and where you are located. 73, Phil.

HUDSON DIVISION

NORTHERN NEW JERSEY — SCM, Winfield G. Beck, W2CQD — Johnnie Melnichook, CRM, c/o Fleet Post Office, San Francisco, Calif., formerly of Woodbridge, in recognizing many of "Ye Ole Ragchewers" of 160 (and especially FUP), writes "Pulleez, keep the No. N. J. news in *QST!*" He sends regards to all the boys from the banks of the Raritan and asks for IVP's complete address. Another letter was received from GGZ, secretary of the Clifton Radio Club, which operates WKKQ, WERS station. Here's the lineup: MEF, radio aide; KEG, chief operator; GOM, emergency control operator, IGE, NEZ, GGZ and MB, mobile operators, and HDJ, walkie-talkie. The Clifton Radio Club, FWT, will hold its regular business meeting the first Friday of each month for the duration. The club is active other evenings, servicing and building WERS equipment. LMB, of the Jersey Shore Amateur Radio Association, writes: "Whenever an unusually heavy snowstorm or hurricane hits Central Jersey it's a sign that the JSARA is having its monthly meeting. This month's meeting was held at the home of GMR. ARRL Director W2DSY brought interesting notes re postwar amateur radio.

MIDWEST DIVISION

KANSAS — SCM, Alvin B. Unruh, W9AWP — TYV, SP (v) 1c, formerly Wichita Airport Control Tower operator, is in flight control in NATS, South Pacific, and expects to move on soon. He reports good reception of the States, Australia and China, as well as the "Jungle Network." LXD, SP (v) 1c, formerly stationed at Wichita with the shore patrol, is now in Chicago, and operates at WHHI-1 for WERS. GSW built an electronic keyer for his postwar rig. VVV requests current dope and QTH of "that ham down in Pittsburgh who was in the National Guard." ASD changed his job as final assembly B-29 electrical test technician to radio and electronic test technician with Boeing flight-test crew. LTB, chief operator at KGPZ, reports the c.w. operator's position sports three shiny new HRO receivers. 73, Abie.

MISSOURI — SCM, Mrs. Letha A. Dangerfield, W9- OUD — KIK sends us this dope: RNK is keeping his ear in by copying commercials on c.w.; TBU is a proud papa and is out at sea with the merchant marine — and that indicates that PUV over in England is an uncle. FOR/FIR, whose address we have been wanting for MVE, has made WAC in person as a member of the merchant marine. TGN visited 2KDC who lived in Joplin for quite a bit several years ago. Charlie has a wife and jr. operator now. After eighteen months with PAA, two months training in Calif., six in New Caledonia, and back to California, from where he made a number of trips to Hawaii on the Navy ships operated by PAA, KCG is back with Highway Patrol and is very glad to be in Missouri and to find our brother, ex-9IGW, now 4HLN, there in Jeff. City with the Patrol. Alex wants the QTH of PYF. BMS has made a cute quick-test gadget for service work using a 6E5 which works very nicely, and with OUD has been planning a rig for 80, 40 and 20.

NEBRASKA — SCM, Arthur R. Gaeth, W9FQB — We of the KHKN network and the Nebraska section wish to extend our heartfelt sympathies to Delmar L. Chaloud, KHKN-29, who lost his XYL recently, and to the family of WOA/KAAJ, radio aide, who was instantly killed in a traffic mishap on Mar. 3rd. WOA was very prominent on 10-, 20- and 160-meter 'phone and will be missed by all who knew him. ZPZ, KHKN-33, visited the Des Moines and Cedar Rapids gang in February. Ex-ASC/ESC, formerly of Minn., now KHKN-37, was initiated into the AK-SAR-BEN Radio Club. Paul Russtsein, KHKN-36, is a new member of the net. FQB, KHKN-10, was appointed code instructor for the KHKN net, and heard Des Moines Tower on Mar. 14th, near 125.6 Mc. YDC, KHKN radio aide, reports that the Council Bluffs gang are about to activate with thirty-five units. Cliff Allwine, KHKN-39, while taking off from a flight of slippery steps, crash landed, and was confined to his home for a couple of weeks. EZZ, KHKN-58, now is operator at KOWH. Lt. BZV, in Corsica, promises to report each month. Capt. HTE, says that the public relations officer has sent in a couple of newspaper items to the *World Herald*, that will tell what he is doing. RT2c SHH, somewhere in the Pacific area, ran into IPZ who is now chief radio technician. Ultrahigh freak for the books, as follows: A carrier with b.c. music was interfering with a local airways station on 125.6 Mc., and was found by the FCC to be a 1938 a.c./d.c. receiver with 456 kc. i.f.'s. The oscillator coil was tapped down 1½ turns and the audio was superimposed upon this stage, which acted as a suppressor modulated rig, emitting a signal on the above-mentioned frequency regardless of where the b.c. set was tuned. Sgt. NYU, radio repairman in an air engineering squadron, reports working with YRD, and in the past with RQO and 6STX. Pvt. ex-MUK/K6TXV, in India, ran into NPL, and they went to see RSW who was out. Mac built the one-tube WERS transceiver described in *QST*, and say its works FB. Congrats to ex-FNY, who has acquired an XYL. Art.

NEW ENGLAND DIVISION

CONNECTICUT — SCM, Edmund R. Fraser, W1KQY — During a recent stay in Albany your SCM spent quite a few hours with Andy Henderson, ex-AMZ/8DHU, now 2NIY. Steve Tabor, former West Haven WERS radio aide and member of GB, writes from Sampson, USNTC, "What a life and what a head of hair I ain't got. 73 to the gang." Mary Creaven, former Hamden WERS operator for WJLH, now in the WAVES, sends 73 to the gang from Treasure Island. Mary hopes to contact 6TI and 6RBQ to see how WERS performs on the West Coast. ATH, MEF, JQK, MVH, and LTZ are taking Class A exam with Dunbar.

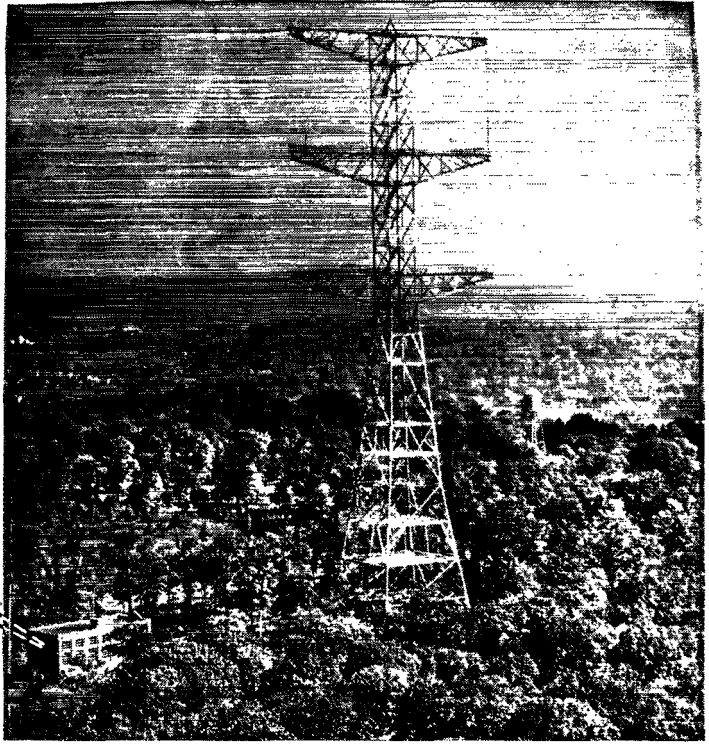
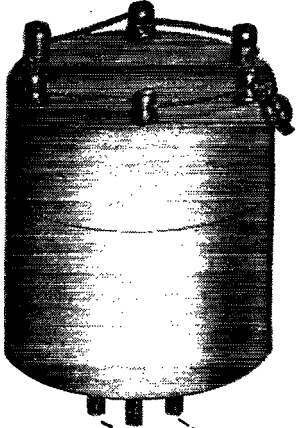

Pioneer FM station uses BLILEY CRYSTALS

When Major Armstrong's station W2XMN went on the air from Alpine, New Jersey on July 18, 1939, radio history was in the making. This first FM transmitter to be put in service, built by REL, employed the Armstrong crystal-controlled phase shift modulation.

Bliley crystals are doing an excellent job in this outstanding FM installation.

For advanced engineering it is

always worthwhile to specify Bliley crystals. An outstanding example of this is the discovery and development by Bliley engineers of ACID ETCHED CRYSTALS*. This technique was an established part of Bliley production before Pearl Harbor. It is now recognized as a prerequisite to dependable service in military equipment.

It is a good habit to consult Bliley engineers when new de-

velopments are in the making. Our specialized engineering can often be of real assistance toward solution of your design problems. This kind of service has made Bliley the foremost producer of quartz crystals for amateur and commercial radio in peacetime and for our armed forces in time of war.

+

**Acid etching quartz crystals to frequency is a patented Bliley process. United States Patent No. 2,364,501.*



Bliley CRYSTALS

Do more than before . . .

buy extra War Bonds

BLILEY ELECTRIC COMPANY
UNION STATION BUILDING • ERIE, PENN.

Harper, Limoncelli, Pratt, Galvin, Bates, Ann Cadari and Jane Terrill, all WJLH WERS operators. Katharine Jackson, with the assistance of Betty Doyle and Jane Terrill, did an excellent job of running the district during test periods in the absence of KQY recently. CTI writes that WERS activity in the WJQA district shows signs of increase. WJQA-31 was blessed with the birth of his 4th harmonic, a daughter. WJQA-23 contacted WNYJ-198. CTI has been doing some experimenting with carrier-current but has experienced difficulty in getting his signals through a sub-station. They have two carrier-current stations; one has 25 watts input to a 210, using a QST converter into 3.5 Mc. FXBA receiver. Eli Crumb, reporting for the Norwich-WJTR district, has just completed a new receiver. Improved reception has been noticed on contacts with WKOB-14 in New London and WKNQ-1 in Middletown. ALW, WJTR district radio aide, has been kept busy with his new radio shop in Norwich. WJTR-5 is building a new receiver. A few of the WJTR operators are contemplating taking the amateur exam in the near future. DBM, WKNQ-Middletown district radio aide, now is coming out with an r.f. stage for TR-4s to eliminate radiation. Two of the WKNQ units have been placed in the State Armory and Red Cross buildings to be used in the event that food conditions are experienced in Middletown. EER, WKWG-Waterbury district radio aide, reports the town of Meriden now is licensed to operate in the Waterbury WERS network. WLSB-1, Long Island, N. Y., was contacted by units WJLH-1, 47 and WKOB-14 during a recent inter-district test period. Richard Atwood, district communications officer, WJBB-4 Worcester, Mass., writes that his unit WJBB-11 recently heard Waterbury units WKWG-82 and 70. IND and MVH have completed their superhet receivers for 112 Mc. VB is reported working at G. E. Co. in Bridgeport. QV is with Templeton in New London. MVE is in N. J. with the A. T. & T. Co., where he is working on "K" carrier circuits.

MAINE — SCM, G. C. Brown, W1AQL — TO sent in the following news items: The CAP in Augusta has three sets and plans are being formulated to use them in emergency cases. DEH is with the merchant marine. Al Brown, 2nd operator at DHH, is in the Pacific area. MTZ has been discharged from the Air Corps and is with Harvard Labs. KCO, with a discharge from the Signal Corps, is in charge of the instrument department at Raytheon. KEA is a civilian employee at the Navy Base, Augusta. MNR is radio dispatcher for the Augusta State Police. LYW is doing a little radio service work along with his farming. CMO isn't saying much but watch for that new bang-up rig when we get back on the air again. Attention NBK: Your EC ticket is due for endorsement. The *Bangor News* recently ran a nice article and group picture featuring the Bangor Squadron CAP. Included in the picture were Lt. CBV, radio officer, and HLE, physical training officer. Lt. MacGown advises that the unit has two 115-Mc. sets ready to go. HEN is on the State Staff CAP. DLC recently returned from a business trip to Boston. CRI received a letter from QH, in the Pacific area, saying that Ben has been made CRM. 73. "GC."

EASTERN MASSACHUSETTS — SCM, Frank L. Baker, Jr., W1ALP — We recently met 5JRQ, a lieutenant in the Signal Corps, located at M. I. T. IWG is working at WRUL. More hams at M. I. T.: DVS, PE, 9VEP, JMY, who has been in England for almost a year, is home again. NDI has gone to England for a while to work. HDJ was home for a short time and back to Sioux Falls. BNS now is living in Quincy and is first officer for the American Airlines. LO is back in Boston for a while. The South Shore Amateur Radio Club held its regular meeting with the following present: MMU, FJN, DDO, IS, AUU, JXU, IYU, AKY, IHA, ALP, FWS, CCL, 5JLO, 20NY, Dan Hoxie and Rus and Bob Mugford. Arthur A. Madsen (LSPH), a motion picture operator, is working in Quincy. IGV now is living in Malden and working for Sylvania in Salem. MUI, a navigator in the Air Corps, now is in England. MTQ is home again and enjoying a four-weeks vacation. MXG writes from North Africa. LID sends a V-mail letter from Netherlands East Indies. NFQ says quite a few hams working at Foxboro Co. hope to start a radio club. He is moving WKKL-3 to a new location. NCF is operating State Guard radio in Sharon. JFS sends in more news: These hams are in Hawaii: KON, KJH, LTS, LYG, MQE, ZCC is in Luxemburg. JNK is in New Guinea. JHZ was home after thirty-two months in the Pacific area and visited JFS. TZ visited KZK on New Year's. TY was snowed in. GRV's XYL writes to hams in the services. Les says that AGX and family called on him. Ex-1AFF is enjoying spring. KTY has a radio repair shop in

Danvers. LVZ made pickup and record player. JFS wants to hear from KVR.

WESTERN MASSACHUSETTS — SCM, William J. Barrett, W1JAH — MIM reports again from Ogdensburg, N. Y. Lee says hubby, LDV, is still somewhere in the Pacific as RM1c. MND was wounded in action in Germany Feb. 14th. LXE is overseas with the infantry. Dick Atwood reports for Worcester WERS gang. They have a mobile unit at f.m. station WGTR in Paxton nearly every Sunday, monitoring 112-116 Mc., with hopes of hearing a Pittsfield unit. AQM increased antenna pickup coil to three turns in his TR-4 with marked improvement in performance. IHI has finished 815 m.o.p.a. driven by P.P 76s, while Atwood has similar final driven by HY615; both units using linear tanks. Worcester is ready for statewide WERS test March 25th, with three mobiles stationed at strategic spots for relays, in addition to regular units. Dave Sawyer, of SG-WERS WMSB-138, recently made a twenty-mile contact using self-contained transceiver; 955 acorn, modulated by 184. AGM is superintendent of Belchertown State School, and is anxious to get in touch with nearby hams. 73.

NEW HAMPSHIRE — SCM, Mrs. Dorothy W. Evans, W1FTJ/4 — AXL reports a new CAP-WERS set-up in Claremont under the call WKYQ. IDY has moved next door to his job at the Post Office. HYO is a 1st lieutenant in the Army and is stationed in Indiana. ATE still is on the West Coast and has his wife and son with him. HOV is in India, we hear. LBD still is at Pearl Harbor. JCA sent BFT/FTJ some Jap currency he picked up. News of the birth of Chuck's son didn't reach him for one and one-half months! Our sincere and heartfelt sympathy to CFG and his wife, Edna, on the loss of their only child, Judy, age 6 years. We understand that CMB left a diamond with his YL when he departed after his furlough was up! GDE is a captain in the communications department of the Home Guard. ILN is the proud father of a son born the day after he returned to this country from England. NMB is in the process of forming a ham club in his unit. He has just received promotion to petty officer, 2nd class. He wants the QTH of Nashua boys and would like to hear from them.

VERMONT — SCM, Burtis W. Dean, W1NLO — BD reports that the Vt. State Guard has a dozen SCR 511 "walkie talkies" coming. These are to be used on new WERS frequencies in the 80-meter band. The CAP has procured transmitters and receivers to use in their planes, and is awaiting license and WERS operator permits. AVP is a pfc. in the SG unit at Rutland. LMO has left Northeast Airlines and is flying for American Airlines. BD's XYL received a commission as 2nd Lt. in the Army Nurse Corps LPL and XYL are the proud parents of a son, John Alfred, III, born August 25, 1944. Jack is working for Harvey-Wells Communications in Southbridge, Mass. LPL was formerly chief engineer at WSYB. Your SCM passed the Army physical with flying colors. Dick Evans (LSPH) has applied again for OCS. 73, Burt.

NORTHWESTERN DIVISION

MONTANA — SCM, Rex Roberts, W7CPY — DCZ is radio officer with American Communications and travels to where the DX used to be. He says the Pyramids would make an FB tower for the old sky hook. AGY runs a big (even for Montana) cattle ranch. FQA is RM at sea and his brother, FQB, is a chief radio technician at the Treasure Island school. Ellis Homer, RT3c, is a student at Treasure Island. 6SYX, ex-EGM, RT3c, also a student there, is looking for the QTH of EGN (or K7EGN). EQC and Dorothy Stankey were married in February. Both are members of the Butte Club. 9DVT now is at Corpus Christi, Tex. The Butte Club has two new members, Victor Segna and James Mason. DSS reports himself too busy this time of year to report much. 73, gang. Rex.

OREGON — SCM, Carl Austin, W7GNJ — GNJ/HHH enjoyed a visit with GPS, who is now maintenance inspector with CAA. Plenty of ham ideas were discussed, including "getting 12 kw. peak power from a 6L6," and also the "inductive-capacity coupling," which appeared in March QST. GPS is building a mobile rig to use in connection with his work. It is with regret that we report the death of FAL while working at loggings operations at Molalla, Ore. on Jan. 24th. Earl was the "daddy" of the Oregon 160-meter AARS, and many northwestern hams will remember his businesslike operation on 1865, and later on 1990. Oregon has a new ham in the person of 5FZG. He is radio operator for the merchant marine, and has seen service on Gulf and

(Continued on page 68)

TELEVISION IS HERE!

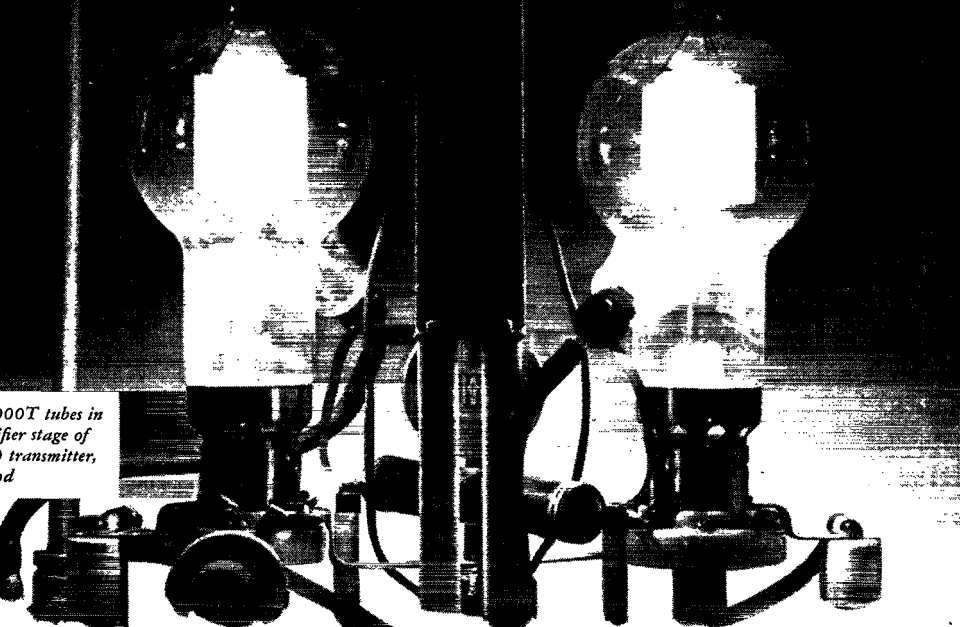

Eimac 1000T tubes in an amplifier stage of W6XAO transmitter, Hollywood

At Don Lee Hollywood... Station KTSL using EIMAC TUBES since 1938

Work on television station W6XAO (Commercial station KTSL) began in November 1930; and thirteen months later, Dec. 23, 1931, it was on the air on the ultra high frequencies, the first present day television to operate on schedule. Today the station occupies elaborate copper sheathed studios which stand 1700 feet above Hollywood with an antenna on a 300-foot tower.

The program log shows almost every type of presentation. Highest in interest and achievement are the remote pick-ups and special event broadcasts made simultaneously or recorded on film for release later. Studio presentations, especially those directed to war activities, have become a duration standard.

Under the direction of Harry R. Lubcke, television station KTSL will

be in daily schedule immediately after the war. Mr. Lubcke says: "We have been using Eimac tubes in our television transmitter since about 1938... We have found them good and reliable performers... their design is such that a favorable ratio of power output to tube and circuit capacitance is obtained... we look forward to using new Eimac tubes which may be forthcoming."

Here again is a statement from a leader in the field, which offers clear evidence that Eimac tubes are first choice of leading electronic engineers throughout the world.

Follow the leaders to

Eimac
REG. U. S. PAT. OFF.
TUBES



EITEL-McCULLOUGH, Inc. 991 San Mateo Avenue, San Bruno, Calif.
Plants located at: San Bruno, California and Salt Lake City, Utah
Export Agents: Frazer & Hanson, 301 Clay St., San Francisco 11, Calif., U. S. A.



Julia Lee Wright, noted Home Economics Director of "The Family Circle" magazine being interviewed, and telecast revealing tricks of her trade.



Two young comedians, Robert Sweeney and Hal March, currently on transcontinental radio show, give a preview of their talents for television broadcast over W6XAO.

Write for your copy of Electronic Telesis—a 64 page booklet fully illustrated—covering the fundamentals of Electronics and many of its important applications. In layman's language.

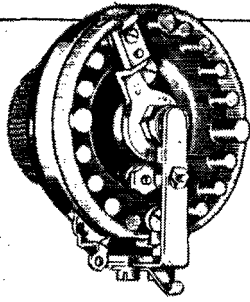

...a HIT
in 1924

TOPS in
Popularity
Today...



Smash hit of 1924, the Mallory K Air-Cooled Rheostat was years ahead of its time. Its direct successors today are tops in popularity too.

Twenty-one years of experience—through peace and war—have tested and proved this product excellence. Correct design, skillful execution, continuous improvement, are the reasons behind this dominance. Mallory Variable Resistors are built to a standard of quality rather than to price. Yet, Mallory has the ability to manufacture in quantity. That's why these products cost no more.

If you need Variable Resistors—Rheostats, Potentiometers, Volume Controls, T and L Pads with dissipation ratings of 9 watts or less—consult your Mallory catalog. Chances are you'll find what you want as a stock item—available for immediate delivery from the shelves of your Authorized Mallory Distributor.

P. R. MALLORY & CO., Inc.
INDIANAPOLIS 6 INDIANA



P. R. MALLORY & CO., Inc.
MALLORY

(Continued from page 66)

Caribbean as well as Pacific Coast shipping. He has been in many countries, including Australia, where he acquired an XYL. She was an Australian radar operator, and John mentions that he had a hard time finding a diamond for her until he ran into VK2GZ, who is an ex-jeweler. Their QTH is Eugene, 73, Carl.

WASHINGTON—SCM, O. U. Tatro, W7FWD—ITL, of Poulsbo, writes that he now has an XYL; he does not know what his postwar rig will be like; he wants a television network; and he found an old buddy through the "war industry and ham participating" column of QST. MH, ex-GUU, is with KRKO after three years as CRT in the USNR. DL is with Seattle City Light. ANZ is a supervising supercargo for the Puget Sound area. EKA is a t/sgt. in the Signal Corps up North. IED is pounding brass in the merchant marine. RY is a b.c. engineer at KOMO. FTR is RM1c at San Francisco after 2½ years in the So. Pacific. ART is a CRT at Pasco. KYEVM, of Ft. Yukon, is at P. of E. at Seattle and K7AOC, of Juneau, is radio service engineer for Pan-Am at Seattle. On Dec. 8, 1941 Earl got back his old call, MH, in place of GUU. HCE, EC, reports HW is in the appliance repair business at Sunnyside. Lt. Comdr. LV thinks steerable microwave beams will be useful for intracity rag chewing. AWX has a new radio shop. FCZ has an occasional ham smoker at his home. CAM flies in his spare time and says AYO is queening a YL at Paine Field. ALH has doped out how to put long antennas over neighbors' property. JLX is in N.W. Airlines office at Yakima Airport. CRCS will interest ERU with his messengers scattered around town and HCE is revamping a freq. standard, is teaching industrial electronics on the side and is called, if a blunder is made, by ARF, who is in his class. HUK, of Seattle, writes from Southern France that the American boys of Japanese ancestry, a number of them hams, are in the thick of it, but follow Section Activities in QST. He says GUN of Walla Walla and ICF of Burlington are in their outfit. ERU climbed a 70-ft. tree to repair FWR's antenna. CWY, BG, EHQ and families were recent callers. *Amateur Wa'Wa* reports that GFI of Spokane, radio operator in the merchant marine, was killed in action in the So. Pacific; and ILJ, a major in Signal and Communications has returned to Naples, Italy, after a short furlough home.

PACIFIC DIVISION

NEVADA—SCM, N. Arthur Sowle, W6CW—Asst. SCM, Carroll Short, jr., W6BVZ. The Reno Army Air Base is organizing an amateur radio club for men who are licensed and those who are interested and wish to be assisted so they can take the exams. TQZ is constructing a deluxe recording outfit to make records of future DX contacts. RXG has become communications officer in Las Vegas squadron CAP. GYX spent several days in the air recently on a CAP search for a missing AAF aircraft. QVP has left Reno to accept a position at the U. of Calif. at Berkeley. QAY removed the ladder from his 10-meter beam a short time ago. IAJ is navigator on a B-17 with the 15th AAF in Italy. BVZ supervised restricted radiotelephone exams for fifteen members of the Boulder City CAP squadron. CUU, who handled much KA1HR traffic in pre-Pearl Harbor days, is operating temporarily at KIKH/KJK in Boulder City. T/4 HDC now is based at a Signal Depot in New Guinea. PZY operated KAHB aboard the ship when three CBS officials were guests of the Los Angeles Dept. of Water and Power on a 100-mile survey of Lake Mead back of Boulder Dam. KMP recently visited Southern Nevada; he is an officer on the Los Angeles police force. DMH is in the U. S. Coast Guard, stationed near San Pedro, Calif. CPM is working with So. California Telephone at Blythe. QQB is now operating KQT in Los Angeles, 73, Art.

EAST BAY—SCM, Horace R. Greer, W6TI—EC, QDE; EC v.h.f., FKQ; Asst. EC v.h.f., OJU; OO v.h.f., ZM. The regular monthly WERS meeting was held March 15th in the control room, Oakland City Hall. C. F. Rothrick, U. S. Navy, gave an FB talk on u.h.f., featuring circuits, transmitters and receivers. Greater Oakland WERS has been going swell ever since it started and will drill three times weekly. EE is to be congratulated on keeping the gang interested in spite of limited rules and regulations. How about the ARRL getting a sponsor to go on the air on a short weekly program? It seems to me that there are so many interesting and thrilling happenings in the ranks of amateur radio that they could be dramatized, giving the general public a better insight into ham radio. A coast-to-coast hookup would be beneficial to all concerned. Would like to have some comment on this. "Another day closer to victory. 77.

WHAT ARE YOU GOING TO DO ABOUT THE NEW ALLOCATIONS?

HERE'S ONE THING YOU CAN DO ABOUT THEM NOW.

Perhaps by the time you read this, all frequency allocations will have been pretty well settled. You'll be thinking about how your present equipment will fit into the future.

Browning Laboratories have always designed and manufactured soundly engineered and ruggedly built equipment for specific services. Right now every available manhour goes into design and manufacture for the Armed Forces. But, looking ahead, if you'd like Browning to have a converter for your specific needs, tell us how you'd like it.

This applies to both AM and FM receiving equipment. Tear out this page now, as a reminder, or write us a letter.



BROWNING
LABORATORIES, INCORPORATED
WINCHESTER, MASSACHUSETTS

HERE IS A HANDY FORM TO HELP YOU see where you stand. If you mail it to Browning Laboratories, it will give you an opportunity to say exactly what you want by way of conversion equipment.

Browning Laboratories, Inc.
750 Main Street
Winchester, Mass.

Gentlemen:

My present AM receiving equipment has ranges of to to
..... to to to to to

It will be satisfactory in the new allocations without a converter.

It will have to be converted to ranges of to to
..... to to to to to

My present FM receiving equipment has ranges of to to
..... to to to to to

It will be satisfactory in the new allocations without a converter.

It will have to be converted to ranges of to to
..... to to to to to

If a dependable Browning Laboratories converter is available, here are the special features it should have to be most useful to me:

.....
.....
.....

NAME _____

TITLE _____

COMPANY _____

ADDRESS _____

hrc

The News About

HARVEY

is going 'round



Purchasing Agents are saying:

If we need tubes, meters, capacitors, resistors, test equipment, or any other radio and electronic components, what do we do? We call HARVEY—he has 'em!

Wartime Agencies are saying:

If HARVEY can't furnish us with the parts we need, he finds them for us — or gives us something that will fill the bill.

Training Schools are saying:

... and besides, we get extra service from his staff. They know the ins and outs of this priority business, and know how to cut through the red tape.

Laboratories are saying:

HARVEY delivers! No time lost on the orders we send to him. That place has good, efficient service.

WHAT THE FIELD IS SAYING IS SO!

WRITE, WIRE OR TELEPHONE HARVEY FOR CRITICAL RADIO AND ELECTRONIC PARTS AND EQUIPMENT!

Telephone: LOngrave 3-1800



103 WEST 43rd ST., NEW YORK 18, N. Y.

(Continued from page 68)

SAN FRANCISCO — SCM, William A. Ladley, W6RBQ — Phone Randolph 8340. ECs, DOT and KZP. OO u.h.f., NJW. BIP is radio and radar technician with the U. S. Air Group, and also is the proud father of a 9-lb. 4-oz. baby boy, born March 7th. LCC is experimenting with wired wireless. AM advises that the Long Beach gang is doing a super job on WERS using home-built superhet, receivers and crystal-controlled transmitters. He states that at Long Beach they often hear u.h.f. stations in the Denver, Colo. area. NKE is at Mare Island. JWF is in England doing his share to keep the radio gear in operation. WN made a trip to N.Y.C. for EIMAC. RBQ's oldest son, Bob, arrived home after fourteen months absence aboard a carrier. The following was received from SFW, radio officer, c/o Postmaster, San Francisco. "Pfc. SPE was killed in France on Christmas Day. Sgt. ROO has completed thirty-six months overseas and is due for Army discharge. Chief Operator RZC met ROO in New Guinea. SDX hopes to pass his commercial exam and may go to sea. LAV still is at his Laguna Honda home and is taking up watch making and turning out some microscopic gear on a midget lathe. Sgt. LNT and SFW recently met in San Francisco. RTH is home from the European theater. LDP is running a radio service shop at 39th and Balboa." 9ILH and 9ICN still are in Southern California. CIS reports from the Admiralties that he spends his spare time monitoring U. S. c.w. and b.c. stations with excellent results. WB is building radio gear for the armed forces. PGB is with the Army as radio engineer. Comdr. 9FA writes from somewhere at sea. Lt. HJP is back on the rock of the Island of Oahu. SG-WERS is operating regularly as KGCW until new State Guard license is received. This new unit is known as Communications Detachment, 1st Battalion, 23rd Regiment, C.S.G. Military courtesy and drill training has been completed and subsequent drill nights will be devoted to radio activities. Lt. KB6ILT reports in from his home in the valley of the moon, where he raises his own chickens. 73, Bill.

*SAN JOAQUIN VALLEY — Acting SCM, Edward H. Noack, W6BXB — GJO still is in the machine shop game. He is becoming interested in c.c. BFH, who is the son of the SCM and who got the OM on the air, is interested in c.c. BCR also is thinking of trying it. BBC left the butcher business to go with the Submarine Instrument Co. in Boston. JIN has an honorable discharge from the Navy and is back in Stockton. Dr. L. W. Saslaw is a new ham in Stockton and is very much taken up with c.c. JSG still is with the Santa Fe Railroad. His hobby was 20-meter c.w. PNM is in the Army teaching c.w. and is located in Tucson, Ariz. The SCM received a fine letter from M/Sgt. QOP of Fresno, who now is at Borne General Hospital, Vancouver, Wash. He sends in the following news: RYW, a captain in the Signal Corps attached to the Infantry, has been overseas 2 1/2 years. Lt. SLA recently graduated from Ft. Monmouth, N. J., and now is going to an advanced school. ONX is in the C.F.O. in the Navy. PVZ is with the Q.M. in France driving a gas truck. S/Sgt. DTL is in France with the AAF working with the British. NRO was discharged from the Army. Harry, who was wounded while in France, was here in March on furlough and will be back on duty soon.

ROCKY MOUNTAIN DIVISION

COLORADO — SCM, H. F. Hekel, W9VGC — YKP is really a big time relative as well as an ancestor. Within the period of three months he became uncle twice and papa for the second time. His sister made him an uncle early in the winter; his sister-in-law, Erna Mae, raised the score to two in Jan. with a boy and on Feb. 21st his wife, Donna, presented him with a 7-lb. 9-oz. boy. After spending several days with his family in Denver he went back East, where he and Al Mills are producing supplies for the battle fronts. Al Mills is with Western Electric in Newark, N. J. He reports that Marvin Juzo, U. S. technician, Marine Corps, who spent a lot of time on Saipan, went through the plant. PVZ still is stationed at Pearl Harbor. VIK is in the thick of things aboard a ship. His address is R. J. Haller, RT2c, c/o Fleet Post Office, San Francisco, Calif. Bob Perske (LSPEH), KFND-22, spent most of a short vacation from boot camp in Denver. Pvt. Grossman (LSPEH), WHNI-3 from Newark, N. J., is in a gunnery school at Lowry Field. Lt. Comdr. Bob Lewis' latest address is APO 113, c/o Fleet Post Office, New York, N. Y. EHC was in Denver in Jan. just long enough to visit his brother, FXQ, between planes. His last report, Jan. 13th, was from his office in Washington, D. C. Here is what his address looks like in print: Office of the Assistant Chief of Air Staff for Training, Communications

"AIR SUPREMACY"

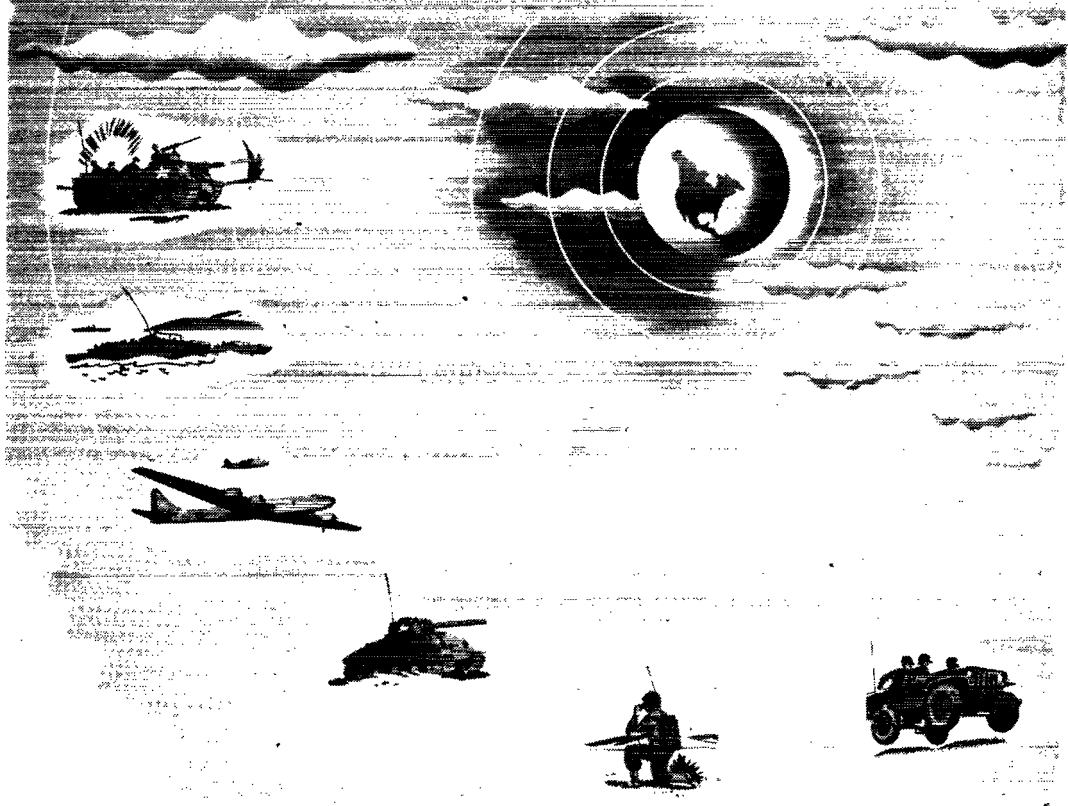

"Control of the air" today means more than massed firepower and numerical dominance by aircraft; it means control of communication channels . . . and better detecting devices—better directional finders—better protective equipment. The air today is filled with high-frequency impulses, activated by radio and radar. And helping assure that supremacy are Delco Radio products, ranging from compact mobile radio sets in combat vehicles, planes and ships, to highly intricate electronic equipment. They represent the effective combination of engineering vision and manufacturing precision that safeguards the performance of all Delco Radio equipment, wherever it serves and whatever its purpose. Delco Radio Division, General Motors Corporation, Kokomo, Indiana.

KEEP BUYING
WAR BONDS

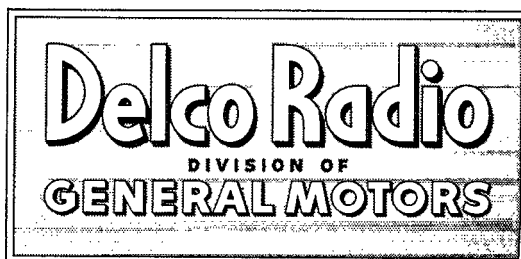

OHMITE RHEOSTATS

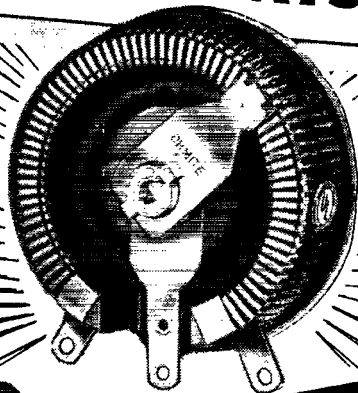

SMOOTH • CLOSE • ACCURATE

Control

• Design engineers everywhere rely on Ohmite Rheostats for smooth, close, accurate control of electronic tubes and devices. The many time-proved features of these control units insure trouble-free operation under toughest service conditions. That's why Ohmite Rheostats are so widely used today in vital military and industrial equipment. Ten sizes ... from 25 to 1000 watts.

Authorized Distributors Everywhere

Send for Ohm's Law Calculator

Solves any Ohm's Law problem with one setting of the slide. Send only 10c in coin for yours.



OHMITE MANUFACTURING CO.
4864 Flournoy St. • Chicago 44, U. S. A.

Be Right with **OHMITE**
RHEOSTATS • RESISTORS • TAP SWITCHES

(Continued from page 70)

Training Division, Radio Branch, Washington, D. C. Had a nice long letter from 2RP, an instructor at the Naval Radio School, Farragut, Idaho, who expects to leave very soon.

EASTERN FLORIDA — SCM, Robert B. Murphy, W4IP — Thwing reports that on March 7th WKNW-30 worked the State Guard station, WKRW-36, at Ft. Lauderdale with R5S5 signals both ways. Thwing says there are prospects of better activities with the purchase of a new receiver. We are becoming more interested in the workings of 112 Mc. and u.h.f. in the overhaul shop at PAA. BYF deserves congratulations on getting the fellows together in local WERS work; he has kept things going from a sick bed. MacArthur really enjoys his work and we all enjoy helping him. A letter from GAJ shows him to be in Belgium; he wants to write Heurx. Paul's buddy, HPJ, has made ACRT in Naval Aviation. He is at Willow Grove, Pa., and is married. 9VRP also is with Holland and they enjoy reading QST in their spare time. Paul wants to be remembered to HAD, BYR and all the gang in Tampa. IYB is struggling along in the aircraft radio shop at PAA; Kosa will be remembered as chief operator at HHP, Port au Prince. CBK sends the following from Orlando: AKV is in Newfoundland and enjoys copying PX on some of the hot circuits; CLW is making regular trips to Tampa; DWI still keeps a hand in on tuning pianos. Baldy sends 73 to KK and CNZ. HYQ writes from Curacao, that he has been on the East Coast the West Coast and in the So. Pacific area with a two months stay in Australia, where he met VK2TO, 2ZC, 2FX, 2AKX and 2YC. Pierce was surprised to see a QSL card from 4NN in 2YC's shack. Stan extends 73 to ASR, ERU, DDB and CPG. Spence, from St. Pete, reports that FHX has gone to sea and PZW spent a short leave with his folks in the ole home town. CNZ is coming out with a special bug adjustment; he seems to have made a name for himself with PAA. DZH is doing close scrutiny work in the screen room for PAA; Russell of WERS fame, WKNB-31, is his able assistant. Ray has one of the finest 112-Mc. jobs in Miami. ETQ is down south with AACs doing a nice job in radio work. Gilbert's wife is doing her part by working in the radio overhaul shop of PAA in Miami. ASR still is plugging along trying to hold up his end of the war game in Daytona Beach. I am still looking to you fellows in the northern part of the section for some reporting. Everything east of the Suwanee River is in the Eastern Florida section.

SOUTHEASTERN DIVISION

WESTERN FLORIDA — SCM, Oscar Cederstrom, W4AXP — Shelby V. Yerby, in the A & R Radio Shop, is our newest ham. Yerby also is an ardent model plane fan and is studying means to control a model plane by radio. The OM visited the A & R Radio Shop and while there had nice QSOs with ECT, JV and 5KPI. JV is a radio engineer in the A & R Shop as well as an old-timer, and so is ECT. Tompkins has been transferred from the station. ECT bought an 8X28 from 6PNI. Bill Langford and wife, Betty, took a trip to Albany, Ga., Bill's home town. He spent three days in Atlanta shopping for ham radio gear. DAO had some 50-watt bottles put up in a box with some more radio gear while having his radio room remodeled. His young son turned the box over and broke both the 50-watters. KB has moved to his mother's old home in Crestview, and is going to put in a turkey and chicken farm at his dad's old saw mill location at Delico. KB will have an ideal ham location at Delico with plenty of room for all kinds of antennas. W. P. Boyd, ACRM, an XW7, is at Bldg. 631 in the A & R Shop. This is the hanger where Foxworth and HLS, ART1c, are working. HLS, formerly an operator at WGTM, is a Class A ham and has a commercial 1st-class phone ticket. Lt. Reed of communications training has been transferred. Bolton made RM2c. Whaley is back at Bldg. 606 in the code room. AXP visited 6PNI at Navy Point. QK paid a visit to DAO. Thanks for a nice report. 73. *The Old Maestro.*

SOUTHWESTERN DIVISION

LOS ANGELES — SCM, H. F. Wood, W6QVV — The Old Man got "took" with flu or something and couldn't get in a report last month. A general meeting of all KGLV operators was held by Walt Matney recently and several pieces of FB equipment were displayed and discussed by Earl Rau, who brought his exceptionally fine v.h.f. receiver along. Stan Lambert displayed a small receiver for automobile use and a new crystal-controlled transmitter. Also some new versions of walkie-talkies were shown. Rudy Jepson says the Valley gang is devoting most of its efforts to new receivers. The whole network, under the watchful eye of the chief monitor

Centralab STANDARD, MIDGET AND MINI Radiohms

● For more than two decades the name CENTRALAB on a volume control has been a synonym for QUALITY.

The long wall-type resistance sector, the smooth performance and the satisfactory operation of these controls are in no small measure responsible for the fame of Centralab. Whether for original equipment or replacement always specify

CENTRALAB Radiohms



Centralab

Division of GLOBE-UNION INC., Milwaukee

Producers of VARIABLE RESISTORS — SELECTOR SWITCHES — CERAMIC CAPACITORS,
FIXED AND VARIABLE — STEATITE INSULATORS — SILVER MICA CAPACITORS

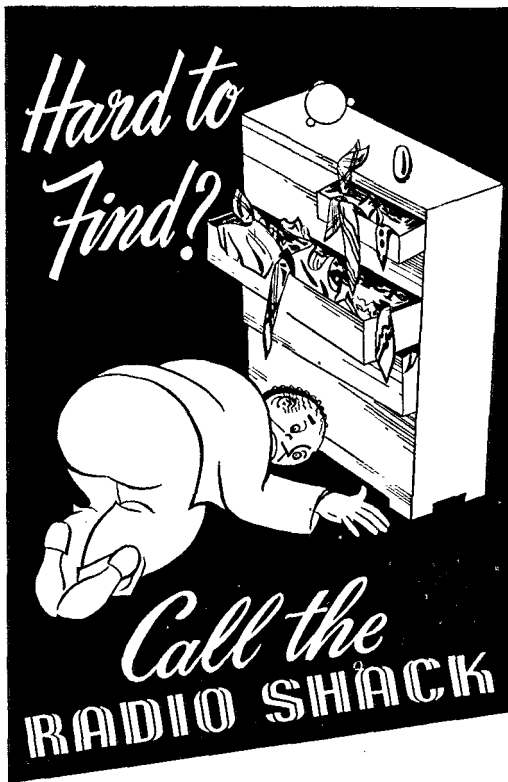

The one odd part you need may be right on our shelves — if not, our super-expeditors know just where to find any of those critical items that stall your production.

We can help you with large quantities, too! Our nation-wide contacts with parts sources — and our twenty years' experience in handling materials for radio and electronic gear — will save you time and trouble.

For help in a hurry, call CAPitol 7530
And for victory,

BUY MORE BONDS

The RADIO SHACK
★ 167 WASHINGTON ST. ★
BOSTON, MASS., U.S.A.

(Continued from page 74)

"Willy" Wilson, is working out nicely and efficiency is increasing with each drill. A subsequent meeting of the KGWE, KGCL, KGIC and KGLV "chiefs" was held in a further endeavor to allocate the different nets to frequencies that will be free from QRM. The Los Angeles City license has been renewed for another year. The KGIC network under the able direction of Fred Stapp, is going strong and the three-element beams have proven very satisfactory. A successful "incident drill" was held, demonstrating the need for services in Inglewood. Several additional mobile units have been added and during the drill simulating flood conditions it was raining "cats and dogs." They are also building several crystal-controlled transmitters and superhet receivers as well as a new crystal frequency-checking station. Fred takes this opportunity to thank KGLV-31 for the great help he has been to the entire net in putting it on "the spot." The KGWE net is busy each drill period. ON, reporting for KGCL, says that everything is progressing nicely and the San Dimas area has been putting on some code practice for the boys. Ora Martin lost his five-element beam during a recent windstorm but most of the boys saved theirs by letting them down. AQQ is building a crystal transmitter for KGCL-8 and unit No. 12 has his ready to take off. FFN is slowly recuperating from his illness. Ora reports the passing of GOX, KGCL unit No. 26 of the Temple City net. MFJ put in a short appearance in Sunny California after many months in the Pacific area where his "battle wagon" took part in most of the major engagements. UQL has been laid up in the hospital in Tacoma for an operation on his foot after having been flown out of the Aleutians. SSU is going farther and farther away on the merchant marine vessel and is gaining a lot of experience. He misses QST on board the boat. KVP, now So. MHC at Naval Training School, San Pedro, says he has been stationed at Cabrillo Beach with 5JSW and HYX. He asks about PWF who, we understand, is on some island. TGY writes that TGO is in the Navy. TOW is finishing high school and wants to go to college and major in radio engineering. He was TGY's protégé and was only twelve when he got his ham ticket. Dick is with the telephone co. and is taking a course from CREI.

ARIZONA — SCM, Douglas Aitken, W6RWW — MLL is pinch-hitting for RWW, who is seriously ill. GS reports that the Tucson Short Wave Club still holds monthly meetings. The 25 Division is being well attended and is talking of incorporating and building a club house. LAI is in Florida and has many plans for postwar hamming. TSZ telephoned RWW on his way through Prescott, RJN is in the Caribbean area with PAA and likes the work. KWI is located at Long Beach. The Tucson Short Wave Club is considering WERS. OZM is planning to rebuild his store to make it larger and streamlined. UOT is home on furlough from Fresno, where he is with a night fighter squadron. OVK is head of the field division of Submarine Signal Co. at Boston. 5GPV is now in La. with the OWI. Fellows throughout the state are reacting very favorably to a proposed statewide association to coordinate local clubs. NRP is somewhere in the So. Pacific. KMZ is teaching in the Oxnard High School in Calif. KSO is chief of the Tube Distribution Bureau at Red Bank, N. J. KOL still is at the Navy aircraft station in Philadelphia. TJH has been ill because of overwork from teaching code and theory classes in Tucson High School as well as working at Davis-Monathan Field. We wish RWW a speedy recovery. How about dropping Doug a few lines, fellows?

SAN DIEGO — SCM, Ralph H. Culbertson, W6CHV — Asst. SCM, Gordon W. Brown, W6APG. WERS is at a standstill at the present time. A total of about forty applications were received and turned over to the radio side. These have been signed and mailed to the FCC in Washington and we are awaiting word on the license. OLN has been helping the radio side with licenses and also in getting the gear ready to go. From all indications the gang is all set to put San Diego on the WERS rolls as soon as the license is received.

WEST GULF DIVISION

NORTHERN TEXAS — SCM, Jack T. Moore, W5ALA — RG advises that IMF is in the Army. ILJ reports from San Pedro that he has completed a course in Naval signal communications and has been awarded the Navy Certificate of Proficiency. HMG is flying a B-25 out of England. IWE now is in New Guinea. HTH is somewhere in the Pacific. IXM is at the Naval Research Laboratory in Washington, D. C. and not on the West Coast, as reported last month, and is now S1c radio technician. 4FYJ has left Lockheed for a job with Philco. DLP thinks the new Hand-book is the best yet. SN reports having trouble in India with

1/5 CK510AX
**The Size of a
 Standard Miniature!**



RAYTHEON CK510AX . . . A DUAL SPACE CHARGE TETRODE AUDIO AMPLIFIER TUBE

Raytheon engineers recently developed a tube radically different in design and performance—yet so *small* that many users were amazed by its capabilities. It is the CK510AX, which is essentially a very low-drain filament type dual tetrode intended for cascade operation as a high-gain audio amplifier.

A unique feature is a space charge grid around the filament—which produces two virtual cathodes, one for each section. Thus from a single filament two individual tetrodes are obtained, between which there is a minimum of interaction.

This tiny tube occupies only one-fifth the physical volume of a standard miniature type, yet voltage gains of approximately 250 may be obtained in the simple circuit illustrated here. The CK510AX is further proof of Raytheon's ability to develop new and better tubes . . . tubes that will be in ever-increasing demand in the new era of electronics to come.

PLEASE DIRECT INQUIRIES TO OUR COMMERCIAL ENGINEERING DEPARTMENT, NEWTON, MASS.



ALL FOUR DIVISIONS
 HAVE BEEN AWARDED
 THE ARMY-NAVY "E"
 WITH STARS



RAYTHEON

RADIO RECEIVING TUBE DIVISION

Newton, Mass. • Los Angeles • New York • Chicago • Atlanta

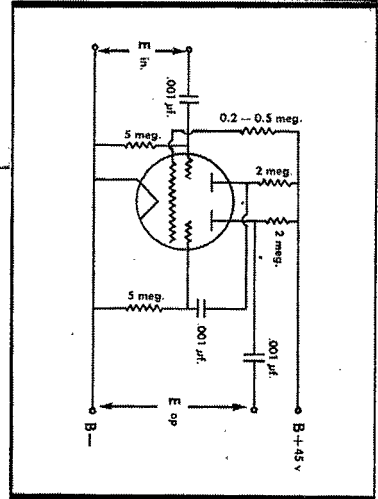

Specifications of CK510AX

Physical:

Bulb	T2X3 Flat Glass
Maximum Length	1.25 inches
Maximum Width385 inches
Maximum Thickness285 inches
Maximum Lead Length	1.25 inches

Electrical:

Filament Voltage	0.625 volts
Filament Current	50 ma
Maximum Plate Voltage	45 volts
Control Grid Voltage*	0
Space Chge. Grid Current	75 to 150 ma
Approx. Voltage Gain	250

*Grids Returned to Negative Filament through 5 megohms.

DEVOTED TO RESEARCH AND THE MANUFACTURE OF TUBES AND EQUIPMENT FOR THE NEW ERA OF ELECTRONICS

"Line Production" Experience IN RADIO MANUFACTURING



From Wilcox's war experience, as one of the largest manufacturers of radio communications equipment, has come many new products... a completely modern mass production factory... a trained engineering staff... plans and the knowledge needed for both war and peacetime products of highest quality and dependability. Look to Wilcox for leadership in radio communications equipment

Model 50A Modulator—
The 1600 watt 50A Modulator, shown at right, may be used for transmitter modulation, or high-powered audio needs.



**WILCOX ELECTRIC
COMPANY, INC.**

Manufacturers of Radio Equipment
FOURTEENTH AND CHESTNUT
KANSAS CITY, MISSOURI

(Continued from page 74)

dive-bombing mosquitoes. JDZ is busy cementing oil wells but takes time to ask about CJJ and send in the following on Coleman hams: AT is repairing radios at Western Auto. CZR is operating a machine at the theater, HLV is working in the post office. AMK is plenty QRL with crystals and frequency work but finds time to ask about EOH and send in the following: LM is busy at McCloskey Hospital. GCQ still is with Santa Fe, DDP is postmaster (and mayor?) of Holland. BEQ is helping to hold down the radio repair shop at Camp Hood, JIB is in the Navy, GGA is chasing Jerries over Europe with his Mustang, DCH is working for Santa Fe, Hal is with Scott White and has sold all of his equipment, DQF holds down the home fort when not trying to teach AMK a thing or two. JHX is doing radio maintenance work for C.A.A. at Love Field. FQY reports a visit from SOXO. George suggests that the Dallas Radio Club hold periodically-called meetings in order to give the local boys a chance to get acquainted with hams that are located in Dallas for the duration. How about it, IUQ? IJC has received an ensign's commission in the USNR. 6SJ has transferred from Lockheed at Dallas to Van Nuys, Calif. FKB is in England for Philco. JSU now is located at the Aircraft Radio Lab. at Wright Field, after having served three years as communications officer for the TCC as a major in the Air Corps. John says his XYL worked for the FCC Radio Intelligence Division in Kingsville, Tex., during his absence and that her code speed now exceeds 40 w.p.m. on the mill.

OKLAHOMA — SCM, Ed Oldfield, W5AYL — HJ, ex-K6SMP, has finally come home to Oklahoma City after having seen a fair portion of the Pacific area shortly before the war and most of the U. S. since. He has been, until recently, employed by the CAA as maintenance chief for the radio division. Was pleased to have a visit from Bob Smolenski, who was assistant operator at 3ENO before the duration. Bob has an operator license but no call. AFX was ill with a heart attack just before Christmas but is up and around now. Heard from Jack Gant, who was working 20-meter phone at Ardmore before the war. Jack is in the Marine Corps serving in the Washington, D. C. area.

SOUTHERN TEXAS — SCM, James B. Rives, W5JC — EIS announces the arrival of a baby girl. Joe is a Marine gunner stationed on the West Coast. HDK sold his amateur station some time ago but manages to keep up his "mike technique" with the rig on the Luscombe airplane when he isn't bowling. We had a nice letter from VL recently. Venable is well pleased with his new assignment as Assistant Technical Editor of QST. He would like to have some technical articles from you fellows in this section. AQN is working at the Marine Hospital in Galveston. ABQ still is on the air at KGZE as police dispatcher. EBT is chief engineer for OWI in Washington. BSP is assistant postmaster and FNH is engineer for Blue Bonnet Hotel in Kerrville. FJX is chief engineer at KNET. EUL was recently transferred from San Antonio to Waco and is code instructor at Blackland Army Air Field. AXI has made a number of trips across the pond with the merchant marine. HHL now is operator at KABC. JMP, chief warrant officer, was in San Antonio for a few days. BKE is assistant to head of Code Division at SAACC. At present Calvin Gref is classified as airborne radar repairman, search equipment, and Garth Parsons is a s/sgt. in land radar in the Marines. They took their 1st-class radiotelephone exams a few months ago and received their licenses immediately. 2nd Lt. Alex Fabris, AAF, also is in radar. JVF now is overseas. James Fischer got his Class B and 2nd-class radiotelephone licenses and is working at Petty Geophysical labs. Lewis Birdsong is a t/sgt. in the Marine Corps and is overseas. Paul Tarradayck worked for KMAC but now is in the Army. M/Sgt. BVG's tour of duty since Sept. 1942 has proved so interesting that he recently refused rotation back to the United States. 73, Jim.

NEW MEXICO — SCM J. G. Hancock, W5EJF — Our latest addition to the c.w. gang is 9DDU, whose family has moved to Albuquerque from Wisconsin. HDN still is sailing the high seas and seeing the world but says he prefers New Mexico and his old QRMer to all the senioritas in South America. IWM is busy in France but has time to dream about that postwar rig and to wonder about IOA, HAG and others of the Albuquerque gang. JYW, ex-9FCE, is instructing as RT2c in the Navy. KKS is in England with the Air Corps. ENI still is sawing bones for the Army in the Bronx. Harold Wheeler is in France slogging through the mud his dad told him so much about. When you fellows pour in the swell reports like you did this month ye ole man has nothing to worry about; even that directional loop I have been messing with seems a push-over. 73, Jake.

REPAIR ANY KIND OF RADIO EQUIPMENT

PREPARE NOW FOR A BETTER JOB AT HIGHER PAY IN THE RADIO-ELECTRONIC FIELD.

Complete Basic Radio-Electronic Training for Beginners... FOR ONLY \$5

EASILY WORTH \$50 IF YOU BOUGHT IT AS A COURSE

No sir! Radio-Electronic Training doesn't have to be expensive to be good. Actually, A. A. Ghirardi's famous 972-page RADIO PHYSICS COURSE book gives you just the training you need—ALL YOU NEED—easier, better, faster—AT A TOTAL COST OF ONLY \$5 (\$5.50 foreign).

No previous training is necessary. RADIO PHYSICS COURSE book carries you, rapidly

through Basic Electricity (over 300 pages) to the latest Radio-Electronic developments. Nothing is omitted or condensed. Each step is made crystal clear by thorough explanations and by more than 500 illustrations. Each section contains Self-Testing Review Questions so you can check your progress every step of the way. There are no lessons to wait for—no monthly payments to make.

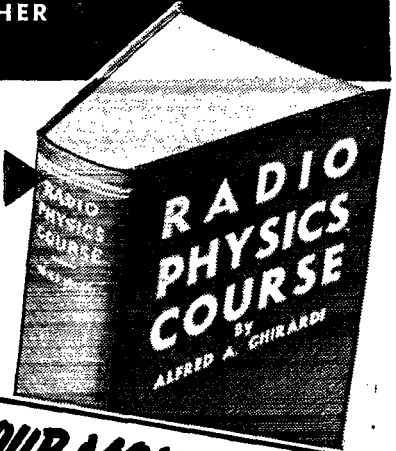

More universally used for home study, by more Signal Corps, Navy and civilian schools and colleges than any other book of its kind!

All you need is a little spare reading time plus a desire to get started NOW to make more money in the rapidly expanding fields of broadcasting, aviation radio, F-M, Television, radio servicing, electronic manufacturing—or any other of Radio-Electronic's fast-growing branches. RADIO PHYSICS COURSE is famous for making it easy for beginners to learn Radio-Electronic fundamentals—at home without an instructor.

You can understand every word without previous training. You'll be pleasantly surprised how easily you'll master the subjects that other books and courses make seem very complicated. Our 5-Day Money-Back guarantee enables you to examine this great book for five full days—and get every cent of your money back if you're not more than satisfied. Send coupon today!

YOUR MONEY BACK
in 5 Days if Ghirardi's RADIO PHYSICS COURSE doesn't teach you EASIER, FASTER, and AT LESS COST than any other Radio-Electronic book or course!

HERE'S HOW TO LEARN MODERN SERVICE WORK *without an instructor!*

Ghirardi's MODERN RADIO SERVICING (see below) is the only single, inexpensive book giving a complete course in modern radio repair work. Written so you can understand it without an instructor! Read from the beginning, it takes you step by step through all phases of the work. Used as a reference book, it serves as a beautifully cross-indexed work for "brushing up" on any job that puzzles you. Explains ALL test in-

struments, how they should be used and why (it even gives all data for constructing your own test equipment); Troubleshooting Procedure and Circuit Analysis; Testing and Repair of Components; Installations, Adjustments, etc., etc.—ALSO How to Start a Successful Radio-Electronic Service Business. 1300 pages; 720 Review Questions; 706 illus. Only \$5 (\$5.50 foreign). 5-Day Money-Back Guarantee!



MONEY-SAVING OFFER

See coupon for special combination offer on MODERN RADIO SERVICING and TROUBLESHOOTER'S HANDBOOK—over 2040 pages representing a complete service library for only \$9.50! (\$10.50 foreign)

HERE'S HOW TO REPAIR RADIOS THE EASY WAY

Ghirardi's big 744-page manual size RADIO TROUBLESHOOTER'S HANDBOOK (below at right) isn't a "study" book. You simply turn to it whenever you want to fix a particular trouble in a particular model and make of radio. Its 404-page Case History Section gives full details on common trouble symptoms, their causes and remedies for practically every Radio in use—over 4000 of them! It describes the trouble exactly—tells you exactly how to fix it—without any elaborate testing whatever!

If you like to tinker with radios the HANDBOOK is your "Open, Sesame!" to fast, efficient work. If you are already a radio man it will help you fix two sets in the time normally required for one—repair cheap sets profitably—train new helpers—substitute parts properly, etc. Also, hundreds of pages devoted to I-F alignment peaks; transformer troubles, tube substitutions and dozens of charts, graphs, helpful hints, etc.—all indexed so you can find them fast. Only \$5 complete (\$5.50 foreign) on our 5-Day Money-Back Guarantee

JUST LOOK UP the model radio you want to fix. The Handbook tells exactly what to do—exactly how to do it!

RADIO & TECHNICAL DIVISION

Murray Hill Books, Inc.,
Dept. Q-35, 232 Madison Ave., New York 16, N. Y.

Enclosed find \$_____ for books checked; or send C.O.D. (U.S.A. only) plus postage. If not fully satisfied, I may return books within 5 days and receive my money back.

RADIO PHYSICS COURSE \$5 (\$5.50 foreign)

MODERN RADIO SERVICING \$5 (\$5.50 foreign)

RADIO TROUBLESHOOTER'S HANDBOOK \$5 (\$5.50 foreign)

MONEY-SAVING OFFER: Modern Radio Servicing AND Troubleshooter's Handbook \$9.50 for the two (\$10.50 foreign)

Name _____

Address _____

City & Dist. No. _____

State _____

STANCOR

Precision-Built

TRANSFORMERS

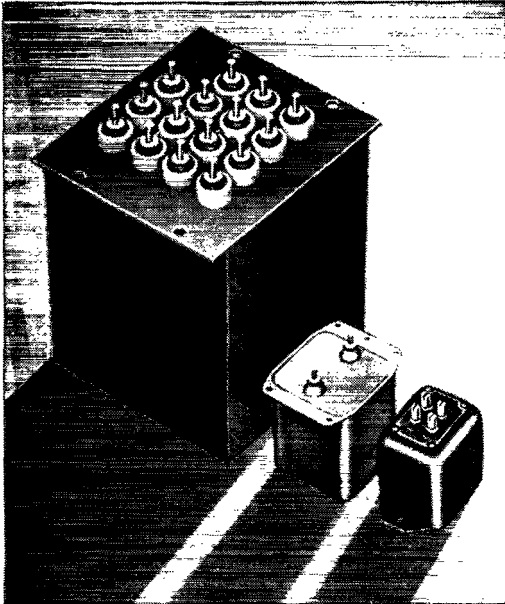

Breathing Spells...

We do have a little time—now and then only—to discuss transformer applications with our fellow “victory manufacturers” who are seeking to improve their war-time units and—also those whose plans include design for the future... Possibly time may be found for you. We'll do our best with your inquiry.

STANDARD TRANSFORMER CORPORATION
1500 N. HALSTED ST., CHICAGO 22, ILL.



The Month in Canada

(Continued from page 59)

much appreciate its return. 3AGD, Frank Dyer, is busy studying languages and music these days, maybe looking forward to some DX QSOs, maybe some of them to music. Capt. Paul Dodderige, 2nd in command, J. Sect., No. 3 Co., 2nd Div., Sigs., is a very busy man these days, but says it really isn't work if you like it as much as he does. 3AAF, Roy Miller, is still doing his stint in the Civil Service on vital radio work. 3CS, Ernie Allard, and 3ADF, Ray Callahan, are expecting to get married early this summer. Best of luck to all four. 3ANQ, Norm Farr, serving with the RCAF as WO2, dropped in to see some of the gang last week. He is taking a V course at No. 1 ATS, after which he expects to return to No. 8 Repair Depot, Winnipeg, Manitoba.

A letter was recently received from Russ. Gladstone, 3APG, who has been with the RCCS fighting in Holland and Belgium. He wrote from a hospital in England where he is recuperating from shrapnel wounds. He is hoping to return to Canada before very long. Flt. Lt. Art Blackford, 3AEX, has recently been discharged from the RCAF and on April 1st started to take a course in electrical engineering at the University of Toronto. During his 3½ years overseas, Art was a Signals officer at one of the Canadian Bomber Group Stations and was working in signals and radar. Since returning to Canada he has built a recording unit using the modulator from his old rig and he has also rebuilt his ham receiver. 3AEV, Flt. Lt. Ev. Brown, who was also a Signals officer at a Canadian Bomber Group Station, is on his way home and may have arrived by the time this appears in print.

Missing in Action

Ken Hager (LSPH) has been reported missing in action since Dec. 17, 1944.

Silent Keys

It is with deep regret that we record the passing of these amateurs:

- W1DIR, William J. Meekin, Rockland, Mass.
- W3GX1, Captain Hobart Walker, Washington, D. C.
- W4HYD, Melvin H. Bloomberg, Miami, Fla.
- W5CIQ, Sgt. Winston V. Bradburry, USA, New Orleans, La.
- W5E00, Lt. Luther C. Smith, jr., USMC, Austin, Texas
- W5JWA, John E. Black, RM2c, USN, Portales, N. M.
- W6GOX, Roy L. Cramer, Los Angeles, Calif.
- W6ROP, William H. Hafford, Mesa, Ariz.
- W7FAL, Earl Stillings, Bend, Ore.
- W7GFI, A. L. McLeod, Spokane, Wash.
- W8LXV-ex-W8BOQ-ex-W8CCG, George Fagerholm, Bellevte, Ohio
- W8OMJ, H. B. Lingle, DuBois, Pa.
- W8PTR, Joseph Bentkowski, Detroit, Mich.
- W9RUJ, Floyd R. Clarke, RT1c, USNR, Auburn, Nebr.
- W9WOA, Martin C. Boisen, Lincoln, Nebr.
- W9ZAE, ex-W8TOT, Louis E. Kelsey, Indianapolis, Ind.

Designed for the modern 50-kw transmitter!

a G-E high-vacuum, forced-air-cooled tube

Up-to-the-minute in its design characteristics and performance

Powerful for amplifier use in large AM stations

Versatile in its filament operation from direct current or single, 3-, or 6-phase alternating current

Compact—28" high, 14½" in diameter

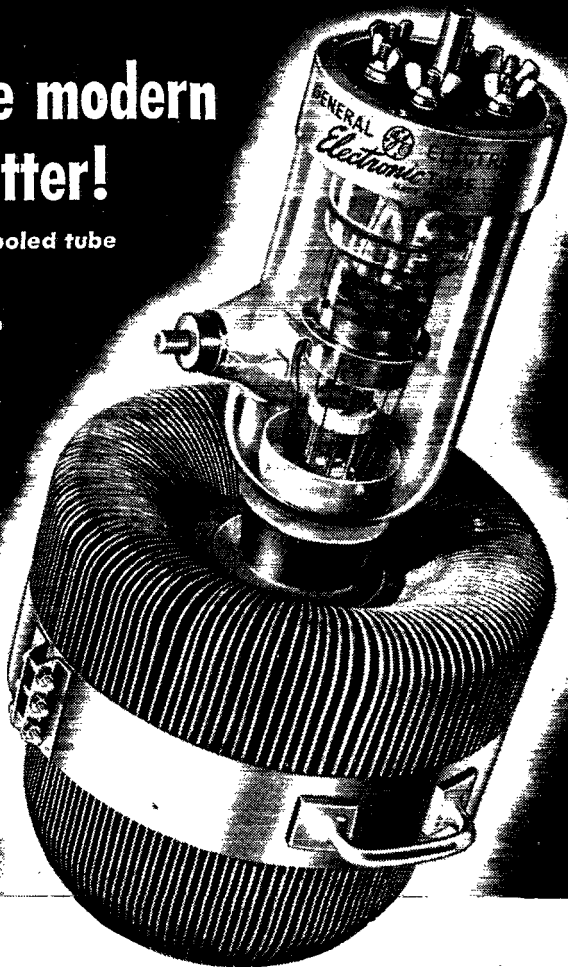

TYPE GL-893-AR. PRICE \$800.

● **Important advancements** in design establish the GL-893-AR as a power amplifier better and more dependable than any predecessor. Its filament structure uses new, improved methods of springing and suspending the loops, so that when the phase-voltages are unbalanced, the tendency of the filament to move and short with the grid is minimized. Improvements in grid construction to reduce the possibility of arcing over, thus making Type GL-893-AR easier to break in.

● **Well-known** for its multi-strand filament which permits, for all classes of service, operation from d-c or single, 3-, or 6-phase a-c, Type GL-893-AR is being used increasingly in modern transmitting sets. A recent, substantial reduction, moreover, has lowered the price from \$1,150 to \$800. Consult your nearest G-E office or distributor for further data about G-E transmitting tubes, or write to:

*Electronics Department
General Electric, Schenectady 5,
New York*

In Class B a-f service, with a signal plate output for two tubes up to 70 kw, the maximum ratings per tube are: plate voltage 20,000 v, signal plate current 4.0 amp; signal plate input 60 kw, dissipation 20 kw. In Class C plate-modulated service, with a power output up to 18 kw, the maximum ratings per tube are: plate voltage 12,000 v, current 2.0 amp; plate input 24 kw, dissipation 12 kw. Highest frequency at full ratings is 5 megacycles; at reduced ratings, 25 megacycles.

Type GL-893-A is available with same design and ratings but with water-cooled anode. Price \$450.

GENERAL  **ELECTRIC**

161-D5-8850

PORTABLE POWER PROBLEMS

THIS MONTH—FISHER CARBANALYZER



TIME-SAVING carbon content analyses of steel samples—from molten metal to report—take only five minutes with the portable, *battery-powered* Carbanalyzer, produced by the Fisher Scientific Company. Leading steel firms employing open hearth or electric furnaces quickly make carbon determinations of each steel batch, achieving close control of steel quality.

CARBANALYZER, powered by Burgess Industrial Batteries, operates over a range of .05% to 1.50% carbon content and is sensitive to a change of $\pm .005\%$. The power requirements of modern control and test instruments are fully met by Burgess Industrial Batteries—the standard of quality for all commercial uses. The types you require may not be immediately available today since industrial battery production is greatly reduced by urgent war needs.

Burgess Battery Co., Freeport, Ill.



FOOD IS A WAR WEAPON—USE IT WISELY!

BURGESS BATTERIES

Chinese Amateur Radio League

(Continued from page 24)

no exception. Even before this period Chinese hams met with difficulty in owning private stations. The limitation of license was one reason. Besides, radio parts are very expensive and are controlled by the government. Most of the Chinese hams can enjoy QSOs only through the facilities of some official organization. At present the CARL has a headquarters station, XUOA, in Chungking and ten or more stations owned by branch organizations. Private stations are rare.

The Chinese government has proclaimed May 5th to be Chinese Amateur Radio Day, and on May 5th every year the CARL holds its annual convention. All members in various districts gather together, listen to speeches and talk about problems from and with the headquarters by means of radiotelephone on the 20-meter band. The fifth convention was held last year, associated with an international amateur radio exhibition. George W. Bailey, president of ARRL, and Kenneth B. Warner, secretary of ARRL, both delivered speeches to the convention by radio, which made the program especially remarkable and interesting.

The Chinese amateurs have appreciated very much the cooperation of ARRL and wish to maintain relationships with it in the future.

V. F. O. Stability

(Continued from page 21)

voltage divider in the power supply to get the various voltages needed. The dropping resistors contribute a lot of heat which causes frequency drift and it requires a long time for the unit to come to a stable temperature. The components in the oscillator circuit should be of the best quality; skimping here will undoubtedly result in inferior performance. The coil form should be one with a very low expansion factor. Probably, after the war, we shall be able to obtain wire for the oscillator coil which will show a very small expansion with heat, such as Invar wire.

Audio-Oscillator Keying Monitor

An audio oscillator for monitoring your keying is a very distinct help; once used most operators wouldn't be without it. Break-in was used here when we were on the air and I wouldn't go back to the old method of working for anything. *QST* has described several good audio oscillators in the past with methods of introducing the tone into the headphones. I could not feed my oscillator directly to the "high" side of the 'phone jack in the receiver so, instead, I used an audio transformer with two separate secondary windings. The receiver feeds into one secondary winding, the audio oscillator into the other, while the 'phones are connected across the primary winding. This works very nicely. The voltage for the plate of the audio oscillator is obtained from a dropping resistor connected in parallel with the grid leak in the 802 stage. A resistor in series with the grid resistor could be used just as well. The

WEAVING COMMUNICATION HIGHWAYS

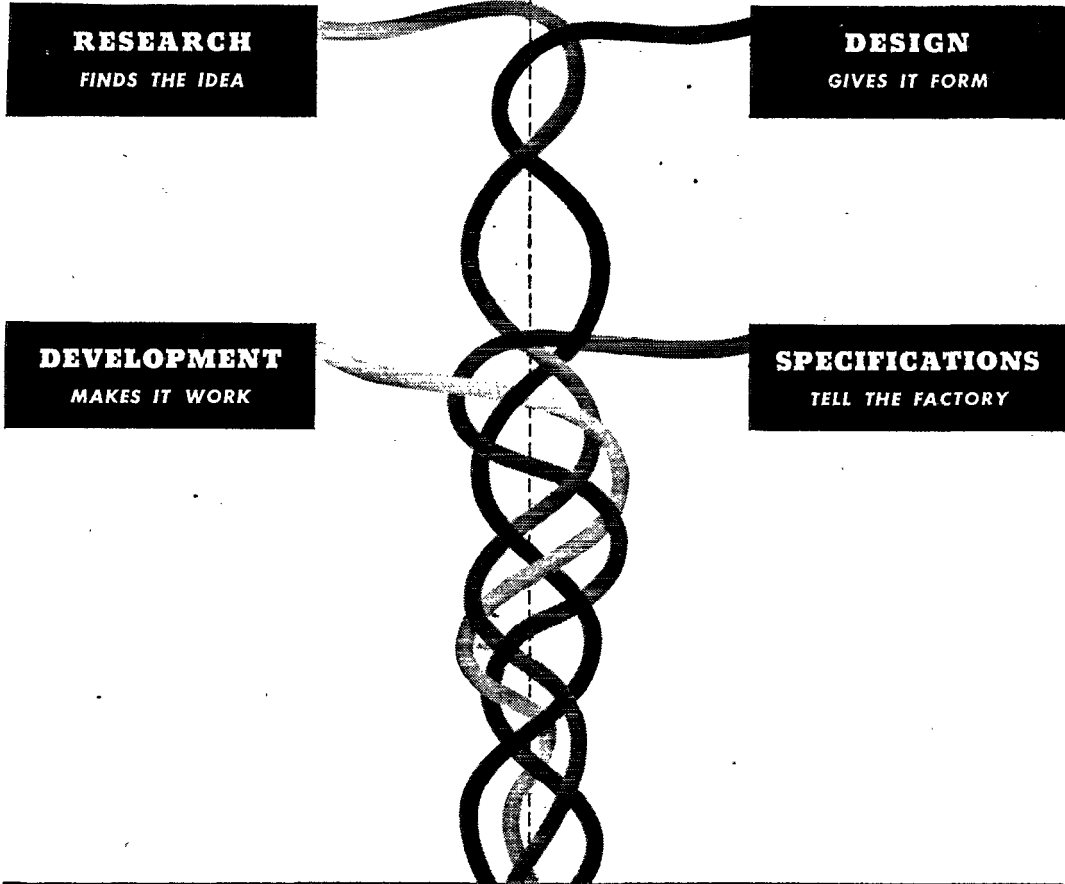

BELL TELEPHONE LABORATORIES

brings together the efforts of 2000 specialists in telephone and radio communication. Their wartime work has produced more than 1000 projects for the Armed Forces, ranging from carrier telephone systems, packaged for the battle-front, to the electrical gun director which helped shoot down robots above the White Cliffs of Dover. In normal times, Bell Laboratories' work in the Bell System is to insure continuous improvement and economies in telephone service.



CM-5 • A design for normal frequency control applications.



Fidelity

Precision ground by crystal craftsmen. Valpey Crystals may be relied upon for high fidelity and perfect service under all conditions of operation.

Tested in the crucible of war from the Arctic to the Tropics, they have earned their right to prominence in the bright world of tomorrow. Your inquiries are cordially invited.

NOW READY—the first of a series of Valpey Bulletins with Binder—FREE ON REQUEST.

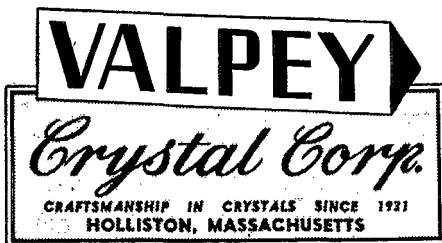

(Continued from page 80)

oscillator draws only 0.2 ma. so, for all practical purposes, it does not affect the operation of the 802 stage at all. The use of a very high value of grid resistor in the a.f. oscillator stage keeps the plate current down. Juggling condenser values changes the tone.

A negative voltage from the tap which is used for the audio oscillator also can be utilized to cut off the r.f. or oscillator tubes in your receiver during the periods when the key is closed. Maybe after the war some of the receiver manufacturers will include a circuit to kill the receiver automatically during transmission periods, or at least bring out a connection to the rear of the chassis so we won't have to "work over" the "innards" of the receivers ourselves. Maybe I'm just lazy!

Splatter

(Continued from page 10)

turing some of the major units of jet propulsion engines. . . . Another old-timer in radio, **Claude L. Robinson, W6KJV** (p. 18), started hamming with a 59 Tri-tet in 1934. Hey! What do you mean — old-timer? Okay, O.M. Just read what Robinson wrote: "Enlisted in the Marines in '19 by stretching my fifteen years a bit. Spent most of my hitch at Pearl Harbor, attending radio school and operating NPM on 600-meter spark and 2400-meter arc. Was bitten by the ham bug in '34, made WAS and WAC in '37, and got my Class A ticket in '42. Hope to have a v.f.o. as stable as crystal control — after V-J Day!"

Two familiar names reappear this month as **E. A. Henry, W9FEN** (Splatter, April, 1945, p. 94), concludes his article (p. 32) on video amplifier design, and "**Sourdough**" (Splatter, May, 1943, p. 66) makes another of his welcome visits (p. 44) from his Pine Notch cabin.

FEEDBACK

WE REGRET that several errors appeared in Fig. 1 of the article, "A Versatile Electronic Key," on page 43 in the March, 1945, issue of *QST*. The filter circuit composed of C_4 , C_5 , and R_5 , and the "B" — return to the cathode of the 6N7 tube were at fault. The corrected circuit diagram is reproduced herewith.

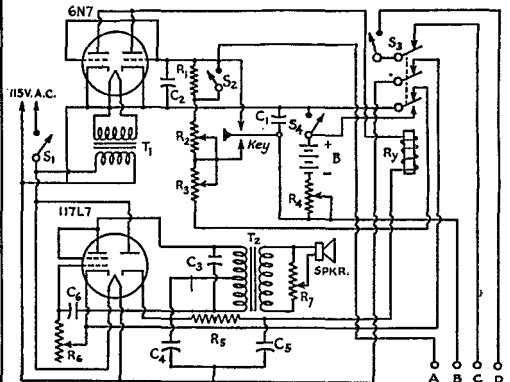
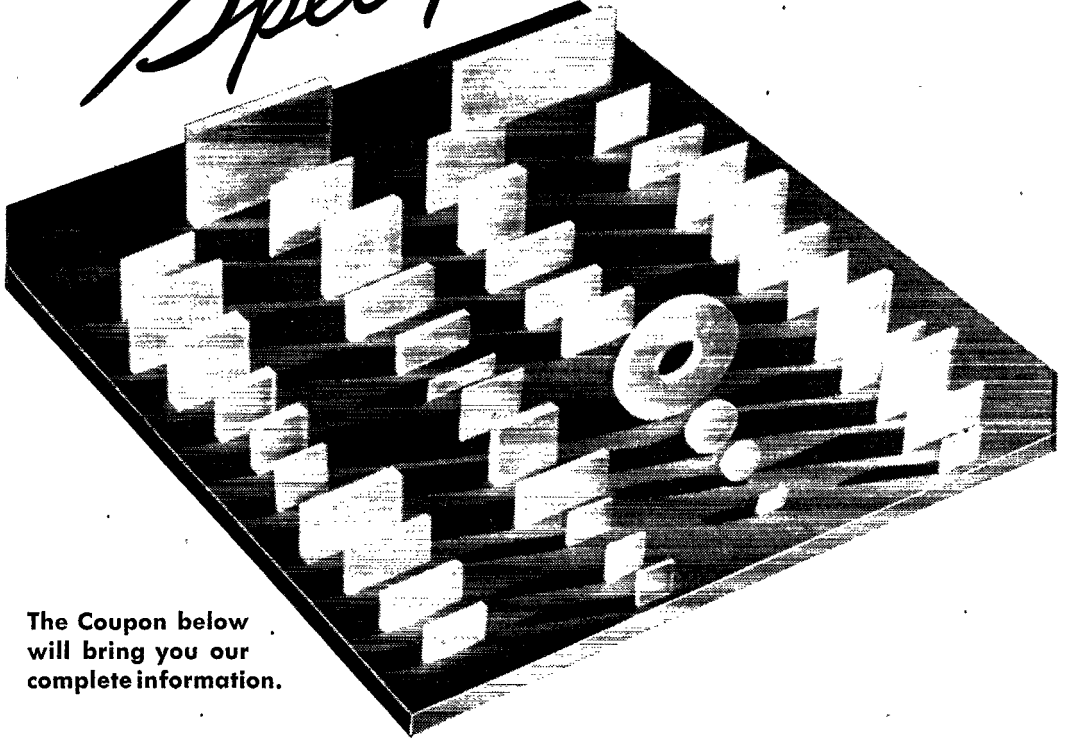

Fig. 1— Circuit diagram of the compact electronic key.

CRYSTAL BLANKS

to Your

Specifications



The Coupon below will bring you our complete information.

Our Crystal blanks are cut to specifications from selected Brazilian quartz and guaranteed free from all impurities, mechanical and electrical imperfections. Dimensions, temperature coefficients and

frequencies are guaranteed within your specifications. Supplied in either "rough-sawed", "semi-finished" or "electrically-finished" blanks as desired. Remember Crystal Products when you need crystals.

MAIL THIS COUPON!

CRYSTAL PRODUCTS CO.,
Dept. O, 1519 McGee, Kansas City, Mo.
Gentlemen: I am interested in

NAME _____
FIRM _____
ADDRESS _____
CITY _____ STATE _____

Crystal

PRODUCTS COMPANY

1519 MCGEE STREET

KANSAS CITY, MISSOURI

Producers of Approved
Precision Crystals for Radio Frequency Control

Radio Set SCR-506

(Continued from page 18)

weather in Schenectady, bundled up in fur flying suits, pumping signals into a recorder at Camp Coles (these records were studied for the valuable data concerning keying characteristics and transmitter stability of production sets under actual field conditions). . . . Work at Camp Coles between 506s on the ground operated by W2AEL, W3ZI and Geo. E. Caspers, W9WAY, and a plane flying the anti-submarine patrol over the ocean. . . . Vehicular and fixed station work in the Pocono Mountains, where A. H. "Bud" Waite, W3HKO, dreamed up auxiliary antennas which later were incorporated in the complete radio set. More and more data were obtained, and it all pointed to the same high order of performance and reliability under really tough conditions.

Caravans South

Then came 1943 and a chance for some good DX. Demonstrations were scheduled in February for the Coast Artillery Board at Fortress Monroe, Va., and the Anti-Aircraft Board at Camp Davis, N. C. A test crew consisting of Capt. J. D. Van der Veer, ex-W9VYB; W1HCU; Paul Kantor, (no license) and the writer made a trek southward, maintaining frequent schedules with the Camp Coles base station near Red Bank. On this trip we worked waterborne-mobile after succeeding in talking the crew of a ferry boat into parking our truck so that the whip antenna would not be covered by the boat's second deck; as "floating-mobile 506" we had fine QSOs with Lloyd Mannamon, W1HUZ, the Camp Coles chief radio operator.

Once ashore we parked beside the historic moat at Fortress Monroe and maintained daily schedules with Camp Coles. Enroute to Camp Davis, we continued the schedules with perfect ease, maintaining frequent and reliable contact with our Camp Coles base as well as between the two test trucks, which often were 30 to 50 miles apart. Inter-truck contacts were usually on voice, for we wanted to test the voice range of the set under the continually varying mobile conditions which simulated convoy operation of a group of vehicles along a highway. At Camp Davis we put on a series of demonstrations and field runs for Col. McGraw, ex-W7HJS, and his interested crew of GIs in the AAA group, and worked Camp Coles each evening.

The 506 Rides Again!

Upon returning to Fort Monmouth we prepared for even more rugged field operations. Capt. Van der Veer, Taylor, W1HCU, and the writer went first to the Cavalry Board and School at famous old Fort Riley in Kansas. There we put the 506 through its paces in a comprehensive series of service tests for the Cavalry. (Members of this Board were among the originators of the basic ideas out of which came the present 506, and they planned wide employment of the set.) Its use in tactical problems by the hard-boiled

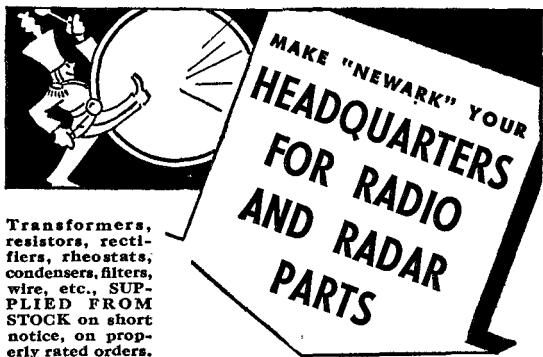

Transformers, resistors, rectifiers, rheostats, condensers, filters, wire, etc., SUPPLIED FROM STOCK on short notice, on properly rated orders.

MAKE "NEWARK" YOUR
HEADQUARTERS
FOR RADIO
AND RADAR
PARTS

FILTER CONDENSERS

NO PRIORITY REQUIRED!
Oil-Filled Oil-Impregnated

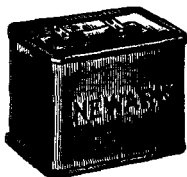

Mfd.	D.C.	Size	Price
1	1000 v.	5 x 3 3/4 x 1 1/2	\$.59
2	2000 v.	4 1/2 x 3 1/2 x 1 3/4	1.50
4	3000 v.	5 x 3 3/4 x 3 3/4	3.75

Listen to Newark's Radio Program Every Tuesday 9-9:30 A.M. Station WJJD—Chicago

BUY ANOTHER WAR BOND
Earn \$6.25 on an \$18.75 investment!

NEWARK ELECTRIC CO.
323 W. Madison St. Chicago, Ill.

ARRL PUBLICATIONS

Serve the Men Who
Serve the Nation

Title	Price
QST.....	\$2.50 per year*
The Radio Amateur's Handbook	
a. Standard Edition.....	\$1.00**
b. Special Defense Edition.....	\$1.00
A Course in Radio Fundamentals.....	50c
How to Become a Radio Amateur.....	25c
Learning the Radiotelegraph Code....	25c
The Radio Amateur's License Manual..	25c
A.R.R.L. Antenna Book.....	50c
Hints & Kinks for the Radio Amateur..	50c
Two Hundred Meters and Down:	
The Story of Amateur Radio.....	\$1.00
Lightning Calculators:	
a. Radio (Type A).....	\$1.00
b. Ohm's Law (Type B).....	\$1.00
*In the United States and Possessions —other Countries \$3.00 per year.	
**Postpaid in Continental U. S. A. —\$1.50, postpaid, elsewhere.	
(No stamps, please)	

**THE AMERICAN RADIO
RELAY LEAGUE, INC.**

West Hartford 7, Connecticut



Youth and Experience — That's one combination that enables Meissner "precision-el" to produce the quality electronic equipment for which Mt. Carmel is gaining national recognition, for skill in electronics is rapidly becoming a tradition in this little city on the banks of the Wabash.

"PRECISION-EL"

You'll find it
in Mt. Carmel, Illinois

Yes, here at Mt. Carmel, the men and women of Meissner bear the name of "precision-el" proudly. It is an honor and responsibility — an honor to be ranked with the most skilled craftsmen in an industry that is precision itself; a responsibility to uphold the Meissner standards of quality, accuracy and dependability.

On this page you will meet a few of the hundreds of men and women in Meissner's employ. Remember that they are your guarantee of performance when you use Meissner products, precision-built by "precision-el."



Light, Airy workrooms like this make any job pleasant. And when it's a precision job in electronics, like those jobs these men and women of Meissner are doing, no wonder they are able to merit the name "precision-el" for their pride in an exacting job well done.



No part is too small to merit the concentration and precision workmanship that characterizes Meissner precision-built products. Here a member of Meissner's "precision-el" shows why the name is so well deserved by the men and women of Meissner.



"Step Up" Old Receivers!

These Meissner Ferrocart I. F. input and output transformers are getting top results in stepping up performance of old worn receivers. Special powdered iron core permits higher "Q" with a resultant increase in selectivity and gain, now available for frequency range 127-206. Ask for numbers 16-5728 input; 16-5730 output. List \$2.20 each.



MEISSNER

MANUFACTURING COMPANY • MT. CARMEL, ILL.

ADVANCED ELECTRONIC RESEARCH AND MANUFACTURE

Export Division: 25 Warren St., New York; Cable: Simontrice

(Continued from page 84)

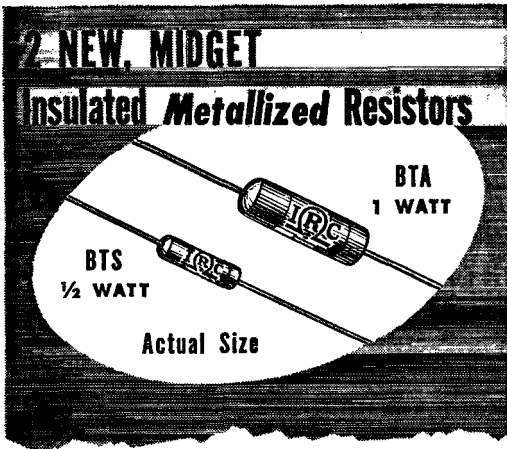

Hardly bigger than bumps on a wire, these two new additions to IRC's BT line can be counted on to do a man-size job. Thoroughly dependable, they embody the high quality standards and engineering principles that have long made TYPE BT resistors "Preferred for Performance." Like other members of the BT family, these tiny newcomers operate at lower temperatures than ordinary resistors of comparative size.



INTERNATIONAL RESISTANCE CO.

DEPT. 18-E, 401 N. BROAD ST., PHILA. 8, PA.

IRC makes more types of resistance units, in more shapes, for more applications, than any other manufacturer in the world.



Founded in 1909

RADIO TELEPHONY RADIO TELEGRAPHY ANNOUNCING

Courses ranging in length from 3 to 9 months. Dormitory accommodations on campus for men and women students. Advanced students eligible for practical training at KPAC, 1 KW broadcast station owned and operated by Port Arthur College. New students accepted each month during year. If interested, write for details.

PORT ARTHUR COLLEGE PORT ARTHUR
TEXAS

cavalrymen confirmed what we had previously discovered — that the SCR-506 was an exceedingly adaptable communications tool, especially when employed in complex nets by well-trained operators. We'll never forget the tale of one tough cavalry sergeant-operator who, after a brief training period, suddenly became aware of the tremendous potentialities behind that frequency change switch and proceeded to work (or so it was claimed by the operator at the School monitoring station) into all five nets at once!

Other important characteristics of the set were becoming evident. Some sets, for example, had been shipped by truck from Camp Davis, N. C., to Fort Monmouth, where they were reshipped by rail to Kansas. Several weeks of traveling time elapsed, and by the time they were finally unpacked and installed at Fort Riley the sets had been severely man-handled. Nevertheless, the transmitters were found to be still within a very few hundred cycles of the original preset frequencies which had been set up when they first arrived at Camp Davis.

From Fort Riley we jumped to the Desert Warfare Training Center, near Indio, Calif., in the heart of that gigantic area containing many camps under the general name of Camp Young. For the benefit of the Desert Warfare Board we put the 506 through a set of tough-and-tumble exercises, the severity of which exceeded any we previously experienced. Included were brutal runs in foot-deep desert dust to test the built-in glass-wool filters, cross-country rides of hundreds of miles in stiff-sprung scout cars over terrain that shook the very fillings out of one's teeth, long periods of operation in the blazing sun during which touching any part of the vehicle meant a blistered operator (while the set, being forced-air ventilated, just sat there smugly and worked on, oblivious to the heat). There were many hundreds of miles of operation during which the antenna was never hauled down from its vertical position! But the highlight of the California desert visit was the reception the 506 caravan received when it arrived at an outpost (and they had OUT-posts in the DTC!) one day and was greeted by the Division Signal Officer, Lt. Col. Sacton, a W9, and his crew of brasspounders, which included a lot of swell GI-hams. We had made a 150 mile cross-country jump just to put on a demonstration for this isolated group, but the reception and the hamfest that followed were worth all the effort and more.

In the summer of 1943 a demonstration crew headed by Lt. R. T. Peck, W8CTP, with W1HCU and the writer, toured the Tennessee maneuver area. There we worked with the troops on maintenance and instruction problems, under actual field conditions. While it was believed that the "enemy" also had some 506s, our side had many of them. — Thus it was only logical that our boys would win the battle — and they did! And that is the way it is working out in actual warfare!

(Continued on page 88)

WANTED IMMEDIATELY

More Raytheon Field Engineers

TO SERVE THE NAVY

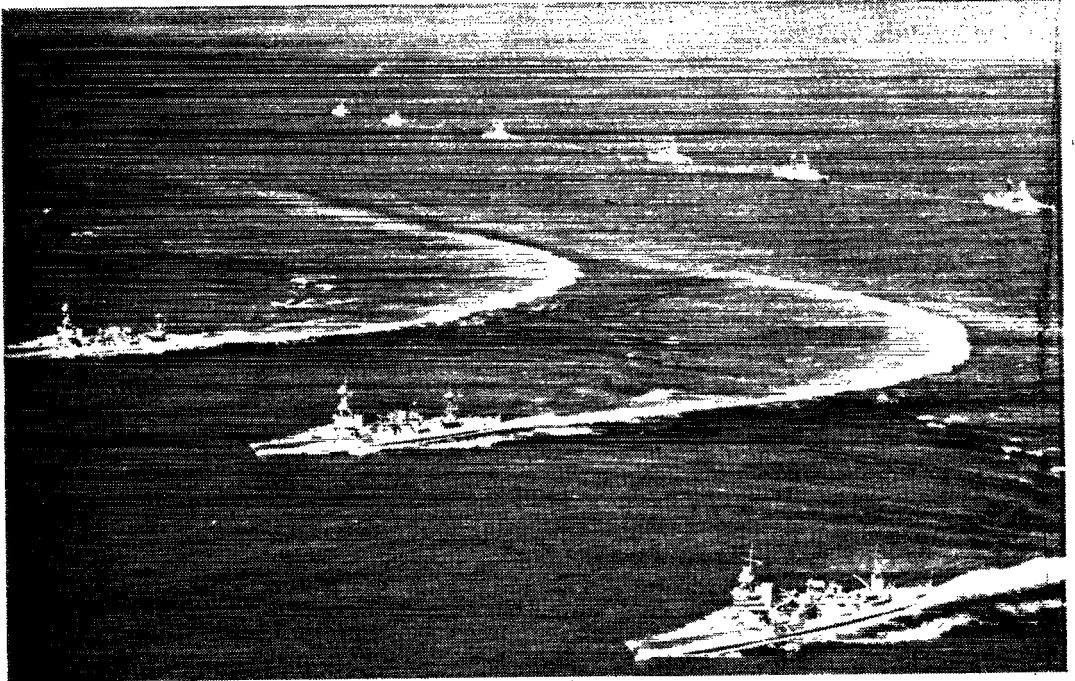

• At a U. S. Base • or Naval Activity Abroad

The United States Navy has asked Raytheon to greatly expand its Field Engineering force to take care of the tremendous quantities of Raytheon Electronic Equipment which is playing an important part in all theatres of operations.

Already many hams have established a reputation in the Raytheon Field Engineering force. If you have had practical experience in building amateur rigs, Raytheon invites you to join this often commended group. The job of Raytheon Field Engineers is the supervision and installation of vital radio

detection gear at a United States base or Naval activity abroad.

Not only will you serve the Navy, but you will also get first-hand information on new electronic developments . . . a field that is advancing at a tremendous pace. The experience you will gain as a Raytheon Field Engineer will be of inestimable value in any future electronic position.

Write to: Clark C. Rodimon W1SZ
Raytheon Manufacturing Company
Field Engineering Division
Waltham 54, Massachusetts

All hiring will conform to War Manpower Commission regulations.



Devoted to Research and Manufacture of Electronic Tubes and complete Electronic Apparatus and Systems.

Wanted ENGINEERS

Radio

★ Electrical

Electronic

★ Mechanical

★ Factory Planning

Materials Handling

Manufacturing Planning

Work in connection with the manufacture of a wide variety of new and advanced types of communications equipment and special electronic products.

Apply (or write), giving full qualifications, to:

R.L.D., EMPLOYMENT DEPARTMENT

Western Electric Co.

100 CENTRAL AVENUE, KEARNY, N. J.

★ Also: C.A.L.

Locust Street, Haverhill, Mass.

Applicants must comply with WMC regulations

FIELD SERVICE ENGINEERS

for

Domestic and Foreign Service

MUST POSSESS GOOD
KNOWLEDGE OF RADIO

Essential Workers Need Release

HAZELTINE CORPORATION

58-25 Little Neck Parkway
Little Neck • Long Island

(Continued from page 86)

Safe Driving and the 506

No story of the tests made on the 506 would be complete without mention of the drivers, both civilian and military, who contributed so much by their skillful handling of the various vehicles under often adverse conditions over long and tiring periods. These men actively participated in the tests as relief operators (on voice) and were always ready at the cry — "Let the antenna up (or down) Joe!" Or to instantly respond to the sometimes muffled cries such as "Pull over to the side!" Two civilian drivers, Fred Horner and "Jo-Jo" Tolarico, from the Laboratories were "standard equipment" on so many of the long 506 trips that they were considered part of the test crew. These, and other, civilian drivers, handled a pair of 1½ ton GI panel trucks safely over a total of 65,000 miles of almost nationwide coverage, without an accident or injury to personnel, equipment or vehicle. No weather was too bad, no road too rough for these boys, and without their skillful driving, the 506 tests could not have been made. Their motto was — "You boys work the radio — and we'll take you there and bring you back!" And they always did.

(Note: The truck wrecked returning from Fort Knox is not included in this mileage as it occurred prior to the use of the regular 506 test trucks.)

Radio Amateurs Aid in Production

We have mentioned a few of the radio amateurs who were associated with the development and testing of the 506. Many others contributed their skill and intense interest to the production of the equipment. For example, at the Bridgeport (Conn.) plant of the General Electric Company, several licensed amateurs watched over the receiver and among them were the following: Robert Gibbs, W1ETC; Wallace Pond, W9WSU, and Gene Duckworth, W9BYZ; and GE engineers George Appell, W2IXL, a GE assistant foreman; Harley Wintle, W1NSL, and Robert Bass, (call unknown), of the GE inspection department; and in the Signal Corps inspection department — Edward Heppert, W9FE, Al Kramer and Mary Vinson, (calls unknown). At the Syracuse (N.Y.) GE plant, G. J. Youngwirth, W2OEG, kept things rolling as GE engineer in charge of the transmitter production while C. H. Crawford, W2CVZ, supervised the component parts inspection.

Description of SCR-506

Out of these gruelling field and laboratory tests came the 506 as it is today, a rugged powerful mobile radio station packaged for efficient operation under the most trying conditions — a military radio set embodying many of the features long found advantageous in amateur equipment, plus the stable mechanical and electrical qualities required for vehicular communication in combat. There was another and terrifically important characteristic of this equipment — it could be, and was, built on a modern production line, thus huge quantities of the sets could be

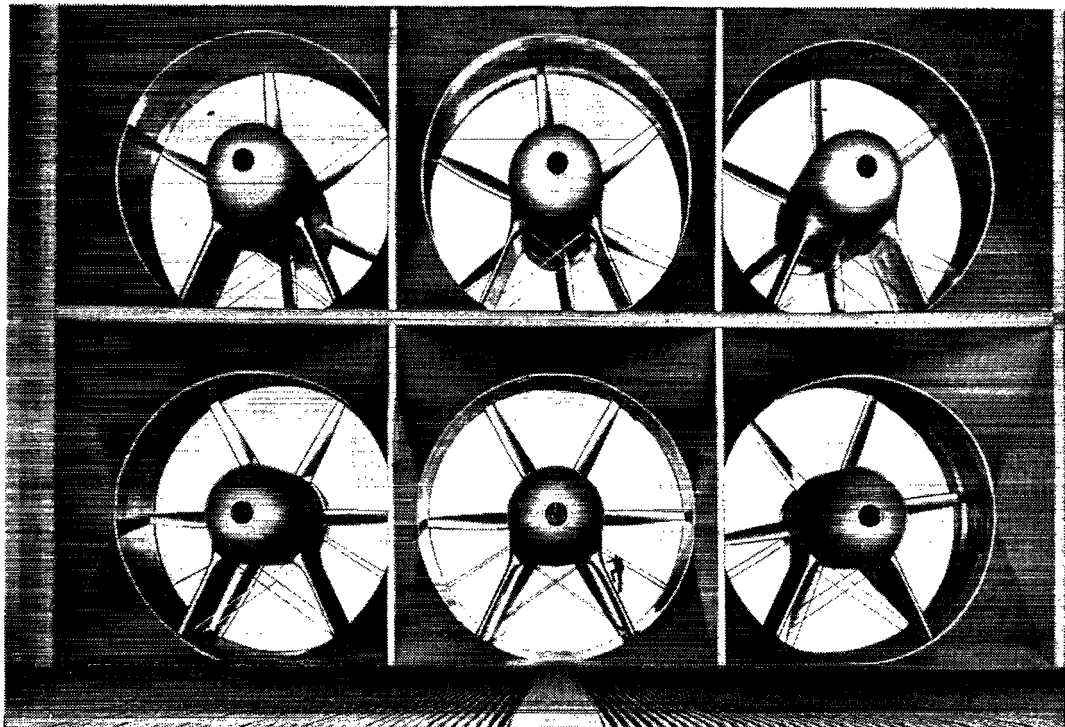

how to tame 36,000 horsepower

Above you see the six giant propellers for one of Uncle Sam's mighty new wind-tunnels — where NACA research engineers are working out the designs for still faster and higher-flying planes.

Driving these 40-foot propellers are six 6000 hp motors, each weighing 57 tons. And in spite of the size of the motors, the complicated system of exciters, generators, spinning shafts and whirling propellers—the speed of each motor must be held to extreme accuracy.

By making a complete study of the system, Westinghouse engineers were able to determine the proper regulator system to do the job. It turned out to be the small, compact electronic regulator shown at

the right. By responding to minute changes in speed, it automatically makes the necessary adjustments—compensating for any fluctuations in power supply or changes in load. Thus, through the delicate sensitivity of electronic tubes, it is possible to tame 36,000 hp.

Accurate speed and voltage regulation is just one of the many practical applications of electronics perfected to meet wartime demands. You may want to know more about this or other electronic developments for your industry. Your nearest Westinghouse office is ready to provide full information . . . or write to Westinghouse Electric & Mfg. Co., P. O. Box 868, Pittsburgh 30, Pa.

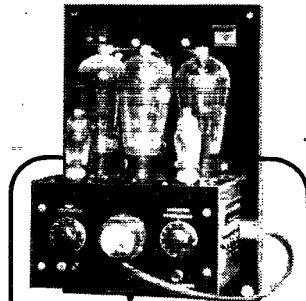

THE ELECTRONIC REGULATOR

Through the sensitivity of electronic tubes, this device accurately regulates the speed by controlling the voltage on the "running" generator, despite fluctuations in power supply or changes in load. J-91071-A



Westinghouse
PLANTS IN 25 CITIES . . . OFFICES EVERYWHERE

Tune in John Charles Thomas, Sunday, 2:30 EWT., NBC.
Hear Ted Malone, Mon. Tues. Wed. Evenings, Blue Network.

Electronics at Work

ELECTRONIC EQUIPMENT FOR INDUSTRY AND HOME • ELECTRONIC TUBES • RADIO AND TELEVISION

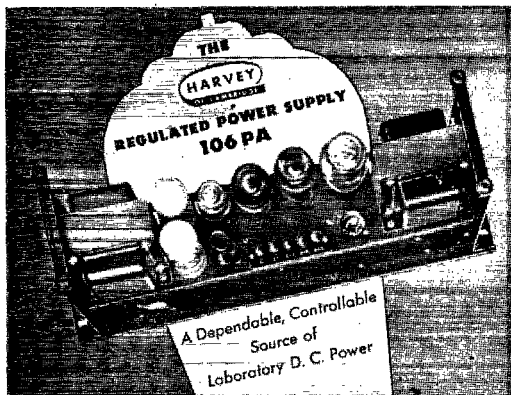

An ideal source of constant voltage for use with pulse generators, amplifiers, measurement equipment, constant frequency oscillators and other equipment requiring regulated D.C. voltage in the 200 to 300 volt range. That is the HARVEY Regulated Power Supply 106 PA.

This precision instrument operates from 115 volts A.C. and has a D.C. volt-

age output variable from between 200 to 300 volts that is regulated to within one percent. Output remains constant even though line voltage varies between 95 and 130 volts.

For complete information on this efficient, dependable instrument, ask us to send you the HARVEY 106 PA bulletin.



HARVEY RADIO LABORATORIES, INC.
451 CONCORD AVENUE • CAMBRIDGE 38, MASS.



PUT YOUR HOBBY TO WORK

Is radio, mechanics or electricity your hobby, or are you interested in becoming a draftsman or engineer? Would you like to work at it in the engineering laboratory of a long-established, growing company, having postwar products with established markets? We have openings for persons with such aptitudes to assist our developmental engineers. Formal scientific education is not a requirement. Our company is located in a small, friendly city in the heart of Connecticut. It is large enough to offer good opportunity for advancement...not so large that individual ability is overlooked. Write me about your qualifications and salary requirements. Your letter will be treated with complete confidence.

William R. Curtiss, Chief Engineer
Connecticut Telephone & Electric Division
GREAT AMERICAN INDUSTRIES, INC.
98 Britannia St. Meriden, Conn.

(Continued from page 88)

delivered to meet the ever growing need for more and better communication.

Heretofore we have referred to the SCR-506 as a "radio set." Actually that is hardly correct nomenclature, as a Radio Set SCR-506 actually consists of a transmitter, a receiver, a mounting base, an antenna-mast base, a five-section whip-antenna, plus microphones, keys, guy ropes, and complete sets of spare parts such as tubes, dynamotors, resistors, condensers, fuses, almost enough extra gear to build another complete outfit.



THE BC-652 is an eight-tube super-heterodyne for the reception of c.w. or amplitude-modulated (voice or m.c.w.) signals over the frequency range of from 2000 to 6000 kilocycles,

in two bands, 2000 to 3500 kc. and 3500 to 6000 kc. A three-tube crystal calibrator built into the upper chassis of the receiver furnishes calibration points with 20- and 100-kc. separation throughout the range of the receiver. This crystal frequency calibrator consists of a 200-kc. crystal (sealed in a metal tube envelope) with two multivibrators following the oscillator. The tolerance of the calibrator crystal is ± 30 cycles over a temperature range from -40° to $+60^{\circ}$ C. The crystal circuit may be adjusted exactly to a harmonic of WWV. The tubes are so wired as to be lighted whenever the receiver is operative. It receives its plate voltage from the receiver dynamotor; thus, the calibrator is available for instant use. The calibrator output is fed into the antenna circuit of the receiver. The calibrator circuit is shown in Fig. 1.

The intermediate-frequency amplifier operates on 915 kc. and has a fairly broad-topped curve with fairly steep sides. This aids in maintaining operating "nets" permitting slight variations or frequency differences in the received signals.

The audio circuit attenuates signals rapidly above 3000 cycles and has an output of 2.5 watts. Three output jacks, two for headphones and one for a loudspeaker, are available. Headphones and speaker may be operated simultaneously.

Band selection is made by one front-panel switch. A manually operated dial with a very smooth mechanism was adapted from a dial designed by J. D. McLean, W2MSA. There is no back-lash in the dial which is turned by a large knob having a small crank for rapid tuning. The dial does not shift under vibration although there is no visible dial lock. A simple ingenious friction-washer behind the tuning knob prevents any shift from vibration or shock.

Receiver controls were reduced to an absolute minimum to prevent confusion in handling the receiver under combat conditions.

The receiver electrical design is strictly conventional consisting of one stage of r.f. amplification, 12SG7; first detector and oscillator, 12K8; 1st i.f., 12SK7; 2nd i.f. and automatic noise

PAVING THE WAY for postwar amateur development, particularly on the ultrahighs (microwaves) and other prospective new techniques, the 1945 Edition of the "Radio Amateur's Handbook" includes diversified material new to its scope, while still retaining its time-proved treatment of the orthodox theory and

practice of amateur radio — refined, modernized, reorganized for maximum convenience whether used as text, reference or constructional manual. This Edition of the "Handbook" contains more pages and more information per page than any "Handbook" yet published. . . . Every subject encountered in practical radio communication is covered, arranged for maximum convenience to the reader, sectionalized by topics with abundant cross-referencing and fully indexed. . . . More than ever the ideal reference work, the 1945 edition also contains practical constructional information on tested and proved gear — always the outstanding feature of the "Handbook." . . .

NEW 1945 EDITION

The Radio Amateur's Handbook

\$1 *Postpaid in Continental U. S. A.*

\$1.50 Postpaid Elsewhere . . . Buckram Bound \$2.00

American Radio Relay League, Inc., West Hartford 7, Conn., U. S. A.



AMATEURS . . .

UNIVERSAL will be able to supply all of its former amateur ops' styles and models of microphones when governmental restrictions are lifted. There will be some new ones, too. In the meantime, the new D-20 dynamic microphones (on priorities only), UNIVERSAL'S first new microphone since Pearl Harbor, has been quickly accepted as something ultra in style and engineering design.

UNIVERSAL MICROPHONE COMPANY
Inglewood, California



We make our own refractories, thereby obtaining the best possible control over the characteristics of

VITROHM RESISTORS and RHEOSTATS

WARD LEONARD ELECTRIC CO.



Radio and Electronic Distributor Division
53 WEST JACKSON BLVD., CHICAGO, ILL.



(Continued from page 90)

limiter, 12C8; 3rd i.f., 12SK7; b.f.o., 12K8; 2nd detector and 1st a.f., 12SR7 and a 6Y6G 2nd. a.f.

The noise limiter suppresses most of the ignition and similar QRM normally present. The noise limiter is connected in the circuit at all times and requires no adjustments of any sort. Fig. 2 shows the basic circuit of the noise limiter.

The choice of the intermediate frequency (915 kc.) represents the best compromise for high image and i.f. rejection ratios with adequate selectivity and sensitivity characteristics. Measurements show the operating sensitivity to be about 1.4 to 2.0 μ v. for a signal-plus-noise to noise ratio greater than ten to one. The c.w. sensitivity is 0.18 to 0.5 μ v.

The receiver is forced-air ventilated by means of a fan, mounted on the end of the shaft of the receiver dynamotor, that pulls air in through a glass-wool filter in the side of the receiver case. Since all apertures of the receiver are normally closed or sealed with felt, the air must be exhausted through another glass-wool filter. Use of two filters prevents dust from entering the receiver during the periods when the dynamotor is not running. This method of ventilation lowers the internal temperature 20 to 30 degrees. This receiver is capable of continuous operation for a period of eight hours at an ambient temperature of 50°C. and a humidity of 90 per cent.

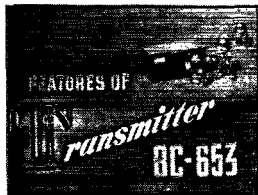

THE BC-653

has an r.f. power output rating of from 50 to 90 watts, over the frequency range from 2000 to 4500 kc. The transmitter has four preset positions and one tunable frequency

position permitting instant selection of any of five frequencies by the use of one manually-operated switch. The tube line-up is simple and straightforward — a 1613 v.f.o., an 807 buffer, and a pair of 814s in parallel. Another 1613 is used as the grid modulator and two VR105s stabilize the oscillator plate voltage. The oscillator operates on the output frequency. The circuits are so arranged that doubling is impossible. Pre-setting of the four frequencies is accomplished by adjusting the frequency controlling condenser, the buffer tuning condenser and the L/C of the final amplifier tank-circuit. Once these controls are set, no further adjustments are required, except to rotate the frequency band-change switch to the desired frequency position.

Adjustment of the tunable position is similar but more flexible. A counter-type dial, calibrated in channel numbers (corresponding to 20 kc. intervals) controls the separate tunable v.f.o. tuning condenser with which is tracked a separate buffer tuning condenser. Thus, when the direct-reading dial is set, for example, on Channel 0, the oscillator and buffer tanks are set for 2000 kc. (Channel 1 is 2020 kc., etc.). The final amplifier tank circuit is adjusted by front-panel control. A choice must be made on the tunable-

FOR FIXED XTAL
CONTROLLED RECEPTION —
THE XC-2 PLUG-IN UNIT

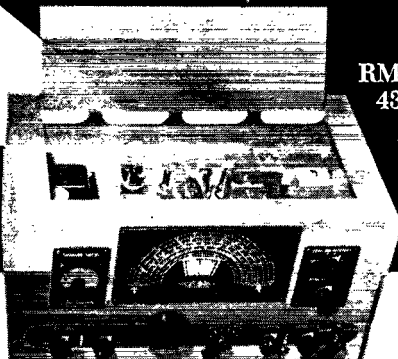

RME
43

YOU CAN NOW HAVE A
FIXED FREQUENCY
RECEIVER WITH XTAL CONTROL OSC.
plus ALL BAND OPERATION*

For fixed frequency operation, simply plug the XC-2 unit into the oscillator tube socket of an RME 43 or 41 receiver. The XC-2 uses the same oscillator tube as the receiver. The crystal, which is furnished, is ground to a frequency either 455 K.C. higher or lower than the frequency of the signal to be received.

Because of its specific characteristics and peak reception, the XC-2 will frequently bring in stations when general coverage equipment fails.

By writing us a card, and designating the frequency at which you wish to operate your RME receiver, we will gladly supply you with the necessary detailed information.

*Subject to priority like all RME equipment.

SINCE
1933



RME

FINE COMMUNICATIONS EQUIPMENT

RADIO MFG. ENGINEERS, INC.

Peoria 6, Illinois U. S. A.

RECEIVING SENDING
CODE Speed *without strain*

CHAMPIONS ENDORSE CANDLER WAY

Get skill, accuracy, speed with the highly endorsed Candler System. Learn to send and receive by telegraph or radio code. Government service and commerce need thousands of better trained operators. Air commerce, mail, freight, etc., demand expert, reliable operators. Good pay. Get the Candler System, the maker of champions. It teaches you the "knack" of sound sense, alertness, speedy sending and receiving without strain. Adventure — good pay. Learn at home or wherever you are. Rush name today for free book.

FREE! **CANDLER SYSTEM CO.**
Dept. 4-E, Box 928, Denver 1, Colorado, U.S.A.
and at 121 Kingsway, London, W.C. 2, England

Electricity
FOR RADIO AND ELECTRONIC APPLICATIONS

Onan
ELECTRIC PLANTS
POWER AND LIGHT FOR EVERY NEED

Onan Electric Generating Plants supply electric service for electronics applications and general uses, mobile, or stationary. Driven by Onan-built, 4-cycle gasoline engines. They are of single-unit, compact design and sturdy construction.

65 models, sizes from 350 to 35,000 watts. A.C. types: 115 to 660 volts, 50, 60, 180 cycles, 1 or 3-phase; 400, 500 and 800 cycles, 1-phase. D.C. types: 6 to 4000 volts. A.C.-D.C. combination types available. Write for engineering assistance and literature. Model shown is from ATC lightweight series.

Over 250,000
Now In Service

D. W. ONAN & SONS
2624 Royalston Ave., Minneapolis 5 Minnesota

... Here's How You Can Qualify for a BETTER RADIO JOB!

... CREI technical training is preparing others for good-paying radio jobs — WHY NOT YOU?

Are you finding yourself in a routine job — a job that any other man can handle just as well as you? Today, radio JOBS are many — but radio CAREERS are few! Now is the opportune time for you to equip yourself with the necessary technical training to qualify for an important engineering position with a sound future.

NOW when industry needs men, is the time for you to investigate radio career training. Your radio experience backed by modern CREI technical training will equip you to share in the good-paying jobs that await trained men . . . and to make good in the important positions that lead to post-war careers with security and happiness!

WRITE TODAY! If you are a professional or amateur radioman and want to make more money — let us prove to you we have something you need to qualify for the better job opportunities that can be yours. To help us intelligently answer your inquiry — please state briefly your education, radio experience and present position.



**CAPITOL RADIO
ENGINEERING INSTITUTE**

Dept. Q-5, 3224 16th St. N. W., Washington 10, D. C.

WANTED *Engineers* ~~TECHNICAL WRITERS~~

Writers isn't really the word for the men (and women) who prepare Hazeltine instruction manuals for the Navy. They spend only 20% of their time in actual writing — the other 80% is getting ready to write.

That "getting ready to write" requires a working knowledge of electronic fundamentals and much experience with Hazeltine's advanced-design equipment. We give you the experience. We expect you to bring with you the basic knowledge and an interest in the important and intensely interesting business of instruction-book publishing.

Write to us, if you are interested and available. Mention your family status and include a summary of your electronic and writing experience. Address Hazeltine Electronics Corporation, Little Neck, Long Island, New York.

(Continued from page 92)

frequency position of the band-change switch between l.f. (low frequency 2-3 Mc. Channels 0 to 50) and h.f. (high frequency 3-4.5 Mc. Channels 51 to 125). After calibrating the tunable position for either l.f. or h.f. operation, using the receiver and the crystal calibrator, frequency setting may be accomplished merely by rotating the direct-reading dial to the *channel* number desired. The antenna circuit is then resonated and the transmitter is ready to operate. The transmitter circuits are shown in Figs. 3 and 4.

Since the crystal calibrator has an accuracy of better than 0.015 per cent, any desired transmitter frequency can be obtained accurately, limited only by the precision of the adjustment and the tolerance of the crystal. Frequencies will be accurately maintained as the manufacturing specifications require an *over-all* transmitter stability within 0.02 per cent (400 cycles at 2000 kc.) under conditions of terminal-voltage changes (starting at 12 volts) between 10 and 14 volts. Also the frequency must remain within 0.05 per cent (1000 cycles at 2000 kc.) under variations of temperature (starting at plus 30°C.) from minus 30°C. to plus 55°C.

In the "calibrate" position only the oscillator is operating and the buffer and final amplifiers are biased well past cut-off. This permits only the weak signal from the oscillator to reach the receiver, which, although still allowing ample signal for calibration purposes, does not radiate — thus reducing interference and possible interception by enemy d.f. equipment.

The v.f.o., the buffer, and the modulator tubes (all heater-types), are supplied with filament power whenever the receiver is turned on. With the operational switch thrown to "c.w. ¼" or "c.w. full," the amplifier tubes are lit and the transmitter dynamotor runs permitting *instant* operation on c.w. When on voice, the pressel switch on the microphone operates a relay which completes the filament circuits of the 814s and starts the dynamotor. As these tubes are very quick heating, they reach full heat before the dynamotor gets up to speed. Both of these functions take place almost before the operator can put his microphone to his lips to speak. In actual push-to-talk operation, an almost imperceptible delay is required between operating the pressel switch and speaking, in order to eliminate completely any clipping of the first word. Grid-modulation of the 814s provides a carrier power of approximately one quarter that of the c.w. output or roughly 15 to 25 watts into the antenna. Either the carbon hand mike, T-17, or the newer "lip" mike, T-45, is used depending on the type of installation.

Full break-in using blocked-grid keying is provided on c.w. Side-tone (about 800 cycles) is fed directly into the headphone circuit of the receiver whenever the transmitter dynamotor is running and the key is closed. The operator does not hear the transmitted r.f. signal in his receiver since the receiver input is shorted, and the receiver i.f. circuits are opened during the time the



*Fine instruments
produced in volume*

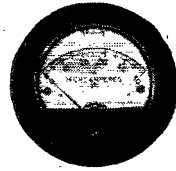

*with precision first...
to last.*

Triplet



**ELECTRICAL INSTRUMENT CO.
BLUFFTON, OHIO**

.. What "Cardioid" means to you ..

Cardioid means heart-shaped. It describes the pickup pattern of the Shure "Uniplex" Microphone which reproduces sounds approaching from the front only. The Cardioid reduces pickup of random noises by 66%. The "Uniplex" is the only Cardioid Crystal Microphone. It is the most economical Microphone with true cardioid performance. High quality reproduction from 30 to 10,000 cycles. For better performance—start at the beginning—with a Shure "Uniplex."

Model 730B "UNIPLEX." *List price . . \$34*

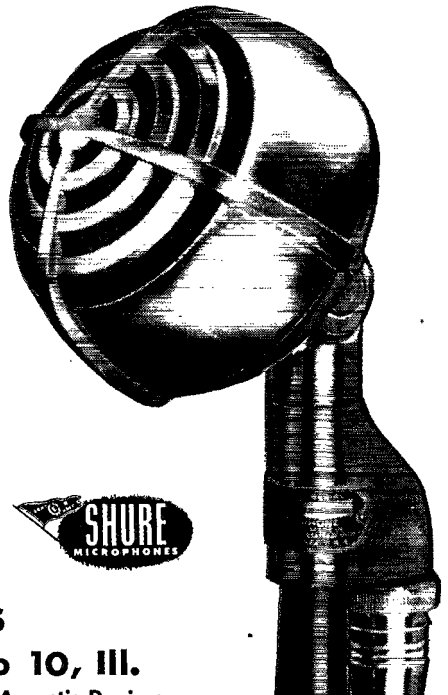

SHURE BROTHERS

225 W. Huron St., Chicago 10, Ill.

Designers and Manufacturers of Microphones and Acoustic Devices

SOUND EQUIPMENT

for
INDUSTRIAL · GOVT. · SCHOOL USE
Available Now!

- **AMPLIFIERS and SOUND SYSTEMS**
Bogen · Masco · Stromberg-Carlson · Talk-A-Phone
Thordarson · Webster · Racine
- **MICROPHONES and PICK-UPS**
Amperite · Astatic · American · Brush · Electro-Voice
Shure · Turner · Universal
- **LOUDSPEAKERS and PROJECTORS**
Altec-Lansing · Atlas · Cinaudagraph · Jensen
Kainer · Stromberg-Carlson (Utah) · University · Wright
- **RECORDERS and RECORD PLAYERS**
Also

RADIO PARTS · RADIO TUBES
INDUSTRIAL ELECTRONIC EQUIPMENT

TELEPHONE BRanch 7-1840

*With proper priority or L-265 certification.

SUN RADIO & ELECTRONICS CO.

212 Fulton Street, New York 7, N. Y.

CLEAN ACCURATE HOLES



cut in radio chassis

Greenlee Punches make this tough job easy. No reaming, filing or tedious drilling. Tool has three parts: *punch* cuts through chassis, *die* supports metal to prevent distortion, *cap screw* is turned with wrench to cut holes. Sizes for holes 3/4" to 3 1/2". Ask your radio supply or electrical jobber or write for folder and prices. Greenlee Tool Co., 1865 Columbia Ave., Rockford, Illinois.

WRITE FOR FREE FOLDER S-119 →



(Continued from page 94)

carrier is on. A relay in the transmitter performs these functions on voice or c.w. as well as changing the bias on the tubes to an operating level, and transferring the antenna from "receive" to "transmit." This relay is so designed that perfect keying is obtained at speeds up to 40 w.p.m. on a bug. The hash from the transmitter dynamotor is below the inherent noise level of the receiver and is not noticeable. This problem was one of the most difficult to solve in production since the units are all contained in such a small space, grounded together and operating from the same primary source.

On 'phone operation, voice side-tone is fed from the microphone circuit directly into the output circuit of the receiver and the operator can monitor himself in that manner.

The transmitter has powerful forced-air ventilation. An exhaust fan, on the shaft of the transmitter dynamotor, pulls air through a six-inch square glass-wool filter (located in the transmitter case immediately to the rear of the 814 amplifier tubes). This air passes through the transmitter and is exhausted through vents on the front of the dynamotor. All seams, and even the spaces around the dial shafts are closed as much as possible, in order to pull all the incoming air through the filter. A terrific volume of air is thus forced through the transmitter, furnishing cool operation under very high temperatures.

FEATURES OF THE antenna systems

THE 506 normally operates into a 15-foot five-section whip antenna mounted on a flexible insulated base. An antenna lead-in 5 to 9 feet long may be used if properly insulated.

For semi-fixed vehicular operation, additional antenna sections, plus guy ropes, are provided which permit the erection of a 25-foot antenna in less than five minutes.

As the 506 was designed exclusively for vehicular operation into short antennas, no provision is made for a doublet, Zepp or other long-wire antennas.

Mounting and Installation

The 506 has a novel and efficient means of inter-connection between the transmitter, the receiver and the mounting base. This base, FT-253, consists of a metal plate, mounted on six shock mounts. At the rear of the base are two sets of connectors which, when the units are properly seated, make all cross-connections. The primary terminals, fuse, and the hash-reducing filters are located in the mounting base. Two heavy shielded leads connect the base to the vehicular terminal box where a 12- or 24-volt d.c. supply is available.

A sturdy means for protecting and mounting the entire set is provided by a chest (CH-74)

(Continued on page 98)

Preparedness



● For peace or war, America has learned the lesson of preparedness. It is but natural, therefore, that Astatic Corporation executives, while pushing wartime production to capacity, take time to prepare for postwar demands. That's why Astatic at the proper time and with the least possible delay, will be prepared to convert its extensive manufacturing facilities to the production of new microphones, phonograph pickups and similar devices for the urgent, postwar demands of radio and phonograph jobbers and manufacturers.

"You'll HEAR MORE
from Astatic"

ASTATIC Crystal Devices
manufactured under Brush
Development Co. patents.

THE *Astatic*
ASTATIC CORPORATION
CONNEAUT, OHIO
IN CANADA, CANADIAN ASTATIC LTD., TORONTO, ONTARIO



INSTITUTES

Offer thorough training courses
in all technical phases of

RADIO and TELEVISION

WEEKLY RATES

DAYS—EVENINGS

VETERANS: RCA Institutes is approved

under G. I. Bill of Rights

For Free Catalog write Dept. ST-45

RCA INSTITUTES, Inc.

A Radio Corporation of America Service
75 Varick Street, New York 13, N. Y.



DeLuxe

SPEED KEY

Model
CP 810

Amateur
Net Price
\$9.75

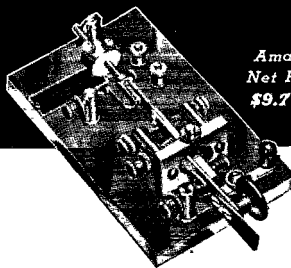

One of the finest commercial or amateur bugs available. Chrome finished base and super-structure. Springs made of selected blue spring steel for uniform performance in all keys. Nine points of adjustment to suit the most critical touch. Fully adjustable. Silver contacts 3/16" diameter.

MODEL CP 510 SPEED KEY • Similar to above except the base is Battleship gray wrinkle finish, Amateur Net Price \$6.75



RADIO—ELECTRONICS

Co-educational training in Airline, Merchant Marine, Press Communications, Electronics, Television. FREE booklet. Address Registrar. Ex-Servicemen: Request FREE copy, G.I. bill of rights

"A Radio School managed by radio men."
45 West 45th Street, New York 19, N. Y.

MELVILLE RADIO INSTITUTE

RADIO-TELEVISION-ELECTRONICS

Prepare now for ever-increasing post-war opportunities. Day and Eve. Sessions. Enroll now for new classes. Consideration given to Veterans eligible for training under the G.I. Bill.

RADIO-TELEVISION INSTITUTE

480 Lexington Avenue, New York 17 (46th Street)
Plaza 3-4585 Licensed by New York State

COMPLETE RADIO TRAINING!

All branches of communications, including television and FM courses from 6 to 18 months' duration. HIGH SCHOOL GRADUATES 17 YEARS OF AGE—prepare for radio operating positions in the U. S. Merchant Marine in 6 months. Complete pre-induction radio training in 3 months. Information supplied to Veterans on radio engineering training.

Write for particulars

VALPARAISO TECHNICAL INSTITUTE
Dept. T Valparaiso, Indiana

TELEGRAPH
Apparatus Co.

325 WEST LAURON STREET • CHICAGO 10, ILL.

only a HAM could do this job...

That ham is interested in advertising as a career. He's young, but he's packed a lot of common sense into those years through ham radio. He'll kick his heels at the chance to combine a hobby and a career with a nationally known manufacturer of radios and radio equipment. We need him at once . . . he'll want to roll up his sleeves and start now!

The job? It leads to the handling of all instruction manuals, trade ads, publicity, catalogs and the thousand and one things that make advertising (and radio) an interesting business. Salary? That depends on you.

We're congenial people who enjoy life in a small Midwestern city, and we're doing our best to make it the biggest little city in America. Our products are known to every ham, and our name is winning national recognition.

Interested? Drop us a line. Tell us about yourself and your ideas. If you're the ham we want, we'll be glad to pay your expenses for an interview.

Box 128 • QST

CRABTREE'S WHOLESALE RADIO

2608 Ross Ave. Dallas 1, Texas

RF Inductors • RF Chokes • IF Transformers
Condensers • Mica Molded Condensers • Trimmer
Condensers • Miscellaneous Apparatus
The F. W. Sickles Co., Chicopee, Mass.

SICKLES Electronic Specialties

This is the fifth issue of QST for 1945. Can you readily find your first four issues? You can if they are kept in a

QST BINDER PRICED AT \$1.50
POSTPAID

(For the duration not available outside of the United States and Possessions.) One set of yearly labels (1922-1946) now provided with each binder

American Radio Relay League, West Hartford, Connecticut

WANTED Electrical Engineer or
Engineering Physicist for
research position in fundamental and applied
electronics. Some industrial experience preferred.
Essential work with excellent postwar prospects.
Write

ARMOUR RES ARCH FOUNDATION
39 West 33rd Street Chicago 16, Illinois

slightly larger than the over-all size of the radio set, thus permitting the equipment to move freely in all directions on its shock mounts. In open vehicles, such as a scout car or a half-track, the same chest is used with an ingenious metal "chimney." Provision is made for mounting the flexible mast base on top of this "chimney," and the antenna lead is run coaxially through the pipe, to the transmitter. This provides a weather-tight and protected mounting for the antenna lead-in and the mast base insulator.

The weight, in pounds, of the main units of the SCR-506 equipment is as follows: transmitter, 143; receiver, 46.5 and the mounting base, 34.0 — making a total weight of 223.5 pounds. The original equipment was much lighter but the almost complete elimination of aluminum from the set made it about 75 pounds heavier.

The receiver (plus the transmitter filaments) draws 7 amperes at 12 volts. The receiver, and the transmitter on full load, c.w., draws 45 amperes and on voice, 33 amperes. On 24-volt operation the primary current drain is approximately three-quarters that at 12 volts.

Both receiver and transmitter dynamotors are available for either 12 or 24 volts. A shift from one voltage to the other requires no changes in the receiver, as the cable connecting the dynamotor to the chassis performs the necessary switching from a series to parallel arrangement of the filament circuits. However, in the transmitter, a series of links in the top of the transmitter are changed manually, and the dynamotor selected for the available voltage.

The 506 is provided with interlock circuits which prevent contact with d.c. of more than 210 volts and all r.f. voltage except for accidental contact with the set's antenna binding post. As the 814s are shunt-fed no d.c. is present on the final amplifier tank coil at any time.

The Next Chapter

With the conclusion of the service and field tests, that portion of the story of the 506 was finished but another chapter had just begun. For the most exciting part of the 506 history is being written right now, day by day, as the armored columns of the armies with their half-tracks, their scout and command cars and many other types of vehicles move inexorably forward in the Battle of Germany. Some day we hope to present that part of the history of the 506. But that is an account which can be rendered only by the brass-pounders who now use the set in combat.

For our part, during the many long and arduous months of preparation testing, and production, we were all motivated by one single purpose — to provide these boys with the best vehicular radio set that our combined effort and ingenuity could produce.

For each of us felt that, wherever a 506 rolled into battle, some part of us would be riding right in there alongside the fighting operator. And when that time came we didn't want to have to make any excuses!

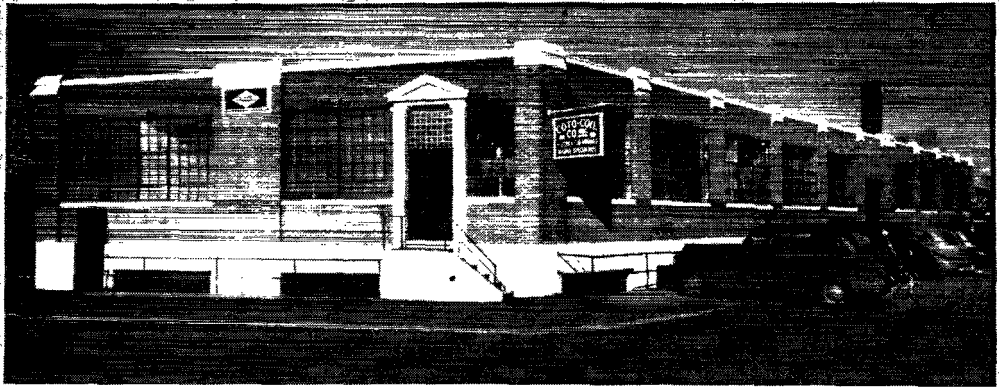

OF THINGS TO COME . . .

This modern building houses a vital portion of the electronic war industry—the home of COTO-COIL. Our half-acre of floor space is devoted exclusively to the manufacture of coils for victory, just as long as the armed forces need them. But, come V-Day, we have plans which include many new gadgets to make the amateur bands more interesting.

COTO-COIL CO., INC.

65 PAVILION AVE.

COIL SPECIALISTS SINCE 1917

PROVIDENCE 5, R. I.

RADIO ENGINEERS At least two years' design and development experience with Radio Communications Equipment manufacturer on items subsequently satisfactorily produced in quantity. Knowledge and experience in two-way mobile equipment, low power transmitters, receivers, and control equipment essential. Permanent position—West Coast Manufacturer. Will pay expenses to coast for interview if qualifications satisfactory. Write, giving complete past experience, employment record, salary received, and technical references.
BOX NO. 126 • Care of QST

WANTED FOREMAN (30-40)

to supervise small electronic assembly dept. Able to read Schematic wiring diagram. Excellent post-war opportunity. Send complete resume and non-returnable photo. W.M.C. rules observed. Box 922, Equity, 113 W. 42nd St., New York City.

COMMERCIAL RADIO INSTITUTE

A RADIO TRAINING CENTER FOR 24 YEARS

Resident Courses Only • Pre-Induction, Broadcast, Service, Aeronautical Television, and Marine telegraphy classes now forming for June 18th. Literature upon request. Veteran training.

Dept. B., 38 West Biddle Street, Baltimore 1, Maryland

LEARN RADIO

Pre-Military training for beginners. Catalog on request. We teach all technical branches of radio. Lic. by the Comm. of Mass. Dept. of Education.

MASS. RADIO SCHOOL

18 Boylston Street

Boston, Massachusetts

RADIO

Courses Qualifying for Service Technician • Laboratory Technician • Electronic Television • Communications Operator • Register Now for New Classes Starting First Monday of each month. Day-Evening Classes • Consideration Given to Veterans Eligible for Training Under G.I. Bill

AMERICAN RADIO INSTITUTE

101 West 63d St.

New York 23, N. Y.

Phone, Wire or Write

WHOLESALE

Radio-Electronic Parts
Tubes, Sets and
Equipment

R. G. SCELİ & CO.

227 Asylum St. Hartford, Conn.

Telephone 2-1144

HAM-ADS

(1) Advertising shall pertain to radio and shall be of nature of interest to radio amateurs or experimenters in their pursuit of the art.

(2) No display of any character will be accepted, nor can any special typographical arrangements, such as all or part capital letters be used which would tend to make one advertisement stand out from the others.

(3) The Ham-Ad rate is 30c per word, except as noted in paragraph (6) below.

(4) Remittance in full must accompany copy. No cash or contract discount or agency commission will be allowed.

(5) Closing date for Ham-Ads is the 25th of the second month preceding publication date.

(6) A special rate of 7c per word will apply to advertising which, in our judgment, is obviously non-commercial in nature and is placed and signed by a member of the American Radio Relay League. Thus, advertising of bona fide surplus equipment owned, used and for sale by an individual or apparatus offered for exchange or advertising inquiring for special equipment, if by a member of the American Radio Relay League takes the 7c rate. An attempt to deal in apparatus in quantity for profit, even if by an individual, is commercial and all advertising by him takes the 30c rate. Provisions of paragraphs (1), (2), (4) and (5), apply to all advertising in this column, regardless of which rate may apply.

Having made no investigation of the advertisers in the classified columns, the publishers of QST are unable to vouch for their integrity or for the grade or character of the products advertised

QUARTZ — Direct importers from Brazil of best quality pure quartz suitable for making piezo-electric crystals. Diamond Drill Carbon Co., 719 Union Bldg., New York City.

COMMERCIAL radio operators examination questions and answers. One dollar per element. G. C. Waller, W5ATV, 6540 Washington Blvd., Tulsa, Okla.

WHY NOT turn your unused equipment into ready cash which may be applied towards new and better equipment after the war? Leo, W9GKQ, offers you the best cash prices for communications receivers and test equipment. Write today for large illustrated catalog. Wholesale Radio Laboratories, 744 W. Broadway, Council Bluffs, Iowa.

CRYSTALS available — all types, including 100 kc., 465 kc. and 100 kc. Broadcast and Aircraft given prompt attention. Scientific Radio Products, Council Bluffs, Iowa.

IMMEDIATE shipment on priority: new SX28As, \$223.00; SX25s, \$94.50; PM23s, \$15.00. In stock without priority: Trimm No. 65, Dependable headsets, \$2.28; No. 100 Featherweight \$6.00; meter rectifiers, \$1.95; coils, transformers, etc. Instructographs for rent. Write for our catalog. Henry Radio Shop, Butler, Mo.

HIGHEST prices paid for used receivers, test equipment, bugs, oscillators. What have you? W9ARA, Butler, Mo.

NEED Dec. 1915 and May 1916 issues QST. Pay any price. Also want old Call Books and Handbooks. W. L. Holst, W9MD, 2553 Winemac Ave., Chicago, Ill.

CRYSTALS: complete units or blanks. All types. Your specifications and tolerances. One or one million. Refinishing and repairing of your present units. Rex Bassett, Incorporated, Ft. Lauderdale, Fla.

FABERADIO crystals will be available to amateurs immediately after hostilities cease. Faberadio, Sandwich, Ill.

RADIO TESTS — Pre-examination Tests for Radio Operators. Tests your knowledge before you appear for commercial radio operator license examinations. Avoids failures. Guides your preparation. Saves your time. Worth investigating at once. Also books for home study. Write for free circulars 5Q. Nilson Radio School, 51 E. 42 St., New York 17, N. Y.

PROMPT Repair Service on meters and electronic instruments. Braden Engineering Co., 3317 Kenmore Ave., Dayton 10, Ohio.

FRITZ for better QSLs after victory! 1213 Briargate, Joliet, Ill.

BUILD radio, complete kit with tubes, \$10.95, details. Radio, 9418J Ave. "A", Brooklyn, N. Y.

CLOSING out small lot of tubes, list on request. Abbott, 2101 Grand Concourse, New York City.

RK-49 tube boxes wanted. Charles J. Bodnar Co., 58 Marbledale Road, Tuckahoe 7, N. Y.

HEADPHONES: latest type, light weight, finest quality, with plug for tuning in on radio, or intercommunication system. 2000 ohm resistance. Headphones: (no headbands, slightly used), \$1.25; Headphones: (no headbands, new), \$1.75; Headphones (with leather covered adjustable headbands, slightly used), \$2.50; Headphones: (with adjustable leather-covered headbands, new), \$3.75, plus 25¢ shipping charges. Send check or money order. Quantity limited. Telephone Wire: insulated, used, suitable for radio or home wiring, 50-ft. lengths, \$1.65; 100-ft. lengths, \$2.95; 500 ft. \$12.75, plus 35¢ shipping charges. Send check or money order. Nico Supply Co., 540 North 17th Street, Philadelphia, Pa.

RADIO tubes, parts, free bargain lists. Potter, 1314 McGee St., Kansas City 8, Mo.

CHANGING frequency? Prompt delivery of Edison fine crystals. Low-drift commercial types available throughout the 100-12, 500 kc. range. Also repairing and regrounding, and crystals supplied to your holders. Ten years of satisfaction and fast service! Send for folder L-5, mentioning your needs. "Edison's", Temple, Texas.

FOR sale: Hallcrafters SX-28 with speaker, perfect condition. Used less than 100 hours. \$190.00. A. J. Minners, Amagansett, N. Y.

SIGNAL Shifter Deluxe 42. Never on air. Coils for 10 and 80. \$45.00. Browning preselector with 1852. Factory built, Brand new, Model 5DX, \$18.00. Send stamp for list, new tubes, transformers, etc. W9GPI, Doyle, 4331 No. Wildwood Avenue, Milwaukee, Ill., Wis.

STANDARD a.c. Teleplex. 10 tapes. Like new. \$25.00. W2HWN.

WANTED: National or Hammarlund receiver. C. Horn, 325 East 163rd St., New York 56, N. Y.

WANTED: 1-1847 iconoscope. Also television parts and equipment. What have you? E. Schwinge, 38 Silver St., Patchogue, N. Y.

WANTED: NTX30. Good condition but tubes not required. A. W. Paul, Jr., Hamilton Ave., Wheeling, W. Va.

SELL RME-69 with matching speaker in perfect condition, \$100.00. DB-20, \$35.00; Comet Pro, all coils, less speaker, \$35.00; f.o.b. Widener, Arkansas. Want Thordarson 300-watt modulation transformer T-14M49 or T-19M17 and T-75D11 and Thordarson T-19P56 — T-19P59 for cash. William Hall, Widener, Arkansas.

SELL Janette rotary converter 110 d.c. to a.c., 500 watts, good. Best offer this month, f.o.b. Maine. WIBIR, Gastonguay, Box 345, Topanga, Calif.

WANTED: Six pairs of Baldwin Type C mica-diaphragm phones, in good condition. Address offer of sale to Claude Gray, c/o W10C, Savannah, Ga.

FOR SALE: SX-24, A-1 condition. Make cash bid. J. Hardison, W4HQM, Route No. 3, Humboldt, Tenn.

CRYSTALS, Bliley 160 thru 20 meters, all first class. W8KJ.

WANTED: National PW-4 tuning unit complete. Condensers 225 µfd. per section. Give description. W8WRO, (Montanye) 5 Madison Ave., Saratoga Springs, N. Y.

ATTENTION, Hams! Transmitter parts such as variable, fixed and oil-filled capacitors, resistors, isolated coil forms and standoffs, overload relays, etc. at a fraction of original cost. Write for bulletin. Western Mass Radio, 835 Chicopee St., Williamansett, Mass.

WANTED: Parts to build two- or three-tube superhet in Ham Handbook. Cash, no trades. What do you have for me? Lt. Lindstrom, Nichols Hospital, Louisville 12, Kentucky.

WANTED: EC-1 or equivalent. W3JVO, Lt. J. Krawczyk, 235 AAFBV, Biggs Field, El Paso, Texas.

HEADSETS. Used army headsets in good condition, guaranteed operating, \$2.50 each. With damaged headband, \$2.00 each, postage extra. Arnold Radio Service, Middletown, Pa.

SELL QSTs 1933-1940, Radio, 1938. Make offer. L. H. Orcutt, 127 South Ave., Penn Yan, N. Y.

FOR SALE, best offer: pair RCA 813, 803, 575-A. Never used. Guaranteed. J. Middleton, W2MKU, 25 Hartford St., Newark, N. J.

NEW 1 kw. safety transmitter built according to specifications in December 1939 QST. Will operate on 10-20-40-80 meters both phone and c.w. Parts are Stancor, UTC, Thordarson, Ohmite, Johnson, and B. & W. Set must be sold due to owner leaving East Coast. Details will be sent. R. Mowery, Box 994, Lancaster, Pa.

SELL National speech modulator. W3QF.

WESTINGHOUSE meters in stock, new 3¼-inch, 0-15 ma., 0-100 ma., 0-300 ma., \$7.20 each. 0-10 r.f. amps., \$12.80. 0-15 a.c. volts, \$7.20. Van Sickle Radio Supply Co., Indianapolis 6, Ind.

SALE. Radiotelephone transmitter, inter-office communications system, few miscellaneous parts. Ernest Austin, 1445 Ogden Street, N. W., Washington 10, D. C.

SELL slightly used WE 295A and RCA 203A tubes, \$5.00 each. W5JGY, MacDowell, 2113 Daisy Lane, Ft. Worth, Texas.

EXCHANGE: Comet Pro for good record changer, or sell and buy same. Bliss, W1DXT, 334 Stanley St., New Britain, Conn.

**"HOGARTH, SURELY YOU MUST
HAVE SOME OTHER POSTWAR
PLANS BESIDES LISTENING TO
YOUR ECHOPHONE EC-1"**



HOGARTH AND ECHOPHONE

have plenty of postwar plans. These plans will see Echophone hit new heights of popularity in the Citizens Radio Communications Service bands—where anything might happen. The EC-1 covers from 550 kc. to 30 Mc. on three bands . . . Electrical bandspread on all bands . . . Six tubes . . . Self contained speaker . . . 115-125 volts AC or DC.

ECHOPHONE
"The Cars of the World"

ECHOPHONE RADIO CO., 540 NORTH MICHIGAN AVE., CHICAGO 11, ILLINOIS

Designed for



Application

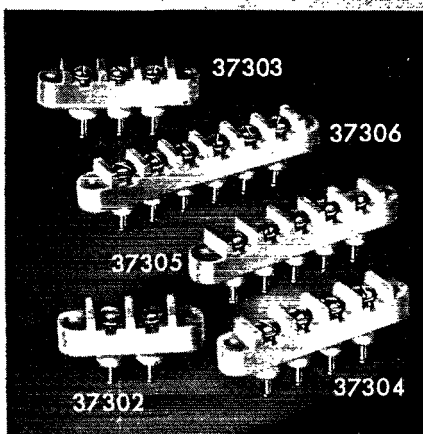

**The No. 37300 Series
Steatite Terminal Strips**

Another exclusive Millen "Designed for Application" product is the series of steatite terminal strips. Terminal and lug are one piece. Lugs are Navy turret type and are free floating so as not to strain steatite during wide temperature variations. Easy to mount with series of round holes for integral chassis bushings. Ideal answer to the "tropicalization" problem.

**JAMES MILLEN
MFG. CO., INC.**

MAIN OFFICE AND FACTORY

**MALDEN
MASSACHUSETTS**



Index to Advertisers

	Page
Abbott Instrument, Inc.	**
Aerovox Corporation	**
American Lava Corp.	**
American Radio Institute	99
American Tel. & Tel. Corp.	81
Amerex Elec. Products, Inc.	Cov. 14
Astatic Corporation, The	97
Ayers Automatic Code Machines	**
Barker & Williamson	**
Billey Electric Co.	65
Brach Manufacturing Corp.	**
Browning Laboratories, Inc.	69
Burgess Battery Company	80
Candler System Company	93
Capitol Radio Engineering Institutes	94
Cardwell Mfg. Corp., Allen D.	**
Centralab	73
Claroat Mfg. Co., Inc.	**
Collins Radio Company	5
Commercial Radio Institute	99
Communications Products Co.	**
Cotb-Coil Co., Inc.	99
Craibtree's Wholesale Radio	98
Crystal Products Co.	83
Delco Radio, Div. Gen. Motors	71
DX Crystal Company	**
Echophone Radio Company	101
Eitel-McCullough, Inc.	67
Electro-Voice Mfg. Co.	**
Electronic Laboratories	**
Galvin Mfg. Corp.	**
Gardiner & Company	**
General Ceramics & Steatite Co.	**
General Electric Co.	79
Great American Industries	90
Greenlee Tool Company	96
Hallicrafters Co., The	1, 2
Hammarlund Mfg. Co., The	7, 63
Harrison Radio Company	**
Harvey Radio Company	70
Harvey Radio Laboratories, Inc.	90
Harco Steel Construction Co.	**
Harvey-Wells Communications, Inc.	**
Hazeltine Electric Corp.	88, 94
Heintz & Kaufman, Ltd.	**
Henry Radio Shop	**
Hytron Corporation	**
Instructograph Company	**
International Resistance Co.	86
Jensen Radio Mfg. Co.	**
Ken-Rad Tube & Lamp Corp.	**
Kenyon Transformer Co., Inc.	**
Knights Company, James	**
Maedel Publishing House	**
Mallory & Co., P. R.	68
Massachusetts Radio School	99
McElroy Mfg. Corp.	103
McGraw-Hill Book Co., Inc.	**
Meck Industries, John	**
Meissner Mfg. Co.	85
Melville Radio Institute	97
Metropolitan Technical School	**
Millen Mfg. Co., James	107
Murray Hill Books, Inc.	77
National Company, Inc.	61, Cov. III
Newark Electric Co.	**
New York YMCA Schools	**
Nilson Radio School	72
Ohmite Manufacturing Co.	72
Onan Electric Co., D. W.	93
Oxford-Tartak Radio Corp.	**
Philco Corporation	**
Pioneer Gen-B-Motor	**
Port Arthur College	86
Premax Products, Inc.	**
RCA Institutes, Inc.	97
RCA Manufacturing Co., Inc.	Cov. IV
Radio Manufacturing Engineers	93
Radio Shack Corporation	74
Raycon Mfg. Co.	75, 87
Ramsey Publishing Co.	**
Radio-Television Institute	97
Seell & Co., R. G.	99
Scientific Radio Products Co.	**
Shure Brothers	95
Sickles Co., F. W.	98
Simpson Electric Co.	**
Sperry Gyroscope Co.	**
Sprague Electric Co.	104
Standard Radio Elec. Co.	**
Standard Transformer Co.	78
Sun Radio & Electronics Co.	96
Taylor Tubes, Inc.	**
Telegraph Apparatus Co.	97
Telex Company	**
Terminal Radio Corp.	**
Thordarson Elec. Mfg. Co.	**
Triplet Elec. Instrument Co., The	95
Turner Company, The	**
United Transformer Co.	**
Universal Microphone Co.	92
Valparaiso Technical Institute	97
Valpey Crystal Co.	82
Vibroplex Company, Inc., The	**
Western Electric Co.	88
Westinghouse Elec. & Mfg. Co.	89
Wholesale Radio Laboratories	**
Wilson Electric Co.	76
Yaxley (Mallory P. R.)	68
Zenith Radio Company	**

All of the above advertisers are cooperating with the O.R.T. to permit publication of an editorially adequate QST during this period of war-rationing of paper. Using less advertising space but at higher rates, they continue their customary support of QST. Some are using smaller space in each issue and some are using space only every second or third issue. Of the latter, those whose advertising does not appear in this particular issue are indicated by the ** above.

When **McELROY** builds 'em
they're good!

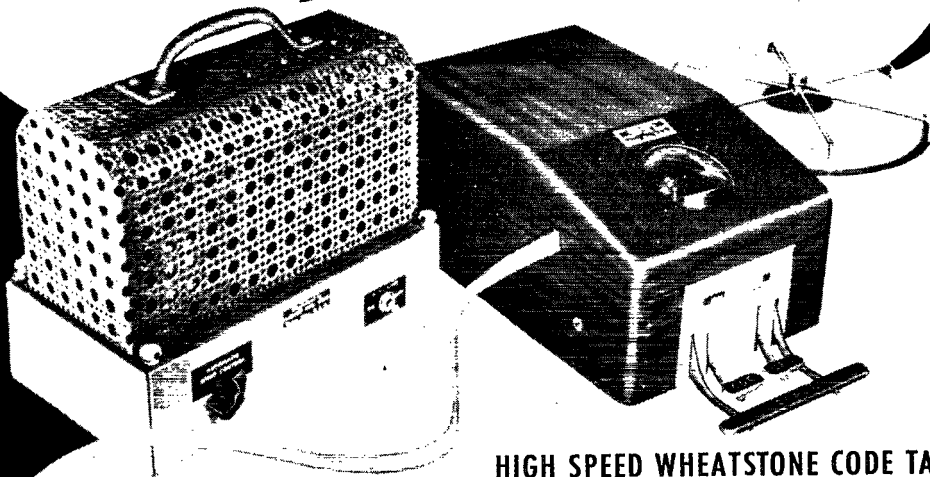

**HIGH SPEED WHEATSTONE CODE TAPE
PERFORATOR . . . MODEL PFR-443-A**

For immediate delivery at a lowered price!

Fast! Versatile! Rugged! Efficient! That's the McElroy Model PFR-443-A which prepares clean and accurate tapes that may be passed through any make of automatic transmitter at speeds up to 300 words per minute. May be set up and operated instantly—anywhere—on land, sea, air. The Keying Unit and the Electronic Drive which form the complete assembly are completely protected against jolts and jars. The PFR-443-A is the only machine of its kind in this country which permits operators to maintain speeds of 30 to 40 words per minute in all Morse combinations assigned to the Russian, Turkish, Greek, Arabic and Japanese alphabets and languages. Priced at \$275.00.

All McElroy equipment is now being delivered promptly for 110-120 volts AC or DC, or any other voltages.



*McElroy engineers never copy . . . never imitate.
We create . . . design . . . build.
We are never satisfied with mediocrity.*

McElroy **MANUFACTURING CORP.**
82 BROOKLINE AVE., BOSTON, MASS.

IT'S THE SEVENTH INNING STRETCH . . . SUPPORT THE SEVENTH WAR LOAN DRIVE



**200°C. CONTINUOUS
OPERATION**

* Ceroc 200

A high-temperature ceramic (inorganic) insulation for copper, nickel and other wire

Many engineers are already familiar with Sprague CEROC 200, a ceramic insulating coating applied to copper, nickel, and other types of wire. Many have already taken advantage of its ability to withstand 200°C. continuous operating temperature in their design of restricted war developments on which details cannot yet be announced. So far reaching are its possibilities for so many electrical products of a later date, however, that we now take this means of announcing it to the trade in general.

Briefly, Sprague CEROC 200 is a flexible, ceramic inorganic insulation for wires used in winding motors, transformers, chokes, and similar equipment, and permitting a very substantial increase in

volt-ampere ratings. It is conservatively rated for 200°C. continuous operating temperature, as compared with 105°C. for conventional organic insulations such as enamels, varnishes, etc. Actually, we believe that Sprague CEROC 200 meets all Class C insulation specifications under A.I.E.E. standards. Thermal conductivity is rapid, and space factor is extremely good. Typical percentages of copper area to total cross-sectional area of finished wire are 96% for AWG #21 wire, and 95% for #24 wire for CEROC 200, by comparison with only 69% and 59% respectively for other insulations that might be used for high-temperature applications.

WRITE FOR BULLETIN—Check the possibilities of CEROC 200 against the more exacting needs of your product of Tomorrow! Write today for Sprague CEROC Bulletin.

SPRAGUE ELECTRIC COMPANY, North Adams, Mass.
(FORMERLY SPRAGUE SPECIALTIES CO.)

*Trademarks Reg. U. S. Pat. Off.

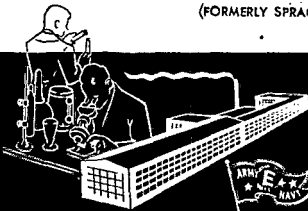

SPRAGUE

SPRAGUE CAPACITORS —*KOOLOHM RESISTORS —*CEROC INSULATION

NATIONAL RECEIVERS ARE THE EARS OF THE FLEET



SPECIAL U. S. NAVY PHOTOGRAPH

...the Navy's
...craft and
...receivers de-
...by National. Shore
...them too.
...shows Waves in
...of the U. S. Naval
...Banner Field,

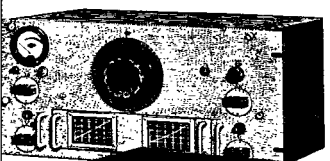

HRO

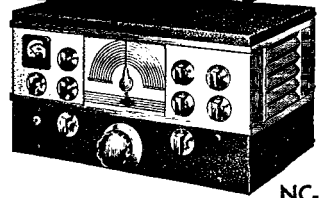

NC-200

NATIONAL COMPANY

MALDEN  MASS, U. S. A.

NATIONAL RECEIVERS ARE IN SERVICE THROUGHOUT THE WORLD

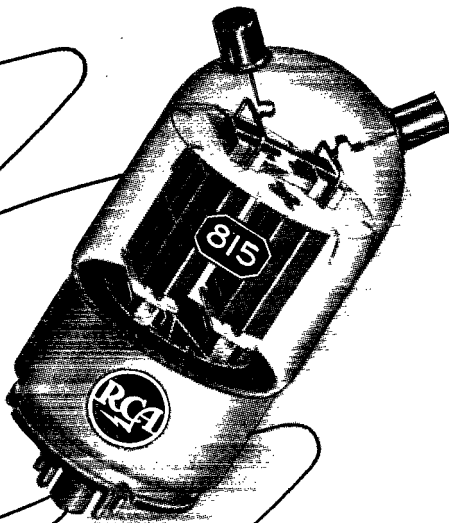

Remember the RCA-815?

INTRODUCED in 1941, this RCA-developed transmitting tube was a natural for the kind of U-H-F transmitter then being planned by amateurs.

The RCA-815 handles 75 watts input (ICAS) at 125 megacycles with less than 0.5 watts driving power. Priced at only \$4.50, this tube was a favorite for U-H-F minded hams—FM or AM—and for 8 reasons:

1. **Small Size:** Glass-button stem structure provides short leads and compactness. Less than 5 inches high.
2. **Two Tubes—One Envelope:** Combining two tubes in one envelope eliminates one socket; saves space; simplifies electrical problems.
3. **Low Driving Power:** At full input, the 815 needs less than 0.5-watt grid drive. That means simplified construction of low-power stages.
4. **No Neutralization:** The 815's beam-power construction ordinarily makes neutralization unnecessary. Circuit stability is thus improved.
5. **Low Heater Power:** The 815 takes only 1.6 amps at 6.3 volts or 0.8 amps at 12.6 volts.
6. **Low Plate Volts:** You can get full CCS input (60 watts, class C telegraph) with 400 volts on the plates; full ICAS input (75 watts) with 500. Ideal for mobile equipment. Provides full output with receiver-type rectifiers.
7. **High Output:** Only a small package, but 815 will give you plenty of wallop right up to 105 mc; and at reduced ratings it will operate up to 225 mc.
8. **Performance:** Only one thing need be said about the performance of the RCA-815; to meet war demands, we increased production of this tube to 46 times the 1941 level. Isn't that fact alone *proof* of performance?

Right now, the RCA-815 is on the Army/Navy Preferred-Type List and our entire production of this

tube is earmarked for low-power mobile and aircraft transmitters used by the armed forces. For these applications the light weight, compactness, and low driving-power requirements of the 815 are unsurpassed.

Come postwar, additional thousands of amateurs can join the ranks of those who have already used and who swear by the RCA-815.

MAXIMUM RATINGS

Class C Telegraph Service (All values are for both units)

	CCS	ICAS
Plate Volts	400	500
Screen Volts	225	225
Plate Current, Ma.	150	150
Grid Current, Ma.	7	7
Plate input, watts	60	75
Screen input, watts	4.5	4.5
Plate dis., watts	20	25
	Units in Series	Units in Parallel
Heater Volts	12.6	6.3
Heater Amperes	0.8	1.6

THE FOUNTAINHEAD OF MODERN TUBE DEVELOPMENT IS RCA



62-6436-67

RADIO CORPORATION OF AMERICA

RCA VICTOR DIVISION • CAMDEN, N. J.

Buy More War Bonds