

# QST

July, 1942

25 cents

35c in Canada

devoted entirely to

# amateur radio



**FOR VICTORY**



**BUY  
UNITED  
STATES  
WAR  
BONDS  
AND  
STAMPS**



# hyper-highs

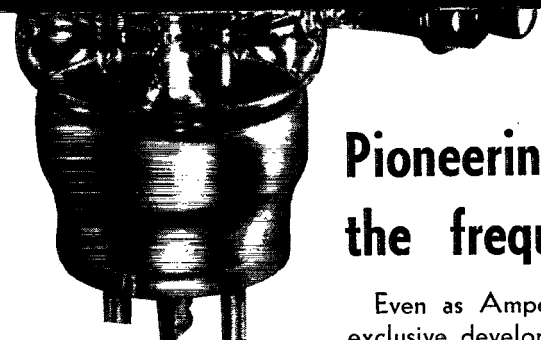

**Pioneering in development of  
the frequencies of the future**

Even as Amperex engineers distinguished themselves by exclusive developments in the design and structure of ultra-high frequency transmitting tubes . . . so are they now intent upon exploring the infinitely higher frequencies.

While these improvements originating in our research and engineering departments are entirely restricted to military operations, they will be released, in due time, for broadcast, industrial and electro-medical applications.

**AMPEREX ELECTRONIC PRODUCTS**

**79 WASHINGTON STREET**

**BROOKLYN, NEW YORK**

*the Commandos*  
could tell you about

**hallicrafters**  
**communications equipment!**

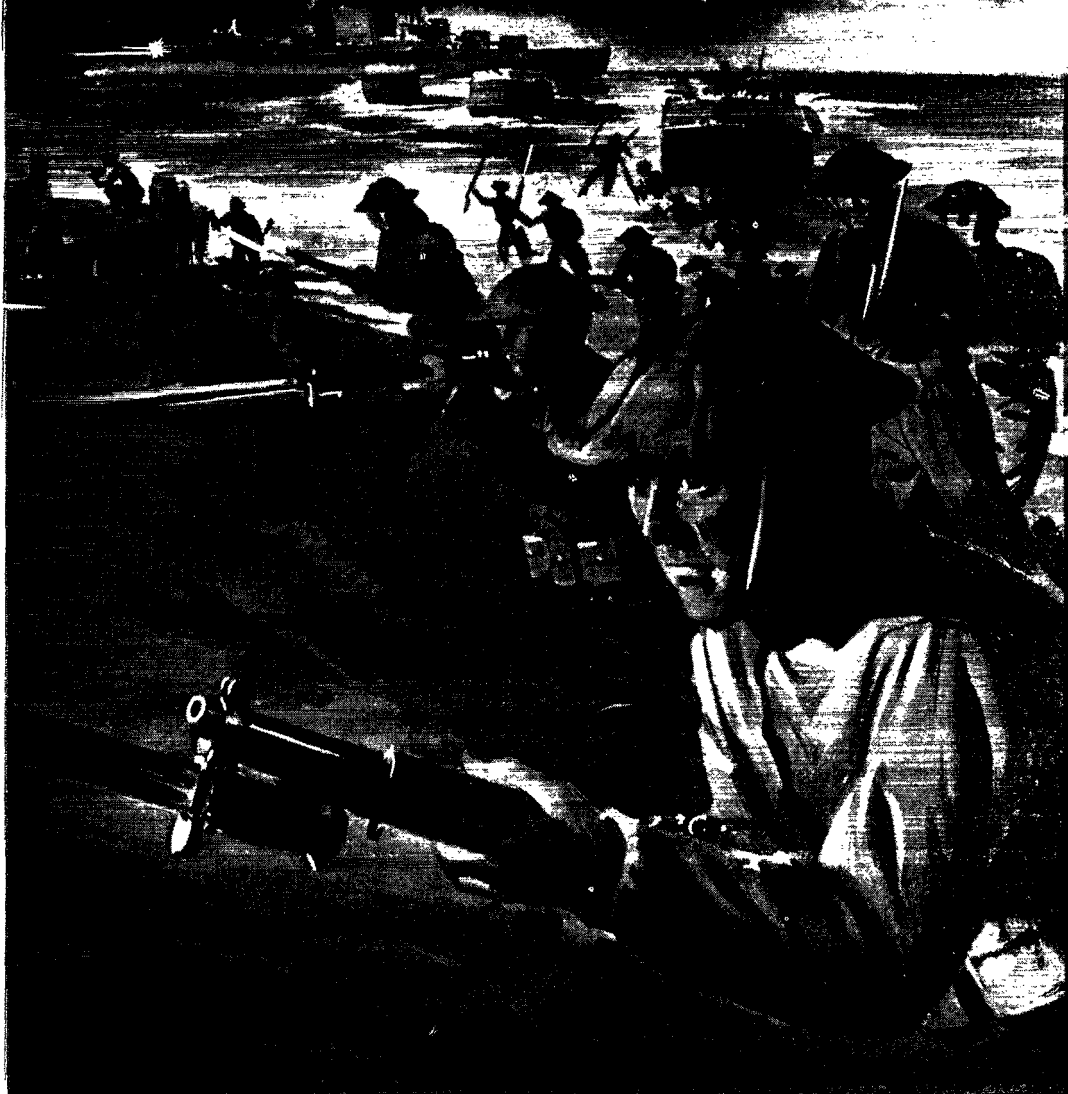

Ready for

**Action!**



**Our Interceptor Command forces are always "Ready for Action" . . . real aggressive American action, and it's up to all of us to back them up!**

Communications are a vital part of our flying forces . . . enables them to transmit orders instantly and accurately no matter what the distance may be. Hallicrafters Communications equipment are always

"Ready for Action" no matter what the operating circumstance, and we are making an all-out effort to back up our armed forces.

**Press Association, Inc. photograph of Hallicrafters Communications equipment in use at Interceptor Command station . . . somewhere in the United States of America.**

**the hallicrafters co.**  
CHICAGO, U. S. A.

**Keep Communications Open!**

JULY 1942

VOLUME XXVI

NUMBER 7



STAFF

Editorial

KENNETH B. WARNER, W1EH  
Editor and Business Manager

CLINTON B. DESOTO, W1CDB  
Assistant Editor

CLARK C. RODMON, W1SZ\*  
Managing Editor

GEORGE GRAMMER, W1DF  
Technical Editor

DONALD H. MIX, W1TS  
BYRON GOODMAN, W1JPE\*  
Assistant Technical Editors

EDWARD P. TILTON, W1HDQ  
Contributing Editor, U.H.F.

VERNON CHAMBERS, W1JEQ\*  
WALTER E. BRADLEY, W1FWH  
Technical Information Service

LOUISA B. DRESSER  
Editorial Assistant

JAMES J. LAMB, W1AL\*  
Research Engineer, A.R.R.L.

Advertising

F. CHEYNEY BECKLEY, W1GS  
Advertising Manager

Circulation

DAVID H. HOUGHTON  
Circulation Manager

RALPH T. BEAUDIN, W1BAW  
Asst. Circulation Manager

\*On leave of absence



OFFICES

38 La Salle Road  
West Hartford, Connecticut

Subscription rate in United States and Possessions, \$2.50 per year, postpaid; all other countries, \$3.00 per year postpaid. Single copies, 25 cents. Foreign remittances should be by international postal or express money order or bank draft negotiable in the U. S. and for an equivalent amount in U. S. funds.

Entered as second-class matter May 29, 1919, at the post office at Hartford, Connecticut, under the Act of March 3, 1879. Acceptance for mailing at special rate of postage provided for in section 1103, Act of October 3, 1917, authorized September 9, 1922. Additional entry at Concord, N. H., authorized February 21, 1929, under the Act of February 28, 1925. Additional second-class entries to cover sectional editions authorized March 20, 1935.

Copyright 1942 by the American Radio Relay League, Inc. Title registered at United States Patent Office.

# QST

devoted entirely to

# AMATEUR RADIO

PUBLISHED, MONTHLY, AS ITS OFFICIAL ORGAN, BY THE AMERICAN RADIO RELAY LEAGUE, INC., AT WEST HARTFORD, CONN., U. S. A.; OFFICIAL ORGAN OF THE INTERNATIONAL AMATEUR RADIO UNION



## CONTENTS

It Seems to Us . . . . .	9
The War Emergency Radio Service . . . . .	11
A Compact Panoramic Radio Spectroscope Adapter <i>George Grammer, W1DF</i>	16
In the Services . . . . .	22
100 Centimeters and Down . <i>Robert F. Shaw, W3AOC/W1LMB</i>	25
The Story of the Signal Corps . . . . .	28
How Recordings Are Made . . . <i>Clinton B. DeSoto, W1CDB</i>	30
25 Years Ago This Month . . . . .	34
P.O.W. . . . .	34
Navy Sparks . . . . . <i>Eddie Dieckmann, W2NDZ</i>	35
Happenings of the Month . . . . .	37
Experimenter's Section . . . . .	43
Rocky Mountain Division Convention . . . . .	47
U.S.A. Calling! . . . . .	48
Easy Lessons in Cryptanalysis: No. 1 <i>John Huntoon, W1LVQ</i>	50
Converting the Amateur-Band Regenerative S.S. Super to Gen- eral Coverage . . . . . <i>Walter E. Bradley, W1FWH</i>	52
A Course in Radio Fundamentals . . . <i>George Grammer, W1DF</i>	54
Off the Ultrahighs . . . . . <i>E. P. Tilton, W1HDQ</i>	63
Correspondence from Members . . . . .	66
Operating News . . . . .	68
Honor Roll . . . . .	69
Hamfest Schedule . . . . .	69
Register with Your Coördinator . . . . .	70
Amateur Activities . . . . .	73
The Month in Canada . . . . .	82
Silent Keys . . . . .	86
Hamads . . . . .	107
QST's Index of Advertisers . . . . .	110

# SPECIAL OFFER

DURING



- **ARRL MEMBERSHIP**  
for one year, including
- **SUBSCRIPTION TO QST**  
(new or renewal or extension)  
and the
- **RADIO AMATEUR'S HANDBOOK**  
Regular or Defense Edition —  
be sure to specify which

**\$3.00**

*U. S. A. Only*

THIS OFFER AVAILABLE ONLY DIRECT FROM

**AMERICAN RADIO RELAY LEAGUE, INC.**  
WEST HARTFORD, CONNECTICUT

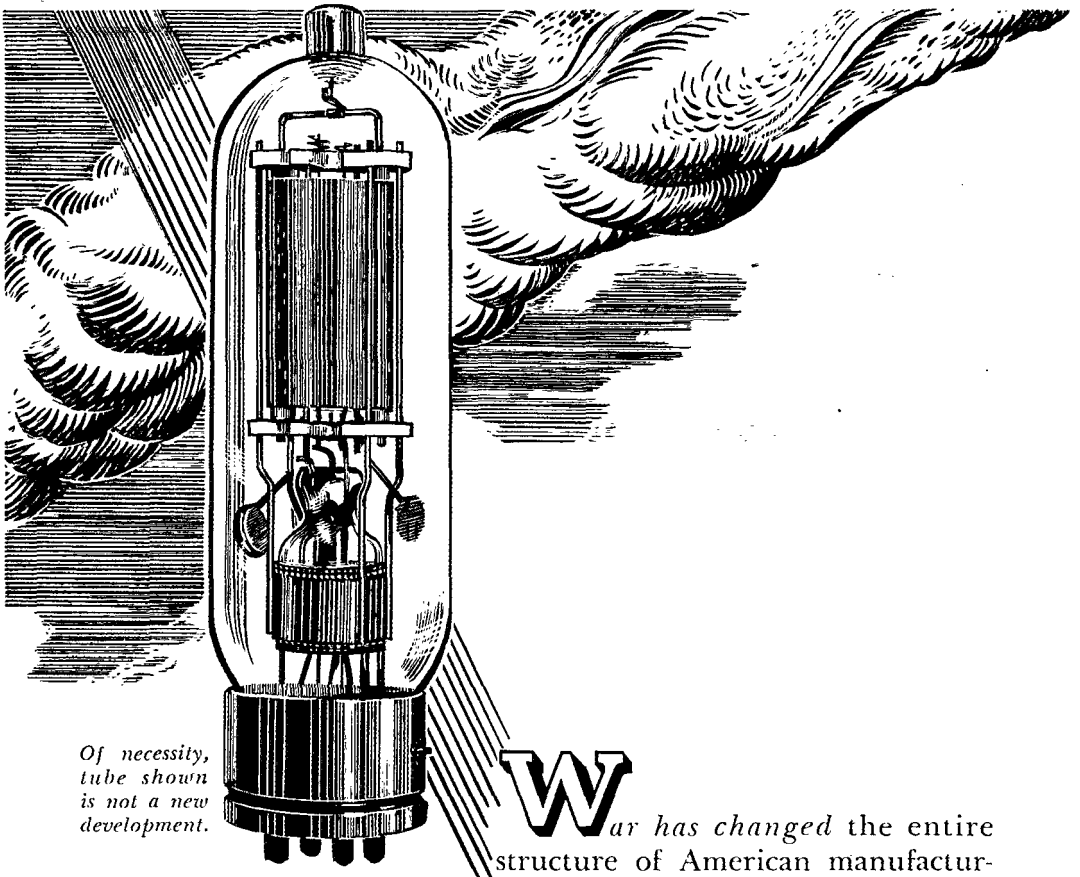

*Of necessity,  
tube shown  
is not a new  
development.*

**W**

*ar has changed the entire structure of American manufacturing with resultant shifting in engineering point of view. Electronic designers are conquering problems never before presented.*

Many defense developments will — when presented to the post-war commercial market — make unheard of changes in electronic scope.

“Secret weapon” is a hackneyed phrase, but would be justified when applied to any number of new applications of electronics. “RADAR,” the u. h. f. aviation locator, may, for instance, be standard equipment on commercial aircraft after the war. Yet it is only one phase of the new developments.

The Raytheon laboratories are well in the vanguard of those developing new devices and usages. When the war is brought to a successful conclusion the RAYTHEON name will mean more than ever before to the engineering world.

## **Raytheon Manufacturing Co.**

WALTHAM AND NEWTON, MASSACHUSETTS

**DEVOTED TO RESEARCH AND THE MANUFACTURING OF TUBES FOR THE NEW ERA OF ELECTRONICS**



## Section Communications Managers of the A. R. R. L. Communications Department

**Reports Invited.** All amateurs, especially League members, are invited to report communications activities, training plans, code classes, theory-discussion groups, civilian-defense building or planning each mid-month (16th of the month for the last 30 days) direct to the SCM, the administrative official of ARRL elected by members in each Section whose address is given below. Radio Club reports and Emergency Coordinator reports representing community organized work and plans and progress are especially desired by SCMs for inclusion in *QST*. **ARRL Field Organization appointments**, with the exception of the Emergency Coordinator and Emergency Corps posts, are suspended for the present and no new appointments or cancellations, with the exception named, will be made. This is to permit full efforts of all in Emergency Corps plans.

ATLANTIC DIVISION				
Eastern Pennsylvania	W3BES	Jerry Mathis	6208 Master St. 9701 Monroe St. Silver Spring P. O. 704 Quinton Ave.	Philadelphia
Maryland-Delaware-District of Columbia	W3CIZ	Hermann E. Hobbs		Linden, Maryland
Southern New Jersey	W3CCO	Lester H. Allen		Trenton
Western New York	W8PLA	Fred Chichester		Sonyea
Western Pennsylvania	W8CKO	E. A. Krall	703 Broadway	East McKeesport
CENTRAL DIVISION				
Illinois	W91LH	Mrs. Carrie Jones	2407 Central Ave.	Alton
Indiana	W9YMV	LeRoy T. Waggoner	1721 Winton St.	Indianapolis
Kentucky	W9ARU	Darrell A. Downard	116 N. Longworth Ave.	Louisville
Michigan	W8DPE	Harold C. Bird	R.F.D. 2	Pontiac
Ohio	W8AQ	E. H. Gibbs	405 Broad St.	Wadsworth
Wisconsin*	W9RH	Emil Felber, Jr.	1625 N. 18th St.	Milwaukee
DAKOTA DIVISION				
North Dakota*	W9YVF	John W. McBride		Lidgerwood
South Dakota	W9QVY	P. H. Schultz	118 N. Yankton Ave.	Pierre
Northern Minnesota	W9FUZ	Armond D. Brattland	Birchmont Rd.	Bemidji
Southern Minnesota	W9YNQ	Millard L. Bender	608 N. Huron Ave.	Spring Valley
DELTA DIVISION				
Arkansas*	W5GED	Ed Beck	2503 Bishop St.	Little Rock
Louisiana	W5DWW	W. J. Wilkinson, Jr.	Room 313, Jefferson Hotel	Shreveport
Mississippi	W5EGE	S. Benton Cain	721 E. Monticello	Crookhaven
Tennessee	W4DDJ	M. G. Hooper	4908 Georgia Ave.	Nashville
HUDSON DIVISION				
Eastern New York	W2LU	Robert E. Haight	356 West 34 St.	New York City
N. Y. C. & Long Island	W2AZV	E. L. Baunach	102 Central Ave.	Massapequa, L. I.
Northern New Jersey	W2LMN	Edward Gursky, Jr.	367 Van Winkle Ave.	Hawthorne
MIDWEST DIVISION				
Iowa	W9AED	Arthur E. Rydberg		Mitchellville
Kansas	W9AWP	A. B. Unruh	1617 S. Seneca St.	Wichita
Missouri*	W9OUD	Letha E. Allendorf	1015 West Third St.	Joplin
Nebraska	W9WKP	Garold Bennett	214 East St.	Hastings
NEW ENGLAND DIVISION				
Connecticut	W1KOV	Edmund R. Fraser	48 Willow St.	West Haven
Maine	W1BAV	Ames R. Millet	37 Morning St.	Portland
Eastern Massachusetts	W1ALP	Frank L. Baker, Jr.	91 Atlantic St.	North Quincy
Western Massachusetts	W1JAH	William J. Barrett	239 Columbia St.	Adams
New Hampshire	W1FTJ	Mrs. Dorothy W. Evans	P. O. Box 312	Concord
Rhode Island	W1HRC	Clayton C. Gordon	70 Columbia Ave., Gaspee	Plateau, Warwick
Vermont	W1KJG	Clifton G. Parker	Box 537	Morrisville
NORTHWESTERN DIVISION				
Alaska	K7GNN	James G. Sherry		Homer
Idaho*	W7AVP	Don D. Oberbillig	P. O. Box 486	Boise
Montana	W7CPY	Rex Roberts	Box 1088	Glendive
Oregon	W7GNJ	Carl Austin	1137 Federal	Bend
Washington	W7EPB	Carl F. Hofmann	4413 East E St.	Tacoma
PACIFIC DIVISION				
Hawaii	K6ETF	Francis T. Blatt	837 16th Ave.	Honolulu
Nevada	W6BIC	Edward W. Heim	509 Claremont St.	Reno
Santa Clara Valley	W6IUZ	Earl F. Sanderson	101 Claremont Ave.	San Jose
East Bay	W6T	Horace S. Greer	414 Fairmount Ave.	Oakland
San Francisco	W6CIS	Kenneth E. Hughes	590 35th Ave.	San Francisco
Sacramento Valley	W6MDI	Vincent N. Feldhausen	113 South Quincy St.	McCloud
Philippines	KA1GR	George L. Rickard	Box 849	Manila
San Joaquin Valley	W6QDT	Antone J. Silva	Route 5	Modesto
ROANOKE DIVISION				
North Carolina	W4CYB	W. J. Wortman	P. O. Box 566	Morganton
South Carolina	W4BQZ/ANG	Ted Ferguson	1213 College St.	Columbia
Virginia*	W8BYE	Thomas S. Jones	2918 Montrose Ave.	Richmond
West Virginia	W8JRL	Kenneth M. Zinn	P. O. Box 132	Clarksburg
ROCKY MOUNTAIN DIVISION				
Colorado	W9CJL	Stephen L. Fitzpatrick	25 Emerson St.	Denver
Utah-Wyoming	W7GZG	Henry L. Schroeder	P. O. Box 731	Laramie, Wyoming
SOUTHEASTERN DIVISION				
Alabama*	W4GBV	Lawrence J. Smyth	808 Winona Ave.	Montgomery
Eastern Florida	W4PEI	Carl G. Schaal	Lakeview Hotel	Clermont
Western Florida	W4ANP	Oscar Cederstrom	Second St. & Bruce Ave.	De Funiak Springs
Georgia	W4AOB	William U. Hanks	4 Hunter St., S.E.	Atlanta
West Indies (Cuba)	CM2OP	Marlo de la Torre	Escobar 110 (Altos)	Habana, Cuba
(Puerto Rico-Virgin Islands)	K4KD	Everett Mayer	24 Lindberg St.	Santurce, P. R.
SOUTHWESTERN DIVISION				
Los Angeles	W6MOM	Ralph S. Chick	1038 Milwaukee Ave.	Los Angeles
Arizona*	W6MLL	Gladden Elliott	218 Loma St.	Nogales
San Diego	W6BZE	Richard Shanks	4033 S. Hempstead Circle	San Diego
WEST GULF DIVISION				
Northern Texas*	W5CY	Gordon Ash	111 So. Ravinna Drive	Dallas
Oklahoma	W5GFT	Russell W. Battern	Box 290	Enid
Southern Texas	W5MN	Horace E. Biddy	1746 Schley Ave.	San Antonio
New Mexico	W5ENI	Dr. Hilton W. Gillett		Lovington
MARITIME DIVISION				
Maritime	VE1DQ	A. M. Crowell	69 Dublin St.	Halifax, N. S.
ONTARIO DIVISION				
Ontario	VE3EF	Flying Officer Donald R. Gunn	c/o Canadian Bank of Commerce	New Toronto, Ont.
QUEBEC DIVISION				
Quebec	VE2CO	Lindsey G. Morris	Apt. 6, 4510 Girouard Ave., N.D.G.	Montreal, P. Q.
VANALTA DIVISION				
Alberta	VE4GE	C. S. Jamieson	581 W. Riverside Drive	Drumheller, Alta.
British Columbia	VE5DD	C. O. I. Sawyer	2634 West 31st Ave.	Vancouver
PRAIRIE DIVISION				
Manitoba	VE4AAW	A. W. Morley	82 Carlton St.	Winnipeg
Saskatchewan	VE4SY	Arthur Chesworth	1071 4th Ave., N.W.	Moose Jaw

\* Officials appointed to act until the membership of the Section choose permanent SCMs by nomination and election.



# UNITED TRANSFORMER CO.

150 VARICK STREET

NEW YORK, N. Y.

EXPORT DIVISION: 100 VARICK STREET, NEW YORK, N. Y. CABLES: "ARLAB"



## КОМПЛЕКТ СТАНДАРТНЫХ ТРАНСФОРМАТОРОВ

Комплект трансформаторов UTC является наиболее полным в мире. Ниже описаны типовые модели стандартизованной продукции UTC.

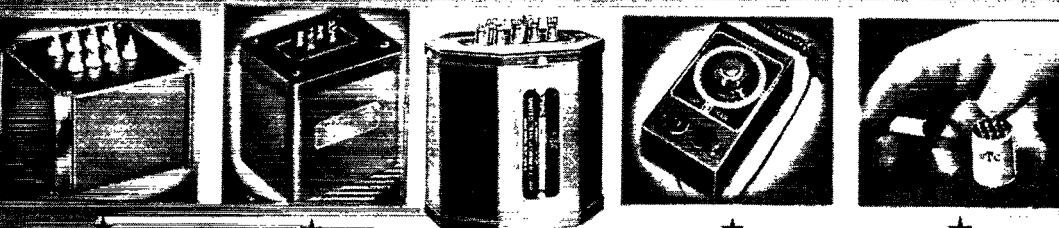

**UTC spells quality in any language!**

Трансформаторы UTC для звукоусилительной установки.

К этой серии принадлежат трансформаторы, которые применяются в радиоприемниках, усилителях, портативных приемниках, а также в других устройствах.

Трансформаторы UTC для высококачественных установок.

Для высококачественных установок, портативных приемников, усилителей, портативных приемников, а также в других устройствах.

Трансформаторы UTC типа "Олеон".

Входные элементы и выходные элементы имеют высокую точность с одной характерной особенностью в диапазоне 40-15000 циклов.

## Специальные трансформаторы, изготовляемые по спецификациям заказчиков.

Значительная часть применяемых в настоящее время высококачественных трансформаторов специально конструируются по спецификациям заказчиков. Среди потребителей специальных трансформаторов UTC имеются такие фирмы как General Electric, Westinghouse, RCA, Western Electric, Bendix и др.

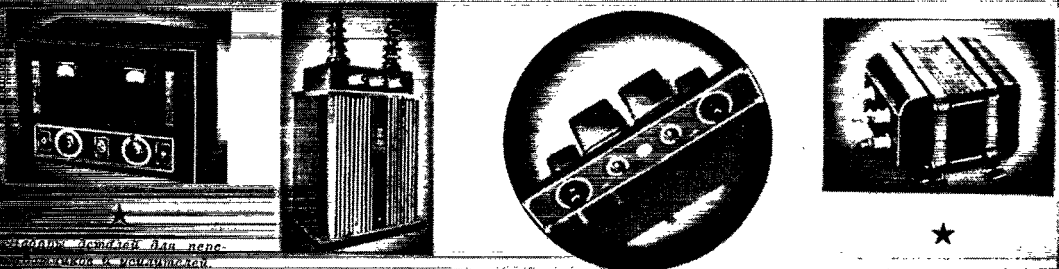

Специальные трансформаторы для переносных приемников.

Специальные трансформаторы для переносных приемников.

Специальные трансформаторы для переносных приемников.

Специальные трансформаторы для переносных приемников.

Специальные трансформаторы для переносных приемников.

Трансформаторы высокой мощности.

Фирма UTC изготовляет трансформаторы мощностью до 1000 ватт (проектируются до 1500 ватт) для высококачественных агрегатов весом в несколько тонн. На рис. сверху показан мощный трансформатор для радиоприемника.

Коэффициент для выравнивания характеристик.

Фирма UTC специализируется в производстве фильтров и комплексов для всех классов радиосвязи.

Многие из этих установок применяются в качестве стандартных в США и других странах.

Промышленные установки.

Промышленный отдел фирмы UTC производит распределительные трансформаторы, бустеры и автотрансформаторы, регуляторы напряжения, выпрямители и проч.

Изготавливаются по спецификациям заказчиков.

Специальные трансформаторы иллюстрируют тенденции и возможности в развитии современных трансформаторов.

# THE AMERICAN RADIO RELAY LEAGUE

## Directors

<i>President</i>	
GEORGE W. BAILEY.....	W1KH 2101 Constitution Ave., N. W., Washington
<i>Vice-President</i>	
CHARLES E. BLALACK.....	W6GG Box 108, Yuma, Ariz.
<i>Canadian General Manager</i>	
ALEX REID.....	VE2BE 240 Logan Ave., St. Lambert, P. Q.
<i>Atlantic Division</i>	
WALTER BRADLEY MARTIN.....	W3QV c/o Naval Air Station, Lakehurst, N. J.
<i>Central Division</i>	
GOODWIN L. DOSLAND.....	W9TSN 11831 Longwood Drive, Chicago
<i>Dakota Division</i>	
TOM E. DAVIS.....	W9VVA 915 W. Becker Ave., Willmar, Minn.
<i>Delta Division</i>	
E. RAY ARLEDGE.....	W68I P.O. Box 286, Pine Bluff, Ark.
<i>Hudson Division</i>	
ROBERT AKERIDGE KIRKMAN.....	W2DSY 250 Albert Place, Elberon, N. J.
<i>Midwest Division</i>	
FLOYD E. NORWINE, JR.....	W9EFC 7405 Hiawatha Ave., Richmond Heights, Mo.
<i>New England Division</i>	
PERCY C. NOBLE.....	W1BVR 37 Broad St., Westfield, Mass.
<i>Northwestern Division</i>	
KARL W. WEINGARTEN.....	W7BG 3219 N. 24th St., Tacoma, Wash.
<i>Pacific Division</i>	
J. L. McCARGAR.....	W6EY 66 Hamilton Pl., Oakland, Calif.
<i>Roonoke Division</i>	
H. L. CAVENESS.....	W4DW 2607 Vanderbilt Ave., Raleigh, N. C.
<i>Rocky Mountain Division</i>	
C. RAYMOND STEDMAN.....	W9CAA 925 So. Gaylord St., Denver
<i>Southeastern Division</i>	
WILLIAM C. SHELTON.....	W4ASR 945 Hurt Bldg., Atlanta
<i>Southwestern Division</i>	
JOHN E. BICKEL.....	W6BKY 1834 E. Whittier Blvd., Whittier, Calif.
<i>West Gulf Division</i>	
WAYLAND M. GROVES.....	W5NW Route 1, Overton, Texas

THE AMERICAN RADIO RELAY LEAGUE, INC., is a non-commercial association of radio amateurs, bonded for the promotion of interest in amateur radio communication and experimentation, for the relaying of messages by radio, for the advancement of the radio art and of the public welfare, for the representation of the radio amateur in legislative matters, and for the maintenance of fraternalism and a high standard of conduct.

It is an incorporated association without capital stock, chartered under the laws of Connecticut. Its affairs are governed by a Board of Directors, elected every two years by the general membership. The officers are elected or appointed by the Directors. The League is non-commercial and no one commercially engaged in the manufacture, sale or rental of radio apparatus is eligible to membership on its board.

"Of, by and for the amateur," it numbers within its ranks practically every worth-while amateur in the nation and has a history of glorious achievement as the standard-bearer in amateur affairs.

Inquiries regarding membership are solicited. A bona fide interest in amateur radio is the only essential qualification; ownership of a transmitting station and knowledge of the code are not prerequisite.

All general correspondence should be addressed to the Secretary at the administrative headquarters at West Hartford, Connecticut.



## Past Presidents

HIRAM PERCY MAXIM, W1AW, 1914-1936  
EUGENE C. WOODRUFF, W8CMP, 1936-1940

## Officers

<i>President</i> .....	GEORGE W. BAILEY, W1KH Washington, D. C.
<i>Vice-President</i> .....	CHARLES E. BLALACK, W6GG Yuma, Ariz.
<i>Secretary</i> .....	KENNETH B. WARNER, W1EH West Hartford, Connecticut
<i>Acting Communications Manager</i> *.....	JOHN HUNTOON, W1LVQ West Hartford, Connecticut
<i>Treasurer</i> .....	DAVID H. HOUGHTON West Hartford, Connecticut
<i>General Counsel</i> .....	PAUL M. SEGAL 1026 Woodward Building, Washington, D. C.

\*The Communications Manager, F. Edward Handy, W1BDI, is on leave of absence.

# "IT SEEMS TO US—"

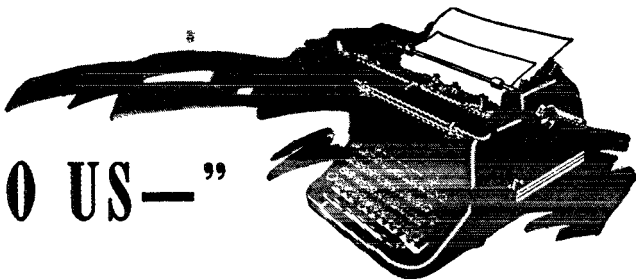

## THE GREEN LIGHT

AFTER months of waiting, the OCD plan for the organization of civilian-defense emergency communications has been enacted. Now we can go ahead. The text of the new rules appears elsewhere in this issue and rates your careful study. It establishes what is called the War Emergency Radio Service.

While the WERS is not an amateur communication system and does not involve the use of amateur stations as such and is not confined to amateur operators, everybody knows that the chief reliance for both operators and apparatus must be put on us. It is our job and we accept it. The need is too great for us to be fussy over our disappointment that we don't get to operate our home stations with our own calls, or to be concerned over the fact that what is called another service is making temporary use of our u.h.f. bands. It will still be we amateurs in our other pants.

This, then, is a bugle call to all you men and women hams who are still home to hit the deck and get in there and do your stuff. Now, while there is still time. Your own home community needs your special ability in its civil-defense communications.

The rules are different this time. The initiative to organize a local communications system does not lie with amateurs. That job will be done by the Citizens' Defense Corps, through its communications officer, acting through his radio aide. There is no longer the device of reactivating an amateur station. The community or district will hold the license, its officers will plan and boss the job, its citizens will supply most of the equipment and man it — all in the common interest. As we see it, here are the things we amateurs must do:

- Give our services as operators
- Lend our u.h.f. apparatus
- Help train more operators
- Help build more apparatus
- Help select the radio aides

Even with WERS operating open to every kind of license holder, there are not going to be nearly enough operators. Too many of us are away from home in the services or on war-

time jobs. Every last one of us who is still available is needed to pitch in and help, not only as an operator but in the work of training other members of our communities in the essentials of radio so that they too may obtain licenses and participate.

Ask yourself where the  $2\frac{1}{2}$ -meter apparatus is to be had for this task. Some of it can still be bought, but not much, considering the extent of the need — not even all the parts we want. The government may arrange some priorities to permit the construction of some new sets for control points — it may happen. But primarily this job is going to be done with the equipment of its amateur participants, because there won't be anything else available in significant quantity. So every last one of us possessing self-powered  $2\frac{1}{2}$  and  $1\frac{1}{4}$  gear must step forward with it and let it be used in the protection of the places we call home. More than that, we'll have to build some more stuff — from the parts we have on hand or can still buy, or from old BCL sets, or from tomato cans if necessary. Fortunately we already have some tried designs, recently published in *QST*, that involve only receiving components that should remain available through the war; these designs of course will be our mainstay.

This is a big proposition. There are millions of people in the CDC. Its organization is complex. The passage of some time will be required before the news and instructions get around and are digested. OCD already has a pamphlet, "The Control System of the Citizens' Defense Corps," but it does not deal with WERS. They must now write and distribute through channels a supplementary manual, instructing their outfits how to proceed. It will be mid-July before this is around the country. If, in the meanwhile, any *QST* reader who encounters these lines has an official place in CDC communications, he may anticipate the arrival of the pamphlet by writing OCD's Washington office, attention Brigadier General Lorenzo Gasser, and asking for whatever advance instructional letter has been issued on the subject. However, if you're just an ambitious amateur without an official connection, don't do this — remember that the right of

initiative lies with CDC, not with us. The CDC plan provides for a communications officer as one of the commander's staff, and he in turn has an aide for radio. The FCC rules for WERS work lodge great responsibilities in this radio aide. He has a heavy job. *He is the man who is going to run this show.* There will be one such aide in each independently-organized community; and if or when OCD organization reaches the state of administration by warning districts, there will be a supervisory aide for each district control center and an aide-on-the-job at each local subcontrol center. Some of them will have so much to do that their jobs very possibly will become full-time paid ones. Most of these aides are yet to be appointed. Now for the point: OCD wants our help in choosing good radio aides.

Amateurs in every community are invited and requested to get together, in club meetings or a special session for CD organization, and make nominations of their first, second and third choices for the post of local radio aide. The names should be given to the local controller or communications officer (frequently the same person). He makes the final selection. One of the names suggested is very likely to be that of the ARRL Emergency Coördinator for the vicinity, since he is generally a leader in this kind of work. But there is no necessary relationship between the EC and RA jobs; this is not necessarily an amateur communication system and the best man for the job may be a commercial operator rather than an amateur. He must be a good administrator, one who can get people to work for him, one in whom you have confidence. Pick good candidates!

Now let's sum up:

The League has asked all its Emergency Coördinators to make a fresh check of all the enrollees in the ARRL Emergency Corps and determine who is still available at home and what useful apparatus they can lend. The ECs are also requested to get as many additional local registrants in the AEC as possible; they want to hear from you if you're not yet in. The EC is then to call a meeting of the local

gang, get nominations for radio aide, pass them on to the CDC controller or communications officer. When the radio aide has been appointed, the EC is to lay before him the offer of the services and the apparatus of the amateur group, with lists of whom and what, and give him any assistance he desires in making contact.

The affiliated clubs have been requested to cooperate with the ECs in this program; in many cases the meeting will be a club meeting. In communities where no EC has been appointed, or where if one exists he is not performing his duties, the clubs are asked to take the initiative, meet and nominate a candidate for EC and ask the SCM to appoint him, while he meanwhile acts as temporary spokesman for local amateurs in the CD relations above outlined.

Individual amateurs are asked to check in with their ECs and state their continued availability. If not yet enrolled in AEC and willing to take part in this work, you are asked to advise your EC. (If you don't know who he is, look in the list of ECs in "Operating News" this issue. If you don't find him there, ask a local ham or drop a card of inquiry to your SCM—address on page 4.) If you have no EC and no local club, you and the other local fellows are asked to have a meeting, nominate a spokesman to represent you before CDC, and send his name in to your SCM with the request that he be appointed EC.

Well, we're off. It has taken a long time. It will take more time before the system is running with any smoothness. Yet the need is urgent and we must move as rapidly as we can. We QSR the request of OCD for your cooperation. We know we don't have to plead with you to join in the work of protecting your own home community. Your talents and your gear are both needed, may be desperately required any night. We must act soon or it may be too late.

And we think, too, that we're all agreed that this time there will be no abuses and no blundering.

K.B.W.

### OUR COVER

THIS month our cover needs no explanation. Proudly, in common with the other major U. S. magazines, we fly the colors, commemorating alike the 166th anniversary of American independence and our mutual resolve that under that banner we shall win Victory.

...—

### ON THE HOOK

THERE's another big issue coming along in August, according to all present signs and

portents. We hope to have some newly-developed gear for the CAP boys that will go a long way in helping to solve their particular problems, for instance. There'll be some other u.h.f. stuff, too, in line with the WERS program described elsewhere in this issue, as well as more invaluable microwave data. Plus a narrative visit to the Noroton Heights radio school, the Navy's outstanding training station; further articles on cryptanalysis and recording; and, of course, the usual departments. There'll be a little something on the lighter side, too.

# The War Emergency Radio Service

## **FCC Establishes Long-Awaited Rules for Civilian Defense Communication on Amateur Frequencies Above 112 Mc.**

ON January 9th the Federal Communications Commission, at the instance of the Defense Communications Board, closed down the several thousand amateur stations that had been reactivated for war emergency communications since Pearl Harbor, and work was begun on a new plan for employing the apparatus and talents of amateurs in civilian-defense communications. The new plan, requested by the Office of Civilian Defense, was calculated to avoid the "loosenesses" and the uneasiness about security that characterized the earlier reactivation of amateur stations. After an interval of nearly five months, during which all work in this field was at a standstill, FCC in early June announced its new regulations.

We present herewith the complete text of the new regulations and urge that every amateur give them a careful reading. They constitute a complete set of regulations, to be known as Part 15 of FCC's rules (just as the amateur regulations constitute Part 12), and are being printed up by FCC as a separate booklet. New forms for the applications, certifications, licenses and permits have also been devised and are now available from FCC.

The War Emergency Radio Service consists of two kinds of stations, civilian-defense stations, in which we amateurs will have a great interest, and state-guard stations, which will concern us only as we may individually be members of a state guard. Both services exist solely for emergency communication in connection with the war. Both operate exclusively in the assigned amateur bands 112-116, 224-230 and 400-401 Mc. The 5-meter band does not appear in the picture.

It will come as no particular surprise to amateurs that these rules do not contemplate the operation of amateur stations, as such. The WERS is an utterly new service, making a temporary employment of amateur frequencies and necessarily counting largely on amateurs and their gear, but not providing that they operate in amateur status. What the plan contemplates is that a license may be given to a municipality or some one of its agencies, to cover the operation of all such stations engaged in emergency civilian-defense communications—fixed, mobile and portable. The individual transmitters will be identified by permanent unit numbers. The call will probably be a four-letter W or K one, to be followed in each case by the number of the unit. The "instrumentality of local government" which applies for the license must submit a detailed plan of its proposed operations, accom-

panied by a map, completely describing its intentions and its proposals for monitoring and supervising and for recruiting its personnel and apparatus. All the operation is to be directed and supervised by the radio aide of the communications officer of the commander of the local Citizens' Defense Corps.

The operators in the WERS must be carefully selected and investigated by the radio aide, who must be able to certify that he is convinced of their loyalty and their operating proficiency. Persons thus chosen must hold some form of FCC operating authority—commercial or amateur license or third-class certificate—and must have fingerprints and proof of citizenship on file with FCC. Note that it is not confined to amateurs; there will be great need to get as many competent persons as possible. But operation in this service may not be done simply by the possession of an FCC operator license. It is necessary for the community to apply for a permit, as a WERS operator, for each licensed operator it wishes to use in its system, which application must be accompanied by two passport-type photographs; and the permit, when received, will bear one such photograph and must be signed by the operator.

Some of the technical matters are going to be annoyingly difficult. The requirement to measure and regularly check frequency will not be easy for these frequencies with inexpensive equipment—or with any available equipment, for that matter. It can be done with a very well-built set of Lecher Wires, operated with great care, and that will probably be the most feasible method.<sup>1</sup> It will be noted that both bands are divided in the center in terms of the stability of the transmitters, the low-frequency half in each case to be permitted only for apparatus in which the carrier frequency will not deviate more than 0.1% (presumably during any given transmission), while the upper half of each band is given over to less stable apparatus which, however, must not deviate more than 0.3%. While we believe it to be recognized by all concerned that, during emergencies, all available apparatus will have to be used, the intention of this regulation is to reserve half the band for the more important circuits between key points, while the outlying stations, particularly the inexpensive portable and mobile ones of which too high a performance cannot be expected, and which operate less frequently, will be segregated in the other end of the band. It is to be noted that

<sup>1</sup>"A Lecher Wire System for U.H. Frequency Measurement," *QST*, October, 1941, page 18.

the rules do not confine the operation of WERS to circumstances where the wire service has actually gone out under bombardment or has become desperately overloaded. While the stations may be used only in needs arising out of enemy activity, they may operate regardless of the state of the wire networks and may, in fact, be given primary responsibilities in preference to the wire system. For instance, instead of tying up all the telephone lines in a control center to bring the local services into action as the result of an emergency, it may be preferable to make one-way radio transmissions from the control room which can be picked up on receivers at the headquarters of each of the local services, much as in police operations. This in itself dictates that part of the band must be reserved for important high-stability transmissions on channels protected against the interference of the usual types of CD gear.

The confinement of the authorized operations to emergencies attendant upon enemy activity makes it impossible for WERS to deal with those precipitated by natural disasters. It is to be deplored that the authority was not extended to cover this other essential field of civilian relief.

The civilian-defense stations may be tested and adjusted, and personnel trained in their operation, in carefully-controlled test periods which are simultaneous all over the nation. The periods are of two hours' duration. For the next few months, while these stations are being set up, there are two such test periods per week, one on Wednesday evenings and one on Sunday afternoons. After November 1st, when it may be felt that the system has been well established, only the Sunday afternoon period will be provided. However, the stations may also participate in the practice alerts and mobilizations that may be ordered by competent authority, upon twenty-four hours' advance notice to FCC.

The power is restricted to a maximum input of 25 watts to the final.

There will not be separate licenses for each transmitter. A blanket license will list and authorize the operation of all of the gear in a particularized communication system. The stations will not be stations of the amateurs concerned, but of the licensee (generally the municipality). Amateur volunteers will be expected to put their u.h.f. gear at the disposal of their communities, so that the latter may "possess" it and control its use.

The radio aide of the CDC communications officer is the all-important master oscillator of this hook-up. He'll have to be a good man, carefully selected, for he must plan and direct the whole system, be responsible for all operations, select and certify the operators and periodically inspect the equipment. There is not yet national uniformity in OCD organization. It seems that generally OCD contemplates its eventual communication organization in terms of its ultimate unit called a Warning District, a region perhaps as

much as 50 miles square and containing just a single organization of the Citizens Defense Corps, with one commander thereof, one communications officer and one radio aide. Where the units are this large it is obvious that the radio tasks are too great for any one man and that there must be a deputy or assistant radio aide for each sub-control center in the district. On the other hand, OCD organization in most of the country is still in terms of independent units for each town, and in these cases the organization and duties seem to be simple and straightforward and reasonable.

We understand that the state-guard operation also mentioned as part of WERS will be under the immediate control of the Army, that applications must move through military channels, and that in general there will not be a disposition to permit any appreciable amount of such operation in communities where the civilian defense is well organized.

This article covers only the high points in the new regs. and leaves unmentioned a host of smaller, but still important, matters. As this is a subject of the greatest interest to all amateurs, we urge you not to content yourself simply with the foregoing résumé but to study very carefully the following text, then see this month's editorial for suggestions on what to do.

## Part 15. — Rules Governing All Radio Stations in the War Emergency Radio Service

### DEFINITIONS

15.1. *War Emergency Radio Service.* The term "War Emergency Radio Service" means a temporary radio communication service intended solely for emergency communication in connection with the national defense and security.

15.2. *Civilian Defense Stations.* The term "Civilian Defense Station" means a station operated by an instrumentality of local government for emergency communication relating directly to the activities of the United States Citizens' Defense Corps<sup>1</sup> or other equivalent officially recognized organization.

15.3. *State Guard Stations.* The term "State Guard Station" means a station operated by a State for communication in connection with the activities of the State Guard or equivalent officially recognized organization.

### APPLICATIONS

15.11. *Applications for Station License.* Applications for authorizations in the war emergency radio service shall be submitted on the prescribed form.<sup>2</sup> A blanket application may be submitted for an authorization to cover the operation of all fixed, portable, mobile, and portable-mobile transmitters proposed to be used in a single coordinated communication system.

### OPERATING SPECIFICATIONS

15.21. *Frequencies.* The following frequency bands are available for assignments to stations operating in the war emergency radio services:

112,000–116,000 kc.  
224,000–230,000 kc.  
400,000–401,000 kc.

<sup>1</sup> The United States Citizens' Defense Corps is an organization of enrolled civilian volunteers established within the Office of Civilian Defense to implement the passive defense.

<sup>2</sup> FCC Form No. 455.

15.22. *Types of Emission.* All stations in the war emergency radio service are authorized to use the following types of emissions: A-0, A-1, A-2, A-3, or special for frequency modulation.

15.23. *Selection of Frequency.* Licensees may select operating frequencies within the available bands provided the equipment is capable of meeting the frequency stability requirements specified in Section 15.25.

15.24. *Non-exclusive Use of Frequencies.* No licensee of any station in the war emergency radio service shall have the exclusive use of any frequency. In the event mutual interference occurs between stations operating simultaneously, the licensees shall be required to coordinate the operation of the stations so as to minimize interference, and make the most effective use of the frequencies available.

15.25. *Frequency Stability.* (a) Transmitting equipment used in the war emergency radio service must be capable of maintaining the operating carrier frequency (without readjustments) within the limits set forth in the table:

Operating frequencies within the bands (Kilocycles)	Maximum deviation band width
112,000-114,000 .....	0.1 of one per cent
114,000-116,000 .....	0.3 of one per cent
224,000-227,000 .....	0.1 of one per cent
227,000-230,000 .....	0.3 of one per cent
400,000-401,000 .....	0.2 of one per cent

(b) Notwithstanding the maximum frequency deviation permitted, all emissions, including those resulting from keying or modulating a transmitter, shall be confined within the frequency band in which the transmitter is authorized to be operated in accordance with the provisions of Sec. 15.25(a).

(c) Spurious radiations shall be reduced or eliminated in accordance with good engineering practice.

15.26. *Frequency Measurement Procedure.* The licensees of stations in the war emergency radio service shall provide for measurement of the transmitter frequencies, shall establish a procedure for checking them regularly and shall maintain adequate records of such measurements. The measurement of the transmitter frequencies shall be made by means independent of the frequency control of the transmitter, and shall be of sufficient accuracy to assure operation within the maximum deviation permitted under Sec. 15.25.

15.27. *Changes in Equipment.* The licensee of a station in the war emergency radio service may make any changes in the equipment that are deemed necessary or desirable unless specifically prohibited from doing so by the terms of the license, provided that:

(a) All changes be made with the full knowledge and consent of the radio aide or the communications officer.

(b) Emissions are not radiated outside the authorized frequency band.

(c) The operating frequency does not deviate more than that specified in Sec. 15.25.

(d) Plate power input does not exceed that authorized in Sec. 15.28.

15.28. *Power.* (a) All stations in the war emergency radio service are authorized to use a maximum unmodulated power input of 25 watts to the plate circuit of the final amplifier stage of an oscillator-amplifier transmitter or to the plate circuit of an oscillator transmitter.

(b) No station shall be operated at any time with a power in excess of that necessary to render satisfactory communication service. In no event shall operations be conducted with power in excess of the authorized power or in excess of the maximum obtainable carrier power output of the transmitter consistent with satisfactory technical operation.

15.29. *Modulation Limits.* (a) The transmitted carrier of stations in the war emergency radio service using amplitude modulation shall be modulated not more than 100%.

(b) The transmitted carrier of stations in the war emergency radio service using frequency modulation shall be modulated so that the total frequency swing arising from modulation shall not exceed 100 kilocycles.

15.30. *Who May Operate Stations.* All stations in the war emergency radio service shall be operated only by a radio operator holding a valid war emergency radio service operator permit, provided, however, that when such stations use

radiotelephony, the licensee may permit such persons as the radio operator deems essential to the emergency, to transmit by voice, on condition that the duly licensed operator maintains control over the transmission by listening and turning the carrier on and off when required, and signs the station off after the transmission has been completed.

15.31. *Logs.* The station licensee shall maintain written records concurrently with the operation of each station with respect to the following:

(a) Location of station during operation.  
 (b) Date and time of operation in local standard (war) time.  
 (c) Identity of station worked and type of communications handled.

(d) Operating frequencies employed.

(e) Names and official titles of persons transmitting by voice over the station whenever such voice transmission is actually carried on by other than a duly licensed operator.<sup>3</sup>

(f) Name of operator on duty.

(g) Signature and title of person maintaining log record. *Provided, however,* that operation in a blackout or during actual air raids, impending air raids or other enemy military action or acts of sabotage, such record of operation shall be reduced to writing at the earliest opportunity and in such detail as may be practicable.

#### IDENTIFICATION OF STATIONS

15.41. *Identification of Transmitters.* The call letters and unit number assigned in the license shall be permanently affixed to the transmitter by the licensee.

15.42. *Transmission of Call Letters.* Stations in the war emergency radio service shall identify themselves by the call letters and unit number assigned to the transmitter at the beginning and end of each complete exchange of communications.

#### LICENSES

15.51. *Control of Equipment.* All equipment for which a license is granted must be owned by or in the possession of the licensee at all times. No license will be granted permitting the operation of a specific transmitter by more than one station licensee in the war emergency radio service.

15.52. *Cancellation Without Notice or Hearing.* A license authorizing the operation of a station in the war emergency radio service is granted upon the express condition that said grant is subject to change or cancellation by the Commission at any time without advance notice or hearing, if in its discretion such action is deemed necessary for the national security and defense and successful conduct of the war.

15.53. *License Period.* (a) Station licenses normally will be issued for a period of one year unless otherwise stated therein.

(b) Dates of expiration of licenses shall be in accordance with the following:

(1) For stations in the states of Alabama, Arizona, Arkansas, California, Colorado, Connecticut, District of Columbia, Delaware and Florida the first day of February of each year.

(2) For stations in the states of Georgia, Idaho, Illinois, Indiana, Iowa, Kansas and Kentucky the first day of March.

(3) For stations in the states of Louisiana, Maine, Maryland, Massachusetts, Michigan, Minnesota, Mississippi, Missouri and Montana the first day of April.

(4) For stations in the states of Nebraska, Nevada, New Hampshire, New Jersey, New Mexico, New York, North Carolina and North Dakota the first day of May.

(5) For stations in the states of Ohio, Oklahoma, Oregon, Pennsylvania, Rhode Island, South Carolina and South Dakota the first day of June.

(6) For stations in the states of Tennessee, Texas, Utah, Vermont, Virginia, Washington, West Virginia, Wisconsin and Wyoming, and for stations in the territories and possessions, the first day of July.

(c) Unless otherwise directed by the Commission, each application for renewal of station license shall be filed on the

<sup>3</sup> This provision does not eliminate the requirement of a licensed operator on duty at the transmitter location who is responsible for the operation thereof.

proper form <sup>4</sup> at least sixty (60) days prior to the expiration date of the license sought to be renewed.

15.54. *Availability of Station License.* The original license shall be associated with the station normally in control of all stations covered by the license, and photocopies of the original license provided by the licensee shall be associated with each of the other stations covered by the license. The original and all photocopies shall be readily available for inspection at any time by an authorized government representative.

#### CIVILIAN DEFENSE STATIONS STATION LICENSEES

15.61. *Eligibility for Station License.* Authorizations for civilian defense stations will be issued only to instrumentalities of local government such as cities, towns, counties, etc.

15.62. *Supplementary Statements.* The applicant shall submit with the application complete and detailed information on the following:

- (a) The proposed plan of operation including:
  1. General operating procedure.
  2. The scope of service to be rendered.
  3. Type of messages to be transmitted.
  4. Methods to be used in monitoring, supervising, and controlling the operation of all stations for which license is requested.
  5. Methods used to measure the operating frequencies of the transmitters.
  6. Provisions for periodic inspection of the equipment.
  7. Source and distribution of the equipment.
- (b) The area in which the stations are to be operated:
  1. If service is to be rendered to adjacent municipalities, the applicant must submit sworn copies of agreements made between the applicant and the adjacent municipalities. Such agreements shall show that the applicant is required to furnish service and the adjacent municipalities agree to accept such service and not to request individual authority, and that such agreements shall provide notification to the Commission sixty (60) days prior to termination thereof.
  - (c) Methods used to ascertain the loyalty and integrity of radio station operating personnel.
  - (d) Plans for enlisting radio operating personnel, and whether they will serve on a paid or voluntary basis.

#### SCOPE OF SERVICE

15.63. *Service Which May Be Rendered.* Civilian defense stations may be used for essential communication relating to civilian defense and only during or immediately following actual air raids, impending air raids, or other enemy military operations or acts of sabotage.

15.64. *Communication With Other Stations.* Within the scope of service permitted under Section 15.63 and during tests and drills, civilian defense stations may be used to communicate with other stations in the war emergency radio service, and with stations in the emergency radio service (police, forestry, special emergency, and marine fire stations) in those cases which require cooperation or coordination of activities. Transmissions not directed to a specific authorized station are prohibited.

#### SUPERVISION AND CONTROL

15.66. *Operational Supervision.* The operation of civilian defense stations shall be directed at all times by a duly qualified "radio aide," provided, however, that the delegation of such supervision shall in no way relieve the licensee of the ultimate responsibility for the proper operation of the stations in accordance with the terms of the station license.

#### RADIO AIDE

15.71. *Definition.* The term "radio aide" means the official designated by the station licensee to direct and supervise the operation of all of the radio stations to be covered in the license for which application is made.

15.72. *Qualifications.* The radio aide shall

- (a) Hold a valid operator's license of any class granted

by the Commission except a restricted radiotelephone operator's permit; and shall

(b) Have been investigated and certified by the station licensee as to his loyalty to the United States and recognized integrity.

15.73. *Certification.* The station licensee shall submit to the Commission, on a prescribed form, <sup>5</sup> the name and address of the initial radio aide and his successor(s), together with a statement from the radio aide that he has accepted such appointment, and the station licensee shall certify:

(a) That the radio aide has been duly investigated by the licensee and is believed to be loyal to the United States and is of recognized integrity; and

(b) That his technical and administrative qualifications are adequate for the proper performance of his duties.

15.74. *Duties.* The duties of the radio aide shall include among others:

(a) The direction and supervision of all radio stations to be covered in the license to assure strict compliance with the terms of the station license.

(b) The provision for the adequate monitoring of all transmissions of the stations under his supervision to assure compliance with the rules and regulations of the Commission, and to guard against the improper use of the radio stations and intentional or inadvertent transmission which might be of value to the enemy.

(c) Inspection of the equipment periodically to insure satisfactory technical operation.

(d) Certification of the names of proposed radio operators after a thorough investigation has been made relative to their loyalty to the United States and their known integrity.

#### TESTS AND DRILLS

15.75. *Tests.* The licensees of civilian defense stations are permitted to make such tests as are necessary for the purpose of maintaining equipment, making adjustments, to insure that the apparatus is in operating condition, training personnel, and perfecting methods of operating procedure provided that such tests shall be conducted only during the following periods:

For tests prior to November 1, 1942:

Time Zone	Eastern	Central	Mountain	Pacific
Wednesdays.	10 PM-12 MID.	9 PM-11 PM	8 PM-10 PM	7 PM-9 PM
Sundays . . .	5 PM- 7 PM	4 PM- 6 PM	3 PM- 5 PM	2 PM-4 PM

For tests subsequent to November 1, 1942:

Time Zone	Eastern	Central	Mountain	Pacific
Sundays . . .	5 PM- 7 PM	4 PM- 6 PM	3 PM- 5 PM	2 PM-4 PM

All times given are local standard (war) time.

15.76. *Drills.* Licensees of civilian defense stations may conduct drills during practice alerts, practice blackouts, practice mobilizations or other comparable situations as may be initiated and ordered by the proper military authority or local civil defense authority, provided that a notice, by mail, of such operations is sent within twenty-four hours after the drill to the Inspector in Charge of the radio district in which the stations are located, and a copy to the Federal Communications Commission in Washington, D. C.

#### STATE GUARD STATIONS LICENSEES

15.81. *Eligibility for Station License.* Authorizations for state guard stations will be issued only to the official state guard or comparable organizations of a state, territory, possession, or the District of Columbia.

15.82. *Supplementary Statements.* The applicant shall submit with the application complete and detailed information on the proposed plan of operation including:

- (a) General operating procedure.
- (b) Scope of service to be rendered.

<sup>4</sup> FCC Form No. 405.

<sup>5</sup> FCC Form No. 455 (a).



- (c) Type of messages to be transmitted.
- (d) Methods to be used in monitoring, supervising, and controlling the operation of all stations for which the license is requested.
- (e) Method used to measure the operating frequencies of the transmitters.
- (f) Provisions for periodic inspection of the equipment.
- (g) Source and distribution of the equipment.

#### SERVICE

15.83. *Scope of Service.* (a) State guard stations may be used only (1) during emergencies endangering life, public safety, or important property, or (2) for essential communications directly relating to state guard activities in instances in which other communication facilities do not exist or are inadequate.

(b) State guard stations may be used to communicate with stations in the war emergency radio service or in the emergency radio services (police, forestry, special emergency, and marine fire stations) in those cases which require cooperation or coordination of activities. Transmissions not directed to a specific authorized station are prohibited.

#### SUPERVISION AND CONTROL

15.84. *Operational Supervision.* The operation of state guard stations shall be directed at all times by an officer in charge of communications or communications officer provided, however, that the delegation of such supervision shall in no way relieve the licensee of the ultimate responsibility for the proper operation of the stations in accordance with the terms of the station license.

#### COMMUNICATIONS OFFICER

15.85. *Definition.* The term "communications officer" means the official designated by the station licensee to direct and supervise the operation of all radio stations to be covered in the license for which application is made.

15.86. *Duties.* The duties of the communications officer shall include, among others:

(a) The direction and supervision of all radio stations to be covered in the license to assure strict compliance with the terms of the station license.

(b) The provision for adequate monitoring of all transmissions of the stations under his supervision to assure compliance with the rules and regulations of the Commission, and to guard against the improper use of the radio stations and intentional or inadvertent transmissions which might be of value to the enemy.

(c) Inspection of the equipment periodically to insure satisfactory technical operation.

(d) Certification of the names of proposed radio operators after a thorough investigation has been made relative to their competence.

#### TESTS

15.87. *Tests.* The licensees of state guard stations are permitted to make such routine tests as are required for the proper maintenance of the stations and the communication system, provided that steps are taken to avoid interference with other stations, and provided further that such testing shall not exceed a total of four (4) hours per week.

#### RULES AND REGULATIONS GOVERNING OPERATORS OF STATIONS IN THE WAR EMERGENCY RADIO SERVICE

15.101. *Licensed Operators Required.* The actual operation of any station in the War Emergency Radio Service shall be carried on only by a duly qualified radio operator holding a War Emergency Radio Service Operator Permit (See Sec. 15.30). The permit shall be in the possession of the operator at all times while on duty, and shall be produced for inspection when requested by an authorized representative of the government or the station licensee.

15.102. *Eligibility.* To be eligible for a war emergency radio service operator permit an applicant shall:

- (a) Hold a radio operator license or permit of any class issued by the Commission.
- (b) Have complied with the provisions of Commission Order No. 75 (fingerprints, proof of citizenship, etc.).
- (c) Be approved by the station licensee and be properly

certified for participation in the activities of the organization.

15.103. *Application Requirements.* An application for each War Emergency Radio Service Operator permit shall be submitted on the prescribed form<sup>6</sup> through the station licensee. This application shall include the name and address of the station licensee together with the name and address of the proposed radio operator, and the class of operator license held by the applicant, and shall be certified to by the radio aide or communications officer that:

(a) The proposed operator has been duly investigated and is believed to be loyal to the United States, and is of recognized integrity.

(b) His technical qualifications are adequate for the proper performance of his duties.

15.104. *Validity of Permit.* (a) The war emergency radio service operator permit authorizes only the operation of the stations licensed to a particular licensee, and is valid for the duration of the war and six months thereafter, but in no event to exceed a period of five years from date of issuance.

(b) The war emergency radio service operator permit is valid only when the photograph and signature of the holder have been affixed thereto.

(c) A photocopy of such permit will not be recognized for the operation of any station in the war emergency radio services.

15.105. *Cancellation of Permit.* (a) A war emergency radio service operator permit is granted upon the express condition that said permit is subject to change or cancellation by the Commission at any time without advance notice or hearing, if in its discretion such action is deemed necessary for the national security and defense and the successful conduct of the war.

(b) The holder of a war emergency radio service operator permit shall surrender such permit to the Commission for cancellation at the request of a station licensee or upon termination of the operator's connection with the station licensee with whom he was previously affiliated.

15.106. *Duplicate Permit.* An operator whose permit has been lost, mutilated or destroyed shall immediately notify the Commission. Any operator permittee applying for a duplicate permit to replace an original which has been lost, mutilated or destroyed shall submit to the station licensee for transmittal to the Commission such mutilated license or affidavit attesting to the facts regarding the manner in which the original was lost or destroyed. If the original is later found, it or the duplicate permit shall be returned to the Commission for cancellation.

15.107. *Renewal of War Emergency Radio Service Operator Permit.* A war emergency radio service operator permit may be renewed upon proper application which should be submitted to the Commission through the station licensee as in the case for an original permit.

15.108. *Suspension of Operator License.* The war emergency radio operator permit may be cancelled and any other class of license held by the operator may be suspended for the violation by the operator of any provisions of law, treaty, rules or regulations of the Commission.

<sup>6</sup> F.C.C. Form No. 457.

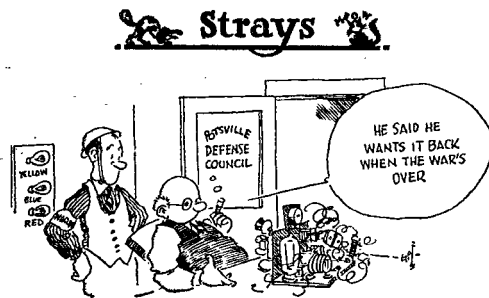

# A Compact Panoramic Radio Spectroscope Adapter

*Circuit and Constructional Details of a Unit Which Can Be Attached to Any Superhet Receiver*

BY GEORGE GRAMMER,\* WIDF

**T**HE general principles of panoramic reception were outlined in March *QST*, with a brief description of an adapter unit which could be used with any superhet receiver.<sup>1</sup> The adapter represents the simplest and least expensive method of getting panoramic reception, and since it can be used with any type of communications receiver it undoubtedly will have more appeal for the amateur than would a panoramic receiver built complete. The panoramic adapter unit to be described uses a 902 2-inch oscilloscope tube, and although this model is a commercial design, it is well adapted both as to circuit and layout to home construction. In general, liberties can be taken with the layout so long as the usual precautions with respect to wiring and arrangement of r.f. stages are observed. With the exception of the special r.f. transformers, the components are those ordinarily available for replacement purposes and consist largely of tubular condensers and resistors.

## Circuit Operation

The complete circuit diagram is shown in Fig. 1. A connection is made to the plate prong of the

\* Technical Editor, *QST*.

<sup>1</sup> Miller, "The Panoramic Radio Spectroscope," *QST*, March, 1942.

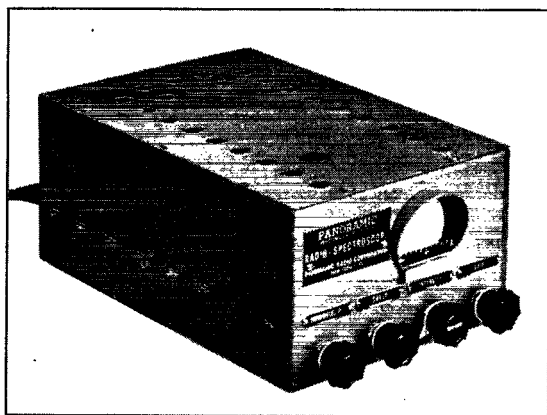

A compactly-built panoramic radio-spectroscope adapter, complete with power supply, which can be used with any communications receiver having an intermediate frequency in the 450-470-kc. region. The cathode-ray tube is the two-inch 902.

mixer tube in the receiver, and some of the mixer output is fed to the first transformer  $T_1$  in the adapter unit through the isolating resistor  $R_1$ . The value of  $R_1$  is made high so that the connection does not detune the first i.f. circuit in the receiver nor load it sufficiently to reduce the receiver gain noticeably. In most receivers the intermediate frequency will lie between 450 and 470 kc., so that  $T_1$  must be designed to operate in this range. The 6SJ7 is a straight amplifier, with the output transformer  $T_2$  tuned to the same frequency as  $T_1$ .

These transformers differ from normal i.f. units only in the fact that they are considerably over-coupled so that all signals within 50 kc. on either side of the frequency to which the receiver is tuned will be passed without undue attenuation in any part of the band. Meeting this requirement means more than simply adjusting  $T_1$  and  $T_2$  to give a flat-topped band 100 kc. wide. The ordinary communications receiver having one r.f. stage has two circuits tuned to the signal frequency (receivers with two r.f. stages have three) and the selectivity of these circuits is such that a signal 50 kc. off resonance will suffer more or less attenuation depending upon the part of the spectrum in which the receiver is operating. At

low frequencies the r.f. selectivity will be quite high, so that the discrimination against a signal 50 kc. off resonance will be great; on the other hand, at a frequency such as 14 Mc. the selectivity will be very much lower, in terms of kilocycles, so that a signal 50 kc. off resonance will go through with very much less attenuation.

Now the ideal condition is that which results in minimum or no amplitude discrimination (in the 100-kc. band) from the antenna to the grid of the 6SA7 mixer in the adapter circuit. Therefore  $T_1$  and  $T_2$  must be adjusted to compensate for the selectivity of the r.f. circuits in the receiver. Since the r.f. circuits will boost signals at the center of the band and attenuate those at the edges,  $T_1$  and  $T_2$  must be adjusted to have a stage selectivity characteristic which has a dip at the center and shows distinct peaks 50 kc. either side of the center. When the peaks are adjusted to boost signals near the

edges to the same extent that the receiver's r.f. selectivity attenuates them, the compensation will be practically perfect over the entire 100-kc. band. In practice such compensation can be secured at only one frequency, since the r.f. selectivity varies with frequency. Hence in an all-wave receiver it is necessary to compromise, which is usually done by making the compensation practically 100% in the 3-Mc. region, accepting the unavoidable undercompensation at lower frequencies and overcompensation at higher frequencies. In using the adapter, this simply means that signals which appear on the screen on either side of center will show amplitude variations with tuning, either increasing or shrinking in height as they travel off the screen when the receiver is tuned. So long as the signal is tuned in the center, however, its height on the screen will give an accurate indication of its relative amplitude — allowing for the usual variations in gain in the receiver's r.f. circuits, of course.

The gain of the first stage in the adapter is controlled by  $R_2$ . This gain control is needed to prevent the stronger signals from exceeding the limits of the cathode-ray tube screen and also to compensate for variations in r.f. gain in the receiver itself from band to band.  $R_3$  provides the minimum fixed bias for the tube and  $R_4$  is the normal bleeder resistor which gives  $R_2$  a large range of control. The screen voltage for the 6SJ7 is taken from the tap between  $R_5$  and  $R_4$ , the tap being by-passed for r.f. as usual.  $R_6$  is a decoupling resistor in the plate circuit.

### Power Supply

The power-supply circuit is somewhat unconventional in that it uses a full-wave voltage-doubling circuit grounded at the center, obtaining by this means the proper value of plate voltage for the amplifier tubes and also the higher voltage required for the cathode-ray tube. Only a single winding delivering about 300 volts a.c. is required for the high-voltage secondary of the power transformer. In Fig. 1, the right-hand pair of elements of the 117Z6GT rectify current which is filtered by condensers  $C_{21}$  and  $C_{22}$  and the choke  $L_1$  and supplied to the plates of all tubes except the 6AC7 reactance modulator. For the latter tube and the screen (oscillator plate) of the 6SA7 converter additional filtering is provided by  $R_{45}$  and  $C_{23}$ .

The left-hand pair of elements in the 117Z6GT rectify the second half of the cycle, and since the current required from this supply is small a resistance-capacity filter ( $C_{24}$ ,  $C_{25}$  and  $R_{48}$ ) is used. The voltage developed in this part of the supply is negative with respect to chassis, and is used to

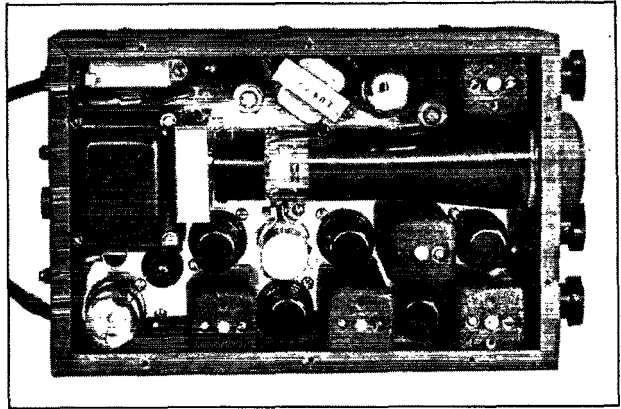

A top view inside the cabinet. The layout of components is described in the text.

supply fixed bias for the 6SA7 converter through the voltage divider  $R_5R_7$ . The bias is slightly more than 1 volt.

### Oscillator Frequency Modulation

The screen (oscillator anode) voltage of the 6SA7 is dropped to the proper value by  $R_{11}$ . The oscillator circuit is the Hartley, the coil and associated tuning, padding and blocking condensers being assembled in one unit designated  $T_5$  in the diagram. This circuit operates at a center frequency of about 356 kc. (actually, the receiver intermediate frequency minus 100 kc., the frequency to which the signal is converted for subsequent amplification in the adapter) and is varied plus and minus 50 kc. by the 6AC7 reactance modulator. The constants of the various components contained in  $T_5$  are given in the caption for Fig. 1 simply as a matter of information, since they are all included in the commercial unit. Plate voltage for the reactance modulator is parallel-fed through  $RFC$  and the decoupling resistor  $R_{49}$ .

The reactance modulator is of the variable-inductance type, the r.f. control voltage for the grid being taken across  $C_{17}$ . The phase of the r.f. current through  $R_{43}C_{17}$  with respect to the current through the complete circuit comprised by  $R_{44}$ ,  $C_{13}$ ,  $R_{43}$  and  $C_{17}$  can be varied over a limited range by  $C_{13}$ , permitting adjustment of the phase relationship between modulator r.f. plate current and tank voltage to the desired value of 90 degrees. The low-frequency control voltage (sweep) for the modulator is applied across  $C_{19}$  through isolating resistor  $R_{42}$  to the grid of the tube. The amplitude of the sweep voltage and hence the frequency band covered by the oscillator is adjusted by the sweep-control potentiometer,  $R_{35}$ . The screen voltage of 6AC7 is regulated by means of the  $\frac{1}{2}$ -watt neon bulb,  $N$ , through the dropping resistor  $R_{39}$ . Good voltage regulation is essential at this point to prevent variations in amplification

in the 6AC7, which might occur with supply-voltage variations and thereby cause the oscillator frequency to shift.

### I.F. Amplifier

The i.f. amplifier, consisting of  $T_3$ , the associated 6SJ7, and  $T_4$ , is tuned to 100 kc. The transformers are designed to be quite sharply peaked so that the pass band is something less than 10 kc. The greater the selectivity of this circuit the higher the "resolution" of the system—that is, the ability to show as separate peaks on the cathode-ray tube screen signals differing in frequency by only a few kilocycles. The screen grid voltage for the 6SJ7 is taken from the same tap which supplies the screen of the r.f. stage in the adapter. Omitting the usual cathode by-pass condenser across  $R_{12}$  helps to stabilize the stage.

The 100-kc. output of the i.f. amplifier is applied to one diode plate of the 6SQ7 final detector.  $R_{13}$  is the diode load resistance and  $C_6$  the load by-pass condenser. The rectified output voltage of the diode is applied to the grid of the triode section of the tube through  $R_{14}$ . The triode section thus acts as a d.c. amplifier and is biased by the rectified voltage from the diode.  $R_{14}$  and  $C_7$  also provide further filtering to remove the r.f. component from the diode rectified output. Plate voltage for the triode section is applied through  $R_{16}$  in a parallel feed arrangement, with  $R_{15}$  in parallel with the series combination of  $R_{16}$ ,  $R_{17}$  and  $R_{18}$  constituting the load resistance for the tube. Headphones can be plugged into  $J_1$  for audio monitoring.

### Sweep Generator

The sweep generator circuit uses the double-triode 7F7, one section being used as an oscillator and the other as an amplifier. The oscillator circuit is the ordinary tickler feed-back arrange-

ment using a midget audio transformer, the frequency being adjusted by means of the variable grid leak formed by  $R_{33}$  and  $R_{32}$  in series. To lock the oscillator at 30 cycles, the desired sweep frequency, a small amount of 60-cycle voltage is taken from the ungrounded side of the 7F7 filament and introduced into the grid circuit through the voltage divider  $R_{31}R_{32}$ . Because of the large amount of feed-back the oscillations are of the blocking type, where the grid is negative enough to cut off plate current completely except for the small portion of the cycle when  $C_{41}$  is almost completely discharged, consequently the plate current occurs in pulses. While the grid is negative (plate circuit non-conducting) condenser  $C_{10}$  in the plate circuit charges through the plate dropping resistors  $R_{38}$ ,  $R_{37}$  and  $R_{40}$ , which limit the rate of charge. The gradual build-up of voltage across  $C_{10}$  forms the saw-tooth voltage wave which is coupled to the grid of the second section of the 7F7 through  $C_{13}$ .  $C_{10}$  discharges rapidly when the oscillator draws plate current, so that the "fly-back" time is negligible enough to make the return trace on the oscilloscope screen invisible.

Part of the plate load,  $R_{29}$ , of the sawtooth amplifier is placed in the cathode circuit, and the sawtooth voltage developed across it and the cathode bias resistor,  $R_{28}$ , is utilized to control the reactance modulator and thus sweep the oscillator frequency over the desired frequency band. The amplitude of the voltage fed to the modulator is regulated by the two variable resistors,  $R_{36}$  and  $R_{35}$ .  $R_{36}$  is adjusted so that with  $R_{35}$  at maximum the saw-tooth voltage applied to the modulator is just sufficient to swing the oscillator frequency over a 100-kc. band.  $R_{35}$  is a panel control of the sweep amplitude, and hence of the width in frequency of the r.f. band being scanned. The band can be "spread" as much as desired by means of this control.

### Cathode-Ray Tube Circuit

In the 902 circuit the usual provisions must be made for adjustment of electrode voltages. The voltage for this tube is obtained by connecting the two power-supply filters in series. Thus the cathode is 300 volts negative with respect to chassis. The ground point comes midway on the voltage divider, which consists of  $R_{21}$ ,  $R_{22}$ ,  $R_{23}$ ,  $R_{24}$ ,  $R_{25}$  and  $R_{26}$  in series with  $R_{46}$  and  $R_{47}$ .  $R_{47}$  supplies adjustable negative bias for the control grid and thus varies the intensity of the pattern on the screen.  $R_{22}$  varies the voltage on Anode No. 1 (positive with respect to cathode) and controls the focusing. The common deflection plates and Anode No. 2 are approximately 130 volts positive with re-

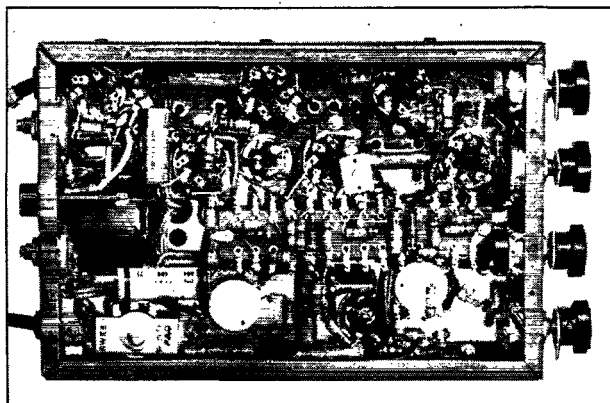

Very little space in the wiring compartment is left unutilized, as shown in this bottom view. The general arrangement in wiring is discussed in the text.

Here are practical details on building a panoramic adapter for simultaneous visual reception of all signals in a 100-kc. frequency band. While the circuit may appear somewhat formidable at first glance, it is readily resolved into sections which in themselves involve no principles or techniques beyond the capabilities of the ordinarily well-informed amateur. Specifically, if you know how superhets work, a bit about oscilloscope circuits, and the principles of simple frequency modulation, you should have no trouble in understanding the operation of the circuit, and no special difficulty in making it work.

spect to chassis, this voltage being taken off at the tap between  $R_{24}$  and  $R_{25}$ . Doc. bias can be applied to the free deflection plates to adjust the pattern to the desired position on the screen; the bias for the vertical plate is obtained from the variable voltage divider formed by  $R_{17}$  and  $R_{18}$  in series, and that for the horizontal plate from the potentiometer  $R_{19}$ . In both cases isolating resistors ( $R_{16}$  and  $R_{20}$ ) are necessary to prevent short-circuiting the a.c. voltages which are also applied to the deflection plates to give the pattern.

The horizontal deflection (saw-tooth) is taken from the plate of the 7F7 through  $C_9$ . The spot on the screen is thus swung horizontally in synchronism with the r.f. oscillator sweep. The vertical deflection (signal) is taken from the plate of the 6SQ7 and applied directly to the free vertical deflection plate.

#### Layout and Construction

The adapter shown is built in a cabinet having outside dimensions of  $7\frac{1}{4} \times 10\frac{1}{2} \times 4\frac{1}{2}$  inches. The base on which the parts are mounted is  $1\frac{1}{2}$  inches from the bottom. The outside view shows the arrangement of the cathode-ray tube screen and the panel controls. The screen is provided with a hood to exclude stray light and also has a frequency scale mounted across the lower edge where the sweep line is positioned for normal operation. The scale is provided with ten equal divisions representing 10-kc. intervals. The four controls on the front (the ones needed in regular operation) are the horizontal positioning control,  $R_{19}$ ; sweep,  $R_{35}$ ; intensity,  $R_{47}$  (the on-off switch is mounted on this control); and gain,  $R_2$ . The vertical positioning,  $R_{17}$ , and focusing,  $R_{22}$ , controls are mounted on the rear wall of the cabinet below the base, and have slotted shafts for screwdriver adjustment. The top and bottom plates of the cabinet are both removable.

The socket for the 902 is mounted on a metal plate which in turn is mounted vertically on the base. (The top of this plate is bent over to cover the high-voltage leads to the socket.) Slots cut in the plate for the socket-mounting screws permit rotating the socket through an arc of about 15 or 20 degrees so that the deflections can be made actually horizontal and vertical. The power transformer is mounted immediately behind the socket plate, in a cut-out in the base which allows the windings and terminals to project through.

The input r.f. transformer,  $T_1$ , is in the upper

right-hand corner in the top-view photograph. The 6SJ7 r.f. amplifier tube is below the 902 near the right-hand edge, with  $T_2$  below the tube in the lower right-hand corner. The next tube to the left along the bottom edge is the 6SA7, followed in order (to the left) by the first i.f. transformer,  $T_3$ , the 6SJ7 i.f. amplifier, the i.f. output transformer,  $T_4$ , and finally, in the lower left-hand corner, the 117Z6GT rectifier. The neon-bulb regulator is just below the power transformer, a little above and to the right of the rectifier.  $T_5$ , the oscillator transformer, is just above the 6SA7 in this view; the 6AC7 reactance modulator is just above  $T_3$ , and the 6SQ7 detector-amplifier is above  $T_4$ . The condenser unit between the 6AC7 and 6SQ7 is a triple unit containing  $C_{21}$ ,  $C_{22}$  and  $C_{23}$ .

The filter choke,  $L_1$ , is mounted in the upper left-hand corner above the power transformer. The sweep oscillator transformer,  $T_6$ , is at the center above the 902, with the 7F7 sweep tube directly to the right. Between this tube and  $T_1$  is the sweep frequency control,  $R_{33}$ , and to the left of  $T_6$  is the horizontal size control,  $R_{37}$ . Both of these are screwdriver-adjusted, with the shafts projecting through the base for adjustment from the top.

The wiring below the base is kept as free from complications as the number of components permits. Condensers and resistors in the r.f. and i.f. circuits are closely associated with the tubes and transformers in the usual "short-lead" style. Resistors and condensers which are not critical as to placement (by-passes, dropping resistors, etc.) are chiefly mounted on a terminal board running from left to right at about the middle of the base in the bottom view. The terminal board is mounted above an inch from the base so that condensers can be wired underneath and resistors on top. The two tubular electrolytics near the upper left corner are the filter condensers,  $C_{24}$  and  $C_{25}$ , for the second power-supply section. In the lower left corner is the sweep padder,  $R_{36}$ , mounted on a bent metal strip which partly conceals the resistor in the photograph.  $R_{33}$  and  $R_{37}$ , which are adjusted from the top of the base, are plainly visible toward the bottom edge in this photograph. The phase-adjusting condenser,  $C_{18}$ , is the Isolantite-insulated mica padder mounted over the 6AC7 socket, slightly to the right of center and just above the terminal board. The other tube sockets can be identified without particular diffi-

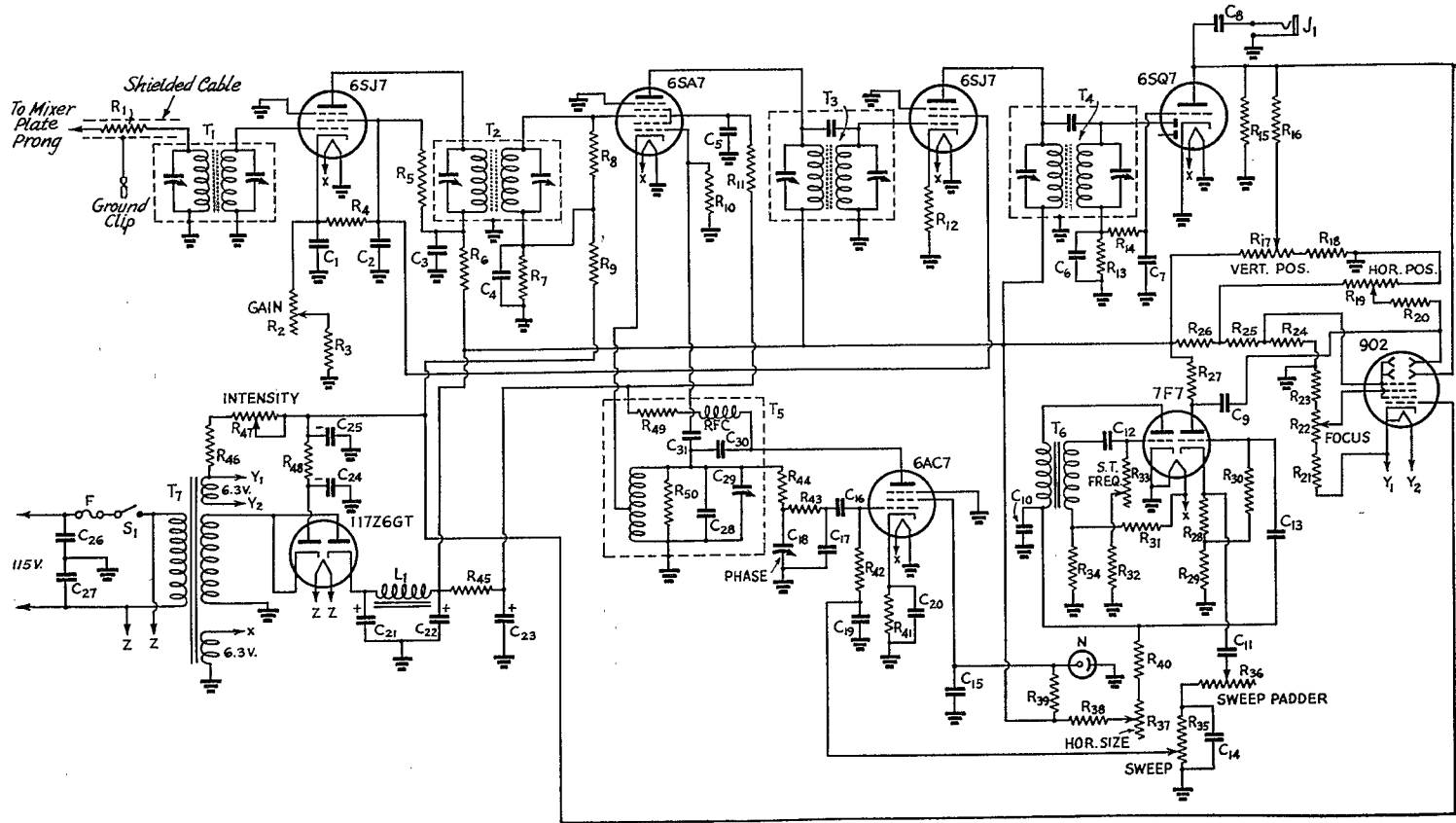

Fig. 1 — Circuit Diagram of the Panoramic Adapter.

$C_1, C_2, C_3, C_4, C_5, C_8, C_{15}, C_{20}, C_{26}, C_{27}$  — 0.01- $\mu$ fd. paper, 600 volts.  
 $C_6, C_7, C_{14}$  — 500- $\mu$ fd. mica.  
 $C_9, C_{18}$  — 0.05- $\mu$ fd. paper, 400 volts.  
 $C_{10}$  — 0.1- $\mu$ fd. paper, 400 volts.  
 $C_{11}$  — 0.25- $\mu$ fd. paper, 400 volts.

$C_{12}$  — 0.01- $\mu$ fd. mica.  
 $C_{16}$  — 100- $\mu$ fd. mica.  
 $C_{17}$  — 30- $\mu$ fd. mica.  
 $C_{18}$  — 1-10- $\mu$ fd. mica padder.  
 $C_{19}$  — 250- $\mu$ fd. mica.  
 $C_{21}, C_{22}, C_{23}$  — 10- $\mu$ fd. electrolytic, 450 volts.  
 $C_{24}, C_{25}$  — 4- $\mu$ fd. electrolytic, 450 volts.

$C_{28}, C_{31}$  — 100- $\mu$ fd. mica (in osc. unit,  $T_5$ ).  
 $C_{29}$  — 30-240- $\mu$ fd. mica padder (in osc. unit,  $T_5$ ).  
 $C_{30}$  — 500- $\mu$ fd. mica (in osc. unit,  $T_5$ ).  
 $R_1, R_{16}, R_{27}$  — 0.25 megohm,  $\frac{1}{2}$  watt.  
 $R_2$  — 10,000-ohm potentiometer.  
 $R_3, R_{12}, R_{24}$  — 200 ohms,  $\frac{1}{2}$  watt.

(Continued on page 21)

culty by comparison with the top view. The controls on the rear end of the cabinet,  $R_{17}$  and  $R_{22}$ , are clearly shown in this bottom view. The tubular bakelite gadget between them, projecting over the top part of the power transformer, is the fuse mounting. The shielded cable to the receiver comes out through the rear in the lower left corner in the bottom view, it runs along the bottom edge to the lower right corner where it makes connections with  $T_1$ . This cable has the isolating resistor,  $R_1$ , mounted at its free end so that it will be as near the mixer (in the receiver) plate as possible. It is soldered to a flat clip made of thin bronze or copper, slotted to fit around the mixer tube plate prong and made small enough so that it will not cause any short circuits when slipped under the tube.

### Testing and Alignment

Adjustment of the unit involves a number of operations, but most of them are quite straightforward. It is probably best first to check the operation of the power supply. At the positive terminal of  $C_{22}$  the voltage to ground should measure 300 volts, approximately, and the same voltage should appear between the negative ter-

(Fig. 1 — Continued from page 20)

- $R_4, R_{43}, R_{44}$  — 50,000 ohms,  $\frac{1}{2}$  watt.
- $R_5, R_{29}$  — 25,000 ohms,  $\frac{1}{2}$  watt.
- $R_6, R_7, R_{28}, R_{45}$  — 5000 ohms,  $\frac{1}{2}$  watt.
- $R_8, R_{18}, R_{21}, R_{23}$  — 0.1 megohm,  $\frac{1}{2}$  watt.
- $R_9, R_{13}, R_{14}, R_{38}, R_{40}$  — 1 megohm,  $\frac{1}{2}$  watt.
- $R_{10}$  — 0.11 megohm,  $\frac{1}{2}$  watt.
- $R_{11}$  — 45,000 ohms,  $\frac{1}{2}$  watt.
- $R_{15}, R_{32}$  — 0.5 megohm,  $\frac{1}{2}$  watt.
- $R_{17}, R_{35}, R_{47}$  — 0.1-megohm potentiometer.
- $R_{19}, R_{22}$  — 0.25-megohm potentiometer.
- $R_{20}, R_{30}$  — 2 megohms,  $\frac{1}{2}$  watt.
- $R_{24}$  — 25,000 ohms, 1 watt.
- $R_{25}$  — 33,000 ohms,  $\frac{1}{2}$  watt.
- $R_{26}$  — See note.
- $R_{31}$  — 500 ohms,  $\frac{1}{2}$  watt.
- $R_{33}, R_{36}, R_{37}$  — 1-megohm potentiometer.
- $R_{39}$  — 75,000 ohms,  $\frac{1}{2}$  watt.
- $R_{41}$  — 1000 ohms,  $\frac{1}{2}$  watt.
- $R_{42}$  — 0.2 megohm,  $\frac{1}{2}$  watt.
- $R_{46}, R_{48}$  — 10,000 ohms,  $\frac{1}{2}$  watt.
- $R_{49}$  — 3000 ohms,  $\frac{1}{2}$  watt (in osc. unit,  $T_5$ ).
- $R_{50}$  — 25,000 ohms,  $\frac{1}{2}$  watt (in osc. unit,  $T_5$ ).
- $T_1$  — R.f. input transformer, 456 kc.
- $T_2$  — R.f. interstage transformer, 456 kc.
- $T_3$  — I.f. input transformer, 100 kc.
- $T_4$  — I.f. output transformer, 100 kc.
- $T_5$  — Oscillator transformer, 356 kc.
- $T_6$  — Saw-tooth oscillator transformer (2:1 or 3:1 midjet audio).
- $T_7$  — Power transformer; two 6.3-v. windings, h.v. winding, 300-v. a.c., 40 ma.
- $L_1$  — Filter choke, 40 ma., 350 ohms (app. 5–10 henrys).
- $F$  — 2-amp. fuse.
- $S_1$  — Toggle switch (on  $R_{47}$ ).
- $J_1$  — Open circuit jack.
- $N$  —  $\frac{1}{2}$ -watt neon bulb without base resistor.
- RFC — 30-mh. r.f. choke (in osc. unit,  $T_5$ ).

Note:  $R_{26}$  needed only in case horizontal positioning control ( $R_{19}$ ) is critical in adjustment or total plate voltage exceeds 300, approximately. It may be omitted in this circuit, the junction of  $R_{25}$  and  $R_{19}$  being connected directly to +B.

Transformers  $T_1$ – $T_4$ , inclusive, are available from Panoramic Radio Corp., New York City.

terminal of  $C_{25}$  and chassis. The voltage should be negative with respect to chassis in the latter case. The total voltage between these two "high" points should be 600, with the hot side of  $C_{25}$  negative and the hot side of  $C_{22}$  positive. The screen voltage on the two 6SJ7s should be approximately 100 (at full gain) measured with a 1000-ohms-per-volt meter.

Since the cathode-ray tube makes a convenient indicating device in alignment of the r.f. and i.f. stages, it is a good idea to put it and the sweep generator into operation before tackling the amplifier circuits. The sweep generator should give no difficulty, although it will be helpful to check the shape of the saw-tooth if an oscilloscope is available for the purpose. A 'scope having the regular complement of amplifiers and a linear sweep is necessary for this. Connect the grounded side of the vertical input of the 'scope to chassis and the high side through a condenser (0.1  $\mu$ fd. or so) to the ungrounded side of  $C_{10}$ , when a saw-tooth should appear on the oscilloscope screen, if the oscilloscope sweep frequency is of the order of 30 cycles. With the vertical amplifier connected to the grid of the saw-tooth oscillator a sharp pulse should appear on the screen. Synchronization can be checked by connecting the 'scope across  $R_{34}$  and adjusting the oscilloscope sweep to include three or more cycles of the 60-cycle voltage which appears across  $R_{34}$ . At each oscillator grid pulse a small transient will appear in the pattern (it may be only a small gap in the 60-cycle trace) and when  $R_{33}$  is adjusted so that one of these appears at the same point on every other cycle the saw-tooth oscillator is synchronized at 30 cycles. If the oscillator is not synchronized the pulses will appear at random.

Checks of saw-tooth waveform also can be made at the cathode of the amplifier section of the 7F7, where the voltage is taken off for the reactance modulator, and at the plate of the same 7F7 section, which furnishes the sweep voltage for the 902. The saw-tooth should be reasonably straight (make allowance for possible poor linearity of the sweep in the oscilloscope at this low frequency) and the fly-back time, or horizontal duration of the vertical part of the saw-tooth, should be very short. Should the oscillator not operate at all (no pattern on the oscilloscope screen), reverse the leads of the plate winding of  $T_6$ .

With the saw-tooth oscillator in operation, apply voltages to the 902. The saw-tooth applied to the horizontal deflection plates should give a horizontal line on the screen, focusing and intensity being adjustable by means of  $R_{22}$  and  $R_{47}$ , respectively. The width of the line can be adjusted by the horizontal size control,  $R_{37}$ , and its position on the screen by  $R_{19}$ , the horizontal positioning control, and  $R_{17}$ , the vertical positioning control. Set the line well toward the bottom of

(Continued on page 100)

# IN THE SERVICES

## RADIOLOCATOR

IN THE May 1942 *QST* "In The Services" column, 3HMX of Grove City College commented that the course of instruction was proving to be wide in scope and somewhat difficult, as the boys are receiving a college course in math and physics in only three months. Writes RM2c Thornton, 5KJW, from Texas A & M: "The only thing that is different here is the weather!" Hi!

RM2c Freeman, 8SIB, relays the doleful news from Grove City College that the class which started in April was quarantined (measles, we betcha!) but are now back in the swing and going OK. Here's the list of hams, all RM2c, taking the course: Howe, 8TJH; Freeman, 8SIB; Schwinn, 2LBR; Gribetz, 2OCE; Shapiro, 2FLJ; Millner, 8SVH; Nemetz, 1IHK; Bennet, ex-2AMM; Zondlo, 2KIN; Spencer, ex-2DEG; Galacki, 2NJW; Daly, 2KTH; Pontus, 3FCR; Goodwin, 2DVU; Davidoff, 2NME; Johnson, 8SBK; Cullen, 1MXZ; Wackford, 8VJV; Marcou, 1DSJ; Remeta, 2LLO; Walsh, 2LOK; MacDonald, 2KMH; Fruscione, 3JLI; Marcoux, 1DEF; Beidleman, 3FYA; Abraham, 2GHT; Keller, 8MLM; Dunn, 2HQD; Katz, 2OAO; Parnham, 2KFK; Legg, 2IPJ; Kochinchak, 2IPR; Goodwin, 2NPI; Horn, 2HWR; Kelso, 8JPR; Eckstein, ex-2BAO; Clark, 2JBL; Eritano, 8WFE; and Quinn, 2MMK.



William Corbett, 8DVP, is rightfully proud of his four sons. Left to right: Richard, shortly due for selective service call; Corbett, sr., formerly a Navy CRM; Harold, 8HKV, a radio sergeant at Ft. Jackson, S. C.; Howard, radioman attached to the 123rd Sig. Radio Intelligence Co.; and Donald. All four boys were trained in radio by Corbett, sr., who is hoping to get a waiver on the age limit so he can again serve!

In and around Chicago we have a full representation of amateurs in radiolocator work this month. RM2c Martin, 9CTQ, is instructor at the Radio Material School; Chapman, 8WHA, is a student at Great Lakes along with Hansen, 8TKG, and Smith, ex-9CLD and 8GTJ. At the Naval Armory the following are schoolmates, all RM2c: James Belshaw, 9BKA; William Belshaw, 9QJM; Campbell, 5JWG; Fisher, 9TEX; Frye, 8NPG; Gaines, 9MPP; Goyette, 9BPU; Greene, ex-9CSR; Greenwood, 8VKI; Gregory, 9TYR; Jensen, 9EOZ; Kirtion, 9MLR; Koorie, 5GYB; Kraehmer, 9ZLG; Levy, 9HXF; P. H. Martin, 8QHL; Robert Martin, 9YAO; McFall, 9BZZ; McGee, 9YZQ; Mosteller, 5JDG; Peters, 9WTO; Roehm, 9BGO; Thraikill, 9QZF; Wilson, 9KQN; Witt, ex-9QII; Word; Wright, 9YAL; RM3c Peaden, 5HHR, and Russell, 9MES.

We have an impressive list of first graduates at the Navy Radio Material School, Chicago, which gives primary radiolocator training. Out of ninety-nine graduates, fifty-five were hams. Of course, the six highest in the class were also amateurs. Nice going, fellows! Lt. Lachman, 9EEH, is in charge. The six high students in order are Crow, 9FHI-5IC; Byard, 8SLO (you can't believe a call!); Gacioch, 8QVY; Feuerstein, 9SXY-9XAU; Gerend, 9OUT; Hensley, 9HUW.

Lined up for inspection are the rest of the class, in alphabetical formation: Butler, 9ZRP; Cillo, 9USK; Clarke, 9RUJ; Conger, 9DDK; Cuckler, 9KLD; Derbak, 9UAY; Doty, 9GGK; Duke, 9OV; DeMunbrun, 9RBV; Eberhardt, 9YWS; Foley, 9CVI; Fox, 8NII; Fristoe, ex-9NNN; Fridg, 8VGH; Frye, 8NPG; Gleason, 9FXK; Grebe, ex-9LAP; Hoefl, 9QXK; Howie, 8TWG; Howlett, 9BEC; Hankins, 9JMY; Helm, 9NYX; Howard, 9ORZ; Keller, 9RKA; Lahr, 9HTA; Martin, 9CTQ; Mercer, 8JST; Mills, 9PYB; A. Mueller, 9NVL; R. Mueller, ex-9OHZ; Mawhee, 9UPP; McCartin, 8VHH; Patrick, 9AUQ; Peterkin, 8FR; Richardson, 9ZDM; A. Rogers, 9OZE; G. Rogers, 9ASX-9VTR; Rutherford, ex-9UEO; Schwartz, 9QZP; Seward, 9YNC; Smith, 9QHO; Stambach, 8WCS; Style, ex-9AFR; Swanson, 9HXP; Sykes, 9YZT; Tiikkainen, ex-9JRJ; Williams, 9SQV; Woodgate, 9IPZ and Zinniel, 9YNN. The instructors are Osterland, 9TJL-9XPR-9XBK-9XBB-9XBT-9XBE (what, no FRS, KCB, LLD or DDS?!); Kusack, 9QEE-9XBK-9XBT; Doering,



9XBK-9XBT and Kuntz, 8SNS-9XBK-9XBT.

Gray, 5IXJ, is at the Navy school at A & M College, Stillwater, Okla., and Mattox, 9KLI, is in Navy radiolocator work "somewhere."

## SIGNAL CORPS

THE S.C. register this month is slimmer than usual. There must be a lot of you fellows who have not sent us ITS information, so hop to it if you want to be among those present.

Olsen, 2IAS, has recently been called to active duty at Ft. Monmouth as 2nd Lt. Phil Latta, 4GTS, is likewise commissioned there and advises that Bill Latta, 4FIN, expects to be in the Air Force this summer. Corp. Gundry, 8KNP, is with the 15th Sig. Service Rgt. Starrett, 1JSL, is training for radio repair and maintenance. Kanter, 9KID, Farnsworth, 6SYP, Brick, 8RES, Boyce, 8ONU, Jamieson, 9GQQ, and Morrele, 6OJS, are just training, all at Monmouth.

Lt. Newberry, 8LOQ-2OKA, is assistant director and officer-in-charge of the Field Radio Department School, Camp Crowder, with 2nd Lts. Kody, 8HRA, Miller, 9TXX, and Stone, 6NJZ, assigned to the same outfit.

Three of the gang have just reported in from Iceland; Corp. Kooops, 2HEM; Corp. Strinck, 3JKN, and Pvt. Lakatos, 8SOP. Let's hear from some more of the overseas fellows.

Sgt. Carmichael, 9SGC, is with the 33rd Signal Co. at Camp Forrest; Lain, 9WHO, is in the Office of the Chief Signal Officer, Washington; Staff Sgt. Hunsucker, 4HEV, and Pfc. Lanzoni, 3FBC, are at Ft. Jackson in the 56th Signal Battalion. Pvt. Soens, 9KCO, recently enlisted and is stationed at Harlingen, Texas. He advises Beranek, 9SBT, is a private at Camp Crowder. Lt. Jordan, 2KUD, is officer-in-charge, Information and Status Section, Office of Chief Signal Officer. Plummer, K4HBW, is stationed in Hqtrs. Signal Office, San Juan, P.R.

Quinn, 9TQD, holding down a watch at WAR, says quite a number of the fellows are at that message center ("signal center," now). Who are they?

Pvts. Talts, 9TXO; Silverstein, 9VUN; and

The response to our requests for ITS information has been heavy. Cards and letters continue to come in each mail and our file has assumed such man-sized proportions we cannot guarantee to mention each new call in the following QST — but it will appear as rapidly as space is available. Don't neglect to send us the dope on yourself in full. Too many send partial data and let us guess the rest. Remember: name, call, rank, or rating, radio duty, outfit, location, status (selectee, reservist or volunteer) and NCR or AARS.



Pfc. Lanzoni, 3FBC; Parado; and Staff Sgt. Hunsucker, 4HEV, use 2MLW's license plates to send regards to all.

Meade, 9KXL, have been in the Army since March and are stationed at Camp Cook, Cal. with the 145th Armored Signal C. A.; Huberman, 2JIL, finds radiolocator work "interesting and swell" at Ft. Hancock, N. J., while Cline, 6QEO, and Barth, 5IFV, are doing their best for the Signal Corps at unnamed places. Pvt. Matthews, 7HMI, is a volunteer radio technician with the Army Alaska Communications System in Seattle, and passes the information that Gruble, 7RT, rates a sergeant's stripes and instructor's job with that outfit.

The Technological High School in Atlanta has trainee repairman courses under the supervision of Krueger, 4YC, with Elliot, 4GFK; Cooper, 4FSH; Hendricks, 4GHZ; 4MHW; Brown, 4FWP; 5KIE; Adams, 4EGV; and Johnson, 4DFT, as enrollees. Ohm's Law hasn't a chance! Conover Jr., 4GIX, son of 4FDT, has been transferred from Atlanta to the submarine service.

## NAVY SEA DUTY

CENSORSHIP regulations do not allow us to connect men and their vessels; suffice it to say that the following have been assigned sea duty of one kind or another. (We can supply postal addresses, if on file, to individuals wanting to contact fellow amateurs in this service.) Here's the list: Lt. Boland, K6SQE; Lt. (jg) Esmiol, 9ZRF; Ens. Burda, 9TUZ, and Bookman, 6NIW; CRM Craig, 3MH, and Janiga, 1NJH; RM1c Colletti, 8QWS, Najork, 2HNN, Hallett, 6OSX, and Stine, 8LAG; RM2c Flanagan, 9CGO, and Holcomb, 9IMB; RM3c Hall, 2NWK, Rickley, 9EUG, and Villar, 4ANI. The Indiana SCM reports Varga, 9WIB, Zimmerman, 9DQK, Chwaliboga, 9GPZ, and Spudic, 9NGB, all together on the same craft. Talbot, 9CZE, likes the ocean life and hopes more amateurs join up. LeRoy, 5GUY, volunteered a

year ago as RM3c and has gone up the line to warrant officer last April. Ensign soon, maybe?

## AIR FORCE

**STAFF SGT. PAPP, 2LBG**, has an interesting job towing aerial targets for antiaircraft fire. Pvts. Spielberg, 9AUM, and Hensley, 5EEB, are S. C. men in communication work at southern air bases. Newly-promoted Sgt. Day, 9INP, is operating at Ft. Riley, Kans. Lt. Huffhines, 5HRU, is taking advanced training at Moore Field. Hockin, 9TYS, at Ellington Field, expects to receive his wings shortly. Pvt. Plonka, 1JVK, operates for an observation squadron at Ft. Dix, and Pvt. Ingraham, 8MRA, has transferred to the Air Force at Salt Lake City. In the pursuit section we find Capt. Bolick, 9HJH, at Los Angeles Hqtrs; Lt. Tutwiler, 3JFL, at Wilmington, N. C., and Sgt. Holland, 7JAW, at McCord Field, Wash.

At the Air Force Gunnery School in Las Vegas, Nev., are Sgts. Beljan, 8SCW, and Medlock, 9NWQ, and Cpl. Strobo, 9YKL, doing maintenance work; Pfc. Pelc, 9OOR, tower operator; and Cpl. Graff, 9NSE, making sweet music in the band! Pvts. Deweese, 9NON; Flynn, 2ILG; Frank, 9VSY, Wheaton (op. only); Kukura, 9TTW; and Geist, 2LFC, are at school at Scott Field, where Trautman, 9KFB, is an instructor. Staff Sgt. Broughton, 8PVN, is training at Keesler Field, Miss. The airways station at Keesler is manned by Tech. Sgt. Hicks, 5KDQ/K6OS in charge; Staff Sgt. Grothe, 9KXO, chief op; Sgt.



Capt. Vendley, 6AAE, member of the Third Army Training Inspection Team, on a visit to Ft. Clark, Texas, found this 55 beer-can vertical antenna on the roof of a cavalry signal section. Guyed at the middle with four wires, bottom fed, it has withstood several windstorms and is an excellent radiator. Capt. Vendley does not recommend the emptying of 55 cans at one time, however.

Solov, 1HVC; Pvts. Palmer, 1JBC; Balcom, 1ELL; Reilly, 2EII; and George, 8TAH. Sgt. Thomas, 8QAN, and Sgt. Jenkins, 4CQR are instructors; and Hammond, 4AGJ, and Hotz, 1FR, are among those present. Pvt. Taffe (call, please?) is assigned to radio maintenance of the ferry command. Pvt. Hannan, 5ERR, is learning Army net operation at Drew Field, Fla. Righter, 3FSE, is temporarily stationed at Bolling Field. Staff Sgt. Kindler, 9PAN, operates the control tower at Duncan Field, Texas. Via the ERC route, Corp. Johnson, 9QAK, is now at the Army Air Base in Salinas, Cal. Sgt. Granahan, 8VGS, is with the 76th Bomb Squadron at McChord Field and Staff Sgt. Walker, 6TYC, is in charge of communications with the 46th B. S. at Fresno, Cal. Pvt. Goggio, 9GHD, is attending weather observer school at Chanute Field and hopes to go to Scott for a commission in communications. Cpl. Petty, 6UFQ, is aboard a bomber at Paine Field, Everett, Wash., and Sgt. Winters, 8PCM, is op with the Army Airways at Kelly Field. Krusniak, 9ZBK, has a berth with the 449th School Squadron at Hendricks Field, Fla., and Golec, 8VGA, is at Ft. Knox, Ky.

The Air Force is well represented with amateurs in the commissioned bracket. Capt. Stewart, 2JRG, is with the 57th Pursuit Group, Boston; Capt. MacKellar, K6OWJ, is at Hickam Field, Hawaii; Lt. Crater, 3FSJ, is at Turner Field, Ga., and Lt. Warner, 9IBC, is among those present (QTH unknown). Lt. Ostler, 6RWY, is at the A. F. Gunnery School, Las Vegas, Nev. Hellmuth, 2BGV, is a 2nd Lt. and communications officer for the 63rd Pursuit Squadron at Farmingdale, L. I., and Tietz, 9QDL, has the same rank and job with the 4th Interceptor Command at San Francisco. 2nd Lt. Eckhardt, 7BBK, holds down a double job as pilot and communications officer with the 49th Pursuit Squadron and Glass, 3FQO, is likewise a 2nd Lt. and communications officer with the 344th Bombardment Squadron at Ft. Myers, Fla.

## MARINE CORPS

**THE** Marine Corps breaks into print this month, and we hope to have many more entries in the near future.

Capt. Phillips, 5IIL, is in medical work at a camp in the Canal Zone; Lt. Martin, 6STT, is Communication Officer with the Fleet Marine Force; and Staff Sergeant Atherton, 6CTP, is stationed at Quantico, Va. with the Post Signal Battalion. Pvts. Sciez, 9YKI, and Shadduck, 7IUY, were finishing schooling with the Marines in San Diego a month ago.

Let's have some more information from amateurs in this outfit; there must be many from whom we have not heard. Those of you not yet in the service, see "U. S. A. Calling," pages 48 and 49. The M. C. needs many engineers, operators, technicians and repairmen for AWS equipment.

# 100 Centimeters and Down

## A Review of Microwave Technique

BY ROBERT F. SHAW,\* W3AOC/WLMB

### In Two Parts — Part I\*\*

THE past few years have brought a tremendous increase of interest in the frequencies above 300 Mc., accompanied by a program of development which, in its intensity and scope, is probably unrivalled in the history of radio. As in all similar cases, hams have had their share in this work, but their participation in this case has been mainly as engineers and technicians with commercial organizations engaged in the work; although the  $\frac{3}{4}$ -meter band was opened to us in 1925, the hams who have actually operated below one meter can almost be counted on the fingers of one hand.

There are various reasons for this — the difficulty of getting results with standard tubes and the expense or unavailability of special types, the low  $Q$  of standard tank circuits with consequent inefficiency or complete suppression of oscillation, the fact that there was still much room for experimental work as well as numerous other activities on the lower frequencies, and many similar reasons. Now that all our activities on the lower frequency bands have been indefinitely suspended, we have a fine opportunity for

In these days no amateur can consider himself well informed unless he knows something about the last few years' developments in the 300-Mc.-and-up field. Here is the transition region between the familiar and the unfamiliar — the latter no doubt destined to become tomorrow's commonplace. This first part of the article deals with new types of tubes; in the second part cavity resonators will be described. A comprehensive bibliography directs the reader to more detailed information.

some more of that pioneering in radio for which hams have always been famous — for there is much that can be done in this field without running afoul of the FCC by actually radiating signals or engaging in communication.

The present article has been written in an attempt to stimulate interest in this field among amateurs. An effort has been made to accomplish two things — first, to give the reader a general view of the developments in microwave technique up to the present time, with special emphasis on features peculiar to the field such as velocity modulated tubes and cavity resonators; second, to assist anyone with sufficient interest in the subject to obtain further information which is beyond the scope of this article. With this latter purpose in mind we have included a very comprehensive bibliography; numbered references in the text refer to this bibliography.

#### Tubes

Most standard tubes, particularly transmitting tubes, give poor results on the ultrahigh frequencies, as most of us have discovered in trying to get rigs working on 5 or  $2\frac{1}{2}$  meters, but the reasons are not so universally understood. Inter-electrode capacities and lead inductances play an important part; the former difficulty can be overcome to some extent by keeping the tank circuit capacity as low as possible, and the latter by making the tube leads a part of a resonant line circuit, as in the case of the tuned filament lines used in some circuits on  $2\frac{1}{2}$  meters and below.

\* 5818 N. 13th St., Philadelphia, Pa.

\*\*Part II of this article, dealing with u.h.f. resonators, will appear in a forthcoming issue.

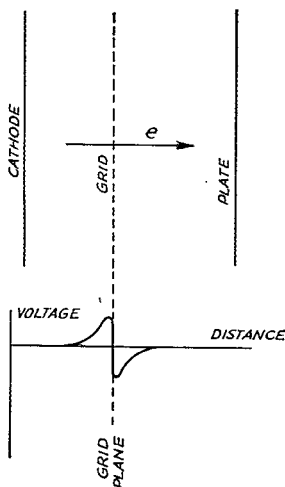

Fig. 1 — Voltage induced in grid by a moving electron, the mechanism by which transit-time effects arise.

The third and, at very high frequencies, most important difficulty is the effect of electron transit time; when the time required for an electron going from cathode to plate to pass through the grid region becomes an appreciable part of a cycle at the frequency used, the effect is to lower the grid impedance. Thus efficiency is lowered, higher excitation is required for a given output, and a tube may refuse to oscillate because not enough power can be fed back from plate to grid.

The way in which this lowering of input impedance comes about is shown graphically in Fig. 1. It is a well-known principle of electro-dynamics that a moving electron induces voltages in any conductors in the neighborhood; thus an electron moving to the right as indicated by the arrow *e* will induce a voltage in the grid as it approaches, and after passing through the grid it will induce a voltage of opposite polarity as it leaves the grid region. At low frequencies these two pulses of opposite polarity are so close together in time that, so far as their effect on the input circuit is concerned, they will cancel each other. But at higher frequencies their separation will become an appreciable part of a cycle, and since the input circuit will have a greater response to such frequencies by virtue of being tuned to the operating frequency, the net result is that there will be components of the induced currents flowing in the input circuit which are in phase with the excitation. Thus the grid current will be increased, just as it would be if the input impedance of the tube was lowered — which is, in effect, exactly what has happened. Unfortunately this increase of input power does not lead to a corresponding increase in output but simply

increases the average kinetic energy of the electrons and results in additional heating of the plate, which is another way of saying that the efficiency is reduced.

Obviously it is possible to reduce tube capacities and lead inductances by reducing tube size, and to overcome transit time effects by reducing inter-electrode spacing. Several tubes have been developed in this way for u.h.f. applications; in some cases this has been accomplished without departing very far from conventional designs, as in the case of the 800,<sup>1</sup> 304A, 831, HK24,<sup>2</sup> HY615,<sup>3</sup> and HY75,<sup>4</sup> to name only a few. The principle was carried further in the case of the acorn tubes and transmitting tubes such as the 316A,<sup>5</sup> 826,<sup>6</sup> and similar types, in which base and glass press were eliminated and leads made short and heavy.<sup>7</sup> The range of operation for negative grid triodes has now been extended to about 675 Mc. in the case of the 1628,<sup>8, 9</sup> and still higher in the case of the W.E. D156548, used in the W.E. absolute altimeter and delivering 5 watts at 750 Mc. These latter tubes have grid and plate leads brought out at each side or each end, making possible perfectly balanced circuits.<sup>9</sup>

Electron transit time has been used to advantage in certain special tubes and circuits, of which the Barkhausen-Kurz oscillator is perhaps the most familiar. In this oscillator the grid is operated at a positive potential and the plate at cathode potential or lower; electrons are accelerated toward the grid, but after passing through the grid wires are retarded by the negative plate and eventually reversed in direction, passing again through the grid wires. The process then repeats itself, the electron oscillating back and forth through the grid until it happens to strike a grid wire. The oscillating electrons induce an alternating voltage in the grid circuit, having a frequency which depends on electrode voltages as well as on the constants of the external circuit. Efficiencies are low and power capability is limited by the fact that the grid must operate at a positive potential, consequently drawing a high grid current and dissipating considerable heat. A pair of 852s in this circuit delivered only 6 watts in one case.<sup>10</sup>

Transit time also plays a part in the operation of the magnetron oscillator; efficiencies and power capabilities of the magnetron are in general better than those of the Barkhausen oscillator, and magnetrons are still used extensively in laboratory work. The excessive size and weight of the equipment, however, has been a drawback to more general use. The theory will not be taken up here, but several references will be found in the bibliography.<sup>11, 12, 13, 14, 15</sup>

A tube has been developed which

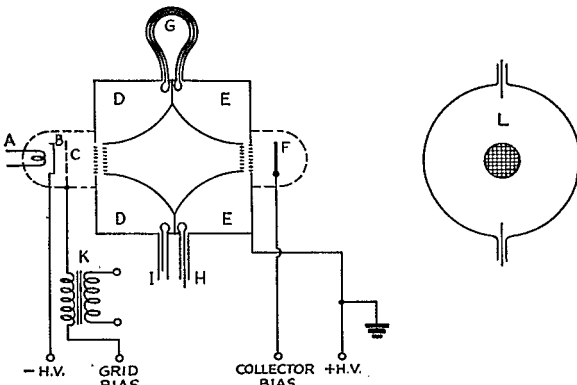

Fig. 3 — The Klystron oscillator in cross section. Letter designations are as follows:

- |                         |   |
|-------------------------|---|
| A — heater              | G — concentric feedback line                                |
| B — cathode             | H — output terminal (concentric line)                       |
| C — control grid        | I — input terminal (not used when working as an oscillator) |
| D — buncher rhumbatron  | K — modulation transformer                                  |
| E — catcher rhumbatron  | L — end view of rhumbatron                                  |
| F — collector electrode |   |

may be considered as a sort of connecting link between conventional tubes and the velocity-modulated tubes to be described later in some detail; it employs space-charge control of the electron flow, but the latter is in the shape of a beam, and the output circuit is inductively coupled to the beam, a separate collector electrode being used. Transit time effects have been reduced by special grid design, and an efficiency of 60% is obtained at 500 Mc., with an input of 100 watts.<sup>16, 17</sup>

### Velocity-Modulated Tubes

In the last four years an entirely different type of tube has been developed. The grid in tubes of the type with which we have been familiar exercises its control by varying the electrostatic field in the neighborhood of the cathode in such a way that the total number of electrons passing from cathode to plate, i.e., the total space current, is varied in accordance with the varying grid voltage. In the new type of tube, the total space current remains substantially constant; a grid of the conventional type may also be included for the purpose of adjusting this total current or modulating the output, but it does not take part in the operation of the tube at ultrahigh frequencies. The actual control grid is so placed that it has negligible effect on the field near the cathode, but it can and does vary the velocities of electrons passing through it; as in the case of the inductive-output tube mentioned above, the electrons form a beam. Because of this feature, tubes of this type are known as "velocity-modulated" tubes.<sup>18</sup>

To show the method of operation, we refer to Fig. 2. We have a beam of electrons travelling from left to right; at A and B are two "grids," which we may think of as wire mesh screens through which the beam passes, and at C and D is a similar pair. Now imagine an alternating r.f. voltage impressed across the gap A-B; an electron passing through the screens A and B will be alternately accelerated or retarded, depending on whether the screen B is positive or negative with relation to A at the instant the electron passes through; it is assumed the electrons are travelling fast enough so that the time they take in crossing the space from A to B is quite small compared to a cycle of the r.f. Thus the electron stream after passing through the "grid" A-B will be made up of alternate groups of fast and slow electrons, as shown at *a*. Now in the space between B and C we assume there is no field, so in this space there are no forces acting on the electrons; they are allowed to "drift" through this space. Since they take a finite time to pass from B to C, the faster ones have a chance to catch up with the slower ones, so that they arrive at the pair of screens

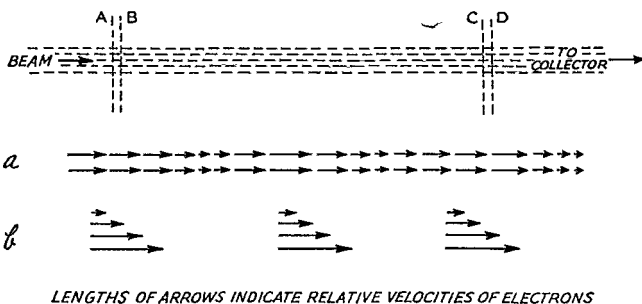

LENGTHS OF ARROWS INDICATE RELATIVE VELOCITIES OF ELECTRONS

Fig. 2 — Velocity modulation of an electron stream.

C-D in bunches as shown at *b*; the time between the arrivals of succeeding bunches will correspond to one cycle of the r.f. grid voltage. Thus by allowing the electrons to drift through the space B-C, the beam has in effect been converted from a velocity-modulated beam into a charge-density-modulated beam similar to that obtained in the inductive output tube. As in that tube, the beam will induce a voltage across C-D and, having given up part of its energy to the output circuit in the form of r.f. power, can pass on to a collector electrode. The analogy to the inductive output tube is not exact, since in the velocity-modulated tube there are both fast and slow electrons in each bunch while in the other case all had substantially the same velocity. However, the practical effect is the same, and the bunching greatly increases the voltage induced in the output circuit over what it would have been if the velocity-modulated beam had been passed through the output grid before the electrons had had time to group themselves. It is this feature which gives the tube its value as an amplifier. Obviously, if some of the output is fed back to the input circuit, the tube can act as an oscillator; if in using it as an amplifier a small part of the output power is fed back, the tube acts as a regenerative amplifier.

Now suppose no signal is being applied to the input circuit. All electrons in the beam will have practically the same velocity, and if the voltage on the collector is gradually reduced, a point will be found where the current to the collector drops off rather sharply. Suppose the collector bias is adjusted so the current is just reduced to zero. Now if a small r.f. signal is applied to the input circuit some of the electrons in the beam will have their velocities slightly increased, and will be able to overcome the potential barrier and reach the collector so that the latter will begin to draw current. Thus we have the tube acting as a detector.

The description above has been reduced to the bare essentials in order to clarify the method of operation; actually there are many factors which enter into the general problem, and the exact

(Continued on page 96)

# The Story of the Signal Corps

***The Army uses the Science of Electronics to Maintain its Lifeline of Communications and Spot the Movements of Enemy Aircraft***

**I**N A war in which men and machines move at breath-taking pace on the ground and in the air, it is essential that vital information be dispatched at an even faster pace. And it is also essential that this information be withheld from the enemy. These twin requirements of secrecy and speed are the guiding principles of the Signal Corps, which provides equipment and personnel for the Army's lifeline of communications.

In fulfilling these obligations, the Signal Corps is now active on an unprecedented scale both at home and overseas. It keeps the Army's technical means of liaison functioning between the War Department General Staff in Washington and the most remote point in any part of the world where an American soldier is stationed. And it keeps the communications going among the units of our forces on the fighting fronts. At home, the Signal Corps is training men by the thousands in the advanced technique of radio, wireless and wire communication. And it has the grave responsibility of procuring, for the ground and air forces of the Army, the best and most rugged in communications equipment — much of it new in design — to the value of billions of dollars.

This complexity of communications is relatively new — but its purpose is a simple and time-honored one. Throughout the history of

nations, honor has been paid to those who delivered needed information at the right place and in the nick of time, from the swift-footed messengers of ancient Greece to the man who carried the celebrated message to Garcia.

Today, while swiftness of foot still counts in certain emergencies, we are able to send most messages at the speed of electrons and radio waves. The major reliance is on electrical communication of the most modern type — a good deal of it more advanced than anything available to the general public. While statistics may no longer be divulged now that we are at war, it can be said that the Signal Corps, continuing its phenomenal expansion, already comprises one of the world's largest aggregations of telegraph, telephone and radio technicians, trained or in training.

In obtaining this personnel, we have been fortunate in the fact that this in peacetime was a radio-minded nation. Former amateur operators and set builders, former radio servicemen and others who made a hobby or profession in the radio field, have given their services to the Signal Corps.

In its current phase of rapid expansion, the Signal Corps is aided also by its own tradition of scientific pioneering. The Signal Corps was the first federal agency to collect weather information — a service which later developed into the Weather Bureau — and it still advances the weather-forecasting art by its development of radio-transmitting balloons for ascertaining conditions in the upper atmosphere. Again, the Signal Corps was the first United States military unit to make use of airplanes — for they could carry dispatches before they were powerful enough to carry guns or bombs. Out of the Signal Corps' original aviation division developed a child that has greatly outgrown its parent. The Signal Corps still serves that child by providing radio compasses to guide airplanes, radio command and liaison sets to coordinate their operations, and inter-telephone equipment for communication among the crew members of bombing planes.

On the other side of the aviation picture, the Signal Corps operates an

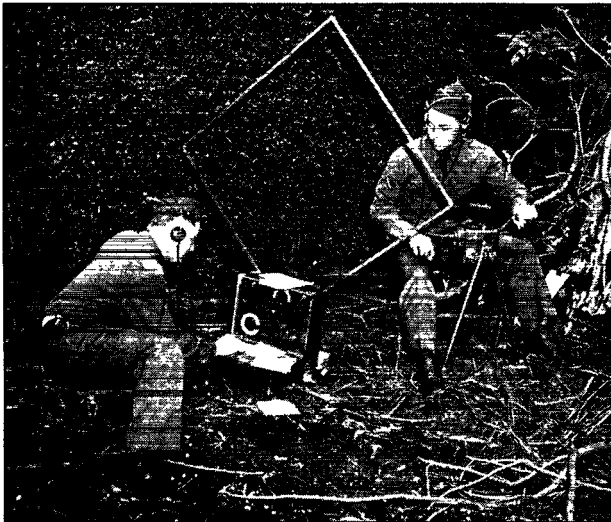

In the field the Signal Corps uses a wide variety of specialized portable equipment, operating from medium frequencies to the ultrahighs. Here a two-man team is seen operating a self-powered set.

aircraft warning service to detect and report the approach of hostile planes. This service makes use of "electrical sentries," a secret device to spot attacking planes many miles from our coasts. Only recently, with the need for recruiting electrical engineers and physicists to operate these detectors, was their very existence made public, but the method was worked out behind closed doors at the Signal Corps laboratories in Fort Monmouth over a period of seven years. Thousands of technical men are now urgently wanted to maintain and operate these devices.

For the men at the front, the Signal Corps has put into service special "walkie-talkie" radio sending and receiving sets, easily carried by one man. Radio sets with push-button control have been installed in tanks, so arranged that the operator talks through a throat microphone and listens through earphones inside his padded helmet. Other equipment has been especially designed for use in scout cars and at field headquarters.

In addition to its mobile units, the Signal Corps operates extensive fixed telegraph, telephone and teletype installations. Here it requires, and is training, large numbers of telegraph, teletype and switchboard operators and men to install and maintain the various types of apparatus.

Signal Corps units are present in all Army organizations from the division up through the Field Army. In smaller units, equipment procured by the Signal Corps is operated by men of the various arms.

In addition to its expanded program of highly technical training for its own personnel — a program that gives Fort Monmouth the aspects both of an Army camp and a technical college — the Signal Corps aids the training program of the entire Army. It does so by its production of training films, which give the trainee an insight into his equipment and tactical problems, and thus creates better soldiers in less time. These educational motion pictures are made partly on location at maneuvers and elsewhere, and partly in the animation studio. A number of former Hollywood writers, directors, cameramen and technicians are now engaged on the Signal Corps film program, which has been multiplied repeatedly as the result of the great demand for the product. And, out on the battlefield, where the fighting is



It looks like a good-sized fixed station, but actually it's a mobile unit of the Signal Corps, used for base communications. These operators work with streamlined comfort and efficiency under all conditions.

thickest, cameramen of the Signal Corps are and will be on hand to take action shots for the information of the Army and the record of history.

The history of the Signal Corps itself began on June 27, 1860, when Albert J. Myer, then an Assistant Surgeon in the Army, was designated the Army's first Signal Officer with the rank of major. On his death twenty years later, Myer was Chief Signal Officer, with the rank of brigadier general. To insure reliable signalling in the early days of telegraphy, the first Signal Officer made use of rockets, flags, and military balloons during the Civil War, in addition to Morse telegraph sets. Among his successors was Brigadier General Adolphus W. Greeley who, among other things, led a celebrated expedition to the Arctic. Today, under the leadership of Major General Dawson Olmstead, the Signal Corps, as part of the Army's Services of Supply, comprises one of the world's greatest organizations of engineers and specialists in radio, telephony, telegraphy, aircraft warning, and the more advanced phases of electronics.

Just as the first World War brought wireless telegraphy of age, the apparatus now being developed for military purposes for the Signal Corps of the United States Army will have its reflection in a higher standard of civilian life after this war is over. Those who now participate in the work of the Signal Corps will be in a position after the war to join in converting the new and secret wartime inventions to the industry and everyday life of the postwar world.

# How Recordings Are Made

## No. 1—Principles of Disc Recording

BY CLINTON B. DE SOTO,\* WICBD

**A**N INTEREST in radio implies an interest in many allied fields—in fact, in the whole subject of electronics and electricity. One of these corollary fields that has long been of interest to the kind of amateur who likes to build gear and explore new techniques is that of recording. This interest has been demonstrated by the volume of correspondence on the subject received by *QST*'s technical staff over a period of years.

Now that it is a matter of necessity rather than choice that many of us turn to these allied fields to satisfy the urge to work with radio apparatus, this interest has increased even above its previous level. Nor is it all a matter of finding something to do with one's spare time, either. There are plenty of new commercial and even military uses for recording these days, and the ARRL Personnel Bureau has already been called on to supply qualified amateurs experienced in recording to fill various specialized jobs—some of them thrilling assignments that any adventurous ham would give his right arm to get in on.

Of course, a comprehensive knowledge of recording is gained only by long study and experience. But the basic fundamentals, both of design and practice, can be summarized in sufficient detail to give the amateur adequate background information either to go into recording as an alternative hobby or to enter a job where such knowledge is essential.

Probably every amateur has done enough casual reading about recording to know the basic elements of the system. Every amateur knows that the process of recording involves the use of a cutter or stylus which engraves on a wax disc a groove corresponding to the frequency and amplitude variations of the sound being recorded, and that in playback the vibrations of a needle riding in this groove are reconverted into sound waves, either directly or through an amplifier.

Every amateur knows, too, that the cutting stylus is held by a cutter head, and that the needle is associated with something on the end of a long arm called the pickup. He knows that the record is placed on a turntable, driven by a constant-speed motor at a speed of 78 or 33 r.p.m., and that the 33 r.p.m. kind is called an electrical transcription.

He knows these things, and possibly even a little more—such as that the groove cut by the

stylus may resemble either the meanderings of a winding stream in flat country (lateral) or an undulating journey over hill and dale (vertical). In the back of his mind is a recollection that in some recording the stylus follows a pre-cut groove on the record, while in other systems it cuts its own way following the explicit directions of a feed-screw.

But concerning the details behind all these general facts the typical amateur is probably more than a little hazy. Not that the technique is so difficult, you understand; it's just that he hasn't had occasion to learn about it before. And there's no better time to begin than right now.

### *Mechanics of Recording*

The problems of recording divide into two general classes: electrical and mechanical. It is about the mechanical problems that the amateur needs most to learn; the electrical details are mostly equivalent to those he has already encountered and solved in his work with speech amplifiers and modulators and the general paraphernalia of radiotelephony.

In the mechanical end, however, he must learn new questions and their answers. He must understand the importance of purely mechanical considerations, of damping and vibration, of mountings and resonance, of the flywheel effect and the constancy of speed of turntables, of the principles of the lathe and the hardness and shape of cutting tools, of the hardness, resiliency, viscosity and homogeneity of recording blanks, of many other matters which, now recognized only as faintly-familiar terms, enter into the mechanics of recording.

To get started on the right track, let us pause at the outset to establish the three major classes of recordings—commercial pressings, electrical transcriptions and instantaneous recordings.

The first two are strictly professional classifications. Commercial pressings are the ordinary 10- and 12-inch records you buy at the music store—fifty million or more of them annually. They are big-business, mass-production products turned out in a factory in the form of thousands of duplicates of a master recording.

These pressings are played on home phonographs and phono-radio combinations, and also to a surprising extent over broadcasting stations. But for high-quality reproduction, for "canned" programs and commercial announcements that

\* Assistant Editor, *QST*.



are undistinguishable from direct pickups in quality of reproduction and freedom from noise, the broadcasters use electrical transcriptions.

Both pressings and transcriptions are made from a master recording on a soft wax blank, which is cut or engraved with an elaborate jewelled-bearing, precision-made cutting head. In the commercial recording studio this wax (metallic soap) blank, which is 17 inches in diameter and 1 to 2 inches thick, is engraved on a massive turntable which alone may weigh as much as 110 pounds, mounted on a concrete block foundation. After your favorite dance band has had its effects permanently preserved in the grooves on this blank, the wax is metalized by sputtering with gold or silver, or by chemical deposition of copper or silver. The master matrix which results is then used as one electrode in an electroplating bath and plated to a thickness of nearly 1/16th of an inch. By the electroplating process the markings on the wax are duplicated in the metal with a fineness as great as 0.00002 inch. This plating is carefully removed from the wax and reinforced with a solid metal plate.

Where only a limited number of duplicates are required, as in the case of electrical transcriptions, copies are made directly from this master matrix. In quantity production, however, additional duplicates called pressing plates or stampers are made from the master. The pressing plate is mounted on a hydraulic press, which is supplied with shellac blanks heated to perhaps 300° F. Every marking on the pressing plate — which is to say, everything recorded on the original wax — is then transferred to the blank under this heavy press. Thousands of exact duplicates of the original soft wax record can be made in this way.

### Instantaneous Recording

The third classification — instantaneous recording — represents just what the name implies: single records that are played back immediately in the same form they are made. In other words, no masters and no copies. You make the one record and you play it. (Processes do exist for making pressings of certain forms of instantaneous recordings, but none are in common use.)

The instantaneous recording field ranges from the work done with high-quality equipment in broadcasting stations, which compares in quality with electrical transcriptions, to the simplest of home-recording equipment. In recent years even the latter has achieved surprising performance, as improved equipment and processes followed commercial popularization.

In fact, the better home recorders turn out records that surpass commercial phonograph records in quality and frequency range. This is because the instantaneous recordings start out in life with the understanding that they won't be required to play as long as the pressings. As a result they can be made of softer, and therefore

more responsive, materials. The shellac pressings, on the other hand, must give many playings regardless of heavy pickups and cheap needles, and so the manufacturers add an abrasive to the shellac, which gives the disc greater resistance to wear by grinding the needle point to the shape of the record groove. It's a case of making the disc wear out the stylus rather than vice versa. Unfortunately, the action of this abrasive results in the familiar hiss noise or scratch when the record is played. Lacking the abrasive filler, the home recordings also lack the scratch.

The same is true of the electrical transcriptions, of course. In this case the abrasive is left out and materials with a high degree of homogeneity such as cellulose acetate or vinylite are used. The playing life is short, but that is of little or no consequence in the broadcasting studios to which the use of such transcriptions is confined.

Somewhat longer life is usually expected of the instantaneous records, and therefore harder, although still abrasive-free, materials are used. The exact nature of the blank used depends on the application, of which a wide range have come into being in recent years. Schools and colleges, industrial concerns, hospitals, theatres, scientific laboratories — there are a large variety of users of instantaneous recordings, apart from the home recordists and the amateur sound-movie makers. And each has his own requirements.

With modern equipment, however, the requirements of each can well be satisfied at reasonable cost. There has been a vast improvement in instantaneous recording technique in the past five years or so, the period during which the field has seen its great impetus. Five years ago the best systems available cut off only a little above 5000 cycles — and were by no means flat below that. Now the technique will permit flat response out to 12,000 or even 15,000 cycles. Even the simpler home recording outfits are good up to 7000 or 8000 cycles. The amplitude range, too, has been

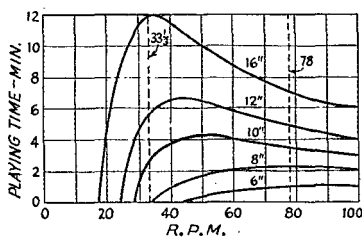

Fig. 1 — Chart showing useful playing time for standard record sizes at various groove speeds. Small records (up to 10-inch) give longest playing time at 78 r.p.m., large records at 33 1/3 r.p.m. Latter speed was adopted originally because it gave longest playing time on 16-inch records used in talking-picture work. Chart is based on 96 lines per inch and minimum diameter required for sine-wave reproduction at 8000 cycles. With closer groove spacing and/or smaller minimum recording diameter, playing time can be extended up to 25%.

extended from perhaps 35 db. to 40 or 45 db. for the home recorders and 55 or even 60 db. for the professional outfits.

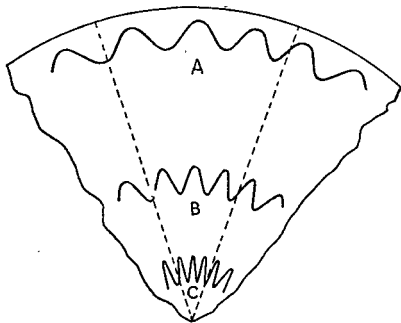

Fig. 2 — Illustrating effect of recording diameter on reproduction quality. Because of the physical dimensions and inertia of the tip of the recording stylus, it cannot make groove configurations having too sharp a radius of curvature. Thus in the illustration shown the stylus is given the same time to execute the smooth gradual curves of A as it is the sharp curves of C. In practice it cannot execute the sharp-radiused curves of C and distortion results. The typical minimum diameter at which distortionless recording is practical is indicated at B. This minimum diameter can only be reduced by restricting the high-frequency range, which is equivalent to enlarging the minimum radius of curvature required.

From the standpoint of playback, even if the stylus would record a compressed groove as shown at C, the playback needle would be unable to follow it.

### Blanks

This improvement has resulted from development in all elements of the system, but particularly in the blanks. Those used now are a great step forward from the obsolete pre-grooved metal or acetate blanks which characterized the early days of home recording.

Present-day blanks are lacquer-coated discs with an aluminum, glass or cardboard base. It is in the lacquer, which is dipped, sprayed, flowed or spun on the surface of the disc to a thickness of 0.006 to 0.010 inches, that the groove is cut. The function of the base itself is to provide a flat, rigid, non-warping support for the lacquer.

The principal requirement of the base is that it be flat and stay flat to record and play back without distortion or "wows." NAB standards stipulate that the maximum permissible warping of the disc from a true plane for satisfactory reproduction is 1/16th inch. In high-fidelity work even the slight variation in thickness produced by coating swirl is objectionable. The lacquer must therefore be applied in such a way as to give a smooth, even surface.

Because it is obviously the cheapest material, cardboard is used for thin, inexpensive blanks; but it suffers by comparison with other materials in that it is never truly smooth, bends under tension and tends to warp. Cardboard blanks usually

show greater surface noise than other types, too. Yet with proper care in cutting and the correct play back needle fair results can be obtained with them.

Up to the time the use of aluminum was restricted as a critical war material it was almost universally used as the base for high-quality blanks. Its characteristics were practically ideal — flatness, non-porosity, freedom from warping, stiffness against bending as well as thermal and hygroscopic changes. Aluminum blanks are used in both thin (flexible), medium and heavy weights.

In the search for a suitable substitute for aluminum, glass has been generally chosen. Apart from its inherent brittleness, glass has almost equally good characteristics, and some engineers claim that it produces even better recordings than aluminum. Breakage has not been a significant problem; even when a recorded blank has cracked the lacquer covering usually holds the pieces in place well enough to permit re-recording when that is considered necessary. The glass blanks in use range in thickness from 0.060 to 0.075 inches, with 0.065 about standard.

Even more important than the base, of course, is the lacquer coating. As applied, this resembles the Duco finish on an automobile more than anything else. Although modern instantaneous blanks are still called "acetate" the term is a misnomer, because cellulose acetate is now seldom used for the purpose. Several bases are used, including nitrocellulose, acetyl cellulose, ethyl cellulose or one of several resins. Each of these substances is brittle in the pure state, and therefore plasticizers are added which serve to keep the coating soft and homogeneous. The kind and amount of the plasticizer determine the hardness of the coating in shear, and thereby control the noise level as well as the cutting characteristics and playing life. Soft records have lower surface noise, but the high-frequency response as well as the durability improve with hardness. The degree of hardness also has an effect on the manner in which the chip or thread behaves, as will be discussed in a later article. Coatings that are too soft, or that are cut before the solvent (used to dissolve the lacquer for the purpose of application) has thoroughly evaporated, will develop distortion later due to changes in the groove caused by surface strains during drying. On the other hand, a hard surface must be cut with care, using a sharp stylus at the correct angle, or the lacquer will tend to tear rather than cut cleanly.

The nitrocellulose base used in the majority of home recording blanks is highly inflammable, and care must therefore be used in handling the chip or thread that results from cutting.

The size of the blank used for a given purpose is regulated by the playing time required and the recording speed used. There are two standard speeds now in use: 33½ and 78 r.p.m. The 78 r.p.m. speed (to be precise, 78.26) is used for all

commercial pressings and practically all instantaneous recordings except those for broadcast purposes, while  $33\frac{1}{3}$  r.p.m. is used for electrical transcriptions and long-playing instantaneous recordings for broadcasting.

From the technical standpoint, the use of higher groove speeds makes it easier to record higher frequencies as well as to avoid waver. Because of the increased wave steepness resulting from the difference in velocity, records cannot be cut at as high a volume level at  $33\frac{1}{3}$  r.p.m. as at 78. Careful design and operation is required throughout with  $33\frac{1}{3}$  r.p.m. equipment, but it is used because of the increased playing time, making it possible to record as much as a 15-minute program on a 16-inch record.

The playing time afforded by records of different sizes at various speeds is shown in Fig. 1. It will be seen that the smaller records are not suitable for recording at  $33\frac{1}{3}$  r.p.m. The reason for this is that the velocity of stylus travel is proportional to the radius as well as the turntable speed. Because the stylus travels slowly when the radius is small, the groove waveform becomes so greatly compressed at the higher frequencies that distortion results. While not as severe, this effect is also present at 78 r.p.m., and consequently there is a recommended minimum inside diameter for recording at both speeds. To meet broadcast standards this minimum diameter must be  $3\frac{3}{4}$  inches for 78 r.p.m. and  $7\frac{1}{2}$  for  $33\frac{1}{3}$ . In home recording work the inside diameter can be reduced to about  $2\frac{1}{2}$  and 4 inches respectively without too serious distortion provided the high-frequency range is restricted.

#### Lateral vs. Vertical Recording

The groove cut in the blank by the stylus in recording is two-dimensional. That is to say, as shown in Fig. 2, it may go from side to side with modulation, or up and down — but never both. With lateral — side-to-side — recording, the groove depth should stay constant, while with vertical — up-and-down, or hill-and-dale — recording the groove should trace a steady line of constant pitch over the face of the blank. When the cutter starts to move in two planes simultaneously, through vibration or other mechanical fault, that means trouble.

As to which is the best method — vertical or lateral — well, that's where even the experts disagree. The lateral method has been used almost exclusively for phonographic and home recordings, but during the past decade or so one school of thought has urged the vertical method for highest-quality transcriptions for broadcasting, talking pictures and the like. Two advantages are urged: one, that the vertical method gives longer playing time, since the space required for one groove is less because it follows a straight line, and therefore more grooves can be engraved on a single blank without crossovers (the stylus

breaking through the wall of one groove into another); and two, that distortion is reduced because of the lessened danger of crossovers, and also because the playback needle is held more firmly in the groove and follows the up and down convolutions more closely, while with the lateral type it tends to slide around in the groove.

To which the partisans of the lateral method reply that, by keeping the amplitude at a reasonable level, very nearly as many grooves can be made as is feasible with ordinary equipment using the vertical method; that the fault of playback needle movement can be overcome by using carefully-made needles whose contours closely fit the groove; and finally that the vertical method may, in fact, introduce even more distortion, owing to tracking error resulting from the manner in which the rounded playback needle point follows the groove. This arises from the difference in shapes of the sharp-faced cutting stylus and the

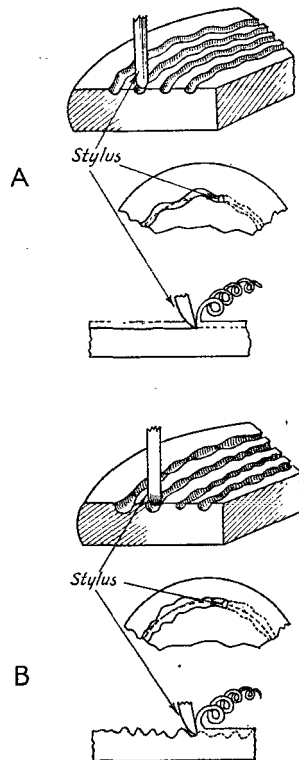

Fig. 3 — (A) Lateral recording, as used in phonographic and most instantaneous recordings. The stylus cuts a groove of constant width and depth but moves from side to side in accordance with the frequency and amplitude of the signal being recorded.

(B) Vertical recording, as used in electrical transcriptions for broadcasting. Stylus follows a constant-pitch lateral contour but moves up and down with modulation, cutting a groove of variable depth (and, since the stylus tip is spade-shaped, variable width).

round-pointed needle; the difference in the contours of the paths traversed causes harmonic distortion at certain frequencies when the radius of curvature of the needle point is of the order of the radius of curvature of the modulated sine wave in the groove. This problem does not arise with a horizontal groove. Another difficulty in the vertical system is that the stylus has more work to do on the down-stroke than on the up-stroke, while in the lateral system the resistance of the coating is equal in either direction.

### Constant Amplitude vs. Constant Velocity

Another point of argument concerns the relationship between the movement of the stylus with modulation displacement and the amplitude of the modulating signal. There are two basic characteristics this relationship may have: constant amplitude and constant velocity. Constant amplitude means that, given a constant input to the recorder, the amplitude of the resulting cut is constant regardless of the frequency. With a constant-velocity characteristic, on the other hand, the amplitude of the cut is inversely proportional to the frequency; i.e., the product of amplitude and frequency is a constant.

Reduced to the simplest terms, this means that with the constant amplitude system the stylus always moves the same distance to right or left regardless of frequency, speeding up on the higher frequencies to travel the additional distance required to execute the increased number of cycles. Additional power must be supplied as

(Continued on page 94)

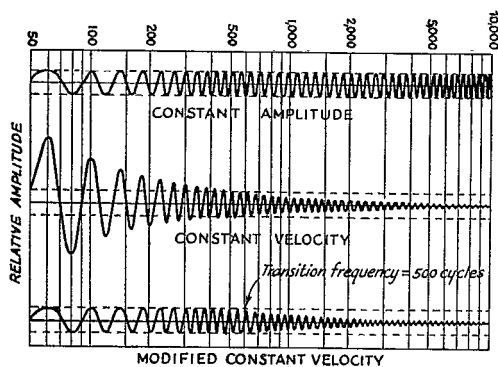

Fig. 4—Wave patterns characteristic of various recording systems. At top is illustrated the constant amplitude method, showing how the velocity of the stylus must increase with frequency to maintain the relative amplitude of stylus travel constant. In the constant-velocity system, the relative amplitude of stylus travel must be inversely proportional to frequency in order that the stylus velocity may remain constant.

The modified system used in commercial recordings is shown at bottom to have a constant-amplitude characteristic below 500 cycles (arbitrarily chosen as the transition or crossover frequency) and constant velocity above. Various manufacturers use different transition frequencies between 250 and 800 cycles.



FROM its sub-chaser cover to its last editorial *QST* for July, 1917, has a thoroughly militant note. The Navy has sent to ARRL a special plea for 2,000 amateurs, who upon enrollment will be sent to operators' schools at Harvard or at the Brooklyn or Mare Island Navy Yards. Innumerable amateurs are already in the service, mostly in the Navy: Prof. A. Hoyt Taylor, 9XM, is now Lt. Taylor, district communications superintendent at Great Lakes, and his assistant is Radio Gunner M. B. West, 8AEZ. Ensign (jc) Cooper, jr., manager of the East Gulf Division, is on duty at the Charleston Navy Yard. Division Manager Mathews, 9ZM, a radio gunner, is censor at Grand Haven and Benton, Michigan, while L. A. Gebhard, 8EA, is assigned as an operator at Grand Haven. Harold Bowen, 1ZF, is Chief Electrician on the U.S.S. *Dryout*. The gear at IEMA has been commandeered for a naval station. The editor says, "It takes some pretty husky optimism to talk about what we are going to do after the war [but] when that glorious day arrives amateur wireless will be unshackled. We will have the use of the air again, and old friendships will be resumed and new ones formed. We are not going to be kept shut-up as some people think, but we will be encouraged to reopen and continue our experimenting. . . . It is a sure thing."

Operating reports still drift in, including the information that six midwestern stations last winter worked both coasts. The clubs are active, and there is considerable interest in studying theory, and in exchanging notes on just what "The Ideal Station" should have in it after the war. That indeed is the subject of the leading technical article by James M. Sommer, 9JI. It also pervades the old Man's "Rotten Resonance" in which Radical takes Final for a ride on the subject of phantom antennas.

From an article on "Useful Ratios and Equations" we glean the following nostalgic item:

The audibility of signals is inversely proportional to the cube of the number of visitors present.

The broadness of a station's wave is inversely proportional to the owner's knowledge.

The velocity of muscular reaction may be expressed as: Speed in meters per second =  $VX$ , where  $V$  is the transformer voltage and  $X$  is the speed of greased lightning.

The current drawn by a homemade transformer cannot be expressed in a general equation, being dependent upon the capacity of the local lighting plant.

### P.O.W.

W6BIL reports that Everett Penning, W6ECU, ex-KB6ECU, was taken in the occupation of Guam and is now being held in custody in Kobe.

# Navy Sparks

## An RMIC Takes You On Destroyer Patrol

BY EDDIE DIECKMANN,\* W2NDZ

**W**HETHER you are five or fifty, a spark of adventure lingers in your heart. If it is now only infinitesimal it will grow into a glorious conflagration as you board our destroyer. Let's pull switches for a few hours and let the winds and salt spray beat about our faces. The sunbeams play in brilliant reflection on the silver torpedo tubes that house the metal fishes ready to leap beneath the liquid brine like vicious sharks and head for their objective.

Hoist aboard the mud-hook and we'll shove off into the realm of that turbulent *Neptunus Rex* and his well-modulated mermaids. Step into our radio shack and join Uncle Sam's league of sea-going brasspounders.

Passing through the small opening of the extending breakwater, the streamlined destroyer noses its way into the open sea. The green waves begin to splash reluctantly at the hull. The unobstructed winds tug freely at your hair as you sit alongside the open port, nimbly pecking at the keys of a weather-beaten mill.

The hours pass swiftly by. Many times the course has changed. Speeding along at twenty-five knots, a foaming comet-like wake follows at our stern.

Then the weather takes on a different look, as we run into a bit of a blow. The horizon looks like a velvet curtain of uncertainty as we speed dead into the dismal overcast.

Havoc is created among the ether waves as blinding serpents race through the velvet sky in zig-zagging confusion. The oscillatory signals of dots and dashes blend beautifully with the static as Nature's crescendo reverberates against your sensitive eardrums. The waves become more and more aggressive as they dash themselves in drunken confusion against the metal hull. The wind is increasing in velocity. Better close the ports while you have the chance! Everything in

\*% U. S. Naval Radio Station, Key West, Fla.

our radio shack must be tied down, if we want to keep it. You'd better secure that typewriter before it comes sliding into your lap like a five-inch shell while you are copying the storm-warning weather advisories.

Things are becoming alive; they squeak and groan and create all sorts of nightmarish noises. Even the old trusted "jamcockpot" now swings like a pendulum from the low overhead as the destroyer begins to roll from port to starboard. The spirit of *Neptunus Rex* is awakening.

The ship lists threateningly to port, and you

feel a sudden sensation of gravitation pulling you backward, chair and all. Instinctively your hands shoot through the air trying to take hold of something, but you can't grasp the small knobs and dials of your receiver and there is nothing to keep you from hitting the deck. The law of the elements takes its course. Just about the time you think you are

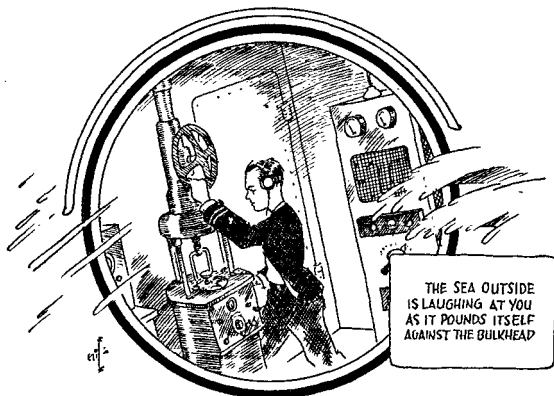

going to break your lid neck another swell lurches the ship to starboard, reversing the pull and shooting you into an upright position. The sea-soaked dyed-in-the-wool brasspounder is used to this, but it's no way to indoctrinate the landlubbing sailor of the comfortable ham shack.

Deep furrows are plowed into the swirling brine as the streamlined bow noses its way through the onrushing swells. As we look through the thick glass of the port we see only the rising and falling liquid mountains spouting high into the misty gray. An unending blanket of foam seems to crest the sea like a bleak and barren no-man's-land in winter. The infuriated wind now howls and whines through the taut sea-soaked halyards. Tons of wind-swept spray come hurtling across the forecastle and crash against the superstructure, where the green water runs down the bulkheads like miniature waterfalls, seeking its way back into the maddened sea. For an infinitesimal second the ship stands completely

motionless. Then it begins to shiver and shake like a dish of jello. Before another second has passed it lurches forward like a delayed salvo and seems to take wings — riding high above the waves.

The masts squeak and groan and you feel you are riding a wild sea-bronco that is trying to throw you. Try pounding brass while going through a storm-torn sea on a destroyer and make it sound like machine stuff. . . . You may have that chance sooner than you expect. If you can do it you are a born sea-going brasspounder and worthy of the praise, and you can congratulate yourself on being allowed to enter the sacred league of fighting navy ops.

Maneuvering through the storm on this sea-bronco, pitching and rolling to a forty-degree angle, now half-submerged, now suddenly shooting into the sky like an albatross and then plunging back into the swirling mass like an overstuffed pelican, you can safely state that you are one of the few who have really been indoctrinated into the realm of Uncle's brass beaters.

Floundering a bit in a storm always brings a queer, watery sensation in the mouth of the novice and the dry-land sailor. Your eyes become diffused, and your head feels as though it were going to split wide open. You try to swallow, forcing whatever it is back down your throat. . . . It can't be done. When this happens there is only one answer, and you had better get the wastebasket or bucket nearest you and keep it securely between your legs, 'cause you are sure going to need it! The bottom seems to have dropped out of your stomach as the destroyer suddenly lurches crazily. The basket goes spinning across the deck like a top. You hurry to the bolted door and throw back the securing dogs . . . open it a little and protrude your aching head into the elements, sharing your breakfast with the fishes.

The wind-scooped spray feels like a million needles as it is hurled against your exposed physiognomy while Neptune roars in hilarious laughter. A muffled voice calls from the bridge. The sea-soaked head comes back into the radio shack. Orders are to take a bearing on Oshkosh beacon. Feeling your way like a homeless dog, you head toward the direction finder, half-heartedly dragging the bucket with you. Slowly the rotary wheel begins to turn as you try to get a zero signal. If you don't curse in silent profanity you're not a sailor. . . . The sea outside is laughing at you as it pounds itself against the bulkhead trying to get in. Just when you think you have a zero signal the blasted thing begins to creep and jump spasmodically as the capacity changes with the roll of the destroyer.

One leg is wrapped around the stanchion while the other braces your body. Now one quick spin of the rotary loop, slap on the brake, give it a little port rudder — and you have that zero signal reading. From this moment on you must be Superman. Magnetic compass reading, rotary loop and clock reading must be obtained simultaneously before another wave hits the ship and changes the capacity again. Hurry. . . ! Ring the doorbell. I mean the indicator bell to the bridge. Shout your bearing into the voice tube. Be careful or you'll get your proboscis bashed in if the destroyer decides to buck or turn bottom-side up. After this turmoil you sink wearily back into your chair wondering why you ever went to sea.

The motor-generators begin to hum as the heat is applied to the commercial transmitter's oversized bottles. A faint signal has reached your ears; the operator from across the foaming voids no doubt has important traffic for you. The crescendo blasts against your ears as the lightning rips the heavens apart. The raging sea has oozed into your shack somehow, making a perfect ground — so keep your fingers away from the hot key. It is not a pleasant sensation to be hurled against the bulkhead of your shack with the impact of a sixteen-inch cannon. Electricity is a strange and almost pathetic mystery as you cruise about the storm-torn sea of Neptune's realm. An adventure you will long remember and probably laugh at many times as you recall the foolish and thoughtless business of war that caused it.

A now-familiar sound reaches your ears as another liquid avalanche comes hurtling with a thundering roar toward your destroyer. The high wind velocity accelerates it to greater momentum. Silently you utter a prayer, hoping that the sea won't come plowing through the bulkhead and tear you and your equipment into the foaming sea. Suddenly the destroyer is sucked under the swirling water as the wave collides with all its tremendous impact. The "tin can" pitches, rolls, lurches, quivers, shakes. The rivets groan under the terrific strain. What a crazy sensation — a drunken feeling overcomes you as you find yourself on deck, wondering how in hell you got there without knowing it.

(Continued on page 32)

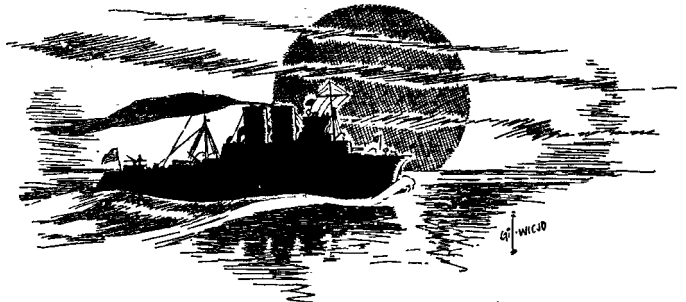

# HAPPENINGS OF THE MONTH



## SOME STAFF CHANGES

**FRANCIS EDWARD HANDY, W1BDI**, for over sixteen years the ARRL communications manager, is off to the wars as a major in the



F. E. HANDY

Directorate of Communications of the Army Air Forces. The Board of Directors at its recent meeting gave him leave of absence for the duration, after which he is to resume the C.M. reins. Handy first joined the League in early 1925, to take over while Traffic Manager Fred Schnell accompanied the U. S. Fleet on a seven-months' cruise to Australia to introduce the Navy to these new-fangled short waves the amateurs had discovered. When Commander Schnell resigned a year later, Handy became the communications manager, and his record since that time is probably known to every amateur alive. What some may not recall is that during that first year here he commenced work on a small manual of amateur station operation, at the request of the Executive Committee. It was deemed desirable to include a certain amount of technical data on the construction and adjustment of stations. When he had finished with that job he had produced, alone, the first edition of *The Radio Amateur's Handbook*, the nickname for which for years was Handy's Handy Handbook. Recently, with amateur operating at a standstill, the long arm of the Army Air Forces reached out and tapped the man who, by years of experience, is well prepared for the job of rationalizing operating procedures in their vast communications system. Major Handy assumed his duties on May 22d and is stationed at Washington. He may be seeing some of you fellows.

John Huntoon, W1LVQ, has been named by the Board of Directors as acting communications manager during Major Handy's absence. Hun-



D. H. HOUGHTON

toon has been an assistant secretary of the League since early '39, which duties he will also continue. In that capacity he has represented Headquarters at many conventions and in talks before innumerable affiliated clubs, and is well known to the gang. He comes honestly enough by this Communications Department appointment, having been for many years our SCM for Illinois (W9KJY) and very active in club affairs in the Chicago area. He is himself a crack operator, with a beautiful fist, and a collection of trophies, including the first prize in the copying competi-



JOHN HUNTOON

tion at the last national convention. Incidentally, he has just been married, so the W9 gals may scratch him off their list.

David H. Houghton, who recently celebrated his twentieth anniversary as *QST's* circulation manager, was appointed the new treasurer of the League, succeeding the late Arthur Hebert. Dave in fact succeeded to many of Mr. Hebert's duties when the latter first became ill, and for the past year was appointed by the Board to serve as acting treasurer. He remains one of the best circulation managers in the country, and maybe you don't think he's busy these days with the great demand for our training literature!

We are pleased to announce the return to our staff as an assistant secretary, after an absence of many years, of Charles A. Service, Jr., W4IE, of Sarasota, Florida. Service is an old-timer in amateur radio, having been practically born as 3ZA in Bala, Pa. He was the vice-president of ARRL immediately preceding the late Charles H. Stewart, was division manager of our Atlantic Division in the days before SCMs, was for some years immediately after the last war a director of the League, and from 1922 to 1925 was assistant secretary at Hartford. With that sort of



C. A. SERVICE, JR.

background he has easily slipped back into harness without missing a single dot or dash.

## NO MORE AMATEUR CRYSTALS

QUARTZ has been made subject to conservation and priorities by WPB Order No. M-146. Hereafter it may be consumed only in the manufacture of radio crystals for use in "implements of war" or in government or airline radio systems, or for the manufacture of telephone resonators or optical parts of implements of war. The purchase of finished crystals for other purposes is prohibited, because of a national shortage. This seems to bar the acquisition of additional crystals by amateurs — even, as we read the order, for civilian-defense purposes. All persons possessing more than 25 pounds of raw quartz, or more than 10 unmounted crystals, must report the fact monthly to WPB on Form PD-484.

## BOARD MINUTES

FOLLOWING UP our brief report of the Board meeting last month, we give you now the complete minutes:

### MINUTES OF 1942 ANNUAL MEETING OF THE BOARD OF DIRECTORS, AMERICAN RADIO RELAY LEAGUE May 8, 1942

Pursuant to due notice and the requirements of the by-laws, the Board of Directors of the American Radio Relay League, Inc., met in regular annual session at The Hartford Club, Hartford, Conn., on May 8, 1942. The meeting was called to order at 9:38 A.M., Eastern War Time, with President George W. Bailey in the chair and the following other directors present:

Charles E. Blalack, Vice-President  
Alexander Reid, Canadian General Manager  
E. Ray Arledge, Delta Division  
John E. Bickel, Southwestern Division  
Hugh L. Caveness, Roanoke Division  
Tom E. Davis, Dakota Division  
Stuart H. Gates, Central Division (alternate, acting)  
Wayland M. Groves, West Gulf Division  
Robert A. Kirkman, Hudson Division  
J. Lincoln McCargar, Pacific Division  
Percy E. Noble, New England Division  
Floyd E. Norwine, Jr., Midwest Division  
William C. Shelton, Southeastern Division  
C. Raymond Stedman, Rocky Mountain Division  
Karl W. Weingarten, Northwestern Division

There were also present Secretary K. B. Warner, Communications Manager F. E. Handy, Acting Treasurer D. H. Houghton, Assistant Secretary John Huntoon and, as technical adviser to the Board, George Grammer, technical editor of *QST*. The meeting was welcomed and briefly addressed by President Bailey.

On motion of Mr. Arledge, unanimously VOTED that the minutes of the 1941 annual meeting of the Board of Directors are approved in the corrected form in which they were issued by the Secretary.

On motion of Mr. McCargar, after discussion, unanimously VOTED that the annual reports of the officers to the Board of Directors are accepted and the same placed on file.

On motion of Mr. Weingarten, VOTED that all acts performed and all things done by the Executive Committee since the last meeting of the Board, and by it reported to the Board, are ratified and confirmed by the Board as the actions of the Board. Mr. Kirkman requested to be recorded as voting opposed.

During the foregoing, Director W. Bradley Martin of the

Atlantic Division and General Counsel Paul M. Segal joined the meeting, at 9:48 A.M.

At the request of Mr. Reid, chairman of the Finance Committee, the report of that committee went over until later in the meeting.

Mr. Reid made his annual report as Canadian General Manager. Moved, by Mr. Norwine, that, to conserve the time of the meeting, the reading of division director reports be omitted except the portions that individual directors consider vital. But, after discussion, the motion was rejected. Consequently, in turn, every division director read and submitted a written report on conditions in his division, for the common information of the Board.

On motion of Mr. Blalack, unanimously VOTED that the Board expresses to Assistant Secretary Arthur L. Budlong its deep sympathy in the loss of his father, and that the Secretary is directed to convey an expression of these sentiments and to send flowers in the name of the Board.

Proceeding to a consideration of subjects raised by individual directors at their own initiative:

Moved, by Mr. Bickel, that ARRL membership pins be so changed as to indicate the attainment of five, ten or fifteen years, etc., of continuous membership. But, after discussion, the motion was rejected.

Moved, by Mr. Bickel, that the location of the 20-meter 'phone band be changed from its present position to frequencies between 14,000 and 14,200 kc. But, after discussion, the motion was rejected.

On motion of Mr. Groves and by a unanimous rising vote, the President was requested to convey to the widow and parents of the late acting director of the West Gulf Division, W. T. Caswell, Jr., W5BB, an expression of the Board's sense of loss in the passing of an admired associate.

Moved, by Mr. Groves, and seconded by Mr. Davis, that all directors submit their annual reports to headquarters by February 1st; that headquarters make copies of the reports and mail same to the individual directors and alternate directors not later than April 1st, incorporating them as part of the annual reports of the officers of the League to the Board of Directors. But, after discussion, the motion was rejected, 7 votes in favor to 8 opposed.

Moved, by Mr. Groves, that, in the event the 1943 annual meeting of the Board is dispensed with, all directors submit their annual reports to headquarters by April 1st, headquarters to make copies of same and mail them to the individual directors not later than May 1st. But, after discussion, with unanimous consent, Mr. Groves withdrew the motion.

Moved, by Mr. Groves, that all future copies of both Handbooks and of other publications of the League carry an invitation to join the League, appropriate application blank for membership to be attached. But, after discussion, unanimous consent being given, Mr. Groves withdrew the motion. Moved, by Mr. Groves, that all future copies of *QST* carry an invitation to join the League, appropriate application blanks for membership to be attached. But, after further discussion, the motion was rejected.

Moved, by Mr. Groves, that the Secretary be instructed to supply each new director and alternate director, upon election, a copy of Cushing's Manual. But, after discussion, the motion was rejected.

Moved, by Mr. Groves, to amend By-Law 40 by adding at the end thereof the words, "and Alternate Directors." The yeas and nays being ordered, the said question was decided in the affirmative: Whole number of votes cast, 15; necessary for adoption, 10; yeas, 10; nays, 5. Those who voted in the affirmative are Messrs. Bickel, Davis, Gates, Groves, Kirkman, McCargar, Noble, Reid, Stedman and Weingarten. Those who voted opposed are Messrs. Arledge, Caveness, Martin, Norwine and Shelton. So the by-law was amended as proposed.

On motion of Mr. Groves, after extended discussion, during which the Board was in recess for three minutes, unanimously VOTED that it is the policy of the Board that, in principle and except in exceptional circumstances, no person shall be appointed to serve as an officer of the League unless he is a licensed amateur.

On motion of Mr. Groves, VOTED, 9 votes to 5, that the Secretary is instructed to investigate the desirability of having a reprint made of the first issue of *QST*, the copy to



conform in every detail as nearly as is practicable to the original, the Board to be advised within 90 days of the Secretary's findings as to the cost and estimated income from the reprint.

Moved, by Mr. Groves, that the Secretary be instructed to systematically list each month in *QST* the various current radio positions, both military and civilian, that are available, listing same in a concise manner giving such pertinent information as to necessary qualifications, location, salary, etc., and so grouping these positions that the reader can tell at a glance the job that best fits his qualifications. But, after discussion, the motion was rejected.

Moved, by Mr. Martin, that no further meetings of the Board of Directors be held until the conclusion of the present war, excepting that the President shall be empowered to call a meeting at any time; the by-laws to be regarded as amended accordingly. But, after discussion, unanimous consent being given, Mr. Martin withdrew the motion.

Moved, by Mr. Gates, that, the edition of Cushing's Manual specified as governing the conduct of meetings of the Board now being out of print, the current edition of same be adopted to govern Board meetings, and that each director and alternate director be provided with a copy at least 90 days prior to each Board meeting. But, after discussion, unanimous consent being given, Mr. Gates withdrew the motion. Moved, by Mr. Gates, that By-Law 42 be amended to substitute the expression "the current Cushing's Manual" for the expression "the Revised Cushing's Manual." The yeas and nays being ordered, the said question was decided in the affirmative: Whole number of votes cast, 15; necessary for adoption, 10; yeas, 15; nays, 0. Every director voted in the affirmative, the President and Vice-President abstaining as required. So the by-law was amended as proposed. On the further motion of Mr. Gates, VOTED that a copy of the current Cushing's Manual shall be provided each director and alternate director at the time his election is confirmed.

On motion of Mr. Martin, unanimously VOTED to reconsider the question of filing and distributing director reports before the annual meeting. Moved, by Mr. Davis, that the directors submit their annual reports on or before March 1st of each year hereafter, and that copies of said reports in their entirety be sent to each director prior to the annual meeting of the Board. Moved, by Mr. McCargar, to amend the pending motion to provide that copies also be sent to alternate directors; but, it being made apparent that that was already provided for by standing instructions, Mr. McCargar, with unanimous consent, withdrew the proposal. Whereupon Mr. Davis' motion was unanimously VOTED.

On motion of Mr. Arledge, unanimously VOTED that, to facilitate filing, the Secretary shall prepare the annual reports of the officers on standard-size paper instead of the present legal-size paper.

On motion of Mr. Arledge, after discussion, unanimously VOTED that the sum of five hundred dollars (\$500) is hereby appropriated from the surplus of the League as of this date for the purpose of defraying the traveling expenses of the Section Communications Managers of the League within the continental limits of the United States, to attend one official ARRL convention within their respective divisions, in the period between this date and the date of the next annual meeting of the Board, reimbursement to be at the rate of two cents per mile, via the shortest commonly-traveled route, plus one night's hotel accommodation at \$2.50, and an allowance of the convention registration fee; allowance of these expenses to be subject to approval by the Communications Manager, upon examination of detailed report of the activities of the Section Communications Manager at the said convention, to be submitted with his expense account; and any unexpended remainder of this appropriation at the date of the next annual meeting of the Board to be restored to surplus.

Moved, by Mr. Kirkman, that the Hudson Division Director be authorized to use a maximum of \$100 per year of the Hudson Division's allocation to underwrite Hudson Division League meetings. But there was no second, so the motion was lost.

Moved, by Mr. Kirkman, that, immediately on the normal reactivation of amateur stations, the Secretary shall compile statistics on the cost of publishing an amateur call

book and submit to the Board. But, after discussion, the motion was rejected.

Moved, by Mr. Kirkman, that the sum of \$10,000 be made available to, and administered by, Mr. Segal to be used for the purpose of getting WIAW on the air, and for investigating thoroughly the proposition of reactivating amateur stations on a range of frequencies above 100 megacycles. But there was no second, so the motion was lost.

Moved, by Mr. Noble, that the annual League dues be reduced from \$2.50 to \$1.50 for members who are in any of the armed forces of the United States, this rate to stay in effect until the first renewal by these members after the war. But there was no second, so the motion was lost.

On motion of Mr. Weingarten, and by unanimous VOTE, affiliation was granted the following societies:

Central Oregon Radio Klub . . . . . Bend, Oregon  
Arctic Amateur Radio Club . . . . . Fairbanks, Alaska  
West Philadelphia Radio Association . Philadelphia, Pa.  
Burlington Amateur Radio Club . . . . . Burlington, Vt.

Moved, by Mr. Weingarten, that the League request the Federal Communications Commission to amend the operators' regulations so as to extend the privileges of the amateur operator to include the operation of police and emergency stations. But, long discussion showing that much in this direction is already being done by FCC, the motion was rejected.

On motion of Mr. McCargar, VOTED that the appropriation of \$500 for permitting the attendance of Section Communications Managers at conventions is also made available to defray the expenses of the QSL Managers of the League, within the continental limits of the United States, to attend one official ARRL convention within the call areas for which they are the respective QSL Managers, during the time between this date and the date of holding of the next annual meeting of the Board, provided that such convention be within a radius of 500 miles of the QSL Manager's place of residence; the arrangement to be subject, in all other respects, to the provisions made for Section Communications Managers.

On motion of Mr. McCargar, unanimously VOTED that the President and Secretary shall study and seriously consider the advisability of increasing the newsstand price of *QST* to increase the spread in yearly cost between such newsstand purchase and the cost of membership, as an inducement to increasing membership in the League.

Moved, by Mr. Caveness, that By-Law 42 be deleted. But there was no second, so the motion was lost.

Moved, by Mr. Stedman, that the \$10,000 appropriation to President Bailey for the defense of amateur radio be restored to its full amount for the same purpose and with the same restrictions as previously. But, after discussion, unanimous consent being given, Mr. Stedman withdrew the motion. On the further motion of Mr. Stedman, unanimously VOTED that the Board, having examined its actions at the 1940 meeting at which it granted the President extraordinary powers to act as a committee of one in all aspects of protecting amateur operation, and in which it made an open authorization of \$10,000 available to him for the defense of amateur frequencies, now reaffirms those actions.

Moved, by Mr. Stedman, that a self-addressed and postage-collect envelope be sent to amateurs whose membership is expiring, at the time the first solicitation is made for renewal. During the ensuing discussion the Board recessed for luncheon at 1:00 p.m., reassembling at 1:44 p.m. with all directors and other persons herein mentioned in attendance. After further discussion, Mr. Stedman's motion was rejected.

On motion of Mr. Shelton, unanimously VOTED that, during the ensuing year, the Secretary shall mail a detailed copy of the quarterly profit and loss statement to each director immediately upon receipt of same from the auditors.

Moved, by Mr. Stedman, that the Secretary arrange for the circulation of *QST* to various government communication stations, where former amateur radio men are on duty; the maximum number of copies possible consistent with cost; particularly to stations outside the U. S. A. But, after discussion, the said motion was rejected.

Moved, by Mr. Caveness, that there be hereby appropriated from the surplus of the League, as of this date, the sum of three thousand two hundred dollars (\$3,200) for the

purpose of defraying the expenses of holding this meeting of the Board of Directors, any unexpended remainder of the sum to be restored to surplus. On motion of Mr. Kirkman, unanimously VOTED to amend the motion to add the provision that the Secretary be instructed to report to the directors the expenses of each director. The question then being on the adoption of the motion as amended, the same was unanimously VOTED.

On motion of Mr. Norwine, after discussion, unanimously VOTED that the sum of three thousand one hundred and twenty-five dollars (\$3,125) is hereby appropriated from the surplus of the League, as of January 1, 1943, for the legitimate administrative expenses of the directors in the calendar year 1943, said amount allocated to the Canadian General Manager and the division directors as follows:

Canadian General Manager . . . . .	\$ 150
Atlantic Division Director . . . . .	200
Central Division Director . . . . .	400
Dakota Division Director . . . . .	200
Delta Division Director . . . . .	150
Hudson Division Director . . . . .	300
Midwest Division Director . . . . .	225
New England Division Director . . . . .	150
Northwestern Division Director . . . . .	200
Pacific Division Director . . . . .	200
Roanoke Division Director . . . . .	150
Rocky Mountain Division Director . . . . .	175
Southeastern Division Director . . . . .	125
Southwestern Division Director . . . . .	200
West Gulf Division Director . . . . .	300
	\$3,125

any unexpended remainders of these funds at the end of the year 1943 to be restored to surplus.

On the request of the Secretary to be relieved of certain instructions, on motion of Mr. McCargar, unanimously VOTED that the instructions to make a certain solicitation of the sentiment of the Philippine members of the League are rescinded, this subject to be reconsidered by the Board at the end of the war.

On the Communications Manager's recommendation concerning League membership in affiliated clubs, on motion of Mr. McCargar, unanimously VOTED to amend the 1935 resolution of the Board to read as follows:

**RESOLVED:** that it is the policy of the League not to grant affiliation to any amateur society unless 51% of the licensed amateurs belonging to the amateur society are also members of the League; that the Communications Manager is hereby directed to make a suitable survey of the affiliated clubs at the end of each year; and that it is hereby declared to be the policy of the League to terminate the affiliation of any society found not to comply with this condition unless it is indicated that the condition is due to effects of the war and beyond the power of continuing efforts of club officers to correct.

On the question of amending the rules on eligibility to the Board of Directors, moved, by Mr. Norwine, to amend the first paragraph of By-Law 12 by adding the following item in the listing of types of candidates declared ineligible:

(g) Any person commercially engaged as an advertising agent in handling the advertising of manufacturers or sellers of radio apparatus intended for use by amateurs.

The yeas and nays being ordered, the said question was decided in the affirmative: Whole number of votes cast, 15; necessary for adoption, 10; yeas, 15; nays, 0. Every director (except the President and Vice-President, who abstained as required) voted in the affirmative. So the by-law was amended as proposed.

Moved, by Mr. Norwine, to amend further the first paragraph of By-Law 12 by adding the following item:

(h) Any person commercially engaged as a radio service man.

The yeas and nays being ordered, the said question was decided in the negative: Whole number of votes cast, 15; necessary for adoption, 10; yeas, 1; nays, 14. Mr. Groves voted in the affirmative. All other directors (except the President and Vice-President, who abstained as required) voted opposed. So in this respect the by-law was not amended.

After further discussion, moved, by Mr. McCargar, to amend further the first paragraph of By-Law 12 by adding the following item:

(h) Any person who derives the major portion of his income from the repair, maintenance and checking of radio receiving apparatus; provided, however, that this subsection shall not be so construed as to hold as ineligible any person who, aside from his regular employment or income, repairs, maintains or otherwise checks said apparatus.

The yeas and nays being ordered, the said question was decided in the affirmative: Whole number of votes cast, 15; necessary for adoption, 10; yeas, 12; nays, 3. Those who voted in the affirmative are Messrs. Arledge, Bickel, Cavness, Davis, Groves, Martin, McCargar, Noble, Norwine, Reid, Shelton and Weingarten. Those who voted opposed are Messrs. Gates, Kirkman and Stedman. So the by-law was amended as proposed.

Moved, by Mr. Martin, that no further meetings of the Board of Directors be held until the conclusion of the present war, excepting that the President shall be empowered to call a meeting at any time; the by-laws to be regarded as amended accordingly. After extended discussion, on motion of Mr. Stedman, unanimously VOTED to lay the matter on the table.

On the question of the desirability of continuing elections for elective offices in the League, moved, by Mr. Stedman, that By-Law 21 be repealed. But there was no second, so the motion was lost. After further discussion, on motion of Mr. Reid, VOTED, 9 to 5, that, purely as a preliminary test of sentiment, it is the sense of the meeting that the Board of Directors ought to be frozen in office for the duration of the war; Messrs. Davis, Kirkman, McCargar, Stedman and Weingarten asking to be recorded as voting opposed. After further discussion, Mr. Reid moved the adoption of the following resolution:

**BE IT RESOLVED,** by the Board of Directors of the American Radio Relay League, that, a state of war existing in the country and a proper compliance with the



**RE-ELECTED**

George W. Bailey, W1KH, unanimously re-elected president of ARRL for two more years.

spirit of League by-laws as they relate to the election of directors and alternate directors and Section Communication Managers not being possible in view of conditions in the membership:

By-Laws 19 to 23, so far as they relate to the election of new division directors and alternate directors, and By-Laws 9 to 11 so far as they relate to the election of new Section Communications Managers, are hereby suspended, effective until the Board of Directors otherwise orders.

But, after further discussion, the said motion was rejected, 6 votes in favor to 7 opposed.

At this point the Board heard supplemental oral reports from the President, Secretary, Acting Treasurer and Communications Manager, in the course of which several actions were taken.

On motion of Mr. Stedman, after discussion, unanimously VOTED that the Secretary is authorized and empowered to execute, on behalf of the League, a lease with Thomas S. Whitman for the premises in West Hartford now occupied by the League for its headquarters' office, for a term of five years, at an annual rental of \$5,700; the lease to provide that if, during the present war or the period of six months immediately following, the Board of Directors shall direct the cessation of the normal business activities of the League, the League shall have the right to terminate the lease upon three months' notice and upon the payment of such portion of three additional months' rent as the premises remain unoccupied by a new tenant.

Communications Manager Handy reported his acceptance of a commission as a Major in the Army Air Forces and asked for leave of absence. After discussion, on motion of Mr. Caveness, unanimously VOTED that leave of absence, without pay, is granted Mr. Handy for the duration of his service in the war, he then to return to the office of Communications Manager; and that John Huntoon, W1LVQ, an assistant secretary of the League, is appointed Acting Communications Manager, to serve as such during Mr. Handy's absence, with no additional compensation for such services. The Chair expressed to Mr. Handy the congratulations and good wishes of the Board. (Applause.)

The Board determined to complete its agenda without recessing for dinner. At this point Messrs. Houghton and Grammer retired from the meeting at the request of the Chair. After discussion of the treasuryship, on motion of Mr. Arledge, unanimously VOTED that David H. Houghton is appointed the permanent Treasurer of the League. On the question of his salary as such, after discussion, on motion of Mr. Stedman, unanimously VOTED that Mr. Houghton's salary as Treasurer is set at \$500 per year, without prejudice to any other arrangements that may exist concerning his salary for other duties.

On the question of appointments to the Finance Committee, on motion of Mr. Blalack, VOTED that the personnel of the Finance Committee for the coming year shall consist of Mr. Reid, chairman, and Messrs. Caveness and Norwine; and that the sum of five hundred dollars (\$500) is hereby appropriated from the surplus of the League, as of this date, for the use of the Finance Committee, any unexpended remainder of this sum on the date of the next annual Board meeting to be returned to surplus.

On motion of Mr. Stedman, unanimously VOTED that

the Board of Directors of the American Radio Relay League, speaking the wishes of the licensed radio amateurs of the United States, renews the pledges heretofore given of whole-hearted cooperation with the communications policy of the Government, tenders the services of the League's official station, W1AW, and expresses the hope that the reactivation of that station can be found consistent with the war effort.

At this point Mr. Reid rendered a report on behalf of the Finance Committee. Messrs. Houghton and Grammer rejoined the meeting, the former being congratulated by the Chair upon his appointment as Treasurer. (Applause.) The Chair read a message from Director Dosland, sending good wishes and regretting his inability to be present. Mr. Shelton reported as chairman of the committee on Ham Haven, recommending that the subject go over for the duration of the war.

Proceeding to the election of President and Vice-President, on motion of Mr. Kirkman, two-thirds concurring, Special Rule A was suspended. The Chair appointed Messrs. Huntoon and Grammer as tellers. Written nominations were agreed upon.

Nominations for President being in order, the tellers announced that the only one nominated was Mr. Bailey. On motion of Mr. Caveness, the Vice-President putting the question, Mr. Bailey by unanimous acclamation was declared reelected for a two-year term. He spoke briefly in appreciation of the honor shown him by his reelection. (Applause.)

Nominations for Vice-President being in order, those nominated were Mr. Blalack and Mr. Caveness. The vote having been taken, the result of the ballot was announced by the tellers as follows:

Whole number of votes cast .....	17
Necessary for election .....	9
For Mr. Blalack .....	12
For Mr. Caveness .....	5

Mr. Blalack, having received a majority of the votes cast, was thereupon declared by the tellers to be reelected Vice-President of the League for a term of two years. He spoke briefly in appreciation. (Applause.)

Whereupon, on motion of Mr. Norwine, the Board adjourned, *sine die*, at 6:43 p.m. Total time in session, 8 hours, 15 minutes. Total appropriations, \$7,325.

  
Secretary

### "TEMPORARY LIMITED" LICENSES

TO MEET the increasing need for operators, FCC has made another relaxation of its rules, especially on behalf of ship operators and limited to the duration of the present war. A new class of license limited to ship work has been set up under the name of "Temporary Limited Radiotelegraph Second-Class Operator License." The code test remains 16 code groups per minute, but the required rating on the regular second-class written examination is now marked down to fifty per cent.

The license will also be issued to any eligible person who has previously held, but does not now hold, a radiotelegraph first- or second-class ticket, and who passes the code test of 16 groups per minute; and to any enrollee at a Coast Guard Maritime Service Radio School who is certified by that service as qualified.

### RENEW YOUR LICENSES!

**Don't** let your amateur licenses expire! Your continued possession of them has many

### OFFICERS' REPORTS AVAILABLE TO MEMBERS

In April of each year the officers of the League make comprehensive written reports to the directors. The Board of Directors has made these reports available to the membership of the League. Interested members may obtain copies postpaid at the cost price of 50¢ per copy. Address the Secretary at West Hartford.

uses, will have many more. You are likely to be very glad you kept them in force.

Try to get in renewal applications 60 days before expiration but don't worry, if you miss the date slightly: FCC will probably treat it as a renewal application up to two or three months after expiration. If you are in the armed forces, remember that FCC Order No. 81 makes it possible to submit an informal application by letter, in lieu of the printed form which is usually required. The letter must set forth the fact that you are serving with the armed forces and must be accompanied by a signed statement of your immediate commanding officer to that effect. If you are going overseas and foresee difficulty in filing your application at the right time, such as late this year, you can send your informal application to FCC before sailing and ask them to hold it until the proper filing dates arrives. Be sure to attach your old license.

### SOME THINGS TO REMEMBER

If you are a licensed amateur in war communications work — military or civilian, manufacturing or research, operating or maintenance or what-not — please report the general dope for the ARRL roster. You might see page 34 November *QST*, if you have it handy. You know why we want this, don't you? It is so that ARRL Headquarters may compile statistics on the amateur's contribution to the war effort, so that we may show that it was wise national policy for the government to have encouraged amateur radio. In short, so that we may be sure of getting our frequencies back. The more we can do on this job now the less there will be to do afterward. Data on confidential assignments and confidential locations are, of course, not wanted; do not mention them. But if you can possibly spare a moment from the work in hand, drop us a line.

Colleges and training schools near you are short of apparatus for use in training radio students. If you are willing to sell, give or rent your apparatus for that purpose, follow the suggestions on page 27 of our May issue.

Government services are calling more frequently for factory-built amateur transmitters and receivers. If you are willing to dispose of yours for the national need, register the data with us after the style of the form on page 17, April *QST*.

Every radio person is needed for a war-time job in radio. The ARRL Personnel Bureau is very busy helping in the large task of finding specialists for trying jobs, suggesting the right job for interested applicants. The keystone of this work is the "Registration of Availability" with ARRL Headquarters. Write us for a form, or see page 27 of the December number.

When you join the League, or whenever you renew your membership, please show whether you have an amateur station or operator's license.

It permits classifying you in the proper grade of membership.

### FINANCIAL STATEMENT

The business operations of the League in the first quarter of this year produced a further comfortable addition to the surplus which has to stand in our organization in place of other capital, the stuff that keeps us rolling through bad times. This quarter is traditionally our best one from the business standpoint. There was some reduction in expenses as some of our customary activities commenced to taper, and our books enjoyed a very good sale as training literature. At the instructions of the Board, the first-quarter operating figures are here given for your information.

#### STATEMENT OF REVENUE AND EXPENSES, EXCLUSIVE OF EXPENDITURES CHARGED TO APPROPRIATIONS, FOR THE THREE MONTHS ENDED MARCH 31, 1942

REVENUES	
Membership dues . . . . .	\$14,277.52
Advertising sales, <i>QST</i> . . . . .	17,545.18
Advertising sales, Handbook . . . . .	2,962.74
Newdealer sales, <i>QST</i> . . . . .	10,025.36
Handbook sales . . . . .	32,178.35
Spanish edition Handbook revenues . . . . .	46.50
Booklet sales . . . . .	2,926.27
Calculator sales . . . . .	335.75
Membership supplies sales . . . . .	2,402.33
Interest earned . . . . .	625.62
Cash discounts received . . . . .	488.99
Bad debts recovered . . . . .	6.90
	\$83,821.51
<i>Deduct:</i>	
Returns and allowances . . . . .	2,454.56
Cash discounts allowed . . . . .	285.12
Exchange and collection charges . . . . .	100.25
Add: Increase in reserve for newdealer returns of <i>QST</i> . . . . .	84.50
	2,924.43
Net Revenues . . . . .	\$80,897.08
EXPENSES	
Publication expenses, <i>QST</i> . . . . .	\$14,168.14
Publication expenses, Handbook . . . . .	18,894.42
Publication expenses, booklets . . . . .	1,130.05
Publication expenses, calculators . . . . .	90.95
Spanish edition Handbook expenses . . . . .	169.78
Salaries . . . . .	22,254.19
Membership supplies expenses . . . . .	2,348.14
Postage . . . . .	1,506.33
Office supplies and printing . . . . .	1,745.53
Travel expenses, business . . . . .	699.83
Travel expenses, contact . . . . .	23.08
<i>QST</i> forwarding expenses . . . . .	915.09
Telephone and telegraph . . . . .	770.28
General expenses . . . . .	1,216.22
Insurance . . . . .	212.57
Rent, light and heat . . . . .	1,167.50
General Counsel expenses . . . . .	250.00
Communications Dept. field expenses . . . . .	109.37
Headquarters Station expenses . . . . .	155.19
Provision for depreciation of:	
Furniture & equipment . . . . .	220.45
Headquarters Station . . . . .	108.97
	\$68,156.08
Total Expenses . . . . .	\$68,156.08
Net Gain before expenditures against appropriations . . . . .	\$12,741.00



# EXPERIMENTER'S SECTION

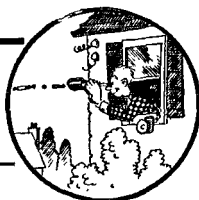

Address correspondence and reports to ARRL, West Hartford, Conn.

## PROJECT A

### *Carrier Current*

REGISTRATIONS under Project A have now reached a point which indicates that several hundred individuals are working with carrier-current equipment. While numerous reports have been received of contacts between pairs of experimenters no group activity has yet been described. R. L. Wardle and his group at Morgantown, W. Va., apparently hold the record thus far with regular communication between three stations. We should like to hear particularly from larger groups who have succeeded in working up nets for local emergency coverage. Has anyone succeeded in doing any relay work yet? Any reports of contacts between adjacent towns or communities would also be of considerable importance.

W2NDK reports a large group working on the project, including W2LWF, W2MGN, W2OHN, W2LVA, W2DXL, W2MGE, W2LTR, W2MDE, W2NFT, W2GYH and W2NEE. A high noise level has limited the contacts thus far to a distance of about five blocks. It appears that the use of c.w. and a highly-selective receiver might be required to combat a high noise level.

W5APG and W5ERS are putting across S-9 plus signals over a distance of  $\frac{3}{4}$  mile with less than nine watts input.

W9BAY in Chicago has been hearing a public service station in Peoria on about 300 kc. This is a distance of about 24 miles.

W2JKD, W2MPI and W2NNA are doing experimental work with carrier current and would like to get in touch with all others interested in the New York metropolitan area and suburbs. Contacts should be made through W2NNA, 1101 Lexington Ave., N. Y. C.

W9YHZ, W9TTP and George Huth in St. Louis report that they have been able to hold two-way contacts between stations each served by different power companies with independent lines. One of the most interesting observations made during the tests was that an a.c.-d.c. b.c. receiver in the house with the transmitter would absorb practically all of the output from the transmitter, while receivers with power transformers had practically no effect. They are now building equipment for the third station which they hope to have in operation soon.

## PROJECT B

### *Light Beams*

GROUP LEADER BOURNE, W1ANA reports that several fellows are working on equipment described in *QST* but that no further reports of progress have been received this month.

## PROJECTS C & G

### *Audio-Frequency Induction and Earth-Current Communication*

I AM SENDING along a few notes on communication by earth current, so called. I notice that some feel it may all be a.f. induction, but I am not ready to agree with that theory. This work is being done by W1KAT of Guilford (Conn.) and myself.

The ground used at my location is about 800 feet between the rods. One connection is to copper tubing in a well about nine feet deep. The connection at the far end is a piece of copper tubing driven into the bed of a brook. Resistance between the rods is approximately 1500 ohms. There is also a readable d.c. voltage of a little less than  $\frac{1}{2}$  volt. For a transmitter I am using a 6C5 speech amplifier feeding a 6A6 Class B modulator, output around 7 watts, with a carbon telephone mike. Voice has been used in all tests.

Both headphones and a speaker have been used for reception. The headphones are just connected between the two receiving ground rods. For speaker reception, the audio end of a b.c. receiver is used, one rod connected to the set ground, the other feeding the grid of the 6F5 through its volume control. Excellent results have been had with this power of 7 watts audio up to  $\frac{1}{2}$  mile. Tests over a greater distance are in the works. Several tests have been made between W1IJ and W1KAT, a matter of ten miles, but no luck so far. However, this is not discouraging under the present setup.

There are so many different checks and tests to

make that it looks like a long program. One very interesting test that has to be made will be what effect the ground resistance has on the signal received, and it means something.

All the tests carried out so far have been in the country with no water pipes within 7 miles with the exception of pipes from a house to a nearby well. Ground resistances of four to five hundred ohms up to 7000 ohms have been used. The ground used at the  $\frac{1}{2}$ -mile distance was 7000 ohms.

Lots of fun and a lot of work but it may be worth while. Anyone interested in comparing notes can be assured of an answer.

*Owen Shepherd, Jr., W1IJ*

## PROJECT E

### *Acoustic Aircraft Detection*

There has been much work done by scientists, in cooperation with the armed forces, on the design and construction of aircraft detectors which operate on the principle of amplifying electrically the sound generated by an airplane or other aircraft at a distance from the detecting station. Very little of this material, however, is of interest to the radio amateur who must needs use equipment which can be built at a reasonable price and without the use of extensive shop facilities. Therefore, it is our intention to develop a detector which can be built for a reasonable amount of money, which uses equipment not too heavily covered by

priorities and which is accurate enough to be of some use to the civilian-defense authorities.

Three things are to be expected of a satisfactory detector. It must be sensitive enough to detect approaching aircraft soon enough to enable the ARP personnel to get into operation. It should have some measure of directivity to provide an approximate idea of the identity and intentions of the plane. It must be simple enough in operation so that non-technical personnel can be pressed into service as operators.

Since the announcement of the organization of this project we have heard from a great many amateurs who have built or are building such equipment. Perhaps a description of their efforts would be of more than slight interest to others of the amateur fraternity.

Observers at an official post in Eastern Massachusetts have built a detector following closely the design shown in March *QST* and have had this installation in operation under the direction of the civilian defense authorities since the middle of March. The chief warden of the post writes as follows:

"Perhaps you will be interested in knowing about our experience with the acoustical listening device in actual use at our observation post since March 15th.

"Nearly all observers from dusk to daylight use the device constantly, even if wind is rather high and it may be necessary to use both volume and tone controls to reduce excess noise. About two-thirds of the day observers use the device, except when very windy, when the visibility is good. Everyone uses the device in foggy or hazy weather. Actual rain drops pound on the reflect-

ing surface so much that the device is nearly always shut off because of noise. As near as we can tell by ear tests, this device is about one and one-half times as sensitive as the average ear.

"As to microphones in use, the crystal mike is a Shure and the dynamic mike is an American Model DST. I have no record of the rated sensitivity of either one, although in actual tests both work well, but the dynamic gives noticeably louder signals on the same outside noise, while the crystal gives us a higher tone on wind noise and a deeper tone on plane noise. While the crystal pickup is less, the contrast seems greater.

"We expect to continue experiments in wind noise reduction and we may be able to help our own conditions, but I feel rather sure each installation will probably have special problems.

"Perhaps the most satisfactory

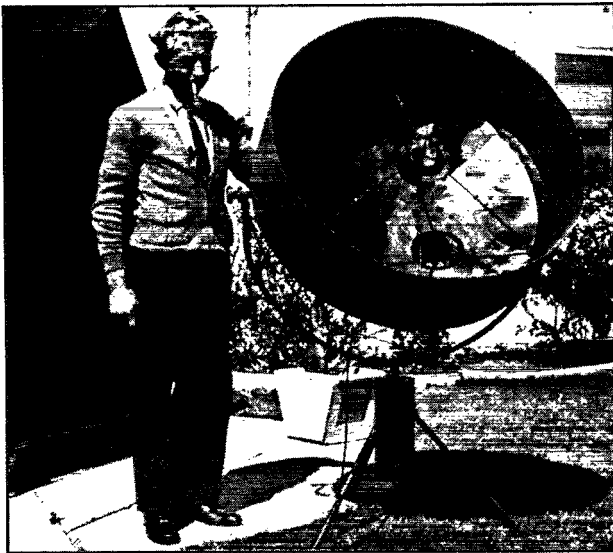

Homemade microphone reflector for directive aircraft detection built by George H. Volker of West Los Angeles, Calif.

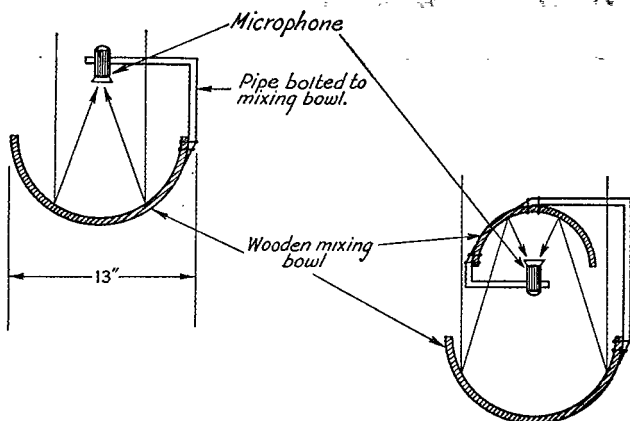

Fig. 1 — Arrangement of "mixing-bowl" acoustic reflectors used by B. C. Barbee of Jackson Heights, L. I.

part of our reactions is a feeling that, even if the observer's vision is directed elsewhere for a short period of time, no plane will be missed which comes within our reporting radius."

Mr. B. C. Barbee, of Jackson Heights, New York, has built two microphone pick-ups, as shown in Fig. 1. The reflectors are discarded wooden mixing bowls which provide some measure of directivity.

Mr. Howard C. Roberts, of the University of Illinois, suggests the use of a tuned audio-frequency amplifier to discriminate between the various sounds which may be present.

Mr. Alfred G. Redfield, of Cambridge, Mass., describes two methods of improving the original detector, as shown in *QST*, by the addition of discarded wooden mixing bowls and a tea cup. This is shown in Fig. 2.

Mr. S. J. Weitzer, of West Orange, N. J., suggests the use of a parabolic reflector to be used in conjunction with the microphone to obtain sharp directional characteristics. Mr. Weitzer also suggests the use of a single pipe eight feet long which would be approximately resonant to the predominant frequency present in aircraft noise. The diameter of this pipe would determine the amount of sound energy reaching the diaphragm.

Mr. George H. Volker, of West Los Angeles,

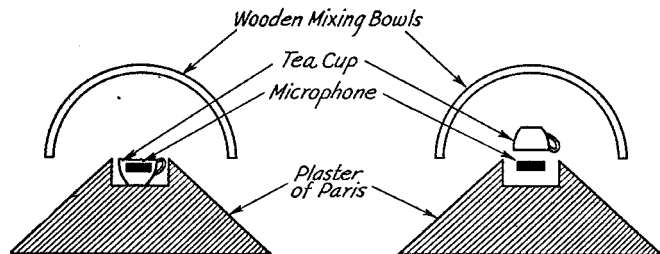

Fig. 2 — Another reflector system suggested by A. G. Redfield of Cambridge, Mass.

Calif., describes an installation which may be of interest to others. His letter follows:

"... Sometime prior to January, 1942, I started work on such a system, building from scratch, power supply, amplifier, mike, etc. Using a 350-volt power transformer with 30-henry choke and two 8- $\mu$ f. condensers and one 28- $\mu$ f. condenser with a 50,000-ohm, 10-watt bleeder, this pack gives perfect d.c. at 320 volts, 100 ma.

"After building several amplifiers, one with three 27's, another with three 56's, transformer-coupled and resistance-coupled, I finally built up the amplifier described in March *QST*, using a 5-inch speaker as a microphone

with matching transformer and another similar unit as a speaker. The amplifier is built on a  $2 \times 4 \times 8$ -inch chassis which fits in a  $4\frac{1}{2} \times 6 \times 8\frac{1}{2}$ -inch can with mike plug, power plug and speaker connection. The mike cord is 25 feet long, 2 wire, rubber covered. On portable use, the unit can be plugged to car battery and 90-volt B supply using 'phones or speaker.

"I now built a 36-inch parabola of 12-inch focal length, made up of ten gores of sheet tin and mounted as shown in the accompanying photo.

"On a recent test at a lookout station, we picked up 22 planes from 2 to 5 p.m., some 8 to 10 miles distant, very clear and sharp. The parabola brings them in right on the nose, but is not too directional. . . ."

As mentioned above, it is necessary to use an amplifier of extremely high gain in order to make the sensitivity of the apparatus as great as possible and to utilize to the fullest extent the directional qualities of the microphone pick-up.

The circuit of such an amplifier appears in Fig. 3. It is a straightforward three-stage resistance-coupled voltage amplifier. The steps taken to eliminate hum result in some unusual circuits. The hum from the power supply is reduced by an electronic voltage regulator. Taking the high voltage from one side of the rectifier filament

may introduce hum into the output of the power supply. This may be eliminated by a center-tapped potentiometer across the rectifier filament winding on the power transformer. Another source of hum is an inequality in the voltages supplied to the plates of the full-wave rectifier tube when the high-voltage winding of the power transformer is not tapped at its exact electrical center. A difference as

small as one per cent in the voltages will cause a measurable amount of 60-cycle hum to appear in the output of the rectifier. This obviously may be cured by placing a potentiometer across the power transformer secondary and adjusting the tap for minimum hum. This did not prove necessary in our case.

Cathode bias resistors are always a source of hum in high-gain audio amplifiers, principally because complete bypassing can never be obtained. It was designed, therefore, to use fixed bias obtained from the power supply. Two-megohm resistors are used for decoupling the bias bus. Still another source of hum which may be cured in the power supply is that caused by random electrons emanating from the filaments of the tubes and striking the cathodes. This can be eliminated by making the filament positive with respect to the cathode. This was accomplished in this case by connecting the filament center-tap to the 25-volt tap on the power-supply bleeder. The circuit of the amplifier itself is conventional in other respects except that all "cold" circuits

are bypassed as well as possible, and that adequate decoupling is incorporated in the first two plate supply circuits.

The chassis on which the amplifier is built is  $6 \times 14 \times 3$  inches. The construction is standard throughout with the exception of the first stage, which is shock mounted and shielded as shown in Fig. 4. Otherwise the only precaution that need be observed is that the power supply, especially the filter choke, be kept as far away from the first stage of the amplifier as possible.

Opinion is divided regarding the worth of high directivity in the microphone. Some point out that there is a relatively small difference between the speed of sound and that of aircraft flight. However, a high factor of directivity will be of value in determining the course of approach of an aircraft, as mentioned on page 40 of May *QST*:

"With such a directive system, the observer notes the angular variation of the sound. As the horizontal bearing changes, this indicates that the approaching aircraft will probably not pass directly overhead. On the other hand, if the

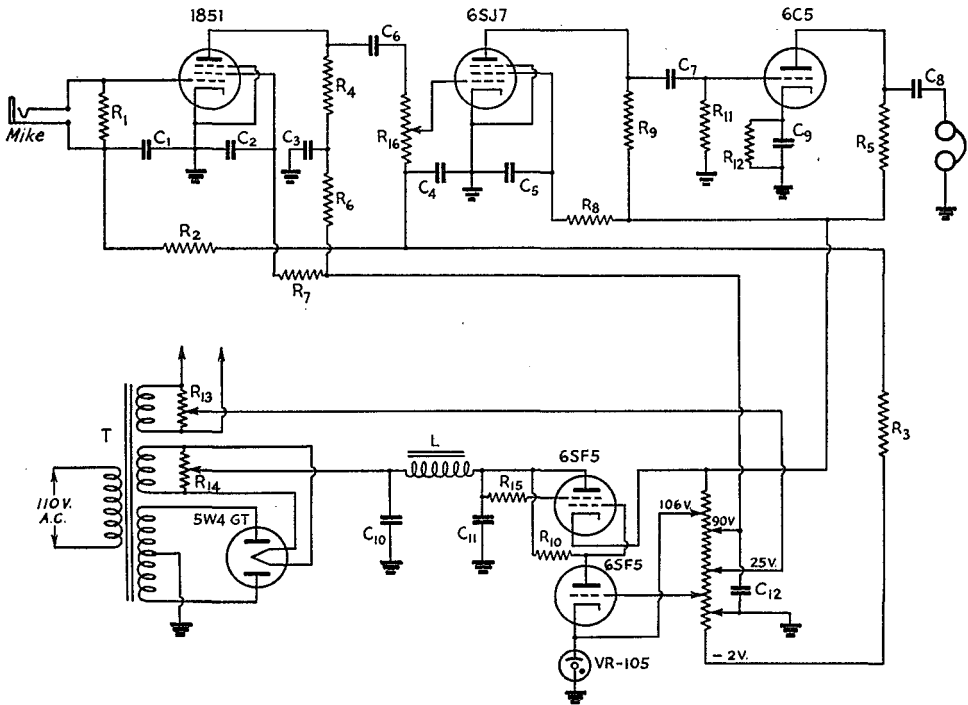

Fig. 3 — Circuit diagram of the high-gain audio amplifier

C<sub>1</sub>, C<sub>2</sub>, C<sub>3</sub>, C<sub>4</sub>, C<sub>5</sub> — 8- $\mu$ fd. electrolytic.  
 C<sub>6</sub>, C<sub>7</sub>, C<sub>8</sub> — 0.1  $\mu$ fd.  
 C<sub>9</sub> — 1  $\mu$ fd.  
 C<sub>10</sub>, C<sub>11</sub>, C<sub>12</sub> — 20- $\mu$ fd. electrolytic.  
 L — 10 hy., 40 ma.  
 R<sub>1</sub>, R<sub>2</sub>, R<sub>3</sub> — 2 meg.  
 R<sub>4</sub>, R<sub>5</sub> — 50,000 ohms.  
 R<sub>6</sub> — 10,000 ohms.

R<sub>7</sub>, R<sub>8</sub>, R<sub>9</sub>, R<sub>10</sub> — 0.1 meg.

R<sub>11</sub> — 0.5 meg.

R<sub>12</sub> — 2000 ohms.

R<sub>13</sub>, R<sub>14</sub> — 50 ohms.

R<sub>15</sub> — 500 ohms.

R<sub>16</sub> — 1-meg. volume control.

R<sub>17</sub> — Voltage divider.

T — 400 volts, r.m.s., each side of center, 200 ma., 5

volts, 4 amp., 6.3 volts, 4.7 amp. (Thordarson T13R16).



horizontal bearing remains unchanged, while the vertical bearing increases, this is an indication that the observer is on the course. . . ."

This in itself seems to justify any additional expenditure of time or energy devoted to the construction of highly-directive equipment. There are three obvious methods of attaining directivity: (1) The microphone may be placed at the focus of a parabolic reflector. (2) An exponential horn may be used with the microphone placed at the throat. (3) An acoustic impedance element, such as is used in NBC's "machine gun" microphone, may be coupled to the microphone.

The use of a paraboloid seems to be out of the question for the larger percentage of amateur constructors. The design of a paraboloid is, in itself, relatively simple, but the accurate construction thereof is rather difficult. In addition to this, the diameter of a paraboloid, to be effective for this service, should be of the order of 8 to 10 feet. The exponential horn is relatively difficult to construct, but on the other hand many amateurs have access

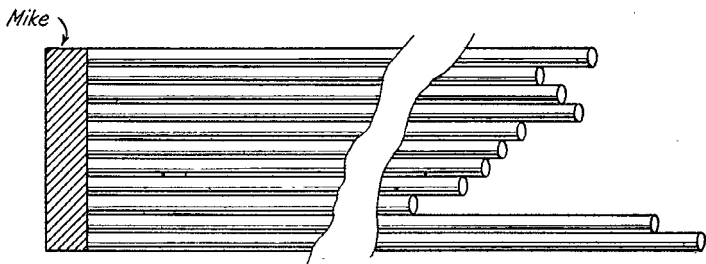

Fig. 5 — "Machine-gun-type" directional pickup.

to public-address loud speaker horns which in many instances will be suitable for the service in question. The design of either the parabolic or exponential type of reflector is beyond the scope of this paper; however, we should be glad to send complete details to any amateur.

The design of an acoustic impedance element, practically speaking, isn't too difficult. That is to say, one need only have a large number of pipes with their axes parallel, rigidly fastened together, and rigidly attached to the microphone as shown in Fig. 5. The longest pipe should have the greatest length that can be mechanically handled, while the others should have a constant decrement of length. Further details may be obtained by communicating with the authors.

The analysis of the sound waves propagated through space to the listening post by an aircraft engine is a tedious task, but physicists tell us that the predominant frequency of a two-motored

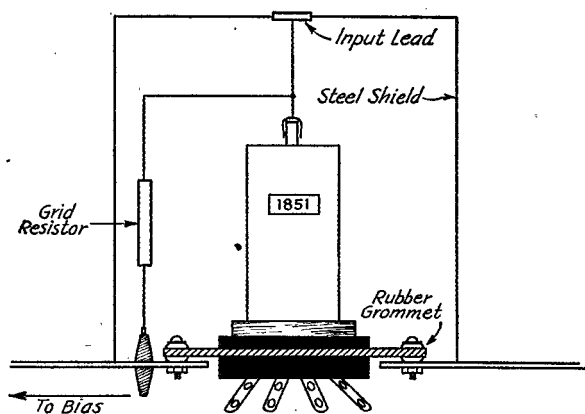

Fig. 4 — Sketch showing method of assembling the 1851 stage of the high-gain audio amplifier.

plane in normal flight is 130 cycles per second. It must be remembered, however, that, in addition to this frequency, a large portion of the propagated energy is to be found in the first five harmonics of the fundamental — 260, 390, 520, and 650 cycles per second. This would seem to indicate that an audio amplifier tuned sharply to, say, 130 c.p.s. would reject a large part of the sound energy. Therefore, until we can develop a "multi-band-pass" circuit, it might be best to use the natural discriminating potentialities of the human ear to analyze the jumble of received sound. This does not require the technical knowledge on the part of the operator needed for

the reading of an oscillograph or wave analyzer.  
— Albert E. Hayes, Jr., and T. Richard Thomas

## Rocky Mountain Division Convention

**Denver, Colo., Aug. 8th-9th**

THE Rocky Mountain Division Convention will this year be sponsored by the Associated Amateur Radio Operators of Denver. This two-day conclave will have many interesting highlights, and plenty of entertainment is in the offing. The Radio Widows, local ladies club, will keep the ladies busy, so don't leave them home. Ticket registration will be \$3.00 in advance, by mail or otherwise, and \$3.50 after 5 P.M. on Aug. 7th. For tickets or additional information address the club secretary, Howard R. Markwell, W9TFP, 355 Monroe St., Denver, Colo.



# U.S.A. CALLING!



## WOMEN FOR MECHANICS

THE Signal Corps needs at once in its laboratories at Ft. Monmouth 250 women to receive training and employment as radio mechanics. They will be paid at the rate of \$120 a month while receiving instruction for a period of six months, then will be full-fledged radio repairmen and mechanics at \$135 a month. The work will be right in the development labs at Monmouth, assisting engineers in research and development — very interesting work. The best candidates are those with some small knowledge of radio, such as comes from being the sister or wife of an amateur, but code knowledge and license possession are not asked.

This is the same position as is referred to under the title Trainee-Repairman in June *QST*, p. 23, and April, p. 25, but the Signal Corps' need is so great that they want to deal direct with women applicants, many and fast. Applicants will be accepted from any part of the U. S. but must report at their own expense when accepted.

Ft. Monmouth, on the ocean, qualifies as a seashore resort. Unlike many posts, there is adequate housing, with attractive furnished quarters at modest rates — \$4.50 and \$5 a week. The training given is valuable, qualifies one for a good position.

Those interested should call, wire or write as quickly as possible to Personnel Officer, Signal Corps General Development Laboratory, Fort Monmouth, New Jersey.

## F.C.C. DEFENSE MONITORING

THE Federal Communications Commission continues to have openings for additional personnel in its national defense monitoring operations. See our article on page 22, May *QST*. While some of these jobs are at primary monitoring and d.f. stations, most of them are at the four-man secondary stations erected particularly for the current emergency and equipped with special apparatus, including mobile units in a car. The work is chiefly surveillance, recording, investigating indications of subversive uses of radio, securing evidence, etc. Each station has a Monitoring Officer, an Assistant M. O. and two operators, for which the customary salaries are, respectively, \$3,200, \$2,600, \$1,800 and \$1,620. The officers must have had some years of progressive paid experience in technical capacities, with substitution of college engineering or radio-institute training permitted. While no credit is allowed for amateur experience, FCC is particularly eager to get competent amateurs in

this work. Operators must have a sustained speed of at least 20 w.p.m., and for certain assignments they must be able to typewrite or teletypewrite. For the operator jobs, see Civil Service Announcement No. 203 at any first- or second-class Post Office; and for the monitoring-officer positions the announcement is No. 166.

## ELECTRONICS TRAINING GROUP

VERY good reports have come back from overseas of the work of this Group. Radio amateurs figure prominently in these reports. There is still plenty of room for college graduates in EE or physics, with preference for those with ham licenses or plenty of commercial engineering experience. Ages, 18 to 35. Chances are that anyone being commissioned now will find plenty of hams for company in the Group. Remember that this training and experience will be wonderful preparation for commercial adaptations of these military devices in later years. Write to Mr. Bailey.

## ENGINEERING STUDENTS AS OFFICERS

DON'T leave college to enlist! The Signal Corps offers commissions as second lieutenant to junior and senior students majoring in electronic physics or electrical engineering, upon graduation. Engineering students should not let the draft interrupt schooling. Get deferment, finish up, serve as an officer. Here's the dope:

You will be temporarily enlisted in the Enlisted Section, Electronics Training Group, Signal Corps. Application for such enlistment should be made direct to the Chief Signal Officer of the Army, Washington. It must be accompanied by a statement by your Dean of Engineering that you may reasonably be expected to graduate. If your college has an ROTC unit, you should have a statement from its Provost Marshal to the effect that you are officer-candidate material. (If no ROTC, a Signal Officer will interview prospects.) When accepted, you are allowed to complete your schooling and, upon graduation, are appointed a second lieutenant. Your Dean of Engineering has further particulars.

## MARINE CORPS

APPOINTMENTS as commissioned officers in the Marine Corps Reserve, for assignment to special aircraft warning duty, are still available for men holding a degree in electrical, communication or radio engineering or electronic physics. There is also a chance for those with two years of college engineering and considerable practical

experience in radio, as well as those who are experienced in u.h.f. design and maintenance. Appointments range from second lieutenants to higher ranks, according to age and experience. If you are interested in serving in the Marine Corps and a bit uncertain about your qualifications, write to Mr. Bailey.

#### **STAFF SERGEANT, MARINE CORPS**

**H**ERE is a chance for many radio operators who have not had the advantage of a college education but have graduated from high school. Appointments with the initial rank of staff sergeant are available in the Marine Corps Reserve to qualified men between the ages of 19 and 35, who will be assigned to aircraft warning maintenance duty. The pay ranges from \$72 to \$122.50 per month, in addition to food, clothing, shelter and medical care.

For radio amateurs who did not graduate from high school there is a chance to enlist as privates in the regular Marine Corps or the Marine Corps Reserve, with assurance that they will be assigned to general communication duty. Apply to the nearest Marine Corps recruiting officer or by letter to The Commandant, U. S. Marine Corps, Washington, D. C. If uncertain of your qualifications, write to Mr. Bailey.

#### **ARMY AIR FORCES**

**A** LARGE number of officers are urgently needed for ground duties of many descriptions. For a list of these duties in detail, refer to June *QST*. Commissions are available in ranks from second lieutenant to major, depending upon age and experience. Send your qualifications to Mr. Bailey.

#### **COLLEGE WOMEN**

**T**HERE are still plenty of civilian appointments as Junior Physicists and Junior Engineers at \$2000 a year available in the Bureau of Ships at Washington, for college women with training in the physical sciences. For those who hold amateur licenses, appointments are immediately available in radiolocator work, in research laboratories, or in the development and installation of communication facilities. Send your qualifications to Mr. Bailey.

#### **OFFICER CANDIDATE SCHOOL**

**S**OME amateur operators seem to think that, if they lack a college education or have not graduated from high school, their chances are hopeless for ever becoming an officer in the Signal Corps. As a matter of fact, they have a very good chance of obtaining a commission as second lieutenant if they are willing to work for it. Any Army recruiting office will enlist an amateur in the Signal Corps if he shows his amateur license to the recruiting officer and, of course, is physically qualified. Refusal to so enlist an amateur means that the officer is not aware of the latest directive.

In such a case, send a telegram to Mr. Bailey. After being accepted for enlistment in the Signal Corps the amateur will be sent to the nearest signal school and, after some weeks of training, there is a fair chance that he will be given an opportunity to attend officers' training school. It then depends upon him as to whether he makes the grade as second lieutenant. Many hams have already done so.

#### **AIR TRANSPORT COMMAND**

**T**HE Army Air Forces offer appointments as second lieutenants in the Air Transport Command to radio amateurs who are willing to serve outside of the continental United States and are willing to go into the air. Commissions are available to amateurs who do not have a college degree, provided that they have had plenty of radio experience and are physically fit. The work will be in communications. This branch of the Army Air Forces is comparatively new and offers some very interesting opportunities for qualified hams. Send your applications to Mr. Bailey.

#### **WOMEN WITH AMATEUR LICENSES**

**I**F YOU are a woman with an amateur license but no college education, you still have an opportunity to obtain a civilian appointment in the Bureau of Ships in Washington, working on radio communication facilities at \$1620 a year. Here is an incentive for the study of radio to obtain an amateur ticket — which is your passport to a worthwhile job. Write your qualifications to Mr. Bailey.

#### **COMMUNICATIONS CADETS**

**Y**OU'VE heard about these Aviation Cadet Examining Boards? There is one near you. One kind of cadet applicant being sought is for non-flying communications officer — to be in charge of radiotelegraph and teletype and directional

*(Continued on page 58)*

### **“Let George Do It”**

W1KH, President of ARRL, amongst several wartime assignments is special assistant for radio in the Office of Scientific Personnel, located in the Academy of Sciences building in Washington. His office passes upon the technical qualifications of thousands of radio specialists needed in the armed services and the government laboratories and arranges for their appointments. That is why many of the items in this department advise that you “Write Mr. Bailey.” Here's his address:

GEORGE W. BAILEY  
2101 Constitution Avenue, N. W.  
Washington, D. C.

# Easy Lessons in Cryptanalysis: No. 1

BY JOHN HUNTOON,\* WILVO

ED WILSON's back doorbell jangled, bringing him from the dinner table. At the door he found the town's newest ham, Jim Bremer, with a copy of *QST* under his arm.

"H'lo, Ed. Did I interrupt your dinner?"

"Yes, pest," Ed said, but he grinned as he spoke. He liked this clean-cut youngster whose entire ham training he had nursed. "Go ahead down to the shack and I'll be with you as soon as I finish."

Alone in the basement room, Jim admired for the hundredth time the expertly-designed amateur layout, the precision construction. Ed was chief engineer of the local b.c. thousand-watter — most of which he had built, too. Presently the conversational noises upstairs subsided; that would be the youngsters being tucked in bed. Ed came downstairs.

"Well, what's worrying you this time, Jimmy m'lad? Going to build an amplifier for the air raid spotters?"

"No," Jim laughed, "I've read the *QST* story on secret cipher solutions and it sounded interesting. You know lots about cryptography from the AARS, and I wondered if you'd help me learn too."

"Sure, pal. The *QST* story was very short, of course, and touched only one phase of cryptanalysis. Tell you what — if you'd like, you can come over here each Monday and we'll have a session on the subject. Okay?"

"That's swell, Ed. Can we start now?"

"Yep, I guess so. Pull up a chair so we can use pencil and paper. That's one thing a cryptanalyst needs plenty of, you know. Now, we'd better begin with transposition. It is the easier of the two types to understand, although I think just as difficult to break down if one doesn't know the key."

"Transposition means the type where the original letters of a message are jumbled or rearranged, doesn't it?" Jim asked.

"That's right, in accordance with a predetermined key. Or, the transposition might be by words instead of letters. Single-letter or 'monoliteral' transposition is most common, however. In its simplest form it is known as a 'route cipher' and is based on a geometric figure having certain dimensions governed by the key. The dimensions are measured in units or 'cells' of one letter each. Ordinary cross-section paper with  $\frac{1}{4}$ -inch squares is indispensable for transposition solutions. You'd better get some tomorrow."

"Okay," said Jim, chin in hand.

\* Assistant Secretary, ARRL.

"We'll use the square and rectangle for purposes of illustration. Now, the plain text message, letter by letter, is written into each succeeding cell in some predetermined sequence, the process being called 'inscription'; and then a cipher message is taken off or 'transcribed' by some other sequence or route. Here, let me show you what I mean: s'pose we have the message . . . ummmmm . . . well, let's take the words **War Emergency Radio Service**. Assume we've agreed that our secret method of communication will be transposition, with horizontal inscription and vertical transcription, the horizontal dimension being five cells."

"What about the vertical dimension, Ed?"

"Well, that will take care of itself, depending solely on the length of the plain text message. Now look . . . we'll write the message by letters in rows of five letters each, so:

```
W A R E M
E R G E N
C Y R A D
I O S E R
V I C E X
```

"If we like, we can insert a false letter or 'null' to fill the lower right corner, but it is not necessary. We've now inscribed the message. Our agreement for transcribing was by vertical columns, so we have the following cipher text:

**WECIV ARYOI RGRSC EEAE E MNDRX**

Catch on?"

"Certainly doesn't look much like the original," Jimmy commented. "Lemme see if I could read it if I were the addressee. First I'd write the cipher text in vertical columns and . . . well, then the plain text would be in perfect order in horizontal rows."

"That's right; just the reverse of the enciphering procedure. Now, that is the fundamental of simple geometric transposition. There are many variations, principally in the routes to be followed. For example, in the above square I could transcribe diagonally and get:

**WEACR RIYGE VOREM ISANC EDERX**

or spirally starting at the upper right hand, and get:

**MERAW ECIVI CEXRD NEGRY OSEAR**

or by reverse spirals, alternate vertical or diagonal, and so on, each giving a somewhat different cipher text. And by *inscribing* by another

system, I have a quite differently-composed square from which to transcribe by an equal number of methods. So, the number of different cipher texts obtainable from even a simple square or rectangle is quite large. And when you consider the use of triangles, crosses and the like — well, there's no end to it."

"How the dickens does anyone ever solve 'em then?"

Ed laughed. "Perseverance mostly, I suppose — plus plenty of experience. But before we get into that, here's another elementary type I'd like to show you. It's called 'nihilist,' and is much the same as the preceding example except that transcription by columns or rows is by a prearranged key rather than in geometrical sequence."

"Hey — talk in words of one syllable, please!"

"Okay. Let me show you. S'pose we have the message, **Now is the time for all good men to come to the aid of their country.** We're going to inscribe it horizontally, transcribe it vertically according to a keyword, **League.**

"Now first of all we assign a number to each letter in the word **League** in its order of appearance in the alphabet. If a letter appears twice, its second appearance takes the next succeeding number. A, of course, is assigned number 1; the next appearing letter in the alphabet is E, the first of which is assigned 2, the second, 3; continuing, G is 4; L, 5; and U, 6; we then have a key **5-2-1-4-6-3**, called a 'derived numerical' key. Under it we write, in rows of six letters, our plain text message."

Ed's worksheet at this point looked thus:

L E A G U E  
5 2 1 4 6 3

n o w i s t  
h e t i m e  
f o r a l l  
g o o d m e  
n t o c o m  
e t o t h e  
a i d o f t  
h e i r c o  
u n t r y x

"I get it," broke in Jim. "You transcribe the columns in an order governed by the index number above it."

"Exactly, Mr. Einstein. And our cipher text reads:

WTROO ODITO EOOTT IENTE LEMET  
OXIIA DCTOR RNHFG NEAHU SMLMO  
HFCYX

"Now, let's see how an unknown key transposition might be solved. Here's one example in the AARS course. The cipher reads:

LYREA SECTU OAEET LMRMT EOTRII  
NLNEA YOVWT E

so let's see what you can do with it. Here's cross-section paper. Go to it." And Ed went over to the workshop table, picked up a template for QST's civilian-defense 2½-meter gear and began transferring it to a brand-new chassis.

Jim busied himself with pencil and paper. Fifteen minutes of hurried notations passed. "Shucks, Ed, I can't get it. I've tried all the possible routes."

Ed laughed. "You'll make a fine cryptanalyst, with that amount of perseverance! But since you're just starting I'll let you off easy. Here, let's see what you've accomplished. Hmmm. Well, here's how it's done:

"We have a 36-letter text. Probabilities are a 6 × 6 square or 9 × 4 rectangle; we can discard 2 × 18 and 3 × 12 unless the others prove fruitless. But which of the two probabilities is it? Let's try the square first. Now as you should know — since it was given in the QST story — any English text is made up about 40% vowels. Of any particular segment of text, the same percentage holds within fairly close limits. But transposition completely changes the normal sequence of letters, and while the total text vowel percentages will indicate English, a count of short segments may be quite different from the normal. What we want to do is find which re-inscription in our process of solution will produce text segments approximating 40% vowels. Let's take your 6 × 6 square first."

"Here's one with vertical inscription of the cipher," said Jim.

"Okay. Now if vertical inscription in a 6 × 6 square is correct, vowel-consonant counts of the horizontal rows should be normal English occurrences. We count like this —" and Ed made penciled notations on Jim's square as follows:

	∪	∩
L E E M H Y	2	4
Y C E T N O	2	4
R T T E L V	1	5
E U L O N W	3	3
A O M T E T	3	3
S A R R A E	3	3

"That's bad. Notice the 'raggedness' of count — from 1 to 5. Well, let's try your other 6 × 6 squares." After some more rapid notations and calculations, Ed added, "No soap. So we try 9 × 4, the vertical inscription first. Like this:"

	∪	∩
L A T E M E H E V	4	5
Y S U E R O N A W	1	5
R E O T M T L Y T	3	6
E C A L T R N O E	4	5

"Much more encouraging," Ed commented. "Notice the more even counts. Of course, this test is not infallible but if we follow up the prob-

(Continued on page 90)

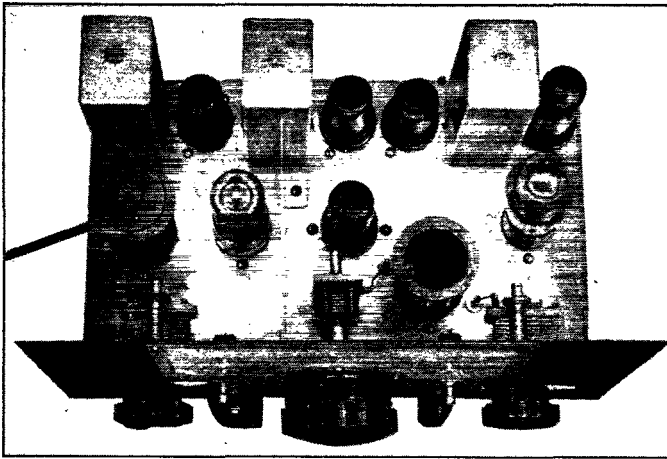

Top view of the seven tube regenerative superhet showing the broadcast-band mixer coil and the novel switch on its top. The new 100- $\mu$ fd. tuning condensers can be seen at the right and left sides of the front panel.

# Converting the Amateur-Band Regenerative S.S. Super to General Coverage

BY WALTER E. BRADLEY,\* W1FWH

ONCE again the amateur finds himself facing a world at war. After that one fateful Sunday we shall never forget we reluctantly shut down our transmitters and ceased operation. This seemed to put those receivers that tuned the amateur bands only in a sad plight. But at least, it will not be necessary to shelve that seven-tube, single-signal, regenerative superheterodyne receiver described on page 206 in the 1942 *Handbook*, because it lacks general coverage. As it stands, of course, it is useful only for relatively small portions of the radio spectrum above and below our former operating channels, since the amateur bands are all it was designed to cover. However, with a minimum of coil winding and the addition of two tuning condensers it can be made to cover the complete range from ten meters right on through the broadcast band.

In converting this receiver it was not intended that its original band-spread capabilities nor the band-spread dial calibrations be completely forgotten. For this reason every single one of the original coils that could be used has been incorporated in the new set of coils. So when the time again comes 'round (and we hope soon) for making use of band-spread in the am-

ateur channels the original coils, even with the new larger condensers, will operate as before. The original function of the receiver, therefore, is unaffected.

Only five new coils are needed. All of the old mixer coils are used so that only one extra one — for the broadcast band, if you want it — is required. Of the old oscillator coils, only those for ten meters and 160 meters are suitable for general coverage. The greatest amount of work, consequently, is entailed in winding new high-fre-

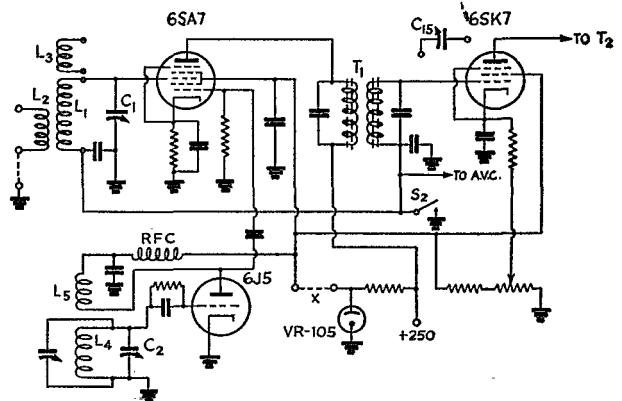

Fig. 1 — Changes to be made: Remove all connections from  $L_3$ , take out  $C_{15}$ , run plate lead of i.f. transformer directly to plate connection of 6SA7. All parts not labeled are same as in original circuit.

\* Technical Information Service, ARRL.

quency oscillator coils. Four of these, plus the broadcast-band mixer, makes the new list complete.

It was hoped that the range could be extended to the 600-meter band, but as this band was approached the mixer began to oscillate because of the proximity to the intermediate frequency of 460 kc. As a matter of fact, at the first try it was impossible to get lower than 800 kc. without throwing the mixer stage into oscillation. After removing the plate lead of the 6SA7 from the tickler winding at the coil socket and running it directly to the i.f. transformer's plate lead wire, it was possible to go down to 490 kc. without running into this difficulty. To do this, though, the r.f. gain control had to be backed off considerably, and  $C_{15}$  (i.f. capacity feedback on the 6SK7) entirely removed.

As is shown in Fig. 1, all connections to the tickler coil  $L_3$  must be removed. For the sake of stability at these lower frequencies, therefore, the regeneration in the mixer stage as well as its accompanying selectivity had to be thrown out. This meant that the regeneration control on the panel would be dead for the time being. It also meant that no jumper wire was necessary in the base of the new mixer coil. True, a certain amount of sensitivity was also lost but, when the i.f. is well aligned, the overall sensitivity is quite good—good enough in fact to bring the background noise up to a fairly high level. The regeneration can be retained, however, if broadcast-band coverage is not required.

The first step in the changeover is the substitution of 100- $\mu$ fd condensers for  $C_1$  and  $C_2$ , the mixer tuning and oscillator band-setting condensers, respectively. The dimensions of the 100- $\mu$ fd Hammarlund condensers differ from the 50- $\mu$ fd. ones only in the length between the two mounting holes. The increased length being only a matter of an eighth of an inch or less readily permitted the

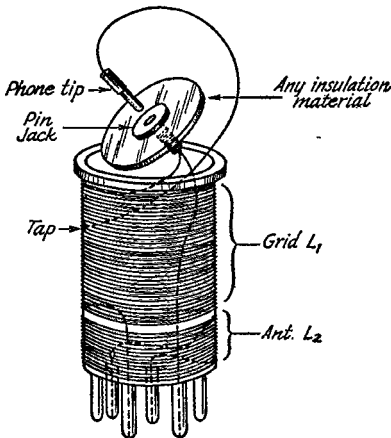

Fig. 2 — Layout of the b.c. band mixer coil.

### COIL TABLE

Band	Coil	Wire Size	Turns	Length	Tap
480-950 kc.*	$L_1$	32	230	2 in.	100
880-1640 kc.**	$L_2$	32	35	$\frac{3}{4}$ in.	—
	$L_3$	—	—	—	—
1340-2700 kc.	$L_1$	32	71	$\frac{5}{8}$ in.	—
	$L_2$	32	26	$\frac{3}{4}$ in.	—
	$L_3$	Original	—	—	—
	$L_4$	—	—	—	—
2.42-4.59 Mc.	$L_1$	—	—	—	—
	$L_2$	Original	—	—	—
	$L_3$	—	—	—	—
	$L_4$	—	—	—	—
4.25-9.5 Mc.	$L_1$	22	27	1 $\frac{1}{4}$ in. space-wound	—
	$L_2$	22	10	$\frac{1}{4}$ in. close-wound	—
	$L_3$	Original	—	—	—
	$L_4$	—	—	—	—
7.62-16 Mc.	$L_1$	18	16	1 in. space-wound	—
	$L_2$	22	6	$\frac{3}{8}$ in. close-wound	—
	$L_3$	Original	—	—	—
	$L_4$	—	—	—	—
17.6-30 Mc.	$L_1$	18	8	$\frac{3}{4}$ in. space-wound	—
	$L_2$	22	6	$\frac{3}{8}$ in. close-wound	—
	$L_3$	Original	—	—	—
	$L_4$	—	—	—	—

\*  $L_1$ , switch open.

\*\* Coils same as for 480-950 kc.  $L_1$ , switch closed.

grid leads coming up through the chassis to be soldered to the new condensers without any changes. The drilling of one additional hole in the chassis for each condenser was the only real work involved in the condenser changeover.

The new coils involve no special problems except in the case of the broadcast mixer coil. Since the tuning ratio of the 100- $\mu$ fd. condenser used limits the range to about three fourths of the band with one value of inductance, while the oscillator with its total of 135  $\mu$ fd. can tune over the entire range and even beyond, it was decided to use a tapped-coil arrangement to obtain complete broadcast-band coverage.

It was believed that a pin jack and a 'phone tip would make the ideal type of switch in this case. Fig. 2 shows how the pin jack is mounted in the center of a disc cut to fit the top of the standard 1  $\frac{1}{2}$ -inch diameter coil form. The wire coming up from the tapped connection to the 'phone tip is squeezed between the edge of the disc and the form, thus helping to keep the disc in place. This coil and its plug-tap arrangement can be seen in the photograph.

When this switch is closed, approximately one-half of the winding is shorted out and the coil will tune from 1640 to 880 kc. When it is open and the additional inductance is introduced, the range is from 950 to 480 kc., giving ample overlap. Similar overlap between bands exists throughout with the exception of a one-megacycle skip between 17.2 and 16.2 Mc., which was considered too inconsequential to warrant winding another oscillator coil. The gap could be filled in by a slight increase in the inductances of the old ten-

(Continued on page 86)

# A Course in Radio Fundamentals

Lessons in Radio Theory for the Amateur

BY GEORGE GRAMMER,\* WIDE

## No. 2—Ohm's Law for D.C. and A.C.

THIS second installment of the course deals mainly with the relationships between current and voltage which are included under the general heading of Ohm's Law for both direct and alternating currents. The experimental work largely consists in the measurement of typical simple circuits and the comparison of the measurements with calculations. The experimenter, if he is to get the most from his experimental work, should appreciate the reasons why observed measurements sometimes differ considerably from those calculated for ideal conditions. A coil, for example, has not only inductance but resistance as well, and the presence of the resistance may make the observed measurements differ considerably from the values calculated on the basis that only inductance is present. And frequently the power consumed in the measuring device may be of the same order of magnitude as that in the circuit being measured.

Results will be affected by inaccuracies in calibration of measuring instruments, and also by lack of precision in reading the instruments. This latter "human factor" can be minimized by taking not one reading but a whole series of them for the given set of operating conditions, then averaging the set of readings to find a "mean" which probably will be nearer the proper value than any one reading alone. For example, the voltage across a circuit element may be read five different times, with the following results:

- No. 1 — 24.5 volts
- No. 2 — 24.3 "
- No. 3 — 25.1 "
- No. 4 — 24.4 "
- No. 5 — 24.8 "

Unless some extenuating conditions make it possible to say without doubt that one or more of these readings is definitely wrong, the *average* of the five — in this example, 24.6 volts — should be used as the true reading.

### ASSIGNMENT 4

Study *Handbook* Section 2-6, beginning page 26. Perform Exps. 7-11, inc.

### Questions

1) Write Ohm's Law in the three forms to solve for  $E$ ,  $I$ , and  $R$  when the other two quantities are known.

\*Technical Editor, QST.

- 2) Define milliampere, microampere.
- 3) A resistance of 50,000 ohms is connected in parallel with one of 25,000 ohms. What is the resultant resistance?
- 4) An inductance of 10 henrys is connected in series with one of 15 henrys. What is the total inductance if the fields of the two inductances do not interact?
- 5) What is the total inductance if the two inductances of Question 4 are connected in parallel?
- 6) Define time constant.
- 7) How does a voltmeter differ from a milliammeter?
- 8) Write the formulas for power dissipated in a d.c. circuit when any two of the three quantities, voltage, current and resistance, are known.
- 9) What is the unit of power?
- 10) Compare ohm and megohm.
- 11) Three resistances, 5, 14 and 22 ohms, are connected in parallel. What is the resulting resistance? If 6 volts is applied to the combination, what is the total current, the current through each resistor, and the power dissipated in each?
- 12) How may a single 0-1 milliammeter be used to measure several ranges of currents and voltages?
- 13) If a current of 350 microamperes flows through a circuit with an applied voltage of 40, what is the resistance of the circuit?
- 14) What is the time constant of a circuit consisting of a condenser having a capacity of 4  $\mu$ fd. and a resistance of 150,000 ohms?
- 15) If two 8- $\mu$ fd. condensers are connected in series, what is the resulting capacity?
- 16) In the following circuit, find the current through each resistor and the voltage across it:

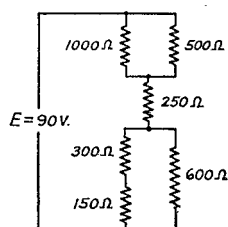

- 17) A d.c. supply of 250 volts is available, and it is desired to provide voltages of 75 and 125 volts with respect to one terminal of the supply by means of a voltage divider. The current drain at the taps will be negligible. What must be the resistance of each section of the voltage divider if the current through the divider is to be limited to 10 milliamperes?
- 18) A load taking 5 milliamperes is connected across the 75-volt section of the voltage divider of Question 17, and a load taking 8 milliamperes across the 125-volt section. What will be the actual value of the voltage at each tap with these loads?
- 19) If the current through the voltage divider of Question 17 is permitted to be 25 milliamperes, calculate the resistance of each section. If the loads specified in Question 18 are applied, what will be the actual voltage at each tap under load? Is the drop in tap voltage with load as great in this case as with the 10-milliamperes divider?
- 20) Calculate the power lost in the two voltage dividers



of Questions 17-19, with and without the load circuits connected.

- 21) If three resistors, 10,000, 40,000 and 12,000 ohms, are available, how can they be connected to give a total resistance of 20,000 ohms?
- 22) If the power consumed in a 50,000-ohm resistor is 2 watts, what is the applied voltage? What is the current through the resistor?
- 23) What are the voltages between the negative terminal and the tap points in the following circuit?

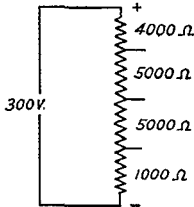

- 24) What is the unit of electrical energy?
- 25) What factors determine the resistance of a conductor?

### ASSIGNMENT 5

Study *Handbook* Section 2-7, beginning page 28.

#### Questions

- 1) Define frequency, cycle, alternation.
- 2) What is a harmonic?
- 3) What are the relationships between cycle, kilocycle and megacycle?
- 4) What is meant by phase?
- 5) What is meant by the peak value of an a.c. wave?
- 6) Define effective value. What is the relationship to the peak value in a sine wave?
- 7) What range of frequencies is considered to be in the audio-frequency spectrum?
- 8) What is the phase relationship between current and voltage in an inductance?
- 9) What is meant by the term "sine wave"?
- 10) What is the average value of an a.c. wave? What is its relationship to the peak value of a sine wave?
- 11) Write the expression for angular velocity.
- 12) Is the current through a capacity leading or lagging the applied voltage? By how many degrees?

*Fig. 1*—Transformerless power supply for use in experiments. The circuit diagram of this supply is given in *Fig. 2*. The baseboard is  $5\frac{1}{2}$  by 11 inches, with the rectifier tube and the filament dropping resistor,  $R_1$ , mounted in the rear left corner. The filter condensers,  $C_1$  and  $C_2$ , and the filter choke,  $L_1$ , are near the rectifier tube. The variable resistor in the foreground is  $R_4$ , with the two bleeder resistors,  $R_2$  and  $R_3$ , just behind it.

The supply delivers an adjustable voltage from 0 to about 100 volts d.c. and provision also is made for 115-volt a.c. output. Switches,  $S_1$  and  $S_2$ , in the a.c. and d.c. lines provide a convenient means for cutting off the voltage when changes or adjustments are made in the associated circuits. The lamp is used for determining the grounded side of the power line. Before plugging into a power socket the open side of the lamp should be connected to ground (water pipe or radiator), then the plug should be tried both ways in the socket. In one position the lamp will light, showing that the common lead is the ungrounded side of the line. When this occurs, reverse the plug so that the common side of the supply will be connected to the grounded side of the line.

- 13) What is the phase relationship of current and voltage in a resistance?
- 14) A frequency of 15 megacycles corresponds to how many cycles per second?
- 15) Convert 1960 kc. to megacycles; cycles.

### ASSIGNMENT 6

Study *Handbook* Section 2-8, beginning page 30. Perform Exps. 12-14, inc.

#### Questions

- 1) What is the reactance of a 250- $\mu$ fd. condenser at 14 Mc.? At 3.8 Mc.?
- 2) Write Ohm's Law for alternating current flowing through a resistance.
- 3) Find the impedance of a circuit consisting of a 2- $\mu$ fd. condenser in series with a resistance of 40 ohms at a frequency of 60 cycles.
- 4) What is the impedance at 60 cycles of a 1- $\mu$ fd. condenser in series with a 1200-ohm resistor?
- 5) What will be the currents through the two circuits of Questions 3 and 4 if the applied voltage is 115? In each case, what is the voltage across the resistor and the voltage across the condenser? What is the power factor of each circuit?
- 6) Find the reactance of an inductance of 15 henrys at 120 cycles. What will be the capacity of a condenser having the same reactance at the same frequency?
- 7) An inductance of  $\frac{1}{2}$  henry and a capacity of 0.05  $\mu$ fd. are connected in series. What is the total reactance of the circuit at a frequency of 1000 cycles?
- 8) If a 200-ohm resistor is connected in series with the inductance and capacity of Question 7, what is the impedance of the circuit? What current will flow if 10 volts is applied to the circuit? What will the current be if the condenser is short-circuited? If the inductance is short-circuited? If the resistor is short-circuited? Calculate the voltage across the inductance, capacity and resistance in each case, and also find the power factor in each case.
- 9) Is power dissipated in a pure reactance?
- 10) Can a d.c. milliammeter be used for measuring alternating current?
- 11) What is meant by the distributed capacity of a coil?

<sup>1</sup>In the first printing of the Standard Edition, the second formula in the right hand column on page 31 was incorrectly given with a  $\times$  instead of a  $+$  sign. The formula should read  $Z = R^2 + X^2$ .

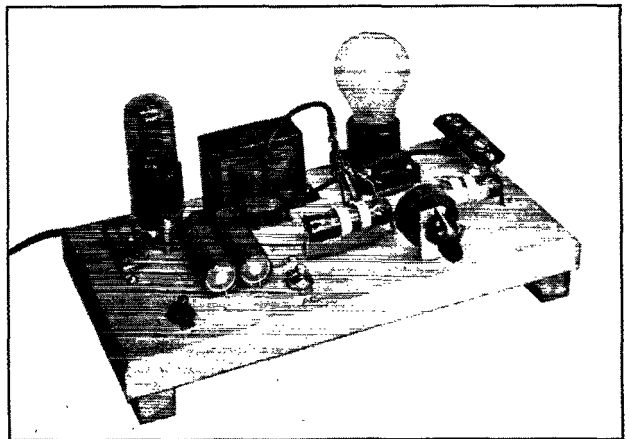

The common terminal is the positive terminal of the d.c. supply, this arrangement being used because the supply will be used for bias in later experiments involving vacuum tubes.

12) What is the distinction between impedance in an a.c. circuit and resistance in a d.c. circuit?

13) If the same current flows through an inductance and a capacity in series, what is the phase relationship between the voltages across them? What will be the voltage measured across the two in series?

14) If the same voltage is applied to an inductance and a capacity in parallel, what is the phase relationship between the currents flowing through them? What will be the current measured in the common lead between the source of voltage and the parallel combination?

15) What are the reactances of the choke coil and fixed condensers used in Exps. 12 and 13? ( $L = 30$  henrys,  $C = 0.1, 0.25$  and  $1 \mu\text{fd.}$ ,  $f = 60$  cycles.)

16) What is the reactance of a  $0.01\text{-}\mu\text{fd.}$  condenser at 30 cycles? If it is in series with a  $0.5\text{-megohm}$  resistor across a voltage of 15 at the same frequency, what is the voltage across the resistor? What voltage will appear across the resistor if the frequency is 10,000 cycles?

17) A 5-henry choke and 1000-ohm resistor are connected in series across 115 volts, 60 cycles. What is the power factor of the circuit?

18) In a circuit containing resistance and reactance, how much of the power supplied is dissipated in the resistance and how much in the reactance?

19) Write the formulas for inductive and capacitive reactance. What units must be used in these formulas?

20) If you know only the applied voltage and the current flowing in an a.c. circuit, is it possible to determine the impedance? The power factor? The resistance and reactance present?

### ASSIGNMENT 7

Study *Handbook* Section 2-9, beginning page 32.

#### Questions

1) If the primary of a filament transformer designed for 115-volt operation has 350 turns, how many turns should be wound on the secondary to give a terminal voltage of 6.3?

2) Assuming that the secondary load on the transformer of Question 1 is to operate at unity power factor and that transformer losses are small enough to be neglected, what size wire should be used for the secondary if the secondary is to deliver 5 amp., allowing 1000 circular mils per ampere? What size wire on the primary?

3) If the transformer of Question 1 is also to have a high-voltage secondary to give 350 volts each side of a center tap (or 700 volts overall), how many turns will be needed on this winding?

4) Describe the operating principles of the transformer.

5) The secondary load on a transformer having a 5-to-1

primary-to-secondary turn ratio is 300 ohms. What is the impedance looking into the primary from the source of power?

6) How does an autotransformer differ from an ordinary transformer?

7) What are the relationships between turn ratio, voltage ratio, current ratio and impedance ratio in a transformer?

8) If the impedance looking into a transformer primary is 5000 ohms when the secondary load is 7500 ohms, what is the primary-to-secondary turn ratio?

9) A transformer is delivering a current of 10 amperes into a resistance load at a voltage of 10. If the transformer efficiency is 85%, what power is taken from the line? If the primary voltage is 115, what is the primary current, assuming a power factor of 1?

10) A transformer has a primary-to-secondary turn ratio of 1.8 to 1. What will be the impedance looking into the primary when the secondary load is a resistance of 6000 ohms? When the secondary load is 4000 ohms? 12,000 ohms? 200 ohms? 10 ohms?

11) A speaker output transformer is designed to couple a 5-ohm voice coil to a pentode output tube which requires a load of 7000 ohms. What turn ratio is required? If the power delivered to the voice coil is 2 watts, what is the voltage across the voice coil, the current through it, and the voltage applied to the primary?

12) Can transformers properly be specified in terms of "primary impedance" when the secondary load is not specified?

13) If the secondary load on a transformer has a power factor of 30%, what percentage of the rated power-handling capability of the transformer can be realized? Which is more descriptive of the actual capability of the transformer, a "volt-ampere" or "watt" rating?

14) On dismantling the five-volt secondary winding of a transformer it is found that the winding has 10 turns. If it is desired to put on a new winding delivering 7.5 volts, how many turns should the winding have? If the old secondary was rated at 8 amperes, what current can be taken from the new winding without overloading the primary?

15) An autotransformer designed for 115-volt circuits has a 250-turn winding. How many turns should there be between one end and a tap which is to deliver 80 volts?

### EXPERIMENT 7

#### Ohm's Law, Voltage Drops

**Apparatus:** A source of d.c. voltage variable from zero to about 100 volts is needed for this experiment. The circuit shown in Fig. 2 is convenient, since it provides for continuous adjustment of the voltage to any value within the range. It is a "transformerless" supply also adaptable to subsequent experiments.

**Procedure:** The initial adjustment of the taps on the power supply output resistor or "bleeder," consisting of  $R_2, R_3$  and  $R_4$  in series, illustrates the principle of Ohm's Law. Before making the permanent connection between  $L_1$  and the top end of  $R_2$ , insert the milliammeter between these two points, using the 100-ma. scale (or the nearest to that provided by the instrument used), close  $S_2$  and measure the current. Take readings with  $R_4$  set at zero and at maximum. Remove the milliammeter and make the permanent connection between  $L_1$  and  $R_2$ . Now read the output voltage (across the whole bleeder) at the two settings of  $R_4$ . With the constants given in Fig. 2, the following readings will be typical:

	$I$	$E$
$R_4$ zero	90 ma.	95 volts
$R_4$ maximum	85.5 ma.	97 volts

With the voltmeter between the common lead (C) and point 1, measure the voltage with  $R_4$  at zero and maximum. Note the maximum voltage, turn  $R_4$  to zero and set the first slider on  $R_3$  (point 2) to give the same voltage. Then turn  $R_4$  to maximum, note the new voltage, turn  $R_4$  to zero and set the second slider (point 3) to this voltage.

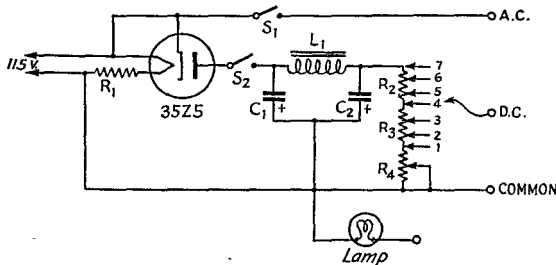

Fig. 2 — Circuit diagram of the transformerless power supply.

$C_1, C_2$  — 40- $\mu\text{fd.}$ , electrolytic, 150 volts.

$R_1$  — 500 ohms, 10 watts.

$R_2$  — 800 ohms, 25 watts, with two sliders.

$R_3$  — 300 ohms, 25 watts, with two sliders.

$R_4$  — 100-ohm wire-wound potentiometer.

$L_1$  — 100-ma. filter choke, app. 20 henrys.

$S_1, S_2$  — S.p.s.t. toggle (preferably with long shank for convenience in mounting).

Lamp — 10-watt lamp.

With  $R_4$  at zero, set the first slider on  $R_2$  (point 5) to about 45 volts and the second slider (point 6) to about 75 volts. When this is done a typical tabulation of voltage readings will be as follows:

Between C and	$R_4$ Zero	$R_4$ Maximum
1.....	0 volts	9 volts
2.....	9 "	17 "
3.....	17 "	25 "
4.....	25 "	33 "
5.....	43 "	48 "
6.....	75 "	80 "
7.....	95 "	97 "

The voltages appearing across the individual resistances constitute voltage drops between points of the complete bleeder circuit, and the sum of these voltage drops must equal the total voltage applied to the bleeder, since the total current flows through each resistor. Thus with  $R_4$  at maximum the drop across it is 9 volts; the drop across  $R_3$  (between points 1 and 4) is 24 volts, and the drop across  $R_2$  (points 4 and 7) is 64 volts. The sum of these three voltages is 97, which is the applied voltage. With  $R_4$  at zero, the voltage across  $R_3$  is 25 and across  $R_2$  70, totalling 95. These values can be checked by measurement between the appropriate points. The bleeder resistances are very small compared to the voltmeter resistance, so that the current flowing through the latter is small compared to the current through the bleeder and no appreciable error is introduced by the fact that the voltmeter current does not flow through all of the bleeder.

By Ohm's Law,

$$R = \frac{E}{I}$$

and the values of the resistances can be calculated from the observed currents and voltages. In the case of the total bleeder, with  $R_4$  at zero

$$R = \frac{95 \text{ volts}}{0.090 \text{ amp.}} = 1056 \text{ ohms}$$

and with  $R_4$  at maximum

$$R = \frac{97 \text{ volts}}{0.855 \text{ amp.}} = 1133 \text{ ohms.}$$

The current must be expressed in amperes when  $R$  is in ohms and  $E$  in volts, hence the milliamperere readings of the meter must be converted to amperes.

Determine the values of the three resistors separately by the same method, using the voltage drops across each for  $E$  in the formula, and the values of current corresponding to  $R_4$  at zero and  $R_4$  at maximum. Thus two sets of voltages and currents are available for checking each resistor, and if the measurements are completely accurate the values of resistance found should be identical. The chances are that the two values so found will not be identical, indicating errors in readings and/or the instrument itself. If the differences are more than a few percent, repeat the measurements of both current and voltage, taking a series of observations and finding averages. Compare the results of this method with the results obtained by the original measurements.

By a similar process, determine the resistance between each pair of taps on the voltage divider. Check the sum of these resistances against the total resistance of the divider.

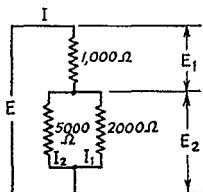

Fig. 3

### EXPERIMENT 9

#### Ohm's Law, Series-Parallel Resistances

**Apparatus:** Same as for Exp. 7, with the addition of three 10-watt resistors, 1000, 2000, and 5000 ohms. The

values need not be exactly as specified, but should be of that order.

**Procedure:** Connect the resistors as shown in Fig. 3, and apply the full voltage from the power supply. Measure the currents and voltages as indicated. A typical set of data would be as follows:

$$\begin{aligned} E &= 85 \text{ volts} \\ E_1 &= 35 \text{ volts} \\ E_2 &= 50 \text{ volts} \\ I &= 34.5 \text{ ma.} \\ I_1 &= 25.0 \text{ ma.} \\ I_2 &= 9.8 \text{ ma.} \end{aligned}$$

The sum of  $E_1$  and  $E_2$  should equal  $E$ , and the sum of  $I_1$  and  $I_2$  should equal  $I$ . Within the limits of error this is the case.

The equivalent resistance of the 5000-ohm and 2000-ohm resistors in parallel can be found by Ohm's Law:

$$R = \frac{E}{I} = \frac{50 \text{ volts}}{0.0348 \text{ amp.}} = 1436 \text{ ohms.}$$

This resistance plus 1000 ohms, or 2436 ohms, is the equivalent resistance of the whole circuit. Checking by Ohm's Law:

$$R = \frac{E}{I} = \frac{85 \text{ volts}}{0.0345 \text{ amp.}} = 2460 \text{ ohms.}$$

By using 0.0348 amp. for the current, the resistance found would be nearer 2440 ohms. Alternatively, the resistance of the "1000-ohm" resistor could be checked by substituting the voltage across it and the current through it in Ohm's Law:

$$R = \frac{E}{I} = \frac{35 \text{ volts}}{34.5 \text{ ma.}} = 1014 \text{ ohms}$$

which value added to 1436 gives a total resistance of 2450 ohms. The measured values can be considered satisfactory, but the observations probably could be improved by taking a series of them and averaging the results.

By the formula for combining resistances in parallel, the resultant resistance of the combination of 2000 and 5000 ohms should be

$$R = \frac{1}{\frac{1}{2000} + \frac{1}{5000}} = 1430 \text{ ohms}$$

which is in very good agreement with the results obtained by measurement.

Rearrange the circuit so that the 1000- and 2000-ohm resistors are in parallel and the 5000-ohm resistor is in series. Measure the applied voltage and calculate the currents and voltages which should result. The step-by-step calculation should be carried through as follows: (1) Find the equivalent resistance of the two parallel resistors; (2) add the equivalent resistance so found to the series resistance (5000 ohms) to find the total resistance; (3) knowing the applied voltage and the total resistance, use Ohm's Law to find the current flowing; (4) using the current so found, determine the voltage drop across the 5000-ohm resistor and across the 2000- and 1000-ohm resistors in parallel; (5) using the voltage drop across the parallel resistors and their known values of resistance, determine the current through each resistor by Ohm's Law. Check the calculated values by measurement. Repeat with the 2000-ohm resistor in series and the 5000- and 1000-ohm resistors in parallel.

### EXPERIMENT 9

#### Ohm's Law, Voltage Regulation

**Apparatus:** Same as for Exp. 8, with the addition of the following fixed resistors: 25,000 ohms, 1 watt; 50,000 ohms, 1 watt.

**Procedure:** Connect the 25,000- and 50,000-ohm resistors in series as shown in Fig. 4-A and, using the appropriate tap on the power-supply bleeder, adjust the applied voltage to some value just slightly less than the full-scale value on a medium range of the voltmeter. For example, if

the instrument has a 30-volt scale a convenient value will be 25 volts. Then by Ohm's Law the current will be

$$I = \frac{E}{R} = \frac{25 \text{ volts}}{75,000 \text{ ohms}} = 0.000333 \text{ amp.}, \text{ or } 0.333 \text{ ma.}$$

The voltage drop  $E_1$  across the 50,000-ohm resistor will be

$$E = RI = 0.000333 \times 50,000 = 16.67 \text{ volts}$$

and the drop  $E_2$  across the 25,000-ohm resistor

$$E = RI = 0.000333 \times 25,000 = 8.33 \text{ volts.}$$

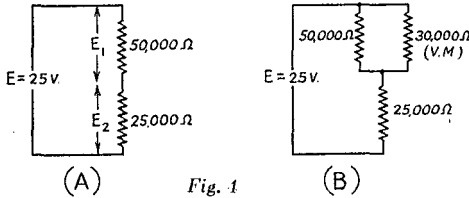

Fig. 1

Measure the current, using the lowest current range which does not send the pointer off scale, and then measure the voltage across each resistor. A typical set of readings for the case given would be as follows:

$$\begin{aligned} I &= 0.36 \text{ ma.} \\ E_1 &= 11.2 \text{ volts} \\ E_2 &= 5.5 \text{ volts.} \end{aligned}$$

The current reading is approximately the theoretical value and the discrepancy is easily accounted for by minor inaccuracies in the instrument, in the rated values of the resistors, and in taking the readings. However, the sum of the voltages across the individual resistors is only 16.7 volts, while the actual applied voltage is 25. The difference is too great to be caused by normal inaccuracies.

The explanation is to be found in the fact that with resistances of this order of value the current flowing through the voltmeter constitutes an appreciable part of the total current flowing through the resistor in series with the meter. Most test instruments have a resistance of 1000 ohms per volt on the voltage ranges, which in the case of the 30-volt scale used in obtaining the above data means that the resistance of the voltmeter is 30,000 ohms. When the meter is connected to measure  $E_1$ , the 30,000-ohm voltmeter is in parallel with 50,000 ohms so that the circuit now is a series parallel arrangement, as shown in Fig. 4-B. The resultant resistance of the two in parallel is

$$R = \frac{1}{\frac{1}{50,000} + \frac{1}{30,000}} = 18,750 \text{ ohms.}$$

This resultant resistance is in series with 25,000 ohms, making the total resistance 43,750 ohms. Solving for the current

$$I = \frac{E}{R} = \frac{25 \text{ volts}}{43,750 \text{ ohms}} = 0.000572 \text{ amp.}, \text{ or } 0.572 \text{ ma.}$$

The voltage drop across the meter and 50,000-ohm resistor in parallel is therefore

$$E = RI = 18,750 \times 0.000572 = 10.7 \text{ volts.}$$

This checks within the limit of error with the value obtained by measurement, 11.2 volts. More accurate results could be secured by determining the value of each resistor separately,

using the method given in Exp. 7, and substituting these figures instead of the rated resistances.

Calculate the circuit conditions when the voltmeter is connected to measure  $E_2$ , using the method just given. Repeat the experiment using different voltage scales on the instrument, adjusting the applied voltage to an appropriate value each time, and compare the data with the original run, in terms of percentage deviation from the true values. Calculate the circuit conditions for each set of data by the method above.

## EXPERIMENT 10

### Ohm's Law, E/I Relationships

**Apparatus:** Same equipment used in Exps. 7, 8 and 9.

**Procedure:** Set  $R_4$  in the power supply at maximum and measure the output voltages at the various taps. Connect the 5000-ohm resistor to the power-supply output terminals and take readings of current and voltage at each tap on the bleeder. In taking voltage readings, be sure the resistor circuit is closed so that the actual voltage under load is measured. Fig. 5 shows the method. If two instruments are available simultaneous readings can be taken, but equally good results can be secured with only one instrument by shifting from current to voltage ranges. Take similar sets of readings with the 2000- and 1000-ohm resistors, and also with the 10-watt lamp. A typical set of data is given at the bottom of the page. The currents are in milliamperes.

Plot the data so obtained on cross-section paper, as shown in Fig. 6. It is convenient to use half-inch blocks for 10-volt and 10-milliampere intervals. Draw a smooth line through each set of points. Not all the points will lie exactly on the line so drawn, because of slight inaccuracies in measurement, so it is necessary to "average" out the results. If a single measurement is poor, the point obtained from it will lie well out of line with the other points, showing instantly that something is wrong. Such a point should be rechecked by measurement.

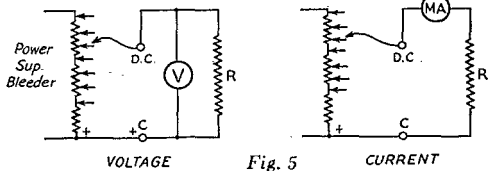

Fig. 5

In the case of the three resistors, it is obvious that a straight line can be drawn through the plotted points. This indicates that the resistance is constant with varying current; in other words, in such a resistor the ratio between current and voltage is fixed, within the limits of the range of voltages applied. Such a circuit is called "linear" because the plotted curve is a straight line. The *slope* of the line, or the ratio between the number of units covered by the curve in the vertical direction to the number of units moved in the horizontal direction, is constant when the line is straight, and is equal to the resistance. It is expressed in this case in volts per ampere. For example, in the interval between 0 and 10 milliamperes, the curve for the 5000-ohm resistor moves through 50 volts vertically, so that the slope of this curve is

$$\frac{50 \text{ volts}}{0.01 \text{ amp.}}$$

Tap	No-Load Voltage	1000-ohm Load		2000-ohm Load		5000-ohm Load		Lamp Load	
		E	I	E	I	E	I	E	I
1.....	8.7	8	7.7	8.4	4.1	8.6	1.7	6.5	23
2.....	17.2	14.5	14.5	15.8	7.6	16.7	3.5	11	32.5
3.....	24.4	20.5	20	22.5	10.9	24	4.6	15.5	40
4.....	34	25.2	25	28	14.5	31	5.8	19.5	45
5.....	50	37	35	41	21	46	8.8	27	58
6.....	80	57	50	66	33	74	14.5	47	78.5
7.....	97	73	72	83	41.3	92	18	64	94.5

This can be stated as 5000 volts per ampere or as 5 volts per milliampere, and will be recognized as simply another way of expressing Ohm's Law, since  $R = E/I$ . The more slowly the line rises the lower is the resistance, as illustrated by the lines for 2000 and 1000 ohms.

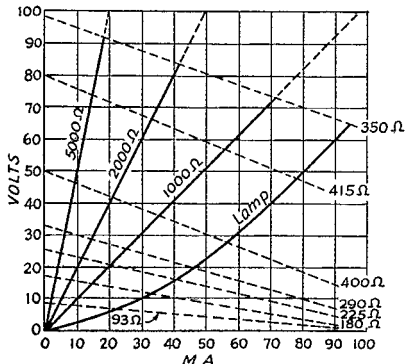

Fig. 6

The curve for the lamp is not a straight line, which means that its resistance is not constant but changes with current. Such a circuit is called "non-linear," and Ohm's Law cannot be applied as simply as in the case of the linear resistors. The increasing amount of power lost in the filament as the current is increased raises the temperature of the filament, and this rise in temperature causes the resistance of the filament to increase. This effect is present in all metallic conductors, but in the case of the ordinary resistors is too small to be noticed over the current range covered by this experiment. The lamp, however, is intended to work with its filament incandescent, hence the change from room temperature to full operating temperature may be several thousand degrees. The resistance at any current will be given by Ohm's Law, knowing the voltage across the lamp, but that same resistance value cannot be used for any other current.

Other types of circuits may be non-linear for different reasons. The vacuum tube is a familiar example, as is also the gas-conduction tube exemplified by the neon lamp. In general, Ohm's Law can be applied directly only to metallic circuits, and then only when temperature effects are taken into account or are small enough to neglect.

The set of curves in Fig. 6 also shows the effect of internal resistance of the power supply. The current flowing in this resistance causes a voltage drop in the same way as in the external circuit, with the result that the voltage actually applied to the external circuit depends upon the current flowing. The larger the current the greater the internal voltage drop, hence the lower the voltage (generally called the "terminal voltage") available for the load. By connecting the series of plotted points which show the voltage at a given tap at no load and with various load resistances, as shown by the dashed lines in Fig. 6, a "regulation" curve is obtained. With this power supply these curves are practically straight lines, indicating that the internal resistance is constant over the range of currents considered. This will not always be true of rectifier-type power supplies, since the internal voltage drop will depend upon the characteristics of the rectifier tube and the filter. However, since the curves in this case are straight, it is possible to determine the effective internal resistance at each tap by taking the slope of the regulation curve at that tap. For example, on the highest tap the voltage changes from 98 at no output current to 63 at a current of 100 milliamperes, approximately. The internal resistance is then

$$R = \frac{E}{I} = \frac{98-63}{0.1} = 350 \text{ ohms.}$$

The approximate values for other taps are indicated in the graph. From this series of curves it is possible to predict the terminal voltage at any tap for any value of external (or

load) resistance, simply by drawing a line, from the origin of the graph, having the proper slope to represent the load resistance. The point where this line intersects the regulation curve gives the terminal voltage at that tap.

## EXPERIMENT II

### Time Constant

**Apparatus:** For this experiment a d.c. source of about 100 volts (the power supply of Fig. 2) and a 0.1 milliammeter are needed. The nearest range to 1 milliammeter on the test instrument will be adequate. Several filter condensers and 1-watt resistors are necessary. Suggested values are 1 μfd. (paper), 8 and 16 μfd. (electrolytic) with at least 100-volt ratings; suitable resistor values are 1, 0.5, 0.25 and 0.1 megohm. An inexpensive bakelite-insulated push-button will be convenient. (These buttons can be obtained at five-and-ten-cent stores.)

**Procedure:** Connect the apparatus as shown in Fig. 7. The time constant of such a circuit is the product of the capacity in microfarads and the resistance in megohms, and represents the time in seconds required for the current from the condenser to drop to 37% of its initial value when discharging. To check time it is necessary to determine one-second intervals, for which purpose any sort of device which makes a tick or other audible indication once each second can be used, such as a clock or metronome. The 5-Mc. standard frequency transmissions from WWV also provide one-second time ticks. In setting up the apparatus be careful to keep the circuit well insulated, since leakage becomes important when the resistance is high.

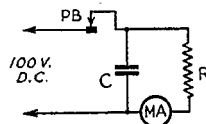

Fig. 7

Using the 1-μfd. condenser and 1-megohm resistor, close the circuit with the push-button and note the current, which should be approximately 0.1 milliampere. Release the push-button on the instant of a time tick and count the time in seconds required for the current to drop to 37% of its value with the push-button closed. The time cannot be measured with a high degree of accuracy, but it should be obvious that with the constants given a time of about one second is required for the instrument pointer to drop to the 37% mark. Repeat with the 8- and 16-μfd. condensers. Then substitute lower values of resistors and follow the same procedure in each case. Tabulate the times required for each set of values.

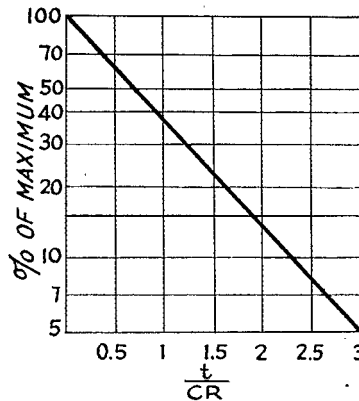

Fig. 8

The way in which the current decreases with time is shown in the graph of Fig. 8. The horizontal values in this

graph are plotted in terms of time in seconds and the time constant of the circuit, the numbers representing the factor by which the time constant should be multiplied to obtain the actual time in seconds. If the time constant is 3 seconds (a 6- $\mu$ f. condenser and 0.5-megohm resistor, for instance), the value 2 on the abscissa would represent  $2 \times 3$ , or 6 seconds. Therefore at the end of 6 seconds the current from such a combination should have decreased to 14% of its initial value. By choosing integral time intervals the accuracy of time measurement can be increased and the appropriate percentage of maximum current read from the graph.

As an example of experimental use of the graph, suppose that the 16- $\mu$ f. condenser and 0.1-megohm resistor are used in the circuit of Fig. 7. On closing the push-button the current should be 1 milliampere with 100 volts applied. Open the push-button and take a reading at the end of exactly five seconds. Say the current at this instant is found to be 0.1 milliampere. Since this is 10% of the maximum current, the quantity  $t/CR$  is found from the graph to be 2.3. Since

$$\frac{t}{CR} = 2.3, C = \frac{t}{2.3R}$$

and since  $t = 5$ ,  $R = 0.1$

$$C = \frac{5}{2.3 \times 0.1} = 21.7 \mu\text{f.}$$

The actual capacity of the condenser at this voltage is therefore higher than the rated value of 16  $\mu$ f.

By a similar method, check the capacity values of the condensers available.

## EXPERIMENT 12

### Alternating Current — Reactance and Resistance

**Apparatus:** This experiment can be performed with the 115-volt line as a source of voltage; provision for connection to the line is made in the power supply of Fig. 2. A multi-range high-resistance a.c. voltmeter is needed. This type is provided in the usual multi-purpose test instrument such as was recommended for this series of experiments. (The moving-iron type of a.c. voltmeter used for tube filament circuits and for ordinary a.c. measurements has too low resistance to be useful.) Since no a.c. current scales are provided on most test instruments, this and the following experiment are based on voltage measurements alone, but if an a.c. milliammeter is available it is helpful to measure current as well as voltage. In addition to the meter there should also be provided paper condensers of 0.1-, 0.25- and 1- $\mu$ f. capacity, and a filter choke of the "30-henry" variety, this being the value of inductance without direct current flowing through the winding. The 1000-, 2000- and 5000-ohm 10-watt resistors used in the previous experiments will be needed, with the addition of a 10,000-ohm 1-watt resistor.

**Procedure:** Connect the 1000-ohm resistor in series with the inductance as shown in Fig. 9-A. Measure the voltage across the resistor and that across the inductance. Repeat with the other resistors substituted. A typical tabulation of readings will be as follows:

Resistance	Voltage Across Resistance	Voltage Across Inductance
1000 ohms . . . . .	20	120
2000 ohms . . . . .	22	118
5000 ohms . . . . .	40	106
10,000 ohms . . . . .	68	89

The line voltage was 122 when these data were taken.

In no case does the sum of the voltages across the resistor and inductance equal the line voltage. This is because the voltage across the resistor is in phase with the current, while the voltage across the inductance is 90 degrees out of phase with the current. Hence the r.m.s. voltages (which are indicated by the instrument) cannot be added directly, but the phase difference must be taken into account. Because of the 90-degree phase difference the voltages are, so to speak, at right angles to each other and must be combined

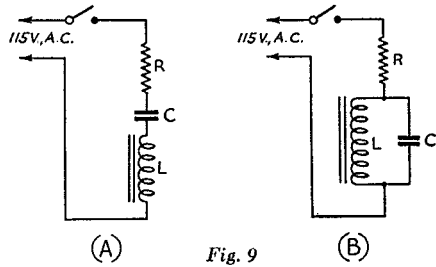

by the law relating the sides of a triangle. This relationship is shown in Fig. 10-A, where  $E_R$  represents the voltage across the resistance,  $E_L$  the voltage across the inductance, and  $E$  the total or applied voltage, all drawn to scale. Since the length of the hypotenuse of a right triangle is equal to the square root of the sum of the squares of the lengths of the other two sides, the total voltage is given by

$$E = \sqrt{E_R^2 + E_L^2}$$

Solving this equation for  $E$  with the observed voltages substituted gives the following results:

Resistance in Circuit	Calculated Total Voltage
1000 ohms . . . . .	122
2000 ohms . . . . .	120
5000 ohms . . . . .	113
10,000 ohms . . . . .	112

with an actual applied voltage of 122. The discrepancy is caused chiefly by the fact that the choke has resistance as well as inductance, so that the voltage across it is not exactly 90 degrees out of phase with the voltage across the resistor. For the present purpose this factor can be neglected and the assumption made that the effects of losses in the choke are negligible.

Take a set of such data, using the highest voltmeter scale which will permit reasonably accurate reading (to keep down the voltmeter current) and calculate the total voltage as described above.

Since in a resistor the current is in phase with the voltage, a line representing the current can be drawn on top of the line  $E_R$  representing the resistance voltage. The voltage  $E_L$  is 90 degrees out of phase with the current and is drawn upward from the current line to indicate that it leads the current by 90 degrees (which is the same as saying that the current lags the voltage by 90 degrees). The angle  $A$  then represents the phase angle between the applied voltage and the current in the circuit. The phase angles for the observations above are 80.6, 79.5, 69.3 and 52.6 degrees, respectively. Construct such triangles to scale, using the observed data, and determine the phase angle between the calculated total voltage and current either by measurement with a protractor or by the use of tables of trigonometric functions.

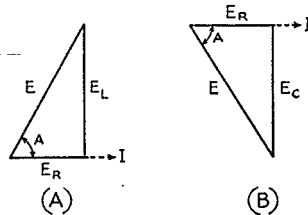

Using the circuit of Fig. 9-B, take readings of voltage across the resistance and condenser, using the series of resistors with each of the three capacity values. In the case of the 0.1- $\mu$ f. condenser it will be difficult to get accurate resistor voltage readings when the resistance is less than 5000 ohms because of the small voltage drop, so the 2000-

and 1000-ohm resistors may be omitted in this case. Tabulate the data and compute the applied voltage from the readings. In a condenser the current leads the voltage by 90 degrees, so that the same triangular relationship between resistance voltage, condenser voltage and total voltages applies, and the same formula may be used for computing the total voltage. In this case, however, the triangle is drawn as in Fig. 10-B with the condenser voltage extending downward from the resistance voltage to indicate that the voltage lags behind the current, which is in phase with the resistance voltage. The angle  $A$  is the phase angle between the applied voltage and the current when the voltages are drawn to scale. Draw the triangles and measure or compute the phase angle for each of the pairs of readings.

The voltage drops are caused by the resistance in the case of the resistor, by the reactance in the case of the inductance or capacity, and by the impedance, which is the combination of resistance and reactance, in the case of the complete circuit. That is,

$$\begin{aligned} E_R &= IR \\ E_X &= IX \\ E &= IZ \end{aligned}$$

Since the current is the same in all elements in a series circuit, the voltages in such a circuit will be proportional to  $R$ ,  $X$  and  $Z$ . Hence the triangles of Fig. 10 show the relationship between resistance, reactance and impedance in series circuits when  $Z$  is substituted for  $E$ ,  $X$  for  $E_L$  or  $E_C$  and  $R$  for  $E_R$  in the drawings. Inductive reactance is indicated by a vertical line drawn upward from the horizontal resistance line and capacitive reactance by a vertical line drawn downward, to indicate the phase relationships. Thus the impedance of a series circuit also can be solved by the triangle formula, or

$$Z = \sqrt{R^2 + X^2}$$

From the triangles previously constructed from voltage measurements, compute the reactance and impedance in each case by taking the length of the resistance voltage line equal to the resistance in ohms and measuring the reactance and impedance to the same scale. This also can be done without measurement by taking the ratio of the voltages and multiplying by the resistance used. For example, with 2000 ohms in the circuit the data above give 118 volts across the inductive reactance and 20 volts across the resistor, with the computed total voltage being 120.

Then

$$\frac{E_L}{E_R} \times 2000 = \frac{118}{20} \times 2000 = 11,800 \text{ ohms for } X_L,$$

and

$$\frac{E}{E_R} \times 2000 = \frac{120}{20} \times 2000 = 12,000 \text{ ohms for } Z.$$

The value of reactance so computed may vary by several per cent in the different cases because of measurement inaccuracies, but should be approximately the same regardless of the resistance used.

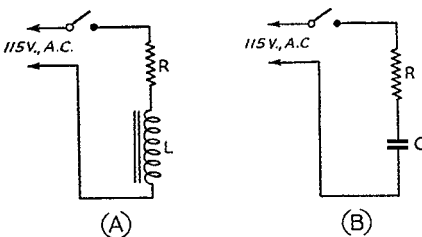

Fig. 11

### EXPERIMENT 13

#### Alternating Current — Series Circuits Containing Resistance, Inductance and Capacity

**Apparatus:** The same equipment is required for this experiment as for Exp. 12.

**Procedure:** Connect the choke coil, 0.1- $\mu$ fd. condenser and the 1000-ohm resistor in series as shown in Fig. 11-A. Read the voltages across the resistance, capacity, inductance, and across the condenser and inductance in series. Substitute the 2000, 5000 and 10,000-ohm resistances one at a time in place of the 1000-ohm unit and again take voltage readings. Repeat the same procedure with the 0.25- $\mu$ fd. condenser replacing the 0.1- $\mu$ fd. unit, and finally repeat again with the 1- $\mu$ fd. capacity.

The following tabulation will be typical of the observed data, when the inductance is approximately 30 henrys and the frequency 60 cycles:

	Resistance, Ohms			
	1000	2000	5000	10,000
When $C = 0.1 \mu\text{fd.}$ :				
Voltage across $R$ . . . . .	7	14	40	67
" " $C$ . . . . .	218	212	190	153
" " $L$ . . . . .	115	112	105	90
" " $CL$ . . . . .	121	119	106	82
When $C = 0.25 \mu\text{fd.}$ :				
Voltage across $R$ . . . . .	52	72	90	97
" " $C$ . . . . .	443	313	161	92
" " $L$ . . . . .	428	313	176	115
" " $CL$ . . . . .	73	51	32	27
When $C = 1.0 \mu\text{fd.}$ :				
Voltage across $R$ . . . . .	10	22	52	78
" " $C$ . . . . .	38	34	27	18
" " $L$ . . . . .	153	148	126	97
" " $CL$ . . . . .	119	116	100	79

The line voltage was 122 when the above data were taken.

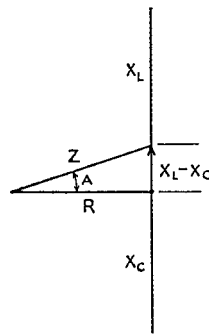

Fig. 12

Since the voltage across an inductance leads the current by 90 degrees and that across a condenser lags the current by 90 degrees, the voltages across an inductance and capacity in series (where both carry the same current) have a phase difference of 180 degrees. In other words, one voltage reaches its positive maximum at the same instant that the other reaches its negative maximum. At every part of the cycle the polarity of one is opposite to the polarity of the other. Hence the total voltage across the inductance and capacity in series is the difference between the voltages appearing across each one. Since the same current flows through all in a series circuit, the same relationships hold between resistance, reactance and impedance. This is shown graphically in Fig. 12, where (as in Fig. 10) the resistance is represented by a horizontal line, the inductive reactance by a vertical line drawn upward to the same scale of ohms, and the capacitive reactance by a vertical line drawn downward. The net reactance in the circuit is the difference between the inductive and capacitive reactances, and is shown as  $X_L - X_C$  on the diagram. The impedance is found by

using the resistance and net reactance in the triangle relationship. If  $X_C$  had been larger than  $X_L$  the net reactance would be drawn downward, since the  $X_C$  line would be longer than the  $X_L$  line and the difference would be in its favor. In such case the phase angle,  $A$ , would be leading since the impedance line would be below the resistance line (remembering that the lines can indicate voltage as well as resistance, reactance or impedance and that the current always is in phase with the voltage in a resistance). In the case illustrated in Fig. 12 the phase angle is lagging. Lead or lag is always taken with the voltage as a reference unless otherwise specified, so that a lagging phase angle means that the current is lagging behind the voltage, and a leading phase angle means that the current is leading the voltage.

When the inductive and capacitive reactances are equal, the net reactance is zero and the impedance is simply equal to the resistance. When this condition exists in a series circuit the circuit is said to be *resonant*, and the current is the same as it would be if only the resistance were present. This current, nevertheless, flows through the inductance and capacity, and because of the reactances of these elements voltages of considerable amplitude can be developed across them. In the above data the circuit is approximately resonant when the 0.25- $\mu$ f. condenser is used, and with the lowest value of resistance the voltage across either  $C$  or  $L$  is several times the line voltage. If the choke coil had no resistance or other losses, the voltage across  $CL$  would be zero at resonance. In the actual data the voltage is not zero, and its value is a measure of the effective resistance of the choke. The term "effective" is used to indicate that the resistance operating is not just the d.c. resistance of the winding, but includes power losses in the iron. In this special case the voltage across  $CL$  and the voltage across  $R$  both represent resistance voltages, hence these voltages are in phase and should add arithmetically to give the applied voltage. That this is so can be checked by adding the voltages for each case, when it will be found that the sum is approximately equal to the applied voltage.

Calculate the applied voltage from the observed data when  $C = 0.1$   $\mu$ f. and when  $C = 1.0$   $\mu$ f., using the triangular relationship as shown in Fig. 12. Using the resistance as a reference, calculate the impedances, or find them graphically from scale drawings of the voltages (the method was described in Exp. 12). Neglect choke resistance and assume that the calculated applied voltage is correct. The effective resistance of the condensers is very low and may be neglected without appreciable error.

#### EXPERIMENT 14

##### Alternating Current — Inductance and Capacity in Parallel

**Apparatus:** The same equipment is required as for Exps. 12 and 13.

**Procedure:** Arrange the circuit as shown in Fig. 11-B. Using the 1000-ohm resistor at  $R$ , take voltage readings across  $R$  and across the parallel inductance and capacity, using successively the 0.1-, 0.25- and 1- $\mu$ f. condensers. Substitute the 2000-, 5000- and 10,000-ohm resistances and repeat the procedure in each case. Following is a typical set of data, taken with the line voltage at 123 volts:

	Capacity, $\mu$ f.		
	0.1	0.25	1.0
When $R = 1000$ ohms:			
Voltage across $R$ . . . . .	6.3	3.5	37
" " $LC$ . . . . .	121	121	118
When $R = 2000$ ohms:			
Voltage across $R$ . . . . .	12	7.5	61
" " $LC$ . . . . .	120	120	105
When $R = 5000$ ohms:			
Voltage across $R$ . . . . .	25	16.5	103
" " $LC$ . . . . .	114	114	66
When $R = 10,000$ ohms:			
Voltage across $R$ . . . . .	43	30	116
" " $LC$ . . . . .	102	103	35

Since  $L$  and  $C$  are connected together in parallel, only one voltage can appear across them. The current in  $L$  may differ considerably from that in  $C$ , however, since these currents will depend upon the voltage and the reactance of the particular element considered. That is,

$$I_C = \frac{E_{LC}}{X_C} \text{ and } I_L = \frac{E_{LC}}{X_L}$$

neglecting the effect of resistance and losses in the inductance. These two currents combine to form the current which flows through  $R$  and the source of voltage, or "line" current. In the condenser, the current leads the voltage by 90 degrees and in the inductance the current lags the voltage by 90 degrees. Therefore the line current is the difference between the two branch currents, just as in the series case (Exp. 13) the total voltage was the difference between the separate voltages across condenser and inductance. In other words, the impedance of the parallel circuit ( $Z = E/I$ ) is higher than the reactance of either branch alone since the total current is less than the current in either branch. Should  $I_C$  and  $I_L$  have the same value the line current under ideal conditions would be zero, indicating that the impedance of the parallel circuit is infinite. In practice this is impossible, since the actual phase relationship between current and voltage in the two branches is not exactly 90 degrees because of the internal resistance present, particularly in the inductive branch. Hence complete cancellation of currents, even when the reactances are equal, does not occur, since such cancellation would require a phase difference of exactly 180 degrees between the two currents. The effect of the internal resistance on line current is relatively small if the reactances of the two branches differ considerably (and if the resistance itself is small compared to the reactance) but becomes more and more pronounced when the two reactances approach equality; i.e., when the circuit is near resonance.

With only an a.c. voltmeter available, it is not possible to measure the various currents in such a circuit. The voltage measurements do, however, give a clue to the way in which the impedance of the parallel circuit changes when the condenser reactance is changed. The lowest voltage drop across the series resistor is obtained when the capacity (0.25  $\mu$ f.) which was nearest to series resonance (Exp. 13) is used, showing that the line current is low and hence the impedance of the condenser and inductance is high. This is just the opposite of the case when the inductance and capacity are in series, since in the series circuit (Exp. 13) the current is highest when the reactances are equal. With other values of capacity the resistance voltage increases, which indicates an increase in line current and hence lower impedance in the parallel circuit.

#### ANSWERS TO QUESTIONS IN INSTALLMENT I

With the exception of those given below, all answers are to be found either in the *Handbook* or in the descriptions of Exps. 1 to 6.

##### Assignment 2:

**Q. 3** — The dry cell is a primary cell because the electrical energy is taken from chemical energy in the materials of the cell. The storage cell is a secondary cell, because electrical energy must first be put into it to cause the chemical changes which are later re-transformed into electrical energy when the cell is discharging.

**Q. 8** — It is not true of a gas because no conduction takes place until a certain critical voltage is reached, causing ionization, while the voltage required to maintain ionization, once started, is more or less independent of the current flowing. Current flow in a vacuum by thermionic means is limited in total to the number of electrons emitted from the hot cathode, and once all electrons are drawn to the plate no further increase in current is possible when the voltage is increased.

(Continued on page 86)





# OFF THE ULTRAHIGHS



CONDUCTED BY E. P. TILTON,\* WIHDQ

INDICATIONS, as this material is being prepared, point to early announcement of the long-awaited OCD plan for emergency communication.<sup>1</sup> Many changes in the amateur picture have taken place since we first laid plans for our part in civilian protection in wartime. Not the least of these is the reduction in the number of amateur operators and stations which will be available for this work. Between actual military service and the various civilian jobs requiring experienced radio men for installation and maintenance of the radio equipment used by our armed forces, probably half of the country's amateurs are already assigned to duties which withdraw them from the ranks of those available for OCD work. Add to this the fact that many of the rest are working long hours in manufacturing plants and laboratories, and it becomes obvious that we stay-at-homes are about to be confronted by a task of the first magnitude.

For one thing, we shall certainly have to build more 112-Mc. equipment of a type which will be useful for emergency work, the u.h.f. building program having stopped abruptly with the termination of all amateur activity around the first of the year. Much has been written regarding transmitters and receivers which were designed specifically for the job at hand. Every amateur who still has spare time on his hands should be working on such gear if there is any possibility of making use of it in his locality. And even if one's own neighborhood does not seem to require OCD communication, the accent which will be placed on the ultrahighs when the current unpleasantness is over makes the construction of 112-Mc. gear a worthy endeavor at this time.

The limitations on power consumption imposed by operation from genemotor or vibrator power supply require that the general recommendations already laid down be followed in the construction of transmitters for emergency work, but more variations are possible in the receiver field. The simple two- or three-tube superregen is a necessity where portable or mobile operation is indicated; but in the case of fixed stations, particularly those to be operated in air-raid warning centers and similar points where the high hiss level of the rush-box might be troublesome, provision for something better might well be made. Receivers of the superhet type need not necessarily be so complex as to preclude the possibility of operation from emergency power supply, and their lower noise level and superior

audio quality will be appreciated by ARP workers, to whom the rush of the superregen might not be the music that it is to many of us! Reproduced herewith are two examples of superhet technique which might well be adapted to emergency work — and the fellow who builds such gear will have something a little better than the rest when the job is done and we get back to radio as a hobby.

The S.I.G. receiver (essentially a conventional superhet r.f. section working into a superregenerative detector operating on the i.f. frequency) has some of the hiss of the superregen, but as the frequency of the detector is not changed during operation it can be adjusted for maximum performance and minimum hiss level; the net result being much easier on the ears than the usual superregen roar. This type of receiver was first described (for 56 Mc.) by the late Ross Hull back in 1935, and simplified versions adapted for 112 Mc. have been written up in recent issues of *QST* by W6OVK. Another worker to report success with the S.I.G. was Bill Adams, W6ANN, of San Pedro, California, who got the receiver shown in the accompanying photo and schematic going shortly before Dec. 7th. Bill found that

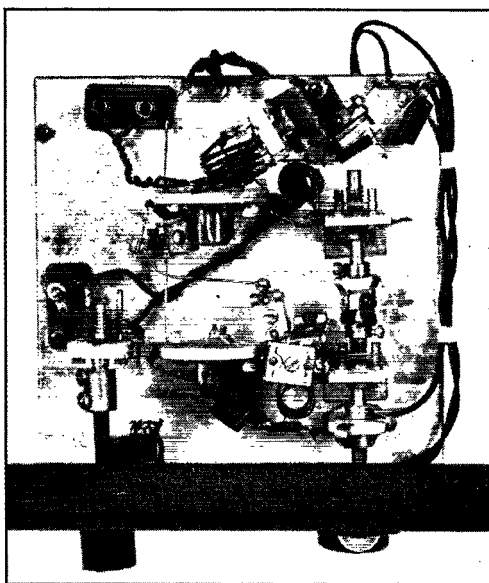

Looking down into the converter of W3HOH. Condenser at the left is for antenna tuning; large coil, center rear, is the output coupling.

Photo by Harry B. Clay, Jr.

\* 329 Central St., Springfield, Mass.

<sup>1</sup> See page 11, this issue. — Editor.

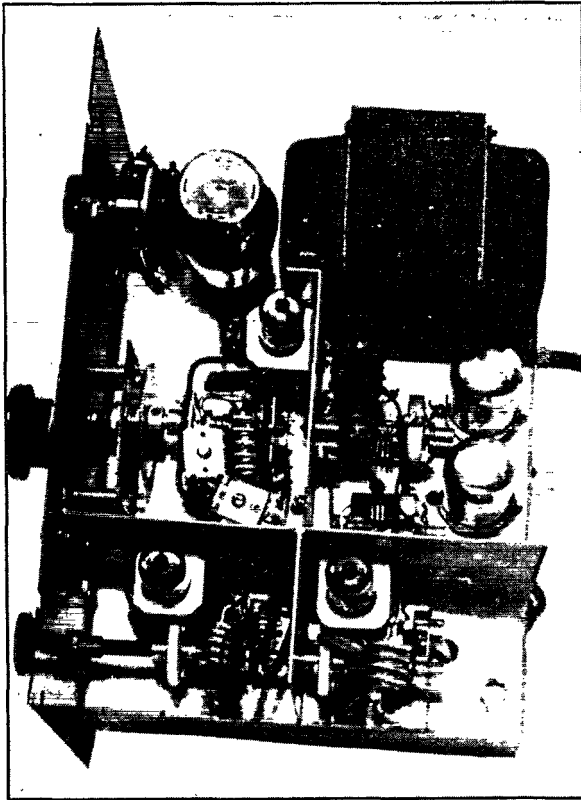

The neat, compact 112-Mc. superhet built by W6ANN. Oscillator is tuned by the vernier dial, center, with r.f. and mixer stages at the bottom of the photo. The two lock-in tubes at the rear are the superregenerative detector and audio stage.

reception of 112-Mc. signals from San Diego, nearly 100 miles distant, was possible with this receiver when they would have been inaudible on the conventional superregen. Using the 9000-series tubes the total heater drain is only slightly over one ampere, and the plate supply might well be "B" batteries or a small vibrapack, though built-in a.c. supply is shown.

In getting this receiver into operation W6ANN first got the superregenerative circuit functioning on about 30 Mc. by tuning it in on his low-frequency communications receiver. The high-frequency oscillator was then tuned to 82 Mc. (this was located on a complete-coverage superregen receiver, but could have been accomplished with lecher wires if necessary). The mixer and r.f. condensers were then adjusted until signals were heard and the coil sizes adjusted for tracking. In these days of no signals on  $2\frac{1}{2}$  the band may be located easily by tuning for the radiation from a superregenerative detector known to be in the band. Moving the rush-box farther away then provides a fair signal for tuning the receiver

up, if no signal generator for u.h.f. work is available. Bill reports that more trouble was encountered in soldering leads to the polystyrene sockets for the 9000-series tubes than from any problems in getting the receiver into operation!

Leader in reported activity on 112 Mc. in 1941 was Ken Kingsbury, W3HOH, of Bernardsville, N. J., with 425 different stations contacted on  $2\frac{1}{2}$  during last year. Living about 30 miles from the center of the country's largest concentration of 112-Mc. stations proved to be something less than an unalloyed blessing, however, and Ken, along with many others in this section, found that something better than a superregen was needed if any signals were to be heard through the New York area Q.R.M. A converter similar to that described by W2HNY in July, 1940, QST, was built and tried.

This unit was designed for use in conjunction with a Hallicrafter 5-10 with the i.f. amplifier switched to the "broad" position. Operated in this way the converter gave excellent results on signals which were reasonably stable, but signals of this sort were few and far between. Then a superregenerative detector operating on 25 Mc. was substituted for the 5-10. Results were satisfactory but for the presence of the superregenerative rush. (We interpolate here that the hiss level can be reduced and almost any degree of gain and selectivity can be obtained by experimentation with this stage.) Operation of the con-

verter was then tried with a Meissner f.m. unit belonging to W2KP. This proved to be the answer — quiet, good-quality reception of all signals, combined with sensitivity and selectivity exceeding that of the superregen.

The W2HNY converter is simplicity itself, consisting of two 955 triodes (they could be 9002s with equivalent results), one as a mixer and the other as an oscillator. The latter is operated on the low-frequency side of the signal, and with the high intermediate frequency used the oscillator stability is adequate. When used in conjunction with an f.m. receiver, the output frequency of the converter should be changed from 25 Mc. (as specified in the original description by W2HNY) to some frequency within the tuning range of the f.m. receiver. Care should be taken to choose some spot where no strong f.m. signal is heard. The only change from the original design was in the size of the output coil (shown at the center, rear, of the chassis) in order to tune to approximately 50 Mc. Readjustment of the oscillator was possible with the trimmers originally specified.

At the time of the close-down, about a dozen of these converters were being used with f.m. receivers in the metropolitan area, W2KP and W3ACC being among the users who reported excellent results. Complete cost of the converter unit is around fifteen dollars, including the two 955s. By substituting 9002s the cost could be held even lower. Power consumption, including that of the f.m. unit, should not be beyond the capabilities of a small vibrapack, provided no high-powered audio is used in the f.m. receiver; and the quiet operation and excellent quality should fit nicely into the OCD picture, especially for use in a control station.

Reports from listeners on the f.m. band indicate that May 2nd was the first big day of the skip DX season. From all indications this would have been the grand opening of the 1942 DX scramble, if . . . ! W1LLL, who has missed as few band openings as anyone we know, felt DX in the air on May 2nd. DX began coming in around 4:15 P.M., with W51C, Chicago, being identified at 4:30. Many other signals were heard but the infrequent signing of calls prevented further identification. Remember how we used to rant and rave when broadcast stations began to exhibit this same failing back in the early twenties?

W4FKN, another reliable 56-Mc. DX enthusiast, of Atlanta, Ga., tuned the range from 30 to 60 Mc. on this date. The f.m. band was full of signals from the Northeast and Middle West as early as 11:00 A.M. One f.m. signal was heard near 60 Mc. (probably an image from a television

sound channel) and commercial c.w. harmonics of WKS/WKI near 58 Mc., and WDS/WQA2 at about 56.7, and a harmonic of WAR near 56 Mc. all served to indicate the possibilities of DX on Five. WAYY and two other police signals were heard near 39 Mc.

From Asheville School, North Carolina, s.w.l. Andrew Gent reports reception of W43B, W2XMN, W67PH, W59NY, W57A, W53H, W55NY, and W59C. These are located in Paxton, Mass., Alpine, N. J., Philadelphia, New York, Albany, Hartford, New York and Chicago, respectively. Do we hear an expression of hope that this North Carolina s.w.l. gets himself a ticket so he can be on Five when the war is over?

In Tucson, Arizona, W6SLO is watching the f.m. band. Neal heard seven stations coming through on May 15th. Not all were identified, but San Francisco, Detroit, and Rochester, N. Y., were heard. This sounds like the W8 sessions Neal used to have all by himself last year about this time. It will be interesting to note just how often reception is possible over distances approaching transcontinental caliber. It may serve to indicate that really long-haul "double-hop" is not the rare phenomenon we once thought it to be — if the stations are going in the right places at the right times.

W7CIL, Salem, Oregon, heard several Southern California police stations between 2 and 3 P.M. on May 2nd, and on the 3rd the police band was very hot from 12:30 to 2:30 P.M. On the 9th some police sigs came through and several signals

(Continued on page 88)

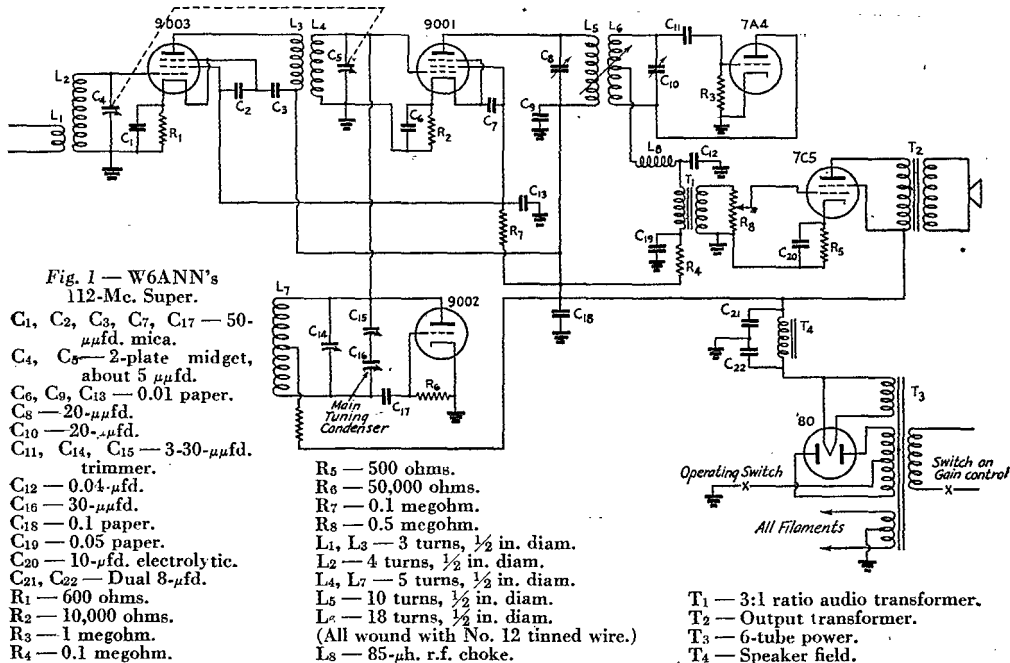



# CORRESPONDENCE FROM MEMBERS

The Publishers of *QST* assume no responsibility for statements made herein by correspondents.

## "BADLY NEEDED"

719 Chapin St., Cadillac, Mich.

Editor, *QST*:

Well, you've done it again. I refer to Grammer's "Course in Radio Fundamentals." It or some outlined course was badly needed. . . .

— *John Hays, W9CYU, ex-K5AC*

## BACK ON THE AIR

Camp Barkley, Texas

Editor, *QST*:

W5JSQ is back on the air! Not rag chewing, perhaps, but still on the air. And all equipment is being furnished by the U. S. Army!

I have only been in the Army six weeks but we are already actively using radio in training. W5FSJ is chief of section for battalion communication with yours truly, W5JSQ, third in command.

No, it's not hamming but it is radio and we feel that we are very fortunate indeed to be able to combine our favorite pastime with service to our country. . . . — *R. L. Ransom, W5JSQ*

## AWVS NOTE

1307 Sixth Ave., New York City

Editor, *QST*:

*QST* just arrived and I'm anxious to thank you for the elegant recognition you afforded the AWVS in your article on YLs and their effort. Although we are not working for public recognition, it is naturally gratifying and at the same time helps the cause along tremendously.

Also, you have no idea how pleased the new "graduates" will be to find their pictures in *QST* — a thrill which you must think back to your pre-ham days to imagine. They have a reverence for the magazine which is very sincere. And they are passing it on to their own students, as most of them are now starting beginning classes.

I notice that Marge Fischer, W2NAI, was not listed as one of our instructors. As she has done so much good work, I would appreciate due credit to her if the opportunity arises. . . .

— *Lenore K. Conn, W2NAZ*

Post Signal Office, Fort Knox, Ky.

Editor, *QST*:

Congrats on the splendid article, "U.S.A.

Calls and the YLs Answer," in May *QST*. I have been hoping for some time that such an article would be written, for the purpose of waking up a lot of YL ops who could help their country out in its hour of need.

Working for the government as a radio op, I know how desperately experienced operators are needed to keep our communication channels, the Army's mainstay of communication, open. I don't think I would be violating any rules or regulations when I say that since the draft has taken so many of our young men, radio has had a tough time trying to keep its head out of water. We get men on the job, and it seems that just when they get broken in so that they are capable of handling the job, they are called to duty, and we are just where we started. Putting women in their places would eliminate this trouble.

From my work on the ham bands, I know at least a dozen women who could, after a little training, handle our government traffic, and why they do not offer their services is beyond me. I should think they would be anxious to help where they are needed most. It is true that it is grueling work, and that returning to housework would seem like paradise after six months of slinging traffic eight or nine hours a day — but believe me, pal, they sure would appreciate their home life again after the duration.

I dunno if it will help any, but I got in radio because my OM said I didn't have brains enough to master it. Maybe that challenge would get other gals in there pitching, huh?

Here's to continued success!

— *Mickey Marglin, ex-W9ZTU*

Fort Hancock, N. J.

Editor, *QST*:

Just got May *QST* and read your article on the work of the YLs in this fracas. Very FB article, OM, but I have one thing to kick about. I quote: "Other YLs engaged in instruction in these classes include W2NSL, W2NRC, W2NFR and W2MYT." This is the first that the boys here knew that W2MYT is a YL. Ray certainly has been holding out on us! . . . Ray is radio sergeant here at Ft. Hancock. That's the only kick I have in regard to your article, OM. Otherwise it is very FB. YLs make very good ops. We could use a few good ops here! . . .

73 es keep 'em rolling — we are.

— *Pvt. Joe Fucetola, W2OHN*

## TEACHING INSTEAD OF HAMMING

Rupert, Idaho

Editor, *QST*:

After several months with the old rig off the air, I wonder how some of the other fellows are spending their time, especially the disabled veterans of World War I like myself. I don't believe there ever was anything that was so much company as the old rig when a fellow can't get around as he would like to.

For myself, I have found another hobby that I feel I get as much out of as if I were hamming. I have started two radio classes, one in the evening for grown-ups (have 43 in that class), and another in the High School for high-school students. We have the fifth period each day, and the students get high-school credit for taking the course. Both classes are gratis. The High School has given me permission to buy certain training equipment, although I have eight keys, three oscillators and an Instructograph that I used while teaching in the CCC camps before they closed up.

I find the new ARRL Handbook a good class book. By starting in at the beginning and giving problems in each phase of the different subjects, the students not only learn radio properly but I find I am getting a lot out of it myself — hi! After six weeks we are now up to R. F. Power Generation, and believe you me, I'll bet that if all hams knew just that far the old signals would have been a lot better, as there is plenty in that book that I never knew was there before.

Our classes are conducted as follows: For the first 20 minutes we have code practice, doing about 8 words per now. Then the next 20 minutes we have theory, and for the last 20 minutes the six keys are put into the circuits of the three oscillators. Around each key (station) there is a group, and they must copy the one they are in contact with. All oscillators are of a slightly different pitch. Man, if you think QRM is bad on the air, you should try to copy in this room! But they are doing it. . . .

— *Louis W. Dspain, W7IEY-W7HZN, W7JBG*

## THE HAM IS PREFERRED

Turner Field, Albany, Ga.

Editor, *QST*:

. . . My ham affiliation means more and more to me as I am made aware of the assistance the personnel from our ranks is furnishing the armed forces. I have been in the Army thirteen years during the last seventeen, and the ham has been the preferred communications man.

Also, the mainstay of the non-commercial radio facility has been and is ARRL, as is being made more and more manifest as letters of the type referred to above are received.

See you in Tokyo, and 73.

— *Tech. Sgt. T. Biggs, W4HBN/HFT, ex-WLJN*

## "KEEP 'EM TALKING"

Fort Monmouth, N. J.

Editor, *QST*:

About a month ago I wrote to you regarding transferring from the Infantry Training Battalion at Camp Croft, S. C., where I was stationed at that time, to the Signal Corps. You replied: "Hold on a while longer. Maybe we can fix you up."

I am happy to say that ten days after receipt of your letter I was transferred to the Signal Corps here at Fort Monmouth, where I am training as a fixed station operator. . . .

Keep up the good work there at Hartford and don't let the League deteriorate because of the suspension of normal operations. We need our organization now more than ever, so let's "keep 'em talking" down in Washington. Thanks again. . . .

— *Pvt. Charles R. Cross, W2FNI*

## ARRL CODE LESSONS IN VE

4510 Girouard Ave., Montreal, P. Q.

Editor, *QST*:

About two months ago you were kind enough to send me a set of lessons covering sending and receiving code. I have found them exceptionally useful and would appreciate it greatly if you could spare another set.

For the past eighteen months the writer and a number of local hams, including VE2HI, 2OU, 2XM, 3AKO, 2HM, 2CJ, 2GO and 2KS have been busy as civilian signalling instructors, and have taught Morse to air force cadets, regimental signal platoons, reserve army signal schools, and other recognized groups. All students are given a code-aptitude test before the course starts. We use the sound system entirely now, although we group the letters for memorizing in a slightly different order than in your lessons. It is the writer's intention of using the ARRL course as a basis for one for use by this particular group. We are committed by the authorities here to see that our students memorize the letters in a certain sequence, hence the necessity for making slight alterations to your printed lessons.

Now for a word or two about good old *QST*. We VEs, having been off the air for two and one-half years now, naturally could not work up much enthusiasm over the contents of *QST* dealing with transmitters and modulators, etc. Lately, however, the story is different. We're all in about the same boat, and for the last two or three months I have found the contents of *QST* extremely interesting, especially articles on such subjects as wired wireless, transmission by induction, the panoramic radio spectroscopy, practice oscillators, etc. Keep up the good work. . . .

— *Lin Morris, VE2CO*



JOHN HUNTOON, W1LVQ, Acting Communications Mgr. GEORGE HART, W1NJM, Asst. Coms. Mgr.

**Civilian Defense Radio Plans Here.** The top news of the month is that a plan covering the use of radio for supplemental channels for defense communications throughout the country for the purposes of civilian protection can now be announced. At last the green light for all those operators who have been impatient to enlist their services in community radio-defense! We know of a dozen cities where blueprints for organization have been ready and ARRL Emergency Coördinators have had friendly conferences with officials — everything ready to go under any suitable plan approved by Washington. Now, g.a.!

Many OCD conferences and discussions on the purposes to be served and safeguards required have resulted in the approval of a plan, that plan now implemented by FCC Order. OCD has indicated the scope of the defense jobs to be done by radio. Some of that Washington information was quoted on page 9 of February *QST*. The new policies and program for civilian defense radio are explained in an article elsewhere in this issue. Please study it carefully, note the manner in which amateurs can contribute and assist and qualify for operating participation in the localities where they are needed.

Some may be disappointed that the civilian defense radio regulations as set up do not provide for outright reactivation of amateur stations. That was tried in December under plans that lacked the supervision and monitoring provisions of the new, and with the December history in mind such plans were thought unwise. But we amateurs have no fault to find with any plan that permits enlistment of amateur facilities, and here is such a plan!

Every operator who can do so and who is needed will wish to be a part of civilian defense radio plans for wartime work in emergencies. To aid in setting up facilities as quickly as possible ARRL has asked SCMs to appoint new Coördinators where we have none, to replace such officials where they have moved or gone into service creating vacancies, and to endorse appointments running out. ARRL has called on each Coördinator to review all Emergency Corps registration records, and ascertain the *present* availability and equipment of the registrant for civilian defense needs. Each Club and Emergency Coördinator has been asked to register the willingness and availability of every licensee where any

operators are found unregistered before. The whole idea is to enable amateur radio to contribute as quickly, efficiently, and usefully as possible in this civilian defense picture. To aid in radio-defense work *every* amateur should make his facilities known in orderly fashion. That does not mean that every amateur should rush to local officials to do this direct. Where amateur groups have leadership locally representations and organization should work through that leadership. Where amateurs are not fully organized in advance they should organize and work through one member as outlined elsewhere in this issue and closely following the seven points on page 48 of February *QST*. We amateurs represent the largest group of operators who can assist our communities by enlistment in skilled civilian defense radio facilities. I know that amateur experience will make it easy for many of you readers to do a great job on this war work. It is a duty to put our skill to work in creating these communication facilities. I am confident that the institution of amateur radio can make a highly creditable record for itself through the opportunity presented. Let's do everything possible to get in this radio work — and carry out all instructions in a responsible and efficient manner!

**Do You Know a Maxim Memorial Award Candidate?** SCMs and Clubs have been asked to advise Hq. of their recommendations of the most promising young amateur, based on 1941 records. You will remember that the FCC licensee under 21 years of age deemed to have made the best contribution to amateur radio by a splendid all-year record or a single great achievement is eligible for the Hiram Percy Maxim Memorial Award. This award was created in loving memory of our founder by Mr. Maxim's daughter and son. Nominees must be League members of either sex who were under age twenty-one at the end of the year 1941. This is not a competition but a search to find young persons who show promise most worthy of encouragement and reward. The nominee, chosen by a committee of all the licensed operators at ARRL Hq., receives a miniature reproduction of the Wouff Hong and a gift of \$100 in cash. To date there are but two nominees for 1941. This is to suggest that any readers who know young amateurs who meet the specifications for operating or constructional excellence, ingenuity, contributions to *QST*, organization for the war effort, general progress in

# Honor Roll

## The American Radio Relay League War Training Program

Listing in this column depends on an initial report of the scope of training plans plus submission of reports each mid-month stating progress of the group and the continuance of code and/or theory classes. All Radio Clubs engaged in a program of defense radio training are eligible for the Honor Roll. Those groups listed with an asterisk teach both code and theory. Others conduct only code classes.

- \*Albany (N. Y.) Amateur Radio Assn.
- \*Baltimore (Md.) Amateur Radio Assn.
- \*Bloom Township High School R.C., Chicago Heights, Ill.
- Bluffton (Ohio) Amateur Radio Club
- Butte-Anaconda Radio Club, Butte, Mont.
- \*Central New York R.C., Syracuse, N. Y.
- \*Central Oregon Radio Klub, Bend, Ore.
- \*Conn. Brasspounder's Assn., Noroton, Conn.
- Dayton (Ohio) Amateur Radio Assn.
- Denver (Colo.) Area Radio Club Council
- \*Electric City Radio Club, Great Falls, Mont.
- Elgin (Ill.) Amateur Radio Defense Council
- \*Eugene (Ore.) Vocational School
- \*Fayette Radio Club, Kincaid, W. Va.
- \*Five Towns War Council, Cedarhurst, L. I., N. Y.
- \*Fort Wayne (Ind.) Radio Club
- \*Freehold (N. J.) Amateur Radio Club
- \*Galveston (Tex.) Amateur Radio Club
- \*Coshen (Ind.) Amateur Radio Club
- \*Green Witch Radio Club, Greenwich, R. I.
- \*Hillsboro Defense Council, South Branch, N. J.
- \*Jackson County A.R.C., Lakefield, Minn.
- \*Joliet (Ill.) Amateur Radio Society
- \*Kerrville (Tex.) Amateur Radio Club
- Logan (W. Va.) Radio Club
- \*Manchester (Conn.) Radio Club

- Merchantville (N. J.) Amateur Radio Assn.
- Miami Valley Emergency Net, Dayton, Ohio
- \*Muskegon (Mich.) Area Amateur Radio Council
- \*Nashville (Tenn.) Amateur Radio Club
- \*Nebraska Signal Corps Club, Omaha, Nebr.
- New Dorp High School, Staten Island, N. Y.
- New Haven (Conn.) Amateur Radio Assn.
- \*Newton (Iowa) Radio Club
- \*Northern Minn. A.R.A., Unit One, Bemidji, Minn.
- The Old River Club, Dayton, Ohio
- Oracle Radio Club, Delphi, Ind.
- \*The Piqua (Ohio) Radio Club
- Port Arthur (Texas) Amateur Radio Club
- \*Portland (Maine) Amateur Wireless Assn.
- Richmond (Ind.) Amateur Radio Assn.
- \*The Sandusky ((Ohio) Radio Experimental League
- \*San Isabel Radio Club, Pueblo, Colo.
- Sedalia (Mo.) Amateur Radio Club
- Shy-Wy Radio Club, Cheyenne, Wyo.
- Vermont Academy Communications Club, Saxtons River, Vt.
- \*Walnut Hills High School R.C., Cincinnati, Ohio
- \*Westerly (R. I.) Radio Club
- Western Maryland Amateur R.C., Cumberland, Md.
- \*West Phila. Radio Assn., Phila., Pa.

technique, etc., send such names at once to the local SCM or club for their investigation or nominating action.

### In Conclusion — Renew Your Licenses.

With this paragraph completed your Communications Manager goes on leave of absence, entering the services. Johnny Huntoon of W1LVQ will carry on ARRL radio-training, civilian defense radio and other organization plans as your Acting Communications Manager. You operators know him well as W9KJY, as ex-SCM of Illinois, or as the assistant secretary who perhaps visited you at a club meeting or convention. Give John the same fine coöperation that you field organization members have extended so generously to me and I am sure our organization will continue to go forward a long way. The best of luck, and one parting thought — keep those FCC station-operator licenses renewed! It is easier to let them slip when one is not brass pounding every day. But FCC handles renewals efficiently and the licenses are important to every one of us. Those in the service can get licenses renewed on letter application (instead of Form 610) endorsed by one's immediate commanding officer. 73 and BCNU.

— F. E. H.

## Hamfest Schedule

**August 23rd, at Justice Park Gardens, Chicago, Ill.**  
The Hamfesters Radio Club will hold their "Annual Picnic and Reunion" at Justice Park Gardens, Archer Ave. at Keene, near 79th St., Chicago. 35¢ per person, as usual.

**July 19th at the H-Bar-H Ranch, near Wheeling, Ill.**  
The "Society Radio Operators" will hold their Annual Picnic at the H-Bar-H Ranch, near Wheeling, Ill., July 19th.

### BRIEFS

The "Radio Code School of the Air" is now being conducted each Monday evening from 7 to 8 p.m. EWT on 11.73, 9.70 and 6.04 Mc. by the World-Wide Broadcasting Foundation (WRUL-WRUW). Bill Chamberlain, ex-W1RV, is the instructor, and his classes are especially suitable for beginners. To date the school has enrolled students in each of the 48 states, all possessions and 49 foreign countries! For an enrollment fee of \$1.50 students receive a manual of instructions, have weekly tests checked, and take a final examination which includes a certificate of proficiency if they pass successfully. Many beginners possessing high-frequency receivers or regular broadcast receivers with high-frequency coverage have found this an excellent way to learn the code. Write to W. W. Chamberlain, Radio Code School of the Air, 133 Commonwealth Ave., Boston, Mass.

## Register With Your Coordinator

THE ARRL Emergency Corps is a group of amateurs, six thousand strong, formed originally to prepare for natural disaster emergency communication and now vitally interested in civilian defense communication. Leading their work are some 700 Emergency Coordinators, who keep comprehensive records on the availability, operating skill, emergency-powered and other equipment of each AEC member under their jurisdictions. AEC members, registered with Coordinators and in many cases already organized by him for civilian defense, doubtless will form the nucleus of personnel for the new War Emergency Radio Service. But many more amateurs will be needed.

Non-AEC members: Get in touch with your Coordinator, by telephone if possible, letting him know you are interested in participating in the WERS setup for your community when it is organized. He needs to know how many men he can count on when he contacts the Radio Aide (if he does not hold that position himself) or Communications Officer. He will probably want to send you registration blanks for his permanent file of data on equipment and personnel.

The Office of Civilian Defense has suggested that we concentrate first on the "critical" area, this in general being the coastal states. We therefore print below a list of ECs in those states, alphabetically by towns:

### ALABAMA

Annisson: John A. Wiegand, 926 Lindberg  
Birmingham: Everette C. Atkerson, Rt. 2, Box 325A  
Camden: Samuel P. Johnson  
Clanton: Grady L. Carter, 507 Eighth St.  
Dothan: Briggs Ogletree, P. O. Box 32  
Evergreen: Fred M. Wright  
Fort Payne: G. C. Green  
Gadsden: Halley D. Williams, Ala. School of Trades  
Geneva: Lee H. Nash, 2 Fleming  
Greenville: Edwin T. Montgomery, P. O. Box 294  
Homewood: A. M. Cramer, 1815 29th Ave., S.  
Kellyton: Otha M. Towns  
Luverne: Marshall C. Martin, Rt. 2  
Mobile: James Robertson, 274 N. Conception  
Troy: Holman Johnson  
Tuscaloosa: Philip S. Mentz, Veterans Facility  
Tuskegee Institute: Henry Hunter, Jr.  
Wetumpka: W. W. Key, Jordan Dam

### CALIFORNIA

Bakersfield: Cleets E. Armistead, 256 Jefferson St.  
Bell: H. Allen Smead, 6717 King St.  
Burlingame: C. F. Busch, Jr., 1537 Howard Ave.  
Calexico: D. C. Strawn, 516 7th St.  
Covina: C. N. Fisher, 1323 E. Bonite Ave.  
Fillmore: Walter A. Stewart, Jr., 357 Blain Ave.  
Fresno: E. S. Martin, 172 Echo Ave.  
Hanford: Gus J. Diesslin, 1412 Middleton St.  
La Jolla: Ralph H. Culbertson, 7126 Eads Ave.  
Thomas H. Wells, 7166 Fay St.  
Lancaster: Charles W. Abern, P. O. Box 419  
Lone Pine: Amon Dolde, General Delivery  
Long Beach: Alvar E. Rohland, 147 Ximeno Ave.  
Los Angeles: Ralph S. Click, 1038 Milwaukee Ave.  
Al Harris, 1201 West 56th St.  
Franklin E. Milton, 10908 Rose Ave.  
Stuart F. Walmsley, 1940 West 84th St.  
Harold F. Wood, 723 N. Las Palmas Ave.  
Menlo Park: Geoffrey Almy, Rt. 1, Box 49  
Modesto: Ralph C. Lowry, Rt. 1, Box 1653A  
Monrovia: Francis L. Vore, 223 E. Lemon Ave.

Oakland: Omar Day, 1441 81st Ave.  
Richmond: A. V. Wright, 660 38th St.  
Riverside: Albert F. Hill, Jr., 1844 Blaine St.  
San Diego: Gordon W. Brown, 4062 Goldfinch St.  
San Francisco: Wally Howland, Rm. 1725, Empire Hotel  
William A. Ladley, 200 Naylor St.  
San Gabriel: Lewis Rogerson, 338 S. Muscatel  
San Jose: Miles Dawson, 400 North 14th St.  
Harry Engwicht, 405 North 3rd St.  
San Leandro: Art Sinclair, 375 Pleasant Way  
San Mateo: Robert E. Leo, 1003 B St.  
San Rafael: Joseph Horvath, 522 3rd St.  
Santa Barbara: E. R. Kluss, 515 E. Micheltorena St.  
Santa Clara: Roy E. Pinkham, 1061 Fremont St.  
Santa Paula: J. Albert Furrer, RFD 1, Box 17  
Santa Rosa: Wm. E. Smith, 3975 Redwood Highway North  
Stockton: Lon M. Hildebrand, 682 N. Central Ave.  
Tulare: Karl W. Krell, Box 523  
Ukiah: Boyd Benham, 1346 Cypress Ave.  
Venice: Earl C. Rau, 745 Brooks Ave.  
Ventura: W. B. Farwell, 543 S. Jones St.  
Whittier: Russell G. Peelle, 437 Haviland Ave.

### CONNECTICUT

Branford: B. W. Thompson, Wilfred Rd, Indian Neck  
Danielson: George R. Caron, 36 Hawkins St.  
Darien: Stanley Crosby, Grove St.  
East Hartford: Porter V. Noc, 63 Sisson St.  
East Haven: William McNeil, 120 Estelle Rd.  
Easton: G. F. Williams, "The Birches," Flat Rock Pk., RFD 1  
Fairfield: Nathaniel Bishop, 4375 Congress St.  
Hamden: Walter M. Shorthouse, 36 Manor St.  
Hartford: Eugene R. Tompkins, 245 Lyme St.  
Litchfield: Floyd L. Vanderpoel  
Manchester: Llewellyn H. Melbert, 93 Tanner St.  
Middletown: Philip S. Rand, Box 1187  
Milford: Harold S. Edwards, 15 Harborview Ave.  
Mystic: Frederick E. Horner, 119 New London Rd.  
New Britain: Stanley C. Perkoski, 61 E. Main St.  
New Canaan: Cedric Root, Box 393  
New Haven: C. Bronson Weed, 224 St. Ronan St.  
New London: Henry G. Appleblad, P. O. Box 763  
Arthur W. Beebe, 274 Conn. Ave.  
New Milford: Walter H. Crooker, Jr., RFD 1  
Norwich: Frank Grover, 78 Geer Ave.  
Old Lyme: Norman Gibbs, Rogers Lake  
Old Mystic: William Welles, c/o Welles Garage  
Putnam: Walter B. Jennings, 108 Grove St.  
Riverside: Charles A. Pirro, Jr.  
Southington: M. E. Chaffee, Southington Savings Bank, Box 447  
Stamford: Richard Edwards, High Ridge  
Torrington: J. Heaton Thompson, 633 E. Main St.  
Waterbury: Roger F. Hamilton, 62 Academy Ave.  
West Hartford: A. L. Budlong, 38 LaSalle Rd.  
West Haven: Ray McKendrick, 46 Center St.  
Westport: William VornKahl, Post Rd.  
Willimantic: Elmer P. Balcom, 217 Mansfield Ave.

### DELAWARE

Wilmington: Gary C. L. Barnes, 210 S. Dupont Rd.

### FLORIDA

Blountstown: J. N. McCaskill, P. O. Box 332  
Bradenton: Bill Sheets, 1305 11th Ave.  
Dade City: A. J. Swanson, Rt. 1, Box 121  
Deland: E. Graff Carr  
Jacksonville: Horace E. Smith, No. 4 Fire Station  
Miami: Alonzo O. Bliss, Jr., 2585 S. Bayshore Drive  
Mount Dora: Frederick C. Beardsley  
Orlando: Gordon B. Woodruff, 15 W. Yale Ave.  
Palm Beach: Guernsey Curran, Jr., P. O. Box 48  
Pensacola: Eddie Collins, 1517 E. Brainard St.  
St. Petersburg: Wilton C. Spence, 940 Bay St., N. E.  
Tampa: Frank C. Fassett, Box 9298, Sulphur Spgs. Sta.

### GEORGIA

Athens: Claude M. Leathers, 835 Hill St.  
Atlanta: James W. Geeslin, 1008 North Ave., N. E.  
Bremen: Olin P. Lawson  
Brunswick: Aubrey E. Bates, c/o Western Union  
Cedartown: Phil. N. McKay, 136 N. College St.  
Chatsworth: J. W. Dooly, 3rd Ave., N.  
Claxton: B. C. Brewton  
Cochran: Lamar Hill  
Columbus: Wesley Scott, c/o Police Dept.  
Lyons: Ernest L. Morgan, RFD 4  
Macon: R. W. Gober, 880 Napier Ave.  
Monroe: V. S. Wright, 235 Felker St.  
Valdosta: W. M. Castleberry, Box 466



## LOUISIANA

Alexandria: R. K. Andrews, 1716 Kelly St.  
Bastrop: Lester B. Barry  
Covington: Fred J. Morgan  
Hodge: M. M. Hill  
Homer: James D. McKenzie  
Jennings: H. H. Hoag, Jr.  
Lafayette: J. J. Butcher, 1013 College Ave.  
Lake Charles: Howard Leveque, 425 Ingleside  
Lake Providence: C. S. Perry  
Many: T. H. Cagle  
Metairie: R. J. Evans, 226 Orion Ave.  
Monroe: Bernie Wilenziak, 511 Bres  
Plaquemine: George Hidaigo  
Natchitoches: John G. Hoop, e/o Natchitoches Oil Mill  
St. Joseph: H. C. Morgan  
Shreveport: Harry Carroll, 1508 Woodrow St.  
Tallulah: E. O. Vaughn  
Ville Platte: F. Gaspard  
Winnsboro: C. C. Graves

## MAINE

Auburn: George Nichols, Jr., 7 Drummond St.  
Deane R. Quinton, 46 Lake St.  
Augusta: Robert H. Parker, Riverside Drive  
Bangor: William J. Gibbs, 16 Thirteenth St.  
Bar Harbor: Chester Sprague, 11 Oak St.  
Bath: J. Edward Pomeroy, 75½ Court St.  
Brooklin: Carleton F. Stewart  
Calais: John C. Reynolds, 22 Elm St.  
Damariscotta: Harold W. Castner, 147 Church St.  
Easton: Harry E. Gray  
Farmington Falls: Robert A. Crosswell  
Hallowell: Cecil C. Grimes, 340½ Water St.  
Hiram: Raymond C. Cotton  
Millinocket: Eugene H. Fairley, 185 Lincoln St.  
Portland: Winfield A. Ramsdell, 1188 Washington Ave.  
Presque Isle: W. S. Unger, 281 Main St.  
Topsham: Fred D. Armes, Box 113  
Waterville: Jasper L. Haines, 47 Boutelle Ave.

## MARYLAND

Annapolis: John L. Pancoast, 135 Spa View Ave.  
Chevy Chase: Roy C. Corderman, 4401 Leland St.  
Cumberland: Wilfred A. Thompson, 428 Baltimore Ave.  
Silver Spring: O. W. B. Reed, Jr., 10702 Lorain Ave.,  
Woodmoor

## MASSACHUSETTS

Allerton: Burgess H. Rudderham, 10 Alden Ave.  
Allston: Herbert C. Sturtevant, 41 Allston St.  
Amesbury: Alfred E. Kaskl, 12 Arlington St.  
Andover: C. Evans Fisher, 60 Haverhill St.  
Arlington: Donald F. Brown, 24 Pine Ridge Rd.  
Belmont: Leon C. Runey, 49 Fairmont St.  
Beverly: Robert S. Clark, 525 Cabot St.  
Boston: James O. Baker, 51 Hemenway St.  
Bridgewater: Carlton E. Peterson, 216 Plain St.  
Brookton: Mark L. MacAdam, 360 Oak St.  
Brookline: Charles L. Gagnebin, Jr., 7 Griggs Ter.  
Cambridge: Beatrice S. Holman, 26 Gray Gardens  
Canton: Frank E. Glennon, 20 Ponkapoag Way  
Chelmsford: Robert A. Wallace, Dalton Rd.  
Chelsea: James A. Ciarlone, 224 Vale St.  
Cohasset: Harold W. Taylor, E. Plain St.  
Cohasset: John M. Hunt, 264 Jerusalem Rd.  
Danvers: Robert Ling, 166 Locust St.  
Raymond B. Morrison, 12 Park St.  
Dedham: Wendell C. Phillips, 27 Court St.  
East Boston: Francis E. Gillespie, 595 Saratoga St.  
East Foxboro: Ernest L. Maxey, East St.  
Everett: Guy A. Bixby, Elsie St.  
Fall River: Wendall B. Sanford, 560 Walnut St.  
Falmouth: Robert G. Walden, 533 Palmer Ave.  
Fitchburg: Frederick M. Gibbs, 812 River St.  
Framingham: Daniel J. Giro, 216 Arlington St.  
Gloucester: Burr L. Town, 7 Hovey St.  
Great Barrington: Culver Dorsey, 1 Benton Ave.  
Harwich: Lawrence B. Robbins  
Haverhill: Richard Arnold, 3 Lockwood St.  
Holtbrook: Wm. O. Hocking, 19 Garfield Rd.  
Jamaica Plain: William E. Jones, 75 Williams St.  
Lakeville: Ettore Gola, Box 268, RFD 3  
Lawrence: Edward V. Krukonis, 196 West St.  
Lexington: Thomas McNamara, 7 Baker Ave.  
Lowell: Raymond O. Mulno, 94 Butman Rd.  
Lynn: Oscar F. Ireson, 255 Boston St.  
Lynnfield Center: Joseph P. Furrer, 511 Lowell St.  
Malden: W. E. Graham, 629 Main St.  
Manchester: Edward T. Maguire, 102 Pine St.

Mansfield: William E. Rider, Jr., 119 Central St.  
Marblehead: Samuel H. Bradish, 34 Russell St.  
Marshfield Hills: B. Merrill Kinsley, Prospect St.  
Melrose: Donald A. McBeth, 177 Lynn Falls Parkway  
Methuen: Henry J. Sevigny, 81 Pleasant St.  
Middleboro: John W. Nye, 23 Pearl St.  
Milton: P. C. Macdonald, Jr., 101 Emerson Rd.  
Nantucket: A. R. Bentley, 1-A Lily St.  
Natick: Edgar S. Parsons, 29 Pitts St.  
Needham: Carlton B. Goss, 595 Webster St.  
New Bedford: George W. Bartlett, 261 Whitman St.  
Newburyport: Clovis N. E. Fontaine, 384 High St.  
Newtonville: Robert L. Williams, 105 Harvard St.  
North Attleboro: Earl C. Batchelder, 537 N. Washington St.  
North Easton: Hollis M. French, 204 Main St.  
North Reading: Joseph H. Washburn, Box 64  
Northampton: George Phillips, 38 Ridgewood Ter.  
Norwood: Chester M. Capen, 22 Morse Ave.  
Peabody: Harold E. Baker, 9 Roycroft Rd.  
Pittsfield: Robert M. Stephens, 12 Marcella Ave.  
Provincetown: Joaquin T. Russe, 120 Commercial St.  
Reading: William A. MacKenzie, 236 High St.  
Revere: Raymond Minichiello, 37 Davis St.  
Rockland: Charles F. Loud, 46 Beals Court  
Salem: Clarence H. LeBrun, 401 Jefferson Ave.  
Saugus: Walter Hamilton, 76 Main St.  
Scituate: Herbert E. Cole, First Parish Rd.  
Earl F. Mott, 25 First Parish Rd.  
Sharon: George C. Wright, 7 S. Main St.  
Somerville: Louis H. Smith, 173 Pearl St.  
South Attleboro: Raymond S. Brown, 26 Rosewood Ave.  
South Walpole: Wilfred J. Sheehan, Box 13  
South Weymouth: Nathaniel M. Domy, 622 Main St.  
Edward Greenwood, 22 Fern Rd.  
Springfield: Louis A. Richmond, 1431 Plumtree Rd.  
Stoneham: Harry A. Gardner, 26 Hillside Ave.  
Carroll O. Peacor, 24 Governor Rd.  
Swampscott: Ralph E. Pierce, 18 Brooks Ter.  
Topsfield: Clarence J. Castle  
Vineyard Haven: Harold S. Lair  
Wakefield: Everett D. Whitney, 149 Salem St.  
Waltham: William A. True, 97 Myrtle St.  
Wareham: L. H. Manamon, Great Neck Rd.  
Watertown: Eunice Randall, 82 Edgewell Rd.  
Wellesley: Erving L. Crandell, 421 Weston Rd.  
Wenham: James D. Wiley, Cedar St.  
West Barnstable: Charles S. Crocker, Box 7  
West Medford: Gustave A. Jacobson, 65 Clewley Rd.  
West Roxbury: Herbert A. Beering, 291 Park St.  
Westfield: Percy C. Noble, 37 Broad St.  
Westford: Carl A. Chaplin, Jr., Leland Rd.  
Weston: Francis Blake, South Ave.  
Westwood: Hollis E. Polk, P. O. Box 81  
Winchester: Dwight B. Hill, 3 Parker Rd.  
Winthrop: Stewart S. Perry, 36 Pleasant St.  
Woburn: Dr. Sidney D. Adams, 10 Valley Rd.  
Wollaston: Walter Berthelsen, 3 Sherman St.  
Woods Hole: Royal S. Dagget  
Wrentham: Fred E. Gould, Pondville Hospital,

## MISSISSIPPI

Holly Bluff: William C. Sharbrough

## NEW HAMPSHIRE

Concord: Robert V. Byron, 12 Humphrey St.  
Littleton: Henry P. Davis, 14 Kilburn St.  
Newton Junction: Lloyd M. Currier

## NEW JERSEY

Belleville: Fred H. Yost, 42 Reservoir Pl.  
Bloomfield: Edward Laycock, 416 E. Passaic Ave.  
Clifton: Neil Bakker, 22 Elm St.  
Cranford: Carl A. Froebel, 700 Division Ave.  
East Orange: Harold R. Richman, 444 N. Maple Ave.  
East Paterson: John Stasinski, 189 Lincoln Ave.  
Elizabeth: John J. Vitale, 106 Orchard St.  
Hackensack: H. P. Gilbert, 89 Willow Ave.  
Ho-Ho-Kus: Chas. F. H. Johnson, Jr., Wearimus Rd.  
Kearny: Samuel Shaw, 529 Chestnut St.  
Kenilworth: Edward Berzin, 45-22nd St.  
New Brunswick: J. J. Boyce, Jr., 22 Seaman St.  
Newark: Barry Krasner, 112 Wilson Ave.  
Orange: Leo R. Scagliozzi, 192 Pierson St.  
Paterson: A. F. McDermott, 742 E. 26th St.  
Perth Amboy: Thos. A. Garretson, 105 State St.  
Plainfield: Joseph H. Harms, 15 Clinton Ter., RFD 2  
Pompton Lakes: George H. Schmitz, 6 Butler St.  
Red Bank: John M. Hollywood, 33 Peters Pl.  
Roselle: Frank Hatler, 421 E. 7th Ave.  
Rutherford: Thomas J. Lydon, 190 Mortimer Ave.

Somerville: William H. Coleman, RFD 3  
Trenton: Theodore Toretti, 11 Livingston St.  
Vineland: Norman Williams, 145 Montrose St.  
West End: Russ Conrow, 121 Cottage Pl.  
Westfield: M. P. Rehm, 205 Edgewood Ave.  
Woodbridge: Geo. Keith Rhodes, 82 Green St.

#### NEW YORK

Albany: Harry C. Condon, 122 Hollywood Ave.  
Amsterdam: Ward J. Hinkle, 68 Lincoln Ave.  
Batavia: Hobart R. Avery, Box 253  
Bath: Knight Hamilton, 110 W. Washington Ave.  
Bethpage: Victor L. Miller  
Binghamton: J. Caleb Phipps, 47 Haendel St.  
Bronx: Vincent T. Kenney, 3330 Fenton Ave.  
Brooklyn: Harold DeMyer, 367-95th St.  
R. E. Nebel, 1104 Lincoln Pl.  
David Talley, 130 Martense St.  
Caledonia: Sylvanus J. Macy, Jr., Quarry Rd.  
Farmingdale: Lt. G. Hellmuth, 63rd Pursuit Squadron, Box 463  
Glens Falls: Arthur A. Johnson, 28 Kensington Rd.  
Gloversville: L. W. Matteson  
Hamilton: H. S. Bradley  
Jamaica: Howard E. Smith, 171-34 119th Rd.  
Lockport: F. Floyd Ziehl  
Lowville: Rev. O. Theodore Anderson, 274 State St.  
New York City: J. L. Brill, 222 West 77th St.  
Ogdensburg: George R. Walsh, Box 113  
Oneida: Walter L. Babcock, 407 Sayles St.  
Port Jervis: Leslie Salisbury, 26 Brooklyn St.  
Poughkeepsie: Robert K. Wingood, 24 Prospect St.  
Riverhead: Gilbert E. Wickizer, 131 Brook St.  
Rochester: William Bellow, 186 Dorsey Rd.  
Rockaway Beach: George F. Gaynor, 212 Beach 117th St.  
Scottia: Lyle H. B. Peer, RD 2, Sacandaga Rd.  
Seneca Castle: G. E. King, Box 57  
Syracuse: Jerome Blaisdell, 5323 S. Salina St.  
Watertown: Elmer Soper, 417 S. Hamilton St.  
Wellsville: Edward McAuslan, RD 1

#### NORTH CAROLINA

Asheville: Cash Gregg, 51 Ramoth Rd.  
Charlotte: J. C. Geaslen, 110 N. Linwood Ave.

#### OREGON

Astoria: Hal C. McCracken  
Baker: John Woodhouse, 2515 7th St.  
Bend: Wendel R. Williams, 236 Lava Rd.  
Corvallis: D. B. Thompson, 539 N. 17th St.  
Enterprise: O. W. Castle  
Forest Grove: Leon McQuary, 206 S. E. 5th Ave.  
Freewater: Cliff Parr, RFD 1  
Grants Pass: Percy T. Booth, 902 K St.  
Heppner: Kenneth A. House  
Lakeview: William Bach  
McMinnville: Royal Mumford, 1031 Storey St.  
Marshfield: Earl B. Stillings, Rt. 2  
Pendleton: J. E. Roden, 519 N. W. 9th  
Portland: Virgil V. Cowan, 4205 S. W. Gabel Lane  
Prineville: Jerry Vergeer  
St. Helens: Richard Hald, 1221 Columbia Blvd.  
Salem: C. N. Olson, 2175 Ferry St.  
The Dalles: Lloyd Taylor, 325 Webster St.  
Tillamook: Paul H. Lewis

#### PENNSYLVANIA

Allentown: Don E. Wilbur, 406 S. 17th St.  
Ashland: Jack N. Weaver, 115 N. 14th St.  
Aspinwall: D. A. Bush, 214 Third St.  
Beaver Falls: Robert A. McClain, 816 Church St.  
Brackenridge: C. L. Gibson, 1062 Roup Ave.  
Chester: M. F. Wardell, 1427 Esrey St.  
Danville: S. Clifton Kindt, 435 Mill St.  
Downingtown: Robert P. Nick, 122 Webster Ave.  
Ebensburg: N. E. Gillin, R. 1, Penn Gables  
Erie: Robert T. Schlaudecker, 3110 Holland St.  
Export: David R. Lauffer, Pike St.  
Franklin: C. R. MacKay, 334 Liberty St.  
Greensburg: Kenneth Immel, 143 Stark Ave.  
Theresa McLaughlin, 131 Talbot Ave.  
Johnstown: G. V. Lichtenfels, RD 5, Sunset Ave.  
Kingston: Frank Meehan, 80 North Thomas Ave.  
Lancaster: Richard Spicer Wenger, 232 N. Mary St.  
Lawrence Park: John T. Krebs, 1043 Napier Ave.  
Lebanon: Lloyd W. Sherman, 508 N. 10th St.  
McKeesport: Andrew Salitros, 2906 Stewart Ave.  
Mohnton: James C. Mohr, 201 N. Church St.  
New Castle: C. A. Brown, 334 Boyles Ave.  
Northumberland: Wm. E. Miller, RD 1

Pittsburgh: G. M. Barker, 1440 Tolma Ave., Dormont  
Pittsburgh: Theodore V. Fabian, 3036 Churchview Ave.  
J. E. Wood, 1224 California Ave.  
St. Marys: H. J. Brock, 228 Church St.  
Skipppack: E. J. Kerns  
Smethport: F. H. Biever, 707 Water St.  
Uniontown: W. P. Holland, 75 McClellandtown Ave.  
Warren: H. L. Passenger, 105 S. Carver St.  
Washington: Wm. B. Marshman, 620 Beech St.  
West Middlesex: F. B. Phillips, RD 2  
York: Paul L. Stumpf, 1367 West Market St.

#### RHODE ISLAND

Anthony: Elmer A. Capwell, 474 Fairview Ave.  
East Greenwich: Vernon S. Allen, 36 Bayview Ave.  
East Providence: Robert E. Young, 15 Orlo Ave.  
Narragansett: Edgar F. Robinson, 30 Walnut St.  
Pawtucket: Albert Savage, 165 Mineral Spring Ave.  
Providence: Theodore Davis, 52 Staniford St.  
Walter B. Marshall, 257 Massachusetts Ave.  
Carlton R. Smith, 338 Adelaide Ave.  
Alphonse Tomaszewski, 118 Whittier Ave.  
Warren: Harold C. Bowen, Asylum Rd.  
Westerly: Myles W. Brennan, 15 Walnut St.

#### SOUTH CAROLINA

Aiken: F. E. Audrey, 715 Newberry St.  
Charleston: Harold Baumrind, 215 King St.  
J. R. Warner, RD 2, Box 52  
Columbia: J. R. Bouknight, 3715 Palmetto St.  
Dillon: Charles Furr, Box 424  
Florence: John G. Witherspoon, 401 S. Graham St.  
Fort Jackson: Sgt. Martin Hunsucker, Co. "B," 56th Signal Bn.  
Fort Moultrie: V. E. Howell  
Georgetown: Richard M. Callon, Black River, Rd.  
Graniteville: David H. Turner  
Greenville: L. D. Hunting, 20 Camp Rd.

#### SOUTH TEXAS

Alice: J. H. Strickland, M.D., P. O. Box 721  
Austin: Harold Callaway, 1920 Newning Ave.  
Beaumont: Garth L. Johnson, 1457 Ave. B  
Beeville: Thomas Hinton Marshall, 100 N. Jefferson  
Brownsville: Chas. F. Wilcox, 242 S. E. Jefferson  
College Station: Texas A. & M. Radio Club, E. E. Bldg.  
Cuere: Bernard B. Thorn, 601 E. Main  
Del Rio: James J. Fenner, Box 796  
Edinburg: Otto Uhrbrock, 721 W. McIntyre  
Edna: Henry N. Dittrich  
El Campo: James L. Hunter  
Fort Stockton: Billy F. Coates  
Galveston: F. Wm. Scharpwinkel, 2213 Ave. "K"  
Gonzales: Raymond V. Davis, Hotel Alcalde, 421 Darst  
Hallettsville: Steve J. Janak  
Harlingen: Joe Q. Handford, 501 E. Madison  
Hempstead: Boyd Sinclair, Box 126  
Houston: Thomas K. Dixon, Jr., 3805 Chevy Chase  
Kerrville: E. T. Butt, Box 569  
Kingsville: Bill Robey, 312 Doddridge St.  
Laredo: Coleman H. Darnell, Box 1213  
Lufkin: Robert L. Kurth, 403 Mantooth  
Marfa: John V. Leftwich, Hqrs. Ft. Russell  
Odessa: Bill Fizer, Box 1327  
Orange: Earl H. Boswell, 204 Bradford  
Fort Arthur: B. E. Emmons, 2610 12th  
Refugio: A. A. Cooper  
Rockspring: S. A. Worley, Box 265  
San Angelo: C. A. Murgatroyd, 1606 S. Van Buren  
San Antonio: Bill Case, 122 W. White Ave.  
San Marcos: W. V. Hearne, N.Y.A., S. W. Texas Teachers College  
Wharton: M. M. Walker

#### VIRGINIA

Clarksville: W. L. Snyder  
Martinsville: Eugene Minter  
Newport News: Walter G. Walker, 217 51st St.  
Richmond: R. N. Eubank, 1227 Windsor Ave., Bellevue  
Roanoke: E. E. Emswiler, Jr., 1408 Woodlawn Ave., Gr. Ct.  
Shenandoah: Charles C. Morrison, 511 Second St.

#### WASHINGTON

Aberdeen: F. W. Linklater, 414 North "H"  
Pomeroy: Bob Bennett, 387 Elm  
Seattle: O. T. D. Brandt, 7708 Latona Ave.  
A. D. Gunston, 7209 Wright Ave., S. W.  
Spokane: Erwin H. Schuler, 523 E. Everett Ave.  
Tacoma: A. E. Paul, 3110 S. 7th St.  
Walla Walla: W. Beale, Rt. 4

# AMATEUR ACTIVITIES

## ATLANTIC DIVISION

**E**ASTERN PENNSYLVANIA — SCM, Jerry Mathis, W3BES — Asst. SCM in chg of EC: W3DVC. Plenty of activity, but few reports. Therefore, I will list what Section news I have stumbled upon personally. We hear that ORS HQE is full lieutenant on a PT boat stationed in the Southeastern section of the country. IKW is RM1c at the Phila. Navy Yard under JLN/ZAE, 2JUJ, an old ORS, is in our Section now and is a captain in the Air Corps Communications. 3CHH is taking charge of an electronics laboratory in Wisconsin. ENX is at Troy, N. Y., working at electronics. GYV wrote a couple of swell letters from Ft. Blanding, where he is with the Ordnance Dept. GML is now an ensign. DPU received his commission as captain in the Air Corps Communications and has left for Washington, D. C. The Navy League Service is training women radio operators. HFD, FLH and BES wired up their very elaborate code practice table, as per the Defense Handbook circuit, for 25 positions. Walter Faries, winner of the Cairo Survey award, is doing the instruction. HTG has had two tankers sunk under him to date and is back for more. HJE is now staff sgt. with the medical corps in the X-ray dept. FRY is building gunnery trainers and pilot trainers for the Navy. GHM is building an all-band 'phone, c.w. and i.c.w. transmitter for the Frankford Radio Club to go with their emergency power plants for a complete emergency setup. The West Philly Club is training radio operators for ham tickets, including a flock of gals. HIO gave an interesting demonstration of talking on a light beam at the York Road Radio Club meeting. GGC has a 6L6 modulated on 160 kc. wired wireless. BXE, who is now with Sperry, attended CHH's farewell party. The U. of P. recently dedicated the world's largest radiographic installation, the construction of which was accomplished in no small way by HXA and HJE. ILK and FLH are air raid wardens. FQG is in secret war work at Philco. GKO and IJN are working on gov't equipment at the same place. JBC is helping FRY make midget a.c.-d.c. transmitters in conjunction with a Navy training project. GQW is at the Signal Corps depot and expects to go into foreign service soon. HXX is building a new modulator and fixing up his various rigs for action.

**MARYLAND-DELAWARE-DISTRICT OF COLUMBIA** — SCM, Hermann E. Hobbs, W3CIZ — W3CDQ is teaching code at Women's Defense School. Mr. Samuel O. Fishlyr has recently joined ARRL and is desirous of becoming acquainted with local hams; present address 1106 Hurley Wright Bldg., Washington, D. C. The Western Maryland Amateur Radio Club has moved from the Public Safety Building to the State Armory where a code instruction table has been set up and classes are going along without an interruption. 40 are in 4 classes weekly. OL is chief instructor with ON, FQL, GME, ECU, JCR, GUT, BWV assisting. The Argument Radio Club is suspending meetings indefinitely because of gas and tire rationing. JHM, president and manager of local broadcasting station and popular amateur was killed in an airplane crash. BWV is playing with phono-amplifiers since he cannot touch his rig. ON tried out carrier-current. OL, JNA and DIC are members of the State Guard. IXP and GUT are fiddling with home movies. AXP is now 1st lieutenant in Air Corps. AQV's XYL is student in one of the club's code classes.

**SOUTHERN NEW JERSEY** — SCM, Lester H. Allen, W3CCO — Asst. SCM: W3ZI. The South Jersey Radio Association is continuing their program on emergency defense work. Members and friends of the DVRA will participate in a small picnic on the second Sunday of August. EBA and JRG are new members in the Civilian Defense Emergency Corps. BAQ has just returned from Chicago. GNM is attending the medical school at Fort Sam Houston. GCU is doing a fine job as Editor of the DVRA News.

GRW has returned home for a few days after riding the high seas as radio operator for our Merchant Marine. GNU is now at Fort Monmouth as a radio engineer. FFE graduated from the University of Pennsylvania. JJX and EEQ are studying at Endicott, N. Y. IDY and AWL are out Long Island way looking into aviation radio. HCL and HAZ have been assigned as permanent instructors in the Signal Corps. EA2JJ is staying in Trenton for a short business trip. HPE has signed up with the Navy in their radiolocator service. ATF is now connected with the Marine Corps.

**WESTERN NEW YORK** — SCM, Fred Chichester, W8PLA — W8SBV is working in the control room of WENY, Elmira. TXB and his xyl WOW are the proud parents of an 8 lb., 11 oz. jr. op. RTW now has the Elmira police radio installed and working fine. He also just finished installing the police radio at Bath, N. Y. The Elmira station, WBLL, is on 33,500 kc., and the Bath station, WEJZ, is on 37,000, both f.m. VNQ and VPN have received their class A tickets. Geo. Bates, W8GPF, an old-timer on 40 and 80 meters, died Sunday, April 12th. SVC has accepted a position with Pan American Airways, Inc., and is stationed in Miami. RLI has just received his QSL from KC4USC. ELK is teaching a radio course in Bolivar. JZT is teaching the government-sponsored course in radio at Alfred University. STD reports that the Central New York Radio Club code classes are progressing rapidly. TJK is now in the Signal Corps school at Camp Crowder, Mo. OYJ, formerly of Ogdensburg, has changed his QTH to Syracuse. WNY news items had to be left out of the last issue of QST because the few items sent in were received after the deadline which is the 20th of the month. What say, fellows?

**WESTERN PENNSYLVANIA** — SCM, E. A. Krall, W8CKO — Asst. SCM in charge of EC, W8AVY, W8TTD has not had much activity in the past month, but is still going strong with the radio classes at Greensburg. Mac, VYU, wishes to state she is a high school YL and not an XYL as represented in this writup two issues ago. HWK is in DuBois as op at WCED. QVP is a corporal in the Signal Corps at Camp Croft, S. C. QAN is with the 59th Air Base Squadron at Keesler Field, Miss. FB, OM, EVE and ASV are in the Navy. MJF is married. OLM is a radio instructor at Camp Croft. UIN is in the Army and KBQ in the Signal Corps. RUD and TGP are experimenting with wired wireless. We are desirous of hearing from the boys at camp, where they are and what they are doing and whether or not their amateur experience has helped them with their duties.

## CENTRAL DIVISION

**ILLINOIS** — SCM, Mrs. Carrie Jones, W9ILH — IHN, DBO, HUX and QWM have taken jobs with the FCC and are staying in Mich. The Joliet Amateur Radio Society has started a class on code and theory, making use of the ARRL plan. The code class conducted by the Elgin Radio Club at the high school has come to a close with 21 persons out of 36 qualifying for their code certificates at 13 w.p.m. OXA is now a lt. in the Air Corps and is instructing flyers. The Cahokia Amateur Radio Club has decided to invest their funds in War Bonds and have started with buying a \$100.00 bond. HQH has built a recorder and is making records to occupy his spare time. JVC is a radio technician in the armored division and from last reports was in Ky. ZEN has joined the Coast Guard. The Kankakee County Radio Club has taken steps toward ascertaining equipment needed for thorough civilian defense. It is working on plans for establishment of radio theory and code classes on the ARRL plan. QLZ spends three evenings a week teaching an E.S.M.D.T. class at LaSalle and one evening a week teaching a code class at Peru. The Starved Rock Radio Club is going out on Field Day this year — just for fun. IBC, 1st lt. AAF, is now at Mitchel Field.

**INDIANA** — SCM, LeRoy T. Waggoner, W9YMV — A Defense Communications Coördinator has been appointed by the State Defense Council and a working plan has been devised by Arnet A. Curry, Chief Coördinator, and approved by the Advisory Committee, on which your SCM serves to represent amateur radio. This plan will utilize the facilities of our state organization. There are several vacancies for appointments as ECs. If your community is without a properly appointed Emergency Coördinator, please

drop me a card offering your services or recommending someone for the job. AB, with BJT and ONB, are on the lines with wired wireless with results not too good. VOA is leaving for a job with the Signal Corps. HUV received QSL card from IU as a surprise reminder of better days. NXU is flying in Mississippi. QG/UHH is now Corps Area Radio Aide, 5th Corps Area. QLW is inspector for USN in Indianapolis. Evansville now needs someone to fill Cart's shoes as EC. Applications, please! AXV is new instructor for NYA at Evansville. GKA has motion picture equipment job at Toledo, Ohio. EHU is civilian radio technician with the Army at Lexington, Ky. PWB has been transferred to Louisville by Eastern Airlines. The Indiana gang has lost a swell fellow and a good friend in the death of Harry Simpson, W9CCG. CPZ is teaching code and theory at Francesville in connection with classes sponsored by the local school. GOU with LZP, RZS and Doc. Lucas have formed a new club at Delphi known as the Oracle Radio Club. The new club has been teaching a code class two nights a week, using the American Legion rooms. BXT is radio operator aboard an Army transport somewhere on the seven seas. NVA says the code class attendance is holding up well at Richmond. The Fort Wayne Radio Club has a hundred hams in the defense setup who are well organized and raring to go. In addition, the club has been conducting Code & Theory classes. KBL has left for Newark, N. J., to work on building radio equipment for the armed services. HNH enlisted in the Signal Corps and is now stationed at Camp Crowder. MVZ finished his low freq. converter and is planning to experiment with wired wireless with MBM. SVZ is with the Army. HZY is in radiolocator work with the Navy. TIY is radio operator for FCC at Hawaiian Islands. GHZ works in Civil Service. HAI was married recently and immediately sent out for overseas. WXG is schooling in Utah for the Navy. PQL is in Services in California. EFG and ZLJ are in the Army. JIM is now in Bloomington. JBN has 600 watt gasoline driven a.c. generator built and in working order for any emergency work. CZD and LPQ have 2½ meter gear all ready to go. HDB is communications officer in Civil Air Patrol as well as radio control of his county and EC of Valparaiso. EMQ has 2½ meter jobs and one 160 and 75 meter rig built in compact case for emergency work. TRN advises that the Goshen Amateur Radio Club has a defense radio school going with over 40 students. DNQ is now stationed with the Medical Corps at Camp Robinson, Ark. Efforts are being made to have Bob transferred to the Signal Corps. DAG has been appointed to the Lexington Signal Depot for training. NNA, stationed at Jackson Barracks, New Orleans, was married April 8. OEK entrained April 9th for service with the U. S. Marines at San Diego. CYQ is serving on a unit board of the WPB in Washington. NZH has just completed teaching a class in radio engineering attended by several hams. YQB attends Navy radio school. FDS is in civil service in New Jersey. W9BDL in Texas. DUT is proud papa of Junior op. RHL is working in Chicago. KQV is now located at Crown Point. Keep up the good work, gang, and let the reports flow in! Keep your weather eye open for new EC candidates. 73.

MICHIGAN — SCM, Harold C. Bird, W8DPE — VQN reports code and theory class coming along very well. They are also trying for a hookup with city police. UCG says some of the gang is with the armed forces. DAQ, VQN, EXJ, WAK, UCG, NZU, NWU and MRK are keeping the club going. FX says wired wireless is receiving lots of attention. ABH reports a junior operator at his house. NOH played around with earth current transmission and reports fairly good results although quite a bit of QRM. Very sorry to report the death of Alvah (BIZ) Bissonette. The Lansing gang gave a picnic on May 24th. The hamfest was a fair success with an attendance of 312. Elwood Ryan, northwestern Detroit EC, has gone with the Signal Corp. Muskegon EC reports theory and code class coming along very well and a possibility of a tie-up with the local police. Get your reports in before May 20th. 73. — Hal.

OHIO — SCM, E. H. Gibbs, W8AQ — Plans are under way for the Dayton group to apply for a number of station licenses for operation under the police dept. Dayton's code classes have 155 students still sticking, out of an original enrollment of 195. FB. Walnut Hills High School club of

Cinci has 11 members enrolled in code classes. Since his graduation from Gallups Island last February 8TWP has been an op in the Maritime Service and drops a line from South America. TYH has been taking a radio technology course at Baldwin-Wallace and is acting as code instructor to the class. GMI was transferred to the naval station at Stillwater, Okla. Let's hear from more of the gang, individuals and clubs so that this column can serve its intended purpose. 73.

WISCONSIN — SCM, Walter Wallace, W9EYH — HMO is code instructor at Naval Radio Training School in Madison. KFB is now an instructor in the Air Corps Technical School at Scott Field. ATL visited NJU, YL ham at Watertown. Mickey is teaching classes in theory and code every Monday night. Her brother, NJT, is radioman second class. LXR has moved to St. Louis Park. We also lose DTE, EC for Kenosha, who leaves the state for a new job. Yours truly also finds it necessary because of new job outside of state to resign as SCM. Thanks for your cooperation fellows and hope we can all meet over the air again some day. Please forward your monthly reports to Emil Felber, Jr., W9RH, who will serve as Acting SCM. 73.

#### DAKOTA DIVISION

NORTH DAKOTA — Acting SCM, John W. McBride, W9YVF — Our regular SCM, W9RPH, is with Army Signal Corp at Omaha. MCV is also at Omaha. YOY and UGC are leaving for Omaha May 15th. QGM is radio technician at Army Depot, Ogden, Utah. BMR at Wahpeton has been doing his bit by teaching two radio classes at State School of Science with 22 students in each class. 16 of his "Grads" have been accepted by N.W. Air Lines and 2 have gone to Signal Corps at Omaha. DNI has signed up with our Navy and will leave as soon as graduation from high school. PQW was with Northwest Air Lines in Yukon Valley but has been transferred to Edmonton where he will be joined by YOO the 15th of this month.

SOUTH DAKOTA — SCM, Ernest C. Mohler, W9ADJ — The gang at Yankton is conducting code classes with ex-DUT as instructor, and two have already received their 30 w.p.m. certificates. YFR just received his ticket before that fateful day and is now experimenting with wired wireless. JMO wants someone to tell him how to get through the line transformers. YFR is using a toy balloon filled with hydrogen to support a light for communication. YOB has been conducting CAF classes for radio telephone third class examinations, and has made arrangements with the RI to have the examination conducted at Rapid City. BLK has accepted a job with the FCC. HYH is moving to Chayenne. Your next report will be from the new SCM, Phil Schultz, W9QVY. Phil is a swell guy and is well known throughout the state. Let's all make it a point to send Phil a report each month on all our activities so that he will have something to work on. You've been a swell gang to work with and I wish to thank you one and all for your cooperation, and "I'll be seein' ya." 73 — Clyde.

NORTHERN MINNESOTA — SCM, Armond D. Brattland, W9FUZ — This SCM is getting the bug to go into full-time service. However, I shall keep writing the monthly reports and make a stab at keeping our gang informed. All mail addressed to me at Bemidji, Minnesota, will be promptly forwarded. Be sure and read page 64 of the May issue, again, which advises members what to report. Any reports not reaching the SCM before the 20th of each month will not be in time. YEQ, who is now teaching at NYA Radio School in Duluth, dropped in for a visit with FUZ. KRG and QCP left for training at Grand Island. KQA has built a code oscillator with pair of 76's and is gradually increasing his code class. The code and theory class of Bemidji Club has moved its equipment to the armory and the club is growing with members from the Minnesota State Guard and Civil Air Patrol participating. FUZ, having received a lieutenant's commission as Communications Officer of C.A.P., is still acting as instructor. Wally Lamb of Thief River Falls has his operator's license and reports YKV back at Holt. Again attention is called to code sessions of St. Paul Radio Club as set forth in last report. Your club or individual efforts might make use of it to attract interested code students. 9:30 A.M. on KSTP each Sunday. 73 and luck. — Army.

**SOUTHERN MINNESOTA** — SCM, Millard L. Bender, W9YNQ — The Jackson County Radio Club has added theory to its code instruction classes. IYJ is leaving Jackson for an electric welder's job in Michigan. HCC is in the Air Corps. Ex-YL KOB is in the hospital undergoing a serious operation. Get the news in by the 15th of the month. *QST* being a technical magazine, the copy has to be sent to Washington to be "reviewed," before it can be printed. KUI, a staff sergeant now, was home for ten days in May. YZW is in the engineers at Camp Robinson at last reports. OMC is an operator in the Air Corps located in Alaska. By the time this goes to print ZSX will be in South America with American Air Lines. 73. — Millard.

#### DELTA DIVISION

**LOUISIANA** — SCM, W. J. Wilkinson, Jr., W5DWW — W5HEJ-HEK are with War Department in Atlanta. DXL has enlisted in Army Air Corps. HUY is leaving for Atlanta and radio job soon. INN is studying Radar in Navy. More info can be used on those leaving for service. Let the SCM know where you go, branch of service, etc.

**TENNESSEE** — SCM, M. G. Hooper, W4DDJ — Biggest news is a letter from Owen J. McReynolds, W4DPS, Pres. TVRA of Knoxville, Tenn., containing the ARRL Emergency Corps Civilian Defense registrations of George Burne Smith, W4FRR; Henry S. Bowling, Jr., W4EDG; Ray C. Evans, W4HDP; J. David Bowman, W4GWV and himself. The Nashville Amateur Radio Club members have had both code and technical instruction. J. A. Rogers, Jr., passed his code test and stood examination last week.

#### MIDWEST DIVISION

**IOWA** — Acting SCM, L. B. Vennard, W9PJR — EFI has seven students in the 15-w.p.m. class and expects to start a class at Harlan soon. WML, Newton Radio Club, is still teaching code and theory to help the boys when called for service. NKC has his 2½-meter rig ready for service and would like to test it. SVI and ACL are both on watch for Uncle Sam and the hours are bad. CCY reports from Alabama this month doing maintenance work for government and was glad he had been a ham as he didn't get any government training. ZQW has joined the Navy Radar and is now RM2c and likes it fine.

**KANSAS** — SCM, Alvin B. Unruh, W9AWP — W9KXB, Topeka, has been appointed Civil Air Patrol communications officer for the second squadron. He reports OZF has gone to Omaha for Uncle Sam. ZAT joined Signal Corps and left for Omaha. GPR is now reported working in a K.C., Kansas defense plant. W9MAE reports RXK and OSJ have been ill with operation and flu, respectively. KXL is now with Uncle Sam's forces. NNU is instructor for N.Y.A. OOU reports that ZGB was back in Emporia for a few days on leave from Navy, and IZJ was also home on furlough. NSZ is working for KTSW. WPN should be added to list of those going to Omaha for radio job. A special meeting of members of the Tri-City Radio Club and their families was held at home of OSY who is entering the armed forces. CPY reports that a big feed was enjoyed by all present. 73 — Abie.

**MISSOURI** — Acting SCM, Wm. G. Skinker, W9AEJ — W9BQZ has completed construction of 112 Mc. equipment, capable of either 110-v. a.c. or 6-v. d.c. operation. YHZ and TTP have succeeded in working ¼ mile with the new wire-wireless using only 12 watts. After a few more tests they expect to increase this range considerably. With less success, they have also been experimenting with earth currents and audio induction. UAM has joined the Emergency Corps. The Sedalia Amateur Radio Plug has organized a code class with 28 enrolled. Theory will be added to the itinerary later. DBD and PFO teach code in A.W.V.S. classes in St. Louis. EZX gives the ladies their theory coaching. Letha Allendorf, SCM from 1937 to 1941, has offered to handle the job again until a new permanent SCM is elected. Send Letha your reports next month. See page four for her address. 73 — Bill.

#### NEW ENGLAND DIVISION

**CONNECTICUT** — SCM, Edmund R. Fraser, W1KQY — Our deepest sympathy to WINRR whose Dad passed away recently. CTT reports the following activities for the Conn. Brasspounders Ass'n: 3A0H/1 who has been

conducting theory classes at CBA and in Bridgeport has accepted a govt. position in Boston. Messrs. Simpson and Henrickson have taken over the theory class at CBA. ATH, Secy. of NHARA, reports the loss of another club member, AMM, who has accepted a Civil Service position in Boston. A Wednesday code class consisting of 15 YL's conducted by AGT is in its third week. UE has been transferred from the U. S. Naval Radio School, Noroton Heights, to Washington, D. C. GC is cooperating with the Civil Aeronautics Patrol in New Haven and vicinity. KKS now working for FCC. NJB is Radio Technician in the Army. FOU was raised to the rank of Major and is in the Air Corp Communications Hdqrs at Wash'n. LMK is in the radio section of Pratt and Whitney Aircraft plant. Your SCM has a letter on file from LFK formerly of North Haven now in the Army at Westover Field. He writes, "The set-up is very interesting. I am one ham who likes the Army because I am doing the work I love."

**MAINE** — SCM, Ames R. Millett, WIBAV — MDS is rank of a Sergeant. The PAWA code and theory class is receiving excellent instruction from Ray Rogers and Phil McCrum. GXY is still at his old job in Bath. CRU is now employed at WGAN. DEO has a recent addition to the family. ANQ, AWT, GKJ and KAD are all at the shipyard in South Portland. MXQ is now a service man with Cressey and Allen Portland. LOA is taking a job with the Signal Corps along with LNI, both in a civilian status. LOA is building another wired wireless oscillator.

**EASTERN MASSACHUSETTS** — SCM, Frank L. Baker, Jr., W1ALP — This last month quite a few more meetings have been held, to talk over plans for the job that the hams can do to help in an emergency. In Quincy a meeting was held of all the cities and towns that come under District Warning Center D in Region 5. Present were EC's IHA, FWS, MON, JXH, EAU, CCL and JCX. One of the EC's was not known by the communications officer in his own town. I think that all EC's should get in touch with the one in charge in his own town. NBC now has his Class A. LEJ and LTR joined the Naval Reserve. MME is also reported as joining the Navy. We also learn of the death of DQD. JOY and MIF are with Signal Corp as radio technicians. Luck to you fellows. The Quincy hams also had a meeting of their own with 17 showing up. A meeting was held in Malden, also one in Reading. The Yankee Radio Club is now holding monthly meetings on the second Thursday of each month. We recently met our old friend George Bailey, KH, in Boston, and despite all the jobs and work and meetings that he has to attend, he looked as though he was in pretty good condition.

**NEW HAMPSHIRE** — SCM, Mrs. Dorothy W. Evans, W1FTJ — BFT was home on leave from active duty with the U. S. Navy recently. AOQ now has his Class A ticket. KMH is considering going into Civil Service work. JDP and XYL MWI are now located down in New Jersey. CMR has accepted a position with Pan-American Airways. KYG is now connected with the FCC. All the N. H. Section mourns the passing of FFZ.

**RHODE ISLAND** — SCM, Clayton C. Gordon, W1HRC — The Westerly Radio Club held its annual "Open House" on April 11th. KRQ has hit the Civil Service jack-pot for a job in Maine and is taking on an XYL. MAE and INN have been appointed assistant ECs in Westerly area. BEH reports organization of the Green Witch Radio Club. This club has already organized radio theory and code classes which meet every Wednesday. CJH is experimenting with wired wireless. NCX is trying his luck with earth current communication.

**VERMONT** — SCM, Clifton G. Parker, W1KJG — General plans are being talked over by the Burlington and Barre gangs for an outing to be held at some central point for amateurs and their families. More details will be available for next month's report. GAE/7 has received a promotion to Aircraft Communicator and has been transferred to Boise, Idaho. His mail address is 3117 4th Ave., South, and imagine Jim would like to hear from the gang. FSV has an operating job at Derby Line. Visitors at your SCM's during the past month were MMU, IDM, JVS, JRU and IQG. MVX is acting as substitute nurse at the Brattleboro Hospital. AZV and MKM are busy with work at an air raid observation post, MKM is filing in any spare hours as a

police photographer and AZV as an air raid warden. LYD reports interesting work with the Army.

#### NORTHWESTERN DIVISION

**IDAHO** — Acting SCM, Don D. Oberbillig, W7AVP — W7EES spent vacation in Boise. He is NBC remote engineer in San Francisco. Al Barnard, former W7, is installation engineer for Navy Dept. BMF spent leave in Boise. He is a radioman in Navy. 9SKY is at Gowen Field, Boise. Tommy Jeo, ex-IQC, is attending radio school at Ft. Monmouth as is EFR. NH is attending radio engineering class in Twin Falls. BCU of Jerome is now at Gowen Field sub-depot in radio work. 2MNZ is also located at Gowen Field.

**MONTANA** — SCM, R. Rex Roberts, W7CPY — BXL, DSS, HEM and D. A. Johnson taking turns giving the theory instructions for Electric City Radio Club. DXQ is vacationing, finishing his new home and grounds for a rest. AST is with the Alaskan Communications. BHB took examinations in Billings for commercial license.

**OREGON** — SCM, Carl Austin, W7GNJ — My apologies, fellows, guess I am slipping, to have missed last month. Our old reliable EC, FNS, is now a first lt. in the Army, leaving vacancy at the moment. QP is a chief electrician now. IDJ, BDE, IBY and GTV are also now in the services. HSL, DZT, HJX and IKK are in Radar. The Central Oregon Radio Klub has sent three men to the Navy, and have more coming up soon. Thirteen ARRL memberships were sent in last month from the C.O.R.K. The club had built a small experimental transmitter, and the members have received actual tuning and neutralizing experience. Some work was done with wired wireless, and the blinker system. Demonstrations of UHF (with dummy ant) have been given, and we hope soon to have some real operating. BGM has left for Schenectady, and will report from there later. It is rumored that BS will soon be with the Navy.

#### PACIFIC DIVISION

**SANTA CLARA VALLEY** — SCM, Earl F. Sanderson, W6IUZ — RM: 6LLW. YU visited the new NBC building in S. F. on April 10th. The club is also planning a week-end field trip to take the place of the ARRL Field Day. TYT is in the Navy. SSA, now temporarily at Ft. Lupton, Colo., is helping 9RGX and 9TX at Brighton give code and theory classes. BNQ is in Army Radio Intelligence Co. at Fort Ord. BUM will soon be in the Navy with a commission. PH is with FBI. LUM is one of the operators of KQCO, Salinas-Monterey police radio station. QNK, LLW, PH and LUM are on both Civilian Defense Council and Red Cross Disaster Committees on radio communications. NHH has joined the: Kaar Engineering Co. staff as asst. manager. Regretfully report OTX listed missing on active duty with the Navy. Wilbur was Secy.-Treas. of the Palo Alto Club for a number of years and very active in amateur radio. DTA is working in shipyards. TGH is now at Eimac. Best of luck, and BCNU. — Sandy.

**EAST BAY** — SCM, Horace R. Greer, W6TI — On May 20th, at the Hotel Leamington, Oakland, Calif., the ARRL East Bay Section Meeting had its regular monthly meeting. The following were present: AUG, UFD, RMM, RJY, SEW, QDE, THO, KGF, HGM, HS, TT, EY, QAZ, UHM, KTI, ACF and Jr. op., MPZ, JJB, TI, JEE, 2ALB and L. Kelsey. Plan on being present at these meetings as everyone is invited. Received a letter from LJC who is now in the service. He says the Navy will immediately classify a ham as RM2c, which is doing right well. Please send in all the dope you can on the gang in the service. 73. — TI.

**SAN JOAQUIN VALLEY** — SCM, Antone J. Silva, W6QDT — Our ex-SCM PPO is in Portland now. WA is now instructor in radio at Army Air Corps School. EJD is holding down a job as chief engineer of KMJ, succeeding WA. KUT, ex-SCM, is now lieut. with electronics group, Signal Corps. HYG, just recently married, has been accepted for officer training at Air Corps Radio School. LJE and PCS are in the Air Corps. JPU, the u.h.f. wizard, is now RM2c and is attending Navy Radar School. RIC has just been commissioned 1st lieut. Air Corps, but unable to report for active duty due to broken leg. LFR is experimenting with gas-powered model planes. ONO is in the Army Signal Corps. RFO is RM2c in the Navy. GFB has been

teaching mechanics at a local high school. MIW is experimenting with audio amplifiers. FKL has moved to Fresno and is now employed at station KFRE. BIL and BIJ are now employed at station KADJ. UAJ is radio operator in the Navy now. BXB has been teaching code to a group of beginners three nights weekly.

#### ROANOKE DIVISION

**WEST VIRGINIA** — SCM, Kenneth M. Zinn, W8JRL — Mr. Edgar Christopher, civilian defense coordinator of communications for Logan and TZT, also of Logan, held a meeting of all active amateurs and made plans for civilian defense operations. The following amateurs attended, WAT, ELJ, VGF, VQV, LSX, KHB and TZT. They also have started a code school sponsored by the Logan Radio Club and had 20 to enroll the first night. Hats off to VXO in South Charleston for the way he, with the help of Miss Bessie Allen, is handling their code class. UDJ is a lieutenant in the Air Corps in the Canal Zone. GWE joined the Navy Department in radio maintenance. UGH is chairman of the Berkeley County defense organization. UAD is a student at West Virginia University. PAJ is now an ensign in the Navy. Fayette Radio Club has a radio theory and code class with 53 enrolled. AHZ is instructor, assisted by H. H. Legg, USO is now service man with Triangle Electric Co. UFT is working in Norfolk, Va. VEU is working in Alley, W. Va. USO and ULU have built a code oscillator to keep their fists in shape. AHZ and USO are experimenting with wired wireless. MARA, instead of holding field day this year, is going to have a good old-fashioned picnic, with XYL's and YL's attending. ONP is working in Norfolk shipyard. EP is working at Morgantown. NIY is teaching radio in NYA school at Arthurdale. NTV is building measuring equipment. KXV is pounding brass about 12 hours a day for the railroad co. The code classes in W. Va., I think, will equal those of any state in the Union. Keep up the good work.

#### ROCKY MOUNTAIN DIVISION

**COLORADO** — SCM, Stephen L. Fitzpatrick, W9CNL — The Denver Area Radio Club Council is starting code classes in local schools 7:30 p.m. to 9 p.m. Monday, Tuesday, Wednesday and Thursday each week with ACB, BQO, CAA, CNL, IDB, TFP, TRR, VIK, VTK and WYX acting as instructors. The ARRL code instructor's guide is being followed. RXM is conducting a ladies' code class of 28 at East High. TFP says the convention tickets are \$3.00. See convention notice elsewhere in this issue. BQO had a chance to help the Army with his 2½ meter rig, but they fixed the break before he arrived. TFP lost his 40-foot tower in a windstorm April 30th. Members of the Associated Amateur Radio Operators of Denver and Electron Clubs have organized a first aid class. MGX visited the AAROD at their last meeting. BQO is proud father of a new daughter. HYN has gone to the Army. YKP is attending a radio class at D. U. OWP is instructing a small group at Windsor, Colorado in theory for Navy examination. CAA is busy with the work as Director for the Rocky Mountain Division of the ARRL. HCP is at the Radar School in Lexington. YCD is home on 10-day furlough. EHC has moved to Layton, Utah. GK of Kansas and ADV were visitors at CDP. CND is reported in the Army. Hamfest held on April 25, 1942, in Denver, Colorado, and sponsored by the Electron Club was enjoyed by all. W9KHQ, Orval Cunningham, Acting SCM, did a fine job, and I wish to extend to him our thanks and appreciation. The AAROD are working hard on plans for the Rocky Mountain Division Convention. Hope to see you all there. 73, till next month. — Stephen, W9CNL.

**UTAH-WYOMING** — SCM, Henry L. Schroeder, W7GZG — Time was when a fellow could get all kinds of dope for QST by spending an evening or two on the 80- and 160-meter bands, but we have to rely on the U. S. mail now, so how's about it? Mail all dope by the 15th. One bit of news is that 7HZI graduated from high school this spring and is lined up for a job with KFBC during the summer months. 7GRL has been sojourning in Kansas for the past month. The gang at Laramie had their meeting with Director Stedman all arranged, but the ol' wx stepped in and changed everything with roads practically in passable for the day. 73. — Hank, W7GZG.

(Continued on page 78)



LAST MONTH we talked about low frequency inductances made from junk box parts and what-have-you. We mentioned that they could be used in filters, but did not say what an amateur could use filters for. Even though it is pretty much old stuff, we have not seen much dope on audio filters in amateur work, so we are going to tell a little about it here.

An audio filter of the low pass type is particularly effective in receiving CW signals, because it provides an excellent AVC as well as reducing background noise and making the signal cleaner. Since the regular AVC does not work on CW, this feature is very nice.

The AVC works this way. If the receiver is overloaded, it delivers very nearly its maximum output signal. A further increase in input will result in more harmonics, but the fundamental will remain about the same. This is an excellent AVC characteristic, but the extreme distortion prevents it from being a useful method under ordinary conditions.

However, this distortion can be eliminated by using a low-pass filter. If the harmonics are rejected, the signal will be a pure sine wave regardless of the overloading. If the CW tone is adjusted to 500 cycles, for instance, there will be no harmonics lower than 1000 cycles. Therefore a low-pass filter cutting off sharply at 800 cycles will allow only a pure sine wave tone to pass.

In addition to making this AVC action possible, a good filter will provide a cleaner signal, because it removes background noise, heterodyne whistles and the like. All things considered, the results are quite spectacular considering the simple equipment required.

It is undesirable to put power through the filter, so it should be located ahead of the output tubes. It should be followed by an audio gain control so that there will be some way of adjusting volume. We will not give any design data here on the actual filter itself, because this can be found in any good textbook. We recommend Smith's "Simplified Filter Design," published RCA Institute Technical Press, New York City. Please do not write us for a copy, because we do not sell them.

A filter is not much help on phone, due to the wide frequency range of the signal. When speech is being received, a restricted frequency range can be used to advantage, but a sharp cut-off is not needed for this purpose. If the receiver has a good tone control, this will serve adequately, and no special equipment is needed.

DANA BACON



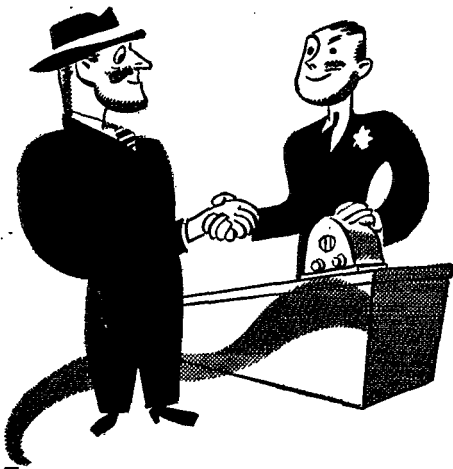

# A Fair Sales-Policy

In the bargain-trays of radio stores, there is one make that is conspicuous by its absence . . . Mallory. There are good reasons why Mallory products are not offered at ridiculously low prices.

Mallory Approved Precision Products have always been built up to quality and not down to price. Quality in the materials used. Quality in their fabrication into radio parts. Quality in their inspection.

We believe our sales-policy is a fair one. It is based on high quality without the penalty of high price. The maintenance of this quality costs Mallory real money, but it is your assurance of dependability.

**P. R. MALLORY & CO., Inc.**  
INDIANAPOLIS INDIANA  
Cable Address — PELMALLO

Use

**P. R. MALLORY & CO. Inc.**

# MALLORY

APPROVED  
PRECISION PRODUCTS

## SOUTHEASTERN DIVISION

**ALABAMA** — Acting SCM, Larry Smyth, W4GBV — W4CIU has built a 2½-meter oscillator that puts out enough soup to "raise a blister." GYX has been on a radio job for Uncle Sam since last fall and is in Texas. IBH is taking Civil Service radio training in Atlanta. GFQ is in radio training in the Navy. IHA has finished a radio course in the Navy. Many Montgomerians, including hams, are taking advantage of the defense radio classes being taught. DPX really knows how to put the "info" across. Along with the technical part they are also teaching code. Let one of your daily good turns be a report for QST. Thanks and 73 — Larry.

**WESTERN FLORIDA** — SCM, Oscar Cedestrom, W4AXP — W4ECT and FJR are the proud parents of a baby boy which arrived April 16th. Rich has been promoted to assistant monitoring officer at Marietta. Congrats. HJA is now at Naval Air Station at Pensacola. He paid a visit to AXP. Luther and some of the gang are thinking strongly of using 110 a.c. lines for QSOs around town. MS is also interested so let's get together on it. Eddie says let's arrange a ham meeting some night. We should meet regularly and discuss things. 1KKA visited Eddie this month. EQR has his rig nearly done. DAO, MS, EQR had nice rag chew over audio oscillator at Gulf Electric Co. store. FIO, formerly of Birmingham, Ala., is now in Spring running radio classes for N.Y.A. He has a nice rig and a fine National Receiver. We had a nice long letter from J. E. Flowers, former NCR member, but now of Uncle Sam's Army at Fort Knox, Ky. DNA gave AXP a nice transformer. BHX is doing his bit as radio instructor at Naval Air Station. UC and ex-BFT are doing some of the same here. EPT is at Army Airport at Mobile as op. Bob Watson, an ex-ham and ex-comm. op., is out at Air Station as instructor. He is studying radio for a ham and commercial ticket. Help your SCM keep this summary going. Best 73 to all. — AXP.

## SOUTHWESTERN DIVISION

**LOS ANGELES** — SCM, Ralph Click, W6MQM — Asst. SCM: W6QVV. Another month has gone by and let's not let it pass without pausing to pay tribute to those hams that have gone over there and given their all for their country. If you cannot qualify for the armed services, why not join up as a civilian? OMQ and CFN are with the FCC at Santa Ana. KWC is flying for Lockheed. SDL and PNH are staff sgt's. in the Marines. PVN married the daughter of RUE and then enlisted in the Navy as RM2c for Radar training. ULE seems to be having his troubles with wired wireless. ULE is going in for light beam communication now. He has access to a 6" diameter reflecting lens. Anyone interested in light beams get in touch with ULE, 748 Glenwood Rd., Glendale, Calif. Keep your eyes on QST for the latest developments and by all means keep your League membership paid up. 73 — Ralph.

**ARIZONA** — Acting SCM, Gladden Elliott, W6MLL — OVK and KMM report they have passed their physicals for Army commissions. OVK is having difficulty getting his police net organized because of the scarcity of ops over 21. IIG is with the Army Air Corps at Scott Field, Ill., in the communication service. RXQ passed his telephone first. TOZ passed his telephone second. RWW has wound up all his code classes for the summer. TBR reports that the Phoenix club has adjourned for the summer. MLL is closing down the radio classes in Nogales High School with seven boys trying for their tickets. Five awards have been made to date on 15 w.p.m. code certificates. RWW and MLL are proposing a Sunday A.M. net. To join just drop a card to some of the fellows every Sunday A.M. That way we can keep in touch with each other. Vy 73. — Elliott.

**SAN DIEGO** — SCM, Richard Shanks, W6BZE — Ass'ts: W6BZR and W6BAM. Well here goes the first report from the new SCM and staff and hope that there is some news of interest to all. BHF is a lieutenant in active service in the California State Guard. CNB joined the U. S. Naval Reserve and is going to radio school at Texas A. & M. BEY is also in California State Guard. HY has gone on a well-earned vacation. EFD is in San Diego working in a local aircraft factory. OOU is very busy delivering gas and oil to all of the Army camps. We hear that MKW is getting the desire to get back on the ocean. BKZ is really busy teaching the Marines how radio works. EOO and AKY are both working in the government experimental lab. in San Diego. The Helix Radio Club has changed meeting



# Proved

# DOLLAR VALUE!

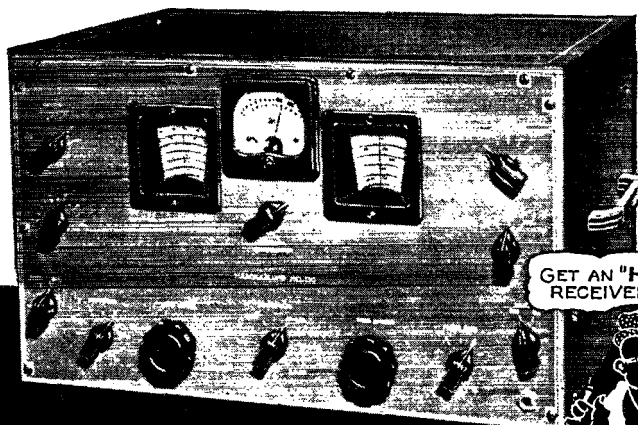

GET AN "HQ" NOW AND YOUR RECEIVER WORRIES WILL BE OVER!



## "HQ-120-X"

HOW does it perform? How will it stand up? And, how soon will it be obsolete? These are all important questions in determining the actual value of any product. The "HQ-120-X" has established a record which answers all of these questions and assures the amateur of the finest dollar for dollar value. Many owners write that the "HQ" outperforms anything they have ever owned. Its ability to "stand up" is proved by the exceptionally few used "HQ" receivers on the market, despite the thousands which have been sold since the "HQ-120-X" was first introduced. As a matter of fact, we know of hams who bought other

makes last year in preference to the "HQ" but who, this year, traded them in on the "HQ-120-X" — no obsolescence in that! So, if you intend buying a new receiver, by all means see and hear the "HQ-120-X." Its up to the minute performance and sound dollar value have been proved by thousands of users.

### MAIL COUPON TODAY!

HAMMARLUND MFG. CO., INC. Q-7  
460 W. 34 St., New York City

Please send "HQ-120-X" booklet

Name.....  
Address.....  
City.....State.....

Canadian Office:  
41 West Ave. No., Hamilton



# HAMMARLUND

EXPORT DEPARTMENT: 100 VARICK ST., NEW YORK CITY

Our experience in  
building precision crystal  
units for the United Nations  
Armed Forces will be reflected  
in better Bliley Crystal Units

for  
the Greater  
Amateur Radio  
of the Future



**BLILEY ELECTRIC CO.**  
UNION STATION BUILDING ERIE, PA.

(Continued from page 78)

nights to the second and fourth Friday. The meetings are usually held at JMR's house and start about 8 p.m. Rex Smith, ex-EOH, has been in the hospital at Norfolk, Virginia, with scarlet fever, but is about ready now to whip the Japs. He has been in the Navy for about a year. Ray Hickman got married recently. He is learning how to be a soldier at Camp Calland. FTT, Carl Boltz, has been experimenting with an airplane-listening device and they tell me he really has something that works. Well, gang, that is about all for this time and remember that I NEED NEWS. 73. — Dick Shanks, W6BZE.

#### WEST GULF DIVISION

**NORTHERN TEXAS**—SCM, George W. Smith, W5HIP — Our last report to the gang. W5CY, your new SCM until election can be held, will file your future reports. 6THK is now in Fort Worth, and is planning to establish permanent residence there. HJX is attending night school at S.M.U. HICS is still in the Navy, and is taking special schooling. The Dallas Club is still doing fine work in defense activities. Send in your reports. Give your new SCM your support. Good luck, and when that V becomes a reality, we will be slapping a bug with you again. SK, George.

**SOUTHERN TEXAS** — SCM, Horace E. Biddy, W5MN — Emergency Coördinators please notify of errors or corrections in following list of ECs. Also ARRL members in towns not listed please notify if appointment desired: BTK, Galveston; BUV, San Angelo; FNA, San Antonio; ILW, Beeville; BGJ, Harlingen; HWQ, Kingsville; HEP, Austin; FFR, Hallettsville; IQQ, Alice; DDJ, Beaumont; CIX, Cuero; FGF, Rocksprings; IRP, Lufkin; CUY, El Campo; GYP, Edinburg; IPJ, Marfa; CAJ, Brownsville; HSV, Laredo; EYV, Refugio; IVU, Edna; IKU, Fort Stockton; IMX, Port Arthur; BSF, Kerrville; FGR, Hempstead; AHK, Wharton; CLV, Orange; AQY, College Station; HBI, Gonzales; IWR, Odessa; JGB, San Marcos; DPI, Del Rio; HPJ, Houston. FNA is radio instructor at Tech High School (San Antonio). KEM is in the Navy as radioman. HBO is in Washington, D. C. JIW has gone to the Navy. JPC now has a class A ticket. HQN reports being in the Civil Service at Naval Air Station. He also reports 9BDL, 9KFF, 9BLC, 9NVB, 5IXQ and 5GYS as there with him. HIQ is in the Signal Corps in New York. IRM is in the Navy as radioman. BTK reports Galveston Amateur Radio Club code classes doing nicely with 45 to 50 students. BD and BI, who are working as radio operators at Brookfield in the National Defense Program paid MN a visit. Southern Texas hams, please report where you are and what you are doing. 73 — MN.

#### BRIEFS

Some of the boys who are trying to keep up on their copying ability by copying press stations are having trouble recognizing some of the punctuation and special signs these stations use. Here are a few that might help you out:

- . (Period) Di-dah-di-dah-di-dah
- AS (Wait) Di-dah-di-di-dit
- , (Comma) Dah-dah-di-di-dah-dah
- : (Colon) Dah-dah-dah-di-di-dit
- " (Quotes) Di-dah-di-di-dah-dit
- ? (Interrogation) Di-di-dah-dah-di-dit
- = (Break — double-dash, paragraph) Dah-di-di-di-dah
- (Hyphen) Dah-di-di-di-di-dah
- (Dash) Two hyphens, spaced
- ' (Apostrophe) Di-dah-dah-dah-dah-dit
- / (Fraction bar) Dah-di-di-dah-dit
- ; (Semicolon) Dah-di-dah-di-dah-dit
- ( ) (Parenthesis) Dah-di-dah-dah-di-dah
- \$ (Dollar sign) Di-di-di-dah-di-di-dah
- AR (End of message) Di-dah-di-dah-dit
- VA (End of transmission) Di-di-di-dah-di-dah
- R (Received — OK) Di-dah-dit
- K (Invitation to transmit — go ahead) Dah-di-dah

— — — — —

The Essex Institute of Radio, 34 Park Place, Newark, N. J., offers a course in radio code and theory for beginners the first of each month and lasting four months, leading to the Amateur Class B license. A real transmitter is on hand operating with a dummy antenna to give students actual theory and operating practice. Write to Walter E. Bathgate at the Essex Institute of Radio for particulars.

**BUILT TO SERVE BETTER**

**AND**

**LONGER**

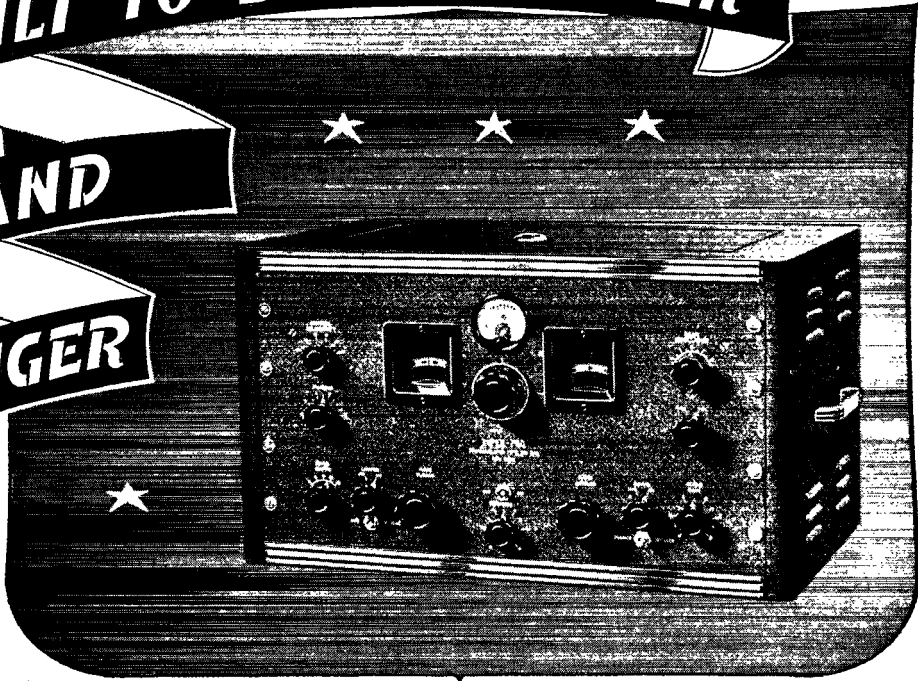

*The*

**SUPER PRO** *Series 200*

THE high standards to which the "Super-Pro" is manufactured, assures the user of the best possible service over a long period of time. That is why "Super-Pro" receivers are used in practically every department of our national government; by a host of foreign governments, and by many important commercials and expeditions.

Early models of the "Super-Pro" have been in continuous service for nearly five years with remarkable satisfaction. As an example of its sound engineering, we find not a single record of band switch failure and that is an extremely important and much used part of any receiver. Slight changes and refinements have been

made from time to time with a result that the "Super-Pro" is, and always has been, one of the finest pieces of communications equipment available. The many hours given to the inspection, testing, and adjustment of each "Super-Pro" by skilled craftsmen are not without results — the record speaks for itself.

**SEND FOR BOOKLET!**

HAMMARLUND MFG. CO., INC. Q-7  
 460 W. 34 Street, New York City  
 Please send "Super-Pro" booklet

Name.....  
 Address.....  
 City..... State.....



Canadian Office:  
 41 West Ave. No., Hamilton

**HAMMARLUND**

Export Address: 100 Varick Street, New York City · Cable ARLAB

# The Month In Canada

## QUEBEC—VE2

From Lin Morris, 2CO:

**C**ONGRATS to 2LE on his promotion to the rank of major overseas; he is believed to be the youngest major in the Canadian army. 2BK was aide-de-camp to the Princess Royal on her inspection of the RCCS in England recently. 2DU is talking light-beam transmission. 2HIO and 2GO were in Montreal on furlough.

3JI and 2GP are home movie fans, while 2DX, who is now located in Ottawa, is a dyed-in-the-wool amateur photographer. 2FK, with an eye on THAT day when we get back on again, is building test equipment. 2PI and 2LR have finished first year engineering at McGill, while 2PW joins the ranks of graduates with a science degree. 2HI is now teaching code to a Women's Volunteer Reserve Corps Unit. 2DA spends four nights a week helping RCAF men with their code.

Gang, you have no idea how hard it is to get news for this column with so many of you scattered far and wide. Please take time out to drop me a line and give me the dope so that the VE2 district will continue to be represented in "Quist."

## ONTARIO—VE3

From Len Mitchell, 3AZ:

**A**T THE annual meeting of the Kirkland Amateur Radio League, held on April 20th, the following officers were elected for the ensuing year: president, 3ALT; vice-president, 3ALW; secretary-treasurer, A. S. Murphy. 3AGM was the guest of the evening and ended up a member, although he has to come 28 miles to attend the meetings. In his address to the meeting, past president 3PH urged all members to give their support to the ARRL.

3PA has joined the Signal Platoon of the Algonquin (Reserve) Regiment, and 3ALU is a corporal in the same.

3AWO has forwarded the following information about members of the Lakeside Radio Club: 3AMB has been with the RCCS somewhere in England since almost the beginning of war. 3AXU is with the RCAF taking a special radio course in Montreal. 3ARN and 3ARC have recently got married—congrats, OMs. 3AQR is experimenting with phono amplifiers. 3AWO has been elected to membership in the AIEE and to the presidency of one of the electrical clubs in Toronto. He has been lecturing and demonstrating in different parts of Ontario for the past several months on "Frequencies, High and Low." The talks have been very well received. John Ogden, also a member of the Club, joined up as radio operator on a freighter. He was last heard from from the vicinity of St. Pierre and Miquelon. 3AWO, 3AQR and 3ARC still hold meetings each week at each other's homes, along with 3ARC's XYL.

3YY and 3IW have recently joined "A" Corps, RCCS (Reserve).

## ALBERTA—VE4

From W. W. Butchart, 4LQ:

**4**XE BROKE the news the other day that he is getting married. His bride is with the CWAC working in Calgary at present. 4ADW has left Edmonton to take up new duties with CPA at Saskatoon. Sorry to lose you, Jack, old boy! 4AKK gassed-up the old puddle-jumper one Sunday morning, loaded in a carfull of friends and drove to Sylvan Lake to visit Mickey, 4WY.

Can you beat it? 4HM is starting to think about getting back on the air again! He showed us an odd-looking piece of machinery the other day which turned out to be part of DeLaval cream separator, and he tells us that it is the nucleus of a rotary beam! Here's hoping you don't have to wait too long to use it, Chas. 4HM has also been doing splendid work on his "Hi-Fi" amplifier. He has it working just about tops now, and boy, can he really roll out the music! Experimental work about finished, he intends to build it up in a good chassis. By the way, 4EA informed us that he has completed his dual-turntable outfit, and it packs away nicely into two small cases.

4EA has bought himself a bicycle, and now saves considerable gasoline going to and from work. This country could do with a lot more chaps who think in those terms! 4LQ received word the other day that he has a commission in the Reserve Army. He will be Signal Officer with the

**MR. RADIOMAN—**

Do you want a  
**BETTER JOB**  
in Radio?



**A BETTER JOB** with increased pay is within the grasp of every radioman who has the ambition and courage to start training now for greater efficiency today and security tomorrow.

You realize, of course, the tremendous opportunities that exist in radio today. You must be aware of the unprecedented demand for highly qualified, technically trained radiomen. But, only the BETTER jobs are open to such men!

- If you now hold a commonplace job in radio . . .
- If you hold a temporary job today and long for a permanent job for the future . . .
- If you have the ambition and desire to hold a position of responsibility with higher pay . . .

. . . then a CREI home study course in Practical Radio Engineering will help you to acquire the necessary technical knowledge and ability which is demanded by the better, higher-paying positions in technical radio.

**Write for Full Information and Catalog Now!**

If you are a professional radioman and want to make more money—let us prove to you we have something you need to qualify for a better engineering job. To help us intelligently answer your inquiry—please state briefly your background of experience, education and present position.



## Capitol Radio Engineering Institute

Home Study Courses in Practical Radio Engineering  
for Professional Self-Improvement

Dept. Q-7, 3224 16th St. N. W., Washington, D. C.

Contractors to the U. S. Signal Corps and U. S. Coast Guard  
Producers of Well-trained Technical Radiomen for Industry

# DEATH *before* DISHONOR!

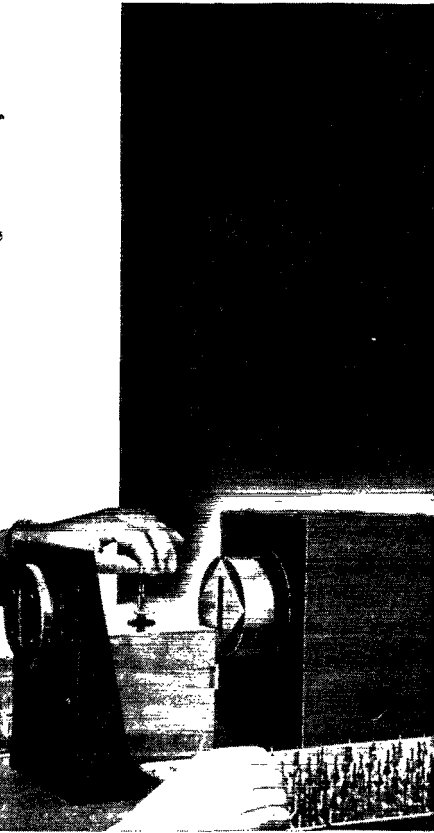

Observation of the stress points on glass bead seals around vacuum tube leads is made with this device. Close-up photo above shows the actual view of a faulty lead. Note the change in polarized light creating distorted shadows which show up stress and strain in beads. Such strain sometimes occurs where metal and glass are sealed together.



Inspecting the entire glass bulb with the help of a polarized light. This device shows up stress and strain on the glass which might be created during the shaping operations.

Casual observation of a vacuum tube does not reveal its flaws. That's why Eimac engineers have developed many devices for the purpose of exposing even slight weaknesses in construction. The above is not a dungeon window, but a close-up photo of a faulty bead on a filament stem as viewed through a special bead testing device. Needless to say, this stem will never reach final assembly . . . better "death before dishonor" to the Eimac tradition of dependability.

Such care in production plus constant research into the phenomenon of the electron tube assures you of the utmost in performance from every Eimac tube . . . provides the answer to why Eimac tubes are first choice by most of the leading engineers throughout the world.

Export Agents:  
**FRAZAR & CO., LTD., 301 Clay St.**  
 San Francisco, California, U.S.A.

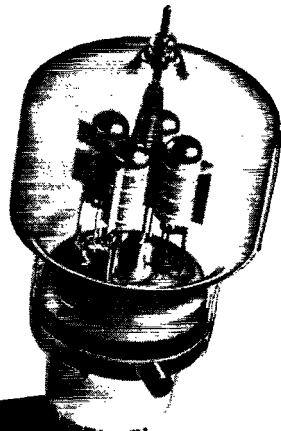

Follow the leaders to

**Eimac**  
**TUBES**



Mfg. by Eitel-McCullough, Inc., San Bruno, California, U. S. A.

#### EIMAC REPRESENTATIVES

California, Nevada  
**HERB BECKER**, 1406 South Grand Ave., Los Angeles, Calif.  
 N. Y., N. J., Penn., Md., Del., Dist. of Col., Maine, N. H., R. I., Conn., Mass.  
**ADOLPH SCHWARTZ**, 262 Grayson Place, Teaneck, New Jersey.

Wash., Ore., Idaho, Mont.  
**GENERAL SALES CO.**, Verner O. Jensen, 2605-07 Second Ave., Seattle, Wash.  
 Colo., Wyo., New Mexico, Arizona, Utah  
**RICHARD A. HYDE**, 4253 Quitman St., Denver, Colo.

Chicago, Illinois, Wisconsin  
**G. G. RYAN**, 549 W. Washington Blvd., Chicago, Ill.  
 N. Caro., S. Caro., Georgia, Tenn., Flor., Ala., Miss.  
**JAMES MILLAR**, 316 Ninth St. N. E., Atlanta, Georgia.

Texas, La., Okla., Ark.  
**J. EARL SMITH**, 2821 Live Oak St., Dallas, Texas.  
 Ohio, Mich., Ky., Ind., Minn., Mo., Kan., Neb., Iowa  
**PEEL SALES ENGINEERING CO.**, E. R. Peel, 154 E. Erie St., Chicago, Ill.



While you may not actually see such tags or signs attached to our stocks of radio parts and equipment, you may be sure that we are **NOT** making vital materials available to any and all purchasers.

Most of this supply was accumulated by us in the normal conduct of business, long before material shortages affected the radio industry. Our policy of maintaining complete stocks on the premises for customer convenience, left us with an extremely valuable inventory.

However, we do not intend to "cash-in." We will abide by the spirit of the restrictions imposed upon all of us. We are cooperating with our government in restricting the sale of this merchandise in order to facilitate production of vital requirements, and are inviting orders from manufacturers or laboratories so engaged.

If we are obliged to turn down your personal request for such a product, please understand that we do so for no other reasons.

**W2IJL • W2LJA • W2PL • W2KWY**

OUR *Best* VALUE IS OUR RECORD OF LOYAL SERVICE

**HARVEY**

*Radio Company of New York*

103 WEST 43rd STREET • NEW YORK, N. Y.

(Continued from page 82)

Edmonton Fusiliers, CA(R). 4AEN, instead of going to Montreal, has been moved to Calgary, which isn't quite so far away from home.

4BW and 4HT now have "E" Troop Cavalry Signals worked up into a pretty nice little unit. 4BW "shanghaied" most of the chaps of his office staff into it too! Yes, boys, Alf Moret of the old R. S. Co. is now in uniform two nights a week, and enjoying it! 4XF makes himself generally useful around "E" Troop.

Word of 4AGZ's safe arrival in England pleased all the Edmonton gang. AGZ holds a commission in the RCAF Radio Technicians Division. 1FQ wrote to 4LQ and enabled him to locate Lt. Gerry Baril, formerly with the Edmonton City Telephone Department. 4AAD, M.D. 13 Signal Officer, spent a few days in Edmonton supervising examinations on XE's Part 2 Signalling School. 4VJ's QTH has been moved to the "sticks." 4VJ's Pop sold his house and has moved to the city outskirts (Bonnie Doon, to anyone with a knowledge of Edmonton). Should make a swell DX set-up Ken, if you can hit it off with 4EY. He lives out there somewhere!

4AHY's brother Roy joined the RCOC in the radio or electrical division. And by the way, Harvey, where's that dope you were going to shoot along to us? We can use any items about the gang.

### MANITOBA — VE4

From Art Morley, 4AAW:

It's BEEN kind of a job collecting this stuff, but you fellows *will* drop out of sight and not let anyone know where you're going. Around No. 2 Training Command Hq. we find a few hams. 3QW is an accountant in W&B dept. 4DH is Sigs 1 and 4AAW just floats around. Happened to be in Portage and found that most of the fellows there had gone. The Navy claims the honor of having 4ALT and 4UB. 4AMT is teaching Morse code at an RCAF school, while 4ANI does the same thing for the Army. They tell me that 4AEE and 4FN are with the Air Force.

I hope the Sask bunch won't mind me butting in, but I ran across a gang up in Prince Albert. 4UG was sitting peacefully in the control tower, and 4TI, along with 4XB, are busy doing technical work. 4XB tells me that W8LIB is floating around in these parts. RCAF claims three more at Macdonald, being 2BS, 4AIY and 4BM. 1DS hung his shingle up at the Flying school at Dauphin after spending some time on the west coast. 4AAH is in training with the Air Force, while 3KG just recently graduated. Bob's a full-fledged pilot now. 4FV of Brandon is flying in bombers as the wireless op. 4AMS tells me that her OM, 4IF, is somewhere over there. 4ABD is Sgt. Wireless & Electrical Mechanic at Yorkton.

Around the Winnipeg district the Navy has already claimed 4XG, 4ABE, 4TJ, and the other night 4AJC gave me a tingle on the 'phone. He was leaving for points east for training as a sub-lieutenant. The RCAF claimed 4QG and 4ABV that I definitely know of. There are several others that I have heard of as being here or there, but they're just rumors. 4NM was last heard of as being with TCA. 4YM hangs out in the local radio station. 4AAW worked his first DX the other day; happened to mention ham radio and found out the fellow I was talking to was ZP1P. That's the way I like to work it — in person MIM. Several have been seen but not heard from. Among these are 4NI, 4EJ and ex-4AG. Incidentally, 4GC looks swell in a Navy uniform.

### BRITISH COLUMBIA — VE5

From C. O. Sawyer, 5DD:

THE B.C. Amateur Radio Association, an association of radio clubs in lower British Columbia, still holds regular meetings, as does the Royal City Amateur Radio Club of New Westminster, the Point Grey and the Totem Clubs of Vancouver. We have received no information of any other clubs of late so cannot say for sure about their activity. The B.C.A.R.A. civilian defense committee has been working on numerous angles in the past two years endeavoring to get some recognition from the authorities. We have pointed out the great usefulness of the ultrahighs, the walkie-talkie sets and other means of communication available through the amateur, but to date all authorities feel that the standard communication systems will suffice. And of course we have not received any support from the federal authorities who are no doubt plenty busy with other headaches.

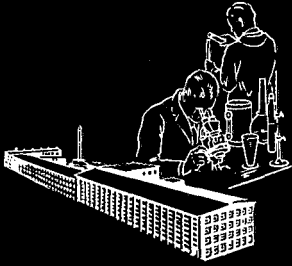

The more exacting your capacitor problem, the better we like it. Since the beginning of Radio, the Sprague reputation has been based on the ability to supply finer units to particular users.

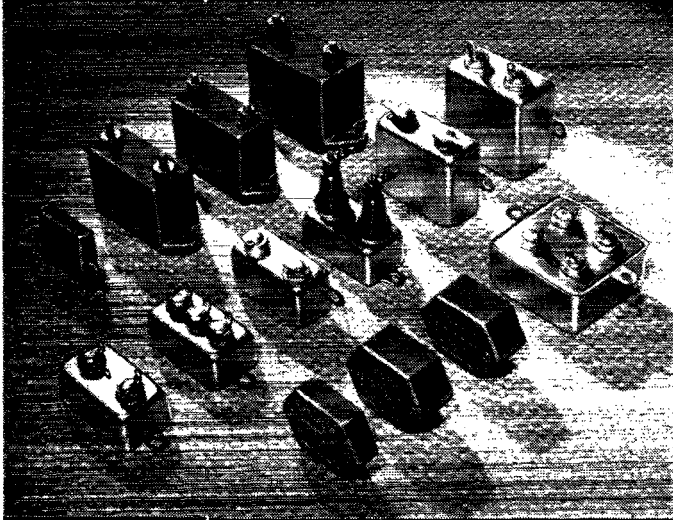

The particular Sprague condenser types illustrated are widely used in exacting Army and Navy applications.

# SPRAGUE

CONDENSERS—KOOLOHM RESISTORS

Quality Components • Expertly Engineered • Competently Produced

SPRAGUE SPECIALTIES COMPANY, NORTH ADAMS, MASS.

NOW—a really high-powered

# RADIO ENGINEERING LIBRARY

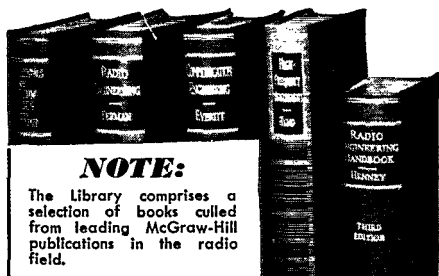

### NOTE:

The Library comprises a selection of books culled from leading McGraw-Hill publications in the radio field.

- ➔ especially selected by radio specialists of McGraw-Hill publications
- ➔ to give most complete, dependable coverage of facts needed by all whose fields are grounded on radio fundamentals
- ➔ available at a special price and terms

THESE books cover circuit phenomena, tube theory, networks, measurements, and other subjects—give specialized treatments of all fields of practical design and application. They are books of recognized position in the literature—books you will refer to and be referred to often. If you are a practical designer, researcher or engineer in any field based on radio, you want these books for the help they give in hundreds of problems throughout the whole field of radio engineering.

5 volumes, 3559 pages, 2558 illustrations

- Eastman's FUNDAMENTALS OF VACUUM TUBES, 2nd edition
- Terman's RADIO ENGINEERING, 2nd edition
- Everitt's COMMUNICATION ENGINEERING, 2nd edition
- Hund's HIGH FREQUENCY MEASUREMENTS
- Henney's RADIO ENGINEERING HANDBOOK, 3rd edition

10 DAYS' FREE EXAMINATION

SPECIAL LOW PRICE

EASY TERMS

Special price under this offer less than books bought separately. Add these standard works to your library now; pay small monthly installments, while you use the books.

### SEND THIS EXAMINATION COUPON

McGraw-Hill Book Co., 330 W. 42 St., N. Y.

Send me Radio Engineering Library for 10 days' examination on approval. In 10 days I will send \$3.00 plus few cents postage, and \$3.00 monthly till \$24.00 is paid, or return books postpaid. (We pay postage on orders accompanied by remittance of first installment.)

Name .....

Address .....

City and State .....

Position .....

Company.....QST 7-42

## Silent Keys

It is with deep regret that we record the passing of these amateurs:

- George K. Bates, W8GFU, Dexter, N. Y.
- F. V. Becker, W3JHM, Cumberland, Md.
- G. E. Cooper, G3PP, Sheffield, England.
- Charles F. Frederick, jr., W8GSH, Claridge, Penna.
- William B. Gagnebin, W1DQD, Waban, Mass.
- Eugene B. Marshall, W7APR, Spokane, Wash.
- J. P. L. McFee, ex-VE4PG, Moose Jaw, Sask.
- Francis Parfitt, ex-W9UPU, Ripon, Wis.
- Frederico de la Parra, XE1FI, Mexico, D. F.
- Harry H. Simpson, W9CCG, Evansville, Ind.
- Gene Thompson, W5KAR, Tulsa, Okla.
- Rocco A. Torra, W1FYT, Boston, Mass.
- Josee Wouters, W1FFZ, Manchester, N. H.

## A Course in Radio Fundamentals

(Continued from page 62)

### Assignment 3:

Q. 4—The magnetizing effect in the second case is smaller because with this method of connection the currents are flowing in opposite directions in the two coils. Consequently the magnetic fields caused by the currents also oppose, resulting in less field strength than with either coil alone at the same current.

## Converting the S.S. Super

(Continued from page 58)

meter oscillator and mixer coils.

The winding of the oscillator coils follows the same pattern as prescribed in the *Handbook* for the 1.75-Mc. band, particularly as regards the tap connection which in all four new oscillator coils now goes to the top of  $L_4$ . Although the oscillator coils down to the 20-meter band were designed to operate on the high-frequency side of the mixer stage, the 20- and 10-meter band coils were designed for the low side, for stability's sake.

Because of the 35- $\mu$ fd. additional capacity in the oscillator tuned circuit, the oscillator range for each band is greater than is really required. Advantage is taken of this fact in the dual range incorporated in the broadcast-band mixer coil. The actual oscillator ranges (not signal frequency) are as follows: 30-17.6 Mc.; 16.0-7.6 Mc.; 9.5-4.25 Mc.; 5.8-2.7 Mc.; 3.6-1.8 Mc.; 2100-940 kc.



Always

Specify  
Centralab

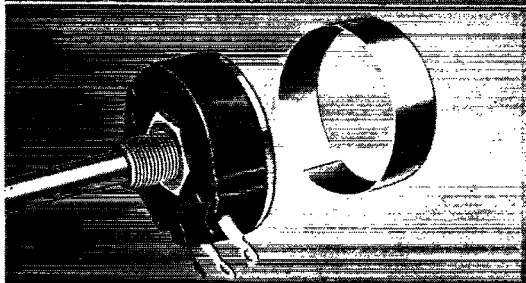

## CONTROLS

Featuring the famous WALL TYPE resistor element which hugs the inner circumference of the black moulded bakelite case. Exclusive non-rubbing contact assures quiet smooth rotation and long life. Available in STANDARD, MID-GET AND ELF with or without switch cover.

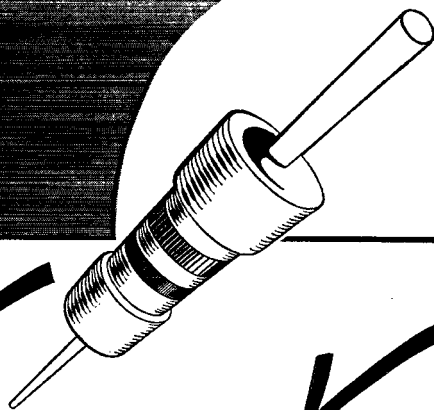

## RESISTORS

Available in two types: RADIAL LEAD and AXIAL LEAD. Both feature a center core of resistance material, surrounded by a dense shock-proof ceramic providing strength and protection against humidity. Core and jacket are fired together at 2500 degrees F: into a single solid unit, hard and durable as stone.

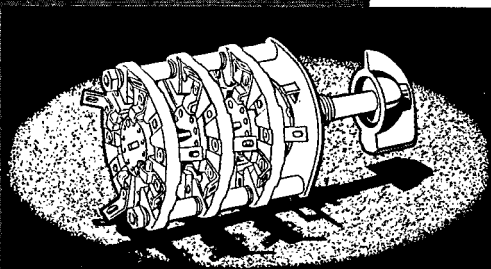

## SWITCHES

Both selector and transmitter switches are available in an infinite number of combinations . . . ideal for high frequency circuits with minimum losses.

Most switches are supplied with an "adjustable stop" index . . . permitting the selection of from two to twenty-three positions.

CENTRALAB through every emergency continues to adhere to its policy of "performance plus" at all times.

The slogan "ALWAYS SPECIFY CENTRALAB" which has appeared in our advertising from the very inception of this name is as timely today as it was fifteen years ago.

Today as then . . . there is no substitute for QUALITY.

Write for Catalogue No. 23

CENTRALAB: Div. of Globe-Union Inc.  
Milwaukee • Wisconsin

For Quick Reference  
NEW

# OHMITE STOCK-UNIT CATALOG 18



## Convenient ★ Helpful ★ Free

Catalog 18 is especially useful today for quick reference. Gives up-to-date information on the wide range of Ohmite stock resistors, rheostats, chokes and switches used in all types of essential applications. Lists over a thousand stock items . . . Gives descriptions, ratings and prices . . . Helps you select the right units for vital jobs, easily, quickly.

Send for your copy of Catalog 18 now. It's FREE. At your Jobber or write.

**OHMITE MANUFACTURING CO.**  
4836 Flournoy St., Chicago, U. S. A.

Be Right with **OHMITE**  
RHEOSTATS • RESISTORS • TAP SWITCHES

## Off the Ultra Highs

(Continued from page 65)

were heard between 40 and 56 Mc. On May 12th, Bake got his new f.m. receiver going and had his first experience with f.m. reception; and even though the signal was coming in via sporadic-E skip the quality and freedom from noise were quite a revelation. W7CIL is sold — f.m. exclusively after the war for Bake! The first f.m. sig, apparently from California, was heard from 11:50 to 12:10. At 3:30 and until 4:50 P.M. K45LA was coming in, with the signal spotty but quality excellent most of the time. Distortion was noticed for short periods but this did not seem to be related to the fading, Bake relates.

WIDLY, reporting from his new location, Prairie du Sac, Wis., says he heard W2XMN on May 12th at 9 P.M., and again on May 16th between 12 and 1 P.M. Henry's erstwhile pal, W1KK, lists the evening of May 18th as a hot one, with Detroit, Chicago, and Milwaukee pounding in hereabouts. And shortly after noon on May 20th, W1KK and your conductor were able to hear W55M, Milwaukee, and a Chicago station on an experimental receiver at the lab where we are employed. To quote W1CGY, who happened by as the Milwaukee signal boomed in on the peak of one of those never-to-be-forgotten surges that only skip DX can produce, "Wouldn't that make you sick!"

Here are some additions to the "Who Is Where Department": A card from Frank Grey, W9LLM, formerly of Downers Grove, Ill., tells us that the new QTH is San Diego, Cal. Reason for the move is not given, but it must be a permanent venture for Frank declares that he's going to make a big noise on Five out there after the war. Address, at present, is care of General Delivery.

Elmer Gockler, W9BDL, turns up as a radio mechanic at the Naval Air Station, Corpus Christi, Texas. He is the only u.h.f. enthusiast in the group of hams at the station, and is having a hard time convincing the boys that his stories of doings on Five are on the level. Address: 450 Indiana Ave., Corpus Christi, Texas.

W7CIL reports that W7DNB has moved from Salem to Portland, Oregon, where he is working for Bonneville Power. W7FFE has left Houlton to go to work in the shipyards at Portland. He will be joined shortly by W7FDJ. W7ERA, Milwaukee, is now in the Navy. Thus it appears that our Oregon representatives on Five are accounted for. Are you away from home? Would you like to hear from some of the u.h.f. gang from time to time? Drop us a line giving your address, if any, and we'll post it in this section at the earliest opportunity.

The last letter received from W6QLZ reported that he was leaving the hospital in El Paso, Texas, where he had spent his army career to date. Just before the close-down, Clyde was doing some heavy experimental work with concentric antennas. He ran into some results which didn't seem to check with published data, and he would

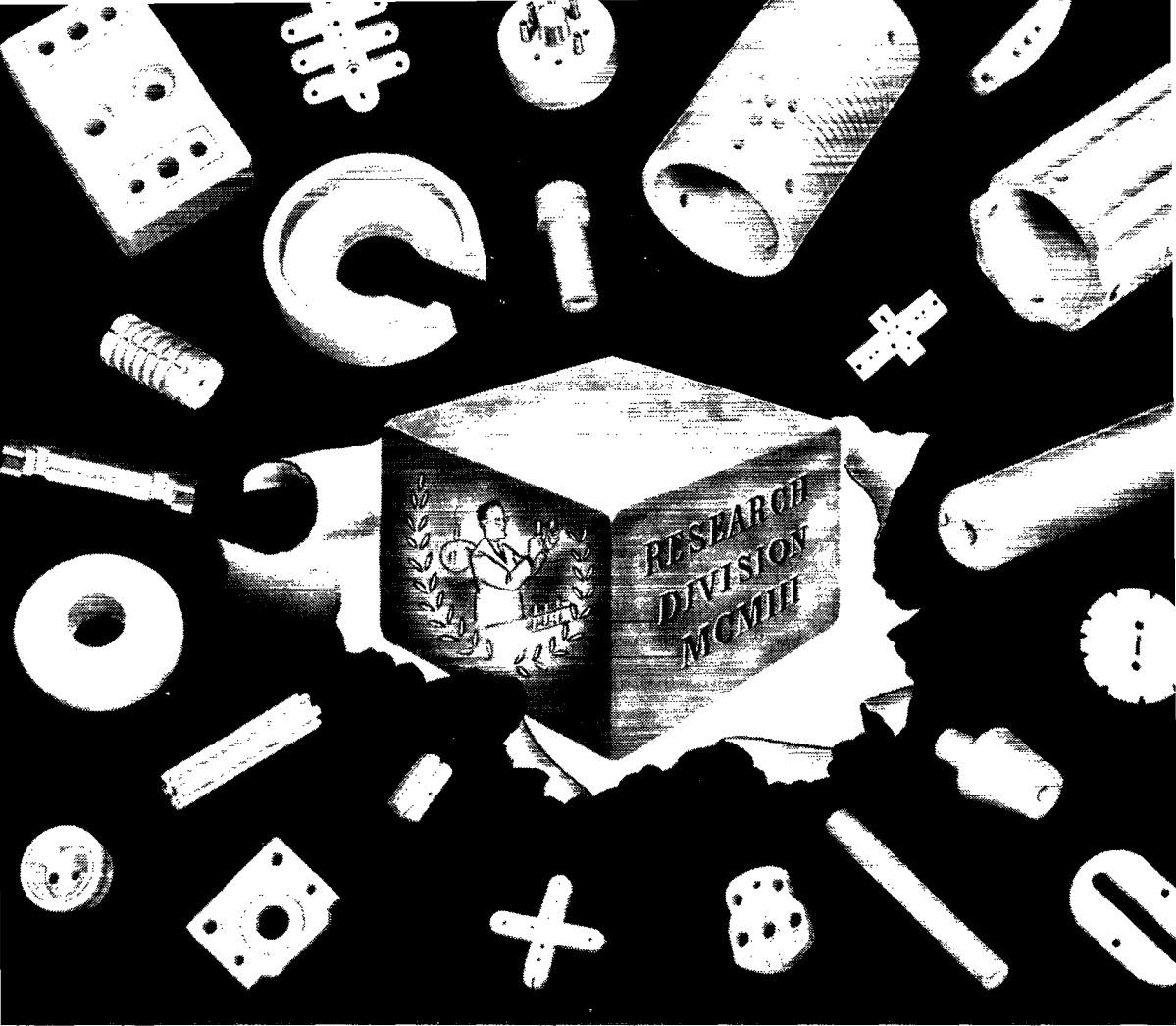

## CORNERSTONE FOR V + 2\*

Some year the war will end.

There will be a swing back to the things we buy because we want them, not because they are a grim necessity. Today's work is to win the war. Executives now driving for all-out production should also be planning for V + 2. Products for tomorrow should be designed today.

For every new product, the cornerstone is Research. The Research

Division of American Lava Corporation is outstanding in its field. It welcomes any call for cooperation in planning for today's production . . . or for long range planning for the insulation of the future.

Meanwhile, for 1942 and as far as we can see, we pledge our utmost efforts to supply our customers with the best in steatite ceramic compositions as rapidly as possible under wartime conditions.

\* 2 years after Victory, probable time required to resume full peacetime production. (Bouquets to the G. E. executive who coined this expression.)



AMERICAN LAVA CORPORATION

CHATTANOOGA, TENNESSEE

CHICAGO • CLEVELAND • NEW YORK • ST. LOUIS • LOS ANGELES • SAN FRANCISCO • BOSTON • PHILADELPHIA • WASHINGTON, D. C.

## How to Get the Best Service from Your

# SHURE Microphone

Are you intimately acquainted with your Microphone? Shure Brothers have prepared an interesting four color booklet, called "Long Live Your Microphone". There are sixteen pages of valuable information about Crystal, Dynamic and Carbon Microphones. "Pointers" on Feedback, Cable, Plugs, Service and other practical matters. This data is based on statistics gathered in the Shure Service Department.

One of these booklets will tell you how to keep your Microphone in "fighting trim".



(Continued from page 88)

like to get comments from others who may have done work with this type of radiator.

Checking over many articles which have appeared in several magazines and handbooks shows, for instance, a considerable variation in the assumed radiation resistance, this being indicated all the way from 25 to over 75 ohms. Clyde says his seemed to work out around 45 to 50 ohms (something less than that theoretical free-space condition which results in a radiation resistance of 72 ohms?), and he wonders if different conductor ratios (upper and lower sections) have any effect on this. The effect of the addition of radials, and the degree of shortening of skirt length from the normal value for the lower quarter wave of a half-wave antenna are factors upon which Clyde would like to receive comments from workers who have used this type of antenna.

## Cryptanalysis Lesson

(Continued from page 51)

abilities first, in the long run we'll solve many more cryptograms per hour. We'll decide to use this layout as a basis for further analysis. Hand me those shears. . . . I'll cut this square into vertical strips so that we can conveniently move them around and try to fit them into their correct places.

"Ah, there we are. Now, let's pick a couple of columns which have letters appearing in frequent trigrams or digrams such as **the, ing, ion, for, th, on, er, re, an** and so on, and try to piece them into rows forming those digrams." Ed experimented with the paper strips, placing this one here, that one there. "See, I've made a word **the** in the top line by using columns 3, 7, and 4. But the other combinations of letters are not very promising-looking word segments; notice:

T H E  
U N O  
O L T  
A N R

"Let's try some more." Ed again shuffled the paper strips. "Hm. . . . This cipher is going to take some experimentation. Ah, here's a possibility: **NCE** appearing in the last line gives good combinations of other letters — and if we put **O** before it for **once** it's even better. See:

E H A V  
A N S W  
Y L E T  
O N C E

"The second row can be nothing but **answer**, and the rest is easy. Simple, huh?"

"Yeah — if you know how," Jim sadly commented.

"Can't learn everything the first night, m'boy. Like getting up code speed, it takes practice. Here are a few you can work on during the week.

**UNITED STATES  
MARITIME COMMISSION  
IS BUILDING  
THE GREATEST FLEET  
THE WORLD  
HAS EVER SEEN!**

**Jensen**

**ANTI-CORROSION  
SPEECH REPRODUCERS  
ARE ON ACTIVE DUTY  
WITH THIS FLEET!**

**Jensen RADIO MANUFACTURING CO.  
CHICAGO, ILLINOIS**

(Continued from page 90)

Don't give up in ten minutes; stick to it. Get that cross-section paper, keep your work neat, and go about analysis in a systematic fashion. Follow up leads when they are encouraging and when your common sense confirms.

"You've gotta scram now, Jimmy, since I've got to get up early tomorrow to check the volume compression circuit at the station. See you Monday."

LHECM ITNAS NISDI TAOUO IIFCA  
NTYGB MMNAO SAITG UX

MRUCN ODARO ITAER ENXYI RCNTR  
ADUON ILECT

AARSC PMSEN DLVAI NISFP RCHET  
OTEAO ENSSR AEELA ETALE CSYWH  
ERNMS D

WDHEG IOENL NIPIE MSTEK MEOWA  
XAZQS EVCEN UDFAP JOANO OERIU  
TWBNS ETYLR

### U. S. A. Calling

(Continued from page 49)

equipment. The applicant must have at least two years of college credits, which must include a year of college physics, unless he is the holder of an amateur or commercial radio license. (That license does help!) A transcript of college record is required. When accepted, the cadet is given 16 weeks of specialized study at the Air Force School at Scott Field, Illinois. The curriculum sounds pretty good. Upon graduation, the aviation cadet is commissioned a 2nd Lieutenant in the Air Force Reserve and assigned to duty. Physical requirements the same as for reserve commissions. Cadets receive \$75 per month while training, plus subsistence, uniforms, etc., and \$10,000 government insurance. Go to your nearest Board for further information.

### Navy Sparks

(Continued from page 36)

A few hours of top speed and the destroyer has outrun the storm's fury, leaving as evidence only the ominous velvet sky astern. Strange what a great difference a few miles of travel makes in the sea. Again we enter smooth waters, and cruise along as though we had never entered the storm area. Smooth as silk is its mirrorlike surface. As evening comes the western sky is painted in gaudy hues of gold and crimson, soon to fade into a multitude of varying colors, until finally the purple tinge sinks into gray, bringing out the celestial diamonds and the silver moon. Neptune's

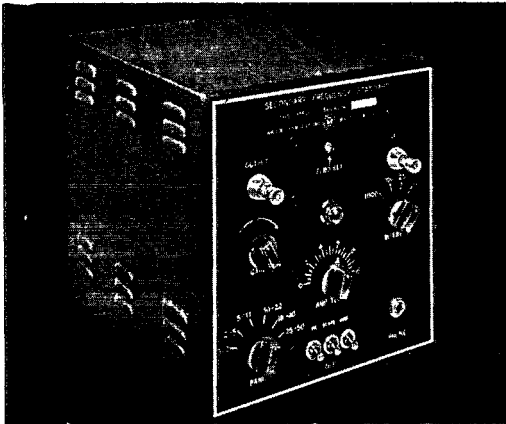

## A Precision Crystal — Secondary FREQUENCY STANDARD

That Has Been "Designed for Application"

A precision frequency standard capable of being adjusted to WWV or some other primary standard and putting out uniformly accurate calibrating signals with 10, 25, 100, 1000 KC intervals. Uses the new GENERAL ELECTRIC No. 18A 1000 KC crystal having a frequency temperature coefficient of less than one cycle /Mc/C°. The crystal is sealed in Helium in a standard metal tube envelope. The self-contained AC power supply has VR150-30 voltage regulator tube.

In addition to oscillator, multivibrators, and harmonic amplifier, a built-in mixer with phone jack and gain control on panel is incorporated

JAMES MILLEN  
150 EXCHANGE ST.



MFG. CO. INC.  
MALDEN, MASS.

## KLEINSCHMIDT OR CREED PERFORATORS

*I would like to buy some, regardless of condition, because I can rebuild them. Will pay cash and a liberal price.*

*If you are interested in the finest of radio-telegraph apparatus—and no maybe about it—write for my latest catalog. Transmitters for schools, etc., ink recorders, auto heads, etc.*



TED McELROY

McELROY MFG. CORP.

82 Brookline Avenue

Boston, Mass.

Remember the **T-40**  
 ... and their **TZ-40**  
 Pace Setting Records!

# More **TAYLOR** Developments Are Coming!

During these days of intensive war effort much new equipment in all lines is in process of development. Important advancements have and are taking place in transmitting tube design. And too, essential mass production methods are helping to bring about many new basic manufacturing economies.

If it were possible now, we'd like of course to pass these new Taylor developments on to you just as we've done time and time again during former years. However, when Victory is achieved, you can depend on Taylor to bring you the latest and best in all Taylor Tubes. When the bands are open again, Taylor will offer new type tubes. Let's all pull together to hasten that day!

"MORE WATTS PER DOLLAR"

**Taylor** HEAVY **CUSTOM BUILT** DUTY **Tubes**

TAYLOR TUBES, INC., 2341 WABANSIA AVE.  
 CHICAGO, ILLINOIS

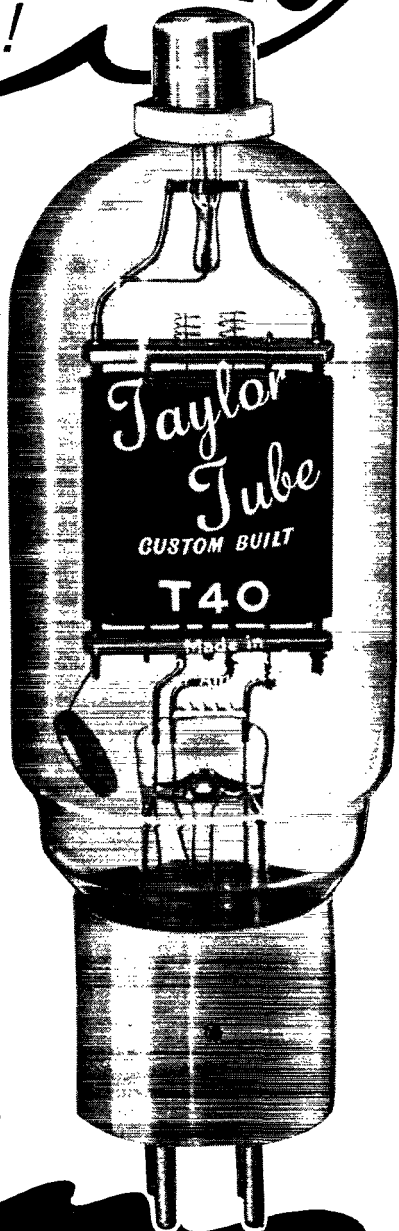

Now Licensed By **RCA!**

WE HAVE  
**TUBES**  
 for most  
**RADIO and ELECTRONIC  
 PURPOSES!**

★  
**MOST TYPES IN STOCK!**

- RECEIVING TUBES
- TRANSMITTING TUBES
- PHOTOTUBES
- RECTIFIERS, etc.

*A Complete Tube Supply*

R.C.A. ● G.E. ● TAYLOR  
 GAMMATRON ● EIMAC ● HYTRON  
 RAYTHEON ● SYLVANIA

Our present stock of tubes is considered quite good in view of the exceedingly heavy demand these days. It is quite possible that the tubes you urgently require may be right here in our stock. Drop us a line today—or phone us. We shall be glad to fill all priority orders to the best of our ability.

WE ALSO HAVE  
**PARTS**  
 of ALL TYPES  
 For IMMEDIATE DELIVERY!

- CONDENSERS
- TRANSFORMERS
- RELAYS
- PLUGS
- PANELS
- RESISTORS
- SWITCHES
- METERS
- JACKS
- WIRE

Also  
**LABORATORY TEST EQUIPMENT  
 AMPLIFIERS and SOUND SYSTEMS  
 COMMUNICATIONS RECEIVERS**

**PURCHASING AGENTS!**

CONSIDER SUN YOUR  
*Complete Source of Supply*

Factories these days are working at top speed on vital war production requirements and may not be able to give your small orders the immediate attention you desire. We believe that we can save you considerable time in your purchases were you to consolidate your requirements with a single source of supply such as ours. We stock everything

★ **HEADQUARTERS for  
 GOVERNMENTAL, INDUSTRIAL and  
 CIVILIAN DEFENSE REQUIREMENTS**  
 For PROMPT SERVICE ★  
 Telephone BARclay-7-1840

**SUN RADIO CO.**  
 212 Fulton Street, Dept. QN New York  
 Cable Address: SUNRADIO NEW YORK

(Continued from page 92)

fury is forgotten as the destroyer secures its mooring lines to the dock, yet in your heart you can hardly wait for the next exciting adventure that lies in store for you in the realm of Neptune's Kingdom. You are an old weatherbeaten brasspounder of Uncle Sam's fighting sea forces; the salt is in your veins along with the virus of the radio bug.

I would not be separated from either of them.

**How Recordings Are Made**

(Continued from page 84)

the frequency increases to maintain the amplitude. With constant velocity the stylus maintains the same rate of speed, swinging out wide on the lower frequencies and shortening its travel on the higher frequencies so that it covers the same lineal distance. The power required is the same for all frequencies.

What difference does it make? Well, even though it sounds like an academic distinction, there are several practical aspects to the choice between the two systems. In the first place, it is not possible to record with one system and play back with the other without severe distortion. You've got to decide on one or the other.

The reason neither one nor the other has been finally decided upon is a matter of men and mechanics. One school of thought argues that all recording should be done on the constant amplitude principle. These are the modernists. Supporting them is the fact that a crystal cutter and pickup, operating without equalization, will cut and reproduce an essentially constant amplitude characteristic.

On the other hand, an uncompensated electromagnetic cutter will cut a constant velocity pattern, and since the magnetic pickup has a similar characteristic it gives a flat response from such a recording.

So it might be said to be a matter of whether you use magnetic or crystal equipment. (If you mix them up you've got to compensate one unit or the other.) In the case of instantaneous recording, using a crystal cutter and pickup, common practice is simply to cut the record constant amplitude without compensation and let it go at that.

Which is all right unless you've got a constant-velocity record to play—and all commercial pressings are modified constant velocity records. In that case you'll have to do some equalizing. There is still a further complication, in that even constant velocity cutters do not maintain that characteristic at the lower frequencies. All such cutters are down something like 15 db. at 50 cycles, to prevent the amplitude becoming so excessive as to cause crossover and echo effects.

In playing modern transcriptions or instantaneous recordings the problem seldom arises, since it is now standard practice to record with



# At Last! All ELECTRON TUBES and Their CIRCUITS — Explained in ONE SIMPLE BOOK — *without Higher Mathematics!*

Now for the first time you can easily master every important application of radio — without previous training in electricity or advanced mathematics — with the help of this single volume, written in plain English! First you get every single fact about electricity that you need to know. Then you begin with the simplest tube, the diode, learn its circuits, and how they are applied in equipment. Next you take up tubes with three and more electrodes, gas-filled tubes, photo-electric cells and cathode ray tubes.

## Takes You from Simplest Principles to the Latest Applications

The whole book is carefully designed for self-instruction — to give you the thorough, broad, basic training you need in order to serve on ships or planes, or in industry. The author explains, with hundreds of clear diagrams, all the applications of greatest practical use today. You can see at a glance the actual working of the most advanced apparatus — frequency modulators, direction finders, ultra high frequency transmitters and receivers, microwaves, etc., etc. You will gain a clear understanding of all present-day electronic methods from this book —

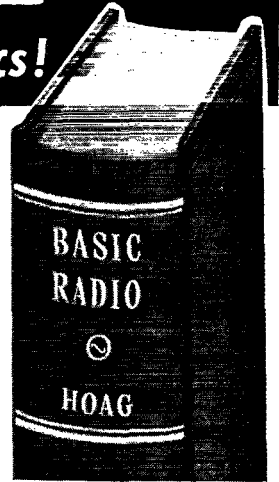

**380 Pages of Real Information!**

Field patterns from Stations  
WCBX and WCRC.

## BASIC RADIO

By **J. BARTON HOAG, Ph.D.**

Professor (T), with the rank of Lieut. Commander,  
U. S. Coast Guard Academy

This famous former University of Chicago professor, now serving the armed forces, knows just the kind of training you need to undertake any radio work with full confidence. The scope of his 380-page BASIC RADIO is shown by a few of its chapter headings: The Electron; A. C. Circuits; Resonant Circuits; Diodes; Triodes; Multielectrode Tubes; Modulation; Detection; Oscilloscopes; A, B and C Amplifiers; A. F. Amplifiers; Feed Back Amplifiers; Direction Finders; etc., etc., etc.

And in addition to all these clear explanations, you are given over 400 practical radio problems and questions to test your growing knowledge.

**SEND NO MONEY** Examine  
5 Days FREE!

Here is your opportunity to prove — entirely without cost — how thoroughly this book will train you in radio. Just mail the coupon, and get it on five days' approval. See how basic radio is explained; how easy it is to understand. Then either return the book or send only \$3.25, plus a few cents postage, in full payment for this complete training.

**D. VAN NOSTRAND CO., INC.**

250 Fourth Avenue

New York, N. Y.

Over  
**425**  
Diagrams &  
Photos!

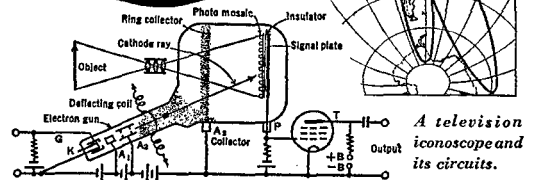
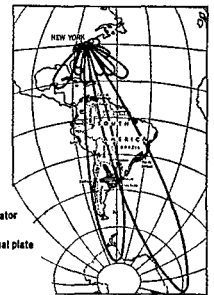

A television  
iconoscope and  
its circuits.

**MAIL COUPON FOR 5 DAYS FREE READING**  
D. Van Nostrand Co., Inc.  
250 Fourth Avenue, New York, N. Y.

Send me BASIC RADIO, by J. Barton Hoag, 380 pages, 5½ x 8½, clothbound. I will send \$3.25, plus a few cents postage, within 5 days after I receive book. Otherwise I will return it and have no further obligation. (We stand postage on orders sent with remittance; same return and full refund privilege.)

Name .....

PLEASE PRINT

Address .....

City.....State.....

Reference.....

Address.....

(QST 7-42)

BUY YOUR



"The Ears of the World"

# COMMUNICATIONS RECEIVER NOW!

Everyone should have a good, full frequency coverage receiver — and these Echophone Commercial receivers are excellent for every purpose!

For the home — receive all local broadcast stations with fine quality — tune in foreign short wave stations for fun and news — copy press stations for code practice — (in the event of an Air Raid alert, local stations shut down. Tune your Echophone Commercial to a S.W. broadcast station in a different part of the country and keep informed).

For the Boys in the Service — receive your home programs, no matter in what distant place you are based. Your sturdy Echophone Commercial in its compact metal cabinet will take lots of hard knocks and still pull 'em in! AC-DC, can work on practically any current.

## IMMEDIATE DELIVERY!

Same day shipment to any part of the U.S.A., its Territories and Possessions, or to any member of our armed forces.

**MODEL EC-1**  
**\$24.50**



A six tube, AC-DC, communications receiver whose "hop" will amaze you! 550 Kc to 30 Mc in three bands, electrical bandspread, BFO, self-contained dynamic speaker — Safety headphone jack, etc. A "knock-out value" at only \$24.50, complete!

## MODEL EC-2

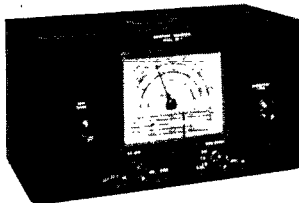

Here's the new and improved version of this popular set. Now with an external speaker (just like EC-3). Automatic noise limiter, pre-selection on all bands, calibrated bandspread, AC-DC, safety headphone jack, 8 tubes, 595 Kc to 30.5 Mc. Bigger value than ever at only \$42.50, complete with speaker in matching cabinet.

**MODEL EC-3**

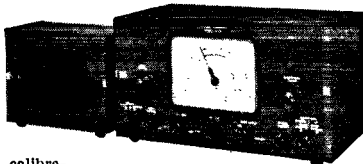

10 tubes, 545 Kc to 30.5 Mc, pre-selection and electrical bandspread on all bands, calibrated, Amateur bandspread, variable selectivity crystal filter, automatic noise limiter, two IF stages, dynamic speaker in matching cabinet, AC-DC, safety phone jack, etc. You'll like the "top-notch" performance of this swell communications receiver! Get yours today for only \$59.50, complete with speaker.

**ORDER TODAY!! Before they are all taken!**

**HARRISON**  
RADIO COMPANY  
12 WEST BROADWAY NEW YORK CITY

(Continued from page 94)

constant amplitude. If you play commercial phonograph records, however, you've still got to cope with it, because these are made with constant amplitude only up to a point variously called the transition frequency, turnover point or crossover point, when they change over to constant velocity. The transition frequency may be anywhere from 250 to 800 cycles. Every time the frequency doubles above the transition point the output voltage drops to one-half. In other words, it goes down 6 db. per octave. This means, of course, that compensation is required when the record is played with a crystal pickup.

Just to confuse the situation still more, quite a number of recordings change over again somewhere above 1000 cycles and from there on have a modified characteristic in between constant amplitude and constant velocity. This gives the highs an over all rising characteristic, which helps to mask the random background noise or hiss resulting from the grit contained in the shellac pressing. Of course, this must also be taken into consideration in equalizing. What it all adds up to is that no one amplifier or equalizer will serve to reproduce all kinds of records with true fidelity. And all you can do about it is play around until you get a pleasing result.

(This article is No. 1 of a series. Part II will discuss practical aspects of recording and the individual elements of the recorder in detail. — EDITOR.)

## 100 Centimeters and Down

(Continued from page 27)

mathematical analysis<sup>19-23</sup> is quite involved. Many practical problems also arise when actual tubes are being designed; the electron beam must be accelerated and focused, the collector must be designed to prevent secondary or rejected primary electrons from getting back into the output circuit, provision must be made for dissipating the heat generated when the beam strikes the collector, etc. Some of these problems are discussed by Hahn and Metcalf<sup>18</sup> and the Varian brothers.<sup>24</sup>

A velocity-modulated tube of the klystron type, which is the type which has been described, is shown in Fig. 3, together with its associated circuit when working as an oscillator. The name "klystron" is derived from the Greek *klyzo*, denoting the breaking of waves on a beach; it was suggested by the "breaking" of waves of electrons on the output circuit. Resonators are of the cavity type, to be described later; tuning over a limited range is accomplished by compressing the thin metal walls of the resonators. The frequency is also affected by electrode voltages. The resonators are often called "rhumbatrons," from the Greek word for rhythmic oscillations — the same root which gives us the word "rhumba." The input resonator is referred to as the "buncher" rhumbatron and the output resonator as the

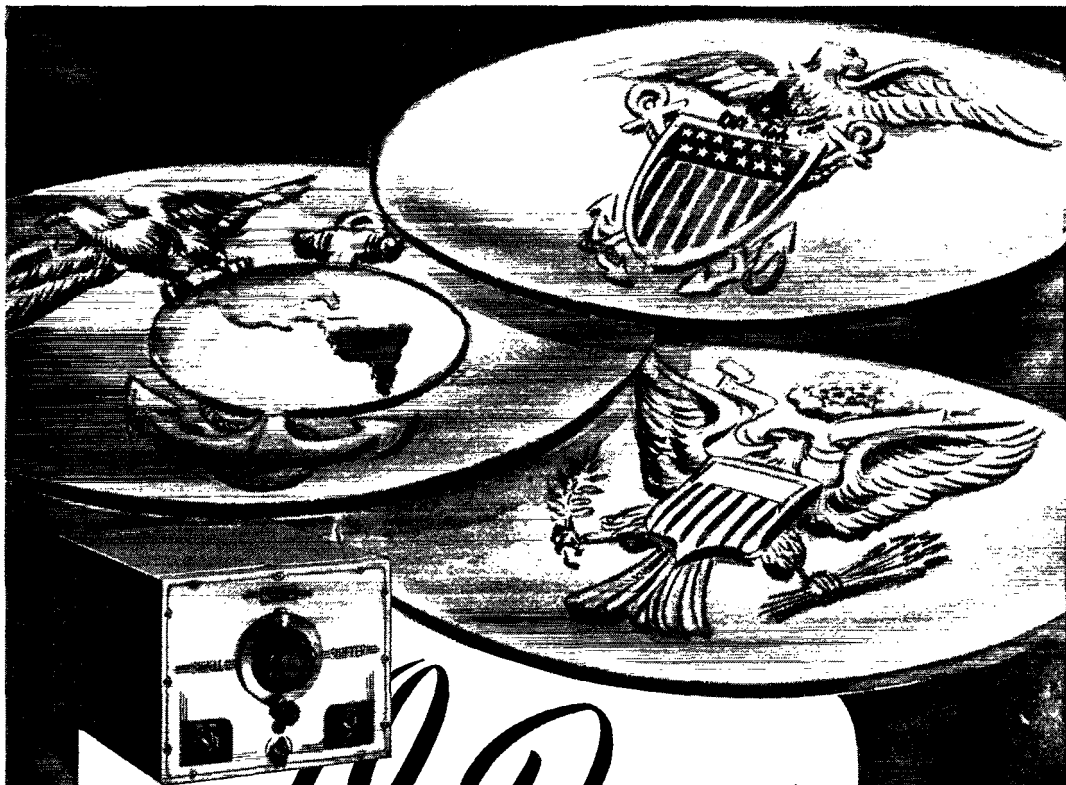

# On Duty!

After the curtailment of amateur activity we visioned a limited demand for Meissner Signal Shifters . . . we overlooked the very important fact that the amateur operators of yesterday would become the war time communications officers and technicians of today!

Considering the enviable reputation established by the Signal Shifter in amateur service, it isn't difficult to understand the heavy present day demand for Signal Shifters in war service. With amateurs on hand to guarantee its versatility, Signal Shifters are found in Government Test Labs, at military communications centers, in the test labs and on the production lines of prominent war equipment manufacturers and in countless other classes of service where stringent war time duty demands equipment of the finest caliber.

Yes, Meissner Signal Shifters have gone on active duty! If you require a stable R. F. signal, that may be varied in frequency over a range of from 1,750 KC to 16,500 KC, don't overlook the Signal Shifter. Complete coverage coils are now available and your consideration of specifications, which we will rush to you on request, may prove the Signal Shifter to be the answer to some troublesome problem.

**Meissner**  
MT. CARMEL, ILLINOIS

"PRECISION BUILT PRODUCTS"

# RADIO TRAINING



FOUNDED IN 1909

**P**ORT ARTHUR COLLEGE, a non-profit-making educational institution, offers a practical radio operator's course. Each graduate receives two months' actual operating experience at the college's commercial broadcast station KPAC. This station is equipped with the latest type 1000 watt high fidelity RCA transmitter — 1250 kc. — directional antenna system. KPAC operates in new modern studios located on the campus.

Radio training at Port Arthur College is designed to qualify the graduate for employment as a broadcast engineer, combination operator-announcer in a studio, combination transradio press operator-announcer, studio control board operator, ground or flight radio operator in airline stations, marine operator on board ship, experimental and development work, radio beacons, government service, radio police patrol, seismograph, or secure a specialist rating in the U. S. Army, Navy, Air Corps and Marine Corps in National and Foreign service.

AUTHORIZED TO TEACH RCA TEXTS  
COLLEGE LEVEL CURRICULUM  
WOMEN STUDENTS ALSO ACCEPTED  
If interested, write for Bulletin R

**PORT ARTHUR COLLEGE**  
**PORT ARTHUR (World-Known Port)**  
**TEXAS**

## • "Three-Way" Transmitter-Receiver for CD and Military Use

Write for Circular CD

## • Radio Remote Control Equipment for Models and Industry

1942 Edition of The Radio Control Instruction Manual, 25c postpaid

**RADIO CONTROL HEADQUARTERS, INC.**

P. O. Box 214

Deal, New Jersey

## EASY TO LEARN CODE

It is easy and pleasant to learn or increase speed the modern way — with an Instructograph Code Teacher. Excellent for the beginner or advanced student. A quick and practical method. Available tapes from beginner's alphabet to typical messages on all subjects. Speed range 5 to 40 WPM. Always ready, no QRM, beats having someone send to you.



### MACHINES FOR RENT OR SALE

The Instructograph Code Teacher literally takes the place of an operator-instructor and enables anyone to learn and master code without further assistance. Thousands have used and endorse the Instructograph System. Write today for full particulars and convenient payment and rental plans.

## INSTRUCTOGRAPH COMPANY

4709 Sheridan Road, Chicago, Illinois

Representative for Canada:

Radio College of Canada, 54 Bloor St. West, Toronto

(Continued from page 86)

"catcher" rhumbatron, for reasons which should be clear from the description of their operation. Efficiencies of about 58% are theoretically possible<sup>21</sup> but actual efficiencies may be much lower; for example, one type of tube is rated to give an output of 10 watts at 10 cm. (3000 Mc.) but requires an input of 250 to 300 watts; on the other hand, a klystron is being manufactured which delivers 200 watts at 40 cm. (750 Mc.) with an efficiency in the neighborhood of 50%.

It is understood that other types of tubes have been developed for the production of microwave oscillations, but, for reasons which will be apparent to everyone, details have not been published and cannot be for the present. We can expect that many interesting developments in this field will be revealed, however, when circumstances permit — let us hope in the not-too-distant future.

### Bibliography

Articles which are mainly descriptive rather than highly mathematical, or which, though the treatment is mathematical, have results tabulated in easily-understandable form, have been marked with an asterisk.

- \* 1. Grammer, "Intermediate-Power Transmitting Tubes," *QST*, Sept., 1933, p. 33.
- \* 2. "New Transmitting Tubes — HK24," *QST*, Jan., 1939, p. 19.
- \* 3. "New Transmitting Tubes — New UHF Tube," *QST*, Jan., 1940, p. 46.
- \* 4. "New Transmitting Tubes — UHF Transmitting Triode — HY75," *QST*, Apr., 1940, p. 27.
- \* 5. Hull, "Working at One Meter and Below," *QST*, Sept., 1936, p. 22.
- \* 6. "New Transmitting Tubes—Type 826," *QST*, Feb., 1941, p. 31.
- \* 7. Haller, "The Design and Development of Three New UHF Transmitting Tubes," *Proc. I.R.E.*, v. 30, p. 20 (Jan. 1942).
- \* 8. RCA Guide for Transmitting Tubes, 1941 edition.
- \* 9. Samuel, "A Negative Grid Triode Oscillator and Amplifier for UHF," *Proc. I.R.E.*, v. 25, p. 1243 (Oct. 1937).
- \* 10. Lindenblad, "Development of Transmitters for Frequencies Above 300 Mc.," *Proc. I.R.E.*, v. 23, p. 1013 (Sept. 1935).
- \* 11. Wolf, Linder and Braden, "Transmission and Reception of Centimeter Waves," *Proc. I.R.E.*, v. 23, p. 11 (Jan. 1935).
- \* 12. Linder, "Description and Characteristics of the End-Plate Magnetron," *Proc. I.R.E.*, v. 24, p. 633 (Apr. 1936).
- \* 13. Kilgore, "Magnetron Oscillators for the Generation of Frequencies between 300 and 600 Mc.," *Proc. I.R.E.*, v. 24, p. 1140 (Aug. 1936).
14. Chang and Chaffee, "The Characteristics of the Negative Resistance Magnetron Oscillator," *Proc. I.R.E.*, v. 28, p. 519 (Nov. 1940).
15. Okabe, "Electron Beam Magnetrons and Type B Magnetron Oscillations," *Proc. I.R.E.*, v. 27, p. 24 (Jan. 1939).
- \* 16. "New Transmitting Tubes — RCA 825, Inductive-Output Amplifier," *QST*, Sept., 1940, p. 78.
- \* 17. Haefl and Nergaard, "A Wide Band Inductive Output Amplifier," *Proc. I.R.E.*, v. 28, p. 126 (Mar., 1940).
- \* 18. Hahn and Metcalf, "Velocity Modulated Tubes," *Proc. I.R.E.*, v. 27, p. 106 (Feb. 1939).
19. Hahn, "Small Signal Theory of Velocity Modulated Electron Beams," *Gen. Elec. Review*, v. 42, p. 258 (June 1939).
20. Ramo, "The Electronic Wave Theory of Velocity Modulated Tubes," *Proc. I.R.E.*, v. 27, p. 757 (Dec. 1939).
21. Webster, "Cathode Ray Bunching," *Jour. App. Phys.*, v. 10, p. 501 (July 1939).
22. Webster, "The Theory of Klystron Oscillations," *Jour. App. Phys.*, v. 10, p. 864 (Dec. 1939).

# KENYON

IS UP TOP "DOWN UNDER" TOO

Kenyon transformers . . . recognized everywhere as being of superior design . . . are "up front" because of the way they are made. When a transformer bears the name of Kenyon you know that it contains the finest of materials and workmanship.

Whether it's a small "A" line unit or a large oil cooled type for modulation, plate and filament supplies, Kenyon can provide the answer to your problem.

**KENYON TRANSFORMER CO., Inc.**  
20 HARRY STREET NEW YORK, N. Y.



wire wound  
**PRECISION  
RESISTORS**  
**Super DAVOHM**

Recommended for use in exacting equipment where accuracy, stability and dependability over long periods of time are of prime importance. Accuracies from  $\pm 1\%$  to  $\pm 0.1\%$  are available.

The Daven catalog lists the most complete line of precision attenuators in the world; Broadcast, sound picture, television and electrical apparatus components, as well as Laboratory Test Equipment.

PRICES AND LITERATURE UPON REQUEST

**THE DAVEN COMPANY**  
158 SUMMIT STREET • NEWARK, N. J.

**YOU MAY NEVER AGAIN  
HAVE THIS  
OPPORTUNITY**

Here is a real opportunity! Radio Code Operators are in demand right now. . . You can have a real place with the Army, Navy, Merchant Marine, or in civilian industry. It's easy to learn to be a Radio Code Operator without leaving your own home. . . You can learn by the Candler System and take advantage of their quarter of a century of success. The Candler System shows you all the short cuts . . . it's easy and very practical. Thousands of successful Candler graduates attest to its thorough teachings . . . find out today, a post card will do — no salesman will call upon you . . . *Send a post card now!*

#### YOUR FREE BOOK

Candler's FREE BOOK OF FACTS is waiting for you — send for your copy today! Find out all the inside facts about learning radio code or boosting code proficiency. It's a fascinating story — Write for your copy today! . . . There's no obligation.



**CANDLER  
SYSTEM COMPANY**

Box 928, Dept. Q-7, DENVER, COLORADO



Priorities  
Perhaps  
maybe  
guess so  
no  
war orders  
uncertain

## YES you can get an ECHOPHONE

New receivers getting scarcer than hen's teeth. Send your order for an Echophone today! Will ship promptly.

EC-1 \$24.50; EC-2 \$42.50; EC-3 \$59.50

A receiver bargain of the year if there ever was one. ACT NOW!

### ARE YOU SET FOR 2½m?

Five models to choose from. Thousands of parts to build 'em from. Write for complete information and prices. (Leo W9GFQ)

Buy the best "ham" insurance in the world: U.S. War Bonds and Stamps.

### FREE CATALOG

Fully illustrated. Everything in radio for the "ham" and service man. You should have one.

## WHOLESALE RADIO LABORATORIES

746 West Broadway

Council Bluffs

Iowa

## NO PRIORITY REQUIRED

### RCA BEAT FREQUENCY AUDIO OSCILLATOR

• IMMEDIATE DELIVERY •

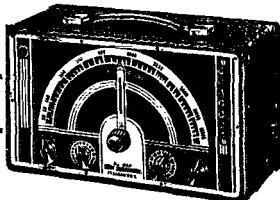

RCA No. 154... The RCA Beat-Frequency Audio Oscillator is a precise instrument for audio testing. Output frequency of from 30 to 15,000 cycles—more than the range of the finest radio receivers—makes the RCA Model 154 ideal for running fidelity curves on receivers, amplifiers and loud-speakers. Complete with 5 RCA tubes . . . . . **\$57.50**

## TERMINAL RADIO CORP.

85 Cortlandt Street New York, N. Y.  
Telephone: WOrth 2-4416

(Continued from page 98)

23. Condon, "Electronic Generation of Electromagnetic Oscillations," *Jour. App. Phys.*, v. 11, p. 502 (July 1940).
- \*24. R. H. and S. F. Varian, "A High Frequency Oscillator and Amplifier," *Jour. App. Phys.*, v. 10, p. 321 (May 1939).

## Panoramic Adapter

(Continued from page 81)

the screen, since all vertical deflections will be upward when supplied from the output of the 6SQ7.

### R.F. and I.F. Alignment

A test oscillator is practically a necessity for the preliminary alignment of the r.f. and i.f. amplifiers, if only to get them on the right frequency. (A 100-kc. oscillator or frequency standard can be used as a substitute in aligning the i.f. stage.) The i.f. should be aligned first, tuning the trimmers in  $T_3$  and  $T_4$  for maximum response throughout. As a trimmer is tuned through resonance the line on the cathode-ray tube screen will move upward, the extent of the movement indicating the amplitude of the output voltage from the 6SQ7. As all four tuned circuits in  $T_3$  and  $T_4$  are brought into line it may be necessary to decrease the strength of the test signal occasionally to keep the line on the screen.

The r.f. circuits ( $T_1$  and  $T_2$ ) can be aligned with the help of a test oscillator tuned to the intermediate frequency in the receiver. Connect the oscillator output between the plate of the 6SJ7 amplifier and ground, using a blocking condenser in the hot lead to isolate the plate voltage. Then adjust  $C_{29}$  in the oscillator transformer,  $T_5$ , to give a beat of 100 kc., which will be amplified and give maximum deflection on the cathode-ray tube screen. The sweep control,  $R_{35}$ , should be set at zero so that the oscillator will not be frequency modulated. Adjust the secondary trimmer in  $T_2$  for maximum response. Then move the test oscillator output to the grid of the 6SJ7 and adjust the primary trimmer of  $T_2$  to resonance. Align  $T_1$  similarly with the test oscillator connected between ground and the clip which goes to the receiver mixer plate prong. This gives a preliminary line-up at the receiver i.f. frequency.

The next step is to adjust the oscillator sweep, and for the sake of illustration we will assume that the receiver i.f. is 456 kc., although it should be understood that the actual frequency will be used in the practical case. With the test oscillator at 456 kc., and with the sweep padder,  $R_{35}$ , at about half scale, increase  $R_{25}$  slowly from zero. As the amplitude of the sweep voltage applied to the grid of the 6AC7 reactance modulator increases, the pattern on the cathode-ray tube screen should change, showing the signal as a hump on the horizontal base line, which should move downward to the position it had originally when no signal was applied to the vertical plates. A suitable height for the signal trace can be ob-



# TWO IRONS IN THE FIRE

● While endeavoring, first, to be of all possible service in the wartime production emergency, the Astatic Corporation at the same time is making an earnest effort to supply users, through authorized jobbers, with Astatic replacement parts for existing radio, phonograph and sound equipment. *Shortage of certain materials makes it necessary that all purchases of Astatic pickup or microphone cartridges be accompanied by old cartridges of similar type.*

## ASTATIC

SEE YOUR RADIO  
PARTS JOBBER

# THE ASTATIC CORPORATION

Licensed Under Brush  
Development Co. Patents

YOUNGSTOWN, OHIO

In Canada  
Canadian Astatic Ltd.  
Toronto, Ontario.

## THE *Minilog* IS THE ANSWER TO **WEBS!**

THE MINILOG is the perfect answer to FCC requirements for log-keeping in the new War Emergency Radio Service. Taking maximum advantage of all short-cuts permitted by the regulations, it answers the special need for compactness and convenience in portable and portable-mobile operation so vital in civilian defense, state guard, and similar communication.

4 x 6 INCHES     SPIRAL BOUND  
60 PAGES

25 cents postpaid  
(No Stamps, Please)

AMERICAN RADIO RELAY LEAGUE  
West Hartford, Connecticut

## *Kleinschmidt or Creed Perforators*

I would like to buy some, regardless of condition, because I can rebuild them. Will pay cash and a liberal price.

If you are interested in the finest of radio-telegraph apparatus—and no maybe about it—write for my latest catalog. Transmitters for schools, etc., ink recorders, auto heads, etc.

**TED MCELROY**

**McELROY MFG. CORP.**

82 Brookline Avenue Boston, Mass.

# LEARN WIRELESS and TELEGRAPHY!

A BOOK EVERY AMATEUR  
SHOULD HAVE —

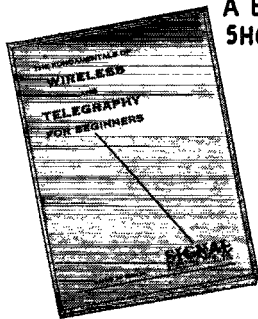

Hundreds of amateurs have  
learned from this book,  
so can you.

Send Now

**15¢**  
POSTPAID  
COIN, OR  
STAMPS

This book gives you the fundamentals of wireless and telegraphy. It contains the codes and how to learn them. Mail your order now to:

**SIGNAL ELECTRIC MFG. CO., Menominee, Mich.**

ESTABLISHED  
1892



**NOW . . . THE MATH YOU NEED**  
to solve everyday radio  
and electrical problems  
**IN THIS NEW BOOK**

Out of the U. S. Navy Radio Materiel School at Anacostia Station comes a complete home-study text that teaches you mathematics from elementary algebra through quadratic equations, logarithms, trigonometry, plane vectors and elementary vector algebra with direct applications to electrical and radio problems.



**Just Out! MATHEMATICS for  
ELECTRICIANS and RADIOMEN**

Based on more than 8 years' experience teaching mathematics to U. S. Navy electricians and radio operators. By N. M. Cooke, Chief Radio Electrician, U. S. Navy. 604 pp., 6 x 9, \$4.00.

**10 DAYS' FREE EXAMINATION**

McGraw-Hill Book Co., Inc., 330 W. 42nd St., New York

Send me Cooke's Mathematics for Electricians and Radiomen for 10 days' examination on approval. In 10 days I will send you \$4.00 plus few cents postage or return book postpaid. (We pay postage if you remit with order.)

Name.....  
Address.....  
City and State.....  
Position.....  
Company..... *QST 7-42*

(Continued from page 100)

tained by adjustment of the gain control,  $R_2$ , or the output of the test oscillator.

Should the signal trace not be in the center of the screen, or should it move horizontally as the sweep amplitude is increased (either or both probably will be the case at first trial), adjust  $C_{29}$  while varying  $R_{35}$  until the signal remains fixed in position on the horizontal base line, regardless of the setting of  $R_{35}$ . When the proper adjustment is found the signal will not necessarily appear in the center of the screen, but it can be brought to center by readjusting the horizontal positioning control,  $R_{19}$ . The phasing control ( $C_{18}$ ) adjustment is not at all critical, and this control may be set simply near but not quite at maximum capacity.

With a 456-kc. signal centered on the screen, tune the test oscillator slowly toward 506 kc., watching the signal trace move horizontally on the screen as the oscillator frequency is changed.  $R_{35}$  should be set at maximum. With the oscillator frequency at 506 kc. the signal trace should be just at the edge of the screen; if it is not, it can be brought there by adjustment of the sweep padder,  $R_{36}$ . Tuning in the opposite direction to 406 kc. then should move the trace to the opposite end of the screen. When this adjustment is made the maximum sweep will be 100 kc. It may be set at any desired figure between 100 and zero kc. by adjustment of  $R_{35}$ .

In this test the amplitude of the signal race probably will vary considerably as the input frequency is varied. The next and final step in adjustment is to align  $T_1$  and  $T_2$  to compensate for the r.f. selectivity of the receiver. Set the receiver at about 3 Mc., set the test oscillator to the same frequency and tune the signal to the center of the screen, using the regular receiver tuning control. Then move the test oscillator frequency 50 kc. higher or lower, putting the signal at one edge of the cathode-ray tube screen. Note the amplitude as compared to the amplitude at the center, and adjust the i.f. transformer trimmers to make the amplitude approximately equal to that at the center. Then move the test oscillator 50 kc. on the other side of the center frequency and readjust the trimmers to make the amplitude equal to that at the center. This will upset the first adjustment, so it will be necessary to go back and forth, making compromise adjustments which finally result in making the gain as uniform as possible over the whole 100-kc. band. The desirable condition, of course, is one in which the height of the test signal does not change as the frequency is varied over the 100-kc. range. Probably it will not be possible to get perfect compensation, but there should be no difficulty in coming reasonably close to it. At frequencies higher than 3 Mc. it is to be expected that the signal amplitude will increase toward the edges of the pattern, and that it will decrease at frequencies lower than 3 Mc.

The frequency-modulated oscillator in the unit provides an excellent means for final alignment of the 100-kc. amplifier. Tune in a test signal to the center of the screen and adjust the trimmers in



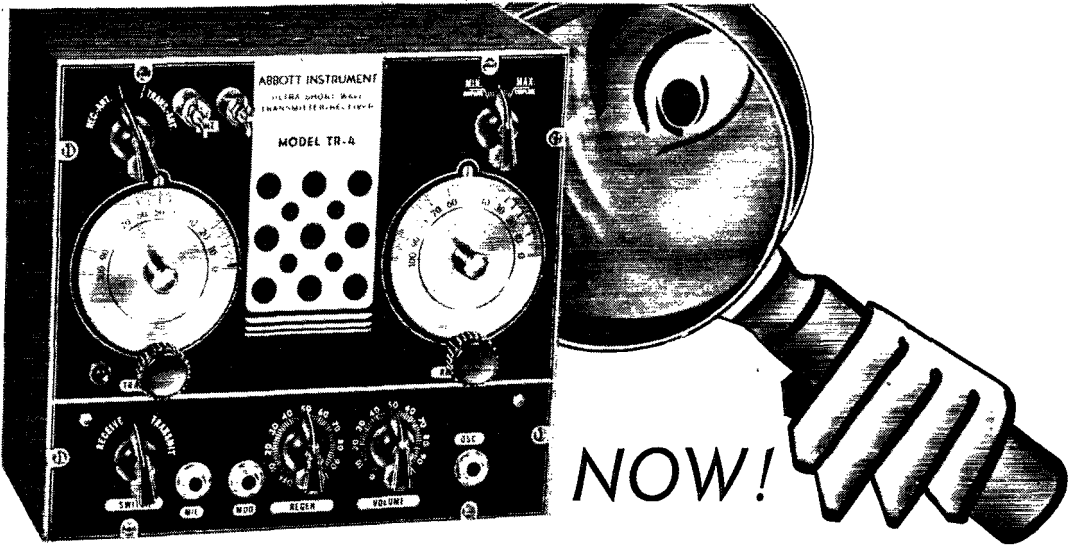

Additional facilities are now available for increased production of ABBOTT ultra-high frequency transmitters and receivers. May we quote on your requirements?

# ABBOTT INSTRUMENT, INC.

8 WEST 18 STREET-NEW YORK, N. Y.

**TODAY... and Tomorrow**

Today's jobs sometimes necessitate changes in form for B&W Air Inductors and Variable Air Condensers—but not in the quality upon which the B&W reputation has been built. Priorities call for full attention on war production—but not to the exclusion of remembering our old friends in amateur radio. When the present job is done—and it will be done!—we'll have some interesting developments to show you.

**BARKER & WILLIAMSON**  
Radio Manufacturing Engineers • 235 FAIRFIELD AVE., UPPER DARY, PA.

## BUY NOW! SAVE MONEY \$1.95 BIG VALUE HIGH VOLTAGE POWER TRANSFORMERS

Guaranteed as illustrated. Made by a big transformer manufacturer.

No. 1549 — 300-0-300...100 Ma. 6.3 V.-3 amp; 5.0 V.-3 amp. .... \$1.95

No. 4140 — 600-0-600 V. — 200 Ma. Filaments: 7.5 V.C.T.-3 A. — 5.0 V.C.T.-3 A. — 2.5 V.C.T.-10 A. Wt. 8½ lbs. .... \$3.45

No. 4240 — 600-0-600 V. — 200 M.A. Filaments: 6.3 V.-4 A. — 6.3 V.-3 A. — 5.0 V.-3 A. Wt. 8½ lbs. .... \$3.45

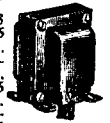

## OIL FILLED AND IMPREGNATED FILTER CONDENSERS

Oil Filled and Oil Impregnated condensers still available at pre-war prices! Real quality too. Guaranteed at Rated Voltage.

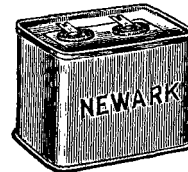

Mfd.	Volts	DC.	Size	Price
1	1000	5	x 3½ x 1½	\$ .59
2	2000	4½	x 3½ x 1½	1.50
8	2000	5	x 3½ x 3½	2.75
4	3000	5	x 3½ x 3½	3.75

**HURRY! ORDER YOURS NOW!**

Write today for **FREE CATALOG!** **DEFENSE FIRST! BUY WAR SAVINGS BONDS AND STAMPS!**

Enclose Dime and get **YOUR CALL LETTERS IN GOLD 2" Decals**—For your Ham Shack!

**ORDER YOUR NEEDS TODAY** from Newark's big stock of **RADIO PARTS**. We have everything you need at the prices you want to pay. Full line **HALLICRAFTERS RECEIVERS** Now in Stock.

**NEWARK ELECTRIC COMPANY**  
323 W. Madison Street Dept. Q Chicago, Illinois

We have a large stock of

## HALLICRAFTERS HAMMARLUND RME

HOWARD

**RECEIVERS, transmitters and all radio supplies of all sorts** at lowest wholesale prices. Order from us for immediate delivery. We specialize in Government and other priority orders and solicit such buyers, as well as civilian and all other customers.

- You get 10-day trial
- YOU get best trade-in

We also have a store at 2335 Westwood Blvd., West Los Angeles, Calif. Write, phone, telegraph us anytime about any radio supplies. It will pay you to deal with us. Your inquiries invited.

## HENRY RADIO SHOP

Butler, Missouri

"World's Largest Distributors of Communications Receivers"

(Continued from page 102)

$T_3$  and  $T_4$  to give the sharpest and most symmetrical pattern. The signal on the screen is actually a trace of the selectivity curve of the 100-ke. amplifier, and corresponds exactly to the *similar* type of trace obtained when aligning an ordinary superhet with the aid of a frequency-modulated test oscillator and oscilloscope.

There is no special reason why the various sections of the adapter cannot be separated if that type of construction is more convenient. It would be possible, for instance, to build the r.f. and i.f. sections (including the reactance modulator and 6SQ7 detector) as one unit and to put the 902 and the sweep circuit in another, including the power supply in the latter if desired or making it still another unit. With minor circuit modifications the 902, sweep and power supply could be incorporated into an oscilloscope, making some of the circuits at least do double duty. Or if an oscilloscope with a low-frequency sweep is already available it should readily be possible to modify it slightly to make it usable for panoramic reception with an r.f.-i.f. unit, thus obviating the necessity for constructing part of the complete circuit. Such modifications will depend upon the particular circuits used in the oscilloscope, but should not offer any particular complications. The chief requirements would be to be able to take out a little of the sweep voltage and apply it to the reactance modulator grid, and to provide a straight-through (d.c.) path to the vertical plates of the 'scope.

## LEARN TO SEND AND RECEIVE CODE

Learn to send and receive code signals, like operators on ships at sea and at commercial and amateur land stations. Intercept distress signals, news flashes, bulletins, and dozens of other kinds of interesting radio communications.

MASTER TELEPLEX teaches you to receive code exactly the way the world's best operators do — by sound. A specially prepared paper tape, running through a machine, operates an automatic key which sends messages to you, at any speed you desire. There are NO PERFORATIONS — NO INK. A marvel of simplicity. As you improve in speed, the machine sends faster, gradually preparing you for top-speed amateur and commercial signals. With the new All Electric MASTER TELEPLEX you learn to send by sending and the signals you send are repeated back to you, exactly as you sent them, thus enabling you to correct your own errors. We furnish a complete course, lend you the improved All Electric MASTER TELEPLEX and give you personal instruction with a MONEY BACK GUARANTEE. Send for our new TELEPLEX FOLDER Q1 today. IT'S FREE.

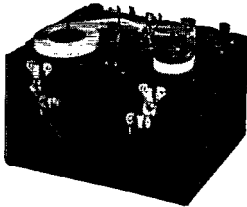

Standard Teleplex — a highly efficient code teacher using heavy specially prepared waxed paper tape, having two rows of perforations. Write for Free folder "Q-7"

"HAM" SPECIAL  
**TELEPLEX CO.** 107 HUDSON STREET  
JERSEY CITY, N. J.

## SICKLES COILS

ALL TYPES OF RF AND IF WINDINGS

Manufactured by

F. W. SICKLES COMPANY

P. O. Box 920

Springfield, Mass.

## WHAT TYPE OF RADIO INSTRUCTION DO YOU NEED?

new

### 1. A QUICK REVIEW

PRE-EXAMINATION TESTS FOR RADIO OPERATORS is the most comprehensive review ever offered. Shows what you know. Tells you what to study. Hundreds of questions. Separate set on each F.C.C. element (2 to 6). Used in conjunction with textbooks RADIO OPERATING QUESTIONS AND ANSWERS and PRACTICAL RADIO COMMUNICATION, it prepares you for license examinations in shortest possible time. Helps avoid failure. Very low cost. Send for circular 5Q on QUICK RADIO REVIEW—TODAY.

### 2. COMPLETE COURSE

Nilson's MASTER COURSE IN RADIO COMMUNICATION — fits you for job, advancement, or license examination. Best home-study course for the man who needs basic training. Covers entire field, same scope as resident school course. Low cost. Nilson graduates have high record of success on license examinations and on jobs. FREE circular 3-Q gives full information. Write TODAY.

NILSON RADIO SCHOOL, 51 East 42nd St., New York

# "Learning the Radiotelegraph Code"

**New and Important Addition to the  
League's Radio Training Literature**

**D**ESIGNED to train students to handle code skillfully and with precision, both in sending and in receiving, this booklet takes first rank among the League's publications which meet today's special training needs. Written by John Huntoon, outstanding crack operator and authority on teaching code, in collaboration with other members of the League Headquarters Staff, it responds to a wide demand for an authoritative and comprehensive text on this important subject. Employing a novel system of code-learning based on the accepted method of

sound conception, it is particularly excellent for the student who does not have the continuous help of an experienced operator or access to a code machine. It is similarly helpful home-study material for members of code classes. Adequate practice material is included for classwork as well as for home-study. There are also helpful data on high-speed operation, typewriter copy, general operating information—and an entire chapter on tone sources. For code practice, including the description of a complete code instruction table with practice oscillator.

*25 Cents Postpaid (NO STAMPS, PLEASE)*

**AMERICAN RADIO RELAY LEAGUE, INC. WEST HARTFORD CONNECTICUT**

QUALITY ABOVE ALL  
**SOLAR**  
CAPACITORS  
Write for Catalog  
SOLAR MFG. CORP.  
BAYONNE, N. J.

**Hams, Defense School Students and Gov't Men**



**Ayers Automatic Code Machines**  
Dept. Q-7, 711 Boylston Street, Boston, Mass.

are learning the code the right way, quickly and easily with the all electric Ayers machine. Built by Code Champion McElroy for our future champions. Largest selection of tapes in World available with each machine. Low monthly rental. Tapes for MacAutos, recording slip and special inks for sale.

**CRYSTALS  
EXCLUSIVELY**



**SINCE  
1934**

**ORDER  
Subject to Priority**

**PETERSEN RADIO CO., Council Bluffs, Iowa**

**HARVEY** RADIO LAB'S, Inc.  
**Manufacturers of  
Radio Transmitters**

**ELECTRONIC APPARATUS**

**447 CONCORD AVENUE, CAMBRIDGE, MASS.**

## **KLEINSCHMIDT OR CREED PERFORATORS**

**I WOULD LIKE TO BUY SOME, REGARDLESS OF CONDITION, BECAUSE I CAN REBUILD THEM. WILL PAY CASH AND A LIBERAL PRICE**

**If you are interested in the finest of radio-telegraph apparatus—and no maybe about it—write for my latest catalog. Transmitters for schools, etc., ink recorders, auto heads, etc.**

**TED McELROY, McELROY MFG. CORP., 82 BROOKLINE AVE., BOSTON, MASS.**

**"BUT I'M PRACTICALLY A WIDOW SINCE HOGARTH GOT HIS ECHOPHONE EC-1"**



***Echophone Model EC-1***

6 tubes, 3 bands. Tunes from 550 kc. to 30 mc. Beat frequency oscillator. Bandsread logging scale. Self-contained speaker. Electrical bandsread on all bands. AC/DC. 115-125 volts. ECHOPHONE RADIO CO., 201 EAST 26TH ST., CHICAGO, ILLINOIS

# HAM-ADS

(1) Advertising shall pertain to radio and shall be of nature of interest to radio amateurs or experimenters in their pursuit of the art.

(2) No display of any character will be accepted, nor can any special typographical arrangement, such as all or part capital letters be used which would tend to make one advertisement stand out from the others.

(3) The Ham-Ad rate is 15¢ per word, except as noted in paragraph (6) below.

(4) Remittance in full must accompany copy. No cash or contract discount or agency commission will be allowed.

(5) Closing date for Ham-Ads is the 25th of the second month preceding publication date.

(6) A special rate of 7¢ per word will apply to advertising which, in our judgment, is obviously non-commercial in nature and is placed and signed by a member of the American Radio Relay League. Thus, advertising of bona fide surplus equipment owned, used and for sale by an individual or apparatus offered for exchange or advertising inquiring for special equipment, if by a member of the American Radio Relay League takes the 7¢ rate. An attempt to deal in apparatus in quantity for profit, even if by an individual, is commercial and all advertising by him takes the 15¢ rate. Provisions of paragraphs (1), (2), (4) and (5) apply to all advertising in this column regardless of which rate may apply.

Having made no investigation of the advertisers in the classified columns, the publishers of *QST* are unable to vouch for their integrity or for the grade or character of the products advertised

\* \* \* \* \*

Gear is short. You can sell your old and extra gear through Ham-Ads.

\* \* \* \* \*

**QUARTZ** — direct importers from Brazil of best quality pure quartz suitable for making piezo-electric crystals.

**Diamond Drill Carbon Co.**, 719 World Bldg., New York City.

**COMMERCIAL** radio operators examination questions and answers. One dollar per element. G. C. Waller, W5ATV, 6540 Washington Blvd., Tulsa, Okla.

**TELEPLEXES**, Instructographs bought, sold. Ryan's, Hanibal, Mo.

**QSL'S**, SWL's. Theodore Porcher, 7708 Navajo, Philadelphia.

**SELL**, in interest of national defense effort, commercial H.D. type components for high power xmitters or complete units. UTC, Thordarson, Eimac, Dunco, Weston, Triplett, etc. Perfect condition, little used. No junk. Box 708, Enid, Okla.

**WANTED**: radio operators for Merchant Marine, must have commercial license, wages \$275 to \$325 monthly. Radio Officers' Union, 265 West 14th St., New York, N. Y.

**SWAP** — Incomplete QSTs 1926-1942 for 35 mm. camera. Corp. Robert Howe, Co. A, 113th Infantry, Mitchell Field, N. Y.

**WANTED**: Meissner 9-1000 push-button tuners or equal. A-1 condition. Give price and description. Grubb, 236 Paiko Drive, Honolulu, T. H.

**LICENSED** operators, qualified for broadcast studios or transmitters. Vacancies. Note FCC Orders 91 & 91-A. Write American Communications Association, 1626 Arch St., Philadelphia, Pa.

**WANTED**: one used Meissner Signal Shifter, will render cash for same. Pfc. W. C. Peters, 145th Arm'd Signal Co., Camp Cooke, APO 255, Lompoc, Calif.

**SELL**: 3 in. RCA cathode ray oscilloscope, in original carton, \$54.50 f.o.b. Also an exceptionally good RCA ACR175 receiver, \$99.50. Dwight Stebbins, Morris, Minn.

**WANTED**: Riders' Manuals, all volumes. W9TWO. Ernest Rufing, 610 Sloan St., Peoria, Ill.

**OLD QSTs**. Buy — sell 1915/41. Files or single copies. W6SN.

**WE** pay cash immediately for used communications receivers and transmitters. Write, telephone, telegraph description. Henry Radio Shop, Butler, Mo.

**WE** still have a large stock of communications receivers, transmitters, code teaching equipment, tubes, transformers, condensers, Vibroplexes, radio supplies of all sorts. You get lowest prices, ten day trial. Your inquiries and orders invited. Henry Radio Shop, Butler, Mo., and 2335 Westwood Blvd., W. Los Angeles, Calif.

**RECONDITIONED** guaranteed communications receivers and transmitters. All makes and models cheap. Free trial. List free. Henry Radio Shop, Butler, Mo.

Urgently required for defense — small quantity of Cardwell Type XR1000PS 43 plate condensers. Write W. J. Brown, 1106 Bromley Avenue, West Englewood, N. J.

**HAMMARLUND** HQ-120-X. McElroy speed key. Richard Storrs, Rocky Hill, Conn.

**CRYSTALS**: General communication frequencies, high quality commercial units meeting FCC requirements. New type E62 and E64 Steatite units now available, smaller and better. Suitable for frequencies in the 1600 to 10,000 kilocycle range. Good advice: place your orders early and with highest priority obtainable — regardless of your supplier. Eidson's, Temple, Texas (Phone 3901).

**WANTED** — good tube and set tester. Also signal generator. WINFT.

**IF** you are a ham and have had four years of combined drafting school training and commercial drafting and want to work for a large airline, send in a record of your schooling and experience to P. O. Box 697, LaGuardia Field, New York Airport Station, New York, N. Y.

**RADIO** headquarters — tremendously large stock of receivers (over 200 on hand), transmitters — all sizes, transceivers — over five different models, radio parts of all kinds. Write to Leo, W9GFG, for that big bargain catalog and reconditioned receiver list today. Wholesale Radio Laboratories, Council Bluffs, Iowa.

**WANTED** — Deluxe Signal Shifter, cash. Give particulars. Earl Lindberg, Maxwell, Nebr.

## PREPARE YOURSELF FOR A COMMERCIAL RADIO POSITION

through a Home Study Course, written for the man who has forgotten higher mathematics and who has had a non technical education. This course qualifies you to pass the Federal Radio Telegraph and Telephone Examinations. An easily read, easily understood course. Moderate tuition fee. Write for particulars.

American Radio Institute, 1123 Broadway, N. Y.

## GOOD JOBS in RADIO for young men age 17 to 20

As older men leave for the Army, RADIO calls for recent high school graduates. Prepare now for jobs in Radio Engineering; Broadcasting; Marine, Aviation, Police Radio; Servicing; Radio Manufacturing. Our streamlined courses give excellent preparation for Army and Navy Service. Expenses low. Write for free catalog.

**THE DODGE TELEGRAPH & RADIO INSTITUTE**  
408-1 Monroe St., Valparaiso, Indiana

## COMMERCIAL RADIO INSTITUTE

A radio training center for over twenty years. Well equipped. Excellent faculty. Practical resident courses in Radiotelegraphy, Broadcast, Servicing, Television, Aeronautical Drafting, Mathematics, Industrial and Studio Technique. Placement bureau. Fall classes now forming for October 5th. Send for catalog. Dept. B.

38 WEST BIDDLE STREET, BALTIMORE, MARYLAND

## LEARN RADIO • TELEVISION

60-page catalog on request. Oldest, largest and best equipped in New England. New classes now forming. Write for new catalog.

**MASS. RADIO SCHOOL**  
18 Boylston Street Boston, Massachusetts

## RADIO TECHNOLOGY



RCA Institutes offer an intensive course of high standard embracing all phases of Radio and Television. Practical training with modern equipment at New York and Chicago Schools. Also specialized courses in Aviation Communications, Radio Servicing and Commercial Operating. Illustrated Catalog on request.

**RCA INSTITUTES, INC.** Dept. ST-42

A Radio Corporation of America Service

75 Varick St., New York 1154 Merchandise Mart, Chicago

Radio Amateurs!  
Radio Servicemen!  
Radio Engineers!

# Be a **RADAR** Specialist with the United States Navy . .

*Here is your opportunity to serve your country and advance yourself at the same time. The U. S. Navy needs 5,000 picked men to install, operate, maintain and repair RADAR equipment—the secret ultra high frequency apparatus used to locate airplanes. If you are an Amateur, Serviceman or Engineer YOU may be eligible.*

*You go into the Navy as a Petty Officer with food, quarters, uniforms, medical and dental care supplied *plus* pay of from \$60.00 to \$106.00 monthly. After the*

*successful completion of eight months technical training you are eligible to immediate promotion to the rank of Chief Radioman with pay up to \$175.00 monthly the first year and up to \$200.00 per month thereafter—with opportunities to remain in the service permanently.*

*Go to your nearest Navy Recruiting Station TODAY (generally in your local post office) and find out how YOU can take advantage of your technical knowledge. THE NAVY NEEDS YOU!*

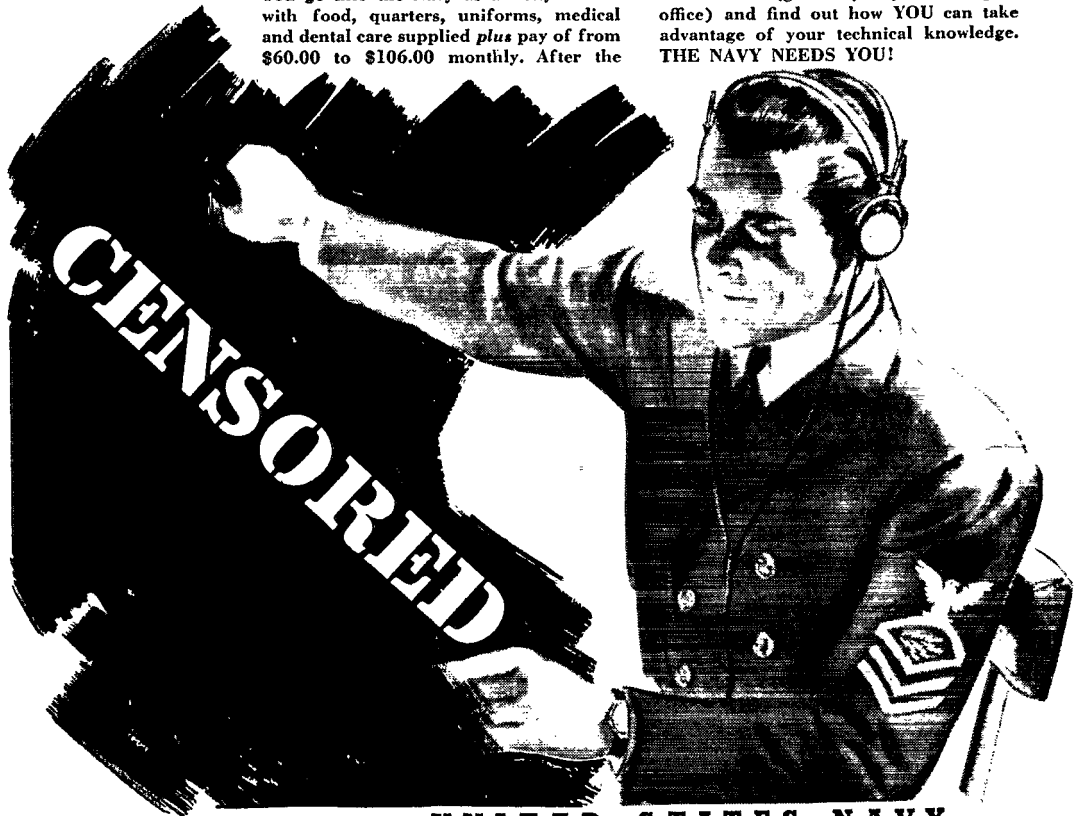

**UNITED STATES NAVY**  
*Ask at Your Local Post Office*

# Your Nearby Dealer Is Your Best Friend

Your nearby dealer is entitled to your patronage. He is equipped with a knowledge and understanding of amateur radio. He is your logical source of advice and counsel on what equipment you should buy. His stock is complete. He can supply your needs without delay. His prices are fair and consistent with the high quality of the goods he carries. He is responsible to you and interested in you.

One of these dealers is probably in your city — Patronize him!

## BALTIMORE, MARYLAND

Radio Electric Service Co.  
3 N. Howard St.  
Everything for the Amateur

## KANSAS CITY, MISSOURI

Burstein-Applebee Company  
1012-14 McGee Street  
"Specialists" in supplies for the Amateur and Serviceman

## BUFFALO, NEW YORK

Radio Equipment Corp.  
326 Elm Street  
W8PMC and W8NEL — Ham service and sound equipment

## KANSAS CITY, MISSOURI

Radiolab  
1515 Grand Avenue  
Amateur Headquarters in Kansas City

## BUFFALO, NEW YORK

Dymac, Inc.  
1531 Main Street — Cor. Ferry — GA. 0252  
One of the Largest Ham Supply Houses in Western New York

## MILWAUKEE, WISCONSIN

Radio Parts Company, Inc.  
538 West State Street  
Complete stock Nationally Known products

## CHICAGO, ILLINOIS

Allied Radio Corporation  
833 West Jackson Blvd.

Complete standard lines always in stock—W9IBC, W9DDM, W9AUK, W9BWP, W9CKD, W9JFM, W9SFW, W9TXZ

## NEW YORK, N. Y.

Harrison Radio Company  
12 West Broadway  
Harrison Has It! Phone WOrth 2-6276 for information or rush service

## CHICAGO, ILLINOIS

Chicago Radio Apparatus Company  
415 South Dearborn Street (Est. 1921)

W9RA and W9PST — Amateurs since 1909

## OAKLAND, CALIFORNIA

W. D. Brill Company  
198 10th Street  
W6KLO — The House of Parts — W6FJX

## DETROIT, MICHIGAN

Radio Specialties Company  
325 E. Jefferson Avenue  
Ham Supplies — National & Hammarlund Sets and Parts

## PROVIDENCE, RHODE ISLAND

W. H. Edwards Company  
85 Broadway  
National, Hammarlund, Hallicrafter, Thordarson, Taylor, RCA

## HARTFORD, CONNECTICUT

Radio Inspection Service Company  
227 Asylum Street  
What do you want? We have it. Radio exclusively

## ST. LOUIS, MISSOURI

Van Sickle Radio Company  
1113 Pine Street  
Owned and Operated by Amateurs

YOU CAN BE SURE  
WHEN YOU BUY FROM

**QST**

**ADVERTISERS**

“Advertising for *QST* is accepted only from firms who, in the publisher’s opinion, are of established integrity and whose products secure the approval of the technical staff of the American Radio Relay League.”

*Quoted from QST’s advertising rate card.*

*Every conceivable need of a radio amateur can be supplied by the advertisers in QST. And you will know the product has the approval of the League’s technical staff*

*Index to Advertisers*

Abbott Instrument, Inc. ....	103
American Lava Corporation .....	89
American Radio Institute .....	107
Amperex Electronic Products, Inc. ....	Cov. II
Astatic Corporation, The .....	101
Ayers Automatic Code Machines .....	105
Barker & Williamson .....	103
Biley Electric Company .....	80
Candler System Company .....	99
Capitol Radio Engineering Institute .....	82
Centralab .....	87
Commercial Radio Institute .....	107
Daven Company, The .....	99
Dodge Tele. & Radio Institute, The .....	107
Echophone Radio Company .....	106
Eitel-McCullough, Inc. ....	83
Hallicrafters Company, The .....	1, 2
Hammarlund Mfg. Company, Inc. ....	79, 81
Harrison Radio Company .....	96
Harvey Radio Company .....	84
Harvey Radio Laboratories, Inc. ....	105
Henry Radio Shop .....	104
Instructograph Company .....	98
Jensen Radio Mfg. Company .....	91
Kenyon Transformer Company, Inc. ....	99
Mallory & Company, Inc., P. R. ....	78
Massachusetts Radio School .....	107
McElroy Mfg. Corporation .....	92, 101, 105
McGraw-Hill Book Company, Inc. ....	86, 102
Meissner Mfg. Company .....	97
Millen Mfg. Company, Inc., James .....	92
National Company, Inc. ....	Cov. III, 77
Newark Electric Company .....	103
Nilson Radio School .....	104
Ohmite Mfg. Company .....	88
Petersen Radio Company .....	105
Port Arthur College .....	98
RCA Institutes, Inc. ....	107
RCA Mfg. Company, Inc. ....	Cov. IV
Radio Control Headquarters, Inc. ....	98
Radio Shack Corporation .....	111
Raytheon Mfg. Company .....	5
Shure Brothers .....	90
Sickles Company, F. W. ....	104
Signal Electric Mfg. Company .....	102
Solar Mfg. Corporation .....	105
Sprague Specialties Company .....	85
Sun Radio Company .....	94
Taylor Tubes, Inc. ....	93
Teleplex Company .....	104
Terminal Radio Corp. ....	100
Thordarson Electric Mfg. Company .....	112
United States Navy .....	108
United Transformer Company .....	7
Van Nostrand Company, D. ....	95
Wholesale Radio Laboratories .....	100
Vaxley .....	78



*Immediate Delivery*  
**NO SHORTAGE!**

*Echophone*



EC-1  
**\$24.50**



EC-2  
**\$42.50**

EC-3  
**\$59.50**



These fine Radio Receivers listed on this page are well suited for the boys in the service.

MAIL ORDERS PROMPTLY FILLED  
 WRITE FOR FREE CATALOG

**hallicrafter**



S-19-R **\$37.50**

**\$54.50** S-20-R

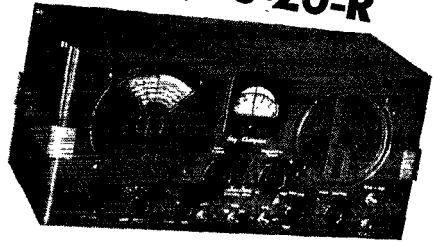

**The RADIO SHACK**  
 167 WASHINGTON ST., BOSTON, MASS., U.S.A.

# THORDARSON

*Quality  
Transformers*

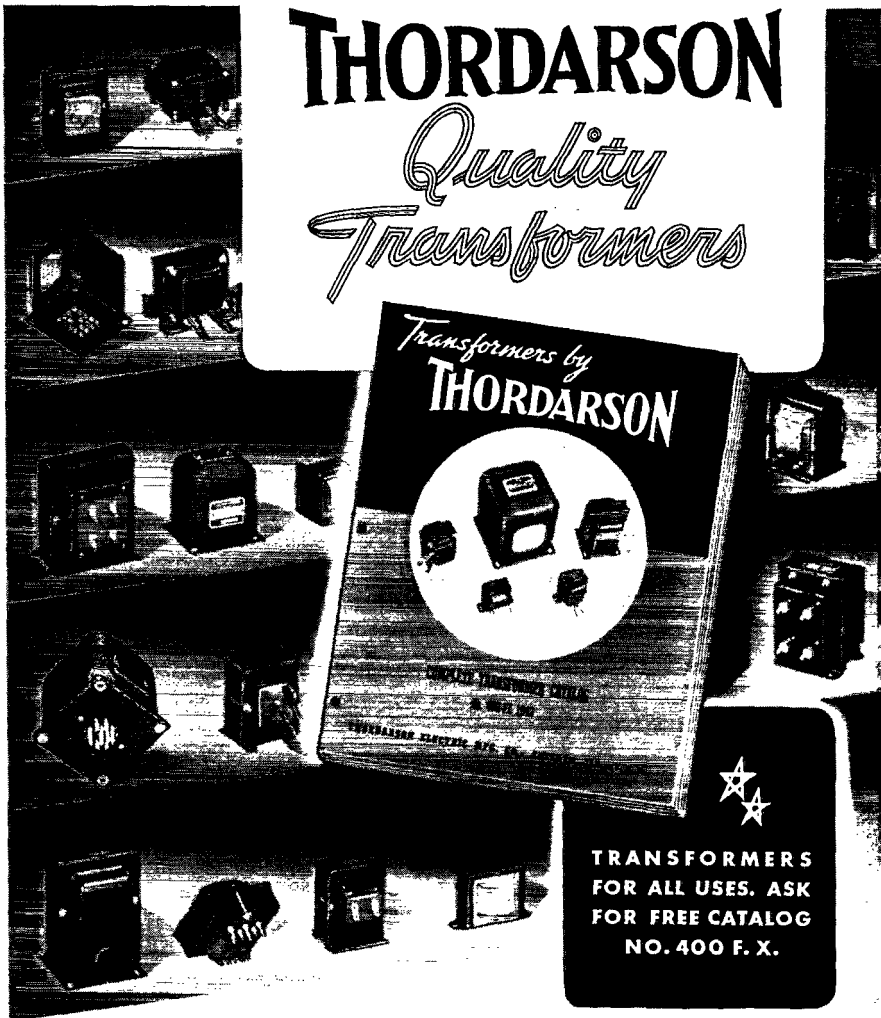

*Other catalogs available* are No. 500, illustrating and describing many types of transformers for broadcast, aircraft, military and other communications uses; Catalog No. 600 covers the complete line of Thordarson amplifiers. The Industrial Department will be glad to discuss with you special types of any characteristics, size or quantity.

## THORDARSON

ELECTRIC MFG. CO.

500 WEST HURON STREET • CHICAGO, ILLINOIS

**TRANSFORMER SPECIALISTS SINCE 1895**



# DOING A JOB



NATIONAL COMPANY, INC.

# 6 WAYS TO MAKE MERCURY-VAPOR TUBES LAST LONGER

No. 3 of a series devoted to extending the life of Transmitting Tubes which may be difficult to replace.

**W**HEN mercury-vapor rectifier tubes are operated at conservative ratings and in conjunction with properly designed smoothing filters, rectifier tube life is materially lengthened. However, there are at least six operating precautions which warrant careful consideration and which have an important bearing upon how long a rectifier tube will last:

★ Heat the tube adequately (without the application of high voltage) the first time it is used. To do this, merely run the filament at rated voltage for sufficient time to assure evaporation of all mercury from the tube bulb and mount before the plate voltage is applied. The reasons for this operation are: (a) liquid mercury that clings to any part of the mount may cause excessive mercury pressure at that point with resultant local arcs; (b) mercury globules that adhere to the anode may act as a pool cathode and cause arc-backs; (c) mercury condensed on the glass may cause mercury-vapor streamers which can produce excessive heating of the bulb.

★ Before putting a rectifier tube into service, always wipe the bulb clean to avoid leakage and resultant heating effects.

★ Before plate voltage is applied, always allow adequate time for pre-heating the cathode to insure

proper mercury-vapor pressure for the best operating conditions. Should the plate voltage be applied too soon, the cathode may be bombarded and harmed because of the high tube drop.

★ Use forced ventilation to obtain specified ambient temperatures as recommended on certain mercury-vapor tube types. On types where forced ventilation is not mentioned, its use may be desirable under some conditions of operation. For any mercury-vapor rectifier, the temperature of the mercury in the base of the tube should be kept within specified limits to insure proper vapor pressure for optimum operation. Too much pressure may cause arc-backs; too little pressure may cause cathode sputtering because the tube drop is high under such operation. Either condition reduces tube life.

★ Maintain filament voltage within the specified limits to provide the proper amount of barium at the surface of the cathode.

★ Limit arc-back current to a reasonable value by including protection in the equipment. Too severe an arc-back may prove disastrous.

Use the RCA Instruction Sheets as your guide to conservative transmitting tube use for long, dependable operation!



## Transmitting Tubes

PROVED IN COMMUNICATION'S MOST EXACTING APPLICATIONS

RCA MANUFACTURING CO., Inc., Camden, N. J. • A Service of The Radio Corporation of America