

QST

may, 1937
25 cents

devoted entirely to

amateur radio

In this Issue—

**DX Contest
Highlights**

**Directive
Antenna
Design**

**Midget U. H. F.
Equipment**

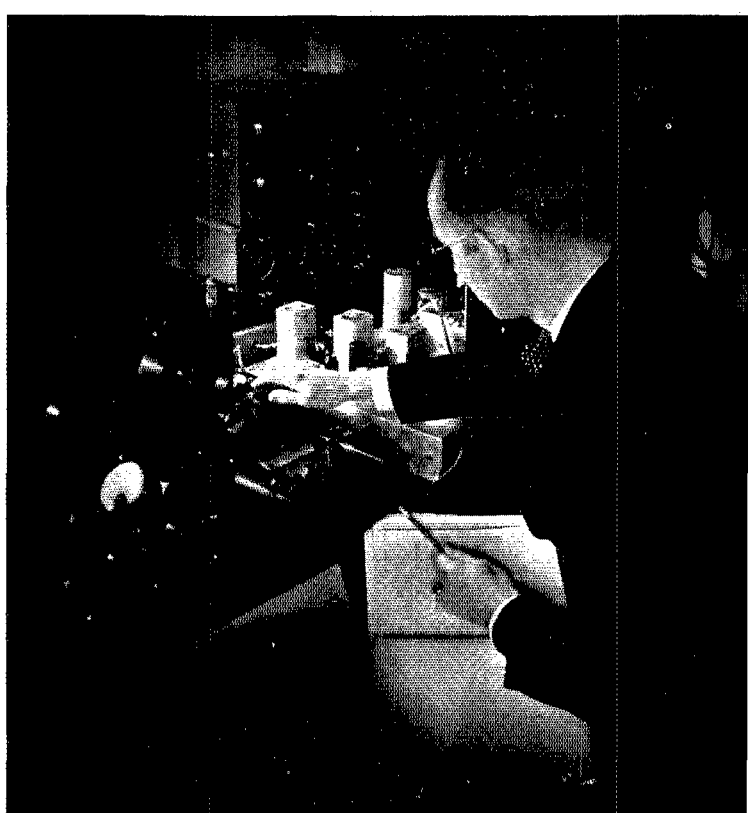



Collins plant is a busy place at any time. Just now, one section in particular is bustling with activity, keeping up with orders for the new 32G.

While we realized that this transmitter was in every way a superb engineering job, we were not prepared for the unusually cordial welcome given it by amateur and commercial users alike.

Incorporating many features usually found only in larger transmitters, the 32G is one of the sweetest jobs we have turned out. Please pardon our apparent immodesty when we say, "IN THE 32G WE'VE REALLY GOT SOMETHING."

COLLINS RADIO COMPANY

CEDAR RAPIDS, IOWA

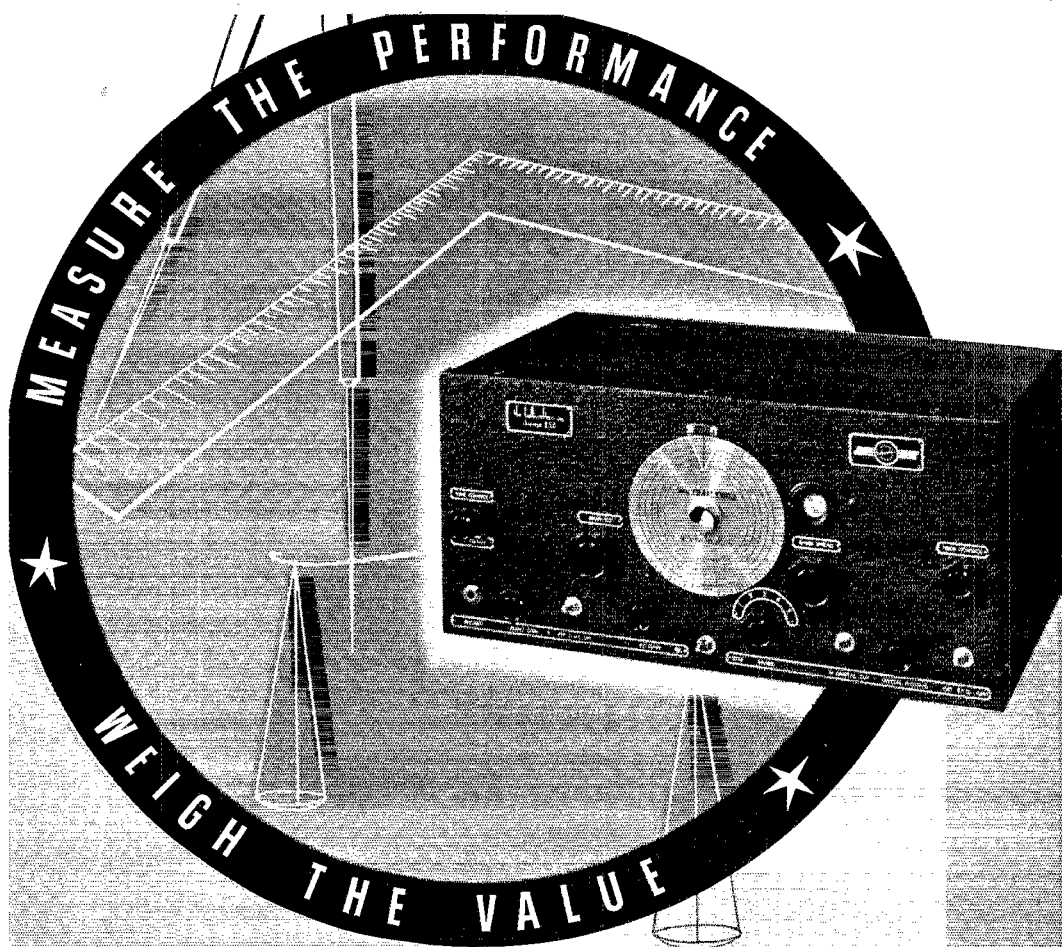

The SKY CHALLENGER

We challenge comparison! Into the Sky Challenger has gone the best efforts—the accumulated experience of many years of radio engineering and construction. Our objective was to make this receiver the greatest value in amateur radio. We have examined the result of our efforts and we find it good.

Now you be the judge—you make the comparison. Ask your dealer to cooperate with you—check the performance of the Sky Challenger against *any* receiver—in your hands lies the verdict.

AMERICA'S LEADING MANUFACTURERS OF COMMUNICATION RECEIVERS

the hallicrafters inc.

2611 Indiana Ave.

Cable Address "Hallicraft" Chicago

Chicago, U. S. A.

Say You Saw It in *QST* — It Identifies You and Helps *QST*

THE SKY BUDDY THE SKY CHIEF THE ULTRA SKY RIDER

THE SKY RIDER COMMERCIAL THE SKY CHALLENGER

YOU MUST HEAR THEM TO WORK THEM

It's the **HALLICRAFTER'S** equipped shack that pulls them in!

In the DX Contests, hundreds of amateurs who have turned in impressive records, are relying on Hallicrafter's receivers, selected for their outstanding performance, to pull in distant stations.

No matter what your purse or purpose, there's a Hallicrafter's Receiver to suit your particular needs. Six communications receivers, every one engineered and built by men who know amateur radio, who are themselves amateurs of long standing by their own choice, and who are thoroughly conversant with the special requirements of a communications receiver.

In our opinion there is no finer general purpose communications receiver than the Super Sky Rider — and we believe that the Sky Challenger is unquestionably the greatest value in amateur radio today!

Perhaps you're interested in Ultra High Frequency reception — there's the Ultra Sky Rider. For the operator who wants the commercial bands we've built the Sky Rider Commercial.

The Sky Chief and Sky Buddy are each outstanding receivers in their class, with performance equal and better than many in much higher price brackets.

See the Hallicrafter's line at our store today, or write for complete particulars! You'll find the receiver you want at the price you want to pay.

Look for the License label — your guarantee of advanced engineering

RADIO EQUIPMENT CORPORATION
326 Elm Street Buffalo, New York

the hallicrafters inc.



THE SUPER SKY RIDER — An 11-Tube 5-Band Super tuning from 40 M C to 535 K C. America's most outstanding communication receiver.

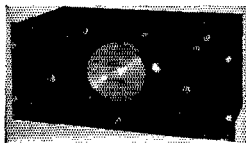

THE ULTRA SKY RIDER — An 10-Tube 4-Band Super designed especially for Ultra High Frequency reception. Tuned from 3.76 to 53 meters.

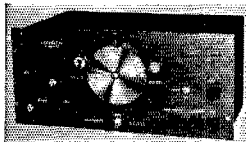

THE SKY RIDER COMMERCIAL — An 11-Tube Super tuning from 20 to 3000 meters. With the "ultra" this "professional" type receiver provides complete coverage.

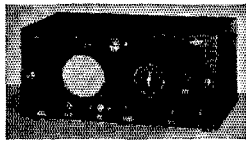

THE SKY CHIEF — A 7-Tube Super with all the latest features tuning from 17.6 M C to 540 K C in 3 Bands.



THE SKY BUDDY — A 5-Tube Junior Communications Receiver with splendid performance. Tunes from 18 M C to 544 K C.

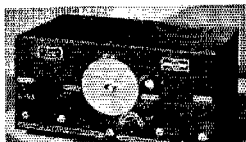

THE SKY CHALLENGER — Hallicrafter's Newest Receiver and Amateur Radio's great value. 9 Tubes. Tunes from 38 M C to 535 K C on 5 Bands. Electrical Band Spread and every feature needed for efficient short wave reception.

QST

devoted entirely to

AMATEUR RADIO

PUBLISHED, MONTHLY, AS ITS OFFICIAL ORGAN, BY THE AMERICAN RADIO RELAY LEAGUE, INC., AT WEST HARTFORD, CONN., U. S. A.; OFFICIAL ORGAN OF THE INTERNATIONAL AMATEUR RADIO UNION

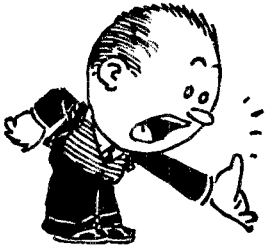

MAY
1937

Volume XXI
Number 5



Kenneth B. Warner (Secretary, A.R.R.L.), *Editor-in-Chief and Business Manager*; Ross A. Hull, *Associate Editor*; James J. Lamb, *Technical Editor*; George Grammer, *Assistant Technical Editor*; Clark C. Rodimon, *Managing Editor*; David H. Houghton, *Circulation Manager*; F. Cheyney Beekley, *Advertising Manager*; Charles Brunelle, *Assistant Advertising Manager*.

Editorial and Advertising Offices

38 La Salle Road
West Hartford, Connecticut

Subscription rate in United States and Possessions and Canada, \$2.50 per year, postpaid; all other countries, \$3.00 per year, postpaid. Single copies, 25 cents. Foreign remittances should be by international postal or express money order or bank draft negotiable in the U. S. and for an equivalent amount in U. S. funds.

Entered as second-class matter May 29, 1919, at the post office at Hartford, Connecticut, under the Act of March 3, 1879. Acceptance for mailing at special rate of postage provided for in section 1103, Act of October 3, 1917, authorized September 9, 1922. Additional entry at Concord, N. H., authorized February 21, 1929, under the Act of February 28, 1925.

Additional second-class entries to cover sectional editions authorized March 20, 1935. Copyright 1937 by the American Radio Relay League, Inc. Title registered at United States Patent Office.

The Contents

Editorials	8
Priority <i>H. W. Castner, W1HIE</i>	8
Post-Mortem — 1937 DX Contests	9
100-Kc. E. C. Oscillator for Frequency Checking <i>Don H. Mix, W1TS</i>	12
A Modulator for the Low-Power Five-Band Transmitter <i>George Grammer</i>	13
Air-Wave Bending of U.H.F. Waves <i>Ross A. Hull</i>	16
What the League Is Doing	19
DX Competition Policy.	21
A Universal Exciter with Variable Frequency Crystal Control <i>James Millen, W1HRX</i>	24
How Would You Do It?	27
Ultra Midget Equipment for Ultra High Frequencies <i>Jack Wagenseller, W3GS</i>	29
A Versatile Oscilloscope Using the 913 <i>Herbert W. Gordon, W1IBY</i>	31
The 1936 Sweepstakes <i>E. L. Battey, W1UE</i>	35
Medium Power Transmitter Especially Designed for 28 Mc. <i>Edwin A. Ruth, 3rd, W2GYL</i>	39
Long Wire Directive Antennas, <i>Robert C. Graham, W8LUQ</i>	42
Skip-Distance Calculation <i>Newbern Smith</i>	47
Dixie Jones' Owl Juice	48
New England Division Convention	48
Amateur Radio Stations <i>W9SDQ, W8DK</i>	49
Hints and Kinks for the Experimenter	
Eliminating I.F. Shift — A Heterotone Circuit — The BH Rectifier for the Ford Coil Plate Supply — Modulation Monitoring with the Oscilloscope Having No Sweep Circuit — Plug-In Chassis Construction — 100-Kc. Calibrating Oscillator — Curing Filament Hum	51
I.A.R.U. News	54
Operating News	56
Correspondence Department	65
Dakota Division Convention	116
QST's Index of Advertisers.	126

PERFORMANCE AT A NEW HIGH

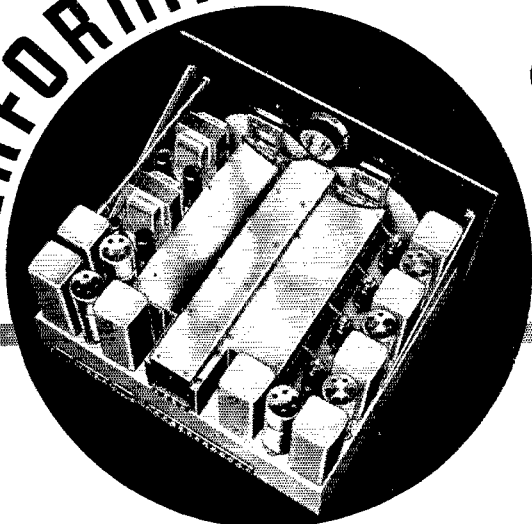

on 10 Meters

THE new 10 meter "Super-Pro", introduced only last month, has already been acclaimed by experienced amateurs, professional operators, engineers, and advanced experimenters, as a truly superior ultra-high frequency receiver.

Such is the unanimous verdict because the new "Super-Pro", using two stages of R.F. on all bands, including the 20 to 40 megacycle band, affords a sensitivity of 0.8 micro-volt (30% modulated) with a signal to noise ratio of 6 to 1 at 28 mc.! In addition, "Super-Pro" image rejection is so high as to provide complete freedom from "two-spot" tuning except in exceedingly rare instances. To be specific, the image rejection ratio at 28 mc. is 150 to 1!

The special design of the new "Super-Pro" electrical band spread system, permits the 28 to 30 megacycle amateur band to be spread over 90 divisions of the dial. This affords comfortable non-critical tuning without an unnecessary amount of dial twisting. Tuning is so arranged as to require only one setting of the main tuning dial for reception on all amateur bands. Switching from one band to another, automatically places the desired amateur band in the center of the band spread dial, thus affording true single dial tuning.

"Super-Pro" selectivity is another outstanding feature. With the variable band-width panel control set at 3 (the most selective position) the band width at 100 times input is only 8.5 kc. With the control at 16 (the least selective position) the band width at 100 times input is 24 kc.

Every "Super-Pro" is accurately calibrated for direct tuning on all bands. Receivers are indi-

vidually checked with crystal controlled oscillators and calibration is held to within a tolerance of plus or minus 1/2%. The 10 meter model provides a tuning coverage of from 1.25 to 40 megacycles in five bands.

A crystal filter model of the "Super-Pro" is also available. The crystal filter circuit is so designed as to afford the hair-breadth selectivity required for completely successful C.W. reception, as well as a wider degree of selectivity required for practical "phone" reception.

There are countless other unusual features in this new "Super-Pro" among which are — calibrated band-width, beat oscillator, audio and sensitivity controls; stand-by switch; AVC-Manual switch, C.W.-Mod. switch; phone-speaker switch; 8 metal and 8 glass tubes, separate humless power supply, rugged self-contained tuning unit with trouble-free cam knife switch.

The performance of the new "Super-Pro" sets a new high mark! Complete details appear in a special bulletin. Send for your copy now!

MAIL THIS COUPON!

HAMMARLUND MFG. CO., INC. 424-438 W. 33rd St., New York	Q-5
<input type="checkbox"/> Please send me new "Super-Pro" booklet. <input type="checkbox"/> Please send me new "37" catalog.	
Name.....	
Address.....	
City.....State.....	



HAMMARLUND'S 25TH YEAR

Section Communications Managers of the A.R.R.L. Communications Department

All appointments in the League's field organization are made by the proper S.C.M., elected by members in each Section listed. Mail your S.C.M. (on the 16th of each month) a postal covering your radio activities for the previous 30 days. Tell him your DX, plans for experimenting, results in 'phone and traffic. He is interested, whether you are an A.R.R.L. member or get your QST at the newsstands; he wants a report from every active ham. If interested and qualified for O.R.S., O.P.S. or other appointments he can tell you about them, too.

Eastern Pennsylvania Maryland-Delaware-District of Columbia Southern New Jersey Western New York Western Pennsylvania	W3EZ W3BAK W3ZX W8DSS W8OFO	ATLANTIC DIVISION James M. Bruning	339 W. Lancaster Ave.	Haverford
Illinois Indiana Kentucky Michigan Ohio Wisconsin	W9KJY W9TE W9AUH W8DPE W8AG W9ATO	CENTRAL DIVISION L. John Huntoon Arthur L. Braun G. W. Mossbarger Harold C. Bird E. H. Gibbs E. A. Cary	327 Brandon Ave. 530 East Morris St. Box 177 R.F.D. 2 300 High St. 3922 No. 19th Pl.	Glen Ellyn Indianapolis Camp Taylor Pontiac Waukegan Milwaukee
North Dakota South Dakota Northern Minnesota Southern Minnesota	W9OEL W9JEB W9OWU W9DCM	DAKOTA DIVISION Hartwell B. Burner Andrew L. Kjar Leonard Hofstad Webster F. Soules	221 West Prospect Ave. 3549 36th Ave., So.	Hope Pierre Elbow Lake Minneapolis
Arkansas Louisiana Mississippi Tennessee	W5ARI W5DKR W5CWO W4DEF	DELTA DIVISION H. E. Velte Eugene H. Treadaway J. H. Weems, Jr. B. G. Lowrey Smith	4415 West 12th St. 2749 Myrtle St. P. O. Box 244 673 Hillcrest St.	Little Rock New Orleans State College Memphis
Eastern New York N. Y. C. & Long Island Northern New Jersey	W2LU W2AZV W2GMM	HUDSON DIVISION Robert E. Haight E. L. Baunach Fred C. Read	511 South Holmes St. 102 Central Ave. 1014 North Ave.	Scotia Massapequa, L. I. Elizabeth
Iowa Kansas Missouri Nebraska	W9NNM W9PB W9CJR W9FAM	MIDWEST DIVISION Owen Williams Harry E. Legler J. Dewey Mills Samuel C. Wallace	108 No. Johnson St. 304 Miami St. Box 205 Green St.	Iowa City Hawatha Mount Vernon Clarks
Connecticut Maine Eastern Massachusetts Western Massachusetts New Hampshire Rhode Island Vermont	W1CTI W1CDX W1ABG W1JAH W1BET W1HRC W1GNF	NEW ENGLAND DIVISION Frederick Ellis, Jr. John W. Singleton Albert N. Giddis William J. Barrett Carl E. Evans Clayton C. Gordon Alvin H. Battison	19 Merrill Rd. Peaks Island 128 Crawford St. 239 Columbia St. 89 No. State St. 192 Washington Ave. 1 Central St.	Norwalk Portland Lowell Adams Concord Providence Windsor
Alaska Idaho* Montana Oregon Washington	K7PQ W7EMT W7CRH W7AJV W7WY	NORTHWESTERN DIVISION Richard J. Fox Carl Eichelberger Russell U. Richmond Eugene E. Lovejoy Robert H. Votaw	Box 301 2810 North 6th St. 5013 N. E. Clackamas Route 1, Box 398	Ketchikan Boise Somers Portland Vancouver
Hawaii Nevada Santa Clara Valley East Bay San Francisco Sacramento Valley Philippines San Joaquin Valley	K6AJA W6BIC W6BFW W6ITV W6SG W6DVE KA1GR W6LFE	PACIFIC DIVISION Otis Hill Edward W. Heim Albert Amantes Harold J. Burchfield Alan D. Whittaker, Jr. Geo. L. Woodington George L. Rickard Angelo V. Astone	Box 952 509 Claremont St. 475 So. 11th St. 2240 106th Ave. 79 Elinor Ave. 716 Redwood Ave. Box 849 729 Safford	Hilo Reno San Jose Oakland Mill Valley North Sacramento Manila Fresno
North Carolina Virginia West Virginia	W4QG W3UVA W8KKG	ROANOKE DIVISION H. S. Carter Charles M. Waff, Jr. Dr. Wm. H. Riheltdaffer	P. O. Box 111 P. O. Box 1212	Winston-Salem Univ., Charlottesville Lost Creek
Colorado Utah-Wyoming	W9FA W7COH	ROCKY MOUNTAIN DIVISION Glen Glasscock Townsend J. Rigby	2164 So. Corona St.	Denver Midwest, Wyoming
Alabama Eastern Florida	W4DGS W4ASR	SOUTHEASTERN DIVISION James F. Thompson William C. Shelton	2248 S. Arlington Ave. 556 Westmoreland Drive "Hillcrest", P. O. Box 652	Birmingham Daytona Beach
Western Florida Georgia-So. Carolina-Cuba- Isle-of-Pines-Porto Rico- Virgin Islands	W4MS *W4PM	Edward J. Collins	1517 East Brainard St.	Pensacola
Los Angeles Arizona San Diego	W6GXN W6LVG W6EOP	SOUTHWESTERN DIVISION Charles W. Davis	2136 NE Boulevard Dr.	Atlanta, Ga.
Northern Texas Oklahoma Southern Texas New Mexico	W5BII W5CEZ W5BDI W5CGJ	WEST GULF DIVISION Richard M. Cobb Carter L. Simpson Ammon O. Young Joseph M. Eldott	Box 185 2010 So. 4th St. 4803 Eli St.	Dodd City Ponca City Houston Chamita
Maritime	VE1DQ	MARITIME DIVISION A. M. Crowell	69 Dublin St.	Halifax, N. S.
Ontario	VE3SG	ONTARIO DIVISION Fred H. B. Saxon	302 Lee Ave.	Toronto, Ont.
Quebec	VE2EE	QUEBEC DIVISION Stan Comach	780 Brault Ave.	Verdun, P. Q.
Alberta British Columbia	VE4LX VE5EP	VANALTA DIVISION Alfred D. Kettenbach D. R. Vaughan-Smith	1221 Burnaby St.	Rockyford Vancouver
Manitoba Saskatchewan	VE4BG VE4EL	PRAIRIE DIVISION A. J. R. Simpson Wilfred Skaffe	635 Garfield St. 2040 McTavish St.	Winnipeg Regina

* Officials appointed to act until the membership of the Section choose permanent S.C.M.'s by nomination and election.

The American Radio Relay League



• **T**HE AMERICAN RADIO RELAY LEAGUE, INC., is a non-commercial association of radio amateurs, bonded for the promotion of interest in amateur radio communication and experimentation, for the relaying of messages by radio, for the advancement of the radio art and of the public welfare, for the representation of the radio amateur in legislative matters, and for the maintenance of fraternalism and a high standard of conduct.

It is an incorporated association without capital stock, chartered under the laws of Connecticut. Its affairs are governed by a Board of Directors, elected every two years by the general membership. The officers are elected or appointed by the Directors. The League is non-commercial and no one commercially engaged in the manufacture, sale or rental of radio apparatus is eligible to membership on its board.

"Of, by and for the amateur," it numbers within its ranks practically every worth-while amateur in the nation and has a history of glorious achievement as the standard-bearer in amateur affairs.

Inquiries regarding membership are solicited. A bona fide interest in amateur radio is the only essential qualification; ownership of a transmitting station and knowledge of the code are not prerequisite. Correspondence should be addressed to the Secretary.

HIRAM PERCY MAXIM, FOUNDER

OFFICERS

President.....EUGENE C. WOODRUFF, W8CMP
State College, Pa.

Vice-President.....GEORGE W. BAILEY, W1KH
Weston, Mass.

Secretary.....KENNETH B. WARNER, W1EH
West Hartford, Connecticut

Treasurer.....ARTHUR A. HEBERT, W1ES
West Hartford, Connecticut

Communications Mgr....E. EDWARD HANDY, W1BDI
West Hartford, Connecticut

General Counsel.....PAUL M. SEGAL
1010 Shoreham Building, Washington, D. C.

Address all general correspondence to the administrative headquarters at West Hartford, Connecticut

DIRECTORS

President
EUGENE C. WOODRUFF.....W8CMP
234 W. Fairmount Ave., State College, Pa.

Vice-President
GEORGE W. BAILEY.....W1KH
74 Webster Road, Weston, Mass.

Canadian General Manager
ALEX REID.....VE2BE
169 Logan Ave., St. Lambert, P. Q.

Atlantic Division
WALTER BRADLEY MARTIN.....W3QV
Box 612, Roslyn, Pa.

Central Division
R. H. G. MATHEWS.....W9ZN
100 East Ohio St., Chicago

Dakota Division
CARL L. JABS.....W9BVH
1822 James St., St. Paul, Minn.

Delta Division
E. RAY ARLEDGE.....W5SI
P. O. Box 286, Pine Bluff, Ark.

Hudson Division
KENNETH T. HILL.....W2AHC
115 Willow St., Douglaston, L. I., N. Y.

Midwest Division
FLOYD E. NORWINE, JR.....W9EFC
120 South Fourth St., St. Louis, Mo.

New England Division
PERCY C. NOBLE.....W1BVR
37 Broad St., Westfield, Mass.

Northwestern Division
RALPH J. GIBBONS.....W7KV
c/o United Air Lines, Pendleton, Ore.

Pacific Division
S. G. CULVER.....W6AN
2962 Russell St., Berkeley, Calif.

Roanoke Division
H. L. CAVENESS.....W4DW
State College Station, Raleigh, N. C.

Rocky Mountain Division
EDWARD C. STOCKMAN.....W9ESA
618 So. Williams St., Denver

Southeastern Division
BENNETT R. ADAMS, JR.....W4APU
1512 Grove Place, Homewood, Ala.

Southwestern Division
CHARLES E. BLALACK.....W6GG
443 Main St., El Centro, Calif.

West Gulf Division
WAYLAND M. GROVES.....W5NW
c/o Humble Pipe Line, Tulco, Texas

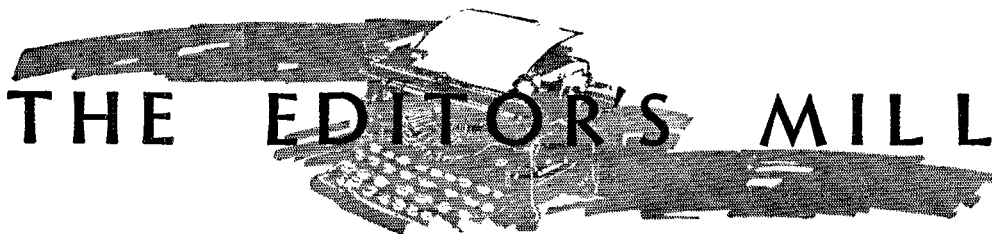

THE EDITOR'S MILL

THOUGHTFUL amateurs occasionally ask us where we imagine amateur radio will be ten years hence, or fifteen. It is a large order for a mere human, isn't it?

However, a few fundamentals seem to stand out. The world's needs for radio frequencies increase. Some day the point will be reached where non-essential services must give way to those for whom the use of radio is imperative. When that time is reached, will amateur radio have become a non-essential service? That day is too far distant to say with accuracy what we must do, but one point seems clear: *it will depend upon what we have made of ourselves.*

When the amateur's position is summarized to-day it is found most satisfying in its content of public service. We are the makers of the art of to-morrow, the suppliers of the personnel and many of the ideas that will carry onward the radio work of the next few decades. We are the reservoir of trained operators and technicians. We supply the communications in emergencies. Our public-service record to-day is positively superb and no one can question the value of the institution of amateur radio—to-day.

To keep our place in the sun we must continue to serve society. We must be sufficiently adaptable to change the nature of that service to meet changing social needs. We do not know what those needs will be. That is why we say that our future is in our own hands—it depends upon our ability to continue a flow of contributions so valuable in the needs of that day that there will be no question of the essential nature of the amateur service.

At this moment, unquestionably the amateur's greatest service is emergency communication. That is why we feel so strongly that every amateur ought to be prepared to aid his community in times when normal communication fails and the dependence is upon amateur radio. To pay the piper for DX chasing, rag-chewing, the sport of contests and other angles of ham radio which are largely the indulgence of a hobby, every one of us ought to make some contribution of service. The greatest respect in which we can so serve to-day is during emergencies. We think it will be so for quite a few years to come. When we are prepared with plans, gear and personnel to do a vital job that nobody else can do, no one can deny the essential nature of the amateur service.

THE technique of radio marches on but every new operator has to master the whole story of operating. He inherits the apparatus improvements of his predecessors but he must traverse the long rough path of learning how to employ them. Last year's new amateurs, after a period of awful dumbness, become reasonably proficient operators. This year's have a long route yet to go.

Much of the interference is caused by unskillful operating and is therefore unnecessary. The chief contribution of unnecessary QRM is made, it seems to us, by too-protracted calling. Why not a brief call and then a listen-in? Maybe the other fellow has picked you up already. If so, he'll answer at once, only too grateful that you didn't keep him waiting by continuing the call another two minutes. If he doesn't reply, you can call him a bit more, again pausing to listen. If he's answering someone else, you'll perceive it and can stop. If he's still "by," you can give him another brief shout.

This doesn't begin to treat the subject but it does tackle the chief factor, too-long calls. The use of break-in of course would provide a better solution. Reams have been written about it but its use is still all too infrequent. But the practice of punctuating calls with brief changeovers to listen a moment is almost as good, so far as calling itself is concerned, and requires no alteration of apparatus. It requires no cooperation by the distant operator. It is also perfectly applicable to 14-Mc. and 28-Mc. DX work, 'phone and c.w.

Please, fellows, can't we have some of this punctuation? Brief blasts of "three times three" or perhaps better "five times two," then a quick listen. It will save a lot of rumpus.

WE'RE certainly ashamed of the fellows who deliberately worked outside the amateur bands during the DX Contest. Doing so deliberately at other times gives amateur radio a black eye and the offender an excellent chance of a pink slip. Doing it during the Contest compounds these offenses with the additional one of taking unsporting advantage of the rest of us. It is plain cheating at a game of skill, and we must say we have no patience with it. We hope the F.C.C. can hang these lads as high as kites. Those who have cheated deliberately can expect no sympathy from us.

We call the attention of those who are inter-

ested in working as close to the edges of bands as is safe, but staying on the *proper* side of the fence, to an article in this issue on the construction of a very simple and inexpensive 100-kc. oscillator.

Intelligently handled it will be a reliable index to how far one may go and still be safe. It will prevent accidental transgressions and therefore is eminently worth owning. K. B. W.

Priority

A True Story

By H. W. Castner,* W1IIE

BEFORE the advent of radio the dictionary defined "priority" as "the quality or privilege of preceding something else." The word was adapted to radio communication and methods devised to make it possible to get important traffic across without delay, but to-day if you can get 1-kw. input to give about 95% output and if you test persistently during the evening with all kinds of squeaks, squawks, blasts and groans and if you call CQ at least twenty-five times and then sign your call at about 50 w.p.m. and make it so that no one can read it, you will probably get "priority" on your channel—for a time at least. This procedure is by far more effective during floods and all disasters where life and death are concerned.

Well, anyway, my story this time relates to a "priority" message just after the War and take it from me, brothers, if you did not suspend traffic in those days when you heard one of them things, you would receive something a little different than an article in *QST* relative to QRM of QRR, etc., etc.

When President Wilson decided to go over to Europe and fix it so that our creditors would be sure to pay up in the future, there was much ado in Navy Radio. My headache was executive duties for the C.O. at NBD and my old shipmate Fred Schnell (W9UZ) was a chief on the president's ship. Suffice it to say that all ships and stations were primed to offer the utmost in service to the Commander-In-Chief.

Although time has dimmed the memory of actual arrangements used to indicate distress during the war, I can still remember the temporary arrangement of a series of S's used about as follows:

SSSS Sighted a Sub.

SSSS SSSS Sighted and pursued.

SSSS SSSS SSSS Sighted, pursued and fired upon.

SSSS SSSS SSSS SSSS Sighted, pursued, fired on, hit and sinking.

Of course the number of groups constituted priority, and it is of passing interest to mention

* Damariscotta, Maine.

that it was often necessary to leave a two-group guy to answer a three, etc. Nothing had priority over a four group.

At the time of our story many such arrangements were still in use, and it was a similar call that caused us at NBD to jump right out of our pants.

Night had fallen, over a stormy sea. Some concern was had on various weather forecasts in the vicinity of the great ship carrying the President of the United States. As the night wore on, every man on every ship and station had an "ear to the ground." We put on a continuous watch on wavelength "J" (600 meters), and the operator on No. 1 spark watch continued up to his neck with the usual traffic on a QSH schedule with various ships. QSH then meant sending paid traffic or Government traffic in groups of ten messages and then QSL all, or a check challenge if necessary, or a repeat. At the Chatham, Mass., RCA station this minute is R. K. Elliott. We called him "RK" for two reasons. First, those were his initials, but of more importance was that that was all he could say if you sent a bunch of traffic at any speed and asked QSL. If some of you fellows who think you can operate could have tried one of those tricks with continuous traffic for four hours, you would have broken out all over with goose pimples.

The old typewriter carriage was banging back and forth on this night with old reliable RK walking it right to 'em, when in rushed a traffic chief waving his arms and hollering like heck, "We have a four-group priority from the President's ship! Get him—get him!"

The poor guy that was QSO NBD may be still trying to get a QSL for all I know, but this is once when he didn't get "RK" from Elliott. A hush came over everybody and everything at the station as old NBD put on the whole 5-kw. and blasted a snappy call on 600 meters. At the "K" breathless operators stood tense and frozen for what seemed hours, when from far across the great expanse of stormy sea, clear and distinct, came the "R"—the call—the preamble—the address—and then this message:

"Please send the President's bathrobe on next mail packet."

Post Mortem—1937 DX Contests

THE Battle of the Beams is over! The power companies have untied their overload relays, the tube manufacturers are working overtime to fill the orders for replacements, and small children have been introduced to gaunt, bearded men with a "No, that isn't the boogie man. That's papa. He was in the DX Contest."

Yes, reference is being made to that little cataclysm, that apparently innocuous but actually mad tussle referred to in the preliminary announcements as the 1937 International DX Contest. The March lion whistled, whined, and groaned during the c.w. portion of the contest from March 6th to 14th, and reared up and roared during the 'phone contest from the 20th to the 28th. Nothing was spared during the conflict. Bands bulged, bottles blazed. Wrists grew weary and tonsils tender. During the c.w. contest the bands were a kaleidoscope of beautiful 'F9x set on a background of chirpy d.c., rectified a.c., rough a.c., raw a.c., and a few things that never were identified. Electron-coupled oscillators flitted through the bands, seeking an opening for a possible contact before moving on to possible more fertile fields. The 'phone contest was more cooperative: everyone would open up to call the same station, then quiet

Everyone is in agreement on but one point. However much they may argue about good/poor operating, good/lousy signals, or long/phased/rhombic/rotatable directional antennas, they will all agree that there was more DX per kilocycle per hour than during any previous contest. You'll agree, too, that conditions must have been better than ever before when you see some of the scores.

It is no easy matter to get the high scores at

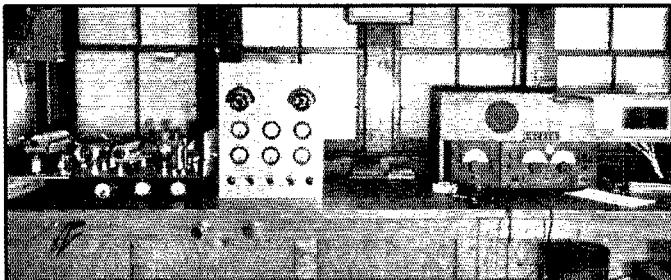

THE TRIM ARRANGEMENT USED AT W2AIW, CHARLES ROGERS OF MANASQUAN, N. J.

Two transmitters are used: a 53 oscillator-doubler, RK20-860 driver, and p.p. 860's final; and one not shown in the picture, a 28-Mc. rig using 6L6 oscillator, 6L6 quadrupler, p.p. 50T's final, running 900 watts input.

this early date. It is exciting in itself to watch the calendar and see the deadline for copy coming closer and closer, with each day bringing in a new score that tops yesterday's high. Understand that the scores to be given have been collected by various means, that they are subject to some revision after cross-checking and confirmation. Some will suffer because they counted Scotland (GM) as an additional multiplier, or counted Puerto Rico and the Virgin Islands as separate countries. Some will find that their computation was slightly in error. And some will be eliminated because they were caught operating outside the band! Yes, the fellow that obeyed the rules is going to be recognized, and the ones who stepped over the line in an effort to take an unfair advantage will be disqualified. While some of the off-frequency operation was accidental, there is no doubt that a great deal of it was intentional. So if in the final Contest writeup you find that Joe Doaks down the street is not listed among the high scorers, although he told you his score was empty-ump, you know the reason why.

* * *

The C.W. Contest

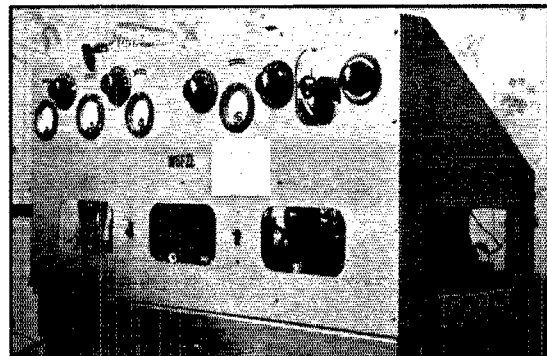

THE TRANSMITTER OF W6FZL, HARRY GROSS, LOS ANGELES, CALIFORNIA, AN EXCELLENT ILLUSTRATION OF GOOD, COMPACT DESIGN

The tube line-up is 53 oscillator-doubler, 807 doubler, 100TH buffer, p.p. 150T's final. The input is variable between 500 and 1000 watts.

The receiver is a revamped Comet Pro, with new dial, regenerative first detector, and crystal filter.

down until another DX station called CQ, resulting in a surge-like effect that was a beautiful thing to listen to (if you weren't in the contest!).

AS WAS the case last year, a station outside the United States and Canada garnered the greatest number of points. Yes, you've

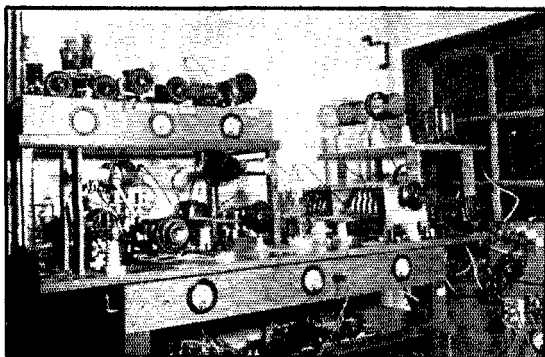

THE BAND-SWITCH TRANSMITTER AT W6GRL, DR. CHARLES STUART OF VENTURA, CALIFORNIA

The 7- and 14-Mc. coils are in place, and by changing coils the transmitter can be operated on 3.5 and 28 Mc. The tube line-up: 53 p.p. oscillator, 6L6 buffer-doubler, 801 buffer, 100TH buffer-doubler, 250TH buffer-doubler (used only on 10 and 20 meters), and p.p. 250TH final.

guessed it. K5AY, whose signal rocked through the States day and night, ran up some 256,997 points during the 89 hours he was on. Operated by J. A. Wilson, ex-W2BXU, K5AY worked 1618 stations and had a multiplier of 53 out of a possible 56 for four-band operation! That averages over 18 QSO's per hour, which is some operating in any language! Phased antennas were used on the higher-frequency bands, giving good coverage of the States. The power? 200 watts input to a 211 final. And there you have the formula for top score in a DX Contest: mix one good operator with some good antennas, set him down at a receiver and any kind of a transmitter, throw the bug weights away and wait for the contest to start.

Last year's high scorer came in a very excellent second this time. XE2N gathered together some 201,520 points with 150 watts input and operation on five bands. He bemoans the fact that more stations did not get up on 160 to grab off the additional multiplier. W6ITH reports that K6CGK had 165,000 points, which would place the Hawaiian station third highest. The fourth highest score reported is from another station utilizing five bands: K7PQ ran

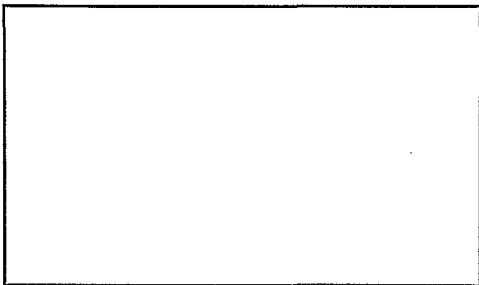

HERE IS ONE OF THE NICEST-LOOKING STATIONS ACTIVE IN THE CONTEST

The tube line-up is 802 oscillator, 6L6 buffer-doubler, 35T driver-doubler, 150T driver, and p.p. 250T's final. A full k.w. is run on four bands, and complete band-switching is used throughout. From the receiving position at the left, any one of four antennas can be selected, as well as several frequencies. His score was 103,265. But W . . . , shown above, selected the wrong frequency too often, operated out of the band, and was disqualified

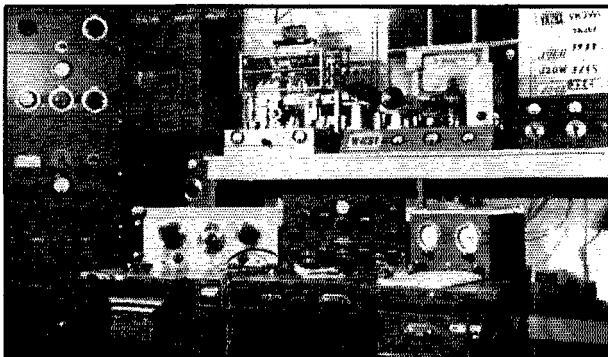

W4CBY OF ATLANTA, GA., OPERATED BY OWNER B. W. BENNING DURING THE C.W. TESTS AND DAVE EVANS, W4DHZ DURING THE 'PHONE PORTION

The station equipment is all home-made except the Super-Pro receiver. Two transmitters were used, one with 852's in the final, the other with HK354's. Seven or eight different antennas were tried during the contests

up 162,968 points by working 1058 stations. He worked W6GRX on five bands. His only regret in the contest is that the bookkeeping involved almost takes all the pleasure out of it. However, there are plenty of contestants who would have suffered that way gladly! Other high scores were from K5AC (who wasn't competing), 135,000; PAOAZ, 90,285; and G6NF, 79,288.

Some of you fellows who were in the contest don't realize how easy the whole thing was. Not that it was easy to raise the stations or fight the QRM, but at least you didn't have the handicap of working in the same office as the highest scoring station, having him tell you each morning of the DX he had worked and that you had always thought was just a misprint in the Call Book. Clark Rodimon, "Roddy" of W1SZ, managing editor of *QST* and the guy that this very minute is hollering for this copy,

turned in the highest score of any W/VE station. That is, of course, if someone else doesn't come along with more than 116,665 points. Burning a hole right through four bands, and digging out weak ones that many passed over, Roddy worked 265 stations in 68 countries, with a multiplier of 147. We're a little proud of the guy, even if he did make the other contestants around the office (including the writer) look like tin-

heard beginners. The input used was around 650 watts into various combinations of wires, including a rhombic that had more major lobes than some of us heard signals.

So close behind W1SZ that it isn't even funny, and national high scorer (HQ stations are not eligible for awards), comes a West Coast station, W6CXW, operated by Henry Sasaki, of Long Beach, Calif. W6CXW needs no lengthy description; he is well known in DX circles 'round the world. Always well up in the scoring of any contest, this is the first time he has been national high station, and the first time a W6 has gained that honor since W6BAX smoked out everyone back in 1930. Considering the fact that East Coast stations have a better opportunity to pyramid multipliers by 3.5-Mc. working of European countries, we think that the achievement of W6CXW is all the more outstanding, and his score of approximately 115,000 looks very pretty in any history book. The only definite thing we know about his work so far is that *six* different antennas were available, at the flick of a switch! We will have the complete data on his work in the final contest writeup.

Into second place comes W2AIW, to redeem the honor of the East Coast, with a score of 105,223. Running 800 watts on 28 Mc., and a kilowatt on the other three bands, W2AIW worked 253 stations and had a multiplier of 139. Two antennas were used: a 14-Mc. array and a 3.5-Mc. Zepp for all-around operation.

Just to add insult to injury, the next highest score comes from another W6. This time it is W6GRL, at Ventura, Calif., whom you recall was the highest W6 last year. He knocked over 94,464 points.

Other high scores: W4CBY, 91,574;

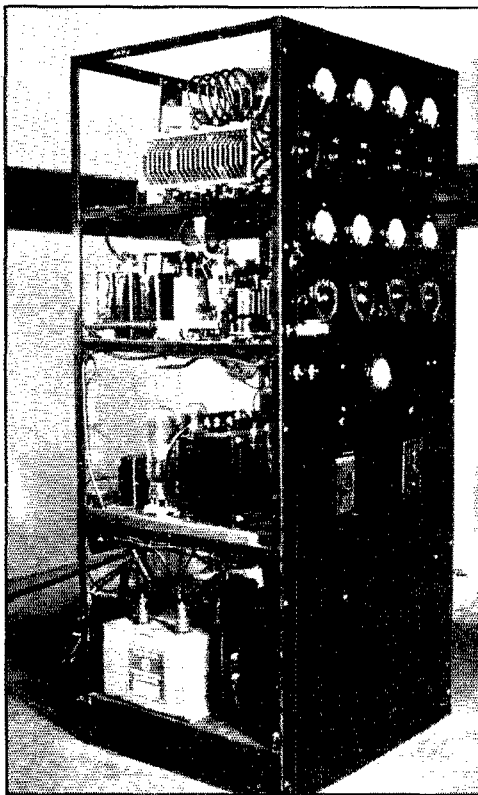

NO POLITICS BROUGHT ABOUT THE SCORES OF W4AH, EVEN THOUGH THE TRANSMITTER IS LOCATED IN THE CITY HALL AT CHARLOTTE, N. C.

T. C. Wood, Jr., uses Class-B 203A's to modulate the p-p. 150T's in the final amplifier. Ten meters was poor, all but the strongest signals being drowned out by the electrical noise in the vicinity. The last morning of the 'phone contest W4AH worked 30 VK and ZL stations in less than three hours.

W9TB, 75,565; W6FZL, 75,208; W6JBO, 72,000 (approx.); W8FJN, 69,328; W6GRX, 66,600; W4AH, 61,530; W8LEC, 57,120; W1ME, 56,304; W2GRG, 50,537; W1TS, 50,700; W1BFT, 50,537.

The highest Canadian score so far is that of VE2AX, whose 60,420 points will most likely make him the highest-scoring station in his country. VE2AX says that many stations were fooled by harmonics, a concrete example being the 7-Mc. harmonic of FM8AD when the Martinique station was on 3.5 Mc. Of course, VE2AX might have been hearing the harmonics of the 3.5-Mc. W stations calling FM8AD on 80, so we won't press the point. But it's worth thinking about.

* * * The 'Phone Contest

W" OPERATORS in the 'phone portion of the contest are thankful for several things. Primary, of course, was the fact that they didn't have to drag their contacts out of the QRM belt that was our 'phone band.

(Continued on page 20)

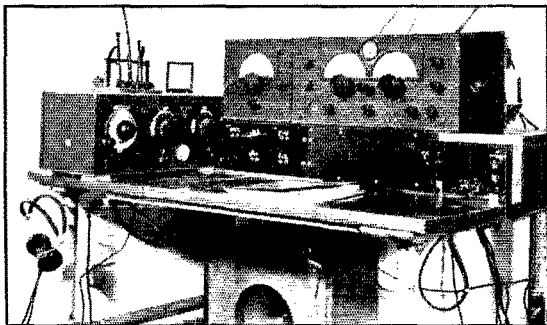

THE RECEIVING POSITION AT W2UK, RALPH THOMAS' STATION AT QUOQUE, N. J.

The crystal exciter unit is readily accessible, facilitating quick frequency change. Grid-modulated 852's are used in the final.

A 100-Kc. E.C. Oscillator for Frequency Checking

By Don H. Mix,* WITS

WHILE casting about for a simple means of checking the frequency of an e.c. oscillator transmitter, particularly when operating near the edges of the bands, the use of a 100-kc. oscillator was suggested. The advantages of a calibrated oscillator operating at this low frequency are at once apparent. To check the frequency of an oscillator operating at 100 kc. it is not necessary to set up elaborate calibrating apparatus nor is it necessary to use a crystal, for the frequency of the oscillator may be set by heating one of its harmonics against one of the many broadcast signals of stations operating at

the first and second "pies." This inductance will tune approximately to 100 kc. with a capacity of 0.001 μ fd. A 100- μ fd. midget variable condenser is connected across the fixed mica condenser to give a tuning range of approximately 5 kc. at the oscillator's fundamental frequency. Maybe we were lucky—considering usual commercial tolerances on ratings,—but in the gadget pictured, with a choke and fixed condenser picked at random from stock, the oscillator hits 100 kc. with the 100- μ fd. condenser at half scale.

The base and panel are made up of two small pieces of one-sixteenth inch aluminum although any available sheet metal which will not bend or spring too easily may be used. The panel is four by five inches and the chassis four by five by two inches. All parts except the 24A tube, grid condenser and leak and fixed and variable tuning condensers are mounted underneath the chassis. While a simple knob might be used for the tuning control, it is much easier to obtain an accurate setting of the oscillator with a vernier dial.

First calibration is quite simple providing only that at least two b.c. stations operating on multiples of 100 kc. may be heard. In most cases it will not be necessary to connect the oscillator to the b.c. receiver. In our case a good beat note was obtained with the oscillator several feet away from the b.c. receiver. The procedure of setting the oscillator to 100 kc. is as follows: First, tune in a b.c. signal at a multiple of 100 kc. such as 700, 800, 900, or 1000 kc., etc. Be sure of the identity of the station, since a difference of one channel (10 kc.) will mean an error of about 250 kc. at 14 Mc. Reduce the beat to zero, being very careful of the adjustment. For greatest accuracy, listen for the slow beats on modulation. Now tune the receiver to a second signal at a multiple of 100 kc. If the oscillator is operating at 100 kc., it should zero beat with all signals at exact multiples of 100 kc. If the oscillator is not operating at 100 kc. it may be adjusted to zero beat with the first signal but at the same setting will not zero-beat with other signals at 100-kc. multiples. In this case, capacity or inductance must be adjusted. As a matter of fact, if any beat note at all is obtained, it will probably be the correct one since the nearest other frequencies which would produce a beat with a signal at say 700 kc. would be 116.6 or 87.5 kc. which would require an appreciable departure in capacity or inductance from the correct values.

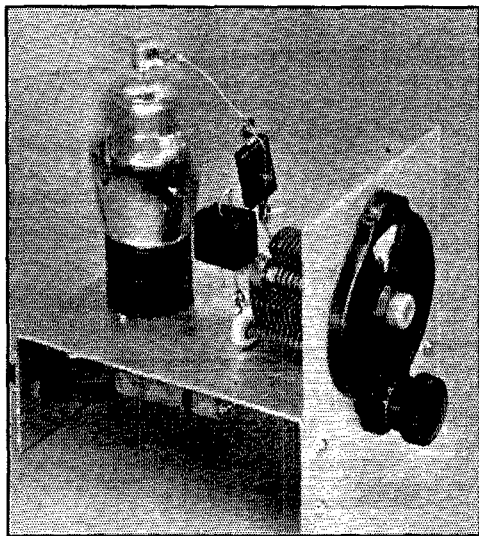

THE 100-KC. OSCILLATOR

The inductance is mounted below the chassis.

exact multiples of 100 kc. These signals are commonly available at all but a few of the twenty-four hours at most points in this country and Canada. The b.c. signal need be only strong enough to make identification possible. Once set, the oscillator provides accurately calibrated signals every 100 kc. from 100 kc. upwards in frequency.

An oscillator of simple construction requiring but a few inexpensive parts is shown in the photograph. Referring to the diagram, Fig. 1, an ordinary 2.5-millihenry r.f. choke is used for the inductance, the cathode tap being placed between

* A.R.R.L. Technical Information Service.

(Continued on page 114)

A Modulator for the Low-Power Five-Band Transmitter

A Metal-Tube Audio Unit Using Class-A 6L6 Output

By George Grammer*

IN DISCUSSING the low-power transmitter described in December 1936 *QST*¹ it was pointed out that one of the design features was that of providing for plate modulation for radiotelephony. The present article is concerned with the description of a modulator primarily intended for working with that transmitter, although it can also be used for modulating other 30-watt input rigs or, with slight modification, as a driver for a higher-power modulator.

In recent years it has become natural to think of Class-B whenever plate modulation is under consideration. This is understandable enough, because Class-B audio amplification offers the opportunity for getting large amounts of audio power at less expense than other systems. For low power levels, however, recent developments in beam tubes have again brought Class-A amplification within the economical price range, partly because it is now possible to get more power at low plate voltages and partly because fewer coupling transformers are required. The smaller variations in plate current with voice input also simplify the power-supply requirements because poor voltage regulation is less serious.

These various factors of cost, power output and simplicity of design were given due consideration in planning the modulator unit pictured herewith. The audio power output necessary for modulating the 30 watts input to the final stage in the transmitter is 15 watts; a pair of 6L6's can deliver this output readily when operating purely Class-A. An important factor is that no driving power for the grids is needed to obtain this output; this eliminates one cause of distortion, permits dispensing with a special coupling transformer, and avoids the necessity for using a driving stage having considerable power output.

The number of tubes required in the speech amplifier naturally enough is a function of the gain needed for the particular microphone used. It seemed reasonable to us to assume that the

owner of a low-power transmitter—since low power is used chiefly because it is inexpensive—naturally would think first of economy when considering a modulation system. Fortunately the less expensive types of microphones also are the ones which give the highest output, so that fewer speech amplifier stages are necessary. Carbon microphones, because they are obtainable at lower cost than any other types, therefore seemed the logical choice, and on looking into the microphone situation it was found that a double-button model could be purchased practically as cheaply as the single-button type. The double-button type is preferable because the push-pull arrangement reduces distortion.

The output level of the low-priced double-

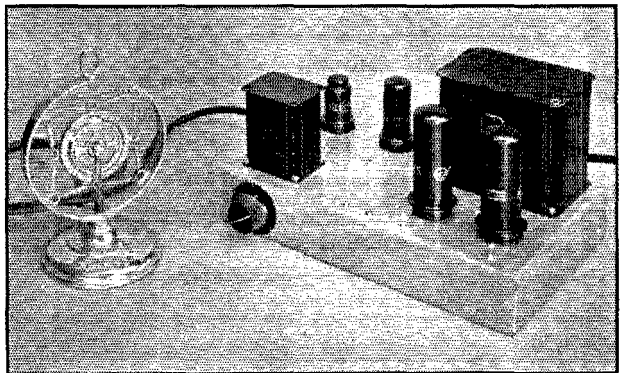

THE SPEECH-AMPLIFIER AND MODULATOR UNIT FOR THE LOW-POWER TRANSMITTER

Using metal tubes throughout, the output stage is a pair of 6L6 beam tubes. The microphone is a double-button carbon type, Shure No. 3-A.

button microphones is such that two speech stages before the modulator give more than ample gain. It might even be possible to use only one, but the extra stage adds little to the cost of the audio section and provides a conservative factor of safety. The tube line-up used in the practical modulator consists of a 6C5 first stage, a 6N7 second stage, and a pair of 6L6's in the third and final stage. The circuit diagram is given in Fig. 1.

CIRCUIT DETAILS

Referring to Fig. 1, the microphone works into the conventional input transformer. The small numbers on the input connections refer to the

* Assistant Technical Editor.

¹—"An Inexpensive Five-Band Low-Power Transmitter," *QST*, December, 1936.

terminal numbers on the type of transformer specified in Fig. 1. Terminals 3 and 4 are joined together and grounded; Nos. 2 and 5 are the microphone button connections. The gain control, R_1 , is connected across the secondary of the microphone transformer. Its rotor connection goes to the grid of the 6C5.

In the 6C5 stage, R_2 is the cathode bias resistor and C_1 the cathode by-pass condenser. R_3 is the plate load resistor and C_2 the plate by-pass condenser. R_{12} is a plate decoupling resistor.

To get push-pull output for the 6L6's in the final stage, the second tube, the 6N7 double

grid-leak resistors, and R_5 is the 6N7 cathode resistor. This resistor preferably should not be by-passed, since some negative feedback helps to equalize the outputs of the two triode sections and thus stabilizes the performance.

In the 6L6 stage, C_8 and C_9 are the grid coupling condensers and R_9 and R_{10} the grid leaks. A semi-variable resistor, R_{14} , provides cathode bias for the 6L6's. The actual value of cathode resistance in use is about 165 ohms, a setting determined experimentally to give optimum performance. The plates of the 6L6's are connected to a push-pull output transformer, T_2 . The

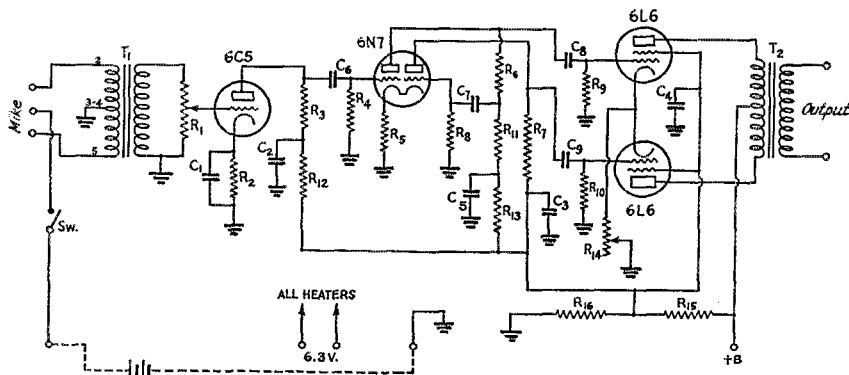

FIG. 1—CIRCUIT DIAGRAM OF THE LOW-POWER MODULATOR

C_1 —10- μ d., 25-volt electrolytic (Aerovox)
 C_2, C_8, C_4 —2- μ d., 450-volt electrolytic (Sprague TM-2)
 C_5 —8- μ d., 450-volt electrolytic (Sprague TM-8)
 C_6 —0.1 μ d., 400-volt paper (Aerovox)
 C_7, C_8, C_9 —0.03 μ d., 400-volt paper (Aerovox)
 R_1 —500,000-ohm potentiometer (Yaxley Y500MP)

R_2 —2000 ohms, 1/2 watt (IRC)
 R_3 —50,000 ohms, 1 watt (IRC)
 R_4 —50,000 ohms, 1/2 watt (IRC)
 R_5 —1500 ohms, 1/2 watt (IRC)
 R_6, R_7 —100,000 ohms, 1 watt (IRC)
 R_8, R_9, R_{10} —100,000 ohms, 1/2 watt (IRC)
 R_{11} —7500 ohms, 1/2 watt (IRC)
 R_{12}, R_{13} —10,000 ohms, 1/2 watt (IRC)
 R_{14} —200-ohm adjustable, 10 watt (Electrad)

R_{15} —5000 ohms, 2 watt (IRC)
 R_{16} —15,000 ohms, 25 watt (Ohmite)
 T_1 —Microphone transformer, double-button to single grid (Kenyon T1)
 T_2 —Output transformer, 6L6's to 5000-ohm load (Kenyon T453)
Sw—S.p.s.t. switch, mounted on gain control, R_1 (Yaxley)

triode, is used as a phase inverter as well as voltage amplifier. The output of the 6C5 is fed through C_6 to the grid of the first triode section of the 6N7; the plate of the same section is coupled through C_8 to one 6L6 grid and part of the voltage developed also is fed to the grid of the second triode section of the 6N7 through C_7 . Not all of the audio voltage is used for this purpose; C_7 is tapped down on the first-section plate load resistor so that the actual audio voltage applied to the second-section grid is the same as that applied to the first-section grid directly from the 6C5. The first-section plate load resistor actually consists of two resistors, R_6 and R_{11} , in series; the values of these resistors have been determined experimentally to give the correct voltage for the second-section grid and should be followed carefully. C_4 is the plate by-pass condenser for the first triode section of the 6N7 and R_{13} a plate decoupling resistor. R_7 and C_8 are the plate load resistor and plate by-pass condenser for the second triode section. R_4 and R_8 are the usual

screen resistors, and R_5 is the 6N7 cathode resistor. This resistor preferably should not be by-passed, since some negative feedback helps to equalize the outputs of the two triode sections and thus stabilizes the performance.

In the 6L6 stage, C_8 and C_9 are the grid coupling condensers and R_9 and R_{10} the grid leaks. A semi-variable resistor, R_{14} , provides cathode bias for the 6L6's. The actual value of cathode resistance in use is about 165 ohms, a setting determined experimentally to give optimum performance. The plates of the 6L6's are connected to a push-pull output transformer, T_2 . The

CONSTRUCTION

The photographs show the construction of the modulator. Referring to the general view, the microphone transformer, T_1 , is mounted at the

left front corner of the chassis and the output transformer, T_2 , at the rear right corner. The 6C5 is directly behind the microphone transformer; between the 6C5 and T_2 is the 6N7. The two 6L6's are at the front of the chassis at the right. The gain control is at the left-hand edge of the chassis.

The bottom view shows how the various parts are placed under the chassis. The volume control, R_1 , has the microphone switch, Sw , mounted on it so that when R_1 is turned to the zero position the microphone circuit is opened. The three plate by-pass condensers, C_2 , C_3 and C_5 , are mounted on the chassis near the upper center in the photograph; the similar condenser at the upper right is C_4 , the screen by-pass.

The 6C5 and 6N7 sockets are at the lower left in the bottom-view photograph. The various condensers and resistors are placed as closely as possible to the tube socket prongs to which they connect, use being made of insulating lugs wherever necessary. The plus "B" connections for these two stages are brought to a multi-lug strip on which the decoupling resistors also are mounted. This strip is visible in the photograph just above the two tube sockets. The cathode resistor and cathode by-pass condenser for the 6C5 are just below the sockets. Power supply leads are brought through a 4-wire cord which terminates in a lug strip near the bottom center in the photograph. The voltage divider resistors R_{15} and R_{16} , and the 6L6 cathode resistor, R_{14} , are along the right-hand edge. All ground connections are made directly to the chassis.

The chassis is of light steel measuring 11 by 7 by 2 inches. Round holes are cut out to permit the transformer terminals to project through for "upside-down" mounting. A three-terminal connection strip is mounted on the side of the chassis near the microphone transformer to make connections to the microphone cable. A similar two-terminal strip is mounted on the rear edge for output connections from T_2 . When used with the transmitter described in the previous issue, the pair of terminals on T_2 intended for a 5000-ohm load should be used. The connections marked "Output" in Fig. 1 should connect to those marked "Mod." in Fig. 1, page 13, December, 1936, *QST*, the "O" terminal on the transformer connecting to the plus-"B" side on the transmitter. This is the only connection between the two units.

TESTING AND OPERATION

The power supply used with the modulator is identical with that described in December *QST*

for the transmitter. Under full load the output voltage will be approximately 380 with an 83-V rectifier. The total "B" current taken by the modulator should be approximately 140 milliamperes with no sound input to the microphone, and should rise to about 150 ma. at full output on speech. This test should of course be made with the transmitter connected and operating, since the plate current to the 6L6's will not rise if there is no load on the modulator. If the current is more or less than 140 ma. with no speech input,

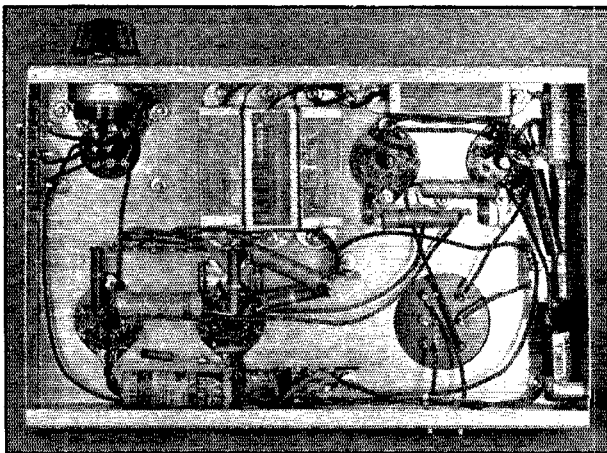

A VIEW UNDERNEATH THE CHASSIS OF THE MODULATOR UNIT

A description of the layout is contained in the text.

the resistor R_{14} should be adjusted to obtain the correct current value.

Before attempting to use the modulator directly on the transmitter it is a good plan to test it on a resistance load, using a 5000-ohm, 25-watt resistor connected across the output terminals. A pair of headphones may be tapped across about 500 ohms of the resistor, if the resistor is of the type having a sliding tap, or a second resistor of a few hundred ohms may be connected in series with the load resistor to form a voltage divider across which the headphones may be connected. It is not advisable to connect the phones directly across the load resistor because the audio voltage is too high for safe operation. With another person speaking into the microphone in a normal tone, the gain control should be advanced to the point where distortion just begins to be perceptible, then retarded to the point where no distortion is apparent. Under these conditions the total "B" current taken by the modulator should vary about as described above. The headphone test also will readily uncover hum, noise, or other troubles, although if the specifications are followed carefully the performance should be entirely satisfactory from this standpoint. The

(Continued on page 110)

Air-Wave Bending of Ultra-High-Frequency Waves

A Review of Recordings and Observations Made on Various Frequencies Over 100-Mile Indirect Paths

By Ross A. Hull*

In Two Parts—Part One**

This article is an "absolute must" for every amateur who has the slightest trace of interest in the ultra-high frequencies. In spite of its length, it is actually a very-much-clipped outline covering observations made by Mr. Hull in the two and a half years of spare time that he has devoted to this particular u.h.f. job. A paper covering all the detailed technical phases of the work has been prepared and a summary of it presented at the annual joint meeting of the International Scientific Radio Union and the I.R.E. at Washington. The complete paper will probably be printed for distribution in scientific circles during the summer.—EDITOR

THERE are still many phases of amateur radio that we know very little about. One of these—and a particularly engaging one—is the behaviour of u.h.f. waves at distances beyond the line of sight. For many years we suffered from the erroneous impression that there was nothing left of the signals beyond the horizon. With frequencies slightly higher than 30 Mc., it was assumed, the ionosphere became quite useless as a medium for bending the waves back to earth, and that without this bending there could be no signals beyond the line of sight. But early experimental work showed that the signals did *not* stop precisely at the horizon; that they could be detected slightly beyond this point. An explanation was readily available. It had been known for many years that light waves take a curved path through the lower atmosphere and are spread behind obstructions through the phenomena of diffraction and refraction. Computations showed that u.h.f. waves actually should not travel in straight lines across the surface of the earth but that they should bend in a curve having a radius of approximately four times the earth's radius. Somewhat similar computations had been used long before to show that, because of this bending of electromagnetic waves in the atmosphere, the sun is visible for at least two minutes and twenty seconds after it has actually passed below the horizon. These computations are also used in astronomical work to correct for the apparent positions of celestial bodies.

THE MECHANICS OF BENDING

Before we get too deeply into observations of this bending business, perhaps it would be well to

* Associate Editor, *QST*.

** (In the second part of this article, to appear in an early issue, further examination of signal trends and fading characteristics will be made. The receiving, recording and record analyzing equipment will also be described.—Editor.)

digress long enough to review a few general ideas as we see them to-day. In very simple terms it can be said that we would have no bending of radio waves if it were not for the fact that their velocity varies in the different media through which they pass. All we need, to make a wave front headed out for space bend back to earth, is to have an atmosphere (or stratosphere) in which the make-up is such as to increase the velocity of propagation the higher the wave front goes. This condition is satisfied most of the time for the lower frequencies because of the existence of layers of increasing ionization far above the earth's surface (the ionosphere). These gradients of ionization, however, are very rarely steep enough or low enough to bend u.h.f. waves back to earth. That they do bend u.h.f. waves back once in a while is fairly well established by the several instances of signals being heard and communication being established over distances of 1000 miles and more. The ionosphere, as we ordinarily consider it, may be the responsible agency. On the other hand, on these instances the bending may occur in the recently-discovered¹ very low layers of ionization. In this discussion, however, where we are to talk exclusively of a brand of bending that gives us signals at 50 or 100 miles, we believe firmly that we can forget ionization and look to other sorts of gradients in the very lowest reaches of the atmosphere—in the very same air in which birds (and men) fly.

In this part of the atmosphere we know that the velocity of the upper edge of the wave front is increased, for instance, if it is travelling into a region of increasingly low atmospheric pressure (which it ordinarily does) or into a region of increasingly high temperature, or into a region of steadily decreasing water vapor content. These

¹ R. A. Watson Watt, "Wireless Waves and the Atmosphere," *Wireless World*, March 5, 1937.

sorts of conditions all provide a negative gradient in the index of refraction of the atmosphere; and a decrease in the index of refraction results in an increase in the velocity of propagation. Under ordinary, clear, settled weather conditions these requirements are partially satisfied in the lower atmosphere. The pressure drops off with height and the water vapor content decreases also. During most of the day, unfortunately, the temperature drops off sharply with height above ground (the condition we don't want). The result, as shown both in theory and practice is a slight bending of five-meter waves in a trajectory or path having a radius of curvature of about four times the earth's radius. Result—we can talk to points slightly beyond the horizon.

VARIATIONS IN "AIR WAVE" BENDING

But this atmospheric condition is by no means a stationary one. Once the sun has set on our sample clear day, the temperature of the surface air begins cooling. By midnight we may well have a gradient that gives a steady increase in temperature for the first 2000 feet above ground. At that time we have all factors tending to increase the velocity of the upper part of the wave front and as a result we have much stronger u.h.f. signals beyond the horizon. Such night-time increase in signal level we will later show to be a very real effect, particularly in the summer when the day-to-night temperature contrasts are so great.

This sort of stable clear weather condition is, as it happens, the condition that ordinarily provides the least bending of all. It generally coincides with the prevalence of what weather men term Polar air. Let an air mass from the tropics drift across this Polar air and we have a set-up in which the temperature may increase irregularly all the way up to eight or ten thousand feet. The result is now a relatively tremendous bending and very intense signals beyond the horizon. Another result is the formation of clouds at the level where the warm and cool air mix and, later, rain. Naturally an almost

infinite number of other atmospheric conditions may exist, with the temperature, water vapor and pressure gradients doing all sort of unexpected things. They all reveal themselves, we hope later to show, in changes in the order of bending and consequent variations in signal level.

All of this, of course, is based on what we now know about bending in the atmosphere. It was far from clear to us a few years ago. We had a picture of u.h.f. propagation but only a very meagre one: no long distance signals because the ionosphere was ineffective; good signals only along the line of sight; weak signals immediately beyond the horizon, possibly resulting from diffraction and refraction, and a rapid falling off beyond that.

FADING OF U.H.F. SIGNALS

In 1931, Jouaust² reported some experiments made with five meters in France between stations slightly beyond the line of sight. The signals were found to vary in strength and this fading was considered to be the result of slow changes in the makeup of the lower atmosphere—particularly in the gradient in the temperature of the air immediately above the earth's surface. This observation (we believe it to be the first on record) that u.h.f. waves were subject to fading received

very little notice at the time and nothing much more was done about it until 1934, when RCA engineers reported observing weak fluctuating signals beyond the horizon. Then G. W. Pickard and Dr. C. F. Brooks began consistent observations of the variations in five-meter signals between the Blue Hill Observatory, Seabrook Beach, N. H. and Mt. Washington, both paths extending somewhat beyond the horizon.

The first real jolt to our own understanding of u.h.f. behavior was had in August 1934, when communication was more or less accidentally established³

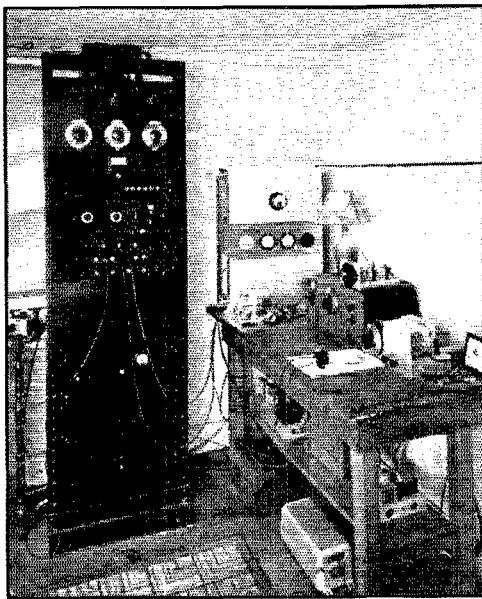

THE ULTRA-HIGH-FREQUENCY EQUIPMENT INSTALLED AT A FARMHOUSE ON THE OUTSKIRTS OF WEST HARTFORD

The relay rack carries most of the power supply gear, the voltage regulators and crystal-controlled receivers for 60.6 and 61.5 mc. Other equipment includes the 41-mc. crystal-controlled converter (using an HRO as the i.f. amplifier), an S.I.G. receiver for general observation of ham signals and superregenerative gear for 60, 112 and 224 mc.

²R. Jouaust, "Some details Relating to the Propagation of Very Short Waves," Proceedings of the I.R.E. March, 1931.

³Ross A. Hull, "Extending the Range of U.H.F. Amateur Stations," QST, October, 1934.

between West Hartford and Boston—a 100-mile path of not one horizon but five with a radius for the clearing ray path of but six tenths of the earth's radius. Here, obviously, was an order of bending far beyond our wildest expectations. More important still was the observation that the signals from these Boston low-powered stations held steadily at very high levels for many hours at a time on some occasions while on others they would either be subject to violent slow

there still remained the five horizons to be bridged even to reach favorably located stations in Boston.

A RECORDING PROGRAM STARTED

In any event, the problems involved led to the institution of a program of recording which has resulted in recording receiving equipment being in operation continuously for the last two years. Hourly tone transmissions on 60.5 Mc. were

made available by Dr. Brooks of Blue Hill and these were recorded photographically⁴ at West Hartford during 1935 and the first few months of 1936. A super-regenerative receiver was used in conjunction with a 12-element directive antenna. The set-up was such that only qualitative observation could be undertaken. Nevertheless, the recordings, studied in conjunction with airplane soundings of the lower atmosphere made at East Boston and Mitchell Field, L. I., proved invaluable in substantiating the belief that the signals, in spite of their high average level, resulted chiefly from refraction in the lower atmosphere and that the enormous variations in signal level were the result of changes in the stratification

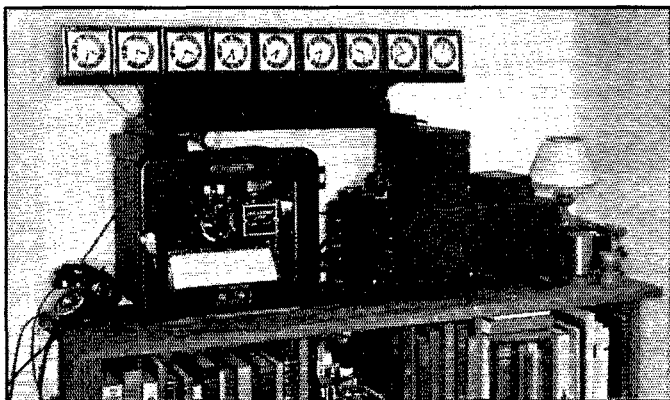

THE SIGNAL RECORDING AND RECORD ANALYZING GEAR

With the Leeds and Northrup recorder, left, and the double-meter photographic recorder, right, three signals can be recorded simultaneously when necessary. Various clock switches are available to start a recorder or transfer receivers at predetermined intervals. The row of clocks and the rack of relays immediately under them belong to the record analyzer. With each successive 5 db increase in the signal level an extra clock is started, thus providing a continuous picture of the percentage of time for which the signal has been riding at various levels.

variations or be absent entirely. Naturally, there was a mad scramble to provide an explanation. It seemed obvious from the beginning that the ionosphere had nothing to do with it. This conclusion seemed reasonable since the lowest signals were invariably had during the day with strongest signals in the early hours of the morning. Then, the fading was much slower than that experienced on the lower frequencies. Further the periods of very highest signal level invariably accompanied those atmospheric conditions which resulted in rain. There was nothing in any of the observations to suggest a relationship with the ionosphere. On the other hand, it was difficult to explain the performance as being the result of diffraction from the intervening ridges of hills. Such a phenomena would not allow such variation in signal strength and would certainly not permit the signal to drop out entirely. But by the same token, it was almost equally difficult to reconcile the very high signals with estimates based on current refraction calculations. Indeed, calculations clearly showed that we should have no signals at all. The favorable location of the West Hartford station—on a small hill 180 feet above the surrounding country and 320 feet above sea level—did not offer a solution since

of the air so frequently found in the atmosphere itself but so infrequently given attention in previous studies. The product of the first few months' work was the basis of a paper read before a scientific group in Washington in May 1935 and published in revised form in June 1935 *QST*.⁵ The one observation considered to be of importance was not that u.h.f. waves were bent beyond the horizon (that was old stuff) but that the bending could so frequently be of such an unexpectedly high order as to bridge a 100-mile path with intervening ridges of hills 1000 feet high, and to put down a field on many occasions as strong as one would normally expect along an unobstructed line-of-sight path.

THE EARLY CONCLUSIONS

The observations reported in this first paper were made chiefly in the winter months and they resulted in this statement, "It appears that an extensive sub-normal temperature lapse-rate anywhere in the regions between 300 and 2500 meters

(Continued on page 76)

⁴ Ross A. Hull, "A Simple Photographic Recorder for the Experimenter," *QST*, March, 1935.

⁵ Ross A. Hull, "Air-Mass Conditions and the Bending of U.H.F. Waves," *QST*, June, 1935.

What the League Is Doing

League Activities, Washington Notes, Board Actions—For Your Information

Havana While the international conferences, such as Madrid and Cairo, set a world standard, rearrangements and special agreements concerning "continental" frequencies may be made at what are called regional conferences. The last such conference in this region was at Mexico several years ago. Another is to be held at Havana in November.

In March last, representatives of the United States, Canada, Mexico and Cuba met in Havana for a preliminary discussion. They adopted numerous resolutions but none of them is yet binding: they were adopted only as a basis for discussion at the real conference which will be held in November, when twenty-three nations of North & Central America will be invited to participate. Much of the work of the conference will relate to broadcasting. Amongst the matters that interest amateurs will be the following:

(1) Changing our 1715-2000-kc. band to 1750-2050 kc., so as to provide expansion for the police service. We would give up 35 kc. at one end and gain 50 kc. at the other end. Since 1715-1750 kc. is not harmonically related to any of our other bands, it should make no difference to us. In fact, since we would gain 15 kc., there would be some net profit on the transaction, even though a signal occupies a little more space at 2000 kc. than at 1700.

(2) Reaffirming all the important amateur bands as available only for assignment to amateurs in the North & Central American region.

(3) A proposal by Cuba that the Latin-American countries be permitted to use 7000-7100 kc. for 'phone. The northern countries would continue to employ the entire band exclusively for c.w. The universal W/VE feeling is that this is a c.w. band, so this threat may be serious. The answer may lie in the report that the Cuban amateurs want this provision to permit daylight work, where 4 Mc. has insufficient range and 14 Mc. too long a skip. If confined to daylight hours, it might not be so bad.

(4) An arrangement permitting intercommunication between all types of stations during emergencies.

These are all proposals for discussion in November, and are not yet actions. The League expects to be represented at the November conference.

Cairo Some of the proposals of other nations for the Cairo Conference are now coming out. We have seen a few items. Japan proposes that all amateurs be limited to a power of 50

watts in the antenna, in order to reduce interference. Australia, proposing carrying allocation up to 150 Mc., suggests retaining the 56-60-Mc. band for amateur and experimental stations, as now provided internationally, and giving us an additional such joint assignment from 120 to 130 Mc. Sweden proposes, amongst other things, the assignment of 1560-2785, 2810-2900 and 2930-3605 kc. to the mobile and fixed services, primarily maritime radiotelephony; and 3605-3635 kc. to aircraft. These proposals cover our entire 1.75-Mc. band and the first 135 kc. of our 3.5-Mc. band. In the case of the frequencies below 2000 kc. the Swedish administration may be talking only of an arrangement for the European region, but the Madrid table provides only one general allocation for all the world for frequencies above 2000. Belgium proposes the elimination of the 1.75-Mc. amateur band, the reduction of the 3.5-Mc. band to 100 kc. and the reduction of the 14-Mc. band to 200 kc. While her first two proposals may be intended only for the European region, she does not so state, and of course her proposal to halve our 14-Mc. band is a frontal attack. Italy proposes reducing the 7-Mc. and 14-Mc. bands in Europe, although permitting them in other regions to continue as they are. She would give European amateurs only 7200-7300 and 14,300-14,400 kc., assigning the other portions of those bands to the fixed and broadcasting services.

These proposals are, we suppose, indicative of what we amateurs shall have to combat at Cairo. As soon as the Book of Proposals can be studied thoroughly, a complete enumeration of the proposals affecting amateur radio will be published here.

Canada Canadian amateur regulations are effective on the first of April of each year, and are then continued without change for a solid year. Last April 1st the Canadian regs were reissued for another year without change from the previous year. Canadian General Manager Reid in January obtained expressions from the affiliated clubs and the S.C.M.'s of Canada, and from many active amateurs. One thing that United States amateurs watch with particular interest is the Canadian regulation concerning 14-Mc. 'phone. This question received particular study in this year's Canadian examination and Mr. Reid reports that, from the replies received, a large majority in Canada are in favor of keeping the 'phone allocation in its present dimension

and in the center of the band. The government at Ottawa has therefore continued the arrangement for another year.

Age Limit? There is a bill before the House Committee on Interstate & Foreign Commerce, H. R. 5376, which would amend Section 303 of the Communications Act to require that all licensed radio operators, including amateurs, be twenty-one years of age or over. It was introduced by Congressman Richard J. Welch of the Fifth California District, San Francisco, on behalf of the A.R.T.A., the labor union of commercial radio operators. It was not intended to cover amateur operators but does so just the same. The League has immediately taken steps to secure the exemption of amateur radio if this bill is enacted. The F.C.C. is not in favor of such an age limit on amateurs and, so far as we are aware, neither is anyone else. Obviously it would have a very serious effect upon us, for, although our average age is about twenty-five or twenty-six, many of us are under twenty-one. The League has asked to be heard when hearings are held on this bill and meanwhile has filed a brief with the committee.

Licensed Operators The Congress recently enacted an amendment to the Communications Act giving the F.C.C. authority, under certain unusual circumstances, to modify the usual requirement that every station must be operated by a licensed operator. The change was enacted primarily for the relief of experimental stations engaged in ionosphere research. A rumor has been going around the country that this bill was sponsored by the A.R.R.L. The League has been in no way connected with it, and it has no effect upon amateur radio. It does not apply to stations for which licensed operators are required by international agreement, as is the case with amateur radio. The Madrid regulations require that the operators of amateur stations be examined both as to technical capabilities and as to the ability to send and receive code. The F.C.C., even if it wished to, which it does not, could not relax the requirement on amateur operation that operators must be licensed.

Changing Address When an amateur station is moved, the filing of an application for amendment of the address of the station license does not in itself authorize the amateur to engage immediately in "fixed" operation at the new address. This may not be done until the amended license is received. In the meanwhile (up to the date of expiration of the license) the amateur may engage in portable operation at the new address, but before doing so he must notify his Inspector of his intention so to do, and he must sign the portable designation. Quite a few amateurs have got into trouble on

this score recently, apparently believing that they were authorized to operate as usual, once they had filed application for amendment. Don't forget that this may be done only in portable status, and that that requires notifying the Inspector.

Harmonic QRM The London short-wave broadcasting station, GSD, operating on about 25 meters, is being interfered with in Canada frequently by the third harmonics of American 'phone stations operating between 3900 and 4000 kc. This station carries the Empire broadcasting of the B.B.C. and is much listened to in Canada. There seems to be a considerable amount of third-harmonic interference from 'phones. All 'phone amateurs would be well-advised to check their emissions for third harmonics and eliminate them if any are found.

Hq. On Air There are fifteen licensed amateurs on the A.R.R.L. headquarters staff. In addition to WIAW, these amateurs operate twelve active home stations (soon to be thirteen), and two without stations at the moment are inveterate experimenters. Interest divides, as it does in any typical amateur group, between the various bands and between traffic, DX, u.h.f. work, experimenting, and rag-chewing. Some of the gang is to be found on, almost any old time. Always psed CU, OM.

The Cover

WE GRABBED the picture in *QST's* Lab this month, not only because Jim Lamb and his gadgets made a swell shot but because we wanted to draw attention to a new story of his scheduled for next month's issue. The story is the outcome of hundreds of hours of development and measurement work and has to do with "Full-Range Selectivity." It discloses ways and means of attaining continuously adjustable selectivity in the superhet all the way from the highest we can use for c.w. to the broadest required for 'phone—a range of over 100-to-1. It's another basic advance in our practical communication technique.

Post Mortem—1937 DX Contest

(Continued from page 11)

Another helpful item was the fact that the DX stations were easy to pick up after a call, most of them being easily recognizable by their accents. Disappointing, however, was the rather poor performance of the 28-Mc. band, which seemed to have acquired a sort of "don't care" attitude after having been jammed with kilowatt after kilowatt in the c.w. contest.

A minor thrill for us around here was the re-

ception of the scores. At first glance, it looked as though W1SZ would repeat his performance, and top the 'phone test with 28,594 points. Then W4CBY, with W4DHZ at the mike, sent in a score of 31,356, and that looked awfully good. Then when W2UK said he had 39,000 points we were certain we knew the highest station, until W4AH told us about his 43,833 points. But we were totally unprepared for the score of W9ARA, which came through just as we started to write this report. Robert Henry, W9ARA of Butler, Mo., worked 250 stations for a score of 45,367! Twenty-three countries were worked on 10 meters, and 38 on the 14-Mc. band. Complete details are lacking, but a rotatable "signal squirter" was used for an antenna. Much credit is due this station because of its location in almost the center of the country.

So there you have the story. We can't be certain that W9ARA is the highest station, because it is a little too early, but it looks very good. High West Coast score (to date) was submitted by W6ITH, who had 23,085 points. Incidentally, you'll find a photograph of W6ITH's rig in the Sweepstakes story. The second highest West Coast score we've heard of is that of W6BAY: 14,000.

Unfortunately, time prevented our obtaining any foreign scores. However, we have it from several sources that K6MNV had approximately 63,000 points, which should make him high-scoring foreign station. K6MNV is well known for his amazing signal on 28 Mc., and we understand from W6ITH that during the contest the Hawaiian station worked all possible districts (14) on ten, and 12 of them on the twenty-meter band. VK2GU, who has the most consistent 28-Mc. 'phone signal on the East Coast of any VK, is reported to have made 27,000 points.

Other scores were: W3CRG, 21,276; W2IXY, 16,164; W2CBO, 15,576; W9BEZ, 15,640; W9YGC, 15,414; W2DSB, 13,846; W6AM, 11,696; W4DCQ, 11,036; W6EJC, 10,362.

GENERAL

Taken as a whole, the 1937 DX Contests were the most successful staged. Unlike the contests of only a few years back, so many contestants made WAC time after time and on different bands that it is useless to recount them all individually. More countries were worked than ever before. More bands were brought into play than ever before. More . . . And yet, stations still persist in the same old time-wasting and un-sporting activities of rough notes, inexcusable key-clicks, and just plain poor operating. The more frequent use of QHM, QLM, etc., would be a great help.

However, worse than ever before was the amount of out of band operation. We have heard many comments on the unfair tactics employed by some to gain a slight advantage. Fortunately

for our argument, the highest scoring stations operated legally at all times. But two scores, of 104,742 and 104,380, had to be disqualified because of out-of-band operation! No doubt others will have to be disqualified also, but these two were almost certain third and fourth place

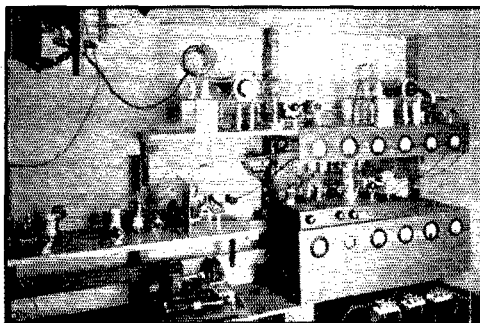

ONE OF THE HIGH-SCORING EIGHTH DISTRICT STATIONS, W8FJN, ROGER LINDLEY, COLUMBUS, OHIO

The HK354 is used as the output stage on 3.5 Mc. and 28 Mc., and drives the p.p. 150T's on 7 and 14 Mc. The input runs around 900 watts on the latter bands.

stations (not counting W1SZ). And that's the sermon for to-day.

To all those who helped so willingly in compiling these early scores, we give our sincere thanks.

—B. G.

DX Competition Policy

THE A.R.R.L. has a double responsibility in connection with supervision of its operating activities. First there are competition rules. In fairness to all it is necessary to see that individuals abide by the rules of the game. After all it is no achievement at all to win or surpass, or accomplish results, DX or otherwise, by unfair means. It is sporting to abide by contest rules; unethical and unfair to break rules. Regulations for activities or sports of any kind have to be enforced by an umpire. Whether accident or intent is responsible for "hitting a foul" or deciding whether the pitch was a ball or a strike, it is the umpire's responsibility to call the play—to make a decision in the interest of fairness to the players. No game demands higher standards of sportsmanship than amateur radio. In our national and international competitions of annual fame, A.R.R.L. is the umpire.

But A.R.R.L. has a second and deeper responsibility to the amateur service that goes beyond the interest of the players in the game alone. A.R.R.L. goes to bat for the amateur service in both international and national representation of that service. "Amateur radio" stands or falls in the conference halls where domestic and inter-

national regulations, legislation or agreements on matters of communication are made, by its respected public relationships. Its record of splendid public service, training value, and all constructive aspects established by amateurs are positive factors; the standards of frequency observance, the record of coöperation and satisfactory relationships with other services, the number of operators violating as compared to the number observing regulations with care—these things count powerfully when examined. On the record, and from the facts may be fashioned strong arguments "for the amateur," or for our adversaries, as the case may be. So it is the first duty of your A.R.R.L. to so conduct amateur affairs that a shining record may be presented and the facts may all have positive rather than

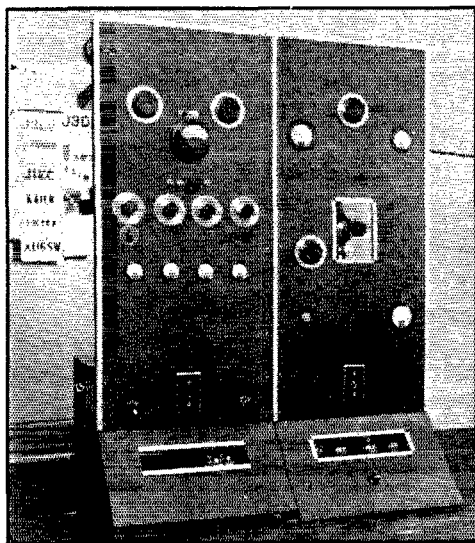

THE NEAT TRANSMITTER OF W. G. SOUTHAM, VE2AX, HAMPSTEAD, QUEBEC

The left hand side of the panel contains the 53 exciter unit and the buffer-final p.p. RK20's. The right hand section includes the p.p. 860's final amplifier. The input usually runs around 500 watts.

negative force. We are glad to say that through A.R.R.L. efforts, the amateur service has a top notch record. The burden of this story is that we must keep it that way and that the League intends to discharge all of its obligations to the fraternity fairly and honestly as it has ever done. Your A.R.R.L. is respected in Washington, and Ottawa. Its spokesmen in scheduled conferences for the early future (the next important North American and world conferences concerning frequency allocation are to be at Havana and Cairo) must continue to have a clean slate for the amateur service, that they may point without fear to the record of present and past amateur operating.

In A.R.R.L.'s 9th International DX Competition there was a tendency toward increased off-frequency operation and other violations. This is the case in point. The off-frequency record has been one of diminishing proportions for a number of years and disqualifications have been less numerous, until this recent history, a pleasant enough record indeed. Perhaps the record has looked so good that precautions have been neglected, by some operators. Hams (too trusting) have depended on other hams being in the band, and matched them kilocycle for kilocycle, hoping to work at the absolute limits of the bands. Or some have deliberately worked outside. At any rate some stations were heard scores of kilocycles off frequency! Factors of safety must be allowed for crystal temperature drift or tank tuning. Even an oven is not absolute insurance unless checks are made. Several frequencies of oscillation for one crystal, transmitter parasites, one must check for all if certainty in adjustment is to prevail. Our contest rules set a time limit but did not penalize any operator for taking all the time necessary to check with accurate markers, WWV. W9XAN-W6XK s.f. transmissions, broadcast station harmonics, etc. Frequency measuring equipment is more reliable, abundant, and inexpensive than ever before, so we must state our belief that too much haste, too small a factor of safety, too little operating distance from the right side of a band edge, too little use of QMH and QML-type operating may have something to do with the contest difficulties.

DISQUALIFICATIONS

To combat this trend, in line with past practice,¹ A.R.R.L. Official Observers in the United States and Canada were asked to do as much special monitoring of the bands as possible during the contest period. A firm policy has been observed this year of barring from QST mention in preliminary and final DX contest reports, and from awards, any operators checked in a violation by two or more Observers with standards of known and sufficient accuracy. We are going to "hew to the line" to the extent of listing the stations that have been so checked by receipt of a satisfactory weight of evidence against them. The *Wouff-Hong* and the *Retlysntch* were designed by T.O.M. for just such emergencies that threaten the fair name of our amateur radio service. All amateurs should be grateful and thankful to the individual observers who coöperated in keeping our hobby self-regulatory. In addition, letters from participants indicated that a great many of those A.R.R.L. checked in the U.S.A. also received notices of violations direct from the F.C.C. so that we have a double check on the accuracy of our Observers' work. Our evidence is concrete. Of course a single F.C.C. citation, if we know about it, is more than enough to disqualify. In two instances where F.C.C. discrepancy citations

were admitted by letter we respected the honesty and good intentions of the writers but, in fairness to others, felt we had to list the calls. In no case where stations have been reported in violation by official sources so that it is a case of violation beyond any reasonable doubt do we believe that that operator rates favorable contest publicity in *QST*, since whether the trouble was caused by carelessness, accident or other reason the result is the same in adding to the record of amateur violations, and is therefore against the best interest of *all* amateurs. We personally sympathize with unintentional offenders. It is our painful duty to umpire, however. The lesson is that greater care *must* be observed.

Our listing of stations¹ observed out of the bands includes a number of foreign as well as W/VE amateurs, in accord with the policy stated in an Official League Broadcast released at the beginning of the contest. We regret the necessity of this listing, and we appreciate that many other stations besides those listed may have been missed inadvertently that were equally at fault. A consistent policy that reduces possible criticism of our off-frequency operating at international conferences, however, requires amateurs of *all* countries to observe their assigned bands. We are glad to report that there was not the required weight of evidence to disqualify any VK's, G's, ZT's or ZL's, which doubtless means that more careful frequency observance is the rule in those countries. One strong station was reported by an observer as breaking a point to point public service station badly so that a message had to be repeated eight times to get it through. If such reports were common, we should seriously consider the abandonment of any activity that might inadvertently stimulate such trouble, but we are convinced that the firm disqualification policy that will remain in effect should operate to make amateurs the world over appreciate the necessity for adhering closely to our exclusive international frequency assignments, lest a threat to these arise in future international meetings.

Next year we may place an *additional* policy in effect in A.R.R.L. DX-competition rules. It will mean increased checking work, but the new

rule will take away the last bit of possible incentive for out of band work. We propose to continue to disqualify stations as necessary, fairly and equitably, and to *then* re-check the scores of stations not so disqualified, subtracting from their scores any credits gained by *working* the stations listed as disqualified. Tell us if you like this plan, please.

A full list of stations reported to us beyond any doubts as off-frequency during the period of the 9th annual DX competition follows these comments. Stations shown with asterisks also had modulated notes. We have not checked foreign amateur regulations for A1-2-3 requirements so do not show any tonal distinctions for remotely located stations. In some few cases the logs have not yet been received, but because these stations were heard calling DX and enjoying the fruits of A.R.R.L.'s official contest arrangements, it is a safe presumption they were taking part in a large or small way. We feel that it is the only fair and impartial thing to include them all. In each case there is evidence beyond a reasonable doubt of the violation. No cases of a single 0.0. report were used to disqualify. Since there are a great many observers reports that were cross checked and weighted depending on the marker-stations used, and the accepted ratings of accuracy of the calibration methods and sources of the particular frequency standards involved, the League cannot enter into correspondence or use additional time in studying records of individual observers again for detailed information. In practically all cases stations received notices direct at the same time information was sent the League.

—F. E. H.

The following are deemed ineligible for DX-
score listings, or awards, in the March 1937 DX
competition in accordance with the above policy.

W1BEQ W1BUX W1DUC* W1FJN W1GLF
W1HP W1IBL* W1IGR W1IJP W1ISS W1JNF
W1KFE W1PL W1RY W1ZB.

W2AZL W2AZN W2BDZ W2BYP W2DZA
W2GJD W2GUP W2GVX W2HEN W2HXI
W2HW W2KAN W2VY.

W3BOP* W3BZE W3DVE W3EFY W3EHW
W3EMM W3EUQ W3EVT W3FPQ W3FQZ
W3FSC W3GAP W3GEA W3GHB* W3GKO
W3QM.

W4AGI W4AUU W4BQO W4BSJ W4CRZ
W4DCZ W4DTR.

W5ASG W5DQD* W5EHM W5FAS W5FBN.
W6AZC W6BYB* W6CUZ W6DTB W6HB
W6HJT W6ITU* W6JJS* W6JKH W6KGD
W6KRI* W6KUR W6LEV W6MHH W6MKL
W6MTC W6NKR W6NYA W6OEH W6OHN
W6TT W6WC.

W7BD W7DXZ W7EK W7ESM W7FMD
W7FTU W7PZA W7JL W7VQ.

(Continued on page 116)

¹ A.R.R.L. Official Observers have been on the job in many a past DX test, but of recent years conditions have not rated the action or attention of our earlier contests, until this year. Among the scores of "disqualified calls" listed prominently in August '28, August '30 and August '31 issues of *QST* in the official report of previous events we are amazed to find that two of the same operators (W7EK and W2BYP) were *then* chalked up as ineligible for awards. Is off-frequency work a habit?! Regrettably, we conclude that renewed and eternal vigilance, with new safeguards will be the price of continued contest success, and we assure amateurs who wrote us about conditions that strict fair play will be enforced or these enjoyable affairs that have evolved with time out of our early 1927 DX announcement will have to be discontinued. "Observers Win, DX Tests Discontinued" (hi!) is a heading that we hope *never* to have to use, however.

A Universal Exciter With Variable-Frequency Crystal Control

Combining Reliability and Convenience in Relay-Rack Construction

By James Millen,* W1HRX

IN RECENT years the trend in both amateur and commercial transmitter design practice seems to be toward the treatment of the exciter as a separate unit. During the past year or so, much progress has been made in the design details of exciter units with a view toward increasing their reliability, compactness, universal applicability, ease of band-shift, and vernier control of frequency adjustment.

In the unit described herewith an attempt has

An effective, dependable circuit
Variable frequency control
Pre-tuned band shifting
Compactness
Universal application
Ease of construction
Relative low cost of component parts

THE CIRCUIT

Though many amateurs favor a Tri-tet oscillator, we have been partial to a triode crystal oscillator with triode doublers, using tubes such as the 53 or 6A6, as originally developed by W1CTW.¹ This system has been described so often that details are scarcely necessary here.

In some layouts, such as used in another recent transmitter employing a variation in the original circuit, a material simplification of the circuit wiring is secured by criss-crossing the functions of the two tubes; half of the first 53 is the oscillator, half of the second 53 is the first doubler; then back to the first 53 for the second doubling and then on to the second 53 again for the final doubling. In this instance, however, the neater arrangement is secured by wiring the triode sections in straight sequence, rather than by "criss-crossing."

Another circuit detail which, while neither new nor original is yet seldom seen in amateur equipment, is the method of using a dummy plug for switching the d.c. meter from one circuit to another, rather than the more general practice of conventional jacks with a plug-and-cord connected to the meter.

By using 6-prong plug-in bases for the pre-tuned tank circuits it is possible to have an independent link-coupling winding on each output tank and to connect all of the corresponding socket terminals in parallel across the output terminals. In practice it will be found advisable, for quick band shift, to have additional tank circuits fitted with the output coils for those bands upon which the exciter is to be operated, inasmuch as the loading of the link circuit appreciably changes the tuning of the tank coil being used in the output stage, as against the tuning of that same tank coil when the output winding is

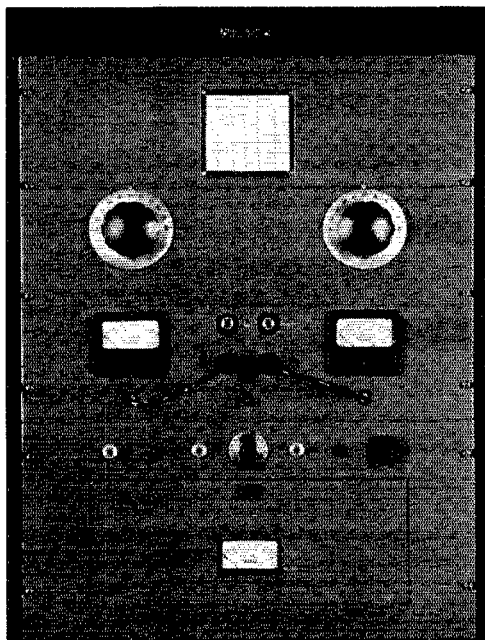

MODERNISTIC APPEARANCE CHARACTERIZES THE TRANSMITTER ASSEMBLY IN WHICH THE EXCITER IS MOUNTED BELOW THE BUFFER-FINAL UNIT

A hinged panel opening gives quick access for changing the shielded plug-in coil units.

been made to consolidate the desirable features of several exciters described in recent issues of *QST*, and to incorporate some of the newer types of components only more recently available, to form a complete unit having the following characteristics :

* Middleton, Mass.

¹ Millen, "Pentode Output Transmitter with Six-Band Exciter," *QST*, Oct., 1934.

open and the stage is being used as a doubler. If, however, the slight additional time required to re-tune the tank is of less importance than economy, then, of course, the one unit can be made to serve double duty by means of a slight retuning operation.

Even at 28 Mc. with such a circuit ample output is obtained to drive a 35T, RK37 or a similar tube as a buffer operating on the final frequency; which, in turn, can fully drive most any final amplifier that can be legally used on the amateur bands. The exciter output will also provide ample excitation for pentodes of the RK-20 type without an additional buffer.

Those many 28-Mc. stations that have been QSO W1HRX on Sundays during the past December and January may be interested to know that the r.f. portion of the transmitter used comprised this exciter driving an RK37 buffer which, in turn, drove a pair of RK38's. The complete assembly, shown in the photo, is in actuality but a relay-rack mounted version of an earlier base-mounted single-unit transmitter that time had proved to be extremely satisfactory.

VARIABLE FREQUENCY CONTROL

It is an easy matter in the design of such an exciter to use a multiplicity of fixed crystals and a selector switch.^{2,3} With present QRM conditions it is frequently more desirable, however, to

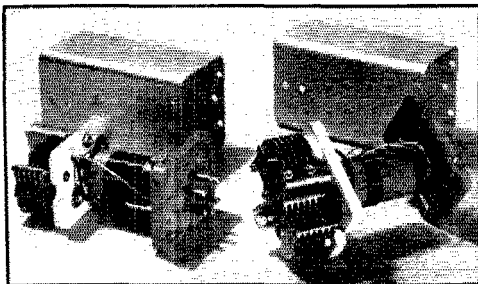

TWO OF THE COIL UNITS WITH THEIR SHIELDS REMOVED TO SHOW THE CONSTRUCTION

be able to make a relatively minor shift in frequency in order to avoid an objectionable heterodyne, and for this purpose the value of the variable air-gap holder with low-drift tunable type crystal cannot be too strongly emphasized.⁴ The usefulness of such an arrangement increases materially with increasing frequency for, while the

frequency of the unit with constant output is of the order of but six kilocycles in the 3.5-Mc. band, this same unit has a range of over 50 kilocycles in the 28-Mc. band!

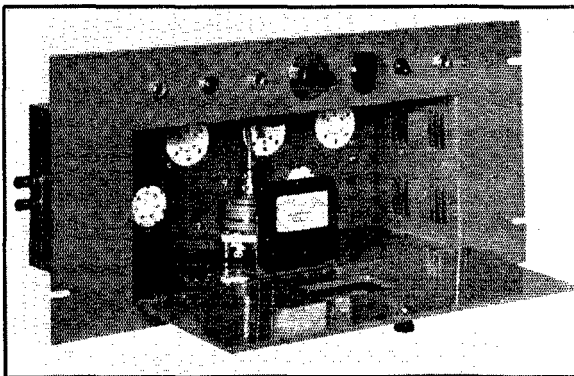

FRONT VIEW OF THE EXCITER UNIT WITH THE COILS REMOVED

The dial in the center is the crystal gap control for varying frequency. A dummy plug is fitted into the four jacks for meter switching. Between the jacks at the left is the pilot light and between those at the right is the on-off toggle switch.

THE COIL ASSEMBLIES

The FXTB exciter tank units of the special 6-prong type were chosen in order to provide ample contacts for the output link circuit as well as to make possible the use of the special Isolantite sockets designed primarily for plug-in coils rather than tubes. In addition to the shield can and the R39 plug-in base these units comprise an Isolantite plate upon which are mounted two double-spaced midget variable condensers, completely isolated from each other so that they may be used in series, parallel, or any other combination desired. To the bottom of the Isolantite plate, directly under the condensers, is fastened an R39 coil form. The photo of the disassembled units shows this arrangement. The Table gives full data for winding the coils.

In the 28-Mc. output unit only one of the dual tuning condensers is used and even that is set at a relatively low value of capacity. At the lower frequencies the two condensers in each unit are connected in parallel. By such an arrangement one condenser is roughly set and then a fine adjustment made on the other, which facilitates accurate tuning.

One of the contact pins is used for grounding the shield. This connection to the shield can be made most easily by means of a soldering lug between the shield and the base (located where it will be gripped by one of the screws) and connected to the pin by a bus-wire jumper. In soldering a screw is used to hold the lug in proper position, and when soldered the shield can be removed at will without breaking the connection. The lug should be of the shakeproof variety, so that there

² Hollister, "A Four-Band Exciter," *QST*, July, 1935.

³ Millen, "A Quick-Switch 'Phone Transmitter for Two-Band Operation," *QST*, Oct. 1935.

⁴ Hollister, "Tuning the Crystal," *QST*, April, 1936.

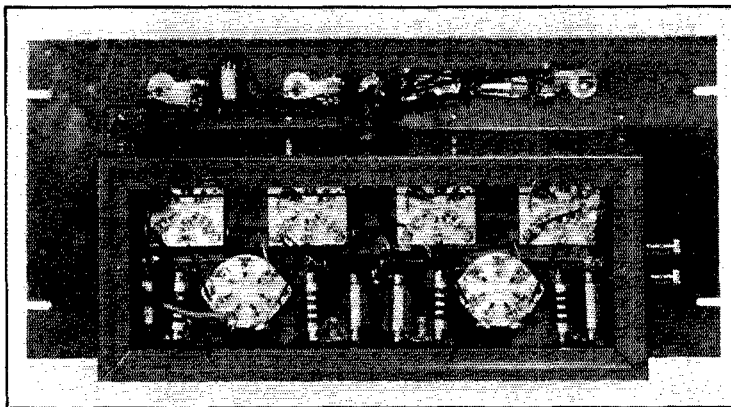

REAR VIEW OF THE UNIT WITH THE BACK AND THE DUST COVER OF THE CONTROLS REMOVED TO SHOW THE WIRING

teur. However, the trend, among most amateurs at least, is away from the home construction chassis, cabinets, and other such metal units requiring considerable shop facilities if a really first-rate final appearance is to be had. On the other hand, the amateur who uses a commercial foundation unit still has all the fun of circuit development and experimentation, and, at the same time, secures a piece of finished equipment that

will be good contact. Often a smooth lug will not bite through the oxide film on the aluminum surface.

he is proud to display.

The foundation unit was originally designed to be as versatile as possible. In our application it is

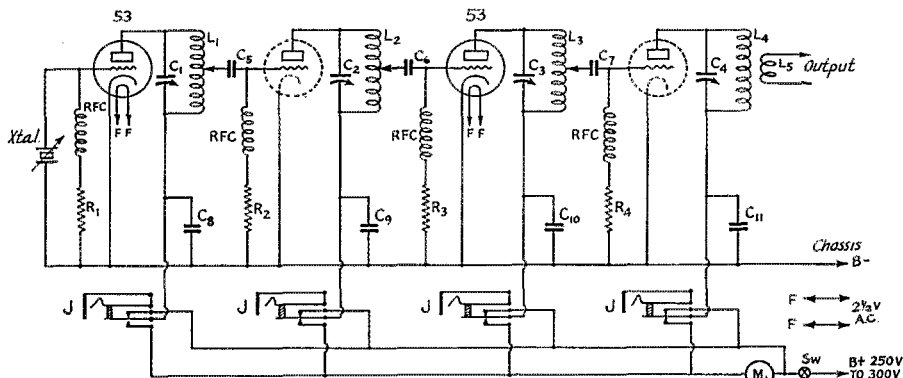

FIG. 1—FOUR TUNED CIRCUITS WITH TWO DOUBLE-TRIODE TUBES ARE USED IN THE EXCITER CIRCUIT. THE TRIODE ELEMENTS ARE DIAGRAMMED SEPARATELY FOR CLARITY

L_1, L_2, L_3, L_4 —Plate coils in shielded units (see coil table).
 L_5 —Output link coil (see table).
 C_1, C_2, C_3, C_4 —Two 35- $\mu\text{fd.}$ ultramidnet tuning condensers in parallel except for 28-Mc. (Included in National FXTB

coil units—see text).
 C_5, C_6, C_7 —100- $\mu\text{fd.}$ mica condensers.
 C_8, C_9, C_{10}, C_{11} —0.01- $\mu\text{fd.}$ mica condensers.
 R_1, R_2, R_3, R_4 —10,000-ohm 2-watt grid-leak resistors.

RFC—2.5-millihenry r.f. chokes (National Type R-100).
 M_1 —0-50 d.c. milliammeter (Trip-lett).

The crystal is a special Hollister type in a National Type CHV Vari-Gap crystal holder.

CONSTRUCTION DETAILS

The metal chassis unit around which this exciter has been constructed is a standard commercially available component but may be readily home-constructed by the more ambitious ama-

mounted behind a standard relay rack panel, in which is cut and mounted a hinged door. This door, of course, is not entirely necessary, and, from a purely performance angle, may well be dispensed with. Furthermore, there is, of course,

(Continued on page 58)

COIL TABLE

Coil	L_1	L_2	L_3	L_4	L_5
Band (Mc.)	3.5	7	14	28	
Coil form dia.	1"	1"	1"	1"	1"
Wire size	28 enam.	24 enam.	24 enam.	24 enam.	20 d.a.c.
Turns per inch	60	24	24	24	
Turns	36	20	9	5	2-turn link
Tsp (turns from plate)	13	4	4		

How Would You Do It?

Announcing the Prize Winners in the Third and the Problem for Fifth in the Series of Practical Problem Contests

THIS problem contest business is turning into a tremendous success. The solutions may not be setting the world afire but at least they are giving us an insight into ham ingenuity which we only glimpsed before.

There is really a wonderful spirit on the part of our contributors all along the line. We feel quite certain that many genuinely valuable contributions will be brought to light before we get through. Of course, this third contest was no slouch! Indeed, we consider that the two winning papers are genuine honest-to-goodness contributions.

Walter Van B. Roberts, W3CHO, rings the big bell this time with a scheme for varying the link coupling without sloppy wires, movable coils, or mechanical attachments to the tanks themselves. It is a glorious example of the virtue of extreme simplicity.

O. K. Blackburn, W9MB, wins by a thin hair the second prize from George A. Bonadio, W80MM. Both provided similar solutions. W9MB's paper got the extra vote. The remaining pile of contributions contained much of interest and almost all of the schemes suggested were perfectly practical. Most of them, however, involved complex mechanical structures and none of them, in the opinion of the judges had quite that clean-cut simplicity and practicability that characterized the winning scheme. Without more fuss, therefore, we hand them to you.

Variable Link Coupling

By W. Van B. Roberts, W3CHO

LINK coupling between tuned circuits is a widely used arrangement offering a number of advantages, perhaps the most important being that the coils may be located quite a distance apart. However, with simple link coupling it is not easy to vary the coupling between push-pull coils without upsetting the symmetry of the arrangement unless, for example, a special coil form is used that permits the link to be moved symmetrically with respect to the coil. Even this requires mechanical moving parts made up to suit the particular job. The arrangement to be described is offered as giving the desired ability to vary the coupling without any moving parts except a single movable clip.

Fig. 1 (a) shows a pair of coils coupled by a link having a total self-inductance L and negligible

resistance. It can be shown that this arrangement is identically equal to that of Fig. 1 (B) which is a pair of coils having direct mutual inductance between them, the coils of Fig. 1 (b), however, having inductances somewhat smaller than those of Fig. 1 (A). Fig. 1 (B) also indicates the exact values of the equivalent inductances and of the equivalent mutual.

Let us suppose that M_1 and M_2 and L are so chosen that the resulting coupling is somewhat greater than desired. The problem then is to find a convenient way to reduce this coupling, preferably without changing M_1 or M_2 since this would involve moving the link turns relative to the coils, which is not easy to do if the link turns are to be kept at the low radio frequency potential points of the coils.

From Fig. 1 (B) it will be seen that the effective mutual between coils can be decreased by increasing L , a fact that suggests Fig. 1 (C) as a simple means for reducing the coupling. In Fig. 1 (C) we have merely an ordinary link coupling with a small series inductance added and provided with a clip connection so that more or less of it may be included in the link circuit. The

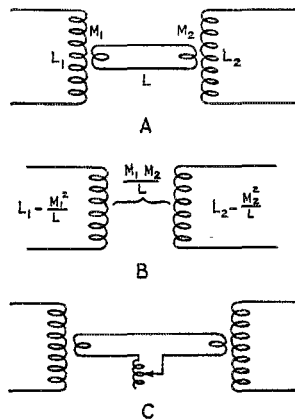

FIG. 1—THE VARIABLE COUPLING SCHEME SUGGESTED BY W3CHO IS SHOWN IN FINAL FORM AT "C."

more of this inductance that is included, the less the coupling, while for maximum coupling the clip is connected directly to the link, thus giving a simple link coupling without any extra inductance. (A ground may be used on one side of the link but it is of course not actually essential.) In order to obtain sufficiently tight coupling when

the extra coil is entirely out of the link circuit, it is important to design the link to have a sufficiently large value of $\frac{M_1 M_2}{L}$. This brings up the

matter of the number of turns at each end of the link. Let us suppose that we have one turn at each end to begin with. What will be the effect of increasing this to two turns at each end? First of all, the mutual at each end will be doubled so that the product of the two mutuals will be increased four times. But at the same time, the self-inductance L of the link circuit will be increased. If, for example, L should thereby be quadrupled, there will be no increase in the effective coupling. In actual practice, however, there is always some self-inductance in the conductors connecting the two link coils together, and also if the two link turns are spread apart a little from each other, then even the inductances of the link turns will not be quadrupled by doubling the number of turns. Hence, in practice increasing the number of turns at each end will increase the effective coupling especially if these turns are not too tightly bunched together. The necessary number of turns in any particular case must be determined by experiment, although in many cases the minimum number is probably known from previous experience.

The usual plug-in coil arrangement for a push-pull coil having three plug terminals for the coil itself, and two more for the link turns may well be used. The link turns might be composed of heavy

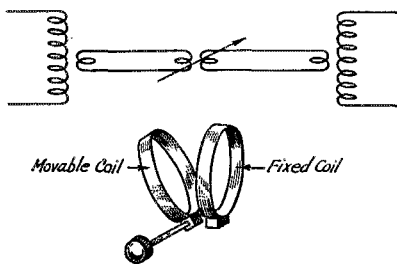

FIG. 2.—W9MB'S PROPOSAL FOR VARIABLE LINK COUPLING

wire covered with spaghetti and wound between turns of the tank coil. As for the decoupling inductance to be inserted in the link circuit, this might be wound on any kind of fixed or plug-in coil form and would preferably be made of bare wire sufficiently heavy and well spaced, to permit easy clip connection to any turn. The size and number of turns is best determined by trial, although as a guide it is obvious that the total inductance of the decoupling coil should be several times that of the rest of the link circuit in order to be able to reduce the effective coupling to a considerable extent. The rest of the link circuit should be several times that of the rest of the link circuit in order to be able to reduce the effec-

tive coupling to a considerable extent. The rest of the link circuit should be made of heavy insulated wire, preferably twisted together to keep its inductance low.

— · · · —

Continuously Variable Link Coupling

By O. K. Blackburn, W9MB

THE simplest and most obvious solution to our hero's latest problem is the division of the link into two parts with variable inductive coupling

(Continued on page 106)

Problem No. 5

OUR hero is making grand progress with his new rig but he is determined to take time out, before it is quite completed, to build himself an inexpensive operating table to serve, as he modestly puts it, "as the nerve center of the entire installation." He is not much of a carpenter and his woodworking tools are rather inadequate. He demands that the ideal design for his requirements would have to be a fairly simple structure. He would be floored, for instance, at the idea of building a layer of drawers. But in spite of its simplicity, the creation must provide him with a thoroughly practical and completely comfortable operating position. There must be room for his standard superhet receiver and its external power supply, a loudspeaker, a small monitor, the usual key, microphone and control switches. There must be some sort of accommodation for message blanks and messages, for miscellaneous notes, for pencils, for the log and call book. There must also be room for the plug-in coils and other miscellaneous gadgets which ordinarily make a junk pile out of so many operating tables. All of these things are usually stacked on the top of a perfectly plain table, but our friend has seen enough arrangements of that sort to feel strongly that the effectiveness of his operating work, the general appearance of the station and his own personal comfort could all be aided if he only had the design of a really well-considered "nerve center." The exact shape and size of the present equipment to be mounted on the bench do not enter the picture since, without much doubt, new—perhaps bigger, perhaps smaller—equipment will take its place long before the furniture is worn out.

Sketches of the proposed bench are required. All important dimensions should be included.

Ultra-Midget Equipment for the Ultra-High Frequencies

A Complete Transmitter and Receiver for Personal Wear

By Jack Wagenseller,* W3GS

THE writer was called upon to design and construct one of the smallest practical ultra-high frequency transmitters that could be conceived. It had to be small because it had to fit into a man's coat pocket, since the purpose for which it was to be used necessitated that it be completely concealed in a person's clothing, antenna, microphone, batteries and all.

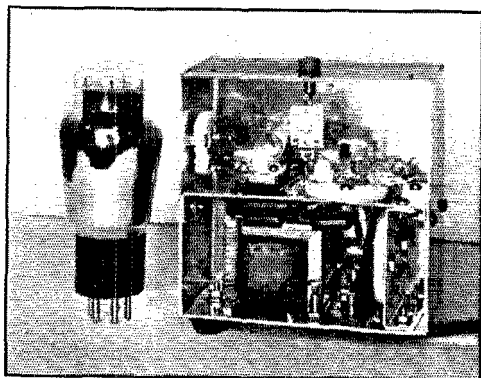

THE RECEIVER CASE IS OF THE SAME DIMENSIONS AS THAT OF THE TRANSMITTER BUT THE WEIGHT IS EVEN LESS

Placement of the components and the method of assembly are described in the text.

A similarly small receiver was also required, but its design is quite simple as compared to the transmitter.

A dozen uses to which a small transmitter of this type can be put immediately suggest themselves. However, it might be mentioned confidentially that the apparatus described was designed and constructed for a duly licensed amateur engaging in a so-called "magic act" where the person with the concealed transmitter interviews people in the audience and a partner on the stage with the concealed receiver apparently "knows all the answers." The exact details as to how this is carried out will be left to the imagination of the reader. The units also have no end of usefulness for novelty remote pickups in which the announcer can walk around in crowds and large gatherings.

The complete transmitter measures only

*Herbach & Rademan, Inc., 438 Market St., Philadelphia, Pa.

4-by-4-by-2 inches and weighs only $1\frac{3}{4}$ pounds. A complete set of batteries for operation of the transmitter weighs only $2\frac{3}{4}$ pounds. These are carried in a specially constructed belt which fastens around the waist. Two Burgess type X30FL midget 45-volt "B" batteries are used for supplying plate voltage. Four small flashlight batteries are connected in series for a filament supply of 6 volts, and a small $4\frac{1}{2}$ -volt analyzer type battery is used for supplying microphone voltage. The "B" batteries mentioned will provide approximately 30 hours continuous operation. The filament batteries must be more frequently replaced and have sufficient capacity for approximately 5 hours continuous service. The flashlight batteries are to be preferred for filament supply since they are economical and easy to obtain. A small container was constructed for these cells in order that they may be quickly and easily replaced. The four cells are held in place and automatically connected in series in

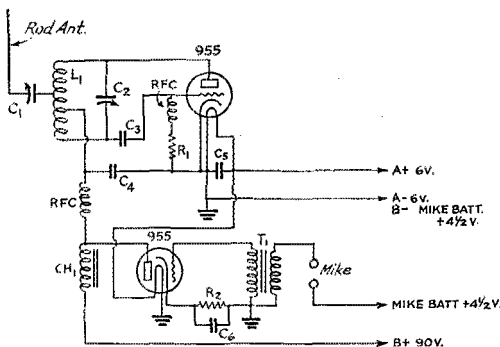

FIG. 1—CIRCUIT OF THE ULTRA-MIDGET TRANSMITTER

- L1—10 turns No. 16 bare wire slightly spaced, $\frac{1}{4}$ -inch diameter, self-supporting on u.h.f. coil base.
- C1—3—35- μ fd. trimmer-type antenna coupling condenser.
- C2—25- μ fd. midget variable tuning condenser (Hammarlund APC 25).
- C3—50- μ fd. midget fixed grid condenser (mica).
- C4—100- μ fd. midget fixed plate by-pass condenser (mica).
- C5—100- μ fd. midget fixed filament by-pass condenser (mica).
- C6—0.1- μ fd. modulator cathode by-pass condenser (tubular).
- R1—25,000-ohm $\frac{1}{2}$ -watt oscillator grid leak.
- R2—1200-ohm $\frac{1}{2}$ -watt modulator cathode resistor.
- RFC—25 turns No. 20 d.s.c., $\frac{1}{4}$ -inch diameter, self-supporting.
- CH1—Midget modulation choke (U.T.C. Type A30).
- T1—Midget microphone transformer (U.T.C. Type A10).

this container by means of spring brass contacts.

The receiver is exactly the same in size as the transmitter but slightly lighter in weight, weighing only 1½ pounds. The battery supply for the receiver is exactly the same as that for the transmitter except that the small microphone battery is, of course, not required in this case.

Most of the constructional details will be furnished on the transmitter since this is by far the more difficult of the two units to construct. A regular Hartley circuit is used with a 955 acorn tube as a self excited oscillator. This is plate modulated by another 955 acorn tube operating in Class-A. Sufficient audio power is developed to modulate the oscillator adequately even when talking quite some distance from the microphone. Either a single- or double-button carbon microphone may be used, but the single button will, of course, be more sensitive with the limited amount of gain available in the modulator.

If it were not for the ultra-midget microphone transformer and ultra-midget modulation choke, the construction of a transmitter this small would be next to impossible. These units measure only 1½ inches square by 1½ inches high, and weigh only 5½ ounces each. The microphone transformer will accommodate either a single- or double-button microphone. These units are standard and are readily obtainable.

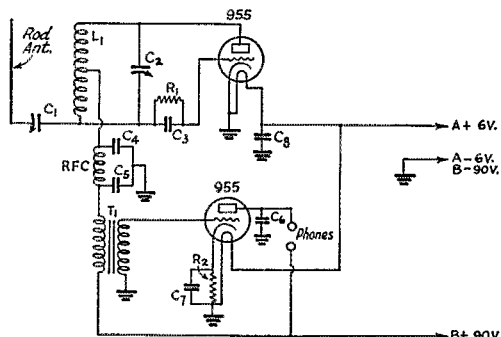
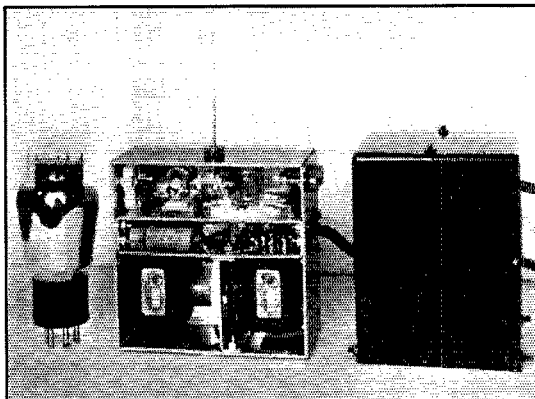

FIG. 2—A "MINUTE-MAN" SELF-QUENCHING SUPERREGEN DETECTOR AND ONE AUDIO STAGE ARE USED IN THE ULTRA-MIDGET RECEIVER

- L₁—Same as L₁ in transmitter.
 - C₁—3-35- μ fd. trimmer-type antenna coupling condenser.
 - C₂—25- μ fd. midget tuning condenser (Hammarlund AFC 25).
 - C₃—100- μ fd. midget fixed grid condenser (mica).
 - C₄—0.001- μ fd. midget fixed plate by-pass condenser (mica).
 - C₅—100- μ fd. midget fixed plate by-pass (mica).
 - C₆—0.001- μ fd. midget fixed by-pass (mica).
 - C₇—5- μ fd. 25-volt audio cathode by-pass (electrolytic).
 - C₈—100- μ fd. midget fixed filament by-pass (mica).
 - R₁—5-meg. ½-watt grid leak.
 - R₂—1200-ohm ½-watt audio cathode resistor.
 - RFC—Same as r.f.c. of transmitter.
 - T₁—Midget audio transformer (Kenyon KA 154).
- Note that positive B voltage is applied to the detector grid through the high-resistance grid leak R₁.

Since it would be practically impossible to construct the transmitter in one piece, to make construction and assembly easy the unit is built in two sections each separately assembled and wired



THE ULTRA-MIDGET TRANSMITTER UNIT, WITH CASE OPENED TO SHOW THE COMPACT CIRCUIT ASSEMBLY

A standard Type 47 tube, at the left, gives an idea of its small size. The battery box at the right is sometimes used instead of the belt supply described in the text.

as completely as possible. The two sections are then placed in the cabinet and the few remaining connections joining the two units are made. The oscillator section is constructed on the top shelf and the modulator assembly constructed on the bottom section. A general idea of the parts layout can be obtained from the accompanying photos. On the top shelf, left to right, are the tank tuning condenser, tank coil, antenna condenser and tube. On the bottom shelf, left to right, are the output choke, tube and input transformer. Fixed condensers, resistors and r.f. chokes are placed where space permits. Battery leads are brought out in a four-wire cable with a midget male cable connector on the end. The battery belt is wired with another four wire cable with midget female connector on the end. Microphone and antenna circuits terminate in small tip jacks.

The receiver is constructed in more or less the same manner as the transmitter. The detector section is constructed on the top shelf and the audio stage on the partition and bottom of the cabinet. The only transformer used in the receiver is a midget audio transformer such as is used in midget broadcast receivers.

An antenna approximately 40 inches long is used for full power output in the 56-Mc. band. However, for very short distances such as in the "magic act," a non-resonant antenna as short as 18 inches may be used with good results. With the non-resonant antenna, the useful transmitting range is approximately one block and with

(Continued on page 128)

A Versatile Oscilloscope Using the 913

Including Linear Sweep, Amplifier and Sine-Wave Audio Oscillator, Adaptable to Both Amateur and Servicing Requirements

By Herbert W. Gordon, W1BY*

AN EXTREMELY useful, if not essential, part of the modern amateur station is the cathode-ray oscilloscope. Its advantages as a measuring device, particularly in connection with checking transmitter performance, have been previously described at length.¹ It is not the purpose of this article to "compete" with contemporary stories on the whys and wherefores of the oscilloscope, but rather to give constructional details of an oscilloscope having a high degree of flexibility which makes it readily adaptable not only to the usual amateur measurements but also to receiver measurements and other uses to which the cathode-ray tube can be put.

In the design of equipment the amateur must always take into consideration two items; cost and purpose. The introduction of the 913 cathode-ray tube has helped considerably in bringing the cost of an oscilloscope within reach of a large number of amateurs. When purpose is discussed, the considerations become more involved. At the outset, it may be

said that amateurs interested only in checking percentage modulation and making routine transmitter adjustments need but build the fundamental circuit around the 913. A 60-cycle sweep (or one taken from the modulator) is all that is needed, and the filament and plate power may be secured from the receiver power pack.

For a wider range of usefulness, however, a more elaborate arrangement must be used. A linear sweep is essential, for instance, for the study

of audio-frequency wave-forms. Likewise, the incorporation of an amplifier in the oscilloscope not only is a necessity for the inspection of voltages too low in themselves to give a good pattern on the cathode-ray tube screen, but also increases the flexibility of the instrument by permitting the reduction of too-large voltages to a value suitable for the 913 deflecting plates. Third, in testing audio amplifiers a source of audio-frequency voltage of good wave-form, controllable in amplitude, is always a necessity, and the inclusion of such a generator in the oscilloscope itself is a decided convenience. Finally, when these elements are

combined with a switching system which gives real flexibility, a piece of equipment with a wide variety of applications results.

The complete circuit diagram of the oscilloscope, with power supplies, is given in Fig. 1. In all, there are eight tubes, including the 913. The linear sweep circuit utilizes an 885 gas triode and a 6K7 as a current limiter in the conventional circuit. A

6N7 double triode is used as an audio-frequency oscillator in the sine-wave circuit previously described in *QST*.² The resistance-coupled amplifier uses a 6J7, readily cut in and out of the circuit by a switch. In the power-supply end there are three high-voltage supplies, two from one transformer. Half-wave rectifiers, with Type 1V tubes, are used for the oscilloscope and sweep circuits. The supply for the 6J7 amplifier and 6N7 oscillator uses a 5Z4 full-wave rectifier with a resistance-capacity filter.

CONSTRUCTIONAL DETAILS

The entire unit is housed in a black-crackle metal box measuring 14 by 8 by 7 inches, provided with the usual chassis to fit inside. All parts

* Waller, "Amateur Applications of the 'Magic Eye,'" *QST*, October, 1936.

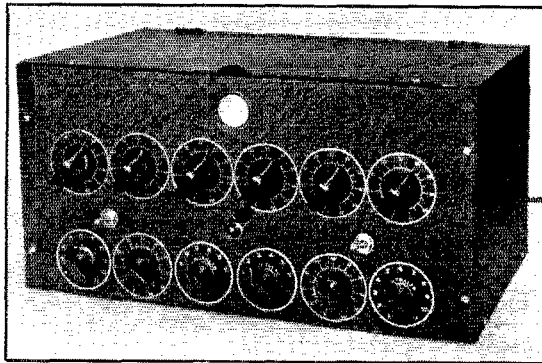

PANEL VIEW OF THE 913 OSCILLOSCOPE
Twelve controls give ample flexibility for all kinds of measurements about the ham transmitter or in service work.

* 77 Oxford St., Hartford, Conn.

¹ Waller, "A Practical Cathode-Ray Oscillograph for the Amateur Station," *QST*, March, 1934; Millen and Bacon, "A Simple Cathode-Ray Oscilloscope," *QST*, April, 1934; Ewing, "Cathode-Ray Monitoring of Received Signals," *QST*, April, 1936; Wilson, "An I.F. Coupling Amplifier for the Cathode Ray Oscilloscope," *QST*, May, 1936; Carter, "A 913 Oscilloscope With Linear Sweep," *QST*, January, 1937.

are mounted on the chassis and panel to facilitate construction and removal. Because the space between the top of the deck and the top of the cabinet is limited, it is absolutely necessary to use metal tubes except as indicated. Glass tubes of the 57 and 6A6 type won't fit.

It is well to check the values of all parts before placing them permanently in position. Since the oscilloscope is used to show up flaws in other devices it must be flawless in itself. RMA standards, when adhered to, are good but too often error enters into the manufacture of items, causing trouble later.

The general arrangement of parts is shown in the top view. The three transformers across the rear of the chassis are (from left to right in the photograph) the power transformer for the amplifier, T_1 , the synchronizing transformer, T_3 , and the power transformer for the 913 and sweep

circuit, T_2 . Between T_1 and T_2 is the 5Z4 rectifier; the two 1V rectifiers are between T_3 and T_2 . The 913 is centrally located above the chassis; to its left in the photograph are the 6J7 amplifier and the 6N7 audio oscillator. To the right of the 913 are the 6K7 current limiter and the 885 gas triode. The various switches and controls are of course mounted on the panel. Nothing is critical about physical layout except that if r.f. is to be applied to one or both sets of deflecting plates the leads which carry the r.f. to the plates should be isolated from the other wiring and parts.

The transformer T_2 is one made by Kenyon especially for the 913. It is small physically and serves admirably. Since the 913 consumes negligible plate power, the transformer's current-carrying capacity is small, hence the bleeder across the power source must be high in resistance to prevent overload. The values recommended take

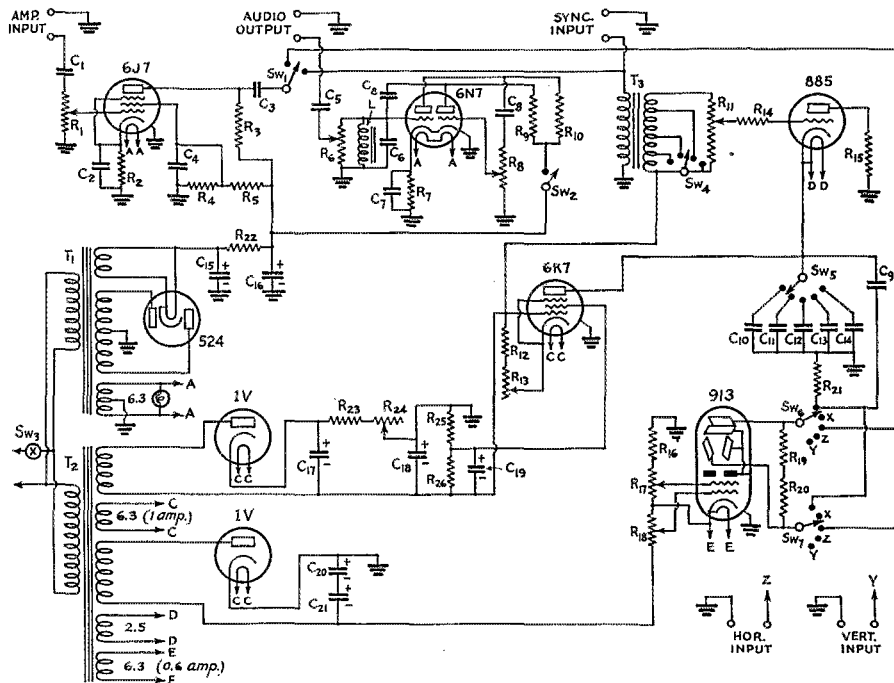

FIG. 1—CIRCUIT DIAGRAM OF THE OSCILLOSCOPE

L—125-mh. iron-core choke (Bud).
 C₁, C₃, C₄, C₅, C₆, C₈, C₉, C₁₀—0.1- μ f. condensers, 400-volt.
 C₂, C₇—16- μ f. condensers, 35-volt.
 C₁₁—0.025- μ f. condenser, 400-volt.
 C₁₂—0.005- μ f. condenser, 400-volt.
 C₁₃—0.001- μ f. condenser, 400-volt.
 C₁₄—0.00004- μ f. condenser, 400-volt.
 C₁₅, C₁₆, C₁₇, C₁₈, C₁₉, C₂₀, C₂₁—8- μ f. 400-volt electrolytic (Tobe Type ET58).

R₁—500,000-ohm potentiometer.
 R₂—300-ohm 1-watt.
 R₃—250,000-ohm 1/2-watt.
 R₄—50,000-ohm 1/2-watt.
 R₅—250,000-ohm 1/2-watt.
 R₆—50,000-ohm potentiometer.
 R₇—1000-ohm 1-watt.
 R₈—500,000-ohm potentiometer.
 R₉—50,000-ohm 1/2-watt.
 R₁₀—50,000-ohm 1/2-watt.
 R₁₁—10,000-ohm potentiometer.
 R₁₂—1500-ohm 1/2-watt.

R₁₃—50,000-ohm potentiometer.
 R₁₄—300,000-ohm 1/2-watt.
 R₁₅—1000-ohm 1-watt.
 R₁₆—125,000-ohm 1/2-watt.
 R₁₇—50,000-ohm potentiometer.
 R₁₈—30,000-ohm potentiometer.
 R₁₉—5-megohm 1/2-watt.
 R₂₀—5-megohm 1/2-watt.
 R₂₁—15,000-ohm 1-watt.
 R₂₂—7500-ohm 1/2-watt.
 R₂₃—7500-ohm 1/2-watt.
 R₂₄—50,000-ohm potentiometer.

R₂₅—40,000-ohm 1/2-watt.
 R₂₆—6000-ohm 1/2-watt.
 T₁—Small power transformer giving 700 volts, c.t., 6.3 volts 1.8 amps, 5 volts 2 amps.
 T₂—Kenyon Type 207 transformer.
 T₃—Kenyon Type 1 transformer.
 Sw₁—S.p.d.t. toggle switch.
 Sw₂—S.p.s.t. switch cover for audio attenuation control.
 Sw₃—S.p.s.t. toggle switch.
 Sw₄, Sw₅, Sw₆, Sw₇—6-position switches (Centralab).

approximately one milliamper. Because of voltage buildup in the condenser-input filter of the high-voltage supply, two 8- μ fd. 400-volt condensers are wired in series to prevent possibility of breakdown. A new type of compact condenser is now available, which helps materially in the space problem.

The 913 tube is mounted on a piece of electralloy cut to the dimensions given in Fig. 2 and bent as shown in the top-view photograph. An Amphenol socket makes it easy to shift the position of the tube so that the deflecting plates can be lined up to give really horizontal and vertical displacement. The whole mounting is fastened to the chassis with wing bolts so that removal is easy should it become necessary to replace the tube.

The five sets of terminal posts—amplifier input, audio-oscillator output, synchronizing input, and horizontal and vertical inputs to the deflecting plates—are conveniently placed in the rear of the chassis.

An aperture of appropriate size is cut in the rear of the cabinet to make the posts accessible.

The use of several different colors of push-back wire and a consistent coding for the colors helps in the connection of switch leads, potentiometers, and other parts. Cabling the wires gives the job that commercial appearance. The liberal use of spaghetti, rubber grommets and bakelite mounting strips is recommended. If the parts are mounted either vertically or horizontally and the wiring made as neat as possible, the oscilloscope will be easy to service.

CONTROLS

In the order of their appearance in the panel view, the controls in the top row from left to right are:

1. Sweep amplitude control, R_{24} . This control varies the width of the pattern when, as normally used, the sweep voltage is applied to the plates giving horizontal deflection.
2. Amplifier gain control, R_1 . When the amplifier is in use, the height of the pattern is controlled by the setting of this resistor.
3. Intensity control, R_{18} . This control should be adjusted for suitable pattern brilliance and need not be touched thereafter during a given set of measurements. In general, the intensity should be as low as possible since the pattern will be more clearly defined under these conditions.
4. Focusing control, R_{17} . Adjust to give uniform spot or line thickness, making the line as fine as possible. There is always some interlocking between settings for intensity and focus, so the two controls should be adjusted back and forth to give the most sharply-defined pattern.
5. Audio oscillator feedback control, R_8 . This control changes the generated frequency to some extent, and also affects the purity of the output

wave-shape. Once set to give the nearest possible approach to a sine wave (as judged by comparison to 60 cycles, for example) it may be left alone.

6. Synchronizing control, R_{11} . Used to lock

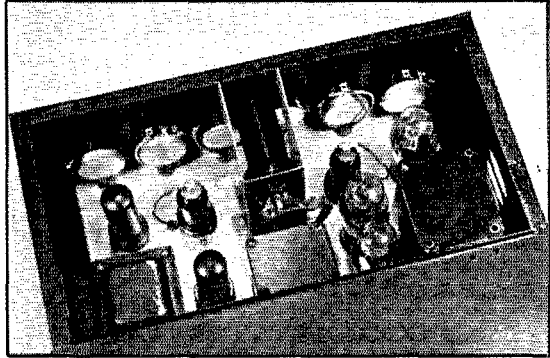

INSIDE THE OSCILLOSCOPE, LOOKING FROM THE REAR
The arrangement of parts is described in the text.

the sweep-circuit frequency to that of the signal under observation, or to a sub-multiple of the signal frequency.

In the bottom row, the controls from left to right are as follows, continuing the numbering started above:

7. Coarse sweep-frequency adjustment, Sw_5 . By selecting condensers of different capacities in the 885 relaxation-oscillator circuit, this switch changes the sweep frequency in roughly harmonic steps. The total frequency range is approximately 4 to 21,000 cycles per second. Lowest frequency will be found with the largest condenser cut in circuit, and *vice versa*.
8. Fine sweep-frequency adjustment, R_{13} . For adjustment to desired frequency between the coarse steps provided by Sw_5 .
- 9 and 10. Input switches for deflecting plates, Sw_3 and Sw_7 . By means of these switches, either set of plates can be connected to (a) sweep-oscillator output, (b) either of the external binding posts marked "horizontal input" and "vertical input," (c) amplifier output, (d) off. It is therefore possible to reverse the horizontal and vertical deflections, thus shifting the pattern by 90 degrees, at an instant's notice, as well as to use either pair of plates for the sweep voltage or the voltage being scanned.
11. Audio oscillator output control, R_6 . The oscillator on-off switch, Sw_2 , is mounted on this control.
12. Synchronizing transformer switch, Sw_4 . This control selects the transformer ratio from the several available with the particular type of transformer used. Not really essential, but may be desirable when an exceptionally large voltage is applied to the "synchronizing input" terminals. Normally, the switch is set so that the whole transformer secondary is in use.

The left-hand toggle switch between the two rows of controls is the a.c. on-off switch, Sw_3 . That at the right is the amplifier output switch, Sw_1 . This switch connects the output of the amplifier either to the deflecting-plate selector switches or to the primary of the synchronizing input trans-

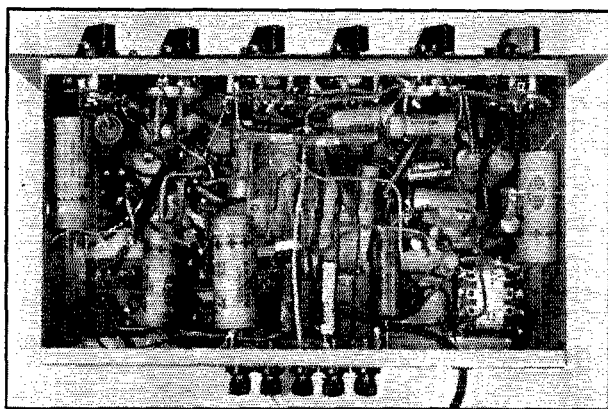

A BOTTOM VIEW OF THE OSCILLOSCOPE

Since all circuits are operating at audio frequency (except external input to one set of deflecting plates in r.f. measurements) no particular wiring precautions need be observed except to provide adequate insulation from the chassis.

former. Ordinarily it is left in the deflecting-plate position.

The large number of controls gives a high degree of flexibility, not only in the measurements of external signal sources which may be made, but also in internal connections.

OPERATION

To get into operation, first set the focusing and intensity controls, R_{17} and R_{18} , at maximum and close the line switch. Sw_6 and Sw_7 should be set to the "off" position, marked "X" in Fig. 1. After the tubes heat, a luminous dot should appear in the center of the screen. The intensity and focusing controls may then be manipulated to make the dot small and sharp and of suitable brightness.

Next, connect the output of the sweep oscillator to the horizontal plates by setting Sw_7 (or Sw_6 , whichever may be connected to the set of plates actually giving horizontal deflection) to the appropriate tap. The dot should change into a line extending across the screen horizontally. To change the length of the line, adjust R_{24} . If the sweep-frequency switch, Sw_5 , should happen to be set at the low-frequency end of the scale, there will not be a continuous line but a slowly-moving dot. The remedy is to increase the sweep frequency.

Now apply the signal to be observed to the "vertical input" terminals and connect Sw_6 to the same terminal ("Y" in Fig. 1). If the signal amplitude is of the order of 25 to 50 volts r.m.s., a pattern of usable size should appear on the screen. To get a stationary figure, connect the signal

source also to the "synchronizing input" terminals (a direct connection between the two sets of binding posts on the oscilloscope is all that is necessary) and adjust the synchronizing control, R_{11} , to lock the sweep circuit to the external frequency. Adjustment of Sw_5 will determine the number of cycles that appear on the screen; with the oscillator on the same frequency as that of the signal one cycle will appear, on harmonics only part of a cycle, and on sub-harmonics a number of cycles depending upon the ratio of signal frequency to oscillator frequency. For example, with the sweep oscillator on 200 cycles locked by a 1000-cycle signal under observation, five cycles will appear on the screen.

Operation of the audio oscillator is quite simple. With the constants given, the frequency will be approximately 1000 cycles per second. The frequency may be varied slightly by adjustment of R_8 , although if this control is advanced too far the tube may go out of oscillation. After a tone to the liking of the operator is found this control need not be touched. Incidentally, a key in series with a headset connected to the "audio output" terminals makes a splendid code-learning set.

In checking an audio amplifier, the output of the audio oscillator should be fed through a twisted line to the input of the stage being studied. Checking the output with 'phones or with the oscilloscope permits excellent comparison. For this test it is easy to shift from the oscillator itself to

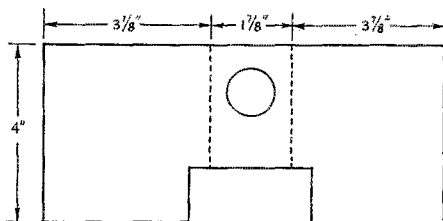

FIG. 2—DIMENSIONS OF MOUNTING FOR THE 913

A piece of sheet electrical alloy cut as shown above is bent to form the mounting visible in the top-view photograph.

the output of the stage under observation merely by flipping the deflecting plate switch.

By increasing the audio amplitude control one can see where distortion starts. If this control is calibrated in terms of volts, audio gain measurements are easily made. Distortion from grid overloading is readily apparent, the pattern flattening on the positive half-cycle and lengthening or cutting-off completely on the negative half-cycle, depending upon the grid bias.

(Continued on page 118)

The 1936 Sweepstakes

Seventh National QSO Contest Results

By E. L. Battey,* WIUE

64,946 QSO's!! That's the total of the 860 operators reporting scores in A.R.R.L.'s Seventh All-Section Sweepstakes Contest! It was a "QSO fiesta" with plenty of contacts for all, a grand party, thoroughly enjoyed both by high and low scorers. Like each of its predecessors the seventh SS "hit the spot."

The '36 SS contest layout was changed somewhat from previous years. Rather than the old "nine-day" plan, activity took place within two 33-hour week ends, each contestant being allowed to operate any 40 hours out of the 66. A second change reduced the former "complete message exchanges" to merely an exchange of "message preambles." This speeded up the contest considerably. Each preamble contained all the essential details needed for each QSO. The "check" portion consisted of the RST report of the station worked, the doing away with the necessity of giving signal reports separate from contest exchanges. These changes in "operating time" and "exchanges" were received with widespread favor, many claiming they made the SS "better than ever." One feature that kept competition "razor sharp" was the procedure of making the preamble numbers correspond with the number of the QSO's. It was always pleasing to note that the other fellow's numbers were only up to 50, while yours had already passed the 100 mark . . . or, similarly, what a shock it was to see another operator's numbers running higher than yours—and how you dug in to cut down his advantage!! Some fun.

THE WINNERS

Certificate awards are being made to the winners in 68 of the 69 League sections. Entries were received from every section except Alaska. Separate

*Assistant Communications Manager.

awards were offered to the C.W. leader and the 'Phone leader in each section. 67 C.W. awards are being made. The following are winners in their respective sections: KA1US WIAPU W1BBN W1BFT W1BVP W1EZ W1IED W1RY W2BMX W2FGG W2HJK W3BES W3EHW W3FMY W3FTK W4BMH/5 (now W5GEA) W4CDC W4CYC W4DTR W4ECH W4ECN W5CPB W5DGP W5DQD W5EGP W5FPD W5KC K6JPD W6FRN W6HJT W6ITY W6IZE W6JMR W6KFC W6MVK W6SN W6TT W7CRH W7DP W7EK W7ESM W8BYM W8CXR W8EMW W8GQB W8KUN W9AWP W9CFB W9ELL W9FFU W9LLW W9MGV

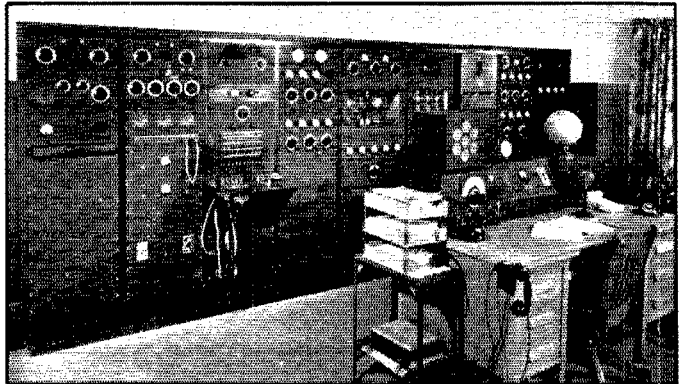

W6ITH—WORKED ALL SECTIONS ON TWO-WAY RADIOPHONE

D. Reginald Tibbetts, W6ITH, P.A.M./O.P.S. is the first operator to succeed in working all A.R.R.L. Sections within the duration of any contest. He worked all 69 in the two week-ends of the 1936 Sweepstakes and he worked them all on two-way 'phone! He made contacts on 6 bands, 112, 56, 28, 14, 3.9 and 1.75 Mcs. His station equipment is as follows, looking at the photo from left to right: The first rack contains ultra-high frequency equipment and remote relaying gear. The second, more ultra-high equipment on 2½ and 5 meters, together with patch panels and power supplies. The third contains a telephone switchboard for remote and local lines, bridging amplifiers, power level indicators and the frequency standard. The fourth rack contains the exciter stages and amplifier stage of the largest transmitter. Line-up: 6L6, 6L6, 100TH, p.p., 50T's; these feed the large middle rack, which contains a pair of Eimac 500T's in push-pull. This outfit runs 1000 watts on any band from 160 to 5 meters. The next rack, or sixth from the left, contains the modulators for the 500T's, four 150T's in push-pull parallel Class A prime. The high level speech tubes which push the 150T's are below, together with power supplies. The next rack contains a high fidelity broadcast receiver with power supplies, amplifiers and miscellaneous equipment. The eighth rack contains a complete 3.9 and 1.75 Mc. 'phone, band switched and running about 100 watts to a pair of '10's push-pull, modulated by another pair in Class B. This transmitter is complete in itself with power supply. The last rack on the right is a complete 56-Mc. transmitter using a pair of 100TH's in the final, modulated by another pair in Class B. This transmitter runs 500 watts on either 28 or 56 Mc. and is crystal controlled from a 6L6, 807, 35T exciter unit. The operating table shows a Sargent Model 21 receiver, speech amplifier gain controls and modulation indicator, calibrated in percentage modulation for each transmitter. The key button unit provides for seven frequencies on 28 and 14 Mc. and four frequencies on 3.9 and 1.75 Mc. Antennas are also switched from the operating position. Many antennas are used, directional diamonds and simple half-wave matched impedance types.

W9NUF W9RQM W9TJF W9TYF W9UBB
 W9VKF W9VOD VE1FB VE2DR VE3ACS
 VE4GE VE4OC VE4SF VE5QP. 12 'Phone
 awards are being made to the following: W3AWH
 W5BXM W5BZR W6BWG W6ITH W6IWU
 W6JSS W8EVF/6 W8OIZ W9ATP W9LLV
 W9PWU. Congratulations to all!

OUTSTANDING SCORERS

First place in the national line-up goes to Hal Pratt, W1EZ, Pownal, Vt., who worked 301 stations in 60 sections, rolling up 54,180 points in 40 hours of operating on the 3.5, 7 and 14 Mc. bands. Vic Clark, W6KFC, Phoenix, Arizona, and Jerry Mathis, W3BES, Philadelphia, Pa., fought a hard battle for second place, Vic winning out by a mere 252 points—W6KFC 51,708, W3BES 51,456. W6KFC ran 50-70 watts input with separate rigs on 3.5 and 7 Mc., '47-'46-'10 on 3.5, 59-59-'10-p.p. '10's on 7. 278 stations were worked in 62 sections. W3BES ran 1 kw. input to p.p. '52's in the final of a four stage crystal rig on 3.5, 7 and 14 Mc. He leads all operators in number of contacts—403 in 64 sections.

The highest scoring Canadian participant is C. S. Jamieson, VE4GE, Drumheller, Alberta—36,801 points, 214 stations, 58 sections. This is the first time that a VE4 has led Canada.

In a forty-hour contest any score above 40,000 is real stuff. After the "big three" we find W3EHW 48,764, W9LLW 47,415, W9RQM 47,123, W1BFT 47,094, W9FFU 45,180, W6MVK 44,103, W4CYC 43,829, W5KC 43,725, W8BYM 43,554, W9RSO 43,200, W9TYF 41,101, W6HJT 40,508. Other commendable scores: W1TS 39,407, W8KUN 39,273, W9NUF 38,852, W4CDC 37,515, W2BMX 37,128, VE4GE 36,801, W2HJK 36,375, W5WG 35,483, W9KEH 35,028, W9ELL 34,844, W4PL 34,692, W1RY 34,427, W6ITY 34,427, W3FQZ 34,265, W9AWP 34,191, W3CHH 34,148, W8AQ 33,856, K5AC (2 oprs.) 33,708, W1AVJ 33,549, W9VKF 33,390, VE2DR 33,065, W1APU 32,661, W6SN 32,562, W1INF (Hal Bubb, opr.) 32,306, VE3ACS 31,248, VE4OC

31,164, W9RCQ 30,912, W9TWC 30,654, W8OFN 30,195, W4BOU 30,109.

ALL SECTIONS WORKED

In every Sweepstakes contest since No. 1 participants have been trying to work all 69 sections within the period of the competition. In the '36 SS one operator succeeded in accomplishing this noteworthy feat—Reg Tibbetts, W6ITH, who worked them all by two-way radiophone. Such records don't "just happen" . . . the operator makes them happen! Station W6ITH had both excellent equipment (see photo!) and an operator who knew how to use it. By using the right band at the right time, and by using all 'phone bands (1.7, 3.9, 14, 28, 56 and 112 Mcs.) he brought the honor to his station. Congratulations, Reg.

Bill Lippman, W6SN, worked all but two sections on 7 and 14 Mc. C.W. W8AQ worked 66 sections, W3BES 64, W1TS W9KEH 63, W6KFC W8BTI W9ELL 62, W4CDC W4CYC W6MVK W8BYM W8OFN W9RQM 61, W1EZ W6GTM W7EK W9FFU W9RSO 60.

53 operators worked 200 or more different stations. W3BES, leader in stations QSO'd (403), worked an average of 10 stations per hour. In the '35 SS he averaged 6.3 per hour and at that time it didn't seem possible to better such a performance! W3CHH with 317 stations averaged about 8 QSO's per hour and W1EZ (301 stations) worked them at nearly as rapid a rate! Others who lost no time in rolling up the contacts include W1INF (opr. Hal Bubb) and W9ELL with 231, W6KFC and W9KEH 278, W3EHW 277, W9RCQ 276, W9LLW 275, W9TYF 273, W5KC 267, W1BFT 266, W9RBN 263, W9RQM 259, W8AQ 257, W6HJT 254, W8OFN 252, W9FFU 251, W8KUN 249, W2HJK 245, W6SN and W9RSO 243, W6MVK and W8BYM 242, W4CYC 240, W2BXA and W7EK 238, VE2DR 235, W1BVP 233, K5AC (two oprs.) 226, VE3AEM 224, W2BMX, W6ITH and VE3JT 223, W9NUF 221, W3FQZ 219, W2FGG 217, W1UE and W2PY 215, VE4GE 214, W9VKF

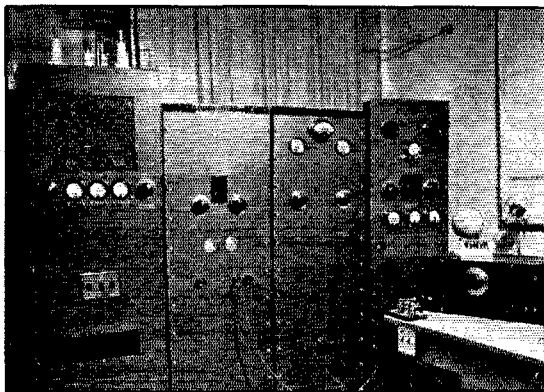

W6MVK, MODESTO, CALIFORNIA

Winner in the San Joaquin Valley Section, T. S. Chow, W6MVK, was also ninth national high. During the contest his rig consisted of 6L6 crystal, '10 buffer, p.p. '10's final. A recent "rebuild" finds the station as pictured above. A corner of an 8-metal tube home built super is seen on the extreme right. The receiver in full view is a home built 13-metal tube super. The transmitting units (right to left): First rack—53 crystal, '10 buffer, p.p. '10's final. Second rack—Class B p.p. 100TH's; 2A3 Class A prime driver; p.p. 6C6 and single 6C6 pre amp.; p.p. 100TH's Class C r.f. stage for 28 to 3.5 Mcs. c.w. Third rack—For 1.75 Mc. 'phone; 6L6 Class A-B modulator and driver; 6L6 crystal, 6L6G buffer-doubler, 100TH buffer or final. Fourth rack—p.p. 150T's final amplifier; 2000 volt power supply. W6MVK uses break-in and "Push-to-Talk."

213, W1AVJ, W1TS and W2CWE 211, W5WG 210, W9GIL 209, VE3IR, W4CDC and W4PL 207, W8FIP 204, W9TWC 203, W2DXO 201. Two hundred QSO's in a 40-hour contest represents at least 5 QSO's each hour. The QSO's must have been flying thick and fast during the SS!

RADIOPHONE PARTICIPATION

'Phone scores were submitted by only sixteen operators. Of these, twelve have already been listed as certificate winners. The highest scoring voice operator is W6ITH, 30,774 points. Ernie, Thelemann, W9ATP, La Sueur, Minnesota is in second place with a score of 4278—87 stations in 38 sections worked on the 28, 14 and 3.9 Mc. bands. In third place is Richard Hyde, W9PWU, Arvada, Colorado.

Using the 1.7, 3.9 and 14 Mc. bands he worked 45 stations in 23 sections, 3071 points. Other 'phone scores include W9NWW 2475 (41 stations, 22 sections), W8EVF 1548 (43 stations, 18 sections) W6IWU 866, W8OIZ 748, W5BZR 689. W8EVF was operating portable in Nevada and was the only operator to submit a score from that section.

CLUB WINNERS

The gavel trophy, with engraved sterling silver band, offered to the club whose members submitted the highest aggregate score, goes to the Frankford Radio Club (Philadelphia, Pa.). The scores of seven participants in this club total 109,524!! FB, Frankford! The runner-up is the Merrimack Valley Amateur Radio Association (Concord, N. H.), 96,488, followed by the Egyptian Radio Club (E. St. Louis, Ill.), 65,944; Montreal Amateur Radio Club, 57,739; Wichita (Kansas) Amateur Radio Club, 56,801; Houston (Texas) Amateur Radio Club, 56,691; Milwaukee Radio Amateurs' Club, Inc., 51,965; Oakland (Calif.) Radio Club, 50,884; 100 Watt Club (Modesto, Calif.), 45,987; Queen City Amateur Radio Club (Toronto), 32,308; Saskatoon Amateur Radio Club (Sask.), 31,407; Bridgeport (Conn.) Amateur Radio Association, 29,749;

Richmond (Va.) Short Wave Club, 27,558; Ottawa (Ont.) Amateur Radio Transmitting Association, 21,918; Merrimack Valley Amateur Radio Club (Lowell, Mass.), 19,442; Starved

Rock Radio Club (Ill.), 16,588; Framingham (Mass.) Radio Club, 9621; Connecticut Brass-pounders Association, 8522; Beacon Radio Amateurs (Philadelphia, Pa.), 7871; San José (Calif.) High School Radio Club, 6617; Min.-Dak. Radio Club, 4625; The Mid-Hudson Amateur Radio Club (Poughkeepsie, N. Y.), 2676. The following amateurs receive certificate awards for making the highest score in their respective

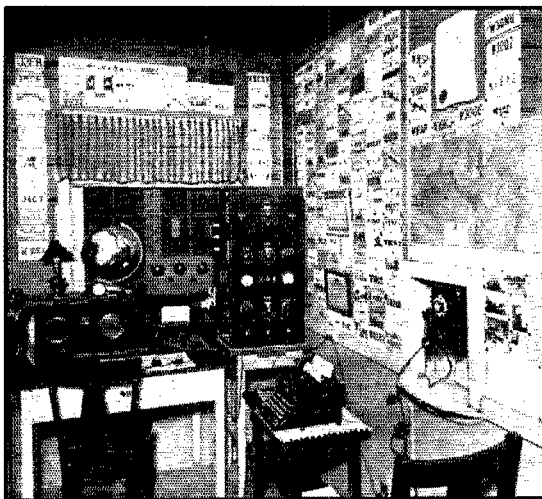

W6KFC, SECOND HIGHEST NATIONAL SCORER

This business-like layout is the shack of Vic Clark, W6KFC, RM-ORS, Arizona certificate winner and second high in the national tally. At the right of the world globe is a '47-'46-'10 rig, which is used at about 50 watts input on 3.5 Mc. only. The rack and panel outfit uses a 59 e.c./c.c. oscillator, 59 buffer-doubler, '10 buffer and p.p. '10's final. This transmitter was used only on 7 Mc. during the SS but is designed for 14, 7, 3.5 and 1.75 Mcs. with about 70-75 watts to the final. Power supplies for both sets are on the bottom shelf of the larger unit. The receiver is an ACR-136.

W3FMY, VE3DA, W1BEF, W1BWJ, W1HYF, W3BGD, W6NCO, W9HEO, W2JKT. Awards are made only in clubs having three or more



W3CHH

317 stations, the second highest number of contacts in the contest (W3BES worked 403), were worked by Joe Frekot, W3CHH. He knocked them off with 600 watts input to the final, the line-up: 802-802-T55-p.p. '52's.

reporting participants. If any club finds that it actually had three participants, but no award has been made, we shall see that credit is given upon receipt of a list of the club members taking part.

TRANSMITTING TUBES USED

The type '10 is still a mighty popular tube. In the 1933 Sweepstakes approximately 28 per cent of all contestants used a single type '10 in the final stage of their transmitters and 10 per cent used two type '10's, total: 38 per cent using type '10 tubes. Three years later, in the 1936 SS we still find approximately 32 per cent of all participants using type '10's! The following approximate percentages show the transmitting tubes in the final stages of transmitters used by operators in the 1936 Sweepstakes:

Two type '10's	16.6%
Single type '10	15.2%
Single "50 watter" (03A, 211, 242, etc.)	11.7%
Two type '46's	6.3%
Single RK-20	5.7%
Single 801	3.1%
Two type '45's	2.5%
Two 801's	2.3%
Single 6L6	2.2%
Single '52	2.1%
Single '45	1.9%

Dozens of other type tubes and combinations were used to a lesser degree. Among the more common types following the above

percentages are found single T55, single '46, two "fifty watters", two '52's, single 50T, two 6L6's, (Continued on page 84)

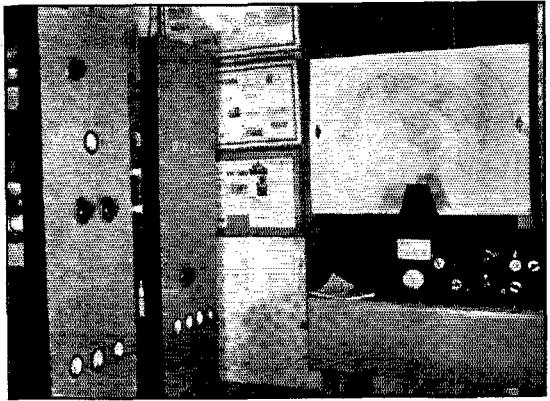

W9RCQ
Wm. G. Baird, Jr., W9RCQ, E. St. Louis, Illinois, worked 276 stations in 56 sections, rolling up a score of 30,912. Behind the panels is an 80Z oscillator, 100TH buffer-doubler and 150T final. A kilowatt is pushed in on 7 and 14 Mcs. The crystal is keyed for break-in. A rotary beam is the radiator on 14 Mc., a doublet on 7 Mc. The receiver is an NC101X, an SW3 being available for portable and standby use.

SCORES

Seventh All-Section Sweepstakes Contest, 1936

(Scores are grouped by Divisions and Sections. . . . The operator of the station first-listed in each Section is winner for that Section unless otherwise indicated. . . . Asterisks denote stations not entered in contest, reporting to assure that stations they worked get credit. . . . The number of sections and number of different stations worked by each station are given following the score. . . . Likewise the "power factor" used in computing points in each score is indicated by the letter A or B. . . . A indicates power up to and including 100 watts (multiplier of 1.5), B indicates over 100 watts (multiplier of 1). . . . The total operating time to the nearest hour is given for each station and is the last figure following the score. . . . Example of listings: W3BES 51456-64-403-B-40, or, Final Score 51456, number of sections 64, number of stations 403, power factor of 1, total operating time 40 hours. . . .)

ATLANTIC DIVISION

W3KT	11086-46-121-B-27
W3FLY	11016-34-112-A-36
W8FKO	10080-45-114-B-21
W3AKB	6408-24- 89-A-19
W8CVS	6293-31-104-B-23
W8OML	6020-35- 88-B-20
W3AOA	6000-30-100-B-16
W3GBD	5999-31- 66-A-14
W3FVC	5247-22- 81-A-18
W3FKJ	5166-21- 82-A-11
W3RTQ	4992-26- 64-A-16
W3GDI	4434-32- 52-A-21
W3DRD	931-19- 25-B-12

¹ Score of opr. Jerry; combined score of two oprs. 52736, 413 contacts. ² Score of opr. CRM; opr. EHM 2450; combined score 7596, 108 stations, 37 sections. ³ Two oprs.—W3FED, W3AVJ. ⁴ Two oprs.—W8NWX, W8VLY. ⁵ Both power factors; high power: 416, low: 5022. ⁶ D.T.R.I. Radio Club; opr. W7EMA. ⁷ Mich. Tech Radio Club; opr. W3CWE. ⁸ State College Radio Club (Mich.); two oprs.—Don Spoor, Jay Jennings. ⁹ Score reduced from 19278 for over 40 hours operation; two oprs.—W8JEM, W8DQC. ¹⁰ Both power factors; high power: 13392, low: 3738. ¹¹ Both power factors; high power: 1496, low: 12812. ¹² Both power factors; high power: 3360, low: 818. ¹³ Both power factors; high power: 5148, low: 468. ¹⁴ Portable at Greenwood, Miss. ¹⁵ Portable at Troy, N. Y.; opr. W8CFL 2016; W3CX 1104; combined score 4620. ¹⁶ Score of opr. W9TJJ; W9SGU 2208; combined score 12000. ¹⁷ Two oprs.—W8NVF, W9HES; only one contact by W9HES. ¹⁸ The Connecticut award goes to WIED since HQs staff members (TS, INF, UE, JFE) are not eligible for prizes. ¹⁹ Hal Bubb, WIJTD, operating. ²⁰ Both power factors; high power: 8106, low: 5715. ²¹ Score of opr. W1LLA; W1GKM 1152; combined score 8249 (Trinity College Radio Club). ²² Phillips Academy Radio Club; opr. W1EFM. ²³ W1FCZ operating. ²⁴ Score reduced from 7474 for over 40 hours operation. ²⁵ Both power factors; high power: 1386, low: 75. ²⁶ The Associated Radio Amateurs of Southern New England, Inc.; five oprs.—W1CPT 2120, W1BOY 549, W1AOP 392, W1DIT 21, W1E19; combined score 9594. ²⁷ Four oprs.—W7FOU, W7BKH, W6MGT, W8LVV. ²⁸ Both power factors; high power: 18073, low: 18. ²⁹ Portable at Las Vegas, Nevada. ³⁰ Both power factors; high power: 854, low: 12. ³¹ Both power factors; high power: 9030, low: 363. ³² W6DLR operating. ³³ No award has been made in the Ca.-S.C.-etc. Section pending receipt of information on individual operator's scores at K5AC; two oprs. (W7CKY and W9CYU) made the score listed. ³⁴ Portable at Pampa, Texas. ³⁵ Oklahoma A. & M. College; ten oprs.—W5AND, 5FLF, 5ELQ, 5FEV, 5ERZ, 5EGR, Don Enright, 5FSL, 5EGA, 5CRW. ³⁶ Both power factors; high power: 972, low: 1740. ³⁷ W5CIS operating. ³⁸ Portable at Austin, Texas. ³⁹ Texas A. & M. College Radio Club; W5EMS operating. ⁴⁰ Two oprs.—George and Bob Long

W3FYW	3645-30- 42-A-18	W3EKE	390-10- 13-A- 5
W3GLY	3432-26- 45-A-13	W3CYO*	40- 4- 5- - -
W3GHM	3192-19- 56-A-34		
W3FXG	2943-22- 36-A-40	<i>So. New Jersey</i>	
W3DYL	1260-15- 28-A- 9	W3FTK	25380-45-188-A-40
W3ANZ	1240-20- 51-B- 8	W3EXB	16032-48-167-B-35
W3CJI	1152-12- 32-A- 5	W3CBB	15962-46-175-B-32
W3FQA	1036-14- 38-B- 5	W3BDL	14526-38-127-A-40
W3ELZ	924-14- 22-A- 7	W3EYF	12393-51-122-B-34
W3MG	742-14- 17-A- 5	W3FBM	5451-23- 79-A-21
W3CNP	612-12- 17-A- 5	W3DQO	3276-26- 63-B-12
W3DDX*	374-11- 17- - -	W3CQE	1080-18- 30- - -
W3EWJ	360-10- 12-A- 3	W3DNU	558-12- 16-A- 5
W3ECG*	128- 8- 8- - -	W3AWH	243- 9- 9-A- 5
W3FOW*	75- 5- 5-A- - -	W3FDF*	90- 6- 6-A- 1*
W3CXU	48- 5- 4-B- 2	Phone	
W3GES*	48- 4- 4-A- - -	W3AWH	3- 1- 2-A- - -

Md.-Del.-D.C.

W3EHW	48764-59-277-A-40	W8EMW	20731-51-137-A-38
W3FQZ	34265-53-219-A-39	W8NWII	16943-45-127-A-34
W3EUJ	20196-51-132-A-32	W8MFB	16416-38-144-A-20
W3FPQ	15120-45-172-B-28	W8EWT	13878-36-129-A-37
W3GFF	9324-42- 75-A-28	W8QIV	13198-44-102-A-38
W3FYS	7455-35- 71-A-34	W8CJJ	13392-54-124-B-31
W3PNI	6622-27- 84-A-21	W8AQE	11760-35-113-A-38
W3FQE	6117-31- 69-A-27	W8PLR	11544-37-110-A-35
W3FSP	5415-21- 82-A-24	W8LDA	7904-38-105-B-23
W3FQB	4617-27- 58-A-13	W8PCU	7781-39- 68-A-29
W3FHT	3312-24- 46-B-12	W8MKA	7712-31- 84-A-28
W3FEL	3081-27- 58-B-17	W8PUM	6240-20-119-A-25
W3DQU	2160-12- 60-A-21	W8LGV	6075-27- 75-A-29
W3FNK	2106-11- 33-A-13	W8FVH	5440-32- 85-B-32
W3GHB	1260-14- 30-A-17	W8NPN	4838-26- 67-A-17

(Continued on page 88)

A Medium-Power Transmitter Especially Designed For 28 Mc.

By Edwin A. Ruth, 3rd,* W2GYL

WITH the rapidly increasing popularity of the 28-Mc. band there has come a desire, if not an actual need, among those who have been active on the 3.5- and 14-Mc. bands to get going on "ten." Some of the phenomenal results that have been accomplished in the past few months, coupled with the continued crowding of the lower-frequency bands, have resulted in an attempt to put a great many of the higher powered rigs on ten meters. Not a little bit of trouble has resulted from this activity and, in a great many cases, transmitters that were perfectly satisfactory on the other bands have been found woefully inefficient and in some instances actually inoperative on the ten-meter band.

With these ideas in mind and a certain amount of experience, gleaned from the construction of other medium-powered transmitters that have been functioning very successfully on the 28-Mc. band, it was decided that our own transmitter should have very much more of a commercial appearance than is generally found in ham radio. We decided to start from scratch and provide ourselves with a rig that would run at approximately 300 watts input and in which every stage would be operating below its full power capacity.

SELECTION OF TUBES

It is not generally understood in amateur engineering circles that running tubes to their highest efficiency is productive of a great many serious effects, not the least of which is the excessive generation of harmonics. This point has been very well stressed in W1EAO's article in the February issue of *QST*. While pushing tubes to their limit may result in more gross watts per dollar, it has the serious advantage of creating a

*23 Fairview Blvd., Hempstead, L. I., N. Y.

great deal of interference at distant receiving stations in the form of harmonics.

The selection of tubes for the speech amplifier portion of the circuit is more a matter of convenience and quality than consideration for the amount of power developed. All these tubes are being operated well within their rated capabilities. A look at the diagram will indicate that the speech amplifier is of a strictly conventional variety.

Any number of tubes suggested themselves for use as modulators but the convenience provided by the zero grid bias feature of the RK31, coupled with past experience in using these tubes to provide modulation for transmitters running at very much greater input than the 300 watts for which the present unit was designed, led to their selection. In one instance a pair of RK31's, operating in Class B at the rated voltage of 1250, provided enough power to modulate 500 watts input to 140%.

In order to make the construction of the r.f. portion of the transmitter as simple as possible, a plug-in coil band-changing arrangement was worked out which would not introduce undue complications and would, as well, hold the number of neutralized stages to a minimum. The tube line-up ultimately chosen comprises a 6C5 as a straight triode crystal oscillator, a 6L6 as a frequency multiplier, and a pair of 807's as a push-pull buffer stage exciting the 250TH in the final stage.

An attempt to put several medium-powered transmitters on 28 Mc. had indicated that the greatest difficulty was to provide sufficient excitation for the proper operation of the final stage. Therefore, the selection of tubes for this transmitter was made with this idea fully in mind and the final result indicates that the excitation on 28 Mc. is very much more than is

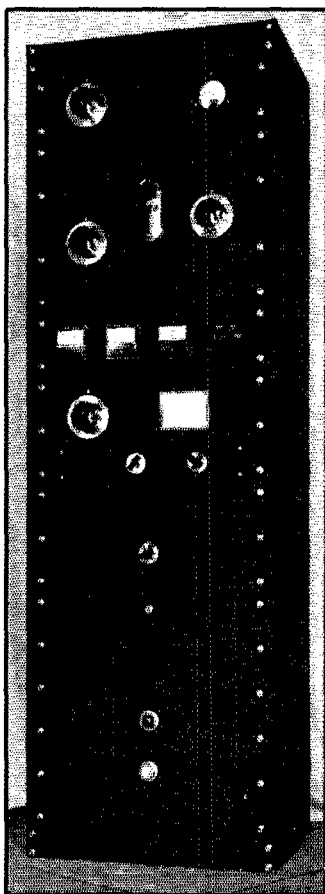

ALTHOUGH DESIGNED WITH SPECIAL ATTENTION TO EFFICIENT OPERATION ON 28 MC. THIS TRANSMITTER IS ALSO ADAPTABLE TO THE LOWER FREQUENCY BANDS

actually required. A direct indication of this abundance of excitation is found in the fact that the Class-C stage, in normal operation at 300 watts input, is operating at four times cut-off bias and the measured rectified grid current is 60 ma.

Reference to the rear view shows that the usual step-ladder construction has been avoided. There are two important reasons for this change. One is that the assembly results in the elimination of long filament leads. No filament lead in this

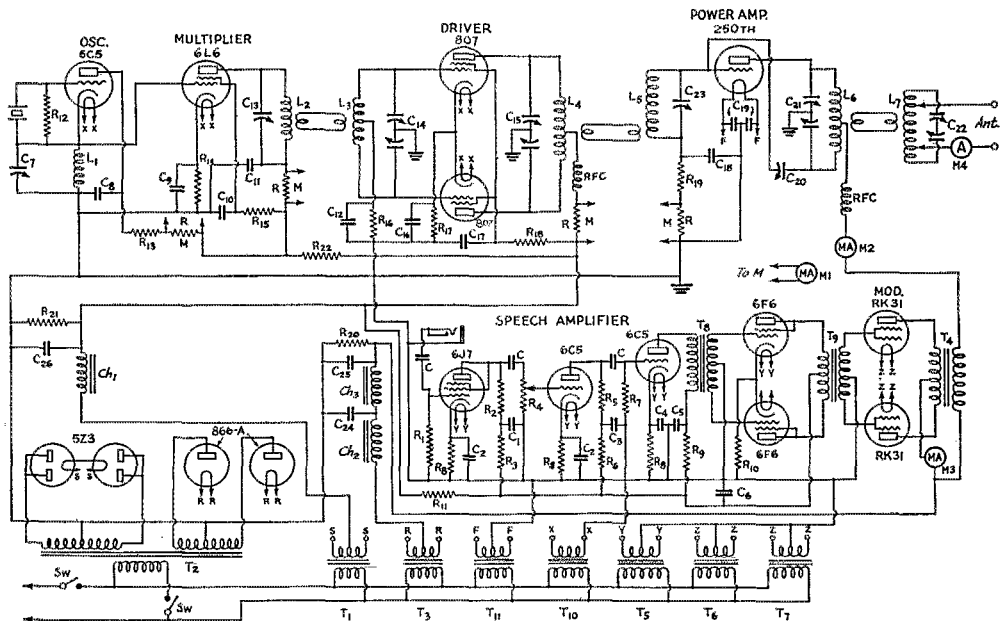

FIG. 1—THE COMPLETE TRANSMITTER CIRCUIT

- L1 to L7—See coil table
- C—0.1- μ fd. 400-volt tubular
- C1, C8—0.1- μ fd. 400-volt tubular
- C9, C4—5- μ fd; 25-volt electrolytic
- C5—0.25- μ fd. 400-volt tubular
- C6—8- μ fd. 400-volt electrolytic
- C7, C18—100- μ fd. midget variable (National UM-100)
- C8—0.004- μ fd. mica
- C9, C10, C11, C12, C16—0.01- μ fd. 500-volt tubular
- C14—Double-section variable, 0.018-inch air gap, 100- μ fd. per section (National STHD-100)
- C15—Double-section variable, 0.026-inch air gap, 100- μ fd. per section (National TMS-100D)
- C17, C19—0.004- μ fd. 1000-volt mica

- C18—0.002- μ fd. 1000-volt mica
- C20—10- μ fd. neutralizing condenser (National NC 800)
- C21, C22—Double-section variable, 0.077-inch air gap, 100- μ fd. per section (National TMC-100D)
- C22—50 μ fd. variable, 0.065-inch air gap (National TMSA-50)
- C24—2- μ fd. 1500-volt filter condenser
- C25—4- μ fd. 1500-volt filter condenser
- C26—8- μ fd. 600-volt filter condenser
- RFC—1-mh. 600-ma. r.f. choke (National R-154U)
- M1—0-200 d.c. milliammeter
- M2—0-500 d.c. milliammeter
- M3—0-250 d.c. milliammeter
- M4—0-2 ampere r.f. meter
- R1—5-meg. 1/2-watt resistor
- R2—0.25-meg. 1/2-watt

- R3, R6—25,000-ohm 1/2-watt
- R4—250,000-ohm volume control
- R5—50,000-ohm 1/2-watt
- R7—100,000-ohm 1/2-watt
- R8—2500-ohm 1-watt
- R9—10,000-ohm 1-watt
- R10—750-ohm 10-watt
- R11—5000-ohm 50-watt
- R12—75,000-ohm 1-watt
- R13—20,000-ohm 1-watt
- R14—5000-ohm 10-watt
- R15, R16—20,000-ohm 10-watt
- R17—200-ohm 10-watt
- R18—10,000-ohm 10-watt
- R19—5000-ohm 25-watt
- R20, R21—50,000-ohm 100-watt
- R22—2500-ohm 10-watt
- R—20-ohm 10-watt (milliammeter shunts)
- T1—10-volt 4-amp. filament transformer (Kenyon T-365)
- T2—Double secondary plate transformer, 1460-volt 500-ma. and 630-volt

- 200-ma. (Kenyon T-660)
- T3—2.5-volt 10-amp. filament transformer (Kenyon T-360)
- T4—Class-B output transformer (Kenyon T-460)
- T5, T10—6.3-volt 3-amp. filament transformer (Kenyon T-351)
- T6, T7—7.5-volt 4-amp. filament transformers (Kenyon T-353)
- T8—Push-pull input transformer, ratio 1:2 (Kenyon T-58)
- T9—Class-B input transformer (Kenyon T-258)
- T11—5.25-volt 12-amp. filament transformer (Kenyon T-357)
- Ch1—14-henry 250-ma. filter choke (Kenyon T-164)
- Ch2—6-21-henry 500-60-ma. swinging choke (Kenyon T-521)
- Ch3—12-henry 500-ma. filter choke (Kenyon T-177)

MECHANICAL LAYOUT

The pictures of the front and rear of the transmitter will give the experienced constructor a great deal more constructional information than we could possibly get into words. One of the significant features of the front panel design is that the controls have been placed where efficiency dictates, rather than "dials in line."

transmitter is longer than three inches. The filaments for the RK30's are supplied by two individual filament transformers located directly above their sockets. The second important result of avoiding step-ladder construction is to provide a "chimney effect" for the whole transmitter so that the heat generated by the tubes rises toward the top of the case and draws in cool air through

the louvres down near the floor. A distinct departure from usual construction is the inversion of the modulator tubes, which has the effect of putting the tubes themselves in plenty of free space along with a material shortening of the leads.

While it is not apparent from the picture, all of the leads in the final plate tank circuit are provided with heavy terminals which are held in place by bolts and lock washers. This has been found desirable to eliminate the overheating and the melting of soldered connections resulting from the high circulating currents in this circuit. The plate connector, at the top of the tube, has been provided with a large bronze cap which is used to dissipate the heat which develops at that point.

It will be seen that all of the wiring used to couple the various units has been cabled but the photograph does not show that the risers from the power supply chassis up to the various other elements in the transmitter are housed in steel conduit, provided with suitable "L" and "T" connectors at the points of branching off to the various components.

The primary electrical circuits are so arranged that it is impossible to open the rear door of the transmitter without removing the main power

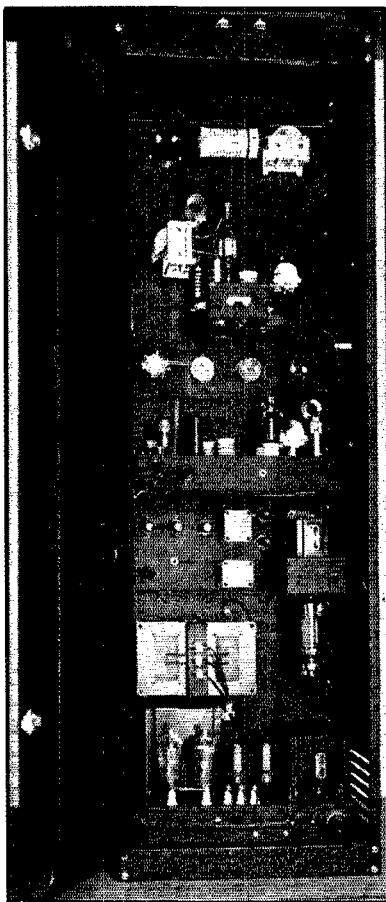

REAR VIEW OF THE TRANSMITTER

plug from its socket. The high voltage stages are wired with Lynch "Giant-Killer" cable.

By the use of suitable sockets and plug-in terminals each separate unit in the transmitter can be removed from the rack with a minimum of effort. As the direct result of this type of construction it is possible to take all of the separate units from the shop, assemble them in the shack and have the transmitter on the air within fifteen minutes.

IN GENERAL

Crystal oscillators, in general, have been the pet peeve of a great many radio designers and authors. We doubt that the arguments for and against particular types will ever be settled to everybody's satisfaction. In our case, we have been concerned only with providing ourselves with a crystal oscillator circuit that will accomplish a predetermined result. The circuit that we have chosen functions in an entirely satisfactory fashion electrically, and it has recommended itself to us mechanically for the reason that it requires a minimum number of parts. We make

no claim for its being the best type of oscillator circuit but it accomplishes what we want.

(Continued on page 50)

COIL DATA

	L_1	L_2	L_3	L_4	L_5	L_6	L_7
28 Mc.	10 t. No. 18 close wound	4 t. No. 18 Length $\frac{1}{4}$ " Link 1 turn at cold end	Split winding 2 t. ea. side c.t. 2 t. link wound in center. Total length winding and link 1"	8 t. No. 14 $1\frac{1}{4}$ " dia. link 2 t. in center. Winding length 2"	4 t. No. 18 Link 2 t. at cold end winding length $\frac{1}{2}$ "	8 t. No. 12 $1\frac{1}{2}$ " dia., length $2\frac{1}{2}$ "	11 t. No. 12 on National XR10A form, full length of form
14 Mc.	Same as above	7 t. No. 18 length $\frac{1}{2}$ ". Link 1 t., cold end	Same as above except 4 t. each side center tap	10 t. No. 18 on National XR13 form. Length $2\frac{1}{4}$ ". Link 2 t. inside center coil form	7 t. No. 18 length $\frac{1}{2}$ " link 2 t., cold end	10 t. No. 12 on National XR10A form, full length of form	Same as above

All wire used is enamel covered.

Long-Wire Directive Antennas

Design Methods for "V"'s and Rhombics

By Robert C. Graham,* W8LUQ

THE more common type of directive array in amateur operation involves a multiplicity of reflectors, directors, phasing elements, radiators, etc., so arranged as to obtain the utmost power gain in a given direction. For obvious reasons these arrays are almost entirely confined to frequencies of 7 Mc. and higher. Moreover, such systems are rarely designed to permit multi-band operation and yet maintain the original directivity pattern with reasonable power gain.

THE LONG SINGLE WIRE

The simplest solution to this problem is a long horizontal single-wire antenna that may be harmonically operated. For this case, however,

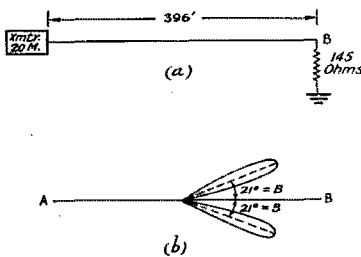

FIG. 1—(A) SIMPLE FORM OF DIRECTIVE ANTENNA, USING A LONG WIRE TERMINATED IN ITS CHARACTERISTIC IMPEDANCE; (B) FREE-SPACE DIRECTIONAL CHARACTERISTIC (MAIN LOBE ONLY) OF THE ANTENNA AT (A)

there still remain the shortcomings of a slight shift in directivity with frequency change, together with a power gain that is not all that might be obtained by other methods. For example, let us assume a wire 6 wavelengths long for 20 meters (396 ft.). To further simplify the explanation let us terminate the far end of this antenna in its characteristic impedance such as a 145-ohm non-inductive resistor (Fig. 1-A). This gives us a non-resonant type radiator and effectively reduces the rear radiation, resulting in a pattern similar to Fig. 1-B. (This diagram represents the theoretical free-space characteristic of the major lobes only.) The resulting directivity and power gain for harmonic operation of this antenna is then in accordance with the table in second column.

THE INVERTED "V"

In 1930 Bell Laboratory experimenters¹ found that by a suitable arrangement of tilting one of

* Engineer, General Cable Corp., Rome, N. Y.

	Angle β (Directivity)	Power Gain (over $\frac{1}{2}$ wave Hertz)
80 meters.....	46.5°	1.25
40 meters.....	30.5°	1.70
20 meters.....	21.0°	3.10
10 meters.....	15.0°	7.20

these long wires an additional increase in directivity and power gain was obtained (Fig. 2-A). By proper control of the length (L) and tilt angle (ϕ) an optimum relationship between these quantities was found to exist (Fig. 2-B) that gave maximum directivity and power gain. This arrangement is vertically polarized and possesses the advantage that only one mast, or supporting structure, is required.

THE HORIZONTAL "V"

In the same year RCA investigators² found that a greater power gain was obtainable along the bisector line of the acute angle made by two tilted wires than along the line perpendicular to the bisector as in the method just described, and that good results were obtained when this system was installed in a horizontal plane (horizontal polarization). This arrangement forms the basis for the well-known horizontal "V" (or "Vee" as it is sometimes called). This radiator (Fig. 3-A) when several wavelengths long may be harmonically operated without any appreciable directivity shift and with much greater power gains than can be obtained with the single wire. Moreover, the resulting power gain is greater than can be

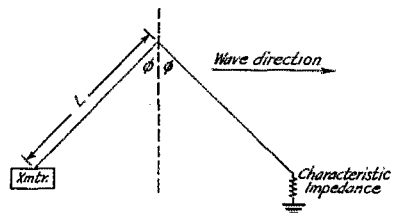

FIG. 2-A—TILTED-WIRE ANTENNA OR "INVERTED V"

produced by the usual reflector-director methods involving 2 or 3 elements.

The open-ended "V" as shown is bi-directional—that is, its major directive pattern is to the front and rear along the bisecting axis. Tilting the whole horizontal plane of the "V" will tend to

increase the low-angle radiation off the low end and decrease it off the high end.

Fig. 3-B shows the dimensions that should be followed for an optimum design to obtain maximum power gain for different-sized "V" antennas. The longer-type systems give good performance on multi-band operation. Angle α is approximately equal to twice the angle of maximum radiation for a single wire equal in length to one side of the "V".

The "V" can be made unidirectional through eliminating the rear pattern by either of the following two methods:

(1) The use of another "V" $\frac{1}{4}$ wave to the rear to act as a reflector.

(2) The termination of the far end of each leg in its characteristic impedance (Fig. 3-C).

The first method is quite cumbersome for amateur practice and restricts correct operation to a single frequency band.

The second method is preferable because the system becomes non-resonant (no standing waves) and is therefore more readily adaptable to multi-band use. However, a serious drawback to this method is the fact that varying ground resistance causes a variation in the terminating resistance. This condition causes reflected losses that may become severe and thereby change the entire action of the system—particularly with harmonic operation.

Should unidirectional properties be the paramount desire it is recommended that an alternate

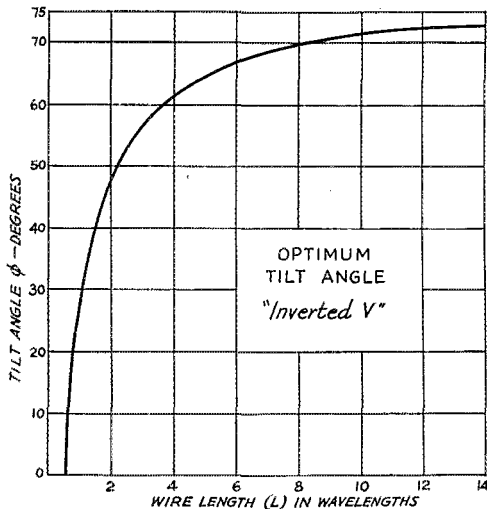

FIG. 2-B—OPTIMUM TILT ANGLE VERSUS WIRE LENGTH (ONE LEG) FOR THE INVERTED "V" ANTENNA

system be used. This brings us to the arrangement of two "V"s placed end-to-end, the system being terminated in its characteristic impedance; in other words, the terminated rhombic.

THE RHOMBIC ANTENNA

The "Rolls-Royce" of unidirectional antenna systems, either for transmitting or receiving, is the *terminated* rhombic, or diamond as it is some-

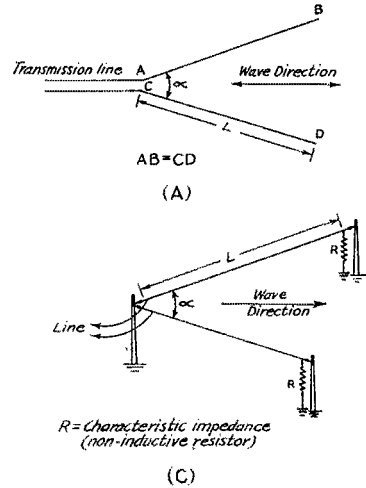

FIG. 3—(A) THE "V" ANTENNA; (C) "V" ANTENNA TERMINATED TO ABSORB BACK RADIATION AND THUS PRODUCE A UNIDIRECTIONAL PATTERN

times called. The *unterminated* rhombic, which is bidirectional and resonant, will be described later. For the present discussion all reference to the rhombic is in its terminated form. This discussion will also pertain to a rhombic installed in a horizontal plane above ground so as to provide horizontal polarization. (*Note:* This system also may be constructed in the vertical plane to obtain vertical polarization, which might be of some practical advantage in ultra-high frequency applications.)

It has only been in the past few years that the amateur has made any really practical use of the rhombic³ and in nearly every case the increase in radiating performance has more than justified the installation. The system was perfected by the Bell Laboratories in the latter part of 1930 chiefly as an improved receiving antenna, and has been in more or less continual use by commercial interests for high-frequency transoceanic service since that time. The rhombic is a direct descendant of the previously-described *inverted "V"* and represents a radical improvement over that system in operation and performance.

The advantages of the rhombic are so numerous that we can conservatively summarize the matter by saying that it is among the best of all known directive systems—that is, by proper design, greater power gain and directivity may be realized for the rhombic than any other ordinary single or multi-wire radiator. The installation is not complicated—certainly a great deal simpler

than the "curtain" arrays. By no means the least of its features (probably a major advantage with the amateur) is an inherently broad frequency characteristic.

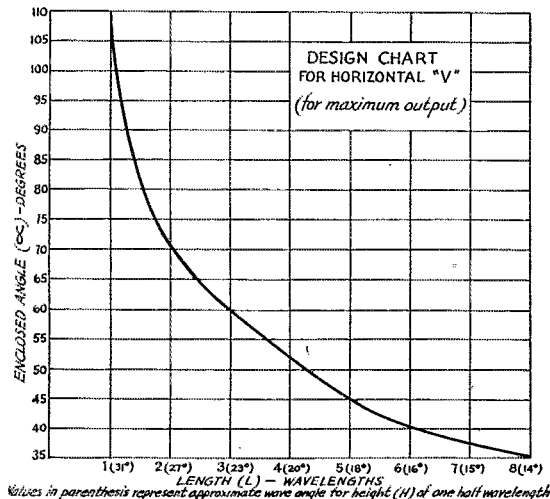

FIG. 3-B—DESIGN CHART FOR HORIZONTAL "V" ANTENNAS

Enclosed angle between wires versus length of sides.

Excellent efficiency is obtained over a 2 to 1 frequency range, and on some of the larger systems a 4 to 1 range may be obtained with fair performance. On this basis it is advisable from the standpoint of multi-band operation to design the rhombic for a fundamental of 20 meters, which will then permit operation on 10 and 40 meters and in some cases satisfactory performance over the entire group of amateur bands.

RHOMBIC DESIGN

Most of the design data thus far given in various amateur publications have been rather vague and, in some cases, a trifle misleading.

As a remedy for this situation it is intended to offer design information in as "digestible" manner as possible. The general theory of the rhombic⁴ will be omitted, but in so doing please do not get the idea that it is just another one of those lucky hit-or-miss systems that "just happened" to work. Some good sound engineering and mathematical principles are involved in the development of the rhombic for which the actual measured results bear out the calculated "theoretical" results to a startlingly close agreement.

First of all, in deciding on a "good location" for the rhombic it is advisable to select as flat

a section of terrain as possible, because any tilt in the horizontal plane of the rhombic will lead to distorted effects upon the wave angle. If the ground is sloping it is good practice to construct the rhombic so that its whole horizontal plane is also sloping parallel to the ground. Of course, any inconsequential short sloping sections of the earth may be neglected for all practical purposes.

Next, the rhombic dimensions are worked out from a given set of conditions for which there exists a single optimum design for maximum output.

To obtain maximum output for an "ideal" condition the only given design factor is the wave angle (or angle of radiation) from which is determined optimum height, length, and angle of tilt (Fig. 4).

This so-called "ideal" design may be classified into either of two alternative arrangements:

(1) *The Maximum Output Method*, in which the greatest possible amplitude for the wave angle is obtained but not with its maximum radius at the line indicating the given wave direction of the directive pattern (Fig. 5-A).

(2) *The Alignment Method*, in which the major lobe of the directive pattern is symmetrical with the wave angle (Fig. 5-B).

The former permits the greatest possible output whereas the latter, at only a slight sacrifice in output, has the features of a better signal-to-noise ratio for reception purposes together with the requirement of less overall space for the installation.

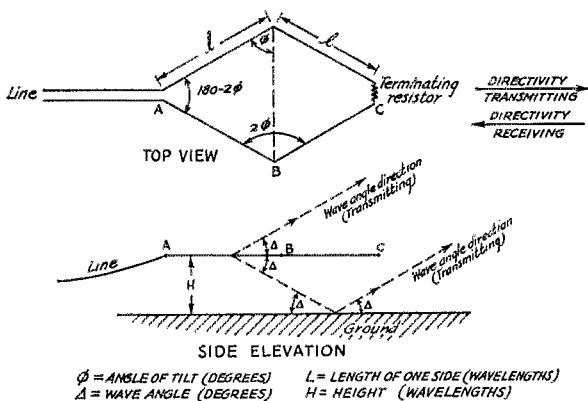

FIG. 4—THE HORIZONTAL RHOMBIC OR DIAMOND ANTENNA, TERMINATED

The design procedure for either condition is shown in Fig. 6, together with several examples of how this chart may be applied. Wave angles from 10° to 30° are shown in the design charts since it is considered that this is the most useful range

for practical use. Something in the range of 12° to 25° is probably the best to strive for to obtain overall DX performance. Higher frequency-band operation of a rhombic produces a lower wave angle than the fundamental frequency-band, and vice-versa for lower frequency-band application. The chart shown in Fig. 6 is computed from the following formulas:

- (1) $H = \frac{\lambda}{4 \sin \Delta}$
- (2) $\sin \phi = \cos \Delta$
- (3) $l = \frac{\lambda}{2 \sin^2 \Delta}$
(for maximum output method)
- (4) $l = \frac{.371 \lambda}{\sin^2 \Delta}$
(for alignment method)

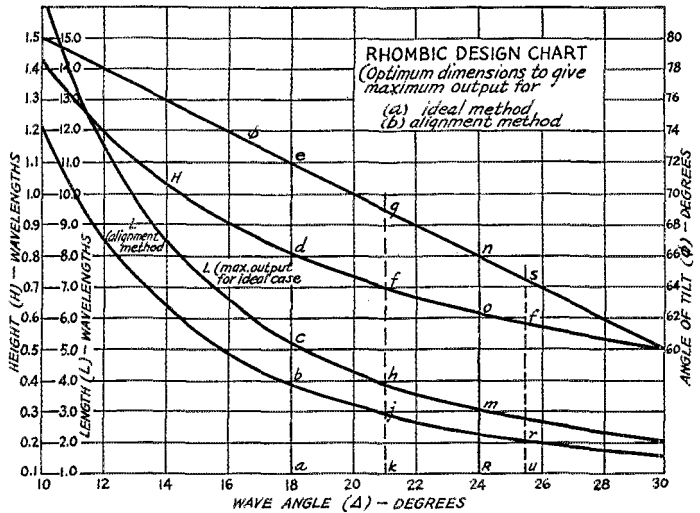

FIG. 6—RHOMBIC ANTENNA DESIGN CHART
The use of the Chart is illustrated by the following examples:

- (1) Given: Desired wave angle (Δ) = 18°.
To Find: H, L, Φ .
Method:
Draw vertical line thru point "a" (18° wave angle abscissa).
Read intersection of this line on each curve on its corresponding scale.
e = angle of tilt (Φ).
d = height (H).
c = length (L) for ideal case.
b = length (L) for alignment case.
Result:
 $\Phi = 72^\circ$.
H = .81 wavelengths.
L (ideal) = 5.25 wavelengths } either may be
L (alignment) = 3.87 wavelengths } used (see text).
- (2) Given: Available and effective height (H) = .7 wavelengths.
To Find: H, L, Φ , Δ .
Method:
Draw vertical line thru point "f" (.7 wavelengths on curve H).
Read intersection of this line on each curve on its corresponding scale.
g = angle of tilt (Φ).
h = length (L) for ideal case.
j = length (L) for alignment case.
k = wave angle (Δ).
Result:
 $\Phi = 69^\circ$.
L (ideal) = 3.9 wavelengths } either may
L (alignment) = 2.9 wavelengths } be used (see
 $\Delta = 21^\circ$ } text).

- (3) Given: Length for 1 side (ideal case) L = 3.0 wavelengths.
To Find: H, Φ , Δ .
Method:
Draw vertical line thru point "m" (3.0 wavelengths on curve L—ideal case).
Read intersection of this line on each curve on its corresponding scale.
n = angle of tilt (Φ).
o = height (H).
p = wave angle (Δ).
Result:
 $\Phi = 66^\circ$.
H = .618 wavelengths.
 $\Delta = 24^\circ$.
- (4) Given: Length for 1 side (alignment method) L = 2.0 wavelengths.
To Find: H, Φ , Δ .
Method:
Draw vertical line thru point "r" (2.0 wavelengths on curve L—alignment case).
Read intersection of this line on each curve on its corresponding scale.
s = angle of tilt (Φ).
t = height (H).
u = wave angle (Δ).
Result:
 $\Phi = 64.5^\circ$.
H = .581 wavelengths.
 $\Delta = 25.5^\circ$.

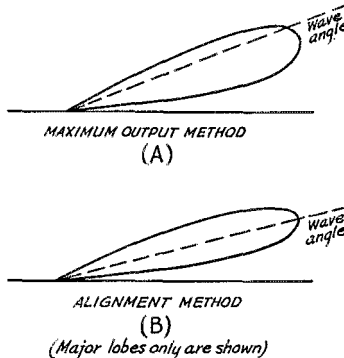

FIG. 5—TYPICAL VERTICAL CHARACTERISTICS FOR THE RHOMBIC Antenna Obtained by the Maximum Output Method (A), and the Alignment Method (B).

where λ = wavelengths
 Δ = wave angle (degrees)
 ϕ = angle of tilt (degrees)
 l = length of one leg (wavelengths)
 H = effective height (wavelengths)

In the event that the situation arises wherein it is impossible to meet these design

requirements for some reason or other (i.e., lack of longitudinal space, height, etc.) there are, fortunately, two compromise design methods that allow operation at only a slight gain reduction over the "ideal" cases just described.

The first compromise method is based on an original given premise of length and height from which is determined the proper angle of tilt and corresponding wave angle

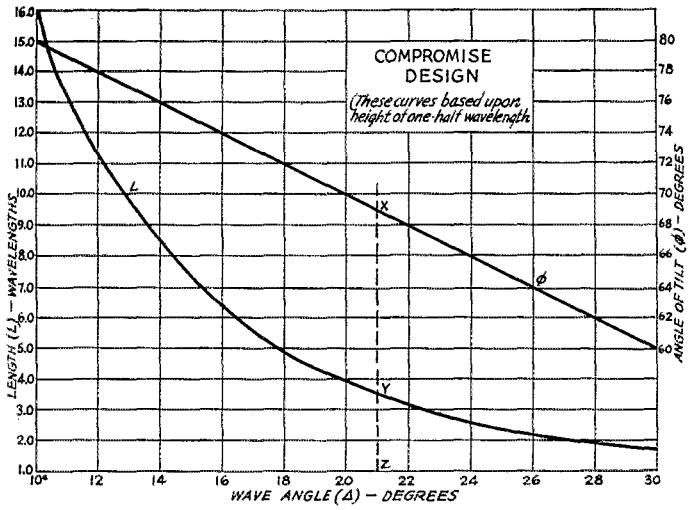

FIG. 7—COMPROMISE METH-OD DESIGN CHART FOR RHOMBIC ANTENNAS WITH FIXED HEIGHT (ONE-HALF WAVELENGTH)

The following example illustrates the use of the Chart:

Given: Height = 1/2 wavelength.
Available length of one leg = 3.5 wavelengths.

To Find:
Angle of Tilt (Φ).
Wave Angle (Δ).

Method:
Place straight edge on curve "L" at 3.5 wavelengths (point y) and draw line XYZ. Read angle Φ from intersection at point X (right hand ordinate) and angle Δ at point Z (intersection of abscissa).

Result:
H = 1/2 wavelength } given.
L = 3.5 wavelengths }
Tilt angle } from
Wave angle Δ = } curves.
21 degrees

for maximum output. Fig. 7 illustrates the procedure to be followed for this set of conditions. This chart is based upon an effective height of 1/2 wavelength, which represents a practical value for most amateurs to deal with. For any different height other than the one shown the curve may be plotted from the expression:

$$\frac{H}{\tan \frac{2\pi H \sin \Delta}{\lambda}} = \frac{\lambda}{2\pi \sin \Delta} \frac{1}{l \sin \Delta} \tan \frac{\pi l \sin^2 \Delta}{\lambda}$$

(Note: the solution of this equation for l in terms of wavelength (λ) may be obtained by the trial and error method.)

The second compromise design method is based upon a premise of a given length (somewhat reduced over the ideal case) and wave angle to determine the remaining optimum dimensions for best operation. Fig. 8 represents the design chart and method

to be followed for this condition. Curves for values of length of 2, 3 and 4 wavelengths are shown, and additional curves for any length may be similarly plotted from the relationship:

(Continued on page 78)

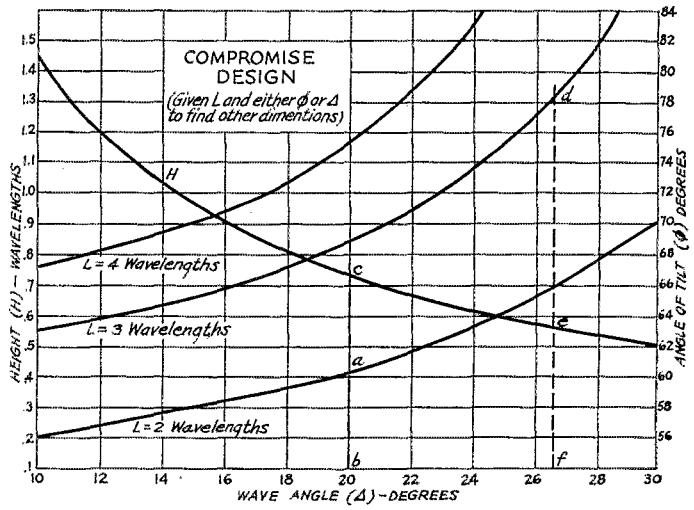

FIG. 8—COMPROMISE METHOD DESIGN CHART FOR VARIOUS LEG LENGTHS AND WAVE ANGLES

The following examples illustrate the use of the Chart:

(1) Given: Length (L) = 2 wavelengths.
Desired wave angle (Δ) = 20°.

To Find: H, Φ.

Method:
Draw vertical line thru point "a" (L=2 wavelengths) and point "b" on abscissa (Δ=20°). Read angle of tilt (Φ) for point "a" and height (H) from intersection of line ab at point "c" on curve H.

Result:
Φ = 60.5°.
H = .73 wavelengths.

(2) Given:
Length (L) = 3 wavelengths.

Angle of tilt (Φ) = 78°.

To Find: H, Δ.

Method:
Draw vertical line from point "d" on curve L=3 wavelengths at Φ=78°. Read intersection of this line on Curve H (point "e") and intersection at point "f" on the abscissa for Δ.

Result:
H = .56 wavelengths.
Δ = 26.6°.

Skip-Distance Calculation*

Rapid Graphical Determination of Secant of Angle of Incidence

By Newbern Smith**

THE secant of the angle of incidence of a radio wave upon the reflecting layers in the upper atmosphere is an important quantity in the elementary theory of sky-wave transmission. By simple refraction theory, neglecting the influence of the earth's magnetic field on the ionosphere, a region of given ionization density, which will return to earth a wave of frequency f at normal (vertical) incidence, will return a wave of frequency $f \sec \phi$, if incident on the layer at an angle ϕ .¹ The critical penetration frequency for this angle of incidence will thus also be greater than the normal-incidence critical

frequency by the factor $\sec \phi$. Furthermore, the evidence indicates that a wave of frequency $f \sec \phi$ incident at angle ϕ upon the layer behaves in other respects also, such as absorption to a considerable extent like a wave of frequency f incident normally.

The angle ϕ depends only on the virtual height of the layer (h) and the distance of transmission (D) along the earth (see Fig. 1). The accompanying chart, which has been in use for some time at the National Bureau of Standards, provides a simple means of determining $\sec \phi$ for any distance up to 5000 km. and any layer height up to 500 km. To use, lay a straight edge on the chart passing through the given virtual height of the layer and the desired distance laid off on the distance scale at the lower left hand edge of the chart (increasing distances lie to the left). The

* Publication approved by the Director of the National Bureau of Standards of the U. S. Department of Commerce.

** National Bureau of Standards, Washington, D. C.

¹ "Studies of the Ionosphere and their Application to Radio Transmission." S. S. Kirby, L. V. Berkner, and D. M. Stuart. *Proc. I.R.E.*, 22, p. 481, 1934.

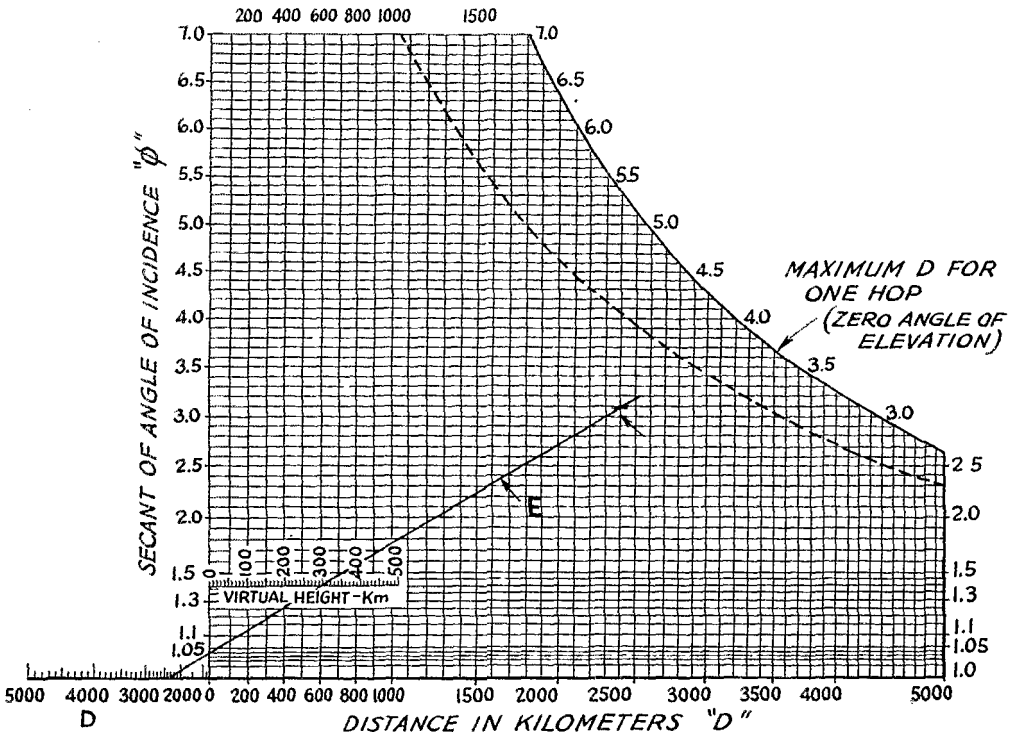

FIG. 2—ALIGNMENT CHART FOR DETERMINATION OF SEC ϕ

The dashed line gives the limit of the chart for $x = 3\frac{1}{2}^\circ$. The thin solid line marked E is the alignment of the straight edge for the example given in the text.

intersection of the straight edge with the vertical line corresponding to the same desired distance on the main distance scale (increasing distances to the right) will give the value of $\sec \phi$.

For example, a distance of 2400 km. and a virtual height of 300 km. will correspond to a $\sec \phi$ of 3.07. For this path, then, a radio wave of frequency 15,000 kc. will behave in many respects approximately like a wave of frequency $\frac{15,000}{3.07} = 4900$ kc. which is incident normally upon the layer.

If the straight edge and the vertical distance line do not intersect to the left of the "maximum D for one hop" line, this indicates an impossible case, where the ray would have to leave the transmitter at an angle below the horizontal.

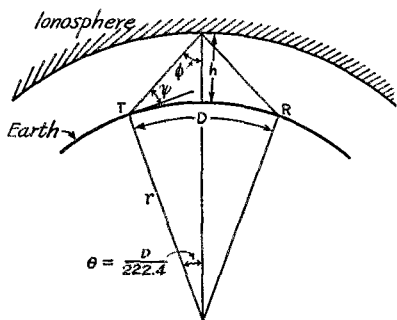

FIG. 1—EQUIVALENT PATH OF A RADIO WAVE BEING PROPAGATED FROM A TRANSMITTING STATION (T) TO A RECEIVING STATION (R) BY ONE HOP

The angle θ is given by the relation:

$$\tan \theta = \frac{r \sin \phi}{h + r(1 - \cos \phi)}$$

Distance between ionosphere and earth greatly exaggerated for clarity of representation.

In this case the height of the layer is too small to permit transmission in one hop, and calculations must be made for two or more hops.

The angle of take off (X) of the waves from the transmitter above the horizontal (and angle of arrival at the receiver) may be calculated from the relation:

$$X = 90^\circ - \phi - 222.4$$

where D = distance of one hop in km.

ϕ = angle whose secant has been determined

The larger X is, the smaller are D and ϕ , for a given layer height h . Thus the practical range of a wave for one hop depends largely on the minimum angle above the horizontal at which enough power is radiated to produce a good signal. This minimum usable value of X depends on the location and antenna structure of the transmitter and receiver, but a practical limit seems to be somewhere around 3° or 4° . The dot-

ted line corresponds to an angle of take-off of $3\frac{1}{2}^\circ$. For effective single-hop transmission, then, the intersection must take place to the left of the dotted line. A point to the right of the dotted line indicates unsatisfactory single hop communication, and in such a case calculations should be made for two or more hops.



DIXIE JONES' OWL JUICE

IT USE TO be that 80m cw sigs went straight up in the air a mile a minute and bounced off the moon or something and come down gosh knows where in the middle of nowhere somewhere and presumably smacked some kind of a furriner in the eye, and the guy next door to you in Bugtussle, Georgia, that you had the sked with couldn't hear you even a little bit. Skip, they called it. You could call this mug and lissen 'till the cows come home and you never would hear him. It turned out later to be that the reason you didn't and he didn't was because you and him wasn't both there a callin' and a lissenin' in the right place at the right time and vice versy, but skip was a good alibi while it lasted. When ARRL trunk lines and AARS nets took up spot frequency operation it made monkeys out of these skip hollerers. I'm glad I don't hear that skip alibi no more. I got purty sicka hearin' it.

—W4IR of the "Dixie Squinch Owl!"

New England Division Convention

Providence, R.I., May 21—22

LITTLE "Rhody" has the honor to carry out the traditions of the annual New England Division Convention to be held in Providence, R. I., at the Hotel Biltmore, on May 21st and 22nd, under the auspices of W1AQ, otherwise known as the Associated Radio Amateurs of Southern New England, Inc.

All New England Amateurs are invited to attend a real old time to-day convention, where old acquaintances will be renewed and new friends made. As in the past the program will prove interesting with prominent speakers, a first class banquet and many surprises.

The registration fee is \$1.50, banquet \$2.00, and a special price for the ladies of \$2.00.

Tickets and further information may be obtained by writing to W1AQ, 54 Kelly Ave., East Providence, R. I.



Amateur Radio STATIONS



W9SDQ, Indianapolis, Ind.

W9SDQ, Eugene M. Howard, of 837 N. Chester Avenue, Indianapolis, specializes in 14-Mc. 'phone operation, and his signal is a familiar one in the 'phone region of "twenty." The outfit behind the signal is shown in the accompanying photographs.

The transmitter is frame-mounted in two sections, the lower, with two shelves, containing power supplies and the upper the r.f. units. The frame is supported by large casters for ease of movement. The r.f. section of the rig consists of a 53 crystal oscillator-doubler followed by an RK23 buffer stage which in turn drives a second buffer using a T-55. The final stage has a pair of 203-A's in push-pull, operated at 400 watts input. In the photograph the 203-A's occupy the top deck of the rack, while just below are the crystal and driving stages with a small power supply for the 53. On the bottom shelf are two power supplies, one giving 1500 volts for the final stage and the other 1100 volts for the modulator and T-55 buffer. The second shelf contains a 600-volt supply for the RK23; the Class-B modulator also is mounted on this shelf. All grid and plate circuits are metered. Four 7-Mc. crystals are used, three for various frequencies in the 'phone section of the 14-Mc. band and the fourth for c.w. A rotary switch on the panel selects the frequency desired.

The low-level speech equipment occupies the upper part of the small rack at the right-hand end of the operating table. The speech line-up includes a Shure 701A crystal microphone working into a 57, pentode-connected and resistance-coupled to a 56. The 56 is transformer-coupled to a pair of 56's in push-pull and these in turn excite a pair of 2A3's. The latter act as drivers for the Class-B modulator, which uses a pair of 930-B's. The output of the driver is coupled to the modulator grids through a 500-ohm line, the modu-

lator proper being located in the transmitter frame. Power supplies for the speech amplifier are on the lower chassis in the rack.

The receiver is an RME-69, equipped with a noise silencer. A Peak pre-selector, on top of the receiver in the photograph, is used for boosting the gain on the weak signals; it gets its power from a supply mounted on the chassis containing the speech-amplifier supplies.

W9SDQ uses a horizontal Johnson "Q" antenna, a half wave long at 14 Mc.

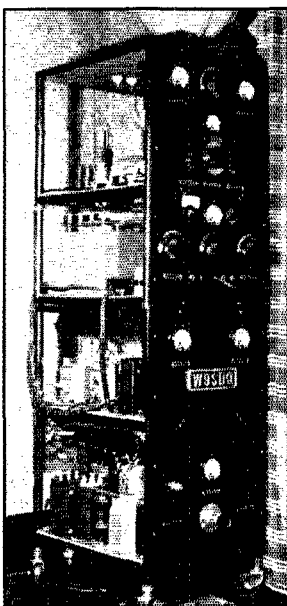

W8DK, Mt. Clemens, Mich.

ASIDE from the obvious neatness of the apparatus, one thing we like about the photograph of W8DK is the roomy operating table. The shelf along the rear edge makes practically the whole table available for elbows and papers, yet brings the apparatus within easy reach.

W8DK is owned by Arthur Grolz, and is located at Joy Ranch, Mt. Clemens, Mich. The transmitter, at the right in the photograph, is built in an enclosed iron frame, mounted on rubber-tired casters so that despite its weight (nearly 900 pounds) it can



easily be pulled out for adjustments or repairs. The r.f. tube line-up consists of a 10 crystal oscillator, a buffer stage with a pair of T-55's, and a final stage using a pair of W.E. 276-A tubes in

when quadrupling frequency. It will be noted that the metal shell of the 6L6 is grounded; this prevents some disagreeable effects that occur otherwise.

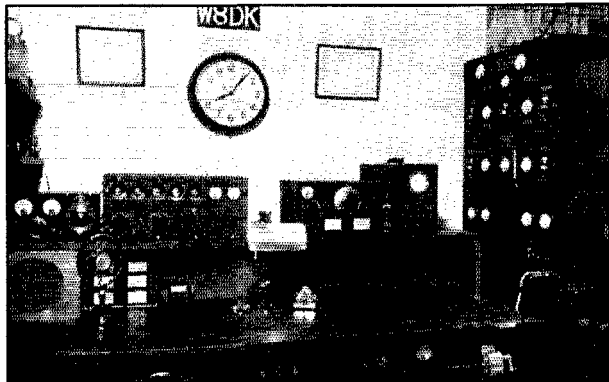

W8DK, MT. CLEMENS, MICH.

push-pull. The input to the final is 450 watts. The crystal is temperature-controlled within very close limits. Separate power supplies are used for each stage, the supply for the final amplifier being capable of delivering a kilowatt if necessary.

The transmitter is used chiefly for 4-Mc. 'phone, with speech equipment starting out with an Astatic D104 crystal microphone working into a 6C6 pentode-connected, followed by a 6C6 triode-connected. This in turn drives a pair of 6B5's in push-pull. The speech amplifier is in the metal cabinet toward the left in the photograph; the fifth tube in the row is an 83-V rectifier for the self-contained power supply. The modulator uses a pair of 212-D's.

The receiver at W8DK is an HRO. Auxiliary equipment includes an RCA Oscilloscope and heterodyne and absorption frequency meters.

A Medium-Power Transmitter Especially Designed for 28-Mc.

(Continued from page 41)

One distinct advantage of this type of oscillator circuit is the ease with which a variable-gap crystal may be employed instead of the fixed-frequency crystal. In operating in the 28-Mc. band we use a 7-Mc. crystal. Operation on the 14-Mc. band is also accomplished with a 7-Mc. crystal, more as a matter of convenience. A 3.5-Mc. crystal can be used for 14-Mc. operation by increasing the coil inductance in the crystal oscillator. The 6L6 frequency multiplying stage output is rich in harmonic content and provides ample excitation for the succeeding stage even

The 807's in the push-pull buffer stage require no neutralization and deliver high output with very little excitation. It will be seen that this circuit is perfectly conventional in every respect.

The choice of the 250TH for the final stage was made after several other types of tubes, rated at somewhat equivalent plate dissipation, had been tried. Because of the low internal capacity and the high amplification factor of this tube, excitation requirements are relatively low and this results in further simplification of the entire transmitter. More than ordinarily good efficiency in the final stage is obtained, particularly when the transmitter is used on the higher frequencies. It will be seen that the various elements in the transmitter are link coupled and here "Giant-Killer" cable is used for the transmission line between the coupling coils.

The antenna matching network has proved to be very satisfactory and it does not suffer from the inherent disadvantages outlined in W1EAO's article to which we have made previous reference. Naturally, the choice of the antenna is a subject which may well be a complete article in itself, and suffice it to say that good results have been had with two horizontal half-waves in phase on the 28-Mc. band; and a vertical half-wave radiator on the 14-Mc. band.

The line-up in the speech amplifier provides a sufficient over-all gain so that practically any type of microphone may be used.

One unique feature of the power supply is that a single transformer, with two secondaries, supplies the plate voltage for the speech amplifier, the modulator and the entire r.f. portion. One of the desirable results is the good regulation obtained under modulation, in spite of the really large job it is made to do.

The recent attention given to the use of Faraday shields between the final tank and the antenna matching networks for the suppression of harmonic radiation have been thoroughly recognized and tried. Their use is suggested as highly desirable. The particular type of shield depends, of course, on the mechanical construction of this portion of the circuit.

Strays

Judging by the way they stretch during a DX contest, there must be a lot of rubber in our bands.

HINTS and KINKS for the Experimenter



Eliminating I.F. Shift—A Heterotone Circuit

HOW many amateurs have noticed an apparent shift of i.f. alignment amounting to several kilocycles when the gain control of a

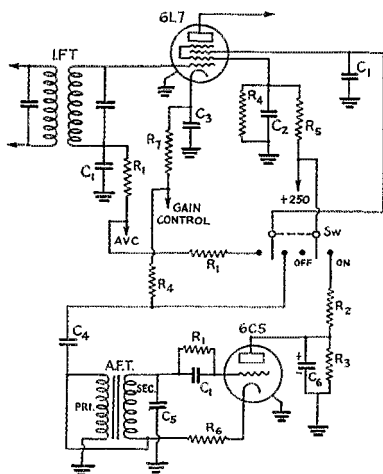

FIG. 1—HETEROTONE OSCILLATOR COUPLED TO A 6L7 I.F. AMPLIFIER

- | | |
|--|---------------------------------------|
| C ₁ —0.01 μ fd. | R ₃ —25,000 ohms, 1 watt. |
| C ₂ —0.1 μ fd. | R ₄ —15,000 ohms, 1 watt. |
| C ₃ —0.5 μ fd. | R ₅ —10,000 ohms, 10 watt. |
| C ₄ —0.25 μ fd. | R ₆ —5000 ohms, 1 watt. |
| C ₅ —0.002 μ fd. | R ₇ —400 ohms, 1 watt. |
| C ₆ —8- μ fd, electrolytic. | AFT—Old audio transformer. |
| R ₁ —100,000 ohms, 1/2 watt. | |
| R ₂ —100,000 ohms, 1 watt. | |

superhet was varied? In a receiver under investigation, the input capacity of the i.f. amplifier tubes seemed to change when the bias was changed by the usual variable cathode resistor with bleeder system.

A look at the properties of tubes shows that the effective input capacity is the sum of several fixed capacities and a capacity which is a function of the voltage amplification and the grid-plate capacity of the tube. From this, it appears that a variable- μ tube would have a variable input capacity, since the amplification decreases as the grid bias is increased. The 6K7 has a grid-plate capacity of 0.005 μ fd. and the 6L7 only 0.0005 μ fd., but the maximum gain is nearly the same for both tubes. Therefore, a 6L7 should perform as well as a 6K7 as an i.f. amplifier with the ad-

vantages of increased stability and only one-tenth the change of input capacity.

A 6L7 was substituted in the receiver and it proved to be even better than expected. The problem arose: What about the oscillator coupling grid? By connecting it to the a.v.c. circuit, the a.v.c. action of the set was materially improved. Heterotone was tried, coupling into the oscillator grid, with immediate approval.

Fig. 1 shows the modified amplifier and heterotone oscillator. Most values are not critical and are subject to variation depending on the a.f. transformer used in the oscillator circuit. The circuit and values were found by cut-and-try. If the 6C5 does not oscillate, reverse the connections to the primary of the a.f. transformer. The oscillator grid of the 6L7 is connected to the a.v.c. circuit only when the heterotone oscillator is off, in order to maintain a fairly constant percentage of tone modulation. Screen-grid coupling of the oscillator to the 6L7 was found less stable in tone frequency and percentage of modulation than oscillator grid coupling, when the gain control was varied. If the set has one voltage divider to supply all screen voltages, it may be advisable to make changes to keep the screen voltage near 100.

—Wilfred H. Conley, W8CZR

The BH Rectifier for the Ford Coil Plate Supply

FOR information on the adjustment of the Ford coil plate supply the reader is referred to the article in the June, 1932 issue of QST entitled

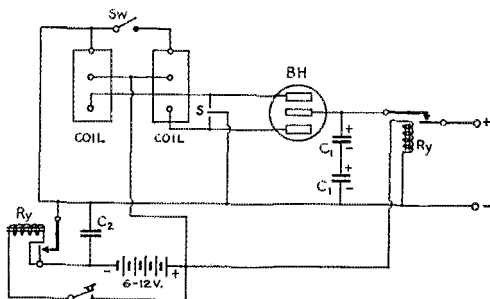

FIG. 2—SPARK COIL PLATE SUPPLY USING A BH RECTIFIER

- | |
|---|
| C ₁ —8- μ fd, 500-volt electrolytic condensers. |
| C ₂ —1 μ fd. |
| R _y —Relays made from generator cut-outs. |
| Sw—S.p.s.t. switch to cut out one coil and save battery drain when lower power is satisfactory. |

"D.C. Plate Supply from Ford Spark Coils," by Davis. But a few things in regard to the BH rectifier should, perhaps, be brought to attention. The BH tube seems to be more efficient than an 80. Using the circuit of Fig. 2, the output is about as follows: One coil at 6 volts, 6 watts; one coil at 12 volts, 12 watts; two coils at 6 volts, 12 watts; two coils at 12 volts, 20 to 25 watts. The output obtained depends to a great extent on the care used and experience of the operator. It is so easy to get pure d.c., or even x.p.d.c. that it is tempting to adjust the self-excited transmitter for maximum antenna current. The supply should be placed some distance from the rig because the coils cause considerable vibration and their magnetic fields may affect the transmitter meters. The primary current is quite heavy so the coil wiring should go directly to the storage battery, not through common leads which also supply the transmitter tube filament, or else the filament voltage for the transmitter tube will fluctuate when keying. A relay must be used to break the primary circuit of the coils if a bug key¹ is used. In tuning up, not more than 6 volts should be used on the coils. Increase power gradually. Electrolytic filter condensers are cheap, but seem to "leak" until broken in, reducing the output. The old "bootleg" BH, which cost about a dollar, is still in use after four years of service and the recent renewal of coil points put the output higher than ever. Coil points are cheap and should be renewed as soon as the output decreases.

This power supply has been used on a crystal controlled rig with T9 results, but a separate supply for the oscillator and doubler stages is recommended. Both the supplies should, in that case, be keyed so break-in might be used. The power supply in use here weighs about 7 pounds with shielding and cost less than \$3. It may be of interest that while operating portable on 3.5-Mc. band, a car radio was in use just under the antenna and about 20 feet from the unshielded coils with no interference whatever.

—Robert F. Valgren, W9ALO

¹ If a key capable of handling the primary current is used, the relay may be omitted.

Modulation Monitoring with the Oscilloscope Having No Sweep Circuit

FIG. 3 shows a simple way to monitor modulation with an oscilloscope which has no linear sweep or amplifier for horizontal displacement. A tuned pick-up coil is connected to one set of plates, while an untuned pick-up coil is connected to the other set. The tuned unit may be a midget tuning condenser and tube socket placed at the oscilloscope terminals where the proper coil may be plugged in. The untuned coil has two or three turns placed near the antenna tank so that it will pick up about the same voltage as developed in the tuned circuit. When the condenser in the tuned circuit is rotated through resonance, a point will be found where a circular outline will appear on the screen. When modulation occurs this circle will increase and decrease in size, giving the appearance of a disc with the unmodulated portion of the carrier appearing as a dark spot in the center.

A bright spot in the center clearly indicates overmodulation. Distortion will also be indicated as circular lines more or less illuminated than the rest of the pattern.

—R. E. Patrie, W9CWD

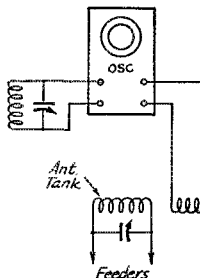

FIG. 3—USING AN OSCILLOSCOPE WITHOUT SWEEP CIRCUIT FOR MEASURING MODULATION

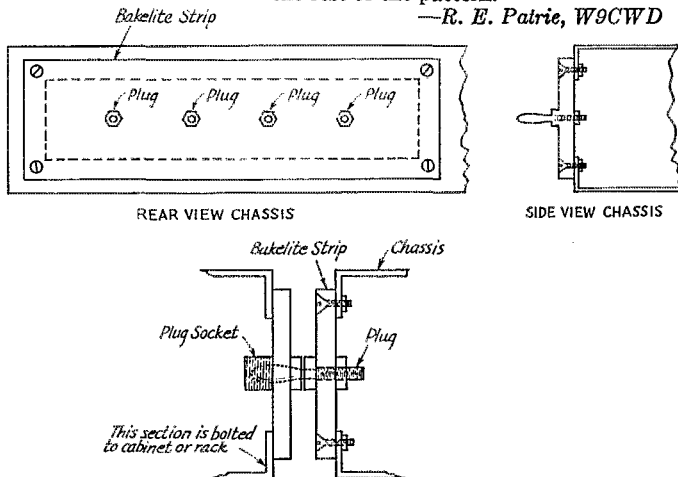

FIG. 4—PLUGS AND JACKS FOR POWER SUPPLY CONNECTIONS IN CHASSIS-TYPE RACK-MOUNTED TRANSMITTERS

Further information on circular modulation patterns is to be found on page 47, March, 1936, QST.—Ed.

— —

Plug-in Chassis Connections

WHILE rebuilding my transmitter I devised the following method of making the chassis connections to the cabinet wiring and found that

it made quite a neat-appearing job. The plugs used on the chassis are similar to plugs used on coil forms and are mounted on a strip of bakelite which is set over a section of the back of the chassis which has been cut out. The plugs on the bakelite base then fit into plug sockets mounted on bakelite in the back of the cabinet. The wiring to these plug sockets can be cabled or put in pipe according to the desire of the builder. The general idea is shown in Fig. 4.

This proves a quick method for removing the chassis from cabinet or rack for inspection or repair.

—Charles F. Yung, W2GAU

100-kc. Calibrating Oscillator

THE circuit of Fig. 5 is used by Charles O. Becht, W9LSZ, for getting 100-kc. calibrating points. The oscillator uses a 6L6 tube with a self-resonant plate coil, and gives harmonics of good strength at frequencies as high as 30 megacycles. The extremely low-C plate circuit and high-re-

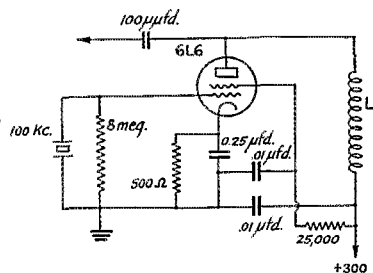

FIG. 5—100-KC. CRYSTAL OSCILLATOR USING 6L6 FOR HARMONIC GENERATION

The inductance L consists of three pi sections, each consisting of 500 turns of 10-strand Litz wire.

stance grid leak contribute to the harmonic output.

Dimensions of the plate inductance, L, used by W9LSZ are given in Fig. 5. Its inductance should be such that the plate circuit will be resonant, in conjunction with the self-capacity of the coil plus the output capacity of the tube and the wiring capacity, at a frequency somewhat higher than 100 kc.

Curing Filament Hum

HUM in the receiver caused by leaving transmitter filaments connected during reception is a common complaint. The only sure cure seems to be that of opening the grid circuit in the transmitter during receiving periods. A method for doing this automatically, suggested by Robert Berler, W2EPC, is shown in Fig. 6. W2EPC writes:

"A three-watt neon lamp was purchased and its base was removed by heating over a flame. The

internal wire resistor was removed from the base of the lamp and then the base was replaced. The 'C' bias lead to the final amplifier is broken at

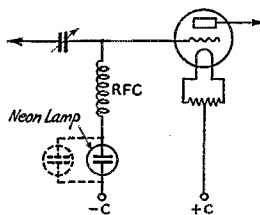

FIG. 6—NEON LAMP IN GRID CIRCUIT FOR CURING HUM FROM TRANSMITTER DURING RECEPTION

A three-watt lamp with base resistor removed is used. Where heavy grid currents are drawn, two or more lamps should be connected in parallel.

the cold side of the r.f. choke and the lamp is connected in series at that point. The neon lamp can safely pass 65 milliamperes, but if more current is drawn, it is advisable to connect two lamps in parallel."

A Universal Exciter

(Continued from page 28)

no necessity for mounting the chassis behind a relay-rack panel, and it may well be mounted in a small cabinet and placed alongside the receiver on the operating table. If the transmitter proper is located some feet from the operating table, such an arrangement is frequently quite desirable, since it makes it possible to QSY quickly without leaving the operating position.

While the present exciter has been designed especially to use the variable-frequency crystal and holder, there is ample room between the two tubes to mount several sockets into which may be plugged a number of standard crystals and holders where several fixed operating frequencies are preferred to the continuously variable range provided by the adjustable crystal.

In the rear view most of the wiring can be seen. There is a handy trick used by commercial companies for wiring jacks that is not generally understood by the average amateur; it is to prepare the leads and solder them to the jack contacts before mounting the jack in place. By so doing, the necessity for soldering in an awkward position is eliminated. It is also possible to skin and tin the wires so that the insulation comes right up to the contact and does so without being frayed or sloppy looking. The jack is then mounted in place, the leads run through the necessary bushings to their proper terminals and, if necessary, re-cut and skinned for soldering to the other pieces of apparatus which are invariably more conveniently located for neat soldering; as are, in this case, the socket terminals.

(Continued on page 70)

• I. A. R. U. NEWS •

Devoted to the interests and activities of the

INTERNATIONAL AMATEUR RADIO UNION

Headquarters Society: THE AMERICAN RADIO RELAY LEAGUE, West Hartford, Conn.

MEMBER SOCIETIES

American Radio Relay League
Associazione Radiotecnica Italiana
Canadian Section A.R.R.L.
Československá Amatérská Vysílač
Deutscher Amateur Sende-und-Empfangs
Dienst
Experimenterende Danske Radioamatører
Irish Radio Transmitters Society
日本アマチュア無線聯盟 Japan
Liga Colombiana de Radio Aficionados

Liga Mexicana de Radio Experimentadores
Magyar Rövidhullámú Amatőrök Országos
Egyesülete
Nederlandsche Vereeniging voor Interna-
tionaal Radioamateurisme
Nederlandsch-Indische Vereeniging voor
Internationaal Radioamateurisme
New Zealand Association of Radio Trans-
mitters
Norsk Radio Relé Liga
Österreichischer Versuchssenderverband
Polski Związek Krotkofalowców

Radio Club Venezolano
Radio Society of Great Britain
Rede dos Emissores Portugueses
Reseau Belge
Reseau des Emetteurs Français
South African Radio Relay League
Suomen Radioamatööritöry.
Sveriges Sändareamatörer
Unión de Radioemisoras Españolas
Union Schwelz Kurzwellen Amateure
Wireless Institute of Australia

Conducted by Byron Goodman

C.C.I.R.:

Not all amateurs are familiar with the participation of the I.A.R.U. in the meetings of the C.C.I.R., the technical meetings held during the five-year intervals between international conferences. It is at the C.C.I.R. meetings that the amateur has an opportunity to show what has been accomplished in the way of technical advancement by *amateur* radio. We will be capably represented at the Bucarest meeting by Messrs. John C. Stadler, VE2AP of Montreal, and James J. Lamb, *QST*'s technical editor, who are busy finishing up their technical studies. They sail from New York on May 4th, will visit the D.A.S.D. at Berlin on May 15th, and will arrive at Bucarest on May 18th, where they will remain until the close of the meeting some time in June. On their return they will visit the R.S.G.B. in London and, time permitting, several other European societies.

The I.A.R.U. is submitting studies on three of the questions proposed for this, the fourth meeting of the C.C.I.R. Question 1 deals with receiver selectivity characteristics, and the amateur contribution shows, among other things, selectivity curves of representative modern amateur communications-type receivers which are in actual use. The fact that amateurs are forced by their overcrowded bands to employ receivers with a higher degree of selectivity than used by other services is clearly shown by this study. It will be remembered that Mr. Lamb's original contributions to the previous C.C.I.R. meeting, on the use of crystal filters, met with widespread interest.

Question 11 treats the use of single-sideband radiotelephony, its application to the higher fre-

quencies for reduced fading and increased communications efficiency, and possible methods of attaining single-sideband communication on the higher frequencies.

The third I.A.R.U. contribution is on Question 16, dealing with the reduction, at the receiving location, of interference caused by electrical installations, or "man-made noise." This presents the "silencer" principles recently described, and should receive the same interest accorded the introduction of the crystal filter.

It is fortunate that amateurs are afforded a chance to participate in these meetings, since we are not only allowed to make our own constructive technical contributions, but also are given opportunity to participate in arrival at interpretations of other questions which might affect our interests.

Map:

A Great Circle Map for British amateurs, and also of some interest to those on the European continent, has been prepared by the "Wireless World" of London and is available through the R.S.G.B. The map is on Plett's Zenithal Azimuthal Graticule, a projection similar to the special type devised for the A.R.R.L. Map of the World. The price is 2/- net.

One thing this map clearly shows is why the G's can work so much good DX. Everything in the world, it seems, is clustered right around them—except for western Oceania. An interesting point is that K6, perhaps the hardest place to work from the British Isles, lies directly over the magnetic North Pole. East coast W's vainly trying to raise elusive J's will heave a sigh of sympathy!

Switzerland:

The Annual Convention of the U.S.K.A. was held at the Kursaal of Berne this year, and was attended by more than 70 amateurs. For 1937, Hans Büchler, HB9AA, was elected president; Dr. Karl Baumann, HB9BY, was elected vice-president; and Rudolf Stuber, HB9T, was elected Traffic Manager.

To all foreign amateurs spending their holidays



SOME WELL-KNOWN AUSTRALIAN AMATEURS, SHOWN ON A HOLIDAY BETWEEN DX CONTESTS

Reading in the usual manner, the back row shows VK4AW, VK4RY, VK4UL, VK4WR, and VK4BB. In the front row, VK4GK Jr., VK4AP, VK4YL, VK2LZ, VK4UR, VK4GK Jr.

in Switzerland the U.S.K.A. extends a cordial invitation to visit the society headquarters.

General:

W1GTX forwards the information that the importation of radio parts for amateurs in Denmark is now prohibited. . . . The amateurs in Niigata, previously using J6 calls, have had them changed to J2 prefixes. . . . The 1937 VK/ZL Contest will be conducted by the N.Z.A.R.T. . . . Amateurs in Latvia are licensed to use the amateur frequencies from 28 to 400 Mc. After showing a certain amount of success in these bands they may be allowed permission to operate in the 14-Mc. band. The power used is under 50 watts. . . . The N.A.R.A. (Newfoundland) advises us that they will no longer accept listener cards for distribution, in view of their overloaded QSL Bureau. SWL's should send their cards directly to the Call Book addresses. . . . VU2LK was the first Indian amateur to take the new license examination, according to VU2LK.

QSL Bureaus:

Following is the list of foreign QSL Bureaus, to which cards can be sent in bulk for distribution in the various countries. Remember, however, that many bureaus now refuse to handle cards and acknowledgements of listeners.

Alaska: Leo Osterman, K7ENA, Customhouse, Wrangell.
Antigua: R. V. Tibbits, High Street, St. Johns.
Argentine: Radio Club del Argentina, Rividavia 2170, Buenos Aires.
Australia: Ray Jones, 23 Landale St., Boxhill, Victoria.
Austria: Willy Blaschek, O.V.S.V., Bahngasse 29, Klosterneuberg.
Belgium: Baron Bonaert de la Roche, ON4HM, Chateau de Marchiennes, Harvengt nr. Mons.
Bermuda: Alfred E. Redman, "Elsing," Middle Road, Devonshire.
Bolivia: Henry E. J. Smith, c/o Standard Oil Co. of Bolivia, La Paz.
Borneo: See Malaya.
Brazil: L.A.B.R.E., Caixa Postal 26, São Paulo.
Canal Zone: John J. Carr, 78th Pursuit Squadron, Albrook Field.
British Honduras: D. Hunter, Box 178, Belize.
Ceylon: A. M. Rahim, "Rillington" Wellawatte, Colombo.
Chile: Luis M. Desmaris, Casilla 761, Santiago.
China: I.A.R.A.C., Box 485, Shanghai.
Colombia: L.C.R.A., Apartado 330, Bogota.
Costa Rica: Federico Gonzalez, Box 384, San Jose.
Cuba: Adolfo Dominguez, Milagros 37, Vibora, Habana.
Czechoslovakia: C.A.V., Post Box 69, Praha I.
Denmark: E.D.R., Post Box 79, Copenhagen K.
Dominican Republic: H. H. Gosling, Calle Cesar Nicolas Penson, Ciudad, Trujillo.
Ecuador: Carlos Cordovez, Box 30, Rio Bamba.
Egypt: F. H. Pettitt, Catholic Club, Mustapha Barracks, Alexandria.
England: R.S.G.B., 53 Victoria St., London, S. W. 1.
Estonia: V. Suigusaar, Erne t. 13-3, Tallin.
Federated Malay States: Reginald J. Bee, Malayan Public Works Service, Kuala Kangsar, Perak.
Finland: S.R.A.L., Pohjola, Box 42, Helsinki.
France: Reseau des Emetteurs Francais, 6 Square de la Dordogne, Paris, 17^e.
Germany: D.A.S.D., Schweinfurthstr. 78, Berlin-Dahlem.
Greece: C. Tavaniotis, 17-a Bucharest St., Athens.
Guam: C. R. Spicer, Naval Communication Office, Agana.
Haiti: Via A.R.R.L.
Hawaii: James F. Pa, K6LBH, 1416D Iunaliho St., Honolulu.
Hong Kong: H.A.R.T.S., Box 651.
Hungary: National Union of Hungarian Short Wave Amateurs, VIII, Matyas-ter 6, Budapest.
India: B. M. Tanna, Satya Sadan, Santa Cruz.
Irish Free State: I.R.T.S., 23, Sth. William St., Dublin.
Italy: via A.R.R.L.
Jamaica: Cyril M. Lyons, 2-B North St., Kingston.
Japan: J.A.R.L., P. O. Box 377, Tokyo.
Java: see Netherlands East Indies.
Yugoslavia: Stephen Liebermann, Meduluceva 9, Zagreb.
Kenya: R.S.E.A., Box 570, Nairobi.
Latvia: L.R.B., Post Box 201, Riga.
Lithuania: L. R. M., Post Box 100, Kaunas.
Luxembourg: J. Wolff, 67 avenue du Bois, Grand Duchy of Luxembourg.
Malaya (and Borneo): J. MacIntosh, c/o Posts & Telegraphs Dept., Penang, Straits Settlements.
Mexico: L.M.R.E., Sinaloa 33, Mexico City.
Morocco: A.A.E.M., BP 50, Casablanca.
Netherlands: N.V.L.R., Post Box 400, Rotterdam.
Netherlands East Indies: Ir. J. M. van Heusden, N.I.V.L.R.A., Burg. Coopsweg, 28, Bandoeng.
Newfoundland: Newfoundland Amateur Radio Ass'n., c/o E. S. Holden, P. O. Box 650, St. John's.
New Zealand: N.Z.A.R.T., P. O. Box 374, Dunedin.
Nicaragua: Ernest Andreas, YN1OP, Estacion Radiodifusora Bayer YNOP, Managua.
Norway: N.R.R.L., P. O. Box 2253, Oslo.
Republic of Panama: R. D. Prescott, Box 32, Panama.
Palestine: Frank H. Pettitt, Catholic Club, Mustapha Barracks, Alexandria, Egypt.
Peru: Radio Club of Peruano, Apartado 538, Lima.
Philippine Islands: George L. Rickard, P. O. Box 849, Manila.

(Continued on page 110)



OPERATING NEWS



Conducted by the Communications Department

F. E. Handy, Communications Manager

E. L. Battey, Asst. Communications Manager

TO-DAY we have a better distribution of interest and occupancy between our several amateur bands than was indicated in the surveys of about two years ago. Recent surveys show that operating interest is somewhat more diversified to-day than it was. More amateurs can work on two or three different bands. Congestion, and utilization of more bands to relieve the situation may have had something to do with it. Technical progress and the wider availability of more flexible and suitable equipment perhaps has been the most potent factor. Better economic conditions that have made the acquisition of more equipment possible have played a part. To-day, also, there is better general appreciation of the relative communicating values, and proper time of use (for optimum results over particular distances) of our different frequencies. The favorable DX conditions on the higher frequencies during this part of the sun-spot cycle have naturally focussed attention on the 14- and 28-Mc. bands.

The long continued good conditions on 28 Mc. have brought about a 584% increase in occupancy and registered interest in that band in a two-year period! Our use of ten meters to-day is about one fifth as great as our use of the 14-Mc. band, however, so it is apparent that this DX territory is still by far the most attractive, since the interference levels are lower, especially if we aim to operate in the whole band, and not confine our work to the low-frequency end.

56-Mc. band work has held continued interest, so that there has been in two years something like a 50% increase in utilization of this territory.

Our four low-frequency bands contain nearly 90% of amateur operating. Comparing occupancy figures of to-day with the survey made some two years ago, an increase of interest in the 1.7-Mc. band amounting to about 22% is shown. 14-Mc. band use has increased nearly 50%. At the same time, decreased registered interest in the 3500- to 4000-kc. band and 7000- to 7300-kc. bands amounting to around 30% and 10% respectively is indicated. This does not necessarily mean that there are fewer stations operating in those bands, since this analysis has been concerned not with the exact amount of occupancy in different bands, but with the *distribution* of individual interest over all the different bands. A tabulation showing

the percentage of all interest represented in *each* band, as now indicated, and as shown in an exactly similar survey of two years ago, best tells the story:

Bands	% Use '35	% Use '37
160	8.66	10.588
80	42.48	28.935
40	27.73	25.19
20	18.19	23.86
10	.687	4.713
5	4.16	6.10
2½	.08	.445
1¼	.013	.169

The most striking thing is the increase in ten- and twenty-meter utilization. With the exception of the increase in 160-meter interest, it may be said that all the higher frequency bands have gained occupancy, and at the expense of the time spent on the lower frequencies. Two years ago we spoke of 3.5- and 7-Mc. bands as "major interest" bands. The figures show why. The 14-Mc. band to-day must enter this classification if such a grouping is to be made. It is better, though, to look upon the more uniform figures as meaning that more amateurs are to-day able to use more bands with their maximum effectiveness, at the time when these bands are best for the given desired type of communication. We have, of course, a varying degree of protection from congestion with the varying "skip effect" on the different bands. Examining the occupancy in proportion to the width of the various bands, without evaluating this particular factor, shows a very fair degree of uniformity through the 160-80-40- and 20-meter bands—a better uniformity than ever in our history. To produce comparable occupancy in the ten-meter region we can stand something like twenty or twenty-five times the present volume of work that goes on there.

Amateurs who find 14 Mc. congested in the busiest or "peak" operating hours have been increasingly going to the 28-Mc. band. This band has somewhat greater width to protect it from congestion. It demonstrates engineering ability to "lick" the problems met in going there. Satisfactory results yield a real return, however. Antenna dimensions make "ten" a fine spot for experimenting with directive radiators and reflectors. Any ham who passed up 28 Mc. in the first section of A.R.R.L.'s DX Competition now knows that he missed a good bet. Portable-mobile

applications in this band have been too thoroughly overlooked. Also it is a sound engineering fact that local coverage using 28 Mc. is even more complete and less subject to spottiness and shadows in the local pattern than is 56 Mc. For local applications in emergency control, circuits on this band might avoid increasing the congestion on higher and lower frequency bands. We'll say no more. It should be unnecessary for us to call attention to 28 Mc. as a fertile field for seasonal and regular use, and exceptional DX when conditions are right.

—F. E. H.

Smithsonian-Roebling Expedition

Truman Smith, WIHQQ, is radio operator on the Smithsonian-Roebling Exploring Expedition, which left Clearwater, Fla., April 1st, planning to return in early July. The ship license, WORG/W10XGY, provides for two-way work with amateurs. WORG operates c.w. on 4160, 8320, 8280 and 16,560 kcs., the call W10XGY ('phone or code) being used on 6425 and 12,862.5 kcs. This expedition will visit and explore many places that have never been visited by a scientist and will collect specimens of all sorts. Diving and dredging equipment is included and submarine specimens and under-sea photographic work as well will be attempted. Mr. Roebling's yacht will visit the Isle of Pines, several ports on the south coast of Cuba and Haiti, Port Au Prince, Cape Haitien. Ports on the south coast of Jamaica, Gatun Lake in the Canal Zone, the Pearl Islands in the Pacific, and the Central American coast from Panama to and including Yucatan will be visited. Amateurs are requested to be on the lookout for WORG/W10XGY. Please report reception or contacts to A.R.R.L., for mention in QST.

—♦♦♦—

W9WIJ (Des Moines, Iowa) handled press into Mason City, Iowa, when that city's communication facilities were disrupted by a snow and ice storm in early April.

—♦♦♦—

March 24th found Aberdeen, Pierre, Huron and surrounding South Dakota towns with disrupted communication facilities due to a severe sleet and snow storm. W9WBU (Omaha, Nebr.) was asked by the telephone company to endeavor to get information from the affected area. W9AVX went to WBU's station and together they established a 1.75-Mc. 'Phone Net with the following stations: W9WWV (Juniata, Nebr.), W9YLC (Bassett, Nebr.), W9LDU (Miller, So. Dak.), W9YDT (Aberdeen, So. Dak.), WNAX (BC station at Yankton, So. Dak.) assisted by broadcasting a request for any amateur in or around Aberdeen to contact Omaha amateurs. W9BJV (Watertown, So. Dak.) on 3.9-Mc. 'phone worked cross-band with the "160-meter" stations. A considerable amount of telephone company traffic was handled with the isolated cities.

—♦♦♦—

TVA Flood Net

The TVA (Tennessee Valley Authority) had never gone in for short-wave radio. It is significant that in a pressing emergency, without time for cumbersome official machinery to operate, they turned to the hams that worked for them: At Knoxville, W4CXY and Bill Ridenhour; at Athens, Gaylord Knight; at Chattanooga, W4CBS, W4CBU and W4CDC; at Muscle Shoals, W4DUD. In Chattanooga the matter was sprung on the boys at 1:30 P.M.; could they get together sufficient radio equipment to go to a strange town and set up a reliable station that could be heard over a 250-mile radius, day and night? The TVA would furnish the car and the destination, the rest of it was up to the hams. By 3:00 P.M. the boys were on their way; destination, Paris, Tenn. At 1:30 A.M. they were in Paris; by 3 P.M. they were set up, antenna erected, and a going concern. They were not off the air for 16 days, which shows how well they did their stuff.

W4DUD put on an even greater demonstration of the two things that make amateurs valuable in an emergency, namely, initiative and the freemasonry that exists among hams. W4DUD left his home QTH, Muscle Shoals, Ala., with a complete transmitter loaded into a truck and supposed to be following him closely while he drove ahead in his car to have a location spotted by the time the truck could make it to the Memphis area. The truck never got to Memphis; it was cold weather and the truck driver took on too much corn as a pneumonia preventative, and wound up in the ditch somewhere. W4DUD put the matter up to the Memphis hams, and in less time than it takes to tell it, he had not one, but two transmitters at his disposal, with receivers to match and a corps of assistants to help.

The station which the Chattanooga hams set up at Paris, Tenn., was the Net Control Station for what at the time had no name, but which we will call the TVA Net. They operated on a frequency of 4282.5 kc. The majority of work was done on 'phone. The stations in the net were: W4AXO, Knoxville, Tenn.; WVKF-1, Athens, Tenn. (U. S. Forest Reserve Stn.); W4BLG, Wilson Dam, Ala.; W4DUD, Memphis, Tenn.; W4LU, Chattanooga, Tenn.; W4DRI, Cleveland, Tenn.; WWKU, Steamboat Hiwassee, anchored in Ohio River in and about Paducah, Ky. (the station on this boat used a U. S. Forestry Service frequency of 3195, and worked mostly on c.w.); W4CBS, Paris, Tenn., Net Control Station. At W4CBS the net frequency was monitored continuously 24 hours a day, and the roll of the net was called every hour. In addition to keeping in touch with members of its own net, the NCS ran regular schedules with stations aboard the U. S. Engineering boats *Yacono* and *Cado*; with a net to the east of which W4AEE was NCS; and with a net of which W4FK was NCS. This "TVA NET" didn't play so prominent a part as some, didn't get the chance to. And because its frequency was off the ham bands, many stations probably never heard it. But it was everlastingly ready, and if the levees above and below Memphis had gone out, its work would have been spectacular. But the levees held, and everybody is glad of that.

—W4PL

Cairo Survey Award Won by Faries

The Oakland Radio Club's *Col. Claire Foster Award* for the individual outstanding work in A.R.R.L.'s Cairo Commercial Occupancy Survey goes to Mr. Walter R. Faries (15 Llanberris Road, Bala Cynwyd, Pa.).

This beautiful memorial plaque was reproduced with the competition announcement, page 24, March 1936 QST. Various individuals and club groups made noteworthy efforts at intervals during the survey-year, and he was in competition with 265 different individual observers. No other observer sent so many reports. His consistent work throughout the whole survey made him get to know most of the observed stations "by their first names" and his work totalled two to three times the volume submitted by his nearest competitors. When the Cairo Committee designated a new 21-Mc. range, some of the observers dropped out, but Mr. Faries did not fail us. Our thanks to the Oakland Radio Club for making the award available to help the program of the A.R.R.L. Cairo Committee in its efforts and program. Congratulations to Mr. Faries on your splendid and continuing work in the survey.

OBSERVERS' HONOR ROLL

Cairo Commercial Occupancy Survey For March 1937

6000-8000 kcs.
Walter Lassak, DE3526/G

21,000-21,900 kcs.
W1BMW

PRIZES FOR BEST ARTICLES

The article by Mr. J. F. Thompson, W4DGS, wins the C.D. article contest prize this month. Each month we print the most interesting and valuable article received marked "for the C.D. contest." Contributions may be on any phase of amateur operating or communication activity (DX, phone, traffic, rag-chewing, clubs, fraternism, etc.) which adds constructively to amateur organization work. Prize winners may select a 1937 bound *Handbook*, QST Binder and League Emblem, six logs, eight pads radiogram blanks, DX Map and three pads, or any other combination of A.R.E.L.L. supplies of equivalent value. Try your luck. Send your contribution to-day!

Re Harmonics!

By J. F. Thompson, W4DGS*

MOST of my operation is 'phone and therefore I am interested in improving the 'phone bands as much as possible and in creating a better feeling toward the 'phone ham by everyone concerned. Recently I got a new Breting 12. In tuning around 9 found hundreds of amateur 'phone signals in places far removed from authorized amateur frequencies, so I undertook to help by Official Observing work. I have sent out over 350 cards, but I have based the following on only 200 cards.

The harmonics fell into several groups. The largest group of cards went to those stations having harmonics between 7800 kc. and 8000 kc. The harmonics in this group were as a rule clean and sharp. When located, the fundamental, however, was usually broad and overmodulated. Some strong harmonics existed with signals of fine quality and sharpness though. From 4 p.m. to 7 p.m. CST the 7.8-8-Mc. band sounded like another amateur 'phone band. QRM from Commercials frequently made it a little hard to get the amateur call correct though most of the time the amateur harmonic held complete sway. This group of harmonics apparently came from 75-meter 'phones.

The second group of harmonics was found from 5400 kc. to 6000 kc. This group, though smaller in number, is probably the most dangerous of all harmonics since they fall in the frequencies allotted to the airways. The signals found here were apparently from 'phones operating in the 160-meter 'phone band. They were as a rule from one to two S points stronger than the fundamental, and many times the fundamental could not be heard while the harmonic was S8 or better! Almost without exception this group of harmonics was found to be broad and obviously from rigs already radiating a harmonic. Overmodulation increased the difficulty because the S meter would swing widely with modulation.

Another popular group of harmonic frequencies are found around 11,800 kc. Most of these also were 160-meter harmonics. These harmonics were all heard in daylight and from stations more than 500 miles away, much farther than the range of even the most powerful 160-meter 'phones. Many of these harmonics were poor in quality but strength!

Then there are parasites not so numerous but, nevertheless, in the wrong places at the wrong time. One card was sent to a high-powered station with an equally high-powered operator who was heard at 790 kc. in the standard broadcast band. He was over 250 miles away. He answered the card in no uncertain terms, stating that he was not operating at that time. I wrote to the operator at the other end of the QSO and he said that he worked the above station five or six times each week on sked and that he knew the operator personally and that the QSO took place at the time reported. He also said that he had warned this operator numerous times about the broadness of the signal, but that the answer was that probably the high-powered signal was blocking the receiver. Of course the high-powered op couldn't have been on the air at that time. What do you think? Another card was sent to an operator whose station was heard S9 on 8350 kc. He called me by long-distance telephone and arranged a sked. He corrected it at once in a fine spirit of cooperation.

* SCM Alabama, 2248 Arlington Ave., So., Birmingham, Ala.

Another card went to a station whose operator was really pitching one. Everybody was there—including the harmonics. He had three of them. One at 3670, one at 5555 and another at 11,110 kc. So the drunken remarks had pretty good coverage. Not so good for the goodwill of Amateur Radio.

Another card went to a station heard operating at 7560 kc. He was a W8 and said he was operating in the 160-meter 'phone band. He was working another W8. During the QSO he said several times that *he had had a hard time getting his second harmonic strong enough so that he could raise the 75-meter 'phone boys in the daytime!* He increased not only his second harmonic but also the others.

Harmonics as a rule were noticed from stations whose operators were blowing about their fine equipment or talking not so much for the operator at the other end of the QSO as for their "great unseen audience." Many of them were from CQ Hounds. You know the type. The ham that thinks he sounds like Mr. NBC and proceeds to tell the world. Many of the harmonics when modulated caused the S meter to rise. The average harmonic, however, was found to be modulated about 80 per cent. Some were broad and burpy on either side. No reports were sent unless the signal strength of the harmonic was S8 or better. They were found interfering with airplanes seeking information from ground stations, ground stations sometimes commenting on the difficulty to the plane in flight. Other harmonics interfered with short-wave relay broadcast stations both foreign and domestic, commercial telephone service and press stations.

It looks like we hams are going to have to learn to properly use the frequencies that we already have before we can reasonably expect to get more frequencies. We cannot expect more if we create a nuisance in using frequencies that we already have.

Attention is called to two articles concerning harmonics and their cure appearing recently in *QST*. The first was "About This Harmonic Radiation Problem," by W1EAO (February *QST*, page 22), the second was "Electrostatic Shielding in Transmitter Output Circuits" (March *QST*, page 19W). All amateurs are urged to read and study both of these articles. The "Faraday shields" explained in March *QST* are now being widely acclaimed by hundreds of amateurs as the answer to their harmonic problems. Check up on your harmonics and avoid any possible QRM to other services. 160-meter 'phones should look for (and suppress) harmonics falling between 5400 and 6000 kc. 75-meter 'phone harmonics fall as follows: 3500-3550 (VE)—between 10,500-10,650; 3850 (VE)—on 11,550; 3900-4000—between 11,700-12,000 kc. Airways, Press and Telephone frequencies within these ranges can experience serious interference from amateur harmonics. Let's prevent it!

G.C.A.R.A. Emergency Transmitter Contest

To promote preparation for emergency communication work the Greater Cincinnati Amateur Radio Association is conducting an Emergency Transmitter Contest for amateurs of the greater Cincinnati area. The contest started March 19th and will end May 21st. Prizes will be awarded for the best sets submitted. Entries will be judged on neatness, compactness, ingenuity, portability and ease of operation from auxiliary power sources in case of failure of the regular supplies. The power input of the transmitter must not exceed 25 watts. It may be designed for either 'phone or c.w. No antenna system is necessary, but the antenna tuning device must accompany the submitted transmitter. An entry blank for this contest may be secured from the club secretary, W8NUP, Ed Dowling, 4989 Western Hills Ave., Cincinnati. This is an excellent type of activity for clubs and it is hoped many more will take steps to encourage emergency preparedness.

Build that portable or emergency power supply now. Be prepared for emergencies. Don't miss the pleasures of communication success in the open during the coming months. Get ready for the annual A.R.E.L.L. Field Day—coming June 19th-20th this year.

Coming Hamfests

Abilene, Texas: The amateurs of West Texas are holding a hamfest in Abilene on May 8th and 9th. All amateurs are invited. Registrations fifty cents. For further details see W5SP, William O. Ansley, P. O. Box 602, Abilene.

Milwaukee, Wis.: The 14th Annual QSO Party of the Milwaukee Radio Amateurs' Club, Inc., will be held Saturday, May 15th, 6:30 p.m., CST, at the Milwaukee Athletic Club, East Mason and North Broadway. Central Division Director Mathews, W9ZN, will be present with latest information on the A.R.R.L. Board Meeting. Tickets: \$2.25. Advance tickets: \$2.00, obtainable through W9GVL, Chas. O. Meyer, 3720A North 6th Street, Milwaukee.

Williamsport, Pa.: The Lycoming Radio Association, Williamsport, invites all the radio amateurs to attend its hamfest scheduled for May 15th at South Williamsport Community Hall. Come early—stay late!

Scranton, Pa.: On Sunday, May 23rd, the Electric City Radio Club will stage its first annual hamfest at Hotel Casey, Scranton. Advance registrations \$1.75; at the door tickets will be \$2.00.

Moose Jaw, Sask.: The Moose Jaw Amateur Radio Club is sponsor of the annual Saskatchewan Convention (Hamfest) to be held in Moose Jaw, May 24th. Secretary Pickford promises a big time.

Cleveland, Ohio: The radio amateurs of Cleveland and their friends, broadcast station engineers, police radio operators, radio service men and others have formed a "Shut-In Day Committee" for the purpose of showing their unfortunate shut-in friends a good time in the form of an outing. This outing will be held at Puritas Springs Park, Cleveland, on August 1st, Sunday, full day. Everyone is invited: amateurs, their friends, shut-ins and their friends, SWL's and the general public. W8LXV, a member of the committee, advises, "For further information write to John E. 'Pop' Garvey, Chairman, 2141 W. 67th St., Cleveland, Ohio."

VE1DQ, Halifax, Nova Scotia, maintains a regular schedule with VE5TV, Nottingham Island, Baffin Land, on 14-Mc. 'phone. This proves a real service since the family of one of the operators at 5TV lives only one quarter mile from 1DQ. Likewise, the lads at VE5RA on isolated Resolution Island have found amateur radio a great blessing in talking to their relatives via VE1DQ.

1.75-Mc. DX

G2DQ worked W1BB on 1.75 Mc. on March 6th and took a contest number from him. W1RB worked both G2DQ and G2PL on March 13th, exchanging numbers with G2PL. It is hoped that some trans-Atlantic tests on "160" can be arranged for late this fall. Tests on previous years have proven most interesting, with quite a number of hams getting across the pond. Much credit is due G6AA (ex-G2II) for his work in the '34, '35 and '36 tests and his very complete report on 1936 work, which is being circulated among the stations concerned.

"On January 10th at 1 p.m. P.S.T., I called CQ on 1972 kc. In accordance with prearrangement, W6MBN picked up my signals and put them out on 28 Mc. Looking over the 28-Mc. band I heard W9GND coming back to me on 'phone. Contact was held without a break until signals faded out. W6MBN had his receiver tuned to my frequency through all this and I fed W9GND's signal to MBN via my transmitter. The most interesting part of the whole experiment was when W9GND called CQ. I picked it up, fed it to W6MBN, who put it on the air on 28 Mc. An answer was picked up by me from W9TTB; his 'phone signals were fed to W6MBN, who retransmitted them to W9GND and a satisfactory contact was made."

—W6AK

Fifty-two days of portable operation have just been completed by W5GI, operating from a point six miles east of Douglas, Ariz. Close to 100 QSO's were made and over 600 words of messages handled. A schedule with W5EJB was made at noon. The set up proved its complete reliability. Three six-volt bats had to be changed but once in the 52-day period. A 12- to 350-volt dynamotor was used with 47-10 layout. Antenna (for 7 Mc.) was a half-wave Hertz center-fed and just 18 feet high. When a 45 m.p.h. wind wrecked the tent and whole works, this antenna on bushes but eight feet high brought a report of S4 at noon. Input to final? 32 watts. Starting January 25th Mr. Wainman is operating W5GI BT 6 from a point near Miscal, Ariz.

W2JBF, Barnegat, N. J., has held the following calls during his amateur career: W3BRH, W2ABP, W4AGD, W2ERV, W3DPZ.

W9NUF, O.R.S., Chicago, says that W9NWE (see page 71, May QST) doesn't know what QRM is. He, W9NUF, lives within two miles of the following 63 hams: W9ABU AI DRN DTN EGA ERL ETP FPP FZ GRV GRY GST HCI IPS IUY JO KF KHA KJH KQW LJX LKF LWW LXR LXX MOB MR RYP MZT NHT OQM ORX PEB RHE RJW RLP RP RUK SAN SFW SG SGZ SPG TMH TPB TRD TRF TTE UAU UHA USR UYN VCB VCX VDA VES VEZ VJB VS WC WFM WFS WTO.

W6MPK thinks he must have worked three brothers: Ixy, Ike and Abe . . . otherwise W2IZY, W1IKE and VK2ABE.

Any Night! Was It You?

By "Herbq"

Time: 9:35 P EST, W-(who?) S7 on the east coast. CQ's six minutes, off 15 seconds, plays with bug eight minutes, sends test five, repeats whole mess six times, and on the ONLY "clear" channel on the 80-meter band. Nice going!

On 600 kc. (long waves to you kids). (?) saying GE to everyone at 10 A.M. Hang over!

On 3810. (.)'s bug being mistaken for his left foot! W(?) with a yard long yoooopft to his keyed xtal sigs.

On A.A.R.S. Net. (.)'s and cohorts trying to out Mac McElroy and sounding like a J PX tape run backwards. Tek tek childred, such sendin' in this day an' age.

Off Freq. (Who) CQing for two hours on 3485 kc.

In print. Frank H. Shaw in "Full Five Fathoms." ". . . it wasn't SOS then—it was PDQ; the international signal that meant distress heralding disaster." Oh, yeah?

To be shot at sunrise (or preferably earlier): (1) These mugs who claim xtal control is more expensive than these lousy self-excited rigs they mess up the band with. First in line (who?) (2) The ditto who knows only one report, i.e. 599X. (3) The expert who can't possibly have a bum note, the fault is always the other fellows receiver. (4) The foney fone that has "all the dope on that" with a bar room tenor's voice, parroting all bits of gab, and with a "handle." Wonder why (who?) is practicing "code" on 80 after claiming to have graduated (!?) into an A-1 fone hound?

What about it . . . was it y o u? Put your own call in each of the spaces above and see if it fits. Should we revive "prehistoric signal" listings, or create a new department like this? If all ham radio operating was patterned after your particular standard, would it rate approbation and public respect? . . . or ridicule? Would you lower or raise the average of amateur operating? Do you make any of the above bulls in current operating? Send in examples that you note if you like. But first, why not spend a few minutes "looking at ourselves as others see us" and looking at those *Handbook* chapters on operating practice and policy. Let's clean up our operating so it becomes impossible to find such absurdities in the game!

How's DX?

How:

Ho-ho! What a DX Contest! More countries, more WAC's, more TBTOC's, more 4BTOC's, and even 5BTOC's, than ever before. Antennas played a still greater part than in previous contests, every conceivable type of directive affair having its own faithful followers who swear by/at it. We've come a long way since the first international contests—imagine the mess we would have been in without crystal control and s.s. supers!

Let's try to analyze the thing a little. In spite of all of the technical advancements, the determining factor is still *Operating*. Yes, "operating" with a capital "O." You all know how efficient K5AY's operating was. At least you should know, he worked enough of you! No wasted effort, no lengthy calls or sign-offs, and always on the band that would hand back the greatest returns for the investment. Take any of the high scores: XE2N, W6CXW, W1SZ, W2AIW. Their signals were good, it's true, but there were others that compared quite favorably. So the laurels still go to the fellow with the ability, an intangible little thing that even the gold of old man Croesus couldn't buy. Maybe that's one of the things we like about amateur radio: it's a game where the race goes to the swift, not to the fellow with all of the world's goods at his fingertips.

Still, it would be nice to own enough land to put up several rhombics, and then have a separate kilowatt on each band. . . .

W3QP suggests a simple little maneuver that might help all concerned. If fellows in this country must test their transmitters on the air, they could at least send "VUV" instead of the somewhat prevalent "test." It would make no difference, except that English amateurs send "test" instead of "CQ." The real solution, of course, is for everyone to test into a dummy load, instead of radiating their test signals.

Where:

Those of you who missed EL2A need not lose out on a contact with Liberia. The representative of that country is now EL2M, Henry Grimes, Box 72, Montrovia. His signal is reported anything from T2 to T3, but usually around 14-125 kc. However, a self-excited oscillator is used so you may find him down around the high-frequency end of the band. Look for him around 8 P.M., E.S.T. But don't think you worked him on 'phone. That one's a phoney. At least, the real EL2M didn't have a 'phone rig up till April. Thanks W2FBA, W1ICA, W1EEO, W8MAH, W9FS, W2KAK Speaking of phonies, there were two ZS2A's in the contest again this year. But we'll venture to say that the real ZS2A's operating made the fake one look like a sissy, so there wasn't much chance of confusing the two Then there was FK7KW, about whom we know nothing except that the prefix is not assigned Also, the real VS1AA (ex-VS2AF) writes to say that anyone who thinks he worked VS1AA between November 9, 1936, and February 7, 1937, was being fooled. You'll know when you work the real one—he never fails to QSL Another bootlegger picked out a good call when he used VQ3MSN, but the real owner writes to notify us that the station is inactive at present But it doesn't pay to think everyone a phoney. No, sir! This column was called to task for hazarding that VS7MB fell into the same category as VS7AL, another phoney. It ain't true! Captain M. Bisdee, Royal Army Medical Corps, Military Hospital, Colombo, Ceylon, writes a much nicer letter than we deserve and says that he operates VS7MB, and it is very much authentic. His 30 watts has only given him a few W contacts so far, but he hopes the W's he did work were not misled by the incorrect utterance in this column. We apologize, and thank Captain Bisdee. The active stations over

there are VS7AR, VS7RF, VS7JW, VS7EB, VS7MB, VS7JG, and sometimes VS7CE and VS7TC Spanish activity continues. W1EZ worked EAB3 (7240 kc. T6c) at 2:30 a.m., W8KBJ worked an EA8 on 'phone, and W1FTR worked EA9AI on 7 Mc. one night at 9 p.m. EAB3 said he was in democratic territory in Spain, whatever that is W6ITH reports a nice 'phone QSO with the yacht *Latitude*, operating out of Manila Harbor. Depending on the location, either KZYL or KAIYL is used. Frequencies in use are 14,036, 14,196, and 14,232 kc. Send your QSL to the yacht via P. O. Box 3232, Manila Two active French Guiana stations are FY8A and FY8C. We'd give you their frequencies but they don't stay put, jumping all around the 14-Mc. band. You can send cards via FY8C, Narolles, Box 43, Cayenne, French Guiana G5RV, who kept a schedule with him for some time, straightens us out on the HS1PJ-HS1RJ affair. They are both under the control of Mr. Sangiem Powtongsook, and HS1PJ works on 14,200 kc., and HS1RJ on 14,360 kc. But you may know all this by now—HS1RJ came through well during the Contest The QRA of VP2LD (7075 kc., T79x) is Louis Devaux, St. Lucia, B. W. I.

When:

Remember when the 28-Mc. reports used to trickle in? You know, "W2... heard the harmonic of W9..." and "W4... reports a brief contact with W6..." Well, that hard-working ten-meter gang is down on 56 Mc., plugging away, and darned if we don't think they're going to do something. You know that G5BY was heard by a W2, of course. ZS1H is on every day at 1600 GMT, and VK2GU is on Mondays and Wednesdays at 7:30 p.m., EST. But the news of the week is reception by W6ITH of JNJ's harmonic, the harmonics from several ZL's and a K6, and several unidentified 'phone carriers! The time: 5:30 p.m., PST. So how's for some of you hard-boiled DX'ers getting down on five with some c.c. power and a good receiver, and giving the thing a chance?

Eighty was swell during the contest for European and African contacts, at least for the East Coast gang. It's a none-too-easy band down in the 4th District though, so the contacts of W4APU with ZS1AA (3502 kc., T9x) and K6JPD are rather outstanding If you didn't try the band during the tests you missed nice ones like OE3AH, FA8H, SM7UC, EI4J, G16TK, VO1W, FM8AD, K7PQ, HB9T, and of course the many G's, F's, D's, and PAO's.

News on ten is the QSO of W6BAM with MX2B, for the first 28-Mc. W-MX work. We hope MX2B will get on often and give more a chance to get Manchukuo on 28 Mc. . . . Ten was anybody's band during the contest—the West Coast taking away plenty of Europeans from the eastern fellows, and VK's and ZL's up to S7 and S8 on the East Coast. No one neglected 28 Mc. this time, and it gave them good ones like SV1KE, YR5AA, HK1JB, K7PQ, YM4AA, FA8IH, I1KN, U2NE, YU7DX, J3FZ, J4CT, J3FJ, J8CF, OA4J, VK7RV, VP2AT, and ZEIJR, as well as the less scarce European and South American countries.

The forty-meter band turned in an awfully good account of itself, what with Asia coming through on the East Coast, and Europe on the other side of the continent. The tendency was to stay on 20, with the band staying open practically 24 hours, but those that tried 7 Mc. grabbed off a lot of multipliers. F8EO, G6NF, GM5YG, G16TK, VS1AB, EI8E, and many others came through to the W6's. HR1UZ, YV5AO, XUSHW, and VP7NR were choice bits for the easterners.

The 14-Mc. band yielded the most multipliers in practically every case, as one would expect. Did you work all of the following: HH5PA; CPIAA; U9ML; FA8DA; KA1US; FT4AK; YJ1A; CN8MI; ZK1RG; U9AW; U6SE; XU8JR; J8CA; KA1MD; YV5AN; PK1RL; VQ8AB; HS1RJ; CR7MB, FB8AD or VP8B? Well, neither did a lot of us, but all of them were on at one time or another

W8MAH sends in a list, helpful to those who still need Asia for WAC. J2LU (14,260 kc., T9x), J2JJ (14,275 kc., T9x), J2MH (914,310 kc., T9x); and U9's can be found off the deep end of 14,400 kc. From 8-9:30 A.M. for the Japanese stations, midnight for the Asiatic Russians And if it's VK6's you need, W8MAH recommends VK6SA (14,050 or 14,280 kc.), or VK6LJ (14,130 kc.), around 9 A.M.

Who:

ZUIT writes to say that he is still convalescing, and cannot stay up as late as he used to. He was sick during the latter part of the S.A.R.R.L. contest, and was running a fever. At that, his best work was exchanging numbers with *32 stations in one hour!* We regret to report the death of SUIAP, killed in the large seaplane he was piloting between Southampton, England, and Alexandria, Egypt. Ice formed on the wings and the plane crashed near Lyon, France GM2BD (14,130 kc.) is looking for W5, W6, and W7 stations each day from 03 to 04 GMT W8CNC reports that VK6LJ (14,130 kc.) needs Mississippi, Vermont, North and South Dakota, Montana, Wyoming, Colorado, Utah, Nevada and New Mexico for

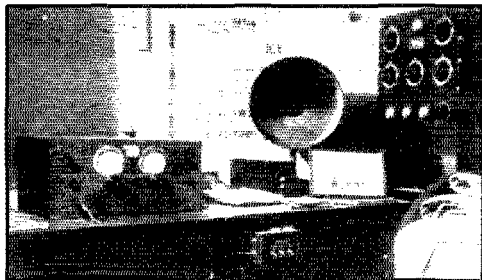

WE WERE CURIOUS ABOUT W2HHF DOWN IN NEW YORK CITY BECAUSE HE WORKS AND HEARS SO MUCH GOOD DX, AND WE THOUGHT SUCH A STUNT WAS IMPOSSIBLE IN THE CROWDED METROPOLITAN AREA.

So here it is: W2HHF, Liscum Diwn, New York City. The receiver is an old model RME9D, with a DB20 pre-selector. The transmitter is a 47 oscillator, 6L6's in parallel doubling, and driving a 203A with 275 watts input. The antenna is conventional, and yet he hears and works stuff like PK6AJ, X8HW, KA1MD, J8CD, FT4AB, U6ST, EA9AH, and KA1US.

So there it is. We still don't know the answer. Unless, of course, it's the ability of the operator. . . .

WAS. He comes through best between 3:30 and 5:30 A.M., EST To add insult to injury, old "8-watt" W5CPT, that low-powered fellow down in Texas, didn't stop in the contest. He made WAC twice during the tests, once on 28 Mc. His WAC's total 6 now, his countries 37. On a "countries per kilowatt" basis, he'd have most of us looking rather ridiculous. But listen, W5CPT, aren't there times when you wish you had just a little more power? Or do you do it just to make us feel futile?

WAC:

U6SE tells those he QSO's that he is in Asia but the I.A.R.U., the international amateur union that issues the certificates, has set up continental divisions that put U6SE in Europe. The A.K.R.L. map shows these divisions, if you're in doubt Latest 'phone WAC's are to Z86AJ, W2HFS, W3ZX, W1SZ, W5AKZ, W1CQY, W1FVO, W3MD, W9NGZ, W9YGC, SU1RO, W3EMM, W8IMS, and I1TKM And all the troubles don't happen to W's. Quoting from *Amateur Radio*, the Australian amateur society magazine: "In 1920 the Pilgrim Fathers landed on Plymouth Rock. During the last VK-ZL test many hams wished, when W stations answered a 'CQ Europe,' that the Plymouth Rock had landed on the Pilgrim Fathers!"

---W1JPE

Irish DX Contest

The Radio Society of Northern Ireland is holding a contest during May week-ends for all amateurs in Ireland (EI and GI) and the rest of the world. The week-ends May 7th-9th, 14th-16th, 21st-23rd, 28th-30th will be used. On each period activity will start at 2400 GT on the Friday and end at 2400 GT on the Sunday. Only one operator will be allowed at each station; if more than one operator, each operator's score counts separately. All stations must exchange RST reports to receive points. Stations may be worked only once during the contest. All amateur frequency bands may be used. Scoring: For contacts between Europe and EI/GI: one point; Africa (above equator): two points; Africa (below equator): three points; North America: three points; South America: four points; Oceania: four points. Irish stations will multiply by the number of countries worked. U.S.A. districts W1-W9 and Canadian VE1-VE5 count as separate countries. Awards: The Leonard Trophy will be awarded for one year to the leading Irish station. A gold medal will go to the leading station outside Ireland, a silver medal to the second high. All entries must reach the Hon. Secretary, R.S.N.I., F. A. Robb, GI6TK, 46, Victoria Avenue, Sydenham, Belfast, N. Ireland, not later than July 31st.

Hungarian DX Contest

The first Hungarian DX Contest will be held on the five week-ends of May under the auspices of the National Union of the Hungarian Shortwave Amateurs. Each period starts Saturday at 1400 GT and ends Sunday at 2400 GT. Six figure serial numbers will be exchanged, one point for receiving, one point for sending, two points if numbers are handled successfully both ways. The serial numbers will be made up as follows: The first three numbers will be the RST report of the station worked, the last three will represent the number of the QSO; thus, in the fifth QSO the number might be 579005, in the one hundredth QSO, 579100, etc. On any given week-end the same station may be worked more than once, if on a different frequency band. The same station may be worked on each week-end. Total points are to be multiplied by the number of different HA stations worked. QSO's with the same station on a different band counting an extra multiplier. At least one participant in every country, but not more than three, will receive a certificate for his contest work. Each district in the U.S.A., Canada, Australia, New Zealand and the Union of South Africa will be considered as separate countries for purposes of the awards. A complete log, containing data on the transmitter and receiver, list of QSO's (with time, call, serial numbers, frequency band, points, etc.) should arrive at the Union not later than August 1st; address: Matyas-ter 8., Budapest, Hungary.

Polish DX Contest

P.Z.K., the Polish Section, I.A.R.U., is holding a DX contest for Polish amateurs and those throughout the rest of the world. The competition starts at 0001 GT, May 16th, and ends at 2400 GT, May 30th. Polish stations will give a serial number, which must be received correctly and reported via QSL card. If the number is not received, or incorrectly received, or the QSL card is not sent, the QSO will not count for either competitor. Points will be scored as follows: VE1, VE2, VE3, W1, W2, W3, W4 and W8 claim four points for each complete SP QSO; VE4 and W9 claim five points per QSO; W5 six points; VE5, W6 and W7 eight points each. Points for 28-Mc. QSO's will be quadrupled. Each station may be worked once only. Special diplomas and a year's subscription to the P.Z.K. magazine will be awarded to the three highest competitors other than those in Poland. A diploma also will be awarded to the highest scorer in each country. QSL cards should be sent to the Polish QSL Bureau, P.Z.K., Lwow, Bielowskiego 6, Poland. Cards received after October 31st will not be considered.

Results SARRL Contest

THE Rand Daily Mail Trophy presented for the Golden Jubilee Long Distance International Radio Contest, which was organized by the South African Radio Relay League, has been won by an American amateur, Mr. Clark C. Rodimon, WISZ of West Hartford, Conn., U.S.A. with a score of 2368 points. The competition, which took place during the four weekends of January, attracted entrants from nearly all parts of the world and more than 5000 cards were received from competitors. The trophy is designed in the form of a single silver aerial mast standing on a map of Africa etched on a portion of a silver globe.

The runner-up was WITW. The certificate winners are as follows: WISZ, W2CJAI, W3CHH, W4AAU, W5EUG, W60DD, W7EHT, W8JMP, W9AEH, VE1EA, VE2DR, VK2DG, VK3MR, VK5RX, VK7CL, ZL1HY, ZL3JX, G5RI, OZ3FL, K6CGK, F8TQ, PY1AZ, LU6AX, OE3FL, J2JJ, HAF8D, YM4AA, VO4Y, D3CSC, KA1SL, ON4NC, HB9J, PA0AZ and I1KN.

The African winner was ZT2Q with ZU6P second high. The certificate winners in Africa are as follows: ZSIAN, ZTIAG, ZU1T, ZS2X, ZT2Q, ZS4U, ZS5AH, ZT5Z, ZU5G, ZS6AJ, ZT6Y, ZU6P, VQ8AF, CR7GF and ZE1JJ.

Received via radio from ZT6AU, April 12th.

Briefs

The Swedish East Asiatic Film Expedition is enroute to the Far East. The expedition's radio station, SMVQ, uses 6 Mc. for work with G stations and 14 Mc. for contacts with radio amateurs. Operation is at 0600 and 2100 GT (1:00 a.m. and 4:00 p.m. EST) daily. Please report all contacts or reception to A.R.R.L.

The Battleship *New York* has been ordered to England as the U. S. Navy's representative at the coronation of King George VI. W3DTO, who is making the cruise, has a special souvenir QSL made up in honor of the occasion and will send one to any amateur he hears on schedule during the cruise. Anyone interested send a QSL card to W3DTO's home address, making a schedule for any time between 11:00 A.M. and 3:00 A.M., EST, any day from April 20th to May 20th. These will be, of course, "listening schedules" only, since W3DTO cannot transmit.

And during the flood there was the ham who said, "CQ, CQ Portsmouth, Ohio—41 people needing food and children."

Congratulations to A.R.R.L.'s Southeastern Division Director, Ben Adams, W4APU, on the addition to his family of Miss Carolyn on March 10th!

W5EHR, Oklahoma City, Okla., is transmitting television images on approximately 1975-kc. The scanning disc used is a 3-spiral, 45-hole affair, and turns at 900 r.p.m. A transmission is made each Sunday at 8:00 A.M.

The height of something-or-other in diplomacy is reported by W9CA. A W4 answered his CQ and then wanted to sign off right away. W9CA said, "What's your hurry to sign off?" The W4 replied, "No hurry here, OM, just thought that with a signal as good as yours you would want to be working DX." MIM

"There certainly isn't any justice. For the past two weeks I have been hearing stations calling EL2M, but up until last night had just about decided that I couldn't find him. Last night, however, I heard a well-known W8 calling EL2M. A few minutes later I contacted this W8 and asked him what the frequency of the EL was. Whereupon he comes back with, 'Darned if I know, OM, I was calling him just because everybody else was.' It's not right, Hi."

—W5EOW

In QSO with W4DQH, Nashville, Tenn., on 14-Mc. 'phone, W5FIY, Okemah, Okla., gave him a message for a friend. W4DQH said to look for him next evening—that he would probably have an answer. But they did not click as arranged. The following morning on his scheduled contact with VK2OQ, W5FIY was surprised to receive the reply from Nashville, relayed from W4DQH to VK2OQ. A 25,000-mile journey to cover a 900-mile distance wasn't bad traveling for that message, considering that no time was lost! Hi.

Radio operator examinations for the balance of the year 1937 scheduled to be held in Winston-Salem, N. C., will be held in the Civil Service Room, Post Office Building, instead of the Reynolds High School Building as previously announced.

W3BEI, Audubon, N. J., was unintentionally omitted from the list of stations shown in April QST as assisting in the flood emergency work. The only 3.9-Mc. 'phone active in his locality, he took all traffic for Jersey points, received by 'phone, then distributed on the 3700-ke. Jersey Net, also via "75" 'phone to shore points. Quite a percentage of his work was with W1SZ, W3FJU and W8BRC.

O.B.S.

The following is a supplement to the list of A.R.R.L. Official Broadcasting Stations in October QST (page 122): W5AOZ, W5BLQ, W5DOK, W9IYL, W9RUJ, W9RZA, VE1EV.

BRASS POUNDERS' LEAGUE

(February 16th-March 15th)

Call	Orig.	Del.	Rel.	Extra Del. Credit	Total
W3FTK	56	48	1288	8	1400
W3EOP	59	11	840	2	912
W6ITH	185	147	395	101	828
W8MQX	49	418	312	—	779
W7DUE	197	16	522	16	751
W8KUN	27	52	634	24	737
W6JTV	57	207	291	154	709
W1TP	31	24	600	6	661
W6MTP	8	8	627	2	645
W1ST	368	68	180	—	616
W3SN	98	106	408	—	612
W6KFC	20	52	519	20	611
W1OR	123	141	322	23	609
W8LSP	15	3	45	532	595
W8JTT	565	1	2	—	568
W8PYZ	33	65	422	32	552
W4PL	34	36	453	25	548
W9RMN	7	29	489	20	545
W1WC	56	30	448	7	541
W2ECP	43	18	461	9	531
W1HEX	81	74	312	52	519
W3BWT	43	71	345	60	519
W8QAN	60	62	336	61	519
W8AQE	102	70	296	47	515
W1FNV	93	82	316	22	513
W9ESA	35	89	324	65	513
W5CZ	69	81	348	10	508
W6CII	60	120	210	114	504

MORE-THAN-ONE-OPERATOR STATIONS

Call	Orig.	Del.	Rel.	Extra Del. Credit	Total
KAIHR	924	547	736	535	2742
W9BNT	69	289	156	—	514
W3ECA	39	57	365	50	511

These stations "make" the B.P.L. with total of 500 or over. One hundred deliveries + Ex. Del. Credits also rate B.P.L. standing. The following one-operator stations make the B.P.L. on deliveries. Deliveries count!

W6GVU, 432	W2DBQ, 153	W2GGE, 118
W3QJP, 302	W1KXP, 146	W1FRO, 117
W3EWT, 247	W8NDE, 138	W1MIV, 110
W6IOX, 232	W7APS, 132	W2ISQ, 107
W1AW, 213	W8CEU, 128	W6JVG, 106
W6GLD, 194	W7HD, 127	W9KJY, 106
W1UE, 179	W9PTU, 127	W9GMT, 103
W6IMI, 171	W1KH, 124	More-than-one-opr. W5FSK, 120

A. A. R. S.

Call	Orig.	Del.	Rel.	Extra Del. Credit	Total
WLXB (K6GDC)	200	225	954	—	1382
WLYH (W6BMC)	12	17	308	12	639

WLYB (W6IMD) and WLMI (W6GXM) made the B.P.L. on 111 and 110 message deliveries respectively.

MORE-THAN-ONE-OPERATOR STATIONS

Call	Orig.	Del.	Rel.	Extra Del. Credit	Total
WLM (W3CKL)	445	257	1496	—	2198

WLU (W9BNT) made the B.P.L. on 184 message deliveries.

A total of 500 or more, or 100 deliveries Ex. D. Cr. will put you in line for a place in the B.P.L.

A.R.R.L. Headquarters Operators

Hal Bubb, "Hal," Chief Opr. W1AW

The following calls and personal signs belong to members of the A.R.R.L. Headquarters gang:

W1AL, J. J. Lamb, "jim"
W1AW, A.R.R.L. Headquarters Operators Club
W1BAW, R. B. Beaudin, "rb"
W1BDI, F. E. Handy, "fh"
W1CBD, C. B. DeSoto, "dc"
W1DF, George Grammer, "gg"
W1EH, K. B. Warner, "ken"
W1ES, A. A. Hebert, "ah"
W1GS, F. C. Beekley, "beek"
W1JEQ, Vernon Chambers, "vc"
W1JFN, A. L. Budlong, "bud"
W1JPE, Byron Goodman, "by"
W1JTD, Hal Bubb, "hal"
W1SZ, C. C. Rodimon, "rod"
W1TS, Don Mix, "don"
W1UE, E. L. Battery, "ev"

STATION ACTIVITIES

CANADA

MARITIME DIVISION

MARITIME—SCM, A. M. Crowell, VE1DQ—EA reports some FB work during the DX contest; he worked G2PL on five bands both before and during the contest; he also got an S8 from FARIH on 3.5 Mc. EX had a week's holidays during the contest—stuck a nail in his foot!! AX has returned to 14 Mc. with a new rig. AW has been swatting 'phone DX via 14 Mc. BC and XYL are changing QTH, the latter will soon operate under her own call, OW. Congratulations, Mrs. B. BV goes home from Halifax week-ends to work the old DX. FQ is getting new rig ready on 14 Mc. after getting fixed up for unlimited 'phone. KW, new traffic man, has been scheduling EY. FO has been trying a Class "B" linear amplifier. Fredericton news via JO: HM has new rig about finished—2A5, pair 2A5's and pair tens. VE3DX, attending college here, has his comm. ticket. AJ is trying to raise a power transformer. AM, local R.I., is working DX on 28 Mc. FX is on 7 Mc. with '47-'46-pair '46's. JO has rebuilt using 59 e.c. osc. and '45 amp.-15 watts. St. John: The Loyalist City Amateur Radio Club, newly organized here, is starting off right by appointing EEE as press agent for the St. John gang to handle notes for the S.C.M. FB and thanks fellows! HL has been elected first president of the club. AK, AY, DH and EJ are preparing to hit the air. BA, GO and FK keep 14 Mc. hot. FL gets out well on 1.75-Mc. low-power 'phone. IG works with IF with a nice transmitter on 28 Mc. IZ doesn't help the power company much with his 15 watts. CM, FC and FU work 3.5-Mc. c.w. EI is still going strong after the European contacts. GP is building a new modulator. JW is a new ham. JN's junior 3-watt 1.75-Mc. 'phone is very consistent over 100 miles. BF, IE, CE, FL and JN have a nice 1.75-Mc. 'Phone Net. EE is looking for a W5 and W7 for all districts in Canada and U. S. on 3.9-Mc. 'phone. EN and HZ were heard testing on 56 Mc. EV is in line for O.B.S. being already O.P.S. Prince Edward Island: EY is now net control for the Maritime Net. DQ has been keeping schedules since Feb. 20th with VE5TV, Nottingham Island, handling notes and personal messages to and from the boys "in isolation" and their families in Halifax. Both VE5TV and VE5RA (Resolution Island) have had several enjoyable chats with their XYL's and friends via 14-Mc. 'phone and DQ, Newfoundland News (via VO1W): VO1D has a new Hallicrafters Challenger. VO1H is waiting for generator for portable. VO1I and IJ are as active as ever. VO1K has 6L6 on 14 Mc. VO1M is active on 3.5-Mc. 'phone and c.w. VO1O has his 6L6's working now. VO1P has second rig now with pair of 808's in final. VO1S is going to build a receiver for herself. VO1W is active on 7 and 3.5 Mc.; he sends code practice every Tuesday and Thursday at 7

p.m. on 3525 kc. VO1X is building 6L6 crystal and pair tens, 120 watts. VO1C is new local. VO1Y, new local, has tern. rig, single '10 TNT. VO1Z, new local, has single '10 osc.; he is a brother of VO1G. VO2Z is active on 'phone, as also is VO4Y. VO3P is going strong on 14, 7 and 3.5 Mc. VO3Y is new in the ranks and puts out a T9X signal on 3.5 and 7 Mc. with his '10 TNT. VO3F at Belle Isle has daily schedules with VE2MS at Harrington Harbour. VO3R, the first VO3 and one of the oldest VO's, is entering on its tenth year handling Grenfell Mission traffic thru W1KH daily. VO3X has scrapped his TNT and built a c.c. rig, 89 crystal and 807 final.

Traffic: VE1HH 74 EY 30 EY 10. VO1W 11.

ONTARIO DIVISION

ONTARIO—SCM, Fred H. B. Saxon, VE3SG—R.M.'s: VE3ABW, DU, GT, MB, QK, TM, WK, WX. P.A.M.: NX, DC (Doc. Jaffray, Dunlask) reports traffic for first time in fifteen years. On March 1st the Hamilton Club entertained 90 hams, gathered together from Beamsville, Dundas, Brantford, Waterloo, Strathroy, Kitchener, London, Collingwood, Mimico, Toronto and Weston. The speaker was Mr. Kelterbourne of Canadian Westinghouse. UF has gone north to Timmins. TM is fast becoming a dyed-in-the-wool 'phone man. DU had three weeks holidays and QSO'ed 56 Europeans on 28 Mc. WK has Mac-Key. My thanks to those who submitted logs in the Section QSO contest. I have a record of 55 taking part. AAG gets the 3.5-Mc. crystal for the best log, having 16 T9X and 5 T9 reports for a total of 21 contacts. GT addressed the International Alumnae Association for an hour and a quarter on Ham Radio. SS is new O.R.S. in Welland. DH in St. Catharines is after O.R.S. ticket. North Toronto Club had demonstration of just what is possible with 6L6 and 6L6G. AAY, of Rogers Radio Tubes, told the Wireless Association all about the new short-wave station, CFRX, at Aurora. ZE has installed Faraday screen and is pleased with it. TA has rebuilt. DV has new super. On Sunday, March 14th, between 10 and 11 a.m., a successful and most enjoyable 56-Mc. QSO was held between NH, SP, and OJ of Hamilton and ADO of Toronto. 81TD of Niagara Falls, N. Y., came to Toronto for the demonstration. LL has high-power 'phone rig on 14 Mc. LV overhauled receiver and exciter unit. CD is active on 3.9-Mc. 'phone. AGG has an '03A on 14 Mc. AGM has a half-kw. rig ready to go. Wireless Association executive for 1937: Pres., XJ; Vice-Pres., SX; Secy-Treas., AEX; Publicity Mgr., ADG; Exec. Comm., IB, IX, NF and MJ. TO is on 14-Mc. 'phone and c.w. YB is rebuilding whole station from waste basket up. FH had new crystal for 'phone work at 3874 kc. PT is having ticket endorsed for 3.9-Mc. 'phone. OI got U9MF and SUI5G for WAC. YS has 211 in final. ACF is on regularly from Collingwood. FP is rebuilding with pair of 100TH's in final. TG is putting in single 100TH. AHY, A1H and AMZ are new hams in Welland. DO and VZ are operating R.C.N.V.R. station in Hamilton. DJ will change QTH to Hamilton first of May for the summer months. AMT is new in St. Catharines. XY has 59 e.c.-6L6 rig on 7 and 3.5 Mc. TH is building up exciter unit as described by 6CUH in QST. 80YJ and 80ZN visited the Cardinal gang. XS is changing to 'phone. UO has new receiver. 32 stations reported a total of 1024 messages handled in the month, which is splendid. This personal message to those of you who do not handle traffic: "Please send me a letter or a postcard on the 16th of each month, reporting news of your station or of your friends." Thanks, gang. 73—CUL.

Traffic: VE3WK 173 SG 165 QK 140 ABW 94 TM 68 HV 53 WX 45 OI 32 DH 27 MA 26 DU 22 AGM 18 XL 17 KM 14 DW 13 CG-GT 12 QB 11 ZE 10 VD 13 SS 8 AET-OKT 7 CD-MB 6 UO 4 NC-DC-ABC 3 DJ-LI 2. (Jan.-Feb.: VE3AMU 16 MA 15 WX 22.)

QUEBEC DIVISION

QUEBEC—SCM, Stan Comach, VE2EE—We regret very much to report that our old pal "Doc" DG has found it necessary to resign the positions of Route Manager and Trunk Line Station; the boys will miss that snappy fist at the Montreal end. BF is rebuilding to an RK-23. IL has been working some real DX on 7 Mc. GO

has given up his ORS. CO is selling out and rebuilding. IJ and IY are on 14-Mc. 'phone. BP made a business trip to Vancouver and met some of the Winnipeg boys on his way back. KF has built a rack job, is active on the Tri-Colour Net and has received his O.R.S. AB and AC are active on 28 Mc. HH is using a T-20 final. DR worked a PK for his 73rd country. LL is visiting the boys across the Mason-Dixon Line. EY operating at LA, Lake St. Joseph, worked HD, Quebec City, on 56 Mc. AB is now O.O. LE, KO, NI, AB, HL, IT, AC, EC, GB, KF and HT are heard regularly on 3.5-Mc. 'phone. BU spent an enjoyable week-end at Hartford, saw all the tricks at Headquarters and visited Ed Handy at home. IN is having trouble with that high power. KM is going high power. We understand that AX came out top man in the DX Tests. Congrats, Gordy. EW made a tidy score in the tests. CR, DR, BV and LV lost some sleep over it, but are practically normal again. DD has returned to Grand Mere. I.V. put in a 6L6 doubler. EX is building a high-power final. DM has completely rebuilt in a new rack. ER moved to Western Ave., the old QTH. BK is building a modulator, T-20's Class B. HE has been very active on 14-Mc. 'phone. MM is suffering badly from harmonics. BN is very active on 14 Mc. KK has new rig using band switching. EE sent VP3BG a transformer, but Davey Jones intercepted it en route. HO is building a small rig for DV. FU is now on 14,248 kc. from Labrador under the call VO6L. The M.A.R.C. has been discussing the location of this year's picnic grounds. Watch for the announcement and let's have the usual FB turn-out.

Traffic: VE2DR 39 DG 168 AB 13 HT 53 BU 29 IN 8 KM 2 FC 26 LC 7 HH 3.

VANALTA DIVISION

ALBERTA—SCM, Alfred D. Kettenbach, VE4LX—DR says if you chaps don't want your DX cards he will start to paper his shack with them; he reports hundreds of unclaimed DX cards on hand. Send that envelope today!! CT is on 14 Mc. GE is carrying on the trunk line. KI is breaking into the traffic game. LA knocks them over on 28 Mc. ACF is new amateur in High River. IN keeps the rag chewers busy on 3.9-Mc. 'phone. JJ rebuilt his 14-Mc. rig. WX is new O.O. for the southern part of Alberta. The Edmonton Club is busy preparing for the big hamfest. DON'T forget the dates. ALBERTA HAMFEST in EDMONTON, JULY 10TH-11TH. AH built new power supply. BJ is active again. BV has trouble with modulator. BW moved rig back to the house, as too much QRN at the store. CX is on 3.9-Mc. 'phone. EA has FB rig with 170 watts input. FR is building special rig for 14 and 28 Mc. HA is working DX. HM, working four bands regularly now, has some nice DX on 28 Mc. HT made W.A.C. IZ is now W.A.C. and W.B.E. on 14 Mc. JO visited LQ and AEN. LQ works four bands consistently; he speared African on 14-1.75-Mc. 'phone. MR stays on 7 Mc. NS moved to Grand Prairie and will be on 3.9-Mc. 'phone. KK is Grande Prairie has worked all U. S. districts except First on 1.75-Mc. 'phone. PH turns in enviable score in DX contest, 41 countries. PX is new call in Edmonton. SZ is on 28-Mc. 'phone. VJ put up new vertical antenna. XF has B.C.L. trouble and tries Faraday screen. YD is on 3.5 Mc. with FB new rig. YY worked 7 Mc. with 2 watts input. ZP, back in Edmonton between seasons work, rolled up FB score in DX contest. ZW is increasing power on 1.75-Mc. 'phone. AAB got new rig to perk on 14 Mc. AAD snagged OA and G with new rig on 14 Mc. ABH is on 28 Mc. ADW is rebuilding again. ADZ is working lots of DX. AEN worked his first VK on 7 Mc. with low power. KZ continues to snare the hard-to-work DX stations. CY is getting new oscilloscope. GD had nice QSO with India.

Traffic: VE4WX 32 LQ 25 GE 14 QK 10 HM 7 CT-AFI 3 KI 1.

BRITISH COLUMBIA—SCM, D. R. Vaughan-Smith, VE5EP—A club has been formed at Trail known as the Trail-Rossland Amateur Radio Club with RL president, AA vice-pres., and HX secy-treas. Congratulations, gang, and hope your club will enjoy a long and successful career. The Victoria Short Wave Club's annual banquet was a roaring success. The O.K.A.R.C. had the pleasure of writing the front page of the *Amateuer*. The new Westminster gang raided the Collingwood Club for a social. The B.C.A.R.A.

entered its new rig in the DX contest. The B.C. 'phones were all set for complete wire tie-up the night of Feb. 17th when telegraph companies lost their east connections. Several isolated points were given fine service by the stations concerned. Those taking part were JF, BJ, DD, DL, HU, CB, CH, SW, ON, IH, KN, MO, DW, GZ, CU, IA, GR and FO. Not all on 'phone, but c.w. stations cooperated with the 'phones and gave complete coverage of B.C. UK of Fernie asks for O.R.S. appointment. CT in Duncan keeps in touch with the Island Net and tells us of TZ, a blind amateur at Chemainus, who would like to schedule someone else who is new on the air. SW of Victoria has been bitten by the traffic bug and wants O.R.S. It's a toss-up between GI and EH as to which one beats the other in the DX contest. AC is having a lot of grief with 6L6. JL took his good ship to S.F. and then didn't even get ashore. AG showed EO he could get out beyond the back fence. RS, PT, JH and EP were ops. at 9AJ for the DX contest. BQ operates separate rigs on 3.9 and 1.75 Mc. AL is hard at work with new rig, probably a T55 in the final. Once again, please let's have a little more dope for next month.

Traffic: VE5AC 22 CC 16 OK 23 KQ 15 EP 42 NG 3 SW 6.

PRAIRIE DIVISION

MANITOBA—SCM, A. J. R. Simpson, VE4BG—Trunk Line Station GC is still on the job. With a pair of push-pull '10's RA keeps several schedules weekly. AAW's antenna blew down; he schedules CQ at Waldron, Sask., AFF at Dauphin, Man. and 9WLL. VE3AHA was a visitor to Winnipeg to have an operation. AFF at Dauphin keeps in the swim with a '47 crystal, '46 doubler and pair of 250's final. AAH is now CZ3A for Wings Ltd. at Favourable Lake. AEL is heard consistently. AEB at Reedy Creek, in addition to rag chewing, keeps having occasion to find his station useful in securing doctor's attention for the Indians on this reserve, and wishes to pass his thanks to IU, WQ, ABE and AB for their assistance on several occasions. TV up at The Pas is looking forward to the spring break-up so he can come to Winnipeg for a visit and renew acquaintances with all the old gang. OQ at Brandon reports the forming of a radio club there. On Feb. 18th the St. James Radio Club put on a display of radio amateur equipment at St. James Hall. ADX was presented with a mouth organ used in the first CKY broadcast in 1921. Various apparatus was displayed by YO, GJ, ADX, SO, AGA, ACM and the club station FF. AE with his push-pull T55's has a real high-power rig. AG devotes his operating time to 3.9-Mc. 'phone. VE4QF is high power. The Mid American-Dakota Division A.R.R.L. Convention is being held on May 21st, 22nd and 23rd at the Hotel Lowry in St. Paul. Anyone able to attend this convention will be assured of a fine time with plenty of action. This is a first-class opportunity to meet a lot of those W9's you have contacted, and you can find out all about it by writing to the Convention Committee at 1860 Prospect Avenue, St. Paul, Minn.

Traffic: VE4GC 30 AAW 106 RA 117 AEL 3.

SASKATCHEWAN—SCM, Wilfred Skafte, VE4EL—S.A.R.C. is busy testing equipment for next Field Day. QZ with 100 watts to 6L6G worked TF3GM, also VK's, ZL's and K6's. UG has a T20 and plans T55's as final. XB with 105 watts to two '10's on 14 Mc. works numerous Europeans. 4IQ on 14 Mc. uses 6A6 crystal osc.-doubler. TW and TN are working out on 14-Mc. 'phone. RJ installed Faraday shield and cleaned up parasitics and harmonics nicely. SP and UC operate joint 'phone on 3.9 Mc. UD is close to W.A.S. on 'phone. PQ has new outfit: 6A6 osc.-doubler and 6L6 final. The Saskatoon gang are "raring to go" to hamfest at (Moose Jaw, we presume). PG tried 59 and 6L6 crystal osc., but went back to p.p. '45's. XM has good time working VE's and W's on UK's 14-Mc. 'phone, 20 watts Class A. CQ holds nightly schedule with AAW. BN visited Chicago and brought home 500-volt genemotor, 12-volt charging plant and a few 6L6G's. QM, QD, ML, OS, GZ and EL keep 3.5-Mc. 'phone open, and LJ, ACR, CM and IV do likewise on 3.9 Mc. KJ visited IM at Yorkton. QM keeps nightly schedule with OW.

Traffic: VE4CQ 85 PQ 28 QZ 8 PG-EL 7 UL 4 QM 3.

(Continued on page 100)

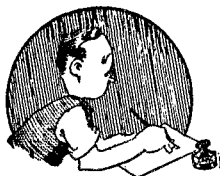

CORRESPONDENCE

The Publishers of *QST* assume no responsibility for statements made herein by correspondents

Flea-Power

358 W. Oakland St., Toledo, Ohio

Editor, *QST*:

I heartily support W1EXZ's suggestion that a portion of the 80 meter band be set aside for flea-power work, although I would like to see a similar section designated in each band. The special sections need not be large, but I suggest that the power limit be fifteen watts.

Not only would this give the low power fellows a chance to get out, but I'm sure the high power chaps who have already worked everything would have a new stimulus to see what they could do with low power. I predict WAC's proudly qualified by their owners as to the small power used. And it would give those of us who want to build and test low-power emergency transmitters a chance to see what they will do. From personal experience a good distance away from North American QRM I know low-power rigs can get across if only the signals have a chance to be heard. The biggest thrill I have yet had in ham radio was when VQ8AH in Mauritius told me he had only ten watts input.

But it would have to be a F.C.C. regulation, with an effective check-up by the F.C.C. monitoring stations.

I've gone in for high power, but only in self defense. I'd much rather spend my time seeing what I could do with low power. I think there are many others who feel the same way about it. . . . Let's spend our dough on the intake end.

—Norman B. Underwood, W8DYM-KA7NU

2941 Hering Ave., Bronx, New York

Editor, *QST*:

Today, in most hobbies the "sporting spirit" holds sway. Smaller bore rifles, lighter rods and line are the trend in hunting and fishing. Lowering power is the equivalent in amateur radio.

Every month in *QST* we read of the accomplishments of low- and flea-powered stations. It seems that a few watts of r.f. will cover any earthly distance. On 80 meters I found that I could easily contact W1-2-3-4-8-9 and VE1-2-3 with 5½ watts input to an e.c. oscillator. Yep, I got thrills out of those QSO's!

How about it, fellows? Why not a more general lowering of power? It doesn't mean rebuilding. All you need to do is couple your antenna to the oscillator or buffer stage of your big rig and fire,

but don't be shy about using that full quarter kw. when you feel it necessary. . . .

—Phil Reich, W2HUG

Cando, Sask.

Editor, *QST*:

I have just read with interest the article . . . on flea-power operation, and I heartily endorse the suggestions. It is really about time that the "forgotten man" with his little two watter is given a break. Lord knows, he has done enough work and poured forth enough effort to merit it!

Better still, I say, that the flea-powered lads be given a whole band to sport around in, while we are about it, and limit the whole band to twenty-five watts. There are hundreds and hundreds of VE hams that have no high power and would welcome the suggestion with open arms. Let's keep the ball rolling!

—Howard Walker, VE4BN

7509 Boyer St., Mt. Airy, Phila., Pa.

Editor, *QST*:

. . . Think it's about time the A.R.R.L. gave special recognition to him who does it with flea power. A good percentage of WAC's are made with more than 100 watts. Why not have a WAC for less than 25 watts, as W1EXZ says, that is low power? . . .

—Alan P. Buffington, W3EEW

1910 N. Second St., Philadelphia, Pa.

Editor, *QST*:

With great pleasure I read about "The Flea Power Association" in *QST*.

In his article he says those fellows with high-powered rigs are occasioning lots of QRM and therefore the little fellow is always handicapped. I think his idea is wonderful to some extent, but if the hams with low-powered rigs choose the proper time to operate our stations, I think it would work much better.

. . . I have noticed that operation of my station between the hours 8 A.M. and 11 A.M. is much better. There is not so much congestion and I always get my man. I hope all those boys using flea power rigs will choose the right time and when congestion on the air is at a minimum.

—Francisco Bou, W3ESX

501 West 133rd St., New York, N. Y.

Dear Eddie:

Lotss fellers hve been sending letters to this column suggesting that power be limited. We gotta do sumpin abt this QRM on the bands.

Abt six in the evening ya finish dinner and as ya feel the world is a vy fb place ya decide to go on the air and hve a ragchew wid W3B --- so ya crank up the ole rig es get on. Ya hear a feller wid a vy fb R9 sig CQing so ya give him a call. He comes bk es sez, "Fb R9 hr." So ya go ahead es tell him abt the rig, etc. He cums bk es sez "ND QRM." Then he sez, "Using 20-toob super wid xtal hr!" Then QRM snows him under.

Why not give low power a trial? How abt a contest? Have the contest last two week-ends as the Sweepstakes did and limit the power to 25 watts. Why not make a Rag-Chewers contest of it? Have each QSO last at least a half hour in order to get two points for the contact. Also it may be a gud idea to count a ragchew with a DX station as 6 points. It wud be fun to chew the rag with a DX stn for a change. Practically all DX contacts are the 73 CUL type.

Let's hear from some of you fellows abt it.

—Wm. J. LaHiff, W2IVT

EDITOR'S NOTE.—Representative of a large amount of mail expressing opinions on this subject are the above letters. Other excerpts next month.

"A Peculiar Phenomenon"

Florence, Italy

Editor, QST:

Having closely followed the interesting developments of amateur activity in the 28-Mc. band I wish to attract the attention of experimentally-minded amateurs to a peculiar phenomenon which I suppose not yet well known but worth further study.

When 10-meter stations are at full activity if one happens to tune his receiver on the 20-meter band he is often able to hear many "CQ ten" as well as other 10-meter communications coming through quite distinct and strong. The effect was often noticed by the writer particularly on stations located at relatively moderate distances (1500-2000 km.) from the receiving spot, but sometimes on real DX too. Usually this happens on c.w. signals, but although not yet confirmed some 'phones have been received in this unusual way also. The effect has been practically noticed on no other band except 10 meters.

The first thing one would be inclined to recognize as the cause of this strange sub-harmonic type of reception could be some spurious radiation from multiplier stages preceding the final amplifier reaching the antenna system, perhaps with the undesirable and unwanted help of some parasitic coupling in the transmitter itself. There are, however, the following points making this assumption a wrong or at least an objectionable one, viz.:

1. Many local tests have always given negative results of sub-harmonic reception from nearby transmitters.
2. Many of the sub-harmonics heard possessed the distinctive notes of self-excited rigs for which obviously the above mentioned assumption must be at once rejected.
3. Reception of telephone transmissions. (This point, however, as already noted, needs further confirmation.)

There were no faults or tricks in the receiver used and in this regard I must point out the effect was noted on many receivers of different design.

In conclusion I am inclined to suggest the hypothesis that the cause of this sub-harmonic reception is due to an effect of propagation of radio waves (like the Luxembourg or Tellegen effect, for instance). This hypothesis has to be positively validated by other experiments, but in the meantime I will be very much obliged to you if you kindly publish this letter in QST asking the cooperation of other amateurs throughout the world in solving this intriguing problem.

—Pier Luigi Barcellini

EDITOR'S NOTE.—Not only in Italy is this effect observ-

able, although we have always attributed it to fundamental radiation from a doubler-final. That it may be a consequence of extraordinary propagation conditions is indeed an exciting prospect. Here is a highly suggestive field for immediate amateur research.

Let Them Finish

Chicopee Falls, Mass.

Editor, QST:

A new problem is approaching rapidly. It seems to be time for a few remarks on the superfluous signal problem. The last two months I have noticed unprecedented discourtesy in the calling of foreign stations by U. S. amateurs. When a new or uncommon foreign station comes on the air, this condition is obvious. Every time the foreign station stops sending even though he is QSO with a station, dozens of U. S. stations can be found calling him. It appears as though they hope to be able to bury the U. S. station who is in communication with the foreigner. Such action is certainly most unbecoming to any intelligent, sensible human being.

It seems to me that just a little commonsense would point out the baseness and foolishness of such discourtesy. Carried to the extreme, it would be impossible for any station to QSO a foreign station. If amateur stations would QRX until the QSO was finished, the number of QSO's a foreigner could make per hour would be increased many times and all would be satisfactory contacts, too.

Incidentally, such operating could be classed as superfluous transmission. In some cases it might even be classed as willful interference. Please read Sec. 303, (m), 4 and 5, of the Radio Act of 1934. The maximum penalty is suspension of license for two years.

So, in the name of fair play and courtesy, as well as the Law, think it over and watch your step.

—C. J. Madsen, W1ZB

Temperature Coefficient and Frequency

1302 Jackson St., Fort Wayne, Ind.

Editor, QST:

There seems to be a quite general belief that as far as frequency drift goes when operating a crystal controlled transmitter at high frequencies it is better to use the highest frequency crystal that it is possible to get. This has been inferred many times. For example see the article on page 41 of the March issue of QST entitled "A 56-Mc. Crystal-Controlled Transmitter With 61.6 Output."

The fact of the matter is that no matter what order of doubling is used the frequency drift is fixed by the temperature coefficient of the crystal and given the same temperature coefficient it makes no difference if you use a 160-meter rock to operate on 5 meters or a 20-meter one.

Consider a crystal ground for a fundamental frequency of 2-Mc., with a drift of 4 cycles per Mc. per degree, doubling twice to 8-Mc. A shift of one degree in temperature will cause a frequency drift of $2 \times 4 \times 4$ or 32 cycles at 8-Mc. Now another crystal with the same temperature coefficient ground for 8-Mc. fundamental operation will have a drift of 4×8 or 32 cycles if the temperature varies one degree.

In general if you wish the lowest possible drift on 5 meters it is better to use a 40-meter crystal instead of a 20-meter one because the usual 20-meter crystal has a temperature coefficient about four times as large as the better 40-meter ones; and the crystal will cost you less money.

—R. H. Severance, W9UUN

More on 29-30 Mc.

10 Maple Place, Irvington, N. J.

Editor, QST:

... After doing a considerable bit of listening and some
(Continued on page 68)



EUROPEAN DEVELOPMENTS. This page is being written this month in Istanbul, Turkey, and as has often been the case of late, with just time to reach Hartford by "dead-line" if tomorrow's "Simplon Orient Express" to Paris makes connection with the Thursday sailing of the Bremen from Cherbourg.

So many weeks have slipped by since I was last at the factory in Malden that it seems strange to be writing about things back there — and yet past experience has shown the importance of withholding comment on European radio developments until full investigations in our own laboratories under our own conditions of application have indicated more concretely the possibilities for their future adaptation to amateur radio. Only too well do we remember the claims made for a ceramic high voltage fixed R.F. condenser dielectric with an unbelievably high dielectric constant and low loss factor. On this page many months ago we commented upon our inability even to begin to substantiate the manufacturer's claims in our own laboratory measurements. Even so, we really have high hopes for some of the things we have seen over here this winter being adaptable to amateur needs in our own country. In particular it seems safe just to mention that the Europeans know how to mold the extremely low loss polystyrol dielectrics even better than we have been able as yet to do under ideal laboratory conditions at home. — But of all that, more later.

2000 PER CENT OVERLOAD. On our many travels we like to visit as many as possible of the amateurs with whom we have talked over the air. In retrospect, the stations we have seen in this way are particularly notable for their ingenuity. There seems to be no limit to the strange and wonderful things that are done to adapt old equipment to new uses. Our most lasting impression along this line is the Class B output transformer used by Lewis Gilmer a year or so ago at W9MTC. Perhaps it struck us the way it did because we compared it with the very correct equipment of Thorn Donnelly's Lake Bluff Radio Club, to whose select membership W9MTC belongs.

At all events, we found a pair of 203A's delivering some half a kilowatt of modulation through a little Class B transformer probably designed for not over twenty-five watts. The transformer had been removed from its case, and all leads had been carefully fanned out to separate them as much as possible. The stripped core and coil had been suspended in a large glass beaker of transformer oil. At last reports this contraption was taking its punishment bravely. Of course, the trick was in the generous use of transformer oil which provided convection cooling for the core and coil as well as insulation for the leads. Strangely enough, the speech quality was not at all too bad.

BATTERY MODEL OF THE NC-101X. A new model of the NC-101X specially adapted to operation from batteries was completed just before I left home and is by now available from all of our regular franchised dealers. In addition to eliminating the power supply, certain other changes were made to reduce the B-supply current as much as possible. These include the use of series resistors instead of voltage dividers, and the elimination of one output tube (single 6F6 instead of PP 6F6's). What with one thing and another, the new model requires only 35 MA (at 180 V.) instead of 115 MA. Similarly, to save the A-battery, the dynamic speaker is of the type which gets its field from a permanent magnet. These are the major changes.

JAMES MILLEN





A Statement of Policy

For over twenty-five years, Yaxley products have meant progress in radio. And the passing of each year means further advances from the use of Yaxley products as well as those produced by the parent company—Mallory.

Every month, Mr. Radio Amateur, advertisements will bring you a brief glance at various Mallory-Yaxley products, and services of P. R. Mallory and Company, and its Yaxley Manufacturing Division. In them we can touch only the high-spots of the amateur radio applications of a few products—though there are hundreds of others that you use and need.

Write for helpful information. Send us your questions on amateur radio or service problems. Whether or not your letter concerns some specific application of a Mallory-Yaxley product, it will receive careful and prompt attention by engineers who are licensed amateurs, and who have your viewpoint. We are at your service—always!

P. R. MALLORY & CO., Inc.
INDIANAPOLIS INDIANA
Cable Address—PELMALLO



Correspondence Dept.

(Continued from page 66)

QSO'ing on the 28-Mc. band I am beginning to believe the saying that amateurs are slightly demented is true. On the week-ends when activity is at its greatest one can readily reach the conclusion that despite amateur howls about QRM, the gang at large really likes it. Take a listen, OM. A curve drawn of the number of stations per kilocycle looks like a grid voltage plate current curve with 29-Mc. at cut-off and 28-Mc. saturation. And we find by operating experience if you shift to the 29-Mc. end to avoid QRM and incidentally stop QRM'ing the gang that is "most piled up," that the number of QSO's per number of calls made, goes down as the frequency is increased.

To my mind the latter feature is most important. Here we have a "new band" that as yet has not frozen into a set routine. Already we find however that fellows will call CQ and then listen over a small portion of the band. These trick sines that indicate the Caller is going to listen for Callee in a certain part of the band are all right on the crowded and narrow 7-Mc. band. It seems to me there is no excuse for their use on a band like the 'phone portion of the 28-Mc. band. Just because a man operates on the other end of the band is no sign he is a social outcast, in fact, he may be doing you a favor by staying off "your" frequency. If a CQ or "general inquiry" is made, the least a courteous operator can do is to take a listen over the whole band.

The other point I wish to make is on the activity in the exclusive c.w. assignment, 29-30 Mc. Do we find the brass-pounders in that luscious megacycle reserved for their exclusive use? *We do not.* Merrily the dots and dashes burp through 'phone QSO's and an intensive search between 29 and 30 Mc. reveals a few commercial harmonics (PCT 29.0 at R5 on the east coast indicates good transatlantic conditions), an occasional foreigner, and a rare W in the ratio of 500 to 1.

A good deal of the c.w. operation in the 'phone band is that of fellows who also operate 'phone. They do not wish to shift frequency and I feel that such dual operation is to be encouraged. However, before we lose that extra megacycle wouldn't it be a good idea to open up this territory to unrestricted use? The present set-up has proven itself unsatisfactory after a full year's trial. As the QRM in the other half of the band is becoming more and more severe as each week passes by it seems that the time is ripe for a change to improve conditions.

—D. A. Griffin, W8AOE

North Wales, Pa.

Editor, *QST*:

Suppose you start a list of Calls Heard, 29 to 30 Mc.: March 1st, to 14th: (W9FJR) W6QG.

Boy, ain't that an imposing list of stations heard for many hours of listening on a supposedly active ham band!

Old man W9FJR and myself claim that we certainly are a specially-privileged pair of hams—in fact, the only two hams in the world who have a frequency allocation all for themselves. If you don't believe it, we can show any ham our station licenses, which say we are allowed to use the frequencies between 29 and 30 Mc. for c.w. transmissions. Rather fortunate, eh what?—especially when you listen on 28 Mc. and hear the 'phone men trying to chew the ears out of a c.w. guy who has the nerve to break up his 1-kw. signal. Oh, h — eek.

—John J. Michaels, W3FAR

"Lonely Kilocycles"

315 Wade St., Bridgeport, Conn.

Editor, *QST*:

For a year I have operated 160-meter 'phone and believe there lies the height of QRM. Contacts on this band are more enjoyable due to the closer personal feeling towards one another. Because of low-power DX and simplicity of equipment and operation this band is becoming brighter in the eyes of the newcomers as well as the old-timers. Naturally this means many more new stations in the same territory and hence much more QRM. What should be done about this situation? Well, what about the c.w. part of the

More GRID-MODULATED POWER OUTPUT from the HK-154

Here are the facts

More 100% grid-modulated power output from the Type 154 GAMMATRON than from other comparable tubes. The "154" GAMMATRON is particularly adapted to grid modulation because of its low mu and capability of overload. It is the only tube available that has the characteristics capable of giving high efficiency grid modulation with good linearity. It stands alone in this field; there is no comparable tube on the market.

The "154" GAMMATRON is a low-cost tube! It gives you such GAMMATRON features as: Tantalum plate, Tantalum grid, Nonex glass envelope, extremely high vacuum, no "getter," tungsten supports, more than ample filament and many others. Its ultra-conservative rating is 50 watts plate dissipation.

Investigate the possibilities of this GAMMATRON for use in your phone transmitter. See how easy it is to put a 65-75 watt carrier on the air. Retain your present low power equipment. Simply add a "154" GAMMATRON as grid modulated final amplifier. Here is real phone economy, low cost audio equipment, inexpensive power supply, minimum of parts.

Send for article by Frank C. Jones describing the HK-154 10-80 Meter Grid-Modulated Phone Transmitter.



\$12.50

**AT YOUR
DEALER'S**

HEINTZ AND  KAUFMAN
LTD

SOUTH
SAN FRANCISCO

CALIFORNIA
U.S.A.

HAVE YOU TRIED THE "SALT-SHAKER" MIKE?



**Ideal for amateurs
... you'll be surprised
by its LOW PRICE!**

Western Electric's brand new "Salt-Shaker" is a 2-in-1 mike. It's *non-directional* when you want it to be. And when you don't—just put on the scientifically designed acoustic baffle and it becomes *directional*.

Either way, it's a great mike—engineered by Bell Telephone Laboratories—that gives you regular Western Electric broadcast quality.

At its low price, you will not want to do without the "Salt-Shaker." Write Graybar Electric, Graybar Building, New York, for full details.

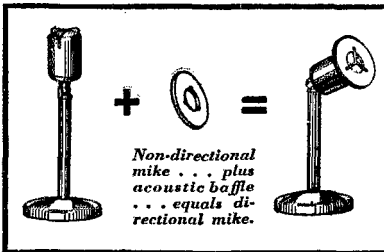

Western Electric
BROADCASTING EQUIPMENT
Distributed by GRAYBAR Electric Company

band? Is this band of 85 kc. crowded? I should say not. I think that these 85 kc. are just being wasted. Night after night I have listened and could hear only 5 or 6 c.w. stations. Now why can we not just as well operate 'phone there and really do justice to those 85 lonely kilocycles?

—N. Howard, W1JBV

One of Many

Savanna, Ill.

Editor, *QST*:

Will you please publish my thanks to the gentleman who is using my call on forty and ten and gathering in all those hard-to-get QSL's? I am especially proud of the German card I received a month ago and thanks a lot for the VE2. I have worked several but have been unable to get a QSL. Incidentally, I need Florida, Nevada, Idaho, and Colorado for WAS. A VE5, VE1, or VO1 would also fill a gap in the wall and keep the mosquitoes out.

Moreover, if he will kindly make his identity known I will be glad to drop around and make the depth of my feelings known in a more touching manner.

—Robert Hicks, W9UET

Phantom CQ

3577 Germantown Ave., Chestnut Hill, Pa.

Editor, *QST*:

From Bill Ellsworth, W3FED, comes the following idea: that CQ is entirely unnecessary and superfluous. Says he, why not have a phantom or assumed CQ? A station wanting to send a general call for a rag chew, or what have you, would call "de W3QP de W3QP de W3QP K." It is obvious what is meant, and what a swell saving in time! Directional call would be: "Calif de W3FED Calif de W3FED" or "Calif Calif de W3FED W3FED W3FED." Looks very simple and desirable to me. Just omit the "CQ" entirely and the gang will know what's wanted without it, perfectly.

—Jack Morgan, W3QP

A Universal Exciter

(Continued from page 65)

Another commercial trick for securing neat wiring is the use of dummy lugs, such as those between the r.f. chokes and the resistors. These handy little gadgets can be obtained from any radio dealer.

While commenting on wiring, it might be well to suggest that whenever a switch is mounted on the panel of the unit, such as the B-supply switch in this instance, a pair of terminals be located at some handy place in the rear and connected across the switch terminals so that should it be desirable at any time to control the switching by either an extension lead or a relay, it will not be necessary to remove the complete unit from the rack and half-disassemble it in order to delve into the interior to get at the switch contacts. This point is particularly applicable to power supplies, which, sooner or later, you will want to control either directly or by relays from a master switch on the operating table. After all, in our anxiety to get a new transmitter on the air, most of us at first have at least six switches to throw, in various parts of the room, before being able to shift from "send" to "receive." Sooner or later, however, we settle down to at least a brief spell of just plain operating, during which time we all take a little pride in seeing just how quickly we can shift;

QUIET PERMANENT RUGGED

"THE NAME TELLS YOU
IT'S A MASTERPIECE"

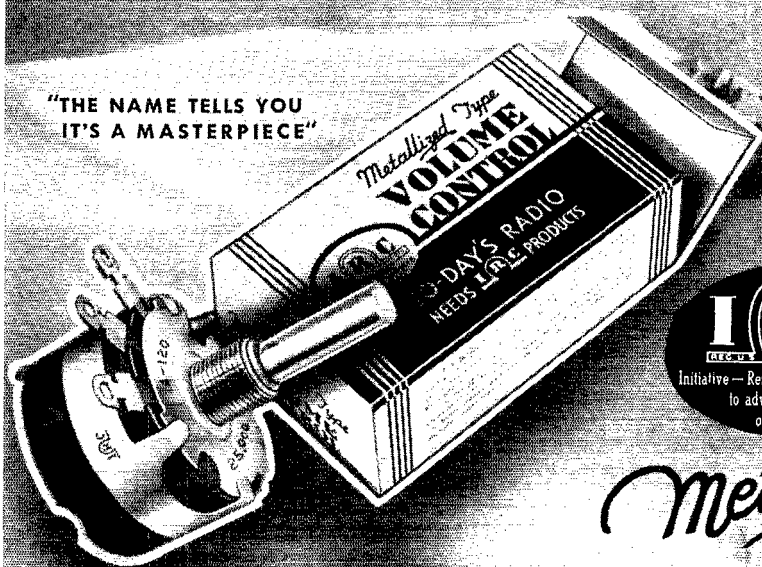

Metallized

VOLUME CONTROL

INTERNATIONAL RESISTANCE COMPANY

401 NORTH BROAD STREET, PHILADELPHIA, PA.

Factories or Licensees in Canada, England, France, Germany, Italy, Denmark and Australia

MAKERS OF RESISTANCE UNITS OF MORE TYPES, IN MORE SHAPES, FOR
MORE APPLICATIONS THAN ANY OTHER MANUFACTURER IN THE WORLD

Say You Saw It in QST — It Identifies You and Helps QST

EFFICIENCY

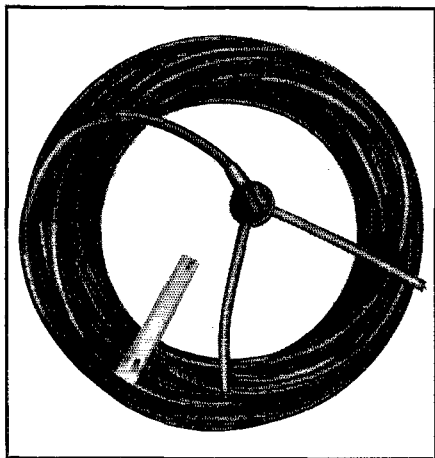

**IS MORE IMPORTANT
THAN POWER INPUT**

100% FLEXIBLE

Bassett Concentric Feeder

is rapidly replacing less efficient transmission systems all over the world in low, high, and ultra high frequency applications.

BCF-50

A complete, sealed system for use on any frequency.

\$9.75

Other types available

BASSETT RESEARCH CORPORATION

1436 Maccabees Building
Detroit

MIMS RADIO COMPANY

Texarkana, Ark.

RADIOLAB

Kansas City, Mo.

Or your local dealer

which calls for a single master switch or a "press-to-talk" button.

It will be noted from the photographs that wherever leads are taken through a metal partition a rubber grommet is used. Such practice, while not necessarily essential, in the end invariably pays for itself in the elimination of insulation breakdown at a time when repairs are difficult and inconvenient. Such a grommet is also used in the chassis hole through which passes the flexible drive to the crystal holder.

The standard G.R. jack-top output terminal posts are used, rather than conventional binding posts, so that should this exciter at any time be used with more than one final amplifier for operation on different bands, much awkward work behind the relay rack in shifting leads is reduced to the simple operation of changing plugs.

Long-Wire Antennas

(Continued from page 46)

$$\sin \phi = \frac{l - .371 \lambda}{l \cos \Delta}$$

Regardless of which design method is followed the pertinent fact remains that *there is an optimum set of dimensions for the rhombic to obtain maximum results under a specific given condition.*

Briefly summarizing, with all other dimensions being correct any increase in length causes an increase in power gain and a slight reduction in wave angle. An increase in height also causes a reduction in wave angle and an increase in power gain but not to the same extent as a proportionate increase in length.

TERMINATING THE RHOMBIC

The rhombic, when terminated in its characteristic impedance, becomes unidirectional and non-resonant and should be operated as such to realize the best overall results, either for transmission or reception.

Experiments have shown that a value of 800 ohms is correct for the terminating resistor for any properly constructed rhombic and that the system behaves as a pure resistive load under this condition. Higher or lower values of resistance cause the rhombic to act as a reactive load, thereby considerably reducing the efficiency of the broad frequency characteristic.

This terminating resistor must be capable of safely dissipating $\frac{1}{2}$ the power output (to eliminate the rear pattern) and be absolutely non-inductive. Such a resistor may be made up from a carbon or graphite rod or from a long 800-ohm transmission line. If the carbon rod or a similar form of lumped resistance is used the device should be suitably protected from weather effects, i.e., covered with good asphaltic compound and sealed in a small light-weight box or fibre tube.

The 800-ohm value of terminating resistance may be substantially lowered by running an equal and parallel-connected wire under each leg of the rhombic. For instance, a distance of about 12 inches separation between two such parallel connected wires for each leg will permit the use of a 600-ohm terminating resistor. This is of

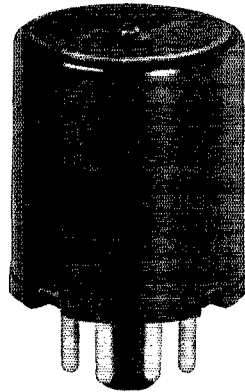

A NEW
CRYSTAL FILTER

BRUSH ANNOUNCES THE CRYSTAL "TRANSFILTER"

●
TYPE "A" 465 KC

(only one frequency available)

INTERMEDIATES

LIST \$10⁰⁰

●
The **BRUSH**

DEVELOPMENT COMPANY
3320 PERKINS AVENUE
CLEVELAND, OHIO

New!

Transco

Cathode Ray

OSCILLOGRAPH

A professional oscillograph, with all the important features, in compact kit form.

TRANSCO Engineers proudly present this new, sensational, precision instrument

AT A **NEW** LOW PRICE

ONLY
\$19⁹⁵



FREE

Diagrams — Literature

The something new and advanced in the field is TRANSCO's 913-CR Cathode Ray Oscillograph giving a range of performance never before achieved in an instrument at anywhere near this price! Just consider the features incorporated in this new, unusually stable instrument: Built-in Oscillator; Linear Sweep with 5 position switch for selection of sweep frequencies; Vertical Beam Centering Control; Vertical Amplifier with provision for cutting amplifier in or out; Linear Sweep Amplitude Control; Fine Frequency Control; Self-Locking Synchronization Circuit which keeps image locked at any frequency.

“WHAT'S NEW?”

Plenty! Lots of 'ham' items including NEW TELEVISION KIT being prepared. Keep abreast of developments, write for FREE information, technical data, etc. TRANSFORMER CORP. OF AMERICA Dept. CR, 69-71 Wooster St., N. Y. C. Please send me complete kit of parts for your 913-CR CATHODE RAY OSCILLOGRAPH with complete instructions, diagrams, pictures, etc. I enclose \$..... and will pay balance plus postage when it reaches me. (¼ deposit on C. O. D. orders.)

COMPLETE KIT OF PARTS

Cathode Ray Oscillograph as assembled by TRANSCO Engineers reaches you complete, all ready to assemble at a saving of approximately 40%. Kit consists of: Steel Cabinet Etched Metal Control Panel All Sockets, Transformers, Condensers, etc. (Everything but tubes!) Complete, Simplified Instructions with numerous diagrams, pictures, etc. Learn about this — TODAY! Use the convenient coupon below.

SENT FREE

Name.....
Address.....
City.....State.....

For Cathode Ray diagrams, pictures, etc., CHECK HERE

particular advantage where 600-ohm connecting lines and coupling equipment are available or more practical to use.

A terminated rhombic also requires an impedance match at the input end to prevent reflection losses or standing waves. The transmission line in this case is untuned and may be any length. To accomplish this, the 800-ohm terminated rhombic should be fed with an 800-ohm transmission line and a 600-ohm rhombic by a 600-ohm transmission line.

An 800-ohm line may be constructed from No. 16 A.W.G. wire spaced 20 inches or from No. 18 A.W.G. wire spaced 16 inches. The 600-ohm line, which is the common form for most Zepp feeders, is constructed from No. 12 A.W.G. wire spaced 6 inches.

The 800-ohm line is somewhat ungainly to install. It may be replaced by low-impedance lines of the concentric or twisted pair variety by the incorporation of a coupling network between the 800-ohm and low-impedance line connection. Such a coupling unit might be installed in a box at the base of the first pole or supporting structure. If such an arrangement is used it will be necessary to change the network constants for each different band of operation.

The coupling methods for the transmission line of a terminated rhombic to the final amplifier are straightforward. Either link, direct capacity, or impedance network types of coupling are the preferred methods to use.

THE UNTERMINATED (OPEN ENDED) RHOMBIC

The unterminated rhombic is a bi-directional and resonant system and closely resembles the open “V” in operation and performance. The same design details apply to the unterminated rhombic as for the terminated type. Ordinary 600-ohm tuned feeders are preferable to use for the unterminated rhombic and “V” and may be coupled to the transmitter by the usual parallel- or series-tuned resonant circuits. Matched-impedance lines may be used on these resonant systems by the use of the well-known matching sections or “stubs” but such procedure is not readily adaptable to multi-band work.

If bi-directional properties are desired an open “V” of the same overall length is preferable to the unterminated rhombic. For example, a “V” of 5 wavelengths on a side has a greater power gain than an unterminated rhombic with legs 2½ wavelengths long (5 wavelengths total for one complete side of the rhombic). On the other hand a “V” of only 2½ wavelengths on a side has less power gain than an undetermined diamond 2½ wavelengths on a leg.

The only instance where an unterminated rhombic should be used in place of the open “V” is where it would be impossible to install a “V” of the same overall length due to insufficient dimensions of available space.

To realize the full benefits from a rhombic or “V” some provision should be made to permit the use of the array as a receiving antenna by the incorporation of suitable relay or switching

(Continued on page 106)



NOW!

SMALL END-LEAD RESISTORS *In a New and Convenient Package*

- Still the same ceramic covered resistor and like all Centralab Resistors, it is thoroughly insulated from all adjacent parts. The end leads permit conservation of space.
- Its smaller mass results in reduced capacity coupling of adjacent parts.
- Resistor is 11/16" long, 1/8" diameter and has a rating of 1/2 watt.
- Change to CENTRALAB for greater efficiency. » » »

CENTRALAB Division of Globe-Union Inc.
MILWAUKEE

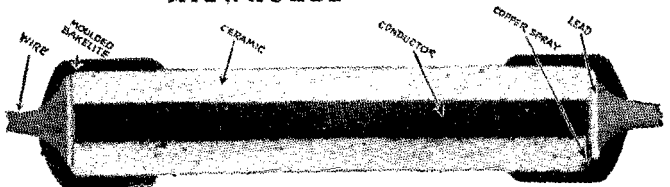

CENTRALAB

Say You Saw It in QST — It Identifies You and Helps QST

Now—a high-powered—

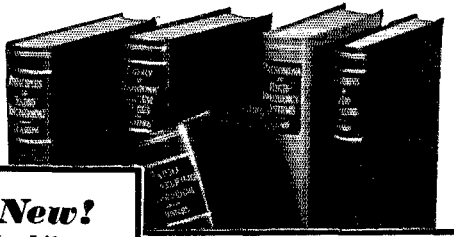

New!

The Library now comprises a revised selection of books culled from latest McGraw-Hill publications in the radio field.

**RADIO
ENGINEERING
LIBRARY**

- especially selected by radio specialists of McGraw-Hill publications
- to give most complete, dependable coverage of facts needed by all whose fields are grounded on radio fundamentals
- available at a special price and terms

These books cover circuit phenomena, tube theory, networks, measurements, and other subjects—give specialized treatment of all fields of practical design and application. They are books of recognized position in the literature—books you will refer to and be referred to often. If you are a researcher or experimenter—if your interest in radio is deep-set and based on a real desire to go further in this field—you want these books for the help they give in hundreds of problems throughout the whole field of radio engineering.

5 volumes, 3064 pages, 2000 illustrations

1. Glasgow's **PRINCIPLES OF RADIO ENGINEERING**
2. Terman's **MEASUREMENTS IN RADIO ENGINEERING**
3. Chaffee's **THEORY OF THERMIONIC VACUUM TUBES**
4. Hund's **PHENOMENA IN HIGH-FREQUENCY SYSTEMS**
5. Henney's **RADIO ENGINEERING HANDBOOK**

Special Low Price and Easy Terms

Bought singly, the five volumes comprising this library would cost you \$25.00. Under this offer you save \$1.50 and, in addition, have the privilege of paying in easy installments beginning with \$2.50, 10 days after receipt of the books, and \$3.00 monthly thereafter. Already these books are recognized as standard works that you are bound to require sooner or later. Take advantage of these convenient terms to add them to your library now.

SEND THIS ON-APPROVAL COUPON

McGraw-Hill Book Co., Inc.
330 W. 42nd St., New York, N. Y.

Send me Radio Engineering Library, 5 vols., for 10 days' examination on approval. In 10 days I will send \$2.50, plus few cents postage, and \$3.00 monthly till \$23.50 is paid, or return books postpaid. (We pay postage on orders accompanied by remittance of first installment.)

Name

Address

City and State

Position

Company QST-5-37

(Books sent on approval in U. S. and Canada only.)

Strays

For those who like an aluminum finish, W2HNX recommends "Aluminum Armorise," made by the Carter Paint Co., Liberty, Ind. This paint uses a varnish base instead of banana oil so that it flows like enamel and does not rub or flake off.

— . . . —

Air-Wave Bending of U. H. F. Waves

(Continued from page 18)

above the surface of the earth is accompanied by a high 60-Mc. signal level over the path. . . ." In other words, it was concluded that the high signals coincided with an atmospheric condition in which the temperature of the air did not fall off with an increase in height as rapidly as under conditions considered normal for a clear settled day. The observations which had been made prior to the installation of the recorder had indicated much higher signals during the fall of 1934 when temperature gradients were known to have been at least no more favorable than in the winter. We expressed the thought then that "the higher signal levels of the warmer months probably result from the higher specific humidity prevailing during that time." Aside from the splendid assistance given us during this work by Dr. Brooks and his associates at Blue Hill we had at all times the full coöperation of many Boston and New York amateurs, James Millen, W1HRX and Harner Selvidge, W1FQV at Harvard University maintaining regular nightly observation schedules for several months.

GETTING A LONG-TIME PICTURE

By May of 1936, the recording receiver having been running some eleven thousand hours, we had accumulated a great deal more information on the way signals behaved under a great variety of atmospheric conditions and were able to present, in a second paper, the seasonal variations—which showed a very great increase in average signal during the summer—and curves showing the average hour-to-hour variations during the four seasons. These diurnal curves revealed that while the water vapor characteristic was of tremendous importance, its effect in increasing the bending seemed to be dependent primarily on the existence of a favorable temperature characteristic. This was indicated by the fact that the summer day signals were not greatly in excess of the winter signals in spite of the much more favorable summer water-vapor condition. Only at night time, when cooling of the surface air provided the necessary temperature stratification, did the summer signals rise appreciably above those of the winter. Again, during this period, splendid ham coöperation was forthcoming, W1OM, W1NF, W1MJ and others maintaining nightly schedules continuously over a period of six months or so.

All of this work was still qualitative but it definitely clinched, in our own mind anyway, the

Handy...and for 1000 Uses



UNIVERSAL AC-DC POCKET VOLT-OHM- MILLIAMMETER

For laboratory, shop or field use.
Handy pocket size yet sturdy
and precision built.

SIZE
3 1/16" x 5 7/8"
x 2 1/8"

MODEL 666

DEALER
PRICE

\$15.00

• Model 666

Has 3" Sq. Triplet rectifier type Instrument.

AC-DC Voltage Scales Read: 10-50-250-500-1000 at 1000 ohms per volt.

D.C. Milliampere Scale Reads: 1-10-50-250.

Ohms Scales Read: Low 1/2-300; High, 250,000.

Black Molded Case and Panel.

SEE YOUR JOBBER
WRITE FOR CATALOG

Low Loss Selector Switch.

Complete with Alligator Clips, Battery and Test Leads.

DEALER PRICE.....**\$15.00**

A complete instrument for all servicing and other needs. Can be used for all AC-DC voltage, current and resistance analyses.

Black Leather Carrying Case, with Finished Edges and Strap, Model 669, supplied extra. Dealer Price,

\$3.00

THE TRIPLETT ELECTRICAL INSTRUMENT CO.

255 Harmon Ave., Bluffton, Ohio

Without obligation please send me

More information on Model 666

I am also interested in

Name

Address

City..... State.....

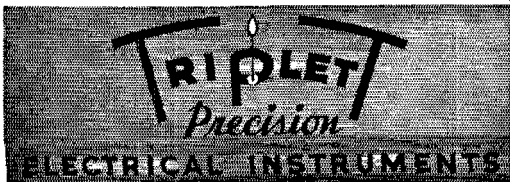



**HARVEY SAMPSON —
W2IJL**

12 years ago he established the Harvey Radio Co., New York, radio equipment distributors. Harvey says . . .

"There's a world of difference between 'clerk' and salesman. The clerk merely takes merchandise off the shelf, wraps it, and accepts money. But a salesman, alert and ambitious, persuades his customer to buy the better grade of goods which gives better satisfaction . . ."

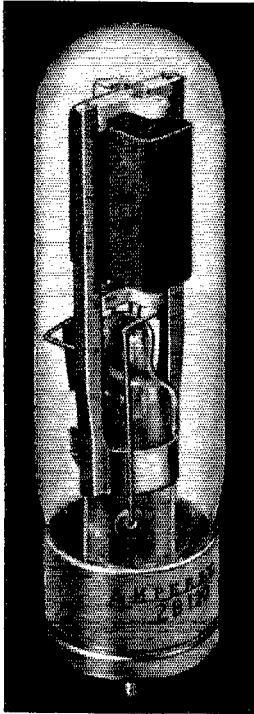

AMPEREX ZB 120

This new amateur CLASS "B" TUBE is winning instant acceptance not only from alert salesmen who make it their business to KNOW and recommend a superior product, but from amateurs who find it to be the best tube for use in a Class B Modulator stage, Class B Linear stage, as a Frequency Multiplier, or as a Grid Modulated Power Amplifier. It is a practically distortionless Zero Bias Amplifier, a high current low voltage tube that also lends itself readily to all experimental operations. Write for our bulletin containing charts and valuable operating and application notes.

Amplification Factor 90
Grid to Plate Transconductance at 100 ma. 5,000
Filament Voltage 10 volts
Filament Current 2 amps
Maximum Allowable Plate Dissipation 75 watts

\$10

AMPEREX
ELECTRONIC PRODUCTS, INC.
79 WASHINGTON STREET, BROOKLYN, N. Y.

belief that of the few possible agencies, temperature and water vapor gradients in the lower atmosphere were giving us this extraordinarily pronounced bending. Diffraction, we were forced to admit, was probably providing us with a steady sub-audible signal, but the observation that the signals disappeared entirely at times admittedly left us with no better reason to include diffraction in the discussion than the theoretical demand for its existence.

We were handicapped then, as we still are, by the lack of similar observations on the part of amateurs in other parts of the world. An examination of atmospheric conditions at places other than Hartford and Boston shows no reason why equally favorable or perhaps still more effective atmospheric gradients should not exist. Surprisingly, though, we still are unaware of any communication or recording link operating on the u.h. frequencies over a comparable path elsewhere. Or should we say, we know of no other set-up in which prolonged observations of signal variations have been related with variations in atmospheric conditions. Obviously, we could make much more rapid progress if recordings or frequent observations were made available in a wide variety of locations. Without any doubt, an organized group of amateur transmitting and recording links located according to some plan in various parts of the country, reporting their daily findings to some centralized office and working with the assistance of the Weather Bureau, could amass a pile of invaluable data which could not be equalled by any other group in existence. We look fondly toward the organization of some such project.

RECORDING ON A QUANTITATIVE BASIS

But to return to our story. By July 1936 we had reached the point where further qualitative observations were considered to be unjustified. The existing transmission and reception equipment, because of various forms of instability, were obviously unsuited for quantitative work and an entirely different line-up was planned. At about that time, the Yankee Network had begun operation of an experimental transmitter at Squantum, on low flat land on the outskirts of Boston. This transmitter, being higher in power than that used at Blue Hill, and being crystal-controlled, was considered to be a particularly appropriate one for recording. For the West Hartford end, a crystal-controlled receiver was assembled for operation with a Leeds and Northrup recorder, loaned for the work by the Yankee Network. Calibration equipment was provided so that the signal field could be measured in microvolts per meter. Then, with a simple dipole antenna, a program of continuous recording of carrier level was begun in August. This installation has already piled up six thousand hours of operation and is headed for more.

Needless to say, these continuous records proved to be infinitely more informative than the hourly tone signals previously recorded. There was revealed at once a whole series of types of



A DISTINGUISHED NEW FAMILY ACCEPTED IN THE FIELD OF RADIO TRANSMISSION

TEMCO, although a new name in the field of radio transmission, has made an enviable reputation and won acceptance by the creation of a complete line of transmitters embodying modern electrical design, quality of workmanship and standardization of the following features: Multi-frequency band switching exciter unit, simplicity of control, fidelity of transmission, over-abundance of excitation to assure efficient high frequency operation, attractive appearance.

"1000" A custom built transmitter with DeLuxe features to meet the demands of the discriminate buyer who requires every modern refinement in design and operation. Outstanding among these is the exclusive TEMCO automatic plug-in chassis with interconnecting channeling. A separate desk mounting speech amplifier with 2 channel mixer and remote control is also furnished as standard equipment.

"600" Has the same mechanical and electrical features as the 1000 plus built-in cathode ray oscilloscope. The only difference is in the power rating.

"350" Lower in power rating yet incorporating the same electrical features found in the 600 and 1000 watt units. Modified in mechanical design.

"100" A unit to fulfill the expectations of those demanding maximum efficiency in a 100 watt transmitter at reasonable cost. Features identical with the 350.

Write for complete descriptive literature which is now available on all models. Please indicate power classification in which you are interested. Address attention W2KR

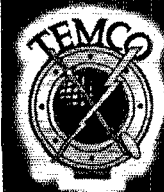
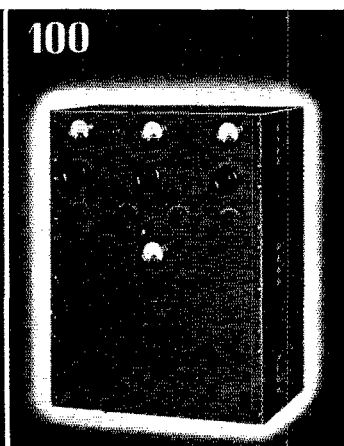
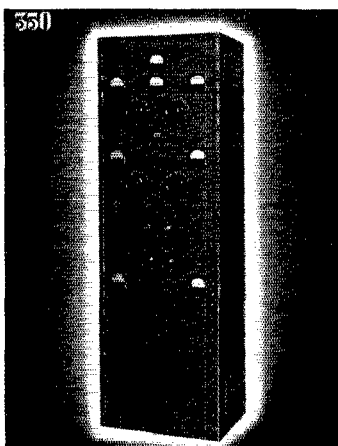
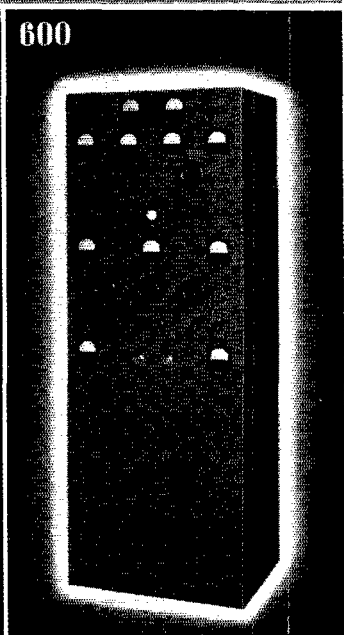
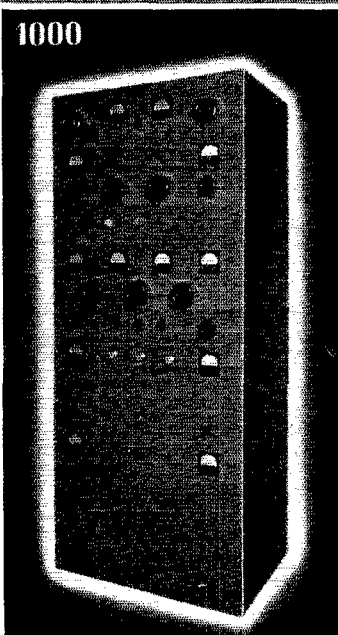

Transmitter Equipment Manufacturing Co., INC.

130 CEDAR STREET • NEW YORK, N. Y.

Designers and Manufacturers of Radio Transmitting and Accessory Equipment

ANOTHER NEW CARDWELL

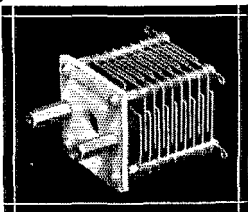

EO-100-FS A FIXED AIR CAPACITOR. Same space required for mounting as Dual Trim-air Midgets.
 Capacity 100 Mmfd. Insulation Isolanite
 Plates Aluminum Airgap050"
 Overall Length 2 1/4" (incl. mtg. posts)
 Regular Trim-Air Brackets may be used for mtg.

Other capacities and airgaps can be supplied upon request. Write us concerning your requirements.

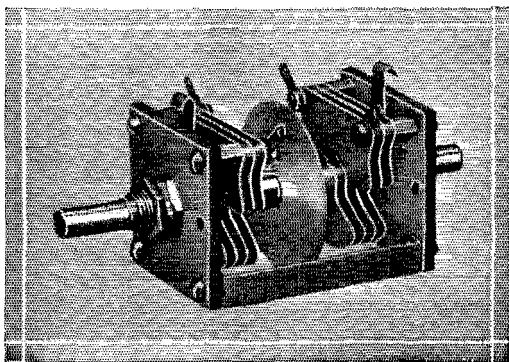

ER-25-AD For push pull 5 and 10 meter buffer amplifiers, phasing controls on S.S. supers, and for portable gear of any type. Cap. 25-25 Mmfd. 1000 volts. Net price **\$1.62**

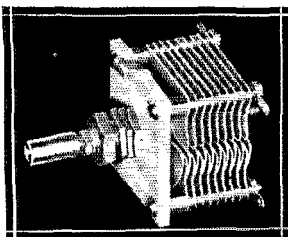

EU-75-AB

Illustrates one of five sizes of new balancing capacitors. Very useful in bridge work. Max. Cap. either side, 75 Mmfd.

Net price **\$1.50**

EU-140-AB

Illustrates one of five sizes of new balancing capacitors. Very useful in bridge work. Max. Cap. either side, 140 Mmfd.

Net price **\$3.18**

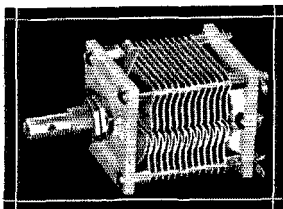

**THE ALLEN D. CARDWELL
 MANUFACTURING CORPORATION**
 83 PROSPECT STREET, BROOKLYN, NEW YORK

fading (each one obviously related to the type of air mass prevailing) and the records in general showed all sorts of minor trends and irregular behavior not previously made apparent. In addition, the stability of both transmitter and receiver gave us much more confidence in the recording as an undistorted picture of actual signal variations along the path. Of course, this continuous recording immediately introduced new difficulties. The recorder, turning out some 50 feet of 10-inch wide record each week, soon forged so far ahead of us that we seriously doubted our ability to get enough time to reduce the records to some working form. The hourly tones of the previous work had been measured from the photographic record, mean values being then taken for each day and for each hour of the day each week—a sufficiently tedious business. With this new program we required a reduction of the recordings in terms of signal level versus percentage of time—a procedure which, when done by hand, takes almost as much time as did the production of the recording itself. The outcome was the development and construction of an automatic record analyzer to be described later. This same device, after having served to reduce all existing recordings, was fitted to the recorder itself so that the signal is now not only recorded but integrated automatically as well.

In addition to the 41-Mc. receiver, two other crystal-controlled receivers (to be described) were provided. One for the Yankee Network 61.5-Mc. station, WIXAC, and the other, on 60.6 Mc., for a new crystal-controlled transmitter installed at the Blue Hill Observatory. These additional receivers, together with a new double-meter photographic recorder,* have enabled us to make simultaneous recordings on different frequencies to the tune of some singularly interesting results.

SOME FADING CHARACTERISTICS

This recent phase of the program has brought to light a great many interesting phenomena which, unfortunately, space does not allow us to recount in detail. In general, however, the recordings show that on the three frequencies studied, signals are low and subject to low-amplitude and rapid fading (about one fade per minute) when a fresh air mass of Polar origin prevails over the path during the day. The fluctuations show a definite slowing down toward evening while simultaneously increasing in strength to the early hours of the morning. This high and stable signal is maintained until slightly after sunrise when it again breaks up into increasingly rapid fading while dropping to a lower and lower level toward the middle of the day.

The explanation deduced to cover this behavior is that Polar air has a relatively small water-vapor content and a temperature which

* Based on the same scheme as that employed in the earlier recorder but fitted out with many mechanical refinements, this apparatus was constructed with facilities made available through the courtesy of James Millen and was contributed by him to the program.—A THOR.

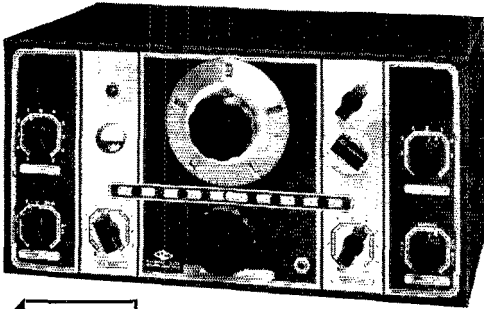

ONLY
\$27.60

DOWN
Balance
\$10.80
Per Month
1 YEAR
TO PAY

NATIONAL NC 100X
Complete (Cash Price) \$147.60

NATIONAL NC-100X the "Perfect" Super-Het! Amazingly selective, high sensitivity, low noise level. A wonderful performer. Full coverage, individual built-in plug-in coils, shifted by knob on front panel. 540 to 30,000 KC coverage in 5 ranges. 12 tubes, one stage RF, two IF, P.P. Pentode 10 w. audio output. Full AVC circuit. Built-in power supply. Single and double antenna connections. Latest type crystal filter. "Electric Eye" tuning indicator. Large, latest type Dynamic Speaker in cabinet to match.

NOW! Lower Down Payments Than Ever Before! EASY TERMS

These receivers are among the best values money can buy. Our 6% EASY CREDIT PLAN makes it easy to own one. Compare our rates. Send down payment with your order today. Set will be shipped as soon as credit is O.K.'d. Entire transaction 1 week. Order now!

	Cash	Down 6 Months	9 Months	12 Months
	Price	Payment	Payments	Payments
NATIONAL NC-100X complete with tubes, crystal and speaker in cabinet.	\$147.60	\$27.60	\$21.10	\$14.21
NATIONAL NC-100 complete with tubes and speaker in cabinet.	\$125.10	\$20.10	\$18.58	\$12.50
NATIONAL NC-101X complete with tubes, crystal and speaker.	\$129.00	\$24.00	\$18.58	\$12.50
NATIONAL HRO with tubes and coils.	\$179.70	\$29.70	\$26.14	\$17.67
NATIONAL HRO with tubes, coils and power supply.	\$195.60	\$35.60	\$27.84	\$18.83
HAMMARLUND SUPER PRO complete with tubes, crystal and speaker.	\$255.70	\$35.70	\$38.08	\$25.78
ACR-155 complete with tubes and built in speaker.	\$74.50	\$14.50	\$11.00	\$7.39
ACR-175 complete with tubes, crystal and separate speaker.	\$119.50	\$19.50	\$17.74	\$11.93
RME-69 complete with tubes, crystal and speaker in cabinet.	\$151.20	\$26.20	\$21.94	\$14.77
HALLIGRAFTER SX-11 complete with tubes and crystal. Speaker \$12.00 extra.	\$99.50	\$19.50	\$14.36	\$9.66
HALLIGRAFTER ULTRA SKYRIDER with tubes and crystal. Speaker \$12.00 extra.	\$114.50	\$19.50	\$16.90	\$11.37
				\$8.59

NEWARK HAM BARGAIN

Newark Ham Bargain in Plate Transformer and Chokes to Match. These Transformers and Chokes are fully enclosed in silver finish. All Guaranteed. You can now build that new Rig at a much lower cost.

Manufactured by UTC

- 20462A — 750-1000 each side of center, AC, at 300 mills. \$5.70
- 20462B — 1000-1250-1500 AC each side of center, 300 ma. \$7.35
- 20462C — 1500-2000-2500 each side of center, AC, at 300 mills. \$11.95
- 20462D — 1000-1250-1500 AC each side of center, at 500 mills. \$11.75
- 20462F — Smoothing choke 20 hy. — 200 MA — Lug terminals. \$1.75
- 20462FS — Smoothing choke 5-25 hy. — 200 MA — 2500 volts — Insulation — Lug terminals. \$1.75
- 20462G — Smoothing choke 20 hy. — 300 MA. \$3.25
- 20462GS — Smoothing choke 5-25 hy. — 300 MA — 3500 volts — Insulation. \$3.25
- 20462H — Smoothing choke 20 hy. — 400 MA. \$4.00
- 20462HS — Smoothing choke 5-25 hy. — 400 MA — 5000 volts — Insulation. \$4.00
- 20462I — Smoothing choke 20 hy. — 550 MA. \$5.50
- 20462IS — Smoothing choke 5-25 hy. — 550 MA — 6000 volts — Insulation. \$5.50

Vari-match Modulation Transformers

- VM-1. Will handle any power tubes to modulate a 20 to 60 watt class C stage. Maximum audio output 30 watts. \$4.70
 - VM-2. Will handle any power tubes to modulate a 40 to 120 watt class C stage. Maximum audio output 60 watts. \$7.35
 - VM-3. Will handle any power tubes to modulate a 100 to 250 watt Class C stage. Maximum audio output 125 watts. \$11.76
 - VM-4. Will handle any power tubes to modulate a 200 to 600 watt Class C stage. Maximum audio output 300 watts. \$19.11
- Thordarson No. T6878 Plate and Filament Transformer, 600-0-600 V. at 200 MA. 2 1/2 V. at 10 amp. 5 V. at 3 amp. 7 1/2 V. at 3 amp. **\$2.45**
- Thordarson Transformers, 115 V. — 60 Cycle 400-0-400-200 Ma. 6.3 V. — 5 Amp. C.T. 5 V. — 3 Amp. Electrostatic Shield Fully Shielded. **\$2.95**

DON'T WAIT until you have ready cash. Buy now on easy credit, at today's prices. Your saving will more than offset the small cost of our low rate 6% credit plan. Prices have already advanced about 20% during past month, and are sure to go much higher! Prices guaranteed for this month only!

VERY SPECIAL OIL FILLED AND OIL IMPREGNATED FILTER CONDENSERS

Lucky Purchase of 10,000, all well known makes, enables us to offer astonishingly low prices. All Guaranteed at rated voltages. Already sold down to limited supply and going fast. Order now!

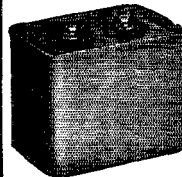

Cap.	Voltage	Size	Weight	Price
1 mfd.	2000 V. DC 5	x 3 1/4 x 1	1 1/2 lbs.	\$1.25
2 mfd.	2000 V. DC 5 1/2	x 3 1/4 x 2 1/4	3 lbs.	1.50
8 mfd.	2000 V. DC 5 1/2	x 3 1/4 x 4	4 lbs.	2.75
9 mfd.	3000 V. DC 5 1/2	x 3 1/4 x 11	9 lbs.	7.25
	(including 2 1/2" Bakelite standoffs)			
4.4 mfd.	1500 V. DC 5	x 3 1/4 x 1 1/2	1 1/2 lbs.	1.75
5 mfd.	1500 V. DC 3 1/2	x 3 1/4 x 1 1/2	1 1/2 lbs.	1.90
5.2 mfd.	1500 V. DC 5	x 3 1/4 x 2 1/4	2 1/2 lbs.	2.00

Added To Our Technical Staff
Harry Harrison W9LLX
Leo B. Wilcox W9BHM
Write to them about your problems.

NEW

Time Payments on parts and tubes totalling \$60.00 or more.

WRITE FOR DETAILS

ORDER DIRECT FROM THIS AD—NOW

Receivers listed in this ad are best values anywhere. Order today on EASY TERMS. Send your down payment with order. Set will be shipped immediately upon approval of your credit. Entire transaction in 1 week. No red tape. Full details of any item, with complete NEW CATALOG FREE upon request.

FILAMENT TRANSFORMERS

- If you like to save money on quality merchandise here's some real bargains.
- 2.5 Volts, 10 Amps — 2500 Volts Insulation — No. 2510. \$0.95
- 5 Volts — 4 Amps. \$1.00
- Volts Insulation — No. 50S. \$0.95
- 6.3 Volts, 3 Amps — 1600 Volts Insulation — No. 63S. \$0.95
- 7.5 Volts, 3 Amps — 1600 Volts Insulation — No. 75S. \$0.95

CHOKES

- 18 Henries, 125 M.A., \$1.15 A real quality choke. Resistance 130 Ohms. No. NS115. \$1.15
- Thordarson No. T6877 Heavy Duty Choke, 15 henries at 250 MA. \$1.95

FREE!

WRITE TODAY for New Bulletin of parts, tubes, and accessories. Just off press.

RAYTHEON TUBES



- RE-10. . . \$3.50
- RE-20. . . 15.00
- RE-20A 17.50
- RE-23. . . 4.50
- RE-25. . . 4.50
- RE-25B 3.90
- RE-28. . . 34.50
- RE-35. . . 8.00
- RE-36. . . 14.50
- RE-37. . . 8.00
- RE-38. . . 14.50
- RE-39. . . 3.50

Just Released by **TAYLOR!**
T20. . . . \$2.45
866 Jr. . . 1.00

Complete Stock RCA Transmitting Tubes in Stock
New 806 \$24.50
807 3.90
913 5.60

Bliley Crystals
BC3. . . . \$3.95
LD2. . . . 4.80
HF2. . . . 6.50

EIMAC
35T. . . . \$8.00
50T. . . . 11.50
100T. . . 13.50
150T. . . 20.50
250T. . . 24.50

NEWARK ELECTRIC COMPANY

226 W. MADISON ST. Dept. Q CHICAGO, ILL.

Does this name mean anything to you?

LEEDS
is pleased to
Announce their
APPOINTMENT —

Western Electric
AMATEUR
BROADCASTING EQUIPMENT

15 years of honest and faithful service to manufacturer and consumer is again rewarded.

Our appointment as Graybar agents for WESTERN ELECTRIC Amateur Broadcasting Equipment is something to be justly proud of, and we feel certain our friends will respond generously. Anything in Western Electric Amateur Broadcasting Equipment can now be obtained from us immediately.

WESTERN ELECTRIC TUBES

- 300-A. Class A audio, 12½ watt output. \$9.75
 - 304-B. Ideal ultra high frequency triode. 12.50
 - 305-A. 85 watt screen grid U.H.F. 38.50
 - 306-A. R.F. pentode — the perfect frequency multiplier. 10.80
 - 307-A. A.F. and R.F. pentode. 13.65
 - 316-A. Ultra high frequency triode; 7½ w. output on 500 MC. 10.50
 - 242-C. 100 w. general purpose. 15.00
-
- 633-A. "Salt Shaker" Dynamic mike; broadcast quality at the new low price of. 42.50
 - 1002-C. Phones. 8.30



LEADS THE FIELD

45 Vesey Street
New York City
Tel. COlrandt 7-2612
Cable Address: "RADLEEDS"

World Wide Service to Amateurs
See April issue for many other Leeds specials

drops off sharply and smoothly with height during the day. In such an air mass, appreciable turbulence is caused by the heating of the surface air and the resulting convection. It is the sort of air eagerly waited for by pilots of sailplanes who require, for effective flight, the upflow of heated air (thermals, they are termed). This turbulence, considered to be the direct cause of the rapid signal fading, is reduced after sundown because of the surface cooling. Gradually the lowest layer of the atmosphere drops to a temperature lower than that of the air above it. This condition, during the night, gives us the steady and relatively strong signals. Turbulence again sets in with the rising of the sun, and heating of the surface air again destroys the temperature inversion that had been so helpful in producing the strong bending during the night.

THE EFFECT OF TROPICAL AIR

This behavior, of course, applies only to a stable condition in fresh Polar air. Such an air mass becomes rapidly modified by the continued heating of its lower level and by the assimilation of added water vapor. This, as far as the weather is concerned, involves the formation of cumulous clouds and a reduction in that high order of visibility which characterizes fresh Polar air. During this phase signals take on a much more ragged fading characteristic and attain a higher level for a given time of day than previously. This type of air rarely prevails for long in this part of the country and within a day or two one ordinarily expects a low pressure area to come in across southwest part of the country spreading over the Atlantic States a layer of warm tropical air. This circumstance shows itself in the signal recording as a tendency for the minor fluctuations to group themselves in a sort of wave motion, the surges becoming longer in duration and higher in amplitude as the tropical air reaches down toward the surface. By mid-evening on a day when such a tropical disturbance is approaching, the signal will ordinarily have reached a mean level of something more than 200 microvolts per meter, holding this level with very slight fluctuation over periods of an hour or more, then suffering a momentary deep fade. For three or four hours prior to the actual beginning of precipitation, the signal is prone to ride with substantially no variation at a level in excess of 300 microvolts per meter.

The beginning of precipitation is usually accompanied by a complete change in the character of the signal, the change apparently being slow or rapid, apparently depending on the extent to which the area of precipitation covers the signal path. Ordinarily, the change is in the development of very small amplitude and rapid fading which carries the signal to a lower but still fairly steady level. This, however, is not always the case. In several outstanding instances, the extremely high level was maintained for several hours after precipitation had started. The study of conditions surrounding such exceptional cases is, of course, very much a part of the work.

RME - 69

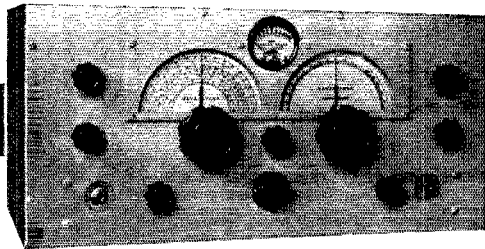

I. F. TRANSFORMERS

tell an interesting story, especially the units which enter into RME — 69 receivers.

Upon intermediate frequency transformer design and construction depends to a marked extent the high frequency selectivity of a superheterodyne.

The coefficient of coupling between primary and secondary determines whether an RME transformer is used in the 1st, 2nd or 3rd stage, in order to obtain the desired results.

Wound in honeycomb fashion, on specially designed machines, thoroughly impregnated and individually tested for proper characteristics before going into the receivers, using the best 10/41 Litz wire — these transformers last indefinitely in *any* climate.

Write for Bulletin 69

RADIO MFG. ENGINEERS

Peoria, Illinois

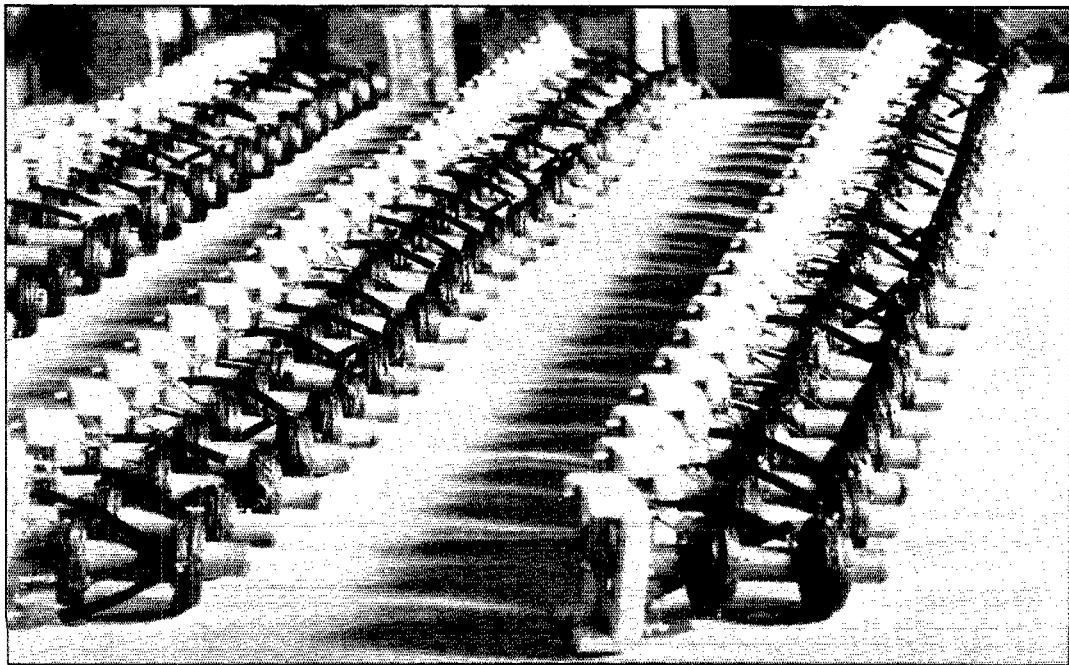



**A NEW
BEGINNER'S
RIG
USING
STANCOR
TRANSFORMERS**

●A 40 watt transmitter for c.w. operation that can be built for less than \$40.00 . . . including tubes, crystal and meter. Crystal control . . . capacitive coupled . . . only 2 tuned circuits using the new 6L6G and the new Taylor T20. . . It's one of the simplest and most dependable beginner's rigs ever designed. **FREE Schematic Drawings on Request**

**S T A N D A R D
T R A N S F O R M E R
C O R P O R A T I O N**
850 BLACKHAWK STREET • CHICAGO

**FILAMENT - DROPPING
RESISTORS**

SEND for FREE Bulletin 107. Complete data with diagrams for operating the newer type of 6.3 volt or 5 volt tubes on your 7.5 volt filament supply without sacrificing costly equipment already in use. Ask your dealer or write us.



OHMITE
MANUFACTURING CO.
Manufacturers of Rheostats,
Resistors and Tapswitches
4831 Flournoy St. Chicago, Ill.

HANDBOOK
PAGES
518-519
CATALOG
SECTION

The 1936 Sweepstakes

(Continued from page 38)

Listen my children,
And you shall hear,
That "SS" squeak,
Still in my ear. . . .
—W8BKE

single 150T, single 800, single 804.

CHOICE OF FREQUENCY BANDS

7 Mc. is still out in front as the most used band during the Sweepstakes. 79 per cent of all contestants did some of their operating on "forty" in the '36 SS. 14 Mc. replaced 3.5 as the second most popular contest band, with 50 per cent doing some operating there. 3.5 Mc. is a close third with 48 per cent. While "one-band" operation is not recommended during a contest, some operators chose to stick to their favorite stamping grounds. 22 per cent used 7 Mc. exclusively, 12 per cent remained on 3.5 Mc. and 6 per cent didn't leave 14 Mc. The most popular combination of bands used was 7 and 14 Mc.—22 per cent . . . followed by 3.5, 7 and 14 Mc.—18 per cent, 3.5 and 7 Mc.—14 per cent, 3.5 and 14 Mc.—1.3 per cent. 28 Mc. was used by 2 per cent of all participants. 56, 1.7 and 112 Mc. were used by a very few.

Many conclusions can be drawn from the work of the winners. There seems no question that use of several bands pays dividends. 48 per cent of the section winners used the 3.5, 7 and 14 Mc. combination. 33 per cent used 7 and 14 Mc. 1 per cent used 3.5 and 7 Mc. While two winners did succeed by sticking to one band only, they were the exception rather than the rule. It is in the matter of working sections that use of bands is most important. If you pass up the lower frequencies you will miss the more local sections, if you skip the high frequencies you'll find it difficult to get the distant sections. If you plan to enter the SS (or any other contest) get your rig working on all bands and you'll have a better chance of coming out on top.

POWER

The power classifications in the '36 SS were the same as those introduced first in the '35 contest. Operators using 100 watts or less multiplied their basic score by 1.5 for final score. Those using over 100 watts multiplied by 1. It is interesting to note that the number of operators working under each power classification is the same for both '35 and '36—75 per cent using 100 watts or less, 24 per cent using over 100 watts, 1 per cent operating under both classifications. Since operator proficiency is such an important factor in station accomplishment it is almost impossible to arrive at any definite decision regarding high vs. low power. The two operators who worked the greatest number of stations, W3BES and W3CHH, used high power. The third high in number of stations, W1EZ, used under 100 watts. The next high in number of stations, W1INF and W9ELL, used high power. It seems logical to believe that an operator using high power can usually work them faster than one with lower input. The leaders in number of sections worked, W6LTH (69), W6SN

A. C. RELAYS

Made by

Allen-Bradley

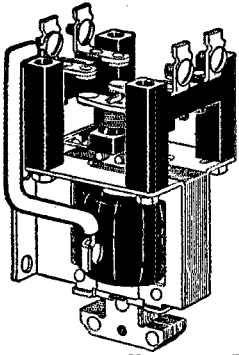

These A. C. solenoid relays are ideal for remote control of transmitters, for control of crystal ovens, and for any general remote control application except for keying. THESE RELAYS WILL NOT OPERATE IN KEYING SERVICE. Silver-to-silver double-break contacts are used throughout.

The maximum contact rating is 10 amp. at 220 v. or 3 amp. at 550 v. The relay coils are wound for 115 volts 60 cycle alternating current. Relays for other voltages can be supplied on special order. Use coupon below.

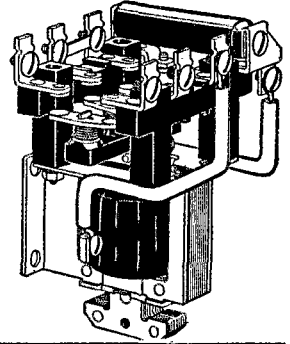

Type No.	Poles	Nor- mally	Action	Circuit Diagram	Price		Type No.	Poles	Nor- mally	Action	Circuit Diagram	Price	
					Open	In Cab.						Open	In Cab.
A107	1	Open	SP ST		\$3.50	\$4.50	A177	1	Closed	SP ST		\$7.50	\$8.50
A117	1	Closed	SP ST		4.50	5.50	A207	2	Open	DP ST		4.00	5.00
A127	1	Open and Closed	SP DT		5.00	6.00	A217	2	Closed	DP ST		6.00	7.00
A137	1	Open	SP ST		4.00	5.00	A227	2	Open and Closed	DP DT		7.00	8.00
A147	1	Closed	SP ST		5.00	6.00	A237	2	Open	DP ST		4.50	5.50
A157	1	Open and Closed	SP DT		5.50	6.50	A247	2	Closed	DP ST		6.50	7.50
A167	1	Open	SP ST		6.50	7.50	 <p>Radiostat—A stepless graphite compression rheostat for primary of 550 watt filament or plate supply transformer. Range 4 to 150 ohms. Price \$6.50</p>						

ORDER BLANK—MAIL WITH REMITTANCE TO

Allen-Bradley Co., 108 W. Greenfield Ave., Milwaukee, Wis.

Enclosed find money order for \$..... for which please send me, shipping charges prepaid, the following items:

..... for..... Volts..... Cycles

Name.....

Address.....

Build or Rebuild with the "STREAM-LINE" POWER HOUSE

(Patent Allowed)

"A Lap Ahead
o' the Field"



Plate Transformers
Swinging (1st Position)
and Filter (2nd Position)
Chokes and Modulation
Transformers

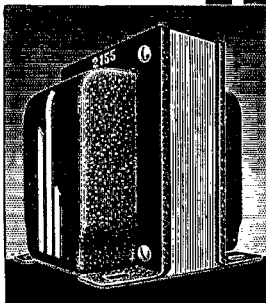

"STREAM-LINE" in design, appearance and performance. Radically new design saves up to 25% in space and weight on your chassis. All-over housing clamps core all-around, preventing lamination hum, shields, protects coils, keeps moisture out. Coils GTC "Pull-Push" moisture-proofed. Ample insulation provides large safety factor. Ask your jobber or write for Bulletins 35 and 42 with diagrams — FREE!

GENERAL TRANSFORMER CORP.
518 S. Throop Street Chicago, Illinois

"AIR INDUCTORS"

Trade Mark

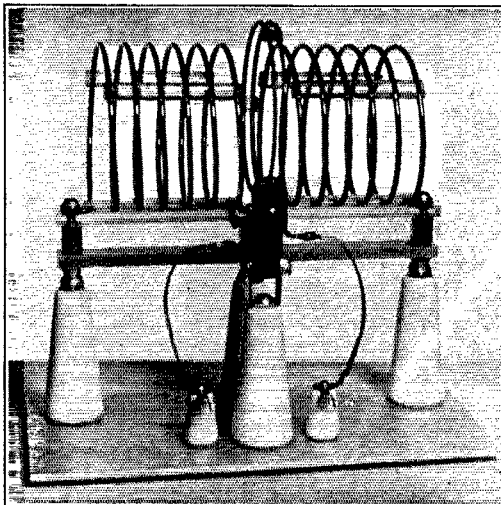

The New B & W SWINGING LINK ASSEMBLY is the practical solution to complete control of loading from the final stage to low impedance feeders. When used with our special antenna impedance matching coil it will work into either high or low impedance lines.

Most complete line of transmitting coils on the market. See them at your local jobber or write direct for catalog

BARKER & WILLIAMSON
RADIO MANUFACTURING ENGINEERS
ARDMORE, PENNA.

(67), W8AQ (66) and W3BES (64), all used high power. The leader in "sections worked" in the group below 100 watts is W1TS, who worked 63.

LOW POWER ACCOMPLISHMENTS

The records of a few operators who used what can really be termed "low power" are refreshing in this game where the common urge is to run the power up, up, up. . . . W1JAH using a 6L6 e.c. oscillator running at 3 watts input worked 48 stations in 19 sections! With a Hartley oscillator on 3.5 Mc. and a TNT for 7 and 14 Mc., with inputs of from 9 to 12 watts, W8FDA, veteran of the low power ranks, made 16,821 points—134 stations, 42 sections; tube used was a '71A, and W8FDA uses the same B batteries were used in the '35 SS!! W1EXZ believes in low power—he ran only 1.75 watts to a 12A7 but he worked 14 stations in 7 sections in a few hours of operating . . . and that is something under present day QRM conditions. W9VES with 20 watts input scored 24,048—168 QSO's, 48 sections. W8LCO hit 4790 points with 16 watts; 52 stations, 31 sections in 17 hours. 12 watts into a '45 TNT on 14 and 3.5 Mc. brought 5301 points to W5FJR (60 stations, 31 sections). VE4CQ had his fun with 2 watts to an '01A TNT, working 25 stations in 12 sections. 10 watts brought VE3QB 57 QSO's in 31 sections, 5058 points. The possibilities of low power are too often under-estimated. The reason that the above champions of low power get results is that they have confidence in their signals. The old adage "You've gotta make calls if you wanta get results" is particularly true on low power—but don't be afraid to make the calls . . . you may be surprised at the DX you can raise. The practice of calling anything you can hear is a good one to follow.

SIDELIGHTS

"Would like to tell anyone who thinks contests are a lot of bunk to get into the SS and see if their operating ability is really so hot."—VE4KX. W5ETZ, New Mexico, operated on one frequency only—14,100-kc., but he made 111 contacts in 43 sections. W9SCW, Iowa, stuck to 7032-kc., working 90 stations in 34 sections. 84 per cent of W9WWT's 179 contacts resulted from his CQ's. Add smiles: "As hopeless as the chap who answers a 'CQ SS' and expects to get a ragehew." Break-in operation was one of the secrets of contest success and should be more widely used. A difficult question: To call that W5 in New Mexico or the W1 in Vermont, both on the same frequency!? Irony: W9TWC called his first off at Louisiana all through the contest with no results—then his first QSO after the contest was with W5CRE, Shreveport. Did you meet any of those lads using self-excited rigs who swooped down on your frequency without warning and snatched away the QSO's without even a "thank you"?—but it's all in the game. "The contest provided a fine test for my newly built transmitter"—W9TSQ. There was less trouble than usual from the uninitiated asking "What does SS mean." VE3GT ran into only one such case, yet he worked 191 stations. "Enjoy these contests more each year. . . . The contest seemed snappier and better advertised than any previous one."—W9DGS. W8PGG estimates that at least 90 per cent of the stations on the air during the two week-ends were in the SS. That seems like a conservative estimate! Believed to be the most haywire antenna was that used at W6NEN: It consisted mainly of bell wire with regular 110 volt line wire here and there; it had about 40 splices and 5 angles; no insulators used at all and at no point was it more than 2 feet from the house. If you ever get discouraged over your antenna, remember W6NEN's maze. Definition for Sweepstakes Contest: "It's a tornado, cyclone and dead calm all mixed up like a Tom and Jerry. One min-

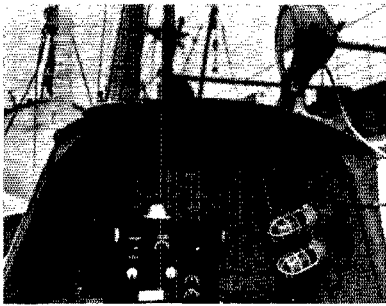

Interior View S. S. Pennsylvania Lifeboat
Showing Standard Radio Equipment



ALL'S WELL

on the Pennsylvania Lifeboats!
Emergency Radio — Powered by Burgess

When emergencies arise at sea, life saving equipment must be sturdy and reliable.

The S. S. Pennsylvania of the Panama Pacific Line carries lifeboats fitted out with portable RCA emergency radio-telegraph equipment which enables them to contact other ships. Burgess Batteries were chosen to supply the portable power for this apparatus — because Burgess Batteries have

proved themselves equal to the strain of long, hard service under the most trying conditions.

Profit by the experiences and tests of skilled engineers. You, too, need dependable portable power. Use Burgess.

BURGESS BATTERY COMPANY
Freeport, Illinois

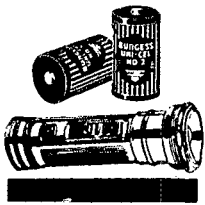

BURGESS



Say You Saw It in QST — It Identifies You and Helps QST

MODERN

Type HFM

Mobile Crystal Control

for 5- and 10-Meter

PHONE—CW—ICW

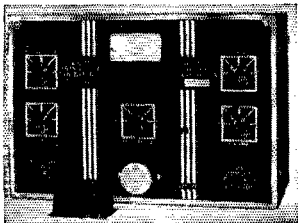

- Single 40 Meter Crystal for All Bands
 - 40 and 20 Meter Portable CW
 - Complete With Coils for 5-10-20 and 40 Meters
- H-F-M
TRANSMITTER
\$48.00

"Type TR-6A6"

- Non-radiating Rec'vr
 - 7 Tubes—Jensen Dynamic Speake
 - New 6E6 Unity Coupled
 - 10 Watt Carrier
 - 100% Modulation
 - Duplex Operation—PHONE • ICW
- TRANSMITTER—RECEIVER

\$39.75

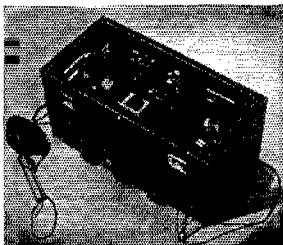

RADIO TRANSCIVER LABORATORIES

8627 — 115 Street, Richmond Hill, New York

ute they're all calling, another minute the band sounds nearly dead, then WHAM bedlam again breaks loose." One of the contest's keenest joys was working a W9 who turned out to be somewhere besides Chicago! Hi. A burned out '01A is offered by Mr. Sweep Stakes for the best guess as to the number of Chicago hams active in the contest—it seemed like millions. And why were the W3's so often in Philadelphia? How the directional CQ's popped up during the last hours of the contest . . . bearing down on the missing sections! Says W3KT, president of the Frankford Radio Club, gavel winner, "The idea of club competition is very good . . . among other things it helps to keep up interest in a club." In the 1935 SS W9TYF made 259 contacts in 50 sections in 90 hours of operation; in 1936 he made 273 contacts in 53 sections in 40 hours. W9RQM bettered his 1935 performance in both stations worked and sections worked, operating about 12 hours less. "Found that the SS is the time to work unusual places. Worked two more states towards "W.A.S."—W1FSV. W3FKZ worked the one state needed for W.A.S.—New Mexico. W9WEN worked five new states, W5DB four and W5EGP two new ones. W6JMR worked some new stations in New Mexico and now claims W.A.S. 2 (worked all states twice). Contest curses: Blown apparatus, school, work and the need for sleep. "I think W6TT, W7DXZ and W7EAL should have their honesty rewarded. These hardy souls were the only operators in over fifty-five to give me less than TS."—VE4YX. QSO's in the '36 SS averaged about 76 per reporting participant.

Aside from the fact that it furnished good operating fun, the SS had its more serious side—it actually improved the operating ability of many amateurs; it provided an excellent opportunity to test station equipment; it gave practice in proper message preambles; it brought together hundreds of operators, all working with a common purpose, thereby furthering the spirit of fraternalism—the spirit of amateur radio! See you in the '37 SS!!

Scores

(Continued from page 54)

W8JTT	4418-31- 48-A-10	W8MUE	10101-37- 91-A-21
W8QHX	4272-24- 60-A-28	W8NDO	9999-33-103-A-29
W8ADV	3931-29- 71-B-17	W8MKK	7258-38- 99-B-29
W8LFV	2967-23- 43-A-25	W8KBM	6723-27- 83-A-24
W8NWZ	2622-23- 38-A-15	W8QES	3036-22- 47-A- 9
W81PS	2048-21- 33-A- 9	W8NEK	1200-16- 25-A- 9

NEW
Reduced
PRICE

ASTATIC

MODEL K-2

NOW
Only
\$27.50



The famous Astatic Non-Directional Dual Diaphragm Dual Unit Studio Model K-2 is now within the purse range of every amateur. Never before has a crystal microphone of this quality been offered at so low a price.

Featuring

**The New Astatic
PLUG and SOCKET and
CABLE PROTECTOR**

Furnished equipped with the exclusive Astatic plug and socket connector, permitting instant interchange with Astatic D-2 or D-104. Plus the new Astatic Spring Cable Protector which prevents cable breakage at mounting.

Licensed under Brush Development Co. Patents

ASTATIC MICROPHONE LABORATORY, INC.

DEPT. Q, YOUNGSTOWN, OHIO, U. S. A.

Pioneer Manufacturers of Quality Crystal Devices

**SEE YOUR
ASTATIC
JOBBER**

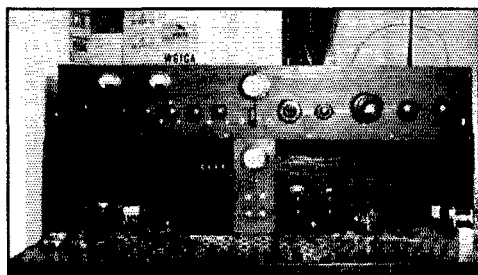

W9RQM

Sixth highest national scorer and winner of the Wisconsin certificate was Reno Gotsch, W9RQM, O.R.S.—47,123 points. His station layout differs from the usual run and offers a new idea in conserving space. The rig used during the contest was a 59 e.c./c.c. oscillator, '46 buffer, '10 final. The present rig is a 59 e.c./c.c., '46, '10 and T55 final running at 200 watts input on 28, 14, 7, 3.5 and 1.75 Mcs.

W8ETT	1759-21- 30-A-26	W8WNV	1139-17- 34-B-15A
W8JUF	1701-21- 27-A-10	W8OWC	600-10- 20-A- 7
W8OAG	1633-17- 33-A- 8	W8QEI	105- 5- 7-A- 4
W8ERZ	1418-21- 23-A- 9	W8NQL*	40- 4- 5- - -
W8MNV	1103-15- 25-A-15	W8MSZ	27- 3- 3-A- 1
W8PCM	522-12- 15-A-13	Phone	
W8PNL	480-11- 15-A- 6	W8OIZ	748-11- 34-B-18
W8KXA*	72- 4- 6-A- 2		

CENTRAL DIVISION

W. Pennsylvania		Illinois	
W8KUN	39273-53-249-A-38	W9NUF	38852-59-221-A-37
W8FIP	23664-58-204-B-34	W9KEH	35028-63-278-B-36
W8OYK	23388-58-193-B-39	W9RCQ	30912-56-276-B-39
W8OIX	18840-40-187-A-38	W8VCS	24048-48-168-A-34
W8MZB	15630-45-120-A-28	W8MUX	23250-50-155-A-34
W8ESN	15309-42-125-A-33	W8VFFZ	22308-44-175-A-40
W8MOT	10654-36-126-A-32	W8PNE	22260-53-144-A-40

EVERYONE LIKES THE NEW EIMAC 100TH

▲ The "DX" Man

A powerful, clean cut signal on even the highest amateur communication frequencies assures the "DX" man of the greatest possible results from his equipment.

▲ The "Traffic" Man

Two band operation merely by the "flick" of the final tank tuning condenser will appeal to the "traffic" man. Outputs of 150 watts or more from a single 100TH when used as a doubler is just one of the unusual capabilities of this new tube.

▲ The "Experimenter"

Accidental overloads during adjustment will not harm the 100TH. The 100TH provides a useful tool for the exploration of the following: Ultra high frequency phenomena — Frequency multiplication at a relatively high power level — Class "B" audio work. The ease of neutralization even at the highest frequencies and the freedom of parasitic oscillations are just two advantages of the extremely low interelectrode capacities of the 100TH.

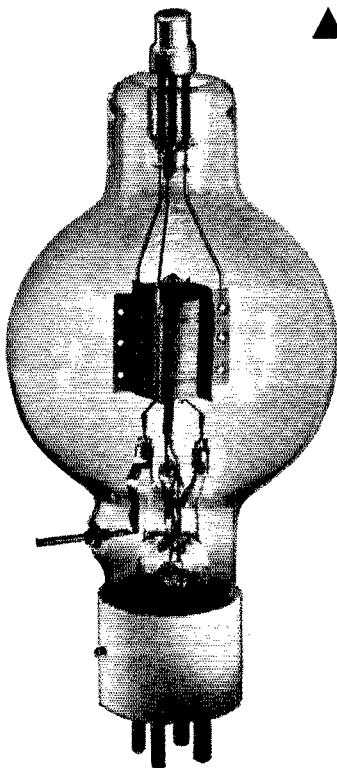

EIMAC 100TH

▲ The "High Power" Man

The power capabilities of the 100TH are usually sufficient to satisfy the most "rabid" high power man. For those men that must run a "California kilowatt" the use of the 100TH as a buffer or a buffer-doubler leaves little to be desired.

▲ The "Phone" Man

A clean, powerful carrier with a full rounded modulation envelope are readily obtained even on 56 megacycles with the new 100TH. In Class "B" audio outputs of 500 watts may be obtained from a pair of these tubes. An output of 260 watts with 1250 volts may be obtained with the 100TH tubes operating with zero grid bias.

▲ The "Rag Chewer"

The new and improved type of thoriated filament plus tantalum electrodes assures the user of the 100TH of phenomenally long filament life plus complete freedom from failures caused by gas. If you want a transmitter that will "stay put" year after year the 100TH will certainly be your choice.

You Will Like Your 100TH

SEE THIS NEW TUBE TODAY AT YOUR DEALER'S

Only \$13.50

EITEL-McCULLOUGH, INC.

San Bruno, California, U. S. A.

Say You Saw It in QST — It Identifies You and Helps QST

FOR BETTER PERFORMANCE

● For powerful, clean-cut phone signals that "click-off" the QSO's, use a Shure 70S — the first crystal microphone specially designed for high-efficiency voice transmission! Doubles power on intelligibility speech frequencies. Used by police radio, airways, and commercial stations. **List Price, with Desk Mount..... \$25**

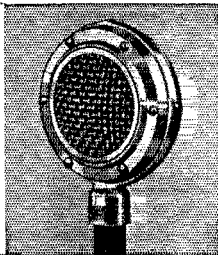

Completely New — Utterly Different! Ask your Jobber about the new Shure ZEPHYR Balanced-Tracking Crystal Pickup — or write for Bulletin 143QA today. Shure Crystal Devices are licensed under patents of the Brush Development Company. Shure patents pending.

See us at Booths 71 and 72 — Radio Parts Manufacturers National Trade Show — Chicago, Stevens Hotel, June 10-13.



Introducing new developments for entirely new applications



Fully described in supplement to technical bulletin 536. Send for your copy *List Price*

Type A 3500 interstage — 3000-5500 kc. range	4.00
Type A 3502 diode — 3000-5500 kc. range	4.00
Type C 3550 BFO — 3000-5000 kc. range	2.50
Type U 100 interstage — 13,250 kc.	2.00
Type L 150 inductance tuned converter — 262 kc.	2.50
Type L 250 inductance tuned diode — 262 kc.	2.50
Type L 101 inductance tuned converter — 465 kc.	2.50
Type L 200 inductance tuned diode — 465 kc.	2.50
Type S 101 converter — 465 kc.	2.50
Type S 200 diode — 465 kc.	2.50
Type G 1601 air tuned converter — 1600 kc.	10.00
Type G 1600 air tuned interstage — 1600 kc.	10.00
Type G 1604 air tuned diode — 1600 kc.	10.00
Type G 1605 air tuned silencer — 1600 kc.	8.00
Type G-1 1601 air tuned band expansion converter — 1600 kc.	12.50
Type GH 1600 air tuned band expansion interstage — 1600 kc.	12.50

ALADDIN RADIO INDUSTRIES, INC.
466 q West Superior Street, Chicago, Illinois
Licensee of Johnson Laboratories, Inc.

W9WWT	19525-55-179-B-40	Michigan	22805-55-139-A-32
W9FZX	18560-49-116-A-39	W8GQB	13371-42-106-A-18
W9UUM	15867-41-130-A-39	W8ONK	12048-37-122-A-32
W9VEE	15300-51-150-B-33	W80TC	8880-37- 81-A-23
W9UTT	14649-38-133-A-30	W8OSD	4095-21- 68-A-15
W9NQI	14099-39-122-A-35	W8OGV	3245-21- 52-A-15
W9IPT	13398-44-103-A-33	W8GUP	2992-22- 69-B-13
W9TKN	12012-44- 91-B-36	W8MTE	2061-24- 43-B-16
W9IYA	12005-49-124-B-25	W8NXT	1534-22- 24-A-5
W9TQL	11934-36-113-A-21	W8EGI	1350-18- 25-A-10
W9NPT	10940-39- 94-A-32	W9YX	1260-21- 30-B-8
W9WFS	10928-36-101-A-24	W8MRP	1035-15- 23-A-10
W9CCP	10767-37-100-A-26	W8PGG	378- 9- 15-A-4
W9KMN	10512-38- 94-A-35	W8SSH	200-10-10-B-4
W9IVD	9680-44-113-B-25	W8DSQ	144- 8- 8-A-5
W9MHD	9637-37- 87-A-22		
W9AZP	8955-45-100-B-22		
W9TCK	7805-35-115-B-2		
W9INY	6604-37- 60-A-28		
W9UHQ	5673-31- 63-A-16		
W9GMT	5438-37- 70- 15-A		
W9SIV	5351-29- 61-A-17		



PAUL McCAMPBELL, W4CDC

Tennessee Section winner, W4CDC worked 207 stations in 61 sections for a grand total of 37,515. The 7- and 14-Mc. bands were used with p.p. 35T's in the final stage.

Ohio	43554-61-242-A-37
W8BYM	33539-66-257-B-40
W8AQ	30195-61-252-B-40
W80FN	23430-62-189-B-31
W8BTI	22124-43-172-A-29
W8OIL	21858-48-183-A-37
W8OMB	19300-50-190-B-37
W8PMB	18360-51-189-B-42
W8JHN	17150-56-188- 2300
W8NTQ	15822-48-111-A-33
W8PKZ	15592-45-117-A-35
W8PMT	14308-46-145- 3811
W8OQV	13961-41-115-A-38
W8MCO	13080-40-112-A-31
W8OYY	11814-44- 90-A-26
W8ENA	11328-43-120-B-27
W80FB	8282-36- 77-A-31
W8KZO	8140-27-101-A-30
W8BKE	7956-39- 68-A-21
W8LOF	7844-42- 92-B-23
W8DAE	7525-35-108-B-19
W8IMH	7128-44- 81-B-30
W8PZZ	5798-28- 70-A- 9
W8IAW	4790-31- 52-A-17
W8LCO	3281-27- 41-A-26
W8PGI	2325-25- 31-A-15
W8CKF	1260-15- 23-A- 9
W8ORM	



PROSE WALKER, W2BMX

His operating skill netted him 37,128 points and first place in the Eastern New York Section. He used a 53 oscillator-doubler, '45 buffer and p.p. Taylor 756's running at 96 watts input.

W8NXM	558-12- 17-A- 7
W8LZE	297- 9-11-A- 4
W8NMR	234- 9-11-A- 3
W8CMI*	90- 6- 8- -
W8DWH	45- 3- 5-A- -

Wisconsin	47123-61-259-A-38
W9RQM	29415-53-187-A-39
W9EYH	22518-54-209-B-35
W9GIL	16638-47-121-A-40
W9VDY	14384-38-126-A-36
W9SES	12226-39-105-A-25
W9RKP	10314-36- 97-A-20
W9FTH	10125-45-113-B-21
W9UIT	9270-45-103-B-23
W9PRA	5265-26- 69-A-29
W9UTE	2730-26- 35-A- 6
W9AKT	884-17- 26-B- 8
W9LUC	376-10- 13-A- 8
W9KXK	231- 7-11-A- 7
W9VTP	32- 4- 4-B- 1
W9RH	3- 1- 1-A- -
W9PQY	

W9RSL	5130-30- 58-A-21
W9TZV	4899-23- 71-A-10
W9TAY	4779-27- 59-A-19
W9OMA	4725-35- 69-B- -
W9EBX	4464-31- 48-A-20
W9WHF	3838-29- 44-A-20
W9SRT	3225-25- 43-A-18
W9NMO	2912-26- 57-B- 6
W9GPK	2812-25- 38-A-22
W9MGN	2700-25- 36-A-12
W9RBR	2337-19- 41-A-22
W9NGA	1950-20- 33-A- -
W9MGO	1860-20- 32-A-11
W9NWE*	1720- - - - -
W9TUY	1428-17- 28-A-19
W9DAZ	1080-20- 26-B- 6
W9WEN	1032-16- 22-A-16
W9MCC	882-14- 21-A- 4
W9OQW	800-16- 25-B-11
W9NIU	799-13- 21-A-15
W9SKR	459- 9- 17-A- 4
W9BJJ	288-12- 12-B- 3
W9TAD	288-12- 8-A- 5
W9YTV	180- 6-10-A-13
W9RSL	144- 6- 8-A- 5
W9UGW	60- 4- 5-A- 7
W9FTX	32- 3- 4-A- 8
W9WR	28- 4- 4-B- 1
W9NDB	4- 1- 2-B- -

Indiana	41101-53-273-A-40
W9TYF	30654-52-203-A-39
W9TWC	24150-50-162-A-39
W9EGQ	1730-39- 62-A-34*
W9SAL	4896-36- 68-B-13
Q9KPN	3- 1- 1-A- -
W9WCE*	
Phone	
W9LLV	3- 1- 1-A- 4
Kentucky	
W9ELL	34844-62-281-B-39
W9RBN	29925-57-263-B-36
W9KOX	1922-21- 31-A- -

DO YOUR DARNDDEST-
I HAVEN'T POPPED
OUT IN YEARS!

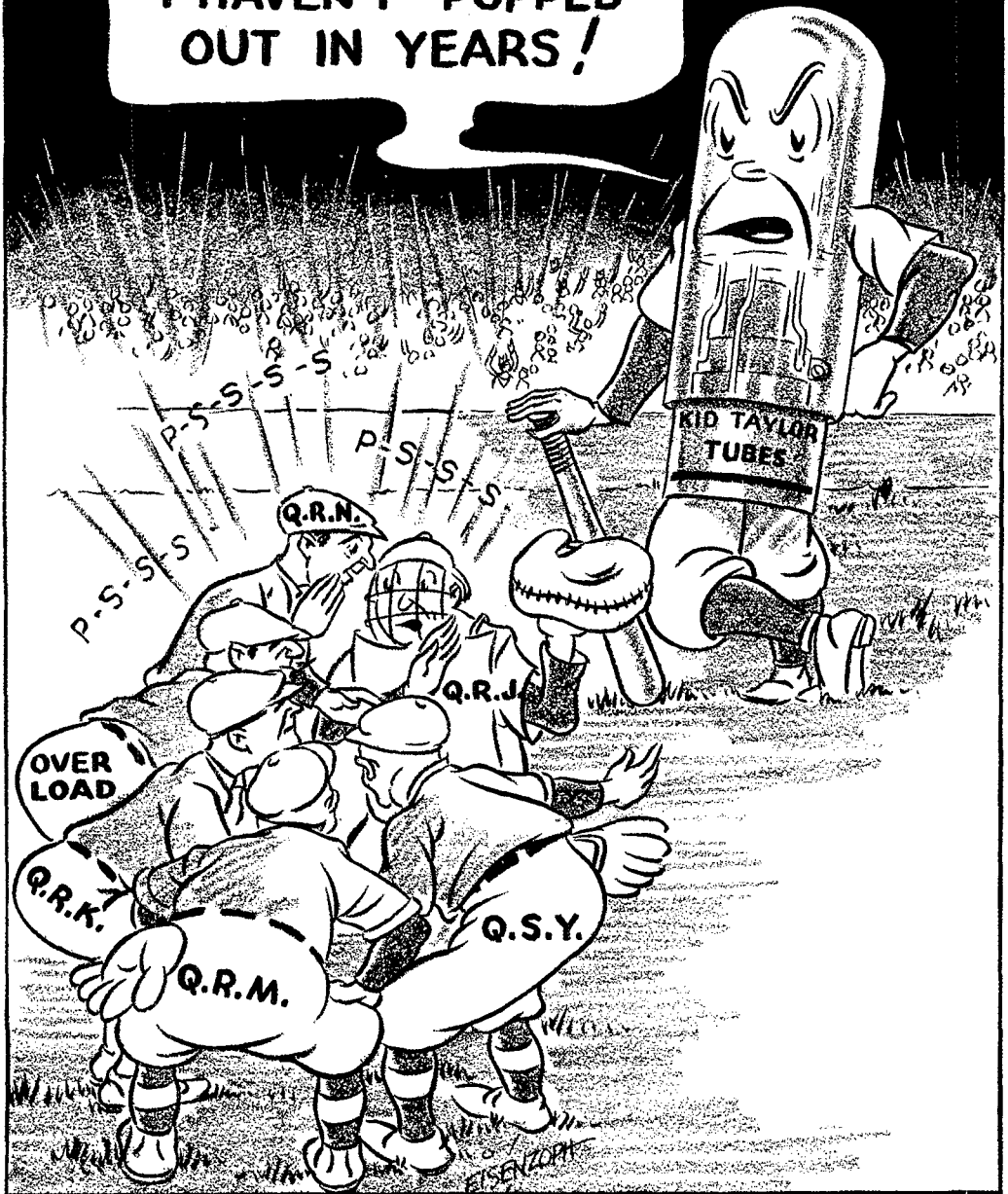

"More Watts Per Dollar"

Taylor HEAVY **CUSTOM BUILT** DUTY **Tubes**

TAYLOR TUBES, INC., 2341 WABANSIA AVE., CHICAGO, ILLINOIS

Say You Saw It in QST — It Identifies You and Helps QST

Why are tubes with SPEER GRAPHITE ANODES better than tubes with anodes of any other material?

SPEER GRAPHITE ANODES FOR TRANSMITTING, RECTIFYING TUBES



This booklet tells. Write for it!

SPEER CARBON COMPANY ST. MARYS, PA.

Dakota Division

North Dakota

W9UBB 13345-41-109-A-21
W9DGS 12900-43-101-A-28
W9EOZ 12374-46-135-B-24
W9DMM 3250-25-50-A-25
W9SWC 2808-26-37-A-18
W9WLI 189-7-9-A-4
W9YUJ 135-5-10-A-6

South Dakota

W9VOD 15318-46-112-A-37
W9FOQ 13222-43-104-A-23
W9YEZ 2139-23-31-A-23
W9SEB 1170-13-30-A-11
W9YNW 15-2-3-A-3

So. Minnesota

W9VKF 33390-53-213-A-40
W9SNW 15261-46-110-A-29
W9TKX 13800-40-117-A-24
W9EFK 9090-45-101-B-20
W9BQJ 4611-29-53-A-11
W9EYL 1045-19-28-B-9
W9KUI 651-14-16-A-6
Phone
W9ATP 4278-38-87--23*
W9TKX 6-1-2-A--

No. Minnesota

W9TJF 25096-53-168-A-39
W9DNY 11750-39-101-A-38
W9SYX 10824-41-88-A-39
W9BRA 6789-31-73-A-19
W9HEO 2583-21-41-A-22
W9OWU 1530-15-34-A-8
W9TIV 604-13-16-A-6
W9IGZ 512-11-16-A--
W9KYE* 32-4-4--

DELTA DIVISION

Arkansas

W5EPD 8550-38-75-A-26
W5EIJ 6356-30-62-A-22
W5EJR 5301-31-60-A-34
W5CVO 300-8-13-A-6
W5BMX 60-4-5-A-1
Phone
W5BMX 108-6-6-A-4

Louisiana

W5KC 43725-55-287-A-39
W5WG 35483-37-210-A-40
W5CRE 5616-43-83--22*

W4BAO 3424-32-54-B-12
W4DDJ 3180-30-60-B-27
W4CBA 1566-18-29-A-11

Hudson Division

Eastern New York

W2BMM 37128-56-223-A-37
W21QT 28350-54-175-A-40
W2EWD 20654-49-143-A-39
W2KBK 14112-42-113-A-25
W2HAN 10350-30-115-A-28
W2HNH 10177-31-113-A-38
W2HKZ 7360-28-83-A-31
W2HYC 6392-34-94-B-20
W2JKT 2409-22-37-A-23
W3CXX 2016-21-32-A--1*
W3QY 955-13-24-A-7
W2ISQ 859-11-26-A-8
W2DWO 144-6-9-A-7
W2BJX 27-3-3-A-1
W2CDM 24-3-4-B-1

N. Y. C.—L. I.

36375-50-245-A-36
29880-48-211-A-39
23558-45-176-A-40
23355-45-140-A-37
19502-49-210-B-33
W2ESZ 18125-43-144-A-38
W2AHC 17136-51-168-B-33
W2GDF 16290-39-137-A-36
W2HMJ 16236-33-164-A-35
W2BT 13485-31-146-A-26
W2EYS 9243-26-119-A-40
W2GP* 8517-34-84-A--
W2DXL 7812-31-85-A-28
W2HAY 7752-38-68-A-23
W2ION 7110-30-80-A-26
W2IIT 6876-36-96-B-31
W2HUG 5325-25-71-A-20
W2JAU 5244-23-74-A-17
4002-29-70-B-17
W2BPN 3000-25-60-B-15
W2JWF 2805-22-45-A-14
W2JN 2430-18-47-A-20
W2FKM 2184-14-52-A-18
W2BMG 1985-19-35-A-16
W2OQ 1892-22-43-B-14
W2GVX 1612-26-31-B-10
W2HBO 1596-14-38-A-8
W2EYG 1344-16-28-A-16
W2JY 1236-15-29-A-13
W2HSV 832-19-25-B-7
W2GQ 684-12-19-A-12
630-14-15-A-7

WE OFFER —

Specialized personal service of genuine value that is not available from other jobbers.

Time sales of all receivers and transmitters with terms arranged to suit you and 6% finance charge. We finance our own paper. Trade in your equipment for the down payment.

Complete stock of all amateur apparatus at net prices.

TRADE IN YOUR RECEIVER

All receivers shipped on ten day trial. You need send but \$5.00 with order, balance C.O.D. These receivers in stock:

RME-69s Complete.....	\$151.20
The new 1937 Breting 14s.....	99.00
The new RCA ACR-155.....	74.50
RCA AGR-175s.....	119.50
The new 1937 Super Pro.....	238.14
The new Hallcrafters Sky Challenger S-15.....	69.50
Hallcrafters Sky Buddys.....	29.50
Hallcrafters Sky Chiefs.....	44.50
Hallcrafters 1937 Super Skyriders S-11.....	89.50
Hallcrafters Ultra Skyriders S-10.....	99.50
The new Patterson PR-15.....	109.50

TRADE IN YOUR TRANSMITTER

All Collins, Harvey, RCA, RME, Temco, All Star transmitters at net prices. Sold on terms to suit you with two years to pay and 6% interest charges.

HENRY RADIO SHOP

211 North Main Street BUTLER, MISSOURI

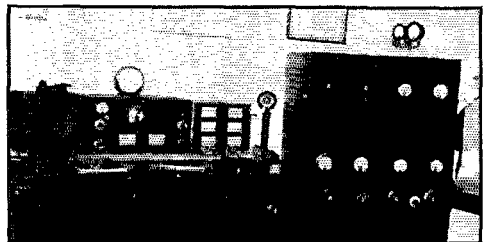

W5BYM, LAKEWOOD, OHIO

A. W. Kovatch, W5BYM, ORS won the Ohio award with the twelfth highest national score—43,554. The transmitter consists of '47-'10-'03A combination on all bands. The antenna is a 3.5-Mc. Zepp.

W5FHH 2448-24-52-B-13	W2HYA 528-11-16-A-5
W5FVD 1454-19-26-A-19	W2JYU 450-12-13-A-4
W5DAQ 980-20-25-B-7	W2HVU 360-10-19-B--
W5FYS 75-5-6-A-2	W2AJR 163-7-8-A--
W5DGB 43-4-4-A-1	W2HRT* 3-2-2--
W5GCM 27-2-5-A-5	

Mississippi

W4BMH 15456-46-113-A-36*
W5KFF 2800-25-56-B-12
W5FTT 98-7-7-A-9

Tennessee

W4CDC 37515-61-207-A-37
W4PL 34692-56-207-A-38
W4DJR 12099-37-109-A-35

No. New Jersey

W2FGG 28958-45-217-A-38
W2PY 26322-41-215-A-39
W2BXA 24700-52-238-B-39
W2EQQ 21385-53-139-A-32
W2HZY 18318-43-141-A-27
W2QL 15345-45-171-B-39
W2HXI 14355-33-145-A-26
W2FOA 12728-43-148-B-25
W2GGW 10544-33-107-A-14
W2DZA 9212-47-100-B-24
W2JJE 6006-22-93-A-30

Multi Match

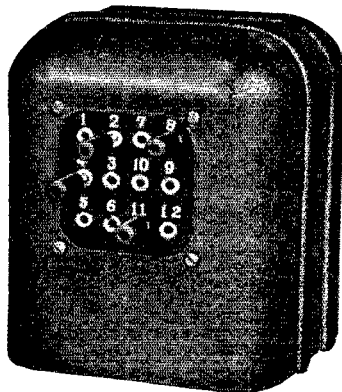

MODULATION



TRANSFORMERS



BY

THORDARSON

WITH THE NEW FEATURE "PLUG-IN-TERMINAL BOARD"

The only Modulation Transformer built with "Plug-in-Jack Terminal Board." Match any tube to any load instantly with simple plug and jack connection. A sensational departure from soldered terminals and connecting posts. New graceful space saving streamline case design. Absolute moisture and humidity proof construction throughout. Will safely withstand tropical climates.

COMPARE THESE FEATURES

1. "Plug in Jack Terminals" for input and output.
2. Complete variable matching.
3. New modernistic case design.
4. Moisture proofed.
5. Minimum space factor permits easy chassis mounting.
6. Completely compound filled.
7. Double varnished and baked.
8. Moderate price.

FURNISHED IN FIVE SIZES AS FOLLOWS

	Connected	
	Series	Parallel
T-11M74 For up to 40 watts		
Max. Pri. M.A.D.C. per side...	100	...
Max. Sec. M.A.D.C.....	80	160
T-11M75 For up to 75 watts		
Max. Pri. M.A.D.C. per side...	145	...
Max. Sec. M.A.D.C.....	145	290
T-11M76 For up to 125 watts		
Max. Pri. M.A.D.C. per side...	210	...
Max. Sec. M.A.D.C.....	160	320
T-11M77 For up to 300 watts		
Max. Pri. M.A.D.C. per side...	250	...
Max. Sec. M.A.D.C.....	250	500
T-11M78 For up to 500 watts		
Max. Pri. M.A.D.C. per side...	320	...
Max. Sec. M.A.D.C.....	320	640

FREE

Write Dept. Q-75 today for Bulletin SD-275
or see your parts distributor.

FREE

THORDARSON ELECTRIC MFG. CO.

500 W. HURON ST., CHICAGO, ILL.

Demand "Power by Thordarson"

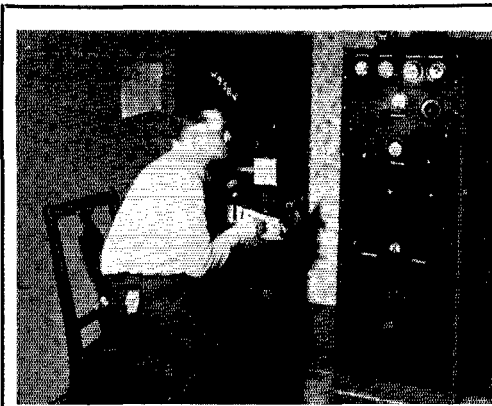

EVER WORK HIM?

W9SBV "gets around" with his rig. He is using a Turner VT-73 and tells us he gets perfect reports on his quality.

NEW CRYSTAL HANDSET

Now for the first time you can have a handset with crystal mike. Write for Bulletin No. 27. Ask for Bulletin 10-B too — it's full of mike dope.

THE TURNER COMPANY CEDAR RAPIDS, IOWA

Licensed under patents of the Brush Development Company

DO YOU WANT TO LEARN WIRELESS and TELEGRAPHY?



TWO BOOKS EVERY AMATEUR SHOULD HAVE —

Send Now!

25¢
COIN, MONEY ORDER
OR STAMPS
Each
POSTPAID

Hundreds of amateurs have learned from these books, so can you.

These books give you the fundamentals of wireless and telegraphy. They contain the codes and how to learn them. Mail your order now to:

SIGNAL ELECTRIC MFG. CO., Menominee, Michigan

ESTABLISHED
1892



W2CW	5292-28- 65-A-26	WINE	3425-25- 69-B- 6
W2GKE	5063-25- 69-A-35	WIKBJ	2648-21- 42-A-14
W2ECO	5016-33- 78-B-19	WIKAY	2568-16- 55-A-19
W2IVC	4463-25- 60-A- -	WIGVK	2014-19- 53-B-16
W2CMC	3174-23- 46-A-15	WITPI	1755-15- 40-A-14
W2IVU	3001-23- 44-A-22	WIJTD	1296-16- 27-A- 3
W2JSC	2371-22- 45-A-20	WIGVV	1260-18- 35-B- 5
W2CFW	2775-25- 37-A-12	WIBFS	1062-12- 30-A- 8
W2GME	1647-18- 31-A- 9	WIES	918-17- 27-B- 8
W2JKH	1555-15- 35-A-17	WIDUC	858-11- 26-A-10
W2ASY	1400-20- 35-B-20	WIC9Y	750-15- 25-B- 4
W2KAK	1056-16- 24-A-16	WIGKM	693-11- 20-A- 3
W2GTA	1050-14- 25-A-16	WJUSO	525-10- 18-A-15
W2IYM	897-13- 24-A- 6	WIHR	520-13- 20-B- 5
W2GCC	609-14- 16-A- 3	WIJFN	495-11- 15-A- 2
W2CGG*	570-10- 19-A- -		
W2ICJ	459- 9- 17-A-12	Maine	
W2DMN*	252- 9- 14-B- -	WIAPU	32661-57-192-A-39
W2HYX	60- 4- 5-A- 1	WIGKJ	20115-45-149-A-40
W2CJX*	12- 2- 2-A- -	WICDX	16065-42-129-A-25
W2HVM*	2- 1- 1- - -	WIIRB	8138-35- 78-A-33
		WICFO	2187-18- 41-A- 9
		WIDHH	264-11- 12-B- -
		WIASG	140- 7- 10- - -

MIDWEST DIVISION

Iowa

W9CFB	24219-54-156-A-38
W9AEW	18582-57-163-B-38
W9UOX	13938-46-101-A-31
W9RQR	13566-39-120-A-34
W9FDL	11123-49-115-B-18
W9SCW	9180-34- 90-A-29
W9JMB	7223-46- 80-B-27
W9TLL	6120-30- 70-A-14
W9WVY	4212-26- 27-A-26
W9PGG	1320-17- 26-A-10
W9NVF	800-13- 22-A- 8 ⁸¹⁷
W9DIB	651-14- 16-A- 7
W9OSH	372- 8- 17-A-10
W9CCE	288- 8- 12-A- 3

Kansas

W9A9V	34191-58-198-A-39
W9CWP	29400-56-175-A-39
W9AHR	19118-55-120-A-31
W9UTK	18704-39-112-A-30
W9VBU	9636-44-110-B-40
W9YAH	6966-36- 65-A-26
W9BEZ	1512-21- 36-B- 8
W9SIL	1296-18- 24-A-13
W9CYV	780-13- 21-A- 4
W9MFH	648-12- 18-A- 8
W9UEG	555-15- 10-B-10
W9OWZ	456- 8- 19-A-17
W9HLL	207- 6- 12-A- 8
W9VVR	168- 7- 8-A- 4
W9FRK	84- 4- 7-A- 6

Missouri

W9LLW	47415-58-275-A-38
W9RSO	43200-60-243-A-34
W9VLP	19050-50-127-A-34
W9PWH	13464-44-104-A-33
W9ARH	11254-41- 92-A-29
W9QUD	7020-30- 78-A-22
W9AUB	6954-39- 61-A-29
W9VAV	4563-26- 60-A- -
W9EYM	3549-26- 46-A-20
W9IFR	2898-23- 42-A-14
W9KIK	2262-26- 31-A-19
W9YTC	1403-23- 30-B-16
W9WCM	731-17- 22-B-11

Nebraska

W9MGV	20272-51-134-A-36
W9DMY	17385-57-154-B-26
W9MZF	11514-38-102-A-39
W9VPT	10800-50-112-B-23
W9WPF	3375-30- 38-A-21
W9VUL	3375-25- 45-A-18
W9YDZ	1012-15- 26-A-14

NEW ENGLAND DIVISION

Connecticut

W1TS	39407-63-211-A-39 ¹⁸
W1INF	32306-58-281-B-40 ¹⁸
W1UE	28958-45-215-A-40 ¹⁸
W1JPE	16800-50-112-A-23 ¹⁸
W1IED	13821-56-161- -34 ²⁰
W1BHM	11223-43-131-B-26
W1APA	10542-42-127-B-21
W1SZ	10150-50-103-B-20
W1EAO	3803-31- 93-A-28
W1JR	6525-29- 75-A-34
W1JLN	5940-33- 95-B-27
W1BHI	5580-30- 63-A-20
W1JUD	4743-34- 47-A- -1
W1HYF	4347-23- 63-A-12
W1BDI	3813-31- 62-B-13
W1JXV	3503-31- 57-B-26

Massachusetts

W1RY	34427-59-196-A-39
W1ENW	20726-41-171-A-40
W1ICA	18000-50-120-A-28
W1GJJ	11759-39-101-A-24
W1BEF	11340-36-158-B-36
W1IQH	10914-34-111-A-33
W1IFG	9870-35- 94-A-24
W1ISW	8415-34- 84-A-18 ²²
W1BWB	5364-41-104-B-22 ²³
W1ABJ	7859-26-101-A-24
W1CJP	7034-37-101-B-43 ²⁴
W1IWC	6732-28- 98-A-22
W1BTT	6384-28- 76-A- -
W1INA	6138-33- 93-B-19
W1IEU	6021-27-111-B-31
W1BMW	4200-26- 56-A-19
W1IVX	3384-24- 47-A-20
W1FKS	1461-25- 37- -9 ²⁵
W1DDM	884-17- 26-B- 8
W1ALP	840-14- 20-A-14
W1IIN	828-12- 23-A-25
W1EMG	624-13- 16-A- 3
W1JKN*	459- 9- 18-A- 7
W1GUA	288- 8- 12-A- 7
W1IUV	260-10- 13- - -
W1EPZ	243- 9- 9-A- 4
W1CTR	189- 6- 11-A-10
W1GMD	180- 6- 10-A- 4
W1JDE	136- 8- 9-B- -
W1IHL*	136- 8- 9-B- 5
W1BDV	75- 5- 5-A- 1
W1ALB	66- 4- 6-A- 4
W1ASI	50- 5- 5- - -
W1ACH	4- 1- 2-B- 1
W1IQO*	3- 1- 1-A- 2

W. Massachusetts

W1BVP	23613-51-233-B-40
W1EOB	22073-45-165-A-30
W1GUO	8073-26-105-A-31
W1DLD	7812-42- 93-B-22
W1BIV	3465-22- 53-A-22
W1JAH	2736-19- 48-A-14
W1JAD*	2076-24- 33-A-23
W1JLL	1125-15- 26-A- 8
W1IIP	660-11- 20-A-12
W1IEI	476-14- 17-B- -
W1EXZ	294- 7- 14-A- 9

New Hampshire

W1BRT	47004-50-268-A-40
W1AVJ	33549-53-211-A-38
W1IVU	10368-37- 98-A-22
W1IP	8700-29-100-A-19
W1HOU	3188-24- 68-B-25
W1JCA	2237-21- 38-A-10
W1JGC	1953-21- 31-A-12
W1HOV	72- 4- 6-A- -
W1JWJ	21- 1- 1- - -

Rhode Island

W1BBN	19500-50-195-B-40
W1AQ	9594-41-119-B-34 ²⁶
W1GBO	5544-28- 66-A-22
W1IAV	3668-26- 47-A- -
W1KCS	3078-19- 54-A-16
W1BJA	1800-20- 30-A-20
W1AOP	18- 3- 3-B- -

Vermont

W1EZ	54180-60-301-A-40
W1FSV	6723-27- 83-A-14

**HIGH CHARGING RATE
AT LOW SPEEDS—**

DELCO-REMY
Generator for Ford Police Cars

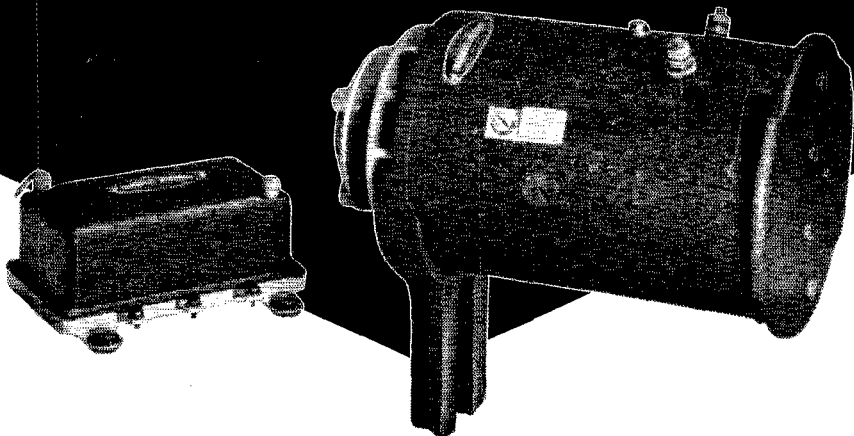

Delco-Remy Generator Model 973-M is especially adapted to radio-equipped Ford police cars. The extremely low cut-in and high output of this Special Service Generator at cruising speeds make it ideal for city police car use.

The Delco-Remy current and voltage regulator, used with these generators, causes no radio interference, gives accurately controlled voltage which is reflected in better lighting without bulb failures ... more dependable igni-

tion ... increased battery life. As an extra precaution against ignition noises and outside interference, Model 973-M is provided with a shielded harness.

City police departments using radio-equipped Ford cars need the Delco-Remy Model 973-M Special Service Generator. Any Branch or Electrical Service Station of United Motors Service will install this or any other Delco-Remy generator to meet your requirements. Let them analyze your problem and suggest the right equipment.

Delco-Remy

ANDERSON, INDIANA



Delco-Remy products are sold and serviced in the United States and Canada by United Motors Service.

World's Largest Manufacturer of Automotive Electrical Equipment

Say You Saw It in *QST* — It Identifies You and Helps *QST*

JUST OUT!

The New

SPRAGUE CONDENSER

Catalog

Chock-Full
of Helpful
Information



FREE!

A complete listing of famous Sprague Condensers... Hundreds of duplicate replacements — new small size dry electrolytics — new Trimmers, Mica and Rectangular Transmitting Types, and Facts About Condensers.

Don't miss it! — Write today.

SPRAGUE PRODUCTS CO., North Adams, Mass.

USE SPRAGUES and Note the Difference

THE F. W. SICKLES CO. presents

"SILVERCAP"

Permeability Trimmed Intermediate Frequency Transformers

OUTSTANDING FEATURES: 1. High stability under varying conditions of temperature and humidity. 2. Good selectivity and "Q". 3. Small size: $1\frac{1}{4}'' \times 1\frac{1}{16}'' \times 4''$ shield. 4. LOW COST. 5. Fixed condensers having "Q" and stability comparable with air dielectric types. 6. Movable iron cores for tuning. 7. High merit moisture proof coils.

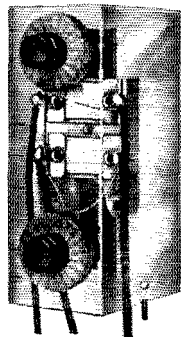

The "Silvercap" is an entirely new type of capacitor with less than 0.002% per degree drift.

SINGLE STAGE KIT List Prices
No. 6504. Interstage..... ea. \$2.00
No. 6521. Diode..... ea. \$2.00

TWO STAGE KIT
No. 6562. Interstage. (Two used) ea. \$2.00
No. 6563. Diode..... ea. \$2.00

BEAT FREQ. OSCILLATOR
No. 6577..... ea. \$2.00

CRYSTAL FILTER COILS
No. 6740. Input..... ea. \$2.00
No. 6741. Output..... ea. \$2.00

NOISE SILENCER COIL
No. 6742. Single tuned. Center-tapped..... ea. \$2.00

All units designed for 460 Kc.

THE F. W. SICKLES COMPANY
300 Main St., Springfield, Mass.

NORTHWESTERN DIVISION

Idaho
W7ESM 5166-31- 56-A-29
W7FFQ 4293-27- 53-A-33
W7CMI 270- 9- 10-A- 8

Montana
W7CRH 21546-57-127-A-30
W7EWR 5655-29- 66-A-21
W7BSU 4836-39- 62-B- 4
W7CPY 4742-29- 55-A-19

Oregon
W7DPP 3861-26- 50-A-16
W7FCM 1476-12- 41-A-22
W7EZK* 578-11- 20-A- 6
W7FPN* 290- 8- 18-B-14
W7ENU* 40- 4- 5-B- 5
W7EBQ* 2- 1- 1- - -

Washington
W7EK 28320-60-238-B-38
W7EZH 22344-49-154-A-40²⁷
W7CMB 18504-49-133-A-38
W7EGE 18091-53-177- -38²⁸
W7DXZ 16125-48-114-A-25
W7FVK 14985-45-117-A-35
W7DJS 12126-43- 96-A-28
W7EYD 7298-41- 90-B-23
W7FUG 7904-39-107-B-29
W7LD 6672-32- 70-A-26
W7RTR 4716-24- 66-A-19
W7EHU 3204-24- 45-A-20
W7FSD 864-12- 24-A-18
W7TFZ 585- 6- 33-A-18
W7APR 576- 8- 24-A- -
W7BHW 370-10- 19-B- 8
W7FEZ 325-13- 13-B- 4
W7CWN 234- 6- 13-A- 7

PACIFIC DIVISION

Hawaii
K6JPD 6240-39- 80-B-17
K6CGK 2850-19- 50-A-19
K6NRF 972-12- 27-A- 9

Nevada
Phone
W8EVF 1548-18- 43-B-15²⁹

Santa Clara Valley
W6JHT 40508-55-254-A-37
W6CUZ 5250-35- 75-B-18
W6NCO 3201-22- 49-A-17
W6NCD 2268-21- 38-A-12
W6MTD 1148-15- 26-A- 9
W6KZG 252- 6- 14-A- 6

East Bay
W6TTP 14014-49-142-B-34
W6LHE 5916-34- 89-B-28
W6LME 4234-39- 64-B-24
W6GJA 3284-24- 48-A-15
W6EJA 2806-23- 61-B-19
W6KEK 2400-16- 50-A- -
W6HH 135- 5- 9-A- 7
W6MKG 90- 5- 6-A- -
Phone
W6ITH 30774-69-223-B-35

San Francisco
W6JMR 13158-51-129-B-29
W6ABR 12354-41-105-A-37
W6CIS 12054-49-123-B-25
W6IFH 43860-40-117-B-37
W6MGL 6072-23- 89-A-34
W6NEN 6038-25- 82-A-31
W6JDG 4098-28- 83-A- -
W6LCS 378- 7- 18-A-13
Phone
W6JSS 45- 3- 5-A- 2

Sacramento Valley
W6IZE 7733-37-106-B-31
W6MNR 7200-19- 50-A-26
W6BNH 60- 4- 5-A- 2
W6MBY 3- 1- 1-A- 1

Philippines
KAIUS 728-14- 27-B-30

San Joaquin Valley
W6MVK 44103-61-242-A-39
W6HIP 1872-12- 53-A-15
W6GUR 816-17- 24-B-12
W6MKO 804-12- 35-B-14

W6OFD 12- 2- 2-A- -
Phone
W6IWU 866-14- 33- -24³⁰

ROANOKE DIVISION

North Carolina
W4ECH 11484-44-133-B-26
W4DVI 7176-39- 93-B- -
W4DWB 1844-15- 36-A-12
W4CEI 1392-24- 30-B- 9

Virginia
W3FMY 15708-51-155-B-38
W3FV 9393-45-116- -25³¹
W3EXQ 3140-23- 46-A-29
W3PQP 3131-29- 53-B-18
W3GBC 2070-15- 47-A-19
W3MQ 1584-16- 34-A-20
W3EHL 352-11- 16-B- -
W3DJJ 192- 6- 16- - -
W3AVR* 2- 1- 1- - -

West Virginia
W8CKR 14976-48-105-A-32
W8KWM 13583-47 146-B-33
W8PMA 10191-43-123-B-38
W8LGN 8977-35- 87-A-34
W8PQQ 7917-39-105-B-35
W8OXO 6096-32- 64-A-29
W8LIT 5292-25- 63-A-26
W8KKG 3902-34- 56-B-13
W8KXC 1878-24- 39-B-12
W8ASI 576-12- 16-A- 4
W8HD 300-10- 15-B- 4
W8ATX 352- 9- 15-B- -

ROCKY MOUNTAIN DIVISION

Colorado
W9FFU 45180-60-251-A-40
W9WVF 27103-57-159-A-32
W9RRS 22418-49-153-A-38
W9TSQ 6930-35- 66-A-21
W9DQD 3139-23- 46-A-18
W9TDR 2174-23- 32-A- 9
W9SJT 795-10- 27-A-19
W9BUL 608-16- 20-B- 4
W9GLG 444-12- 19-B-12
W9YGM* 2- 1- 1- - -
Phone
W9PWU 3071-23- 45-A-12
W9NWW 2475-22- 41-A-16
W9GLG* 3- 1- 1-A- -

Utah-Wyoming
W6FRN 21375-50-143-A-35
W6KOP 15750-42-131-A-39
W7CY 11515-49-122-B-20
W6NPU 545-11- 18-A-11
W6MJZ 491- 7- 25-A-14
W6LLH 240- 8- 10-A-10
W7COH 84- 4- 7-A- 1

SOUTHEASTERN DIVISION

Alabama
W4CYC 43829-61-240-A-40
W4BQU 30108-52-194-A-32
W4DMZ 19932-47-142-A-34
W4APU 10816-52-106-B-19
W4DS 3510-26- 45-A- -
W4ELQ 2001-23- 29-A-12
W4DXI 1530-17- 31-A-18
W4BEY 420-10- 14-A- 4

Eastern Florida
W4DTR 20856-44-161-A-40
W4EFM 6045-31- 66-A-27
W4CKM* 4415-27- 35-A-17
W4SV 984-16- 21-A- 6
W4DVO 624-13- 16-A- 4
W4GS 192- 8- 8-A- 2
W4EGL 18- 2- 3-A-25

Western Florida
W4EON 7806-36- 74-A-24³²

GA., S. C. etc.
K5AC 33708-53-226-A-40³³
W4AMM 11628-38-104-A-35
W4VX 10962-36-102-A-20
K5A Y 5748-34- 87-B-18
W4ECCZ 4995-30- 56-A-18
W4BIN 990-15- 30-A- 5
W4DJT* 338- 9- 13-A- 3
K5AV 3- 1- 1-A- 1

IT'S EASY TO OWN A *Powerful*

MODERN TRANSMITTER
IF YOU BUILD IT FROM THE

Utah

ADD-A-UNIT
TRANSMITTER KIT

ONLY
\$49⁷⁵

LESS TUBES,
METERS, CRYSTAL

- ★ 80 watts input
- ★ Completely self-contained
- ★ Sensational New Circuit
- ★ Operates on 10-20-40-80-160 meter bands
- ★ Additional units plug in — no re-wiring
- ★ Uses standard tubes available anywhere
- ★ True professional style

Now you can own a transmitter with a "kick" in it — and keep your schedules consistently! We show you how to build it yourself — at a fraction of the cost of a factory assembled job. You'll always be glad you started with this UTAH transmitter. Later on you can plug in additional units and have a complete professional style 400 Watt Phone Transmitter! Each kit is a complete unit, easily assembled and wired. Each part is tested by UTAH so you know it's right. Start *now* and start *right* with this UTAH kit. See your UTAH jobber. If he is not listed, write direct to us — TODAY! Address department Q-5.

THESE UTAH JOBBERS]

WERE SELECTED

because they are capable and willing to serve amateurs with fairness and understanding. See your closest UTAH jobber:

Akron: Brighton Sporting Goods
 Baltimore: Wholesale Radio Parts Co.
 Bridgeport: D'Elia Electric Co.
 Buffalo: Dymac Radio Co.
 Chicago: Montgomery Ward & Co.
 Allied Radio Corp.
 Cincinnati: Radio Supply Co.
 Cleveland: Radio Servicemen's Supply Co.
 Columbus: Hughes Peters Elec. Corp.
 Dayton: Standard Radio Parts
 Detroit: Radio Specialties Co.
 Fort Wayne: Pembleton Laboratories
 Hartford: Stern Wholesale Parts
 Indianapolis: Van Sickle Radio Co.
 Louisville: P. I. Burks
 New York: Harrison Radio Co.
 Philadelphia: Radio & Electric Service
 Providence: City Hall Hardware Co.
 Rochester: Beaucaire, Inc.
 Toledo: Toledo Radio Specialties Co.

UTAH RADIO PRODUCTS COMPANY

TORONTO
ONTARIO, CANADA

CHICAGO, U.S.A.
15 YEARS OF LEADERSHIP

BUENOS AIRES
(UCOA RADIO PRODUCTS CO.)

Say You Saw It in QST — It Identifies You and Helps QST

New "PRECISION" MULTIMETER SERIES 830



This 11 range "PRECISION" service instrument contains a large 3 inch D'Arsonval type meter of 2% accuracy. 5 D.C. voltage ranges: 0-10; 0-100; 0-250; 0-500; 0-1000 at 1000 ohms per volt. 4 D.C. current ranges: 0-1 ma; 0-10 ma; 0-100 ma; 0-250 ma. 2 resistance ranges: Low ohms shunt method. 0-500 ohms. As low as 1/2 ohm. High ohms reading. 0-300,000 ohms. Selector controlled throughout. Small in size: 4 1/2 x 7 x 2 1/4.

\$10.95

Precision Apparatus Corp.
821 EAST NEW YORK AVE., BROOKLYN, N. Y.

SOUTHWESTERN DIVISION

Arizona
W6KFC 51708-62-278-A-40
W6MAJ 988-14-23-A-10
W6NXO 855-10-29-A-9

Los Angeles

W6SN 32562-67-243-B-39
W6LCA 25245-51-169-A-34
W6BXL 12663-42-101-A-19
W6MTP 11578-31-125-A-37
W6KPE 10553-35-101-A-26
W6MNA 10610-40-88-A-25
W6KJG 10011-47-110-B-21
W6KXN 8558-35-83-A-29
W6IOX 7714-39-102-B-22
W6ACL 6300-45-70-B-17
W6NLL 5910-32-90-A-32
W6CVO 5198-35-50-A-25
W6KYM 3366-34-51-B-21
W6LFX 3244-21-53-A-22
W6NAH 1368-16-29-A-4
W6KVK 1304-11-40-A-30
W6IDW 1275-17-25-A-10
W6MXC 1176-14-28-A-10
W6BGF 842-17-17-A-7
W6MQS 600-10-23-A-6
W6OCN 600-10-20-A-26
W6JTM 282-8-15-B-11
W6LEB 50-5-5-B-2

Phone

W6BWG 136-8-13-B-3
W6MPK 66-6-6-B-6

San Diego

W6ITY 34427-59-198-A-39
W6LDJ 24255-55-148-A-35
W6GCX 22288-56-199-B-26
W6LHN 19158-53-121-A-27
W6LVB 15180-44-117-A-13
W6GTM 13950-60-78-A-30
W6HLP 7273-36-101-B-
W6MNV 4175-23-61-A-12
W6NGN 1776-16-37-A-19
W6NVL* 84-7-7- - -

WEST GULF DIVISION

Northern Texas

W5DQD 21230-55-191-B-36
W5EOU 7020-36-76-A-23
W5EFN 3096-24-43-A-24
W5BAM 2081-19-37-A-14
W5FCQ 1560-20-26-A-3
W5GGU 1056-16-22-A-6³⁴
W5ARV 658-14-24-B-7
W5FZU 270-6-15-A-3
W5AWT 12-2-2-A-2

Oklahoma

W5EGP 23447-49-161-A-39
W5CUX 21227-53-134-A-31
W5AQE 12577-39-108-A-33
W5EGQ 12474-42-101-A-24
W5YJ 12054-49-131-B-30³⁵
W5BDX 8770-37-70-A-18
W5FLU 7237-34-71-A-28
W5EHY 5441-31-60-A-26
W5EYH 4698-29-55-A-23
W5FFH 3900-26-50-A-15
W5FFW 2712-31-58- -16³⁶
W5FSK 2208-23-48-B-³⁷
W5FXG 2040-20-34-A-15
W5FIK 1867-15-42-A-13
W5CJZ 696-14-17-A-6
W5FFK* 231-7-11-A-2
W5FKL* 75-5-5-A-3

Southern Texas

W5CPB 26175-50-177-A-37³⁸
W5DBE 20830-48-148-A-39
W5BDI 20592-52-132-A-40
W5DB 18450-50-123-A-26
W5CWW 17043-46-125-A-28
W5EAL 18369-47-110-A-25
W5AQY 14256-44-108-A-³⁹
W5DAW 11220-40-103-A-31
W5FZD 11155-37-109-A-30
W5DMB 8610-35-83-A-32
W5FSD 7248-32-76-A-26
W5ARO 5424-32-57-A-17
W5EEK 4131-27-51-A-
W5DWN 360-10-12-A-6
W5GAY* 360-8-16-A-11

W5DOM 120-8-10-A-3
W5EWZ 11-1-4-A-6

New Mexico

W5DGP 23166-54-144-A-36
W5FRR 13997-43-109-A-18
W5ETZ 13868-43-111-A-22
W5CJP 13536-47-97-A-29
W5ENI 32-4-4-B-1
W5DZY 12-2-2-A-2

CANADA

Maritime

VE1FB 6750-30-79-A-27
VE1BK 6675-25-91-A-21
VE1EV 6660-30-74-A-
VE1GI 6180-27-82-A- -

Ontario

VE3ACB 31248-56-187-A-40
VE3DR 29691-49-207-A-40
VE3GT 28841-51-191-A-40
VE3ACM 28815-55-164-A-28
VE3JT 26255-59-223-B-30
VE3AEM 25916-39-224-A-33
VE3OI 18351-46-136-A-36
VE3ZE 16134-44-129-A-40
VE3SD 11681-39-129-A-33
VE3HP 14576-41-119-A-26
VE3DA 12222-42-146-B-32
VE3ABD 10004-41-122-B-40⁴⁰
VE3AJB 9690-34-96-A-38
VE3AJX 9120-32-95-A-25
VE3NS 7398-36-71-A-28
VE3SS 6642-27-82-A-18
VE3QB 5058-31-57-A-23
VE3DU 4361-33-44-A-15
VE3AME 4290-26-55-A-30
VE3ALH* 3498-22-51-A-16
VE3IW 3024-24-43-A-21
VE3PE 2601-17-51-A-20
VE3ZU 2316-23-34-A-27
VE3ER 2136-24-45-B-10
VE3HV 1392-16-30-A-12
VE3OT 618-12-18-A-5
VE3SG 576-12-16-A-4
VE3UF 479-11-15-A-6
VE3UX 360-10-12-A-3
VE3AID 135-6-8-A-5
VE3MB* 32-4-4- - -
VE3MA 6-1-2-A- - -

Quebec

VE2DR 33065-47-235-A-39
VE2EE 16600-50-167-B-35
VE2IN 14625-39-127-A-26
VE2AA 7875-35-77-A-26
VE2JD 6720-28-81-A-29
VE2JI 5275-25-77-A-37
VE2EP 5133-29-59-A-20
VE2LC 3673-24-52-A-21
VE2EX 2310-24-33-A-16
VE2LI 1815-22-30-A-19
VE2LU 1200-16-25-A-7
VE2BX 984-16-23-A- -
VE2HI* 288-8-12-A- -
VE2FG 270-9-10-A-2

Alberta

VE4GE 36801-58-214-A-40
VE4BH 6510-35-63-A-27
VE4VJ 1555-17-31-A-19
VE4PZ 990-11-30-A-18

British Columbia

VE5QP 19202-51-132-A-35
VE5PW 9006-33-99-A-38
VE5QA 6165-30-73-A-34
VE5OK 5625-25-78-A-37
VE5FW 4633-22-71-A-31
VE5II 451-9-13-A-3
VE5ID 102-4-9-A-4

Manitoba

VE4SF 12061-43-96-A-28
VE4KX 11092-47-119-B-21
VE4YO 4914-28-61-A- -
VE4EV 1800-20-30-A-11

Saskatchewan

VE4OC 31164-56-188-A-38
VE4QZ 24300-50-165-A-35
VE4YX 9288-36-85-A- -
VE4MB 5487-31-87-A-26
VE4PQ 1620-18-25-A-12
VE4CQ 828-12-25-A-15
VE4TX 39-2-7-A-3

1937



1947

Will Your Present Audio and Power Units Be
Obsolete Ten Years from Today?

The Kenyon line now includes a number of Universal Transformers which entirely eliminate obsolescence. Solves the amateurs problems in a most practical and economical manner.

KEN-O-TAP

IS THE PRACTICAL SOLUTION TO
THE MODULATION PROBLEM

KEN-O-DRIVE

IS THE MODERN ANSWER TO
CRITICAL DRIVER OPERATION

KEN-O-DYNE

IS THE MODERN METHOD OF MATCHING
OUTPUT TUBES TO SPEAKERS

Kenyon Transformer Co., Inc.
840 Barry Street, New York, N. Y.

Export Dept., 25 Warren St., New York, N. Y.
Cable Address: SIMONTRICE, NEW YORK

The 1937 Edition of the RADIO AMATEUR'S HANDBOOK

FOR FOUR MONTHS OUR TECHNICAL AND EDITORIAL GROUPS WORKED ON THE REVISION AND ELABORATION OF THE RADIO AMATEUR'S HANDBOOK FOR ITS 1937 EDITION. MANY IMPORTANT TECHNICAL DEVELOPMENTS DURING THE PAST YEAR AND SWEEPING CHANGES IN OPERATING TECHNIQUE AND METHODS CALLED FOR ENLARGEMENT OF THE BOOK AND REWRITING OF ALMOST ALL CHAPTERS. SOME IDEA OF THE EXTENT OF THE REVISION MAY BE HAD FROM THE FACT THAT TWO HUNDRED NEW ILLUSTRATIONS ARE INCLUDED, MOST OF THEM BEING PREPARED ESPECIALLY FOR THIS NEW EDITION. ● SPECIAL ATTENTION HAS BEEN GIVEN TO THE NEW DEVELOPMENTS IN NOISE SILENCERS FOR SHORT-WAVE RECEIVERS AND TO THE NEW TECHNICAL TRENDS IN CIRCUIT DESIGN. A WEALTH OF NEW MATERIAL IS ADDED TO WIDE FIELDS OF TRANSMITTER PLANNING, CONSTRUCTION AND ADJUSTMENT. THE CAPABILITIES OF THE NEW TUBES ARE EXPLOITED TO THE FULL IN THE TRANSMITTER DESIGNS PRESENTED. EXTENDED SPACE IS ALSO GIVEN TO THE EVER-IMPORTANT SUBJECT OF ANTENNAS, THE NEW IDEAS IN COUPLING METHODS BEING TREATED IN PARTICULAR DETAIL. THE ULTRA-HIGH FREQUENCIES COME IN FOR A BIG SHARE OF THE SPACE ALSO, NEW AND ADVANCED EQUIPMENT BEING DETAILED TO ILLUSTRATE THE NEWER TRENDS IN THIS RAPIDLY-GROWING FIELD. ● AS IN PREVIOUS EDITIONS FULL ATTENTION HAS BEEN GIVEN TO CHARTS AND TABLES OF GENERAL INFORMATION FOR THE RADIO ENTHUSIAST; THE VACUUM TUBE TABLES, FOR EXAMPLE, OCCUPYING SEVENTEEN PAGES AND BEING, WITHOUT DOUBT, THE MOST COMPLETE AND DETAILED TUBE LIST EVER PUBLISHED. ● THE BASIC PURPOSE OF THE HANDBOOK IS TO PRESENT A COMPLETE TREATMENT OF EVERY PHASE OF MODERN AMATEUR RADIO FROM ELEMENTARY THEORY THROUGH ADVANCED PRACTICAL APPLICATION, WITH EMPHASIS ALWAYS ON IDEAS AND METHODS THAT HAVE SHOWN THEIR WORTH IN THE FIELD. THIS NEW EDITION, WE FIRMLY BELIEVE, WILL FULFILL THIS PURPOSE MORE EFFECTIVELY THAN ANY OF ITS PREDECESSORS.

**\$1 postpaid in Continental U.S.A.—\$1.25 postpaid elsewhere
Buckram Bound \$2.50**

American Radio Relay League ■ West Hartford, Conn.

Station Activities

(Continued from page 64)

HUDSON DIVISION

EASTERN NEW YORK—SCM, Robert E. Haight, W2LU—EGF continues his good traffic work. GZF is active with A.A.R.S. ISQ made B.P.L. with new rig, 60 watts. LU is looking for interested hams for N.C.R. members. HYC contacts F8EO on 3571 kc. BLU reports DX coming thru on 3.5 Mc. CC is on 7280 and 14,370 kcs. UL hears CTC on 14 Mc. JWT, new O.O., thumbs his way to HAN's via 56 Mc. HCM is rebuilding for greater efficiency. JRG needs Nevada and New Mexico for W.A.S. CJS QSO's 5ENI (Doc Gillett) on 3.5 Mc. JSL is new R.C.C. member. KFB plans new rig, 6L6 and pair of T20A's, 150 watts. JRG reports JCY recently appointed Lt. Comdr. in N.C.R. EGI is now Radioman 1st Class N.C.R. IUA has new RME-69. HXD, HF, JRG and JCY are members of the Horse Traders Ass'n of New England. Westchester Amateur Ass'n held 1st annual dinner in White Plains with 100 present. JAM jams power up to 200 watts on 56 Mc. JWT reports HAN is A.A.R.S. and prospective O.R.S. JWT is R.C.C. HNH worked SUICH on 14 Mc. using 40 watts to a '45 final. ITK reporting for HUM says HUB is working DX on 28 Mc. BDB won local DX contest. IVS and HUM are still sticking around Florida. IUR is active on 7 and 14 Mc. DC recommends BYP and VO for O.P.S. ACB is being heard in Europe on 3925-kc. 'phone. CYW reports new receiver with 6C5 and 6F6 and has his directive antenna almost completed. FQH located in Schenectady will be on 56 Mc. KFP is new ham in Albany on 56 Mc. JRX on 56 Mc. with 6L6's M.O.P.A. HYO is on 56 Mc. FDI is building M.O.P.A. 56-Mc. transmitter. JSQ is revamping for 28 Mc. ILL is rebuilding for 1/2-kw. 14-Mc. 'phone. JGM is a consistent performer on 1.75-Mc. 'phone. DSK is Albany's veteran on 1.75-Mc. 'phone. "The Heckler's Net" is on Sunday afternoon with JHQ, Cohoes, JJH, Troy, 8LQU, Amsterdam, 8NTY, Johnstown, 8ITH, Gloversville and DSK, ILL, JSQ and JQI, Albany, present. HTU has a new 1937 Sky-riider and with 400 watts is stepping out on 14-Mc. 'phone and c.w. FBA is heard in all parts of the world on 28-Mc. 'phone. JRX is back on 1.75-Mc. 'phone after month's experimental work on 56 and 28 Mc. KCI is changing from breadboard to rack and panel, works 1.75-Mc. 'phone and 14-Mc. c.w. HJA added a Nat'l Oscilloscope to the shack's equipment. JKT leaves E.N.Y. for work in N.J. We wish him luck. QY is active with N.C.R. duties. KBT gets RST 589x in Minn. with 60 watts on 3.5 Mc. GWY is still concentrating on 56-Mc. operation, along with GFD; between them, they keep Poughkeepsie on the 56-Mc. map. DOS has a fine location, at Freedom Plains, a few miles east of Poughkeepsie; he works 3.5- and 7 Mc. consistently. CVT built a nifty little 56-Mc. transmitter, crackle-finishing the chassis and in general doing an FB job on it. HES works 7 Mc. every day, mostly in the morning. CGT completed an FB complete new transmitter, using T-200 in final. KGU got his first taste of DX during the contest. BJX, after almost two years' solid operating on 3.5, deserted that band for 7 Mc. during the DX tests. HVS is building new outfit to use T-200 with about 999 watts on it. CDM led the local pack during the DX contest, garnering 44 QSO's in 24 countries on 4 continents, for a total of 3144 points. EOD is Poughkeepsie's only active 3.9-Mc. 'phone station at present.

Traffic: W2GZF 457 ISQ 225 LU 105 HYC 72 BLU 23 CC 17 UL 10 JWT 20 HCM-JRG-JSL 6 JQI 4 CJS 2 EGF 531.

NEW YORK CITY AND LONG ISLAND—SCM, E. L. Baunach, W2AZV—HTI is out for O.P.S. appointment. AVS recommends GEE for O.P.S. BMG, HYA, IPX and other local A.A.R.S. met at CLA for a get-together. OQ is alternate N.C.S. for southern N.Y.S. Net, call WLNS on 3497.5 kcs. DBQ reports great membership increase in A.A.R.S. 56-Mc. Net. JOO sends his first report. JBL is sailing for the West Indies. On February 22nd a Jr. op arrived at GDF. Congratulations. KI can work break-in with his dynamotor-driven portable outfit. BGO has been working on his new rig since the flood. APV is waiting for Spring to put up a signal squirter. PF now has an HRO. JEQ is moving to new QTH. JFP is trying to get HF-100 final to work on 14-Mc. 'phone. EVA is rebuilding 63 crystal, RK-20 and 150T final. HXT has new RME69 and reports that Sarg of K5AA is coming to N.Y.C. CHK had a tough job drilling his steel rack with a small hand drill. BXR just returned from a trip to Honolulu; he visited K4RJ, K5AF, WLV and

K6BILL. TC is on 500 watts 'phone at his new QTH in Malverne. JTP's 28-Mc. antenna blew down so now he is on 56 Mc.; he and JZA are trying out 2 1/2 meters portable-mobile. ESK is on 3552 and 7008 kc. with 300 watts. HBO worked E18B on 3.5 Mc. BYK and HHW worked plenty of DX in the contest. BVE was jolted a bit by 1000 volts. AZV has been experimenting with electrostatic shielding in the output circuit of his transmitter. New officers of the C.C.N.Y. Radio Club: IFS, chief op., ICR, secretary, IYI, treasurer. The Radio Club of Brooklyn now has its own club room at 3922-16th Ave. Meetings are held every Friday at 8:00 p.m., code class every Tuesday night at 8:00 p.m. and technical sessions Thursdays at 8:00 p.m. All are welcome. Don't forget the Long Island Net every night on 3710 kc. at 8:00 p.m. If you have any traffic to unload, listen for DBQ.

Traffic: W2DBQ 376 BMG 251 JBL 162 PF 113 BGO 63 OQ 56 EYS 53 DQW 45 KI 130 GDF 28 AZV 28 CHK 23 JFP 15 HXT 14 US 13 14W 12 CP-HJT-HGO 11 ESK 10 AHC-CIT 6 AA 5 HBO-BKP 4 JEQ 5 DLR 4 IHT-JOO 2 HAK 1.

NORTHERN NEW JERSEY—SCM, Fred C. Read, W2GMN—The N.N.J. traffic system is now organized for spot-frequency operation with four nets on spot frequencies of 3565, 3630, 3640 and 3650 kc. and a main distributing net composed of the net control stations also operating on a spot frequency. HFB has new superhet receiver. CJX did good work in DX contest. HRN paid visit to League Headquarters. HFT has new 14-Mc. antenna. HXI has worked 43 countries. HTW and GAS are at Stamford, Conn. GGE is planning new transmitter. GVZ has portable emergency rig with dynamotor for operation on all bands. FB! The QSP Club held a dance at Neptune on April 9th. After spending four and one-half years working W and V stations, EQS finally hooked G6WY and then ran wild, working XE2N, XE2W, G2ZQ, E18B, CM5YG, K5AY, K6JPD, K6CGK, VO1W and FM8AD all on 3.5 Mc. with 35 watts input to a '46 final. GZG has new electric phonograph set-up for entertaining his friends. FFY is working on relay rack job. FLB is back on 1.75-Mc. and other 'phone bands after long absence. JDO is getting out nicely on 56-Mc. 'phone. GYY's new QTH is 300 feet away from GZG and 500 feet from JME—and they're all 'phones with plenty of input. HLLX was heard in England on 3.9-Mc. 'phone using 50 watts. A certain very nice YL will soon be Mrs. W2DAC. Congratulations, Bill, and lots of happiness. The QSP Club has been holding interesting monthly meetings at Elizabeth. All traffic men are urged to attend The O.T.C.R.A. is having an attendance contest. There will be prizes. IBR is still having trouble with his final. IAP is back on 3.5 Mc. IKD has efficient 56-Mc. rig in car. The O.T.C.R.A. visited the N.B.C. control rooms under the guidance of BKX. The U.C.A.R.A. had big hamfest in Elizabeth on March 20th. IYG has new 500-watt rig. ICD is planning to build new transmitter. JUC is new O.R.S. JMX has O.P.S. appointment. HTX has been operating portable at school. Please send interesting news items to your S.C.M. on the 16th of each month.

Traffic: W2GGE 468 (WLNQ 101) BCX 301 (WLNQ 279) BZJ 142 GVZ 117 CGG 92 HCO 70 FOP 69 GMN 68 HQL 55 ECO 50 ENZ 41 HBQ 36 HTW-1 30 HXI 27 LAP 23 HFT 21 CJX 16 ICJ 14 CIZ 11 TQM 1 (WLNQ 27).

NEW ENGLAND DIVISION

CONNECTICUT—SCM, Frederick Ells, Jr., W1CTI—Following stations make the B.P.L.: HSX, JXP, AW, UE and IMV. HSX has been appointed R.M. and leads the Section with a fine total this month. JXP is doing fine work in both Nutmeg and Humdinger nets. IMV is now O.P.S. IKE is having a swell time in N.C.R. ITI has JYJ acting as second operator. KGX is working fine DX on 14 Mc. with 5 watts to a 53. KJI, KJP, KKS and JYE applied for O.R.S. KFN says New Haven and West Haven gang cover all frequencies 1.75 to 56 Mc. TD scored 4384 in O.R.S. party. DWP finds time to push traffic on 'phone. FB. CSC operates on 7, 14 and 56 Mc. and did good work in the DX contest. BBS is working on 1.75-Mc. 'phone rig. HPI celebrates his 30th year of activity in amateur radio and made W.A.C. on 9th DX Contest. BIH has a new Halliarafter Sky Challenger. IYB has 350 watts on 3.5, 7 and 14 Mc. EAO took part in O.P.S. party, Maxim Relay, and DX Contest. In spite of O.O. work during DX Contest Ray managed to get across on four bands and tried for fifth (1.75 Mc.). JOR looks for traffic on 3620 kc. KAY has 550 watts input now. KJP has a new 802-T55 rig on 3566 kc. DLX moved to Niantic. BGJ works during the day and studies law at night. AQF is active on 1.75-Mc. 'phone. JLL is changing QTH. CUH is

working DX on 14 and 7 Mc. CEJ plans test transmissions on 56 Mc. if he can locate an automatic keying unit. HTS put up an icicle shed to save feeders, but no ice this year! JXR put in band change rig. FVO made W.A.C. on 14-Mc. 'phone. VB tried a BC receiver without a beat osc. on 3.5 Mc. C.W. and worked CTI. R.M. GME resigned his appointment because of ill health. Sorry to lose you as R.M., Russ, but glad that you can continue with Nutmeg Net work. HYF is interested in bowling. EAO has been appointed P.A.M. for Conn. and is particularly interested in the 3.9-Mc. 'phone band. ARB is active on 28-Mc. 'phone. GBX keeps CBA on the air on 7 and 56 Mc. IOV has taken up printing as a side line. Sixteen stations reported their traffic by radio via the Nutmeg Net. Flood CTI with reports on the 16th. DOW's rig is down because he is wall papering the shack. ES schedules 8CMP and 3CAB. GYT is head-quarters for Unit 2, Section 1, N.C.R. EFW is trying out 28-Mc. coils in the SW45. INV is doing good work with A.A.R.S. on 1.75-Mc. 'phone.

Traffic: WHSX 519 JXP 479 AW 364 UE 282 IMV 234 IKE 224 AFB 223 ITI 175 GKM 109 BDI 95 GME 75 CTI 63 JYE 54 KFN 44 TD-JQD 36 JPE 34 INP 30 DWP-JHK 20 HXZ 18 CSC 16 BFS-JUD 13 HPI-BH-IYB 12 JTD 11 APW 10 EAO 9 JOR-KAY 8 BNB-KJP-BEO 7 DLX-CJZ-BGJ 5 KBJ-AQF 4 JLL 2 FNM 1 HYF 16 FAJ 129 CUH-CEJ-JXR 4 ES 49 KV 261 (WLG1 50) DMP 209 JMY 133 FRK 47 APZ 106 FE 119 DOW 3 BUE 2 GYT 7 EFW 6.

MAINE—SCM. John W. Singleton, W1CDX—IST is leading in the traffic contest. INW just missed making the B.P.L. Mrs. Swasey (GOJ's mother) took her exam for an operators ticket. HSD is an active member of the P.T.N. IBR is new member of the P.T.N. IVV is making good use of his new O.R.S. ticket. DHH is rebuilding for all bands, c.w. and 'phone. KAM is new ham in Lewiston. ATA has a position in Chicago. GPJ is having a good time on 1.75-Mc. 'phone. JWR is rebuilding. EZR is back on 3525 kc!

Traffic: W1IST 616 INW 437 GOJ 374 HSD 106 IBR 85 IVV 66 IKC 12 DHH 6.

EASTERN MASSACHUSETTS—SCM, Albert N. Giddis, W1ABG—IWC keeps E. Mass. in the B.P.L. list. IHI did a little rebuilding. DDE got his Commercial ticket. EPE is proving to be a good traffic man. AKS is A.A.R.S. eipher expert. KH schedules VO3X. AGX has outfit in a desk rack. BEF reports from Wilkes-Barre, Pa. JTM is going after O.R.S. appointment in earnest. HKK is interested in O.P.S. appointment. EPZ has gone in for crystal grinding. FCR handles ski reports to *Boston Herald*. BFR worked twelve countries on 3.5 Mc.! HCH is looking for schedules. JZU got a new bug but is afraid to use it! (Too bad a lot more of us don't feel the same!) HKY craves an Asiatic contact. DMF came out of retirement! WV has worked thirty-four states on 28 Mc. JPX has all-band operation with his harmonics! KKM is new station at Ft. Devens. The Eastern Mass. Section has enjoyed a successful season with fine participation in all amateur activities. Congratulations to those who have been outstanding and thanks to those who, though not leaders, have cooperated so well with the S.C.M. in making this one of the leading Sections in the country. At this time next year another man will be conducting the affairs of your Section since I do not intend to run for re-election. I am making this statement now so that you may give more thought to choosing my successor so that the high standing of our Section may be upheld. Cheerio and don't let "spring fever" get the best of you!

Traffic: W1IWC 541 ABG 409 FRO 367 IHI 337 DDE 330 HWE 242 EPE 238 AKS 268 KH 167 AGX 156 EMG 142 BEF 140 BMW 113 JTM 101 QW 66 (CC1C 20) JNU 64 HKK 53 EPZ 45 FCR 39 IIN 44 BFR 39 RE 34 JDV 22 HCH 19 JZU 8 JMS 10 HKY-DMF 8 (Jan.-Feb. W1FCR 43).

WESTERN MASSACHUSETTS—SCM, William J. Barrett, W1JAH—B.P.L. is getting to be a habit with IOR—keep it up, Chet! Heck turns in nice total for IOT, and asks about getting the gang on West. Mass. frequency evenings. How about it, gang? IDG is keeping nice bunch of schedules. BKG spends spare time fooling around 1.75 and 28 Mc. DUZ handled considerable flood traffic. BVR attended Old Timers banquet in Hartford; Perce has new Gross standby receiver, rebuilt by BAP to operate from batteries. There's a thought, fellows—get your receivers lined up so they are available for emergencies when a.c. fails. GUO had 9 QSO's for the month. ISN handled traffic from U.S.S. *Quincy* and U.S.S. *Vincennes* at Boston Navy Yard. BNL reports his 7-Mc. skywire refuses to perk on 3.5. KFV reports for the Springfield gang. Thanks, OM. KLN

is new ham in Springfield. IOE got 35T and new Skyriider. JQ has 805's on 1.75 and 3.5 Mc. GJJ has transmitter trouble. KFV applies for O.R.S. HJR still reports from college in Indiana—he's operating on 14 Mc. and would like a buzz from the West. Mass. boys. KJK made first report. AJ has temporary antenna up and is ragchewing again. COI has 7-Mc. crystal ground to put him on 29,960 kc. How about some activity on the upper half of 28 Mc. before we get a Cairo Survey pulled on us? IJR is rebuilding rack and panel. JXN inquires about O.R.S.

Traffic: W1IOR 609 IOT 387 IDG 271 BKG 89 (WLG 101) DUZ 67 BVR 66 (WLG 139) AJD 30 JAH 28 GUO 23 ISN 8 BNL-KFV 7 HJR 6 KJK 3 AJ-AREH 2 COI 1.

NEW HAMPSHIRE—SCM, Carl E. Evans, W1BFT—The last meeting of the M.V.A.R.A. was held at APK's shack with a very interesting demonstration of a cathode-ray oscilloscope by GHJ. BII is raising hounds. GKE has changed his oscillator to an RK-39 and reports a very noticeable increase in exciter output. AVJ's T-200 certainly went places, particularly on 28 Mc. during the DX contest. HOV doubled the input to his RK-20 merely by increasing suppressor and screen voltages and shorting out his input filter choke. EAW QSYed to 56 Mc. for a change. GMH has been appointed O.P.S. BDN's O.P.S. has been renewed. ESB suffered a compound fracture of the skull and brain concussion due to a fall while installing an antenna. We understand he has finally pulled thru and will be back on his feet soon. We all wish you a speedy and successful recovery, Gil. EAL has been attending the legislature in Concord. IVU is increasing power. BFT WAcEd during the DX contest. IP is looking for the northern N. H. fellows. CEA is still on the farmers' net. ITF has his break-in troubles ironed out now but is still using a 6L6 oscillator. IDY is building a new transmitter. The N.H.E.N. has given up the new net procedure after two tries and is reverting back to the one first used on 3840. Drills on 3840 are now being held twice monthly, on the first and third Sundays at 11:00 a.m.

Traffic: W1IP 661 PFL 335 (WLG 54) BFT 160 GMM 134 GHT 118 IDY 60 CEA 56 ITF 26 JDP 11.

RHODE ISLAND—SCM, Clayton C. Gordon, W1HRC—JLM (Jim Laird) says I had his call down in error as JHN last report—sorry. CAB has transmitter on all bands, 1.75 to 56 Mc., 'phone and c.w. and has HF-100 on 28 Mc. with 200 watts input. JPJ has new 14 Mc. rig, '47 crystal—'46 doubler—'10 final with 7-Mc. crystal donated by JLM. IAV has kw. rig nearly done. BDS is on 14-Mc. 'phone with pair of HF-100's p.p. in final. KCG (Ed. Dolan) at 42 Franklin St., Westerly, is an old timer who has been away for several years and is now back. BIT has gone steel rack and panel finally with HF-100 on 14-Mc. 'phone. JRZ in Greenwood is on 28 Mc. KGAUG (Thomas Stacey) is now at Fort Adams. FOV at Narragansett Pier has HF-100 on 14 Mc. BVI is spending most of his time on 1.75-Mc. 'phone. HJ had JNO as second op. during DX contest. HPE is working the foreigners on 28 Mc. JNO home weekends is on 3.9-Mc. low power 'phone. IRF is back on the air after nine months' lay-off. JFK is having antenna trouble. IHW made R.C.C. on 1.75-Mc. 'phone. IYL is on 56 Mc. JFG is having feed back trouble on 14 Mc. The P.R.A. will take charge of the R.O.W.H. initiation ceremony at the Convention. HRC has new c.r. "silly-sock" and finds the FBXA is really quite a receiver when line-up is made with c.r. AFO took a day off to do some FB work in the DX contest. JDX is having good luck experimenting with Reinartz crystal substitutes, in L6L circuits. JUE has crystal on 56 Mc. ISI is prime-mover in Hope High Radio Club, with the "Baron" as his press agent.

Traffic: W1IEG 143 (WLG 387) INU 383 GTN 263 QR 251 (WLG 35) JPJ 154 (WLG 34) INT 108 IAV 5 JNO 3 CAB 17 IRF 1.

VERMONT—SCM, Alvin H. Battison, W1GNF—C.R.M.: 1FSV. R.M.: 1EZ. P.A.M.: 1AVP. FSV reports another fine traffic total; he needs but four more states for W.A.S. AD is back on 3.9-Mc. 'phone. IDW is rebuilding with an Amperex HF100. EZ worked 57 different countries in the DX tests with his new experimental antennae! AAK has installed a pair of 35T modulators. JPZ needs only seven more states for W.A.S. FN constructed a vacuum tube voltmeter. JRU visited BD. JMO has returned to the 1.75-Mc. 'phone band. KJG and JRU joined the A.A.R.S. HEV is installing crystal control. ILX and GAE are testing their A.E.C. transmitters. The Morrisville fellows are forming a radio club. ELR is back on 28-Mc. 'phone. GNF is working in Springfield (Home of the Amateur Telescope Makers). IQG has antennae troubles. TV and GXP schedule

(Continued on page 104)

Coto

LO-LOSS INDUCTORS

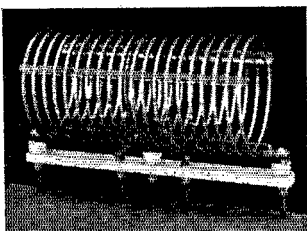

Wise and thrifty Amateurs are insisting on COTO Lo-Loss Inductors, because they are extremely efficient, provide easy, quick band-changing, and are low in cost.

Available in high and low power TANKS, with and without Links; C. T. BUFFERS, with and without Links; Straight BUFFERS, also ANTENNA types.

See them, and the COTO STEATITE PLUG-IN MOUNTINGS at your local jobbers. Bulletin Q4-3 sent on request.



RADIO PRODUCTS
 PROVIDENCE R. I., U. S. A.
 EXPORT ADDRESS - 100 VARICK ST., N. Y. C., N. Y.

A.R.R.L. QSL Bureau

FOR the convenience of its members, the League maintains a QSL-card forwarding system which operates through volunteer "District QSL Managers" in each of the nine United States and five Canadian districts. In order to secure such foreign cards as may be received for you, send your district manager a standard No. 8 stamped envelope. If you have reason to expect a considerable number of cards, put on an extra stamp so that it has a total of six-cents postage. Your own name and address go in the customary place on the face, and *your station call should be printed prominently in the upper left-hand corner.*

- W1—J. T. Steiger, W1BGY, 35 Call Street, Willimansett, Mass.
- W2—H. W. Yahnel, W2SN, Lake Ave., Helmetta, N. J.
- W3—R. E. Macomber, W3CZE, 418 10th St., N. W., Washington, D. C.
- W4—B. W. Benning, W4CBY, 520 Whiteford Ave., Atlanta, Ga.
- W5—E. H. Treadaway, W5DKR, 2749 Myrtle St., New Orleans, La.
- W6—D. Cason Mast, W6KHY, 423 East E Street, Ontario, Calif.
- W7—Frank E. Pratt, W7DXZ, 5023 So. Ferry St., Tacoma, Wash.
- W8—F. W. Allen, W8GER, 324 Richmond Ave., Dayton, Ohio.
- W9—George Dammann, W9JO, 319 Sherman Ave., Evanston, Ill.
- VE1—J. E. Roue, VE1FB, 84 Spring Garden Rd., Halifax, N. S.
- VE2—C. W. Skarstedt, VE2DR, 236 Elm Ave., Westmount, P. Q.
- VE3—Bert Knowles, VE3QB, Lanark, Ont.
- VE4—Dr. J. J. Dobry, VE4DR, Killam, Alberta.
- VE5—E. H. Cooper, VE5EC, 2024 Carnarvon St., Victoria, B. C.
- K4—F. McCown, K4RJ, Family Court 7, San-turce, Puerto Rico.
- K5—John J. Carr, K5AV, 78th Pursuit Squadron, Albrook Field, Canal Zone.
- K6—James F. Pa, K6LBH, 1416D Lunalilo St., Honolulu, T. H.
- K7—Leo E. Osterman, K7ENA, Customhouse, Wrangell, Alaska.
- KA—George L. Rickard, KA1GR, P. O. Box 849, Manila, P. I.



MR. E. H. RIETZKE PRESIDENT OF CREI



"I realize the need for training . . . but what can CREI do for me?"

CREI offers you a thorough, modern course in Practical Radio Engineering, written for the man who is serious about getting ahead in Radio. It helps you to progress from the "mechanic" stage into the ranks of the expert specialist. It gives up-to-the-minute instruction in what goes into modern Radio apparatus, so that you can look at it with the eyes of the engineers who designed it and appreciate the results they are trying to obtain. If you realize the importance of technical training, send for the CREI booklet that describes our courses and your future in detail.

Write for
FREE BOOK
"A tested plan for a future in practical radio engineering."

CAPITOL RADIO ENGINEERING INSTITUTE

WASHINGTON, D. C. Dept. NEW YORK CITY
14th and Park Road Q-5 29 Broadway



🐞 Strays 🐞

Note on bugs slipping on varnished tables (we've had several such suggestions recently): W1EH says why put the thing on a varnished table? A desk blotter will keep it from walking, provided the rubber feet aren't glazed over, and is a good thing to use anyway, especially on a table which the op doesn't want to scratch or otherwise mar.

FOR BETTER RADIO

USE HAMMARLUND

TRANSMITTING CONDENSERS

- 1 MAXIMUM RIGIDITY—
LIGHT WEIGHT—
ISOLANTITE INSULATION
- 2 ALUMINUM END
PLATES—TABLE OR
SHELF MOUNTING
- 3 BERYLLIUM CUSHION
DISC FRONT BEARING—
REAR BALL BEARING—
SILVER PLATED
WIPING CONTACT
- 4 HEAVY WIDE SPACED
ALUMINUM PLATES—
ROUND EDGES FOR
HIGHER VOLTAGES
- 5 SINGLE AND SPLIT
STATOR TYPES—19
SIZES—20 TO 500
MMF.—VOLTAGES
1000 TO 10,000
- 6 FULLY GUARANTEED

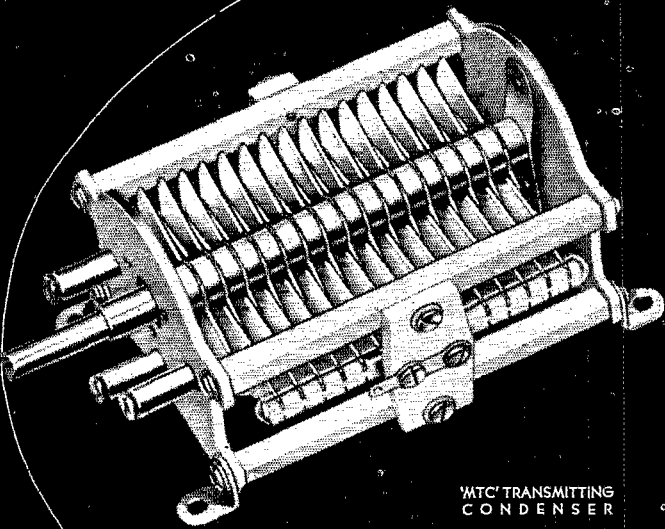

"MTC" TRANSMITTING
CONDENSER

WRITE DEPT. Q-5 FOR
THE "MTC" BULLETIN

HAMMARLUND MANUFACTURING CO.

424-438 West 33rd Street, New York

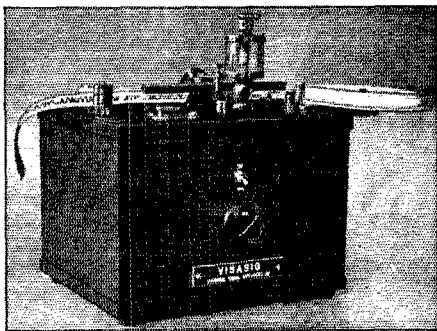

VISASIG Full Automatic Siphon
Tape Recorder

Records code signals from receiver up to and over 100 wpm
VISASIG with electrically driven tape puller, constant
level ink feed and 1500 ft. tape capacity
complete in one unit..... **\$59.00**

Price F.O.B. New York City

UNIVERSAL SIGNAL APPLIANCES
64 West 22nd Street New York City

Visasig Blueprints \$1.00

NEOBEAM OSCILLOSCOPE

Makes HIGH
FIDELITY easy—
helps modernize old
equipment.

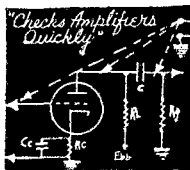
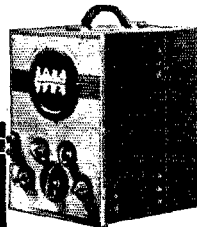

Self-contained power
supply, sweep system,
high gain amplifier,
and calibrated input.

By attaching just one test prod, as illustrated above, you are ready to check every part of your audio system.

Before your eyes—as plain as daylight—is an image of sound—a true story of the fidelity of your amplifier, so simple even the less technical layman understands.

Now it is easy to adjust the plate and grid loads of the amplifier until each stage can portray a clear HIGH FIDELITY tone on the full 4" calibrated screen of the NEOBEAM.

The image has contrast—orange against black—you see every detail of hum and distortion.

The NEOBEAM OSCILLOSCOPE comes complete with tubes and ready to operate. Full satisfaction guaranteed or money back. \$40.00 net.

SUNDT ENGINEERING COMPANY

Affiliate of Littelfuse Laboratories

4246 Lincoln Avenue

Chicago, Illinois

(Continued from page 101)

AVP. BCF visited AVP. EHB has a new "V8." GJV has formed a radio club at Arlington High School. JHU is using an '04a on 7 Mc. FIW is operating from the C.C.C. Camp in East Thetford. JVT is a very enthusiastic new amateur.

Traffic: W1FSV 513 GNF 18 AVP 15 GAE 11 AHN 4.

ATLANTIC DIVISION

EASTERN PENNSYLVANIA—SCM, James M. Bruning, W3EZ—R.M.'s: 3AKB, 3AQN, 3EOP, 8ASW. P.A.M.: 3EOZ. 3GMK has new 6-tube receiver. 3AGK put the finishing touches to new rig. 3EJW heard lots of 3.5-Mc. DX during contest. 8OML worked a ZL and a VK on 14 Mc. using R.C.A. Spiderweb as transmitting antenna. 8EKG is now D.N.C.S. of PAZ. 8GLQ is looking for a good 3.5-Mc. crystal. 3FXZ says it is a lot of fun to copy messages from Hawaii; she should know because her log shows forty-eight individual messages handled last month directly with K6NXD. 3CZS installed horizontal doublet receiving antenna. 3EDC put up a new Zepp. 8ASW manages to get in a few rag chews over the week-end at home and some operating at 8AVK during the week. 3CHH got one new country out of the DX contest. 3DXX now runs 100 watts; Ted would like some daytime traffic schedules. 8PCL was on 14 Mc. a while last month; Bob has applied for O.R.S. 8UV tries 'phone with his RK-20's and has a fine time Sunday afternoons. 3EON using one watt of power has worked north to Nova Scotia, west to Iowa and five Cubans. 3FPW put up new antenna and within a half hour worked three continents. 8EU continues to crowd thirty-six hours work into each twenty-four hour day. 3ECA would like schedules with anyone having traffic for, near, through or towards Phila. 3EUP yells "Stop the press!" After three years' effort to work Europe, George contacted three stations in a row. Perseverance pays premiums. 3DGC sends his first traffic report for ten years; Ed was formerly an O.R.S. with the call 3VT. 8DIG had to cancel his O.R.S., O.O. and D.N.C.S.-A.A.R.S. jobs due to pressure of business, and sends 73 to the gang. "Dig" has always been a live wire and his work is appreciated. Good luck. 3ETM was severely bitten by a mad DX bug after he worked G5BL on 3.5 Mc. 3QP continues his daily schedule with 6CUU and easily makes the Brass Founders' League on deliveries. Wish we had more "Delivery-boys" and fewer "WPA-relayers." 3GJY has new NC101X receiver and is going after the three missing states for W.A.S. 8FLA worked some good 3.5-Mc. DX before the contest. 3EOP sends a belated report that he copied WLM at 45 w.p.m. in the recent tests. 3BGD more than doubled his DX contest score over that of last year and also reports that the "Beacon Radio Amateurs" Club had equally good results. 8BFF sent in a fine sheet of Official Observations. 8OST is back on the air with a 6L6 crystal rig. Stations reporting "usual activity" were 3AKB, 3EOZ, 3EZ and 3IU. 3BRZ reports excellent results with the V antenna; he now gets S7 and S8 reports from the ZL and VK gang. The Main Line Radio Club at annual election of officers selected the following: 3EOZ pres., 3FRY vice-pres., 3GHP secy. and 3EZ treas. The Electric City Radio Club (Seranton) will give a crystal Super-Skyrider for door prize at their hamfest in May. See 8OST for details of meeting.

Traffic: W8EOP 912 (WLQB 181) ECA 511 QP 383 EWJ 294 AKB 187 FXZ 103 ETM 94 GJY 48 ADE 43 EDC 85 DGC 22 GLQ 21 EZ 20 DXX 19 GHP 12 CHH 8 FPW-GMK 7 BGD 1. W8RKG 144 FLA 131 (WLQC 53) UV 34 HKS 32 PCL 11 OML 7 ASW 6 EU 1.

MARYLAND-DELAWARE-DISTRICT OF COLUMBIA—SCM, Edgar L. Hudson, W3BAK—R.M.'s: 3CQS, 3CXL, 3EQU, Chief R.M.: 3BWT. SN has new rig with 150T final. BKZ has pair of Eimac 100TH's in final; he has worked 53 countries. FSP has applied for A.A.R.S. EZN is rebuilding. CDG took part in M.M. relay, made W.A.S., was in DX contest, did some rebuilding, all in one month. GFF had 1500 QSO's in less than a year. EYX is keeping daily schedule with Phila. FNG has a T55 final. ETE, BAK and CDQ report active. GBB is operating aboard the S. S. *Plow City*, KJVG, a coast-wise freighter operating between Galveston, Texas and Atlantic Coast ports. GRX and GSK are new hams in Annapolis. With deep regret the Washington Radio Club records the passing of two of its members: C. T. Bidwell, 56, ex-Atlantic Division Director. Mr.

Bidwell died February 19, 1937. William H. Phillips, 16, a new member of the Club, was studying for the coming examinations to obtain his license when death overtook him. Bill died February 18, 1937.

Traffic: W8CXL 254 (WLM 2198) SN 612 BWT 519 BKZ 126 CAB 53 FSP-KA 24 EZN 14 GKZ 13 FPQ 9 CIZ 128 CDG 11 GFF 8 EYX 6 GKT-FIU 5 FNG 4.

SOUTHERN NEW JERSEY—SCM, Carroll D. Kentner, W3ZX—FXM recently became a member of R.C.C. ZI is having trouble with his Net crystal. BIR has been under the weather but has managed a little activity on 56 and 14 Mc. FBM has QSO F8, PAO, EI, FM on 3.5 Mc. with 9 watts input. GMY worked a few in DX contest and will be on 3.5 Mc. soon. BEI has new transmitter operating on 14-Mc. 'phone and c.w. ZX found competition stiff in DX contest. FGK again leads the Section with a rip-snortin' total. Jim has taken on operator job in Nat'l Guard to fill in his spare time. DYP landed his first foreign contact by QSO with G6WV, and then went on a spree working XE2N, XE2W, G2ZQ, EI8B, CM5YG, K5AC, K5AY, K6JPD, K6CGK, and FMSAD on 3.5 Mc. with 35 watts input to a '46.

Traffic: W8FTK 1400 FBM 50 QL 10 DQO 6 EFM 18 (WLNJ 28) BYR 94 AEJ 22 ZI 175 BO 46 DNU 137 GMY 1 FTX 2 BEI 19 CES 1 KW 5 ZX 28 EEQ 5 VE 38.

WESTERN NEW YORK—SCM, Charles Smith W8DSS—C.R.M.: JTT R.M.'s: 8BJO, 8AQE. L.O.: 8CSE. P.A.M.: 8CGU. The Rochester Hamfest drew a crowd of over one hundred and fifty central and western New York hams. All enjoyed the good food, fine speakers, nice prizes and many new personal contacts. This Section broke a record this month when three of the boys made the B.P.L. MQX headed this group, closely followed by JTT and AQE. CSE, PLA and BJO also had fine totals. KMC sends regards to the gang thru JQE from U.S.S. *Pennsylvania* in San Diego. GWY is testing with WBZ and WBZA for harmonic radiation. FUG keeps very busy with A.A.R.S. 2HTX operating portable reports from Ithaca. KYR is looking for reliable schedules. OXI kept schedules with OCH during latter's visit to Florida. JTT and NMR are active again. NWZ lost nice traffic schedule with 1BEF. JMI and DLK are active in Buffalo area. AOR, GZM and QDP are getting traffic conscious. CGU has been busy examining O.P.S. applicants. LUQ made 57,000 points in the DX contest. AQE has been keeping his schedules from a sick bed. JTT is now working steadily in Erie, Pa., and is on the air only during week-ends. BJO blew his power supply again. QHX and BFG are still strong for DX. AKC, DX and PUS are rebuilding. FCG is trying to sign up some members for the A.A.R.S. The first QSO with the new rig at GWT was with an African. LFB has moved to Penn Yan. BHK, LGV and NTY were active in DX contest. LGS has a first-class commercial ticket. NWT cut all the tendons in his right wrist in an accident at his work. Cayadutta Radio Ass'n held its first annual hamfest with twenty-seven attending. AXE is preparing to pound brass on the Great Lakes again this year. MBW passed his O.P.S. test with flying colors. DII participated in the American Bowling Congress in New York. DSS has two transmitters, one of which has an input of 200 watts. 73.

Traffic: W8MQX 779 JTT 568 AQE 515 CSE 391 PLA 290 BJO 209 JQE 179 GWY 149 FUG 92 KXA 81 DHU 70 HTX 68 KYR 65 NWY 55 OXI 40 DSS 39 JMI 35 PCW 29 FCG 27 LUQ 22 CGU 21 DLK 15 QDP 11 BFG-GZM 5 AOR-QHX 3 LGV 1.

WESTERN PENNSYLVANIA—SCM, Kendall Speer, Jr., W8OFO—R.M.'s: 8KUN, 8KWA, 8MOT. New O.R.S.: GBC. Prospective O.R.S.: JSU. Additions to the W. Pa. O.R.S. Net: GBC, LGD. KUN is high man with a total of 737. QAN makes B.P.L. again on both total and deliveries. QAN is to be commended for his consistent making of B.P.L. on total and deliveries. NDE went B.P.L. on deliveries. OFO rebuilt the following lineup: 6L6-T20-T814 and bought a new Sky Challenger. UK's mother passed away during the latter part of February. Our sympathies, Pat. JSU blew his entire power supply and is on with low power while rebuilding. CMP will be at the Erie Convention, 8YA/WLMA is alternating net control with WLM on the A.A.R.S. special frequencies. AXD says KDM received his radiophone first-class license. FSZ got home from college in time to enter the DX contest and worked eleven countries. OIZ has put in a T20. ODH is consistently working DX on 7 Mc. KXP is on the air with a 6L6 while rebuilding.

Traffic: W8KUN 737 QAN 519 KWA 378 NDE 270 OFO
263 UK 76 JSU 74 CMP 57 KOB 53 YA 46 (WLMA 349)
LGD 19 MIW 16 AXD 8 FSZ-GBC 1.

ROANOKE DIVISION

NORTH CAROLINA—SCM, H. S. Carter, W4OG—Badin: EIT is on with a new rig; he has worked 34 states and plenty of DX. EIU has worked 42 states and lots of DX. Charlotte: BX is on 3.9-Mc. 'phone and 7-Mc. c.w. CXC has new rig running about 500 watts input. BFB has about finished his new kw. rig. EJE, DSY, DST, DHW and DIS are all active. Durham: RV is putting up new 14-Mc. vertical. OC has new Collins transmitter. Kings Mountain: DOQ has new bottle and is ready to go on the air with much more power. CEI tried in the DX Contest, and succeeded in raising South Carolina! Greensboro: MR's new tower blew down; he also lost his father. You have our deepest sympathy. OM, EQQ, a new ham, is on 14 Mc. with '10's in p.p. Raleigh: EG has been very sick; hurry up and get well. OM, Wilmington: FT has 100TH's in his 28-Mc. rig. EC is interested in high-frequency equipment for use in his professional work. BQZ has portable rig with output of about 20 watts for use on all bands. BPL has returned from South Carolina. EEL is working with suppressor grid modulation on an RK-20. GPT has new RME-69 with pre-selector and noise silencer. Fort Bragg: CVQ spent some time in the flood area handling traffic, and is back now with a pair of 100-T's on 'phone. He wants to see an Emergency Net organized in North Carolina. Anyone interested in an Emergency Net please let your S.C.M. hear from you. Winston-Salem: 4NC, CFR, ABT, RA and OG were in on the DX contest; ABT led the gang in working the most stations. RA and OG worked their first J's. DCQ went into the 'phone DX contest with wonderful results. BWC lost his mother. You have our deepest sympathy. AHF plans to be on soon with a 14-Mc. 'phone rig. DGV is dividing his time between rag chewing and experimenting, and works both 3.9- and 14-Mc. 'phone.

Traffic: W4DW 91 ABT 38 ECA 22 GJN 19 AGF 8
DCS-EG-BVD 6 BDU 3 RV 2 BHR-DWB 1.

VIRGINIA—SCM, Charles M. Waff, Jr., W3UVA—BIW worked U9AW in contest for his W.A.C. GPC worked a G on 3.5 Mc. with a '46 final! FB, CSY worked 24 countries in contest using a T-55 final. UVA worked all continents in 2 hrs., 51 min., March 14th; stations worked were OA4J, K7PQ, VK2QE, G16TK, XU8JR and ZS5U. GTS is ex-3DHL and ex-K6JPT at Langley Field, Va.; he is using an RK-20 final. Welcome! GJP has separate rigs for 3.5 and 7 Mc. BFW is moving to Richmond. EMM made 104,544 pts. in DX contest, 268 contacts on 4 bands; he made W.A.C. eight times, working U3FZ, J4CT, J2CB, J2LU, J5CE, J2MH, J8CA, and XU8JR. CHE made about 55,000 pts.; FQP 39,000, and GAP 25,000. FGJ is new O.P.S. The Richmond Short Wave Radio Club is having FB meetings these days. Out-of-town hams are invited to meetings at Y.M.C.A. on alternate Tuesdays. EXW made 12,000 pts. in contest. AJ has Virginia 'Phone Net going strong. Traffic: W3GTS 261 (WLQE 74) GPC 27 CSY 20 GJP 5 FZG 4.

WEST VIRGINIA—SCM, Dr. Wm. H. Riheldaffer, W8KKG—Wheeling Radio Club was organized with CDV president and CWY vice-president. Dale Phillips, Sr., has a new Class B ticket and will operate K8J while Dale, Jr., is in Pittsburgh. Wheeling 56-Mc. actives include CWY, CXR, FVU, KRU. PQQ worked some nice DX in the contest. NAU resumed schedules with Tennessee; he went to Johnson City with EWM. NSE applied for O.R.S. Ten members of night radio class join M.A.R.A. KVX is active on 3.5 Mc. NTV finds SW3 is berries on 28 Mc. EP put in four tens for a final. OFD is trying to drive RK-20 on 28 Mc. with 59 tri-tet. MIS is worried with bus wire and bugs since rebuilding. JRL has new rotating beam on 28 Mc. which actually worked in DX contest. ANU is new member of R.C.C. ELO picked up 3000 points in O.R.S. party. OLV has had 1429 QSO's. OXO has new RME-69 and W.A.S. No. 248. QPZ is new reporting station in Princeton. MCL won the second monthly QSO contest of Bluefield Amateur Radio Club and has 38 states since the first of the year. OFE has nice new rack and panel with cabinet around it. NLE has new 7-Mc. crystal and is going DX hunting in a big way; he is attending Bluefield College.

Traffic: W8MCL 82 HD 137 OXO 16 LXF 8 OLV 6
MZT 7 ELO 3 ANU 26 NTV 10 PQQ 2 HWT 52 CFB 38
LII 24 JRL 13 CZ 36.

National Balloon Races and Mile High Air Races

THE National Balloon Races and Mile High Air Races which were held in Denver, Colo., last season and offered an interesting opportunity for the experienced 56-Mc. operators in the district. The officials in charge of the Air Races praised to the highest extent the work done by amateurs. The radio operators were appointed official judges, two men in each one of the Pylons on the closed course, 56-Mc. transceivers, reinforced by equipment built up by the local hams, were used. Base stations were set up on top of the Administration Building at the Denver Municipal Airport. Base stations 1 and 2 called all Pylons, and gave the correct position of each racing plane as it took to the air. The planes roared across the starting line and around the first Pylon. As each plane made its turn at the three Pylons, the hams called the base stations and gave their official O.K., and at the same time they made written record of the sequence. As the race progress, the positions of the planes changed so many times, that an official announcement of the winner's time and speed would not have been possible for several minutes after the finish, had any other form of communication been used. So efficiently did the short-wave radio communication work that official time and speed of the winner was given to the crowd before the last planes had finished the race.

Positions for the races: W9ESA and W9MKN at Base Station No. 1 were in communication with W9EPC and W9FKQ in Pylon No. 1 and W9GBQ and W9WRO in Pylon No. 2. W9FCK and W9DSB operating Base Station No. 2 were in communication with Pylon No. 3 where W9MXXM and W9FA officiated. W9NWW was stationed at the base stations on one end of a telephone line to A. L. Williams at the announcer's stand. By rotating each day, everyone was given a chance to operate one of the base stations.

On July 4th, Col. Roscoe Turner made a record flight from Denver to Pikes Peak and return, using a Boeing Transport fully loaded. W9HDU and Russell Ramsey located at the airport in Colorado Springs, while W9USP and W9YAE were stationed at the top of Pikes Peak (with W9KNZ's equipment) where they reported weather conditions to Col. Turner at the Denver Airport and also checked him as he turned around the famous peak. The thermometer stood at 32 degrees and snow was falling at the summit as Col. Turner made his turn and started back to Denver. The reports from the hams on the peak furnished a breath-taking description of the record flight which was carried over the network of the National Broadcasting Co. thru KOA. To these Colorado Springs amateurs—orchids for a job exceptionally well done.

The world record for the 550-cubic inch racing ships over a 100-kilometer course, was shattered by Rudy Kling of Lamont, Ill., when he flashed his blue monoplane around the course at a little more than 228 miles per hour. Stationed 31 miles from Denver's Airport, W9ESA and his 3.5-Mc. c.w. rig installed in an automobile, together with W9FCK and C. D. Garroute, flashed the official O.K. to W9EPC receiving at the finishing line in front of the grandstand, as Kling made his turn at the north end of the course, the air race announcer was able to tell the crowd that a world's record was broken, even before the small blue ship came to rest on the Airport.

All newspaper reporters received their information from the amateurs. The times, speeds, and stories of the many fliers were made available to them by records kept by the fellows. A great many of the newsmen as well as officials praised the work of the boys who worked so successfully for the three-day period. W9LNB, Bill Hayes, A. L. Williams, and C. D. Garroute proved to be indispensable as relief operators, helpers, and general utility men. C. D. Garroute took pictures of the bunch, also some very fine actions pictures of the race. A. L. Williams faithfully handled the job at the speakers' platform on that end of the telephone line. W9LNE and Bill Hayes gave their time and efforts as relief operators.

It was the first Air Meet in Denver, and a faultless job, the result of all members working together under the capable direction of W9NWW and W9ESA, who worked untiringly for three months in advance to make the races a success.



CONDENSERS FOR EVERY
AMATEUR REQUIREMENT

WORLD'S LARGEST EXCLUSIVE MANUFACTURERS
OF CONDENSERS FOR MORE THAN 27 YEARS

CORNELL-DUBILIER

1002 HAMILTON BOULEVARD • SO. PLAINFIELD, NEW JERSEY

Long-Wire Antennas

(Continued from page 74)

methods in the line. The directivity effects and power gain are readily noticed when used for reception. The signal-to-noise ratio is also greatly improved along the major horizontal directive lobe. Many cases have been known where received signals on the usual doublet were so far below the noise level that it was practically impossible to determine that the signal was actually there—but by the use of the "V" or rhombic the same signal was brought up to a good QSA5 level.

For rhombics 2 wavelengths on a leg or greater, and for "V"'s 4 wavelengths on a side or greater, power gains of 18 to 30 over a single half-wave Hertz are obtainable for the same transmitter power, which makes these systems a veritable "power plant" for low-power transmitters.

A few final hints should not be amiss at this point:

(1) In figuring harmonic lengths for the proper length of each side, etc., the following formula will give the result with reasonable accuracy:

$$\text{length in feet} = \frac{492 (2K - .05)}{\text{freq. (in Mc.)}}$$

K = number of wavelengths

(2) Before this length is correctly determined and cut it is advisable to play safe by using hard drawn or some other forms of "stretchless" wire to maintain the original dimensions.

(3) In figuring directions be sure to use a great circle map—the usual straight maps will throw you a long way off on your beam calculations.

Moral: "Be the ham who owns one!"

BIBLIOGRAPHY

- 1 Bruce, "Developments in Short Wave Directive Antennas," *Proc. I.R.E.* August, 1931.
 - 2 Carter, Hansell and Lindenblad, "Development of Directive Transmitting Antennas by RCA Communications, Inc." *Proc. I.R.E.* October, 1931.
 - 3 Carter, "Circuit Relations in Radiating Systems," *Proc. I.R.E.*, June, 1932.
 - 4 Hull and Rodimon, "Plain Talk about Rhombic Antennas," *QST*, November, 1936.
 - 5 Moore and Johnson, "Directed Vertical Radiation with Diamond Antennas," *QST*, April, 1937.
 - 6 Bruce, Beck and Lowry, "Horizontal Rhombic Antennas," *Proc. I.R.E.* Jan., 1935.
- A.R.R.L. *Amateur Handbook* (Antenna Chapter).

How Would You Do It?

(Continued from page 88)

between them. The link coils on the tank coils may be the usual two or three turns wound between the turns of the tank coil windings at the coldest point and permanently connected to plugs on the form in the usual manner. The vari-

Bruno's NEW LOW COST WIDE RANGE HIGH OUTPUT HUMLESS MICROPHONE

Not just another Mike!

Based on an exclusive Bruno construction feature, the rugged Velotron embodies the high fidelity characteristics of the velocity, surpasses the output of the diaphragm type crystal and is as low priced as the best carbon. The Velotron is a true velocity microphone utilizing a static, instead of the customary magnetic field.

Check these outstanding characteristics found only in the

BRUNO VELOTRON

☆ Highly directional ☆ Low feedback level ☆ Variable Frequency response (30 to 14,000 cycles) ☆ Output level — 50 db. (Zero level 6 milliwatts) ☆ Absolutely humless ☆ Thoroughly shielded ☆ Not affected by varying temperatures or changing atmospheric conditions.

Complete with shock absorber and ball swivel. Cable connector and cable extra. Model H only \$19.50 list. Model H also available for portable use.

Get your jobber to demonstrate the New Velotron to you! . . . write direct for complete descriptive catalog.

ONLY
\$19.50
LIST

BRUNO
LABORATORIES, INC. 34 WEST 15th ST. N.Y.C.

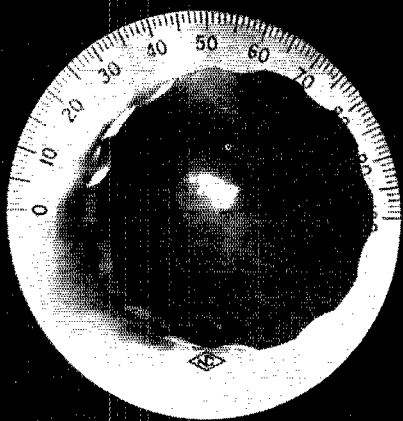

TYPE O DIAL

The National Type O Dial is definitely a handsome piece of equipment. The circular-grained, solid nickel-silver dial is $3\frac{1}{2}$ inches in diameter. Numerals and division lines are clean-cut and accurate. The large bakelite knob is well proportioned and comfortable to the hand. For safety, the dial is positively insulated from the hub by a large bakelite boss. Ask to see the National Type O Dial at your dealers.

NET PRICE
\$.90

NATIONAL COMPANY, INC., MALDEN, MASS.

DIVIDENDS

from your "Junk-Box"

by applying the money-saving ideas in

HINTS & KINKS

(VOLUME TWO)

For the—

WORKSHOP
RECEIVER
TRANSMITTER
PHONE WORK

KEYING SYSTEMS
FREQ. METERS &
MEASUREMENTS

POWER SUPPLY
ANTENNA SYSTEMS
ULTRA-HIGH FREQ.

128 pages of dope—GOOD DOPE

Price 50¢ postpaid from A.R.R.L., West Hartford, Connecticut

HARVEY'S

CONVENIENT to EVERYWHERE

89-807 TRANSMITTER

This transmitter is completely described in December 1936 *QST* page 28. This kit is complete in every detail, all that is needed is a soldering iron and elbow grease. Parts include RCA tubes, Bileys xtal, Bud drilled and punched chassis, Cornell-Dubilier condensers, **\$18.95** and Coto coil. Complete at the sensationally low price of **\$18.95**
Power supply for the above rig is composed of UTC and **\$7.95**
Cornell-Dubilier parts and costs



BILEY CRYSTAL

VF1 — within 5 kc. of specified minimum frequency in the 80 meter band **\$8.00**

NEW PRECISION MULTI-METER SERIES 830 — D.C. — Volt — Ohm — Milliammeter. **\$10.95**

NEW RCA AERODYNAMIC MIKE **\$15.90**

NEW HAMMARLUND SUPER PRO with ten meter band complete with crystal, tubes and speaker. **\$255.77**

NATIONAL NC101X — The ideal amateur band receiver. With crystal, tubes and speaker **\$129.00**
Same receiver with famous National Built in "S" Meter. **\$145.00**

NATIONAL NC100X — General coverage receiver complete with tubes, crystal, speaker. **\$142.50**
Same receiver with built in "S" meter **\$157.00**

NEW RCA ten meter transmitter ACT 20. **\$129.50**

NEW SKY CHALLENGER BY HALLICRAFTER. **\$69.50**

JOHNSON Q with feeders shipped straight for ten. **\$5.63**

TRIPLETT modulation monitor. **\$24.83**

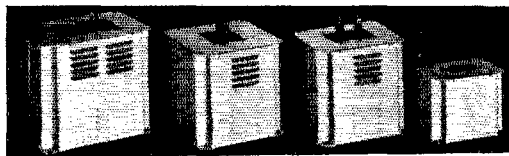

NEW HARVEY CHOKES

20 hy 200 ma. Smoothing 5-25 hy 200 ma. Swinging. **\$1.75**
20 hy 300 ma. Smoothing 5-25 hy 300 ma. Swinging. **\$3.29**
20 hy 400 ma. Smoothing 5-25 hy 400 ma. Swinging. **\$4.10**

20 hy 550 ma. Smoothing 5-25 hy 550 ma. Swinging. **\$5.59**
Cased, can be mounted in any position. Ceramic insulators, high voltage insulation. Guaranteed 3 months.

The Value of the Month

HARVEY HIGH FIDELITY AUDIO UNIT

32 watts of high fidelity audio for modulation or PA work. Highest quality parts used throughout. UTC, Cornell-Dubilier, IRC, etc. May be used with a crystal, ribbon or dynamic mike, preamplifier not necessary. Tubes used in this kit — 6J7-6J7-6C5-616 PP. Furnished with drilled and punched black crackle chassis and heavy duty self contained power supply.

Price complete, less tubes **\$19.40**

Kit of RCA Matched Tubes **\$5.74**

OUR *Best* VALUE IS OUR RECORD OF LOYAL SERVICE

HARVEY

Radio Company of New York

103 WEST 43rd STREET • NEW YORK, N. Y.

CABLE ADDRESS: "HARADIO"

able coupling coil assembly may be mounted for front of panel control at a point where it is fairly well isolated from other r.f. fields. The diagram, Fig. 2, gives an outline of the idea which can be varied to suit individual cases. A vernier dial or a small worm gear would make the adjustment easier. This split link can be used to eliminate the last trace of capacity coupling between two tanks by either grounding one or both sides at the point of coupling or by introducing a Faraday shield between the two coils where the link is split. This will not usually be necessary, but it will turn the trick if other methods fail. This variable coupling is also useful for reducing power in c.w. work. The two coils of the "vario-coupler" may be wound on celluloid with No. 18 or 20 cotton covered wire and fastened in place with coil dope. Three turns about 3 inches diameter are suggested for each coil.

— . . . —

Think about these two schemes, gang. They are, of course, just basic ideas. There is still plenty of work to be done in fitting them appropriately into practical installations. But both of them most certainly have a future in practical ham work. Here, anyway, is the next in the series.

— . . . —

Before we pass on to the essential rules and regulations we might ask whether you, dear reader, have a hero in your home. Ours has turned in some problems of general interest so far but before we know it he will have his station completed and be so engrossed in operating that his only real problem will be keeping peace with the family. What we mean is that we should appreciate deeply any list of practical problems that any of you fellows may have bumped against.

Now, the rules:

1. Solutions must be mailed to reach West Hartford before the 20th of the publication month of the issue in which the problem has appeared. (For instance, solutions of problem given in the March issue must arrive at *QST* before March 20th.) They must be addressed to the Problem Contest Editor, *QST*, West Hartford, Conn.

2. Manuscripts must not be longer than 1000 words, written in ink or typewritten, with double spacing, on one side of the sheet. Diagrams and sketches may be in pencil, but must be neat and legible.

3. All solutions submitted become the property of *QST*, available for publication in the magazine.

4. The editors of *QST* will serve as judges. Their decision will be final.

Prizes of \$5 worth of A.R.R.L. station supplies or publications will be given to the author of the solution considered best each month, \$2.50 worth of supplies to the author of the solution adjudged second best. The winners have the privilege, of course, of stating the supplies preferred.

—R. A. H.

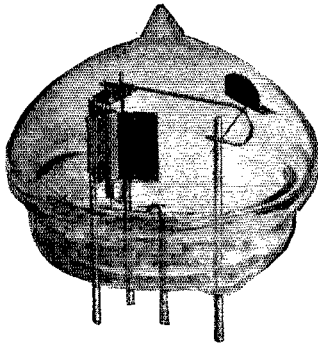

The "door knob" to UHF THE WE 316 A

THE "acorn" series and now the "door knob" 316 A — developments of the famous Bell Labs — open doors to new ultra high frequency communication. The "pie plate" construction gives us a transmitting "acorn," good up to 750 mc.

THE RADIO SHACK is proud to be the Western Electric distributor of Amateur and experimental equipment for this section, and to assist those interested in communication and experimental work. Have you seen the WE 316 A "door knob"?

THE RADIO SHACK is an extraordinary place. Specializing in ham and other communication gear, it carries an unusual stock of those hard-to-get items — from 1½ volt double triodes with type 30 characteristics for weather balloons and hearing aids, to UTC VM5 1 kw modulation transformers. Here are a few of the outstanding lines:

ALADDIN ■ AMPERITE ■ CARDWELL ■ CLOUGH BRENLE ■ ASTATIC ■ BIRNBACH ■ BLILEY
BUD ■ COTO COIL ■ HALLICRAFTERS ■ IRC ■ JENSEN ■ WESTON INSTRUMENTS

WOULD YOU BE INTERESTED IN A BULLETIN OF SPECIALS?

How about writing for information on your problems?

THE RADIO SHACK ■ 46 BRATTLE STREET ■ BOSTON

Radio Operator's
Course
Complete in
Telegraphy—
Telephony

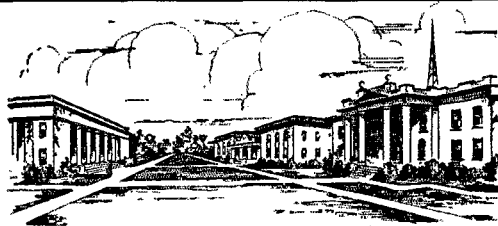

Practical
Experience
Studio—
Transmitter—
Announcing

AVIATION RADIO A new complete training embracing advanced work for amateurs, or operators — twelve months' study required for the average amateur to graduate — excellent opportunity for men interested in commercial airlines. Applicant for enrollment must be high school graduate, or college student. We confer degree — Science of Radio — to graduates of this course. If interested, write for aviation radio details.

P. A. C. is an endowed, educational institution — not privately owned, not operated for profit, college rank maintained. Course consists of maximum knowledge necessary to secure Commercial Telegraph Second-class, and Radio-telephone First-class government licenses. Course includes Wireless Code, Radiophone, Announcing, Microphone-Studio Technique, Service, Television, Police, and Aeronautical Radio. We are authorized to teach RCA texts. At the completion of course you receive practical studio technique experience in our commercial broadcast studios located in the administration building, and experience as an operator on K P A C (500-Watt Commercial transmitter located on the campus, owned and operated by the college), and inter-departmental marine communication experience.

If interested, write for Bulletin R

PORT ARTHUR COLLEGE ■ PORT ARTHUR (World-known port) TEXAS

SPECIAL TO AMATEURS

Piezo-Electric Crystals — \$2.50 EACH POSTPAID

Until supply is exhausted . . . we offer small 80 meter band crystals unmounted; accurate calibration, excellent oscillators. Limited quantity.

SCIENTIFIC RADIO SERVICE

"The Crystal Specialists Since 1925." University Park, Hyattsville, Md.

110 VOLTS AC

Anytime Anywhere! With

KATOLIGHT PLANTS

350 watt 110 v. 60 cycle AC Plant \$ 63.00

550 watt 110 v. 60 cycle AC Plant 149.00

With available 6-volt DC

Other Models Up to 10,000 Watts.

Special to Amateurs (May and June Only)

300 watt 110 v. AC Generator Only \$19.95

8, 12, 22 and 110 volt Rotary Converters,
AC and DC Generators. Complete Plants.

Write for Details

KATO ENGINEERING COMPANY
Mankato, Minnesota, U.S.A.

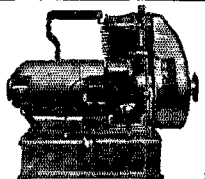

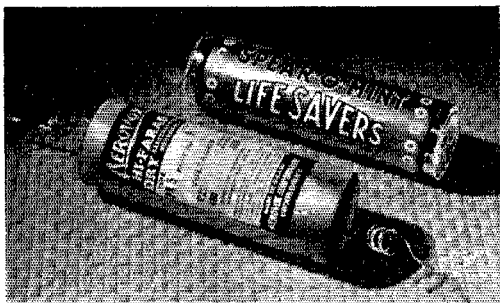

Compact Goodness

Light and compact. Completely sealed.

Bare wire leads $2\frac{1}{2}$ " long.

25, 50, 100, 200 and 450 v. working.

2 to 50 mfd.

Lots of capacity and voltage for little money.

AEROVOX Type PR tubular electrolytics fit anywhere. You can bank on them. They won't let you down. Yet they cost so little!

DATA

Latest catalog covers a most complete line of condensers and resistors.

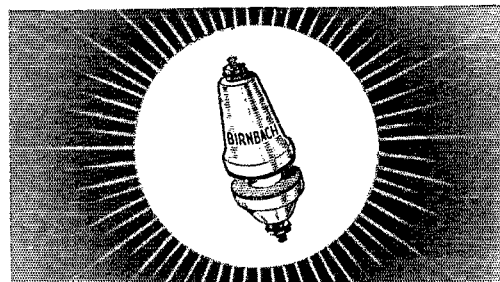

BIRNBACH INSULATORS ARE SPECIFIED BY LEADERS

When leading designers lay out their new rigs they naturally specify parts that can "stand the gaff" yet are priced right. It's no wonder, therefore, that most designers specify Birnbach because Birco products give you the highest possible quality at the lowest possible price.

Improved Cone Standoff Insulators

Made of STEATITE, the better ceramic. Complete range of heights. Condenser, coils, tube sockets, etc., can be mounted with minimum labor. White glaze.

	No.	Heights	List
	430	$\frac{3}{8}$ "	10c
	431	1"	15c
	431J	1"	20c
	432	$1\frac{1}{8}$ "	20c
	432J	$1\frac{1}{8}$ "	25c
	433	$2\frac{1}{4}$ "	25c
	433J	$2\frac{1}{4}$ "	50c

NEW TRANSMITTING SOCKETS

- Side Wiping Contacts No. 434, 50 watt
 - Brass, Nickel Plated Shell \$1.25 List ea.
 - Highly Vitrified, Low No. 435, 10 watt
 - Absorption Base 90c List ea.
 - All Brass Hardware ● Low Prices
- SPECIAL LOW PRICES in Large Quantities



BIRNBACH RADIO CO. INC.
145 HUDSON ST. BIRCO NEW YORK, N. Y.

I. A. R. U. News

(Continued from page 55)

Poland: P. Z. K., Bielowskiego 6, Lwow.
Puerto Rico: Francis M. McCown, Family Court No. 7, Santurce.
Portugal: R. E. P., Rua Dos Sabarteiros 159-3, Lisbon.
Rumania: Victor Cantuniari, Str. Matei Basarab, 3 bis Buchresti IV.
Salvador: J. Frederico Mejia, 7a Calle Poniente 76, San Salvador City.
South Africa: S.A.R.R.L., P. O. Box 7028, Johannesburg.
Spain: U.R.E.L., Apartado 262, Madrid.
Sudan: c/o Frank H. Pettitt, Catholic Club, Mustapha Barracks, Alexandria.
Sweden: S.S.A., Stockholm 8.
Switzerland: U.S.K.A., Neu Allschwil near Basle.
Tanganyika: see Kenya.
Uganda: see Kenya.
Uruguay: U.S.W.C.G., Box 37, Montevideo.
U.S.S.R.: C.B.S.K.W., I Samoteahny, 17, Moscow.
Venezuela: R.C.V., Torre a Madrices No. 8, Caracas.

Strays

Amateurs using phase-inverting amplifiers, or contemplating using them, will be interested in the June, 1936, issue of the *Aerovox Research Worker*, which deals with this subject. Because of increasing interest in inversion, additional copies have been printed and upon request will be sent by the Aerovox Corporation, 70 Washington Street, Brooklyn.

W9SRS writes that a strong but inexpensive antenna rope can be made by treating heavy cotton fish cord, which can be obtained from any dealer handling fish-line supplies. The size used by W9SRS is about the thickness of an ordinary lead pencil. The treatment consists of immersing the cord in two pints of rubber auto-top dressing, using a gallon paint can having a tight-fitting lid. First coil the rope carefully in the can, then pour in the top dressing, cover tightly and let set for at least twenty-four hours.

To dry, pull out the top end of the rope and attach it to a post or tree, walk back with the can and the rope will pull out with no tangling. Stretch tightly and tie the other end to another post and let the rope dry. When dry, the rope will be quite flexible and much stronger than before treating, as well as practically waterproof. W9SRS has used such a rope for over two years, and recent examination indicated that it was apparently as strong as when new.

A Modulator for the Low-Power Five-Band Transmitter

(Continued from page 15)

hiss which is characteristic of a carbon microphone is not amplifier noise, of course; cutting off the microphone battery by means of *Sw* will show how much of the residual background is caused by microphone hiss and how much is generated in the amplifier itself. The latter should be negligible. Occasionally a microphonic tube will cause noise and howling; this can be checked by tapping

ANNOUNCING - UHX-10 TRANSMITTER

Fixed - Portable - Mobile

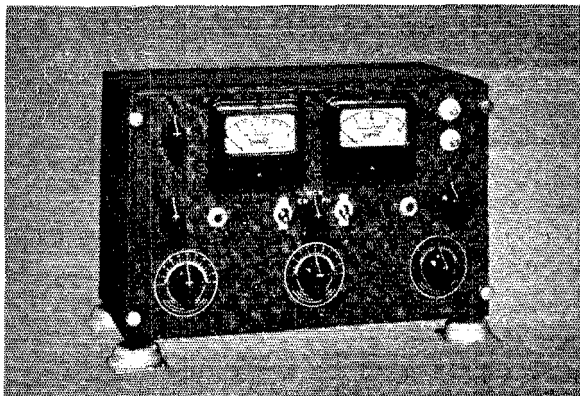

FOR
AMATEUR, COMMERCIAL, EMERGENCY
SERVICE

1500 — 60,000 KC. COVERAGE
CRYSTAL OR ELECTRON COUPLED
CONTROL
A.C. OR BATTERY OPERATION
PHONE — MCW — CW OPERATION
NOMINAL RATING 10 WATTS OUTPUT
COMPACT — LIGHT — RUGGED

WRITE FOR FULL DETAILS

HARVEY RADIO LABORATORIES, INC.

12 Boylston St., Brookline, Mass.

Export: 25 Warren Street, New York City.

Cable: "Simonrice"

AMATEUR RADIO *Map of World*

I.A.R.U.—W.A.C.

All known districts
and sub-divisions

Principal cities
of the world

Divisions

Six colors
and black

Countries designat-
ed by prefixes

U. S. inspec-
tion districts
and examining
points

180 prefixes in
large red letters

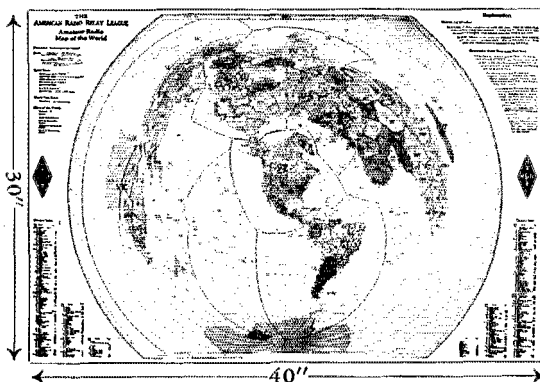

230 countries
indexed

PRICE
\$1.25
POSTPAID

2% accuracy for dis-
tance measures in
miles and kilometers

Time zones — legal
and Greenwich

A. R. R. L.
W. HARTFORD
CONNECTICUT

FOR AMATEURS ONLY

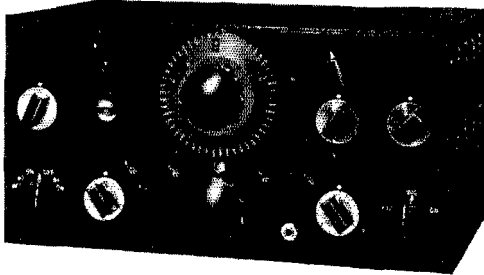

The new National NC-101X was designed for the amateur bands only. Has all the features of the NC-100X. Complete bandspread for the 10, 20, 40, 80, and 160 meter bands. With crystal, all tubes, built-in power supply, and 10" dynamic speaker chassis. Net to amateurs \$129.00. All other receivers in stock.

NATIONAL · HALLICRAFTERS RME · HAMMARLUND · RCA

Trade in your old receiver — liberal allowance!

VALUES FOR HAMS!

National CRM oscilloscope	\$11.10
RME DB-20 preselector	42.60
Triplett modulation monitor	24.83
The new RCA Aerodynamic microphone	15.90
Thordarson ham special T-6878, 600 volts each side of C.T. 200 ma. 7½ volts, 3 amps.; 2½ volts, 10 amps.; 5 volts, 3 amps.	2.45
Stancor plate transformer — 1000-750-500 volts each side of C.T. — 300 ma.	5.75
Stancor Class "B" transformers for 6L6's — Input \$2.17 Output	5.00
Unmounted power crystals — guaranteed — 40 meters	1.95
80, 160 meters	1.50
Biley crystals — BC3, \$3.95, LD2, \$4.80, HF2, \$6.50; VF1, \$8.00. A variety of frequencies in stock.	

ALL TAYLOR TUBES IN STOCK

T-20, \$2.45	T-55, \$8.00	866 Jr., \$1.00	866, \$1.65
866A tube			\$.98
866 filament transformer			1.16
Sylvania 211C — heavy duty — guaranteed			6.75

Write for information on the new Thordarson Multimatch Modulation Transformers — we have the complete line in stock

All mail orders promptly filled

FREE AMATEUR HANDBOOK!

Last month we offered free Stancor Amateur Transmitter Handbooks. The response was so gratifying that we now repeat the offer! If you have not already written in for the book of amateur transmitter circuits, why not send for your copy now? It's FREE!

SUN RADIO COMPANY

227 FULTON STREET NEW YORK CITY

SUN RADIO CO., DEPT. B5
227 Fulton Street, New York City

Please send me FREE copy of Stancor Transmitter Handbook

Name.....

PRINT ADDRESS IN MARGIN BELOW

each tube with the finger or a pencil while listening to the output of the amplifier with the microphone off. A pronouncedly microphonic tube should be replaced.

The recommended button current for the type of microphone specified is 3 to 5 ma. per button, with a maximum limit of 10 ma. Although a 3- or 4.5-volt battery with a 200-ohm potentiometer connected across it could be used to control the microphone current, we have found it satisfactory simply to use a single No. 6 dry-cell battery for the source of microphone current, no adjustment being needed.

The modulator unit always should be grounded, using a connection between the chassis and a good ground connection such as a cold water pipe or the radiator of a hot-water heating system. Such a ground often will reduce hum, and will prevent motorboating and howling when the transmitter is in operation by reducing r.f. pickup. The microphone cable should be shielded, with the shield grounded to the chassis; an unshielded cable is prone to pick up r.f. and cause overloading and distortion, if not oscillation, in the audio amplifier.

When the various tests and precautions described above have been carried out, modulation of the transmitter is simple. The r.f. end may be placed in operation on a suitable frequency and the antenna loading adjusted to make the final r.f. stage take 80 milliamperes, with all circuits adjusted to resonance. Under these conditions the input is approximately 30 watts, with the power supply described in December *QST*, and the load presented to the modulator by the modulated r.f. stage is for all practical purposes correct in value. If a current indicator such as a low-range r.f. ammeter or a shunted flashlight bulb is used in the antenna circuit, the current should rise slightly—about 10% or so—when the microphone is spoken into. First adjust the modulator gain control so that with normal speaking the plate current of the final r.f. stage shows a slight flicker, then retard the control slightly so that the plate current is steady under modulation. The correct adjustment will permit attaining 100% modulation on the voice peaks, which is the limiting operating condition.

The modulator design is such that when an attempt is made to secure more than sufficient output for 100% modulation by running up the gain, distortion commences so that no particular benefit is secured. Drastic overmodulation such as can usually be obtained with a Class-B modulator is practically impossible with the Class-A system because the 6N7 driver output flattens off immediately when the 6L6 grids start to draw current—which they do when the 15-watt output level is exceeded. This means that distortion starts suddenly and increases very rapidly, a condition which is readily recognized by the receiving operator, and can be checked easily at the transmitter by the use of a listening monitor such as a pickup coil, crystal detector and headphones, or a similar arrangement using a rectifier tube.

STATION OPERATING SUPPLIES

For full enjoyment of your operating activities
you will want these forms designed to meet
your needs

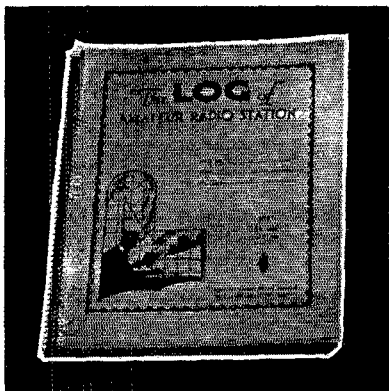

HANDY TO USE

The most interesting feature of the new LOG BOOK is the incorporation of spiral binding. This permits the book to be folded back flat at any page, requiring only half the amount of space on the operating table and making it easy to write on. The log-sheet has been re-designed by the Communications Department so that there is space provided for recording the number of messages handled and QSL's sent and received. General log information (prefixes, etc.) has been brought up-to-date. The LOG BOOK price has been reduced and is now 35c per book, 3 books for \$1.00, postpaid.

FOR PRESTIGE

The radiogram blank is now an entirely new form, designed by the Communications Department to comply with the new order of transmission. All blocks for fill-in are properly spaced for use in typewriter. It has a strikingly-new heading that you will like. Radiogram blanks, $8\frac{1}{2} \times 7\frac{1}{4}$, lithographed in green ink, and padded 100 blanks to the pad, are now priced at 25c per pad, postpaid.

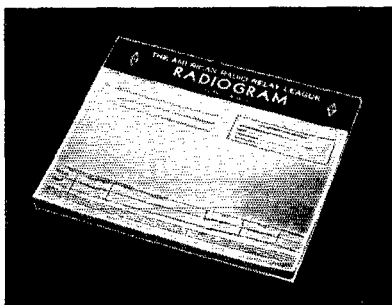

FOR CONVENIENCE

Radiogram delivery cards embody the same design as the radiogram blank and are avail-



able in two forms — on stamped government postcard, 2c each; unstamped, 1c each.

AMERICAN RADIO RELAY LEAGUE, INC.
WEST HARTFORD, CONNECTICUT

Improves Your 'Fist'

Cuts Effort in Half

Insist on The Genuine Martin

VIBROPLEX

SEMI-AUTOMATIC KEY

Simply press lever—
machine does the rest

**JUNIOR
ONLY
\$12.50**

Small and more compact. Large contact points. Black japanned base. A low priced key with world famous Vibroplex Quality. Other models, \$17 and \$19.

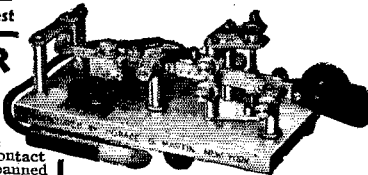

Vibroplex's machine speed, superior signal and effortless operation assures the user the fastest, best and easiest way to send. Experienced operators know this—that's why over 100,000 of them use only the Vibroplex key.

Faster than the fastest hand sender—less than half the effort. Easy to learn. Easy to use. Easy to own. Order to-day! Insist on the Genuine Martin Vibroplex key. Accept no substitute. Liberal allowance on old Vibroplex. Money order or registered mail. Write for FREE illustrated catalog just off the press.

**FREE
CATALOG**



THE VIBROPLEX CO. Inc.
832 Broadway New York, N. Y.

RADIO

ENGINEERING, broadcasting, aviation and police radio, servicing, marine radio telegraphy and telephony, Morse telegraphy and railway accounting taught thoroughly. Engineering course of nine months duration equivalent to three years of college radio work. School established 1874. All expenses low. Catalog free. DODGE'S INSTITUTE, Day Street, Valparaiso, Indiana

JACOBS ADJUSTABLE SEPARATOR (Improved)

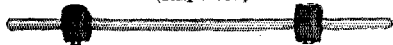

U. S. Patent 1,950,170—March 6, 1934—others pending
Using this improved glass Separator 2 wire R.F. feedlines of any separation from 1" up to and including 9" used in conjunction with Hertz Antenna Systems (Zepp Antennas) may be rapidly and efficiently constructed. \$1.75 for a set of 6.

CHARLES F. JACOBS (WZEM)
270 Lafayette St., New York, N. Y.

FASTEST WAY TO LEARN CODE

Easy, Fascinating—LEARN BY EAR to be a GOOD OP.

The New All Electric Master Teleplex Code Teaching Machine is exactly what thousands are looking for. No experience needed. Ideal for beginners—steps up WPM for ALL Ops. There is no guesswork with Master Teleplex, because it records your sending in visible dots and dashes. You SEE and HEAR exactly how you are making your signals. You learn code the way you'll be using it—by SOUND.

Complete course included at no extra charge. Used by many schools and several governments for teaching code. Low cost, easy terms. MONEY BACK GUARANTEE. Send now for booklet Q-5, no obligation. Post card will do.

The "Ham" Special

We are the originators of this type instrument

TELEPLEX CO. 72-76 CORTLANDT ST. NEW YORK, N. Y.

A 100-kc. Oscillator

(Continued from page 12)

Probably the best stations to use for checking purposes are those on the clear channels 700 kc. (WLW), 800 kc. (WBAP-WFAA) and 1000 kc. (WHO). These stations are receivable over most of the country for the greater portion of the

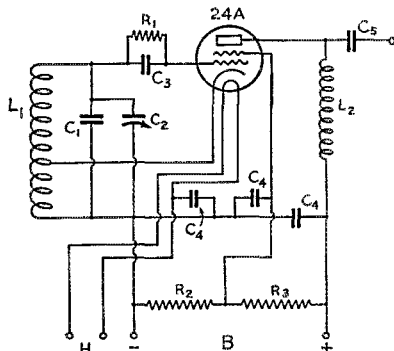

L₁, L₂—National R-100 2.5-mh. r.f. chokes; L₁ tapped between first and second "pies" above ground.

- C₁—0.001- μ fd. mica.
- C₂—0.0001- μ fd. midjet variable.
- C₃—0.00025- μ fd. mica.
- C₄—0.1- μ fd. paper.
- C₅—0.001- μ fd. mica.
- R₁— $\frac{1}{2}$ meg., $\frac{1}{2}$ watt.
- R₂—50,000 ohms, 2 watts.
- R₃—10,000 ohms, 1 watt.

twenty-four hours. All broadcasting stations are required to maintain their frequencies within plus or minus 50 cycles, and most of the larger ones such as those mentioned above do considerably better. WLW, for instance, can be relied upon to be within a few cycles of 700 kc. so that with care in setting the oscillator on this station the harmonics can be taken to be accurate within a kilocycle or so at 14 megacycles. Still more accurate settings can be obtained by using WWV's transmissions on 5000 and 10,000 kc., the schedules for which are given in each issue of QST.

After the oscillator has become thoroughly warmed up, it should hold its calibration over periods of several hours. Continuous operation is not necessary, however, because it is a simple matter to check against a b.c. signal whenever a high-frequency check is desired.

To pick up beats at amateur frequencies, a short wire connected to the output terminal should provide a signal of good strength at frequencies below 14 Mc. At higher frequencies, it may be necessary to connect the output terminal to the antenna post of the receiver. With this connection, good signals should be obtained up to the 300th harmonic, or 30 Mc.

An oscillator of this type will be found useful in lining up the high frequency circuits of a receiver and for receiver calibration. With points available at each 100 kc. throughout all amateur bands, an accurate curve of calibration is easily drawn.



TESTED AND OK'd

UNDER LOAD

UNIVERSAL acceptance of any product is only possible when that product is outstanding in performance and reliability. To enjoy such a reputation, rigid supervision and adherence to strict standards is required throughout all manufacturing processes.

An example of Bliley thoroughness is the test oscillator pictured above. This is a specially designed oscillator having an adjustable dummy load and indicating meters in every important circuit. Each crystal unit is fully tested, both with and without load, before being OK'd for shipment.

For assured performance use Bliley Crystal Units in your transmitter. For the best all around mounted crystal, choose the LD2 Unit, priced at \$4.80 — your distributor has them in stock for the 40, 80 or 160 meter bands. Bliley Electric Co., Erie, Pa.

BLILEY CRYSTAL UNITS

DON'T SHORT CHANGE YOUR POWER SUPPLY

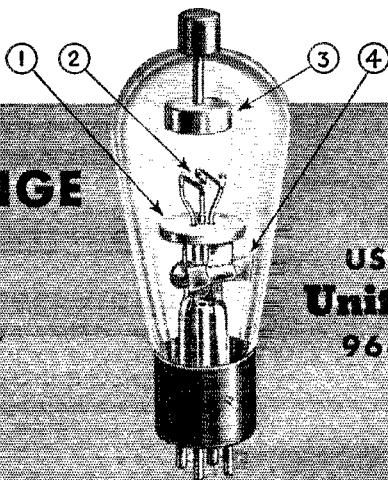

USE
United
966

1. Large Svea metal baffle to deflect heat from bottom of bulb keeping condensed mercury temperature in proper relation to ambient temperature.
2. Ideal tube temperature conditions and radiation protect filament life.
3. Deep cup anode of processed Svea metal, free from occluded gases.
4. Measured mercury pellet controls mercury volume. **ABSENCE OF EXCESS MERCURY PREVENTS AMALGAMATION ON ELEMENTS AND GETTER. RESULTS: CLEAR BULB FOR RADIATION, LESS HEATING TIME DELAY.**
5. All UNITED 966 rectifiers are pre-shipment tested at 3200 volts DC to assure that they are *Built to Take It.*

\$1.75

UNITED ELECTRONICS COMPANY — 42 SPRING ST., NEWARK, N. J.



THE TERMINAL BULLETIN

is off the press and we'd like you to have it! It is, we modestly admit, a departure from the conventional catalog, for it lists practically every recently introduced amateur radio item! The latest products in amateur radio — by the most reputable manufacturers — plus our "personalized" service — means you can't go wrong at TERMINAL!

In stock — the complete line of Thordarson multimatch modulation transformers and oscilloscope foundation kit, the new Simpson meters, the new B & W swinging link assembly, the Bassett concentric feeder — and the ultra-modern crystal controlled mobile or fixed transmitter, just put out by Radio Transceiver Laboratories.

REMEMBER — TERMINAL HAS EVERYTHING IN AMATEUR RADIO

P.A. Equipment now on display — a public address system for every purpose — amplifiers to fill every requirement — if you can't drop in to see this complete line, write for descriptive literature.

FOR YOUR COPY OF THE TERMINAL BULLETIN,
CLIP THIS COUPON — AND MAIL TODAY!
IT'S FREE!

• **TERMINAL** •
RADIO CORPORATION
80 CORTLANDT ST., NEW YORK, N. Y.
BILL FILLER ADOLPH GROSS

TERMINAL RADIO CORPORATION
80 Cortlandt Street, N. Y. C.
Rush new Terminal Bulletin.

Name.....

Address.....

City..... State.....

FREE!

DX Contest Policy

(Continued from page 23)

W8AWF W8BAI W8BTI* W8BWB W8DJW
W8DME W8FFJ* W8FTC* W8HGW W8HW
W8JMP W8KCM W8KTI W8LAP W8LKT
W8LUQ W8LYK* W8MCY W8NRM W8NWE
W8OFN W8PLR W8PQQ* W8QDA* W8QHP*.

W9AIO W9AJA W9BMM W9CES W9CVI
W9DVW W9EME W9FS W9FZP* W9GHN
W9GY W9HUZ W9LEZ W9OJK* W9PV
W9RSO W9RVP W9TKX W9TWC W9VDD.

VE1EK VE1EX VE2EW VE3ADM VE4GE
VE5EH.

D3DSR D4GAD D4KSD D4NXR D4YFI
F3KH FA8DA LA6C LA6U LY1J OK2OP
OZ3X OZ8JB PA0DC PA0KK PA0PN PA0QZ
PA0UN PA0UV SM5QU YU7DX.

To operators inadvertently betrayed by undetected equipment faults we extend our sincerest regrets; to intentional offenders (if any) we express the belief that you may never have appreciated the potential harm off-frequency work might cause the amateur service, or thought that your choice of a channel might be considered unfair or unsporting by brother amateurs and participants, with the parting injunction that you consider these things; to all amateurs the suggestion that increased care in adjustment be employed to avoid out-of-band radiations with our request for your full cooperation. Also to all, our assurance that we shall not neglect our duty, even though many amateur friends may be in these lists. Our hope for 100% frequency observance in the next!

Dakota Division Convention

St. Paul, Minn., May 21-22-23

THE A.R.R.L. Dakota Division-Mid American Convention to be held at the Hotel Lowry, St. Paul, Minn., on May 21st, 22nd, 23rd will present, as one of the largest of all amateur conventions, a most pretentious and well arranged program. Fine modern technical exhibits will be contrasted with radio antiques combed from the ham shacks of old timers. The most informed speakers obtainable including Dr. Hartig, Dr. Reinhartz, Boyd Phelps and others will lecture, and leading manufacturers will send technical experts and motion pictures for conduction of demonstrations.

High lights of the entertainment program will be the Army Net, Navy Net and Phone Association luncheons; a mammoth stag and the grand banquet at which at least 1500 hams and their friends will break bread together. Special entertainment has been provided through the convention for the ladies.

Tickets are \$2.75 and advance registration may be secured by sending check or money order to W9JIE, 1200 Fauquier Street, St. Paul, Minn.

BE SURE TO SEE AND HEAR THE NEW 1937



Bretting

"14"

"PRECISION BUILT" COMMUNICATIONS RECEIVER

Many New Features Include:

TWO STAGES PRE-SELECTION
SUPERIOR 10 METER OPERATION
CONTINUOUS BAND SPREAD

AUDIO FOR SPEECH EQUIPMENT
EFFICIENT CRYSTAL CIRCUIT—
34,000 TO 550 KC IN FIVE BANDS

AMATEUR NET PRICE.....\$99.00

COMPLETE WITH 12" SPEAKER, TUBES AND XTAL

DOWN PAYMENT ONLY.....\$11.50

IMMEDIATE DELIVERY

Write at Once for Descriptive Literature and Complete Details

DELAWARE RADIO SALES COMPANY

405 DELAWARE AVENUE

W3DQ

WILMINGTON, DEL.

— EASTERN DISTRIBUTORS —

CUSTOM
BUILT.....

HEADSETS

For the best DX choose
Trimm's Featherweight

TRIMM
1770 BERTEAU AVENUE

Write for information
RADIO MFG. CO.
CHICAGO, ILLINOIS

GULF RADIO SCHOOL

Radiotelegraphy

Radiotelephony

Radio Servicing

SECOND PORT } 1007 Carondelet Street
U. S. A. } NEW ORLEANS, LA.

T. R. McELROY

WORLD'S CHAMPION RADIO TELEGRAPHER

175 Congress Street, Boston, Mass.

FLASH

New 1938 Model Mac Key.....\$9.50

See description next issue

5500 JOBS FOR CW MEN

■ AVAILABLE SOON ■

No license required. Eight hours per day. Year around. 65 to 80 cents per hour. If you can copy 15 words per minute, write

CODE-CRAFT Q 6703 Dunham Ave.
CLEVELAND, OHIO

Epco STORAGE BATTERY ELIMINATOR

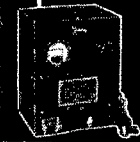

Supplies filtered D.C. suitable for operating auto radios, public address systems. Voltage adjustable from 4½ to 9 volts at 10 amps. Write for detailed information.

\$19.75 As Illustrated Variable Voltage \$15.75 Model B 6 volts-5 amps. Fixed Voltage

ELECTROPAK



Supplies rectified D.C. for operating relays, solenoids and remote controls. Voltage ranges from 6 to 24 volts, rated at 2 to 15 amps. Operates on 110 volt A.C.

ADAPTOPAK

Operates A.C. radios in D.C. districts and 110 volt A.C. radios in autos and trailers.

ELECTRICAL PRODUCTS CO. 6539 RUSSELL ST.
DETROIT, MICH.

LEARN CODE RIGHT

Tapes for Every Need — Even Airways — Send You Typical Messages by Instructograph.

It's easy and practical to learn or improve your Radio or Morse code. With an INSTRUCTOGRAPH you may practice at your convenience, at any speed. Buy or Rent, at low cost. Send for full information to-day to —

Instructograph Co., Dept. Q-5
912 Lakeside Place Chicago, Illinois
Representative for Canada
Radio College of Canada
853 Bay St., Toronto



WE ALSO HANDLE: HALLICRAFTER and R.M.E. SHORT WAVE RECEIVERS — MICROPHONES — VIBRO-FLEXES — TAYLOR TUBES . . . CASH OR TERMS

MODERNIZE YOUR EQUIPMENT

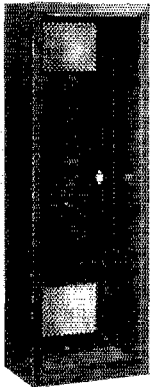

AT LOW COST by using our fully enclosed rack cabinet

Fabricated from sheet steel, electric welded construction, hinged rear door. Over all dimensions 61" high, 20 3/4" wide, 14" deep. 1 1/2" x 1 1/2" x 1/8" steel uprights for mounting panels. Hole spacing std. Panel mounting space 56", accommodating 19" width panels. Black crinkle finish with black enamelled stripe strips.

NO ASSEMBLING
SHIPPED READY TO USE

\$18.95 each

Other sizes of cabinets available — send for circular

Dimensions
61" high, 20 3/4" wide,
14" deep

Mfd. by LEFEBURE CORPORATION
CEDAR RAPIDS, IOWA

Mims SIGNAL SQUIRTERS

ROTARY BEAM ANTENNAS

20 and 10 METERS ONLY

Full descriptive information and details of our kits making it easy for you to "PUT YOUR SIGNAL WHERE YOU WANT IT — WHEN YOU WANT IT THERE." Send 5c for your copy.

Mims Radio Co.

[M. P. Mims, W5BDB]

P. O. Box 504 Texarkana, Ark.

Trindl ELECTRIC ARC WELDER



Works Off Any Storage
Battery or Ordinary Light Socket

This new electric arc welder is made possible by the invention of a low voltage carbon. Auto batteries may be used without removing from car. Uses about same current as four headlight bulbs. Can be used on electric light socket by using a Trindl converter in place of battery. Broken parts are simply melted together by the white hot electric arcs, in just a few seconds. Produces about 7000 degrees heat.

Hottest Flame Known

Melts iron and steel instantly. Welds fenders, radiators, holes in bodies, milk cans, tanks, brazes broken castings. Works on anything iron, steel, brass, copper, tin or galvanized metal. Permanent repairs made for almost nothing. Used by factories in many operations. Positive money back guaranteed by a responsible firm.

AGENTS

Men with cars to sell mechanics, repairmen, farmers, radio and battery shops, factories. Five minute demonstration makes sales. Up to 150% profit. Write today.

TRINDL PRODUCTS 2229 KR Calumet Av.
CHICAGO, ILL.

A Versatile Oscilloscope Using the 913

(Continued from page 34)

The general procedure for checking modulation in a transmitter has been described previously so need not be gone into in detail. The specific method for this oscilloscope is as follows:

1. Couple a small amount of r.f. from the modulated stage through a loop and twisted line to the "vertical input" terminals, setting S_w^6 to the appropriate tap.

2. Feed the output of the audio oscillator to the microphone terminals or jack through a shielded line.

3. Turn on the transmitter and adjust the coupling loop to give a rectangular-shaped pattern on the screen between 1/4 and 3/4 inch high.

4. Advance the speech-amplifier gain control to give fairly complete modulation.

5. Set the sweep frequency controls, S_w^5 and R_{13} , to show two or three audio cycles in the modulated wave. Adjust the speech gain to bring the valleys in the modulated wave just to the reference line, the limiting condition for 100% modulation. Then comparison of the modulated waveform with the original audio oscillator waveform will readily show distortion, non-linear modulation, etc. Percentage modulation also can be measured by using methods described in the papers to which reference already has been made. The oscilloscope also is readily adaptable to the familiar "triangle" or "wedge" pattern modulation measurements.

For other applications, the builder is referred to such texts as RCA's *Cathode Ray Tubes*, and Rider's *The Cathode Ray Tube at Work*. The oscilloscope has a wide field of usefulness in receiver alignment and general service work.

Finally, a precaution: Do not allow a bright spot to stay at one place on the phosphorescent screen, since the coating material will be burned. Keep the spot moving; in other words, always have a sweep of some sort applied to at least one set of deflecting plates.

Strays

Daily Ursigrams furnished by Science Service are now being broadcast in plain English by W1XAL on 11.79 Mc. from 4:55 to 5:00 P.M. to 0:45 P.M. E.S.T. Data on observations of sunspots, solar radiation, magnetism, ionized layer heights and other phenomena are given. As many amateurs know, the Ursigrams are now being broadcast daily in code from NAA; the new service from W1XAL gives the same information but in a form which does not require decoding.

Speaking of rapid QSY, consider this one told to W1IGR by G6MK: Hearing VK6SA on the high-frequency of 14 Mc. and having no edge-of-the-band crystal, G6MK proceeded to dash out to G8OY's shack, found him at home, lifted the crystal out of his transmitter, rushed back again, got the rock in his own rig just as VK6SA was signing off, and made contact! No one can say there wasn't some speed involved!

"I WAS STUCK—MISSING ALL THE FUN"
 "COULD NOT EVEN GET MY LICENSE—ALMOST GAVE UP"
 "I MAILED THE CANDLER COUPON—MY FIRST STEP TO SUCCESS"
 "NOW I'M A SKILLED OPERATOR—THANKS TO WALTER CANDLER"

CANDLER Training Will Do the Same for YOU!

As you read these words you don't concentrate on each individual letter. At a glance, you grasp several words — faster than anyone can write them. The same is true when you talk. Without thinking of separate letters, you talk whole words. The CANDLER system will teach you to read and send code with the same ease and speed. It's very interesting. Just a matter of practicing the right way. Ask any skilled operator about the CANDLER system. Thousands of them, including Champion McElroy, owe their speed to CANDLER training. A few days of practice under CANDLER instruction is worth months of *undirected* effort. Get started right. The only difference between you and a skilled operator is the coupon below. Mail it today! Walter Candler will do the rest!



CANDLER SYSTEM COMPANY

Department G-5
 Asheville, N. Car.

MAIL COUPON TODAY FOR FREE BOOK

CANDLER SYSTEM COMPANY
 Dept. G-5, Asheville, North Carolina
 Please send me Free Book of Facts

Name

Address

City..... State.....

PRECISION CRYSTALS



Crystal Holder

Highest quality crystals one-inch square, carefully ground for frequency stability and maximum output. Be sure of your transmitter frequency—use PRECISION CRYSTALS.

'X' cut PRECISION Crystals carefully ground for maximum power supplied within 0.1% of your specified frequency and calibrated to within 0.03% are priced as follows: 1750, 3500 and 7000 kc. bands—

\$3.00 each. Add \$1.00 to above price if plugin, dustproof holder is desired. (Holder as illustrated to fit G.R. jacks or round holder to plug into a tube socket can be furnished.) G.R. jacks to plug illustrated holder into — \$.15 pair.

Low frequency drift crystals (Type LTC) having a drift of less than 5 cycles per million per degree C. are supplied at the following prices: 1750 and 3500 kc. bands — \$3.50 each; 7000 kc. band — \$4.00 each. Holder \$1.00.

'AT' cut crystals for commercial use quoted on at your request. When ordering our product you are assured of the finest obtainable. Now in our seventh year of business.

PRECISION PIEZO SERVICE

427 Asia Street Baton Rouge, La.

RADIO ENGINEERING



RCA Institutes offer an intensive course of high standard embracing all phases of Radio. Practical training with modern equipment at New York and Chicago schools. Also specialized courses and Home Study Courses under "No obligation" plan.

Illustrated Catalog on request

RCA INSTITUTES, INC. Dept. ST-37

75 Varick St., New York 1154 Merchandise Mart, Chicago
 Recognized Standard in Radio Instruction Since 1909

LOW PRICED! EASY TO ERECT! STEEL ANTENNA TOWER

HAMS!—Here's the ideal antenna tower—can also be used as a vertical radiator. Strong! Light weight! Extremely rigid! Comes in 20 ft. sections, with 5 ft. tip, knocked down, for building towers 25, 45, 65, 85, or 105 ft. high, as you wish. Easy to erect. Easy to climb.

Tower Legs— $\frac{1}{2}$ " x $1\frac{1}{4}$ " x $1\frac{1}{4}$ " x 20 ft. Low carbon rail steel angle. Galvanized after fabrication.

Cross Bars— $\frac{1}{2}$ " x $\frac{3}{4}$ " x $1\frac{1}{2}$ " mild steel, spot welded to form X brace. Baked black enamel.

Bolts— $\frac{1}{4}$ " USS x $\frac{3}{4}$ "—1035 steel, cadmium plated. **Guy Wire**—300 ft. No. 9 galvanized with each 20 ft. section. Tower weighs $4\frac{1}{2}$ lbs. per foot when assembled.

**Order Direct From
 WINCHARGER CORPORATION
 Dept. QST-5
 Sioux City, Iowa**

50¢
 f.t.
 I. o. b. Sioux City, Iowa

At Last! A Perfected AUTOMATIC SENDER

Save your fist. Let the Automatic Sender raise your stations for you. Repeats calls or messages indefinitely. Length of messages unlimited. Sends from 2 to 70 words a minute. Motor driven. Entirely automatic. Built-in tape perforator. Absolute uniformity in spacing of characters. Used with buzzer or oscillator, makes excellent code teacher for novice and speed-builder for the advanced amateur. Complete with 4 rolls of tape and full instructions. No extra equipment needed. If your dealer can't supply you, write us.

only \$12.50

Postpaid in U. S. A.
 Patent Pending

MONEY-BACK GUARANTEE

Gardiner-Levering Co. Haddon Heights, N. J.
 New York, N. Y.

Where to buy it

A directory of suppliers who carry in stock the products of these dependable manufacturers.



ALBANY, N. Y. Uncle Dave's Radio Shack 356 Broadway
 BALTIMORE, MD. Radio Electric Service Company 3 North Howard St.
 BOSTON, MASS. Radio Shack 46 Brattle Street
 HARTFORD, CONN. Radio Inspection Service Co. 227 Asylum Street
 NEWARK, N. J. Wholesale Radio Service Co., Inc. 219 Central Ave.
 NEW YORK, N. Y. Gross Radio, Inc. 51 Vesey St.
 NEW YORK, N. Y. Harrison Radio Co. 12 West Broadway
 NEW YORK, N. Y. Wholesale Radio Service Co., Inc. 100 Sixth Ave.
 POTTSVILLE, PENN. E. Norwegian & George Sts. Sylvester Radio & Supply Co., Inc.
 READING, PENN. George D. Barbey Company 404 Walnut St.
 SPRINGFIELD, MASS. T. F. Cushing 349 Worthington St.

BOSTON, MASS. Radio Shack 46 Brattle Street
 BURLINGTON, VERMONT Vermont Hardware Co., Inc.
 CAMDEN, NEW JERSEY Radio Electric Service Company 811 Federal Street
 GREENWICH, CONN. Mead Stationery Company 252 Greenwich Ave.
 HARTFORD, CONN. Radio Inspection Service Co. 227 Asylum Street
 MONTREAL, CANADA Canadian Electrical Supply Co., Ltd. 285 Craig Street, West
 NEWARK, N. J. Wholesale Radio Service Co. 219 Central Avenue
 NEW YORK, N. Y. Bruno-New York, Inc. 460 W. 34th St.
 NEW YORK, N. Y. Sanford Samuel Corp. 136 Liberty St.
 NEW YORK, N. Y. Wholesale Radio Service Co. 100 Sixth Avenue
 NEW YORK, NEW YORK Harrison Radio Company 12 West Broadway
 NEW YORK, NEW YORK Grand Central Radio, Inc. 124 E. 44th Street
 PHILADELPHIA, PENN. Eugene G. Wile 10 S. 10th Street
 PHILADELPHIA, PENN. Raymond Rosen & Company 117 North 7th St.
 PHILADELPHIA, PENN. M & H Sporting Goods Company 512 Market Street
 PHILADELPHIA, PENN. Radio Electric Service Company 3145 N. Broad Street
 PHILADELPHIA, PENN. N.E. Corner 7th & Arch Streets Radio Electric Service Company
 PITTSBURGH, PENN. Cameradio Company 963 Liberty Ave.
 POTTSVILLE, PENN. E. Norwegian & George Sts. Sylvester Radio & Supply Co., Inc.
 READING, PENN. Bright & Company 8th & Elm Streets
 SPRINGFIELD, MASS. T. F. Cushing 349 Worthington Street



ALBANY, N. Y. Uncle Dave's Radio Shack 356 Broadway
 BALTIMORE, MD. Radio Electric Service Company 3 North Howard St.
 BOSTON, MASS. H. Jappe Company 46 Cornhill

Where to buy it

A directory of suppliers who carry in stock the products of these dependable manufacturers.

SPRINGFIELD, MASS. 1540 Main Street
S. S. Kresge Radio Department

WASHINGTON, D. C. 938 F Street, N. W.
Sun Radio & Service Supply Co.

RME
RECEIVERS -- PRE SELECTORS
AMATEUR RADIO EQUIPMENT
RADIO MFG. ENGINEERS, Inc.
PEORIA ILLINOIS

ALBANY, NEW YORK 356 Broadway
Uncle Dave's Radio Shack

BINGHAMTON, NEW YORK 95-27 Sturges Street
Radio Testing Station

BUFFALO, NEW YORK 216 E. Genessee Street
Dymac Radio

HARTFORD, CONNECTICUT 210 Chapel Street
Stern Wholesale Parts Company

NEW YORK, NEW YORK 12 West Broadway
Harrison Radio Company

PITTSBURGH, PENNSYLVANIA 963 Liberty Ave.
Cameradio

ROCHESTER, NEW YORK 244 Clinton Ave., N.
Radio Service Shop

RAYTHEON
AMATEUR TUBES

ALBANY, NEW YORK 356 Broadway
Uncle Dave's Radio Shack

BOSTON, MASS. The Radio Shack 46 Brattle Street

BOSTON, MASS. Selden Radio Company 28 Brattle Street

BUFFALO, NEW YORK 326 Elm Street
Radio Equipment Corp.

CONCORD, NEW HAMPSHIRE 80 N. State Street
Carl B. Evans

NEWARK, NEW JERSEY 219 Central Street
Wholesale Radio Service Co.

NEW YORK, N. Y. 12 West Broadway
Harrison Radio Company

NEW YORK, N. Y. 100 Sixth Avenue
Wholesale Radio Service Co.

TRIPLET
INSTRUMENTS

ALBANY, N. Y. 356 Broadway
Uncle Dave's Radio Shack

BOSTON, MASS. Radio Shack 46 Brattle Street

BOSTON, MASS. Selden Radio Company 28 Brattle St.

MONTREAL, CANADA 285 Craig Street, West
Canadian Electrical Supply Co., Ltd

NEWARK, N. J. 219 Central Ave.
Wholesale Radio Service Company

NEW YORK, N. Y. 100 Sixth Avenue
Wholesale Radio Service Company

PITTSBURGH, PENN. 963 Liberty Ave.
Cameradio Company

POTTSVILLE, PENN. E. Norwegian & George Sts.
Southwest Radio & Supply Co., Inc.

READING, PENN. 404 Walnut Street
George D. Barbey Company

WHEN WE SAY

'LIGHTNING'

We're thinking of that funny stuff that comes zooming out of the skies, right through the QRM, lighting up everything in a flash!

AND WHEN WE SAY

LIGHTNING
CALCULATORS

We mean that these gadgets bring an answer right through mathematical QRM just like that — in a clear flash!

Type A, \$1.00 Type B, \$1.00

For problems involving frequency, inductance and capacity, in design of radio frequency circuits. Direct reading answers for size of coils and condensers for any range between 400 kc. and 150 mc.

Gives direct reading answers to calculations involving current, resistance, voltage and power with scale for resistance of copper wire and scale for calculating decibel gain or loss.

Type C, \$.50 Type D, \$.50

More information on electrical conductors than you could find in a book full of tables.

Gives decibel gain or loss when input and output voltages, currents or power are known.

Type E, \$.50 Type F, \$.50

Direct reading total resistance of resistors connected in parallel, and total capacity of condensers connected on series.

Permits measurement of resistance, from 1 ohm to 1 megohm by use of a voltmeter. Makes an ohm-meter of your voltmeter.

Prices include postage from the
AMERICAN RADIO RELAY LEAGUE
West Hartford, Connecticut

Standard Frequency Transmissions

Date	Schedule	Station	Date	Schedule	Station
May 5	C	W9XAN	June 2	C	W9XAN
May 7	B	W9XAN	June 4	B	W9XAN
	A	W6XX		A	W6XX
May 12	BB	W9XAN	June 9	BB	W9XAN
May 14	BB	W6XX	June 11	BB	W6XX
	A	W9XAN		A	W9XAN
May 15	BX	W6XX	June 12	BX	W6XX
May 16	C	W6XX	June 13	C	W6XX
May 21	A	W6XX	June 18	A	W6XX
May 28	B	W9XAN	June 25	B	W9XAN
	B	W6XX		B	W6XX
			June 30	C	W9XAN

Time (p.m.)	Sched. and Freq. (kc.)		Time (p.m.)	Sched. and Freq. (kc.)	
	A	B		BB	C
8:00	3500	7000	4:00	7000	14,000
8:08	3600	7100	4:08	7100	14,100
8:16	3700	7200	4:16	7200	14,200
8:24	3800	7300	4:24	7300	14,300
8:32	3900		4:32		14,400
8:40	4000				
	Time (a.m.)		Sched. and Freq. (kc.)		
				BX	
			6:00	7000	
			6:08	7100	
			6:16	7200	
			6:24	7300	

The time specified in the schedules is local standard time at the transmitting station. W9XAN uses Central Standard Time and W6XX, Pacific Standard Time.

TRANSMITTING PROCEDURE

The time allotted to each transmission is 8 minutes divided as follows:

- 2 minutes—QST QST QST de (station call letters).
 - 3 minutes—Characteristic letter of station followed by call letters and statement of frequency. The characteristic letter of W9XAN is "O"; and that of W6XX is "M."
 - 1 minute—Statement of frequency in kilocycles and announcement of next frequency.
 - 2 minutes—Time allowed to change to next frequency.
- W9XAN: Elgin Observatory, Elgin National Watch Company, Elgin, Ill., Frank D. Urie in charge.
W6XX: Don Lee Broadcasting System, Los Angeles, Calif., Harold Perry in charge.

Schedules for WWV

EACH Tuesday, Wednesday and Friday (except legal holidays), the National Bureau of Standards station WWV will transmit on three frequencies as follows: noon to 1:00 P.M. E.S.T., 15,000 kc.; 1:15 to 2:15 P.M., 10,000 kc.; 2:30 to 3:30 P.M., 5000 kc. On each Tuesday and Friday the emissions are continuous unmodulated waves (c.w.); and on each Wednesday they are modulated by an audio frequency. The audio frequency is in general 1000 cycles per second.

Ultra-Midget Equipment

(Continued from page 30)

the antenna tuned to resonance the range is approximately one-half mile under average conditions.

At one glance a dozen both proper and improper applications of the midget units present themselves. However, it must be emphasized that a Federal license is required for operation of any transmitter regardless of how small its power output may be. This is imperative.



W8MEE would like to get in touch with any hams who make their own transmitting tubes.

HAM-ADS

(1) Advertising shall pertain to radio and shall be of nature of interest to radio amateurs or experimenters in their pursuit of the art.

(2) No display of any character will be accepted, nor can any special typographical arrangement, such as all or part capital letters be used which would tend to make one advertisement stand out from the others.

(3) The Ham-Ad rate is 15c per word, except as noted in paragraph (6) below.

(4) Remittance in full must accompany copy. No cash or contract discount or agency commission will be allowed.

(5) Closing date for Ham-Ads is the 25th of the second month preceding publication date.

(6) A special rate of 7c per word will apply to advertising which, in our judgment, is obviously non-commercial in nature and is placed and signed by a member of the American Radio Relay League. Thus, advertising of bona fide surplus equipment owned, used and for sale by an individual or apparatus offered for exchange or advertising inquiring for special equipment, if by a member of the American Radio Relay League takes the 7c rate. An attempt to deal in apparatus in quantity for profit, even if by an individual, is commercial and takes the 15c rate. Exclusions of paragraphs (1), (2), (4) and (5) apply to all advertising in this column regardless of which rate may apply.

Having made no investigation of the advertisers in the classified columns, the publishers of QST are unable to vouch for their integrity or for the grade or character of the products advertised.

QUARTZ—direct importers from Brazil of best quality pure quartz suitable for making piezo-electric crystals. Diamond Drill Carbon Co., 719 World Bldg., New York City.

RADIO engineering, broadcasting, aviation and police radio, servicing, marine and Morse telegraphy taught thoroughly. All expenses low. Catalog free. Dodge's Institute, Byrd St., Valparaiso, Ind.

NATIONAL—Hammarlund, RCA-RME used sets, 60% off list. W3DQ, 405 Delaware Ave., Wilmington, Del.

QSL's, W2SN, Helmetta, N. J.

CLASS B transformers—Universal for two or four 46's, 6L6's, 210's, 800's, etc., \$7.75 pair postpaid. 70 watts audio from 46's, 100 watts from 10's. Write for details. WSUD, Douglas, Mich.

CALLBOOKS—new DX calls, new prefixes, thousands of new W and VE calls, in the Summer, 1937 Radio Amateur Call Book. Sent postpaid \$1.25, or a whole year (four issues) for \$4. (In foreign countries \$1.35 and \$4.35.) Your call and QRA printed in large type \$1 per year. Radio Amateur Call Book, 610 S. Dearborn, Chicago.

TELEGRAPH speed keys in kit form, only \$2.89. A post card brings full information, Electric Specialty Mfg. Co., PO Box 645, Cedar Rapids, Iowa.

AMATEUR radio, commercial radiotelephone and radiotelegraph licenses, complete training. Resident and correspondence courses. Every graduate a licensed operator. N. Y. Wireless School, 1123 Broadway, N. Y.

WANTED: AC generator 110-volt 60-cycle 5 k.w. or more. All letters answered. W4AFK.

THERMOCOUPLE ammeters repaired, \$2.50. W9GIN, 412 Argyle Bldg., Kansas City, Mo.

CRYSTALS: Nice stock Edison's T9 40 meter crystals, \$1.60. Satisfaction Guaranteed. Ceramic holders, \$1.10. C.O.D. orders O.K. WADDF, Stratford Ave., Nashville, Tenn.

INTERNATIONAL stamp exchange for licensed hams only. W7GQE, Goldbeach, Oregon.

CRYSTALS: Mounted in beautiful bakelite holders, GR plugs. Within five kilocycles. 160-80m V, \$3.75. 80m X, \$2.75. Catalog. Ham Crystals, 1104 Lincoln Place, Brooklyn, N. Y.

QSL's—Special introductory offer extended. Radio Headquarters, Ft. Wayne, Ind.

SELL: 3 kilowatt A.C., 110 v. generator, 600 watt, 110 v. Delco. W5EFV, Alva, Okla.

SELL: 1 kilowatt transmitter, 2500 volt power supply and other parts. List for stamp. W5EFV.

WANT: Metal lathe, welding torch, 16 m.m. camera and projector. W5EFV.

DETROIT and vicinity, W81M's 7 Mc. 1/2 k.w. transmitter, \$150. Will not ship. Come and get it. P.O. Box 63, Port Huron, Mich.

QSL's, Cartoons. Free samples. Theo. Porcher, 7708 Navajo St., Philadelphia, Penn.

QSL's. Free samples. Printer, Corwith, Iowa.

BEST offer takes QST's April 1923 through 1933. Arthur Howard, 2328 Miner, Ft. Wayne, Indiana.

SPECIAL: Reconditioned Emerson generators. Input 6 volts 1.75 amperes. Output 135 volts 20 ma., \$3 f.o.b. Walter Ashe Radio Co., St. Louis, Mo.

QSL's, SWL's, quality 3 color cards, 75¢ a 100. Lapco, 344 W. 39 St., Indianapolis, Ind.

BRAND—new Universal tubes. 3-250's, 2-210's or 2-281's for \$1. Send for list. Archie Brunner, 89 Lehigh, Newark, N. J.

SW-3 in perfect condition, \$25. 2.5 volt A.C. tubes included. 160 m, 80 m, 40m bandsread and 20m full coverage coils. W8ODT.

5-tube, all-wave, factory-built rec. Complete \$15. Andrews, Birmingham, Ohio.

SELL—M. G. 110-220 motor Ac-500 v. or 1000 v. D.C. at 500 milliamperes. A-1 shape. Best offer takes it. W8NGD, Dravosburg, Penn.

QSL's, QSL's. R999 service. Samples? (Stamp) W8DED, Holland, Mich.

BLILEY crystals. Postcard C.O.D. orders accepted. W8DED.

RADIO, \$2.50 year. W8DED.

QSL's and SWL's. Samples. Baker, 204 Carroll, Akron, Ohio.

RIDER'S Perpetual Service Manuals wanted. Roberts, N. Lincoln Ave., Washington, N. J.

WANTED: Antique radio sets, parts, tubes, catalogs, magazines, cuts, for museum. All letters answered. W6LM.

TRANSFORMERS, custom-built. Plate specials—any voltage. Compound-filled cases. 1/2 KVA—\$11; 1 KVA—\$17; 2 KVA—\$23. Baker Engineering, Ft. Wayne, Indiana.

FOR exchange: one D76527 Western Electric amplifier, Rack mounting. A. H. Dreesen, Mansfield Centre, Conn.

QSL's, 300 one-color cards, \$1. Samples. 2143 Indiana Ave., Columbus, Ohio.

SELL: Kennedy Universal and two step. Best offer. W6AAE.

SELL: National SW3, power supply, tubes, phones, 10 (fb dx), 20, 40, 80 coils. Hall, Hampden-Sydney, Va.

CQ, CQ, cash or exchange for used nationally advertised apparatus: improve or build your rig by selling or exchanging your extra parts. Write for quotations. Satisfaction guaranteed. Radio Apparatus Exchange, 704 Francis St., St. Joseph, Mo.

BETTER QSL's—SWL's. Fritz, 203 Mason, Joliet, Ill.

QSL's. Free samples. (stamp) Lowest prices. Mac's, 97 Everett Ave., Chelsea, Mass.

CRYSTALS: Zero cut. Guaranteed to compensate at near zero without oven. 80-160 meters, \$1.85. Forty meters, \$2. Holders 75¢ postpaid. Fisher Lab., 4522 Norwood St., San Diego, Calif.

QSL's by Maleco. New designs. Samples. Maleco, 1512 Eastern Parkway, Brooklyn, N. Y.

QST file 1916 to date. Best offer. Stamp for details. Fred Marco, 1099 Jeannette, Desplaines, Ill.

TRANSMITTING tubes exchanged or repaired few 86¢ at 95¢. W2AWZ, Dobbs Ferry, N. Y.

FABERADIO has sold hundreds of 75¢ crystals and there are more left. 160 and 80 meters, high output, prompt service. Ask the fellow who uses one. Faberadio, Sandwich, Ill.

Precision blanks for commercial and amateur grinders. Faberadio.

EARLY issues QST—Oct. 1916, Jan. to Aug. 1917, June to Dec. 1919, 50¢ each; 1920 to 1925 all issues 35¢ each. Derrick, Erlton, N. J.

CRYSTALS: unconditionally guaranteed, X cut, 160-80 meter, within ten kilocycles, \$1.50. Exact frequency, one inch square, \$2.50. Small X cut, 80 meter semi-finished blanks, including carborundum, three for \$1.20. Dustproof, plug-in holders, 85¢. William Threm, W8FN, 4021 Davis Avenue, Cheviot, Ohio.

SW3, power supply, four sets coils, like new—\$24. W2HWN.

CRYSTALS—for limited time only, 80 and 160 meter crystals mounted in new type shielded dust-proof holder, \$1.25. Highest quality and fully guaranteed. Stock up now. White Radio Lab, Standpoint, Idaho.

GENERAL Electric 24/750 volt 200 mill ball bearing dynamotors with filters, \$25. On twelve volts deliver 375. Westinghouse 6-15 volt 500 watts with propeller, \$10. 500 watt 500 cycles with exciters, \$10. Slightly used \$6. 900 cycle 200 watts, \$15. Henry Kienzie, 215 Hart Blvd., Staten Island, N. Y.

CRYSTALS: new holder for AT-V cuts. Contact, air-gap type. Round molded bakelite, socket plug-in, \$1. Regular style, 90¢. X-cut 80m, \$1.25; 40m (large), \$1.50. AT-V cuts: 160-80m: \$1.75; 40m \$2.25. Satisfaction guaranteed. C.O.D.'s accepted. Star Crystal Co., 1324-Y Georgia, Kansas City, Kansas.

T9 crystals: Edison's high activity, fracture resisting 40 and 80 meters only, \$1.60 postpaid. Powerful, dependable X cut, fully guaranteed. Close frequency always supplied. Unsolicited testimonials and repeat orders tell the real story—they're unbeatable. T9 superlapped ceramic plug-in holders, \$1.10 postpaid. C.O.D. orders accepted. Commercial crystals users inquire prices. Eidson's, Temple, Texas.

BARGAINS—meters, etc. See Hamad in April QST. W2FL, 181 Greenwood Ave., E. Orange, N. J.

RECEIVER—RCA Communications Model ACR 136. Like new. Complete. First \$40 takes it. Arthur Lukach, 35 E. 84 St., N.Y.C.

TRANSMITTER kits. WSANT.

RECEIVER headquarters—new and used. WSANT.

TRANSMITTING tubes—new and used. All makes. WSANT.

UTC varimatch transformers in stock. WSANT.

G. E. Pyranol condensers. WSANT.

AIR-WOUND coils. WSANT.

NEW and used plate transformers. WSANT.

MOUNTED crystals, \$3. WSANT.

FB7 bandspread coils. WSANT.

ALL lines of new and used equipment. Parts bought, sold, and exchanged. Write to Southern Ohio's only amateur owned amateur business. Jos. N. Davies, WSANT, 2767 N. Bend Rd., Mt. Airy, Sta. A, Cincinnati, Ohio.

CRYSTALS: 1" square 80 X-cut \$1, Lo-Drift \$1.25, 160 X-cut \$1.25, Lo-Drift \$1.50. Within 15 kc. of specified frequency. Guaranteed. Wolverine Crystal Service, Calumet, Mich.

SELLING out—write for complete list. W2HTP.

LARGE stock miscellaneous equipment and tubes at attractive prices. Write for list. Radio Station WLAP, Lexington, Ky.

RADIO Handbook, 1936 edition, 60¢ prepaid continental U.S.A.; 75¢ elsewhere. Radio, 7460 Beverly, Los Angeles.

WHAT voltage do you want? Auto transformers for changing plate or filament voltages on any or all stages. Plate transformers for any voltage at any current rating. Taps where you want them. Any type power transformer built to your specification. Write us. Larco Labs., 1616 Hoge Avenue, Zanesville, Ohio.

TRANSMITTERS constructed. Complete or units. Your parts or new. State requirements fully. Superior workmanship. Howard Radio, 5514 Lake St., Chicago.

CRYSTALS: Completely mounted. Plug-in bakelite holder. X-cut 160-80m \$1.75, 40m \$2. AT-cut 160-80m \$2.25, 40m \$2.75. New 20m \$4.25. Unconditionally guaranteed. Post card C.O.D.'s O.K. Premium Crystal Co., Box 2250-E, Kansas City, Mo.

BUY, sell, or trade certain prewar QST's. W9ZT, 1623 Irving Ave., N., Minneapolis, Minn.

SELL used 204A and socket, \$9.50, 203A, \$4.75, 865, \$3.50. Kenneth Schultz, Midwest, Wyoming.

TELEPLEXES, instructographs, omnigraphs, vibroplexes, meters, receivers, bought, sold, traded. Ryan Radio Company, Monroe City, Mo.

WANTED: manufacturer desires to contact exporter or importer of Brazilian quartz for supplies. Send for information and prices care Edison's, Temple, Texas.

QSL'S. Better designs; better stock; better workmanship. Free samples to hams only. W2FJE, 143 DeKalb Ave., Brooklyn, N. Y.

BIG transformers cheap. G.E. 8000V centertapped. 4.25 KVA—Builtin Primary switch gives RAC 2000 to 4000V in 6 steps. Oil-filled. Worth \$150; \$20 f.o.b. Write details W1BES, 143 Eastwood Ave., Providence, R. I.

3-204A's for sale—used but perfect, \$10 each; 2-838's new, \$9 each; Thordarson all new 2-T5489 400ma, 1000V, \$10 each; T6316 500 ma swinging, \$6.50; T6410 500 ma regular choke, \$8; Class B T7511, \$11. W1BES.

HAMSTAMPS—Individualize your QSL's.

HAMSTAMPS—Photographic reproductions, postage stamp size, of you—your rig—anything.

HAMSTAMPS—100 stamps \$1, gummed, perforated, from your favorite snapshot. Negative unnecessary.

HAMSTAMPS—samples, 1730 East 17th St., Brooklyn, N. Y.

NAT-SW3 complete, pwr supply, amp, dynam spkr, 10-40 band-spread, 20-80-160 general coverage-wks. FB on 10. W9FYF, Ashley, Mo.

SELL: AGS \$40, SX5 Super-Skyrider \$40, SX6 \$40, PR-10 \$45, ACR-136 \$45, SX9 \$59, Breding 12 \$64, PR-16C \$64, RME9D \$64, other sets. W9ARA, Butler, Mo.

TRANSFORMERS—1200 watt 1200-2200 3000 each side, \$21.75. Frank Greben, W9CES, 2012 S. Peoria St., Chicago, Ill.

16mm. Camera Victor model 5 turret head. Lenses f.1.5-1", f.1.5-15mm, f.3.5-3". Filter, case, 750 watt projector, case, screen. All new condition. Also two new 500 watt tubes. Trade for transmitter—fone 200 watts or more. Factory built preferred. W2EDW.

WANTED—men for television. W1GPU.

EX 2UB selling out transmitting recording talking picture equipment. Send for list. Hallock, care Socony, 26 Broadway, N. Y.

EO-1 Cable, designed by Graham, manufactured by General Cable Corp., sold by W8DT. Mail card for data.

ALL Star Senior; all coils, speaker, \$25. W2JDI.

QSL'S. Free introductory offer. W8JDW, Lima, Ohio.

SACRIFICE: new latest model gamatron 354C in factory carton never used, \$17.50. W4BMR.

BARGAINS—keys, regularly \$1.50-75¢. Used RCA carbon plate 203A's—perfect condition—\$4. 50 watt sockets—50¢. New RCA 201's—85¢. W.E. 3 arm decade boxes—\$3. 7/18 silicon bronze wire—one buck per hundred. W.E. 600A microphone—\$7. G.R. 358 wavemeter, perfect, \$10. 872's, \$4. 575's, \$6. Send for list of new and used transmitting and laboratory equipment. M. L. Trautman, 35 Ellis Ave., Irvington, N. J.

HAMAD MONEY

Lots of you people take in lots of money from the ads on this and the preceding page.

We suggest that you invest \$2.50 of yours in a year's membership in the A.R.R.L.

You will save exactly fifty cents of what you now pay to buy QST on the newsstands, will have membership instead of a mere interest in the organization which fraternalizes and protects the amateur, plus the many advantages pertaining thereto.

So cash that money order you just got and write out a new one, sending your name and address and \$2.50 for a year's membership and 12 issues of QST to

THE AMERICAN
RADIO RELAY LEAGUE, INC.
West Hartford, Connecticut

RADIO COURSES

RADIO OPERATING; Prepare for Gov't License Exam. ●
RADIO SERVICING; Including Short Wave ● AMATEUR
CODE ● ELECTRONICS ● TELEVISION ●

Day and Evening classes—Booklet upon request

NEW YORK YMCA SCHOOLS

4 West 63rd Street, New York City

Unconditionally
Guaranteed

PR
CRYSTALS

Powerful
Reliable

X cut 7000 KC = 5 KC . . \$1.85 3500 or 1750 . . \$1.65
Low Drift ATCUT = 5KC 40-50-160 2.25

PETERSEN RADIO CO.
COUNCIL BLUFFS, IOWA
Formerly Omaha Crystal Labs.

Your Nearest Dealer Is Your Best Friend

Your nearest dealer is entitled to your patronage. You can trust him. He is equipped with a knowledge and understanding of amateur radio. He is your logical and safe source of advice and counsel on what equipment you should buy. His stock is complete. He can supply your needs without delay. His prices are fair and consistent with the high quality of the goods he carries. He is responsible to you and interested in you.

Patronize the dealer nearest you—You can have confidence in him

ALLENTOWN, PENNSYLVANIA Radio Electric Service Co. 1024 Hamilton Street Complete stocks transmitting equipment	PHILADELPHIA, PENNSYLVANIA Radio Electric Service Co., Inc. N. E. Cor. Seventh & Arch Sts. All nationally-advertised lines in stock
ATLANTA, GEORGIA Wholesale Radio Service Company, Inc. 430 West Peachtree Street, N. W. "The World's Largest Radio Supply House"	PHILADELPHIA, PENNSYLVANIA Eugene G. Wile 10 S. Tenth Street Complete Stock of Quality Merchandise
BALTIMORE, MARYLAND Radio Electric Service Co. 3 N. Howard St. Everything for the amateur	PITTSBURGH, PENNSYLVANIA Cameradio Company 963 Liberty Avenue "Ham" Headquarters for Pennsylvania-Ohio-W. Virginia
BUFFALO, NEW YORK Radio Equipment Corp. 326 Elm Street W80BK — Ham, service and sound equipment — W80LB	PROVIDENCE, RHODE ISLAND W. H. Edwards Co. 32 Broadway National, Taylor Tubes, Hallicrafters. Complete amateur supply house
BUFFALO, NEW YORK Dymac Radio 216 E. Genesee Street Complete Line Ham and BCL Equipment Cl. 2080	PROVIDENCE, RHODE ISLAND Kraus & Company 89 Broadway Everything for the amateur and serviceman
JAMAICA, L. I. Wholesale Radio Service Company, Inc. 90-08 166th Street (Merrick Road) "The World's Largest Radio Supply House"	RICHMOND, VIRGINIA The Arnold Company 527 W. Broad Street W3EHL—"The Virginia Ham Headquarters"—W3FBL
MONTREAL, CANADA Canadian Elec. Supply Co., Ltd. 285 Craig St., W. Quality parts and equipment for discriminating buyers	ROCHESTER, NEW YORK Radio Service Shop 244 Clinton Avenue, North Complete stock amateur-BCL parts. Standard discounts. W8NUC
NEWARK, N. J. Wholesale Radio Service Company, Inc. 219 Central Avenue "The World's Largest Radio Supply House"	SYRACUSE, NEW YORK Roy C. Stage, W8IGF Complete stock of standard Ham & BCL parts Standard Discounts. Free technical service
NEW YORK, N. Y. Gross Radio, Inc. 51 Vesey Street Fair dealings plus fair prices. Anything in radio	SPRINGFIELD, MASS. S. S. Kresge Company 1540 Main Street Standard discounts on standard lines. Advisory service: W1JQ, W1FOF
NEW YORK, N. Y. Wholesale Radio Service Company, Inc. 100 Sixth Avenue "The World's Largest Radio Supply House"	WHEELING, WEST VIRGINIA Cameradio Company 30 Twelfth Street Complete stock of amateur Equipment at standard discounts
PHILADELPHIA, PENNSYLVANIA Consolidated Radio Corp. 612 Arch Street Ham receivers, Transmitting tubes, Collins transmitters, etc.	

You Are Protected When You Buy From QST Advertisers

“Advertising for QST is accepted only from firms who, in the publisher’s opinion, are of established integrity and whose products secure the approval of the technical staff of the American Radio Relay League.”

Quoted from QST’s advertising rate card.

Every conceivable need of a radio amateur can be supplied by the advertisers in QST. And you will know the product has the approval of the League’s technical staff.

For Your Convenience QST'S INDEX TO ADVERTISERS IN THIS ISSUE

Aerovox Corporation	110
Aladdin Radio Industries, Inc.	90
Allen-Bradley Company	85
Amperex Electronic Products	78
Astatic Microphone Laboratory	88
Barker & Williamson	86
Bassett Research Corporation	72
Bendix Radio Corporation	Insert
Birnback Radio Company	110
Bliley Electric Company	115
Bruno Laboratories, Inc.	106
Brush Development Company	73
Burgess Battery Company	87
Candler System Company	119
Capitol Radio Engineering Institute	102
Cardwell Mfg. Corp., Allen D.	80
Centralab	75
Code-Craft	117
Cohen's Sons, Ltd., I. S.	109
Collins Radio Company	Cov. 2
Cornell-Dubilier Corporation	106
Coto-Coil Company, Inc.	102
Delaware Radio Sales Company	117
Delco-Remy Corporation	95
Dodge's Institute	114
Eitel-McCullough, Ltd.	89
Electrical Products Company, Inc.	117
Gardiner-Levering Company	119
General Transformer Corporation	86
Gross Radio, Inc.	127
Gulf Radio School	117
Hallcrafters, Inc., The	1, 2
Hammarlund Mfg. Company	4, 103
Harvey Radio Company	108
Harvey Radio Laboratories, Inc.	111
Heintz & Kaufman, Ltd.	69
Henry Radio Shop	92
Instructograph Company	117
International Resistance Company	71
Jacobs, Charles F.	114
Kato Engineering Company	109
Kenyon Transformer Company	98
Leeds	82
Lefebvre Corporation	118
Mallory & Company, P. R.	68
McElroy, T. R.	117
McGraw-Hill Book Company	76
Mims Radio Company	118
National Company	Cov. 3, 67, 107
Newark Electric Company	81
New York Y. M. C. A. Schools	124
Ohmite Manufacturing Company	84
Petersen Radio Company	124
Port Arthur College	109
Precision Apparatus Corp.	98
Precision-Piezo Service	119
RCA Institutes, Inc.	119
RCA Manufacturing Company	Cov. 4
Radio Mfg. Engineers, Inc.	109
Radio Shack	109
Radio Specialties Company, Inc.	109
Radio Supply Company	117
Radio Transceiver Laboratories	88
Scientific Radio Service	109
Shure Brothers	90
Sickles Company, F. W.	96
Signal Electric Mfg. Company	94
Speer Carbon Company	92
Sprague Products Company	96
Standard Transformer Corporation	84
Sun Radio Company	112
Sundt Engineering Company	103
Taylor Tubes, Inc.	91
Teleplex Company	114
Terminal Radio Corporation	116
Thordarson Electric Mfg. Company	93
Transformer Corp. of America	74
Transmitter Equipment Mfg. Company	79
Trimm Radio Mfg. Company	117
Trindl Products	118
Triplet Elec. Instrument Company	77
Turner Company	94
United Electronics Company	115
United Transformer Company	113
Universal Signal Appliance Company	103
Utah Radio Products Corporation	97
Vibroplex Company	114
Western Electric Company	70
Wilson, Willard S.	111
Wincharger Corporation	119
Yaxley	68

"Built Like a Battleship"

YOU WILL BE PROUD TO OWN THE NEW

GROSS CP-55 OR CB-55

COMPARE
and
CHECK THESE FEATURES

- Full 95 Watts input
- Ten Meter Operation
- New Taylor T20 tubes
- For operation on 10-20-40-80-160 meters
- Built-in power supply
- 3 stages, 42 Osc, 6L6 buffer, 2-T20's in final

Kit \$ **42.70** Less tubes, meters,
crystal — One set
coils included in price

The "CP-55" uses the marvelous new T-20's in the output stage. These real transmitting tubes will give outputs and performance not possible with ordinary receiving tubes — their price is very low.

The ideal unit for the beginner or the "Old Timer" desiring an additional Transmitter for operation on 10 meters, or any other band. In the CP-55 you have available an Xmitter having real power at a ridiculously low price.

Compare the construction of the "CP-55" with units selling at many times its price. Only finest components are used such as Cardwell Condensers, Seatite Sockets, IRC Resistors, Cornell Dubilier and Aerovox Condensers, etc.

The addition of a modulator unit which is available converts the CP-55 into a fine Radiophone Transmitter.

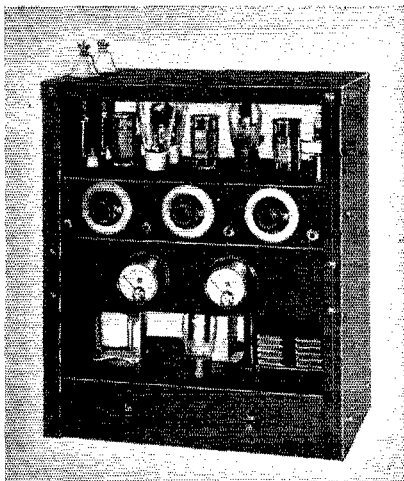

"CW-55" RF Unit only as used in the CP-55 including one set coils, less tubes, xtal, meters. Kit \$18.95
Two full size surface type meters 7.00
Coils per set, any amateur band listed in features 2.85
Kit of Matched tubes for RF Unit 6.60
One 83 Tube for power supply65

"CB-55"

The Radiophone version of the "CP-55" — Also sensationally low priced
All Bands Including 10 Meters
Bulletin gives Details

NEW! "THE STANDBY" (2 TO 2000 METERS) 3-TUBE A.C. AND D.C. RECEIVER

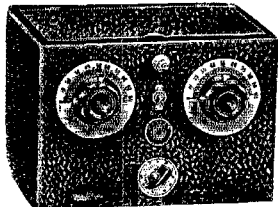

This excellent 2 to 2000 meter receiver is offered with full realization of the present-day need of the amateur for a dependable "standby" receiver which will cover practically all of the radio bands in use today. Super regeneration, which is the most efficient form of detection at these frequencies, is used from 2 to 15 meters. The R.F. stage is effectively used over the entire tuning range. Throughout the entire tuning range, there are no skips or dead spots. Loud speaker volume is available from practically every station received.

- 1000 to 1 tuning ratio ● Super regeneration below 15 meters
- Automatic change over from straight to super regeneration
- Power supply incorporated
- Individual antenna tuning for high and low wave ranges
- 1-6J5C detector, 1-6J7 R.F. stage, 1-12A7 audio amp. and rectifier.

Complete kit of parts, less coils, tubes, cab. . . . \$7.59
2-5-10-meter coils (set of 3)95
9.4 to 15 meter coil39
15-200 meter coils (set of 4)95
200-310 meter coil .39
310-550 meter coil .39
550-1050 meter coil .60
1000-2000 meter coil60
Metal cabinet . . . 1.50
Kit of three tubes 2.40
Wired and tested in our lab., add. 2.00

WRITE IN FOR FREE NEW CATALOG ON HAM AND P. A. EQUIPMENT

20% DEPOSIT WITH ALL C. O. D. ORDERS

REMIT BY M. O. INCLUDE POSTAGE

Cable Address: GROSSINC

GROSS RADIO, INC., 51 VESEY STREET, NEW YORK CITY

CHINESE COPY



An authentic reproduction of an imported lamp carton label. Due to lack of knowledge of the underlying design principles only 10% of such "Chinese copies" will pass Federal specifications.

"Free from Engineering"

As leaders in transformer development, the UTC Research Staff prides itself on the many revolutionary designs released during the last few years. It is only natural that competitive manufacturers copy these new developments. Some of these copies, however, have low efficiency and poor frequency response. Some have a new gadget, case or terminal arrangement to give the impression of originality, but which only detract from the simplicity and efficiency of the original design. The inferior characteristics of duplicates only bolster the progress of UTC... the line which is a year ahead.

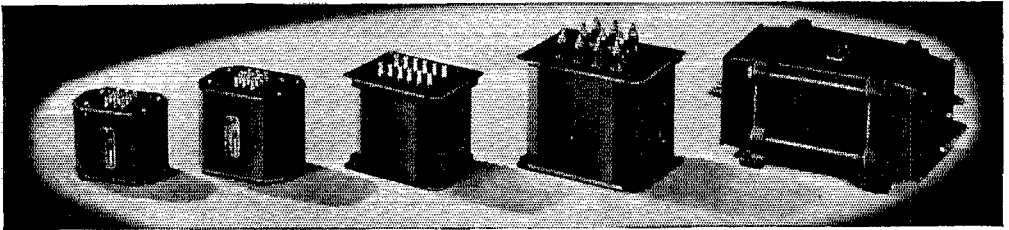

VARIMATCH MODULATION TRANSFORMERS

UTC VARIMATCH Modulation Transformers Will Match ANY Modulator Tubes to ANY RF Load...

VM-0 Maximum audio output 20 watts	\$3.00
VM-1 Maximum audio output 30 watts	\$4.80
VM-2 Maximum audio output 60 watts	\$7.50
VM-3 Maximum audio output 125 watts	\$12.00
VM-4 Maximum audio output 300 watts	\$19.50
VM-5 Maximum audio output 600 watts	\$42.00

VARIMATCH INPUT TRANSFORMERS

Varimatch Input Transformers will take care of Practically every driver requirement.

PA-50AX Single 89, 53, 56, 6CS, etc. to class B 53, 6A6, 89, etc.	\$3.30
PA-51AX Single 56, 6CS, 45, 59, 6L6, 2A3, etc. to class B 46, 59, 79, or A prime 42's, 45's, etc.	\$3.30

PA-52AX Push Pull 45, 59, 2A3, etc. to class B 46, 59, 841, etc. \$3.90

PA-53AX Push Pull 45, 59, 2A3, 6L6, etc. to class B 210, 801, 800, 35T, RK-18, 203A, ZB-120, etc. \$4.50

PA-59AX 500 ohms line to 805, 838, 203A, 210, 800, ZB-120, etc. \$4.50

PA-238AX Push Pull Parallel 45, 2A3, 6L6, etc. to push pull parallel 838, 203A, ZB-120, or to class B 204A, HF-300, 849, etc. \$10.50

PA-512 500 ohms line to class B, 150T, HF-300, 204A, etc. \$12.00

PA VARIMATCH TRANSFORMERS

The new UTC PA Varimatch transformers will match practically any tube in their power range to a 200/500 ohm line or to any voice coil.

PVM-1 For all audio tubes up to 12 watts	\$3.00
PVM-2 For all audio tubes up to 30 watts	\$4.80
PVM-3 For all audio tubes up to 60 watts	\$7.50
PVM-4 For all audio tubes up to 125 watts	\$12.00
PVM-5 For all audio tubes up to 300 watts	\$19.50

LINE VARIMATCH TRANSFORMERS

The UTC LINE VARIMATCH units will match any single or group of voice coils to a 500 ohm line. Impedance range is from .2 to 75 ohms in 50 combinations... UTC LINE VARIMATCH AUTOFORMERS will match one to ten 500 ohm lines or LVM 500 ohm windings to the 500 ohm output of an audio amplifier.

LVM-1 12 watt Line Varimatch unit	\$2.70
LVM-2 30 watt Line Varimatch unit	\$4.20
LVM-3 50 watt Line Varimatch unit	\$6.00
LVM-10 12 watt Line Varimatch Autoformer 500, 250, 167, 125, 100, 83, 71, 62, 50 ohms.	\$2.70
LVM-11 30 watt Line Varimatch Autoformer	\$4.20
LVM-12 60 watt Line Varimatch Autoformer	\$6.00
LVM-13 125 watt Line Varimatch Autoformer	\$10.80
LVM-14 300 watt Line Varimatch Autoformer	\$15.00

NEW VARIMATCH BULLETIN

See your distributor for the new bulletin listing details, valuable application information and technical tables.

ALL PRICES SHOWN ARE NET TO AMATEURS

UNITED TRANSFORMER CORP.

72 SPRING STREET

NEW YORK, N. Y.

EXPORT DIVISION, 100 VARICK STREET NEW YORK, N. Y. CABLES: "ARLAB"

THE TML — ACTUAL SIZE

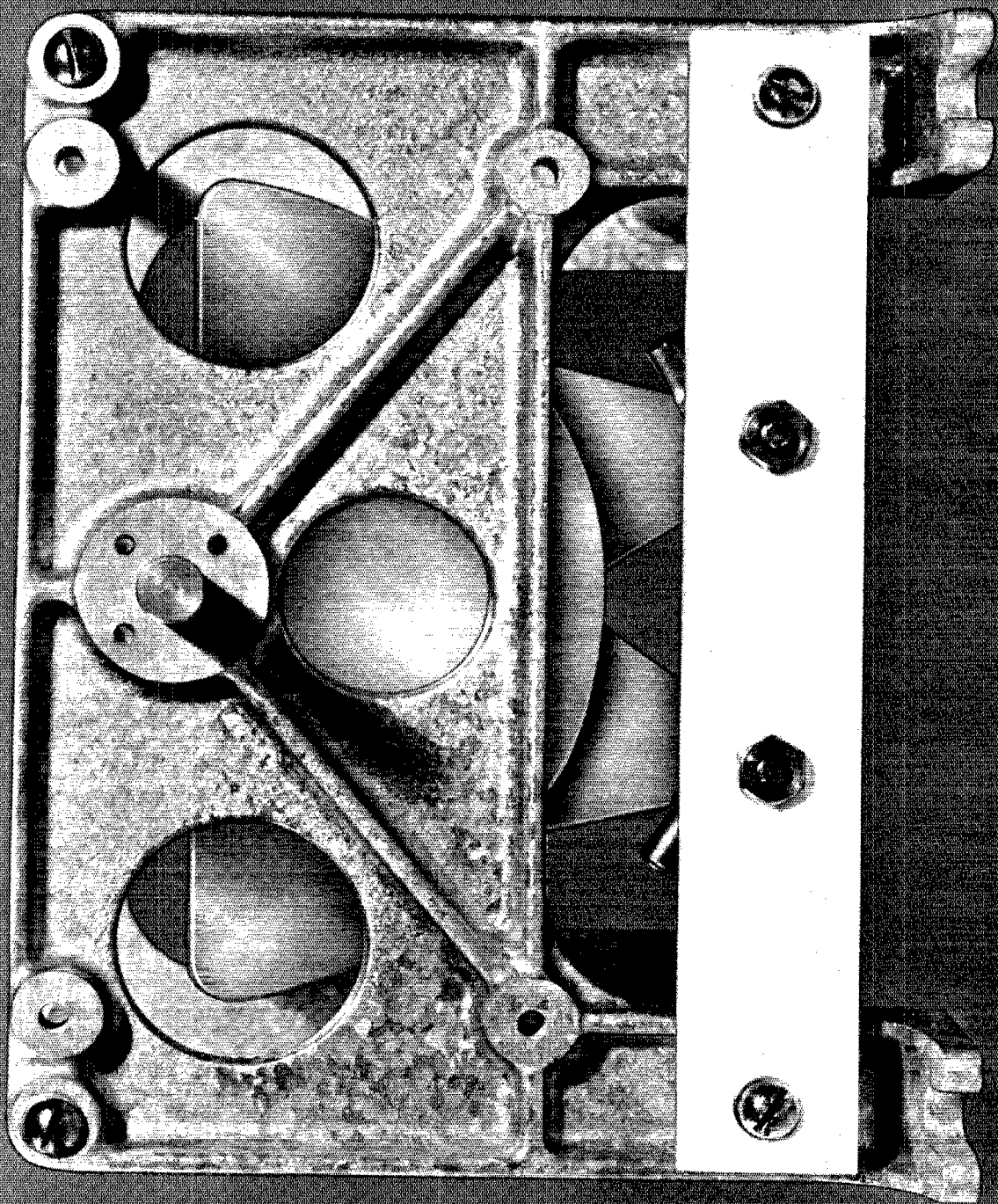

This actual size picture of the TML gives some idea of its ruggedness, its high roll-over-handling ability, its thorough fitness for heavy duty jobs. Its price is right, \$49.90 Net for the 50 mm., 15,000 V. model. Another National product your dealer is glad to show you.

NATIONAL COMPANY, INC.

RCA offers you a Tube for every Purpose

AT A PRICE FOR EVERY PURSE

USE THESE OUTSTANDING TYPES IN YOUR TRANSMITTER FOR GREATER EFFICIENCY, RELIABILITY AND ECONOMY

Type	Price	Use	Plate Volts*	Grid-Bias Volts*	Nominal Output-Watts Class C Single Tube	Nominal Output-Watts Class B Mod. Two Tubes
TRIODES						
RCA-801	\$3.45	Buffer, Power Amplifier	600	-150	25	45
RCA-805	15.00	Power Amplifier, Doubler	1500	-105	215	370
RCA-806	24.50	Power Amplifier, Doubler	3000	-600	450	660
RCA-808	10.00	Power Amplifier, Doubler	1500	-200	140	185
PENTODES						
RCA-802	\$3.90	Oscillator, Buffer/Doubler	500	-100	16	—
RCA-803	34.50	Power Amplifier	2000	-90	210	—
RCA-804	15.00	Power Amplifier	1250	-100	80	—
BEAM POWER TUBE						
RCA-807	\$3.90	Oscillator, Buffer/Doubler	400	-50	25	—
RECTIFIERS						
			Max. Peak Inverse Volts	Circuit 2 Tubes	RMS Plate Volts per Tube	Max. d. c. Load Current Amps.†
RCA-866	\$1.75	Half-wave, Mercury-Vapor	7500	Full Wave	2650	0.5
RCA-872	14.00	Half-wave, Mercury-Vapor	7500	Full Wave	2650	2.5

*Rated value for Class C telegraphic service

†With choke input filter

RCA also offers the RCA-834 Triode at \$12.50 for ultra-high frequency power amplifiers, the acorn tube types RCA-955 at \$3.00 and RCA-954 or 956 at \$5.00 for ultra-high-frequency receivers.

For all oscillographic applications use the RCA-913 one-inch tube at \$5.60 and RCA-906 three-inch tube at \$15.00.

Use RCA ALL THE WAY and get the best value money can buy.

RCA presents the "Magic Key" every Sunday, 2 to 3 P. M., E. D. T., on NBC Blue Network



for Amateur Radio

RCA MANUFACTURING COMPANY, Camden, N. J. • A Service of Radio Corporation of America

A New Achievement for a Famous Name

A great drama of life and death was enacted when the raging waters of the Ohio and Mississippi spread terror and disaster during the recent flood. Out of this great drama emerged the nation's cast of heroes whose efforts saved thousands of lives from watery graves and controlled the inevitable aftermath of disease. ★ Bendix is proud to have been able to play a part in the timely rescue efforts of the many governmental and independent agencies. The Coast Guard rushed men, boats, planes and communication trucks, some equipped with Bendix transmitters, receivers and other equipment to the flooded area.

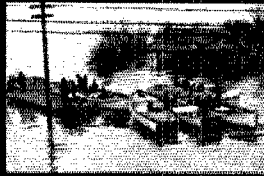
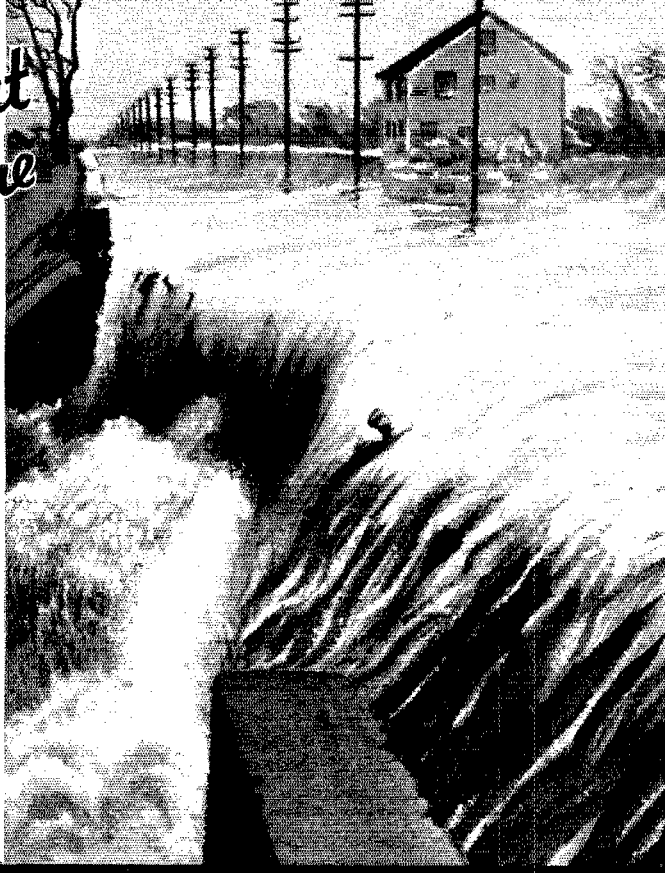

PHOTOS COURTESY U. S. COAST GUARD

In cooperation with the Naval Reserve, Army and Amateurs, they established a joint emergency radio network to facilitate rescue work and relieve human suffering. ★ Such occasions as this bear testimony to the reliability and efficiency of Bendix Radio products under all conditions. Bendix Radio Corporation provides complete research, engineering and manufacturing facilities for every type of radio equipment.

PARTIAL LIST OF BENDIX RADIO PRODUCTS

- Hurricane-proof Spike Antennas
- Antenna Arrays
- Low Temperature Coefficient Quartz Crystal and Holders
- Variable Condensers
- Fixed Condensers
- Inductances
- Frequency Standards
- Frequency Monitors
- Frequency Meters
- Precision Gear Drives
- Synchronizers
- Audio Analyzers
- Modulation Monitors
- Tube Testers
- Set Testers
- Remote Control Devices
- Capacity Standards
- Field Intensity Meters

Direct All Correspondence to BENDIX RADIO CORPORATION 9th and Kearny Sts., N. E., Washington, D. C.

BENDIX

RADIO CORPORATION

NEW YORK

WASHINGTON

DAYTON

CHICAGO

OAKLAND

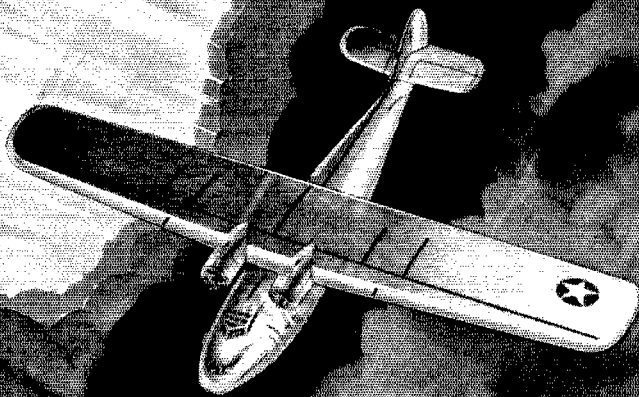

Honolulu must be ahead!

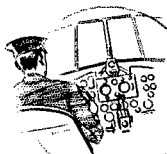

Out of the storm-swept skies that erased all visibility, a dozen sea-planes alighted on the land-locked waters of Pearl Harbor... and Man once again defeated the

elements. These twelve Navy planes had spanned the 2553 miles of open sea from San Diego to Honolulu, thus completing the longest over-water mass flight in aviation history. *With the weather as thick as pea soup and visibility nil, these fliers flew with confidence toward a mile square spot in a vast ocean. They knew their goal **MUST** be ahead! Adverse weather conditions were forgotten, for these PBY-1 Consolidated long-range patrol boats were kept on a sure course with the unfailing precision and dependability of Bendix Radio Direction Finders. *When efficient performance is

needed, over land or sea, Bendix equipment will not fail. Bendix Radio Corporation offers the finest engineering facilities for the development and manufacture of aircraft radio products of every type for use in commercial, naval and military aviation.

PARTIAL LIST OF BENDIX AVIATION PRODUCTS

Transmitters	Intercommunicating Telephones
Receivers	Ground Station Equipment
Direction Finders	Traffic Control Transmitters
Radio Compasses	Receivers
'Approach' and 'Glide Path' Land- ing Systems	Radio Ranges
Radio-Instruments	Field Localizers
Radio-Mechanical Devices	Marker Beacons
	Quartz Crystals and Holders

Direct All Correspondence to BENDIX RADIO CORPORATION 9th and Kearny Sts., N. E., Washington, D. C.

BENDIX

RADIO CORPORATION

NEW YORK

WASHINGTON

DAYTON

CHICAGO

OAKLAND