

QST

DEVOTED ENTIRELY TO

AMATEUR RADIO

PUBLISHED SINCE 1915 BY THE AMERICAN RADIO RELAY LEAGUE, INC.

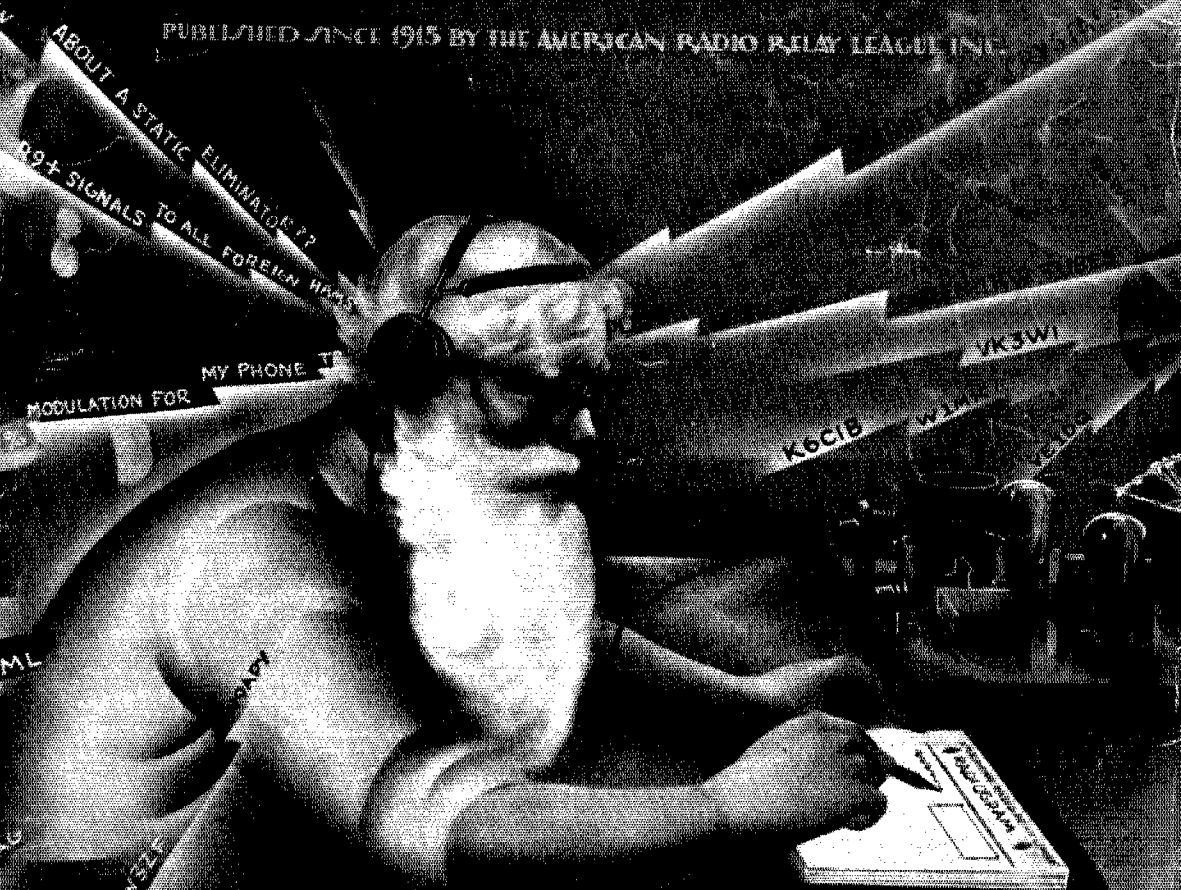

DECEMBER

25¢

—*And Now*

The New SEVENTH Edition

... OF ...

The Radio Amateur's **HANDBOOK**

NOW IN ITS EIGHTY-NINTH THOUSAND

By the Headquarters Staff of the A. R. R. L.

▶ **WE** TAKE GREAT PLEASURE in announcing the new Seventh Edition of the greatest of all amateur reference works. Completely overhauled during the past five months by the technical and editorial staffs of the A.R.R.L. and QST, it represents the most thorough revision of this famous manual since the first edition in 1926.

- Each chapter has been scrutinized for necessary alterations and changes made to bring the material up to the minute. Practically all of the old material on transmitters, receivers, antennas and frequency meters has been thrown out bodily and replaced by the latest dope from League Headquarters. From start to finish it represents the latest in the way of amateur information, indispensable, as always, to the older amateur and beginner alike.
- For the beginner, the latest in low-power transmitters and simple receivers, with complete information on how to get started, how to learn the code, how to build and adjust your apparatus and how to operate your station.
- For the advanced amateur, the latest news on screen-grid receivers, stable transmitters, dynatron and other frequency-measurement apparatus. A whole new chapter on radiotelephony; hot new dope on antenna feed systems. A fund of information no real ham can do without.

Red-and-Gold Paper Covers—\$1.00

Stiff Buckram Binding \$2.00—Postpaid anywhere

◀ **MORE THAN EVER YOU NEED A
HANDBOOK—GET YOURS TODAY!** ▶

AMERICAN RADIO RELAY LEAGUE, HARTFORD, CONN., U. S. A.

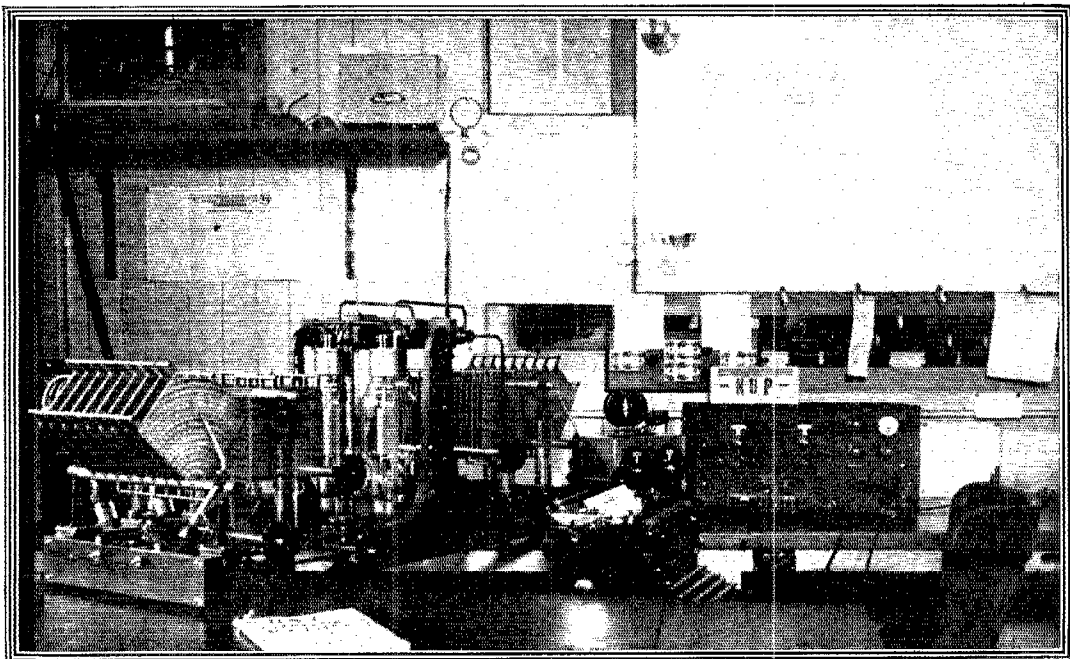

KUP, San Francisco

During the first half of 1930, KUP of the *San Francisco Examiner* handled 1,250,000 words of press, weather, stock quotations and financial survey, besides the daily quota of deadhead traffic handled as an accommodation to operators at sea. The last half of 1930 will probably exceed one and a half million words. At present KUP holds a record for transmission of more words in a six months period than any other station of its kind in the world.

KUP's half-kilowatt transmitter is of

the tuned plate, tuned grid, self-excited type. Two DeForest Audions, 504A type, are employed in parallel.

"I sincerely hope we shall be able to co-operate with you in developing widespread interest in DeForest Audions, and that within the next six months we may prove that the DeForest 504A will outlast any other tube sold. I feel most confident in them," states R. G. Martin, Manager of KUP.

And why not? After all, there is no substitute for twenty-five years' experience.

WRITE for catalog on DeForest transmitting tubes for every conceivable purpose. Also do not hesitate to place special transmitting and receiving problems before our Engineering Department.



DE FOREST RADIO
COMPANY
PASSAIC, NEW JERSEY

Export Department:
304 E. 45th Street,
New York City, N. Y., U. S. A.

QUALITY CONDENSERS

GENERAL RADIO COMPANY has been designing and building amateur experimental and laboratory condensers for more than fifteen years. Why not avail yourself of our accumulated experience? Although our soldered plate condensers are built by precision instrument makers, they cost no more than others. The following are three representative instruments.

Type 557 Amateur-Band Condenser carries 4 rotor plates 2 of which are complete circles giving the high zero capacitance required in band-spanning condensers. Especially useful in frequency meters. Price \$3.25.

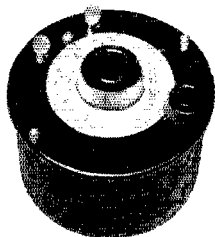
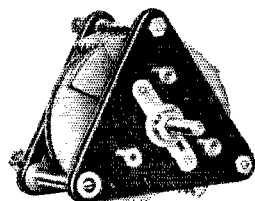

Type 247 Variable Air Condensers are furnished in 4 different models with a scale calibrated in micromicrofarads. Useful as an experimental capacitance standard.

Type 334 Variable Air Condensers are made in 4 different models for use on amateur transmitters. Maximum voltage 3500 volts, peak.

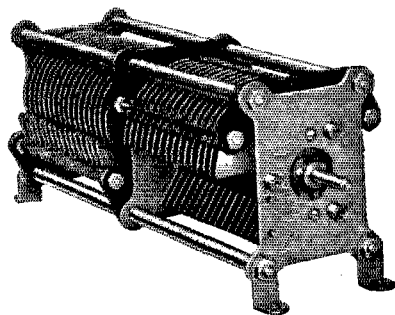

A bulletin describing our complete line of amateur equipment will be sent you on request. Ask for Bulletin 932-Q.

GENERAL RADIO COMPANY

OFFICES

LABORATORIES

FACTORY

CAMBRIDGE A, MASSACHUSETTS

Pacific Coast Warehouse: 274 BRANNAN STREET, SAN FRANCISCO

It Packs the Punch

Capacity
8 MFD
Peak Voltage
430 DC
Can Negative



Radio Set designers, builders and service men are invited to get in touch with our engineering department, and hear more about successful tested circuits embodying Sprague Condensers in their design

HERE'S a heavy-weight wallop in fly-weight form—the new Sprague electrolytic condenser. Packing 8 MFD capacity and a rating of 430 volts DC into a space of only $1\frac{1}{8}$ " diameter x $4\frac{1}{4}$ " high overall.

And what advanced construction you'll find inside—the can! A one-piece rolled edged anode of pure aluminum, without welded joint or soldering. Absolute prevention of liquid leakage thru practically a one-piece rubber top with integral vent. Unequaled flexibility in mounting, due to standardized size and form. And individual screw socket mounting that makes attachment or adjustment almost instantaneous.

The Sprague Condenser is engineered and constructed for maximum efficiency in practical use. Let us send you illustrated folder showing in detail how the Sprague excels all other types.

SPRAGUE SPECIALTIES COMPANY
NORTH ADAMS, MASS.

SPRAGUE

Electrolytic CONDENSER

Section Communications Managers of THE COMMUNICATIONS DEPARTMENT, A. R. R. L.

Eastern Pennsylvania Maryland-Delaware-District of Columbia Southern New Jersey Western New York Western Pennsylvania	W3ZF W3BBW W3ATJ W8CKC W8CFR	ATLANTIC DIVISION Don Lusk Forrest Calhoun Bayard Allen John R. Blum Robert Lloyd	116 West Wyoming Ave. 1636 Thomas Ave. 416 Mount View Ave. 44 Seward St. 175 Allegheny Ave.	Germantown, Phila. Baltimore, Md. Mount Holly Dansville Emsworth (Pgh) Pa.
Illinois Indiana Kentucky Michigan Ohio Wisconsin	W9APY W9BKJ W9BAZ W8DVH W8BAH W9VD	CENTRAL DIVISION Fred J. Hinds George Graue J. B. Wathen, III Ken Conroy Harry A. Fummonds C. N. Crapo	3337 Oak Park Blvd. 824 Home Ave. Mockingbird Valley 7553 E. Robinwood Ave. 2073 West 85th St. 2111 E. Newton Ave.	Berwyn Fort Wayne Louisville Detroit Cleveland Milwaukee
North Dakota South Dakota Northern Minnesota Southern Minnesota	W9BVF W9DNS W9BVH W9EFK	DAKOTA DIVISION Guy L. Ottinger Howard Cashman Carl L. Jabs J. C. Pehoushek	326 6th Ave., So. 121 N. Spring Ave. 1822 James St. 60 Melbourne Ave., S. E.	Jamestown Sioux Falls St. Paul Minneapolis
Arkansas Louisiana Mississippi Tennessee	W5ABI W5WF W5AKP W4SP	DELTA DIVISION H. E. Velte F. M. Watts, Jr. J. W. Gullett James B. Witt	315 No. Jackson St. 1716 Park Ave. 1708 23rd Ave. 832 N. Fifth Ave.	Little Rock Shreveport Meridian Knoxville
Eastern New York N. Y. C. & Long Island Northern New Jersey	W2QU W2BGO W2WR	HUDSON DIVISION H. J. Rosenthal V. T. Kenney A. G. Wester, Jr.	Box 740 1836 Hone Ave. 50 Princeton St.	New Rochelle Bronx Maplewood
Iowa Kansas Missouri Nebraska	W9DZW W9CET W9RR W9FAM	MIDWEST DIVISION H. W. Kerr J. H. Amis L. B. Laizure Samuel C. Wallace	915 Lincoln Ave. 8010 Mercier St. Green St.	Little Sioux Topeka Kansas City Clarks
Connecticut Maine Eastern Massachusetts Western Massachusetts New Hampshire Rhode Island Vermont	W1CTY W1AOL W1WV W1WJ W1ATJ W1BCR W1IT	NEW ENGLAND DIVISION Frederick Ellis, Jr. C. W. Brown M. W. Weeks Leo K. Pelouquin V. W. Hodge C. N. Kraus Clayton Paulette	7 Union Ave. 269 No. Main St. 40 Norfolk Rd. 24 Arthur St. 227 Main St. 92 Keene St.	Norwalk Brewster Chestnut Hill Worcester Claremont Providence North Troy
Alaska Idaho Montana Oregon Washington	WWDN W7AKZ W7AAT-7QT W7UN W7ACS	NORTHWESTERN DIVISION W. B. Wilson Oscar E. Johnson O. W. Viers Wilbur S. Claypool Eugene A. Piety	U. S. LHT Fern 422 Antone St. Route 11, Box 247 912 No. Ainsworth St.	Ketchikan Sandpoint Red Lodge Milwaukie Tacoma
Hawaii Nevada Los Angeles Santa Clara Valley East Bay San Francisco Sacramento Valley Arizona Philippines* San Diego San Joaquin Valley	E6CIB W6EAD W6EQF W6NX W6CZR W6WB W6DON W6BWS EA1JR W6EOP W6BVY	PACIFIC DIVISION L. A. Walworth Keston L. Ramsay B. E. Sandham F. J. Quemont J. Walter Frates C. F. Bane Everett Davies Russ Shortman John R. Schultz Harry A. Ambler E. J. Beal	2737 Ferdinand Ave. 1151 Buena Vista Ave. 4508 8th Ave. 1348 Hanchett Ave. 439 62nd St. 262 Castro St. Rt. 5, Box 380 519 W. Madison St. 4101 Hamilton St. Box 246	Honolulu Reno Los Angeles San Jose Oakland San Francisco Sacramento Phoenix Calauan, Laguna, P. I. San Diego Newman
North Carolina Virginia West Virginia	W4DW W3CA W8JM	ROANOKE DIVISION H. L. Caveness J. F. Wohlford D. B. Morris	State College 118 Cambridge St. 703 Maryland St.	Raleigh Roanoke Fairmont
Colorado Utah-Wyoming*	W9ESA W6DPJ	ROCKY MOUNTAIN DIVISION Edward C. Stockman C. R. Miller	618 So. Williams St. 134 E. 2nd North St.	Denver Provo, Utah
Alabama Florida Georgia-So. Carolina-Cuba- Isle-of-Pines-Porto Rico- Virgin Islands	W4AHP W4AII W4RZ	SOUTHEASTERN DIVISION Robt. E. Troy, Jr. Harvey Chafin M. S. Alexander	516 Cloverdale Rd. 6002 Suwanee Ave. 47 2d Ave., S. E.	Montgomery Tampa Atlanta
Northern Texas Oklahoma Southern Texas New Mexico	W5RJ W5CF W5ZG W5AII	WEST GULF DIVISION Roy Lee Taylor W. J. Gentry H. C. Sherrod Leavenworth Wheeler, Jr.	1614 St. Louis Ave. 538 N. Pottenger St. 4715 Crockett Blvd. Box 33	Ft. Worth Shawnee Galveston Valmore
Maritime*	VE1DQ	MARITIME DIVISION A. M. Crowell	69 Dublin St.	Halifax, N. S.
Ontario	VE3FC	ONTARIO DIVISION E. C. Thompson	266 Queensdale Ave.	Toronto, 6
Quebec	VE2AC	QUEBEC DIVISION Alphy Blais	Box 221	Thetford Mines
Alberta British Columbia	VE4EC VE5AL	VANALTA DIVISION Fred Barron J. K. Cavalsky	Warwick Apts., 95th St. 4368 Blenheim St.	Edmonton Vancouver
Manitoba Saskatchewan	VE4HR VE4FC	PRAIRIE DIVISION A. V. Chase W. J. Pickering	109 Lanark St. 514 19th St. W.	Winnipeg Prince Albert

*Officials appointed to act until the membership of the Section choose permanent SCMs by nomination and election.

LEEDS Listening Monitor

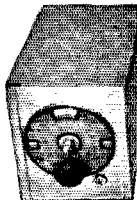

For checking your note, its stability and whether D.C. or not. THE ONLY SURE CHECK. Gives you an accurate idea as to what your signal sounds like to the other fellow. The Leeds Monitor is encased in an aluminum shield, 5" x 6" x 9" overall, 3 plug-in coils having a range of 15 to 90 meters are supplied. Completely shielded, with batteries self contained. Supplied with A. & B. batteries, but without 1-UX, 199 tube. Special..... **\$15.00**

LEEDS 50 WATT SOCKET

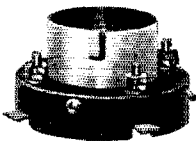

Heavy special porcelain base. Double phosphor bronze springs, high grade construction throughout. Extra special price..... **\$2.45**



The Home of RADIO
**45 VESEY STREET
NEW YORK**

**New York's Headquarters
for
Transmitting Apparatus
When in Town Visit Our Store**

*All parts for Nov. Q. S. T.
push-pull transmitter in
stock at special prices.*

*Bakelite Zepp Antenna
Feeder Spreaders; all drill-
ed; size 10 1/2" x 3 1/4" x 1/4"
Special 6 for \$1.00*

Leeds Plug-in Dust-proof

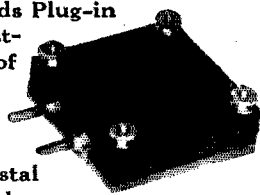

Crystal Holder

To meet the demand for a carefully constructed, reasonably priced Crystal Holder, LEEDS Labs are now presenting this item. Accurately machined and constructed of excellent material throughout, this holder will give thorough satisfaction. List price, \$6.00. Special offer. **\$4.25**



COPPER COIL

Make your own transmitting and receiving coils. Copper tubing transmitting inductance.

	Size of tubing		
	3/16"	1/4"	5/16"
Inside Dia.	3/16"	1/4"	5/16"
2 1/8"	9c	10c	12c
2 3/8"	9c	10c	15c
3 1/8"	10c	12c	17c

Prices per turn

LEEDS RADIO LABORATORIES

Precision Custom Built Short Wave Receivers and Transmitters

This department under the supervision of the Short-Wave Specialist, Jerome Gross. We design, construct and advise on any material for the "Ham" Broadcasting station or laboratory. Write Jerry Gross for advice on any of your problems.

A representative Ham Station, incorporating the LEEDS trio; Ham Receiver, 7 1/2 watt Transmitter and Listening Monitor, in a neat efficient layout. This combination is ideal for the beginner or anyone interested in an effective popular priced station.

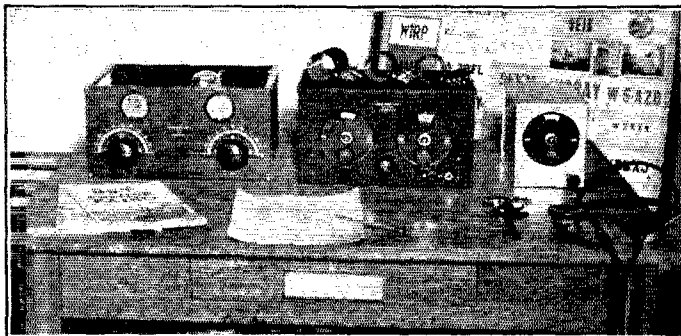

Write for our circulars on our products. Quotations on special transmitters, etc., supplied upon application.

LEEDS Short Wave Receiver

The successful operation of any Short Wave Receiver depends almost entirely upon its handling (smooth regeneration control, etc.). The LEEDS Short Wave Receiver has flawless regeneration control from 20 to 80 meters with only 22 1/2 Volts on the detector tube. No fringe howl is present, and absolutely no hand capacity is found to disturb tuning. Many of these receivers have been sold to people who have tried more elaborate jobs, only to discover that a simpler well balanced receiver would be more efficient and satisfactory for their work.

Three 201-A tubes are used, one as the detector, and two audio stages.

The Universal type has a continuous range from 15 to 100 meters, using three plug-in coils.

The Amateur type incorporates a Cardwell 201-B adjustable type condenser for tuning which can be adjusted to give any spread of the bands desired. The set is supplied with 20, 40 and 80 meter coils to cover the Amateur Bands.

Universal or Amateur type Receiver completely constructed and tested, price..... **\$37.50**

General Radio 50 ohm Rheostat

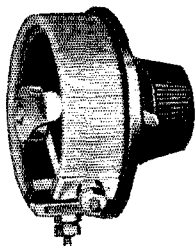

Type 214-A

Your filament voltage regulation problem solved inexpensively. Excellent for use as primary control in your filament transformer; for the 50 watt, UX 852 or 7 1/2 watt.

Price... **\$1.50**

LEEDS Copper Tubing Transmitting Inductance Units

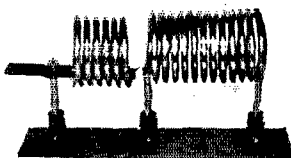

Wound with heavy copper tubing to diameter of 3". Easily varied antenna coupling device. Size of unit 5 1/4" high, 14" long overall. Satisfactory for use up to 250 watts, with straight oscillators or in power amplifier circuits.

80 meter type.....	\$11.00
40 meter type.....	\$10.00
20 meter type.....	\$9.00

This unit is used in all of our Special Transmitters

PLEASE PRINT YOUR NAME AND ADDRESS PLAINLY TO AVOID DELAY

WRITE FOR SPECIAL PRICE LIST

MAIL ORDERS FILLED SAME DAY
10% Cash Must Accompany All C. O. D. Orders

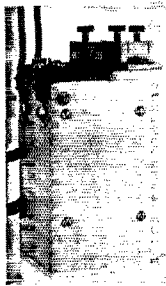

MESCO
1-2" Spark Coil
The coil of a 101 uses. Can be used as a peaked audio choke with fixed condensers, etc. Many other uses will suggest themselves to the experimenter.
Reg. \$7. Special **\$1.50**

LEEDS

The Home of RADIO
45 VESEY STREET
NEW YORK

New York's Headquarters
for
Transmitting Apparatus
When in Town Visit Our Store



Dubilier Condensers

400 Volts D. C.
Working Voltage

Type 902—3 Mfd.,
—3" high, 2" wide,
2 1/4" deep. List **\$1.35**
\$4.50. Special.....
7 Mfd.,—5" high, 2" wide,
4 1/2" deep. List **\$1.75**
Special.....

Special 866
Filament Transformer
2 1/2 volt — 10 amps. 10,000 volt insulation. **\$5.45**

Thordarson Transformer
150 watts, 400 volts each side of centre tap at 375 M.A. 5 volt filament, centre tap. Fine for power supply for 7 1/2 watter or for crystal control power supply. Specially priced for a short time only. Each. **\$3.50**

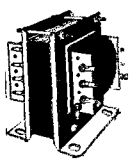

EVERYTHING IN
ACME JEWELL PYREX
BRADLEY FLERON
THORDARSON
ELECTRAD NATIONAL
LYNCH SIGNAL
FLECHTHEIM
NATIONAL RECTOBULB
GENERAL RADIO
CARDWELL AEROVOX
WESTON
IN STOCK



NEON GLOW LAMPS

Made by General Electric Co., type G. 10, standard base, 101 uses, as illustrated in QST May issue page 17.
Price only 65c

Standard electric socket for tube. 15c

WIRE

No. 14 Enamel 3/4c Foot
No. 12 " 1c
No. 10 " 1 1/2c
Any length up to 1000 feet



Special LEEDS lead in bowls made of Pyrex. Two cups size 3 1/4" dia. x 2 1/2" high; supplied complete with 18" brass rod, nuts and washers.
Price complete. **\$2.25**
Larger size cups 6" dia. x 4 1/4" high; complete set two cups. 24" brass rod, nuts and washers.
Price complete. **\$4.25**

BIG SCOOP—Mesco Keys
Standard for 20 years. Lists from \$3 to \$5. We just bought a big quantity. Better get them while they last at these special prices.

No. 101 95c
No. 103 \$1.75
No. 244 1.75

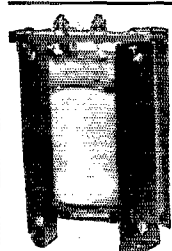

FILTER CHOKE

30 Henry, 150 Mill — special heavy choke, good for filter circuits for transmitters up to and including one UX852, or as a modulation choke on medium power transmitters.
Specially priced at **\$3.25**

THORDARSON DOUBLE FILTER CHOKES

Contains Two 18 Henry 250 Mill Chokes

Heavy duty, rugged double Filter Reactor for Filter Circuits in Transmitters, Power Amplifiers, "B" Eliminators and various other purposes. Each Choke has a 2000 Volt insulation and the D.C. resistance of each Choke is 108.5 ohms. When connected in series this Filter Reactor has a capacity of 36 henries at 250 mils, and when connected in parallel 18 henries with 500 mils carrying capacity.

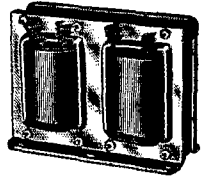

Model T-2458
Special **\$6.25**



Hardwick, Hindle Bleeder Resistors

ALSO THE NEW ENAMELED SLIDE RESISTOR IN VARIOUS SIZES

We recommend HH Resistors for the following voltages:
500 to 600 volts — 50,000 ohms — 100 watt \$2.75
500 to 600 volts — 50,000 ohms — 200 watt 3.25
1000 volts — 60,000 ohms — 100 watt 2.95
1000 volts — 100,000 ohms — 100 watt 2.95
1000 volts — 60,000 ohms — 200 watt 3.45
1500 volts — 80,000 ohms — 100 watt 3.60
1500 volts — 80,000 ohms — 200 watt — double unit 6.25
2000 volts — 100,000 ohms — 200 watt (double unit) 6.50
100 watt resistors. Size 6 1/4" x 1 1/4"
200 watt resistors. Size 8 1/2" x 1 1/4"

All Above Complete with mounting brackets



200 Watt Centre Tapped Transmitting GRID LEAK

Size 8 1/2" x 1 1/4" complete with bracket mounting
5,000 ohm. Special \$2.25
10,000 ohm. Special 2.70
15,000 ohm. Special 2.95
20,000 ohm. Special 3.25
30,000 ohm. Special 3.75
50,000 ohm. Special 4.50

PLEASE PRINT YOUR NAME AND ADDRESS PLAINLY TO AVOID DELAY | WRITE FOR SPECIAL PRICE LIST | MAIL ORDERS FILLED SAME DAY 10% Cash Must Accompany All C. O. D. Orders

The American Radio Relay League

The American Radio Relay League, Inc., is a non-commercial association of radio amateurs, bonded for the promotion of interest in amateur radio communication and experimentation, for the relaying of messages by radio, for the advancement of the radio art and of the public welfare, for the representation of the radio amateur in legislative matters, and for the maintenance of fraternalism and a high standard of conduct.

It is an incorporated association without capital stock, chartered under the laws of Connecticut. Its affairs are governed by a Board of Directors, elected every two years by the general membership. The officers are elected or appointed by the Directors. The League is non-commercial and no one commercially engaged in the manufacture, sale or rental of radio apparatus is eligible to membership on its board.

"Of, by and for the amateur," it numbers within its ranks practically every worth-while amateur in the world and has a history of glorious achievement as the standard-bearer in amateur affairs.

Inquiries regarding membership are solicited. A bona fide interest in amateur radio is the only essential qualification; ownership of a transmitting station and knowledge of the code are not prerequisite. Correspondence should be addressed to the Secretary.

DIRECTORS

President
HIRAM PERCY MAXIM
W1AW
Drawer 2102,
Hartford, Conn.

Vice-President
CHARLES H. STEWART
W3ZS
St. David's, Pa.

Canadian General Manager
ALEX. REID
VE2BE
169 Logan Ave.,
St. Lambert, P. Q.

Atlantic Division
EUGENE C. WOODRUFF
W8CMP
234 W. Fairmount Ave.,
State College, Pa.

Central Division
D. J. ANGUS
W9CVO
P. O. Box 596,
Indianapolis, Ind.

Dakota Division
CY. L. BARKER
W9EGU
Henning, Minn.

Delta Division
M. M. HILL
W5EB

P. O. Box 274,
Natchitoches, La.

Hudson Division
A. LAFAYETTE WALSH
W2BW

220 West 42d St.,
New York City

Midwest Division
LOUIS R. HUBER
W9DOA

517 East 4th St.,
Tipton, Iowa

New England Division
FREDERICK BEST
W1BIG

13 East Crescent St.,
Augusta, Maine

Northwestern Division
K. W. WEINGARTEN
W7BG

3219 No. 24th St.,
Tacoma, Wash.

Pacific Division
ALLEN H. BABCOCK
W6ZD
65 Market St.,
Southern Pacific Co.,
San Francisco

Roanoke Division
W. TREDWAY GRAVELY
W3BZ
Box 245,
Danville, Va.

Rocky Mountain Division
PAUL M. SEGAL
W9EEA
Box 1771,
Denver, Colo.

Southeastern Division
HARRY F. DOBBS
W4ZA
292 Spring St., N. W.
Atlanta, Ga.

West Gulf Division
FRANK M. CORLETT
W5ZC
2515 Catherine St.,
Dallas, Tex.

OFFICERS

President HIRAM PERCY MAXIM, Hartford, Conn.
Vice-President CHARLES H. STEWART, St. David's, Pa.
Secretary KENNETH B. WARNER, Hartford, Conn.
Treasurer ARTHUR A. HEBERT, Hartford, Conn.
Communications Manager F. EDWARD HANDY, Hartford, Conn.

GENERAL COUNSEL

PAUL M. SEGAL, 1010 Shoreham Bldg., Washington, D. C.

ADDRESS ALL GENERAL CORRESPONDENCE TO THE EXECUTIVE HEADQUARTERS AT HARTFORD, CONN.

EDITORIALS

WE HAVE a birthday! Fifteen years ago this month, when the American Radio Relay League was only a year and a half old, the first issue of *QST* was brought out. Published privately by Hiram Percy Maxim and Clarence D. Tuska, the founders of the League, in response to the need which had been found for some sort of regular bulletin, its object was "to help maintain the organization of the A.R.R.L. and to keep the Amateur Wireless Operators of the country in constant touch with each other." That has been its aim ever since.

There is just one copy of this precious first issue at Headquarters. We dug it out of the safe to-day and had a look at it for the first time in years. Old and battered, what joyous memories this little blue-covered booklet of twenty-four pages brought back to us! Your present editor was a young lad back in Illinois in those days, struggling with the intricacies of "wireless" and rapidly getting nowhere at all. *QST* came as manna from heaven. And did we know whether we wanted to subscribe or not! The publishers hoped that after financing three issues the magazine would find enough response to carry itself. They advertised that "Every amateur will help himself and help his fellows by sending in twenty-five cents for a three-months trial subscription." Our two bits, we remember, started for Hartford that same day, and there were enough others who thought the same way to carry *QST* on to its present indispensable position in our radio lives.

How we realize our venerable age when we let it sink in that all that was fifteen years ago! And what perfectly tremendous changes there have been since then! Those were the toddling days of amateur radio, when all transmission was by spark, with the rotary gap gaining favor, when most reception was on crystal detectors, with a few fortunate amateurs owning "audions." Let us pause and shed a tear for those childhood days when life was simpler. Honestly, they were swell in many ways!

The first issue of *QST* had ten pages of reading matter and seven pages of paid advertisements, with the rest given over to data and notices. The war was on in Europe and the United States

was becoming national-defense conscious. We find the President of the League writing to the Secretary of War and the Secretary of the Navy, offering the facilities of the League. Editor Tuska comments that "The great possibilities of the American Radio Relay League, with its organization of over six hundred relay stations in nearly every state of the Union, are bound to attract prominent attention." In that first issue, too, *QST* started its campaign for "precise, orderly and efficient" traffic handling. "Reliability & Celerity" was a slogan of the day — only the printer spelled it "celebrity." Regular hours for working were stressed by the editor, for, "unless the other man is a regular nighthawk and sits up half the night every night in the week, he misses him."

The leading (and the only) technical article in this issue was "Pictured Electro-Magnetic Waves," by Clarence D. Tuska, Assoc. I. R. E. he who was our first secretary and editor. Talk about technical, you fellows who think *QST* is "too technical!" It started out that

way. This article was very much too technical, with all those queer pictures of electro-magnetic and electro-static strain lines around a vertical antenna — you know, those funny diagrams we never could understand. There was other technical material, too, in the way of photos of several stations of members. Three pages were given over to a list of new members of the League, every one with call letters but a few of them still self-assigned initials, for the radio law was not yet operating in remote sections of the country. Members in those days had to fill out a two-page questionnaire in making application. DX was but a few miles and a man's equipment had to be known before his desirability as a relay station could be deduced. Applicants had to describe their aeriels, including "number of wires in aerial and space between," and answer "Do you use a spark coil or transformer?" and "Is your spark gap rotary, fixed or quenched?" The League advertised for sale its "List of Stations Book," tabulating the relay stations of the A.R.R.L. This book "shows what relay stations are within your range; gives name of owner, complete address, call letters, sending power, kind



of gap used, number of words can receive per minute, listening-in hours, what license is held, telephone connection or not." That, folks, was the forerunner of the Handbook.

But the "ads" in that first number! You youngsters who know amateur radio only in terms of high-frequency tube transmission and screen-grid detection and are bored stiff with any DX under ten thousand miles really missed a lot, and don't you forget it. What grief the old-timers encountered, what a rotten ratio of dollars-per-mile their investments gave them! But what real thrills were theirs when the old junk-pile did percolate and they clicked with another equally thrilled chap at the tremendous DX of 278 miles! Believe it or not, it all happened. So in this first issue of *QST* we find advertisements of the apparatus of the day. Prominent is the rotary gap, "required in every transmitting station by the Federal authorities" because "this type of gap produces a pure wave of low damping decrement," a note that "cannot be mistaken for static." Hi! And do you remember the very essential double-pole double-throw switch to short the 'phones while sending, to keep from burning your ears off! Then there was a Universal Detector Stand, "capable of holding crystals up to and including $\frac{3}{4}$." No, not quartz plates, but rectifying crystals for detectors. This one was a complicated gadget with a hollow standard, a ball, a spring, a thumb-screw, an arm, a set-screw and a few more jiggers, so made that it "remains permanently in adjustment under jars and vibrations of every description." You poor moderns who never had a real hot argument as to whether it was better to use a silicon detector with a hard blunt point or a galena crystal with a cat-whisker made of a strand of iron wire taken from a piece of what used to be called "picture wire" — you missed a really precious part of amateur life.

There were many other interesting ads, too: Duck's Big Wireless Catalog, on which so many

of us of that day were raised; Arnold's loose-coupler guaranteed to "tune up to 3500 meters on a fair size Antenna"; that ingenious microphone amplifier, the Multi-Audi-Phone, with its typical testimonials; several brands of 'phones; a page of Mignon's original and very pretty long-wave receivers — and just one advertisement of an audion detector. And there was a "straight-line key" with the merit that "fading signals caused by varying resistance of contact points are entirely eliminated."

What a story of radio progress and amateur accomplishment is presented by the pages of *QST* for the past fifteen years! To get a startling comparison one has only to contemplate the small transmitter described in our columns last month, apparatus which, at a total cost of forty-five dollars including power supply and tubes, will send signals half way around the world. When our first issue appeared this money would just about pay for a one-inch spark-coil transmitter, normal DX five city blocks, world's record ninety miles — with nobody able to understand how the chap had done it. Of course there was romance aplenty in the crash of a good blue-white spark, and wet-nursing an electrolytic interrupter was an excellent apprenticeship in radio engineering, but nowadays we use our watts for communicating instead of for the creation of heat, light and sound. We look back with justifiable pride upon those fifteen years and the part that *QST* has played in their development. *QST* has an enviable position in radio literature to-day, a place which demonstrates the soundness of the fundamental ideas of our founders. Ours is a cooperatively maintained magazine, successful because every one of us, as members of the League, feels a personal interest in *QST* and does his bit to help. It is a splendid example of the ability of American amateurs to build together, something of which we think each one of us can be proud to-day.

K. B. W.

Strays

The annual index to *QST* for 1930 (Volume XIV) has been published as the second section of the December number, and sent to every member of the League. Newsstand readers may obtain a copy of this index for 4 cents in stamps.

QST's unusual cover illustration this month comes as a contribution from the Radio and Television Institute, of Chicago. It is the work of Mr. P. E. Willman, art director of that school, and was provided through the kind cooperation of Mr. F. H. Schnell, their chief of staff, to both of whom grateful acknowledgment is made.

A newspaper write-up on a BCL set mentions the fact that it has a total of seven tubes, including the *pacifier* tube. Evidently the Milkotron has found a commercial application already!

An interesting booklet entitled "The Photolytic Cell" is being published by the Photo-Electric Division of the Arcturus Radio Tube Company, Newark, N. J. There are five chapters, devoted to discussions on photo-electric phenomena, present-day photo-electric cells, the photolytic cell, the light source, and amplifiers. The price is twenty-five cents.

W3LA wants to know when the broadcast stations are going to have automatic power controls 180 degrees out of phase with natural fading!

A Two-Tube A.C. Receiver

By George Grammer, Assistant Technical Editor

THOSE who follow the trend of amateur radio in *QST* cannot help but be conscious of two important developments in receiver construction. We refer, of course, to the a.c.-operated receiver and the screen-grid detector. Several times in the past year the thorough practicability of the a.c. receiver has been pointed out; and the testimony of Rydberg, Doty and other experimenters, as well as the graphical study by Robinson, certainly must have convinced the most skeptical that the screen-grid detector is capable of greater sensitivity than the triode.

Some experiments in the *QST* laboratory with screen-grid detectors convinced us that, for c.w. reception at least, a two-tube receiver will give all the sensitivity and volume that the average amateur requires—speaking, of course, of the man who prefers to wear 'phones instead of receiving via the loud-speaker. Admittedly more care is needed in stringing the receiving antenna and adjusting it for best results when the detector is not isolated from it by a coupling tube; but the chap who is willing to give the antenna question a little attention will have few difficulties.

Aside from the greater sensitivity of the Type '24 tube as a detector and the consequent desirability of using it with any type of receiver, there is a great deal of satisfaction in being able to plug into a light socket to get power to run the set—and know that there is no battery to be charged after several hours of continuous operation.

We must confess, however, that there is one thing lacking in the receiver. When planning the set a means of controlling volume was not given a thought, since it was not expected that two tubes would give more than comfortable signal strength. It should have been incorporated, however, because the set really needs one. The "sock" of many ham signals is too great for real comfort, especially with a good receiving antenna.

The circuit is the "old standby" regenerative

detector and one stage audio, capacitively coupled to the antenna, and with such modifications as are necessary or desirable for a.c. tubes. Most amateurs need no introduction to this arrangement, having used it at one time or another in their "ham" experience. A diagram is shown in Fig. 1, and the various photographs show the arrangement of the apparatus.

The panel is a piece of $\frac{1}{8}$ -inch sheet aluminum, 7 inches high and 12 inches wide. On it are mounted the drum dial which controls the tuning condenser, the regeneration control resistor, and the "B" cut-off switch.

The remaining apparatus is mounted on the sub-panel, which is also sheet aluminum, 12 inches wide and 6 inches deep. The sub-panel mounting brackets (Silver-Marshall) are one inch high. The sub-panel method of construction is used for several reasons, chief of which is the desirability of separating the r.f. and power wiring as much as possible and shielding them from each other. The metal sub-panel accomplishes both these things. In addition practically all wiring is concealed, with the result that the receiver pre-

sents a neat appearance when being exhibited to visitors.

Three five-prong sockets are required, one for the plug-in coils and two for the tubes; the variety used in this particular set are sub-panel sockets of the type widely used by broadcast-receiver manufacturers. It is not necessary to use the same style, of course, although they lend themselves nicely to sub-panel wiring and are inconspicuous. Some of the mail-order houses carry them if they are difficult to obtain locally. However, substitution of the garden variety of socket will add few difficulties to the construction and will affect the performance not a whit. As a matter of fact, the same is true of most of the other apparatus in the set; parts that are incorporated in it, with the exception of only one or two items, were used simply because they were available or because they had a pleasing appearance—worthy enough reasons for any constructor, but

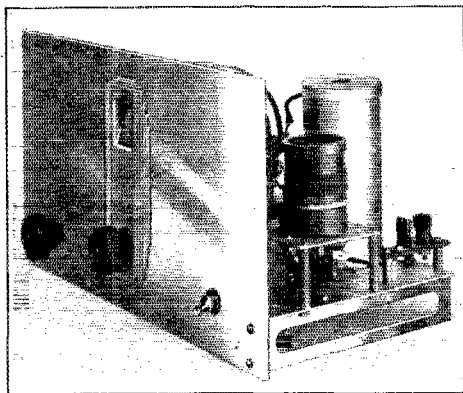

THE FRONT PANEL AND PART OF THE
"CHASSIS"

This photograph shows the detail of the coil and antenna condenser mountings. The detector tube shield is also visible.

having very little to do with the actual electrical performance of the set. On the other hand, a different tuning condenser and a dial not of the drum type will probably necessitate an entirely different layout for the receiver. The same constructional principles will apply in any case; so that even though a radical change in the layout is made there need be no sacrifice of efficiency.

The tuning condenser is a National Type SE-100 with several plates removed for band-spread-

and tuning condenser. The mounting for the coil socket is made from a piece of $1/16$ th-inch aluminum 2 inches by $2\frac{1}{2}$ inches, supported at each corner by brass sleeves $1\frac{3}{8}$ " long bolted to the sub-panel.

The antenna coupling condenser is mounted on a 2-inch strip of bakelite which is supported above the sub-panel by two spacers sufficiently long to give ample clearance for the screws holding the condenser and antenna binding post. The con-

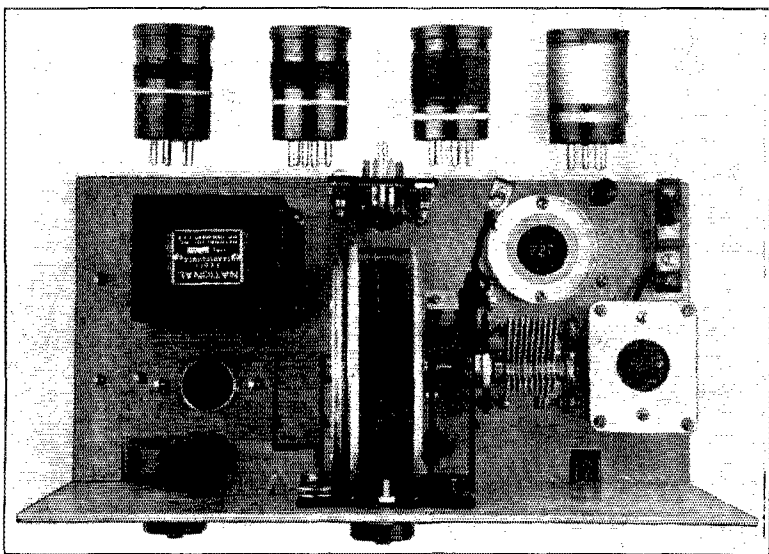

THE TOP OF THE SUB-PANEL

The audio coupler, audio amplifier tube socket and regeneration-control resistor are to the left of the drum dial. Connections are brought out to the cable socket to the rear of the dial. Tip-jacks for the 'phones are mounted on this socket. This photo also shows the method of mounting the tuning condenser, grid condenser and leak, and shows the coil socket and antenna condenser mountings from another angle. The ground binding post is mounted on the sub-panel between the detector tube socket and the antenna condenser.

ing. The drum dial is a National Type HS, which is the projector dial with special mounting brackets for the Type SE condenser. To the right of the condenser, as shown in the top view of the receiver, is the mounting for the coil socket, and just behind the latter is the mounting for the antenna coupling condenser and the antenna binding post. The reason for these two special mountings is obvious when it is remembered that the sub-panel is metal. There are really several reasons for the special coil socket mounting, however. First of all, with the type of socket used all the connections would have had to be made *under* the sub-panel if the socket had been mounted directly on it; this was undesirable because all r.f. wiring should be above the sub-panel, insofar as possible, to isolate it from the other wiring. Raising the socket keeps the r.f. wiring above the sub-panel, and in addition makes possible short, direct leads between coil socket

and antenna condenser. The mounting for the coil socket is made from a piece of $1/16$ th-inch aluminum 2 inches by $2\frac{1}{2}$ inches, supported at each corner by brass sleeves $1\frac{3}{8}$ " long bolted to the sub-panel. The antenna coupling condenser is mounted on a 2-inch strip of bakelite which is supported above the sub-panel by two spacers sufficiently long to give ample clearance for the screws holding the condenser and antenna binding post. The con-

denser itself consists of two strips of thin brass about a half inch wide, bent as shown in the photograph. One strip, a simple right-angle bend, is held in place by the antenna binding post; the other is fastened to the bakelite strip by a small machine screw and nut. This piece is bent around the vertical portion of the other strip in the form of a narrow "U". The separation between the two is about $1/16$ th inch. Greater or less coupling may be desirable in certain cases; the larger the capacity of the condenser the greater is the signal strength, within limits, but as the capacity is increased the selectivity decreases, so that a compromise between signal strength and selectivity is necessary to suit individual tastes. In general, with a good-sized receiving antenna the condenser should be small; with a short indoor antenna more capacity is allowable. The size shown is satisfactory for a medium-sized antenna (length about 50 feet).

SPREADING THE BANDS

To spread the various bands satisfactorily the capacity ratio of the tuning condenser must be adjusted for each band so that stations will not be unduly crowded. With a high-ratio vernier dial it is not altogether advantageous to spread the bands over too great a portion of the scale; beyond a certain point there is no gain in ease of adjustment, and the amount of time required to tune over a band is out of proportion to its width. This particular condenser and dial are designed for 270-degree rotation, with a 150-division scale. A spread of 50 to 75 divisions is ample for easy tuning — covering a band after a CQ is a laborious process with greater spread because of the high vernier ratio of the dial — and ultra-fine adjustments of the number of turns on the coils and the spacing between tuning condenser plates (always necessary if a band is to cover very nearly the whole dial scale) is not required. In addition the overlap allows some leeway in changing detector tubes and antennas; a tube with slightly different interelement capacity than the one for which the coils were cut will not throw part of the band off the scale, and neither will an antenna of different characteristics.

This type of tuning condenser is a particularly easy one to alter for band spreading, since the stationary plates can be removed without difficulty. The nuts holding the stationary plate assembly to the insulating strip on the front of the condenser should be removed; then the two screws holding the rear strip to the frame should be taken out and the stationary plates can be lifted out. The condenser is re-ramped for this receiver has two stationary sections insulated from each other. One consists of one plate and the other of two, each section being mounted on one of the insulating strips. Three-quarter inch 6/32 machine screws are used to hold the two stator sections in place. Fig. 2 shows more clearly how these changes are made.

The connections between the condenser and the coil socket are made as shown in Fig. 3. The single plate alone may be used, or the two sections may be connected in parallel. With the single-plate stator only, the 7000- and 14,000-kc. bands will be amply spread on the dial scale, while with the two sections in parallel the 1750- and 3500-kc. bands will cover a goodly portion of the dial. The change from one condenser section alone to two in parallel is made automatically by connecting a

jumper between the coil-form prongs which connect to the two stator sections of the tuning condenser when the coil is placed in the socket.

The grid condenser and leak are mounted directly on the tuning condenser. This is done by removing one of the small 6/32 screws from the fixed condenser and fastening the condenser to the frame of the tuning condenser by one of the screws which holds the single stator-plate section in place.

SUB-PANEL WIRING

The detector tube socket is just behind the tuning condenser in the top view of the receiver. This tube has an individual tube-shield can. The audio amplifier socket is to the left of the drum dial, and the coupling unit is mounted on the sub-panel behind it. All connections are brought out to a

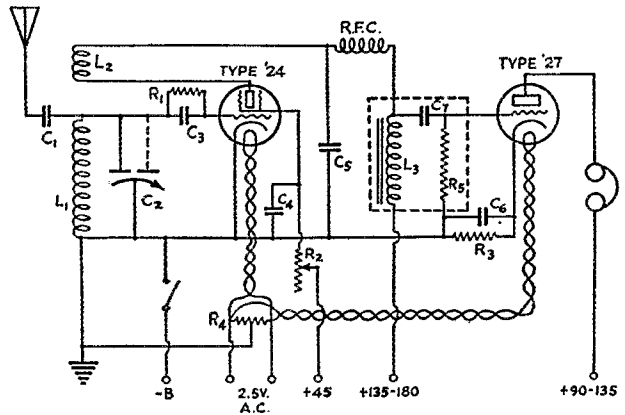

FIG. 1.

- C₁ — Antenna coupling condenser; see text for details
- C₂ — Split stator condenser; see text
- C₃ — 100 μfd.
- C₄ — 5 μfd.
- C₅ — 200 μfd.
- C₆ — 1.0 μfd.
- R₁ — 10 megohms
- R₂ — 100,000-ohm variable resistor
- R₃ — 2000 ohms
- R₄ — 20-ohm center-tapped resistor
- R.F.C. — Receiver-type r.f. choke
- L₁, C₁, R₅ — National Screen-Grid Detector Coupler, Type S-101. If a home-made coupling is assembled, C₁ should be about .006 μfd. and R₅ 2-1/2 megohms. See text for details of L₁.

COIL DATA

Band	L ₁	L ₂
1750	70 turns No. 32 s.c.c.	10 turns No. 32 s.c.c.
3500	37 " " No. 22 d.s.c.	6 " " No. 30 s.c.c.
7000	19 " " " " "	4 " " " " "
14,000	8 " " " " "	4 " " " " "

All coils are close-wound except the 14,000-kc. grid coil. The spacing between turns on this coil is adjusted until the band is covered. Spacing is approximately half the diameter of the wire.

Yaxley cable socket, upon which are also mounted tip-jacks for the 'phones.

The arrangement of the parts and wiring underneath the sub-panel is shown in another photograph. All connections are made with flexible braid-covered "hook-up" wire, and it will be noticed that no attempt has been made to make the wiring "look pretty." The parts are so arranged that the few r.f. leads which come below the sub-panel are as short and clear of other wir-

ing as possible, and the leads to the heaters of the tubes and the dial light are as far from other wiring as the necessary placement of parts will permit. These leads, carrying 2.5 volts a.c., are twisted to reduce hum troubles from stray a.c. fields.

The end view of the receiver shows two wires from the coil socket going through the sub-panel. These are the tickler leads, and they may be seen

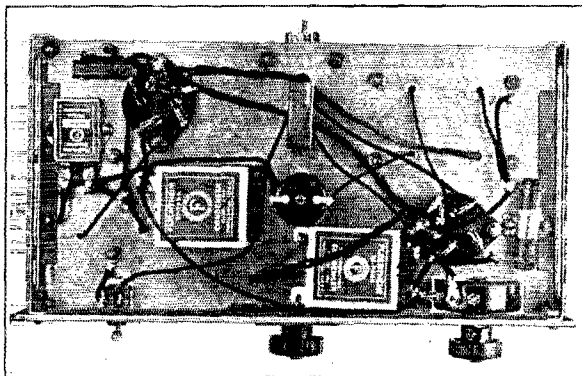

UNDER THE SUB-PANEL

The center-tapped resistor for the heater leads is mounted directly underneath the ground binding post. The small condenser to the left is the plate by-pass condenser; the one below the detector tube socket is the screen-grid by-pass condenser. The r.f. choke is in the center. The cathode resistor for the '27 is at the extreme right, held in place by a home-made bracket. The by-pass condenser across the resistor is mounted between the r.f. choke and the front panel. The metal piece behind the r.f. choke is a bracket which rests on the table and serves as a mechanical support for the sub-panel.

at the left in the bottom view. One, the B plus side, goes to the 200- μ fd. plate by-pass condenser, and the other goes directly to the plate terminal on the detector tube socket.

Aside from these two r.f. wires and the heater leads, the arrangement of the parts and the other wiring is largely a matter of getting things to fit in. There are no particular precautions to be observed in laying out the audio frequency equipment and wiring nor the "B" leads.

COIL ADJUSTMENTS

The coils are wound on 5-prong manufactured forms $1\frac{1}{2}$ inches in diameter. The specifications given are not to be followed too religiously, because undoubtedly there will have to be cutting and trying to get the bands to come within the desired limits on the dial scale and to get smooth control of oscillation. Probably the best plan to follow is to wind each of the coils with two or three turns more than specified; then, with the detector tube and antenna which will be used for regular reception, adjust the size of the antenna coupling condenser for best results; following this the coils themselves may be operated upon, if necessary. Since the size of the tickler coil affects the tuning range to some extent, it is well

to get the tickler fixed up first, after which small adjustments may be made to the grid coil to get the band on the dial. The coils should be adjusted so that the center of each band comes at about the center of the dial scale.

The adjustment of the tickler size is important if maximum signal strength is to be secured. A Type '24 screen-grid detector gives the best signals when the actual voltage on the screen is approximately 22. Therefore every effort should be made to so adjust the tickler that the voltage on the screen will be 22 and not 10 volts or 40 volts. This is most easily done by first putting on a few more turns than will be needed; then, with the screen-grid lead connected to the 22-volt tap on the "B" battery or eliminator (if the latter make sure that the voltage is actually 22), take off tickler turns one at a time until the tube just oscillates with the regeneration-control resistor set so the resistance is all cut out. This adjustment should be made with the antenna and ground connected to the set because more screen-grid voltage is required to make the detector oscillate when the antenna is connected, and the object is to find the correct number of tickler turns to use under normal operating conditions. Then with 45 volts on the screen-grid tap the regeneration control resistor will be at about half scale for oscillation.

The size of the grid leak will have some effect on the smoothness of oscillation.

In general, louder signals and smoother oscillation control will result if the resistance of the leak is as high as possible. 10 megohms is a good value; with less than 5 megohms the signal strength may drop off somewhat and the tube is likely to go into oscillation with a thump instead of "sliding" in.

THE AUDIO AMPLIFIER

Because of the high plate impedance of the screen-grid detector ordinary audio coupling transformers cannot be used, nor can the 'phones be placed directly in the detector plate circuit with satisfactory results. The National Screen-Grid Coupler used in this set is excellent for the purpose. Resistance coupling may be used, of course, in which case the resistor in the plate circuit of the detector should have a value of about 200,000 ohms. The signal strength will usually be greater with impedance than resistance coupling, and less plate voltage is required because of the smaller voltage drop through the impedance. The values of C_7 and R_5 will be the same with either resistance or impedance coupling. A good coupling impedance for the plate circuit of the '24 may be made by connecting the primary and secondary of an audio transformer

in series; if this is done a good-quality transformer should be used. Peaked amplification may be used as well, substituting a tuned impedance for L_3 — a manufactured peaking device such as the Aero Hi-Peak will function satisfactorily. A peaked amplifier will help out considerably in reducing hum if hum is noticeable.

Automatic bias, supplied by the resistor R_2 in series with the cathode of the Type '27 amplifier, maintains the grid of the amplifier at the correct operating point. R_2 does not seem to be very critical, and 2000 ohms is a good value. The audio by-pass condenser, C_3 , across the bias resistor may be omitted if desired, although its use increases the signal strength noticeably. It also increases the hum level in the same ratio, however.

The size of the r.f. by-pass condenser, C_5 , is likely to have a considerable effect on the signal strength. The reactance of a condenser of even .001- μ f.d. capacity (a common size of r.f. by-pass condenser) is low enough, compared to the impedance of the coupling device, to shunt a considerable portion of the audio energy away from the grid of the amplifier. C_5 should not be larger than 250 μ f.d.

The shield about the detector tube requires some explanation, since it is not required for any reasons of receiver efficiency. When the set was first built a quite strong "induction" hum (distinctive as compared with filament hum because of its high pitch) was present — not a hum caused by a.c. operation of the tubes, since it was just as strong when the receiver was entirely d.c. operated. A little experimenting uncovered the cause. The house wiring itself set up a strong field to which the receiver was of course subjected. So long as the grid of the detector was connected to the filament through a high-resistance leak the induction hum was strong, although on shorting out the grid leak it disappeared. Naturally the hum could only be present when a difference of potential could exist between grid and filament, and the logical way to bring both to the same potential — with respect to the induction field — was to connect the grid directly to the filament, which obviously could not be done, or to shield the tube. The latter was done and the induction disappeared almost entirely. The only point of pickup at present is the short length of grid lead from the grid condenser to the cap of the tube. The pickup from this lead is so small that it was not deemed necessary to shield it.

ANTENNA EFFECTS

There are a few disadvantages resulting from coupling the detector tube directly to the antenna, most of which can be overcome with care. One of these is the effect of the antenna on receiver tuning. Unless the antenna is tightly strung and rigidly supported there will be a waver in incoming signals when the antenna swings in

the wind. This is unlikely to happen with an indoor receiving antenna. A change in antennas will almost certainly change the calibration of the receiver, even though the bands may still be entirely within the limits of the dial scale. If the antenna coupling condenser is fairly large the selectivity of the receiver may suffer. For distant reception with an oscillating detector this is no disadvantage, but it is important with 'phone reception when the detector is not oscillating or if

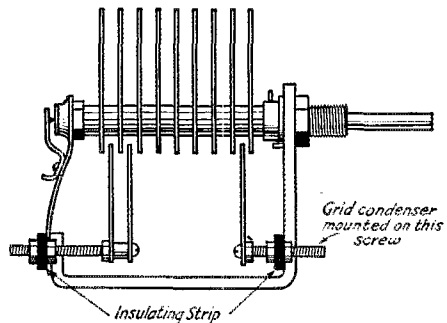

FIG. 2. — HOW THE TUNING CONDENSER IS REMODELLED

The stator is made into two sections, insulated from each other, one consisting of a single plate and the other of two plates.

there are stations nearby whose signals are likely to "blot out" part of the band.

These things may be overcome in the receiver itself by the addition of an antenna coupling tube. On the other hand, the coupling tube adds comparatively little to the signal strength, and if the precautions with regard to the construction of the antenna and the coupling condenser are kept in mind little trouble will be experienced.

The question of "dead spots" is also important. If the fundamental or a harmonic of the antenna happens to resonate at some spot within the tuning range of the receiver it may be difficult, if not impossible, to make the detector oscillate in the vicinity of such resonance points. Lowering the capacity of the coupling condenser will generally help, although this often results in loss of signal strength on either side of the dead spot. The best remedy is to change the length of the antenna so that dead spots do not appear on any of the amateur bands. No exact specifications can be given, but a little experimenting with different antenna lengths will usually result in determination of a satisfactory length. When this has been done the regeneration control need hardly be touched to cover any one band unless it is desired to keep right on the very edge of regeneration.

While the set is built primarily for a.c. operation of the filaments, either batteries or "B" substitutes may be used for the plate and screen-

grid voltages. Many "B" substitutes, while entirely adequate for broadcast receivers or audio amplifiers, fall down miserably when used with short-wave receivers with oscillating detectors. This receiver works well with 135 volts of "B" batteries, and since the total current drain is only of the order of 5 or 6 milliamperes, the batteries will last a long time. In fact, the signal strength with only 90 volts on the detector plate is only slightly less than with 135. Some "B" substitutes give excellent results—if a well-filtered one is

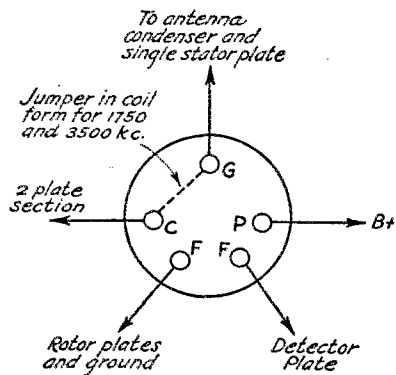

FIG. 3. — COIL FORM AND SOCKET CONNECTIONS

available a quick trial will show whether or not it is suitable. In one instance the hum with a particular "B" substitute was less than when batteries were used for the plate supply—probably due to some "hum-bucking" effect. One difficulty with "B" substitutes, however, even though they may be entirely satisfactory from the standpoint of hum elimination, is that variations in the line voltage may cause the signals to waver in the same way as a swinging antenna.

The amount of filament hum in the receiver seems to be almost entirely a function of the detector tube. Ordinarily the audio amplifier introduces no appreciable hum—if the audio tube alone hums it is a sign of a defective tube or wrong connections in the set. The center-tapped resistor across the heater leads eliminates most of the hum very effectively.

Detector tubes, however, will probably be found to vary considerably. With a good one the hum will be so low in volume that the 'phones have to be pressed tightly to the ears to hear it at all; with others it may be strong enough to be annoying. With average tubes the hum is usually so far below the signal and background level that it is not noticeable—in fact, it is usually necessary to disconnect the antenna to hear it with the tube oscillating. With some detector tubes it will be found that although a very weak hum may be heard with the tube not oscillating, this disappears entirely as soon as the tube goes into os-

cillation. With other tubes the reverse may be true. Since tube manufacturers are constantly striving to improve their product, it is reasonable to expect that less difficulty with hum will be experienced as time goes on. With only a small percentage of '24's will the hum be sufficiently strong to be bothersome unless the operator is excessively critical. The worst feature of a poor tube is the modulation it puts on the incoming signals. With such a tube no signals will be pure d.c.; if such is the case it is a sure indication that the tube is a "modulator" as well as a detector. Oddly enough, the amount of audible hum seems to be unrelated to signal modulation; a "modulator" tube may be perfectly quiet, and on the other hand a tube with a comparatively high hum level may not modulate the signals at all.

With this particular receiver, there was no difference in the amount of hum either with or without a ground connection, so long as the center-tap of the filament resistor was connected to the metal frame of the set, to which the negative "B" is also connected.

The switch in the negative "B" lead is a practical necessity if a transmitter is used and the operator does not care to have his ears deafened every time the key is pressed. A filament switch would be of little value, since the tubes continue to operate for some time after the filament current is turned off, and the time required for them to heat to an operating temperature after the current is switched on would make practical communication impossible.

In conclusion, we can say without qualification that the signal strength with a simple set of this type will surprise anyone not familiar with the results obtainable with screen-grid detectors. Many amateurs claim that a screen-grid detector and one stage of audio amplification is the equal of a detector and two audio stages using Type '01-A tubes. Even if the gain is not so great as that, it is certain that two tubes in such a rig will give much louder signals than the corresponding "detector and one step"—with a much greater gain in sensitivity to the weaker signals.

Strays

W9FUR informs us that a very good map of the world can be purchased from the National Geographic Society, Washington, D. C., for one dollar. It is laid out in such a way that DX measurements are easily made.

The following was sent us from the *Erie Dispatch-Herald* of February 23, 1930, by Raymond Wagner:

"Sale—Aero call short-wave converter, must be water-heater; gent's bicycle, 30-inch wheels, child's auto, large wheels, an old-fashioned bed, Freid-Eisman radio and speaker."

Someone, please page Warshawsky.

Amateur Radio at Eastern States Exposition

By Clinton B. DeSoto

WHAT about that d.c. signal signing WIESE you heard during the week of September 14th-20th last fall? It wasn't listed in any call book and . . . you're right! There's a story behind it all. Here it is:

The call WIESE derived both its initials and its existence from the Eastern States Exposition, "America's premier industrial and agricultural exhibition." The station, which was part of an extensive program of coöperation between Junior Achievement, Inc. and the A.R.R.L., was set up in a booth in Junior Achievement Hall, on the exposition grounds at West Springfield, Massachusetts.

know, is a national organization that provides programs of work for boys and girls of cities and towns, along lines of industry, commerce and homemaking. The work it does for urban boys and girls is similar to that done in rural areas by the national 4-H Club groups. With these aims, and because of its extended field of activity, the inclusion of amateur radio as one of its constructive programs was logical, and the details of coöperation with the League together with a plan for development were first begun in April and May of this year, when Assistant Secretary A. L. Budlong and Mr. Frank W. Barber, Counselor in Field Service of Junior Achievement, held a series of conferences.

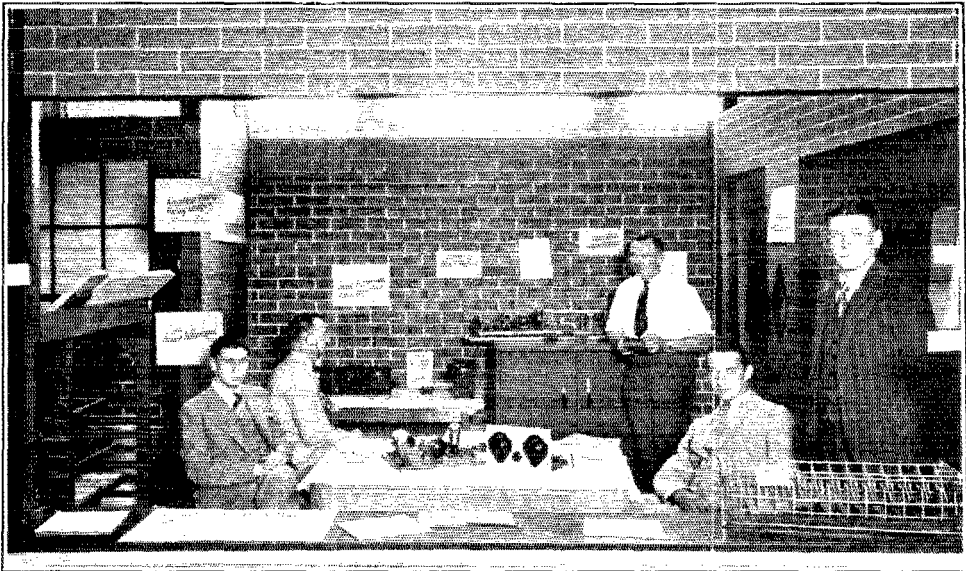

WIESE AND THE OPERATING STAFF

Left to right: Phillip Gould, W1ALZ; John R. Blum, W8CKC, chief operator; Howard Barton, W8IH; Robert H. Peterson, W1LI; and the author. The big variable condenser in the lower right-hand corner is used in the tank circuit of the modulated final stage of W8IH, high-powered 'phone at LeRoy, N. Y.

The other principal part of this program was the instruction of a selected class of boys gathered from all the Eastern states, between the ages of fourteen and twenty, in the art of amateur radio; teaching them the code, and delivering a planned series of talks by members of the Headquarters staff on the different portions of the course of study.

Junior Achievement, as many of you may

The annual national exhibit of Junior Achievement clubs together with their products and activities is held during the Eastern States Exposition, in the large building owned by Junior Achievement. Inasmuch as this is the principal national event held by the organization during the year, it devolved upon A.R.R.L. to coöperate fully in the new program in which we were participating. One of the results was WIESE and the

remainder of the exhibit of which it formed a part, installed for the edification of such of the 300,000 people attending the Exposition as passed by our booth.

THE STATION IN DETAIL

WIESE was of necessity a low-powered affair, since its purpose was not only to supply an exhibit to arouse the interest of passersby and handle messages filed by them, but also to demonstrate to Junior Achievement members and leaders the simplicity and economy with which such apparatus could be effectively constructed. The equipment used was admirably suited for this.

The transmitter was the low-power push-pull set using receiving tubes built by George Grammer, Assistant Technical Editor, and described by him in the November issue of *QST*. Its output was fed into a Zepp antenna 132 feet long, strung between flag poles on diagonal corners of the roof of the building. The height was such that the vertical 45-foot feeders just reached the stand-off insulators on the transmitter to which they were attached.

The receiver was the little two-tube set designed by Ross Hull, altered according to the description which appears in the new 7th edition of the *Handbook*. Type '30 tubes were employed, their power being derived from two dry cells and one standard "B" battery. The ultimate in simplicity, wasn't it?

This receiver, while fully capable of bringing in signals at a comfortable volume when one of the Zepp feeders was switched in for an antenna, was needed for demonstrations, and was replaced in the station by WILI's receiver, which had two audio stages and used Type '01-A's. Receiving conditions were quite terrible, of course. Our nearest neighbor was a printing establishment running a large job press by an electric motor which played a constant symphony in the 'phones while working. It was so nearly in resonance with the few lone a.c. signals still to be heard that one could almost hear the beat notes!

In addition, there was, of course, a monitor, a frequency meter, and the usual small related apparatus. Ralph Beaudin's single control transmitter (pictured in *QST* for December, 1929) was taken along for demonstration to the class, and also formed part of the exhibit.

That was the equipment used. It was selected with two requirements in mind; simplicity and economy. A glance at the station log and reports received — excerpts from which will follow — show that it possessed still another in good degree; effectiveness. Credit for this may be largely due the staff of operators. There were four of them spending the week in Springfield as guests of Junior Achievement. The chief operator was John R. Blum, W8CKC, of Dansville, N. Y., who is well known as SCM of Western New York.

With him was Howard C. Barton, W8IH, of LeRoy, N. Y. Robert H. Peterson, WILI, came from Worcester, Mass., for the week, while Phillip C. Gould, W1ALZ, was down from Bangor, Maine.

These men came in response to a hurried call for volunteers sent out just before the event, after we had learned from Mr. Barber that he desired such assistance, and the localities from which he wished it to come. They did splendid work; each of them was a fine operator, and the way they handled WIESE, the remainder of the exhibit, and the thousand and one other details with which they were confronted, is worthy of commendation and hearty thanks.

The Exposition opened on Sunday, September 14th, at 2:00 p. m. On Saturday Ralph Beaudin and the writer loaded all the components of the station, a lot of *Handbooks* and other League supplies, into the w.k. flivver and set out for the grounds near Springfield, Mass. Clouds hung low and heavy in the sky; rain threatened moment by moment; and after pleading hastily with a watchful traffic cop we parked and unloaded the equipment. That Zepp was put up in record time, with the clouds almost encircling our ears on top of the roof. As soon as it was all up the weather cleared away nicely. . . .

The station was completed that afternoon, but there was time left for no more than two half-hearted and ineffectual calls. On Sunday things opened brightly and continued so. Long before the official opening time the aisles were filled with people, and the amount of interest displayed in the exhibit was intensely gratifying. About the middle of the afternoon W8CKC and W8IH strode in, and were promptly set to work at the operating position. A little later Bob Peterson showed up, and stations were being worked. WIESE was on the air!

That evening at 10 o'clock the three ops retired to the dormitories provided by Junior Achievement, and proceeded to become children again — for a night! Cast ruthlessly into a wild, howling mass of hundreds of energetic boys between the ages of twelve and twenty, they settled down on their beds amid the demoniac din which reigned only to become targets for apples, tomatoes, numerous other sometime edibles, wet paper balls, soap and all the other playful gestures of friendly American boys, for an endless eight hours. The next night they moved!

Phil Gould might also have been in evidence that first night, but sad to state, calamity befell him, and it was not until the next day that he did stagger in. As has been said, our call to these, and other men was a belated one, and W1ALZ had not received the instructions he required to direct his activities upon arrival. As a result he wandered over the entire 175-acre Exposition grounds vainly searching for us all that night and part of the next day.

A DISSERTATION ON CRYSTAL CONTROL

It was this same Gould of W1ALZ who told us of a visit paid the radio shack on one of the Navy destroyers (name withheld by request!) and the ragchew with the op that followed. Gould gazed intently at various parts of the equipment, and then, pointing to the big transmitter, asked, "Do you use a crystal in that?"

The op replied indulgently. "Oh, no, we haven't used crystals for years. You won't find one in a Navy receiver anywhere!"

Gasping, but determined, Phil tried again. "I mean in the transmitter."

Clyde J. Houldson, Technical Information Service, outlined the use, construction, and operation of receivers, taking care also of the many other duties encountered during each day.

On the succeeding days transmitters, elementary theory and operating practice were gone over with the remnant of the class, and some of the preliminary work reviewed for a newly arrived group. The procedure of the organization provided for separate groups of boys and girls to be in attendance each half week, and this rendered the organizing of the course more difficult. All of the fellows reached are going to become splendid amateurs very shortly, though, and will

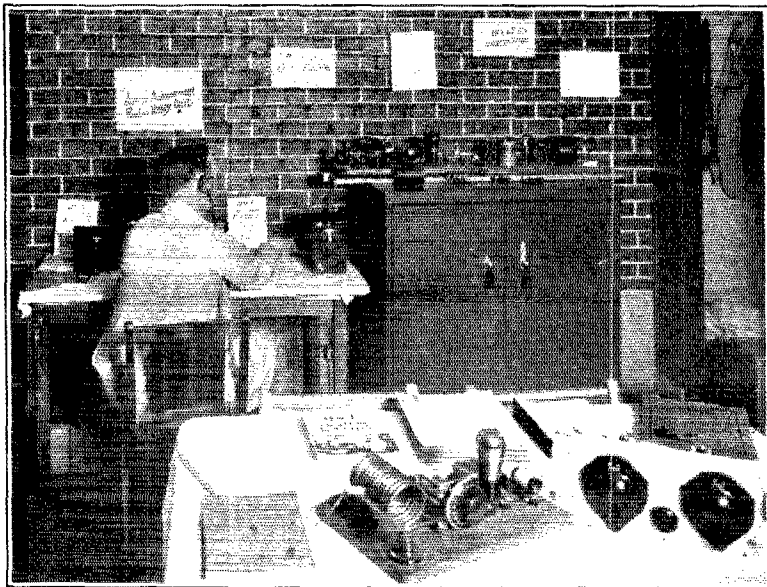

IN ACTION AT THE OPERATING POSITION

John Blum pounds out one of the numerous "love and kisses" messages. The single-control transmitter and two-tube receiver in the foreground were used in the class instruction.

"Why, no. We use vacuum tubes in the transmitter, too."

Monday was Governor's Day, and during the forenoon the chief executives of many of the Eastern States went past the exhibit. Some of them displayed a real interest in our station, and received a good deal of information. In the afternoon A. A. Hebert, in his capacity as Fieldman, addressed the boys of Junior Achievement on amateur radio in general, and had a most interested audience. After this discussion the selected class received the first code lesson.

E. L. Battay, Assistant Communications Manager, represented Hq. on Tuesday, and outlined all the activities of the amateur to the class, explaining the what, why, and wherefore, as well as giving another code lesson. On Wednesday,

help us immensely. Each of them returned to his club filled with enthusiasm for amateur radio, and it won't be much of a task for them to communicate that enthusiasm to their clubmates and neighbors.

Several New England amateurs stopped by the booth each day, and some very interesting personal contacts resulted. We had the pleasure of meeting W1AJJ on Saturday, a YL well known in New England who recently joined forces with W1AZW in a life QSO. Dozens of old-timers now off the air, stopped by, and so great was their interest in the little transmitter that many of them expressed their intention of getting back on the air soon.

While speaking of the transmitter, we can't

(Continued on page 72)

Standardization in the Field of Radio Engineering

By Beverly Dudley*

THE necessity of making, adopting, and using standards may be readily observed in everyday life, for standards and standardized products contribute materially to the wealth, convenience and simplicity of our already complex lives. The statement that a piece of paper is nine inches wide and twelve inches long immediately conveys a definite impression of a particular size of sheet to all those who hear the remark and who are familiar with the English units of measurement. The statement means little or nothing to those who are not acquainted with the English system of measurements, for they have no conception of the standard inch. The definite impression that is conveyed to those familiar with the inch depends entirely upon the fact that the inch is a standard unit of measurement, that the length of the inch does not vary, and that it is universally accepted, at least in English speaking countries.

A standard may be defined as "that which is established by authority, custom, or general consent, as a model or example," and there are a number of different kinds of standards. Standard weights and measures are perhaps the most common although standards may also be originated on nomenclature, uniformity of dimensions, methods of test, test procedure, safety precautions, etc. But whatever the type, in order that it be a true standard, it must be accepted and recognized as such by everyone having occasion to use the particular "standard."

In the field of radio engineering standards are as important — if not more important — as in any other technical or engineering field because of the complexity of the subject. Readers of *QST* who glance over a copy of *Wireless Weekly* or *Experimental Wireless and the Wireless Engineer* will immediately notice the unfamiliar terms such as "valve" for vacuum tube, "reaction" for regeneration, and "note magnification" for audio amplification, which are in common use in England. But it is not necessary to go to English publications to find terms that are unfamiliar, or whose meaning is obscure. Such terms as "power detector" and "linear detector," for instance, may have a very definite and limited meaning to a certain group of radio men; it may represent an absurdity to another group. A few terms, such as "microsynchronize" for instance, may mean

nothing at all, except to the originator of the term, and even this is doubtful. To make system out of chaos and to assure that engineers and other technical men engaged in the radio field will all speak the same "shop language," it is necessary to use standard nomenclature and definitions and provide for standard tests and test procedure.

The necessity of standardizing nomenclature was early recognized by the Institute of Radio Engineers and in 1913 their first "Report of the Committee on Standardization" was published. This was followed by subsequent reports issued in 1915, 1922, 1926, and 1929, and at the present time the standardization project is progressing rapidly. Standardization is dynamic — not static — and it is continually necessary to revise and enlarge the scope of standardization reports to include new developments. Several years ago there was no necessity for including in the standardization report such terms as "photo-electric tube," "television," "tetrode," or "megacycle;" to-day these terms are frequently used.

The mechanical structure of the present standardization committees is given in Fig. 1, from which it will be seen that the standardization set-up is a fairly complex but entirely complete system. The structure may be divided into two parts, representing the two types of standards published. The left half of the diagram deals with the standards of the Institute of Radio Engineers; the right half of the diagram deals with "American Standards" as published by the American Standards Association. While this diagram would seem to indicate that there are in reality two radio standards, this is not actually the case; in the final analysis there is only one set of "American Standards," as explained below.

The Committee on Standardization, appointed by the Board of Direction of the Institute of Radio Engineers, has the power to make all Institute standards, subject to the approval of the Board. It is composed of men in all branches of the industry and in various parts of the world who are responsible for the Institute standards. The Committee is headed by Dr. J. H. Dellinger, Chief of the Radio Section of the National Bureau of Standards, who as Chairman of the Committee on Standardization is largely responsible for the work of the widely scattered Committee. The Committee as a whole, consisting of forty-six members in six countries, does not itself originate much of the work; several sub-committees, known

* Assistant Secretary, Institute of Radio Engineers, 33 West 39th Street, New York, N. Y.

as Technical Committees have been appointed to consider the technical points and to create the standards on four phases of radio communication; receiving, transmitting, vacuum tube, and electro-acoustic, devices.

The four Technical Committees are composed of a smaller number of men — usually about a dozen — than the main Committee on Standardization, and in general, the members of the Technical Committees are picked because of their specialized training and experience along definite lines. The Technical Committees gather, originate, determine and prepare the standards in

“The A. S. A. is a federation of forty-three national technical societies, trade associations, and governmental bodies whose chief purpose is to bring together manufacturers, distributors, consumers, technical specialists, and any others directly concerned with a particular standardization project; to assure that a preponderance of these interests wishes to have a national standard; to bring about the organization of a technical committee composed of official delegates of all important bodies interested to formulate the standard; and finally, when such a committee has prepared the standard and given it substantially

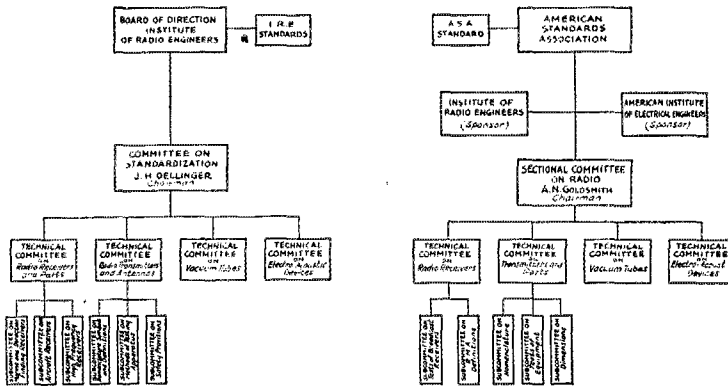

FIG. 1

their respective fields of activity, as well as in any related field of activity that may affect them. There is, naturally, some overlapping of the work of these Technical Committees, and a single subject, such as a vacuum tube oscillator for instance, may be considered and defined by two or more Technical Committees, each from a different point of view. The reports of the four Technical Committees are forwarded upon completion to the Committee on Standardization for rejection, criticism, comment, revision or acceptance. The Committee on Standardization correlates the work of the four Technical Committees, prevents duplication, makes sure that the definitions and standards are uniform and consistent within themselves as well as with those proposed by other Technical Committees, and circulates these tentative standards for comment and criticism. When the Committee on Standardization is assured that its recommendations represent a true consensus of engineering opinion, its report is brought to the Board of Direction for approval and for publication in the I. R. E. Yearbook as the standards of the Institute of Radio Engineers.

On the right half of Fig. 1 is the diagram showing the mechanical structure of the various committees for the generation, preparation and adoption of an "American Standard," under the direction of the American Standards Association.

unanimous approval, and the American Standards Association is definitely assured that the standard represents a real national consensus, to make it an "American Standard." A chief function of the American Standards Association is the judicial one of determining whether a national consensus has been reached.

Having determined that national standards on radio communication were desirable, and following requests from a number of radio organizations, the Bureau of Standards organized a conference on January 12, 1923, the result of which was agreed that the American Standards Association form a Sectional Committee on Radio. The Institute of Radio Engineers and the American Institute of Electrical Engineers were appointed by the A. S. A. sponsors for this standardization project in the field of radio engineering. The Sectional Committee is composed of representatives accredited for the purpose by various organized groups concerned with the project. The members of the Sectional Committee on Radio represent the following organizations:

- American Institute of Electrical Engineers.
- American Radio Relay League.
- American Railway Assn. (Telephone and Telegraph Section).
- Bell Telephone System.
- Department of Commerce.

Department of Interior.
 Institute of Radio Engineers.
 Inter-Department Radio Advisory Committee
 (Gov. Depts.).
 National Assn. of Broadcasters.
 National Electrical Mfrs. Assn. (Radio
 Division).
 National Electric Light Assn.
 National Fire Protection Assn. and Under-
 writers' Laboratories.
 Navy Dept.
 Radio Corporation of America.
 Radio Manufacturers' Assn.
 War Department.

It will be observed that this list includes bodies representative of practically all of the larger organizations likely to be interested in the standardization project on radio engineering.

Sectional Committees are made up of representatives, designated by various bodies concerned with the project assigned to the committee, and of additional specially qualified individuals. The Sectional Committee on Radio is, in general, concerned with the formal adoption of standards on radio matters and it may — and does — assign its work in whole to Technical Committees. It is essential that the completed work of a Sectional Committee shall be considered by all of its members and that their individual decisions shall be recorded and exhibited.

Four Technical Committees of the Sectional Committee on Radio, which correspond in name and function to the Technical Committees of the I. R. E. Committee on Standardization have been appointed to originate, gather, and prepare standards. The Sectional Committee on Radio is concerned with guiding and directing the work, and to a greater extent, of approving or rejecting the recommendations of the Technical Committees. The work of preparing the standards is carried on freely and simultaneously by the Technical Committees (and all other interested bodies) in order that the differing viewpoints of the several groups may be fully utilized and the most broadly suitable standards produced.

Although the diagram shows two distinct sets of standardization committees and two sets of standards — the I. R. E. and the A. S. A. — it should not be assumed that there are actually two independent and unrelated standardization reports. The I. R. E. standardization report relates specifically to the engineering side of radio communication, and consequently is generally technical and somewhat limited in scope. The standards accepted by the A. S. A. must be acceptable to the representatives of the organizations as a whole, and the A. S. A. standard must represent a consensus of opinion of the greater portion of those actively engaged in the radio field before it may become an American Standard. But insofar as the standards relate to radio engineering, the A. S. A. standards are essentially the same as the

I. R. E. standards and the A. S. A. looks to the Institute of Radio Engineers and the American Institute of Electrical Engineers, as sponsors of the radio standardization project, to vouch for the technical qualifications of the proposed standards. The A. S. A. standard is the final authority on commercial and engineering standards in this country (but should not be confused with the National Bureau of Standards which is the final authority on legal standards in the United States) and because its standards represent the consensus of a larger and more general group than the I. R. E. standards, there is more time required for an A. S. A. standard to be adopted and published than for an I. R. E. standard. The formulation, acceptance, and publication of the final standards applying to radio engineering are, therefore, seen to be somewhat long and drawn-out processes. While at first this might seem to be a decided disadvantage, in reality it is a most important advantage. Standardization can be carried out too quickly or too prematurely, and if this is done, more harm than good is done, for faith is lost in the standardization project.

And now that we have given an outline of the general method of formulating and adopting standards for radio engineering, let us inquire more into their use. The importance of standards is not fully appreciated by those having little occasion to refer to them, and for this reason, their importance is likely to be belittled by the vast majority who need them most. The reports of the Committee on Standardization of the Institute of Radio Engineers are available without cost to its members, and at a nominal cost to non-members. This report, issued every few years, is widely used by radio and communication engineers. It may have little direct importance to the amateur who is interested only in the proper design and operation of his station, but it does affect his station and operation, indirectly at least, for the technical articles appearing in *QST* frequently use these reports for obtaining exact wording and specifications for test methods. A practical example of this occurs in connection with "The Modulometer" in the August, 1929, issue of *QST* where the I. R. E. definition for modulation factor is employed. Frequent reference is made to the I. R. E. report even though no footnote calls attention to the source of information.

But in another way the amateur affects these standardization reports and is in turn affected by them, for the American Radio Relay League is represented in a number of subcommittees, Technical Committees, as well as in the Committee on Standardization and the Sectional Committee on Radio. The connection between the League and the Institute on the various committees pertaining to standardization is mutually beneficial, even though the direct and indirect effects may not be readily apparent to the general membership of the two organizations.

The Doublet Antenna

A Hertz Antenna With Two-Wire Matched Impedance Feed

By Clyde J. Houldson, W1KP*

JUDGING by the number of letters that come to the Technical Information Service desk, many amateurs are experiencing difficulty in coupling the push-pull transmitters — which have been described from time to time in *QST* — to the Hertz antennas that are generally used and really load each tube equally, which is the ideal condition when using tubes connected in push-pull. About the only suitable type of coupling that has appeared is the one which employs the "split" antenna coupling coil, as shown in the article "Advanced Transmitter Design" in June, 1930, *QST*. The single-wire fed type of antenna described by WSGZ in September, 1929, *QST* was an ideal one for use with a single tube in the output stage, but difficulty is experienced in coupling a push-pull transmitter to a single wire feeder.

The antenna system to be described uses a two-wire matched impedance feeder system which

the plate tank inductance to secure the right load conditions.

HOW IT WORKS

The antenna proper is our old friend the Hertz. It is fed by a two-wire transmission line of any desired length and which is untuned. There are no standing waves; consequently there is practically no radiation or leakage from the feeders.

The feeders do not connect exactly at the current loop (center of antenna) but are tapped on slightly off the point where the current is a maximum. The purpose is to make the impedance across the output of the feeder system match the impedance of the transmission line, thereby securing maximum power transfer and at the same time eliminating radiation by the feeder system.

The adjustment of a transmission coupling to the antenna requires an understanding of simple single-phase transmission line phenomena.¹ Any transmission line has a characteristic surge impedance which depends upon the size and spacing of the conductors composing it, and also upon the impedance of the terminating network. When the proper adjustment of the line is secured (at radio frequencies) it will act as a pure resistance connected across the output of the last stage of the transmitter.

As a rule the transmission lines used for radio frequencies have a characteristic impedance of 500 to 800 ohms. Generally, however, a 600-ohm line is most used, especially in commercial work.

For amateurs who wish to calculate the impedance of the transmission line in use, the following formula can be used and will give quite accurate results for an outdoor open transmission line:²

$$Z_0 = 276 \log_{10} \frac{2D}{d}$$

Where Z_0 is the characteristic surge impedance of the line in ohms; D is the distance between the center of the two conductors composing the transmission line; and d is the diameter of the conductors.

In using this formula distance between conductors and wire diameter must be in the same units (i.e., in inches or millimeters, etc.).

¹ "Some Transmission Line Fundamentals," by G. A. Boddie, *Electrical Journal* for Jan. and Feb., 1928.

² "Electric Oscillations and Electric Waves," by G. W. Pierce, "Matching the Transmission Line to the Antenna," *QST*, Jan., 1928.

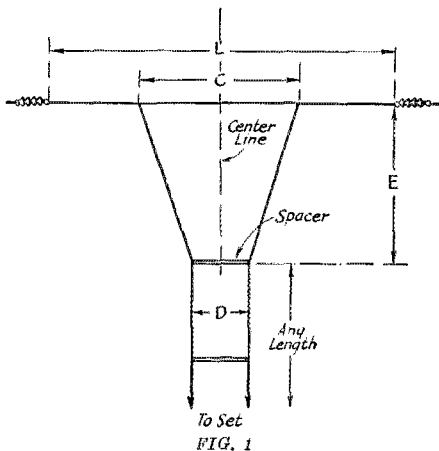

is quite suitable for use with push-pull transmitters, and is known as the "doublet" antenna system.

Success of this antenna system depends entirely on three important dimensions (referring to Fig. 1) namely the value C or coupling, E known as feeder clearance, and L , the length of the antenna. All three of these must be correct for the particular operating frequency and the only adjustment remaining is varying the taps on

* Technical Information Service, A. R. R. L.

It can be said generally that the proper termination of a transmission line is one of the most important adjustments of the entire transmitting system, and will have a great influence on the efficiency of the station, affecting both the range and the quality of the signals.

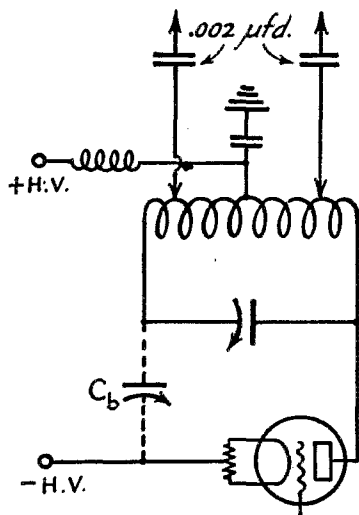

FIG. 2

The greatest transfer of energy from the plate tank coil to the antenna is obtained when the termination impedance just equals or matches the characteristic impedance of the transmission line. If we assume the line having a characteristic impedance of 600 ohms, then to obtain the maximum transfer of energy, the impedance of C must also be 600 ohms.

When the system is correctly balanced, each conductor composing the transmission line is at equal but opposite potential to the other and any radiation from the line is thoroughly neutralized. When the transmission line is not balanced, radiation from the feeders is very likely to occur but out of phase with the antenna radiation and likely to affect the total radiation seriously. Also, if the phase balancing and impedance matching are not obtained, all of the power which is delivered the transmission line will not be passed on to its ultimate load, the Hertz radiator. The power which the radiator does not take will surge back and forth from end to end of the transmission line (reflections) until the energy is finally dissipated in radiation and by the resistance of the transmission line itself. However, when the impedance of C equals the impedance of the transmission line, a matched condition exists and practically all the power delivered to the line from the output stage will be delivered to the antenna, the only loss being the I^2R loss in the transmission line conductors. This loss is really negligible.

By following the formulas very closely, the correct values can be obtained and perfect matching of impedances can be very nearly approached, leaving only the adjustment of the antenna coupling clips on the plate tank coil to complete the matching process.

The antenna coupling clips are connected an equal number of turns either side of the center of the plate tank inductance. To load the set the clips are moved along the coil (from center) until the tubes draw the normal plate current recommended by the manufacturers.

CONSTRUCTION AND OPERATION

After deciding on the frequency at which the system is to operate, the length of the antenna is determined. In order to secure maximum power output for a desired frequency the formula below can be used.

$$L_{(feet)} = \frac{492,000}{F} \times K$$

$$L_{(meters)} = \frac{150,000}{F} \times K$$

Where L (Fig. 1) is the antenna length in feet or meters for a desired frequency F , and K is a constant depending on the frequency band.

For frequencies below 3000 kc., K is 0.96

“ “ between 3000 and 28,000 kc., K is 0.95

“ “ above 28,000 kc., K is 0.94

F is the frequency in kilocycles.

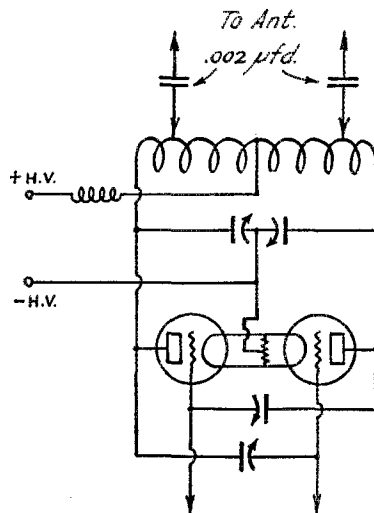

FIG. 3

The coupling or value C (Fig.1) must also be determined:

$$C_{feet} = \frac{492,000}{F} \times K_1$$

$$C_{meters} = \frac{150,000}{F} \times K_1$$

K_1 has different values for the various frequency bands.
 K_1 is 0.25 for frequencies below 3000 kc.
 K_1 is 0.24 " " between 3000 and 28,000 kc.
 K_1 is 0.23 " " above 28,000 kc.
 F is the fundamental frequency in kc.

The other remaining value is the feeder clearance E (Fig. 1), and it is important that this clearance be maintained when constructing an antenna of this type.

$$E_{feet} = \frac{492,000}{F} \times K_2 \text{ or}$$

$$E_{meters} = \frac{150,000}{F} \times K_2$$

K_2 is 0.30 for all bands and F is the frequency in kilocycles.
 The above equations, as stated before, are for feeders having a characteristic (surge) impedance of 600 ohms and will not apply to feeders of any other impedance. An impedance of 600 ohms is standard in commercial work and is convenient

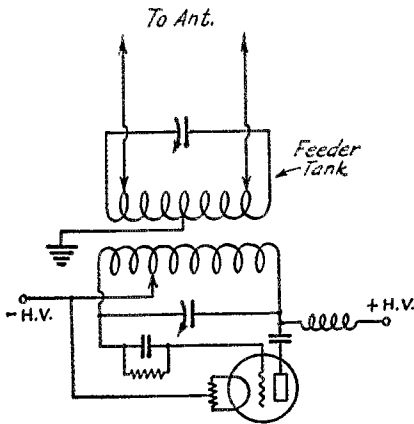

FIG. 4

and quite satisfactory for amateur use. The proper spacing of the wires composing the feeder system for a 600-ohm transmission line can be computed to a very close approximation by this formula:

$$D = 98 \times d.$$

Where D is the distance between the centers of the wires composing the feeder system and d is the diameter of the wire. If the diameter of the wire is in inches the spacing of the wires will be in inches, and if the wire diameter is in millimeters the spacing will be in millimeters.

For the convenience of both U. S. and foreign readers, the diameters of the various sizes of wire most used will be found as follows:

B. & S. Gauge	Diameter in inches	Diameter in millimeters	Nearest Equivalent British S.W.G.
No. 10	0.1019	2.59	No. 12
" 12	0.080	2.05	No. 14
" 14	0.064	1.63	No. 16

The wires composing the feeder system can be any convenient length that suits the particular location, successful operation with feeders 1200 feet long being quite common. Since the majority of amateurs reside in cities, where space for an

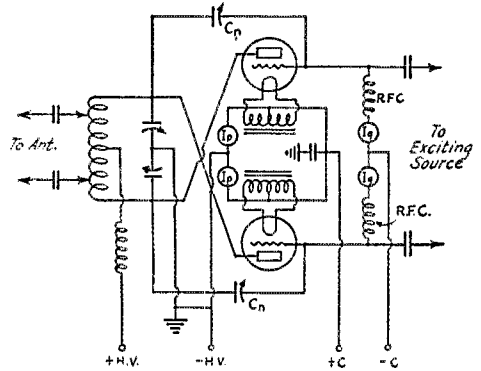

FIG. 5

antenna is usually at a premium, it is not expected that many amateurs will have to exceed this length.

The formulas are practically self-explanatory — but probably one example would help. Suppose the antenna's fundamental frequency is to be 3500 kc.

First it would be necessary to solve for the antenna length.

Substituting the proper values in the formula,

$$L_{(feet)} = \frac{492,000}{3500} \times .95$$

$$= 133.54 \text{ ft.}$$

Next we would need to solve for the coupling C for 3500 kc.,

$$C_{(feet)} = \frac{492,000}{3500} \times .24$$

$$= 33.73 \text{ ft.}$$

Next would be the feeder clearance:

$$E_{(feet)} = \frac{492,000}{3500} \times .30$$

$$= 42.17 \text{ ft.}$$

In this example, we will use No. 12 B. & S. enameled wire, which has a diameter of 0.080 inches. Therefore the spacing of feeders should be

$$98 \times 0.080 = 7.84 \text{ inches}$$

Therefore you have the complete data for an antenna suitable for operating on 3500 kc. Re-

ferring to Fig. 1, the length L should be 133.54 feet; the coupling value C should be 33.73 feet or 16.86 feet each side of the center-line of the antenna; and the feeder clearance should be 42.17 feet. The spacing D between feeder wires is 7.84 inches. No. 12 B. & S. wire also may be used for the antenna. Well soldered connections should be made where the feeders join the antenna, of course.

It is important that you follow the four dimensions very closely. Otherwise the system will not operate as a doublet antenna — or even may fail to operate entirely.

The spacers used for the feeders may be either glass or well seasoned wood boiled in paraffin.

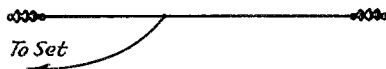

WRONG METHOD
FIG. 6

The main requirement is that the feeders be accurately spaced throughout their entire length. If any turns or bends have to be introduced into the feeder system before it reaches the transmitter it is essential that the feeder system be rigidly supported and that the bends be gradual and not sharp right-angles.

This is just the type of antenna that many amateurs have been looking for, especially those using the push-pull type transmitter. In this case, the tubes must be loaded equally for best results. Several diagrams are given in Fig. 1 showing the general arrangement, while Fig. 2 shows circuits using a single tube in the output stage. The condenser C_b connected from the "free" end of the tank circuit to the filament circuit may be necessary where the circuit plate-filament capacity is greater than a few $\mu\text{fd.}$ and should be of a value equal to the tube plate-filament capacity. Its purpose is to make the tank circuit electrically symmetrical about the center by balancing the plate-filament capacity which is in parallel with the other side of the tank inductance. This capacity is hardly necessary with a Type '52 tube (which has a negligible plate-filament capacity) but should be used with tubes having appreciable circuit plate-filament capacity — including socket and wiring capacity. A capacity of about 10 $\mu\text{fd.}$ or so will usually suffice.

Fig. 3 shows the connections when using two tubes in push-pull as the final stage. In both cases the positive high voltage is fed in at the center of the plate tank inductance and the usual r.f. by-pass condenser is connected there. This places the center of the tank coil at ground poten-

tial with respect to the r.f., both ends of the coil being "hot."

In all diagrams the antenna blocking condensers have a capacity of 2000 $\mu\text{fd.}$ These fixed condensers should have a voltage rating which is somewhat higher than the plate voltage used on the output stage. This is advised for several reasons. As a rule the negative high voltage is grounded; therefore, if the transmission line should become grounded or the insulation of the antenna system fail, condensers having a low voltage rating would invariably blow and thus short the d.c. power supply. The use of the condenser is not only a safeguard to the station equipment but also to life, because if the condensers were omitted, any-

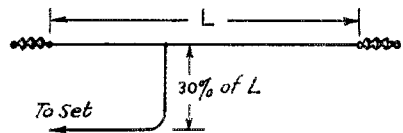

CORRECT METHOD
FIG. 7

one coming in contact with the transmission line or antenna would probably receive the plate voltage used on the last stage, through his body to ground. On high power installations this might result in very severe shock or even death. By using the condensers, r.f. only exists on the transmission line while the transmitter is operating. This is not as dangerous as the high-voltage direct current used at some stations. The use of the coupling condensers is especially recommended to amateurs who live in apartment buildings, where the transmission line as a rule must take a long circuitous path to reach the roof where the antenna is located.

Fig. 4 illustrates the method of connecting this type of feeder to the output of a transmitter when it is impossible to arrange the plate tank circuit to give the required balance. The feeder tank circuit will be similar in construction to the usual transmitter tank circuit. As with the other arrangements, the clips are adjusted symmetrically on either side of the inductance center until the maximum power is being transmitted to the antenna. This will occur, of course, when the impedance across the feeder input is equal to the surge impedance of the transmission line.

As stated before, best results will be obtained when each tube draws an equal value of plate current. This condition is desired particularly when operating two tubes connected in push-pull in a radiophone transmitter. The arrangement shown in Fig. 5 will easily accomplish this. An extra filament transformer (or winding) will be necessary. A milliammeter to measure the plate current of each tube can be used or a jack can be

placed in each negative return circuit so that the current of either tube can be read merely by inserting the milliammeter plug into either jack. This will require only one plate current milliammeter. The use of two meters is of course the ideal method; but the plug and jack method can be used to accomplish the same thing (i.e.) balance the plate current drawn by each tube. Grid current meters also may be connected in the grid circuit as shown in Fig. 5. This helps a great deal in the adjustment of the grid excitation clips which connect to the tank coil of the preceding stage. The excitation can be adjusted until the grid current for each tube is identical.

When the grid current has been balanced, the

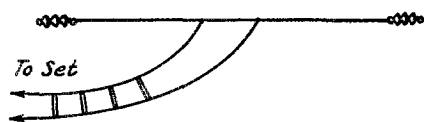

WRONG METHOD
FIG. 8

plate voltage can be applied to the last stage. Then the antenna coupling clips are adjusted until an equal value of current is flowing in each plate circuit, indicating that the load is balanced and that each tube is carrying its share of the load.

For an arrangement of this sort, it is essential to use "matched" tubes or tubes which possess identical characteristics. If this is not done, trouble will be experienced in balancing the plate input to each tube, even though the grid excitation of each is the same. This arrangement is usually termed a "balanced push-pull amplifier" and is especially recommended for use in the Class B linear amplifier stage of a 'phone transmitter. It is also quite suitable to use in the final stage of the better class of code transmitter.

A FEW PRECAUTIONS

Certain factors must be kept in mind when designing a Zeppelin or single-wire fed Hertz and the same holds true for the doublet antenna. These important factors have been pointed out in the discussion and it is urged that they be adhered to or else the system will not operate on the desired frequency or fail to operate entirely.

As shown in Fig. 6 the feeder system should never follow the antenna back to the point where it enters the "shack." It can be safely said that nine out of ten of the amateurs experiencing difficulty with the single-wire fed Hertz and writing into the Technical Information Service were using the general arrangement shown in Fig. 6. This is not recommended under any circumstance. The

feeder should run straight away from the antenna for at least 30 percent of one-half wavelength as shown in Fig. 7. From there the feeder can continue in any direction to the shack and transmitter. The same applies to the doublet antenna, and the arrangement shown in Fig. 8 is *not* recommended. It is very important that the feeders run the required distance as shown in Fig. 9. This is to prevent interference of the feeder with the radiation of the antenna, and vice versa.

Many amateurs who live in cities are constantly writing in saying that they are pressed for room to erect a half-wave Hertz antenna for operating on 3500 kc., and that they desire to use a bent type of antenna. This is all well and

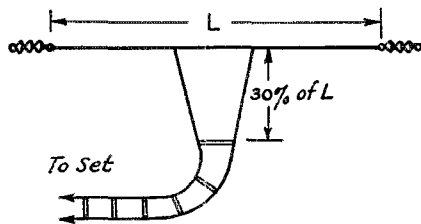

CORRECT METHOD
FIG. 9

good as many city apartment dwellers use the bent type and secure very good results. However, if you find it necessary to employ the bent type at your location because of lack of room, remember it is always best to steer clear of sharp angular bends in the antenna. If bends are absolutely necessary make them well rounded ones. However, the best results will be obtained if the horizontal part of the antenna is one straight run. The bent type should be used only where the space available does not permit the straight-run type.

Although this type of antenna system may be operated at harmonics of its fundamental frequency with some degree of success, its characteristics are more particularly suited to operation at its fundamental frequency only.

When designing a system of this type it is urged that one of the wire sizes that is shown be used. Also use the spacing of feeders, coupling, feeder clearance, etc., that are correct for the desired operating frequency.

This type of antenna has been used by a number of amateur stations and also is used with success in several commercial high-frequency communication systems.

Strays

W9DOS sends us one of those "Believe it or not" cartoons showing a century plant which grew 30 feet in ten weeks out in San Diego. He wants to know where to obtain seeds for such a plant. So do we. Any of you Californians have any dope on this? We want to raise some masts.

Who's Who in AMATEUR WIRELESS



ALLEN H. BABCOCK



LOUIS R. HUBER

The old familiar heading reappears after many years. While not planned as a monthly department, from time to time *QST* will present brief sketches of some of those amongst us whose activity in amateur radio has made them of general interest to our readers. We have pleasure in presenting this month two members of the Board of Directors of the A.R.R.L., and it just happens that they are the oldest and the youngest members of that body. Permit us:

Allen H. Babcock, Consulting Electrical Engineer of the Southern Pacific Company with offices in San Francisco, is the Director of the Pacific Division of the A.R.R.L. He was first elected to the League's Board in 1923 and has been constantly returned to that body by his members ever since. He lives in Berkeley, across the Bay from San Francisco, where he owns and operates W6ZD.

Mr. Babcock was born at Buffalo, N. Y., August 12, 1865. His education was received in the public schools of Oakland, Calif., at Phillips Exeter Academy, the University of California and Lehigh University. He has had a long career in electrical engineering, commencing in 1891 with the Thompson-Houston Electric Co. at San

(Concluded on page 78)

Louis R. Huber, retiring director of the League's Midwest Division, was born at Tipton, Iowa, on January 10, 1908, and his age is therefore exactly that of the average of League membership.

His start in radio came at the age of eight, gathering bits of wire, *à la* Skeezix, while the telephone men were at lunch. The inevitable half-inch spark coil was acquired at the age of ten, fond parents giving the use of the barn for station purposes if Marconi would promise not to bore too many holes in the wall. The invitation was accepted, the promise as inevitably broken. Three years later the government licenses were secured and 9DOA was on the air with a ½ k.w. Packard and rotary, only to be displaced in 1922

(Concluded on page 82)

A New Type of Crystal Holder

By C. W. Klenk, W9AAU-W9ZK*

SOMETIME ago, when it was decided to adopt crystal control on the transmitter at W9ZK, difficulty was experienced in finding a suitable device to hold the crystal properly and at the same time to allow changing the crystals by the "plug-in" method. Nothing on the market was found to be quite satisfactory. Therefore it was necessary to devise a holder that would meet the conditions. With the aid of my dad, Dr. C. L. Klenk of W9AAU-W9ZK, a device was evolved which was in every way satisfactory. Because it worked out so well the writer desires to pass the idea on to the amateur radio fraternity.

The holder, plugged into the mounting, is shown in a photograph. As the mounting base

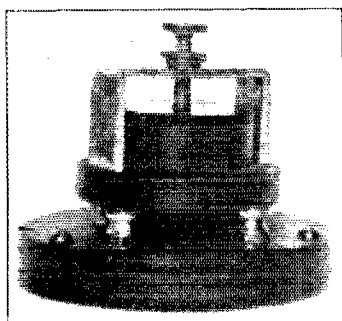

THE CRYSTAL HOLDER AND MOUNTING BASE

was made to conform to certain specifications peculiar to the equipment at W9ZK, the writer will not waste space or time describing it. The pictures give an idea of its appearance anyway.

This mounting is ideal in that it is possible to secure a micrometer adjustment of tension on the crystal. Also it is possible to adjust to allow an air space between the upper plate and the crystal which is ideal for shifting the frequency a slight amount.¹ The crystal is protected from dust and dirt and remains permanently adjusted. The holder is rugged enough to allow dropping, but since the crystal is quite fragile it is not advisable to make a habit of this.

One photograph shows the holder with its parts disassembled. In Fig. 1 is a detailed assembly drawing showing a plan view and a cross section of the elevation as well as the complete specifications.

The holder comprises a bakelite base, an inverted "U" bracket, two pieces of felt, two ground brass plates, a thumbscrew and lock nut for adjustment, a piece of bakelite tubing, a bakelite cover, and two G. R. plugs. The base is machined in a lathe from half-inch sheet bakelite, rounded

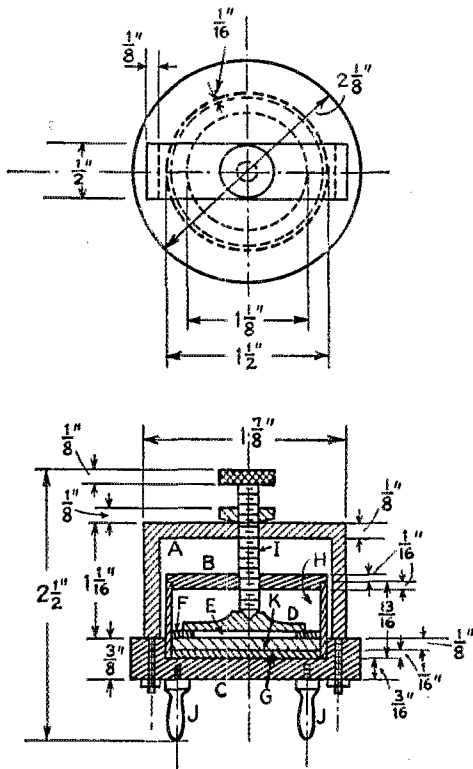

FIG. 1.—DETAILS OF THE CRYSTAL HOLDER

Material used: A, brass; B and C, bakelite; D, brass; E, quartz crystal; F and G, felt; H, bakelite tube; I, brass machine screw, 12-48 thread; J, General Radio plugs; K, brass.

and hollowed out to take the end of the short piece of tubing. This tubing is cemented in place. Into the bottom of this cup is placed a piece of good quality felt cut to conform to the inside diameter of the tubing. Over this felt is placed a disc of brass of the same diameter, which has been turned out and cut to size, the top surface having been ground flat and smooth. On this brass plate is placed another piece of felt of the same size and quality only it has a hole cut

* 3148 Halliday Ave., St. Louis, Mo.

¹ For details of this feature see "QSY With Crystal Control," QST, September, 1930.

in the center to provide space for the quartz crystal. The hole should be cut slightly larger than the actual dimensions of the crystal to allow for sideward expansion of the felt when it is subject to the compressive force of the thumbscrew. Over the crystal and part of the felt is placed the top plate, made of brass with the under surface ground perfectly smooth. The top

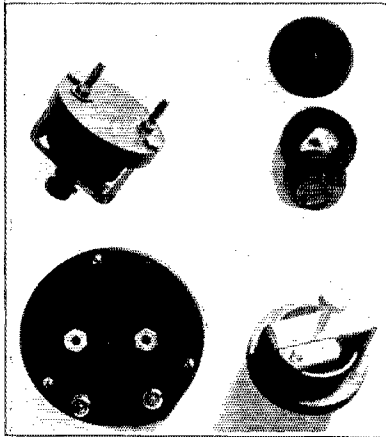

THE MOUNTING BASE AND BOTH ASSEMBLED AND UNASSEMBLED CRYSTAL HOLDERS OF THE TYPE DESCRIBED

of the plate tapers from the edges to the center and in the center a recess is made to take the tip of the thumbscrew. The bakelite cover (with a hole cut through the center to allow passage of screw shank) is then placed snugly on the top of the bakelite tube. The inverted "U" bracket is fastened to the base of the holder. The screw is placed through the threaded portion of the bracket and turned down until it engages with the recess in the top of the upper plate. Following this the screw is tightened until the crystal is properly held in place. The lock nut prevents the thumbscrew from loosening and allowing the crystal to get out of adjustment.

The two C. R. plugs are fastened under the bakelite base. One is connected directly to the brass bracket which makes a connection to the upper plate. The other is connected through the base by a flexible lead to the lower plate.

The piece of felt surrounding the quartz plate regulates the amount of tension. Turning down the thumbscrew compresses the felt and brings the upper plate nearer to the crystal. Turning the screw in the opposite direction releases the tension on the felt and it expands, pushing the upper plate away from the crystal. By this method the desirable air space between the crystal and the upper plate can be obtained with very close precision. The felt placed under the lower plate acts as a cushion for the whole as-

sembly and also tends to keep the surfaces of the two plates parallel to each other. Any small inaccuracies as the result of grinding are compensated by this means.

In building this type of holder extreme care must be taken in getting parallel surfaces on the upper and lower plates. Accurate machining and then careful grinding are absolutely essential in securing the desired results. The two plates may be ground by hand, rubbing them together and using fine valve grinding compound as a grinding medium. After the grinding is completed the plates are polished with jeweler's rouge. Then each part of the holder must be cleaned thoroughly to remove all traces of grease and moisture, especially from the surfaces of the ground plates. It is advisable also to clean the felt pads thoroughly. A very convenient cleaner is carbon tetrachloride, commercially known as "Carbona." It is a non-combustible, quick drying liquid which can be obtained in nearly all drug stores for about forty cents a pint.

This type of holder has only one drawback; it does not readily lend itself for use in a thermostatic oven which is used to keep the crystal at a constant temperature. Unless the frequency is close to a band limit, however, fifteen to twenty degrees variation in temperature does not cause a serious change in the frequency at which the crystal vibrates, at least as measured by the change in dial setting on the average short-wave receiver.² The advantages of this mounting are so numerous as to overcome this one small drawback. However, we are working on a crystal holder for use in a constant temperature oven and as soon as we have successfully completed it we shall present a description of it to the amateur fraternity.

² With a 3500-ke. crystal the change in frequency may be as much as 1 kc. for a 15° C. rise in temperature. The heating is reduced when the oscillator is operated at a plate voltage of less than 250 volts and no more than sufficient excitation. See "Crystallizing Crystal Grinding," *QST*, April, 1930, for further information. — EDVOR.

Changes in Regulations

THE Federal Radio Commission on September 22d last made two amendments in its General Order No. 84 which contains the regulations for amateur stations, as published in *QST* for May 1930, page 16.

The first of these is of no importance, being the transposition of paragraphs (f) and (g) of Section I.

The other change eliminates the text of Section IX, providing for the routing administration of amateur stations by the Radio Division of the Department of Commerce, acting in the name of the Commission. It substitutes the following new text: "These regulations shall be administered in

(Continued on page 84)

The Story of W1MK

By F. E. Handy, A.R.R.L. Communications Manager

This article is too long. Had we printed it as originally written, the story would have filled twenty pages instead of twelve. What we must realize is that the present W1MK represents the culmination of a relatively tremendous amount of development work. In the last six years or so W1MK has pointed out millions of words to amateurs the world over; but simultaneous with that activity there has been continuous experiment, frequent modification and steady technical progress. Because W1MK is probably the best-known amateur station in the world and because it has never been the subject of a descriptive article in QST, we believe the present story to be completely justified.—EDITOR.

THE present W1MK is relatively well known to League members everywhere in view of its regular operation and prominent part in different A.R.R.L. activities. This was not so with the modest station to represent Headquarters which went on the air about six or seven years ago for the first time. At that time the League was located in the downtown business section of Hartford at 1045 Main Street and this early station was situated in the old Traffic Department office.

The first set-up, while an example of satisfac-

tory design for the day and time, would fail to meet a number of the present-day requirements. Four UV-202 tubes were paralleled in a Hartley rig. An edgewise-wound coil of copper strip ten or more inches in diameter was used. With the tuning condenser practically "out" the set got down to about 77 meters. An m.g. power supply and an antenna well in the clear were the bright spots in this arrangement. Of course the frequency stability was nothing like what we can get in modern transmitters but it sufficed for pre-historic times — or at least no criticism was offered. This outfit

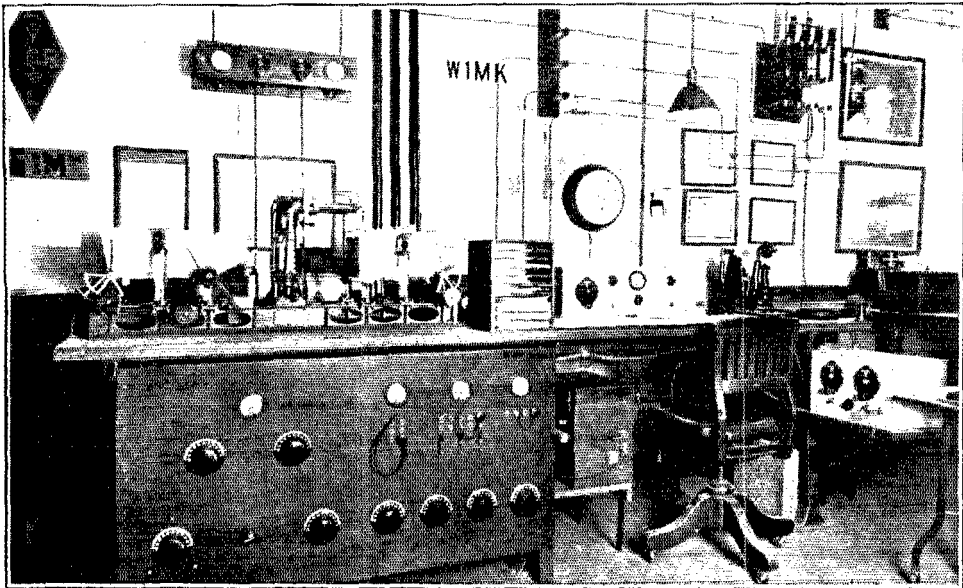

A.R.R.L. HEADQUARTERS STATION W1MK

The receiver and an accurate synchronous electric clock are directly in front of the operating position. The key and all control switches necessary for full operation of the station are just at the right, together with the telephone and the listening monitor. Messages are filed in the box at the left so that they may be located without interrupting the keying. The two transmitters shown at the left may be keyed simultaneously in sending information addressed to all League members, or they can be worked separately.

The t.p.t.g. transmitter on top of the table normally works on 3575 kc., although interchangeable coils are provided for operation in other bands. The large bakelite panel which shows up prominently in the foreground is the new oscillator-amplifier transmitter usually operated crystal-controlled and capable of 500 watts output with a high degree of frequency stability. This transmitter is used for 7000 and 14,000-kc. work.

The temperature control box for the crystal is located on a shelf below the table just to the right of the new transmitter. The General Radio precision frequency-meter is at the extreme right.

was operated by volunteer staff-member operators during the noon hour each day.

The reason for the establishment of this station was the growing need for collecting Hartford-bound radiograms which must otherwise be mailed in from outside points. At that time 3500 kc. was comparatively new territory so there was ample daylight operation on this frequency. No one at Headquarters was much interested in the DX possibilities of this makeshift equipment so there was practically no operation outside the noon-hour period. Nevertheless, this low-power

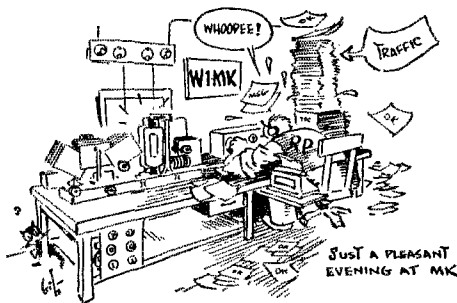

77-meter station got across to a fellow ham in the Netherlands for at least one satisfactory contact before the set was dismantled — not a bad record for the power and frequency used, even today. (The experience is well-remembered by the writer since it was necessary to show the Dutch QSL to some of the skeptics about the office.)

When Headquarters moved into larger offices at 1711 Park Street in April of 1925 the little set went along too. However, it was soon to be supplanted by a more powerful outfit using two fifty-watt tubes. This in turn was replaced by a single 250-watt tube with self-rectified power supply. These transmitters were allotted space in the Circulation Department. The location was such that visitors and clerks often yielded to the temptation of twisting dials, thus throwing the outfit out of adjustment — or worse, off frequency, although this did no damage since the antenna was invariably off-tune. The transmitter received unintentional jolts and jars from the nearby addressing machinery and from handling of heavy bundles of *QST*'s and often went haywire because of experimentation. The operating desk was in a conference room somewhat removed from the transmitter. When the keying relay would stick, the unlucky operator might frequently have been seen dashing wildly across the corridor, slamming doors and getting at the set in the Circulation Department to correct the difficulty.

Several volunteer operators, each keeping once-a-week "tricks," kept this station on the air for a considerable time. Evening schedules were attempted in addition to the noon-day shifts. To

assist neighboring broadcast listeners who had the infamous single-circuit receivers two score or more wavetraps were distributed with effective results and a fixed cooperative policy was established. The location was nevertheless impractical for satisfactory communication work. Interference from buzzers, dial telephones, dictaphone motors, street cars, a theater sign flasher, battery charging station, some beauty-parlor violet-ray generating equipment, and other equally incurable interference sources made operating unpopular and sometimes well-nigh impossible. It was hard for amateurs in radio contact with Headquarters to believe the interference was as bad as indicated by the operator, but listening in to-day will still show a remarkably high noise level.

The Board of Directors reviewed the whole matter of Headquarters' Station operation at its 1927 annual meeting, considering the existing makeshift equipment, the unsatisfactory location and determining the policy to be followed. The Communications Manager was ordered to proceed with the installation of a powerful station in a suitable location where it might be operated effectively and be of genuine service to the amateur fraternity as well as a credit to Headquarters. It is a result of this Board order that we have the fine equipment and installation that has become so well known since it was placed in operation in February, 1928.

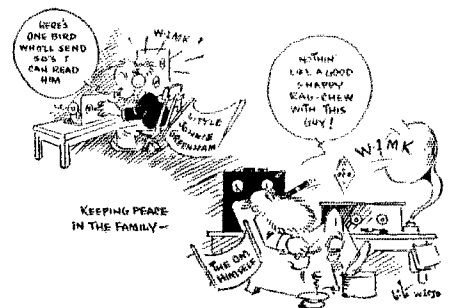

Several possible locations were examined and rejected before a location at Brainard Field, Hartford's airport and one of New England's best flying fields, was chosen. The existing apparatus was taken down and the inferior parts discarded. Wherever possible, parts were set aside to be built into the new station. The best quality procurable in all kinds of equipment was desired but the size of the installation job made economy an important consideration. A good friend of amateur radio who had long desired to see a top-notch station on the air at Headquarters donated a substantial part of the power supply equipment, the three-unit Escro motor-generator that has given such a good account of itself. This machine consists of a two-h.p., two-phase, 220-

volt motor, a 2000-volt 750-milliamper generator, and a 15-volt exciter which furnishes both field current for the generator and filament current for several Type '04-A tubes.

A three-section telescoping wood mast with a ladder-like main section to facilitate climbing was put up to support the far ends of the antennas. The height of the mast was made the maximum permitted by the "gliding angle" which must be maintained to permit landings without danger at every flying field. Two horizontal Hertz-type antennas were erected, both well in the clear, one supported at the near end on a brick chimney and the other supported at the near end on a short mast on the Communications Section building. One antenna is a half-wave 3575-kc. affair, the other a full-wave 7150-kc. antenna. These frequencies were chosen in harmonic relation, the 3575-kc. frequency as a "marker" or beacon to assist radiophone amateurs in complying with the regulations and locating their transmissions in the assigned 3500-3550-kc. 'phone band. Two-wire voltage (Zepp) feed is used to both antennas, the feeders in each case being a single quarter wave-length in length. A separate receiving antenna is provided to facilitate break-in when conditions permit and to eliminate the necessity for changing antennas on the receiver.

POWER SUPPLIES

Within certain limits radio equipment can be accommodated to different building arrangements. Once a satisfactory location is found where there is room for antennas to be erected in the open and the noise level is low enough to make good reception possible, a study of the physical arrangement is necessary. One should separate the transmitters and power supply equipment from the receiving and operating location as much as practicable. Remote control would be ideal where break-in operation is desired but since the best of apparatus sometimes breaks down the transmitters and power supplies must be within a moderate distance. In our particular station space considerations have almost dictated the placement of apparatus.

Two rooms were available for all equipment. Only one had enough light and offered enough space for the operating position, so from the first it was evident that generators, batteries, relays and all messy or noisy power supply or auxiliary equipment should be relegated to the smaller back room. This room was not large enough to take care of the transmitters, as was desired, to get them away from the receiving tuner; in addition the proposed equipment for our 1928 station

had to be accessible so that the frequency of one or both transmitters might be changed at will, both from band to band and slightly to avoid interference. Thus our transmitters were placed on the bench with the receiver, though with some trepidation in view of the power involved.

To insure continuity of operation two different types of power supplies were installed, one to be used with each transmitter normally, but either capable of handling both sets simultaneously in case of need. Although the photograph which

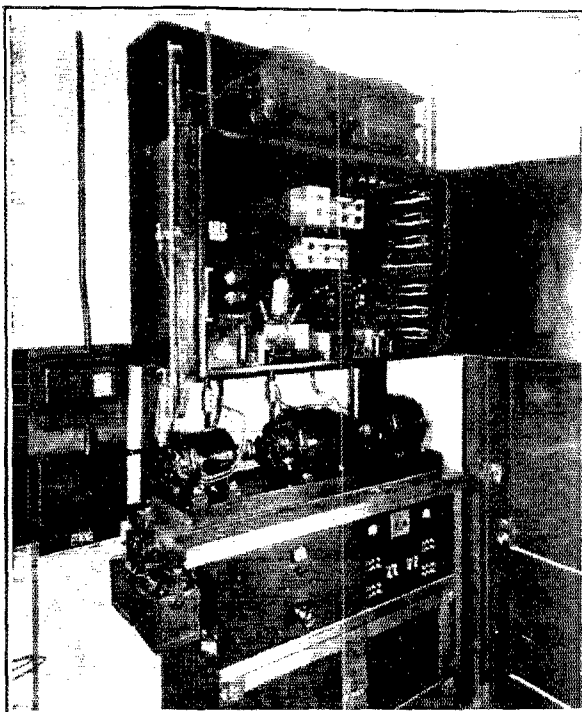

THE POWER EQUIPMENT

A description of the apparatus is contained in the text.

shows the power room and apparatus is not a recent one it gives a good idea of the equipment. Above a cabinet for supplies is the charging panel for the batteries which operate the receiver, monitor, and several different six-volt relays. The light radio-type storage cells have been replaced by husky banks of Willard stationary-type glass-encased cells which stand up better in heavy-duty service. Cabinet, charging panel, and high voltage generator are supported on a heavy steel frame. The rotating machinery is supported on cork to absorb vibration, and is mounted well above the high-water mark reached by our last New England flood. At the left is the switch which throws 220 volts on the driving motor for the high-voltage machine when actuated by the six-volt relay mounted in the same box. The large

metal box mounted on the wall is of $\frac{1}{8}$ " steel. This cabinet is full of high and low voltage fuses, switches, six-volt relays, keying filters, center-tapped resistors and numerous other auxiliaries indicated in the power supply diagram, in addition to its main purpose, which is to house the mercury-arc rectifier, all its auxiliary keep-alive circuit equipment, the "bleeder" resistance and several component parts of the filter system.

culty in the use of mercury-arc rectifiers to arise from the "hash" set up by inductive kicks due to the interruption of the current in keep-alive circuits which makes reception impossible unless the arc and transmitter are some distance away. At W1MK there is none of this trouble since the arc is 100% shielded in the grounded iron cabinet, and even the control leads run through about sixty feet of conduit, also grounded. It is impossi-

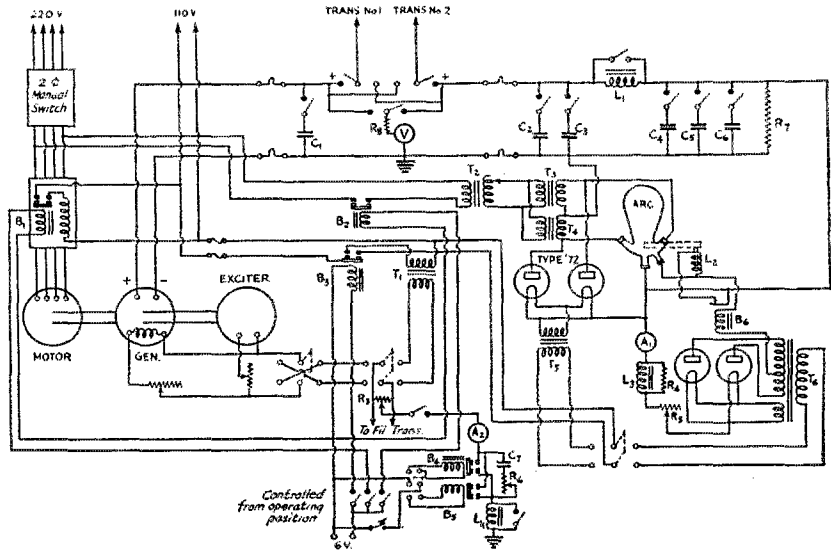

FIG. 1. — POWER SUPPLIES AND CONTROL EQUIPMENT

*T*₁ — Filament transformer for '04-A's
*T*₂ — 1-kw. transformer with tapped secondary for regulating primary voltage on high-voltage transformers
*T*₃ — 2-kw. transformer, 110-2200 volts
*T*₄ — Filament transformer for '72's
*T*₅ — Keep-alive transformer, secondary voltage 60, center-tapped
*L*₁ — 30-henry choke
*L*₂ — Solenoid for tipping arc
*L*₃ — Keep-alive choke, 5 henrys
*L*₄ — Keying choke, 12 henrys
*C*₁ — 4- μ fd.
*C*₂ — 5- μ fd.
*C*₃₋₆ — 2- μ fd. each

*C*₇ — 2- μ fd., 1000-volt condenser
*R*₁ — Generator field rheostat
*R*₂ — Filament rheostat for '04-A's
*R*₃ — Center-tap resistor, 75 ohms
*R*₄ — 2000 ohms
*R*₅ — 30 ohms, adjustable by clip
*R*₆ — 15-ohm rheostat
*A*₁ — 0-4 amp. d.c. ammeter
*B*₁ — Starting relay for generator
*B*₂ — Line relay for power transformers
*B*₃ — Line relay for keep-alive transformer or '72 filament transformer
*B*₄, *B*₅ — Keying relay and spare
*B*₅ — Solenoid relay for arc-starting mechanism

During 1929 a pair of Type '72 rectifier tubes were added and used for a time. These could be used interchangeably with the mercury-arc rectifier equipment and offer certain advantages in neatness, quietness in operation and compactness, but it became apparent that once the initial investment in accessory equipment for the mercury-arc circuit had been made, replacement of the Tungars in the keep-alive circuit and of the arc itself could be made at a lower cost. Because of this operating economy the original arc-rectifier equipment is still in use.

Many amateurs have found a common diffi-

ble to tell by the receiver if the arc is running — unless you press the key.

Individual capacity units in the filter system can be removed by operating the "disconnect" switches that are in series with each condenser. On occasions when there have been troubles in the filter system this has made it possible to remove quickly the defective unit without any great delay in normal operating schedules. All equipment in a station like W1MK gets severe service and must be rated for continuous operation. We prefer to service the equipment and locate troubles outside of operating hours and have therefore

installed plenty of fuses and "disconnect" switches for the isolation and ready location of trouble which is always sure to crop up sooner or later where many circuits and parts must function simultaneously.

Two 50,000-ohm 44-watt resistors in series across the 2000-volt filter system improve the regulation and protect filter condensers from ripples and transients, at the same time protecting the operator from some deadly "jolts" by draining the charge off the condensers at the instant the high-voltage transformers are taken off the line.

Three two-inch conduits contain all the wires connecting the power-supply equipment, low, high, and intermediate voltages, to the apparatus in the operating room.

STATION EQUIPMENT

The best obtainable electrical and mechanical construction was desired in the transmitter for the new station made possible by the Board's action. The main unit must be capable of working in different amateur bands; it must meet certain further specifications, as must also the second transmitter or auxiliary, although the requirements for this were easier to meet.

The t.p.t.g. transmitter shown in the photograph, using two Type '04-A tubes, was obtained as the best answer to the first problem. This set is extremely flexible and with a little experience any amateur can change frequency from band to band quickly and easily once the proper settings have been determined. Ruggedness in construction insures long useful life. Electrically self-controlled, the circuit (shown in Fig. 2) is very simple as well as immune from most of the troubles which may be expected with a multi-stage transmitter. Such a set is ideal for quick frequency changing, break-in operation, etc. Equipped with adapters for Type '52 tubes it can be made to work at 14 mc. The limitations of '04-A's make it desirable not to attempt operation on frequencies higher than 7 mc., since the circuit will become unstable in the vicinity of 14 mc. unless special precautions are observed, and in any case tube life may be shortened.

When this t.p.t.g. transmitter was first placed in operation at Headquarters one unusual trouble was noted. Good results were obtained except that at 3575 kc. after the first few dots and dashes had been transmitted the note became a perfect 500-cycle modulated affair. Everything was overhauled from power supply to filament bypass condensers, without result. The transmitter was suspended on cushioned shock absorbers — still no result. Finally, in desperation, after some weeks of looking for the "perfect d.c." it was found that insertion of rubber strips between each turn of both the plate and grid coils effected an absolute cure. Some wooden clamps were procured and provide the permanent remedy to this day. Apparently the interaction of the fields of the plate and grid coils was sufficient to start a mechanical vibration, which occurred only with the multi-turn coils used for the 3575-kc. frequency. Of course this would never have been noticed with a modulated power supply. For a simple difficulty it occasioned quite a lot of frantic trouble-shooting!

An auxiliary transmitter, a simple High-C Hartley circuit using one Type '04-A, was constructed and placed permanently on 7150 kc. for use mainly during simultaneous transmissions of

general information for members.

A completely rebuilt receiver was installed at the new station and served for most of 1928 operation. It was partially but not completely shielded. As one visitor tactfully put it, "the r.f. from the transmitter didn't do it any good." But though the tube life may have been short, the sensitivity was good and many successful contacts were put through with its use.

A General Radio Precision Wavemeter was added to other equipment as a practical necessity for

keeping the station on frequency.

PROGRESS

In any station the best of equipment will wear out or become obsolete. Modern stations will remain modern only if those behind the station exert themselves. The history of this station, like that of most every really worthwhile amateur station, is a story of continuous improvements.

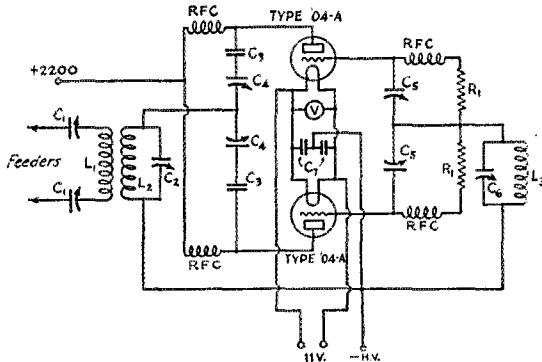

FIG. 2. — THE 500-WATT TUNED-GRID TUNED-PLATE TRANSMITTER

- C₁ — 250- μ fd. transmitting condenser
- C₂ — 280 μ fd.
- C₃ — .002 μ fd.
- C₄ — 100 μ fd.
- C₅ — 100 μ fd.
- C₆ — 280 μ fd.
- C₇ — .08 μ fd.
- L₁ — 10 turns of 5/16" copper tubing 5 3/4" inside diameter
- L₂ — 12 turns for 3500 kc.
- 7 " " 7000 kc.
- L₃ — 11 turns for 3500 kc.
- 5 " " 7000 kc.
- R₁ — 5000 ohms
- RFC — Radio frequency chokes

PROGRESS

In any station the best of equipment will wear out or become obsolete. Modern stations will remain modern only if those behind the station exert themselves. The history of this station, like that of most every really worthwhile amateur station, is a story of continuous improvements.

In most amateur stations it is a simple matter to shut down to rebuild or experiment. Not so with WIMK. The station has very definite responsibilities to the membership and every effort has been made to make operation every scheduled night go off just as per schedule — with a few extra nights of operating thrown in for good measure. At the same time constructional projects have not been neglected by any means.

It is completely shielded and all power supply leads are by-passed, which results in very low r.f. pick-up from the powerful transmitters which are adjacent. A noticeable improvement in tube life, and more important, a reduction in noise level, resulted from the installation of the new receiver. As shown in the diagram, transformer-coupled audio amplification is available, or "peaked" amplification to improve selectivity

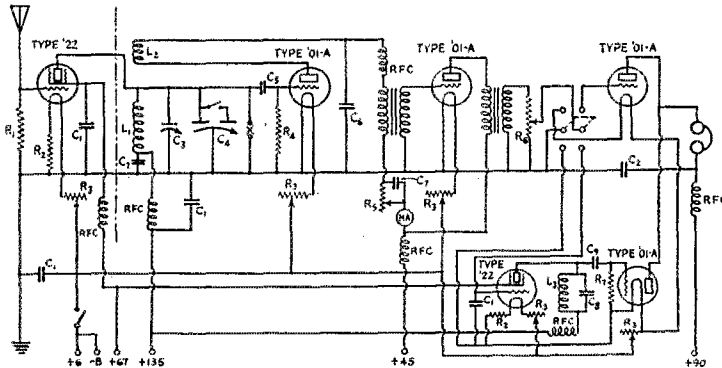

FIG. 3. — WIMK RECEIVER

- | | |
|--|--|
| C_1 — 1 μ f. | R_2 — 8 ohms |
| C_2 — .005 μ f. | R_3 — 30-ohm rheostat |
| C_3 — Beat-note condenser — two plate midget | R_4 — 6 megohms |
| C_4 — Rebuilt condenser having two stator sections adjusted for band spreading | R_5 — 100,000-ohm variable resistor |
| C_5 — 100 μ f. | R_6 — 500,000-ohm " " |
| C_6 — .002 μ f. | R_7 — 100,000 ohms |
| C_7 — .25 μ f. | RFC — Receiver-type r.f. choke |
| C_8 — .025 μ f. | No data on coils is given because they must be made by the "cut-and-try" process to cover each band. Values are approximately the same as with any receiver designed for band spreading. |
| C_9 — 500 μ f. | |
| R_1 — 10,000 ohms | |

A listening monitor and a new receiver were recognized as necessities of the first water. These were built by the writer and by "RP" respectively and placed in operation in the station early in 1929.

The circuits of both monitor and receiver are shown. Both instruments are built in aluminum cabinets. The monitor consists of a detector and two-stage amplifier, and is provided with a regeneration control. It is in reality a rather complete receiver, lacking only an antenna coupling coil. External batteries are normally connected for operation of the listening monitor by the Yaxley cable-plug which is located in the rear center. Additional "A" and "B" dry-cell batteries are fastened to an aluminum shelf inside the monitor with brass straps and may be used for operation as a 100% "portable" monitor or receiver, and are connected in the circuit by throwing two double-pole double-throw switches. A single additional tube is provided in a crystal oscillator circuit, and a shelf with switch-jaw elements makes it possible to plug in a crystal for monitoring or measuring purposes.

The new receiving set requires little explana-

tion. It is completely shielded and all power supply leads are by-passed, which results in very low r.f. pick-up from the powerful transmitters which are adjacent. A noticeable improvement in tube life, and more important, a reduction in noise level, resulted from the installation of the new receiver. As shown in the diagram, transformer-coupled audio amplification is available, or "peaked" amplification to improve selectivity is provided at the throw of a switch. Three 1000-turn honeycombs tuned with a .01- μ f. paper condenser are plugged in permanently, or may be replaced by the primary of 712 transformers or other peak-producing combinations if desired. A stage of '22 untuned r.f. amplification precedes the detector and recently this has been made into a tuned radio-frequency stage, appreciably boosting the signal level. An ample number of coils is provided for all the amateur and expedition bands, and a plug-in midget condenser can be placed across the regular two-section band-spread condenser to boost coil ranges to almost any frequency that may be required. Possibly an

a.c.-operated receiver may supplant the present model at some future date but other jobs loom ahead of that in importance.

THE NEW TRANSMITTER

Excellent results were obtained with both t.p.t.g. and auxiliary Hartley transmitters from the date operation of the new WIMK commenced. However, difficulties were encountered because of tube troubles and certain limitations applying to any self-controlled transmitters made themselves felt.

Satisfactory frequency stability has always been obtained on the 3575-kc. frequency. One trouble that could not be overcome was a certain frequency drift that would invariably occur during transmission on the higher frequency bands because of changes in the spacing of the tube elements ('04-A's) with even small temperature changes. The transmitter, while steady and easy to copy, would "climb" gradually to a slightly different frequency, the change being of the order of several kilocycles with inputs 75% normal, so it was necessary for receiving operators to re-tune slightly for the signal after an interval

of no transmission. Reducing plate voltage and current might limit the amount of change but would not get around the trouble altogether.

Therefore it was decided that a new main unit for the station, to have excellent frequency stability as its goal, and using modern high-frequency tubes, must be constructed. The t.p.t.g. set must continue to "hold down" 3575 kc. where its performance left little to be desired, but a new transmitter should be added for all work in the 7- and 14-me. bands where it is hardest to maintain a station on a single channel. Space limitations made it difficult to see where any amount of apparatus could be installed, but it finally appeared that the best location for the new transmitter would be in place of the superseded auxiliary unit beneath the operating table. A shelf and drawer were removed to make the space available and a design as compact as possible worked out after preliminary experiments to determine the best possible set-up. While no amateur will have occasion to duplicate the exact arrangement or combination of equipment about to be described, it is believed that many of the features involved can perhaps be modified and included in stations of various size where oscillator-amplifier transmitters are being considered in the interest of improved frequency stability.

The new high-power unit had to be adjusted to work from the existing high-voltage plate supplies, for economy's sake if for no other reason. The oscillator must operate as a frequency control with plate voltage as low as practicable to keep temperature changes in the tube and in the crystal itself (when used) to an absolute minimum. A number of amplifier stages and doubler stages to supply adequate excitation to the high-power end in spite of low voltage on the control end must be incorporated. Shielding must be used in low-power and intermediate stages to eliminate undesired feed back, especially where the equipment must be confined in a small space. Separate power supplies for low- and high-power ends on the new transmitter were desired not only to prevent coupling between stages through the power supply but to avoid unnecessary losses in resistors and fluctuations in plate supply voltage that would endanger the equipment and make adjustment of the low-power end unduly difficult because of poor voltage regulation. If and when crystal control was to be used it should be possible to shift from one crystal to another at the will of the operator. Also, in a drafty room

subject to wide temperature variations the crystal must be protected from physical changes from any source, and preferably housed in a mounting held at constant temperature to minimize frequency changes as much as possible. A plug-and-jack metering system was considered desirable both to eliminate the necessity for a large number of meters and to make it possible to quickly adjust each stage, to locate troubles, defective tubes, etc.

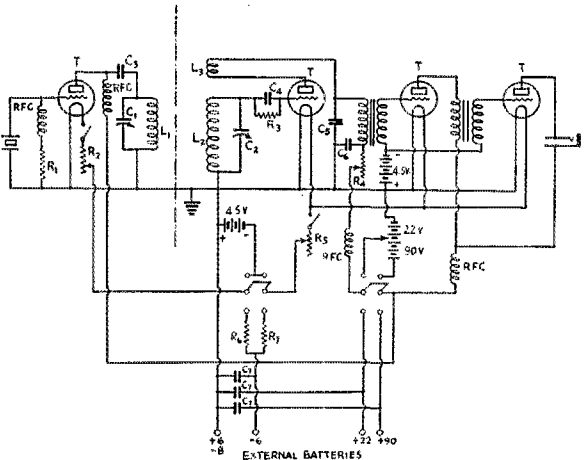

FIG. 1. — THE MONITOR AND CRYSTAL OSCILLATOR

- C_1 — 550 μ fd.
- C_2 — 75 μ fd.
- C_3 — .005 μ d.
- C_4 — 100 μ fd.
- C_5 — .005 μ d.
- C_6 — .25 μ d.
- C_7 — 1 μ d.
- R_1 — 8 megohms
- R_2 — 25-ohm rheostat
- R_3 — 4 megohms
- R_4 — 50,000-ohm variable resistor
- R_5 — 10-ohm rheostat
- R_6 — 42 ohms
- R_7 — 16 ohms
- RFC — Receiver-type r.f. chokes
- L_1 — 28 turns of No. 22 wire, space wound on 1 1/4" form (1 1/2" length winding)
- L_2 — 55 turns of No. 30 d.s.c. on old tube base (space-wound to cover the 3500-ke. band)
- L_3 — 8 turns of No. 30 d.s.c. on same tube base 1/4" from L_2
- T — The monitor may be used with Type '99 or '30 tubes for portable use, but is ordinarily used with '01-A's in the station because of their ruggedness

In the high-power stages it was decided to use Type '60 and Type '61 tubes, these tubes being as readily available as any high-power, high-frequency tubes, and being screen-grid "bottles" the necessity for neutralization might thus be avoided and undesired feedbacks and instability kept at a minimum. The problem was to plan a circuit layout giving adequate gain, providing the necessary doubling and quadrupling of frequency, and sufficient excitation for both 7- and 14-me. operation, all without too much difficulty in changing frequency.

Preliminary experiments indicated that three Type '10 tubes might be controlled by a 3500-ke. crystal and arranged in doubler-amplifier or doubler-doubler combinations for 7-mc. or 14-mc. operation. However, a single '10 tube gave a mighty low output at 14 mc. although perhaps satisfactory from the 7-mc. operating standpoint. It was useless to attempt to increase 14-mc. output by adding another '10 in parallel; this was tried but the inter-element capacity of the tubes,

another Type '10 tube which may be operated either as a 14-mc. doubler or as a neutralized amplifier on 7 mc. The output of this tube excites a push-pull amplifier using two Type '10 tubes which may be operated on either 7 or 14 mc., giving sufficient output to fully excite the '60 on either band. All the amplifiers following the crystal tube are neutralized, even when operating as doublers, to prevent undesired feedback between stages and to allow the transmitter to be

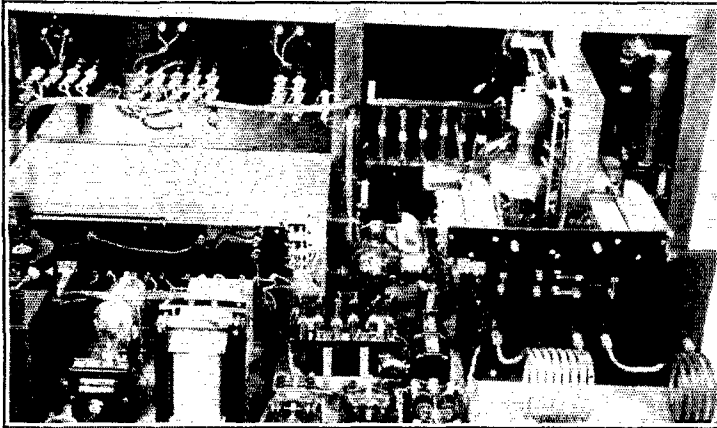

COMPLETE ASSEMBLY OF THE NEW 500-WATT OSCILLATOR-AMPLIFIER TRANSMITTER AT W1MK

Five Type '10 tubes in the aluminum cabinet (at left) are followed by '60 and '61 screen-grid amplifying stages (at right). The jacks to check filament voltage as well as individual plate and grid currents on each tube are mounted on the panel above the shielded cabinet. External C-bias batteries are connected through a Yaesley cable-plug. The 7-prong-socket is below the platform which carries the whole assembly. To the left of the Type '66 rectifiers is the special filament transformer for all Type '10 tubes and the '60. At the right is a Thordarson 30-henry choke and the filter condenser block. One telegraph-sounder 6-volt relay connects all filament transformers to the 110-volt source at the same time a similar relay in the power supply room connects the stand-by circuits for the mercury-vapor high-voltage rectifier. A second telegraph-sounder relay turns on the 600-volt transformer of the low-voltage power-supply unit shown in the left foreground at the same time another relay in the power room actuates the 3000-volt equipment. The Leach relay at the right is the keying relay for this transmitter. Just back of the relays on the same sub-base is mounted the 225,000-ohm voltage divider from which bias for blocked-grid keying of '60 and '61 stages is obtained. The key-thump filter may also be seen just behind the relays.

The screen-grid resistors for the '60 are mounted back of the panel above the '60. On the extreme right of the assembly back of the panel are screen-grid resistors for the '61. The feeder condensers are on a skeleton mounting in front of the '61 and obscure some of the detail of the '60 and '61 tank circuits, also the r.f. chokes which are mounted directly at the tube terminals. The screen-grid by-pass condensers are mounted under the platform to make the leads short and get these bulky units out of the way. Above the antenna coupling coil is the switching arrangement which makes it possible to connect an r.f. ammeter in either side of the feed line. The four-turn tank coil of the '61 used for 14-mc. operation is shown in place on the extreme right.

fairly high in the first place, added when the tubes were paralleled, effectively by-passing what little grid excitation could be obtained. After much experimenting with different tube combinations to build up the 14-mc. energy to a value sufficient to fully excite the Type '60 amplifier, the line-up shown in the transmitter diagram, Fig. 5, was decided upon as being the most suitable. A Type '10 oscillator on 3575 ke. is followed by a 7-mc. doubler, which in turn feeds into

shifted from one band to the other with a minimum of adjustments.

Since the maximum of flexibility is necessary in a transmitter which must be shifted rapidly from one frequency to another and from one band to another to meet schedules (and avoid QRM, when necessary), the tuning condensers on each stage except the last are made sufficiently large to cover both 7 and 14 mc., thereby eliminating the necessity for plug-in inductances. The crystal oscillator and the first doubler are permanently tuned to 3.5 mc. and 7 mc. respectively. The only coil changing necessary is in the tank of the '61 stage. The neutralizing systems employed on the low-power stages are designed to permit wide changes in frequency without necessity for readjustment of the neutralizing condensers. The screen-grid tubes in the two final stages do not require neutralization. The tank circuits are Low-C on 14 mc. and fairly High-C on 7 mc.

The second doubler output tank is fed d.c. in the center, locating the voltage node at that point and making both ends of the tank "hot." This method of connection is ideal for feeding a single-ended stage into a push-pull amplifier, because it obviates the necessity for inductive coupling between the stages and requires no additional apparatus. At the same time it also makes possible easy neutralization of the single-ended amplifier. Coupling out of the push-pull stage into the single Type '60, however, cannot be accomplished in quite so simple a manner,

since a direct connection of one end of the push-pull tank to the filament of the following tube (or coupling at this end through a condenser) would place one end of the tank at ground potential with respect to r.f. and unbalance the amplifier. It was found that the excitation was ample with the grid connection to the '60 taken off one end of the push-pull tank, leaving the other end of the tank free. The push-pull stage was highly desirable because in it the tube capacities are in series, which eliminated the objection to two tubes in parallel mentioned previously.

During the preliminary testing of the transmitter after the constructional work had been finished a rather unusual condition made itself apparent. There was evidence of a strong parasitic oscillation in the push-pull stage which absolutely wrecked the frequency stability and quality of the signal. The usual remedies for such parasites were tried without result—furthermore it was impossible to determine the frequency of the parasitic, even though frequency meters which would go down to three meters were available. The answer was finally found to be in the r.f. choke coils which were in the d.c. plate and grid leads. Evidently the two chokes (ordinary commercial pie-wound chokes) acted like the plate and grid coils of a tuned-plate, tuned-grid transmitter, and a low-frequency oscillation was set up. The grid and plate tank coils on this stage offered practically no reactance to low frequencies, with the result that there was a vigorous oscillation. Removal of the plate and grid chokes in the push-pull stage completely eliminated this trouble.

The keying system used with this transmitter is one which departs somewhat from usual amateur practice, although often employed in commercial transmitters. It is a form of "blocked-grid" keying, utilizing a voltage-divider across the high-voltage plate supply so arranged that when the key is up part of the plate voltage on the last two amplifiers is applied between the grids and filaments of the tubes so that the plate current on both is reduced to zero. It is a very effective form of keying, and one which gives complete cut-off of power output. As shown in the transmitter diagram, resistors to the value of 225,000 ohms are connected across the 2200-volt supply, with a tap brought out at 75,000 ohms from the negative end. The negative terminal is connected to the positive side of the "C" bias batteries, while the 75,000-ohm tap is connected to the filament center-taps of the '60 and '61. The key is connected directly across the 75,000-ohm resistor, and when closed short-circuits it. When the key is open the drop across the 75,000-ohm

resistor [560 volts] acts as additional bias for the last two amplifiers. The Type '10 tubes in the transmitter are not keyed, but run continuously during an entire period of transmission.

One other feature of the transmitter is worthy of some comment. The desirability of a plug and jack metering system has been mentioned previously, and in order to measure plate current in each stage a separate jack is provided in the plate

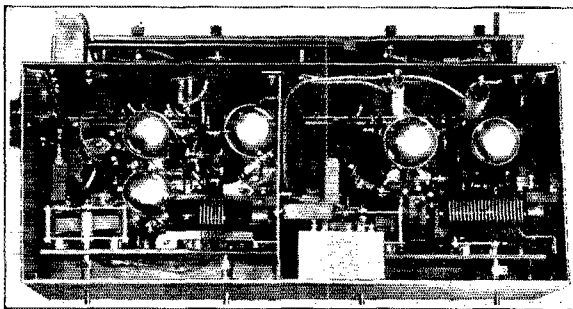

THE LOW-POWER STAGES OF THE NEW TRANSMITTER

From right to left are the 3500-ke. oscillator, 7000-ke. doubler, 7000-ke. neutralized amplifier or 14,000-ke. doubler, and neutralized push-pull amplifier working on either 7000 or 14,000 kc. All tank coils (of No. 14 wire on notched forms) are placed at right angles and as far apart as possible to eliminate undesired feedback. All terminals for plate, grid and filament circuits are brought out to the bakelite panel shown at the top of the photograph (back of the box). Behind the terminal board are the center-tapped resistors for each tube. The resistor at the right is the 10,000-ohm unit which drops the oscillator plate voltage to ± 20 . Individual r.f. chokes and by-pass condensers are used in all plate and grid bias leads with the exception of the third and push-pull stages.

Grid-leak bias is used on the oscillator to avoid any danger of feedback through a common C-bias source. A wooden base is used in each half of the cabinet for mounting the parts. Neutralizing condensers are supported on brass angles screwed to the baseboard. A slot sawed in the condenser shafts makes adjustment possible by use of the gadget shown resting on the supports for the terminal board.

circuit of each tube. If common filament supply had been used for all the Type '10's in the transmitter these jacks would have had to be placed in the positive high-voltage lead to each tube, which would have meant that the jacks on the panel would be at a rather high d.c. potential above ground and the operator would have to be extremely careful in handling the plugs. To bring each jack to ground potential, therefore, it was necessary to have a separate filament supply for each tube so the jacks could be placed in the negative leads. A special transformer was built for this purpose, employing the core and primary winding of an old transformer of suitable power rating. Separate filament windings were put on this transformer for each of the Type '10 tubes and also the Type '60, the latter of course requiring a higher filament voltage. An entirely separate transformer furnishes filament power to the '61. A slight correction of plate-current readings is necessary to take grid current and screen-grid current into account with this method of connection. This is important only on the '60 and '61

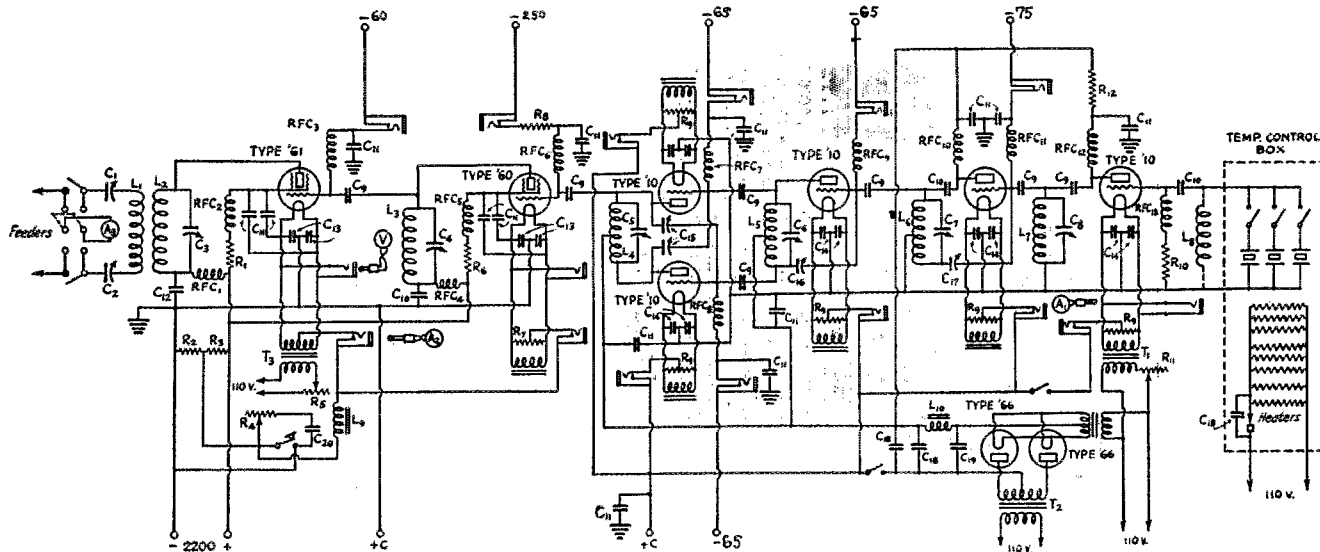

FIG. 5 — THE CRYSTAL-CONTROLLED 7- AND 14-MC. TRANSMITTER

- L₁ — 8 turns of 5/16" copper tubing 3 3/4" inside diameter
- L₂ — 7000 kc. 9 turns 5/16" copper tubing 3 3/4" inside diameter
14,000 " 4 " " " " " "
- L₃ — 5 turns on R.E.L. 20 meter transmitting inductance form
- L₄ — 8 turns No. 14 enamelled wire on R.E.L. receiving coil form
- L₅ — 6 " " " " " " " " " " " "
- L₆ — 10 " " " " " " " " " " " "
- L₇ — 20 " " " " " " " " " " " "
- L₈ — 4 1/2 turns of No. 30 d.c. c. on 1 3/4" form
- L₉ — 1 1/2-henry choke
- L₁₀ — 30-henry choke
- C₁, C₂ — Cardwell 440-μfd. transmitting condenser
- C₃ — R.E.L. 100-μfd. 5000-volt condenser
- C₄ — Cardwell 440-μfd. transmitting condenser
- C₅ — 250 μfd. variable condensers, receiving type
- C₆ — 100-μfd., 5000-volt condenser
- C₁₀ — 500 μfd.
- C₁₁ — 1 μfd.
- C₁₂ — .002 μfd.
- C₁₃ — .002 μfd., 5000-volt rating
- C₁₄ — .015 μfd.
- C₁₅ — Pilot J-15 midget cut down to 7 plates, double-spaced
- C₁₆ — Pilot J-23 " " " " " " " " " "
- C₁₇ — Pilot J-7 midget
- C₁₈ — 4 μfd.

- C₁₉ — 3 μfd.
- C₂₀ — 1 μfd.
- R₁ — 40,000 ohms
- R₂ — 75,000 ohms
- R₃ — 150,000 ohms
- R₄ — 200-ohm rheostat
- R_L — 12.5-ohm rheostat
- R₆ — 90,000 ohms
- R₇ — 140 ohms, center-tapped
- R₈ — 60,000 ohms
- R₉ — 200 ohms, center-tapped
- R₁₀ — 15,000 ohms
- R₁₁ — 50-ohm rheostat
- R₁₂ — 10,000 ohms
- T₁ — Rewound transformer with separate filament windings for all tubes except the '61
- T₂ — Thorndarson T-2950 transformer, 675-675 volts, 200 ma.
- T₃ — 12 volt, 175-watt filament transformer
- T₄ — Thorndarson T-2680 filament transformer for '60's
- RFC₁ — 1 1/2" winding of No. 30 s.s.c. wire on 1/2" form
- RFC₂ — Silver-Marshall Type 277 chokes
- RFC₃ — 2 3/4" winding of No. 30 s.s.c. on 1/2" form
- RFC₄ — 3 3/4" " " " " " " 3/4" " "
- A₁ — 0-50 d.c. milliammeter
- A₂ — 0-500 " "
- A₃ — 0-3 amp. r.f. ammeter (shunted)
- V — 0-15 a.c. voltmeter

stages, where the total space current may differ considerably from the plate current.

Although the oscillator is designed primarily for crystal control, it may be made self-controlled by switching over to a resonant grid coil in place of the crystal, thus allowing the transmitter to be set on any frequency desired within the amateur bands. It is usually operated, however, with the crystal in the circuit.

The following table shows the actual measured values of plate voltage, plate current and grid bias on each of the tubes in the transmitter under operating conditions:

	E_b	I_b (ma.)	E_c
Oscillator, Type '10	220	36.5	-22 (leak)
1st doubler, Type '10	580	40	-75
2nd amplifier or doubler.			
Type '10	580	60	-65
Push-pull amp., Type '10 (2)	580	160 (total)	-65
Power amp., Type '60	2200	200	-370
Power amp., Type '61	2200	380	-60

The bias on the '61 is not at all critical, and 45 to 135 volts may be used under the operating conditions. With higher plate voltage, however, more bias would be required. The tube is being run well under its normal rating in this transmitter, both to prolong its life and to utilize the present 2200-volt power supply without adding expensive equipment for higher voltages. Of the total bias on the Type '60 tube, 120 volts is supplied by the 60,000-ohm leak, and the remainder by batteries.

THE TEMPERATURE-CONTROL BOX

Real frequency stability, even with crystal control, is not attained unless the crystal is maintained at constant temperature. The low plate voltage used on the crystal tube is advantageous because the crystal does not heat from too-strong mechanical vibration when the transmitter is operating. The remaining problem is to keep the crystal temperature constant in spite of the wide variations in room temperature which are encountered at our location. The temperature-control box shown in the photograph is designed to take care of this factor.

The outside box, made of quarter-inch wood stock, is $9\frac{1}{2} \times 14\frac{1}{2} \times 14\frac{1}{8}$ inches. The inner aluminum box is of riveted construction and is large enough to contain three crystals and their holders on the bottom floor. Between the crystal chamber and the heaters is an attenuation layer of asbestos wool $3/32$ " thick, and a $1/4$ " transite box. The heaters are mounted on each face of this box. Eight $1/4$ -ampere Ohmspun heaters are used, one each on the top, bottom and ends, and two each on the front and back. This unit sits in the center of the outer box.

Transite is necessary for mechanical rigidity of the inner hinged box shown in the photograph, but asbestos mill board (which is poorer mechanically, but a better heat insulator) is the material used in the outer-box construction.

$1/4$ -inch slabs of Transite are used for partitions and double air spaces, two in series between the inside chamber and the outer wall, built into the sides and bottom. Wood stock is used for the outside container and for the different supporting corner posts and cleats for holding the Transite partitions.

Since this temperature-controlled box is designed to remain connected across the 110-volt a.c. line continuously, heat insulation is impor-

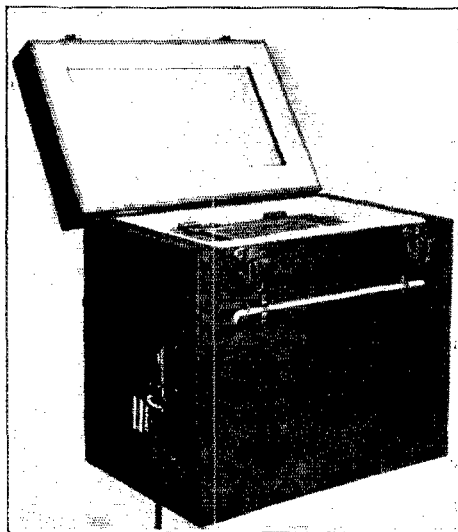

THE TEMPERATURE-CONTROL UNIT

A special Faichney 20-50° C. angle thermometer is mounted on the front and the Cenco bi-metallic thermo-regulator on one end of the box. One of the eight Ohmspun heater units is shown mounted on the lid of the hinged inner box. Trunk clasp fastenings effectively pull down the cover and seal the opening

tant. This is the reason for using two compartments instead of a single dead-air space around the inner chamber. Considerable savings in the electric light bill may be made by seemingly insignificant improvements in the heat-insulating properties of the box. For a box designed to reach a constant temperature more quickly, fewer air chambers are required in the interior construction and a thinner attenuation layer is advisable to permit the crystal to get up to operating temperature in a reasonable length of time.

The cost of such a home-built box to hold three crystals is approximately \$30, which, of course, does not include labor, the principal item. The box is assembled for the most part with small nails and screws, the cost mentioned including the special "angle" thermometer (20 to 50 degrees C.), the Cenco thermo-regulator, and two trunk clasps for clamping the cover down tightly and preventing heat leakage.

The precision of the regulation of the bi-metallic type regulator is approximately plus-or-minus $1/4$ -degree Centigrade under the best conditions

and under fair conditions a temperature control of plus-or-minus one degree Centigrade is obtained. Of course the inner box maintains the crystal at a temperature much more constant than this, which is the variation which obtains in the air chamber. The crystals at W1MK are held at 45° C. While the precision of the regulator itself is not so great as may be obtained with mercury-type thermostats, the fact that these require a relay and an auxiliary battery (since the mercury



ROBERT B. PARMENTER, "RP" OF W1MK

column cannot handle much current) make them less desirable for most amateur installations. To handle over 300 watts a relay is recommended for use with even this type of regulator, but the contacts will handle that amount of power supplied at 110 volts with just an occasional cleaning.

Good circulation of air is essential in a temperature-control box to insure uniformity of temperature in all parts. The thermostat must be installed where the circulation of air is most rapid to secure best results. A .25- μ fd. condenser is used across the contacts to reduce sparking, and a small pilot lamp is connected across the contacts to show that the device is in operation.

OPERATION AND PERSONNEL

The present station is operated several hours daily (except Wednesday and Saturday) on 3575 or 7150 kc., and has been on the air regularly since February, 1928. Many hundreds of contacts with amateurs and members have been recorded. Certain periods are provided exclusively for schedules. General operation in other published periods permits communication with the many

who wish occasional contact with Headquarters for any reason. Information of general interest and timely character is addressed to A.R.R.L. members twice each evening of operation. Reports indicate that such special and official broadcasts are copied by a large "audience." The traffic records of the station speak for themselves as well as the performance in such special communication problems as the coöperation with "The Arctic Patrol" (Army Air Corps flight January, 1930), work with WSBS, DAIV and other plans of lesser magnitude.

For regular operation at W1MK ability of several kinds is required. The operator must be able to send slowly or speedily as a situation demands. Patience, tact, accuracy (above all), and initiative in building up traffic outlets properly distributed geographically — all these and other qualities are needed. The keeping of schedules and handling of traffic must be understood thoroughly. The operator must be able to set an example in every department of operating procedure. The discipline of the commercial operator together with the viewpoint of the ideal amateur is required. How fortunate we were in securing this sort of an operator is well known: Robert B. Parmenter, formerly of W9TW, KUTZ, W9OX-W9WR came to Hartford in February of 1928 just as the installation was receiving the finishing touches. "RP" as he is familiarly known, has kept W1MK on the air ever since. Other operators visiting the station sit in for a twirl at the dials occasionally. Members of the Headquarters staff may be recognized when they operate by their personal "sines" which are listed in every issue of QST. In times of emergency which require that the station be on the air continually EV, AH and FH will usually be found to be the members doing volunteer duty behind the key.

Our Headquarters' Station often has to account for itself on extremely short notice. Since equipment has certain definite limitations, the facilities have sometimes been overloaded by overlapping operating programs dictated by circumstances of the moment. Suffice to say that the station must cater to many different types of operating activities dedicated to the interest of League members. The many schedules and obligations of the station make operating at W1MK a real job.

Much could be said about operating practices, observation of trespassers in and out of our bands, policy of acknowledging every QSL, adherence of different stations we schedule to the given frequency and time, transmission conditions in different bands and seasons, and like subjects, but these things make another story. Our present purpose has been simply to record the work of the station and to touch on the various parts of the equipment in a general way.

Standard Frequency News and Schedules

W1XP, W9XAN and W6XK in Regular Operation—Special Calls Assigned to S. F. Stations

THE early morning hours of November first, with but a few DX hounds as witnesses, saw the completion of the A.R.R.L. Standard Frequency System's organization program. Right on the tick of 4:00 a.m., P.S.T., the new West Coast station, W6XK, opened up with its first scheduled transmission. We knew that Harold Peery and his assistants had made a good job of it because the signals rolled in a good QSA 5 here in Hartford, with a good d.c. note and right on frequency.

A special call for the standard frequency transmissions had been assigned to the Elgin station. It is W9XAN. The Round Hill station will continue to sign W1XP. The description of the standard frequency equipment at the latter station, which was tentatively scheduled for this issue of *QST*, will appear in the January issue instead. The article is by Howard Chinn and is packed with information on frequency measurement and the method of transmitting standard frequency signals as well as a wealth of constructional data on frequency standards, multi-vibrators and other equipment.

The three stations are on for all scheduled transmissions. Unfavorable conditions and skip-distance effects will account for failure to hear transmissions on some frequencies at certain distances and must be taken into account. QRM continues to be a serious handicap and many amateurs have suggested that those amateur stations operating on the frequencies used during a standard frequency transmission stand by while their frequency is being transmitted. This would require only an eight-minute "QRX" and would mean a lot to the fellows who are trying to use the s.f. signals. Let's have a little more coöperation and a reduction in QRM.

Here are the schedules for December and January. The schedules for December are the same as published in November *QST* with the exception that W9XAN's Schedule BX on December 6 has been eliminated. This early morning schedule will be transmitted once every four weeks by W6XK, however.

Dec. 26, Friday	BB	W1XP
	B	W9XAN
	A	W6XK
Dec. 27, Saturday	BX	W6XK
Dec. 28, Sunday	C	W8XAN
Jan. 2, Friday	BB	W6XK
	B	W1XP
	A	W9XAN
Jan. 4, Sunday	BB	W9XAN
	C	W6XK
Jan. 9, Friday	C	W6XK
Jan. 11, Sunday	C	W1XP
Jan. 16, Friday	A	W1XP
	B	W9XAN
	B	W6XK
Jan. 23, Friday	BB	W1XP
	B	W9XAN
	A	W6XK
Jan. 24, Saturday	BX	W6XK
Jan. 25, Sunday	C	W9XAN
Jan. 30, Friday	BB	W6XK
	B	W1XP
	A	W9XAN

STANDARD FREQUENCY SCHEDULES

Friday Evenings			Friday and Sunday Afternoons		
Schedule and Frequency			Schedule and Frequency		
Time	A	B	Time	BB	C
(p.m.)			(p.m.)		
	kc.	kc.		kc.	kc.
8:00	3500	7000	4:00	7000	14,000
8:08	3550	7100	4:08	7100	14,100
8:16	3600	7200	4:16	7200	14,200
8:24	3700	7300	4:24	7300	14,300
8:32	3800		4:32		14,400
8:40	3900				
8:48	4000				
<i>Saturday Mornings</i>					
Schedule and Frequency					
			Time		
			(a.m.)		
			BX		
			kc.		
			4:00 7000		
			4:08 7100		
			4:16 7200		
			4:24 7300		

The time specified in the schedules is *local standard time at the transmitting station*. W1XP uses Eastern Standard Time, W9XAN, Central Standard Time, and W6XK, Pacific Standard Time. Schedule BB transmitted by W1XP is intended particularly for European amateurs and starts at 2100 G.C.T. Schedule BX is transmitted especially for amateurs in Oceania and the Far East. It is transmitted starting at 1200 G.C.T. by W6XK. Reports on these special schedules are particularly desired, not only from overseas hams but from those in the Americas also.

Although the frequencies of the transmitting stations are not guaranteed as to accuracy, every effort is made to keep to within 0.01% of the announced frequencies. The frequency standards

DATES OF TRANSMISSION

Date	Schedule	Station
Dec. 5, Friday	BB	W6XK
	B	W1XP
	A	W9XAN
Dec. 7, Sunday	BB	W9XAN
	C	W6XK
Dec. 12, Friday	C	W6XK
Dec. 14, Sunday	C	W1XP
Dec. 19, Friday	A	W1XP
	B	W9XAN
	B	W6XK

are calibrated against the National Frequency Standard. Frequent checks on the transmissions are made by laboratories equipped with accurate frequency standards and the transmissions are also checked by the U. S. Department of Commerce monitoring stations.

TRANSMITTING PROCEDURE

The time allotted to each transmission is 8 minutes, divided as follows:

2 minutes — QST QST QST de (station call letters).

3 minutes — Characteristic letter of station, interrupted by call letters and statement of frequency. Characteristic letter of W1XP is "G," of W9XAN is "D," and of W6XK is "F."

1 minute — Statement of frequency in kilocycles and announcement of next frequency.

2 minutes — Time allowed to change to next frequency.

THE TRANSMITTING STATIONS

W1XP: Massachusetts Institute of Technology, Round Hill Research, South Dartmouth, Mass., Howard A. Chinn in charge.

W9XAN: Elgin Observatory, Elgin National Watch Company, Elgin, Ill., Frank D. Urie in charge.

W6XK: Don Lee Broadcasting System, Los Angeles, Calif., Harold Peery in charge.

Do not forget to QSL the transmissions. All reports should be sent to the A.R.R.L. Standard Frequency System, Hartford, Conn. A record will be made at Headquarters and the report will be then forwarded to the proper station. S. F. report blanks can be obtained from Headquarters, free and postpaid, upon request.

QRX for Standard Frequency Transmissions.

— J.J.L.

Corrections

An error in the diagram of W7GP's receiver on p. 47 of the October issue put 45 volts on the fila-

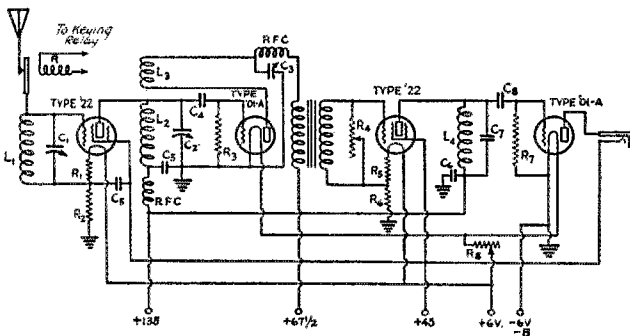

ment of the peaked audio tube, with the result that there was no screen-grid voltage on the two Type '22's in the set or plate voltage on the last

audio amplifier. The corrected diagram appears herewith.

In the description of the new Ward Leonard plate resistors on p. 40 of November QST, substitute the word "possible" for "impossible" in the third line above the photograph.

The left-hand term of the equation in footnote 3 on page 28, November QST, should have been $(2\pi f)^2$ instead of $(2f)^2$.

In the article on "Volume Level Indicators," November QST, the circuit diagrams of Fig. 2 and Fig. 5 should be transposed. This will be immediately apparent to anyone familiar with the Modulometer.

The author has since written us that it might be better to use a volume-indicator coupling transformer of higher primary impedance than 500 ohms in Figs. 4 and 6, since a low-impedance primary will absorb too much power from the circuit. An ordinary audio transformer with the primary connected to the output of the speech amplifier should work well and draw negligible power.

Strays

The name "Pyrex" is applied to several varieties of glass made by the Corning Glass Works, chief of which are the "chemical-resistant glass" and "electrical-resistant glass." In order to avoid clumsy wording, "Pyrex" will be used in QST to refer only to the electrical-resistant glass unless otherwise stated.

Louis S. Miller, Brockton, Mass., and W1ASZ, Pawtucket, R. I., have both written us suggesting that the insulating plugs on Ford transmission covers make excellent stand-off or lead-in insulators. The spring should be removed and a bolt inserted through the hole after the fashion of G.R. insulators.

A tip for the fellows who are too much inclined to "nerve sending" with the finger tips and who tire out trying to send a continuous message of any length: Try operating with the nails and knuckles of the first two fingers lying on top of the key with the thumb coming up under the edge of the flange to aid in making characters. The bent-over knuckles form a natural spring which relaxes easily after each pressure, with the result that there is less stuttering and balling-up of characters, and a long message is easier to send even at a good clip. There is no effort of hanging onto the key all the time.

— W9FO

Experimenters' Section

Converting the Four-Tube Receiver to A.C. Operation

By W. K. McCulla, W9AE-W9BTU*

IT WOULD appear from the number of photographs in QST and from the personal experience of the author, that there are many of Hull's four tube plug-in coil and condenser receivers in operation among the gang.¹

The following is a brief description of one of these receivers which has been successfully converted to a.c. operation, making use of plate

two plates spaced approximately $\frac{3}{4}$ inch apart. The purpose of this condenser is to vary the beat note on a received signal without touching the main tuning control of the receiver.

The condenser C_4 , normally a grid condenser, in this particular circuit merely acts as a blocking condenser. Grid bias for the detector tube is supplied by a small 22½-volt "C" battery mounted in the set. The positive was connected to the ground, negative connected to the grid through a Hammarlund radio-frequency choke.

The regeneration is controlled by a 200,000-

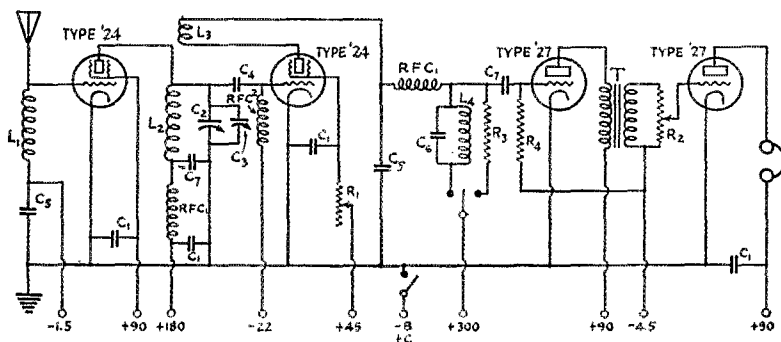

FIG. 1

- L_1 —Antenna coils wound on old tube base
3500 kc.—30 turns No. 30 s.s.c. wire
7000 kc.—30 turns No. 30 s.s.c. wire
14,000 kc.—15 turns No. 30 s.s.c. wire
 L_2, L_3 —Same specifications as in original set
 L_4 —Ford coil secondary without core
 C_1 —1 μ f.
 C_2 —Tuning condensers same specifications as in original set
 C_3 —Beat note condenser described in text
 C_4 —.01 μ f.

- C_5 —.002 μ f.
 C_6 —.015 audio tuning condenser
 C_7 —.006 μ f.
 R_1 —200,000-ohm variable resistor
 R_2 —200,000-ohm potentiometer
 R_3 —75,000 ohms
 R_4 —2 megohms
 T —Audio transformer
 RFC_1 —Receiver-type r.f. choke
 RFC_2 —Hammarlund Polarized r.f. choke

The heaters of the tubes are connected in parallel and supplied from a 2.5-volt transformer. Heater wiring is not shown in the above diagram.

rectification in the detector circuit, or as the broadcast fraternity call it, "linear power detection." The circuit is shown in Fig. 1.

In place of the 10,000-ohm resistance in the antenna circuit a four-prong socket was mounted on the sub-panel and a semi-tuned antenna inductance was substituted for the resistor. "C" bias for the first '24 is secured by a 1½-volt dry cell shunted by a radio-frequency by-pass condenser, also mounted on the sub-panel.

In this particular receiver, no changes were made in the coil and tuning-condenser assembly with the exception that C_3 was added. This was a small Pilot condenser in which all plates but one stator and one rotor were removed and those

ohm resistor in series with the screen-grid lead to the detector tube.

By means of a selector switch either a peaked audio system or one having a flat amplification characteristic is available. The optimum output coupling resistance for a screen-grid detector is in the neighborhood of 200,000 to 250,000 ohms. Experimenting with this receiver, however, showed that the voltage amplification was not greatly decreased or any great amount of distortion introduced by the use of a lower value of resistance. With a tickler coil suitable for use with a 200,000-ohm resistor in the plate circuit of the detector it was impossible to control oscillation with the switch on the peaked-audio system side, because of the smaller voltage drop through the choke compared to that through the resistor;

* 148 S. Genesee Street, Waukegan, Ill.

¹ Described in November 1928, QST and in the Handbook.

75,000 ohms was the most workable compromise and was therefore used.

If the receiver shows a tendency to have a bad fringe howl it can be eliminated by changing the value of the resistance R_4 . In this particular case R_4 had a value of two megohms.

The purpose of the switch in the B minus lead is to afford a means of taking the plate voltage off the tubes during transmission periods.

It will be noticed that the cathodes of all tubes operate at ground potential. It is the custom in most broadcast receivers to supply the grid bias

Judicious use of by-pass condensers aids in maintaining proper radio frequency paths. The lead from the condenser C_4 to the tube is encased in a Carter screen-grid lead shield. No other shielding is used in the receiver.

Because of an unusually poor location, it is impossible at W9AE to hear any amateur stations other than those within the limits of the United States. It might be said, however, that an audio frequency volume increase of about two to one over the previous performance of the d.c. set resulted from the conversion to the circuit shown.

Some trouble was experienced with bad "bubbling" in some of the Type '24 tubes tried. This noise can be cured by placing them across a 6-volt battery for five minutes with no plate voltage on.

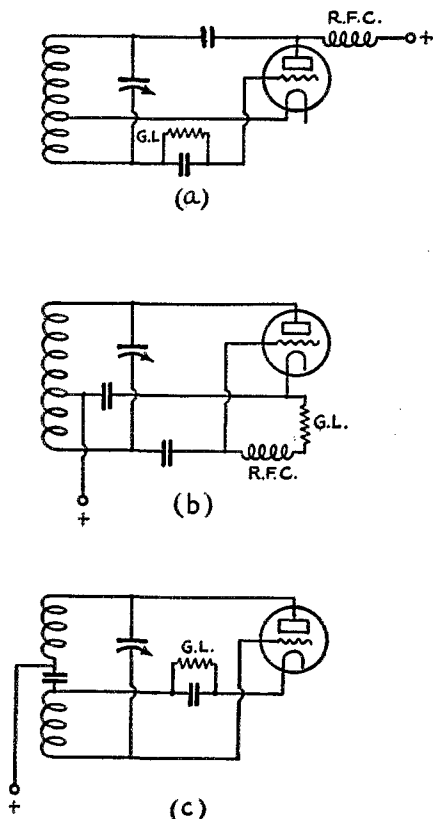

FIG. 2

between the ground and the cathode, to aid in hum elimination. However, in this receiver no particular advantage was noticed by so doing.

This set is operated with a.c. for the filament lighting and batteries to supply the plate current. Inasmuch as the total over-all drain is only eight milliamperes, no particular economy could be anticipated from building a power supply for the plate current. However, should it be desirable, no difficulty should be experienced in the construction of an adequate a.c. plate supply.

A CHOKELESS HARTLEY CIRCUIT

"A short time ago I set for myself the problem of devising a short-wave transmitter which would not require any radio-frequency choke, and which would yet be more simple than the Hoffman balanced Colpitts or the t.p.t.g. I took a pencil and paper and drew all the simple sending circuits with which I was acquainted and tried to alter them so as to eliminate the radio-frequency choke. I soon hit upon (b), Fig. 2, which is electrically the same as the ordinary Hartley circuit (a). However (b) still has a radio-frequency choke, but it is now in the grid circuit because the positive plate supply is connected at a point of zero r.f. voltage, while the grid leak cannot be connected at such point without splitting the coil as in (c). But let's look at our grid leak before discarding (b). Yes, it's made just like we suspected it was, out of a very large number of turns of very fine resistance wire wound on a porcelain tube. Why cannot it be used as a grid leak and grid r.f. choke rolled into one? There is no good reason why it cannot and at least one good one why it should be, for its high distributed resistance quite effectively keeps it from resonating at some frequencies and absorbing power.

"A 14,000-ke. transmitter was immediately built to test out this idea. It used a Type '10 tube as an oscillator and a wire wound 10,000-ohm resistor which cost 25 cents at the dime store in the rôle of grid choke and leak. The plate voltage was between 600 and 700 volts and introducing a plate r.f. choke did not change the plate current at all. A grid choke was not tried because the mere fact that the tiny grid leak did not burn up proved that it could not be carrying an appreciable amount of r.f.

"This circuit adjusts exactly like the standard Hartley circuit and requires fewer parts than any of the other 'chokeless' circuits with which I am familiar. The only precaution is to see that the grid leak is of a type which has inductance and to be sure that the grid condenser will stand the full plate voltage. The first layout that I built works

so beautifully that it is now the only transmitter in use at my station."

— Roger M. Wilson, W6AMJ

QSY WITH CRYSTAL CONTROL

"Having read Mr. Boyd Phelps' article on QSY with crystal control in the September issue of QST, I am prompted to write about the method in use at W9CIR. There is considerable satisfaction in being able to QSY to any part of the band in spite of the fact that only one crystal is in use.

"As is well known, in grinding a crystal a condition is often met where hundreds of parasitic oscillations are set up on each side of the main frequency. As an experiment the writer decided to try to build up the strength of these oscillations so they could be used to excite a buffer amplifier.

"A coil was placed in the grid circuit of the crystal stage to produce regeneration. This gave the desired results, and sufficient excitation was obtained to swing the grid of a buffer. The grid coil was then tapped at every turn, and this enabled the proper harmonic to be picked up and amplified. Later, a variometer was substituted for the tapped coil, and QSY was then possible over the entire 3500-kc. band.

"In shifting frequency it is only necessary to turn the variometer to a pre-determined setting and bring the tank circuit into resonance, returning the amplifier tanks, of course. The entire operation takes but a few seconds, and the crystal has at no time shown a tendency to jump to any other frequency."

— Frank Weidenbach, W9CIR-KGDA

D.C. HOUSE CURRENT SUPPLY FOR THE TRANSMITTER

"Just a line for the sake of those poor 'hams' who, as I, have d.c. in their homes and can't afford an m.g. or dynamotor, and who would at least like to QSO an adjacent district instead of being limited to that in which they live. 'B' batteries are always possible as a means of getting a little voltage for a plate supply, but they cost plenty and don't last very long. So one must resort to the house current.

"Now, it's easy enough to connect the plate to the positive and the filament center-tap to the negative; the problem arises in getting sufficient voltage to work something more than just locals. In most d.c. equipped houses this is done easily enough by drawing 220 volts from the line. Sounds impossible that 220 volts can be drawn from a 110-volt line, but it is done in this manner:

"Test the plug nearest the back of the house by sticking the two wires about 1½ inches apart in a potato. The one which turns the potato slightly green is the positive. Take this wire and test for ground (to find out which terminal of your

line at this point is grounded) by placing the middle terminal of an ordinary electric-light bulb on a place of good ground and touch the other terminal with one of the wires from the socket that you just tested. If the bulb lights when you touch it with the positive terminal, for example, then it stands to reason that the negative terminal is grounded. The same procedure is gone through for one of the sockets in the front of the house. It will usually be noted that the opposite terminal to that in the back is grounded. I say usually; because, knowing practically nil about house wiring, I don't know much except that my house and a couple of others that I have tested are wired this way. That is to say that if in the front the positive is grounded, the negative will be grounded in the back; or vice-versa.

"The rest is easy. Just take those two ungrounded terminals, one from in front, and one from in back, attach them to the transmitter at the correct places; and, Presto! you have 220 where you had before 110 volts.

"Any house line may, and probably will, have a slight commutator ripple. This gives a more or less good r.a.c. note, and if a pure d.c. note is desired, a choke of about 150 or 200 turns of No. 24 to 30 wire wound on an iron screw or some such will effectively eliminate the ripple. I have been using 150 turns of No. 28 wire on a 1½ inch screw and when the transmitter is tuned properly I get xtal reports consistently.

"With this rig and the xmitter circuit shown in December, 1929, QST I have worked all districts but the 6th and 7th. I hope to work them this winter by putting two Type '01-A's in parallel, instead of just the one tube.

"If this system of plate supply is used, it would be as well to get a couple of one-ampere fuses to put in the two line leads. Also, don't try any form of direct coupling because if the antenna is not perfectly insulated it is likely to form a short circuit between ground and one of the plate-juice leads. If you use one of those trick antennas wherein the feeder is supposed to be 9 feet off center, couple it to the tank coil by putting a fixed condenser in the feeder somewhere. This will not affect the signal as far as decreasing QSA goes and may help in giving a steadier, better note, depending on various conditions. At any rate, be mighty sure your antenna does not swing because there is a large capacity between antenna and ground, caused by the fact that the normal opposite pole of either of your plate leads is grounded. The least swing, therefore is very noticeable. To eliminate a slight swing that I got whenever the people in the houses opposite me put out clothes to dry (my antenna is attached to the pole there) I put one of those five-cent screen-door springs between the antenna and this pole and now have very steady sigs; even on Mondays!"

— A. F. Smith, Jr., W2BXJ

Some trouble can be saved in determining whether or not it is possible to get 220 volts from the house line by inspecting the service meter. If there are three wires coming into it the 220 is available, and may be taken directly from the two ungrounded terminals (on the house side of the meter, of course) or from sockets at different parts of the house as described above. Ninety volts of heavy duty "B" batteries in series with the 220 so obtained will make quite a respectable power supply for a Type '45 tube — or two of them in a rig such as was described in last month's *QST*.

THREE-BAND TRANSMITTING ANTENNAS

The problem of fitting an antenna for the three most popular bands into a limited space is always a puzzling one for the beginner, or for that matter for the advanced amateur as well. One suggestion was made in the January, 1928, issue of *QST*; we present herewith a few more from various sources.

The first of these is explained in the following letter from Don L. Spender, W1HD:

"A new antenna system for efficient operation in the three principal amateur bands (3.5, 7 and 14 megacycles) was recently installed at W1HD. It is suitable for erection in the limited amount of space available to the average amateur, and permits quick and easy shifting from one band to another. It has proved to be so eminently satisfactory in operation that it was decided to set forth the details for the benefit of any brother amateur who may be cramped for antenna space, as is the case at W1HD.

"The system consists of a fundamental Hertz antenna, of a length suitable for operation in the 7-mc. band. A length of 65 feet is usually about right. This is fed at the near end by a 16-foot Zeppelin feeder. The system as it now stands is suitable only for operation in the 14-mc. band.

"By cutting into the feeder two matched loading coils as shown in Fig. 3, wound in the same direction, of such proportions that the feeder will tune to 7 mc., the antenna may be operated in this band with practically the same efficiency as the usual 7-mc. Zeppelin antenna with 25- to 30-foot feeders. Then, by cutting out the loading coils, tying the feeders together and adding a separate wire (a so-called 'counterpoise') long enough to allow fundamental operation in the 3.5-mc. band the system will work in the latter band with good efficiency.

"The usual 7-mc. Zeppelin antenna may of course be operated, with a counterpoise, in the 3.5 megacycle band; but the system described is probably more effective, because the feeder is only of the order of 16 feet or so in length; hence, when used with a counterpoise, the transmitter is coupled at a point much closer to the voltage node than can be the case when using 25- to 35-foot feeders.

"The loading coils used at W1HD are 12 turns each of 12 gauge wire, space-wound on 2-inch

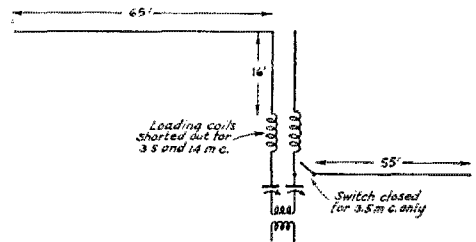

FIG. 3

bakelite tubing; the coils are wound in the same direction, and are set up parallel to each other a distance apart about equal to the spacing between the feeder wires. The number of turns on these coils was determined by reference to a thermometer placed in the center of the antenna, with the transmitter operating at constant frequency and input in the 7-mc. band.

"The counterpoise used with the system here is 55 feet long; this length may vary slightly with different installations."

Southeastern Division Sections Consolidate

AT the suggestion of E. W. Mayer, K4KD, the Porto Rico-Virgin Islands Section of the Southeastern Division has been combined with the Georgia-South Carolina-Cuba-Isle of Pines Section operating under SCM Alexander, W4RZ. The amount of activity and number of stations reporting in Porto Rico and the Virgin Islands was deemed insufficient to warrant a separate section. Amateurs who previously reported their activities to former SCM Mayer should now report to SCM M. S. Alexander, W4RZ, 47 Second Avenue, S. E., Atlanta, Georgia.

Strays

A Pyrex test tube coated on outside and inside with tinfoil makes an excellent high-voltage blocking condenser which tests OK at 3000 volts.

— W6BRI

W7II suggests using a variable resistor in series with the negative high-voltage and center-tap of the filament transformer for obtaining "C" bias for a modulator tube. A separate filament winding is required for each tube so supplied. When the resistor is used, separate "C" batteries are not required, but it must be kept in mind that bias so obtained reduces the plate voltage by the amount of bias voltage.

I. A. R. U. NEWS

Devoted to the interests and activities of the
INTERNATIONAL AMATEUR RADIO UNION

President: H. P. MAXIM

Vice-President: C. H. STEWART

Secretary: K. B. WARNER

Headquarters Society:

THE AMERICAN RADIO RELAY LEAGUE, Hartford, Conn.

MEMBER SOCIETIES

American Radio Relay League

Asociacion E. A. R.

Associazione Radiotecnica Italiana

Canadian Section, A.R.R.L.

Deutscher Amateur-sende-und Empfangsdienst

Experimenterende Danske Radioamatorer

Lwowski Klub Krotkofalowcow

Nederlandsche Vereeniging voor Internationaal Radio-amateurisme

New Zealand Association of Radio Transmitters

Norwegian Radio Relay League

Radio Society of Great Britain

Reseau Belge

Reseau Emetteurs Français

South African Radio Relay League

Sveriges Sandareamatorer

Union Schweiz Kurzwellen Amateure

Wireless Institute of Australia

Wireless Society of Ireland

Conducted by Clinton B. DeSoto

ONE of the most important questions affecting amateur operating procedure is always one for which a comprehensive, definite and determinate answer has never been secured, namely, the exact status of amateurs regulations in all the countries of the world.

As previously reported in these columns, one of the resolutions passed at the Antwerp Congress in July was concerned with this problem. It embodied a request to I.A.R.U. Headquarters to prepare a pamphlet containing data to be submitted by various sections giving the laws governing amateur radio in each country. This request was referred to Union member-societies in Calendar No. 4, and it is hoped that all members will coöperate to the extent of supplying copies of the amateur regulations existing in their respective countries.

This provides for only eighteen of the principal nations of the world, out of a possible total of seventy-odd countries wherein are located amateur stations. It is therefore that this present means is taken to request the amateur society of each country, colony, protectorate, or political land area, possessing individual regulatory codes, to forward to Union Headquarters at the earliest possible moment copies or translations of all laws affecting amateur operation. Other pertinent information concerned with licensing, numbers of active transmitters, memberships, etc. will also be appreciated. Where no active society is in existence, individual amateurs are requested to supply the needed information, in the interests of

international coöperation and to further international understanding.



Hartford Times Photo

HIRAM PERCY MAXIM, PRESIDENT OF THE I.A.R.U., SENDING OUT THE SIGNAL WHICH OPENED THE W.I.A. 1930 RADIO EXHIBITION AT MELBOURNE

(See the Australian Report in this issue.)

The effort of national amateur societies at the present time should be directed toward securing

the granting of as great a percentage as possible of the amateur privileges as set aside by the International Radiotelegraph Convention to amateurs in their own countries, and at the same time an eye should be kept turned toward future conferences empowered to alter the international code.

The primary step toward these goals should be acquainting the people of your nation, the officials of your government, with the value of the work done by amateurs. Let us suggest here that you turn once more to the editorial in the September issue of *QST*, and read it over again. Now is the time to start a program of international publicity, with each society accepting responsibility for a national unit in the complete scheme. Now is the time to create that favorable background, that intense sympathy for the amateur and his endeavors, those good wishes for his ultimate success in the coming international parleys. It is urged that every amateur organization consider the establishment of a publicity service for its own country, for the purposes suggested above.

We return once more to the subject of DX time-tables. Have you checked over the results obtained thus far in the autumn season with those published in this department during the winter and spring months of last year? Do they still hold good as to times, places, bands, etc.? Probably they will have changed by some noticeably large degree. If such is the case it is your call to work out a comprehensive listing of the results obtained at the present time, making it as detailed and as definite as time and opportunity permit, and send it along to this department.

To show that we will do something about it, here's some dope on reception of W stations in New Zealand:

From August 15 to March 30

On 14 mc. stations are heard from 0100 to 0500

On 7 mc. stations are heard from 0500 to 1200 (Only Pacific Coast stations heard between 0800 to 1000)

On 3.5 mc. from 0700 to 0830

March to August

On 7 mc. from 0730 to 0130

Few stations heard on other bands and at other times.

Which brings to mind the unusual success enjoyed by New Zealand amateurs in hearing United States stations on the 3.5-mc. band, during the autumn months. According to reports eighty meters has been "hot" down at the Antipodes this year.

We record with pleasure the issuance of another WAC for 'phone certificate. This time it is to Frank R. Neill, GI5NJ, of "Chesterfield," Whitehead, Belfast, Ireland. His is the fourth WAC for 'phone extant; the second in the British Isles.



ONE OF THREE SIMILAR DISPLAYS SUBMITTED BY OA4J ALONG WITH THE ACTUAL CARDS IN APPLYING FOR HIS WAC CERTIFICATE

One of the many interesting points brought out by amateur experience in connection with the study of wave propagation is the apparently intense strength of North American signals in Iraq, and the rela-

tively great difficulty experienced in receiving YI signals on the American end of the circuit. This could obviously be due, in the main, to the numbers of stations on this side and the resulting difficulty in hearing any foreign signals reliably, but experience seems to point out even more attenuation than can thus be accounted for.

Nevertheless, a surprisingly large percentage of U. S. WAC Club members have obtained their Asian contact through some one of the many enterprising stations located in Iraq.

AUSTRALIAN REPORT

By W. G. Sones, Dir. Fed. Publicity, W. I. A.

Mention has been made previously of the temporary concessions which Australian amateurs have enjoyed in regard to telephone operation between 1715 and 1200 kc. (150 to 250 meters) and also for operation in the 3.5-mc. band.

The most important item of news this month is a further extension of the concessions until January 31st, 1930. The use of the band is of course subject to non-interference with other services and there are very definite hours of working during the week-ends, particularly on Sunday between 10:30 a.m. and 12:30 p.m., 3:00 and 4:30 p.m. and 6:00 to 6:30 p.m. being prohibited. The hours have always been observed as a silent period, however, because of interference with B.C.L.'s, so that this is not in the nature of an additional restriction. Instead, it is regarded as a concession,

(Continued on page 64)

Calls Heard



VE2AP, John Stadler, 4334 Westmount Ave., Westmount, P. Q., Canada

w4afk w4ahl w4abt w4aim w4ft w4lm w4kl w4pe w4pf w4rx w4sk w4tiv w5aak w5alc w5aly w5alq w5aza w5bay w5ani w5hii w5pa w5rr w5td w5uf w5afi w5aaj w5atj w5ac w5bcx w5bjf w5brv w5bvm w5bxv w5efa w5egh w5yx w7wix w7hx w7iy w7wl w9adi w9aiv w9bbv w9beu w9cfa w9bqh w9exr w9ddq w9dwi w9ddq w9drd w9ddr w9deaj w9ebo w9ecz w9fvw w9fyn w9gek w9giz w9lah w9law py2ab py2ay py2az py2ba py2bk py2bm py2de lu3dh lu6aj lu8dy celah x9a oa4j oa4z exlaf ex2ac cm3me cm2jt cm2ah cm2xd cm2wa cm5fc nj2pa on4dt on4fe on4gn on4jc f8ol fo8hs f8mrc et1aa kfr6 kfr7 g2cj g2ma g2vq g5ml g5yg g6hp g6ut g6wt g6xb

W4LY, E. R. McCarthy, 12 Forest Hill Drive, Asheville, N. C.

ae1bd ae8ag an2p ar2j? celaa celah ce1wi ce2ab ce2ao ce3ac ce3bf ce3ch ce3c ce3r ce5aa ce7aa cebag ckv cm1by cm2ay cm2jm cm2jt cm2sh cm2xa cm2xd cm5cx cm5fl cm5lu cm5ni cm8cx cm8dy cm8le cm8uf cm8yb cm8rux cmz5 cmz6 cmz7 cmz9 cmz15 cmz16 cmz51 cmz53 cm8mb eplaa cr4ad cxlaf cx1fb cx1fc cx2ab cx2ak cx2ck cx1ap ex7 et1aa et1ac et1ae et1bx et1by et1ew et1db et2aa et2ac et3ad et4ez et4ay et4rh et4xn ear10 ear21 ear41 ear65 ear96 ear98 ear136 ear137 ear149 eari xearn eu2kbm f8aja f8aly f8awx f8aw f8bl f8ct f8da f8dh f8dz f8ef f8er f8ex f8fa f8fo f8fk f8fr f8fbv f8fem f8gdb f8hr f8hw f8mrc f8pam f8px f8rm f8ami f8sua f8wrg f8zb ef8axo fm8cr fm8fiz fm8fm fm8ih fm8mst iq8rpx iq8hpx iqpm iqgt it1mu fura fny frfk fzb g2bm g2ej g2gm g2kf g2ma g2ap g5by g5bz g5dy g5jf g5ky g5ml g5mo g5ms g5qv g5rg g5uq g5yg g6bd g6nt g6rd g6rb g6rr g6pv g6wt g6xb g6xq g6za g6zl haf1c haf3c helenn hel1g helle he2jc he2jm he2jo hf3ch fn5 hj5x hlla hh7e hhy j2cb k4aan k4ac k4akv k4dk k4fd k4kf k4ni k4rf k6afd k6aff k6bla k6boe k6edd k6dmq k6dqf k6emb k6epb k6erh k6est k6etf k6zee k7anq k7lh k7pq kfr4 kfr5 kd5v kfuv kfzt krrn1 kaloe kalca kalce kalcm kal1d kal1h kal1ba lulcz lu2aa lu2ar lu2ea lu2dj lu2fi lu3fb lu3de lu3dh lu3fa lu3he lu3oa lu3pa lu4ai lu4da lu4dc lu4dq lu4bi lu4hj lu5ac lu5hi lu6ag lu6aj lu6fc lu6se lu7ei lu7ie lu7jt lu8de lu8dj lu8dt lu8dy lu8e lu9ce lu9de lu9dt nj2pa nj8mrc nn1micca4a oa4e oa4j oa4io oa4oo oa4p oa4q oa4r oa4s oa4t oa4z oh3na on4aa on4au on4caa on4dj on4dv on4eu on4fe on4fm on4fp on4ft on4gu on4gw on4hp on4j on4k on4m on4n on4nj on4o on4q on4r on4s on4w on4z xoz7aw pa0qf pa0xg pa0zf pa9arj pk1aj pk2aj pk3bm pk3bo pj1d pm6a py1aa py1ah py1al py1ay py1bh py1ca py1cd py1cl py1em py1er py1eg py1id py1tm py2ak py2al py2ay py2ba py2bf py2bj py2bk py2bk py2ek py2gz py2ie py2if py2ig py2ih py2ii py2ik py3aw py3aq py3bf py3dh py7ak py8ia py2qg py2rd q1la rkv rxc sm5yf splaa st2a su8rs sx5m ti2ea ti2hv vetap velas velba velbd velar velca velce velda veldq veldr velde velae velai velad velad vel4ba vel5b vel5d vel5e vel4bq vel4bu vel4bx vel4c vel4ck vel4dq vel4dw vel4ek vel4ec vel4fk vel4fp vel4fv vel4g vel4gq vel4hj vel4he vel4hu vel4hy vel4ie vel4kl vel4pt vel4r vel4v vel4xb vel5a vel5ao vel5aw vel5bl vel5bh vel5ef vel5ep vel9bj vel9ce vel9s vk2an vk2ax vk2eb vk2ch vk2ca vk2dy vk2ek vk2go vk2h vk2hb vk2hc vk2hl vk2jj vk2kj vk2kk vk2lj vk2lv vk2nb vk2nc vk2ns vk2ot vk2pk vk2rc vk2rx vk2su vk2vk vk2wp vk2wu vk3ag vk3cm vk3cx vk3dp vk3dy vk3dx vk3go vk3hk vk3k vk3l vk3jo vk3ml vk3pa vk3pb vk3pm vk3pp vk3wx vk3xo vk3ak vk3ax vk4bh vk4fj vk4ga vk4fm vk4rj vk4ok vk4uk vk4vk vk4zx vk4zy vk5bj vk5by vk5gr vk5hg vk5it vk5ja vk5wh vk5wr

vk6fl vk6nk vk6sa vk6wr vk6mu vk7dx vk7dh vk7rb vo8ae vo8an vo8aw vo8mc vo8zr vq2pa v2zb v2zb v6ah v7al v7ap v7aj vu2ax vis vjp vvs wdde wfa wfat wftb xc xaf xda xoq x8ctb x3a x5a x9a c9b x9d xu2uu ynlv ys1ap ys1x ys1xb z1lag z1lan z1lao z1ffa z1flm z1flu z1llw z1lfx z1lly z12ab z12ax z12an z12ac z12bz z12bx z12bz z12gh z12gx z12xc z13af z13ai z13aj z13as z13cm z14ab z14ap z14ax z51p z52a z54m z56d z55u ztlj ztlr zu6d zu6n zu8k ziv 10 meters (some are probably harmonics) w1da w1zz w1axw w4al w4hj w4nj w4te w4gw w5aot w6am w6dam w6bax w8ddk kfu5 g1kc ce2ab ct8r hjo w4mi

W9ANQ, A. Herrmann, Jr., 653 Mill Ct., Waukegan, Ill.

7000-kc. band
cm5fc cm5fl cm8yb k4kd k6bxw k6eqm k6erh k6oa hel1g nj2pa nn1mic ve2ca ve4ec ve4cu ve5cr ti2rs ys1x cab cabl kfr6 obe

14,000-ke band
celah ce2ab ce5aa cm2jm cm2sh cm2xx cm5ex cm8uf cm8yb cx2ak g2bm g2gf g5bj g5bz g5bp g5hv hel1g he2je he2jm k4akv k4kd k6erh lu9dt oa4e oa4j oa4l oa4q oa4t oa4z on4fp py1ah py1aw py1id py2ax velam vel1dq ve2ac ve2ay ve4ai ve4be ve4bq ve4ha ve4he ve4ie vk2hb vk2vj vk2zk vk3cx vk3dc vk3hm vk3jk vk3lp vk3ok vk5gr x9a ys1ap ys1x z1lao z1las z1lfr z1llw z12bx z13cm z14bo kfu5

VE5AL, King Cawalky, 4868 Blenheim St., Vancouver, B. C., Canada

14,000-ke. band
vel1ew vel1dm ve2ba ve2ai ve2be ve2bh ve2ca ve3af ve3ak ve3aq ve3bm ve3bc ve3ce ve3et apl1 celac ce2ab ce3ab ce3bf cm2sh et1aa f8fk f8da f8fx f8j f8pa f8zx g2aj g5by g5ml g5ux g6qb he2om k6cte lu3de lu3dh lu8en lu9dt oa4d oa4h oa4o oa4p oa4q on4ar on4hc pylax py1ah py2qa sc1ah ti2hv vk2hc vk2jw vk3ax x5u x9a xk8ru z12be

7000-ke. band
wladw w1bkf w1rk w1om w2af w2alu w2abi w2api w2acd w2aql w2bud w2bos w2cc w2fr w2cov w2se w2up w2sg w3aix w3ahv w3ckl w3ckl w3eb w3gt w3ys w4ak w4afs w4agz w4et w4ew w4paa w4lp w4gn w4rp w4rm w4rz w4ty w4vk w5aea w5aqe w5aav w5afx w5agp w5aau w5bbe w5bcb w5bck w5bhw w5bh w5bcx w5la w5lr w5pe w5pp w5rj w5rv w5rq w5ql w5rg w5qx w5td w5ap w5av w5aq w5ayg w5amb w5bdl w5bcq w5bt w5be w5buq w5bbh w5scr w5eft w5cp w5ti w5yg w9ara w9aqx w9a'n w9bhg w9bvk w9brn w9bze w9bwt w9bze w9vcn w9eas w9ebd w9elk w9lk w9un ve2be be2bh ve3bm ve3czkalkr kal1d k6avi k6axw k6bhl k6bra k6bxw k6ejs k6ceu k6de k6ddm k6dmm k6eqm k6ero vk1ax vk2ch vk2hk vk2hc vk2hw vk2jo vk2ju vk2jz vk2jz vk2jl vk2kl vk2kj vk2ku vk2no vk2oj vk2wu vk3ac vk3ax vk3bk vk3go vk3ja vk3jk vk3jo vk3mx vk3tm vk3rk vk3bh vk4do vk4kr vk5dx vk5hd vk5gk vk5lj vk5mb vk5it vk5wr vk6nk vk7ch vk7ka vk7wm z1aa z1bb z1bi z1lf z1lfe z1lt z1ab z12be z12bi z12bz z12gk z12gn z13am z13ae z13as z13ab z13aw z13cm z13vf z14ao z14bg ao5li celah estj em2yb hel1g j1dv j1xa lu2p rx1aa xclah xw2 kh1dv sien wfat wbs

VK3CX, Alan G. Brown, 8 Mangarra Road, Canterbury, E. 7, Victoria, Australia

14,000-ke. band
wlala wlapq wlaqt wlaze w1bhm w1bux w1cmx w1cwo wlii w1zz w2adp w2ajp w2alo w2ano w2apl w2atk w2ayj

(Continued on page 86)

Correspondence

The Publishers of QST assume no responsibility for statements made herein by correspondents.



Washington Licenses

FEDERAL RADIO COMMISSION
WASHINGTON, D. C.

September 22, 1930.

My dear Mr. Maxim:

As you know, the Radio Act of 1927 makes the Federal Radio Commission responsible for the issue of radio licenses, including those of amateurs. Early in the existence of the Federal Radio Commission the duty of administering licenses to amateurs was delegated to the Radio Division, Department of Commerce, for reasons that existed at that time.

Since the Federal Radio Commission has now been provided with adequate facilities as regards office space and personnel, there is no longer any reason why the provisions of the Act should not be carried out by the Commission. Steps have been taken this day by the Commission to bring this about. A copy of the order is inclosed. [See article, "Changes in Regulations," in this issue. — *Ed.*]

As you know, the Commission has always been interested in the amateurs of the country and appreciates the good work which has been done by them. The Commission desires that all matters connected with the administration of amateur licenses be carried on in the most efficient and satisfactory manner. Any suggestions from you as to improving the procedure in the issue of amateur licenses will be gladly received by the Commission.

Yours very truly,
C. McK. SALTZMAN,
Chairman.

VOQH

East Greenland Expedition for Museum
of American Indian Heye Foundation

Editor, *QST*:

You have no idea what a source of comfort and relief it was to have the amateur radio men and girls in America and Europe come to our call, taking our messages back and forth to loved ones. After all, they are the ones who appreciate it more. We wish it could be possible to give all the amateurs a trip to the land of polar bears, musk oxen, icebergs and continuous days. The only thing we can do however is send our warmest thanks and best wishes to all the amateurs.

— R. A. Bartlett

Technical Articles

Worcester C. P., South Africa

Editor, *QST*:

Relative to your editorial in the August number, it is strange that out here with our S.A.R.R.L. effort the editor is asked why he does not furnish more technical articles. The reply is that our magazine "QTC" is more or less of a family magazine and too — technical articles are out of place; while we all get *QST*, or should.

And so while we sympathize with the complainants we hope that with your resources you will continue your present policy in the matter of technical articles.

More power to your elbow.

— S. H. Walters, ZU1D

Lids or Beginners?

Thomasville, Ga.

Editor, *QST*:

A short time ago I became interested in radio. To be exact I put my first transmitter on the air in 1910, just twenty years ago, not long enough for me to forget that I was not born with my knowledge of radio. I have always believed in listening to the other fellow instead of doing the talking myself.

I have been reading *QST* some ten years and this is my first letter. The reason for this epistle is the letter from A. D. Middleton, WSUC and W8AKA, in the October issue — page 56.

Every man has a right to his opinion. The fact that it does not conform with our own does not alter that right. I wish to take issue with WSUC on the last part of his letter, wherein he refers to the numbers of "lids" on the air to-day.

From my observation there is a greater interest in amateur radio to-day than at any other time since the little unpleasantness across the pond. This increased interest has given us an unusual number of beginners. These beginners are the only material from which to make the amateur and commercial operators to pound the brass when our ears are dulled and our fists will no longer separate the dots and dashes.

I may be mistaken, but I think most of this interference in our bands comes from the beginners, caused not through malice but ignorance. Brother, don't call them "lids" until you know they are. Look up their records. If they have "been on" a sufficient length of time to know



Why Not Go Round the World . . .

Let **RADIO** Pay Your Way

RADIO needs more men like you today . . . Positions now open for "radio fans" who want to get somewhere in radio . . . men who think radio . . . who are radio minded . . . men who play and work at radio. Why not use the knowledge you already have as a stepping stone to success in radio? All you need is the practical up-to-the-minute training that RCA gives you. RCA Institutes actually trains you for success in radio . . . you learn under the direction of RCA experts. You get the practical as well as the theoretical knowledge . . . the "how" as well as the "why" of radio. You, too, can make good in radio . . . so, why not start today!

*A Commercial Radio License
Can Easily Be Yours*

The entire radio world needs trained men NOW. On ship and shore the demand is constant. Large broadcasting stations, manufacturers, dealers, as well as steamship companies are continually asking for men who have the knowledge and the confidence

to hold a well-paid position in Radio. You, too, can now get that knowledge . . . You can be trained for a good paying radio job.

RCA is the world's largest radio organization. It sets the standards for the entire radio industry. And the RCA Institutes' home-laboratory training course enables you to learn the secrets of radio quickly. It enables you to obtain a thorough, practical education in radio in your spare time . . . You get the inside information, too, because you study right at the source of radio achievement. You learn radio by actual experience with the remarkable outlay of apparatus given to every student.

For the added convenience of students who prefer a Resident Study Course, for class room instruction, RCA Institutes, Inc., has established Resident Schools in the following Cities:
New York . . . 75 Varick St.
Boston, Mass. . . 899 Boylston St.
Philadelphia, Pa. . . 1211 Chestnut St.
Baltimore, Md. . . 1215 N. Charles St.
Newark, N. J. . . 560 Broad St.
Chicago, Ill. . . 222 North Bank Drive
Home Study graduates may also attend any one of our resident schools for post-graduate instruction at no extra charge.

*See For Yourself Why RCA Graduates
Earn Big Money in Radio*

Clip this coupon now . . . send for this free book. Or, if you wish, step in at one of our resident schools and see for yourself how RCA Institutes actually prepares men for success in radio. Come in and get this free book or send

for it by mail. Everything you want to know about radio. Each page packed with pictures and descriptions about the amazing opportunities in this vast, world-wide, money-making profession.

Clip this Coupon NOW!

RCA INSTITUTES, INC.

A Division of Radio Corporation of America



RCA INSTITUTES, Inc.
Dept. QST-12, 75 Varick St., New York
Gentlemen: Please send me your FREE 40-page book which illustrates the brilliant opportunities in Radio and describes your laboratory method of instruction at home!

Name.....
Address.....
.....

Cunningham RADIO TUBES

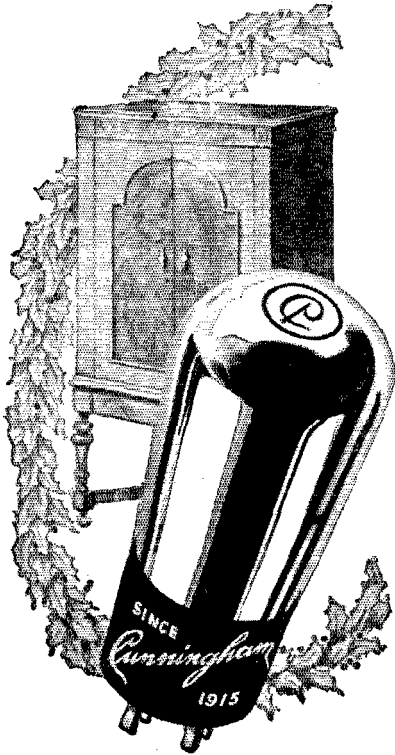

Where Accuracy Is Vital!

Pioneers that have seen service at the two poles on the most hazardous adventures of man, can need no greater endorsement.

Use them in every socket and be certain of results.

E. T. Cunningham, Inc.

New York San Francisco Chicago
Dallas Atlanta

better than they are "lids" and I have no sympathy for them.

In all my career I have never been too learned or too busy to explain in understandable language anything that a beginner asked, even though he could not converse in terms higher than "two turns on a two-inch coil."

Here is my conception of a drive against the "lids." Make contact with him; find out whether he is a beginner or a "lid." If the first, tell him what is right and wrong — if necessary write him a letter. If he proves to be a genuine "lid" tell him where to get off. If he persists in malpractice advertise him to other hams. Nature will take its course.

Amateur radio has been my greatest hobby, commercial operating my vocation and taking sides with the beginner my greatest weakness and pleasure. I never expect my name to blaze on memorial tablets for great achievements, but if when it appears in *QST* under "Silent Keys" some ham says "Bless his memory, he helped me over some rough spots," then I will stand by in peace.

Yours for better conditions.

— Ellis E. McBride, W4KX

Tolerance

Tallahassee, Fla.

Editor, *QST*:

It was with much amusement that I read the letter by Mr. A. D. Middleton in the Correspondence Section of October *QST*. He seems to have a grievance against the world in general, and against the poor hams in particular. Of course, we all cannot sop up *all* the dope that is published in *QST*, while it seems that W8UC thinks that is the main requirement.

I must admit that I agree with him in reference to these birds who sit on their keys and forget to get up. But if he has never served in any branch of the commercial racket or the Government radio business, he has never heard any QRM. I served on board the U.S.S. *North Dakota*, and when we were stationed in Cuba or down around South America, the Old Man didn't take the QRM as an excuse for not getting N.A.A.'s press schedule every night. Many days we had to stand watch with lightning pounding down in the sea all around us. QRM? QRN? You ain't heard nothin'.

As to a man sending hash — what does this amateur game amount to anyway? I am new in the ham game, only having been on the air since last June, but I will say that all my QSO's were with fine fellows, and while our topics of discussion were only things concerning WX or radio or something on that order, I cannot consider that as hash. I am just as proud of those QSO's as if I were still serving Uncle Sam and all were important messages. I am in this game for the fun that I can get out of it, and while there is no excuse for a man holding down his key any longer than necessary, I believe it is all in the game.

Here's hoping that W8UC-W8AKA gets a

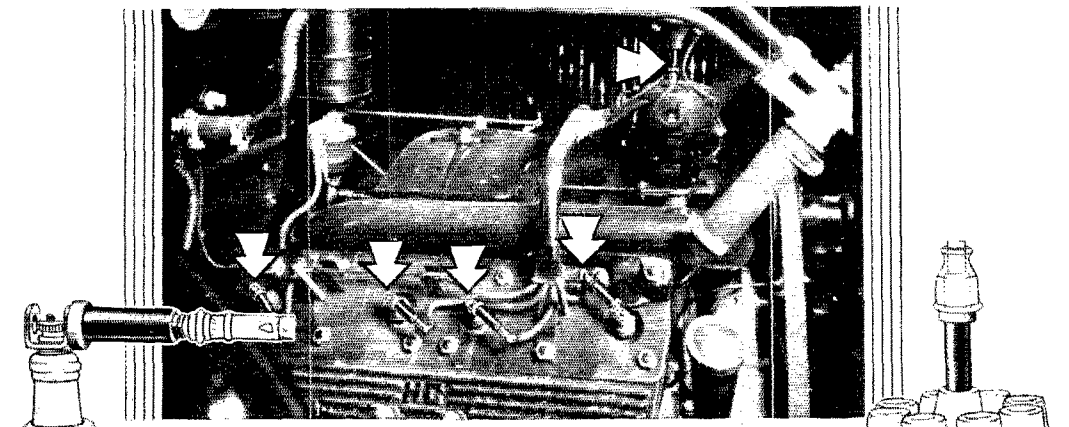

On Radio-Equipped Cars Stop Interference by Installing Bradley Suppressors

BRADLEY Suppressors are special solid molded resistors, now used by prominent car manufacturers to provide individual resistors for each spark plug and for the common cable to the distributor on radio-equipped cars.

They increase the resistance of the high tension ignition system and minimize the disturbing oscillations in the ignition circuit which interfere with the radio receiver in the car. When used with suitable bypass condensers in other parts of the circuit, shielded ignition cables are unnecessary.

They do not affect the operation of the motor. The sturdy construction of Bradley Suppressors adapts them for the severe service in which they are used. Heat and moisture and age have no effect upon their performance. Their design is the result of more than a quarter century of experience in the manufacture of solid molded resistors. They are the last word for motor car radio.

For complete information address
Allen-Bradley Co.
108 W. Greenfield Ave., Milwaukee, Wisconsin

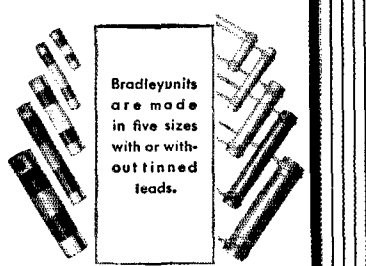

Bradleyunits are made in five sizes with or without tinned leads.

Bradleyunits are solid molded resistors unaffected by temperature, moisture or age.

Their accurate calibration, great mechanical strength and performance make them ideal for providing correct C-bias, plate voltage, screen grid voltage and for use as gridleaks and as fixed resistors in resistance coupled circuits.

All units are color-coded to meet any radio set manufacturer's specifications.

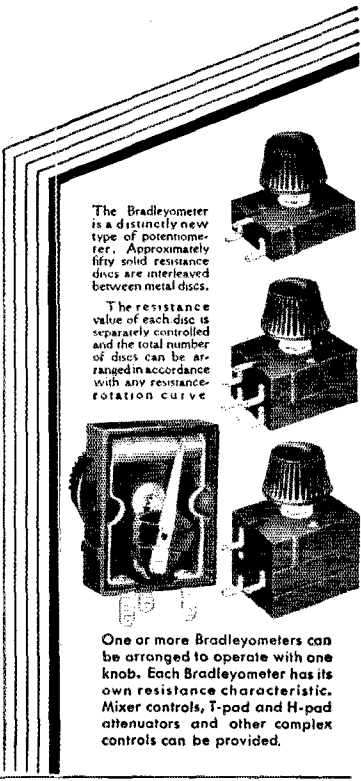

The Bradleyometer is a distinctly new type of potentiometer. Approximately fifty solid resistance discs are interleaved between metal discs.

The resistance value of each disc is separately controlled and the total number of discs can be arranged in accordance with any resistance-rotation curve.

One or more Bradleyometers can be arranged to operate with one knob. Each Bradleyometer has its own resistance characteristic. Mixer controls, T-pad and H-pad attenuators and other complex controls can be provided.

ALLEN-BRADLEY RESISTORS

Produced by the makers of Allen-Bradley Control Apparatus

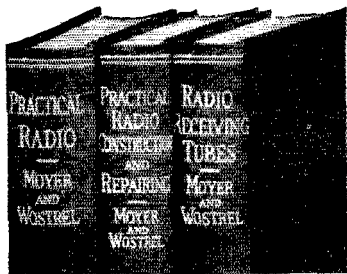

993 pages
5 1/2 x 8 inches
561
illustrations

Complete data on construction and repair of modern radio sets

These three books cover the entire field of building, repairing and "trouble-shooting" on modern broadcast receiving sets. The Library has been brought right up-to-the-minute in every respect, including the very latest developments in the design and manufacture of equipment. The recent interest in short-wave reception is reflected in a section which deals with the construction of this type of receiver.

Radio Construction Library

By JAMES A. MOYER

Director of University Extension, Massachusetts
Department of Education

and JOHN F. WOSTREL

Instructor in Radio Division of University Extension,
Massachusetts Department of Education

THESE three books embody not only a thorough home-study course, but a ready means of reference for the experienced radiotician. Step-by-step information is given on wiring, "trouble-shooting", installation and servicing to get the best tone quality, distance and selectivity in broadcast reception in all types of sets.

Practical data is given on radio equipment such as antenna systems, battery eliminators, loud speakers, chargers, vacuum tubes, etc., etc.

A section is devoted to the identification of common faults in receivers and methods of making workmanlike repairs.

The three books are profusely illustrated with understandable diagrams of hookups, connections, loud speaker units, installation work and antenna erection — as well as numerous photographs, tables and charts which clarify the text.

See this Library for 10 Days Free
No Money Down — Small Monthly Payments

It is your privilege to examine this Library for 10 days without cost. If it proves satisfactory, send an initial payment of only \$1.50 and \$2.00 a month until \$7.50 has been paid. Otherwise return the books.

McGraw-Hill FREE EXAMINATION COUPON

McGraw-Hill Book Company, Inc.
370 Seventh Avenue, New York

You may send me the Radio Construction Library, three volumes, for 10 days' free examination. I agree to remit an initial payment of \$1.50 at the end of 10 days and \$2.00 a month until the price of \$7.50 is paid — or — I will return the books.

Name

Home Address

City and State

Position

Name of Company QST-12-30

different view on life, and that he will answer a few of these long CQ's and work the man to the bitter end.

— S. M. Douglas, W4ACB

Suggestions

1928 Lewis Ave.,
Long Beach, Calif.

Editor, QST:

I would like to offer a couple of suggestions for improvements in operating practice. Both ideas have been used at W6DZK for several years, and they work well — when the other operator understands them.

The first is this: Why not, at the end of each CQ, sign TOP, or BTM, indicating at which end of the band you intend to start listening. Thus, if the other operator hears you sign BTM, and his wave is near the bottom, then he knows that he need only give you a short call.

The second suggestion is merely to alternate the end of the band at which you start listening. This practice would probably eliminate such statements as: "I can't raise him," he always starts listening at the top of the band and my wave is at the bottom," etc. A good station nearly always hears one or more answers to calls before covering the width of the band.

Possibly these ideas have been submitted before, but I failed to notice them. At any rate, please take them for what they are worth.

— Orin C. Lewis, W6DZK

The suggestion is a good one but may lead to confusion unless we define the "top" and "bottom" of a band. In spite of QST's many adjurations to hams to think in terms of kilocycles instead of meters, there are many to whom the high-frequency end of a band is the "bottom" and not the "top." Maybe some sort of system using the words "high" and "low" instead of "top" and "btm" would overcome this — or better yet "hf" and "lf." — Editor.

Commercial Operating

M.S. Pacific Sun

Editor, QST:

As to your query, "Do tankers have port holes," I am taking the liberty of presenting my views on commercial operating in verification of as well as in contradiction to the letter from Mr. M. R. Rathbone.

I have followed the sea as a commercial operator for over five years and have been on passenger ships, freighters and tankers. I feel that I am in a position to give an unbiased view of living conditions as well as of the moral association into which the average commercial operator is thrown.

I have at no time ashore found men so willing to be of assistance, men so willing to go out of their way to do you a favor as the larger percentage of seagoing mates and engineers. I have found them at all times willing to give a hand to the man who comes on board a vessel to assume his duties as radio operator for the first time. Mr. Rathbone has assumed a most unfair as well as

the brilliant opportunities
"CeCo Radio Tubes are the standards by which
we make our radio tube comparisons."
J. N. Schoenberg, Post Standard Stores, Philadelphia, Pa.

Increasing use of high-quality phone transmitters by amateurs created demand for rugged, long-lived, powerful modulator tubes . . . capable of withstanding heavy overloads and high voltages. The new CeCo 250 Tube with its rugged filament, high emission, negligible grid current and super vacuum is well adapted for this service."

DO YOU KNOW!

1. The CeCo Engineering Laboratory operates station WIXAC for testing and developing power tubes.

2. The CeCo Power Pentode P5 can be used as a buffer amplifier in transmitters or as an output amplifier in receivers.

● CeCo Radio Tubes are licensed under the patents and applications of the Radio Corporation of America and affiliated companies.

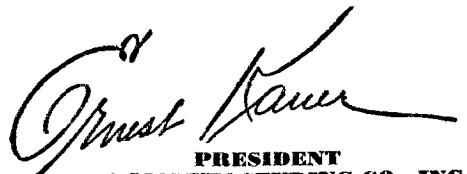
**PRESIDENT
CECO MANUFACTURING CO., INC.
PROVIDENCE, R. I.**

CeCo Radio Tubes

The Candler System Courses Are Outstanding Contributions to the Telegraph Fraternity

**TWO PROMOTIONS
IN FOUR MONTHS**
"Received two promotions in four months since taking SYSTEM; am being considered for another. The ease with which I telegraph and use "mill," not to mention other improvements, has repaid me a thousandfold." — K. M. Martin, 2033 Webster St., Oakland, Cal.



WALTER H. CANDLER, author *Psychology of Telegraphy, Telegraphic Technique, Originator The Candler System, will direct you personally.*

"THE SYSTEM improved my ability in telegraphing and using "mill" far beyond anything I had anticipated; it's more than you claim." — M. R. Rathbone, Chief Opr., S.S., Galawall, c/o Lassco, Wilmington, Calif.

The three **CANDLER SYSTEM COURSES** embody the results of 19 years Scientific Research and Experience by the author in training and developing thousands of leading Morse and Radio operators all over the world. You can "step up" to the bigger, better position through **THE CANDLER SYSTEM**. It eliminates all "hit-and-miss" procedure.

CANDLER SYSTEM Senior Course: A Post Course of Intensive Training for Developing Sending and Receiving Speed by Scientific Methods. Trains Brain, Muscles and Nerves to Co-ordinate in doing Fast, Accurate work. Develops Power of Concentration and gives you Confidence. Corrects Faulty sending, relieves Glass Arm and increases receiving Speed to a remarkable degree.

CANDLER SYSTEM Junior Course of Scientific CODE Instruction. Gives you the "right start." Takes you quickly from zero to 20 or more words per minute. Every detail is scientifically taught in this interesting course.

RADIO-TOUCH-TYPEWRITING: Only Typing Course that teaches you correct use of "Mill" in telegraphing. Use all fingers and copy anything you can read easily and accurately.

"Just finished Junior Course. Send and copy much faster; have more confidence. Inspector 5th Dist. gave exam. for Amateur Licenses. Passed tests without any trouble. Could have copied twice as fast, where formerly could just about get the limit and wasn't sure of it either." Geo. Peters, W8AW1, 230 River St., Scranton, Pa.

The Candler System Gives You Speed

Stop guessing and wasting time. Put yourself under the direction of this recognized authority, known the world over for his scientific work and contributions, and you can be sure of satisfactory results. Utilize the scientific methods of **THE CANDLER SYSTEM** in achieving your goal. Make a start by mailing the coupon today!

THE CANDLER SYSTEM CO. QST 12-30
6343 So. Kedzie Ave., Chicago, Illinois.

Without obligating me in any way, send information on the course or courses I have checked:

- CANDLER SYSTEM Junior Course For Beginners**
 - CANDLER SYSTEM Senior Course For Radio Operators**
 - RADIO-TOUCH-TYPEWRITING COURSE**
- My present speed is: Sending wpm, Receiving wpm.
- I want to qualify in both American Morse and Continental.
 - I am giving in a letter further information about myself, my ambitions, etc., to enable you to give me your personal advice.

Name Age

Street

City State

(PRINT)

narrow view with regard to the official personnel of our American Merchant Marine, and I am sure that he has had time to regret his statement. As for the education of the present mate or engineer, has Mr. Rathbone taken into consideration the three or more years he has had to work and study to be able to procure his license? Not in a nicely lighted and heated college but in a school of hard knocks, in a battle with the elements wind, sea, heat and cold as well as a necessary course of study. Is not that in itself a liberal education?

As for the morals of our Merchant Marine as a whole, I think they are above reproach. Did Mr. Rathbone stop to consider the position into which the average sea-going man is thrown? If he had, I believe he would have been more lenient with his condemnation. I have at no time found men more respectful and solicitous of the companionship of a good woman than a sailor. To prove my statement, take the YL's on any merchant vessel and see for yourself the courteous treatment which they will receive. I doubt if it can be surpassed by any body of men ashore.

As for the actual living conditions, I heartily agree with Mr. Rathbone. Many operating berths are decidedly inadequate due to meagre accommodations and to their placement. Steamship companies lose hundreds of dollars each year because of the continual change of operators on these undesirable vessels. It would be well if the owners would take the interests of the operator to heart when designing the radio room and his living quarters. The meals on board vessels of the American Merchant Marine vary in accordance with the allowance per day per man but more so with the ability and knowledge of the steward's department on each vessel. On passenger ships meals vary mostly with the size and run of the vessel and quite a variety of edibles can be expected which should be more than satisfactory to suit the most fastidious operator.

As for the romantic and adventurous side of operating, Mr. Rathbone seems to be something of a cynic. After five years of operating, I find I still enjoy a visit to a foreign port or a trip up the Mississippi. From an educational point of view, I believe a trip to Europe, the museums and art galleries of Brussels, Amsterdam, Antwerp and many others too numerous to mention will more than repay the average operator for the time expended in procuring his ticket.

At the present writing, there is more than a surplus of operators and any berth is not to be overlooked. Runs cannot be picked at random and the new operator should not be discouraged if his first ship contains all the disadvantages that can be expected from an operating standpoint.

— L. E. Littlejohn, Ex-5NE, WQDL

Some Heavy Traffic

75 New Haven Ave.,
Milford, Conn.

Editor, QST:

I am writing this as an open letter of appreciation to those stations on 3.5 mc. who helped

BYRD'S Antarctic Radio Equipment

The advanced types of receivers, transmitters, and navigation aids that triumphed on this epochal flight now fully described in this book.

TELEVISION

Mr. C. F. Jenkins, father of television and radio movies, gives you in his own words complete directions for building practical television equipment.

INTERFERENCE ELIMINATION

Tracking down troublesome interference and eliminating it, systematically outlined by W. F. Fleming, radio engineer.

RADIO AUTO-ALARM

New automatic device on ships to keep the SOS watch while operator is off duty—fully described in this book.

Latest BROADCASTING Equipment

Temperature-controlled Piezo crystal oscillator, 100% modulation panel, and other new apparatus, completely described, with instructions for operation.

SHORT-WAVE Apparatus

Latest types of commercial and amateur short-wave apparatus; directions for securing operator's and station license.

MARINE and AERIAL Radio Equipment

Radio beacons; arc radio transmitter for ships; Reed course indicator; latest developments in high frequency transmitters.

New RADIO LAWS and REGULATIONS

New regulations governing all classes of operators' licenses, U. S. Laws, and I. R. T. C. laws.

The Latest Data!

Complete and up-to-date information covering the entire field of Radio—all arranged for ready reference in this one big guide book

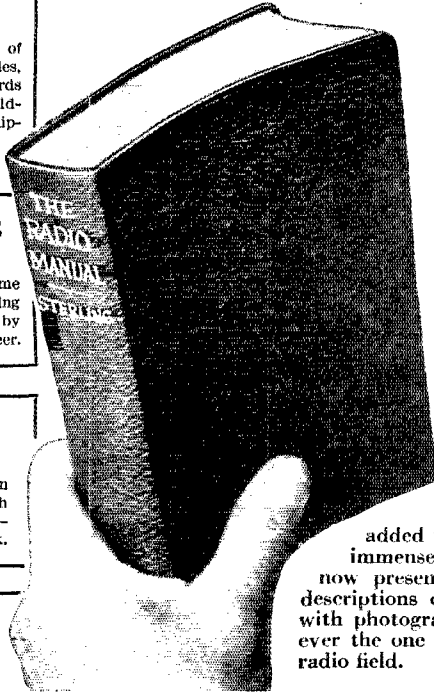

THE RADIO MANUAL

A Handbook for Students, Amateurs, Operators and Inspectors

Here's the answer to every question about the principles, operation and maintenance of apparatus for radio transmitting and receiving. No detail has been omitted, from elementary electricity and magnetism for the beginner to television and radio movies. Important new chapters have been added to bring it right up-to-the-minute, and an immense volume of facts never before available is now presented in the book. Included are detailed descriptions of standard equipment, fully illustrated with photographs and diagrams. It is now more than ever the one complete handbook covering the entire radio field.

A Complete Course in Radio Operation IN ONE VOLUME
Enables You to Qualify for Gov't License as Operator or Inspector
20 Big Chapters Cover:

Elementary Electricity and Magnetism; Motors and Generators; Storage Batteries and Charging Circuits; The Vacuum Tube; Circuits Employed in Vacuum Tube Transmitters; Modulating Systems and 100% Modulation; Wave-meters; Piezo-Electric Oscillators; Wave Traps; Marine Vacuum Tube Transmitters; Radio Broadcasting Equipment; Arc Transmitters; Spark Transmitters; Commercial Radio Receivers; Marconi Auto-Alarm; Radio Beacons and Direction Finders; Aircraft Radio Equipment; Practical Television and Radio-movies; Eliminating Radio Interference; Radio Laws and Regulations; Handling and Abstracting Traffic.

Prepared by Official Examining Officer

The author, *G. E. Sterling*, is Radio Inspector and Examining Officer, Radio Division, U. S. Dept. of Commerce. The book has been edited in detail by *Robert S. Kruse*, for five years Technical Editor of *QST*, the Magazine of the American Radio Relay League, now Radio Consultant. Many other experts assisted them.

Mail This Coupon Today!

Examine it FREE!

The 1930 edition of "The Radio Manual" has just been published. Nearly 800 pages, 369 illustrations. Bound in Flexible Fabrioid. The coupon brings the volume for free examination. If you do not agree that it is the best Radio book you have seen, return it and owe nothing. If you keep it, send the price of \$5.00 within ten days.

D. Van Nostrand Co., Inc.
250 Fourth Avenue, New York

Send me the Revised edition of THE RADIO MANUAL for examination. Within ten days after receipt I will either return the volume or send you \$5.00, the price in full. (QST 12-30)

Name.....

St. and No.....

City and State.....

Business Connection.....

QST Can Help You With Your Christmas List

CAN'T you picture certain of your friends (particularly the fellow who borrows your copy) who would be as delighted as you are with *QST*?

A subscription present is unique, too. It serves as a monthly reminder of your thoughtfulness.

A yearly subscription costs only \$2.50, little enough for the ones you have in mind. And — we'll send an appropriate gift-card conveying your Christmas Greetings.



QST
1711 Park St., Hartford, Conn.

Please send *QST* to the following, find my check enclosed, and send out the Greeting cards for me.

1.
.....
.....
2.
.....
.....
3.
.....
.....

me so splendidly in a recent bit of traffic handling.

With no schedules being prearranged, I took 170 messages from the Philadelphia Radio Show, where W3IC, W3IA, W3AW and W3AKY were operating W3ATC at the U. S. Naval Reserve Booth. The fine operating of these fellows enabled me to receive the traffic without any trouble. It was just another one of the "long shots" and I had my doubts as to whether I would be able to clear the hook. However, as the log here shows, the next twelve stations worked each took a fair sized slice of these messages, so that all traffic was cleared within twenty-six hours after the last one had been received from W3ATC. With several of these stations, schedules were made for different hours of the day in order to route the traffic as fast as it was received.

The following stations have my sincere thanks for their splendid coöperation: W1CNE, W1WU, W1WV, W2CIA, W3AMH, W8BDG, W8CHC, W2CGO, and W8CPE. To W8CHC, the deepest gratitude is extended for his wonderful help in taking from me 105 of these messages in the surprising time of 130 minutes. To fully appreciate this feat, you must realize that the check on these messages was close to 2400 words, with some very difficult combinations in a large number of the addresses.

In my opinion this shows in a measure the attitude of the general amateur toward traffic, and it makes a fellow feel great when everyone says "Sure QSP, MK GA." More power to you all and happy days.

— E. F. Scholz, W1AMQ

Saving the Wrist

Iota, La.

Editor, *QST*:

This may be of interest to many hams, as the scientific wonder I will unfurl before them is a boon never dreamed of in this great amateur game. I have invented a machine for a great many of the amateur fraternity which will be known to them as the "CQ es CALL BLURRER." This machine is the wonder of wonders, and is designed to save certain hams from a "CQ wrist." A "CQ wrist" is one that cannot stop until thirty or forty are made and then the wrist is so tired that it is unable to make the sign, making only a slur.

This machine has a minimum of thirty and a maximum of two hundred CQ's. Of course the setting most used is between thirty and forty before signing. The machine also makes your call, as the manufacturer puts that in when the machine is ordered.

It has one knob which controls the amount of CQ's to be emitted thereby enabling the ham to set it at the desired speed and amount of CQ'ing to be done. It also will make a clear sign three times or slur just once at the operator's pleasure.

Utopia at last has arrived for the terrible CQ hound and he can easily purchase one of these wonderful machines, direct from the manufacturer, "CQ es CALL BLURRER" Machine Co., Inc.,

A SAFE GUIDE

in the selection of insulation for Radio Transmitting and Receiving Sets

PYREX
RADIO INSULATORS

Where they are used and what leading authorities say about their performance

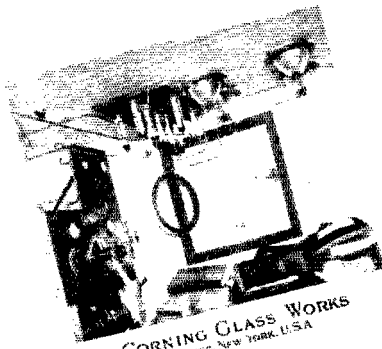

CORNING GLASS WORKS
CORNING, NEW YORK, U.S.A.

OVER 300 broadcasting stations, leading radio telegraph systems, the United States Army, Navy, Air Mail, Coast Guard and Ice Patrol Services, explorers like Commander Byrd, and exacting amateurs everywhere have utilized PYREX Insulators in many spectacular achievements.

Regardless of whether you are sending or receiving — on land, sea or airplane — you should be thoroughly familiar with the PYREX Antenna, Strain, Entering, Stand-off and Bus-bar Insulators that are helping these leaders to make radio history.

The new PYREX Radio Insulator booklet lists all types and sizes with data that you will want for ready reference.

Return the coupon for your copy, and if you want further advice on any insulation problem, our Technical Staff will answer your questions promptly.

Send the coupon for your copy

CORNING GLASS WORKS
Corning, N. Y.

Gentlemen:

Please send me copy of your new bulletin on Radio Insulators.

Name

Address

QST 12-30

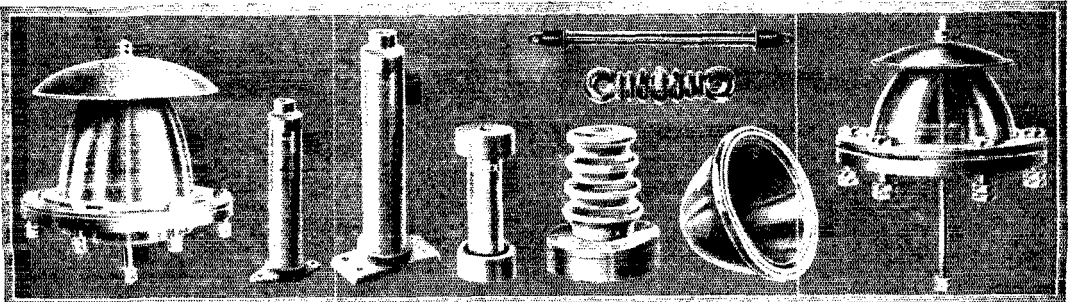

PROOF POSITIVE » » of TRIAD SUPERIORITY » » *the new* T-210 Tube!

A new TRIAD T-210 tube! Functions equally well as power amplifier and oscillator. Assures longer life and far better service than ever before. Has thoriated tungsten filament — can be easily reactivated. Molybdenum construction (instead of nickel) — eliminating grid and plate emission which is the chief cause of noisy tubes.

Here is another actual proof of TRIAD'S superiority — and of the progressive spirit which has won national recognition for TRIAD Engineers.

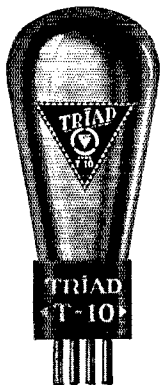

Send now for Triad bulletin T-210 and for information regarding the remarkable improvements that have been carried out throughout the entire Triad line. A special price is extended to Licensed Amateurs and Members of A.R.R.L.

TRIAD Tubes are fully licensed under all R.C.A. General Electric and Westinghouse Electric Mfg. Co. Patents

Triad Manufacturing Co.
Pawtucket, R. I.

of this city, for the modest amount of \$44.50, prepaid.

There's hoping that the amateur fraternity will greatly appreciate my marvelous invention and that I may secure many orders for this wonderful instrument (postage prepaid).

— R. L. Tomps, W5MH

Re: Traffic CQ's

Burlington, Wis.

Editor, *QST*:

We read with much interest the letter from Roy R. Wallace, W6ERU, in the September issue.

While W9EBO is not purely a traffic station, we have handled as many as three hundred messages in one month and are always glad to QSP any time to any place.

We too have tried directional CQ's without much luck, so as an outcome of this experience are much in favor of the set of CQ signals as outlined by W6ERU, as we firmly believe that this system would do away with a lot of needless QRM by letting the other fellow know just what is wanted by our CQ.

A practice which we have always used here is to never answer the ham who sends his CQ 15 or 20 times and then signs. There is ONLY ONE RIGHT WAY to do anything and if any ham cannot send his CQ in the proper way, he is merely admitting to the rest of the gang that his station is poorly operated.

We are with you, W6ERU. Constructive criticism is always welcome — let's hear from more of the gang.

— M. F. Whitton, W9EBO

Getting S. F. Transmissions

Dexter, Mich.

Editor, *QST*:

It is common practice when listening to the Standard Frequency transmissions to tune the receiver to zero beat with the incoming signals and then tune the frequency meter to be calibrated to zero beat with the receiver and the S.F.S. at the same time. While this practice is OK and very accurate, I have a much more convenient method.

If the frequency meter is of the heterodyne type, tune the receiver to the incoming signal in the usual manner, then back just off the point of oscillation and no beat note will be heard. Now tune the meter to beat with the incoming signal and the audio beat note will be heard in the "cans." Tune to zero beat, and you have the meter in step with the transmitting station and don't have to worry about the receiver. After tuning in the signal with the frequency meter it will be found that the tuning on the receiver is rather broad and the beat note of the same audio pitch regardless of receiver adjustment.

Sometimes it will be an advantage to use the frequency meter in this way to bring in a weak signal when working skeds, and BOY! that's

MERRY CHRISTMAS FOR THE STATION WHEN YOU INSTALL THIS SENSATIONAL RECEIVER!

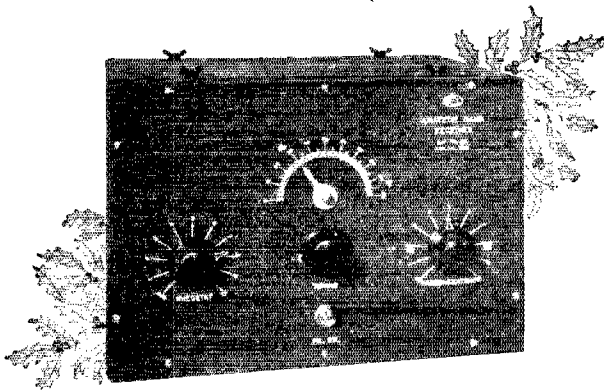

The most practical Amateur band Receiver yet developed — designed for Amateur work by the oldest reliable manufacturer of Short Wave equipment. Just see these outstanding features:

- 1 — Employs new super sensitive 2-volt non-microphonic battery operated tubes
- 2 — Spreads each amateur band over the full range of the dial
- 3 — Equally efficient for DX, CW or fone reception
- 4 — Thoroughly tried and tested circuit guaranteeing consistent results
- 5 — Screen grid RF — detector — power audio
- 6 — Readily calibrated for each band
- 7 — Easily assembled and wired

A complete kit comprising all necessary parts to build this record-breaking Receiver — includes drilled and engraved panel, metal cabinet and three special Amateur band plug-in coils allowing each band to be spread over the entire tuning dial.

Price \$30.00

*Don't slip up on the finest Christmas
treat you could ever have hoped for!*

Write for our large loose leaf
handbook full of information,
kept up to date by regular
bulletins. Price only 50c.

Our booklet 50 describes this
Modern Short Wave Receiver
together with a "bang up"
Transmitter.
Write for it, It's FREE!

RADIO ENGINEERING LABORATORIES, INC.

100 WILBUR AVENUE

LONG ISLAND CITY, N. Y.

Export Department, 116 Broad Street, New York City

This Issue Completes the 1930 Series of QST

You'll want to keep these
copies as a unit

A few years from now *QST* copies of to-day no doubt will be scarce. Every reader of *QST* appreciates its reference value. We are daily reminded of this fact by the many requests we get for back copies, many of which we cannot supply.

If you have the 1920 series of *QST* — and probably you have not — you are one of the few. Even 1922 and 1923 copies are getting scarce. And copies before the war! Well, let's change the subject.

Next year you will be looking for a certain 1930 issue of *QST*. You had better resolve right now to keep your copies in a

QST Binder

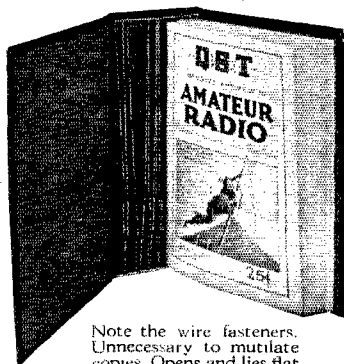

Note the wire fasteners. Unnecessary to mutilate copies. Opens and lies flat in any position.

One-fifty each postpaid

A binder will keep your *QST*s always together and protect them for future use. And it's a good-looking binder, too.

QST
1711 Park St., Hartford, Conn.

where the scheme shines: Tune approximately with the receiver out of oscillation and do the rest with the frequency meter. If the incoming sig is steady you will get a beautiful beat note and practically eliminate background noise due to local QRN from loose wiring systems and vacuum cleaner motors.

In this way the frequency meter serves not only as a standard of measurement but as a separate heterodyne oscillator.

— R. O. Williams, W8AJC

I.A.R.U. News

(Continued from page 50)

in view of the fact that several new stations have been authorized to operate in the band between 200 and 250 meters.

Moreover, complaints of interference with B.C.L. sets from amateur operation will in future be investigated by the Dept. with the assistance of an officer of the W.I.A. This latter concession has been made possible by the fact that the Institute has definitely proved that it is able to effectively control the operations of its members by virtue of their loyalty to the movement.

The 1715- to 2000-ke. band is used mainly for experimental broadcast experiments, and there are more stations operating in Victoria than in any of the other divisions, for some reason or other. In this state there are about 20 stations operating, and some sort of wavelength allocation has become necessary. Stations are allotted wavelengths from the top of the band down, with 20-ke. separation between allocations. The scheme works out very well, but has occasionally been upset by a stray non-member station coming in and heterodyning. No further trouble is ex-

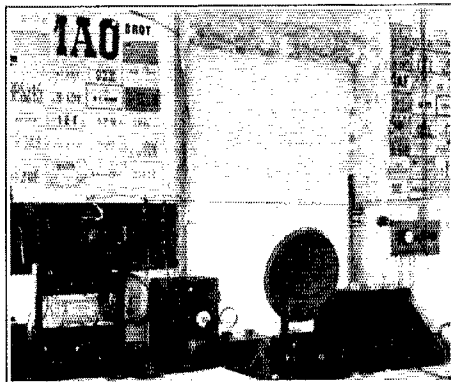

AU1AO, THE STATION OF V. SOLOMIN, SENNAJA 57, BIISK, SIBERIA

pected from this source as the Dept. has in the public interest sanctioned our scheme and notified these "outside" stations that they are to observe our allocations. The Fed. Executive therefore has just cause to be proud of the result of the negotiations, and the faith which the Radio Dept.

(Continued on page 66)

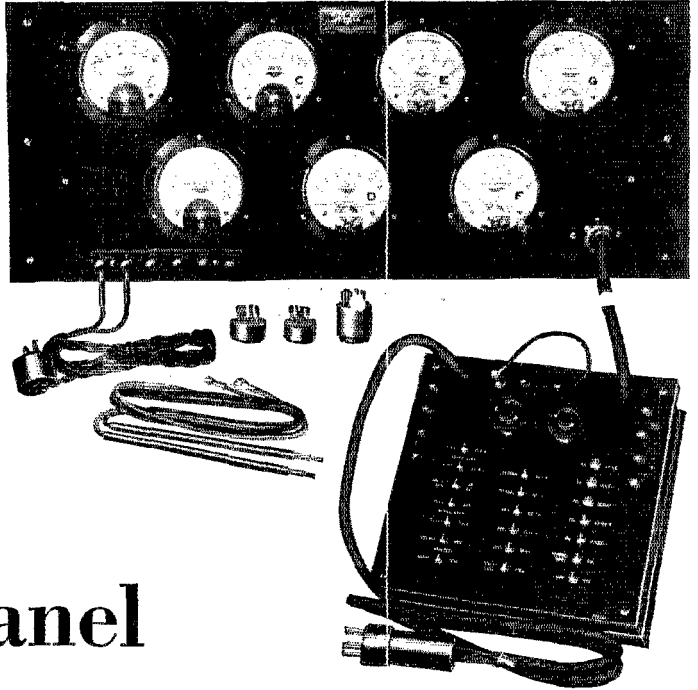
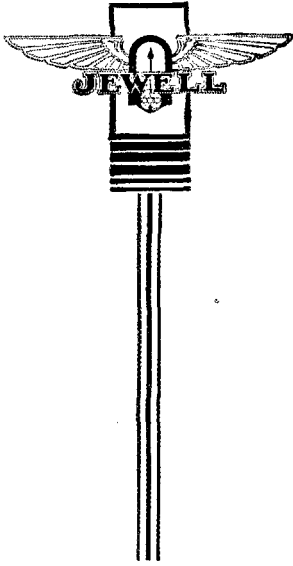

A Test Panel for Production Troubles

THE Jewell Pattern 579 Service Test Panel is the last word in high speed testing equipment. Seven meters operated by remote control from a movable control panel, with color coded buttons that save time and eliminate errors, solve your unusual production test problems.

Overall dimensions of the panel are 30" x 12 $\frac{1}{4}$ " x 4" with the back of the panel totally enclosed to protect instruments and connections. The remote control measures 8 $\frac{1}{8}$ " x 8 $\frac{5}{8}$ " x 4".

Your plant needs this equipment. Send for data today.

JEWELL ELECTRICAL INSTRUMENT CO.
1 642-C Walnut Street, Chicago

Pattern 579 Service Test Panel with remote control is one of the recent Jewell achievements. Seven large 5-inch meters with clean-cut, legible scales and knife edge type pointers, remote control with push button switches of the selective type, color coding of instruments and push buttons all combine to make the Pattern 579 the most convenient, rapid, and accurate equipment for laboratory testing of radio receivers.

30 YEARS MAKING GOOD INSTRUMENTS
JEWELL

579 Service Test Panel

Say You Saw It in *QST* — It Identifies You and Helps *QST*

THIS NEW STYLE

MERSHON Electrolytic Condenser INVERTED TYPE

In Your Transmitter Filter Gives You A Clearer Note and "Puncture Proof" Operation.

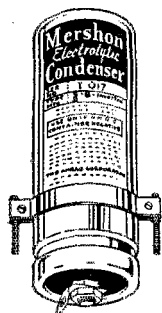

Mershon Condensers have almost unlimited life. They actually improve with use.

Voltage surges that would ruin an ordinary condenser have no effect on them.

Their use in your transmitter gives it a pure D.C. note hard to improve upon.

NDR, Augusta, Maine, says, "Using bank of Mershons got new NDR on the air and got Xtal report first QSO." WIBES says, "Blew a 4,000 volt bank of — condensers before acquiring the Mershons, but have had no trouble since." WICCP says, "Had 'RAC' report before, but now am getting 'DC' and 'pure DC'."

The success of Mershon Condensers is based upon years of development

and actual experience in service. These quotations from the letters of prominent "hams" are typical of the many received in our daily mail.

Mershons cost less than ordinary condensers of similar capacity and voltage rating, and may be obtained from any one of forty parts distributors. If your distributor does not stock them, write us. We will put you in touch with one that does.

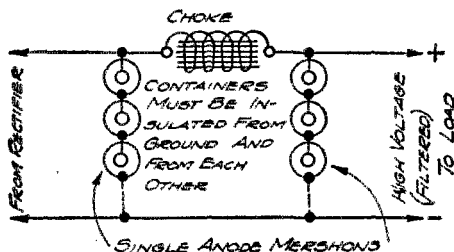

A very effective circuit for high-voltage transmitter filters, using Type Single-8 or Single-18 Mershon Condensers in series groups. Other circuits in the new Mershon booklet "Puncture Proof Filter Condensers." Write for FREE copy.

Manufactured Exclusively by

THE AMRAD CORPORATION

395 College Avenue
Medford Hillside, Mass.

THE AMRAD CORPORATION
395 College Avenue
Medford Hillside, Mass.

Send me promptly prices and information on Mershon Condensers for my transmitter. Diagram enclosed.

Send me your booklet "Puncture Proof Filter Condensers."

NAME

STREET

CITY

STATE

has been pleased to place in our ability to control ourselves.

Federal Convention will take place in Melbourne in October, and delegates from every state will be assembled in conference for the best part of a week beginning October 20th. Incidentally, foreign amateurs who happen to visit Australia on any pretext are assured of a welcome if they will communicate with the Headquarters of any Division in the capital cities. The necessary address can be obtained on application to the Radio Inspector at the central post office for the city. Poor conditions continue for DX work, but there are very definite signs that the approaching spring season is ushering in better ones. It is a pity that there are not more DX contacts attempted on the 3.5-mc. band as conditions above 6-mc. are definitely better than below at present.

The 28-mc. band is being systematically explored, and in view of the poor conditions on the other bands, more and more men are being attracted there. VK3CZ had a very interesting QSL from HAF1G, who reported his 27-mc. signals in Austria. He had discovered immediately after the date of the report that he was outside the band, so that the exact indication is excellent proof of the accuracy of the reception.

The Victorian Division is holding an amateur exhibition in September which will be given over to a display of amateur work and equipment. It is planned to have I.A.R.U. Headquarters address us through the cooperation of the commercial 'phone stations and we are hoping that the stunt will come off successfully. I think we will just about gain the record for a long distance "attendance" of the H.Q. gang at a local convention, won't we? (And, as was chronicled in this department last month, the affair was carried out very successfully, although 'phone was not used as proposed. Instead, Pres. Maxim pressed a key and opened the exhibition by means of this signal. — C. B. D.)

Ross Hull has gone back to the United States, and while we feel the loss of such an excellent radio man, we are pleased to think that an Australian should receive the honor of a more attractive and lucrative appointment in America.

BRITISH NOTES

By J. Clarricoats, Hon. Sec. R.S.G.B.

The Fifth Annual Convention held in London on September 26th and 27th proved an unqualified success. Some 150 members from the British Isles were present at the various meetings, which were presided over by Mr. Gerald Marcuse. The Convention opened at 6 p.m. on September 26th when the President made his opening speech of welcome. This was followed by the announcement of the election of new District Representatives. Messrs. G. W. Thomas, G5YK, and J. W. Mathews, G6LL, then read a paper entitled "The Progress of 28-mc. Transmission and Reception." This paper is being published in the October issue of the *T. & R. Bulletin*, and can be forwarded to all interested non-members on payment on one shilling.



Photo-Electric RADIOTRON UX-867

RATING AND DATA

Anode Supply Voltage (Maximum) 200. Volts
 Anode Current (Maximum) 20 Microamperes
 Window Diameter 1.25 inches

Approx. Sensitivity

Dynamic 25. Microamperes/lumen
 Static 30. Microamperes/lumen

Maximum Overall Dimensions

Length 6 5/16 in.
 Diameter 2 9/16 in.
 Socket UX or Navy Type

For Experimental purposes only.

Photo-Electric Radiotron UX-867 is a highly sensitive, general purpose photo-cell of the central anode type. An output of from 1 to 5 volts can be obtained with excellent fidelity.

A limited quantity of UX-867 Radiotrons is available for sale to amateurs possessing station licenses.

NET PRICE \$17.50

Rectifier Radiotrons UV-217-A and UV-217-C

For the benefit of amateurs who wish to increase their Rectifier power without incurring the expense of purchasing new filament heating transformers, we are offering Rectifier Radiotrons

UV-217-A Rating

Filament Voltage 10 Volts
 Current 3.25 Amperes
 Maximum A.C. Supply Voltage
 (RMS) 1500 Volts
 Maximum D.C. Load Current 200 Milliamperes
 Length 7 7/8 in.
 Diameter 2 5/16 in.
 Socket Type Standard 50 watt
 (RCA No. UT-541)
 Net Price \$20.00

Instruction books giving complete technical information concerning the above, and other Transmit-

ting Radiotrons will be sent gladly upon receipt of a request accompanied by your station call letters.

UV-217-A and UV-217-C at a new low price. These rectifiers have standard "50 watt" filaments requiring 3.25 amperes at 10 volts.

UV-217-C Rating

Filament Voltage 10 Volts
 Current 3.25 Amperes
 Maximum A.C. Supply Voltage
 (RMS) 3000 Volts
 Maximum D.C. Load Current 150 Milliamperes
 Length 8 1/2 in.
 Diameter 2 5/16 in.
 Socket Type UT-541 and Clip
 Net Price \$20.00

Engineering Products Division

RCA VICTOR COMPANY, Inc.

Camden, New Jersey

District Offices:

261 Fifth Avenue
New York City

100 West Monroe Street
Chicago, Illinois

Santa Fe Building
Dallas, Texas

235 Montgomery Street
San Francisco, California

Say You Saw It in *QST* — It Identifies You and Helps *QST*

AMERTRAN

TRADE MARK REG. U.S. PAT. OFF.

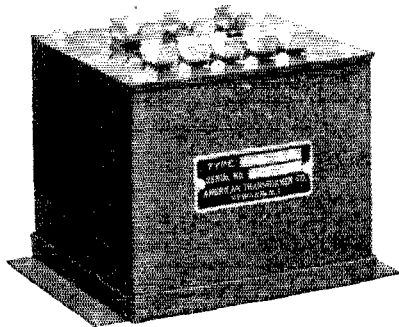
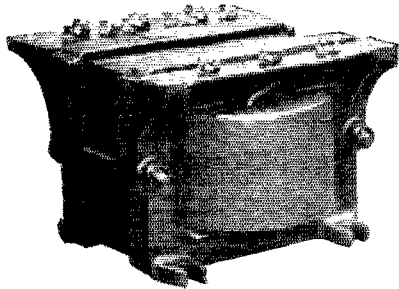

Equipment

Filament Heating Transformers, Plate Transformers and Radio Filter and Modulation Chokes, designed to meet amateur requirements, are of the same high quality that has made AmerTran products outstanding in a highly competitive field.

Bulletin 1066 gives complete descriptions and diagrams of new equipment. Every amateur should have this informative Bulletin as a guide in ordering new equipment.

American

Transformer



Company

172 Emmet St.

Newark, N. J.

AMERICAN TRANSFORMER CO.
172 Emmet St., Newark, N. J.

Please send me Bulletin 1066 containing complete information on AmerTran Transformers, for better radio reception.

Name.....

Address.....

Q. S. T. 12-30

At the conclusion of the meeting, two charabanc parties proceeded to visit the stations owned by Messrs. Mathews and Clarricoats. The Saturday programme commenced with a Delegates Meeting presided over by Mr. H. Bevan Swift (Acting Vice-President). Many important decisions were reached, and recommendations made to the full meeting later in the day.

The usual souvenir photograph was taken just prior to the business meeting.

Mr. Marcuse's first duty at this meeting was to present the Society's trophies, each recipient being greeted with acclamation.

The main business meeting dealt with many matters of local R.S.G.B. and B.E.R.U. interest, chief perhaps (as far as our colonial membership is concerned) was the decision to provide a new coat badge incorporating the letters B.E.R.U. One other very important decision was made which will, we believe, prove of immense interest throughout the world. This is the inauguration of an "Empire Radio Week" when every endeavour will be made to work Empire stations. This week will extend from Sunday, February 22nd, to Saturday, February 25th. Full details will be published shortly; meanwhile, suggestions from Colonial groups will be appreciated.

Convention concluded officially with the annual dinner held at Pinoli's Restaurant, Wardour Street, London. At this event a very great surprise was given to the members by the arrival, direct from Jersey by seaplane, of Miss Barbara Dunn, G6YL. This was the first occasion the OM's of the R.S.G.B. had been given an opportunity of meeting our first and only active YL member at one of our National gatherings. During the evening she was presented by the President with the cup she won in the recent 1.7-mc. tests. A further surprise was provided by the Honorary Secretary. Thanks to generous offers made by British radio manufacturers, he was able to offer over 25 valuable prizes to the persons present. The prizes were "drawn for" by the members and presented by Miss Dunn. Twenty-two firms made contributions. The presence of Mr. Drudge-Coates (ex Y-DCR), Mr. Shrimpton (ZL4AO) and Mr. Le Cheminant (VS7AB) added great interest to the gathering, all three gentlemen giving or responding to the toasts of the evening. Mr. Arthur Watts proposed the toast of the Society Overseas, whilst Mr. H. B. Old welcomed the guests. Mr. Gibbs (representing the *Daily Mail*) responded.

The Society at Home was proposed by Mr. Drudge-Coates and the Honorary Secretary replied.

During the toast speech to the President, given by Mr. Bevan Swift, he presented to Mr. Marcuse a large batch of QSL cards upon which each doner had written "Thanks, OM." as a mark of appreciation for the work he had done on behalf of amateur radio. The final toast of the evening was proposed by Mr. Bevan Swift when he called for all present to show their appreciation of the work carried out by the Honorary Secretary.

NOVEMBER 1930 **KEY KLIK** Vol. 1 No. 1

DEVOTED TO THE AMATEURS AND EXPERIMENTERS NEEDS.



PUBLISHED BY: AMERICAN SALES CO., 219 WARREN ST., N.Y. CITY

Our November issue of "Key-Klik" was mailed to every licensed "Ham" in the country. If you are not on our mailing list send us your name at once. (See "Key-Klik" for our offer of Free QSL Cards)

He Thought He Would Take the Chance—

Bill, the second op, was just putting the finishing touches on the keying circuit and Jack, the first op, had placed the last power wire in position. "Well, I guess she's about ready to 'perk' now," Bill said. "Yes, looks as if our labors of this past month are beginning to bear fruit. Isn't she a knockout, though?" "Sure enough, but look what it cost you." "Here goes, and may the first QSO be with a foreigner," said Jack as he threw the power switch. Things began to happen. A crackling noise and a thin wisp of smoke seemed to find its way from the middle of the transmitter and Jack literally flew at the power switch and with a wrench that seemed to possess every bit of his anger, sorrow and pathos, disconnected the power from his transformers. But it was too late. "Whew," from Bill, "what happened now?" The words froze on his lips as he noticed the expression on Jack's face. Too often had he heard the sharp staccato cracks of the high voltage breaking through the insulation of his filter condensers. Jack felt downcast. "Happened? The condensers blew out and took the rectifying tubes along with them. There goes a month's work and money." "But how could the condensers blow when they are rated at 2000 volts and the transformer only gives 1500?" Jack looked at him shamefully. "I know that, but I thought I'd take a chance on these condensers — they certainly looked good."

When you come to think of it, did Jack really have to take a chance in buying his radio equipment? He had planned his "superb" transmitter time and again, went over every little detail, end on end. He had spent money on apparatus and bought equipment of a questionable character from a company of questionable name. That is where he made his mistake. Just imagine how much better Jack would have felt if he knew that he was dealing with a company that had been catering to the amateurs for 11 years, practically since the inception of the hobby, and that every piece of apparatus he purchased was unconditionally guaranteed by the seller. The American Sales Company (since 1919) has been supplying the wants of the amateur and has reached the point of being the largest amateur supply house in the country, only through its untiring efforts in dealing squarely with the amateur. Do you have to suffer Jack's fate?

BARGAINS IN TRANSMITTING EQUIPMENT

TRANSFORMERS

- AMERICAN 2.5 volt transformers — two windings at 11 and 3 amperes. For mercury vapor tubes. \$2.75
- AMERICAN 3000 volt center-tapped transformers — tapped at 2000 v. Filament windings: 2.5 volts at 10 amps. 7.5 volts at 3.75 amp. \$13.00
- AMERICAN 4000 volt center-tapped transformers — tapped at 3000 v. Filament windings: 2.5 volts at 10 amps. 7.5 volts at 3.75 amps. \$16.50
- THORDARSON 175 watt — 1150 volts center tapped, two 7.5 and one 3 v. windings. \$4.25
- THORDARSON 250 watt — 1200 volts center tapped, two 7.5 and one 3 v. windings. \$5.75
- THORDARSON 100 watt — 700 volts center tapped, one 5 and one 2.5 v. windings. \$3.75
- THORDARSON 100 watt — same as above but for use with 25 cycle A.C. current. \$4.25

CONDENSERS

- DUBILIER Filter Condenser, 1.75 mfd., 1000 working voltage D.C. \$1.35
- DUBILIER Filter Condenser, 7 mfd., 600 working voltage D.C. \$2.50
- DUBILIER Filter Condenser, 4 mfd., 600 working voltage D.C. \$1.80
- DUBILIER 11.75 mfd. condenser, 3 mfd. at 1000, 4 mfd. at 600 and 4, 5 and .25 mfd. at 160 working voltage D.C. \$3.75
- STROMBERG-CARLSON Filter Condenser, 3.5 mfd. at 600 working voltage D.C. \$1.50
- AEROVOX 7 mfd. Condenser, 2 mfd. at 1000, 2 mfd. at 800 and 3 mfd. at 400 working voltage D.C. \$3.00
- DUBILIER Plate Stopping Condenser, .000125 mfd. at 1000 volts. \$3.35

CHOKES

- AMERICAN 30 henri, 300 mil chokes. \$9.75
- THORDARSON Filter Choke, 30 henri — 150 mils. 3000 volts insulation test. \$3.25
- THORDARSON Double Filter Choke, contains two 18 henri — 250 mil chokes. \$6.25
- AMERTRAN Filter Choke, 20 henri — 250 mils. D.C. resistance 110 ohms. \$10.80
- R.C.A. Double Filter Choke — contains two 30 henri — 100 mil chokes. \$11.75

CONDENSERS

- FLECHTHEIM HIGH TENSION Filter Condensers, with porcelain insulators, guaranteed.
- 1500 volts — 1 mfd. \$2.70
- 2 mfd. 5.10
- 4 mfd. 8.70
- 2000 volts — 1 mfd. 6.00
- 2 mfd. 9.00
- 4 mfd. 15.60

Write for special prices on 3000 volt condensers and type HS & HV.

SPECIALS

- BRADLEYSTAT, type E210, current capacity 10 amperes, for transmitters. \$9.95
- R.C.A. Power Rheostats, will carry up to 2.5 amperes. \$4.40
- R.C.A. Power Rheostats, (heavy duty) will carry 15 amps., for large tubes. \$3.00
- CENTRALAB Gain Controls for tone transmitters, 0-250000 ohms. \$7.75
- AMERICAN 50 watt transmitting sockets, made from heavy bakelite. \$2.45
- R.E.L. Frequency meters, separate unit for each band, accurate. \$15.00
- VIBROPLEX new and improved, direct from factory in red, green or blue base. \$17.00
- WESTINGHOUSE 13600 ohm transmitting grid-leak. 60 watts. Tapped at 6000, 6000 and 1300 ohms. \$1.50
- AMERICAN 250 watt transmitting sockets, 2 ends. \$2.55
- UNIVERSAL No. 1089 modulation transformer — 200 ohms. \$6.85
- PILOT SUPER-WASP, D.C. kit, all parts complete for excellent receiver. \$29.50
- PILOT SUPER-WASP, A.C. kit, practically humless, for short waves. \$34.50
- PILOT Short Wave Plug in coils, set of five for all bands. \$4.95

AMERICAN SALES COMPANY, 219 Warren St., NEW YORK, N. Y.

Weston *model*

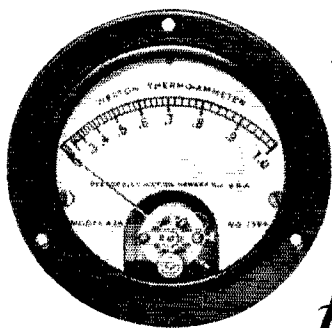

425 for use on radio frequency

MAXIMUM output of any transmitter in short wave work is determined by the radio frequency output as indicated by the milliammeter in the antenna circuit. Naturally the reliability of this measurement is of utmost importance to every operator.

The reliability of Weston instruments is without equal. Their design and quality of workmanship give them the dependability in service that overcomes the exceedingly slight difference in cost which would be offset by less reliable operation.

The Weston Model 425 was designed and developed particularly for short wave work. It is a Thermo-Couple type instrument, accuracy 2%, made as Ammeters, Milliammeters and Thermo-Galvanometers.

The Ammeters, made in ranges of one to twenty amperes, may be used on D.C. or A.C. of any frequency. They have a safe overload capacity of 50%.

The Milliammeters, made in ranges of 125, 250, and 500 milliamperes, are for use on A.C. only. They are ideal for short wave transmission because they have a very low internal resistance, give true current value without any frequency error and do not disturb the constants in the transmitter.

Model 425 is designed for flush panel mounting. In size and appearance, it exactly matches the companion Model 301 D.C. and Model 476 A.C. Voltmeters, being $3\frac{1}{4}$ inches in diameter.

For more complete information, write for Circular JJ.

Weston Electrical Instrument Corp.
602 Frelinghuysen Avenue Newark, N. J.



It is not proposed to deal with other matters in this British report because of the space already taken up with the Fifth Annual Convention, but an attempt will be made next month to remedy this omission.

NEW ZEALAND REPORT

By D. Wilkinson, Vice-Pres. N.Z.A.R.T.

This winter has undoubtedly been the poorest on record in New Zealand for DX. Very little has been done during the months of May, June, July and August on either the 14- or 7-mc. bands. The 11-mc. band has been a complete washout, while 7-mc. has been bothering similarly in that DX signal strength has dropped to almost zero after dusk in the evening.

During the lull most of the stations have been concentrating on 3.5-mc. operation, especially with regard to experimental 'phone, and some excellent results have been obtained. Communication with Australia and distance up to about 2000 miles have been covered with even low-powered outfits. At the same time, however, skip distance has been very noticeable this winter on the 3.5-mc. band in New Zealand, making QSO's within a range of 200 miles very difficult shortly after dark. During the whole year American c.w. and 'phone stations have been regularly received very well for this band, and everything points to a return of the 1924 conditions next year, with international QSO's once again in the vicinity of 80 meters. ZL2BE has already made a number of contacts with W-stations this winter on this band with a power input of 200 watts, and reception of European stations has been reported.

The DX season is now returning, and during the past few weeks several European contacts have been made on the 7-mc. band in spite of the heavy QRM from W-stations in the early evening. Conditions on 14 mc. are still not of the best, but by the beginning of October should return to normal as indicated by past years.

NORWEGIAN NOTES

By G. H. Petersen, Pres. N.R.R.L.

We want to draw attention to the new address of the N.R.R.L. which is Post Box 2253, Oslo. All correspondence for the N.R.R.L. as well as for members of the Board should be sent to this address. We ask you to kindly direct QSL cards to "NRRL-QSL." Correspondence for any Norwegian amateur will be forwarded. This corrects the information given in the I.A.R.U. News for September, 1930.

Activity is fine, judging from latest reports, and conditions on the two principal bands, 7- and 14-mc., are improving. LA1G announces his comeback from a new QRA, and swears by the horizontal Hertz which has brought him QSA 5 reports from all Europe and QSA 3-4 from PY and LU. He is eagerly searching for his old VK and ZL friends now on 14 mc. Other stations report good European results.

We have gotten a temporary permit to operate on 3750 kc., chiefly to arrange for some inland relay tests. These will take place on October 29th

FROM VOQH = Homeward Bound

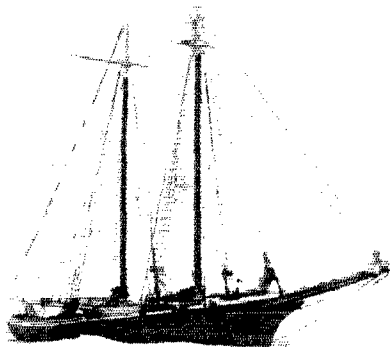

OUT of the fastnesses of the Arctic, the staunch little schooner "Effie Morrissey" has again snuggled safely into her berth in home waters.

Her coming was not unheralded, because on September 26th her unfailing and efficient transmitter, out over many leagues of tossing ocean, sent this message →

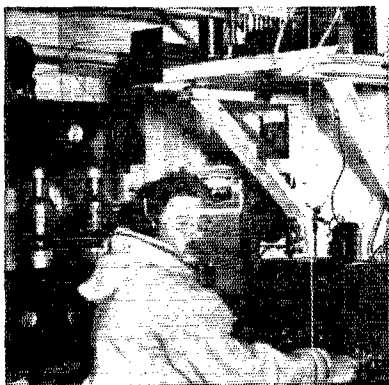

Ed. Manley, Operator of VOQH, aboard the "Effie Morrissey"

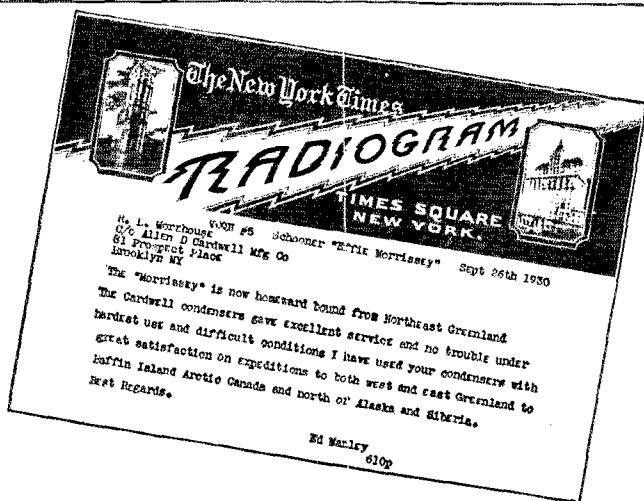

From Pole to Pole, East and West, wherever Radio is known, the good, rugged Cardwell has rendered valiant service under trying conditions.

Your outfit may never be called upon to meet the test of salt water, salt air, extremes of heat and cold, shocks and unavoidable abuse; nevertheless, a transmitter or receiver, if worth building at all, deserves CARDWELLS for efficiency and long service. Send for literature.

The Allen D. Cardwell Mfg. Corp'n

81 Prospect Street, Brooklyn, N. Y.

CARDWELL . . . "THE STANDARD OF COMPARISON"

GUARANTEED . . . NEW RADIO BARGAINS

International Microphone—Two button for public address systems and transmitters. Speech or music. \$9.75

Complete Phone and CW Transmitter 15 to 30 Watts, \$39.50 Including tuned plate, tuned grid oscillator with provision for crystal control. Wired for one or two UX 210 tubes. One or two UX 250's as modulators, two stages of speech amplification. Mounted in beautiful two-tone Walnut cabinet. Has ample space for A.C. power supply. Price includes one Stromberg-Carlson microphone.

Power Supply unit for 15 to 30 Watt Transmitter \$19.75. Will deliver 600 volt 150 milliamperes for plate current. Has filament for 281, 210, 250, 227, and 226 tubes.

World Wide Triple Screen Grid Short Wave Receiver. A four-tube short wave receiver for the highest efficiency for code, phone and ample output for television experiments. Uses 224 in a K.B. stage, a 224 detector, a 224 resistance coupled audio feeding into a 245 power tube. Tubes used make a minimum of microphonic noises and are so wired to be used on a 6 volt storage battery. A set of 10 plug-in coils are furnished with this set covering from 14 to 550 meters. Other coils can be made to cover lower frequencies. \$28.50

World Wide 2 tube Short Wave Receiver. \$11.75. A two-tube receiver in a beautiful shielded metal cabinet. An ideal all around set which will give loud speaker reception on many stations. Very flexible in tuning. Complete with a set of 6 clip-in coils. Covers 14 to 550 meters. Can be used with any standard base tubes.

Tubes UX type, 30 day replacement guarantee. No. 210, \$2.25; No. 250, \$2.35; No. 281, \$1.85; No. 280, 95c; No. 245, \$1.25; No. 224, \$1.25; No. 227, 75c; No. 226, 65c; No. 171, 75c.

Low Power Transmitter, adaptable for phone or code. With plug-in Coils. \$14.75

Short Wave Sets, one tube complete with 5 coils, 14 to 550 meters. \$6.45

Auto Radio — Uses 3-224, 2-227 tubes and 1-245 Power tube, single dial, tremendous volume. Compact. Fits any car. We guarantee this set to perform better than sets selling up to \$150. \$20.00

Stromberg-Carlson telephone transmitter on desk stand, \$2.75
B Eliminator, Dry. 180 volts, will operate up to 10-tube set, with 280 tube, fully guaranteed. \$6.75

250 or 245 Power Condenser Blocks, 13 Mfd., 1000 volt A. C. test, tapped 2, 2, 2, 4, 1 and 1 mfd., 1 mfd., \$4.75

2 Mfd. Condenser Packs, 2000 volt A. C. test, \$7.90
1500 volt. \$3.80

Double Chokes, 30 henry each, 160 mils., 1500 vt. test, shielded, 150 mils. \$3.75

No. 1003 Power Transformers, shielded, Sec. 600 V. for one 281, one 250, one 227, four 226 tubes and 2 chokes. \$5.00

AG-A, B, C. Power Packs, completely assembled. \$8.75

250 V. B. also has A. C. filament for up to 9-tube set. Can be used as B eliminator. Make your battery set all electric, or build your A. C. set around this pack. 280 tube for this pack, 95c extra.

ORDERS SHIPPED PROMPTLY

CHAS. HOODWIN CO.

4240 Lincoln Ave. Dept. M-8 Chicago, Illinois

ANNOUNCING!

Our new Amateur Catalogue, the finest of its kind, containing the most complete line of supplies ever assembled in one catalogue.

Over thirty-five pages of nothing but supplies for the Amateur and short-wave enthusiast. Also sound equipment.

Every manufacturer we represent makes quality merchandise and it is with great pleasure that we can sell you these quality products.

Let us send you a catalogue with our compliments, then your name will be on our mailing list for the future.

Remember, We Pay the Postage

218 Chestnut Street

HALL'S
Quality Apparatus

Harrisburg Pa.

to November 2nd, and many amateurs are already testing their gear on this wave. Our present permit extends only until the end of November, but all Norwegian transmitters will welcome reports and QSO's in this band, particularly from the more nearby countries, to test the utility of this wavelength for schedules.

Amateur Radio at the Eastern States Exposition

(Continued from page 19)

forbear to mention the one day when the station was for a short time transformed into an experimental layout, merely in the hope of slightly increasing the already respectable wallop of the signals.

The filter — which, as you will note by turning to pages in November *QST*, consisted of a choke coil and electrolytic condenser in a brute force arrangement — was shorted out. After much re-viling of the monitor, micrometric adjustment of the angles of antenna coupling coils, hairbreadth changes in the setting of tuning condensers, and careful plotting of the readings shown on W1L1's antenna milliammeter (on which changes of a very few r.f. milliamperes could be read) the set was eventually put on the air at 6:00 p. m. W3PX was called by Blum, chief op, and worked. The note was reported crystal d.c. QSA 5, and W3PX could not be shaken from that description!

Now for heaven's sake, you fellows who are using similar sets, don't set forth immediately to lay a ten-penny nail or a rusty hairpin across the terminals of your filter on the strength of that report! If you do you'll get a.e. and an application of the Wouff Hong as you deserve — nothing more. It takes four cracker-jack ops and a magic potion to make d.c. out of even particularly well behaved r.a.c.

The station log gives us the following data; twenty-five stations were worked — some of them more than once — in seven districts. This was in five days, as the first and last days the station was not on the air. Inasmuch as traffic handling and not DX or an effort to fill the station log was the end in view, the results were eminently satisfactory. All reports were QSA 4 and 5, and operating was confined to daytimes. While the work wasn't spectacular, consideration of the conditions and the times gives one a lot of respect for the low-powered set.

A large number of messages was originated at the booth during the week, a considerable percentage of which passed through W1MK. RP's assistance in disposing of this traffic was invaluable. Many of the messages were of rubber stamp character, but some were of considerable interest. One of the Springfield papers carried a headline to the effect that flat pocketbooks were replenished through the station, a thought derived from messages requesting more cold cash from the home folks with which to meet the exigencies of existence.

The operation of W1ESE was a good example

The New A. C. Traffic-Tuner

NATIONAL A.C. THRILL-BOX SW5

Many new features, not previously found, have been developed by NATIONAL CO. Engineers for this remarkable all-purpose, high-frequency receiver — assuring a high degree of trouble-proof operation, a continuous tuning range, equal adaptability to phone or C. W., and absence of hum.

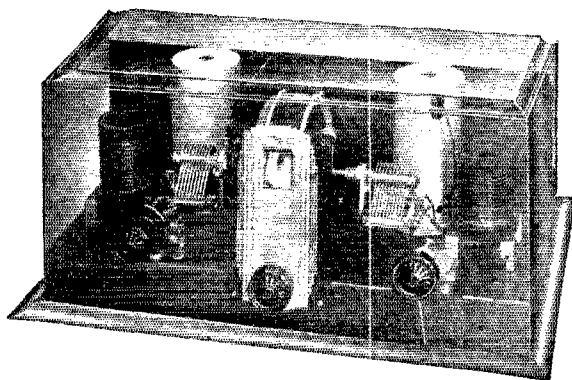

Equally Effective on Phone or C. W.



THE R. F. TRANSFORMERS

Standard set of four pairs. Covers 21.2 to 2.61 m.c. Special coils available for 33-21.2 m.c. and 2.61-1.5 m.c. ranges. R-39 forms giving low loss, with high mechanical stability. Blank forms available for experimental use.



THE TUNING CONDENSERS

New NATIONAL model SE — special H. F. variable condenser with insulated main bearing and constant impedance pigtail —

270 degree straight line frequency plates. This new design makes gang-tuning possible on short waves.

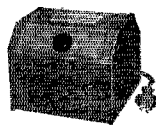

THE POWER SUPPLY

A separate and specially designed unit made with filter sections for humless high-

frequency operation. 180 volt B, 2.5 volt filament supply. Equipped with cord and soft rubber covered connecting plug.

Licensed under R C A Patents

A MECHANICALLY and electrically stable true A. C. High-Frequency Traffic-Tuner and Receiver for amateur use. Will work with different sorts of antennas without readjustment except of antenna trimmer. Once trimmer is set, Thrill-Box tunes and logs with true single control. Extremely simple to operate. 1080 dial degrees available between 21.2 m.c. and 2.61 m.c. Easily adapted to still wider spreading of bands, if desired. Works down to 33 m.c. Very smooth sensitivity control, no grunting, no back-lash, or clicking on higher frequencies. No hand capacity. DOUBLE SCREEN GRID, with 224 grid-leak detection. Push-pull audio, with special phone-jack before the last stage.

See Description of Transformers, Condensers and Power-Supply at left

Also made in new Low-drain D. C. Model, using 230, 231 and 232 tubes. Easily assembled with genuine NATIONAL Radio Parts.

Write today for Amateur Bulletin No. 141-Q12

NATIONAL

RADIO PARTS



NATIONAL COMPANY, INCORPORATED, MALDEN, MASS.

Say You Saw It in QST — It Identifies You and Helps QST

Official Radio Service Manual

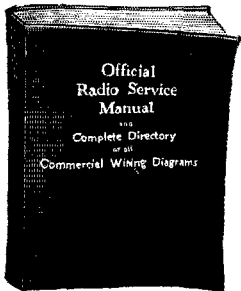

and
**Complete Directory
of all
Commercial
Wiring Diagrams**

**IN LOOSELEAF FLEX-
IBLE LEATHERETTE
BINDER**

Over 1,000 Diagrams and Illustrations, etc. 352 Pages 9" x 12". Weight 3lbs.

Hugo Gernsback, *Editor*
Clyde Fitch, *Managing Editor*

\$3.50 Per Copy

Never in the history of radio has there ever been published a service manual, so complete, as this new OFFICIAL RADIO SERVICE MANUAL. It is a veritable encyclopedia of service information — worth several times its price. Its educational value is of great importance, not only to service men, but to everyone interested in radio.

Hundreds of wiring diagrams, as well as important data, of commercial receivers since 1927, and some many years earlier, have been collected and placed at the disposal of radio service men. Additional service data for new receivers as they appear on the market will be supplied at trifling cost.

The OFFICIAL RADIO SERVICE MANUAL contains also a most comprehensive instruction course for servicing any manufactured radio set, also many important articles on Amplifiers, Automotive Radio, Antennas, Condensers, Detectors, Meters, etc.

*Send cash, check or money order
today for this important radio work*

GERNSBACK PUBLICATIONS, INC.
Dept. 300 98 Park Place, New York, N. Y.

I am enclosing herewith \$3.50 (check or money order) kindly send me prepaid one Official Radio Service Manual.

Name

Address

City and State

High Frequency Transmitters—Receivers Laboratory Equipment and Special Apparatus

designed and constructed to meet your requirements
Submit your specifications for estimates

Soundly Engineered and Well Built Jobs Guaranteed
HOLMES C. MILLER RADIO ENGINEER
P. O. Box 105 Palo Alto, Calif.

ON THE PACIFIC COAST IT'S RADIO SUPPLY

*Everything for the Amateur
and Experimenter*

Weston, Thordarson, Mershon, Amertran, National, REL, Signal, Flechtheim, Clarostat, Rectobulb, Pyrex, Vibroplex, Lynch, Parvult, Cardwell, Allen-Bradley, Aerovox, Jewell, Universal Mike, Ward-Leonard, CeCo, ARRL Handbook, Pilot, Leach, Durham — and many others — *send for the dope.*

RADIO SUPPLY COMPANY

912-14 So. Broadway Los Angeles, Calif.
W6FB1 Local in Building

of the splendid efficacy of low-power under present conditions. That matter has been tested and proved to our full satisfaction!

WHAT IT'S ALL ABOUT

And that was triumph indeed. In fact, there were many such triumphs which were overshadowed by the principal objects of this coöperation. The new interest aroused in old-timers now out of the game was another. But the important ends we sought were equally successful. As an experiment in a new field it was productive of results and a fund of experience for future workers.

By this we do not mean to-day that the operation of a small amateur station in a booth at a show or exposition is a new experiment. But the second great purpose, that of instituting and training a class of selected boys in the principles and possibilities of amateur radio, is both new and, as we have proven, worthwhile.

There is a wonderful opportunity awaiting all of us in the advocating and assisting in work of this sort among boy's clubs and boys as individuals in our vicinities. This has a universal application and is not confined alone to Junior Achievement clubs, but if you have a J.A. club in your vicinity it gives many opportunities for leadership to those trained in or having hobby experience with any of its programs. Those of you who have inclination and ability for such work will gladly be given an opportunity to discuss any angles of it, or have any questions answered, by writing in to Headquarters.

It seems to us that the club plan is one particularly applicable to beginning amateurs. It results in an initial pooling of effort and expense, as well as the profit and pleasure which results. Eventually, of course, each budding club-member-amateur will have his own station on the air, but during the period while he is learning the principles of amateur radio his activities are controlled and guarded sufficiently so he will not be creating unnecessary interference, or becoming any of the other numerous sore spots beginners so readily become.

From the time he first learns the letter "A" of the code until a sufficiently long time has elapsed since the issuance of his license, he works with help and supervision in the quickest, most efficient way. He always has guidance and counsel when it is most needed, and his mistakes are thereby reduced to a minimum. This means more enjoyment for him in the successful application of his new hobby, and safeguards the interests of other amateurs who might be affected by any prolonged bungling on his part.

This pooling of effort is not only advantageous to the beginner; it represents real economy in the use of our restricted frequency allocations. And the result is new strength to amateur radio.

The system used in training this class of boys was a comparatively simple one, and can be organized by any one with very little effort. Time was allowed for six code lessons, so the alphabet and numerals were divided into five lessons, leaving the last open for abbreviations and extra

1. The Vitrohm Plaque Resistor, non-inductive and non-capacitative, is ready. Standard resistance value 5000 ohms, handles the grid of a 50 watt and the price is only \$2.00. Get the dope today.

2. If you haven't received your supply of the snappy new Q.S.L. cards, write for them today. Your call letters will be imprinted in outline letters. There is no obligation for this service.

1. new!
2. free!
3. ??????!

3. We have a very important matter to discuss with Radio Club Secretaries. Write at once giving the name of your organization and number of members.

Club Members — if your secretary misses this, tell him to drop us a line.

Ward Leonard Electric Co.
 Mount Vernon, N. Y.

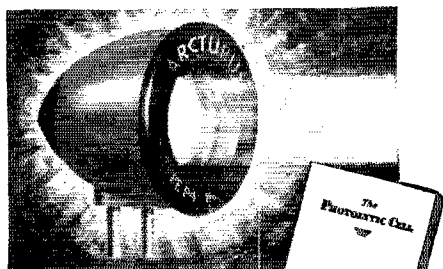

Let this FREE
 book introduce you to
 photo-electric research

Perhaps you will be the one to discover a money-making new application for the Arcturus Photolytic Cell. Based on a new principle, this cell insures more efficient operation of any photo-electric device. Our new free book gives complete performance data and circuit diagrams; shows how to use this improved cell in various applications. Write for it today.

Photo-Electric Division
 Arcturus Radio Tube Co., Newark, N. J.



ARCTURUS
PHOTOLYTIC CELL
The Electric Eye for Every Industry

MADE BY THE MAKERS OF ARCTURUS BLUE TUBES

POWERTYPE CRYSTALS

*For Amateurs, Commercial Stations
 and Dealers*



THE STANDARD OF COMPARISON
 POWERTYPE crystals are recognized as the best.

No off frequency operation with
 POWERTYPE CRYSTALS

FULLY GUARANTEED BY A RELIABLE COMPANY

Ground by experts and calibrated from precision standards. Crystals for amateurs ground to approximate frequency and calibrated to better than 1/10 of 1%.

1715-2000 kilocycle band	\$10.00
3500-4000 kilocycle band	15.00
7000-7300 kilocycle band	20.00
One inch oscillating blanks	4.00
Plug-in dust proof mounting as illustrated above	6.00

550-1500 kilocycle band — calibrated at any temperature plus or minus 500 cycles desired frequency complete with plug-in dust proof mounting — \$45.00. Constant temperature heater oven less crystals \$150.00. We do any kind of special crystal grinding for any frequency.

Grinding instructions furnished with crystal blanks.

You may order direct from this ad C.O.D.

FREE Send name, no obligation, for full information on crystals, holders, blanks, heater ovens, etc.

"CLEAR AS A CRYSTAL"

AMERICAN PIEZO SUPPLY COMPANY
 1101 Huron Building Kansas City, Kansas

Specialists in frequency precision

Xmas Specials

DONGAN POWER TRANSFORMERS. 250 Watt. With ballast tube in primary to keep voltage steady, output is 1500 CT, 7 1/2 CT, 2 1/2 CT, 1 1/2 and 15 Volts. Without ballast tube output is 2000 CT, 10 CT, 3 CT, 10 and 20 Volts. Neat black metal case with terminal board. 15 lbs. \$5.25
Special Ballast Tube. \$1.00

THORDARSON — POWER TRANSFORMERS: 250 Watt. 1200, 7 1/2, 7 1/2 and 3 \$5.75
175 Watt. 1125, 7 1/2 and 3 — \$4.25. 150 Watt. 800 and 5. \$3.00

(All windings center-tapped)
Double Choke. Each section 18 Henry, 250 MA. \$6.25
Single Choke. 30 Henry, 150 MA. \$3.25

W.E. HAND MICROPHONES. Very sensitive. Switch in handle. Ideal for home recording, transmitters, etc. \$3.95

PARCON FILTER CONDENSERS. Highest grade. Neat metal cases with novel stand-off insulators. Guaranteed.
DC Working Voltage. 1 Mfd. 2 Mfd. 4 Mfd.

2000 Volts	\$3.95	\$6.95	\$12.45
1800 "	3.00	4.50	7.95
1000 "	1.50	2.30	3.80
650 "	1.05	1.70	2.90

SPECIAL .002 MFD., 2250 Volt (Wig.) Mica Condensers. . \$1.05
FARADON 3 1/2 MFD. BLOCKS. Contains 1 1/2 Mfd., 1000 Volt, and 2 Mfd., 600 Volt (DC Working). Neat black case. Ideal for 210 filter. Six for \$7.25. Each \$1.45

2 MFD. 1000 VOLT FILTER CONDENSERS. Unceased. Highest grade. A quantity may be series-paralleled for any desired voltage and capacity. 85c each. Four for \$3.20. Eight for \$6.00. Twelve for \$8.20. Twenty for \$12.50.

SANGAMO 5000 Volt Test Condensers. .002, .001, .0005, .00025 Mfd. \$1.20

DUBILIER .002 MFD., 6000 VOLT WORKING MICA CONDENSERS. \$1.95

IMPORTED FRENCH PHONES, 4000 ohms. Sensitive. . . \$1.75

GUARANTEED TUBES — 60-Day FREE Replacement.
UX-210 \$3.75, UX-250 \$3.95, UX-281 \$2.75, UV-224 \$1.65,
UX-245 \$1.00, UX-112-A \$1.65, UX-280 85c, UV-227 \$1.10,
UX-171-A \$1.35, UX-226 \$1.05, UX-201-A 85c. For those who prefer a lower priced tube of good quality we offer the following with a 5-Day replacement guarantee. UX-250 \$2.10, UX-210 \$2.00, UX-281 \$1.50, UX-245 70c, UX-280 70c, UV-227 70c, UV-224 \$1.05, UX-226 65c, UX-171-A 75c.

H & H Toggle Switches or Beaver 3 Amp. 125 Volt Snap Switches 20c each. Per doz. \$1.75
Mahogany Bakelite Knobs, 1 1/4" 7c each. Doz. 75c

Complete Lines and Lowest Prices on

Acme, Akra-Ohm, Bradley, Cardwell, Electrad, Jewell, Lynch, Sangamo, Sprague, Universal, Vibroplex, and many others.

SEND FOR CATALOG

"Quick Service" "Quality Merchandise"
Deposit required. Postage extra. No orders under \$2.50

HARRISON RADIO CO.
189 Franklin St. Dept. T New York City

QUARTZ OSCILLATING CRYSTALS

POWER CRYSTALS — Guaranteed — easy oscillators. One-inch square sections ground to your approximate specified frequency which is stated with a precision of one-tenth of one percent.

3500-4000 Kc. band	\$7.50
7000-7400 Kc. band	12.00
One-inch oscillating blanks	3.00

Orders will be filled within twenty-four hours after they are received.

PRECISION PIEZO SERVICE

427 E. Asia Street Baton Rouge, La.

P A C E N T

Duo Lateral COILS

Radio engineers and laboratories with real records of accomplishment use Pacent Duo Lateral Coils. They come in all standard turn ratios.

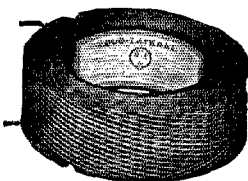

Write for information
and prices

PACENT ELECTRIC CO., INC.
91 Seventh Avenue New York City

practice. A half hour each day was devoted to drilling on the selected group of letters during each of the first four days, with constant review and the insertion of words and sentences to create and hold interest. On the last two days 45-minute sessions were held, to wind the lessons up properly.

After Mr. Hebert's speech on Monday, which dealt with amateur radio in general terms, the balance of the week was given over to the consideration of the following units (one each day) as has been mentioned before.

1. The background and tenets of existence of amateur radio, with a review of activities, history and character. Regulations, frequency bands, etc., were explained.

2. The receiver, dealing with practice, construction and elementary theory. For this demonstration the two-tube set shown in the foreground of two pictures was used.

3. The transmitter, with the same points brought out as above, including an explanation of the theory of oscillatory circuits, and the operating theory of rectifier-filter power supply systems. The single-control set and the WIESE transmitter were used in this lesson for purposes of illustration.

4. Elementary radio theory, of the practical nature permitting understanding of the principles underlying design of capacity-inductance values, antenna lengths, etc.

5. Operating practice, using WIESE as an object lesson.

It's all very easy. And yet, with a little application on the part of instructor and student, it is absolutely amazing the amount of practical amateur radio knowledge gathered by a young fellow who, when he starts, thinks UX-210 is a chemical formula. Try it with the non-radio boy's clubs in your locality, organizing a special radio class or subsidiary of your regular radio club. It is one of the most worthwhile things you can do and is also a lot of fun.

For help of any kind write in to Headquarters. We have a special booklet (*How To Become a Radio Amateur*) prepared to simplify and standardize such training, and they will be gladly supplied at 10¢ each or \$1.00 a dozen. Organized beginner's amateur radio clubs represent the solution of one of our toughest problems. Let's get them going.

Strays

If no suitable brackets are available for mounting miget condensers in a readboard layout the ones used for holding window shades will serve very nicely. The necessary holes are already drilled. — W3CA.

W5WN suggests that the panel saw in the July "X" Section can be made to cut circles if the back of the hack-saw blade is cut off with a pair of tin snips. The blades are generally highly tempered only on the side that carries the teeth, the other side being left soft to prevent breakage.

Two Way Radio Link Never Interrupted — Capt. Yancey's Radio Makes New Records —

Here's the Story behind These Headlines

The Yancey plane (ESCO equipped) in its non-stop flight to Bermuda maintained direct two way communication with New York. Darkness forced the plane down a little short of its goal. The plane floating on the sea remained in communication with New York.

Later, on its "Good Will" flight to South America the Yancey plane, on the ground at the Canal Zone, maintained two way communication with New York. Zeh Bouck, Radio Operator, said—"I believe this is without doubt a record for Airplane transmission, and it shows very clearly what we could have done had we been forced down in some of the jungle over which we have flown during the last few weeks."

And on July 1, this last record was broken — the Yancey plane, on the ground at Buenos Aires, communicated uninterruptedly for more than an hour with the New York Times Station, 5838 miles away.

The Yancey plane was equipped with an "ESCO" wind driven generator to supply radio power while flying, and a battery operated "ESCO" dynamotor for ground work.

"ESCO" has a very complete line of wind driven generators, and dynamotors for airplane service. Let "ESCO" Engineers help you with your power supply for communications.



Type NA Airplane Generator

ELECTRIC SPECIALTY COMPANY

225 SOUTH ST.

STAMFORD, CONN.

Manufacturers of motors, generators, dynamotors and rotary converters

U. S. NAVY SURPLUS

General Electric 24/750-volt 150-watt Dynamotors . . . \$27.50
 General Electric 24/1500-volt 350-watt Dynamotors . . . 37.50
 500-watt 500-cycle generators with exciters 7.50
 Westinghouse 6-15 volt 500-watt 15.00
 Westinghouse 200-watt 900-cycle 25.00
 Westinghouse 27.5/350-volt 30 mills 7.50
 Twins for double voltage or current 15.00
 Shafts for external drive \$3.00 additional
HENRY KIENZLE, 501 E. 84th Street, New York
Pioneer Distributor of Government Surplus
 Complete list on request

STUYVESANT ELECTRIC CO., INC.

53 Walker St. New York

FREE CATALOGUE

LATEST RADIO BUYS AT BIG SAVINGS

WRITE TO-DAY

YOUR A.R.R.L. EMBLEM



The League Emblem comes in four different forms. Its use by Members is endorsed and encouraged by the League. Every Member should be proud to display the insignia of his organization in every possible way.

THE PERSONAL EMBLEM. A handsome creation in extra-heavy rolled gold and black enamel, 1/2" high, supplied in lapel button or pin-back style. The personal emblem has come to be known as the sign of a good amateur. It identifies you — in the radio store, at the radio club, on the street, traveling — you can spot an amateur by it. Wear your emblem, OM, and take your proper place in the radio fraternity. Either style emblem, \$1.00, postpaid.

THE AUTOMOBILE EMBLEM. 5 x 2 1/4", heavily enameled in yellow and black on sheet metal, holes top and bottom, 50c each, postpaid.

THE EMBLEM CUT. A mounted printing electrotype, the same size as the personal emblem, for use by Members on amateur printed matter, letterheads, cards, etc. \$1.00 each, postpaid.

THE "JUMBO" EMBLEM. How about the shack wall or that 100-footer? Think of the attention this big yellow-and-black enamel metal emblem will get! 19 x 8 3/4", same style as Automobile Emblem. \$1.25 each, postpaid.

The American Radio Relay League, Hartford, Conn.

SERVICE MEN WANTED

To Install and Service Sound Equipment in
Theatres, Schools, Lodges, etc.

If we are not already represented in your locality
— we have a place for you.

NATIONAL SOUND SERVICE BUREAU

Exec. Office, 723 7th Ave. — New York

A nation-wide organization of sound equip-
ment manufacturers, users of sound equip-
ment, and hundreds of installation and serv-
ice engineers located in every part of the
country.

If you can qualify as a competent Sound Engineer, we
have a place for you — if not, we arrange to train you —
arranging work for you in your spare time as assistants to
our regular engineers, until such time as you can qualify.
A thorough knowledge of Radio is a wonderful asset.

USERS

of sound equipment.
Our service is avail-
able to you. We main-
tain competent men
available immediately,
day or night.

MANUFACTURERS

of sound equipment.
Our organization of
sound men is avail-
able to service and in-
stall your equipment
anywhere, any time.
Write Us.

Write Us at Once for Full Details

FIRE!

The New Handbook is HOT

and its cover is
FIRE DEPARTMENT RED

If your cover isn't red, it isn't the
New Improved Revised Enlarged
Superior Seventh Edition

HANDBOOK FACTORY, 1711 Park, Hartford, Conn.
SEND IT AT ONCE

(Name)

(Street or P. O. Box)

(City and State)

Who's Who

(Continued from page 28)

Francisco, and continuing successively with
Standard Electric Co. of California, California
Central Gas & Electric Co., and the North Shore
Railroad. In 1903 he became the electrical en-
gineer of the Harriman Lines, in 1909 electrical
engineer for the Southern Pacific Co. Since 1912
he has been Consulting Electrical Engineer for
that company.

Mr. Babcock's participation in general techni-
cal activities has been impressive. He is a Fellow
and a past vice-president of the American In-
stitute of Electrical Engineers, member and past
president of the Engineers' Club of San Francisco.
He is a member of the American Association for
the Advancement of Science and of the Astronomi-
cal Society of the Pacific. In 1924 he represented
the United States as principal delegate to the
Inter-American Electrical Communications Con-
ference, held in Mexico City. He is an honorary
member of *La Sociedad Geografica y Estadistica*
(Mexico). He is a representative of affiliate
membership in the Society of Automotive En-
gineers.

Always of distinctly nautical leanings, Mr.
Babcock holds a commission as Lieutenant-
Commander in the U. S. Naval Reserve and has
had several lengthy cruises with the fleet in active
duty. He is an expert amateur navigator, yachts-
man and fisherman, and a member of the San
Francisco Yacht Club and the Berkeley Country
Club.

In amateur radio he has been equally active.
He pounds brass pretty steadily at W6ZD,
particularly with Hawaii. Most of his radio
efforts, though, necessarily go to his duties as
Division Director. He is a vigorous director,
keeping closely in touch with affairs through the
large Pacific Division, maintaining an extensive
correspondence, and frequently visiting the
larger centers in person, particularly at the time
of conventions and hamfests. Not *The Old Man*,
he is yet one of the elders in the League, both in
years and in counsel.

The Roanoke Division Con- vention

WITH real Southern hospitality the Rich-
mond Short Wave Club, through its
chairman, "Bob" Eubank, welcomed the
delegates attending the first Virginia A.R.R.L.
Convention at the Hotel Richmond, Richmond,
Virginia on September 19th and 20th. The largest
registration was the first day and every minute
was taken up with something worthwhile.

The "dutch" lunch at noon on Friday enabled
those present to get acquainted and kept the
crowd together so that when the afternoon meet-
ing was called to order the Winter Garden room
was well filled with an enthusiastic crowd. Chair-
man Eubank introduced Director Gravely
W3BZ, one of the real old timers; one who has

QST Oscillating Crystals

"THE STANDARD OF COMPARISON"

AMATEUR BANDS:

Winter is coming, and no doubt you are going over your transmitter removing those weak links so as to get the most possible efficiency from your set.

One item of great importance is the *frequency stability* of your set. Does it *stay on one frequency*? If not, our *power crystals* will solve that problem. SCIENTIFIC RADIO SERVICE crystals are *known to be the best obtainable*, having ONE single frequency and highest output. With each crystal is furnished an accurate calibration guaranteed to *better than a tenth of 1%*. *New prices for grinding power crystals in the amateur bands* are as follows:

1715 to 2000 Kc band.....\$15.00 (unmounted)
 3500 to 4000 Kc band.....\$20.00 (unmounted)
 7000 to 7300 Kc band.....\$40.00 (unmounted)

BROADCAST BAND:

Power crystals ground in the 550-1500 Kc band accurate to plus or minus 500 cycles of your specified frequency fully mounted for \$55.00. In ordering please specify type tube, plate voltage and operating

temperature. All crystals absolutely guaranteed regards to output and frequency and delivery can be made within two days after receipt of your order.

CONSTANT TEMPERATURE HEATER UNITS:

We can supply heater units guaranteed to keep the temperature of the crystals constant to better than a tenth of 1 degree centigrade for \$300.00. Two matched crystals, ground to your assigned frequency in the 550-1500 Kc band with the heater unit complete \$410.00. More detailed description of this unit sent upon request.

ATTENTION AIRCRAFT AND COMMERCIAL RADIO CORPORATIONS:

We invite your inquiries regards your crystal needs for Radio use. We will be glad to quote special prices for POWER crystals in quantity lots. We have been grinding *power crystals* for over seven years, being *pioneers* in this specialized field, we feel we can be of real service to you. We can grind *power crystals* to your specified frequency accurate to plus or minus .03%. All crystals guaranteed and prompt deliveries can be made. A *trial will convince you.*

SCIENTIFIC RADIO SERVICE

"THE CRYSTAL SPECIALISTS"

P. O. Box 86

Dept. P-12

Mount Rainier, Maryland

ALUMINUM BOX SHIELDS

Beautiful Silver Dip Finish Any Size to Order
 Monitor Size 10" x 6" x 7" high.....\$3.25
 Stage Shields 9" x 5" x 6" high.....1.89
 Knock Down Coil Shields, 5" x 5" x 5", special.....1.00
 1 1/4" plug-in forms, 44 grooves to the inch, UX or UY...49c.
 Mesco Telegraph Key 96c. Syracuse 35 Condensers 59c.
 Phosphor bronze drum dial cable by foot or mile.....\$2.95
 Bakelite 50 watt sockets.....
 .001 Variable Condensers, \$1.25. Please include postage.
 BLAN, THE RADIO MAN, INC.
 89A Cortland Street New York City

FIRST QUALITY QUARTZ CRYSTALS

Scientifically Prepared for Maximum Power and Unconditionally Guaranteed 1 in. square sections (close to your specified frequency), supplied promptly at the following prices:

40-75 meters.....\$20.00
 75-100 meters.....12.50
 100-200 meters.....9.00
 200-600 meters.....15.00
 1 in. Tested blanks, 200-600, 400-600 meters.....4.00
 Dustproof Bakelite mounts.....3.00

(A Calibration furnished with each crystal)
 Sections of any practicable dimensions made to order
 (Charges for grinding to exact frequencies given on request)

J. T. Rooney, B. Sc., 4 Calumet Bldg., Buffalo, New York
 "A pioneer crystal grinder"

YOUR GOLDEN OPPORTUNITY!

LIMITED QUANTITY LEFT! YOU MUST ACT QUICKLY!

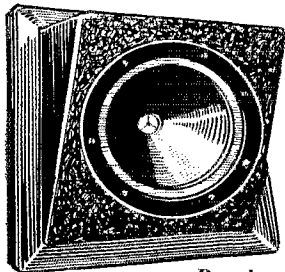

Brand new in original cases, Field Supply for 110 V. AC Operation. \$6.50 extra.

BRAND-NEW

GUARANTEED



12-Inch DYNAMIC SPEAKERS

Regular Price \$110.00 Our Price

Standard 12" speakers mounted on cast iron panels. Operate on a field of 110 V. DC, 1000 ohms with 100 mill. drain.

\$15

Terms: 25% with order

Balance C. O. D. or Sight Draft

Specify Express or Freight

RAYMOND ROSEN & CO., INC.

(Radio Amplification Division)

117 North 7th Street

Philadelphia, Pa.

FREE!

**RADIO DEALERS
SET BUILDERS
AGENTS
SERVICEMEN
OUR BARGAIN
BULLETIN IS
WAITING FOR
YOU**



**This COUPON means
MONEY for YOU**

use it now

**BALTIMORE
RADIO CORPORATION
47 Murray St., New York City**

Gentlemen: Kindly send me your latest BARGAIN BULLETIN.

Name

Address

City..... State.....

FOR YOUR FRIEND

Who Wants to Be an Amateur

"How to Become a Radio Amateur," a helpful booklet for beginners, describing simple apparatus and telling the whole story. Ten cents postpaid, \$1 per dozen copies.

**American Radio Relay League
HARTFORD, CONN.**

Maximum Power Crystal Blanks

Bethesda crystal blanks are tested for maximum power and output, and are unconditionally guaranteed to be free from any and all defects.

Price of zero angle or x cut blanks ground to within 1/1000 of an inch in thickness of the

50 to 500 meter band	\$4.25 per section
500 to 700 meter band	\$4.50 per section
40 meter band	\$6.00 per section
20 meter band	\$7.00 per section

Blanks on the V or 30° angle plane to within 1/1000 of an inch in thickness of the 80 or 160 meter bands, \$4.25 per section. — Prices include postage and are C.O.D. or cash with order. — Special quotations to Dealers, and on orders of 5 or more blanks. Crystal sections on hand, or cut to order in any shape, size, or plane, for Laboratory or Basic science research work for Universities. A trial order will convince you of the high standard of our product. Special attention given every order.

BETHESDA CRYSTAL LABORATORY
P. O. Box 43 Bethesda, Md.

represented his division so well for many years. Mr. Gravely spoke on the duties of the director and what it means to one to have the constructive cooperation of the members: he then introduced Mr. Chas. H. Stewart, Vice-President of the A.R.R.L., who has looked after the legislative end of the League so efficiently for a long time. Mr. Stewart said he was present to enjoy himself as a "ham" and intended to do so all through the convention and before the convention was over was made a member of the "young squirt" family by Doc. Woodruff, the "Sherlock Holmes" of the Board of Directors. (The young squirt family now consists of Gravely, Stewart and Hebert.) Major W. G. Hawthorne, U. S. Marine Corps, Quantico, Va., and one of the active "hams" in the division under the call-letters of W3AFT, gave a talk on the equipment used by the signal section of the Marines and showed some of the portable transmitters and receivers used in the field. The compactness and ruggedness of the outfits showed careful design and manufacturing. Thanks are due the Major for all his trouble. Fieldman Hebert from Headquarters had brought Ed. Handy's new Dynatron Frequency Meter and did his best to convince the gang of the importance of each amateur station having an accurate measuring instrument. The importance of keeping within our frequency bands cannot be overlooked any more. Mr. M. M. Brisbane, Service Engineer, RCA-Victor, gave a lecture on condenser microphones as used in broadcasting stations. The afternoon ended with Lieut. Wilson, U.S.N.R. showing three reels of movies. Dinner found group after group of fellows who had become real friends together and the air buzzing with ham-talk.

The evening was devoted entirely to an illustrated lecture by L. S. Fox, Engineer, National Carbon Co., on tube construction, and made one appreciate the amount of research work conducted by his firm.

The traffic meeting on Saturday morning was in charge of SCM, J. F. Wohlford, W3CA, and general discussions on Communications Department affairs took place. Lieut. Wilson, U.S.N.R. brought out the benefits to be derived in enrolling in the Reserve, which remarks were supplemented later by Lieut. E. C. Rogers of the Navy. Capt. N. L. Baldwin, the Army-Amateur Liaison Officer from Washington, discussed the importance of the Army-Amateur net now being placed on an efficient basis and with a master control station (WLM and W3CXL) located in Washington. Our fellows should realize more and more the importance of these two services and extend full cooperation. Don Lusk, although an SCM for the Atlantic Division was present with his OW, and that brings to mind there were several OW's and YL's present.

The convention was favored by two representatives from the Radio Division in the persons of Mr. L. C. Herndon, Radio Supervisor and his assistant Mr. G. E. Sterling, of the third district. They were kept busy with examinations.

With some 25 automobiles in the line — looking just like a parade — a trip was made to the



**SPECIAL AUDIO AND OUTPUT TRANSFORMERS
FOR PRECISION CIRCUITS**

Now made in U. S. A. on 48hrs. notice

Ferranti specially designed precision audio and output transformers suitable for the exacting requirements of broadcast stations, laboratories, recording devices, amplifiers, telephone lines, special testing and other uses, where a flat curve is required over a wide frequency range, are now made in the U. S. A.

These transformers have curves flat within less than 1 db. between 35 and 8000 cycles. The above curve of 600 ohm line to line transformer is typical. Transformers of this class can be furnished for tube to line, line to speaker, line to line, line to tube, microphone to tube and other numerous requirements.

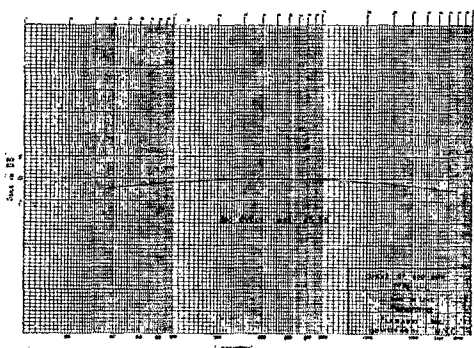

Curve of 600 OHM Type L. L. Transformer—
Tube line to line

FERRANTI, INC.

130 WEST 42nd ST., NEW YORK



**And now
Ellis Model 10N
for Amateur
Radiophone!**

The Ellis Model 10N Microphone at \$25.00 list is something entirely new in microphones at this price. By means of a special gold plated corrugated metal diaphragm developed at our laboratory we have attained many of the advantages of the stretched metal diaphragm. Your jobber can secure this for you if he does not have it in stock. Write for details of mechanical and electrical characteristics.

ELLIS ELECTRICAL LABORATORY

Sales Corporation

337 WEST MADISON ST.

Chicago, Illinois

BECOME A RADIO OPERATOR

See the World, Earn a Good Income,
Duties Light and Fascinating

LEARN IN THE SECOND PORT U.S.A.

Radio Inspector located here. New Orleans supplies operators for the various Gulf ports. Most logical location in the U. S. A. to come to for training.

Our students qualify for the various branches of radio. Runs to all parts of the world. Positions Ashore and Afloat. Special courses. Day and Night classes. Enroll any time. Oldest and Largest Radio School South.

Literature on request.

GULF RADIO SCHOOL

844 Howard Ave.

New Orleans, La.

JOHN F. RIDER

announces

A personally written and personally conducted

ADVANCED HOME STUDY COURSE

for serious minded

RADIO SERVICEMEN

EXPERIMENTERS

PROFESSIONAL SET BUILDERS

who wish to increase their earning power, prepare themselves for future radio developments and better their financial condition.

JOHN F. RIDER, Steneck Trust Bldg., Hoboken, N. J.

QST 1

Dear Mr. Rider: Please send me all details about your SPECIAL HOME STUDY COURSE without any obligation upon my part.

Name

Address

City State

Say You Saw It in QST — It Identifies You and Helps QST

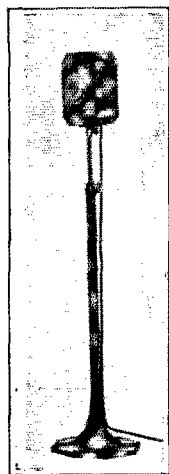

NEW!!

Our model 30 line of Condenser Microphones using the new low drain tubes. Elaborate two stage amplifier. 6 or 12 V. filament operation. Priced up to \$250.00.

COLOR!

Pine tree ripple finish in black, black and gold, black and silver, brown, brown and gold.

SIGNAL LIGHTS

Wired in red and green signal lights.

UNIT

Our new and improved type "B" Unit with a sealed-in chemical dryer. Sold separately.

\$100.00

Microphone comes with tubes and 30 ft. 7 wire Packard shielded cable.

DEALERS WRITE
FOR PROPOSITION

ASTATIC MICROPHONE LABORATORY

YOUNGSTOWN, OHIO, U.S.A.

21 OLIVE ST.

On the West Coast

PACIFIC ENGINEERING LABORATORY CO

5155 S. Gramercy Place, Los Angeles, Cal.

A Larger Rectobulb TYPE R4 Now Ready

Fil. Volts 5

Fil. Amps. 10

Peak
Current
2.5 Amps.

Max. Inv.
Peak Volts
7000

Fits UX socket and
has plate cap and
connection.

Price \$20

NATIONAL RADIO
TUBE CO.

3420 Eighteenth Street
San Francisco 7 Calif.

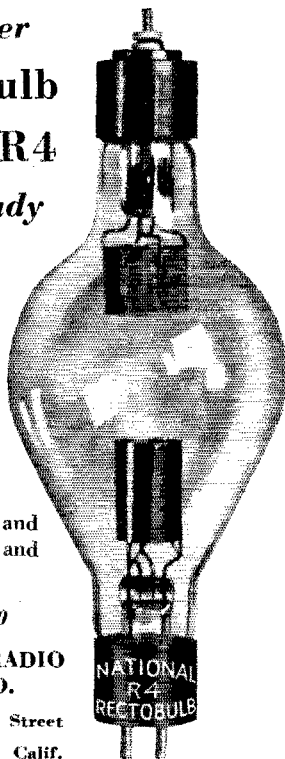

air-port where an opportunity was given to examine the Department of Commerce radio beacon and weather station, followed with a visit to Broadcasting Station WRVA, where "Bob" Eubank is the chief operator. The final technical talk took place in the Red Room while the Winter Garden was being prepared for the banquet. Miss Elizabeth M. Zandonini, (our own W3CDQ) from the Radio Division Bureau of Standards, gave an illustrated lecture on the piezo-electric oscillators as used by the Bureau. We are thankful to Dr. Dellinger for permitting Miss Zandonini to bring slides along — for they always help a lecture. There were so many speakers that Doc. Woodruff, WSCMP, did not have an opportunity to speak on "chokes" until the banquet, but as he was the "Roastmaster" he found a chance to give a bully good talk. With a good orchestra and a side "skit" by two pickaninnies the entertainment feature was well carried out during the banquet. With the distribution of prizes as a finale the first Virginia convention came to a close with the gratitude of all present being expressed to the Radio Manufacturers for their donations and to the Richmond Short Wave Club and the convention committee for such a pleasant affair.

— A. A. H.

Who's Who

(Continued from page 28)

by c.w. Followed a half dozen very active years, during which Mr. Huber was president of the Tipton Radio Club and held a variety of A.R.R.L. positions: O.R.S., O.W.L.S., O.B.S., member X-Section, R.C.C., Asst. Division News Manager, and S.C.M. for Iowa.

These activities and qualifications caused him to be called to headquarters in the spring of 1928 to become Assistant to the Communications Manager. He put in a year and a half at Hartford but felt obliged in 1929 to return home to resume his studies at the University of Iowa, which had been interrupted by the sojourn at headquarters. Brasspounding was now divided between W9YA, the University station, and W9DOA, which had become crystal-controlled in 1927. In the fall of 1929 Mr. Huber was elected director of the Midwest Division, and has represented them this year. He was commissioned Ensign in the U. S. Naval Reserve and appointed executive officer for Section Eight (Iowa) of the naval communications reserve. Meanwhile he continued active in club work, organizing the Iowa Amateur Radio Club at the university's seat, Iowa City, and having a good share in planning several of the conventions at Ames, annual Midwest Division affairs.

This fall he transferred his activities to Seattle in order to enroll in the School of Journalism at the University of Washington. His unfortunate distance from his division made it seem desirable to him to resign his post as director, as a consequence of which a special election is now in process to choose his successor in the Midwest. Meanwhile he maintains his interest in amateur matters and has become a member of the Seattle Radio Club.

REPLACEMENT TRANSFORMERS

by THORDARSON

Install Tone Quality in unsatisfactory sets by replacing inferior, obsolete, or worn out units with **THORDARSON REPLACEMENT TRANSFORMERS** . . . it is what the set owner hears . . . the improvements in audio amplification . . . that makes pleased customers.

THORDARSON Replacement Transformers are constructed according to the true high standard set by all **THORDARSON** apparatus . . . and they are almost universal in application.

R-101

Replacement Input Transformers for push-pull tubes in output stage

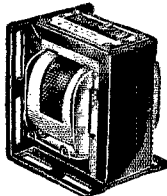

T-2971-E T-3381

Replacement Power Transformers T-3381 for single "171" tube in output stage. T-2971-E for "171" push-pull tubes in output stage.

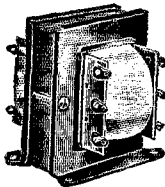

A small stock of **THORDARSON Replacement Transformers** enables you to recondition a wide variety of sets, with minimum investment in stock. For sale at all good Parts Dealers everywhere.

SEND TODAY for the new catalog of Replacement Power and Audio Transformers.

THORDARSON

Transformer Specialists Since 1895

Thordarson Electric Mfg. Co., Huron, Kingsbury and Larrabee Sts., Chicago, Ill.

Radio Operators Wanted

Radio operators are officers aboard ships. Well paid, pleasant work, travel. You can qualify in a short time in our well-equipped school under expert instructors.

Write now for free booklet on "Opportunities in Radio."



WEST SIDE YMCA RADIO INSTITUTE
111 West 64th Street, New York Established 1910

We Beg Pardon

Due to the unexpected demands for our new products, shipments were somewhat delayed. However, we have now increased our facilities and shipments of our type WM-1 wavemeter and type MM-1 Monitor can be made immediately. We thank our customers for their patience.

Type WM-1 Wavemeter: Aluminum case, large micro-vernier dial, readings to 1/200 of full scale, neon bulb resonance indicator, coils for 20, 40 and 80 meter bands. Fully calibrated, with graphs. . . . \$9.50

Type MM-1 Monitor: Aluminum case, micro-vernier dial, coils for 20, 40 and 80 meter bands. Complete with tube and batteries. . . . \$12.50

Send for Data Sheets

COLUMBIA SPECIALTY CO.
Engineering Dept. — LUDlow 7738

1038 Longwood Avenue New York City

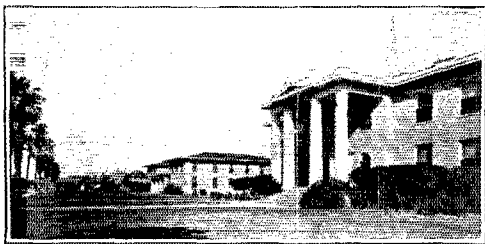

. . . Fill in attached coupon for details

PORT ARTHUR COLLEGE
PORT ARTHUR (world-known port) TEXAS

PAC RADIO TRAINING

offers Travel . . . New Sights, Good Pay and Comfortable Living . . . Abundant Leisure for Study.

Port Arthur College, Port Arthur, Texas
Please send details concerning Radio Course to

Name

Street or Box

City and State



for phones or C. W.

This husky well filtered power supply is just the thing.

Get that 1931 pure D.C. note and laugh at QRN. Send us your order today and build your new station around this wonderful unit. Uses two 281s as rectifiers, or mercury filled rectobulbs. Supplies both filament and plate current for four 210 tubes. Priced for less than you can buy the parts to build it.

Price \$25.00

without tubes

Special Deluxe for phone, nickel plated \$30.00

Monitors to match complete \$7.50



GENERAL ENGINEERING CORP.
CHARLOTTE MICHIGAN



Changes in Regulations

(Continued from page 30)

accordance with the Radio Act of 1927 as amended." The practical effect of this is to take out of the hands of the Supervisors of Radio the actual licensing of amateur stations and to centralize this work for the whole country at the offices of the Commission in Washington. General Saltzman, chairman of the Commission, explains in a letter printed in this month's "Correspondence" that the duty of issuing amateur licenses belongs to the Commission, under the law, and has been but temporarily handled by the Radio Division. The Commission now possessing adequate facilities for doing the work, it now takes it over, as provided in the Radio Act.

The regulations of course continue to provide that normal amateur applications complying with the regulations shall be issued without more ado, and at this writing the issuing and renewal of station licenses is proceeding smoothly and promptly at Washington.

Application blanks must still be obtained from the Supervisor, and the filled-in form must still be filed with the Supervisor. It is not to be mailed direct to the Commission. (The Supervisors still issue operator's licenses.) In the past the greatest delay in issuing amateur licenses has been caused by the improper or incomplete execution of the application form. Supervisors have often had to return an amateur's application for correction or to secure missing data. With the forms now going to Washington, such delays will be greater. It is important, then, to make an adequate answer to each question.

Applications for renewal of station license must be filed with the Supervisor at least thirty days prior to expiration. It is up to the individual amateur to write for the renewal application blanks in time to comply with this requirement. Otherwise a prized call may be lost, and if renewal is not received by the expiration date of the old license, operation must cease until the new one arrives. Remember, too, that both station and operator licenses must be displayed conspicuously in the station.

— K. B. W.



It seems we were a bit too hasty in making that remark about the lack of a tube with a plug-in filament in *Strays* a month or so ago. Don Hawley, of Plant City, Fla., informs us that such a tube was described in one of the popular magazines not long ago. Anyhow this tube is a heater-type gadget, and we were thinking of d.c. tubes!

If your ears are getting corns from wearing the 'phones and you can't beg, borrow or steal a set of regular cushion pads, visit the Amateurs' Paradise and invest a pair of dimes in the same number of bath sponges. Cut a hole in the center of each and enlarge it on one side so the cans will fit tightly, and you're all set to be a boiled owl. W9PA sent us this one.

Measure Easily Resistance—Voltage—Current

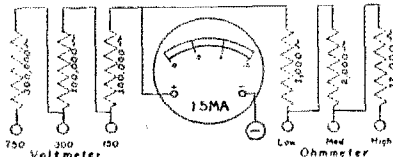

Super Akra-Ohm wire-wound Resistors and Shunts afford an inexpensive means to build test equipment for the measurement of resistance, voltage, and current with accuracy.

A combination for the measurement of voltages and resistances is shown in the above diagram.

Super Akra-Ohm wire-wound Resistors are manufactured in any value from 100 ohms to 10 megohms. They are carefully designed to insure an accuracy of one per cent and a constant permanency of calibration. Their use is highly recommended for Laboratory Standards, High Voltage Regulators, Telephone Equipment, Television Amplifiers, Grid and Plate Resistors, Electrical Apparatus, and Test Equipment, etc.



Prices range from \$1.25 for 100 ohms to \$4.00 for 500,000 ohms

Send us your dealer's or jobber's name and we will send you a copy of **Bulletin 73-C**

We manufacture special multiplying resistors for A.C. voltmeters. Full information will be sent on request.



Shalleross Mfg. Company
ELECTRICAL SPECIALTIES
200 PARKER AVENUE
Collingdale, Pa.



Duovac Announces

TRANSMITTING TUBES

*of exceptional precision
and uniformity*

DUOVAC Transmitters are made to extremely rigid specifications and with great care. They are capable of handling large overloads if used intelligently.

Each tube is thoroughly tested before shipping, and is guaranteed as to electrical characteristics and mechanical construction.

*Order direct from factory
enclosing check or money order.
No red tape—immediate delivery!*



Dr. Paul G. Weiller, formerly with Westinghouse, in charge of Duovac Transmitting Tube production.

D U O V A C

The Precision Radio Tube

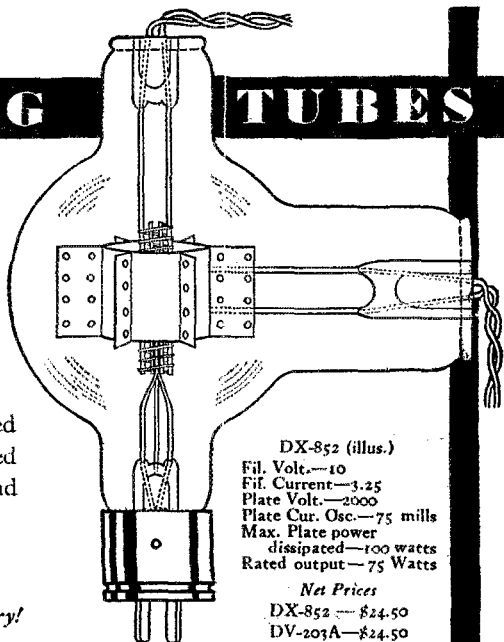

DX-852 (illus.)
Fil. Volt.—10
Fil. Current—3.25
Plate Volt.—2000
Plate Cur. Osc.—75 mills
Max. Plate power
dissipated—100 watts
Rated output—75 Watts

Net Prices
DX-852 — \$24.50
DV-203A — \$24.50
DV-211 — \$24.50

Duovac Radio Tube Corp.
360 Furman Street
Brooklyn, N. Y.



CHRISTMAS

with its joy and good will—why not extend its spirit over the whole year? The fund from the sale of Christmas seals in December will carry help and education against tuberculosis throughout all 1931.

The National, State & Local Tuberculosis Associations of the United States

**Buy Christmas Seals
Fight Tuberculosis**

Say You Saw It in QST — It Identifies You and Helps QST

RESISTORS

**No longer
any problem**

Our resistors are accurately rated, maintain their tolerance and are noted for their rugged strength and quietness. All types from 1 ohm to 200 megohms—the choice of leading engineers, the largest radio manufacturers and the majority of service men.

Our Resistor Replacement Guide shows clearly and concisely: (1) how to locate cause of trouble in radio sets,

(2) proper types and values of resistors to use in radio receivers.

**Write for
it today.**



MADE
BY THE
MAKERS
OF



**INTERNATIONAL
RESISTANCE CO.**
2006 Chestnut St., Phila., Pa.

!! HEAVY DUTY QUARTZ PLATES !!

FREQUENCY RANGE

14,000-kc. to 500-kc.

PRECISION: One tenth of one percent

PRICES

Without holder
all frequencies \$12.00

With holder (sealed)
\$20.00

FOR THE FIRST TIME

1. Fundamentals on waves as low as 20 m.
2. All crystals power crystals.
3. All crystals one price.

Delivery prepaid, terms cash, no discounts

K. W. CRYSTAL LABORATORIES

c/o W1AWK, 420 Memorial Drive

Cambridge, Mass.

PERFORMANCE

That will put your station right among the top-notchers — make yours a famous call — that's every operator's dream. Build it and operate it by the Ham's Bible, equip it with a power plant engineered exactly to QST's specifications and your dream will come true. High efficiency rectifiers, power and filament transformers, filter reactors, that out-perform "built-to-sell" apparatus two to one. Complete engineering data sheets are eye openers. Get yours NOW.

Rectifier Engineering Service, 4837 Rockwood Rd., Cleveland, Ohio

HAM PROTECTION

NEW! RENEWABLE HIGH VOLTAGE LITTELFUSES to protect broadcast equipment, etc. 1000, 5000 and 10,000 volts. Sizes: 1/16, 1/8, 1/4, 3/8, 1/2 amps. in each voltage. Price — 35c to 95c. Renewals — 10c to 20c. Low Voltage Littelfuses — 10c to 20c. Sizes: 10 mil., 1/32, 1/16, 1/8, 1/4, 3/8, 1/2, 1, 2 amps. "Quicker than a Short-Circuit."

Write for new catalog

LITTELFUSE LABORATORIES
1772 Wilson Ave. Chicago, Ill.

TRANSMISSION CONDENSERS



Send for interesting data and price sheet on Transmission Condensers with working voltages up to 3000 D.C. for use with the following tubes: 203A, 204A, 210, 500W, 851, 852, 860, 865.

CORNELL ELECTRIC MFG. CO.
Long Island City New York

Do you know that the latest Radio Amateur's Handbook is available in bound form — \$2.00 per copy, postpaid.

When ordering a copy of this new seventh edition, look at your present copy and determine if you want your next copy in more permanent form.

All You Need to Learn TELEGRAPHY Morse or Continental with Teleplex

Guaranteed to teach you the world's most fascinating profession — by hearing real messages — sending them

Interesting — simple — you learn quickly — at HOME

Teleplex is the Master Teacher. Used by U S Army, Navy and reading, radio and telegraph schools Write for Folder Q-12.

TELEPLEX COMPANY
76 Cortlandt Street, New York

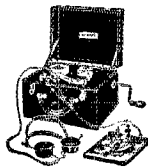

Build Your Own Radio Cabinet

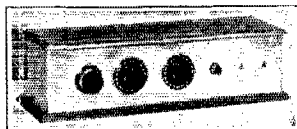

Write for particulars about our knock down cabinets
No. 10 Mahogany (2 tube size inside 11 1/4 L. x 7 D. x 5 9/16 H.) \$1.00 F.O.B. Mill. No. 20 Walnut (3-4 tube size inside 12 L. x 8 D. x 6 3/4 H.) \$1.90 F.O.B. Mill. No. 30 Mahogany (Special size inside 25 L. x 7 D. x 5 9/16 H.) \$2.50 F.O.B. Mill. No. 40 Low Boy (Walnut). Price and details on request.

Price includes wood parts, hinges, filler and stain for finishing. All orders are cash or 25% advance on C.O.D. shipments. Height shown is net measured from top of 3/4 inch mounting board.

THE FOREIGN & DOMESTIC VENEER CO.
Box 1067, Knoxville, Tenn.

ACME WIRE PRODUCTS

Coils — Magnet Wire Wound
Magnet Wire All Insulations
Varnished Insulations
Parvoit Filter and By Pass Condensers

All products made to Recognized Commercial Standards including those of:
National Electric Mfrs. Assn.
Radio Manufacturers Assn.
American Society for Testing Materials

For more than 25 years manufacturers and suppliers to the largest and most discriminating users.

THE ACME WIRE CO. NEW HAVEN, CONN.

Branch Offices:

New York Cleveland
52 Vanderbilt Ave. Guardian Bldg.
Chicago
842 N. Michigan Ave.

William D. Tullis, Radio Operator, Station WUE,
Fort George Wright, Washington

14,000-ke. band

1ake 2atz 3rab 4vj 5zo 4at 5alp 5ain 5dqe 5bex 5nug 5bnz
6ezz 6cub 6ekm 6og 6exd 6dep 6dke 6dpp 6eub 6aix 6exq
6vq 6dmk 6eep 6bat 6dtd 6dyo 6eqw 6eri 6ess 6arp 6ap
6dse 6car 6ele 6bqk 6diz 6cr 6agr 6akw 6es 6bhy 6eop 6ebo
9dz 9fur 9cif 9gme 9afn 9fbh 9are 9isg 9ek 9fkc 9eci
9bvh 9ep 9ed 9ads 9dnt 9gau 9edil

W9AFN, P. B. Lovgren, 7846 Euclid Ave., Chicago, Ill.

3500-, 7000- and 14,000-ke. bands CW

w6aan w6ae w6adl w6aed w6aep w6aer w6age w6ags w6ajj
w6aim w6ake w6akf w6alu w6ama w6amq w6any w6aoa
w6aob w6ast w6ati w6atm w6avd w6awd w6awy w6ba
w6bbp w6bcd w6bch w6bck w6bgl w6bjd w6bht w6bif
w6bjf w6bkk w6bnc w6bqg w6bpm w6bqy w6brv w6bvc
w6bvg w6bsk w6bsj w6bst w6bxw w6bxy w6by w6bzy
w6byz w6bzr w6cal w6car w6caz w6cbp w6cdr w6cf w6fo
w6gex w6ch w6chy w6cii w6cis w6cp w6enx w6eox w6eok
w6eqz w6esj w6esp w6ete w6etk w6etp w6euj w6eum w6ewt
w6eww w6cwx w6eyi w6eri w6dae w6deu w6def w6ddl
w6dep w6dgj w6dgn w6dgv w6dio w6dkw w6dkx w6dly
w6dmi w6dnh w6dni w6dob w6dqh w6dqy w6dwi w6dww
w6dxc w6dyj w6dym w6dyy w6dza w6dzu w6dzz
w6ebg w6ebx w6ecn w6edd w6edj w6eem w6eep w6efs
w6efv w6egk w6egu w6eke w6eke w6ejc w6ejh w6ell w6eou
w6epz w6eqq w6equ w6ere w6eri w6esa w6etr w6euh w6eup
w6evy w6exq w6eyc w6eyw w6eza w6ezg w6eal w6fc w6h
w6id w6jn w6jm w6jj w6ka w6kg w6kq w6lx w6lb w6lx
w6ms w6mi w6oj w6qp w6sa w6sv w6tm w6uc w6ud w6uu
w6wb w6wi w6yau w6zq w6zg w6zz w6zz velr velco veldr
ve2ac ve2bb ve2am ve2ca ve3dn ve3bd ve3da ve3dw ve3et
ve3hd ve3he ve3ke ve3kx ve4af ve4bx ve4ei ve4gf ve4go
ve4hh ve4ho ve4jg ve4af ve5am ve5aw ve5bj ve5al ve5aj
k4ac k4dk k4kd k4ni k4rf kfu5 kfr6 kdv5 k6alm k6odd
k6cog k6dqk k6dud k6egd k6evw k6ewb k7abs k9zzg cm2jm
cm2jt cm2ra cm2rz cm2sh cm2xa cm2yb cm5fl cm5xc
cm8st cm8uf cm8yb ct1aa ct1bx earl13 f8rf f8dot f8mrc
g5by g5yx g6ut oa4j oa4r oa4t oa4z lu3dh lu3fa lu3pa
py1aa py1ah py1aw py1er py2ak py2ay py2bg py2ih py2jk
py3ab py3ab py3ia py9hc ce1ah ce2ab ce3bf ce5aa vo8ae w8lk
vo8mc h6ifg h6zjm nn1nic nn1fx nn1nic nn1zj ex2ak yslfm
yxlx rx1aa t2rs n2pa tm2elo lap ex7 qqla cabl wft wfa
wfat wye wlm xwlm xee xebm x9a xlg xlj x29a xda pxmg
nkf nagk nuj kfzt sfen zllbb zlzac z4fam vk2kj vk2rx vk3up
vk5km pklijr

14,000-ke. 'phone band

w5ql w6aj

3500-ke. 'phone band

w1aby w1ld w2agt w2bee w2gj w2hy w3aex w3bj w3cv
w3oo w4aeu w4hn w5awp w5kx w6abf w6bbj w6ean w6kt
w7acq w7alw w7ant w8acb w8ahz w8ajh w8akw w8aws
w8azo w8bfh w8buw w8byr w8cww w8ccz w8clh w8cjd
w8cmu w8cww w8cy e w8dzg w8dpp w8dsl w8lh w8rd w8wf
w9ajq w9ath w9ata w9bag w9bjc w9bqp w9bpt w9bty
w9bvp w9bw w9bwt w9cdd w9cii w9cld w9cma w9daq
w9dbe w9dzt w9edw w9ehd w9egq w9ewe w9ewx w9fzl
w9get w9ghx w9gku w9jr w9mm w9mp w9kb w9cqx

W1PE, Arthur E. Berg, 62 Hemman St., Rosin-
dale, Mass.

14,000-ke. band

cm2jm cm2sh cm8uf cne ct1aa ct2au cx1af f8aly f8ca f8dmf
f8to f8jq f8kz f8mrc f8rvi f8wsg fm8ih fm8pzz g2qm g5bj
g5by g5hz g5dj g5ml g5mt g5vl g6mt g6rb g6vr g6wt g6zj
haf8b ls3dh lu3de lu3fa lu4da lu6jf nl8sz oa4j oa4z on4jc
on4re on4us pa0q pa0f pa0wr py1as py1cm py2ab py2ag
py2ay py2ba py2bi py2bg py2bk py2bl py2bm py2bo py2bj
py9an ve2be ve8bm ve8gx ve8wk ve4ae ve4bb ve4bu ve4cl
ve4x ve4je vo8ae vo8mc w5aa w5ada w5afb w5agz w5ani
w5ark w5ary w5bhz w5go w5mx w5rr w5vq w5wcp w6aj
w6ave w6bax w6bhp w6bto w6bt w6cii w6cpi w6ctw
w6ddb w6dck w6dep w6efs w6egh w6egk w6ejc w6elp
w6ewm w6ph w6tg w6vj w7aaq w7ahx w7aic w7be w7bvo
w7do w7fh w7it w7lk w7sx w7vy wdde x9a xee

14,000-ke. 'phone band

w1uh w1aze w6asj

Bigger Than Ever

Our new catalog shows the whole JOHNSON line, partly illustrated here — a line of such quality that no purchaser of Broadcast, Public Address, Laboratory, or Amateur equipment can afford to overlook it.

In addition we distribute the products of most manufacturers of similar equipment. We believe this to be the most complete presentation of such merchandise available. Our stock is good, shipments fast, prices the best.

Send for it today. Price to individuals, 10c, refunded on first order.

E. F. JOHNSON CO.
Waseca Minnesota

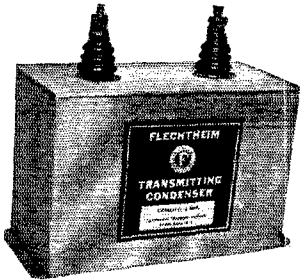

Type TH 200 — 2 mfd
2000 v. D.C. — 1600 rms R.A.C

Planning A New X-Mitter?
Rebuilding Your Old One??
Need Some Real Good Condensers???

THEN, BE SURE TO GET

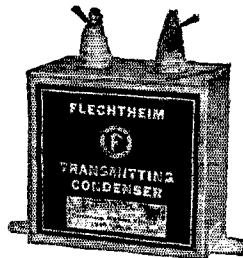

Type T 200 — 2 mfd
1500 v. D.C. — 1000 rms. RAC

FLECHTHEIM

SUPERIOR CONDENSERS

YOU GET THE VERY BEST WHEN YOU BUY

FINEST **L**EAST **E**XPENSIVE **C**ONDENSERS **H**AVING **T**HE **H**IGHEST **I**MPROVING **M**ODULATION **S**UPPLY

Among Other Users, ARE: Western Air Express, Pan-American Airways, Southern Air Transport

Ur QSL crd w1 bring u latest catalog es name of nearest Dealer 73 w2afs

"USED BY OVER 50% OF THE BROADCASTING STATIONS"

A. M. FLECHTHEIM & CO., INC. 136 Liberty St., New York, N. Y.

(Established 1911)

NEW! NEW! NEW!

LAFAYETTE

Wide World
SHORT-WAVE
RECEIVER

It's here! Perfect short-wave reception with the new Lafayette Wide World Short Wave Receiver. A. C. Push-pull amplification. Double Screen Grid. 9 to 550 metres. Absolutely guaranteed. Fully wired, complete with power unit, at a sensationally low price. Write for full particulars TODAY.

Many Other Bargains!

Wholesale Radio Service Company, the reliability house of radio, is featuring short wave apparatus of known quality. Write for our 1931 Radio Catalog — "the guide book of radio quality" — sent absolutely FREE. It's yours for the asking!

WHOLESALE RADIO SERVICE CO., INC.
36 VESEY ST. Dept. M-11 NEW YORK

Guaranteed Radio Bargains

FRESHMAN type 'N' power packs. Brand new and in original cartons. Can be used to power a 210 oscillator or a 250 power amplifier. It solves the problem for getting pure d.c. power supply. D.C. output is 500 volts at 70 mills with taps at 135 and 50 volts. A.C. output is 7 1/2 center-tapped for 2 210's or 250's; 2 1/2 c.t. to 227 and two 1 1/2 center-tapped windings for 226 tubes. Has a plug for the field coil of a d.c. dynamic speaker. A 281 is used as a rectifier. Price, less tube..... **\$10.75**

DONGAN 250 watt transformer with line ballast resistors. Insures absolutely steady voltage regulation. Completely mounted and shielded. Terminal lugs at top. Resistors furnished free. Secondary high voltage output is 1500 volts, center-tapped at 750 volts. Filament output is 15, 7 1/2, 7 1/2 center-tapped, and 2 1/2 center-tapped. Get your order in fast as there are very few left. Price complete..... **\$6.50**

KNIGHT 150 watt transformers. Ideal for 210 power supply using half-wave rectification. High voltage is 600 volts. Filaments are two 7 1/2 center-tapped windings, 2 1/2, and 1 1/2 volts..... **\$2.75**

COLUMBIA 30 henry, 200 mill chokes. A real rugged choke for heavy duty power filter supply. Mounted..... **\$2.50**

THORDARSON 30 henry 150 mill chokes..... **\$3.25**

THORDARSON 20 henry 250 mill chokes..... **\$3.75**

COLUMBIA 30 henry 120 mill chokes, mounted..... **\$1.30**

GRID LEAKS Wire wound and enamel coated. For all tubes up to 250 watts. 10,000 ohm, **\$95**. 5,000 ohm, **\$65**

TUBES of high quality and durability. Guaranteed to stand up. FREE 30 day replacement. Type N281, **\$1.60**; X250, **\$2.05**; N224, **\$1.20**; X171-A, **\$70**; X280, **\$90**; X245, **\$1.20**

COLUMBIA TRANSMITTING FILTER CONDENSERS Newer and better. We have been swamped with orders since these extra heavy duty condensers were offered. Insulated binding post terminals. And with a REAL replacement guarantee.

Capacity	Working Voltages		
	1000 d.c.	1500 d.c.	2000 d.c.
1 mfd.	\$1.50	\$3.10	\$3.95
2 mfd.	\$2.40	\$4.60	\$6.95
3 mfd.	\$3.90	\$6.95	\$11.50

COLUMBIA GRID AND PLATE blocking condensers. Made with the same strict specifications as our high duty condensers. You can't go wrong with these condensers in your set. They DON'T break down!

Working Voltage	0005	001	002
	1000 d.c.	\$90	\$90
2000 d.c.	\$1.05	\$1.05	\$1.05

See our engineering department ad on page 0000 for s.w. apparatus.

Orders are cash or C.O.D. All merchandise fully guaranteed.

COLUMBIA SPECIALTY CO.

1638 Longwood Ave. New York City

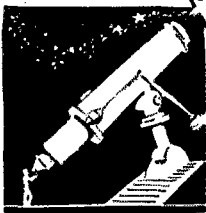

Searching the Infinite

Out across space, giant telescopes are bringing new stars into our ken. In millions of radio receivers **CENTRALAB** volume controls are helping to reach out across space to bring in noiseless, sputterless reception.

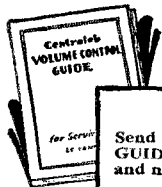

**Dealers
and Servicemen:**

Send 25c for new **VOLUME CONTROL GUIDE** giving control circuits for old and new sets.

SEND THIS COUPON NOW

Centralab

CENTRAL RADIO LABORATORIES

Dept. 320F, Keefe Ave. and Humboldt Milwaukee, Wisconsin

Enclosed find 25c for your new **VOLUME CONTROL GUIDE**.

Name

Address

City State

LU4DQ, Moises Tapiero, 214 Espana St., Bahia Blanca (Bs As) Argentina

14,000-ke. band

wlabd w1bux w1bvl w1cmx w1cqr w1da w1zi w1zz w2aeb w2ai w2ait w2ag w3hg w3zb w4ly w4wt w5aot w5awd w6ajm w6apd w6awf w6baw w6bar w6byb w6bsn w6car w6ctp w6czm w6de w6dmk w6dtz w6ejc w6etc w6id w6jp w6ln w7mo w8adz w8bti w8cx w8dgp w8dgg w8dgc w8dps w8fbw w9fur w9dgh w9pv w9s ac2al ac3fr xu2uu celal celak ce2bm ce3bm ce3ca ce3ch ce3cr ce3da ce5aa ce7aa cm2to cx2bt cxwck ear10 ear21 ear96 f8aap f8ex f8orm f9ar ct1bx ct1by g2gm g2kf g5bj g5rm g6ko g6mc g6gc g6rb g6wl g6wn g6mu haf3c he2jm helfg j1dn j2cb j3fz k6acw k6avl k6bhl k6boe k6etf oa4j oa4p oa4q oa4t oa4x oa4z oh2nad oh2naw ok1ab on4bc on4j oz7t pa0fp pa0fr pa0xv py1ah py1aw py1bt py1bz py1cd py1ed py2ak py2aq py2bk py2bm py2bz py2if py2lk py2im py3ac py3ag py3ao py3aq py3de py3gv py3gf py3iw py3ru py3wa py8ia py9ac py9lc ve2bh ve3bk ve5bl vk2ek vk2na vk3go vk4bb z1ian z1ax z1ba z1fb z1fc z1fu z1fv z1fw z1fr z1ze z1zg z1zbp z1zch z1zq z1zaw z1zao z1zax z1be sp3ar ti2ea x9a zplac zp1ba zp2ab zsn zst4 zuld zu6e

ONR470, M. de Waepenaert, Rue Soeurs-Noires 22, Termonde, Belgium

14,000-ke. band

wiae w1sep w1aiq w1aky w1apq w1aqd w1aqt w1awu w1aze w1bad w1bhm w1bjp w1bob w1bwa w1cek w1cft w1cmx w1com w1dp w1ds w1og w1ok w1ve w1vz w1wa w1wv w2aey w2afr w2ah w2amr w2arb w2atk w2aze w2bai w2bak w2bbh w2bda w2bia w2biv w2bka w2bkw w2bro w2bvk w2bwc w2byr w2cua w2jn w2ju w2jz w2oa w2qd w2wo w2wl w2zg w3acx w3ada w3ajd w3alp w3aac w3fb w3ut w3zac w4aef w4ql w4vs w8aik w8afm w8alh w8ath w8auu w8axa w8bbl w8bbp w8bji w8bkw w8dae w8dgp w8djp w8dpo w8duw w8ez w8kr w9aja w9exw w9ka k4kd velac ve3da ve5ao vo8ae cm5cx py1ca py1ah py1fb zslp z54m z55u z55d zu6w zt5r

W3AFU-W3BHV, Washington, D. C.

7000- and 14,000-ke. bands

ct1aa ct1bd ct2aa ct2ac d4cc ear16 ear21 ear65 ear113 ear149 f8aix f8am f8bw f8cs f8da f8dmi f8dot f8lx f8myl f8rgf f8ror f8saw f8wr f8xd f8zic g2ao g2gf g5is g5wk g6gd g6rb g6th g6up g6vp g6vr g6xp g6xn illl ilas nj2pa on4gn on4jk on4kw xon4wm pa0qf py1ak sp3vb su8ra ve5ao vo8an vu2zk z54a z54m

S. S. Exford, George Brown, Opr., Box 920, 25 South St., New York, N. Y.

1000 to 2000 miles east of New York

w1aft w1abd w1cpo w1bq w1bke w2abe w2ay w2jc w2kl w3ajh w4abt w4tt w5pa w5aha w5no w6vv w6cf w9axh w9cfw w9epi kfr6 py7aa k7ak 33cs

2000 to 3000 miles east of New York

w2anh w4tt w4tf w4qe w4kd w4qd w4gk w5ds w8acu w9car w9eye fo1jc sp3be f8em f8aap g8aq helfg yb1x y8an x4a

3000 to 4000 miles east of New York

w1gw w1ben w1sh w1ajq w1bea w1rw w1ack w1ajy w1add w2ap w2af w2aao w2bbm w2bnu w2bf w2ci w2anr w2bqj w2qf w2cjj w2cec w2byx w2bds w2cdl w2gg w2bvy w2afr w2ze w2ach w3kr w3bbk w3arz w3dq w3aor w3ckl w3dk w3pt w3kq w3bwt w3na w4vb w4uj w4aj w4mh w4ajq w4dv w4va w4mm w4he w5ww w8tn w8chl w8aff w8bps w8chq w8adj w8cwu w8acu w8bft w9cfa

4000 to 5000 miles east of New York

w1azd w1cg w1bn w1mk w1ben w1bil w1rp w1apz w1qy w1agn w1ajc w1caa w2ano w2bda w2qn w2ecx w2bmm w2ban w2ayz w2bkw w2bxi w2am w2bm w2bkg w2apk w2cuo w3la w3awn w3rd w3cvt w3bqi w3bnu w4pf w4vw w4nb w4gk w4eg w4rx w4br w4adw w4aef w4afw w5bcx w5ww w8ya w8vy w8doa w8bno w8bps w9bkw cm2xc

Sending Is EASY

With the **Easy-Working Genuine Martin No. 6**

New VIBROPLEX

(Reg. Trade Marks: Vibroplex Bug; Lightning Bug In Colors Blue Green Red)

The smoothest, easiest-working bug on the market. Easy to learn. Easy to operate. Makes sending easy.

Black or Colored, \$17. Nickel-Plated, \$19

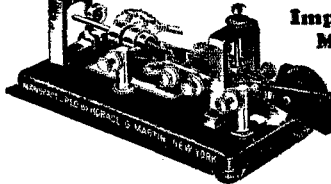

Improved MARTIN Vibroplex

Black or Colored, \$17
Nickel-Plated, \$19

Special Martin Radio Bug — Extra large, Specially Constructed Contact Points for direct use without relay. Black or Colored, \$25

Old Vibroplex accepted as part payment
Remit by Money Order or Registered Mail
THE VIBROPLEX COMPANY, Inc.
825 Broadway, New York City
Cable Address: "VIBROPLEX" New York

We prepared our New SEVENTH EDITION of The Radio Amateur's HANDBOOK

to appear exactly at the time our stock of the previous edition was exhausted, but a printer's over-run leaves on hand about

200 copies of the SIXTH EDITION (Blue Cover)

We hate to see them go to waste. Perhaps there are some amateurs to whom even the ridiculously low price of \$1 for the Handbook was a lot of money. The Sixth Edition is not to be scorned; it is still filled with intensely valuable modern material. Here's a chance to save half the price. While they last,

50c Postpaid

American Radio Relay League
Hartford, Conn.

Massachusetts Radio and Telegraph School

18 Boylston Street, Boston

Send for Catalogue

Tel. Hancock 8184 Established 1905

TRANSFORMERS

Guaranteed — Mounted — Complete
1 KVA 3 phase 1500-2000 v. each side \$40.00
700 watt 1000 — 1500 each side 14.50

250 watt 500 — 750 — 1000 each side
unmounted \$10.00; mounted \$11.50
Auto-Transformers, Chokes, Polyphase and 25-cycle
Transformers. Add \$2.00 for fil. winding

WENCES FRANK GREBEN Chicago, Ill.
1927 So. Peoria Street, Pilsen Sta.

Power Transformers for the Amateur

Built to withstand overloading and abuse. Mounted ready to use. 110 volt 60 cycles. 250 watt 550, 750 each side center, two 7½ volt CT 4 ampere windings, weight 21 lbs. \$10.50. 150 watt 650-0-650, 7½, 7½ CT windings \$7. Same except 550-0-550 \$6. 700 watt 1000, 1500 volts each side center \$14.50. 250 watt 550, 750, 1000 volts each side center \$10. 1000 watt 1500, 2000 volts each side center \$21.50. Filament transformers, center tapped, 5000 volt insulation. 2½ volt 10 ampere \$3. 7½, 7½, 4 ampere \$3.50. 10 volt 6 ampere \$3.50. 10 volt 13 ampere \$5. 5 volt 10 ampere \$4. 5 volt 20 ampere \$6.50. Transformer 350-0-350, 5, 2½, 2½ volts \$4.50. Unmounted filter condensers, 3½ MFD 1000 volt \$1.75. 2 MFD 750 volt 75c. 3 MFD 600 volt 50c. 2 MFD 35c. Enameled copper wire per 100 feet, No. 14 70c. No. 12 90c. No. 10 \$1.50. Postage extra. Electrone Labs., 834 N. Randolph St., Phila., Pa.

WIRELESS EGERT

179 GREENWICH ST., NEW YORK CITY

The Oldest Radio House

Something New—Something Different

Watch for our ad each month

Thordarson 30 Henry 150 Mill Choke \$2.95
Signal R 112 K Key 1.39
Western Electric Sockets for N peanut tubes39

Wireless Egert Filament Transformers

Guaranteed 8000 V insulation
2½ V — 10 Amperes for 1 V 866 \$4.35
7½ V — 5 Amperes for 210-250-281 4.35
10 V — 7½ Amperes for 203A-211-852-860 5.65
12 V — 10 Amperes for 204A-212D 5.65
Thordarson Transformer 5 V — 20 Amperes 10,000 Volt
insulation for two 876 rectifier tubes, list \$40.00

Write for Our Discount

Amertran 2.5 V — 14 Amperes Filament Transformer 3000
V insulation \$4.75

Complete parts to build transmitter described in last
month's QST, less tubes and meters \$44.75

EVERY PART GENUINE AND GUARANTEED

New Vitrohm Plaque Resistor

Absolutely non-inductive and non-capacitive
Standard values 5000 ohm, list \$2.00

Write for Our Dealers Discounts

We distribute:

Weston — Jewell — National — Vibroplex — Signal —
Ward Leonard — Hardwick, Hinde — Thordarson —
Cardwell — Flechtheim — Electrad — Vaxley — R.E.L.
— Universal.

All technical questions cheerfully answered

Special discounts on every standard item

Write for net price. Mail orders filled the same day received.
Must be accompanied by 10% cash of order
plus postage charges.

How Much Power Do You Want?

There's an
ELECTRAD-
Loftin-
White
AMPLIFIER
KIT

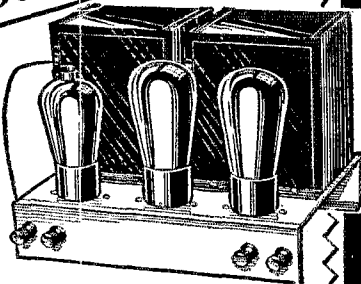

To Meet Your Needs

Better tone—economy—ease
of assembly and operation
feature the Electrad line of
Loftin-White Direct-Coupled
Amplifier Kits. Three models,
'45, '50 and '750 push pull
meet all usual requirements.
Licensed under Loftin-White
and R.C.A. Patents.

Write Dept. Q-12, for literature

175 Varick Street, New York, N. Y.

ELECTRAD INC.

HAM-ADS

(1) Advertising shall pertain to radio and shall be of nature of interest to radio amateurs or experimenters in their pursuit of the art.

(2) No display of any character will be accepted, nor can any special typographical arrangement, such as all or part capital letters be used which would tend to make one advertisement stand out from the others.

(3) The Ham-Ad rate is 15¢ per word, except as noted in paragraph (6) below.

(4) Remittance in full must accompany copy. No cash or contract discount or agency commission will be allowed.

(5) Closing date for Ham-Ads is the 25th of the second month preceding publication date.

(6) A special rate of 7¢ per word will apply to advertising which, in our judgment, is obviously non-commercial in nature and is placed and signed by a member of the American Radio Relay League. Thus, advertising of bona fide surplus equipment owned, used and for sale by an individual or apparatus offered for exchange or advertising inquiring for special equipment, if by a member of the American Radio Relay League takes the 7¢ rate. An attempt to deal in apparatus in quantity for profit, even if by an individual, is commercial and takes the 15¢ rate. Provisions of paragraphs (1), (2), (4) and (5) apply to all advertising in this column regardless of which rate may apply.

PLATE power for your set, the very heart of its performance. For quietness, DX ability, life-long permanence, absolute dependability, lowest ultimate cost, no other plate source even approaches the achievement of an Edison steel alkaline storage B battery. Built painstakingly; every joint pure nickel, upset electrically welded. Genuine Edison Electrolyte. Our list describes complete batteries, construction parts, enameled aerial wire, silicon steel. Available immediately, filament and plate transformers for the new 872 rectifier, complete plate power units. Rectifier Engineering Service, 4837 Rockwood Road, Cleveland, Ohio.

THE finest in radio for amateur, broadcast and marine. The most modern short-wave receivers. Four to ten tube designs. Radiophone CW transmitters of any power or type. We make a complete line of apparatus, including speech amplifiers, filter coils, inductances, power units, etc. Any special apparatus, designs, built to order, using your parts if desired. Prices on request. New bulletin lists complete line of apparatus. Write for copy. Enssall Radio Laboratory, 1527 Grandview St., S. E., Warren, Ohio.

AMATEURS — experimenters, builders. We serve over 4000 I.R.E., A.R.R.L., etc., experimenters and "nuts." Full discounts. \$50,000 stock approved parts — no sets. Over four pounds catalog, circuits, data, prepaid, 50c. Weekly bulletins (new items, results of experiments, etc.), 20 weeks \$1. Sample experimenters' "Over the Soldering Iron" magazine, 25c. Transmitting data, price list, etc., 25c. Kladrag Radio Laboratories, established 1920, Kent, Ohio.

LEARN Wireless (Radio) Morse telegraph. School, oldest and largest; endorsed by telegraph, radio, railway and government officials. Expenses low — can earn part. Catalog free. Dodge's Institute, 7 Wood St., Valparaiso, Ind.

C.E. 1000-watt transformers, 1100-2200-4400 each side center tap. Used by Cornell, Navy and 300 hams. Guaranteed unconditionally, \$12. P.O.B. Write for other sizes and voltages. Detroit, Fred G. Dawson, 5740 Woodrow, Detroit, Mich.

CRYSTAL holders \$3.50, ovens \$25. Build receivers, transmitters or power supplies. Smith, W2BRQ, 65 Glenwood Rd., Montclair, N. J.

SELL — 1000 volt 500 watt Robbins and Myers motor generator 110-220 a.c., \$50. 1000 volt 250 watt Westinghouse motor generator, \$45. Kenneth Axline, Wenona, Ill.

TRADE 250 watt tube new, for motorcycle. Give full dope. Joseph Martonosi, 118 South Main St., South Bend, Indiana.

WANTED — Western Electric 211D tubes, will exchange 208A radiotrons for them. Wynne Radio Company, Raleigh, N. C.

GREBE CR13 eighty meter receiver never used, \$8. Zenith four tube BCL \$5. 350 volt motor-generator \$9. 500 cycle motor-generator with 1/2 h.p. drive, \$10. WE212D socket, \$3. Crystal holder, \$4.50. W9AS.

WILL trade Winchester 12 GA. automatic shotgun for xmitting apparatus. What have you? W6BRV, Route 2, Box 878, Modesto, Calif.

FOR sale — one t.p.t.g. Aero radiophone 7.5 watt xmitter complete with 500V plate supply unit and rectifier tube, \$55. One 5 tube broadcast battery receiver, \$12.50. One 3 tube s.w. receiver Aero coils in mahogany cabinet, \$15. 90V B half wave B eliminator with tube \$8.50. B A Raytheon tube \$2.50. 2400 meter coupler \$1.50. Mershon condenser new \$2.50. 3 tube broadcast receiver no cabinet, \$3.50. Hammarlund 11 P1 double spaced condenser \$1.50. Meters, miscellaneous radio parts. Want cash, physical or chemical laboratory equipment. W2SU, R. N. Daly, 35 Tichenor St., Newark, N. J.

FOR sale — National 4 tube S.W. Thrill Box receiver, \$15. J. L. Johnson, 354 College St., Macon, Georgia.

SELL — new Esco motor generator set 750V 227 mil. 1/2 horse 60 cycle a.c. motor mounted on steel frame, \$65. Cost \$110. Complete W8AYO 4 tube a.c. receiver as in April QST. Some outfit. First check for \$30, takes it. Don Farrell, W8DSP, 2113 Hickok Ave., Syracuse, N. Y.

TRADE: General Radio 224-L precision standard wavemeter for G.R. 452-C voltage divider and other apparatus. Paul E. Griffith, 45-B Quad., Iowa City, Iowa.

SALE — Ultradyne L2 with cabinet and tubes, R.C.A. 100A loud speaker. Best offer takes it. Aero 3 tube receiver. Other parts. Marcus Beekman, Natchez, Miss.

W8QH selling out. Aero 7 1/2 Watt CW transmitter complete. Aero two stage receiver. G.R. wavemeter. New Radio Correspondence Course with code, cost \$120. No baywire junk. Write for details.

SWAP — used Radiotron 203A for a 211, or a Radiotron 211 for a 203A. Riley Parsons, W8BXV, Old Forge, N. Y.

KENNEDY receiver 175-1000 meters with two stage amplifier \$15. One set Aero coils complete \$5. One National 4 tube Thrill Box \$25. Sherwood, W5BE, Albuquerque, New Mexico.

HAMS: Get our samples and prices on printed call cards made to order as you want them. W9APY finds, 19 S. Wells St., Chicago, Ill.

SELL — QST back numbers to 1923. Make offer. Robert Hutcheon, 109-46 142nd St., Jamaica, New York.

ANY type transmitter or receiver built to order. Workmanship guaranteed. For information write Midwest Amateur Radio Service, 309 E. 4th St., Ottumwa, Iowa.

TRADE — Remington auto-loading rifle, 22 long rifle calibre, like new. Want Teleplex, 210 power supply and filter, parts. W. H. Becker, 1307 Walton St., Houston, Texas.

TUBES — selected seconds, 210, 250, 281, 224s, \$1.35. Other types, 85c. W8CXW, Trenton, Ohio.

SELL — Supreme Radio Diagonometer, model 400B, price \$125. Elmer F. Moritz, 311 De Clark St., Beaver Dam, Wis.

QSLs, 100 two color \$1.00. Samples, W9CKA, Corwith, Iowa.

WANTED — August, September and December 1919 QSTs. John E. Phillips, 111 Grove St., New Haven, Conn.

POWER crystals — ground to your approximate frequency. Frequency stated accurate to .1 of 1%. Unconditionally guaranteed. 3500-kc. band, \$4.95. 7000-kc. band, \$6.95. Unfinished blanks, \$1. W2CCR, 157 East 89 St., New York City.

FILTER chokes, new 15 Henry 150 mills, \$1 postpaid. Robert Thompson, 1608 Columbus, Bay City, Mich.

FOR sale or trade, all the equipment in a 500 watt broadcasting station. What part of it can you use? Lowell Ecker, Sedan, Kansas.

BARGAIN — new Pilot super wasp shortwave receiver with power pack. Thirty dollars. E. N. Butz, 41 Brownell Ave., Hartford, Conn.

MOTOR generator set 650 volt generator, 32 volt motor, \$42. W9AVB.

OSCILLATING crystals, highest quality, \$2 up. Write W6BCX.

TRADE 900 cycle alternator and transformer for receiver or what have you? W7QK.

QSL cards, two colors, \$1 per hundred. Free samples. W8DTY, 257 Parker Ave., Buffalo.

SELL — UX852 in perfect condition, \$16. W8CED, Lansing, Mich.

SHORTCUTS to Code Reading Speed — any Govt. test — least time least effort bar nothing. Radio — Hispeed — Morse — Shortcuts \$5 each money order. Xmas special — December only — Hispeed FREE with Radio if requested with order. Hams and beginners using Radio report raised to 25 in few days — with Hispeed increased to 35 in few hours. Morse readily memorized — used without mixup. Reports from many users prove reading speed acquired easily — booklet on request. Dodge Radio Shortcut, Box 100, Mamaroneck, New York.

110 Power Unit \$27.50, supplies filament, plate and grid voltage for 210 oscillator and 250 modulator, also 227 amplifiers. Output 600w, very smooth, fine for 1931 phone. Nearly new. Cost \$55.00. Thordarson, Faradon, Dongan parts. With two new DeForest 481s. Also sell 3530KC Crystal Controlled phone set cheap. E. J. Bromley, W9CSM, Whitewater, Wis.

SPECIAL — Eight tube superheterodyne with interchangeable coils for wave lengths fifteen meters to two hundred meters. All General Radio parts receiver in solid walnut cabinet, worth \$50, will sell for \$25. Vibrox heavy contacts \$25. Your price \$16. UX 250 new \$5. Acme .008 30 Henry choke \$22.50, sacrifice for \$5. R.C.A. UP1627 50 Henry choke \$5. Pyrex leadin bowls \$1.50 each. R.C.A. inductance \$3. James C. Gill, 710 W. Main St., Galion, Ohio.

QSL cards, message blanks, wall cards, stationery, Hillcrest, Cranestown, Pa.

A.R.R.L. sweater emblems make fine Christmas gifts. They are made of best quality yellow and black felt with embroidered symbol, 5 x 8 inches. M. O. or currency only accepted. Price \$1.00. Eric Robinson, 135 Jefferson Road, Webster Groves, Mo.

POTTER Condensers: 2-mfd. 1000-test voltage \$2.50; 1-mfd. 2000-test \$2.50; 1-mfd. 2500-test \$3.25; 2-mfd. 2000 test \$4.00. Aluminum square-foot 85c; Lead 85c. "Ham-List" 2c. Curtis, 1109 Eighth Avenue, Fort Worth, Texas.

CASH for tubes, meters. W9FME, Kingman, Kansas.

10 watt xmitter, power supply, Jewell meters. For best offer, W9GKF, Early, Iowa.

THE HY-7, the outstanding shortwave super. First with: Space charging first detector, an adequately high amplifying frequency, the "pick-up" problem solved for shortwave supers, nearly equal tuning ranges, each oscillator coil doing double duty, and first to be prominently successful. 25c gets the latest dope and our catalog. Hatry & Young, Hartford, Conn.

REGULAR \$30 Exide batteries, 2, six volt, 180 amps. perfect condition. Special at \$6.95. M & H, 512 Market St., Philadelphia.

TRADE for best a.c. broadcast receiver offered or fifty bucks. Transmitter, 210 tube, coils, Jewell Hoyt meters, relay, Cardwell condensers, key, s.w. receiver, wavemeter, parts galore. Smith, 3001 Holdrege, Lincoln, Neb.

METERS, d.c. panel mounting, ranges: 10, 24, or 45 milliamperes, 10 or 60 amperes, \$3 each, 2500 volts at \$10. Jas. Cox, Box 151, Ft. Sam Houston, Texas.

SELL or trade — surplus apparatus. Radio Corporation dynamic speaker. Want Cardwell 147-B. Hosea Decker, Delaware, Ohio.

FOR sale — Silver Marshall a.c. short wave bearcat. Factory wires, tubes, speaker, coils, including broadcast only \$65. Used one month. W9FKW, 234 Littleton, Lafayette, Ind.

5-WATT tubes. Brand-new at \$1.00 each. These are rugged, thoroughly tested tubes. Reumo Tube Co., 115 Newbury Ave., Atlantic, Mass.

SILVER-Marshall 737 Bearcat A.C. short wave receiver, wired, \$82.00 net; kit \$70.00 net. All S-M parts in stock 40% and 2% to ham. Write for our special price list on standard parts. Radio Inspection Service Co., 26 Allen St., Hartford, Conn.

POWER crystals: — Guaranteed excellent oscillators. One inch square sections ground to within one-tenth of one percent of your specified frequency. Special Christmas offer: 3500 kc. band, \$7.50. Blanks, \$3.00. Precision Piezo Service, 427 Asia St., Baton Rouge, La.

CRYSTALS: High grade oscillators anywhere in 160 or 80 Meter band, \$4.50. Crystals calibrated to .1% of your stated frequency, 1 to 4 m.c. \$9.00. High Precision 100 kc. bars \$9.00. Collman & Bliley, W8GU, 34 West 8th St., Erie, Pa.

OMNIGRAPHES, Teleplexes, Codegraphs, Wasps, 50 watters, transformers, transmitters, receivers, Rectobulbs, Bought, sold, traded. Ryan Radio Co., Hannibal, Mo.

SELL — complete station or parts. List, Hal Miller, W8CMM, Sidney, Ohio.

CRYSTALS ground to your frequency, 3500-kc. \$5. 1" oscillating blanks, \$2. W8AKW, R. L. Tedford, 1804 Waltham Ave., College Hill, Cincinnati, Ohio.

GENUINE G. E. transmitting tubes, type CG1162, rated at 5 watts, 750 volts plate, 7.5 filament. For shortwave c.w. or phone. Only \$1.25 each. Neon tubes 50; Type 281a, \$1.50. Surprise package, \$1. Sent C.O.D. E. Huinagel, 879 S. 18th St., Newark, N. J.

7½ watt fone complete, \$85. Payments accepted. Thordarson 600 volt c.t. 7½ volt c.t. 7½ volt c.t., \$8.50. 1100 volt 4000 watt transformer, \$15. Want 211s, 203As, 212Ds. Merle Honey, Ringman, Kans.

ALL parts for the November push-pull '45 transmitter. Get our prices. Hatry & Young, Hartford, Connecticut.

GENERATORS — new 275 volt will give 400 volts, \$8. Used, \$5. 500 cycle 200 watt alternators, \$8. 900 cycle \$8. Geared honey-comb mountings, \$1. Microphones, \$1. R. Wood, 46-20 102nd St., Corona, N. Y.

NEW low prices on type 866 mercury tubes, firsts \$6 each. No seconds this month. E. Ewing, Jr., 29 S. LaSalle St., Chicago, Ill.

VICTOR Dubilier unmounted condensers, 1000 volts 4 mfd. \$1.50, 2 mfd. \$1, 1 mfd. 75c. 600 volts 2-2½-3 mfd. 15c. each mfd. Send money order including postage. Radio Specialty Co., 1903 North 18th St., Philadelphia, Penn.

PARTS for transmitters, power amplifiers. Tubes, switches, Magnavox dynamic speaker, air column speaker, lots of bargains. Must sacrifice station account college. Write your needs quickly. W3AGW, Edw. Mohl, 2201 N. Fourth St., Philadelphia, Pa.

TRANSFORMERS — made to your order. Amateurs, Custom Builders, Servicemen: We build power transformers and chokes to your specifications. For power amplifiers, radio receivers, transmitters, etc. Quality products, quick service, moderate prices. Write for quotations, stating voltages, current, approximate physical dimensions, and number desired (if more than one). Baker Engineering Labs., 2131 Curdes Ave., Fort Wayne, Ind.

CRYSTALS: I grind, test and calibrate each plate myself, and guarantee complete satisfaction. 700-kc. \$15. 3500-kc. \$12. W9DRD, Herbert Hollister, Edwardsville, Kansas.

WESTERN Electric 211E tubes, perfect. \$12. R.C.A. 104 speaker, \$25. Goldberg, 1903 N. 18th St., Philadelphia, Penna. SELL or trade double button mike, low power transmitter, surplus equipment. W2CJT, Seaford, N. Y.

SACRIFICE — need money. Complete T.P.T.G. hundred-watt high-C; includes five meters: — 2.5 V.C.A., 500-0-500 M.A., 0-250 M.A., 0-15 V.A.C., 0-2,000 V.D.C.; two 211E's, one new, other used 38 hours; three .002-3,000 V. Faradons; two U.C-490A 1 mfd. Faradons, 1,000 V.D.C. working, matched impedances; two newest type Potter 804, 1 mfd., 2,000 V.D.C. working; two 20-plate double-spaced Cardwells; three grid leake: one PT537 RCA hundred-watt rheostat; one PR535 forty-watt rheostat; two new R3 Rectobulbs, used 38 hours; thousand-watt GE pole transformer, center-tapped, cleaned up, voltages up to 2,000-4,000; two home-made filament transformers, hundred, and forty watts respectively; Aero receiver, 1931 construction with monitor light, duplicate sets LWT 125 coils, in mahogany cabinet, two extra heavy duty Ray-O-Vac B's; new Prestolite eighty ampere-hour A.; monitor, all inside Hammarlund aluminum shield box; pair Baldwins; GR wavemeter; one 1-KW key; two type '10 tubes; one 110-2,000 V.A.C. Westinghouse voltage transformer, one 750-0-750 V.A.C. meter transformer — both excellent filter chokes; stand-off insulators; copper tubing; two boxes other standard high-grade stuff not needed in this transmitter. This equipment is not junk. Sell for \$120. Cost \$290. Inquiries solicited. Address Watson, Box 615, International House, Berkeley, California; after December 19, 1223 Olive Avenue, Long Beach, California. Set at Long Beach address.

F5CO motor generator, 32-10-500 volt, 200 watt, two units, four bearings, complete with starter. Perfect condition. Sell for \$45. W1ANS, Milford, N. H., R.F.D. 2.

Q R A SECTION

50 c. straight with copy in following address form only:

W1FT — G. Donald Meserve, Box 252, Noroton Heights, Conn.

W2CJY — George Rulfs, Jr., 166-37 89th Ave., Jamaica, N. Y.

W4EA — J. H. B. van Weelden, Scottish Rite Cathedral, Mobile, Ala.

W6AM-W6ZZA — Don C. Wallace, 4214 Country Club Drive, Long Beach, Calif.

W1MK

A.R.R.L. Headquarters

R. B. Parmenter, Chief Op. "rp"

The following calls and personal sines belong to members of the A.R.R.L. Headquarters gang:

W1AKW-W1KP Clyde J. Houldson "ch."

W1BAW R. B. Beaudin.

W1BDI-W1XL F. E. Handy "fb."

W1CBD-W9KL Clinton B. DeSoto "do."

W1CEI J. J. Lamb "jim."

W1DF Geo. Graumer "hg."

W1EH K. B. Warner "kb."

W1ES A. A. Hebert "ah."

W1FL-W2JR G. Donald Meserve "dm."

W1SZ-W1BIZ C. C. Rodimon "rod."

W1UE E. L. Battey "ev."

HILET

announces volume controls and resistors special to your specifications. Send us data for quotations. Adjustable Gap. Chokes — 100 H, 80 MA, 21 lb., \$12.00. 60 H, 160 MA, 22 lb., \$12.00. 30 H, 320 MA, 27 lb., \$14.00. 20 H, 500 MA, 32 lb., \$18.00. ½ H, 4000 MA, 22 lb., \$12.00. 20 H, 1000 MA, 190 lb., \$48.00. 30 H, 1000 MA, 225 lb., \$58.00. 20 H, 1500 MA, 240 lb., \$68.00. 30 H, 1500 MA, 290 lb., \$78.00. 20 H, 2000 MA, 310 lb., \$98.00. 30 H, 2000 MA, 350 lb., \$120.00. Transformers, 750 watt, 1500-1850 each side, \$19.50. 500 watt, 1000-1500 each side, \$15.00. 250 watt, 500-750-1000 each side, \$10.50. 150 watt, 325-375 each side, \$9.00. Filament — any voltage, tapped primary, \$6.50. Specials to order. Prices are mounted with leads. For Deluxe model with fuse and terminals add \$3.50. One Day delivery.

HILET ENGINEERING CO., Orange, N. J.

To Our Readers who are not A.R.R.L. members

WOULDN'T you like to become a member of the American Radio Relay League? We need you in this big organization of radio amateurs, the only amateur association that does things. From your reading of *QST* you have gained a knowledge of the nature of the League and what it does, and you have read its purposes as set forth on page 6 of this issue. We should like to have you become a full-fledged member and add your strength to ours in the things we are undertaking for Amateur Radio. You will have the membership edition of *QST* delivered at your door each month. A convenient application form is printed below — clip it out and mail it today.

A bona fide interest in amateur radio is the only essential qualification for membership

AMERICAN RADIO RELAY LEAGUE
Hartford, Conn., U. S. A.

I hereby apply for membership in the American Radio Relay League, and enclose \$2.50 (\$3 in foreign countries) in payment of one year's dues, \$1.25 of which is for a subscription to *QST* for the same period. Please begin my subscription with the issue. Mail my Certificate of Membership and send *QST* to the following name and address.

Do you know a friend who is also interested in Amateur Radio, whose name you might give us so we may send him a sample copy of *QST*?

Thanks

For Your Convenience

QST'S INDEX OF ADVERTISERS IN THIS ISSUE

Acme Wire Company	88
Allen-Bradley Company	55
American Piezo Supply Co.	75
American Sales Company	69
American Transformer Co.	68
Amrad Corporation	66
Arcturus Radio Tube Co.	75
Astatic Microphone Lab.	52
Aurisma, Inc., Ad.	86
A.R.R.L. Application Blank	94
A.R.R.L. Booklet	80
A.R.R.L. Handbook	70, 80, 91, Cover II
A.R.R.L. Log Book	Cover III
Baltimore Radio Corporation	80
Bethesda Crystal Laboratory	80
Blan, The Radio Man, Inc.	79
Burgess Battery Company	Cover IV
Candler System Company	58
Cardwell Mfg. Corp., Allen D.	71
Celco Manufacturing Co.	57
Central Radio Laboratories	90
Columbia Specialty Company	83, 89
Cornell Electric Mfg. Co.	87
Corning Glass Works	61
Cunningham, Inc., E. T.	54
DeForest Radio Company	1
Duovac Radio Tube Corp.	85
Electrad, Inc.	91
Electric Specialty Co.	77
Electrore Laboratories	94
Ellis Electrical Laboratories	81
Ferranti, Inc.	81
Flechtelm & Co., A. M.	89
Foreign & Domestic Veneer Co.	87
Frost, Inc., Herbert H.	86
General Engineering Corp.	84
General Radio Company	2
Gensback Publications, Inc.	74
Greben, F.	91
Gulf Radio School	81
Hall's	72
Harrison Radio Company	72
Hilet Engineering Co.	93
Hoodwin & Company, Chas.	72
International Resistance Company	85
Jewell Electrical Instrument Co.	65
Johnson Company, E. F.	88
Klenzle, Henry A.	77
K. W. Crystal Laboratories	87
Leeds Radio Company	6, 7
Littlefuse Laboratories	87
Manhattan Electric Bargain House	96
Massachusetts Radio & Telegraph School	91
McGraw-Hill Book Co.	56
Miller, Holmes C.	74
National Company	73
National Radio Tube Company	82
National Sound Service Bureau	78
National Tuberculosis Association	85
Parent Electric Co.	76
Pilot Radio & Tube Corp.	95
Port Arthur College	83
Precision Piezo Service	76
QST Binder	64
QST Christmas Suggestion	60
Radio Engineering Laboratories	63
Radio Supply Company	74
RCA Institutes, Inc.	53
RCA Victor Company	67
Reetner Engineering Service	87
Rider, John F.	81
Rooney, John T.	79
Rosen & Co., Raymond	79
Saugamo Electric Company	Insert
Scientific Radio Service	79
Shalloross Mfg. Co.	84
Sprague Specialties Company	4
Stuyvesant Electric Co.	77
Telex Company	87
Thordarson Electric Mfg. Co.	85
Triad Mfg. Company	62
Van Nostrand Company, D.	59
Vibroplex Company	90
Ward Leonard Electric Co.	75
Weston Electrical Instrument Corp.	70
West Side Y. M. C. A.	83
Wholesale Radio Service	80
Wireless Egert	91

A Little Different But...

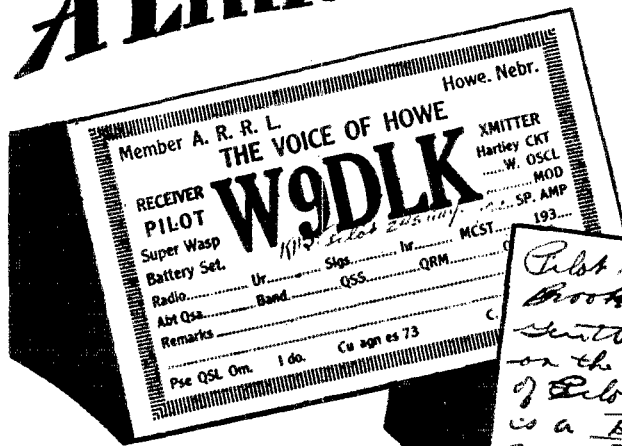

The station card of W9DLK, perhaps the most flattering testimonial any radio manufacturer ever received, is just one of the thousands Pilot is continually receiving from all over the world.

*Pilot Radio & Tube Corp.
Brooklyn
Sentiment in ear of
on the other side what I took
of Pilot. The Super Wasp
is a BEAR CAT. He is the
245 two amp. This makes a
real sp amp.
A. Tucker*

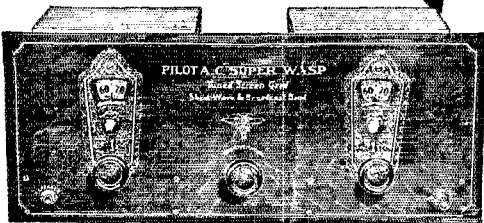

IN KIT FORM

\$29⁵⁰

KIT K-110: The battery-operated Super-Wasp. Batteries and Tubes extra.

\$34⁵⁰

KIT K-115: The A. C. Super-Wasp. Use your own ABC pack or Pilot K-111, specially designed for the Super-Wasp. Power Pack and Tubes extra.

FROM missionaries marooned in the heart of darkest Africa, from ship's officers on vessels plying to most far off ports of the globe, Pilot has had enthusiastic word of Super Wasp short wave reception of broadcasting, voice and code.

The Pilot Radio & Tube Corp. has never for a single moment forgotten the immense debt it and all other radio manufacturers owe to the licensed radio amateurs, particularly for their pioneer work on short waves. We have believed the Super Wasp to be a good set. When one of the men who has put short waves on the radio map honors us by making the Super Wasp his official ARRL receiver we hope to be pardoned for believing the Super Wasp to be—a GREAT SET.

PILOT RADIO & TUBE CORPORATION

Chicago Office
234 S. Wells Street

LAWRENCE, MASS.
New York Office—525 Broadway

San Francisco Office
1278 Mission Street

OFFICES IN PRINCIPAL COUNTRIES OF THE WORLD

PILOT SUPER-WASP RADIO
FOR LONG AND SHORT
WAVE RADIO RECEPTION

BARGAINS ARMY AND NAVY RADIO SURPLUS



Switchboard, 8 line portable Western Electric, magneto ringing; dry cell talking circuit; 8 drops, 26 anti-capacity 12 to 10 terminal key switches, regular price \$175.00, special \$30.00

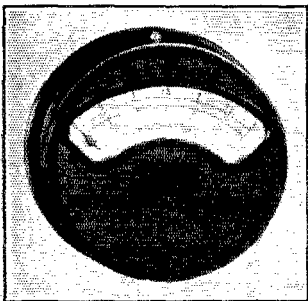

Meters, switchboard, Weston A.C. and D.C. ammeters, voltmeters, frequency meters, watt meters, new and used, \$12.50 to \$25.00 each. All priced at less than half net market value.

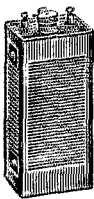

Edison Storage Battery Cells



Type A-4, 1.2 volts, 17 1/2 amp, first class, nickel alkali, \$3.50
Type A-6, 1.2 volts, 225 amp., nickel alkali, \$4.00
Type M-8, 1.2 volts, 11 amp., zinc used, per cell, \$1.50



Anti-Capacity Switches, W.E. 6-8-10-12 Terminals, all with Platinum Contacts, value \$3.50 each. Our price, 95c each. Lots of 6 \$5.00

Generator, airplane, Signal corps, with shaft, can be used as motor, 12 volt 33.6 amps. 5000 R.P.M. \$10.00
Generators, 12 volt, 60 amp., has automatic controls Westinghouse 32-150 volt 80 mts. 2 amp Dynamos, Regular price \$120.00. A few pair left at West. Elec. switchbd. control panel for dynamotors, has switches, 0-50-500 voltmeter, complete filter system, etc. Special 8.00
Double filter RC-A chokes, contain two 30 Henry 80 mill chokes. Weight 6 lbs.95
Ammeter, Weston No. 425 thermo-couple 0-2 amp., mid. on large bakelite base with D.P. hi voltage switch 7.50
Ampere hour meter, Sangamo, battery charge and discharge, type MS 0-300 scale, capacity 15 amp. 10.00
Milliammeter, Westinghouse, 0-150, surface mfg., b. con. 5.00
Voltmeter, Westinghouse, type C.A. 0-25, zero adjustment, flush mounting 5.00
Voltmeter, model P, 3 scale, 0-5, 0-7.5, 0-150 for measuring A, B and C voltages. 1.00
Motor generator, Holtzer Cabot, 110 D.C., 220 A.C., 500 watt, 500 cycle. Bas. bearing 50.00
Complete line 500 cycle motor generators 1/4 to 1 K.W.
Transformers, Simon, 220 to 11,500 closed core, 1/2 K.W., 500 cycle, "pancake" secondary 5.00
Transformer, Ameriran, oil immersed, 1 K.W., 500 cycle, 220-8000 volt 10.00
Transformer West. Elec., output, No. 02 A, 4 to 1 ratio 3.50
Transformer West. Elec., output, No. 202 A, 5 to 1 ratio 3.50
Transformer West. Elec., impui, No. 201 A, 7 to 1 ratio 3.50
Condensers, transmitting, Murdock .002 mfd. 2,000 volt, ideal for plate bypass 2.50
Condensers, Wireless Specialty, copper glass leyden jar, 10,000 working voltage .003 mfd. 2.00
Condenser, Dubilier, mica, op. volts 12,000 cap .0004 10.00
Condenser, Dubilier, mica, volts 40,000 cap .0012-.001-0008 or .003 25.00
Condenser, Dubilier, mica, op. volts 8500 cap. .004 7.50
Condenser, Dubilier and Wireless Specialty, op. volts 12,500 cap .004 12.50
Condensers, West. Elec. 21 A.A., 1 mfd. 1000 volt 3/4 in. test 1.00
Condenser Block RC-A 600 volt Nol 8333 for Radios 18-33 and 51. Price, each 1.35
Headphones, West. Electric No. 194W same as C.W. 834, 2200 ohms, D.C. slightly used 5.00
Holtzer Cabot, "Mike" Utah type, carbon granular transmitter. Special95
Western Electric Radiophone Transmitter unit, 320W. Special 1.50
Dynamotor, GE Navy Airplanes 24/750 volts. Aluminum frame, unusually good for airplane test work. Specially priced, 500 mts. 27.50
Dynamotor, aircraft 32/275 volt, with shaft, 5.00
U. S. Navy head phones, excellent for practice and instruction purposes, pair75
NAVY Dynamotors General Electric 24/1500 volts, 233 mts. 37.50
Coils, Retardation, West. Elec. Co. 57C, .83 ohm, 2 windings 7.00
Ret. coil West. Elec., No. 65 A, 1800 ohm 12 henry 2.00
Ret. coil West. Elec., No. 66 A, 85 ohm 1.3 henry 1.50
Ret. coil West. Elec., No. 64 B, 11 ohm 1 henry 1.50
Telegaph and buzzer, portable, with 190 ohm contact, 2 zone 4 contact platinum contact high frequency buzzer, 2 telephone toggle switches, potentiometer, sending key, 3 mfd. condensers, transformer and 2 choke coils, receiver, 830. valve 5.00
Magnets, Army mine and ringer type, 4 large magnets 1.00
Sounders, Signal Corps, 120 ohms, adjustable. 2.50
Spark transmitter, complete, airplane type, rotary gap, transformer, mica condenser, 200 watt 500 cycle with Gen. self excited ball-bearing 25.00
Generators, Westinghouse 110 volt, A.C. 800 cycles, 200 watts, self excited 15.00
Generator 1/4 kw. 500 cycle, 300 volt, self excited, can be hand driven 25.00
Volumeter, D.C. portable, new Weston model 45, 3 scale 0-1.5-150 guaranteed 1/2% accuracy 40.00
Ammeters, D.C. portable, new Weston model 45, 3 scale 0-1.5-150 with 3 scale external shunt and leads 1/2 of 1% accuracy 40.00
Headphone, Radio School, leather headband, 75 ohm 1.50
Keys, transmitting, Navy, back connected on bakelite base. 2 kw., 1/4-inch silver contacts 5.00
Charging panel, Navy type, S.E. 899, 32 volt, Ward Leonard, var. and fixed res., Weston voltmeter and ammeter, Sangamo ampere hour meter. Complete with all switches. 30.00
Receivers, Navy, C.N. 240, 1000-10,000 meters 50.00
Receivers, S.E. 143 and I.P. 500 100-150
Relay West. Elec. low voltage, 2 upper and 3 lower platinum point screws, 3 contact arms 5.00
Extra platinum contact screws or arms35
Receiver, Type 123, 175-775 meters. Especially recommended for "standby" for coastal Broadcast stations as required by Dept. of Commerce. 50.00

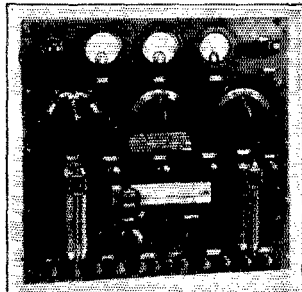

New U. S. Navy 250 watt tube transmitter (trans-atlantic aircraft type) 600-1000 meters, 73 to 100 mile range. Original cost \$1200.00, special. . \$75.00

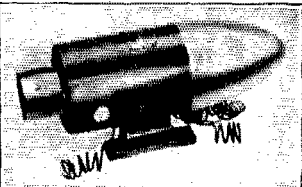

Navy Aircraft Dynamotor, Gen. Elec., new, 24,000 volts, 1 amp., with pulley driven by motor, or propeller, giving 24 volts output for filament, 1000 volts plate. Weight 75 lbs. Value \$250.00. Special price \$75.00

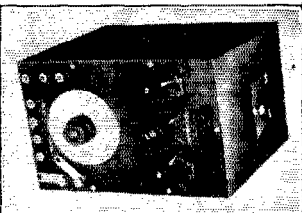

Radio Frequency "Driver" 6000 to 30,000 meters Navy Type SE1603, highly sensitive. Cost \$180.00. Our price \$25.00

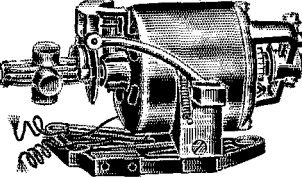

Edison Universal motor 1/50 h.p. with governor and Regulator. Has one thousand uses. Price, each \$3.50
Rheostats for above75

Motors back geared 110 A.C. variable speed, auto reversible (Sacoxy oil burner type) has over one thousand uses, a very good buy \$7.50
Motor generator, R & M, 110 D.C., 3 1/2 h.p., 2 kw. 200 D.C. 80 amp. Great for large station filament supply. 125.00
SPECIAL - U. S. Army instruction book on telephony or telegraphy. Hundreds of pictures and diagrams 1.00

Largest Radio and Electric Supply House in U. S. specializing on Army and Navy Surplus. Write us your particular requirements. Sufficient postage and deposit of 20% required on C.O.D. orders. NO C.O.D. ON CANADIAN ORDERS. DUE TO LIMITED GOV'T SURPLUS WE DO NOT ISSUE CATALOGS.

MANHATTAN ELECTRIC BARGAIN HOUSE, Dept. Q, 105-7 Fulton St., New York City

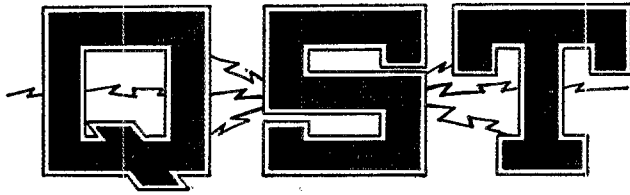

A Magazine Devoted Exclusively to Radio Amateur

VOLUME XIV

DECEMBER, 1930

NUMBER 12

Published in two sections of which this is Section II

INDEX TO VOLUME XIV

for the issues of

1930

INDEX TO VOLUME XIV

1930

AIRCRAFT RADIO

A. R. R. L. Cooperates With the "Arctic Patrol" in Mid-winter Maneuvers (Handy).....	29, May
A Multi-Range Receiver With Four Tuned Circuits (Kruse).....	21, Oct.
Airplane Radiophone Communication Experiments (Vincent).....	9, May
Correction.....	32, July
Amateur Radio at the All-American Air Races. Radio Control of Airport Lights (Gostin).....	11, Apr.
The New Arbella — KHLJQ.....	19, Apr.
The Springfield Air Races.....	52, Aug.

AMATEUR RADIO STATIONS

Amateur Radio at Eastern States Exposition (De Soto).....	17, Dec.
G5BY Wins 1929 Station Description Contest Cup (J. J. L.).....	17, Jan.
The Story of WIMK (Handy).....	31, Dec.
VE2CA.....	53, July
WIAOF.....	50, Apr.
WIKH.....	45, Feb.
W4CV.....	52, May
W5ZG-W5VY.....	47, Nov.
W7GP.....	45, Oct.
Correction.....	44, Dec.
W9ANZ.....	43, Aug.
W9BAG.....	42, Jan.
W9BAN.....	51, Sept.
W9BVH.....	48, Mar.

AMATEUR REGULATIONS AND LEGISLATION

Changes in Regulations.....	30, Dec.
Display Your Licenses.....	90, Sept.
Editorial.....	7, Jan.
Our Regulations Are Revised (Warner).....	16, May
Out-of-Band Policy (Warner-Terrell).....	64, Aug.
President Maxim Testifies at Washington.....	23, Apr.
Stray.....	36, Mar.
"The First Conviction Under the Radio Act (Quimby)....."	78, Oct.
"Twenty-Meter" Phone Authorized (K. B. W.).....	34, Aug.
	26, Jan.

AMPLIFIERS — AUDIO AND RADIO

A High-Gain Direct-Coupled Power Amplifier (Fleming).....	37, Mar.
A Multi-Range Receiver With Four Tuned Circuits (Kruse).....	21, Oct.
A Potential Divider for Use at Radio Frequencies (Exp. Section).....	78, Sept.
Audio Frequency Selectivity (Exp. Section)—Bibliography.....	84, Jan.
Bias for the Power Amplifier (Exp. Section).....	37, Aug.
Further Switching Devices (Exp. Section).....	51, May
Matching the Speaker to the Output Tube (Thomson).....	31, Jan.
Neutralizing Radio-Frequency Amplifiers (Foreman).....	31, Oct.

ANTENNA SYSTEMS

A Note on High Frequency Antennas (Exp. Section).....	48, Jan.
An Old Timer Gets Back in the Game (Hubbell).....	26, Nov.
Coupling the Single-Wire Feeder Antenna to a Push-Pull Transmitter (Exp. Section).....	33, June
Dummy Antennas (Omer).....	15, Aug.
Ham Band Antenna (Exp. Section).....	48, Apr.
Inductively Coupling to "Ethereal Adornments" (Exp. Section).....	46, Apr.
Lead-In Insulators (Exp. Section).....	44, Oct.
NKF Experiments Above 28 Megacycles (Lamb).....	9, Apr.
Replacing Antenna Halyards on an Eighty-Foot Mast (Robbins).....	15, Feb.

Stray.....	26, Jan.
The Doublet Antenna (Houldson).....	23, Dec.
The Single-Wire-Fed Hertz (Exp. Section).....	40, Oct.
Three-Band Transmitting Antennas (Exp. Section).....	45, Dec.
Tuned Antennas for Receiving (Exp. Section).....	39, Oct.
Tuning the Oscillator to the Single-Wire Feed Hertz Antenna (Exp. Section).....	50, May

ARMY AMATEUR

Army-Amateur Notes:	
V, January.....	I, Feb.
IV, April.....	V, Oct.
V, May.....	56, Apr.
Changes in the Regulations for the Army-Amateur Radio System.....	58, May
Operating Directive No. 1 (1930-31).....	
Splendid Cooperation (Davison).....	
The Army-Amateur Radio System (Smith).....	

BEGINNERS

Amateur Radio at Eastern States Exposition (De Soto).....	17, Dec.
Another Angle on the Beginner Problem (Pipp).....	70, Aug.
Beginners!.....	V, Apr.
Beginners, Attention!.....	VI, Oct.
Constructive Work on Phone (Ensor).....	IV, Nov.
Passing the Government Examination for Amateur Operator's License (Dudley).....	52, June
Correction.....	35, Jan.
Part I.....	39, Feb.
Part II.....	52, Apr.
Wanted — Code Practice Volunteers.....	II, Oct.
	III, Nov.

BETTER OPERATING PRACTICES

A Good Method of Calling (Haltiwanger).....	60, May
A Shake Up (Storck).....	VI, Sept.
A Suggestion (Vincent).....	56, June
A Suggestion for Handling Traffic (Wallace).....	64, Sept.
A Warning.....	II, Apr.
Check — and Double Check (Harrison).....	58, Apr.
Check Your Frequency (Mayer).....	I, May
Editorial.....	7, Feb.
From an O. O. (Pugsley).....	7, Mar.
High Quality Signals (Lists of).....	60, July
	VI, Jan.
	II, Mar.
	V, May
	36, June
Is This Operating? (Mayer).....	I, Apr.
Know the Law — and Take Heed (Turner).....	II, Oct.
Making and Keeping Schedules (Hubbell).....	I, Mar.
New Year's Resolutions in Order.....	II, Jan.
Notes on Frequency Observance (F. E. H.).....	I, May
Off Frequency Stations (F. E. H.).....	I, Mar.
Off Frequency Operation (Kennedy).....	62, Sept.
Passing the Government Examination for Amateur Operator's License (Dudley).....	35, Jan.
Correction.....	Part I, 39, Feb.
Part II.....	52, Apr.
GRM (McCarthy).....	58, Nov.
QSP (Neubrecht).....	64, July
Radio Division Checks Up Amateurs (F. E. H.).....	I, Sept.
S. F. (Grewel).....	52, Oct.
Some Comparisons (Boland).....	32, Jan.
The Off-Frequency Problem (McWatters).....	58, June
Useless Efficiency? (Sullivan).....	VI, Sept.
Warning — Off Frequency Stations.....	IV, Feb.
Why Keep a Log? (Gibbs).....	35, June
Your Log (Hubbell).....	47, July

BOOK REVIEWS

A B C of Television (Yates).....	88, Jan.
Elements of Radio Communication (Morecroft).....	86, Jan.
English and Science (McDonald).....	88, Jan.
How to Pass U. S. Government Radio License Examinations (Duncan and Drew).....	86, Jan.
Photo-electric Cells (Campbell and Ritchie).....	86, Oct.

Practical Radio Construction and Repairing (Moyer and Westrel).....	80, Mar.
Principles of Radio (Henney).....	78, Mar.
Radio and Its Future (Codel).....	90, Sept.
Radio Telegraphy and Telephony (Duncan and Drew).....	86, Jan.
Radio Traffic Manual and Operating Regulations (Duncan and Drew).....	88, Jan.
Riding the Air Waves (Palmer).....	84, Oct.
Storage Batteries (Vinal).....	86, Oct.
The Radio Manual (Sterling).....	78, Mar.

BREAK-IN

(See KEYING)

CALLS HEARD

51, January	59, July
57, February	63, August
54, March	57, September
55, April	51, October
57, May	53, November
51, June	51, December

COILS

A Handy Way to Lay Out Coils (Exp. Section)	41, July
A Method of Measuring Capacity and Inductance (Exp. Sec.).....	47, Sept.
A Neat "Clip" for Transmitter Coils (Exp. Section).....	42, July
A Simple Primary Reactor (Exp. Section).....	44, Oct.
High Frequency Inductances (Ausman).....	38, Feb.
Impedance Measurement with the Pliodynatron (Exp. Section).....	39, July
Low Loss Coils (Exp. Section).....	45, Nov.
Matching the Speaker to the Output Tube (Thomson).....	31, Jan.
Mountings for Transmitting Coils (Exp. Section).....	41, Aug.
Notes on Radio Frequency Resistance of Inductances (Exp. Section).....	52, Feb.
Winding Data for the Tube-Base Coil (Grammer).....	26, Feb.
Winding Form for Copper Tubing (Exp. Section).....	43, Oct.

CONDENSERS

A 5-Meter Variable Capacity (Exp. Section).....	43, Nov.
A Method of Measuring Capacity and Inductance (Exp. Section).....	47, Sept.
A Micro-Condenser for Amateur Band Tuners (Dinger).....	24, Jan.
A New Condenser for Amateur Tuners (B. D.)	34, Mar.
A New Electrolytic Condenser.....	54, May
Calculating Capacity of the Micro-Condenser (Exp. Section).....	47, Apr.
Electrolytic Condensers and a High-Voltage Rectifier (Rodman).....	31, Mar.
Filament By Pass Condensers (Exp. Section).....	12, Oct.
Revolutionary — and How! (Luther).....	27, Apr.
The QST Lab. Capacity Bridge (Dudley).....	27, Sept.

CONTESTS

G5BY Wins Station 1929 Description Contest Cup (J. J. L.).....	17, Jan.
Los Angeles and East Bay Sections Conclude Traffic Contest.....	III, Mar.
Navy Day — 1929 (Battley).....	18, Jan.
Navy Day Competition.....	I, Oct.
The All-Section Sweepstakes Contest (Battley)	43, May
The Roberts' Cups.....	VI, Oct.
The Third International Relay Competition (Battley).....	17, Aug.
Trophies and Certificates for the January and February Contests (Handy).....	15, Jan.

CONVENTIONS

Atlantic Division Convention (Erie) Announcement.....	66, June
Atlantic Division Report.....	90, Sept.
Central Division Convention (Dayton) Ann.....	8, Aug.
Report.....	14, Nov.
Hudson Division Convention (New York) Ann.....	11, May
Report.....	42, Aug.
I. R. E. Convention (Toronto) Ann.....	90, Aug.
Midwest Division Convention (Ames) Ann.....	88, Apr.
Report.....	41, May
Report.....	32, Aug.

Midwest Division Convention (Topeka) Ann.....	14, Aug.
Report.....	88, Nov.
New England Division Convention (Worcester) Ann.....	15, Mar.
New England Division Convention (Worcester) Ann.....	45, Apr.
New England Division Report (Worcester) Ann.....	38, July
New England Division Convention (Portland) Ann.....	32, Aug.
New England Division Report (Portland) Ann.....	18, Nov.
Northwestern Division Convention (Spokane) Ann.....	8, Aug.
Northwestern Division Report (Spokane) Ann.....	78, Nov.
Pacific Division Convention (Honolulu) Ann.....	8, Aug.
Report.....	38, Nov.
Pacific Division Convention (Sacramento) Ann.....	35, Sept.
Report.....	82, Oct.
Radio Manufacturers' Association Convention Roanoke Division Convention (Charlotte, N. C.) Ann.....	29, Mar.
Roanoke Division (Charlotte, N. C.) Report.....	25, May
Roanoke Division Convention (Richmond) Ann Report.....	41, Sept.
The Pacific Division Convention (1929) Report The Southeastern Division Convention (1929) Report.....	78, Dec.
The West Gulf Division Convention (1929) Report.....	50, Feb.
The Vanalta Division Convention (Vancouver) Report.....	41, Mar.
West Gulf Division Convention (Houston) Ann.....	44, Feb.
Report.....	30, Nov.
Report.....	88, Sept.
Report.....	80, Oct.

DX TABLES

Tables showing best times to work foreign stations:		
I.A.R.U. News		
50, Jan.		51, April
56, Feb.		34, June
53, March		50, Dec.

EDITORIALS

Page 7 of every issue except as follows:
September, Page 11
December, Page 9

EMERGENCY AND RELIEF WORK

Amateur Radio Scores Again.....	III, Feb.
Naval Reserve Cooperates With Red Cross.....	29, Aug.
Naval Reserve Holds Its First National Emergency Drill (Lee).....	25, July

EXPEDITIONS

All-American Mohawk Malaysian Expedition (Seelman).....	52, June
Byrd Contact.....	V, Apr.
DAIV.....	51, Aug.
Expeditions.....	III, Jan.
Expeditions.....	I, Sept.
Finding the Expeditions.....	39, Apr.
Hamming With a Portable in Africa (De Vinna)	33, Aug.
Second Roumanian Arctic Expedition (Bassett)	27, July
The Story of PMZ (Wells).....	35, June
WDDE.....	9, Aug.
With IPH in Mexico (Sandham).....	47, July
With IPH in Mexico (Sandham).....	17, Sept.

EXPERIMENTERS' SECTION

January, page 47:	
An A.C. Receiver.....	
A Novel Crystal Mounting.....	
A Note on High Frequency Antennas.....	
A Delayed Time Relay for the Transmitter.....	
Audio Frequency Selectivity.....	
Bibliography on Methods of Obtaining Audio Frequency Selectivity.....	
February, page 51:	
Notes on the Monitor (Grammer).....	
Reducing the Static/Signal Ratio.....	
Notes on Radio Frequency Resistance of Inductances.....	
Bibliography on Constant Frequency Transmitters.....	
March, page 45:	
An Effective Break-In Arrangement (McAuly).....	
Regeneration Control.....	
Operating Tubes in Parallel at 14 mc. (Penny).....	
The Space Charge Detector.....	
Phone Transmitters.....	
Bibliography on 'Phone Transmitters.....	

Page numbers in Roman Numerals refer to Communications Department in issue indicated.

April, page 46	
Inductively Coupling to "Ethereal Adornments" (Washburn)	
A Simple Resistance Bridge	
Calculating Capacity of the Micro-Condenser (Stedman)	
Improving the Transmitter	
Ham Band Antenna (Wallace)	
Frequency Standardization	
Bibliography on Frequency Measurements	
May, page 48:	
A Simple Method of Checking Modulation Percentage	
A Useful Amateur Tuning Arrangement	
Novel Receiver at W9ALT	
Tuning the Oscillator to the Single-Wire Feed Hertz Antenna	
Further Switching Devices	
Bibliography on Crystal Control	
June, page 33:	
Coupling the Single-Wire Feeder Antenna to a Push-Pull Transmitter	
Concerning the Bibliography	
July, page 39:	
Impedance Measurement With the Pliodynatron (Zottu)	
An Unusual R.F. Choke	
A Panel Saw	
A Handy Way to Lay Out Coils	
Eliminating Key Clicks	
The Resistance Bridge in the April "X"-Section	
A Neat "Clip" for Transmitter Coils	
A Flexible Receiver (Harrison)	
August, page 31:	
7-Mc. Crystals (Hollister)	
Bias for the Power Amplifier	
Some Harmonic Peculiarities	
Screen Grid Detectors in Push-Pull	
Converting the Single Control Transmitter to Push-Pull	
An A.C.-Operated Receiver with D.C. Tubes	
Three-Wire Remote Control with Mercury Vapor Rectifiers (Hubbell)	
Mountings for Transmitting Coils	
Re: Screen-Grid Detector	
September, page 47:	
A Method of Measuring Capacity and Inductance (Briggs)	
Tuned Filters	
A Receiver with Push-Pull R.F. and Detector	
Exploring the 56 Megacycle Band (Hooton)	
Eliminating Hum	
A Potential Divider for Use at Radio Frequencies (Hale)	
October, page 39:	
Tuned Antennas for Receiving	
The Single-Wire-Fed Hertz	
An A.C. Combination Receiver (Wall)	
The Space-Charge $\frac{2}{3}$ Detector	
Filament By Pass Condensers	
A Useful Lamp Bank	
Line Pad for Remote Control	
Winding Form for Copper Tubing	
A Simple Primary Reactor	
November, page 41:	
Radiophone Reception (Vincent)	
An All-Purpose Filament Transformer (Douglas)	
A 5-Meter Variable Capacity (Somerset)	
Remote Control (Thisse)	
Another Stunt for Changing Bands (Alexander)	
Magnifying the Dial Scale (Moats)	
Low Loss Coils	
Protecting the Rectifier (Hurley)	
Inductive Grid Leaks	
Clickless Keying	
A Good Relay (Payne)	
Another Use for Automatic Power Control	
FICTION	
An International 'Phone Dilemma (The Alaskan)	27, May
Cooperating with the B. C. L. (The Old Connecticut Yankee)	16, Mar.
Hams Are Born — Not Made ("Felix")	27, Jan.
Harmonious Harmonies (Uncle Jimmy and the Boys)	36, Sept.
Revolutionary — And How! (Luther)	27, Apr.
Say, Son — The Old Man	35, Mar.
	40, Apr.
	26, May
	22, Aug.
The Milkotron (Darrow)	31, Nov.
While Listening In (Taylor)	32, Feb.

FREQUENCY CALIBRATION AND CONTROL

A.R.R.L. Headquarters to Have an Accurate Frequency Standard (J. J. L.)	8, May
Bibliography on Frequency Measurements (Exp. Section)	49, Apr.
Bringing Frequency Measurement Up to Date (Grammer)	21, Sept.
Change in Standard Frequency Schedules	8, Feb.
Changes in A.R.R.L. Standard Frequency Service (J. J. L.)	47, May
Experiments With Dynatron Oscillators (Susmeyan)	33, Sept.
Frequency Standardization (Clapp and Crawford)	9, Mar.
Frequency Standardization (Exp. Section)	48, Apr.
Official Frequency System (J. J. L.)	41, Jan.
	30, Mar.
Official Frequency System Progress (J. J. L.)	23, July
Standard Frequency System News (J. J. L.)	31, Aug.
	40, Sept.
	38, Oct.
Standard Frequency News and Schedules (J. J. L.)	39, Nov.
Standard Frequency Signals and Schedules (J. J. L.)	43, Dec.
Stray	29, Mar.
The Dynatron Frequency Meter (Grammer)	9, Oct.
WWV Standard Frequency Schedules	88, Aug.
	8, Jan.

FILTERS

(See POWER SUPPLY)

I.A.R.U. DEPARTMENT

49, January	45, July
55, February	49, August
52, March	55, September
53, April	49, October
55, May	51, November
34, June	49, December

KEYING

A Delayed Time Relay for the Transmitter (Exp. Section)	18, Jan.
A Good Relay (Exp. Section)	40, Nov.
An Effective Break-In Arrangement (Exp. Section)	45, Mar.
Clickless Keying (Exp. Section)	46, Nov.
Eliminating Key Clicks (Exp. Section)	41, July
Plate Supply Filters and Keying (Coe)	39, Jan.
Remote Control (Exp. Section)	43, Nov.
Stray	34, Mar.
Three-Wire Remote Control with Mercury Vapor Rectifiers (Exp. Section)	40, Aug.

MISCELLANEOUS

A New Section Created in Pacific Division (E. H.)	32, Nov.
Angus Elected Central Division Director	84, June
A.R.R.L. Election Results	38, Jan.
Babeock Relected	88, Apr.
Doings at Headquarters (C. C. R.)	36, Feb.
	15, Mar.
	86, June
	12, Sept.
	37, Oct.
Election Notices (Central Division Special Election)	30, Feb.
Election Notices (Section Communications Managers)	35, Mar.
	14, Mar.
	31, May
	49, July
	11, Nov.
Election Notices (Directors' Elections)	39, Sept.
	34, Oct.
Election Results	14, Mar.
	VII, May
	50, July
	IV, Nov.
Financial Statements	49, Apr.
	68, June
	84, Oct.
	86, Dec.

Page numbers in Roman Numerals refer to Communications Department in issue indicated.

Huber Resigns	44, Oct.
Movies Available	29, Mar.
Mr. Terrell Reports on the Amateur	8, Feb.
New O.R.S. Certificate Issue Ready (F. E. H.)	1, Nov.
Preparing an Article for QST (Lamb)	35, Oct.
Southeastern Divisions Sections Consolidate	48, Dec.
Staff Changes	15, May
Standardization in the Field of Radio Engineering (Dudley)	20, Dec.
The Annual Meeting of the A.R.R.L. Board (Warner)	20, July
The Federal Radio Commission Reports	8, Apr.
The President's Corner (Maxim)—Looking Ahead	20, Oct.
Time Signals from W9XAM	8, June
United States Civil Service Examination	8, Mar.
What Feeling Exists Between American and Foreign Amateurs? (Brockert)	37, Nov.
Who's Who in Amateur Wireless (Allen H. Babcock and Louis R. Huber)	28, Dec.

MONITORS

Another Use for the Automatic Power Control (Exp. Section)	46, Nov.
Dummy Antennas (Omer)	15, Aug.
Notes on Frequency Observance	1, May
Notes on the Monitor (Exp. Section)	51, Feb.
Stray	78, Feb.
The Dynatron Frequency Meter (Grammer)	9, Oct.

OBITUARY

Charles S. Taylor, 1883-1930	90, July
Clyde Elden Darr, 1879-1929	25, Feb.
Silent Keys	
88, Jan.	88, June
78, Feb.	86, July
49, April	76, Oct.

OFFICIAL BROADCASTING STATIONS

Changes and Additions	
VI, Jan.	39, June
VI, Feb.	52, Aug.
XVI, March	V, Sept.
III, April	III, Nov.
Lists of Stations	IV, May
	III, Oct.

POWER SUPPLY

(See also AMATEUR RADIO STATIONS)

A Compact and Inexpensive Chemical Rectifier (Parsons)	15, July
A Complete Push-Pull C.W. Transmitter at Low Cost (Grammer)	8, Nov.
A New Line of Power Transformers and Chokes	30, Sept.
A Power Supply for the Low-Power Transmitter (Grammer)	23, Feb.
A Power Transformer for the Lean Purse (Harrington)	25, Jan.
A Simple Primary Reactor (Exp. Section)	41, Oct.
A Three-Phase High-Voltage Rectifier (Tribbey)	37, Feb.
An All-Purpose Filament Transformer (Exp. Section)	42, Nov.
An Old Timer Gets Back in the Game (Hubbell)	26, Nov.
Easy Correction of Line Voltage (Warren)	28, Feb.
Electrolytic Condensers and a High-Voltage Rectifier (Rodimon)	31, Mar.
Getting That D.C. Plate Supply (Grammer)	9, June
How Filters Work (Ester)	58, Oct.
Plate Supply Filters and Keying (Coe)	39, Jan.
Protecting the Rectifier (Exp. Section)	45, Nov.
Stray	34, Oct.
The A B C of Filter Design (Zottu)	34, Apr.
Correction	86, July
Three-Wire Remote Control with Mercury Vapor Rectifiers (Exp. Section)	40, Aug.
Tuned Filters (Exp. Section)	48, Sept.

RECEIVING — GENERAL

A Flexible Tube and Set Tester (Jones)	21, Feb.
Correction	52, Apr.
A Panel Saw (Exp. Section)	40, July
A Useful Amateur Tuning Arrangement (Exp. Section)	49, May
An A.C.-Operated Receiver with D.C. Tubes (Exp. Section)	39, Aug.
An Unusual R.F. Choke (Exp. Section)	40, July

Another Stunt for Changing Bands (Exp. Section)	44, Nov.
Another Use for the Automatic Power Control (Exp. Section)	46, Nov.
Audio Frequency Selectivity (Exp. Section)—Bibliography	84, Jan.
Converting the Four-Tube Receiver to A.C. Operation (Exp. Section)	45, Dec.
Eliminating Hum (Exp. Section)	50, Sept.
Further Switching Devices (Exp. Section)	51, May
Low-Loss (Clarkson)	60, Oct.
Magnifying the Dial Scale (Exp. Section)	44, Nov.
Matching the Speaker to the Output Tube (Thomson)	31, Jan.
Radiophone Reception (Exp. Section)	41, Nov.
Re: Screen Grid Detector (Exp. Section)	41, Aug.
Reducing the Static/Signal Ratio (Exp. Section)	52, Feb.
Regeneration Control (Exp. Section)	45, Mar.
Screen Grid Detectors in Push-Pull (Exp. Section)	38, Aug.
Some Constructional Kinks (Grammer)	41, Mar.
Some Harmonic Peculiarities (Exp. Section)	36, Aug.
Stray	14, Feb.
"	90, Apr.
"	14, Aug.
The Operating Characteristics of Vacuum Tube Detectors (Robinson)	23, Aug.
Part I	42, Sept.
Part II	41, Oct.
The Space-Charge π Detector (Exp. Section)	46, Mar.
The Space Charge Detector (Exp. Section)	46, Mar.
The Superiority of Screen-Grid Detectors (Hydberg and Doty)	43, Apr.
Tuned Antennas for Receiving (Exp. Section)	39, Oct.
Winding Data for the Tube-Base Coil (Grammer)	26, Feb.

RECEIVERS

(See also AMATEUR RADIO STATIONS)

A Flexible Receiver (Exp. Section)	43, July
A Multi-Range Receiver With Four Tuned Circuits (Krusse)	21, Oct.
A Receiver With Push-Pull R.F. and Detector (Exp. Section)	48, Sept.
A Two-Tube A.C. Receiver (Grammer)	11, Dec.
An A.C. Receiver (Exp. Section)	47, Jan.
An A.C. Combination Receiver (Exp. Section)	40, Oct.
An All-Service Portable Receiver (Chinn)	39, May
Airplane Radiophone Communication Experiments (Vincent)	9, May
Correction	32, July
Improvements in the High-Frequency Receiver (Gluck)	31, Feb.
Novel Receiver at W9AIR (Exp. Section)	49, May
Radio Control of Airport Lights (Gostin)	19, Apr.
Revolutionizing High-Frequency Tuner Design (Hoffman and Mix)	9, Feb.
Something New in Receiver Design (Stevens)	15, Nov.
The A.C. High-Frequency Receiver (Dudley)	9, Jan.
The Band-Box Superhet (Anderson)	17, June
The High-Frequency A.C. Receiver at W8AYO (McFarlin)	23, Apr.
Your Broadcast Receiver as a Short-Wave Superhet (Grammer)	8, July

RECTIFIERS

(See POWER SUPPLY)

REMOTE CONTROL

(See KEYING)

RESISTANCES

A Non-Inductive Resistor	40, Nov.
Correction	44, Dec.
A Simple Resistance Bridge (Exp. Section)	46, Apr.
A Useful Lamp Bank (Exp. Section)	42, Oct.
Accurate Wire Wound Resistors	34, Jan.
Line Pad for Remote Control (Exp. Section)	43, Oct.
Stray	35, Aug.
The Resistance Bridge in the April "X" Section (Exp. Section)	42, July

TRANSMITTING — GENERAL

(See also AMATEUR RADIO STATIONS)

A Chokeless Hartley Circuit (Exp. Section)	45, Dec.
Advanced Transmitter Design (Lamb)	21, June
An Old Timer Gets Back in the Game (Hubbell)	26, Nov.
Correction	44, Dec.

Bibliography On Constant Frequency Transmitters (Exp. Section).....	54, Feb.
D.C. House Current for the Transmitter (Exp. Section).....	47, Dec.
Filament By Pass Condensers (Exp. Section) ..	42, Oct.
How Our Signals Look (Griffith).....	27, Oct.
Improving the Transmitter (Exp. Section).....	47, Apr.
Inductive Grid Leaks (Exp. Section).....	45, Nov.
Locking the Transmitter (Turner).....	29, Feb.
Neutralizing Radio-Frequency Amplifiers (Foreman).....	31, Oct.
Operating Tubes in Parallel at 14 mc. (Exp. Section).....	46, Mar.
Some Constructional Kinks (Grammer).....	41, Mar.
Stray.....	15, May

TRANSMITTERS — CRYSTAL CONTROL

(See also AMATEUR RADIO STATIONS and TRANSMITTING — 'PHONE)	
7-Mc. Crystals (Exp. Section).....	36, Aug.
A New Type of Crystal Holder (Klenk).....	29, Dec.
A Novel Crystal Mounting (Exp. Section).....	47, Jan.
Bias for the Power Amplifier (Exp. Section).....	37, Aug.
Bibliography on Crystal Control (Exp. Section)	51, May
Bibliography on Crystal Controlled Constant Frequency Transmitters (Exp. Section).....	54, Feb.
Crystallizing Crystal Grinding (Lamb).....	41, Apr.
NKF Experiments Above 28 Megacycles (Lamb)	9, Apr.
Quartz Crystal Paets (Hollister).....	29, Jan.
QSY With Crystal Control (Phelps).....	31, Sept.
QSY With Crystal Control (Exp. Section).....	45, Dec.

TRANSMITTING — 'PHONE

(See also AMATEUR RADIO STATIONS)	
A Modern 50-Watt Radiophone Transmitter (Chinn and Hendricks).....	19, Nov.
A Simple Method of Checking Modulation Percentage (Exp. Section).....	48, May
Airplane Radiophone Communication Experiments (Vincent).....	9, May
Correction.....	32, July
Bibliography on 'Phone Transmitters (Exp. Section).....	47, Mar.
Comments on 14 Mc. 'Phone (Phelps).....	58, Mar.
Editorial.....	7, Jan.
14-Mc. 'Phone Transmission (Dudley).....	17, Mar.
Line Pad for Remote Control (Exp. Section)...	13, Oct.
Radio Control of Airport Lights (Gostin).....	19, Apr.

Stray.....	46, Nov.
Vacuum Tube Layouts for Telephone Modulation (Spitzer).....	17, Feb.
"Vacuum Tube Layouts — " Corrected (Spitzer).....	55, Mar.
Volume Level Indicators (Omer).....	33, Nov.
Correction.....	44, Dec.

TRANSMITTERS — LOW POWER

A Complete Push-Pull C.W. Transmitter at Low Cost (Grammer).....	8, Nov.
A Low Power Transmitter.....	18, Apr.
Converting the Single Control Transmitter to Push-Pull (Exp. Section).....	39, Aug.

TUBES

A Correction (Mitchell).....	58, Feb.
A Potential Divider for Use at Radio Frequencies (Exp. Section).....	78, Sept.
Distortion Rule Obtainable.....	8, Jan.
New DeForest Tubes.....	24, July
New Two-Volt Tubes (G. G.).....	22, July
QST Adopts a System of Uniform Tube Designation (J. J. L.).....	28, May
The Dynatron (Newhold).....	33, Feb.
The Operating Characteristics of Vacuum Tube Detectors (Robinson).....	Part I, 23, Aug. Part II, 42, Sept.
Vacuum Tube Layouts for Telephone Modulation (Spitzer).....	17, Feb.
"Vacuum Tube Layouts — " Corrected (Spitzer)	55, Mar.

ULTRA-HIGH FREQUENCY

28-Mc.	III, Jan.
28-Mc. Experimenters.....	VI, Feb.
A 5-Meter Variable Capacity (Exp. Section)...	43, Nov.
Advanced Transmitter Design (Lamb).....	21, June
Exploring the 56 Megacycle Band (Exp. Section)	49, Sept.
High-Frequency Inductances (Ausman).....	38, Feb.
High-Frequency Notes (Rodimon).....	26, Oct.
Hunting Trouble on 28-Mc. (Blais).....	21, Jan.
International Communication on 28 Megacycles (Rodimon).....	21, May
Making Practical Use of the 56-Mc. Band (Long)	13, Sept.
More Progress on 28 Megacycles (Rodimon)....	29, June
NKF Experiments Above 28 Megacycles (Lamb)	9, Apr.

Page numbers in Roman Numerals refer to Communications Department in issue indicated.



Outstanding ...

To the amateur and to every other user of dry cell batteries. Outstanding because of unequalled performance under most severe as well as all ordinary circumstances.

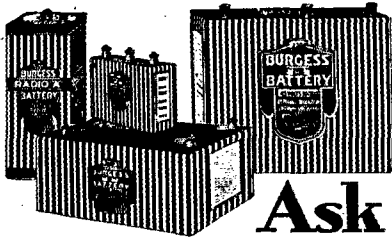

Ask *any* Radio Engineer"

BURGESS BATTERY COMPANY

MADISON,

WISCONSIN

Sets built to sell

—must satisfy

tone-conscious

ears...



*Sangamo Transformers
in the audio end give your
set a "tone" advantage
over competition*

Successful custom builders and manufacturers know the importance of *tone quality*. Fully 90% of all receiver sales are made or lost on the first hearing. Nothing takes the place of accurate reproduction. Today, the buying public judges by *tone* more than by *price!*

The only way to be sure of tone quality is to be sure of the transformer you use.

Obviously, transformer building, an exact science in itself, should only be undertaken by an organization of specialists. Sangamo is such an organization.

30 years of research experience combined with unsurpassed precision manufacturing facilities guarantee in Sangamo Transformers the most satisfactory amplification over the entire musical frequency scale.

Sangamo "A" Line Transformers give your set a "tone" advantage over competition. The cost is a little higher, but they cut your selling costs by lowering sales resistance.

SANGAMO ELECTRIC COMPANY
SPRINGFIELD, ILLINOIS, U. S. A.

*Manufacturers of Precision
Electrical Apparatus for
30 years.*

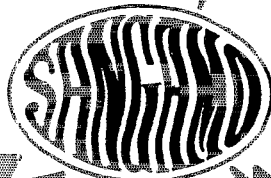

(see reverse side)



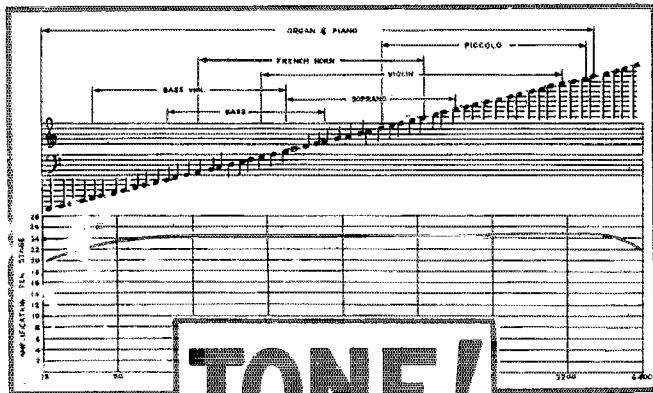

TONE!

Curve of Type "A" or Sangamo Straight Audio Transformer showing uniformity of amplification at all audible frequencies.

True Tone—

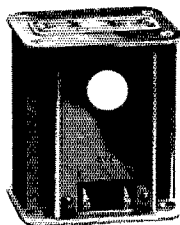

is the real basis of comparison for a receiving set.

"X" Line Transformers

Type AX straight audio amplification. List price.....\$6.00

Type BX Push-pull Input unit. List price.....\$6.50

Type CX-171 Push-pull Output Transformer, for 171 or 250 power output tubes for cone speaker. List price.....\$6.50

Type DX, same as CX except for 210 and 112 power tubes. List price.....\$6.50

Type HX Push-pull Output for 171 or 250 Power Output tubes to match the impedance of moving coil of Dynamic loud speakers. List price.....\$6.50

Type GX, same as HX except for 210 and 112 power tubes. List price.....\$6.50

Type E Output Choke to match impedance of the various type power tubes. List price.....\$5.00

"A" Line Transformers

Similar to X Line but with special core metal to give greater amplification at low frequencies

Type A straight audio amplification. List price.....\$10.00

Type B Push-pull Input Transformer for all tubes. List price.....\$12.00

Type C-171 Push-pull Output, for 171 or 250 type power tubes with cone speaker.....\$12.00

Type D-210, same as C except for 210 and 112 power tubes.....\$12.00

Type H-171, Push-pull Output for 171 or 250 power tubes for Dynamic Speaker. List price.....\$12.00

Type G-210, same as type H except for 210 and 112 tubes.....\$12.00

Type F Plate Impedance for use as a choke to prevent oscillation and for impedance coupled amplifiers. List price.....\$5.00

PIN THIS TO YOUR LETTERHEAD AND MAIL

SANGAMO ELECTRIC CO.

Springfield, Illinois, U. S. A., Dept. W-94

(For manufacturers) I am interested in engineering data regarding your transformers and condensers.

(For set builders) Please send circulars describing your apparatus and latest audio hook-ups. I enclose 10c to cover cost of mailing.

Name.....

Address.....

Unusual facilities for furnishing transformers with or without cases ready for mounting and quick assembly with the receiver. Prices on application.

The Sangamo Type "A" Condenser

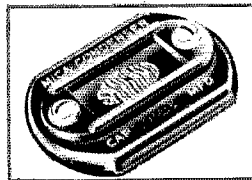

Every sound characteristic is affected by the quality of the fixed condensers in a set. Sangamo builds accurate mica condensers, molded within an overall enclosure of genuine bakelite with only the terminals brought outside. Moisture, heat, shocks or jars will not alter their characteristics nor affect operation after the set leaves the factory.

Sangamo "Illini" Condensers

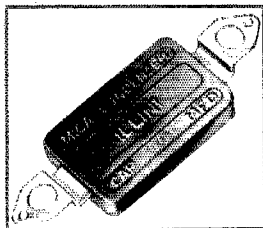

"Illini" Condensers are standard with those manufacturers who insist on ratings being actually what the specifications call for. Manufactured by exclusively designed equipment, held to the tolerances your engineering department demands, Sangamo Condensers will reduce to a negligible quantity inspection department rejects and "reassembly" losses in profit.

Sangamo High Voltage Condensers

Tested at 5000 volts D. C. and 3500 A. C. and built to Sangamo standards, known throughout the radio world, amateurs, commercial men and manufacturers have learned to depend on Sangamo High Voltage Condensers. Accurately rated and adequately tested—these condensers offer the maximum protection in high voltage, high frequency circuits.

Prices on request