

# HAM

AN ARGUS SPECIALIST PUBLICATION

February 1986 £1.20

# RADIO

# TODAY

## TRANSVERTERS GALORE!

Convert from HF to 4 or 6m with this state-of-art design by G3WPO

Louis Varney, G5RV, tells the Marconi story

Starting out on the shortwaves

## THE PYE POCKETPHONE PHOENIX

Out of the ashes onto 70cm Conversion by G4HCL

Leap over the rest with our mini hula antenna for 2m

Win the SMC Polarphaser - as reviewed inside



RADIODIFF







# OMEGA POWER

14 MEREDITH ROAD, WORTHING, SUSSEX BN14 8EA  
TEL. 0903 35644

## Co-Ax Plugs, Sockets, Adaptors

P1 standard 50 OHM BNC plug	£0.88
P2 50 OHM solderless crim type BNC	£1.00
P3 chassis mounting BNC socket	£0.94
P4 single hole chassis mounting BNC socket for panels up to 4mm thick	£0.88
P5 single chassis mounting BNC socket for panels up to 7mm thick	£0.88
P6 double ended BNC female socket	£1.26
P7 double ended bnc plug/plug	£1.97
P8 BNC T connector socket/plug/socket	£2.83
P9 BNC T connector socket/socket/socket	£2.83
P10 elbow BNC socket/plug	£2.32
P11 BNC line socket female/female	£1.13
P12 PL259 standard plug 9.5mm internal dia.	£0.55
P13 Reducer for PL259 5.2 internal dia.	£0.15
P15 standard PL259 with built in reducer 5.2mm internal dia.	£0.45
P16 Right angle PL259 for RG58/U	£0.88
P17 Solderless PL259 with built in reducer for RG58/U	£0.88
P18 SO239 4 hole mounting chassis socket	£0.44
P19 SO239 female/female coupler	£0.52
P20 PL259 male/male coupler	£0.68
P21 PL259 (push on) SO239 quick disconnect	£0.95
P22 right angle PL259/SO239	£1.16
P23 PL239 T connector female/male/female	£1.37
P24 SO239 T connector female/female/female	£1.44
P25 N type plug to BNC socket	£2.42
P26 BNC plug to N type socket	£1.87
P27 N type plug to SO239	£2.50
P28 PL259 to N type socket	£2.28
P29 Phono plug to SO239	£0.55
P30 3.5mm plug to SO239	£0.75
P31 BNC plug to SO239	£1.20
P32 PL259 to BNC socket	£1.20
P33 standard co-ax plug to BNC socket	£1.02
P34 Phono plug to BNC socket	£1.35
P35 Phono plug to F type socket	£0.59
P36 pus in F type plug to F type socket	£0.57
P37 PL259 to phono socket	£0.75
P38 BNC plug to phono socket	£0.94
P39 F type plug to phono socket	£0.66
P40 F type plug to BNC socket	£1.13
P41 F type socket to phono socket	£0.60
P42 PL259 plug to plug	£2.10
P43 F type socket to 3.5mm jack	£0.68
P44 phono socket to standard co-ax socket	£0.52
P45 standard co-ax plug to phono socket	£0.66
P46 TNC plug	£2.75
P47 N type in line socket for RG8/9U	£1.54
P48 N type in line socket for RG58	£1.54
P49 N type T connector female/male/female	£3.45
P50 N type single hole mounting chassis socket	£1.20
P51 N type four hole mounting chassis socket	£1.68
P52 N type elbow male/female	£3.11
P53 N type T connector female/female/female	£3.45
P54 N type double ended female/female	£2.00
P55 N type double ended male/male	£2.40
P56 N type plug for RG58 cable	£1.52
P57 N type plug for RG8 cable	£1.56

## Co-Ax Relays

CR1 PCB type co-ax 50 OHM maximum input 150w PEP at 500MHZ maximum operating frequency 2.5GHZ insertion loss .2db at 2.5GHZ supply 12VDC VSWR 1.2-1	£16.95
CR2 Mast Head changeover relay 3 N type terminated socket 2 in 1 out completely waterproof complete with DC cable and	

changeover box. Frequency 1MHZ-1.2GHZ VSWR 1.2-1 at 500MHZ VSWR less than 1.3-1 at 1.2GHZ insertion loss.3db at 500MHZ .6db at 1.2GHZ power handling 50w max £79.95

## Mike and Power connectors

Please note that it is the line socket on the end of the mike

MC1 2 pin in line socket	£0.65 ea.
MC2 2 pin chassis mounting plug	£0.65 ea.
MC3 2 pin in line plug	£1.40 ea.
MC4 3 pin in line socket	£0.65 ea.
MC5 3 pin chassis mounting plug	£0.65 ea.
MC6 3 pin in line plug	£1.45 ea.
MC7 4 pin in line socket	£0.70 ea.
MC8 4 pin chassis mounting plug	£0.75 ea.
MC9 4 pin in line plug	£1.65 ea.
MC10 4 pin right angle line socket	£1.40 ea.
MC11 5 pin in line socket	£0.80 ea.
MC12 5 pin chassis mounting plug	£0.75 3a.
MC13 5 pin in line plug	£1.65 ea.
MC14 6 pin chassis mounting plug	£0.80 ea.
MC15 6 pin chassis mounting plug	£0.80 ea.
MC16 6 pin in line plug	£2.30 ea.
MC17 7 pin in line socket	£1.35 ea.
MC18 7 pin chassis mounting plug	£1.15 ea.
MC19 7 pin in line plug	£2.05 ea.
MC20 8 pin in line socket	£1.45 ea.
MC21 8 pin chassis mounting plug	£1.20 ea.
MC22 8 pin in line plug	£2.80 ea.

## CO-axil Cable

C1 pope H100	£0.75 p.m.
C2 pope RG58C/U	£0.30 p.m.

## Telephone Accessories

T1 modular telephone t adaptors	£2.50 ea.
T2 2/4a telephone master socket	£3.50 ea.
T3 2/6A slave ext socket	£3.00 ea.
T4 5m ext leads with modular plug and socket	£2.50 ea.
T5 10m ext leads with modular plug and socket	£4.00 ea.

## AC Power leads

AC1 3 pin IEC plug and lead right angle with 2m cable 250v AC 6 amp Yaesu Trio mains lead	£2.50 ea.
AC2 3 pin IEC plug and lead straight with 2m cable 250v Ac 6 amp Yaesu Trio mains lead	£2.50 ea.
AC3 2 pin fig 8 type plug with 2m cable	£1.00 ea.

## Trimming Tools

TT1 complete set of 4 double ended trimming tools Hexagonal and rectangular heads	£1.75 ea.
---	-----------

## DC Power Sockets

DC1 centre hole 2.1mm dia shaft length 10mm	£0.25 ea.
DC2 centre hole 2.5mm dia shaft length 10mm	£0.25 ea.
DC3 centre hole 2.1mm dia shaft length 14mm	£0.25 ea.
DC4 centre hole 2.5mm dia shaft length 14mm	£0.25 ea.

P&P £1.00. Co-ax 10p p.m. All mail will be sent by normal post unless otherwise requested.

# HAM RADIO CONTENTS

## TODAY

VOLUME FOUR No. 2 FEBRUARY 1986

Consultant Editor  
Steve Ireland, G3ZZD,  
Editor  
Dave Bradshaw, G1HRT,  
Assistant Editor  
Julie Darby, G1CKF,  
Advertisement Manager  
Dave Gadsden, G4NXV,

Published by:  
Argus Specialist Publications Ltd.,  
1 Golden Square,  
London W1R 3AB  
Telephone 01 437 0626  
Distributed by:  
SM Distribution Ltd.  
Printed by:  
The Garden City Press Ltd.  
Design by:  
Argus Design Ltd.

ABC

Subscriptions: UK £17.30; o/seas sur £21; USA sur \$28; o/seas air £39. Ham Radio Today, Subscriptions Dept., Infonet Ltd., Times House, 179 The Marlowes, Hemel Hempstead, Herts HP1 1BB (tele: 0442 48432).

Ham Radio Today is normally published on the first Friday in the month preceding cover date. The contents of this publication including all articles, designs, plans, drawings and programs and all copyright and other intellectual property rights therein belong to Argus Specialist Publications Limited. All rights conferred by the Law of Copyright and other intellectual property rights and by virtue of international copyright conventions are specifically reserved to Argus Specialist Publications Limited and any reproduction requires the prior written consent of the Company. © 1986 Argus Specialist Publications Ltd.  
All reasonable care is taken in the preparation of the magazine contents, but the publishers cannot be held legally responsible for errors. Where mistakes do occur, a correction will normally be published as soon as possible afterwards. All prices and data contained in advertisements are accepted by us in good faith as correct at the time of going to press. Neither the advertisers nor the publishers can be held responsible, however, for any variations affecting price or availability which may occur after the publication has closed for press.

## REGULAR COLUMNS

LETTERS.....	.6
RADIO TODAY.....	.10
MICRO' NET.....	.18
RADIO TOMORROW.....	.51

## CONSTRUCTION

A MINI HULA ANTENNA FOR 2m.....	.14
<i>A vertically polarised indoor aerial from John Heys, G3BDQ.</i>	
GET ONTO 70 WITH A PYE POCKETPHONE.....	.26
<i>The first in our series adapting 'junk' to the amateur bands. By Chris Lorek, G4HCL.</i>	
TRY A TRANSVERTER.....	.33
<i>From Ten to Four and Six; an all mode transverter design from Tony Bailey.</i>	
A 2m SSB LINEAR Pt 2.....	.56
<i>The construction of this 80W linear by Geoff Pike, G1JEQ.</i>	

## FEATURES

THE MARCONI STORY — THE EARLY YEARS.....	.22
<i>Louis Varney, G5RV, describes the formative years of radio.</i>	
TECHNOLOGY ROUNDUP.....	.31
<i>What is this 'magical' substance GaAs found in certain mast head pre-amps? Ian Poole, G3YWX, explains.</i>	
START LISTENING ON THE SHORTWAVES.....	.42
<i>Many radio amateurs have yet to explore the delights of SW - this is what they're missing.</i>	
SIDESWIPEs.....	.50
<i>William, G8QRM, takes a look at contesting.</i>	
LOG IT FOR POSTERITY.....	.54
<i>A New Years plea from Stan Crabtree, G3OXC.</i>	

## REVIEWS

A STARTER FOR TWO — THE IC02E.....	.40
<i>Steve Ireland, G3ZZD, peruses the Icom handie talkie.</i>	
PHASING AROUND.....	.48
<i>Tony Bailey, G3WPO, reviews the SMC Polarphaser.</i>	
COMPETITION TO WIN THE POLARPHASER.....	.13
STOP PRESS.....	.21
<i>Trevor Butler, G6LPZ, reports on the 1985 RSGB annual meeting.</i>	
NEXT MONTH IN HRT.....	.30
ADVERTISEMENT INDEX.....	.59
FREE READERS ADS.....	.60
Classified.....	.64
Emporium Guide.....	.66



# HIGHER AND HIGHER WITH

## 2 New models to raise ICOM Amateur frequencies to 1.2GHz.

### IC-1271E Fantastic new multimode 1.2GHz Transceiver

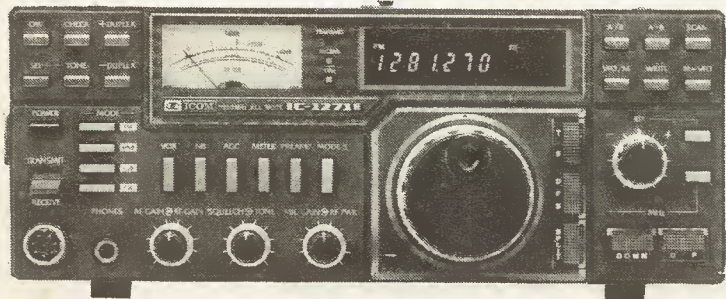

ICOM, a pioneer in 1.2GHz technology are proud to introduce the first full feature 1240 - 1300 MHz base station transceiver. Features include: multimode operation, 32 memories, scanning and 10 watts RF output. The IC-1271E allows you to explore the world of 1.2GHz thanks to a newly developed PLL circuit that covers the entire band, a total of 60MHz, SSB, CW and FM modes may be used anywhere in the band making the IC-1271E ideal for mobile, DX, repeater, satellite or moonbounce operation. The IC-1271E has outstanding receiver sensitivity, the RF amplifiers use a low noise figure and high-gain disc type GaAs FET's for microwave

applications. The rugged power amplifier provides 10 Watts which can be adjusted from 1 to 10 Watts. A sophisticated scanning system includes memory scan, programme scan, mode-selective scan and auto-stop feature. Scanning of frequencies and memories is possible from either the transceiver or the HM12 scanning microphone. 32 programmable memories are provided to store the mode and frequency in 32 different channels. All functions including memory channel are shown clearly on a seven digit luminescent dual colour display. The IC-1271E has a dial-lock, noise blanker, RIT, AGC fast or slow and VOX functions. With a powerful 2 Watt audio output the IC-1271E is easily audible even in a noisy environment. The transceiver operates with either a 240V AC (optional) or 12 volt DC power supply. A variety of options include IC-PS25 internal AC power supply, IC-EX310 voice synthesizer, the TV-1200 TV transceiver adaptor and the IC-EX309 computer interface. The IC-1271E is the most compact and lightest all-mode 1200 MHz transceiver currently available.

### IC-R7000 VHF/UHF scanning receiver

Causing quite a stir at the moment is the ICOM IC-R7000. This new receiver is able to give high frequency coverage up to 1.3MHz without sacrificing SSB stability which is maintained throughout the IC-R7000's entire frequency range. For simplified operation and quick tuning, the IC-R7000 feature direct keyboard entry. Precise frequencies can be selected by pushing the digit keys in sequence of the frequency or by turning the main tuning knob. FM/AM/SSB modes, frequency coverage 25-1000 MHz and 1025 - 2000MHz (25 - 1000MHz and 1260 - 1300MHz guaranteed specification). The IC-R7000 has 99 memories available to store your favourite frequencies including the operation mode. Memory channels may be called up by simply pressing the memory switch, then rotating the memory channel knob or by direct keyboard entry. A sophisticated scanning system provides instant access to most used frequencies. By depressing the Auto-M switch. The IC-R7000 automatically memorises frequencies in use, while the unit is in the scan mode. This allows you to recall frequencies that were in use. Scanning systems include memory selected frequency ranges or priority channels, scanning speed is adjustable. Narrow/wide filter selection. Five tuning speeds: 10Hz, 100Hz, 1.0KHz, 10KHz and 25KHz. All functions including memory channel readout are clearly shown on dual-colour fluorescent display with dimmer switch. The IC-R7000 has dial-lock, noise blanker, S-meter and attenuator. Options include RC-12 infra-red remote controller and a voice synthesizer.

For a more detailed specification of the competitively priced IC-R7000 contact your authorised ICOM dealer or telephone us direct on 0800 521145, our FREE Linkline service for Amateurs and SWL's.

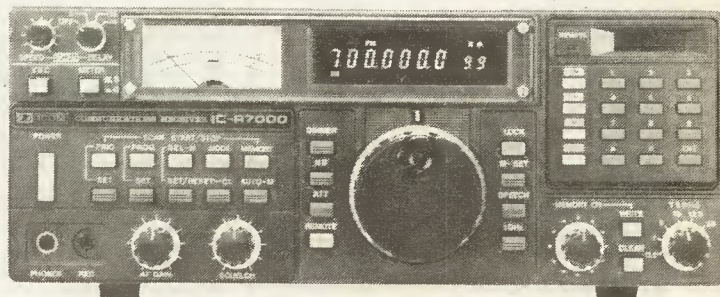

Thanet ICOM Thanet ICOM Thanet ICOM Thanet ICOM Thanet ICOM Thanet ICOM Thanet ICOM







# LETTERS

## THE RAE — A FAILING EXAM?

Sir, May I, as a lapsed internal examiner for schools, take a closer look at the RAE? Last May I scored a credit in each section of the paper and the surprise I felt at this feat made me think deeply on the structure of the papers. I came up with these, admittedly contentious, conclusions which I can only defend by claiming them to come straight from the heart.

Paper 1 seems generally to be a free gift, and it shouldn't be. Assuming, and it is only an assumption, a 40% pass level then 14 correct answers scores a pass. Since 23 questions deal with licence conditions it is possible to gain a pass in Paper 1 without knowing anything about transmitter interference — some 12 questions. I should have thought more emphasis on this extremely important branch of our hobby would go far to silence the perennial complaints in the amateur media about interference, not all of which comes from the whipping boys of the CB fraternity and radio pirates.

More central is the state of Paper 2. At the same pass rate correct answers required are 24 out of a total of 60. It is this paper which is responsible, I believe, for the bulk of the failure rate. Because the examining board calls in the question papers immediately after the exam it is not easy to analyse their content over a period of time. From my own experience, however, I am quite certain that at least ten of the questions put to me had no obvious relation to the syllabus. One frequently encounters questions in an examination which one understands but for which, alas, one has no correct answer. It is rarer to encounter questions that cannot be understood as such. Ten of these I encountered in my own ordeal, chiefly, although not entirely, connected with circuit recognition.

The comments I have made cut no ice without a systematic analysis of the papers in question. However, I can claim to be no slouch in the matter of passing public examinations, having taken fifteen at tertiary level. In addition, I have marked papers at University level and have been an internal examiner for CSE, setting and marking papers for a number of years.

Little of my experience has been in the technical field, excepting for some Statistical Mathematics. But I have had a lifetime's casual interest in amateur radio, starting at the feet of my SWL grandpa by ripping basket coils apart for devilment, graduating to the odd crystal set and ending up as an Infantry Signaller using the first X-tal's ever put into service. In consequence I feel I can recognise a question on a subject I know next to nothing about; and I recognised ten such in the RAE.

One last comment. The questions are objective-type. These are great for marking and shifting through computers. Hence, and quite understandably, the reluctance of the Examining Board to release its question papers, since it is a decided chore to develop four likely answers to ninety five questions twice a year.

Three undesirable consequences flow from this practice. The syllabus becomes relatively rigid, being subservient to the questions that can be asked in terms of it. The question papers are not subjected to constant scrutiny by informed radio amateurs and others who are able to point out flaws, such as those I may be pointing out in this letter. Objective-type papers only test one's knowledge in areas of interest to those setting the paper; should the examinee possess relevant knowledge in other areas it goes unexamined.

This last consequence can be self-defeating. Einstein is reputed to have failed his first university examination in Higher Mathematics because the Examining Board wasn't interested in questioning him about his peculiar views on the curvature of space. What unknown genius may have sat the RAE, passed or failed, and taken with him into obscurity his arcane knowledge on the construction of intergalactic QRP CW rigs from binliners and apple cores?

**Trevor M. Artingstoll**

## THANKS RON AND SHIRLEY

Sir, I would like to thank Ron Ray and Shirley Hesketh for their efforts in putting together the HRT Morse course. For my birthday last November, my unsuspecting XYL presented me with the two tapes which go to make this course and so

began my introduction to the world of morse.

I cannot believe that anybody can honestly call trying to learn morse fun; however, the morse course, for me at least, certainly made the whole process a lot less painful than I imagined it was going to be.

I started the course with zero knowledge of the basic morse code but found their method of tuition easy to digest and was surprised just how quickly I came to firstly recognise the characters and thereafter build up my receive speed.

The acquisition of a morse variation to my class B licence from April was an additional help but did temporarily cast doubts in my mind about the random five letter group approach as used by Ron and Shirley. The majority of operators I spoke to during practise sessions were of the opinion that being conditioned early to hear groups of five letters tends to produce difficulties for the learner later on when trying to distinguish longer words during receiving plain language.

As it happened I found no drawbacks later on, having started with five letter groups. In fact, I found that during plain language receive I was faithfully copying down exactly what I heard deliberate mistakes and all and was not in the habit of presupposing words or letters.

I found that 15 minutes per day, every day, produced a reasonable rate of progress; longer sessions did not seem to be any more productive and in any case guaranteed forthright comments from the XYL about her sanity!

Tape 2 side 2 is mainly at the Post Office test speed, however after numerous playbacks, the tension of the tape began to vary which produced some interesting results with me trying to copy at speeds that were varying from an estimated 10-18wpm; all good practice.

I would like to extend my congratulations via your letters page to Ron and Shirley for putting together such a well thought out tape and also my sincere thanks to Ray, G4MRJ, and Archie, G2WQ, for the time they gave me for morse practice skeds.  
**T Cattley, G0CWZ.**

## TRANSISTOR EQUIVALENCE

Sir, I have recently completed



construction of the FM Talkbox 2m receiver designed by G3WPO and G4KEI (HRT February '84), and have been having problems in getting it to work satisfactorily. In particular, the performance of the front end seems to be somewhat short of ideal. In the assembly instructions, Q1 and Q2 are specified as 3SK51 and 3SK60, whereas the devices received in the kit were 3SK45. In the absence of technical data I assumed that all these devices were equivalent and so went ahead and soldered them into the circuit.

When the moment of switch-on came, everything seemed to be working except that no signals could be received. Investigation showed that Q1 and Q2 had both failed, possibly through mishandling on my part, in not observing proper precautions. My obvious need was then to obtain a couple of replacements. From the Cirkit catalogue, it appeared that 3SK45 was no longer available and the 3SK85 would be a suitable replacement (although FPAK instead of JEDEC TO-72) so a couple were duly obtained and soldered, with suitable precaution, into the circuit.

This time, some degree of success was achieved, in that signals were just heard when an aerial was

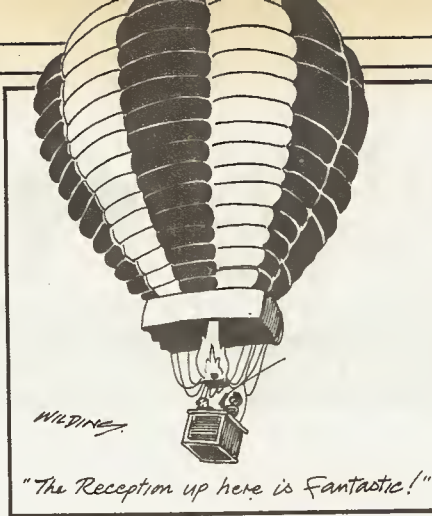

connected. In spite of attempts to align the receiver, very little improvement could be obtained in sensitivity. At this point, I contacted G3WPO and Cirkit, who now sell the kit, for advice. Both were very helpful and gave me plenty of advice.

Being one of those people who is never satisfied, I wanted to establish the real cause of the problem for myself. So with the help of data sheets kindly supplied by Cirkit, I set about the problem in detail.

The first thing I found was that contrary to my expectation 3SK85 was not equivalent to 3SK51/3SK60. For example, taking the Q1 circuit (RF

amplifier) where  $V_{DS} = 12V$ ,  $V_{G2S} = 4V$  and  $V_{G1S} = 0V$ , the drain characteristics for the 3SK60 indicate a typical drain current of 3mA. Under these conditions one could expect quite a healthy forward transfer admittance of the order of 10mA/V.

Applying the same working voltage conditions to the 3SK85 results in a typical drain current of 17mA. At  $V_{DS} = 12V$ , the channel dissipation would then be over 200mW — the maximum specified for the device. Allowing for the likely spread of DC characteristics, it seems probably that the 3SK85 would fail through over dissipation. If this has happened, one might assume that the only way I was able to receive any RF at all was via the gate 1 to drain capacitance (typically 0.03pF). No wonder the gain was low!

I am now almost sure that changing Q1 to a 3SK60 will solve the problem, but puddings need to be proved. . . Has anyone else had similar problems?

Dennis Hickman, GW4 ZTE.

Please address correspondence to:  
Ham Radio Today,  
1, Golden Square,  
LONDON W1R 3AB

# HAVE YOU HEARD?

## Looking for a handheld? Read on!



No doubt you will have heard of Kenpro and their reputation for uncompromising quality. But have you heard just how good Kenpro's new VHF/UHF handhelds are? Since our first Kenpro's started to arrive at their new homes, we've received many letters and telephone calls from delighted owners. Just one example is G3 YGI who writes. . ."Extremely pleased — performance has amazed me." Listen out from Kenprofessional owners on the airwaves. Hear and be assured Kenpro will not sing and dance but they will communicate extremely well. Have you heard it? Kenprofessionals know it!



KT200EE VHF Transceiver. 140-150MHz — £169 + £5.00 p&p  
KT400EE UHF Transceiver. 430-440MHz — £189 + £5.00 p&p

£1000 INSTANT CREDIT. HP/PERSONAL LOANS AVAILABLE. RWC CREDITCARD (written details on request) please telephone.



# HI-TEC WORLDWIDE LTD

584, Hagley Rd West, Quinton, Birmingham B68 0BS. Tel: 021-421 8201 (24hrs) Telex: 334303 TXAGWM-G



# AE

# AMATEUR ELECTRONICS

# AE LTD

Open Tues - Sat.  
9.00 - 5.00 pm

TELEPHONE 021-327-1497/6313

BY FAR THE LARGEST

PHONE THE REST THEN PHONE THE BEST FOR FAST DELIVERY, PROMPT

**S. EAST MIDLANDS**  
A.J.H., 151a Bilton Rd., Rugby,  
Warwickshire. Tel: 0788 76473

**EAST ANGLIA**  
Eastern Comms, 31 Cattlemarket St.,  
Norwich. Tel: 0603 667189

**SOUTH WEST**  
Uppington, 12-14 Pennywell Rd.,  
Bristol. Tel: 0272 557732

## YAESU PRODUCTS

<b>FT 757GX</b>	HF transceiver gen coverage all modes	739.00
FC-757AT	Automatic antenna tuner	255.00
FP-757GX	Switched mode PSU - 50% duty	160.00
FP-757HD	Heavy duty PSU - 100% duty	175.00
FIF-65	Computer interface Apple II	47.15
FIF-80	Computer interface N.E.C.	109.25
FIF-232C	Computer interface RS-232	57.00
FAS-14R	Remote antenna selector	64.40
MMB-20	Mobile mount	18.00
FP-700	Matching power supply	150.00
FC-700	Matching antenna unit	104.00
FP-757GX	When purchased with FT-757GX	100.00



**FT-757GX £739**

XF-8.9KC	CW filter (600 Hz)	19.95
XF-8.9KCN	CW filter (300 Hz)	19.95
<b>FRG-8800</b>	Gen coverage Rx. 150 kHz-30 MHz. AM. CW SSB N8FM	475.00
FRV-8800	Converter 118-174 MHz	80.00
FT-726R	Multimode transceiver 2m fitted	775.00
21/22/28	HF module	210.00
50/726	6m module	185.00
430/726	70cm module	255.00
SAT-726	Duplex module	95.00
XF-455MC	300Hz CW Filter (Ceramic)	44.85
FT-290R	2m Portable/mobile/base/multimode	£315.00
FL-2010	10W linear for above	39.00

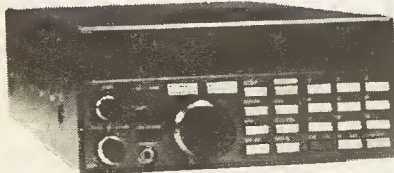

**FRG-9600 £449**

### AGENTS

#### SHROPSHIRE

Syd Poole, G31MP, Newport, SALOP. (0952) 812134

#### NORTH STAFFS

Bob Ainge, G4XEK. (0538) 754553

#### WALES & WEST

Ross Clare, GW3NWS (0633) 880 146

MMB-11	Mobile mount	30.00
NC11C	Charger	11.50
CSC-1A	Case	5.00
	Antenna telescopic (spare)	6.15
YHA 15	Helical antenna	7.65
YM-49	Spkr mic	20.20
YH-1	Headset mic	14.95
SB-2	Switching unit	13.80
MF-1A3B	Mobile mic	18.00
YM-49	Spkr mic	20.20
MF-1A3B	Mobile boom mic	18.00
SB-2	Switching unit	13.80
<b>FT-205R</b>	2m synth FM handie 350mw/3W	239.00
<b>FT-205RH</b>	2m synth FM handie 500mw/5W	249.00
NC-15	Base stn charger/adaptor	59.00
NC-18	Standard charger (FNB-4)	9.60
NC-9C	Standard charger (FNB-3)	9.60
FF-501DX	Low pass filter	29.90
LB	Log book	2.30
QTR-24D	World Clock	33.35
YH-55	Headphones	15.35
YH-77	Headphones (lightweight)	14.95

## DUAL BANDER



**FT-2700RH £499**

MH-12A2B	Spkr mic	16.50
MMB-21	Mobile Mount	7.65
YH-2	Headset mic	15.35
PA-3	DC adaptor	18.00
FNB-3	10.8V batt pack	30.65
FNB-4	12V batt pack	34.90
FBA-5	Bat case for 6AA dry cell	6.50
<b>FT-203</b>	2m synth handie thumbwheel tuning + FNB-3	195.00
<b>FT-203</b>	2m synth handie thumbwheel tuning + FNB-4	199.00
<b>FT-203R</b>	2m synth handie thumbwheel tuning + FBA-5 (accessories as for FT-209R)	175.00
<b>FT-2700 RH</b>	Dual band receiver 2m and 70cm. Full duplex. Scanning priority. 10 mems. Dual VFO	499.60
FVS-1	Voice synthesiser module	20.70
<b>FT-270R</b>	2m FM transceiver 25W. Scanning mems. Dual VFO	315.00
<b>FT-270 RH</b>	2m FM transceiver 45W. Scanning mems. Dual VFO	365.00
FVS-1	Voice synthesiser 270R/270RH	20.70
YHA-44	¼ wave helical antenna	7.65

## FT-726R

£775



YH-1	Headset mic	14.95
SB-2	Switching unit	13.80
MF-1A3B	Mobile boom mic	18.00
YM-49	Spkr mic	20.20
YH-1	Headset mic	14.95
SB-2	Switching unit	13.80
MF-1A3B	Mobile boom mic	18.00
FT-980	HF transceiver with gen coverage RX (CAT system)	1450.00
<b>SP-980</b>	External speaker with audio filter	78.95
FC-757AT	Automatic antenna tuner	255.00
FIF-232C	Computer interface RS-232	57.00
FIF-65	Computer interface Apple II	47.15
FIF-80	Computer interface N.E.C.	109.25
XF-8.9HC	CW filter (600 Hz)	28.75
XF-8.9HCM	CW filter (450 Hz)	29.90
XF-8.9HCN	CW filter (300 Hz)	29.90
XF-455MC	CW filter (ceramic)	49.85
XF-455MCN	CW filter (ceramic)	44.85
NC-8C	Base stn. charger/adaptor 208/708	64.80
NC-7	Base stn. charger 208/708	34.65
NC-9C	Standard charger	9.60



**FT-980 £1,450**

YHA-44D	½ DC grounded antenna	9.95
YM-24A	Spkr mic	23.75
PA-3	DC adaptor	18.00
MMB-10	Mobile mount	7.65
FNB-2	Battery pack	27.02
FBA-2	Battery pack adaptor (NC8A-NC-7)	3.85
<b>FT-703R</b>	70cm handie thumbwheel tuning + FNB-3	235.00
<b>FT-703R</b>	70cm handie thumbwheel tuning + FNB-4 (Accessories as for FT-209 - FT-203R)	239.00
<b>FT709R</b>	70cm handy portable synthesiser (3 options)	from 239.00
FRV-7700/A	VHF converter	49.00
FRV-7700/B	VHF converter	49.00
FRV-7700/C	VHF converter	49.00
FRV-7700/D	VHF converter	49.00
FRV-7700/E	VHF converter	49.00
FRV-7700/F	VHF converter	49.00
FRT-7700	Antenna tuning unit	49.85
FRA-7700	Active antenna	43.70
FF-5	Filter	10.75

**FREEPOST -  
MAIL ORDER  
ENQUIRIES**

**Amateur Electronics Ltd.  
FREEPOST  
Birmingham B8 1BR**

**510-512 ALUM ROCK ROAD,  
ALUM ROCK, BIRMINGHAM B8 3HX**



# ARE

# AMATEUR RADIO EXCHANGE LONDON

# ARE

RETAILER IN THE COUNTRY

TELEPHONE 01-992-5765/6

ATTENTION, FREE POST SERVICE, KEENEST PRICES & EXCELLENT PART EXCHANGE

**NORTHERN**  
Holdings, 45 Johnston St.,  
Blackburn. Tel: 0254 59595

**EAST MIDLANDS**  
R.A.S. Notts., 3 Farndon Green,  
Wollaton Park, Nottingham. Tel: 0602 280267

**YORKSHIRE**  
A.J. Hooker, 42 Nether Hall Rd.,  
Doncaster. Tel: 0302 25690

## YAESU ANTENNAS

M150-GSX	2m 1/4 / whip	7.35
RSL-435S	70cm 5/8 over 5/8 / whip	28.50
RSM-4M	Mag mount for above	16.95

## MICROWAVE MODULES

MML144/30LS	inc preamp (1/3w l/p)	82.90
MML144/50S	inc preamp, switchable	92.00
ML144/100S	inc preamp (10w l/p)	149.95
MML144/100HS	inc preamp (25w l/p)	149.95
MML144/100LS	inc preamp (1/3w l/p)	169.95
MML144/200S	inc preamp (3/10/25 l/p)	299.00
MML432/30L	inc preamp (1/3w l/p)	145.00
MML432/50	inc preamp (10w l/p)	129.95
MML432/100	linear (10w l/p)	299.00

## B.N.O.S.

LPM 144-1-100	2m, 1W in, 100W out, preamp	181.00
LPM 144-3-100	2m, 3W in, 100W out, preamp	181.00
LPM 144-10-100	2m, 10W in, 100W out, preamp	197.00
LPM 144-25-160	2m, 25W in, 160W out, preamp	217.00
LPM 144-3-180	2m, 3W in, 180W out, preamp	247.00
LPM 144-10-180	2m, 10W in, 180W out, preamp	247.00
LP 144-3-50	2MN, 50W out, preamp	108.00
LP 144-10-50	2M, 10W out, preamp	108.00
LPM 432-1-50	70cm, 1W in, 50W out, preamp	197.00
LPM 432-3-50	70cm, 3W in, 50W out, preamp	197.00
LPM 432-10-50	70cm, 10W in, 50W out, preamp	167.00

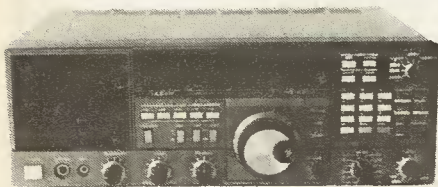

FRG-8800

£475

## TOKYO HY POWER

<b>ATU's</b>		
HC-200	HF bands ATU 200W PEP	82.95
HC-400L	HF bands ATU 350W PEP	175.75
<b>LINEARS VHF</b>		
HL-30V	30W 2m linear 0.5-3W input	45.00
HL-35V	VHF linear 0.5-5W (3W in 30W out)	69.95
HL-82V	85W 2m linear 10W input	144.49
HL-110V	110W 2m linear	199.00
HL-160V	160W 2m linear 10W input	244.52
HL-160V25	160W 2m linear 25W input	209.75
<b>LINEAR UHF</b>		
HL-20U	20W 70cm linear	82.90
HL-30U	30W 70cm linear	119.00
HL-60U	60W 70cm linear 10W input	198.99
HL-120U	120W 70cm linear 10W input	356.85
<b>PREAMPS</b>		
HRA-2	2m mast head pre-amp	94.99
HRA-7	70cm mast head pre-amp	103.29



## NOW IN STOCK

<b>70cms</b>		
432-5B	5 Ele	16.95
432-19T/ATV	19 Ele	35.60
432-17X	17 Ele Crossed	49.17
432-17T	17 Ele Long	39.20
<b>2M</b>		
144-5	5 Ele	19.55
144-7T	7 Ele	24.15
144-8T	8 Ele Long	31.26
144-14T	14 Ele	46.71
144-19T	19 Ele	55.88
144-6X	6 Ele Crossed	39.75
144-GP	Ground Plane	14.41
<b>4M</b>		
70/3	3 Ele	30.12
70/5	5 Ele	45.74
<b>POWER SPLITTERS</b>		
<b>70cms</b>		
	2 Way	19.55
	4 Way	23.00
<b>2M</b>		
	2 Way	25.50
	4 Way	28.75

## T.E.T. ANTENNAS

		Discount	
		SRP	Price
AX210N	10 element crossed Yagi, 2 metres	74.94	59.00
HB15F2T	2 element 15 meter beam	60.66	48.50
HB15M2SP	2 element 15 meter mini beam	69.49	55.59
HB210S	10 element 2 meter beam	47.99	38.40
HB23SP	2 element tri-band beam 10, 15, 20m	172.50	138.00
HB23M	2 element tri-band beam (mini) 10, 15, 20m	169.50	135.90
HB32SP	3 element dual-band beam 10, 15m	168.64	134.99
MLA4	HF band 100p antenna	105.60	84.40
MV3BN	Vertical antenna 10, 15, 20m	45.95	36.79
MV3BHR	Vertical antenna 10, 15, 20m + trapped radials	78.00	67.00
QTU10S	10 element 430 MHz Yagi	67.90	54.32
SQ007	Double quad 430 MHz	66.99	53.59
SQ10	10 meter quad mono band antenna	97.50	78.00
SQ15	15 meter quad mono band antenna	106.89	85.59
SQ22	Double quad 144 MHz	58.95	47.00
SQY06	Swiss quad/yagi 144 MHz 6 element	45.75	36.60
SQY08	Swiss quad/yagi 144 MHz 8 element	52.74	42.00
SSL218	Double 144 MHz slot Yagi 9 element	144.78	115.89
TE214	14 element long Yagi 144 MHz	74.39	59.50



£100 instant credit

Details on request

## DATONG PRODUCTS

PC1	Gen. Cov. Con	137.40
VLF	Very low frequency conv.	29.90
FL2	Multi-mode audio filter	89.70
FL3	Audio filter for receivers	129.00
ASP/P	r.f. speech clipper for Trio	82.80
ASP/A	r.f. speech clipper for Yaesu	82.80
ASP	As above with 6 pin conn	89.70
D75	Manual RF speech clipper	56.35
D70	Morse Tutor	56.35
MK	Keyboard morse sender	137.40
RFA	RF switched pre-amp	33.90
AD270-MPU	Active dipole with mains p.s.u.	51.75
AD370-MPU	Active dipole with mains p.s.u.	69.00
MPU	Mains power unit	6.90
DC144/28	2m converter	39.67
PTS1	Tone squelch unit	45.00
ANF	Automatic notch filter	67.85
SRB2	Auto Woodpecker blanker	85.25

## FT 790R and the NEW FT 690R NOW AVAILABLE

T30	30 Watt 3.5-500 MHz dummy load	8.05
T100	100 Watt 3.5-500 MHz dummy load	35.20
T200	200 Watt 3.5-500 MHz dummy load	42.55
BL40X	50 ohm-50 ohm 1-1 Balun 1kw pep	16.90
BL50A	50 ohm-50 ohm 1-1 Balun 4kw (pep) 2kw (cw)	19.84
SA450N	2 way antenna switch, 'N' connectors	18.40
SA450M	2 way antenna switch SO239 connectors	14.49
YM1X	3.5-150 MHz 120 Watt SWR/PWR meter	21.49
<b>Insulators</b>		
AE/EGG	Ceramic egg insulator	0.40
AE/DOG	Ceramic dog bone insulator	0.60
<b>TOYO</b>		
T430	144/432 120W	44.65
T435	144/432 200W	49.35
<b>HI-MOUND MORSE KEYS</b>		
HK702	Up down keyer marble base	30.95
HK703	Up down keyer	29.35
HK704	Up down keyer	19.95
HK705	Up down keyer	15.49
HK706	Up down keyer	16.96
HK708	Up down keyer	14.95
HK802	Up down solid brass	86.31
HK803	Up down brass	82.64
HK808	Up down keyer	39.95
MK704	Twin paddle keyer	13.50
MK705	Twin paddle keyer marble base	25.65
<b>KENPRO</b>		
KP100	Squeeze CMOS 230/13.8v	82.50
KP200	Memory 4096 Multi channel	169.50

## COMING SOON

★ FT 770 70cm Mobile ★

All the features of the FT 270 but on 70cms

373 UXBRIDGE ROAD,  
ACTON, LONDON W3 9RN

FREEPOST -  
MAIL ORDER  
ENQUIRIES



Amateur Radio Exchange  
FREEPOST  
London W3 9BR



# RADIO TODAY

## Leicester Post-Script

Readers of last month's HRT will be aware of the controversial incident at the Leicester show, in which Ray Withers Communications had a piece of gear confiscated by roving DTI inspectors. The item in question was a mixer/FM modulator which at the time was operating into a dummy load, at a frequency not unadjacent to the VHF broadcast band.

Immediately after the confiscation, it was unclear exactly how the DTI could justify their action; the law is anomalous, in that while it is illegal to import or manufacture equipment to operate in the 88-108 MHz band, it isn't illegal to own equipment, nor is it illegal to advertise it for sale or hire (although the DTI have every intention of changing this).

However, it now appears that the item was seized on the grounds that it was being used illegally, ie it was

transmitting. Obviously, there is a problem here — is operating into a dummy load transmitting or not? Most people would say not, but rather unluckily for Ray Withers Communications, the unit was at the time being received by a scanning receiver on their own stand. If the law is applied so strictly, then a lot of radio

amateurs could be prosecuted for breaking the law — for example, operating any high frequency oscillator could be illegal, because it most certainly will transmit something.

We'll be watching this case with some interest, because if the law is applied so rigorously, it could affect us all.

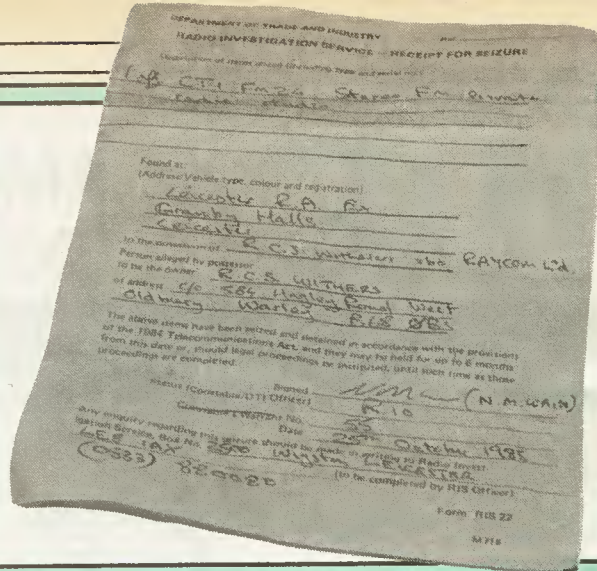

## Repeater News

The Isle of Wight 70cm repeater on RB4, which offers good mobile coverage on the island and the S Coast from Chichester to the Isle of Purbeck, appears to be suffering a small amount of interference. Listening to the signals, it is apparently difficult to tell whether the repeater is suffering QRM from a cosited PMR user or if there is a fault on the machine giving intermittent desense.

The RMG, who are currently changing the structure of their committee, will shortly be holding elections for 20 corresponding members to oversee or look after the interests of small groups of

repeaters. Each corresponding member, whose responsibility will be to a designated area manager, presently on the committee, will look after about 10-15 repeaters. In this way, it is hoped to lighten the workload of an already pressed committee and also involve more people in repeater management. The basis of the election will be one vote per repeater for the group they wish to represent them. The elected group will then put forward their chosen rep. Details of the designated areas will be announced shortly and full details of the revised system will be circulated by the RMG.

New appointments to the RMG are Paul Elliott, G4MQS, who will have

responsibility for special projects and Dave Smith, G4DAX.

The 70cm RTTY repeater, GB3MT, located on Winter Hill has undergone recent technical changes. The transmitter is being upgraded while a new antenna and duplexer system has been fitted. The antenna system comprises of two commercial Jaybeam six element yagis that are slant polarised and six Pi cavity filters have been fitted to ensure maximum rejection of the unwanted cosited transmitters.

*The VHF Committee have just released RB8 to the RMG for allocation as a repeater channel. RB8 was formerly used by Raynet.*

## 75 Successful Years

Derby and District Amateur Radio Society, incorporating Derby Wireless Club 1911, will celebrate its 75 anniversary during 1986. The society is reputed to be the oldest local radio club in the world.

An invitation has been extended to its members to attend a reception hosted by His Worship the Mayor, in the Council House on January 8th 1986. Permission has been granted by the Derby City Council for an amateur radio station to be established within the confines of the Council on the same evening. The station will endeavour to establish contact with 'twin linked' cities throughout the world.

The society plans at least one event per month throughout the year each from a different location within the City of Derby, and a special QSL will be sent for each radio contact. It is intended to award a special certificate to celebrate the 75th anniversary of the society; details will be announced later. A callsign to listen for throughout 1986 will be GB3ERD.

## New Products

One product shown but not described in last month's Radio Today, the very latest scanning receiver, the Icom R7000, now available in the UK. It will cover 20MHz to 1Ghz and 1025 to 2000 MHz (approximately), with a claimed resolution 100Hz SSB or 25Hz FM or AM. The cost of the unit is about £849 (prices had yet to be

fixed at the time of going to press), and it is available from Arrow Electronics, amongst others.

From ARE Communications comes what could be the first accessory for the R7000 — a UHF converter. This converter will add 800MHz to the received frequency; for example, with

the converter in action, if your receiver is set to 550MHz, you will actually be receiving 1350MHz. We hope to be taking a look at this little gadget in the near future, so we'll keep you posted (and we'll take a look at the R7000 as soon as we can fight our way through the queues!).



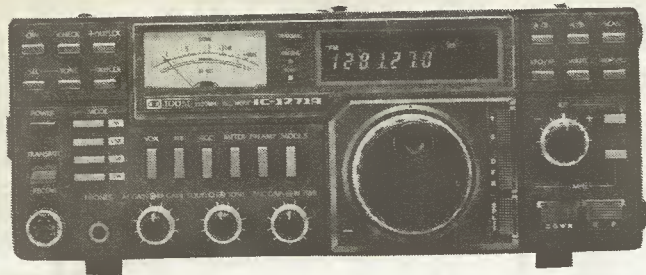

### Get Into Gigs!

The latest in the line of Icom rigs has just been announced by Thanet Electronics. The IC1271E is a base station transceiver that covers 1240 to 1300MHz with 10 watts of RF output. The front end GaAsFETs provide very good receive sensitivity ideal for the scanning facilities it incorporates along with 32 memories. The IC1271E operates on AM, FM, SSB and CW and has a variety of optional extras.

The basic rig costs £959 and is available, along with any further information, from Thanet Electronics, Hern Bay, Kent (telephone 0227 363859).

### Make Light Work?

Mike Austin (as seen at rallies on the Fortop stand) has started manufacturing under his own trading name, DC to Light. The aim of the business is to produce finished products to fill the parts of the market which are either not available or are too highly priced.

The initial product range includes a 50MHz transverter with 144MHz IF, 70cms ATV transceiver, power supply, demodulator/VSWR bridge/power meter, and a range of stacking units to hold all the individual units.

Smart black and alloy instrument cases will mean the new range be appealing to the eyes as well as the pocket.

New products will be available shortly, with 24cm FM ATV, and a dedicated 2 metre FM talk-back transceiver, in the pipeline.

DC to Light will be making its presence known at several rallies during the '86 season. Inbetween times the products will be available by mail order, or from certain retail outlets who will be

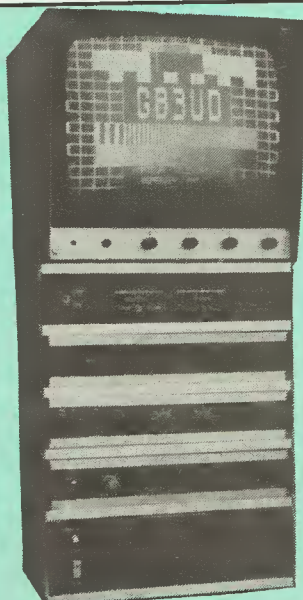

As we were going to press we heard that the 24cm ATV FM transmitter is now available at a cost of £210.95 for the 2W version, and £255.75 for 10W.

pleased to supply the items required.

A shortform catalogue is available on receipt of a SAE. DC to Light, 15 Bursley Way, Bradwell, Stoke on Trent, ST5 8JQ, tel (0782) 639406.

### Did You Know

The Police are having all their mobile radio communications moved from their present VHF band to 140 and 150MHz as requested by the WARC in 1979. This will involve install-

ing new equipment at 250 hill top sites and the phased replacement of the 25000 radios. The total cost of the project is expected to be £64 million and will have to be completed by 1989.

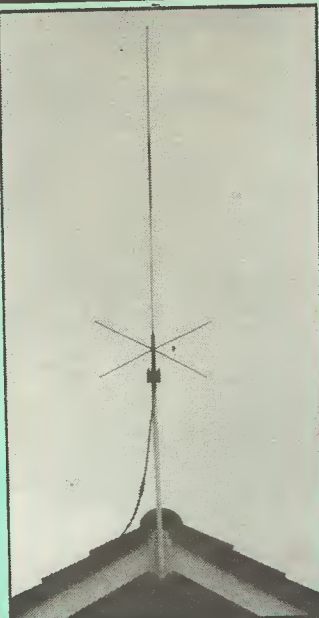

### A Colinear to Withstand All Weathers?

High prevailing winds can be a real problem for your aerials but imagine what it would be like if accompanied with a fair amount of salt spray from the sea. Well, Barry Green, G1EVI, has just these problems living on Romney Marsh. Having found that

commercial antennas couldn't stand the strain, he along with G1EVH, set out to design and construct a suitable vertical antenna.

The result was a 2m (5% over 5%) colinear giving 6dB gain and built of aluminium and PVC using the Marconi principle to obtain the phase changes necessary to feed the top element. After six months use atop Barry's roof it still gives excellent performance and has shown no signs of damage, despite the 'delightful' summer we've had.

The aerial is 3.14m in overall length, weighs 1.2kg and has a wind load of 4.6kgf at 100mhp. It comes with 0.5m of UR67 cable fitted with an N type socket and is pre SWR'd to 145MHz. It can handle up to 100W and has a face mounting diameter of 25mm.

The Uvral X2 as it is called is only available from the manufacturer Buckley's (Uvral) Ltd, Beta Works, Range Road, Hythe in Kent, CT21 6HG, at a price of £28.27 plus £1.50 p and p. Barry can supply further details on 0303 60127.

### Amateurs To Help Third World?

A novel way for radio amateurs to help Third World countries is under investigation by Frensham Heights School Amateur Radio Club. The idea for a new form of aiding developing countries came during a sponsored contest in which the school's radio society contacted Alastair, ST5ALR, an American amateur working with a relief agency in central Sudan. As a result the school is funding a crop-planting programme run by three boarding schools in Kordofan province, Sudan.

The school is now compiling a directory of amateurs in Third World countries who are Europeans engaged in contract work. The idea is that this directory would be used by other radio clubs (or even possibly individuals) to make contact and to set up links to supply and/or fund local aid and development schemes.

The intention is to set up small-scale projects and links based on personal contacts, on the 'act locally, think globally' principle.

Obviously, the project will be dependent on satisfying the regulatory condition in the various countries involved, and these obstacles may prove prohibitive in some cases. Another difficulty faced is that the response from radio amateurs is likely to be small. Even allowing for this, the school have been very disappointed with the lack of interest they have experienced from the clubs and individual amateurs they have already contacted. So if you're interested, get in touch with Dick Jones, G1JCD, Frensham Heights School Amateur Radio Club, Frensham Heights, Rowledge, Nr Farnham, Surrey, GU10 4EA.

Please note the winner of the Microwave Modules transverter competition will be announced next month.



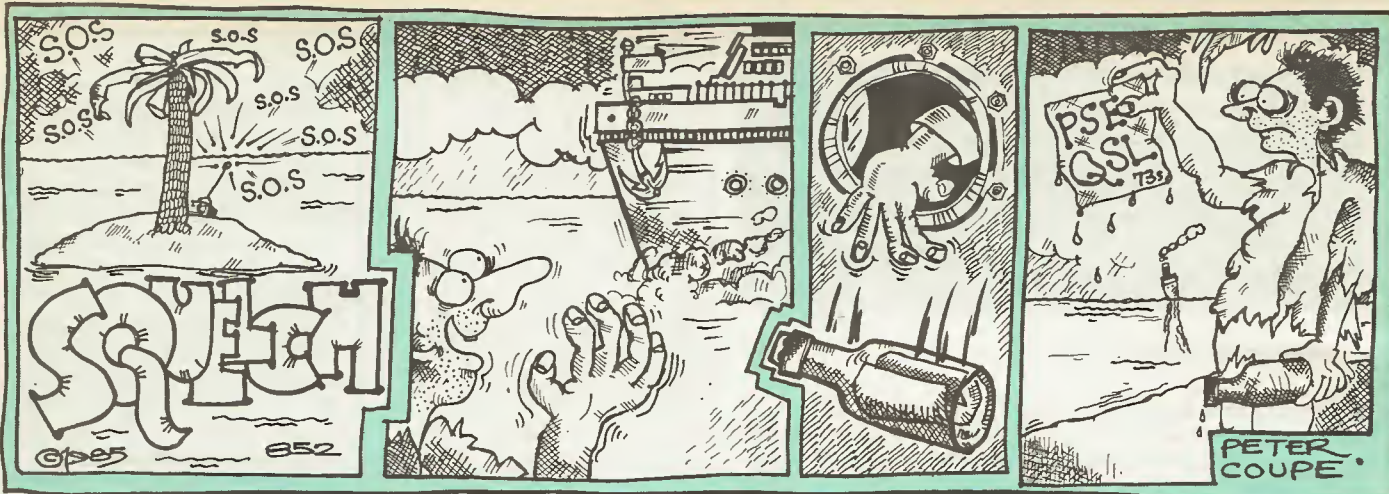

### Community Radio Experiment Starts in UK

A new chapter in the history of broadcasting starts early this year with the introduction of 21 community radio stations.

The stations will be on both VHF and MW and will fall into three categories. The first is the 'small neighbourhood' with transmitter power restricted to 25W EMRP on MW and 10W ERP on VHF. The service area for this type of station is intended to be about 5km, and a licence fee of £100 per annum will be payable.

The second category is the 'larger neighbourhood station' and there will be only two licences issued in this category. The first is to be issued to an area in NW Wales where the service will be on MW and have an ERMP of 100W. The second licence will be for the Shetland Isles which will also be on MW but the ERMP will be on 1kW. The coverage area for both of these stations is about 10km and a licence fee of £100 is applicable in these cases.

The third category in the new structure will be termed 'community of interest' and three licences are being issued - two on VHF running 100W ERP and one on MW radiating 100W ERMP. The licence fee for these is a mere £500 per annum.

All stations licenced for VHF operation will be expected to use vertically polarised transmissions and operators can use stereo or mono. The stereo transmissions must conform to the Zenith G E Pilot tone multiplex system currently being used in the UK.

The initial experiment will be for a two year period with the licences renewable after 12 months. The Home Office have stated that there will be no guarantee to extend the period after the initial trial.

Operators will be allowed to raise capital by advertising, sponsorship or grants if available. Advertisements and programmes must not 'offend good taste, or decency or be likely to encourage or invite crime or lead to public disorder or be offensive to public feeling'.

It is hoped to encourage a time share system similar to that used in Netherlands under the control of the Dutch PTT. This allows for two or more companies to share the same facilities and provide programming of differing content.

The technical standards that are being laid down by the Home Office appear at first glance to be very light. So much so that a well qualified radio engineer would be in a position to build his own transmitter. The callsign of the station will be made by agreement with the Home Office who will monitor the output material and transmitter quality. Just like amateur stations, these new community stations will be expected to keep a log of operating times and use their agreed callsign at the beginning and end of each transmission period.

The 21 stations selected are to be chosen from the 266 applications received by the Home Office on the closing date of 31st October '85. The selection and monitoring of the new service will be made by an independent advisory panel appointed by the Home Secretary.

The station areas that have been chosen for a community radio station are listed below.

1. Small neighbourhood stations: Dumfries, Rhondda, Wirral, Sunderland, Calderdale, Solihull, Rutland, Colchester, Cambridge, Penzance, Aylesbury and Purbeck all on VHF and Lincoln on MW. The London area will have three stations with a broad geographical spread - two on VHF and one on MW.
2. The two large neighbourhood stations will both be on MW covering Shetland Isles and NW Wales.
3. Community of interest stations will be based in Greater Manchester on VHF, North London and South London on MW.

Further details of these new services can be obtained from the Home Office, room T664, 50 Queen Annes Gate, London WC1H 9AT.

### New Pocomotor

Dewsbury Electronics have announced an addition to their range of Pocom decoders. The new decoder, the AFR1000 offers fully automatic decoding of Baudot radio teletype signals, both CCITT numbers 1 and 2 up to 100 baud, AMTOR and SITOR (ARQ and FEC) and the manual decoding of ASCII up to 300 baud, inclu-

ding eight channel press broadcasts. A new and novel feature is an auto speed check mode which automatically determines the speed of transmission. The AFR1000 comes complete with composite video output and RS232 interface for printers and costs around £350. Dewsbury Electronics are based at 176 Lower High Street, Stourbridge, telephone 0384 390063.



# COMPETITION

Win a 'Polarphaser' donated by SMC (Southampton).

*If you are either horizontally or vertically polarised on VHF, become an all rounder with this automatic phasing harness. It will reduce your signal loss on oppositely polarised signals to 3dB. An essential piece of equipment if you want to work any satellites and if you work a lot of mobile stations from base.*

So what do you know about the Polarphaser?

1. Does the Polarphaser need equal length feeders from the two antennas?

A yes    B no    C doesn't matter

2. What modes of transmission can the Polarphaser be used with?

D FM only    E SSB only    F all modes

3. What mode of antenna polarisation is recommended for reception of Oscar 10?

G elliptical    H clockwise    I anti clockwise

4. When used in clockwise polarisation mode to receive a purely vertically polarised signal, will the signal be:

J weaker    K stronger    L the same

5. In a normal phasing harness system, how many degrees of phase shift are needed in the actual harness itself to get circular polarisation at the antennas?

M 1/4 wave    N 1/2 wave    O depends on spacing between the two dipoles

6. When the Polarphaser is used in a linear polarisation mode, you must use a linear amplifier at the transmitter end.

P true    Q false    R only with SSB

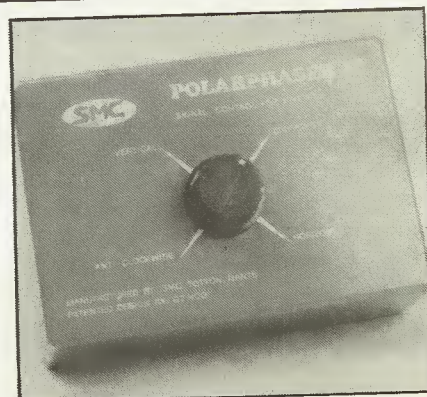

## How To Enter

Look at the questions nearby on polarisation and using the Polarphaser. Each question has a number of possible answers. Choose which you think are the correct answers and write them in sequence on the coupon below. For example, if you think the answer to question 1 is A and question 2 is D, your sequence will begin A, D...

**IMPORTANT:** write your choice of the order on the back of your envelope in addition to the coupon. Send your entry to Polarphaser Competition, Ham Radio Today, No 1 Golden Square, London W1R 3AB. The closing date for the competition is first post, 10th February 1986.

Complete the coupon fully and clearly — if you are the winner this will be used as a label. All correct entries will be placed in a hat and the winner drawn by some totally unbiased person who cannot enter the competition. You may enter as many times as you like, but each entry must be on an official coupon — not a copy — and sealed in a separate envelope.

## The Rules

Entries will not be accepted from employees of Argus Specialist Publications, South Midlands Communications or Garden City Press. This restriction also applies to employees families and agents of the above companies. The How To Enter section forms part of the rules.

NAME .....

ADDRESS .....

.....

.....

..... Post Code .....

Your choice of answers .....

Complete fully and clearly. If you are the winner, this will act as a label for your prize. Post to Polarphaser Competition, Ham Radio Today, 1 Golden Square, London W1R 3AB to arrive before second post on the 10th February 1986. Don't forget to follow the advice in the How To Enter section including *writing your choice of the answers on the back of the envelope!*



# A Mini Hula Antenna for 2m

In January 1963 J M Boyer, W6UYH, described in 'Electronics' a small but efficient vertically polarised antenna which he called a "directional discontinuity ring radiator", or 'DDRR' for short. This antenna gave effective and vertically polarised radiation from small horizontal loops which were positioned just a few feet above the ground when designed for the HF bands. I can remember putting together such an antenna in my roof space twenty years ago, cut to operate on the 3.5MHz band.

## The DDRR For HF

This experimental version had a diameter of some 18 feet and used aluminium garden edging supported two feet above a ground plane of chicken wire. The antenna certainly worked but it was very frequency conscious — it had a

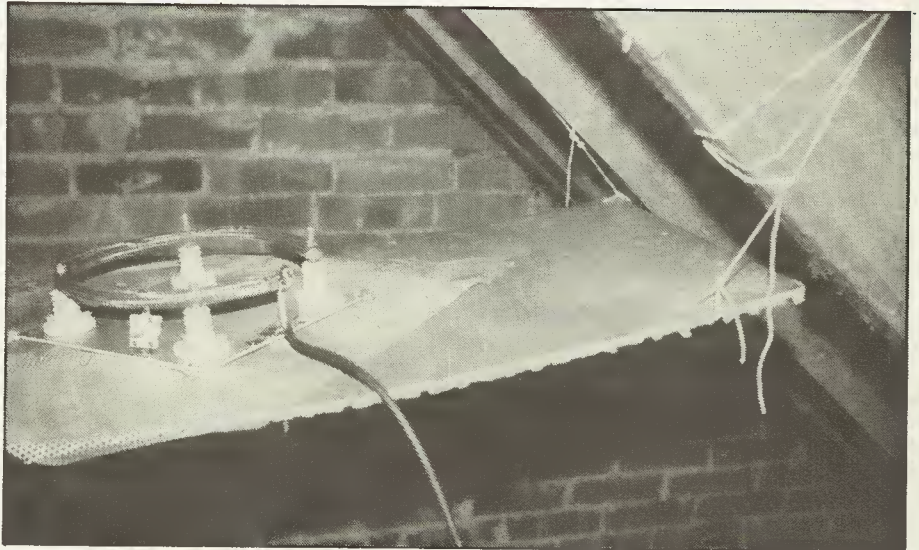

The Mini Hula hanging up in the G3BDQ loft. The simplicity of the design and its small size make this antenna ideal when space is at a premium. Note the way the tuning capacitor 'C' is soldered directly between the ring and the base plate.

described a 7MHz version. Although the design data for DDRR antennas has been published to in-

*John Heys, G3BDQ, has come up with a rather novel way of talking to other vertically polarised 2m stations with this cheap, small and easy to build design for indoor and mobile use.*

very narrow bandwidth and required a retune if a frequency change of only 10kHz was made. Climbing up into the roof area at frequent intervals was most inconvenient to say the least so after a few weeks trial the DDRR was dismantled.

To achieve a reasonable bandwidth, the diameter of the conductor making up the radiating ring must be large — on 80 metres it should be at least 5 inches. An in depth analysis of DDRR antennas was made by R B Dome ("A Study of the DDRR Antenna" QST, July 1972) and previously in the December 1971 issue of the same magazine W E English, W6WYQ,

clude all our amateur bands (ARRL Antenna Handbook, 14th Edition 1983). I have not seen any other published work relating to their possible operation on the two metre band.

## The 2m Version

The narrow bandwidth disadvantage inherent in DDRR designs for the HF bands vanishes when contemplating a VHF model. On two metres, ¼ inch diameter tubing should work well, but since I am always on the look out for cheap and easy approaches, I decided to use a conductor ring made from a short piece of UR67 coaxial cable.

This has closely woven copper screening and, when its black plastic outer covering is removed, has a diameter of about 8mm. The necessary 17 inches can easily be bent into shape and held in place by the supporting insulators. A full quarter wave on 2m is about 19 inches but the shortened ring is brought to resonance by using a small 2 – 10 pF tuning capacitor and the inherent self capacitance of the antenna.

The ring must be positioned about 1 inch (1.2 inches was the distance used for the prototype) above a conducting ground plane. For correct operation of a DDRR antenna, the ground plane must extend outwards to a distance 25% more than the diameter of the conductor ring. I was unable to find a local supply of copper faced fibreglass board larger than 6 inches square so this size had to be used as the basic antenna ground plane. To ensure correct operating conditions, the four corners of the board were soldered to a 1 square foot sheet of perforated zinc which



## Final Adjustments

It is best when first testing a Mini Hula indoors to make sure that it is in the clear and well away from large 'earthy' objects such as rigs, power packs, etc. My version was placed atop a wooden step ladder in an adjoining bedroom but not so distant that frequent adjustments were tiresome! Find a steady and fairly constant signal such as emanates from a repeater or a beacon (at the G3BDQ QTH, GB3VHF is always an S9 plus signal) and adjust 'C' for maximum signal strength. If this is not at the minimum capacity setting of the variable capacitor, snip a short piece from the ring and try again. If the maximum has still not been reached at the highest capacity setting unsolder and move the tap point of the capacitor a little nearer the open end of the ring. With low transmit power and an SWR meter in the antenna feeder, check for impedance match.

If at first the SWR reading is 'in the red' do not be alarmed at this stage for it can be reduced. The point where the coax connects at the earthy end of the ring is fairly critical and several changes may be needed to find just the point of lowest SWR. Tuning 'C' must also take place when the feed tap is moved. At resonance the tuning will also bring down the SWR. A few minutes spent in this way 'fiddling' with the two variables brought down the SWR on the prototype antenna from a nasty 1:2.5 to a sensible 1:1.3 on 145.5MHz. This rose to 1:1.6 when the transmitter was tuned to 144.4MHz which indicates a good wide bandwidth. The tests were made when using the full sized zinc ground plane which had been laid on to a thin piece of hardboard. The antenna was eventually taken up into the loft and suspended from handy tie points with string as shown in the photo nearby.

## The Mini Hula's Effectiveness

Contacts were immediately made via the local repeater and also the one in neighbouring Kent, followed by a succession of simplex FM QSO's with fixed and portable stations up to 40 miles

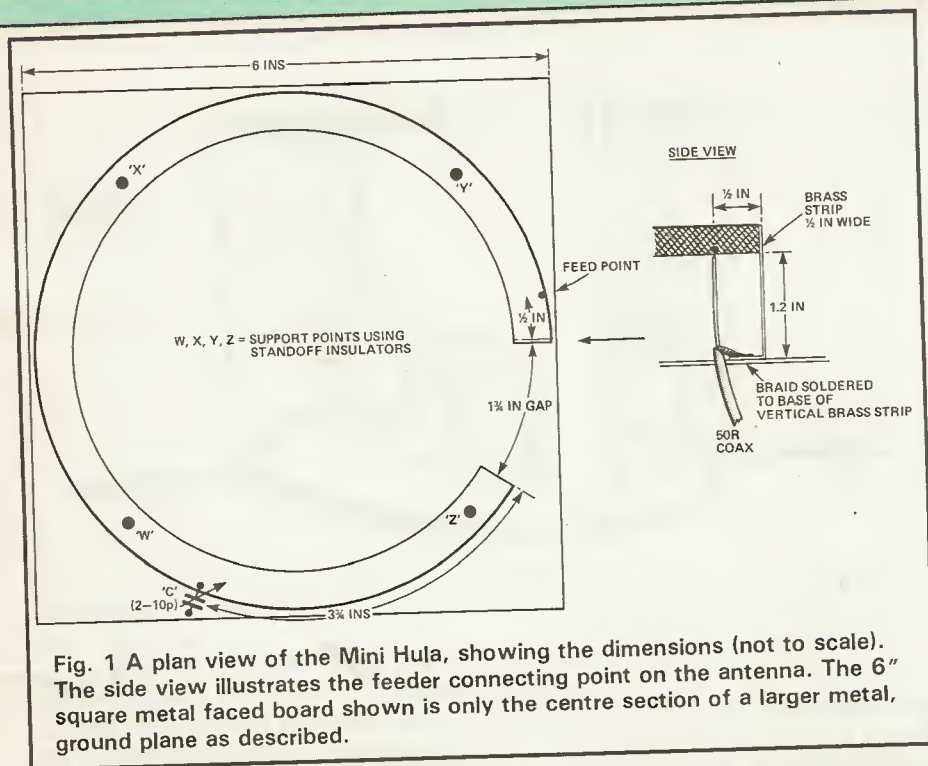

Fig. 1 A plan view of the Mini Hula, showing the dimensions (not to scale). The side view illustrates the feeder connecting point on the antenna. The 6" square metal faced board shown is only the centre section of a larger metal, ground plane as described.

had seen former service in the door of a food cupboard! Any conducting material such as aluminium, copper or zinc will be suitable as an 'extended' ground plane.

The plan view of the 'Mini Hula' is shown in Fig. 1 together with the detail of the feeder connection. The plan is not strictly to scale. One end of the ring is soldered to a half inch wide strip of thin brass or copper which is itself soldered down to the base plate. This metal strip also supports its end of the ring at the correct height of 1.2 inches. A 50 ohm impedance coax feeder has its inner soldered to a point about 1/2 inch from the 'earthy' end of the ring and for the lowest SWR readings, the best place to solder the coax braid was right at the bottom of the copper/brass strip. The ring itself is supported by four ceramic 'stand off' insulators, found in junk boxes. A useful tip to remember when drilling through the coax making the ring is to 'tin' with solder the surface where the drill enters and leaves.

## Mind The Hot End!

A fundamental snag concerning DRR type antennas relates to the very high RF voltages which can be present at the 'open' end of the ring. Voltages even exceeding 4kV will be present when using transmit powers of 100 watts, so any tuning capacitor connected at

that 'hot' end of the ring must be able to withstand such voltages without flash-over. The basic design data suggests that a capacity somewhere between 2 and 5pF will tune the DRR on the two metre band but the writer did not have to hand any suitable variable capacitor for this function. Instead a larger capacitor, an air spaced 2-10pF variable having 'normal' 1mm plate spacings was used, although it was connected some 3.75 inches back from the high voltage end of the ring, where the impedance is considerably lower. There is nothing original or unique in this idea, I can remember using a high capacity (100pF) capacitor as a 'bandsread' tuning capacitor for an O.V.O. short wave receiver fifty years ago by tapping it across the final lower turn of the detector grid coil!

There is a 1.75 inch gap between the ends of the ring. At first this was made to be only 1 inch spacing, but in order to make the antenna tune the band another three quarters of an inch was cautiously snipped away bit by bit from the high impedance end! The inner conductor wire of the UR67 which makes up the ring was left in situ and soldered to the folded back braid at the ends. It can be removed but there would be no advantage in doing this and it would in no way affect the working of the antenna or its dimensions.



away. The power used was about 12 watts and the Mini Hula seemed to work equally well in all directions and not display any noticeable nulls in its radiation pattern. Many of the stations contacted seemed amazed to receive such strong, often S9 signals, from the tiny indoor antenna. The only other antenna used on the 2m band at my QTH is a 16 element horizontally polarised Tonna and it has been found that for local and semi-local contacts with vertically polarised stations the Mini Hula is the most effective unless the big beam is turned exactly on to the other station. It is not claimed that this small antenna can outperform a good 'Slim Jim' or col-linear but it will certainly hold its own against any vertical quarter wave antenna.

For outdoor or mobile use the Mini Hula must be very well protected from dampness. Its very high 'Q' is easily affected by moisture and leakage. It has however a wonderfully low profile and could easily be completely enclosed within a shallow plastic container. If a strong magnet was attached to the base of such an arrangement, the antenna would



resemble a warning lamp when put on to the roof of a motor vehicle. The writer does not go mobile these days so cannot report on any results obtained 'on the road'.

Finally, this antenna is in no way related to the well known 'Halo' family of antennas which are all horizontally polarised and are Hertzian types. The DDDR operates as a leaky waveguide radiator and even closely resembles the quarter

wave Marconi antennas which are tuned against ground on the LF bands. Soon we shall have the six metre band so a Mini Hula design for this new band is worthy of consideration. Such an antenna will have a ring diameter of just over 16 inches and this will lie only about 1.5 inches above its ground plane. By scaling up the measurements of the two metre DDDR, the design of a six metre version is not difficult.

# The WINNERS

of the ASP DREAM HOLIDAY Competition

Argus Specialist Publications Ltd. are pleased to announce the winners of the fabulous Dream Holiday Competition.

As seen in the national press

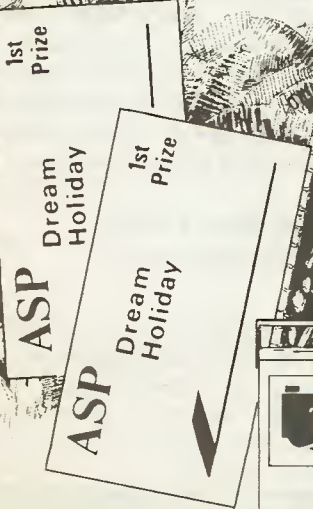

**FIRST PRIZE**  
-a holiday anywhere in the world up to a value of £2,500 has been awarded to Mr K. Gouldthorp of 2 Woodside Road, Radcliffe-on-Trent, Nottingham NG12 2HJ.

**Second Prize**  
-the very latest in portable video camera/recorder (worth over £1300) goes to Mr C. K. Duffy of 63 Cross Flats Place, Beeston, Leeds LS11 7JN.

**Third Prize**  
-the ever popular BBC Model B Micro computer plus software package, awarded to Master P. W. Dawson of 11 Ladieside, Brae, Shetland ZE2 9SX.

And the winner of the  
**fourth prize**  
-a superb Minolta X700 camera with 50mm lens and flashgun is Mr Lee Sullivan of 3 Admers Wood, Vigo Village, Meopham, Kent DA13 0ST.

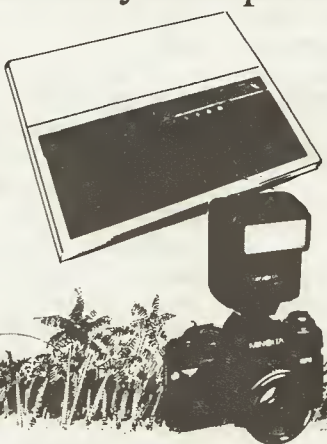
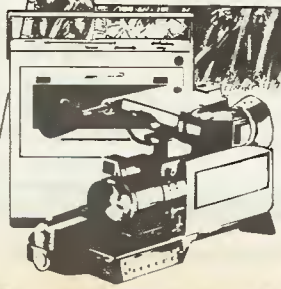

ASP would like to thank everyone who entered the competition, and CONGRATULATIONS to Mr Gouldthorp for his winning sentence which we've printed below.

“...to combat boredom by the beach, keep magazines in easy reach!”



# TUNE INTO THE WITHERS TOP 10!

First Come-First Served for these Once Only Bargains

TURN THAT BEAM KOPEK ROTATORS 50kg loading **£38.50**

DATONG AND DRAE MORSE TUTORS **£49.50**

TRAVELLING JIM 2m **£6.95**. Incl. coax and plug **£8.95**

FT 290R + Nicads, charger, listen on input **£299**

Sun gutter mount + cable assembly, PL259 fittings **£9.25**

HI-Q INSULATION TRAP-FORMER **£6.99**  
G5RV HF MULTI-BAND DIPOLE ANTENNA 1/2 size **£12.95** full size **£14.95**

STEEL QUAD SPIDERS for 2ELE Quad Aerials **£12.50**

100 WATT 0-500MHz Dummy Loads (200 watt intermittent) with lead and PL259 connector **£12.50**

REVC0 RS 2000E Ext. Coverage 60-179 & 380-520MHz. AM/FM. 70 memories, Auto search, lock priority **£219**

ORDERS UNDER £50 SEND £2.50p&p  
SEND SAE FOR LATEST BARGAIN LIST



## HAND HELD. PRICES HELD!

UHF/VHF PORTABLES ..... for only **£169**  
MULTIMODE/PORTABLE ..... from only **£299**  
MOBILES ..... from only **£99**  
CELLULAR RADIOS ..... from only **£995**

### SPECIAL DEAL

ALINCO ALM  
203E ONLY **£209!**



We stock a huge range of top name products at the lowest prices in the UK!



£1000 INSTANT CREDIT  
HP/PERSONAL LOANS AVAILABLE  
RWC CREDIT CARD (written details on request) please telephone for leaflets

SALES ★ SERVICE ★ ADVICE

## R.WITHERS



584, Hagley Rd West, Quinton  
Birmingham B68 0BS

Tel: 021-421 8201 (24hrs)  
Telex: 334303 TXAGWM-G

## GREAT NEW SOFTWARE

The RX-4 Multimode receive program for  
SSTV - RTTY - AMTOR - CW

No expensive hardware is needed. This program has everything you want, including Text and picture store for instant recall, save and printer dump. Frequency scale and fine-tune adjustment for accurate, easy tuning and a long list of other top features. For SPECTRUM (not 16k), BBC-B, CBM64, VIC20 (+ at least 8k). Tape only **£25**. Spectrum needs no hardware, the others use the same interface as our RTTY/CW program (see below).

### RTTY and CW TRANSCEIVE

You don't need a pricey terminal unit with our program, although if you already have one it will perform superbly with that, too. Split screen, type ahead, 26 saveable memories, auto CR/LF, preset-baud rates and shifts, receives any shift automatically, autotrack CW to 250 Wpm, QSO review to screen or printer and much more.

For BBC-B, CBM64, VIC20 (+ at least 8k). Tape **£20**. Interfact kit **£5**, ready-made **£20** inc all connections (state rig). CW-only version for SPECTRUM (no hardware needed) **£12**.

And superb programs for BBC-B, CBM64, VIC20, SPECTRUM, ELECTORN

MORSE TUTOR Britain's best. Absolute beginner to over 40 wpm. Easy, effective, with full learning guide. Tape **£6**. For ZX81-16k also.

LOCATOR, QTH or Maidenhead locator or lat/long. Distance, headings, contest points, converts between locator and lat/long. Tape **£7**.

LOGBOOK Date, band, mode, call and remarks. Instant callsign search. Screen/printer output. VIC20 needs expansion. Tape **£8**.

RAE MATHS All the practice and testing you need. With comprehensive reference sheet. Tape **£9**. For ZX81-16k also.

Any BBC-B, CBM64, VIC20 program available on disc at **£2 extra**. BBC: state 40/80 tk.

Price includes VAT and p&p by return 1st class inland, airmail overseas, Channel Island, Eire, BFPO Europe deduct 13%.

technical software (HRT)

Fron, Upper Llandwrog, Caernarfon, Gwynedd LL54 7RF.  
Tel: 0286 881888

## FARNBOROUGH COMMUNICATIONS

FOR ALL YOUR AMATEUR REQUIREMENTS



Call Mick G4MPW for best bargains.

Instant HP Terms. Ask for details!

Call and bargain with MICK G4MPW  
DRAE ● MICROWAVE MODULES ● J.BEAM  
SHURE MICS ● ADONIS MICS ● WELZ ●  
OSKERBLOCK ● BENCHER ● TVI FILTERS  
● CABLES ● MIRAGE AMPS  
● RSGB PUBLICATIONS ●  
AND SO MUCH MORE



97 -Osbourne Road, North Camp  
Farnborough. Tel: 0252 518009  
Mon-Sat 10.6



## BECOME A RADIO AMATEUR

Train now for the Radio Amateur Licence examination. No previous knowledge needed, only a few hours per week of home study for 3 to 6 months. Post coupon now for details or tel. 062 67 6114(24 hr service).



British National Radio & Electronics School P.O.Box 7, Teignmouth, Devon, TQ14 0HS



FREE brochure without obligation from:—  
British National Radio & Electronics School  
P.O. Box 7, TEIGNMOUTH, DEVON, TQ14 0HS

Name .....

Address .....

HRT/2

BLOCK CAPS PLEASE



# MICRO NET

Many moons ago (about five or six actually!) I commented in Micro' Net on the way in which software for any new era of interest tended to pursue a similar course of evolution to that which had been followed by software in other areas. By this, I meant that the initial

*Dave Bobbet, G4IRQ, has a look at the latest generation of amateur radio software — the compilation program — and rings up the RSGB's Data-Box.*

number crunching/problem solving type of program would subsequently be upstaged by increasingly complex and sophisticated packages as time went by. You can certainly see this process at work by looking back at the number and diversity of amateur radio related programs. We are now in a position where new 'support' programs, for example, tend to be fairly comprehensive packages which offer all the old favourites bundled together in convenient menu-driven form with much improved graphics presentation.

Amongst other items, we will be taking a look at just such a program this month as an example of the sort of compilation program which is currently being marketed. In addition to this, we will also be having a guided tour of the RSGB's experimental Prestel-type service 'Databox' which is up and running in Potters Bar.

## Bodging Bugs

In the course of the Amprom review (HRT December '85) I pointed out that there was a problem associated with a clash between the abbreviations used by Acorn for their official disc system and that used to 'call' the 'Amprom' chip into action. Andrew Woods, G1MPM, who is currently studying Computer Science at Thames Polytechnic, dropped me a line to say that there was a way around this bug which in practice simply means shifting the Amprom chip to one of the other EPROM sockets on the circuit board.

As explained in the article, the BBC micro has five EPROM sockets, each of which can hold a program stored in chip form. When a '\*' command is issued, it

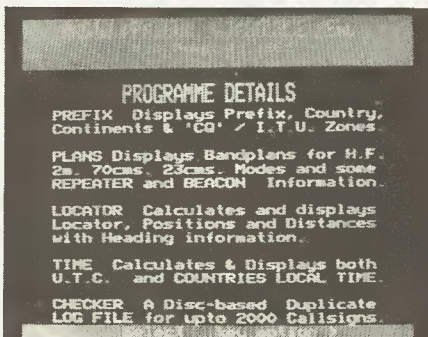

Screen shot of the Peysoft program details page.

is offered to each EPROM in turn until it is recognised, whereupon the appropriate action is taken. So as this process takes place by working from right to left, all that has to be done is make sure that the most important of the two chips which have a clash in '\*' commands (in this case the DFS chip) is positioned to the right of the less important chip — viola, problem solved!

My thanks go to Andrew for bringing this 'bug bodge' to my attention. Perhaps I could also mention that other reader's hints and tips are, likewise, always welcome.

## Radio Amateur Datasource Disc

Following on from the earlier comments concerning 'compilation' radio software, we do have just such a suite of programs for review this month which are designed for use with the Sinclair Spectrum and BBC micro's. Peysoft has produced 'Datasource' in cassette versions for both machines and also offers a 40 track disc version for the BBC in addition to a microdrive variant to suit the Spectrum. The BBC disc version is a largely self-explanatory menu-driven program offering five separate 'sub-programs'.

Once the initial Menu screen appears, the user has the option of either going directly to whichever program is required, or alternatively, a 'Program Details' screen (see photo) can be selected which offers a handy memory jogger by providing a brief resume of the functions available within each program.

There are five programs in the suite: Country Prefixes, Band Plans, Maidenhead Locator, Local Time Zones and a Callsign Duplicate Checker/Disc-File. Each of these offers a number of

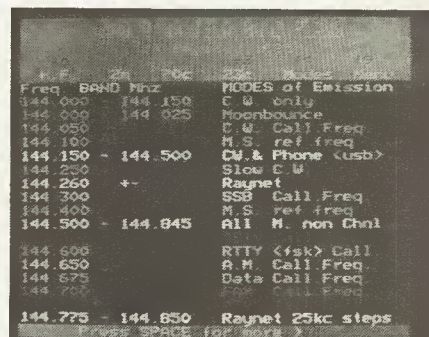

Screen shot of the Peysoft 2m bandplan page.

further options, for example the Country Prefixes program can work in any of three ways — by being given only the prefix, only the country name, or only the continent. In the case of the first two options, the program supplies the missing information so that the prefix, country, continent, ITU and 'CQ' zones can all be found and to save typing the latter parts of call-signs and country names can be omitted. A similar display is provided if only the Continent name option is selected except that in this case all the information on the countries in that continent is displayed.

The Band Plans program gives the usual details on the HF, 2 metre, 70 cms and 23cm amateur bands plus a reminder of some of the common modes of emission — the photo nearly shows a page of the 2m band plan data. The Maidenhead Locator program is the only part of the suite which requires modification by the user and this simply consists of inserting your own longitude and latitude into the program and avoids the chore of having to re-type your own locator or longitude or latitude all the time. The program will calculate distance and bearing using either long/lat or Maidenhead locators and, to take care of those awkward souls who never seem to know where they are there is a further option which can calculate somebody else's locator for them from the long/lat.

The Local Times program calculates (not surprisingly perhaps!) the local time in any country but as is usual in such cases, it does not take account of daylight saving times because these tend to vary somewhat from place to place. As well as being able to reset the UTC reference clock it is also possible to 'page' through all the country's local times if required, but most people will be quite happy with checking on only one country at a time simply



Fig. 1 The simplified diagram of the RSGB 'Data-box' database.

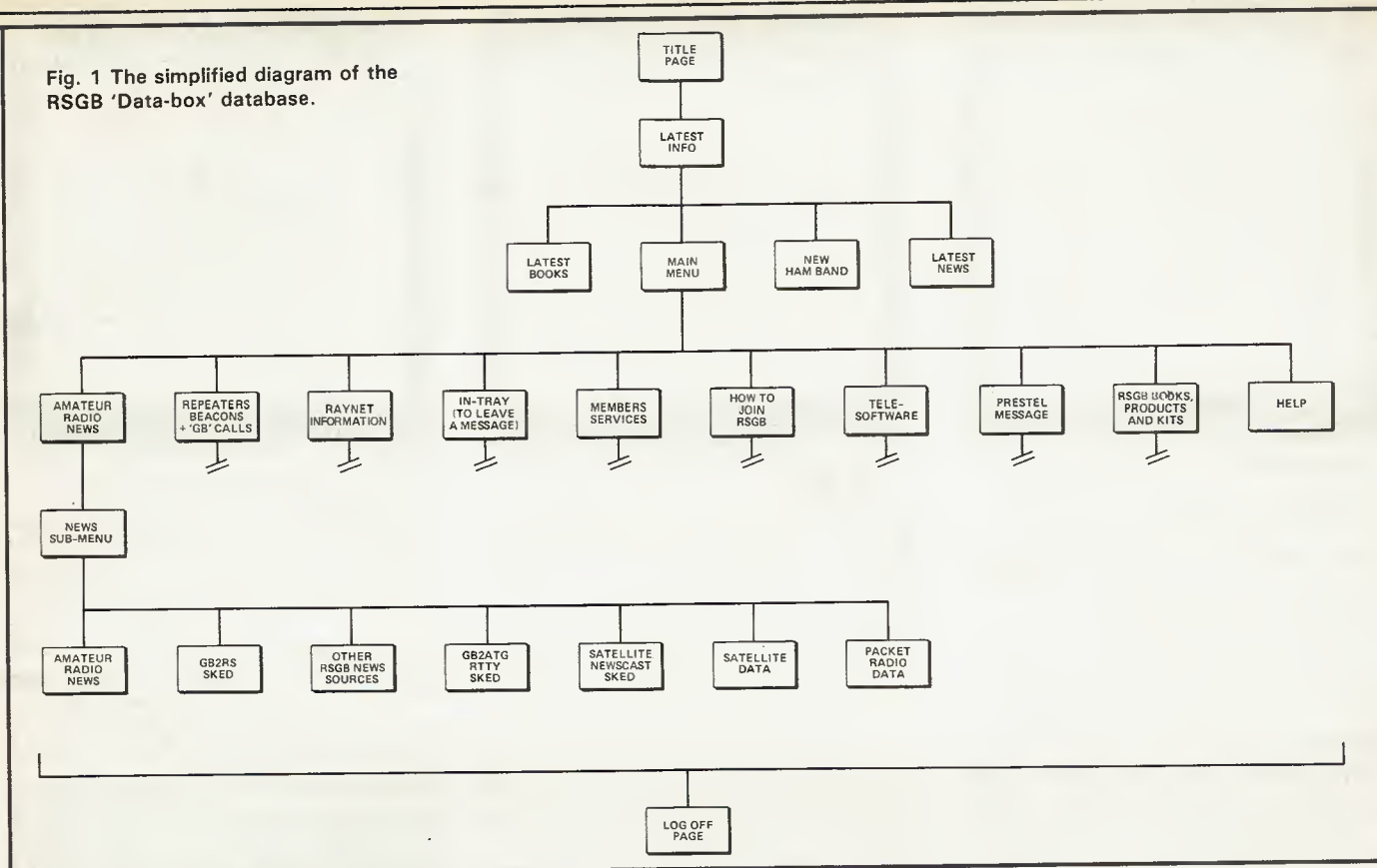

by typing in its name. I felt that one nice touch was that the program reminded you if the International Dateline had been crossed so that you weren't talking to the other station 'tomorrow'.

The final option available with the package is the Callsign Duplicate Checker & Disc File which can hold up to 2000 callsigns and indicate if the QSO is a duplicate or not. This could be quite handy for avid contest buffs because only non-duplicate QSOs are logged and the log itself can be 'backed-up' to disc every now and again so as to protect against power failures or other micro nasties.

One of the problems with reviewing any software is that buyers tend to put a subjective price on different sorts of programs depending upon just how useful that particular program may be to

them. When it comes to 'compilation programs' the situation is the same as with music 'compilation albums', ie are there enough songs on it which I *do* want to hear so as to justify having to buy the ones which I don't want.

In the case of the 'Datasource' suite, I think that it does represent quite good value for money in so far as it offers a choice of four programs which, if bought individually would cost considerably more than all four bundled together.

### RSGB 'Data-box'

I was rather interested to learn recently that the RSGB is now experimenting with a Prestel-type service called 'Data-box' which is aimed specifically at SWL's and radio amateurs and can be dialled direct.

Perhaps I should point out that this service is quite separate and distinct from the more usual Prestel service, which is available on subscription through British Telecom. The RSGB is also intending to offer a similar service on BT's own Prestel network in the near future.

Data-box is found on Potters Bar (0707) 52242 and is accessed by using a Prestel compatible modem plus attendant software, in my case the set-up was a BBC micro, a direct connect modem and a Prestel ROM chip. If Potters Bar happens to be a local phone call for you then you're laughing but it can be extremely expensive to use the Data-box if you're further away. It would probably be better to wait until the RSGB pages appear on 'real' Prestel and join that instead (further details can be obtained on Freephone Prestel).

A screen shot of the Data-box's main menu.

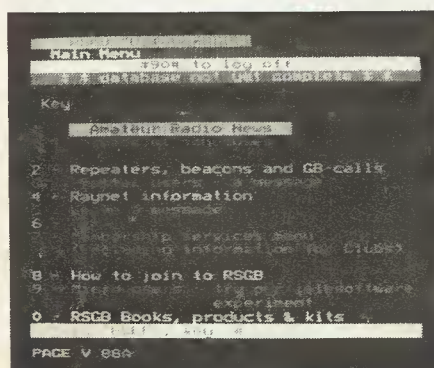

The 'Amateur Radio News' page on Databox.

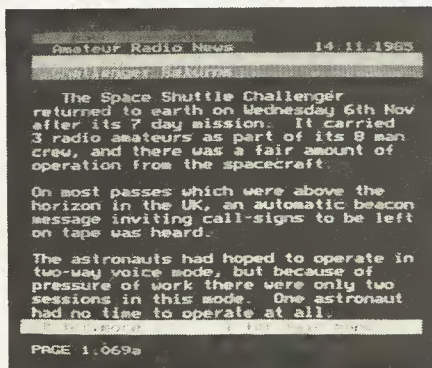

The 'RTTY News Broadcast' schedule.

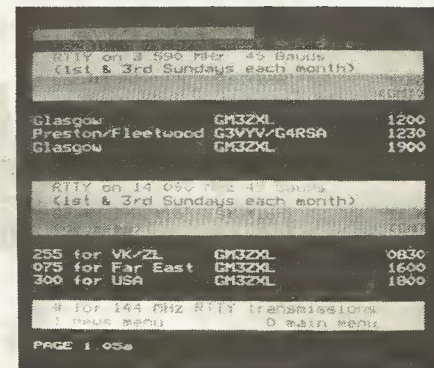



```

RSGB "Databox"      1.03b
GB2RS SUNDAY local news broadcasts
Reception Main Mode QRG Time
area reader Beam Mix Local
Aberdeen GM42JK SSB N 144.250 1030
Aberdeen GM4HNG FM N 145.525 1130
Aberystwyth GW4JXJ FM 145.525 1030
Anglesea GW6DOK FM 145.525 1000
Aylesbury G3MCH FM 145.525 1200
Birmingham G3BA SSB SW 144.250 0930
Birmingham G3BA FM 145.525 1000
Brighton G3ZVE FM 145.525 1100
Bristol G4KQJ FM 145.525 1030
Bristol G3ZNY SSB W 144.250 1100
Caithness GM6LXN FM 145.525 0930
Cambridge GR8VV FM 145.525 1030
Cambridge GR8VV SSB NE 144.250 1100
Carlisle G41AA SSB N 144.250 0930
Carlisle G41AA SSB W 144.250 1030
Cleveland G4KUX SSB NNN 144.250 1000
Clwyd GW4TEQ FM 145.525 1100
Clwyd GW4TEQ FM 145.525 1930
E more schedule 0 main menu

```

Printout of the Data-box GB2RS news schedule.

As with BT's Prestel, the Data-box is essentially based upon a tree structure, that is to say that you enter the system at the top of the tree with a title page and select your area of interest by using the main menu (see photo nearby). You then follow a route (excuse the pun!) out along the appropriate branch until you come to a further sub-menu which offers more specific options and once one of these is chosen the journey continues until the required pages are reached. Data-box employs a very simple structure and so (unlike BT's database with 750,000+ pages) it is quite difficult to get lost — although I suppose anything is possible if you really try! Fig. 1 gives an idea of the overall structure of the service and the screen photos of the Amateur Radio News page and the BARTG RTTY schedule shows the end product.

The remaining illustrations are printouts which were taken directly from the computer. This was done mainly because the screen colours are difficult to reproduce in black and white and also to show how some of the data can be made use of immediately. I should perhaps just mention that where 'E' signs appear they were in fact '#' signs on the original screen version and are due to a certain amount of stupidity on the part of my terminal software.

Without doubt the most useful part of the RSGB system is the facility to access data concerning schedules, general news and repeater information, which is either unobtainable or requires you to crawl out of bed in a semi-comatose state at some unearthly hour on a Sunday morning. Most modern terminal software offers direct printing facilities to get data onto paper, but I do have one big gripe: information pages should *always* have some sort of indication of exactly when they were last updated. As you can see from the GB2RS schedule and the 2m repeater list this has not yet been done on the Data-box so there is room for improvement there.

The other omission which I found to be rather strange was that the only

```

RSGB "Databox"      885a
In-tray - please read instructions

```

This 'In-tray' is not quite like the Prestel Mailbox you are used to. When you press 1 to continue you will be asked for a page name and a frame ID. We suggest you use your 'c/s' or 'RS number' as the page name. Use the letter 'a' as your first frame ID and 'b' for subsequent frames etc.

When you have finished your message press E. You will then be asked to 0=redit, 1=send or 2=cancel.

If you send your message you will be asked if you wish to type another, just press E to return to the database. Happy with instructions? - key 0  
Return to main menu - 1

Printout of the 'In-tray' facility page.

satellite data which was available when I was on the system related to the NOAA series of spacecraft. There was nothing on the RS series or any of the OSCAR vehicles, I can only assume that this is not the normal state of affairs.

### Why Don't You Log Off?

Before doing that, I also took a quick look at the Telesoftware on offer through Data-box. Sadly there was but one elementary program written in Basic which calculated Maidenhead Locators from longitude and latitude so there wasn't anything very exciting there.

Other information is available such as that concerning reciprocal licences but this particular part had clearly not yet been implemented as there was only a page telling users to write to the RSGB. It would be very useful to have that info on the database and it would certainly cut down on the RSGB's own paperwork quite considerably too — maybe in the final version of Data-box? Just as with 'real' Prestel it is possible to communicate with the system operators via the 'In Tray' facility where a letter can be typed in, edited if necessary and then 'sent' when you are happy with the final version — although it is not possible to send letters to other users.

By way of summary it must be said that the RSGB's Data-box *is* said to be experimental and to be frank — it looks it. Quite a bit of information which people would want from a radio orientated database is absent and the information which is offered gives no indication of its age and thus reliability. Obviously, the final version of both the 'Data-box' facility and the RSGB pages on BT's Prestel system will be improved and Micro' Net hopes to come back and take a second look at the RSGB services in a few months time.

### More On Prestel

In addition to the usual contact ad-

```

RSGB "Databox"      3.001a
Special message for Prestel users

```

11.10.85  
=====

Clubspot 810 hope to provide the Society with training very soon so that we can begin to utilise the Prestel pages that have been allocated to us. Check this page for the latest information.

In the meantime our header page is up and running on Prestel on page 810625.

key 9 for Prestel front page or  
1 for main menu

Printout of the Data-box Prestel User Message.

addresses which will be found ITB (In The Box!), readers who wish to contact me will soon be able to do so via the BT Prestel system by 'writing' to my Prestel Mailbox number. Although it has not yet been allocated, hopefully we should have been notified of the number by the time this issue goes to press and you will find it, naturally, ITB.

### Address Box

PEYSOFT  
1 Retreat Cottages,  
Church Lane,  
Broadbridge Heath,  
HORSHAM,  
West Sussex.  
RH1 3ND

Tel: (0403) 69835

Prices (inc. VAT and p&p)	
BBC cassette	£6.75
BBC 40 track disc	£7.95
Spectrum cassette	£6.75
Spectrum microdrive	£7.95

RSGB Data-box Service  
Potters Bar (0707) 52242

Pages start on page no. 810625

To write to Micro' Net either:  
Micro' Net  
Ham Radio Today,  
1 Golden Square,  
London  
W1R 3AB

or:

Micro' Net,  
PO Box 49,  
Colchester,  
Essex  
CO3 3SF

Prestel Mailbox No 01 9999045



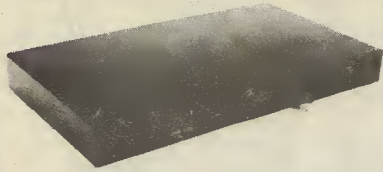

TVHF 230c  
**£334.90** + £5 p&tp  
inc. 15% VAT

## All 9 hf Bands from a 2m multimode!

Transverters once had a reputation for being a second best approach to getting on to any band. With careful system design this need not be so. People have favourably compared the receive performance of the TVHF 230c when coupled to a modern vhf transceiver to that of prestige hf transceivers costing well into four figures! Even with a budget 2m rig, the performance will be better in most respects than the sort of hf transceiver available second-hand at the same price! On transmit, the signal generated is very clean, and the 10W pep output is enough to work the world with a decent antenna. Of course, if you want to be a really big signal, then this power is just right for driving a variety of power amplifiers! (If you have a valve vhf amplifier, then an hf linear becomes a very simple thing to build — a pair of 4CX350's will burn as big a hole in 20m as 144MHz!!)

Chris Bartram G4DGU



**muTek limited** — the rf technology company



Dept. H.R.T., Bradworthy, Holsworthy, Devon EX22 7TU (0409 24) 543

# STOP PRESS

## RSGB Wins Morse Test Contract

There were just four items on the agenda for the 59th annual meeting of the RSGB held at the Institute of Electrical Engineers on 7th December. This did not prevent a flurry of sometimes heated exchanges across the floor amid some startling announcements from the retiring President including a statement relating to the administration of the morse tests by the RSGB.

In her address in the open meeting, Joan Heathershaw touched on the developments of the Society during the past year. The major achievement, 50MHz, being overshadowed by the announcement (despite a claimed embargo) that the RSGB has been given the contract to run the morse tests for radio amateurs. Both British Telecom International and the City and Guilds Institute were in competition to undertake operation but failed to secure the deal. We await more details as we go to press and the embargo passes as to the exact details; although in the words of Mrs Heathershaw "the Society will need skilled and dedicated volunteers" to operate this extension to the RSGB's services.

The annual meeting signified the announcement of the new Council. The new ordinary members are John Heys, G3BDQ, Angus McKenzie, G3OSS, Norman O' Brien, G3LP, Francis Rose, G2DRT, and Ken Willis, G8VR. In zone C, Mr Greenwell, G3AEZ, was elected with just 14 more votes than George Benbow and zone E saw the appointment of Mr E Case, GW4HWR, unopposed.

The only motion of the day requiring the 267 members present (145 more than last year!) to voice their opinion by a show of hands developed into quite a saga involving a 'poll' vote. Called by Ian Abel, G3ZHI, the full vote - on the re-appointment of the auditors - was wholly supported by the members present on the first vote. However, the poll vote required the proxy votes to be considered and revealed where the majority of these lay: Ian Abel 22, Peter Crosland 43, Joan Heathershaw 762, Willie McClintock 124, Geoff Smith 71, and Bob Barrett 121, plus a number who had a single to a mere handful of proxy votes. The final vote was 1305 votes for and 2 opposed with 106 abstentions. The auditors were re-appointed.

The open meeting that followed included a discussion on a number of written questions submitted before the meeting had started by those present. The meeting ended at 6.45pm.



# The Marconi Story - the Early Years

Guglielmo Marconi was born on 25 April 1874 in Bologna, Italy. He was the second son of Giuseppe Marconi, a wealthy landowner, and Annie Jameson, a daughter of the famous Jameson family of Irish whiskey fame.

metres range had already been demonstrated under laboratory conditions in 1888 by the German scientist Heinrich Hertz and, about the same time, by Professor Popoff in Russia.

These scientists had based their

discovery of the principle of Electromagnetic Induction, based upon previous work done by Ampere and Oersted. This discovery led to the large scale generation of alternating and direct current electricity but at that time the nature of the force which Faraday had discovered was not understood. It was not until 1855 that the mathematician James Clerk Maxwell, in his paper "Faraday's Lines of Force", succeeded in explaining Faraday's findings mathematically.

Maxwell built a model to illustrate Faraday's Law of Electromagnetic Induction, which stated that changes in a magnetic field produced an electric force. He suggested that the process was reversible and that changes in the electric

*The beginnings of radio were an exciting time especially when a young Italian, Guglielmo Marconi, became involved as Louis Varney, G5RV relates...*

When he was five years old, he was taken to a private school in Bedford, England, where he received primary education for two years. He then returned to Italy and went to school in Florence. His formal education was completed at Livorno where he studied physics under Professor Rose.

From an early age he showed that he had an original and inventive mind and, as a teenager, he came under the influence of the renowned Professor Righi, whose scientific papers on electromagnetic radiation he studied diligently. As a result he chose, from the various branches of physics, to specialise on the subject of Hertzian waves.

## The Inventors of Wireless

The vast majority of people think of Marconi as the "inventor of wireless", however, this is not strictly true. The production of electromagnetic waves in space and their detection at a distance of a few

experimental work on the theories and practical experiments of, such great physicists as Michael Faraday who, in 1831, announced his

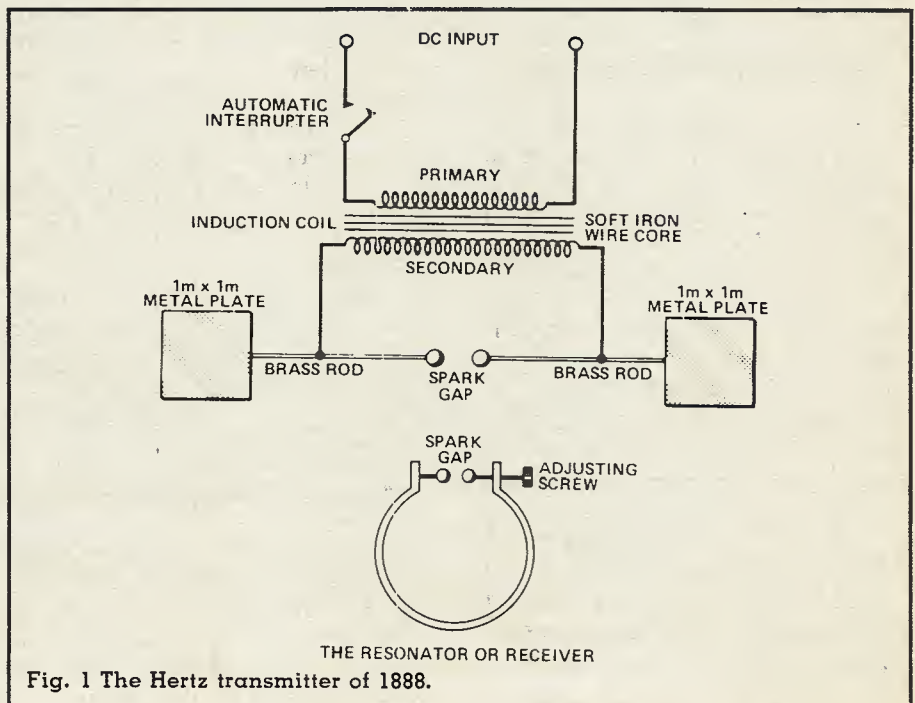

Fig. 1 The Hertz transmitter of 1888.



force would produce a magnetic field. This concept of interchangeability led to the thought that all changes in electric and magnetic fields cause electromagnetic waves in space. He used this model to illustrate his 1862 paper "Physical Lines of Force" in which the basic Maxwell equations were given. He fully developed these in the classic treatise of 1865, "A Dynamical Theory of the Electromagnetic Field" where he expounded the electromagnetic wave theory.

Maxwell conducted experiments to establish the rate of propagation of these waves which, he found, tallied closely with that of light waves whose velocity in space had been determined by Fizeau. This led him to state; "We have strong reason to believe that light itself — including radiant heat and other radiations, if any, is an electromagnetic disturbance in the form of waves propagated through their electromagnetic field according to electromagnetic laws".

In a short article such as this it is impossible to do justice to the work done by scientists before Marconi, which made it possible for him to adapt and improve upon the crude experimental equipment used by them to demonstrate the radiation and detection of "wireless waves". The breakthrough came in 1888 when Heinrich Hertz announced that he had succeeded in producing what he described as "an outspreading of electric force".

### The Hertz Transmitter

Hertz's apparatus was very simple. The transmitter consisted of an induction coil, producing an alternating voltage of some thousands of volts from a low voltage interrupted DC source. The secondary winding was connected across a spark gap, each ball of which was in turn connected by a short metal rod to a metal plate measuring about 1m x 1m, suspended about 1½m above the floor of the laboratory. The

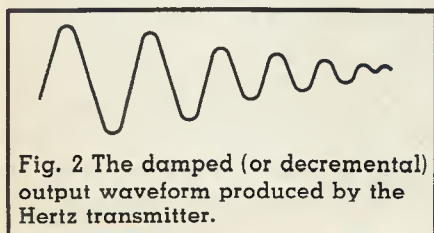

Fig. 2 The damped (or decremental) output waveform produced by the Hertz transmitter.

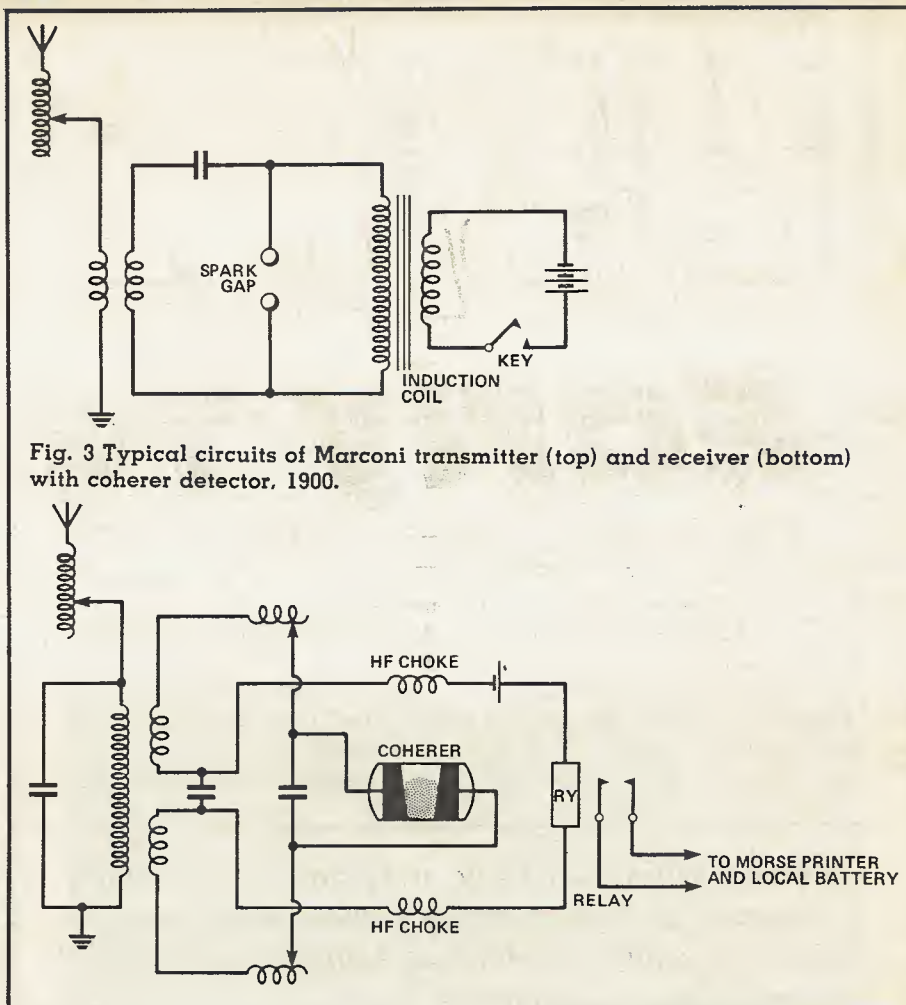

Fig. 3 Typical circuits of Marconi transmitter (top) and receiver (bottom) with coherer detector, 1900.

receiver, or resonator, consisted simply of a metal loop cut at one point, the two ends being fitted with small brass balls just out of contact with one another. The radiation was detected visually by the presence of tiny sparks which jumped the gap when the "receiver" was brought within a few metres distance to the transmitter.

The circuits of both transmitter and receiver are shown in Fig. 1. This simple system produced a "damped-wave" of the form shown in Fig. 2, which, as the system was completely untuned, spread over a vast range of radio frequencies. Such a system was quite unsuitable for the practical transmission and reception of signals conveying intelligence, even if such an idea had occurred to Hertz.

### Marconi's Improvements

Marconi, in his experimental work, had always in mind the transmission and reception of telegraphic signals, using morse code which was devised for use on telegraph lines in the 1830's. He

considerably improved on the rudimentary types of transmitters and "receivers" used by Hertz and other scientists and used the coherer detector invented by the French scientist Edouard Branly in 1890. He also developed the crude, but vitally important, "syntony" experiment demonstrated by Sir Oliver Lodge in 1889. He was the first to use tuned circuits in both transmitter and receiver and to include HF choke coils to isolate the relay, which operated the morse printer, from the HF circuits of the receiver.

He became the first to conceive and to use the idea of an elevated aerial (held aloft at first by a kite and later supported by masts) and an earth connection to transmit and receive wireless signals. This was an enormous step forward and resulted in increasing the range of a transmitter from a matter of metres to miles and later to span the Atlantic in his famous Poldhu, Cornwall, to Glace Bay, Newfoundland, tests of 1901. The circuits of his transmitter and receiver of 1900 are shown in Fig. 3. Such circuits enabled the



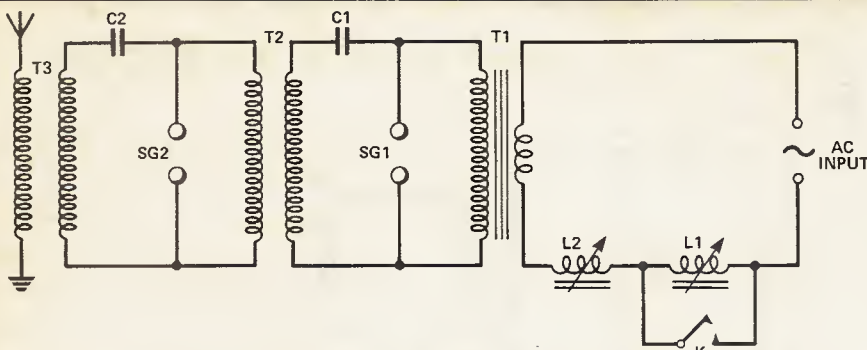

Fig. 4 The circuit of the Poldhu transmitter. The AC input supplied by a 25kW Mather and Platt alternator delivering 2000V at 50Hz was stepped up to 20000V by the transformer, T1, and fed to the primary of the oscillation transformer, T2, via C1 which then discharged across the spark gap, SG1. The secondary of T2 in turn charged C2 via the primary winding of T3. C2 then discharged across the second gap, SG2, exciting the serial and earth system via the secondary winding of T3. Keying was effected by short circuiting one (or both) of the variable choke coils L1, L2. The wavelength of the transmitter was calculated to be about 366m.

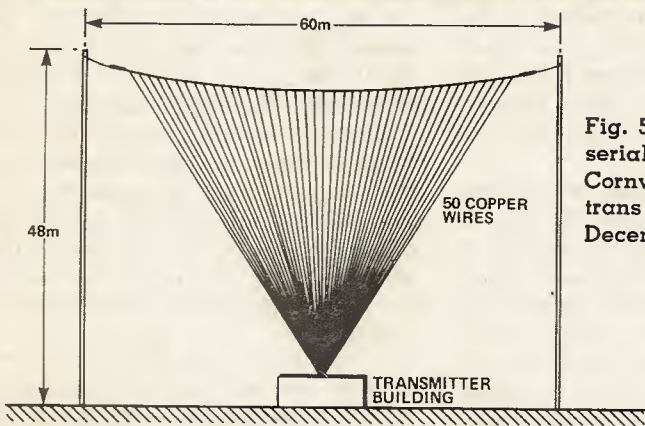
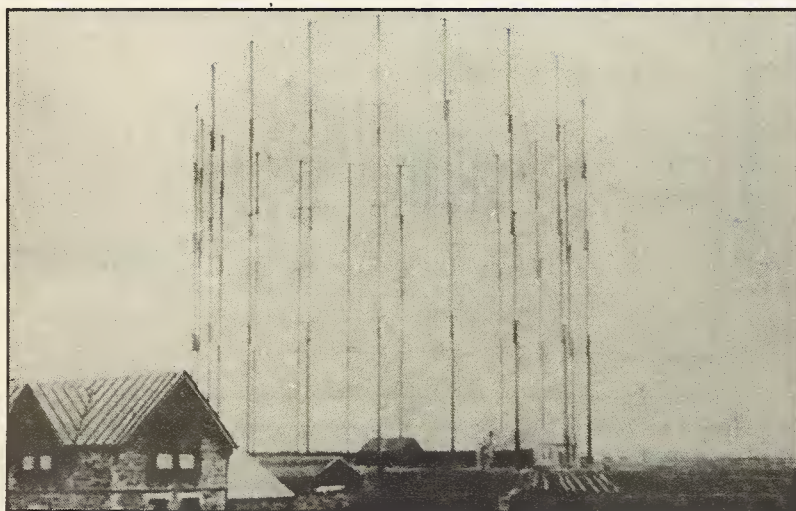

Fig. 5 The transmitter serial used at Poldhu, Cornwall, for Marconi's trans Atlantic tests in December, 1901.

transmitter to radiate a broadly tuned signal and the receiver to be tuned to a particular transmitting station. Previously, it was impossible to use an untuned receiver which was located within the range of two or more untuned transmitters operating simultaneously. The circuit of his Poldhu transmitter is shown in Fig. 4, and its aerial in Fig. 5.

It is well known, of course, that Marconi first approached the Italian government with the idea of the commercial exploitation of his wireless system in the late 1890's. He was bitterly disappointed when his offer was rejected and, when he could not even obtain private financial backing in his own country.

In 1896 he came to England to take out the world's first patent for

wireless telegraphy and to seek the financial backing he needed to form a commercial wireless company. This he was able to do through the help of A A Campbell Swinton, an eminent electrical engineer, who provided him with a letter of introduction to William H Preece, at that time Chief Engineer of the British Post Office, Preece helped him to arrange demonstrations of his wireless system to the Post Office, the War Office and the Admiralty. On July 20th, 1897, Marconi's Wireless Manufacturing Company, the first in the world, was founded.

Marconi had an unerring judgement in selecting competent and enthusiastic electrical engineers to assist him in his continuing experiments after the formation of the Marconi Company, so that research continued apace, as indeed it does to this day.

The invention of the diode valve by Sir Ambrose Fleming in 1904, followed by Lee DeForest's (USA) patent for the triode valve in 1906 made positive a vast improvement in receiver sensitivity and transmitter performance, once valve design and construction problems had been overcome.

In these days of the virtual universal use of "black box" equipment by radio amateurs, it is amusing to recall a clever "dodge" practised by Marconi in December 1896. The occasion was a lecture given by William Preece in which he gave an account of Marconi's experiments to the British Association. Marconi assisted the lecturer by giving a practical demonstration of the working of his wireless equipment to the audience. He had enclosed both the transmitter, which Preece operated from the rostrum, and the receiver which he carried amongst the audience, in black boxes to add to the mystery. Whenever Preece depressed the transmitter key, a bell rang in the box in Marconi's hands!

Readers who would like to read the full story of Marconi and the Marconi Company are referred to W J Baker's excellent book "A History of the Marconi Company", published by Methuen & Co Ltd, London 1970, to which reference had been made when writing the present article.



# RISE TO A NEW LEVEL OF VHF AND UHF OPERATION WITH THE YAESU FT-726R

## FEATURES

### THREE BANDS... PLUS

You choose the plug-in RF Modules for the bands you want to use.

### THREE MODES... PLUS

Sideband selectable SSB, FM and CW are all included, with dual synthesized VFOs.

### ELEVEN STANDARD MEMORIES... PLUS

All memories store mode (as well as band, of course).

**SATELLITE OPTION... PLUS**  
With the optional plug-in satellite IF unit installed, full duplex cross-band capability is provided.

**NOW! ADD THREE HF BANDS!**  
An HF module for the 21, 24.5 and 28 MHz bands.

### DUAL METERS... PLUS

Another first for V/UHF operation.

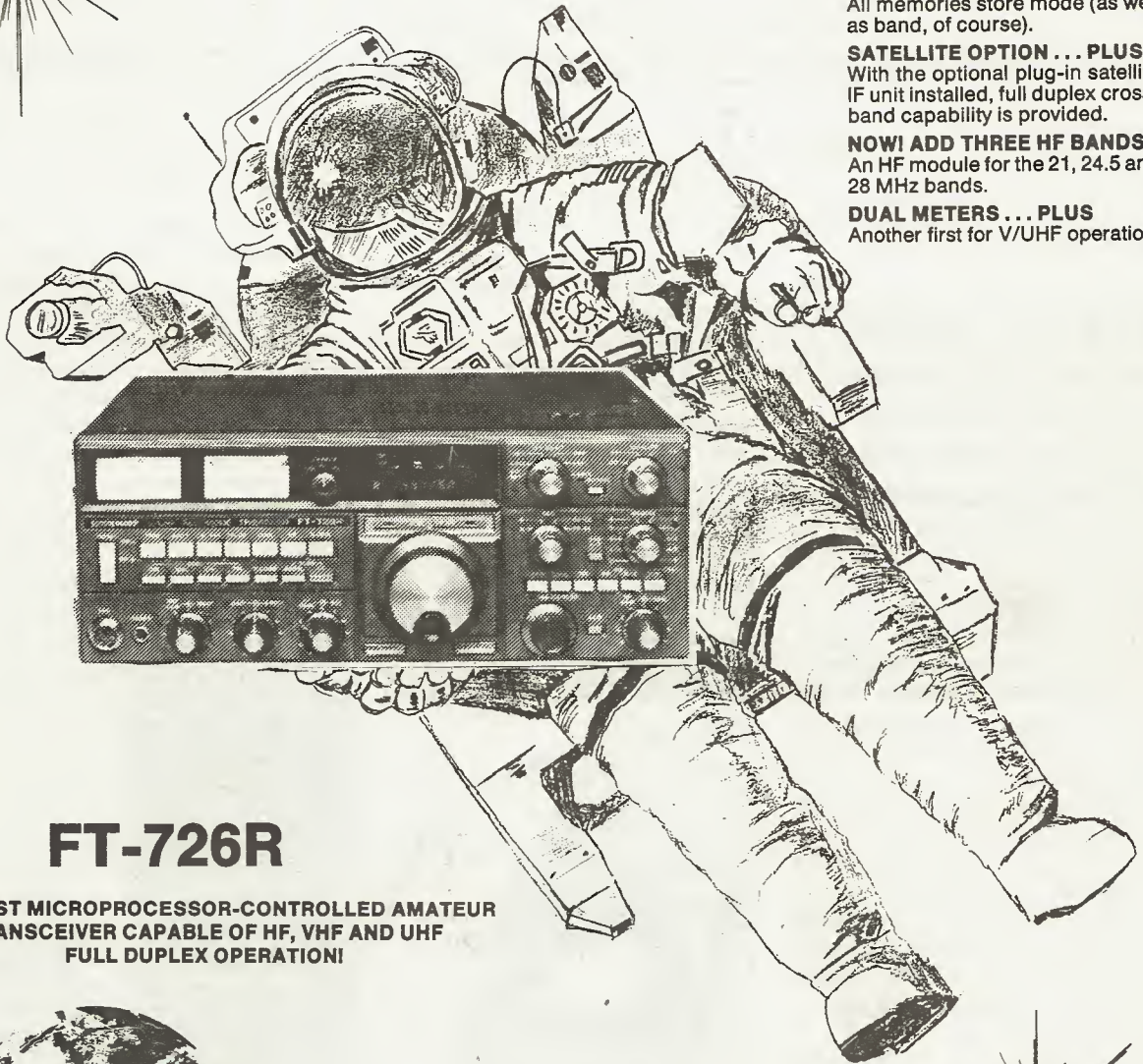
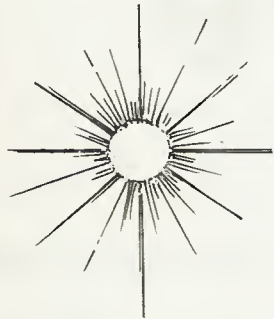

## FT-726R

THE FIRST MICROPROCESSOR-CONTROLLED AMATEUR  
TRANSCIVER CAPABLE OF HF, VHF AND UHF  
FULL DUPLEX OPERATION!



AMATEUR  
ELECTRONICS **AE** LIMITED

510/512 Alum Rock Road Alum Rock Birmingham B8 3HX Telephone 021-327 1497/6313

Amateur Electronics Ltd.  
FREEPOST  
Birmingham B8 1BR



FREEPOST -  
MAIL ORDER  
ENQUIRIES



Amateur Radio Exchange  
FREEPOST  
London W3 9BR



# Get On To 70cm With A Pye Pocketphone

One often hears Pye 'Pocket-phones' on the air, as well as being visible at rallies and junk sales, sometimes at startlingly low prices. Many amateurs shy away from these because of one reason — they are reluctant to delve inside

*Chris Lorek, G4HCL, introduces the phoenix of the junk heap and brings you 70cm with a modified Pocketphone.*

them and get them going on frequencies of interest. The vast majority of buyers only purchase them if they know someone 'in the trade' who has the necessary equipment and knowledge to get them going. It's rather a pity, as especially on 70cm you only need one or two channels for local natter user. Ask any amateur on 70cm who has spent a fortune on an FM black box, how often does his rig get shifted off the local repeater? There are of course the countryside travellers who need a synthesized scanning box of tricks, but for 5% of the price you can indulge in 95% of your local activity!

These sets can be very useful indeed for applications such as RAYNET, where one needs a set which can stand up to being soaked in the rain and mud, be run over by cars (and ambulances!) and still carry on working. Mine did after being dropped onto a concrete road and promptly run over by a vehicle!

Some amateurs think you need stacks of test gear to align one of these sets onto the band. When I first purchased a second hand PF5UH in Devon ten years ago, I got it operational using only a 2m

rig — 70cm rig would have been better — a cheap power meter and a matchstick, in a basement flat shared with three other loony students. No expert knowledge, no circuit diagrams or manuals, but many mistakes! But then the saying "you learn by your mistakes" and this article will, I hope, be of some use in saving you time, trouble, and my first mistakes! Next time you see an ex-professional rig going at a low price don't shy away, you'll end up with a bargain rather than a useless piece of junk.

## First — Find Your Animal

The Pye Pocketfone 70 range of equipment is just what it says, a *range*. There is absolutely *no* outside difference, besides the real label, between a 78MHz AM rig and a 432MHz FM rig in the range. Your friend may think he recognises one by sight at a rally, and may unwittingly recommend one to you for purchase because it 'looks like' the one he's got. Also beware of the advert or description of a rig as a 'PF70'. *There is no*





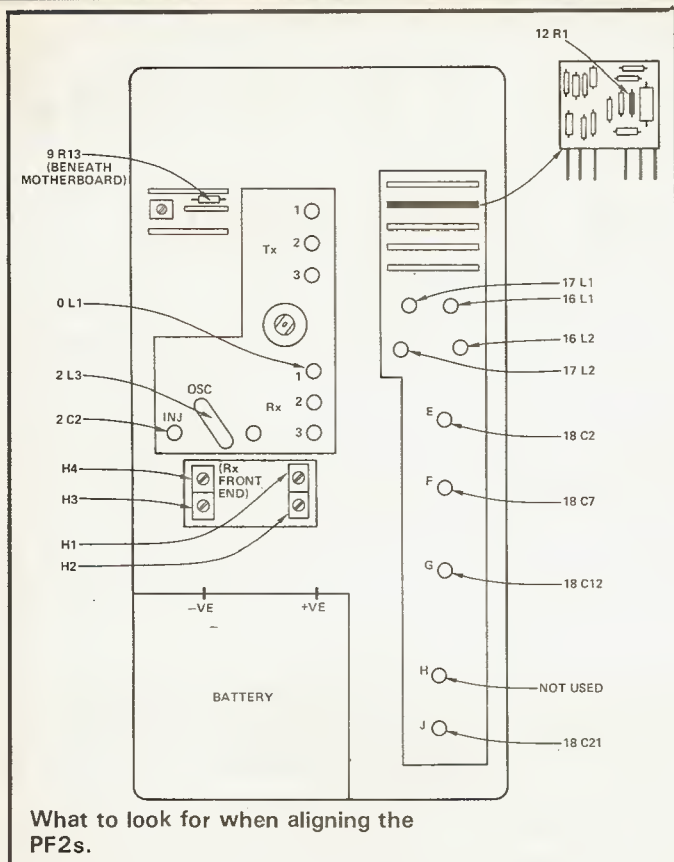

What to look for when aligning the PF2s.

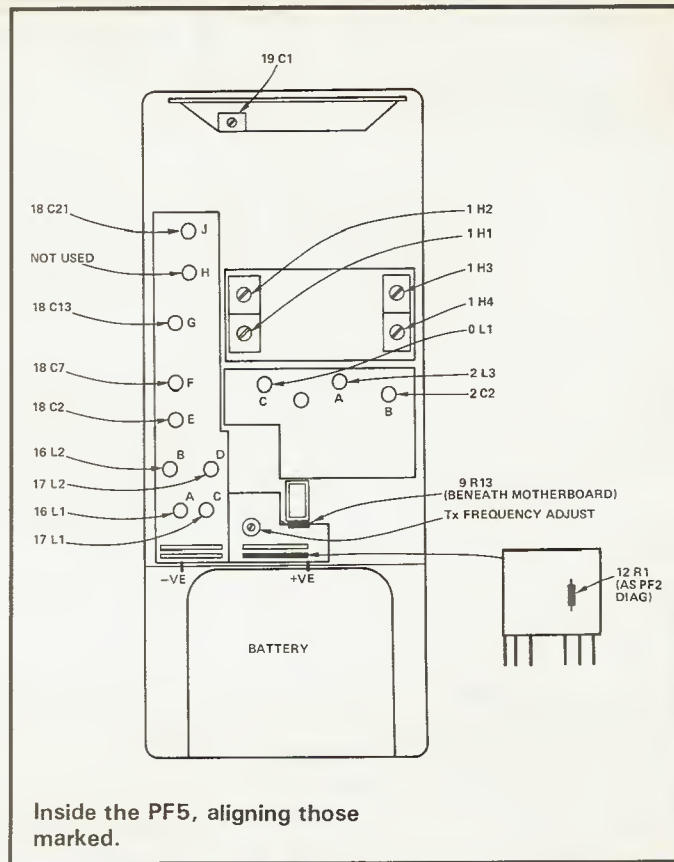

Inside the PF5, aligning those marked.

such rig as a 'PF70'.

If someone describes a rig he's selling as a PF70 then beware — *he doesn't have a clue what he's talking about*. So many people have been conned in the past, often due to ignorance on both sides. If you are looking for a rig suitable for 70cm, then examination of the rear label will reveal an equipment type number. If it is one of those below, then it is a bargain.

**PF2UB** — three channel UHF FM bodyworn rig, with external speaker/microphone.

**PF2UH** — three channel UHF FM handheld rig, with internal speaker/microphone.

**PF5UH** — single channel UHF FM handheld rig, with internal speaker/microphone and internal aerial.

Sometimes the equipment type number will be followed by '2e', for example 'PF5UH2e'. Unless you're desperate for one, or it is very cheap, I would recommend you leave it alone. This is special, intrinsically safe equipment designed for use in hazardous areas such as oil rigs, where sparks or whatever could be very unwelcome! Of course, if you work in a petrol station... The insides of these are

coated with a rubbery 'gunge' which is extremely difficult to remove when fault finding, they give lower Tx output power, and — theoretically — need special tools to remove batteries and so on.

If you see a low audio frequency marked on the 'code' section of the label, ie code 94.81Hz, then I would also recommend you choose another, this shows that the set is fitted with a sub-audible tone lock circuit. It is possible to remove this and fit required links to enable normal operation. This requires removal of the main board from the case, but it is much easier to choose a different one from the inevitable pile on the rally stand. These tone lock sets are fairly rare though and only exist on the PF2UH and PF2UB.

The PF2UB can be stuck in your pocket or fixed onto your belt and clip the speaker/mike to your lapel — saving your top pocket from being weighed down but still enabling you to hear a call without deafening everyone around you. The aerial socket is a miniature TNS which is sometimes difficult and expensive to get plugs for. Make sure you get a matching aerial or change the socket for a BNC or similar, although this will involve a bit of filing. The transmit audio has

a characteristic 'tight trousers' effect from the external mike, due to its small enclosure.

The PF2UH is basically a PF2UB inside, but with a mechanical switch Tx/Rx changeover rather than a miniature relay. The speaker/mike is internal to the set making the case size slightly longer. The transmit audio is improved over the PF2UB and the set gives better range because you have to hold the rig to your face to talk, ie away from your body. This may, of course, be done with the PF2UB but requires two-handed operation as a result. The aerial socket is a standard size TNC, which is again difficult to get hold of, but replacement with a BNC is mechanically easier due to their similarity in size.

The PF5UH is a small handy size which means there is not much room inside for a toneburst unless you are good at miniature construction. The aerial is internal to the set, thereby giving slightly worse performance than an external aerial. This may be removed and a BNC can easily be fitted to the set top, possibly offering worthwhile improvement. The circuitry is similar to the PF2UH but with the absence of three channel capability.

All three sets use a similar 15V



NiCad battery. It is important to ensure you get one of these included in your purchase as spare batteries are more rare than the sets themselves. Internally, they are made up of several series-connected cells. If your battery is not charging or is only developing a low voltage, it may be prised open with care and the faulty cell(s) identified and replaced. Spare cells are available from Radiospares. Note that for home use, a stabilised 13.8V power supply is ideal for powering the set — a PF2UB makes a useful three channel base rig.

The circuitry comprises several 'daughter' boards on a larger 'mother' board. This makes fault finding and component replacement fairly easy, as the boards can easily be desoldered if required. There are two different types of receiver front end, — passive and active. The passive front end is fitted to earlier sets and is identified by a rectangular metalblock with two large tuning screws on top, which form miniature tunable cavities. The active front end is identified simply by the absence of the metal block, which is replaced by a board with four small coil cans, one at each corner, with PTFE type tuning slug adjusters. The passive front end is good at getting rid of unwanted signals and would, therefore, make a good 'listen through' receiver, although it is slightly less sensitive than the active front end model. This may be worthwhile checking before purchase.

## Getting It Tuned Up

No, they don't need 'converting' to 70cm! The sets are made in two frequency ranges: 405-440MHz and 440MHz-470MHz. Most of those available on the secondhand market in this country will be the latter of the two. However, there is very little difference in circuit values between them and, unless you wish to use the set below 432MHz, you would be very unlucky indeed if your set didn't tune down easily. I have never had any problems and have adjusted over 50 sets, because of a built-in 'overlap' provided by the manufacturers. Sometimes, the active front end tuning adjusters are right at the bottom, because the coils are different between the

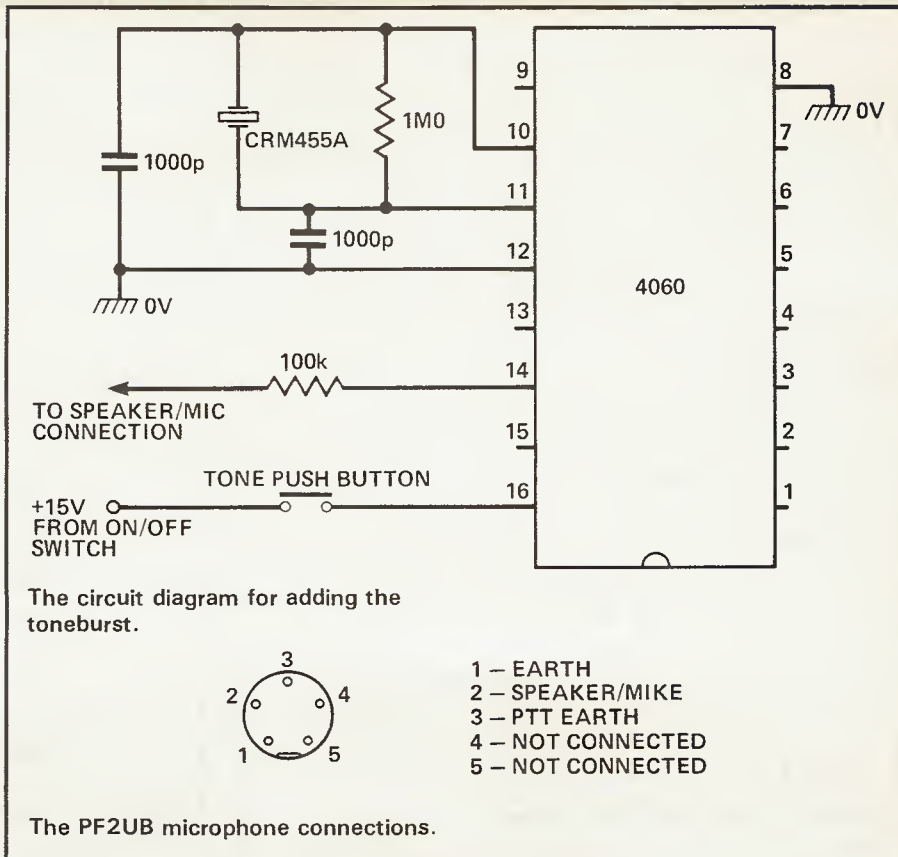

bands. But reasonable sensitivity is still achieved and it is just not worth the hassle in trying to change them for one extra dB or so in receive performance. The passive front end has no problem in covering right down beyond 430MHz.

The ideal equipment for alignment is, of course, professional gear such as a signal generator and the like. Owners of this type of equipment will not need me to tell them how to use it. If you have these then by all means ignore my suggested methods and do it the proper way following the basic procedure. To others, a tunable 70cm or 2m rig with 'S' meter is useful, and some form of 70cm power indication, a field strength meter, absorption wavemeter, or in-line power meter and aerial/load.

## Crystals

First of all, the rig has to be crystallised on the required channel. The formulae are:  
receiver,  $\text{xtal freq} = (\text{carrier freq} - 23.455 \text{ MHz})/5$ ; transmitter,  $\text{xtal freq} = (\text{carrier freq})/27$ .

Both crystals are wire-ended HC18/u size, and may be obtained for about £5.50 a pair (check first) ex-stock on popular amateur fre-

quencies from:

PM Electronic Services, 2 Alexander Drive, Heswall, Wirral, Merseyside L61 6XT. Tel. 051 342 4443;

Quartzlab Marketing Ltd, PO Box 19, Erith, Kent. DA8 1LH. Tel. 01-318 4419.

There will be a 23.000MHz crystal in each set, which should be left alone as it is the receiver conversion crystal. In the PF2UB and UH the crystals are located beneath the channel switch/Rx, IF screen. To remove this, first undo the channel switch nut carefully, then using a pair of long-nose pliers remove the larger notched round nut securing the screen. Remove the screen, and fit the required crystals in the marked positions, replacing the screen after of course. There will be a piece of insulated wire sticking out of a hole in the screen, remember to re-thread this through the hole as it can be used later. On the PF5UH the transmit crystal is plugged into the lower part of the set and is often visible, although sometimes it has a piece of sponge above it to hold it in place. The receive crystal is beneath the Rx IF screen, which may be removed by undoing two or three screws and lifting off. Remember to re-thread the insulated wire through the hole.



## Tx Alignment

Initially supply the set with 10V only, if you only have 13.8V or 15V from the battery then place a few diodes such as 1N4001's in series with the power leads to drop 0.6V for each diode. Monitor the current taken with a multimeter, set at around the 100mA range. Key the transmitter and tune 16L1, 16L2, 17L1 and 17L2 in that order for maximum current drawn. If you don't have a multimeter, then monitor the transmitter frequency on an adjacent 70cm receiver — or even one-third of the frequency on a 2m receiver — and tune for maximum signal. You may like to do this even if you have a multimeter, to help you. Don't use a metallic object such as a jeweller's screwdriver, as this will alter the correct tuning points. Use a plastic tool or a filed down matchstick or cocktail stick. When you have got an absolute maximum by tuning and re-tuning until you can't get any more, increase the supply voltage to 13.8V, or 15V if you've only got the battery as a voltage source.

Place a power meter in the aerial line, or look at the deflection on a field strength meter or similar. Using a larger non-metallic tool shaped as a flat-bladed screwdriver, tune 18C2, 18C7, 18C13 and 18C21 for maximum output, re-tuning as required for absolute maximum. These will each need about three or four turns clockwise to get onto 70cm. On the PF5UH tune 19C1 for maximum radiation when using the internal aerial.

The transmitter deviation will already be set to near the required amount and I suggest that you leave well alone. However, for those with access to a suitable deviation meter who wish to set their deviation to within that last half a kilohertz, a select-on-test resistor, 12R1, may be altered in value for the required level. Note that the microphone gain is designed as a fixed level and may not be adjusted, this is a peak deviation adjustment only.

This concludes the Tx power alignment, and you may now net the frequency by the trimmer next to the Tx crystal. This may be done by looking at the centre-zero meter, or by tuning to zero beat on SSB,

on an adjacent receiver either on 2m or 70cm, or at a pinch for the best readability (least distortion) with another amateur. Those with a digital frequency meter will no doubt know how to use it of course!

## Receiver Alignment

This is where we need that bit of insulated wire poking out of the receiver. Connect a multimeter, set to the 10V range, positive to the wire and negative to any screen. Using your filed down matchstick again, tune 2L3 for a dip in the meter reading. This will be at about three turns of the core into the former from being flush with the top.

Now we must find a 70cm signal, preferably variable in level. This can be either a local station with changeable aerial arrangements like a rotatable beam or variable power, or a local repeater that a friend can bring up for you. A very useful means of tuning is a 2m transmitter at a third of your receive frequency — monitor the weaker third harmonic radiated. Variation in level can be achieved by switching in different aerials at the transmitter and/or receiver and using the portable's aerial and varying its position for weak signals, tuning as necessary. In the past, I have used the third harmonic of a 2m rig, wandering down the road, rig and adjuster in hand, tuning as I went. The neighbours odd looks were casually ignored!

First of all, try to get the receiver roughly on frequency by tuning the receive crystal trimmer, OL1, for best reception (least distortion) on a strongish signal. This will ensure that you will at least hear something when tuning the rest of the receiver! In the active front end, use the non-metallic screwdriver-shaped adjuster previously employed on the transmitter PA and tune the four slugs, H1,2,3 and 4 for the best quieting signal. In the passive front end with the metal block, first loosen slightly the small locking screws in each of the adjusters, just enough to allow rotation of the two large adjusters. Tune the two adjusters, not necessarily with a non-metallic tool, for the best quieting signal. Note the tuning will be fairly sharp. Then tighten the two locking screws, checking that

this doesn't alter the tuning position.

Repeat the tuning of 2L3 for best dip and the front end alignment above as necessary to give absolute best in quieting signal. Carefully adjust 2C2 for the best quieting with the screwdriver-shaped tool. This tuning is sharp and there will be two tuning points — choose the one which gives the best quieting. Now, using an accurate frequency source such as a repeater, tune the receiver finally onto frequency with OL1 for least distortion on a modulated signal.

The squelch is pre-set with a select-on-test resistor and normally should not require modification. However, you may vary the squelch threshold by changing the value of 9R13, or in fact even fitting a small potentiometer in its place.

## Fitting A Toneburst

There are many toneburst circuits around that are suitable for fitting into these rigs. About five years ago, I knocked up a simple circuit that has proved popular with many local amateurs, no doubt someone else has a similar circuit. It is about the only circuit I have found that will perform well in a PF5UH without suffering from RF instability, due to the proximity of the transmitting aerial plate. With care in construction, by soldering components directly to the legs of the IC, it may be fitted on top of the Tx/Rx switch. In the PF2 there is ample room of course.

The ceramic resonator deliberately oscillates at slightly lower than 455kHz due to the two 1000pF capacitors to ground and is divided to 1750Hz in the 4060 IC, appearing as a square wave at pin 14. This waveform has only components at odd harmonics, which means it is nicely converted to a sine wave by the transmit audio filtering circuits in the pocketphone! The CRM455A type resonator is available from Circuit and Tandy, the remainder of the components from any good electronics retailer.

Take power via a 'tone' push button from the on/off switch on the volume control. Any of the screens in the set may be used as a negative supply. Feed the toneburst audio output to the



speaker/microphone directly (make sure you choose the unearthened side!) in the PF2UH, or PF5UH — this is the yellow wire on the small plug/socket connection on the PF5UH — or to the speaker/microphone connection shown below in the case of the PF2UB. In this case, the 'Tx' push button on the PF2UB case, which is wired in parallel to the PTT on the mic, makes an excellent tone button (remember to disconnect the original wires first).

### Replacement Aerial

Sometimes you may find it difficult to obtain a rig with an aerial, they always have a habit of getting lost before appearing for sale, or you may wish to fit a BNC to couple an external aerial for home use. Rather than purchase an expensive Japanese portable whip or helical with BNC base, I have found my portable helical design shown below to be a reasonable performer. In a test using accurate

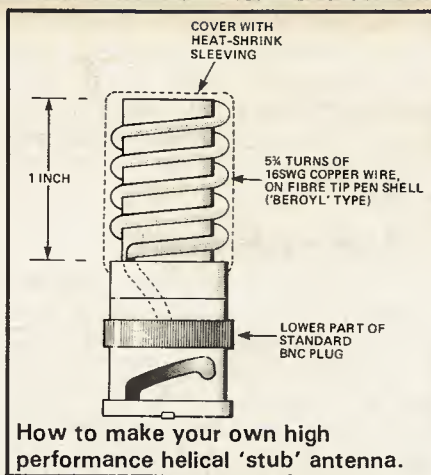

laboratory equipment, when mounted on a Yaesu FT708R, it was found to outperform the supplied 1/4 wave whip by 0.6dB! Excellent results are also given on the PF5UH and PF2UH. A number are in use by several amateurs in my locality.

### Conclusion

I hope this may give some amateurs at least an insight as to

how simple it is to get a cheap, abundant rig, going on the air. It is beyond the scope of this article to give fault-finding information with complete circuit diagrams. However, I have found that the vast majority of faults in the past have been mechanical problems such as broken battery connections, faulty on/off switch, or flattening by bulldozers (often evident, this one!).

Sometimes solder joints between daughter boards and mother board become open circuited from mechanical shock, such as dropping the set, and in this case flexing the board gives intermittent operations. If this happens, carefully remove the main board, in the PF5UH by unscrewing the three retaining screws, in the PF2UB/UH by removing the securing nuts on the controls. Carefully 'hinge' the board out and spend half an hour or so resoldering all the connections, being wary of solder bridges.

Good luck and have fun on 70cm!

# HAM

# RADIO

# NEXT MONTH

# TODAY

### THE TRIO TS940S — THE COMPLETE BASE STATION RIG

This HF transmitter and general coverage receiver has been really put through its paces by Chris Lorek, G4HCL, and he comes up with one or two interesting results!

### AERIAL BENT IN EIRE

A DXpedition to get across the pond on 2m  
Dave Green, G4OTV, relates this rather wet and windy tale.

### PSE, PSE, PSE QSL!

John Heys, G3BDQ, describes what some fanatics will do to receive that elusive QSL card from Outer Mongolia.

### HOW TO CONVERT A PYE WESTMINSTER

Okay so they're a bit big and bulky, but they're one of the cheapest ways of getting onto 70cm.



# Technology Roundup

GaAs technology has been shown to give vast improvements over its rivals and it can be used to great advantage in many areas where previously state-of-the-art silicon technology ruled supreme.

used in field effect transistors which give a great improvement over other state-of-the-art technologies which can be used by radio amateurs. These GaAsFET's are shown to give a much lower

*GaAsFETs have already begun to make quite an impact on receiver front ends but what is this 'magic' substance GaAs? Ian Poole, G3YWX, reveals all.*

Although it has many applications, probably the most publicised use within amateur radio circles is in low noise receiver front ends for VHF and above.

## What is GaAs?

GaAs, or to use its full name, gallium arsenide is a semiconductor material which exhibits the same basic semiconductor properties that are possessed by the more familiar silicon and germanium. However it differs from them in that it is a compound and not an element. Any chemistry scholars will know that both silicon and germanium are group IV elements, whereas gallium arsenide is a compound of a group III and a group V element. This leads to certain properties which make it possible to use it in light emitting diodes amongst other things.

The main advantage of gallium arsenide is its high electron mobility — the ease with which the electrons or holes can move around the material. The actual electron mobility is about seven times that of silicon and about two and a half times that of germanium. This leads to lower transition times and therefore higher attainable frequencies which stretch well into the microwave region — performance unmatched by silicon bipolar technology.

Gallium arsenide is normally

noise figure than silicon devices and this makes them a very attractive proposition for receiver front ends. They are also found to have a higher gain and better cross modulation characteristics than silicon bipolar transistors making them an ideal choice for use within high performance receivers.

Another advantage which has been exploited less so far in the amateur radio field is the high power capability. But as high power GaAsFET's are being used increasingly in commercial fields, it is likely that we will be seeing more of them.

Although all FET's obey the same basic principles of controlling the flow of electrons through a channel by the application of a potential on the gate which sets up a field, there are several ways in which this can be achieved. For silicon there are JFET's, MOSFET's, enhancement mode and depletion mode FET's and accordingly the GaAsFET's are slightly different. Firstly a GaAsFET is a depletion mode device and if no bias is applied a current will flow in the channel, ie it is normally on. Then if a negative bias is applied to the gate the current will progressively fall.

Unlike the family of MOSFET's (still very popular at VHF) where the gate is physically separated from the channel by an oxide layer, the gate on a GaAsFET consists of

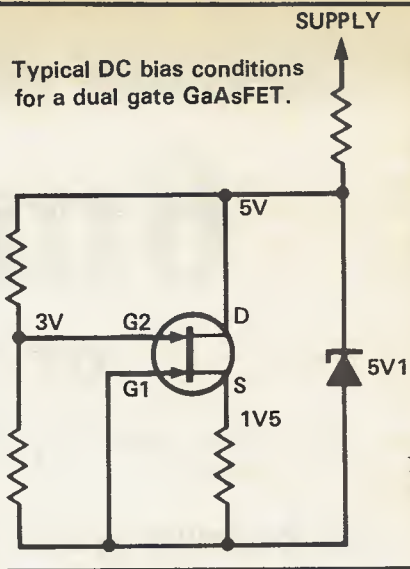

a Schottky barrier diode which makes it similar in many respects to a JFET. However, this diode is exceedingly small — the dimensions being measured in microns. Therefore if a positive voltage is applied to the gate causing any current to flow, the diode will almost certainly fuse and destroy the device. It is imperative that any biasing arrangements prevent this from happening even during turn on. It is also necessary to take precautions to prevent static from destroying the gate, especially when handling or soldering them.

## Other Applications

Apart from using gallium arsenide for low noise and high power microwave applications, its high speed capabilities are being exploited in integrated circuit technology. Recently some very high speed dividers have been introduced, as well as phase comparators with a use up to about 1GHz — much higher than anything else which is available. In addition to this, some random access memories (RAM's) have been fabricated with access times around 4nS for a 16k bit device. However, as GaAs technology is still in its infancy there are very few VLSI devices using gallium arsenide, but with current research into the use of this semi-conductor it may not be too long before super fast processors appear on the scene. In the mean time beware of leaving a receiver with a GaAsFET connected to an aerial during a thunderstorm as it may be damaged — but that really goes for any receiver.



# 6m is Here!

## or will be very soon

Why not explore this new and interesting band with the  
Cirkit 6m Transverter?

As featured in this issue of Ham Radio Today from the well known  
author and designer - Tony Bailey G3WPO

Get on the band quickly with this all mode linear transverter kit from 28MHz to 50MHz which can also be built for the 4 metre (70MHz) band. High performance design suitable for modern transceivers can be driven to 0.5W pep SSB or 1W CW/FM from as little as 1mW drive - on board PIN/resistive attenuator for higher levels up to 1W. RF VOX all-mode switching with adjustable delay for automatic or PTT operation - IMD better than  $-35\text{dB}$  at 0.5W pep. Double section low pass filter on the transmit output reduces harmonics to better than  $-45\text{dB}$ . RF output power (relative) monitoring is also provided on board.

The receive section features  $-129\text{ dBM}$  ( $=0.08\mu\text{V}$ ) sensitivity (SSB bandwidths 10dB S/N + N) for both versions equivalent to a noise floor (MDS) of  $-136\text{dBm}$  and a system noise figure of around 4dB when used with a modern HF transceiver.

Overall gain is  $+14\text{dB}$ . Separate Schottky ring mixers are used on both Rx and Tx sections for best performance with extensive matching and high level stable LO generation.

The transverter runs from  $+12$  to  $13.8\text{V}$  power supplies and can thus be used as a base station or for portable operation if required. A matching PA kit is planned for the near future.

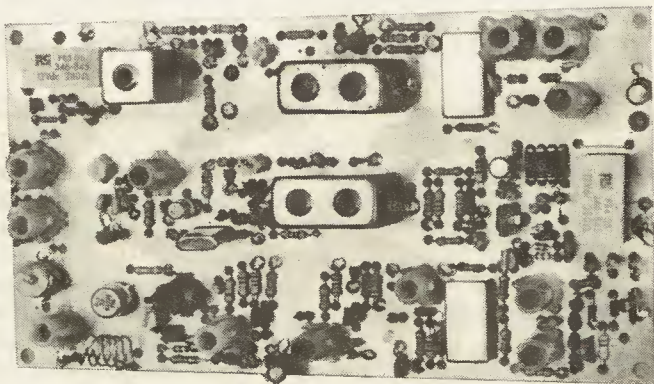

6m Version	stock no. 41-03006	price £58.00
4m Version	stock no. 41-03004	price £58.00

Please allow 28 days for delivery

### Multi-band up-converter

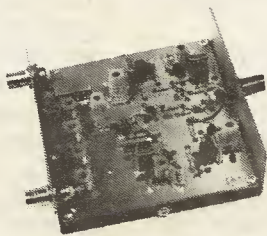

A converter to allow reception of four bands in the range 27-70MHz, using a 2m receiver/transceiver as the IF stage. Conversion is from the CB band, the 10m band, the 6m band or the 4m band using separate on-board dc switched oscillators. Sensitivity is typically  $0.7\mu\text{V}$ . Tuned pre-amplifiers, 40-28005, 40-08006 and 40-08004 are recommended for use with these converters, improving sensitivity to around  $0.2\mu\text{V}$  for 12dB SINAD on an FM signal. Supplied as a kit with PCB and all board-mounted components (including all four oscillators), sockets and undrilled case.

stock no. 40-28003 price £39.76

All prices include VAT.

Please add 60p for postage and packing

### Multi-band pre-amps



Designed for use with the Multi-band up-converter, 40-28003, but also useful for extra gain and selectivity in other systems. Supplied as a kit with double-sided PCB, all board-mounted components, undrilled case and sockets.

10m pre-amp	stock no. 40-28005	price £8.33
6m pre-amp	stock no. 40-08006	price £8.33
4m pre-amp	stock no. 40-08004	price £8.33

## Cirkit Holdings plc

Park Lane, Broxbourne, Herts. EN10 7NQ.

Telephone (0992) 444111

or from our other retail outlets at:

200 North Service Road, Brentwood, Essex. CM14 4SG.

Telephone (0277) 211490

53 Burrfields Road, Portsmouth, Hampshire. PO3 5EB.

Telephone (0705) 669021



# Try a Transverter — From Ten To Four and Six

Hopefully, by the time this article appears, the 50MHz allocation for the radio amateur will have been given practical blessing and all class A licensees will have access to this new and exciting band. Over

of -5dBm and, on the transmit side, a basic power output of 1W FM/CW or 0.5W SSB plus power amplification up to 20/15W with the matching PA.

Other features are: RF sense

available for both items from Cirkit Holdings PLC.

## Some Problems

There are a number of design features which have to be taken into consideration before starting on a design for a 6m transverter from 28MHz — the main one is the mixer system chosen. On transmit, the second harmonic of the drive source is 56MHz, not far away from the wanted frequency. Besides being present in the drive signal, this unwanted product will also be unavoidably generated as a result of distortion in the mixing process. While the input signal can be filtered to reduce this to a low level, the mixer distortion is more problematical.

*Transfer your attentions from 10m to 70 and 50MHz with this transverter design — which can run up to 10-20W with the matching PA — from Tony Bailey, G3WPO.*

the past few years, a limited number of experimental licences have been issued with very worthwhile results even allowing for the restricted out-of-TV-hours operation allowed. European contacts are possible on both 50 and 70MHz (where the allocation is available to overseas amateurs) and on 6m, transatlantic QSO's are eagerly sought after during the summer months.

For all those with a transceiver covering 28-30MHz, here is a design for an all mode linear transverter and matching PA which will allow you to get on the new band at power levels of up to 20W of FM/CW or 15W of SSB. It can also be built for the 70MHz amateur allocation with a very similar specification and full constructional details are given for both versions.

Within the constraints of a reasonable price and performance curve, the design offers — when used with a modern HF transceiver as the drive and IF source — a sensitivity of around -129dBm for 10dB S/N+N (0.08uV PD in 50 ohms). It has an intercept point

switching with adjustable hang period; a drive requirement of 0dBm (1mW) minimum up to 0.4W by an on board resistor/PIN diode attenuator system; full low pass filtering for minimum harmonic output and a repeatable PCB design for both transverter and PA. Kits are

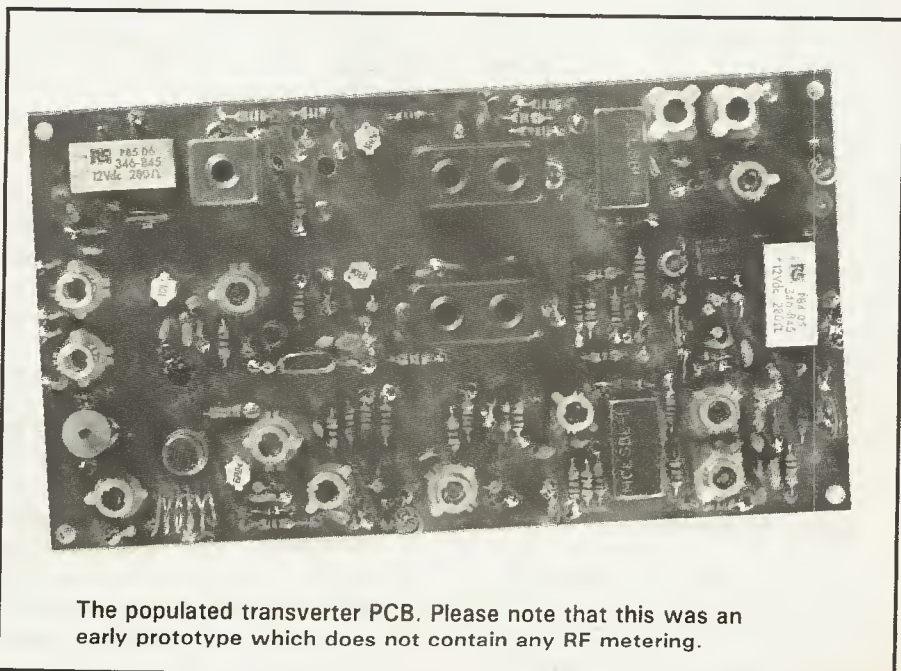

The populated transverter PCB. Please note that this was an early prototype which does not contain any RF metering.



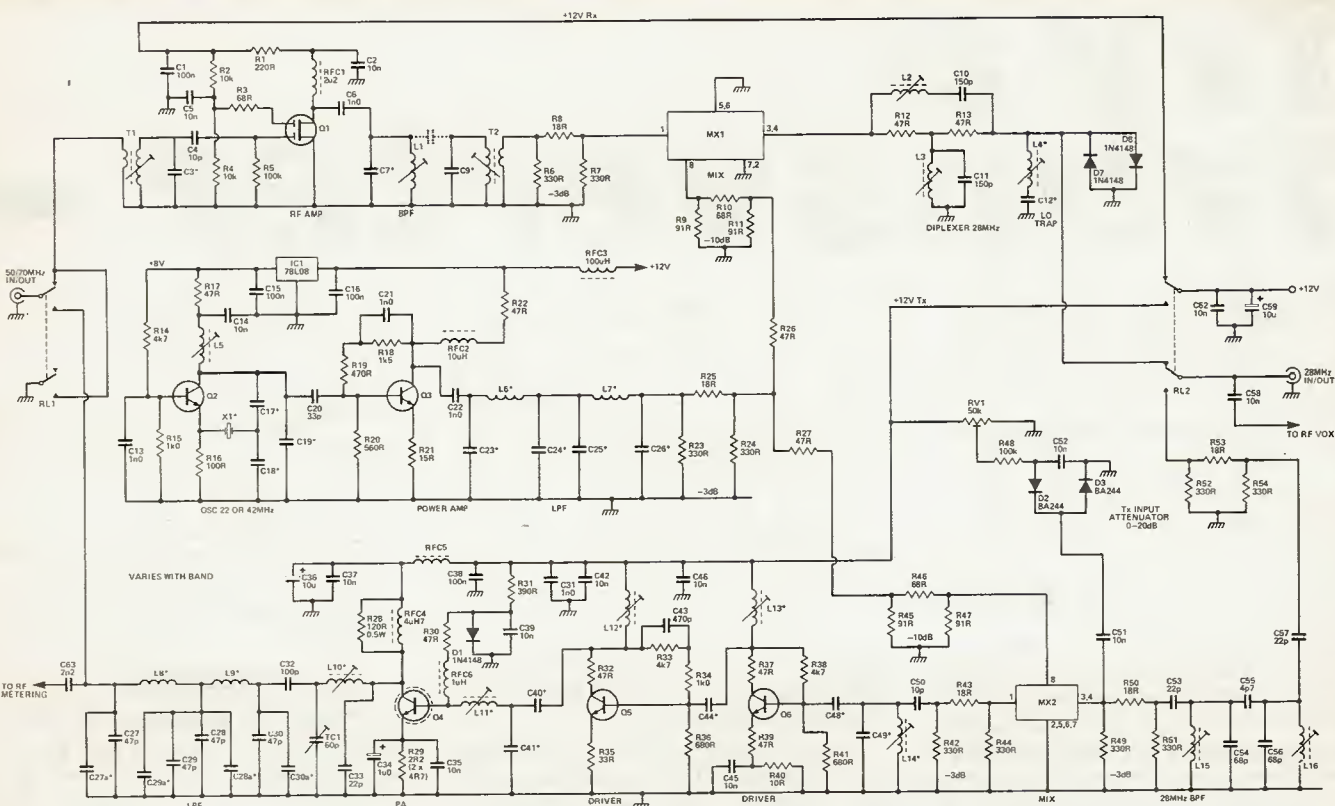

Fig 1. The circuit diagram for both 4 and 6 m versions of the transverter.

The chosen mixer is a Schottky diode double balanced type (SBL-1), which offers very good performance at a reasonable price. Providing the drive signal for the conversion process is kept at a low level — around  $-13\text{dB}$  on the local oscillator injection ( $+7\text{dBm}$ ), — the unwanted products can be kept to a manageable level and removed by a subsequent series of tuned stages in the PA strip. Another advantage of this low level of drive is that third order IMD products are also around  $-40\text{dB}$  in the early stages.

Another unwanted signal generated is the second harmonic of the local oscillator ( $2 \times 22\text{MHz}$ ) at  $44\text{MHz}$ , again kept at low levels by the previously mentioned ideas. Also, the second harmonic of the actual transmit signal is slap in the middle of the FM broadcast band, so low pass filtering before feeding to the antenna is a necessity if you want to avoid knocks on the door — or worse!

### How It Works

Looking at the circuit proper; signals from the antenna are link coupled into T1 which provides initial selectivity for the amplifier

stage. Thence to the gate of Q1, a 3SK88 UHF MOSFET amplifier. There are a large number of devices that could be used at  $50\text{MHz}$ , some offering much lower noise figures, but the 3SK88 offers a very good return for its cost — very low noise figures are not a vital necessity at  $50$  or  $70\text{MHz}$ . When used with a TS830S, the system noise figure was around  $4\text{dB}$  and this should be repeatable with any similar rig.

Following Q1 is a screened bandpass filter, L1 and T2, with a  $-3\text{dB}$  nose bandwidth of around  $2\text{MHz}$  for  $6\text{m}$  and  $1\text{MHz}$  for  $4\text{m}$  removes out of band signals. The top coupling between the two inductors is by residual circuit strays and no physical capacitor is used. The narrower response on  $4\text{m}$  is obtained by using a higher capacitance to inductance ratio than for  $6\text{m}$ .

The mixer matching is important if unwanted IMD products are to be avoided and hence a  $-3\text{dB}$  pad is inserted after the filter to assist  $50\text{ohm}$  matching into the SBL-1 mixer. With an input signal of  $50\text{MHz}$ , the conversion oscillator required is  $22\text{MHz}$  ( $42\text{MHz}$  for  $70\text{MHz}$ ) to give the required output of  $28\text{MHz}$ . Again matching on the output stage is im-

portant and unwanted output products can be reflected back into the mixer to give even more products so a diplexer follows the mixer. This provides a good  $50\text{ohm}$  match for the wanted product at  $28\text{MHz}$  which is passed on to the main receiver. Unwanted products are rejected by the series/parallel tuned circuits and absorbed in the  $47\text{ohm}$  resistors.

The LO signal required for the SBL-1 needs to be at a level of  $+7\text{dBm}$  ( $5\text{mW}$ ) for optimum conversion gain, so a high level amplifier is a necessity. Crystal oscillator Q2 generates a stable  $22\text{MHz}$  ( $42\text{MHz}$ ) signal which is then amplified up to around  $+20\text{dBm}$  ( $100\text{mW}$  or  $2.2\text{V}$  in  $50\text{ohms}$ ) by Q3. This may seem a bit over the top when only  $+7\text{dBm}$  is required in the end, but it is essential when driving a  $50\text{ohm}$  double balanced mixer to resistively terminate the oscillator port for matching purposes. Thus a higher drive level is required in the first place to overcome the loss in the pad plus driving two mixers in this design. Following the amplifier, a multi-pole low pass filter (L6/7) reduces the harmonic content at  $44\text{MHz}$  and above to very low levels and allows only the  $22\text{MHz}$  signal



through into a  $-3\text{dB}$  resistive matching pad.

At this point, the LO signal is split — separate mixers are used on receive and transmit paths — by R26/27. It then passes through a further matching pad at  $-10\text{dB}$  to give the required  $+7\text{dBm}$  at the mixer LO port.

For the transmit path, input signals are initially applied to a resistive  $50\ \Omega$  pad (R52/53/54), and on via a 28-20MHz bandpass filter (L15/16 at  $-3\text{dB}$ ) to reduce any harmonic content of the input signal. A further  $-3\text{dB}$  pad matches into the IF port of an SBL-1 mixer. Depending on the input drive level, the initial attenuator can be varied in value to achieve  $-3\text{dBm}$  at the input of the second pad ahead of the mixer. Further fine control is available at the IF port via the PIN diode attenuator (D2/3) and RV1 which has practical control range of around  $-10\text{dB}$ . The values required for different drive levels are given in the constructional detail. This dictates a minimum input drive level at 28MHz of  $1\text{mW}$  with an initial  $-3\text{dB}$  pad. Most HF transceivers can provide this at their low level transverter outputs.

The mixer input port sees  $-6\text{dBm}$  of drive, which is the sort of level we need for minimum spurious and IMD. With a conversion loss of  $-7\text{dB}$ , the output of the mixer will be at around  $-13\text{dBm}$  ( $0.095\text{mW}$ ) plus low unwanted mixing product levels and good IMD. Any attempt to drive the mixer at a higher level — which is possible — will simply produce a lot more spurious and poorer IMD so don't try it!

The following linear PA strip uses three stages for an overall stable gain of  $+43\text{dB}$  to achieve a saturated output level of  $1\text{W}$  for FM and CW. This reduces to  $0.5\text{W}$  PEP for SSB use for an IMD level of around  $-32\text{dB}$ . Interstage screening was not found necessary but the layout is critical to achieve this. The first two stages (Q5/6) use E-line equivalents of the 2N3866 (ZTX327) while the PA uses a BLY33. Other devices were tried but this was found to be the most satisfactory. All stages are biased on for linear operation, the PA using the voltage drop across a diode (D1) to maintain a stable bias voltage in the presence of RF drive.

The output signal contains a

higher harmonic drive level than would be acceptable for direct application to an antenna; so further filtering is provided in a two stage low pass filter (L8/9). This has a cut off at around 58MHz, reducing the second harmonic to below  $-55\text{dB}$ . From here signals pass via the output changeover relay to the antenna.

### The Changeover Relays

When using a transverter such as this, there are two ways in which the receive/transmit changeover can be achieved. Either the relays can be manually switched via a line from the driving transceiver when it goes to transmit. If the transceiver has VOX control for SSB then this is a viable method, or RF VOX sensing can be used where the application of drive is sensed, rectified and used to switch the relays over. For SSB use, some form of delay is needed to prevent the circuits immediately switching back to receive as soon as you stop talking.

This design has facilities for both methods. For manual switching, the relays can be controlled by earthing the 'Relay Control' pin, using an external relay or an output from the transceiver which goes low on Tx. Alternatively the PTT switch could be used.

For RF sense switching, a small amount of 28MHz RF is sniffed off by C58, which is permanently connected to the transceiver Tx/Rx input. This is rectified by D4/5 and used to control a very sensitive op-amp circuit, IC2. As soon as the rectified voltage exceeds that of the reference applied to pin 2, the output at pin 6 immediately switches high — thus switching on MOSFET Q7 and turning on the relays. The delay is determined by charging capacitor C61 and the setting of RV2 and can be varied over a few hundred milliseconds to about 1.5 seconds. The use of an op-amp does mean that the remaining period is independent of the RF input level and doesn't vary for short bursts of speech. External control of a PA is allowed for on the PCB.

A rudimentary form of power output monitoring is provided by rectification of the output signal through D9/10 and RV3. This will drive a  $100/200\ \mu\text{A}$  FSD meter and

will give a visual indication that output power is actually being achieved when the unit is boxed up.

Diodes D7 and D8 protect the input to MX1 at the moment RF is applied at 28MHz when still in receive mode before the changeover has occurred. The trap consisting of L4 and C12 is to remove residual LO feedthrough from the mixer preventing it getting directly into the receiver at 22 or 42MHz. Although this is already at a low level without the trap, it does help prevent problems occurring in receivers with poor front end selectivity.

### Construction

The transverter is built on one double sided PCB whose top foil is a continuous earth plane with etched areas where components pass through to the underside. All components mount on the top with earth connections being made directly to the top foil by soldering.

There are a number of general points concerning component mounting which should be made. Unless instructed otherwise, horizontal mounting capacitors and resistors lie *against* the PCB top surface to give short leads. Vertical mounting resistors have one end of the body against the PCB — always follow the layout diagram as to which end is which — with the other soldered directly to the top foil where indicated by a cross at the end of the lead. Note that some components are soldered at the earthy end on *both* sides of the PCB to take an earth through to the underside of the board. These points can be ascertained by visual inspection when constructing.

Capacitors such as disc ceramics should be pushed into the PCB holes as far as they will easily go without straining the leads on the body — many will go right to the board others within a few mm. *Never* have leads longer than 4mm above the top surface of the PCB as this will lead to instability. Transistors other than Q4 are pushed into their holes until the underside of the device is about 4mm above the PCB. *Never* leave all the excess lead that come with the device above the PCB.

The transverter is built in stages so that you know each part





"THE RX IS ALMOST FINISHED - I'VE JUST GOT TO FIT THE MEMORY..."

of the circuit is functioning. This is much easier than building the whole thing and then trying to find possible faults in several stages. We start by building and testing the crystal oscillator stages. Note that you should make sure that you have the correct value component in place for the band you are building — all this information is given in the component list at the end of the article.

1. Insert and solder the ten 1mm dia PCB pins at the places indicated by a circled cross on the layout diagram. In each case, these are pushed in from the underside of the board as far as they will go, then the splines are pushed hard into the board using a blunt nosed tool. Solder top and bottom where necessary. Cut off the excess pin above the board on the two pins located to the lower right of MX1 and above the source of Q1.
2. Using insulated hook-up wire, solder in the link located underneath RL2.
3. Insert and solder RL1 and RL2. Then IC1 (78L08) with the centre lead soldered to the top foil, and solder in C15, C16, C14, RFC3. Apply +12 to -14V to the +12V pin and check that +8V +/-0.2V appears at the output pin of IC1. Also check that earthing the relay control pin switches over both relays.
4. Insert and solder R14, R17, R16, C13, and Q2. Next L5; note

that the shaded portion on the layout shows the location of the shorter of the two shoulders on the inductor — these positions must be followed throughout whenever an indicator of this type is used. Carry on with R15, X1, C18, C20, C17, C21, C19, R20, R19, C21, R18, R22, RFC2, R21, Q3, C23, C24, C25, C22, L7 and L6.

5. Insert one of the copper screening cans over L6/7 until it is against the PCB, then solder the lugs on the underside and at both ends of the can on top. Then C26, R23, R25 and R24.
6. Apply power to the unit and, with a frequency counter probe on either end of R25, adjust the core of L5 until the oscillator starts. Remove and reapply power adjusting L5 until the oscillator starts up reliably each time. Make sure that the cores of L7/8 are removed for 6m and level with the top of the can for 4m operation.

### The Receive Side

7. Insert and solder the inductor for T1, C3, R4, C4, C5, R5, R2, R3, C2, RFC1, C6, C7, R1, C1, C9, R6, R8, R7, MX1 — orientate the package so that the MCL legend stamped on top is in the same position as indicated — R9, R26, R10, R11, R45, R46, R27, R47, and MX2. These latter components for the Tx stages must be in place to get the correct LO drive level to the Rx mixer. Note that the

mixers have pins 7 and 8 connections reversed on the PCB to aid layout — this does not affect operation.

8. Carry on with C10, C12, R12, C11, R13, D7, D8, L4, L3, L2, C59 and C62.

9. Take a length of 24 swg enamelled copper wire and solder one end into the top left hand hole by the side of inductor T1. Wind the wire down past the left hand side of the inductor and round until you can feed it down through the other hole at the lower right of the inductor (1 1/2 turns). The wire should rest on the top of the short shoulder and level with it on the other side (ie you are trying to get the link winding as low as possible on the coil). Solder this end in place on the underside. Insert the single tinned screening can and solder both lugs on the underside. There is no need to solder the can to the top foil.

10. Insert and solder the inductors for L1 and T2, then repeat the link winding as in 9 above for T2, starting at the top right hand corner. Insert and solder the screening can in place.

11. Take Q1 and place it in position on the underside of the board so that the legend on it is facing up through the board and can be read from the top. It must be orientated with the long (drain) lead facing C6. Solder all four leads into place on the underside with the transistor seated in the hole.

### Rx Alignment

You can now connect the output of the transverter to your 28-30MHz receiver via a length of coaxial cable from the pins next to RL2. The antenna input can be connected to a suitable signal generator of a 50MHz (or 70MHz) antenna if available. Set the cores of L2 and L3 3mm into the former and leave at this setting. Apply power and initially adjust the cores of T1, L1 and T2 for maximum noise in the 28MHz receiver. If you have a generator, for 6m tune to 51MHz (29MHz at the IF) and for 4m, 70.5MHz (28.5MHz at IF) and adjusting the generator output as required, re-adjust the cores for maximum noise at this tuning setting. The converter is now set up for a -3dB bandwidth of



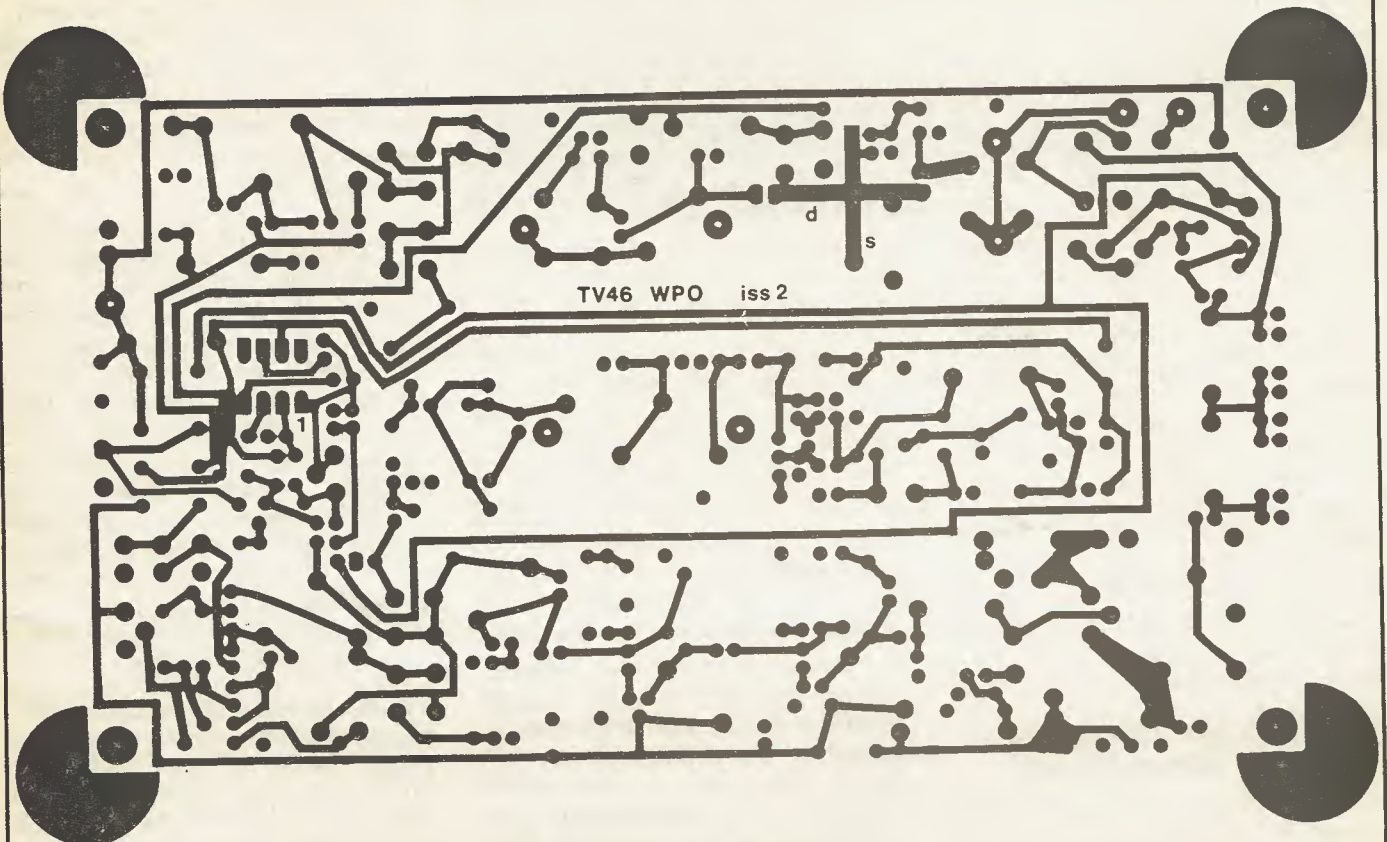
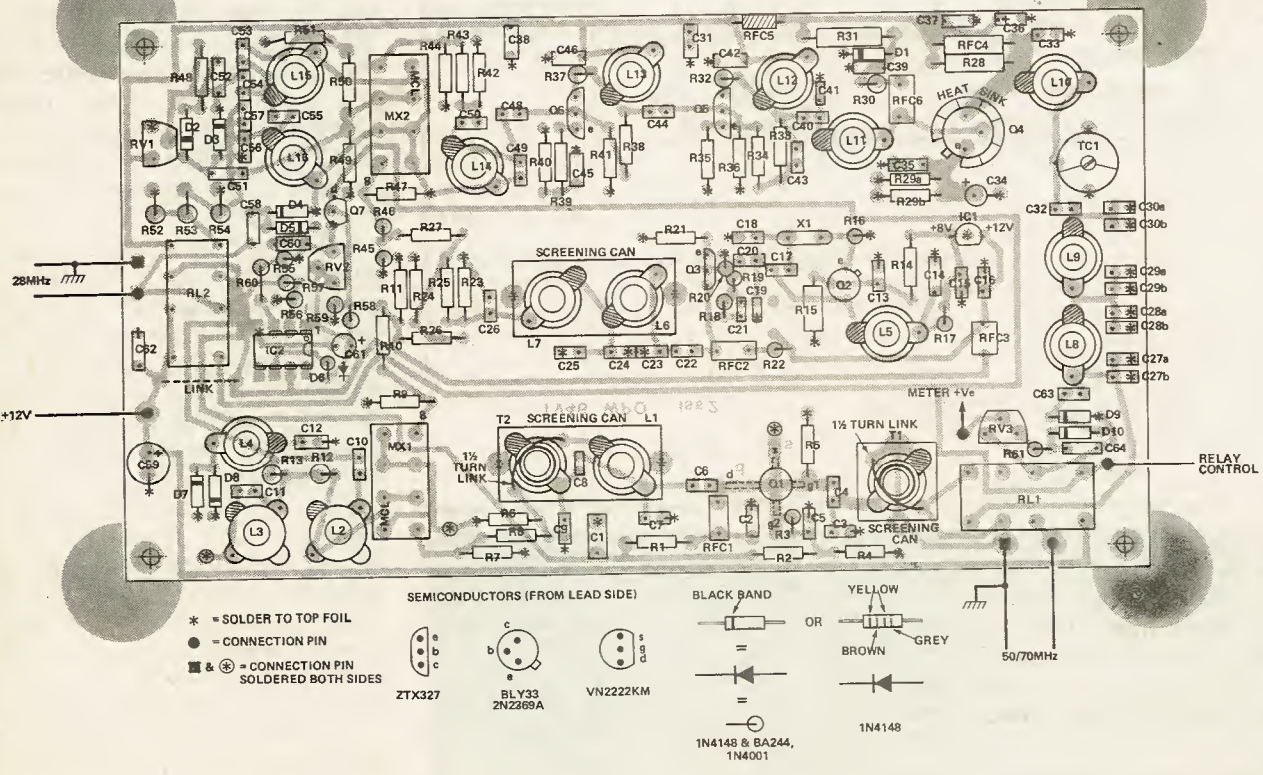

Fig. 2 The foil pattern for the transverter.

Fig. 3 The component overlay.





**Table 1. Input attenuator values, all are 0.5W carbon film type 5%.**

Input Power Range	Attenuator Value	R52/54	R53
1-10mW	-3dB	330R	18R
10-100mW	-13dB	82R	110R
100-500mW	-25dB	56R	430R

50-52MHz or 70-71MHz depending on the version built. Final tweaking can be from an off-air signal at the centre frequency later.

Connecting an aerial should enable signals to be heard on both bands providing you have active stations or a beacon nearby. During the summer you may also hear other services on both bands, especially European FM broadcast on 4m. So don't get worried about this being some form of IF breakthrough! 4m is also occupied by illegal cordless telephones amongst other things.

### On To The Transmitter — The RF Sense Circuit

12. Insert and solder IC2 (solder pin 4 on both sides), D6 (the correct way round — cathode

facing bottom of board), R59, R58, C61, RV2, R55, R57, R56, R60, C60, D5, D4 and C58.

13. Whilst avoiding touching the leads, insert and solder Q7 (the metal tab can be touched) making sure that you solder the source (lower) lead both top and bottom.

14. Next, select the correct values of R52, 53, 54 from **Table 1** for the maximum input power you are going to use. Do not exceed 400mW input in any case. Solder into place.

15. Preset RV2 to mid position, remove the 28MHz input coaxial cable if in place, then apply power. Touching the 28MHz input pin should result in the relays switching over. They may even go into continuous on/off oscillation with no input cable due to the sensitivity.

Reconnecting the cable to the transceiver should stop this. Applying the correct drive level from the 28MHz transmitter should result in the circuit changing over at power levels of 1mW upwards, with switch off delay determined by the setting of RV2.

16. Carry on with the remainder of the construction working from the top left of the board through the PA strip to the output low pass filters and metering circuitry. Points to note are that the diodes D3, D2 are pin type and not IN4148 as used elsewhere. Also Q6 and Q5 should be fitted with as short leads as possible — the PA transistor Q4 should be fitted so that the underside of the can is 1mm only above the PCB foil (ie as close as possible without the can shorting out). Then the heatsink is fitted over the top with the gap facing C35.

17. When you have finished fitting all components, connect a 50 ohm power meter on SWR bridge and 50 ohm dummy load to the output pins and set RV1 fully anticlockwise. Preset the tops of the cores and position of trimmers as in **Table 2**.

18. Apply power then put the module into transmit by applying as little CW drive at 29MHz (for 4m use 28.3MHz) as will switch the VOX circuit over. Slowly turn up the drive until power is indicated on the in-line power meter. Using the correct trim tool, adjust the cores of L14, L13 and L12 to peak the reading — do this several times as they interact.

Readjust the drive so that you have around 0.8 — 1W output — or until the output power starts to fall off as the drive is increased — then adjust L11, L10 and TC1 for maximum output power. Reduce the drive again to about 0.2-0.3W output and repeak L16-L12. Then increase again to 1W out and repeak the remaining inductors/trimmer. The final power out should be between 0.8 and 1.2W at 13.8V supply. Varying the drive level should result in a smooth power output transition with no sudden jumps from low to high power which indicates instability.

To set the drive exactly, check that the input drive level is within the range indicated for the input attenuator used, then with con-

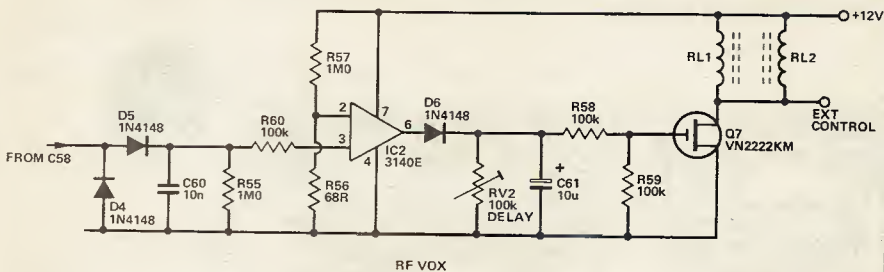

**Fig 4. The circuit diagram for the RF metering.**

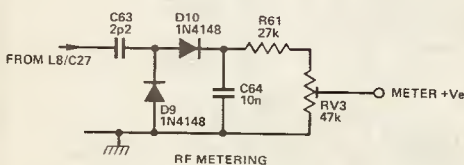

Inductor	6m	4m
L15, L16	3mm out of former	same
L14	1mm out of former	1mm into former
L13	1mm out of former	2mm into former
L12	4mm out of former	1mm into former
L11	3mm out of former	3mm into former
L10	2mm into former	1mm into former
TC1	Half meshed	Half meshed

**Table 2. The setting of the inductors for alignment.**  
Note low pass filters have the cores removed.



tinuous drive, adjust RV1 so that the output power just starts to drop off (say from 1.1 to 1.0W). If this occurs at minimum setting of RV1 then reduce the drive until it occurs at 2/3-1/2 travel from the earthy end. The preset is then left at this setting and the drive level maintained for 1W output on FM/CW and 0.5W PEP on SSB (or DSB if you happen to use this mode).

Using SSB drive, the maximum output for the desired linearity is 0.5W PEP, which will indicate at about 0.2W on a non-peak reading power meter. Never try to drive the unit at higher levels than this or you

will get very unpopular with other band users.

The finished unit will need to be screened inside a metal enclosure. There are a large number of ready made boxes available, a diecast box being the best answer, with BNC output and SO239 input a good combination. Power should be fed in via decoupled connectors to prevent RF radiation from the power leads. Don't forget to include an output to control an external relay for the matching PA if used.

Kits of parts for the transverter, for either the 4 or 6m versions are

available from Cirkit Holdings PLC, Park Lane, Broxbourne, Herts, EN10 7NQ (Tel: 0992 444111) or at their retail shops. They include all components, drilled, tinned and screen printed PCB, screening cans, wire, relays, crystal etc, and come with full instructions. Price is £58.00 for either version inc VAT and the PCB costs £7.50. Orders should be accompanied by 60p postage and packing.

Next month Tony will describe the design of a matching power amplifier which gives 15W out on SSB (PEP) and a minimum of 20W on FM and CW.

## 4m/6m Transverter Parts List.

### RESISTORS

R1	220R
R2,4	10k
R3,10,46,56	68R
R5,48,58,59,60	100k
R6,7,23,24,42,44,49,51	330R
R8,25,43,50	18R
R9,11,45,47	91R
R12,13,17,22,26,27,30,32,37,39	47R
R14,33,38	4k7
R15,34	1k
R16	100R
R18	1k5
R19	470R
R20	560R
R21	15R
R28	120 R 0.5W
R29	2 off 4R7 in parallel
R31	390R
R35	33R
R36,41	680R
R40	10R
R52,53,54	See Table 1
R55,57	1M0
R61	27k

All 0.25W 5% carbon film unless stated otherwise.

RV1,3	50k 10mm vert preset.
RV2	100k 10mm vert preset.

### CAPACITORS

C1,38	100n
C2,5,14,35,37,39,42,45,46,51,52,60,62,64	10n
C3	4m 15p
	6m 33p
C4,50	10p
C6,13,21,22,31,58	1n
C7	4m 39p
	6m 33p
C8	not used
C9	4m 47p
	6m 39p
	150p
C10,11	4m 68p
C12	6m 150p
C15,16	100n monolithic cer
C17	4m 47p
	6m 56p
C18	4m 100p
	6m 220p

C19	4m not used
	6m 68p
C20	33p
C23,24,25,26	4m 47p
	6m 150p
	47p
C27,28,29,30	6m only 15p
C27a,28a,29a,30a	100p
C32	22p
C33,53,57	1uF tantalum bead
C34	10uF radial electrolytic
C36,59,61	4m 8p2
C40	6m 10p
	4m 18p
C41	6m 22p
	470p
C43	4m 15p
C44	6m 33p
C47	not used
C48	4m 27p
	6m 10p
C49	4m 22p
	6m 39p
	68p
C54,56	4p7
C55	2p2
C63	5-60pF foil 10mm
TC1	

All are ceramic disc unless otherwise stated.

All values 1n and less 2.5mm spacing, rest 5mm except monolithics 2.5mm. Disc or plaquette type ceramics can be used. All electrolytic types are 16V minimum working.

### SEMICONDUCTORS

Q1	3SK88
Q2	2N2369A
Q3,5,6	XTX327
Q4	BLY33
Q7	VN2222KM
IC1	78L08
IC2	CA3140E
D1,4,5,6,7,8,9,10	1N4148
D2,3	BA244 PIN type
MX1,2	MCL SBL-1

### RF CHOKES

RFC1	2.2uH Toko 7BS
RFC2	10uH Toko 7BS
RFC3	100uH Toko 7BS
RFC4	4.7uH axial type
RFC5	4 turns 24 swg en Cu on FX1115 bead
RFC6	1.0uH Toko 7BS

### INDUCTORS

L1	4m S18 yellow Fe core
	6m S18 white Fe core
L2,3	both MC108 blue Fe core
L4	4m S18 green Fe core
	6m S18 white Fe core
L5	4m S18 green Fe core
	6m S18 white Fe core
L6,7	4m S18 white Fe core
	6m S18 white no core
L8,9	4m S18 blue no core
	6m S18 white no core
L10	4m S18 orange Fe core
	6m S18 green Fe core
L11	4m S18 yellow Fe core
	6m S18 white Fe core
L12	4m S18 yellow Fe core
	6m S18 violet Fe core
L13	4m S18 green Fe core
	6m S18 white Fe core
L14	4m S18 orange Fe core
	6m S18 green Fe core
L15,16	both S18 white Fe core
T1	4m S18 violet Fe core with 1/2 turn link over cold end.
	6m S18 white Fe core with 1/2 turn link over cold end.
T2	4m S18 yellow Fe core with 1/2 turn link over cold end.
	6m S18 white Fe core with 1/2 turn link over cold end.

### RELAYS

RL1,2	DCPO 12V flatpack. RS 346-845 or Fujitsu FBR244 series DO12-02CE or Omron G2V282P 47 12V
-------	--

### CRYSTALS

X1	4m 42.0000MHz HC18/U
	6m 22.0000MHz HC18/U (3rd ovt)

### MISCELLANEOUS

1 double sided PCB. 2 off S18 dual cans; 1 off S18 single can; 1 off TO5 sink (tall type); 24 swg en Cu wire; length RG174A/U; 10 off 1mm PCB connection pins.



# Icom IC02E— A Starter for Two?

TR2300, very popular rigs indeed but these were 'portables' not 'handhelds'. Other Japanese companies such as FDK were producing good cheap crystallised handhelds. But without doubt the rig to have

cy, such as the local repeater or calling channel, whilst operating on another frequency or memory channel. With this function selected, the IC02E will listen on the priority channel for one second in every five second period.

An LCD display is employed for frequency and function read out. This will display the memory chan-

*As the successor to the very popular IC2E, the IC02E has a lot to live up to. Steve Ireland, G3ZZD, assesses whether it has 'made the grade' with a side long glance at the competition.*

was the IC2E, which offered synthesised 'thumbwheel' frequency control, up to a couple of watts of RF, really rugged and one handed operation without tennis elbow.

With the arrival of Trio's TR2500 and Yaesu's FT209, handhelds reached a new level of sophistication: keypad entry, memories, scanning and considerably higher power than ever before. Almost simultaneously, Icom launched the IC02E, successor to the IC2E and providing comparable facilities to the other companies' offerings. Interestingly, Trio and Yaesu integrated 'big rig' features into their new handhelds, while Icom's offering seemed largely, and ironically, overlooked. Perhaps this was partly because the IC02E looks very like its predecessor. Same style grey-green casing, so what is new?

nel number, duplex mode (ie for 600Hz repeater shift), scan mode (MS or PS), lock function, battery condition etc, as well as the operating frequency. A back light is included for night time portable or mobile operation and a dot line read-out across the bottom of the display serves as an 'S' meter on receive and RF output indicator on transmit.

The IC02E will provide two levels of RF output. With the ICBP3 NiCad pack supplied, which provides 8.4V, the rig should give 3W RF switched to HIGH power and 0.5W when switched to LOW. With 13V supply, from either a

## What's New?

The IC02E offers 'multi purpose scanning' as compared to the thumbwheel switches of the old IC2E. Either the ten memories channels of the rig may be scanned, the whole band or a segment of it may be scanned, on entry of the upper and lower frequency limits of the range desired.

An autostop facility is provided, the scanning being stopped when a signal is received and resumed when the signal disappears. A 'priority' channel function is also available, allowing you to keep an ear on a favourite frequen-

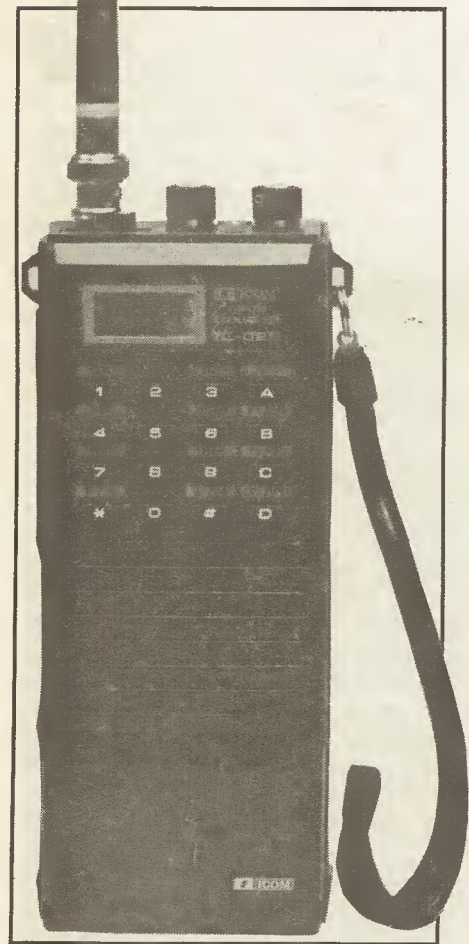

The first piece of transmitting equipment acquired by a newly licensed radio amateur is frequently a handheld transceiver for 2m. The 'big three' Japanese manufacturers competed fiercely for this section of the market, regularly updating their product range. During 1984, both Trio and Yaesu launched new ranges of models; the TR21E and the TR2500 and the FT203 and FT209 respectively.

Up to 1983/4 the clear leader in the 'heard on the air' stakes seemed to be Icom with its IC2E. Yaesu had the FT290 and Trio the

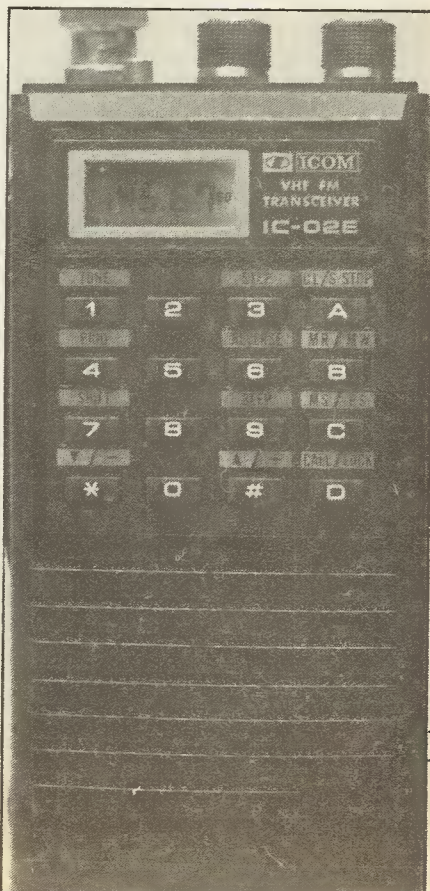



mains PSU, car battery or the accessory ICBP7 NiCad pack, the rig will give 5W at high power, similar to the FT209RH.

## Ergonomics

Two rotary potentiometers are used, for volume and squelch control, both situated on the top panel. To the left of these are located the high/low power and display back light push buttons. Above these are four sockets: a BNC 50 ohm for either an

external matched antenna or the quarter wave helical supplied with the rig; a 3.5mm female jack for either an 8 ohm external speaker or the earphone supplied; a 2.5mm female jack for an external dynamic or electret microphone; and a 3.5mm male jack for an external 13V DC supply. All the required plugs are contained in the accessory pack supplied with the rig. Other standards are a belt clip, wrist strap, NiCad charger BC2501E and rain proof socket cap for the top panel. A protective carry case can be obtained as an accessory.

On the left hand side of the case is a FUNC button, which selects the function of a particular key on the central keypad. Most of these keys have dual functions. Below this is the PTT and toneburst buttons, contained within the same housing. The surfaces of these buttons are flush with the IC02E case.

There is a male 3.5mm jack socket on the ICBP3 NiCad pack for connecting up the charger along with a red LED to indicate the presence of the charger voltage output. This is very useful as most people will probably connect the NiCad charger to the mains via a 'shaver' type adaptor plug, or similar, and will want to be sure

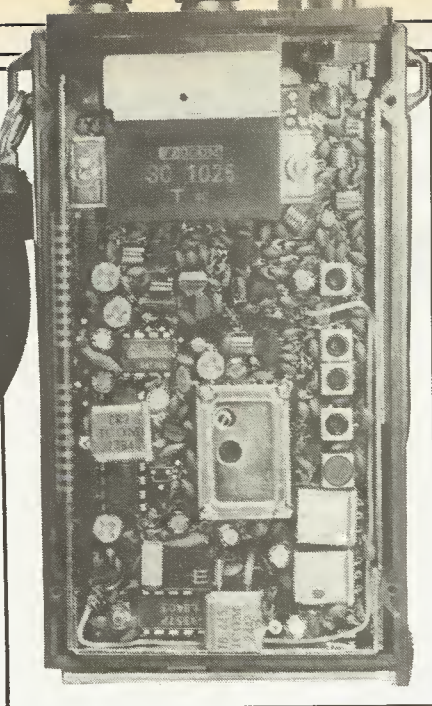

that charging is being achieved via this rather weak link. Nothing is more frustrating than finding your NiCads are still flat after a night of apparent charging!

## On The Air

The double conversion receiver (first IF 16.9MHz, second IF 455kHz) has a claimed sensitivity of 0.25µV for 12dB SINAD. Although no laboratory measurements were taken, two weeks use on the Sussex coast showed that it is certainly very sensitive indeed. The Kent repeater, GB3KN, some fifty miles distant, could be heard using the helical antenna from inside a bungalow. A Trio TR9130 multimode with an indoor 'slim jim' antenna produced similar strength signals. The receiver selectivity is also excellent, very little 'bleedover' being noticed from very strong local signals with the channel spacing set at 12.5kHz.

Programming the memories and scanning facilities was easily achieved using the keypad. Similarly as with the FT209R/RH, the facilities are more sophisticated than is necessary for this particular operator, only a couple of the memories being used, along with the scanning facilities. The 'priority channel' facility was very useful to monitor the local repeater whilst working simplex and the switching to and fro did not prove too much of a distraction or cause any 'copy' to be missed.

The transmit and receive audio are both excellent. The quality from the tiny electret internal microphone received praiseworthy reports such as "thought you were using a desk mike". The smooth receive audio was comparable in quality to that of my base station TR9130. Maximum audio output is a claimed 500mW, a little low for mobile use, where the optional HS10 headset will probably be used.

The only criticism of the rig's operation was the stiffness of the PTT switch. During an average length transmission, this was such that the fingers of my right hand often became rather stiff as well. With more use, this stiffness could well have vanished, being a product of the newness of the rig.

A twelve hour overnight charging was adequate to keep the rig going on receive for most of the next day, with four or so ten minute QSOs during the course of the day.

The deviation of the transmitted signal was reported to be well within  $\pm 5$ kHz by very local stations.

## Conclusions

The IC02E performed beautifully and I have very little criticism to offer. There is the stiff PTT switch and the manual contains a block diagram but no circuit, frustrating for the curious and DIY minded. On the other hand, there is a troubleshooting section in the manual which should enable the correction of simple faults and general 'finger trouble'. The inclusion of a 'rapid results' pocket guide summarising the operation of the CPU controlled facilities proved very useful. I could not understand why a simple dust and moisture proof case was not included as standard with the rig. Surely this would have only put a quid to two onto the price tag.

At the time of writing this review, the Trio 2500 was available at around £260, the FT209R at £240 and the IC02E at £269. All three regularly vary in price compared with each other with dealers and importers offering special offers on them. In terms of facilities and specification there is virtually nothing to choose between them. This is definitely a case of trying them all out and finding which one suits you best.

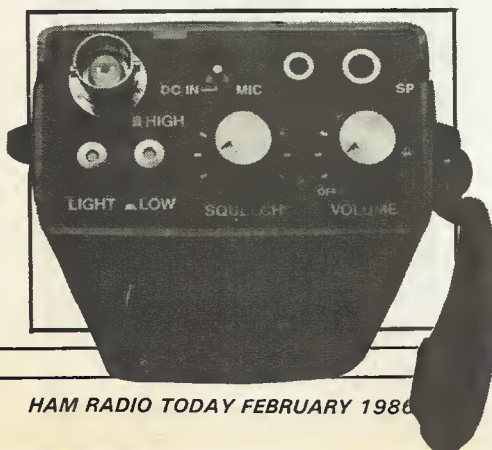



# Start Listening on the Shortwaves

Just bought yourself a new general coverage transceiver or receiver, but don't know what to do with it? Between the amateur bands (and sometimes in them, too, I hear you say!) are the broadcast stations. Most amateurs' experience of

*If you've never explored the short wave bands, this article will reveal what you are missing and how easy it is to start.*

broadcast stations begins and ends with Radio Tirana in the 40m band, along with its associated jamming. This is a shame, because many stations broadcast informative and even entertaining programmes and their power is such that even when conditions are poor on the amateur bands, it is usually still possible to receive good signals from a number of stations.

## Where Are They?

Like amateurs, broadcast stations are supposed to stick to inter-

nationally agreed, well-defined broadcast bands. If you stray as much as 100Hz above 3800kHz (in an attempt to make that elusive Caribbean station who is only working W's hear you) some thoughtful European will inform you "out of band" (thus proving that he has accurate digital frequency readout). However, the broadcast stations have no such qualms about straying even hundreds of kHz above and below the limits of the official broadcast bands. The international broadcasting bands are at, roughly, 11, 13, 16, 19, 25, 31, 41 and 49 metres. In addition the 75-metre band is used for broadcasting in Europe and Asia, whilst there are bands used for broadcasting within the tropics at 60, 90 and 120 metres. Although Radio Moscow, in particular, is using the 60 metre-band for international broadcasting and it certainly is not in the tropics!

The recent WARC conference has agreed to expand the official limits of almost all the broadcast bands and even allocated a new band, at 22m (13600-13800

Metre-band	Official frequency limits	Broadcast stations actually use (approximate frequencies)
11	25670-26100	25650-26100
13	21450-21750	21450-21800
16	17700-17900	17500-18100
19	15100-15450	15005-15700
22*	No allocation	13600-13800*
25	11700-11975	11500-12100
31	9500-9775	9350-9995
41	7100-7300	7000-7500
49	5950-6200	5895-6255
75	3900-4000 (Asia) 3950-4000 (Europe & Africa)	3900-4060

\* the 22 metre-band will be allocated to international broadcasting from 1989.

Table 1 The "official" and "actual" broadcast bands.





kHz). Many broadcast stations are already using frequencies outside even the expanded WARC bands — even though the expansions are not supposed to come into effect until 1989 — and a few stations are also already using the 22m band. Table 1 shows the official limits of the current broadcast bands, and also the frequency limits actually in use, the 'de facto' situation.

Most stations broadcast a news bulletin, often followed by a political commentary and usually end their programme with a musical or cultural feature. How interesting these programs are will depend on your interest in the country concerned, or your own political viewpoint. There's no denying that most of the Eastern European countries broadcast stations do have exceedingly boring programmes. The one that takes pride of place in this respect is Radio Tirana in Albania.

### Awful Albania

Albania may be a difficult country to work on the amateur bands, but hearing Radio Tirana is no problem at all, even in the amateur bands. Their 500kW transmitters pump out such rivetting features as "The Marxist-Leninist Movement Throughout the World is Growing in Scope and Strength" in a bewildering variety of languages including Indonesian, Swedish and, of course, English. Albania is a highly isolationist country and Radio Tirana's broadcasts echo this policy, to the extent of being quite vitriolic at times. The inevitable result of this is that their broadcasts in certain languages — notably Russian and some East European languages — are heavily jammed, as anyone tuning across the 40m so-called exclusive amateur band in the evenings can't have failed to notice. Radio Tirana uses a number of frequencies in the 40m band, including 7065kHz which it uses for its English language programmes.

Thankfully, not all stations are like Radio Tirana. Standards of programming vary enormously; from the professionalism of the BBC World Service, which is on the air 24 hours a day, 365 days per year; to certain other stations which broadcast one news bulletin a day in English which sounds like the

**RAD**

**PENANG**

31M 9515 Kc/s  
41M 7200 Kc/s  
41M 7300 Kc/s  
60M 4985 Kc/s  
62M 4790 Kc/s

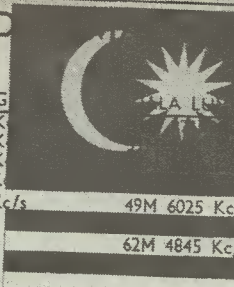

**RECEPTION REPORT AND CONFIRMS YOUR**

**KINABALU**

41M 7270 Kc/s  
42M 7145 Kc/s  
61M 4950 Kc/s  
62M 4845 Kc/s ✓

**VOICE OF MALAYSIA**  
(SUARA MALAYSIA)

19M 15280 Kc/s  
25M 11900 Kc/s  
49M 6175 Kc/s

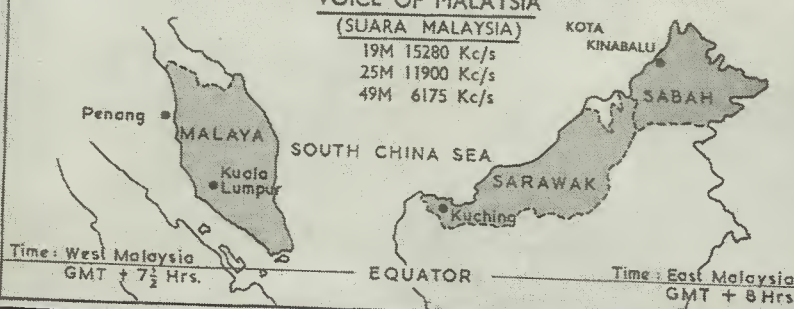

announcer is translating it as he/she goes along. Most stations broadcast a 30 minute or one hour programme in each language that they use. The same programme is repeated several times a day, to different areas of the world at various times and on what they hope are suitable frequencies for that particular target. Some stations change frequency every few weeks, others hold on to old favourites for years, or even decades!

### Reception Report and QSLs

Most stations are interested in receiving reception reports from their listeners. This is not always because they wish to know how well they are being received in their target areas, but often just to prove to their governments that they have listeners at all! To encourage listeners to send in reception reports and comments and criticisms on the contents of the programmes, stations offer QSL cards, programme schedules, books, pennants, calendars, listener's clubs with membership certificates, competitions often with valuable prizes and all manner of similar goodies.

Collecting QSLs from broadcast stations can be at least as enjoyable as collecting them from amateurs. For a start, many stations print very exotic QSLs with glossy pictures of the country concerned, or often the station, anten-

na masts etc. There is actually a lot more skill involved in trying to get "DXCC", or QSLs from broadcast stations in 100 different DXCC countries, than there is in obtaining DXCC on the amateur bands. One reason for this, of course, is that broadcast stations only exist in those countries with their own separate government ie there are no broadcast stations (or at least one broadcasting to an international audience) in such DXCC countries as Midway Island, Mellish Reef, Crete, Sardinia, Corsica, Guernsey etc.

So how does one go about starting a collection of broadcast band QSLs? First, you've got to hear your station. It is well beyond the scope of an article like this to give the operating schedules of all stations that can be heard in Britain. For a start, most international broadcast stations do change their operating frequencies quite often and some even change the times of their programmes (eg many put their programmes one hour earlier — with respect to GMT — in the summer, when they, and Britain, are on summer time). The best way to find out when stations are on the air and in which language, at which time, is to go out and buy a copy of the World Radio and TV Handbook. Unfortunately, this is a costly tome — the 1985 edition has a UK cover price of £17.95 — but for anyone really interested in what there is to hear on the broadcast bands the WRTH, as it is known, is invaluable.



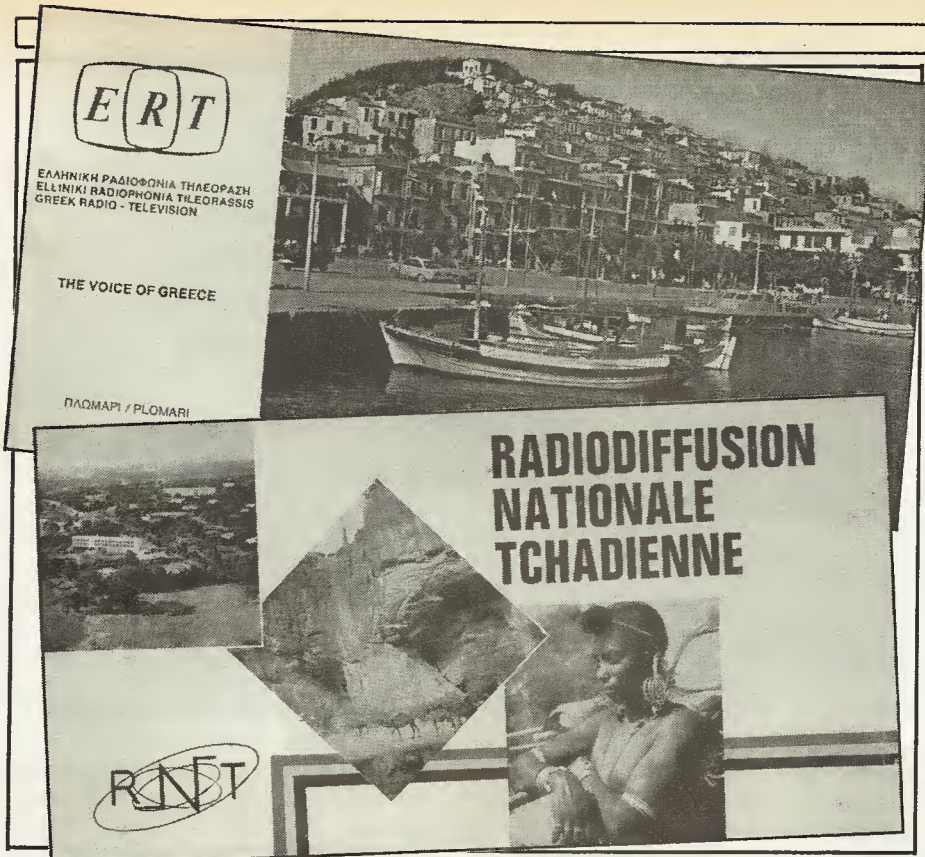

For those who cannot afford this amount, or who just want to find out what can be heard easily in this country, I have compiled a list of broadcasts in English, based on schedules sent out by various stations and on my own listening. It is by means complete: there are many stations which do broadcast in English and can be heard with ease in the UK but which are not included in the list; there are others which are on the list but which have a number of other programmes in English — especially in the middle of the night (our time) when most stations broadcast to the USA.

### The QSL Quest

But to get back to our quest for the QSLs. Assume you have heard the broadcast from Radio Netherlands at 1130 GMT on

5955kHz. Write out a reception report on a sheet of paper (it is better to use writing paper than QSL sized cards for reports, I think) in the following manner. Give the *date* of the broadcast which you have heard. Give the *time* that you have been listening: *always* give the time in GMT. Some stations now announce the time in UTC: this is exactly the same as GMT for all practical purposes. Give the *frequency* that you have been listening on. Most stations announce the frequencies that they are using, so this should present no problem, even if you are using a transistor portable radio with little or no frequency calibration. Then give the reception quality.

This can be done either in words, or preferably, by using a reporting code. Most stations

S (Signal strength)	I (Interference)	N (Noise)	P (Propagation disturbance)	O (Overall reception)
5 Excellent	_____	Nil	_____	Excellent
4 Good	_____	Slight	_____	Good
3 Fair	_____	Moderate	_____	Fair
2 Poor	_____	Severe	_____	Poor
1 Barely audible	_____	Extreme	_____	Barely detectable

Table 2. The SINPO code, recommended for reporting of reception quality to broadcast stations. It is often abbreviated to SIO, in which case only three parameters are given in the reception report. Some stations use "F" instead of "P", where "F" stands simply for "Fading" as opposed to the more general "Propagation disturbance" which would include such things as Auroral activity etc.

prefer reporters to use SINPO code, or a shortened version of this, the SIO code. These letters stand for Signal strength, Interference, Noise, Propagation disturbance and Overall merit. In the SIO code deterioration of reception due to noise and propagation disturbances are ignored. For each letter a rating of 1-5 is given, 1 being the worst and 5 the best. So a SINPO rating of 55555 would be absolutely perfect reception — though very unlikely on today's overcrowded broadcast bands. A more likely SINPO rating may be 43433: this would mean a strong signal, with moderate interference, slight noise (ie QRN; local noise or static), some fading and moderate overall reception quality. It is of great use to most stations if you can identify the source of any interference (eg in the Radio Netherlands example, it may be from, say, Radio Moscow on 5950 kHz).

Give the station some idea of the type of receiver and antenna you are using. It is far more impressive if the station is being very well received on a transistor portable with telescopic antenna indoors, rather than on a £1500 communications receiver or transceiver with resonant beam or dipole antenna on a 50 foot tower! Finally, if you would like to receive a QSL in reply, a) say so and b) prove that you did actually hear the transmission that you said you did by giving some unique details of the programme that you heard. That is to say, do not simply write "news followed by commentary and music" but be more specific (see example reception report).

Send off the reception report — by all means with a covering letter telling them honestly what you thought of their programmes — and sit back and wait for the QSLs to start rolling in. Here is a problem — you do not necessarily know the address to which to send the reports. Again, most stations actually do want to hear from their listeners, so they do announce their address (you will probably have to listen at the very end of the transmission for this, though). In many cases it is extremely simple, the best example being "Radio Moscow, Moscow, USSR". The World Radio and TV Handbook does list the correct addresses for most stations.



## Real DXing

So, far I have dealt exclusively with international broadcast stations, and listening to them can be called short wave listening. When international broadcast stations are using powers of typically 250kW or even 500kW into antennas with up to 20 or 21 dB gain, resulting in ERP's of many *megawatts*, it can hardly be called "DXing", even if the signal is coming from Australia!

However, it *is* possible to be a DXer on the broadcast bands as well. There are a number of stations which use much lower powers than those mentioned, although they are usually broadcasting to a national or even just a local audience rather than an international one. I have a QSL from Radio Station 4VEH in Haiti which states that they were using just 250 watts — lowish power even for an amateur station today, and positively QRP for a

broadcast station!

Many of these low power stations broadcasting for a local or national audience use frequencies in the so-called tropical bands, around 120, 90 and 60 metres. In Europe the same frequency bands are used for point-to-point communications, teleprinters and all sorts of other traffic, so there will often be a lot of interference when trying to receive these stations. It is perhaps not really the place to start if a newcomer to broadcast DXing, especially for those with simpler receivers without particularly good selectivity. But for those of you who become tired of the same old political commentaries from Prague, Tirana, Moscow or even Washington, it is great fun trying to hear some local "ju-ju" music from Lagos, even if it is overlaid by an S9 + teleprinter!

For those who want to give it a try, the 60m band is definitely the most productive of the three tropical bands. Broadcast stations may be found between, roughly, 4485-5100kHz and tuning around during mid-evening you will hear, typically Radio Afghanistan on 4740kHz; Radio Africa No.1 broadcasting from Gabon, West Africa, on 4810kHz; and a number of stations from the USSR broadcasting in both Russian and local languages. The strongest of these tend to be Radio Dushanbe in Tajikistan on 4635kHz, Radio Baku in Azerbaijan on 4785kHz and Ashkhabad Radio in Turkmenistan on 482kHz. All of these stations broadcast a lot of local music which is almost never heard anywhere else.

The stations mentioned here should be audible on even a fairly simple short wave receiver, perhaps on a portable with a telescopic antenna. If, however, you have a communications receiver (or a transceiver with general coverage receive facilities) what can be heard on these frequencies? **Table 3** shows what should be heard on a fairly good evening using a reasonably communications receiver.

## The Oriental Challenge

A real challenge for DX-ers is offered by Far Eastern stations broadcasting to local audiences in the tropical bands — as much of a

Frequency kHz	Station and languages transmitted
4485	Ufa Radio, USSR (in Russian and Bashkirian)
4740	Radio Afghanistan, Kabul (in Pushto and Dari)
4760	Radio Station ELWA, Monrovia, Liberia (in English and African languages)
4780	Radio Petrozavodsk, USSR (in Russia and Karelian-Finnish)
4783	Radio Nationale du Mali, Bamako (in French and African languages)
4785	Radio Baku, Azerbaijan, USSR (in Azerbaijani)
4800	Radio Lesotho (in English and African languages)
4810	"Africa No.1", Libreville, Gabon (in French)
4815	Radiodiffusion-Television du Birkinia, Ouagadougou, Burkina Fasso (Upper Volta — in French and African languages)
4820	Radio Botswana, Gaborone (in English and African langs)
4820	Radio Khanty Mansiysk, USSR (in Russian)
4825	Ashkhabad Radio, Turkmenistan, USSR (in Turkmen and Russian)
4835	Radio Nationale du Mali, Bamako (in French and African languages)
4845	Radiodiffusion Television du Mauritanie, Nouakchott, Mauritania (in Arabic and French)
4860	Radio Moscow (External Services in East European languages, English etc)
4865	Radio Beijing, Peking, China (in Chinese)
4870	Radiodiffusion Television du Benin, Cotonou, Benin (in French and African languages)
4890	Radiodiffusion Television du Senegal, Dakar (in French and local languages)
4895	Radio Moscow "Mayak" (2nd programme) (in Russian)
4910	La Voix de la Revolution, Conakry, Guinea (in French and African languages)
4915	Ghana Broadcasting Corporation, GBC-1, Accra (in English and African languages)
4930	Radio Moscow "Mayak" (2nd programme) (in Russian)
4940	Radio Kiev, Ukraine (in Ukrainian)
4957	Radio Baku, Azerbaijan, USSR (in Azerbaijani)
4980	Ecos del Torbes, Venezuela (in Spanish)
4990	Radio Nigeria, Lagos (in English and African languages)
4990	Radio RSA, Johannesburg, South Africa (External Service in English and other langs)
4990	Radio Yeravan, Armenia, USSR (in Armenian and other Middle Eastern languages)
5020	Radio Tirana, Albania (Home Service in Albanian)
5035	Radio Alma Ata, Kazakhstan, USSR (in Kazakh and other Central Asian languages)
5040	Radio Tbilisi, Georgia, USSR (in Georgian)
5047	Radiodiffusion Television Togolaise, Lome, Togo (in French and African languages)

Table 3. Just some of the stations that should be audible in the 60 metre band during a morning or evening of good conditions. At night the band is crowded with South American stations, mainly from Venezuela, Colombia and Brazil. Among the first of these to fade in during the late evening is "Ecos del Torbes" on 4980, listed above. Another is Radio Sutatenza in Colombia on 5095.



To: Radio Netherlands, Hilversum, Netherlands.

Reception report from F Bloggs, 73 Some Road, Anywhere, England.

Date: Wednesday 13th November 1985

Time: 1130-1225 GMT

Frequency: 5955 kHz

Reception quality: SINPO 55444 (occasional local noise, some fading and distortion)

Receiver: Sony ICF-5900W (transistor portable receiver with three shortwave bands)

Antenna: Internal telescopic aerial, indoors.

Programme details:

1130-1138 News

1138-1153 "Newsline" including report on attempted coup in Liberia

1153-1225 "Wednesday Report" including how Netherlands is helping India with its agriculture, and "Dutch Diary" on terrorism-prevention measures.

Please send me a QSL card if you find this reception report to be accurate.

Yours sincerely,

*Fred Bloggs*

(F Bloggs)

Table 4. A typical reception report with enough details to earn the sender a QSL card. Most stations would also prefer some comments or constructive criticism of the programmes. This sort of reception report is really only suitable for sending to international broadcast stations, who request such reports. If trying to get a QSL from a small South American local station broadcasting primarily to a local audience, a more friendly letter would probably be better, without using the SINPO code. Instead attempt to describe how well (or badly) their signal was coming through.

challenge as trying to work the west coast of North America on 80m. These stations broadcast throughout their day and evening time and usually go off the air for the day at around midnight local time. This is typically around 1400 GMT, just as the 60m band, for example, is beginning to open to that part of the world. For frequencies of around 5MHz and below, it is of course necessary to have a darkness path for most if not all of the distance between the transmitter and the receiving location. In practice, this restricts this aspect of DX-ing to the winter months.

It is noticeable that conditions do vary a lot from day to day with, at best, occasionally really strong signals from Radio Singapore, Radio Malaysia, Radio, Nepal amongst others. One of my best DX QSL cards comes from the National Broadcasting Commission of Papua New Guinea, received one January afternoon from fade-in at 1325 GMT until they signed-off at 1401 GMT (just as the signal was beginning to "peak"! ) on 4890kHz. The station was using a power of 10kW, really quite low power for broadcast stations these days.

There are also many tens of stations in Indonesia which also tend to sign-off for the evening at 1400 GMT. Some of them, using between 5 and 50kW of power, are relatively easy to hear, given good conditions and a decent receiver and antenna. Many use very low power indeed, sometimes just a few watts, and to receive a QSL from such a station would be an achievement indeed.

Don't forget, these powers quoted are AM carrier power and you have to be able to receive enough understandable modulation to be able to give some programme details for the station to be sure that you did in fact hear them. This is generally considerably more difficult than receiving a "you are 4 by 4" type report from a YB station on 80m SSB.

### Competition Time

If you start listening on a regular basis to certain stations, you will eventually be asked by those stations to participate in one of their competitions. What you have to do and what the prizes are

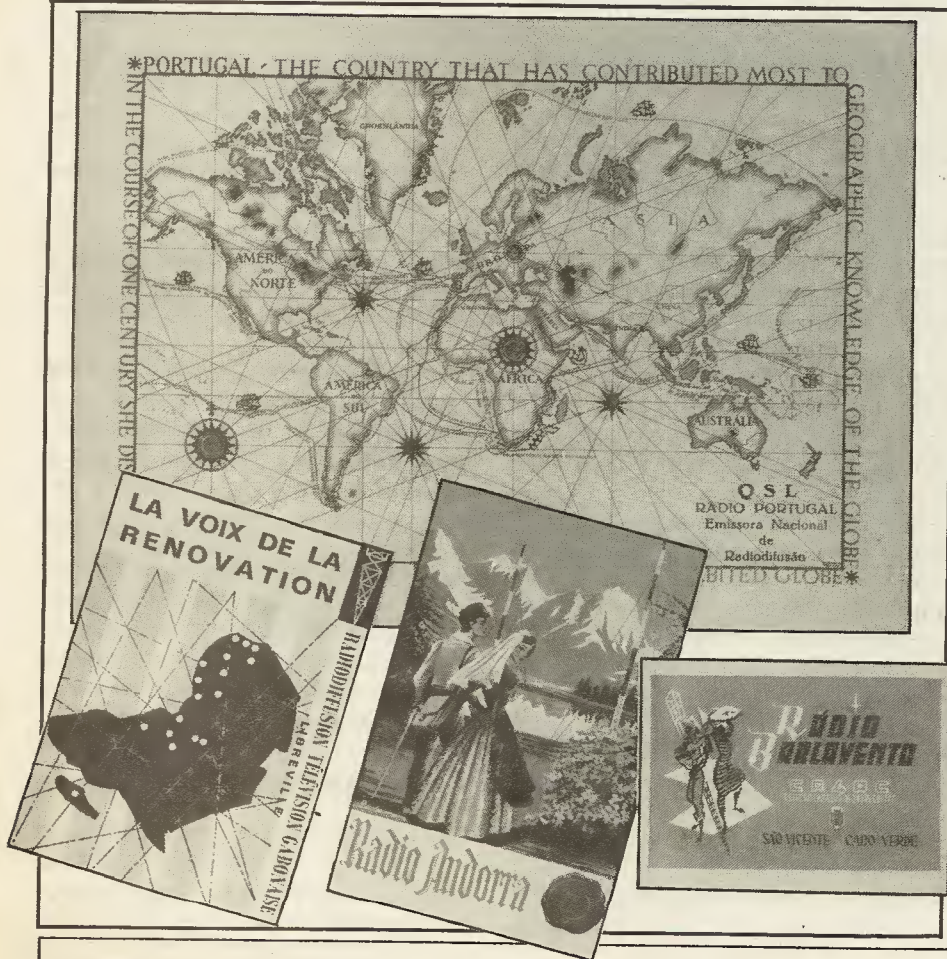



Table 5. English language broadcasts audible in Great Britain. The following is a selection of broadcasts in English from broadcast stations which are generally speaking, well received in Britain. Only those broadcasts starting between 1900 and 2115 are listed: a complete list for the full 24 hours would be several pages in length.

GMT	Station	Frequencies (kHz)
1900-1930	Radio Prague	5930 7345
1900-1930	Voice of Vietnam	10040 12020
1900-1930	Radio Afghanistan	5900 6020
1900-1930	Radio Canada International	5995 7235 11945 15325 17875 (M.-F. only)
1900-1955	BRT, Belgian Radio and TV	1512 5895
1900-2000	Radio Moscow World Service	5980 6045 7150 7310 7400 9830 9865
1900-2000	BBC World Service	3970 5975 6180 7325 9410
1900-2000	Radio Beijing (Peking)	8260 9860 11500
1900-2000	Radio Station HCJB (Quito)	15270 17790
1900-2000	Voice of America	6040 9760 11760 15205
1915-2000	Radio Berlin International	1359 6080 6115
1920-1930	Voice of Greece	7395 9420 11645
1930-2000	Radio Finland	6120 9530 11755
1930-2000	Radio Sofia	6070 9700
1930-2030	Voice of the Islamic Republic of Iran	9022
1935-1955	RAI, Italian Radio	7275 9710 11800
2000-2030	Radio Canada International	5995 11945 15140 15325 (M.-F. only)
2000-2030	Voice of Israel	7410 9009 9435 9815 12025
2000-2030	Radio Prague	5930 7345
2000-2030	BBC World Service	648 3955 3970 5975 6010 6180 7325 9410
2000-2100	Radio Moscow British Service	5980 6045 7150 7230 7240 7310 7400
2000-2150	Radio Pyongyang (North Korea)	6576 9350 11655
2005-2105	Radio Damascus	9565 12085
2030-2100	Voice of Vietnam	10040 12020
2030-2100	Radio Portugal	7155 9605
2030-2100	Radio Polonia (Warsaw)	6095 7285 (M.-F. only)
2030-2100	Radio Tirana (Albania)	1395 7065
2030-2315	BBC World Service	5975 6180 7325 9410
2050-2105	Vatican Radio	1530 6190 7250 9645
2100-2130	Radio Budapest	9585 9835 11910
2100-2150	Voice of Turkey	7215
2100-2200	Radio RSA (Johannesburg)	9585 11900
2100-2200	Radio Moscow World Service	5980 6045 7290 7310 9450
2100-2200	Radio Beijing (Peking)	8260 9860 11500
2115-2245	Radio Cairo	9805

depends on the stations concerned, though most international broadcast stations run some sort of competition from time to time. Perhaps the most famous one amongst the short-wave listening fraternity is the annual competition by Radio Havana Cuba. The first prize is a week's all-expenses paid holiday in Cuba which has prompted the now standard joke that the second prize is two weeks holiday. . . I have never heard of anyone actually winning this one, but presumably people do.

Other stations which in the past have run competitions with holidays as prizes are Radio Polonia, Warsaw (before the recent troubles in that country), Radio Moscow and even Radio Portugal. Radio Japan recently ran an essay competition with a Sony short wave radio as the first prize and many other stations have regular competitions with books (often

merely propaganda material from the East European countries), African wood-carvings, sets of postage stamps for collectors and so on as prizes go.

But listening to broadcast stations shouldn't be just a mercenary venture, nice though it may be to receive an exotic QSL card or win a holiday from time to time. One can learn a tremendous amount about other countries, especially if you have an interest in a particular country and make a point of listening to a broadcast from the station in that country every evening.

Stations I would particularly recommend in this respect are Radio Canada International, Radio Netherlands, Radio Sweden International, and Swiss Radio International. If you are particularly interested in sport Radio Berlin International (from East Berlin) carries a lot of sport news, naturally with the emphasis on the East German

teams, although they cover major European sports meetings also.

If you are interested in the situation in the Middle East, the Voice of Israel and Radio Damascus present diametrically opposed points of view every evening, with Radio Cairo coming somewhere in between. Radio RSA in Johannesburg provides a very different point of view from the one you will usually hear on the reasons for the troubles in that country. Radio Beijing in Peking has toned-down their broadcasts a lot since Mao Tse-Tung died: they now concentrate far more on Chinese culture and music than on reading quotations from the little red book. And if there are no good comedy programmes on television, you can always tune to 7065kHz at 2030 and listen to another exciting episode of "The Marxist-Leninist Movement Throughout the World is Growing in Scope and Strength"!



# Phasing A Round



Most of you will know of the need for circular polarisation when dealing with satellite communications. Here continual changes in signal polarisation due to spin, changing attitude and Faraday rotation imparted by the ionosphere mean the

tages. Even in normal 2m terrestrial communications it can produce spectacular results over linear polarisation. I bet many of you have crossed yagis but only use them in either vertical or horizontal modes — missing out on what is possible

***Circular polarisation is not only for satellite working, on VHF it can be the answer to many of your reception/transmitter problems. This unit 'harnesses' your crossed yagis' power.***

use of linearly polarised (ie purely horizontal or vertical) antennas for either transmission or reception result in much fading. This is due to the polarisation first matching that of the antenna system, then slowly changing to intermediate polarisations, many indeterminate, and probably through the opposite polarisation when the attenuation will be at its worst.

## **Not Just Satellites**

It isn't only with satellites that circular polarisation has advan-

with circular — because of the difficulty in constructing a suitable phasing harness and setting the whole thing up.

Now an easy way is available, the SMC 'Polarphaser', a simple looking box which can take your two feeders from the crossed Yagi. It gives you the ability to have vertical, clockwise, anti-clockwise, horizontal — and a few in between — simply by rotating a knob!

Before you set out, perhaps we had better have a look at why you would want to have circular

polarisation, especially if you are not interested in satellites.

## **Obstruction Effects**

The normal vertical or horizontally mounted antenna radiates linearly polarised signals in the direction of its main lobe ie the electrical field is vertically or horizontally polarised in space. It will maintain this polarisation as long as it meets no obstructions or is not being reflected off the ionosphere. Inevitably it will meet an obstruction and then things begin to happen.

There are two effects from an obstruction. One will be loss of signal strength depending both on frequency of the signal — more loss at higher frequencies — and the polarisation of the obstruction relative to the signal polarisation. The other effect results from reflection of the signal off the object itself. Part of it will change polarisation depending on the nature of the object. This change occurs at every reflection. So by the time the signal gets to its destination, its polarisation is unlikely to bear much resemblance to the original.

If you do have means of changing polarisation between vertical and horizontal, try listening to some distant stations — say repeaters — and which polarisation gives the best reception. You may be surprised to find that horizontal may actually be better and often equally as good as vertical, despite the vertical polarisation of the originating stations antenna.

The actual effect on signal strength due to polarisation changes is well documented. A vertically polarised signal that has shifted through 45 degrees can be expected to produce a loss of 3dB (half an 'S' point) when received on a vertically polarised antenna. In theory, shifting through to 90 degrees (ie now with horizontal polarisation) would produce an infinite loss — in practice the signal is never exactly 90 degrees out and the actual loss is 15-25dB or 2-4 S points. Over short distances, these are the sort of figures you would obtain when no opportunity has occurred for further polarisation shift.

For some reason, horizontally polarised signals are less likely to change their mode than vertical. This may have influenced the choice of this mode for DX working



(ie SSB and CW) rather than vertical. Vertical for mobile use was more intentional as it is a convenient omnidirectional method and it is easier to use a whip than a halo. But, like a base station, the polarisation of a mobile signal will be continually changing, especially in built up areas.

### Circular

When using a circularly polarised antenna (crossed yagi or helix), the electrical field rotates around the axis of the direction of propagation so that it rotates through 360 degrees in one wavelength. What this means is that when such an antenna receives a linearly polarised signal, it doesn't matter whether it is vertical, horizontal, or anywhere in between, the loss is a constant 3dB. Compare this with both ends using linear antennas and a loss of up to 25dB!

If both stations are using circular polarisation, there will be very few polarisation induced losses incurred. However, life is not that simple as there are two types of circular polarisation — clockwise and anti-clockwise. This depends on which way the signal is 'threaded' or rotating. Opposite types will give rise to an even larger loss than opposite linear polarisations — up to 30dB or more. It is important that both ends use the same sense. Also, one station receiving another off the back of a similarly circular polarised antenna will suffer from this problem. Some time ago, a suggestion was made that stations in the northern hemisphere use clockwise rotation — not a bad idea and one which could be followed by experimenters.

So far, we have discovered that circular polarisation will give a gain of up to 20dB compared with linear cross polarisation and a loss at the most of 3dB. Another advantage of circular polarisation is that it is much better at getting into built up areas and dips in the terrain than linear polarisation. The circular signals have more opportunity to be reflected from similarly polarised surfaces.

In the past, besides a pair of equal length feeders from the two yagi dipoles, you needed a means of producing the circular polarisation required. This can be produced easily by a simple 'phasing harness'



where one feeder is lengthened by an electrical quarter wave. This gives a 90 degree phase shift to the dipole which has the extra feeder. Not only this, but you also have to have further quarter wave transformers to bring the paralleled 25 ohm impedance of your two 50 ohm cables back up to 50 ohms again. Unfortunately, this only gives one polarisation mode; for more you have to introduce yet more lengths of feeder and switch them.

### Help At Hand

The 'Polarphaser' overcomes these problems by using a series of 10 printed circuit strip inductors. These simulate the feeder lengths required, selected by a rotary switch mounted on the board. Any of the four main modes can be selected instantly, plus intermediate polarisations depending on the position of the switch. The whole assembly is mounted inside a grey finished diecast box, with UHF (SO239) connectors for the transmitter feed, and two feeders from the antenna. The three sockets are not actually identified, either on the unit or in the instructions, as to which is which but one could guess correctly that the two close together at one end are the two aerial inputs.

A one page instruction leaflet tells you how to set up the unit simply — this involves connecting everything up and tuning to a known, strong, vertically polarised signal such as a local repeater. You then rotate the knob until a null is found the position for horizontal polarisation — the null is much sharper than the peak for setting up purposes. The knob is then loosened and retightened so that it shows horizontal.

Interestingly as 360 degrees phase shift is available, it doesn't matter at all if the original feeder lengths are not equal — the unit

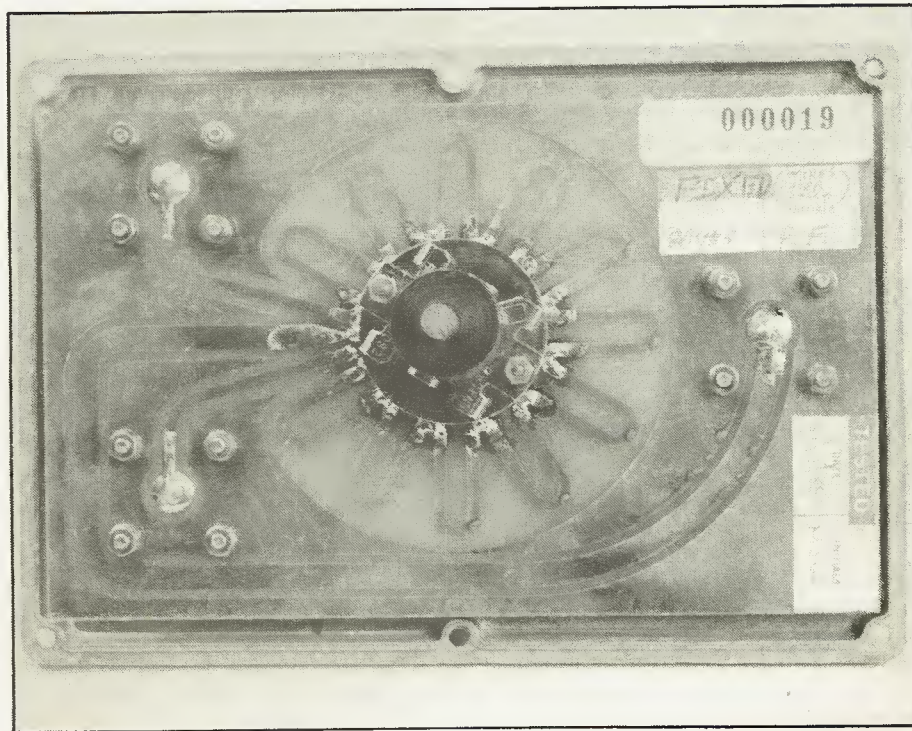



can compensate for any unmatched lengths as these will always be within its range. The two crossed antennas need to be mounted at 45 degrees on the mast rather than at 90 degrees. This also helps eliminate problems caused by the mast being in the same plane as one set of elements.

The one thing you still will not know is whether the two circular modes are actually correct. This can only be ascertained by checking against a known thread circularly polarised signal and then reversing the feeders if incorrect. This isn't actually a problem — just set for best signal strength.

The review sample worked well when set up on receive and transmit and maintained a low VSWR on the antenna feedlines — better than 1.5:1 over 2 metres at all polarisation modes. A small trimmer accessible through a hole on the back allows the VSWR to be set to optimum over the band. There will always be an indicated VSWR present as antennas, plugs, sockets, feeders and probably the VSWR bridge are never perfect 50 ohm matches.

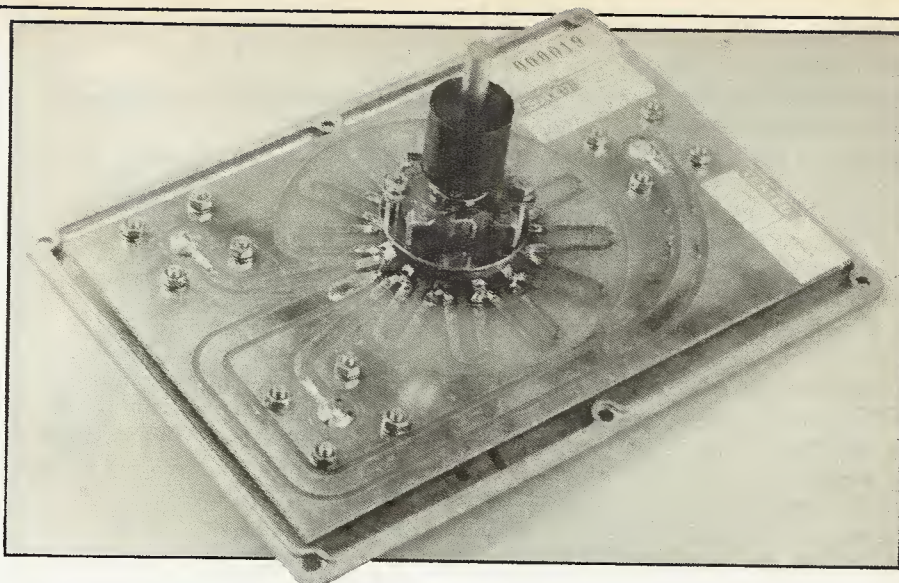

In use, the predicted effects on mobile and satellite signals were as expected, removing flutter through polarisation changes when using one of the circular modes. Some base stations were readable at certain rotations of the knob, which could hardly be heard at either vertical or horizontal, indicating that the polarisation arriving at the antenna was considerably distorted.

To be able to simply rotate the knob on a (grey) box for best signal strength is a considerable asset over say just two switched polarisations. And avid 2m operator will find this relatively cheap unit of immense use when DX chasing — the satellite user will find it invaluable. Thanks to SMC Southampton for the loan of the unit which costs £49 inclusive of VAT.

# Sideswipes

## The Goosed Farmer

Xavier Haddoq, goosed farmer, diabetic, occasional paranoid and inebriate, drew me gently towards him by the throat. Intimating that QRM was not exactly flavour of the month, he did such a dance I thought that he had relieved himself over an electric fence.

Haddoq had fallen foul of the local contest club. This gentle band of fools, having dragged the mobile pissoir they call a radio caravan to the summit of Lids' Leap, attempt to drink themselves to the top of the results table. They often end up under it.

Goose farm has just gone hi-tech, even the geese are goosed by computer. In the wee small hours the club's beam, of twenty kilowatts ERP, felt its way through Haddock Gap, over and into Goose Farm. Much DX was worked, plus the auto loo flush and every alarm in the place. This is what we call an

electro-magnetic compatibility problem. Haddoq had another word for it, after being woken up thirteen times in the night.

The duty op. was quite cooperative. He turned the beam away. This should have been the end of the matter, until a careful and polite investigation, plus some public relations rubbish. Not so. The contest fanatic in charge appears ordering the beam back through Haddock Gap. As an exercise in public relations this is like the Argentine invasion of the Falkland Islands. Words were said, something 'happened' to the generator. Now both sides would rather fight than talk. The farmer can do nothing. That's why he's goosed.

It's up to him to be RF proof. What a way to find out. The contest club all laughed till the tears ran down their legs. They are within their rights.

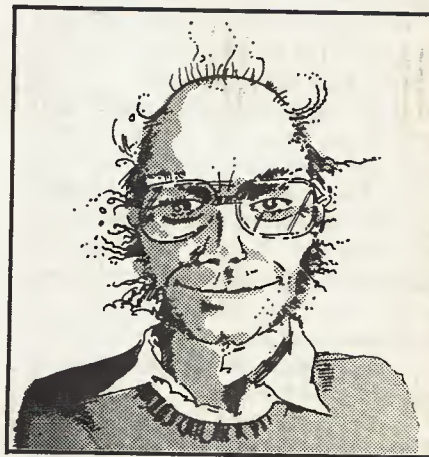

The only time 'Hams' are noticed is when we cause trouble. These tales grow in the telling. Some poor little wimp of a local applied for permission for a mast and the neighbours almost lynched him. I wonder why?

Perhaps one day, our toys will be taken away. They will be within their rights. We can all then chant in chorus, "It's not my fault." Oh yes?

**69's de William, G8QRM**

PS 69's is four (for) less than 73's.



# RADIO Tomorrow

*Your at-a-glance guide to what's happening around the clubs, on the air and in general radio-wise.*

- |       |   |        |  |
|-------|---|--------|--|
| 1 Jan | Cheshunt DARC: natter night.<br>S E Kent (YMCA) ARC: natter night.<br>Denby Dale (Pie Hall) DARS: noggin n' natter.   |        |  |
| 2 Jan | Pontefract DARS: AGM.<br>Telford DARS: open meeting.<br>N Wakefield RC: chairman's chat.  |        |  |
| 3 Jan | Clifton ARS: club meeting.<br>S Manchester RC: meets every Friday in the Norris Road Community Centre, Sale, at 8pm.<br>Dunstable Downs RC: the Idiots construction contest.<br>Nunsfield House CA ARG: shack night.  | 9 Jan  | Community Centre, Yockleton Road, Lea Village.<br>Farnborough DRS: off the cuff film night with G4MBZ.<br>Three Counties ARC: <i>Computer Basic</i> .<br>Glenrothes DARC: meeting every Wednesday in the Library, Leslie from 7.30pm.<br>Conwy Valley ARC: <i>Construction and Function of ATUs by GW3HGL</i> .<br>N Wakefield RC: <i>visit to the Blood Transfusion Service HQ</i> .<br>Abergavenny and Nevill Hall ARC: meets every Thursday.  |
| 6 Jan | Welland Valley ARS: meets every Monday at Welland Park Community College, Market Harborough.<br>Borehamwood and Elstree ARC: meeting at the Organ Hall Club, Bairstow Close, Borehamwood, starting at 7.30pm.<br>Basingstoke ARC: <i>23cm Operation by G3NNG</i> .<br>Southdown ARS: meeting.<br>Welwyn Hatfield ARC: <i>Demonstration of RTTY systems</i> .<br>Todmorden DARS: judging the construction competition.<br>Pontefract DARS: annual junk sale.<br>S Tyneside ARS: meets every Monday at the Martec Club, S Shields Marine and Technical College at 7.30pm. Visitors and new members welcome.<br>Morecambe Bay ARS: <i>Audiology by G1PMZ</i> .<br>Braintree DARS: meeting at the Braintree Community Association Centre, Victoria Street, Braintree.<br>Worcester DARC: <i>Police Communications</i> . | 10 Jan | Ayr ARG: natter night.<br>Clifton ARS: club meeting.<br>Amateur Radio and Computer Club: meeting at the Crown, Bishops Waltham.<br>Radio Society of Harrow: activity night.<br>Dartford Heath DFC: DF hunt.<br>Wimbledon DARS: meeting at St Johns Ambulance HQ, 124 Kingston Road, Raynes Park.<br>Nunsfield Hse CA ARG: <i>WW2 Radio Collection</i> .  |
| 7 Jan | Rugby ATS: <i>RSGB region rep Glen Ross, G8MWR</i> .<br>Fylde ARS: AGM.<br>Chester DRS: AGM.<br>Dartford Heath DFC: pre hunt meeting.<br>Bury RS: meets every Tuesday at the Mosses Centre, Cecil Street.<br>Stevenage DARS: discussion on AFS contest, at Sitec Ltd Ridgemoor Park, Telford Avenue, Stevenage.<br>Wolverhampton ARS: night on the air, your problems solved.   | 13 Jan | S Cheshire ARS: <i>Talk by the local Crime Prevention Officer at the Victoria Club, Gatefield Street, Crewe, starting at 8pm</i> .<br>Dorking DRS: informal.<br>Chester DRS: construction contest winners talk about their equipment.<br>Bury RS: <i>Getting started on RTTY with G3VC</i> .<br>Wolverhampton ARS: discussion night.   |
| 8 Jan | White Rose ARS: test gear night.<br>S E Kent (YMCA) ARC: quiz for the G2CJC Trophy.<br>Denby Dale and Pie Hall ARS: AGM.<br>Mirfield RC: meets every Wednesday at the   | 14 Jan | Dorking DRS: informal.<br>Chester DRS: construction contest winners talk about their equipment.<br>Bury RS: <i>Getting started on RTTY with G3VC</i> .<br>Wolverhampton ARS: discussion night.<br>White Rose ARS: natter night.<br>S E Kent (YMCA) ARC: natter night.<br>Hastings ERC: <i>Aerials</i> .<br>Telford DARS: VHF NFD planning.<br>BT (Reading) RC: meeting.<br>Denby Dale (Pie Hall) DARS: noggin n' natter.<br>Havering DARC: AGM at the Fairkytes Arts Centre, Billet Lane, Hornchurch.<br>Worcester DARC: informal. |
|       |   | 15 Jan | Pontefract DARS: junk sale.<br>N Wakefield RC: visit to Pontefract junk sale.<br>Clifton ARS: club meeting.<br>Fylde ARS: AGM.<br>Radio Society of Harrow: film show.<br>Dunstable Downs RC: junk sale.<br>Nunsfield House CA ARG: <i>Model Engineering</i> .<br>Worcester DARC: quiz vs Cheltenham ARA at Cheltenham.   |
|       |   | 16 Jan | Glenrothes DARC: meeting.  |
|       |   | 17 Jan | Welwyn Hatfield ARC: top band activity night.  |
|       |   | 19 Jan |  |
|       |   | 20 Jan |  |



MUGTOWN DX  
EVENING

©CqW/3COI 346

"... AND I WOULD ALSO APPRECIATE  
YOUR QSL - MY CALL IS ....."



- |  |   |  |   |
|--|---|--|---|
| <p>21 Jan</p> <p>22 Jan</p> <p>23 Jan</p> <p>24 Jan</p> <p>28 Jan</p> <p>29 Jan</p> <p>30 Jan</p> <p>31 Jan</p> <p>3 Feb</p> | <p>Todmorden DARS: informal chat.<br/>Morecambe Bay ARS: AGM.<br/>Braintree DARS: meeting.<br/>Fylde ARS: informal and morse class.<br/>Chester DRS: meeting.<br/>Midland ARS: meeting.<br/>Stevenage DARS: RTTY by G3OVT and G4DOX.<br/>Wolverhampton ARS: <i>The Radio Regulatory Dept</i> by Keith Townsend, G4PZA.<br/>White Rose ARS: <i>Amateur Radio in Japan</i> by JY9WR/G4ATZ.<br/>S E Kent (YMCA) ARC: <i>Amateur Television</i> by G3ZYZ.<br/>Denby Dale DARS: open discussion.<br/>Farnborough DRS: constructional contest winner G8 ATK.<br/>Three Counties ARC: <i>Beekeeping</i> by G0BUZ.<br/>Telford DARS: <i>SSTV</i> by G4IUT.<br/>Havering DARC: <i>SHF DX</i> by G8DPB.<br/>Conwy Valley RC: meeting.<br/>Pontefract DARS: project evening.<br/>N Wakefield RC: <i>Weather</i> by staff at Leeds Weather Centre.<br/>Ayr ARG: homebrew competition.<br/>Clifton ARS: club meeting.<br/>Radio Society of Harrow: activity night on 15m.<br/>Wimbledon DARS: meeting.<br/>Nunsfield Hse CA ARG: <i>Grand Shack Reopening</i>.<br/>Dorking DRS: AGM.<br/>Chester DRS: WOORE lecture and Satellite Communications videos.<br/>Wolverhampton ARS: night on the air, discussion groups.<br/>Verulam ARC: <i>Weather Satellites</i>.<br/>White Rose ARS: natter night.<br/>Denby Dale DARS: <i>Fire Service Communications</i> G4YTE.<br/>Rugby ATS: <i>visit to BTI Radio Station, Rugby</i>.<br/>S E Kent (YMCA) ARC: <i>Films</i> by G3VSU.<br/>Darenth Valley RS: <i>talk by Chris Ridley of KW TenTec of Chatham. The club meets in the Crockenhill Village Hall near Swanley at 8pm.</i><br/>Telford DARS: <i>Test Equipment</i> by G6UDX.<br/>Pontefract DARS: <i>Making Transparencies</i> by G4ISU.<br/>N Wakefield RC: meeting.<br/>Clifton ARS: club meeting.<br/>Radio Society of Harrow: <i>Contests For All</i> by G4JNZ.<br/>Dunstable Downs RC: film show.<br/>Nunsfield Hse CA ARG: <i>Alan Dunford, G3XOF</i>.<br/>Borehamwood and Elstree ARC: meeting.<br/>Basingstoke ARC: <i>Wood and Douglas equip-</i></p> | <p>4 Feb</p> <p>5 Feb</p> <p>6 Feb</p> <p>7 Feb</p> <p>9 Feb</p> <p>11 Feb</p> <p>12 Feb</p> <p>13 Feb</p> <p>14 Feb</p> <p>15 Feb</p> <p>17 Feb</p> | <p><i>ment. Community Centre, Sycamore Way, Winklebury.</i><br/>Southdown ARS: meeting.<br/>Todmorden DARS: AGM.<br/>Morecambe Bay ARS: <i>Wood and Douglas kits, G. Rouse.</i><br/>S Tyneside ARS: meets every Monday at the Martec Club, S Shields.<br/>Braintree DARS: meeting.<br/>Worcester DARC: <i>Talk</i> by G3PQR.<br/>Dartford Heath DFC: prehunt meeting.<br/>Bury RS: meets every Tuesday at the Mosses Centre, Cecil Street.<br/>Stevenage DARS: construction evening.<br/>Wolverhampton ARS: <i>Transmitter Testing - frequency, power, deviation etc.</i><br/>White Rose ARS: <i>DXpedition to Laccadives (VU7) video.</i><br/>S E Kent (YMCA) ARC: natter night.<br/>Mirfield RC: meets every Wednesday.<br/>Three Counties ARC: <i>Satellite TV</i> by G8CMQ.<br/>Glenrothes DARC: meets every Wednesday in the Library, Leslie.<br/>Pontefract DARS: homebrew show.<br/>Havering DARC: surplus equipment and junk sale.<br/>N Wakefield RC: social night.<br/>Dunstable Downs RC: AGM.<br/>Abergavenny and Neville Hall ARC: meets every Thursday.<br/>Ayr ARG: <i>On To 6m</i> by GM4NFC.<br/>Amateur Radio and Computer Club: meeting at the Crown, Bishops Waltham.<br/>S Manchester RC: meets every Friday in the Norris Road Community Centre, Sale.<br/>W Kent ARS: surplus equipment sale.<br/>Nunsfield Hse CA ARG: AGM.<br/>Clifton ARS: club quiz.<br/>Dartford Heath DFC: DF hunt.<br/>Bury RS: <i>Installing Your HF Station - avoiding the pitfalls</i> by G4JAG.<br/>White Rose ARS: natter night.<br/>Farnborough DRS: <i>My favourite piece - an equipment evening by the members.</i><br/>Havering DARC: informal.<br/>Conwy Valley RC: <i>Test Equipment</i> by GW3JGA.<br/>Pontefract DARS: project evening.<br/>N Wakefield RC: on the air.<br/>Wimbledon DARS: meeting.<br/>Nunsfield House CA ARG: surplus sale.<br/>Clifton ARS: meeting.<br/>Glenrothes DARC: meeting.<br/>Todmorden DARS: informal chat night.<br/>Morecambe Bay ARS: film show.<br/>Braintree DARS: meeting.</p> |
|--|---|--|---|



18 Feb Rugby ATS: *Talk by DTI, RIS.*  
Midland ARS: meeting.  
Stevenage DARS: junk sale.  
Wolverhampton ARS: discussion night.

19 Feb White Rose ARS: surprise night!  
Three Counties ARC: *Steam Railways by G3ZRM.*  
BT (Reading) RC: meeting.  
Havering DARC: *Contest Operating demonstration and talk.*  
Worcester DARC: informal.

20 Feb N Wakefield RC: *Coach visit to Jorvik Museum, York.*

21 Feb Ayr ARG: *ZS Radio by ZS6CBF.*  
Nunfield House CA ARG: technical filmshow.  
Clifton ARS: video evening.

23 Feb Cambridgeshire Repeater Group junk sale/rally extravaganza! At Pye Telecommunications, St

Andrews Road, Cambridge starting at 10.30 am. Many trade stands and the 'monster' junk sale, bring and buy/auction. Bargains guaranteed! Free parking, refreshments available admission 50p. Talk in on S22.

25 Feb Wolverhampton ARS: night on the air.  
26 Feb White Rose ARS: natter night.  
Farnborough DRS: open evening for RAE and CW students.  
Havering DARC: pre contest briefing and informal.  
27 Feb N Wakefield RC: meeting.  
28 Feb Wimbledon DARS: meeting.  
Clifton ARS: meeting.

**Will club secretaries please note that the deadline for the April segment of Radio Tomorrow (covering radio activities from 1st March to 1st June) is 28th January 1986.**

### Contacts

Abergavenny & NH ARC	GW4XQH	0873 4655
Alyn and Deeside ARS	GW4RKX	0244 660066
Axe Vale ARC	Bob	029 74 5282
Ayr ARG	GM3THI	Ayr 42313
Barking RES	R. Woodberry	01 594 4009
Bath DARC	G4UMN	Frome 63939
Basingstoke ARC	Dave	07356 5185
Biggin Hill ARC	GOAMP	0689 57848
Borehamwood Elstree ARS	Tony	01 207 3809
Braintree RS	J. Roberts	0376 44857
Brighton DARS	Peter	0273 607737
Bristol ARC	G4YOC	Bitton 4116
Bristol (Shirehampton) ARC	Ron.Ford	0272 770504
BT (Reading) ARC	G4MUT	0734 693766
Bury RS	G1PKO	0282 24254
Cambridge DARC	D. Wilcox	0954 50597
Cheshunt DARC	Roger Frisby	0992 464795
Chester DRS	Alan	0244 40055
Chichester DARC	C. Bryan	0243 789587
Clifton ARS	RA Hinton	01 301 1864
Conwy Valley ARC	GW4VVW	0492 636376
Coventry ARS	R. Tew	0203 73999
Darenth Valley RC	G1NMX	Orpington 26951
Dartford Heath DFC	Pete	0322 844467
Denby Dale DARC	G3SDY	0484 602905
Derwentside ARC	G1AAJ	0207 520477
Donegal ARC	EI3BOB	074 57155
Droitwich DARC	G4HFP	0299 33818
Dudley ARC	John	0384 278300
Dunstable Downs RC	Phill Morris	0582 607623
East Kent RS	Stuart	0227 68913
East Lancashire ARC	Stuart	0254 887385
Edgware DARS	John	01 306 4342
Exeter ARS	Roger Tipper	0392 68065
Fareham DARC	Brian	0329 234904
Farnborough DRS	Mr Taylor	0252 837581
Fylde RS	PRO	0253 737680
Galashiels DARS	GM3DAR	0896 56027
G. Peterborough ARC	Frank	0733 231848
Halifax DARS	D Moss	0422 202306
Harrow RS	Dave Atkins	0923 779942
Hastings ERC	Dave Shirley	0424 420608
Haverhill DARS	Rob Proctor	0787 281359
Havering DARC	GOBOI	04024 41532
Hornsea ARC	Norman	0262 73635
Horsham ARC	Pete Head	0403 64580
Inverness ARC	Brian	0463 242463
Kidderminster DARS	Tony	0562 751584
Kingston DARS	G3ODH	Epsom 26005
Leighton Linlade RC	Pete Brazier	052 523 270

Loughborough ARC	Philip	0509 412043
Loughton DARS	G6FWT	01-508 7190
Maidenhead DARC	John	0628 28463
Maidstone YMCA S/C ARS	G4AYD	0622 29462
Maltby ARS	Ian Abel	0709 814911
Medway ARTS	Tony	0634 578647
Midland ARS	G8BHE	021382 0086
Mid Sussex ARS	G1FRF	0791 82937
Mid Ulster ARC	DF Campbell	0762 42620
Mid Warwickshire ARS	G4TIL	Southam 4765
Morecombe Bay ARS	G3PER	Heysham 52659
N. Cornwall RS	J. West	0288 4916
N. Staffs ARS	G6MLI	0782 332657
N. Wakefield RC	S. Thompson	0532 536633
Newbury DARS	G3VOW	0635 43048
Oswestry DARC	Brian	0691 831023
Pontefract DARS	GOAAO	0977 43101
Preston ARS	George	0772 718175
Rhyl DARC	GW1AKT	Nantglyn 469
Shefford DRS	G4PSO	Hitchin 57946
S. Bristol ARS	Len Baker	0272 834282
S. Cheshire	Chris	Kidsgrove 73185
S. Lakeland ARS	Dave	0229 54982
S. Manchester ARC	Dave Holland	061 973 1837
S. Tyneside	G4XWR	S. Shields 543955
S. E. Kent (YMCA) ARC	John	0304 211638
Southdown ARS	P. Henly	0323 763123
Stevenage DARS	Frank, G4ISO	Baldock 892765
Stockton DARS	John Walker	0642 582578
Stowmarket DARS	M. Goodrum	0449 676288
St. Helens DARC	A. Riley	051 430 9227
Swale ARC	B. Hancock	0795 873147
Telford DARS	Tom Crosbie	0952 597506
Three Counties ARC	Keith, GOBTU	0730 66489
Tiverton (SW) RC	G. Draper	03634 235
Todmorden DARS	Mr Gamble	070 681 2494
V White Horse ARS	Ian White	Abingdon 31559
Verulam ARC	Secretary	St Albans 59318
WACRAL	G4NPM	0795 873147
Wakefield DRS	G8PBE	0924 378727
Welland Valley ARS	J. Day	0858 32109
Welwyn Hatfield ARC	Dave	07073 26138
West Kent ARS	B. Guinnessy	0892 32877
Westmorland RS	G. Chapman	0539 28491
White Rose ARS	G4YEK	0423 884481
Willenhall ARS	G4LWI	0902 782036
Wimbledon DARS	G3DWW	01 540 2180
Wirral ARS	Cedric	051 625 7311
Wirral DARC	Gerry Scott	051 630 1393
Wolverhampton ARS	Keith	0902 24870
Worcester DARC	D. Batchelor	0905 641733
Worthing DARC	Roy	0903 690415
308 ARC (Surbiton)	Dave Davis	01 399 5487



# Log It For Posterity!

I was very surprised to see a news item recently stating that American amateurs were no longer required to keep a log of their operations. Perhaps I am a little pedantic, but to me radio logkeeping is part and

during normal operations.

1. The *time* of all transmissions should be recorded in Greenwich Mean Time. In the UK we are fortunate that during the winter months this is the same as local time, and

column is headed D R (Dial Reading). This is a habit going back to my old homebrew days but now it records the digital (or otherwise) frequency reading. My mode or 'class of transmission' is invariably CW so no MODE column is allowed for. On the rare occasions that I use a microphone I enter SSB and underline it in the REMARKS column.

I believe that the sequence of Log entries are very much a personal affair. As long as the necessary information is recorded and can be extracted, you are complying with the 1949 Wireless Telegraphy Act. Another advantage of 'rolling your own' Log is that the sequence can coincide with your QSL card layout. This can speed up sessions devoted to the writing out of QSL cards.

Using my design for columns, I have over half a page — more than 4" of space remaining for remarks. This is usually sufficient for notes made during an over. My notes are usually abbreviated but in sufficient detail to ensure all necessary information is recorded. Again, depending upon personal taste, further columns can be ruled up and act as QSL checks. Ticks can be made when you send a card out — and when received. Temperature can be recorded at the commencement of a session.

Shortwave listener Logs can be drawn up on the same lines whether it is amateur or broadcast stations that are monitored. Here again the operator can use his or her imagination as to column headings. It may be useful to have wider spaces for signal reporting to describe types of fading or interference. The date and means of posting a QSL card can also be recorded.

Purely for nostalgic reasons I still 'SIGN ON' for a period of

*Log keeping may seem a time consuming chore, but it does have some distinct advantages as Stan Crabtree, G3OXC, explains.*

parcel of the whole business that goes under the banner of amateur radio operations.

As an ex marine operator perhaps I was schooled along too strict a line. On ships, keeping watch on 500kHz, it was a requirement that an entry should be made in the official Log Book "at least every 15 minutes". During periods of non operation this meant the entry of another ship's call sign in between the often pseudo "silence period observed" endorsement at 15 and 45 minutes past each hour. The only time I couldn't manage this was on a trip between Japan and the Panama Canal during daylight hours!

My amateur log serves as more than just a record of contacts. It is a complete diary of events. Everything to do with the station is recorded from the often fruitless calls of 'CQ' on ten metres (not previously mandatory but well worth entering) to the erection of a new antenna. Apart from the required signal reports, locations and names, I also jot down whatever item of interest crops up in the following exchanges. Perhaps he's using 2 watts! Or he may be 83 years old.

## The Regulations

Let's look at the regulatory requirements for a fixed station log

only one hour different when the clock goes forward in the summer. We never have to calculate the date — a necessary task for amateurs on the other side of the globe. Incidentally, the abbreviation UCT appearing on DX QSL cards is the updated version — Universal Coordinated Time — but is the same as GMT.

2. The *calls signs* of other stations worked or called.

3. The *frequency or waveband* on which the transmission took place and the *mode* of that particular transmission eg CW, SSB etc.

4. A further requirement is that Log entries be made at the time of the transmission, no gaps should appear between successive entries and the Log Book should not be loose leaf.

## A Personalised Log

Whilst a commercially produced Log Book is not especially expensive I prefer to use a plain A4 stiff backed book, which I rule up to suit my needs. An example of my log is shown in Fig. 1. The date is written on a separate line therefore the first column bears the time. To me, who called who is irrelevant so the second column is headed STATION WORKED — this saves the space of one column. Signal reports come next in two columns and then the wave band of operation. I like to know the actual frequency for reference and the next



TIME	STATION WRKD	SENT	RECVD	F Q	D/R	MODE	REMARKS
1305	G4PBK	569	569	10	101	CW	Jeanis Thornbury Bristol 1COM 720
19	PAØVSS	449	549	10	108	"	Tan HEEMSKERK TS 130V needs QSL
1325	Off watch.						
27 JULY 1983							
1930	On watch						
1958	PYØFE	579	599	21	020	CW	Fernando de Noronha - File up via PYIBVY
2006	CN9CL	589	589	21	002	-	Wolf ASILAH - DLØ01
2205	TR8JLD	579	569	21	004	.	Box 484 Liberville Gabon
07	W3NX	579	589	14	025	.	Ray Delaware
11	N4LS	599	579	.	025	.	Linn
2235	VP2MM	599	599	.	034	.	Alex Montserrat via AB1U
2250	Off watch						
30th JULY 1983							
2230	CW watch	-	-	-	-	-	On watch
2245	CQ	-	-	1.8	35	CW	N'Reply
2302	SM5AKT	579	599	1.8	41	"	Lars
04	G3TNO	589	599	.	46	.	Male Horsham W. Sussex
15	E14DW	589	599	.	61	.	Ken ex GM3SSB Donegal IC 740
27	OK3CSB	579	589	.	66	.	Jano C Komario - needs QSL

Fig. 1 An extract from G3OXC's homebrewed Log Book.

operation much the same as I did at sea many years ago. If you spend a lot of time listening at least you have a note of the times. Apart from basic operating signals it is well worthwhile recording anything that relates to your station in the station Log. Additions, changes and usage of equipment is an example. On the social side it is handy to record the visits of callers whether they be amateurs or not. It is of course necessary that should another person operate your station his signature and callsign should endorse all transmissions made.

### Logs As Evidence

A few years ago I was accused of causing TVI. As it happened, the allegation was made in a wild and unsuccessful attempt to obstruct

an antenna planning permission application. Thanks to keeping an accurate Log I was able to counter attack by requesting dates, times and types of interference. Furthermore, I was able to produce a Log that sported the signature of two GPO engineers of the 'Interference Squad'. The log had an entry which showed that no spurious or unwanted radiation had been detected from my equipment running at full power on all the HF bands.

A well kept Log may also be worthwhile in the event, however remote, of your call being pirated. If the illegal operator further violates the accepted rules of amateur communications you may be called to task, however wrongly. Again your record of operations could save the day. It may not prove you were not using the offending operator's fre-

quency at the time but it could be useful to show you were operational on another frequency with a different mode!

Apart from being a mandatory requirement, keeping a good Log can retain the memory of your amateur radio operations for a lifetime. I take great pleasure occasionally browsing through old Logs, noting the call signs and reading the comments. I know of at least one Old Timer who has kept his Logs intact since pre-war days. I'm sure there are many more.

I'll end with a plea to the many newcomers to our hobby; both transmitting amateurs and short wave listeners. Don't think of logkeeping as a chore to be tolerated - consider instead its future contribution to your own posterity and possibly amateur radio history.



# A 2m SSB Linear **PART 2**

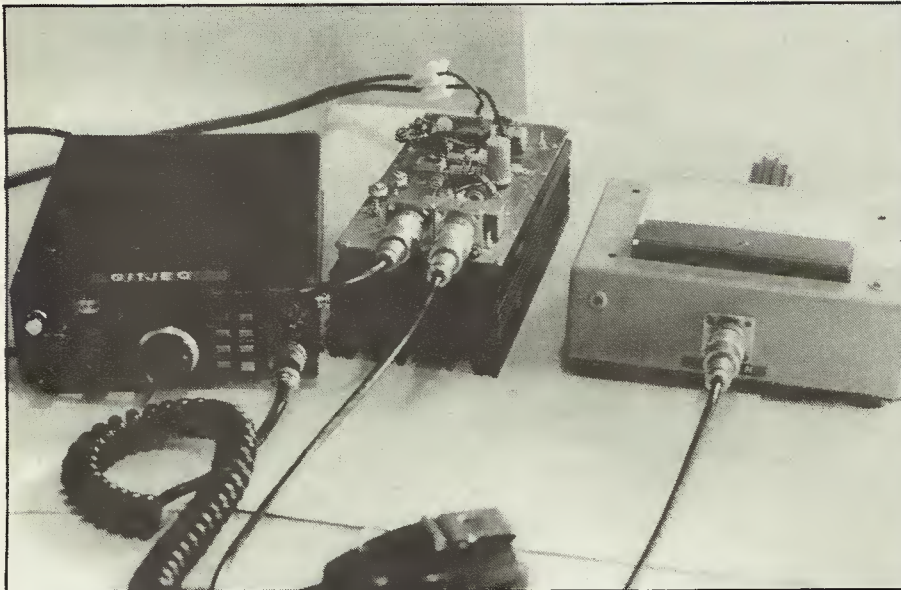

The amplifier is constructed on a piece of double sided 1oz copper fibreglass board measuring approximately 190mm x 80mm. Do not use 2oz board as this will affect the values of the airline inductors. The

PCB with a 4mm tap or a centre punch with a fine point. This will enable location of the holes for mounting the components. Drill all the holes for the top foil first as this will help centre the bottom layout

to the etchant.

The locating holes for the upper and lower foils are also the centres of Q2 and Q3. Open the Q2 mounting hole to a diameter of 10mm and similarly open Q3 to 13mm. Cut with a saw and file, for the flange to pass through the PCB — but do not make the clearance for the flange excessive. With all the holes drilled, the PCB is set on the heatsink and a 4.5mm (3/16") hole drilled for the Q2 stud and two holes drilled for Q3 — these devices are not fitted until later. Similarly, drill at least four holes (with 6BA clearance) to provide support for the PCB on the heat-sink.

Solder the Veropins, ensuring a good joint on both top and bottom sides. Components C9, C10, D4, C16, C17, D6 and C18 cannot be fitted until Q2 and Q3 have been soldered into position. However, mount the remaining components and check for connection on the top foil. Do not forget the wire link between the relays. A wire link is also needed underneath the board from 'A' to 'B' and from 'B' to 'C'. This carries the +13.8V supply to the T/R relays and Q2 and helps to set the quiescent collector current in Q2 and Q3.

Take care when winding the six hole ferrite sleeve and bead RFCs so that no shorted turns occur. Also ensure that the location of C13, C14 and C15 is within the few millimetres indicated on the layout. The board is now placed on the heatsink over the four 6BA studs, or bolts as suitable, and Q2 the 2N6082, can be checked for alignment and clearance. It is better to have a little extra clearance in the 6BA mounting as this eases alignment of the transistors.

The leads of Q2 are bent as in Fig. 5. These 90° bends will help in soldering in and, if necessary,

## *Geoff Pike, G11JEQ, describes the construction and alignment of this 80W linear.*

width of these inductors is not too critical, since it is length that mainly determines the overall inductance. The foil patterns for top and bottom sides are shown in Fig. 3 and Fig. 4.

If you are etching your own boards, I find the best way is to mask the top and bottom with magic tape or regular masking tape. Draw the pattern onto the tape and then cut away the areas of the tape where copper is needed. Spray both sides with grey car primer a few times, then remove the remaining tape. The exposed copper will be etched, while the painted copper will be protected from the etchant.

Before drawing the bottom layout on the tape, gently tap the

with respect to the top. It may be easier to protect the area under the relays using an etch resistant pen rather than the tape. This method of making PCBs results in a reasonably tidy and neat appearance.

After cleaning the board, clear all the holes out and those requiring Vero-pins should be suitably opened to allow a good fit. Ensure that the relays RL1 and RL2 fit without undue pressure on the pins. All the holes that do not have an earth connection on the top foil should be opened just to the depth of the copper layer using a 2.5mm drill. Alternatively, these holes can be made by scraping away some of the primer paint and exposing the areas



**The component overlay diagram for the 80W SSB linear amplifier.**

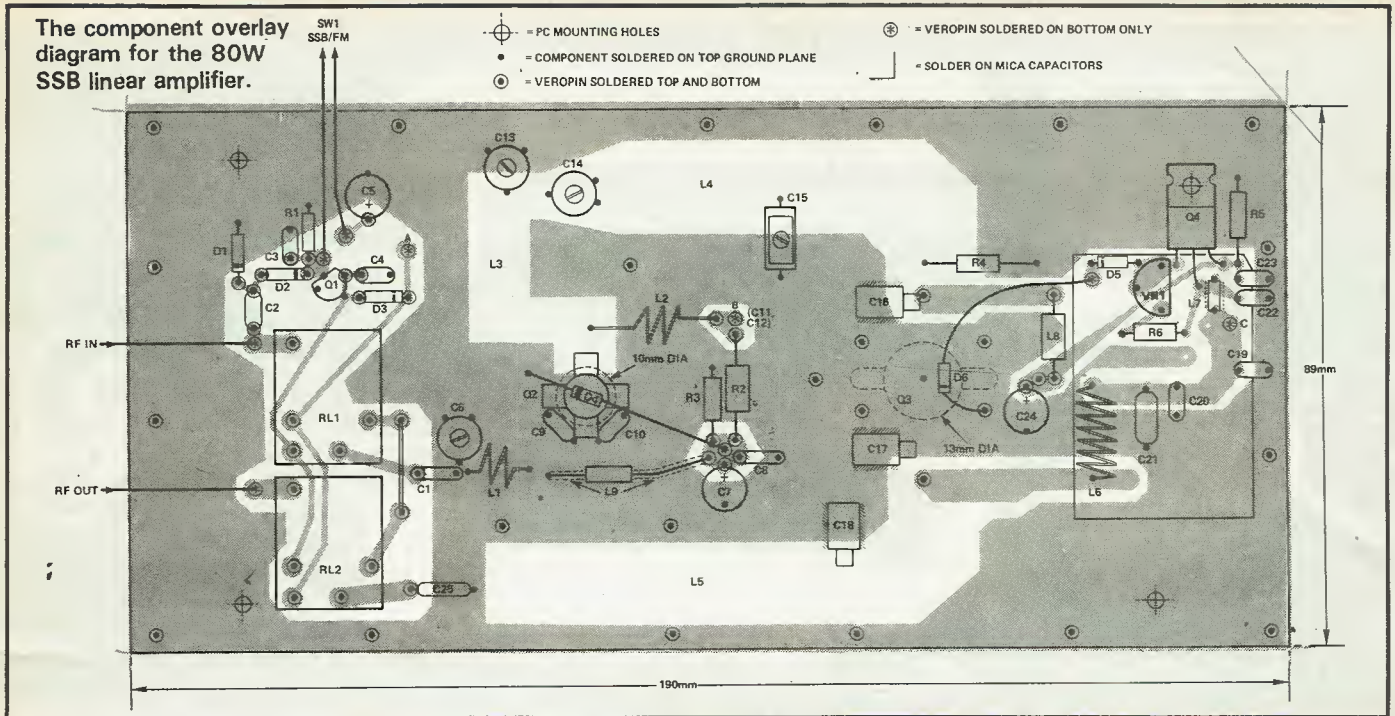

removal. Also the slight downward slope of the leads will avoid any strain on the transistor when finally installed. Lightly tighten the nut on the stud of Q2 for the moment. Fit and check that Q3 clears its cutout and bolt down with suitable screws into the heatsink. Check that there is no undue pressure on either transistor and that their orientation is correct. Finally, solder them into position.

C11 and C12 have to be fitted on the under side of the board. C16 and C17 should be fitted as close as possible to the body of the transistor ensuring that a good flow of solder goes on to the capacitor sides. C9 and C10 must have their leads as short as possible before soldering into place. Add a smear of heatsink compound before soldering in D4 and D6 as well as smearing the flange and stud of the transistors.

Q4 does not need a heatsink although the mica washer which is its bush should be smeared with some compound. The switch SW1 and the RF connectors are left to the individual to position. My versions had SO239s soldered directly to the top ground plane so ensure short connection to the Veropins.

C18 can be fitted as indicated or just tacked into place to allow easy adjustment if required. Take care when doing this as L5 is at 13.8V.

Just before tuning up, solder the negative supply leads as near

as possible to the emitter of Q3 and the positive supply to point C. Check for shorts and that all the relevant components are clear of the top foil. Finally check the polarities of the diodes and electrolytic capacitors and the clearance between the PCB and the heatsink.

**Tuning Up**

You will need a power indicator, a 50 ohm dummy load rated at no less than 50W and an ammeter to measure the collector current. Before applying any RF the  $I_{CQ}$ , the quiescent collector current, in Q2 and Q3 must be set. Set VR1 to maximum resistance and switch

on. Check that everything is okay and limit the current by means of a 2 ohm 10W resistor which should prevent any disasters.

Set  $I_{CQ}$  in Q2 to 20-25mA — you may find it easier to do this with L2 temporarily up ended which may cause Q2 to oscillate. Adjustment is made by changing R2, with fine adjustment via R3 if needed. Total current from the PSU should be about 100-120mA at this stage.

Reconnect L2 and disconnect the +13.8V supply to Q2 via the wire link. Switch on again; this time Q3 and Q4 should be drawing all the current from the PSU which should be quite low. Adjust VR1 to

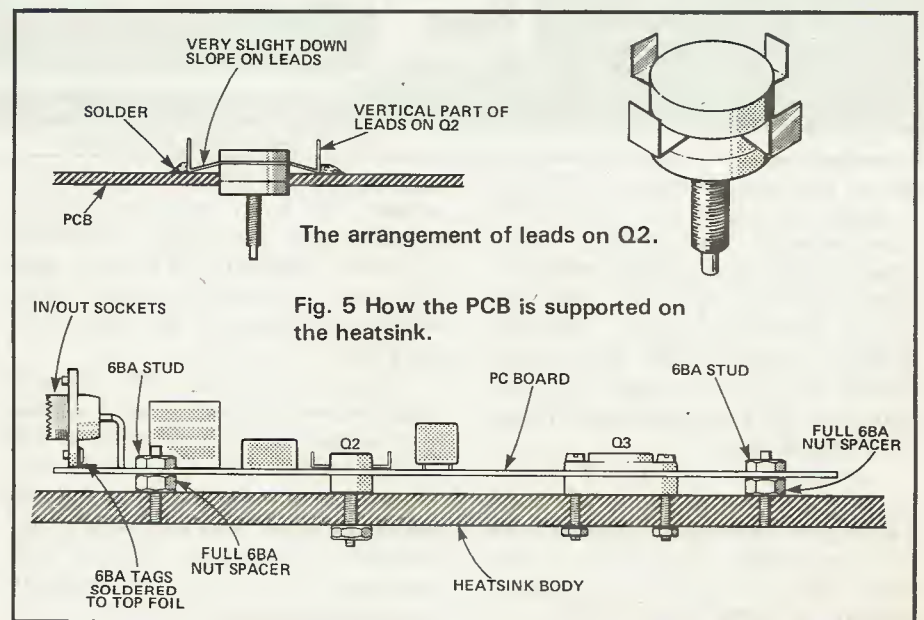

The arrangement of leads on Q2.

Fig. 5 How the PCB is supported on the heatsink.



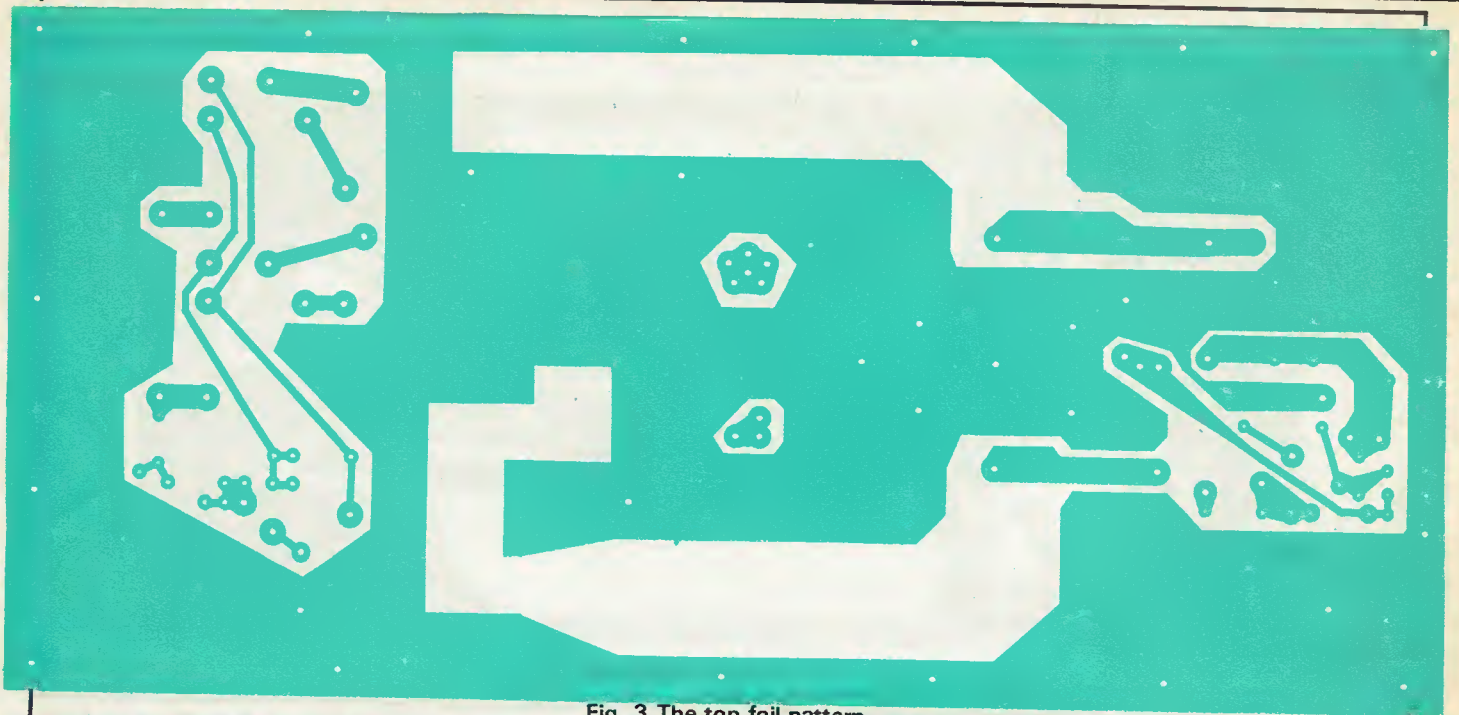

Fig. 3 The top foil pattern.

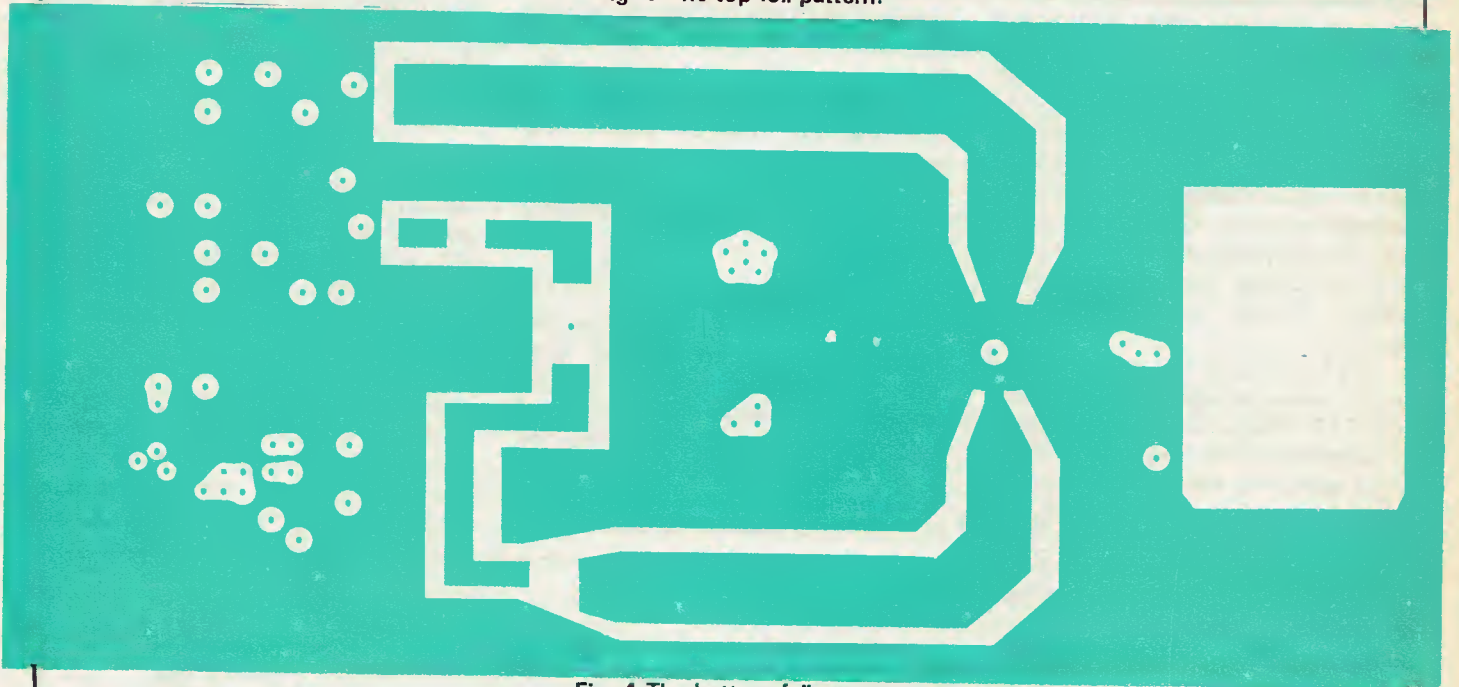

Fig. 4 The bottom foil pattern.

get an indicated current of 100mA — about 20mA of this goes in the bias network. Ensure that D6 is close to Q3's body. Disconnect the power and reconnect the wire link to Q2. Switch on again, with the limiting resistor still in circuit. Preset C6 to 1/4 mesh, C14 to maximum C13 to half and C18 to max less 1/2 turn.

Connect up the power meter and dummy load and your transceiver and apply no more than 3W, preferably only 2W. If the relays fail to change over, this is due to a high input VSWR so

reduce to low power if possible. Adjust C6 such that the relays come in and out reliably. Restore full input and tune C14, C13 and C15 for maximum power out, which is unlikely to be more than 20-25W.

If all is working well, disconnect the limiting resistor and retune for maximum power but only for 10 second bursts. This will prevent excessive dissipation in the output transistor while you are tuning up. Watch the collector current and make sure it does not rise too much ie more than about 15A max. The

typical current should be in the region of 11 to 12A.  $I_{Cq}$  should not be overheating. If you see any of these signs of that RF is being emitted when none is being put in, ie instability, then stop, you have a fault. If the SSB delay time is not suitable, change the value of C7 to an appropriate value.

### My Results

With an FT290R connected via 70cm patch lead to the amplifier, another 70cm patch lead to the power meter, and a 13.8V supply



to the transceiver and linear, approximately 20-25W was achieved on low power. On high power the power out was in the region of 75-80W. When tuned to 144.250MHz, the linear's output

was 80W which fell to 75W at 144.575MHz.

While in use, take care to avoid overheating and if the heatsink gets too hot to touch, the amplifier should be switched off and allowed

to cool. When monitoring the collector current do not talk it up on SSB instead, try to average it to half of the maximum FM value as this will avoid excessive IMD products.

Components List					
<b>RESISTORS</b>					
R1	100k, 0.25W	L8	6 hole ferrite bead.	C17	220pF mica wrapped
R2	220R, 0.5W	L9	2R2 0.25W resistor with ferrite beads each end.	C18	100pF mica wrapped
R3, 5	27R, 0.5W			C21	100nF cer plate, 50V
R4	22R, 0.5W			C25	1000pF 350V silver mica
R6	820R, 0.25W				
VR1	4k7 vert preset				
<b>INDUCTORS</b>		<b>CAPACITORS</b>			
L1	2 turns on 8mm (ID) .7mm long 20 swg silver plated wire.	C1	18pF cer plate, 50V	<b>RELAYS</b>	
L2	3 turns on 6.5mm (ID). 8mm long 20 swg silver plated wire.	C2, 9, 10	47pF cer plate, 50V	RL1 and RL2	OUR, Cirkit stock no. 46-70050
L3, 4, 5	airline inductor on PCB.	C3, 4, 11, 19, 22	1nF cer plate, 50V	<b>SEMICONDUCTORS</b>	
L6	12 turns on 6.5mm (ID). 15mm 20swg wire.	C5	470uF 10V radial electrolytic	Q1	BC108
L7	4 turns on 30swg wire.	C6, 13, 14	5-60pF film trimmer	Q2	2N6082
		C7, 24	220uF 10V radial electrolytic	Q3	MRF247
		C8, 12, 20, 23	10nF cer plate, 50V	Q4	TIP31A
		C15	5-80pF mica compression trimmer	D1, 2, 3	1N4148
		C16	470pF mica wrapped	D4, 5, 6	1N4001
				<b>MISCELLANEOUS</b>	
				1oz double sided PCB; one switch SPCO (FM/SSB); wire; Veropins; 4x6BA bolts and nuts.	

## HAM RADIO TODAY FEBRUARY 1986 ADVERTISERS INDEX

<b>ARE Communications.....67</b>	<b>Microwave Modules.....68</b>
<b>Amateur Electronics .....8-9, 25</b>	<b>Mutek Ltd.....21</b>
<b>BNR &amp; ES.....17</b>	<b>Omega Power .....2</b>
<b>Cirkit Holdings .....32</b>	<b>R. Withers Communications.....17</b>
<b>Farnborough Communications ....17</b>	<b>Technical Software.....17</b>
<b>Hi-Tec Worldwide .....7</b>	<b>Thanet Electroncis .....4-5</b>

**Don't forget, when calling an advertiser, mention  
Ham Radio Today — it helps them and us.**

**73's Dave Gadsden, G4NXV, Advertisement Manager**



# Free Readers' ADS!

## WANTED

**WANTED** Eddystone power unit type 924 for EB36 receiver. Good price offered. Tel Peterborough 0733 236634.

**YAESU FT101Z** or similar complete rig wanted in mint condition. Please telephone 0732 356712.

**ZENITH R7000** trans-oceanic 150kHz-30MHz no gaps plus FM band, air band, public service band 88-174MHz. SSB American portable made about 1980 very expensive when new. Would swop for R1000, R600, FRG 7000 WHY Brian 01 736 6581.

**WANTED** Yaesu FT480R Mark 2 Phone 0633 272871, Harold GW1LLN.

**WANTED** modern Solid state HF transceiver (preferably with general coverage receiver) suitable for base or mobile cash waiting for right rig. G3YHK Felixstowe 286616.

**WANTED** RF amp/mixer module for burndept 3-CH UHF handheld. Burndept part number 69299. Must be fully working. Make some cash from that smashed up Burndept, please write to Patrick G1CHB, 127 Victoria Road, Bridgnorth, Salop QTHR.

**WANTED** circuit diagram/service manual ham international Jumbo CB either copy or loan contact David 0290 51354 6pm-7pm costs incurred will be met.

**WANTED** information c/diagrams for the following Trio 7800 2 mtr FM and also Kenwood TR7010 2 mtr CW S SB will pay postage both ways if allowed to copy only otherwise purchase outright. Mr Copeland, 32 Pine Tree Grive, Moreton, Wirral.

**WANTED** Pye FM ex-commercial equipment VHF and UHF also accessories speakers mics etc. G4KZX Newhaven 516033.

**COMMODORE** computer owners WHY not link up with my computer. 300 baud telephone 0472 47898 no voice contact, or write to

66A Harold Street, Grimsby, South Humberside DN32 7NQ for details. I hope to have 1200/75 baud soon.

**WANTED** Belcom LS102L Nato2000. For sale Yaesu FT101 perfect condition offers Multimode 2. Also Concord 2 legal FM 8 gov stamped £120 ovno. Phone 0283 221870.

**WANTED** Palm 2 or similar handheld. Faulty or tatty no problem but must be cheap. Peter (GU1DKD) 0481 25893.

**WANTED** for building general coverage receiver. Denco type 1fts, three 18/1.6MHz, one type 17/. Please tel Fleetwood 70433 any evening reverse call if preferred.

**WANTED** information Oric 48K computer radio RTTY Prestel in fact anything on Oric software, hardware. Phone evenings 0572 Oakham 55154.

**WANTED** HF transceiver must be working, otherwise condition is immaterial. Also ATU suitable for 100W plus power handling. Also digital frequency meter 50MHz plus vertical multi band base antenna. Can collect. Please telephone Roy GO-BZT. Sedgley (09073) 78792.

**WANTED** Marconi Mercury type 1017 receiver and hallicrafter S85/S86 and S-53A receivers. Please write to Marris, 35 Kingswood House, Farnham Road, Slough, Berks SL2 1DA.

**WANTED** Murphy type 618 Tx (AP100333) amp power unit (AP100336). Marconi Elletra Rx (similar to Eddystone 840). Aerial plug AM type 161 (10H/184). Marconi type 889A or 966A power units with plugs and cables. G4FUY QTHR Reading 733633.

**WANTED** ATU 80-10 metre bands 200 WT PEP rates manual tuning similar to SEM transmatch etc. Tel Stroud STD 04536 2385. 6m onwards.

**WANTED** Morse Tutor. Telephone Upminster (Essex) 27578.

**WANTED** manual circuit for Vortexion CBL stereo tape recorder also Pye PE80 table model or any unusual old multiband short wave receivers. Alan Judge 106 Bicknor Road, Maidstone, 0622 50709.

**WANTED** Bug keys, dedicated CW operator/collector reqs. any semi-automatic mechanical keys by McElroy, Lionel, Viborplex, Eddystone etc, any age any condition. Phone G3TSS 043-471 3125.

**WANTED** Yaesu YO91 scope also any accessories for FT107M including transverter modules and desk microphones. Phone Reading (0734) 596485. After 9pm or weekends.

**WANTED** AR88 signal strength meter, metal trims, badge, valves, any inexpensive Heathkit equipment will exchange my KW160 top-band Tx and Sharp portable SW Rx with digital display, G4VNG 0733 231639.

**CIRCUITS** wanted for Airmec wave analysers. Types 853 30kHz to 30MHz and 248 5MHz to 300MHz P.G. Robins, 290 Priory Road, St Denys, Southampton SO2 1LS.

**WANTED** general coverage HF receiver Trio R600 or similar. Mist have SSB and digital frequency readout. Details and price to G. Miles, 7 Dobbin Close, Rawtenstall, Rossendale, Lancs, BB4 7TH or tel: Rossendale (0706) 220344.

**WANTED** inexpensive HF transceiver any condition considered also Rollercoaster coil. Please phone Plymouth 47157 G3XMY.

**WANTED** Datong active antenna model AD370. Also world radio TV handbook. Please contact Paul on (0926) 498388 or write P. Lawrence, 5 Congreve Close, Woodloes, Warwick CV34 5RQ.

**WANTED** handbook (or photocopy) of Heathkit RG-1 receiver. Also old, dead, dying or working, Heathkit RA1 receivers and codar AT5

transmitters condition and prices to Marris, 35 Kingswood House, Farnham Road, Slough, Berks SL2 1DA.

**WANTED** Ten tec argonaut, Trio TS120V or FT707. G4FUY QTHR Reading 733633.

**WANTED** FT101, FT250, HW100 or HW101 WHY? Tel 0934 28563 G3JUT.

**MIZUHO MX4** wanted. Good price paid depending upon condition. G4RJC Upminster (04022) 21523 not Sundays.

**WANTED** circuits info components transformer for Mullard 5-10 audio amplifiers would be grateful for any help with these. Please contact Richard Talbot, 35 Caldecott Road, Abingdon Oxon OX14 5EZ.

**WANTED** Yaesu YK-901 keyboard to match up with my Yaesu YR-901 RTTY reader. Also Yaesu FRG-7700M late one. Colchester 394336 Essex.

**WANTED** purchase or loan for copy, handbooks or circuits, data for Multi-Elmac "PMR-7" receiver and "PSR-12" PSU also KW Valiant transmitter nd PSU and Dependapac (London) toroidal, transistorised transmitter PSU prices and details to G3FCK, Newbury 40750.

**WANTED** Sinclair Spectrum computer 48K as soon as possible. Wanted power supply 15 amp plus. Wanted ATU for FT77 one little SEM transmatch or similar. Phone 0282 37768 cash waiting.

**WANTED** Yaesu FT790R 70cm multimode, or similar. Will collect if reasonably local. For details contact Rob, G1GHA QTHR or telephone 021-350 1473.

**WANTED** Trio R300 receiver please send details and price to Ted Kimber, 1 Moorlands, Bishops Lydeard, Taunton TA4 3PG.

**WANTED** RTTY Genie, any model with manuals and software. Hardware working or not. Please write to G4SQF, Brian Harrington, 237 Norton



East Road, Norton Canes, Staffs.

**WANTED** VFO700S for my TS700S 2m multimode must be in GWO with instructions and CCT sheet unmodified. Frank G1ZB Tel Marshchapel 595.

**WANTED** Trio Sp930 speaker, SM220 station, monitor, copy World at the Finger Tips, mini beam 28/14MHz, G3AOS, 3 Church View Terrace, Sutton Lane Ends, SK11 0DT, **WANTED** FT707, FP707 PSU, FT700 ATU, mic etc. Must be in mint condition with manuals. Good price paid. Phone 0282 59320 anytime.

**YAESU FT707S** (10 watt model) any condition, also valve QRO HF linear WHY. I will collect. Phil, 3 Ryecroft Close, Hemel Hempstead, Herts HP2 4PL.

**WANTED** KW202 Rx or Trio TR310 Rx must have service manual and must be in excellent condition. Mediocre ones considered. Ring Peter Beavan 061-747 8831.

**WANTED** Yaesu FR50B Rx FV50B VFO any 2m transverter, homebrew or WHY also any digital frequency display unit for HF. For sale or exchange for any of above Cobra 148GTL DX 27MHz multimode. Peter Hunter 2 Huxley Close, Norwich, Norfolk NR1 2JS.

**WANTED** service manual or circuits for an advance UHF millivoltmeter model VM79 and a Philips digital millivoltmeter model PM2421. Details to G3NSF QTHR or phone (0582) 62621.

**WANTED** IC701PS working or repairable, must be affordable. George, Kidderminster 741690.

### EXCHANGE

**EXCHANGE** my new Panasonic RF-B600L communications receiver for AOR 2001 scanner must be in mint condition. Mr Bannister 051 263 6724.

**SWAP** FT203R with charger speaker mic and spare battery pack for 70cms equipment. WHY? Prefer mobile. Phone Bob daytime 0732 458800 (Sevenoaks, Kent).

**EXCHANGE** Eddystone 750 Rx modified RF SSB added in excellent condition, for Heath

HW8 icvr also in good condition and working, buyer to deliver and collect, write first K.C.A. Terry G3GSY 344 Mill Road, Deal, Kent CT14 9BQ.

**HAVE** JIL SX 400 professional scanner 26.520MHz No (gaps) in mint condition with PSU. Few months old exchange for Yaesu FT757 GX or Trio TS430S. Phone 0524 791414 Lancs.

**EXCHANGE** FDK 2m FM mobile tcvr 25 watt for a 2m FM hand held charger. Good condition tel (0235) 24379.

**EXCHANGE** Epson PX-8 64K-LAP computer complete bought 85, for TRS80 model 100 lap-comp and printer. Also SM-220 scope-monitor thandar TF200 and TP600 case s/manuals Welz SP400 150-500MHz S10R/POW 15 watt 70cms FM amp 100 MW in working OK ring 0473 85526 any time not QTHR.

**EXCHANGE** Commodore 8050 dual floppy disk drive as new, for good SSB transmitter, Nato 2000 Hygain or anything similar. Must be clean and have all bands. Tel 0724 854424 anytime.

**EXCHANGE** FT290R excellent condition with NiCads charger etc Alinco 30 watt linear, with preamp for FT221, TS700, IC211E or similar. Some cash adjustment if needed. Alan, 1 Manor Terrace, Terrington St Clement, Norfolk PE34 4NF or ring Kings Lynn 829075.

**EXCHANGE** Petter WIH stationary engine rare model. For 2 mtr rig as FT290R or WHY. Phone 0872 77407 evenings.

**HAVE** KW2000 SSB/CW transceiver 90W PEP side band vgc exchange for FRG7 or similar. Mr Smith, 4 Ancrum Court, Stirches, Hawick.

**EXCHANGE** video Genie computer, two SSSD disk drives with interface. Lots of software for good general coverage receiver or 2m hand held. Peter Talbot, 7 Kings Road, King's Heath, Birmingham B14 6TU. Tel 021 444 5660 after 6.30pm.

**EXCHANGE** TR9130 6 months old still guaranteed used little for FT290R and FT790R. Sell Dragon 32 with games £70. TF995 sig gen 1.8 220M £60. Advance RMS voltmeter £15

ono. Phone 788239 (Nottingham) Concorde Mk2 ideal rig 10 metres £100 ono. Phone 788239.

**EXCHANGE** FT102 and SP102 with FM/AM for FT757 both boxed as new also have for sale SK610 base and chimney with 4CX350A. Phone Dave Rotherham 67471.

**EXCHANGE** Gestetner 460S automatic electric duplicator in good working order, suitable for a club for a fairly modern two meter mobile or handheld. Evenings Chichester 779479 (long ring please).

**EXCHANGE** NEC PC8000 + monitor + dual discs + printer + 40 x 5.25" discs, games, CPM, ASM, WP etc for FT77/707/102 or general coverage TCVR. Write Glenn (G6VRQ) Granary Cottage, High Park, Uffculme, Devon.

**EXCHANGE** high quality metal detector, many finds, excellent condition, 4 levels of discrimination, for good receiver or Rx/Tx with good coverage. Metal detector is complete with case, headphones, tools, books etc. Contact WT Johnston, Fern-down, Dorset 891538.

**SWAP** HF for VHF. I have Yaesu FT200/250 HF transceiver (3.5MHz to 29MHz. 300W output. USB/LSB/CW/AM) and FP200/250 power supply. Totally mint condition. Fully checked. Boxed. Will swap for 2 metre multimode transceiver. Tel 084 82 314 (SW Scotland).

**EXCHANGE** 12" double ended sailing boat as new condition combination trailer included approx value £300 for FT290 or similar two metre multimode plus small linear or rotator. Tel Tony Norwich 405531.

**A SUPERB** Yaesu FTV901R transverter 2m 70cm 50MHz. Boards fitted - 1 new never used 2 metre C5 fibre class co-linear by Jaybeam. Micro module ATV converter for sale or exchange for HF transceiver mobile or base and HF amplifiers cash either way. Scarisbrick (Lancs) 880345. **EXCHANGE** Yaesu FC700 ATU for FC 902ATU plus cash as required. FC 700ATU comes complete

with manual. In mint condition. FC902ATU must be in good condition. I am prepared to pay up to £60 plus FC 700ATU. Telephone Midcalder 880345.

**EXCHANGE** Logan organ two manual 13 pedals sustain draw bars voices and effects 2 speed rotary speaker auto rhythm auto bass arpeggio and memory excellent condition £425 ono or exchange HF Tx/Rx FT101ZD or similar phone John G1LUG Coventry 450476.

**EXCHANGE** or sell. Leslie organ speaker, immaculate teak cabinet. Great sound. Adaptor kit suits any organ. Wanted: good general coverage receiver: multimode 10 mtr transceiver: FTV901R 70cms module: FV901DM VFO: or WHY. R. Edge, 6 Yeomans Way, S. Anston, Sheffield. Dinnington 569577.

**HAVE** HF-VHF 5 digit LED frequency counter, Ham multi-mode II Tx, 3 amp 0-25V Var PSU, Eagle DMM, SWR meters, Oric Atmos 48K computer with all leads. Plus lots more in exchange for Trio R600 or any similar Rx. Please tel 0278 428633.

**EXCHANGE** my FT208R handheld with PSU/charger, leather case, speaker mic and two antennas all mint and in original boxes for an Icom 251E multimode plus cash adjustment, or buy your 251E for cash. Tel Laurence on 607 4124 (London, evenings).

### FOR SALE

**GENUINE** astatic D104 microphone C/W UG8 stand £35 ono. Shure 444T microphone £35 ono. Heathkit SB610 monitor scope requires slight attention £70. Martin G3ZZS Plymouth 707550.

**SALE** FC102 ATU slight mods £110. FT707S 10W with H/B VFO £300 FT101ZD mk2 with filter fan mic £350. FV101Z VFO £70. FRG7 fitted SSB filter £95. FT227R low gain Rx £90. Carriage extra. Collect 101ZD? G410T QTHR. FT790R 70cms multimode, carrying case, strap, ni-cads, charger, rubber, helical and



mobile 3x518 £270 (2m multimode reqd.) Tel 0622 672116.

**FT101E** transceiver 10-160m, AM, LSB, USB, CW (600Hz). AC/DC (240V, 12V), fan speaker, leads, manual, good condition. Phone Hemel Hempstead (0442) 45030 £350 ono.

**KW 2000A** complete with mains PSU recent KW overhaul, manual with KW modifications. Plus Yaesu desk microphone and Daiwa all mode active filter and spare 6164's. All for £230. Phone Geoff G4OWH 0373 812274 Somerset.

**YAESU FT290R** carrying case, nicads, charger, m/modules 144/30LS linear, Mutek SLNA/144S preamp, SWR meter, the lot no offers thank you bargain £375. Wanted IC251E base multimode G1ECY QTHR (Gerry) 01-890 9733.

**AR 2001** receiver new unwanted gift £280. Clark, Hythe, Kent 0303 68132.

**YAESU FR101DD** and FL101 Tx vgc £425. Kenwood R599 Rx, dark front panel, late model £200. TS280 2m FM 80 channel £95. Trio TR2200 £50. Ring Dursley 811454 after 6pm.

**KDK 2025 2M FM TRX**, 144-146MHz will Rx up to 150MHz, scans thru' 10 memories, or all or part of band. 3 watts or 25 watts, vgc. Also Adonic MM202S mobile safety mic wired KDK (nice audio) both £135 ono ideal set up. 01 247 6097 (daytime).

**HAM-MASTER HM2025 2** meter FM transceiver 2.5/25W scan, memory, etc. boxed as new £135 ono, Superstar AM/FM/SSB/CW converted 28.05MHz to 30.00MHz, good performer £110 ono, Colonel FR360 AM/SSB, frequencies include 28.365 to 28.805 (10M SSB) £45 G0BHQ Tamworth 250038 (Staffs).

**CW TX/RX** terminal, using ZX81 computer and G4IDE eprom. Boxed with built-in power supply, interface, narrow filter, side-tone, transmitter keying relay, full data and computer software included £50 or exchange for Datong FL2 or 150MHz and counter. GM4EWM phone 0343-84 2530.

**FOR SALE** Ham int major

**M588 FM AM SSB** transceiver perfect condition 26.515MHz to 27.855MHz with 40 channel fitted £80 ono CTE international AL linear valved 500 watt FM/AM 1000 watt SSB 26-30MHz with pre-amp £150 ono. Tel 0570 470 362.

**FOR SALE** Uniden CR201 eceiver plus Scarab MPTU1 decoder and software. Interfaces with BBC 'B' for RTTY. Both virtually unused! Sell together £199 (+£6P+p) or split: receiver £145 (+£5p+p) decoder £55 (+£3p+p). Phone Ian Crawford, Banbury (0295) 720812 (Ansafone).

**DRESSLER EVV2000 GAAS** preamp will handle 1KW PEP brand new unused complete with interface £70. Phone Tiverton Devon 252593.

**FOR SALE** CTE international Galaxi 1000W linear (variable) 26-30MHz AM/FM/SSB £250 ono (0332) 42394 (evenings).

**SCOPES** Cossor 1035, Telequipme NT S42, Solartron CD1400. Mike G4IJI Leeds 0532 822968.

**FOR SALE** Yaesu FR101 receiver complete with 2 metre converter and home brew digital frequency counter, £175 also FRG7 general coverage receiver superb condition, £125. Tel Duncan on Wrexham 357612.

**KENWOOD TS430S** £600 AT250 ATU £200 Drae 24A PSU £80 as new G2DYM dipole and poles £80 IC240 £100 3 element colinear £130 Phone Salisbury (0722) 780396.

**SONY 2001** receiver state of the art as new with PSU £75 HF5V 10-80 vertical with radial kit £50 3 months on oper. Wanted 70 cms mobile 2 meter base - 01 764 6767 evenings.

**FOR SALE** Murphy receiver B40 ex Navy working order, need space at home £50. Tel Brighton 737 800 G1RFY.

**FT290R UNMODIFIED** £180. Tokyo hi-power HL35V linear (35W) £35. Drae 6 amp power supply £20. Jaybeam 5 ele Yagi £5. Complete 2M station for £235 ono. Phone 01 590 5490. Please ask for Martin (G1LHK).

**YAESU VHF converter FRV**

7700 type 'A' 118-150MHz Unused £35. Catronics FM2 meter amplifier 10 watts in 35 watts out. With spare power transistor and circuit £20 Tel 0282 68548.

**JAYBEAM 12XY/70** £35 5XY/2M £20 both with phasing harnesses. Jaybeam PMH2/70 50e phasing unit new £12. 24 element X or XY 70m sandpiper £22 new. G3AAG Hampshire 0730 892143 or 893534.

**COLLINS KWM-2A**, matching speaker, matching power supply SM-2 deskmic, h/book, spare valves, £370. Military 1940s HRO with coil-packs, p/supply £35 homemade ATU (large) £25 Tel 0642 456327 Cleveland buyers to collect. Contact Peter 10am-4.30pm days.

**EPROMS** for CB conversions including veroboard layout and instructions £5. Eproms blown for BBC computers and CB circuit diagrams available. Send SAE for full details. Chris Womack, 4 Mill Close, Ackworth, Pontefract, Yorkshire WF7 7PU. Tel 0977 611395 after 6pm.

**NATIONAL** Panasonic RF 2800 digital display FM SW ham bands BFO upper lower side bands batt or mains instruction book little used £90 SX200N scanner receiver 26-514 16 memories AM + FM 12 or 230V instruction book original box as new, £180 Phone Peel I.O. Man.

**TELEPRINTERS** Creed 2300 (1979) solid state multi baud rate, tape reader/puncher paper BT line terminal/PSU £45. Creed 444 45 & 50 baud, tape reader/punch, paper £15 free desk/stand with each. Tech-inf available. M/modules, 2m linear 10W in 100W out as new condition, preamp £90. G6BDY QTHR Kidderminster 755501.

**IC271E** new boxed £550 or take in part exchange digital ham receiver, FRG7700 etc or scanner, FT7B. Mobile multimode 2M, etc all offers considered also for sale FDK 700AX 5-10-100KC steps mars model £145 boxed OWHY. 42 Tregundy Road, Perranporth, Cornwall, TR6 0EF.

**TS430** fitted FM PS 430, SP430, SP230, AT230, used for receive only £750.

Charlie G1GDW. Tel 0385 43102 anytime. Postage extra.

**IC271E** complete with muTek front end and in original packing. This radio has worked over 100 squares with a little help from G6JNS! £550 reason for sale, going HF. Phone 0905 620041 anytime.

**SHACK CLEARANCE XF-9B** filter plus USB/LSB xtals £30. Shinwa LPF 1000W £20. Heathkit HD-20 100kHz xtal calibrator £6. 100kHz xtal oscillator modules, 5V supply £5. 4.5-20 pf small ceramic trimmers £1.20. P Smith, 3 Raven Avenue, Tibshelf, Derbyshire, DE5 5NR.

**TEN TEC** Argonaut 509 QRP SSB/CW transceiver. 80-10m 5W, with full break-in and suitable power supply. Excellent condition. Boxed £230 G3ZZD QTHR 01-348-9780 after 7.30pm.

**BARGAINS** SWL shack clearance, selling redifon 2182Rx marine receiver. Marconi marine receiver covers 4 distress bands, coastguard (type 10-8) Solatron digital voltmeter LM 1426 100MV-1000V serviced 20/10/82. Pye pocket-phone 435.175MHz with charger preamp ex speaker and spare batteries offers WHY Brian, Brighton (0273) 559373.

**KENWOOD** Trio TS120V power supply PS30 linear TL120 ATU AT120 Adonis mike 530. Kenwood mike 53S HF amateur radio full 27m coverage £400 or exchange car or caravanette worth £400. Phone 01-517 3588 or write Box 17, Dagenham, Essex RM8 3PU.

**IC271E** in excellent condition and complete with muTek board in original packing. This rig has worked over one hundred squares with some help from G6JNS! £475 due to need for HF gear Phone 0905 620041 anytime.

**FOR SALE** TS120S 100 watt SSB transceiver. Solid state. Excellent condition. Not used mobile. Boxed with accessories £345. Wanted FRG7700 must be late one, mint condition, unmodified. Also wanted, Trio 2300 in good condition. Please tel Jeff, Llanelli 0554 753186.







## YORKSHIRE

••RADIO AMATEURS AND 'C.B.' PEOPLE TALK TO••

**LAE** 34 NEW BRIGGATE LEEDS, LS1 6NU  
COMMUNICATIONS CENTRE

ELECTRONIC COMPONENTS - TELEPHONES  
VIDEO - AUDIO LEADS - STYLII **UNIACE**  
LEEDS 452657 the PROFESSIONALS! TELECOMMUNICATIONS

**TRIO ICOM YAESU**  
LARGE RANGE OF ACCESSORIES

## LEICESTERSHIRE

**ELLIOTT  
ELECTRONICS**  
FOR THE RADIO ENTHUSIAST

26-28 BRAUNSTON GATE,  
LEICESTER.  
TEL: 553293  
Open: Mon-Sat 9.00am to 5.30pm

## DEVON

### AGRIMOTORS

Merton CB & Radio Centre  
Merton Garage & Post Office, Merton,  
Nr. Oakhampton EX20 3DZ.  
Open 6 days 9-6  
(Sundays by appointment)  
Specialists in 934MHz  
Suppliers of all 27MHz and 934MHz equipment

## DURHAM

**IAN FISHER COMMUNICATIONS**  
of Stanhope CB Works, Bondisle Way, Stanhope,  
Bishop Auckland, Co. Durham DL13 9TY.  
Tel: (0388) 528464

Distributors of 934 MHz equipment. We carry a full range of 934MHz aeriels. The **COMTEL** scanner transmitter/receiver. The **UNIACE 400**. Also in stock **POPE H100** 11mm and 6mm diameter coaxial cable. Plus cordless telephones all at very competitive prices.  
Open Mon-Sat. 10.30am-6.00pm.

DON'T LEAVE  
IT TO CHANCE  
ADVERTISE NOW -  
Call Stuart Taylor  
01-437 0699

## MERSEYSIDE

**ARE Communications Ltd**  
FOR - YAESU, ICOM & KENWOOD  
Phone us for the best deals on all amateur  
radio equipment. **A BK**  
32 Bridge St., Earlestown,  
Newton-Le-Willows, Merseyside.  
Phone: Peter G4KKN on 09252-29881  
Opening hours Tuesday-Saturday.  
10pm-5am

## HAM RADIO TODAY

## CLASSIFIED

### Lineage:

35p per word (minimum 15 words)

**Semi Display: (minimum 2 cms)**

£7.00 per single column centimetre

Ring for information on series bookings/discounts

All advertisements in this section must be prepaid.

Advertisements are accepted subject to the terms and

conditions printed on the advertisement rate card (available on request)

01-437 0669  
EXT 391

Send your requirements to:  
Stuart Taylor  
ASP Ltd.,  
1 Golden Square,  
London W1R 3AB

## BOOKS AND PUBLICATIONS

### SERVICE MANUALS

Ham Concorde 2, Ham multi-mode 2, Ham Jumbo 2, Ham Viking, Ham Puma, Cobra 148  
GTL DX, PC 879 and PB010.  
Colt 1600 DX, Tristar 777,  
York 863, York 861.

All above at **£6.00 + £1.00 p&p** each.

Other, rigs and spare parts available.

10m conversion for FMCB rigs  
**£30 + £1.50 p&p**

Details on request.

### CBT

1 Prince of Wales Road,  
Swansea. (Tel: (0792) 463821.

## SERVICES

### SERVICE MANUALS

For Most Makes, Model, Age of Electronic Equipment. Amateur Radio, Vintage Wireless, Test Equipment, Audio, Music Centres, Televisions, Colour and Mono, Video, Old Military Equipment etc, etc. Thousands stocked.

See enquiries and quotation by return.

Unique 'Techni-Guides', Repair Manuals, Data Information from valve equivalents to IC identification etc, etc.

**MAUNTON TECHNICAL SERVICES**  
Dept HRT

### New Service for Amateurs

PCB's from your own artwork from under £25 each including VAT & postage. Good discounts for quantities and club projects.

Please send S.A.E. for sample and details to:

**GOREW, C+L Circuits**  
Kings Hill Ind. Estate,  
Bude, Cornwall.

## MISCELLANEOUS

**HEATHKIT U.K.** spares and service centre. CEDAR ELECTRONICS, Unit 12, Station Drive, Bredon, Tewkesbury, Glos. Tel: 0684 73127.

## COURSES

**COURSES - RADIO AMATEURS EXAMINATION City & Guilds.** Pass this important examination and obtain your licence, with any RRC Home Study Course. For details of this and other courses (GCE, professional examination, etc.) write or phone - **THE RAPID RESULTS COLLEGE**, Dept JN4, Tuition House, London SW19 4DS. Tel: 01-947 7272 (9am-5pm) or use our 24 hr Recordcall Service 01-946 1102 quoting Dept. JN4.

## RIG DOCTOR

### POWER SUPPLY REPAIRS

We offer a fast repair service on most makes of D.C. power supplies in the 1 to 30 amp range, crowbar circuits, etc. also fitted.

For full details please ring  
**0536 743496**

## SOFTWARE

### MORSE READER PROGRAMMES

**SPECTRUM BBC 'B' DRAGON**  
CBM 64 VIC 20  
ZX81 16K ATARI 600/800XL  
AMSTRAD 464

Sinclair computers need NO interface, others use simple on transistor (BC107 or similar) interface. Programmes sell tracking 8/30WPM. All connections to existing sockets. Cassette with full instructions and interface circuit where required £5.00 inc P&P interface built and tested £9.50 inc P&P.

### RTTY

FOR YOUR 48K SPECTRUM

Many drives: 10 programmable memories, split screen morse ident four baud rates etc, etc. NO TERMINAL UNIT just a simple filter! Cassette with full instructions, circuit and fitter layout £9.50 or SAE for full details.

### FILTERS

We also supply a range of Filters suitable for use with our programmes.

RTTY ONLY Supplied unboxed but fully tested and fitted with leads £5.00

RTTY/CW The switched dual purpose filter is supplied in a smart black ABS box and is fitted with plugs to fit your Spectrum £11.50

RTTY/CW SUPER Specification as above but with the addition of a tuning indicator LED circuit for perfect tuning £13.50

CW ONLY Supplied unboxed but fully tested and fitted with tests £7.00

All the above run from 9 volts DC and are fitted with a battery connector. Battery not supplied.  
ALL GOODS DESPATCHED BY 1st CLASS POST

**JEP ELECTRONICS**  
NEW ROAD COMPLEX  
NEW ROAD  
KIDDERMINSTER  
DY10 1AL

Tel: (0562) 753893

## COMPONENTS

**R.F. Transistors. Specialist Components for Transmitters.** Unelco Capacitors. Sparague Mica Trimmers (500V). **Sole Agent for solid state Microwave R.F. Transistors supplied to full specification.** Full 2N range supplied. Special SD range 1W-100 WATT output 1 to 100 MHz. Preamplifiers for 2 meters and 70cms. Power Amplifiers with and without switching. Aligned and ready for use. Due to exchange fluctuations we cannot price. Send S.A.E. for full lists.

Phone: (0243) 823603. Modular Electronics, 1 Coniston Close, Felpham, Bognor Regis, Sussex.

## LABELS

### LABEL IT!

**PROFESSIONAL QUALITY LABELS AND BADGES MADE TO ORDER**  
Low cost • Various colours and styles • Engraved by us • Very hard-wearing waterproof plastic or metal

**Fast efficient service**

Write to Rob Thomson for FREE details

### THOMSON

Electronics  
Radio Communication Specialists  
Basement Office, 5 David Place,  
St. Helier, Jersey. Tel: 0534-75170

## CARDS

**QSL CARDS.** Gloss or tinted cards. SAE for samples to TWROG Press, Dept HRT. Penypont, Gwilllydan, Blaenau, Ffestiniog, Gwynedd, LL41 4EP.

## CARDS, STICKERS

**HIGH CLASS QSL CARDS.** Competitive prices, free artwork. SAE for samples stating ham or breaker to: J.S. Coates, 57 Worrall Street, Morley, Leeds LS27 0PJ.

**TO ADVERTISE IN THIS SPACE**  
RING 01-437 0699







# EMPORIUM GUIDE

## SCOTLAND



### SCOTCOMMS

OPEN TUES-FRIDAY 10am-12.30pm. 2pm-5pm  
SAT: 9am-1pm. 2pm-4pm. CLOSED MONDAY

25 Morton Street, Edinburgh 15  
Tel: 031-657-2430

## W. MIDLANDS

### HEWARD'S HOME STORES LTD.

(Est. 1963)

822/4 Kingstanding Rd., Birmingham B44 9RT.

Tel: 021-354 2083

G4RJM with 38 years in The Radio Trade  
Ham Equipment urgently wanted!  
Open: Mon-Sat 9-6

## KENT

### Thanet

ELECTRONICS

95 Mortimer St, Herne Bay  
Tel: (0227) 369464

Open Mon-Sat 9-5.30pm  
except Thursday 9-1pm

## LONDON

### PROTEL AERIALS AND COMMUNICATIONS

Manufacturers and suppliers of aerials and accessories, DXTV equipment and aerials also other specialist aerials. Large range of bracketry and masts also available.

295-297 Ballards Lane, N12. Tel: 01-445 4441

TRADE ENQUIRIES WELCOME  
Details on request.

## SURREY

### GUILDFORD COMMUNICATIONS

34 Aldershot Rd., Guildford

Open Mon-Fri 8am-6.30pm  
Sat 8am-5.30pm

Secondhand wanted



ICOM

ASDEN  
TOTSUKO



BARCLAYCARD

VISA

0483-574434

## W. MIDLANDS

### DEWSBURY ELECTRONICS



RXs, from YAESU, JRC, ICOM.  
Stockists of microwave modules, B.N.O.S., M.E.T.,  
GAMMA, DATONG, ICS, TASCO.

Open Mon-Sat, 9-30-5.15

176 Lower High Street  
Stourbridge (0384) 390083



### DRESSLER UK LTD

191 Francis Rd., Leyton, E10

Open 9-5.30 Monday-Friday 10-5 Saturday

Authorised dealers for:

Dressler, Yaesu, Icom, Standard, Trio/Kenwood,  
Datong, SCM, Microwave Modules, Tonna  
Tel: 01-558 0854/556-1415 Telex: 8953809

## MIDDLESEX

### AMCOMM

Authorised Icom dealer

OPEN 10am - 5.30pm TUES-SAT. CLOSED MONDAY

NORTHOLT RD., S. HARROW  
MIDDLESEX  
TEL: 01-422 0985

## AVON

### Booth Holdings Bath

6 GOLF CLUB LANE,  
SALTFORD,  
BRISTOL

Tel: 02217 2402

Open: Tues-Sat 9am - 9pm  
Close Mondays

TO ADVERTISE IN  
EMPORIUM GUIDE  
PHONE STUART  
ON 01-437-0699  
Ext. 289

## HANTS

### FARNBOROUGH COMMUNICATIONS

97 Osborne Rd., North Camp,  
Farnborough. Tel (0252-518009)

Open: 6 days 10-6

Yaesu, Icom, FDKs, Mosley aerials, Jaybeams,  
G. Whips

## BIRMINGHAM

### CENTRE ELECTRONICS

354 Stockfield Road, Yardley, Birmingham B25 8JP  
Specialist in the sale and service of Ex Government  
and Vintage Radio and Test Equipment.  
(Many spares in stock).

Telephone enquiries to 0676 32560

Special delivery  
service

Shop open Thursdays, Fridays  
and Saturdays

## NORFOLK

D.P. HOBBS (Norwich) Ltd  
13 St. Benedicts Street, Norwich  
Tel: 615786

Open Mon-Sat 9-5.30

Closed Thurs

Stockists of:



YAESU, FDK, ICOM, JAYBEAM  
& Electronic Component Specialists

## NOTTINGHAMSHIRE

### SP ELECTRONICS

48 Limby Road  
Hucknall, Nottingham  
Tel: (0602) 640377

Open Monday-Saturday 8.30-5.30

## NOTTINGHAMSHIRE

### R.A.S. (NOTTINGHAM)

P. Owen G8JUS

3 FARNDON GREEN, WOLLATON PARK  
NOTTINGHAM. Tel: 0802 280267

FDK Open: Tues-Fri 10-5.30. Sat 9-5 TONNA

YAESU: FDK: ICOM: TONNA

HALBAR: WELZ: ANTENNAS & OWN GW5 H.F.

### R. WITHERS COMMUNICATIONS

584 Hagley Road West  
Oldbury, Warley B68 0BS

(Quinton B'Ham) Tel: 021-421 8201/2/3

Opening hours 9.00-5.30pm. Late nights Thurs-Fri.  
For all your communication requirements send SAE for  
latest used list and latest info.





# A.R.E. Communications Ltd.

PHONE: 09252-29881

38 BRIDGE ST., EARLESTOWN,  
NEWTON-LE-WILLOWS, MERSEYSIDE.

We have the largest stock of amateur Radio Equipment to be found under one roof anywhere in the UK.

We stock all makes, and have the facilities available for you to try the equipment to make sure it's exactly what you are looking for.

## YAESU FT290 AND FT690

PROBABLY THE MOST POPULAR MULTI MODE 2 METRE TRANSCEIVER EVER MADE. ALSO NOW AVAILABLE FOR 6 METRES



OUR PRICE **£289** FOR 2m **£249** FOR 6 METRES

## NEW ICON ICR7000

THE PROFESSIONAL ONE 25MHz-2GHz. ALL MODE 99 MEMORIES KEYBOARD ENTRY OR VFO CONTROL 6 TUNING SPEEDS .1-1-5-10-12½-25KC. DIAL LOCK. OPTIONAL INFRA RED CONTROL & VOICE SYNTHESISER



**£849**

## YAESU FT757GX

ANOTHER ONE OF YAESU'S SUPER STARS THE EVER POPULAR HF TRANSCEIVER THAT REQUIRES NO EXTRAS.

COMPLETE WITH FM, SSB, CW, AM, GENERAL COVERAGE RX AF SPEECH PROCESSOR SCAN & MEMORIES **£699**

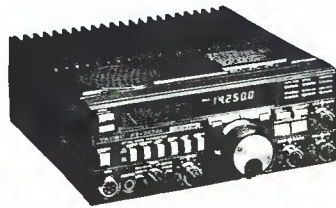

## ICOM IC3200

DUAL BAND MOBILE OR BASE TRANSCEIVER 2 METRE & 70 CM BUILT-IN DUPLEXER 2 ONLY LEFT



LIST PRICE **£495**  
OUR PRICE **£425**

## YAESU FT726

2 METRE - 70CMS & 6 METRES OR HF ALL IN ONE RIG THE COMPLETE BASE STATION DUAL VFO 25 OR 12.5KC STEPS 11 MEMORIES PLUS MANY MORE FEATURES FROM **£749**

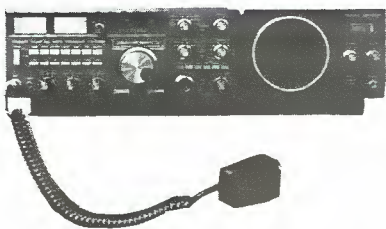

## HAND-HELD TRANSCEIVERS

All Popular Models from Stock

FT203	FROM <b>£169</b>
FT209	FROM <b>£270</b>
FT209RL	FROM <b>£239</b>
FT703	FROM <b>£205</b>
FT709	FROM <b>£225</b>
FT709	FROM <b>£225</b>
TH21	<b>£159</b>

HEAVY DUTY BATTERY FOR TH21 & TH41 **£29**

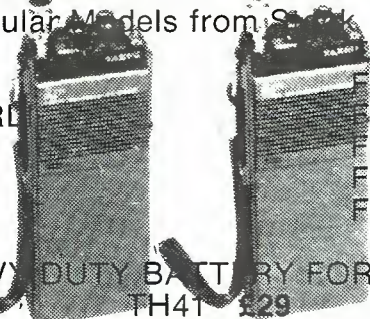

## YAESU FRG9600

ALL MODE SCANNING RECEIVER. COVERS 60-905 MHz TUNE BY KEYBOARD OR CENTRAL CONTROL VARIABLE STEP SIZES AM, FM OR SSB. THE SCANNER WITH MORE FUNCTIONS THAN MOST. AND NOW AVAILABLE WITH HF CONVERTER See opposite column.



**THIS MONTH'S SPECIAL**  
**KENWOOD TS940 WITH AUTO ATV**  
OUR PRICE **£1695 INC VAT**

## CONVERT YOUR SCANNER TO 1.3GHz OR HF OR BOTH

A.R.E. COMMUNICATIONS HAVE DEVELOPED 2 CONVERTERS TO MATCH MOST VHF SCANNERS.

IF YOU OWN AN AOR2001 THE CONVERTER WILL TUNE TO 1.3GHz OR IF YOU HAVE AN FT9600 YOU CAN CONVERT DOWN TO HF TUNING FROM 100KC TO 30MHz - A TRULY GENERAL COVERAGE RECEIVER **£89 EACH**

Phone 09252-29881 for all mail order—Access & Barclaycard accepted

Trade enquiries welcome

All prices include VAT and are correct as we go to press

Opening hours: Tuesday-Saturday  
10am-5pm





# MICROWAVE MODULES LTD

## PICTURE THE SHAPE OF THINGS TO COME

But proving that beauty is a little more than skin deep we're taking the lid off our secret

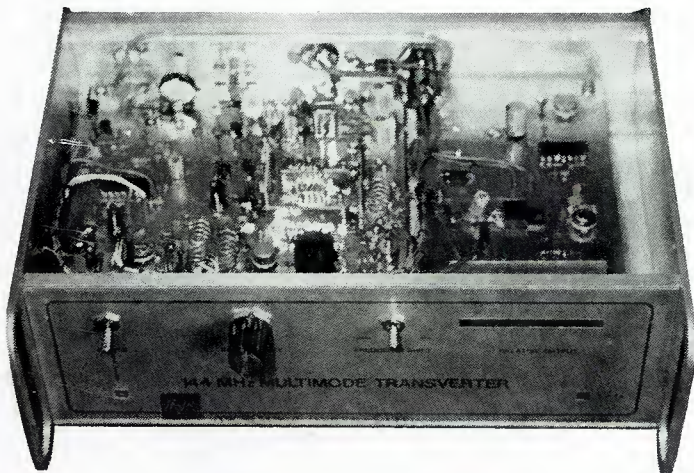
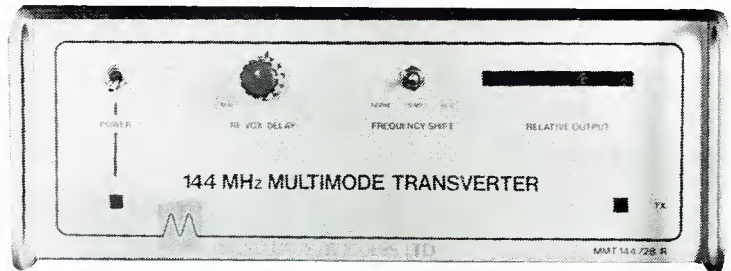

**Price  
£236.90  
inc. VAT**

- 25 watts TX output
- GaAsFET RF stage
- Transmit ALC circuit
- 13.8V DC operation
- Repeater shift (Simplex, Normal, Reverse)
- High level double balanced receive mixer
- LED bargraph power output indicator
- RF VOX - adjustable delay  
- PTT override

New and exciting products are in store this year so follow our progress closely.

### PRICE LIST FROM 1st JAN 1986

		TOTAL inc. VAT	POST RATE
MML28/100-S	10m 100W Linear, 10W input	129.95	C
MML144/30-LS	2m 30W Linear, 1 or 3W input	94.30	B
MML144/50-S	2m 50W Linear, 10W input	106.95	B
MML144/100-S	2m 100W Linear, 10W input	149.95	C
MML144/100-HS	2m 100W Linear, 25W input	159.85	C
MML144/100-LS	2m 100W Linear, 1 or 3W input	169.95	C
MML144/200-S	2m 200W Linear, 3, 10, 25W input	334.65	D
MML432/30-L	70cm 30W Linear, 1 or 3W input	169.05	C
MML432/50	70cm 50W Linear, 10W input	149.50	C
MML432/100	70cm 100W Linear, 10W input	334.65	D
MMC435/600	70cm ATV Converter, UHF output	35.65	A
MTV435	70cm ATV 20W Transmitter	197.80	B
MM2001	RTTY to TV Converter	189.00	B
MM4001-KB	RTTY Transceiver with keyboard	299.00	D
MMS1	The Morsetalker	115.00	B
MMS2	Advanced Morse Trainer	169.00	B
MMT144/28	2m Linear Transverter, 10W o/p	129.95	B
MMT144/28-R	2m Linear Transverter, 25W o/p	236.90	B
MMT432/28-S	70cm Linear Transverter	195.50	B
MMT1296/144-G	23cm Linear Transverter	258.75	D
MMX1268/144	1268MHz Transmit Up-Converter	195.50	D
MMC50/28	6m down to 10m Converter	35.65	A
MMC144/28	2m down to 10m Converter	35.65	A
MMC144/28-HP	2m High Performance Converter	47.90	A
MMC432/28-S	70cm down to 10m Converter	39.90	A
MMC432/144-S	70cm down to 2m Converter	39.90	A
MMK1296/144	23cm down to 2m Converter	129.95	B
MMK1691/137.5	1690MHz WX Satellite Converter	145.00	B
MMG144V	2m RF Switched GaAsFET Preamp	37.90	A
MMG1296	23cm GaAsFET Preamp	75.00	A
MMG1691	1690MHz GaAsFET Preamp	129.95	B
MMD1500P	1500MHz Divide by Ten Prescaler	119.60	A
MMR3/25	3dB 25 Watt Attenuator	19.95	A
MMR7/3	7 dB 3 Watt Attenuator	14.50	A
MMR15/10	15 dB 10 Watt Attenuator	14.50	A

Postage/Packing Charges: A = 1.84 B = 3.91 C = 4.60 D = 5.98



WELCOME

## MICROWAVE MODULES Ltd

BROOKFIELD DRIVE, AINTREE, LIVERPOOL L9 7AN, ENGLAND  
Telephone: 051-523 4011. Telex: 628608 MICRO G  
CALLERS ARE WELCOME, PLEASE TELEPHONE FIRST

**HOURS:**  
MONDAY-FRIDAY  
9-12.30, 1-5.00  
E & O.E.