

# HAM

AN ARGUS SPECIALIST PUBLICATION

MARCH '84

# RADIO

*Morgan*

95p

# TODAY

**The Longest Callsign  
in the world**

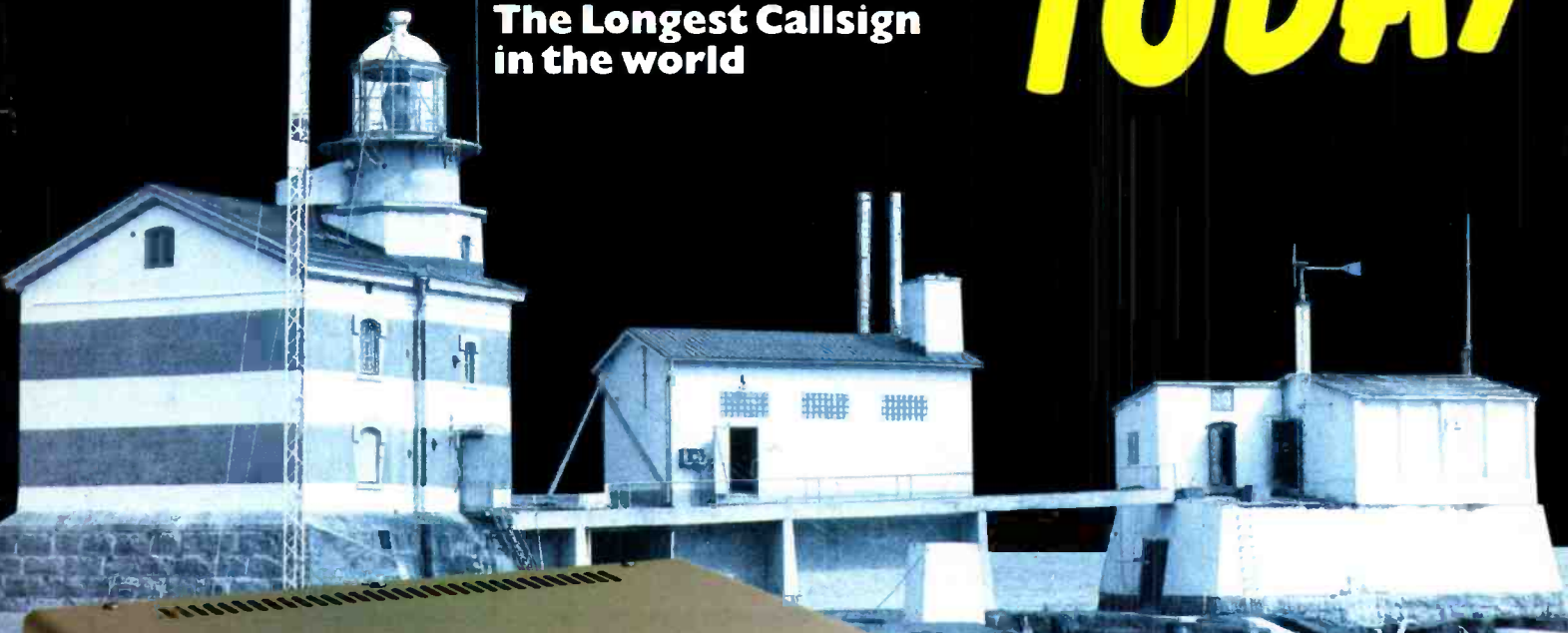

**National Wireless  
Museum visited**

**Belcom LS20/XE  
2m Handheld reviewed**

**Miniaturising Quad  
Elements for HF**

**Polar-easation Change!**



**SPECIAL REVIEW: Angus McKenzie  
investigates the new  
Icom 271 + muTek front end  
– the ultimate 2m performer?**

# CUT IT OUT!

A 'Western Which Report' about:-

## ROTATORS

Various advertisers will naturally try to persuade you that their product is best (and we are no exception, of course!) but what we will not do is mislead you. So the following are FACTS taken from Manufacturers specifications on their products.

- Fact 1: Even small rotators will turn a fairly large antenna, what they will not do is KEEP IT STATIONARY under strong wind conditions. To do this requires good BRAKE TORQUE. This is measured in Kg. cms.
- Fact 2: Low voltage rotators (24v ac) require higher current. This causes a greater voltage loss along the cable than with a higher voltage motor unit. Cable voltage loss will reduce rotational torque.
- Fact 3: Some rotators use unbalanced braking. Under strong winds, this places an unbalanced stress on the casing of the motor unit and can cause it to fracture. Balanced braking is thus superior.

Position	Make	Model	Brake Torque kg cms	Cost per kg cm	Price £	Comment
1	Emoto	1102MXX	10,000	2.40	240.35	75% better braking torque than HAM-4 and costs less
2	Emoto	1103MXX	10,000	2.46	246.10	
3	Emoto	1102MSAX	10,000	3.17	317.40	
4	Emoto	1103MSAX	10,000	3.20	320.85	
5	Western	WE-1145	1,000	4.00	39.99	
6	Emoto	105TS	3,000	4.06	121.90	92% better braking torque than CDE AR-40 and over £50 cheaper
7	Emoto	502SAX	4,000	4.22	169.05	New model! 50% better b. torque than similarly priced Kenpro KR400RC and Daiwa DR7500R
8	Daiwa	DR7600R	4,000	4.25	170.00	
9	Kenpro	KR600RC	4,000	4.45	178.00	
10	CDE	HAM 4	5,700	4.54	258.75	Has single brake. Emoto 1102/3 have twin balanced braking
11	Daiwa	DR7500R	2,000	6.00	120.00	
12	Western	FU-400	1,500	6.13	92.00	188% better b. torque than similarly priced AR40
13	Emoto	103SAX	1,500	6.36	95.45	53% better b. torque than CDE CD-45 and £41.40 cheaper
14	Kenpro	KR400RC	2,000	6.37	127.50	
15	Kenpro	KR250	600	7.50	45.00	
16	CDE	Big Talk BT1	920	10.00		
17	CDE	AR22XL	520	13.00		
18	CDE	CD45	920	14.87	136.85	
19	CDE	AR40	520	17.47	90.85	

These figures may have changed. As no current prices were available, information taken from last available

From this you will see that the WE-1145 rotator is a very good buy! We even think we are selling it too cheaply! And here's another FACT. When we used to sell another brand of rotator, we had to increase our stock of spares to over £1,200 to ensure that we had adequate spares! We have been able to reduce that stock by 90% by selling Emoto due to their reliability. You don't believe us? Then next time you go to an exhibition just take a look at the Emoto range and then the other brands. See which ones have 'grotty' little screws underneath to which you have to try and attach the multi-way cable! See which have decent input plugs. See which have stainless steel hardware and then come back and tell us! (We told you so!)

## BEST BUYS

FOR: VHF Antennas: WE-1145. Smaller HF. Ant: FU-400, 10BSAX or 105TS. Larger HF. Ant: Emoto 1102/3

**SO CONSULT THE EXPERTS! WE HANDLE ONLY "FIT AND FORGET" QUALITY ROTATORS.**

## It's Western for KENWOOD and YAESU

Since we first introduced the "Yaesu Musen" brand name to the UK market in 1970 and more recently the "Kenwood" name for Amateur Radio equipment, you can buy with confidence where experience counts. We maintain links with the factories for spares though we maintain stocks also. We also have extensively equipped service facilities with extensive (and expensive) test equipment. It's gratifying to hear that more and more discerning prospective customers object to the "knocking and false rumours" put around by our competitors. Remember, Kenwood is THE brand name throughout the world. It's only for UK that Trio is used. At WESTERN we are not part of any illegal price ring and we are pleased to supply KENWOOD brand equipment known and recognised throughout the world.

**"W.E." will not be under-cut! Prices forced down by "W.E." from the KENWOOD STABLE FOR . . . the discerning DX-OPERATOR . . . OR . . . DX-SWL NOW ONLY £1099 for the TS-930s . . . and . . . £279 for R-1000**



Since at WESTERN we sell both Yaesu and Kenwood, we do not try to push a prospective purchaser into a particular brand of equipment . . . we have no "axe to grind" one way or the other.

Our MD (He's spoilt! He just takes home what he fancies for a trial evaluation) thought he'd try the top of ranges FT-1 and TS-930S. He promptly brought the FT-1 back to the stock room. Then he took the FT-102. He hitched the FT-102 and TS930S up together but brought the FT-102 back. Said he's got too old and lazy to bother with controls like PA Tune, PA Load Pre-selection tuning when the TS-930S does the same job with less knobs. The Noise Blanker really cuts old "Woody Woodpecker" down to size! UA's will have to find something new to annoy a TS-930S owner. How often have you found a rare DX-station only to discover he has a good pile-up too! With the 9.30 you just press "M In" and store his frequency in the memory and carry on tuning round or QSO elsewhere. Then to come back smack onto the rare DX you just select Memory instead of the VFO, and up pops your DX station. Since there are 8 memory channels there are more than enough for anyone.

The R-1000 is an uncluttered simple to use and excellent general coverage receiver. It brings the world to your fingertips in seconds. With its PLL synthesised receiver you get excellent stability and accuracy.

### FEATURES ARE:

- Covers 200kHz to 300MHz continuously
- 30 1MHz bands
- Noise Blanker
- Terminal for external tape recorder

- Built-in 12 hr quartz digital clock with auto-timer facility to switch 'On' at pre-determined time
- 'S' meter and dimmer control to panel lighting
- Built-in 4" speaker
- Built-in attenuator to prevent overloading
- Digital readout to 1kHz and analogue dial

**Special Bargain of the Month. Yaesu FT-980 £999 only. Special Guarantee**

THANK YOU GENTLEMEN!

ALL SOLD ON ONE DAY RECENTLY!

TS-530S Kenwood to Mr. S. of Fife

TS-530S Kenwood to Mr. S. of Liverpool

TS-930S Kenwood to Mr. F. of Ross-Shire

R-2000 Kenwood to Mr. W. of Grimsby

## NEW LINE OF FILTERS

FILTERS DJOAV Carriage paid (send SAE for leaflet)

1554	HPY	High pass filter	£8.62	1558	LSY	Loud speaker 125 watt	£6.80
1555	HPM45	High pass module	£3.45	1559		220v/6A Mains twin toroid	£5.75
1556	HPY170	High pass	£8.62	1560		Plug extension	£1.15
1557	MTY	Braid breaker	£6.90	1561		ES-1 complete kit of cat. nos. 1554-61 inc.	£34.50

• ACCESS • BARCLAYCARD • H.P. ARRANGED • DINERS CLUB • PART EXCHANGE

**Western Electronics (UK) Ltd**

FAIRFIELD ESTATE, LOUTH, LINCS LN11 0JH  
Tel: Louth (0507) 604955 Telex: 56121 WEST G

OPEN HOURS: 09.00-12.00, 13.00-17.00 Mon/Fri; Saturdays: By Appointment.

AGENT:

NORTHERN IRELAND  
Tom Greer G14TGR  
Norma Greer G14TBP  
Tel: 023126645

# HAM RADIO TODAY

## CONTENTS

VOLUME TWO NO.2 FEBRUARY 1984

**Editor**  
Dave Bradshaw  
**Assistant Editor**  
Steve Ireland, G3ZZD

**Advertisement Manager**  
David Gadsden, G4NXV  
**Classified Sales Executive**  
Debbie Miller

**Managing Editor**  
Ron Harris  
**Chief Executive**  
T. J. Connell

**Published by:**  
Argus Specialist Publications Ltd.,  
1, Golden Square,  
London W1R 3AB.  
Telephone: 01-437 0626

**Distributed by:**  
SM Distribution Ltd.

**Printed by:**  
The Garden City Press Ltd.

**Subscription Rate:**  
UK £14.00  
O/Seas Sur: £14.45  
O/Seas Air: £27.00  
Ham Radio Today,  
Subscriptions Dept,  
PO Box 35,  
Wolsey House,  
Wolsey Road,  
Hemel Hempstead,  
Herts, HP2 4SS

Ham Radio Today is normally published on the first Friday in the month preceding cover date. The contents of this publication including all articles, designs, plans, drawings and programs and all copyright and other intellectual property rights therein belong to Argus Specialist Publications Limited. All rights conferred by the Law of Copyright and other intellectual property rights and by virtue of international copyright conventions are specifically reserved to Argus Specialist Publications Limited and any reproduction requires the prior written consent of the Company. © 1983 Argus Specialist Publications Ltd. All reasonable care is taken in the preparation of the magazine contents, but the publishers cannot be held legally responsible for errors. Where mistakes do occur, a correction will normally be published as soon as possible afterwards. All prices and data contained in advertisements are accepted by us in good faith as correct at time of going to press. Neither the advertisers nor the publishers can be held responsible, however, for any variation affecting price or availability which may occur after the publication has closed for press.

## REGULAR COLUMNS

LETTERS .....	4
RADIO TODAY .....	6
RADIO TOMORROW .....	8
METRE WAVE .....	49

## CONSTRUCTION

<b>POLAREASATION CHANGE!</b> .....	10
<i>Horizontal and vertical polarisation from a single Yagi</i>	
<b>2m FM TALKBOX</b> .....	21
<i>The transmitter section gives 1 to 1.5W of RF and has speech processing</i>	
<b>MINIATURISING HF ANTENNAS</b> .....	29
<i>Try capacitive loading for cheap, compact antennas!</i>	

## FEATURES

<b>THE LONGEST CALLSIGN?</b> .....	13
<i>G4JVG/OH0/OJ0? Steve Lowe decided to go to Market Reef</i>	
<b>SETTING UP A CLUB STATION</b> .....	18
<i>Tim Wander, G6GUX, gives some first hand experience</i>	
<b>GB4HRT AT BREADBOARD</b> .....	32
<i>The HRT staff go special event station</i>	
<b>VISIT TO THE NATIONAL WIRELESS MUSEUM</b> .....	34
<i>Trevor Butler and Sharon Metcalfe have a day out</i>	
<b>SEMICONDUCTORS</b> .....	45
<i>Dave Bradshaw steps up to the lectern</i>	

## REVIEWS

<b>BELCOM LS-20XE 2m FM HANDHELD</b> .....	40
<i>Trevor Butler finds this a handful</i>	
<b>IC271E + MUTEK</b> .....	52
<i>The ultimate performer? Angus McKenzie investigates</i>	
<b>ADDENDUM</b> .....	44
<b>NEXT MONTH IN HAM RADIO TODAY</b> .....	51
<b>ADVERTISEMENT INDEX</b> .....	66
<b>Emporium Guide</b> .....	63
<b>Classified</b> .....	65
<b>Free Readers Ads</b> .....	60

# LETTERS

## DOWN UNDER CALLING

Hi there, from an avid radio enthusiast from Down Under. I have been reading your magazine since the first copy hit the bookstands in Australia and I must say that I'm quite impressed from the array of articles on various topics I have read in your magazine.

I thought I must write and tell you at least one opinion from Australia, although I'd say that there are many more than just myself who enjoy your literature.

I quoted myself as a radio enthusiast because I'm studying for my Novice licence to be held on the 15-11-83 and hopefully I'll be talking to you chaps by Christmas, instead of just logging you in my shortwave book.

Quite enjoyed 'Radio Yesterday' and hopefully there will be more articles like this in the near future.

Amateur Radio is the greatest thing that has ever happened to my life, as it brings the young and old and people of all nations together with a special bond, that being the love of radio, whatever facet it may be.

Hope you have a Merry Christmas and a Happy New Year 1984.

**Micheal J Charteris**

*Michael tells us that he would like to trace his ancestors, and to this end he would very much like to hear from any other radio amateurs (in the UK) who share his surname, or anyone from the town of Amisfield in Scotland who knows a bit about local history — if you're interested, write to us at the mag, and we'll pass the letter on. He even sent us a tea-towel and some postcards as a bribe!*

## INACCURACIES

Sir, I read your Magazine with much interest each month, but do not wish to comment, or add to the correspondence about baboons. However, I seem to remember that it was once said that a million baboons with typewriters could eventually produce Shakespeare!

With that in mind, I am disturbed at the present apparent lack of either proof reading, or what may be worse, the ignorance, or unwillingness of the typist to look up a word of which the spelling is in some doubt. Again I do not propose to list such inaccuracies, with the exception that on page 55 I see the unusual word "superceded". The complete O.E.D. does not seem to have heard of the word, but does admit that occasionally "supercede" is erroneously used for supersede.

With this in mind, therefore, I am tempted to query — without prior reference to the Department of Trade and Industry your most important instruction that our logs should be kept, using "UCT". I have many letters from Standard Frequency and Time Signal Stations around the world, and the curious exception of one from France, Univeral Co-ordinated Time is invariably represented by "UTC".

May I suggest that if your instruction leading to the item in your Magazine came from the DTI, or from the City and Guilds Institute, does refer to UTC as UCT, I would still be tempted to query it with the source, for it seems very unlikely that something which has almost complete world-wide acceptance (I include the States, Canada, South Africa, Australia, in addition to Rugby and Hurstmonceaux) should either arbitrarily change the usage for such a minor purpose as log keeping, or, alternatively, lead to a massive correction exercise in many publications — not least the several volumes of Admiralty List of Radio Signals, Handbooks from the N.O.L., etc.

**R.A. Ledgerton, G2ABC**

*As regards the proof reading and spelling we all make mistakes and with the pressure on the editorial staff at HRT it is hardly surprising! By the way, you spelt universal univeral and the Assistant Editor just happens to have a BA degree in English among his qualifications. Regarding UTC, that does seem to be the generally used abbreviation. However, as the term stands for Universal Co-ordinated Time UCT makes more sense, I think.*

## MOSFET LINEAR

Editor, Several of our club members read with great interest your article on the linear amp. for 144 MHz using the Hitachi 2SK317X2 (HRT March).

I have been asked to enquire of you if you have proceeded any further since that article, and if so, is any more information available? Can you let me know where one can obtain these devices (2SK317s)?

May I take this opportunity to congratulate you and your staff on the excellent magazine you publish and wish you every luck in the building of the linear.

With any luck, if the devices get used enough, the price will reduce?

**Stuart Alexander, G6LZG**  
Hon Sec, East Kent Radio Society

*The work on the linear is still going on,*

*albeit slowly now that Frank has left and has to work for a living! (Provocative — Asst.Ed) As to the source, we don't know of one at the moment (we've tried the usual outlets), though we would provide information regarding their supply if and when we publish the design.*

## ATUs ON VHF

Sir, In the December issue, the G3UUS article on 2m wire antennas was interesting but rather misleading, especially to beginners, about the use of ATUs.

It just isn't true that every HF station uses an ATU to match the impedance of the Tx to the antenna. Many stations use single and multi-band antennas which give a good match without the need of an ATU.

Use of an ATU isn't a particular goal to aim for. G3UUS asks "why should VHF be any different?". Well, because small, efficient, high-gain and directional antennas with closely predictable performance and characteristics are readily available on VHF, and because ATUs cost time and money, take up space, need adjustment and introduce extra losses on transmit and receive.

If the VSWR of your VHF beam changes significantly as it rotates, because of proximity of metal objects, using an ATU won't alter the effect, only provide a way of compensating for it at the Tx, at the cost of an overall loss of system efficiency. Few Txs would object to a minor change in VSWR, which in any case doesn't measure output or efficiency.

A VHF ATU clearly has its uses if you are experimenting with wires or any non-resonant antennas, but it is wrong to imply that its use has major benefits in a typical VHF set-up — much better to move your beam (or the offending drain-pipe!).

**John Butcher, DA1DC/G4GWJ**

*While agreeing with your point about the commercial availability of readily available, well-matched 2m Yagi antennas, the point of the article was to encourage people to experiment with wire antennas at VHF — for which an ATU is necessary. Drain-pipes and antennas are often not readily movable, and whilst an ATU cannot compensate for distortion in the radiation pattern, it can at least bring the SWR down so that rigs with SWR-protected PAs are at least feeding the antenna as much power as is available. The ATU will not improve the efficiency of the antenna but can effectively help the overall*

efficiency of the system.

That said, ATUs at VHF should not become an excuse for poor matching between the feeder and antenna, especially with low impedance aerial systems — which is all too often the case on HF.

## 290 TROUBLE

Sir, I feel a serious problem I recently experienced with my FT290R could be a salutary warning to other owners.

I purchased a Mutek preamplifier and fitted it according to instructions and eventually reassembled the set, one of the final tasks before replacing the lids was to re-locate and fasten the battery holder into place.

Using the rig in the car, mobile, I found the result to be superb, almost as though I had purchased a new rig. As I was heading on to the continent to operate mobile and portable stroke Papa Alpha, I charged the nicads fully before leaving home.

My consternation at the car filling with smoke (and smell) from the "sizzling" but switched off 290 can be well imagined, as I headed towards the German border.

I stopped and removed the unit from its housing, using gloves, as I burnt my fingers attempting to remove it without, placed the rig in the passenger well and continued my journey, only to find it was still "cooking" and belching smoke. On stopping, the battery pack was opened, again using gloves, and the "gooey" remains of the nicads and plastic battery holder were removed forthwith.

On inspection in the hotel bedroom later that evening the cause of the problem was located, although it was considerably far too late to be of value. It transpired that on fitting the metal battery holder tray back into the set, the positive battery lead had been trapped between the metal case and an earthing post, hence the eventual dead short of the fully-charged nicads.

Plugging the 290 back into the car housing produced an unintelligible jumble on the display, an operating squelch and very little else, causing the heart to sink into the boots.

However, switching off the back-up battery switch for a few seconds remarkably returned the set to full working order, albeit with a display that was literally 'on-the-blink'. Dismantling the front escutcheon and cleaning away all of the "burn-out"-produced "gunge" from the display area and plugs and sockets cured the problem, and the 290 now works as well as ever, including the Mutek front end.

Discussing this problem with other owners in the same area, I discovered at least three other sets which had suffered the same fate. All have recovered successfully, which just emphasises how robust the modern transceiver can be.

Another problem experienced by local 290 owners, which also causes problems with the nicad pack, is the external power supply connector

socket, not disconnecting the nicads when on an external supply, another point to watch out for.

Trusting you will consider this worthwhile printing, and it may save other 290 users suffering the same fate.

**Norman Bedford, G4NJP**

## TOTSUKO TR2100M

Sir, With reference to Julian Moss's letter in Jan '84 HRT, I think he ought to take a closer look at the spec. sheet.

There it states that RF O/P power is 1W PEP ( $\pm 20\%$ ) at "low" and 10W PEP ( $\pm 20\%$ ) at "high". The power on "whistle" will give you RMS power, the same as on CW. Therefore Julian's rig was producing 2W PEP at "low" and 21.8 W PEP at "high", well over spec. also, his problems with RF O/P power changing with supply voltage could be cured by putting 13.8V via the external power lead to the rig and tuning the Tx on low power via a power meter into a dummy load, as follows:

Select 'low power' on rear panel and tune L21, L22, L23, L24, T4, T5, T6, T7, T8, all located at the rear of the main circuit board. Go through the tuning a couple of times to ensure maximum power and optimum tuning is obtained.

Next select 'high power' on the rear panel and tune T2, T1, T3, T4 on the linear unit (same side as the loudspeaker) again for max. power (repeat at least a couple of times). NB: do this tuning with 'CW' selected on the rear panel.

Generally speaking, I agree with his findings on the receiver — something ought to be done about that first mixer: any offers? Anyway, my set is always drifting all over the place, even after a reasonable warm-up. There was also a jitter (or FM-ing) which I cured. The output from the transmitter gave some spurious emissions and had to be returned, also I found that the mic. amp's O/P was pretty grotty, so I did another simple mod. After all that the rig is quite good value for money at £115, it just needs the rough edges taken off.

Finally, anyone requiring any mod info on charging nicads in situ, and morse keying mod (at present the mic key has to be operated as well as the morse key I/P at the rear panel) then send a large SAE to: New Idea Ltd, 133 Flaxley Road, Stechford, Birmingham B33 9HQ.

I hope the enclosed mods sheets will be of use to your readers.

**Robert Parry, G4UCL**

*Due to lack of space we are unable to reproduce Robert's suggested modifications this month; however, all being well, we will bring them to you next month.*

## FAIR COMMENT?

Sir, As a person currently working towards the May RAE and struggling with morse (Class A or bust, I say), I

picked up my first copy of HRT today. It is the December issue (you remember, one with all the letters about the farewell editorial by F. Ogden). I love letters columns, but this one in particular got the old adrenalin flowing. Oh the vitriol! The controversy! The wit! Great stuff — just what a letters column should be like!

The contents of the letter, and presumably their subject too (which I have not seen) are nonetheless disturbing for those like myself who are trying to 'get in' to the hobby.

May I illustrate the reservations implanted by the aforementioned bitter exchanges in this way:

The 19th edition of the RSGB 'Guide to Amateur Radio' has a forward panel headed 'To CBers: "Come on in!"', and goes on to say 'Amateur radio seeks and welcomes all those who are genuinely interested in radio for "self training, intercommunication and technical investigations"'. As a CBer, I draw great comfort from this!

On the other hand, the recent correspondence in your journal and its raison d'être would suggest a not insubstantial body of opinion, perhaps yet unvoiced, which disagrees with the 'official' RSGB line.

So, are new amateurs, ex-CB or otherwise, going to continue to be welcomed? I hope so, or six months of headache and graft, not to mention of cash, are going to be wasted.

The increase in the number of licence 'attempts' is not at all surprising, given: (a) the growth in leisure activities is widespread, and the black box manufacturers are responding like any other consumer electronics companies; (b) CB folk have developed their interest in radio communication and are moving over to ham radio, mostly, one suspects, to get away from the half-wits who seem intent on ruining CB.

For this latter reason, it is reasonable to expect that ex-CBers will have a much healthier respect for all the regulations than some would like to give credit for. After all, they are moving over because they WANT regulation and control!

Whatever the reasons for the growth in the number of licences issued, that growth is surely inevitable. Those who feel so bitter about amateur radio losing its exclusivity would be better directing their energies towards better-regulated use of the frequencies available. Those who sneer at the 'old reactionaries' would do well to remember the latter's contribution to the expertise and knowledge held in the amateur radio fraternity.

I'm not proud — when I get on the air, I'll talk to anybody! I'd like to help people if I can, and hope to receive similar consideration. Please, God, let there be a clear frequency!

**Arthur Wardell**

Please address correspondence to:  
Ham Radio Today,  
1, Golden Square,  
LONDON W1R 3AB.

# RADIO TODAY



Jim, GM3ZMA, with the complete GB3LU repeater — less the antenna of course!

## The Shetland Repeater, GB3LU

From time to time over the years, amateurs in Shetland have discussed the possibility of having a 2m repeater somewhere in the islands. However, the great leap forward took place on 17 December, 1981, when, at a special meeting of the Lerwick Radio Club (GM3ZET), it was decided "to proceed with a 2m repeater project, with the repeater being sited on the Ward of Bressay". The initial site proposed, at Ward of Bressay, was at the BBC/IBA station which is located some 226 m ASL on

the Island of Bressay which lies just offshore from the town of Lerwick.

The Lerwick Radio Club had two great strokes of luck in executing the plan to construct a repeater. Firstly, the Club had, in the person of Jim Butler, GM3ZMA, a person of great technical expertise, and virtually single handed Jim has constructed the complete Rx/Tx/Logic unit which forms the heart of the repeater — indeed Jim has even constructed a complete spare repeater unit! Secondly, the Club received generous financial aid from the Leisure and Recreation Department of Shetland Islands Council, and it is doubtful if the project could have got off the ground, let alone in-

to the air, without Jim's technical ability and the financial help of the Local Authority.

The Rx/Tx units are Pye R460/T460 units modified for 2m use, while the logic is based on the GB3US Mk I design with some modifications by GM3ZMA. The duplexer was purchased from Wacom Products Inc, of Waco, Texas, USA, and duplexer performance is first class. The repeater channel, by the way, is R3.

In the summer of 1982 it was decided to locate the repeater not on the Island of Bressay, but on the summit of Shurton Hill (ZU64d) which lies some 3 kilometres west of Lerwick. This site is much more accessible than the previous one and there is easy vehicular access to the equipment hut. The repeater is housed in the Local Authority (Department of Construction) radio hut and a 6.5 m lattice mast was erected to carry the antenna which is a Hustler G6-144B colinear with about 12 m of Heliac feeder to the Tx/Rx unit. The base of the mast is a couple of metres below the actual highest point of the hill (175.55 m AOD) at about 173.55 m AOD with the base of the actual antenna at approximately 180.00 m AOD. At this location, winds of 125 m.p.h. are not uncommon.

While Jim deserves the lion's share of the credit for the project, a number of others were involved in the spade work such as concreting the antenna base, excavation, mast erection, etc. and those were: Frank (GM4SWU), Tommy (GM4LER), Hans (GM4SSA), Billy (GM8RUI), and Arthur (GM4LBE) who has also been responsible for the paper work of the project.

The repeater has been completed now for a number of months and has been tested as a split frequency fixed station and found to give excellent coverage over the entire islands. The licence to operate the repeater is now being awaited with some impatience, and as the application was submitted on 23 March, 1982, it is hoped that we will not enter a third year of waiting.

Photographs courtesy GM4LBE.

## G5RV For £10

Amtron UK of 7 Hughenden Road, Hastings, market a natty antenna insulator kit for £5.60 which will enable the purchaser to make up a nice open-wire fed G5RV with some bell wire from the local 'Woolys'.

The kit consists of 25 spreaders, which is ample for a 33 foot section of open-wire feeder, and 3 end/centre insulators. If 14/16 SWG wire is used for the feeder, an impedance of very close to 300 ohms should result. Both insulators and spacers are moulded from 'ultra violet stabilised co-polymer polypropylene' (!) which means that they withstand sun and rain pretty well. Whatever, it beats boiling

wooden dowelling in vats of paraffin wax to make your spacers!!!

## CB Licence Changes

Important changes affecting the use of Citizens' Band radio will be introduced in the new CB licence which will come into effect from 1 February 1984.

Announcing the alterations in the CB licence, Mr Alex Fletcher, Minister with responsibility for radio regulatory matters in the Department of Trade and Industry, said in reply to a Parliamentary question from Sir Patrick Wall MP (Beverley) in December:

"A number of changes to the existing CB radio licence are to come into effect on 5 March 1984. Licences and licence renewals taken out from this date will only be valid if the licence holder is aged 14 or over. Children under this age will still be able to use CB but only under the supervision of an older person. Those under 14 whose licence will expire after 5 March 1984 may continue to operate under their own licences until such time as they fall due for renewal.

"Other changes to the licence are aimed at clearing up areas of misunderstanding and include an explicit ban on the playing of music and the retransmission of radio and television broadcast material. To help counter abuse of channel 9, the new licence will also incorporate a note drawing attention to the CB Code of Practice and highlighting the recommendation that channel 9 should be used for emergencies and assistance only."

More freedom in the construction of antennae to be used with 27MHz equipment is to be allowed and the licence conditions are to be relaxed so that any person will be permitted to operate CB under the direct supervision of the licensee.

## W2AU Balun Designer Retires

Paul Wandelt retired from the Microwave Filter Company Board of Directors at a board meeting in October 1983. At the meeting, Wandelt was elected an honorary lifetime member of the board and was awarded the Golden Balun, a gold-plated replica of a Ham radio product he designed 20 years ago!

## World's Steepest Railway

A Gloucestershire company has developed a unique method of erecting giant TV and radio transmitter masts — by building a railway up the side! When Alan Dick and Company Limited of The Barlands, Cheltenham won the £1 million

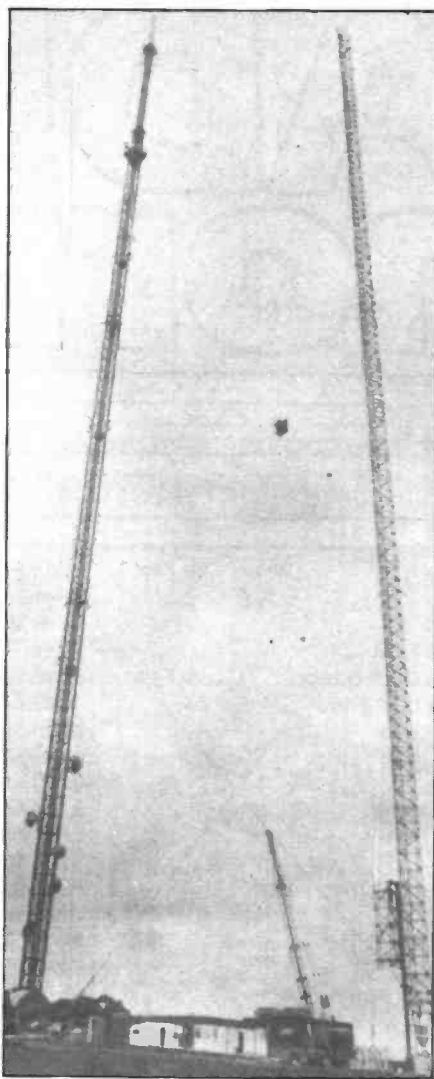

Another section for the top of the BBC Holme Moss mast is hauled up the 'world's steepest railway'. The mast on the left is to be dismantled.

contract from the BBC to build new 750 ft masts at Holme Moss in the Pennines and at Sutton Coldfield, near Birmingham, they realised a new method of construction was required.

"The conventional method of hoisting-up mast sections on a derrick with ropes and winches could have proved rather difficult — and indeed dangerous — at Holme Moss," said John Means, the company's structures director. "Even at 100 ft it is often very windy indeed and our mast erection team would have had great difficulty controlling large steel sections on the end of a rope."

So the Alan Dick mast design team came up with a simple, yet brilliant idea. First they fixed "railway tracks" to each 25 ft section of the mast as it was being assembled in the factory. Then they designed a special derrick-on-wheels to move up the 'tracked' mast as it was assembled — with the next mast section attached to it.

The rig was first used at the Sutton

Coldfield site, then transferred to the Home Moss site; in both cases it proved safer, easier and quicker than conventional methods.

The photograph shows a new section going up the side of the mast (to the right) at Holme Moss; the old mast (on the left) will be dismantled next year when the new is commissioned. The new mast will give circular polarisation.

## Radio Rescue — Episode 594

News has reached us via a rather circuitous route of another radio amateur involved in a life-saving link. The amateur involved is Paul Consitt (no we don't know his callsign, that was one of the pieces of information lost along the way) of Norton-on-Derwent near York, who received an SOS for some drugs needed for treatment of cancer in a two year-old Yugoslavian boy — in Yugoslavia. The request was passed on to York District Hospital, who contacted the manufacturers of the drug concerned, and a consignment was later put on board a Yugoslavian air-liner.

## Order Your Pizzas By Radio

But from the USA! Apparently, the FCC regulation forbidding commercial communications over the air was briefly rescinded for a few weeks in September, and then reinstated. This was all part of an effort to *clear up* the confusion over what constituted prohibited communication...

## Calling Meteor Scatterers!

The British Meteor Society would like to hear from you! They have been conducting research on radio scattering for more than 10 years and would like to compare notes with anyone who has experience in this field. Contact them through Robert A Mackenzie, FRAS, AFBIS, 26 Adrian Street, Dover, Kent.

## More Traps

G2DYM aerials of Uplowman, Tiverton, Devon now manufacture lightweight aerial traps for 3.7, 7, 10, 14, 21, and 28MHz, enabling the tailoring of an optimised trap dipole to cover your favourite bands from 160 - 10m. No prices were supplied with the press release but the weight of the traps is apparently only 4 ounces each — certainly light on your antenna and hopefully on your pocket as well.

# RADIO Tomorrow

*Your at-a-glance guide to what's happening around the clubs, on the air and in general radio-wise.*

- |   |   |
|---|---|
| <p>3 Feb Cambridge DARC: informal<br/>South Manchester RC: Fault Finding<br/>Harrow RS: Contest Forum</p> <p>4 Feb RSGB 7MHz Phone Contest (4th/5th)</p> <p>5 Feb HAM FEAST! at the Mosses Centre, Cecil Street, BURY. Doors open 11 am. Bring and buy. Food available. Talk-in S22.<br/>RSGB 144MHz CW</p> <p>6 Feb Stourbridge ARS: informal<br/>Leighton Linslade RC: ring PRO for details<br/>Swale ARC: informal<br/>Stowmarket DARS: Junk Sale<br/>Braintree DARS: <i>Amateur transmitters - theory and practice</i></p> <p>7 Feb Chichester DRC: Club night in the 'Long Room'<br/>Fylde ARS: <i>Public Service Radio by G6DNK</i><br/>Stevenage DARS: <i>European Space Agency in Guiana by G3TIK</i></p> | <p>8 Feb Lincoln SWC: <i>Astrophotography by G4GZA</i><br/>Fareham RC: Natter Night<br/>Nene Valley RC: Natter Night<br/>Wirral DARC: Technical Film Night</p> <p>9 Feb Edgware DARC: ring PRO for details<br/>Colchester RA: Designing and Production of PCBs<br/>MORSE CLASS! Commences Brooklands Technical College, WEYBRIDGE, Surrey for ten weeks from 6.30 - 8pm. Details from Chris Roberts on Weybridge 53300 Ext. 246<br/>Ipswich RA: Repeater Groups Meeting (GB3PO/GB3IH)<br/>Edgware DRS: Talk by Bosch Ltd<br/>Cambridge DARC: <i>In Your Shack (talk)</i><br/>South Manchester RC: <i>Audio Visual Evening by G6MOQ</i><br/>Harrow RS: informal and practical<br/>11 Feb RSGB 1st 1.8MHz Contest</p> |
|---|---|

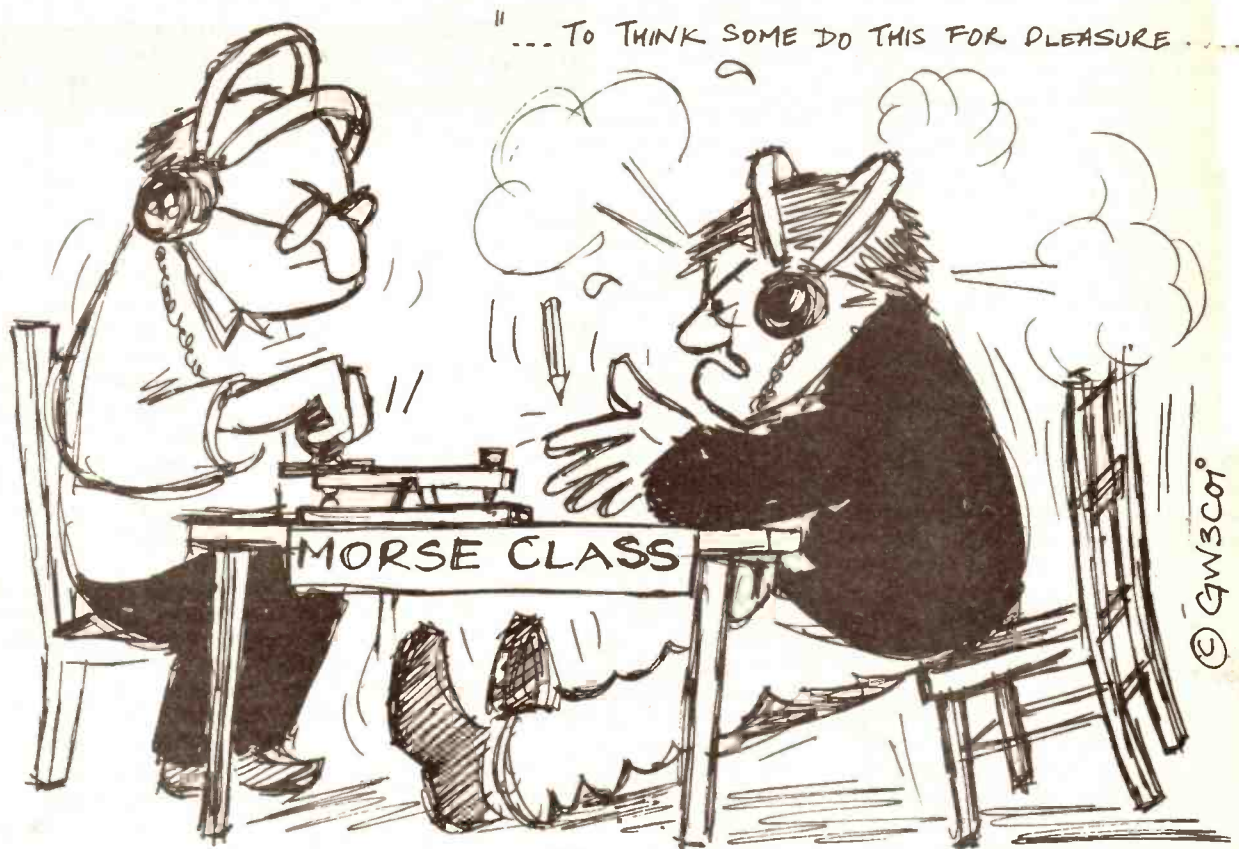



13 Feb	Exeter ARS: <i>Transmitter Valves by G8ROJ</i> Swale RC: informal	1 Mar	East Kent RS: <i>QRP Working by G3ROO</i>
14 Feb	Bury RS: <i>Earthing by G3NKL</i>	2 Mar	Axe Vale ARC: <i>Static Protection for ICs by G3RSJ</i>
15 Feb	Lincoln SWC: CW/RAE class Fareham RC: <i>Did Morse Get It Right? by G3CCB</i> Three Counties ARC: Film Show from Shell Nene Valley ARC: <i>Six Metres by G4BAO</i> (T.B.C. – poss. 22 Feb) Galashiels DARC: Discussion regarding Borders Rally at Kelso	3 Mar	RSGB 144/432MHz + SWL Contest
16 Feb	East Kent RS: natter night Chichester DRC: <i>GB3VR – the Video Repeater by G8KOE</i>	5 Mar	Stourbridge ARS: informal Leighton Linslade RC: ring PRO for details Swale ARC: informal Stowmarket ARS: Junk Sale Braintree DARS: <i>Radio Propagation</i>
17 Feb	Cambridge DARC: informal South Manchester RC: T.B.A.	6 Mar	Fylde ARS: <i>Electronics and Air Traffic Control by J. Jefferson (Sen. ATC, Blackpool Airport)</i> Stevenage DARS: <i>The Worked All Britain Scheme by G4ISO</i>
18 Feb	Nene Valley RC: Special Event Station for Well- ingborough Girl Guides – GB4WGG ARRL DX CW Contest (also 19 Feb)	7 Mar	Lincoln SWC: CW/RAE Class
19 Feb	RSGB 432MHz Fixed Stourbridge ARS: ring PRO for details Swale ARC: informal Braintree DARS: <i>Collecting and Renovating Old Radio Equipment by John Brown</i>	8 Mar	Colchester RA: Film Evening
21 Feb	Fylde ARS: informal and morse class Stevenage DARS: <i>Talk by Cambridge Repeater Group</i> Biggin Hill ARC: Demonstration Of 10GHz Operation	10 Mar	RSGB Commonwealth Contest (till 11 Mar)
22 Feb	Lincoln SWC: activity night Fareham RC: natter night Wirral DARC: Visit by Local Trader	12 Mar	Exeter ARS: <i>Static and Chips by G3RSJ</i> Swale ARC: informal
23 Feb	Edgware DARC: Discussion on Contests 1984 Colchester RA: <i>Making the Micro Work by Robbin Cobbold</i>	14 Mar	Lincoln SWC: <i>Amateur Radio on a Shoestring by G3RJV</i> Wirral DARC: <i>Power Supplies by G6ALH</i> Ipswich RA: <i>Talking Books for the Blind</i>
24 Feb	South Manchester RC: T.B.A.	16 Mar	Sutton and Cheam DRS: Constructional Contest
25 Feb	South Manchester RC: The Quadrupal Night 160m DF Hunt (good grief! – Ed). You've got to be very keen or plain mad to do this (according to the SMRC PRO!)	17 Mar	RSGB Town and County 1.8MHz Phone Contest
28 Feb	RSGB 7MHz CW Contest (till 26 Feb)	19 Mar	Stourbridge ARS: AGM Swale ARS: informal Braintree DARS: <i>DF Hunting by G4PQY</i>
29 Feb	Dudley ARC: <i>TV Outside Broadcasting by Joe Jacobs</i> Lincoln SWC: CW/RAE Class Three Counties ARC: <i>Computers and RTTY</i> Nene Valley RC: Video Show of Heard Island DX- pedition (VKOH1) Ipswich RA: <i>Building the Orwell Bridge by S. Cooper</i>	20 Mar	Fylde ARS: <i>DF Equipment for 160m by G3AEP and G8GG</i> Stevenage DARS: AGM Biggin Hill ARC: ring PRO for details
		21 Mar	Lincoln SWC: CW/RAE Class
		22 Mar	Colchester RA: <i>Marconi and his work</i>
		24 Mar	Sutton and Cheam DRS: Annual Dinner at 'The Woodstock' Swale ARC: informal
		26 Mar	Dudley ARC: <i>DX-ing from a Difficult QTH by G3ZPF</i>
		27 Mar	Lincoln SWC: AGM Agenda/Activity Night
		28 Mar	Wirral DARC: <i>Treasure Hunt by G6SNO</i> Ipswich RA: Constructors Contest
		1 Apr	RSGB ROPPOCCO Contest III

Will Club Secretaries please note that the deadline for the May segment of Radio Tomorrow (covering radio activities from 3rd April – 1st June '84 is 5th March.

#### Contacts:

Abergavenny ARC	D. Ffestin Jones	0495-79617
Axe Vale ARC	Bob Newland	Lyme Regis 5282
Biggin Hill ARS	Ian Mitchell	0959-75785
Braintree DARC	Pat Penny	0376-26487
Bury RS	Brian Tydesley	Bury 25454
Cambridge Repeater Grp	Chris Lorek	0354-740672
Cheshunt DARC	Roger Frisby	0992-464795
Chichester DARC	Terry Allen	024358 463
Colchester RA	G3FIJ	0206-851189
Dudley ARC	Mrs C. Wilding	Codsall 5636
Edgware DARC	Roger Williams	0792-404422
Exeter ARS	Roger Tipper	Exeter 75858
Galashiels DARC	A. Walker	0896 56027
Harrow RS	David Atkins	0923 779942
Leighton Linslade RC	Pete Brazier	Heath and Reach 270
Lincoln SWC	Pam Rose	0427-788356
Maesteg ARC	M.R. Carey	Maesteg 734668
South Bristol ARC	Len Baker	0272-834282
South East Kent ARC	Alan Moore	Dover 822738
South Manchester RC	Dave Holland	061 973 1837
Swale ARC	B. Hancock	0795 873147
Swansea ARS	Roger Williams	0792-404422
West Kent ARS	Peter Reeve	0892-24689

# POLAREASATION CHANGE!

Like so many other enthusiasts nowadays, I began with the basics — the ubiquitous Yaesu FT-290R, a length of UR67 coaxial cable and an omnidirectional antenna. And, like many of my contemporaries, too, I was thrilled with the initial results. Be-

chains and electric motors to achieve the desired result. Not being an engineer, however, and wanting a tilting device that was both simple to construct and reliable in operation, I turned to a neighbour for help.

My co-designer-cum-inventor,

designs for tilting my beam through 90 degrees.

One of them required three control cables — so that was forgotten immediately — while two others needed two separate lengths of wire/rope/cord and would almost certainly have caused tangling problems. But the fourth idea seemed both brilliant and foolproof.

Apologies in advance if our design is merely a copy of someone else's previous brainwave, but, as we're all in this friendly hobby together(!), I doubt if the original instigator of the Anderson-Atkinson 'polariser' will be too upset.

***Steve Anderson, G6VBU, wanted a single beam aerial to use on 2m, but, having chosen an eight-element yagi, he was only half-way there. . . Not all operators are content to limit their VHF/UHF activities to either the SSB/CW or FM modes, hence the creation of this cheap, simple, but effective, mechanical device for changing polarisations.***

ing able to work into Holland and Denmark on 2½ watts — albeit during lift conditions — was certainly an encouragement for me to buy a QTH locator map and to start filling in those all-important squares. But the shortcomings of my 5/8ths groundplane were all too apparent, despite my DX successes and regular, flat-band QSOs over a radius of 40-50 miles. Sooner or later I had to obtain a beam.

Having studied the merits of cross-yagis, quads et al — at least Latin's not a requirement of the RAE studies! — I decided to buy one of the most popular kinds of two-metre antenna, 'fitted and working', as it were: my new eight-element yagi performed excellently in its horizontal plane, but I was soon frustrated by its limitations on FM.

Yet, at the same time, I was determined not to spend about £90 to buy a 90-degree 'tilt-over' rotator, and wasn't keen either on building a second yagi on the same boom to give me a choice of polarisations. If for no other reason than that I couldn't justify spending more precious pounds on another 21 metre of low-loss feeder — and the window frame in my shack is already full of cable! — I decided there had to be a more effective answer. The one aerial would have to serve both my needs. I'd heard of radio amateurs using pulleys, Malcolm Atkinson, has but a passing

interest in our hobby, but he's always willing to lend a hand in solving my problems around the home and garage. I explained the requirement to him and, within five weeks, he and I had come up with four different

## Construction

Basically, the device consists of two heavy-duty hinges available from any good hardware shop positioned together and joined on both outer faces by metal reinforcing plates. The

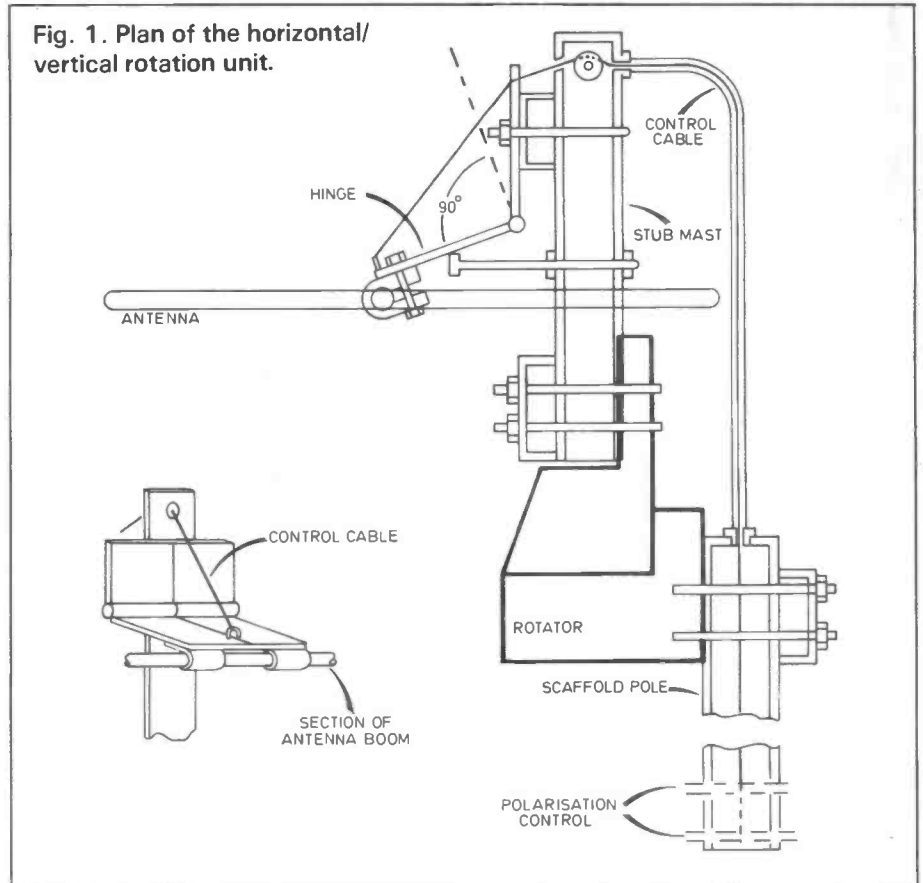

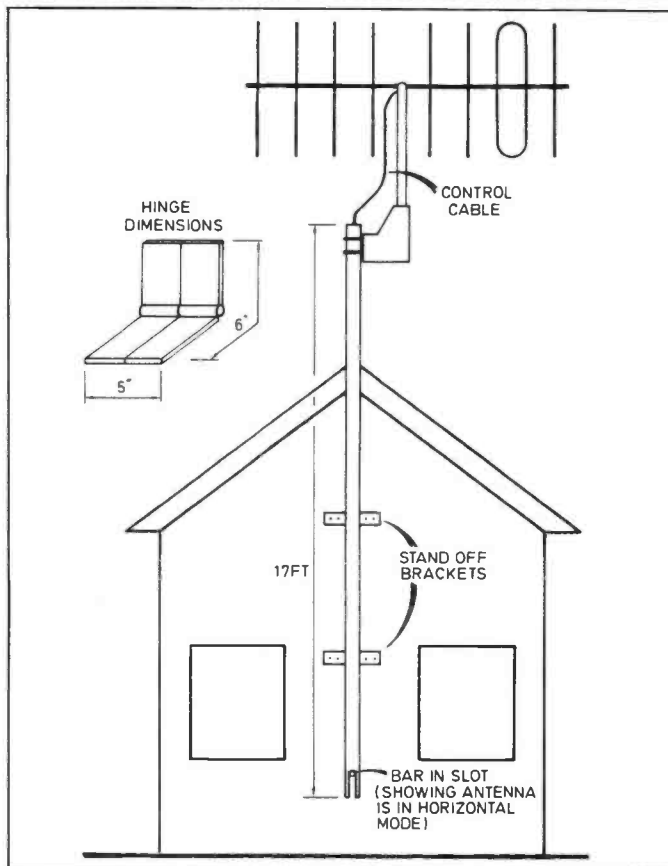
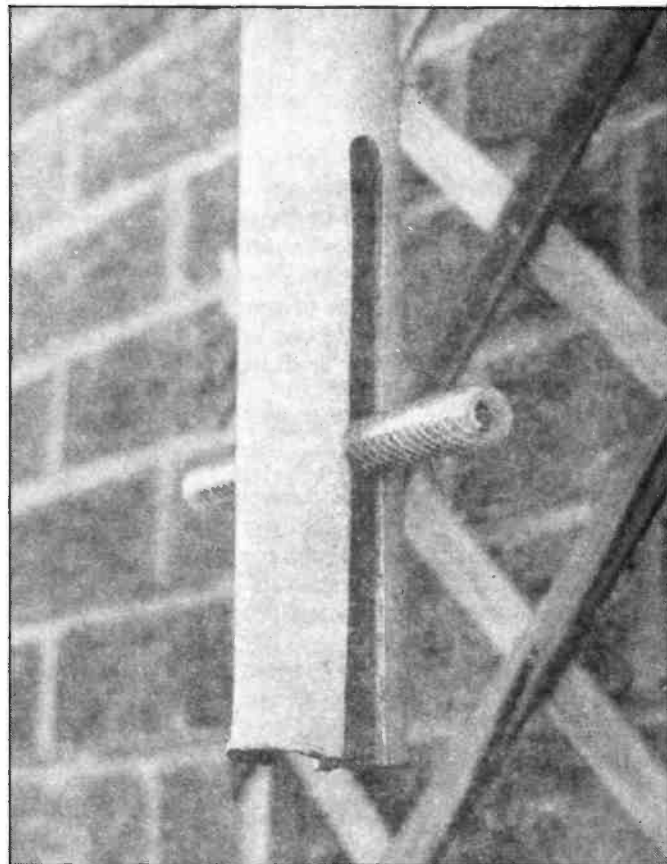

Fig. 2. Complete antenna system as fixed to the G6VBU bungalow.



The polarisation control, mounted just out of reach of the neighbourhood children . . .

two hinges thus become one, measuring about four inches from end to end. The antenna is then connected to the bottom plate — either by small U-bolts or similar clips — while the other section of the hinge is fastened to the aerial stub mast protruding from the rotator. A strong cable is then attached to the bottom, movable part of the hinge, whose downward action is limited to the appropriate distance by a bolt passing beneath it through the stub mast. Sounds complicated, I know, but, as the diagram and photographs show, it could hardly be more straightforward.

The cable connected to the bottom part of the hinges then passes through a small hole near the top of the stub mast. From there, it is enclosed in an outer cable which leads to the top of the scaffold pole carrying the rotator. The other cable terminates at this point, the inner "core" then dropping down the scaffold to the bottom (in this case six feet above ground level, the entire structure being fastened by stand-off brackets to the gable end of our bungalow). A simple slot is then cut into the bottom section of scaffolding. The cable terminates in a steel bar roughly the size of a ball-point pen, and it is this one control

which determines the polarisation of the aerial.

All the operator has to do is pull the cable up or down about four inches to move the position of the hinge. No springs are necessary, as the weight of the bottom section of hinge and the aerial device are sufficient to keep the hinge itself in its openmost position. So much for theory . . . But how does the "polariser" work in practice and are there any problems?

### A Testing Time

First things first. All the materials used in the device were bought, scrounged or found locally and cost no more than about £5. Our prototype took many hours to make — precisely because it was a prototype — but subsequent copies of the polariser could probably be knocked up in an afternoon. But back to the problems. In a nutshell, there have been none since the 'research and development' work was completed, principally on the workbench.

Two aspects of the design did bother me initially, the first being whether the movement of the rotator through 360 degrees would cause the bowden cable arrangement to

become too tight and, therefore, unworkable. But there are no difficulties on this score, since the stub mast is much shorter than the cable suspended in free space from the top of the stub mast, around the rotator and into the scaffold pile. The other potential difficulty was with standing wave ratios while the device was in its vertical position: i.e. "seeing" through a section of either rotator or aluminium stub mast. But, as the hinge swings outwards when the antenna is vertically polarised, it enables the aerial to stand about four inches clear of the mast, thereby reducing the effect of any RF reflections.

To be fair, the SWR readings are not brilliant, but certainly acceptable in the circumstances. When horizontally polarised, the beam is obviously presented with a clearer path for both transmitting and receiving. Depending on the direction of the rotator, the beam exhibits an SWR of between 1.2:1 and 1.4:1.

### Conclusions

In its vertical position, the beam returns slightly inferior figures — as is to be expected — but the worst VSWR I've recorded is 1.7:1 and that's on one specific frequency

when the rotator is in one specific heading. The yagi is, by the way, located within several feet of a large antenna array for broadcast television/radio reception.

The 'polariser' certainly seems to work without any problems, taking no more than a few seconds to operate. As for the hinge — a possible source of difficulty in the damp weather — it's been liberally covered in grease and oil, as has the cable (most of which is protected by the scaffold pole).

### Final Thoughts

I'm not claiming the device will suit every kind of aerial, but my Jaybeam has performed admirably with its new tilting partner and enabled me to make many more forays into those distant squares.

But, with a QTH at almost sea level in the Vale of York and an antenna with just 9.5 db's of gain, I suppose I could do with a few more elements and a few more watts . . .

I wonder what Malcolm's doing this weekend?

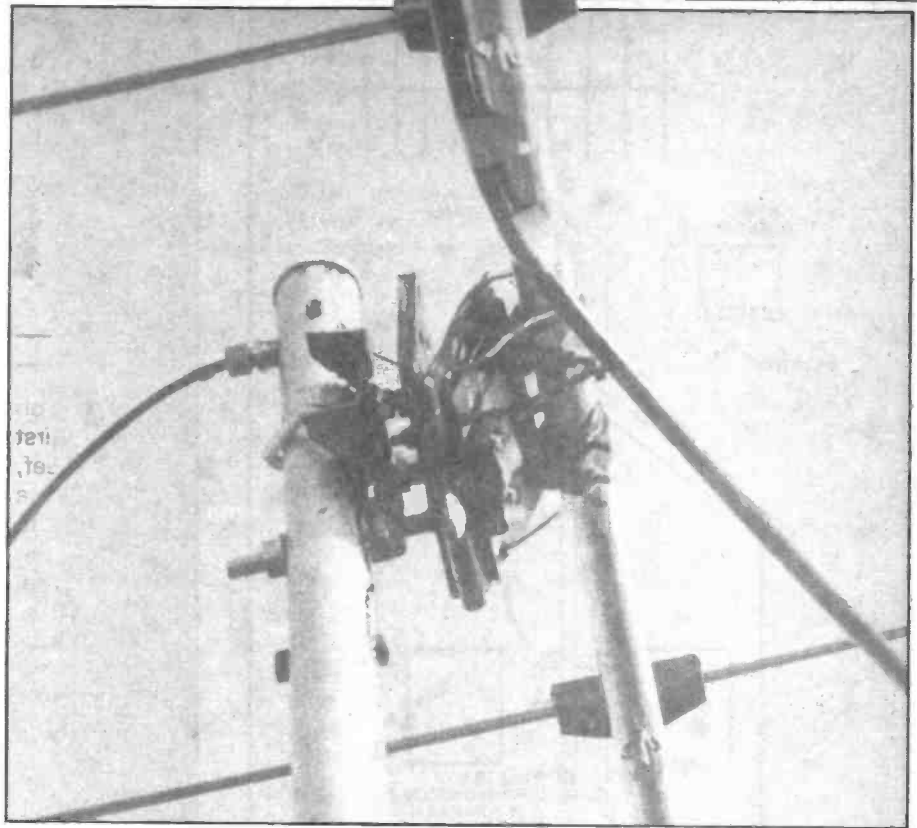

Close-up showing the construction of the rotator hinge.

G3WPO  
G4KEI  
20 FARNAM AVENUE HASSOCKS  
WEST SUSSEX BN6 8NS

HASSOCKS (07918) 6149

## WPO COMMUNICATIONS

Again a full resume of our products — full catalogue on receipt of 50p in stamps, or shortform catalogue for s.a.e. Try one of our kits this Winter — the very best detailed instructions from an award winning design source.

**NEW!! 2 METRE FM TRANSCEIVER** — The February issue of this magazine contains an article on the 6 channel receiver and the March issue details the Transmitter. Full Rx kit of parts (less channel crystals) at £39.50. 6 Channel Transmitter (1 watt) at £32.90 (ex crystals). PCB's for either @ £3.80. Buy both units together for £68. Case for rig £7.50 (undrilled).

**CAPACITY-ADD-ON UNIT** — What's this? A clever design which enables a Digital Frequency Meter to turn into a Digital Capacitance Meter. Measures from 1 pF to lots of uF's. Only two connections needed to your DFM. Complete kit with case & pcb only £18.20. Works off +5 to +15v supply.

**VHF PRESCALER** — enhance your counter for £8.50! Divide by 10 prescaler which will raise the upper limit of your counter to 150MHz plus (typically 200MHz). Small, and comes with case.

**ANTENNA MATCHING UNIT** — the only kit on the market. Suitable for SWL's or QRP (up to 5/10 watts). Covers 1.5 - 30MHz, and intended for end-fed antennas or G5RV types. Match your aerial to your Rx and get more signals through. Easy to build and complete with case. £28.50

**SIX METER CONVERTER** — join in the 50MHz fun and listen with our 28MHz i.f. converter. It is very sensitive, 20dB gain (variable so as not to overload your Rx) and easy to align. +12v needed. All coils prewound. PCB and components mounted on it are £14.00, or complete with diecast box and BNC connectors £19.00

**LOW COST TRANSCEIVERS — OUR MOST POPULAR kits with hundreds sold.** Two versions — the DSB80 for 3.5 - 3.8MHz, and the DSB160 for 1.8 - 2.0MHz. Superb receiver (lots of people have been very complimentary about it) with on-board audio amplifier (1 watt). Double sideband (DSB) transmitter and CW with 3 watts or more output. VFO controlled and +12v operation. All built on one pcb and the kit is complete with slow motion drive, but no speaker or mic. Price for either kit is £37.45. We also have a punched case for the rig @ £23.35 including hardware, and if you want to go all the way, a Digital Readout (ready built and which will fit the case) @ £24.10 including mounting bezel. All three items for £79.00. **IDEAL FOR BEGINNERS or QRP enthusiasts or as relief from your Black Box.** Comprehensive instructions are included. **DISCOUNTS** for Club purchases of 5 or more. These rigs are easily capable of working Eu Dx as many people have proved.

**AGENTS — (UK) AMATEUR RADIO EXCHANGE  
(Holland) FIRMA LAMMERTINCK**

**GET ON TO HF WITH OUR TRANSVERTERS** — if you have a 2 metre multimode transceiver, then you can use all its facilities (memories, scan etc) on the HF bands BOTH TRANSMIT AND RECEIVE. We have two versions, one for 160/80 & 40 metres, and the other for 20, 15 & 10 metres. Either version just plugs in to the VHF rig, and the unit converts to 2 metres on receive, and down to HF on transmit. RF sensing for changeover avoids any mods to your rig. Very sensitive when used with any 2M rig and offers 2 watts minimum on Transmit — usually 3 watts (any mode your 2M rig has). Compact unit built on 2 printed circuit boards. It also offers direct frequency translation from your VHF rig dial i.e. 14.213 = 144.213MHz. Kits come complete with the 3 crystals required. Priced at £81.00 for either version (pcb pair only for either @ £8.50). A good example of saving money by building it yourself.

**PROJECT OMEGA** — we have had an overwhelming response to these kits for a **HIGH PERFORMANCE HF TRANSCEIVER**, as being described in this magazine, and over 150 people are well into constructing it with lots of complimentary reports on the receiver, its a bit too complex to describe in full, but offers all HF bands in 1MHz segments, and most of the facilities found on far more expensive rigs. Intended for full break-in CW, but SSB also part of the design, if you would rather know what goes on in a Black Box, then try building it though! It is not cheap, but you should be proud of the result. Briefly, kits available so far are: Central IF Processing Unit (74.50), Presetor (14.85), Notch Filter (12.50), Active Filter (16.65), Synthesised VFO (109.00 inc crystals), Frequency Display (33.00), QRP PA (21.80), Logic/antenna switch (solid state 100W — 17.65) and Low Pass Filters (33.00), TX/RX SSB Adaptor/VOX (59.50), HF Preamp (13.50), 100W PA, FM and AM units, VHF transverter, In-Line SWR bridge, and a ready punched and screened case (Feb/Mar about £25). Diecast boxes for modules are supplied separately. PCB's can also be bought alone if wanted. Full instructions and corrections included. We have a **MAILING LIST/NEWSLETTER** for this project — ask to be put on it if you are interested in building it.

**70CM PREAMP** — a low noise, very small preamp which could be built into most rigs if needed. Either built @ £8.50 or a kit @ £6.50

**2 METRE PREAMP** — again, very small and low noise. Kits at £5.00 or ready built for £7.00. Ideal for Phase III satellite reception.

All prices include VAT. Post free over £10, otherwise +60p. Allow 1-4 weeks for delivery if not ex-stock. All kits are complete with components (including bolts etc), pcb's (drilled and tinned), wire and comprehensive instructions. Alignment/debug service available. **EXPORT** — please write for prices. **CASH WITH ORDER — MAIL ORDER ONLY. TELEPHONE MON - FRI 10am - 4pm.**

**COMING SOON** — More single band TRANSCEIVERS 160-10M. Watch this space for details.

# The Longest Call-sign in the World?

Which DX-er has not gazed longingly at the small dots of islands in his atlas, or at some strange prefix shown on his "Radio Amateur's Prefix Map of the World", and dreamed of operating from such a rare country? For me the dream came true in the summer of 1983, when I was one of the four operators on the expedition to Market Reef.

I soon started country chasing on the HF bands, and one of the first countries I worked was Market Reef, on 80 metres SSB. They had a tremendous pile-up, but I was able to work them very easily, as Stockholm is only about 110 kms. from Market Reef and signals were extremely strong each way. The station was both a "local" and "DX", at the same

contacted on the Aland islands, OH0, but his reply was very discouraging. He answered that it was necessary to have permission to land there, that one could not go in an ordinary boat, that if the weather turned bad one could be stranded there for days or even weeks. In short, he made it seem so difficult as to be not worth the trouble, and he recommended that if I wanted to be DX I should hire a small cottage on the Aland islands and operate from there instead. This I did, in fact, but it was not the same as operating from Market Reef!

I had therefore almost given up any hope of ever getting to be one of the Market Reef operators when one day in July 1982 my telephone rang and it was Lars, SM5GMG, asking if I could help a fellow radio amateur. One of the "big guns" from Texas, George, K5KG, had been invited to take part in the 1982 Market Reef expedition and was flying from the United States to a business-meeting in Saudi Arabia, breaking his journey in Stockholm in order to go on the expedition.

Lars asked me if I could take George from Stockholm to the Aland islands where he would meet the other expeditioners and from where they would embark for the journey to Market Reef. I willingly agreed and we took the car ferry from Kappelskär, a small port north-east of Stockholm, to Mariehamn, the capital town of the Aland islands.

## Reconnaissance

In Aland we stayed with Kee, OH0NA, who was the leader of the expedition, and George and I spent some hours looking at Kee's vast collection of photographs, newspaper clippings and movies of Market Reef before I had to return to Stockholm and George, Kee and the others left for their expedition. Before I left, though, Kee surprised me by

*Have you ever wondered what it would be like to be on DXpedition to a rare and distant island? Steve Lowe, G4JVG, found that getting there is far from plain sailing. . .*

The dream started, however, several years earlier when, after a lengthy period as a G8, I eventually passed the morse test and received my class "A" licence just in time to start a new job in Stockholm, the Swedish capital. Indeed, it was the prospect of living abroad with the possibility of obtaining a reciprocal class "A" licence that jolted me into getting my morse up to standard for the test.

time! I began to try to find out more about Market Reef to determine whether or not it would be possible to go there myself, but finding out about the place did not prove to be easy.

For a start it was not even shown in my atlas, so I did not really know exactly where it was, although I had, by then, determined that it was somewhere between Sweden and Finland. I wrote to an amateur I had

Just some of the equipment taken on the Expedition. OH0RJ and PA0GAM sitting on the 50 foot tower.



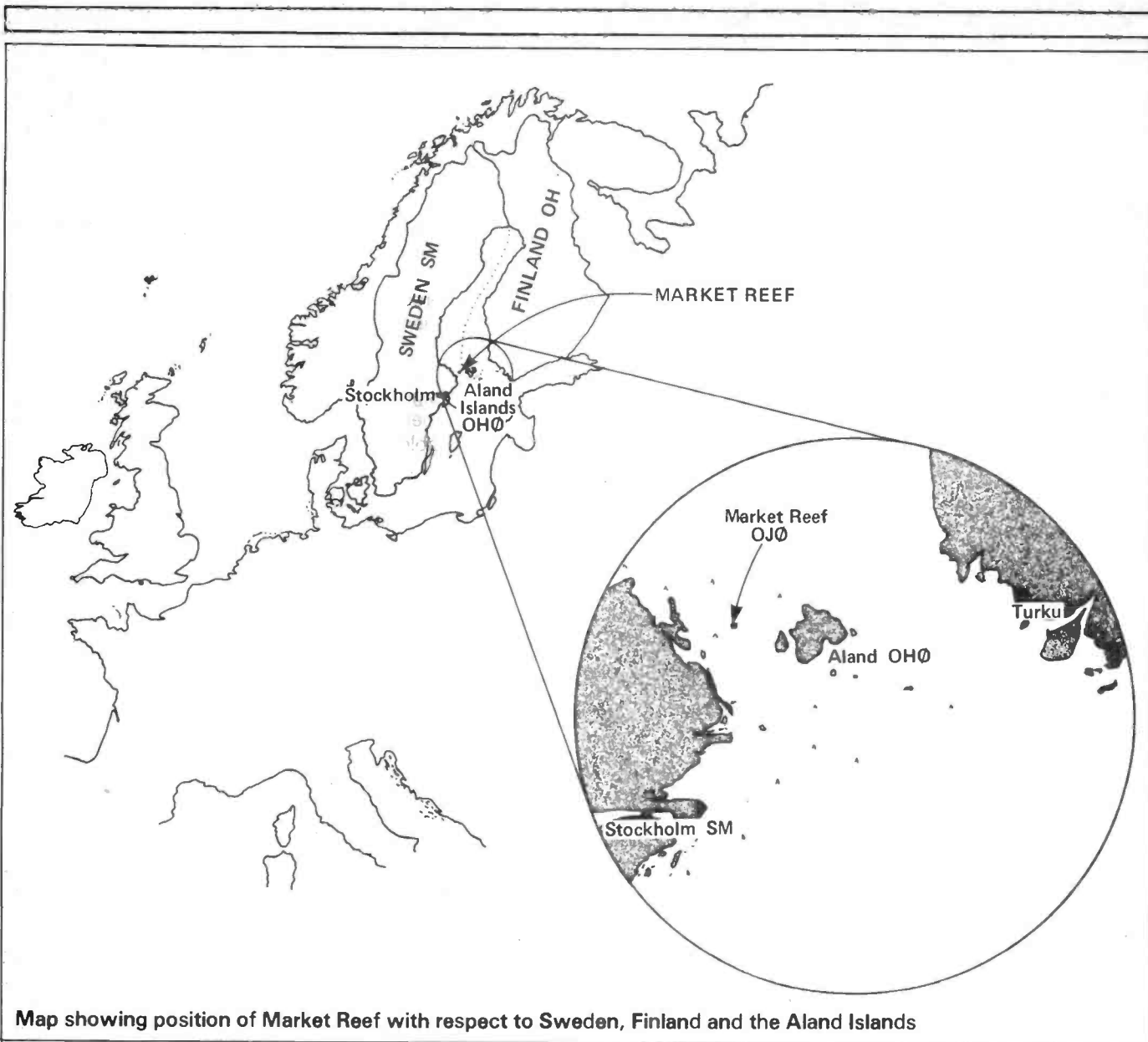

Map showing position of Market Reef with respect to Sweden, Finland and the Åland Islands

saying that if I could find the time, I could go along with them. Alas, I had to be in my office the next morning, so regrettably the offer was turned down, though I did attempt to extract some sort of promise from Kee that if there was going to be another expedition there next year he would consider me.

In the spring of 1983, when I was beginning to think of my summer holidays, I contacted Kee and reminded him of our meeting the previous summer. At that point, he had made no preparations for another expedition, but said he was willing to go himself and that I was welcome to come along provided that the dates could be worked out satisfactorily, that the boat could be hired, and that permission could be obtained from the Finnish authorities. Then it was all down to the weather: we had to pray that it would be calm enough to allow

us to make the journey, and once there remain calm enough so that we could leave when we wanted.

Where, then, is this exotic place, and why is it counted as a separate country for DXCC purposes? To answer the first question it will probably be necessary to refer to a map of Sweden and Finland. Market Reef is located about half-way between the Swedish coast and the Finnish Åland islands, at  $60^{\circ} 18' N$  latitude,  $19^{\circ} 08' E$  longitude, about 110 kilometres north-east of Stockholm.

The island is only about 310 metres long and 85 metres wide at its narrowest point and is kidney-shaped, but only the most detailed maps of the area will show the island at all. It should be shown on coastal charts, however, as there is a lighthouse there called Market ("the Mark") or Markets Fyr ("the Mark's Light"), and it is for this reason that

the name Market Reef came to be used for the island itself when radio amateurs started operating from there.

Back in the early '70s, some enterprising Finnish amateurs noticed that the borders of the Åland islands, and in particular the borders of the county of Eckerö in Åland, extended into the Åland Sea to the west of the islands, but *not* as far as the Märket lighthouse. Now, the Swedish-Finnish border runs a zig-zag course across the island on which the lighthouse is located, and the lighthouse itself is administered by the Finnish authorities, so part of the island was Finnish but was not, officially, part of the Åland islands group.

Using the DXCC Countries List criterion no. 3, these Finnish amateurs applied for separate country status for their new find, on

the grounds that the Finnish-administered part of Market Reef was separated from Finland by the "foreign" (in DXCC terms) territory of the Aland islands. Aland is itself counted separately from Finland "by reason of Government" (DXCC Countries List criterion no. 1), i.e. it has its own parliament and is in a similar situation to Finland as the Channel Islands or Isle of Man are to the United Kingdom. After lengthy consideration, no doubt, the ARRL DX Advisory Committee announced that Market Reef should indeed be counted as a separate entity, and so a new "country" was born.

At about the same time as I started making preliminary plans with Kee for the expedition I was contacted by Gerben, PA0GAM, who is the editor of the DX-press DX bulletin, and who expressed great interest in becoming a member of the team. I advised him to get in contact with Kee, as leader of the planned trip, but meanwhile sent him the licence application forms. Kee meanwhile applied for permission for the three of us plus Lars, OH0RJ, who had also been on several previous Market Reef expeditions, to land on the island and make use of the lighthouse and associated buildings.

### Bureaucracy Strikes!

Prior to 1975 the lighthouse had been manned continuously and Kee had been one of the team of lighthouse-keepers who lived on Market Reef in shifts throughout the year. It was whilst he was resident there that he received the callsign OJ0MA in addition to his OH0NA call which he used when at his home on the main Aland island. A number of other OJ0 callsigns had also been issued by the Finnish licensing authorities to people operating from Market Reef, and the OJ0 prefix came to be known by radio amateurs throughout the world as being allocated to Market Reef, whilst OH0 was recognised as being exclusively the Aland Islands.

In reality, OJ0 was a *special* prefix, and when the Finnish authorities made a decision not to issue any further special callsigns they reverted to using OH0 for Market Reef as well as for Aland. The reason for this is that the *postal* address of the lighthouse on Market Reef is the village of Storby, which is in Aland.

When one applies for a Finnish reciprocal licence one is required to give the exact *postal* address of where the station is to be located, and so, although Gerben and I each applied individually for licences and we both respectfully requested that OJ0 callsigns should be issued (invoking the fact that 1983 was World Communications Year — "wouldn't OJ0WCY be considered suitable?") we were eventually issued with our own calls /OH0.

Although Kee had kindly said that we could use his OJ0MA callsign (which was still valid), both Gerben and I felt that it would be preferable to use our own calls, since OJ0MA had been used for expeditions there every year for several consecutive years and we thought that a new call would generate more interest. But we could hardly use G4JVG/OH0 and PA0GAM/OH0 as everyone would assume we were merely in Aland and not on Market Reef.

callsigns known to either of us, which was particularly gruelling for Gerben as he intended to operate mainly CW (there are actually thirty-six "dahs" in PA0GAM/OH0/OJ0!) We believe our callsigns were the longest ever to have been used — if anyone knows differently I would be interested to hear from them.

According to that well-known DX-er and expeditioner, Martti Laine, OH2BH/OH0BH, the Finnish licensing authorities have now recognised the dilemma, and in future will issue OH0M- callsigns for operation from Market Reef. Foreigners would be given their own calls /OH0M. OH0 followed by any letter other than "M" would continue to be the Aland islands.

### Getting There

But before we started using those horrendous callsigns we had to get to the island. . .



The Boat 'Merit' being loaded

We decided the only solution was to add the additional suffix "/OJ0" after the callsign. In this way we complied fully with the licence regulations, and everyone we contacted knew where we were located. In these days of weird and wonderful callsigns, it did not cause too much confusion or strange comments, though one American, talking across town to his friend who had just worked us, was heard to say "they can't be in OH0 and OJ0!" In 1982, George had operated as K5KG/OH0/OJ0, so the procedure was not entirely unknown.

This provided us with the longest

I met Gerben at Stockholm's Central Railway Station after his journey from the Netherlands, and the net day we drove the 100 kms. to Kappelskär and took the Viking Line car ferry to Mariehamn, retracing the journey I had made with K5KG just a year earlier.

The weather was superb, the temperature was 25°C with a light wind giving the sea just a slight swell. It was therefore with some surprise that on arrival in Aland we were greeted by a somewhat despondent Kee. He was very pessimistic about our chances of getting to Market Reef the next day as planned, and

even refused to make any promises about whether we would get there at all. Imagine our feelings, after all the preparation, the waiting, the licence application, the travelling, only to be told that despite the apparently excellent weather we could not even attempt to land on Market Reef.

The reason, very simply, was that the wind, light though it was, was a northerly one — the worst possible direction. It meant that the only place a boat of any size can pull up to the rocks on the island was exposed to the waves coming all the way down the Gulf of Bothnia to the north. The sea is very shallow all around Market Reef except immediately off the rocks on the north side of the island, where it plunges to a depth of sixty metres, and with such deep sea, Kee knew that it would be much too rough to get a boat even close to the island.

### Waiting

Gerben and I spent a day at Kee's home in Aland, operating his station consisting of a Drake TR7, an Alpha linear, to a Hy-Gain TH3 Mark 3 beam, and telling everyone that we expected to be on OJ0 a day later than originally planned. That evening we listened intently to the Swedish shipping forecast, something which I had never bothered to do before, but which now I realised how important it must be to those thousands of people who make their living from the sea. The general synopsis doesn't sound promising. . . now here come the reports from coastal stations. . . Finska Utö. . . now, Märket! — winds northerly, 7 metres per second. Well, we had by then prepared ourselves for this disappointment — we wouldn't be going to Market the next day.

In the morning, after operating late into the night as G4JVG/OH0, we all listened to the shipping forecast again. No change. We prepared ourselves for another day of waiting, and started telling people that we should now be on OJ0 *two* days later than planned. That evening the shipping forecast told us that the situation was much the same: still 7 metres per second wind on Märket, but it had now veered to north-west. I was very despondent, but Kee explained that the general synopsis was promising — a high pressure system should bring south-westerly winds in a day or two: "we're on our way, but not tomorrow", he said.

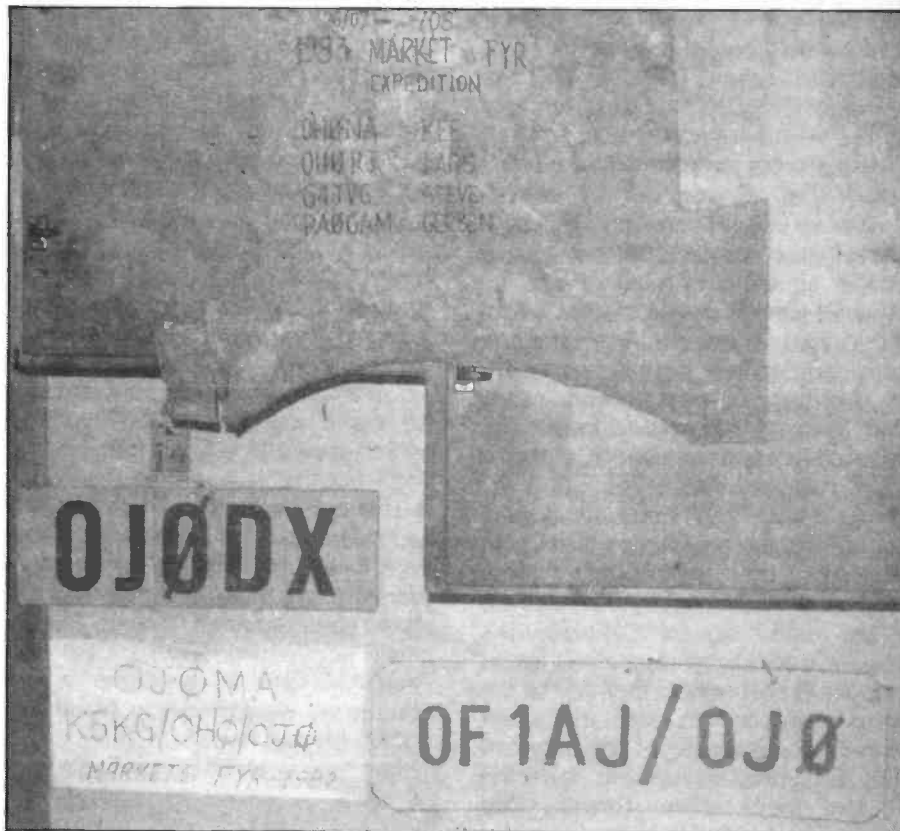

G4JVG was here!

The next morning's report sounded even worse to a land-lubber like myself: the wind speed had *increased* to 10 metres per second, but Kee now thought that there was a fifty-fifty chance we would be leaving the next day as he expected the wind direction to change again soon.

We spent another day operating with our /OH0 callsigns, although our hearts were not really in it: I could not summon up much enthusiasm for operating from Aland when we should have already been on Market Reef for a couple of days. After listening to the evening weather report, though, Kee announced that we could make an attempt to get there the next day. Kee's complete station had first to be taken apart, and this necessitated Kee climbing his 110 foot tower to remove a long length of RG8 co-ax and his remote antenna switch, which would be useful to have on Market Reef. We also took down and dismantled the TH3 beam, and packed the TR7 and Alpha linear in suitcases, so that they should be protected from salt water spray during the journey.

### Noah's Ark

Early the next morning we drove the 40 kms from Kee's house at Saltvik across the island to the small

harbour village of Storby, on Aland's west coast. Here we met Lars, OH0RJ, and Bruno, a retired seafaring type with whom Kee had already made arrangements to transport us to Market Reef in his boat, "Merit". "Merit" proved to be a ten-metre open deck clinker built fishing vessel, entirely constructed by Bruno himself, who had apparently used the artists' impressions of Noah's Ark found in some children's Bibles as the blueprints for his vessel. It had a high prow and stern and sat very high in the water but it was obvious from the way that it had been painted and varnished that Bruno had spent many many hours of tender loving care on his boat. He had equipped it with radar, VHF ship-to-shore radio and a tiny cabin with one seat immediately behind the wheel.

"Merit" was ideal for our purposes as there was plenty of open deck space for the long antenna elements of the TH3 and the Hy-Gain 402BA 40-metre beam. We also took a three-section 50-foot tower, and in addition to Kee's TR7 and Alpha, I had brought along my Drake T4XC and R4C combination and a National NCL-2000 linear, and Lars was taking his Yaesu FT-901DM and Heathkit SB-230 linear. Add to this several hundred metres of RG8, two heavy-



duty rotators and rotor cable, three two-metre stations, a Cue Dee 15144A 15-element two-metre beam, dozens of plugs, sockets, distribution boards, soldering irons, wattmeters and multi-meters, back-up batteries, hundreds of log sheets, and clothes, sleeping bags and enough food for four people, not just for the planned week but for two to three weeks ("just in case") and the total equipment transported to Market Reef probably amounted to somewhere between one and a half and two tons!

The gear was quickly stowed on board "Merit" and we were off, in jubilant spirits to be on our way after so many delays. Someone had brought a bottle, so we toasted each other, Bruno, "Merit", and for a successful expedition, and sat down for the two and a half hour journey. The weather was still very good, with warm sunshine, but almost as soon as "Merit" had left the shelter of the last headland and was in the open sea it became very windy and soon the boat was rolling and pitching violently. After a while waves were breaking over the bows and I could

understand why Kee had packed his equipment so carefully. We scrambled around to the bows, using all available handholds, and repositioned the rest of the gear, attempting to weatherproof my linear and the now soggy cardboard boxes containing our food with plastic dustbin-liner bags which Lars had thoughtfully brought for just this purpose. After about a hour we could just see the speck of red on the horizon which was the Market Reef



Panorama of Market Reef after arrival of DX-pedition

lighthouse, but by this time the sea was so rough that Kee and Bruno were now saying it would be impossible to land. Gerben and I must have looked suitably mutinous, for "Merit" continued, though we were now feeling more and more depressed at the probability of yet another delay.

The lighthouse loomed larger and larger, at first occasionally disappearing behind the swell of the sea and then remaining in sight all the time until suddenly we were there. Bruno took "Merit" around to the northern side of the island, the only place where a boat the size of his could land, but we could all see that it would be quite impossible today: the waves were smashing right over the rocks which rose sheer out of the sea for about ten feet and "Merit" would be dashed against the rocks and broken up in minutes if he had tried to moor there then.

*Still want to go on a DXpedition?! Next month, Steve will be recounting how the expedition eventually got to the Island and activated G4JVG/OH0 /OJ0.*

# IT LIVES AGAIN!

From the past it came, growing daily, striking terror into the hearts of lesser publications, and spreading its influence across the country in its quest to infiltrate every town, every home, every mind.

Not a horror story, but a success story. And if electronics theory strikes terror into you, then you need the help of **Electronics — It's Easy**. Originally a long-running series in Electronics Today International, **Electronics — It's Easy** was printed as a set of three books. They sold out. It was reprinted as a single volume. It sold out. Now this phenomenally successful publication is available again, in its third reprint. **Electronics — It's Easy** is a comprehensive and simply-written guide which explains the theory (and the practice) of electronics step by step. Every aspect of the subject is covered, starting with the basic principles and working through to the how and why of today's technology.

You can obtain your copy of **Electronics — It's Easy** by mail order using the coupon below. Make cheques or postal orders payable to ASP Ltd, alternatively you may pay by Access or Barclaycard.

Send to: Sales Office (Specials),

513 London Road, Thornton Heath  
Surrey CR4 6AR

Please send me . . . . . copies of Electronics —  
It's Easy. I have enclosed £ . . . . . (£4.95 each  
including p&p).

NAME .....

ADDRESS .....

Please debit my account

My Access/ Barclaycard No. is .....

Signature .....



# Setting Up A Club Station



The upsurge in new callsigns over the past two years must mean that many interested amateurs have not been heard in the air due to the very high cost of amateur equipment. A radio club, with equipment for general use sounds fantastic, but it doesn't happen overnight and involves a large amount of hard work.

The first stage is to ensure that enough people are interested and that they are prepared to do some work. With this in mind an enthusiastic (!) committee should first be elected, and then the long grind begins.

allies, especially if documentation has to be signed or someone must take overall responsibility for equipment and premises.

## Equipment

The first thing to remember is that everybody's interests are different but a club should serve the majority. SSTV or RTTY can come at a later date! The most important hurdle is finance, students cannot live by beans and eggs alone despite what the adverts say. The average

Japanese blackbox is beyond the reaches of many people and, yes, 10m CW or FM for £30 may be great unless, like our club, Class B calls outnumber Class A by 18 to 2.

## Raising the money

Everybody is trying to raise money for so many good causes, the trick is to keep people interested, and above all ask nicely:

- (a) Ask anyone who might donate actual money, equipment or materials. These are obviously rare occurrences so elect a treasurer who can be polite.
- (b) Ask anyone who might donate unwanted equipment fondly known as 'junk'. This need not be RF orientated, there is a lot of old computer or TV equipment around that can be cannibalised or even sold at some car

---

*Some guidelines and possible pitfalls to starting a radio club at college, school, university or even, in your town by Tim Wander, G6GUX, BSC.*

---

## Authorisation

Unfortunately the modern world is ruled by bureaucracy and seemingly ridiculous regulations. To form any society or club within any institution means that permission must be obtained, often from the most surprising quarters. The first thing to be remembered is that certain departments are totally allergic to RF. This usually includes any area using computers or audio-visual aids. Departments using public address or hi-fi equipment (drama studios, conference centres etc) should also be avoided.

If you are starting a radio club at a college it may be useful to co-opt a member of staff (look in Physics or electronics department for lapsed amateurs!). They can provide useful

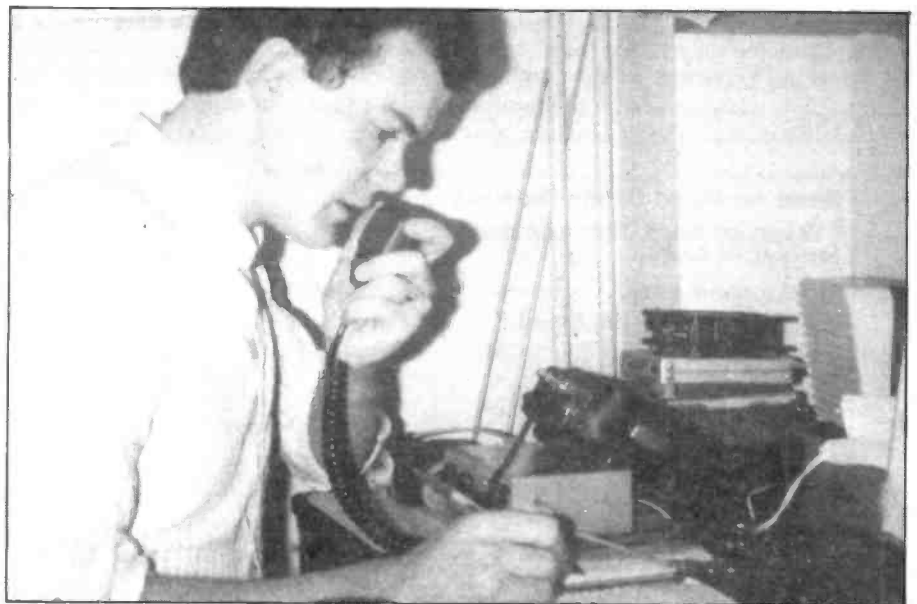

Cupboard 2m Contesting with G8ZEZ

boot sale or local fete.

(c) Fund raising (types of) activities are manifold but legal requirements must be met. Sponsored events and raffles need licences — and careful control — but can raise surprisingly large sums. Sponsored events could include demonstration stations at garden fetes or jumble sales — which involve a lot of hard work but can be great fun.

(d) Contact the nearest radio club and ask for help and advice. They may also have some second hand equipment for sale and will be sympathetic to your aims.

(e) If all fails, call a club meeting, get everyone there and list all the equipment that members are willing to lend for regular club sessions. This can be difficult; my battered rig regularly stands several nights a week club useage.

(f) Remember that the first money comes from membership fees. 30 members at say £4 each can provide a good start for any club!

## The Shack

The next step must be to bring it all together in the hallowed shack. This should be the focus of the new club so checks must be made concerning access (especially after normal hours). All buildings tend to have some deserted cupboard that can be turned into a regular meeting place/coffee hut/DX chasing shack. Once permission has been received the station can be installed. The rules governing the use and installation of the shack are perhaps obvious (but just as obviously ignored).

All connections must be safe and secure (especially mains). One surefire way of becoming unpopular is to burn the place down or electrocute your only Class A licensee. If you don't understand it, don't play with it. . . .

Security is vital; money is scarce, so do not give it away. If the room can be locked: lock it, if not fit a lock! Check who has to have access other than club members (ie cleaners) and ensure that they have keys *and* that they lock up. At Aston we found it necessary to restrict keys to just three club members (the committee) who were directly responsible for the shack.

Keep the shack tidy; not only does this make it easier to work in, but it prevents cleaners cleaning things that



Special Event Station at the Students Union — HF conditions laughable!!

shouldn't be (ie computer discs) or moving things that can't be moved. Ensure that the club is insured, not only against fire and theft but also against accidents.

## Antennas

Again, the key is permission; all amateurs face the potential problem of erecting antennas and then getting them to stay up. Authority must be gained from many different sources. Find out *who* you have to talk too; this may include staff, building or estates departments, safety officers, even insurance companies. There is nothing more irritating than putting up a 15 foot pole, with a 16 ele antenna, rotator and masthead preamp atop it only to have to take it down because it spoils the view of the gas works.

When permission has been confirmed, check before you put it up that (a) it works, and is robust enough to withstand the elements. The wind tends to blow harder on the rooftops and water down your coaxial equals a nasty SWR. (b) Check the antenna is secure; if necessary guy it and use a nice solid steel pole (our 2" aluminium pole bent at an alarming angle one stormy night). If necessary, use an alignment bearing and park the rotator after use.

When putting the antenna up, wait for good weather; the DX will wait for another day — wet roofs and high winds is not a safe combination. If you can't manage the job even on a good windless day, admit it and find someone who can — even if this

means professional help. If you plan things properly this should be a once only job.

Once it is up ensure that little children can't swing on it on an 'open day' or borrow 10 feet of your hard earned coax late one night.

## Activities

Once you have a station use it, but ensure that you use it properly. Refer regularly to those licence regulations you once had to learn.

(a) Affiliate the club to the RSGB; the Rad Comm can be shared among the more poverty stricken members. The QSL bureau is also very useful, get some cards done, preferably with your own eye-catching design. The local college arts department can often help, especially in terms of the cost. Get some envelopes off to the RSGB bureau, as soon as possible, remember you've got to send them enveloped if you want some QSL cards back to cover the bare shack walls.

(b) Get some events going: demonstration stations, regular meetings, rally trips, even CW lessons, will get the club moving. Ensure that people know what is happening, try a regular club net or newsletter.

(c) Ensure the club gets publicity, but make sure it is *good* publicity. Tell people what the antenna is, advertise demonstration stations but explain what is going on during operation. Try articles in local newspapers, posters or plain word of mouth.

(d) Apply for a club callsign and try and organise a special event callsign — attempt to make both meaningful and well used.

### First Step

Remember, the first step is always the hardest, but nothing ever gets done unless someone makes a move. Being a founder committee member can be great fun, and you can even put a plague over the club door with your name on.

Over the period of two years at the University of Aston we have set up, through subscriptions and a student union grant, a well used and very enjoyable station. All those who worked G3UOA and GB8UOA will know us to be nice people and, yes, your QSL cards are in the bureau somewhere. The founding committee have now moved into the 'real' world where hopefully we can earn enough pennies to buy a black box or build our own. We have left behind a fairly well equipped station to a very active club. Amateur radio will never quite seem the same again after two years in a cleaners cupboard.

### Estimated Costs

(1) The Shack — hopefully free (plead) but offer to pay for locks if necessary. (2) Insurance — around (£20-£25) for complete cover (Negotiate). (3) Antenna — VHF beams from £15 to £35 (try second hand). (4) Coax — beware cheap imitations, the losses are not worth it. The new L-100 from Westlake looks very interesting and not too expensive, depending on the run. (5) Rigs — Personally I feel it is a false economy to go for VHF FM only, ie Trio TR 2300, unless accompanied by a single sideband rig (consider the new Totsuko TR-2100M at £110). Secondhand equipment provides the cheapest method of getting on air; you could consider a secondhand multimode such as a FT290 for around £190. These are only suggestions, other more comprehensive articles have appeared on the purchase of equipment.

A linear amplifier for 2m is a useful purchase. Once again, consider secondhand (ie. 25W for around £50 or 100W for £90). For HF there are numerous valve or valve-transistor

'hybrid' secondhand rigs on the market capable of excellent performance — we found a Yaesu FT401 for £200. If this figure seems high, consider initially going for a listening set-up only. HRO or B40 ex-service receivers, old but good, can be found for £25-£30. Oh yes, HF antenna systems can come pretty cheap if you use your initiative — our G5RV was made up from old transformer windings. Don't forget essential miscellaneous expenses like connectors, QSL cards, licence and affiliation fees!

### Conclusions

I estimate somewhere around £400 to provide a complete 2m base station, antenna and operating facility. This may seem like a very high sum, but with, say, 25 members, it's only £16 each for the use of an excellent station for three or four years. Not that members should necessarily have to raise *all* the money, of course. If you are setting up a college station, don't forget your exams and course work as well! Good luck—wherever your club is to be.

# SETTING UP A STATION . . .



**FT757GX**  
£625.00 inc

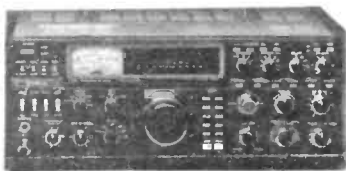

**TS930S**  
£1150.00 inc



**TRIO TS430's**  
£736.00



**TS830S**  
£697.00 inc



PA  
OPERATING CONSUL  
WORTH £69.95  
**FREE**  
WITH ANY OF THESE  
TRANSCIVERS

..... **See the Professionals** .....

*You'll find all you need at Photo Acoustics. We can offer help and advice, the chance to try out the gear and financial facilities too. We offer Creditcharge Instant Finance and accept Access and Barclaycard. Part exchange welcome. Come and see us: Derek G3TGE, Roy G3TLE & Kerry G6IZF - or phone 0908 610625.*

**Photo Acoustics Ltd.**  
● OF NEWPORT PAGNELL ●

Four minutes from the M1. Exit Junc. 14. Head for the High St., Newport Pagnell. We're at No. 58. Parking at rear, opposite, or round the corner in Silver St.



# 2m FM Talkbox

There is nothing particularly out-of-the-ordinary about the Transmitter circuit, except possibly for the use of a speech processing chip. The availability of a cheap integrated circuit (IC1 KB4417) which can handle the microphone input, amplify it to a usable level, and add VOGAD (Voice

the PA up to the milliwatts level. The PA itself (Q7 - 2N4427) provides around 1 to 1.5 watts output into 50 ohms, via the matching network L7/L8/C30/C31. Its input capacitance is tuned out by L6.

Antenna switching facilities are provided on the PCB by a small double

flat against the PCB upper surface after soldering both sides. 2. Fit one of the trimmer capacitors (CT on the circuit) near the edge of the PCB, and in addition to soldering the two earth connections under the board, also solder them carefully to the top of the PCB. Use a hot soldering iron very quickly to achieve this without melting the body of the trimmer. 3. Now fit the remaining trimmers taking care to solder one of the earth pins to both sides of the PCB. 4. Solder in IC1 with pin 3 soldered directly to the top foil, and the two presets VR1/VR2. 5. Solder in all resistors and capacitors except R21, R26, C4, C7, C12, C16, C20, C24, C27, C28, C29, C49, C50, C52 and C53. All resistors are fitted vertically and should have the end with the longest lead connected to earth where required (shown with a cross on the lead). When fitting the small ceramic capacitors *take care* not to

***The 'Talkbox' transmitter section will give 1 - 1.5W of RF and has VOGAD speech processing too! By Tony Bailey, G3WPO, and Chris Gaston, G4KEI.***

Operated Gain Adjusting Device), together with clipping saves a lot of discrete components and gives useful features. The VOGAD part of the circuit means that once the circuit is correctly set up, varying levels of audio reaching the microphone are adjusted to the same output level, avoiding over deviation and other problems. The clipping is normally adjusted to only clip on speech peaks, so that the horrible sounding audio often associated with clipping circuits is avoided. The nominal impedance for the microphone needed is around 600 ohms (dynamic type) but the circuit will work satisfactorily with many other types.

Like the receiver, the transmitter operating is crystal controlled - in this case, the fundamental operating frequency is around 12MHz using a simple Colpitts FET oscillator, Q1. Frequency modulation of this oscillator is achieved by applying the audio output from IC1 via FET Q8, to the oscillator circuit at the junction of C2/C3.

To get to the final 144MHz output frequency, a series of multipliers are used, after a buffer stage at 12MHz (Q2). Q3 triples to 36MHz, Q4 doubles to 72MHz and finally Q5 to 144MHz. Q6 acts as a driver for

pole changeover relay, the extra pole handling the supply voltage switching for the receiver.

## Construction

Like the receiver, this unit is built on one double sided PCB as an aid to reproducibility and stability. The same comments concerning component mounting and lead lengths apply

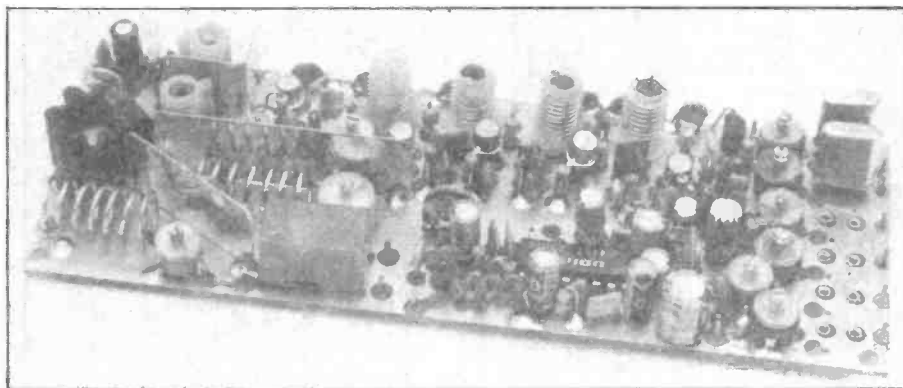

Assembled Talkbox transmitter PCB as were made for the receiver module.

1. Insert and solder the 14 1mm dia PCB connection pins. These are pushed in from the underside of the board with some force needed to get them right in. Note that some need soldering both sides. Also note that the pin shown below L6 is snipped off

force the component in so far that it breaks the body of the capacitor. 6. Fit and solder in position all the prewound coils L1 - L6. 7. Solder in position the remaining trimmer capacitors C21, C26, C30 and C31. 8. Solder in C24 (near L5) with its earth connection made to the ground

## Circuit of 2m FM Talkbox transmitter

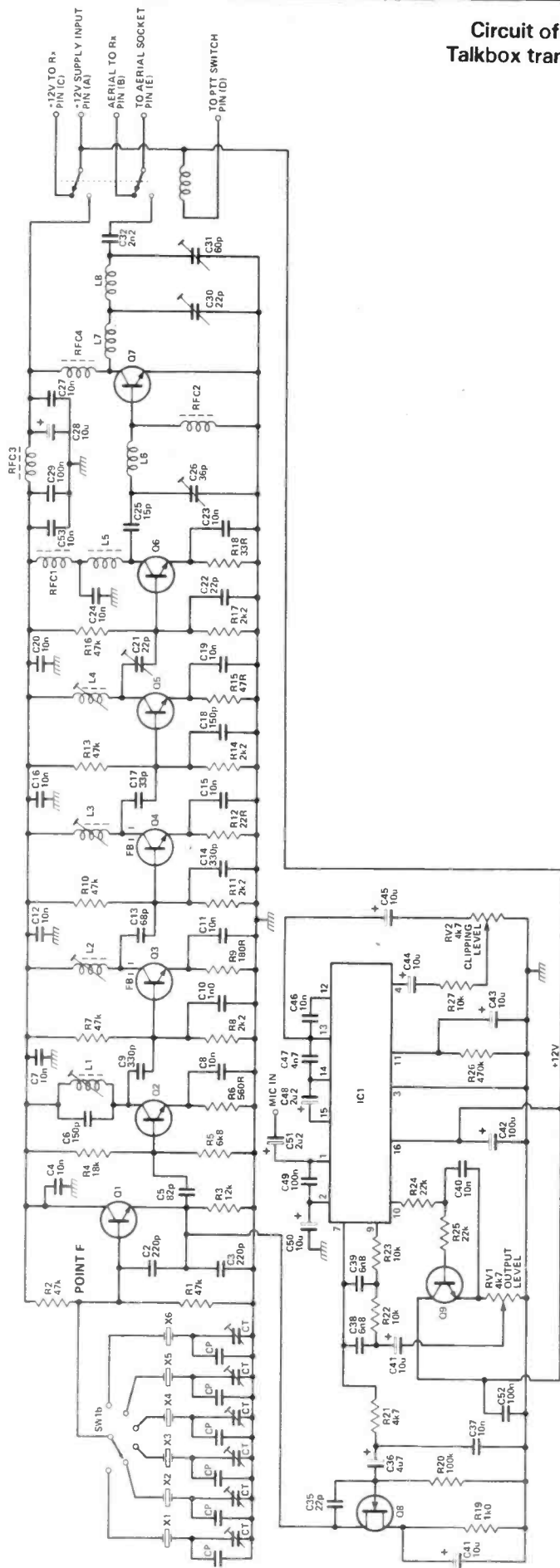

plane. 9. Solder in all six capacitors shown as CP (between the crystal positions) with the earth leads soldered directly to the top foil of the PCB.

10. Bend a small tinplate screen 15mm high and 30mm long into an L-shape, the longest leg being 17mm. Fit this screen between L5 & L6, the short leg being between Q6 and C25 with the edge of the screen positioned flush with the edge of the PCB. Allow about 1mm clearance between C25 and the screen. Solder the screen in position using a couple of solder tacks to the ground plane. 11. Wind, using the information in the component table, the chokes RFC1, 2 and 3. Space the wire around the bead rather than bunch it together. 12. Solder RFC1, 2 and 3 into position, spacing the ferrite about 1mm off the board. The earth connection of RFC2 is made direct to the ground plane.

### Easy Does It

13. Solder in C4, C7, C12, C16, C20, C27, C28, C29 and C53 making sure the earth leads are connected to the ground plane. In the case of C28, carefully bend the -ve lead at 90 degrees to the case, snip the lead down to about 3mm and solder to the earth plane. 14. Wind L6, L7 and RFC4 using 20 swg (or 1mm dia) enamelled or tinned copper wire, wound onto a 6mm (or 1/4") diameter drill shank, and pull out the turns to fit the spacing of the holes in the PCB. Position the coils and RFC4 allowing about 2mm clearance from the PCB, then solder in place. 15. Cut a tinplate screen 15mm high and 45mm long, position between C31 / L8 and C19 / L6, with equal spacing between L6 / L8, then solder at each end. 16. Cut another screen 15mm high and 25mm long, position as shown with one end near to the relay position and solder at both ends. 17. Insert and solder RLY1. 18. Now solder all the transistors into place with the exception of Q7. Make sure that the case outlines agree with the diagram. Ensure that Q3 and Q4 have small ferrite beads placed over the collector leads before insertion - *push the transistor down onto the bead before soldering*. 19. Push the heatsink onto Q7, then fit Q7 through the PCB so that it is about 1mm clear of the board surface (it must not touch it!), then solder the three underside connections. 20. Finally, solder in the small gold-

plated cage jacks – these are used as sockets for the crystals. It is easiest to do this by pushing a pair onto a surplus crystal, then pushing this through the PCB holes, soldering into place on the underside with the tops of the jacks resting against the PCB.

As a final check, look closely at the board and check for solder bridges and components inserted the wrong way round. Also, *make sure that all earth connections needed to the top foil have been made.* Finally, *check with a multimeter that no DC short exists between the +12v connection and the earth plane.*

## Alignment

You will need as a minimum, a multimeter, some means of monitoring the RF output (SWR Bridge or power meter) and a 50 ohm dummy load (or a 2 watt 47 ohm carbon composition resistor). It is also important that the correct trim tools for the cores are used as they will easily break otherwise (these are supplied with the kit of parts from WPO Communications).

1. Connect an earth direct to the top foil of the PCB, +12v power lead to point A – preferably with a 500mA max milliammeter in series – and the dummy load to point E, using coaxial cable with the RF power monitoring device in series with the coax lead. Also insert one of the crystals and connect the appropriate pin to point F using a short length of insulated wire.

2. Preset the cores and trimmers as follows:

- L1 Core 1mm out of former
- L2 Core 3mm out of former
- L3 Core 2mm out of former
- L5 Core 3mm into former
- C21 1/3 meshed
- C26 2/3 meshed
- C30 1/2 meshed
- C31 1/2 meshed
- VR1 mid travel
- VR2 mid travel

3. Connect a piece of wire to the PTT pin (point D) – earthing this will switch the transmitter on. Apply the +12v (to +14v) and earth point D – *the current consumption should be low at this stage but must not exceed 400mA.* 4. Some output power should now be indicated – firstly adjust C30/C31 for maximum, followed by C21/C26 (this keeps the dissipation of the output stages down).

5. If you have no output power,

carefully adjust L1/L2/L3 until some power shows, then go back to step 4. 6. Peak all trimmer and cores including L6 until there is no further increase in output power – you should achieve 1 - 1.5 watts.

7. The adjustment of the processing circuit is best carried out over the air with another station. VR1 controls the output level, thus setting the deviation, and VR2 the onset of clipping. For best results VR2 should be set

so that *clipping only occurs on speech peaks* and no noticeable distortion is present. VR1 is then adjusted for the right amount of audio on-the-air when in contact with another station. Alternatively, an audio signal generator set at 1kHz can be fed into the microphone input, and the output monitored at pin 7 of IC1, setting VR2 so that the peaks of the sine wave just start to flatten.

8. To set the channel crystals on

Transmitter overlay diagram

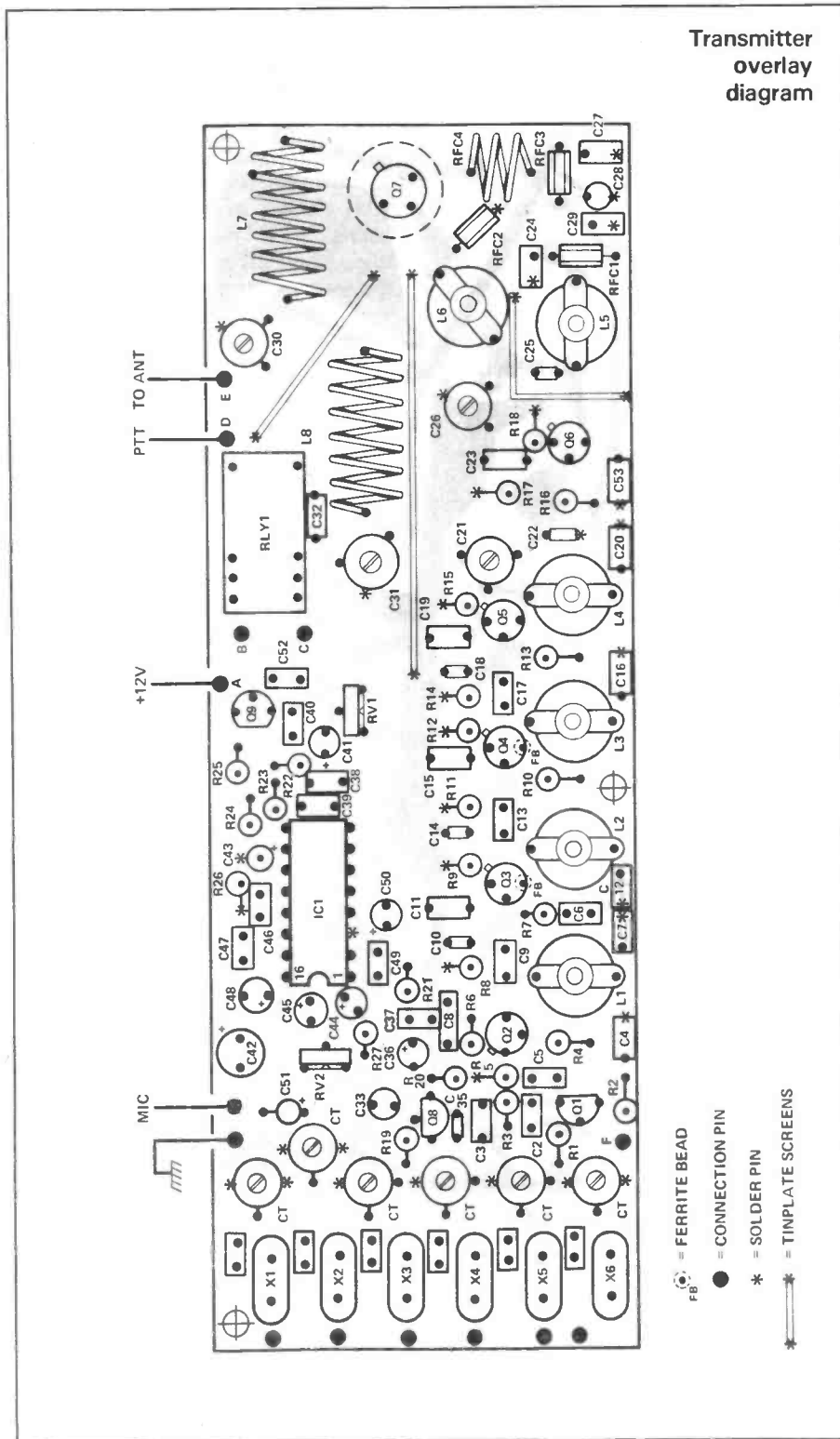

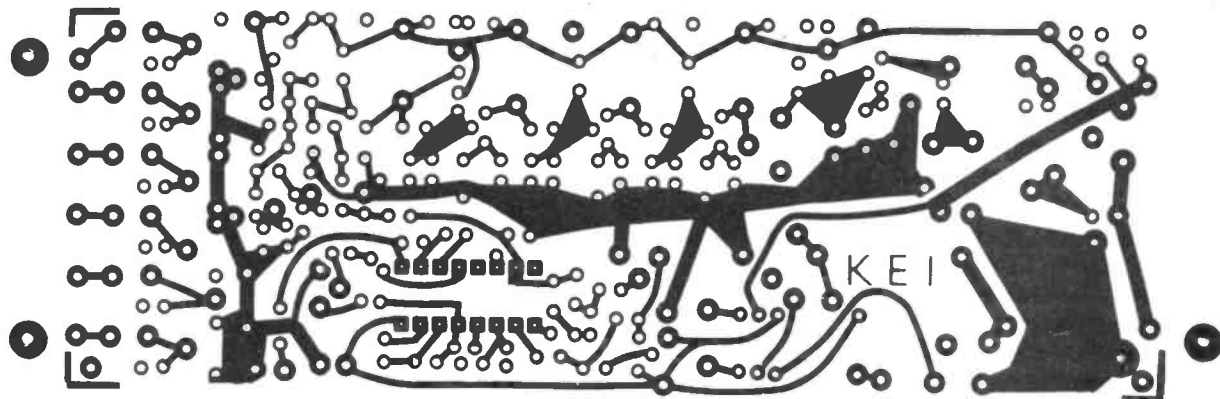

Transmitter PCB foil pattern

frequency, either use a frequency counter at 2 metres, or coupled to one of the multiplier stages, and adjust the appropriate trimmer for the correct frequency. Alternatively, it can be done over the air when in contact with another station who has an accurate frequency read out on his transceiver/receiver.

In case of any problems with alignment, lack of RF output etc, *first check for incorrect assembly* as this is likely to be the cause of most malfunctions.

### Multi-channel

If only one channel is required then the wire connecting point F to the crystal can be left connected as

during alignment. Otherwise, a 6 way rotary switch is needed for channel selection. The wires to and from this switch should be kept as short as possible – if too long the extra loading imposed on the oscillator circuit may prevent it from oscillating.

### The Case

The prototypes were built into an ABS plastic 'Verocase' as shown in the drawings and photographs. These are fairly self explanatory we hope. The case is RS type 509-585 or similar. As shown, space is available for the speaker (4 to 8 ohm miniature type) and a battery pack for portable use. The latter holds 10 AA size batteries and NiCads are recommended.

The necessary connections for charging are also shown with two connectors on the back, one for +12v for base station use, and another for a constant current 45mA charge input – a suitable circuit is given for this using a 3 pin regulator which seems the easiest way of attacking the problem.

Two antenna connections are provided – a rear panel SO239 for mobile or fixed use, and a front panel BNC for portable. These are interconnected using a piece of coaxial cable.

You could also add a Tone-Burst if needed – this wasn't given as part of the main design as most Repeaters only need an initial burst to open, and a whistle (*you just put your lips together and blow – L. Bacall*) is much cheaper than a special circuit!

Complete Talkbox – neat ain't it and somewhat cheaper than an IC2E!

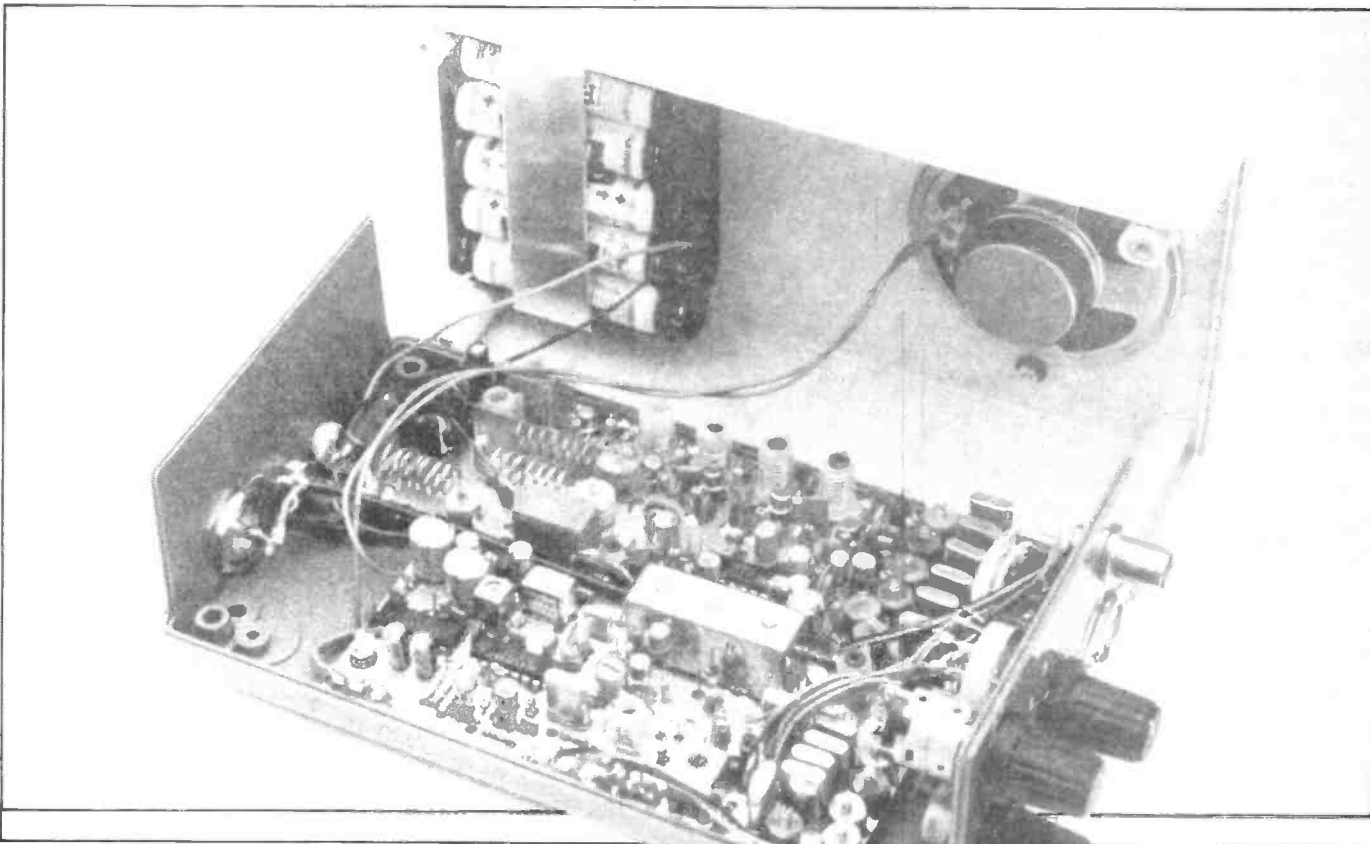



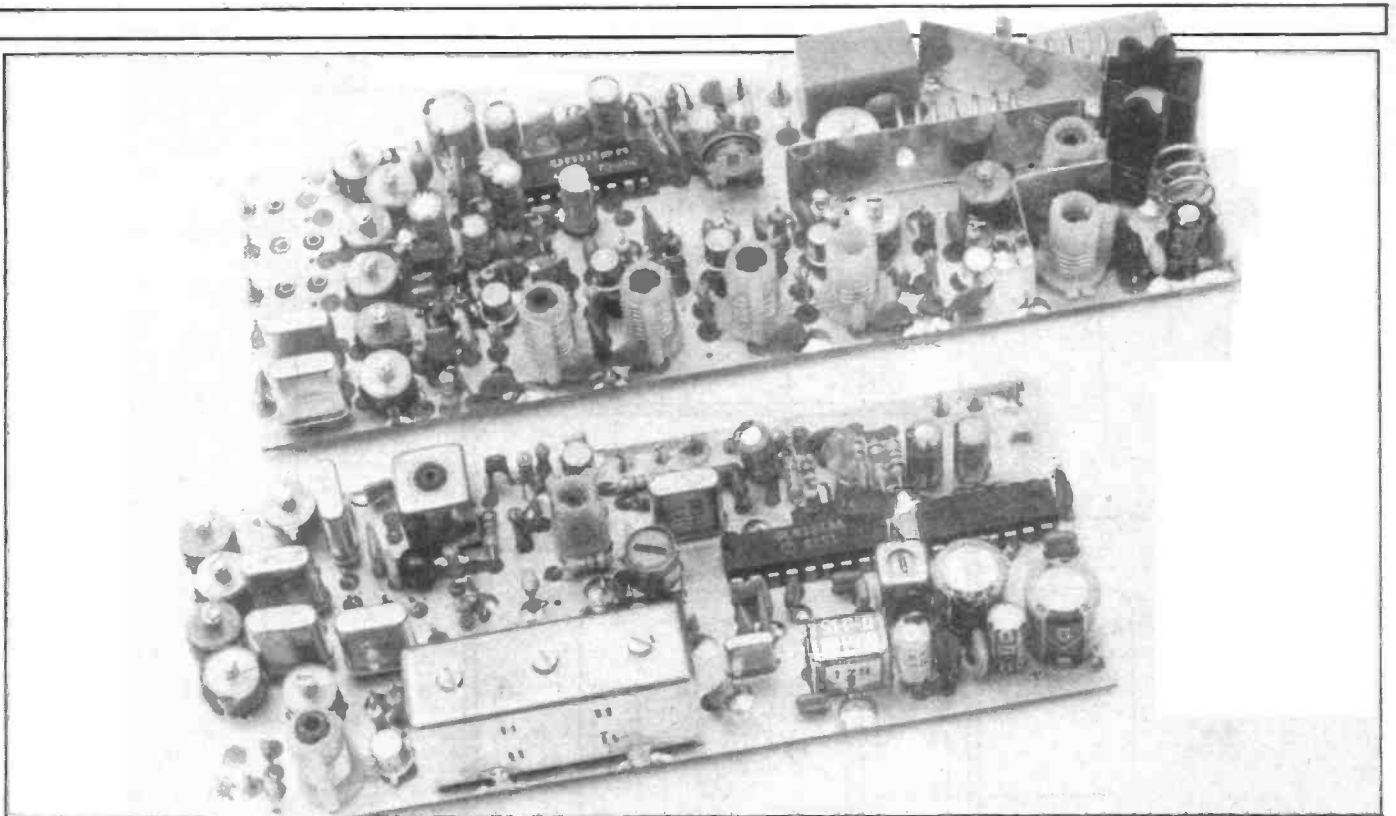

Transmitter and Receiver PCBs — remember not to mount components more than 3-5mm above the PCB surface

### Component Listing

R1, 2, 7, 10, 13, 16	47k	C25	15pF ceramic disc
R3	12k	C26	36pF foil trimmer
R4	18k	C28, 41, 43, 44, 45, 50	10uF 16v radial electro
R5	6k8		
R6	560R	C29, 49, 52	100n monolithic ceramic
R8, 11, 14, 17	2k2	C31	60pF max foil trimmer
R9	180R	C32	2n2 ceramic disc
R12	22R	C33, 34	not used
R15	47R	C36	4.7uF 16v radialelectro
R18	33R	C38, 39	6n8 mylar
R19	1k	C42	100uF 16V radial electro
R20	100k	C47	4n7 mylar
R21	4k7	C48, 51	2.2uF 16v tantalum bead
R22, 23, 27	10k	IC1	KB44 17
R24, 25	22k	Q1, 9	BC238 or BC239
R26	470k	Q2-Q6	2N2369A or BSX20
		Q7	2N4427
		Q8	BF256 or 2SK55
All 5% carbon film 0.25 watt		L1	TOKOS18 coil 8.5 turns ferrite core (white)
RV1, 2 4k7 vertical 10mm preset		L2	TOKOS18 coil 7.5 turns ferrite core (violet)
CP (6 off), C22, 35 22pf Ceramic disc		L3	TOKOS18 coil 4.5 turns ferrite core (yellow)
CT (6 off), C21, 30 22pF or 36pF max trimmer		L4, 5	TOKOS18 coil 3.5 turns (orange) L4 has no core L5 has ferrite core
C2, 3 220pF ceramic disc		L6	TOKOS18 coil 2.5 turns aluminium core (red)
C4, 7, 8, 11, 12, 15, 16, 19, 20, 23, 24, 27, 37, 40, 46, 53		L7, 8	7 turns 20 swg wire on 6mm former to fit board
C5 10n ceramic disc			
C6 82pF ceramic disc		RFC1, 2	2 turns 26 swg (0.4mm dia) enamelled copper wire on ferrite bead
C9, 14 330pF ceramic disc			
C10 1n ceramic disc			
C13 68pF ceramic disc			
C17 33pF ceramic disc			
C18 150pF ceramic disc			

RFC3	3 turns 20 swg wire wound on 6mm former to fit board
RFC4	3 turns as RFC1

### Miscellaneous

RLY1 — Miniature 2 pole c/o relay type OUB (Ambit); Crystals — 12MHz range 30pF parallel resonance type HC25/U (Frequency = signal frequency + 12)  
12  
Also required: 1 TO5 push on heat-sink; 12 Cage Jacks type CG1 (Ambit); 1 2 pole 6 way rotary switch and 14 1mm dia PCB connection pins

### Kits

A complete kit of parts as per the component lists, excluding crystals and microphone is available from WPO COMMUNICATIONS for £32.90 including VAT & P&P. This includes a drilled and tinned PCB, but not the tinfoil screens. Both the receiver and transmitter kits are available together for £68.00 inclusive. PCBs alone are £3.80.

The case is also available for £8.20 — the rest of the case hardware should be available from most retail stockists or through Ambit International. See last months article for crystal stockists.

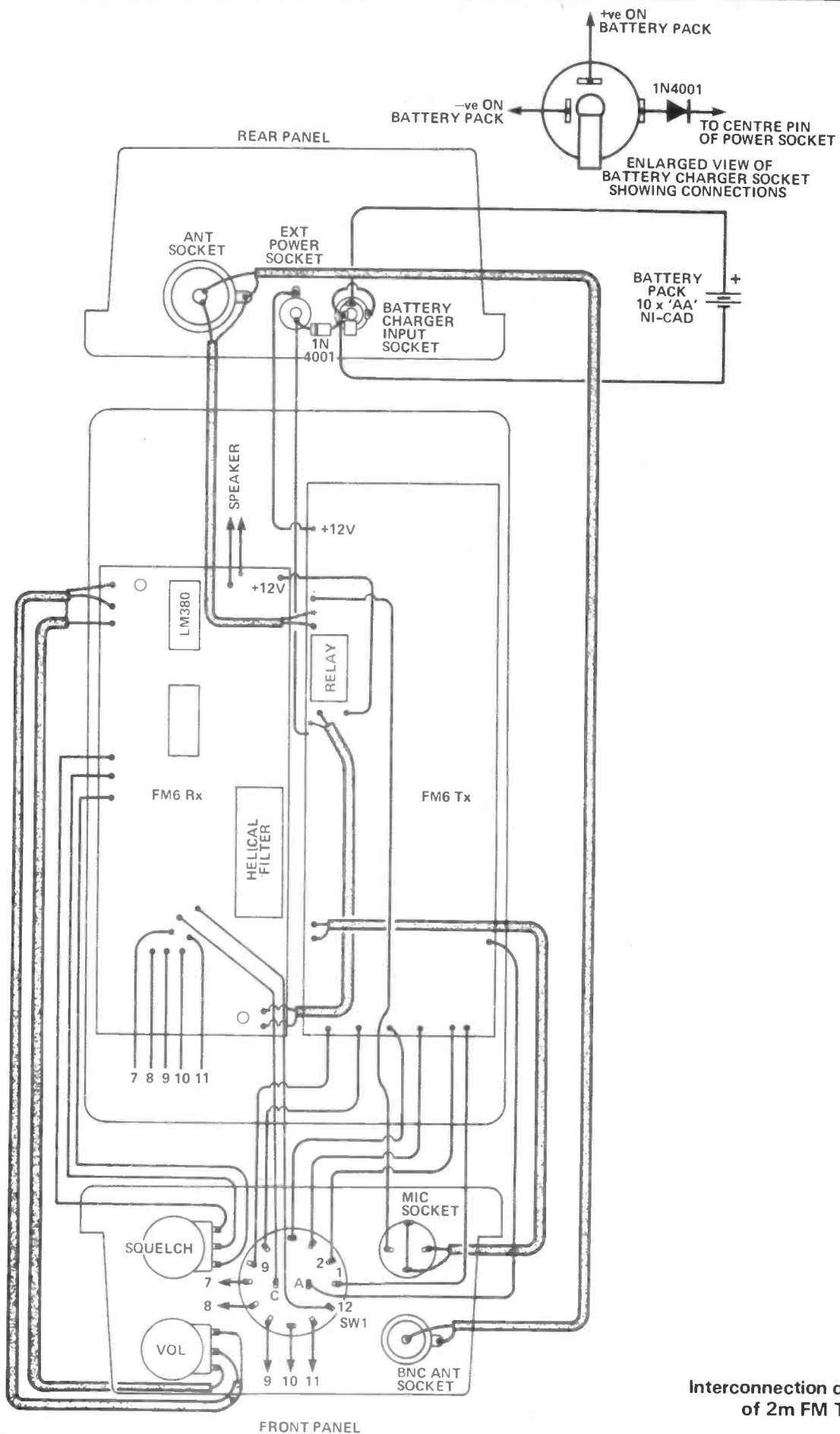

Interconnection diagram of 2m FM Talkbox

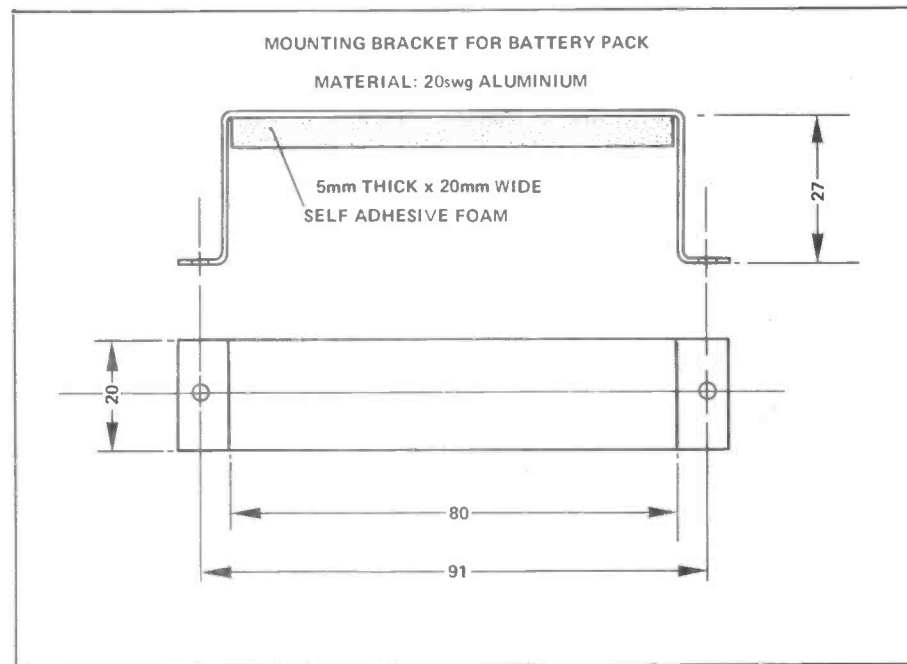
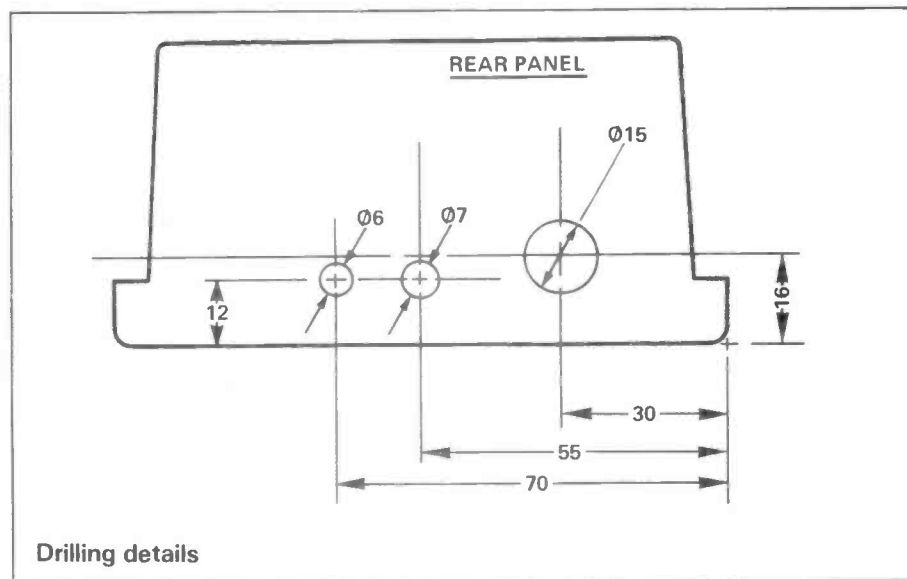
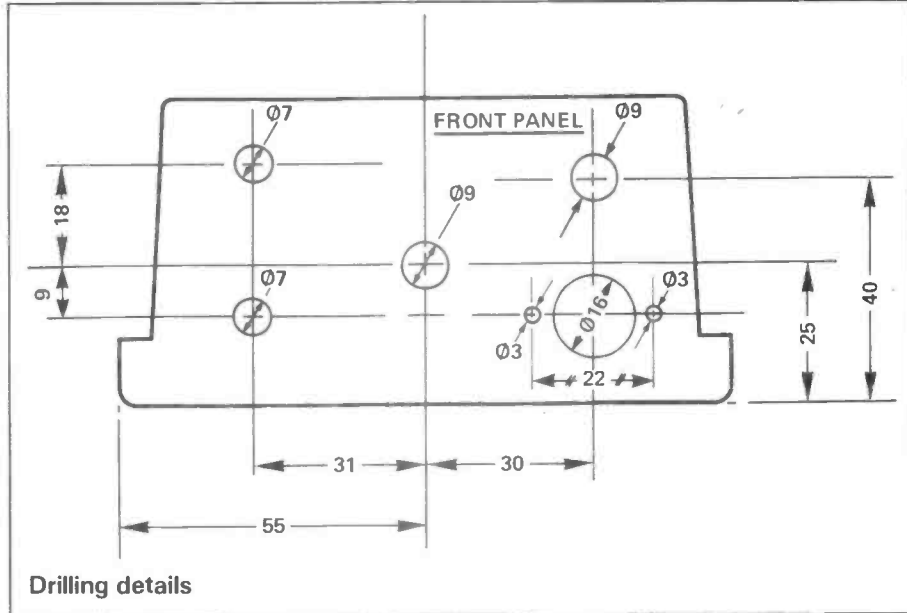
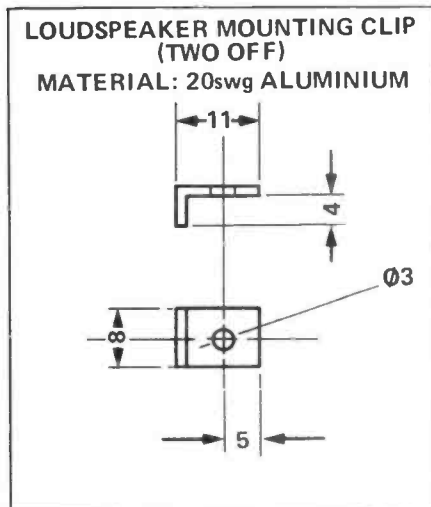
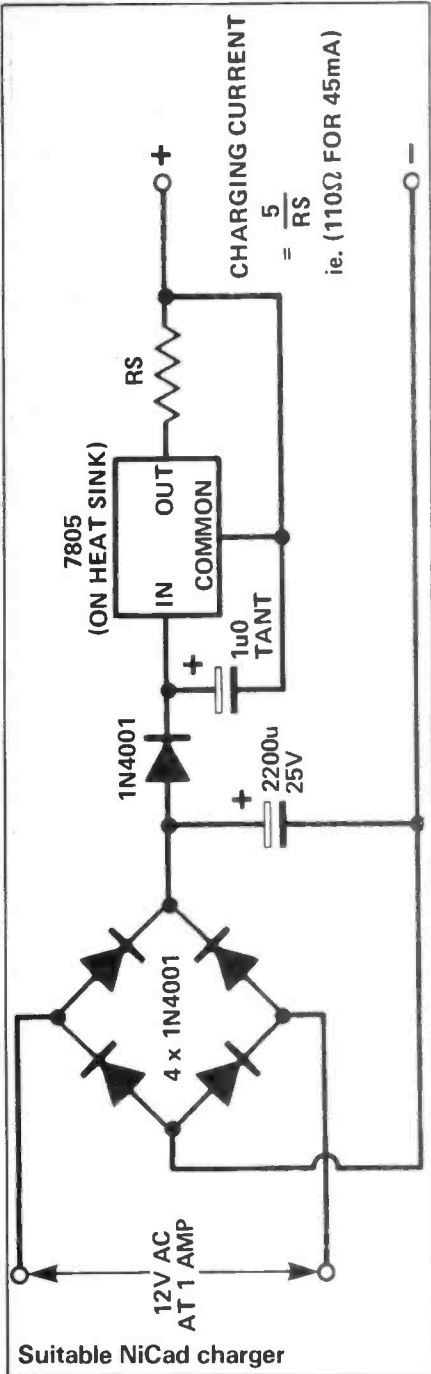

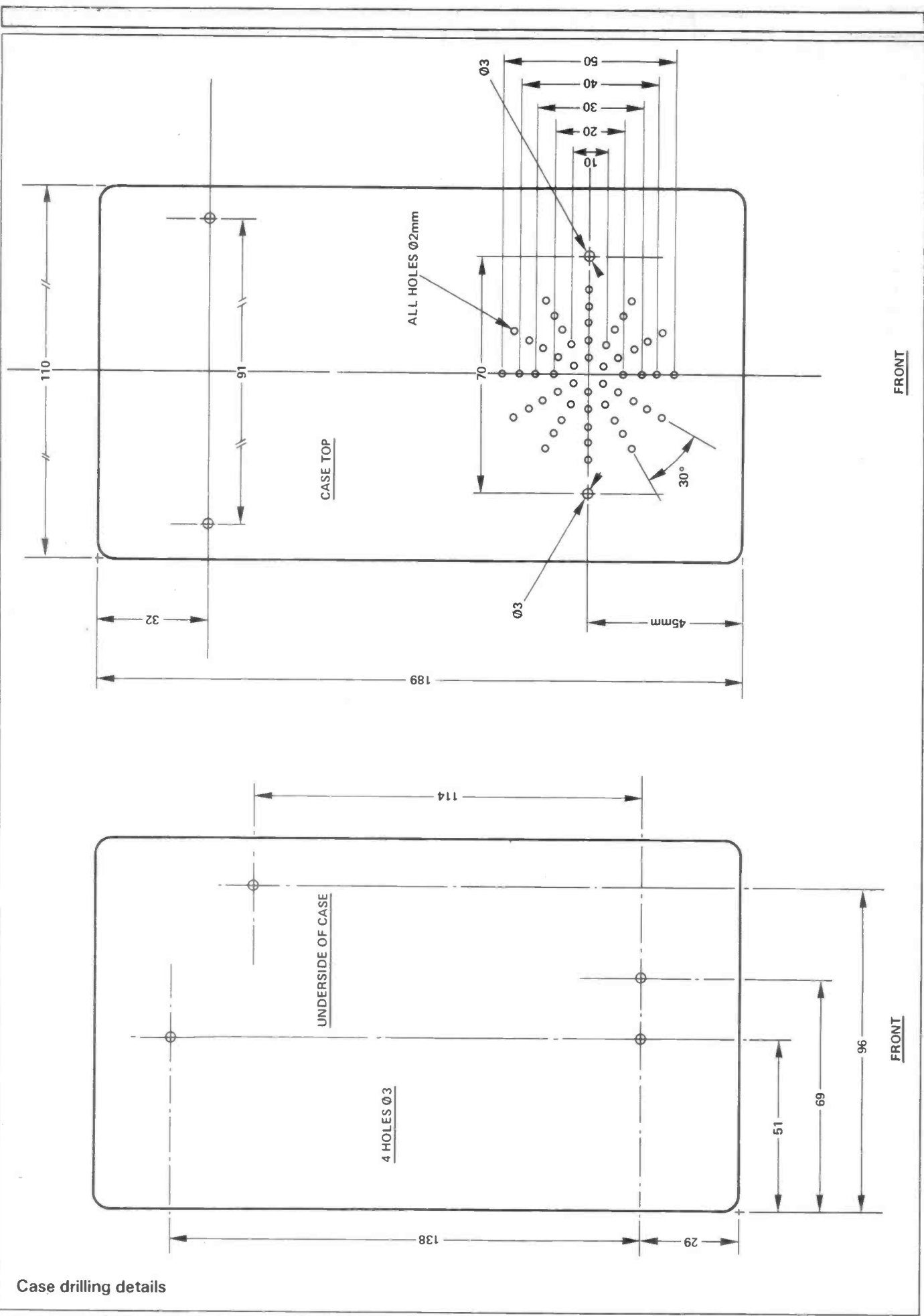

# Miniaturising HF Antennas

A number of methods of reducing the physical size of both radiating, and parasitic elements of directive arrays has appeared in the amateur press over the last few years. Indeed, a considerable number of new 'miniature' commercially made systems have appeared (and some less effective ones have quickly disappeared)! All appear

operating frequency, and the reflector to a frequency about five per cent lower than the operating frequency.

Despite about 6 months of much upping and downing and tuning the array, the results can only be described as disastrous! The F/B ratio was about 10db and the forward gain (loss) was, from both local field-

the *worst possible place at a current maxima*.

The next step was to set-up a full sized quad loop as a reference against which I could compare the loaded loops. I then tried various combinations of loading the reduced sized elements and found that the most effective arrangement was a 21MHz sized loop loaded CAPACITIVELY as shown in Fig. 21. No matter how hard I tried, the 28MHz sized loop was always *well* down in performance on both a full sized loop and a half-wave dipole at the same mean height. Tables 20 and 21 give an idea of how my loaded elements performed. I used in the end, on 20 metres, a 2 element capacitively loaded quad, with dimensions as for a 15 metre quad; the 2 elements were spaced eight feet apart and the reflector tuned to five per cent (approx.) LF of the driven element. The capacitive loading wires were made up in a manner similar to open wire feeder, the spacing being one inch from the loading wire to the loaded element. Please note: anchor the loading wire securely, as the tuning will change dramatically if the whole lot is allowed to flap around in the wind.

Tables 20 and 21 give detailed

*Concluding his present series on Urban Antenna Farming, Malcolm Healey, G3TNO, shows how to construct capacitively loaded antennas for excellent DX results.*

to work with considerably varying degrees of effectiveness; some are little better than rotary air-cooled dummy loads, whilst others appear to produce an effective low angle of radiation with good front-to-back ratios.

Radio amateurs have soon discovered that ALL loaded elements are to a degree somewhat less effective than their full-sized counterparts. The amount of degradation in performance depends to an extent on the methods a miniature element is 'loaded' to reduce its size. Figs 20 - 23 show just a few of the methods I have tried. It has also been noted that the amount of loading required has a considerable effect on performance, ie a 40 metre dipole sized element will *not* be able to radiate as effective a signal on 160 metres, regardless of the loading employed, as a reduction in size of 4:1 is usually too great for even reasonable results, although it will work after a fashion.

## First Steps

My experiments with 'loaded' beams started with a 2 element quad array using the arrangement of Fig. 20. The basic element size was similar to the dimensions of a full-sized 10 metre array, but loaded by the inductor in the uppermost wire to become resonant on 20 metres. The radiating element was tuned to the

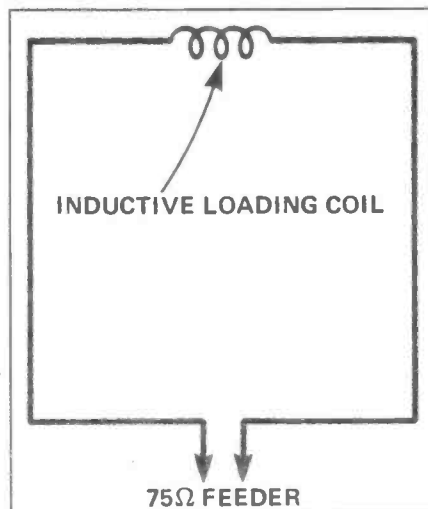

Fig. 20 Inductively loaded quad loop strength measurements and reports off air, about -6db down on a reference dipole at the same height.

## Head Scratching

At this point I scrapped the loaded quad and retired to lick my wounds! I then gave myself time to think about the reasons for the poor performance of the array and came to two conclusions. Firstly, that the stacking distance between the two current maximums in the loops of the array *were too close to each other* to achieve much, if any, stacking gain; and secondly, that the unwanted resistive loss of the loading coil was in

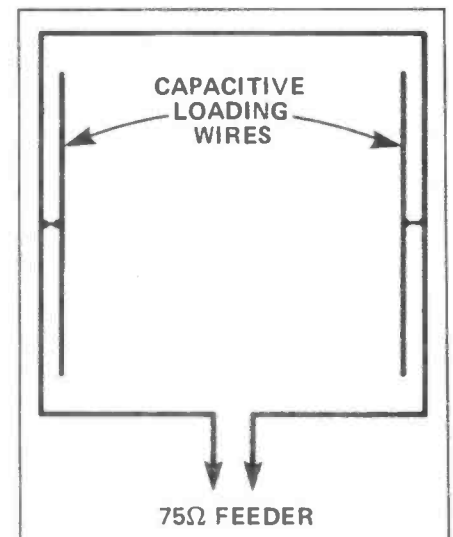

Fig. 21 Capacitively loaded quad loop

Reference Aerial	Aerial Being Tested	Results of Aerial Being Tested	
		Local Tests Using Q.R.P.	Off Air Tests
Full Sized Quadloop	Inductive loading as Fig. 20, 28MHz size, loaded to 14MHz band.	- 6 to - 7db at right angles to plane of loop. - 18 to - 20 db off ends of loop.	Very poor for Dx working. 2-3 "S" points down on Ref. aerial 2:1 VSWR frequencies much narrower than full size loop.
Full Sized Quadloop	Inductive loading as Fig. 20, 21MHz size loaded to 14MHz band.	- 3 to - 4db at right angles to plane of loop. - 18 to - 20db off ends of loop.	Poor for Dx working. 1 1/2 to 2 points down on Ref. aerial. 2:1 VSWR frequencies have a greater spacing than above, but still narrower useable bandwidth than full sized loop.
Full Sized Quadloop	Capacitive loading as Fig. 21, 28MHz size, loaded to 14MHz. <i>BUT NOTE:</i> Needed 3 loading wires per side. This is <i>NOT</i> considered to be practical in a permanent installation as the results are too variable due to wind moving loading wires and loop. This causes severe de-tuning.	- 3 to - 4db at right angles to plane of loop. - 17 to - 19db off ends of loop.	This loop was only tried for a few days as the de-tuning caused by the loading moving, relative to the loop, gave problems with ATU and Tx tuning and loading varying. Dx approx. 2 "S" points down on Ref. aerial.
Full Sized Quadloop	Capacitive loading as Fig. 21, 21MHz loop size, loaded to 14MHz.	- 1 to 1.5db at right angles to plane of loop. - 22 to - 24db off ends of loop.	This loop gave a good account of itself to Dx, and appeared to be approx. 1/2 "S" point down on full sized loop. Some Dx stations could detect no difference between the loaded/unloaded loops.

**Table 1** shows the G3TNO's experiments in loading HF quad loop antennas.

results of my experiments with a variety of capacitively loaded antennas on a variety of the HF bands. At this stage, perhaps I should add that this form of loading is known as capacitive because the loading effect is produced by the *proximity* between the loading wire and the basic element. Remember your RAE capacitance theory?  $C = E_o E_r \times a/d$  where  $E_o$  and  $E_r$  are the Permittivities of free space and the material of the dielectric respectively, and  $a$  is the

area of the plates and  $d$  the distance between them. Thus the two wires form the plates of a capacitor.

Tables 20 and 21, it is hoped, also illustrate that "over-compressing" an aerial system is *very* detrimental to the overall performance. It has also been found that heavily loaded elements are difficult to tune, and are subject to much greater changes of performance due to climatic conditions. The performance with heavily loaded elements

in general is not worth the trouble or effort. In particular loading using inductors or traps should be avoided almost at all costs, particularly if using inductively or trap-loaded elements to produce a beam array. I have found it very noticeable that stations using mono-band beams put in *much* stronger signals than stations using trapped multi-band arrays. It is far better to realise the full potential gain of an unbroken element on frequencies higher than the design frequency, say, using open wire feed, for example, than to "throttle it" using traps. Reference to various sections of 'HF Antennas For All Locations' is well worth while in this respect, before lashing out on a commercial beam. If something simpler is envisaged the W8JK or modified W8JK will cover all bands 10-30MHz (See HRT Feb 83) and gives a very good account of itself at almost ZERO cost.

### Final Suggestions

I have found that the following points *are* important if you wish to radiate and receive effectively from the average urban location, and also to stay alive (see point 1).

1. Make sure that the local planning authority will allow you to put up the aerial of your dreams, and even if they do, check that it won't upset your neighbours unduly. It is amazing how much 'artificial' TVI and BCI can be generated by putting up an unsightly array, never mind connecting the rig to it and actually using it!
2. *Do not* feed balanced aerials, such as dipoles and quads, with an unbalanced line. This can cause BCI and TVI problems, and also induce noise into your own receiver as well as the "Hot" (with RF) chassis problems. Use instead balanced-feed arrangements such as; balanced output ATU and balanced feeders, or a coax feeder from the TX to a balun and then via balanced feeders to the aerial proper. (Some beams use so-called GAMMA matching. These are ok to feed directly with coax.)
3. *Always* use an ATU. Remember that your nearby amateur population are unlikely to wish to hear you having 7MHz QSO's when they are on 14 and 21MHz. This applies particularly to many

NYLON ROPE TO SUPPORT

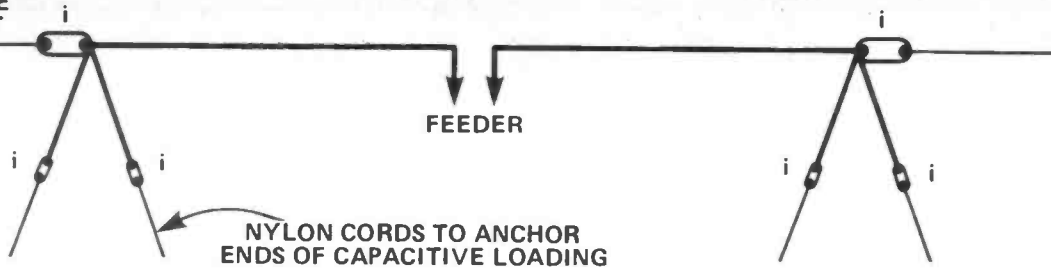

Fig. 22 Capacitive end loading of wire dipoles i = INSULATORS

modern solid state rigs whose harmonic attenuation is less than perfect. I used to have this problem myself from a station 7 miles away. His 28MHz (fourth) harmonic was around S5 when he was on 7MHz! He cured the problem by inserting a decent ATU when told of the problem.

4. Don't run excessive power to try to make up for the shortcomings of a poor aerial. Make the aerials work properly, then you won't need the extra power and you get the advantage of a decent aerial on receive too!
5. Don't expect a simple trapped dipole to work well on all bands, IT WON'T! You can always get better results from multi-band aerials of other types e.g Fan dipoles or verticals. You also won't get the problem of visual 'droop' in the aerial, common with W3DZZ-type trap dipoles!
6. Do disconnect *all* feeders from the rig when you are not at home. Static can cause a lot of damage to a rig; during some severe winter snowstorms, I have observed my ATU flashing over.
7. Do have a go at making your own aerials; it is much cheaper than buying off the shelf, and you can "custom make" it to your requirements. After all, it is *the* most important part of your set-up for effective results.
8. Do note at least what aerial you are using at any one time in your log-book. This assists with future aerial comparisons.

### Acknowledgements

Many thanks to the hundreds of operators and SWLs who took the trouble to give me comparative reports on the various aerials tested over a period of twenty years. Be warned, I am still playing! Also thanks to Anne G6CXF for turning my scribbled notes into English like what we can all read.

Reference Aerial	Aerial Being Tested	Results of Aerial Being Tested	
		Local Tests Using Q.R.P.	Off Air Tests
½ wave dipole	102ft. dipole. Two 10 foot loading wires attached to each end of dipole. Tuned to 3.55MHz.	No local test tried as I could not get the test source aerial distant enough.	Gave identical results to the ref. dipole. VSWR curve much flatter than when used as G5RV type dipole.
W3DZZ trap dipole	102ft. dipole. Two 10 foot loading wires attached to each end of dipole. Tuned to 3.55MHz.	No local test tried as I could not get the test source aerial distant enough.	Outperformed W3DZZ on 3.5MHz by 1-1½ "S" points both to Dx and EU.
½ wave dipole	Basic VK2ABQ 2 element as in Fig. 27a.	+ 4 to + 5db over ref. dipole. F/B ratio approx. 20db.	Very good Dx results. To VK and ZL typical reports on beam 58. On ref. dipole 55.
½ wave dipole	Modified VK2ABQ 2 element as in Fig. 27a.	+ 4 to + 5db over ref. dipole. F/B ratio approx. 25db.	Just as good to Dx as the first VK2ABQ tried. Slightly smaller turning circle. Slightly improved rejection from back of array.

Table 2 shows the effects of capacitive loading on a variety of HF antennas.

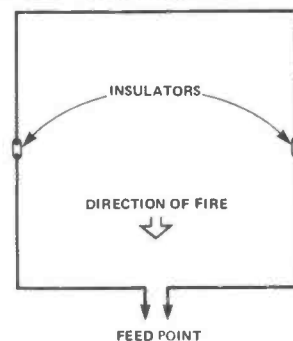

Make up as a quad loop mounted horizontally. Tune loop to required frequency using a 2 turn loop link at feed point and GDO. Cut loop at points indicated, fit lightweight

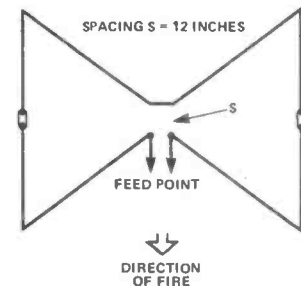

insulators at points indicated (I used coat buttons). NOTE length around loop before cutting is approx. one wavelength at operating frequency.

Fig. 23 VK2ABQ (top) and modified VK2ABQ antennas. The modified version uses the increased capacity between the two elements to effectively improve the F/B ratio of the antenna.

# GB4HRT at Breadboard '83

Every year Argus Specialist Publications is involved in an Electronics/Computing exhibition in London under the banner of 'Breadboard'. Those of you out there who are hardened electronics enthusiasts may well have visited the exhibition in one of its past incarnations, or at least been aware of its existence.

## ***Steve Ireland, G3ZZD, spills the beans as the HRT team take to the airwaves, special event station style.***

With the enormous increase in interest in Computing and Amateur Radio, the base of the exhibition has broadened to include these interests — and to take on board the ASP publications concerned with them.

Which is here HRT comes in. A few months ago the Editorial staff were asked for their suggestions for an 'Amateur Radio Activity Area'. Hardly batting a typewriter ribbon, the idea of a Special Event Station presented itself automatically — well, almost, somewhat stimulated by Sharon Metcalfe's article in November HRT and a 'half' in the local pub. This was definitely the thing to do — we'd meet our readers on-the-air as well as over an exhibition counter, while simultaneously demonstrating the wonders of communication, amateur radio style, to the uninitiated. What a nice idea and it sounded so straightforward — we patted ourselves on the back and headed homewards.

### **Antenna Antics**

At a previous Breadboard exhibition a HF radio station had been set-up with the transmitter feeding a long-wire antenna. The story went that, after a few hours of operation, the station was forced to close down because it was driving a fairly high percentage of the other nearby electrical apparatus haywire. The lesson seemed clear — use balanced antennas sited well away from the exhibition hall. What better place than on the roof, we thought, and the roof is sure to be high!

Parallel half-wave dipoles were constructed for 80, 40 and 20 and a Halbar 'Slim Jim' antenna purchased for 2m. Contact was then established with Ron Smith Aerials Ltd of Luton. Ron, it turned out, had previously erected many antennas on the roof of the Cunard Hotel, in downtown Hammersmith, where the exhibition was

to be held. There was one snag — because of the situation of the HRT stand a cable run of 200m would be necessary for each antenna. Luckily, we could hire the cables, but, one thing was certain — our 2m signal was going to be *very* attenuated by the time it reached the antenna. There was the compensation, however, that the antenna would be 150 feet high and in the clear. Even 100mW goes quite a long way from that height!!

The day before the exhibition started the author found himself offering to assist in the aerial erection. Clutching two reels of coaxial cable I gamely followed Ron and his mate up through the winding upper levels of the Cunard. Passing through what looked like a boiler room Ron asked me if I was scared of heights. I mumb-

ed incoherently into the two reels of coaxial cable I was carrying and, following Ron through a door, found myself out in the air again. Pausing to catch my breath, I looked around and suddenly found myself walking along the central spine of a sloping roof about 120 feet above the ground. My distress was immediately noted and the rest of my 'aerial rigging' was spend watching the incredible alacrity of Ron and his mate as they sped easily around the roof.

### **Rigs**

After some consideration we decided that we would have on show, and in operation, a variety of today's radio equipment, both commercial and 'homebrew'. Tony Bailey of WPO communications kindly supplied us with a number of built-up projects that we have featured in HRT, including the DSB80 and the G4DHF transverter — and last, but not least, a number of Project Omega modules. On the commercial side of things, a Trio TS430S and a Yaesu FRG7700 was very kindly loaned to us by Photo Acoustics of Newport Pagnell. All this, along with the honourable addition of the Advertisement Managers FDK Multi-750E 2m multimode, added up to a pretty effective demonstra-

**G6LPZ and G3ZZD contemplate a gift from a reader — which was not the FRG7700!**







# Visit to The National Wireless Museum

Have you visited the National Wireless Museum recently? Indeed have you heard that it is a thriving museum on the Isle of Wight? Until we were asked to investigate it for Ham Radio Today, we didn't even know of its existence! Our visit turned out to be a very pleasant surprise.

moved to the Isle of Wight and with the help of local radio amateurs founded the museum at its present home in Arreton Manor.

Arreton Manor is situated in the middle of the Isle of Wight and can be reached by car or by bus from Newport (the buses don't operate in winter, so check first!). It is an

Wireless Museum existed you could almost be forgiven for missing it entirely! As you come down the steps from the Manor house and look up into the sky you will get your first inkling that the room upstairs from the souvenir shop is a radio shack. Nestling between the trees is a trap-dipole for use on 80m/40m and this belongs to the station with the permanent "special" call sign GB3WM. (Unfortunately the manor is in a hollow making 2m operation impossible.)

The museum houses a very interesting collection of wirelesses, radiograms and televisions with accompanying manuals, magazines and QSL cards. All these have been donated and Mr. Byrne advises anyone wishing to sell equipment to contact an auction room, as there is no money available for purchase by the museum. All the same, radio amateurs visiting the Isle of Wight on holiday frequently come with their cars loaded! For others who wish to give articles but are unable to find transport, Mr. Byrne often makes trips round Britain to collect them.

As well as the museum display, there is a wealth of equipment in storage, some being restored by dedicated amateurs. The first impression we had of the museum was that it was too small to display everything to advantage. Indeed Mr. Byrne said that he would like larger premises, preferably on the mainland, if some could be found. However, the equipment on display gives a chronological record of the history of wireless, and as such is of great interest to radio enthusiasts. Some of the articles are displayed in rotation so that visitors returning in future years will still find some items new to them. Let us tell you about some of the sets we saw, interspersed with some of the interesting facts that Mr. Byrne told us.

*Are old radios fascinating to you — or are they merely a nuisance that neighbours keep asking you to repair? A visit to the National Wireless Museum would change your mind. Trevor Butler, G6LPZ, and Sharon Metcalf, G6LCC, have been to have a look.*

The museum was started by Douglas Byrne, G3KPO, when he was the Secretary of Peterborough A.R.S. some twenty years ago. He collected some old equipment to display as a feature at a rally that he was helping to organise and this promoted great interest. In successive years so many amateurs donated early wireless sets, and didn't want them back again, that the collection was started. In 1970 he

Elizabethan manor-house, fully furnished with genuine Tudor pieces, and it has fascinating displays of dolls, thimbles, spinning wheels and sewing machines. The house is open from April to October, inclusive, from 10am to 6pm Mondays to Saturdays and from 2pm to 6pm on Sundays, and it is run on the same lines as most stately homes, with tearooms and a souvenir shop.

Indeed without knowing that the

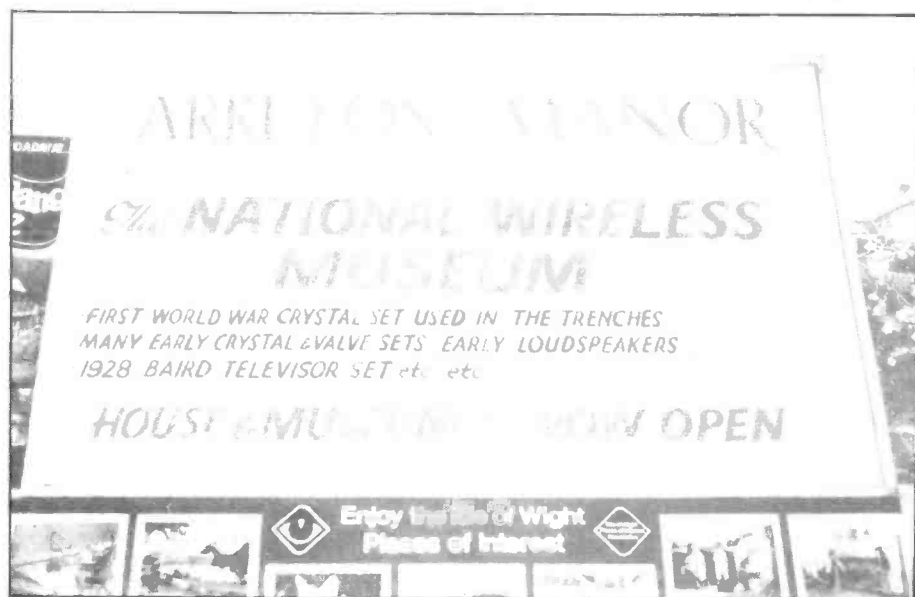

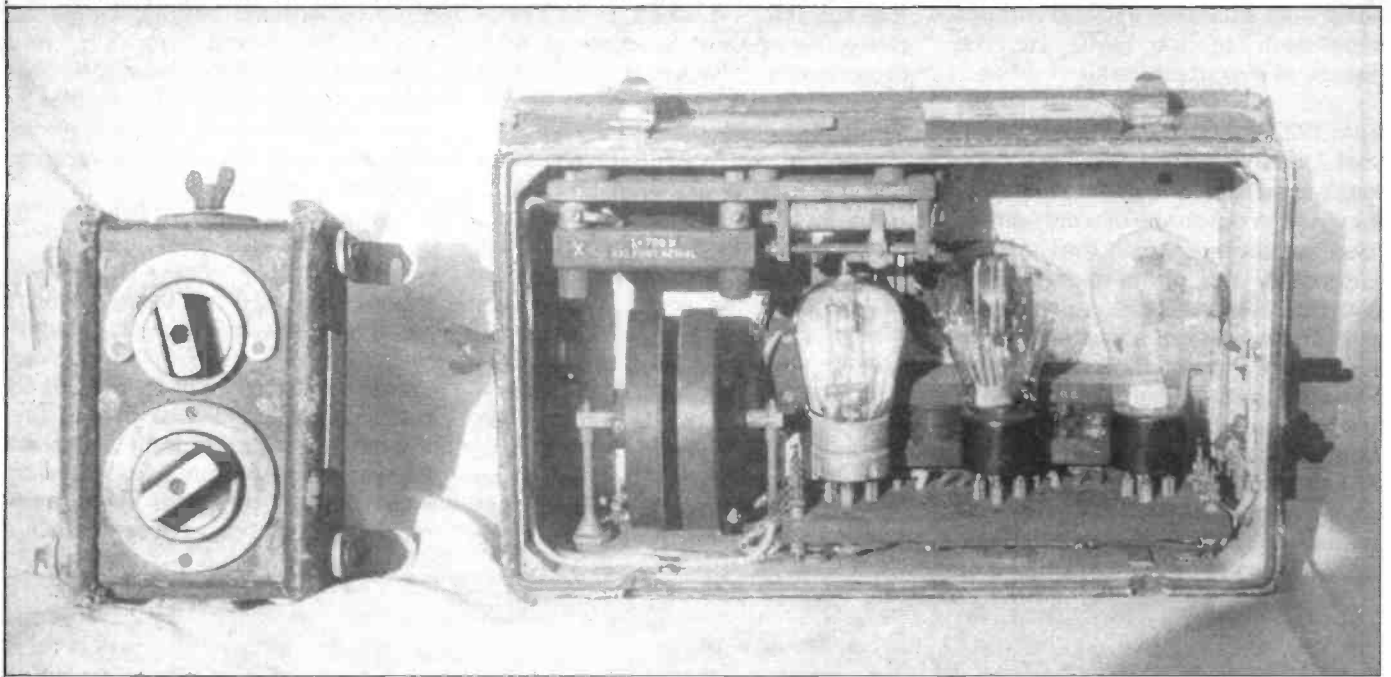

**Tunable aircraft receiver with separate control unit from 1918**

There is a large collection of crystal sets dating from 1911 (see **Photo 1**). The first sets were built by watchmakers and used in Britain by them and other interested amateurs to receive the regular time signals and weather reports transmitted on 2600m from the Eiffel Tower. It was in this way that time was first standardised and where these signals could not be received, train drivers could set their watches in, say, London and 'take the time' with them to Edinburgh.

Among these early sets is a brand new trench set from the First World War: it is a crystal set of the type used to send and receive spark signals and has a double crystal detector (a Perikon detector). Since crystals afford no amplification, a headphone set is needed with such equipment and there are ones of various dates on display. There is also a collection of Morse keys, including one from a WW1 warship. Unfortunately these keys are in a glass case so all would-be key-bashers on a nostalgia kick are out of luck here!

Another WW1 set is an aircraft receiver Mk 3 made in 1918 (see **Photo 2**). This is in two parts (à la Pye Cambridges!) with the receiver stored in the body of the aircraft while the pilot had a separate tuning control box. This was necessary because, although it could only receive one station, there was considerable drift in frequency.

The boom in the manufacture of crystal sets came in the early 1920's

with the advent of British stations broadcasting to the general public. The Marconi Company's Two-Emma-Toc in 1921 and 2LO the following year started the ball rolling. Five other manufacturers also started stations and all six joined together to form the British Broadcasting Company, which received its licence from the Post Office in January 1923. To entitle the public to receive these transmissions, a ten shilling licence fee was payable when a receiver was bought, half of which was used to finance the BBC.

### Set Approval

Manufacturing companies had to have their receivers 'approved' by the Postmaster General. The sets

were tested for non-interference and approved sets carried a special BBC stamp with the words "Type approved by the Postmaster General" and bore a registration number (beginning to sound like CB isn't it?). Set number 619 is on display and is typical of the early 1920's. At this time all commercial sets were double crystal, with a means of switching rapidly between the two, and this set is no exception.

Between October 1923 and July 1924 a constructor's licence could be bought for fifteen shillings and there are several examples of home-built sets. In spite of the necessity for 'approval' of commercially built sets, it is interesting to note that

**Early receiver made to resemble a book – note awful pun on cover! On LHS budget matchbox crystal receiver – only sold to people living close to the transmitter.**

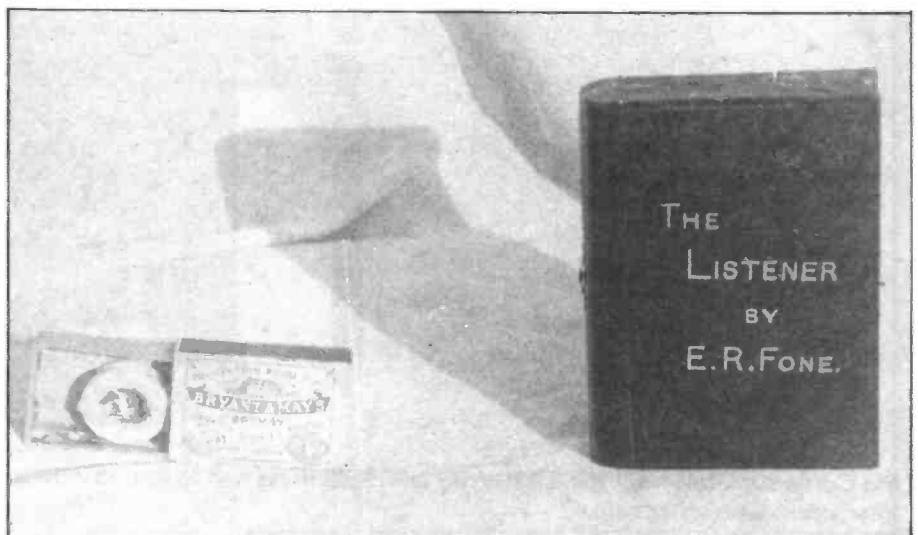

home built sets were allowed without submission to the PMG (to the dismay of manufacturers!).

The approval of sets continued from 1922 until mid-1924, and gives a useful dating system for these early wirelesses. An unusual set of this time was in the shape of a cat (similar to early drawings of Felix the Cat). Unfortunately the photo didn't come out: the 'cats whisker' is positioned as the cats whisker, a paw is the tuning control and headphones are connected to the tail! This exhibit is one of many donated by its original owner. Another novelty set is in the shape of a book entitled "The Listener by E.R. Fone" (see Photo 4). This was made in about 1926 by Kenmac Radio Ltd.

It is a crystal set with tapped inductance tuning and is covered with green rexine (others of the same type were made with a red rexine or tortoiseshell finish).

As crystal sets became more popular 'kits' could even be bought from Woolworth's at 6d a time. These consisted of a cat's whisker crystal and a pair of tweezers (after all, handling the crystal would ruin it!). It also encouraged pedlars in London's Oxford Street to sell sets made in Bryant and May matchboxes. Such a set is the Markon crystal set 15871, made 17/6/'23, and this is a crystal detector with two coils. It was such a simple design that hundreds were made. By choosing a

pitch underneath Selfridges, the set could be heard working into headphones. This position was critical, for there was a transmitter on the roof of the store. Once at home, invariably nothing could be received on these insensitive sets!

### Valves Appear. . .

Around this time (1922-1924) there were also a few valve receivers made. One example is the "Radcom" made in 1923 and so named long before the existence of the RSGB! By the licensing conditions of the day, the maximum length long wire aerial allowed was one hundred feet. This was limited because the early receiving sets could cause severe

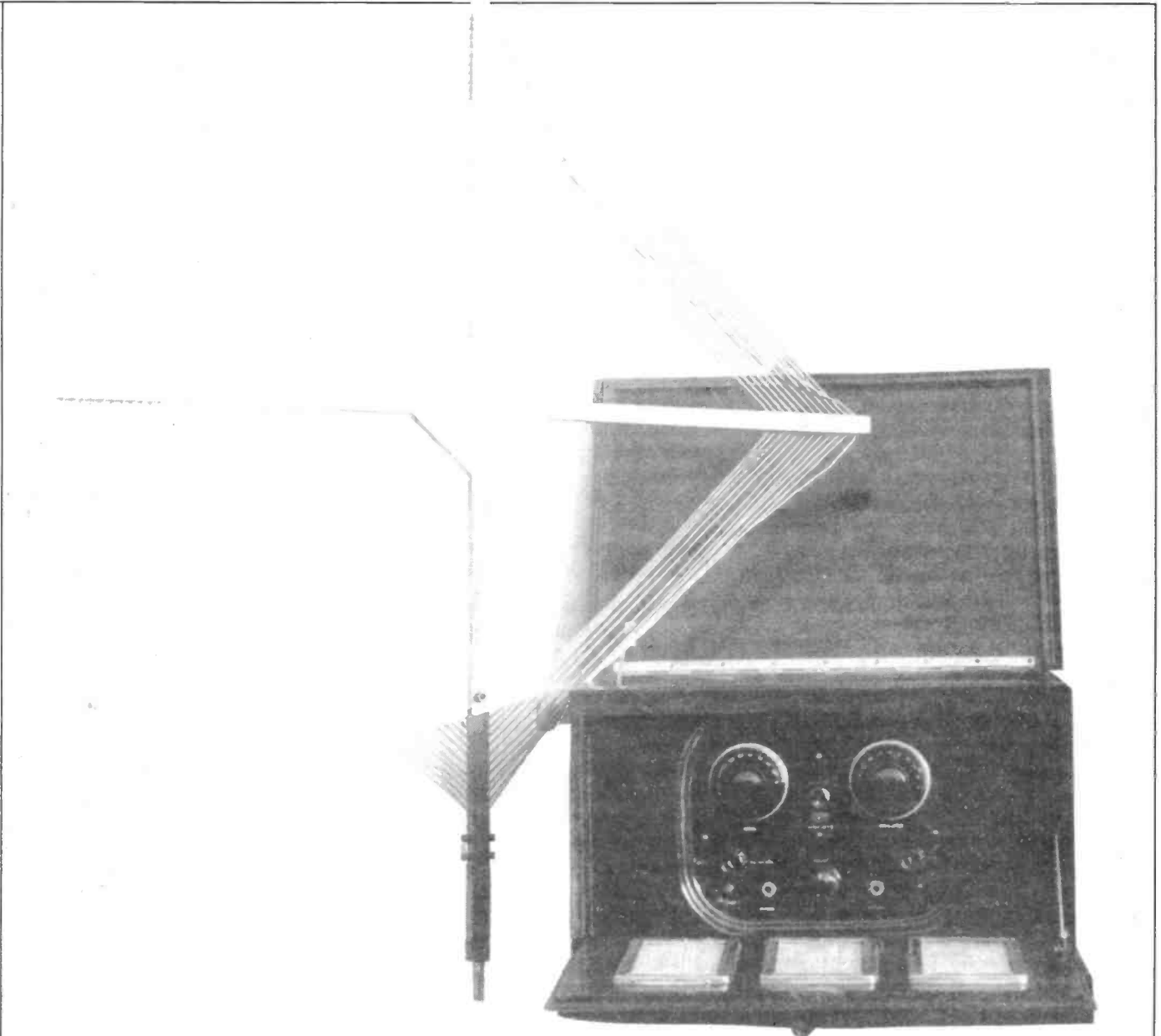

Big Curtis superhet from the 1920s. By law, superhets had to run on indoor loop antennas so as not to cause any interaction with other sets.

interference in neighbouring receivers if mishandled! This maximum length was invariably used as the first valves gave little amplification; however, manufacturers soon changed this.

For example, there is Marconi's four-valve cabinet receiver made in 1924 which would have been considered 'long range' as it has a two stage RF amplifier. A 1926 seven-valve Curtis double-circuit superhet receiver even has a compass built into it's beautiful inlaid wood case. A Philips four valve mains set of 1928 is housed in a metal case instead of the more usual wood or ebonite. It has a screen grid HF stage and pentode output, includes a speaker, transformer and a four-position wave-change switch (instead of plug-in coils).

One home-built radio made in Bedford in the 1920s, has seven valves, each having it's own rheostat so that each filament current could be increased independently to get a bright glow (and provide variable heating for the room no doubt!). Depending on the signal strength, this radio could use just one valve or all seven, the idea being to fire up as few valves as possible and so use less current and conserve the batteries.

There is a three valve radio for use on 700m wavelength with three 'portholes' cut in the case so that the colour of the filaments could be seen clearly and the current adjusted as necessary. However it was more usual to enclose the receiver in a handsome cabinet. One 1922 wireless even has the case made out of a gramophone record and the grooves are still visible!

### ... Then Mains

At first the cabinet would have housed just the receiving crystals/valves while having visible battery terminals, but between 1927 and 1929, 'all mains' sets appeared. The cases were then tidied up and became the more decorative shapes associated with early wirelesses. Some designers attempted to put the horn speaker inside the cabinet as well but it took the invention of balanced armature and moving coil speakers to make viable self-contained wireless sets. Bakelite as well as metal was used for some cases although the majority were made of wood and wirelesses became an integral part of the furniture.

Many wirelesses from the late

2 foot high SG Brown Horn speaker – 1925



1920's and early 1930's are on display although it is very sad to note that several of the fine, wooden-cabinet sets have been vandalised by visitors stealing their control knobs. A 1929 American 'Majestic' mains set is one such unfortunate item and of course it's wooden knobs are irreplaceable.

### Horns A Plenty

The museum has various loudspeaker horns such as those used with the early wirelesses. The HMV logo of the dog sitting in front of a huge horn does indeed give the impression of the size of some horns. One horn manufactured by S.G. Brown in 1925 is noticeable for its large (2ft) horn projecting from a tiny loudspeaker. Horns came in all shapes and sizes, the richest people owning the largest, most expensive ones!

In the home, many people did not like the traditional horn shape and so camouflaged their loudspeakers. This was sometimes done by the horn 'folding' into mahogany boxes or being hidden inside pottery figures. There is even a lacquered papier mâché Confucius on display. This hides an 'Andia' loudspeaker with the horn facing downwards. There is also a bust of Beethoven housing a portable loudspeaker.

On the larger side, there are speakers from public address systems

such as that from the old Ventnor cinema. There is the whole system from Gamages hardware and electrical store in London. This is complete with switching between six departments. Another PA system is from Shanklin Pier and came complete with all it's valves in working order.

### Valves Of All Sizes. . .

On the subject of valves, the museum has a large collection ranging from French ones made in the First World War, a three pin valve arranged with two pins at one end and one pin at the other, a VT31 with 250W dissipation, the first Catkin metal valve, VMP4K, made by the Marconi Company to TV valve 305200A with very large fins for cooling, and, more recently, TV valves from the transmitter at Rowridge on the Isle of Wight.

Rather than just separate valves you may well be interested in a German three valve set made by the Loewe Radio Company in the mid-1920's. Germany had introduced a tax that manufacturers had to pay depending on the number of valves used. Hence at first sight this wireless only appears to have one valve. On looking closely you realise that the valve in question is a 3NF multiple valve containing three triodes and interconnecting components in just



Receiver made by Loewe RC of Germany circa 1928 with three triode valves in one – so much for integrated circuits!!

Genuine Edison Bell crystal set from early 1920s.

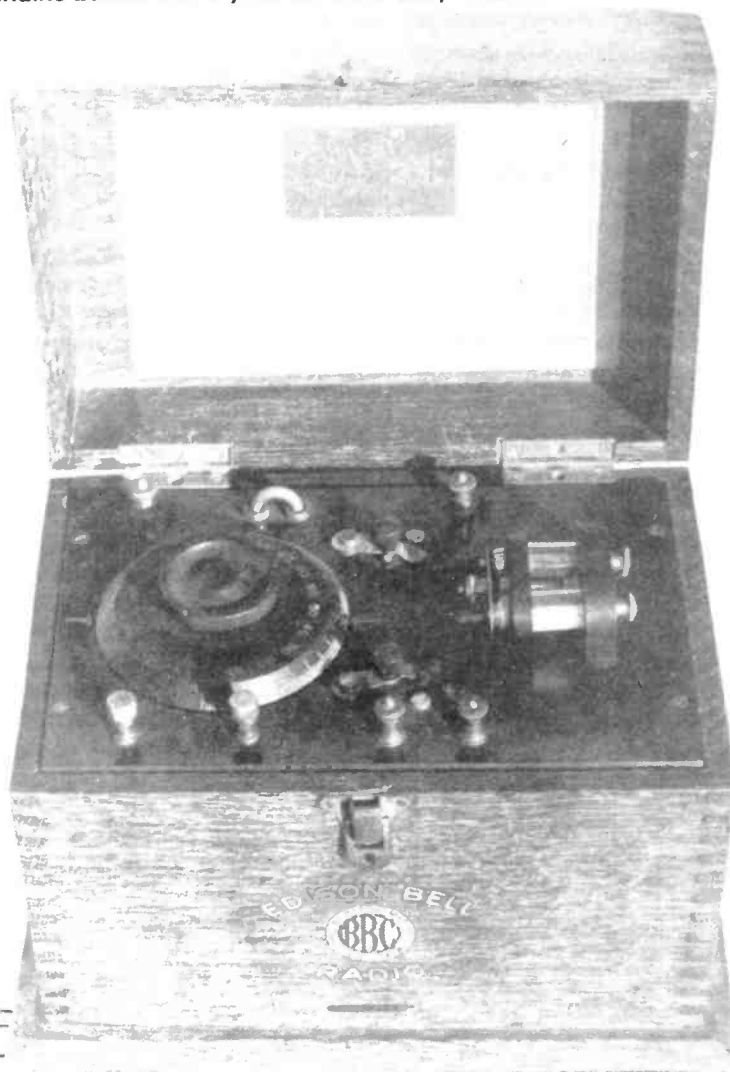

one large envelope (and hence only one lot of tax to pay!).

There are various other components and meters of the late 1920's and 1930's on display. At this time every radio shop sold components to "build your own" wireless set. Wireless magazines of this time gave full instructions and free blueprints so no previous technical knowledge was necessary.

### And Forerunners to HRT

Along with actual radio equipment, the museum is always looking out for old magazines, books, photographs and QSL cards. Mr. Byrne is trying to set up a library of old technical manuals, especially early television servicing ones. Among the interesting magazines and books on display are 'Hello Boys! The Wireless Uncles' Annual', a June 1925 Modern Wireless magazine priced at 1/-, Wireless and TV Review Vol. 1, No. 4 from March 1935, costing just 6d, and a broadcasting station guide given as a supplement to Wireless World published 9th November 1934. From May 1937 there is even a photograph signed by all the announcers on the first television programme.

One of the saddest times for the museum was when a widow donated all her husband's wireless collection and told Mr. Byrne that she had thrown away all his manuals and QSL cards. The message here is please don't throw out anything connected with the early days of radio without asking the museum if they'd like it! A special plea goes out to anyone who might have a 1920's mail order catalogue from the hardware and electrical store A.W. Gamages Ltd. of London E.C.1. The information of the different wireless sets available with their prices would be an invaluable addition to the museum.

Although it is entitled the National *Wireless* Museum, the museum also has an interesting collection of televisions. One early set is a 30 line domestic television made by Logie-Baird in 1931. It had to be used in a darkened room and the picture was viewed through 30 holes in a disc rotating 12½ times per second. The picture would have been very flickery and seen on a neon (!) tube giving a size of 3" by 2".

Since the speed of the disc was variable, due to a changing motor speed, it had to be continually

adjusted by a potentiometer while viewing. With a radio tuned to the top end of the Medium Waveband and the TV to the lower end of the MW, sound and pictures were possible. The sound and vision could even be synchronised using a blip on the screen making this set quite sophisticated for it's time. Transmissions for this TV receiver would have been for about one hour a day in the late evening (after other stations had closed down).

This set has been overhauled by Plessey recently, and it is interesting that ATV enthusiasts have been working on 30 line TV in the last couple of years, and there are now two of these sets in working order on the Isle of Wight. (The actual number of these sets which were made probably runs into hundreds, so who's hiding all the rest? Look out for 30 line ATV on Top Band!)

There is a large 1936 television with a small vertically set tube (and a reflector) which could be switched between receiving the Baird 240 line system and the Marconi 405 system. This duality only lasted for about six months because the Marconi system gave a so much better picture that it was adopted as the national standard (and didn't it last a long time!). This TV set is also combined with a wireless and such combinations became very popular. There is an HMV radiogram and television of the 1950's which was a luxury set of the time (receiving only one TV station of course). This is an enormous piece of furniture in it's polished wood cabinet.

### Other Antiquities

As well as wirelesses, loud-speakers, televisions and their attendant 'software' there is also a tuning coil from the transmitter of the old Radio Caroline (which had been confiscated by the police), a gold-plated gramophone (which was a presentation piece), an early oscilloscope (oscillograph) and a direction-finding station from north Lincolnshire (which will soon be restored to working order). As you can see anything of this vintage (especially pre- World War Two) is of interest, so please don't hesitate to contact Mr. Byrne, G3KPO QTHR, if you have any old wirelesses, magazines, etc..

After the visit, we followed up Mr. Byrne's suggestion of reading

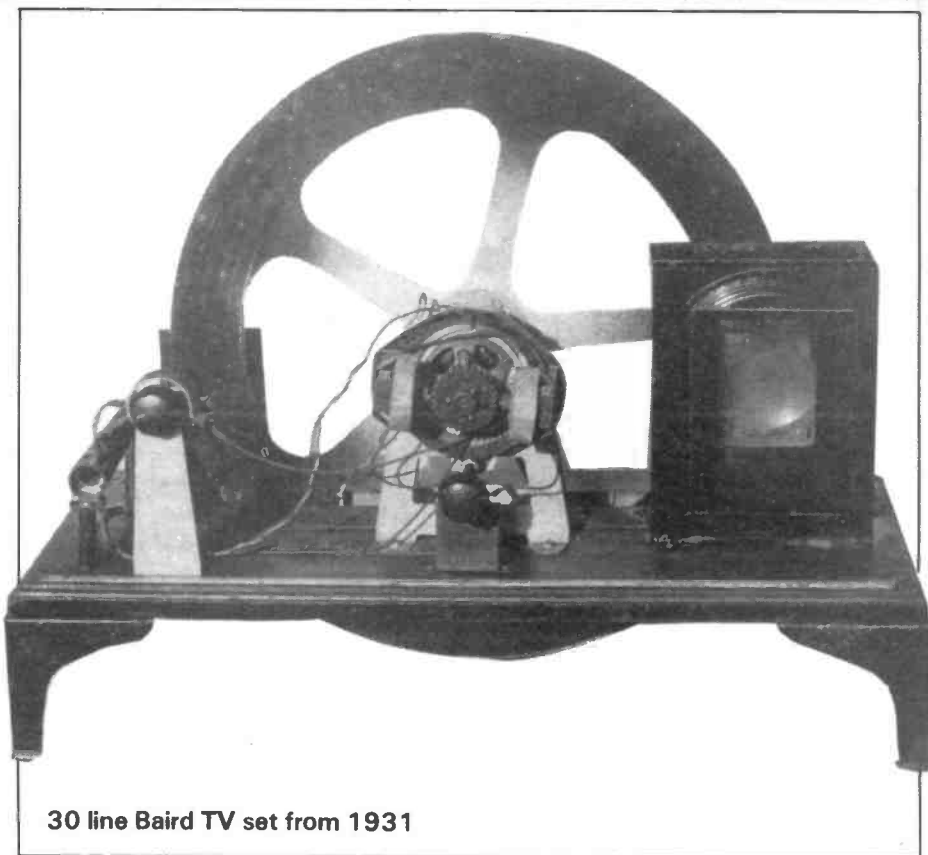

**30 line Baird TV set from 1931**

'Early Wireless' by Anthony Constable (published by Midas Books) which proved to be a well-detailed book with many illustrations. If this article has whetted your appetite for the history of wireless, do try to visit the National Wireless

Museum (try the book as an introduction if you can).

If you combine it with a look over Arreton Manor, it would make an interesting day out for the whole family and we're sure that you'll find the museum as fascinating as we did.

**The first electrostatic speaker – circa 1920!**

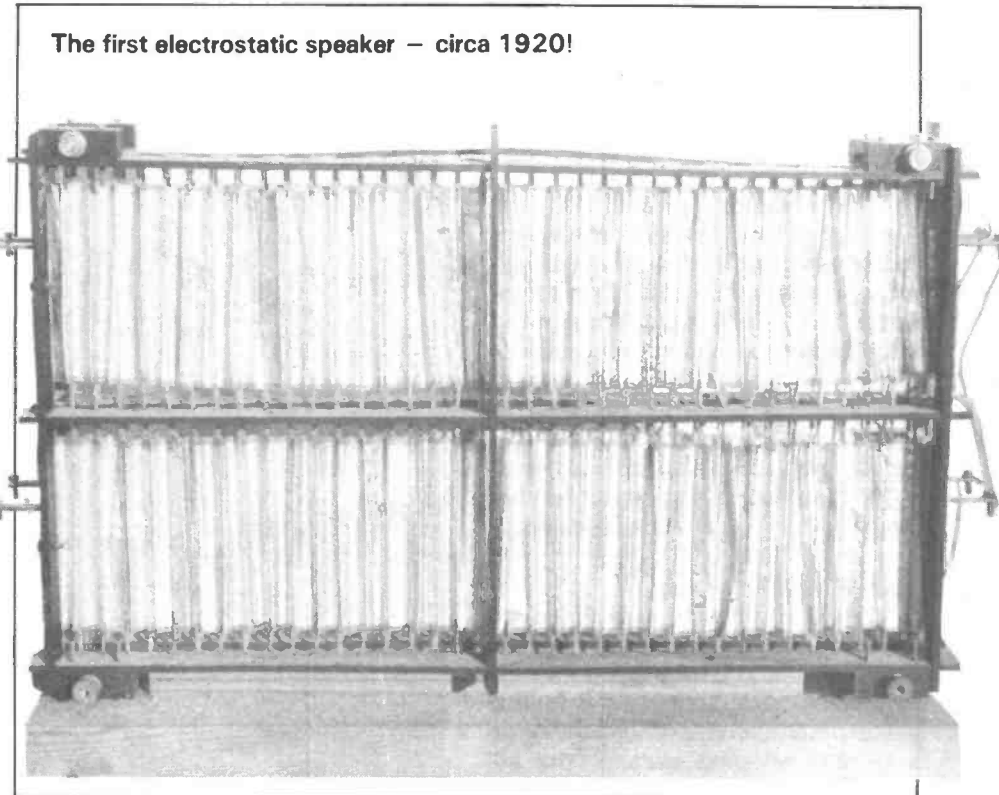

# REVIEW: Belcom LS20/XE Handheld Transceiver

Having been the proud owner of what has been described as "the world's most popular 2 metre hand-held", the Icom IC2E, I was enthusiastic when offered the chance to review the latest piece of equipment for the growing 'portable' market, the LS20XE from Belcom, imported by Lowe Electronics.

frequency selection and a combined squelch, on-off and volume control. I have never had cause to complain about thumb-wheel switches and have used them in many applications as they do save space and, apart from the fact that they are difficult to operate in the dark, they do provide the easy answer for frequency control

the addition of 5kHz to the dialled frequency. In the LS20X version, this switch activates a fixed memory. Perhaps a little difficult to operate, especially with long fingernails, this control could not be confused with any other, as is the case for example on the IC2E.

A turning range of 140-149.995MHz is possible at the least (frequencies up to 153.995MHz are mentioned in the data) although internal adjustment would be required to effect this. The standard setting covers the complete 2 metre amateur band. Other controls are located to the side of the rig and hidden under a slide-off plastic cover.

*A diminutive hand-held 2m station for a little over £100 — you're certain to think it worth investigating. So did we, and Trevor Butler reports.*

At first glance it seemed considerably smaller than other 2m FM hand-helds and turned out to be a compact 140(h) × 69(w) × 26mm(d). So where do Belcom find room for all the innards? — other hand-held are hardly spacious inside, something I have found when trying to repair them!

The price of the LS20XE (the name's too long) is also an important factor which will I am sure encourage sales, for its price (£128) is competitive. A quick look through the advertisements within this publication will reveal that other similar equipment is currently available at prices well in excess of this. Do Belcom neglect quality or facilities in order to produce equipment at this price? . . . . . all is to be revealed.

## Controls

Whilst not having many frills, all the basic requirements are to hand on this "little baby" — the top of the unit containing a BNC socket either for the helical antenna supplied with the rig or a 50ohm antenna system, the inevitable thumb-wheel switches for

on equipment of this size.

Adjacent to these switches is a locking switch, coloured orange, for

**Trevor Butler (though he'll be known to us as 'Kate Bush' from now on) tries the headset out for size.**





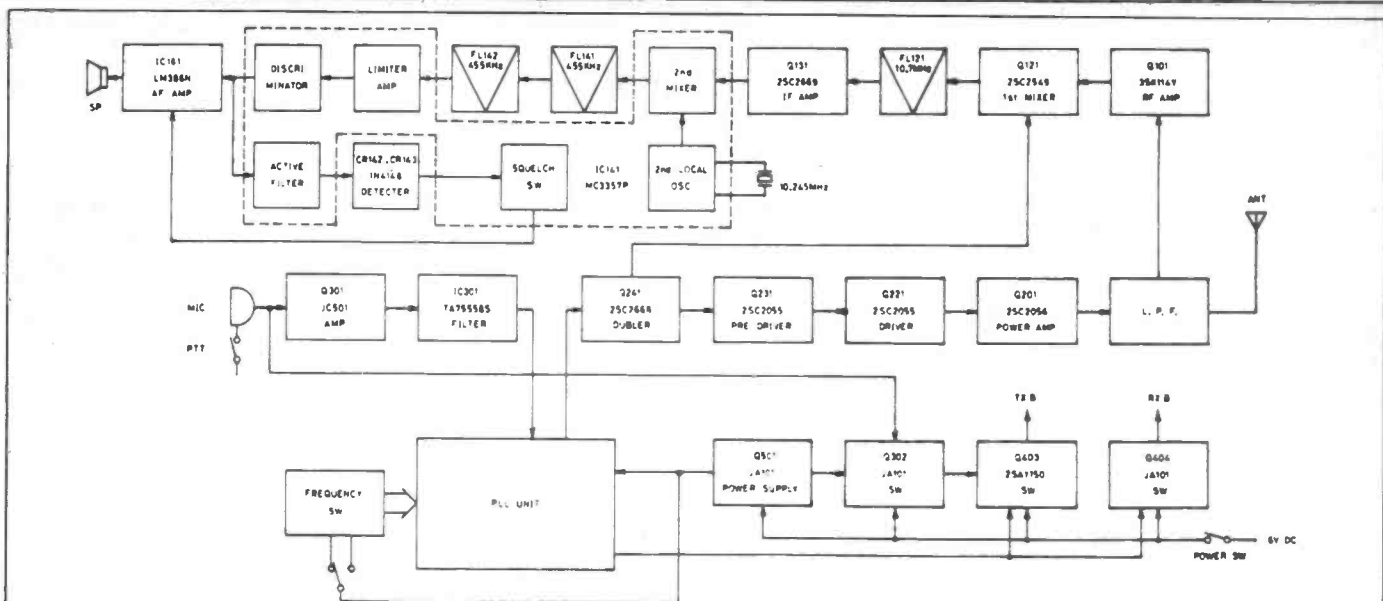

Fig. 1. Block diagram of the transceiver — all this for just over £100!

This was stiff in use and the danger of it breaking rather worried me. With the cover removed, three switches are exposed and are attached to one of the internal PCBs. The switches have very short levers which do not stand very proud, here, fingernails come in very handy!

The first of these switches selects automatic tone-burst, providing about 0.6 sec of 1750Hz tone, the second decides the power output. High power is rated at 1W, medium at 500mW and low power at 100mW, certainly useful to conserve batteries. The last switch selects simplex or repeater usage, +600 and -600 settings being available to cater for different overseas markets.

Whilst auto-tone burst is a good feature, it is a pity that once selected it is also operative in the simplex mode. A quick look at the circuit diagram prompted a simple modification so as to activate the tone burst, still switchable, when in repeater shift mode only.

The speaker is located with the microphone insert under the front grill. There are three sockets on the rig, below the PTT switch. These are for external mic and speaker use, with a third switch for an external 6V DC supply. Apart from a belt clip to the rear and a carrying strap from the base of the BNC socket, that's about it from the outside.

### Design

A dual gate MOSFET device ensures both high sensitivity and good dynamic range from the double conversion superhetrodyne receiver.

Synthesiser controlled and with low power CMOS Integrated Circuitry, power consumption of the LS20/XE should be very low, I thought. The Block Diagram is reproduced here to show the transmit and receive path through the equipment.

### Power-full?

One worrying thought to cross my mind at the beginning of the review was the low current capabilities of the internal batteries. As supplied, four dry-cell size AAA cells are provided, although to save on cost it is suggested that Nickle

Cadium replacement are obtained. Current consumption would indeed need to be low if these are to last any appreciable time. Although a replacement set could be carried in the pocket, it was found difficult to change the batteries in the dark, and especially to observe the correct polarisation. Measurements were made with regard to the current drain and RF output performance, and these are reprinted at the end of the article.

An external, regulated supply of 4.5-6.5 V DC may be connected to the LS20/XE. This will run the rig and,

The interior of the LS20XE is not the neatest we've ever seen for certain!

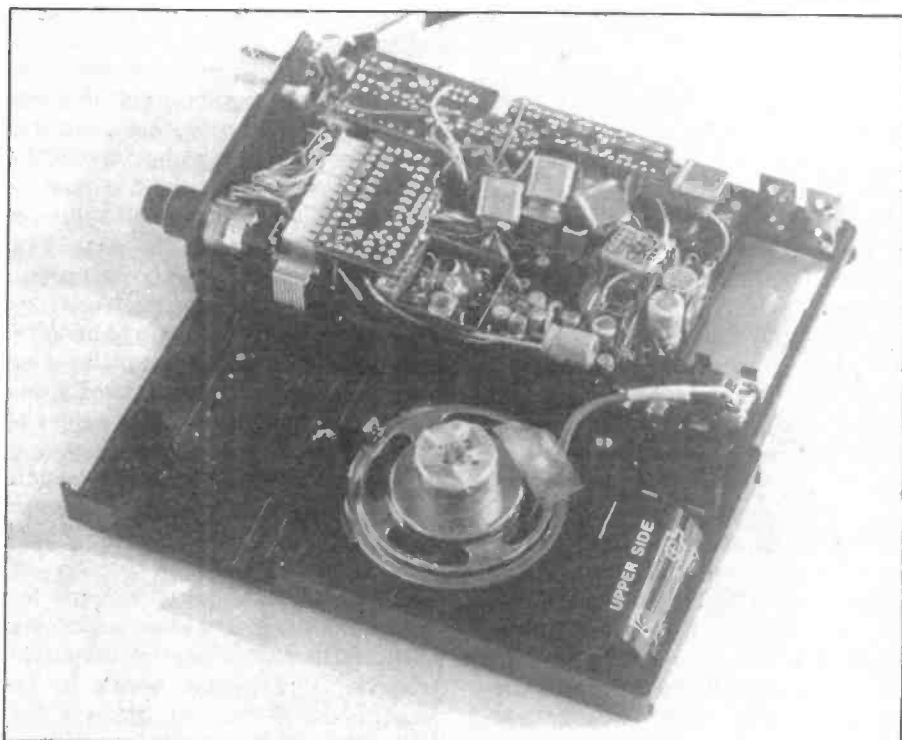

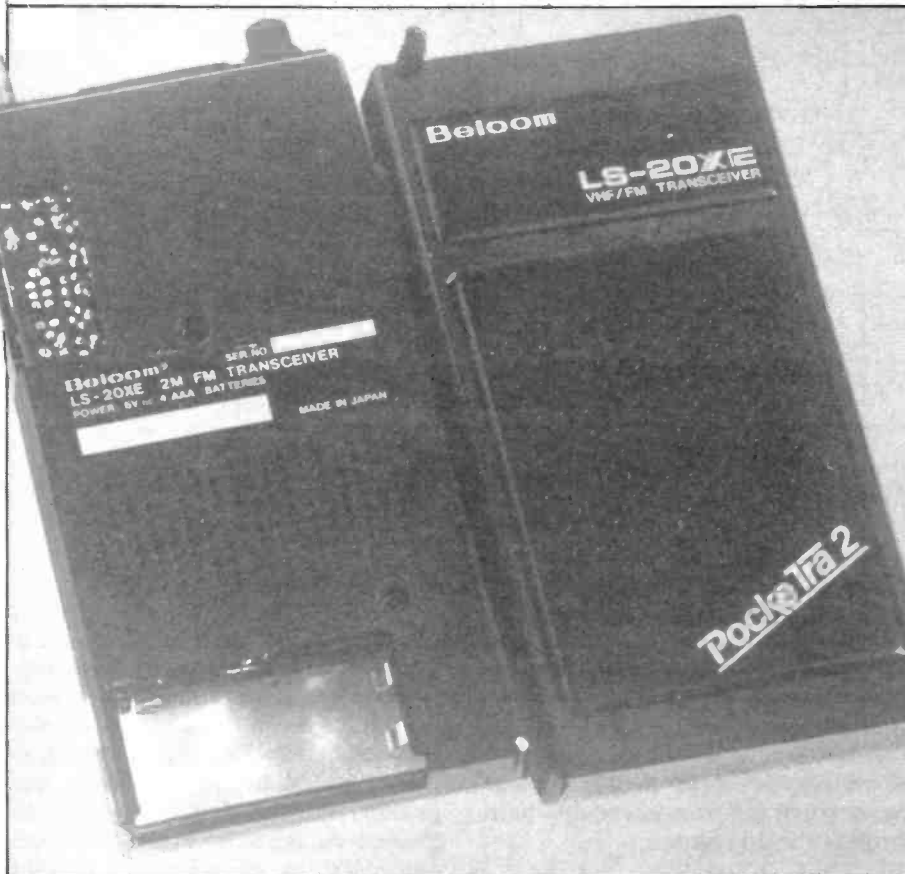

The case opened out — you can see the three switches mounted on the PCB (see 'Controls') at the top left.

if fitted, charge internal Ni-Cads. If dry-cells are fitted these must be removed to prevent damage. A simple arrangement allows for the dual function of the DC supply — the positive side being switched upon insertion of the plug. Ni-Cad charging is via a fixed resistor.

### Extras

A number of accessories have already been produced for this new rig, and apart from the run-of-the-mill additions like chargers, speaker mic, carrying case and alternative antenna, there are two items of particular interest. The first, called a CP615, is an add-on battery pack holding 4 'C' cells and is designed to attach to the user's belt, or to be held in the hand, a connecting cable being supplied. This unit will obviously allow for increased amount of usage over the internal batteries.

Indeed, were the manufacturers themselves worried about the expectancy of those internal cells? Priced at just over £10, the extra battery pack is useful if sometimes rather cumbersome.

The second, especially interesting, extra would virtually warrant a review of its own if it worked on

other equipment — a VOX headset. Designed specifically for the LS20 range of transceivers, this lightweight unit connects directly to the rig, thereby disabling the internal mic and speaker, allowing for voice operated transmit and personal receiving.

Whilst on paper this seems an excellent idea, it does not take long to realise why a whole host of this type of unit are not flooding the amateur radio market. I took the device out and conducted a thorough field trial. As I walked down the street, I met a neighbour who remarked "Who do you think you are, Kate Bush?" (I didn't understand the comment either!) Whilst replying to him, I inadvertently allowed the rig to be VOX operated and consequently was transmitting! Not only did stray comments to neighbours activate the circuitry, even high traffic noise was a problem. There is a sensitivity switch on the head set which *in theory*, should eliminate these problems . . .

As supplied, the VOX circuitry will allow the rig to linger in transmit for about half a second after audio of a sufficient level, has been detected. In practice, this period needs to be lengthened slightly to prevent the receiving station hearing a continually

interrupted transmission which can be irritating to listen to.

As far as I was concerned, this was an inherent problem with using VOX on FM. Perhaps it is more suited to SSB use. Having said this, the headset was very comfortable, although I am not sure how many people would walk down the street in daylight wearing one, seemingly talking to themselves! At £19.50, it was perhaps an expensive addition, and an extra that won't work directly on most other two metre transceivers since the operating voltage for the VOX circuitry is obtained from the LS20/XE.

### A Quick Delve

Although it wasn't possible to gain access to the VOX circuitry within the headset, a few minutes was all it took to reveal the inside of the LS20/XE itself. The cover is separated by removing two screws and prising apart the two sections. As snap-on type connectors have been used this can be tricky business — these tend to break-off all too easily! The front removed and the remainder on the bench, the speaker lead can be removed from its socket-leaving an assortment of coloured components visible, veritably littered with connecting wires. Three glass fibre circuit boards make up the innards; the main board, a tone-burst board and close to the thumb wheel switches, the potential divider board. The boards are interconnected by a number of miniature plug and sockets.

These plugs and sockets, whilst allowing for easy removal, do take up valuable space in such a small unit, certainly space which could be better utilized. The tone-burst board literally came away in my hands, being fixed by double-sided sticky foam tape. The five crystals mounted on this board were hanging from the edges of the board at random angles, held in by the mere fact that, when the unit is closed up, everything inside is so closely packed that the crystals are not free to move!

A certain amount of 'inhibit' circuitry is located on the potential divider board to prevent 'out of band' transmissions, an interesting idea which uses perhaps an unnecessary amount of circuitry. This circuitry may be easily overcome — thereby giving a full 10MHz coverage suitable for a UHF transverter. It must be said that money seems to have been saved on

the construction side, the interior of this rig resembling a Hong Kong built Audio Amplifier or Taiwanese CB rig rather than a Japanese amateur radio transceiver. Colleagues passing the rig, lying open on the bench, were not over impressed. Comments like "Just like Mum used to make" and "Which trainee assembled that?" were muttered, although, as we shall see, in operation the equipment worked satisfactorily.

It was interesting to note that standard size components were used, whereas 'E-line' or smaller would have saved space. In the rigs construction cost seems to have been the overriding factor. The rear of the speaker was covered in sticky tape to prevent it shorting onto the board below; also, a couple of hungry ½ watt resistors were spotted, and looked as though they might be doing nasty things to the current drain figures. It was noticed that Nippon (NEC) 2SC series of transistors had been heavily employed throughout.

Hot wax had been poured over a number of the components and allowed to cool to prevent any inside movement; this was particularly noticeable in the VCO compartment which itself is screened with thin copper sheet. There is, however, no overall screening the case being entirely plastic, and thus no effective earth 'ground-plane' is available to provide anything for the helical antenna to work against — kitchen foil might help here!

### In Operation

Having seen inside perhaps discovering how the rig is available for its price, with the economics made on the construction and design, I decided that a test of the rig's performance was probably a fairer assessment of its value for money. After all, it would be purchased to be used and not to be examined inside — although an investigation into the construction of any piece of equipment can be indeed revealing.

Comparing the received signals on the LS20/XE, I found these similar, audibly, to the performance of the IC2E (using helical antennas on both rigs). During these tests, there was something of a VHF 'lift' on; many repeaters were audible which aided the measurement process by providing good reference points. It must be stated that the IC2E could withstand more physical movement (ie stand being moved into a more un-

favourable position than the LS20/XE) before signals were below the noise and this may be because of its superior ground-plane over the Belcom. When comparisons were being made using fixed antenna there was virtually no audible difference between the performance of the two rigs. Neither of these hand-helds have any sort of 'S' meter — not that they can usually be trusted anyway!

Having established that the receive side of the LS20/XE is by no means deaf (certainly with the low transmitter RF output there is little chance of being heard without hearing the other station), the speaker and audio performance needs to be discussed a little. The speaker performance was a little poor overall, audible distortion occurring at anything from ¾ to maximum volume level.

Trying to hear stations over and above high background noise such as traffic was a little difficult and the volume was turned up high. Although the received audio became rather 'raspy' and lacking in base, it was still quite, acceptable. The claimed AF output specification is more than 100mW at 8 ohms with 10% THD. Several comments were made about the performance of the 'squellch' circuitry as well: the squellch seems to open and close at the same level and this hysteresis problem became annoying when receiving stations on the squellch threshold.

Not being terribly impressed with the received audio, I obtained some reports on the audio quality being produced on transmit. Reports using the internal mic tended to suggest that it was rather 'woolly' and somewhat 'bassy'. However, reports using the VOX headset were far more favourable: "crisp", "excellent crisp response" and "pleasant to the ear".

A little disappointed by the reports with the internal mic, I endeavoured to improve the audio of the inbuilt mic insert by varying the distance between it and the voice

source. At about 3½ to 4 inches reports of "woolly" audio were still obtained, indeed, a distance of 2 to 1½ inches seemed to make little difference, yet, at between 1 and ½ inch away, the modulation level came right up — *without distorting*.

### Handbook?

The 'Operation Manual' as it's called cannot be regarded as a comprehensive guide or service manual. Being an eight page A5 size document it simply describes the basic functions and their operations, lists available accessories and gives instructions on battery insertion. Two loose-leaf circuit diagrams are also included, which between them cover the operation of the rig. Further technical information is available on the publicity leaflet and this tends to supplement the handbook supplied.

### Lab Test

Whilst a full laboratory test was not performed, a number of measurements were obtained and these are listed alongside the published specifications.

### Conclusion

Generally a fine piece of equipment, very compact, externally neat, and exceptionally 'handy' to use *and* at a competitive price — however, with less than 1 Watt of RF is below the claimed specification. I feel that more consideration could have been put into the internal construction and design, even at the risk of increasing the price. Having said this, I would buy one tomorrow if I didn't already have a satisfactory hand-held for use on 2m!

Retailing at £128, the LS20/XE is available from Lowe Electronics and their distributors and agents throughout the UK. Some of the accessories *may* be a little hard to obtain.

	Specification	6V DC	Findings
RF Output on Transmit	High 1W	700mW	360mW
	Medium 500mW	440mW	250mW
Current Drain:	Receive, No signal 20mA	38mA	27mA
	Receive, with Signal 85mA	42mA	32mA (at min Vol)
	Tx Hi Position 500mA	410mA	310mA
	Tx Med. Position 350mA	380mA	275mA
Equipment used:			
Hewlett Packard 435A Power Meter; Bird 'Tenuline' 10db Att; Farnell L30 Stabilised Power Supply and an Avo '8' Multimeter.			

# Addendum

## 2m Talkbox (Feb 1984)

On page 13:

Capacitor labelled C near Q4 on circuit is C39, 47pF

C35 is 22pF

R8 is 150R

C13 should be 1n0 not 10n

Junction of R18 and R19 is point A (shown on overlay)

C33 is 150pF

C35 is 22pF

R25 is 470R

Unlabelled capacitor near T4 is internal capacitor of T4

On page 14.

Capacitor below F2 on overlay diagram is C17 not C10

The foil pattern was printed as a mirror image of the correct orientation — a correct version is given below.

## Project Omega Part 7 (Feb 1984)

On page 58:

On the overlay diagram, D3 is shown the wrong way round!

## Newcomers' Forum (Jan 1984)

The 160m band now extends from only 1.81 to 2.0 MHz (sob, sob — G3WPO and G3ZZD) and DX contacts take place just above 1.81 MHz, not below it.

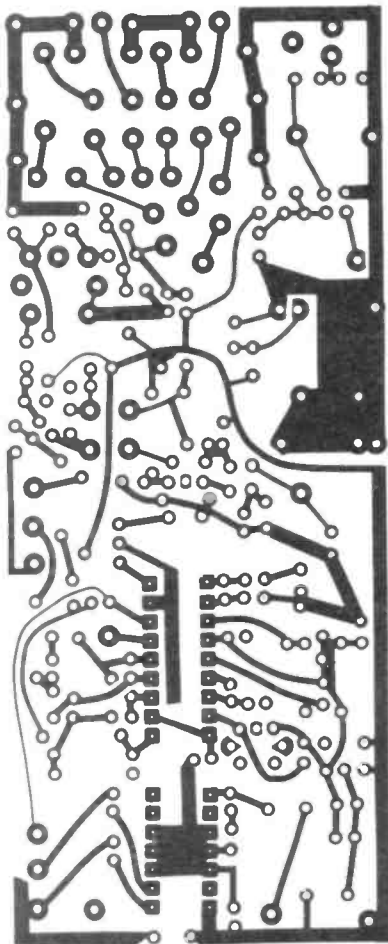

## THE GAMMA TWIN 2 METRE FOLDED 1/2 WAVE ANTENNA

Copyright Gamma Aerial Products 1982

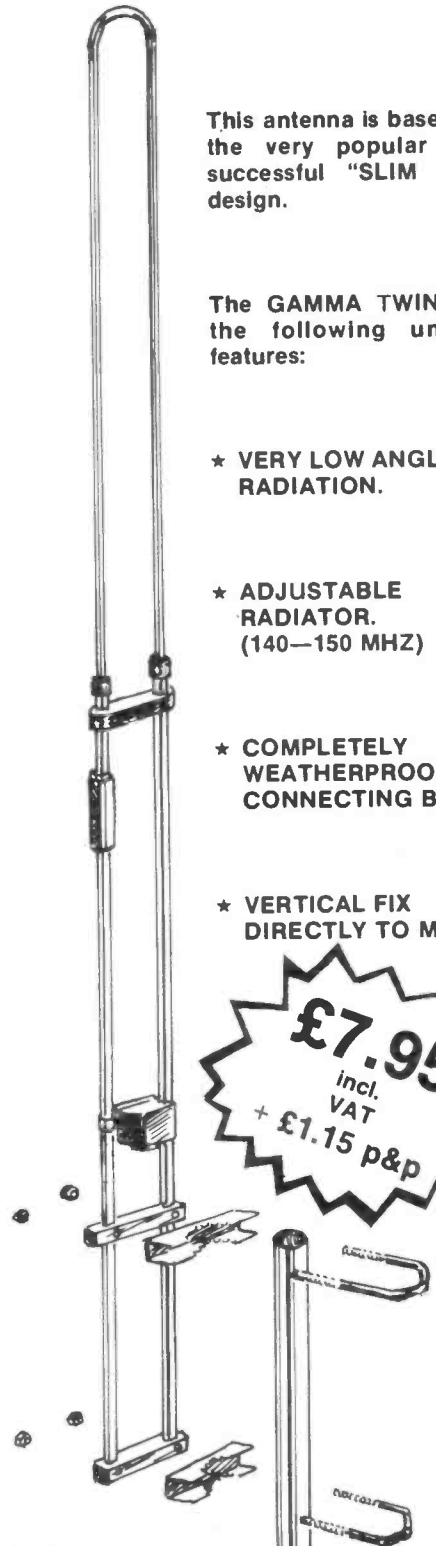

This antenna is based on the very popular and successful "SLIM JIM" design.

The GAMMA TWIN has the following unique features:

- ★ VERY LOW ANGLE OF RADIATION.
- ★ ADJUSTABLE RADIATOR. (140—150 MHZ)
- ★ COMPLETELY WEATHERPROOF CONNECTING BOX
- ★ VERTICAL FIX DIRECTLY TO MAST

**£7.95**

incl. VAT  
+ £1.15 p&p

Available from your usual stockist or direct from the manufacturers

**Gamma Aerial Products**  
MANUFACTURERS OF AMATEUR RADIO & CB ANTENNA  
BALDS LANE, LYE, STOURBRIDGE  
WEST MIDLANDS LYE 891132/891474  
TRADE ENQUIRIES WELCOME

# Semiconductors

Although the passing of a significant reverse current by a normal diode would generally occur at such a high voltage that the diode would be destroyed, there are diodes designed so as to pass current when a particular reverse voltage is reached. These diodes are known as Zener diodes, after the discoverer of one of the mechanisms involved.

plain, as in Fig. 1. Electrons are free to move around in the plain, but when they get near the dimple, they fall in, and they will roll around the inside of the dimple rather like a marble rolling around in a bath-tub. (This properly applies to an isolated atom, the situation of an electron in a bond is more complicated but essentially the same.)

having 'tunnelled' through the potential barrier to get there; once outside the atom, the electron is swept away and will not return to the atom, and a hole is left behind.

If there are a number of similar atoms (or rather, bonds) within the same area, all experiencing the same voltage field, then they will all begin to give up electrons at the same voltage gradient.

*Shirley Hesketh is, unfortunately, not in the best of health, and we're sure all Ham Radio Today readers will join us in wishing her a speedy recovery. To keep the ball rolling, so to speak, Dave Bradshaw takes a look at just a few of the many different types of diode there are.*

There are in fact two processes involved, one, as already mentioned, is Zener breakdown, and the other is called avalanche breakdown; Zener breakdown happens at higher voltages than avalanche breakdown in general, but which process occurs at what voltage is decided by the design of the diode.

## Zener Breakdown

In Zener breakdown, one of the bound electrons involved in a bond is pulled out of the bond and away from the two atoms that it was associated with. Actually, the electron does not actually get pulled over the attractive potential barrier that holds it within the bond, but it *tunnels through* the barrier. This needs a little explaining!

In terms of energy, we can visualise an atom consisting of a nucleus which creates a dimple in a

Applying a voltage (or rather, a voltage gradient) across the region of the dimple has the effect of tilting the plain around the dimple as shown in Fig. 2; the stronger the voltage gradient, the more the plain tilts. However, the plain would have to tilt a very long way before the electrons would 'fall' out. This is where the electron's special nature comes into play, because the electron is not like a marble!

As a sub-atomic particle, an electron does not have a precisely defined position, but a probability distribution. As the plain around the dimple tilts further, eventually the point is reached at which the probability field of the electron extends to point outside the dimple on the plain (Fig. 3). At this point, there is a finite probability of the electron being outside the atom, so that given enough time, the electron will actually pop up outside,

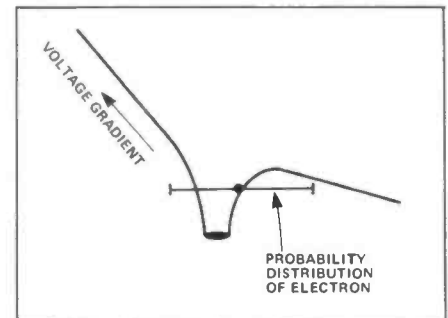

Fig. 2 Applying a voltage across the depletion region tilts the plain. The probability spread of the electron is shown diagrammatically; actually, the electron itself is spread over the indicated width.

## Avalanche Effect

The other way that electrons can leave the bond is by being knocked out by other electrons striking them. Suppose that there is a free electron in a particular region in a piece of semiconductor. If a voltage gradient is applied across this region, the electron will accelerate away from the negative pole towards the positive one, as in Fig. 4.

Before the electron gets very far, it is likely to suffer a collision. It is actually moving within a crystal lattice, and as a result can take up motion only in ways that are permitted by the regularity of the crystal. Over-simplified slightly, the electron obviously cannot take a path that takes it through the atomic centres; the electron's path is dictated by the regular crystal.

However, there are two things that, from the electron's point of view, break up the crystal's regularity: these are irregularities in the crystal structure (this includes impurity atoms) and thermal vibrations in

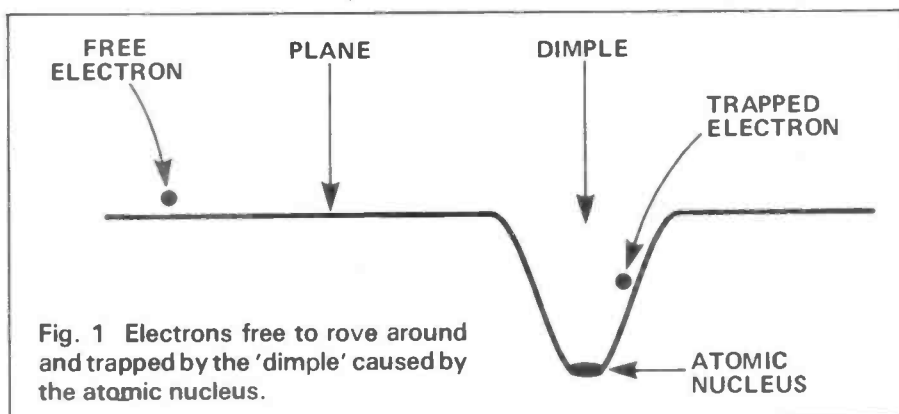
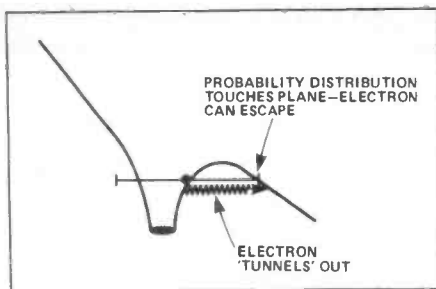

Fig. 1 Electrons free to rove around and trapped by the 'dimple' caused by the atomic nucleus.



**Fig. 3** Once the probability distribution touches the plain, the electron can escape, which it will do very quickly.

the crystal. This means that there is in general a certain distance that the electron is likely to travel before it collides with the crystal; this distance is called the mean free path. The electrostatic field applied to the crystal means that the electron will accelerate between these collisions.

At some value of electric field, the electron will have enough speed just before it collides to knock another electron out of a bond, leaving behind a hole. The 'original' electron and the 'new' electron will accelerate again in one direction, until they strike the crystal again, knocking more electrons out; the hole will accelerate in the opposite direction, acting just like a positive electron, and it can strike the lattice itself, knocking out an electron and creating a hole. These two processes repeat over and over, building up a very large number of electrons and holes.

### Where?

Both the processes described can take place only within the depletion layer; neither can take place in the p-type region or the n-type region because the presence of conductors in both these regions; however, the depletion region is exactly the right area to have these effects taking place, because it is here that the voltage gradient will be greatest, and it is here that the behaviour of the diode is decided.

By controlling the width of the depletion region by altering the dop-

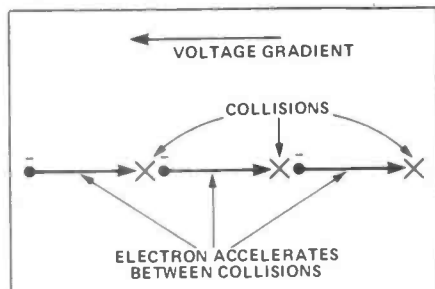
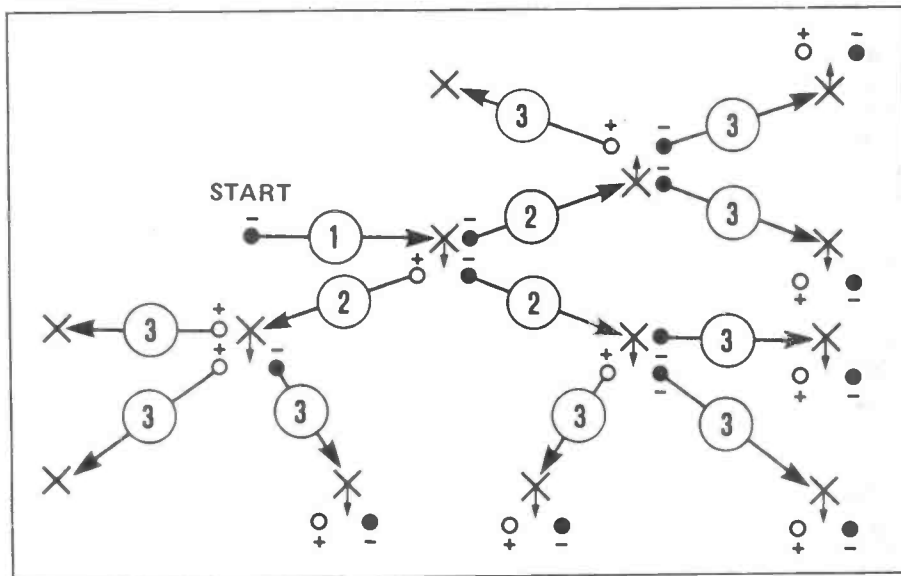

**Fig. 4** The electron accelerates between collisions, but at each collision loses all its speed and starts again from rest.

ing levels of the p-type and n-type semiconductors, the voltage gradient for any particular voltage applied across the diode can be decided at manufacture. The mean free path can be determined, also by the altering the doping levels. Thus the voltage at which the diode will break down, by one or the other of the two mechanisms, can be determined.

down at voltages below 5V, the breakdown voltage decreases as the diode gets hotter; for diodes with break-down voltages above 5V, the voltage increases as the temperature increases. For a breakdown voltage of about 5V, the diode will actually neither increase nor decrease its voltage as the temperature rises.

A practical consequence of this is



**Fig. 5** When the avalanche effect occurs, one electron accelerates (1) and on collision knocks out another electron leaving a hole. These both accelerate (2) along with the original electron, and on collision, knock out more electrons creating more holes; these accelerate (3) and so on.

### Electrical Characteristics

Figure 7 shows the ideal and typical characteristics of the Zener diode; ideally, a Zener diode should have a very definite voltage at which it breaks down, and whatever the current through the diode, the voltage across it should stay the same. In practice, diodes do not turn on as sharply as one might like; there is a small region where the current increases and the voltage also increases. There is then an extended region in which the voltage increases only slightly as the current increases over several decades.

This region terminates at a point at which the power dissipation limit of the device is reached. As ever, the power dissipated in a diode is equal to the voltage across it times the current through it. Once this reaches the maximum dissipation of the device, the device is likely to be no more.

Another factor that affects the Zener diode's behaviour is the dependence of the breakdown voltage on the temperature of the diode. For diodes constructed so as to break

that as electronic equipment warms up after being switched on, and Zener diode voltages will change very slightly.

Figure 8 introduces the symbol for a Zener diode and shows a simple voltage stabiliser that uses a Zener diode. More sophisticated circuits use Zener diodes at voltage references.

### Varicap Diodes

Most of the time, the junction capacitance is a nuisance in radio diodes. However, there is at least one sort of diode, the varicap or Varactor diode that uses the junction capacitance to obtain a very useful effect.

The junction capacitance arises out of the very structure of the diode. The two conducting regions, the p-type region and the n-type region form the plates of a capacitor, while the depletion region varies as the reverse voltage across the region varies (obviously, when the diode is forward biased, the small capacitance is completely swamped by the forward resistance), and, as stated last

month, the depletion region will widen as the voltage increases. As a consequence, the capacitance falls as the voltage increases; the form of this variation is shown in Fig. 9; for the mathematically minded, the relationship between voltage and capacitance is given approximately by

$$\frac{1}{C^2} = aV + b$$

where the constants  $a$  and  $b$  will depend on the semiconductor materials used and the structure of the diode.

Normally, diodes are not manufactured to give particularly predictable voltage against capacitance characteristics or particularly high junction capacitances (typical junction capacitances are of the order of a few pF); however, they will exhibit a change in capacitance with voltage. However, specially made varicap diodes will offer rather more predictable behaviour!

### Schottky Diodes

Last month it was pointed out that because of the 'storage' of minority carriers on either side of the junction of a diode, conduction would continue for a few microseconds after the forward voltage had been removed. One way to avoid this, and so to make the diode react faster, is to have no minority carriers at all! This can be done by, instead of p-type semiconductor, using a metal instead. Although one half of a conventional diode has, effectively, been removed, the diode will still work, because there is still a depletion region. Electrons can leave the n-type semiconductor for the metal, but not vice-versa. The reason for this is again a matter of energy.

You will doubtless have heard about energy bands in semiconductors. This is nothing really that complicated and it follows on from what

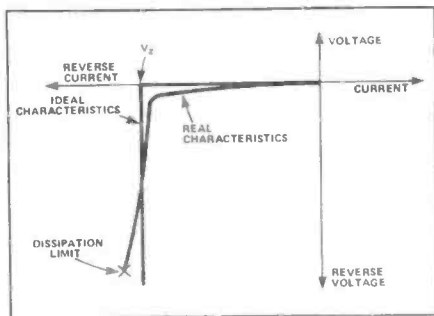

Fig. 7 Zener diode characteristics — ideal and real.

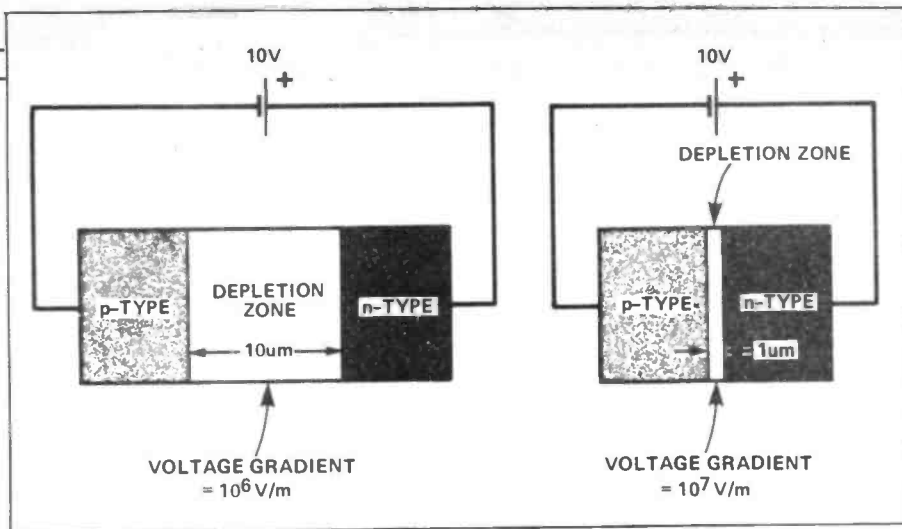

Fig. 6 The effects on the voltage gradient of different depletion zone widths.

was said earlier about there being only certain types of electron motion permitted by the crystal that the electron finds itself in. As it happens, there are a range of forbidden energies at the very bottom of the range of energies that a free electron might have. This is the so-called **band gap**.

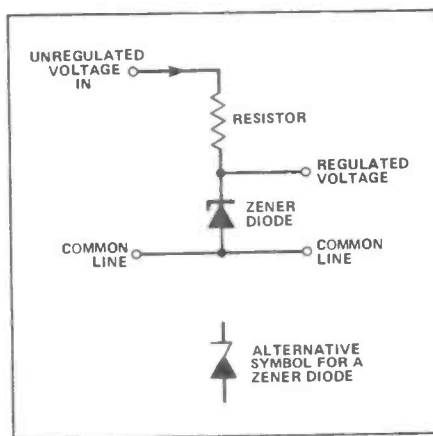

Fig. 8 A simple Zener diode voltage regulator.

Within a metal, no such band gap exists, and electrons will have any energy, up to just above a maximum known as the Fermi energy (the situation is complicated by no two electrons being able to have exactly the same motion and so exactly the same energy — this is a physical law).

The result of this is that the electrons which are free to rove around inside a semiconductor have higher energy than those inside the metal. As a result, electrons from the semiconductor can 'drop down' to the level of those in the metal, crossing the depletion region, whereas those in the metal cannot 'climb up' to the level in the semiconductor. Result: electrons can travel one way but not the other.

Because the electrons are the majority carrier in both the n-type

semiconductor and in the metal, there are no minority carriers involved in the diode action. This leads to very low turn-off times for the diode, in the region of 0.1 ns (nanoseconds,  $10^{-9}$ s). It also has lower on resistance, lower noise and better resistance to burning out. Schottky diodes are widely used in high-speed integrated logic (called Schottky TTL) and in microwave converters.

### Tunnel Diodes

Quite a lot was said about tunnelling in Zener diodes above; however, it

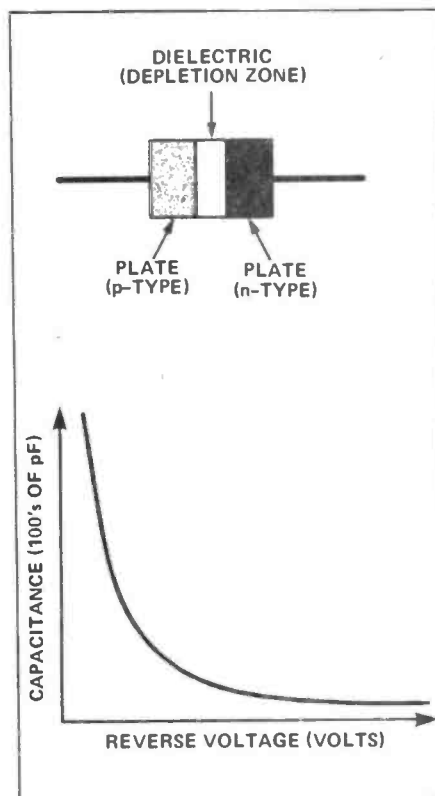

Fig. 9 A diode as a capacitor; the capacitance against voltage for a typical varicap diode.

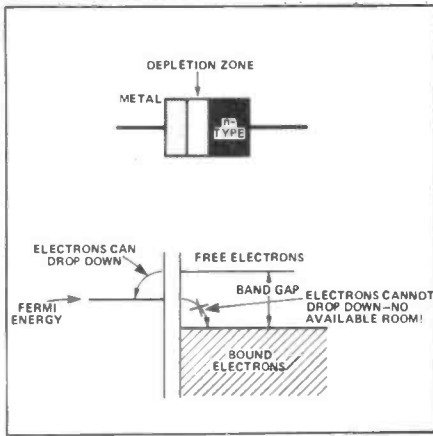

Fig. 10 Schottky diode construction and energy diagram.

should be said that there are other diodes that use tunnelling, confusingly called Tunnel (or Esaki) diode. The tunnelling involved is not the same as that in the Zener diode.

In a tunnel diode, the doping of the p-type and n-type regions is made very strong, and the depletion region is made very narrow. As a result, it is possible for electrons to tunnel across the depletion region. Another vital factor for tunnelling to occur is that there must be permitted energy levels for the conduction electrons with the same energy on either side of the depletion region.

At zero voltage across the depletion zone, there will be equal diode

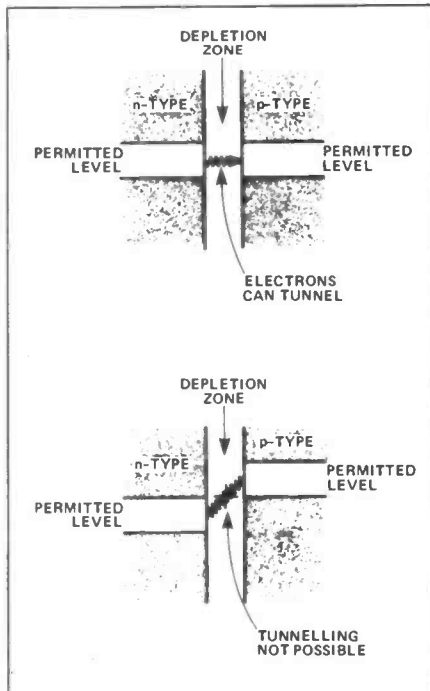

Fig. 11 Tunnel diode energy level diagrams (a) at zero volts or at very low forward voltage; (b) at a forward voltage of 0.13 volts or so.

tunnelling in both directions, from the p-type to the n-type and vice-versa. As described last month for a conventional diode, applying a reverse voltage pulls the depletion zone wider, stopping tunnelling, so the diode does not conduct in the reverse direction.

With small forward voltages, the number of electrons crossing from the n-type to the p-type steadily increases, while the number of electrons going in the opposite direction decreases; this leads to a forward current that rises much more steeply and at a much lower forward voltage than a conventional diode. However, at a forward voltage of around a tenth of a volt, another effect begins to make itself felt, because at these voltages, the equivalence of the two permitted energy levels on the two sides of the depletion zone is beginning to break up; the application of a voltage across the diode shifts the energy levels with respect to each other.

From this point, the current actually decreases as the forward voltage increases. This region is said to exhibit **negative resistance**; however, this is not *real* negative resistance, the diode doesn't pass negative current for a positive forward voltage.

At a point where the tunnel effect has been more or less completely broken up, the characteristics of the tunnel diode become more or less the same as the conventional diode. The curve given for a conventional diode, in Fig. 12, may seem unfamiliar but note the scale of the current; silicon diodes do conduct fairly weakly before the rapid rise in current for forward voltages of 0.6 V or more.

The low forward voltage make the tunnel diode very useful as a low-signal-level detector; other uses make use of its very high speed and include microwave amplification, video circuitry, and super high-speed logic. A similar negative resistance is exhibited by Gunn diodes, which are used as microwave oscillators.

### Opto-diodes

When an electron falls into a hole at the depletion region, while forward conduction is taking place, some energy is given up. In most diodes, this simply pops up as heat being dissipated in the diode. However, with certain semiconductor materials (notably Gallium Phosphide), and after a good deal of rather com-

plicated mathematics has gone into deciding the amount of doping in the n-type and p-type regions, it is possible to persuade this energy to come out as light. As a result, the forward voltage of an LED is rather higher than that of a normal diode.

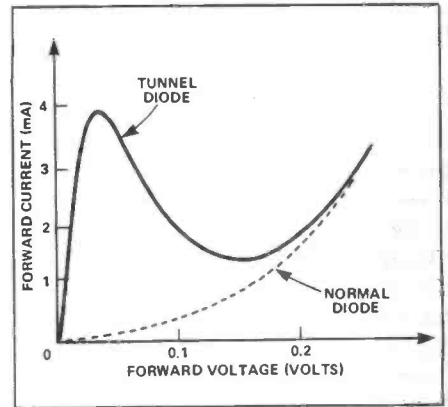

Fig. 12 Tunnel diode characteristics.

The converse process is also possible: light can 'lift' a diode out of a bond, creating a hole as it goes. So in a reverse biased diode, light striking the junction can make electron-hole pairs, that will then be pulled in opposite directions by the voltage gradient. If enough light falls on the junction, enough electron-hole pairs will be created to generate an appreciable current flow.

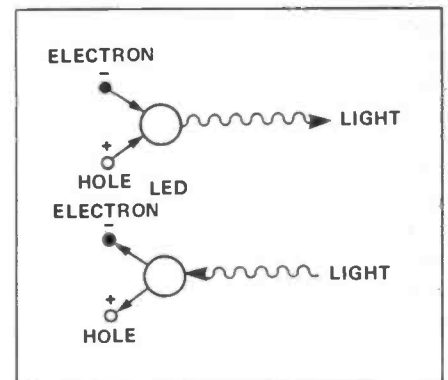

Fig. 13 LED and photodiode use the same process - but in opposite directions.

As with LEDs, there is some rather complicated physics involved, and as a consequence not all diodes can be used as photodiodes. However, getting a bit ahead of ourselves, it was well known that certain germanium transistors could act as phototransistors. OC70Ps were 8/- each while just plain OC70s were 3/6 - but you could turn an OC70 into an OC70P just by scratching off the black paint!



# Metre wave

Listen to that SM6 working from South Sweden back to a man in Mid-England on 432.2MHz! It is hard to believe that human ears can decipher signals at such low levels, yet those two pairs obviously do: their owners reply to one another after each over that all has been received "100 per cent".

understand what is being transmitted to him from the other end, simply because the morse code and the recognised abbreviations are being employed. Maybe "Ingleesh not spoken here" – but it doesn't matter. Mister Morse overcomes that barrier to conversation.

Thus has it been since the dawn

---

*Jack Hum, G5UM, reminds us that Monday night is a key night on 2m and gives some hints on learning and saying it with morse metrowave-wise.*

---

Listen to that HB9 on his mountain top near Newcastle (Neuchatel) in Switzerland talking to his opposite number near Newcastle, England, on 1.3GHz, each barely audible to the other. Yet, once again, the exchange of reports is "Readability Five, 100 per cent copy".

Now go on to observe how that YU-man, keenly determined to work his first XM square on 144MHz, catches the expedition station in West Wales solely through his expertise at being in the right place frequency-wise at the right time and operating in the right way with the *very* briefest of calls.

Three different observations on three different metre-wave bands but all of them having one factor in common: each of the contacts described was made on the A1A telegraphy mode, each of them demonstrating that CW will get through when all else fails.

Lest that last sentence suggest that you only use telegraphy "... when all else fails", rid yourself of the thought forthwith. For tens of thousands of hams the world over the A1A mode is the preferred one that provides a *lingua franca* to allow Venice to talk to Valparaiso or Jarrow to talk to Jakarta in the sure knowledge that each recipient will

of amateur radio in the early years of this century. Morse not only always got through, but it was always intelligible to those who practised it – wherever they might be. And still is.

## Morse on the metrewaves

In the context of this column, though, a more recent dawn must occupy our attention, that of the dawn of serious VHF and UHF communication within – and from – these islands. You can date that particular dawn quite precisely to the Spring of 1946, the time of the Great Resumption of amateur radio after World War 2.

That was the time when only two modes of transmission were current. One of them was telegraphy, available to all because all licensees were morse-men. To secure the coveted "ticket" in those days you were compelled to pass at "twelve per" (the no-morse Class B licence was still 18 years into the future).

The other available mode was amplitude-modulated telephony. Inter-communication between the two modes was regarded as quite a normal procedure. Nightly on 'Two' you would hear telegraphy operators calling and working telephony ones, and vice versa.

But in the late 1940s and onwards a serious deterrent to the use of telephony was its propensity to cause TVI to the burgeoning millions of new television receivers that were being put into British homes as fast as the TV dealers could install them. Amplitude modulation also had a special aptitude for finding its way into the domestic audio systems of the time. Two decades were to pass before the problem cured itself: by the early Seventies the changeover on the metre-wave hambands occurred from outmoded AM to FM. The coming of FM ushered in the repeater age and the great surge of mobile activity concomitant with it.

Telephony had also now become the dominant mode in use in the metre-wave spectrum, not solely because TVI-proof FM had become the norm, but also because the majority of occupants of 'Two' and 'Seventy' were Class B phone-only licensees. Telegraphy seemed to be on the way out.

## Make it Monday

To counter this tendency the suggestion was made in a VHF commentary column of the day that Monday night should be designated 144MHz CW activity night. The thought was happily translated into practice by A1A enthusiasts countrywide with the results which can be heard today. Over the subsequent ten years Monday evening has come to be regarded as the time when plenty of CW contacts on 'Two' are assured.

Even more encouraging is the evidence that those who dip a tentative fist into Monday's morse pool enjoy it so much that they dip and dip again, both on Mondays and on other nights of the week, often developing their skills at CW so effectively as to persuade them that telegraphy is *the* mode to be employed.

Table 1  
THE TELEGRAPHY AREA OF "TWO"  
as designated by the European VHF/UHF Bandplan

144.000MHz	Spot frequency: UK use forbidden.
Up to 144.015MHz	Earth-Moon-Earth transmissions.
144.050MHz	CW Calling Frequency (to be vacated after contact has been established).
144.100MHz	Meteor scatter reference frequency.
144.150MHz	Upper limit of cw-only area
144.15 to	
144.500MHz	Mixed telegraphy and single-sideband area.

Where does all this happen? What does the European Metre-wave Band Plan tell us about telegraphy on 'Two'? Answer: see **Table 1**. The diagram delineates the very considerable amount of frequency space which is designated "CW Only", an area wider than most of the CW portions of the HF bands – and much more noise-free. Although the bandplan terminates the telegraphy-only segment at 144.150MHz it recommends the use of CW in the J3E (single sideband) segment, a valuable provision that allows morse operators to attract the attention of SSB stations who might not otherwise hear them.

Next question: what will be heard within the CW area at the bottom end of 'Two'? Answer: stations from all over the UK (and beyond when lifts in propagation occur), often at such low signal levels as to be workable only on the key. These signals however often increase in strength after the operator has established your location from The Callbook and turned his antenna in exactly your direction.

What morse speeds will these stations use? Answer: almost any, from very slow to quite fast. Often, the very slow turn out to be older-timers, sending at the speeds of the newer-timers enjoying their first go on-the-key. To transmit faster than the other person's sending speed is a foolish exercise which inevitably

results in requests for repeats.

To the reader of *HRT* as he (or she) essays the delights of the low end of 144MHz a couple of immediate conclusions will suggest themselves:

One, the spaciousness of the area available for telegraphy use; and –

Two, the marvellous training ground which this area offers for learners of the morse code. How to improve your morse speed? Why, listen on Monday Night CW Activity Night on Two Metres! Here may be found signals at all levels, telegraphy at all speeds, and abbreviations in profusion to be learned.

### Say It Quicker

A word about those abbreviations will be germane in the current context of morse on the metre waves. Many a newly arrived Class A operator on 'Two' is heard to spell everything out in longhand – when the shorthand of the accepted morse abbreviations would have permitted *more* information to be transmitted in *less* time. Some of these 'shorthand' terms are to be found in **Table 2** herewith.

Now comes the inevitable and natural question: "I would like to become one of those newly-arrived Class A operators. How do I go about it?" To master the morse code must be Job Number One for those readers who wish to enjoy the delights of

telegraphy on 'Two'. To many it is an Onerous duty and nothing has been said in the foregoing paragraphs as to how best to fulfil it. Nothing will. No attempt will be made here to duplicate the many thousands of words of advice which have been printed and spoken on the subject of 'getting the morse speed up'. However, perhaps you will permit me two observations by way of conclusion.

Memorizing morse at the age of 14 is easier than at age 40. Yet this factor need be no deterrent to the individual who accepts that the mastery of any discipline comes only from a constant familiarisation. Learning to drive a vehicle, learning to read music (or even just learning to read!), learning shorthand, or indeed doing any duty *by rote* can become second nature in a matter of months. *The more you do of it the better you get.*



"I FAILED MY MORSE COURSE, COULDN'T REMEMBER IF I WAS BEFORE 'E' OR VISA VERSA!"

Secondly, about this reiteration business in the morse code context: aim to commit to memory each week four letters and four figures from the morse table. Whistle them aloud when nobody is about (or perhaps when they are, if you happen to be at a ham meeting!). Send silently to yourself the letters and figures you see on the index plates of passing vehicles.

The magic 12 wpm will be achieved more quickly than you think – and the appointment with the Morse Code Examination Centre soon arranged! After that, aim for a working optimum of 15wpm, or better if you can. Never think "Twelve per" is all you need. You can do better than that. Make your debut on 144.05MHz on that magic Monday an impressive one!

Table 2  
A DOZEN ACCEPTED ABBREVIATIONS TO SPEED YOUR FINGER-TIP TALKING

Never send PLEASE. Send PSE  
Never send THANK-YOU. Send TKS or TNX  
Never send FOR. Send FER or FR  
Never send WEATHER. Send WX  
Never send SIGNALS. Send SIGS  
As for HERE or HEAR: Send HR  
Do not send S9 AURORAL: but S9A  
In place of TRANSMITTER send TX  
In place of RECEIVER send RX  
In place of CRYSTAL send XTAL  
In place of ANTENNA send ANT

Many more accepted abbreviations will be memorised as a consequence of listening in the cw area of 2m, notably those Q-groups particular to telegraphy, eg, QRQ, QRS, QTH, QRO, QRP et al.

# TALK TO THE WHOLE WORLD

Study now for the  
**RADIO AMATEUR'S  
EXAMINATION**

We have had 40 years successful experience  
in training men and women for the  
G.P.O. Transmitting licence.



FREE R.A.E. brochure without obligation from:-

**British National Radio & Electronics School**  
READING, BERKS. RG1 1BR

Name .....

Address .....

HRT/3/846

BLOCK CAPS PLEASE

## WOOD & DOUGLAS

A NEW MODE and a new FREQUENCY?  
FMTV has arrived on 24 cms so get on  
'24' in '84



using some of our new products:-

### VDIF Demodulator Strip

The apparently hard part made easy. First of all convert the signals from the frequency you are receiving to approximately 52MHz. This could be the first i.f. at 24cms, or using doppler Gunn oscillators, at 10GHz. Feed this 52MHz signal into the VDIF where it will be amplified, limited and then demodulated in an NE564 phase lock loop. The recovered signal is then amplified and processed to give two 1V ptp standard video signals with the ability to select positive or negative modulation sense. A 6MHz signal is filtered off for audio detection and the phase lock loop gives an a.f.c. signal for front end tracking. There is also an a.g.c. signal which can be used for 'S' meter applications. Everything you need on a single board measuring 5" x 3". There is a minimum amount of setting up, four coils to adjust and one trimmer capacitor. The video amplifier is fixed value discrete components and needs no aligning. The use of NE592 integrated video amplifiers has been avoided to ensure no degrading of the potential video bandwidth. Once adjusted it will not need touching again. The demodulator is exceptionally linear over approximately 15MHz. This board simply works and works well.  
Price in kit form £38.95, £52.65 assembled and tested.

Having removed the headache on receive systems, what of transmit? There are two approaches that you can pursue - high level varacter multiplication and low level direct output. The following products are to be initially offered.

### UFM01 UHF Power Oscillator

This small module (1.6" x 2.5") gives a free running 50mW signal at 400MHz. The dimensioning of the board is such that sufficient deviation is obtained for direct transmission at 400MHz. This can then be reduced by the multiplication factor to final frequency for other bands. There is a minimum video processing circuit to allow direct connection of 1V ptp 75R signals. The board is voltage stabilised to minimise drift. In use the module should be followed by our standard 70LIN3/LT to increase the power to 500mW and then any of our 70FM series amplifiers can be applied to give currently 40W maximum output. For 24cms use, the stability is adequate. For higher orders of multiplication some form of frequency lock will be needed. This could take the form of a skeleton VIDIF without the post detector amplifier.  
Price in kit form £17.95, £24.80 assembled and tested.

### WDV 400/1200 Varacter Tripler

Due to appear in early 1984, a BXY35a varacter tripler for 400MHz to 1200MHz. This will be a boxed finished unit suitable for 10W input power levels. Provisional pricing indicates the £40 - £50 range.

Our commercial experience in wide band FM links have enabled the amateur market to benefit from these exceptional designs. This is only the beginning of the MDTV product range from W & D.

Kits and modules are offered on our usual 'no external hardware' basis just high standard, well designed electronics with a backup you know you can rely on. Products for MDTV will not be available through our agents due to the experimental nature of their use. Please send your orders direct to W & D and if possible give some detail of the application. This will help us to assess the demand and usage of these state of the art modules.

Prices include VAT at the current rate. Please include 75p postage and handling. Please check stock position before ordering although delivery will never usually be more than 28 days. Further details on receipt of a large S.A.E.



Unit 13, Youngs Industrial Estate  
Aldermaston, Reading RG7 4PQ  
Tel: 07356 5324 Telex: 848702



# HAM RADIO TODAY

## NEXT MONTH

NEXT MONTH IN HAM RADIO TODAY

REMEMBER THE DSB80?  
MEET THE DSB-2!

Simple, low-power DSB/CW transceiver with  
super-stable synthesised VFO. It will work  
on either 160, 80, 40, 30 or 20 metres!

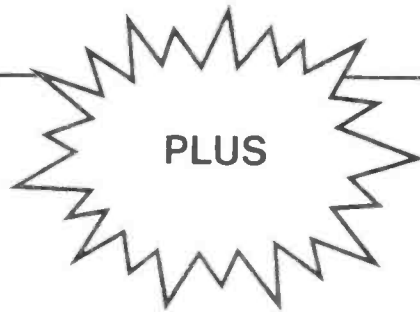

Alinco 70cm linear reviewed

Going abroad? Get a reciprocal licence!

Brand new series - RF Building Blocks, by  
Frank Ogden

Receivers - we scrutinise the various  
measurements used to assess RF performance  
and say what they mean and how they affect  
what you hear

### STOCK CRYSTALS

#### CRYSTALS FOR 2 METRES

£1.90 FOR ONE CRYSTAL

#### TX CRYSTALS

HC6/U 4 & 8MHz 30PF  
HC25/U 12MHz 30 & 40PF  
HC25/U 18MHz 25 & 20PF

#### RX CRYSTALS

44MHz SERIES RES  
44MHz SERIES RES  
14/15MHz 20 & 30PF

£1.74 WHEN 2 OR MORE PURCHASED

#### CHANNELS IN STOCK

RO TO R7, S11, S20 TO S23  
RO TO R7, S8, TO S23  
RO TO R7, S8, TO S23

#### 4 METRE CRYSTALS FOR 70.25 IN HC8/U AT £2.25 each

TX 8.78250 RX 29.78000 6.74666

#### 70CM CRYSTALS £5.00/pr or £2.80 each

For Pye PF1 PF2 & PF70 series. Also Wood & Douglas  
SUB(433.2) RB0 RB2 RB4 RB6 RB10 RB11 RB13 RB14 RB15.

Also for MULTI U11 - SU12, SU16, SU18, and SU20.

#### CONVERTER CRYSTALS IN HC18/U AT £2.85 each.

22,000, 38,666, 70,000, 96,000, 116,000, 101,000, 101,500, 116,000

#### FREQUENCY STANDARDS £2.75 each

HC6/U 200kHz 455kHz 1000kHz 3.50MHz 5.00MHz 10.000MHz 10.700MHz  
HC18/U 1000kHz 7.00MHz 10.70MHz 48.00MHz 100.00MHz

#### TONEBURST, I.F. & MPU CRYSTALS IN HC18 £2.25 EACH

7.168MHz (For 1750 Hz Tone), 10.245 (For 10.7 I.F.)  
3.2768 5.06888

#### YAesu CRYSTALS for FT101a FT901 & etc £4.00 each

Many available ex stock (A list is available on request see S.A.E.)

A stamped addressed envelope with ALL enquiries please



**QuartzLab**

MARKETING LTD.

### QUARTZ CRYSTALS

### MADE TO ORDER CRYSTALS

#### FUNDAMENTALS

#### FREQUENCY RANGE

6 TO 30kHz £23.00  
30 TO 80kHz £15.00  
80 TO 159kHz £10.90  
160 TO 999kHz £7.00  
1 TO 1.5MHz £10.76  
1.5 TO 2.5MHz £5.00  
2.5 TO 4.0MHz £4.75  
4 TO 21MHz £4.55  
21 TO 25MHz £8.50  
.25 TO 30MHz £8.50

#### PRICE

#### 3rd OVT

#### 5th OVT

#### 5th, 7th &

#### 9th OVT

#### OVERTONES

#### FREQUENCY RANGE

21.00 TO 65.00MHz

60.00 TO 110.00MHz

110.00 TO 126.00MHz

126.00 TO 150.00MHz

150.00 TO 250.00MHz

#### DELIVERY

2.0 TO 125.0MHz 2 TO 3 weeks

1.0 TO 2.5MHz 3 TO 4 weeks

Other frequencies 6 to 8 weeks

#### PRICE

£4.55

£5.75

£7.00

£8.00

£9.00

Unless otherwise requested fundamentals will be supplied for 30pf load capacitance and overtones for series resonant operation.

HOLDERS: PLEASE SPECIFY WHEN ORDERING - also HC25/U supplied for XTLS above 3MHz

HC13/U 6-200kHz HC6/U & HC33/U 170KHZ-170MHz HC18/U & HC25/U 2-250MHz

DISCOUNTS: Price on application for 10+ units to same frequency/spec. or bulk purchase of mixed frequencies. We supply xtals for use in U.K. repeaters.

COMMERCIAL CRYSTALS: available on fast delivery and at competitive prices.

EMERGENCY SERVICE: for XTALS 1 to 125MHz. Add the surcharge for each XTAL. Days refer to working days.

4 days + £12, 6 days + £7, 8 days + £5, 13 days + £3.

CRYSTAL SOCKETS HC6 & HC25 £0.20 each. MINIMUM ORDER CHARGE £1.50

TERMS: Cash with order post inc. to U.K. & Ireland. Cheques & P.O.'s to QSL LTD.

ALL PRICES ARE EX VAT PLEASE ADD 15%

Telephone: 01-690 4883 24Hr Ansafone: Erith (03224) 30830

Telex: 8813271 GECOMS - G (Attention QUARTSLAB)



# Icom 271+muTek

## the ultimate

# 2m transceiver?

Some months ago I reviewed the IC251E multimode 2M transceiver fitted with a Mutek front end, looking particularly at the qualities of the front end performance. Fairly recently the IC271E was released, and it was inevitable that Mutek would design a front end board for it as well. We have looked very deeply into the performance of this new model, and it seems quite clear that whilst the RF performance is superb, there are criticisms on the audio performance as it stands, but simple modifications can improve matters.

### Facilities

This rig includes FM, upper and lower SSB and CW modes, but excludes AM. Two VFOs are incorporated; each of these can be used with a different mode selected so one can be set up for SSB and the other for FM for example. 32 memories are included, each of which can also store mode. The rig is microprocessor controlled. The appearance matches Icom's completely new range of equipment, the front panel being fairly similar to that of the IC751 HF transceiver. Three VFO tuning rates

are built in, 2kHz and 50kHz per rev for SSB, and 50kHz and 250kHz per rev for FM, steps being 10Hz (100Hz if turned fast) and 1kHz for SSB, and 1kHz or 5kHz steps for FM. The step size button gives the smallest steps when 'out' on SSB but 'in' on FM-

which is very confusing. The next button down, when pushed in, allows the memory channel to be changed whilst the bottom button, to the right of the VFO, selects split operation between VFO A and B. Small buttons select VFO A or B, A = B, scan start/

stop, VFO or memory, memory write and memory to VFO. RIT covers the range  $\pm 9.990\text{kHz}$ , but this is not indicated to more than 100Hz accuracy, the maximum discrimination of the basic frequency display. The RIT can be switched in and out without losing the predetermined offset, but an additional 'clear' button when depressed returns the RIT to no offset. Two additional buttons on the right select 'up' or 'down' in MHz steps, hardly necessary in the UK. I would have much preferred that these buttons select 25kHz steps for FM, which would have been very useful indeed.

On the left side of the front panel are buttons to select offset 'write' (this changes the internal 600kHz repeater offset if necessary), 'check', which allows listen on input when in duplex mode, + and - repeater shifts and tone/selective calling, an option not required in the UK. Other buttons select mode, VOX, noise blanker, AGC slow or fast, meter function on FM (discriminator centre or S meter), RF preamp on/off (disabled with the Mutek modification), and mode selective scan (allows scanning memories of one mode only). It is possible to search between memories one and two when this facility is pre-selected, and this feature is particularly useful on SSB.

Underneath the VFO dial is a button which, when depressed, locks the VFO frequency, and furthermore, if the optional audio speech frequency readout is fitted, pressing this button produces audio speech readout. The SP read out would be a boon to blind operators as it worked very well indeed. Three concentrically mounted pots are provided to adjust RF and AF gain, RX tone/squelch (active on all modes) and TX power output and mike gain. The tuning knob can either rotate very freely, or the tension on its spindle can be increased to apply a degree of friction.

### *The ultimate performer for 2m? Angus McKenzie, G3OSS, investigates and draws some interesting conclusions.*

#### **Rear View**

The back panel of the IC271E contains only an SO239 socket for the aerial, spring-loaded earth terminal, a 3.5mm external loudspeaker jack, another 3.5mm jack for a key

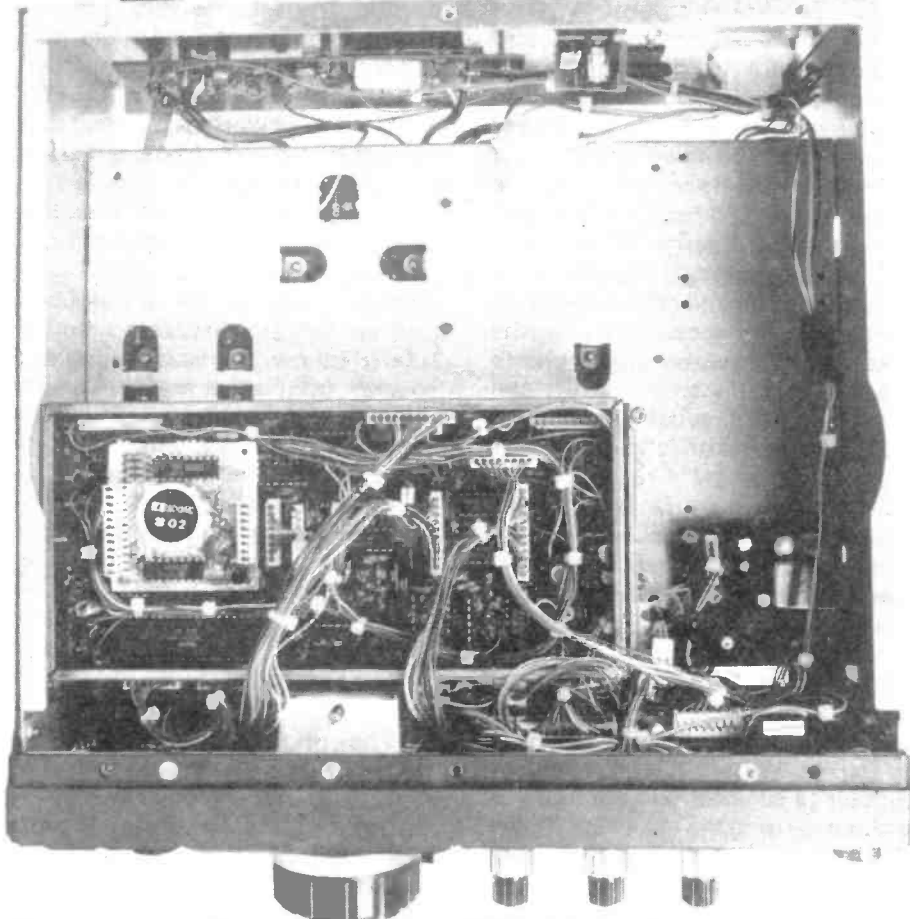

**Open space on the underside of the IC271E is for the optional mains PSU.**

and, finally, a 12V DC interconnection socket. An optional internal mains supply with IEC mains socket can be fitted, but this was not supplied. Two rubber bungs cover up holes which can accommodate optional extras, including, for example, an interface socket for providing control of linears etc. Not only did the review sample omit this option, but the option was not available from Icom, despite the basic rig having been on the market for many months. I feel most strongly that important interfaces should be built in, rather than be optional extras, for the price seems high enough without options! On the top panel, there is a bug-hutch cover

provides 'up' and 'down' frequency buttons, PTT and a toneburst button for repeater access use. The HM15 is an electret complete with amplifier having a low output impedance. The mic input socket is nominally rated for use with 600 ohm mics.

In an attempt to screen off interference from the frequency display, a very flimsy metal coated plastic screen is affixed around the display section to decrease noise break through into the receiver RF circuitry. Mutek informed me that this was nowhere near good enough when the rig was fitted with their board, and so they are also supplying a greatly improved screen.

#### **Ergonomics**

The main tuning knob on SSB changes frequency in 10Hz steps, or when speeded up allows 100Hz steps. Unfortunately, when this is rotated fast the optical sensor ceases to pick up all the pulses and so, particularly on FM, one rotation can sometimes give much less shift than would be expected, and I found this rather irritating. The IC251 had the

under which there is a row of five pots for setting CW delay, VOX gain, VOX delay, anti VOX and CW side tone level. We could not find any switches for altering scanning rate, or for selecting open or closed channel scanning.

The supplied microphone incor-

same problem incidentally. The memories worked extremely well and it was useful to have the mode memorised as well. Unfortunately, on CW the receive passband is that provided by the SSB filter, and I do not believe a separate CW filter is available. I would have preferred an auto-toneburst facility when using the FM repeater mode capable of being switched on and off. However, at least the toneburst control was on the mike. A MOX switch allows one to lock the rig on transmit – which can be very useful avoiding the sore thumb syndrome on long overs! I am always irritated by a rig that omits MOX, and there are far too many of these around. The frequency display is very clear and also indicates, in different colours, the selected functions at a glance.

We come now to the first ergonomic criticism; the fact that the microphone gain control has to be set very near minimum for SSB, and way up for FM. We all found it extremely difficult to set SSB gain on transmit without causing the mike amp clipper to come into play, resulting in some of the most disgusting distortion that I have had reported for ages.

## SUBJECTIVE TRIALS On Transmit

When transmitting SSB I was first given many reports which were about as bad as I have received in many years of operating. Friends accused me of having had a sex change operation, and almost everybody reported very bad spikey distortion if the mike gain was further than around 10% up

from minimum. Surely this is ridiculous. At low settings of the mike gain control, there was a very marked LF and MF loss in response. On FM, however, most stations reported that the quality was very good, but just a few complained that the transmission was very slightly muffled. The SSB transmissions, no matter how distorted the audio was, seemed to be reasonably narrow, the IF passband itself on SSB transmit being around 2.3kHz bandwidth, thus cutting out 'splatter' from earlier stages. The PA two-tone tests were very difficult to interpret for each of the two tones inserted into the mike input were so badly distorted as to wreck the conventional two-tone display on our Hewlett Packard 250MHz scope. The transmission was however said to be reasonably narrow by everybody.

## On Receive

The receive audio response seemed rather muffled on both FM and SSB. The receive RF performance though was absolutely superb throughout, Mutek's front end being about as 'bomb proof' as I have ever noted. No IM Products could be heard at all and there seemed to be a lack of general 'bubbling' on the band, resulting from what, at the time, seemed to be an exceptionally good reciprocal noise performance. RF sensitivity was extremely good on all modes, the receiver noise being lower than aerial noise! The AGC characteristics seemed fairly good, but slow AGC was too fast. It was useful to switch AGC speeds, although, for me, there was much too

much IF gain. Even with long AGC, there was a tendency to hiss 'pumping' on many received stations if they stopped talking for a second or so. The only way we found of overcoming this is to reduce the RF gain control, but this spoils the S meter reading. This point was discussed with Mutek who agreed that less IF gain would be better, but nevertheless stated that many users prefer more IF gain – which, in my opinion, may give the definite *impression* of super sensitivity but is unnecessary as the rig has this in any case! Would it not be possible for the RF preamp button, made redundant by the introduction of the Mutek board, to reduce IF gain by 12dB or so?

The audio reproduction seemed to be generally muffled (see the extensive comments on response in the lab. tests section). Although plenty of audio gain was available on the receiver on SSB, the gain control had to be turned way up on FM, thus showing the same inconsistency as previously found with the TX mike gain. The squelch control worked well, and the 'S' meter seemed reasonable on SSB – although it did not seem to rise up enough on very strong signals. On FM, the meter could just be said to be suitable for indicating the presence of a signal!

## Excellent Facilities

I very much liked all the facilities provided for memories, VFOs and scanning, and soon got used to these. Fortunately, Icom have avoided their dual function control syndrome, which I have previously found extremely confusing on many of their other rigs. It was very useful to have 30W output available on SSB (25W on FM), particularly as the receiver was so sensitive, and so transmit and receive have about the same equivalent relative improvement in performance as over an average 10W output 2m multimode with the usual poorish front end sensitivity. A 5dB increase in transmit power is coupled with a 5dB improvement in the receive sensitivity – if, of course, you have the Mutek front end.

## Laboratory Tests

We felt it important to delay carrying out any lab tests until the field trials had been completed so that we could investigate any problems found

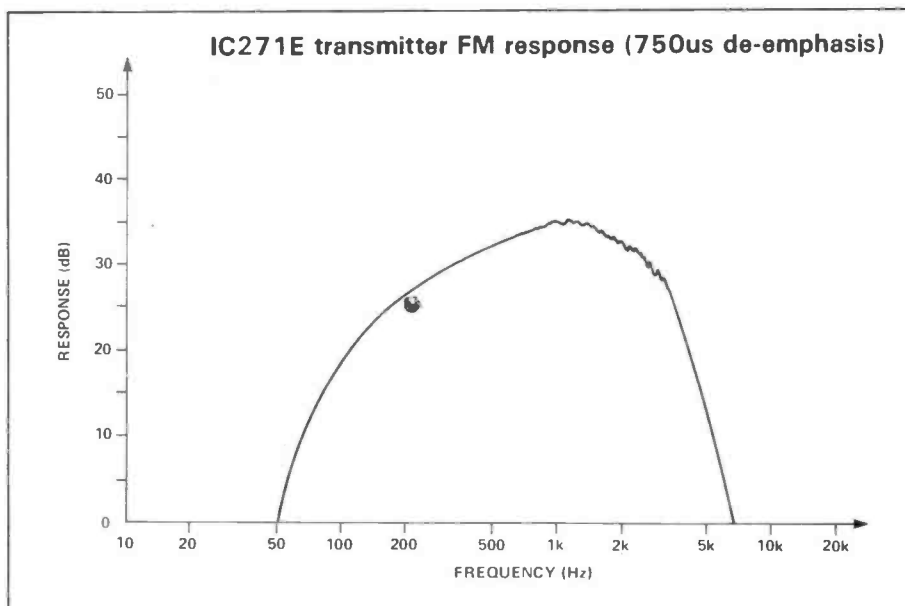

## LABORATORY RESULTS

### Receiver Measurements

#### Sensitivity for 12dB Sinad, FM (1kHz modulation, 4kHz deviation)

144.0 MHz	-125.5 dBm
145.0 MHz	-125.5 dBm
145.9 MHz	-124.5 dBm

#### Sensitivity for 12dB Sinad, USB (1kHz beat note)

144.35 MHz	-129dBm
------------	---------

#### Selectivity, FM

-/+ 12.5 kHz spacing	-72.2 / -69.3 dBm
-/+ 25.0 kHz spacing	-80.1 / -80.8 dBm

#### Selectivity, SSB

3dB Bandwidth	2.3 kHz
6dB Bandwidth	2.5 kHz
40dB Bandwidth	3.5 kHz
60dB Bandwidth	3.6 kHz
80dB Bandwidth	3.7 kHz

#### SSB Shape Factor 1.6

#### RFIM Ratio (3rd order intermod to give 12dB Sinad), FM

25 / 50 kHz spacing	83dBm
50 / 100 kHz spacing	83dBm

#### RFIM Ratio (3rd order intermod to give S9 product), SSB

20 / 40 kHz spacing	46 dB
---------------------	-------

#### Calculated RF intercept point +1 dBm

#### Audio quieting, FM (at 12 dB Sinad) -17 dB

#### Reciprocal Mixing performance, FM and SSB

Spacing	Reciprocal Mixing Ratios (12 dB Sinad)		
	FM	SSB	SSB (Ref Noise)
25 kHz	88.5 dB	96 dB	107 dB
50 kHz	95.5 dB	103 dB	114 dB
75 kHz	98.5 dB		
100kHz	101.5 dB	109 dB	120 dB
200kHz	105.5 dB	112 dB	123 dB
500kHz	109.5 dB		

#### Capture Ratio 3.7 dB

#### Audio output for 10% THD (8 ohms) 1.9 Watts

#### 3dB Limiting point, FM -130 dBm

#### Distortion & noise, FM @ 125mW into 8 ohms from -90dBm Carrier

4kHz deviation	2.2%
3kHz deviation	3.7%
2kHz deviation	4.7%

#### S Meter Readings; RF levels required.

S Point	FM	SSB
1	-123 dBm	-120 dBm
3	-117 dBm	-99 dBm
5	-113 dBm	-87 dBm
7	-110 dBm	-77 dBm
9	-105 dBm	-68 dBm
9 + 20	-99 dBm	-59 dBm
9 + 40	Never Reached	-53 dBm
9 + 60	Never Reached	-47 dBm

### Transmitter Measurements

#### Output Powers (W)

	FM	CW	SSB (Tone)	SSB (PEP)
144.0 MHz	25.0	25.5	24.5	31.0
144.5 MHz	25.0	25.5	24.5	31.5
145.0 MHz	24.5	25.0	24.5	31.0
145.99 MHz	25.5	25.5	24.5	31.5

#### Carrier Frequency Accuracy at 144.8 MHz, FM

+10Hz

#### Repeater Shift Accuracy 600kHz +/- 20Hz

#### Peak Deviation, FM 5.1 kHz

#### Minimum RF output power, FM 1.3W

#### Carrier Frequency Accuracy at 144.35 MHz, SSB

150Hz

#### Residual Noise and Carrier ref full output, SSB

approx -40dB

#### Harmonic and spurious output -70 dB

in the subjective performance. In a nutshell, the audio performance is poor, but the RF performance was found to be superb.

### Receive Side

The receive RF sensitivity showed a front end noise figure which we estimate to be only very slightly worse than 2dB, interpolating from all the RF sensitivity measurements, which can all be seen to be excellent.

Note that the SSB sensitivity appears at first to defy the laws of physics, but we later found out the reason for this! The considerable HF cut in the audio amplifier severely limited the effective noise bandwidth to just over 1kHz, causing an apparent improvement in sinad performance of around 2.5dB. The RFIM performance was stunningly good, and calculations of the intercept point from both FM and SSB tests showed it to be an excellent +1dBm, *superb* for a VHF rig. The

blocking performance was excellent, and reciprocal noise tests were almost at the limit of our test equipment, for we had to use a crystal controlled very low noise oscillator on 2m for the high level input to see the *real* performance of the rig itself. Without doubt, this is the quietest synthesiser that we have yet encountered on an amateur rig. This of course contributes to the very clean sound when you tune across the band.

Both the FM and SSB selectivities

were excellent, and I found that signals off-channel seemed to 'knife' right out. It is amazing that we were able to take the 80dB down-point of the filter, which was only 100Hz further out than the 60dB down point. Not only does this show superb filter design and matching, but it confirms the incredible reciprocal mixing performance. The product detector seemed a good one, and the discriminator also had fairly low distortion. We applied a special test to check the audio response on both SSB and FM, because of the subjective criticism. We first drove the box from a signal generator set to give a 1kHz beat note on the audio output, AGC being set on fast, and the RF input level set on -70dBm (70uV). We then stepped the generator in 100Hz

problem however may be elsewhere. The FM response also showed too much HF cut for the same reason. However, you have a tone control after all on the receive side, so if you want to have more de-emphasis than the normal 750uS, then use the tone control - rather than having signals permanently muffled!

Just under 2W output was given for 10% distortion into an external 8 ohm load, which should be loud enough for normal use, but if you wish to use a higher quality speaker which is below average sensitivity then there is not really enough power to take account of sharp transients. This, however, is a complaint that I frequently make on most modern 12V rigs. Distortion was reasonably low at lower volume control settings.



up and down on weaker signals, or was permanently stuck full scale on the stronger ones.

### Transmit Side

The transmitted audio power was well within specification, and the power control reduced power on all modes down to just over 1W output. The frequency accuracy on transmit on FM was within 10Hz or so, the repeater shift also being very accurate. On SSB, there was an error of around 150Hz though, partly due to the fact that the counter only gave readings in 100Hz increments. We checked for the presence of spurious and harmonics and the spectrum analyser screen was absolutely clean down to around -70dB, the limit of measurement. FM deviation peaked at around 5.1kHz, both on speech transients and much shouting. We noted that the test toneburst (to get through to the transmitter) required the mike gain control to be very well up. The transmitted FM response from mike socket input to carrier, which is shown in the accompanying graph, is reasonably flat - when the deviation meter used had a de-emphasis of 750uS switched in. Although the effect of the HF filter network can be seen to cut 3kHz by around 5dB, which is reasonable, although I would have preferred it to be slightly more flat and with a steeper cut starting above 3kHz.

Now we come to a major problem; that of the transmitted response on SSB. We drove the microphone input socket from a very low source impedance through a very large capacitor, 10uF. Our source signal was a B & K 1902 dual signal source, with one of the frequencies disabled for this test and set to 12mV sine wave output. The maximum sensitivity was at 1.5kHz, and having set the power control at maximum, and

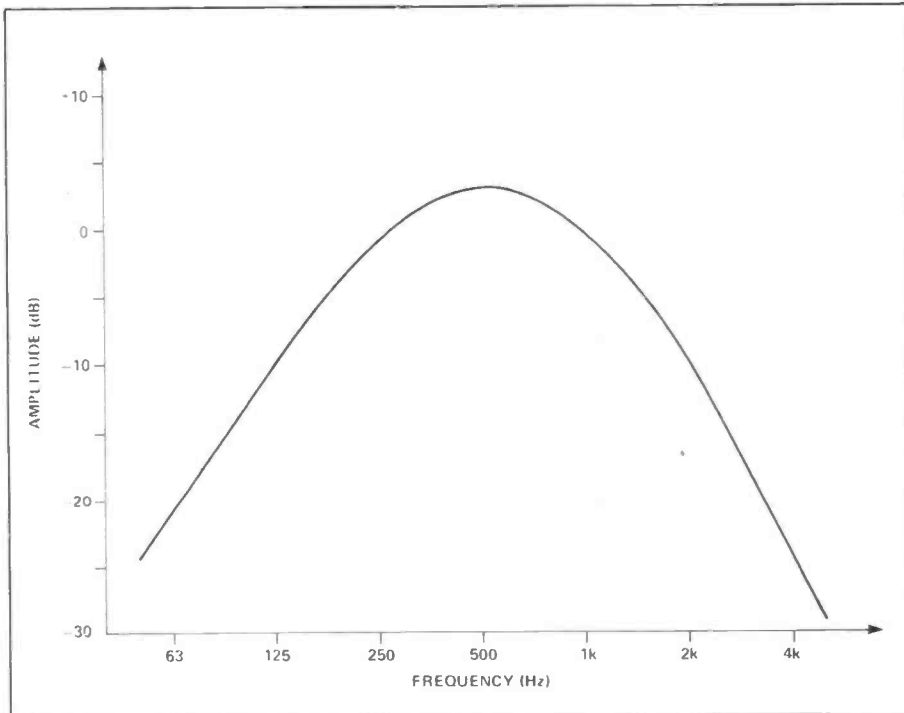

IC271E received audio response on FM (no pre-emphasis)

increments, allowing the AGC to maintain a sensibly flat output from the product detector until the IF filter had a major effect. We noted that the audio output lumped up nearly 2dB at 500Hz, but the response above 1kHz fell gradually to reach around 9dB below the 500Hz level by 2.5kHz. Above this frequency the IF filter, of course, came well into play. It is quite clear that there was much too much HF cut, due possibly to C159 being too high in value, and I suggest that this could be reduced to a much lower value which might allow an improvement in HF sound quality, coupled with a greater intelligibility of consonant and sibilant sounds. The HF cut

A 4kHz deviation signal with modulation at 1kHz reproduced with acceptably low distortion proving that the discriminator was reasonably clean.

The 'S' meter tests showed indeed that above S9 the scale was badly squashed: an indication of 60dB over 9 represented only a true 21dB over 9 signal. On FM, even 1mW input did not budge the + meter much above S9. Lower signal strength indications on SSB were reasonably spread out, averaging at 6dB per S point. On FM though, the S meter only gave just over 2dB per S point.

When the IC271E was receiving FM the 'S' meter waved violently





noise and carrier breakthrough was around  $-40\text{dB}$  which is reasonable enough. Finally, we checked the power consumption on transmit which varied from around 2A minimum power to 5.8A maximum on FM, peaking 6A on SSB. On receive, the rig took around 1.2A.

### Conclusions

I have no real reservations *at all* as to the RF performance of this rig, as it seems to be one of the finest I have yet had the pleasure of measuring. Mutek's front end design must be said to be 'state of the art': a comparison of this receiver with an average transverter and HF rig, shows how good the Mutek circuitry really is. However, whilst being quite happy with the FM audio performance, I am of the opinion that the transmit performance on SSB is much too poor, and this fact alone forces me to withhold a strong recommendation, *unless the importers can make modifications on all models to put matters right\**. Changing C159 in the audio amplifier on receive may clear up the receive audio problem. It is unfortunate that you cannot really put right the transmitted SSB audio easily, for the design is such that SSB and FM have the same basic response, and improving SSB would make FM much too woofy as the FM pre-emphasis would disappear. It seems such a terrible shame that Icom's VHF equipment designers have yet to learn that a response flat from around 400Hz to 2.7kHz or so, is very important both on transmit and receive, and that a tone control can be used on RX to adjust it from flat. In my opinion, any speech tailoring on transmit should either be variable with a pot, or at least switchable 'in' and 'out'. Alternatively, the user could be recommended to choose a mike with speech tailoring, such as the excellent Heil microphone which seems to pack plenty of 'punch'.

All in all, my final reaction to this rig is to down-rate it for bad audio, despite its *magnificent* RF performance. Criticism to Icom, then, but high praise to Mutek. Icom will be releasing a 100W output version of this transceiver fairly soon, and it is to be hoped that they will improve the audio as otherwise that version too could have problems. I must emphasise that Thanet Communications and Mutek have not only been extremely helpful to me in the review of

the output level at around 3W, ie 10dB below full output, by adjusting the mic gain control. We then noted the RF power output achieved when we swept the audio slowly from low to high. Mike Hatch, my colleague, and I soon found why I had appeared to have had a sex change, for whilst we set the 1.5kHz at a nominal 0dB point 800Hz was  $-3.4\text{dB}$ , 600Hz  $-7\text{dB}$ , and 400Hz  $-13\text{dB}$ . The response was moderately flat above 1.5kHz to about 2.6kHz, above which frequency the IF filter attenuated the response extremely rapidly. It can thus be seen that the 3dB bandwidth is around one and a half octaves, hardly enough to give any reasonable reproduction of the human voice.

We then had a good look at the circuit diagram and here we feel that there are some weird anomalies. The

input of the first mike amp stage, IC1A, is a virtual earth type, and the 0.1uF capacitor in series with 2.7Kohms, with the mike gain pot giving most of the source impedance, obviously contributes considerably to the LF loss. What concerns me though, is the strange circuit between IC1A and B, and also the fact that Icom keep in the clipper (IC1B) for SSB. This clearly contributed to the distortion, for if you turned the mike gain up only slightly, the audio was immediately subjected to very nasty clipping. It struck me that Icom would have been better advised to drive the SSB section directly from the output of IC1A, allowing ALC to act more appropriately as a limiter. The preset SSB internal gain pot could then be set as desired - to allow a similar mike gain position to be used for SSB and FM.

When the mike gain was set to minimum, we noted that the residual

The pen chart shows IC271E receive AGC recovery time at differing signal levels.

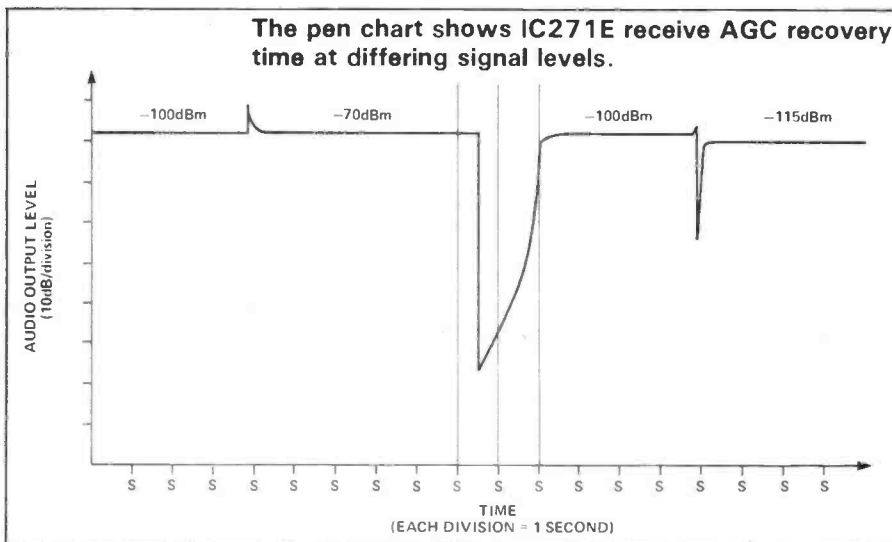

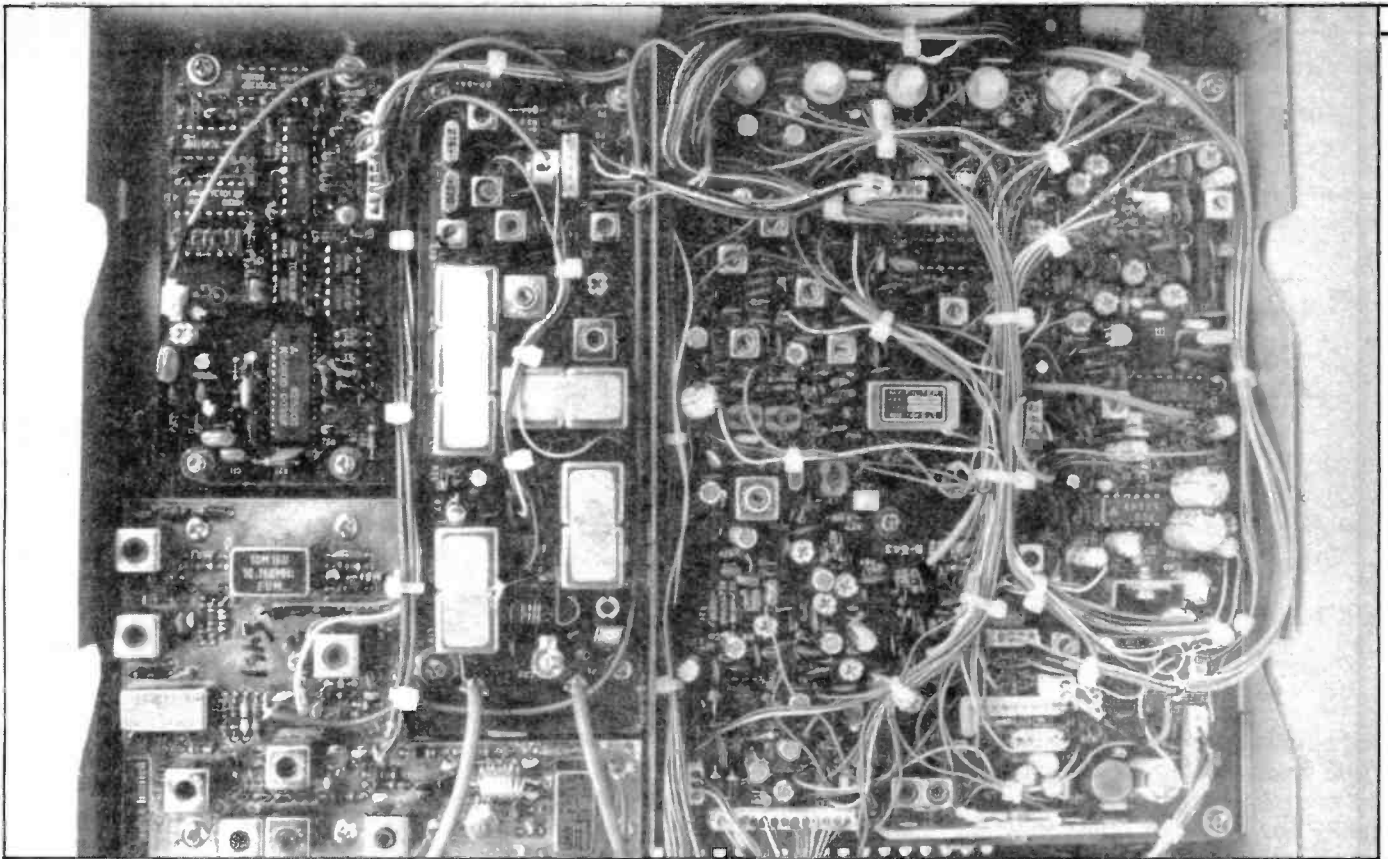

Top view of IC271E with muTek board lower LHS

this rig, but have both taken critical comments most reasonably.

#### \*IMPORTANT POSTSCRIPT

At the last moment, and just before handing the copy to the editor, Thanet informed us of some modifications which they thought would help, and so we tried these out. The input series capacitor to IC1A on the mike amp was changed from 0.1uF to 0.3uF (C4). The feedback resistor of 150 Kohms around IC1A (R11) was changed to 15Kohms. The symmetry control, preset pot R18, was very carefully adjusted to obtain equal clipping for positive and negative going parts of the waveform, applying an oscilloscope to the output pin 7. This control had been completely mis-set at the factory. We then altered C159 on the receiver audio board which interconnects pin 2 of IC13 to earth by changing from 0.1uF to 0.01uF.

Sending 12mV from the B & K audio oscillator into pins 1 and 7 (earth) of the mike socket, we then adjusted the mike gain to halfway, and altered the SSB gain preset R82 to obtain full PEP output. We checked the SSB response and found this to be excellent, with the following measurements referred to 0dB at 1.5kHz, mike gain adjusted for 3W output:

300Hz - 11dB, 400Hz - 6.5dB,  
500Hz - 5dB, 560Hz - 3dB,  
2.4kHz - 3.5dB, 2.6kHz - 9dB.

All things considered we feel this response is ideal for the microphone supplied. The distortion was minimal up to the ALC action, and no distortion was apparent on the scope monitoring pin 7 of IC1B. The receive audio response radically improved to only 3dB down at 2.6kHz in the audio amplifier, with bass cut rolling off below 500Hz on SSB. The 3dB bandwidth was thus 2.1kHz which is nearly an octave wider!

#### On Air Again

We put the modified rig on the air and were given excellent modulation reports on SSB. We swung the beam antenna round whilst talking so that the receiving stations could hear the transmission from signal strengths varying from noise to S9. Comments were made that readability was excellent even at very low levels, thus proving my criticisms of the original modulations were valid. The transmission was said to be quite 'punchy' with very clear articulation. The received audio on all modes was vastly superior and never muffled, as it had been originally. The tone control gave plenty of adjustment for those

who want woofy noises. I most strongly recommend these modifications but there is one snag. The FM mike gain is insufficient, but removing diode D2 improved this considerably although it was still not quite sufficient if you like to speak back from a mike. It occurs to me that this diode D2, should in fact be in on SSB rather than FM, which would then allow R11 to be 47Kohms. This would give 10dB more gain on FM, with the D2/R6 (820ohms) to cut down the SSB gain by 12dB - thus restoring the gain on SSB again. The FM response would now be too 'bassy', and I suggest changing the value of C17 (0.1uF) to a lower value to cut some bass. You may then have to make a slight change to the preset R29 to bring the deviation up a little.

The new value for C17 is being determined by Thanet Communications, the importers. They tell me that they will issue a modification sheet to dealers and users. They also inform me that several other Icom rigs have the same transmit SSB audio circuitry in them; IC290, IC490, IC451 and IC471. I recommend that the same modifications could be applied to these as well. With these modifications carried out, the IC271E with Mutek front end now receives a very warm recommendation indeed.



**Realistic DX100L** receiver brand new boxed £65. KW2000A H.F. rig K.W. serviced £175. Brand new pair boxed 6146B tubes £15. J.V.C. stereo cassette radio recorder never used £65. Contact John Randall 243 Paddock Road, Basingstoke, Hants.

**Super eight zoom cine** and dual eight projector for sale or exchange for amateur radio gear (circa £55) W.H.Y.?

Stacey, 3 Westpark, South Molton, Devon, EX36 4HJ. Tel. 07695-3382.

**Short wave magazine.** November 1964 to april 1979. With indexes. Buyer to collect £15. G.D.O. required. Must be FB condition. Pryse (G3WXT), 36 Hart Road, Byfleet, Surrey. KT14 7NH.

**Have Dymar 2m (145MHz) FM** portable transceiver including eight ni-cad packs and professional charger. Would exchange for MM morse talker, datong or similar morse generator or sinclair spectrum. Roy 09073 78792.

**Wanted FM board** for FT1012D. Also CW narrow filter. Cash waiting. Nick G4UKO, Maidstone 859129.

**Kenwood amateur bands** transceiver, TS520SE. 160-10m. Built in power supply and speaker. MC35S microphone. Instruction manual, packing case, mint condition, £295. GEC auto transformer 230V to 110V. 500W. £6. "Advance" voltstabs CV100A. Circuit, £6 each. Edwards, 01-445 4321 (North London).

**Tono 9000E** £480 partridge supermatch A.T.U. and mini-antenna 3.5 to 30MHZ £30 electron, oric, BBC programs: morse tutor £4.50 QTH locator £4.50 BBC RTTY £5 Pye PFIRX adapter £5 T. Tugwell 11 The Dell, Stevenage, Herts. Tel 0438 354689.

**Microwave Modules** 30 watt power & pre amp as new £50 DSB-80 built in case digital readout £20 G6KLD not QTHR 161 Boundary Rd., Wood Green N22. 01-888-1393.

**70cm linear transverter**

**MMT432/144R** 2 metre input 10W output. With standard 15dB attenuator plus 7dB attenuator to suit FT290R etc. Value £14.50 mint condition. Lack of spare time forces sale £160 ono. Tel 01 446 4932 evenings.

**Cushcraft skywalker** 3-element 20 metre beam. Unused - still in box. £60. Ring Ian Spalding G4RYM Derby (0332) 363981 daytime.

**Wanted xtal filters:** AM9MHz filter XF9C or D and HF filter around 45MHz or similar. B. Hendriksen Arnhemsest R.113 6974 AH Leuvenheim, Holland.

**Belcom Liner 2** with preamp £70. Pye Cambridge A.M. £20. Polaroid camera £20. Pye PF2 with DE1 MIC £60. G6MEN Southport (0704) 74792.

**Acetronic games computer** plus invaders module. £25.00. New Cine Projector. Many refinements. Still boxed. £40.00. May exchange for 2mtr or U.H.F. gear. Phone Skelmersdale 25991 (evenings).

**AR88** for sale. Buyer collects. Phone after 8pm 0622-87160.

**Tower.** Lattice. Tilt-over. Telescopic 35ft. Complete. Winches, cables, motor, £200. 3-ELE beam. £50. G3XVH QTHR. 01-202 7939.

**Communications receiver** realistic DX-300 10KHz to 30MHz all modes quartz synthesized digital display MINT and boxed £135.00 or part exchange for 2m hand held phone Storrington 2435.

**Have you a faulty and unwanted** HRO receiver? Reading school amateur radio club is looking for one as a re-building project. Coils and handbook welcome. Will collect. Tel Reading (0734) 61406 daytime. 871330 evenings.

**Claud Lyons variac** 2KVA codar R.F. preselector model P.R.30 for sale or swap W.H.Y. Tel. Welwyn Garden City 39270.

**Drake R4C,** 1.8KHz filter, 160m mint condition; manual, £245; collector's vintage cameras, Thornton-Pickard

press. Super ruby. F2.8 £65. Kodak 1917 autographic, £30. 1920s gramophones, H.M.V. Table model with doors. £65. H.M.V. Portable £30; exchange good H.F. Transceiver. Bournemouth 510400.

**Trio TX599** plus JR599. Separate transmitter receiver in good working order. 6 meter transverter £250 ono. Ring 061-231-4690 after 6 pm for details.

**FT902DM** MIC pristine condition throughout unbelievable but used 12 minutes Tx only minimal Rx use certified by holdings as to specification bargain £565 new 902DM transverter available to purchaser price negotiable more details John RS52155 01 857 8096.

**Exchange B&H 16mm** 636 sound projector for 70cm's transceiver. Or reflector telescope or 16mm cine camera. G8BSK 290 Priory Road, St Denys, Southampton SO2 1LS.

**Wanted MX4.** 4M ant. 4m linear amplifier W.H.Y. 01-856-4123.

**ICOM 720A.** As new £600. Sommerkamp ATU £50 Sommerkamp PSU £70 or complete base station £660. Telephone Knottingley 88600.

**Sale.** CWR 680 telereader £120. Yaesu hand Mic. 50KM £4.50. YD148 desk Mic. dual £10. Ricoh digital clock mains £4. KW aerial switch 4way

£7.50. Labgear VHF/UHF aerial amp mains 3 O/P £8. Postage extra. G410T QTHR Folkestone 76063.

**Wanted RCA AR88D** communication receiver in good working condition will collect please write Mike Cross P.O. Box 97 Wrexham Clwyd.

**ICOM 720A** HF transceiver with IC.P520, IC.AT500, IC.2KL500, IC.2KLPS, SM5 microphone IC.FL32CW filter IC.FL34AM filter ICBC10A/E backup. HK706 handkey. CT300 welz dummy. Daiwa S.W.R.CN620A. Datong D70 tutor, ICOM251E VHF Multimode. TONO9000E sender/decoder TONOGRT1200G 12" display. Almost unused. Offers to: Hesp. 1, Evesham Grove. Sale. Cheshire M33 2EY.

**Yaesu, FT107M** HF SSB transceiver, INT PSU, digital memory VFO, grey £599 TA32JNR & AR40 rotator £95 HARRIS HF SSB transceiver 3 x 6146, collins filter, heavy duty PSU, ideal conversion, spares, £45. 9ELE 144MHz tonna £12. G3TSO (028 575) 532

**Two metre rigs:** totsuko TR2100M (SSB 10W) with nicads, £90. MIZUHO MX-2 (SB 200MW) £60. AR240A. Many extras, (FM 2.5W) £85. Will part exchange any above for mint FT290R. J.V. Moss. Colchester 572685.

**Phillips G7000** video games plus 26 games £70. Nigel Alford Fairseat 823598.





**SAVE £4.25 by receiving a FREE magazine binder when you subscribe to.....**

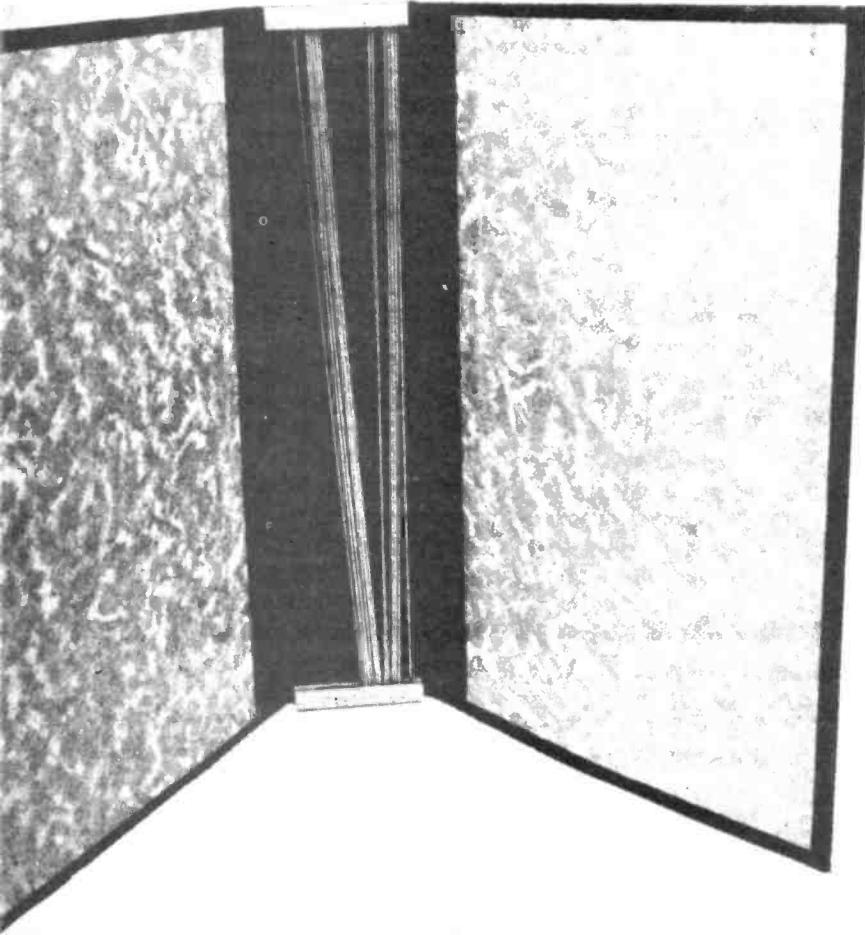

It's true, by subscribing to *Ham Radio Today* you will not only receive your personal copy direct to your door for a whole year but also have a superb magazine binder in which to keep your copies AND IT'S FREE!

All you have to do to receive your FREE binder is book a new subscription or renew an existing subscription to *Ham Radio Today*.

What could be simpler? Normally priced at £4.25, these attractive binders will hold approximately 12 issues of *Ham Radio Today*.

Not for you any longer the chore of having to track down dogeared copies of your favourite magazine, instead you will merely go to your bookshelf and they will be waiting for you in pristine condition. Don't miss out on this outstanding offer — subscribe today and receive your FREE binder within 14 days of your order being received.

**SPECIAL OFFER**

**SUBSCRIPTION ORDER FORM**

Cut out and send to:  
**HAM RADIO TODAY**  
**SUBSCRIPTION DEPT**  
**PO BOX 35**  
**WOLSEY HOUSE**  
**WOLSEY ROAD**  
**HEMEL HEMPSTEAD**  
**HERTS HP2 4SS**

Please send my free binder and commence my personal subscription to **HAM RADIO TODAY** with the

*I am enclosing my (delete as necessary) Cheque/Postal Order/International Money*  
 Order for £.....  
 (made payable to ASP Ltd)  
 OR  
 Debit my Access/Barclaycard\*  
 (\*delete as necessary)  
 Insert card no.



.....

Please use **BLOCK CAPITALS** and include post codes.

**NAME (Mr/Mrs/Miss)** .....  
 (delete accordingly)

**ADDRESS** .....

.....  
 ..... **POSTCODE** .....

**Signature** .....

**Date** .....

**SUBSCRIPTION RATES**  
 (tick as appropriate)

- £14.00 for 12 issues UK
- £14.45 for 12 issues Overseas Surface
- £27.00 for 12 issues Overseas Air Mail

# EMPORIUM GUIDE

## AVON

**Booth Holdings Bath**

6 GOLF CLUB LANE, SALT FORD, BRISTOL  
Tel: 02217 2402  
Open Tues-Sat 9am-9pm  
Close Mondays

Radio Communications  
Amateur P.M.R. Marine

**UPPINGTON**  
Tele-Radio Ltd

12 14 PENNYWELL ROAD, BRISTOL, BS5 0TJ

## CHESHIRE

**PARBOOTHAM & CO LTD**

58-62 Lower Hillgate, Stockport  
Tel. 061-480 4872 Open: Mon & Wed 9-6  
late nights Tues & Fri 9-7pm. Sat 9-5.30.  
Closed Thurs  
Yaesu, Sommerkamp, Diawa, Jaybeam, Kenpro,  
Weltz, Datong

## DW ELECTRONICS G3X CF

Amateur Radio Supplies  
71 Victoria Rd, Widnes  
Tel: 051-420 2559  
Open Mon-sat 9-6 (closed Weds) Sun 9.30-12  
We supply Yaesu, Trio, Kenwood, Tonna, Jaybeam,  
Microwave Modules, Datongs etc

## HAMPSHIRE

**FARNBOROUGH COMMUNICATIONS**  
97 Osborne Rd, North Comp,  
Farnborough. Tel. 0252-518009  
Open: 8 days 10-6  
Yaesu, Icom, FDKs, Mosley aerials, Jaybeams,  
G Whips

**CALBRESO LTD**  
258 Fratton Road  
Portsmouth  
Tel. 0705 735003  
Open 10.30am-6pm 6 days  
Sunday by appointment  
COMMUNICATIONS EQUIPMENT  
COMPONENTS, BOOKS, ACCESSORIES

## KENT

**Thanet Electronics** 

143 Reclver Rd., Herne Bay  
Tel. 02273-63859  
Open: Mon-Fri 9-5.30  
(Closed for lunch 1-2)

**SCARAB SYSTEMS**  
AMATEUR RADIO SOFTWARE

 STOCKISTS

29 Stafford Street, Gillingham  
0634-570441

## AMTRONICS (TONBRIDGE) G4 SYZ

THE AMATEUR RADIO SPECIALISTS IN KENT

IT'S AMATEUR RADIO  
from AMTRONICS

8 Tollgate Buildings  
Hadlow Road, Tonbridge, Kent  
Tel: (0732) 361850

FDK, AZDEN, YAESU, JAYBEAM,  
FORTOP, DATONG, etc.

## LANCASHIRE

**ISHERWOODS ELECTRONICS**  
Hozler Street, Blackburn  
Tel. 0254-57818  
Open: Mon-Fri 9-5, Sat 10-1  
An Aladdin's Cave of Components

**HOLDINGS/AMATEUR ELECTRONICS NORTH WEST**

Full range of T.E.T. & YAESU + J BEAM,  
DRAE, DATONE, etc, etc.  
Consult G3LLL  
15 mins junct. 31 M6. Free parking  
45 Johnston Road, Blackburn  
Tel: (0254) 59595  
Closed Thursday

## LEICESTERSHIRE

**ELLIOTT ELECTRONICS**  
FOR THE RADIO ENTHUSIAST

26-28 BRAUNSTON GATE,  
LEICESTER. TEL: 553283

Open: Mon-Sat 9.00am to 5.30pm

TO BOOK THIS  
SPACE PHONE DEBBIE  
TEL: 01-437 0699

## W. MIDLANDS

**DEWSBURY ELECTRONICS** 

176 Lower High St, STOURBRIDGE  
Tel: (0384) 390063

Open: 9.30-5.15. Closed Thurs. & Sun.  
ACCESS/BARCLAYCARD

**NEW IDEA LTD**  
133 Flaxley Road,  
Stechford, Birmingham

Stockists of Yaesu, Trio, Kenwood,  
Totsuko, Tonna Antennas, Bantex.  
Full servicing repairs on all makes of  
amateur radio. Open Mon-Sat, 10am-7pm,  
Sundays, 10am-1pm  
Tel: 021-784 3129

**HEWARD'S HOME STORES LTD.** (Est. 1963)  
822/4 Kingstanding Rd., Birmingham  
B44 9RT. Tel. 021-354 2083

G4RJM with 38 years in The Radio Trade  
Ham Equipment urgently wanted!  
Open: Mon-Sat 9-6

## W. MIDLANDS

**THE COMM CENTRE**  
(BIRMINGHAM)

584 Hagley Road West  
Oldbury, Warley B68 0BS

021-421 8201 021-550 9324

Opening hours: 9.30-5.30 Tues-Sat.  
Late nights Thursday and Friday  
For all your communication requirements

## GREATER MANCHESTER

**BETA COMM**

231 Chorley Rd., Swinton,  
Greater Manchester.  
Tel: 061-793-1010  
Open: 7 days a week.  
TRIO, YAESU, ICOM, GWHIP.

## NORFOLK

**Eastern Communications**

36 Cattle Market Street  
NORWICH  
(0603) 667189

OPEN MON-SAT  
10.00am - 5.00pm

MAIL ORDER



**D.P. HOBBS (Norwich) Ltd**  
13 St. Benedicts Street, Norwich  
Tel: 615786

Open Mon-Sat 9-5.30  
Closed Thurs  
Stockists of:  
YAESU, FDK, ICOM, JAYBEAM  
& Electronic Component Specialists

# EMPORIUM GUIDE

## NORFOLK

### SPANNER CITY CB CENTRE



Open 6 days  
9am-6pm

Parkside Garage  
Thursford  
Fakenham  
Tel: Thursford  
402

Grandstand  
LA 83  
27 to 934 MHz  
TRANSVERTER

## SOMERSET

**AVCOMM LTD**  
25 Northload Street,  
Glastonbury  
Tel: 0458-33145  
Open 9.30-5.30. Closed Wed

## YORKSHIRE

4 Cross Church St, Huddersfield Tel:  
Open: 6 days 9-5.30. 0484 20774  
Closed Weds. Thurs 9am-8pm  
G4MH Mini Beam  
*'Always a good selection of new & 2nd hand equipment in stock'*  
**Amateur Radio Shop**

## NOTTINGHAMSHIRE

**R.A.S. (NOTTINGHAM)**  
P. Owen G8UUS  
3 FARNDON GREEN: WOLLATON PARK  
NOTTINGHAM: TEL: 0602 280267  
Open: Tues-Fri 10-5.30. Sat 9-5  
YAESU: FDK: ICOM: TONNA  
HALBAR: WELZ: ANTENNAS & OWN GW5 H.F.

## SUSSEX

SOUTHDOWN  
**RADIO** (opp.  
SUPPLIES EASTBOURNE Railway  
Tel: (0323) 639351 Stn.)  
Open: Mon-Sat 10-6 (Closed Tues)  
Stockists of: Yaesu, Trio, Tonna, FDK etc +  
secondhand and ex-Government equipment in  
stock

DISCOVER THE WORLD WITH AMATEUR RADIO FROM  
SALERS 27 COOKIDGE STREET LEEDS LS2 3AG  
LEEDS 452657 OPEN MON-SAT  
9am-6pm  
TRIO ICOM YAESU  
LEEDS AMATEUR RADIO MAIL ORDER & SERVICE DEPT OPEN MON-FRI  
60 GREEN ROAD MEANWOOD LEEDS LS6 4JP TEL 782224 8.30am-5pm  
BRITISH MADE LAR PRODUCTS

## SCOTLAND

**AXDON**  
32 Atholl Street, Perth  
Tel. 0738-23753. Open: 6 days  
ICOM, TONA, TONO, RSGB Books, Maps &  
log books. Full range of components  
Mail order available — send for price list.

**TELECOM**  
6 New Street, Barnsley  
South Yorkshire  
Tel (0226) 5031  
Specialists in Yaesu, Icom  
and So-Kamp

**JAYCEE ELECTRONICS**  
JOHN GM30PW  
20 Woodside Way, Glenrothes, Fife KY7 5DF  
Tel: 0592 756962  
Open: Tues-Sat 9-5.  
Quality secondhand equipment in stock. Full range of TRIO  
goodies. Jaybeam - Microwave Modules - LAR.

### GUILDFORD COMMUNICATIONS

34 Aldershot Rd., Guildford  
Open Mon-Fri 8am-6.30pm  
Sat 8am-5.30pm  
Secondhand wanted  
FDIC ASDEN  
TRIO TO75UK4

## TYNE & WEAR

Approved Dealer  
**ALYNTRONICS**  
ICOM  
129 Chillingham Rd, Newcastle-upon-Tyne  
Tel: 0632 761002  
Open: Tues-Sat 10am-6pm

TO BOOK THIS  
SPACE — PHONE  
ASP CLASSIFIED  
01-437 0699

Please include my business details in the next available issue of Ham Radio Today

Business Name: .....

Address: .....

.....

.....

Tel. No: .....

Open Hrs: .....

Contact (Office Use Only): .....

Post to:

Emporium Guide, Ham Radio Today, 1 Golden Square, London W1.



## Lineage:

30p per word (minimum 15 words)

**Semi Display: (minimum 2 cms)**

£6.00 per single column centimetre

Ring for information on series bookings/discounts

All advertisements in this section must be prepaid.

Advertisements are accepted subject to the terms and conditions printed on the advertisement rate card (available on request)

01-437 0699

EXT 212

Send your requirements to:

Debbie Miller

ASP Ltd.,

1 Golden Square,  
London W1

## SOFTWARE APPLICATIONS

### SCARAB SYSTEMS

39 Stafford Street  
Gillingham  
Kent ME7 5EN  
Tel. (0634) 570441

RAE, I, T, M, U, 1  
VISA

RTTY PROGRAMS for ZX81, SPECTRUM, VIC-20 and DRAGON 32 — as these programs come in various packages, please write for details.

BBC £9.20

PET £7.50

Morse tutor programs at £5 each for SPECTRUM, BBC, DRAGON 32, TRS80. More BBC programs CWOSO complete RX/TX program £7.50.

Multifile — a versatile filing system £10.25.

Telltext 21 page video magazine £15.

All prices include VAT and postage. Write for further details of these and other programs.

**WANTED.** Amateur radio, technical and business software for all popular home micros.

## EQUIPMENT

New boxed 7289//CX100A5 ..... £28  
New boxed QY4-250A valves ..... £35  
New boxed QB3-300 (3-125A) valves ..... £25  
New boxed ITT 4CX 250B valves ..... £17.50  
Ex Equipment VHF 4CX 250 bases ..... £15 each  
Ex Equipment IMAC SK640 HF bases ..... £8.50 each  
680pf & 1200pf 10kV High power HF Capacitors ... £3 each  
100pf 5kV TX Capacitors ..... £2.50 each  
300pf variable capacitors wide spaced suitable 1KW  
..... £15 each  
850+850pf split stator wide spaced capacitors  
..... £17.50 each  
4 x 450pf variable capacitors ..... £2.50 each  
Many RF components available for HF - & SHF amplifiers  
please telephone with requirements.

### AVCOMM LTD

25 Northoad St., Glastonbury  
Tel: 0458 33145

## COURSES

### COURSES - RADIO AMATEURS EXAMINATION

City & Guilds. Pass this important examination and obtain your licence, with any RRC Home Study Course. For details of this and other courses (GCE, professional examination, etc.) write or phone — THE RAPID RESULTS COLLEGE, Dept. JN2, Tuition House, London SW19 4DS. Tel: 01-947 7272 (9am-5pm) or use our 24 hr Recordcall Service: 01-946 1102 quoting Dept. JN2.

**NEW!!** Scientifically prepared five-day courses to get you through the R.A.E. examination: 01-346-8597.

**NOW AVAILABLE:** 'Questions & Answers' the self test manual for R.A.E. Students. £2.75 pp. Peter Bubbs (Tuition), 58 Greenacres, Bath BA1 4NR. SAE for details.

## SOFTWARE EDUCATIONAL

Pass RAE and MORSE with your micro RAE MATHS tests you completely on all RAE formulae and gives all the practice you need to become perfect in this most important aspect of the exam.

Don't let your maths make you fail. Use this program to PASS.

**MORSE TUTOR.** Absolute beginner to any test standard. Introduces characters in stages for faster, easier learning. Completely flexible amount and speed from 1 to 40 wpm or more. Random letters, figures, words or typed plain language. You won't find a better program.

Both programs are menu-driven, easy to use and come with full instructions. For Commodore 64, Spectrum or ZX81 16K. Morse tutor also for Dragon and VIC20.

All tapes only £6 inc. p&p from Richard Wilmot, GW3RR1 Fron, Caernarfon, Gwynedd LL54 7RF Tel: 0286 851886

## CARDS, STICKERS & BADGES

**RADIO CAROLINE SOUVENIRS.** Send S.A.E. for all the Caroline News in our magazine. Send £3.00 subscription to: Caroline Movement, Dept. B, BCM-BFRM, London WC1N 3XX.

**PERSONALISED** QSLs, Amateur, or CB, 1000 £13.75. S.A.S.E. for samples. H. Hope, 89 Derwent Street, Blackhill, Consett, DH8 8LT.

**1000 FULL COLOUR** personalized Q.S.L. cards £40 plus £2.50 p&p. Club discounts. Send S.A.E. to PO Box 99 Northampton NN2 6HV.

## AERIALS

### HARD DRAWN COPPER AERIAL WIRE

140c 14 swg £6.90

50 metres 60 swg £5.90

GRSV TYPE AERIALS

1/2 size £12

full size £13.95

All items post paid

1 Orchard Way, Fontwell Arundel, Sussex BN18 0SH

## FOR SALE

**2 METER SSM** from £119, FM from £150.00. Full range ICOM, FT77 £4.60. 10M Linears from £16. 2M from £39.50. 70cm transceivers from £140. Guildford Communications 0483 574434.

### NEW POPES H100 50 OHM SUPER LOW LOSS COAX

\*About 1/2 the loss of UR67. Attn figures per 100ft.

144MHZ... 1.65 db; 432 MHZ... 2.12 db

1296 MHZ... 4.49 db

\* Fits normal PL 298s and N Plugs.

PRICE 80p per M (post 5p per m)

50.99m less 10%

Discount 100m or more less 20%.

SAE for full data and Sample

W. H. WESTLAKE, GBMW, Clawton, Holsworthy, Devon

**NEW PRODUCT!** Elbug no moving parts. Electronic Morserrey. £27.50, or S.A.E. to El-Tronics, P.O. Box 393, Chelmsford, Essex.

## FOR SALE

**2 METER SSB** Transceivers from £138. Full range including ICOM, TRIO, YAESU, ASDEN, ETC. Credit facilities. Guilford CB, 0483 574434

**ADVERTISING** used equipment is fast and easy with List-a-Rig. Send £1.00 for every 40 words or less for immediate entry. For a copy of the latest list send two 1st class stamps G3RCQ 65 Cecil Avenue, Hornchurch, Essex. P.S. Don't forget we buy and sell Amateur Radio Equipment. Tel: 04024 55733.

**CERAMIC TAG STRIP** (Jackson) 15 Tags 10 for £1. 6 Way Stand off terminals 10 for 75p. List 15p + S.A.E. Durrant Components, 9 St Marys St, Shrewsbury.

## RTTY

**RTTY TERMINAL BOARDS.** TTL output for computer £35 incl. and for teleprinter £39 incl. All boards come completely wired and tested with FSK and AFSK. S.A.E. for details to B. Brookes Electronics, 2 Leicester Street, Norwich. Tel: (0603) 24573. Stockists of Yaesu, Icom, Standardm Tona, Drae, Scanners, Sun, etc.

### COMPUTER RTTY

Use your micro to transmit and receive

RTTY

PL1 - PLL RTTY Terminal unit

170Hz Shift ..... Transmit & receive

Also handles ASCII ..... TTL in/out

Kit ..... £3.50 ..... Built £17.50

FP1 - Two channel active filter & PSU

for PL1. Requires 15/0/15v AC.

Kit ..... ££7.25 ..... Built £10.75

Software for the DRAGON 32

RTTY send-recv program by

G4BMK

Split screen receive - Type ahead

buffer. QSO review & many other

features.

Cassette £12.00

ROM Cartridge £21.00

**MORSE transceive program up to**

**150 wpm!**

Cassette £9.75 Cartridge £18.50

Hardware interface also available.

Please add postage to all orders -

U.K. 60p Overseas £1.50

Other hardware available for the

DRAGON 32

For further details & full price list

please send LARGE S.A.E. to:

**PNP COMMUNICATIONS**

62 Lawes Avenue, Newhaven

East Sussex BN9 9SB

P. Simmons G3XUS

Tel: (0273) 5114465

Callers by appointment only please.

# HAM RADIO TODAY

## CLASSIFIED ADVERTISEMENT — ORDER FORM

IF YOU HAVE SOMETHING TO SELL  
DON'T TURN THE PAGE — TURN TO US!

**RATES OF CHARGE:** 30p per word (minimum of 15 words)

Advertise nationally in these columns to over 60,000 readers for only 30p per word (minimum charge 15 words). Simply print your message in the coupon and send with your cheque or postal order made payable to Argus Specialist Publications Ltd. to:  
**CLASSIFIED DEPT. HAM RADIO TODAY**  
 145 Charing Cross Rd, London WC2H 0EE.  
 Tel. 01-437 0699  
 Please indicate classification required.

Name .....  
 Address .....  
 .....  
 Tel.No.(Day) .....

Please place my advert in Ham Radio Today for  months. Please indicate number of insertions required.



OR Debit my Access/Barclaycard  
(Delete as necessary)



--	--	--	--	--	--	--	--	--	--	--	--	--	--	--	--	--	--	--	--

# ADVERTISEMENT INDEX

Asp Morse/Software .....	IBC
B.N.R&E.S.....	51
Gamma Aerial Products.....	44
Kw-Ten-Tec Ltd .....	OBC
Photo Acoustics Ltd .....	.20
P.M.Components .....	.33
Quartslab Marketing .....	.51
Western Electronics .....	.IFC
Wood & Douglas .....	.51
W.P.O. Communications .....	.12
Avcomm Ltd .....	Classified
PNP Communications .....	Classified
Richard Wilmot.....	Classified
Scarab Systems .....	Classified
W.H.Westlake .....	Classified
Emporium Guide.....	83,84

And don't forget, when calling an advertiser, mention Ham Radio Today, it helps them and us.

73's David Gadsden G4NXV  
 Advertisement Manager

# HAM RADIO TODAY MORSE COURSE

The most effective route yet to your Class A amateur licence!

Professionally produced for HAM RADIO TODAY by Shirley Hesketh G4HES and Ron Ray G3NCL, this advanced interactive learning system makes use of the stereo cassette format to provide tuition to the 12wpm test standard.

With its carefully designed structure, we think that the HRT MORSE COURSE is more effective than either morse classes or electronic morse generators.

Based on TWO C-60 cassettes, it offers the controlled prompting so necessary for the initial stages of morse tuition, followed by carefully paced test material to bring the student up to speed. Full tuition notes are provided with the cassettes.

To receive your MORSE COURSE simply fill in the coupon below and return it to: 'HRT MORSE COURSE', Argus Specialist Publications Ltd, No1 Golden Square London W1R 3AB



Please send me the 'HRT Morse Course' at £11.45 all inclusive of P & P and VAT. I enclose cheque/ PO for £..... (payable to ASP Ltd) OR Debit my Access/ Barclaycard (delete as necessary)

Please use BLOCK CAPITALS

Name (Mr/ Mrs/ Miss) .....

Address .....

..... Postcode .....

Signature ..... Date .....

Please allow 21 days for delivery

# TEN-TEC, INC.



OF  
THE  
USA

## THE "CORSAIR" STATION



### A NEW LEVEL OF ACHIEVEMENT IN HF AMATEUR COMMUNICATION

#### The refinements:

- 10-160M with new bands
- SSB/CW
- 200 Watts input
- Full break-in on CW
- Built in speech processor
- Noise blanker
- Built in speaker
- Variable notch filter
- Passband tuning
- Low noise pre-amp
- Dual speed QSK
- 5 function meter
- 6 digit, 2 colour counter
- Compression loaded speaker and a full range of accessories
- PSU
- Desk mic
- Paddle heyers
- ATUs
- PSU/Speaker

**THE STATESIDE SUCCESS — Corsair HF Transceiver £715 + VAT and carriage**

and now \_\_\_\_\_



## THE "ARGOSY II"

A new h.f. transceiver with unique features at a  
LOW PRICE

- QRP or 100 Watts
- 10-80 metres
- SSB / CW
- Notch filter
- Full CW break in
- Mobile/portable
- Solid state
- 3 function meter
- Built in SWR bridge
- ALCon high/low power
- Digital readout
- 9 bands
- Built in speaker

**Argosy III HF Transceiver £397 + VAT and carriage. Full range of accessories available**

Come and see the full range of this superb equipment at the only authorised UK distributor. Try the stations in our own shack and feel the quality yourself. Est. since 1955 we are probably the countrys longest serving amateur dealer with first class workshop/service facilities and friendly licensed staff to help you. Come and see our full range of amateur equipment. Components, Antennas, Kits etc.



**JUST ASK FOR: ROWLEY G8KW JOHN G3HCH or CHRIS G8GKC**

Credit terms available at 10% deposit. Write or call for full details.



# KW TEN-TEC LTD.

**Vanguard Works, Jenkins Dale,  
Chatham, Kent. Tel: 0634 815173**