

SEPTEMBER 1977 / \$1.00

# I AM RADIO HORIZONS

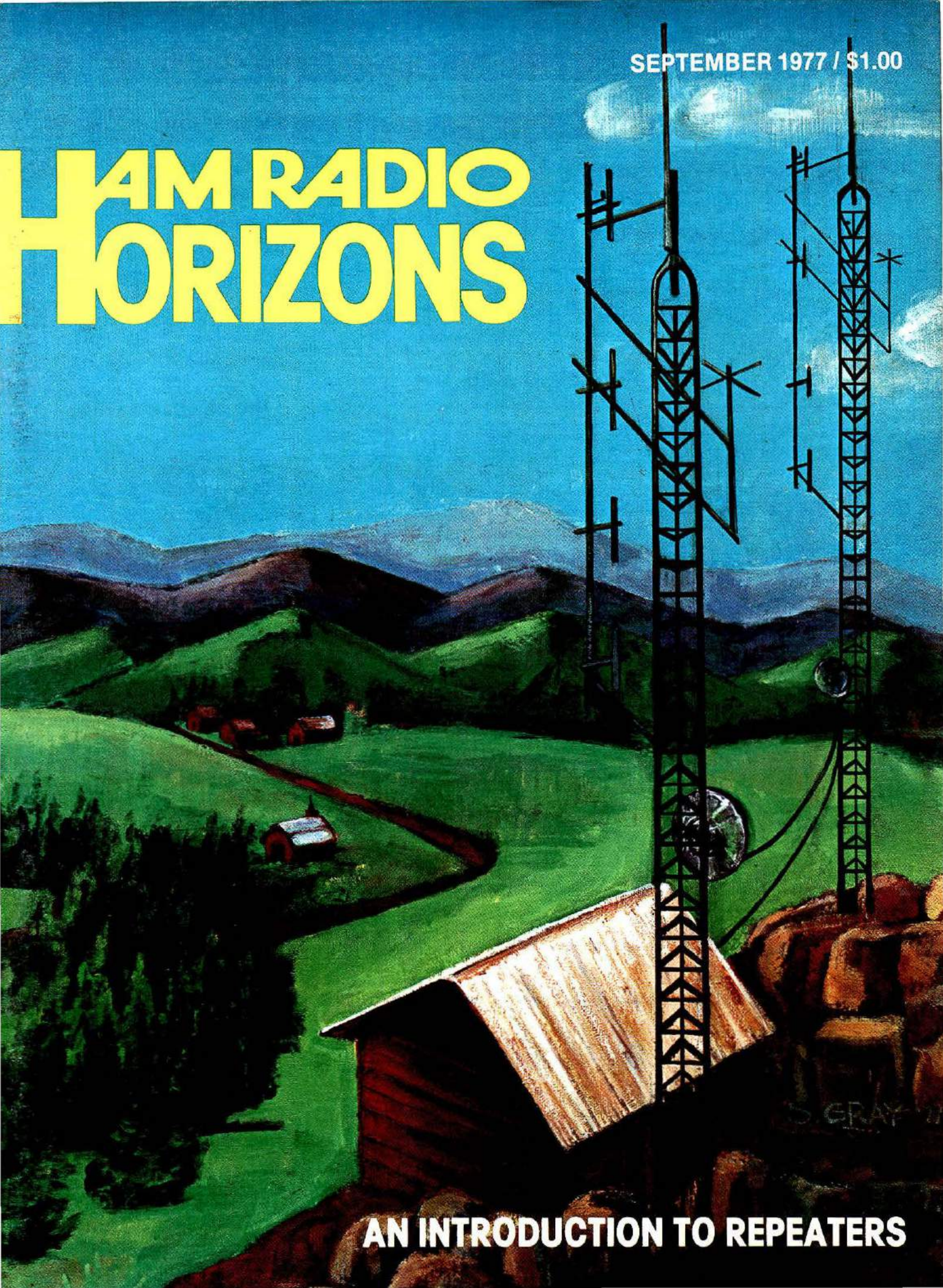

AN INTRODUCTION TO REPEATERS



# For the **SERIOUS CW/SSB OPERATOR...**

**500 Hz crystal filter  
now included**

*for extra fine cw reception—  
it's not an option*

**While operating cw, you  
may receive with either  
the 2.1 kHz or the 500 Hz  
crystal filter—**

*they are front panel selectable!*

**Full rated at 250 watts  
cw input**

*Ideal for the upgraded  
Novice/Technician class licenses*

**the TR-4Cw  
is a great  
pile-up puncher  
for DX chasing  
and contesting—**

*it runs more  
power output than  
most transceivers  
run input!*



TR-4Cw with RV-4C Remote VFO

## the **New** Drake **TR-4Cw** sideband/**cw** transceiver

The serious DX chaser, contester, and traffic handler knows the value of power when the going gets rough in heavy QRM. He also knows the value of sharp receiving selectivity to pull the other guy through the roar.

The NEW Drake TR-4Cw is a great combination of transmit power and receive selectivity. It runs 300 watts PEP input on ssb, and 260 watts input on cw. It is very conservatively rated at these power levels.

When transmitting cw, you're not "locked" into the cw receiving filter as in some rigs. You have your choice of either filter—they're front panel selectable. The cw filter is standard—not an option.

**Drake TR-4Cw, Ssb/Cw Transceiver**  
**Drake AC-4, Ac Supply**  
**Drake DC-4, Dc Supply**  
**Drake RV-4C, Remote VFO**  
**Drake 34PNB, Noise Blanker**



To receive a **FREE** Drake  
Full Line Catalog, please send  
name and date of this publication to

**R. L. DRAKE COMPANY**



540 Richard St., Miamisburg, Ohio 45342  
Phone: (513) 866-2421 • Telex: 288-017

Western Sales and Service Center, 2020 Western Street, Las Vegas, Nevada 89102 • 702/382-9470



# Call 1-800-633-3410 for Kenwood\*

\*YAESU, DRAKE, ICOM, CDE, HYGAIN, CUSHCRAFT, NPC, TPL, TRISTAO, NEWTRONICS, DENTRON, REGENCY, ROHN, WILSON, TEN-TEC, MCM & MFJ

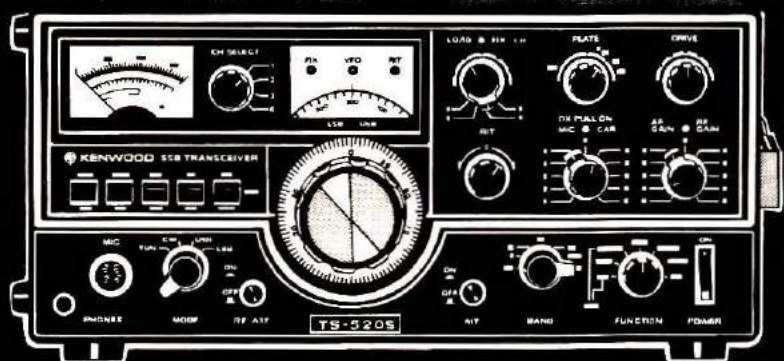

## DG-5 digital display unit

DG-5 • Has rear-panel connectors • 6-digit display (LED) • Mixes the carrier, VFO, & heterodyne frequencies • Display hold.

**179.00** list price. Call for quote.



## Introducing the Kenwood TS-520S SSB transceiver...

**649.00** is list price. Call for quote.

The new TS-520S is the up-dated successor to the TS-520. It has these exciting new features: 160 thru 10 meter coverage • Provisions for connecting the DG-5 (optional) digital frequency display • New speech processor with audio compression amplifier • Vernier tuning on PLATE control • Final amplifier with S-2001A tubes for long life & superb linearity • Built-in AC power supply (DS-1A DC-DC converter, optional) • RF attenuator, front panel activated • Provision for separate receive antenna • Plus all other great features of the TS-520!



### KENWOOD TR-7500 2m FM transceiver, available soon!

Features: • PLL synthesized • 100 channels (88 pre-programmed) • 12 extra programmable channels • Single knob channel selection • 2-digit LED frequency display • Powered tone pad connection • Helical resonators in receiver • Plus much more.

**Price to be announced...**

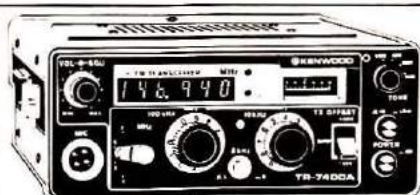

### KENWOOD TR-7400A 2m FM transceiver

Features: • CTCSS provisions, encode and decode • 25 watt output RF • Solid-state final stage • LED readout • PLL gives 800 discrete channels • Repeater offset circuit • PLL unlock protection circuit • MOS FET.

**399.00** list price. Call for quote.



### KENWOOD TR-2200A 2m FM transceiver

Features: • Solid-state construction • 2 watts HI, 0.4 watts LOW output • 12 fixed channels (6 supplied) • ¼ wave telescoping antenna • Rechargeable Ni-Cad batteries • Lighted channel indicators • Hand-held microphone.

**229.95** list price. Call for quote.

Remember, you can call TOLL-FREE: 1-800-633-3410 in U.S.A. or call 1-800-292-8668 in Alabama for our low price quote. Hours: 8:30 a.m. to 5:30 p.m., Monday thru Friday.



# Long's Electronics





# THIS MONTH'S

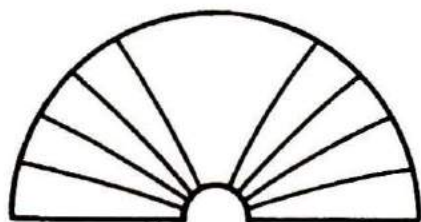

# HORIZONS

## Repeaters

A traveler's companion, a public-service tool, a club project, a vhf operator's dream machine: Whatever you call them, repeaters are a fascinating part of the Amateur's world. Author Patton talks about a few of the things they can do for you, and how you can join the thousands who use these hilltop "machines" every day.

## The Secret Society

"What do you do when you've worked them all?" is a question in the same category as "What do you give a man who has everything?" It could be that there is more than a smattering of truth in what Author Blasi has to say about old DXers who never die.

## Questions? — And Answers!

We promised to help you on the way to getting your Amateur

license and here is another step in that direction. W1SL digs into the questions and explains the material behind the answers. The idea is that when you understand the reason for the question, the answers should be that much easier to remember.

## Show Off Your Hamshack

Some of the Amateur stations in the olden days deserved to be hidden in the attic or basement, for both safety and aesthetic reasons. The neat, compact, colorful equipment available today lends itself to being an integral part of your home. Now is the time to take ham radio from under the bushel basket and tell the world that you are a doer, not a dreamer.

## Old-Time Broadcasting

In the old days, broadcast stations were not the glass and glitter that we've become accustomed to today. Bob Baird tells us how it was in 1934.

## Time, And Time Again

Perhaps the most widely used, least understood — and perhaps least thought about — *free* services provided by the governments of technically advanced nations are the standard time services broadcast on internationally agreed-upon frequencies and receivable anywhere in the world.

## How To Pass . . .

Most of us have felt the sinking sensations that accompany lack of preparation when the moment of truth is at hand. If you want to avoid sleepless nights, sweaty hands and clammy feet, let Dee Logan tell you how it was to face the FCC examiner . . . and heed his words of wisdom.

## Star Light DX

Good DXers are made, not born. As with any human endeavor, practice and experience improve your DX-ability, but there are tricks of the trade, too. Listen as Bob Locher, W9KNI, passes on some hints that he learned the hard way while becoming one of the top DXers in the land. Knowing the tricks doesn't guarantee that you'll work them all, but it will give you a good start.

**HAM RADIO HORIZONS** September 1977, Volume 1, No. 7. Published monthly by Communications Technology, Inc., Greenville, New Hampshire 03048. One-year subscription rate, \$10.00; three-year subscription rate, \$24.00. Second-class postage paid at Greenville, New Hampshire 03048 and additional offices.



# This NEW MFJ Super Antenna Tuner . . .

matches everything from 160 thru 10 Meters: dipoles, inverted vees, random wires, verticals, mobile whips, beams, balance lines, coax lines. Up to 200 watts RF OUTPUT. Built-in balun, too!

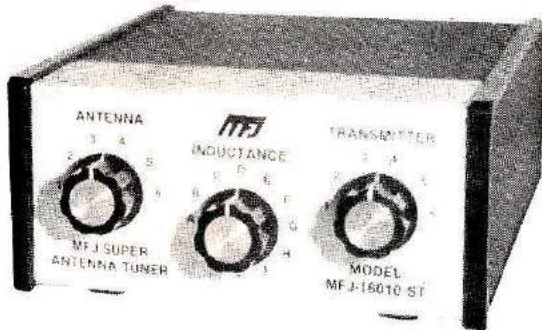

# \$ 69<sup>95</sup>

With the **NEW MFJ Super Antenna Tuner** you can run your full transceiver power output — up to 200 watts RF power output — and match your transmitter to **any** feedline from 160 thru 10 Meters whether you have coax cable, balance line, or random wire.

You can tune out the **SWR** on your dipole, inverted vee, random wire, vertical, mobile whip, beam, quad, or whatever you have.

You can even operate all bands with just one existing antenna. No need to put up separate antennas for each band.

Increase the usable bandwidth of your mobile whip by tuning out the **SWR** from inside your car. Works great with all solid state rigs (like the Atlas) and with all tube type rigs.

It travels well, too. Its ultra compact size 5x2x6 inches fits easily in a small corner of your suitcase.

The secret of this tiny, powerful tuner is a wide range 12 position variable inductor made from two stacked toroid cores and high quality capacitors manufactured especially for MFJ. For balanced lines a 1:4 (unbalanced to balanced) balun is built in. Made in U.S.A. by MFJ Enterprises.

This beautiful little tuner is housed in a deluxe eggshell white Ten-Tec enclosure with walnut grain sides.

SO-239 coax connectors are provided for transmitter input and coax fed antennas. Quality five way binding posts are used for the balance line inputs (2), random wire input (1), and ground (1).

Try it — no obligation. If not delighted, return

it within 30 days for a refund (less shipping). This tuner is unconditionally guaranteed for one year.

To order, simply call us toll-free 800-647-8660 and charge it on your BankAmericard or Master Charge or mail us an order with a check or money order for \$69.95 plus \$2.00 shipping/handling for the MFJ-16010ST Super Antenna Tuner.

Don't wait any longer to tune out that SWR and enjoy solid QSO's. Order today.

## MFJ ENTERPRISES

P. O. BOX 494 H

MISSISSIPPI STATE, MS. 39762

CALL TOLL FREE. . 800-647-8660

**\*\* Please mention HORIZONS when you call \*\***

# This NEW MFJ Deluxe Keyer at \$69.95 . . .

gives you more features per dollar than any other keyer available.

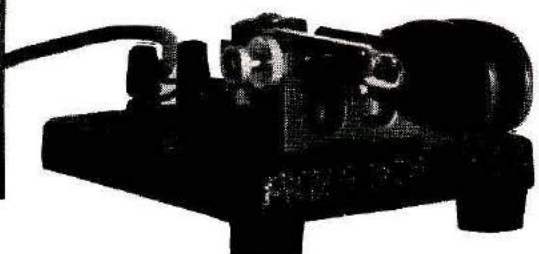
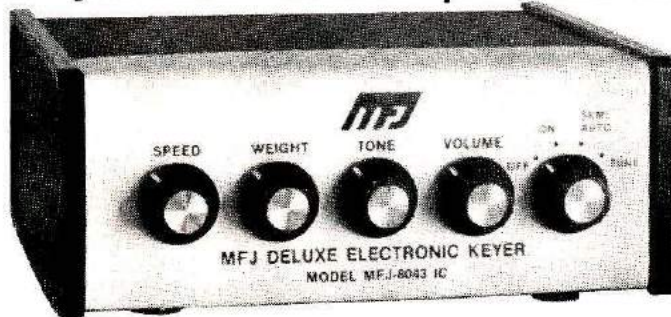

Based on the Curtis 8043 IC keyer-on-a-chip, the new MFJ Deluxe Keyer gives you more features per dollar than any other keyer available.

Sends iambic, automatic, semi-automatic, manual. Use squeeze, single lever or straight key.

Iambic squeeze key operation with dot and dash insertion lets you form characters with minimal wrist movement for comfortable, fatigue-free sending.

Semi-automatic "bug" operation provides automatic dots and manual dashes. Use a manual straight key to safely key your transmitter or to improve your list.

Dot memory, self-completing dots and dashes, jam-proof spacing and instant start for accurate and precise CW.

Totally RF proof. No problems, whatever.

Ultra-reliable solid-state keying. Keys virtually any transmitter: grid block, —300V max., 10 ma, max.; cathode and solid state transmitters +300V max., 200 ma, max.

All controls are on the front panel: speed, weight, tone, volume, function switch. Smooth linear speed control. 8 to 50 WPM.

Weight control lets you adjust dot dash space ratio; makes your signal distinctive to penetrate thru heavy QRM for solid DX contacts.

Tone control. Room filling volume. Built-in speaker. Ideal for classroom teaching.

Function switch selects off, on, semi-automatic/manual, tune. Tune keys xmtr for tuning.

Completely portable. Take it anywhere. Operates up to a year on 4 C-cells. Miniature phone jack for external power (3 to 15 VDC).

Beautiful Ten Tec enclosure. Eggshell white, walnut sides. Compact 6x6x2 inches.

Three conductor quarter-inch phone jack for key, phone jacks for keying outputs.

Optional squeeze key. Dot and dash paddles have fully adjustable tension and spacing for the exact "feel" you like. Heavy base with non-slip rubber feet

eliminates "walking". \$29.95 plus \$2.00 for shipping and handling.

Try it—no obligation. If not delighted, return it within 30 days for a refund (less shipping). This keyer is unconditionally guaranteed for one year.

To order, simply call us toll-free 800-647-8660 and charge it on your BankAmericard or Master Charge or mail us an order with a check or money order for \$69.95 plus \$2.00 shipping/handling for the MFJ-8043 keyer and/or \$29.95 plus \$2.00 shipping/handling for the squeeze key.

Don't wait any longer to enjoy the pleasures of the new MFJ Deluxe Keyer. Order today.

## MFJ ENTERPRISES

P. O. BOX 494 H

MISSISSIPPI STATE, MS. 39762

CALL TOLL FREE. . 800-647-8660



# ATB-34

## THE COMPLETE 3 BAND ANTENNA

BY

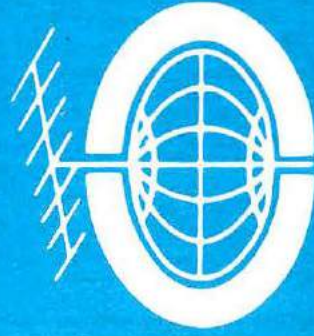

# Cushcraft

**IN STOCK WITH YOUR LOCAL DEALER**

**IN CANADA:**

SCOTCOMM RADIO LTD. - 4643 Levesque Blvd. - Chomedey, Laval, Quebec

**WORLDWIDE:**

MAGNUS - 5715 North Lincoln Ave. - Chicago, Ill., U. S. A. 60659

CORPORATION

P. O. BOX 4680, MANCHESTER, N. H. 03108



September, 1977  
Volume 1, Number 7

# HAM RADIO HORIZONS

## CONTENTS

**T.H. Tenney, Jr., W1NLB**  
Publisher

**James R. Fisk, W1HR**  
Editor-in-Chief

### Editorial Staff

Thomas F. McMullen, Jr., W1SL  
Managing Editor

Patricia A. Hawes, WA1WPM  
Executive Editor

Charles J. Carroll, K1XX  
James H. Gray, W2EUQ  
Assistant Editors

### Publishing Staff

Fred D. Moller, Jr., WA1USO  
Advertising Manager

Cynthia M. Schlosser  
Assistant Advertising Manager

Therese R. Bourgault  
Circulation Manager

Ham Radio Horizons  
is published monthly by  
Communications Technology, Inc  
Greenville, New Hampshire 03048  
Telephone 603-878-1441

Subscription rates are  
\$10.00 per year, worldwide

Copyright 1977 by Communications  
Technology, Inc. Title registered  
at U.S. Patent Office

### The Cover

High hills, tall towers, good  
antennas and repeaters go  
together in a new way of life  
for mobile amateurs. An  
introduction starts on page 12.  
Original oil painting by  
Sandra Gray

**Introduction to Repeaters 12**

Gerald R. Patton, WA3VUP

**The Secret Society 24**

Dr. J. Michael Blasi, W4NXD

**Those Exam Questions? And Answers! 27**

Thomas F. McMullen, W1SL

**Be Proud of Your Hamshack 32**

Charlene Babb Knadle, WB2HJD

**Early Day Broadcasting 34**

Robert Baird, W7CSD

**Time Signals and Stations 42**

James H. Gray, W2EUQ

**Pass Your General Class Exam 56**

Devere Logan, W1HEO

**Starlight DX 62**

Robert C. Locher, W9KNI

**1977 Sweepstakes Winners 70**

T. H. Tenney, W1NLB

**Activities Calendar 76**

**Ad Check 78**

**Ad Scan 77**

**Advertiser's Index 78**

**DX Forecaster 74**

**Focus and Comment 8**

**Newsline 11**

**Product Showcase 72**

**Propagation Chart 75**

**The View from Here 6**

**This Month's Horizons 2**



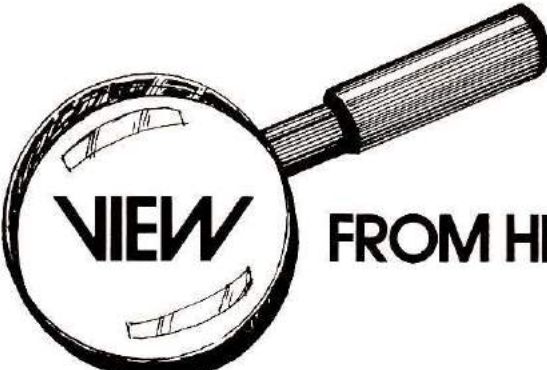

## THE VIEW FROM HERE

At one time or another I suppose most amateurs have wondered why our diodes and transistors are numbered as they are with 1N, 2N and 3N numbers. To the newcomer, it must look like a meaningless bunch of random numbers — and it isn't a great deal more to the oldtimer! Receiving-tube numbers follow certain guidelines, as do many transmitting tubes, so what happened to solid state? To say that it is a numbering system that grew on us isn't too far from wrong — but that's getting ahead of the story.

During the early days of radio, each vacuum-tube manufacturer numbered his tubes as he saw fit. When there were only a few tube types available — with very little difference in their characteristics — this was no great problem. In fact, if you look in any of the pre-1930s radio books, you'll see that none of the circuits specify what tube to use; it didn't make that much difference.

With the invention of the tetrode and pentode, and the introduction of tubes with vastly different characteristics, however, the problem became pretty sticky. The replacement problem was particularly bad, so in 1933 the industry voluntarily adopted a numbering system that called for a number, a letter and another number. The first number denoted the filament voltage range, the middle letter was a serial designation, and the last number indicated the number of useful elements for which terminals were provided (including internal shield and shell connections). The 2A3, for example, was a three-element (triode) tube with a 2-volt filament; the 6E6 was a double triode with a 6-volt filament. This is pretty much the system still in use today.

Transmitting tubes didn't run into the standardization bugbear until 1942. With the war, and the great number of tube types being manufactured, a standard number-letter-number system was adopted for transmitting and special-purpose tubes. Examples of devices assigned numbers from this system are the 1N21, 2C39, 2E26, and 3E29. The first number indicated the power rating of the heater: 1 for zero power, 2 for up to 10 watts, 3 for up to 20 watts, and so on. The letter indicated the structure or function: B for diodes, C for triodes, D for tetrodes, E for pentodes, N for crystal diodes and rectifiers, etc. The final number was a serial designation, started at 21 to avoid conflict with the receiving-tube system.

Except for the use of 1N for semiconductor diodes, this system was scrapped in 1946 for a purely numerical system starting at 5500. Although several manufacturers wanted a numbering system for diodes (and later transistors) that told the user more about the device than a simple serial system, none was ever agreed upon. In the meantime, the system we use today kept growing. The first digit came to indicate the number of elements minus one — thus a 1N34A is a diode, a 2N706 is a triode, and a 3N159 is a tetrode; the N indicates a solid-state device, and the last number is the order of registration.

This brings up another question — who decides precisely what number will be assigned to a particular transistor or IC? The answer is an industry sponsored committee that registers all new transistors (and vacuum tubes), assigning the next open number in the system. If the system doesn't make much sense to you, don't feel too badly; a number of professional groups in the past have tried to put some meaning into it, but without a great deal of success. The big argument against any new numbering system at this point concerns the great number of solid-state devices already on the books — making any new numbering system impractical.

**Jim Fisk, W1HR**  
editor-in-chief



ICOM wants you to

# Begin with the Best

As you develop your skills, increase your participation in Ham Radio activities, and add hardware for ever-increasing flexibility of operations, you'll come to know ICOM. Just ask any old Ham. ICOM is the quality name in VHF/UHF Amateur Radio equipment because it is simply the best. ICOM is the line you'll want to move up to for unequalled quality and features.

But you needn't wait until you can trade in a truck load of equipment to reach up to ICOM. You can begin building your Amateur Radio operations with reasonably priced ICOM units that have flexible add-on features when you purchase your very first voice transceiver. And when you are installing ICOM's top-of-the-line fixed station unit, the ICOM equipment you began with will probably still be an important integral part of your active hardware.

Don't delay in moving up to ICOM: begin with the best.



Clockwise from lower left: IC-211 4MHz, 2 meter, All Mode Transceiver; IC-245 Mobile 2 meter Transceiver; IC-22S Mobile VHF FM Transceiver; IC-502 Portable 50 MHz SSB Transceiver; IC-215 Portable 2 meter FM Transceiver; IC-30A Mobile UHF FM Transceiver.

Ask your dealer for ICOM's complete product line catalog, or mail your request to an address below.

VHF/UHF AMATEUR AND MARINE COMMUNICATION EQUIPMENT

Distributed by:



# ICOM

ICOM WEST, INC.  
Suite 3  
13256 Northrup Way  
Bellevue, Wash. 98005  
(206) 747-9020

ICOM EAST, INC.  
Suite 307  
3331 Towerwood Drive  
Dallas, Texas 75234  
(214) 620-2780

ICOM CANADA  
7087 Victoria Drive  
Vancouver B.C. V5P 3Y9  
Canada  
(604) 321-1833



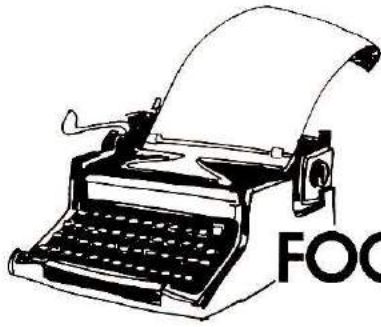

## FOCUS & COMMENT

This code thing seems to be a great hangup with a lot of would-be amateurs. Reports from FCC Field Office people indicate that less than half of those taking their amateur examinations pass the code test — often the success rate is nearer 30 per cent.

That's a shame, because there are so many aids available to those who want to learn. There are more firms marketing code-practice tapes and oscillators, more books telling you how to do it, and more magazine articles that offer encouragement and advice. Additionally, there are more clubs offering code and theory classes to help the beginner; he never had it so good.

What, then, is holding the numbers down? Is there a technique to teaching/learning that most instructors have not yet discovered? With such a great range of talent and experience available in amateur radio, the variations on the code-learning theme should be almost endless.

Or could it be that there are just too many things to do these days — things that distract and detract the beginner from the absolutely essential time and concentration needed to learn a new language. (That's all code is, really, a method of speaking that uses sounds different from those we learned for voice communication.) TV sets offer exciting movies in an effort to get your attention; there's something doing at the school; the family plans for a picnic, camping trip, weekend guests, or whatever, do not include time for listening to the dit-dahs. The list of other activities is long, and growing all the time.

There's nothing we at *Horizons* can do about the distractions, but we can try to help you get your priorities arranged. You need incentive, and the incentive we can offer is to tell you how great the world of amateur radio is once you are in it. Most of the contents of *Horizons* is designed to do just that. Imagine sitting in the heat of summer in Ohio or Missouri and listening to a station near the South Pole while you have your morning coffee or orange juice. How about listening to the only radio operator on a remote Pacific island chat for an hour with a radio friend in Indiana. These thrilling things are for real; I heard both of these distant amateurs just the other day, and I was using a rig built from a kit, and the simplest of antennas — a dipole. The stories we have planned for *Horizons* will tell you more of the exciting things that can be done with amateur radio.

There are several articles about learning the code waiting to be put into print. It seems that there are as many ways of teaching code as there are instructors for the classes. A slightly different slant to something will often reach someone who had trouble getting the point before; we'll try several in the hope that one will make sense to you.

Perhaps we should find out which clubs have an unusually high success rate, and ask them to tell the rest of the world how they do it. But, in the final analysis, it is up to you. You have to find the time and provide the will power. Summertime distractions and activities will soon be over, and you'll be settling back into the normal fall routine of school, work, housekeeping, or whatever. Put aside a few minutes somewhere in the day. There is still time to give yourself a great Christmas present — a new amateur license.

**Thomas McMullen, W1SL**  
Managing Editor



# SERVING HAMS BETTER

NORTH, SOUTH . . . EAST, WEST.  
ALL LEADING BRANDS . . . IN-DEPTH STOCKS . . . NEW/USED EQUIPMENT



**DRAKE**  
TR-4C W SSB transceiver



**YAESU**  
FT-101EE SSB transceiver



**KENWOOD**  
TS-520 SSB transceiver



**TEMPO**  
2020 SSB transceiver

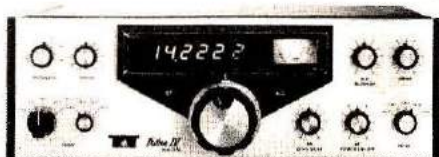

**TEN-TEC**  
Triton IV Digital SSB transceiver

## HY-GAIN TH6DXX

De Luxe, 6 element Hy-Gain Thunderbird, covers 10, 15, 20 meters. Separate low loss traps for each band. Hy-Gain Beta match for low VSWR with 50 ohm line.

Longest element: 31.1 ft.  
Boom: 24 ft.  
Turning radius: 20 ft.  
Wind load: (80 mph): 156 lbs.  
Max. wind survival: 100 mph.  
Surface area: 6.1 sq. ft.  
Net weight: 57 lbs.

*in stock*  
at  
Ham Radio Outlet



## BIRD 43

Model 43  
**THRULINE  
WATT  
METER**

0.1 - 10,000 watts.  
0.45 - 2300 MHz.

**Standard of  
the industry!**

## TRI-EX W-51 TOWER

Our "package" deals  
can't be beat!

The "package"  
antenna, tower, rotator  
*Inquire*

Every-day special  
**CDE HAM II**  
rotator  
12995



OVER THE COUNTER (Mon. thru Sat. 10AM to 5:30PM). PHONE, WRITE. SAME DAY SHIPMENT MOST ITEMS.

# HAM RADIO OUTLET

### SOUTH

Anaheim, Calif. 92801  
2620 W. La Palma, (714) 761-3033

### NORTH (Main Office)

Burlingame, Calif. 94010  
999 Howard Ave., (415) 342-5757  
5 miles south on 101 from S.F. Airport.

### SOUTH

Van Nuys, Calif. 91401  
13754 Victory Blvd., (213) 988-2212



**Bob Ferrero,**  
K6AHV/W6RJ.

Jim Rafferty,  
W9UCE/K6AAR,  
other well known hams,  
give you courteous,  
personalized service.



• ATLAS • BIRD • CDE • COLLINS • CUSHCRAFT • CURTIS • DENTRON • DRAKE • EIMAC • HUSTLER  
• HY-GAIN • ICOM • KENWOOD • KLM • MOSLEY • SWAN • TEMPO • TEN TEC • TRI-EX • YAESU • more.



# henry radio

a name that says it all

For over 40 years...dedicated to amateur radio...to offering the finest products...to dependable service.

## TEMPO 2020



A unique SSB transceiver providing an unusual combination of advanced engineering and operating features. Operates USB, LSB, CW and AM with 80 through 10 meter coverage. Some of its many features include: phase lock loop (PLL) oscillator circuit, hybrid digital frequency presentation, advanced solid-state design (only 3 tubes), built-in AC and 12 VDC power supplies, CW filter (standard), cooling fan (standard), built-in VOX and semi-break in CW keying, crystal calibrator and WWV receiving capability, dual RIT control, plus many many more.  
 Tempo 2020...\$759.00 Tempo 8120 external speaker...\$29.95 Tempo 8010 remote VFO...\$139.00

## KENWOOD



### TS-520

"The trend setter..the hottest little rig on the air." You have heard it on every band..Kenwood's go-every-where/do-everything transceiver. SSB & CW on 80 thru 10 meters, built-in AC & 12VDC power supply, VOX, RIT, noise blanker and all the other features you want. The 520's low price...\$629. Write for full description on the 520 as well as Kenwood's new TS-820 TS-700A 2-meter transceiver and the R-599D/T-599D "twins."

## Henry Radio's

## TEMPO "ONE"



... a proven name, a proven value. Look at the specifications, look at the price tag, ask any of the thousands of Tempo ONE owners about its reliability . . . and the reason for its unparalleled popularity will be obvious.

Frequency range: All amateur bands 80 through 10 meters • Operates SSB upper and lower sideband, CW and AM

The Tempo "ONE" ..... \$399.00  
 AC/one, 110-220 volt 50/60 cycle power supply ..... \$99.00  
 DC/1A, 12 volt DC power supply ..... \$120.00

## YAESU FT-101E



More radio from the radio company! Includes a potent R.F. speech processor, a refined clarifier control for pushbutton, independent clarifier operation. 160 meter crystal included. And all the other features that have made the FT-101 series of transceivers among the world's most popular are still here: 260 watts SSB PEP and globe circling power on CW and AM. 160 to 10 meters range.

The FT-101E ..... \$729.00  
 FT-101EE...\$649.00 FT-101EX...\$589.00

Now, meet Henry Radio...



Walt Henry  
W6ZN  
ANAHEIM



Ted Henry  
W6UOU  
LOS ANGELES



Bob Henry  
W0ARA  
BUTLER

Plus a large staff of highly qualified sales and service personnel pledged to serve you. Henry Radio carries large stocks of all major brands. We take trade-ins, sell used equipment and offer better terms because we carry our own financing. Our reconditioned equipment carries a 15 day trial, 90 day warranty and may be traded back within 90 days for full credit toward the purchase of new equipment. Export inquiries solicited. Also, military, commercial, industrial, and scientific users...please write for information on our custom line of high power linear amplifiers and RF power generators.

We stock the Bird Model 43 Wattmeter and accessories.

Prices subject to change without notice.

# Henry Radio

11240 W. Olympic Blvd., Los Angeles, Calif. 90064 213/477-6701  
 931 N. Euclid, Anaheim, Calif. 92801 714/772-9200  
 Butler, Missouri 64730 816/679-3127



# NEWSLINE

---

FCC DOCKET 20777, the bandwidth Docket, (June Newsline) became effective April 15th. Under the First Report and Order on Docket 20777, all Amateur transmitters had to meet the stringent harmonic and spurious radiation requirements. On June 2nd, however, the FCC modified the Report and Order, exempting all Amateur transmitters and transceivers (but not amplifiers) made prior to April 15th from the requirements, effectively "grandfathering" existing equipment. However, individual Amateurs are still responsible for meeting the specifications set forth in Docket 20777 in the operation of their own stations, even though the equipment itself was grandfathered.

FCC's June 2nd Relaxation applies only to the sale of non-complying equipment, and users are still expected to use it in such a way (with appropriate filters or antenna tuner) that their stations meet the tighter requirement. All Amateur equipment made after April 15th must meet the new specs, of course, but existing equipment made before that date can be marketed until January 1st, 1978.

18-YEAR-OLD GENERAL CLASS, or higher, Amateur license holders will be permitted to administer Novice exams effective June 13th. The amendment to Section 97.28 (b) of the rules came about as a result of a Petition for Rule Making filed by WB4EKC.

ANOTHER RESCUE AT SEA was accomplished with Amateur Radio help after the German motor-sailer See Loewe (Sea Lion) went aground at 22°46.5'N., 73°51'W. June 9th. Captain Koehler of the See Loewe appeared on 14212 kHz and picked up FG0DDV/FS7, the North Jersey DXpedition to St. Martin, with W2DIE at the mike. Coast Guard stations in Honolulu and Miami were alerted and came up on frequency, along with the Cutter Diligence and — as dawn approached — Coast Guard aircraft 7218.

The See Loewe, apparently aground near Crooked Island in the Southern Bahamas, reported her prop gone and hull holed. FG0DDV/FS7 held the frequency through the night, serving as the relay between the stricken vessel and the various Coast Guard stations, until the operation was secured.

THE AO-D SATELLITE'S LAUNCH date has officially been set back to February 15th and could slip even a month or so longer. The Amateur spacecraft is rapidly approaching completion, with the battery-charge regulator due from Germany momentarily and an improved final transponder package coming from Japan by late summer. No problem is expected in meeting the new launch date.

THE BOY SCOUTS RECEIVED a complete portable Mode A and B OSCAR satellite terminal from COMSAT Laboratories in ceremonies June 6th. The station, built by the COMSAT Radio Club, will be kept in Geneva and used at Boy Scout activities worldwide. OSCAR 7 was put on Mode B for much of the day for the event.

Moscow's Central Radio Club has "no information" about a future Russian Amateur satellite, in response to TU2EF's question relayed by UK9AAN — but said they might know more in October!

AIRBORNE VHF/UHF "DXPEDITION" over California is planned for Saturday, September 17th. Operation on 2 meters through 10 GHz, plus ATV and OSCAR is scheduled. Details from WA6YOB.

OPERATORS OF "CLASSIC" RADIOS are invited to participate in the Fall Classic Radio Exchange September 25th. Phone and CW operators will call "CQ Exchange" or "CQ CX." Write K8SJ.

EXTENSIVE ELECTRONIC CONTROLS used in 1977 autos are causing RFI problems — a recent Illinois Bell notice warned that the "cruise control" in 1977 Cadillacs (and presumably other GM cars) is sensitive to strong RF fields, which could cause sudden speed up or slow down. Some electronic skid control braking systems have locked up from RFI, and complete engine failure in fuel-injected engines has been reported by two-meter vhf-fm operators.

RADIO CONTROL ENTHUSIASTS should apply for their own Class-C CB licenses instead of operating with a "blanket" club license, suggests the Cleveland Radio Control Airs. The group says a Class-D push to give them Class-C channels is based on the low number of Class-C licensees.

ICOM'S NEW HF TRANSCEIVER, the IC-701, made its debut at the ARRL National Convention in June. It's a compact, all-solid-state 160-10 meter transceiver, synthesized in 100-Hz steps with digital readout. Price (with accessories) is likely to be in the \$1500 range, with delivery around the year's end.



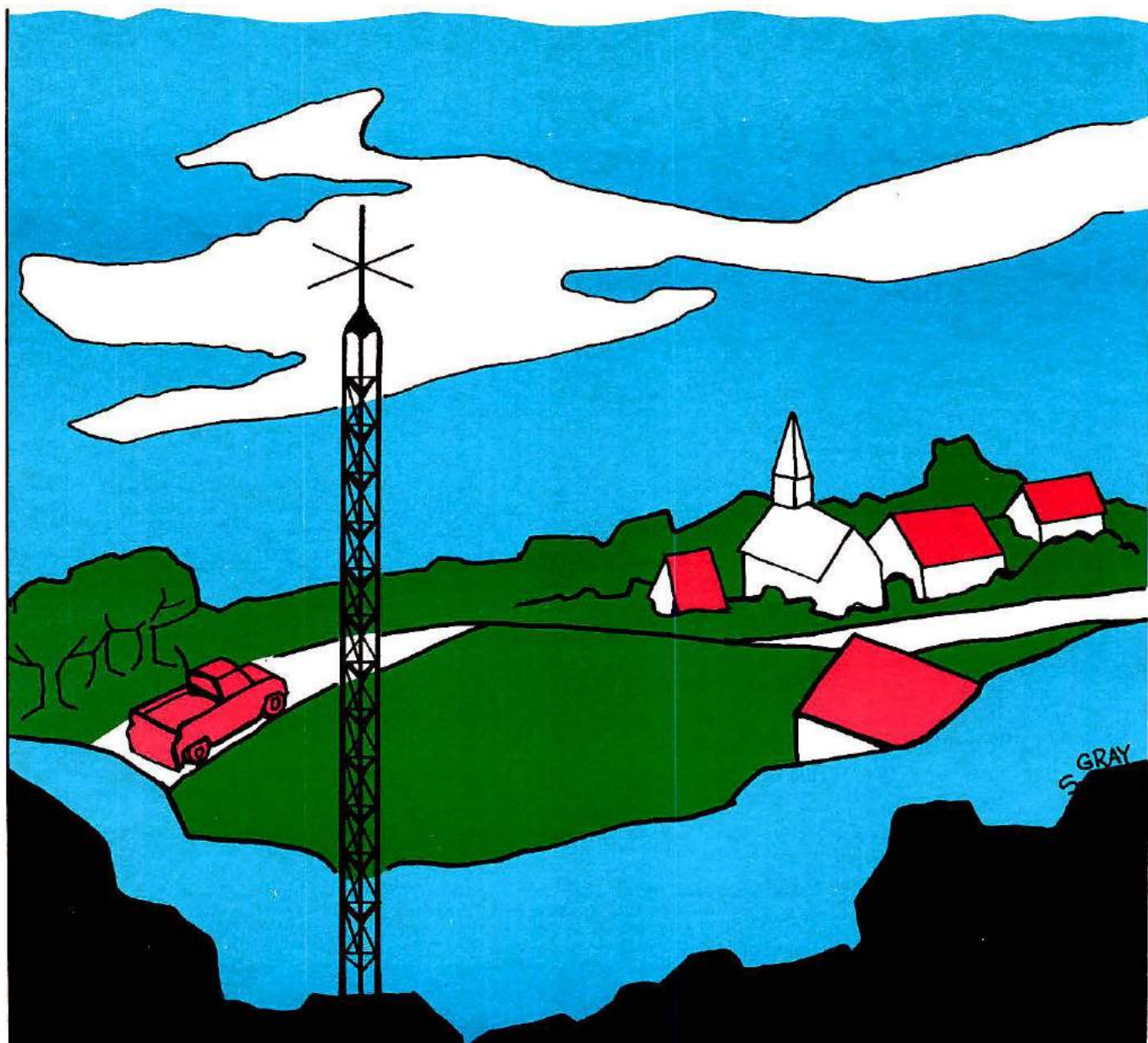

## Repeaters — A Companion In Your Travels . . .

*A wireless extension cord to get your signal to distant places*

BY GERALD R. PATTON, WA3VUP

It's a cold, rainy, windswept night. The temperature is near freezing as Len is wending his way homeward at 1:30 AM; he has just gotten off second shift at the machine shop. There is a two-meter transceiver under the dash of his car but it is quiet — not many people are up at this hour. Sensitive to the sound and feel of the road under his tires — he has been over this road during this season of sudden temperature changes before — he eases up on the speed a bit at the first hint of icing. Over the crest of a hill, just starting down, and the headlights brighten a scene that brings his heart to his throat: A tractor-trailer has just jack-knifed and turned on its side, blocking the roadway; one set of dual wheels is still spinning slowly.



Len silently offered thanks that he had slackened his speed, and was able to steer safely to the shoulder of the road to miss the massive trailer. From the corner of his eye he saw the driver struggling to open the heavy door to climb out of the battered cab. "Good, he's okay, but there'll be a flock of cars along here soon when the second shift from that electronics plant heads homeward." While Len is thinking about the cars, he is already reaching for the microphone. "Anyone monitoring? This is WB8 — with urgent traffic." The

repeater carrier silences his receiver — then identifies, "de WR8ZZZ." More quiet; a *pssst* as the repeater ceases to transmit; then it's quiet again. "Hmmm . . . everyone must be really conked out after a good movie on TV this evening. Let's try the Leaning Hills machine." A quick "click-click" of the switches on the rig; hit the mike button — again the rhythmic code spelling out the repeater call . . . "Ah, good! WR8XXX, this is WB8-- autopatch with an emergency." A quick touch of a button on the front of his transceiver brings a familiar dial-tone buzz in response. "Blip-bleep-bleep"

for the universal 911 emergency number. "I'm glad the Leaning Hills crew installed that; it sure beats trying to explain to a sleepy telephone operator what ham radio is." "Emergency dispatch." "Hello, I'm an Amateur Radio operator calling to report an accident. Over." "Yes, sir, what is your location?" "State highway 27, approximately 1 mile north of Seven Lakes road. Over" "What is the nature of the accident?"

In short order the information is passed along to the efficient dispatcher. He understood about Amateurs and repeaters: The Leaning Hills Repeater Association had done their public relations work well, and the county sheriff had welcomed the chance to augment the coverage of the vast rural area that he had jurisdiction over. Len turned the volume up loud, left the window down so he could hear any call, and ran back to see how the trucker was making out.

"You okay? I just called in a report and the Sheriff's Patrol will be here in just a few minutes." "Yeah, kinda shaky, and I think I lost a tooth, but I'll make it." "Right! Take it easy, but give me a couple flares to stick up on top of the hill — the next guy along might not know the road enough to stay out of trouble."

Flares set, Len and the trucker sat in the car to keep warm, and perhaps to dry out a bit from the wind-driven stuff that lingered between solid and liquid. "Hey, how'd you get a report in? My CB set has been dead for the last half hour — couldn't raise anyone."

"Yeah, it's a lonely piece of road this night for sure, but this is a ham radio set and we use repeaters." "You use what?"

The explanation continued for some minutes until the flashing blue lights heralded

### Glossary of Terms

**Autopatch** is a term used by fm and repeater operators to refer to the automatic connecting of their repeater to the telephone lines by means of a phone-patch system. The term phone-patch comes from the days when radio stations (broadcast, short-wave, and message services) could connect the transmitter and receiver to the telephone lines by means of a patch cord at the control location. Now, such connections are made by means of relays that can be activated by remote control, as from your car or from a handheld transceiver with the proper tone-code devices attached.

**COR** (Carrier Operated Relay) is a switch, either mechanical or solid-state, that turns on a transmitter when the associated receiver senses a received signal (carrier). When the carrier is no longer present, the COR shuts the transmitter off.

**Duplexer** is a series of highly selective tuned circuits, usually cavities made of copper or brass, that will pass a signal at one frequency while rejecting that at a nearby frequency. The duplexer thus separates the incoming signal for the receiver from the outgoing one from the transmitter, and allows both the receiver and transmitter to be connected to the antenna system at the same time without the need for a switching relay.

**Frequency pairs** are needed for repeater operation because, at the moment, it is not practical to have the transmitter and receiver both operating on exactly the same frequency. The receiver (input) and transmitter (output) are separated by an agreed-upon number of kHz or MHz, and this "standard" is in general use nationwide for the convenience of the operators.

**Simplex** means that two Amateurs talk directly to each other, without the use of a repeater. The term stems from commercial practices and definitions wherein with simplex only one station could transmit at a time, and had to pause while the other party replied. In duplex operation, both can transmit at the same time, and both can hear the other at the same time, just as you do in ordinary face-to-face or telephone conversation.

**Squelch** is a circuit that silences your receiver when nothing is being received. A receiver that has no squelch usually emits a rushing, hissing noise from the speaker or headphones when there is no signal present at the input. The presence of a carrier (signal) causes the hiss to change, and this *change* is detected and used to turn on the quiet (squelched) audio stages of the receiver.



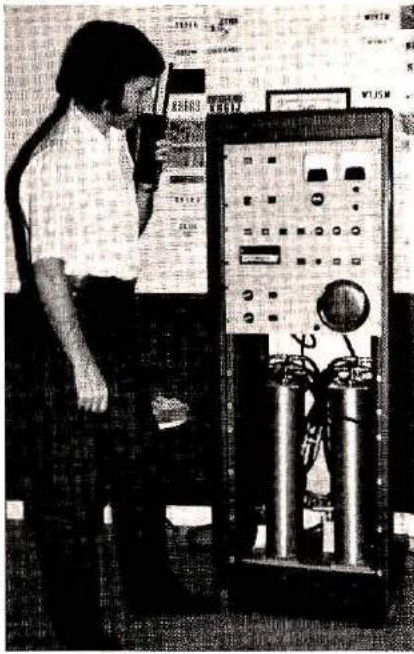

Repeaters are complex receiving and transmitting stations that permit signals from low-power units, such as hand-held or mobile transceivers, to be boosted and retransmitted over great distances. Because of the complexity and expense, most repeaters are maintained by a club of amateurs who are willing to provide a service for their fellow hams. Here Joe, K3OBU, checks the operation of the repeater installation at WR3ABZ just after final assembly. The WR prefix is currently being used to designate a repeater station (photo courtesy K3OBU).

the arrival of the Sheriff's deputy. The situation in competent hands, Len waved to the two figures standing by the cruiser, and eased back to the icy pavement to continue his way toward the warm bed that he had been looking forward to from the moment he punched the clock at the end of his shift.

Unreal? Unusual? Not particularly. Thousands of repeaters listen around the clock. Hundreds of Amateurs use them to handle communications for emergency situations every week.

Another town, another climate . . . a familiar transceiver and again a sequence of tones, longer this time. No dial tone is heard to indicate a connection to the public communications system. This is obviously a planned group of numbers to activate

some electronic machinery. "This is W4--- starting a test of the Citrus Coast emergency network. Stations please."

"WB4---, Little Bayou."  
 "WA5---, Flats Landing."  
 "WA5---, . . ."

The check-in process continues and the operator smiles. The hurricane season is starting and it is nice to know that if one comes thundering across the Gulf the whole coast will have a communications system at the ready. It took months of planning and more months of midnight and weekend oil to get the repeaters linked and iron the lumps out of the control system. Each voice that answers is from a control station for an Amateur repeater that covers a segment of the coast. No matter where "ground zero" happens to be, the entire five-state network will be ready to send help through its tie-in with the Civil Defense and American Red Cross agencies concerned.

So a repeater is great for emergencies and public service work, but what can it do for you? Listen a little longer . . .

Imagine sitting back in your easy chair, picking up your two-watt handheld transceiver, hearing no interference whatever, and contacting a friend using a similar unit fifty miles away. Does this sound like an impossible dream? It would if you're familiar only with Citizens-Band operation and have not had the opportunity to listen to Amateur radio repeater stations on your public-service band monitor or

scanner. However, to the average Amateur operator this type of interference-free contact is commonplace. Want to know more? Great! Here is a brief introduction to the fantastic world of ham operated repeaters.

### What is a repeater?

Our two ham friends are able to talk to each other just as I described, but the thing that makes it all possible is the repeater station, often called a "machine." A repeater is simply a station that receives relatively weak signals from individual amateur stations, whether fixed-location (base), mobile, or handheld, on one frequency, and re-transmits these signals on another, nearby frequency. Because these transmissions occur on frequencies in the vhf (very high frequency) or uhf (ultra high frequency) parts of the radio spectrum, where signals travel essentially line of sight, the higher above the local terrain the repeater is located, the better its coverage area will be.

There is nothing mysterious or magical about the operation of a repeater, although its effects frequently amaze even long-time repeater users. The basic major components of a repeater are a receiver, transmitter, carrier-operated relay (COR), duplexer, and antenna system. The receiver, of course, picks up the signals from the individual stations. The signal opening the squelch of the receiver causes the COR to turn on the transmitter of the

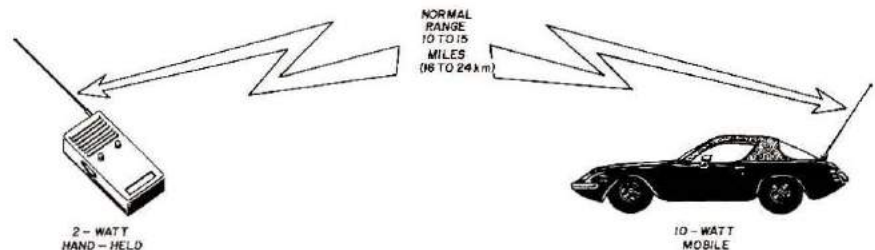

Fig. 1. The normal range between two low-powered vhf transceivers is not very great. If one or both units can be located on a very high hill or building, the range can be extended. Conversely, poor locations, such as among tall buildings or between hills, can restrict the range to 5 miles (8km) or less.



repeater. The audio from the receiver is fed into the transmitter and is broadcast on the transmitter frequency. When a duplexer (resonant-cavity device) is part of the system, the same antenna is used simultaneously for both reception and transmission. When a duplexer is not used, two antennas, physically separated as far as possible, are needed to perform these functions.

From time to time you may hear "alligators" and "rabbits" mentioned on your local repeater. Far from meaning that the repeater site has been invaded by alligators or overrun by rabbits, these are terms used to describe a repeater that talks better than it hears (big mouth and little ears), or one that receives signals from much more distant locations than it can reach with its transmitter (big ears and little mouth).

Most, though by no means all, repeater operation takes place on the upper half of the amateur two-meter band, from 146 to 148 MHz. This section of the band is divided into standard-frequency pairs — one for receive and one for

transmit — for repeater operation; in addition, several frequencies are reserved for simplex (direct, unit to unit, without a repeater) operation (see **Table 1**). This band is over five times higher in frequency than Citizens Band, but an important difference is in the mode of emissions. Whereas CB transmissions use either a-m or ssb, amateur repeater operation uses fm. This is significant because fm is inherently immune from many types of interference, such as ignition noise and static, which plague a-m and ssb receivers. Two a-m signals received simultaneously produce howling heterodyne noises; when the same situation occurs with fm signals, the stronger signal merely "captures" the receiver, and the weaker signal is not even heard.

#### Public service

There are now more than 2000 licensed amateur repeaters operating in the United States, with many more in the planning or licensing stage. It's easy to understand why most repeater users who do much operating while



Many repeater stations use one antenna for both receiving and transmitting. Because both must be on at the same time, it takes some fancy circuitry to keep the incoming signals out of the way of the outgoing one. The device that does the job is called a *duplexer*. This one was home-made, by K3OBU, but many clubs buy such equipment. The adjustment and connecting of this complex part of a repeater requires considerable expertise on the part of the maintenance crew. Many of the more technically inclined members of a club find this type of challenge a rewarding part of amateur radio (photo courtesy K3OBU).

mobile away from their home location avail themselves of the use of a repeater directory, such as the one published annually by the *American Radio Relay League (ARRL)* in Newington, Connecticut.

Repeater operation has literally changed the nature of Amateur Radio, particularly concerning one of its basic reasons for existence: public service. Years ago, there were not many really effective local Amateur Radio networks. Many hams will remember that during the "six-meter days" when use of the 50-MHz band with a-m or ssb was popular for local work, it was often necessary to run more than 100 watts of power just to contact a station across town. The rigs themselves, of course, were nowhere near as small and compact as today's two-meter gear. Furthermore, there was generally very little interconnection between these local groups by any reliable means. It is now sometimes stated, only half jokingly, that it used to be easier to contact a European country to get a rare

**Table 1.** Repeater frequencies are normally shown in an abbreviated form, such as 01/61. The first frequency in this example would be 146.01 MHz, and the second would be 146.61 MHz. To talk through this machine, you would transmit on 146.01 MHz (the repeater *input*) and listen on 146.61 MHz (the repeater *output*). On the 146-MHz pairs, the input is 600 kHz *lower* than the output. On the 147-MHz pairs, the input is 600 kHz *higher* than the output of the repeater.

146-MHz Pairs		147-MHz Pairs		Simplex Channels	
Input	Output	Input	Output		
146.01	146.61	146.40*	147.00	146.40*	147.42
146.04	146.64	147.60*	147.00	146.43*	147.45
146.07	146.67	146.43*	147.03	146.46*	147.48
146.10	146.70	147.63*	147.03	146.49	147.51
146.13	146.73	147.66*	147.06	146.52**	147.54
146.16	146.76	147.69	147.09	146.55	147.57
146.19	146.79	147.72	147.12	146.58	147.60*
146.22	146.82	147.75	147.15		147.63*
146.25	146.85	147.78	147.18		146.66*
146.28	146.88	147.81	147.21		
146.31	146.91	147.84	147.24		
146.34	146.94	147.87	147.27		
146.37	146.97	147.90	147.30		
146.40*	147.00	147.93	147.33		
146.43*	147.03	147.96	147.36		
146.46*	147.06	147.99	147.39		

\*Optional in certain areas, reverse pair

\*\*Recommended National Simplex Frequency



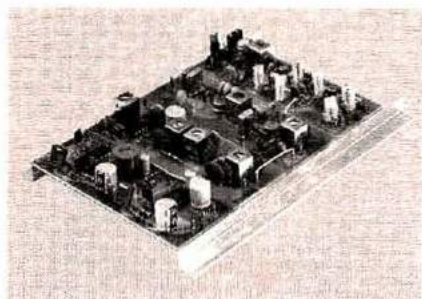

Receivers and transmitters for vhf fm can be built from kits. This receiver uses the modular concept of construction — it has an audio board, high and low i-f boards, and a front end or converter board. The converter/rf board may be changed to suit the band you want to receive, from 50 to 420 MHz. Transmitters of similar construction are available (photo courtesy VHF Engineering).

serum than it was to maintain communications with the local Red Cross unit on the other side of town during a disaster.

Today, repeaters probably contribute more to public service activities than any other single operation of amateur radio. Month after month, public service columns of the various Amateur Radio magazines are filled with reports of persons being assisted in many ways through the efforts of Amateur operators active on repeaters from coast to coast. It may be helping a disabled motorist, providing coordination for a March of Dimes Walk-A-Thon, or even helping a private pilot (equipped with a two-meter handheld) in need of landing information at a small field in the local area. Weekly nets for the ARRL-sponsored Amateur Radio Emergency Corps and/or Civil Defense related RACES (Radio Amateur Civil Emergency Service) organizations are a regular part of many repeaters' public-service contribution.

Sometimes the efforts of hams dedicated to installing and maintaining repeater stations pay off in unexpected ways. Not long ago, a group of

hams were on their way down from their repeater site on a snowmobile, which was needed due to the high altitude and bad weather conditions at the site. The snowmobile went off the path and into a deep ditch along the treacherous route down the mountain. The only means they had to call for help was (you guessed it!) a two-meter handheld transceiver operating through the repeater station they had just repaired.

One of the greatest public service and personal convenience tools ever to be available to ham operators is the repeater equipped with autopatch. No, this is not the same thing that we used to do with our cars on the city streets to shorten the lives of our tires. An autopatch is an interface and control device that allows the repeater to interconnect with the public telephone system on command. With the simple addition of a *Touch-Tone*\* type "pad" to any individual transceiver, even a handheld unit, it becomes possible to obtain a dial tone on the repeater and place a telephone call. Imagine calling the police department directly from the scene of an accident from your mobile rig. The possibilities for

public service with this system are endless, but its use, as with any amateur radio facility, is strictly limited to public-service and personal-convenience calls. No business calls, please.

I mentioned earlier that repeaters are operating on frequencies other than the two-meter band. There are some on the six-meter band (50-MHz), many more on the 1¼-meter band (220 MHz), and the 70-cm band (450 MHz) is rapidly becoming the second most popular repeater band as compared to two meters. Recently, repeater operation on parts of the ten-meter band (29 MHz) was also authorized by the FCC. It remains to be seen whether this band will offer practical conditions for such operation in a few years when the increase in sunspot activity causes DX, or distant, signal propagation to occur on ten meters and hence interfere with repeater activities.

#### Open or closed?

Open repeaters are those where any licensed amateur operator is welcome, regardless of whether or not he is a member of the local repeater organization. These machines generally operate on

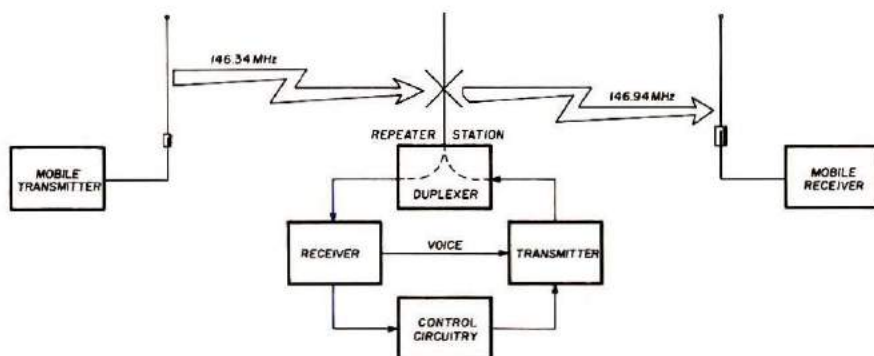

**Fig. 2.** The signal from a mobile (or portable) transmitter is picked up by the antenna at the repeater location, and fed into the duplexer. The duplexer is a signal splitter (in simplified terms) which feeds the signal to the receiver. The receiver then recovers (detects) the audio from the incoming signal, and passes it along to the transmitter. Control circuitry that is separate from the audio path turns the transmitter off at the proper times. Telephone lines can be connected for either control or autopatch use, if desired by the club members and trustee of the repeater. The transmitter generates a carrier on a frequency that is different from the one just received, and frequency-modulates it. This new signal goes back through the duplexer, and out to the antenna, where it is radiated to be picked up by another mobile unit many miles distant.

\**Touch-Tone* is a trade name of the Bell System signalling devices.



the carrier-access principle; merely keying your own transmitter activates the repeater. Closed repeaters are operated solely for the convenience of their sponsors, whether a group or an individual. These repeaters usually require a tone burst or continuous subaudible tone (known as CTCSS, or Continuous Tone Coded Squelch System) to access the repeater. The required tone frequency is not made public; therefore, use of the machine is limited to members of the club with the proper information and equipment on their own rigs.

There has been some controversy over the concept of a closed repeater and whether it is in keeping with the spirit of Amateur Radio; however, it helps to remember that you as an individual station owner are under no obligation to invite outsiders to use your equipment. There seems to be little legal justification to suggest that owners of a closed repeater should not have the same right to restrict the use of their equipment.

Then, too, in many of the crowded metropolitan areas some repeaters are located too close to each other, and some means must be found to prevent users of one machine from turning on the other one. A tone-access system is often used for this purpose.

Open repeaters fortunately greatly outnumber closed machines, so the mobile-station operator has little difficulty in finding repeaters to use during his travels. Furthermore, in locations where there is a closed repeater, there is almost always one or more open repeaters, too. Here again, carrying a repeater directory in your car can be invaluable.

#### Who runs the repeater?

A repeater can be owned and operated by one individual ham at his home location, or by a group (club) especially formed to license and maintain a repeater on a mountaintop site many miles from civilization.

In the case of an individual, he would be the sponsor and *licensee* of the station. The



Some club members build their own repeater station equipment, and others save time by purchasing many of the units needed. This repeater, by VHF Engineering of Binghamton, New York, is a complete package consisting of the receiver, transmitter, and power supply. It is available either as a kit, or wired and tested. All that is needed in addition to this unit is a duplexer, antenna, and connection to either a telephone line or radio circuit so the repeater can be controlled from a remote point.

repeater would still have a distinctive WR prefix call sign,\* but the license would simply be issued as a secondary station of the owner's regular station callsign. In the case of group sponsorship, one member of the group is chosen, usually on the basis of involvement, experience, and possibly physical proximity to the site, to be the club license *trustee*. This individual then holds the club license and is legally responsible for the proper technical operation of the repeater and for the content of all traffic on the repeater. *Control operators* are normally assigned by the trustee to also be responsible for the emissions of the station when it is operating during the time periods for which they are assigned. Naturally, the individual users of the repeater are also responsible for their own conduct on the air.

The control operators must be able to shut down the transmitter of the repeater under circumstances where improper operation may result. This is done by remote control (unless the operator is also at the repeater site) using one of

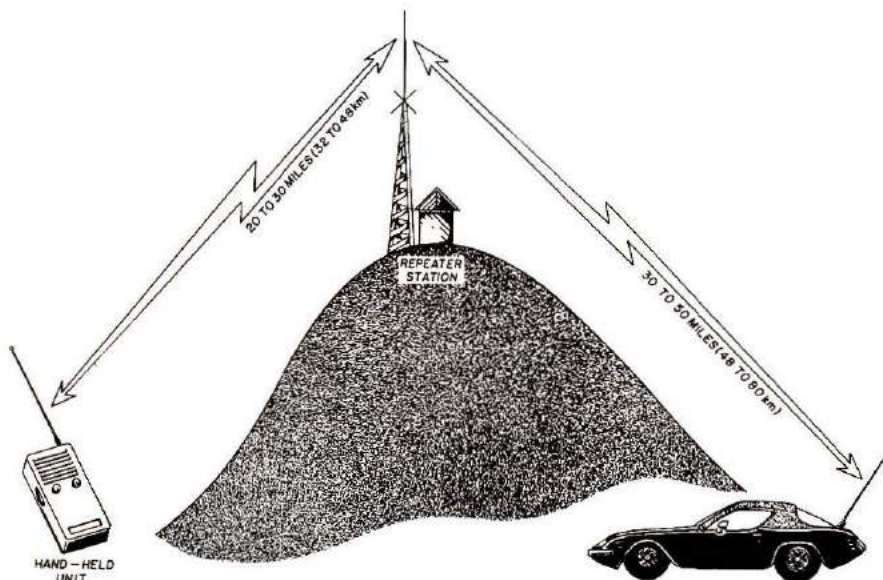

**Fig. 3.** A repeater can extend the range between two low-power units. The repeater itself is often located high above the surrounding terrain or buildings. It also has the advantage of being able to run more power than most mobile units can put forth. An excellent antenna at the repeater site, and the usual low noise level at the remote location, also helps the repeater perform very well. Some "machines" with excellent sites can provide coverage of over 100 miles (160km) between mobile stations.

\*At the present time the FCC is considering a move to drop the requirement for distinctive callsigns for repeaters.





Tall buildings in large cities collect their share of repeater equipment. Here a Cushcraft 4-dipole antenna is part of the Chicago FM Club's 220-MHz repeater. The skyline to the south of the repeater site includes the Sears Tower, Standard Oil Company building, First National Bank, and others among the tallest buildings in the city (photo courtesy Chicago FM Club).

several methods. One popular method uses a telephone line to the site with a decoder to receive and execute commands from the control operator. Another method uses a radio-control link (above 220 MHz) to turn the repeater off or on. In addition to simple on/off control, many other commands can be sent to the repeater site by remote control, including autopatch off/on, antenna switching, repeater linking, switch to emergency power, and the like. A complex control system capable of executing multiple command functions often has a *Touch-Tone* decoder to interpret tone commands that are received via telephone or on the radio-control link.

Some of the controls needed to ensure proper operation are built into the equipment at the site. These could include a tail timer, which holds the transmitter on the air for a few seconds (not more than five) after keying the repeater, a time-out timer, fault timer, and

CW (code) or voice-identification device.

The tail timer lets you know that the repeater is on the air and that it is receiving your signal. It also saves wear and tear on the COR caused by weak mobile signals chopping in and out of the receiver. The time-out timer, while not strictly required, is usually set for three minutes. It turns the transmitter off after a signal has been received without interruption for three minutes (or any pre-set time), thereby helping to meet one of the FCC requirements for automatic repeater operation. Also, users of the repeater quickly become accustomed to breaking their transmissions every minute or so to reset the timer; this gives other stations who may need the use of the machine a chance to break in.

The fault timer is simply a fail-safe device that shuts down the repeater if its transmitter "runs wild." FCC rules require that a repeater station, when in use, identify itself by its assigned callsign at intervals not exceeding five minutes. Although this is usually accomplished by a CW identifier that automatically sends the repeater callsign periodically, along with your retransmitted voice, a number of imaginative repeater groups use recorded identifications, sometimes featuring a sensuous female voice announcing the callsign, location, and so on. This is not at all a bad change from the rather staid *didahdah didahdit . . .* of the CW identifier heard on most repeaters.

### Who pays?

One factor I shouldn't overlook in answering the question about who runs the repeater is money. A sad fact of repeater life is that they "eat" money. In most cases financial support is required for power, possibly for rental of that ideal mountaintop site, for telephone line control or

autopatch functions, for insurance, maintenance, and so on. Where does it come from? Well, it's not legal to charge individual operators to use the station, and no repeater group that I know of has any desire to do so. Typically, a small group of hams contribute the initial sum necessary to get the repeater on the air and hope for purely voluntary contributions from some of the users of the machine to help defray the continuing costs. In some cases local Civil Defense units will contribute to the operation of a repeater through its RACES program.

Of course, if you travel a great deal and have occasion to use many repeaters as you drive through their coverage areas, nobody expects you to give money to all of these organizations. It is generally accepted that if you help to support one repeater, perhaps in your home area, you are "doing your duty" to maintain this valuable nationwide system of repeaters for yourself and all the other operators who have come to depend on them

To be effective, a repeater station must have its antenna on a high spot, which often means on top of a good tower as well. Here K3OBU and WA3CMQ install the Stationmaster antenna at the top of their 100-foot (30m) tower (photo courtesy K3OBU).





when away from home.

### Choosing a rig

The tremendous growth and popularity of repeater operation has spawned a large assortment of new rigs from many manufacturers, both domestic and foreign.

Magazines such as *Ham Radio Horizons* are blessed with advertisements from these companies, which make it easy for you to get information and compare specifications about various models.

Most units come equipped for mobile operation on 12 volts dc and would therefore require the use of a separate power supply for operation as a fixed-location station. There are, however, some rigs available with both supplies built in. Several firms specialize in handheld (or HT)\* units designed for two meters, and a few models are also available for the uhf repeater bands. Repeaters have made the use of one-and two-watt handheld units extremely popular because of the relatively long-range contacts possible with a small transceiver that can easily be carried with you anywhere.

One of the biggest decisions you face when you are ready to purchase a home-station or mobile rig is choosing the type of frequency selection in the rig. Crystal-controlled rigs, most of which require two crystals per channel (one for the transmitter and the other for the receiver), are available in basic models in the \$200 price class. These units come equipped for at least one frequency pair (usually 146.52 MHz, a simplex channel) and possibly more. An average price for additional crystals is \$5.00 to \$6.00 each, or \$10.00 to \$12.00 per channel.

Several years ago, about the only type of vhf fm rig

\*Handy-Talkie and Walkie-Talkie are trade names for Motorola equipment.

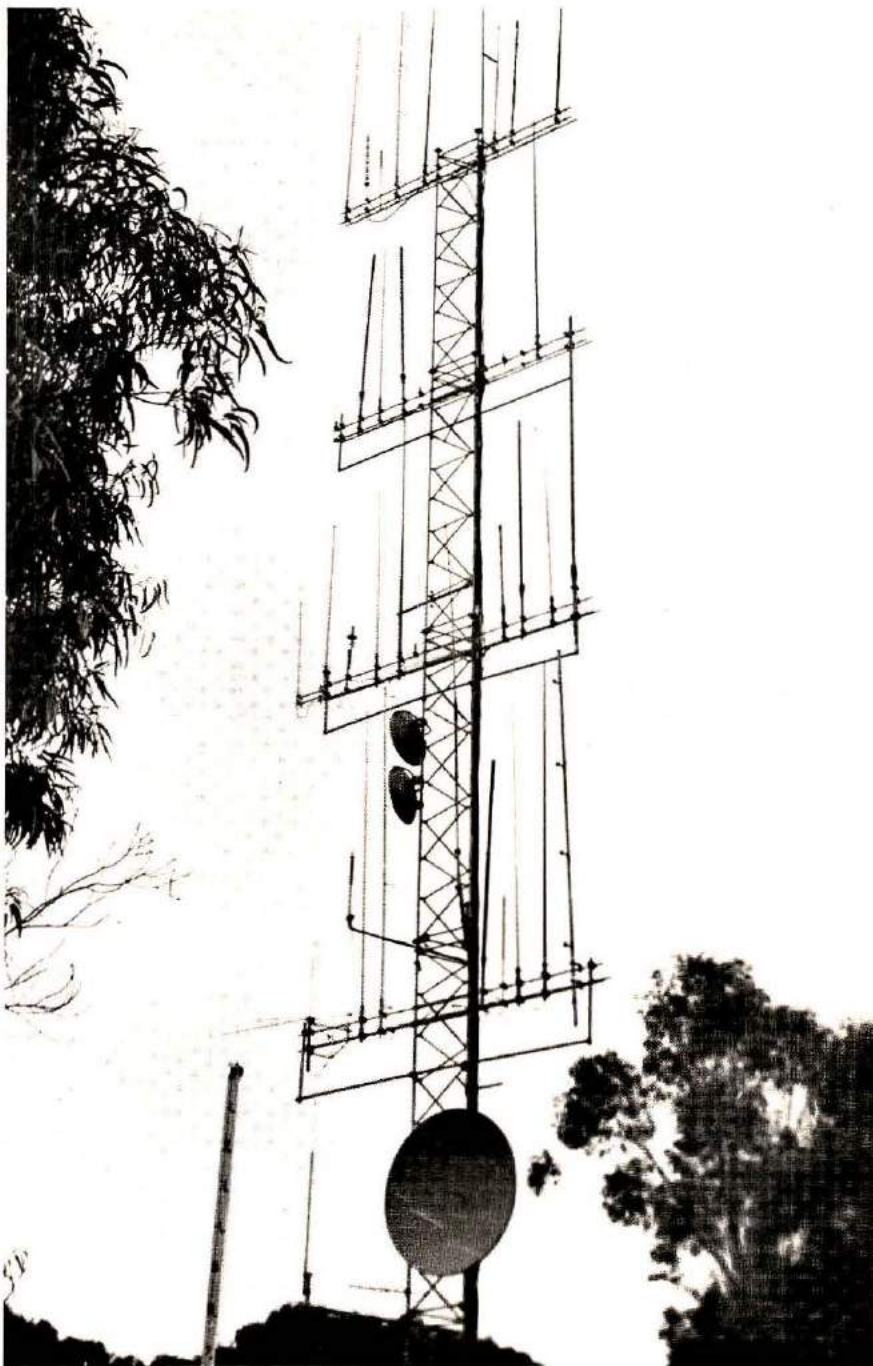

When there is only one good, high, location in an area, and it has just one tower on it, things do get crowded. This spot, San Pedro hill, at Palos Verdes, California, is the location of more than 70 repeaters! (Photo by West).

available was the crystal-controlled variety. Recently, however, a whole new breed of units has become available that require no individual crystals at all for channel selection. These units are *frequency synthesized*, often with digital displays to indicate the operating frequency. When you

want to switch to another repeater or simplex frequency, it's as easy as turning a few knobs. With most synthesized radios, it's a simple matter to *invert* from the standard repeater input/output pair and listen directly to the other station's signal. This is a very convenient way to determine





There are many handheld units available to the amateur. Some of them are single-channel transceivers, others have 2 or more channels. Recent developments have produced a synthesized package that can be added to some transceivers to permit selection of any frequency you need to work, simplex or through repeaters. This Hy-Gain Model 3806 is a 2-meter unit, popular with many users.

whether you can work the other station simplex; or, if a station happens to time-out the repeater, you may be close enough to pickup the rest of his comments by listening to him directly.

As might be expected, the more sophisticated circuitry used in synthesized rigs makes their initial cost higher than that of crystal-controlled units. These rigs are available in kit form in the \$300 price class or as wired-and-tested units from \$400 up. However, if you plan to travel or use many repeaters, you can save a great deal of money in the long run and enjoy real versatility with a synthesized radio.

A new type of hybrid unit has just been introduced by one major manufacturer for under

\$300 which doesn't require the use of crystals, but instead is programmed for twenty-two different frequencies using a diode matrix board inside the set; the programmed frequencies can be easily changed by removing some of the diodes and replacing them in the correct "pattern" for the desired new frequency.

Whatever type of rig you choose, vhf and uhf operation requires only relatively small and inexpensive antennas; a quarter-wave antenna for two meters is approximately 19 inches (47cm) long.

This information clearly indicates that setting up a station for two meters need be no more costly than the average Citizens-Band station, and the antenna can be quite a bit smaller physically!

#### Operating hints

Now, let's assume you've received your Amateur Operator License (Technician class or higher) and that you're ready to begin operating over a repeater for the first time. One of the first differences from the lower bands is the procedure used when you want to call any station for a contact. Due to the channelized operation, calling CQ on a repeater immediately identifies you as a newcomer (it's not illegal, just frowned upon by many users).

In many areas, calling "QRZ the frequency?" followed by your callsign is accepted practice. For example: "QRZ 61? This is W3XXX." However, this is not logical in the strictest sense of the meaning of QRZ? ("Who is calling me?"), when there wasn't anyone on the frequency before you called.

In many areas, the recommended method is to merely announce that you are listening on the repeater. In the case of an emergency where assistance is needed, announce this fact loudly and clearly. The control operator on duty may be too busy with his own activities to answer a casual call, but he'll do his best to respond immediately to a distress call.

Repeater operation, especially in heavily populated areas, is largely an informal break-in/break-out format. The single word "break" followed by your callsign is sometimes used to break into a conversation in progress on the machine. This is used when the breaking station has something positive to add to the discussion and should be timed in a way that it will not cause total disruption to the QSO in progress. Observe common courtesy when breaking, just as you would in a face-to-face conversation between several people.

Another complete repeater package, except duplexer and antenna, is offered by Spectrum Communications, of Norristown, Pennsylvania. The SCR 1000 is available as an assembled unit.

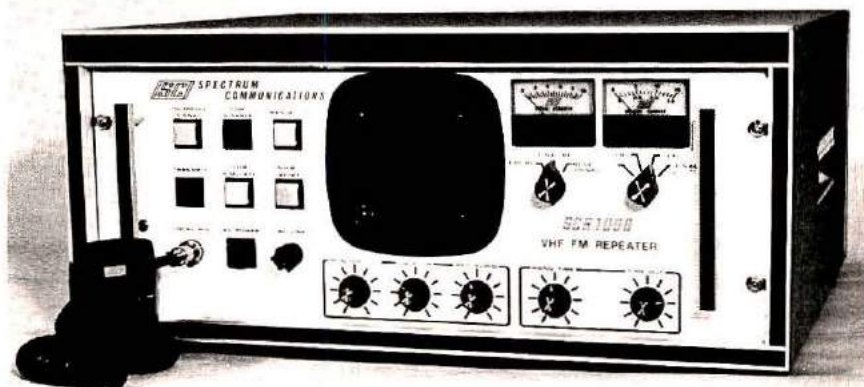



The double word "break-break" usually indicates that it is very important for the breaking station to be recognized without delay. This procedure might be used by a disabled motorist wanting to use the autopatch, for example. The triple word "break-break-break" is used only in cases of extreme emergency, where lives or property are in danger.

Because repeater time may be at a premium in the area where you're operating, observe the FCC rules regarding station identification, but don't over-identify. The rules require that you identify your own station at the beginning of a transmission or exchange of transmissions, at least every ten minutes during a QSO, and that you identify the station with whom you're talking *and* your own callsign at the end of the QSO. However, identifying both stations at the beginning and end of each individual transmission wastes a great deal of air time and is completely unnecessary. Further, since November 26, 1976, the requirement for mobile and portable identification has been deleted by the FCC. There's certainly nothing wrong with informing the other station that you're operating mobile or at a fixed location away from home, but constantly adding this designation to your callsign is, again, wasteful and unnecessary.

A few common terms that you'll frequently hear on two-meter fm are deviation, quieting, and ERP. Deviation refers to the frequency swing above and below the carrier frequency as you modulate your fm signal. Most repeaters are set up to accept a deviation of  $\pm 5$  kHz, which is known as narrow-band, as compared to the outdated commercial-service wide-band deviation of  $\pm 15$  kHz.

Quieting simply means the extent to which your signal "quiets" the background noise

of any given fm receiver. "Full quieting" means your signal is as good as it can be, with all background noise eliminated.

ERP stands for Effective Radiated Power, and is of particular interest to the licensee or trustee of a repeater, because he is required to calculate the ERP of the station for entry in the repeater log. Limits are set by the FCC on the ERP of repeaters according to their height above average terrain. This calculation includes such factors as transmitter output power, feedline and duplexer loss, and antenna gain.

### Autopatch operation

It is estimated that about one-third of the repeaters in the United States currently have autopatch capabilities, and that this facility is planned for another third of the repeaters. The popularity of autopatch is due to its exceptional convenience in placing personal telephone calls through the machine and its unequalled value as a public-service tool. Each repeater group has its own requirements for gaining access to the patch and identification, but some things are common. A *Touch-Tone* access code, which may be as simple as the asterisk (\*) button, or as complex as a multi-digit sequence, "brings up" the patch. By this, I mean that the dial tone will be heard on the repeater. Another code, frequently the pound-sign button (#), "drops" the patch. You would, of course, identify your station before using the autopatch, but this is where the procedure varies due to differences in logging. Sometimes you will be required to identify again after the dial tone begins, so that your callsign will be recorded on the tape log of autopatch calls. When you complete your telephone call, you must sign off using the repeater callsign and your own; for example, "This is W3XXX clear

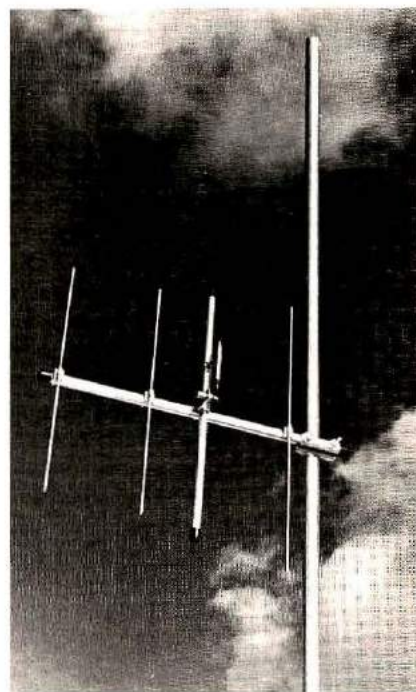

There are times when directional coverage is desired by an amateur who wants to use a distant repeater, or by a repeater station to cover a specific area. Because most repeater stations have their antennas vertical, a directional antenna (Yagi) must be the same. This Cushcraft four-element beam was designed with fm and repeaters in mind.

WR3XXX autopatch."

Logging suddenly rears its ugly head when using autopatch because all autopatch conversations are currently considered to be third-party traffic (you are the first party, the repeater is the second party, and the person on the telephone is the third party). So both you and the repeater have the responsibility of logging these calls. The repeater usually meets its responsibility with the help of a tape recorder; you should use a small log book for yours. Your callsign is a permanent entry in the book, so entering the call of the repeater, name of person called, and a brief description of the call will complete this requirement.

One of the stickiest wickets ever to come along in rules interpretation involves the separation and definition of personal and business



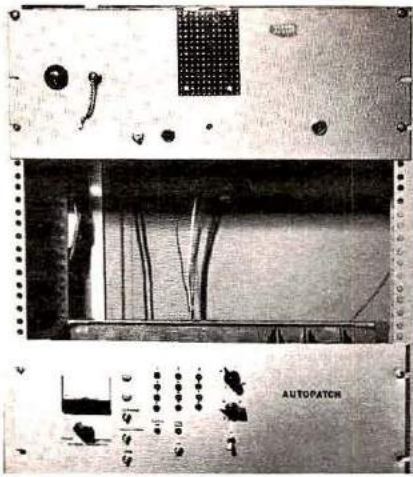

Many of the repeater clubs have members that delight in building most of the equipment needed for the installation. The Chicago FM Club has this mostly homebrew 220-MHz repeater to serve local amateurs on that band. The top panel hides the receiver and transmitter, and the bottom one contains logic circuitry for control as well as the Auto-patch device (photo courtesy Chicago FM Club).

autopatch calls. Any business use, or use for gain, is strictly illegal. This means, for instance, that you could not phone your office to find out if you had any calls. On the other hand, calling home to let your spouse know that you're on your way is perfectly all right. However, you could not pick up any business calls from your wife, either.

Calling ahead to a restaurant to place an order would not be legal, because it would contribute to the commercial gain of a third party (the restaurant). Suppose, however, that your car was disabled along the road and you wanted to call a towing service to come to your aid. You might point out that this would contribute to the business operation of the towing service, and you would be correct; this call, however, would be legal because of the obvious emergency situation which prevails. There are many borderline cases more subtle than these examples, and very few clear-cut interpretations are available. The best advice is that if the slightest question exists in your mind as to the

legality of a call you want to place, don't do it on the repeater; use the regular landline.

Remember, if you place a borderline autopatch call, you not only jeopardize your own operating privileges, but those of the control operator and trustee as well. Furthermore, you also call into serious question the matter of competition with commercial mobile-telephone services, which could have adverse effects on repeater licensing and autopatch use for Amateurs. Ordinary personal use of the autopatch system is not competition to any commercial service, so it is obviously in our best interests to avoid even the slightest appearance of business use.

### New Developments

New advances in amateur repeater operation occur constantly as various sponsoring groups around the United States and Canada try new ideas and experiment in ways that commercially operated repeater stations, by definition, could never duplicate. The concept of Amateur repeater linking, now permitted by the FCC, is one very exciting frontier. Repeaters in various geographical locations can be linked together by one of several means so that a station transmitting to one repeater is also heard through at least one other machine, or perhaps through a "chain" of repeaters. In this way, it *could* be possible for a handheld unit in New York City to transmit a sequential tone command to a local repeater, thereby activating an extensive link all the way down the East Coast, and be answered by another handheld in, say, Miami. A more common application of linking, and one that is in use today in several areas, is the capability to link two or three regional repeaters together to more effectively deal with disaster situations, disseminate

weather warnings, and the like.

Some repeaters are equipped with bulletin-transmitting devices that can be activated by a tone command to play a recording of the latest ARRL bulletin or some other Amateur-Radio related information; perhaps a list of the repeater's capabilities. Other machines let you know if your transmitter is slightly off frequency by sending a short tone.

Repeaters are not limited to voice communication, either. There are a number of radio teleprinter (RTTY) repeaters now operating where individual Amateur stations equipped with an RTTY printer can receive messages from distant hams through the repeater even if the receiving Amateur is away from his station. The message is neatly printed and waiting for him when he returns home.

Other groups are operating amateur television (ATV) repeaters in the 450-MHz band. One of these groups has even devised an ingenious system for superimposing a digital relative-signal-strength indication on the picture transmitted from the repeater. This makes it very convenient for any individual operator to determine how well he is being received by the repeater, and he can immediately see the result of any changes he might make in antenna position or power output by watching the digital readout.

Not many years ago the vhf and the uhf amateur bands were comparatively barren. Now, in many areas, the two-meter repeater band is entirely occupied, with no more pairs available, and the other bands are being used more and more. It is an exciting period of growth that has sparked interest in many new hams and probably nearly as many "oldtimers," Amateurs who had been inactive for a number of years and then "came back" to Amateur Radio after discovering the excitement and thrill of repeater operation. **HRH**



# The Century/21 started with a clean sheet of paper...



**OBJECTIVE:** To design a no-compromise HF transceiver for the beginning Ham or Old Timer and at an economical, affordable price.

**CRITERIA:** Cw transmit, cw and ssb receive. Full break-in. 70 watts input. Full band coverage 80-15 meters, 1 MHz on 10. All solid state. Instant,

no-tune band change. Built-in regulated power supply. Overload protection. Linear crystal mixed VFO. Direct frequency readout. Offset receiver tuning, defeatable. Built-in speaker. Sensitive receiver section. High selectivity — three position. Sidetone with adjustable level. Full line of matching accessories.

## THE RESULT... TEN TEC *Century/21*

The Century/21 was designed and tooled from scratch for high performance cw. A unique Double Direct Conversion receiver performs as well as the conventional superhet. Broadband transmitter with instant break-in is a highly desired luxury. Accessory keyer and crystal calibrator available now, with additional accessories to follow. And . . .

### THE AFFORDABLE PRICE:

Century/21, Model 570 .....\$289.00  
Century Keyer, Model 670 ..... 29.00  
Century Calibrator, Model 276 ..... 29.00

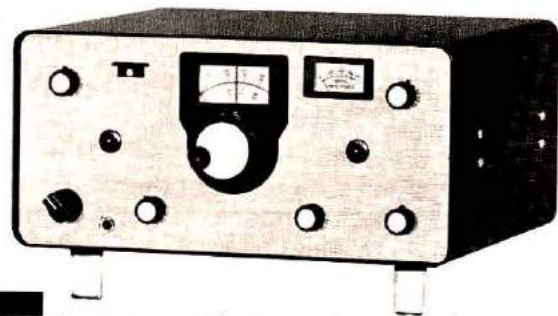

For further information, write:

**TEN-TEC, INC.**  
SEVIERVILLE, TENNESSEE 37862  
EXPORT: 5715 LINCOLN AVE., CHICAGO, ILL. 60646



# The Secret Society

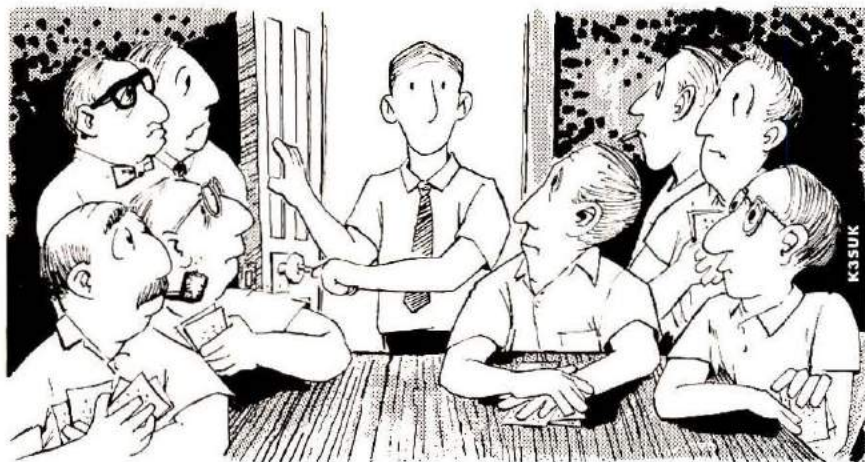

BY DR. J. MICHAEL BLASI, W4NXD

*What will you do when you confirm over 300 DXCC countries?*

Several months ago one of my very good amateur friends was passing through my section of the country. Since the welcome mat is always out, he didn't hesitate to stop by for a bit of Southern hospitality.

Jim works for an electronics firm and travels around the world, spending anywhere from a day to three months in any one place before he moves on. This brings him in touch with a great many amateurs, and he'll usually have an interesting story or two if I can get him going on the subject.

You all know how important DX has become in the last few years — DXpeditions, money for QSLs, pileups, and publicity. When the DX fever hits, it's worse than the Asian flu! If there is a DX club in the area where Jim is staying, he gets in touch with some of the prominent members and attends a few meetings.

This story happened in southern California. This makes everything very

believable, because you know how things are out there as far as ham radio is concerned. One of the clubs Jim visited had some of the top DXers in the world. There were at least eight fellows who had confirmed over 300 countries. Naturally this had no small effect on their personality; their noses tilted a bit upward, among other things.

He was supposed to be in that part of the country for a few months, so the club loaned him a key to the club house so he could operate the station. One afternoon he managed to have a bit of free time, so he dropped by to see if 20 meters was open. He didn't expect to see anyone there, so he was a bit surprised to find the eight club members who had more than 300 countries. They weren't using the rig — just sitting around the meeting table. They stopped talking as soon as he came into the room.

Jim didn't give it much thought at the time, but about

five days later, the same thing happened. The third time it happened he was sure that something was going on that he wasn't supposed to know about. They usually left as soon as he arrived but on the third visit Jim found something on the floor — a QSL card. After a few minutes, when he finally realized what was going on, he had a good laugh.

The next week he found them all there and mentioned the QSL card. He was right, they did have something cooking among themselves. The card was from a commercial station in South America thanking one of the big DXers for his SWL report!

It seems that these fellows had worked just about every country in existence and just sat around the shack waiting for something to happen. One of them made a little one-tube super-regenerative receiver and started to log foreign broadcast stations. Then he sent a report to them. He got more of a kick out of that SWL card than anything he had done in the past five years.

Before long, he and his select group of DX buddies were seeing who could get the most SWL cards using little one-tube receivers. Naturally, they couldn't let this get out or they'd be the laughing stock of the club. The little meetings they had were to compare their new SWL cards; Jim just happened to be there.

Jim and I can't tell you who these fellows are, and I'm sure they're not going to talk about it on 20 meters, but if you want a few laughs, the next time you work one of the big time DXers in W6-land, ask how Radio Peking is coming through these days!

HRH



# Here's REAL state-of-the-art value from the leader in Amateur Radio

Only \$669<sup>95</sup>



## HEATHKIT SB-104A transceiver now with IMPROVED sensitivity

We've taken the world-famous SB-104 transceiver and made it EVEN BETTER! A newly designed front end receiver circuit board offers improved SSB sensitivity of 0.5  $\mu$ V for 10 dB S+N/N. And this board is fully assembled and tested for greater reliability and reduced assembly time. All the other great 104 features remain — true digital readout, all solid-state design, 100 watt/1 watt output, plus the ease of operation and kitbuilding value that have made it a standard for SSB/CW transceivers.

**SB-104A SPECIFICATIONS:** Frequency Coverage: 3.5 MHz through 29.7 MHz amateur bands, 15 MHz WWV receive only. Frequency Stability: Less than 100 Hz/hr drift after 30-min. warmup; less than 100 Hz drift for  $\pm 10\%$  change in primary voltage. TRANSMITTER — RF Power Output: High Power: SSB: 100 watts PEP  $\pm 1$  dB; CW: 100 watts  $\pm 1$  dB. Low Power SSB: 1 watt PEP (minimum); CW: 1 watt (min.). Carrier Suppression and Unwanted Sideband Suppression: —50 dB down. Harmonic Radiation: —40 dB below 100 watt output. Spurious Radiation: —40 dB within  $\pm 4$  MHz of carrier; —60 dB farther than  $\pm 4$  MHz. RECEIVER — Sensitivity: 0.5  $\mu$ V for 10 dB S+N/N for SSB. Selectivity: 2.1 kHz minimum at —6 dB, 5 kHz max. at —60 dB. (2:1 nominal shape factor). CW Selectivity: (with accessory CW filter) selectable 2.1/4 kHz. Dimensions: 5 $\frac{1}{4}$ " H x 14 $\frac{1}{2}$ " W x 13 $\frac{1}{2}$ " D.

Only \$199<sup>95</sup>



## HEATHKIT HR-1680 top-performing solid-state SSB/CW receiver

The one to have for Novice, General or Extra-Class! Brings you world-wide SSB and CW clean, clear and crisp with a double-conversion superhet receiver, AGC controlled IF and RF, 4-pole crystal filter and a two-stage active audio filter. All solid-state components help eliminate heat buildup and drift, and contribute to excellent frequency stability on all bands.

It's easy to build with NO-INSTRUMENT alignment, and easy-to-use with full front panel controls, an extra-large dial spinner, and built-in AC power supply.

**HR-1680 SPECIFICATIONS:** Frequency Coverage (MHz): 3.5-4.0, 7.0-7.5, 14.0-14.5, 21.0-21.5, 28.0-28.5, 28.5-29.0. Sensitivity: Less than 0.5  $\mu$ V for 10 dB S+N/N for SSB operation. IF Selectivity: 2.1 kHz minimum at 6 dB down, 7 kHz maximum at 60 dB down. Intermodulation Distortion: —60 dB. Image Rejection: 50 dB or better. IF Rejection: 60 dB or better. Frequency Stability: Less than 100 Hz per hour drift after 30 minutes warmup. Less than 100 Hz drift for 10% change in line voltage. Dial Backlash: 50 Hz or less. Input Impedance: 50 ohms unbalanced. Power Requirement: 120 or 240 volts AC (60/50 Hz) 27 watts maximum or 11.5 VDC to 15 VDC at 0.75 amperes maximum. Dimensions: 12 $\frac{1}{4}$ " W x 6 $\frac{1}{4}$ " H x 12" D.



## And Here's a GUARANTEED way to get your Novice License-or your money back!

Only \$24<sup>95</sup>

We've developed a Learn-at-home Novice License Course that's so good we GUARANTEE it! Effective "programmed" learning text plus audio cassettes teach you all you need to

know to get your Novice License. If, for any reason, you fail, we give you your money back! It's the fast, easy, effective way to learn about Amateur Radio and get yourself on the air!

# FREE!

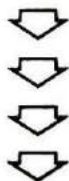

## THE NEW HEATHKIT CATALOG

Nearly 400 fun-to-build kits including Amateur Radio equipment, stereo hi-fi, digital clocks and weather instruments, color TV, test equipment, auto and marine accessories, and lots MORE!



**SEND FOR IT TODAY!**

Remember: "There's more for the Ham at Heath"!

Heath Co., Dept. 348-330, Benton Harbor, Michigan 49022

HEATH  
Schlumberger

Heath Company, Dept. 348-330  
Benton Harbor, Michigan 49022

Please send me my FREE Heathkit Catalog.  
I am not on your mailing list.

**FREE!**

Name \_\_\_\_\_

Address \_\_\_\_\_

City \_\_\_\_\_ State \_\_\_\_\_

AM-355 \_\_\_\_\_ Zip \_\_\_\_\_



# ME-3 microminiature tone encoder

Compatible with all sub-audible tone systems such as: Private Line, Channel Guard, Quiet Channel, etc.

- Powered by 6-16vdc, unregulated
- Microminiature in size to fit inside all mobile units and most portable units
- Field replaceable, plug-in, frequency determining elements
- Excellent frequency accuracy and temperature stability
- Output level adjustment potentiometer
- Low distortion sinewave output
- Available in all EIA tone frequencies, 67.0 Hz-203.5 Hz
- Complete immunity to RF
- Reverse polarity protection built-in

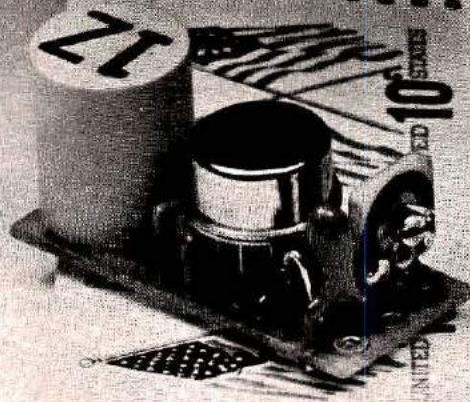

**\$29.95 each**

Wired and tested, complete with K-1 element

**communications specialists**

P. O. BOX 153  
BREA, CALIFORNIA 92621  
(714) 998-3021



K-1 FIELD REPLACEABLE,  
PLUG-IN, FREQUENCY  
DETERMINING ELEMENTS

**\$3.00 each**





## QUESTIONS & ANSWERS

BY THOMAS McMULLEN, W1SL

One of the attractions that sets the Amateur Radio Service apart from any other is the freedom that they enjoy in the pursuit of their hobby. They can choose frequencies to use, modes to employ, equipment to buy (or they can build their own). They can talk to any other Amateur in any part of the world, and can delve into the many types of activities that keep the Amateur bands alive almost around the clock.

Of course, this freedom is earned — all freedoms are. The Amateur earns his by two basic means: One is by providing a useful service, as defined by the FCC; the other is by passing an examination to prove that he is qualified to properly use the sections of the radio spectrum that have been allocated to Amateur Radio. No other service enjoys this freedom — indeed they never even come close to it. Most are restricted to a single frequency, and the equipment is very stringently controlled and cannot be tampered with — repairs must be done by a properly licensed person. Equipment engineering and design work is done in a laboratory where there are definite goals to be met — no trying a pet circuit “just to see what will happen.”

In short, there are many possibilities open to you as an Amateur, once you have shown a willingness to learn a few

basic rules, principles, and theories, and have proved that willingness by answering some not-too-difficult questions.

I'll cover the questions for the Novice examination first, and those for the General Class at a later date. The FCC Study Guide, SS bulletin 1035, February, 1976, for the Novice questions, and SS Bulletin 1035C, for the General Class questions, will be used in presenting the material.

One additional comment before I start digging into the questions — some people who have taken the exams have been bothered by what they term “trick questions.” The FCC assures me that there are no trick questions; some of them are worded in such a manner that guessing or haste can lead to the wrong answer. However, if you *know* the subject matter, careful reading of the questions will make it clear what it is they are asking.

The material in the Novice examination covers nine distinct areas of study: Rules and Regulations; Radio Phenomena; Operating Procedures; Emissions Characteristics; Electrical Principles; Practical Circuits; Circuit Components; Antennas and Transmission Lines; and Radio Communication Practices.

### Rules and Regulations

This part of the examination is designed to test your knowledge in the various rules

governing the Amateur Service. It is important that you know what to do as well as what not to do. I'll be the first to agree with you that this is not the most thrilling part of studying for an Amateur License, but if you think about the reasons for the rules and what they do for Amateurs in the manner of protection, you can see that they are worth putting up with.

Most of the rules follow good common sense principles; some of them are to protect the Amateur Service and the Amateur frequencies from encroachment by commercial interests, and some were accepted in order to satisfy International agreements. On this latter point — many Amateurs today do not realize that at one time Amateurs were in grave danger of not being allowed to exist. Many nations were eager to get their share of the “communications pie” and greed and commercialism and jealousy were the order of the day. Much give and take at numerous conferences led first to an agreement that there could be such a thing as an Amateur Service, but they were forbidden to talk to Amateurs in other countries. Then someone realized that you cannot stop a radio signal at a border or shore, so back to the conference table they went. The next step was an agreement that Amateurs could talk to each other, but could not handle messages (this would put them in direct competition with the postal authorities in much of the world). In many countries that agreement still stands. Because you will be using frequencies that reach to all parts of the world, these International agreements are important to you.

Anyway, back to the questions. The first subject in this section is Basis and Purpose. To put it quite simply, this is the justification for the Amateur Radio Service to exist. They are not mere words put together in high-sounding



principles, but were carefully formulated so that the Amateur Service could be defended against those who would like to take that part of the spectrum for their own use. Basis and Purpose can be found in part 97.1 of the FCC Rules and Regulations. The text reads as follows:

#### 97.1 Basis and purpose

The rules and regulations in this part are designed to provide an amateur radio service having a fundamental purpose as expressed in the following principles:

(a) Recognition and enhancement of the value of the amateur service to the public as a voluntary non-commercial communications service, particularly with respect to providing emergency communications.

(b) Continuation and extension of the amateur's proven ability to contribute to the advancement of the radio art.

(c) Encouragement and improvement of the amateur radio service through rules which provide for advancing skills in both the communications and technical phases of the art.

(d) Expansion of the existing reservoir within the amateur radio service of trained operators, technicians, and electronics experts.

(e) Continuation and extension of the amateur's unique ability to enhance International good will.

Those five paragraphs form an argument for the Amateur Service that is, like apple pie and motherhood, difficult to be against. A question in the exam could pertain to any one of the paragraphs, for example: A fundamental purpose of the Amateur Service is to

- (a) buy new equipment
- (b) buy used equipment
- (c) build larger antennas
- (d) continue and extend the amateur's proven ability to contribute to the advancement of the radio art.

Obviously, the answer is (d), which can be found in paragraph (b) of part 97.1. Note that the question has multiple-choice answers, and only one will be correct. My example is somewhat easy to work with, but in actual questions on the exam there may be several answers that could *almost* fit. If you have thoroughly studied the rules and regulations

section, you'll have no trouble recognizing the correct answer. Now, let's move on to the next subject in this part of the study guide.

Once you have rationalized the existence of an Amateur Service, the next step is to define it and the parts that go into an Amateur station. That is the purpose of this section of the rules, designated 97.3. It gets rather lengthy, but it is likely that you will be concerned with just a few parts of it in your Novice test. You should become thoroughly familiar with paragraphs (a), (c), (d), (e), (f), and (p). The entire section is printed here because there is a slight chance that you might be asked something about other parts, and you'll surely need to know more of it for a higher grade of license.

#### 97.3 Definitions

(a) *Amateur radio service.* A radio communication service of self-training, intercommunication, and technical investigation carried on by amateur radio operators.

(b) *Amateur radio communication.* Non-commercial radio communication by or among amateur radio stations solely with a personal aim and without pecuniary or business interest.

(c) *Amateur radio operator.* A person interested in radio technique solely with a personal aim and without pecuniary interest, holding a valid Federal Communications Commission license to operate amateur radio stations.

(d) *Amateur radio license.* The instrument of authorization issued by the Federal Communications Commission comprised of a station license, and in the case of the primary station, also incorporating an operator license.

*Operator license.* The instrument of authorization including the class of operator privileges.

*Interim Amateur Permit.* A temporary operator and station authorization issued to licensees successfully completing Commission supervised examinations for higher class operator licenses.

*Station license.* The instrument of authorization for a radio station in the Amateur Radio Service.

(e) *Amateur radio station.* A station licensed in the amateur radio service embracing necessary apparatus at a particular location used for amateur radio communication.

(f) *Primary station.* The principal amateur radio station at a specific land location shown on the station license.

(g) *Military recreation station.* An amateur radio station licensed to the person in charge of a station at a land location provided for the recreational use of amateur radio operators, under military auspices of the Armed Forces of the United States.

(h) *Club station.* A separate amateur radio station licensed to an amateur radio operator acting as a station trustee for a *bona fide* amateur radio organization or society. A *bona fide* amateur radio organization or society shall be composed of at least two persons, one of whom must be a licensed amateur operator, and shall have:

- (1) A name.
- (2) An instrument of organization (e.g., constitution).
- (3) Management, and
- (4) A primary purpose which is devoted to amateur radio activities consistent with 97.1 and constituting the major portion of the club's activities.

(i) *Additional station.* Any amateur radio station licensed to an amateur radio operator normally for a specific land location other than the primary station, which may be one or more of the following:

*Secondary station.* Station licensed for a land location other than the primary station location, i.e., for use at a subordinate location such as an office, vacation home, etc.

*Control station.* Station licensed to conduct remote control of another amateur radio station.

*Auxiliary link station.* Station, other than a repeater station, at a specific land location licensed only for the purpose of automatically relaying radio signals from that location to another specific land location.

*Repeater station.* Station licensed to retransmit automatically the radio signals of other amateur radio stations.

*Special Event Station.* Station licensed at a specific land location for operation related to the celebration of an event, past or present, which is unique, distinct, and of general interest to either the public or to amateur radio operators, for the purpose of bringing public notice to the Amateur Radio Service.

(j) *Space radio station.* An amateur radio station located on an object which is beyond, is intended to go



beyond, or has been beyond the major portion of the earth's atmosphere. (Regulations governing this type of station have not yet been adopted and all applications will be considered on an individual basis.)

(k) *Terrestrial location.* Any point within the major portion of the earth's atmosphere, including aeronautical, land, and maritime locations.

(l) *Space location.* (Reserved)

(m) *Amateur radio operation.* Amateur radio communication conducted by an amateur radio operator from an amateur radio station. May include one or more of the following:

*Fixed operation.* Radio communication conducted from the specific geographical land location shown on the station license.

*Portable operation.* Radio communication conducted from a specific geographical location other than that shown on the station license.

*Mobile operation.* Radio communication conducted while in motion or during halts at unspecified locations.

(n) *Control.* Techniques for accomplishing the prerequisite responsibilities for the immediate operation of an amateur radio station. Must be one or more of the following:

(1) *Local control.* Manual control, with the control operator monitoring the operation on duty at the control point located at a station transmitter with the associated operating adjustments directly accessible. (Direct mechanical control, or direct wire control of a transmitter from a control point located on board any aircraft, vessel, or on the same premises on which the transmitter is located, is also considered local control.)

(2) *Remote Control.* Manual control, with the control operator monitoring the operation on duty at a control point located elsewhere than at the station transmitter, such that the associated operating adjustments are accessible through a control link.

(3) *Automatic Control.* The use of devices and procedures for control so that a control operator does not have to be present at the control point at all times. (Only rules for automatic control of repeater systems have been adopted. Automatic control of all other types of amateur radio stations must be approved by the Commission on a case-by-case basis.)

(c) *Control link.* Apparatus for effecting remote control between a control point and a remotely controlled station.

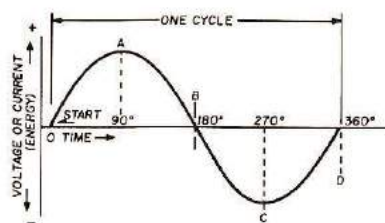

**Fig. 1.** A cycle is a complete rotation or movement of a voltage through its phases, returning to the starting point. By convention we think of a voltage (or current) cycle starting at a zero reference, increasing to its maximum amplitude in the upward (positive) direction, then crossing the zero point and continuing in the negative direction to a peak. From there it returns toward the zero point, where it is ready to start the second cycle. The concept of degrees-of-movement during a cycle is very useful in analyzing behavior of circuits that have ac flowing through them.

(p) *Control operator.* An amateur radio operator designated by the licensee of an amateur radio station to also be responsible for the emissions from that station.

(q) *Control point.* The operating position of an amateur radio station where the control operator function is performed.

(r) *Antenna structures.* Antenna structures include the radiating system, its supporting structures, and any appurtenances mounted thereon.

(s) *Antenna height above average terrain.* The height of the center of radiation of an antenna above an averaged value of the elevation above sea level for the surrounding terrain.

(t) *Transmitter.* Apparatus for converting electrical energy received from a source into radio-frequency electromagnetic energy capable of being radiated.

(u) *Effective radiated power.* The product of the radio-frequency power, expressed in watts, delivered to an antenna, and the relative gain of the antenna over that of a half-wave dipole antenna.

(v) *System network diagram.* A diagram showing each station and its relationship to the other stations in a network of stations, and to control point(s).

(w) *Third-party traffic.* Amateur radio communication by or under the supervision of the control operator at an amateur radio station to another amateur radio station on behalf of anyone other than the control operator.

(x) *Emergency communication.* Any amateur radio communication directly relating to the immediate safety of life of individuals or the immediate protection of property.

(y) *Automatic retransmission.* Retransmission of signals by an amateur radio station whereby the retransmitting station is actuated solely by the presence of a received signal through electrical or electro-mechanical means, i.e., without any direct, positive action by the control operator.

Paragraphs (a) and (c) are self-explanatory, telling what the Amateur Service is, and who an Amateur Radio operator is. In (d) you have the definition of the licenses. This is an important section to understand. Normally, you obtain both a station and an operator's license. The operator's license tells everyone of your qualifications. If you go to visit W1AW and want to operate the equipment, your operator's license tells the control operator what bands and modes you are qualified for. If I come to visit you, your station license tells me what type of station is licensed at that location. There are some interesting situations that arise from a licensee of one class visiting the station of an operator with a different class of license and privileges. We'll cover those later, after you have learned enough about the basic rules to pass your test.

Parts (e) and (f) define an Amateur Radio station and a primary station. The mention of a primary station infers that there are other types of stations, and indeed that is true. As a Novice Class licensee, you will not be concerned with them for the time being, but later on you'll learn about secondary stations, auxiliary link stations, repeater stations, and more.

Control operator (p) is an interesting section; a key word in the definition is *also*. As station licensee, you are responsible for the emissions from the station, but appointing



a control operator does *not* let you off the hook. In other words, if WA1WPP comes over to visit, and I say, "I would like to hear how my station sounds from down the road, you be the control operator for a while and keep an eye on things." Off I go, listening to the quality of the signal. Suddenly, he moves the frequency until the station is out of the band. We have trouble, with a capital T. He is in the soup for doing a "no-no", and so am I, because the station is licensed to me. So watch it, Harold!

A question in this part of the examination might go something like this:

The principal Amateur Radio station at a specific land location shown on the station license is:

- your high-school radio-club station
- a primary station
- the part of your yard that has an antenna on it
- your father's radio workshop

You have studied section 97.3 very well, of course, and know that the correct answer is (b).

### Novice class operator privileges

This is the part that you have been waiting for. You have gone through all this business of what is an Amateur station and why do they exist, and you have been wondering "what's in it for me?" Right? Your privileges are spelled out in part 97.7, as follows:

#### 97.7 Privileges of operator licenses.

(d) *Novice Class.* Those amateur privileges designated and limited as follows:

(1) The power input to the transmitter final amplifying stage supplying radio frequency energy to the antenna shall not exceed 250 watts, exclusive of power for heating the cathode of a vacuum tube(s).

(2) Radio telegraphy is authorized in the frequency bands 3700-3750 kHz, 7100-7150 kHz (7050-7075 kHz when the terrestrial location of the station is not within Region 2), 21,100-21,200 kHz, and 28,100-28,200 kHz, using only type A-1 emission.

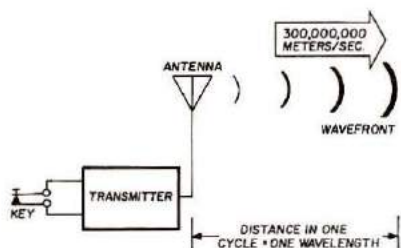

Fig. 2. When you close the key of a transmitter you start a wavefront moving through space. The distance that the wavefront travels in the time that your transmitter emits one cycle of radio-frequency energy is the *wavelength* of that frequency. Your antenna is what, in modern terms, is called an interface — it couples the energy from your transmitter to the space around it.

The Region 2 reference pertains to areas of the world designated by international treaty; the United States is in Region 2, but you might be a Novice class licensee on a United States Territory or Possession located in Region 3, in Western Samoa, for example. In that case, you would be authorized to operate between 7050 and 7075 kHz.

The paragraphs spell it out pretty well, and I cannot suggest any trick for learning them, so you'll just have to commit them to memory. When it comes time for the test, however, there are a couple of things to keep in mind so that you understand the question. Note the language used in the power limitation part. It says the "power input to the transmitter final amplifying stage . . ." In the definition for power input as it applies to other classes of license privileges, they use the term "plate power input to the transmitter final amplifying stage . . ." This is quite a different matter. Plate power input is that being used in the plate circuit alone. For your Novice test, it will most likely include *all* the power input to the tube, exclusive of that used to heat the cathode. This includes the power being fed to the last stage by the previous stage, the power used by the tube screen-grid (if it has one), and the power used by the plate circuit. The total of all of

these circuits must not exceed 250 watts. In other words, *read the question carefully.*

Another example of the care that you must use in answering the questions is shown by the following:

A Novice station being operated on 7091 kHz is:

- working DX
- interfering with another station
- not within its authorized frequency band
- crystal controlled

All four of the answers given could apply, *but only one is the right answer*, and that is (c).

### Radio phenomena

Let's look ahead a few sections for a change of pace, and talk about a more interesting segment of electronics. This section is one of the most useful ones you can study because it tells you how your signals get from one place to another. You'll need to know this to avoid calling CQ on a dead band sometime, or to figure out when to look for stations in a certain part of the world to be coming through. This Radio Phenomena section includes the following subjects:

- Sky wave
- Ground wave
- Refraction
- Sunspot cycle
- Skip distance
- Wavelength
- Ionosphere

These are not presented in any logical order, so I'll pick out number 6, Wavelength, to start with because the whole radio propagation system depends upon this wavelength factor.

A wavelength is the distance that your radio-frequency wave (or *wavefront*) will travel during one *cycle*. Now it appears that before I can talk about wavelength I'll have to explain cycle. A cycle is the complete swing of something through all of its motions (positions, areas) back to its starting point. There are plenty of examples in nature — the moon goes



through a cycle of four phases (full moon, new moon, first quarter, last quarter). The earth goes through four seasons; insects and plants go through cycles; and so on.

Alternating current goes through a cycle too, and radio-frequency waves or energy are a form of alternating current. It naturally starts at zero (Fig. 1) because before anything is turned on, there is no current flowing and no voltage present. As time progresses, the energy (voltage and current) builds up until it reaches its peak at point A, which is 90 degrees, or one-quarter of the cycle.

There is no hard rule that says it should always start in a positive, or upward direction; it is a convention that we have become accustomed to using in our thinking and drawing. After the energy reaches a peak in one direction, it starts a decay, or decrease, toward the zero-potential line again, and at point B it crosses that line, which is 180 degrees, or half of a cycle. The energy builds up in the negative (or opposite) direction until it reaches a peak there, point C, at 270 degrees, or three-quarters of a cycle. The inevitable decrease follows, to bring it again to the zero line, for one complete cycle. It is then ready to start all over again. This whole business was easy to follow in the early days when the only ac that they knew about was generated by a rotary coil, turning inside a magnetic field. Now we use electronic circuits to generate the ac used at radio frequencies, but it comes out just the same as if it were being done by a spinning coil.

Now to tie this in with wavelength, you must remember that when you close the switch (key) to start sending a signal, you start a wavefront moving through space (Fig. 2). It will keep moving as long as you hold the key down. Wavelength is the distance that the wave will travel during one cycle of the energy from your transmitter. If

you are operating a transmitter in the Novice band at, say, 3700 kilohertz, the wave will travel 81.08 meters during one cycle. Note the emphasis on the word cycle. You are operating on 3700 kilohertz (kHz) which is the same as 3.7 million cycles per second. The term hertz is used to mean *cycles-per-second*, to keep you from wondering what cps stands for (cucumbers-per-season?).

You can see that the wave is moving pretty fast if it got 80 meters away during just one of those 3.7 million cycles! The velocity of a wavelength in space is 300,000,000 meters per second, and that is how you obtain the wavelength:

$$\lambda (\text{wavelength}) = \frac{300,000,000}{f (\text{hertz})}$$

Using the frequency we were just talking about:

$$\lambda = \frac{300,000,000}{3,700,000}$$

or, to get rid of some zeroes above and below the line:

$$\lambda = \frac{300,000}{3700} = 81.08 \text{ meters}$$

In the very early days of radio, Amateurs and commercial stations alike used the wavelength term to describe where they were operating, often carrying the figure out to 4 or 5 decimal places, which became quite cumbersome. Many short-wave broadcast stations still use the meter and fractional meter system to inform their audiences where to look for them on their receiver dials.

Oh, yes, if you want to turn that formula around and find a frequency when the wavelength is given, it is:

$$f = \frac{300,000,000}{\lambda (\text{wavelength})}$$

In the next installment of Questions and Answers, I'll continue with the Rules and Regulations section, and time permitting, dig a little more into this wavelength thing and how it ties into the manner in which signals get around the world.

# 2 METER FM

and HF too ...  
Summer Specials On  
**HAND HELDS**



Standard  
Wilson  
Plus Antennas  
All Other Accessories

In Stock!  
Call or Write for  
**Erickson's Deal**

- Ameco • ASP • Atlas
- Belden • Bird • CDE
- CES • Collins • Cushcraft
- Dentron • Drake • HAL
- Hy-Gain • Icom • KLM
- Kenwood • Larsen • MFJ
- Midland • Mosley • NPC
- Newtronics • Nye
- Regency • Shure • Swan
- Standard • TPL • Tempo
- Ten-Tec • Wilson • Yaesu



An Excellent Selection of Fine  
Used Equipment Always in Stock

Hours: 9:30-9 Mon. & Thurs,  
9:30-5:30 Tues, Wed. & Fri. 9-3 Sat.

**ERICKSON COMMUNICATIONS**  
5935 N. Milwaukee Ave.  
Chicago, IL 60646  
(312) 631-5181





## A house is not a home

**BY CHARLENE KNADLE, WB2HJD**

My friend Anne is an artist; the walls of her home are lined with her paintings. Jack is fantastic at woodworking; his living room is furnished with handmade furniture and lighted with lamps of his own creation. Tom is a photographer; the many moods of his family appear in clusters and montages throughout his house. My husband and I are ham radio operators — why shouldn't our house reflect this?

Some people can tell right away. Those who are

accustomed to looking up (and there are some — I know people who determine where the North is by checking to see which way TV antennas are aimed) see the tall Rohn tower laden with a variety of Yagis, dishes, and corner reflectors, and they know. Others glance into the backyard at the children's climbing apparatus, and they know: It is two sections of AB216 tower.

Once they are in the house there is little doubt. A rig is always on, and a variety of sounds emanate from a room at the back of the house. You don't go down to get to the

hamshack, you don't go up. (No basement or attic station for us!) You go straight back, to what was meant to be a bedroom. On your way, you pass a full-wall bookshelf with large sections devoted to a collection of Amateur Radio magazines. In the shack itself, there is another bookshelf containing the current issues.

The house is large enough for elbow room, but small enough that the *on-the-air* voice can be heard by anyone who chooses to listen (from almost anywhere except the kitchen which has its own sounds). The hamshack is comfortable





On your way to the shack, you pass a full-wall bookshelf largely devoted to amateur radio books and magazines.

enough to attract the curious, and there are times when the whole family gathers there.

The room is conducive to work; it is there that I have my typewriter. The chest of drawers is deceptive — it contains tools. The children use a spare microphone and ask that it be hooked to the oscilloscope so they can watch their own modulations. Dick drills holes in the boom of a Yagi antenna while he listens on 432 MHz.

"That's fine for you," you say. "It works because you're both hams."

Well, what about my artist friend Anne? Her husband does not paint, yet their home is her gallery; he does not object. Tom's photographs do not

The chest of drawers is deceptive — it contains tools. There are plaques on the wall that mark Dick's achievements as an experimenter and writer.



offend his non-photographer wife. (Do your needlepoint, homemade curtains, plants, or sculptures offend your husband?) To some eyes, a soldering gun next to an unfinished chassis full of wires and transistors is a work of art; so be it. (Is it offensive for you to have your sewing machine out for weeks?)

I love seeing evidence of work in progress, of creative people involved in a project. It smells of life. When my friend Nora closed a door and said, "I can't let you see our study; it's a mess," I felt a twinge of regret. It was probably the most interesting room in her whole better-homes-and-gardens house.

There is too much standardization today. Advertisers lead us to believe that a certain look is right, and we fly in a flurry trying to achieve it. Advertisers and designers have never heard of Amateur Radio. That's how the basement/attic/garage syndrome got started in the first place. One thing the big CB boom may do for us hams is to take Amateur Radio out of the closet. It's socially acceptable now.

In fact, there is status in it. Give it a try. Casually leave your two-meter rig on a living-room chair (if you can spare it) when people are likely to be coming in. Everyone who knows a good buddy will fall all over each other trying to top one another with radio stories. "And what *is* the difference between CB and Amateur Radio, anyway?" they'll ask you with a look of admiration. You're the expert now. (I've heard it said that a ham is a CBER with a PhD, but I don't think that's the right attitude. Today's CBER is more of a

A crewel kit for the "Shack Sweet Shack" plaque including yarn, directions, and design stamped on linen, is available from Greenwood's, RFD 2, Hollis Street, Groton, Massachusetts 01450 for \$14.95. Needlework and thread-count kits are also available on request from Greenwood's.



The room is conducive to work. It is here that I have my typewriter, and the children have a spare microphone that can be hooked to an oscilloscope.

status seeker rather than a potential ham who failed.)

How many CBERs do you know who can fix their rigs if something goes wrong? (A handful of hams are doing very well for themselves installing and servicing CB rigs.) In this crepe-paper world anybody can have anything, with a little money. What you can't buy is ability. Sure, your choices make a statement about you, but so does a room full of components and some tools. It shows that you can *do* things, not just *buy* things.

So if someone at your house is a ham, let it show. Bring the hamshack up from the basement; down from the attic. Use an antique rig to make a lamp. Display your call letters by the front-door knocker. Create a wall display of QSL cards that tells your visitors a story. But especially, leave the door to the hamshack open. We're part of a pretty special and capable group. Let's live it up!

HRH

Husband Dick, K2RIW . . . "make a display of cards on a door to show people where you can talk to."





# BROADCASTING...



BY BOB BAIRD, W7CSD

When I was about fourteen years old, I visited radio station KFBL in Everett, Washington. The old broadcast station was located on the second floor of a 1900-vintage building whose first floor was occupied by Leese Brothers Radio Sales and Service. The Leese Brothers owned the shop, the radio station, and — presumably — the building, although I can't say for sure. This probably accounted for the "BL" of KFBL, standing for "Brothers Leese".

The station was started way back at the dawn of commercial radio broadcasting in 1922 or 1923 and, from what I have been told, a 1000-volt storage battery was used for the power supply. This probably was true, because when I visited there the old open-blade knife switches mounted on slate panels were very much in evidence.

Eventually the station came under new ownership and management, and acquired the call letters KRKO. In 1934, with a brand-new First Class Radiotelephone license in my pocket, I began my career with KRKO as a part-time operator, disc jockey, announcer, and general factotum. My license,

incidentally, was printed on white paper (not the familiar blue paper that appeared later) and bore the name *Federal Radio Commission*, which had been crossed out and replaced by the words *Federal Communications Commission* neatly typed in above the old letters.

By 1934, the Leese Brothers' radio shop had been replaced by the Log Cabin Beer Parlor.

In the concrete sidewalk outside the big double doors leading up to the station, were brass letters that boldly stated ST. JAMES HOTEL. These had come from an earlier, and perhaps kinder, era, although part of the upper floor of the old building sometimes served as sort of a hotel — when it was not empty!

At the top of the creaky wooden stairs, visitors turned

In the four years before KDKA went on the air in 1920, Dr. Frank Conrad, Assistant Chief Engineer of Westinghouse, used this transmitter to send out radio telephone programs. Located on the second floor of a garage at the rear of his home in Wilkensburg, Pennsylvania, the transmitter was station 8XK — one of the forerunners of modern radio (photo courtesy KDKA).

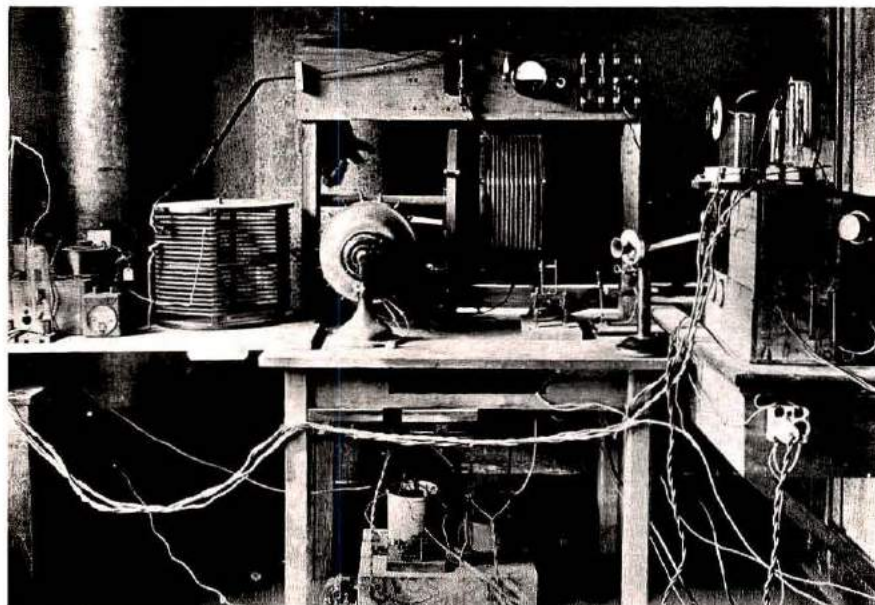



right into the part of the building that housed the station. If someone mistakenly turned left at the top of the stairs — as occasionally happened — he might be embarrassed to find himself in an empty building, or a hotel occupied by guests, depending upon the month and year.

The station occupied three rooms opening on a hall. The back room housed the transmitter, control room, announcer's booth, and record-playing equipment. The center room was a live-program studio lined with heavy drapes for sound-proofing and echo-suppression, and the front room was a combination record library and business office. There was no plumbing in the radio station, so any station employee who might have need of same quickly placed a 15-minute transcription of *Ted Rio Rita* on the turntable and

dashed downstairs to the beer parlor.

The station antenna was a 60-foot flat top strung above the roof between two-poles located at opposite ends of the building, and the "ground" system was a scramble of wires (counterpoise) lying on the roof.

#### Equipment

The station had a rated power output of 50 watts. Its transmitter consisted of a crystal oscillator using a type 210 tube, a buffer stage using another 210 tube, and a final amplifier consisting of a pair of tin-plate 203A tubes, modulated by a 212D tube in a Heising circuit. All of this was mounted behind three panels, some slate and some bakelite, each about 6 feet (1.8 meters) high and 2 feet (60cm) wide. There were two other similar panels. Part of one panel held a frequency monitor and a



Aeriola Jr. was the first popular-priced home radio receiver. This tiny crystal set, designed by KDKA engineers in 1921, employed earphones, had a range of 12-15 miles (19-25km) and sold for \$25. At last there was a set simple enough to be operated by non-technical fans and inexpensive enough to be afforded by every household (photo courtesy KDKA).

broadcast receiver, while the other was full of unused knife switches and switchboard meters of a by-gone era.

A separate steel-and-wire cage held the power supply which consisted of a mercury-arc rectifier and associated oil-bath container.

The control table held two old-style hysteresis, aluminum-disc-type, 78 rpm phonograph motors and Audak pickups with quarter-pound (0.55kg) "wrist action" heads. These used steel needles that had to be changed for every record. An audio-mixing board (made of wood) was mounted directly above the control table, and the announcer's carbon mike was suspended on several lengths of water pipe and an elbow or two.

The audio equipment itself was mounted in a wooden box under the table and, as I recall, consisted of a single 271A tube whose output was fed across the room to the transmitter modulator. Two 16-inch (41cm) transcription tables, driven by 1/3 horsepower motors and a worm gear box, were mounted on cast-iron pedestals. One of these did not work.

The studio contained a piano

#### Glossary of Terms

**Heising Modulation** is an inexpensive modulation system named for its inventor. The plate of an audio tube is connected to the plate of an rf tube through a large coil (transformer winding) and both are connected to a common high-voltage power supply. The varying audio signal causes the plate voltage to vary and thereby modulates the rf carrier.

**Mercury-Arc Rectifier** is a glass bottle, or tube, containing metallic mercury which, when heated, vaporizes and ionizes under application of high voltage. The ionized gas conducts current from one plate to the other of the two-plate (diode) tube.

**Hysteresis Motor** is a synchronous motor that operates without poles or dc excitation because of losses in the magnetic material of its coils produced by a rotating magnetic field.

**Carbon Mike** is a microphone containing tightly-packed grains

of carbon which, when vibrated by sound waves, change their electrical resistance and — hence — current flowing through them, at an audio rate. The changing current is applied to the audio amplifier to produce modulation.

**Y-Cut Crystal** is a quartz crystal that is cut so that its major faces are perpendicular to the Y axis of the natural crystal. When voltage is applied across these faces, the crystal vibrates at a frequency depending upon its thickness.

**Condenser Microphone** is also called a capacitor or electrostatic microphone. Two thin plates, separated by an insulating material, such as air, are caused to vibrate by sound waves. The vibrations cause changes in the electrostatic field between the plates when voltage is applied to them. The changing field causes a change in current flow, which is then applied to a modulator tube or stage.



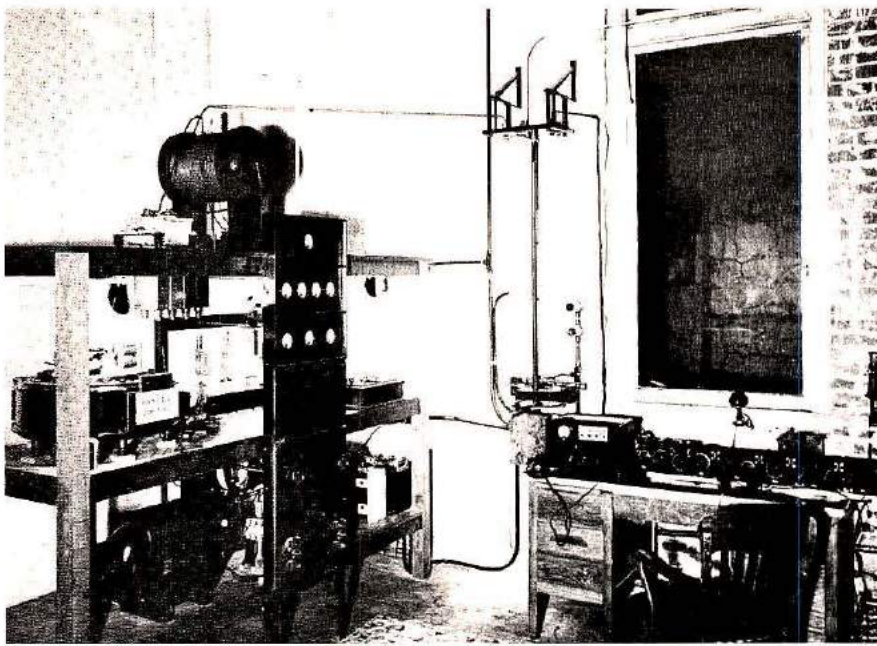

Typical transmitter and control room of an early broadcast station, circa 1923. Notice the large antenna-loading coil and the operator's console — a far cry from today's stations.

and a good Remler condenser microphone with a preamplifier. There was a monitor speaker and amplifier hooked into the system somewhere. Modulation meters had not yet been thought of, and oscilloscopes were in their infancy, so the modulation indicator was a piece of neon tubing mounted on top of the front panel of the transmitter and connected to the final amplifier stage. If it flickered under modulation, we were in business! And that, dear reader, is all we had!

#### Opening procedure

The first thing we did every morning was to take a dart, made from a steel pen-point, a match, and a paper tail, out of one wall of the control room and throw it at the opposite wall. If we did not do this, the station would be certain to go off the air sometime during that day. Honest Injun!

The second thing we did was turn on all the filaments and, after a few seconds, turn on the power. This did not fire up the final amplifier, however. To do that, we had to rock the mercury-arc rectifier back and forth to establish the arc, and

then push another switch. If we were lucky, about 1500 volts would be delivered to the Heising modulator, and the remainder of about 800 volts would be fed to the final

amplifier stage. Next, we had to adjust the oscillator frequency by turning the tuning knob or, if worse came to worse, we had to readjust the thermostat of the crystal oven; and thereby hangs a tale.

#### The red light episode

To begin with, the crystal oscillator in that old bucket of bolts was *battery* biased. "This cannot be," you say? That's right, it couldn't be, but it was! It would never begin oscillating by itself, but with the buffer connected it would oscillate — and did, every day. Just to see what would happen, I disconnected the buffer one day, and the oscillator did not "take off." Normally, the buffer was powered at the same time as the oscillator, so everything worked when we turned it on.

An unusual feature of this particular circuit was that the oscillator would perform, regardless of where the tuned circuit resonated, and we could shift the frequency by several hundred cycles (Hertz) just by turning the knob of the plate-

This was the original transmitter room used to broadcast KDKA's famous Harding-Cox Election results on November 2, 1920. It was located in East Pittsburgh, Pennsylvania (photo courtesy KDKA).

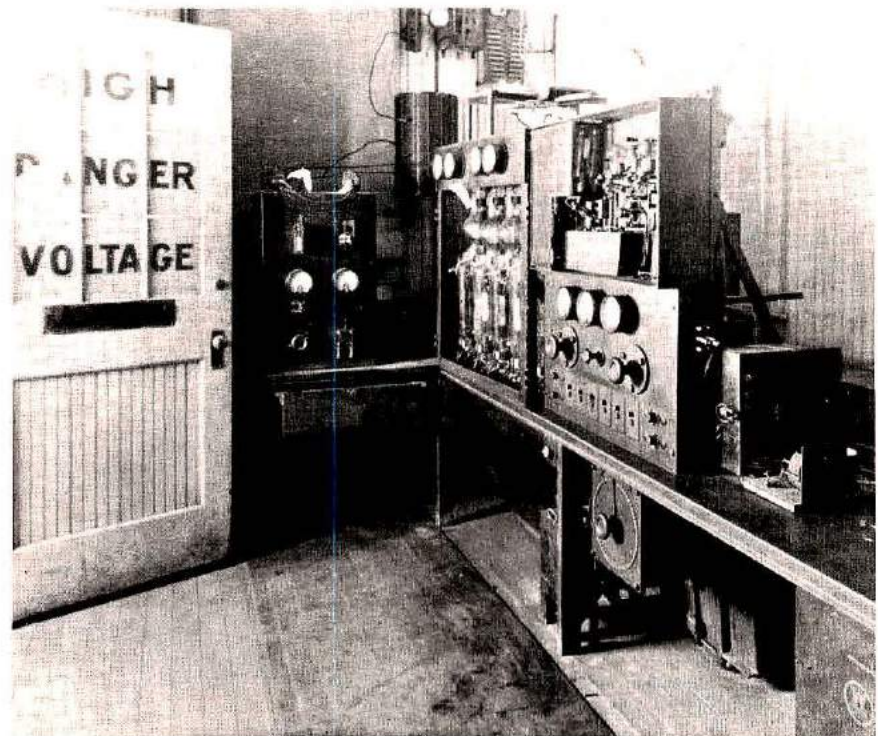



tank capacitor (we called them condensers in those days). I suspect that was the reason for the battery bias — to help stability. Incidentally, there were absolutely no circuit diagrams of anything in the station!

In those years, the FCC required that the transmitter output frequency be within 50 Hz of the station's assigned frequency. The oscillator crystal was Y-cut, with one corner chipped off, which made it very temperature sensitive. The crystal oven had been made from an old "B-eliminator" case lined with asbestos and heated by two 25-watt light bulbs. The thermostat was a piece of hard rubber on a threaded shaft having a contact on one end. When the hard rubber expanded, the movable contact at the end of the rod touched a fixed contact which actuated a relay, and turned the lights off. By adjusting the threaded shaft, we could set the oven for a particular temperature.

In this way, by adjusting temperature and observing frequency regulation, we could finally achieve the proper setting to place our output frequency within the permitted plus or minus 50-Hz tolerance.

Now the joker in all of this is that one of the bulbs in the temperature control box (crystal oven) was white, and the other, red. I had been warned that if the red bulb should ever go out, I was to run down immediately to the drug store and get another. Well, eventually the red bulb did burn out, but I didn't go to the drug store; I merely replaced the red bulb with a spare white one that was at hand. In a couple of hours, I had the transmitter frequency stabilized to within about 10 Hz. The next morning, we were off by about 200 Hz, so I adjusted everything again. The second morning, same song — second verse, and it just repeated the same thing all week. Finally, I got another red bulb, replaced the white one,

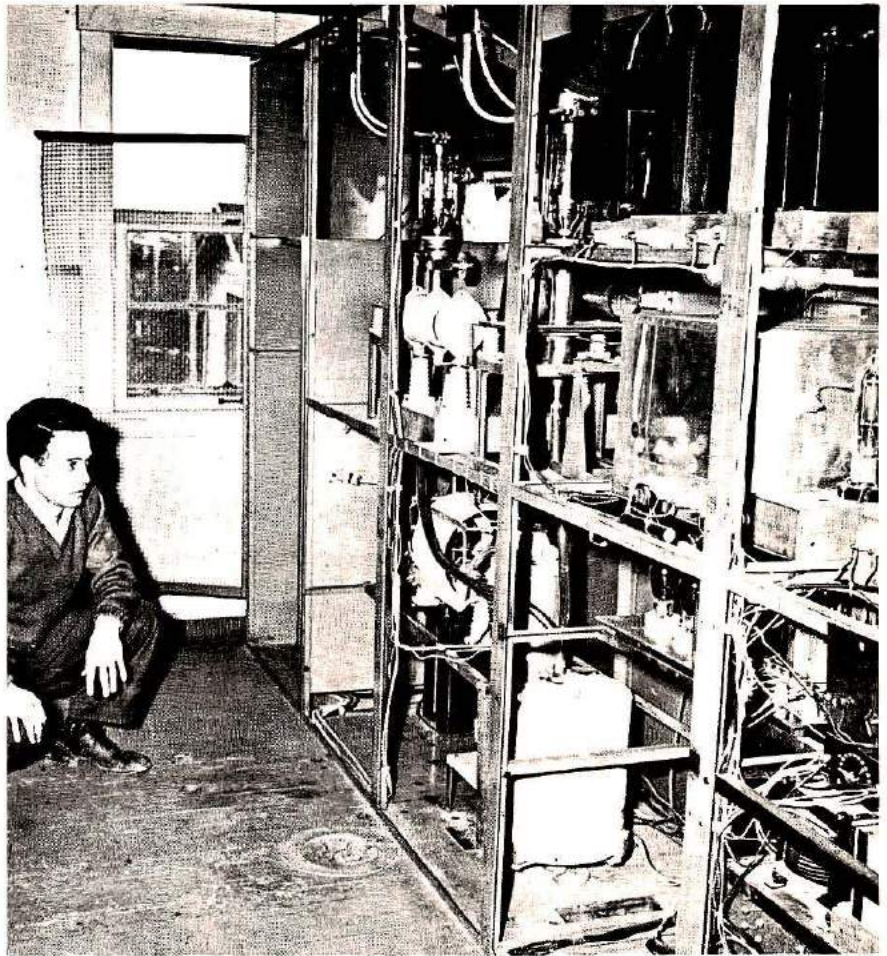

The more elaborate, high-power stations used built-in cabinets and racks to hold the power supply components, including a huge transformer, shown at the bottom of the picture in front of the operator. Note the high-voltage leads at the top, connected to the rectifier tubes. Definitely a "kluge" today, but the "last word" in the 1920s and early 1930s.

made one more adjustment, and had no trouble for months! Spooks? Maybe so.

### The mercury vapor episode

The mercury-arc rectifier consisted of a gargantuan glass bulb with two "arms" protruding at the sides. The center portion of KRKO's rectifier was about 4 inches (10cm) in diameter, and stood about a foot (30cm) high. The "arms" were each about 2 inches (5cm) in diameter, and curved outwardly and upwardly away from the body of the tube. At the end of each arm was an anode (high-voltage) contact.

I never really liked this monster very well, and I observed that if it should ever blow up, the control room would be a very unhealthy

place; breathing mercury vapor can be lethal! So, as you might expect, one dark night it went — *Kapow! Klink!* I held my breath, rushed out to fresh air, and — in about ten minutes — came back in. All was silent and dark; broadcasting was at an end for that evening.

It was immediately decided that the mercury-arc rectifier had to go, never to return. So, late that same night, we managed to scrounge a couple of 866 tubes and a filament transformer from a local ham, and we were back on the air in the morning with our revitalized power supply.

I poured the mercury out of the broken rectifier bottle into an empty "Coke" glass, nearly filling it. I estimate that this amounted to about 5 pounds





A soloist was expected to ignore the "Silence" sign in this 1925 KDKA studio located at a Westinghouse building in East Pittsburgh. The studio was amply padded to help subdue any unwanted sounds during the early live broadcasts (photo courtesy KDKA).

(2.3kg) of mercury. I placed the glass — full of mercury — on the floor of the studio, next to the couch. Now, in those days, we had a newsman at the station whose normal blood-alcohol content approached 30 per cent. The next day I found him lying on the couch with a tall drink of some kind placed on the floor, only a short distance away from the glass of mercury. He was in no condition to tell which was which and, although I'm sure that he could have never raised that 5 pounds of mercury to his mouth, I did remove it with great speed!

#### **The case of the open-blade knife switch**

As I've already mentioned, there was one panel full of unused switches and meters. There was even one spring-loaded knife switch, good for 500 amps. On the front panel of the section containing the modulator and final amplifier was a real live knife switch in series with the 1500 volts B+. Needless to say, that open-bladed switch was hotter than a firecracker, and everybody knew it. Nevertheless, it was common practice to open the switch just slightly, thereby establishing an arc to light a

piece of paper. Having lit the paper, it was possible to light a cigarette without the aid of a match; and it seemed that operators and announcers were always without matches.

Well, one bright day, the Radio Inspector came along and inquired about this knife switch, wondering what it was doing on the front panel. When informed it was in the high voltage lead, he immediately wrote out a citation. Solution: The operator-in-charge took the knife switch and mounted it behind the front panel in the same holes, but with only the bare bolts showing. It's always better to be safe than sorry!

#### **The case of the burned out Heising resistor**

One day, the Heising "dropping" resistor burned out, and the duty operator called me on the phone for help. By the time I got there, he was trying to measure the resistance of the pieces of the resistor with an ohmmeter. He said, "The resistor wasn't labeled and I can't figure out what the values of the broken pieces are." (My observation is that this is the level of a lot of present-day holders of First Class Radio Telephone licenses.) I said, "The input was 1500 volts, and

we delivered 800 volts to the final. That gives a drop of 700 volts at a plate current of 125 milliamps. Unless Ohm's law has been repealed, we need 700 divided by 0.125, which equals about 5600 ohms." So we went down and bought a 5000-ohm, 100-watt resistor and got back on the air in about an hour.

#### **The phantom of the organ**

Much has been written about slips of the tongue that have gotten out thru a supposedly turned-off mike. I don't recall anything worse than, "Hey, Pat, where's my cigarettes?" We did get a buxom soprano, who had to stand back three feet from the mike to keep from overloading it, on the air one time. The wall was paper thin, anyway, and the announcer forgot to turn off the "announce" mike. About the time this babe got wound up, the announcer leaned back and said into the announce mike, "Home to the laundry lady, home to the laundry." This was a bit of a sticky wicket.

But the one that amused me the most was the drunk on the *Phantom of the Organ* program. Several times a week after the last show, we put on an organ-music program from one of the local theaters. We called it *The Phantom of the Organ*, and it really was fun to climb down inside the orchestra pit and watch this old boy perform. The organ was a three-keyboard job with forty-seven tabs on it, and the old gent could really make it talk.

We would place the Remler condenser mike right in front of the first row of seats in the theater and, for that day and age, it did a remarkable job. One night, the announcer put the show on the air and then climbed down into the pit to watch the organist. But, after the show, an inebriate had failed to leave the theater. Just in between numbers when the music was very soft, he got up in front of the mike and said: "Shay, mishter, will you play



*I Love You Truly* for my wife at home?"

### The barter system

A 50-watt station in competition with other stations 25 miles away had a pretty rough time in the middle of the Depression. Cash was hard to come by. To stay alive at all, it was necessary to sell "time" paid for in trade. The power and telephone bills were paid by advertising. I never got a paycheck in cash, but received cords of wood, suits of clothes, typewriters, and permanent waves for my mother. I tried to get a diamond engagement ring for my wife-to-be one time, but that was too hard to negotiate.

At the time I left, there were hundreds of dollars-worth of laundry or dry-cleaning credit; consequently nobody did their own wash. The manager's wife was getting a fur coat and a grand piano, but they didn't have enough groceries. The church and the local mortuary were outstanding cash accounts. Nobody would be paid off in sermons or caskets!

We had a paunchy cowboy singer who hocked his guitar to buy a marriage license. He didn't have any money to pay

the preacher, but he knew the preacher to be an avid fisherman. So, several weeks later he got a nice fishing pole in payment on an account, and took it over to the preacher in return for his services. Operating on the barter system was a real headache!

One of the local hams became quite interested in building a condenser mike. He was very successful; in fact, the station bought the mike from him and suspended it with salt water fishline from the ceiling and walls in the control room, thus retiring our old WE 387W carbon mike. But hereby hangs a tale . . .

In the Puget Sound area the humidity gets pretty high, and the spacing between the stretched-aluminum diaphragm and the back plate of a capacitor head on such a mike is only a few thousandths of an inch. Also, the potential difference between the two surfaces is several hundred volts, dc. Well, when the weather got a bit wet, the thing would arc over. Several cures were tried, but a thin rubber membrane stretched over the back plate finally did the job.

Besides the Remler

condenser mike there was one really good piece of equipment in the station: An International frequency monitor, the granddaddy of modern counters. It started out with a temperature-controlled 50-kHz quartz bar which drove either some kind of a multivibrator or blocking oscillator that produced markers every ten kilohertz, the full length of the broadcast band. For normal operation, a short pick-up antenna was placed near the transmitter, the dial tuned to the proper frequency, and the frequency deviation observed directly from a meter.

In conjunction with a TRF receiver, we had an old three-dial tuner; a Grebe, with the Chinaman on the front panel. You could stuff the frequency meter antenna inside the Grebe's detector coil, tune in stations as much as a hundred miles away, and read out their deviation. This was very helpful to neighboring stations that had frequency-meter troubles. It was the only one of these I have ever seen, but it was a Jim Dandy.

### DX in the broadcast band

You wouldn't expect to get many DX reports with 50 watts on 1370 kHz, but, when we did, I expect the horizontal antenna was responsible. Each month we made a 20-minute frequency check with a monitoring station at about two o'clock in the morning. Almost invariably we received a letter from someone in New Zealand, giving the names of the records we had played and requesting an acknowledgement card. **HRH**

This tent atop the Westinghouse K building in East Pittsburgh, Pennsylvania, was KDKA's first studio. It was the cause of some of early radio's "rare" moments, like the whistle of a passing freight train heard nightly at 8:30 PM. A tenor's aria was once abruptly concluded when an insect flew into his mouth. This make-shift studio remained in use until late 1921 (photo courtesy KDKA).



### Author's note:

The events and equipment I describe are as I remember them and are indeed true, to the best of my knowledge. Most of the incidents were either personally observed, or related by others of earlier experience. I presume them to be reasonably accurate.



# DenTron Radios... Built by Americans for the whole world.

One of the greatest pleasures ham radio brings is contact with distant lands. What other organization can boast of daily communication among its members throughout the world?

It's a great hobby and we want to make it more fun for you!

DenTron antenna tuners do just that. Our Super Tuners are the only tuners on the market capable of matching everything between 160 and 10 meters, plus handling 1-3 KW PEP.



G.



F.

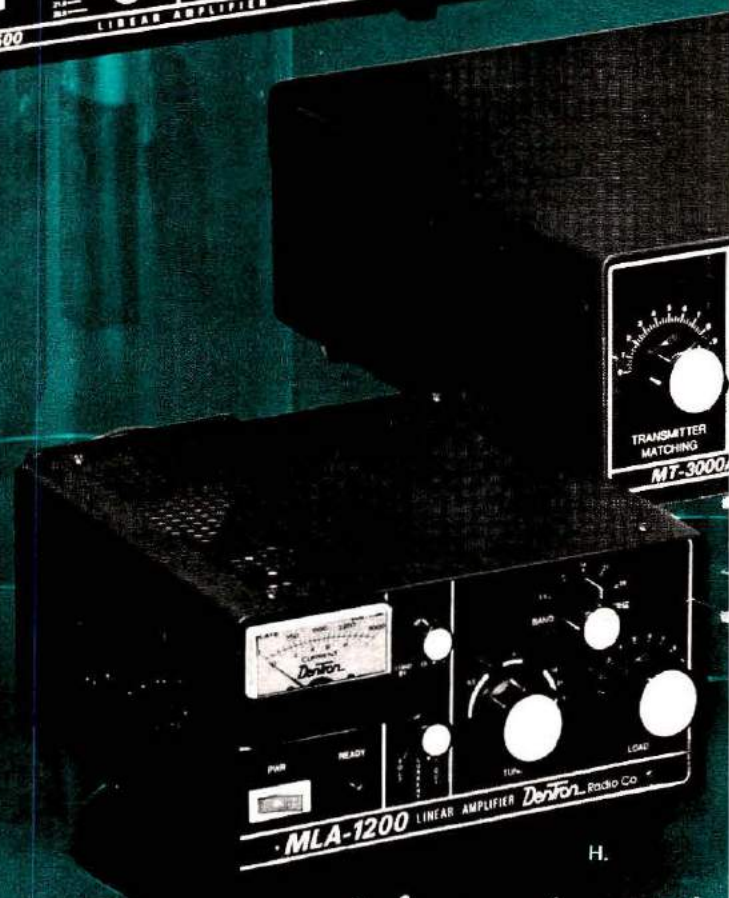

H.

*Professional hams depend on*



**A. The Original Super Tuner 1KW PEP \$129.50.**

If you're new at ham radio you'll find it's invaluable.

**B. Super Super Tuner 3KW \$229.50.**

If you've added more power to your station it's a must. Both the Super Tuner and the Super Super Tuner match balanced feed, coax, random or long wire. Both transfer maximum power from the transmitter to the antenna.

**C. NEW! The MT-3000A \$349.50.**

The MT-3000A was designed for the serious ham interested in professionalizing his station. It is a rugged antenna tuner that easily handles 3KW PEP. It has built-in dual watt meters, and a built-in dummy load. The antenna selector switch: (a) enables you to by-pass the tuner direct; (b) select the dummy load or 5 other antenna systems.

**D. 80-10 Wire Tuner \$59.50.**

Our random wire tuner handles 500 watts and is ideal for the ham on the move.

**E. W-2 Watt meter \$99.50.**

DenTron's dual in-line Wattmeter allows you to read forward and reflected watts simultaneously.

**F. SuperAmp \$574.50.**

The SuperAmp is one of the best amplifier values currently on the market. It covers 160-10 meters, and features four 572B triodes in grounded grid. With it add 2000 watts PEP SSB and 1KW CW power. No other amplifier delivers so much at such a reasonable price.

**G. NEW! MLA-2500 \$799.50.**

The MLA-2500 is one of the world's finest high performance military amateur amplifiers. It was designed for the discriminating buyer who knows and appreciates precision plus power. Coast along with a full 2000 watts PEP input on SSB, 1000 watts DC input on CW, RTTY, or SSTV. The heart of the MLA-2500 is a heavy duty, self contained power supply, and it features 2 Eimac 8875's.

**H. NEW! MLA-1200 \$399.50,**

external AC supply, \$159.50, DC supply \$199.50. The MLA-1200 shares many fine features with its famous big brother, the MLA-2500, but also has a few distinctive features of its own. It employs a single Eimac 8875, running 1200 watts PEP or 1KW DC. It incorporates the same built-in ALC as the 2500. The MLA-1200 is the smallest 1200 watt linear amplifier on the market, great for your mobile home, boat or car!



**DenTron**

Radio Co., Inc.

2100 Enterprise Parkway  
Twinsburg, Ohio 44087  
Phone (216) 425-3173



*DenTron for Amateur fun!*



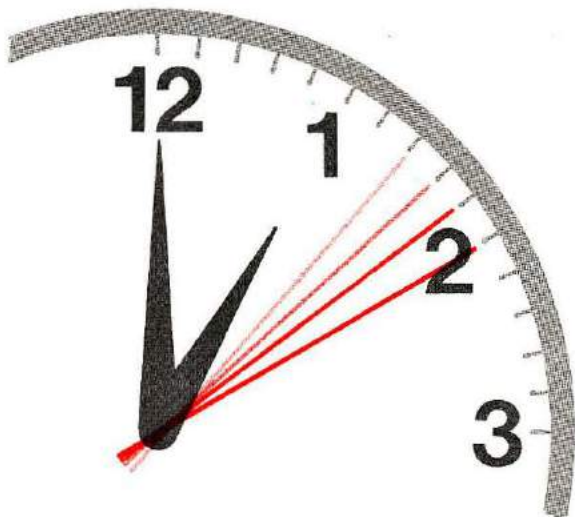

# Time and Time Again

*"When the tone returns, the exact time will be . . ."*

BY JAMES H. GRAY, W2EUQ

"My watch has stopped again! What time is it, anyway?" Sound familiar? This scene is repeated daily, with variations, everywhere on earth by thousands of people in all walks of life. Like it or not, we live by the clock, and the world's work depends upon knowing what time it is.

Astronomers and observatories, airlines and marine shipping companies, electric power and telephone companies, radio and TV broadcasting stations, research laboratories, scientific and industrial organizations, navigators, and even Radio Amateurs and shortwave listeners have a need to know the correct time to successfully carry on their activities. Man regulates his life by the clock and apparently has always done so, even in prehistoric times, if the pyramids, Stonehenge, and Mayan sundials and calendars are meaningful.

Sundials gave way to water clocks which, in turn, yielded to weight-operated clocks, and finally to spring-driven timepieces. These familiar and ordinary watches and clocks, in turn, were replaced by electrically or electronically regulated devices which depend upon mechanical

tuning forks or piezo electric crystal oscillators to provide increasingly accurate time information. For laboratory and similar standards, even these aren't accurate enough, and the major standards are now controlled by "atomic clocks," in which atoms of the elements cesium or rubidium provide the frequency — hence, time — control.

In the United States, the

National Bureau of Standards operates radio stations WWV, WWVH, WWVB, and WWVL which provide standard signals together with many other useful services; and in Canada, the National Research Council operates radio station CHU, which provides the time service.

Let's take a look at these two major facilities in more detail, with an eye toward the type of

A view of both WWVB/WWVL and WWV (right) from the top of one of the antenna-support towers. The steering-wheel-like objects at the lower left are anti-static or anti-corona devices (*photo courtesy US Department of Commerce*).





information that is provided and by what means.

### WWV and WWVH

For more than 50 years, the National Bureau of Standards, (NBS), under the United States Department of Commerce, has provided internationally-recognized time and frequency standards for worldwide users of this service.

Since the inception of the broadcast services from radio station WWV in 1923, NBS has continually improved and expanded its time and frequency dissemination services to meet the needs of a growing community of users in the United States and elsewhere. NBS has made, and continues to make, major contributions to the nation's space and defense programs, to worldwide transportation and communications, and to a multitude of industrial operations.

In addition, NBS provides a convenient, highly accurate time service to thousands of users throughout the world. Its services are available from station WWV and WWVB in Fort Collins, Colorado, and from WWVH in Kaula, Hawaii. Beyond this, a new calibration method using network television is also available.

NBS broadcasts continuous signals from its high-frequency radio stations WWV and WWVH on 2.5, 5, 10, and 15 MHz. These widely-spaced frequencies practically insure that users anywhere in the United States can receive at least one of them at any time of the day or night to receive needed time and frequency information. Except during times of severe magnetic disturbances, which tend to make all reception of radio transmission impossible, listeners will find that the frequencies above 10 MHz provide the best daytime reception, while frequencies below 10 MHz provide the best night-time reception.

Services provided by these

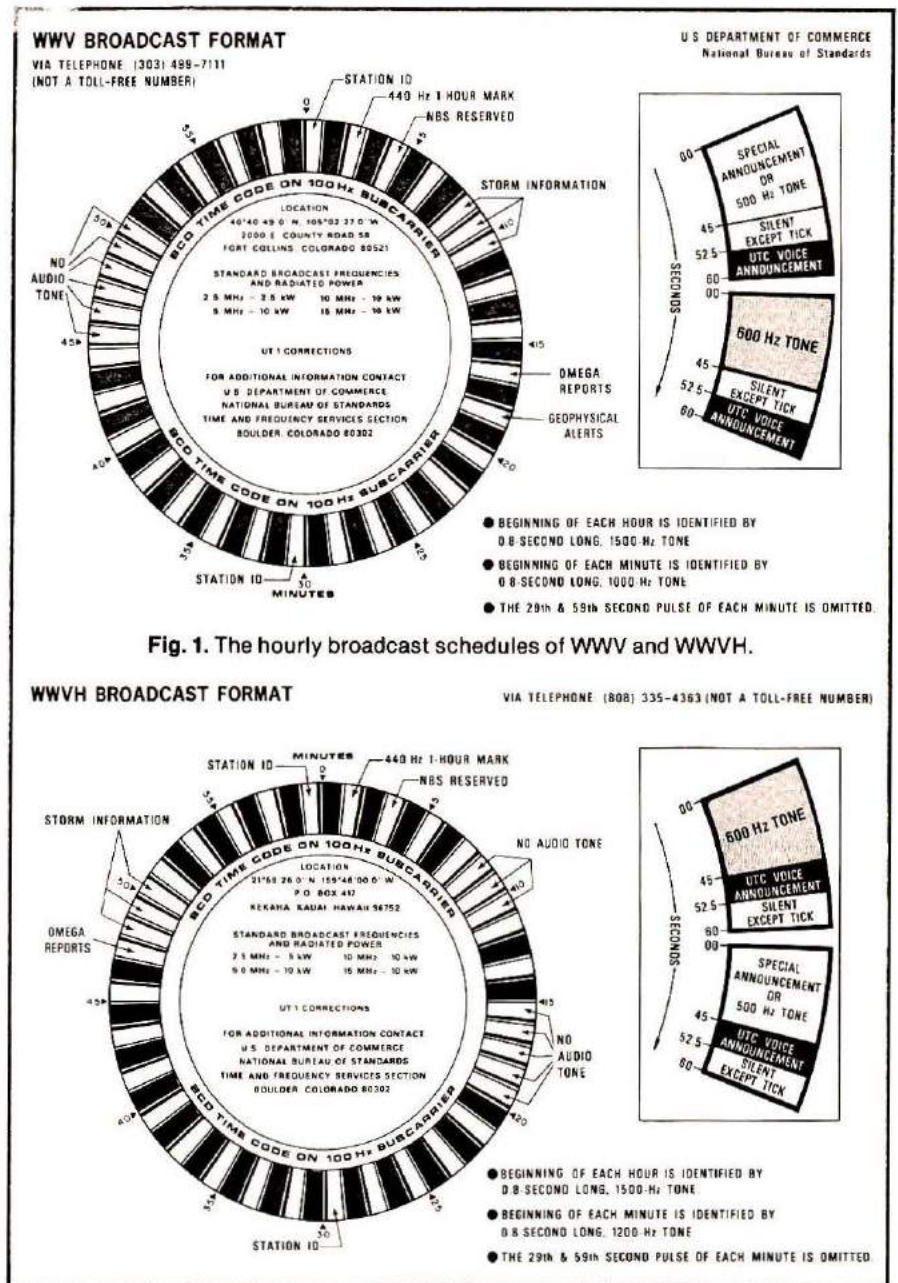

stations include: time announcements, standard time intervals, standard frequencies, geophysical alerts, marine storm warnings, time corrections, and a BCD time code. The format of the broadcasts, and the hourly schedule is shown in Fig. 1.

### Accuracy and stability

The NBS Primary Frequency Standard in Boulder, Colorado, controls all time and frequency broadcasts from its stations. The transmitted frequencies are accurate to *one part in 100 billion* at all times, and day-to-

day deviations are normally less than *one part in 1000 billion!* Changes in the propagation medium, however, cause disturbances which result in fluctuations of the carrier frequency *as received* by the user. Such fluctuations can be much greater in magnitude than the uncertainty described above.

### Time announcements

Voice announcements are made from WWV and WWVH once every minute and, to avoid confusion, a man's voice is used on WWV and a woman's





The 25-MHz dipole antenna near the WWV building. It is center fed by means of the 3-1/8 inch (8cm) transmission line you can see in the left foreground (photo courtesy US Department of Commerce).

voice on WWVH. The WWVH announcement comes first, at 15 seconds before the minute — while the WWV announcement occurs at 7½ seconds before the minute. The tone markers, however, are broadcast simultaneously from both stations but may not be received simultaneously because of propagation effects.

The time referred to in the announcements is *Coordinated Universal Time* (UTC), meaning that it is coordinated by the International Time Bureau (BIH) through international agreements, so that time signals broadcast by the many nations which provide a time and frequency service will be in close agreement.

The specific hour and minute mentioned in the broadcasts is actually the time in the time zone centered around Greenwich, England, and may be considered generally equivalent to the better-known *Greenwich Mean Time* (GMT). UTC differs from your local time by an integral number of hours, depending upon the time zone in which you live.

Many charts and maps are available to help you find the time anywhere in the world at a given GMT, and some clocks have appropriate dials to automatically give both GMT and the time at various

locations around the world. For example, Eastern Standard Time is five hours behind GMT, while Eastern Daylight Time is only four hours behind GMT.

The UTC time announcements are expressed in the 24-hour clock system — i.e., the hours are numbered beginning with 00 hours at midnight through 12 hours at noon to 23 hours, 59 minutes just before the next midnight. Among the many Amateur Radio operators, you will find that DXers and OSCAR users almost invariably use GMT (UTC), or “Zulu” time, in preference to local time. This is done so that stations at both ends of the circuit can be talking about the same time on particular days, and not different times on different days.

“Zulu” time may sound strange, but the logic becomes obvious when you understand the background. For convenience in specifying time, the military has divided the earth into 24 time zones, and has assigned to each time zone a letter of the alphabet (see Fig. 2). The “Z” time zone happens to coincide with Greenwich, England through which the zero meridian of longitude passes. Inasmuch as the letter Z can be confused with the letter C in voice transmissions, it has become customary to assign

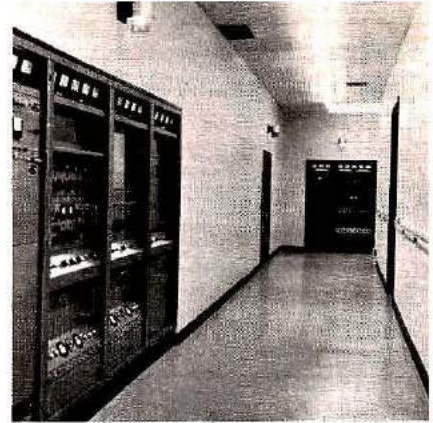

The transmitters are located along corridors, with space behind the equipment racks for maintenance operations. These are in the WWV building (photo courtesy US Department of Commerce).

phonetics to each letter of the alphabet. Quite naturally, Z became the phonetic “Zulu” or “Zebra”. Hence Zulu time means GMT.

#### Standard time intervals

The sounds most frequently heard on WWV and WWVH are the pulses that mark the seconds of each minute, except for the 29th or 59th second pulses which are omitted completely. The first pulse of every hour is an 800-millisecond pulse of 1500 Hz. The first pulse of every minute is an 800-millisecond pulse of

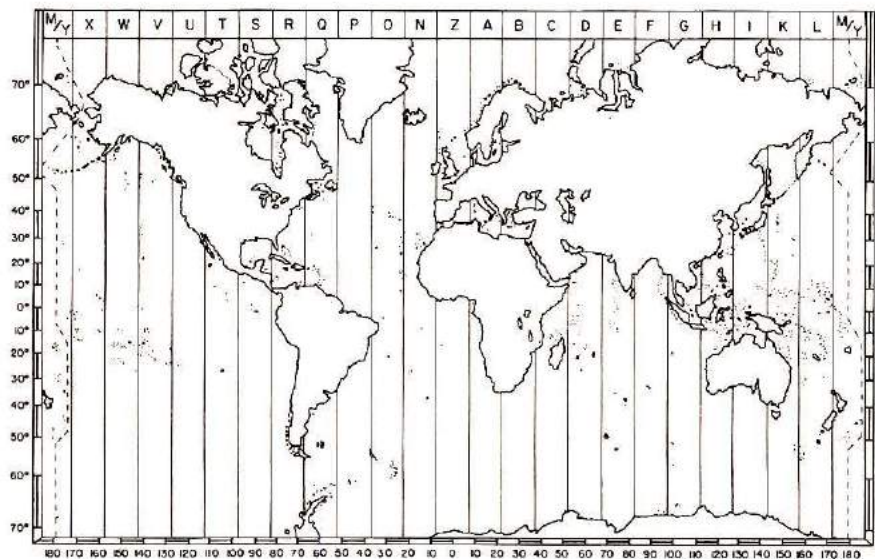

Fig. 2. World map showing the military time zones of the world identified by letter designators. Z (Zulu) time corresponds to GMT.



# THESE TWO WORDS SHOULD ALWAYS BE USED TOGETHER:

## Wilson ... and 2-Meter!

The newest and hottest 2-Meter rig,  
is the Wilson WE-800 . . .

It is totally portable, powered by  
internal rechargeable Ni-Cad  
batteries, and weighs less than  
4 lbs.

The C-MOS synthesizer allows 800  
channel selections, and the unit has  
the feature of a Hi/Lo 1 or 12 watt  
power option switch (when used  
as a mobile or base).

Additional features include 600 KHz offset up or down.  
2 additional offsets available for non-standard repeaters, and  
five channel pre-programmed matrix selector.

The WE-800 is truly the ideal equipment for the discriminating  
amateur who wants a "go anywhere" radio. The Wilson  
WE-800 is priced under \$400.00.



Isn't it about time you afford yourself the  
best in two-meter equipment? The Wilson  
gear is quite affordable.

For example, the 2-Meter Hand-Held Model  
1405 SM is a switchable 1 and 5 watt, six  
channel unit powered by 10 "AA"  
rechargeable nickel cadmium batteries.

Tough? You bet . . . the Lexan®  
outer housing will allow rough  
and rugged use. 500 milliwatts of  
audio power will get the signal  
through even in high noise areas.



1405 SM



WE-800

Portable 800 Channel  
Synthesized 2 Meter Radio

Through efficient engineering, the unit provides  
60 dB intermodulation protection in heavy  
RF traffic areas. Separate speaker and  
microphone are built into the design of the radio.

Wilson 2-Meter Hand-Helds are priced from  
\$192.95 and a complete line of accessories and  
tone options are available.

Join the thousands of Hams now on the air world-  
wide with the affordable Wilson portables.

Other Quality Amateur Equipment from Wilson includes Antennas, Rotors, Towers

Want more information and specifications on these products? Contact:

Your Local Dealer or the Consumer Products Division,

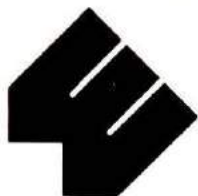

# Wilson Electronics Corp.

4288 SO. POLARIS • P. O. BOX 19000 • LAS VEGAS • NEVADA • 89119

(702) 739-1931 • TELEX 684-522



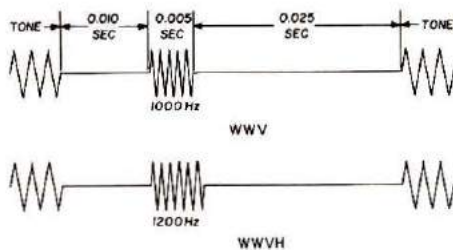

Fig. 3. Format of WWV and WWVH seconds pulses.

1000 Hz at WWV and 1200 Hz at WWVH. The remaining seconds pulse are brief audio bursts (5-millisecond pulses of 100 Hz at WWV and 1200 Hz at WWVH) that resemble the ticking of a clock. All pulses commence at the *beginning* of each second and are transmitted by means of double-sideband, amplitude modulation. Each seconds' pulse is preceded by 10 milliseconds of silence and followed by 25 milliseconds of silence to avoid interference which might make it difficult or impossible to pick out the seconds pulses. **Fig. 3** illustrates this total 40-

millisecond protected zone surrounding each seconds pulse.

### Standard audio frequencies

In alternate minutes during most of each hour, 500- or 600-Hz audio tones are broadcast. A 440-Hz tone, the musical note A above middle C, is broadcast once each hour. The 440-Hz tone, in addition to being a musical pitch standard, can also be used to provide an hourly marker for chart recorders, or other automatic devices.

Announcement segments of forty-five seconds' duration are available on a subscription basis to other Federal agencies to disseminate official and public service information. The accuracy and content of these announcements are the responsibility of the originating agency, not necessarily NBS.

**Propagation forecasts.** These useful forecasts, which occurred at 14 minutes past each hour, have been

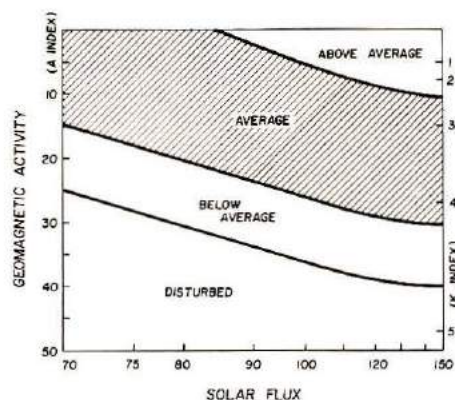

Fig. 4. Graph showing the relationship between Geomagnetic and Solar flux indexes, and their combined effect on ionospheric propagation of radio waves.

discontinued, some of the information contained in them has been transferred to the Geophysical Alerts segment of the format.

**Geophysical alerts.** Current alerts are broadcast in voice from WWV at 18 minutes after each hour, and from WWVH at 45 minutes after each hour. The messages are changed daily at 0400 UTC with provisions to

Table 1. High-frequency time and frequency-standard stations, listed by callsign.

Call sign	Location	Carrier Frequency (MHz)	Modulation*
ATA	New Delhi, India	10 & 15	1000 Hz + voice
CHU	Ottawa, Canada	3.330, 7.335 & 14.670	Voice
FFH	Paris, France	2.5	—
IBF	Rome, Italy	5	—
JJY	Tokyo, Japan	2.5, 5, 10, & 15	1000 Hz + voice
LOL	B. A., Argentina	5, 10 & 15	440 & 1000 Hz + voice
MSF	Rugby, England	2.5, 5, & 10	Voice
OMA	Prague, Czech.	2.5	1000 Hz
RAT	Moscow, USSR	2.5 & 5	10-second pulses
RCH	Tashkent, USSR	2.5	10-second pulses
RIM	Tashkent, USSR	5 & 10	10-second pulses
RWN	Moscow, USSR	10 & 15	10-second pulses
VNG	Lyndhurst Australia	4.5, 7.5, & 12	1000 Hz
WWV	Fort Collins Colorado, USA	2.5, 5, 10, & 15	440, 500, 600 & 1000 Hz + voice
WWVH	Kehaha, Hawaii	2.5, 5, 10, & 15	440, 500, 600, & 1200 Hz + voice
ZUO	Olifantsfontein, South Africa	2.5 & 5	—
GBR	Rugby, England	15.95 & 16 kHz	—
HBR	Pragins, Switzerland	75 kHz	—
JJF-2	Chiba, Japan	40 kHz	—
WWVB	Fort Collins Colorado, USA	60 kHz	—

\*All stations broadcast basic one-second time pulses, but some have additional modulation, as indicated.



provide real-time data alerts of outstanding geophysical events. These are followed by a summary of selected solar and geophysical events during the previous 24 hours.

Among the various events of interest to Radio Amateurs for purposes of following radio propagation conditions, are the Solar Flux and the Geomagnetic A Indexes. For best propagation of radio signals on the high-frequency bands, a relatively high Solar Flux and low geomagnetic A Index are desirable. The Solar Flux is measured at 2800 MHz and consists of radio "noise" whose magnitude has proven to be analogous to the magnitude of the energies that excite the E and F layers of the ionosphere. Solar-flux magnitude ranges from about 68 to 150, and can be roughly equated to smoothed sunspot numbers and MUFs.

The Geomagnetic Activity A Index indicates how well the ionosphere has performed with respect to the reflection and/or absorption of radio signals, particularly in the polar regions. An A Index of 0-7 means excellent reflection of signals, whereas an Index of 50 or over



This building is where the low-frequency transmitters, for stations WWVB and WWVL, are located. The towers support large wire antennas, but the largest is out of the photograph to the left. Prospective visitors should check with the US Department of Commerce in Boulder, Colorado, about the availability of tours at the WWV transmitting site (photo courtesy US Department of Commerce).

would indicate that a major magnetic storm is taking place with severely disturbed, if not disrupted, radio propagation conditions. In-between values

indicate the relative condition of the earth's electromagnetic field.

The Solar K Index is also given on the 18-minute after the hour broadcasts, and is updated every six hours. The K Index ranges from 0 to 9 and corresponds to the A Index from 0 to 50, respectively.

Fig. 4 shows the relationship between the various indexes and expected radio propagation conditions.

**Marine storm warnings.** At 8, 9, and 10 minutes after each hour, weather information about major storms in the Atlantic and eastern North Pacific oceans is broadcast in voice by WWV. Similar storm warnings covering the eastern and central North Pacific are given from WWVH at 48, 49, and 50 minutes after each hour. Additional one-minute segments at 11 minutes after the hour (WWV) and 51 minutes after the hour can be utilized under unusually severe

The building for WWVH in Hawaii is no less neat and functional than its stateside counterparts (photo courtesy US Department of Commerce).





widespread storm conditions. The brief messages are designed to tell mariners about storms in their areas. If no storms exist, that information will also be given. The ocean areas for which the U. S. has warning responsibility have been delegated by international agreement.

The National Weather Service issues regular broadcasts at 0500, 1100, 1700, and 2300 UTC from WWV; and 0000, 0600, 1200, and 1800 UTC from WWVH. These broadcasts are updated effective with the next-scheduled announcement following the time of issue.

**Silent periods.** These are periods with no *tone* modulation, but with continuing carrier frequency, seconds' pulses, time announcements, and 100-Hz BCD time code. The main silent periods extend from 45 to 51 minutes after the hour on WWV and from 15 to 20 minutes after the hour on WWVH. An additional 3-minute period from 8 to 11 minutes after the hour is silent on WWVH.

#### BCD time code

A binary-coded decimal (BCD) time code is transmitted continuously by WWV and WWVH on a 100-Hz subcarrier, and provides a standard timing base for scientific observations made simultaneously from different locations, such as astronomical events for example, or signals telemetered from satellites, where time markers superimposed directly on the recording aids data analysis.

#### UT1 time corrections

The UTC time scale broadcast by WWV and WWVH runs at a rate that is almost perfectly constant because it is based on ultra-stable atomic clocks, and meets the needs of most users. Somewhat surprisingly, some users of this service need time signals that are not this stable. For navigation and satellite

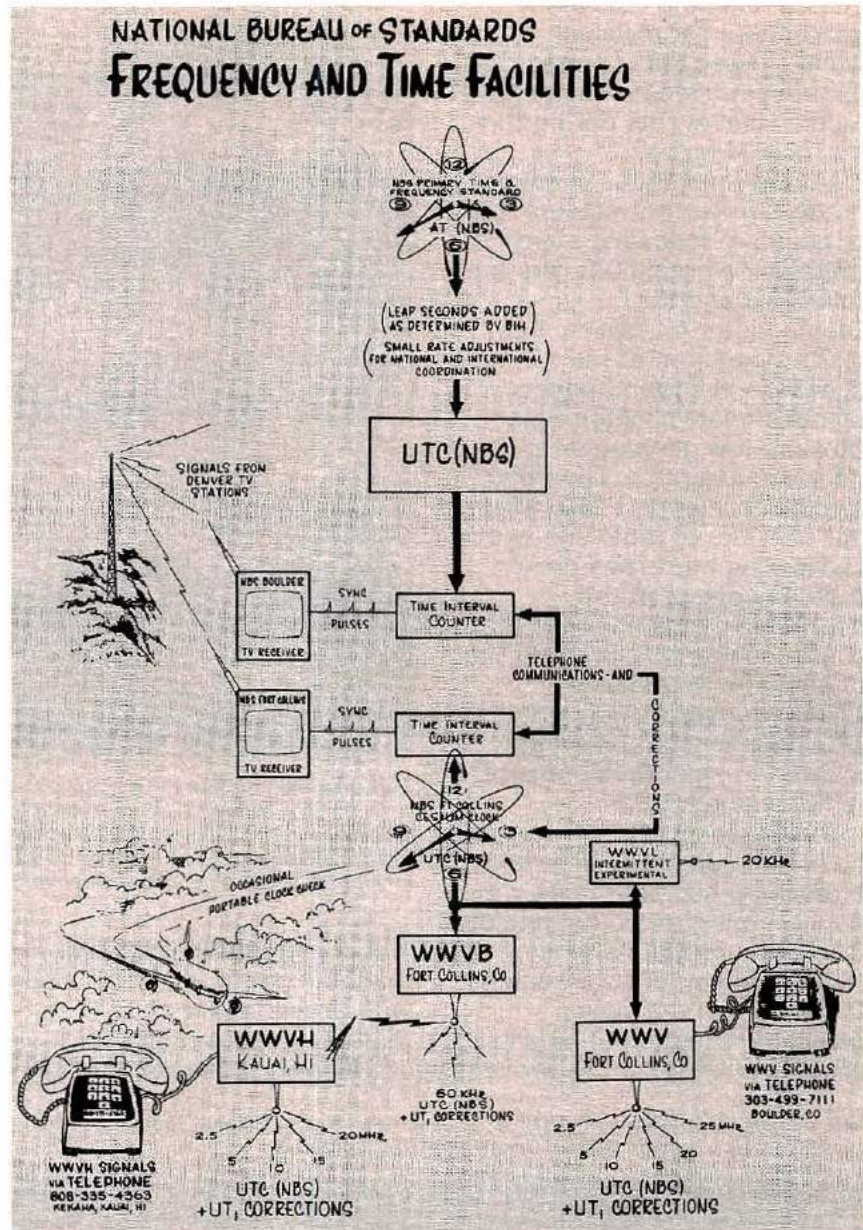

Fig. 5. The NBS frequency-control system.

tracking purposes, a time scale that slows down or speeds up with the earth's rotation must be used. The particular time scale needed is known as UT1 (inferred from astronomical observations) and is included in the UTC broadcasts at two levels of accuracy.

For those who need to know UT1 to only within about one second (most navigators), occasional corrections of exactly one second are inserted into the UTC time scale to keep UT1 and UTC time within plus or minus 0.9 second of each other. The

correcting second insert is called a *leap second* and performs a function similar to that provided by the missing day every four years called *leap year*. As mentioned previously, the BIH regulates and coordinates the use of the leap second by international time and frequency broadcasting stations and bureaus of standards.

#### WWVB

WWVB transmits continuously on a standard radio carrier frequency of 60 kHz. Standard time signals,



# The Lightweight Champ.

## 8040-A Receiver

The **Kantronics 8040-A Receiver** offers a great way to monitor CW transmission on **80 and 40 meters**, at a price that's nice to your pocketbook! This compact, **battery operated** unit is perfect for code practice on W1AW or for portable use with a long wire antenna.

Coverage runs from 3.650 - 3.750 MHz on 80 mtrs., and 7.050 - 7.150 MHz on 40 mtrs. The **8040-A** has good sensitivity and a special **preselector circuit** to peak the rig for differing antenna impedances.

The vernier dial action makes station selection smooth and accurate. The unit works with headphones or an eight ohm speaker. Take the **8040-A** along on vacation to brush up your code speed for that new ticket, or to improve your reception ability with that portable QRP transceiver.

The **8040-A is great stuff** for the prospective ham as well as the veteran CW operator. Pick up a lightweight champ today!

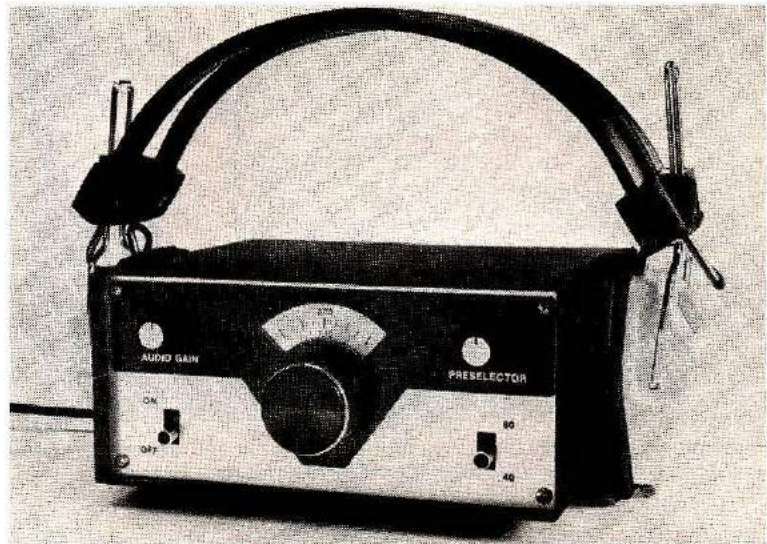

## Code Speed-Building Kit

The **Kantronics Code Speed-Building Kit** offers perfect **computer generated** code practice recorded on 60 minute tape cassettes. Learn the code at five WPM, or increase your proficiency with tape speeds up to 20 WPM. A sturdy **brass key** is included with **code practice oscillator** to improve sending. Buy each piece separately, or the kit at a special discount!

Name \_\_\_\_\_  
PLEASE PRINT

Address \_\_\_\_\_  
STREET OR RFD APT#

\_\_\_\_\_  
CITY STATE ZIP CODE

Card# \_\_\_\_\_ Exp. date \_\_\_\_\_

Signature \_\_\_\_\_

- \_\_\_\_\_ 8040-A Receiver \$59.00
- \_\_\_\_\_ 8 ohm Headphones \$10.95
- \_\_\_\_\_ Speed-Building Kit - \$19.95
- \_\_\_\_\_ Brass Code Key - \$3.95
- \_\_\_\_\_ Practice Oscillator - \$13.95
- \_\_\_\_\_ Cassette Tape - \$3.95
- \_\_\_\_\_  5wpm  7½wpm  10wpm  13wpm
- \_\_\_\_\_  16wpm  20wpm

KS & MO residents add 3% tax.  
Please add \$1.00 postage/handling  
per receiver or kit.

\$1.00 Postage/handling

\$ \_\_\_\_\_ Total enclosed.

- Check  Money order  Master Charge
- Bank Americard

NO CASH OR C.O.D. ORDERS, PLEASE!

**KANTRONICS, INC.**

1202 East 23rd St. Lawrence, Kansas 66044 Telephone 913-842-7745





The main building, left, and generator building, right, for time and frequency station CHU, in Canada (photo courtesy Canadian National Research Council).

time intervals, and UT1 corrections are provided by means of a BCD time code. The transmitting station is located on the same site as WWV, and effectively covers the entire continental United States. The frequency of WWVB is normally within its prescribed value to better than one part in 100 billion, and day-to-day deviations are normally less than 5 parts in 1000 billion. At this low carrier frequency, effects of the propagation medium on received signals are relatively minor; therefore frequency comparisons better than 1 part in 100 billion are possible by using appropriate receiving and averaging techniques.

#### WWVL

WWVL is an experimental station that broadcasts only on an intermittent basis, depending upon need and availability of funds. Transmissions can be made available on a subscription basis to public organizations and other Federal agencies.

#### Control of frequency

Fig. 5 is a simplified diagram of the NBS frequency control system, which depends upon the Primary Time and

Frequency Standard. This standard includes a number of cesium-beam clocks, up to two primary cesium-beam frequency and time standards, and computer-aided measurement and computation methods which combine all of the clock data to generate an accurate and uniform time scale, called AT (UTC). Another scale, UTC (NBS), is also generated by adding leap

seconds and small corrections to AT (UTC), as needed, to keep UTC (NBS) synchronized with the internationally-coordinated time scale, UTC, maintained by the BIH.

#### Canada — CHU

Astronomical observatories are always among the first facilities to generate and use accurate time information, furnished by daily — and nightly — observations of the sun, planets, and moons of our own solar system, as well as the stars of other systems. So it was in Canada, where radio time signals were first broadcast by radio during 1927 from the Dominion Observatory in Ottawa; although time signals had been sent over telephone lines from that source to the local Ottawa broadcast stations since 1923.

The first regularly broadcast transmissions from the Observatory were experimental, supplied by low-power battery-operated transmitters on wavelengths of 20.41, 40.82, and 90 meters because of their proximity to the bands used by Radio Amateurs, who at that time were the main users of "short" waves. In 1929 the

This is the antenna for 7335 kHz. The guys are fiberglass, believed to be the first such use in Canada (photo courtesy Canadian National Research Council).

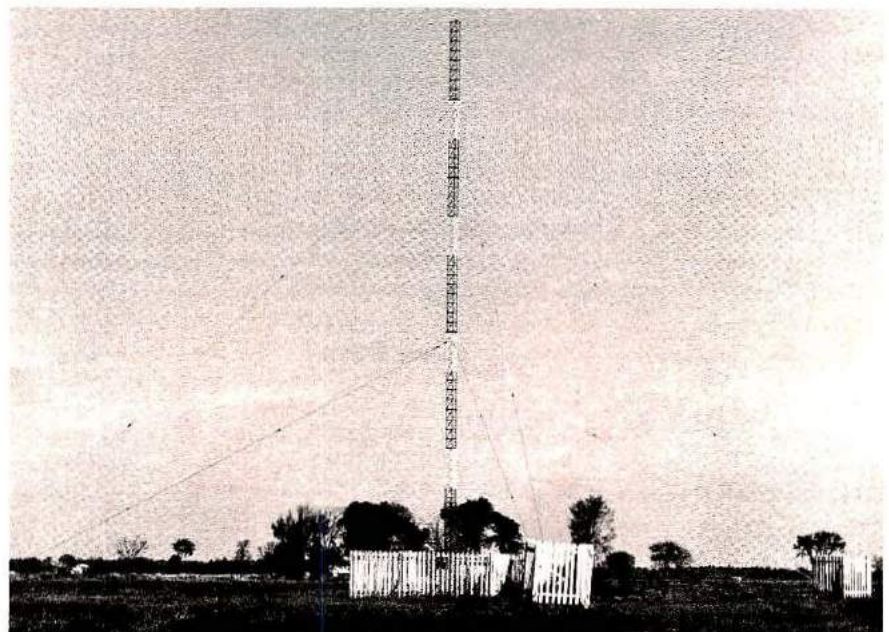



callsign VE9OB was authorized, and reasonably consistent, full-time transmissions began.

In 1942 the time service station was operating under the call CHU, using three 75-watt transmitters, with the call identified in Morse code. In 1946, power was increased to 500 watts, and in 1954, recorded voice announcements replaced the code. These, as well as the time signal pulses, originated in the Observatory and were sent to the transmitter site — approximately ten miles away — over telephone lines.

During 1960, a completely self-contained system was developed and installed at the transmitter site. The system consisted of relatively stable crystal oscillators which provided the basic source for synthesizing the three operating frequencies: 3330, 7335, and 14670 kHz. The crystal oscillators also provided the source for operating the synchronous motor-driven clocks which controlled the time signal. At the same time an automatic recording for the voice announcement was installed.

In 1963 the crystal units were replaced by an atomic frequency standard, and the electro-mechanical clocks by solid-state digital units. In 1964 English-French language voice

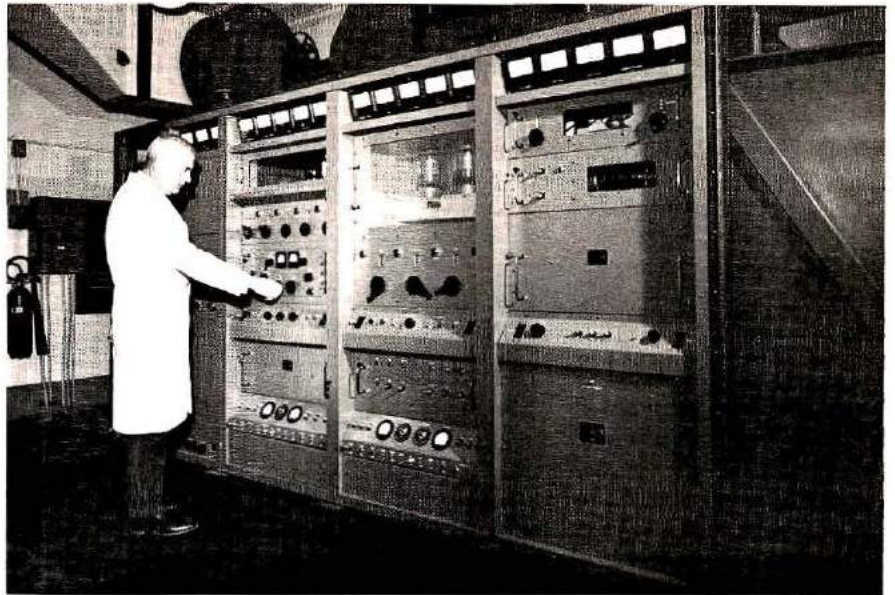

The 40-kW, 7335-kHz, transmitter at CHU. VE3BCL at the controls (photo courtesy Dominion Observatory).

drums were installed, and the present identification established. On April 1, 1970, the Canadian National Research Council assumed responsibility for Canadian time services, including the operation of CHU.

#### Who uses CHU?

The first users of CHU's services were scientific and survey parties. In fact, the initial "wireless" transmissions from the Observatory were made to a nearby field seismological station to coordinate field results with

those obtained at the Observatory. Since those early days, gradual but steady improvements in consistency of service, accuracy of information, and output power have increased the usefulness and range of CHU to a point where anyone possessing even the most inexpensive short wave receiving set can use the Time Service.

#### Data transmitted by CHU

The broadcasting format of CHU is shown in Fig. 6. Three types of information are provided: Standard frequency,

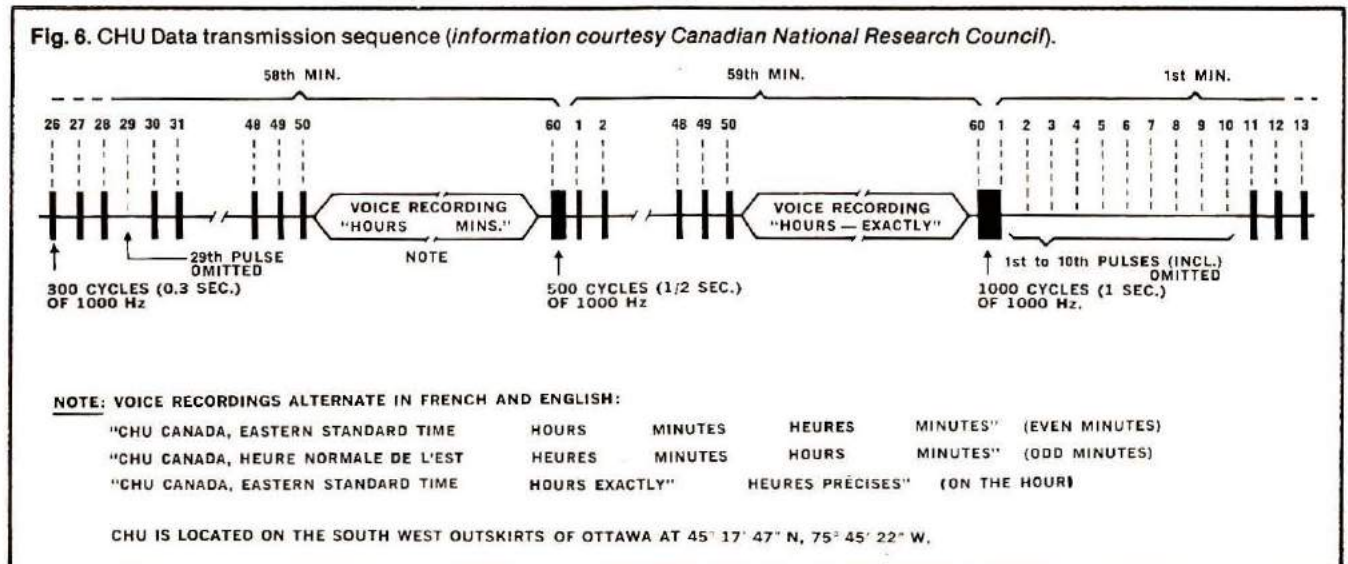





Transmitters line both sides of the corridor. The small units on the right are standby transmitters, which have been replaced by higher-powered ones. An automatic monitoring and switching system is used to change to a standby transmitter in case of failure, and to sound an alarm to bring an operator to fix the trouble (*photo courtesy Canadian National Research Council*).

standard time, and a means of automatically updating compatible digital clocks.

**Frequency.** CHU's basic frequency source is a cesium atomic standard which is used to control the three broadcast frequencies to an accuracy better than a few parts of a cycle. It must be remembered, however, that broadcasts for precision calibration purposes are affected by signal propagation delays which vary depending upon the distance from the transmitter site, and by delays which occur in the display and receiving equipment itself. For example, when the National Research Council compares signals from WWV, Fort Collins, Colorado, with CHU's transmissions, a delay of seven milliseconds must be included in the calibration calculations!

**Time.** Eastern Standard Time is transmitted by CHU in the form of tone pulses identified by voice announcements in

English and French. The time is based on the atomic second which *gains* on Universal Time at the rate of about one second per year. This is adjusted by one second, exactly, when required — usually on either

\*Years ago, the measurement of time was based on rotation of the earth (Universal Time, UT) which was shown to lack uniformity. Astronomers then adopted the period of revolution of the earth around the sun for the year 1900 as the basis for the measurement of time, and called it *Ephemeris Time*. Ephemeris Time forms the basis for all astronomical calculations and forecasts, but is not readily available for day-to-day use.

As physical sciences developed, the pendulum yielded to the quartz clock and then to the atomic clock as the primary time keeper. Today, the cesium atomic clock is the primary source of accurate time measurement, because in 1967 the International Bureau of Weights and Measures defined the second as 9,192,631,770 periods of the radiation corresponding to the transition between two hyperfine levels of the ground state of the cesium 133 atom. This offered a firm and unchanging basis for scientists of the world to standardize their previously varied measurements.

December 31st or June 30th of each year.\*

### CHU today

CHU is celebrating its "Golden Anniversary" this year, and invites interested persons to visit the facilities, 15 miles (24 km) from the center of Ottawa, where station personnel will conduct them on guided tours of the installation.

### Acknowledgements

Special thanks to Roger Beehler, Chief, Time and Frequency Division and Sandra L. Howe, Technical Assistant, Time and Frequency Services Section, National Bureau of Standards, for providing the information on which this article is based. Of particular interest are *NBS Special Publication 432, Report 267-3 (Rev. 76) Standard Frequencies and Time Signals*, and *NBS Technical Note 681, A Satellite-Controlled Digital Clock*, from which the information in this article was drawn.

Special thanks also to Dr. Costain, Director, and Mr. Syd Sheard — VE3BCL — Chief Engineer, Time and Frequency Section (CHU), National Research Council, of Canada, for making this information available to *Ham Radio Horizons*. The material presented in this article was drawn heavily from a document titled, *National Research Council — Radio Time Service CHU*. The remainder was obtained from *Service Bulletin B-27* and *Service Bulletin TF-B-59*.

The Division of Physics of the National Research Council of Canada has published a comprehensive, illustrated, booklet in French and English titled *Standards of Time and Frequency in Canada*, which thoroughly discusses the cesium atomic clocks, how they are set up and maintained, and touches on future standards, plans, and techniques.

HRH



# MORSE CODE COURSES

INCLUDES SPECIAL PREP FOR THE NEW COMPREHENSIVE CODE EXAM

*Specially Designed for Beginners*

OUR 2 NOVICE COURSES TAKE YOU FROM DAY 1 (NO KNOWLEDGE OF ANY CODE) THRU 6 OR 8 WORDS PER MINUTE.

## NO CLASSES - LEARN AT HOME

THIS NEW METHOD SUCCESSFULLY USED BY PEOPLE FROM 10 THRU 65 YEARS OLD.

INCLUDES EXCLUSIVE NOVICE TRAINING SCHEDULE ALL REFERENCE MATERIALS, CHECKING SHEETS TO VERIFY ACCURACY, INFO ON OTHER HAM LICENSE REQUIREMENTS.

STANDARD 2 TRACK MONAURAL CASSETTES PROVIDE 60 MINUTES EACH OF SCIENTIFICALLY PREPARED CODE PRACTICE (LETTERS, NUMBERS, PUNCTUATION, CODE GROUPS, WORDS) CASSETTES ARE DESIGNED TO MINIMIZE LEARNING PLATEAUS, EMPHASIZE NEW MATERIAL

SET 1	0-6 WPM (Novice License)	6 CASSETTES	\$15.95
SET 2	0-8 WPM (Novice License)	7 CASSETTES	17.95
SET 3	7-14 WPM (General Class License)	3 CASSETTES	8.95
	First class postage required per CASSETTE		0.40

SPECIALISTS - OUR ONLY PRODUCTS ARE TAPE COURSES  
**THE HERRMAN CO.**  
 DEPT J, BOX 1101, LARGO, FLA. 33540

**CLUBS - GROUPS** ANY 10 OR MORE SETS  
 5% OFF + 25¢ PER CASSETTE 1st CLASS SHIPPING

## NEW VISUAL CODE READER AND ELECTRONIC KEYS



Works with any keyer, including squeeze keyer in speeds from 7 WPM to 40 WPM. Both in a single unit.  
**Model CR101EK \$249**

from **ATRONICS**

- Display letters, numbers, and commonly used punctuation visually as Morse Code signal is received.
- Operating speed 5 to 50 WPM at selected speeds.
- All Solid State.
- Makes code learning faster and easier.
- A single connection to your receiver or transceiver speaker puts it into operation.
- Hard copy read-out of CW available with TU-102 TTY interface Module accessory.

Our popular, lowest priced CODE READER KIT  
**Model KCR101 \$149**  
 Ready made CODE READER... **Model CR101 \$225**

BUY FACTORY DIRECT & SAVE! SEND FOR FREE LITERATURE.  
 USE YOUR BANKAMERICARD OR MASTER CHARGE

P.O. BOX 77, ESCONDIDO, CA 92025 (714) 745-1971

# Atronic

More details? Ad Check page 78.

# the famous HAM KEYS

The keys that are easy to put your fingers on!



JUST DIAL  
**1-800-325-3636**  
 TOLL FREE



### Model HK-1

- Dual-lever squeeze paddle
- Use with HK-5 or any electronic keyer
- Heavy base with non-slip rubber feet
- Paddles reversible for wide- or close-finger spacing

**\$29<sup>95</sup>**

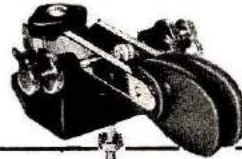

### Model HK-2

- Same as HK-1, less base for incorporation in own keyer

**\$19<sup>95</sup>**



### Model HK-3

- Deluxe straight key
- Heavy base no need to attach to desk
- Velvet smooth action

**\$16<sup>95</sup>**

Navy type knob, only \$2.75

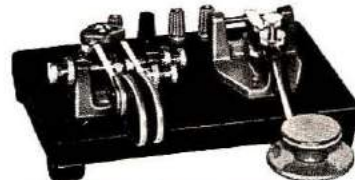

### Model HK-4

- Combination of HK-1 and HK-3 on same base

**\$44<sup>95</sup>**

- Base only with rubber feet \$12.00

Terminals, red or black, \$.75 each



BRAND new

### Model HK-5 Electronic Keyer

- Iambic Circuit for squeeze keying
- Self-completing dots and dashes
- Dot memory
- Battery operated with provision for external power

**\$69<sup>95</sup>**

- Built-in side-tone monitor
- Speed, volume, tone and weight controls
- Grid block or direct keying
- For use with external paddle, such as HK-1

Same day shipment... PREPAID

We welcome the use of your



## HAM RADIO CENTER, INC.

8340-42 Olive Blvd. • P.O. Box 28271 • St. Louis, MO 63132



# Don't miss Chicago's 7th annual

## SEPTEMBER 17-18

### Manufacturer's displays • Forums

**\$5000** in prizes. All-weather flea-market and camp area open Friday. LADIES PROGRAMS  
TICKETS: \$2.00 in advance, kids under 12 free.

For tickets & info. write: Radio Expo, box 1014, Arlington Hts, IL 60006

## AMATEUR PRODUCTS GALORE!

### ICOM

Forget crystals forever with the exciting new IC-22S, 146-148 MHz, 10 watt mobile transceiver. Includes 22 channels programmed by you to any 15 kHz channel between 146 and 148 MHz. Optimized mobile versatility at a hard-to-beat price. Call us today!

### YAESU



**FT-101E TRANSCEIVER**

Popular? I guess! Over 200,000 units of this FT-101 series are in service around the world. 10 thru 160M, SSB, CW, AM, built-in WWV reception, solid state, RF speech processor, VOX, AC or DC operation are some of the many reasons for this rig's popularity. We'll be happy to discuss the many fine features of the FT-101E with you today.

Call or visit with us today for assistance in selecting the Amateur product that is the most likely to meet your operating requirements.



## RSE HAM SHACK

1207 W. 14 MILE, CLAWSON, MICHIGAN 48017  
313-435-5660



### KENWOOD

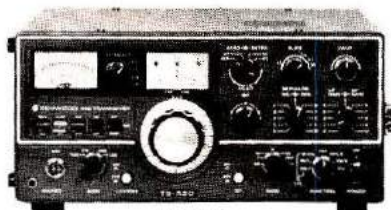

**TS-520S  
160-10M TRANSCEIVER**

Ask around about Kenwood's TS-520. It's in constant use around the globe and has a record of reliability that is universally admired. USB, LSB, CW, operates AC or DC, WWV receiver, RIT, VOX and noise blanker are some features that make the TS-520 a very welcome companion in your shack.

Also, come in and ask about the NEW Kenwood TS-820 that has all of the great features found in the TS-520 plus so many truly unique operating advantages that it is the Pacesetter of the industry.

### KLM

Multi 2700 all-mode transceiver has too many well thought out features to list here. FM, SSB, AM, CW, 2 way OSCAR (2m xmit, 10m rcv), 143-149 MHz coverage, 12 VDC/115VAC. Built in VFO, 10 watts out. Come in today for complete details.

## Send For Your Copy Today!

Kenmore Corp. publication \$2.95

### 1977 AMATEUR RADIO EQUIPMENT DIRECTORY

Standard SSS TPL -hg gain SINCLAIR  
ROBOT VIBROFLEX YAESU DRAKE  
Henry Radio KLM Rockwell International Apron  
RESNAIS WAVE-MAN the antenna SPECIALTY CO. ATLAS  
Calkreuth MARINE C&R WIRELESS Denton  
Larsen Antennas QRP INTERCOM ET TOR  
Glenview Manley Electronics G&B ELECTRONICS  
SPECTRUM NEJ Enterprises SWAN  
KENWOOD Hulco ICOM

Featuring ham radio equipment of over 60 manufacturers, contains descriptions, pictures, specifications & prices . . . no advertisements! A must addition to every ham library. (136 pages)

**\$2.95 Postpaid (U.S.)**

**KENMORE CORP — Dept. A**  
9 James Ave. Kendall Park, NJ 08824  
CLUB DISCOUNT 15% (MIN. 10 COPIES)

### MAIL NOW

Enclosed is my  Check  MO for \$2.95  
Please send the 1977 Amateur Radio Equipment Directory.

Name \_\_\_\_\_  
Address \_\_\_\_\_  
City \_\_\_\_\_ State \_\_\_\_\_ Zip \_\_\_\_\_





## Where are your QSL cards?

Keep your QSL cards organized and easily accessible. Display them in 3 pocket, crystal clear, vinyl pages. NuAce QSL binders with 23 rings are vinyl covered in blue, black, ginger or red.

**Only \$6.95**

for 10 page binder that holds 60 cards.

Send check or M. O. for immediate delivery or write for information. Add \$1.00 for postage & handling. Satisfaction Guaranteed. Return within 10 days for full refund.



**NUACE**  
ACE ART COMPANY

Ace Art Company, Inc., Dept. HH  
24 Gould St., Reading, MA 01867



## Glade Valley School Radio Session

18th Year — July 30 thru August 12, 1977

Hams do it with more frequencies! Improve your slice of the spectrum by upgrading.

Glade Valley School in the Blue Ridge Mountains of North Carolina offers an intensive two week Radio Session in code and theory starting at your level.

Expert instructors and close association with fellow amateurs offer an opportunity for Saturation-Learning.

Novices upgrade to General, Techs become General and Advanced and Advanced become Extras.

FCC exam available at close of session.

C. L. PETERS, K4DNJ, Director  
P. O. Box 458, Glade Valley, N. C. 28627  
Please send me the Booklet and Application Blank for the 1977 Glade Valley School Radio Session.

Name \_\_\_\_\_ Call \_\_\_\_\_  
Address \_\_\_\_\_  
City/State/Zip \_\_\_\_\_

# VLF CONVERTER

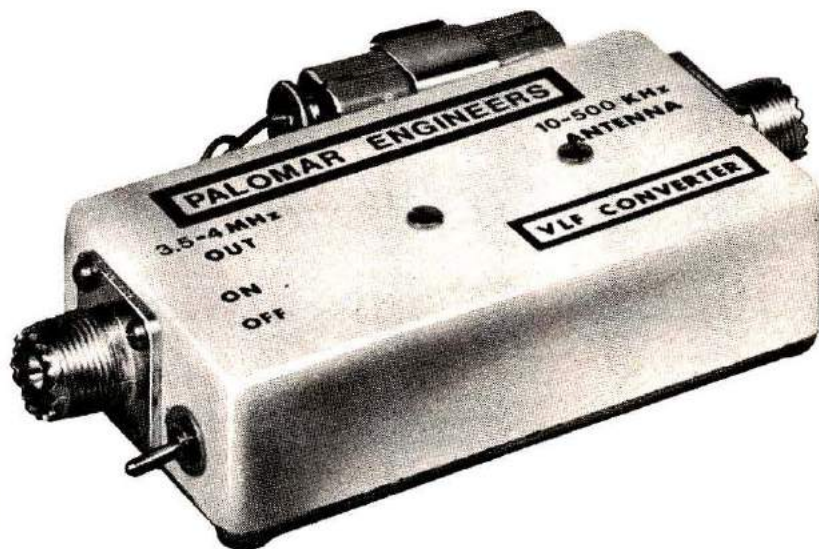

- New device opens up the world of Very Low Frequency radio.
- Gives reception of the 1750 meter band at 160-190 KHz where transmitters of one watt power can be operated without FCC license.
- Also covers the navigation radiobeacon band, standard frequency broadcasts, ship-to-shore communications, and the European low frequency broadcast band.

The converter moves all these signals to the 80 meter amateur band where they can be tuned in on an ordinary shortwave receiver.

The converter is simple to use and has no tuning adjustments. Tuning of VLF signals is done entirely by the receiver which picks up 10 KHz signals at 3510 KHz, 100 KHz signals at 3600 KHz, 500 KHz signals at 4000 KHz.

The VLF converter has crystal control for accurate frequency conversion, a low noise rf amplifier for high sensitivity, and a multipole filter to cut broadcast and 80 meter interference.

All this performance is packed into a small 3' x 1½' x 6' die cast aluminum case with UHF (SO-239) connectors.

The unique Palomar Engineers circuit eliminates the complex bandswitching and tuning adjustments usually found in VLF converters. Free descriptive brochure sent on request.

Order direct. VLF Converter \$55.00 postpaid in U.S. and Canada. California residents add sales tax.

Explore the interesting world of VLF. Order you converter today! Send check or money order to:

**PALOMAR ENGINEERS**

P.O. Box 455, ESCONDIDO, CA. 92025 — Phone [714] 747-3343





# How to pass your Amateur Radio exam In just six tries!!

BY DEE LOGAN, W1HEO

What? You say you passed your General Class FCC exam on your first try? Wonderful! You normal types fill me with awe — and I'm seldom awed except in the presence of certain centerfolds and rare DX.

I mean, it only took me *six* trips to the FCC before I made it. Sure, I can see you smirking at me. You're just like the whiz-bangs who zip through

mysterious algebraic formulas without using a calculator or toes. Well, for me it just wasn't all that easy, and I get the word from lots of non-engineering types that it wasn't easy for *them* either!

So, for the benefit of all you poor souls who break into a cold sweat at the thought of entering the not-so-friendly halls of the "Friendly Candy Company" in pursuit of that treasured ticket, here's how I did it.

Let me begin, as they say, at the beginning.

A couple years back the ham-radio bug bit me. When I saw a ham friend of mine spin those dials, swing his beam, and swap stories with guys several light years away, I was hooked! But I didn't know beans about electronics.

"The exam is a breeze," said my good buddy — with a grin; "A couple of nights with the license manual is all you need to pass your General."

To show you how misinformed I was, I actually believed him. I jogged to the local radio emporium and scooped up a license manual that promised instant success. I returned to my abode for a quick look.

The stuff seemed a bit obscure to me, but I memorized the answers in the manual and did the same with an old code record that someone had loaned me. I thought to myself: "What the heck, you don't have to *understand* it to pass it, do you?" *Do you!*

## First Try

My first try was not really a try at all. The night before the exam I decided to loosen up by participating in a group therapy session held in honor of a friend about to enter the rarified atmosphere of matrimony. This did little to prepare me for the doom awaiting next morning in the dark, foreboding halls of the Federal Building.

Attempt number one ended as quickly as it began. After filling out the required forms, I joined a dozen pale sheep awaiting the start of the code tape. What happened after that is just a blurred, dream-like memory. The sounds filling the room were a strange, alien code. I didn't recognize one character of the Morse. I do recall how my hand refused to move across the paper and how my mind froze in confusion. After five minutes, my paper contained only a mass of





scribbled, unique hieroglyphics.

I had clutched. I had failed my first attempt to scale that majestic, mysterious mountain of hamdom! I hung my head, retreating to the security of my friend's ham shack.

"I don't understand it," he said sympathetically. "You seemed so highly motivated that I thought you'd be a cinch to pass on your first time out." He eyed me cautiously. "How many words per minute were you copying before you went down to the FCC?"

I confessed: "Well, I was getting *almost* everything at 13, but I figured that the letters I missed might not be sent in the one minute I needed to pass."

He threw up his hands and groaned. "You need a buffer. If you must copy 13 words a minute, make sure that you can copy at least 15 before you try, that way you'll have a margin for error."

I didn't like the ring of those words. The number 13 loomed ever-larger in my mind, which by this time had the firm resolve of a dish of hot *Jello*. I went back to my code records. Night after night I hunched over the paper, my head firmly squeezed by a pair of earphones, and an endless stream of ditty-ditty-dum-dums turning my aching brain into Fuzz City.

After several weeks of self-denial and long hours of straining for every dit or dah as if my life depended on it, I felt

ready for my second tilt at the windmill.

The night before the trip to the FCC, I avoided the temptation to unwind with the local chapter of Grape Worshipers Anonymous; instead, I turned from temptation and retired at an early hour.

As I lay in the blackness, my head was filled with echoing Morse-code transmissions. Sleep eluded me. I kept thinking about tomorrow; how it would be all-or-nothing-at-all; how I already blew it once; how I'd better be sharp; and what was Ohm's law, anyway? My last recollection of time was the grandfather clock striking three.

Shortly thereafter the alarm clock drilled into my sleep-sodden brain, and I slipped out of bed in a heavy fog, groping for my slippers. My lack of sleep ruined any thought of breakfast, so I quickly shaved and dressed for my trip to the Federal Building.

#### And try again

Once again I filled out the papers and took my place with the nervous hopefuls. I was strangely relaxed this time, my nerves calm. With my head nodding toward my chest, the Morse code tape began . . .

"Hey buddy, you can leave now." The voice cut through my sleep like a high voltage arc. I looked around at the empty desks. I was alone in the room. "You slept through the whole thing," said the FCC examiner, "so we'll see you in another 30 days. Get some sleep!"

I couldn't tell my ham friend the truth about sleeping through an FCC test, so I simply avoided all contact with him for the next month. I religiously kept at the Morse, my copying speed climbing beyond 15 words-per-minute. The third test would be a snap.

#### And again

Well, actually, it wasn't that at all. I got down to the Federal



building in plenty of time, but found that it was strangely dark, the door was locked. I checked my watch and then went out of the building to a nearby news stand, where I inquired as to the whereabouts of the Federal employees.

"You been on the moon, Mac?" growled the newsboy, "Today's a Federal holiday. Everything's closed!"

I sheepishly bought a paper and turned for home, muttering several uncivil things about the civil servants of America.

#### So near, and yet . . .

Following another period of Morse review, I returned to the now-familiar halls of the FCC offices and took my place with the expectant multitudes. My previous visits had removed some mystery, and I felt calmer than I did the first time, although still a bit fidgety. When the code tape began its old sweet song I didn't panic, nor did I immediately begin writing. My mind reeled once again, and the dittydumdittydum whirred in a stream of strange sounds. "Don't clutch," I scolded myself. "You know it, so write it!" I made an effort to relax, while moving my pencil, forcing it to write those characters that were identifiable. Gradually I gained control of myself, and more and more characters formed under my pencil. A few words were popping out of the scribbings. And then the Morse tape ended.



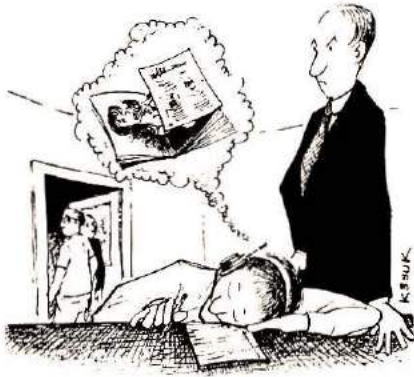

"Turn in your papers, please," said the examiner in his usual don't-mess-with-the-old-FCC voice.

One by one the examiner graded the papers, and one by one my fellow sufferers got up and left. A few bright individuals passed and smiled at me in triumph. When my name was called it was simply to invite me to leave once again. "Too bad, you missed by only one letter."

I moaned in agony, my world crumbling into a zillion pathetic pieces. Again I traced my weary way homeward, wondering if a ham license was worth the suffering and pain.

"It is worth the effort!" insisted my ham friend, consoling me later over a steaming mug of coffee. "You know the code, so you just have to relax and not freeze in the clutch. It's mind over matter."

It was a week before I could bring myself to pick up the earphones and crank up the code record one more time, but at last I did it. A few days later I was feeling better, and some confidence crept into my buzzing brain. But, to help me overcome the psychological barrier, I consulted with my family doctor who agreed to prescribe a one-day dose of tranquilizers to get me over the hump.

#### Failed again

Trip five to the FCC office found me wonderfully relaxed and happily looking forward to

meeting many fine old friends down at the cheery examination room. Ah, what a day! I smiled good morning at the scowling face handing me another form 610, and took my seat with a group of apparently nervous souls. My, I felt good!

Soon I was listening to the Morse tape with calm attention. My hand moved smoothly over the paper, and a delicious flow of letters were forming themselves as if by some mysterious force. I didn't miss a character, and grinned with relief as my name was called with those who had sailed gracefully over the Morse code hurdle.

"The rest should be a snap," I told myself, accepting the written exam from the still-scowling face. "You know that license manual cold."

As I began reading the questions, an uneasiness began creeping over me. The test looked a bit like a General class type, but the multiple-guess answers didn't resemble the license manual variety in the least. I began writing, but my euphoria soon vanished, replaced with the sinking feeling experienced by students who have neglected to prepare themselves for an examination.

"You mean you *memorized* the license manual, and that wasn't enough?" My friend quizzed me in a consoling manner, brandishing a smoking soldering iron. "That's usually all you need if you've done any reading in electronics at all. You *have* done some other reading, haven't you?" His question was met by my guilty silence.

"When I told you to look over the license manual I assumed that you knew basic electronics and all you needed was the portion dealing with rules and regulations," he said. "I guess you need to do some reading before you tackle that General exam."

Armed with a towering stack of books, I began the slow

process of building my understanding of electronics. I digested the electron theory, whipped Ohm's law two falls out of three, sunk my teeth into a variety of oscillators, drove forward into amplifiers, soared over antennas, and bounded at last into the final chapter of the *Radio Amateur's Handbook*.

#### I am ready

My friend stared me in the eyes. "You *should* be ready, but if you don't mind I'd like to test your readiness. You must *understand* Amateur Radio if you want to be more than a plug-it-in-and-modulate-it-ham," he declared.

For the next three hours I was given the third degree. If I hesitated, the answer was extracted painfully, by forcing me to go step-by-step through basic theory. We pulled out the books now and again to verify some things. Then, when no further questions popped up, my friend declared me ready to go forth into battle.

"Tomorrow you will take your General test and you will pass!" He was emphatic. "To make sure that you're relaxed, I'll drive you down and wait for you. Now go home and sleep!"

I did sleep. Like a baby. No doubts crossed my mind, and since the Morse test was behind me, the written





examination seemed to be a much smaller obstacle that it had in the beginning. I arose next morning, refreshed and confident.

I PASSED THE TEST my sixth time out. I wasn't a bit nervous, since I'd prepared myself well enough to remove the source of the greatest fear of all: the unknown.

The examiner gave me a genuine smile when he looked over my papers, saying simply, "Congratulations!" He called me by my first name and shook my hand.

I bounded out the door, skipped down the front steps and into the waiting car. "Don't tell me, let me guess!" smiled my ham friend.

Well, I don't have to tell you how we celebrated that evening. We finished off a complete bottle of Colpitts '56, zipped down to Hamburger Haven for a Super Whopper topped off with a double-frosted Fribble and then ended the day by firing up the rig on 20 meters and having a ragchew with the high priest of Xanadu.

So, that's my story. Maybe there's some guidance in there somewhere for you struggling would-be hams. If you practice what I just preached, you should pass your test in less than six tries. Oh, yes. There's just one last irony in all this: When I received my Amateur Radio license in the mail, I discovered that they spelled my name wrong! **HRH**

Need help in getting your Amateur license? *ham radio's* Communications Bookstore has a neat package that we would like to send to you. It tells you about the study guides and code-practice tapes, and some "package" deals too. Get started today — write "I Want To Be A Ham," *ham radio's* Communications Bookstore, Greenville, New Hampshire 03048.

**you're carefree  
when you  
know you've  
got the  
very best!**



## Larsen Kūlrod® antennas

Repeater or simplex, home station or mobile, 1 watt or 50 . . . what really counts is the intelligence that gets radiated. Jim Larsen, W7DZL found that out years ago when he was both hamming and running a two-way commercial shop. That's when he started working with mobile antennas . . . gain antennas that didn't waste power in useless heat. Today, thousands and thousands of Larsen Antennas are being used. We call it the Larsen Kūlrod® Antenna. Amateurs using them on 2 meters, on 450 and six call them the antenna that lets you hear the difference.

Larsen Kūlrod Antennas are available for every popular type of

**Illustrated . . .** Larsen JM-150-K Kūlrod Antenna and mount for 2 meter band. Comes complete with coax, plug and all mounting hardware. Easy to follow instructions. Handles full 200 watts.

mount. For those using a 3/4" hole in their vehicle we suggest the LM mount for fastest, easiest and most efficient attachment.

For the 3/8" hole advocates there's the JM mount . . . fully patented and the first real improvement in antenna attaching in 25 years.

And for the "no holes" gang there's the unbeatable MM-LM . . . the magnetic mount that defies all road speeds.

Send today for data sheets that give the full story on Larsen Kūlrod Antennas that let you hear the difference and give you carefree communications.



Dealer Inquiries Invited

**Larsen Antennas**

11611 N.E. 50th Ave. • P.O. Box 1686 • Vancouver, WA 98663 • Phone: 206/573-2722  
In Canada write to: Canadian Larsen Electronics, Ltd.  
1340 Clark Drive • Vancouver, B.C. V5L 3K9 • Phone: 604/254-4936

® Kūlrod . . . a registered trademark of Larsen Electronics



## HALF-SIZE FULL PERFORMANCE Multi-Band HF Communications Antennas

ESPECIALLY SUITABLE FOR THE NEW AMATEUR



75-10 HD

THOUSANDS IN USE

### MOR-GAIN HD DIPOLE SPECIFICATIONS

MODEL	BANDS (Meters)	LENGTH (feet)	PRICE
40-20 HD	40/20	36	\$49.50
40-10 HD	40/20/15/10	36	59.50
80-40 HD	80/40 + 15	69	57.50
75-40 HD	75/40	66	55.00
75-40 HD (SP)	75/40	66	57.50
75-20 HD	75/40/20	66	66.50
75-20 HD (SP)	75/40/20	66	66.50
75-10 HD	75/40/20/15/10	66	74.50
75-10 HD (SP)	75/40/20/15/10	66	74.50
80-10 HD	80/40/20/15/10	69	76.50

NOTE: 75 meter models are factory tuned to resonate at 3950 KHz. (SP) models are factory tuned to resonate at 3800 KHz. 80 meter models are factory tuned to resonate at 3650 KHz.

### WHY MOR-GAIN?

**NOVICE LICENSE OPERATION.** The MOR-GAIN HD Dipole is the ideal antenna for the new or Novice operator. As the Novice progresses to higher license classes, he can easily re-tune the HD Dipole to the new frequencies of his higher license frequency privileges. The HD Dipole is thus a one-time investment. HD Dipoles are available for all Novice frequencies.

**LEAST COST.** Dollar for dollar, the HD dipoles are the highest performance least cost multi-band antennas on the market today. For Example: the 5-band 75-10 HD dipole costs less than \$15.00 per band - an unbeatable low cost.

Contact your favorite dealer or order direct from MOR-GAIN today. Write for fully descriptive four page brochure.



Manufactured & Guaranteed by  
**MOR-GAIN**  
2200N South 4th Street  
Leavenworth, Kansas 66048  
(913) 682-3142



## DON & BOB'S SUPER STATION BUYS

**SPECIALS** Kenwood TS-700A, call for quote (list price... \$599) Hy-Gain Handi Talkie - Call for quote (list price \$189.95). NEW Ham X Rotor - Turns 28 sq. ft. of antenna. Delivery in August. List price, \$325. Your price \$289.

We Have Telex headsets, Bird wattmeters, Janel preamps. KLM antennas, linears, accessories - All In Stock.

**ROTORS** KLM KR400 - \$85.00, CDE Big Talk - \$79.00, CDE Ham II - \$129.00.

CETRON 572B Tubes \$24.95/ea.

**CABLE** 5/32", 6-strand, soft-drawn guy cable. For mast or light tower, 3¢ foot.

**BELDEN COAX CABLE:** 8237 RG8 19¢ ft., 8214 RG8 foam 23¢ ft., 8448 rotor cable 14¢ ft., 8210 72 ohm kw twinlead \$19/100 ft. 8235 300 ohm kw twinlead \$12/100 ft. PL259 49¢; UG175 adapter 19¢; PL258 double female \$1.00.

**NYLON CORD** 5000 ft. + per roll \$15.00

CALL US FOR QUOTES ON: ATLAS 350XL, KENWOOD TS520, TS700A, TR7400A, FT-101E, TEMPO 2020 & ETO ALPHA. ALL IN SEALED CARTONS.

### CALL US FOR QUOTES ON ITEMS NOT LISTED

TERMS: All prices FOB Houston. Quotes Good 30 Days. All Items Guaranteed. Some items subject to prior sale. Send letterhead for Amateur dealers price list. Texas residents add 5% tax. Please add postage estimate, excess refunded.

### MADISON ELECTRONICS SUPPLY, INC.

1508 McKinney Houston, Texas 77002  
713/658-0268 Nites 713/497-5683

## YOUR BEST BUY IN 2 METER GEAR

AMCOMM  
S 2 25



Your Price?  
Too Low To Publish!  
But... You Must Act Now!

AMCOMM'S S 2 25 is a 2 meter, synthesized, VHF-FM transceiver with variable output power (1-25 watts), 800 frequencies in 5 kHz steps, 4 selectable splits, panel mounted signal/power meter and digital readout (6 digits). CALL US TODAY! You probably won't believe this SPECIAL INTRODUCTORY OFFER!

psssst \$399.00

TODAY call or write for your very best deal on: Drake, Ten-Tec, Regency, Mosley, Hy-Gain, Telex, Wilson, Antenna Specialists, Rohn and Astatic.

## "HAM"BUERGER

ELECTRONIC EQUIPMENT DISTRIBUTOR

WA3Z1D 68 North York Rd.  
WB3GXP Willow Grove, Pa. 19090  
WB3HOF 215-659-5900



## bind'em AND find'em!

Keep those valuable issues of Ham Radio HORIZONS like new! Prevent smears, tears and dog ears — bind 'em in the handsome, 2-color buckram binders now available from Ham Radio's Communications Bookstore.

Each binder comes complete with gold-stamped date labels and is fully washable.

In the future, you'll be happy you did it now!

Ham radio HORIZON Binders \$5.95

Order HR-HBDL 3 for \$15.95

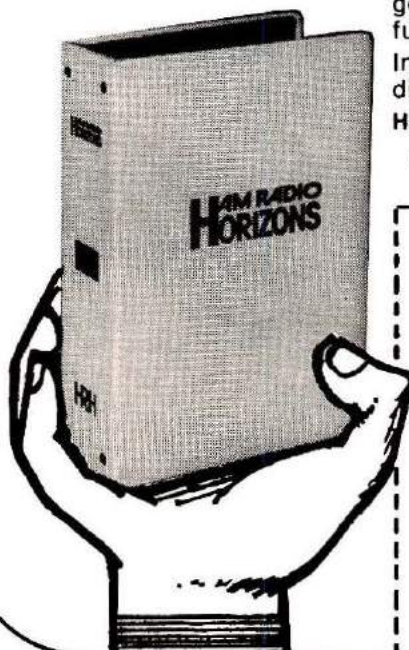

ham radio's  
communications  
bookstore

Greenville, N.H. 03048

Here's my payment for the HORIZON binders.  \$5.95  \$15.95

Name \_\_\_\_\_

Address \_\_\_\_\_

City \_\_\_\_\_

State \_\_\_\_\_ Zip \_\_\_\_\_



**NEW! \$32.50**

plus \$1.50 s/h  
NY res. add tax



**CMOS Electronic Keyer**

Features:

- State-of-the-art CMOS circuitry
- Self completing dots and dashes
- Dot and dash memory
- Iambic keying with any squeeze paddle
- 5-50 WPM
- Speed, volume, tone controls, side tone and speaker
- Low current drain CMOS-battery operation
- Deluxe quarter-inch jacks for keying and output
- Handsome eggshell white base — woodgrain top
- Compact and portable — 1 7/8" x 4 1/4" x 6 1/4"
- Grid block keying
- Wired and tested — fully guaranteed — less battery



Electronics, Inc.  
1106 Rand Bldg.  
Buffalo NY 14203



502-886-4534



**YAESU — TEN-TEC — TEMPO**

- WE HAVE FULL SERVICE ON WARRANTY AND NON-WARRANTY RADIOS.
- ALL NEW DIGITAL MODELS ARE NOW IN STOCK.
- CALL US SOON FOR PERSONAL SERVICE.



TEN-TEC  
544 DIGITAL

TRENTON, KY. 42286

**COHOON**  
AMATEUR SUPPLY

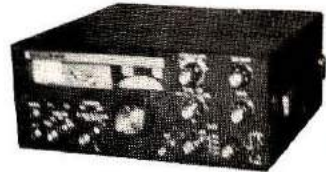
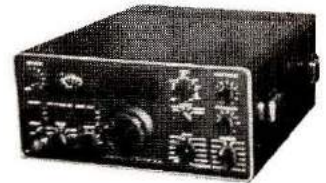

**The exciting 'Dominator' speech processor... \$69<sup>95</sup>**

Shipped prepaid by first insured air mail

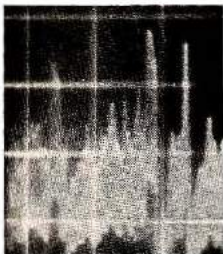

WITHOUT DOMINATOR

Finally, whether your interest is FM, AM, or SSB, there is a speech processor that delivers **high quality audio** while still providing up to 10 db increase in talk power, that will make you **proud of your signal**.

**SUPERIOR AUDIO QUALITY MAKES THE BIG DIFFERENCE**

- RC tailored networks featuring plug-in ICs
- Highest quality "MIL" spec components
- Rugged glass epoxy circuit board
- U.S. made ICs for easy availability
- Optimized frequency response
- Installs easily in mike lead
- Broad range impedance match
- Totally self-contained—perfect mobile or fixed
- Over 700 hour av. battery life with 9v. Ev. 276 or equiv. (not included)—no worry about separate supplies, adapters, or hum.
- Beautiful, incredibly rugged die-cast alum. cabinet
- Sophisticated filter network for harmonic suppression
- Negative feedback for minimum distortion and freedom from overload.
- Plug-in ICs for easy serviceability



WITH DOMINATOR SWITCHED IN

These specs sound exciting because the Dominator is a fantastic performer. A glance at the 'scope photos shows how your signal can be stronger with that added punch to work through the pile-ups and still get comments like "Great modulation quality, OM!"

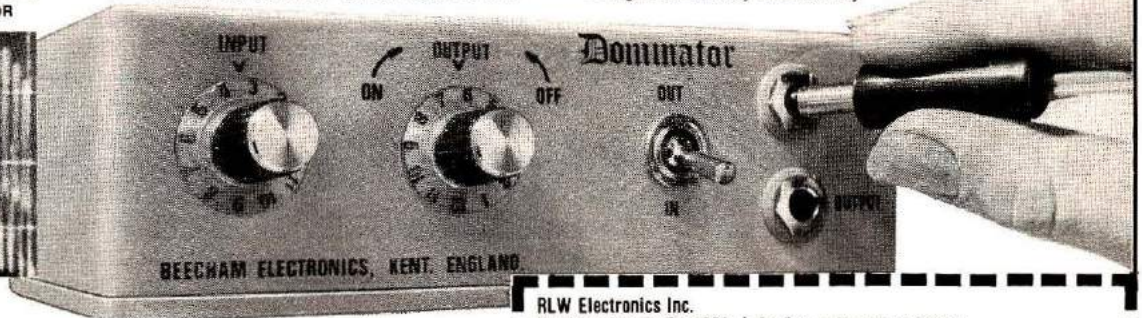

Order now while money-saving factory to you price is still in effect and receive at no additional cost a pair of three-conductor PTT plugs, a mike lead, and a factory installed connector block with five uncommitted terminals.

The Dominator is custom manufactured by Beecham Electronics of Kent, England to the highest quality standards of today's state-of-the-art circuitry. It is covered by a one-year limited warranty, with your only cost being postage, in the event you need to return it to the factory for service. The Dominator is available by mail order only at this low, money-saving, pre-store price. Your unit will be shipped prepaid directly from the factory in England. There is a small duty, (about 7%), which is collected by your postman when he delivers your Dominator.

RLW Electronics Inc.  
Hawkins Avenue-Box 221, Lake Grove, New York 11755

The DOMINATOR is for me! Please rush by prepaid & insured air mail \_\_\_\_\_ unit(s) at \$69.95 each. A total of \$ \_\_\_\_\_ is enclosed. I understand that I will pay my Postman a small add'l charge for duty when he delivers my DOMINATOR.

Name \_\_\_\_\_  
Street \_\_\_\_\_  
City \_\_\_\_\_  
State \_\_\_\_\_ Zip \_\_\_\_\_

New York residents send appropriate Local & State Sales Tax.

Imported exclusively by RLW Electronics Inc., Hawkins Avenue - Box 221, Lake Grove, New York 11755. Phone (516) 742-1595





# THE FAR HORIZON

**Star Light, Star Bright  
Which DX  
can I work tonight**

BY BOB LOCHER, W9KNI

Last night, conditions were poor for DXing. The static level was high and, if any DX was coming through, I couldn't hear it at my station. But, tonight is different, and propagation conditions may be somewhat better.

Midsummer, like any other season of the year, has its own peculiar conditions to challenge the DXer. Poor midday propagation, frequent days of high noise levels that make DXing difficult at best, and poor conditions on ten and eighty meters, are some negative aspects of the summer season. On the other hand, morning and evening openings on fifteen and twenty meters more than make up for the failings of ten and eighty; at least when the static

diminishes to a reasonable level.

I settle into my chair, placing my headphones over my ears. The coffee is hot, the receiver is warm, and I'm ready to do some prospecting. As I turn my antenna to a direction slightly west of north, I check my note pad.

Let's see: The DXpedition to the Laccadives isn't due for another four days, and probably will be delayed, anyway. DXpeditions to rare locations are almost always at least five days late. Hmm . . . VS9MB has been reported active from the Maldives around 0230Z at about 14060 kHz; better keep an ear open for him. 9K2DR in Kuwait has been showing up around 0330Z near 14020 kHz. I need that one, too, so I'll keep a

sharp lookout for him as well.

Casual tuning is fun, and often yields very pleasant surprises, but you are more likely to snag the rare ones if you have some idea of where and when to look. You discover where and when to look by listening for DX, by listening to other stations on the bands talking about what they have worked, by reading the DX columns in some of the magazines, and by reading the DX bulletins subscribed to by many DXers.

I spin the dial down to the bottom edge of the band, switch the receiver to its wide selectivity position, and slowly begin tuning up the band. I glance at the clock: It's 0130Z — plenty of time for casual tuning before I start stalking



the VS9's frequency. The noise level is definitely down tonight; things look promising.

The bottom 5 kHz of the band is quiet; no activity, except for a high-speed ragchew between a W2 and W6. Then, a touch higher, I hear the evening's first DX. It's UK0MCA calling CQ DX. I listen to him carefully for a minute. Siberia is very common, but he will give me a quick idea of conditions. Hmm . . . his signal is pretty steady, with little fading. S-6 to 7, and there's no trace of the flutter that transpolar signals often display shortly before the band is wiped out by a solar disturbance. Yes, we may have a fairly good evening on our hands. The UK0 finishes his call, and a W4 starts calling him. I tune on. A little higher, I hear a loud station by backscatter. It's obviously an American, because his backscatter signal is S-9. He's obviously working a bit of DX, probably a choice bit, judging by the way he's sending.

It's usually easy to tell when a fellow is tied into a good DX contact; his spacing and timing

have a different rhythm from what you normally hear — his nervousness is showing through. Naturally, I listen carefully — it may be something I need too . . .

QTH MD MD BT LYNN LYNN  
PSE QSL QSL HW COPY?  
JT1AT DE W3BWZ KN

JT1AT — That's Gat, in Mongolia! A rare catch, indeed, an exotic bit of DX. I caught him two weeks ago, on his CQ, but I'll listen a bit anyway. Hearing him come through revives the thrill I had when I heard him come back to me on my first call; besides, listening to him for a minute will give me a better feeling for band conditions.

R W3BWZ DE JT1AT R OK LYNN TNX  
RPT BT QSL BOX 369 ULAN BATOR  
BOX 369 ULAN BATOR  
73 73 SK W3BWZ DE JT1AT SK

Yes, good signals tonight. How I'd love to visit Ulan Bator, the capital of Mongolia! Someday, maybe . . . but anyhow, he's in the logbook. Soon I'll receive his QSL card, a valued souvenir of a rare and exotic place. There are a number of stations calling him now, so

once again I begin tuning higher. Part of the excitement of tuning the band is that you never know what will show up in the next kHz.

A little higher, I hear a UK9 and a UW0 QRMing each other on the same frequency. They're both Siberians and obviously can't hear each other because of their closeness and the skip. I continue tuning . . . Just above them, I hear a fairly strong CQ DX, and I recognize him instantly. It's VU2BK; he has one of the strongest signals out of India and a distinctive fist that makes him easy to spot. He's also very active. His signals are good tonight, so I know the band is in fine shape. He signs, and three stations begin calling him: A W4, a VE3, and a UK0 in Siberia.

Next, I run across UL7PBR in the Soviet Kazakh. On the great circle map, Kazakh is a little east of north, and it's a bit early for him to be so strong — particularly since I'm not beaming directly at him. A very good sign. Because that part of the world is showing signs of life, I bring the antenna around a little and stop it on due north. The UL7 picks up an S unit from the improvement in heading. I listen for a moment. Then, a bit higher, I hear a strong UA9 — another Siberian. Just as I'm about to tune on, I notice a weak station underneath him and pause — you never can tell. I switch in the sharp filter just as the strong UA9 signs clear; I listen intently — then laugh. It's a PY from Brazil coming in off the back of my antenna.

I switch back to the wide filter and continue tuning, but I reflect on the PY I just heard. You can't be too careful when tuning a band. Rare DX is most easily worked without a pileup in hot pursuit, especially if your station is less than competitive in terms of signal strength. If you find a rare one calling CQ, you might be able to nail him on the first call — with a little luck — when only one or two

Amateur Radio is a hobby pursued by many people in all types of occupations. You can't get higher up the scale than JY1, His Majesty King Hussein, of Jordan (*photo courtesy WA3HUP*).







Here is Zal, VU2DK, at his operating position with plenty of equipment to put forth a great signal. The transmitter and amplifier shows that he does a good job of building in far-away India (photo courtesy KØHUD).

others are competing with you. Maybe none! But, in ten minutes, it's a pretty safe bet that tens or even hundreds will be in there fighting it out on the line of scrimmage. Let me tell you, it's a lot more fun listening to the angry mob after the DX contact is safely recorded in your log book than it is if he is on your need list!

A good DXer should be able to show a good account of himself in a pileup, but careful tuning puts the bulk of the good cards on the wall. The trick of tuning a band is to identify all the signals you can — to separate the wheat from the chaff — as opposed to tuning for the forty-over-S9 pileup. The fact is, if you've been tuning a band for any length of time, and come across a pileup, you goofed somewhere. You should have been in there before the pileup found the DX station.

I continue the search, tuning past myriads of DX stations representing exotic locations all over central Asia; but, I've worked all the countries I've heard tonight, and I'm looking for something new. Even

though I haven't called anyone tonight, I'm enjoying the evening. As the minutes tick away, the opening unfolds, deeper and deeper into Asia, and slowly moving east.

I come across UH8HBA calling CQ. UH8, Turkomen, is one of the rarer Soviet Republics. I've worked a couple

UY5LK and UA6HZ enjoy their DX operating from the Soviet Union. On the wall behind them is a checklist that shows the countries and zones worked on each band for the CQ World Wide contest. (photo courtesy WA3HUP).

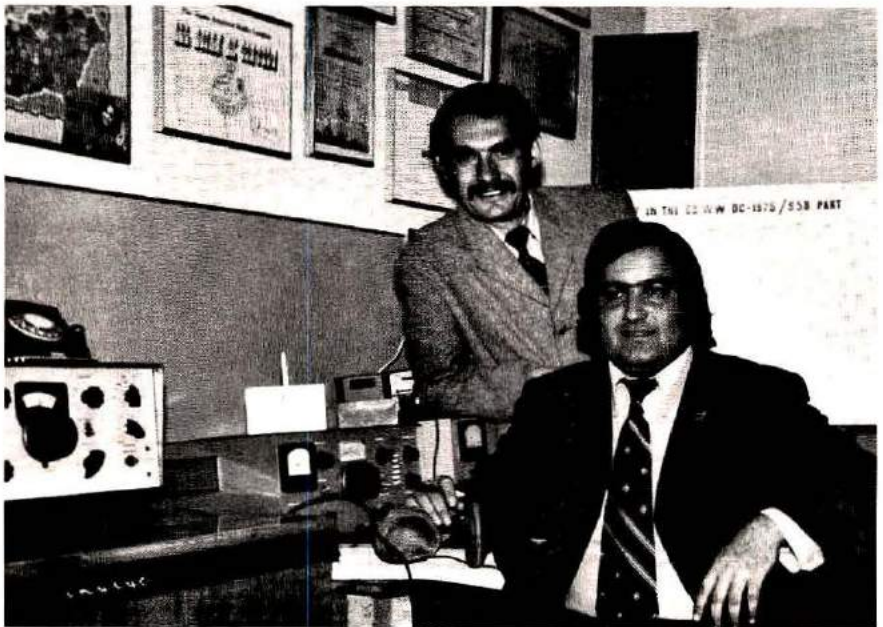

of 'em, but still no QSL received. I bring the vfo up to zero-beat his frequency, and wait. His signals are pretty good — there may be a bit of a pile going on this one. He signs, but I pause a moment before calling. Yes, there are at least three stations beginning a call, nearly all zeroed on each other. Quickly, I move the vfo about 300 Hz higher, just clear of the others, and I begin my call. I make it a short one —

UH8HBA DE W9KNI W9KNI AR

— and listen. He's in there, coming back to somebody, but still being covered by one of the stations calling him. I think I got him though, because he started up right after I signed. Ah, yes . . .

W9KNI DE UH8HBA R

The trick of pausing a moment can often pay dividends, but using it is tricky. If you are fairly sure that a number of stations will be calling the DX, it almost always pays to use this technique. Where it hurts is when only one other station calls the DX. The DX operator hears the first station and directs his attention to that signal. The other signal, starting up a







moment later, has a much poorer chance in that particular case.

So, the pause has its advantages and drawbacks, but, if you know you're in a fight, it's generally a wise maneuver. Don't think you have ten seconds to make a careful analysis though, unless there's a large pileup. In fact, within one second, you should decide whether you need to move your vfo or not. If not, you should start calling immediately. If so, you should be moved and calling within another second. On the other hand, if the pileup is huge, then the delayed call is useful. The pause, if used, is generally applied to the small pileup; the delayed call to the larger pileup.

I have a short QSO with the UH8, and continue tuning as I complete logging the contact. Nothing else of great interest shows up, so I turn the antenna into the Antarctic for a few moments' look. I still need several of the island groups down there.

Right at the bottom of the band I strike pay dirt!

R W5XBK DE VP8MX R FB JACK NOT  
KEEP YOU MUST QRT IN TWO MINS  
FOR COMMCL SKED QSL OK 73  
W5XBK DE VP8MX SK

South Georgia! I know he's on South Georgia, because I saw a note in a DX column, and have been looking for him ever since. I listen carefully — the W5 is just barely readable. I move my vfo in — zero in on him, then up just a hair, perhaps 150 Hz. The W5 starts to sign clear, and I start,

VP8MX DE W9KNI W9KNI AR

I call at a rather high speed — if he's about to close down I want to give him the impression that I'm not going to take all day.

OK JACK 73 SK NW W9KNI VP8MX  
TNX 579 579 NAME DAN DAN MUST  
QRT GA BK  
R VP8MX DE W9KNI TNX  
579 579 CHICAGO CHICAGO OP BOB  
BOB QSL OK TNX 73 SK DE W9KNI  
R 73 SK CL

Just like that, in less than 2 minutes after I first heard him,

he's gone — but not forgotten! I sit there almost stunned for a moment. Then I fill out the line in the logbook. There's a mob of stations calling him now, but he's gone, definitely QRT. I'd been looking for him for months — then, in a matter of two minutes I catch him and he's gone. You always have to listen to your hunches. Otherwise, why would I have turned my antenna away from a good transpolar opening? But I did it, and I'm glad.

Now, I turn my antenna back to the north, the road to Asia. As I begin my sweep of the band, I reflect on my early days as a DXer; and, thinking about zero beating, I chuckle. I had read a couple of articles about DXing, and they, too, made a major point of zeroing the vfo on a station.

Well, I was a little confused about what they meant. Frankly, I took a different definition of zero beating to heart. I would tune to a station I wanted to work, then stop with a 500-Hz note coming out of the receiver. Then, I would bring the vfo up to a dead zero note, like the bottom of the audio passband. But, I didn't work very much DX that way. Then, one of the friendly old

timers showed me how it was done.

The real problem is really one of definition. The term *zero beating* is accurate in a sense but, unfortunately, two senses are possible. A more descriptive way to put it is to *overlap* a signal with your vfo. It's really a simple technique: You listen to the signal you want to zero, and bring your vfo into the passband of your receiver. In other words, you should hear both the station you want to zero, and your own vfo. Now, carefully move the vfo into the spot where you completely cover the other signal. In other words, your vfo drowns him out, or QRMs him; because it's on exactly the same frequency that he is. Then, and only then, are you zeroed. It is very important to successful DXing that you know how to do this — and a surprising number of would-be DXers don't.

Many transmitter/receiver combinations in use today are capable of transceive operation. While transceiving is very useful for ssb operation, it will kill you in the CW pileups. Since most of the separate transmitter/receiver combinations also permit independent

Joto, YO3QK, seems to be enjoying some good operating conditions in Romania (photo courtesy K0HUD).





operation of their vfos, this is the only way to go. It is difficult, if not impossible, to zero a station reliably using transceiver techniques. If you use a transceiver for your operating, by all means get an external vfo for it. While these are not as good for CW DXing, as separate receivers and transmitters, there are a lot better than the single vfo.

Hmm . . . It's 0220Z now, about time for that VS9 in the Maldives to show up. Let's see . . . 14060 kHz. Beam heading . . . hmm . . . straight north is close enough. Nothing there. I start tuning around the frequency a bit. There's another Siberian. Today must be a Soviet holiday — the band is absolutely jammed with Siberians. Aha, there's another VU2 in India going QRZ? Listen to that mob of U (Russian) stations after him!

I ease back across 14060 — hey, there's a CQ.

CQ CQ CQ DX DE VS9MB VS9MB  
CQ CQ CQ DX DE VS9MB AR K

Needless to say, I'm ready before he signs. I give it the old hesitation stutter-step — and listen in awe. There must be fifty stations calling him, all on a lousy short CQ. I jerk the vfo down almost a full kHz — strictly at random — there is no way I'm going to make myself heard through the middle of that mob. I sign — the hordes are still calling frantically. I can hear him come back to somebody — too much QRM to read him. I catch the calls of some of the other stations — there are UA9s, UA0s, UK0s, UW9s, UW0s, a UL7, plus a motley assortment of Ws, and VEs. The pile clears, and he's definitely in contact with someone. Yes, it's UK9AAN, the fellow with that seven-element Yagi.

Hmmm. If I'm going to have a shot at this fellow, it's obvious that I'm going to have to try a tail-end call. If I'm lucky, he may catch the W prefix, and listen for the longer haul DX, namely, me.

I set up just below UK9AAN

and, as he starts to sign clear, I drop in a crisp W9KNI and sit back, picking up the pencil to log him in. Hah! As the rig switches back to receive, I hear about six U stations finish their tail-end calls, at least three of them dead on my frequency.

I begin considering the matter. Maybe one new country tonight is enough, and I'll get a quick QSL back from VP8MX, too. The pileup on the VS9 continues to grow — to expand — and it's all Siberians he's working.

Well, I can't blame them. The Maldives are rare for any DXer, no matter where he's located. It's kind of like a YV0 on Aves island for United States hams — very rare, but a chip shot for us when its on, and almost impossible for the Soviet DXers when we have skip.

I listen to the VS9 for a bit to try to determine his operating pattern, in case I get another shot at him. I can't really make one out, though, except that he prefers fairly slow fists, and seems to favor stations a few hundred Hz above him. Otherwise, it's plain-vanilla straightforward stuff — no tail-end calls accepted.

As I listen, the band starts to fade and, within a matter of minutes, the polar path is gone. Sometimes the band closes rather suddenly like this, but at other times it will slowly shift.

Well, sports fans, you can't win them all. But, what the heck — it wouldn't be as much fun if you worked everything on the first call, or even the first time you hear it. Besides, that fellow will be on again, maybe next time without the short skip, so that we North Americans can get a better shot at him. Now I know that the reports of his time and frequency are accurate; and I have a bit of an idea about how to work him.

I glance up at the clock. It's getting late, and, tomorrow, I have a full day's work before me. I take a last quick look over the band, and shut down the station. There's always tomorrow!

HRH

## NEW! IC KEYSER

The World's Greatest  
Sending Device

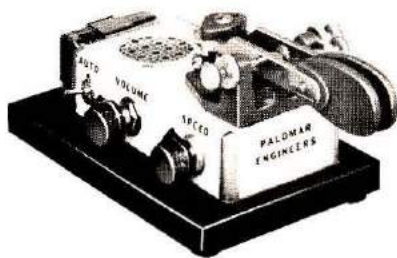

Adjustable to Any  
Desired Speed

Now available from Palomar Engineers — the new Electronic IC KEYSER. Highly prized by professional operators because it is EASIER, QUICKER, and MORE ACCURATE.

It transmits with amazing ease CLEAR, CLEAN-CUT signals at any desired speed. Saves the arm. Prevents cramp, and enables anyone to send with the skill of an expert.



Equipped with large specially constructed contact points. Keys any amateur transmitter with ease. Sends Manual, Semi-Automatic, Full Automatic, Dot Memory, Squeeze, and Iambic — MORE FEATURES than any other keyer. Has built-in sidetone, speaker, speed and volume controls, BATTERY OPERATED, heavy shielded die-cast metal case. FULLY ADJUSTABLE contact spacing and paddle tension. The perfect paddle touch will AMAZE you.

Every amateur and licensed operator should know how to send with the IC KEYSER. EASY TO LEARN. Sent anywhere on receipt of price. Free brochure sent on request.

Send check or money order. IC KEYSER \$97.50 postpaid in U.S. and Canada. IC KEYSER LESS PADDLE and non-skid base \$67.50. Add 6% sales tax in California.

Italy write i2VTT, P.O. Box 37, 22063 Cantu.

Fully guaranteed by the world's oldest manufacturer of electronic keys. ORDER YOURS NOW!

## PALOMAR ENGINEERS

BOX 455, ESCONDIDO, CA 92025  
Phone: (714) 747-3343



## R-X NOISE BRIDGE

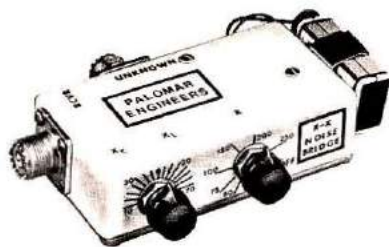

- ✓ Learn the truth about your antenna.
- ✓ Find its resonant frequency.
- ✓ Adjust it to your operating frequency quickly and easily.

If there is one place in your station where you cannot risk uncertain results it is in your antenna.

The Palomar Engineers R-X Noise Bridge tells you if your antenna is resonant or not and, if it is not, whether it is too long or too short. All this in one measurement reading. And it works just as well with ham-band-only receivers as with general coverage equipment because it gives perfect null readings even when the antenna is not resonant. It gives resistance and reactance readings on dipoles, inverted Vees, quads, beams, multiband trap dipoles and verticals. No station is complete without this up-to-date instrument.

Why work in the dark? Your SWR meter or your resistance noise bridge tells only half the story. Get the instrument that really works, the Palomar Engineers R-X Noise Bridge. Use it to check your antennas from 1 to 100 MHz. And use it in your shack to adjust resonant frequencies of both series and parallel tuned circuits. Works better than a dip meter and costs a lot less. Send for our free brochure.

The price is \$49.95 and we deliver postpaid anywhere in U.S. and Canada. California residents add sales tax.

Italy write i2VTT, P.O. Box 37, 22063 Cantu. Elsewhere send \$52.00 (U.S.) for air parcel post delivery worldwide.

Fully guaranteed by the originator of the R-X Noise Bridge. ORDER YOURS NOW!

# PALOMAR ENGINEERS

BOX 455, ESCONDIDO, CA 92025  
Phone: (714) 747-3343

# STEP UP TO TELREX

## Professionally Engineered Antenna Systems

### Single transmission line "TRI-BAND" ARRAY

MONARCH  
TB5EM/4KWP

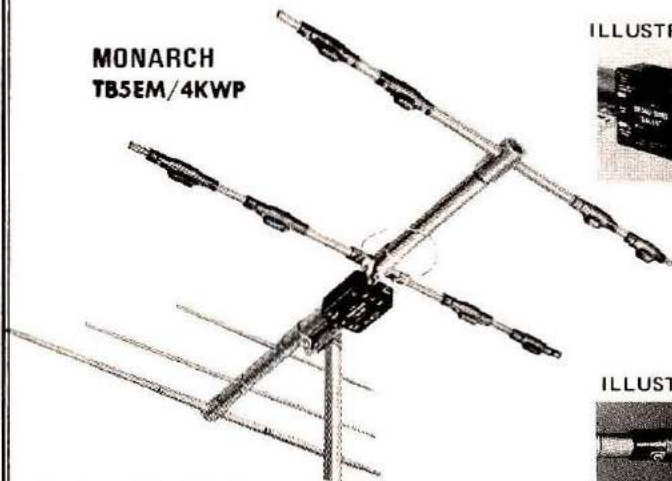

ILLUSTRATION BALUN



ILLUSTRATION TRAP



By the only test that means anything ... on the air comparison ... this array continues to outperform all competition ... and has for two decades. Here's why ... Telrex uses a unique trap design employing 20 HiQ 7500V ceramic condensers per antenna. Telrex uses 3 optimum-spaced, optimum-tuned reflectors to provide maximum gain and true F/B Tri-band performance.

For technical data and prices on complete Telrex line, write for Catalog PL 7



## ANTENNA SWITCHES



Model 377

**BARKER & WILLIAMSON  
COAXIAL ANTENNA  
CHANGE-OVER  
RELAY**

Economical and reliable. Can be operated from VOX circuit for completely automatic operation or from PTT or manual T/R switch. Receiver input is automatically grounded when the relay is in the Transmit position. Wide AC operating voltage range and low operating current.

• specifications	
Power Rating	1000 watts CW (2000 watts SSB) Less than 1.15:1, DC to 150 MHz
VSWR	0.015 Ampere, 48 to 130 volts AC
Power Requirements	UHF Type SO-239
Connectors	3 1/2" x 1 1/2"
Dimensions	1 lb.
Shipping Weight	

Model 377 \$17.95



Model 375

**BARKER & WILLIAMSON  
ANTENNA  
SELECTION  
SWITCH**

6 outputs with automatic grounding

Protax Model 375 \$18.95

Please add \$2.00 shipping.

G.R. WHITEHOUSE & CO.  
15 Newbury Drive Amherst N. H. 03031

## CFP . . . FOR ALL YOUR AMATEUR NEEDS



DRAKE TR4CW

ORDER TODAY! Write or  
Call WA2KTJ, WB2LVW

CUSHCRAFT    ATLAS  
CIR (Astro 200)    TEMPO  
DENTRON    TEN TEC  
DRAKE    YAESU\*

\*Remember, we take care of your warranty repairs during warranty for Yaesu.

Transmitter sales to licensed amateurs only.

WANTED: Good clean trades!

Mail Orders accepted. N. Y. residents add sales tax. SASE will get our list of used Amateur Equipment.

## CFP COMMUNICATIONS

211 NORTH MAIN STREET  
HORSEHEADS, N. Y. 14845  
PHONE: 607-739-0187

STORE HOURS: Tues. to Sat. 10-6. Fri. & Sat. subject to Hamfests. Closed Sun. and Mon.



Calling  
All Hams...



...All Hams  
Call Us!

It's Toll Free... So Dial Away!

# 1-800-325-3636

### FOR NEW OR USED AMATEUR RADIO GEAR

... we're specialists and carry *in stock* most of the famous-brand lines. Or, we will talk trade.

### FOR FAST, DOOR- STEP DELIVERY

... give us a call. You'll be amazed; for we guarantee we'll ship your equipment the same day. Plus, most shipments are **PRE-PAID**.

### TO SAVE MONEY

... join thousands of our satisfied customers who buy from us as easily as from their local supplier. So, remember your call is *Toll Free*.



We welcome your Master Charge or Bank Americard



## HAM RADIO CENTER, INC.

8340-42 Olive Blvd. P.O. Box 28271 St. Louis, MO 63132

## a GREAT BOOK about a GREAT MAN

### HIRAM PERCY MAXIM



**HIRAM PERCY MAXIM**, Father  
of Amateur Radio (Revised Second  
Printing)  
by Alice Clink Shumacher

Known to the world as the inventor of the Maxim Silencer; pioneer with 49 patents in the auto industry — built and drove the first car in the State of Connecticut. Above all honored by hundreds of thousands of hams as the "Father of Amateur Radio" — that's Hiram Percy Maxim.

A biography of Maxim's genius and productivity tracing his efforts to organize, guide, promote and 3 times save Amateur Radio from being legislated out of existence. Every Amateur should read this account and make the new full-color softbound edition a cherished volume in their library.

Order HR-HPM Now Only \$4.50

### ham radio's communications bookstore Greenville, N.H. 03048

Enclosed is check or money order for \$4.50 — rush a copy of Hiram Percy Maxim to me!

Name \_\_\_\_\_

Address \_\_\_\_\_

City \_\_\_\_\_

State \_\_\_\_\_ Zip \_\_\_\_\_

### MAXI TUNER SOLVES ANTENNA PROBLEMS!



### THE FINEST ANTENNA TUNER AVAILABLE

- Presents 50-75 Ohm Resistive Load to Your Transmitter Using Virtually Any Antenna System
- Improved Ultimate Transmatch Circuit Matches Coax, Random Wire and Balanced Antennas
- Continuous 1.7-30 MHz Coverage
- 229-203 Rotary Inductor (28  $\mu$ H)
- Rugged Cast Aluminum Turns Counter
- Handles 3 KW PEP
- Monimatch SWR Circuit
- Heavy Duty Balun
- Velvet-Smooth 6 to 1 Vernier Tuning
- 0-100 Logging Scale on Capacitors
- Available in Kit Form or Assembled
- One Year Factory Warranty
- Available without SWR for use with your present SWR meter or wattmeter.
- Custom Vacuum Capacitor Designs and Individual Components Available

Call or Write for Pricing, Spec Sheet, and FREE Amateur Market Antenna Tuner Comparison Chart That Tells It Like It Is!

**RF POWER** P. O. Box 11  
**COMPONENTS** Ladysmith, WI 54848  
(715) 532-3971



# 1977



## Sweepstakes

BY SKIP TENNEY, W1NLB

The 1977 *Ham Radio Horizons* — *ham radio Magazine* Sweepstakes was a fabulous success. More entries than any previous *ham radio Sweepstakes*, plus an exciting set of prizes, all added up to an important piece of 1977 amateur radio history.

Clarence C. Bickford, KØRHP was the grand prize winner. Bick is really excited about his two new Kenwood transceivers, a TS-820 and a TR-7400A. His TS-820 is a modern ssb-CW-FSK transceiver covering all six bands, 160 through 10 meters. It also offers many exciting features such as a true rf speech processor, i-f-shift passband tuning to help minimize interference problems, and phase-locked loop circuitry to provide maximum calibration versatility and accuracy. Bick's radio is also equipped with the optional DG-1 digital readout (which we understand is now coming factory installed on most TS-820s) and Kenwood's accessory CW filter to provide extra selectivity for CW operation. He also received a DS-1A dc-to-dc converter which allows 13.8 V dc operation in addition to the standard 120/220-volt internal power supply.

The second half of the grand prize was a TR-7400A. This hot new synthesized 2-meter mobile fm rig features full 4-MHz coverage and 25 watts of output power. Of particular interest is the TR-7400A's new squelch system which offers a choice of continuous-tone-

encoded squelch, tone-burst operation, or carrier-operated squelch to provide maximum flexibility for all kinds of operating conditions. KØRHP will certainly have no problem keeping up with all the two meter excitement in his area with this versatile new vhf package.

Bick is retired from government service, so he should be able to find the time to make good use of the TS-820 on his favorite hangouts on 80 meter ssb and 40 meter CW plus making some new friends on 2 meters. Congratulations to you, KØRHP.

Our next two winners received Kenwood TS-820s identical to that described

before. One went to William Locke, W4RPU. Bill plans to use his new rig in conjunction with a station he has set up for his high school science students, certainly a very generous and worthy use of this new equipment. WB9QBA, George Gruetzmacher, a student specializing in computer and electronic subjects, was the next winner. I'm sure you'll be hearing him and his new TS-820 very soon on 40- and 15-meter CW — if you haven't already.

A Kenwood TR-7400 two-meter fm transceiver was given to each of the next two winners. Jack G. Langley, KØMER, an aircraft maintenance electrician, was

The *ham radio* people gather for the big event — drawing the winning entries in the 1977 *ham radio Sweepstakes*.







Irene Hollingsworth, Assistant to the Editors, reaches for the paper that will reveal a winner.



Horizons Managing Editor Tom McMullen, W1SL, reaches into the box that almost overflows with entries in the 1977 ham radio Sweepstakes.



Therese Bourgault, Circulation Manager, checks to see if the winner has included his telephone number, then reads the name and call.

particularly anxious to get going on two meters with his prize because a tornado had recently destroyed his hf antennas. Our last winner was Harold J. Tune, W8LZE, who is retired from the General Electric Company. Hal is currently active in message

handling on 80 meter ssb and 75 meter RTTY but is looking forward to finding out all about 2-meter fm with his new TR-7400A.

We also had the pleasure of awarding 32 books from our special ham radio BOOK BONANZA. The books were offered with the cooperation of Howard W. Sams and Company and TAB Books. This was a portion of our contest where

we had buried call letters in the catalog text. If you found your call in the text you would receive the particular book being described.

Thanks again to all of you who took part in this year's contest and congratulations to our winners. To those who didn't win, keep your hopes up, you'll have another chance next year; maybe it's your turn to be our next winner. **HRH**

## QUALITY KENWOOD TRANSCEIVERS ... from KLAUS RADIO

The TS-820 is the rig that is the talk of the Ham Bands. Too many built-in features to list here. What a rig and only \$830.00 ppd. in U.S.A. Many accessories are also available to increase your operating pleasure and station versatility.



**TS-820  
160-10M TRANSCEIVER**

Super 2-meter operating capability is yours with this ultimate design. Operates all modes: SSB (upper & lower), FM, AM and CW. 4 MHz coverage (144 to 148 MHz). The combination of this unit's many exciting features with the quality & reliability that is inherent in Kenwood equipment is yours for only \$599.00 ppd. in U.S.A.

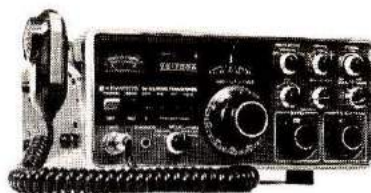

**TS-700A  
2M TRANSCEIVER**

Guess which transceiver has made the Kenwood name near and dear to Amateur operators, probably more than any other piece of equipment? That's right, the TS-520. Reliability is the name of this rig in capital letters. 80 thru 10 meters with many, many built-in features for only \$629.00 ppd. in U.S.A.

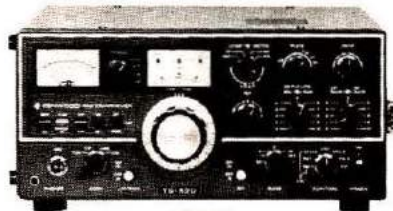

**TS-520  
80-10M TRANSCEIVER**



**TR-7400A  
2M MOBILE TRANSCEIVER**

This brand new mobile transceiver (TR-7400A) with the astonishing price tag is causing quite a commotion. Two meters with 25W or 10W output (selectable), digital read-out, 144 through 148 MHz and 800 channels are some of the features that make this such a great buy at \$399.00 ppd. in U.S.A.

Send SASE NOW for detailed info on these systems as well as on many other fine lines. Or, better still, visit our store Monday thru Friday from 8:00 a.m. thru 5:00 p.m. The Amateurs at Klaus Radio are here to assist you in the selection of the optimum unit to fulfill your needs.

# KLAUS RADIO Inc.

8400 N. Pioneer Parkway, Peoria, IL 61614  
Jim Plack W9NWE — Phone 309-691-4840



## PRODUCT

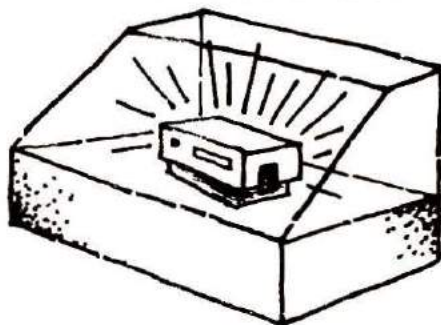

## SHOWCASE

### MFJ Deluxe Keyer



The new MFJ deluxe electronic keyer is based on the Curtis 8043 IC, and provides more features-per-dollar than any other keyer on the market. Iambic, automatic, semi-automatic, and manual keying are selectable, and you may use a squeeze, single-lever, or straight key. The deluxe keyer also provides a dot memory which insures self-completing dots and dashes, jam-proof spacing, and instant-starting for accurate and precise CW. In addition to all these features, the keyer is totally rf-proof!

Virtually any transmitter may be keyed: Grid block-keyed transmitters at -300 volts, 10 milliamperes, maximum; cathode and solid-state-keyed transmitter at +300 volts, 200 milliamperes, maximum. All controls are on the front panel for easy, quick access, and include speed, weight, tone, volume, and function switch. The speed control is smoothly variable from 8 to 50 words per minute.

The MFJ deluxe keyer is completely portable and operates for up to a year on only 4 "C" cells. The enclosure measures a com-

pact 6x6x2 inches (15x15x0.8cm) and contains a built-in speaker. A three-conductor key jack and phono jacks for keying outputs, as well as a miniature phone jack for external power (3 to 15 volts dc.), are provided in the cabinet.

The price of the MFJ deluxe electronic keyer is \$69.95, plus \$2 for shipping and handling. Unconditionally guaranteed for a full year, the keyer may be returned within 30 days for a full refund (less shipping), if not satisfied.

MFJ also offers an optional, companion squeeze key with fully adjustable paddles and a heavy base with non-slip rubber feet at only \$29.95 plus \$2 for shipping and handling.

For further information and ordering instructions, write to MFJ Enterprises, Box 494, Mississippi State, Mississippi 39762, or use *ad check* on page 78.

### Remote Vfo for the Triton IV

Ten-Tec has announced its *Model 242 Vfo* — an exact duplicate of the Triton IV vfo assembly housed in a separate but matching enclosure. A front-panel mode switch with LED indicators permits the operator to select any one of six different modes of operation: Triton transmit and receive, remote transmit and receive, Triton transmit — Remote receive, Remote transmit — Triton receive, Triton transmit-receive, or Remote transmit-receive. Regardless of the mode selected, instant CW break-in operation is retained.

For fixed-frequency operation, a two-position crystal oscillator may be selected as the remote generator. Out-of-band crystal frequencies as much as 100 kHz from the 40- and 80-meter band edges, and 200 kHz from the 20-, 15-, and 10-meter band edges, may be used; as well as any in-band frequencies.

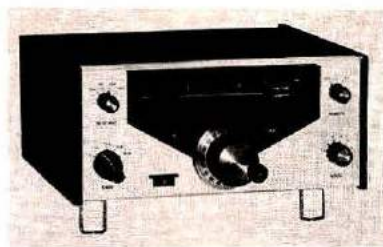

The *Model 242* comes with interconnecting cable, less crystals for 29.0 to 30 MHz vfo operation or crystals for fixed-frequency modes. Extra ten-meter crystals for 29.0 to 29.5 MHz, and 29.5 to 30 MHz are available.

Frequency accuracy is plus/minus 1 kHz from the nearest calibration point. Power is taken from the transceiver source, and stability is the same as for the Triton IV. The *Model 242* contains 1 IC, 13 transistors, and 10 diodes. The enclosure size is 4.5 x 10.375 x 8 inches (11.4x26.3x20.3cm), overall, the weight is only 4 pounds (1.8 kilograms), and the price is \$169. Additional information may be obtained by writing to Ten-Tec, Inc., Sevierville, Tennessee 37862, or use *ad check* on page 78.

### Mobile Communication Console For Fast, Secure Installation



Hartzell Manufacturing Company has just introduced a new mobile communications console that provides a means of installing *all* radio, communications and electronic equipment conveniently and neatly, quickly and securely! Equipment can be mounted prior to installation in the vehicle, and, once installed, all



equipment is rigidly secured, with no threat of loose or flying units during emergency situations.

The console puts all equipment at the fingertips of the operator, yet is centrally located, utilizing normally unused space. Fabricated from 20-gauge steel and heliarc welded, the console features double hems with rounded edges and two coats of baked-on, scratch-resistant epoxy paint.

Installation and mounting holes may be located according to the requirements of your equipment. Consoles, with equipment intact, can readily be changed from car to car at a fraction of normal time! Periodic in-shop servicing can be easily accomplished with all equipment processed at one time.

Typical units that can be mounted on the Hartzell Console include: amateur or CB radio, vhf control head, electronic siren, mobile repeater, light bar switch, remote speaker, scanner, cigar lighter, microphone clasps, and map lights.

Priced under thirty dollars in single units, generous quantity discounts are available. For further information contact B. David Vickroy, Hartzell Manufacturing Co., 702 Kumler Ave., Dayton, Ohio 45407; or telephone (513) 278-7316; or use *ad check* on page 78.

## Semiconductor Handbook

Radio Shack has just published a book that almost every Amateur, electronics hobbyist and experimenter will want; it's the new *Archer Semiconductor Reference Handbook*, containing a compilation of data on Archer brand semiconductors.

This *Handbook* includes a valuable cross-reference listing for replacement of transistors, diodes, and other interchangeable devices, and covers more than 36,000 different semiconductors. The cross-reference/

replacement listings are computer-selected and are based on careful analysis of the important parameters of the listed devices.

The *Handbook* also has sections on the care and handling of transistors, soldering precautions, case styles and dimensions, how to test transistors, and a glossary of words, symbols, and abbreviations.

The *Archer Semiconductor Reference Handbook* contains 128 pages, is priced at only \$1.95, and is available exclusively from Radio Shack stores and dealers. If there is no Radio Shack dealer near you, write to H. L. Siegel, 2617 West Seventh Street, Fort Worth, Texas 76107 to find out where you can get your copy of this useful *Handbook*.

## We Don't Claim That Your ALPHA Linear Will Run A Kilowatt Key-Down FOREVER . . .



. . . But We Don't Put A Time Limit On It, Either.

YOU'LL PROBABLY NEVER SET A BRICK ON YOUR KEY FOR 26,000 MINUTES. BUT WE DID IT TO ILLUSTRATE WHAT ETO'S NO TIME LIMIT (NTL) CONTINUOUS DUTY RATINGS REALLY MEAN TO EVERY ALPHA AMPLIFIER OWNER.

**April 7th:** A standard ALPHA 76 was taken from production, loaded up to a full 1000 watts key-down dc input, and left operating with a brick on the key.

**April 25th:** The '76 was still operating completely normally, delivering about 675 watts of continuous rf carrier output into a very hot dummy load — after 18 days — 435 hours — some 26,000 consecutive minutes key-down at a full kilowatt. You may have seen the same unit running key-down all day long the following week-end at the Dayton Hamvention. It's still as good as new — a fact which will surprise no one who knows how all ALPHA's are built. You'd expect no less.

The point is, every ALPHA linear amplifier — including the power- and value-packed ALPHA 76 and the exclusive NO-TUNE-UP ALPHA 374 — is meticulously engineered and built to handle continuous operation IN ANY MODE AT MAXIMUM LEGAL POWER [NTL] . . . No Time Limit. And ETO's warranty on every ALPHA amplifier protects you FOR EIGHTEEN MONTHS — FIVE TIMES LONGER than most amateur equipment warranties!

### ALPHA: SURE YOU CAN BUY A CHEAPER LINEAR . . . BUT IS THAT REALLY WHAT YOU WANT?

A LINEAR AMPLIFIER IS A BIG INVESTMENT . . . MAKE IT WISELY. For an enlightening glimpse at what goes into the design of every ALPHA by ETO's power professionals, or to aid you in comparing one linear with another, call or write for our brief guide entitled, "EVERYTHING YOU ALWAYS WANTED TO KNOW ABOUT (COMPARING) LINEARS . . . BUT DIDN'T KNOW WHOM TO ASK." We'll also send you fully detailed and illustrated literature describing the entire ETO line of superb ALPHA power amplifiers and ALPHA/VOMAX — the new split-band speech processor that's your key to rf clipper type "talk power" combined with easy mike-line installation and low-distortion, practically foolproof operation.



EHRHORN TECHNOLOGICAL OPERATIONS, INC.  
P.O. BOX 708 — INDUSTRIAL PARK  
CANON CITY, CO. 81212 PHONE (303) 275-1613



# DX forecaster

## September, 1977

### Propagation special

Conditions between September 3rd and 10th should be very unusual. Expect strong geomagnetic field disturbances accompanied by marked ionospheric and atmospheric phenomena, particularly on the 6th and 7th. These disturbances will effect both vhf and hf bands. Minor disturbances may occur on the 16th, 19th, 23rd, 25th, 27th and 29th.

### Autumn equinox

As mentioned in March *Horizons*, the equinoxes (periods of equal-length day and night) occur twice a year — in the spring and fall. The autumn equinox occurs on September 23rd, when the sun is overhead at the equator, making the terminator (line of darkness) parallel with the earth's meridians of longitude. The ionosphere tends to be more uniform than usual at the equinoxes, and often provides optimum propagation conditions. As always, the sun's behavior rules propagation, and solar disturbances can occur at any time, but DX will be good! Static levels are decreasing, and absorption of lower-frequency signals is less than during the summer months; so 40 and 80 meters begin to come alive again for DX.

On top of this seasonal improvement, an improvement will be brought about by increasing sunspots as cycle 21 heads upward. This means higher useable frequencies and

a big improvement in DX on 20, 15, and 10 meters. Therefore, during the month of September, it will pay you to keep a sharp lookout for DX at the times shown on the chart, and particularly during the hours immediately before and after sunrise and sunset. At these times, turn your beams north or south, and look for clear signals following the twilight path over the poles. Across-the-equator propagation, between the US and Latin America, the South Pacific, Asia, and South Africa, can bring choice morsels to your plate.

*Twenty meters* remains the top DX band, and will be open to one part of the earth or another from early morning until late evening, local time.

*Fifteen meters* already shows more signs of life than it has in a long time. Although not as consistent as twenty, nor open as long, fifteen tends to be less crowded and offers good signal propagation for low-power stations. When the band is open, signals will be clear and surprisingly strong, with little interference — of either the man-made or natural variety. Ten meters will occasionally open to South and Central America, and rarely — but excitingly — to Africa!

*Forty, eighty, and 160* will be improving over their summertime lack-luster performance. Static levels are lower, absorption is less, and

DXers are returning from outdoor to indoor activity. On 40, listen at the low end of the band for CW DX, and your best chance to work a new country. Early morning hours, before or about sunrise, are very good for 160-meter and 80-meter DX opportunities.

### Short skip

Summer-type short skip will remain until the end of the month, at least, so expect distances from 250 miles (400 kilometers) to 2000 miles (3200 kilometers) depending upon the band and time of day you operate.

*VHF openings* by way of Sporadic-E and auroral propagation may occur in September. Keep a sharp ear tuned for aurora between the 3rd and 10th of the month, and around the 23rd! Some tropo could occur then, as well. Happy DXing!

### Corrections and acknowledgements

A very small printer's devil was seen absconding with a number 4 from this column in the April issue. He had replaced the 4 with an 8, making the lunar eclipse wrong by four days. The eclipse did, in fact, take place on April 4th, as predicted; and the period between that date and April 10th was disturbed. We did not catch the error in time to correct it.

The design of the graph relating solar flux density and geomagnetic activity (June *HRH*) apparently originated with George Jacobs, W3ASK.\* We attributed the source to the *ISWL Monitor* for December 1976. Sorry, George. **HRH**

\*George Jacobs, W3ASK, and Theodore J. Cohen, W4UMF, "A Breakthrough in Simplifying Ionospheric Propagation Forecasts," *CQ*, March, 1975.



**WESTERN USA**

**MID USA**

**EASTERN USA**

GMT	WESTERN USA							MID USA							EASTERN USA													
	PDT	N	NE	E	SE	S	SW	W	NW	FAR EAST	CENTRAL ASIA	EUROPE	S. AFRICA	S. AMERICA	ANTARCTICA	NEW ZEALAND	AUSTRALIA	FAR EAST	EDT	N	NE	E	SE	S	SW	W	NW	
0000	5:00	15	—	—	20	15	15*	15*	20	—	—	—	—	—	—	—	—	—	7:00	20	40	—	—	—	—	—	—	—
0100	6:00	15	—	—	20	—	—	—	20	—	—	—	—	—	—	—	—	—	8:00	20	80*	—	—	—	—	—	—	—
0200	7:00	20	—	—	20	20	15	20	20	—	—	—	—	—	—	—	—	—	9:00	20	80*	—	—	—	—	—	—	—
0300	8:00	20	20	40	20	20	20	20	20	—	—	—	—	—	—	—	—	—	10:00	—	80*	40	80*	40	20	—	—	—
0400	9:00	20	40*	40	—	20	20	20	20	—	—	—	—	—	—	—	—	—	11:00	—	80*	40	—	80*	20	—	—	—
0500	10:00	—	40*	40	40	20	20	20	20	—	—	—	—	—	—	—	—	—	12:00	—	80*	40	—	80*	40	—	—	—
0600	11:00	—	40	—	40	20	20	20	20	—	—	—	—	—	—	—	—	—	1:00	—	40	—	—	80*	40	—	—	—
0700	12:00	—	—	—	40	—	40	20	20	—	—	—	—	—	—	—	—	—	2:00	—	—	—	—	80*	40	—	—	—
0800	1:00	—	—	—	40	—	40	40	40	—	—	—	—	—	—	—	—	—	3:00	—	—	—	—	80*	40	40	40	40
0900	2:00	—	—	—	40	—	40	40	40	—	—	—	—	—	—	—	—	—	4:00	—	—	—	—	80*	40	40	40	40
1000	3:00	40	—	—	80*	40	40	40	40	—	—	—	—	—	—	—	—	—	5:00	—	—	—	—	40	80*	80*	80*	80*
1100	4:00	40	—	—	80*	40	40	40	40	—	—	—	—	—	—	—	—	—	6:00	—	—	—	—	20	80*	40*	20	20
1200	5:00	40	—	—	40	40	80*	40	40	—	—	—	—	—	—	—	—	—	7:00	—	—	—	—	—	20	20	40*	20
1300	6:00	40	—	—	—	—	80*	40	80*	—	—	—	—	—	—	—	—	—	8:00	40	20	—	—	—	20	20	40*	20
1400	7:00	40	—	—	—	—	80*	40	80*	—	—	—	—	—	—	—	—	—	9:00	20	20*	—	—	—	20	20	20	20
1500	8:00	20	—	20	—	—	—	—	20	—	—	—	—	—	—	—	—	—	10:00	20	20*	—	—	—	15	20	20	20
1600	9:00	20	20	20	20	—	20	20	20	—	—	—	—	—	—	—	—	—	11:00	—	—	15	15	15*	20	20	20	20
1700	10:00	20	20	—	20	—	20	20	20	—	—	—	—	—	—	—	—	—	12:00	—	—	—	15*	15*	20	—	—	—
1800	11:00	20	—	—	15*	—	—	—	20	—	—	—	—	—	—	—	—	—	1:00	—	20	15*	15*	15*	—	—	—	—
1900	12:00	—	20	—	15*	—	—	—	20	—	—	—	—	—	—	—	—	—	2:00	—	20	15	20*	15*	—	—	—	—
2000	1:00	—	20	—	15*	—	—	—	20	—	—	—	—	—	—	—	—	—	3:00	—	20	15	20*	15*	—	—	—	—
2100	2:00	—	20	20	15*	—	—	—	20	—	—	—	—	—	—	—	—	—	4:00	—	20	—	20	15	15	—	—	—
2200	3:00	—	20	20	15*	—	—	—	20	—	—	—	—	—	—	—	—	—	5:00	—	20	—	20	15	15	20	15*	20
2300	4:00	—	—	20	20	—	15	15*	20	—	—	—	—	—	—	—	—	—	6:00	—	20	—	20	15	15	20	20	20
		—	—	20	20	—	15*	15*	20	—	—	—	—	—	—	—	—	—	7:00	15	40	—	—	20	20	20	20	20









**RATES** Regular classified is available at 50¢ per word. Display classified (1 inch deep x 2 1/4 inches wide) is \$50, or at the 12x rate is \$35. All Ad Scan payable in advance. No cash discounts or agency commissions allowed.

**HAMFESTS** Sponsored by non-profit organizations receive one free regular classified ad (subject to our editing). Repeat insertions of hamfest ads pay the standard rate.

**COPY** No special layout or arrangements available. Material should be typewritten or clearly printed (not all capitals) and must include full name and address. We reserve the right to reject unsuitable copy. **Ham Radio** cannot check each advertiser and thus cannot be held responsible for claims made. Liability for correctness of material limited to corrected ad in next available issue.

**DEADLINE** 15th of fourth preceding month.

**SEND MATERIAL TO:** Ad Scan, Ham Radio Horizons, Greenville, N. H. 03048.

**CUSTOM EMBROIDERED EMBLEMS**, your design, low minimum. Informational booklet, Emblems Dept. 65, Littleton, New Hampshire 03561.

**DIGITAL ELECTRONICS:** Your Ham headquarters in New Orleans. Representing Drake, Ten-Tec, Atlas, KLM, Hy-Gain, Tri-Ex, Rohn, Regency, Midland, Wilson, CDE, Dentron, Larsen, Nye-Viking, New-Tronics, Standard, Swan, B&W, Millen, Amidon, and W2AU. Call or write Chuck, W5VJG for quotes. Trade-ins accepted. BankAmericard & Mastercharge. Digital Electronics, Inc., P.O. Box 30566, New Orleans, LA 70190. Call Toll Free 800-535-9598 (out of state only). LA residents: phone call credited on purchase, call 504-968-9879.

**UR TRIPOLE MULTI-BAND**

All-band antenna. 50 to 5 Meters plus 160, 5 SWL, M. Bands. Built-in bakon. 2 KW PEP rating. No reuning, tap or trap changes. 80 to 120 is inverted-V or horizontal. Available in kit form or assembled.

Guaranteed. Tests residents add 5% sales tax. Send postal card for information on TRIPOL antennas and feedline kits.

Universal Radio Co. Dept. H3  
Box 26841 El Paso, TX 79925  
Telephone (512) 552-1919

**FREE LICENSING CLASSES** in Flushing, NY area. Send inquiries to FRATS (Flushing Radio Amateur Technical Society), 62026 Boelsen Crescent, Rego Park, NY 11374.

**QSL's** with class! Unbeatable quality — reasonable price. Samples. QSL's Unlimited, Box 27553, Atlanta, GA 30327.

**ATTENTION MICHIGAN HAMS!** See us for Collins, Drake and Ten-Tec gear. W8RP, W8UXO, W8VGR. Purchase Radio Supply, 327 E. Hoover Ave., Ann Arbor, MI 48104. Ph. 313-668-8696.

**FREE PASSES** are available to HAM RADIO HORIZONS subscribers upon request, from Cal-Comm/Expo'77, the first total communications show anywhere! Seminars will be held at the new Los Angeles Bonaventure Hotel, and free shuttle service will be provided back & forth to the Convention Center. September 24 - 26, 1977. Interested individuals may obtain COMP tickets by writing: CAL-COMM/EXPO'77, 809 E. Victoria, Dominguez Hills, CA 90745. Phone 213/CAL-COMM.

**MOBILE IGNITION SHIELDING** provides more range with no noise. Bonding strap sale less than 50¢ each. Literature. Estes Engineering, 930 Marine Drive, Port Angeles, Wash. 98362.

**CINCINNATI HAMFEST:** Sunday September 18, 1977 at the improved Stricker's Grove on State Route 128, one mile west of Ross (Venice) Ohio. Flea Market, Contests, Model Aircraft Flying, Food and Beverages all day. Advance Ticket Sales \$7.50 — Tickets at the Gate \$8.00 — covers everything. For further information: Lillian Abbott K8CKI, 1424 Main Street, Cincinnati, Ohio 45210.

**BARC International Field Day**, Burlington, VT. August 13-14 at the Old Lantern (same location as last year). Starts at 7AM Saturday and closes 5PM Sunday. This year's hamfest is dedicated to the memory of K1URQ. Camping at site, flea market both days, early bird registration \$3.00 (\$3.50 at door). Talk-in on 01-61. Write Burlington Amateur Radio Club, P.O. Box 312, Burlington, VT. 05401 for information and advance tickets.

**WYOMING**

Ranch land. Antelope, deer, elk, wild horses — Your "Antenna Ranch." 10 Acres \$35 down, \$35 month. FREE info — maps — photos. Owner.

Dr. Michael Gauthier, K6ICS  
9550HH Gallatin Rd., Downey, CA 90240

**TECHNICAL MANUALS**

Ameco	Hayden-Rider	Sams
ARRL	RCA	Tab
Cowan	Radio Callbook	T. I.
Gilfer	Radio Pub.	

Postage 35¢ per book. PPD 5 or more books.  
**MADISON ELECTRONICS SUPPLY, INC.**  
1508 McKinney, Houston, TX 77002  
713-658-0268

**PENNSYLVANIA — HARRISBURG** — Sunday, September 18, 1977 4th Annual Electronic Swap Fest of the Central Pennsylvania Repeater Association. Park and Shop Garage, 200 Block of Walnut Street, Center City, Harrisburg. Indoor parking for 1100 cars, so come rain or shine. Starts at 8:00 a.m. Registration \$3.00. No charge for tailgating, wives or children. Talk-in on WA3KXG 146.16/76 146.52/52 Information: Roger Urban W3HUP Phone 717/761-7178.

**DISCOVER RADIO ASTRONOMY**, the newest branch of amateur radio! Learn how in The Radio Observer, the only magazine devoted entirely to the hobby. Sample copy \$1.00 from The Peterson Press, 657HR Circle Drive, Santa Barbara, CA 93108.

**CODE PRACTICE OSCILLATORS**, hand keys, electronics keyers, other products. Free catalog. Globalman Products, Box 246, El Toro, CA 92630. 714-533-4400.

**NEED HELP** For your novice or general ticket? Complete audio-visual theory instruction. Easy, no electronic background necessary. Write for free information: Amateur license instruction, P.O. Box 6015, Norfolk, Virginia 23508.

**ENGRAVED NAMETAGS** 1 1/2" x 2 1/2" — \$3.00. QTH added-\$0.50. Black, blue, red, green, walnut. White letters. Beveled. Locking pin. Other colors available. Tag-It Co., Box 2062, Indianapolis, In. 46206.

**In ORLANDO**

The "New Guys On The Block" have those hard-to-find parts for Amateurs, plus

KLM	Mini-Products	Bearcat 210
Hy-Gain	Shure	and much
Cushcraft	Astatic	more!

**LAFAYETTE RADIO ELECTRONICS**  
Assoc. Store  
1911 Hwy 17-92, Maitland, FL 32751  
Dick K4RYR 305-831-2271 Bob W4YYS

**THE "CADILLAC" of QSL's!** — New! Samples: \$1.00 (Refundable) — MAC'S SHACK, Box #1171-G, Garland, Texas 75040.

**FREE Catalog.** Solar Cells, Nicads, Kits, Calculators, Digital Watch Modules, Ultrasonics, Strobes, LEDs, Transistors, IC's, Unique Components, Chaney's, Box 27038, Denver, Colo. 80227.

**CODE OSCILLATOR KIT, \$3.00.** Postpaid. Bud's HACKits, 1325 Ridgeway, Medford, Oregon 97501.

**ICOM 22S — \$249.95, IC-245 \$439.00.** Cushcraft ATB-34 \$199.95 plus shipping. Write for other specials on Ten-Tec, Drake, Swan, Midland, Hy-Gain, Dentron, KLM and MFJ. Also, used gear. **HAM BONE RADIO**, Division of Stereo Repair Shop, 3206 Erie Blvd. East, Syracuse, N.Y. 13214. (315-446-2266) 73, Lee WA2ACF & Art WB2YPP.

**SST T-1 RANDOM WIRE ANTENNA TUNER**

All band operation (160-10 meters) with most any random length wire. 200 watt output power capability. Ideal for portable or home operation. Toroid inductor for small size. 3 x 4 1/4 x 2 3/8. Built-in neon tune-up indicator. QO-259 coax connector. Guaranteed for 1 yr., 10 day trial. Compact — easy to use... only \$29.95 postpaid. (Add Sales Tax in Calif.) (213) 376-5887

SST ELECTRONICS, P.O. BOX 1, LAWDALE, CA. 90260



# AD CHECK

... for literature, in a hurry — we'll rush your name to the companies whose names you check.

Place your check mark in the space between name and number. Example: HRH \_\_\_ 150.

Ace Art ___ 416	Heath ___ 060
Atlas ___ 198	Henry ___ 062
Atronics ___ 382	Herrman ___ 568
Butternut ___ 603	Icom ___ 065
CFP ___ 022	Kantronics ___ 605
Cohoon ___ 559	Kengore ___ 073
Comm. Center ___ 534	Kenwood *
Comm. Spec. ___ 330	Klaus ___ 430
Cushcraft ___ 035	Larsen ___ 078
Dentron ___ 259	Long's ___ 468
Drake ___ 039	MFJ ___ 082
E. T. O. *	Madison *
Elect. Dist. ___ 044	Mor-Gain ___ 089
Erickson ___ 047	Palomar ___ 093
Glade Valley ___ 213	RF Power ___ 542
"Ham" Buerger ___ 604	RLW ___ 606
HR Report ___ 150	RSE ___ 607
Ham Center ___ 491	Radio Expo *
Ham Radio ___ 150	Telrex ___ 377
Hartzell ___ 609	Ten-Tec *
HORIZONS ___ 150	Trac ___ 608
Ham Outlet ___ 595	Whitehouse ___ 378
	Wilson ___ 123

\*Please contact this advertiser directly.

Limit 15 inquiries per request.

September, 1977

Please use before October 31, 1977

Tear off and mail to  
**HAM RADIO HORIZONS — "Ad Check"**  
 Greenville, N. H. 03048

NAME \_\_\_\_\_

CALL \_\_\_\_\_

STREET \_\_\_\_\_

CITY \_\_\_\_\_

STATE \_\_\_\_\_ ZIP \_\_\_\_\_

## Beginning Aug. 1 Call Toll Free 800-228-4097

for prices on Yaesu, Tempo, Swan, Ten-Tec, Icom, MFJ, Nye-Viking, Drake and Hy-Gain.

Until Aug. 1 or Nebr. residents call 402-466-3733.

### DRAKE

TR4-CW 80-10m hf trans. with CW filter	reg. \$649.00	Now \$589.00
34PNB Noise blanker for TR-4C	reg. \$100.00	Now \$90.00
RV-4C Remote VFO/speaker	reg. \$150.00	Now \$134.95
AC-4 AC power supply for TR-4C & T-4XC	reg. \$120.00	Now \$109.00
DC-4 DC power supply	reg. \$135.00	Now \$124.00
L4B Linear amplifier	reg. \$895.00	Now \$789.00
SSR-1 Gen. coverage rcvr. 5-30 MHz	reg. \$350.00	Now \$279.00
R-4C 80-10m receiver	reg. \$599.95	Now \$539.95
4-NB Noise blanker for R-4C	reg. \$70.00	Now \$64.00
T-4XC 80-10m transmitter	reg. \$599.95	Now \$539.95
TV-3300LP Low pass filter	reg. \$26.60	Now \$19.95
MN-2000 Antenna Tuner	reg. \$240.00	Now \$219.95
MN-4 Antenna Tuner	reg. \$120.00	Now \$109.95
1525 Encoder Microphone	reg. \$49.95	Now \$45.95
TR-33C, 2m Portable Xcvr	reg. \$229.95	Now \$209.95

### HY-GAIN

TH6DXX 6 element super Thunderbird	reg. \$249.95	Now \$209.95
TH3-MK3 3 element tri-band	reg. \$199.95	Now \$169.95
204BA 4 element 20m beam	reg. \$189.95	Now \$159.95
Hy-Quad, 2 el. Quad, 10-20 meters	reg. \$219.95	Now \$189.95
TH3JR 3 element tri-band	reg. \$144.50	Now \$129.95
TH2MK3, 2 element tri-band	reg. \$139.95	Now \$124.95
402BA 2 element, 40m	reg. \$199.95	Now \$169.95
203BA 3 element 20m	reg. \$129.95	Now \$109.95
153BA 3 element 15m	reg. \$79.95	Now \$69.95
103BA 3 element 10m	reg. \$54.95	Now \$49.95
DB10-15A 3 element 10, 15m	reg. \$149.95	Now \$134.95
18HT Hy-Tower, reg. \$279.95	Now \$239.95	
28DQ Trap Doublet 40, 80m	reg. \$49.95	Now \$44.95
58DQ Trap Doublet 10 thru 80m	reg. \$79.95	Now \$69.95
12AVQ 10-20m vertical	reg. \$37.95	Now \$33.95
14AVQ/WB 10-40m vertical	reg. \$67.00	Now \$57.00
18AVT/WB 10-80m vertical	reg. \$97.00	Now \$84.95
LA-1 Lightning Arrestor	reg. \$44.95	Now \$39.95
BN-86 Ferrite Balun	reg. \$15.95	Now \$14.95
203 3 el 2m beam	\$12.95	
205 5 el 2m beam	\$16.95	
208 8 el 2m beam	\$19.95	
214 14 el 2m beam	\$26.95	
273 4 el J-Pole	\$49.95	
3806 2m Handheld	reg. \$189.00	Now \$169.00
3750 Transceiver	reg. \$1895.00	Now \$1695.00

**CALL FOR DAILY SPECIALS  
 OPEN 7 DAYS A WEEK**

Talk to Bob, WBØRQZ, Joe, WAØWRI, Don, WBØYEZ, Roy, WBØWWA, or Bill WBØYHJ.  
 2% discount for certified check or money order.

**TOLL FREE AFTER AUG. 1, 800-228-4097.** Nebr. residents call 402-466-3733 collect.

## Communications Center

2226 North 48th Street  
 Lincoln, NE 68504

# AD INDEX

Ace Art Co.	55
Atlas Radio	Cov. IV
Atronics	53
Butternut Electronics	79
CFP Communications	68
Cohoon Amateur Supply	61
Communications Center	78
Communications Specialists	26
Cushcraft	4
Dentron Radio Co.	40, 41
Drake Co., R. L.	Cov. II
Ehrhorn Technological Operations	73
Electronic Distributors	79
Erickson Communications	31
Glade Valley Radio Sessions	55
"Ham" Buerger	60
HR Report	65
Ham Radio Center	53, 69
Ham Radio Magazine	65
Ham Radio HORIZONS	65
Ham Radio Outlet	9
Heath Company	25
Henry Radio Stores	10
The Herrman Company	53
Icom	7
Kantronics	49
Kengore Corporation	54
Trio-Kenwood Corp.	Cov. III, 80
Klaus Radio	71
Larsen Electronics, Inc.	59
Long's Electronics, Inc.	1
MFJ Enterprises	3, 79
Madison Electronics Supply	60
Mor-Gain	60
Palomar Engineers	55, 67, 68
RF Power Components	69
RLW Electronics	61
RSE Ham Shack	54
Radio Expo	54
Telrex Labs	68
Ten-Tec	23
Trac Electronics	61
G. R. Whitehouse & Co.	68
Wilson Electronics	45

### Foreign Subscription Agents for Ham Radio HORIZONS

Ham Radio Austria Karin Ueber Postfach 2454 D-7850 Loerrach West Germany	Ham Radio Holland MRL Electronics Postbus 88 NL-2204 Delft Holland
Ham Radio Belgium Sterehouze Brusselssteenweg 416 B-9218 Gent Belgium	Ham Radio Italy STE, Via Manligo 15 I-20134 Milano Italy
Ham Radio Canada Box 114, Goderich Ontario, Canada N7A 3Y5	Ham Radio Switzerland Karin Ueber Postfach 2454 D-7850 Loerrach West Germany
Ham Radio Europe Box 444 S-194 04 Upplands Vasby Sweden	Ham Radio UK P.O. Box 63, Harrow Middlesex HA3 6HS, England
Ham Radio France Christiane Michel F-89117 Parly France	Holland Radio 143 Greenway Greenside, Johannesburg Republic of South Africa



# YOUR YAESU HQ



FRG-7 Receiver  
General Coverage  
.5-29.9 MHz  
SSB, CW, AM

Unprecedented Versatility

## A GOOD PLACE TO START

FULL YAESU LINE AVAILABLE

Request Catalog

ELECTRONIC DISTRIBUTORS, Inc.

Communication Specialists  
for over 38 years

1960 PECK STREET

MUSKEGON, MICH. 49441

TEL. (616) 726-3196 TELEX 22-8411

## This MFJ Super CW Filter . . .

gives you 80 Hz bandwidth, and extremely steep skirts with no ringing for razor sharp selectivity that lets you pull signals out of heavy QRM.

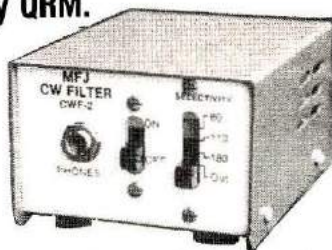

# \$27.95

Can you imagine hearing ONE CW signal on the crowded Novice bands on a Sunday afternoon? That's what 80 Hz bandwidth, extremely steep skirts, and no ringing will do for you.

Simply plug it into your receiver or transmitter to drive phones or connect it between audio stages for full speaker operation.

Bandwidth is selectable: 80, 110, 180 Hz. Response is at least 60 dB down one octave from center frequency for 80 Hz bandwidth. Center frequency is 750 Hz. No impedance matching. No insertion loss.

Drastically reduces noise. Up to 15 dB improvement in S/N ratio.

8 pole active IC filter. Low Q cascaded stages eliminates ringing. Months of operation from 9-volt battery. 2 3/16x3 1/4 inches.

Try it—no obligation. If not delighted, return it within 30 days for a refund (less shipping). This filter is unconditionally guaranteed for one year.

To order, simply call us TOLL-FREE 800-647-8660 and charge the CWF-2BX filter on your BankAmericard or Master Charge or mail us an order with check or money order for \$27.95 plus \$2.00 for shipping and handling.

Don't wait any longer to eliminate QRM on all bands. Order today.

## MFJ ENTERPRISES

P. O. BOX 494 H  
MISSISSIPPI STATE, MS. 39762  
CALL TOLL-FREE 800-647-8660

## GET ON THE AIR

# Today

OPERATE LEGALLY WITHOUT  
AN FCC LICENSE  
in the 160-190 kHz band!

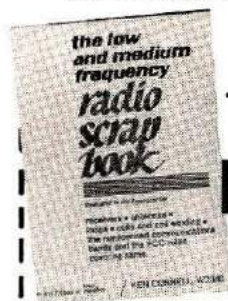

ham  
radio's  
bookstore

Greenville, NH 03048

Enclosed is check or money order for \$6.95 — rush my Scrapbook to me!

Name \_\_\_\_\_

Address \_\_\_\_\_

City \_\_\_\_\_ State \_\_\_\_\_

Zip \_\_\_\_\_

The LOW & MEDIUM FREQUENCY RADIO SCRAPBOOK (Revised Third Edition) by Ken Cornell, W2IMB is the most complete publication available to those interested in the frequencies between 10 and 1600 kHz. An informal scrapbook format that introduces and examines simple, effective and easily-built equipment and antennas.

Full information on FCC rules and regulations. This may become a new Amateur band after WARC '79 — why not get a head start today?

Order HR-LF

Only \$6.95

AT LAST!  
AN AFFORDABLE  
FIVE BANDER.

## THE HF5V TRAP VERTICAL ANTENNA

COVERS 80 THROUGH 10 METERS  
WITH AUTOMATIC BANDSWITCHING  
and features:

- EASY, FAST ASSEMBLY
- STURDY ALUMINUM ALLOY CONSTRUCTION
- HIGH Q TRAPS
- FIBERGLASS MOUNTING POST
- RADIAL WIRE
- 27 FT. HEIGHT

DX PROVEN!

ONLY \$64.95\*  
plus \$3.00 shipping cont. U.S.  
\$14.00 Alaska & Hawaii



BUTTERNUT  
ELECTRONICS  
COMPANY

ROUTE ONE  
LAKE CRYSTAL, MN. 56055  
phone 507-947-3126

S.A.S.E. for information on this and other models.

\*MN. residents add 4%.



# KENWOOD'S NEW TS-520S AND DG-5 DIGITAL FREQUENCY DISPLAY

## A NEW STANDARD IN ECONOMY TRANSCEIVERS

The NEW TS-520S combines all of the fine, field-proven characteristics of the original TS-520 together with many of the ideas, comments, and suggestions for improvement from amateurs worldwide. Kenwood's ultimate objectives... to make quality equipment available at reasonable prices.

### FULL COVERAGE TRANSCEIVER

The new TS-520S provides full coverage on all amateur bands from 1.8 to 29.7 MHz. Kenwood gives you 160 meter capability, WWV on 15.000 MHz., and an auxiliary band position for maximum flexibility. And with the addition of the TV-502 and TV-506 transverters, your TS-520S can cover 160 meters to 2 meters on SSB and CW.

### DIGITAL DISPLAY DG-5 (option)

The new Kenwood DG-5 provides easy, accurate readout of your operating frequency while transmitting and receiving.

### OUTSTANDING RECEIVER SENSITIVITY AND MINIMUM CROSS MODULATION

The new TS-520S incorporates a 3SK-35 dual gate MOSFET for outstanding cross modulation and spurious response characteristics. The 3SK35 has a low noise figure (3.5 dB typ.) and high gain (18 dB typ.) for excellent sensitivity.

### NEW IMPROVED SPEECH PROCESSOR

A new audio compression amplifier gives you extra punch in the pile ups and when the going gets rough.

### VERNIER TUNING FOR FINAL PLATE CONTROL

A new vernier tuning mechanism allows

easy and accurate adjustment of the plate control during tune-up.

### FINAL AMPLIFIER

The new TS-520S is completely solid state except for the driver (12BY7A) and the final tubes. Rather than substitute TV sweep tubes as final amplifier tubes in a state of the art amateur transceiver, Kenwood has employed two husky 6X4 tubes (equivalent to 6146B) tubes. These rugged, time-proven tubes are known for their long life and superb linearity.

### HIGHLY EFFECTIVE NOISE BLANKER

An effective noise blanking circuit developed by Kenwood that virtually eliminates ignition noise is built-in to the TS-520S.

### RF ATTENUATOR

The new TS-520S has a built-in 20 dB attenuator that can be activated by a push button switch conveniently located on the front panel.

### VFO-520 — NEW REMOTE VFO

The VFO-520 remote VFO has been designed to match the styling of the TS-520S and provide maximum operating flexibility on the band selected on your TS-520S.

### AC POWER SUPPLY

The TS-520S is completely self-contained with a rugged AC power supply built-in. The addition of the DS-1A DC-DC converter (option) allows for mobile operation of the TS-520S.

### EASY CONNECTION PHONE PATCH

The TS-520S has 2 convenient RCA phono jacks on the rear panel for PHONE PATCH IN and PHONE PATCH OUT.

### CW-520 — CW FILTER (OPTION)

The CW-520 500 Hz filter can be easily installed and will provide improved operation on CW.

### AMPLIFIED TYPE AGC CIRCUIT

The AGC circuit has 3 positions (OFF, FAST, SLOW) to enable the TS-520S to be operated in the optimum condition at all times whether operating CW or SSB.

The TS-520S retains all of the features of the original TS-520 that made it tops in its class: RIT control • 8-pole crystal filter • Built-in 25 KHz calibrator • Front panel carrier level control • Semi-break-in CW with sidetone • VOX/PTT/MOX • TUNE position for low power tune up • Built-in speaker • Built-in Cooling Fan • Provisions for 4 fixed frequency channels • Heater switch.





## Specifications

Amateur Bands: 160-10 meters  
plus WWV (receive only)  
Modes: USB, LSB, CW  
Antenna Impedance: 50-75 Ohms  
Frequency Stability: Within  $\pm 1$   
kHz during one hour after one  
minute of warm-up, and within  
100 Hz during any 30 minute  
period thereafter

### Tubes & Semiconductors:

Tubes ..... 3  
(5Z001A x 2, 12BY7A)  
Transistors ..... 52  
FETs ..... 19  
Diodes ..... 101

Power Requirements: 120/220 V  
AC, 50/60 Hz, 13.8 V DC  
(with optional DS-1A)

Power Consumption: Transmit:  
280 Watts Receive: 26 Watts  
(with heater off)

Dimension: 333(13 $\frac{1}{4}$ ) W x 153 (6-0)  
H x 335(13-13 $\frac{3}{16}$ ) D mm(inch)

Weight: 16.0 kg(35.2 lbs)

### TRANSMITTER

RF Input Power: SSB: 200 Watts  
PEP CW: 160 Watts DC

Carrier Suppression: Better than  
-40 dB

Sideband Suppression: Better  
than -50 dB

Spurious Radiation: Better than  
-40 dB

Microphone Impedance: 50k Ohms  
AF Response: 400 to 2.600 Hz

### RECEIVER

Sensitivity: 0.25  $\mu$ V for 10 dB

(S+N)/N

Selectivity: SSB: 2.4 kHz/-6 dB,

4.4 kHz/-60 dB

Selectivity: CW: 0.5 kHz/-6 dB,

1.5 kHz/-60 dB (with optional  
CW-520 filter)

Image Ratio: Better than 50 dB

IF Rejection: Better than 50 dB

AF Output Power: 1.0 Watt (8  
Ohm load, with less than 10%  
distortion)

AF Output Impedance: 4 to 16  
Ohms

### DG-5

#### SPECIFICATIONS

Measuring Range: 100 Hz to  
40 MHz

Input Impedance: 5 k Ohms

Gate Time: 0.1 Sec.

Input Sensitivity: 100 Hz to 40

MHz ... 200 mV rms or over, 10  
kHz to 10 MHz ... 50 mV or over

Measuring Accuracy: Internal time  
base accuracy  $\pm 0.1$  count

Time Base: 10 MHz

Operating Temperature: -10° to  
50° C/14° to 122° F

Power Requirement: Supplied  
from TS-520S or 12 to 16 VDC  
(nominal 13.8 VDC)

Dimensions: 167(6-9/16) W x  
43(1-11/16) H x 268(10-9/16) D  
mm(inch)

Weight: 1.3 kg(2.9 lbs)

## DG-5 (optional)

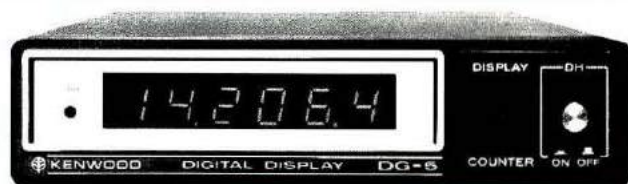

The luxury of digital readout is available on the TS-520S by connecting the new DG-5 readout (option). More than just the average readout circuit, this counter mixes the carrier, VFO, and heterodyne frequencies to give you your exact frequency. This handsomely-styled accessory can be set almost anywhere in your shack for easy to read operation... or set it on the dashboard during mobile operation for safety and convenience. Six bold digits display your operating frequency while you transmit and receive. Complete with DH (display hold) switch for frequency memory and 2 position intensity selector. The DG-5 can also be used as a normal frequency counter up to 40 MHz at the touch of a switch. (Input cable provided.)

NOTE: TS-520 owners can use the DG-5 with a DK-520 adapter kit.

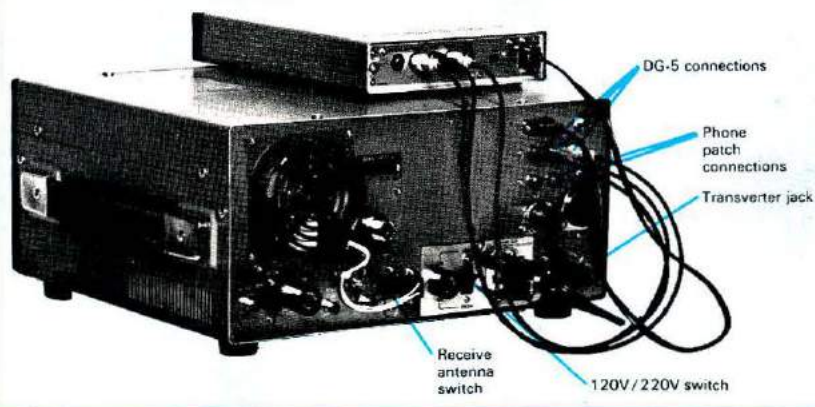



# This is the ultimate in a ham radio station



3



4



5



1

2



## ATLAS 350-XL

ALL SOLID STATE SSB / CW TRANSCEIVER  
350 WATTS • 10-160 METERS

The 350-XL was designed to fill all the operating requirements of the ham operator. Whether you operate fixed, portable, or mobile, SSB, CW, RTTY, or SSTV, the 350-XL can handle it.

### 1. ALL SOLID STATE CONSTRUCTION

Eight IC's, 44 transistors, and 49 diodes. Final transistors are fully protected against infinite SWR and thermal runaway.

### 2. AUXILIARY FREQUENCY RANGES

The 350-XL will operate on up to 10 additional 500 kHz segments of the spectrum between 2 and 23 MHz by insertion of optional crystals in the auxiliary range selector. This will provide for MARS operation, reception of WWV, and certain commercial or semi-military applications.

On band 6, the 350-XL will operate only from 28 to 30 MHz. It will not operate between 23 and 28 MHz.

### 3. DIGITAL READOUT

This accessory provides precise frequency readout to within 50 Hz. Dot Matrix L.E.D.'s with 6 digit display.

### 4. MATCHING AC SUPPLY

Provides 14 volts filtered and regulated DC for both low and high current circuits of the 350-XL. Has front facing speaker

and phone jack, and provision for installation of additional accessories soon to be announced. Operates on 100 to 130 and 200 to 260 volts AC, 50-60 Hertz.

### 5. AUXILIARY VFO

With the optional Model 305 Auxiliary VFO you have a second tuneable VFO for tuning to a separate transmit or receive frequency covering the same 500 kHz range as the primary VFO. Colored LED's indicate VFO being used.

Alternately the Model 311 crystal oscillator may be inserted to provide up to eleven crystal controlled channels.

Atlas 350-XL (less options)	\$895.
Model DD6-XL Digital Dial Readout	\$195.
Model 305 Plug-in Auxiliary VFO	\$155.
Model 311 Plug-in Auxiliary Crystal Oscillator	\$135.
Model 350-PS Matching AC Supply	\$195.
Plug-in Mobile Mounting Bracket	\$65.

Other optional features to be announced.



**ATLAS**  
RADIO INC.

417 Via Del Monte, Oceanside, Ca. 92054  
Phone (714) 433-1983