

# Amateur Radio's Technical Journal

A CWC/I Publication



**Build It!  
8 Great  
Projects**

**Repeater Peeper**  
Page 50

**Soup Up  
Your IC-730**  
Page 10

**Radio Robotics?**  
Page 30

**VIC Memory  
Expansion**  
2 articles

**Ready Recipe**  
Page 6

**30-Watt**

**VHF Blaster**  
Page 4

**6-Meter**

**Wildcat!**  
Page 57

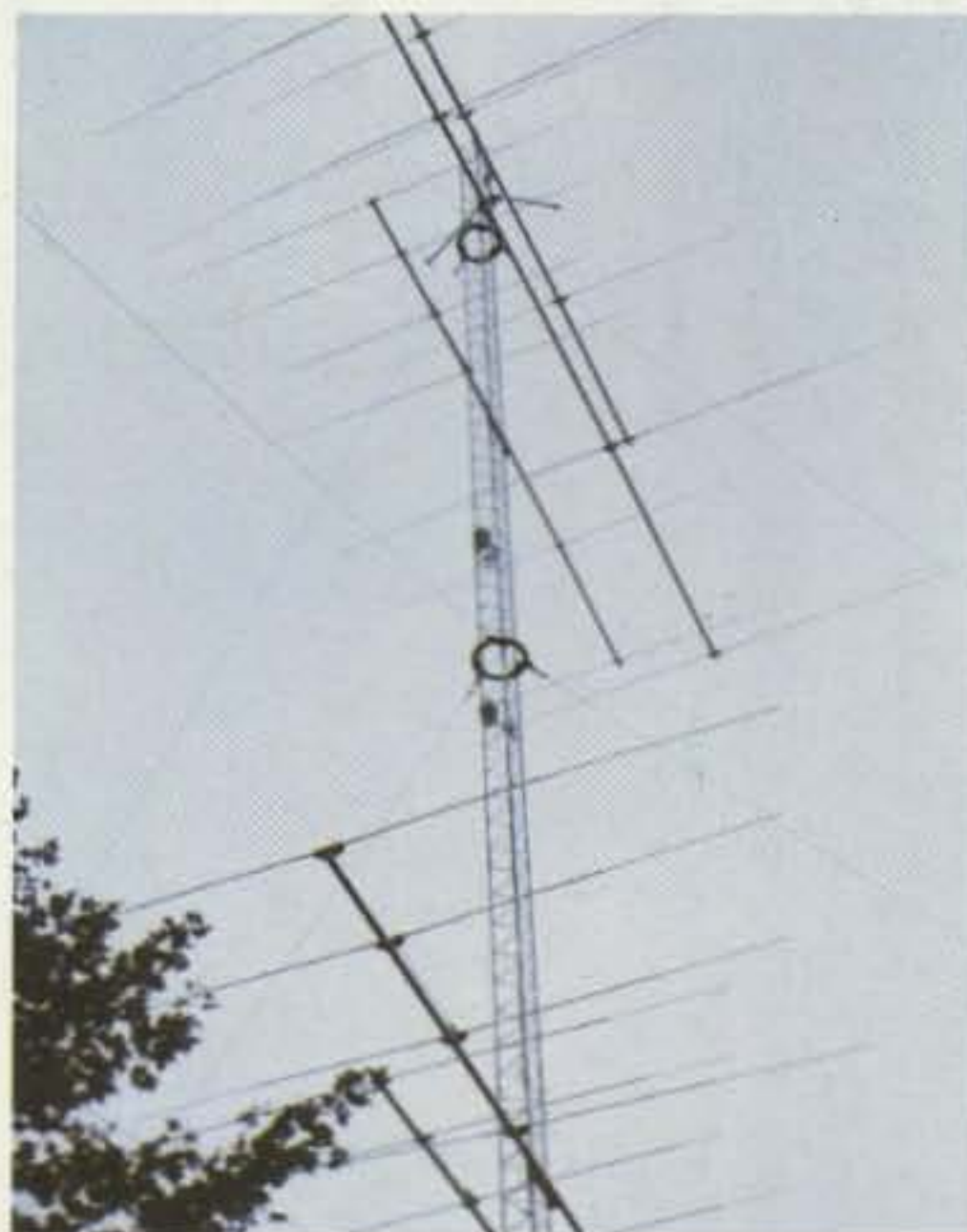

Winning—7

### Eight Mods for the IC-730

☑ Customize your ICOM! Snip here, solder there, and enjoy perfection. . . . . N6HI 10

### VIC RAMification: Part I

☑ Here's how to turn 3 ICs and half an hour into 24K of extra VIC-20 memory. . . . . Brefini 18

### VIC RAMification: Part II

☑ W6LOB fills the 3K gap of Part I with a quick piggyback RAM expansion. . . . . W6LOB 22



Blast Away—34



Linosa Island—89

### Transistors: A Biased Approach

In Part II, we evaluate base current and gain and use this information to design a working transistor circuit. . . . . KC0EW 26

### Automate the FT-757

☑ Ready for robot radio? An inexpensive micro is all that you need to computer-control your Yaesu. . . . . KA6IFQ 30

### That Glorious Gonset

☑ With 300 Watts on 2 meters, the Gonset 972 thumbs its nose at solid state. Rebuild one and be heard! . . . . . KT2B 34

### A Space-Saver Seven Megger

☑ Stuffing full-wave 40m loops into tiny places is W8TYX's specialty. We finally got him to tell us how he does it. . . . . W8TYX 44

### Shoestring RTTY

☑ Build a commercial-quality computer interface for under \$30. . . . . W9ODK 46

### Is Your Repeater Dying?

☑ With this 16-channel telemetry encoder, you have a remote chance of finding out. . . . . WA4TEM 50

### How Good Is Six?

☑ Try 50 MHz with a transceiver you've built from scratch. There's no greater pleasure than saying, "I did it myself!" . . . . . KL7GLK 57

Never Say Die—4

What?—6

QRX—7

Barter 'N' Buy—56

Special Events—65

Review—66

DX—67

Letters—69

RTTY Loop—70

Satellites—71

Ham Help—

71, 74, 91

Awards—72

Reader Service—80

New Products—82

Contests—84

Fun!—85

73 International—88

Dealer Directory—94

Propagation—94



# IC-02AT

## ICOM 2-Meter Handhelds

If you want a 2-meter handheld with exceptional features, quality built to last and a wide variety of interchangeable accessories, take a look at the ICOM IC-02AT and IC-2AT handhelds.

**Frequency Coverage.** The IC-02AT covers 140.000 through 151.550MHz and the IC-2AT, 141.500 through 149.994MHz...both include frequencies for MARS operation.

**IC-02AT Features.** ICOM's top-of-the-line IC-02AT handheld has the following outstanding features:

- DTMF direct keyboard entry
- LCD readout
- 3 watts standard, 5 watts optional (with IC-BP7 battery pack)
- 10 memories which store duplex offset and PL tone (odd offset can be stored in last 4 memories)
- Frequency dial lock
- Three scanning systems: priority, memory and programmable band scan (selectable increments of 5, 10, 15, 20 or 25KHz)

**IC-2AT Features.** The IC-2AT is ICOM's most popular handheld on the market. The IC-2AT features a DTMF pad, 1.5 watts output and thumbwheel frequency selec-

tion. The IC-2A is also available and has the same features as the IC-2AT except DTMF.



**Accessories.** A variety of slide-on battery packs are available for the IC-02AT and IC-2AT, including the new long-life 800mAh IC-BP8 which can be used with both handhelds.

Other accessories include the HS-10 boom headset, HS-10SB PTT switchbox, HS-10SA VOX unit (for IC-02AT) and an assortment of battery pack chargers.

**The IC-02AT and IC-2AT** come standard with an IC-BP3 NiCd battery pack, flexible antenna, AC wall charger, belt clip, wrist strap and ear plug. See the IC-02AT and IC-2AT 2-meter handhelds at your local ICOM dealer.



# ICOM

First in Communications

ICOM America, Inc., 2380-116th Ave NE, Bellevue, WA 98004 / 3331 Towerwood Drive, Suite 307, Dallas, TX 75234

All stated specifications are approximate and subject to change without notice or obligation. All ICOM radios significantly exceed FCC regulations limiting spurious emissions. 02AT1084

# 6 STORE BUYING POWER

**NEW!!**



TH-21AT/  
TH-41AT



TR-2600A

TM-211A/TM-411A

HERE'S WHERE  
YOU GET THOSE  
LOW, LOW PRICES ON  
**KENWOOD**

**PLUS FREE SHIPMENT**

MOST ITEMS UPS SURFACE (Continental U.S.A.)

CALL NOW OR  
DROP INTO ANY OF  
OUR SIX LOCATIONS

**ESTABLISHED  
FAVORITES**



TS-930S



TS-430S



TW-4000A



**R-71A**  
GENERAL  
COVERAGE  
RECEIVER



**IC-751**



**IC-745**  
SUPER SAVINGS! CALL!



IC-02AT  
IC-04AT



**SALE!**

B-3016 SALE \$199.95  
B-1016 SALE \$249.95  
B-108 SALE \$159.95  
B-23A SALE \$ 89.95  
D-1010 SALE \$289.95

**BIRD**  
MODEL 43  
AND  
ELEMENTS



CALL FOR PRICES



FT-726R



TOP CHOICE FOR OSCAR



FT-757GX



FT-203R

DON'T MISS  
THESE  
BARGAINS!  
CALL!



FT-209RH

**TRISTAO SALE**

MA-40 SALE \$549  
40' 2 SECT TUBULAR TOWER  
MA-550 SALE \$899  
55' 3 SECT TUBULAR TOWER  
**IN STOCK**

**KLM SALE**

KT-34A SALE \$329  
KT-34XA SALE \$469  
40M-2 SALE \$309  
CALL FOR LOW, LOW PRICES  
80 THRU 1 1/4M KLM ANTENNAS

**ALLIANCE**

ROTOR SALE

HD-73 \$99.95  
U-110 \$54.95



**SALE**  
IN STOCK

W-51 \$899  
W-36 \$549  
LM-354 \$1599

**PERSONALIZED  
SERVICE**



BOB FERRERO, W6RJ  
President

JIM RAFFERTY, N6RJ  
VP, So. Calif. Div. Anaheim

Managers:

GEORGE, WB6DSV Burlingame  
GREG, N6PO Oakland  
BOB, K7RDH Phoenix  
GLENN, K6NA San Diego  
AL, K6YRA Van Nuys  
and other active amateurs

**FREE SHIPMENT**

UPS SURFACE (Continental U.S.) (MOST ITEMS)

**TOLL-FREE PHONE**  
INCLUDING ALASKA AND HAWAII

**800-854-6046**

(Calif. and Arizona customers please phone or visit listed stores)

PHONE HOURS: 9:30 AM to 5:30 PM PACIFIC TIME.

STORE HOURS: 10 AM to 5:30 PM Mon. through Sat.

**HAM  
RADIO  
OUTLET**

**ANAHEIM, CA 92801**

2620 W. La Palma,  
(714) 761-3033, (213) 860-2040,  
Between Disneyland & Knotts Berry Farm.

**BURLINGAME, CA 94010**

999 Howard Ave.,  
(415) 342-5757,  
5 miles south on 101 from S.F. Airport.

**OAKLAND, CA 94609**

2811 Telegraph Ave.,  
(415) 451-5757,  
Hwy 24 Downtown. Left 27th off-ramp.

**PHOENIX, AZ 85015**

1702 W. Camelback Rd.,  
(602) 242-3515,  
East of Highway 17.

**SAN DIEGO, CA 92123**

5375 Kearny Villa Rd.,  
(619) 560-4900,  
Hwy 163 & Clairemont Mesa Blvd.

**VAN NUYS, CA 91401**

6265 Sepulveda Blvd.,  
(818) 988-2212,  
San Diego Fwy at Victory Blvd



AEA • ALLIANCE • ALPHA • AMECO • AMPHENOL • ANIXTER  
MARK • ANTENNA SPECIALISTS • ARRL • ASTRON • BELDEN  
BENCHER • BIRD • BUTTERNUT • B & W • CALLBOOK

COLLINS • CURTIS • CUSHCRAFT • DAIWA • DRAKE • DX EDGE  
EIMAC • HUSTLER • HY-GAIN • ICOM • J.W. MILLER • KANTRONICS  
KENWOOD • KLM • LARSEN • LUNAR • METZ • MFJ • MICRO-LOG

MINI-PRODUCTS • MIRAGE • NYE • PALOMAR • ROBOT • ROHN  
SHURE • SIGNAL ONE • STONER • TEMPO • TEN-TEC • TRISTAO  
TRI-EX • VIEWSTAR • VQCOM • YAESU and many more!

Prices, specifications, descriptions subject to change without notice. Calif. and Arizona residents please add sales tax.

# HUSTLER

## DELIVERS RELIABLE ALL BAND HF PERFORMANCE

Hustler's new 6-BTV six-band trap vertical fixed station antenna offers all band operation with unmatched convenience. The 6-BTV offers 10, 15, 20, 30, 40, and 75/80 meter coverage with excellent bandwidth and low VSWR. Its durable heavy gauge aluminum construction with fiberglass trap forms and stainless steel hardware ensures long reliability.

Thirty meter kits (30-MTK) for 4-BTV and 5-BTV are also available.



Don't miss our 30 meter excitement.  
HUSTLER -  
STILL THE STANDARD OF PERFORMANCE.

# HUSTLER

3275 North "B" Avenue  
Kissimmee, Florida 32741

An **AMERICAN** Company

✓123

## Get this catalog to SAVE MONEY! It's free!

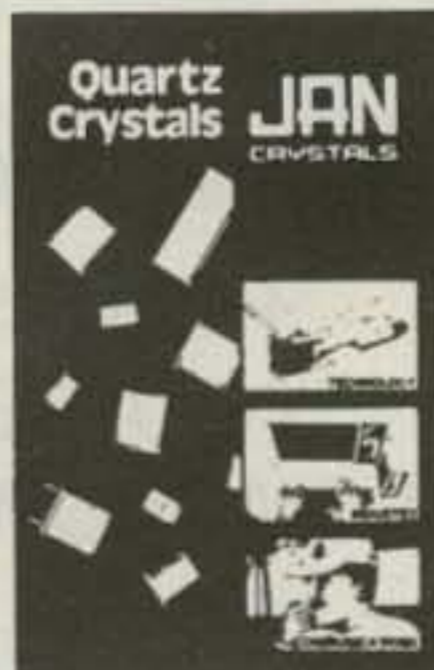

Quality Crystals Available for  
Communications Industry  
Marine VHF Scanners  
Amateur Bands CB Standard  
Microprocessor CB Specials  
"Just One or Hundreds"

Our low prices result from modern equipment and technology, efficient trained employees, and low sales costs. Call us.

### JAN CRYSTALS



P.O. Box 06017  
Ft. Myers, FL 33906  
Call (813) 936-2397  
✓273



73: *Amateur Radio's Technical Journal* is a member of the CW Communications/Inc. group, the world's largest publisher of computer-related information. The group publishes 53 computer publications in 24 major countries. Nine million people read one or more of the group's publications each month. Members of the group include: Argentina's *Computerworld/Argentina*; Asia's *The Asian Computerworld*; Australia's *Computerworld Australia*, *Australian Micro Computerworld*, *Australian PC World* and *Directories*; Brazil's *DataNews* and *MicroMundo*; China's *China Computerworld*; Denmark's *Computerworld/Danmark* and *Micro Verden*; Finland's *Mikro*; France's *Le Monde Informatique*, *Golden (Apple)* and *OPC (IBM)*; Germany's *Computerwoche*, *Microcomputerwelt*, *PC Welt*, *Software Markt*, *CW Edition/Seminar*, *Computer Business* and *Commodore Magazine*; Italy's *Computerworld Italia*; Japan's *Computerworld Japan* and *Perso ComWorld*; Mexico's *Computerworld/Mexico* and *CompuMundo*; Netherland's *CW Benelux* and *Micro/Info*; Norway's *Computerworld Norge* and *MikroData*; Saudi Arabia's *Saudi Computerworld*; Spain's *Computerworld/Espana* and *MicroSistemas*; Sweden's *ComputerSweden*, *MikroDatorn*, *Min Hemdator* and *Svenska PC World*; the UK's *Computer Management*, *Computer News* and *Computer Business Europe*; the US's *Computerworld*, *Hot CoCo*, *inCider*, *InfoWorld*, *MacWorld*, *Micro Marketworld*, *Microcomputing*, *PC World*, *RUN*, *73* and *80 Micro*.

# MPA

# INFO

## Manuscripts

Contributions in the form of manuscripts with drawings and/or photographs are welcome and will be considered for possible publication. We can assume no responsibility for loss or damage to any material. Please enclose a stamped, self-addressed envelope with each submission. Payment for the use of any unsolicited material will be made upon acceptance. All contributions should be directed to the 73 editorial offices. "How to Write for 73" guidelines are available upon request. US citizens must include their social security number with submitted manuscripts.

## Editorial Offices:

Pine Street  
Peterborough NH 03458  
Phone: 603-924-9471

## Advertising Offices:

Elm Street  
Peterborough NH 03458  
Phone: 603-924-7138

## Circulation Offices:

Elm Street  
Peterborough NH 03458  
Phone: 603-924-9471

## Subscription Rates

In the United States and Possessions:  
One Year (12 issues) \$25.00  
Two Years (24 issues) \$38.00  
Three Years (36 issues) \$53.00

## Elsewhere:

Canada and Mexico—\$27.97/1 year only, U.S. funds. Foreign surface mail—\$44.97/1 year only, U.S. funds drawn on U.S. bank. Foreign air mail—please inquire.

## To subscribe, renew or change an address:

Write to 73, Subscription Department, PO Box 931, Farmingdale NY 11737. For renewals and changes of address, include the address label from your most recent issue of 73. For gift subscriptions, include your name and address as well as those of gift recipients.

## Subscription problem or question:

Write to 73, Subscription Department, PO Box 931, Farmingdale NY 11737. Please include an address label.

73: *Amateur Radio's Technical Journal* (ISSN 0745-080X) is published monthly by CW Communications/Peterborough, Inc., 80 Pine Street, Peterborough NH 03458. Second class postage paid at Peterborough NH 03458 and at additional mailing offices. Entire contents copyright © 1984, CW Communications/Peterborough, Inc. All rights reserved. No part of this publication may be reprinted or otherwise reproduced without written permission from the publisher. Microfilm Edition—University Microfilm, Ann Arbor MI 48106. Postmaster: Send address changes to 73, Subscription Services, PO Box 931, Farmingdale NY 11737. Nationally distributed by International Circulation Distributors.

# WHAT THE COMPETITION CALLS "NO LOST WORDS OR SYLLABLES" WE CALL NOISE

**THE COMPETITION:** "HI HONEY I (NOISE BURST)M FIXING YOUR (NOISE BURST)VORITE SUPPE (NOISE BURST) BARBECUE HAMB (NOISE BURST)GERS. THEY WI (NOISE BURST) BE READY AT 6: (NOISE BURST) WILL YOU MA (NOISE BURST) IT IN TIME? (NOISE BURST)"

Samples (heard as bursts of noise) displace your phone party's audio for as long as it takes your transceiver to T/R. The above example assumes a transceiver T/R time of about 150 mS (typical)

**PRIVATE PATCH II:** " HI HONEY I AM FIXING YOUR FAVORITE SUPPER...BARBECUE HAMBURGERS. THEY WILL BE READY AT 6:30. WILL YOU MAKE IT IN TIME?"

Thousands of PRIVATE PATCH II owners are enjoying the commercial communications quality that only a VOX based, simplex autopatch can deliver.

## PRIVATE PATCH II IS PRICED AT LESS THAN HALF OF OUR COMPETITORS "FAVORITE COMMERCIAL SIMPLEX VOX PATCH"

### SAMPLING VS. PRIVATE PATCH II

The performance of a sampling patch is totally dependent on the T/R speed of your radio. Such is not the case with PRIVATE PATCH II. PRIVATE PATCH II will give excellent results with any radio. Synthesized and relay switched types included.

PRIVATE PATCH II requires only three connections to your radio (MIC, PTT and SPKR audio). If these connections are made inside your radio PRIVATE PATCH II does not interfere with the normal use of your radio. Otherwise for a quick and easy interface you may plug PRIVATE PATCH II Into the MIC and SPKR jacks. A 10 minute job! Unlike sampling patches, connections are not required to the squelch, discriminator or power. And best of all, modifications are never required.

Controlling and talking through PRIVATE PATCH II is almost always quicker and easier than using a sampling patch. This is because you may talk or send control commands the instant you press the PTT button. The ability to break in or take control is assured by interrupt control logic. The interrupt controller creates a window (similar to sampling) but is seldom heard in normal quick back and forth communication. With a sampling patch you press the MIC button for one to five seconds before talking on each and every transmission. This is very frustrating for the mobile, and causes confusion for each party.

The sampling process reduces the effective range of your base radio. This is because if a sample, and a signal fade coincide, the sampling patch thinks the mobile is not transmitting. This causes a sampling patch to become erratic at ranges still very useable by PRIVATE PATCH II. PRIVATE PATCH II will not diminish the range of your system.

PRIVATE PATCH II has two more range extending tricks not available to a noise sampled autopatch.

1. You may use a linear amplifier with no loss of performance
2. You can operate through any repeater from your base station.



### FEATURES

- CW ID (free ID chip) • Selectable tone or pulse dialing • User programmable toll restrict • Five digit access code • Ringback (reverse patch) • Busy channel ringback inhibit (will not transmit on top of someone) • Three/six minute "time-out" timer is resettable from the mobile • 115 VAC power supply • Modular phone jack and seven foot cord...and many more.

#### ALSO

- ✓ 14 day return privilege — when ordered factory direct.
- ✓ One year warranty — compare to their six months.

### CONTACT A LOCAL DEALER TODAY

**AMATEUR ELECTRONIC SUPPLY**  
Milwaukee WI, Wickliffe OH,  
Orlando FL, Clearwater FL,  
Las Vegas NV

**COLES COMMUNICATIONS**  
San Antonio TX

**ERICKSON COMMUNICATIONS**  
Chicago IL

**HAM RADIO OUTLET**  
Anaheim CA, Burlingame CA,  
Oakland CA, San Diego CA,  
Van Nuys CA, Phoenix AZ

**HENRY RADIO**  
Los Angeles CA, Anaheim CA,  
Butler MO

**JUNS ELECTRONICS**  
Culver City CA, Reno NV

**MIAMI RADIO CENTER CORP.**  
Miami FL

**MIKES ELECTRONICS**  
Ft. Lauderdale

**N&G DISTRIBUTING CORP.**  
Miami FL

**PACE ENGINEERING**  
Tucson AZ

**THE HAM SHACK**  
Evansville IN

**CANADA:**  
**DOLLARD ELECTRONICS**  
Vancouver, BC



**CONNECT  
SYSTEMS  
INCORPORATED**

23731 MADISON ST., TORRANCE, CA 90505  
PHONE: (213) 373-6803



# W2NSD/1 NEVER SAY DIE

editorial by Wayne Green



The response to my editorial asking for letters from hams interested in a DXpedition to Taiwan has been underwhelming. One.

I visited Tim Chen BV2A, the only licensed amateur on Taiwan, in October and he is still enthusiastic. He says that the government will cooperate if there are any Americans interested in operating from this very rare country for a few days.

I was looking at this DXpedition as a test to see if there would be any interest in 73 organizing a series of DXpeditions to the rarer countries. I had in mind DXpeditions with about a dozen hams so we would be able to operate stations around the clock for about four days in each spot. This would make most trips last about a week—allowing one day to get there, one to set things up, four days to operate, and one to get home.

By running a series of DXpeditions, 73 would be able to assign one ham full-time to organizing



Here is the group of hams that got together for dinner in Hong Kong in October—about a dozen VS6 and a dozen US hams.

the efforts, going along to help with the formalities, and setting up the stations. A second ham would be in charge of the filming and videotaping of the DXpedition, as well as the PR for it, nationally and internationally.

Such a DXpedition series could generate considerable interest in amateur radio via expo-

sure on television and in magazines and newspapers.

Indeed, we need something dramatic such as this if the hobby is going to survive. I doubt if you realize how far down the new ham numbers have sunk. Just this year we've dropped from almost 3,000 new hams a month to about 700. If the curve of new licensees of the last two years continues as it has, we will reach zero per month in 1986.

While we have had a slight growth in the number of total licensed hams in the last twenty years, surveys indicate that much of this is due to the license being free and running for five years. The number of active American hams has dropped by about 46% in twenty years. We sure need something!

A series of well-publicized DXpeditions could conceivably generate interest in the hobby. I estimate that it would cost about \$3,000 for each of a dozen hams going on the trip to make

## STAFF

**EDITOR**  
Wayne Green W2NSD/1

**EXECUTIVE/MANAGING EDITOR**  
Susan Philbrick

**ASSISTANT MANAGING EDITOR**  
Steve Jewett

**TECHNICAL/INTERNATIONAL EDITOR**  
Perry Donham KW1O

**EDITORIAL ASSISTANTS**  
Nancy Noyd  
Richard Phenix  
Chris Schmidt

**DESIGNERS**  
Diane Ritson  
Linda Drew

**ASSOCIATES**  
Robert Baker WB2GFE  
John Edwards K12U  
Bill Gosney KE7C  
Chod Harris VP2ML  
Dr. Marc Leavey WA3AJR  
Bill Pasternak WA6ITF  
Peter Stark K2OAW

**ADVERTISING**  
1-800-441-4403

**SALES MANAGER**  
Jim Gray W1XU

**ASSISTANT SALES MANAGER**  
Nancy Ciampa

**SALES REPRESENTATIVE**  
Ross Kenyon KA1GAV

**GRAPHIC SERVICES DIRECTOR**  
Christine Destremes

**PRODUCTION MANAGER**  
Joyce Pillarella

**MANUFACTURING CONSULTANT**  
Susan Gross

**TYPESETTING MANAGER**  
Dennis Christensen

**FILM PREP**  
Robert M. Villeneuve

**PHOTOGRAPHY MANAGER**  
Nathaniel Haynes

**VICE PRESIDENT/GENERAL MANAGER**  
Debra Wetherbee

**VICE PRESIDENT/FINANCE**  
Roger Murphy

**ASSISTANT GENERAL MANAGER**  
Matt Smith KA1EI

**ASSISTANT TO VP/FINANCE**  
Dominique Smith

**MARKETING MANAGER**  
Pamela Esty

**DIRECTOR OF CIRCULATION**  
William P. Howard

**ASSISTANT CIRCULATION MANAGER**  
Frank Smith

**DIRECT AND NEWSSTAND SALES MGR.**  
Raino Wirein  
1-800-343-0728

**DIRECTOR OF CREDIT SALES AND COLLECTIONS**  
William M. Boyer

**PUBLISHER**  
John C. Burnett



### QSL OF THE MONTH

To enter your QSL, mail it in an envelope to 73, 80 Pine Street, Peterborough NH 03458, Attn: QSL of the Month. Winners receive a one-year subscription (or extension) to 73. Entries not in envelopes cannot be accepted.

Continued on page 72

# KENWOOD

...pacesetter in amateur radio

## TS-930S "DX-traordinary"

### TS-930S

We call it "DX-traordinary" because the TS-930S has now become the favorite rig of the serious contester! Its superior capability for full break-in split-frequency operation, the speed and convenience with which its eight memory channels can be accessed, its unsurpassed receiver dynamic range and its remarkable ability to select the desired signal during periods of heavy QRM, utilizing VBT, Slope tuning, IF Notch filtering, and tuneable audio filtering, have all combined to make this the rig that gives you the EXTRA EDGE!

The TS-930S is loaded with all the special features that you always wanted in an HF transceiver. Full coverage of the 160 through 10 meter bands, including the new WARC frequencies, (easily modified for HF MARS), plus a general coverage receiver that can tune any frequency from 150 kHz to 30 MHz. Operation in the SSB, CW, FSK, and AM modes, with selectable full or semi CW break-in. All solid-state, with 250 watts PEP input on SSB,

CW, FSK, and 80 watts input on AM. SWR/power meter. Triple final protection circuits plus two cooling fans built-in. 10-Hz step synthesized frequency control. Available with optional automatic antenna tuner built-in, another industry first! Dual digital VFO's. Eight memory channels that store both frequency and band information, with internal battery back-up, (batteries not supplied). Dual mode adjustable noise blankers, especially effective in eliminating "woodpecker" type interference. SSB IF slope tuning, for maximum rejection of interference. CW variable bandwidth, with pitch and side-tone control. IF notch filter. Tuneable audio peaking filter. Unique six digit white fluorescent tube digital display is easy-on-the-eyes during those long contests. RF speech processor, for higher average "talk-power." SSB monitor circuit. 4-step RF attenuator. VOX. 100-kHz marker. AC power supply built-in, 120, 220, or 240 VAC.



#### TS-930S Optional Accessories:

AT-930 automatic antenna tuner, SP-930 external speaker, with selectable audio filters, YG-455C-1 (500 Hz), YG-455CN-1 (250 Hz), YK-88C-1 (500 Hz) CW filter, YK-88A-1 (6 kHz) AM filter, all plug-in type. SO-1 commercial stability TCXO, MC-60A deluxe desk microphone, MC-80 and MC-85 communications microphones, MC-42S mobile hand microphone, TL-922A linear amplifier (not for CW QSK), SM-220 station monitor, PC-1A phone patch, SW-2000 SWR/power meter, 160 ~ 6 meter, SW100A SWR/power/volt meter 160-2m HS-4, HS-5, HS-6, and HS-7 headphones.

Isn't it about time you stepped into the winner's circle?

More information on the TS-930S is available from authorized dealers of Trio-Kenwood Communications, 1111 West Walnut Street, Compton, California 90220.

*Specifications and prices are subject to change without notice or obligation.*





# WHAT?

## NEWS FROM THE PUBLISHER

Welcome to our 25th Anniversary year!

As publisher, it's my job to make sure that 73 remains the best *vox clamantis in deserto* in the world of amateur radio. As readers, it's your duty to make sure that your voices are heard. More on that later.

We have a few changes in store for this year, including making sure that 73 offers more operating tips and news than we've had in the past. We'll also provide more of a forum for our readers. You asked for it, you get it.

Upcoming new features? Watch for:

- "Believe It or Else" (guest editorials)
- "Dear Advertiser" (unedited answers)
- "73 Thanks..." (Elmers, emergency ops, PR efforts, etc.)
- "Ask an Extra" (KW1O fields the question of the month)
- "73-on-the-Air" (regular skeds return to ARS W2NSD/1)
- "Who's This?" (puzzle profiles of 73 staffers and advertisers)
- "Seen a 73?" (photos of unusual 73s)
- "73 Congratulates..." (job promotions, ticket anniversaries, hamfest reports, etc.)

Another new feature you'll be seeing is more letters. So write. Try not to be too wacko. And don't think that writing isn't important, either. It is.

Write a short letter or send a card to an advertiser, too. When was the last time you spent 15 minutes and 20 cents to thank someone for advertising with a bunch of renegades like us? You're in the driver's seat, sure: 72.6% of you will spend more than \$250 on ham gear during the next six months, according to our July-September, 1984, reader surveys. But sending a thank-you has never hurt anyone.

Two final news notes:

- If you have a contribution for any of our new features, send it to me. The sooner we get it, the sooner we print it.
- Set aside Sunday, March 24, for H-Day. Details next month.

Again, welcome to our 25th Anniversary year! Take part. For almost a quarter of a century, 73 has fought for you, in spite of you, and because of you. Thanks.

*here is the next generation Repeater*

## MARK 4CR

The **only** repeaters and controllers with REAL SPEECH!

No other repeaters or controllers match Mark 4 in capability and features. That's why Mark 4 is the performance leader at amateur and commercial repeater sites around the world. Only Mark 4 gives you Message Master™ real speech • voice readout of received signal strength, deviation, and frequency error • 4-channel receiver voting • clock time announcements and function control • 7-helical filter receiver • extensive phone patch functions. Unlike others, Mark 4 even includes power supply and a handsome cabinet.

Call or write for specifications on the repeater, controller, and receiver winners.

Create messages just by talking. Speak any phrases or words in any languages or dialect and *your own voice* is stored instantly in solid-state memory. Perfect for emergency warnings, club news bulletins, and DX alerts. Create unique ID and tail messages, and the ultimate in a real speech user mailbox — only with a Mark 4.



**MICRO CONTROL SPECIALTIES** ✓49

Division of Kendecom Inc.

23 Elm Park, Groveland, MA 01834 (617) 372-3442



## WARC Wish?

**THE WARCS ARE COMING!** The FCC has released a Notice of Proposed Rulemaking (PR Docket 84-960) that details the implementation of our new allocations. Here's what they've got in mind.

• **30 METERS:** Amateurs with a General-class license or above will have 10.100 to 10.150 MHz available for CW or RTTY, with no special power limitation. Effective immediately, the 10.109 to 10.115 "window" no longer exists. Remember, you're still allowed only 200 Watts PEP on this band.

• **17 METERS:** Forget about the 18.068-18.168 segment for a while. The FCC says that access to this band will not be available until 1989.

• **12 METERS:** Things are a bit brighter for the 24.890 to 24.990 allocation. The National Telecommunications and Information Administration (NTIA) says that shared use of the band by amateurs with government fixed stations would not be a problem. The Commission would like to open this band as soon as possible. Right now, the band plan looks like this: 24.890-24.930 CW/RTTY and 24.930-24.990 CW/SSB. Amateurs with a General or higher license will be allowed to operate on 12 meters, with no special power restrictions.

Remember, these are just proposals—with the exception of 30 meters, you can't use these new frequencies until the FCC issues a final Report and Order. Watch "QRX" for further details.

## Megachamp!

**OUTRAGEOUS** is the word that came to mind when I opened a letter from **John Kanzius K3TUP**. John has won 73's 40-meter SSB Championship for two years running, and he wanted us all to see why. The antenna in the photograph is a KLM 4-element monobander. I don't want to know how high it is! What isn't shown is the rest of the farm: 6 over 6 on 10 and 15 meters, 6 over 5 on 20 meters, a 4-element phased vertical array for 80 meters, and a W1CF quarter-wave sloper on 160 meters! For the curious, John says that the aluminum is .9 wavelengths high for the lower antennas and 2.25 wavelengths up for the rest! Feeding all of this are a pair of Kenwood TS-930Ss, a Rockwell KWM-380, and an Alpha 77D. Any more questions?

## 220 Vote!

**TWO VERY IMPORTANT VOTES** are due soon from the FCC. The first involves the **LMCC petition** for additional spectrum in the land-mobile service. The inside scoop is that

LMCC will not receive any allocation in the 800-MHz reserve, and that leaves chunks of 220 MHz up for grabs. If this vote goes against amateur radio, it will mean an NPRM aimed at an orderly transition to commercial interests on this band. The other vote concerns the highly-touted **Personal Radio Communication Service (PRCS)**, which seemed to be a low-cost alternative to cellular telephone. General Electric, which already has invested millions of dollars in research and development, decided to table their efforts early last week. This clears the way for the Commission to lay PRCS to rest.

## Head Ham

**RAJIV GANDHI**, Prime Minister of India, is also VU2RG! His Excellency is not the only ham in the Gandhi family—**Sonia Gandhi**, Rajiv's spouse, holds VU2SON. How long will it be before we hear a "heads of state" net on 20 meters?

## Log Jam

**ON THE DX FRONT**, there's bad news from Africa. What used to be XT Upper Volta is now **XT Burkina Faso**. The bad news is that the new name doesn't fit the "QTH" column in the logbook! From **Gus Browning's DX'ers Magazine** comes word of an expedition to ZA Albania, and the word is, "Don't hold your breath..." According to Gus, several DL stations are trying to gain permission to operate, including DJ0UJ, but chances are less than slim that governmental blessings will be issued. The *DX'ers Magazine* is a good way to stay on top of the

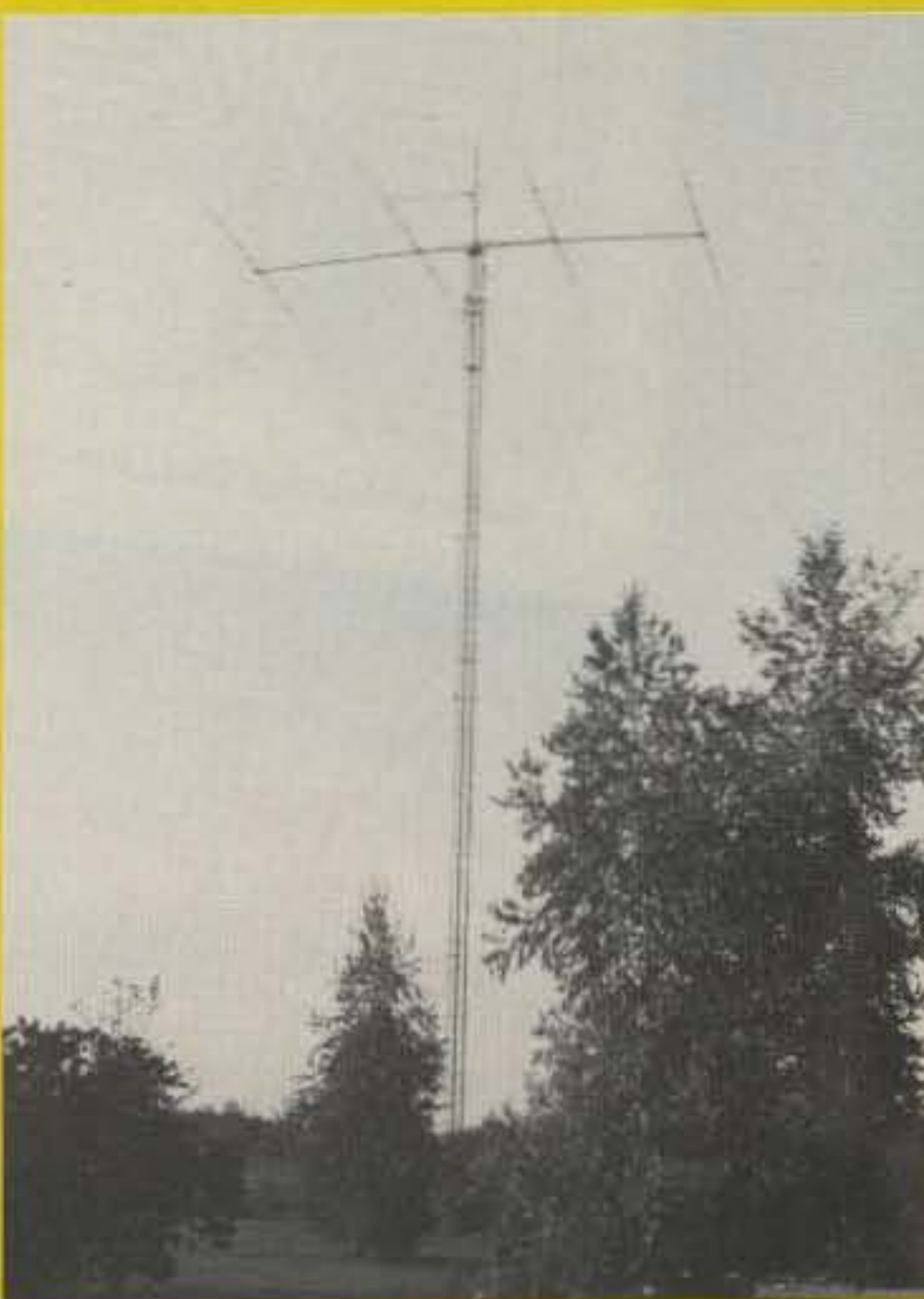

*K3TUP's monster aluminum.*

changing DX scene, and you can reach Gus at PO Drawer DX, Cordova SC 29039.

## Packet Draft

**A NATIONAL PACKET REGISTRATION PROGRAM** is underway through the auspices of the **Central Illinois Packet Radio User Society (CIPRUS)**. These folks are trying to create a list of every packet-radio enthusiast in the country. If you are active on this mode, please send the following information to CIPRUS: callsign, name, address, and miscellaneous information (digipeater, mailbox, grid locator, etc.). Mail this, along with a very large SASE, to CIPRUS, PO Box 4143, Peoria IL 61607. This kind of service does not come cheaply. According to **Greg Smith N9AGC**, "...we will not turn down any donations toward paper costs that you would care to make."

## Form Fact

**A NEW FORM 610** is being passed out by the FCC. It reflects the changes in the testing structure and includes spaces for VE certification. Your local VEC or the FCC can supply you with a copy.

## Digital Paper?

**THE FOURTH ARRL Radio Computer Networking Conference** will be held in San Francisco, California, on March 30, 1985. Technical papers are being solicited on all aspects of amateur digital communications, including packet switching, meteor scatter, and satellite systems. Topics may include network architecture, proposed standards, hardware/software, protocols, modulation and encoding schemes, applications, and practical experience. The deadline for camera-ready manuscripts is March 1, 1985. Papers should be mailed to **Marian Anderson WB1FSB, ARRL**, 225 Main Street, Newington CT 06111. If you plan to present a paper, you should request an author's kit and identify the title of your proposal as soon as possible.

## ICOM, They Go

**AFTER READING IN "QRX"** that 73 had moved to plush new offices, **ICOM America, Inc.**, decided to do the same. They've built a beautiful new 40,000-square-foot corporate headquarters in Washington State. The new address is: **ICOM America, Inc.**, 2380-116 Avenue NE, Bellevue WA 98004. I've seen a picture—the building looks like a giant IC-02AT lying on its side!



|       |      |       |       |
|-------|------|-------|-------|
| 114.8 | 2000 | 118.8 | 2100  |
| 115.9 | 2011 | 123.0 | 2150  |
| 117.2 | 2022 | 127.3 | 2200  |
| 118.5 | 2033 | 131.5 | 2250  |
| 119.8 | 2044 | 135.8 | 2300  |
| 121.1 | 2055 | 140.1 | 2350  |
| 122.4 | 2066 | 144.3 | 2400  |
| 123.7 | 2077 | 148.6 | 2450  |
| 125.0 | 2088 | 152.9 | 2500  |
| 126.3 | 2099 | 157.2 | 2550  |
| 127.6 | 2110 | 161.5 | 2600  |
| 128.9 | 2121 | 165.8 | 2650  |
| 130.2 | 2132 | 170.1 | 2700  |
| 131.5 | 2143 | 174.4 | 2750  |
| 132.8 | 2154 | 178.7 | 2800  |
| 134.1 | 2165 | 183.0 | 2850  |
| 135.4 | 2176 | 187.3 | 2900  |
| 136.7 | 2187 | 191.6 | 2950  |
| 138.0 | 2198 | 195.9 | 3000  |
| 139.3 | 2209 | 200.2 | 3050  |
| 140.6 | 2220 | 204.5 | 3100  |
| 141.9 | 2231 | 208.8 | 3150  |
| 143.2 | 2242 | 213.1 | 3200  |
| 144.5 | 2253 | 217.4 | 3250  |
| 145.8 | 2264 | 221.7 | 3300  |
| 147.1 | 2275 | 226.0 | 3350  |
| 148.4 | 2286 | 230.3 | 3400  |
| 149.7 | 2297 | 234.6 | 3450  |
| 151.0 | 2308 | 238.9 | 3500  |
| 152.3 | 2319 | 243.2 | 3550  |
| 153.6 | 2330 | 247.5 | 3600  |
| 154.9 | 2341 | 251.8 | 3650  |
| 156.2 | 2352 | 256.1 | 3700  |
| 157.5 | 2363 | 260.4 | 3750  |
| 158.8 | 2374 | 264.7 | 3800  |
| 160.1 | 2385 | 269.0 | 3850  |
| 161.4 | 2396 | 273.3 | 3900  |
| 162.7 | 2407 | 277.6 | 3950  |
| 164.0 | 2418 | 281.9 | 4000  |
| 165.3 | 2429 | 286.2 | 4050  |
| 166.6 | 2440 | 290.5 | 4100  |
| 167.9 | 2451 | 294.8 | 4150  |
| 169.2 | 2462 | 299.1 | 4200  |
| 170.5 | 2473 | 303.4 | 4250  |
| 171.8 | 2484 | 307.7 | 4300  |
| 173.1 | 2495 | 312.0 | 4350  |
| 174.4 | 2506 | 316.3 | 4400  |
| 175.7 | 2517 | 320.6 | 4450  |
| 177.0 | 2528 | 324.9 | 4500  |
| 178.3 | 2539 | 329.2 | 4550  |
| 179.6 | 2550 | 333.5 | 4600  |
| 180.9 | 2561 | 337.8 | 4650  |
| 182.2 | 2572 | 342.1 | 4700  |
| 183.5 | 2583 | 346.4 | 4750  |
| 184.8 | 2594 | 350.7 | 4800  |
| 186.1 | 2605 | 355.0 | 4850  |
| 187.4 | 2616 | 359.3 | 4900  |
| 188.7 | 2627 | 363.6 | 4950  |
| 190.0 | 2638 | 367.9 | 5000  |
| 191.3 | 2649 | 372.2 | 5050  |
| 192.6 | 2660 | 376.5 | 5100  |
| 193.9 | 2671 | 380.8 | 5150  |
| 195.2 | 2682 | 385.1 | 5200  |
| 196.5 | 2693 | 389.4 | 5250  |
| 197.8 | 2704 | 393.7 | 5300  |
| 199.1 | 2715 | 398.0 | 5350  |
| 200.4 | 2726 | 402.3 | 5400  |
| 201.7 | 2737 | 406.6 | 5450  |
| 203.0 | 2748 | 410.9 | 5500  |
| 204.3 | 2759 | 415.2 | 5550  |
| 205.6 | 2770 | 419.5 | 5600  |
| 206.9 | 2781 | 423.8 | 5650  |
| 208.2 | 2792 | 428.1 | 5700  |
| 209.5 | 2803 | 432.4 | 5750  |
| 210.8 | 2814 | 436.7 | 5800  |
| 212.1 | 2825 | 441.0 | 5850  |
| 213.4 | 2836 | 445.3 | 5900  |
| 214.7 | 2847 | 449.6 | 5950  |
| 216.0 | 2858 | 453.9 | 6000  |
| 217.3 | 2869 | 458.2 | 6050  |
| 218.6 | 2880 | 462.5 | 6100  |
| 219.9 | 2891 | 466.8 | 6150  |
| 221.2 | 2902 | 471.1 | 6200  |
| 222.5 | 2913 | 475.4 | 6250  |
| 223.8 | 2924 | 479.7 | 6300  |
| 225.1 | 2935 | 484.0 | 6350  |
| 226.4 | 2946 | 488.3 | 6400  |
| 227.7 | 2957 | 492.6 | 6450  |
| 229.0 | 2968 | 496.9 | 6500  |
| 230.3 | 2979 | 501.2 | 6550  |
| 231.6 | 2990 | 505.5 | 6600  |
| 232.9 | 3001 | 509.8 | 6650  |
| 234.2 | 3012 | 514.1 | 6700  |
| 235.5 | 3023 | 518.4 | 6750  |
| 236.8 | 3034 | 522.7 | 6800  |
| 238.1 | 3045 | 527.0 | 6850  |
| 239.4 | 3056 | 531.3 | 6900  |
| 240.7 | 3067 | 535.6 | 6950  |
| 242.0 | 3078 | 539.9 | 7000  |
| 243.3 | 3089 | 544.2 | 7050  |
| 244.6 | 3100 | 548.5 | 7100  |
| 245.9 | 3111 | 552.8 | 7150  |
| 247.2 | 3122 | 557.1 | 7200  |
| 248.5 | 3133 | 561.4 | 7250  |
| 249.8 | 3144 | 565.7 | 7300  |
| 251.1 | 3155 | 570.0 | 7350  |
| 252.4 | 3166 | 574.3 | 7400  |
| 253.7 | 3177 | 578.6 | 7450  |
| 255.0 | 3188 | 582.9 | 7500  |
| 256.3 | 3199 | 587.2 | 7550  |
| 257.6 | 3210 | 591.5 | 7600  |
| 258.9 | 3221 | 595.8 | 7650  |
| 260.2 | 3232 | 600.1 | 7700  |
| 261.5 | 3243 | 604.4 | 7750  |
| 262.8 | 3254 | 608.7 | 7800  |
| 264.1 | 3265 | 613.0 | 7850  |
| 265.4 | 3276 | 617.3 | 7900  |
| 266.7 | 3287 | 621.6 | 7950  |
| 268.0 | 3298 | 625.9 | 8000  |
| 269.3 | 3309 | 630.2 | 8050  |
| 270.6 | 3320 | 634.5 | 8100  |
| 271.9 | 3331 | 638.8 | 8150  |
| 273.2 | 3342 | 643.1 | 8200  |
| 274.5 | 3353 | 647.4 | 8250  |
| 275.8 | 3364 | 651.7 | 8300  |
| 277.1 | 3375 | 656.0 | 8350  |
| 278.4 | 3386 | 660.3 | 8400  |
| 279.7 | 3397 | 664.6 | 8450  |
| 281.0 | 3408 | 668.9 | 8500  |
| 282.3 | 3419 | 673.2 | 8550  |
| 283.6 | 3430 | 677.5 | 8600  |
| 284.9 | 3441 | 681.8 | 8650  |
| 286.2 | 3452 | 686.1 | 8700  |
| 287.5 | 3463 | 690.4 | 8750  |
| 288.8 | 3474 | 694.7 | 8800  |
| 290.1 | 3485 | 699.0 | 8850  |
| 291.4 | 3496 | 703.3 | 8900  |
| 292.7 | 3507 | 707.6 | 8950  |
| 294.0 | 3518 | 711.9 | 9000  |
| 295.3 | 3529 | 716.2 | 9050  |
| 296.6 | 3540 | 720.5 | 9100  |
| 297.9 | 3551 | 724.8 | 9150  |
| 299.2 | 3562 | 729.1 | 9200  |
| 300.5 | 3573 | 733.4 | 9250  |
| 301.8 | 3584 | 737.7 | 9300  |
| 303.1 | 3595 | 742.0 | 9350  |
| 304.4 | 3606 | 746.3 | 9400  |
| 305.7 | 3617 | 750.6 | 9450  |
| 307.0 | 3628 | 754.9 | 9500  |
| 308.3 | 3639 | 759.2 | 9550  |
| 309.6 | 3650 | 763.5 | 9600  |
| 310.9 | 3661 | 767.8 | 9650  |
| 312.2 | 3672 | 772.1 | 9700  |
| 313.5 | 3683 | 776.4 | 9750  |
| 314.8 | 3694 | 780.7 | 9800  |
| 316.1 | 3705 | 785.0 | 9850  |
| 317.4 | 3716 | 789.3 | 9900  |
| 318.7 | 3727 | 793.6 | 9950  |
| 320.0 | 3738 | 797.9 | 10000 |

Communications Specialists TE-64

# Food for thought.

Our new Universal Tone Encoder lends it's versatility to all tastes. The menu includes all CTCSS, as well as Burst Tones, Touch Tones, and Test Tones. No counter or test equipment required to set frequency-just dial it in. While traveling, use it on your Amateur transceiver to access tone operated systems, or in your service van to check out your customers repeaters; also, as a piece of test equipment to modulate your Service Monitor or signal generator. It can even operate off an internal nine volt battery, and is available for one day delivery, backed by our one year warranty.



- All tones in Group A and Group B are included.
- Output level flat to within 1.5db over entire range selected.
- Separate level adjust pots and output connections for each tone Group.
- Immune to RF
- Powered by 6-30vdc, unregulated at 8 ma.
- Low impedance, low distortion, adjustable sinewave output, 5v peak-to-peak.
- Instant start-up.
- Off position for no tone output.
- Reverse polarity protection built-in.

## Group A

|         |          |          |          |
|---------|----------|----------|----------|
| 67.0 XZ | 91.5 ZZ  | 118.8 2B | 156.7 5A |
| 71.9 XA | 94.8 ZA  | 123.0 3Z | 162.2 5B |
| 74.4 WA | 97.4 ZB  | 127.3 3A | 167.9 6Z |
| 77.0 XB | 100.0 1Z | 131.8 3B | 173.8 6A |
| 79.7 SP | 103.5 1A | 136.5 4Z | 179.9 6B |
| 82.5 YZ | 107.2 1B | 141.3 4A | 186.2 7Z |
| 85.4 YA | 110.9 2Z | 146.2 4B | 192.8 7A |
| 88.5 YB | 114.8 2A | 151.4 5Z | 203.5 M1 |

- Frequency accuracy,  $\pm .1$  Hz maximum - 40°C to + 85°C
- Frequencies to 250 Hz available on special order
- Continuous tone

## Group B

| TEST-TONES: | TOUCH-TONES: | BURST TONES:        |
|-------------|--------------|---------------------|
| 600         | 697 1209     | 1600 1850 2150 2400 |
| 1000        | 770 1336     | 1650 1900 2200 2450 |
| 1500        | 852 1477     | 1700 1950 2250 2500 |
| 2175        | 941 1633     | 1750 2000 2300 2550 |
| 2805        |              | 1800 2100 2350      |

- Frequency accuracy,  $\pm 1$  Hz maximum - 40°C to + 85°C
- Tone length approximately 300 ms. May be lengthened, shortened or eliminated by changing value of resistor

Wired and tested: \$79.95



**COMMUNICATIONS SPECIALISTS**

426 West Taft Avenue, Orange, California 92667  
(800) 854-0547/ California: (714) 998-3021



four connections for the new circuit may now be made:

- The +dc power connection goes to control line CW8, available at pin 4 of J13 on the main circuit board.

- The ground connection goes to SPE, the speaker ground, available at pin 2 of J18 on the main circuit board.

- The keying connection goes to KEY line, available at pin 3 of J18 on the main circuit board.

- The output connection goes to either end of resistor R114 on the main circuit board.

To adjust the new sidetone oscillator, proceed as follows: Key down (dummy load, please!) and adjust the **FREQ** control to 750 Hz or your preferred pitch. Then adjust the **FILTER** control to the same frequency by adjusting it for the loudest and clearest-sounding output tone. Last, adjust the **LEVEL** control for the desired output volume.

Although the improved sidetone-oscillator circuit is a bit more work than the other modifications in this article, I'm sure that if CW operation is one of your main interests, you will agree that the beautiful clean-keyed sine wave that this oscillator circuit produces is worth the extra work!

### Improved CW-Filter Switching

When both the FL-45 CW crystal filter (500 Hz) and the EX-203 active audio filter options are installed, the stock filter-switching arrangement that ICOM designed seems backwards: It works out so that when you are in either CW mode (CW or CW-n, the narrow position), the 150-Hz-wide EX-203 audio filter is switched in, but the 500-Hz-wide FL-45 filter is switched in only in the CW-n position.

If you stop and think about this, I'm quite sure you will agree that it doesn't

seem to make much sense to leave a 150-Hz-wide filter in the circuit and switch a 500-Hz filter in and out; the exact opposite makes much more sense: Leave the 500-Hz filter in the circuit in both CW mode positions and add the 150-Hz active audio filter into the circuit only in the narrow CW position.

Fortunately, the 730 is "cold switched." This means that rather than actually re-routing signals directly through front-panel switch contacts, most 730 panel switches actually switch a dc control voltage which controls signal routing on the boards. To rewire the 730 to allow for the improved CW-filter switching, proceed as follows:

- Remove the green wire from pin 1 of plug P-1 which "hangs" off the EX-203 filter board and carefully fish it out of the short cable into which it is harnessed. Let this green wire hang free for now, and mount the EX-203 as per ICOM installation instructions.

- Locate the two wires, green and blue, coming from P-6, plugged into J4 on the second i-f board. Cut both these wires at the point where they pass behind the center of the S-meter. The short end of the blue wire may be taped at the end and discarded. (Tuck into nearby wiring.) The short green wire should be connected via a length of insulated wire (preferably green) to the green wire which you pulled out. Tape over all connections to prevent possible shorts.

- Two wires are left to connect: the long blue and the long green. Splice the long green to the white wire coming from pin 1 of J1 on the detector board.

- Splice the long blue to the red wire coming from pin 4 of J1 on the detector board. Again, tape over all spliced connections.

### Improved Audio-Filter Operation

My EX-203 active audio

CW filter, as supplied, rings and adds audio distortion. To tame it down, I replaced both resistors R2 and R9 (originally 560k) with 270k resistors. This cleaned things up nicely and provided nearly equal audio-output level from a centered signal whether the filter is switched in or out.

After the resistors have been changed, re-peak the two filter stages by adjusting R7 and R14 trimmer potentiometers on the EX-203 board for maximum output with a 750-Hz audio note, with the rig in the narrow CW mode and a medium-strength carrier received.

I believe that optimum adjustment of an audio filter is somewhat a matter of individual taste. If you wish to experiment with the characteristics of the EX-203 audio filter, you will find that (1) overall gain can be adjusted by changing the value of resistors R1 and R8, (2) bandwidth can be adjusted by changing the value of resistors R2 and R9, and (3) center frequency may be adjusted by varying the value of resistors R7 and R14. All these values interact somewhat, so you may have to play with resistor values awhile to get exactly the characteristics you prefer.

### Panel-Lamp Brilliance

The panel-meter illumination from the S-meter on the 730 is very bright, and I found that to be distracting during mobile operation. It was so bright that it made me squint when I looked at it, and it seemed to disturb my night vision. Fortunately, there is an extremely simple fix for this problem: Simply break the path of the source wire that feeds dc to the S-meter lamp and insert a 24-Ohm, 1/2-Watt resistor in series with it. Tape over any exposed connections to avoid potential shorts later.

The S-meter lamp will now glow a mellow yellow color, much dimmer than

the stock configuration but still plenty bright enough to read the meter very easily. A bonus is the much-prolonged bulb life you may now expect due to the lower bulb current.

### Auto Memory Hold

The 730 has two vfo frequency memories plus a memory for each band. Unfortunately, whenever you turn the power off, all memories are lost. During mobile operation, this means that if you turn the rig off when you leave the car, you will have to reprogram all the memories when you return. A simple modification will allow the 730 to keep its memories alive even when the rig's power switch is off, so long as the rig remains connected to a source of +12-volt-dc power. To implement this change, proceed as follows:

- Remove the red wire plugged into jack J8 on the logic unit.

- Cut the plug off this red wire and set it aside. Tape over the end of the red wire so that it cannot short to anything and hide it away in a group of nearby wires.

- Solder a 10-inch wire to the top-rear terminal of the power switch. Route this wire along any convenient cable bundle to jack J8 on the logic unit.

- Solder the plug that was cut from the red wire to the free end of the new power-switch wire (discarding any excess length) and plug it into J8 on the logic unit.

Both vfo frequencies and all band memories will now be held in memory as long as dc power remains supplied to the rig's main power connector. Current drain when the rig is turned off will be about 18 mA—not a significant drain on your car battery, and a small price to pay to avoid the nuisance of having to reprogram memories every time you return to your car!

This modification comes

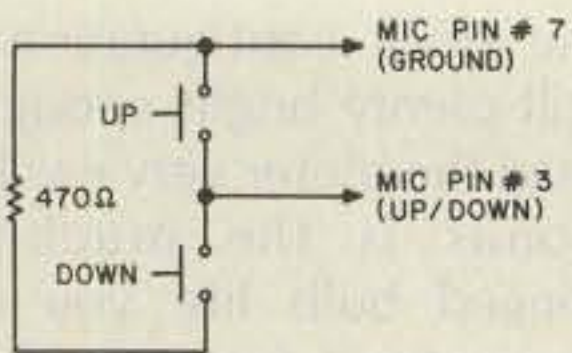

Fig. 2. Adding up/down tuning to the ICOM 730.

with a free bonus: The memory jack on the rear of the rig now connects to nothing, so you may feel free to use it for any desired spare function via the taped red wire that was cut from the J8 plug.

### Up/Down-Tuning Microphone

I must admit it: I have tried ICOM's own optional up/down-tuning mobile microphone for the 730 and I didn't like it for two important reasons. First, it has a very uncomfortable box shape, the feel of which I did not care for, and second, the push-buttons are too hard to push—and especially to

hold down for the prolonged period of time required to scan across a band.

I solved this problem by carefully removing the microphone cartridge and pre-amplifier from the hand-held microphone supplied and carefully repackaging them into a microphone I liked better (that had the necessary push-buttons for up/down tuning). This preserved the exact audio characteristics of the original stock microphone yet allowed for up/down tuning from the microphone—a great convenience for mobile operation.

The up/down-tuning function is actually already implemented in the 730. To use it, you must wire up your microphone switches as shown in Fig. 2, adding a 470-Ohm resistor for up/down control.

### Cooling-Fan Control

The 730's cooling-fan circuit has two modes of operation. First, the fan runs at low

speed at all times when in the transmit mode (push-to-talk operated, key down, or transmit switch depressed). Second, high-speed fan operation occurs when the heat-sink temperature exceeds approximately 75 degrees Celsius, a condition which triggers a thermal switch, causing the fan to run at high speed during both transmit and receive until the heat sink cools back down.

There really are times, however, when it is not necessary to have the fan running at all, such as during periods of QRP operation or whenever the transmit power or duty cycle is low. A switch can be installed that will allow you to bypass the fan in its low-speed mode. This will save battery power, eliminate unnecessary fan noise, and prolong fan life.

To provide a switch selection of fan operation on transmit but still leave the emergency mode of fan op-

eration on overheat, simply lift one end of resistor R24 on the power-amplifier board and insert an SPST switch in series. A common mini-toggle switch will fit perfectly in the hole left in the rear-chassis panel if J5 (the memory backup jack) is removed. (This jack is not used anyway if you have done the Auto Memory Hold modification in this article.) My new switch is labeled "Fan Normal/QRP."

All of the modifications described in this article have been in my 730 for at least one year now, with absolutely no ill effects observed. I feel that they have significantly enhanced the capabilities of my mobile and CW operations. I hope you will find some of them to be useful improvements to your own 730 operations. Perhaps they will even help you get a step or two closer to having your own ultimately perfect rig for your own style of operation. ■

## LIMITED ANTENNA SPACE? B & W OFFERS SIX SOLUTIONS!



Barker & Williamson offers six new multiband trapped dipoles made to fit in less space than conventional antennas. You may not have room for that dream antenna farm, but no longer need limit your operating to one or two bands. These new antennas provide low SWR on every band making a great companion for today's solid state rigs.

- Direct feed with 52 OHM Coax
- 1 KW CW, 2 KW P.E.P. SSB
- SO-239 Termination

| MODEL     | BANDS                  | LENGTH  | PRICE    |
|-----------|------------------------|---------|----------|
| AS - 160  | 160, 80, 40, 20 METERS | 137 Ft. | \$129.00 |
| AXS - 160 | 160, 30 METERS         | 96 Ft.  | 99.00    |
| AS - 80   | 80, 40, 20 METERS      | 78 Ft.  | 99.00    |
| AXS - 80  | 80, 40, 15 METERS      | 64 Ft.  | 99.00    |
| AS - 40   | 40, 20, 15, 10 METERS  | 40 Ft.  | 129.00   |
| AS - 20   | 20, 15, 10 METERS      | 23 Ft.  | 99.00    |

ADD \$2.00 SHIPPING & HANDLING

ALL OUR PRODUCTS MADE IN USA

**BW BARKER & WILLIAMSON**

Quality Communication Products Since 1932

At your Distributors. Write or Call

10 Canal Street, Bristol, PA 19007

(215) 788-5581

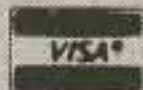

## State of the Art Kits by Hal-Tronix, Inc.

### KEYERS AND OPTIONAL MEMORY KITS

**ACCUKEYER KIT** ..... \$16.95  
THIS ACCUKEYER KIT IS A REVISED VERSION OF THE FAMOUS WB4VVF ACCUKEYER, BUT WITH SIDE TONE ONBOARD. COMES COMPLETE WITH ALL ELECTRONIC PARTS, LESS SOCKETS, POWER SUPPLY AND CASE.

**ACCU-MEMORY 1101** ..... \$16.95  
LOW COST METHOD OF ADDING MEMORY TO THE ACCUKEYER. COMES WITH TWO 1101 MEMORIES. GIVING YOU 2 CHANNELS CAPABLE OF 30 CHARACTERS PER CHANNEL. COMES COMPLETE WITH ALL ELECTRONIC PARTS INCLUDING SOCKETS, LESS CASE AND POWER SUPPLY.

**ACCU-MEMORY 2102** ..... \$21.95  
LOW COST METHOD OF ADDING LARGER MEMORY TO THE ACCUKEYER. PROVISIONS FOR 4 2102'S (ONLY 1 2102 COMES WITH THE KIT) HAS THE CAPABILITY OF 4 CHANNELS WITH 120 CHARACTERS EACH. COMES COMPLETE WITH SOCKETS, LESS 3 OF THE 2102'S, LESS POWER SUPPLY AND CASE.

### SPECIAL OFFER

#1 BUY THE ACCUKEYER AND 1101 OPTION TOGETHER ..... (ONLY) \$32.00  
#2 BUY THE ACCUKEYER AND 2102 OPTION TOGETHER ..... (ONLY) \$37.00  
#3 BUY THE ACCUKEYER AND 2102 OPTION ALONG WITH THREE EXTRA 2102'S AND SOCKETS ..... (ONLY) \$40.00

**PROXIMITY KEYS** ..... \$19.95  
KEYER PADDLE ENABLES ONE TO GENERATE DOTS AND DASHES WITH THE TOUCH OF A FINGER (NO MOVING PARTS) COMES COMPLETE WITH ALL ELECTRONIC PARTS LESS CASE AND POWER SUPPLY.

### VARIOUS CLOCK KITS

**HAL-5314 (Most Famous Clock Kit)** ..... \$12.95  
6 DIGIT ELECTRONIC CLOCK KIT, 12 OR 24 HOUR FORMAT, COMPLETE KIT LESS POWER SUPPLY ADAPTOR AND CASE. RUNS OFF ANY 12 VOLT A.C. SOURCE REQUIRES 250 MA.

**HAL-5375 (Alarm Clock Kit)** ..... \$16.95  
6 DIGIT ELECTRONIC CLOCK KIT, 12 HOUR FORMAT ONLY, OPERATE ON 12 VOLTS A.C. OR D.C. HAS TIME BASE ONBOARD. COMES COMPLETE LESS POWER ADAPTOR AND CASE.

**HAL-79 (Student Class Kit)** ..... \$7.95  
4 DIGIT BASIC ELECTRONIC KIT, WITH OPTIONS AND PROVISIONS TO MAKE IT AN ALARM CLOCK AND A D.C. OPERATED CLOCK. COMPLETE LESS OPTIONS, POWER SUPPLY ADAPTOR AND CASE.

**OPTION #1 - TO MAKE IT AN ALARM CLOCK** ..... \$2.95

**OPTION #2 - TO MAKE IT A D.C. 12V CLOCK** ..... \$4.95

**CLOCK CASE - Reg. \$6.50 Clock Case - When Bought with Clock Kit** ..... (ONLY) \$4.50

**12 VOLT A.C. ADAPTOR - Reg. \$4.95 - When Bought with Clock Kit** ..... (ONLY) \$2.95

**60HZ TIME BASE** ..... Complete - \$4.95

**CRYSTAL TIME BASE KIT USING MM5369** ..... Complete - \$4.95

**HAL NTSC RF MOD** ..... \$19.95  
BUILD YOUR OWN VIDEO RF MODULATOR, A MINI T.V. TRANSMITTER, FOR CHANNELS 3 OR 4 USING A S.A.W. OUTPUT FILTER KEEPING CO-CHANNEL INTERFERENCE AT A MINIMUM. COMES COMPLETE LESS CASE, POWER SUPPLY AND HARDWARE.

**NOTE: CASE, POWER SUPPLY AND HARDWARE** ..... ENCLOSE \$12.95 Extra

**HAL FG 100** ..... \$69.95  
FUNCTION GENERATOR KIT, 1 HZ TO 100 KHZ IN FIVE BANDS. AMPLITUDE AND OFFSET ADJUSTABLE. OUTPUT IMP. 500 OHMS. WAVE FORMS - SINE, SQUARE AND TRIANGULAR AND TTL CLOCK 0 TO 5V LEVEL. 200 NS RISE AND FALL TIME. COMPLETE KIT WITH CASE AND POWER SUPPLY AND ALL ELECTRONIC PARTS INCLUDING MANUAL.

**SHIPPING INFORMATION:** ORDERS OVER \$25 WILL BE SHIPPED POST-PAID EXCEPT ON ITEMS WHERE ADDITIONAL CHARGES ARE REQUESTED. ON ORDERS LESS THAN \$25, PLEASE INCLUDE ADDITIONAL \$2.50 FOR HANDLING AND MAILING CHARGES. SEND 20¢ STAMP OR SASE FOR FREE FLYER. MICHIGAN RESIDENT ADD 4% SALES TAX. CANADIAN ORDERS ADD \$5.00 POSTAGE IN U.S. FUNDS.

**HAL-TRONIX, INC.**  
P.O. BOX 1101 - DEPT. 7  
SOUTHGATE, MICH. 48195  
PHONE (313) 285-1782



"HAL" HAROLD C. NOWLAND  
WBZXH

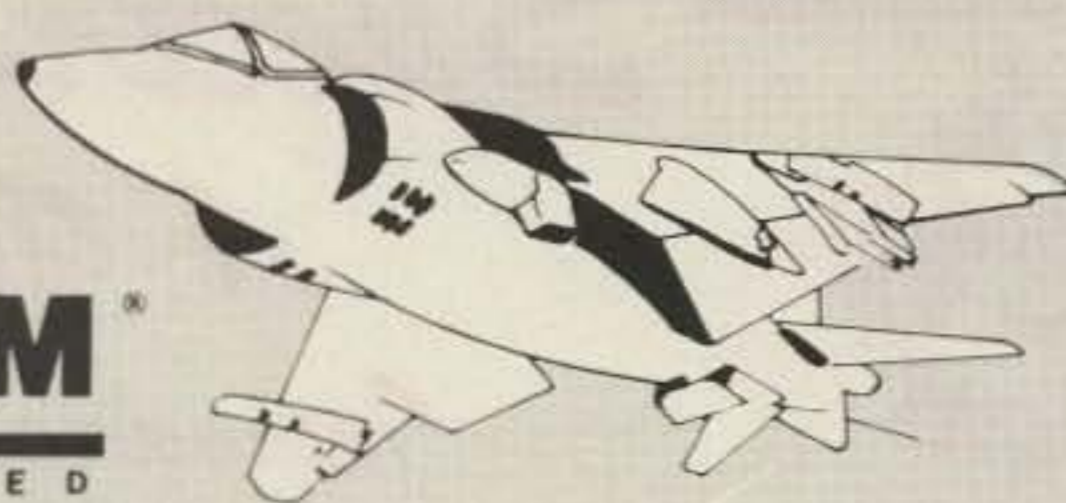
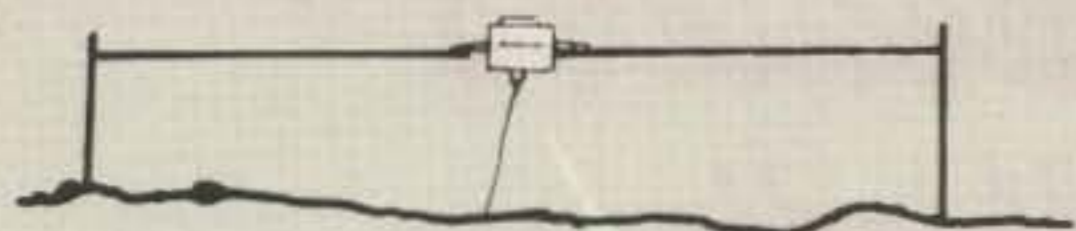

**AUTOMATIC  
ANTENNA MATCHER**

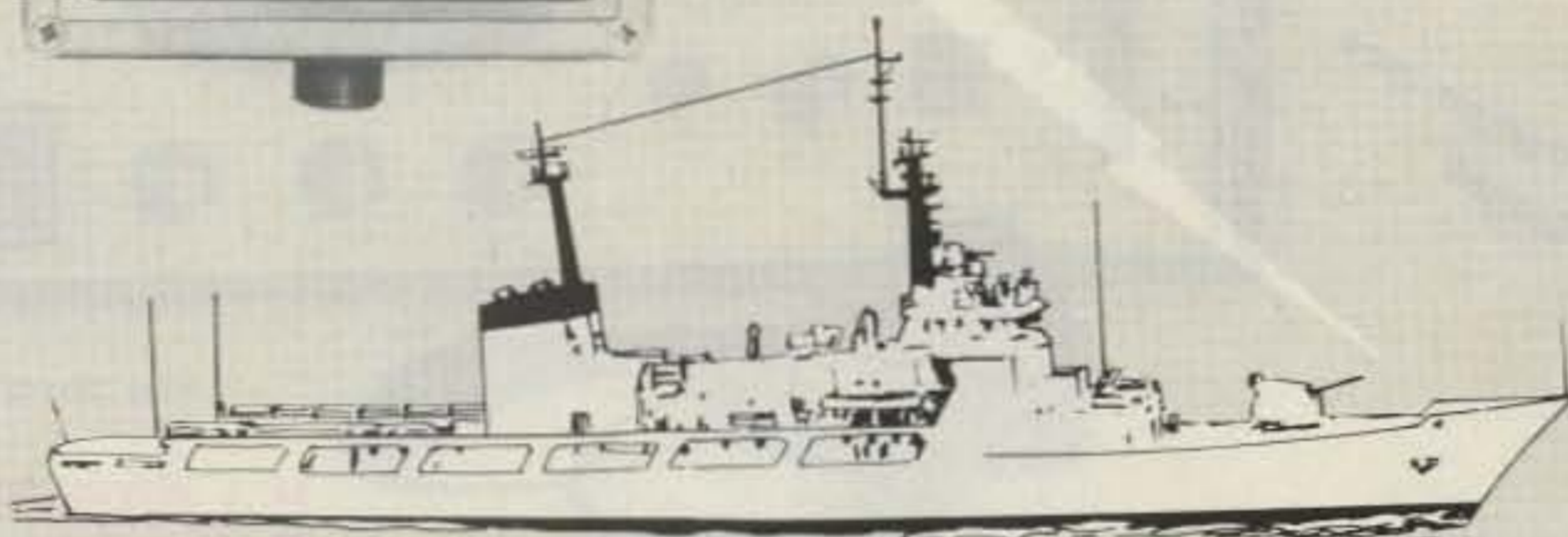
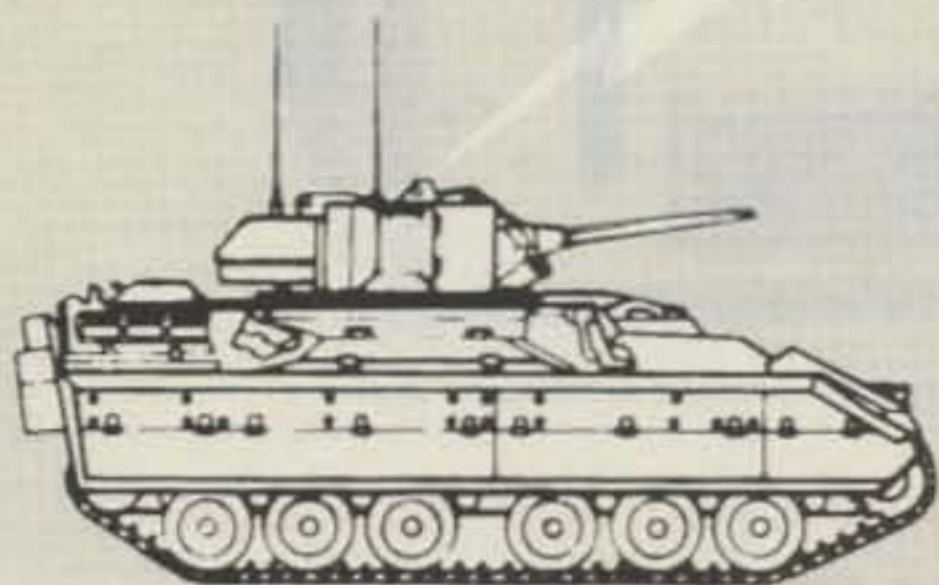

**ONE ANTENNA .3 TO 70 MHZ.  
VSWR 1.5:1 OR LESS**

UNEXCELLED FOR "FREQUENCY HOPPING"

- \* NO MOVING PARTS !
- \* 5 YEAR WARRANTY !
- \* INSTANT MATCHING !
- \* 50 OHM INPUT !
- \* LOW NOISE !
- \* DIPOLE !
- \* MARINE !
- \* AMATEUR !

- \* 100% SOLID STATE !
- \* NO CONTROL LEADS !
- \* LIGHT WEIGHT !
- \* HIGH EFFICIENCY !
- \* 200 TO 2KW. P.E.P. !
- \* LONG WIRE !
- \* MILITARY !
- \* AVIONICS !

**★ MADE IN AMERICA, BY AMERICANS. ★**

*Over 2,000 Satisfied Users*

**"NEW R.F. GROUNDLESS LONGWIRE MODELS  
NOW AVAILABLE"**

CONTACT

**MAGNUM DISTRIBUTORS INC.**

1831 South Dixie Highway, Pompano Beach, Florida 33060

305-785-2002 • Telex 514365 (English FTL)

54

**new**

# Spectrum Repeaters

## A Generation Ahead!

### Introducing The SCR2000X Microprocessor Controlled Repeater



Totally  
Microprocessor  
Controlled

High Performance  
RF Stages



New "Sharp" Appearance—Brushed Aluminum Panel

**It's time to replace your old Repeater or  
install that new system!**

The SCR2000X Microprocessor controlled repeater is the newest addition to the Spectrum Hi Tech Repeater Line. It combines the latest state of the art digital techniques with the best of Spectrum's highly refined RF technology to yield "The Ultimate Repeater"! Operating convenience and flexibility are emphasized without sacrificing traditional Spectrum reliability and ruggedness. Go with the world leader in Amateur Repeaters! Call or write today for details. Sold Factory Direct or through Export Reps. only. (Other Deluxe & Basic Repeaters Also Available.)

#### STANDARD FEATURES:

- Autopatch/Reverse Patch, W/O & 1 Inhibit
- Dial Pulse Converter
- Autodialer
- Phone line & "over the air" command modes. Virtually all functions may be turned on/off remotely.
- Touch Tone Control of 'Timeout', 'Hang Time', Patch Timeout, TX Inhibit/Reset, Patch & Reverse Patch Inhibit/Reset, P.L. On/Off (w/optional P.L. board), etc.
- Up to 6 Auxiliary Functions. More with TTC300.
- Full 16 Digit Decoding with Crystal Controlled Decoder IC
- Touch Tone Mute
- Unique Courtesy tone
- "Kerchunk Killer"
- Timeout Warning Tones
- Automatic CW ID & ID Command
- Remote Programming of 3 Timers for 2 different timing cycles, or No Time Out
- Microprocessor Memory 'Battery Backup'
- Autopatch AGC for constant levels
- Local Status Indication via 12 Function panel LED Display
- Front Panel Touchtone Pad for Local Control & Phone line access.
- Full Panel Metering: Rcvr. & Xmtr. functions plus Voltages & Currents
- **New-Improved: RCVR., UHF Xmtr., Power Supply!**
- 30-75 Watt VHF & UHF Models
- 100-150 Watt Final Amps Available

■ **SC200X Controller & Interface Boards also available.**

#### SCR77D Desktop/Portable Repeater

**new**

#### APPLICATIONS

- Ideal for low power local use
- Portable/Mobile at the scene of an Emergency
- Increase coverage at parades or other Public Service events
- "Mountaintopping" with battery pack
- Full Duplex Computer/Data Links
- Export Rural Telephone
- Compact, Rugged
- Self Contained
- 10W UHF. Built-in Duplexer
- 15W VHF External Dpxr.
- Optional Autopatch & P.L.
- AC or 12 VDC Input



# SPECTRUM

Export Orders Welcomed

1055 W. GERMANTOWN PK., DEPT S1



# Spectrum Repeater Boards & Sub-Assemblies

New FL-4 UHF  
Helical Resonators

These are professional "Commercial Grade" Units—Designed for Extreme Environments (–30 to 60° C.)

All Equipment Assembled & Tested. For 10M, 2M, 220 MHz, & 450 MHz



COMPLETE SHIELDED RCVR. ASSY.

VHF & UHF Receiver Boards  
SCR200A-VHF SCR450A-UHF

**Totally Advanced Design!**  
8 Pole Front End Filtr. + wide dynamic range—reduces overload, spurious Resp. & Intermod.  
Sens. 0.25  $\mu$ V/12dB SINAD typ.  
Sel. -6dB @  $\pm$  6.5 KHz. -130dB @  $\pm$  30KHz. (8 Pole Crystal + 4 Pole Ceramic Filtrs.  
'S Meter', Discriminator & Deviation Mtr. Outputs!  
Exc. audio quality! Fast squelch! w/0.0005% Crystal. ("Super Sharp" IF Filtr. also avail.)

## Complete Receiver Assemblies

Rcvr. Bd. mounted in shielded housing.  
Completely asmbld & tested, w/F.T. caps, SO239 conn.

As used in the SCR1000. Ready to drop into your system!

UHF Rcvr. Assy. Now Available w/Super Sharp FL-4 Helical Resonators. Greatly reduces IM & "out of band" Interference!

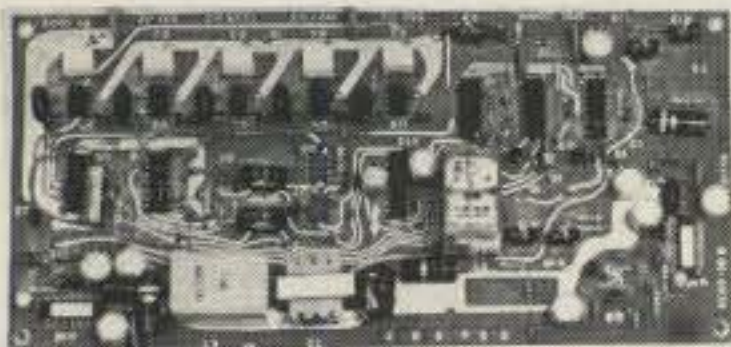

## SCAP Autopatch Board

Provides all basic autopatch functions  
Secure 3 Digit Access; 1 Aux On-Off function, Audio AGC; Built-in timers; etc. Beautiful Audio!  
Q1 inhibit bd. also available  
Write/call for details and a data sheet

## RPCM Board

Used w/SCAP board to provide "Reverse Patch" and Land-Line Control of Repeater  
Includes land line "answering" circuitry

## Lightning Arrester For SCAP

Gas Discharge Tube shunts phone line surges to ground  
Handles up to 40,000 Amps!  
The Best device available to protect Autopatch equipment from lightning damage. \$17.00 + S/H.



FL-6

## FL-6 Rcvr. Front-End Preselector

- 6 Hi Q Resonators with Lo-Noise Transistor Amp (2M or 220 MHz).
- Provides tremendous rejection of "out-of-band" signals w/ out the usual loss! Can often be used instead of large expensive cavity filters
- Extremely helpful at sites with many nearby VHF transmitters to "filter-out" these out-of-band signals



## SCR 500 VHF/UHF LINK/CONTROL RCVR.

- SCR200A or SCR450A rack mounted
- Available with or without meters and power supply



## ID250A CW ID & Audio Mixer Board

- 4 Input AF Mixer & Local Mic. amp.
- PROM memory—250 bits/channel.
- Up to 4 different ID channels!
- Many other features. Factory programmed.

## CTC100 Rptr. COR Timer/Control Bd.

- Complete solid state control for rptr. COR, "Hang" Timer, "Time-Out" Timer, TX Shutdown/Reset, etc
- Includes Inputs & Outputs for panel controls & lamps

## Repeater Tone & Control Bds.

For SCR1000/4000 & CTC100/ID250 only

- TMR-1 "Kerchunker Killer" or "Time Out Warning Tone" Bd.
- TRA-1 "Courtesy Tone Beeper" Board
- PSM-1 Power Supply Mod Kit replaces Darlington pass transistor.
- Improved! Now includes "audio mute" CRT circuit and "emergency power" i.d. option.



## IMPROVED SCT410B TRANSMITTER ASSY.

## SCT110 VHF Xmtr/Exciter Board

- 10 Wts. Output 100% Duty Cycle!
- Infinite VSWR proof
- True FM for exc. audio quality
- Designed specifically for continuous rptr service. Very low in "white noise."
- Spurious .70 dB. Harmonics –60 dB
- With .0005% xtal.
- BA-30 30 Wt. Amp board & Heat Sink, 3 sec. L.P. Filter & rel. pwr. sensor. BA75 75 Wt. unit also available.

## SCT110 Transmitter Assembly

- SCT110 mounted in shielded housing
- Same as used on SRC1000
- Completely asmbld. w/F.T. caps, SO239 conn.
- 10, 30, or 75 Wt. unit.

## SCT 410B UHF Transmitter Bd. or Assy.

- Similar to SCT110, 10 Wts. nom.
- Now includes "on board" proportional Xtal Osc./Oven circuitry for very high stability!
- BA-40 40W. UHF AMP. BD. & HEAT SINK.

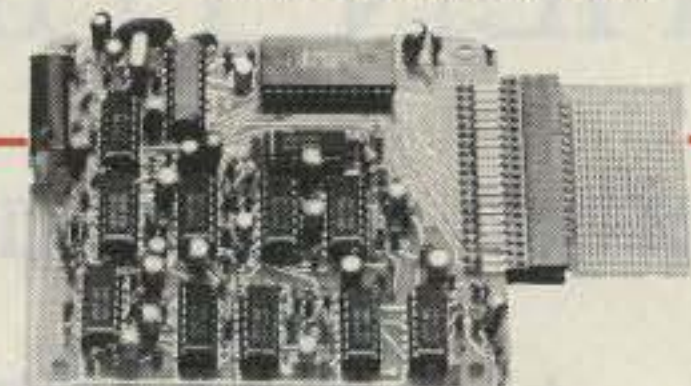

## TTC300 TOUCH TONE CONTROLLER

- High performance, super versatile design
- Uses new high quality Xtal Controlled Decoder IC, w/high immunity to falsing
- Decodes all 16 digits
- 3 ON/OFF Functions per Main Card. Easily expandable to any no. of functions w/ Expansion Cards.
- Field Programmable via plug-in Coded Cards
- Latched or pulsed outputs; many unique 3-digit codes available. *Not basically 1-digit as with competitive units.*
- Transistor Switch outputs can directly trigger solid state circuitry or relays, etc. for any type of control function.
- Interfaceable to Auxiliary Equipment
- Low Power Consumption CMOS Technology. 5VDC Input. Gold-plated connectors.

# COMMUNICATIONS CORP.

Call, or  
Write for  
Data Sheets

INQUIRE ABOUT 'SURPLUS' RX & TX BOARDS. REDUCED PRICE!

Norristown, PA 19403 • (215) 631-1710

# COMMUNICATE

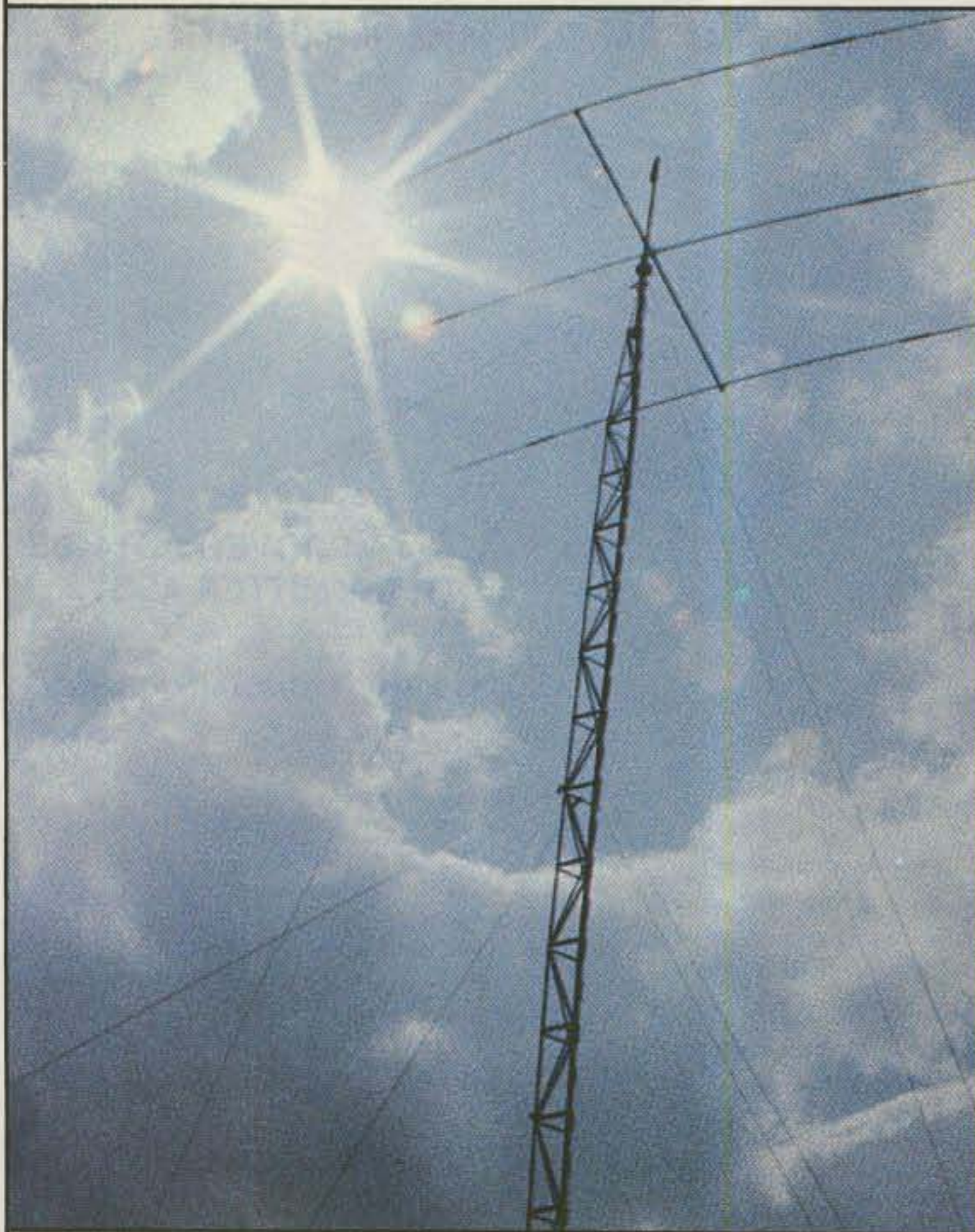

International Edition
April 1984 \$2.50  
Issue #263

## 73

### Amateur Radio's Technical Journal

A Wayne Green Publication

**Bargain Basement Signal Monitor**  
Page 20

**Masada!**  
Page 94

**Microwave Yourself**  
Page 42

**Mobile Whiplashes**  
Page 56

**Inside Dayton**  
Page 10

**Europe on \$0 a Day**  
Page 48

**The Saga of Ishmod**  
Page 64

**Doing It at Dayton**  
This month's Letterbox handbook helps attendees and the room alike. **W4ZDF 10**

**Me and My Stupid Old PMOS Converter**  
At last, there's an answer to get 12 V from a +5V supply. Why not? Read on! **W5TIB/1A 14**

**Watch That Signal!**  
Hold out your old oscilloscope and turn it into a signal monitor. The cost is only a coin and the price is right. **W4RTH 20**

**Digital Design: How to Interface ICs**  
Connect ICs to the outside world with these hints from the author of "Digital Basics". **K4DPS 30**

**Emulate an EPROM Elephant**  
The portable EPROMs never forget. Well, hardly ever. **W4GMB 40**

**Crystal Microwave**  
Overlapping is the part of the spectrum it up to you. Here's a simple way to do it. **W4WIS 42**

**Take a Trip to Europe**  
Have fun from the world's top DXL make it possible. **W4VRS 48**

**Four Bands, One Whip**  
Qualify your mobile operating site. Use a whip. But don't blame us. **K4J 54**

**Dayton Damns—10**

**Sun Fun—100**

**The Corlog Solution**  
What's the key to winning contests? Put an SSB and the program at the base of your station and find out. **N4KQ 62**

**Ishmod's Journal**  
What happened in 1983? Results released in 1984. **W4GMB 64**

**The Terminal Terminal Unit**  
Build the terminal unit for your personal computer. **K3RFB 70**

**Wheeling and Dealing with Preamps**  
For a better, more sensitive SSB, use a preamp. Here's a great antenna. **W4VRS 84**

**How to Have a Sunny Field Day**  
Want to have a sunny field day? Here's how to get the most out of your field day. **W4VRS 100**

**Featureless Op-Amp Filter Design**  
Featureless filters can be made. Just follow this simple step-by-step guide to a perfect featureless filter. **W4VRS 102**

**Never Say Die—6**  
**73 International—92**  
**Ham Help—**  
**115, 116, 122, 133**  
**New Products—116**  
**RTTY Loop—118**  
**Columns—119**  
**DX—120**  
**Social Events—122**  
**Fair—124**

**FCC—125**  
**Letters—127**  
**Dr. Digital—128**  
**Reader Service—129**  
**Reader Service—130**  
**Reader 'N' Buy—131**  
**Awards—132**  
**Satellites—133**  
**Dealer Directory—162**  
**Propagation—162**

FIRST WITH US,  
THEN THE WORLD!

Better communications start with your subscription  
to **73 Amateur Radio's Technical Journal**

**YES!** Start my no-risk subscription today and send me 12 issues of **73** for \$19.97. I'll save 33% off the newsstand price!

CHECK/MO     Bill Me

Name \_\_\_\_\_  
Address \_\_\_\_\_  
City \_\_\_\_\_ State \_\_\_\_\_ Zip \_\_\_\_\_

Canada & Mexico \$22.97, 1 year only, US funds drawn on US bank.  
Foreign Surface \$39.97, 1 year only, US funds drawn on US bank.  
Foreign airmail, please inquire. Please allow 6-8 weeks for delivery.

**73 Amateur Radio's Technical Journal**  
PO Box 931, Farmingdale, NY 11737 **351R6**

# TRS80\* RTTY/CW

- ROM-116
- RTTY/CW



\*TRADEMARK OF TANDY CORP.

FLESHER CORP. • P.O. BOX 976 • TOPEKA, KS • 66601  
(913) 234-0198 307



## 7 MILLION TUBES FREE CATALOG

Includes all Current, Obsolete, Antique, Hard-To-Find Receiving, Broadcast, Industrial, Radio/TV types. **LOWEST PRICES**, Major Brands, In Stock.

UNITY Electronics Dept. S  
P.O. Box 213, Elizabeth, NJ 07206



## CALL LONG DISTANCE ON 2 METERS

Only 10 watts drive will deliver 75 watts of RF power on 2M SSB, FM, or CW. It is biased Class AB for linear operation. The current drain is 8-9 amps at 13.6 Vdc. It comes in a well constructed, rugged case with an oversized heat sink to keep it cool. It has a sensitive C.O.R. circuitry, reliable SO-239 RF connectors, and an amplifier IN/OUT switch. The maximum power input is 15 watts.

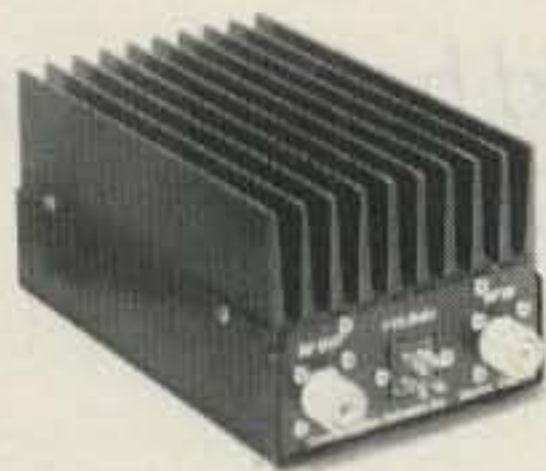

Our products are backed by prompt factory service and technical assistance. To become familiar with our other fine products in the amateur radio market, call or write for our free product and small parts catalog.

Model 875  
Kit \$109.95  
Wired & Tested \$129.95

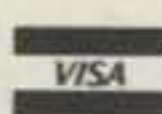

**CCI** Communication Concepts Inc.

2648 North Aragon Ave. • Dayton, Ohio 45420 • (513) 296-1411 14



# 1985 CALLBOOKS

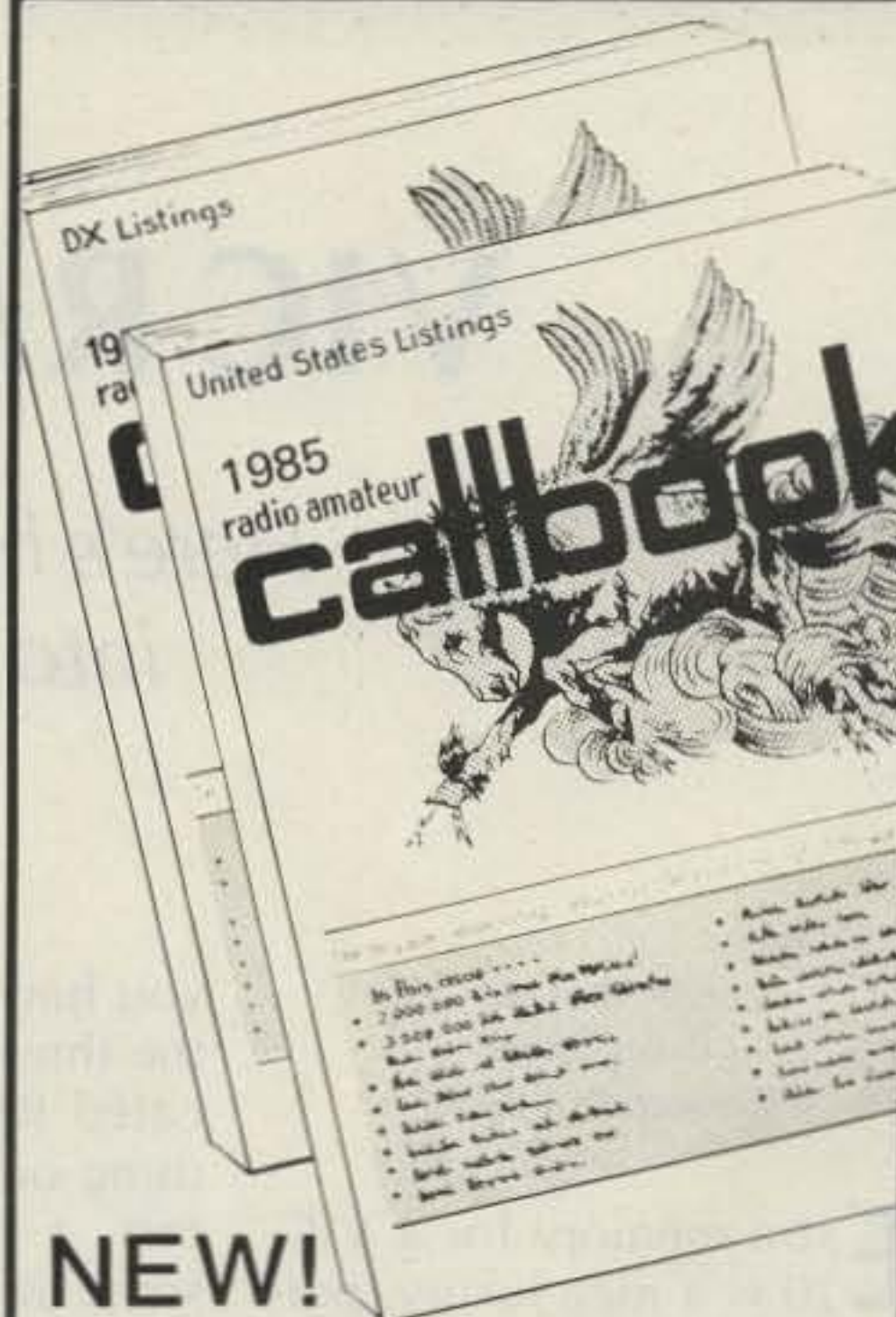

## NEW! Special North American Edition

As an added bonus, the 1985 U.S. Callbook also lists the amateurs in Canada and Mexico! You get the complete and accurate U.S. listings (prepared by our own editorial staff), all the usual up-to-date Callbook charts and tables, PLUS Canada and Mexico. Now that's real value!

**The best just got better!**

Of course, Canadian and Mexican amateurs are also listed in the 1985 Foreign Callbook. Don't delay! The great new 1985 Callbooks were published December 1, 1984.

**Order your copies now!**

|   | Each    | Shipping | Total   |
|---|---------|----------|---------|
| <input type="checkbox"/> U.S. Callbook    | \$21.95 | \$3.05   | \$25.00 |
| <input type="checkbox"/> Foreign Callbook | 20.95   | 3.05     | 24.00   |

Order both books at the same time for \$45.00 including shipping within the USA.

Order from your dealer or directly from the publisher. Foreign residents add \$4.55 for shipping. Illinois residents add 6% sales tax.

### Keep your 1985 Callbooks up to date.

The U.S. and Foreign Supplements contain all activity for the previous three months including new licenses. Available from the publisher in sets of three (March 1, June 1, and September 1) for only \$15.00 per set including shipping. Specify U.S. or Foreign Supplements when ordering. Illinois residents add 6% sales tax. Offer void after November 1, 1985.

RADIO AMATEUR  
**callbook** INC. 61  
Dept. B  
925 Sherwood Dr., Box 247  
Lake Bluff, IL 60044, USA

Tel: (312) 234-6600

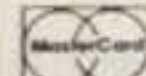
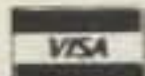

## PACKET RADIO



### ASCII—USA/AX.25 HDLC CONVERTER

USA/AX.25 is the AMRAD approved digital format STANDARD used on amateur packet radio networks.

PAC/NET board only \$80.00  
Assembled/Tested. No ICs. 90day warranty

Package of all ICs except 2-2716 EPROMs \$80.00

## PAC/NET SYSTEM

PAC/NET SYSTEM \$240.00

System Tested 4.5 x 6" board complete with all ICs and programmed EPROMs personalized for each purchaser. Requires only single 8-10 volt 1/2 amp power. 1 year guarantee of hardware/software/AX.25 standard RS232 serial ASCII at any user baud rate. RS232 HDLC for 202 modem used for AFSK or direct to RF equipment for FSK.

Custom Systems Custom Programming

**BILL ASHBY**  
— AND SON —

K2TKN—KA2OEG 201-658-3087  
BOX 332 PLUCKEMIN N.J. 07978

## Finally, A Highly Detailed and Accurate National Scanner Manual

# MONITOR AMERICA

The Communications/Travel Guide

ONE EASY TO USE VOLUME  
INTERSTATE ROAD MAPS ■ MONITORING LAWS  
AM/FM RADIO ■ EMERGENCY PHONE NUMBERS  
MAJOR METRO AREA COVERAGE

State Police/Highway Patrol  
Civil Defense ■ Conservation  
National Parks/Forests/Mnmts  
State Transportation/Highway  
Complete Entertainment Industry  
Air, Marine, Ski Areas/Patrols  
Ham C.D./Emergency Nets  
News Media/Traffic Copters  
Weather ■ Travelers Info Svc.  
Sports Teams, Race Tracks  
Amusement Parks ■ Casinos  
Tourist/Cultural Attractions

**Great for the road and for the home.**

We pride ourselves on our up-to-date detailed listings of codes, channel & unit designators, district breakdowns, maps, as well as frequencies and their exact usages.

Send \$14.95 + postage and handling  
\$1.25 (book rate) or \$2.75 (1st class)  
MA Residents please add 5% sales tax

to: **SMB Publishing** 319  
P.O. Box 244 ST  
Natick, MA 01760

# VIC RAMification: Part I

*Here's how to turn 3 ICs and half an hour into 24K of extra VIC-20 memory.*

Gary P. Brefini  
12 Bailey Street  
Foxboro MA 02035

**E**xtra memory for a VIC-20 is a nice luxury, particularly when you have just finished editing a program but find that there are not quite enough memory locations for those DIM statements. This happened to me recently while preparing a VIC-20 Basic program to design yagi antennas. The solution is, naturally, more memory. But how? This article will show

you how to completely fill the three 8K blocks of allocated RAM for the VIC-20 using only 3 ICs, 3 capacitors, a mother board, and some wire. Your construction effort will be worth it when your video monitor, after power-up, reads: "28159 BYTES FREE."

The *VIC-20 Programmer's Reference Guide*<sup>1</sup> explains the memory map for the VIC-20, so I will not go into detail about it. However, the VIC does have two areas in which to add additional memory: a 3K space

from addresses \$0400 to \$0FFF and a 24K section from addresses \$2000 to \$7FFF. When the 24K expansion area is used, Basic cannot reside in the smaller 3K area. The memory expansion project in this article is designed to fill the larger 24K area.

The 24K area is composed of three contiguous 8K blocks. Block #1 resides in locations \$2000 to \$3FFF, block #2 resides in locations \$4000 to \$5FFF, and block

#3 is located in memory at \$6000 to \$7FFF. Filling these locations gives the Basic programmer an additional 24K of usable Basic on top of the factory-installed memory of the VIC-20, which is 5K bytes. When the 24K memory is installed, the VIC's kernel program re-adjusts locations of various housekeeping routines, such as the screen buffer, so that a large contiguous area of available RAM is dedicated to the programmer.

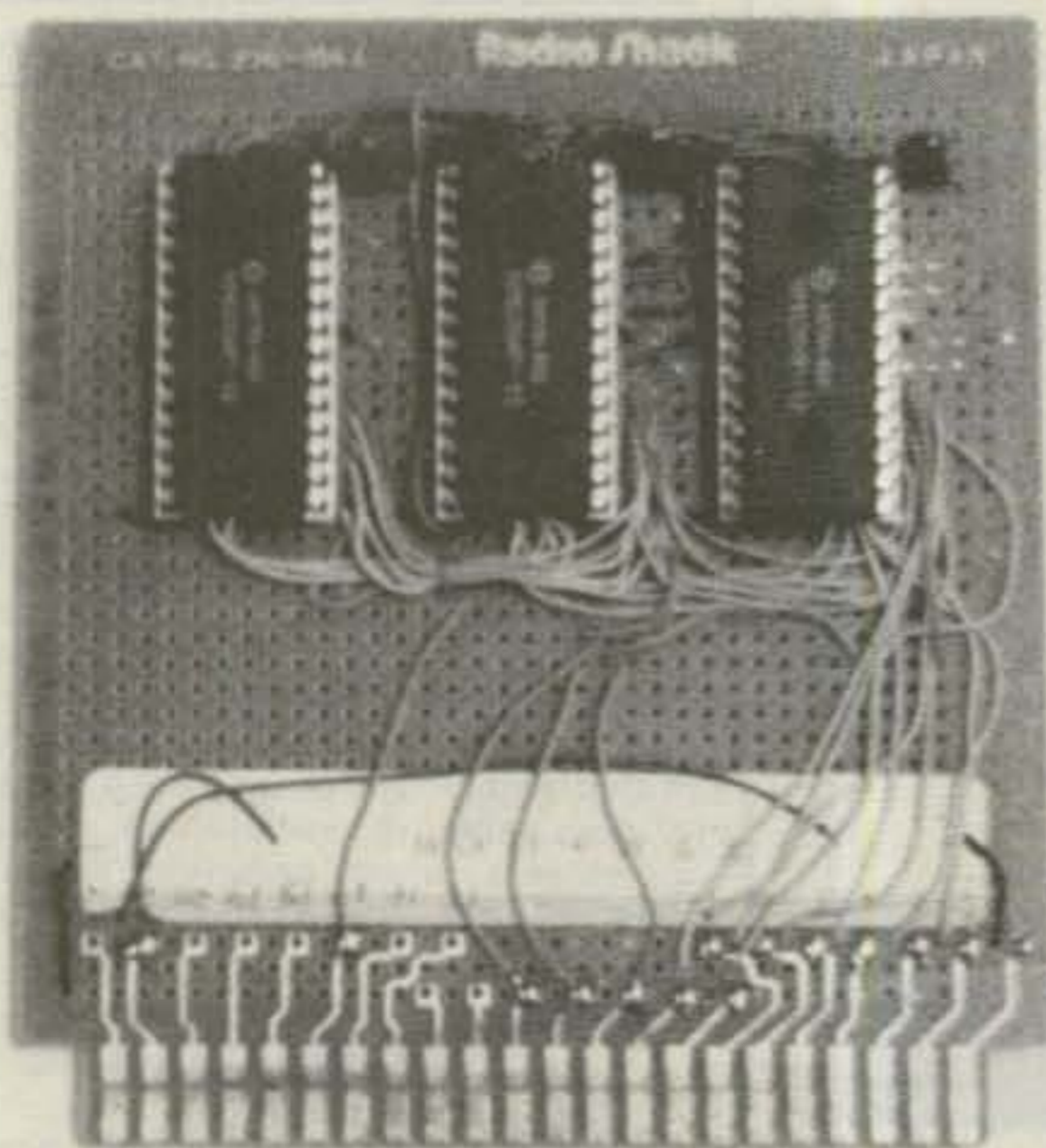

Photo A. Top view of the completed memory-expansion board.

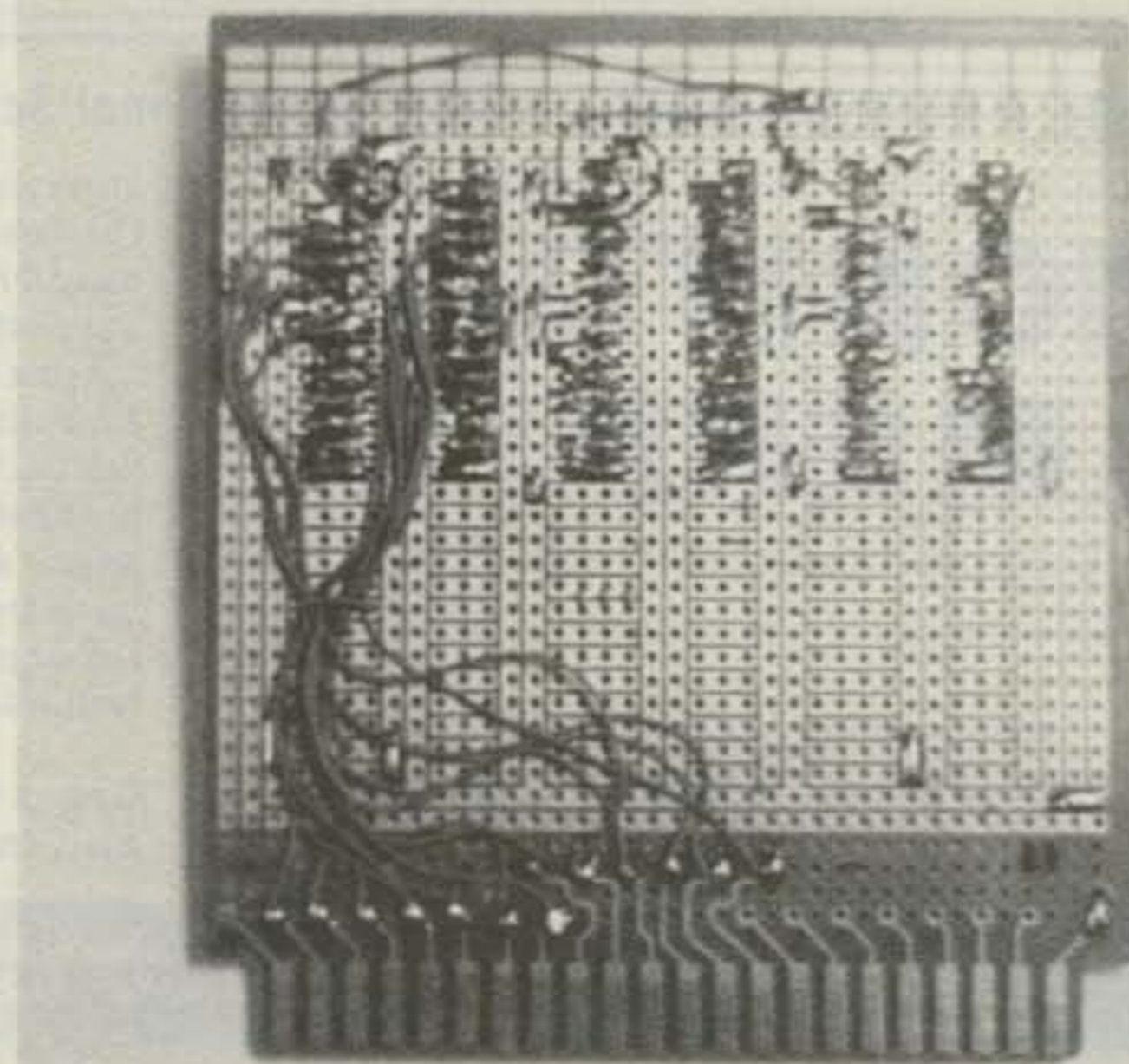

Photo B. Underneath the memory board. Point-to-point soldering was used in lieu of wire-wrapping.

## Board Design

Any memory expansion for the VIC must be done via the 22/44-pin expansion port at the right rear of the keyboard case. This connector is an industry standard card-edge connection, so locating a mother board is no problem. I chose the Radio Shack 276-154A board. This is a 3-voltage-source plug-in board with a 22/24-pin card-edge connector.

The next step was the selection of the actual ICs to be used for the memory. I had previously built a 3K expander using 2114 RAM chips. These RAM chips are 4K-bit devices arranged as 1K of half bytes or nibbles. Each 1K byte of memory requires a pair of 2114s. It was a lot of point-to-point wiring for that 3K board. Granted, it was fun and only took 3 hours to build, but a 24K RAM board constructed out of 2114s would need 48 ICs! So I decided to look around at available high-density static RAM chips. I found that Hitachi makes a 64K-bit device (HM6264) arranged as 8K by 8 bytes. Perfect! All that is required is 3 of these beauties and my VIC would be fully populated with memory.

Fig. 1 shows the schematic for the 24K-byte RAM board that plugs directly into the expansion port. Using the HM6264 RAMs makes the interfacing to the port simple, since no additional bus buffering is required. That's due to the on-chip tri-state buffers and the fact that each chip can be selected by lines already available at the VIC's port without decoding logic. Each chip draws only 40 milliamps, which is no problem for the VIC's built-in power supply.

The circuit is fairly straightforward. Each HM6264 IC has the address, data, and write-enable lines tied in parallel. Only the chip-select lines are uniquely connected to the card-edge connector. Note that there are two chip-select lines on

each HM6264. Pin 20 is the inverted chip select and pin 26 is the non-inverted chip select.

Pin 26 is used if one desires a power-down operation. If not, pin 26 should be tied high to +5 volts. I

chose the latter option. This leaves the inverted chip-select line, pin 20, of each HM6264 to be tied individu-

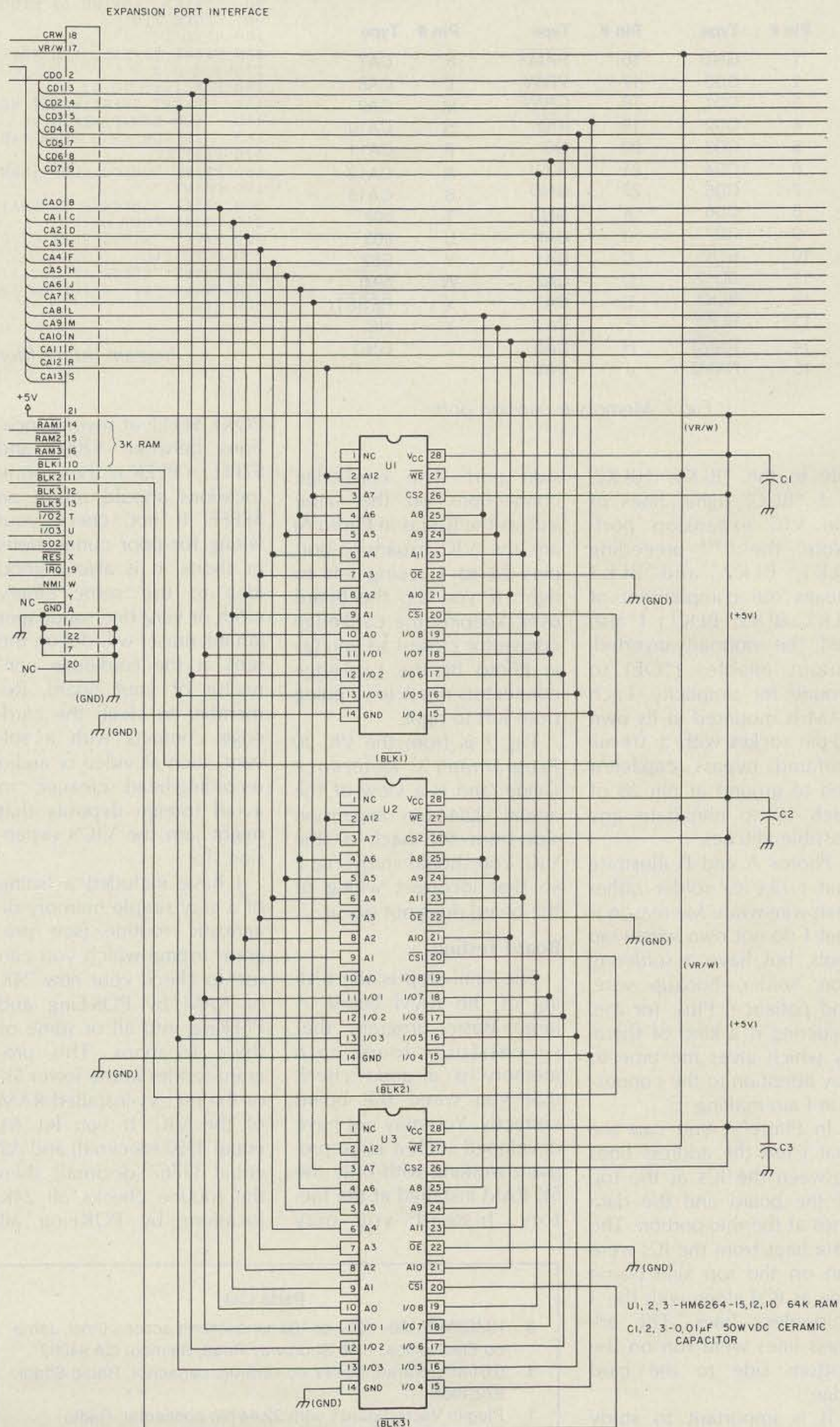
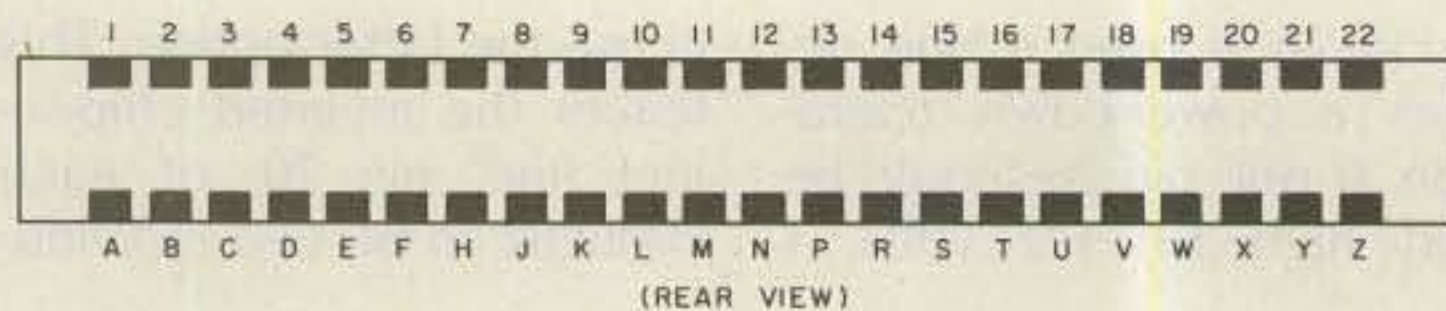

Fig. 1. Schematic of 24K RAM circuit.



| Pin # | Type | Pin # | Type | Pin # | Type  |
|-------|------|-------|------|-------|-------|
| 1     | GND  | 16    | RAM3 | K     | CA7   |
| 2     | CD0  | 17    | VR/W | L     | CA8   |
| 3     | CD1  | 18    | CR/W | M     | CA9   |
| 4     | CD2  | 19    | IRQ  | N     | CA10  |
| 5     | CD3  | 20    | NC   | P     | CA11  |
| 6     | CD4  | 21    | +5V  | R     | CA12  |
| 7     | CD5  | 22    | GND  | S     | CA13  |
| 8     | CD6  | A     | GND  | T     | I/O2  |
| 9     | CD7  | B     | CA0  | U     | I/O3  |
| 10    | BLK1 | C     | CA1  | V     | S02   |
| 11    | BLK2 | D     | CA2  | W     | NMI   |
| 12    | BLK3 | E     | CA3  | X     | RESET |
| 13    | BLK5 | F     | CA4  | Y     | NC    |
| 14    | RAM1 | H     | CA5  | Z     | GND   |
| 15    | RAM2 | J     | CA6  |       |       |

Fig. 2. Memory-expansion port.

ally to the \*BLK1, \*BLK2, and \*BLK3 signal lines of the VIC expansion port. (Note: the "\*" preceding BLK1, BLK2, and BLK3 means the complement of BLK1, BLK2, BLK3.) I also tied the normally-inverted-output enables (\*OE) to ground for simplicity. Each RAM is mounted in its own 28-pin socket with a .01-microfarad bypass capacitor tied to ground at pin 28 of each IC to eliminate any possible glitches.

Photos A and B illustrate that I like to solder rather than wire-wrap. My reason is that I do not own wire-wrap tools, but have a soldering iron, solder, hookup wire, and patience. Plus, for me, soldering is a kind of therapy which gives me time to pay attention to the connection I am making.

In Photo A you can see that I ran the address lines between the ICs at the top of the board and the data lines at the mid-portion. The data lines from the ICs were run on the top side (same side as ICs) along with the 3 chip-select lines. The address lines were run on the bottom side to the card edge.

It is important to study the sense of how the board plugs into the VIC's expansion

port. The card-edge connections on the same side as the ICs (as in Photo A) are the VIC expansion-port pins 22 to 1, going left to right. If you flip the board over, keeping the card-edge connector closest to you (as in Photo B), the card-edge connectors run A to Z, going from left to right.

Fig. 2 is from the *VIC-20 Programmer's Reference Guide* and is a view of the actual 22/44-pin expansion slot from the back of the VIC. You should study Fig. 2 so that incorrect wiring of the board does not occur.

### Board Testing

The final step is the testing of the RAM board. A large Basic program that successfully loads into memory is a good check that you wired the board correctly. You may not have developed such a large program working with only the 5K RAM installed at the factory. Instead, you may

```

10 REM: 24K MEMORY DIAGNOSTIC ROUTINE
20 REM: G.P. BREFINI JUNE 1984
30 PRINT " "
40 PRINT "INPUT START ADDRESS IN "; "DECIMAL?": INPUT A1
50 PRINT " ": PRINT "INPUT END ADDRESS IN ";
60 PRINT "DECIMAL?": INPUT A2
70 FOR I=A1 TO A2
80 PRINT "POKING AT MEMORY ADD# "; " ";I
90 POKE I,0
100 NEXT I
110 PRINT ">>>>> END POKE <<<<<<"
120 SUM=0.0
130 FOR I=A1 TO A2
140 PRINT "PEEKING AT MEMORY ADD#"; " ";I
150 SUM=SUM+PEEK(I)
160 IF SUM <> 0 THEN 240
170 NEXT I
180 PRINT "CHECK SUM=";SUM
190 PRINT " "
200 PRINT "CHECKED ";A2-A1;"BYTES"
210 PRINT "OUT OF:"
220 PRINT "BYTES FREE "; FRE(0)
230 GOTO 260
240 PRINT "ERROR AT LOCATION # ";I
250 PRINT ">>> CHECKSUM ERROR <<<"
260 END

```

Program listing. Memory diagnostic routine.

POKE \$FFFF at several locations between \$2000 and \$7FFF. A PEEK at these same locations should return an \$FFFF. If not, check your wiring for poor connections or shorts. It is also a good idea to use some emery cloth or very fine sandpaper (an ink eraser will do) on the tabs at the card-edge connector of your board. Remember to clean the card-edge contacts with a solvent, such as video or audio recording-head cleaner, to avoid foreign deposits that might jam the VIC's expansion slot.

I have included a listing of a very simple memory diagnostic routine (see program listing) which you can use to check your new 24K of RAM by POKEing and PEEKing into all or some of these locations. This program resides in the lower 5K of the factory-installed RAM of the VIC. If you let A1 equal 8192 (decimal) and A2 equal 32767 (decimal), then the routine checks all 24K locations by POKEing all

zeros, then PEEKing and forming an all-zero checksum if the memory is operating correctly. It takes about a half-hour to check all 24K locations. You could just check a few sub-blocks over the 24K range if you are in a hurry.

The hardest task in building this board was in orienting the connections of the address lines and data lines on the board to the VIC's expansion-port signals. In addition, the HM6264 is a relatively new static RAM chip, and it is not as available as is the 2114. But as we all know, this situation will improve as time goes by. I have listed some suggested part sources along with a parts list at the end of this article.

Building this 24K RAM board will be a rewarding experience, especially when you need that extra memory! Good luck. ■

### References

1. A. Finkel, N. Harris, P. Higginbottom, M. Tomczyk, *VIC-20 Programmer's Reference Guide*, Commodore Business Machines, Inc., and Howard W. Sams and Co., Inc., First Edition, 1982, pp. 124-125.
2. Joel Swank, "The Enhanced VIC-20; Part 2: Adding a 3K-Byte Memory Board," *Byte*, March, 1983.
3. Hitachi *IC Memory Data Book*, #M10, available from Hitachi America, Ltd., 1800 Bering Drive, San Jose CA 95112.

### Parts List

- |   |  |
|---|--|
| 3 | HM6264P (150-, 120-, or 100-nanosecond access time), Jameco Electronics, 1355 Shoreway Road, Belmont CA 94002. |
| 3 | 0.01-microfarad, 50-WV dc ceramic capacitor, Radio Shack 272-1065.   |
| 1 | Plug-in Vectorboard® with 22/44-pin connector, Radio Shack 276-154A.   |

# Take it with you.

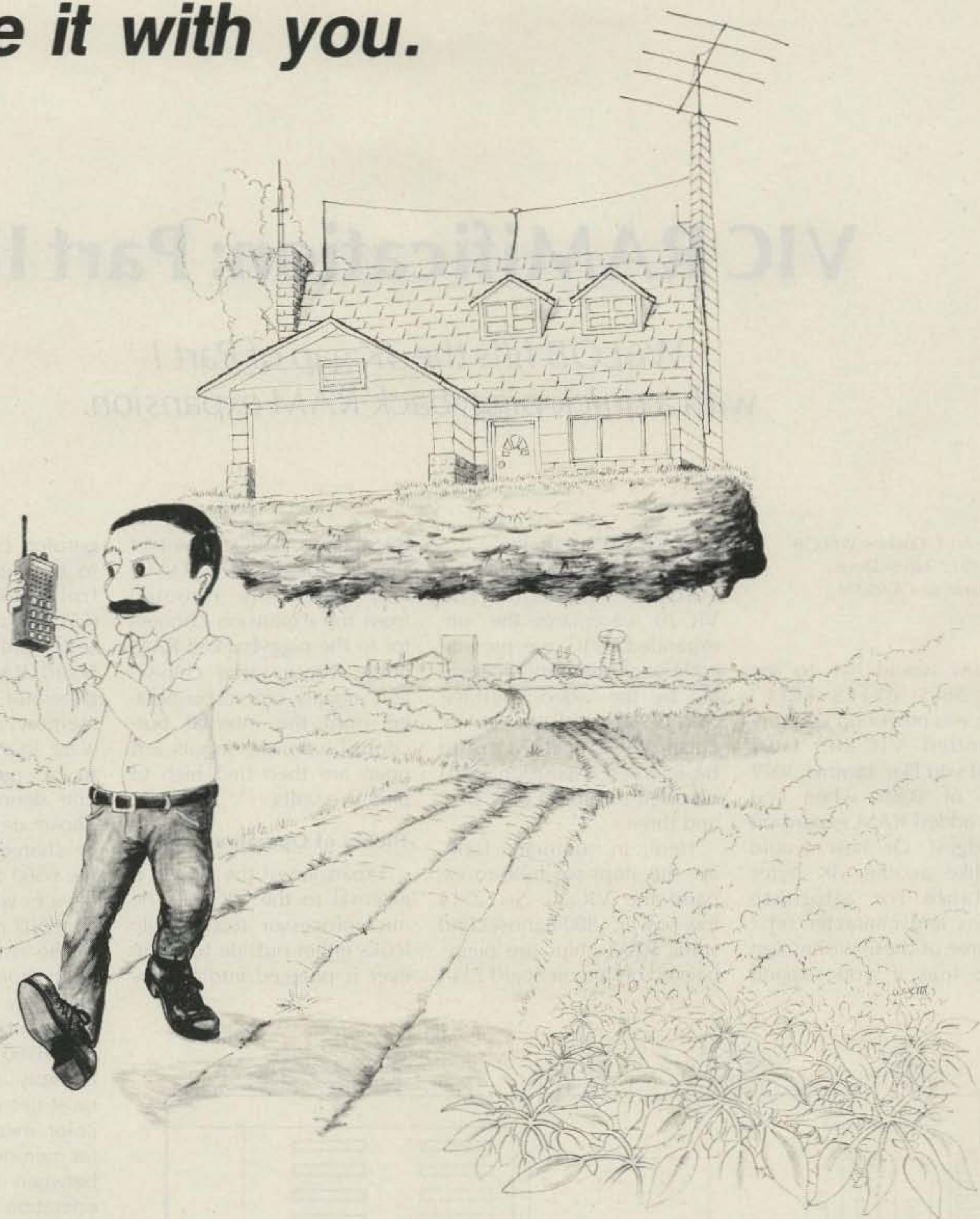

ShackMaster™ puts your home station in the palm of your hand. Whether portable, mobile, around the yard or around town you'll be linked through your handheld to your high performance equipment at home. Even call home from any Touch-Tone phone and operate.

Scan the bands, change modes, select antennas, turn gear on and off – all from your Touch-Tone keypad. Check into nets, work skeds, ragchew and DX without being tied down to the shack.

Exchange electronic mailbox messages with your family – like "I'll be late", or "All is OK". Or talk with your family directly through *ShackPatch™*, with you in remote control of your home station. Report traffic accidents or disabled motorists through your home phone while mobile or portable with *PersonalPatch™*.

All the power of your home station (and more) really can follow you anywhere... to find out more about ShackMaster™ just write, send us your QSL, or call and talk with us at 408-749-8330.

# acc

advanced  
computer  
controls, inc. <sup>✓127</sup>

10816 Northridge Square • Cupertino, CA 95014

(408) 749-8330

# VIC RAMification: Part II

*W6LOB fills the 3K gap of Part I with a quick piggyback RAM expansion.*

John T. Cocking W6LOB  
18812 Aspesi Drive  
Saratoga CA 95070

How would you like to see "6655 BYTES FREE" when you power up your unexpanded VIC-20? How would you like another 3072 bytes of Basic when you have added RAM expansion cartridges? Or how would you like another 3K bytes available for alternate screens and character sets? All three of these wishes can come true if you expand

your VIC-20 internally.

By adding 3072 bytes of static RAM inside the VIC-20, we enlarge the "unexpanded" VIC, we provide additional memory accessible by the video interface chip (6560), and we can recover the 3K of RAM lost to Basic when expansion RAM is added to blocks one, two, and three.

Here, in summary form, are the steps we take to expand the VIC-20: Six 2114 low-power, 300-nanosecond static RAM chips are piggybacked on the on-board 2114

RAM chips. The chip-select signals for RAM1, RAM2, and RAM3 are rerouted from the expansion connector to the piggybacked RAM chips. These same chip-select signals are disconnected from the internal bus-control gate; the inputs left open are then tied high to plus five volts.

## Theory of Operation

Expansion of the VIC-20 is external to the VIC-20. The microprocessor (6502) chip looks either outside to whatever is plugged into the ex-

pansion connector or inside to the video interface controller (6560), the VIAs (6522s) for keyboard, cassette, and other I/O, the on-board RAM, the character-generator ROM, and color memory. Note that the software ROMs are considered to be outside the VIC-20. The definition of inside is: Those devices which must be shared by the 6502 and the 6560 are "inside," those devices which concern only the 6502 are "outside."

The inside devices are isolated from the outside devices by three-state octal bus transceivers (74LS245s). The 6560 is a DMA (direct memory access) device. It must get at screen memory, color memory, and character memory while the 6502 is between clock cycles. The operation of the 6560 must not affect any expansion device. Similarly, any access the 6502 makes to an external device must not affect internal devices. In addition, the 6502 must be able to access internal devices (RAM, character memory, color memory) without causing bus contention, a fancy label for a data traffic jam. The bus transceiver is controlled by a 13-input NAND gate (74LS133). When the 6502 looks for external devices, address decoding delivers a low signal on one of

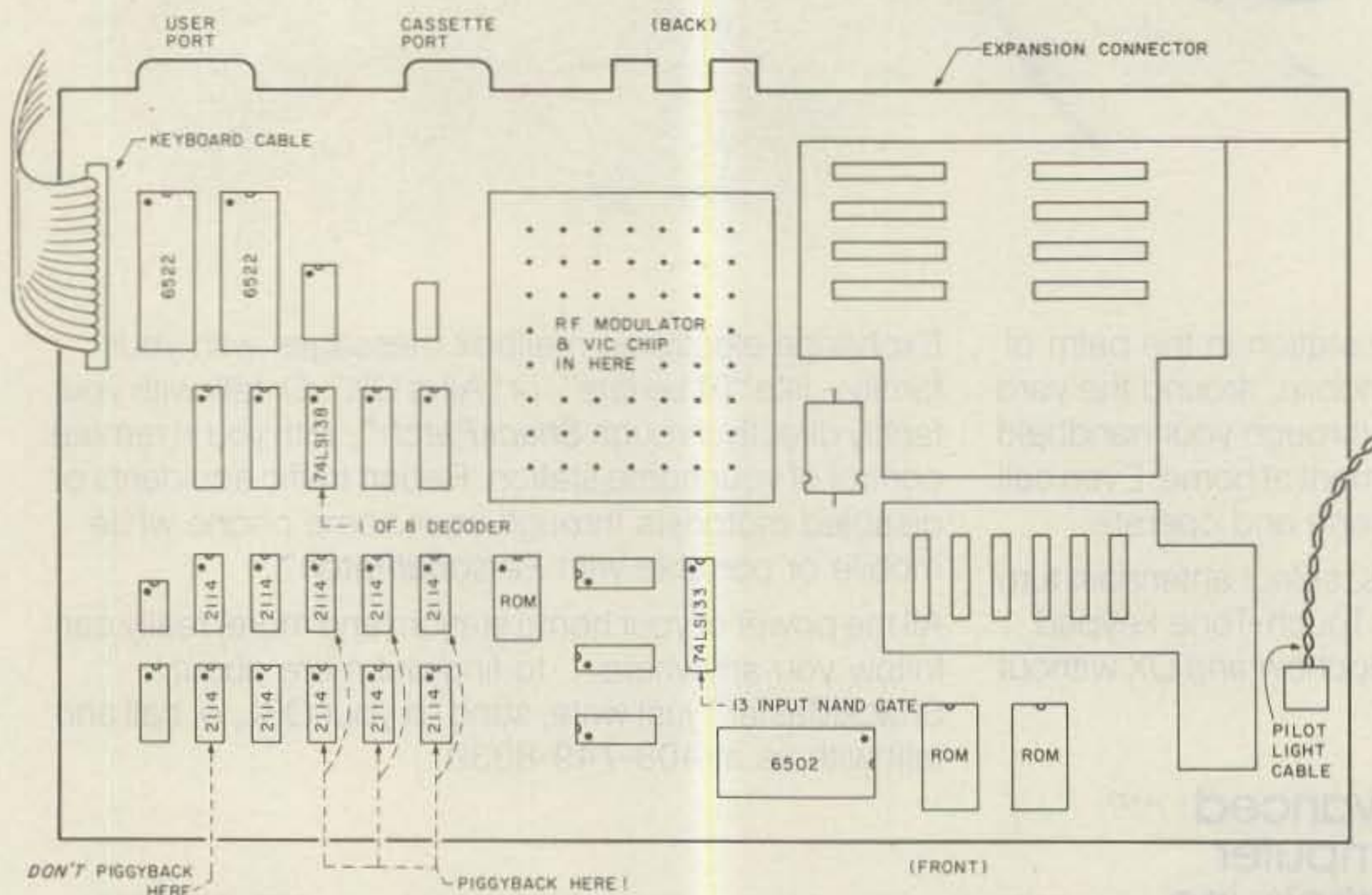

Fig. 1. Inside the VIC-20. Piggyback your new memory only where shown.



the 13 inputs to the 74LS133, causing its output to go high, which in turn puts the bus transceiver in a high-impedance (don't care) state, isolating the internal devices from the external data bus.

If we are to add memory inside, we must alter the VIC-20's definition of what is internal and what is external. The definition as it stands in an unmodified VIC-20 is: Any device whose address when decoded causes the 74LS133 to disable the bus transceiver is an external device. RAM1, RAM2, and RAM3 fit this definition. Our modification will add 3K of RAM as internal devices connected to the inside data bus. We must also redefine RAM1, RAM2, and RAM3 as internal devices. This means removing these signals from the expansion connector, removing them from the 74LS133, tying the now empty inputs high, and connecting the signals to the chip selects of our piggybacked RAM chips.

### Materials and Tools

Here is a list of materials and tools we will need to perform our expansion of the VIC-20:

1) Six low-power, 300-ns 2114 static RAMS—JDR Microdevices, 1224 S. Bascom Avenue, San Jose CA 95128 carries the 2114L-3 at 8 for \$13.45.

2) Wire-wrap wire.

3) Low-power soldering iron (30 Watts).

4) Extra-thin resin-core solder.

5) X-acto® knife with #11 blade.

6) Phillips screwdriver (to open up the VIC).

7) Volt-ohmmeter for continuity testing.

8) "Third-hand" vise.

In addition to the "hardware" items, there is also the software. We need a RAM test program, an alternate program load-address procedure, and a program to move the screen to our new-

ly added memory. The two programs, RAMTEST (Program listing 1) and SCRMOV (Program listing 2) should be keyed in and saved before any hardware modification is undertaken. The alternate load-address procedure is executed in direct mode: POKE 43,1: POKE 44,16: POKE 4096,0: CLR.

### Procedure

1) Open up the VIC. There are three Phillips screws under the front edge of the VIC. Remove these and gently lift the front. The case is hinged at the back. Unplug the keyboard cable and the power-indicator lamp cord.

2) Locate the 2114s. You may have a VIC that uses 2K-by-8-bit RAM chips. If so, you will have to follow a different procedure. The procedure for both types of RAM chip is essentially the

same, but only the 2114 chip is covered here. The 2114s are located in the lower-left corner of the board. They occur in two rows of five columns. Each column makes up one K of random access memory, so five columns equal five K.

3) Locate the chip-select gate (74LS138). The 74LS138 is located on the row of chips directly above the 2114s, in the upper row, third from the left. This chip is used as an address decoder and it provides chip-select signals (low) for each 1024-byte piece in the first 8192-byte block, which we could call BLK0. We are interested in the select lines for RAM1, RAM2, and RAM3. These signals travel to the expansion connector and also to the data-bus control chip, the 74LS133.

4) Locate the data-bus controller (74LS133). This

|      | 74LS138 | 74LS133 | Expansion Connector |
|------|---------|---------|---------------------|
| RAM1 | pin 14  | pin 4   | pin 14              |
| RAM2 | pin 13  | pin 5   | pin 15              |
| RAM3 | pin 12  | pin 6   | pin 16              |

Table 1.

chip is located in the middle of the board toward the front edge. Its function is to "tri-state" the data-bus transceiver chips whenever RAM1, RAM2, RAM3, or other off-board devices are accessed. Table 1 shows the connections of the chip-select signals. It would be wise to verify the specifications presented with a VOM.

5) Cut traces. This step is taken to stop the VIC from shutting off the data-bus transceiver when RAM1, RAM2, or RAM3 is accessed. To cut the traces, you must first remove the VIC board from the case bottom. There are eight Phillips machine screws to remove. There also may be a sheet of rf shielding taped to the bottom of the board. Remove this also. The traces which must be cut are at pins 4, 5, and 6 of the 74LS133 and pins 14, 15, and 16 at the expansion connector. Use the X-acto knife for this task.

*Warning:* When you turned the board over, the relative position of the pins changed. What was once on the left is now on the right. Be extra careful you are cutting the right traces. Also, make two cuts very close together and pry out the tiny chunk of copper—don't let it get under any of the chips. Wet the end of your little finger and remove the scrap from the board. Now, using a short piece of stripped wire-wrap wire, connect 74LS133 pins 4, 5, and 6 to 74LS133 pin 15. This will ensure that these three inputs will stay high (tied to plus five volts). Verify these new connections (and disconnections) with the VOM.

6) Install 2114s. This step takes the most time. We are going to piggyback six new 2114 RAM chips on top of six of the on-board 2114s. Whatever you do, do not use the left-most column of on-board 2114s for piggybacking. This is the lowest 1K block of RAM which is used by the operating system and the 6502 chip itself.

### RAMTEST

```

10 PRINT "RAM TEST"
12 A=1024: B=4095
14 FOR I=A TO B
16     PV=85: GOSUB 24
18     PV=170: GOSUB 24
20 NEXT I
22 PRINT "TEST COMPLETE": END
24 POKE I,PV
26 IF PEEK(I)=PV THEN RETURN
28 PRINT "ERROR AT ADDR. ";I
30 PRINT "DATA IS"; PEEK(I)
32 PRINT "SHOULD BE";PV
34 RETURN

```

Program listing 1.

### SCRMOV

```

10 POKE 36869,144
12 POKE 648,4
14 FOR J=217 TO 228: POKE J,132: NEXT J
16 FOR J=229 TO 250: POKE J,133: NEXT J
18 POKE 43,0: POKE 44,6: POKE 1535,0
20 CLR:NEW

```

Program listing 2.

This area includes "page zero" and the processor stack in page one.

Use the middle three columns for piggybacking the new RAMs. Make sure that all the pins on the new 2114s are parallel. Test fit them on the on-board RAMs. The new chips should fit snugly without forcing. Now locate the chip select (pin 8) on each of the new 2114s and bend it outward until it is parallel to the circuit board. Put each chip into the third-hand vise and lightly tin the inside of each of the pins. Place the six new 2114s piggyback on the middle six on-board RAM chips.

Leave some breathing room between the on-board chip and its piggyback partner. Be sure you have oriented the new chips correctly. Pin 1 on these chips is generally indicated by a little dimple on the top of the chip. Pin 1 should be at the upper-left corner. Now, it is time to solder on the new chips. Tack-solder each to pins 1 and 10. Pin 10 is diagonally opposite pin 1. After each chip has been tacked on, briefly touch each pin's junction with the soldering iron. Check continuity of pin 1 of the new chip to pin 1 of an on-board chip without a piggyback partner. Do this for each pin with the exception of chip-select pin 8. Note any pins showing an open circuit. Use the tip of the X-acto knife to gently push and hold the pin while applying the soldering iron. Retest while applying the soldering iron. Retest the continuity with your VOM.

7) Prepare the chip-select lines which will connect each column (three of them) to one of the chip-select outputs of the 74LS138. The lines are made of three-inch lengths of wire-wrap wire. Strip one inch off one end and 1/8 inch off the other end. Tin the short end. The long end is connected to the chip-select pins, which are sticking out of the piggybacked RAM chips. Make a very small loop in the long

stripped end right next to the insulation and slip it on the chip-select pin of the 2114 in the top row. Then, loop a turn around the chip-select pin of the 2114 directly below in the column. Solder the two connections. Now solder the short stripped-and-tinned end to pin 14 of the 74LS138. This column is now RAM1. Repeat for the next column, connecting its chip-select line to pin 13 of the 74LS138. This column becomes RAM2. The last column is connected to pin 12 of the 74LS138 and becomes RAM3. Check the continuity of these connections with the VOM. Now make a non-continuity check to ensure that the RAM1, RAM2, and RAM3 select lines are *not* connected to pins 4, 5, and 6, respectively, of the 74LS133.

8) This completes the hardware modifications. Before you put your VIC-20 back together and plug it in, here are some items you should check very carefully: First, are there any loose chunks of solder or bare wire lying around on the board? Second, are there any solder bridges between pins on the piggybacked RAM chips? The third point may sound silly. It isn't. I installed one of my 2114s backward. I found out during testing. So, be sure your 2114s are all pointing north. After your work passes this visual inspection, reinstall the board in the case bottom.

9) Button up the VIC. Tape the shield back. Be sure it is oriented correctly. Fasten the circuit board to the case bottom. Do not get the screws for mounting the board mixed up with those for fastening the case bottom to the case top (keyboard). Hinge-in the case top and connect the keyboard plug on the left and the power-on light plug on the right. For initial testing, you may want to leave the case top free or even off to the side a little. For final assembly, fasten the case top to the bot-

tom with the three long screws.

### Testing

For the initial "blue smoke" test, keep the expansion slot empty. Turn on the VIC. You should see "6655 BYTES FREE." If you do not, turn off the VIC immediately, reread the procedure, then open up the VIC again and check out each step, using the VOM where necessary. If you received the same old "3583 BYTES FREE," then the VIC is not aware of the RAM that has been added. The chip-select signals for RAM1, RAM2, and RAM3 may still be disabling the internal data bus. Verify that these signals are not connected to the 74LS133 and also that the RAM1, RAM2, and RAM3 inputs to the 74LS133 are connected to +5 V.

If you get nothing on your screen, then perhaps one of your 2114s is installed backwards. This has happened to me. I discovered my mistake by using my finger to see if any of the piggybacked chips were hotter than normal. One of them was very hot, and that is how I discovered the error. I replaced the backwards chip, correcting the malfunction. I learned two things from my error. First, it is necessary to check and double-check work of this kind. Second, the VIC-20 is quite sturdy; you don't have to be afraid of modifying your VIC.

Assuming that you now have received the power-up message of "6655 BYTES FREE," you should run a memory test on locations 0400h through 04FFFh. The RAMTEST program in Program listing 1 will serve, although if you have a better one, use it. To test the memory which you have just added, execute the alternate load-address procedure in direct mode, then load and run the RAMTEST program. The RAMTEST provided executes in approximately sixty-five seconds. Run the memory test more than

once. If the test fails, the bad address will be displayed on the screen. From the address you can determine whether RAM1, RAM2, or RAM3 is bad. The display of the data at the failure point enables you to locate the malfunctioning chip. The failure is probably caused by an address line or a data line. Check out the connections to the chip which caused the memory-test failure. Also, check the chip-select line. Only after you have verified that all the connections are sound should you consider replacing the chip.

### Moving the Screen

Here is where we recover the "lost" 3K of memory. Power down the VIC, plug in your memory expansion, power back up, and note the "BYTES FREE" message. In my case, it read "28159 BYTES FREE." Now load and run the SCRMOV program (Program listing 2). Clear the screen and execute ?FRE(0) in direct mode. My VIC-20 responded with 31230, which is 3071 bytes more than the power-up message. You should see a comparable increase in available memory. This added memory, unlike a plug-in 3K expansion, may also be used for alternate screens. One final warning: There are many programs which do *not* run with memory expansion. For these programs, you must execute the alternate load-address procedure before you load and run the program. ■

### References

- Nick Hampshire, *VIC Revealed*, Hayden Book Company, 1982.
- A. Finkel, N. Harris, P. Higginbottom, and M. Tomczyk, *VIC-20 Programmer's Reference Guide*, Commodore Business Machines, Inc., and Howard W. Sams and Co., Inc., 1982.
- John Heilborn and Ran Talbott, *VIC-20 User Guide*, Osborne/McGraw-Hill, 1983.
- Jim Butterfield, "Alternate Screens," *Compute!'s First Book of VIC*, Compute! Books, 1982.

# LISTEN LEARN SEND



## A triad of C-64 cartridges to enhance your Radiobility

### Listen to RTTY/CW with the SWL—Short Wave Listener

Microlog's answer for the short wave listener who doesn't need transmitting capability. The "SWL" is essentially the receive portion of the AIR-1 program in permanent ROM with both demodulators on board for dual tone RTTY and single tone Morse reception, housed in a small 3" x 2-1/2" x 7/8" enclosure. With speaker in/out and practice hand key jacks, it needs no other connection or power supply. Just plug it in and it's ready to run, as simple as that. Copies all speeds of RTTY baudot, ASCII to 300 baud, and Morse to 150 wpm. It has keyword or manual keyboard control of your printer and received buffer storage. Unshift on space, word wrap around, real time clock, and the famous AIR-1 style on screen tuning indicators mean you never have to take your eyes off the screen for perfect copy tuning. Surprise your favorite SWL with the Microlog "SWL" cartridge for the Commodore 64. Just \$64.00 complete. Including connecting cable and demo cassette.

### Learn Morse with the Expert Morse Coach

A complete Morse code tutor in a convenient plug-in cartridge for your Commodore "64". The Morse Coach means business. It's not a toy program or a simple random code generator. Originally developed jointly by Microlog and several government agencies experienced in Morse instruction, it's the quickest way to Morse proficiency. The method works—you start from absolutely no knowledge of Morse, progress through the alphanumeric symbols, and on to any speed desired. The "alphabet" part of the program introduces new characters and plots the progress on a bar-chart. The speed/test section correlates the input, analyzes mistakes and provides a printout of the analysis/test results on your Commodore printer. As a bonus, it also boosts typing skill. Every club involved in amateur radio instruction should have at least one Morse coach to use as a "loaner". Let's get the "VEX" program off to a flying start with the Microlog Morse coach at \$49.95.

### Send CW by Keyboard with the CW-1 Transmitter Module

Why buy a memory keyer when for \$49.95 you can have a cartridge for your C-64 with all the CW transmit and memory capability of the AIR-1! Permanent ROM program and transmitter keying circuits give you perfect Morse up to 149 wpm. Will key tube type and solid state rigs. Huge 28000 character text buffer with split screen display for correcting pre transmit text. Eight programmable chain memories of 512 characters each, and two ID memories provide easy contest or rag-chew operation. Top line display shows transmit speed and real-time transmittable clock. Word/line mode and normal character mode for effortless operation. For learning, a random code generator and paced (long spacing) outputs are available on command. The direct output to a printer makes a great "letter writer" too.

Original AIR-1, \$199.00 (with Amtor, \$279.00). AIRDISK, \$39.95. AIRDISK cartridge \$59.95. Microlog Corporation, 18713 Mooney Drive, Gaithersburg, MD 20879 Tel: 301 258-8400

Copyright © 1984 Microlog Corporation

**MICROLOG** 51

INNOVATORS IN DIGITAL COMMUNICATION

# Transistors: A Biased Approach

*In Part II, we evaluate base current and gain and use this information to design a working transistor circuit.*

Bob Myers KC0EW  
413 Edgewood Drive  
Loveland CO 80537

In Part I of this look at transistors, we covered some of the basics of how bipolar transistors behave and went through a simple analysis using only the fact that the base-to-emitter voltage drop is fairly constant. To wrap up this look at basic transistor operation, we now need to consider the effects of base current and beta on our calculations. Remember the two fundamental facts

we discussed last time: first, that the drop from the base to emitter is constant (at about 0.7 V for a silicon transistor), and second, that the collector current is some multiple of the base current. The number that you multiply the base current by to figure the collector current is called beta (sometimes written as just the Greek letter,  $\beta$ ), and that's what this article is all about.

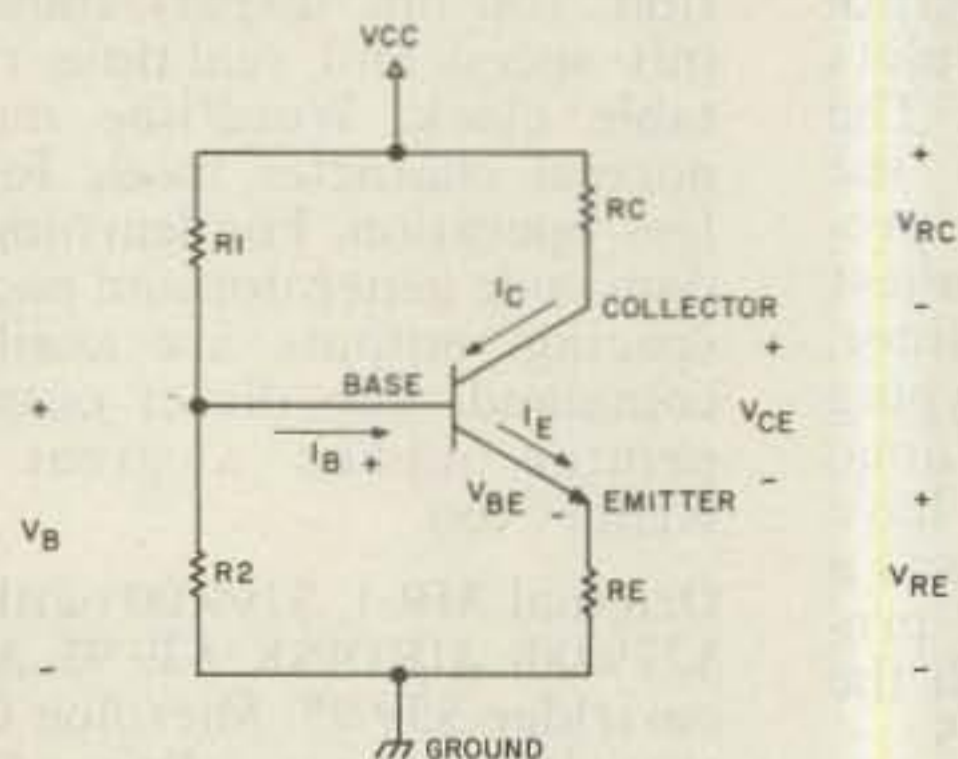

Fig. 1. An NPN transistor in a biasing network. Base, collector, and emitter currents ( $I_b$ ,  $I_c$ , and  $I_e$ , respectively) are indicated by arrows. Voltages at the base ( $V_b$ ), across the collector resistor ( $V_{rc}$ ), the emitter resistor ( $V_{re}$ ), and from collector to emitter ( $V_{ce}$ ) are also indicated.

Let's look again at the basic NPN transistor in a biasing network, just like we started the last time (Fig. 1). The arrows in this diagram represent the currents in each of the three leads of the transistor and show the directions in which we normally consider these currents to be flowing. (Note that the arrow on the emitter of the NPN symbol is pointing in the same direction as the emitter current—an easy way to remember it.) We still want to be able to set the collector voltage and current to some set of desired values, i.e., to "properly bias the transistor to a given dc operating point." Last time, we ignored beta and the base current and simply used the voltages around the circuit and the base-emitter drop to figure all the currents. But now, the situation gets a little more complicated. The emitter current is not the same as the base current—both the base and collector currents are shown flowing in to the transistor, and the emitter current is flowing out. The emitter current is the sum of the

base and collector currents. So, if the collector current is beta times the base current, the emitter current must be "beta + 1" times the base current. Knowing the emitter current (and the drop across the emitter resistor) won't do a thing for us as far as getting the collector voltage and current unless we know beta.

Well, that seems like a simple enough problem. All we have to do is look at the spec sheet for the transistor we're using, plug the number for beta into our calculations, and we're done. Well, right now I'm looking at a spec sheet for the ever-popular 2N2222A, a typical general-purpose small-signal transistor. The beta for this part can be anywhere from 100 to 300—a 3-to-1 range! And not only could you expect a variation from part to part, but the beta of a given part will change with temperature, frequency, and a number of other conditions including, of all things, collector current! We're not going to be able to simply plug a number in and go—we don't know the number.

What we'll have to do is to figure out the real effect of beta and then work out some way to keep our design going for any beta within the possible range. Otherwise, a design that works with one part might not work with the next, or might not even work from day to day.

We'll work on figuring out the collector current as a function of the base voltage and beta. Once we have the collector current, the collector voltage is easy (it's just the supply voltage minus the drop across the collector resistor). Notice that this ignores any dc load on the collector other than the collector resistor—OK if we're ac-coupled to the next stage, but keep this in mind.

Well, even if the relation isn't as simple as it used to be, finding the emitter current and voltage will give us something. With the emitter current equal to "beta + 1" times the base current, and the collector current simply beta times the base current, we could say that these two currents are related as  $I_c = \beta/(\beta + 1) \times I_e$ . The emitter current, thanks to Ohm's Law, still has to be the emitter voltage divided by the emitter resistance, or  $I_e = V_e/R_e$ . We know the relation between collector and emitter currents, so we can write  $I_c = \beta/(\beta + 1) \times (V_e/R_e)$ .

Aha! Looks like we now need to bring in our other piece of information—that the emitter voltage is 0.7 volts less than the base voltage. Doing this, we write  $I_c = \beta/(\beta + 1) \times ((V_b - 0.7)/R_e)$ .<sup>\*</sup> Whether it looks like it or not, we're a lot closer now to our goal. If we can get  $V_b$  in terms of the supply voltage and  $R_1$  and  $R_2$ , we're done. But  $R_1$  and  $R_2$  aren't the simple divider they were last time—not all the current through  $R_1$  is making it to  $R_2$  since the base is taking some.

This complicates matters somewhat, but don't give

up. We can simplify the situation by replacing the circuit to the left of the base ( $V_{cc}$ ,  $R_1$ , and  $R_2$ ) with an equivalent, as shown in Fig. 2. Here,  $V_{th}$  is the voltage that would have been produced by the  $R_1$ - $R_2$  divider if the base current hadn't been there.  $R_{th}$  is simply the parallel combination of  $R_1$  and  $R_2$ . The "th" modifier comes from the fact that this is what's called a "Thevenin equivalent" circuit, named for the man who first described it. A little thought will convince you that this equivalent will perform just like the real circuit it replaces—increase the base current and the drop across  $R_{th}$  increases, lowering the base voltage. Using this equivalent, we can now write  $V_b = V_{th} - (I_b \times R_{th})$ .

The base current,  $I_b$ , is just the collector current divided by beta, so we can write  $V_b = V_{th} - ((I_c/\beta) \times R_{th})$ . This equation and the one marked with an \* above have only one term between them that we can't either simply plug in or easily calculate— $I_c$ , the collector current, which just happens to be what we're looking for. Pulling these two together and solving for  $I_c$  (and here I'll wave my algebraic magic wand and skip a few steps so we can get on with this) gives  $I_c = (\beta \times (V_{th} - 0.7))/(R_{th} + (\beta + 1) \times R_e)$ .

This looks pretty formidable, but let's take a close look and see what it means. An increase in the number on the bottom ( $R_{th} + (\beta + 1) \times R_e$ ) will reduce the collector current, and an increase in the number on top ( $\beta \times (V_{th} - 0.7)$ ) will increase it. This just says that making  $R_{th}$  ( $R_1$  and  $R_2$  in parallel) bigger or making  $R_e$  bigger will cause the collector current to go down. This is as expected—increasing  $R_{th}$  should decrease the base current; an increase in  $R_e$ , for a given emitter voltage, must reduce the current in the

emitter and the current in the collector. Similarly, increasing  $V_{th}$  (by raising  $V_{cc}$  or  $R_2$ ) should increase the base current, and so increase the collector current.

Notice that beta appears in both the numerator (upstairs part) and denominator (downstairs) of this expression. If it weren't for  $R_{th}$  down below, we might be able to ignore beta. For example, if beta were equal to 100, we'd have an expression with 100/101 in it—which is pretty darn close to one, and so it could be tossed out. But just maybe we can choose the values for the biasing network so that we don't care about beta—which is the whole idea.

Now that we have an expression for  $I_c$ , we can begin to try some designs and see how well they work for varying betas. Before we do this, let me give you a few basic rules of thumb that will usually make this job simpler. First, since we want to minimize the effect of beta on  $V_b$ , try to make the current through  $R_1$  considerably larger than the base current—say 10 to 100 times as big. We've talked about setting the collector voltage, but what we're usually going to be interested in is the voltage that the transistor sees from the collector to emitter ( $V_{ce}$ ). Transistor specs will always list a maximum allowable  $V_{ce}$ , and we'll want to keep our designs running well within this spec. So, the last two rules deal with this voltage: First, the voltage across the emitter resistor ( $V_e$ ) should be

about the same as  $V_{ce}$ . Second, the supply voltage,  $V_{cc}$ , should be around four times  $V_{ce}$  (three to five is really OK). This will help keep  $V_{ce}$  stable without being excessively large.

With these rules in mind, we'll try a design. Let's go ahead and use the 2N2222A and try for, say, a 5-mA  $I_c$  with a 10-V  $V_{ce}$ . Using the rules mentioned above,  $V_{cc}$  should be about 40 V and  $V_e$  should be equal to  $V_{ce}$  at 10 V. With a 5-mA collector current and about the same in the emitter, the emitter resistor will be about 10 V/5 mA, or 2,000 Ohms. Similarly, the collector resistor will have to drop about 20 V, so it should be 20 V/.005 mA, or 4,000 Ohms. The base should be at about 10.7 volts (0.7 V higher than the emitter) and we want the current through  $R_1$  to be 10-100 times the base current. With the "worst" beta specified for a 2N2222A being about 100, the base current will be 5 mA/100 = 0.05 mA. We'll make the current in  $R_1$  about 20 times this, 1 mA. This gives a value for  $R_1$  of  $(40 V - 10.7 V)/1 mA$ , or 29.3k.  $R_2$  is then  $10.7 V/(1 mA - 0.05 mA) = 11.3k$ .

We now have values for all resistors in the biasing circuit and  $V_{cc}$ . This is shown in Fig. 3. Now that the first pass design is finished, we'll plug these values into our expression for  $I_c$  and see how well we did.  $R_{th}$  is  $R_1$  and  $R_2$  in parallel, or 8.2k.  $V_{th}$  is just  $V_{cc} \times R_2/(R_1 + R_2)$ , which is 11.1 V, and we'll use 100 for beta, as we did in the original design.

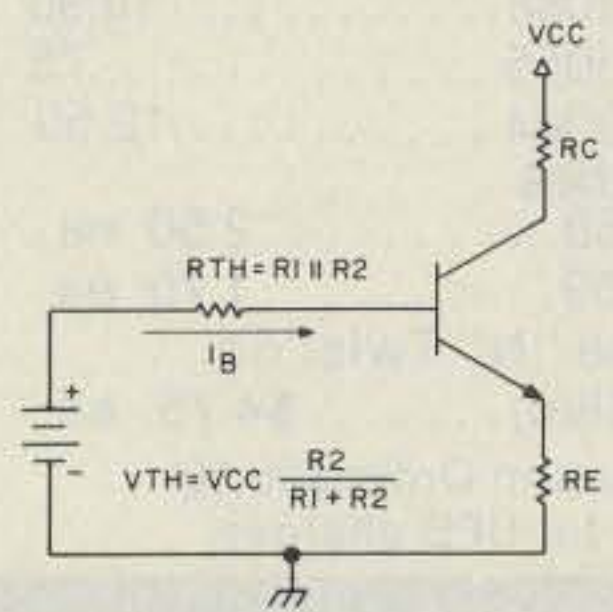

Fig. 2. The base biasing network is replaced by the "Thevenin equivalent" to simplify calculations.

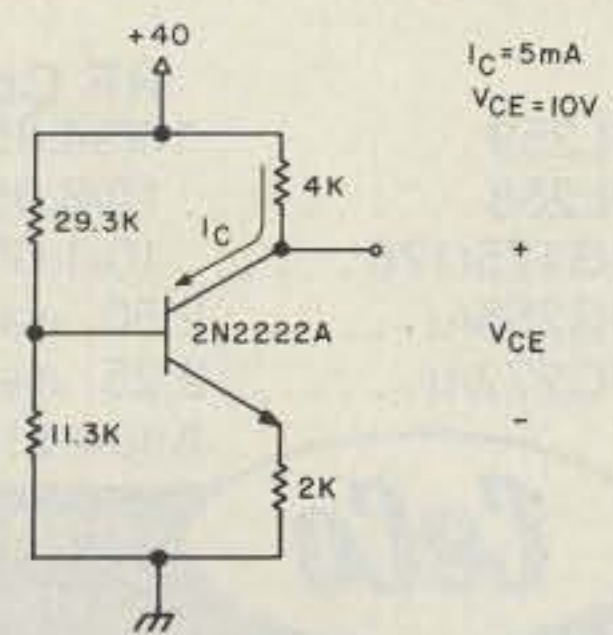

Fig. 3. The circuit designed in the example.

This gives  $I_c = (100 \times (11.1 - 0.7)) / (8.2k + (101 \times 2k)) = 4.9 \text{ mA}$ , and since  $V_e = 2k \times (4.9 \text{ mA} + 4.9 \text{ mA}/100) = 9.9 \text{ V}$ , and  $V_{rc} = 4k \times 4.9 \text{ mA} = 19.6 \text{ V}$ , then  $V_{ce} = 40 \text{ V} - 19.6 \text{ V} - 9.9 \text{ V} = 10.5 \text{ V}$ .

These values are pretty close to what we wanted, but let's see what happens with the other extreme for beta—which for the 2N2222A is about 300. Here,  $I_c = (300 \times (11.1 - 0.7)) / (8.2k + (301 \times 2k)) = 5.1 \text{ mA}$ , and  $V_e = 2k \times (5.1 \text{ mA} + 5.1 \text{ mA}/300) = 10.2 \text{ V}$ ,  $V_{rc} = 4k \times 5.1 \text{ mA} = 20.4 \text{ V}$ ,  $V_{ce} = 40 \text{ V} - 20.4 \text{ V} - 10.2 \text{ V} = 9.4 \text{ V}$ .

Again, these are close to our design goals. What's happening here—a three-to-one change in beta, and only a 5-6% change in the output? Look at Fig. 1 again. The emitter resistor is the key to the circuit's stability; as the output current goes up, so does the voltage across the emitter resistor. This forces the base voltage

up (constant base-emitter drop, remember?), which in turn forces the base current, and hence the collector current, down.

The emitter resistor is acting to provide negative feedback to control the collector current. So, one way to make the circuit more tolerant of changes in beta is to increase the value of the emitter resistor. Another is to increase the current in R1 in proportion to the base current. This means making R1 and R2 smaller, which reduces  $R_{th}$ . As with everything, there are trade-offs to consider—increasing  $R_e$  will raise the emitter voltage for a given emitter current, possibly requiring larger  $V_{cc}$ , etc. Decreasing R1 and R2 means that more current will be required by that side of the biasing network. There will also be other constraints placed on these component values by the signal gain and input/output impedances required of this

stage, which is another whole area we haven't covered yet—ac performance.

While we're not yet to the point of doing single-stage amplifier design, these articles should have given you a better understanding of how bipolar transistors work and how to begin to design with them. I should mention one other thing, something which I've kept till last because it throws another variable into the works. Throughout this discussion, I've treated the base-to-emitter drop as a constant, at 0.7 V. Actually, it wanders around a bit, too; it can cover as much as a half-volt range or more. But fortunately, the transistor manufacturers will usually supply specs for  $V_{be}$  for various base or collector currents. Simply choose the number that's right for your design and plug it in everywhere I've had "0.7 V" above. If you can't find a spec for this drop, go ahead and use 0.7

until you can find (or measure) a better number.

This two-part article has been concerned strictly with the dc performance of transistors. We haven't really looked into how they work as amplifiers or how to design for desired gains or input/output impedances. But we've come a long way toward a better understanding of these circuits already. The dc biasing of the transistor has to be right before anything else will work, so make sure that you understand everything we've discussed here. Then begin looking at some simple amplifier designs and how they work—check out some examples in the various handbooks and see if you can apply what you already know about how a transistor behaves to these circuits. And maybe in the near future, if you'd like to see it, I'll come back with another article or two on simple amplifier design. ■

## Your Ham Tube Headquarters!

TUBES BOUGHT, SOLD AND TRADED  
SAVE \$\$\$—HIGH \$\$\$ FOR YOUR TUBES

Call Toll Free 800-221-0860  
Tubes

|               |         |             |         |
|---------------|---------|-------------|---------|
| 3-400Z .....  | \$85.00 | 7360 .....  | \$10.00 |
| 3-500Z .....  | 85.00   | 7735A ..... | 27.50   |
| 4-400A .....  | 80.00   | 8122 .....  | 110.00  |
| 4CX250B ..... | 55.00   | 8156 .....  | 12.50   |
| 572B .....    | 55.00   | 8643 .....  | 82.50   |
| 811A .....    | 12.00   | 8844 .....  | 26.50   |
| 813 .....     | 30.00   | 8873 .....  | 175.00  |
| 6146B .....   | 7.00    | 8874 .....  | 195.00  |
| 6360 .....    | 4.25    | 8877 .....  | 495.00  |
| 6883B .....   | 6.75    | 8908 .....  | 12.50   |

### Semiconductors

|                |         |               |         |
|----------------|---------|---------------|---------|
| MRF 245/SD1416 | \$30.00 | MRF 644 ..... | \$23.95 |
| MRF 454 .....  | 18.95   | SD1088 .....  | 19.95   |
| MRF 455 .....  | 13.95   | 2N3055 .....  | .75     |
|                |         | 2N6084 .....  | 12.50   |

### RF Connectors

|                 |           |                   |            |
|-----------------|-----------|-------------------|------------|
| PL259 .....     | 10/\$4.95 | M358 .....        | 2.50 ea.   |
| PL258 .....     | 10/8.95   | M359 .....        | 1.75 ea.   |
| UG175/176 ..... | 10/1.60   | Type "N" Twist on |            |
| UG255/u .....   | 2.50 ea.  | (RG8/u) .....     | \$4.75 ea. |
| UG273/u .....   | 2.25 ea.  | Minimum Order     | \$25.00    |

Allow \$3.00 min. for UPS charges

**CeCo**

COMMUNICATIONS, Inc.

2115 Avenue X Brooklyn, NY 11235

—111 SERVING THE INDUSTRY SINCE 1922

Phone (212) 646-6300

Call CECO For Your CCTV Security And Color Production Requirements

## GLB PACKET RADIO CONTROLLER

Now you can get  
in on the fun on  
packet radio!

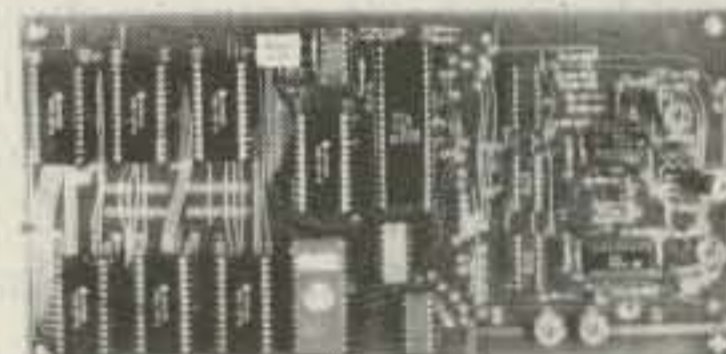

MODEL PK1  
(shown with 14K RAM  
and 8K ROM)

- Ready to operate—wired & tested —LOW COST
- Easy to learn, easy to use
- Built-in packet Modem
- Use with computers, terminals, teletype machines
- RS232 serial interface—45 to 9600 baud
- Uses both ASCII and Baudot
- Programmed for both AX.25 & VAO at 1200 or 600 baud
- Automatically recognizes protocol of incoming messages
- Over 60 commands
- Custom call sign option
- Stores received messages until requested at a later time
- "Block" and transparent modes for transferring computer data
- Operates as an unattended repeater
- Activates teletype motor to print messages
- Board accepts up to 14K of RAM
- Can be customized for LANS and up to 56K RAM

|   |          |
|---|----------|
| MODEL PK-1 wired & tested w/4K RAM  | \$149.95 |
| Additional memory (up to 14K total)   | 10.00/2K |
| Manual only—credited with purchase (add \$2.00 for shipping)                          | 9.95     |
| RTTY adapter board  | 17.95    |
| Custom cabinet kit—includes on/off switch, LED pwr indicator, reset button & pwr jack | 34.95    |
| Dimensions: 4.5 x 9.5 x 1.5 inches  |          |
| Pwr required: +12 VDC, approx. 200 ma.  |          |

Contact GLB for additional info and available options.

We offer a complete line of transmitters and receivers, strips, preselector preamps, CWID'ers & synthesizers for amateur & commercial use. Request our FREE catalog. MC & Visa welcome.

**GLB ELECTRONICS**

1952 Clinton St. Buffalo, NY 14206

716-824-7936, 9 to 4

—269



**HF Equipment** Regular SALE  
 IC-740\* 9-band 200w PEP xcvr w/mic \$1099.00 **869<sup>95</sup>**  
**\*FREE PS-740 Internal Power Supply & \$50 Factory Rebate - until gone!**

- PS-740 Internal power supply..... 159.00 **149<sup>95</sup>**
- \*EX-241 Marker unit..... 20.00
- \*EX-242 FM unit..... 39.00
- \*EX-243 Electronic keyer unit..... 50.00
- \*FL-45 500 Hz CW filter (1st IF).... 59.50
- \*FL-54 270 Hz CW filter (1st IF).... 47.50
- \*FL-52A 500 Hz CW filter (2nd IF) 96.50 **89<sup>95</sup>**
- \*FL-53A 250 Hz CW filter (2nd IF) 96.50 **89<sup>95</sup>**
- \*FL-44A SSB filter (2nd IF) ..... 159.00 **144<sup>95</sup>**
- SM-5 8-pin electret desk microphone 39.00
- HM-10 Scanning mobile microphone 39.50
- MB-12 Mobile mount..... 19.50

\*Options also for IC-745 listed below

- IC-730 8-band 200w PEP xcvr w/mic \$829.00 **569<sup>95</sup>**
- FL-30 SSB filter (passband tuning) 59.50
- FL-44A SSB filter (2nd IF)..... 159.00 **144<sup>95</sup>**
- FL-45 500 Hz CW filter..... 59.50
- EX-195 Marker unit..... 39.00
- EX-202 LDA interface; 730/2KL/AH-1 27.50
- EX-203 150 Hz CW audio filter ..... 39.00
- EX-205 Transverter switching unit 29.00
- SM-5 8-pin electret desk microphone 39.00
- HM-10 Scanning mobile microphone 39.50
- MB-5 Mobile mount..... 19.50
- IC-720A 9-band xcvr/.1-30 MHz rcvr \$1349.00 **869<sup>95</sup>**
- FL-32 500 Hz CW filter..... 59.50
- FL-34 5.2 kHz AM filter ..... 49.50
- SM-5 8-pin electret desk microphone 39.00
- MB-5 Mobile mount..... 19.50
- IC-745 9-band xcvr w/.1-30 Mhz rcvr \$999.00 **789<sup>95</sup>**
- PS-35 Internal power supply..... 160.00 **144<sup>95</sup>**
- CFJ-455K5 2.8 kHz wide SSB filter 4.00
- HM-12 Hand microphone ..... 39.50
- SM-6 Desk microphone ..... 39.00

\*See IC-740 list above for other options (\*)



- IC-751 9-band xcvr/.1-30 MHz rcvr \$1399.00 **1199**
- PS-35 Internal power supply..... 160.00 **144<sup>95</sup>**
- FL-32 500 Hz CW filter (1st IF) ..... 59.50
- FL-63 250 Hz CW filter (1st IF) ..... 48.50
- FL-52A 500 Hz CW filter (2nd IF).... 96.50 **89<sup>95</sup>**
- FL-53A 250 Hz CW filter (2nd IF).... 96.50 **89<sup>95</sup>**
- FL-33 AM filter..... 31.50
- FL-70 2.8 Khz wide SSB filter ..... 46.50
- HM-12 Hand microphone ..... 39.50
- SM-6 Desk microphone ..... 39.00
- CR-64 High stability reference xtal 56.00
- RC-10 External frequency controller 35.00
- MB-18 Mobile mount..... 19.50

- Options: 720/730/740/745/751 Regular SALE
- PS-15 20A external power supply..... \$149.00 **134<sup>95</sup>**
  - EX-144 Adaptor for CF-1/PS-15.... 6.50

# ICOM

- Options - continued Regular SALE
- CF-1 Cooling fan for PS-15..... 45.00
  - EX-310 Voice synth for 751, R-71A 39.95
  - SP-3 External base station speaker ... 49.50
  - Speaker/Phone patch - specify radio 139.00 **129<sup>95</sup>**
  - BC-10A Memory back-up..... 8.50
  - EX-2 Relay box with marker ..... 34.00
  - AT-100 100w 8-band automatic ant tuner 349.00 **314<sup>95</sup>**
  - AT-500 500w 9-band automatic ant tuner 449.00 **399<sup>95</sup>**
  - AH-1 5-band mobile antenna w/tuner 289.00 **259<sup>95</sup>**
  - PS-30 Systems p/s w/cord, 6-pin plug 259.95 **233<sup>95</sup>**
  - OPC Optional cord, specify 2 or 4-pin 5.50
  - GC-4 World clock..... 99.95 **94<sup>95</sup>**

HF linear amplifier Regular SALE

- IC-2KL w/ps 160-15m solid state amp 1795.00 **1299**
- VHF/UHF base multi-modes Regular SALE

- IC-251A\* 2m FM/SSB/CW transceiver \$749.00 **499<sup>95</sup>**
- \*\$50 Factory Rebate - until gone!**
- IC-551D 80 Watt 6m transceiver..... \$699.00 **599<sup>95</sup>**
- EX-106 FM option..... 125.00 **112<sup>95</sup>**
- BC-10A Memory back-up ..... 8.50
- SM-2 Electret desk microphone .... 39.00

- IC-271H 100w 2m FM/SSB/CW xcvr 899.00 **759<sup>95</sup>**
- PS-35 Internal power supply..... 160.00 **144<sup>95</sup>**
- PS-15 external power supply..... 149.00 **134<sup>95</sup>**
- CF-1 Cooling fan for PS-15 ..... 45.00
- EX-144 PS-15/CF-1 fan adaptor 6.50
- AG-25 Mast mtd. GaSFET preamp 84.95
- IC-471H 75w 430-450 SSB/CW/FM xcvr 1099.00 **989<sup>95</sup>**
- PS-35 Internal power supply..... 160.00 **144<sup>95</sup>**
- PS-15 20A power supply..... 149.00 **134<sup>95</sup>**
- CF-1 Cooling fan for PS-15 ..... 45.00
- EX-144 PS-15/CF-1 fan adaptor 6.50
- AG-35 Mast mounted preamp ..... 84.95

- IC-271A 25w 2m FM/SSB/CW xcvr... 699.00 **619<sup>95</sup>**
- PS-25 Internal power supply..... 99.00 **89<sup>95</sup>**
- AG-20/EX-338 2m preamplifier.... 56.95
- IC-471A 25w 430-450 SSB/CW/FM xcvr 799.00 **699<sup>95</sup>**
- AG-1 Mast mounted 15dB preamp 89.00
- PS-25 Internal power supply..... 99.00 **89<sup>95</sup>**

- Common accessories for 271A/H and 471A/H
- SM-6 Desk microphone ..... 39.00
  - EX-310 Voice synthesizer ..... 39.95
  - TS-32 CommSpec encode/decoder ... 59.95
  - UT-15 Encoder/decoder interface... 12.50
  - UT-15S UT-15S w/TS-32 installed ... 79.95

VHF/UHF mobile multi-modes Regular SALE

- IC-290H 25w 2m SSB/FM xcvr, TTP mic 549.00 **489<sup>95</sup>**
- IC-490A 10w 430-440 SSB/FM/CW xcvr 649.00 **579<sup>95</sup>**
- VHF/UHF/1.2 GHz FM Regular SALE
- IC-22U 10w 2m FM non-digital xcvr 299.00 **249<sup>95</sup>**
- EX-199 Remote frequency selector 35.00
- IC-27A Compact 25w 2m FM w/TTP mic 369.00 **329<sup>95</sup>**
- IC-27H Compact 45w 2m FM w/TTP mic 409.00 **369<sup>95</sup>**
- IC-37A Compact 25w 220 FM, TTP mic 449.00 **359<sup>95</sup>**
- IC-47A Compact 25w 440 FM, TTP mic 469.00 **419<sup>95</sup>**
- UT-16/EX-388 Voice synthesizer... 29.95
- IC-120 1w 1.2 GHz FM transceiver.... 499.00 **449<sup>95</sup>**
- ML-12 10w amplifier..... 339.00 **299<sup>95</sup>**

- 6m portable Regular SALE
- IC-505 3/10w 6m port. SSB/CW xcvr \$449.00 **399<sup>95</sup>**
  - BP-10 Internal Nicad battery pack 79.50
  - BP-15 AC charger..... 12.50
  - EX-248 FM unit..... 49.50
  - LC-10 Leather case ..... 34.95
  - SP-4 Remote speaker ..... 24.95



Hand-held Transceivers

- |                        |                                |
|------------------------|--------------------------------|
| <b>Deluxe models</b>   | <b>Regular SALE</b>            |
| IC-02AT for 2m.....    | 349.00 <b>299<sup>95</sup></b> |
| IC-04AT for 440 MHz    | 379.00 <b>339<sup>95</sup></b> |
| <b>Standard models</b> | <b>Regular SALE</b>            |
| IC-2A for 2m.....      | 239.50 <b>189<sup>95</sup></b> |
| IC-2AT with TTP.....   | 269.50 <b>199<sup>95</sup></b> |
| IC-3AT 220 MHz, TTP    | 299.95 <b>239<sup>95</sup></b> |
| IC-4AT 440 MHz, TTP    | 299.95 <b>239<sup>95</sup></b> |

Accessories for Deluxe models Regular

- BP-7 425mah/13.2V Nicad Pak - use BC-35 67.50
- BP-8 800mah/8.4V Nicad Pak - use BC-35.... 62.50
- BC-35 Drop in desk charger - all batteries ..... 69.00
- BC-60 6-position gang charger, all batts SALE **359.95**
- BC-16U Wall charger - BP7/BP8..... 10.00

Accessories for both models Regular

- BP-2 425mah/7.2V Nicad Pak - use BC35..... 39.50
- BP-3 Extra Std. 250 mah/8.4V Nicad Pak ..... 29.50
- BP-4 Alkaline battery case..... 12.50
- BP-5 425mah/10.8V Nicad Pak - use BC35 49.50
- CA-2 Telescoping 2m antenna..... 10.00
- CA-5 3/4-wave telescoping 2m antenna..... 18.95
- FA-2 Extra 2m flexible antenna ..... 10.00
- CP-1 Cig. lighter plug/cord - BP3 or Dlx..... 9.50
- DC-1 DC operation pak for standard models 17.50
- LC-02AT Leather case for Dlx models w/BP-7/8 39.95
- LC-2AT Leather case for standard models..... 34.95
- LC-11 Vinyl case for standard models ..... 17.95
- LC-14 Vinyl case for Deluxe models w/BP-7/8 17.95
- RB-1 Vinyl waterproof radio bag ..... 30.00
- HH-SS Handheld shoulder strap ..... 14.95
- HM-9 Speaker microphone ..... 34.50
- HS10 Boom microphone/headset..... 19.50
- HS-10SA Vox unit for HS-10 (deluxe only) 19.50
- HS-10SB PTT unit for HS-10..... 19.50
- ML-1 2m 2.3w in/10w out amplifier..... SALE **79.95**
- ML-25 2m 2.3w in 20w out amplifier ..... SALE **179.95**
- SS-32M Commspec 32-tone encoder ..... 29.95

Shortwave receivers Regular SALE

- R-71A 100 Khz-30 Mhz digital receiver \$799.00 **689<sup>95</sup>**
- FL-32 500 Hz CW filter..... 59.50
- EX-310 Voice synthesizer ..... 39.95
- RC-11 Wireless remote controller... 59.95
- CR-64 High stability oscillator xtal 56.00
- R-70 100 Khz-30 Mhz digital receiver 749.00 **569<sup>95</sup>**
- EX-257 FM unit..... 38.00
- IC-7072 Transceive interface, 720A 112.50
- FL-44A SSB filter (2nd IF)..... 159.00 **144<sup>95</sup>**
- FL-63 250 Hz CW filter (1st IF) ..... 48.50
- SP-3 External speaker ..... 49.50
- CK-70 (EX-299) 12v DC option..... 9.95
- MB-12 Mobile mount..... 19.50



**HOURS: Mon. thru Fri. 9-5:30; Sat 9-3**  
 Milwaukee WATS line 1-800-558-0411 answered evenings until 8:00 pm Monday thru Thursday  
**Please use WATS line for Placing Orders**  
 For other information, etc. please use Regular line

**Order Toll Free: 1-800-558-0411** In Wisconsin (outside Milwaukee Metro Area) 1-800-242-5195

# AMATEUR ELECTRONIC SUPPLY<sup>®</sup> Inc.

4828 W. Fond du Lac Avenue; Milwaukee, WI 53216 - Phone (414) 442-4200

## AES BRANCH STORES

- |  |   |   |   |   |
|--|---|---|---|---|
| <b>WICKLIFFE, Ohio 44092</b><br>28940 Euclid Avenue<br>Phone (216) 585-7388<br>Ohio WATS 1-800-362-0290<br>Outside Ohio 1-800-321-3594 | <b>ORLANDO, Fla. 32803</b><br>621 Commonwealth Ave.<br>Phone (305) 894-3238<br>Fla. WATS 1-800-432-9424<br>Outside Florida 1-800-327-1917 | <b>CLEARWATER, Fla. 33575</b><br>1898 Drew Street<br>Phone (813) 461-4267<br>No In-State WATS<br>No Nationwide WATS | <b>LAS VEGAS, Nev. 89106</b><br>1072 N. Rancho Drive<br>Phone (702) 647-3114<br>No In-State WATS<br>Outside Nevada 1-800-634-6227 | <b>Associate Store</b><br><b>CHICAGO, Illinois 60630</b><br>ERICKSON COMMUNICATIONS<br>5456 N. Milwaukee Avenue<br>Phone (312) 631-5181<br>15 min. from O'Hare! |
|--|---|---|---|---|

# Automate the FT-757

*Ready for robot radio? An inexpensive micro is all that you need to computer-control your Yaesu.*

**A**re you a ham who is thinking about buying (or just bought) a Yaesu FT-757 with the idea of computer-controlling it? If so, this article is for you. The design details of a simple interface are described. Also, some general program development information is given. A specific example using the Radio Shack MC-10 Micro Color Computer as a controller is shown. Finally, a program for the MC-10 which lets you send commands to the radio, remotely set frequency, and scan a large number of stored frequencies is included.

The FT-757 is a fully-synthesized HF transceiver and general-coverage receiver containing three microprocessors. A smaller package

and a much simpler overall design is the result of this innovation. The main microprocessor, an MC-146805G, controls the synthesizer frequencies and permits functions like storing and retrieving frequencies from memory, band stepping, and dual vfo operation. These and other useful functions can be enabled by controls on the front panel.

A feature of particular interest is the interface connector on the rear panel of the radio. This connector accepts serial data from a personal computer and allows the operator to duplicate some functions under program control. It should be noted that the radio design does not permit complete remote control through the

serial interface. Functions such as mode, sideband selection, and receive bandwidth can only be controlled manually at the front panel. However, the computer interface does provide an enhancement of the existing radio functions.

Any computer with an RS-232 serial interface capable of driving a printer can be used to control the radio. Fig. 1 shows the serial data format. Note that each data byte contains one start bit (logic 0), 8 data bits (logic 0), and one or more stop bits (logic 1). It is sent at a data rate of 4800 bits per second. The levels of this signal are TTL-compatible which must be 0 to 0.3 volts for a logic 0, and 2.7 to 5.0 volts for a logic 1.

The standard RS-232 serial data output of a computer swings both positive and negative, and it exceeds the interface voltage limits of the radio. An adapter circuit

must be provided between the radio and computer. RS-232 devices send a negative voltage level for a logic 1, so the adapter must also invert the data stream. Yaesu will sell an interface unit specifically intended for this function.

For those eager to try computer control, the circuit shown in Fig. 2 provides a low-cost method. An NPN transistor provides the necessary level translation and inversion. The resistor in series with the base and the diodes help isolate the computer from the radio. The radio has its own internal pull-up resistor to 5 volts, so the collector can connect directly to the radio serial input. No external power supply is required. The high base resistance and the use of the radio's internal power minimize the risk of damage to the microprocessor due to excessive voltage.

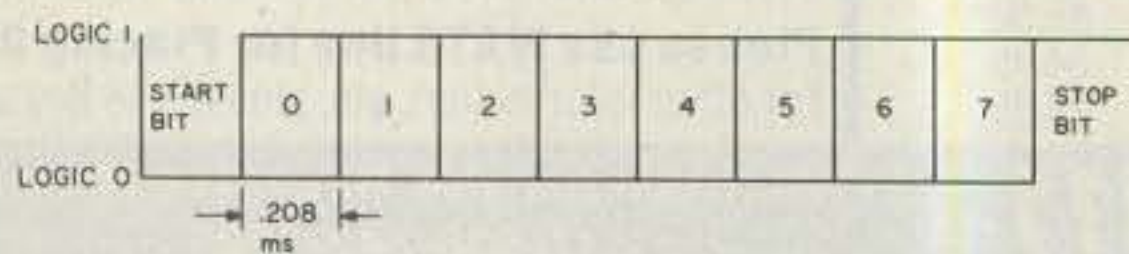

Fig. 1. Serial data format.

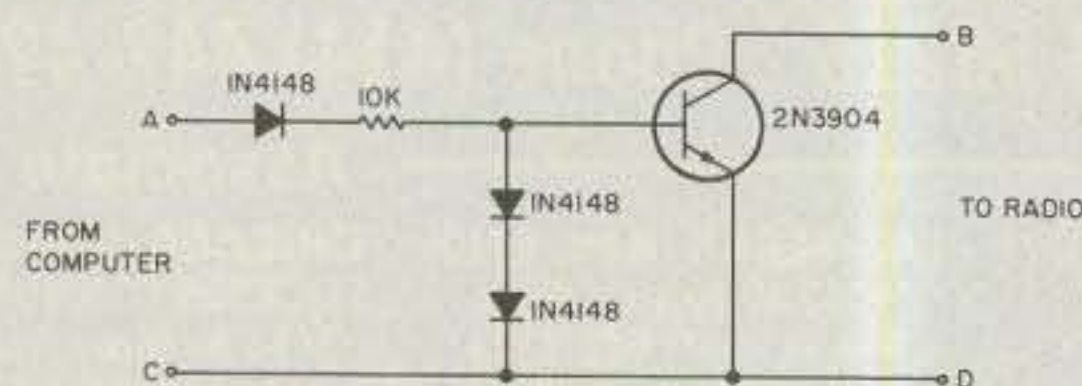

Fig. 2. RS-232 interface circuit.

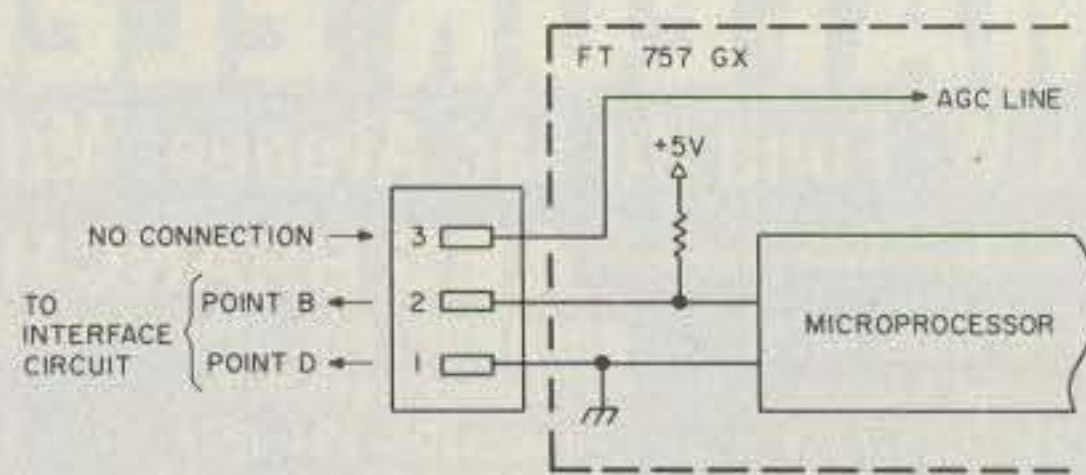

Fig. 3. Radio interface connection.



Construction is not critical, but care must be taken to prevent the circuit output (point B) from shorting to the input (point A) or serious damage to the radio may result. The circuit can be built into a small box or installed directly within the computer.

The completed circuit should be tested prior to connection to the radio. Connect point B to a 1000-Ohm resistor which in turn is connected to a +5-volt supply, and connect the negative supply lead to point D. Connect a 9-volt battery or similar voltage source between points A and C. When A is at +9 volts, B should be less than 0.2 volts, and when A is at -9 volts (reversing the battery), B should be at +5 volts.

The serial input can be found on the rear panel of the FT-757; it is labeled REMOTE. A special interface plug is available from Yaesu for connecting to this serial input. I recommend that you use this part, which can be obtained from your local Yaesu distributor, or write to Yaesu Electronics, PO Box 49, Paramount CA 90723, and ask for part number P1090234. The \$1.91 cost includes shipping and handling. If you are unable to get this part, then a temporary plug can be made from a 14- or 16-pin, dual-inline IC socket. Just cut the socket in half (between the rows), trim one half until three adjacent pins remain, and carefully file the plastic until it fits into the serial input socket on the radio.

The connections to the radio are shown in Fig. 3. The center pin is the data line. The ground pin is the one directly below the letter R in the label REMOTE on

| No. | Command       | Data |   |   |   |    | Function   |
|-----|---------------|------|---|---|---|----|--|
|     |               | 1    | 2 | 3 | 4 | 5  |  |
| 1   | SPLIT         | X    | X | X | X | 01 | vfo-A/vfo-B SPLIT ON and OFF.                    |
| 2   | MR/VFO        | X    | X | X | X | 02 | Exchange operating freq. between memory and vfo. |
| 3   | V ► M         | X    | X | X | X | 03 | Write vfo data into memory.                      |
| 4   | D LOCK        | X    | X | X | X | 04 | Lock tuning dial.                                |
| 5   | VFO A/B       | X    | X | X | X | 05 | Exchange operation between vfos A and B.         |
| 6   | M ► V         | X    | X | X | X | 06 | Write memory data into operating vfo.            |
| 7   | 500 UP        | X    | X | X | X | 07 | Step up 500 kHz (BAND UP).                       |
| 8   | 500 DWN       | X    | X | X | X | 08 | Step down 500 kHz (BAND DOWN).                   |
| 9   | CLAR          | X    | X | X | X | 09 | Activate or deactivate clarifier.                |
| 10  | Frequency set | ⊙    | ⊙ | ⊙ | ⊙ | 10 | Enter new operating frequency.                   |
| 11  | V ◄ M         | X    | X | X | X | 11 | Exchange freq. data between vfo and memory.      |

Fig. 4. Command codes.

the radio. The third pin should be left unconnected. This pin has a voltage derived from the radio's agc line. It could be used to measure signal strength.

With the interface installed the computer can send control data to the radio, but the format must be correct for the radio to interpret the commands. To explain how this process works, we must first understand how the computer sends information and what the radio is expecting to receive.

The numbers that a user would type into the computer to select a frequency are decimal (based on powers of ten). When a number is sent over the serial output using an LPRINT command, the number has been translated by the computer to its ASCII equivalent. ASCII (American Standard Code for Information Interchange) is a method of encoding numbers, letters, or symbols to provide compatibility between computers and peripheral devices like printers. The code is sent in binary (based on powers of two) and uses 7 bits, or 128 different numeric values for this representation.

The radio is designed to receive 11 different com-

mand codes, which are listed in Fig. 4. The table was taken from *CAT System Serial I/O Data Manual for the FT-757 GX*, available from Yaesu. One of these codes, the frequency-set command, is used to establish the radio frequency setting. Seven decimal digits (10 MHz to 10 Hz) are required to define each frequency. Inside the radio, BCD (Binary Coded Decimal), which uses 4 bits to represent a decimal digit, is the format used for the digits of the frequency setting.

Since each byte the computer sends contains 8 bits, the 7 frequency digits can be sent in 4 bytes. A fifth byte, the command, is required to tell the radio that the preceding 4 bytes represent a frequency. An example of a command setting the radio to 12.34567 MHz is shown in Fig. 5. The remaining 10 command codes require the same 5-byte format with the fifth byte being the command. The data in the preceding 4 bytes, which are not used in the command, is ignored by the radio.

To send the two BCD digits in one 8-bit byte requires a method to overcome the

computer's tendency to put everything it sends in ASCII format. Fortunately, there is a command common to most computers that use Basic which will solve the problem. The CHR\$(n) command is used when a programmer wants to specify the 8-bit serial data byte directly. The value, n, is a number between 0 and 255 and is the decimal equivalent of the 8-bit data byte.

The problem remaining is to get the computer to convert a seven-digit decimal frequency into the equivalent seven BCD values. Next, it must combine these values into four 8-bit bytes. After adding a fifth command byte, the computer must send these bytes to the radio at the proper data rate.

The problem is solved by first generating an algorithm (a sequence of steps) to turn a two-digit decimal number into an 8-bit data byte, formatted as two BCD digits. Generating algorithms can often be simplified by looking for patterns in numbers.

Fig. 6 shows how such a pattern appears here. The decimal frequency number, its corresponding binary byte in BCD format, and the

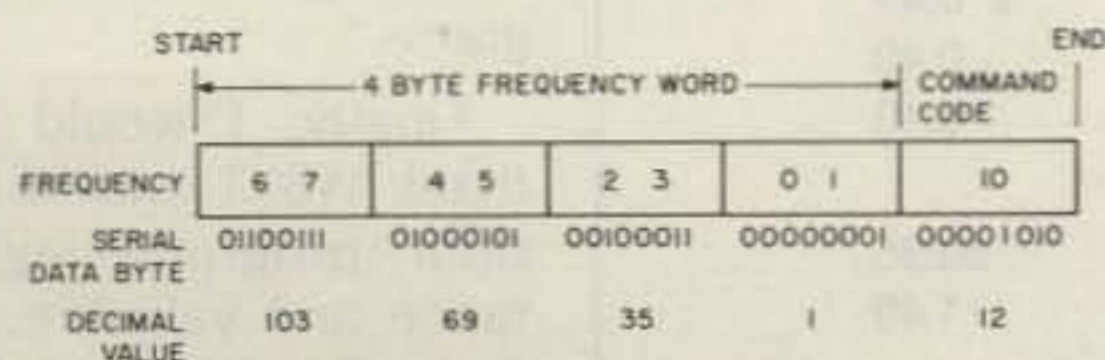

Fig. 5. Command setting frequency to 12.34567 MHz.

| Two-Digit Decimal Number | 8-Bit Serial Data Byte | Decimal Equivalent of Serial Data Byte |
|--------------------------|------------------------|--|
| 06                       | 00000110               | 06                                     |
| 16                       | 00010110               | 22 = 16 + 6                            |
| 26                       | 00100110               | 38 = 26 + 2*6                          |
| 99                       | 10011001               | 153 = 99 + 9*6                         |
| N                        | —                      | $N + \text{INT}(N/10)*6$               |

Fig. 6. BCD algorithm and data pattern.

### Notes on the Use of the Interface Circuit

1. Insert the DIN plug into the MC-10 serial I/O socket.
2. Insert the flat connector into the remote socket of the FT-757.
3. Insert the tape into a tape player connected to the MC-10 and CLOAD.
4. Type RUN and enter.
5. The control codes are as follows:
 

|                    |   |
|--------------------|---|
| S = Split mode     | F = Enter frequency                             |
| M = MR/vfo         | E = Save frequency just entered                 |
| > = vfo => memory  | / = Manually scan stored frequencies            |
| L = Dial lock      | H = Automatically scan (HOP) stored frequencies |
| V = vfo A/B        | Spacebar = Exit either scan mode                |
| < = Memory => vfo  |   |
| U = Band step up   |   |
| D = Band step down |   |
| C = Clarifier      |   |
| = = Memory <=> vfo |   |
6. Pressing the above keys will execute the indicated function. When F is selected, the frequency must be typed in MHz, and the enter key pressed.
7. If a frequency is to be saved, press E after entering the frequency.
8. The stored frequencies can be manually scanned (press /) or automatically scanned (press H).

decimal equivalent of the binary byte are shown. This decimal equivalent is the value used in the CHR\$ function to transmit the byte. The examples show that by taking the integer part of one-tenth the frequency, multiplying it by 6, and adding the product to the frequency, the decimal equivalent results. Thus, with this algorithm and use of the CHR\$ function, a two-digit frequency can be sent as a two-digit BCD value.

The rest of the problem consists of breaking up the 7-digit frequency into 4 two-digit numbers. The Basic program listed in Fig. 7 performs this task by dividing the frequency by 10 and using the integer function a multiple number of times. The numbers are stored in an array which, after use of the CHR\$ function, is sent out the serial port by using the LPRINT or similar command.

Commands not requiring a frequency value are handled similarly. The first four bytes sent can be any value since they are ignored by the radio. The fifth byte, however, must represent the de-

sired command. The CHR\$ function converts the decimal command value into the binary value needed by the radio. An LPRINT command is then used to send the 5 bytes to the radio, just as before.

A controller incorporating the circuitry and program techniques just discussed was developed using the Radio Shack MC-10 Micro Color Computer. Although many computers will work, this one was chosen for several reasons. It has the necessary RS-232 serial output already built in. The computer is small, it uses the Basic programming language, and it is very inexpensive.

The RS-232 output of the MC-10 connects to the input

```
10 F1=F/10
20 FOR J=1 TO 4
30 F2=INT(F1): F1=F1-F2
40 F2=F2+INT(F2/10)*6
50 A(J)=F2
60 F1=100*F1
70 NEXT J
80 LPRINT CHR$(A(4))+CHR$(A(3))+CHR$(A(2))+CHR$(A(1))+CHR$(1);
```

Fig. 7. Program listing to create two-digit numbers.

of the adapter circuit. A 4-pin DIN plug (Radio Shack 274-007) must be used here. Connect pin 4 of the computer output to point A, and pin 3 to point C. With the output of the adapter circuit connected to the radio as described earlier, the interface between the computer and radio is complete.

A program listing for the MC-10 is shown in Fig. 8. This program is intended to be used without a continuously-connected TV monitor. A menu which lists the program functions is shown in the box (item 5) of notes. This menu can be cut out and taped to the MC-10 housing.

Carefully type the program into the MC-10, and CSAVE it to tape. Run the program. The functions are enabled by pressing the appropriate key. For example, to enable the dial lock, press L. The LOCK indicator on the radio display should be on. Pressing L a second time disables this function. To enter a frequency, press F, then type the desired frequency in megahertz and press ENTER. The frequency should now be visible on the radio display. The frequency just entered can be saved in the MC-10 by pressing E. All frequencies saved can be scanned manually by pressing /. They can be scanned

```
10 REM***757 CONTROL PROGRAM***
20 REM***BY ERIK FOUNTAIN***
30 DIM A(4),B(100): Z=0: N=1
40 FOR I=2024 TO 20243
50 READ D: POKE I,D
60 NEXT I
70 DATA 49,49,60,55,54,214,232
80 DATA 39,8,22,7,54,15,23,126
90 DATA 249,219,126,250,27
100 POKE 17032,126:POKE 17033,79
110 POKE 17034,0: POKE 16932,10
120 B$="SM)LV(UDCF=EH/"
130 A$=INKEY$
140 FOR I=1 TO 14
150 IF A$=MID$(B$,I,1) THEN 180
160 NEXT
170 GOTO 130
180 IF I>11 THEN 220
190 IF I=10 THEN 210
200 GOSUB 400: GOTO 130
210 M=1: GOSUB 400: GOTO 130
220 IF I=13 THEN 270
230 IF I=14 THEN 370
240 IF M<>1 THEN 130
250 M=0: Z=Z+1: B(Z)=F3
260 GOTO 130
270 FOR N=0 TO 2
280 F=B(N): I=10: GOSUB 410
290 FOR P=1 TO 1000: NEXT
300 IF INKEY$=CHR$(32) THEN 130
310 NEXT N
320 GOTO 270
330 N=1
340 A$=INKEY$
350 IF A$=CHR$(32) THEN 130
360 IF A$<>"/" THEN 340
370 F=B(N): I=10: GOSUB 410
380 N=N+1: IF N>2 THEN 330
390 GOTO 340
400 INPUT "F=";F: F3=F
410 F1=F/10+.0000005
420 FOR J=1 TO 4
430 F2=INT(F1): F1=F1-F2
440 F2=F2+INT(F2/10)*6
450 A(J)=F2
460 F1=100*F1
470 NEXT J
480 LPRINT CHR$(A(4))+CHR$(A(3))+CHR$(A(2))+CHR$(A(1))+CHR$(1);
490 RETURN
```

Fig. 8. Program listing for the MC-10.

automatically by pressing H. To exit either scan mode, press the spacebar.

This program is simple. It is intended to serve as an elementary example. The techniques shown here can be used to develop more elaborate programs for individual applications. It can provide an opportunity for you to be really creative. The serial control capability makes the FT-757, which is already packed with features, even more appealing.

The MC-10 is the only computer I have tried as a controller, and I have experienced no significant radio frequency interference problems. Other computers may cause such interference, so verify that no problem exists before spending time writing programs.

Finally, I would like to thank W6XT and N6MN for their programming assistance and valuable suggestions. Good luck and happy programming. ■

| Parts List                       |             |             |                   |
|----------------------------------|-------------|-------------|-------------------|
| Qty                              | Part Number | Description | Approximate Price |
| <b>Interface Circuit</b>         |             |             |                   |
| 1                                | 2N3904      | Transistor  | \$ 0.49           |
| 3                                | 1N4148      | Diode       | 0.49              |
| 1                                | 10k         | Resistor    | 0.10              |
| <b>Controller</b>                |             |             |                   |
| 1                                | MC-10       | Computer    | 59.95             |
| 1                                | 274-004     | Connector   | 1.49              |
| Both available from Radio Shack. |             |             |                   |



**The  
HAM SHACK**

**NOW!**



**the  
HAM STATION**

220 N. Fulton Ave. — Evansville, IN 47710



AEA  
ARRL  
ALLIANCE  
AMECO  
AMERITRON  
AVANTI  
ASTRON  
B & W  
BENCHER  
BUTTERNUT  
COILCO  
CONNECT SYSTEMS  
CUSHCHAFT  
DIAWA  
ENCOMM  
HAL  
HUSTLER

HY-GAIN  
ICOM  
KLM  
KANTRONICS  
KENPRO  
LARSEN  
MFJ  
MIRAGE  
NYE VIKING  
RADIO CALL BOOK  
SHURE  
TEN-TEC  
UNADILLA  
VALOR  
WELZ  
YAESU

**Large Stock At Discount Prices—For Orders & Quotes Call 1-800-523-7731**

For More Indepth Information & Service Call (812) 422-0252 • Indiana Orders (812) 422-0231

& C.O.D.S Welcome—Freight, F.O.B. Evansville—Prices & Availability Subject to Change

*"Happy New Year"* from Dan, Sandi, Laura, Rick, Mark, Steve, & Brian

\*Name change was prompted by threatened legal action concerning possible Trademark infringement.

**USED EQUIPMENT**

|                                       |          |
|---------------------------------------|----------|
| <b>AEA</b>                            |          |
| CP-1/64 Interface Pkg . . . . .       | \$185.50 |
| <b>AZDEN</b>                          |          |
| PCS 300 H.T. . . . .                  | \$175.50 |
| PCS 3000 2 Mtr. . . . .               | 209.50   |
| <b>DENTRON</b>                        |          |
| 80-10AT Tuner . . . . .               | \$ 39.50 |
| <b>DRAKE</b>                          |          |
| T4XB, R4B, AC4, MS4 . . . . .         | \$425.00 |
| SW4A Rcvr . . . . .                   | 95.00    |
| 1525EM TT Mic . . . . .               | 39.50    |
| <b>ENCOMM</b>                         |          |
| HT-1200 2M H.T. . . . .               | \$149.50 |
| ST-144 2M H.T. . . . .                | 185.50   |
| ST-142 2M H.T. . . . .                | 209.50   |
| ST-7T 440 MHZ H.T. . . . .            | 169.50   |
| Spkr/Mic. . . . .                     | 20.00    |
| <b>HAL</b>                            |          |
| KG-12 12" Monitor . . . . .           | \$ 99.00 |
| <b>HEATHKIT</b>                       |          |
| HW101, P.S. . . . .                   | \$249.50 |
| HW101, P.S. CW . . . . .              | 269.50   |
| SB600 Spkr . . . . .                  | 25.00    |
| P.S. 9000 P.S., Dual Clocks . . . . . | 149.50   |
| VL-1180 10/80 2M Amp . . . . .        | 95.00    |
| <b>HYGAIN</b>                         |          |
| HDR300 25 Sq. Ft., Digital . . . . .  | \$399.00 |
| <b>ICOM</b>                           |          |
| 720A Gen. Cov. . . . .                | \$629.50 |
| 740 Xcvr . . . . .                    | 579.50   |
| 740, Internal P.S. . . . .            | 679.50   |
| 740, FL45 . . . . .                   | 609.50   |
| 740, Keyer . . . . .                  | 609.50   |
| PS20, Spkr . . . . .                  | 155.00   |
| PS15 . . . . .                        | 99.00    |
| R70 Rcvr . . . . .                    | 459.00   |
| 402 432Mhz Xcvr (OSCAR) . . . . .     | 199.50   |

|                                 |          |
|---------------------------------|----------|
| <b>ICOM</b>                     |          |
| 2AT 2 Mtr. H.T. . . . .         | 175.00   |
| AG-1 UHF Pre-Amp . . . . .      | 59.50    |
| 7072 Interface . . . . .        | 69.50    |
| <b>KANTRONICS</b>               |          |
| The Interface . . . . .         | \$ 69.50 |
| TR80C Hamsoft . . . . .         | 45.50    |
| Ti-99 Hamsoft . . . . .         | 69.50    |
| Vic 20 Hamsoft . . . . .        | 29.50    |
| Vic 20 Hamsoft . . . . .        | 59.50    |
| <b>KENWOOD</b>                  |          |
| TS820S . . . . .                | \$529.50 |
| Vfo 820 . . . . .               | 129.50   |
| TS520, CW . . . . .             | 429.50   |
| SM220 Monitor Scope . . . . .   | 249.50   |
| SM220, BS-5 Pan Kit . . . . .   | 299.50   |
| SP230 Spkr, Filters . . . . .   | 49.50    |
| TS 130 SE, CW . . . . .         | 499.50   |
| Vfo 120 . . . . .               | 99.50    |
| TS180 S/DFC Xcv . . . . .       | 449.50   |
| MC-80 Desk Mic Up/Dwn . . . . . | 39.50    |
| TR2400 H.T. . . . .             | 175.50   |
| TR7400A 2M . . . . .            | 179.00   |
| PS30 Power Supply . . . . .     | 99.50    |
| SP180 Spkr, Filters . . . . .   | 49.50    |
| <b>MFJ</b>                      |          |
| 484 Grandmaster Keyer . . . . . | \$ 99.50 |
| 752 Dual Filter . . . . .       | 49.50    |
| CWF-2 Filter . . . . .          | 19.50    |
| 101 24 Hr. Clock . . . . .      | 19.00    |
| 1020 Indoor Ant. . . . .        | 55.50    |
| <b>TEN-TEC</b>                  |          |
| Hercules Amp . . . . .          | \$999.00 |
| 580 Delta . . . . .             | 419.00   |
| 544, CW, NB . . . . .           | 369.50   |
| 509 Argonaut . . . . .          | 229.00   |
| 570 Century 21 . . . . .        | 239.50   |
| 277 Tuner, MTR . . . . .        | 55.50    |
| KR50 Keyer . . . . .            | 69.00    |

|   |          |
|---|----------|
| <b>TEN-TEC</b>                            |          |
| 645 Keyer . . . . .                       | 55.00    |
| 234 Speech Processor . . . . .            | 69.50    |
| Vfo-Delta . . . . .                       | 125.00   |
| 2KW Roller Inductor Tuner . . . . .       | 199.00   |
| 280 P.S. . . . .                          | 99.50    |
| 2425 2 MTR Amp . . . . .                  | 59.00    |
| <b>YAESU</b>                              |          |
| FT102, AM/FM, SSB Filter . . . . .        | 699.50   |
| FV-102 DM Scanning Vfo w/Memory . . . . . | 239.50   |
| FT901 DM, CW, AM . . . . .                | 639.50   |
| FT 107 M/DMS/FP107E . . . . .             | 589.50   |
| FT 101 ZD MK II . . . . .                 | 525.00   |
| FT 101 EE, CW . . . . .                   | 399.50   |
| FT 101 EX, Fan, DC . . . . .              | 399.50   |
| FT 101 B. . . . .                         | 299.50   |
| FT 301 D/FP301 . . . . .                  | 499.50   |
| FRG-7 Rcvr . . . . .                      | 175.00   |
| FT 207R H.T. . . . .                      | 149.50   |
| FT 208R H.T. . . . .                      | 189.50   |
| FT 202R H.T. . . . .                      | 69.50    |
| NC-7 Desk Chgr . . . . .                  | 25.50    |
| Spkr/Mic - 207 . . . . .                  | 25.00    |
| PA-2 Mobile Adptr/Chgr. . . . .           | 25.00    |
| YR-901, YK-901 Reader, KY Brd . . . . .   | 459.00   |
| YH 55 Head Phones . . . . .               | 12.50    |
| FT 221 All Mode . . . . .                 | 269.50   |
| <b>MISC.</b>                              |          |
| Dumont 304A Scope . . . . .               | \$119.00 |
| Eico 460 Scope . . . . .                  | 69.00    |
| Palomar M827 Pwr/Swr . . . . .            | 95.00    |
| Tempo One, P.S., Spkr . . . . .           | 239.50   |
| Amp Supply Aim-1 . . . . .                | 109.00   |
| VHF PA 10-140 10 AMP . . . . .            | 129.00   |
| ARR 2M Pre-Amp P144 VDA . . . . .         | 20.50    |
| Pace Mx H.T. -10 xtals . . . . .          | 85.00    |
| Micro Craft Reader . . . . .              | 99.50    |
| NC270 Rcvr . . . . .                      | 69.50    |
| Diawa CNA 1001 Autotuner . . . . .        | 225.50   |
| KDK2015R 2 MTR, TT Mic . . . . .          | 175.00   |

# That Glorious Gonset

*With 300 Watts on 2 meters, the Gonset 972 thumbs its nose at solid state. Rebuild one and be heard!*

**Y**ou remember summertime. Hot weather. Ice cream. A dip in the pool. And lots of great propagation on two meters! You want to take advantage of some of the sporadic E, tropo, and aurora you've heard on 144 MHz, but your signal just isn't quite up to snuff.

Assuming you have fairly good antennas in place, the answer may be more power. And a good cheap way to get it is to convert a relic from the past to do the job for you. Many readers will recall the old Gonset company of California. Among their more forgettable products were the venerable

Gooney Bird and Sidewinder series of transceivers for 50 MHz and 144 MHz. However, they did at one time make a line of amplifiers that were a great value and still are, if you can find them.

If you are willing to do a little scrounging and soldering (and drill an occasional hole or two), then this conversion is for you. It won't cost much (about \$125-\$130 all told) and will yield an amplifier that will give you as much as 250-300 Watts of output for as little as 1-2 Watts of drive in the AB<sub>1</sub> mode. Sounds good? Read on!

The Gonset 903/972 series of amplifiers were sold to amateurs and commercial interests alike. 903s pop up at hamfests on occasion, but not cheaply, as they feature a built-in ac supply and will run as much as 400 Watts of output! The 972, however, is a beast of a different sort. Built originally as a 13.8-volt-dc version of the 903, it ran about 90 Watts of output using a 4X150A tube and found use as a mobile power amplifier for business-band use. In fact, many of these are still in service.

The 972, as it is configured, is a real current hog. Power requirements for full output are 13.8 V dc at 35 Amperes, so I wouldn't recommend using it as a mobile amplifier. But electri-

cally it is essentially a 903 with a dc inverter to provide the necessary plate, screen, grid, and filament voltages.

I found my 972 at the Yonkers ARC auction in January, 1984. After studying the tables full of electronic goodies, I noticed a large grey chassis with a screened cover. After removing several nondescript items from on top, it was revealed to be the coveted 972A. This one looked like it had been bounced around a truck for some time, but mechanically it appeared to be fine. Since I had driven some distance and found what I was looking for (sort of), I persuaded the auctioneer to "bump" the order somewhat and put it up for bid.

A spirited round of bidding followed, whereupon the price was driven up to \$80.00, at which point I prevailed. Shortly thereafter, while making settlement at the head table, my opponent came up, took a long look at the 972, and said to me, "Just what is that thing, anyway?" Oh, the fates are cruel.

Our group trundled home and I hastily removed the cover of my prize. All appeared OK and the tubes displayed markings and date codes circa 1974. A quick reference to the owner's manual (invaluable) told me what was to go. After locating the soldering iron and a pair of diagonal cutters, I

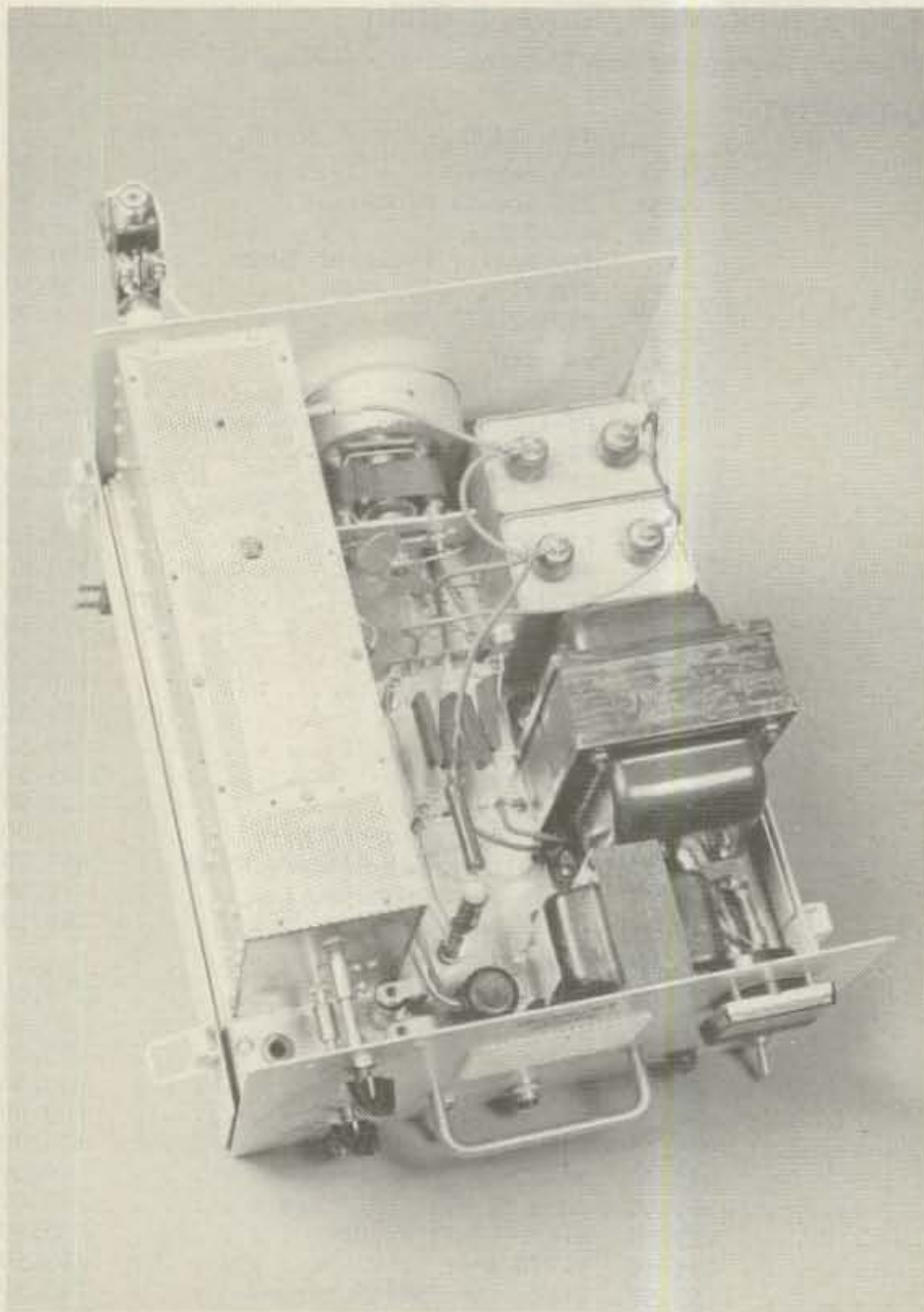

Photo A. Layout of converted 972 after construction is done.

went to work. Refer to Figs. 1 and 2 to see the top and bottom layout of the 972 with the spring latch cover and bottom removed.

Assuming you've read this far, I am sure you have the appropriate tools in hand, so let's begin the conversion. The following items from the top of the chassis will have to be removed: C7, T1, CR3-10, CR11-18, R2, R7, R8, R6/C23, R11, R14, R15, and R17, as well as the assembly marked Heat Sinks. Also, remove the assembly marked Blower Oscillator but *not* the blower. Leave the rf chassis and 8-pin plug and socket intact, as well as the sockets for V1 and V2. Remove the tubes (2 x 0B2) as you'll have to replace them with 0A2s.

Save all the power resistors, as you will need some of them later. The rest of the components can be trashed. Also, remove the low-pass filter assembly from the rear panel. You won't need it and it won't handle the power you'll be running when you're finished. The unit was only put on for FCC certification purposes and the amplifier runs cleanly enough without it.

Now, it's time to tackle the chassis underside. Flip the unit over and remove the following components: K1, C1, C2, C8-9, C24-25, T2, PL1-2, R1, R5, CR2, R12-13, R9-10, R37, and CR19. Leave R25 and 26, as these are used in the rf power sensing circuit. R27 can be removed. Discard the other components except C8 and C9, which can be used in the bias supply. Also, retain the Bakelite™ support plate that they were on to hold the bias-supply parts.

You will now need to locate a high-voltage plate transformer, preferably something on the order of 1200-1400 volts of output at about 350-400 milliamperes. You'll also need to locate a multi-tap power-supply transformer with the following voltages avail-

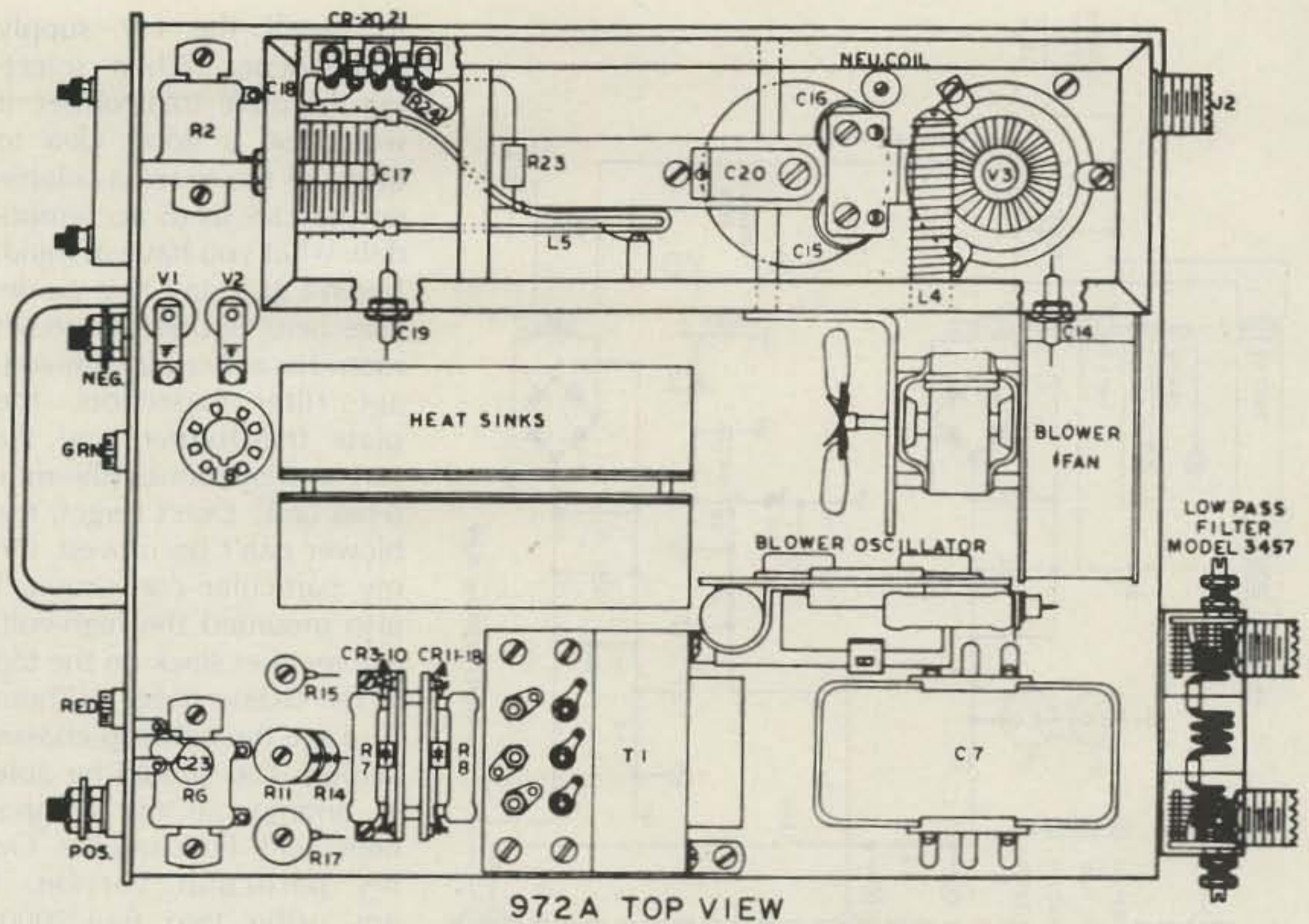

Fig. 1.

able: 350-400 volts at 50 milliamperes and 6.3 volts at 2.5 Amperes. If it also has a 5-volt winding, so much the better. Incidentally, this latter transformer is commonly found in smaller TV sets from about the same period. The last transformers you'll need are: 25.2 volts at 3 Amps (common

Radio Shack item) and a transformer for the grid-bias supply. The latter can be either a 6.3-volt unit with its 117-V-ac primary connected backwards to the 5-volt winding on the multi-tap transformer, or a standard 117-V-ac primary/125-V-c-t secondary at 15 milliamperes.

Additional items required are filter capacitors for the HV supply, screen supply, and bias supply, HV diode rectifiers for the plate and screen, low-voltage rectifiers for the bias supply, various zener diodes, ballast and dropping resistors, indicators, fuse holders, switches, and a meter for the front

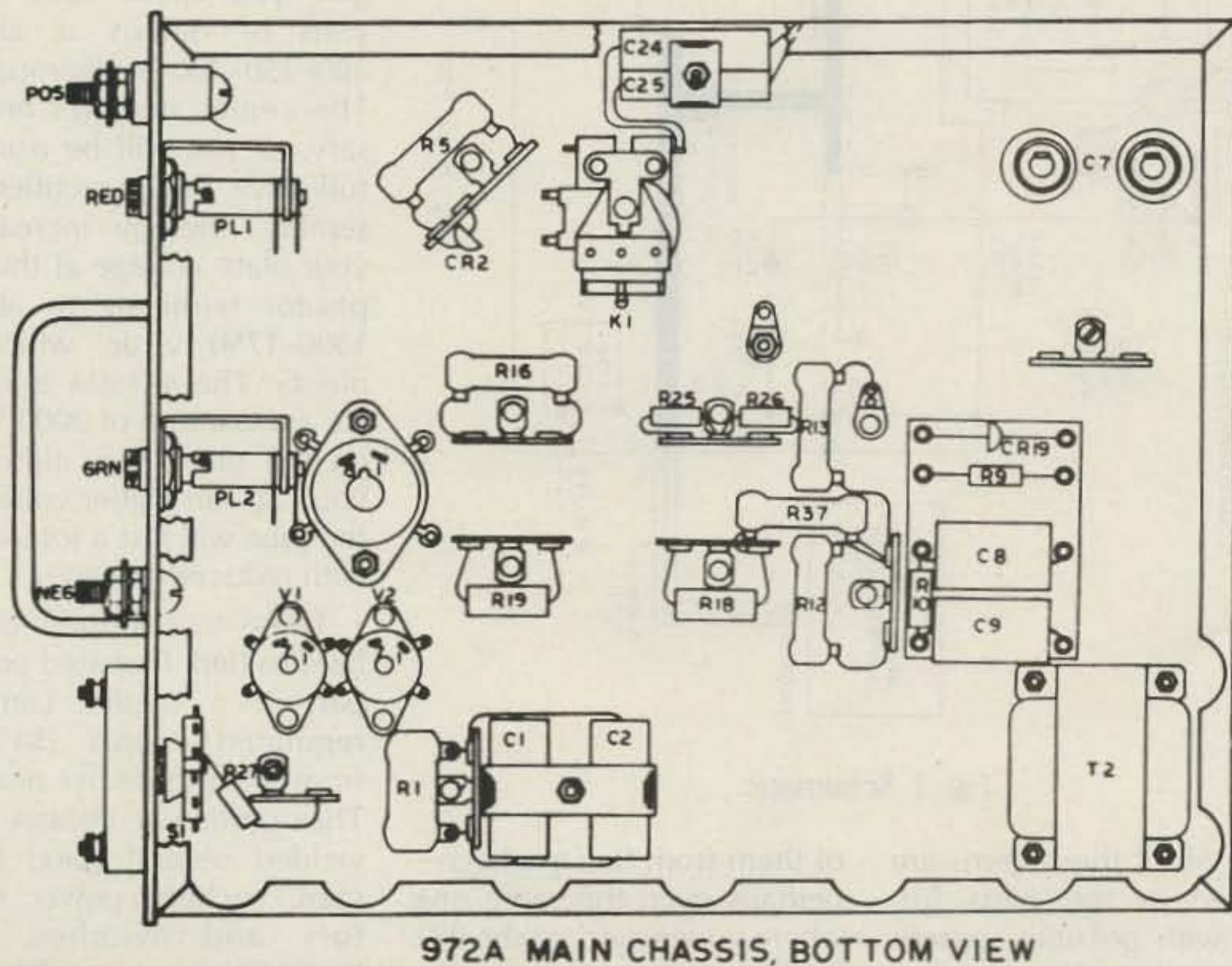

Fig. 2.

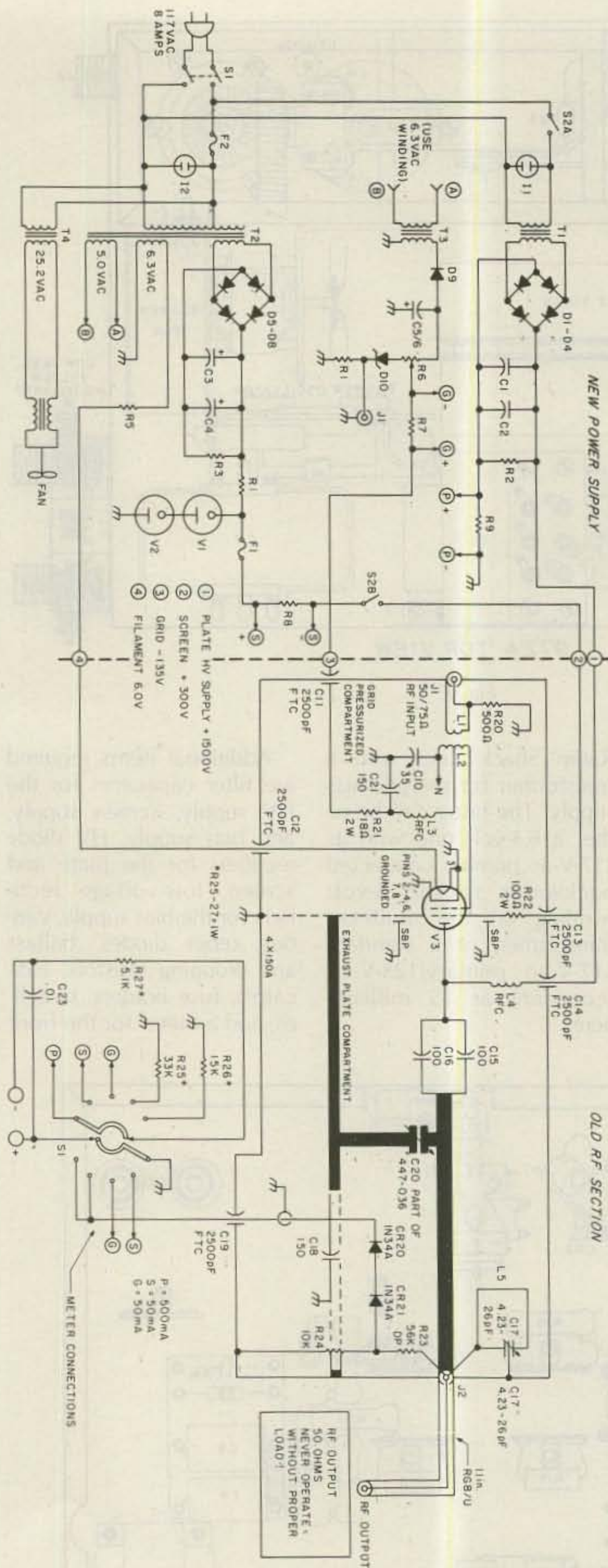

Fig. 3. Schematic.

panel. All of these items are itemized in the parts list, along with possible sources for each item. You may be able to come up with most

of them from flea markets—perhaps even the same one where you picked up the 972 itself!

The first line of business is

to install the HV supply components. When selecting the plate transformer, it would be a good idea to measure the space available on the chassis to accommodate what you have in mind. I won't give any firm guidelines here, but allow enough room for at least 2 high-voltage filter capacitors, the plate transformer, and the screen transformer (the multi-tap unit). Don't forget, the blower can't be moved. On my particular conversion, I also mounted the high-voltage rectifier stack on the top of the chassis (refer to Photo A to see the new top chassis layout). You should be able to arrange all the components with little trouble. On my particular version, I am using two 6- $\mu$ F/2000-volt filter capacitors for the plate supply filter. The original transformer shorted out after a month and the replacement just made it between the capacitors and the multi-tap transformer. If you plan this carefully, you might be able to use a lot of the existing mounting holes on the chassis.

As was mentioned earlier, you should try to locate a plate transformer that will give you about 1200-1400 volts of output at about 300-350-400 milliamperes. The center tap isn't necessary, as you will be using a full-wave bridge-rectifier assembly, thereby increasing your plate voltage at the capacitor terminals to about 1500-1750 V dc, which is plenty. The 4X150A is rated for a maximum of 2000 V dc on the plate and, although you can run higher voltages, the tube will last a lot longer with reduced voltages.

These transformers aren't hard to find. I located one as part of a surplus Lambda regulated supply (\$15.00) from a scrap dealer nearby. That particular chassis also yielded several good filter caps, sockets, power resistors, and switches. Fair Radio Sales in Lima, Ohio, is an excellent source for the

transformer. As a matter of fact, they can probably supply most of the parts needed for the conversion, and a copy of their latest catalog would be most helpful.

Once you have mounted the plate supply, filter capacitors, and rectifier assembly, you should now mount the multi-tap transformer for your screen and filament voltages. I located mine just behind the front panel, but forgot to allow enough clearance for the meter, so it sticks out from the panel a bit. Oh, well! Locating the multi-tap transformer behind and just to the right of the screen mesh in the panel is an excellent location, mainly because the holes have already been drilled to pass the various leads through to the underside of the chassis! (How lazy can you get?) It is a simple matter to then use an existing terminal strip (which you've already stripped of components) to mount the full-wave bridge circuit for the screen supply (should yield about 350-400 volts); the filament leads will make it to the 8-pin socket without any trouble. This socket feeds the various voltages (except plate) to the 4X150A; such as screen, bias, filament, and also a return that carries sampled rf voltages for the power output meter.

Assuming you now have the multi-tap transformer working, the next step is to wire up and test the two supplies (plate and screen). You should pick up some HV test-probe wire (5-kV insulation, #18 stranded) for hookups on the plate. This is a common item and most electronics supply houses have it on the shelf. The balance of your hookups can be made with #22 for everything except the filament and blower connections. It would also be a good idea to procure a premolded, 3-conductor, #16 ac power cord with plug and bare ends (about 4-5 feet). Or, you can buy the wire and plug at an

electrical supply house for a modest cost.

Wire the plate supply as shown in the schematic (Fig. 3). Keep the leads short and retain the connector that goes to the HV-bypass feed-through capacitor on the rf deck. Wire both capacitors in parallel but don't ground them as yet. Also, don't ground the — lead on the full-wave bridge! Connect the — sides of the filter caps and the — of the full-wave bridge together. You will also have to construct a bleeder assembly for the supply to improve regulation and to discharge the capacitors when not in use. Using the long 4-40 screws that held up the original bleeder assembly, salvage the 100k, 20-W and 25k, 25-W resistors that were previously stripped from the chassis. Configure a series resistance using the two of 125k Ohms and connect across the high-voltage + and — terminals (we're still above ground here). This will result in a bleeder current of 10-15 milliamperes, depending on your actual plate voltage. You'll need a dissipation of about 20 Watts total in the resistors and you have 45 available, so you are all set.

The next step is to either find, make up, or buy a .3-Ohm, 2-Watt resistor for your meter shunt. These are not uncommon at hamfests and you can string together different values to make it up. This then goes from your — connection (capacitors, full-wave bridge, and bleeders) to ground. This ground return path is at a low potential voltage, which makes it a very safe place to put a meter in the circuit to measure plate current. With the indicated shunt and about 1600 volts on the plate, the meter reads about 500 mA full scale. We'll get to the meter hookups later.

Test your supply by applying ac to the primary and using a Simpson 260 or equivalent meter with a 5-kV range. Look for correct

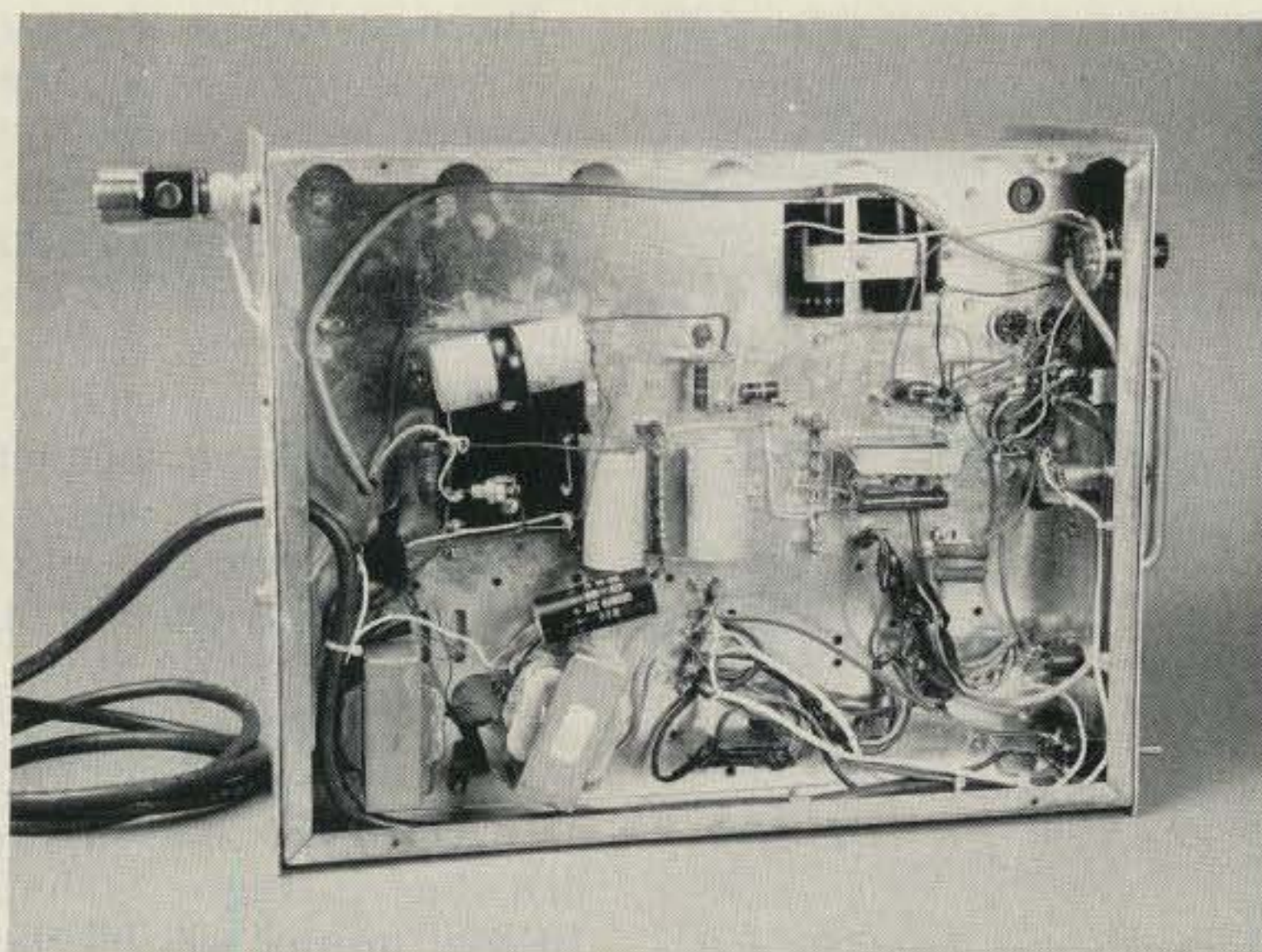

Photo B. Bottom view of the 972 with all final wiring in place.

plate voltage, then cut the power and verify that the bleeders are doing their job. Plate voltage should drop to zero in about 10 seconds. If all is well, you're ready to wire up the screen-voltage supply. Locate the windings desired (in my case, it was a 700-V-c-t unit, so I used one side and the center tap for 350 volts) and wire up the screen full-wave bridge. This can be done on an adjacent terminal strip under the chassis, or you can mount a new one. You'll need to locate two 40- $\mu$ F, 450-V-dc electrolytics for the filter capacitors. Again, these are common items at hamfests. Whatever you use, the desired filtering is about 75-90  $\mu$ F at 450 V dc.

Once this is done, you will have to configure the resistors: first, a dropping resistor for the regulator tubes. Simple calculations will yield the value needed: In my case, the output of the full-wave bridge with filter capacitors was about 435 volts. The maximum screen current on the 4X150A is 30 milliamperes, and the VR tubes ( $2 \times 0A2$ ) don't want to see more than 300 volts. The required drop is  $435 - 300 = 135$  volts/.030 = 4500 Ohms. Assuming normal use of the amplifier in class AB<sub>1</sub>, chances are you won't exceed 20-25 milliamperes of screen current (unless you're driving the living

daylights out of the tube) and one of the 5000-Ohm, 10-Watt resistors you stripped from the chassis will fit the bill perfectly. Your screen dissipation will be on the order of 3-4 Watts, so the 10-W rating is more than enough.

Now that you have dropped the voltage to the VR tubes, you'll also need to make up a screen bleeder. The guiding factor is that you want the screen supply to dissipate as fast or faster than the plate supply; otherwise, you'll pop the screens on the tube. I've also used a fuse here for extra protection—more on that shortly.

What kind of bleeder current do you need? Well, not much! The screen of the tube doesn't draw much to begin with, so the bleeder current ought to be on the order of about 5-10 milliamperes. Let's do some calculations:  $300 \text{ volts}/.010 \text{ mA} = 30\text{k Ohms}$ . Some experimentation is in order here to determine the time constant, and rather than use math, I just tried several different values until the satisfactory current was reached, especially in relation to plate-discharge current. This value is close to what I actually used, which is about 33k Ohms. At this level, all you need is a 2-Watt resistor.

Make sure that the VR tubes are the last piece of the chain that goes to pin 3

on the octal socket. This is the most critical supply in the amplifier and it must be filtered and regulated extremely well for the amplifier to behave itself in a linear mode. If you want extra protection, such as if the plate supply fails, install a 1/10-Amp AGC fuse (not a slow-blow) in series with the screen-voltage line. This will prevent tube blowouts.

Once you have established that the screen and plate supplies are up and running, the next step is to tackle the bias supply. If you have located the 117-V-ac/6.3-V-ac filament transformer, simply hook up the 6.3-V-ac leads to the 5-V-ac winding on the multi-tap. This will yield about 95-100 volts from the now-backwards primary winding. A single diode is sufficient for this supply, as it doesn't draw much current at all and regulation is not a problem. You'll see about 120-130 volts at the output, but here's the catch: You must hook up the diode reversed, since we need negative bias! No sweat here, as the cathode (banded) end goes to one side of the transformer, with the other transformer lead grounded. The output is taken from the anode side of the diode and a 40- $\mu$ F, 250-V-dc capacitor from the salvaged parts is connected backwards from it to ground—minus to the anode, plus to ground. Next, locate or buy a 5k, 5-Watt potentiometer, a 33-volt, 5-Watt zener, and a 1k, 2-Watt resistor. This is your bias network and should be connected as per the schematic.

When the key line at J1 is shorted, the 1k resistor is taken out of the line, thereby allowing the zener to do its thing and provide an adjustable range of about 50-120 volts dc. Removing the ground raises the standby voltage back to about 135 or so, putting the tube in hard cutoff. Mount the components on the Bakelite board that was rescued ear-



Photo C. The finished conversion with new lettering and a new paint job.

lier from the garbage and locate the bias-adjustment pot in a convenient location. I placed mine behind the filter caps inside the chassis to prevent accidental readjustment.

Note: If you chose the more conventional 117-V-ac/125-V-ac transformer, simply hook it up to your ac source and wire as before on the secondary. Your voltage range will be greater when adjusted and will sit at about 150-160 volts when on standby.

Verify that your supply will give you from -130 to -50 volts when J1 is grounded and R1 is adjusted. It should be a smooth adjustment and be stable when set. Where you

set this pot will determine your class of operation. For example, a setting of -100 to -90 volts will put you in class C and the tube will need more drive for a given power output. This is appropriate for FM use only. Dropping the voltage to about -60 to -50 volts will put you in about class AB, where the idling plate current will be close to 80-100 milliamperes, and you'll need only about 1-2 Watts of drive for full power output.

OK, let's step back and inspect our work. The plate supply is now up and running. The screen and grid-bias supplies are also behaving as intended. You're almost done, believe it or not!

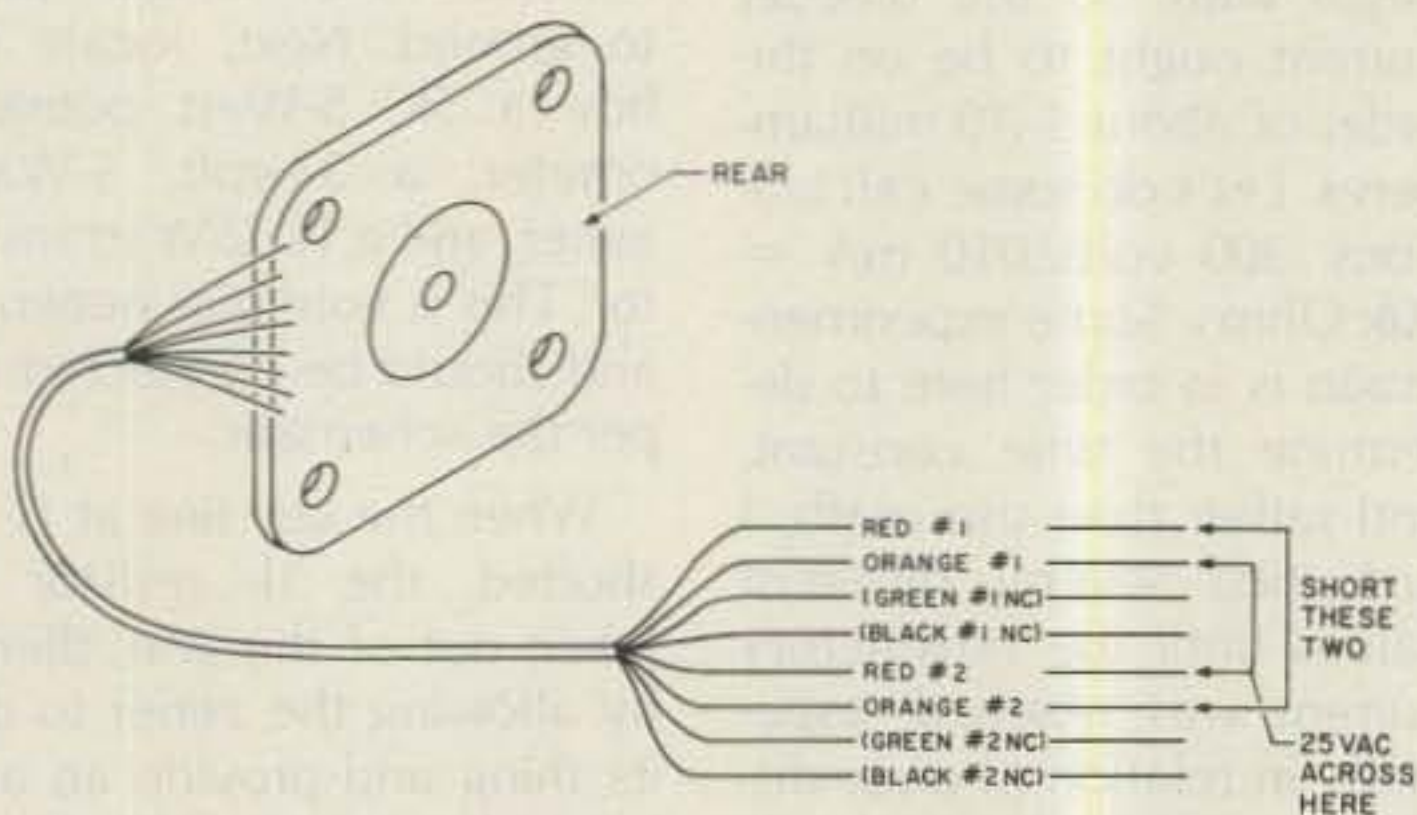

Fig. 4. Wiring diagram for modified blower. Of the eight wires, don't use either set of black or green wires. You'll need to determine which are the correct pairs by shorting one of the red wires to one of the orange wires and connecting 25 volts across the other two. If the blower won't turn, try the other red wire to the same orange wire and change 25-volt connections accordingly.

The next step is an easy one. You'll have to drop the filament voltage to the 4X150A to exactly 6.0 volts, as per Eimac's ratings. To do that, you need to know the filament current requirements (2.1 Amperes), and using simple math we find that  $6.3 - 6.0 = .3$  volts need to be dropped. Also,  $.3 \text{ volts} / 2.1 \text{ Amps} = .14 \text{ Ohms}$ .  $(2.1 \times 2.1) \times .14 = 6.1 \text{ Watts}$ . So, you'll need a .14-Ohm, 6-Watt resistor? Well, my past experience has shown that the average .1-Ohm, 10-Watt resistor will fill the bill, yielding a filament voltage around 6.08 volts. For the intermittent use the tube will get, you're not shortening its life by any drastic amount, or even any appreciable amount! So, go ahead and use a .1-Ohm, 10-Watt resistor. These always show up in surplus houses and flea markets for a song. (I bought 5 at Dayton for 10¢ apiece.) Run the wire from this resistor to pin 8 on the octal socket and ground the other side of the filament lead for the return. If you haven't done so already, also hook up the grid bias to pin 2 of the octal socket.

If you want to use the multimeter switch and meter to also measure grid and screen current (and who doesn't?), you'll need to dig up or buy a couple of 3.3-Ohm, 2-Watt resistors. When the meter leads are across these resistors (in series with the screen and grid supplies), the meter scale reads about 30 mA full scale, which is perfect. Use one resistor for each supply. You can use existing terminal strips to secure the resistors, which should be installed right before the voltage goes to the octal socket.

By now, the bottom of your supply should be looking something like Photo B. Notice the neat layout and extensive use of cable ties and dressed leads. This makes troubleshooting a lot easier.

The next step is to install

the new blower supply. This is nothing more than a Radio Shack 25.2-V-c-t, 6-Amp transformer. You'll have to wire the blower very carefully, however, as it was designed to run from a flip-flop supply that is nowhere near 60 cycles. The trick is to find the red and orange enameled wires and wire them in a series-parallel arrangement, as shown in Fig. 4. I fried another transformer by not doing this, as the current demands became excessive.

At this point, it would be a good idea to check all of your wiring. You should have plate, screen, grid, and filament voltages both in position and working correctly. The blower should also come up to speed and the transformer may run a little warm, but that's it! Again, refer to Photo B for the final layout. You may have to jockey the blower transformer around a bit to find the best compromise to get at the leads (which are quite long) and clear the other components. Take your time and be neat. Mark your wires well for later identification when hooking up the switches and lamps.

Now, the fun part begins. You are ready to install the switches and indicator lamps on the front panel, the fuse holder for the ac mains, a power cord on the back, and a jack for switching the bias control when in standby. It might be a good idea to consider sanding and repainting the chassis (see Photos C and D). If you are so inclined, you can also reletter all of the controls with transfer type and then spray the panels with a clear finish, like Krylon, for protection. Chances are if your 972 looks anything like mine did when I picked it up, it'll need a paint job.

It's time to do the front panel! One item I didn't scrimp on was a meter. Celectro makes a fine unit with a front-panel scale of 0-1 mA (catalog #D1-1012). It retails for about \$15.00 and



### Microwave Test Equipment

**RMSG Signal Generators**  
Manual tuning • 8-30  
VDC input • .1 to .7 volt  
output to tuned detector  
• narrow band electrical  
tuning • -1, 3.7-4.2 GHZ,  
\$51.16 • -5, 2.3-2.45 GHZ \$61.16 • with  
battery clip and on off switch, -2, -6,  
\$53.95, \$63.95.

**RMVO Voltage Tuned Oscillators**  
+ 12 VDC bias • -1 to -12 VDC tuning •  
1"x1½" PCB • -1, 2.1-2.5 GHZ, \$24.95  
• -2, 1.8-2.1 GHZ, \$24.95.

**RMVA Variable Attenuator**  
10 to 60 DB, 1 to 6 GHZ, \$14.95.

Also: Test Antennas, Diode Detectors,  
Dual Directional Couplers, and Line  
Stretchers.

**ROENSCH MICROWAVE**

R.R. 1, Box 156B, PH: 816-963-2550  
BROOKFIELD, MISSOURI 64628



## dataLOG

Amateur Radio Logbook program for  
the Radio Shack Color Computer with  
32k RAM, one or two disk drives and  
optional printer.

- Twenty-four hour clock
- Up to 1550 QSO's per disk
- Autolog TIME, DATE, BAND and MODE
- Instant file scan for previous QSO's
- Search by CALL, PREFIX or DATE
- Edit, update QSO/QSL information
- Seven printout routines including ALPHASORT
- Complete documentation included

dataLOG ..... \$39.00

add \$1.50 for postage and handling

dataLOG

P.O. Box 10531 • Jacksonville, FL 32247

## TOP SECRET

### MONITORING TIMES

"...the BEST communications news source." (T. Harbaugh)

"Your publication has helped monitoring grow and brought  
the thrill of listening back." (P. Steckbeck)

"Your magazine transcends simply listening to the powerful  
shortwave stations to include both interesting frequency  
listings and fascinating technical articles." (S. Westerman)

"My hobby could not be complete without MT's  
information-filled pages every month." (J. Henault)

SEND FOR YOUR FREE SAMPLE TODAY!

Grove Enterprises  
P. O. Box 98, Brasstown, NC 28902  
704-837-9200

✓352



# NOW THERE ARE 3!

### THE ARRL AMATEUR RADIO CALL DIRECTORY

Whether you are *DXCC Honor Roll*  
bound or just beginning to collect QSL  
cards for the WAS award, you'll find the  
addresses you need quickly and easily.  
There are over 453,000 listings of U.S.  
Amateur Radio licensees listed alpha-  
betically in callsign order. The section  
covering club stations is the most accu-  
rate to be found. Only \$15.75 in the U.S.  
and \$19.75 in Canada and elsewhere.

### NAME INDEX

Have the name but need the Call? This  
handy book lists licensees alphabetically  
by last name, then gives their call, you  
can refer to the *Call Directory* for  
address information. \$25.00 in the U.S.,  
\$28.50 in Canada and elsewhere. U.S.  
Listings.

### GEOGRAPHICAL INDEX

Handy listing by State, City, Street and  
Call. Perfect for the travelling amateur.  
\$25.00 in the U.S., \$28.50 in Canada and  
elsewhere. U.S. Listings.

### COMBINATION PRICES

ARRL AMATEUR RADIO CALL  
DIRECTORY AND NAME INDEX  
OR GEOGRAPHICAL INDEX  
\$36.50 U.S., \$44 in Canada or else-  
where. ALL THREE: CALL DIREC-  
TORY, NAME AND GEOGRAPHI-  
CAL INDICES: \$50 in the U.S., \$61.00  
in Canada and elsewhere.

### 1984-85 EDITIONS HOT OFF THE PRESS

Enclosed is my check or M.O. for \$\_\_\_\_\_

Name \_\_\_\_\_

Address \_\_\_\_\_

City \_\_\_\_\_ State \_\_\_\_\_ Zip \_\_\_\_\_

Payment in U. S. funds only. Prices subject to  
change without notice.

✓226

BUCKMASTER PUBLISHING  
WHITEHALL  
ROUTE 3, BOX 56  
MINERAL, VA 23117  
(703) 894-5777

## NEMAL ELECTRONICS

### COAXIAL CABLE SALE

This Month's  
Specials  
Same Day  
Shipping

#### POLYETHYLENE DIELECTRIC

RG59/U mil spec 96% shield.....14¢/ft.  
RG213 noncontaminating 95% shield mil spec. 36¢/ft.  
RG174/U mil spec. 96% shield.....10¢/ft.  
RG11U 96% shield, 75-ohm mil spec.....25¢/ft.  
RG8U 96% shield, mil spec.....\$29.95/100 ft. or 31¢/ft.  
RG6A/U double shield, 75-ohm.....25¢/ft.  
RG58AU stranded mil spec.....12¢/ft.  
RG58 mil spec. 96% shield.....11¢/ft.

#### LOW LOSS FOAM DIELECTRIC

RG8X 95% shield.....\$14.95/100 ft. or 17¢/ft.  
RG59/U 70% copper braid.....9¢/ft.  
RG8U 80% shield.....18¢/ft.  
RG58U 80% shield.....07¢/ft.  
RG58U 95% shield.....10¢/ft.  
RG59U 100% foil shield, TV type.....10¢/ft.  
RG8U 97% shield 11 ga. (equiv. Belden 8214).....31¢/ft.  
Heavy Duty Rotor Cable 2-16 ga, 6-18 ga.....36¢/ft.  
Rotor Cable 8-con. 2-18 ga, 6-22 ga.....19¢/ft.

RG8U-20 ft. PL-259 eg. end.....\$4.95  
RG214U dbl silver shield, 50 ohm.....\$1.55/ft.  
BELDEN Coax in 100 ft. rolls  
RG58U #9201.....\$11.95  
Grounding strap, heavy duty tubular braid  
3/16 in. tinned copper.....10¢/ft.  
3/8 in. tinned copper.....30¢/ft.

#### CONNECTORS MADE IN USA

Amphenol PL-259.....79¢  
PL-259 Teflon/Silver.....\$1.59  
PL-259 push-on adapter shell.....10/\$3.89  
PL-259 & SO-239.....10/\$5.89  
Double Male Connector.....\$1.79  
PL-258 Double Female Connector.....98¢  
1 ft. patch cord w/RCA type plugs each end.....3/\$1.00  
Reducer UG-175 or 176.....10/\$1.99  
UG-255 (PL-259 to BNC).....\$2.95  
Elbow (M359).....\$1.79  
F59A (TV type).....10/\$2.15  
UG 21D/U Amphenol Type N Male for RG8.....\$3.00  
BNC UG88C/U, male.....\$1.25  
3/16 inch Mike Plug for Collins etc.....\$1.25  
UG273 BNC to PL-259.....\$3.00

#### FREE CATALOG

COD add \$2.00—FLA. Res. add 5% Sales Tax

Orders under \$30.00 add \$2.00

Connectors—shipping 10% add'l, \$3.00 minimum

Cable—Shipping \$3.00 per 100 ft.

12240 NE 14th Ave., Dept. 73, No. Miami, FL 33161 Call (305) 893-3924

✓412

### Parts List

#### Plate Supply

|       |  |            |          |
|-------|--|------------|----------|
| T1    | 117-V-ac primary, 1200-1400-V at 300-mA secondary            | Fair Radio |          |
| D1-D4 | 1N5408 type, 3 A, 1000 piv                                   | Jameco     | 3/\$1.29 |
| C1-C2 | Either three 4 uF at 20000 V dc<br>or one 12 uF at 2000 V dc | Fair Radio | 4.00     |
| R2    | Bleeder—from 972 parts                                       | Fair Radio | 12.00    |

#### Screen Supply

|       |  |                    |         |
|-------|--|--------------------|---------|
| T2    | 117-V-ac primary, 700 V c-t at 50 mA<br>6.3 V at 3.5 A<br>5.0 V at 2.0 A | Fair Radio         | 5.95    |
| D5-D8 | 1N4007 type, 1 A, 1000 piv   | Jameco             | 10/1.29 |
| C3-C4 | 50 uF, 350 V, axial  | Fair Radio         | .65     |
| V1-V2 | 0A2 regulator tubes  | Fair Radio         | 2.50    |
| R3    | Bleeder—from 972 parts   |                    |         |
| R1    | Dropping resistor—from 972 parts   |                    |         |
| F1    | Fuse, 1/10 A, 250 V, AGC   | jobber/flea market |         |

#### Grid-Bias Supply

|       |  |                    |         |
|-------|--|--------------------|---------|
| T3    | 117-V-ac primary, 6.3-V secondary (hook up backwards to 5-V winding on T2) | Fair Radio         |         |
| D9    | 1N4004 type, 1 A, 400 piv  | Jameco             | 12/1.29 |
| C5-C6 | From 972 parts   |                    |         |
| D10   | 33-volt, 5-Watt zener (ECG or HEP)   | jobber/flea market |         |
| R4    | 1000-Ohm, 2-Watt carbon  | jobber/flea market |         |
| J1    | RCA female chassis mount jack  | Radio Shack        |         |

#### Miscellaneous

|       |  |                      |      |
|-------|--|----------------------|------|
| F2    | Fuse, 8 A, 250 V (AGC-8 or MDL-8)  |                      |      |
| M1    | 0-1-mA miniature panel meter (Calectro D1-1012)                              | jobber/flea market   |      |
| R5    | .1-Ohm, 10-Watt resistor   | Fair Radio           |      |
| R6    | 5k-Ohm, 2-Watt potentiometer   | Jameco               |      |
| R7-R8 | 3.3-Ohm, 2-Watt resistors  | Jameco               |      |
| R9    | .3-Ohm, 2-Watt resistor  | Fair Radio           |      |
| S1-S2 | DPST switches, 8-A, 125-V-ac rating  | Fair Radio           |      |
| I1-I2 | NE-51-type indicator lamps, or preassembled<br>120-V-ac indicator assemblies | Jameco               |      |
| T4    | 117-V-ac primary, 25.2-V secondary   | Radio Shack 273-1512 | 5.99 |
|       | Fuse holder (2)  | Jameco               |      |
|       | Ac cord and plug   | jobber/flea market   |      |
|       | Shaft couplings (2) and extensions   | Fair Radio           |      |
|       | Knobs, 1/4" (3)  | Radio Shack          |      |

Note: Prices and sources for some parts are not specific due to widespread availability, both surplus through Fair Radio and at flea markets. You should have little trouble finding what you need. For a free copy of Fair Radio's latest catalog, write Fair Radio Sales, PO Box 1105, Lima OH 45802.

is available in most electronics parts stores. With the shunts called for, it will give you the current ranges desired—0-500 mA for plate current and 0-30 mA for screen and grid current. If you're clever, you might find a way to mount it to cover the two terminal-strip knockouts. If you're lazy (like me), you can mount it above the Meter callout and leave the other hole blank. The leads that went to the terminal strip now go right to the meter. I ran all new shielded two-conductor cables to all sampling points and the meter itself. *Caution:* Check the polarity on the grid-current resistor,

otherwise the pointer will go off scale reversed and possibly damage the movement.

Eimac tells us that 4X150As last longer if the filament voltage is allowed to come up without plate and screen voltages for about 3 minutes. To facilitate this and solve the tricky problem of bringing the plate and screen voltages up at the same time, I wired up a Plate switch on the front panel. This is nothing more than a DPST switch, one side of which controls the plate primary supply and the other of which cuts off the screen voltage right before the octal socket. If you place the switch as I did,

you'll find that it lines up perfectly with the socket. An indicator light can be placed across the primary to show plate power is "up."

A good place for the ac mains fuse is right behind the meter on the top chassis. I used a clip-in-type fuse holder. If it blows, the cover can be quickly removed to gain access. Make this a 8-10-Amp MDL slow-blow for the current surge when the plate capacitors charge up. Wire your primary ac switch to bring up the grid-bias supply, filament voltages, and blower. Install an NE-51-type indicator across the transformer primary. If you are using a multi-tap

transformer, wire its primary in parallel with the blower. This will bring up the grid supply, blower, filament, and screen, but the screen won't be in the circuit until you throw the plate switch.

Now you are ready to test the tube! You'll need a couple of voltmeters capable of reading 0-250 V dc and 0-2000 V dc. Connect the minus lead of the first to the bias line and ground the positive lead. Using high-voltage probes, *carefully* connect the positive lead of the second meter to the capacitor terminals and the negative lead to the minus side of the supply—*not ground*. Connect the HV-to-rf-compartment plug and plug in the octal plug. If you haven't done so, remove the screws that hold the rf compartment cover down. *Be careful—there is plenty of high voltage present!*

With the 4X150A in the socket and seated, turn the ac power on. Wait three minutes for the tube to warm up. Then, turn the plate supply on. You should be seeing about 1500-1700 volts on the plate and -135 to -150 volts on the grid. (You can also verify the 300 volts on the screen if need be, but the 0A2s should be glowing purple at this point.) With the bias-adjust control at its maximum resistance, ground J1. You should see somewhat of a drop in the grid voltage. While keeping J1 grounded, adjust R1 for about 100 milliamperes of plate current. Then, remove the ground from J1, and the plate current should drop to zero.

Again, ground the key line and verify that the plate current is back at about 100 milliamperes idling. If so, you have now set the tube to run in class AB<sub>1</sub>—linear. The blower should be forcing a little warm air around the tube chimney. At this point you are running about 150 Watts dissipation (not power). If the above instructions check out, you're

# Orbit



**ORBIT** is the Official Journal for the Radio Amateur Satellite Corporation.



For a **SAMPLE COPY** please send \$2 to:

(AMSAT), P.O. Box 27, Washington, DC 20047.

TRIONYX INC MANUFACTURER OF ELECTRONIC TEST EQUIPMENT 600 MHZ FREQUENCY COUNTERS \$ 159.95 2 METER 5/8 WAVE HT

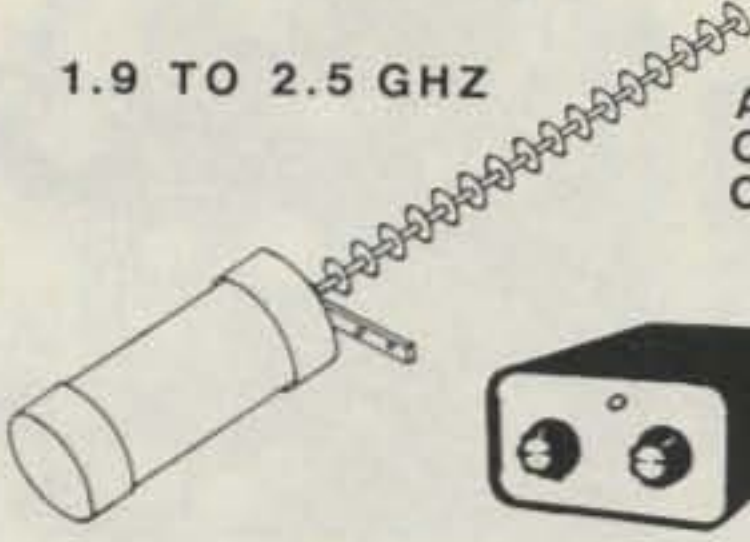

## COMPLETE SYSTEMS

1.9 TO 2.5 GHZ BUILT ANTENNA AND VARIABLE TUNER OPERATES ON TV CHANNELS 2 THRU 6

**\$59.95**

ALL SYSTEMS INCLUDES DETAILED INSTRUCTION

|   |   |
|---|---|
| <p>DOWN CONVERTER BOARD &amp; PARTS KIT</p>  <p><b>9.95</b></p>  | <p>VARIABLE POWER SUPPLY BOARD &amp; PARTS KIT</p>  <p><b>9.95</b></p> <p>ALUMINUM CABINET ALL HOLES PRE-PUNCHED <b>\$6.95</b></p>                       |
| <p>MICROWAVE ANTENNA KIT ..... <b>\$9.95</b><br/>                 DOWN CONV KIT ..... <b>\$9.95</b><br/>                 POWER SUPPLY KIT <b>\$9.95</b><br/>                 CABINET..... <b>\$6.95</b><br/> <b>\$36.80</b></p> | <p>ALL RG59/U COAX CABLES COME WITH CONNECTOR ATTACHED</p> <p>100 FT ..... <b>\$15.95</b><br/>                 75 FT ..... <b>\$13.95</b><br/>                 50 FT ..... <b>\$10.95</b><br/>                 3 FT ..... <b>\$2.50</b></p> |

DC TO DC H.T. CHARGERS \$9.95 AMATEUR TV MICROWAVE SYSTEMS AND KITS

**TRIONYX INC** 104 PHONE OR MAIL (317) 291 7280 291 2995  
 6219 COFFMAN RD. INDIANAPOLIS, IN 46268  
 ADD \$3.50 FOR SHIPPING

VISA MasterCard American Express

ANTENNA \$ 12.95 RUBBER DUCKS FORM \$6.95 TO \$7.95

# NCG Co. NEW-TECHNOLOGY HIGH-QUALITY

AFFORDABLE TRANSCEIVERS FOR ALL. WINNERS IN COMPARISON HANDS DOWN!

**10/160 M HF TRANSCEIVER**

**40-15-6 M NEW TRI-BANDER**

**15 M 15 METER MOBILE**



JUST SLIGHTLY AHEAD! WITH THE QUALITY YOU HAVE ALWAYS LOOKED FOR!

4 MEMORIES - 3 WAY AUTO SCAN, DUAL VFO, IF SHIFT, CW-W, 400 Hz. CW-N 200 Hz. ALL 9 BANDS PLUS MARS. BUILT IN AC/DC POWER. SSB. CW OR RTTY. I.F. TUNE 3-STEP TUNING SPEED, 200 WATT PEP, MICROPHONE IMPEDANCE 600-50K OHM HAND MIC. INCLUDED.

**\$849.50**

40, 15 AND 6 METERS ARE YOUR BASE STATION OR MOBILE WITH AC/DC BUILT IN POWER SUPPLY CW-N 200 Hz OR USB, 2.S0239 ANTENNA CONNECTORS, HAND MIC. BUILT IN TV FILTER LITTLE TO NO TV INTERFERENCE, 20 WATTS PEP, MARS ON 40 AND 6 METERS.

**\$445.50**

A GREAT QRP RIG WITH THE BIG RIG SIGNAL, 2 WATTS OR 10 WATTS OUT, BUILT IN CW SIDE TONE, DIGITAL DISPLAY, HAND MIC. TOP MOUNTED SPEAKER. MOBILE BRACKET, RIT OR FINE TUNE TX&RX. +4KHz, 21 TO 21.450 MHz SIGNAL TO NOISE MORE THAN 10dB DOWN.

**\$249.50**



254

90 DAY WARRANTY ON ALL TRANSCEIVERS - DIRECT FROM NCG OR YOUR DEALER

WE HAVE 1.2 GHz BASE/REPEATER & MOBILE ANTENNAS

1275 N. Grove Street, Anaheim, CA 92806 (714) 630-4541

NOTE: PRICES AND SPECIFICATIONS SUBJECT TO CHANGE WITHOUT NOTICE OR OBLIGATION.

# AMATEUR TELEVISION



## KPA5 1 WATT 70 CM ATV TRANSMITTER BOARD

- **APPLICATIONS:** Cordless portable TV camera for races & other public service events, remote VCR, etc. Remote control of R/C airplanes or robots. Show home video tapes, computer programs, repeat SSTV to local ATVers. DX depends on antennas and terrain typ. 1 to 40 miles.
- **FULL COLOR VIDEO & SOUND** on one small 3.25x4" board.
- **RUNS ON EXTERNAL 13.8 VDC** at 300 ma supply or battery.
- **TUNED WITH ONE CRYSTAL** on 426.25, 434.0, or 439.25 MHz.
- **2 AUDIO INPUTS** for a low Z dynamic and line level audio input found in most portable color cameras, VCRs, or home computers.
- **APPLICATION NOTES & schematic** supplied for typical external connections, packaging, and system operation.
- **PRICE ONLY \$159** delivered via UPS surface in the USA. Technician class amateur license or higher required for purchase and operation.

**WHAT IS REQUIRED FOR A COMPLETE OPERATING SYSTEM?** A TV set with a TVC-2 or TVC-4 420-450 MHz to channel 3 downconverter, 70 cm antenna, and coax cable to receive. Package up the KPA5, add 12 to 14 vdc, antenna, and any TV camera, VCR, or computer with a composite video output. Simple, eh?

**CALL OR WRITE FOR OUR COMPLETE CATALOG & more info** on atv downconverters, antennas, cameras, etc., or who is on in your area.

**TERMS:** Visa, Mastercard, or cash only UPS COD by telephone or mail. Telephone orders & postal MO usually shipped within 2 days, all other checks must clear before shipment. Transmitting equipment sold only to licensed amateurs verified in 1984 Callbook. Calif. include sales tax.

(818) 447-4565 m-f 8am-6pm pst.

**P.C. ELECTRONICS**  
Tom W60RG Maryann WB6YSS



2522 Paxson Lane  
Arcadia CA 91006

ready to drive the tube and make power.

*Note:* If at this point the idling current still reads zero or very low, you may either have a bad tube or insufficient screen voltage getting to the tube. Check all connections carefully.

Connect your exciter (preferably 1-2 Watts—an HT is fine for tests) to the input connector on the back using

a short length of cable. Connect either a 300-Watt dummy load or an antenna to the output jack on the back. Turn the plate switch on and key your rig or exciter. Using a dummy load, peak first the grid and then the plate-load controls on the front panel for maximum output with minimum grid and plate current. On most of the 972s, you will also have to tune

the plate capacitor for resonance. This is a screw next to the tube inside the plate compartment. *Caution: This screw has plate voltage on it. Be careful! Use a noninductive tuning tool to make the adjustment.* In most cases, once you set this screw, you can make excursions across 2 MHz or so without an appreciable loss in power.

Carefully tune plate and grid for maximum output. You'll find that in AB<sub>1</sub> it will take only about 1-2 Watts to give 250-300 Watts of output power. Not bad, eh? That's close to 20 dB of gain, and think of what your 16-dB-gain antenna can do with that! If you prefer to run more drive power, simply set the idling current lower to about 50 mA, and it will take more drive (5-10 Watts) to achieve full output. What is full output? The 4X150A is rated at about 250 Watts maximum dissipation and peak current of 400 mA in SSB operation. Keeping the current down to 300-350 mA is a good idea, and you'll still be making lots of power.

The 4CX250B can be substituted with equally effective results. The only difference is that 4X150As are frequently available at flea markets for as low as \$5.00 each, used, while good used 4CX250Bs generally run more than \$15.00 each. You'll also find the spectral purity of this amplifier is excellent, making it ideal for repeater use. It'll sit all day and run 100 Watts without breathing hard!

You can obtain shaft couplings and extensions at flea markets to bring the plate-load and grid-tuning controls out to knobs on the

front panel as I did. Or, you can just make the adjustments with a screwdriver, as they won't drift much. The key line to J1 can be hooked up to any radio with an external-amplifier keying jack. If you prefer, the circuit in Fig. 5 shows a simple rf sniffer using a Darlington transistor to switch a relay and establish bias. Additionally, if you have a Dow-key relay for the antenna line, you can hook it to the output and use the spare contacts to set the bias. Simply run the line from J1 to the relay instead and ground the closure contact. 12 V dc for the relay can be obtained from a diode off the tap on the blower transformer (sneaky, eh what!) and the jack on the rear panel can be used now to create the ground return for the relay operating voltage. This is the method I use, with an ICOM IC-740 driving an MMT 144-28 into the amplifier. The ICOM has an RCA jack that will key on transmit.

And there you have it! A 300-Watt, tube-type VHF amplifier for a nominal sum and some weekend work. If this doesn't get you on 144-MHz aurora, I don't know what will! If you have any questions about the amplifier when building it, send along a SASE for the reply, and I'll try to help out.

I would like to thank Steve Katz WB2WIK, who was most helpful with the conversion and convinced me to write this article, Mike Crawford WA2VUN, who punched the front panel at his shop, and my wife, Gayle KA9ESB, who sees all these "boxes" disappearing into the basement and doesn't give it a second thought. ■

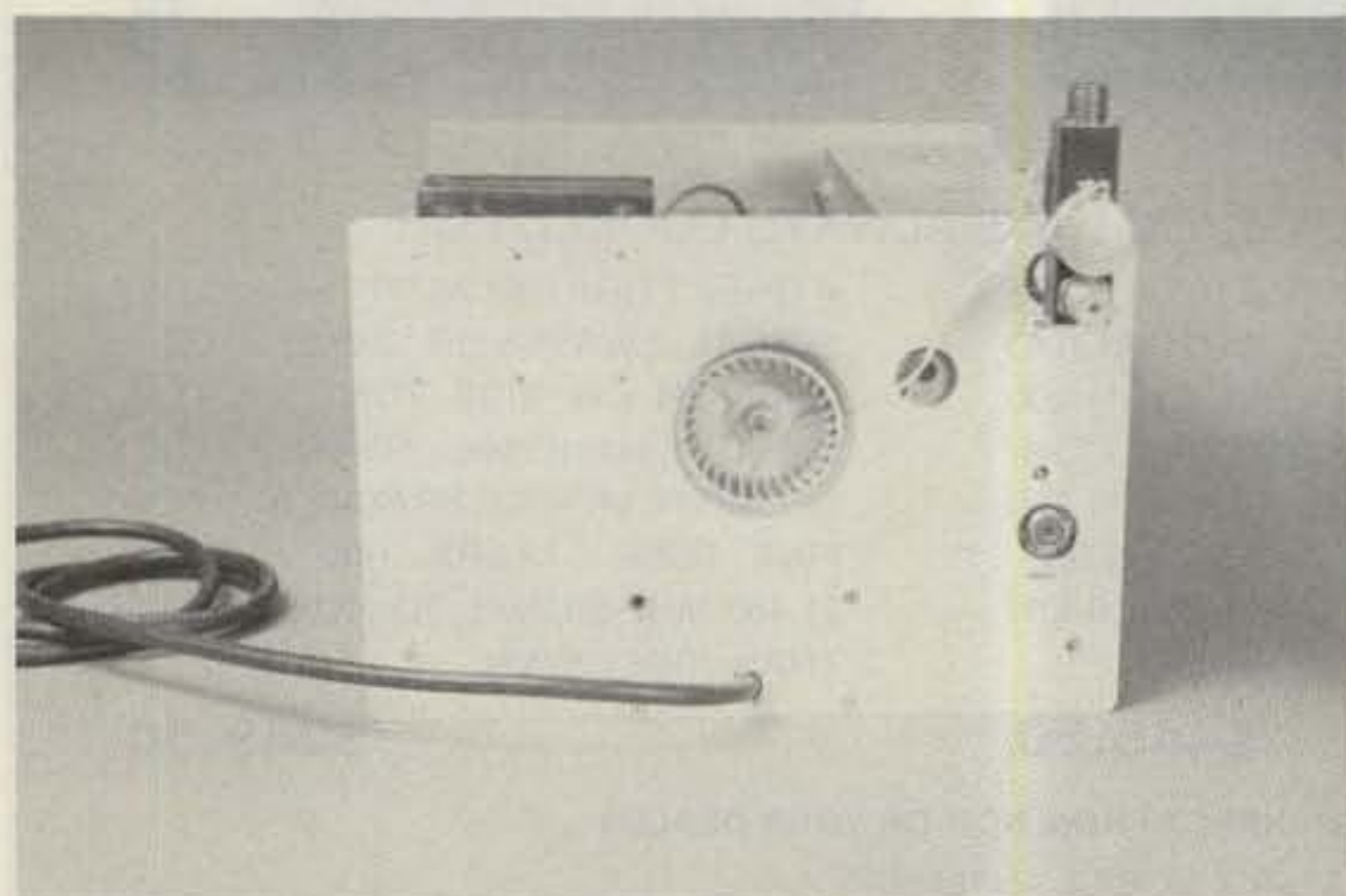

Photo D. Rear view of the completed unit after repainting. Note the position of the rf keying jack.

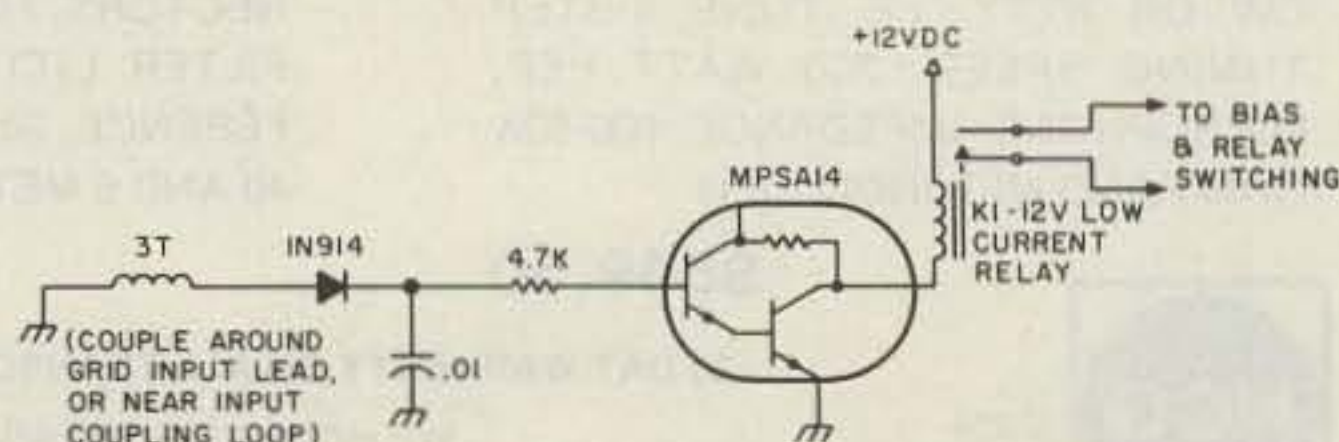

Fig. 5. Rf sniffer circuit—for keying with any radio using sensed rf.

WE SHIP WORLDWIDE

# Barry Electronics Corp.

WORLD WIDE AMATEUR RADIO SINCE 1950

Your one source for all Radio Equipment!

For the best buys in town call:  
212-925-7000  
Los Precios Mas Bajos en Nueva York...



Ring in the New Year  
With the best of Barry's New Gear

KITTY SAYS: WE ARE NOW OPEN 7 DAYS A WEEK.  
Saturday & Sunday 10 to 5 P.M.

Monday-Friday 9 to 6:30 PM Thurs. to 8 PM  
Come to Barry's for the best buys in town.

ONV Safety  
belts-in stock



ICOM

IC-R71A, IC-751, IC745, IC-27A/H, IC-37A  
IC-47A, IC-271A/H, IC-2KL, IC-471A/H



YAESU

FT-ONE, FT-980, FT-757GX  
FT-726R, FT-77, New 2-meter coming

YAESU FT-203/103R  
FT-209RH  
FT-1903  
ICOM IC2AT  
ICO2AT  
IC-04AT  
Land-Mobile H/T  
Midland/Standard  
Wilson Mini-Com II  
Yaesu FTC-2203, FT-4703  
Icom IC-M12 (Marine) M700  
Tempo M-1



SMART PATCH

CES-Simplex Autopatch 510-SA Will Patch FM  
Transceiver To Your Telephone. Great For  
Telephone Calls From Mobile To Base. Simple  
To Use - \$319.95.

KENWOOD



FLUKE 77  
stocked

R-600, R-1000, R-2000, TS-930S/AT,  
TS 430S, TR2600A/3500, TR 7950,  
TW-4000A. Kenwood Service/Re-  
pair. TH-21AT, TH-41AT, TM-211A/  
411A & TS-711A/811A



ROCKWELL/COLLINS  
KWM-380

VoCom/Mirage/Daiwa Large inventory of  
Tokyo Hy-Power Saxton Wire & Cable  
Amplifiers &  
5/8 HT Gain Antennas IN STOCK

AMERITRON AUTHORIZED DEALER



Computer Interfaces  
stocked: MFJ-1224  
AEA CP-1, PK-1, DR. DX  
Phillystran Authorized  
Distributor



ALPHA AMPLIFIERS  
Repeaters Stocked:  
Spectrum Communications  
Yaesu FTR-2410, Wilson  
ICOM IC-RP 3010 (440 MHz)  
ICOM IC-RP 1210 (1.2 GHz)

SANTEC  
ST-222/UP  
ST-142/UP  
ST-442/UP  
HT-7



MFJ Models  
900, 981, 941C, & 941D

HAM MasterTapes—  
Beta or VHS Tapes

MURCH  
Model  
2000 A,  
A-LS, B  
in stock

JBC soldering line in stock.

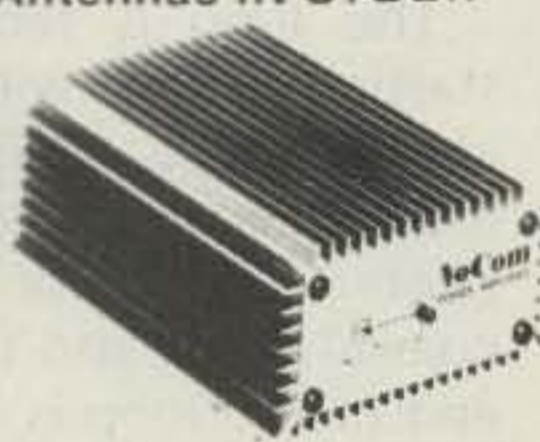

MICROLOG-AIR I, Air Disk

KANTRONICS

UTU, Interface II, Challenger

EIMAC  
3-500Z  
572B, 6JS6C  
12BY7A &  
4-400A

BIRD  
Wattmeters &  
Elements  
In Stock



AEA 144 MHz  
AEA 440 MHz  
ANTENNAS



Complete Butternut Antenna  
Inventory In Stock!

Heil microphones &  
equalizers in stock

Long-range Wireless  
Telephone for export in stock

BENCHER PADDLES,  
BALUNS, AUDIO FILTERS,  
IN STOCK

Fox-Tango Filters  
LUNAR PREAMPS STOCKED  
DENTRON IS BACK IN STOCK!

DIGITAL  
FREQUENCY  
COUNTERS

Trionyx-  
Model TR-1000  
0-600 MHz  
Pro-Corn Engineering  
0-1 GHz



New TEN-TEC  
2591 HT, Corsairs stocked

Tri-Ex Towers  
Hy-Gain Towers  
& Antennas, and  
Rotors will be  
shipped direct to  
you FREE of  
shipping cost.

MAIL ALL ORDERS TO BARRY ELECTRONICS CORP., 512 BROADWAY, NEW YORK CITY, NY 10012.

New York City's LARGEST STOCKING HAM DEALER  
COMPLETE REPAIR LAB ON PREMISES

"Aqui Se Habla Espanol"

BARRY INTERNATIONAL TELEX 12-7670  
TOP TRADES GIVEN ON USED EQUIPMENT  
Monday-Friday 9 A.M. to 6:30 P.M.  
Thursday to 8 P.M.  
Saturday & Sunday 10 A.M. to 5 P.M. (Free Parking)

AUTHORIZED DIST. MCKAY DYMEK FOR  
SHORTWAVE ANTENNAS & RECEIVERS.

IRT/LEX-"Spring St. Station"

Subways: BMT-"Prince St. Station"

IND-"F" Train-Bwy. Station"

Bus: Broadway #6 to Spring St.

Path-9th St./6th Ave. Station.

Commercial Equipment  
Stocked: ICOM, MAXON,  
Midland, Standard, Wil-  
son, Yaesu. We serve  
municipalities, busi-  
nesses, Civil Defense,  
etc. Portables, mobiles,  
bases, repeaters...

We Stock: AEA, ARRL, Alpha, Ameco, Antenna Specialists, Astatic,  
Astron, B & K, B & W, Bash, Bencher, Bird, Butternut, CDE, CES, Collins,  
Communications Spec. Connectors, Covercraft, Cubic (Swan), Cushcraft,  
Daiwa, Dentron, Digimax, Drake, ETO (Alpha), Eimac, Encomm, Heil-  
Sound, Henry, Hustler (Newtronics), Hy-Gain, Icom, KLM, Kantronics,  
Larsen, MCM (Daiwa), MFJ, J.W. Miller, Mini-Products, Mirage,  
Newtronics, Nye Viking, Palomar, RF Products, Radio Amateur Callbook,  
Robot, Rockwell Collins, Saxton, Shure, Swan, Telex, Tempo, Ten-Tec,  
Tokyo Hi Power, Trionyx TUBES, W2AU, Waber, Wilson, Yaesu Ham and  
Commercial Radios, Vocom, Vibroplex, Curtis, Tri-Ex, Wacom Duplexers,  
Repeaters, Phelps Dodge, Fanon Intercoms, Scanners, Crystals, Radio  
Publications.

WE NOW STOCK COMMERCIAL COMMUNICATIONS SYSTEMS

DEALER INQUIRIES INVITED. PHONE IN YOUR ORDER & BE REIMBURSED.

COMMERCIAL RADIOS stocked & serviced on premises.

Amateur Radio Courses Given On Our Premises, Call

Export Orders Shipped Immediately. TELEX 12-7670

## A Space-Saver Seven Megger

*Stuffing full-wave 40m loops into tiny places is W8TYX's specialty. We finally got him to tell us how he does it.*

When my only antenna, a roof-mounted vertical for 7 MHz, failed during the winter, I was not able to repair it because of the cold weather. I needed a replacement, but no trees, towers, or tall buildings were available for supports. After some experimentation I arrived at a (more or less) horizontal loop antenna which has performed surprisingly well.

Fig. 1 shows the general layout of the loop antenna. It is a closed loop with a total electrical length of about one wavelength at 7 MHz. I used no. 20 copper wire because that is what I had; the size of the wire is not important.

The loop begins under the house eaves about 8 feet above the ground and continues to the corner of the house about 24 feet away.

The loop continues from the corner of the house to the corner of the garage, a distance of about 24 feet. The corner of the garage is about 7 feet above the ground. From there the loop continues to the peak of the garage roof, a distance of about 11 feet where it reaches its highest point, about 11 feet above the ground. The loop then continues to the far corner of the garage, a distance of 19 feet, descending to a height of about 7 feet.

From there the loop goes to the eaves under another corner of the house, a distance of about 25 feet; the height here is about 8 feet. The loop then goes vertically down the side of the house about 5 feet. The purpose of this "jog" in the loop is to add length and make the antenna resonant at the desired frequency in the 7-MHz band. The loop then goes horizontally for a distance of about 7 feet, then more or less vertically back up to the eaves, and then horizontally for a dis-

tance of 6 feet back to the starting point.

The loop is fed at the starting point with RG-8 coaxial cable. One end of the loop is connected to the center conductor of the coaxial cable and the other end of the loop is connected to the shield.

The jog in the loop, described above, was not in the original version of the antenna. It was added after measurements with a noise bridge showed that the resonant frequency of the antenna was too high. The dimensions cited above were not "designed." Rather, I used the space and the supports which were available and then adjusted the overall length of the loop to make it resonant at the desired frequency near the low end of the 40-meter band.

If you build a similar antenna, use what you have in the way of space and supports and start with a total length of the loop equal to about one wavelength at the desired operating fre-

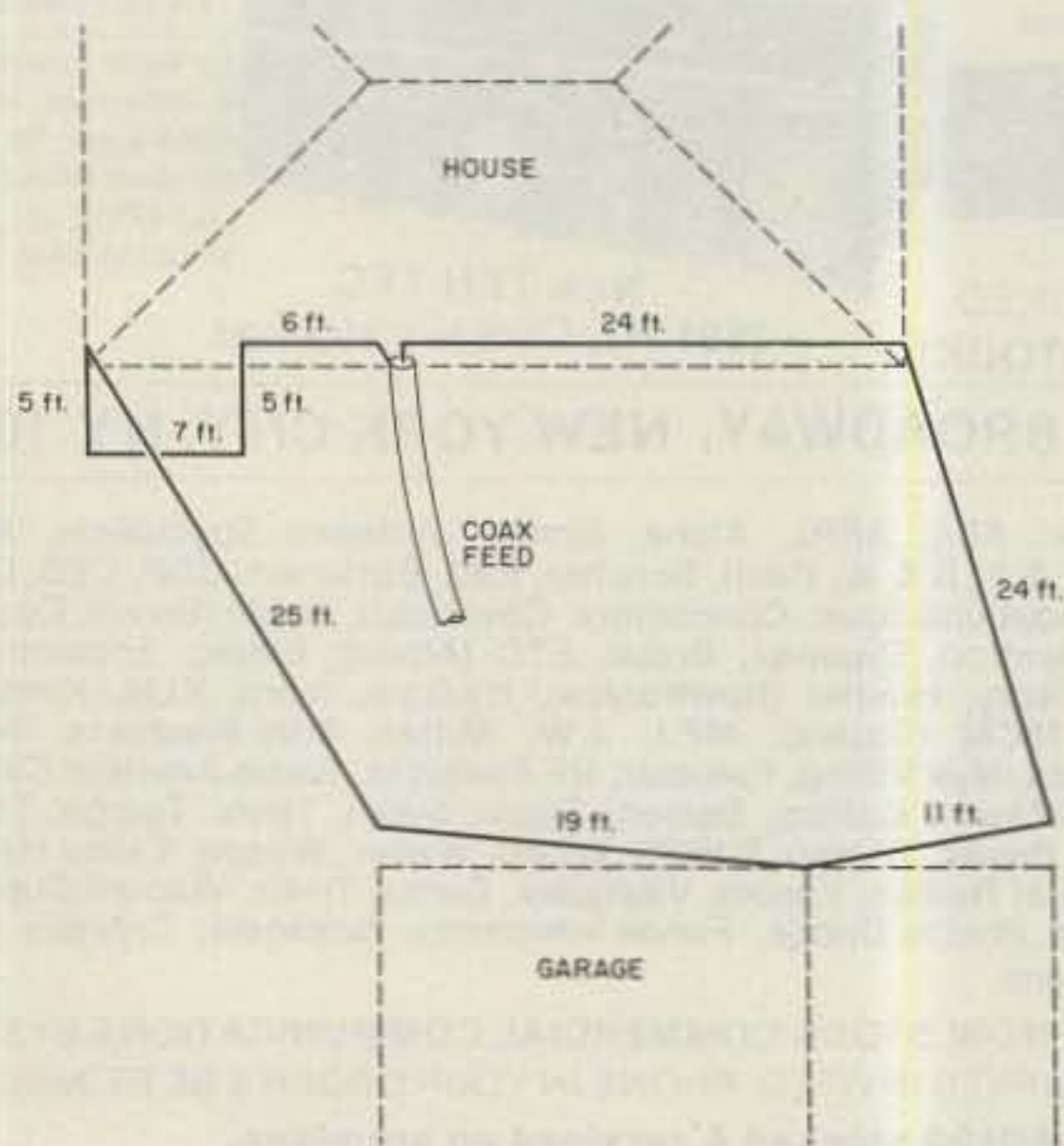

Fig. 1. General layout of the loop antenna.

quency. A wavelength is given by the expression:  $\lambda = 935/f$  where  $\lambda$  = wavelength (feet) and  $f$  = frequency (megahertz).

After you have erected the loop with the calculated total length, measure its resonant frequency using a grid-dip meter, an SWR bridge, or a noise bridge. The calculated length is just a starting point. The resonant frequency of the antenna will be affected by the presence of nearby objects and its height above ground. Adjust the length of the loop to obtain the desired resonant frequency. An increase in length will decrease the resonant frequency, while a decrease in length will increase the resonant frequency.

Fig. 2 shows the vswr (voltage-standing-wave ratio) of the completed loop as a function of frequency for the 40-meter band. These measurements were made at the far end of a

50-foot length of RG-8 coaxial cable which was connected to the loop. The bandwidth for a reasonable vswr covers most of the CW portion of the 40-meter band. I do not have equipment to measure the impedance of the antenna, but the minimum vswr of 1.2 to 1 indicates that the driving impedance at resonance is a reasonable match for the 50-Ohm impedance of the coaxial feedline. Measurements of my (repaired) vertical antenna are shown for comparison.

A horizontal loop antenna radiates most of its energy at high angles with respect to the earth. So this is not a low-angle DX antenna. However, on 7 MHz it performed well on short hops out to a few hundred miles. The best DX I worked using this antenna was OK1APV in Czechoslovakia, but band conditions were good that night. It

consistently performed well with stations out to about 500 miles; beyond that distance my vertical antenna did better.

After the 10-MHz band opened, I shortened the overall length of the loop and made it resonant for that band. Fig. 3 shows the vswr of that loop across the 30-meter band; it is less than 1.2 to 1 over the entire band. I have worked VK3AGW twice using this simple antenna.

If you are stuck without an antenna or just want to

try a different type of antenna, give this horizontal loop a try. It's not a world-beater for DX, but it is simple, easy to put up and adjust, and works reasonably well. That's a good combination. ■

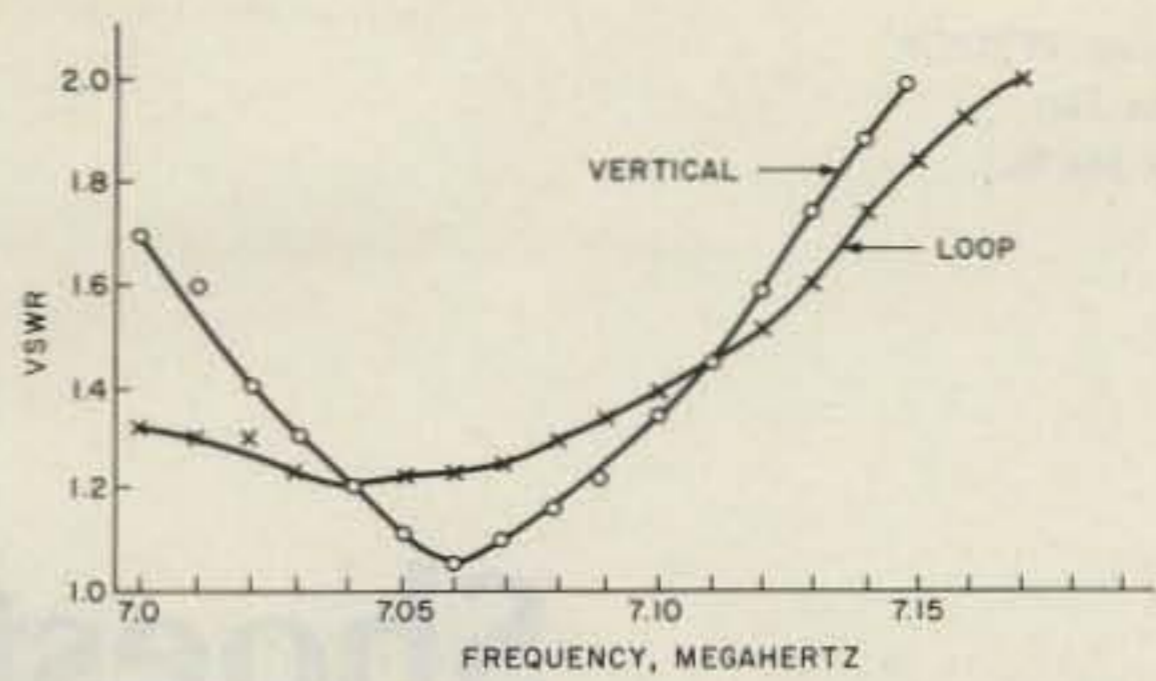

Fig. 2. The vswr of the 7-MHz loop.

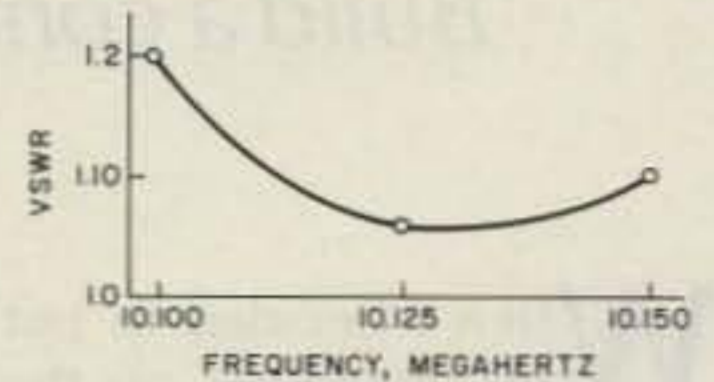

Fig. 3. The vswr of the 10-MHz loop.

## BEEPERS!



**IF YOU HAVEN'T HEARD OUR BEEPERS YOU'RE NOT LISTENING!**

What's a BEEPER? Sometimes called a "courtesy beep," both Faxscan BEEPERS add a gentle high frequency beep automatically to the beginning of each transmission and a low beep at the end. "Talk-over" is a thing of the past! INTRODUCING BP-4 "The PRO" BEEPER. The PRO is state-of-the-art beeping! Includes a digitally-programmable timer (use it for ID or timeout warnings), an automatic "Slumber Mode" for long battery life (9V battery required—not included), and programmable volume control of the unique double 4-beep timeout warning. No speaker! Uses a piezo-transducer!

Hook-up's a snap with either model! Interfaces to virtually all modern gear. Manual supplied with each BEEPER. Available in three versions:

- "A" versions are complete with case, cable, industry-standard 4-pin connectors
- "B" versions are the same as above but without connectors. Add your own!
- "C" versions are circuit-board models for custom installations. Perfect for repeaters or building INTO your rig

**BEEPERS ARE A FAXSCAN EXCLUSIVE!**

| BP-4 "The PRO" BEEPER | BP-3 "The Original" BEEPER |
|-----------------------|----------------------------|
| A- \$79               | A- \$59                    |
| B- \$69               | B- \$49                    |
| C- \$49               | C- \$29                    |

Ohio residents add 6% sales tax

FAXSCAN INC. 99  
3148 Dorf Drive • Dayton, Ohio 45418

## HOT ROD ANTENNA

Achieve 1 or 2 db gain over ANY 1/2 wave two meter telescopic antenna. The AEA model HR-1 Hot Rod™ antenna was designed by Dr. D.K. Reynolds (designer of the IsoPole) to deliver maximum performance for any hand-held transceiver with a BNC fitting.

The factory-tuned HR-1 is 20% shorter, lighter and places far less stress on your hand-held connector and case. It will easily handle over 25 watts of power, making it an excellent emergency base or mobile antenna. In the collapsed position, the Hot Rod antenna will perform like a helical quarter wave.

The Hot Rod antennas can be expected to make the same improvement to hand-held communications that the IsoPole brand antennas have made to base station operations. Why pay more when the best costs less?

Prices and Specifications subject to change without notice or obligation.

**ADVANCED ELECTRONIC APPLICATIONS, INC.**

P.O. Box C-2160,  
Lynnwood, WA 98036  
(206) 775-7373  
Telex: 152571 AEA INTL

**AEA** Brings you the Breakthrough!

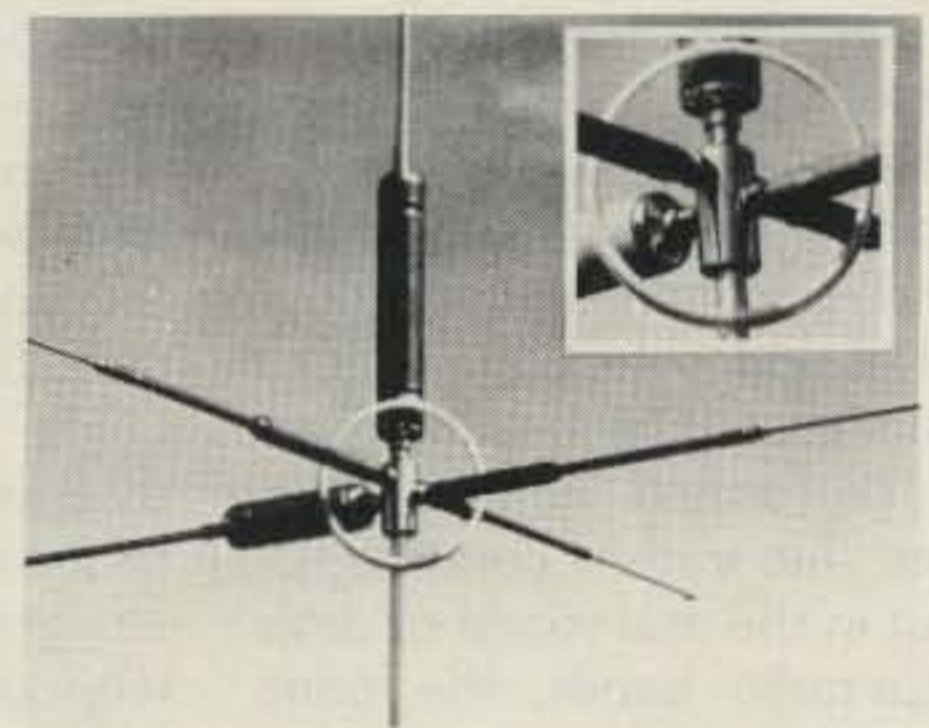

**X-PANDA-FIVE \$15.00**

(Plus \$1.50 Shipping & Handling. Florida Residents Add 5%.)  
(Foreign orders please add \$5.00 US funds for Shipping)

- X-PANDA-FIVE converts your Hustler or Hy-Gain mobile antenna from one to five bands. Add as many resonators for the bands you wish to operate. Adjust resonators for minimum SWR, no stopping to change bands any more.
- X-PANDA-FIVE with proper resonators and good ground plane makes an ideal system for apartments and condominiums.
- X-PANDA-FIVE can be used to make a multi-band antenna system for vans, campers, motor homes and travel trailers.
- X-PANDA-FIVE will accept either regular or super size resonators

Name \_\_\_\_\_  
Cali \_\_\_\_\_  
QTH \_\_\_\_\_

To: J.L. INDUSTRIES  
P.O. Box 547, Hallandale, FL 33009

# Shoestring RTTY

*Build a commercial-quality computer interface for under \$30.*

When I decided to put my computer on the air and see what was happening on the RTTY scene, I set out to design and build a simple interface that would provide accurate decoding of received Teletype® and CW signals and allow the computer to key either the FSK or the CW input of the transceiver. I wanted to spend less money but, hopefully, get as much performance as buying a commercially made interface.

My first attempt was a very simple circuit using phase-locked-loop tone decoders to detect the mark and space tones. It had post-detection filtering and one bandpass filter on the input. It performed perfectly under "laboratory conditions," but in the real world of amateur-radio bands, the print-out was often rather confusing. Something better was obviously needed.

Having heard that active filters were hard to design, build, and adjust, I was reluctant to begin design of a filter-type decoder. I rather cautiously breadboarded a basic state-variable filter circuit using the TL-084 bi-FET op amp and found that it worked perfectly on the first try, didn't oscillate or ring, and provided a very high Q at the design frequency which came out exactly where the formulas had predicted. Since that was the hard part of the design, the rest went smoothly and I was on the air with just a few days work and only about \$30 spent out of the ham-radio budget.

Fig. 1 shows the circuit diagram of the interface. I feel it is about as simple and straightforward as possible without compromising performance. All switching is done with single-pole switches and no tuning is re-

quired after initial setup. The switching arrangement lends itself well to push-button operation and a very modern look is possible using the switch assembly shown in the accompanying photographs.

## How It Works

The audio signal enters at J1 and goes through a band-pass filter (BPF) centered at 2210 Hz. This filter is used only for 170-Hz-shift RTTY and can be switched out with S1 for wider shifts.

The signal then goes to U1, a 741 op amp, which with S2 closed operates as a limiter, producing a square-wave output at the frequency of the strongest signal in the passband. With S1 open, the op amp operates as a conventional amplifier that does not clip the signal at normal volume levels. Normal operation is in the FM or limiting mode, which pro-

vides better performance on weak or noisy signals. The AM mode can prove useful if there are two signals close together and the tendency of the limiter to capture the stronger signal is not desirable.

The output of U1 is then attenuated slightly by the voltage divider consisting of R4 and R5 so as not to overload the following filter stages. It is fed to the inputs of three BPFs consisting of a 2125-Hz filter for the mark tone and 2295- and 2550-Hz filters for the space tones corresponding to 170- and 425-Hz shifts, respectively. The reason for choosing these shifts is that my primary interests are in ham operation on the HF bands (nearly all 170-Hz shift) and commercial shortwave teletype (usually 425-Hz shift). Any shift can be copied in the single-tone mode (selected by S4). Since 850-Hz shift



The completed interface. The round object above the switches is the tuning meter.

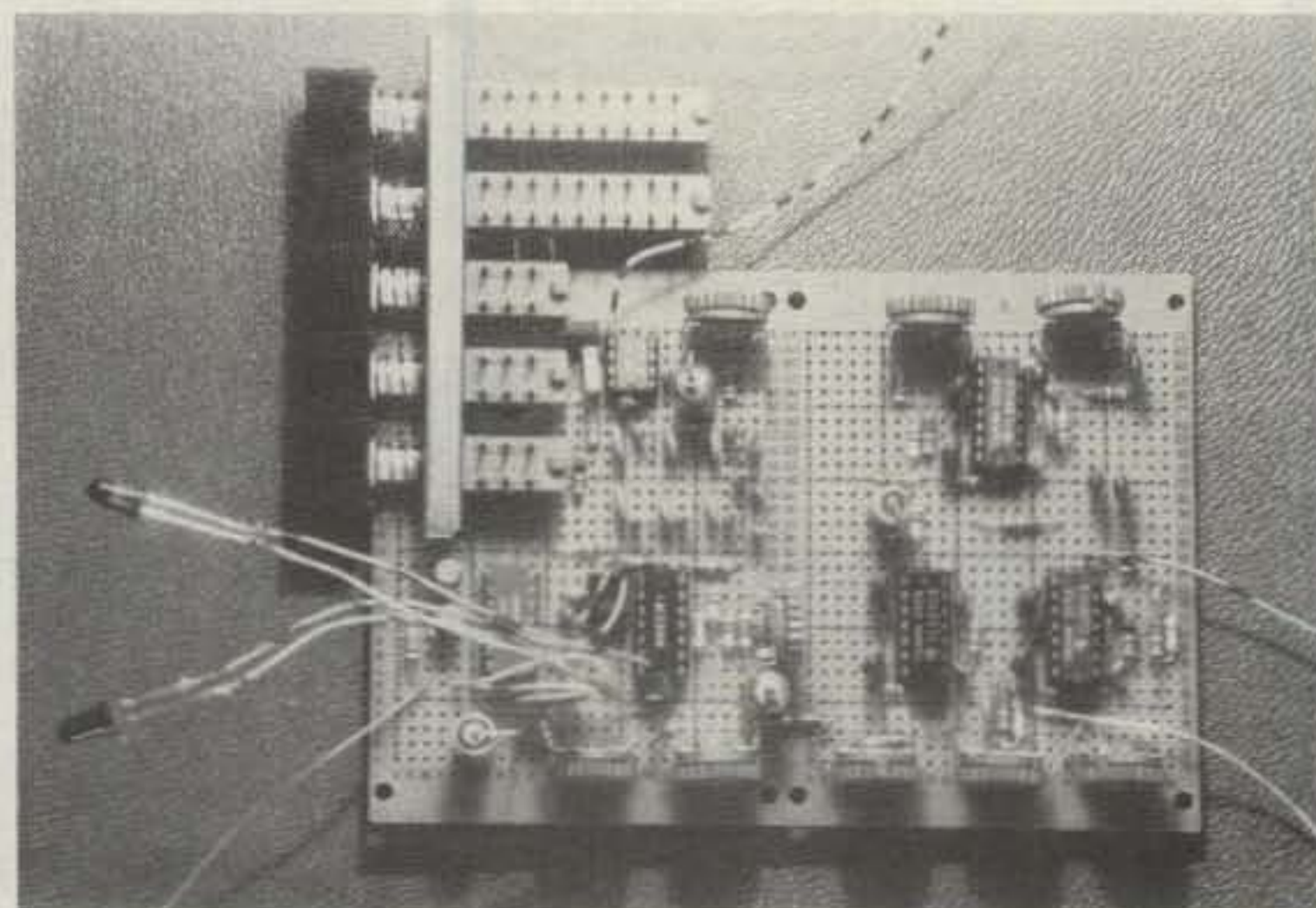

The circuit board with the switch assembly attached.



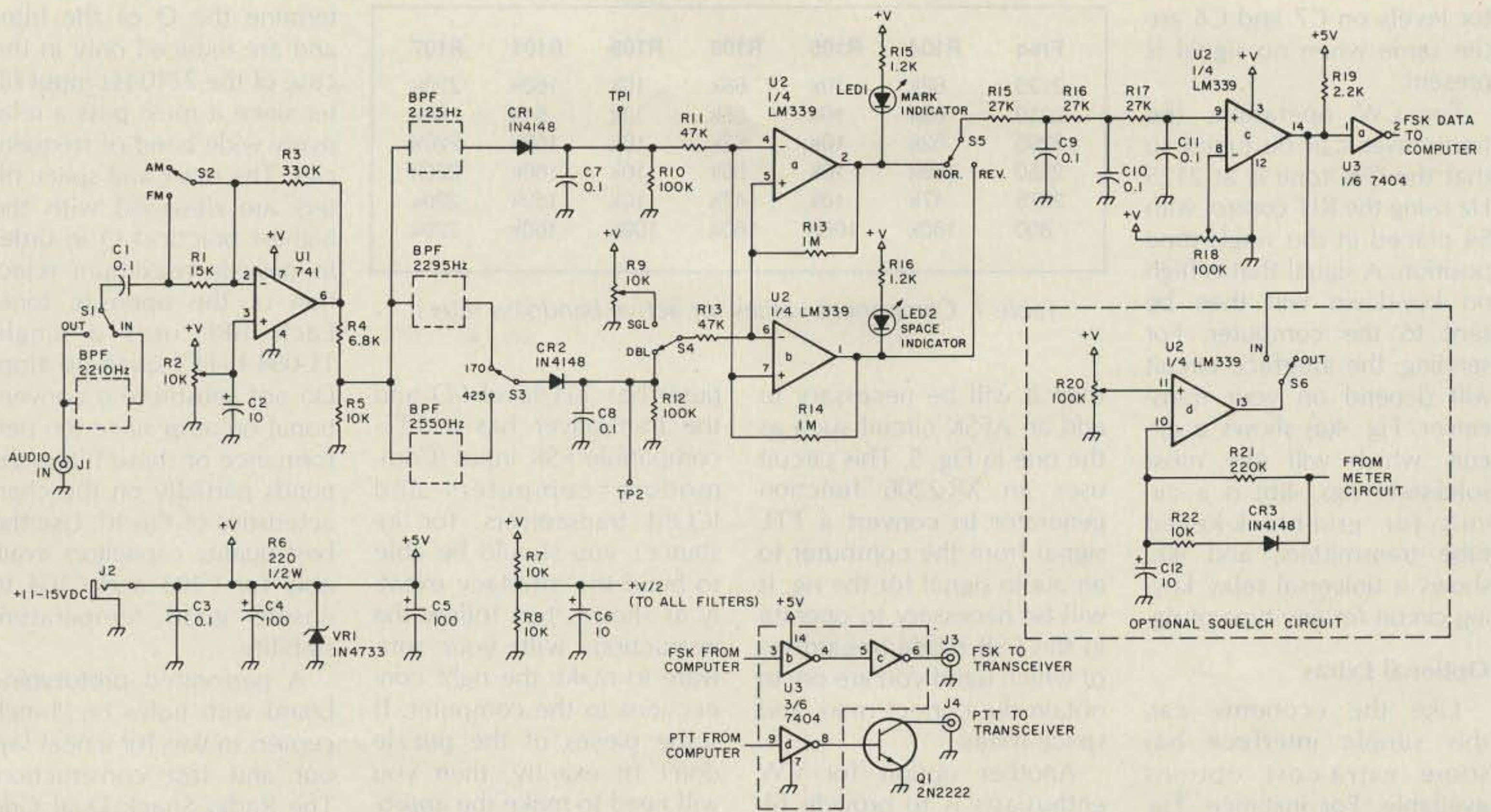

Fig. 1. Computer interface.

is used mostly on VHF where signals are strong and clear, I would recommend using single-tone detection rather than adding another filter. A 2975-Hz BPF could be substituted for the 2550-Hz filter, or all three shifts could be implemented by using a three-position switch at S3. After the BPF stages, CR1 and CR2 half-wave rectify the output signals of the filters and, in conjunction with C7, C8, R10, and R12, provide dc levels corresponding to the strengths of the mark and space tones.

Two sections of U2, an LM339 quad comparator,

are connected so that when the mark tone is present, the output of U2a goes low and U2b goes high. The presence of the space tone produces the opposite condition. The comparators will respond to relatively small differences in the detector dc levels, allowing for maximum signal-to-noise ratio. Since the difference between the levels of the two signals is detected rather than comparing each one to a set level, very weak and noisy signals can be decoded fairly accurately; i.e., the noise level coming out of each filter is assumed to be the same, so

any difference must be due to the frequency changes in the FSK signal.

The outputs of U2a and U2b drive the LED mark and space indicators. S5 selects normal or reverse shift and sends the appropriate output to the three-pole passive post-detection filter consisting of R15-R17 and C9-C11. U2c squares the output of the filter and converts it to a TTL level, which is inverted by one section of a 7404 hex inverter, U3a. A TTL signal which is high on mark and low on space is now ready to be sent to the computer.

U3b and U3c simply buffer the computer FSK signal to be sent to the FSK input

of the transceiver. U3d and Q1 provide a push-to-talk output so the computer can automatically switch the transceiver to the transmit mode.

The power supply requires a source of regulated dc power, typically 13.8 volts, which is available in most ham stations. Since the current required at 5 volts is very small, a simple zener diode regulator is used. The voltage divider consisting of R7 and R8 provides a reference for all the active filter circuits. It is important that all the filters be supplied with the same reference because this ensures that the mark and space detec-

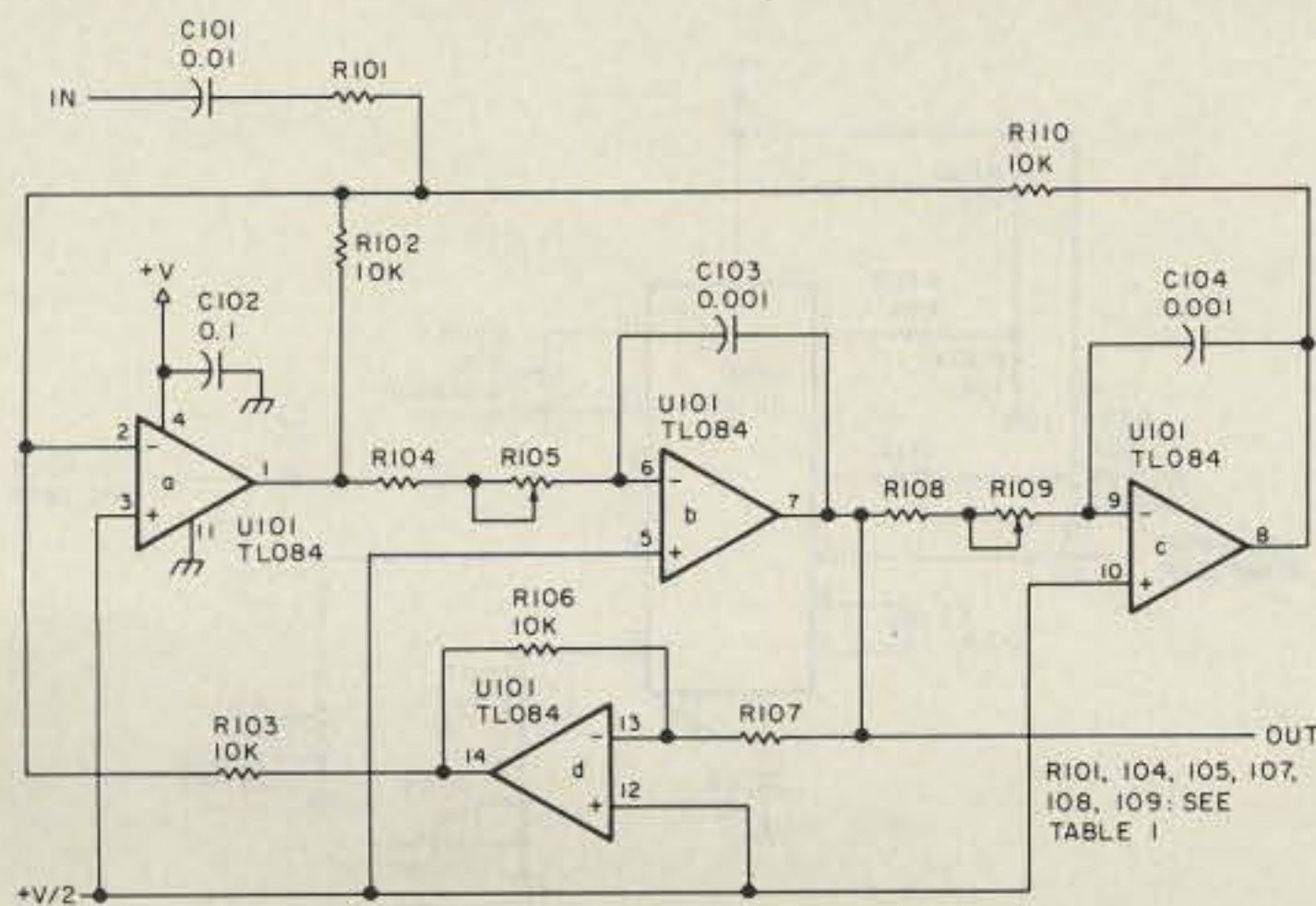

Fig. 2. Bandpass filter.

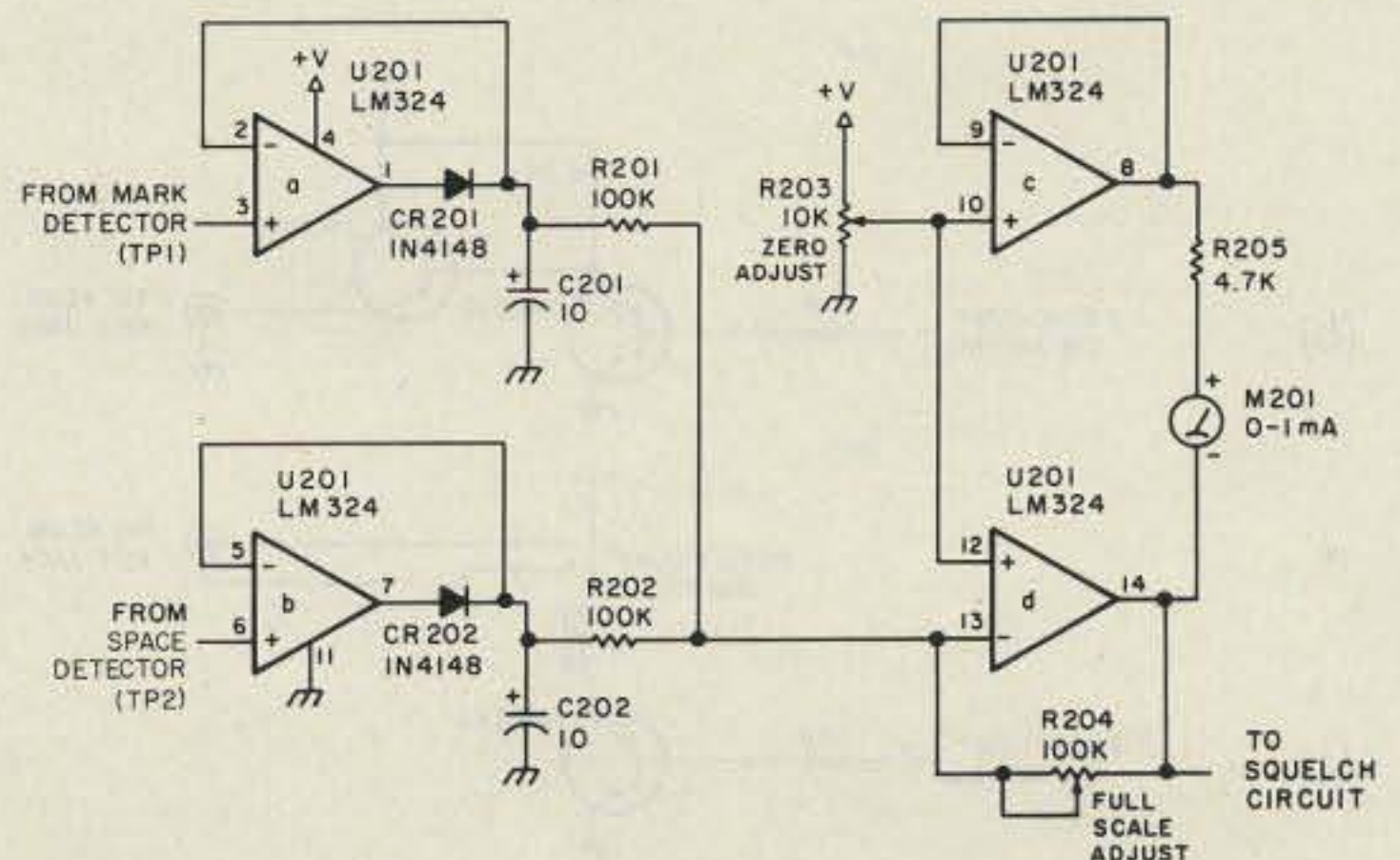

Fig. 3. Tuning indicator (optional).

tor levels on C7 and C8 are the same when no signal is present.

For CW operation, the transceiver can be tuned so that the CW tone is at 2125 Hz using the RIT control with S4 placed in the single-tone position. A signal that is high on key-down will then be sent to the computer. For sending, the interface circuit will depend on your transceiver. Fig. 4(a) shows a circuit which will key most solid-state rigs, 4(b) is a circuit for grid-block-keyed tube transmitters, and 4(c) shows a universal relay keying circuit for any type of rig.

### Optional Extras

Like the economy car, this simple interface has some extra-cost options available. For instance, Fig. 3 shows a tuning-meter circuit using an LM324 quad op amp and a 0-1-mA meter which is very useful in making the fine-tuning adjustments required for accurate copy. It is very easy to use—just tune for maximum meter deflection and you are exactly on frequency. If you build the meter circuit, then adding a squelch to prevent on-screen "babbling" when tuning between signals is simple. The final section of the LM339 (U2d, Fig. 1) and a few extra components are all that is needed.

If your transceiver is not equipped for FSK operation,

| Freq | R104 | R105 | R108 | R109 | R101 | R107 |
|------|------|------|------|------|------|------|
| 2125 | 68k  | 10k  | 68k  | 10k  | 160k | 220k |
| 2210 | 68k  | 10k  | 68k  | 10k  | 51k  | 68k  |
| 2295 | 62k  | 10k  | 62k  | 10k  | 160k | 220k |
| 2550 | 56k  | 10k  | 56k  | 10k  | 160k | 220k |
| 2975 | 47k  | 10k  | 47k  | 10k  | 160k | 220k |
| 800  | 160k | 100k | 160k | 100k | 160k | 220k |

Table 1. Component values for active bandpass filters.

then it will be necessary to add an AFSK circuit such as the one in Fig. 5. This circuit uses an XR-2206 function generator to convert a TTL signal from the computer to an audio signal for the rig. It will be necessary to operate in the LSB mode (regardless of which band you are on) to obtain the correct mark and space tones.

Another option for CW enthusiasts is to provide filters in the 800-Hz range for the input and mark BPFs and suitable switching to select CW or RTTY. This is not included on the schematics because I felt it was not sufficiently important to warrant the increased complexity. Those who operate computer CW a lot may wish to do this, however. Table 1 lists component values for a tuning range of 650-950 Hz.

### Construction

Before beginning construction, you will have to investigate the manuals for your computer, the software you will be using with it, and your transceiver. If the com-

puter has TTL-level I/O and the transceiver has a TTL-compatible FSK input (Commodore computers and ICOM transceivers, for instance), you should be able to build the interface exactly as shown. Just follow the instructions with your software to make the right connections to the computer. If some pieces of the puzzle don't fit exactly, then you will need to make the appropriate modifications. For instance, some computers have RS-232 I/O which will require level conversion to TTL. There seems to be some standardization among RTTY software programs as to polarities of input and output signals; however, this may not be true in all cases. Polarity conventions assumed here are: mark, high; space, low; key-down, high; PTT, low to transmit. As soon as you sort out all your polarities and levels, you are ready to start building.

Each block labeled BPF in Fig. 1 represents the active bandpass-filter circuit of Fig. 2. Each filter circuit is the same except for some resistor values which are listed in

Table 1. Component values for active bandpass filters. Do not substitute a conventional op amp since the performance of these filters depends partially on the characteristics of this IC. Use the best quality capacitors available for C103 and C104 to ensure good temperature stability.

A perforated prototyping board with holes on .1-inch centers makes for a neat layout and fast construction. The Radio Shack Dual Grid Board #276-161 is just the right size for this simple interface. Construction is not critical because operation is at audio frequencies. The TL-084s have a very high input impedance, so be careful to prevent stray coupling which could cause oscillation and ringing or reduce the effectiveness of the filter circuits. Use ferrite beads on all input and output leads and house the unit in a tight metal box to prevent rf from getting into the circuit. Shielded cables on all input and output lines including the cable to the computer are good practice, as well.

### Alignment

When construction is completed you will need to

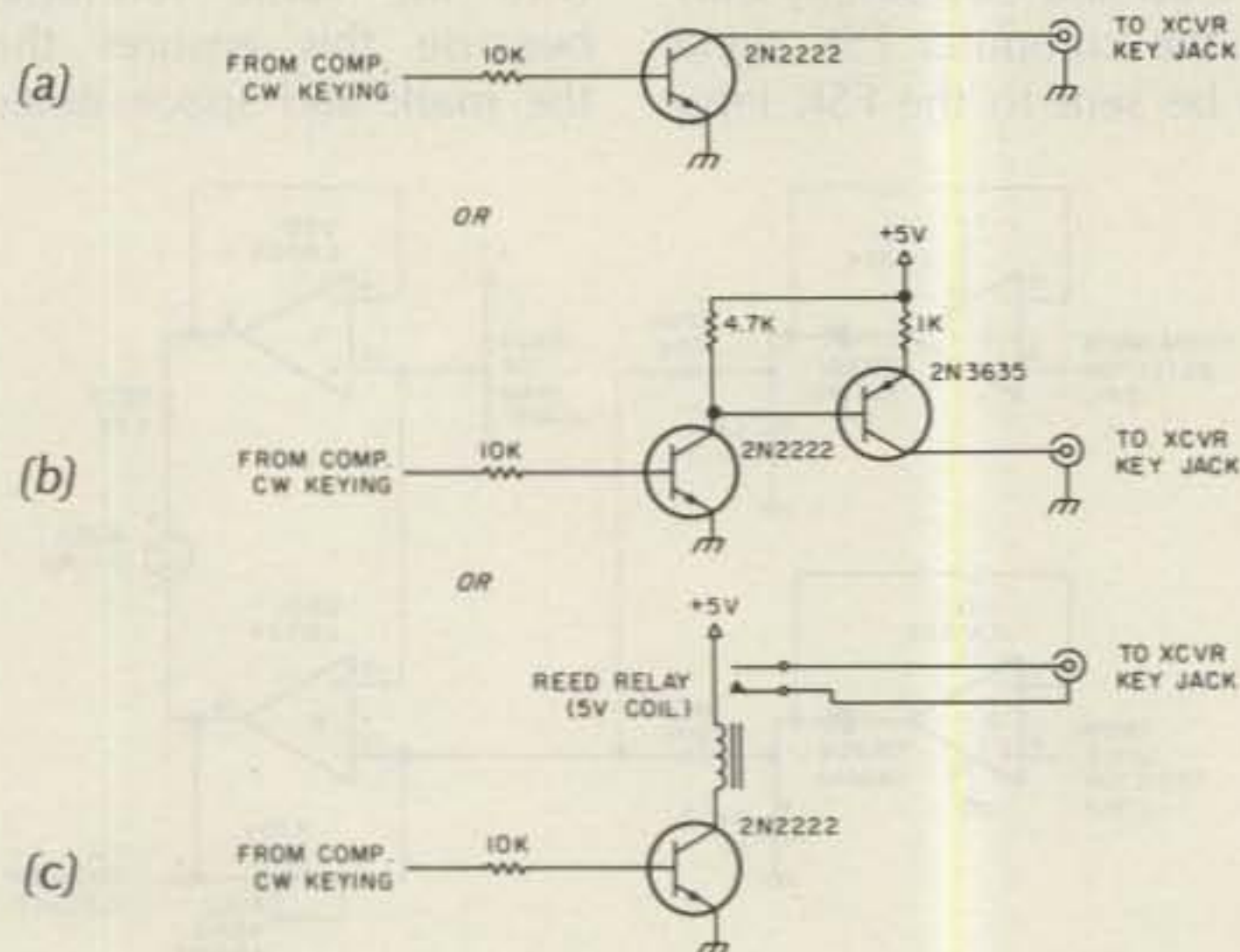

Fig. 4. CW keying circuits.

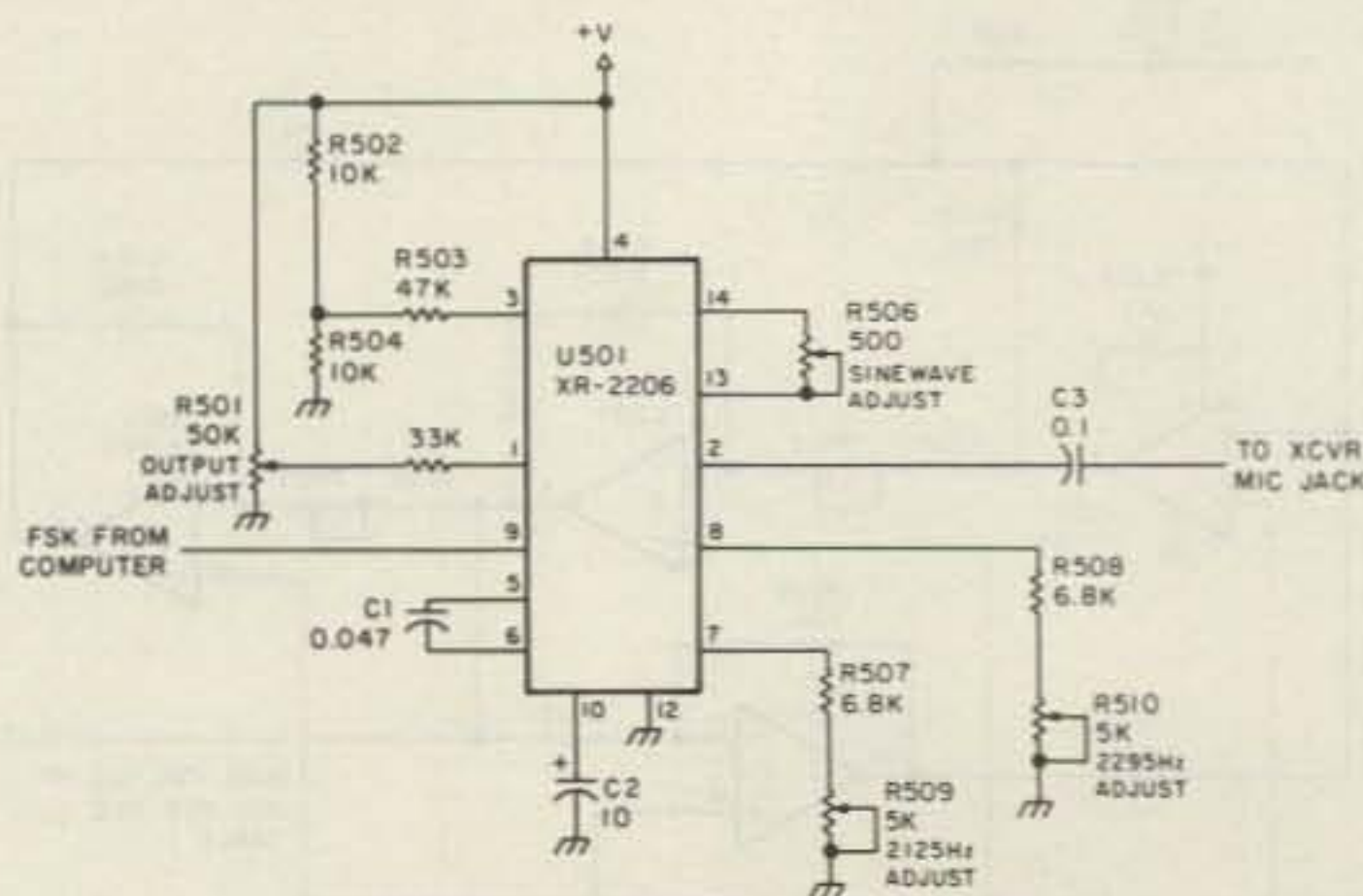

Fig. 5. AFSK circuit.

adjust all the pots for proper operation. How the unit performs will depend on how well the initial adjustments are made. To align the active filter circuits, you will need an audio signal generator or function generator and a frequency counter or an oscilloscope with very accurately calibrated horizontal sweep.

To align each filter, apply a signal of the correct frequency to the input and, observing the output with a scope, adjust R105 and R109 carefully for maximum output. If the frequency-determining capacitors, C103 and C104, are not close to their nominal values, you may find that the maximum output occurs at one extreme or the other of the pot's adjustment range. If this happens, it will be necessary to change the value of the resistor in series with the pot to the next higher or lower value. When you have peaked the filter to its center frequency, adjust the frequency control of the signal generator and observe that the output falls off rapidly and equally in both directions. You can now be assured that the filter is working correctly and will provide good performance.

Next, apply a sine wave of about 2 kHz to the audio input. With S1 in the OUT position and S2 in FM, increase the level until the output at pin 6 of U1 just becomes a square wave. Adjust R2 for the most symmetrical square wave possible. Change S2 to AM and observe that the output of U1 is now a sine wave.

If you are using the tuning meter of Fig. 3, adjust R203 to zero the meter with no audio applied and set R204 at mid-range. When adjusting R203, begin at the ground end and turn it only until the meter first reads zero.

You are now ready to put the interface on the air since the remainder of the adjustments are made with actual

RTTY signals. Begin by connecting only the receiver audio and the computer. Load and run your software. Set S1 to IN, S2 to FM, S3 to 170 Hz, S4 to double-tone, S5 to normal, and S6 to OUT. Set R9 and R18 to mid-range. Tune in a strong clear signal until both mark and space LEDs are flashing. Tune the receiver carefully (preferably using a 10-Hz tuning rate) until the tuning meter reaches maximum deflection. Increase receiver volume until there is no further increase in meter indication and adjust R204 so that the meter reads about 80% of full scale. Print should be appearing on your screen. Adjust R18 in each direction until print begins to become garbled, then set it midway between these points. Switch to single-tone and adjust R9 so that copy is as good or nearly as good as it was. The adjustment of R18 is not critical on a good signal but becomes increasingly more so as signal quality worsens, so experiment a little with this control on poor signals before putting the lid on the box.

Now switch in the squelch and adjust R20 so that the squelch circuit does not interfere with normal copy but prevents any garbage from appearing on the screen when tuning between stations. Note that the squelch drops out quickly but takes a few seconds to pick up. It is normal for a few extraneous characters to be printed during the squelch tail.

If you are using the AFSK circuit of Fig. 5, connect a frequency counter and/or oscilloscope to the output and set all pots to mid-range. Ground pin 9 and adjust R510 for 2295 Hz; adjust R509 for 2125 Hz with pin 9 open. Adjust R506 for the best sine wave at the output. Set R501 to minimum and connect the AFSK signal to the mike jack of your rig; switch the rig to transmit in the LSB mode and leave the

## WORK THE U.H.F. BANDS

Add a transverter or converter to your existing 10m, 6m or 2m equipments. Choose from the largest selection of modules available for DX, OSCAR, EME, ATV.

### TRANSVERTERS



### POWER AMPLIFIERS

all models include RF VOX & Low Noise RX Pre-Ampl. (no pre-amp in MML432-100)

|           |             |               |             |          |
|-----------|-------------|---------------|-------------|----------|
| 2 Meters: | 100W output | MML144-100-LS | 1W or 3W in | \$239.95 |
|           | 100W output | MML144-100-S  | 10W input   | \$199.95 |
|           | 50W output  | MML144-50-S   | 10W input   | \$149.95 |
|           | 30W output  | MML144-30-LS  | 1W or 3W in | \$109.95 |

|          |             |              |             |          |
|----------|-------------|--------------|-------------|----------|
| 432 MHz: | 100W output | MML432-100   | 10W input   | \$369.95 |
|          | 50W output  | MML432-50    | 10W input   | \$199.95 |
|          | 30W output  | MML432-30-LS | 1W or 3W in | \$209.95 |

1268-1296 MHz: Coming soon. Watch for details.

### ANTENNAS

|              |         |
|--------------|---------|
| D8-2M        | \$63.40 |
| 1296-LY      | \$47.95 |
| 10XY-2M      | \$69.95 |
| 70 cm/MBM 48 | \$59.95 |
| 70 cm/MBM 88 | \$89.95 |

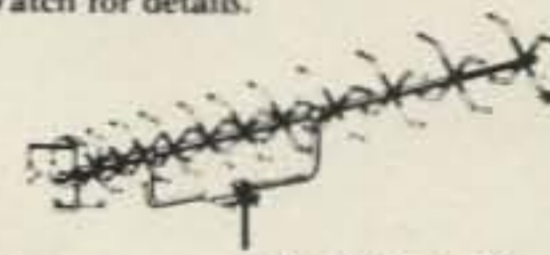

70/MBM 48

Send 40¢ stamps for full details of our VHF/UHF items.

Pre-selector filters Pre-amplifiers Antennas  
Low-pass filters Transverters Crystal Filters  
Varactor triplers Converters

**si**

Spectrum International, Inc.  
Post Office Box 1084S  
Concord, Mass. 01742 USA ✓436



mike gain control in the usual position for phone operation. Increase R501 until you reach the output power you intend to use for RTTY operation.

### Operation

Now that the alignment is completed, all that remains is to make the final connections to your transceiver and put your computer on the air. Most of the operating instructions depend on the software that you are using. You will find that usually it won't be necessary to touch the interface—all control will be from the computer keyboard and the transceiver tuning dial. For ham RTTY and ASCII operation, set the interface controls as follows: FM, 170-Hz shift, double-tone, normal polarity, squelch in. These settings should work for 99% of all ham communications. Now and then you might find that someone is using reverse polarity. To copy a nonstan-

dard shift or CW, switch to single-tone detection. The squelch must be switched out in this mode since it will never drop out on a single tone. The majority of commercial communications use 425-Hz shift and reverse polarity.

Now you can begin to enjoy keyboard operation. Whether you are a newcomer to this mode of operation or a RTTY old-timer, you will no doubt find exploring the world of computerized communication very interesting. This simple interface will provide good performance on RTTY, CW, and ASCII up to 110 baud. You will be able to chat with other hams, check into special-interest nets, leave messages for friends on radio bulletin boards, and if you have general-coverage receive, check out the press services, ship-to-shore communication, etc., outside the ham bands. Hope to see you soon on RTTY. ■

# Is Your Repeater Dying?

*With this 16-channel telemetry encoder, you have a remote chance of finding out.*

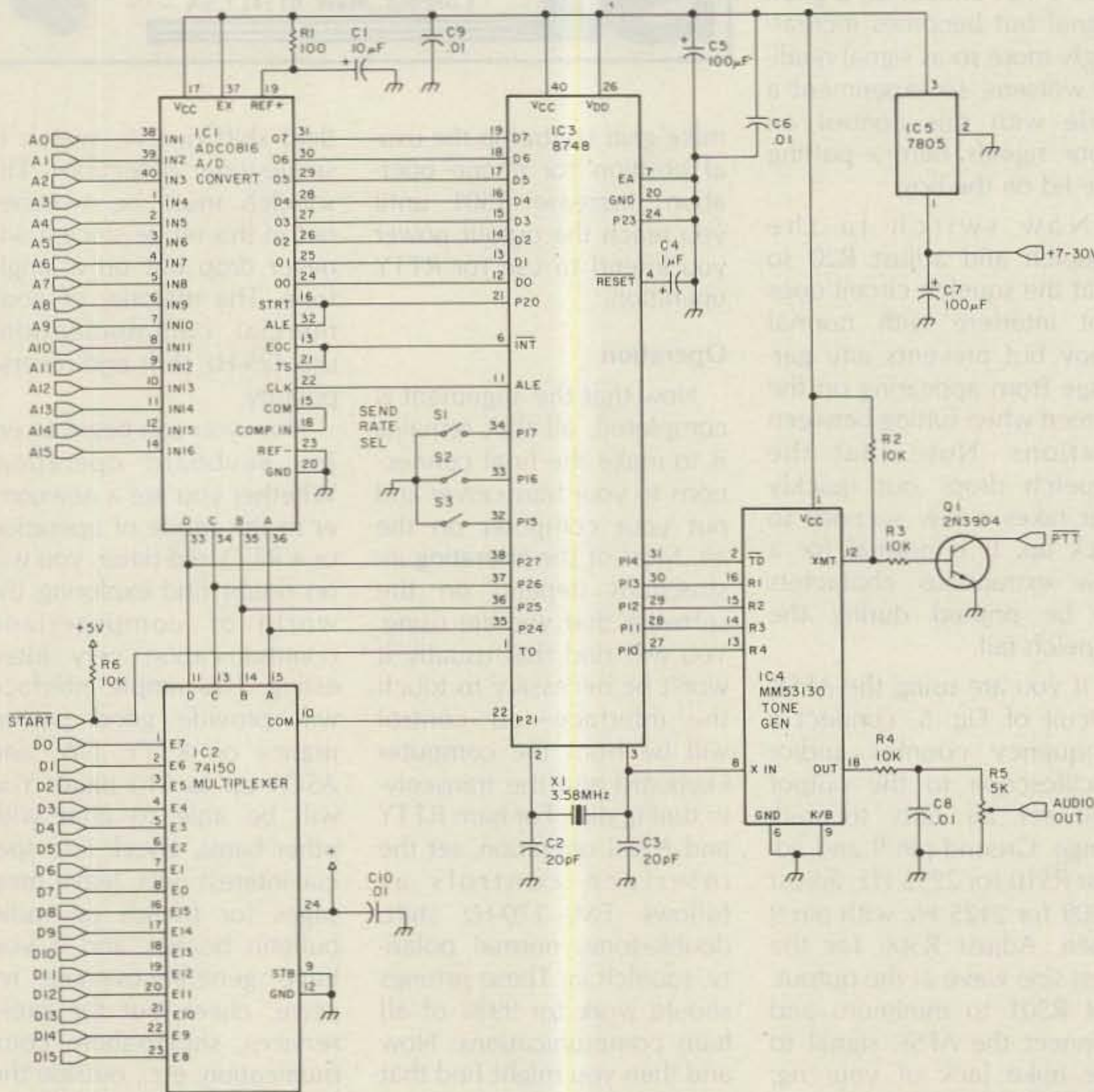

Fig. 1. Schematic.

**W**hy go to all the trouble to downlink your repeater's telemetry at a speed and format that only a computer can handle? After all, most computers are not very portable. Modems and FSK generators can be expensive. Voice synthesizers tell your data to the world. Reading repeater parameters while mobile or portable can be exceedingly difficult.

This simple telemetry encoder will take a 6-millisecond "snapshot" of 16 analog and 16 digital channels and then downlink them as a series of high-speed touchtones™. When used with the touchtone data display that I described in the December, 1984, issue of 73 and a handie-talkie, you can have an inexpensive, secure system for readout of repeater parameters wherever you are.

### Circuit Description

I like to keep circuits as simple as I can to minimize construction time. Therefore, I used an Intel 8748 mi-

```

0000      0010 ***** TOUCHTONE TELEMETRY ENCODER ROUTINE *****
0000      0020 ***** BY ROBIN RUMBOLT WAMTEK 3/28/83 *****
0000      0030      ORG      0
0000 15    0040 START  DIS      I
0001 24 00 0050 XMIT   JMP      0100H
0003      0060      ORG      100H
0100 35    0070 XMT   DIS      TONT      ; DISABLE TIMER INTERRUPT
0101 88 20 0080      MOV      R0,#20H
0103 45    0090      CLR      F1      ; SET FIRST TIME THRU FLAG
0104 85    0100      CPL      F1
0105 27    0110      CLR      A      ; INITIALIZE PORTS
0106 39    0120      OUTL    P1,A
0107 3A    0130      OUTL    P2,A
0108 AA    0140      MOV      R2,A
0109 36 00 0150      JTB     XMT      ; WAIT FOR START LINE TO GO LOW
010B FA    0160 REDAW  MOV      A,R2      ; BEGIN READING ANALOG DATA
010C 47    0170      SWAP    A
010D 3A    0180      OUTL    P2,A      ; OUTPUT CHANNEL ADR TO A/D
010E 9A 01 0190      ORL     P2,#1H      ; GENERATE START PULSE
0110 9A 0F 0200      ANL    P2,#0FEH
0112 8F 0F 0210      MOV      R7,#0FH      ; SET CHANNEL COUNTER
0114 EF 14 0220 HERE  DJNZ   R7,HERE  ; WAIT FOR A/D CONVERSION
0116 15    0230 HERE2  DIS      I
0117 B6 16 0240      JNB     HERE2      ; CHECK FOR END OF CONVERSION SIGNAL
0119 08    0250      INS     A,BUS      ; READ IN DATA
011A A0    0260      MOV      BR0,A      ; STORE IT
011B 18    0270      INC     R0
011C 1A    0280      INC     R2
011D FA    0290      MOV      A,R2
011E 03 F0 0300      ADD     A,#0F0H
0120 C6 24 0310      JZ      DIG      ; CHECK FOR ALL ANALOG CHANNELS READ
0122 24 0B 0320      JMP     REDAW      ; IF NOT, GET NEXT CHANNEL
0124 27    0330 DIG   CLR      A      ; GET READY TO READ DIGITAL CHANNELS
0125 AA    0340      MOV      R2,A
0126 FA    0350 REDIG  MOV      A,R2
0127 47    0360      SWAP    A
0128 43 02 0370      ORL     A,#02H
012A 3A    0380      OUTL    P2,A      ; OUTPUT DIGITAL CHANNEL ADR
012B F0    0390      MOV      A,BR0
012C 97    0400      CLR      C
012D F7    0410      RLC     A
012E A0    0420      MOV      BR0,A
012F 0A    0430      IN      A,P2      ; INPUT CHANNEL DATA
0130 37    0440      CPL     A      ; INVERT THE BIT
0131 53 02 0450      ANL    A,#02H
0133 97    0460      CLR      C
0134 67    0470      RRC     A      ; SHIFT IT IN TO DATA WORD
0135 40    0480      ORL     A,BR0
0136 A0    0490      MOV      BR0,A
0137 1A    0500      INC     R2
0138 FA    0510      MOV      A,R2
0139 03 F8 0520      ADD     A,#0FBH
013B C6 44 0530      JZ      MDIG      ;CHECK TO SEE IF BIT BELONGS IN SECOND DATA WORD
013D FA    0540      MOV      A,R2
013E 03 F0 0550      ADD     A,#0F0H
0140 C6 47 0560      JZ      BGN      ; CHECK FOR ALL CHANNELS READ
0142 24 26 0570      JMP     REDIG      ;IF NOT, GET NEXT CHANNEL
0144 18    0580 MDIG  INC     R0
0145 24 26 0590      JMP     REDIG
0147 88 20 0600 BGN   MOV      R0,#20H
0149 8A 00 0610      MOV      R2,#0H      ;INITIALIZE REGISTERS
014B EF 12 0620      MOV      R7,#12H
014D FA    0630 MV   MOV      A,R2      ;GET CHANNEL NUMBER
014E AB    0640      MOV      R3,A
014F 34 E0 0650      CALL   CONV      ;CONVERT TO BCD
0151 FD    0660      MOV      A,R5
0152 53 F0 0670      ANL    A,#0F0H      ;PICK OUT FIRST DIGIT
0154 47    0680      SWAP    A
0155 C6 59 0690      JZ     A1      ;IF IT IS ZERO DO NOT SEND IT
0157 34 B0 0700      CALL   OUTA      ;ELSE SEND IT
0159 FD    0710 A1  MOV      A,R5
015A 53 0F 0720      ANL    A,#0FH      ;PICK OUT SECOND DIGIT
015C 34 B4 0730      CALL   OUT      ;SEND IT
015E 23 0C 0740      MOV      A,#0CH      ;SEND HYPHEN
0160 34 B4 0750      CALL   OUT
0162 F0    0760      MOV      A,BR0      ; GET CHANNEL DATA
0163 18    0770      INC     R0
0164 AB    0780      MOV      R3,A
0165 34 B0 0790      CALL   CONV      ;CONVERT TO BCD
0167 FC    0800      MOV      A,R4
0168 C6 6C 0810      JZ     E1      ; IGNORE LEADING ZERO
016A 34 B8 0820      CALL   OUTA
016C FD    0830 B1  MOV      A,R5
016D 53 F0 0840      ANL    A,#0FH
016F 47    0850      SWAP    A
0170 34 B4 0860      CALL   OUT      ;SEND DIGIT
0172 F5    0870      MOV      A,R5
0173 53 0F 0880      ANL    A,#0FH
0175 34 B4 0890      CALL   OUT      ;SEND NEXT DIGIT
0177 27    0900      CLR      A
0178 34 B8 0910      CALL   OUTA      ;SEND A BLANK
017A 1A    0920      INC     R2
017B EF 4D 0930      DJNZ   R7,MV
017D 24 B0 0940      JMP     XMT      ; CHECK FOR ALL DATA SENT
017F 03 04 0950 ADT  ADD     A,#4H      ;ADD EXTRA TIME TO 1ST DIGIT SENT
0181 45    0960      CLR      F1
0182 24 96 0970      JMP     CON
0184 96 B8 0980      OUT    JNZ     OUTA      ;TOUCHTONE OUTPUT ROUTINE
0186 23 0A 0990      MOV      A,#0AH
0188 43 10 1000      OUTA   ORL     A,#10H
018A 39    1010      OUTL    P1,A
018B 89 E0 1020      DELAY  ORL     P1,#0E0H
018D 09    1030      IN      A,P1      ;READ IN RATE SELECT SWITCH VALUE
018E 53 E0 1040      ANL    A,#0E0H
0190 47    1050      SWAP    A
0191 77    1060      RR      A
0192 03 02 1070      ADD     A,#2H
0194 76 7F 1080      JF1    ADT      ;CHECK FOR FIRST DIGIT DELAY
0196 AE    1090      CON    MOV      R6,A
0197 23 3A 1100      GO     MOV      A,#3AH      ;SET ONEWARD TIMER FOR DELAY
0199 62    1110      MOV      T,A
019A 55    1120      STRT   T
019B 16 9F 1130      WAIT   JTF     NEXT      ; WAIT FOR TIMER OVERFLOW
019D 24 9B 1140      JMP     WAIT
019F EE 97 1150      NEXT  DJNZ   R6,GO
01A1 99 E0 1160      ANL    P1,#0E0H      ;KILL TONE OUTPUT
01A3 EE 02 1170      MOV      R6,#2H
01A5 23 3A 1180      GO2   MOV      A,#3AH      ; SET TIMER FOR OFF DELAY
01A7 62    1190      MOV      T,A
01A8 55    1200      STRT   T
01A9 16 AD 1210      WAIT2  JTF     NEXT2
01AB 24 A9 1220      JMP     WAIT2
01AD EE A5 1230      NEXT2 DJNZ   R6,GO2
01AF 93    1240      RETR
01B0 27    1250 CONV  CLR     A      ; BINARY TO BCD CONVERSION ROUTINE
01B1 AC    1260      MOV      R4,A      ; TAKES BINARY VALUE FROM R0 AND PUTS
01B2 AD    1270      MOV      R5,A      ; RESULTS IN R4 & R5
01B3 FB    1280 S100 MOV      A,R3
01B4 03 9B 1290      ADD     A,#9BH
01B6 AE    1300      MOV      R3,A
01B7 E6 EE 1310      JNC     A100
01B9 1C    1320      INC     R4
01BA 17    1330      INC     A
01BB AB    1340      MOV      R3,A
01BC 24 E3 1350      JMP     S100
01BE FB    1360 A100 MOV      A,R3
01BF 03 65 1370      ADD     A,#65H
01C1 AB    1380      MOV      R3,A
01C2 FB    1390 S10 MOV      A,R3
01C3 03 F6 1400      ADD     A,#0F6H
01C5 AE    1410      MOV      R3,A
01C6 F2 CB 1420      JB     7,AD10
01C8 1D    1430      INC     R5
01C9 24 C2 1440      JMP     S10
01CB FB    1450 AD10 MOV      A,R3
01CC 03 0A 1460      ADD     A,#0AH
01CE AB    1470      MOV      R3,A
01CF FD    1480      MOV      A,R5
01D0 47    1490      SWAP    A
01D1 6B    1500      ADD     A,R3
01D2 AD    1510      MOV      R5,A
01D3 93    1520      RETR

```

Fig. 2. Program listing.

coprocessor to simplify the circuitry. The circuit shown in Fig. 1 uses only 5 ICs, if you count the voltage regulator.

IC1, a National ADC0816, is an 8-bit A/D converter combined with a 16-channel multiplexer. Given a channel address, a start pulse, and some clock pulses, this converter can do a complete conversion in just a few microseconds. The ADC0816 has an on-board

analog multiplexer which eliminates the need for an external multiplexer. This multiplexer connects one of its 16 input lines to the input of the A/D converter, depending on which input is addressed by the microprocessor.

IC2, a 74150 16-bit multiplexer, does the same job as IC1, except that it does it for digital signals. A 74C150 would be a better choice for this spot (since it is CMOS

and therefore has a much lower current drain), but I didn't have one, so I just plugged in the regular TTL version instead. If you have a 74C150, you can just substitute it since the two ICs are pin compatible.

The 8748 microprocessor, IC3, controls the whole show. It addresses and operates the A/D converter, the digital multiplexer, and the touchtone generator. It receives data, converts it to

the proper format, and then outputs it at the switch-selected rate.

The National MM53130 touchtone generator, IC4, not only generates the standard 16-digit tone pairs, but it also outputs a push-to-talk signal for keying the downlink transmitter. This PTT signal is only present while the tone is on, however. So, if you do not want your transmitter to drop out between tones, you might

### Parts List

|   |            |  |        |
|---|------------|--|--------|
| 1 | R1         | Resistor, 100 Ohms, 1/4 W, 20%             | \$ .06 |
| 4 | R2-R4, R6  | Resistor, 10k Ohms, 1/4 W, 20%             | .24    |
| 1 | R5         | Trimpot, 5k Ohms, 1/4 W, 20%               | .59    |
| 1 | C1         | Capacitor, 10 $\mu$ F, 16 V, electrolytic  | .49    |
| 2 | C2-C3      | Capacitor, 20 pF, 50 V, disc ceramic       | .39    |
| 1 | C4         | Capacitor, 1 $\mu$ F, 16 V, electrolytic   | .49    |
| 2 | C5, C7     | Capacitor, 100 $\mu$ F, 35 V, electrolytic | 1.58   |
| 4 | C6, C8-C10 | Capacitor, .01 $\mu$ F, 50 V, disc ceramic | .32    |
| 1 | Q1         | Transistor, 2N3904 NPN or equivalent       | .30    |
| 1 | IC1        | IC, ADC0816 A/D converter                  | 9.95   |
| 1 | IC2        | IC, 74150 16-line multiplexer              | 1.35   |
| 1 | IC3        | 8748 microprocessor (see text)             | 50.00  |
| 1 | IC4        | IC, MM53130 DTMF encoder                   | 5.95   |
| 1 | IC5        | IC, LM7805 5-V regulator                   | 1.59   |
| 1 | X1         | Crystal, 3.579 MHz, TV burst               | 1.99   |
| 2 | ----       | 40-pin IC socket                           | .98    |
| 1 | ----       | 24-pin IC socket                           | .33    |
| 1 | ----       | 18-pin IC socket                           | .24    |
| 1 | S1-S3      | 3- or 4-position DIP switch                | 1.19   |
| 1 | ----       | PC board (see text)                        | 10.00  |

want to add a small delay circuit. The one advantage that the MM53130 has over other touchtone generator

chips is that it will accept either 2-of-8-type inputs or standard 4-line binary inputs. Other generator ICs

accept only the 2-of-8-style inputs.

Lastly, a 7805 three-terminal, 5-volt regulator is used to supply a constant voltage for the entire circuit.

### Software

The microprocessor program that runs the telemetry encoder is shown in Fig. 2. Since it is commented fairly well, I'll just briefly outline it here:

Lines 40-60 direct the microprocessor to the transmit program located at address 100 hex. I put the transmit-routine start point at that location in order to make room for the data-display routine that was described in the previous article. Neither program is very long, so I put them both in memory simultaneously. That way I could easily swap the processor from one circuit to another. When the microprocessor first wakes up or is reset, it

immediately goes to location 0 for its first instruction. That is why I put the vector there.

Lines 70-150 form the instruction loop that the processor stays in until the start line is grounded. When that happens, the processor begins executing lines 160-590, which comprise the part of the program that reads all the analog and digital channel values and stores them in memory.

Once the data is all gathered, it must be formatted and sent out to the touchtone generator. Lines 600-940 take care of these chores.

Program instructions at lines 950-1240 form the OUTPUT subroutine which routes the data to the touchtone generator and ensures proper pulse durations.

The CONVERT subroutine, lines 1250-1520, performs a binary-to-BCD conversion on all channel numbers and

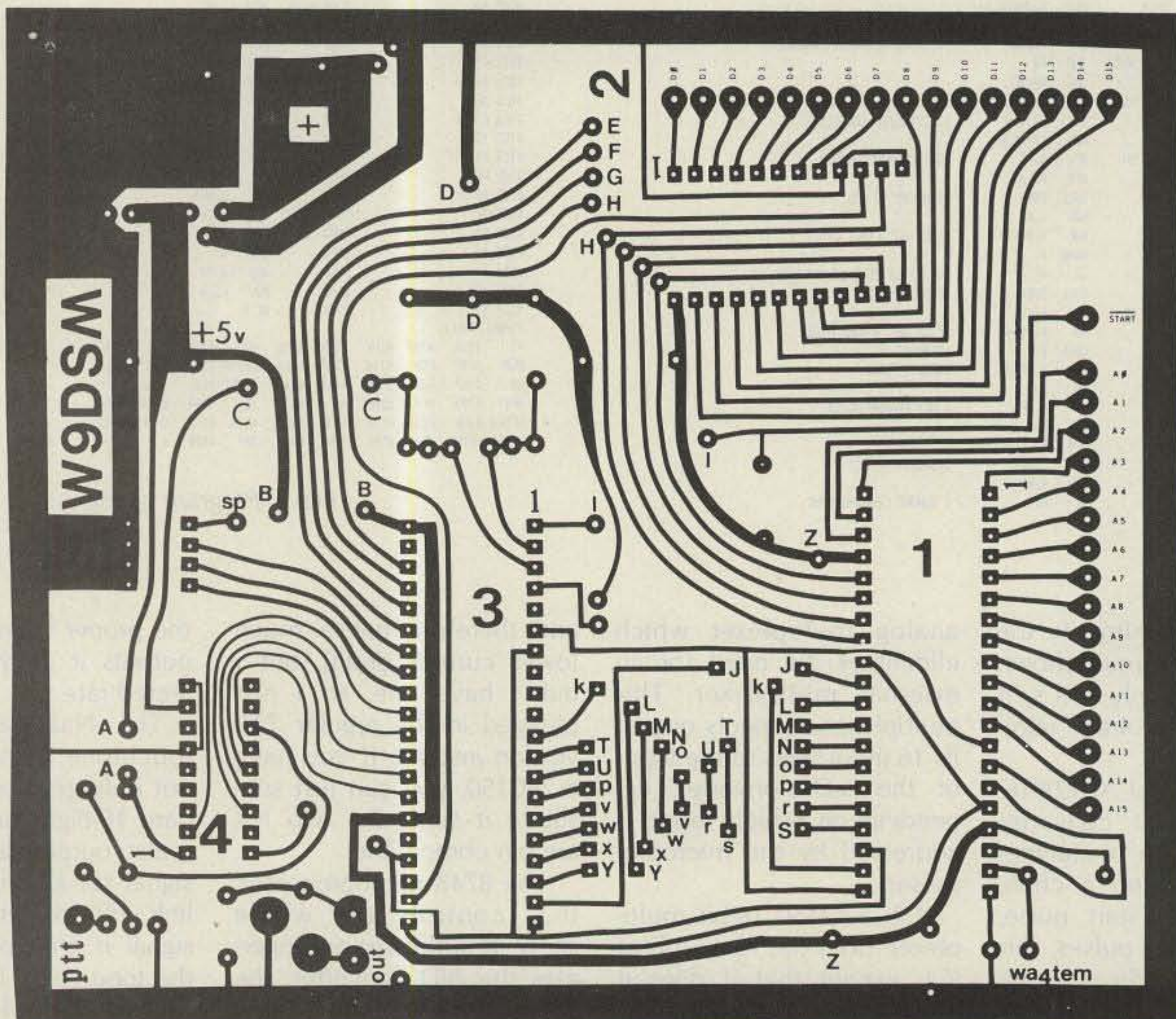
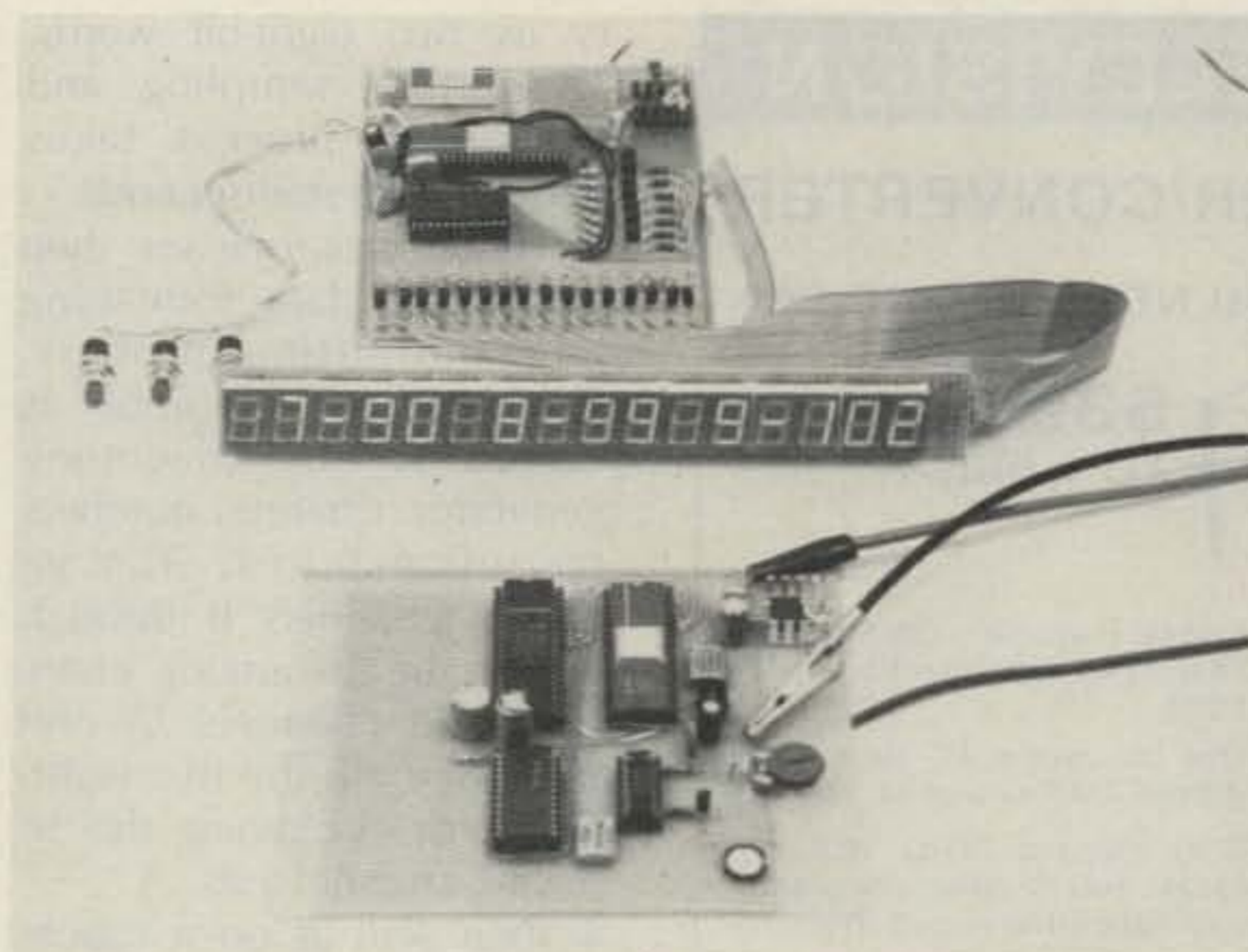

Fig. 3. PC board, foil side.

data. I convert all numbers to BCD instead of sending them out in hex format because the touchtone generator can only generate 16 tone pairs and the display unit uses three of those for special symbols. That doesn't leave enough characters to represent the hex characters 0-9 and A-F. So I had to send everything in BCD.

### Construction

A printed circuit board was developed for this circuit and is shown in Fig. 3. The parts-placement diagram is shown in Fig. 4. Due to the relatively large number of lines needed to interconnect the ICs, about 25 jumpers were needed on the board. These could have been eliminated by using a



Touchtone telemetry encoder prototype shown with data display unit.

double-sided PC board, but that would have made the board much harder to duplicate. The jumpers are all designated by single letters

A-Z. Simply connect points labeled with the same letter: A to A, B to B, C to C, etc. I recommend that all parts be installed on the board be-

fore wiring the jumpers, except for jumpers E through H. These jumpers are very close to the end of IC2 and might be more easily installed before the IC socket is soldered on. Note that in this group only jumper H is labeled on both ends. This is due to the fact that there just wasn't room to put labels on the board. These few jumpers are short and are shown on the parts-placement diagram. Also note that jumper Q is not labeled on the board, but it is shown on the parts-placement drawing (near pin 25 of IC3).

Two sets of holes have been provided for crystal X1, a TV color-burst crystal. This is to allow easy use of either the large or small style of burst crystal.

The regulator, IC5, should

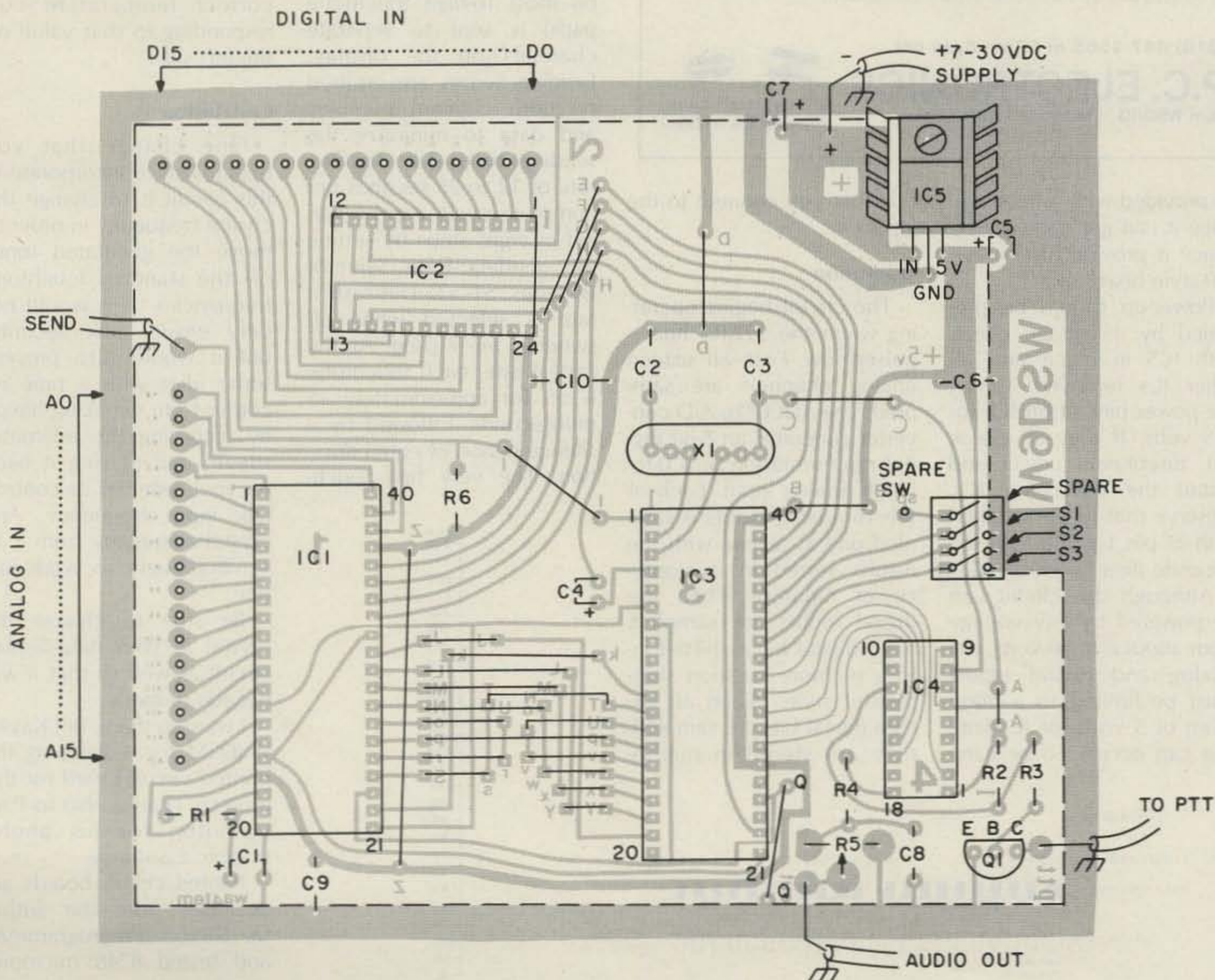
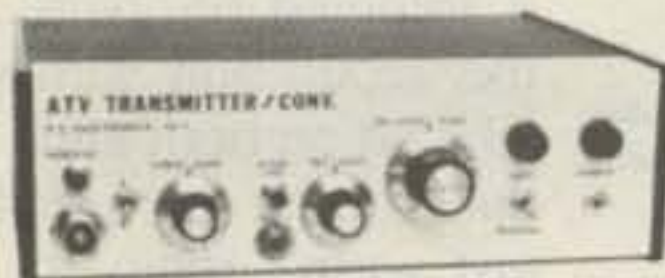

Fig. 4. Parts placement.

# AMATEUR TELEVISION

## ATV TRANSMITTER/CONVERTER

ALL YOU NEED IN ONE BOX



**\$399** delivered  
TC-1 plus

- **OVER 10 WATTS PEP OUTPUT.** Crystal controlled continuous duty transmitter. Specify 439.25, 434.0, 426.25 standard or other 70 cm frequency. 2 freq. option add \$26.
- **BASE, MOBILE, or PORTABLE.** Use the builtin AC supply or external 13.8 vdc. Do parades, Marathons, CAP searches, etc.
- **TWO VIDEO AND AUDIO INPUTS** for camera, TVRO, VCR, or computer. Wide bandwidth for broadcast quality color video and computer graphics. Standard broadcast subcarrier sound which is heard thru the TV speaker.
- **RECEIVE ON YOUR STANDARD TVSET** tuned to channel 3 or 4. Sensitive varicap tuned TVC-2L downconverter covers simplex and repeater freq. over the whole 420-450 MHz 70 cm amateur band.
- **ATTRACTIVE 10.5 x 3 x 9 CABINET.**

CALL OR WRITE FOR OUR CATALOG or more information on ATV antennas, transmit modules, cameras, etc. or who is on in your area. See chapter 14 1984 ARRL Handbook

TERMS: Visa, Mastercard, or cash only UPS CODs by telephone or mail. Postal money orders and telephone orders usually shipped within 2 days. All other checks must clear before shipment. Transmitting equipment sold only to licensed amateurs, verifiable in the 1984 call book.

(818) 447-4565 m-f 8am-6pm pst.

**P.C. ELECTRONICS**

Tom W6ORG Maryann WB6YSS



2522 Paxson Lane  
Arcadia CA 91006

be provided with a heat sink since it can get quite warm. Space is provided for a TO-220-style heat sink.

Power-up should be preceded by a voltage check with IC5 in place and all other ICs removed. Check the power pins of all ICs for +5 volts. If they all check out, disconnect power and install the remaining ICs. Observe that IC4 is installed with its pin 1 pointing in the opposite direction from IC3.

Although this circuit can be powered by any voltage from about 6 to 30 volts, the analog and digital inputs must be limited to a maximum of 5 volts (or IC damage can occur). So be care-

ful what you connect to the inputs.

### Operation

The circuit begins operating when the START line is pulsed low. First, all sixteen analog channels are sampled. The ADC0816 A/D converter generates an 8-bit digital representation of a 0-to-5-volt analog input. Each of the 16 analog inputs is sampled one at a time with the results stored in microprocessor memory. Then the digital inputs are sampled. Each digital bit is shifted into a memory location shift-register style. When all sixteen digital bits are sampled, they are stored in memo-

ry as two eight-bit words. The entire sampling and conversion process takes only about 6 milliseconds.

The microprocessor then begins the data formatting and outputting process. First, a channel number is output to the touchtone generator. Channel numbers range from 0 to 17. That includes channels 0 through 15 for the 16 analog channels, and channels 16 and 17, which are the two eight-bit words containing the 16 digital channel bits. A "-" is then sent (# on a touchtone pad) to serve as a separator between channel number and data. Next, the channel's data is retrieved from memory and converted to a three-digit BCD number ranging from 0 to 255. Then these three digits are sent. Lastly, a space (D on most 16-digit touchtone pads) is sent to separate channels on the display. Leading zeroes are omitted on both channel numbers and data to minimize the sending time. The sending rate of 12 to 25 seconds per complete cycle can be varied in eight steps by setting the Sending Rate Selector switches, S1-S3. The fastest rate is selected when all switches are closed. At the fastest rate, each touchtone is on for approximately 35 milliseconds, followed by a silence period of equal duration. The very first touch-

tone sent in a cycle (channel 0) is held on slightly longer to allow transmitters and receivers in the downlink system to come alive. The resulting format and timing of all this outputting is shown in Fig. 5.

To easily interpret the displayed analog data received on the downlink, I made use of a simple nomograph shown in Fig. 6. Numbers from 0 to 255 are scaled along one side of the vertical line. Numbers representing whatever data is to be measured can be put on the left side of the line. For example, if you are measuring temperature, a scale from -40 to +150 degrees may be drawn on the left of the line. Then if the downlinked data reads 182, you can simply find 182 on the right side of the line and read the correct temperature corresponding to that value on the left side.

### Conclusion

One change that you might wish to incorporate in this circuit is to change the crystal frequency in order to move the generated tones off the standard touchtone frequencies. This would not only ensure link security, but it would also prevent some idiot with a tape recorder from wreaking havoc by recording the telemetry stream and playing it back on your repeater or control-link input frequency. Any crystal frequency from 1 to 4 MHz ought to work just fine.

Be sure to change the crystal in your data-display circuit as well so that it will decode properly.

I want to thank Bill Kaylor W9DSM for developing the printed circuit board for this project. Thanks also to Paul Hamilton for his photographic assistance.

Printed circuit boards are available from the author for \$10.00. Preprogrammed and tested 8748 microprocessors are available for \$50.00. ■

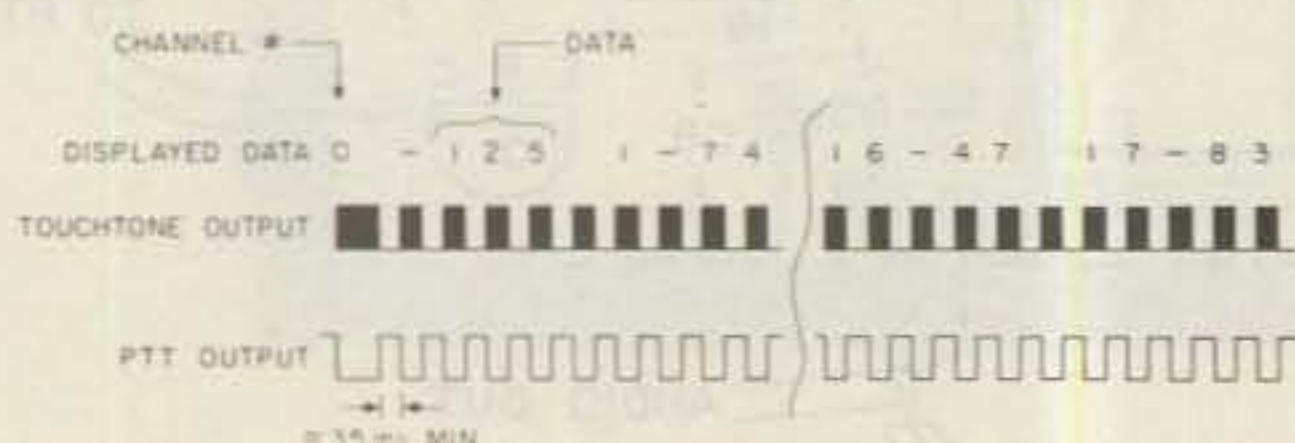

Fig. 5. Timing diagram.

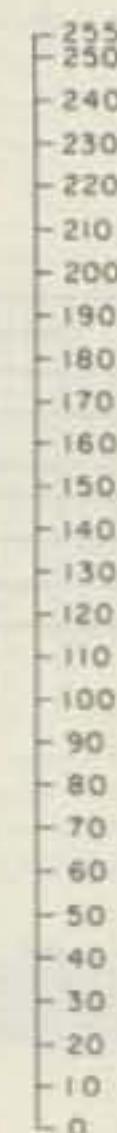

Fig. 6. Nomograph.



**COMPUTER<sup>®</sup>**  
**TRADER** ✓280  
**MAGAZINE**

★ ★ ★ LIMITED TIME OFFER ★ ★ ★  
**BAKER'S DOZEN SPECIAL!**

\$12.00 for 13 Issues

Regular Subscription \$15.00 Year  
Foreign Subscription: \$55.00 (air mail)  
\$35.00 (surface)

Articles on MOST Home Computers, HAM Radio, hardware & software reviews, programs, computer languages and construction, plus much more!!!

Classified Ads for Computer & Ham Radio Equipment

**FREE CLASSIFIED ADS**  
for subscribers

Excellent Display and Classified Ad Rates  
Full National Coverage

**CHET LAMBERT, W4WDR**  
1704 Sam Drive • Birmingham, AL 35235  
(205) 854-0271  
Sample Copy \$2.50

**SANTEC handhelds**

**ST-142** **259<sup>00</sup>**  
For 2-Meters

Free \$9.95 Mob. Quick Charge Cable

ST-222 H/T (220 MHz) . . . . \$279  
ST-442 H/T (440 MHz) . . . . \$285  
LS-202 (2-M FM/SSB-H/T) \$229



**FM-2033** **265<sup>00</sup>**  
25 Watt 2-Meter FM

FM-4033 (220-mHz) . . . . . \$329  
FM-6033 (6-Meters) . . . . . \$279  
FM-7033 (440-mHz) . . . . . \$329

FREE UPS Brown Shipping-Add \$1.65 for COD  
N.C. Res. Add 4 1/2% Sales Tax. Sorry No Cards.

The Nation's Largest Mail Order SanteC Dealer

**WILLIAMS RADIO SALES**

600 LAKEDALE ROAD, DEPT. C  
COLFAX, N.C. 27235  
(919) 993-5881 Noon to 10 P.M. EST

**FREE CATALOG!**

Features Hard-to-Find Tools  
and Test Equipment



Jensen's new catalog features hard-to-find precision tools, tool kits, tool cases and test equipment used by ham radio operators, hobbyists, scientists, engineers, laboratories and government agencies. Call or write for your free copy today.

**JENSEN TOOLS INC.** | 7815 S. 46th Street  
Phoenix, AZ 85040  
(602) 968-6231 ✓354

**ALL BAND TRAP VERTICAL ANTENNAS!**

FULL 1/4th WAVE - All Bands! Automatic Selection with proven Hi-Q Traps. 5 Models-ALL self supporting Ground or roof mount. HEAVY Double wall seamless Aluminum lower section - HI STRENGTH FIBER-GLASS TUBING OVER-ALL. NO WOBBLY, LUMPY TRAPS - NO UNSIGHTLY CLAMPS needed Same size all the way up 1 1/4" - Traps hidden inside. You can use it in a 1 ft. sq. Backyard! Neighbors will never know this is a Hi-Power ALL Direction DX Antenna. FOR APARTMENTS, ROW HOUSES, MOBILE HOMES - CONDOS etc. where minimum space and neat appearance is MANDATORY! Instant "Drive In" ground mount (included). Use with or without radials (included) (All angle roof mount - Extra) COMPLETELY PRE-TUNED - NO ADJUSTMENTS NEEDED EVER! NO TUNER NEEDED Over All Bands (except 80 meter - 400 KC) SWR 1-1 to 2-1 at Band edges, Std, SO239 connector - 52 ohm for any length RG58U - RG8U feedline. Matches ALL MAKES TRANCEIVERS. 2000 Watt PEP, input power. Shipped - PREPAID IN USA. Assembles in 10 min. using only screwdriver. WEATHERPROOF!

No.-AVT80-10 — 5 Band — 25'6" — \$199.95  
No.- AVT40-10 — 4 Band — 18'9" — \$149.95  
No.- AVT20-10 — 3 Band — 11'4" — \$119.95  
(2 - 30 Meter Models - Write for Inf.)

SEND FULL PRICE FOR PP DEL IN USA (Canada is \$10.00 extra for postage, clerical, Customs etc.) or order using VISA, MASTER CARD or AMERICAN EXPRESS. Give Number and Ex. date. Ph 1-308-236-5333 9AM-6PM weekdays. We ship in 2-3 days. Prices may increase, so order NOW AND SAVE. All Antennas Guaranteed for 1 year - 10 day money back trial, if returned in new condition. Free Inf.

**WESTERN ELECTRONICS** ✓80  
Dept. A7-1 Kearney Nebr. 68847

**Quality Service Low Price**

**\$20.00/1000**

4 Choices of colored card stock  
Send SASE for samples & ordering information

**Horizon Printing Co.**  
315 South Craig Pl.  
Lombard, IL. 60148

**\$15 DTMF DECODER \$15**

The LJM2RK decoder kit converts your receiver into a special receiver or control. When a user-selected time-tone combination is received, the output provides a relay control for activating speakers or other devices.

INPUT: Audio from transceiver, scanner, etc.  
OUTPUT: SPST (N.O.) relay.

FEATURES: Single or dual tones adjustable over the 16 digit Touch Tone range • Adjustable response time • Relay output • Manual or auto reset • Single tone ON latching with different single tone reset OFF • Operates on 12VDC • Interfacing of multiple boards for multi-digit sequential activation and reset.

APPLICATIONS: Call-up system • Repeater or commercial controls • Etc. limited only to your imagination •

LJM2RK decoder kit includes all component, relay, and P.C. Board. . . . \$15 plus \$1.50 shipping.

LJM2RC enclosure kit includes molded case, speaker, input cable. . . \$5 plus \$1.50 shipping.

For information and to order write:

**THE METHENY CORPORATION** ✓205  
204 Sunrise Drive, Madison, IN 47250

**MAE-3, YAGI MICROWAVE ANTENNA**  
—High quality up to 60 dB gain 1.9–2.5 GHz-50 mile range possible clear TV picture, pre assembled probe with down converter, 1.9–2.5GHz, power supply and RF amplifier, 1.9–2.5GHz, 30dB gain, with co-ax cable included. All mounting hardware, for fast and easy installation. Special **\$89.95**. Available by phone or mail order only. Check or money order, 5% Shipping and Handling on all orders. **KASHIWAGI ELECTRONICS CORP., 4954 West Charleston, Las Vegas, Nevada 89102** Phone: (702) 878-5747.

**ENGINEERING CONSULTING INTRODUCES**

**TOUCHTONE™ DTMF to RS-232-C 300 BAUD INTERFACE**

**TOUCH TONES**

- Use your computer to decode DTMF touchtones.
- Receive all 16 digits as fast as they can be transmitted.
- Easily program your computer in BASIC to decode multi-digit "strings", display digits, sound alarms, observe secret codes, control relays, remote base.
- Simple to use, just provide +12 VDC and audio, hook two wires to the RS-232-C serial input on your computer, enter a simple BASIC program and begin to decode.
- Sample BASIC program and instructions included.
- L.E.D. Indicator

**"Decode-A-Pad" Model DAP-1**  
Wired and Tested **\$89.95**

Includes shipping USA. Cal. addresses add 6%. ✓327  
VISA and MasterCard accepted, or send check M.O. to

**ENGINEERING CONSULTING**  
583 CANDLEWOOD ST., BREA, CA 92821  
714/671-2008

**COLLINS TUNER**

Collins 180Y-1 Antenna TUNER for 2-30 MHz; has dual section air variable 50-1600 and 30-600 pf (0.065" min/0.156" max gap) and 2.9" dia 14-turn roller inductor of 0.19" dia tubing, ceramic tap switch, 3/100 pf 7500 V doorknob capacitors. Controls C and L Select, Var C and L; 7x12.5x16.8, 33 lbs. Used . . . . . **\$99.50**

**GRAINGER AM 4531 Linear Amp**, 120-152 MHz; 10 W in, 50 W out using 8122 tube in P-A. 115/230 VAC; 7x19x14.5, 50 lbs. Used-not tested . . . . . **\$195.00**

**JENNINGS UCS-300-7.5 Vacuum Variable Capacitor**, 9-300 pf 7500 V max; 3 lbs sh. Unused . . . . . **\$99.95**

**DOUBLE POLE ANTENNA RELAY ASSEMBLY** for Am-4531, consists of two SPDT Amphenol 360-11896-1003 coaxial relays rated at 500 watts to 500 MHZ. Each has N and 2-BNC connections; 115 VAC coils. No. 0017094, used . . . . . **\$24.95**

Prices F.O.B. Lima, O. • VISA, MASTERCARD Accepted.  
Allow for Shipping • Send for New FREE CATALOG '84  
Address Dept. 73 • Phone: 419/227-6573

**FAIR RADIO SALES** ✓22  
1016 E. EUREKA • Box 1105 • LIMA, OHIO • 45802

# BARTER 'N' BUY

Individual (noncommercial) ..... 25¢ per word  
Commercial ..... 60¢ per word

Prepayment by check or money order is required with your ad. No discounts or commissions are available. Please make your payment to 73. Rates for multiple insertions are available on request.

Advertising must pertain to amateur radio products or services. No special layouts or positions are possible. All advertising copy must be submitted typewritten (double-spaced) and must include full name and address. Copy limited to 100 words, maximum. Count only words in text. Address, free.

73 cannot verify advertising claims and cannot be held responsible for claims made by the advertiser. Liability will be limited to making any necessary corrections in the next available issue.

Copy must be received in Peterborough by the 5th of the second month preceding the cover date.

Send to Barter 'N' Buy, c/o Nancy Ciampa, Advertising Department, 73, Elm Street, Peterborough NH 03458.

**WANTED:** Cash paid for used speed radar equipment. Write or call: Brian R. Esterman, PO Box 8141, Northfield IL 60093; (312)-251-8901. BNB030

**MILITARY TECHNICAL MANUALS** for old and obsolete equipment. 80-page catalog. \$3.00. Military Technical Manual Service, 2266 Senasac Ave., Long Beach CA 90815. BNB045

**MAGICOM RF SPEECH PROCESSORS**—Add 6 dB of average output with genuine rf clipping in your transmitter's i-f stage. Custom engineered for Kenwood TS-120, TS-130, TS-430, TS-520, TS-530, TS-820; Drake T-4X, TR-7; Yaesu FT-102. Excellent speech quality, simple installation, affordable prices! SASE for data and cost. Magicom, PO Box 6552A, Bellevue WA 98007. BNB101

**REPAIR**, alignment, calibration. Collins written estimates, \$25; non-Collins, \$50. K1MAN, (207)-495-2215. BNB117

**IMRA**—International Mission Radio Association helps missionaries by supplying equipment and running a net for them daily except Sunday, 14.280 MHz, 1900-2000 GMT. Br. Bernard Frey, 1 Pryer Manor Rd., Larchmont NY 10538. BNB123

**NEW HAM-SWL SOCIETY** for unity of thought & learning. Open to all. Many topics, awards, free ad space in periodical, society net, museum participation. Shack pics & QSLs welcome. Writers needed. SASE for info to RCSW, 32 Applegate, Bennington VT 05201. BNB197

**CHESS PLAYERS**—Radio-chess schedules, matches, tournaments. Details. K2VJ, Box 682, Cologne NJ 08213. BNB207

**CX7 REPAIRS**. Mark Mandelkern, 2315 Derby St., Berkeley CA 94705; (415)-549-9210. BNB213

**SCHEMATICS:** Radio receivers 1920s/60s. Send name, brand, model no., SASE. Scaramella, PO Box 1, Woonsocket RI 02895-0001. BNB214

**HAM RADIO REPAIR**, tube through solid

state. Robert Hall Electronics, PO Box 8363, San Francisco CA 94128; (408)-729-8200. BNB219

**HAM TRADER YELLOW SHEETS**, in our 23rd year. Buy, swap, sell ham-radio gear. Published twice a month. Ads quickly circulate—no long wait for results. SASE for sample copy. \$9 for one year (24 issues). POB 356, Wheaton IL 60189. BNB220

**DX HEADING MAPS** for Boston, NYC, Phila., Baltimore, Detroit, Atlanta, Chicago, New Orleans, Saint Louis, Dallas, LA. 11 x 17 \$1.75 pp. 22 x 34 \$5.95 pp. Specify city. Bill Massey W2HOJ, PO Box 397, Hainesport NJ 08036. BNB221

**YOUR IC-720** can become a sophisticated computer-controlled scanner. Keyboard frequency entry, 64 memories, memory scan, mode scan, station lists, more. No interface required, just a cable—directions included. Software cassette for Commodore 64, \$14.75 pp. David Oliver W9ODK, RR 2 Box 75A, Shevlin MN 56676. BNB228

**HIGH-QUALITY, LOW-COST** courtesy beepers for your transmitter or repeater. Kit \$14, assembled \$18. YBM Enterprises, 8502 N. Oketo Ave., Niles IL 60648. BNB231

**GREAT CIRCLE BEARINGS**—stop guessing. Send us your QTH or your latitude and longitude and get a personal accurate computer printout of headings and mileage from your own QTH to over 500 cities and countries throughout the US and the world. \$3.95. APCA Systems, PO Box 978, Arbutle CA 95912. BNB233

**C-64 AND VIC-20** ham software: Over a dozen programs for each computer. LSASE for catalog. Specify computer. Walt KA9GLB, 4880 N. 49th St. Dept 7, Milwaukee WI 53218. BNB248

**COMMODORE 64 CW INSTRUCTOR PROGRAM.** Generates CW on TV speaker. Random code, keyboard input, or pre-recorded "CW Tests." Character speed and

spacing set independently. Designed for classes and increasing code speed. \$15.00—diskette or cassette (specify). N7BCU, Dennis Olver, 22000 S. Tonya Ct., Beaver-creek OR 97004. BNB249

**QSLs** on wood grain, glossy, and brightly-colored card stocks. Samples 40¢, QOF Press, Dept. 2, 505 S. Barstow #212, Eau Claire WI 54701. BNB250

**DIGITAL AUTOMATIC DISPLAYS** for FT-101s, TS-520s, Collins, Drake, Heath, Swan, and others. Six 1/2" red LED digits in a 5"-wide by 1-1/2"-high by 9"-deep metal cabinet. See last month's ad. Write for prices and information. GRAND SYSTEMS Dept. A, PO Box 3377, Blaine WA 98230; (604)-530-4551. BNB251

**TS-1000, TS-2068, TI 99/4A, VIC-20 SOFTWARE:** Free catalog: Turn your programs and projects into profits. Antenna design, circuit design, code practice. Midwest Software Co., 9922 Harwich Dr., Crestwood MO 63126-2318. BNB252

**KENWOOD TS-430S OWNERS ONLY!** Jabco's Stop Scan! All-mode, squelch-operated (when the squelch breaks the scan stops!), adjustable resume scan delay. Automatic operation ("HOLD" overrides Stop Scan). 6-wire connection (4 plug into existing sockets, 2 solder). No mods! No cut traces! Small 1-3/4" PC board. Easy kit with instruction manual—\$18.95. Assembled (100% checked and guaranteed) with manual—\$28.95 (Indiana residents include 5% sales tax). Jabco, R1 Box 386, Alexandria IN 46001. BNB253

**BUILD ONE-TRANSISTOR HAM RECEIVER**, or simple way to change radio to hearing aid, or no-chemical printed circuit boards. Process instructions, each \$2.00. Kenneth Hand WB2EUF, PO Box 708, East Hampton NY 11937. BNB254

**GET IN NOW**... the demand for burglar alarms is everywhere. Learn this booming business. It's easy. We can help you. Starting information: \$2.00. Dynamic Security Marketing, PO Box 1456-H, Grand Rapids MI 49501. BNB255

**COMMODORE 64 5-BAND DXCC LOG** includes custom beam headings, distances to DX, plus continent, country, zones QSOed/QSLed on any band, phone or CW, upon country name or call sign entry. Diskette and instructions \$18.99, ppd. Sondor Software, PO Box 416, Sarnia, Ontario, Canada N7T 7J2. BNB256

**1.2-GHZ EQUIPMENT WANTED:** I would like to trade the following mint-condition equipment for the ICOM RP-1201 repeater and/or the IC-120 mobile transceiver. I have: Atlas 210-X with power supply in excellent condition, IC-4AT new, IC-2AT new, and Clegg FM-27 2-meter synthesized 25-Watt mobile, in fine shape. No modifications on any of this equipment. Blaine Hamrick WB5LSJ, PO Box 610173, DFW Airport TX 75261. BNB257

**EXPIRED HAM LICENSE PLATES** wanted for collection: Will pay reasonable price

for plates in good shape, and of course will pay all postage. Blaine Hamrick WB5LSJ, PO Box 610173, DFW Airport TX 75261. BNB258

**JENNINGS UCSSL-1000 VACUUM VARIABLE CAPACITORS**, 10 through 1000 pF at 5000 kV with gear drive train and mounting bracket. Ideal for that linear amplifier or tuner: \$59.50. HP608C lab-quality signal generator, 10 MHz through 480 MHz, perfect for HF/VHF/UHF alignment: \$345.00. HP614A signal generator, 900 MHz to 2100 MHz: \$345.00. HP618B, 3.8 GHz through 7.6 GHz: \$375.00. Jerrold 900C sweep generator, 500 kHz to 1200 MHz: \$345.00. Antique National Radio NC-TV7M, table top, 7" TV in original grey HRO-style metal cabinet: \$245.00. Collins new 637T-1 portable dipole, 3 MHz through 30 MHz dipole reel-type antenna: \$245.00. All equipment lab checked. We accept M/C, Visa, or check. Phone Bill Slep, (704)-524-7519, Slep Electronics Company, Highway 441, Otto NC 28763. BNB259

**QSLs** to order. Variety of styles, colors, card stock. W4BPD QSLs, PO Drawer DX, Cordova SC 29039. BNB260

**THE DX'ERS MAGAZINE.** Up-to-date, informative, interesting. Compiled and edited by Gus Browning W4BPD, DXCC Honor Roll Certificate #4. Send for free sample and subscription information today. PO Drawer DX, Cordova SC 29039. BNB261

**TUBES FOR SALE:** ham, audio, communications, marine and aircraft. We match pairs for audio. Have CCTV cameras. Free antique tube with \$100.00 order. Write ARS Electronics, 7110 DeCelis Place, Van Nuys CA 91406. Phone: (818)-997-6200. Tel-ex (RCA): 215706ARSE. BNB262

**COLOR COMPUTER CONTESTERS!** Detect dupes. Log up to 2560 calls. K0TW Contest Program now available from K0TW (no middle man). Machine language, requires minimum 16K. \$9.95 for tape version or \$1 (refundable) for detailed description. Tom Workman K0TW, Rt. 9 Box 688, Tucson AZ 85743. BNB263

**QSLs AND RUBBER STAMPS.** Top quality. QSL samples and stamp information, 50¢. Ebbert Graphics D-7, Box 70, Westerville OH 43081. BNB264

**COCO OWNERS**—Free software and hardware brochure. CoCoNuts, POB 9866, San Jose CA 95157-0866. BNB265

**ELECTRONICS TECHNOLOGY COURSE.** 34-credit, excellent for FCC license prep., \$50. Trade for 2m or 450 transceiver. K6KZT, 2255 Alexander, Los Osos CA 93402. BNB266

**BEARING AND DISTANCE CHART.** 23 pages of data lists. Antenna headings and distances to 600+ locations worldwide. Computer-generated chart is based on your QTH. User's guide included. Allows you to aim your dipole or beam toward areas you wish to work. Legible print, bond paper, vinyl cover, shipped flat. \$10.00 complete (CA add 6 1/2 %). Dawn Mackey, Box 1157, Felton CA 95018 (XYL NW6U). QSL for info/sample. BNB267

**RTTY**  
TU-470 Full Featured RTTY/CW Terminal Unit  
Call For Special Prices  
(913) 234-0198 ✓23  
FLESHER CORP. • P.O. BOX 976 • TOPEKA, KS • 66601

**MULTI-BAND SLOPERS**  
ALSO-DIPOLES & LIMITED-SPACE ANTENNAS  
Outstanding performance of W9INN antennas is well known! Now enjoy multiband BIG-SIGNAL reports! Automatic bandswitching • Very low SWR • Coax feed • 3kw power • Compact • FULLY ASSEMBLED to your specified center frequency each band • Easy to install • Very low profile • Complete instructions • Your personal check accepted

|   |              |           |
|---|--------------|-----------|
| 4-BAND SLOPER - 160, 80, 40, 30, or 20M   | 60 ft. long  | \$ 48 ppd |
| 3 -- -- -- 160, 80, 40M                   | 60 ft. --    | \$ 43 --  |
| 2 -- -- -- 80, 40M                        | 40 ft. --    | \$ 35 --  |
| 3 -- -- NO-TRAP DIPOLE - 160, 80, 40M     | 113 ft. long | \$ 71 --  |
| 2 -- -- -- 80, 40M                        | 85 ft. --    | \$ 55 --  |
| 9-BAND SPACE-SAVER DIPOLE - 160 thru 10M* | 46 ft. long  | \$ 85 ppd |

\* Requires wide-range tuner (80, 40, 20, 15M without tuner)  
SEND SASE for complete details of these and other unique antennas  
W9INN ANTENNAS 312-394-3414  
BOX 393-S MT. PROSPECT, IL 60056

**RTTY FACTORY**  
**INVENTORY REDUCTION SALE**  
• DM-170 • TU-170 • TU-170A • TU-1200  
• TU-470 • All Reduced For Big Savings  
CALL TODAY (913) 234-0198 ✓308  
FLESHER COPR. • P.O. BOX 976 • TOPEKA, KS • 66601

# How Good Is Six?

*Try 50 MHz with a transceiver you've built from scratch. There's no greater pleasure than saying, "I did it myself!"*

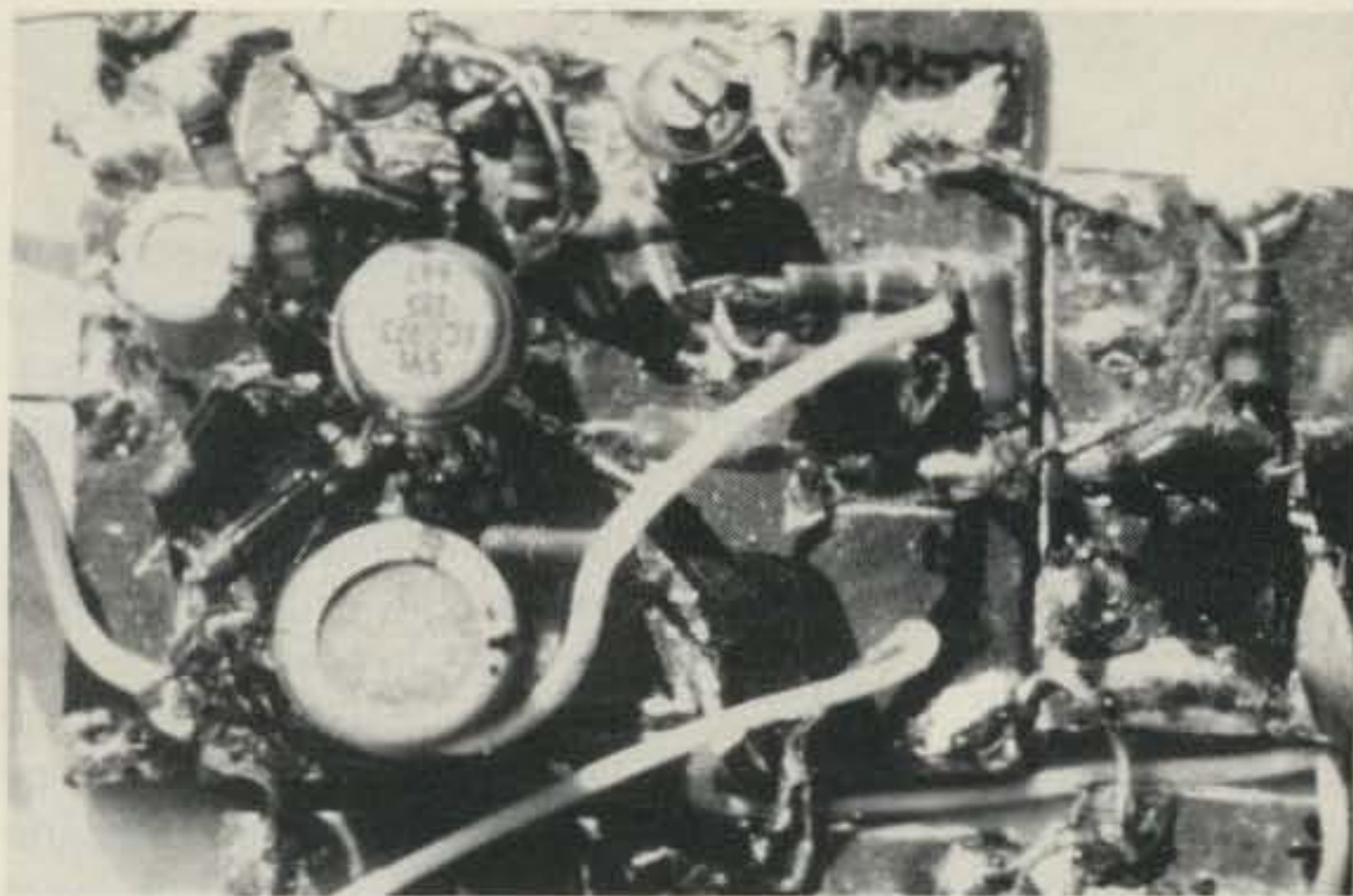

Photo A. Close-up of balanced modulator showing X-acto®-knife "cut and slash" construction technique.

Larry Jack KL7GLK  
#1 East Lake Drive  
Bay Ridge, Annapolis MD 21403

This would be a good evening for a test, I thought. Several conversations drifted through the speaker as I glided along the bottom of the six-meter phone band. There was a strong summer E opening to the south. "Well, here goes," I said, and I let out a CQ. I had just finished building the transceiver that afternoon and, although its transmitter is only half a

Watt, by the end of the opening it had netted ten states and a Caribbean island. I had faith in my simplistic design, but this performance was even better than I had expected.

This is an article on how to construct a six-meter sideband transceiver. I originally planned to write it in a concise, technical manner, when a non-ham friend's observation made me re-

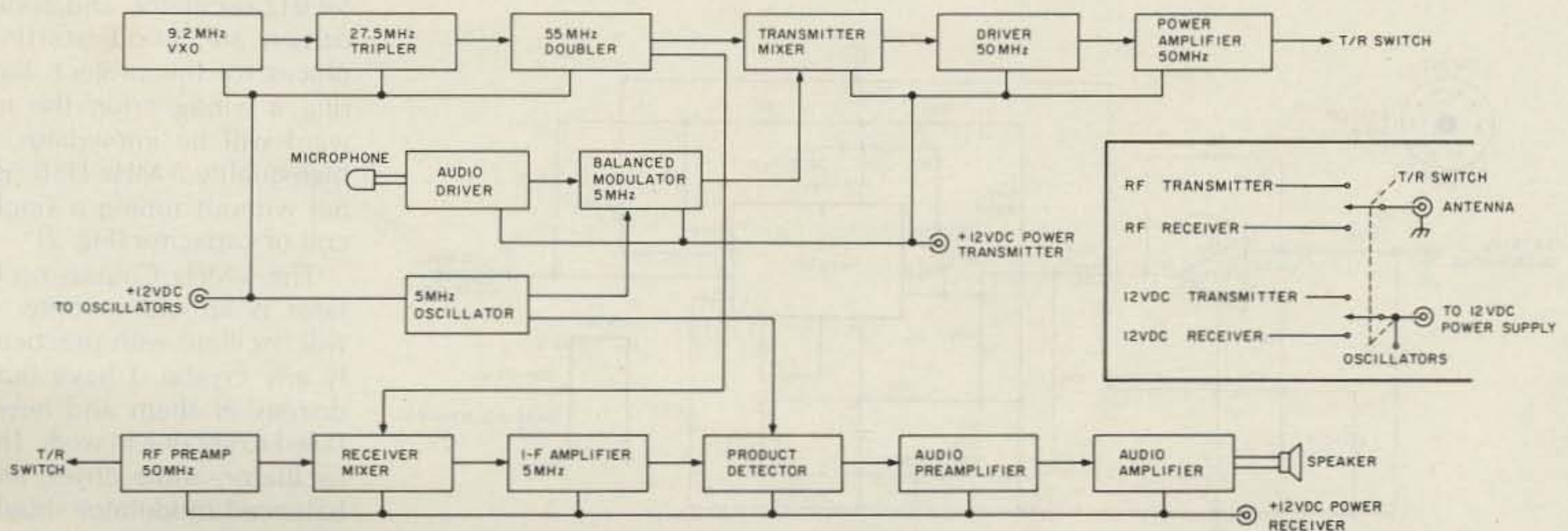

Fig. 1. Block diagram of a 50-MHz transceiver.



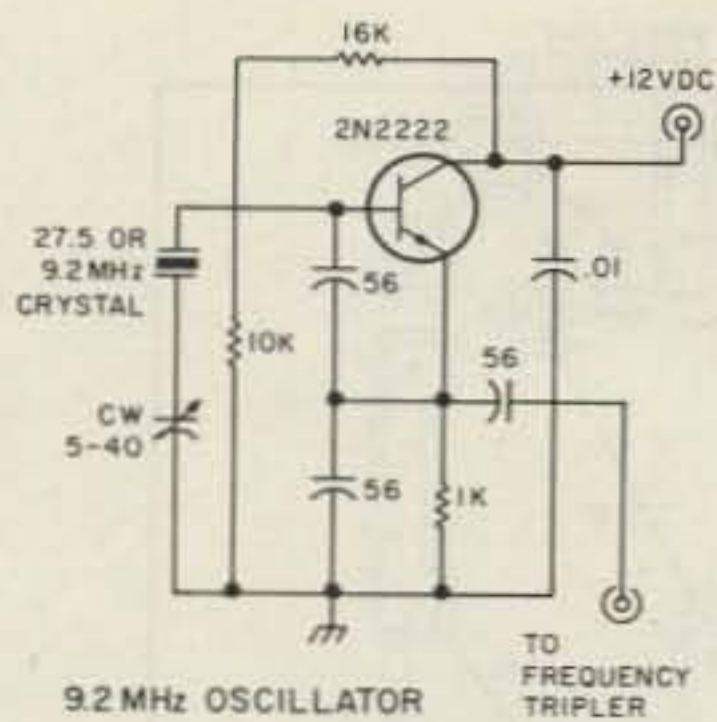

Fig. 4. 9.2-MHz vxo.

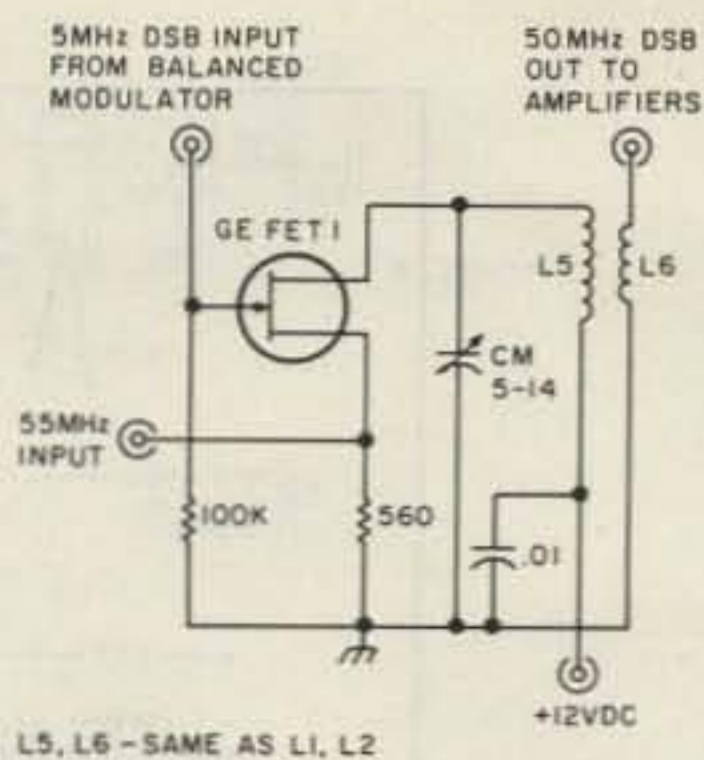

Fig. 7. Transmitting mixer.  
L5, L6 - SAME AS L1, L2

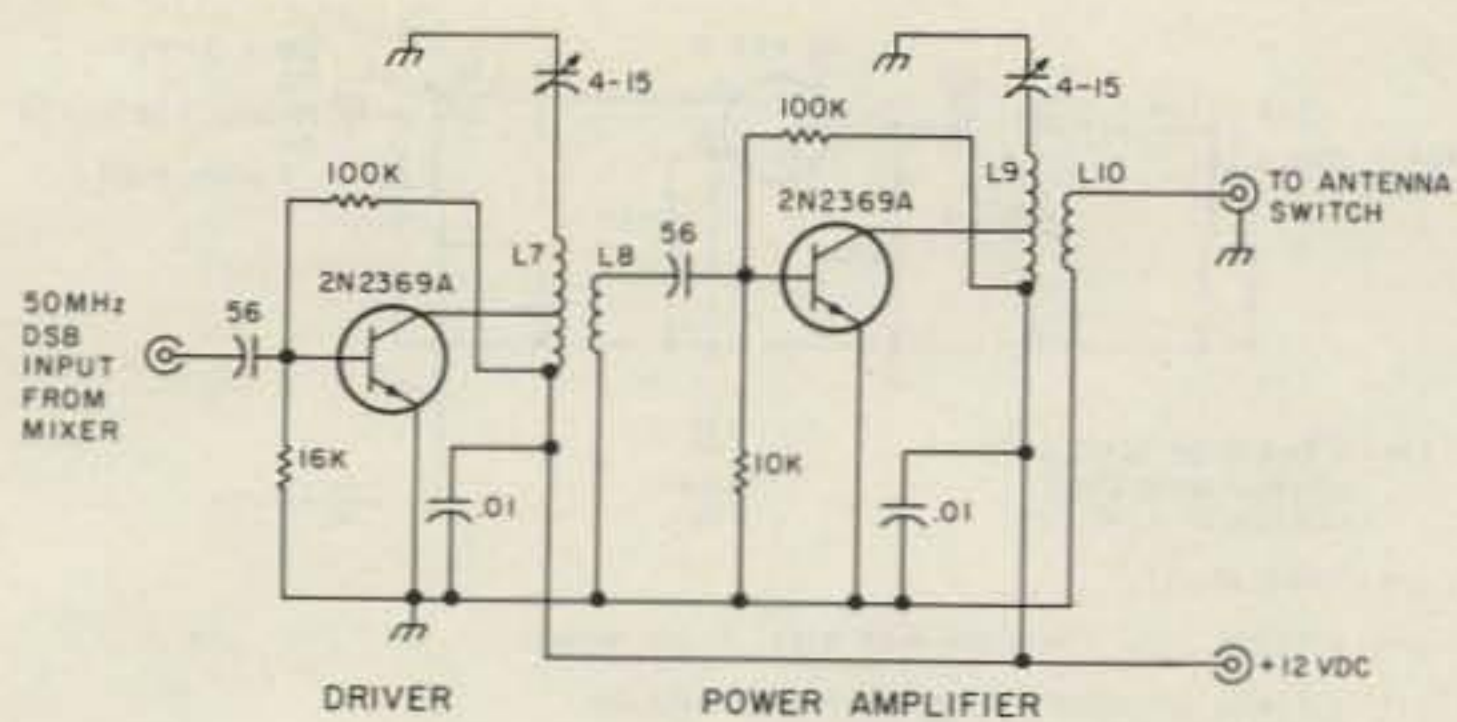

Fig. 8. Driver/power amplifier.  
L7 - SEE TEXT - 9 TURNS, 1/2 IN. DIAMETER, #24 WIRE, CLOSE WOUND  
L8 - 3 TURNS, 1/2 IN. DIAMETER #24 WIRE NEAR COLD END OF L7  
L9, L10 - SAME AS L7, L8

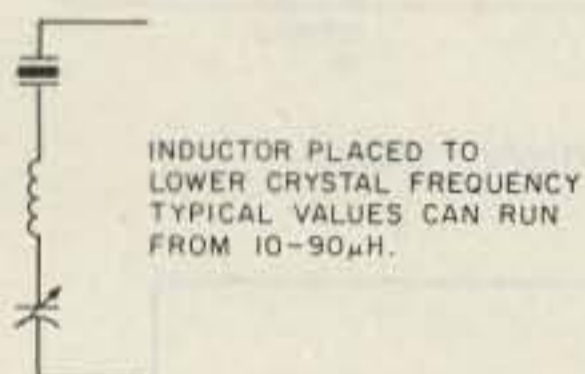

Fig. 5.

strength meter (FSM) can be used to verify both the oscillator output and the DSB coming from the ECG-973. This just about guarantees that everything is right. A double check by listening on 5 MHz will be especially rewarding as you tune through a superbly clean, crisp sideband signal. Only a slight adjustment to  $R_N$  will be necessary to null the carrier to better than 50 dB.

At this point some may ask, "Why not filter the DSB and make SSB?" You can, I have, and it works. If you have a crystal filter and change the mixing frequencies accordingly, this will produce a fine SSB generator. Personally I have found almost universal acceptance of DSB on VHF. Most stations have such sharp receivers that they never even

detect the other sideband. So unless you tell them you are operating DSB, they will never know. Building crystal filters can be an enlightening (tricky) business, and DSB is so much easier. Why fight?

### Construction

The balanced modulator as well as all the other circuits are built on copper-clad glass-epoxy boards. I have learned that it is easier to build and test one stage at a time before proceeding on. Therefore, each circuit section is an individual square of PC board. Revisions occur all too frequently before arriving at a final circuit. This happens even when following a design that is known and proven. I recommend buying the best quality boards available because there is nothing more frustrating than having the copper foil peel away from the cheap PC board which has been heated once too often.

Each circuit section is approximately 2 inches square and these are wired together.

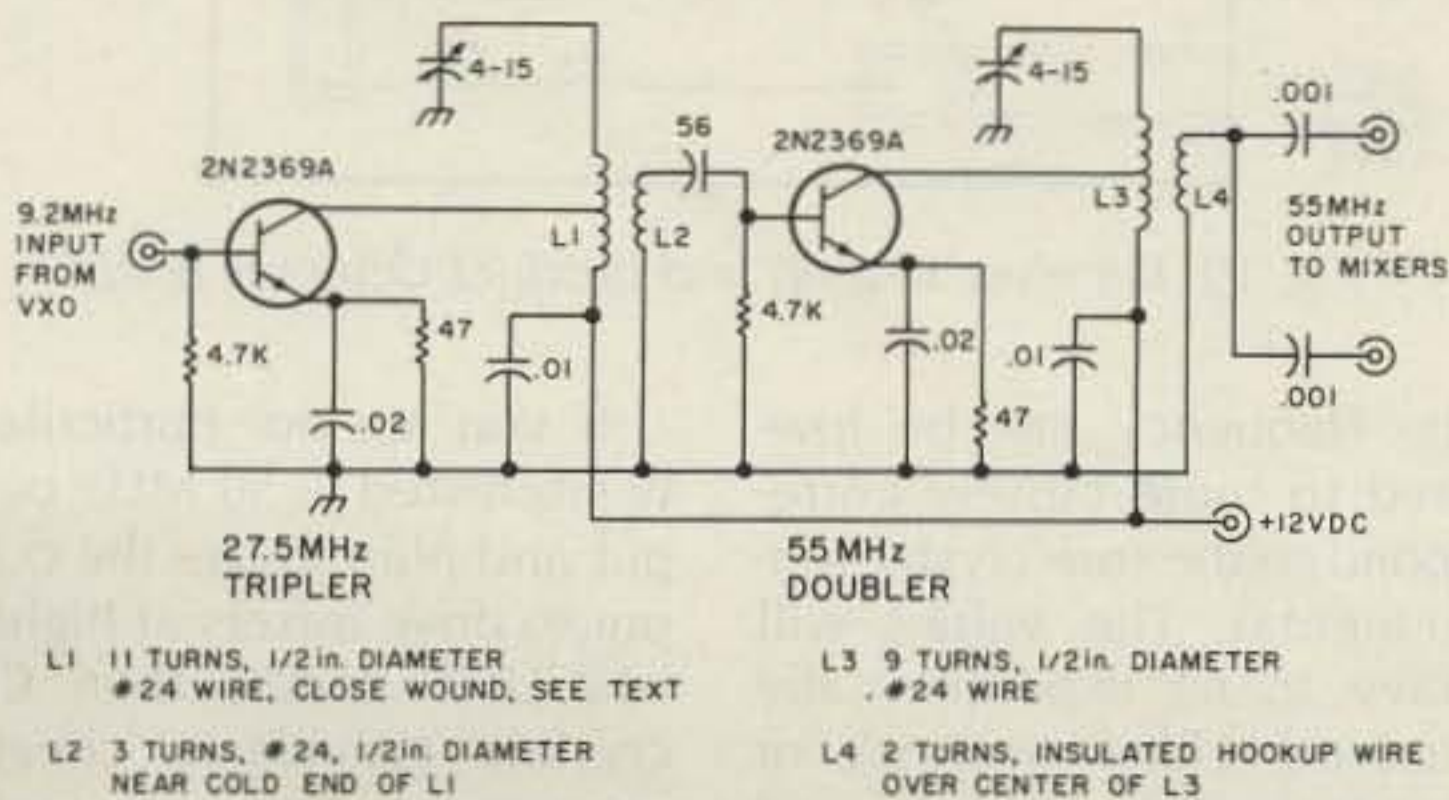

Fig. 6. 9.2-to-55-MHz doubler/tripler.

er. Rather than elaborately planning out the wiring routes and component placements as required when etching PC boards, I use an X-acto® knife to cut away the copper foil and establish isolated islands to solder to. The effect isn't much to look at but it is quick, effective, and easily modified.

### Vxo and Frequency Multipliers

This variable crystal oscillator (Fig. 4) exacts a cost but returns certain valuable benefits. The cost is the loss of band coverage as compared to a vfo; the benefits are extreme frequency stability when compared to that same vfo. This vxo also uses a Colpitts oscillator, operating at 9.2 MHz. This is multiplied six times to 55

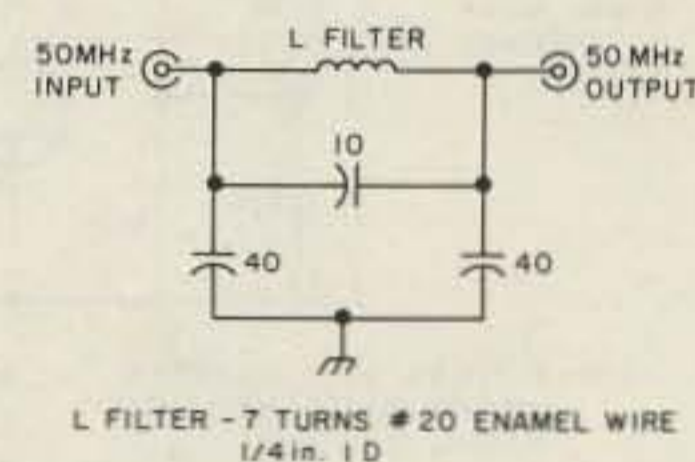

Fig. 9. Transmitting TVI filter.

MHz, which then feeds both the transmitter and receiver mixers. At 9 MHz the oscillator's frequency can be warped about  $\pm 6$  to 9 kHz by  $C_W$ . This comes out to a 40-to-60-kHz swing at 50 MHz.

My own unit operates between 50.105 and 50.160 MHz. The addition of more crystals would mean greater frequency coverage. The nice thing about the vxo is its stability. From a cold

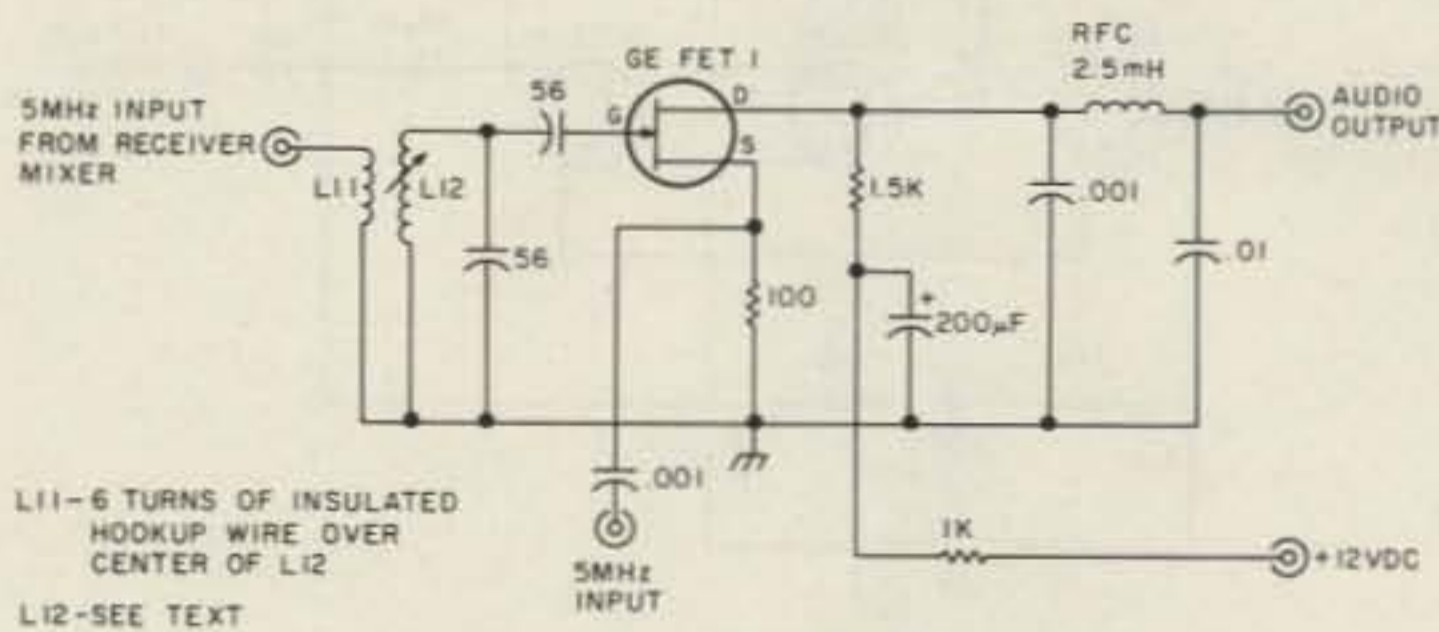

Fig. 10. Product detector.

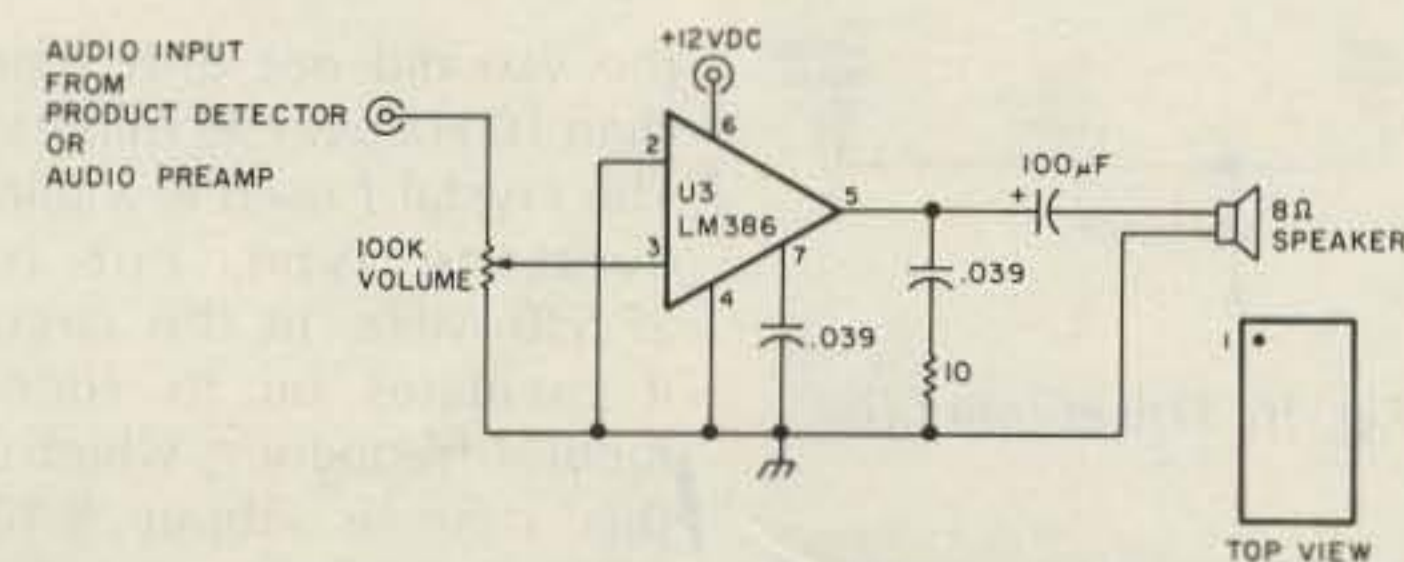

Fig. 11. Audio amplifier.



It is not until the first multiplier that we reach the

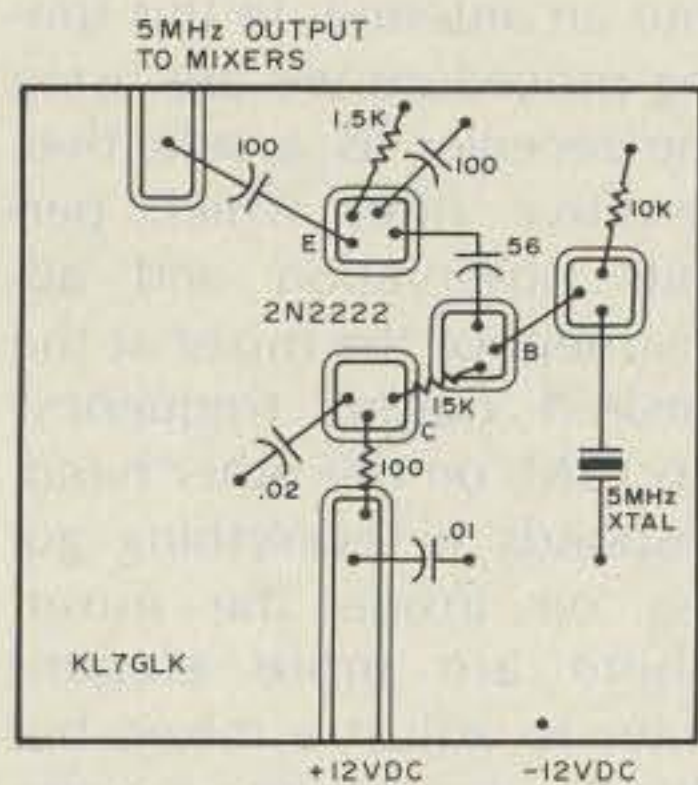

Fig. 20. 5-MHz crystal-oscillator board.

first tuned circuits. A grid-dip meter and a frequency counter will ensure 27.5 MHz coming from the tripler in Fig. 6. The following doubler should be checked also to make sure it is passing only 55 MHz. The output coils of these and all the other stages of the transceiver are 1/2-inch-diameter mini-duct, 36 turns to the inch. They can be wound freehand if desired. In either case the linking coils are placed near the cold (capacitor-bypassed) end of the tank coil. The tun-

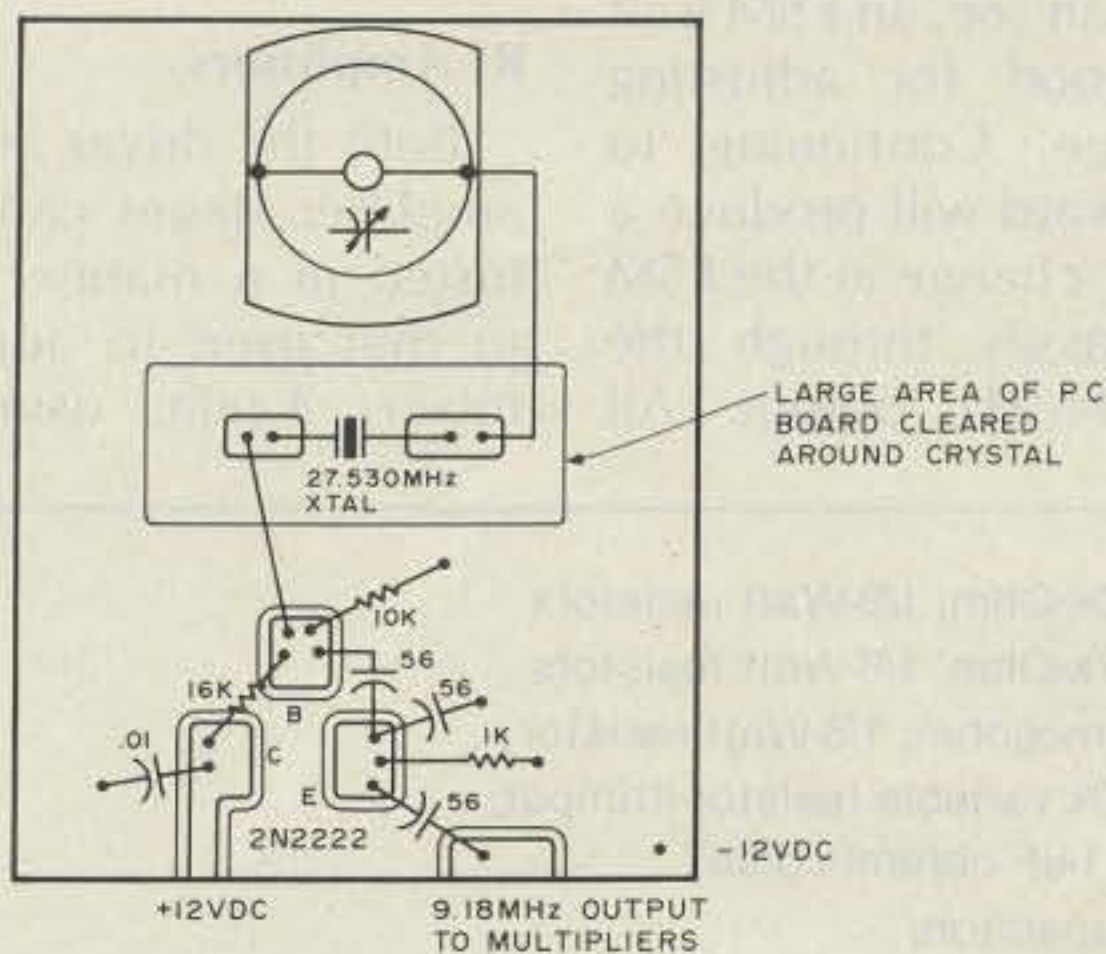

Fig. 21. 9.18-MHz vxo board.

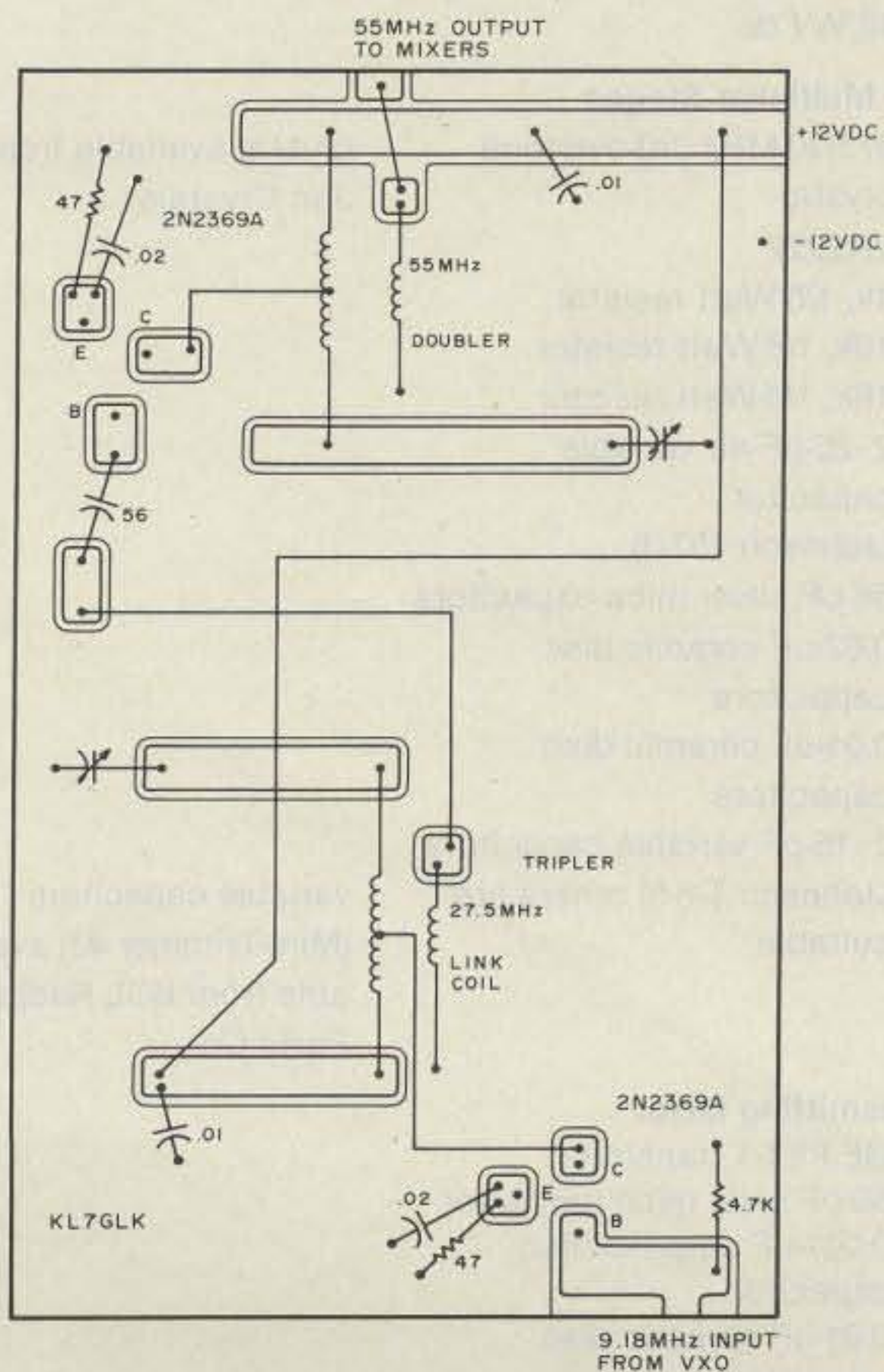

Fig. 22. 9-to-55-MHz multiplier board.

ing capacitors are all Johnson air variables, type T-6-5.

These are nice because they solder vertically to the PC board. I seem to use them by the handfuls for VHF circuits.

### Transmitting Mixer

If there is a transmitter stage that can give trouble,

it is here. The circuit is straightforward enough, but be careful in tuning it up. Make sure it is 5 and 55 MHz only that appear on the gate and source of the FET and that  $L_5$  is tuned to 50 MHz. Tuning up a transmitting mixer can be confusing because of the presence of the local-oscillator

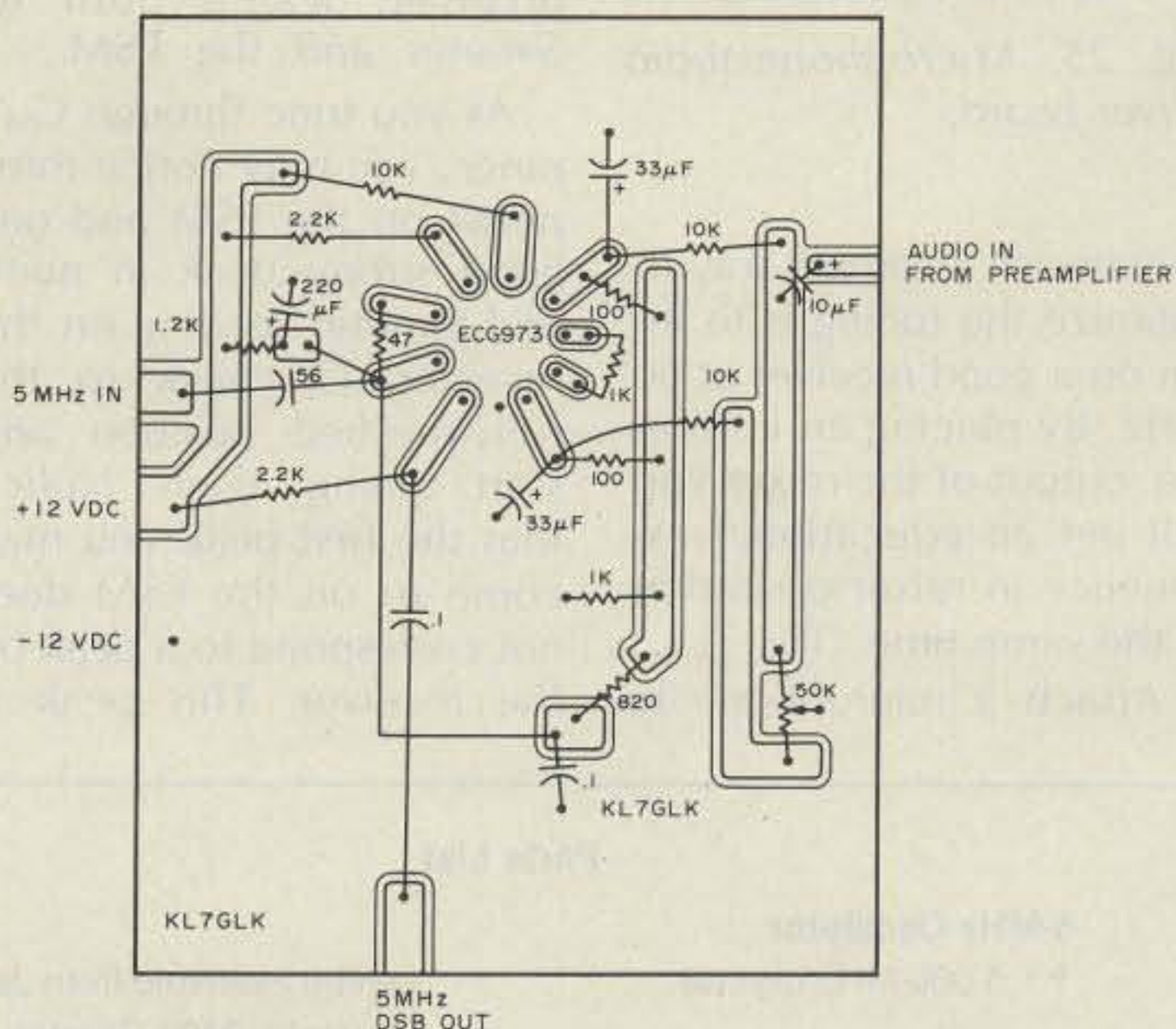

Fig. 23. Transmitter balanced-modulator board.

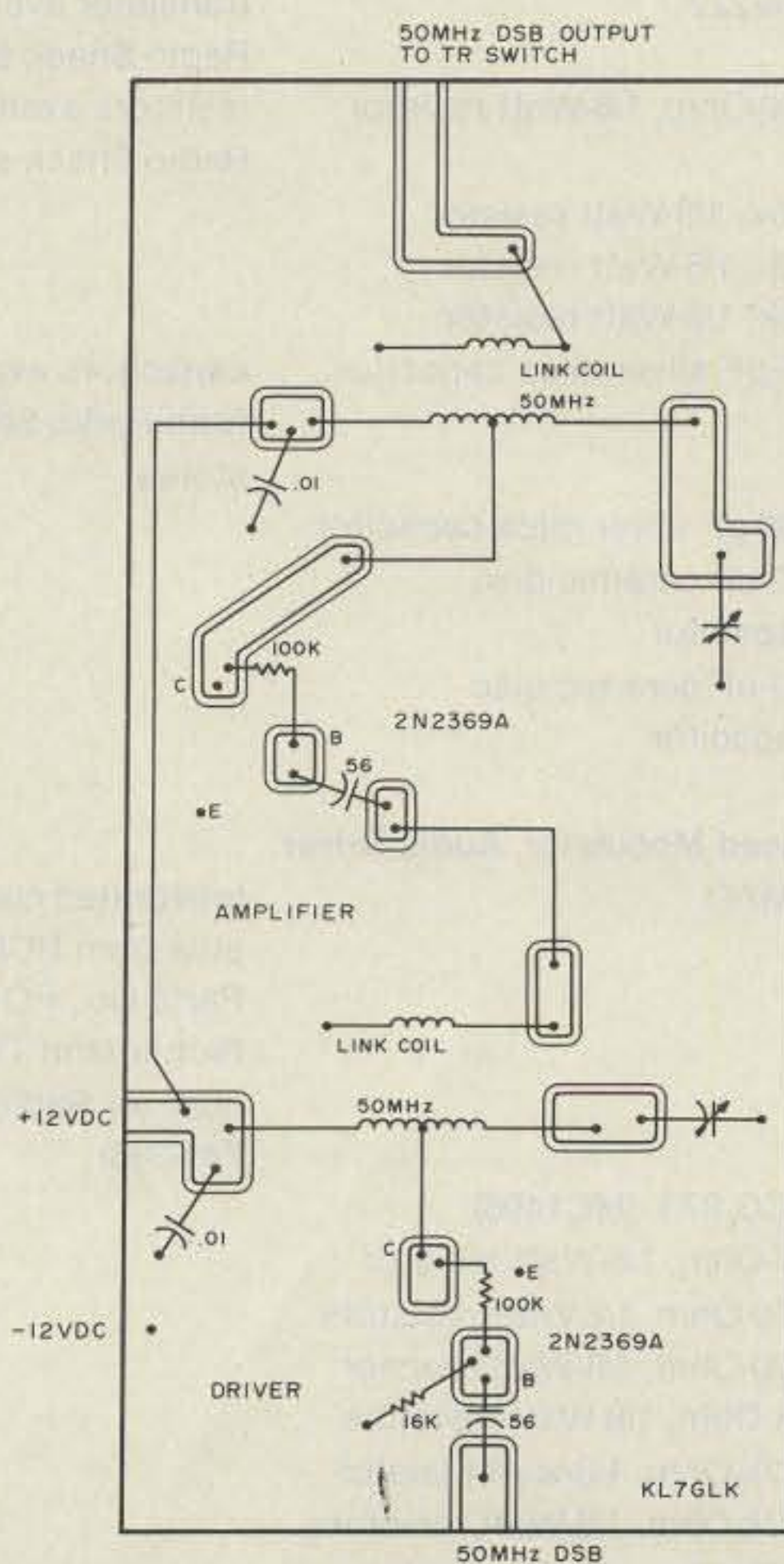

Fig. 24. Transmitter driver and amplifier board.

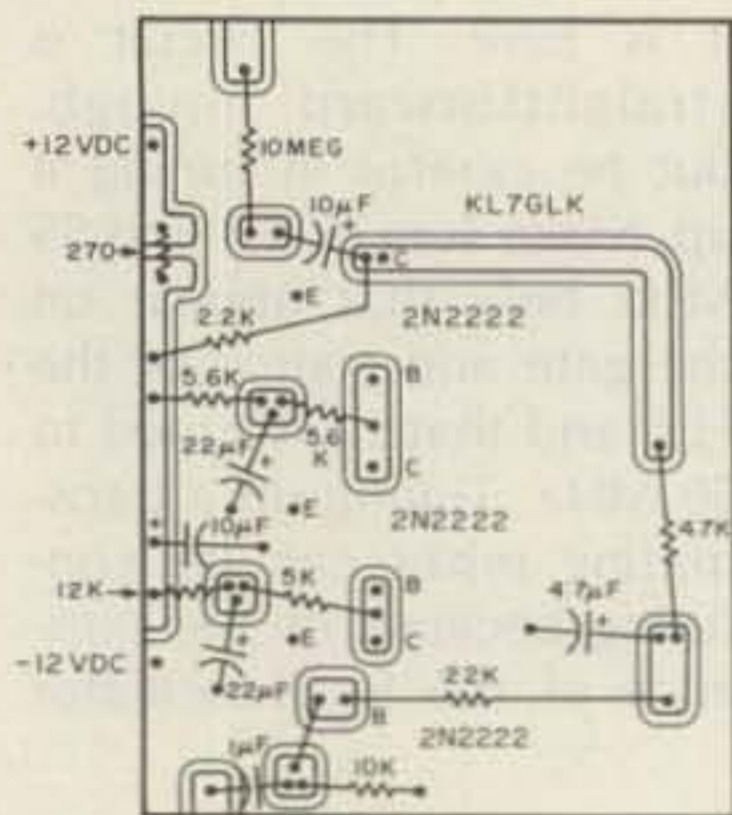

Fig. 25. Microphone/audio driver board.

frequencies. A simple way to optimize the tuning is to listen on a good receiver at 50 MHz. By placing an FSM at the output of the mixer you will get an educational experience in mixer operation at the same time. (Fig. 7).

Attach a microphone to

the audio driver but place it so that it will pick up only a minimum of sounds (insulate it by wrapping it in a piece of cloth, etc.). What you want is a low-level white-noise-modulated DSB signal entering the mixer. The mixer stage tunes roughly 45 to 65 MHz so start at the fully-meshed position of  $C_M$ . Listen to the receiver, watch both its S-meter and the FSM.

As you tune through  $C_M$ 's range, you may notice three peaks on the FSM and one good strong peak in noise and S-meter reading on the receiver. Go back to the fully-meshed position and start tuning again. Notice that the first peak you may come to on the FSM does not correspond to a peak on the receiver. This peak is

more than likely a weird combination of mixer products, or a fifth harmonic of the vxo. In any case it is not what is wanted. Touch up the tuning on the output stage of the doubler and tripler to minimize this as much as possible, but not to the extent of changing the injection from 55 MHz.

Go on tuning  $C_M$  upward until you find an even peak in the receiver S-meter and noise. This is 50 MHz. Notice that the FSM reading has not changed much. There is a lot of rf activity going on inside the mixer. As you can see, an FSM isn't much good for adjusting this stage. Continuing to tune upward will produce a dramatic change in the FSM as it passes through the vxo's 55-MHz output. All

this should go to show why it is not a good idea to use a transmitting mixer directly into an antenna. In this tuning procedure we are using the receiver as a selective, sensitive filter which permits observation and adjustment of the mixer at the desired output frequency. An FSM, on the other hand, responds to everything going on inside the mixer. There are more elegant ways to adjust a mixer, but they require expensive equipment and they may not be as sensitive as this simple technique.

### Rf Amplifiers

Both the driver and final amplifier stages can be adjusted in a manner similar to that used to adjust the mixer. Again, using only

### Parts List

#### 5-MHz Oscillator

- |   |                               |  |
|---|-------------------------------|--|
| 1 | 5.000-MHz crystal             | crystal available from Jan Crystals, 2400 Crystal Drive, PO Box 06017, Fort Myers FL 33906 |
| 1 | 2N2222                        | transistor available from Radio Shack stores   |
| 1 | 100-Ohm, 1/8-Watt resistor    | resistors available from Radio Shack stores.   |
| 1 | 1.5k, 1/8-Watt resistor       |  |
| 1 | 10k, 1/8-Watt resistor        |  |
| 1 | 15k, 1/8-Watt resistor        |  |
| 1 | 56-pF silver mica capacitor   | capacitors available from Radio Shack stores   |
| 1 | 100-pF silver mica capacitor  |  |
| 1 | 0.2-uF ceramic disc capacitor |  |
| 1 | 0.1-uF ceramic disc capacitor |  |

#### Balanced Modulator, Audio Driver

- |   |                              |   |
|---|------------------------------|---|
| 1 | LM741                        | Integrated circuits available from BCD Radio Parts Co., PO Box 119, Richardson TX 75080-0020 (or Radio Shack for 741-386) |
| 1 | ECG 973 (MC1496)             |   |
| 1 | 47-Ohm, 1/8-Watt resistor    |   |
| 2 | 100-Ohm, 1/8-Watt resistors  |   |
| 1 | 820-Ohm, 1/8-Watt resistor   |   |
| 4 | 1k-Ohm, 1/8-Watt resistors   |   |
| 1 | 1.2k-Ohm, 1/8-watt resistor  |   |
| 2 | 2.7k-Ohm, 1/8-Watt resistors |   |
| 1 | 4.7k-Ohm, 1/8-Watt resistor  |   |

- |   |   |
|---|---|
| 3 | 10k-Ohm, 1/8-Watt resistors             |
| 2 | 47k-Ohm, 1/8-Watt resistors             |
| 1 | 1-megohm, 1/8-Watt resistor             |
| 1 | 50k variable resistor (trimpot)         |
| 4 | 0.1-uF ceramic disc capacitors          |
| 2 | 10-uF electrolytic capacitors, 15 WV dc |
| 1 | 22-uF electrolytic capacitors, 15 WV dc |

#### Vxo, Multiplier Stages

- |   |   |  |
|---|---|--|
| 1 | 27.530-MHz 3rd-overtone crystal                                 | crystal available from Jan Crystals                                      |
| 1 | 2N2222  |  |
| 1 | 1k, 1/8-Watt resistor   |  |
| 1 | 10k, 1/8-Watt resistor  |  |
| 1 | 16k, 1/8-Watt resistor  |  |
| 1 | 2-25-pF air variable capacitor (Johnson 157-3)                  |  |
| 3 | 56-pF silver mica capacitors                                    |  |
| 2 | 0.02-uF ceramic disc capacitors                                 |  |
| 2 | 0.01-uF ceramic disc capacitors                                 |  |
| 2 | 2-15-pF variable capacitors (Johnson T-6-5) others are suitable | variable capacitors (Mini-Trimmer #3) available from BCL Radio Parts Co. |

#### Transmitting Mixer

- |   |                                 |
|---|---------------------------------|
| 1 | GE-FET-1 transistor             |
| 1 | 56-pF silver mica capacitor     |
| 1 | 0.001-uF ceramic disc capacitor |
| 1 | 0.01-uF ceramic disc capacitor  |



white noise into the balanced modulator, these stages are adjusted for maximum output by listening on 50 MHz. This technique allows us to select against any mixer outputs except 50 MHz. Once this is accomplished, an FSM and pilot-lamp bulb across L10 will show output only when you speak into the microphone. Both the driver and final tank coils are fairly selective against passing any 55-MHz energy to the antenna. Once the radio is properly shielded and bypassed, I can get away without a TVI filter. A filter is still a good idea and I've included a simple low-pass design just in case (Fig. 9).

The final amplifier shows no resistor in the emitter lead. Without one, the in-

put power is about half a Watt. By inserting a variable resistor here the input can be varied down to a few milliwatts for those who like real QRP.

### Receiver

This receiver's design allows a certain amount of flexibility in its construction. It can be kept simple or expanded as the builder desires. Basically it is an rf amplifier, a mixer, a product detector, and an audio amplifier. 55 MHz mixes with 50; the difference—5 MHz is directly converted to audio by mixing with 5 MHz in the product detector. The audio is then amplified.

Having grown up with the idea that good receivers are supposed to be complex, I still find it difficult to

believe anything this simple can work so well.

### Product Detector

A product detector is nothing more than a mixer whose output is in the audio range (Fig. 10). L12 is 50 turns of #30 enamel wire, wound on a 3/8-inch-diameter iron-slug-tuned coil. The tune-up of this stage is easy; adjust L12 to 5 MHz with a grid-dip meter. If the audio amplifier (we are

stepping ahead a little here) is attached and a longwire antenna is hooked to L11, you should be rewarded with a strong signal from WWV on 5 MHz. Notice that if your oscillator is exactly on 5 MHz, you will hear no beat note with WWV. If not, the frequency difference in Hz (or kHz) will appear as the heterodyne frequency.

### Audio Amplifier

You will notice I skipped

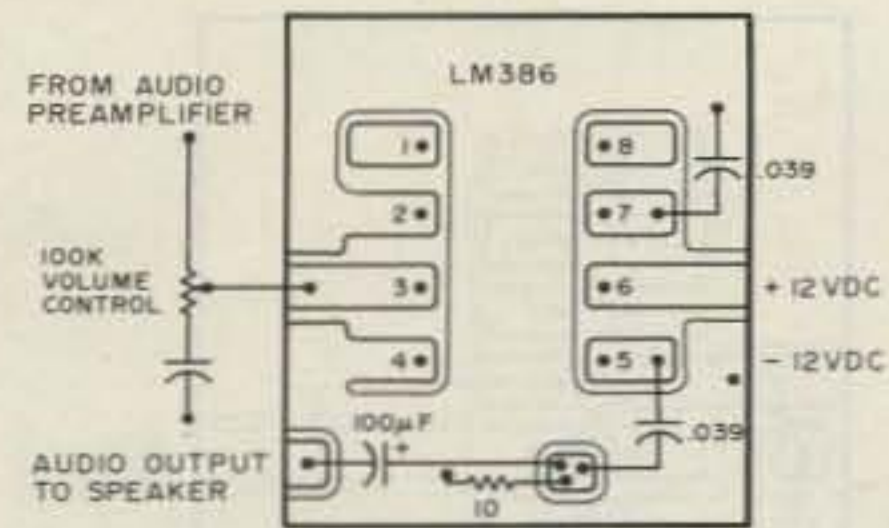

Fig. 26. Receiver audio preamp board.

- 1 560-Ohm, 1/8-Watt resistor
- 1 100k, 1/8-Watt resistor

#### Drivers and Power Amplifier

- 2 2N2369A transistors
- 2 56-pF silver mica capacitors
- 2 0.01-µF ceramic disc capacitors
- 2 2-15-pF air variable capacitors
- 1 10k, 1/8-Watt resistor
- 1 16k, 1/8-Watt resistor
- 2 100k, 1/8-Watt resistors

#### Product detector

- 1 GE-FET-1
- 1 2.5-mH rfc (choke)
- 1 100-Ohm, 1/8-Watt resistor
- 1 1k-Ohm, 1/8-Watt resistor
- 1 1.5k-Ohm, 1/8-Watt resistor
- 1 56-pF silver mica capacitor
- 2 0.001-µF ceramic disc capacitors
- 1 0.01-µF ceramic disc capacitor
- 1 200-µF electrolytic capacitor 15 WV dc

#### Audio Amplifier & Preamp

- 3 2N2222
- 1 LM386
- 1 10-Ohm, 1/8-Watt resistor
- 1 150-Ohm, 1/8-Watt resistor
- 1 270-Ohm, 1/8-Watt resistor
- 1 2.7k-Ohm, 1/8-Watt resistor
- 2 5.6k-Ohm, 1/8-Watt resistors
- 1 10k-Ohm, 1/8-Watt resistor
- 1 12k-Ohm, 1/8-Watt resistor
- 1 22k-Ohm, 1/8-Watt resistor
- 1 47k-Ohm, 1/8-Watt resistor

from BCD Radio Parts Co.

from Radio Shack

available from Radio Shack stores

- 1 51k-Ohm, 1/8-Watt resistor
- 1 10-megohm, 1/8-Watt resistor
- 1 100k variable resistor (trimpot)
- 2 0.039-µF ceramic disc capacitors
- 1 1-µF electrolytic capacitor, 15 WV dc
- 1 4.7-µF electrolytic capacitor, 15 WV dc
- 2 10-µF electrolytic capacitors, 15 WV dc
- 2 22-µF electrolytic capacitors, 15 WV dc
- 1 100-µF electrolytic capacitor, 15 WV dc
- 1 8-Ohm, 0.5-Watt PM speaker, 3-inch diameter

#### Receiver Mixer

- 1 GE-FET-2
- 1 100-Ohm, 1/8-Watt resistor
- 1 560-Ohm, 1/8-Watt resistor
- 1 100k-Ohm, 1/8-Watt resistor
- 2 56-pF silver mica capacitors
- 1 0.001-µF ceramic disc capacitor
- 1 0.01-µF ceramic disc capacitor
- 1 2-15-pF air variable capacitor (T-6-5)

#### Receiver Rf Preamp

- 1 GE-FET-1
- 1 100-Ohm, 1/8-Watt resistor
- 1 220-Ohm, 1/8-Watt resistor
- 1 10-pF silver mica capacitor
- 2 2-15-pF air variable capacitors

#### Receiver I-f Amplifier

- 1 2N2222
- 1 100-Ohm, 1/8-Watt resistor
- 1 560-Ohm, 1/8-Watt resistor
- 1 4.7k-Ohm, 1/8-Watt resistor
- 1 56-pF silver mica capacitor
- 3 0.1-µF ceramic disc capacitors

#### Miscellaneous Parts

BNC antenna connector, DPDT switch for T/R, 6" x 5" x 4" aluminum box, miniature microphone jack, and hi-Z microphone.

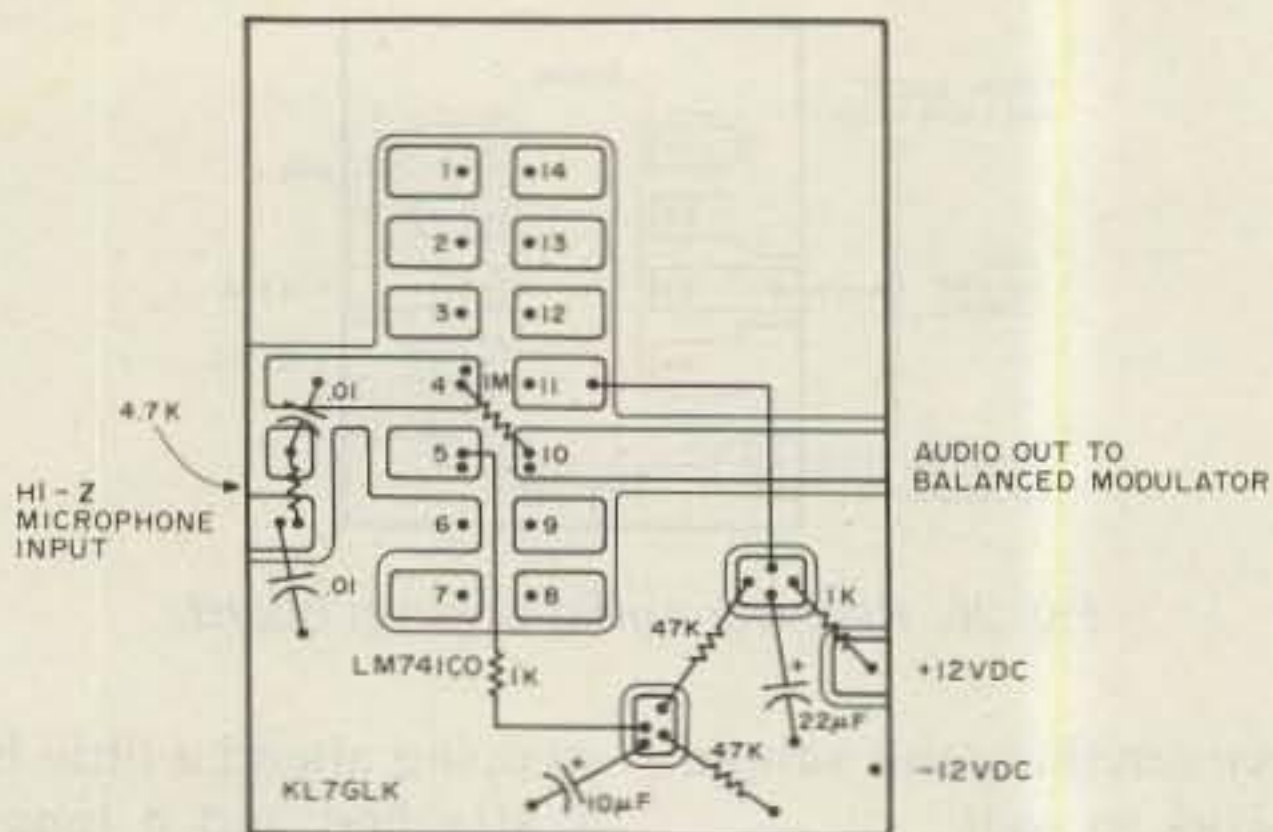

Fig. 27. Receiver audio amplifier board.

a stage, the audio preamplifier. The LM386 will provide enough audio gain to drive a pair of headphones for tuning up the receiver. The preamp can be added later. In fact, if headphones alone are adequate, the preamp can be skipped altogether. With a direct-conversion receiver it is important to have as much gain as possible into the audio section. If the preamp is omitted, place a 10- $\mu$ F capacitor across pins 1 and 8 to increase the voltage gain from 40 to about 200.

### Mixer

The receiver mixer is practically identical to the transmitter. Fortunately it is much simpler to adjust. L15 is identical to L12 and it is dipped for 5 MHz.  $C_p$  is peaked for 50 MHz. With 55 MHz on the source, a six-meter signal should now be evidenced as an audio signal. Go back and touch up L12 for the best response with the product detector.

### Rf Amplifier

This rf amplifier is a compromise. I traded high gain for stability. When designing this transceiver, one of the things I kept in mind was a design that others could easily build. It is true that higher-gain preamps can be built, but they may require individualized attention to get them stabilized and working properly. This grounded-gate design still offers considerable gain but is rock stable. It will tune up cleanly right from the start. Another can be used for more gain if you wish.

Initially set  $C_A$  and  $C_B$  to 50 MHz with a grid-dip meter. Apply a six-meter signal, fine adjust the capacitors, and repeak the coils of the mixer and product detector for the best response.

### The Basic Receiver

These four stages, the rf preamp, mixer, product detector, and audio amplifier, are essentially the receiver.

There was a band opening the evening I completed these stages and I spent several hours just listening to the activity through a set of headphones. There isn't enough audio with this configuration to drive a speaker, so I added an i-f amplifier and an audio preamp.

### I-f Amplifier

A single 2N2222 (Fig. 13) increases the audio output some. It also isolates the mixer from the product detector. Originally, I was going to use it to drive a ceramic filter since I feared the selectivity of such a simple receiver couldn't be much. But the more I listened the more I realized just how sharp this little product detector was. I could tune five separate QSOs between 50.110 and 50.120. Sure, they splattered on each other, but when the product detector was locked onto a desired signal, the voice came through sharp and clear. If you want more selectivity, a crystal filter can be added, but believe me, this is a good receiver without one.

### Audio Preamp

The i-f stage hasn't enough gain to use a speaker with the LM386 audio amplifier. Direct-conversion receivers require large amounts of audio amplification, thus, they are prone to microphonics. This one is no exception. Be sure to firmly solder everything down

on the receiver. The circuits will produce a characteristic ring whenever they are tapped if not securely attached. Fortunately, with the small components used, microphonics should not be a problem.

This preamp (Fig. 15) exhibits a very high gain; I would estimate it to range somewhere around 100 dB. It can drive the daylights out of an LM386 (and your eardrums as well if you use headphones). We now have plenty of gain for room-size-speaker operation, although the three-inch PM speaker I've used doesn't do it credit.

### Loose Ends

By now you probably realize that a product detector is not tolerant of a noisy power supply. Voltage regulators that appear quiet for other uses set up a howl when used with this direct-conversion receiver and its high-gain audio stages. Filtering the incoming power lead, the power-line filter in Fig. 16 cures the problem.

Now add some sort of a T/R switch (a DPDT will do) to switch for both the rf and 12-volt functions. You are ready to go on the air.

Where to next? If you have gotten this far you've learned plenty about sideband, mixers, product detectors, and VHF in general. 50 MHz is just the start—see you on the microwaves! ■

**SOTRON ANTENNAS**  
**BIG ON PERFORMANCE**  
**SMALL ON SPACE**  
 MODELS FROM 160-10 METERS  
**NO TUNERS! NO RADIALS!**  
 PERFECT FOR LIMITED SPACE  
 APPLICATIONS: BOATS, APARTMENTS,  
 VACATION HOMES AND MORE.  
 80-METER..... \$63<sup>95</sup> plus \$47<sup>75</sup> Shipping  
 \*40-METER..... \$52<sup>95</sup> plus \$37<sup>75</sup> Shipping  
 ASK FOR PRICES ON OTHER MODELS  
 \*SEE REVIEW IN OCTOBER 73  
**VISA BILAL COMPANY MasterCard**  
 298 S.R.2, BOX 62, DEPT. 73  
 EUCHA, OK 74342 (918) 253-4094

IF YOU COMBINE 1.3 - 1296 and 249.95 WHAT DO YOU GET?  
 A COMBINATION THAT YOU CAN'T BEAT.

7216 COUNTER  
  
 1.3 IS THE FREQUENCY  
 1296 IS THE BAND  
 \$249.95 IS THE PRICE

- Frequency Range 10Hz to 1.3Ghz
- 4" 8 Digit LED Display
- Automatic decimal point
- 5 1/2" x 6" x 2" all metal case
- Built in pre-scaler
- 1 year warranty
- Input impedance 1M ohm/20 pf to 100 Mhz - 50 ohm above 100 Mhz
- Accuracy  $\pm 1$  ppm (.0001)
- Reads 1296 Mhz Band
- Stability  $\pm 1$  ppm/hour
- Stability  $\pm 1$  ppm/Mo.
- 115v operation
- Temp  $\pm 3$ ppm 20 to 50 C.

MASTER CARD OR VISA ACCEPTED  
 CALL 716-874-5848 or WRITE:  
 328  
**DIGITAL Instruments Inc.**  
 636 Sheridan Drive,  
 Tonawanda, New York 14150  
 (716) 874-5848  
 15 DAY - NO HASSLE  
 RETURN GUARANTEE

The Best Place  
 To Find  
 New & Used  
 Electronic  
 Equipment  
 Buy-Sell-Trade  
 Our 5th Year  
**NUTS & VOLTS**  
 MAGAZINE  
 PO BOX 1111-G • PLACENTIA, CA 92670  
 137 714-632-7721  
 JOIN 1000s OF READERS NATIONWIDE  
 U.S.A. SUBSCRIPTIONS (MONTHLY)  
 1 Yr - \$15.00 1st Class; \$10.00 3rd Class  
 LIFETIME - \$35.00 - 3rd Class Mail Only  
**VISA** With Free Classified Ad **MasterCard**

**NUTS & VOLTS**  
 HAM GEAR  
 COMPUTERS  
 SOFTWARE  
 SCANNERS • OPTICS  
 TEST EQUIPMENT  
 MICROWAVE  
 SATELLITE  
 AUDIO VISUAL  
 NEW PRODUCTS  
 COMPONENTS • KITS  
 ANTIQUE ELECT.  
 PUBLICATIONS  
 PLANS • SERVICES

# SPECIAL EVENTS

Listings in this column are provided free of charge on a space-available basis. The following information should be included in every announcement: sponsor, event, date, time, place, city, state, admission charge (if any), features, talk-in frequencies, and the name of whom to contact for further information. Announcements must be received by 73 Magazine by the first of the month, two months prior to the month in which the event takes place. Mail to Editorial Offices, 73 Magazine, Pine St., Peterborough NH 03458.

## OAK PARK MI JAN 6

The Oak Park ARC will present its annual Swap-n'-Shop on Sunday, January 6, 1985, from 8:00 am to 3:00 pm, at Oak Park High School. Admission is \$2.75 and tables will be available for \$8.00. Features will include Novice exams—given at 11:00 am, refreshments, and free parking. Talk-in on 146.52. For more information, send an SASE to Oak Park ARC, c/o Jeff Smith N8FMQ, 459 Madison, Birmingham MI 48008.

## SOUTH BEND IN JAN 6

A hamfest swap and shop will be held on Sunday, January 6, 1985, at the Century Center, downtown on US 33 Oneway North between the St. Joseph Bank Building and the river, South Bend IN. Open tables are \$1.00 per foot in a carpeted half-acre room. The Industrial History Museum is in the same building. Four-lane highways lead to the site from all directions. Talk-in on .52/.52, .99/.39, .93/.33, .78/.18, .69/.09, and 145.29. For more information, contact Wayne Werts K9IXU, 1889 Riverside Drive, South Bend IN 46616, or phone (219)-233-3507.

## WEST ALLIS WI JAN 12

The West Allis Radio Amateur Club will sponsor the "Original" Annual Midwinter Swapfest on Saturday, January 12, 1985, beginning at 8:00 am, at the Waukesha County Expo Center Forum (take I-94 to Co. F, south to FT, west to Expo). Admission is \$2.00 in advance and \$3.00 at the door. Four-foot tables are \$3.00 in advance (December 31st deadline) and \$4.00 at the door. Food will be available. For tickets, send an SASE to WARAC Swapfest, PO Box 1072, Milwaukee WI 53201.

## TUSCALOOSA AL JAN 12

A special-event station will be held on Saturday, January 12, 1985, commemorating the 63rd anniversary of the Tuscaloosa Jaycees. KE4TN will operate from 1300-2300 UTC on that date and will be offering an 8-1/2" x 11" certificate to all contacts. To receive the certificate, send your QSL card only (no SASE needed) to the Tuscaloosa Jaycees, PO Drawer L, Tuscaloosa AL 35404, or to KE4TN's *Callbook* address.

## ISSAQUAH WA JAN 13

The Issaquah ARC will sponsor the Rats Nest and Crooked Stick QSO Contest, an antenna experimenters' contest and QSO party, on January 13, 1985, from 1800Z to 2300Z. The frequencies will be CW—21.060 to 21.200 MHz, and SSB—21.350 to 21.450 MHz. A Rat Catcher's cer-

tificate will be available for anyone contacting three or more IARC members. Exchange your name, QTH, antenna type, IARC membership (Y or N), and send your log by February 1, 1985. For results or more information, send an SASE to IARC, c/o Steve Pack WB7VAS, 4609 158th Avenue SE, Bellevue WA 98006.

## RICHMOND VA JAN 13

The Richmond Amateur Telecommunications Society will sponsor the eighth annual Richmond Frostfest on Sunday, January 13, 1985, from 8:30 am to 3:30 pm, at the Virginia State Fairgrounds. General admission is \$4.00. Flea-market spaces are \$3.00 without a table and \$7.00 with an 8-foot table. Booths with side curtains and backdrops are available to dealers and exhibitors and the building will be open Saturday afternoon for setup (there will be armed security at all times). The entire show will be indoors with no outside tailgating. The deadline for booths is December 30, 1984, and for the flea market January 10, 1985. For more information, write Richmond Frostfest, PO Box 1070, Richmond VA 23208, or call Bill Scruggs N4DDM at (804)-272-8206.

## SOUTHFIELD MI JAN 20

The Southfield High School Amateur Radio Club will sponsor its 20th annual Swap and Shop on January 20, 1985, from 8:00 am to 3:00 pm, at Southfield High School, 24675 Lahser, Southfield MI. Admission is \$2.50. Two 8-foot reserved tables are \$20.00 and each additional reserved table is \$10.00 (paid in advance). Tables will be available at the door. Doors will open at 6:00 am for exhibitors. There will be plenty of parking and food. All profits go toward electronics scholarships and to support the activities of the Southfield High School Amateur Radio Club. For more information, advance tickets, and/or reservations, write Mr. Robert Younker, Southfield High School, 24675 Lahser, Southfield MI 48034. Indicate with your reservation whether you will need wall space and/or electrical outlets. All table reservations will be confirmed.

## SAFFORD AZ JAN 26

The Eastern Arizona Amateur Radio So-

ciety will hold amateur-radio license examinations on Saturday, January 26, 1985, from 9:00 am to 3:00 pm, at the National Guard Armory, 4001 1st Avenue, Safford AZ. Prior to the registration deadline of January 21st, send a completed 610 form, a copy of any license, and \$4.00 (registration fee) to EAARS, PO Box 402, Thatcher AZ 85552. For more information, call Richard N7DZH at (602)-428-6560 between 7:00 am and 3:30 pm.

## YONKERS NY JAN 27

The Yonkers Amateur Radio Club will sponsor the Yonkers Electronics Auction on Sunday, January 27, 1985, from 9:00 am to 3:00 pm, at Lemko Hall, 556 Yonkers Avenue, Yonkers NY. Admission for buyers and sellers is \$3.00 each; children under 8 will be admitted free. New and used equipment will be auctioned and can be inspected from 9:00 am to 10:00 am. There will be plenty of seats and parking and the auction will start at 10:00 am sharp. Unlimited free coffee will be available all day. The club will charge a 10% commission on the first \$100 and 5% on the remainder on successful sales only. Talk-in on 146.265T/146.865R, 440.150T/445.150R, and .52 direct. For more information, write YARC, 53 Hayward Street, Yonkers NY 10704, or phone (914)-969-1053.

## HOUGHTON MI JAN 29-FEB 5

The Michigan Technological University Amateur Radio Club and the Copper Country Radio Amateur Association announces a radio celebration of our winter carnival festivities in the northernmost part of Michigan's Upper Peninsula. A certificate will be issued to all amateurs who make one contact with any participating ham in Copper Country between 0000 UTC January 29, 1985, and 0000 UTC February 5, 1985. Frequencies are 3.630, 7.090, and 14.095 RTTY; 3.705, 7.085, 7.125, 14.085, 21.085, and 28.185 CW; 3.930, 7.285, 14.305, 21.385, and 28.500 phone. (On CW, listen for CQ WC.) Send your QSL and \$1.00 to cover postage and handling to Howard Junkin N8FHF, 106 W. South Avenue, Houghton MI 49931.

## MANSFIELD OH FEB 10

The 24th annual Mansfield Midwinter Hamfest/Auction will be held on Sunday, February 10, 1985, beginning at 8:00 am, at

the Richland County Fairgrounds, Mansfield OH. Tickets are \$3.00 in advance and \$4.00 at the door. Tables are \$5.00 in advance and \$6.00 at the door. Half tables are available. There will be an auction and flea market in large, modern, heated buildings. An ARRL/VEC license exam will be held at the Mansfield Campus of the Ohio State University/North Central Technical College (less than two miles from the hamfest) at 1:00 pm on the day of the hamfest. To take the exam, send an SASE, a 610 form, and a check for \$4.00 payable to ARRL/VEC to Lloyd Nelson N8BAZ, 630 Oak Street, Lot 82, Mansfield OH 44907. Talk-in on 146.34/94. For additional information or advance tickets or tables, send an SASE to Dean Wrasse KB8MG, 1094 Beal Road, Mansfield OH 44905, or phone (419)-589-2415.

## MARLBORO MA FEB 17

The Algonquin ARC will hold its annual electronics flea market on February 17, 1985, at Marlboro Junior High School Cafeteria. Doors will open for sellers' setups at 8:30 am and to the public at 10:00 am. General admission is \$1.00; sellers' tables are \$7.50 in advance (before February 9th) and \$10.00 at the door. Food will be available. Talk-in on .01/.61 and .52. For table reservations or more information, write to AARC, PO Box 258, Marlboro MA 01752.

## 150TH ANNIVERSARY SPECIAL EVENT VICTORIA, AUSTRALIA

A special commemorative callsign, VI3WI, part of the 150th anniversary celebration of the European settlement in Victoria, will be on the DX bands until at least April 30, 1985. VI3WI will be activated on a roster basis by selected members of the Wireless Institute of Australia and its affiliated clubs. All DX bands and all modes will be used and a commemorative QSL is available, either direct or via the VK3 QSL Bureau. A special award certificate is also available for radio contact with Victoria between November, 1984, and April 30, 1985. Contact (SWLs log) one station in VK3 during the award period to qualify. A QSL card for the qualifying contact, endorsed with a congratulatory message on Victoria's 150th anniversary, plus \$2.00 or equivalent, should be sent to Victoria 150 Award, Wireless Institute of Australia, 412 Brunswick Street, Fitzroy 3065, Victoria, Australia.

INTRODUCING THE MOST POWERFUL LOGGING PROGRAM EVER FOR THE C-64

### "Contender Plus II"

FEATURES: 2000 Entries per single sided disk (9 items per entry); Two or dual disk option; Auto or manual time/date logging; Auto or manual band/mode logging; Edit/update features: forward/reverse scan fully menu driven; complete log review; Print complete log to printer; print dup sheet to the screen or printer; Print QSL labels auto/manual; Print QSL cards auto/manual; WAS summary and report to screen or printer; DXCC summary and report to screen or printer. Faster than basic. Detailed user manual.

Contender Plus II ONLY \$34.95

CONTENDER PLUS (without DXCC) \$29.95  
CONTENDER \$19.95 (without WAS DXCC and two drive option)  
DEMO Disk \$3.50.

for FREE Fact Sheet or to order write:

CRUMTRONICS  
SOFTWARE DIVISION  
P.O. BOX 6187  
FT. WAYNE, IN 46896

-314

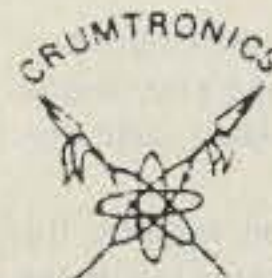

## TOUCHTONE™ DECODER KIT

### DTMF Receiver Kit

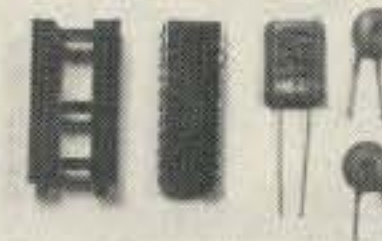

- Complete DTMF Receiver (SS1201)
- Receive all 16 standard DTMF digits
- No front end filters needed
- Output either hex or BCD format

- CMOS low power (29ma @ 12 V.D.C.)
- Excellent speech immunity
- Includes 3.58Mhz crystal, 22 pin I.C. socket, resistor and capacitors, data sheet, schematics
- "Digit Valid" detection, "DV" goes high after a valid tone pair is sensed
- Make your own "SELLCALL", repeater decoder, etc.
- Quantity discounts available

**\$22.95** Includes shipping USA  
(Add 6% CA address)

SEND CHECK OR MONEY ORDER TO:  
**ENGINEERING CONSULTING**  
583 CANDLEWOOD ST., BREA, CA 92621  
714/671-2009

# REVIEW

## REGENCY HX1000

Regency Electronics, Inc., has finally made available their long-awaited model HX1000, a hand-held automatic keyboard-programmable 30-channel, six-band monitor receiver. Rather than racing other manufacturers to be "first on the market," Regency has taken their time and produced a quality portable FM scanning receiver which surpasses any I've seen.

### Physical Description

The Regency HX1000 is a double-conversion superheterodyne scanner designed to receive narrowband-FM communications in the amateur, public-safety, and land-mobile bands at 30-50, 144-174, and 440-512 MHz. Its microprocessor-controlled circuitry permits keyboard entry of frequencies into 30 channels to be scanned, either individually or in any combination.

At first glance, even a seasoned operator could be fooled into thinking the Regency is a portable transceiver. The radio is housed in a case closely resembling a handle-talkie in virtually every aspect. Measuring 2-3/4" x 7-3/4" x 1-9/10" and weighing approximately 1 1/4 pounds, the HX1000 has the feel of a conventional hand-held transceiver.

All frequency entries and status information are visible on the liquid-crystal display (LCD) on the center of the front panel.

Immediately below the LCD is the 16-key keyboard used to program and control the scanner. Along the bottom of the keyboard are slide switches for priority scanning and the night-display lamp.

Atop the scanner are found on-off/volume and squelch controls, a BNC connector, and a miniature jack with an attached dust cover.

A jack for an external nicad wall charger is on the bottom of the unit, as are con-



The Regency HX1000 hand-held scanner.

tacts for a drop-in charger, available from Regency as an accessory.

In a departure from the Regency "made-in-America" tradition, the HX1000 is manufactured in Japan. However, this in no way detracts from Regency's reputation for quality.

The scanner comes handsomely packaged and is complete with such accessories as a nicad battery pack and connector cable, a plug-in wall charger, earphones, and a rubber helical antenna.

### Operation

Operation is simple and easily learned. Upon removal from the shipping package, the user need only install the rubber helical antenna on the BNC connector and the battery pack in the compartment on the rear, and you're ready to begin programming.

Frequency programming into the 30 channels is accomplished in the manual mode by first keying in the frequency in megahertz, pressing Enter, and then keying in the channel number to which the frequency is to be entered (e.g., 01, 07, 24, etc.). The frequency is now entered into the selected channel unless the Error display appears, indicating that the intended frequency is outside the vco-lock range.

Once 30 frequencies (or any lesser number, according to the user's needs) have been entered, they will remain in the scanner's memory until reprogrammed or until the battery is disconnected. In order to automatically sample the channels entered, the Scan key is pressed. Whenever activity is located, the scanner will stop on that channel and monitor until the transmission ceases, then resume scanning.

In addition to functioning as a scanning receiver, the HX1000 can also search any selected frequency range within a band for active frequencies. Searching is keyboard-programmable using the Search Prog key to open the memory, and the Lower and Upper keys to enter the desired search limits, which are preserved in memory until changed. Search limits are retained when the unit is turned off. Searching is initiated with the Search Scan key and proceeds to check for activity on all frequencies between the lower and upper limits.

Searching is completed at a rate of approximately 17 seconds per megahertz on VHF and eight seconds per megahertz on UHF. When activity is located, the unit either remains on the frequency for four seconds (in the Search-Delay mode), or remains stopped indefinitely pending a keyboard command to proceed (in the Search-Hold mode). Frequencies located while searching may, if desired, be stored directly in one of the unit's 30 channels.

In the event that an extremely strong signal causes the search to stop on a frequency immediately before or after the actual carrier frequency, one-step frequency increment keys are provided to move the searching upward or downward one step at a time. With the squelch fully open, these keys may be used to manually step up or down from a frequency during searching, and will step continuously at a slow rate while depressed.

On the VHF bands, frequencies are programmable in increments of 5 kHz, and in increments of 12.5 kHz on UHF, with corresponding search steps.

As a battery-conservation feature, the LCD clock has a switch, located inside the

battery compartment, which can either be set to furnish power to the clock at all times, or only when the scanner is turned on. In the latter position the clock must be reprogrammed each time the scanner is turned on in order to maintain correct time.

Each time a key is pressed, a beep is heard, verifying the entry. This beep is audible only through the earphones when this accessory is used. It cannot be silenced.

Priority scanning of channel one is controlled by a front-mounted slide switch. The scanner samples the frequency in channel one once every two seconds and switches to it if activity is noted. When scanning a number of channels or listening to a lengthy transmission, this feature can be quite handy to keep tabs on a local repeater or emergency frequency. This feature functions in the manual mode as well.

Selectable scan-delay is available, covering all channels. This delay keeps the scanning action stopped for two seconds on the channel after transmissions cease.

The LCD is multi-functional, displaying not only the frequency in megahertz but also the channel number, and indicates whether priority is engaged and if scan-delay and channel lockout are present. Also, it shows "Batt" when recharging of the nicad pack is necessary, and also serves as the clock display.

To facilitate night viewing there is a display back light, incorporating a battery-conservation feature which discontinues power to the lamp if it is left on for more than 20 seconds. This light is more than just a novelty; it not only illuminates the display at night, but also provides sufficient light to operate the keyboard.

A leather carrying case is supplied which has an opening to access the wall-charger jack and a transparent plastic covering over the keyboard. This permits keyboard operation with the case on while protecting keys from dust and moisture. A sturdy metal belt clip is also included and may be used with or without the leather carrying case. The clip is installed with two Phillips-head screws onto the back of the scanner, and it is necessary to remove these screws each time you want to remove or replace the carrying case (the screws go through the leather case and into the back of the scanner). This can create a problem when it's necessary to reset the microprocessor, as you have to remove the belt clip to remove the carrying case to access the battery compartment and switch.

Upon inspection of the circuitry, one finds that the compact complexity of the HX1000 is made possible by stacking the PC boards atop one another. The rf package is on the board immediately visible when the back cover is removed. Concealed behind this are the programming-logic and synthesizer boards, connected to the keyboard and the rf board via jumper wires.

Examining the boards, I noted that all are connected with brass spacers to the die-cast aluminum chassis. This makes the boards somewhat more vulnerable to damage due to physical shock to the outer case and, combined with the glass of the LCD, underlines the importance of using care in handling.

### User Comments

Upon examining the HX1000 and comparing it to other synthesized hand-held, base, and mobile scanning receivers, I find that it excels in both the quality of the scanner's construction, sensitivity, and clarity of audio. All operational characteristics either meet or exceed those listed in the owner's manual, and the keyboard

configuration and programming sequence are easy to learn and remember.

In searching across the bands, remarkably few birdie frequencies were encountered—an unusual observation with a newly-introduced scanner.

The LCD readout is highly visible under various lighting conditions when viewed straight on and provides enough information to the user without adding any unnecessary and confusing graphics.

According to specs published in the owner's manual and sales advertisements, the HX1000 covers ranges of 30-50, 144-174, and 440-512 MHz (subdivided by Regency into six bands). The manual states that should you attempt to enter an out-of-band frequency, "Error" will be displayed. However, this display is apparently triggered only when the vco fails to lock, and not upon recognition of an illegal keyboard entry. Thus, it is possible to enter frequencies far outside the listed ranges. My unit was able to be programmed to search and scan from 25-60, 116-190, and 305-530 MHz! While different radios will be able to cover slightly different frequency extremes due to manufacturing tolerances, it is a safe assumption that most units should be able to cover at least 5 MHz above and below the published band limits.

Note that the radio was designed to operate at maximum sensitivity only within the standard bands, and when venturing farther from the regular band limits a corresponding decrease in sensitivity will be noted. Even so, signals on 10- and 6-meter FM and in the 410-420-MHz range were as readable as regular channels on VHF-low and UHF, respectively.

This coverage of frequency ranges outside the regular bands including 6 and 10 meters, added to the regular 2-meter and 440-450-MHz coverage, makes the HX1000 a super low-cost synthesized receiver for amateur VHF/UHF FM communications. With 30 channels at your fingertips, there is more than ample memory capacity to store your favorite repeater or simplex frequencies.

The nicad wall charger supplies the scanner's appetite for 200 mA of charging current (this is the value marked on the charger, and differs from the value of 100 mA specified in the owner's manual). However, the powerful battery doesn't have to spend much time in the charger before it's ready to go.

The scanner exhibits excellent sensitivity, clearly pulling in Ohio stations at the author's home near Pittsburgh PA, while both nearby base and mobile "brand name" scanners on the same frequency showed no evidence of a received signal with squelch fully open! Further, there was no evidence of intermodulation interference under most conditions (certainly superior to several other synthesized units I've tried). Selectivity was also excellent. Sensitivity is rated at 0.5  $\mu$ V on VHF and 0.7  $\mu$ V on UHF, both as measured at tune-up, 12 dB Sinad. Selectivity is down 6 dB at  $\pm$  7.5 kHz and down 50 dB at  $\pm$  18 kHz.

The rubber helical antenna supplied with the scanner provides very good reception compared to other portable scanner antennas. Nevertheless, one is tempted to attach an external antenna to the top-mounted BNC connector in an effort to further improve reception (particularly if using the HX1000 as a mobile scanner). Regency cautions against this, however, stating that other antennas may cause improper impedance matching and may cause "reduction in effective receiving range, increase of spurious radiation, and excessive battery drain." No antenna impedance rating is listed in the specs. Still, one is tempted to experiment.

To facilitate easy operation of the HX1000, the owner's manual is well written and contains complete and concise operating instructions.

Regency's suggested list price for the HX1000 is \$329.95, but various mail-order firms specializing in scanners have been selling the unit for between \$206 and \$250 plus shipping.

#### Conclusion

The Regency HX1000 is a superior receiver which makes a handy addition to any shack. Its portability and performance make it a truly useful receiver for emergency operations and for monitoring VHF/UHF amateur and public-safety systems, exceeding the capabilities of many contemporary base and mobile scanners. Of all the scanners I have owned, the HX1000 is among the best in price, performance, and versatility.

For additional information, contact *Regency Electronics, Inc.*, 7707 Records St., Indianapolis IN 46226-9989; (317)-545-4281. Reader Service number 485.

Louis Smith II N3BAH  
Latrobe PA

### MINI JINI AND THE ORGANIZED HAMSHACK

Pity your poor reviewer! I'm absolutely buried under new software packages for use with home computers in the ham shack. I know, it's not a pretty sight.

I doubt that I'll get much sympathy for my situation. After all, it is fun getting to try out new products. Sometimes, though, it becomes tiresome, seeing the tenth software package to do the same thing. It's particularly trying when the instructions are unclear, the program is poorly written, and the results just don't seem worth it.

That's the way this particular Sunday afternoon was going until Mini Jini rose to the top of the stack!

First of all, I didn't even have to load the program. It comes on a plug-in cartridge for the VIC-20 and C-64 computers. Then, I didn't even have to tell it to run. When I turned on my machine, like magic the credit page and then a menu appeared.

Weary from trying to decipher instruction manuals that didn't tell me what I needed to know, I approached Mini Jini expecting more of the same. Jini Micro Systems advertises this package as being written in plain, simple English. That advertising claim turned out to be absolutely on the mark!

A forty-page instruction manual comes with Mini Jini, but it doesn't really take very long to read the simple instructions and go through the examples provided. I also found the instructions well indexed, a definite plus for any instruction book.

What is Mini Jini? In two words, it is a record keeper. What? No fancy terms like data base or electronic spreadsheet? Not

for Mini Jini. Remember, it's written in English!

In computer terms, Mini Jini is a data base and offers the features you would expect to find in such a program. It will let you keep a top-notch logbook, track your QSL cards, record progress towards awards, or serve as a foreign phrase book. If you must have a non-ham reason for buying it, you can generate financial statements, keep an inventory of your household goods, or track junior's academic progress...all with the same program!

The main menu for Mini Jini lets you create, look through, order (alphabetize), search, or fix a file. You can print the information to the screen or a printer. Additionally, you can save and load files you create to disk or tape.

If that's not enough, a feature called math pack allows you to do calculations on the different entries in your number files.

Mini Jini makes efficient use of memory space. The Commodore 64 version has a capacity of 500 45-character records with four fields or less. A fully expanded VIC-20 allows a similar number of records.

There are many logbook programs on the market. Some of them are quite good. Almost all of them are considerably less expensive than Mini Jini. So why buy this program?

In most cases, logbook programs are exactly that and can't do anything else. In their favor, many of them provide beam headings, DX prefixes, zones, and other information that Mini Jini does not. If you are inclined to create them, Mini Jini can handle all of these functions and a lot more. With the dedicated systems, you are stuck with the limitations of the program.

Creating files on Mini Jini is just as easy as falling off a log. If you are really lazy, the Organized Hamshack series of overlays is available for \$12.00 (disk) and \$9.00 (cassette) to complement Mini Jini in the ham shack. The overlays (another one of those new-fangled computer words) provide 13 different file types for you to use, including a logbook (one in English and one in Spanish!), a DXCC log, a ham station inventory, and a mailing list.

One of the more unique files included is a "Ham DXtionary," so you can cross-reference frequently used foreign phrases.

The overlays, particularly ones like the DXtionary, would be much more impressive if they actually included a good number of useful entries. Only the format is provided, however, with one or two examples. Understand that for the price, I don't consider this a shortcoming, only a suggestion for a possible addition to the product line!

Mini Jini, at \$49.95, is a full-featured record keeper. It will take care of the club mailing list for you, organize your emergency call-out lists, allow you to have vir-



AEA's TI-1 tuning indicator.

tually "instant memory" while on the air, and help you figure your taxes at the end of the year. Incidentally, the files created by Mini Jini are compatible with several word-processing packages such as Wordpro and Papermate.

Mini Jini is available through *Fox Tango Corporation*, Box 15944, West Palm Beach FL 33406; (305)-683-9587. Reader Service number 481.

Jim Grubbs K9EI  
Springfield IL

### AEA'S TI-1

Here's a new station accessory that you ought to know about, especially if you're a RTTY enthusiast and don't happen to have a scope to tune in those narrow-, medium-, and wide-shift signals. The TI-1 is a tuning indicator (bet you guessed that already) that can help easily and quickly tune your receiver to the exact frequency for decoding RTTY/AMTOR and ASCII.

You will need a source of 12 volts dc at just a few mils to power it, and you'll need a patch cord and a couple of 3.5-mm plugs to connect the TI-1 to your interface (or your receiver, depending upon the particular hookup you have). That's all there is to it. In my own case, I hooked the audio from the receiver through the TI-1 and into the AEA MicroAmtor interface...simple in/out.

There is a switch on top that allows you to select 170-Hz, 425-Hz, and 850-Hz shifts, and there is an internal speaker if you want or need it (the speaker can be switched on and off).

The tuning operation is simplicity itself. On the top of the box is an LED strip in which the LEDs occupy a "window" about

2 inches wide and 1/2 inch high. When the TI-1 is turned on, you don't see much of a display until you tune across a signal, and then it's really impressive. The mark and space tones light up the LED—and you can actually see the separation. Very bright at the mark and space locations, shading off to a duller red in between. To properly tune the signal, line up the bright mark and space tones with the respective "pips" on the box just underneath the window. Believe it or not, they exactly fit, and when the mark LED is brightest and lined up exactly on the mark pip, you have exact frequency tuning.

Just for fun, I tried some different widths and switched the filters in and out so that I could watch the signals spread and narrow, depending on which tone pair I was tuned to.

Just in case you can't remember which frequency is which, just look at the box—it's all there in white numbers on black crackle: 2125 at the low end; 2295, 2550, and 2975 at the high end. In between, you see the shift widths, just so you can't forget: 170, 425, and 850 cycles.

My impression of all this was that this is a really neat, useful, and simple device that can make RTTY tuning a snap for anyone. I wouldn't hesitate to recommend it, and it doesn't seem possible that even a scope and the crossed lines could more accurately or easily tune in the RTTY frequency shifts.

For more information, contact *Advanced Electronic Applications, Inc.*, PO Box C-2160, Lynnwood WA 98036; (206)-775-7373.

Jim Gray W1XU  
73 Staff

# Dx

Chod Harris VP2ML  
Box 4881  
Santa Rosa CA 95402

### DXING ON THE LOW BANDS

The Federal Communications Commission (FCC) finally dropped the other shoe in its proposed expansion of the phone subbands. This process began in 1982

when the FCC suggested increasing the phone frequencies on 20 meters. When they did grant additional phone spectrum, the FCC mentioned they were looking at expanding the other high-frequency phone subbands as well. So, on September 1, 1984, General and higher-class licensees gained new phone frequencies.

In case you have been living in a cave the past few months and haven't heard

about the changes, here are the new frequencies:

Extra-class operators gain 3750-3775 and 21,200-21,250. Advanced-class ops can now use phone on the new subbands of 3775-3800 and 21,225-21,270. Generals gain access to 3850-3890 and 21,300-21,350. All three classes get new phone frequencies on 10 meters: 28,300-28,500. Of course, all these changes are in addition to the previously existing phone subbands.

With the declining sunspots, the effect of the increased phone frequencies on the 10- and 15-meter bands won't be very obvious for a few years. 10 meters has always enjoyed ample phone spectrum,

even at the peak of the sunspot cycle. Also, most rigs have the frequencies below 28,500 on a separate band from the commonly used region between 28,500 and 28,700. I would suspect that the new phone subband on 10 won't have much effect on DXers. Perhaps some of the localized communications and nets will leave the more heavily used frequencies for this new subband. We'll have to wait and see.

The expansion of the 15-meter phone band will have some immediate effect on DXers and DXing, an effect which will grow in importance as the sunspots again make 15 a worldwide band. The extra 50 kHz which the Extras gained is prime DXing country. Much of the worldwide phone

DX activity takes place between 21,200 and 21,300 on 15 meters, and now US Extras have twice as much subband in which to stalk the elusive DX operator. The 45 kHz the Advanced-class DXer gained is again very prime DX territory.

Of all the increases in the subbands, however, the most important is the new 25-kHz segment on 75 meters which the Advanced operators now enjoy. The Extras gained the same amount of subband, and the Generals were rewarded with 50 kHz also, but the new frequencies will have the most impact on Advanced DXers.

The reason the Advanced DXer is the real winner in this phone subband expansion is the "DX Window" on 75 meters: 3775-3800. As any phone operator who has listened to 75 meters can tell you, 90% of all the phone DX on 75 meters is within this window or just below it. Seldom does one hear much DX above 3800. As a result, phone DXers with Advanced licenses had been just about frozen out of 75 meters—until now.

The primary reason DX stations congregate in the 3775-3800 window is international amateur frequency allocations. Only in International Telecommunications Union (ITU) Region 2 (North and South America) are amateurs allowed to operate up to 4000 kHz on 75 meters. Region 1 amateurs (Europe and Africa) cannot use 75 above 3800. In fact, the interference levels above 3800 are so bad in many places in Region 1 that even *listening* for amateur stations above that frequency is a waste of time. So DXers have a very limited overlap of phone frequencies on 75 meters.

So Advanced-class phone DXers have won a real plum: access to the best 25 kHz in the entire 75-meter phone subband! This, coupled with the declining higher-frequency propagation which pushes DXers off 15 and 20 meters, means much more activity in low-band DXing. Let's look at some of the thrills and frustrations involved in DXing on the lower frequencies, and some of the ways around them.

Many hams associate DX with 20 meters, and then 10 and 15. Relatively few amateurs think seriously about DXing on 40 and 80 (much less 160 meters!). Why is this? Three main factors keep the majority of DXers off 40 and 80 meters: too much noise, weak signals, and the need to work split (on phone). We'll see how you can handle each of the stumbling blocks, without investing in a three-element, rotatable 80-meter yagi.

#### Combating Noise

The only time 75 meters is quiet is when it's not open. Newcomers to the band are quickly disheartened by the unbelievably high QRN levels, especially in the summer. How can anyone hear DX signals between 40-over-9 static crashes? Even in the dead of winter, the interference level can be murder. And built-in noise blankers seem to provide little relief.

The solution to the problem of noise is simple: you need a poor antenna. That's right, a lousy, high-loss antenna. The worse your antenna, the less noise you receive. With a good dummy load (which makes a pretty bad antenna), you won't hear any noise at all. Of course, you won't hear any DX either. What you need is an antenna which only receives DX, and not the noise.

Since nobody has seen fit to invent one yet, we have to settle for an antenna which only receives in one or two directions. Here comes that 3-element beam, you say. But you don't need the beam. Remember, we were looking for a poor antenna, not a good one. Lousy, directional antennas for 80 meters include Beverage antennas and loops.

The Beverage antenna is simply a very long wire stretched a few feet off the ground, aimed in the direction you want to hear. The longer the wire, the more directional the antenna. At least a few hundred feet helps on 80, and a quarter-mile is great! The Beverage doesn't have to be anything fancy. A roll of transformer wire hanging from bushes and tree limbs works fine. Take care to keep the wire above head level in high-traffic areas. You can run the wire along wooden fences—it doesn't have to be exactly straight to be effective. Since the antenna is only used for receiving (see below), there is no need for any insulators.

An alternative to the Beverage for the DXer who simply can't stretch out a quarter-mile of wire is the loop antenna. Check the various handbooks and antenna books for details.

Both the loop and the (unterminated) Beverage are bi-directional antennas: They receive relatively well in two opposite directions and very poorly in others. The loop works best broadside to the loop, while the Beverage works best along the axis of the antenna. Since the noise on the lower bands comes from all different directions, these antennas greatly reduce the level of received noise. They only hear noise in the same direction as the signal, which is only a fraction of the total.

Two precautions with either antenna: They are receiving antennas *only*, and neither antenna will provide much in the way of received signal strength from the DX station. Since these antennas can only be used for receiving, you must find some way to prevent accidental transmissions into the antenna. Some full-feature transceivers have an external receive-only antenna jack somewhere. Check the transverter jack for such a connection if there is no obvious jack. If you try to rely on manually switching between a receiving and a transmitting antenna, you will "cook" your loop or Beverage while trying to work a rare one. Install either a simple relay circuit or an automatic switch if you can't work out an internal connection to the transceiver. Of course, owners of separate receivers and transmitters have no problem "smoking" their receive-only antenna.

The final difficulty with Beverage and loop antennas is the poor signal strength such lousy antennas provide to your receiver. You may well find you need a preamplifier in the line to boost the DX signal to a readable level. Again, make certain there is absolutely no way you can transmit into your preamp, or someday you will!

#### Dealing with the Weak Signals

The same preamp which compensates for the losses of the receiving antenna will help overcome the handicap of the poor signal strengths of the DX station. However, a preamp won't do *your* signal any good. Weak signals simply don't hack it on 80 meters, and transmitting amplifiers are definitely the norm. Even a good amplifier is not enough to be loud on 80—you also need an effective antenna to work DX.

The secret to an effective DX antenna on the lower frequencies is low-angle radiation. That is, radio signals traveling parallel to the ground and not straight up. Many amateurs use a relatively low dipole for 40 and 80 meters. While excellent for local, short-range communications, such a low dipole is one of the poorest choices for DX. A glance at almost any antenna book will show the cause: at low heights above the ground, dipoles radiate almost straight up. All of your signal goes

straight up and straight down, and little goes off toward the faraway DX station. You need an antenna which concentrates more rf in the lower angles for better long-distance communications.

What kind of antenna does this, besides the three-element beam? A high dipole will work, as will a vertical over a good ground. By "high" I mean high in terms of wavelength: a minimum of one-half wave high. That's about 130' on 75 meters. That's high! Since most of us don't have two 130'-high supports in our backyard, we pass over dipoles for DX on the low bands.

Verticals *theoretically* radiate much of their rf at very low angles. However, those nice charts in the antenna books are based on a *perfectly conducting ground*, not those two radials you managed to sneak into your yard. The worse the ground, the less low-angle radiation escapes from your vertical. Again, a "good" ground is something completely out of the question for many amateurs. To get good low-angle radiation from a vertical requires 120 one-half-wavelength radials, a circle 260' in diameter with 3 miles of wire!

Not many DXers have *that* much dedication to the hobby. Fortunately for the rest of us, any radials will help, and the more the merrier. Even doubling the number of radials from 2 to 4 will make a difference. As with the Beverage, the radials don't have to be exactly straight—just string them out wherever you can.

Some amateurs are more serious about their grounding system. 9L1CA covered his entire front lawn with criss-crossed wires before seeding. The lawn grew up over the wires and the system worked splendidly with a pair of 80-meter loaded verticals. And one southern-California 80-meter DXer still laments "the one that got away" when he had rolled up his chicken-wire grounding system to mow the lawn.

For DXers fortunate enough to have a tower for the high-frequency antennas, several antennas will provide better results than a simple inverted vee on the low bands. Many hams have had very good success with sloper antennas. These very simple antennas are single wires running from near the top of the tower (where the coax shield is grounded to the tower) out in the direction of the DX. Little tuning is required. In some cases this sloper will provide good low-angle radiation and good DXing. Switchable slopers in different directions can cover the world.

Another antenna for hams with a tower is a half-wavelength loop antenna, with the peak hung from near the top of the tower. You can stretch out the loop facing the direction you desire and feed it in one corner. The loop is more broadbanded than the sloper, but it requires more real estate. Both antennas are simple, easy to build and use, and well worth the effort for the low-band DXer.

#### When and Where

Okay, we've got a good receiving antenna up and running and our transmitting antenna has good low-angle radiation. Now how do we find DX on the low bands? The best time to find DX on 40 and 80 meters is when the maximum usable frequency (MUF) is just above those bands. When the MUF is very high, above 14 MHz, the low bands are washed out with absorption. Only at night do 40 and 80 provide good DX possibilities. In fact, one of the best times to look for DX is just before and during local sunrise. Sunset is the time to look for DX to the east. In the wee hours of the morning, local time, when few nearby stations are on the air, is another prime

time for low-band DX. (I will talk more about sunrise, sunset and the grey line in a future column.)

As to *where* to look, you have to pay attention to international frequency allocations outside the United States. While you can work some "local" DX, such as the Caribbean, on frequencies above 3800, most long-haul 75-meter DX hovers around 3775-3800.

On 40 meters, the international allocations outside North and South America limit amateurs to frequencies below 7100. Thus, on phone you must listen in the 7050-7100 range for DX stations on phone. Those stations will announce "listening frequencies," such as, "listening on 7183."

You, of course, cannot transmit phone on 7060, or wherever the DX station is. Even if you could, he isn't listening on that frequency, so it would be a waste of time to call him there. (But that doesn't seem to stop people from trying, or others from griping about the practice.) You must transmit on 7183, or thereabouts, while listening at 7060. Sometimes the same situation applies on 75, where the DX station is well below the US phone subbands. Russians, for example, can often be found around 3642, a "hole" in the very heavy 80-meter interference in that part of the world.

#### Working Split

You need to be able to transmit on one frequency while listening to another. Most rigs let you do this over a limited frequency range. It's called RIT or clarifier, or some such name. But the frequency splits on 40- and 80-meter phone are far outside the range of your RIT.

You can try spinning the dial back and forth between the two frequencies, but the chances of this working are not good. More likely, you'll end up transmitting out of the stateside phone band, and have half the world yelling at you.

Far better is a second receiver, or extra vfo, or one of the fancy new rigs with all kinds of memories and programs to handle "working split." Ideally, you want to be able to listen to *both* the DX frequency and the one on which you are sending, so the second receiver is the best solution. It doesn't have to be anything fancy; almost any halfway decent amateur receiver will do, especially with a directional antenna and preamplifier.

If you use a memory switch or extra vfo to split your transmit frequency from your receive frequency, use the fixed frequency on the DX station and tune your transmitting frequency. The DX station is not going anywhere, as he isn't even listening to the frequency on which he is sending. (Actually, he relies on the stations he is working to tell him if his transmit frequency remains clear.) So lock the fixed frequency on the DX station and then tune your transmitting frequency in the range given by the DX station.

If he sends "listening 7183," you tune around 7183 and call him. Don't bother to send *his* call, just send yours. Listen down below 7100 for his reply. If you can, also listen to his listening frequency for the station the DX station last worked. If you can transmit on the same frequency as the last station worked, you stand an excellent chance of being next in the pileup. And the only way you can do this is if you can listen to your transmit frequency.

The proper procedure takes some finesse. The trick is to listen to *both* the DX station and your own transmitting frequency at the same time. While the DX station is listening for his report, you tune around the listening frequency for the sta-

tion giving the report, the station in contact with the DX station. You won't find him right away, and sometimes the DX station will tune away soon after the contact, but with practice and perseverance, you'll locate the other station. Zero-beat your rig on that frequency.

Then, when the DX station says, "QRZ," you jump in with your call. You know the DX station is listening on that frequency; he just finished a contact there. If your timing is good, bang!, another new one in the log!

A good example of how important this technique can be was seen in Ron Wright's DXpedition to the Kermadec Islands last March. On CW Ron said he was "listening up," as is common practice. Actually, Ron worked many stations below his transmitting frequency. The only way to know this is to listen to both Ron and the station he is working. Once you note that he is working stations below his transmitting frequency, you can zero-beat the last station worked and call Ron. Without the ability to listen to your own

transmitting frequency, your chances of working Ron were significantly reduced.

With these hints in mind, you should be able to work your share of DX on the low bands during the winter. DXing on 40 and 80 meters is not for everyone. It is not an after-dinner activity. It means going to bed after dinner and getting up in the middle of the night to pick through static and interference, and probably hear nothing at all. On the other hand, some nights 75 meters provides some of the most exciting and satisfying hours of DX. Most of my

fondlest memories of DX are of late nights when "the band was open" on 75: working dozens of rare Russian republics as the sun rose over Asia, giving scores of "peanut whistles" their first DX on 75 in a late-night WAS net, working Europeans from the Galapagos, with YS9RVE as emcee, and many more episodes.

So give 40 and 80 a try. Next time we'll discuss some of the ways you can listen to both your own frequency and the DX station at the same time! Stay tuned.

## LETTERS

### SPECTRUM LOSS

In reading your September commentary on the Morse-code requirements, technology, and the future, a thought occurred to me. If many areas of the USA are not utilizing the spectrum above 450 MHz, and we are in fact risking the loss of that precious spectrum, why not make a communicator or an ASCII-only class of license for something like 1296 MHz? Seems to me that here would be a perfect location to try the idea out, and just how many present users would be put out? Just how many people are using 1296 or 10,000 MHz? What percentage of hams? Just maybe we would be aghast to find out how many hams have ever used 1296, much less a Gunn-diode transceiver.

As you know, modern 1.2-GHz equipment is now produced by at least one company (ICOM) that also produces an off-the-shelf repeater for 1.2 GHz. Computer clubs are rich and crazy enough to promote a great way to ship 1200-baud data without wires and without the monthly bill from the local phone company. Maybe this would be an angle to consider.

I'll bite on your comment. What does one have to do to petition this kind of an idea to the FCC, or would it be a waste of time because some self-styled organization would dropkick the idea out of the stadium as soon as they heard it?

John Lockwood  
Orem UT

*One merely writes one's proposal to the FCC, Washington DC 20554, preferably with innumerable (16) copies and the original notarized. And yes, the likelihood is that the organization you referred to will fight you tooth and nail.—Wayne.*

### NO VOICE

I am writing this note out of appreciation for your dedication to amateur radio. I have been instructing classes in my town for several years in both Novice- and General-class code and theory. Very few school-age children apply, and overall I have a very high dropout rate. No one else in town (we have 12 or 13 hams in a town of 6000) wants to teach a class, so if it gets done, I do it. Very few have dropped out because of the code. Only those who couldn't spell had trouble. Most left because the Novice license includes no voice privileges.

Traditionally, Novices had voice on 145-147 MHz. I believe that since the Novice ticket is a 10-year renewable license,

some voice privileges should be included. Wouldn't it be swell if the FCC allowed 200 Watts PEP phone for Novices in the new 10-meter phone band at, say, 28.325 to 28.375 MHz? This would give incentive to aspiring Novices, create a new market for SSB equipment, and provide lots of use for converted CB sets. Since we'd like to attract the young computer set, perhaps we could also ask for Novice RTTY privileges using ASCII on 28.190 to 28.200 MHz. Then we could offer Novices with computer/modem experience a place to play.

What do you think, Wayne? I don't know how to go about petitioning the FCC. Can you help me? Are these good ideas? How about changing the CW test for amateurs to: Novice, 5 wpm; Technician, 10 wpm; General, 15 wpm; Advanced, 20 wpm; Extra, 25 wpm. Is this too hard on the amateur community? Then how about: Novice, 0 wpm; Technician, 5 wpm; General, 10 wpm; Advanced, 15 wpm; Extra, 20 wpm? There, we haven't hurt the Extras, the Advanced can cope with 15, the Generals get a break, Technicians get no change, and the Novices have to know code to operate anyway, so why test them? Just let them have at it.

Larry W. Garens KC5OQ  
Brady TX

*Fine, see my comments to Lockwood.—Wayne.*

### KEEP PUSHING

Keep up the good work! I enjoy your editorials immensely. It's very nice to read views which are both innovative and futuristic. Your dedication to amateur radio and the advancement of electronic technology is very evident and appreciated.

I have been teaching senior high school for sixteen years with varying success in inspiring students to study for their ham ticket. You hit the nail right on the head—kids today do suffer from the immediate gratification syndrome. The only goals they perceive as worthwhile are immediate. I have tried too many different approaches to detail, but I can't get past the immediate gratification problem. It's worse today than it was 10 years ago. At one time I had 14 licensed hams in school. Each year it has become fewer until now I have only one. I like your idea of trying a no-code license. I know 15 years ago I had a lot of trouble with the code, but I didn't suffer from immediate gratification syndrome and I made it.

It's too bad the league didn't pick up on no-code licensing before you started the push. It seems certain people can't stand

the thought of Wayne Green being right again! Keep pushing, Wayne, for no-code licensing; you know you are right, I know you are right, and a lot of other people know you are right but won't admit it!

I have come to the conclusion that people who think like us are in the minority because technology has moved too fast for most to comprehend. A lot of hams, teachers, administrators, school boards, and parents are too naive to comprehend the type of education needed by their children to survive in our technological society of today. Someone once said that you never stop learning. What we have to do, Wayne, and others like us, is *never stop teaching!*

Phillip Wedge WB9PCI  
Sun Prairie WI

### HINT

I read with great interest "Perfboard and Solder-tail?" in the July, 1984, edition of 73, and also AF9Q's letter concerning additional techniques. One hint that I would like to share concerns the way AF9Q (and

probably many others) cuts out the copy of the board layout. I have used a slightly different method for quite some time and have turned out some very nice boards.

After obtaining a good copy of the layout (thus preserving the original) and taping it to the board, I use a sharp, pointed tool such as an ice pick to carefully pierce through the paper and into the copper board. Not only does this system tell you exactly where to drill the hole, but the dent serves as a pilot hole for the bit. I know from experience what one slip of the drill can do to a board!

Robert Gooch, Jr. N3DRW  
Baltimore MD

### LISTEN

While I find your editorials interesting as well as informative, you have failed to put any effort into helping the new Novice. In your editorials you have harped on the subject of getting teens involved in amateur radio. That is all well and good, but any campaign to get teens involved will be

## MOVING?

Let us know 8 weeks in advance so that you won't miss a single issue of 73.

Attach old label where indicated and print new address in space provided. Also include your mailing label whenever you write concerning your subscription. It helps us serve you promptly. Write to:

**73** Amateur Radio's  
Technical Journal

Subscription Department  
P.O. Box 931  
Farmingdale NY 11737

- Extend my subscription one additional year for only \$19.97  
 Payment enclosed  Bill me

Canada and Mexico \$22.97/yr. only US funds drawn on US bank. Foreign Surface \$39.97/yr. only US funds drawn on US bank. Foreign Airmail, please inquire.

*If you have no label handy, print OLD address here.*

Name \_\_\_\_\_

Address \_\_\_\_\_

City \_\_\_\_\_ State \_\_\_\_\_ Zip \_\_\_\_\_

*print NEW address here:*

Name \_\_\_\_\_

Address \_\_\_\_\_

City \_\_\_\_\_ State \_\_\_\_\_ Zip \_\_\_\_\_

AFFIX LABEL

of no avail if you or others in the amateur community fail to realize that there are at least two major problems facing the new Novice.

First, the Novice subband at 40 meters is not totally useable due to broadcast stations like the BBC using a great portion of this band. Have you approached the FCC about this? Has the ARRL done anything? If so, I haven't seen it.

Second, it seems as though the amateur community is not generally willing to make a QSO with a Novice due to his

mistake-ridden, slow-fisted style. Is it any wonder why more people, including teens, are not willing to put forth any effort to become a part of the amateur fraternity?

Another large problem that teens face is money. Look at the ads in your magazine. The equipment is not cheap by any stretch of the imagination. How can anyone be expected to become interested in ham radio under these conditions?

Will we lose the 220-MHz band? Unless something is done to encourage our Novices things will get worse. Then the ques-

tion of a no-code license crops up. The excuse that code is too hard to learn or to cope with is a feeble one. Just look at the pre-teens who are "coping" with it. If a pre-teen can do it, why can't a few adults?

I am very surprised to see that no one seems to care about these problems instead of the dead no-code issue. I agree that we as amateur-radio operators do need to be concerned about losing spectrum, but shouldn't we be more concerned about bringing teens into amateur radio, and making it attractive enough for them

to stay? If you are not aware of the problem of broadcast stations on the 40-meter Novice band, listen! If you are not aware of the lack of consideration given our Novices, listen!

Can you not see what is happening? Take a good look at our Novice subbands. Then write your editorial so that our Novices know that you, the FCC, and the ARRL care.

Bill Dethlefsen KA9RAP  
Chicago IL

# RTTY LOOP

Marc I. Leavey, M.D. WA3AJR  
6 Jenny Lane  
Pikesville MD 21208

Well, I see by the old calendar on the wall that the Orwellian year, 1984, has passed us by, and Happy New Year to you all!

Gotta start out this month with a quick look back. In November, 1984, I detailed a scheme thought up by Jim Conner W3HCE for interfacing a Heathkit® HD-3030 RTTY terminal unit to the station. Well, Jim passes along that there are two errors in the main schematic, shown in Fig. 1 of the column: 1) pin 4 of S1C should go to pin 1 of the VHF transmitter plug—not to pin 2 of the VHF transmitter plug, and 2) pin 4 of S1G should go to pin 3 of S1E—not to pins 3 and 4 of S1D. Otherwise, according to Jim, all is correct as published. I will be interested to hear from those of you who put this interesting interface to use.

Continuing in the New Year/new broom department, back in September, 1984, I mentioned that Tom Zeltwanger KG3V has a RTTY program available, but I stated that it was for the wrong computer! Sorry about that, Tom. To set the record straight, Tom's program is for the Commodore 64, only. I am sure he would like to hear from you, at PO Box 62, State College PA 16804, if you are interested.

A question relating to a really old column has been received from Dayton Johnson W0ZI. Dayton was looking at the listing of Murray versus AMTOR codes published in November, 1983, and questions whether the Murray is not inverted. Well, Dayton, it all depends on how you look at it. For example, in my list I stated that the code for the letter A is 11000. With 1 representing mark and 0 representing space, this is the way the character is usually presented. Similarly, the ASCII letter A is

01000001. However, and this is the root of the confusion, the ASCII code is sent from the least significant bit to the most significant bit, that is, from right to left. The Murray, on the other hand, is sent from left to right, most significant to least significant.

The practical application of this is that the parity bit, if used, appears as the most significant bit, which is the last one sent. So, if you do not use a parity bit on ASCII, the stop bit or bits take its place. There is no parity bit in Murray, and the way the bits are presented goes way back to the days of punched tape. In that medium, the leading 1 of the Murray A would be at the upper edge of the tape, so, reading top down, 11000 would be the logical reading. Of course, ASCII punched tape looks the same way, but the characters are transmitted in the reverse order. Hope that clears things up.

Another little mistake, let's call it a typo. Back in August, 1984, I mentioned that a company called QEI, Inc., had acquired much of the old stock from the Northern Radio Company, manufacturers of some of the older RTTY gear. Unfortunately, a printer's gremlin scrambled their address. Write QEI at 60 Fadam Road, Springfield NJ 07081, if you like. Thanks and tip of the keyboard to Jeffrey Gornstein KD2BE for the correction.

Here's an item of interest for Spanish-speaking amateurs. The magazine *RTTY Journal* is now being published in Spanish, with Juan Rydzik LU4EGE as editor. If you are interested, drop them a note at *RTTY Journal* (Spanish edition), PO Box 64, 1706-Haedo, Buenos Aires, Argentina. Be sure to tell them you read about them in 73's "RTTY Loop," OK?

Until recently, when I used the term "mailbox" in this column, it referred to the place that I pick up the letters that you readers send me. But these days, mailbox

| CALLSIGN                     | FREQUENCY | SYSTEM | ACCESS  | CITY            | STATE     |
|------------------------------|-----------|--------|---------|-----------------|-----------|
| AJOX                         | 14.087.7  | HAL    | ?????   | LAUREL          | MS        |
| KOKXR                        | 3.626.0   | ????   | KXRZW   | VERMILLION      | SD        |
| KOVKH                        | 14.087.7  | HAL    | MSOVKH  | RAPID CITY      | SD        |
| K1VYQ                        | 14.097.5  | RATT   | :K1VYQ  | RIDGEFIELD      | CT        |
| KB1S                         | 14.087.7  | HAL    | MSOKB1S | WESTWOOD        | MA        |
| W1PW                         | 14.097.5  | CROWN  | PHZW    | MORGAN HILL     | CA        |
| N1BLB                        | 14.097.5  | CROWN  | BLBZW   | BLUE BELL       | PA        |
| W1CDM                        | 14.097.5  | MACRO  | CDMZW   | LEMON GROVE     | CA        |
| W1UKZ                        | 14.085.0  | RATT   | :W1UKZ  | SCITUATE        | MA        |
| WA1IUF                       | 14.097.5  | MACRO  | IUFZW   | NEW HAVEN       | CT        |
| WB2IIF                       | 14.080.0  | MACRO  | IIFZW   | SPRINGLAKE HTS  | NJ        |
| AD4V                         | 14.087.7  | CUSTOM | MS0D4V  | KNOXVILLE       | TN        |
| K4CJ                         | 70.322.5  | ????   | K4CJZW  | LAKEMONT        | GA        |
| K4CZ                         | 7.098.5   | HAL    | CZZW    | LEXINGTON       | KY        |
| K4ILC                        | 14.077.1  | HAL    | K4ILCZW | MIAMI           | FL        |
| K4K0Z                        | 14.087.7  | HAL    | MS0K0Z  | BOCA RATON      | FL        |
| K4PA                         | 14.077.1  | ????   | ?????   | RESTON          | VA        |
| K4ZBG                        | 14.077.1  | MACRO  | ZBGZW   | FRESNO          | CA        |
| KA4V                         | 14.077.1  | MACRO  | KA4VZW  | FRANKLIN        | NC        |
| KE4TV                        | 7.085.0   | RATT   | :KE4TV  | SAVANNAH        | GA        |
| W4XN                         | 14.077.1  | ????   | ?????   | ALEXANDRIA      | VA        |
| WB4ZQB                       | 7.087.7   | HAL    | MS0ZQB  | ROBBINSVILLE    | NC        |
| WD4MTC                       | 14.087.7  | HAL    | MS0MTC  | FORT MEYERS     | FL        |
| WD4SGU                       | 14.087.7  | CUSTOM | MS0SGU  | FORT MEYERS     | FL        |
| K5FL                         | 14.087.7  | ????   | MS05FL  | DENTON          | TX        |
| MS0XK                        | 14.087.7  | HAL    | MS0XK   | RICHARDSON      | TX        |
| MS0VX                        | 14.097.5  | HAL    | MS0VX   | HOUSTON         | TX        |
| WBSMXS                       | 14.080.0  | RATT   | :WBSMXS | MATAIRIE        | LA        |
| WBSNYA                       | 14.087.0  | HAL    | MS0NYA  | MIDWEST CITY    | OK        |
| WD5BJQ                       | 14.080.0  | RATT   | :WD5BJQ | MATAIRIE        | LA        |
| KA6CDC                       | 14.097.5  | RATT   | :KA6CDC | HENDERSON       | KY        |
| KH60D                        | 14.097.5  | RATT   | :KH60D  | JACKSON         | MS        |
| W6ZRR                        | 14.087.0  | HAL    | MS0ZRR  | SAN LUIS OBISPO | CA        |
| K7IFG                        | 14.087.7  | CUSTOM | MS0IFG  | PORTLAND        | OR        |
| KV7G                         | 14.087.7  | CUSTOM | ?????   | GLENROCK        | WY        |
| WB70WG                       | 14.097.5  | CUSTOM | QW70WG  | INDIANAPOLIS    | IN        |
| K8EWK                        | 14.087.0  | HAL    | MS0EWK  | COLUMBUS        | OH        |
| KB1F                         | 10.145.0  | RATT   | :KB1F   | BRIGHTON        | MI        |
| K8ZGZ                        | 7.085.5   | HAL    | MS0ZGZ  | MANSFIELD       | OH        |
| KABKYR                       | 3.627.0   | HAL    | ?????   | MANISTIQUE      | MI        |
| WB8ICL                       | 14.087.7  | HAL    | MS0ICL  | YELLOW SPRINGS  | OH        |
| WB8TV                        | 3.635.0   | HAL    | MS0TV   | MOUNDSVILLE     | WV        |
| WB8CEB                       | 7.091.0   | CUSTOM | :CEBZ   | FREMONT         | OH        |
| WB8LZZ                       | 14.100.0  | CUSTOM | MS0LZZ  | MANSFIELD       | OH        |
| K9KJW                        | 14.087.7  | HAL    | MS0KJW  | KENNEY          | IL        |
| W9CD                         | 14.087.7  | HAL    | MS09CD  | OLYMPIA FALLS   | IL        |
| W9JBM                        | 14.087.7  | HAL    | MS0JBM  | HOMewood        | IL        |
| ----- Foreign Stations ----- |           |        |         |                 |           |
| VE3KPK                       | 3.635.0   | MACRO  | ?????   | ONTARIO         | CANADA    |
| VK2HL                        | 14.097.5  | MACRO  | HL2W    | DEE WHY         | AUSTRALIA |
| VK2XY                        | 14.097.5  | MACRO  | 2XYZW   | SYDNEY          | AUSTRALIA |
| YV5CIV                       | 7.040.0   | MACRO  | CIVZW   | CARACAS         | VENEZUELA |
| ZF1GC                        | 14.097.5  | MACRO  | XF1GCZW | GND CAYMAN      | CAYMAN IS |

Fig. 1. Mailbox listing.

has taken on an exciting new meaning. After the fashion of the telephone access BBSs, or bulletin board systems, put online by the computer crowd, these radio mailboxes, or MSOs, represent a new facet of RTTY.

Several months ago I mentioned one such MSO, run by Bob Kling K8GJL of Vandalia, Ohio. Bob states that he is running his over the local 146.25/146.85 repeater, with the cooperation of the repeater control station. For hardware, he is using a VIC-20 computer with a 16K expander. The MSO program is written in Basic and has storage for about 8K worth of messages. He has found this to be adequate for a local two-meter system, sup-

porting about a dozen stations on RTTY. He is using an old tube-type terminal unit, made by Alltronics-Howard, and is keying the VIC-20 through an optoisolator. This proves what I have been preaching for some time—you don't need one of the fancy new demodulators to get on RTTY, especially not VHF RTTY where the "clear channel signal" abounds! Running a massive 500 mW with an old HR2B transceiver, the MSO has been on twenty-four hours a day without problems.

Another system up and running has been the one out in Santa Fe, New Mexico. The Santa Fe Amateur Radio Club has a repeater on 147.81/147.21 that is a backup for their main repeater on 146.22/146.82.

# Hi Pro

## LB-VHF-UHF Repeaters

Hi Pro

TRANSMITTER AND RECEIVER

NOW USED IN ALL HI PRO REPEATERS

ASSEMBLED  
SMALL SIZE  
3 7/8 x 6 1/8"



HI PRO TRANSMITTER  
DESIGNED FOR REPEATER  
SERVICE WITH EXCELLENT  
AUDIO, STABILITY,  
HARMONIC REJECTION  
AND LOW  
SIDE BAND NOISE.

ADJUSTABLE  
POWER  
OUTPUT  
UP TO 5 WATTS  
FROM THE  
EXCITER BOARD  
COOL OPERATION

ASK ABOUT OUR NEW COMPUTER  
CONTROL SYSTEM, AND MICROCONTROL  
AUTO PATCH, AND REPEATER KITS.

HI PRO RECEIVER  
THIS RECEIVER IS THE  
HEART OF THE REPEATER  
AND BOASTS SUPERIOR  
SQUELCH ACTION NEEDED  
FOR THIS TYPE OF  
SERVICE EXCELLENT  
SENSITIVITY, STABILITY  
AND SELECTIVITY

USE THIS RECEIVER  
TO REPLACE THAT  
TROUBLESOME RECEIVER  
IN YOUR PRESENT  
REPEATER



ASSEMBLED  
SMALL SIZE  
3 7/8 x 6 1/8"

Maggiore Electronic Laboratory

590 SNYDER AVE.  
WEST CHESTER, PA. 19380

TELEX: 499-0741-MELCO  
PHONE 215-436-6051



The .81/21 machine has been mostly quiet except for the RTTY tones of Alan Hill N5BGC and the bunch. As of the time he dropped me a note, he was still investigating programs to put on, using a VIC-20 as a control computer. Amateurs in the area might zip up to frequency and check it out.

Another group reaching out over the air is up in Manitoba, Canada. J. Gary Mills VE4CM in Winnipeg writes that a number of the hams in his area are experimenting with 1200-bps ASCII RTTY on two meters. The computer in use at VE4CM is a 6809 machine running Flex; others on the air include TRS-80s with modified ASCII terminal programs. It sounds like a lot of fun and may well develop into a high-tech RTTY network.

Now, here is the biggest list to date! Kris Torrey KA6VQI in Colton, California, sends along a list prepared for the Commodore Communicator. This BBS is no longer on line, Kris writes, because of poor software and board crashes. Anyway, he supplies the list shown in Fig. 1 which includes mailboxes across the United States, and a few foreign countries

as well. I don't know how many of these MSOs are still up; this list was first compiled in October, 1983, but it is the most complete listing I have seen to date.

If you are running an MSO or working through one in your area, why not send the details along to me at the above address. I will keep some kind of record and try to publish an up-to-date list periodically.

Speaking of software, I receive a good number of letters each month asking for program suggestions for this or that computer. In the past, I have tried to answer them from whatever material is at hand from recent communications. I would like to try another way. This month, would each and every one of you who is using a TI-99/4 computer drop me a short note and let me know what kind of software you are using and what you think of it? It does not have to be a long letter, a postcard or QSL is fine. In coming months I will ask for other computers, giving some way to compile a sense of what is in use among RTTY-ers. If responses come in as expected, I should be able to report some information about three or four months after you see

the question presented here. Thanks for your cooperation.

Thanks also for the interesting comments and questions to Russell F. Streep-er WA4BWB, Lynchburg, Virginia, F. C. Horn WA4JPP, Jekyll Island, Georgia, Allen Kempke, Hancock, Michigan, and Gilbert Marazzini, Milan, Italy. I do appreciate hearing from you and I try to answer your questions as soon as possible. And

for those of you who have asked, yes, there are still reprints of several back columns available. Drop me a line at the above address and enclose a self-addressed, stamped envelope for a listing of what is available. In the next "RTTY Loop," more responses to the information that you all tell me is the first that you read when your subscription issue of 73 arrives. Not a subscriber yet? Shame on you—you might miss the next "RTTY Loop!"

## HAM HELP

I need a schematic for an Eico model 751 power supply. Also, how can I improve the frequency stability of an Eico model 753 tri-band transceiver? I will pay for postage and copying.

Patrick Benesch KB4EGJ  
General Delivery  
Loyall KY 40854

moved and I was wondering if someone could help me locate them. I also am in need of its schematic and operator's manual. The info on it is FCC type 6W35/SLT-8, serial number 684756. I will gladly pay any cost incurred.

Frank B. Payne KD6DL  
2712 Los Amigos Dr.  
Rancho Cordova CA 95670

I would like to borrow the schematics and/or instruction manuals for the following Heathkit equipment: DX-35 transmitter, AR-3 receiver, and HD-20 XTAL calibrator. I will pay postage both ways.

Greg Magarie WA1VIL  
33 Barnesdale Rd.  
Natick MA 01760

Can anybody supply a copy of the Eico 324 signal generator operations manual?

H. L. Church W0KXP  
PO Box 126  
Lebanon IL 62254-0126

I need a schematic and power transformer for an Ameco model PCL-P preamp.

T.H. Jenson KE6WE  
910 Kelton St.  
Tehachapi CA 93561

## SATELLITES

### USING THE AO-10 APOGEE PREDICTIONS

Apogee predictions for the month of January are provided for three sections of the United States: Washington DC at 39N 77W, Kansas at 39N 95W, and California at 38N 122W. Times are in UTC and apogee in this case is mean anomaly 128 rounded to the nearest whole hour. Use the chart as a guide in aiming your antenna, then fine-tune the azimuth and elevation values to peak the satellite's beacon signal. If you require more accurate orbital predictions, contact AMSAT at PO Box 27, Washington DC 20044.

### AMSAT-OSCAR 10 APOGEE PREDICTIONS JANUARY 1985

| ORBIT | DAY | TIME | WASH |    | KANSAS |    | CALIF |    |
|-------|-----|------|------|----|--------|----|-------|----|
|       |     |      | AZ   | EL | AZ     | EL | AZ    | EL |
| 1168  | 1   | 0300 |      |    |        |    | 258   | 20 |
| 1169  | 1   | 1400 | 86   | 3  |        |    |       |    |
| 1170  | 2   | 0200 |      |    | 268    | 8  | 250   | 30 |
| 1172  | 3   | 0100 | 274  | 4  | 262    | 18 | 241   | 40 |
| 1174  | 4   | 0000 | 267  | 13 | 255    | 28 | 228   | 49 |
| 1176  | 5   | 0000 | 262  | 16 | 248    | 30 | 218   | 49 |
| 1178  | 5   | 2300 | 254  | 26 | 238    | 39 | 200   | 56 |
| 1180  | 6   | 2200 | 246  | 35 | 226    | 48 | 176   | 58 |
| 1182  | 7   | 2200 | 238  | 37 | 216    | 48 | 167   | 55 |
| 1184  | 8   | 2100 | 226  | 46 | 197    | 54 | 146   | 52 |
| 1186  | 9   | 2000 | 210  | 53 | 175    | 57 | 128   | 46 |
| 1188  | 10  | 1900 | 189  | 58 | 152    | 55 | 115   | 38 |
| 1190  | 11  | 1900 | 178  | 55 | 146    | 50 | 113   | 32 |
| 1192  | 12  | 1800 | 156  | 54 | 129    | 44 | 103   | 24 |
| 1194  | 13  | 1700 | 137  | 49 | 116    | 37 | 94    | 15 |
| 1196  | 14  | 1700 | 132  | 44 | 113    | 31 | 93    | 9  |
| 1198  | 15  | 1600 | 119  | 36 | 103    | 22 | 85    | 1  |
| 1200  | 16  | 1500 | 107  | 28 | 95     | 14 |       |    |
| 1201  | 17  | 0300 |      |    |        |    | 272   | 4  |
| 1202  | 17  | 1500 | 106  | 22 | 94     | 8  |       |    |
| 1203  | 18  | 0200 |      |    |        |    | 266   | 14 |
| 1204  | 18  | 1400 | 97   | 14 | 85     | 0  |       |    |
| 1205  | 19  | 0200 |      |    |        |    | 260   | 16 |
| 1206  | 19  | 1400 | 96   | 8  |        |    |       |    |
| 1207  | 20  | 0100 |      |    | 271    | 4  | 253   | 26 |
| 1208  | 20  | 1300 | 88   | 0  |        |    |       |    |
| 1209  | 21  | 0000 | 276  | 0  | 264    | 14 | 244   | 36 |
| 1213  | 22  | 2300 | 264  | 12 | 251    | 26 | 224   | 46 |
| 1215  | 23  | 2200 | 257  | 22 | 242    | 36 | 207   | 53 |
| 1217  | 24  | 2200 | 250  | 24 | 234    | 37 | 196   | 52 |
| 1219  | 25  | 2100 | 242  | 33 | 221    | 46 | 175   | 54 |
| 1221  | 26  | 2000 | 231  | 43 | 204    | 52 | 153   | 53 |
| 1223  | 27  | 2000 | 222  | 43 | 194    | 51 | 147   | 48 |
| 1225  | 28  | 1900 | 206  | 50 | 173    | 53 | 130   | 42 |
| 1227  | 29  | 1800 | 186  | 54 | 153    | 51 | 117   | 35 |
| 1229  | 30  | 1700 | 164  | 54 | 135    | 46 | 107   | 26 |
| 1231  | 31  | 1700 | 156  | 50 | 131    | 40 | 105   | 20 |

## ATTENTION SUBSCRIBERS

We occasionally make our mailing list available to other companies or organizations with products or services which we feel might be of interest to you. If you prefer that your name be deleted from such a list, please fill out the coupon below or affix a copy of your mailing label and mail it to:

**C.W. Communications/Peterborough  
73: Amateur Radio's Technical Journal  
PO Box 931  
Farmingdale, NY 11737**

Please delete my name from mailing lists sent to other companies or organizations.

Name \_\_\_\_\_

Address \_\_\_\_\_

City \_\_\_\_\_ State \_\_\_\_\_ Zip \_\_\_\_\_

73 Amateur Radio's  
Technical Journal

# W2NSD/1 NEVER SAY DIE

editorial by Wayne Green

from page 4

this work. With six DXpeditions per year, that would call for around 70 hams interested in investing \$3,000 each for the trip of a lifetime. I know I'd get over-subscribed if I asked for Japa-

nese volunteers, but do we have even half that many American hams interested in going on DXpeditions?

Where to? Rare spots—perhaps Iraq, China, Macao, Sarawak, Brunei, Sabah, Lesotho, Swaziland, Fiji, New Caledonia,

Western Samoa—there are lots of rare spots which are exciting to visit. I've been in all of the above and operated from most of 'em, so I know they're fascinating places for visiting and for DXing.

You know, if I could get letters from at least 50 readers willing to sign up for one week of excitement—the memories of a lifetime—I'd start setting up some trips, getting the portable ham gear and the video equipment we'd need to turn out some broadcast-quality tapes. Some of the going can be rough, so no weak hearts or backs, okay?

How'd you like to get away for

a week to some out-of-the-way corner of the world, yet be able to travel on jets and stay at first-class hotels? You'd be on the hot end of the pileups, keeping your log on a picocomputer which would automatically check for duplicate contacts, print the log, and even print QSL cards later on! It would also let you know how many contacts you've made with how many countries, how many prefixes, zones, and so on.

No, we won't be going to places where we'll get shot at, like Spratly.

Are you game?

## AWARDS

Bill Gosney KE7C  
Micro-80, Inc.  
2665 North Busby Road  
Oak Harbor WA 98277

### THE AWARDS PROGRAM OF 73: AMATEUR RADIO'S TECHNICAL JOURNAL

It's been six years since the initial announcement of the 73 Awards Program. Since its introduction in 1979, we've seen the program grow to become one of the most popular challenges facing amateurs today.

Consisting of six domestic and five DX operating achievements, the program has captured the interest of rag-chewers, DXers, and contesters alike.

The requirements are not as easy as one might first imagine. Once you qualify for a 73 award, you know you've earned it. Last month we featured the six domestic awards. Now, here are the five DX awards:

#### WORK THE WORLD DX AWARD

To enhance the enjoyment of working DX, the editors of 73 take special pleasure in introducing the most complex and probably one of the most sought-after DX awards available today—the Work the World DX Award.

#### AWARD RECIPIENTS (as of 9-1-84) WORK THE WORLD AWARD

|                |             |
|----------------|-------------|
| 177. FM7WD     | 194. WB3BVL |
| 178. ZS6FL     | 195. 4Z4VG  |
| 179. WB6TJW    | 196. VE7DRI |
| 180. VE6CNV    | 197. K2NT   |
| 181. N2CBU     | 198. I2YJO  |
| 182. I8QLI     | 199. I2KKL  |
| 183. OZ-DR1239 | 200. WD0AVG |
| 184. OE3HPA    | 201. JR3AKG |
| 185. HK5CKH    | 202. N7AHQ  |
| 186. KD7ET     | 203. IS0KNG |
| 187. IK1AOD    | 204. YB0ZM  |
| 188. W5RKK     | 205. OZ1ACB |
| 189. WB5YPE    | 206. DA1WJ  |
| 190. WB2DHY    | 207. JA1KRU |
| 191. KS1L      | 208. YB0BZZ |
| 192. W6BCQ     | 209. JA9GXY |
| 193. P29NSF    |             |

1. The WTW Award is available to licensed amateurs and SWL stations worldwide.

2. To be valid, all contacts must be made on or after January 1, 1979. There are no band or mode restrictions. Special single-band or -mode achievements may be recognized if you make your request at the same time application is made.

3. The Work the World program consists of six individual continental awards (North American, South American, European, Oceanic, Asian, and African), each of which is a worthy single accomplishment of its own. To be eligible for the 7th and ultimate award (the WTW Award), applicants first earn the continental recognition. Once all six awards have been applied for, the WTW award will be issued to the applicant at no charge. The operator

#### AWARD RECIPIENTS (as of 9-1-84) AFRICAN AWARD

|               |               |
|---------------|---------------|
| 235. FM7WD    | 264. OZ5EDR   |
| 236. ZS6FL    | 265. I2YJO    |
| 237. VE3-9094 | 266. I2KKL    |
| 238. JR7ICN   | 267. KA2PHQ   |
| 239. N4GQO    | 268. JF2MVI   |
| 240. KB2VO    | 269. ZS6BWW   |
| 241. LA4VL    | 270. ZS6BWP   |
| 242. OZ1ACB   | 271. WD0AVG   |
| 243. WB6TJW   | 272. JR3AKG   |
| 244. JY9CW    | 273. JA3CJL   |
| 245. N2CBU    | 274. IT9GFE   |
| 246. I8QLI    | 275. IS0KNG   |
| 247. IK1AOD   | 276. YB0ZM    |
| 248. W5RKK    | 277. KA1CLV   |
| 249. WB5YPE   | 278. N7AHQ    |
| 250. DA1WJ    | 279. JA2-8964 |
| 251. OE3HPA   | 280. YC0EBS   |
| 252. HK5CKH   | 281. JH1DLJ   |
| 253. KD7ET    | 282. JJ1EEA   |
| 254. 5B4MF    | 283. CT1AUO   |
| 255. WB2DHY   | 284. JH1KKT   |
| 256. KS1L     | 285. JA1KRU   |
| 257. W6BCQ    | 286. JH3CBN   |
| 258. K2NT     | 287. SM6DUA   |
| 259. YB0BZZ   | 288. JA9GXY   |
| 260. VE7DRI   | 289. JR6DQC   |
| 261. OE3HCS   | 290. JA8RII   |
| 262. YS9HH    | 291. PY2CXH   |
| 263. PY2DBU   |               |

who earns WTW recognition has truly "worked the world."

4. Requirements for the individual continental awards: North American Award—a minimum of 13 North American countries; South American Award—12 South American countries minimum; European Award—a minimum of 12 European countries; African Award—12 African countries minimum; Asian Award—12 Asian countries minimum; Oceanic Award—a minimum of 12 Oceanic countries.

5. To apply, prepare a list of claimed contacts for each continent. List contacts in prefix order. Include the date and time in GMT and the band and mode of operation.

6. If you are submitting your sixth (6th) continental award, please alert the Awards Manager to this fact.

7. Do not send QSL cards! Have your

#### AWARD RECIPIENTS (as of 9-1-84) EUROPEAN AWARD

|                |               |
|----------------|---------------|
| 350. FM7WD     | 385. KA2PHQ   |
| 351. ZS6FL     | 386. PY2FDO   |
| 352. VE3-9094  | 387. JF2MVI   |
| 353. N4GQO     | 388. KY6I     |
| 354. VQ9JW     | 389. YC0EBS   |
| 355. LA4VL     | 390. CT1AUO   |
| 356. WB6TJW    | 391. JR3AKG   |
| 357. WA9AEA    | 392. HC2DQ    |
| 358. WL7F      | 393. YC5RJ    |
| 359. N2CBU     | 394. JA3CJL   |
| 360. ZS6BWW    | 395. IS0KNG   |
| 361. I8QLI     | 396. YB0ZM    |
| 362. IK1AOD    | 397. JP1FEE   |
| 363. YB0BZZ    | 398. JH7XRB   |
| 364. W5RKK     | 399. JR3AKG   |
| 365. WB5YPE    | 400. JH1FTS   |
| 366. DA1WJ     | 401. OZ7HVI   |
| 367. OE3HPA    | 402. JF2AFJ   |
| 368. PY2TRD    | 403. JE2GJD   |
| 369. PY2DBU    | 404. JR1RMY   |
| 370. KD7ET     | 405. JA2-8964 |
| 371. N7EQT     | 406. JA1KRU   |
| 372. 5B4MF     | 407. JH3CBN   |
| 373. WB2DHY    | 408. SM6DUA   |
| 374. YS9HH     | 409. JA9GXY   |
| 375. KS1L      | 410. JF1VXB   |
| 376. W6BCQ     | 411. JR6DQC   |
| 377. P29NSF    | 412. JR1DTN   |
| 378. YB5NA     | 413. JA8RII   |
| 379. K2NT      | 414. HL1ACW   |
| 380. OE3HCS    | 415. JG1HXC   |
| 381. YC5QZ     | 416. PY2CXH   |
| 382. Hoiss—SWL | 417. DU7EV    |
| 383. I2YJO     | 418. JR7EQL   |
| 384. I2KKL     |               |

#### AWARD RECIPIENTS (as of 9-1-84) SOUTH AMERICAN AWARD

|                |             |
|----------------|-------------|
| 269. KB2VO     | 295. W6BCQ  |
| 270. OZ-DR1239 | 296. P29NSF |
| 271. PY2SZK    | 297. 5B4MF  |
| 272. N4GQO     | 298. K7DBV  |
| 273. JR7ICN    | 299. VE7DRI |
| 274. VE3-9094  | 300. K2NT   |
| 275. ZS6FL     | 301. I2YJO  |
| 276. FM7WD     | 302. I2KKL  |
| 277. WP4ATF    | 303. KA2PHQ |
| 278. WB6TJW    | 304. KA5BQM |
| 279. WA9AEA    | 305. WB2VTD |
| 280. N2CBU     | 306. CT1AUO |
| 281. OZ5EDR    | 307. JR3AKG |
| 282. I8QLI     | 308. HC2DQ  |
| 283. DA1WJ     | 309. OZ1ACB |
| 284. OE3HPA    | 310. YB0BZZ |
| 285. KY6I      | 311. YB0ZM  |
| 286. PY2DBU    | 312. IS0KNG |
| 287. KD7ET     | 313. JA1KRU |
| 288. IK1AOD    | 314. K2YOF  |
| 289. N2EGR     | 315. JH3CBN |
| 290. W5RKK     | 316. JA9GXY |
| 291. WB5YPE    | 317. PY2CXH |
| 292. WB2DHY    | 318. PY1DEA |
| 293. YS9HH     | 319. XE1JIW |
| 294. KS1L      |             |

#### AWARD RECIPIENTS (as of 9-1-84) ASIAN AWARD

|               |               |
|---------------|---------------|
| 207. LA4VL    | 232. 4Z4VG    |
| 208. VQ9JW    | 233. OE3HCS   |
| 209. VE6CNV   | 234. VE7DRI   |
| 210. VE3-9094 | 235. K2NT     |
| 211. ZS6FL    | 236. I2YJO    |
| 212. FM7WD    | 237. I2KKL    |
| 213. WB6TJW   | 238. KA2PHQ   |
| 214. N2CBU    | 239. JF2MVI   |
| 215. JY9CW    | 240. VE7EDA   |
| 216. I8QLI    | 241. JR3AKG   |
| 217. IK1AOD   | 242. JA3CJL   |
| 218. YB0BZZ   | 243. IS0KNG   |
| 219. W5RKK    | 244. YB0ZM    |
| 220. WB5YPE   | 245. JA2-8964 |
| 221. DA1WJ    | 246. JR1RMY   |
| 222. OE3HPA   | 247. OZ7HVI   |
| 223. HK5CKH   | 248. YC0EBS   |
| 224. N7AHQ    | 249. JA1KRU   |
| 225. JR6GSE   | 250. JH3CBN   |
| 226. KD7ET    | 251. SM6DUA   |
| 227. WB2DHY   | 252. JA9GXY   |
| 228. KS1L     | 253. WA1UDH   |
| 229. W6BCQ    | 254. PY2CXH   |
| 230. P29NSF   | 255. PY2DBU   |
| 231. 5B4MF    |               |

list of contacts verified by two amateurs or a notary public.

8. The fee for each continental award is \$5.00 in US funds only. We are sorry, but we can no longer accept IRCs or foreign currency. Checks written on foreign banks must be payable in US funds.

9. Forward your application(s) and fee(s) to: Bill Gosney KE7C, 73 Awards Manager, 2665 N. Busby Road, Oak Harbor WA 98277, USA.

#### 73 DX COUNTRY CLUB AWARD

1. Available to licensed amateurs and SWL stations worldwide.

2. To be valid, all claimed contacts must be made in a single calendar year (January 1 through December 31), beginning January 1, 1979.

3. This award is issued for phone, CW, and mixed modes. Should the applicant wish to recognize a single-band or mixed-band accomplishment, the preference must be stated when making the application.

4. A minimum of seventy-three (73) DX countries must be worked and confirmed

#### AWARD RECIPIENTS (as of 9-1-84) SPECIALTY COMMUNICATIONS AWARD (Class A-1)

- |                  |
|------------------|
| 29. 5Z4DA(RTTY)  |
| 30. W9HR(OSCAR)  |
| 31. IK1AOD(RTTY) |
| 32. I1BRB(OSCAR) |
| 33. YC0EBS(RTTY) |
| 34. YB0ZM(RTTY)  |

from the 73 WTW (Work the World) DX listing.

5. Annual endorsement stickers are available for each succeeding year in which application is made and a minimum of 73 DX countries are worked.

6. To apply, prepare a list of claimed contacts in prefix order. Include each station's callsign, date and time of contact in GMT, mode, and band of operation.

7. Do not send QSL cards. Have your list of contacts verified by two amateurs or a notary public.

8. Award fee is now \$5.00. Endorsements are granted for a fee of \$2.50. Do not send IRCs or foreign currency; they can no longer be accepted. Checks on foreign banks must be payable in US funds.

9. Forward your application and fee to: Bill Gosney KE7C, 73 Awards Manager, 2665 N. Busby Road, Oak Harbor WA 98277, USA.

#### SPECIALTY COMMUNICATIONS ACHIEVEMENT AWARD (CLASS A-1)

1. This award has become very popular, especially with the advent of the new OSCAR satellite and the widespread use of personal computers for RTTY. It is made available to licensed amateurs and SWL stations throughout the world.

2. To be eligible, all contacts must be made on or after January 1, 1979. Only communications via SSTV, RTTY, EME (Earth-moon-Earth), and/or OSCAR will be recognized for award credit. Contacts between stations on OSCAR and EME may be made using the mode authorized in your country. Mixed-mode contacts are not valid, however.

3. To qualify, applicants must work a minimum of ten (10) DX countries from the WTW DX Countries listing. Special recognition will be made for those exceeding the ten-country minimum.

4. To apply, the applicant must prepare a list of claimed contacts in callsign prefix order. Include the date and time in GMT, the band and mode of operation, and a description of your equipment and antenna system used to make the contacts.

5. Do not send QSL cards. Have your list of contacts verified by two amateurs or a notary public.

6. The award fee is now \$5.00 in US funds only. IRCs or foreign currency is not acceptable. Foreign checks must be payable in US funds.

7. Forward your application and award fee to: Bill Gosney KE7C, 73 Awards Manager, 2665 N. Busby Road, Oak Harbor WA 98277, USA.

#### DX CAPITALS OF THE WORLD

1. This award is made available to licensed amateurs and SWL stations throughout the world.

2. All claimed contacts must be made on or after January 1, 1979. There are no band or mode restrictions. Special recognition will be given for single band or mode if requested at the time application is made.

#### AWARD RECIPIENTS (as of 9-1-84) DX CAPITALS OF THE WORLD AWARD

- |             |            |
|-------------|------------|
| 31. W2-6893 | 36. FM7WD  |
| 32. I8HZZ   | 37. YB0ZM  |
| 33. JA1VDJ  | 38. WA8KMK |
| 34. SV1MO   | 39. JH3CBN |
| 35. KI2G    | 40. JJ1EEA |

#### AWARD RECIPIENTS (as of 9-1-84) TEN METER DX DECADE AWARD

- |             |            |
|-------------|------------|
| 12. KA3FUU  | 16. DA2ZF  |
| 13. W2-6893 | 17. I7ZQE  |
| 14. KD5VR   | 18. WB3LTT |
| 15. DA1WJ   |            |

3. To qualify, applicants must work and confirm a minimum of fifty (50) different national capital cities in the world. Only capital cities of those countries appearing on the WTW DX listing qualify. Should a country be contacted whose capital city is not commonly known, go ahead and list it in your application. The awards editor reserves the right to make a final determination.

4. To apply, make a list of contacts made in prefix order. Indicate the station callsign, date and time in GMT, band and mode of operation, the name of the national capital city, and the DX country.

5. Do not send QSL cards. Have your list of contacts verified by two amateurs or a notary public.

#### AWARD RECIPIENTS (as of 9-1-84) THE ANNUAL 73 DX COUNTRY CLUB AWARD

- |                 |                   |
|-----------------|-------------------|
| SSB             | 154. IK0AZG(83)   |
| 134. WA1SMI(82) | 155. IS0KNG(83)   |
| 135. W3BHM(81)  | 156. PY2WE(81)    |
| 136. K4JDJ(83)  | 157. OE3WQB(83)   |
| 137. VP2MO(81)  | 158. DJ7MD(84)    |
| 138. YB0BZZ(83) |                   |
| 139. W5RKK(83)  | <b>CW</b>         |
| 140. WB5YPE(83) | 22. OZ5EDR(82)    |
| 141. YB0ZM(81)  | 23. PT2ACZ(82)    |
| 142. OE3HCS(83) | 24. KK4Y(82)      |
| 143. WA1SMI(83) | 25. PY2FK(82)     |
| 144. KE7C(81)   | 26. VQ9JW(83)     |
| 145. KE7C(82)   |                   |
| 146. KE7C(83)   | <b>Mixed Mode</b> |
| 147. KA2PHQ(83) | 25. KA0MMD(82)    |
| 148. DJ7MD(83)  | 26. W2GVX(82)     |
| 149. 4Z4PS(83)  | 27. W9CC(82)      |
| 150. KZ9A(83)   | 28. JH7VHZ(82)    |
| 151. IT9GFE(83) | 29. LA4VL(82)     |
| 152. OZ1ACB(83) | 30. FM7WD(83)     |
| 153. IK6BOB(83) | 31. DL5LAG(83)    |
|                 | 32. KS1L(83)      |

6. Award fee is \$5.00 and must be payable in US funds. We are sorry, IRCs or foreign currency can no longer be accepted.

7. Forward your application and award fee to: Bill Gosney KE7C, 73 Awards Manager, 2665 N. Busby Road, Oak Harbor WA 98277, USA.

#### TEN-METER DX DECADE AWARD

1. The 10-Meter DX Decade Award is made available to licensed amateurs and SWL stations worldwide.

2. All contacts must be made on the 10-meter band using only low-power

#### AWARD RECIPIENTS (as of 9-1-84) NORTH AMERICAN AWARD

- |               |             |
|---------------|-------------|
| 296. FM7WD    | 317. W6BCQ  |
| 297. ZS6FL    | 318. P29NSF |
| 298. VE3-9094 | 319. K2NT   |
| 299. JR7ICN   | 320. OE3HCS |
| 300. N4GQO    | 321. VE5ADO |
| 301. KB2VO    | 322. YS9HH  |
| 302. WB6TJW   | 323. I2YJO  |
| 303. WA9AEA   | 324. I2KKL  |
| 304. N2CBU    | 325. KA2PHQ |
| 305. PY2DBU   | 326. CT1AUO |
| 306. I8QLI    | 327. JR3AKG |
| 307. DA1WJ    | 328. IT9GFE |
| 308. OE3HPA   | 329. IS0KNG |
| 309. KY6I     | 330. YB0ZM  |
| 310. KD7ET    | 331. JA1KRU |
| 311. IK1AOD   | 332. YB0BZZ |
| 312. N2EGR    | 333. SM6DUA |
| 313. W5RKK    | 334. JA9GXY |
| 314. WB5YPE   | 335. VE7EDA |
| 315. WB2DHY   | 336. XE1JIW |
| 316. KS1L     | 337. HC2DQ  |

#### AWARD RECIPIENTS (as of 9-1-84) OCEANIC AWARD

- |             |               |
|-------------|---------------|
| 223. KA2JJK | 250. JF2MVI   |
| 224. K7DBV  | 251. PY2DBU   |
| 225. ZS6LF  | 252. DA1WJ    |
| 226. FM7WD  | 253. WD0AVG   |
| 227. WB6TJW | 254. JR3AKG   |
| 228. KA6HTC | 255. JA3CJL   |
| 229. N2CBU  | 256. IS0KNG   |
| 230. I8QLI  | 257. YB0ZM    |
| 231. IK1AOD | 258. WA1UDH   |
| 232. YB0BZZ | 259. OZ1ACB   |
| 233. W5RKK  | 260. JA2-8964 |
| 234. WB5YPE | 261. JH3CBN   |
| 235. OE3HPA | 262. KA1KRU   |
| 236. KD7ET  | 263. KC9XL    |
| 237. VE7EDA | 264. JF2AFJ   |
| 238. WB2DHY | 265. JE2GJD   |
| 239. KS1L   | 266. JR1RMY   |
| 240. W6BCQ  | 267. W2-6893  |
| 241. P29NSF | 268. JA9GXY   |
| 242. WB3BVL | 269. W0IKD    |
| 243. JK1PTQ | 270. K7PRH    |
| 244. YS9HH  | 271. I8HZZ    |
| 245. 4Z4VG  | 272. HL1ACW   |
| 246. VE7DRI | 273. KH6JOI   |
| 247. K2NT   | 274. XE1JIW   |
| 248. I2YJO  | 275. I8JKN    |
| 249. I2KKL  |               |

# 1-2-3 GO

## Nominate A Winner For Dayton HAMVENTION '85

- 1. For RADIO AMATEUR OF THE YEAR**  
This person should be an all-around outstanding radio amateur who has made significant contributions to our hobby over an extended period of time.
- 2. For SPECIAL ACHIEVEMENT**  
This person should be a radio amateur of any rank who has accomplished a one-time outstanding achievement such as in emergency work, DXpedition, moon bounce, QRP, etc.
- 3. For TECHNICAL EXCELLENCE**  
This person should be an amateur who has made some outstanding accomplishments in a technical area of our hobby.

Deadline for submission is April 1, 1985.

For additional information write:

**AWARDS COMMITTEE**  
**1985 Dayton HAMVENTION**  
**P.O. Box 44**  
**Dayton, Ohio 45401**

## WTW DX LISTING

### NORTH AMERICA

C6 Bahamas  
 CO Cuba  
 FG Guadeloupe  
 FG, FS Saint Martin  
 FM Martinique  
 FO Clipperton Is.  
  
 FP St. Pierre & Miquelon  
 HH Haiti  
 HI Dominican Republic  
 J3, VP2G Grenada & Dependencies  
 KC4, KP1 Navassa Is.  
 KG4 Guantanamo Bay  
 KL7 Alaska  
 KP4 Desecheo  
 KP4 Puerto Rico  
 KS4, KP3, HK0 Serrana Bank and Roncador Cay  
  
 KV, KP2 Virgin Islands  
 OX, XP Greenland  
 PJ6, 8 Saba Is.  
 VE Canada  
 VE1 Sable Is.  
 VE1 St. Paul Is.  
 VO Newfoundland, Labrador  
 VP2A Antigua, Barbuda  
 VP2D Dominica  
 VP2E Anguilla  
 VP2K St. Kitts  
 VP2L St. Lucia  
 VP2M Montserrat  
 VP2S St. Vincent & Dependencies  
 VP2V British Virgin Islands  
 VP5 Turks and Caicos Islands  
 VP9 Bermuda  
 W, K, N, A United States of America  
 XE Mexico  
 XF4 Revillagigedo Islands  
 ZF Grand Cayman Islands  
 6Y Jamaica  
 4U HQ, United Nations  
 8P Barbados

### SOUTH AMERICA

CE Chile  
 CE0A Easter Is.  
 CE0X San Felix  
 CE0Z Juan Fernandez  
 CP Bolivia  
 CX Uruguay  
 FY French Guiana  
 HC Ecuador  
 HC8 Galapagos Is.  
 HK Colombia  
 HK0 Bajo Nuevo  
 HK0 Malpelo Is.  
 HK0 San Andres & Providencia  
 HP Panama  
 HR Honduras  
 HR0 Swan Is.  
 KZ Canal Zone  
 LU Argentina  
 OA Peru  
 PJ Bonaire  
 PJ Netherlands Antilles  
 PY Brazil  
 PY0 Fernando de Noronha  
 PY0 St. Peter & St. Paul  
 PY0 Trinidad & Martim Vaz Is.  
 PZ Surinam  
 TG Guatemala  
 TI Costa Rica  
 TI9 Cocos Is.  
 VP1 Belize  
 VP8 Falkland Is.  
 VP8, LU South Georgia Is.  
 VP8, LU South Orkney Is.  
 VP8, LU South Sandwich Is.  
 VP8, LU South Shetland Is.  
 VP8W South Grahamland  
 YN Nicaragua  
 YS Salvador  
 YV Venezuela  
 YV0 Aves Is.  
 ZP Paraguay  
 8R Guyana  
 9Y Trinidad and Tobago

### EUROPE

C3 Andorra  
 CT Portugal  
 CT2 Azores  
 DA-DL Federal Republic of Germany  
 DM, DT German Democratic Republic  
 EA Spain  
 EA6 Balearic Islands  
 EI Republic of Ireland  
 EJ0 Aran Is.  
 F France  
 FC Corsica  
 G England  
 GD Isle of Man  
 GI Northern Ireland  
 GJ, GC Jersey  
 GM Scotland  
 GM Orkney Islands  
 GM Shetland Islands  
 GU, GC Guernsey  
 GW Wales  
 HA Hungary  
 HB Switzerland  
 HB0 Liechtenstein  
 HV Vatican  
 I Italy  
 IC Ischia  
 IA Tuscan Archipelago  
 IS Sardinia  
 IT Sicily  
 JW Bear Is.  
 JW Svalbard Is.  
 JX Jan Mayen  
 LA Norway  
 LX Luxembourg  
 LZ Bulgaria  
 M1 San Marino  
 OE Austria  
 OH Finland  
 OH0 Aland Is.  
 OJ0 Market Reef  
 OK Czechoslovakia  
 ON Belgium  
 OY Faeroe Islands  
 OZ Denmark  
 PA Netherlands  
 SM Sweden  
 SP Poland  
 SV Greece  
 SV Crete  
 SV Dodecanese  
 SV Mount Athos  
 TF Iceland  
 UA, UK1, 3, 4, 6 European RSFSR  
 UA1, UK1 Franz Josef Land  
 UA2, UK2F Kaliningradsk  
 UB, UK, UT, UY5 Ukraine  
 UC2, UK2 White RSFSR  
 UO5, UK5O Moldavia  
 UP2, UK2B, P Lithuania  
 UO2, UK2G, Q Latvia  
 UR2, UK2R, T Estonia  
 YO Romania  
 YU Yugoslavia  
 ZA Albania  
 ZB Gibraltar  
 3A Monaco  
 4U ITU, Geneva  
 9A (See M1)

### ASIA

A4X Oman Is.  
 A5 Bhutan  
 A6X United Arab Emirates  
 A7X Qatar  
 A9X Bahrain  
 AP Pakistan  
 BV Taiwan  
 BY China  
 CR9 Macao  
 EP Iran  
 HL, HM North Korea  
 HL, HM South Korea  
 HS Thailand  
 HZ, 7Z Saudi Arabia  
 JA-JR Japan  
 JR6, KA6 Okinawa (Ryukyu Is.)  
 JD, KA1 Ogasawara  
 JT Mongolia  
 JY Jordan  
 KA US Military in Japan  
 OD Lebanon  
 S2 Bangladesh  
 TA Turkey  
 UA, UK, UV Asiatic RSFSR

### UW9-0

UD6, UK6C, D, K Azerbaizhan  
 UF6, UK6F, O Georgia  
 Q, V  
 UG6, UK6G Armenia  
 UH8, UK8H Turkoman  
 UI8, UK8I Uzbek  
 UJ8, UK8J, R Tadjik  
 UL7, UK7 Kazakh  
 UM8, UK8M, N Kirghiz  
 VS6 Hong Kong  
 VS9K Kamaran Is.  
 VU India  
 VU7 Andaman & Nicobar  
 VU7 Laccadives  
 XU Khmer Republic  
 XV Vietnam  
 XW Laos People's Dem. Rep.  
 XZ Burma  
 YA Afghanistan  
 YI Iraq  
 YK Syria  
 1S Spratly  
 4S Sri Lanka  
 4W Yemen  
 4X, 4Z Israel  
 5B4, ZC Cyprus  
 70 People's Dem. Rep. of Yemen  
 8Z4 Neutral Zone  
 9H Saudi Arabia/Iraq  
 9H4 Malta  
 9K Gozo & Comino  
 9M2 Kuwait  
 9M6 West Malaysia  
 9M8 North Borneo  
 9N Sarawak  
 9V Nepal  
 9V Singapore  
 Abu Ail, Jabal Attair

### OCEANIA

A3 Tonga Republic  
 CR8 Portuguese Timor  
 C2 Republic of Nauru  
 DU Philippines  
 FK New Caledonia  
 FO French Polynesia  
 FW Wallis & Fortuna Islands  
 H4, VR4 Solomon Islands  
 JD, KA1 Minami Torishima  
 JV, 7J1 Okino Torishima  
 KB, KH1 Baker, Howland, American Phoenix  
 KC5 Eastern Carolines  
 KC6 Western Carolines  
 KG6, KH2 Guam Island  
 KG6R Rota  
 KG6S Saipan  
 KG6T Tinian  
 KH6 Hawaiian Islands  
 KH7 Kure Island  
 KJ, KH3 Johnston Island  
 KM, KH4 Midway Island  
 KP5, KH5K Kingman Reef  
 KP6, KH5 Palmyra  
 KS6, KH8 American Samoa  
 KW, KH9 Wake Island  
 KX Marshall Islands  
 P2 Papua, New Guinea  
 T2, VR8 Tuvalu Island  
 VK Australia  
 VK Lord Howe Island  
 VK9 Willis Island  
 VK9 Christmas Island  
 VK9 Keeling, Cocos Island  
 VK9 Mellish Reef  
 VK9 Norfolk Island  
 VR1 Macquarie Island  
 VR1 British Phoenix Islands  
 VR1 Gilbert Island  
 VR1 Ocean Island  
 VR3 Christmas Island  
 VR6 Pitcairn Island  
 VR7 Line Island, South and Central  
 VR8 (See T2)  
 VS5 Brunei  
 YB, YC, YD Borneo  
 YB, YC, YD Celebes  
 YB, YC, YD Java  
 YB, YC, YD Sumatra  
 YB, YC, YD West Irian  
 YJ New Hebrides  
 ZK1 North Cook Island  
 ZK1 South Cook Island  
 ZK2 Niue Island

### ZL

ZL New Zealand  
 ZL Auckland & Campbell  
 ZL Chatham Island  
 ZL Kermadec  
 ZM7 Tokelau  
 3D2 Fiji Islands  
 5W Western Samoa

### AFRICA

A2 Botswana  
 C5 Gambia  
 C9 Mozambique  
 CN Morocco  
 CN2 Tangier  
 CR3 Guinea Bissau  
 CT3 Madeira Is.  
 D2, 3 Angola  
 D4 Republic of Cape Verde  
 D6 Comoros  
 EA8 Canary Islands  
 EA9 Ceuta and Melilla  
 EA9 Ifni  
 EA9 Rio de Oro  
 EL Liberia  
 ET2 Eritrea  
 ET3 Ethiopia  
 FB8W Crozet  
 FB8X Kerguelen Is.  
 FB8Z Amsterdam & St. Paul  
 FH Mayotte  
 FR Glorioso Island  
 FR Juan de Nova, Europa  
 FR Reunion  
 FR Tromelin  
 H5 Bophuthatswana  
 IG Lampedusa Island  
 IH Pantelleria Island  
 J2, FL8 Djibouti  
 S7 Seychelles  
 S8 Transkei  
 S9 Sao Tome and Principe  
 ST Sudan  
 ST0 South Sudan  
 SU Egypt  
 TJ Cameroon  
 TL Central African Empire  
 TN Congo  
 TR Gabon  
 TT Chad  
 TU Ivory Coast  
 TY Benin  
 TZ Mali  
 VK0 Heard Island  
 VQ9 Aldabra Island  
 VQ9 Chagos (Diego Garcia)  
 VQ9 Desroches  
 VQ9 Farquhar  
 XT Upper Volta  
 ZD7 St. Helena  
 ZD8 Ascension Island  
 ZD9 Gough Island and Tristan da Cunha  
 ZE Rhodesia  
 ZS1, 2, 4, 6 South Africa  
 ZS2 Prince Edward Island  
 ZS2 Marion Island  
 ZS3 Southwest Africa (Namibia)  
 386, 7 Agalega & St. Brandon  
 388 Mauritius  
 389 Rodriguez Island  
 3C Equatorial Guinea  
 3D6 Swaziland  
 3V Tunisia  
 3X Republic of Guinea  
 3Y Bouvet Island  
 5A Libya  
 5H Tanzania  
 5N Nigeria  
 5R Malagasy Republic  
 5T Mauritania  
 5U Niger  
 5V Togo  
 5X Uganda  
 5Z Kenya  
 6O Somali  
 6W Senegal  
 7P Lesotho  
 7Q Malawi  
 7X Algeria  
 8Q, VS9 Maldiv Islands  
 9G Ghana  
 9J Zambia  
 9L Sierra Leone  
 9Q Republic of Zaire  
 9U Burundi  
 9X Rwanda

equipment (20 Watts output or less). External amplifiers may not be used.  
 3. To be eligible, all contacts must be made on or after October 1, 1978. Contacts may be made on AM, SSB, CW, or 10-meter FM. Mixed-mode contacts may also be claimed. Crossmode contacts do not qualify.  
 4. To qualify, a minimum of ten (10) DX countries must be worked, from the WTW DX listing. Endorsements will be given for 25, 50, 75, and 100 confirmed countries.  
 5. To apply, prepare a list of claimed contacts in prefix order. Include the call-

sign of each station worked, the date and time in GMT, band, mode, and a brief description of the equipment used in making each contact.  
 6. Do not send QSL cards. Have your application verified by two amateurs or a notary public.  
 7. Award fee is \$5.00 in US funds only. Endorsements are \$2.50 each. Sorry, we cannot accept IRCs or foreign currency.  
 8. Forward your application and award fee to: Bill Gosney KE7C, 73 Awards Manager, 2665 N. Busby Road, Oak Harbor WA 98277, USA.

# HAM HELP

---

I am looking for clear-cut information on building or buying TV-receive equipment for the low 6-GHz range.

Eugene Hertel  
RR2 Hillcrest Dr.  
Garden City KS 67846

I need a manual for a Collins 75A2 or 75A2A. I will pay reproduction and shipping costs.

Ken Kolthoff K8AXH#  
#2 Copper Corral  
Plattsmouth NE 68048

# TUBES

| TYPE           | PRICE    | TYPE             | PRICE    | TYPE               | PRICE    |
|----------------|----------|------------------|----------|--------------------|----------|
| 2C39/7289      | \$ 34.00 | 1182/4600A       | \$500.00 | ML7815AL           | \$ 60.00 |
| 2E26           | 7.95     | 4600A            | 500.00   | 7843               | 107.00   |
| 2K28           | 200.00   | 4624             | 310.00   | 7854               | 130.00   |
| 3-500Z         | 102.00   | 4657             | 84.00    | ML7855KAL          | 125.00   |
| 3-1000Z/8164   | 400.00   | 4662             | 100.00   | 7984               | 14.95    |
| 3B28/866A      | 9.50     | 4665             | 500.00   | 8072               | 84.00    |
| 3CX400U7/8961  | 255.00   | 4687             | P.O.R.   | 8106               | 5.00     |
| 3CX1000A7/8283 | 526.00   | 5675             | 42.00    | 8117A              | 225.00   |
| 3CX3000F1/8239 | 567.00   | 5721             | 250.00   | 8121               | 110.00   |
| 3CW30000H7     | 1700.00  | 5768             | 125.00   | 8122               | 110.00   |
| 3X2500A3       | 473.00   | 5819             | 119.00   | 8134               | 470.00   |
| 3X3000F1       | 567.00   | 5836             | 232.50   | 8156               | 12.00    |
| 4-65A/8165     | 69.00    | 5837             | 232.50   | 8233               | 60.00    |
| 4-125A/4D21    | 79.00    | 5861             | 140.00   | 8236               | 35.00    |
| 4-250A/5D22    | 98.00    | 5867A            | 185.00   | 8295/PL172         | 500.00   |
| 4-400A/8438    | 98.00    | 5868/AX9902      | 270.00   | 8458               | 35.00    |
| 4-400B/7527    | 110.00   | 5876/A           | 42.00    | 8462               | 130.00   |
| 4-400C/6775    | 110.00   | 5881/6L6         | 8.00     | 8505A              | 95.00    |
| 4-1000A/8166   | 444.00   | 5893             | 60.00    | 8533W              | 136.00   |
| 4CX250B/7203   | 54.00    | 5894/A           | 54.00    | 8560/A             | 75.00    |
| 4CX250FG/8621  | 75.00    | 5894B/8737       | 54.00    | 8560AS             | 100.00   |
| 4CX250K/8245   | 125.00   | 5946             | 395.00   | 8608               | 38.00    |
| 4CX250R/7580W  | 90.00    | 6083/AZ9909      | 95.00    | 8624               | 100.00   |
| 4CX300A/8167   | 170.00   | 6146/6146A       | 8.50     | 8637               | 70.00    |
| 4CX350A/8321   | 110.00   | 6146B/8298       | 10.50    | 8643               | 83.00    |
| 4CX350F/8322   | 115.00   | 6146W/7212       | 17.95    | 8647               | 168.00   |
| 4CX350FJ/8904  | 140.00   | 6156             | 110.00   | 8683               | 95.00    |
| 4CX600J/8809   | 835.00   | 6159             | 13.85    | 8877               | 465.00   |
| 4CX1000A/8168  | 242.50*  | 6159B            | 23.50    | 8908               | 13.00    |
| 4CX1000A/8168  | 485.00   | 6161             | 325.00   | 8950               | 13.00    |
| 4CX1500B/8660  | 555.00   | 6280             | 42.50    | 8930               | 137.00   |
| 4CX5000A/8170  | 1100.00  | 6291             | 180.00   | 6L6 Metal          | 25.00    |
| 4CX10000D/8171 | 1255.00  | 6293             | 24.00    | 6L6GC              | 5.03     |
| 4CX15000A/8281 | 1500.00  | 6326             | P.O.R.   | 6CA7/EL34          | 5.38     |
| 4CW800F        | 710.00   | 6360/A           | 5.75     | 6CL6               | 3.50     |
| 4D32           | 240.00   | 6399             | 540.00   | 6DJ8               | 2.50     |
| 4E27A/5-125B   | 240.00   | 6550A            | 10.00    | 6DQ5               | 6.58     |
| 4PR60A         | 200.00   | 6883B/8032A/8552 | 10.00    | 6GF5               | 5.85     |
| 4PR60B         | 345.00   | 6897             | 160.00   | 6GJ5A              | 6.20     |
| 4PR65A/8187    | 175.00   | 6907             | 79.00    | 6GK6               | 6.00     |
| 4PR1000A/8189  | 590.00   | 6922/6DJ8        | 5.00     | 6HB5               | 6.00     |
| 4X150A/7034    | 60.00    | 6939             | 22.00    | 6HF5               | 8.73     |
| 4X150D/7609    | 95.00    | 7094             | 250.00   | 6JG6A              | 6.28     |
| 4X250B         | 45.00    | 7117             | 38.50    | 6JM6               | 6.00     |
| 4X250F         | 45.00    | 7203             | P.O.R.   | 6JN6               | 6.00     |
| 4X500A         | 412.00   | 7211             | 100.00   | 6JS6C              | 7.25     |
| 5CX1500A       | 660.00   | 7213             | 300.00*  | 6KN6               | 5.05     |
| KT88           | 27.50    | 7214             | 300.00*  | 6KD6               | 8.25     |
| 416B           | 45.00    | 7271             | 135.00   | 6LF6               | 7.00     |
| 416C           | 62.50    | 7289/2C39        | 34.00    | 6LQ6 G.E.          | 7.00     |
| 572B/T160L     | 49.95    | 7325             | P.O.R.   | 6LQ6/6MJ6 Sylvania | 9.00     |
| 592/3-200A3    | 211.00   | 7360             | 13.50    | 6ME6               | 8.90     |
| 807            | 8.50     | 7377             | 85.00    | 12AT7              | 3.50     |
| 811A           | 15.00    | 7408             | 2.50     | 12AX7              | 3.00     |
| 812A           | 29.00    | 7609             | 95.00    | 12BY7              | 5.00     |
| 813            | 50.00    | 7735             | 36.00    | 12JB6A             | 6.50     |

NOTE \* = USED TUBE

NOTE P.O.R. = PRICE ON REQUEST

"ALL PARTS MAY BE NEW, USED, OR SURPLUS. PARTS MAY BE SUBSTITUTED WITH COMPARABLE PARTS IF WE ARE OUT OF STOCK OF AN ITEM.

NOTICE: ALL PRICES ARE SUBJECT TO CHANGE WITHOUT NOTICE.

For information call: (602) 242-3037

**Toll Free Number**  
**800-528-0180**  
**(For orders only)**

"All parts may be new or surplus, and parts may be substituted with comparable parts if we are out of stock of an item."

**MHz electronics**

PRICES SUBJECT TO CHANGE WITHOUT NOTICE

# "FILTERS"

## COLLINS Mechanical Filter #526-9724-010 MODEL F455Z32F

455KHZ at 3.2KHz wide. May be other models but equivalent. May be used or new, \$15.99

### ATLAS Crystal Filters

|  |       |
|--|-------|
| 5.595-2.7/8/LSB, 5.595-2.7/LSB   |       |
| 8 pole 2.7KHz wide Upper sideband. Impedance 800ohms 15pf In/800ohms 0pf out.  | 19.99 |
| 5.595-2.7/8/U, 5.595-2.7/USB   |       |
| 8 pole 2.7KHz wide Upper sideband. Impedance 800ohms 15pf In/800ohms 0pf out.  | 19.99 |
| 5.595-.500/4, 5.595-.500/4/CW  |       |
| 4 pole 500 cycles wide CW. Impedance 800ohms 15pf In/800ohms 0pf out.          | 19.99 |
| 9.0USB/CW  |       |
| 6 pole 2.7KHz wide at 6dB. Impedance 680ohms 7pf In/300ohms 8pf out. CW-1599Hz | 19.99 |

## KOKUSAI ELECTRIC CO, Mechanical Filter #MF-455-ZL/ZU-21H

|  |       |
|--|-------|
| 455KHz at Center Frequency of 453.5KC. Carrier Frequency of 455KHz 2.36KC Bandwidth. |       |
| Upper sideband. (ZU)   | 19.99 |
| Lower sideband. (ZL)   | 19.99 |

### CRYSTAL FILTERS

|          |            |  |         |
|----------|------------|--|---------|
| NIKKO    | FX-07800C  | 7.8MHz   | \$10.00 |
| TEW      | FEC-103-2  | 10.6935MHz   | 10.00   |
| SDK      | SCH-113A   | 11.2735MHz   | 10.00   |
| TAMA     | TF-31H250  | CF 3179.3KHz                                       | 19.99   |
| TYCO/CD  | 001019880  | 10.7MHz 2pole 15KHz bandwidth                      | 5.00    |
| MOTOROLA | 4884863B01 | 11.7MHz 2pole 15KHz bandwidth                      | 5.00    |
| PTI      | 5350C      | 12MHz 2pole 15KHz bandwidth                        | 5.00    |
| PTI      | 5426C      | 21.4MHz 2pole 15KHz bandwidth                      | 5.00    |
| PTI      | 1479       | 10.7MHz 8pole bandwidth 7.5KHz at 3dB, 5KHz at 6dB | 20.00   |
| COMTECH  | A10300     | 45MHz 2pole 15KHz bandwidth                        | 6.00    |
| FRC      | ERXF-15700 | 20.6MHz 36KHz wide                                 | 10.00   |
| FILTECH  | 2131       | CF 7.825MHz  | 10.00   |

### CERAMIC FILTERS

|            |                |   |       |
|------------|----------------|---|-------|
| AXEL       | 4F449          | 12.6KC Bandpass Filter 3dB bandwidth 1.6KHz from 11.8-13.4KHz | 10.00 |
| CLEVITE    | TO-01A         | 455KHz+2KHz bandwidth 4-7% at 3dB                             | 5.00  |
|            | TCF4-12D36A    | 455KHz+1KHz bandwidth 6dB min 12KHz, 60dB max 36KHz           | 10.00 |
| MURATA     | BFB455B        | 455KHz  | 2.50  |
|            | BFB455L        | 455KHz  | 3.50  |
|            | CFM455E        | 455KHz +5.5KHz at 3dB, +8KHz at 6dB, +16KHz at 50dB           | 6.65  |
|            | CFM455D        | 455KHz +7KHz at 3dB, +10KHz at 6dB, +20KHz at 50dB            | 6.65  |
|            | CFR455E        | 455KHz +5.5KHz at 3dB, +8KHz at 6dB, +16KHz at 60dB           | 8.00  |
|            | CFU455B        | 455KHz +2KHz bandwidth +15KHz at 6dB, +30KHz at 40dB          | 2.90  |
|            | CFU455C        | 455KHz +2KHz bandwidth +12.5KHz at 6dB, +24KHz at 40dB        | 2.90  |
|            | CFU455G        | 455KHz +1KHz bandwidth +4.5KHz at 6dB, +10KHz at 40dB         | 2.90  |
|            | CFU455H        | 455KHz +1KHz bandwidth +3KHz at 6dB, +9KHz at 40dB            | 2.90  |
|            | CFU455I        | 455KHz +1KHz bandwidth +2KHz at 6dB, +6KHz at 40dB            | 2.90  |
|            | CFW455D        | 455KHz +10KHz at 6dB, +20KHz at 40dB                          | 2.90  |
|            | CFW455H        | 455KHz +3KHz at 6dB, +9KHz at 40dB                            | 2.90  |
|            | SFB455D        | 455KHz  | 2.50  |
|            | SFD455D        | 455KHz +2KHz, 3dB bandwidth 4.5KHz +1KHz                      | 5.00  |
|            | SFE10.7MA      | 10.7MHz 280KHz +50KHz at 3dB, 650KHz at 20dB                  | 2.50  |
|            | SFE10.7MS      | 10.7MHz 230KHz +50KHz at 3dB, 570KHz at 20dB                  | 2.50  |
|            | SFG10.7MA      | 10.7MHz   | 10.00 |
| NIPPON     | LF-B4/CFU455I  | 455KHz +1KHz  | 2.90  |
|            | LF-B6/CFU455H  | 455KHz +1KHz  | 2.90  |
|            | LF-B8          | 455KHz  | 2.90  |
|            | LF-C18         | 455KHz  | 10.00 |
| TOKIN      | CF455A/BFU455K | 455KHz +2KHz  | 5.00  |
| MATSUSHIRA | EFC-L455K      | 455KHz  | 7.00  |

### SPECTRA PHYSICS INC, Model 088 HeNe LASER TUBES

|                       |                 |                 |                         |
|-----------------------|-----------------|-----------------|-------------------------|
| POWER OUTPUT 1.6MW.   | BEAM DIA. .75MM | BEAM DIR. 2.7MR | 8KV STARTING VOLTAGE DC |
| 68K OHM 1WATT BALLAST | 1000VDC +100VDC | At 3.7MA        | \$59.99                 |

### ROTRON MUFFIN FANS Model MARK4/MU2A1

|                 |               |          |                       |                |         |
|-----------------|---------------|----------|-----------------------|----------------|---------|
| 115 VAC         | 14WATTS       | 50/60CPS | IMPEDENCE PROTECTED-F | 88CFM at 50CPS | \$ 7.99 |
| 105CFM at 60CPS | THESE ARE NEW |          |                       |                |         |

# MHz electronics

PRICES SUBJECT TO CHANGE WITHOUT NOTICE

**Toll Free Number**  
**800-528-0180**  
**(For orders only)**

"All parts may be new or surplus, and parts may be substituted with comparable parts if we are out of stock of an item."

For information call: (602) 242-3037

# RF TRANSISTORS

| TYPE          | PRICE   | TYPE       | PRICE    | TYPE           | PRICE   | TYPE          | PRICE   |
|---------------|---------|------------|----------|----------------|---------|---------------|---------|
| 2N1561        | \$25.00 | 2N5920     | \$ 70.00 | 40608 RCA      | \$ 2.48 | BFY90         | \$ 1.50 |
| 2N1562        | 25.00   | 2N5921     | 80.00    | 40673 RCA      | 2.50    | BLW60C5       | 15.00   |
| 2N1692        | 25.00   | 2N5922     | 10.00    | 40894 RCA      | 1.00    | BLX67         | 12.25   |
| 2N2857        | 1.55    | 2N5923     | 25.00    | 60247 RCA      | 25.00   | BLX67C3       | 12.25   |
| 2N2857JAN     | 4.10    | 2N5941     | 23.00    | 61206 RCA      | 100.00  | BLX93C3       | 22.21   |
| 2N2857JANTX   | 4.50    | 2N5942     | 40.00    | 62800A RCA     | 60.00   | BLY87A        | 7.50    |
| 2N2876        | 13.50   | 2N5944     | 10.35    | 62803 RCA      | 100.00  | BLY88C3       | 13.08   |
| 2N2947        | 18.35   | 2N5945     | 10.00    | 430414/3990RCA | 50.00   | BLY89C        | 13.00   |
| 2N2948        | 13.00   | 2N5946     | 12.00    | 3457159 RCA    | 20.00   | BLY90         | 45.00   |
| 2N2949        | 15.50   | 2N5947     | 9.20     | 3729685-2 RCA  | 75.00   | BLY92         | 13.30   |
| 2N3118        | 5.00    | 2N6080     | 6.00     | 3729701-2 RCA  | 50.00   | BLY94C        | 45.00   |
| 2N3119        | 4.00    | 2N6081     | 7.00     | 3753883 RCA    | 50.00   | BLY351        | 10.00   |
| 2N3134        | 1.15    | 2N6082     | 9.00     | 615467-902     | 25.00   | BLY568C/CF    | 30.00   |
| 2N3287        | 4.90    | 2N6083     | 9.50     | 615467-903     | 40.00   | C2M70-28R     | 92.70   |
| 2N3288        | 4.40    | 2N6084     | 12.00    | 2SC568         | 2.50    | C25-28        | 57.00   |
| 2N3309        | 4.85    | 2N6094     | 11.00    | 2SC703         | 36.00   | C4005         | 2.50    |
| 2N3375        | 17.10   | 2N6095     | 12.00    | 2SC756A        | 7.50    | CD1659        | 20.00   |
| 2N3478        | 2.13    | 2N6096     | 16.10    | 2SC781         | 2.80    | CD1899        | 20.00   |
| 2N3553        | 1.55    | 2N6097     | 20.70    | 2SC1018        | 1.00    | CD1920        | 10.00   |
| 2N3553JAN     | 2.90    | 2N6105     | 21.00    | 2SC1042        | 24.00   | CD2188        | 18.00   |
| 2N3632        | 15.50   | 2N6136     | 21.85    | 2SC1070        | 2.50    | CD2545        | 24.00   |
| 2N3733        | 11.00   | 2N6166     | 40.24    | 2SC1216        | 2.50    | CD2664A       | 16.00   |
| 2N3818        | 5.00    | 2N6267     | 142.00   | 2SC1239        | 2.50    | CD3167        | 92.70   |
| 2N3866        | 1.30    | 2N6304     | 1.50     | 2SC1251        | 24.00   | CD3353        | 95.00   |
| 2N3866JAN     | 2.20    | 2N6368     | 30.00    | 2SC1306        | 2.90    | CD3435        | 26.30   |
| 2N3866JANTX   | 3.80    | 2N6439     | 55.31    | 2SC1307        | 5.50    | CD3900        | 152.95  |
| 2N3866JANTXV  | 4.70    | 2N6459     | 18.00    | 2SC1424        | 2.80    | CM25-12       | 20.00   |
| 2N3866AJANTXV | 5.30    | 2N6567     | 10.06    | 2SC1600        | 5.00    | CM40-12       | 27.90   |
| 2N3924        | 3.35    | 2N6603     | 13.50    | 2SC1678        | 2.00    | CM40-28       | 56.90   |
| 2N3926        | 16.10   | 2N6604     | 13.50    | 2SC1729        | 32.40   | CME50-12      | 30.00   |
| 2N3927        | 17.25   | 2N6679     | 44.00    | 2SC1760        | 1.50    | CTC2001       | 42.00   |
| 2N3948        | 1.75    | 2N6680     | 80.00    | 2SC1909        | 4.00    | CTC2005       | 55.00   |
| 2N3950        | 25.00   | 021-1      | 15.00    | 2SC1945        | 10.00   | CTC3005       | 70.00   |
| 2N3959        | 3.85    | 01-80703T4 | 65.00    | 2SC1946        | 40.00   | CTC3460       | 20.00   |
| 2N4012        | 11.00   | 35C05      | 15.00    | 2SC1947        | 10.00   | DV2820S       | 25.00   |
| 2N4037        | 2.00    | 102-1      | 28.00    | 2SC1970        | 2.50    | DXL1003P70    | 22.00   |
| 2N4041        | 14.00   | 103-1      | 28.00    | 2SC1974        | 4.00    | DXL2001P70    | 19.00   |
| 2N4072        | 1.80    | 103-2      | 28.00    | 2SC2166        | 5.50    | DXL2002P70    | 14.00   |
| 2N4080        | 4.53    | 104P1      | 18.00    | 2SC2237        | 32.00   | DXL3501AP100F | 47.00   |
| 2N4127        | 21.00   | 163P1      | 10.00    | 2SC2695        | 47.00   | EFJ4015       | 12.00   |
| 2N4416        | 2.25    | 181-3      | 15.00    | A2X1698        | POR     | EFJ4017       | 24.00   |
| 2N4427        | 1.25    | 210-2      | 10.00    | A3-12          | 14.45   | EFJ4021       | 24.00   |
| 2N4428        | 1.85    | 269-1      | 18.00    | A50-12         | 24.00   | EFJ4026       | 35.00   |
| 2N4430        | 11.80   | 281-1      | 15.00    | A209           | 10.00   | EN15745       | 20.00   |
| 2N4927        | 3.90    | 282-1      | 30.00    | A283           | 6.00    | FJ9540        | 16.00   |
| 2N4957        | 3.45    | 482        | 7.50     | A283B          | 6.00    | FSX52WF       | 58.00   |
| 2N4959        | 2.30    | 564-1      | 25.00    | A1610          | 19.00   | G65739        | 25.00   |
| 2N5016        | 18.40   | 698-3      | 15.00    | AF102          | 2.50    | G65386        | 25.00   |
| 2N5026        | 15.00   | 703-1      | 15.00    | AFY12          | 2.50    | GMO290A       | 2.50    |
| 2N5070        | 18.40   | 704        | 4.00     | AR7115         | 20.00   | HEP76         | 4.95    |
| 2N5090        | 13.80   | 709-2      | 11.00    | AT41435-5      | 6.35    | HEPS3002      | 11.40   |
| 2N5108        | 3.45    | 711        | 4.00     | B2-8Z          | 10.70   | HEPS3003      | 30.00   |
| 2N5109        | 1.70    | 733-2      | 15.00    | B3-12          | 10.85   | HEPS3005      | 10.00   |
| 2N5160        | 3.45    | 798-2      | 25.00    | B12-12         | 15.70   | HEPS3006      | 19.90   |
| 2N5177        | 21.62   | 3421       | 28.00    | BAL0204125     | 152.95  | HEPS3007      | 25.00   |
| 2N5179        | 1.04    | 3683P1     | 15.00    | BF25-35        | 56.25   | HEPS3010      | 11.34   |
| 2N5216        | 56.00   | 3992       | 25.00    | B40-12         | 19.25   | HF8003        | 10.00   |
| 2N5470        | 75.00   | 4164P1     | 15.00    | B70-12         | 55.00   | HFET2204      | 112.00  |
| 2N5583        | 3.45    | 4243P1     | 28.00    | BF272A         | 2.50    | HP35821       | 38.00   |
| 2N5589        | 9.77    | 4340P3     | 18.00    | BFQ85          | 2.50    | HP35826B      | 32.00   |
| 2N5590        | 10.92   | 4387P1     | 27.50    | BFR21          | 2.50    | HP35826E      | 32.00   |
| 2N5591        | 13.80   | 7104-1     | 28.00    | BFR90          | 1.00    | HP35831E      | 30.00   |
| 2N5596        | 99.00   | 7249-2     | 10.50    | BFR91          | 1.65    | HP35832E      | 50.00   |
| 2N5636        | 12.00   | 7283-1     | 37.50    | BFR99          | 2.50    | HP35833E      | 50.00   |
| 2N5637        | 15.50   | 7536-1     | 30.00    | BFT12          | 2.50    | HP35859E      | 75.00   |
| 2N5641        | 12.42   | 7794-1     | 10.50    | BFW16A         | 2.50    | HP35866E      | 44.00   |
| 2N5642        | 14.03   | 7795       | 15.00    | BFW17          | 2.50    | HXTR2101      | 44.00   |
| 2N5643        | 25.50   | 7795-1     | 15.00    | BFW92          | 1.50    | HXTR3101      | 7.00    |
| 2N5645        | 13.80   | 7796-1     | 24.00    | BFX44          | 2.50    | HXTR5101      | 31.00   |
| 2N5646        | 20.70   | 7797-1     | 36.00    | BFX48          | 2.50    | HXTR6104      | 68.00   |
| 2N5651        | 11.05   | 40081 RCA  | 5.00     | BFX65          | 2.50    | HXTR6105      | 31.00   |
| 2N5691        | 18.00   | 40279 RCA  | 10.00    | BFX84          | 2.50    | HXTR6106      | 33.00   |
| 2N5764        | 27.00   | 40280 RCA  | 4.62     | BFX85          | 2.50    | J310          | 1.00    |
| 2N5836        | 3.45    | 40281 RCA  | 10.00    | BFX86          | 2.50    | JO2000        | 10.00   |
| 2N5842        | 8.45    | 40282 RCA  | 20.00    | BFX89          | 1.00    | JO2001        | 25.00   |
| 2N5847        | 19.90   | 40290 RCA  | 2.80     | BFY11          | 2.50    | JO4045        | 24.00   |
| 2N5849        | 20.00   | 40292 RCA  | 13.05    | BFY18          | 2.50    | KD5522        | 25.00   |
| 2N5913        | 3.25    | 40294 RCA  | 2.50     | BFY19          | 2.50    | KJ5522        | 25.00   |
| 2N5916        | 36.00   | 40341 RCA  | 21.00    | BFY39          | 2.50    | M1106         | 13.75   |

**Toll Free Number**  
**800-528-0180**  
**(For orders only)**

"All parts may be new or surplus, and parts may be substituted with comparable parts if we are out of stock of an item."

For information call: (602) 242-3037

PRICES SUBJECT TO CHANGE WITHOUT NOTICE

**MHz electronics**

## RF TRANSISTORS (CONTINUED)

|             |         |                  |         |              |          |           |         |
|-------------|---------|------------------|---------|--------------|----------|-----------|---------|
| M1107       | \$16.75 | MRF458           | \$20.70 | NEO2160ER    | \$100.00 | SD1009    | \$15.00 |
| M1131       | 5.15    | MRF464           | 25.30   | NEO21350     | 5.30     | SD1009-2  | 15.00   |
| M1132       | 7.25    | MRF466           | 18.97   | NE13783      | 61.00    | SD1012    | 10.00   |
| M1134       | 13.40   | MRF472           | 1.50    | NE21889      | 43.00    | SD1012-3  | 10.00   |
| M9116       | 29.10   | MRF475           | 3.10    | NE57835      | 5.70     | SD1012-5  | 10.00   |
| M9579       | 6.00    | MRF476           | 3.16    | NE64360ER-A  | 100.00   | SD1013    | 10.00   |
| M9580       | 7.95    | MRF477           | 20.00   | NE64480 (B)  | 94.00    | SD1013-3  | 10.00   |
| M9587       | 7.00    | MRF479           | 8.05    | NE73436      | 2.50     | SD1013-7  | 10.00   |
| M9588       | 5.20    | MRF492           | 23.00   | NE77362ER    | 100.00   | SD1016    | 15.00   |
| M9622       | 5.95    | MRF502           | 1.04    | NE98260ER    | 100.00   | SD1016-5  | 15.00   |
| M9623       | 7.95    | MRF503           | 6.00    | PRT8637      | 25.00    | SD1018-4  | 13.00   |
| M9624       | 9.95    | MRF504           | 7.00    | PT3127A      | 5.00     | SD1018-6  | 13.00   |
| M9625       | 15.95   | MRF509           | 5.00    | PT3127B      | 5.00     | SD1018-7  | 13.00   |
| M9630       | 14.00   | MRF511           | 10.69   | PT3127C      | 20.00    | SD1018-15 | 13.00   |
| M9740       | 27.90   | MRF515           | 2.00    | PT3127D      | 20.00    | SD1020-5  | 10.00   |
| M9741       | 27.90   | MRF517           | 2.00    | PT3127E      | 20.00    | SD1028    | 15.00   |
| M9755       | 16.00   | MRF525           | 3.45    | PT3190       | 20.00    | SD1030    | 12.00   |
| M9780       | 5.50    | MRF559           | 1.76    | PT3194       | 20.00    | SD1030-2  | 12.00   |
| M9827       | 11.00   | MRF587           | 11.00   | PT3195       | 20.00    | SD1040    | 5.00    |
| M9848       | 35.00   | MRF605           | 20.00   | PT3537       | 7.80     | SD1040-2  | 20.00   |
| M9850       | 13.50   | MRF618           | 25.00   | PT4166E      | 20.00    | SD1040-4  | 10.00   |
| M9851       | 20.00   | MRF626           | 12.00   | PT4176D      | 25.00    | SD1040-6  | 5.00    |
| M9860       | 8.25    | MRF628           | 8.65    | PT4186B      | 5.00     | SD1043    | 12.00   |
| M9887       | 2.80    | MRF629           | 3.45    | PT4209       | 25.00    | SD1043-1  | 10.00   |
| M9908       | 6.95    | MRF641           | 25.30   | PT4209C/5645 | 25.00    | SD1045    | 3.75    |
| M9965       | 12.00   | MRF644           | 27.60   | PT4556       | 24.60    | SD1049-1  | 2.00    |
| MM1500      | 25.00   | MRF646           | 29.90   | PT4570       | 7.50     | SD1053    | 4.00    |
| MM1550      | 10.00   | MRF648           | 33.35   | PT4577       | 20.00    | SD1057    | 10.00   |
| MM1552      | 50.00   | MRF816           | 15.00   | PT4590       | 5.00     | SD1065    | 4.75    |
| MM1553      | 50.00   | MRF823           | 20.00   | PT4612       | 20.00    | SD1068    | 15.00   |
| MM1607      | 8.45    | MRF846           | 44.85   | PT4628       | 20.00    | SD1074-2  | 18.00   |
| MM1614      | 10.00   | MRF892           | 35.50   | PT4640       | 20.00    | SD1074-4  | 28.00   |
| MM1810      | 15.00   | MRF894           | 46.00   | PT4642       | 20.00    | SD1074-5  | 28.00   |
| MM1810      | 15.00   | MRF901 3 Lead    | 1.00    | PT5632       | 4.70     | SD1076    | 18.50   |
| MM1943      | 1.80    | MRF901 4 Lead    | 2.00    | PT5749       | 25.00    | SD1077    | 4.00    |
| MM2608      | 5.00    | MRF902/2N6603JAN | 15.00   | PT6612       | 25.00    | SD1077-4  | 4.00    |
| MM3375A     | 17.10   | MRF902B          | 18.40   | PT6619       | 20.00    | SD1077-6  | 4.00    |
| MM4429      | 10.00   | MRF904           | 2.30    | PT6708       | 25.00    | SD1078-6  | 24.00   |
| MM8000      | 1.15    | MRF905           | 2.55    | PT6709       | 25.00    | SD1080-7  | 7.50    |
| MM8006      | 2.30    | MRF911           | 2.50    | PT6720       | 25.00    | SD1080-8  | 6.00    |
| MM8011      | 25.00   | MRF965           | 2.55    | PT8510       | 15.00    | SD1080-9  | 3.00    |
| MPSU31      | 1.01    | MRF966           | 3.55    | PT8524       | 25.00    | SD1084    | 8.00    |
| MRA2023-1.5 | 42.50   | MRF1000MA        | 32.77   | PT8609       | 25.00    | SD1087    | 15.00   |
| MRF134      | 10.50   | MRF1004M         | 31.05   | PT8633       | 25.00    | SD1088    | 22.00   |
| MRF136      | 16.00   | MRF2001          | 41.74   | PT8639       | 25.00    | SD1088-8  | 22.00   |
| MRF171      | 35.00   | MRF2005          | 54.97   | PT8659       | 25.00    | SD1089-5  | 15.00   |
| MRF208      | 11.50   | MRF5176          | 24.00   | PT8679       | 25.00    | SD1090    | 15.00   |
| MRF212      | 16.10   | MRF8004          | 2.10    | PT8708       | 20.00    | SD1094    | 15.00   |
| MRF221      | 10.00   | MSC1720-12       | 225.00  | PT8709       | 20.00    | SD1095    | 15.00   |
| MRF223      | 13.00   | MSC1821-3        | 125.00  | PT8727       | 29.00    | SD1098-1  | 30.00   |
| MRF224      | 13.50   | MSC1821-10       | 225.00  | PT8731       | 25.00    | SD1100    | 5.00    |
| MRF227      | 3.45    | MSC2001          | 30.00   | PT8742       | 19.10    | SD1109    | 18.00   |
| MRF230      | 2.00    | MSC2010          | 93.00   | PT8787       | 25.00    | SD1115-2  | 7.50    |
| MRF231      | 10.00   | MSC2223-10       | 245.00  | PT8828       | 25.00    | SD1115-3  | 7.50    |
| MRF232      | 12.07   | MSC2302          | POR     | PT9700       | 25.00    | SD1115-7  | 2.10    |
| MRF237      | 3.15    | MSC3000          | 35.00   | PT9702       | 25.00    | SD1116    | 5.00    |
| MRF238      | 13.80   | MSC3001          | 38.00   | PT9783       | 16.50    | SD1118    | 22.00   |
| MRF239      | 17.25   | MSC72002         | POR     | PT9784       | 32.70    | SD1119    | 5.00    |
| MRF245      | 35.65   | MSC73001         | POR     | PT9790       | 56.00    | SD1124    | 50.00   |
| MRF247      | 31.00   | MSC80064         | 35.00   | PT31083      | 20.00    | SD1132-1  | 15.00   |
| MRF304      | 36.00   | MSC80091         | 10.00   | PT31962      | 20.00    | SD1132-4  | 12.00   |
| MRF306      | 50.00   | MSC80099         | 3.00    | PTX6680      | 20.00    | SD1133    | 9.50    |
| MRF313      | 11.15   | MSC80593         | POR     | RE3754       | 25.00    | SD1133-1  | 10.00   |
| MRF314      | 29.21   | MSC80758         | POR     | RE3789       | 25.00    | SD1134-1  | 2.50    |
| MRF315      | 28.86   | MSC82001         | 33.00   | RF35         | 16.00    | SD1134-4  | 12.00   |
| MRF316      | 55.43   | MSC82014         | 33.00   | RF85         | 17.50    | SD1134-17 | 12.00   |
| MRF317      | 63.94   | MSC82020M        | 130.00  | RF110        | 21.00    | SD1135    | 10.25   |
| MRF412      | 18.00   | MSC82030         | 33.00   | S50-12       | 23.80    | SD1135-3  | 12.00   |
| MRF420      | 20.12   | MSC83001         | 40.00   | S3006        | 15.00    | SD1136    | 12.50   |
| MRF421      | 25.00   | MSC83003         | 82.00   | S3007        | 10.00    | SD1136-2  | 12.50   |
| MRF422      | 38.00   | MSC83005         | 70.00   | S3031        | 22.00    | SD1143-1  | 10.00   |
| MRF427      | 17.25   | MSC83026         | POR     | SCA3522      | 5.00     | SD1143-3  | 17.00   |
| MRF428      | 63.00   | MSC83303         | POR     | SCA3523      | 5.00     | SD1144    | 4.00    |
| MRF433      | 12.07   | MSC84900         | 60.00   | SD345        | 5.00     | SD1145-5  | 15.00   |
| MRF449/A    | 12.65   | MT4150           | 14.40   | SD445        | 5.00     | SD1146    | 15.00   |
| MRF450/A    | 14.37   | MT5126           | 25.00   | SD1004       | 15.00    | SD1147    | 15.00   |
| MRF452/A    | 17.00   | MT5596(2N)       | 99.00   | SD1007       | 15.00    | SD1188    | 10.00   |
| MRF453/A    | 18.40   | MT5768(2N)       | 95.00   | SD1007-2     | 15.00    | SD1189    | 24.00   |
| MRF454/A    | 20.12   | MT8762           | 25.00   | SD1007-4     | 15.00    | SD1200    | 1.50    |
| MRF455/A    | 16.00   | NEO2136          | 2.00    | SD1007-5     | 15.00    | SD1201-2  | 15.00   |

**Toll Free Number**  
**800-528-0180**  
**(For orders only)**

"All parts may be new or surplus, and parts may be substituted with comparable parts if we are out of stock of an item."

For information call: (602) 242-3037

# MHz electronics

PRICES SUBJECT TO CHANGE WITHOUT NOTICE



## RF Transistors (continued)

|           |         |          |         |          |         |                |         |           |       |             |       |           |        |             |        |
|-----------|---------|----------|---------|----------|---------|----------------|---------|-----------|-------|-------------|-------|-----------|--------|-------------|--------|
| SD1202    | \$10.00 | SD1304-8 | \$ 2.50 | SD1451-2 | \$15.00 | SRF1427        | \$50.00 | SD1244H12 | 25.00 | SD1410-8    | 21.00 | SD1536-1  | 41.00  | SRF2917     | 15.00  |
| SD1212-8  | 4.95    | SD1305   | 3.00    | SD1452   | 20.00   | SRF1431        | 40.00   | SD1262    | 15.00 | SD1413-1    | 18.00 | SD1539B   | 100.00 | SRF2918     | 15.00  |
| SD1212-11 | 4.95    | SD1307   | 3.00    | SD1452-4 | 24.00   | SRF1834        | 40.00   | SD1263    | 15.00 | SD1416      | 28.00 | SD1542HI  | 170.00 | SRF2919     | 15.00  |
| SD1212-16 | 4.95    | SD1308   | 3.00    | SD1453HI | 20.00   | SRF2053-3      | 60.00   | SD1263-1  | 15.00 | SD1422-2    | 24.00 | SD1544    | 28.00  | SRF3071FF   | 50.00  |
| SD1214-7  | 5.00    | SD1311   | 1.00    | SD1454-1 | 48.00   | SRF2092        | 50.00   | SD1272    | 10.95 | SD1428      | 24.00 | SD1545    | 33.00  | SS4006      | 25.00  |
| SD1214-11 | 5.00    | SD1317   | 8.00    | SD1477   | 35.00   | SRF2147        | 22.00   | SD1272-1  | 10.95 | SD1428-6084 | 12.00 | SD1546H1  | 55.00  | SS4152      | 15.00  |
| SD1216    | 12.00   | SD1319   | 2.50    | SD1478   | 21.00   | SRF2225        | 15.00   | SD1272-2  | 10.95 | SD1429-2    | 15.00 | SD1561    | 79.00  | TA7686      | 15.00  |
| SD1219-4  | 15.00   | SD1345-6 | 5.00    | SD1480   | 53.00   | SRF2264        | 25.00   | SD1272-4  | 10.95 | SD1429-3    | 14.90 | SD1574-1  | 6.95   | TA8559      | 15.00  |
| SD1219-5  | 15.00   | SD1347-1 | 1.00    | SD1484   | 1.50    | SRF2265        | 100.00  | SD1278    | 13.75 | SD1429-5    | 15.00 | SD1575    | 6.95   | TA8561      | 15.00  |
| SD1219-8  | 15.00   | SD1365-1 | 2.50    | SD1484-5 | 1.50    | SRF2281        | 5.00    | SD1278-1  | 13.75 | SD1430      | 12.00 | 8F4557    | 25.00  | TA8562      | 15.00  |
| SD1220    | 8.00    | SD1365-3 | 2.50    | SD1484-6 | 1.50    | SRF2371        | 15.00   | SD1278-5  | 13.75 | SD1430-2    | 18.00 | SK3048    | 5.00   | TA8563      | 15.00  |
| SD1220-1  | 9.50    | SD1375   | 7.50    | SD1484-7 | 1.50    | SRF2347        | 50.00   | SD1279-1  | 18.00 | SD1434      | 28.00 | RL501-59  | 15.00  | TA8564      | 15.00  |
| SD1220-9  | 8.00    | SD1375-6 | 7.50    | SD1488   | 22.85   | SRF2356        | 38.00   | SD1279-3  | 18.00 | SD1434-5    | 28.00 | SL501-173 | 15.00  | TA8894      | 15.00  |
| SD1222-8  | 16.00   | SD1379   | 15.00   | SD1488-1 | 28.00   | SRF2378        | 16.00   | SD1281-2  | 8.00  | SD1434-9    | 28.00 | SH714     | 5.00   | TA8899      | 3.55   |
| SD1222-11 | 7.50    | SD1380-1 | 1.00    | SD1488-7 | 27.00   | SRF2572        | 25.00   | SD1283    | 10.00 | SD1438      | 26.00 | SRF112    | 15.00  | TP312       | 2.50   |
| SD1224-10 | 18.00   | SD1380-3 | 1.00    | SD1488-8 | 28.00   | SRF2584        | 40.00   | SD1283-2  | 10.60 | SD1441      | 56.00 | SRF395    | 50.00  | TP1014      | 5.00   |
| SD1225    | 18.00   | SD1380-7 | 1.00    | SD1499-1 | 36.00   | SRF2597        | 25.00   | SD1283-3  | 10.00 | SD1442      | 13.00 | SRF750    | 36.00  | TP1028      | 15.00  |
| SD1225-1  | 15.00   | SD1405   | 21.00   | SD1511H1 | 75.00   | SRF2741        | 40.00   | SD1283-4  | 10.00 | SD1444      | 3.25  | SRF769B   | 20.00  | TBW7        | 5.00   |
| SD1229-7  | 10.95   | SD1408   | 25.00   | SD1520-2 | 18.00   | SRF2747        | 40.00   | SD1289-1  | 15.00 | SD1444-8    | 3.25  | SRF887K3  | 2.50   | TKVF2201/HP | 450.00 |
| SD1229-16 | 10.95   | SD1409   | 18.00   | SD1522-4 | 33.00   | SRF2767H       | 40.00   | SD1290-4  | 15.00 | SD1444-9    | 3.25  | SKF989K   | 15.00  | V222-2      | 25.00  |
| SD1232    | 4.00    | SD1410   | 18.00   | SD1528-1 | 24.00   | SRF2821        | 25.00   | SD1290-7  | 15.00 | SD1446      | 4.03  | SRF1005   | 50.00  | V410IE      | 20.00  |
| SD1240-8  | 13.00   | SD1410-3 | 21.00   | SD1528-3 | 34.00   | SRF2822/2H6603 | 13.50   | SD1300    | 1.25  | SD1450-1    | 28.00 | SRF1018   | 5.00   | V415        | 5.00   |
| SD1244-1  | 14.00   | SD1410-6 | 21.00   | SD1530-2 | 38.00   | SRF2857        | 20.00   | SD1301-7  | 3.00  | SD1451      | 15.00 | SRF1074   | 50.00  |             |        |

## Relays

BNC To Banana Plug Coax Cable RG-58 36 inch or BNC to N Coax Cable RG-58 36 inch.

\$7.99 or 2 For \$13.99 or 10 For \$50.00

\$8.99 or 2 For \$15.99 or 10 For \$60.00

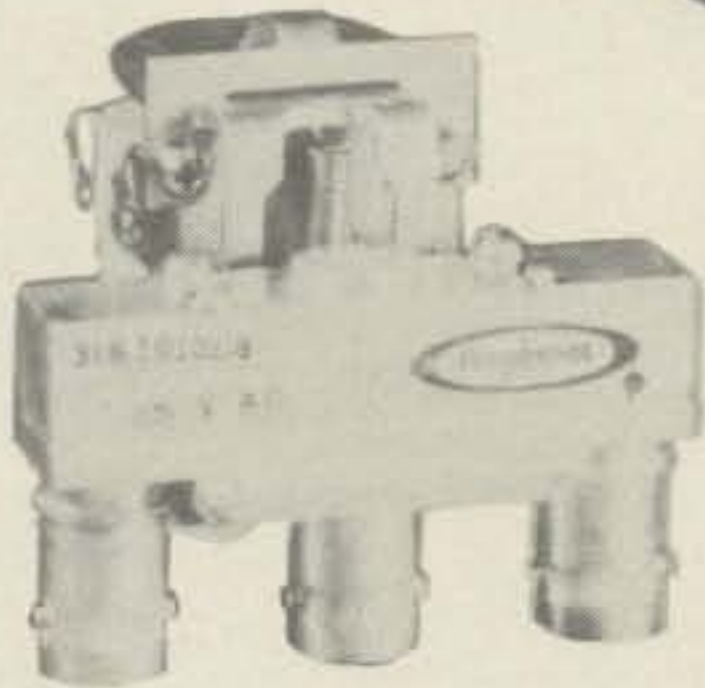
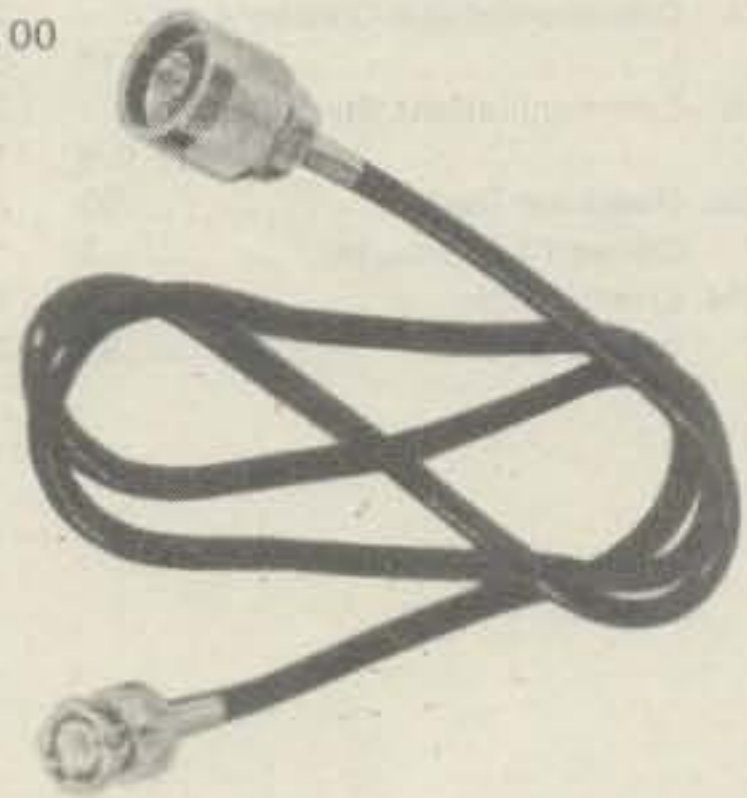

Amphenol  
Part # 316-10102-8  
115Vac Type BNC DC to 3 GHz.

\$29.99

### COAXIAL RELAY SWITCHES SPDT

FXR  
Part # 300-11182  
120Vac Type BNC DC to 4 GHz.  
FSN 5985-543-1225

\$39.99

FXR  
Part # 300-11173  
120Vac Type BNC Same  
FSN 5985-543-1850

\$39.99

TERMS: DOMESTIC: Prepaid, C.O.D. or Credit Card  
FOREIGN: Prepaid only, U.S. Funds, Money Order, or Cashier's Check Only.

C.O.D.' Acceptable by telephone or mail. Payment from customer will be by Cash, Money Order, or Cashier's Check. We are sorry but we cannot accept personal checks for C.O.D.'s. C.O.D.'s are shipped by air only and thru United Parcel Service.

CONFIRMING ORDERS: We would prefer that confirming orders not be sent after a telephone order has been placed. If company policy necessitates a confirming order, please mark "CONFIRMING" boldly on the order. If problems or duplicate shipments occur due to an order which is not properly marked, the customer will be held responsible for any charges incurred, plus a 15% restock charge on the returned parts.

CREDIT CARDS: We are now accepting MASTERCARD, VISA, AND AMERICAN EXPRESS

DATA SHEETS: When we have data sheets in stock on devices we will supply them with the order.

DEFECTIVE MATERIALS: All claims for defective materials must be made within 30 DAYS after receipt of the parcel. All claims must include the defective material (for testing purposes), a copy of our invoice, and a return authorization number which must be obtained prior to shipping the merchandise back to us. This can be obtained by calling (602) 242-8916 or sending us a postcard. Due to Manufacturer warranties, we are unable to replace or issue credit on items which have been soldered to or have been altered in any way. All return items must be packed properly or it will void all warranties. We do not assume responsibility for shipping and handling charges incurred.

DELIVERY: Orders are usually shipped the same day they are placed or the next business day, unless we are out of stock on an item. The customer will be notified by post card if we are going to backorder the item. Our normal shipping method is UPS or U.S. Mail depending on size or the weight of the package. Test Equipment is shipped only by air and is freight collect, unless prior arrangements have been made and approved.

FOREIGN ORDERS: All foreign orders must be prepaid with a Cashier's Check, or Money Order made out in U.S. FUNDS ONLY. We are sorry but C.O.D. is not available to foreign countries and letters of credit are unacceptable as a form of payment. Further information is available on request.

HOURS: Monday thru Friday 8:30 a.m. to 5:00 p.m. Saturdays 8:30 a.m. to 4:00 p.m.

INSURANCE: Please include 25¢ for each additional \$100.00 over \$100.00. UPS ONLY. All insured packages are shipped thru UPS only. If you wish to have it shipped through the post office there is a \$5.00 fee which is additional to the shipping, handling and insurance.

OPEN ACCOUNTS: We regret that we do not issue open accounts.

ORDER FORMS: New order forms are included with each order for your convenience. Additional order forms are available on request.

PARTS: We reserve the right to substitute or replace any item with a part of equal or comparable specification.

POSTAGE: Minimum shipping and handling in the U.S., Canada, and Mexico is \$3.00 for ground shipments, all other countries is \$5.50. Air rates are available at the time of your order. All foreign orders please include 25% of the ordered amount for shipping and handling. C.O.D.'s are shipped AIR ONLY.

PREPAID ORDERS: Orders must be accompanied by a check.

PRICES: Prices are subject to change without notice.

PURCHASE ORDERS: We accept purchase orders only when they are accompanied by a check.

RESTOCK CHARGES: If parts are returned to MHZ ELECTRONICS, INC. due to customer error, the customer will be held responsible for all fees incurred and will be charged a 15% RESTOCK CHARGE with the remainder in CREDIT ONLY. The following must accompany any return: A copy of our invoice, return authorization number which must be obtained prior to shipping the merchandise back. Returns must be done within 10 DAYS of receipt of parcel. Return authorization numbers can be obtained by calling (602) 242-8916 or notifying us by post card. Return authorizations will not be given out on our 800 number.

SALES TAX: ARIZONA residents must add 6% sales tax, unless a signed ARIZONA resale tax card is currently on file with us. All orders placed by persons outside of ARIZONA, but delivered to persons in ARIZONA are subject to the 6% sales tax.

SHORTAGE OR DAMAGE: All claims for shortages or damages must be made within 5 DAYS of receipt of parcel. Claims must include a copy of our invoice, along with a return authorization number which can be obtained by contacting us at (602) 242-8916 or sending a post card. Authorizations cannot be on our 800 number. All items must be properly packed. If items are not properly packed make sure to contact the carrier so that they can come out and inspect the package before it is returned to us. Customers which do not notify us within this time period will be held responsible for the entire order as we will consider the order complete.

OUR 800 NUMBER IS STRICTLY FOR ORDERS ONLY (800) 528-0180. INFORMATION CALLS ARE TAKEN ON (602) 242-8916 or (602) 242-3037.

**MHz** electronics  
2111 W. CAMELBACK ROAD  
PHOENIX, ARIZONA 85015

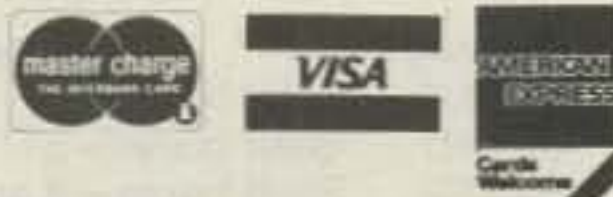

"All parts may be new or surplus, and parts may be substituted with comparable parts if we are out of stock of an item."

For information call: (602) 242-3037

Toll Free Number  
800-528-0180  
(For orders only)

PRICES SUBJECT TO CHANGE WITHOUT NOTICE

# ADVERTISERS

\*Please contact these advertisers directly.  
To receive full information from our advertisers please complete the postage-paid card.

| R. S. No.                              | Page | R. S. No.                     | Page    | R. S. No.                       | Page       | R. S. No.                       | Page     |
|--|------|-------------------------------|---------|---------------------------------|------------|---------------------------------|----------|
| * AEA/Advanced Electronic Applications | 45   | * Dayton Hamvention           | 73      | * Indiana Hamfest               | 81         | * Roensch Microwave             | 39       |
| 127 Advanced Computer Controls         | 21   | 328 Digital Instruments, Inc. | 64      | * J. L. Industries              | 45         | 500 73                          |          |
| * Amateur Electronic Supply            | 29   | 325 Engineering Consulting    | 81      | 273 Jan Crystals                | 2          | Back Issues                     | 81       |
| * Barker & Williamson                  | 12   | 326 Engineering Consulting    | 65      | 354 Jensen Tools, Inc.          | 55         | Dealer Ad                       | 83       |
| 305 Barry Electronics                  | 43   | 327 Engineering Consulting    | 55      | * Kantronics                    | 81, 83     | Mailing List                    | 71       |
| 298 Bilal Company                      | 64   | 22 Fair Radio Sales           | 55      | * Kashiwagi Electronics Corp.   | 55         | Moving                          | 69       |
| * Bill Ashby & Son                     | 17   | 99 Faxscan                    | 45      | * Kenwood                       | 5, Cov. IV | Subscriptions                   | 16       |
| 226 Buckmaster Publishing              | 39   | 23 Flesher Corp.              | 56      | 9 MFJ Enterprises               | 86, 87     | 65 S-F Amateur Radio Sales      | 83       |
| 462 CES, Inc.                          | 96   | 307 Flesher Corp.             | 17      | 48 MHz Electronics              | 75-79      | 319 SMB Publishing              | 17       |
| 111 CeCo Communications                | 28   | 308 Flesher Corp.             | 56      | 54 Magnum Distributors, Inc.    | 13         | 68 Spectrum Communications      | 14, 15   |
| 14 Communications Concepts, Inc.       | 17   | 304 Fox-Tango Corporation     | 83      | * Maggiore Electronic Labs      | 70         | 436 Spectrum International      | 49       |
| 15 Communications Specialists, Inc.    | 8, 9 | 269 GLB Electronics           | 28      | 49 Micro Control Specialties    | 6          | * The Ham Shack/The Ham Station | 33       |
| 280 Computer Trader                    | 55   | 352 Grove Enterprises         | 39      | 51 Microlog Corporation         | 25         | 205 The Metheny Corporation     | 55       |
| * Connect Systems, Inc.                | 3    | 31 Hal-Tronix                 | 12      | 254 National Comm. Group        | 41         | 104 Trionyx, Inc.               | 41       |
| 314 Crumtronic                         | 65   | * Ham Radio Outlet            | 1       | 412 Nema Electronics            | 39         | * Unity Electronics             | 17       |
| * dataLOG                              | 39   | 33 Hamtronics, NY             | 92, 93  | 137 Nuts & Volts                | 64         | * W9INN Antennas                | 56       |
|  |      | * Horizon Printing Co.        | 55      | * Orbit Magazine                | 41         | 80 Western Radio Electronics    | 55       |
|  |      | 123 Hustler, Inc.             | 2       | * P.C. Electronics              | 42, 54     | * Williams Radio Sales          | 55       |
|  |      | 274 ICOM                      | Cov. II | 61 Radio Amateur Callbook, Inc. | 17         | 83 Yaesu Electronics            | Cov. III |
|  |      |                               |         | 268 Ramsey Electronics          | 95         |                                 |          |

## BOOKS, etc.

### AMATEUR RADIO/ELECTRONICS TITLES

| Catalog # | Item                                | Price   |
|-----------|-------------------------------------|---------|
| BK7307    | Behind the Dial                     | \$ 4.95 |
| CT7305    | 5 WPM Code Tape                     | 4.95    |
| CT7306    | 6+ WPM Code Tape                    | 4.95    |
| CT7313    | 13+ WPM Code Tape                   | 4.95    |
| CT7320    | 20+ WPM Code Tape                   | 4.95    |
| CT7325    | 25+ WPM Code Tape                   | 4.95    |
| CT7394    | Code Tapes (any four above)         | 15.95   |
| BK7308    | Contest Cookbook                    | 5.95    |
| BK7321    | A Guide to Ham Radio                | 4.95    |
| BK7322    | Hobby Computers Are Here            | 2.49    |
| BK7393    | Living on a Shoestring              | 7.97    |
| BK7312    | The Magic of Ham Radio              | 4.95    |
| BK7340    | The New Hobby Computers             | 2.49    |
| BK7383    | The New Weather Satellite Handbook  | 8.95    |
| BK7310    | Owner Repair of Radio Equipment     | 7.95    |
| BK7302    | Propagation Wizard's Handbook       | 6.95    |
| BK7351    | SSB... The Misunderstood Mode       | 5.50    |
| BK7368    | VHF Antenna Handbook                | 5.95    |
| SG7357    | Study Guide-Novice Class            | 4.95    |
| SG7358    | Study Guide-General Class           | 6.95    |
| CT7300    | Novice Study Tapes (Set of 3)       | 15.95   |
| LB7360    | Test Equip. Lib. V2—Audio Tester    | 1.95    |
| LB7361    | Test Equip. Lib. V3—Radio Equip.    | 1.95    |
| LB7362    | Test Equip. Lib. V4—IC Test Equip.  | 1.95    |
| LB7365    | Test Equip. Lib. V0—Vols. 2, 3, & 4 | 4.95    |
| BK7315    | World Repeater Atlas                | 2.00    |

### MICROCOMPUTER TITLES

| Catalog # | Item                                 | Price |
|-----------|--------------------------------------|-------|
| BK7384    | Annotated BASIC Vol. 1               | 10.95 |
| BK7385    | Annotated BASIC Vol. 2               | 10.95 |
| BK7390    | Inside Your Computer                 | 12.97 |
| BK7398    | Introduction to TRS-80 Data Files    | 24.97 |
| BK7386    | Kilobaud Classroom                   | 14.95 |
| BK7404    | Mach. Lang. Subroutines for CoCo     | 29.97 |
| BK7400    | Prog. for Electronic Circuit Design  | 14.95 |
| CC740011  | BK7400 with Apple disk               | 24.97 |
| CC740012  | BK7400 with IBM PC disk              | 24.97 |
| CC740013  | BK7400 with TRS-80 disk              | 24.97 |
| BK7388    | The Selectric™ Interface             | 12.97 |
| BK7311    | Some of the Best from Kilobaud       | 10.95 |
| BK7394    | TRS-80 as a Controller               | 12.97 |
| BK7395    | TRS-80/Z80 Assembly Lang. Library    | 34.97 |
| BK7382    | Understanding & Prog. Microcomputers | 10.95 |

### SHELF BOXES

| Catalog # | Item                 | Price    |
|-----------|----------------------|----------|
| BX1000    | Shelf box—1          | 2.00     |
| BX1001    | Shelf boxes—2-7      | 1.50 ea. |
| BX1002    | Shelf boxes—8 and up | 1.25 ea. |

### To Order

**SHIPPING AND HANDLING:** \$1.50 for the first book, \$1.00 for each additional book for US delivery and foreign surface. \$10.00 per book for foreign airmail. Orders payable in US dollars only.

Complete the postage paid card, or itemize your order with payment or complete credit card information (include postage and handling) to: **WG Books, ATTN. Retail Sales, Rte. 101 and Elm St., Peterborough, NH 03458.**

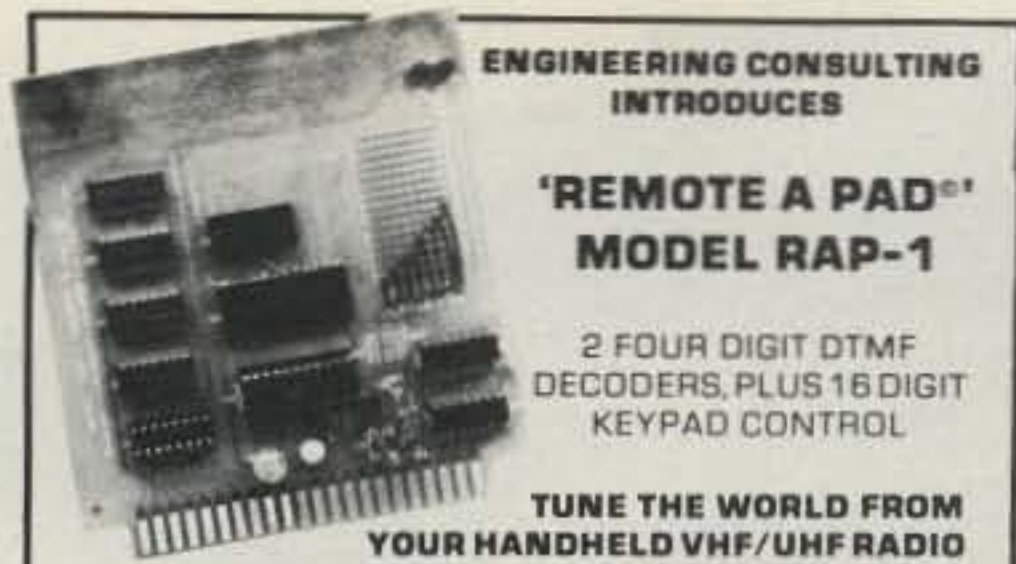

**ENGINEERING CONSULTING  
INTRODUCES**

**'REMOTE A PAD'  
MODEL RAP-1**

2 FOUR DIGIT DTMF  
DECODERS, PLUS 16 DIGIT  
KEYPAD CONTROL

**TUNE THE WORLD FROM  
YOUR HANDHELD VHF/UHF RADIO**

- Audio tones from any source, are converted to solid state switches which control any 16 digit keypad of a radio or other device.
- Some examples you can control include the Pro-Search<sup>®</sup> Rotator (rotate beam remotely), ICOM IC-701 or ICOM IC-211 when using the RM-2 controller, ICOM 7550 & 751, Azden PCS 4000, handhelds such as Yaesu FT-20B, FT-70B, ICOM IC-02AT, and many more.
- Anything you can do manually with your 16 digit keypad, the RAP-1 will do remotely using audio touch tones from any source.
- Two (four digit) programmable access codes are used to operate relays or other on/off functions.

Model RAP-1

**\$149.95**

**'Remote A Pad'**

Remote control  
interface board  
and DTMF  
decoder.

- LED decoder status indicators and momentary plus steady state decoder outputs are provided.
- 22 gold pin card edge connector, 16 pin dip socket and ribbon cable are supplied.
- All CMOS low power drain (30ma), SS1 201 Decoder.
- Hook eight wires (4 rows and 4 columns) in parallel with the existing keypad of the radio you wish to control remotely. Connect audio from any source, 12 volts D.C. and you are in control.
- The dual 4 digit decoders will turn your links on and off using your programmable access code.
- Detailed interface diagrams and instructions included with purchase. Interface cable for Pro-Search<sup>®</sup> \$9.95 (plugs in acc. socket)

**ICOM IC-02AT USER'S  
"AUDIO BLASTER" MODULE**

- Module installs inside the radio in 10 minutes.
- Boosts audio to nearly 1 watt!
- Low power drain (4ma stand by)
- Complete step by step instructions included.
- Corrects the LDW audio problem!
- Drive external speakers to full volume, even signals with low deviation!

Now Available  
for IC-2AT



Model AB-1 **\$19.95** ✓325

Price includes postage and handling, U.S.A. CA res. add 6%

Send check or money order to:

**ENGINEERING CONSULTING**  
583 CANDLEWOOD ST., BREA, CA 92621  
(714) 671-2009

# Kantronics Challenger Delivers Superior Performance at a Knockout price



Suggested Retail **\$99.95**

We believe you won't find a better performing terminal unit for under \$100 anywhere. The CHALLENGER Terminal Unit is designed for RTTY, ASCII, and AMTOR operation. Compare the features below and you'll agree, CHALLENGER's number one in the ring.

- Individual LED's display Mark and Space tones. Scope Outputs available.
- Requires only 5 mVRMS of audio.
- Four Pole Switch Capacitance Filters.
- Crystal Controlled AFSK Tones guarantee consistent RTTY/ASCII/AMTOR tones.
- Direct FSK Keying available.
- Transmits the standard 170 Hz shift. All RTTY shifts received. Receives CW.
- Guaranteed compatibility with six computers when used with Kantronics Software.
- TTL or RS232 level compatible.

For more information contact your  
Kantronics dealer or write:

**KANTRONICS** 1202 E. 23 St.  
LAWRENCE, KS 66046

**73** Amateur Radio's  
Technical Journal

Bargain Basement  
Signal Monitor  
Masada!  
Microcass  
Yearself  
Mobile Whys  
Inside Day  
Europe on  
\$0 a Day  
The Sage  
of Island

**BACK ISSUES**

1977 to June 1980 . . . \$3.00 ea

July 1980 to present . . \$3.50 ea

Add \$1.00 per magazine for shipping. 10 or more back issues add \$7.50 per order for shipping.

Write for your copy today!

**73: Amateur Radio's  
Technical Journal**  
Back Issue Order Dept.  
80 Pine Street  
Peterborough, NH 03458

## INDIANA HAMFEST

(FORMERLY MARTINSVILLE)

**SUNDAY MARCH 10, 1985**

Open at 8:00 A.M.

Located on the Indiana State Fairgrounds  
Indianapolis, IN

The crossroads of four interstate highways  
I-65, I-69, I-70, and I-74.

All Indoors - Heated - Free Parking - Paved Lots  
Forums - Commercial and Flea market dealers

Talk-in on the "Mighty 525" - 145.25 MHz

Come and Enjoy a show by our "Quality" Dealers

# NEW PRODUCTS

## CUSHMAN CE-6488 ANALYZER

Cushman Electronics, Inc., has introduced the 6000-series model CE-6488, making the Spectrum 6000-series radio system analyzer family compatible with the IEEE-488 interface-bus standard (also known as GBIB, HP-IB, and IEC Bus).

This system analyzer offers the versatility of on-board microprocessor-based local control of the instrument for bench or site use, while also providing the ability to add a controller (and peripherals) on an IEEE-488 bus system for fully-automatic computer-controlled test routines.

By defining a computer as the controller of a CE-6488 radio system analyzer in an IEEE-488 test system, stored programs can evaluate a radio's performance and report back to you on either a display or hard-copy printout. In addition to acting as a quality gate to pass or reject a radio on the basis of the test results, the stored test programs allow operators with fewer radio skills to be effective and productive.

For additional information, contact Cushman Electronics, 1525 Atteberry Lane, San Jose CA 95131; (408)-263-8100. Reader Service number 477.



Cushman's IEEE-488-compatible radio system analyzer.

## HEATH AUTOMATIC ANTENNA TUNER

Heath Company has expanded its amateur-radio line to include the new SA-2500 auto-tune antenna tuner. The tuner features a continuously-variable roller inductor that can be preset for 18 different frequencies.

The SA-2500 permits the user to preset high and low frequencies on each of the nine bands from 160 to 10 meters. In the auto mode, the tuner will set the roller inductor to the preselected value and automatically adjust the preset for a proper match. A remote capability allows selected frequencies to be automatically tuned to the proper SWR using only the transmitter's bandswitch, provided the transmitter is equipped for remote operation.

Manual tuning is made easy with three front-panel lever switches and dual wattmeters. The wattmeters read forward and reflected average power and SWR in two ranges. An auto-range circuit automatically switches the wattmeters to the appropriate range.

The SA-2500 effectively tunes and matches unbalanced feedlines and single-wire antennas at the full legal power limit. The SA-2500-1 4:1 balun accessory



The Heathkit SA-2500 automatic antenna tuner.

can be added for use with balanced ladder-line antennas. A front-panel coax switch allows the user to select three different antennas or to bypass the tuner.

Heath's auto-tune antenna tuner installs directly into the transmission line to measure power on all frequencies between 1.8 and 30 MHz—200/2000 Watts in the forward direction and 50/500 Watts reflected. SWR readings on the reflected meter are from 1:1 to 3:1.

Front-panel indicators show when the roller inductor, transmitter, and antenna capacitors are being adjusted, the number of active roller inductor turns, high and low meter range, and when the tuned SWR exceeds the selected ratio.

To receive more information on the SA-2500, write Heath Company, Dept. 150-395, Benton Harbor MI 49022. Reader Service number 478.

## ACE VHF MONITOR

Ace Communications, Inc., has introduced a new VHF FM monitor receiver, model AR-33. The AR-33 is a microprocessor-controlled VHF FM featherweight portable receiver. It covers 140 to 170 MHz in 5-kHz steps. Frequencies are selected by thumbwheel switches, with a slide switch for 5-kHz increments. Features include two field-programmable memory channels, high sensitivity, an OSM coaxial antenna connector, and battery operation. The receiver is 130 mm x 63 mm x 26 mm; it weighs just under 200 grams.

For further information, contact Ace Communications, Inc., 22511 Aspen Street, Lake Forest CA 92630; (714)-581-4900. Reader Service number 480.

## 20-AMP OUTLET STRIP

The new Volector® series 9 20-Amp conditioned power strip features heavy-duty transient-voltage surge suppression. It meets

IEEE Std. 587-1980 Category A and exceeds UL-1449 requirements.

It is rated for 2500 Watts continuous duty and is available with either four or six NEMA 5-20R receptacles. These receptacles will accept both 15- and 20-Amp plugs; therefore this power strip is ideal if your total current drain is slightly over 15 Amps. The strip features a six-foot-long heavy-duty line cord, a pilot light, an on/off switch, and a resettable circuit breaker.

For further information, contact Pilgrim Electric Company, 105 Newtown Road, Plainview NY 11803; (516)-420-8990. Reader Service number 479.

## UHF FREQUENCY COUNTER

Digital Instruments, Inc. (formerly Davis Electronics), has announced their new model 7216 frequency counter. The new counter has a range of 10 Hz to 1.3 GHz and a gate time of 0.1 and 1.0 seconds at 100 MHz as well as .16 and 1.6 seconds at 1.3 GHz. The new Digital Instruments counter has a display consisting of eight .04" LEDs with an automatic decimal point. The prescaler and built-in gate light all fit neatly into the small 5 1/2" x 6" x 2" all-metal blue case. Power requirements are 105-125 V, 50/60 Hz at 3 W, with a safe input of 120 V rms to 10 MHz and 2 V rms above 50 MHz.

Digital Instruments also produces an industrial-quality frequency counter with 1.3-GHz capability and additional features such as a proportional crystal oven, a time-base frequency of 10 MHz with an accuracy of plus or minus 5 ppm, short-term stability of plus or minus 1 ppm/hr after warm-up, and plus or minus 1 ppm at 10 to 50 degrees centigrade. The industrial-quality meter is cataloged as part number 7216A.

For additional information please contact Digital Instruments, Inc., 636 Sheridan Drive, Tonawanda NY 14150; (716)-874-5848. Reader Service number 476.



20-Amp conditioned power strip from Pilgrim Electric.



The new 1.3-GHz counter from Digital Instruments.

## TS430S FILTERS

You can select 3 optional \$60 Fox Tango filters for your TS430S: SSB Narrow (1.8 or 2.1KHz bandwidth), CW Narrow (250 or 400Hz), and AM (6.0KHz). To improve CW or AM reception, you must use one of the filters indicated. For SSB there is a choice: you can add one of the narrow filters, or you can use the improved Filter Cascading Kit.

We recommend the Cascading Kit because it is more effective. It benefits both SSB and CW reception without affecting the other modes or TX. When you just add a narrow SSB filter, the mode switch lets you select either the stock (2.4KHz) filter or the narrow one. Either way, the i-f signal passes through only one filter — the other is idle! In the Fox Tango Cascading Kit two filters are active: the signal first passes through the stock filter and, near the end of the i-f chain, through a second filter — the high quality 8-pole Fox-Tango 2.1 KHz unit and its amplifier board. Here are the results:

|                   | BEFORE<br>(with Stock SSB) | AFTER<br>(with Cascade Kit) |
|-------------------|----------------------------|-----------------------------|
| -30dB Bandwidth   | 3.2 KHz                    | 2.16KHz                     |
| IMD Dynamic Range | 83dB                       | 100dB (50KHz Spacing)       |
| Idle Noise (I-F)  | 0dB (Reference)            | -6dB (below reference)      |

The narrower bandwidth improves selectivity. The greater dynamic range reduces QRM. The reduced noise makes weak-signal reception easier. And, as a bonus, the Shift control works much better. Installation is inboard, instructions are complete, no drilling is required, and only a few soldered connections are needed. However, skill is necessary; your dealer can help if desired.

### INTRODUCTORY MONEY-SAVING SPECIALS

- FTK-430S CASCADING KIT (including filter, board, instructions, etc.) ..... \$ 85.
- FTK-430S with one additional filter (CW or AM - reg. \$60 ea.) ..... \$140
- FTK-430S with two additional filters (CW and AM) ..... \$185.



SPECIFY: Type desired and CW bandwidth if ordered.  
SHIPPING: \$3, Air \$5,  
COD add \$1, Overseas \$10.  
FL Residence add 5% Tax. ✓304

**FOX TANGO CORPORATION**  
Box 15944, W. Palm Beach, FL 33416  
Phone: (305) 683-9587

## ATTENTION

### Foreign Computer Stores/ Magazine Dealers

You have a large technical audience that speaks English and is in need of the kind of microcomputer information that CW/Peterborough provides.

Provide your audience with the magazine they need and make money at the same time. For details on selling 80 MICRO, inCider, HOT CoCo and RUN contact:

**SANDRA JOSEPH**  
**WORLD WIDE MEDIA**  
386 PARK AVE., SOUTH  
NEW YORK, NY 10016  
PHONE (212) 686-1520  
TELEX—620430

# Get The Brain That Fits The Body

The software program you choose does make a difference. Other companies claim "Kantronics compatible", but being compatible does not guarantee peak performance. Using Kantronics software with a Kantronics Interface means we guarantee the system will perform.

Our software is designed for use with any of the Kantronics Interfaces. Whether you choose our original Hamsoft, the popular Hamtext, or one of the Amtor programs, you know you'll be on the air. We guarantee it.

Kantronics currently offers programs for six different computers. No other manufacturer has compatibility or selection like ours. You can't expect top performance from a unit that's operating with the wrong brain. **Get the brain that fits the body. Kantronics Software for Kantronics Interfaces.**

## Kantronics Software

Hamsoft • Hamtext • Supertap  
Hamsoft/Amtor • Amtorsoft

**HAMSOFT** - Send/Receive CW, RTTY, ASCII, Split Screen Display, Message Ports, Type-ahead Buffer, Printer Compatibility.  
○ ■ □ ◆

**HAMTEXT** - Includes all features of Hamsoft plus Text Editing, Receive Message Storage, Variable Buffer Sizes, Diddle, Word Wraparound, Time and Text Transmission.  
○ ■ □ ◆

**HAMSOFT/AMTOR** - Includes all features of Hamsoft plus communi-

cation in all three modes of AMTOR.  
■ □ ◆

**AMTORSOFT** - Includes all the features of Hamtext but is for use with AMTOR ONLY. The APPLE Program is available only as a HAMTEXT/AMTORSOFT combination. ○ ◆ □

**SUPERTAP** - Receive Only CW, RTTY, ASCII, AMTOR, Decode inverted, bit inverted, and unusual bit order, Multiple Line Display, Scope Feature for baud rate measure. ◆ □

- Apple
- Atari
- ◆ TRS-80C
- TI/994A
- VIC-20
- ◆ Comm-64

For more information contact your Kantronics dealer, or write:  
**KANTRONICS** 1202 E. 23 St.  
**LAWRENCE, KS 66046**



## ... at last ... your shack organized!

A beautiful piece of furniture — your XYL will love it!

**\$184.50 S-F RADIO DESK**

**Deluxe - Ready to Assemble**

Designed with angled rear shelf for your viewing comfort and ease of operation.

FINISHES: Walnut or Teak Stain.

Floor Space: 39" Wide by 30" Deep

Additional Information on Request.

Checks, Money Orders, BankAmericard and Master Charge Accepted.

F.O.B. Culver City. (In Calif. Add 6% Sales Tax.)

DEALER INQUIRIES INVITED

**S-f Amateur Radio Services**

4384 KEYSTONE AVENUE • CULVER CITY, CALIF. 90230 — PHONE (213) 837-4870

**SF**

✓65



sored by *Amateur Television Magazine*. The object is to work as many different US states as possible on the video mode. All contacts must be in video form with a minimum of callsign and RSV signal reports sent and received. Count 10 points per SSTV QSO regardless of location, with 100 points awarded for each new state. Contacts with Alaska or Hawaii on SSTV count 500 points. The top scorer will receive a free 3-year subscription to *A5 ATV Magazine*, with 1-year subscriptions going to district leaders. All entrants will receive a special gold specialized-communications certificate suitable for framing. Logs must be sent to Contest Manager, *A5 ATV Magazine*, PO Box H, Lowden IA 52255. Indicate state and score on the front of the envelope. Logs and photos sent will be returned at the close of the contest-judging period. Results should be published in the March or April, 1985, issue of the magazine.

### INTERNATIONAL RTTY ART COMPETITION

The Wireless Institute of Australia is running an International RTTY Art Competition as part of its 75th anniversary celebrations. Entries must not contain more than three overlins and must be sub-

| New Jersey Scores |        |        | Somerset (multi-op) |        | KA2RLW + |  |
|-------------------|--------|--------|---------------------|--------|----------|--|
| Bergen            | KA2OIW | 3050   |                     | KA2OEE | 5181     |  |
|                   | W2CC   | 234    |                     | WA2WJY | 351      |  |
|                   | WA2ASQ | 6      | Sussex              | W2RQ   | 8234     |  |
| Burlington        | KX2W   | 32,912 | Out-of-State Scores |        |          |  |
|                   | W2XQ   | 3500   | Connecticut         | WA1NCN | 165      |  |
| Camden            | KA2QGO | 836    | Maine               | N1PL1  | 312      |  |
| Cape May          | K4FFM  | 650    | Eastern Penn-       |        |          |  |
| Cumberland        | N2BNP  | 315    | sylvania            | WA3JXW | 4        |  |
| Essex             | W2SUE  | 2150   | Maryland/D.C.       | KA3KBZ | 16       |  |
|                   | K2VX   | 253    | S. Florida          | WK4F   | 66       |  |
|                   | WA2ASQ | 110    | Kentucky            | WA4EBN | 299      |  |
| Mercer            | WB2PKG | 2678   | New Mexico          | N5EZA  | 4        |  |
|                   | WB2KEL | 171    | Arizona             | AK7J   | 16       |  |
| Passaic           | WA2ASQ | 1026   | Michigan            | KA8IIN | 84       |  |
| Salem             | NC2V   | 3885   | Ohio                | KA8MPT | 6        |  |
|                   | WB2KMR | 893    | West Virginia       | W8VEN  | 40       |  |
|                   |        |        | Kansas              | N0CLV  | 160      |  |

mitted with a hard-copy printout and Baudot tape.

Categories include: (a) best hand-generated original submitted by its author outside VK, (b) best hand-generated original

submitted by its author who is a VK, and (c) best non-original hand-generated or computer-generated RTTY picture.

The completion closes August 31, 1985, and entries must be sent to: WIA 75 RTTY

Art Competition, Wireless Institute of Australia, 412 Brunswick Street, Fitzroy 3065, Victoria, Australia.

### WEST VIRGINIA QSO PARTY

Starts: 1700 UTC January 26  
Ends: 1700 UTC January 27

Sponsored by the West Virginia State AR Council, this contest is open to single operators only.

#### EXCHANGE:

RS(T), serial number, and state, country, or WV county.

#### FREQUENCIES:

Phone—10 kHz up from lower General band edges. CW—35 kHz up from low end. Novice—35 kHz up from lower band edge.

#### SCORING:

Count 1 point per QSO. WV stations multiply by total WV counties, states, and countries worked. Others multiply by total WV counties worked. Multiply score by 1.5 if running 200 Watts or less.

#### ENTRIES:

Mail logs by February 11th along with a large SASE for results, addressed to: K8BS, PO Box 1694, Charleston WV 25326.

# FUN!

John Edwards K12U  
PO Box 73  
Middle Village NY 11379

### DIGITAL QUIZ

This is hard for me to say, but I have become a total, hopeless computer addict. Friends, I have a micro on my back.

It all started very innocently about four years ago. I was walking past my local Radio Shack Computer Center when I was struck by the sudden, uncontrollable urge to buy a TRS-80 Model III. Shaking slightly, with Mastercard in hand, I entered that den of wasted souls and purchased my first computer. The salesman, dressed in his natty three-piece suit, smiled; I whimpered. Oh, for those clean and wholesome days of amateur radio. Outdoors, with one foot on the peak of my roof and the other twisted in 600 feet of #12 copper wire.

At first, I thought I would only dabble with my new toy on weekends. But soon, those idle weekends grew into idle weeks, months, and years. Now, I'm a dissipated, slobbering mess. In addition to my original Model III I've expanded my addiction to include an IBM PC, Apple IIe, TRS-80 Model 100, Atari 400, and Commodore 64. Sigh. Groan.

Like all addicts, I had to find a way to feed my evil habit (computers aren't cheap), so I became a pusher. That's right, I turned to writing computer books and magazines, both to make money and to snare additional innocent victims. I've written for nearly all of the major computer magazines, most of which are mailed to subscribers in plain brown wrappers. Heaven help me, I even write a computer column in a magazine aimed at doctors. Now, as I find myself hitting silicon bottom, I turn my attention to my favorite fraternity—radio amateurs. The result is this month's column.

Please forgive me. I'm a sick man.

### ELEMENT 1 MULTIPLE CHOICE

- 1) A repeater that carries computer data is often called a:
  - 1) digipeater
  - 2) compeateer
  - 3) datapeater
  - 4) waste of time
- 2) The first popular microprocessor was:
  - 1) Motorola's MC6502
  - 2) Intel's 4004
  - 3) Zilog's Z-80A
  - 4) Kenwood's YE-1
- 3) Which one of the following computer languages was named after Lord Byron's daughter:
  - 1) Pascal
  - 2) Susan
  - 3) Ada
  - 4) Lady
- 4) The first computer, ENIAC, weighed:
  - 1) 30 pounds
  - 2) 300 pounds
  - 3) 3 tons
  - 4) 30 tons
- 5) Which one of the following companies never manufactured computers:
  - 1) General Electric
  - 2) RCA
  - 3) Toyota
  - 4) Singer

### ELEMENT 2 TRUE-FALSE

- |  | True  | False |
|--|-------|-------|
| 1) Control Data Corp. is based in New York City.               | _____ | _____ |
| 2) A popular telephone modem speed is 300 bytes per second.    | _____ | _____ |
| 3) Superconductor devices usually operate at room temperature. | _____ | _____ |
| 4) LED displays require reflected light to view.               | _____ | _____ |
| 5) An RS-232C interface is a parallel port.                    | _____ | _____ |

- 6) AMTOR is a computer language. \_\_\_\_\_
- 7) Each dot on a computer display is called a "pixie." \_\_\_\_\_
- 8) Most people also call a RAM device a "computer on a chip." \_\_\_\_\_
- 9) To start Apple Computer, Wozniak and Jobs sold an old VW beetle. \_\_\_\_\_
- 10) Model 32 Teletypes were once commonly used as computer terminals. \_\_\_\_\_

### ELEMENT 3 FILL IN THE BLANK

- 1) Before vacuum tubes and semiconductors, computers used \_\_\_\_\_ as logic switches.
- 2) \_\_\_\_\_ Univac
- 3) The transistor: Shockley, Brattain, and \_\_\_\_\_
- 4) \_\_\_\_\_ is a program that can imitate a psychiatric interviewer.
- 5) The IBM PC primary microprocessor is an \_\_\_\_\_.

### ELEMENT 4 MATCHING

Match the computer pioneer on the left with his achievement on the right.

- |                          |                                       |
|--------------------------|---------------------------------------|
| 1) Alan Turing           | A) Data processing punch cards        |
| 2) Adam Osborne          | B) Founded IBM                        |
| 3) Thomas J. Watson, Sr. | C) Analytical engine                  |
| 4) Herman Hollerith      | D) First successful portable computer |
| 5) Samuel Morse          | E) Silicon chip                       |
| 6) Charles Babbage       | F) Automatic computing engine         |
| 7) Howard Aiken          | G) Binary electrical code             |
| 8) Gary Kildall          | H) CP/M                               |
|                          | I) Mark 1                             |

### THE ANSWERS

- Element 1:  
1—1 And they're becoming very popular.

- 2—2 Designed by Marcian "Ted" Hoff in 1969.
- 3—2 After Ada Lovelace.
- 4—4 It also had a power dissipation of 150,000 Watts.
- 5—3 Not yet anyway.

#### Element 2:

- 1—False Minneapolis MN.
- 2—False That's 300 bits per second.
- 3—False Most operate at temperatures near absolute zero.
- 4—False You're confusing LEDs with LCDs.
- 5—False A serial port.
- 6—False It's a RTTY format.
- 7—False Pixel.
- 8—False Only if they're not too smart. A random-access-memory unit contains no processing abilities.
- 9—False It was a VW bus.
- 10—False As five-level units, Model 32s were basically used for telecommunications purposes (including amateur RTTY).

#### Element 3:

- 1—Relays
- 2—Sperry
- 3—Bardeen
- 4—Eliza
- 5—Intel 8088

#### Element 4:

- 1—F, 2—D, 3—B, 4—A, 5—G, 6—C, 7—I, 8—H.

### SCORING

- Element 1:  
Five points for each correct answer.
- Element 2:  
Two and one-half points for each correct answer.
- Element 3:  
Five points for each correct answer.
- Element 4:  
Four points for each correct match.
- How did you do?  
1-20 points—You're clean  
21-40 points—A dabbler  
41-60 points—On the road  
61-80 points—Computer junkie  
81-100+ points—In the gutter

# NEW FROM MFJ

**MFJ'S MOST ADVANCED RTTY/ASCII/AMTOR/CW COMPUTER INTERFACE HAS FM, AM MODES, LED "SCOPE" TUNING ARRAY, RS-232 INTERFACE, VARIABLE SHIFT TUNING, 170/850 Hz TRANSMIT, TRUE MARK-SPACE DETECTION.**



**MFJ-1229**  
**\$179.95**

**FREE MFJ RTTY/ASCII/CW software for C-64/VIC-20.**  
Complete package includes MFJ-1229, software on tape, cables for C-64/VIC-20.

Engineering, performance, value and features sets MFJ's most advanced RTTY/ASCII/AMTOR/CW computer interface apart from others.

**FM (limiting) mode** gives easy, trouble-free operation. Best for general use, off-shift copy, drifting signals, and moderate signal and QRM levels.

**AM (non-limiting) mode** gives superior performance under weak signal conditions or when there are strong nearby stations.

**Crosshair mark-space LED tuning array** simulates scope ellipse for easy, accurate tuning even under poor signal-to-noise conditions. Mark and space outputs for true scope tuning.

Transmits on both 170 Hz and 850 Hz shift.

Built-in RS-232 interface, no extra cost.

**Variable shift tuning** lets you copy any shift between 100 and 1000 Hz and any speed (5-100 WPM RTTY/CW and up to 300 baud ASCII). Push button for 170 Hz shift.

**Sharp multi-pole mark and space filters** give true mark-space detection. Ganged pots give space passband tuning with constant bandwidth. Factory adjusted trim pots for optimum filter performance.

**Multi-pole active filters** are used for pre-limiter, mark, space and post detection filtering. Has automatic threshold correction. This advanced design gives good copy under QRM, weak signals and selective fading.

Has front panel sensitivity control.

**Normal/Reverse switch** eliminates retuning while checking for inverted RTTY. Speaker jack. +250 VDC loop output.

**Exar 2206 sine wave generator** gives phase continuous AFSK tones. Standard 2125 Hz mark and 2295/2975 Hz space. Microphone lines: AFSK out, AFSK ground, PTT out and PTT ground.

**FSK keying for transceivers** with FSK input. Has sharp 800 Hz CW filter, plus and minus CW keying and external CW key jack.

**Kantronics software compatible socket.**

**Exclusive TTL/RS-232 general purpose socket** allows interfacing to nearly any personal computer with most appropriate software. Available TTL/RS-232 lines: RTTY demod out, CW demod out (TTL only), CW-ID in, RTTY in, PTT in, key in. All signal lines are buffered and can be inverted using an internal DIP switch.

**Metal cabinet.** Brushed aluminum front. 12 1/2 x 2 1/2 x 6 inches. 18 VDC or 110 VAC with optional AC adapter, MFJ-1312, \$9.95.

**Plugs between rig and C-64, VIC-20, Apple, TRS-80C, Atari, TI-99 and other personal computers.** Use MFJ, Kantronics, AEA and other RTTY/ASCII/AMTOR/CW software.

## 7-IN-1 RTTY OPERATING AID

**MFJ-1221**  
**\$79.95**



Indispensable. Improves any RTTY station.

**1. Crosshair LED "scope" Tuning Array.** Makes tuning quick and easy with dead-on accuracy. Tune for maximum vertical and horizontal display.

**2. Scope Adapter.** Mark/Space outputs for scope.

**3. Shift Indicator.** LEDs indicate 170, 425, 850 Hz shift. Especially useful for RTTY outside ham bands.

**4. Sharp Mark and Space Filters.** Greatly improves copy under crowded, fading and weak signal conditions. For 170, 425, 850 Hz shifts.

**5. Normal-Reverse Switch.** Check for inverted RTTY without changing sidebands and retuning.

**6. Output Level Control.** Adjust signal level into TU.

**7. Limiter.** Evens out signal variation for easier, smoother copy.

Plugs between receiver and TU. Mark is 2125 Hz and Space is 2295, 2550, or 2975 Hz. 10x2x6 inches. Uses floating 18 VDC or 110 VAC with AC adapter, MFJ-1312, \$9.95.

## 24/12 HOUR CLOCK/ID TIMER

Switch to 24 hour UTC or 12 hour format! Battery backup. ID timer alerts every 9 minutes after reset. Red .6 in. LEDs. Synchronizable to WWV. Alarm, Snooze function. Minute, hour set switches. PM, alarm on indicators. Gray/Black cabinet. 5x2x3 in. 110 VAC, 60 Hz.

**MFJ-106 \$19.95**



## MFJ ELECTRONIC KEYS

**MFJ-407**  
**\$69.95**



**MFJ-407 Deluxe Electronic Keyer** sends iambic, automatic, semi-auto or manual. Use squeeze, single lever or straight key. Plus/minus keying. 8 to 50 WPM. Speed, weight, tone, volume controls. On/Off, Tune, Semi-auto switches. Speaker. RF proof. 7x2x6 inches. Uses 9 V battery, 6-9 VDC or 110 VAC with AC adapter, MFJ-1305, \$9.95.

## MFJ PORTABLE ANTENNA

**MFJ's Portable Antenna** lets you operate 40, 30, 20, 15, 10 meters from apartments, motels, camp sites, vacation spots, nearly any electrically clear location where space for a full size antenna is a problem.

**A telescoping whip** (extends to 54 in.) is mounted on self-standing 6x3x6 inch aluminum case. Built-in antenna tuner, field strength meter, 50 feet RG-58 coax. Complete multi-band-portable antenna system that you can use nearly anywhere. Up to 300 watts PEP.

**MFJ-1621**  
**\$79.95**



## MFJ ANTENNA BRIDGE

**MFJ-204**  
**\$79.95**

**MFJ Antenna Bridge.** Trim your antenna for optimum performance quickly and easily. Read antenna resistance up to 500 ohms. Covers all ham bands below 30 MHz. Measure resonant frequency of antenna. Tells to lengthen or shorten antenna. Easy to use, connect antenna, set frequency, adjust bridge for meter null and read antenna resistance. Has frequency counter jack. Use as signal generator. Portable, self contained. 4x2x2 in. 9 V battery or 110 VAC with adapter, MFJ-1312, \$9.95.



## MICROPHONE EQUALIZER

**MFJ-550**  
**\$49.95**



**Greatly improves transmitted SSB speech** for maximum talk power. Evens out speech peaks and valleys due to voice, microphone and room characteristics that makes speech hard to understand. Produces cleaner, more intelligible speech on receiving end. Greatly improves mobile operation by reducing bassy peaks due to acoustic resonances. Plugs between mic and rig. 4 pin mic jack, shielded output cable. High, mid, low controls provide  $\pm 12$  db boost or cut at 490, 1170, 2800 Hz. Mic gain, on/off/bypass switch. "On" LED. 7x2x6 inches. 9 V battery, 12 VDC or 110 VAC with adapter, MFJ-1312, \$9.95.

**ORDER ANY PRODUCT FROM MFJ AND TRY IT-NO OBLIGATION. IF NOT DELIGHTED, RETURN WITHIN 30 DAYS FOR PROMPT REFUND (LESS SHIPPING).**

• One year unconditional guarantee • Made in USA.  
• Add \$4.00 each shipping/handling • Call or write for free catalog, over 100 products.

# MFJ

**MFJ ENTERPRISES, INC.**  
Box 494, Mississippi State, MS 39762

**TO ORDER OR FOR YOUR NEAREST DEALER, CALL TOLL-FREE**

**800-647-1800.** Call 601-323-5869 in Miss. and outside continental USA  
Telex 53-4590 MFJ STKV





# MFJ ACCESSORIES

**300 WATT ANTENNA TUNER HAS SWR/WATTMETER, ANTENNA SWITCH, BALUN. MATCHES VIRTUALLY EVERYTHING FROM 1.8 TO 30 MHz.**



**\$99.95** MFJ-941D

**NEW FEATURES**

MFJ's fastest selling tuner packs in plenty of new features!

- **New Styling!** Brushed aluminum front. All metal cabinet.
- **New SWR/Wattmeter!** More accurate. Switch selectable 300/30 watt ranges. Read forward/reflected power.
- **New Antenna Switch!** Front panel mounted. Select 2 coax lines, direct or through tuner, random wire/balanced line or tuner bypass for dummy load.
- **New airwound inductor!** Larger more efficient 12 position airwound inductor gives lower losses and more watts out. Run up to 300 watts RF power output. Matches everything from 1.8 to 30 MHz: dipoles, inverted vee, random wires, verticals, mobile whips, beams, balanced and coax lines. Built-in 4:1 balun for balanced lines. 1000V capacitor spacing. Black. 11x3x7 inches. Works with all solid state or tube rigs. Easy to use, anywhere.

## RTTY/ASCII/CW COMPUTER INTERFACE

MFJ-1224  
**\$99.95**



Free MFJ RTTY/ASCII/CW software on tape and cable for VIC-20 or C-64. Send and receive computerized RTTY/ASCII/CW with nearly any personal computer (VIC-20, Apple, TRS-80C, Atari, TI-99, Commodore 64, etc.). Use Kantronics or most other RTTY/CW software. Copies both mark and space, any shift (including 170, 425, 850 Hz) and any speed (5-100 WPM RTTY/CW, 300 baud ASCII). Sharp 8 pole active filter for CW and 170 Hz shift. Sends 170, 850 Hz shift. Normal/reverse switch eliminates retuning. Automatic noise limiter. Kantronics compatible socket plus exclusive general purpose socket. 8x1 1/4x6 in. 12-15 VDC or 110 VAC with adapter, MFJ-1312, \$9.95.

## RX NOISE BRIDGE

Maximize your antenna performance!



**\$59.95** MFJ-202B

Tells whether to shorten or lengthen antenna for minimum SWR. Measure resonant frequency, radiation resistance and reactance.

**New Features:** individually calibrated resistance scale, expanded capacitance range ( $\pm 150$  pf). Built-in range extender for measurements beyond scale readings. 1-100 MHz. Comprehensive manual. Use 9 V battery. 2x4x4 in.

## INDOOR TUNED ACTIVE ANTENNA

**NEW! IMPROVED!** "World Grabber" rivals or exceeds reception of outside long wires!

Unique tuned Active Antenna minimizes intermode, improves selectivity, reduces noise outside tuned band, even functions as preselector with external antennas. Covers 0.3-30 MHz. Tele scoping antenna. Tune, Band, Gain, On-off bypass controls. 6x2x6 in. Uses 9V battery, 9-18 VDC or 110 VAC with adapter, MFJ-1312, \$9.95.



**MFJ-1020A \$79.95**

## POLICE/FIRE/WEATHER 2 M HANDHELD CONVERTER

Turn your synthesized scanning 2 meter handheld into a hot Police/Fire/Weather band scanner!

**\$39.95** MFJ-313

144-148 MHz handhelds receive Police/Fire on 154-158 MHz with direct frequency readout. Hear NOAA maritime coastal plus more on 160-164 MHz. Converter mounts between handheld and rubber ducky. Feedthru allows simultaneous scanning of both 2 meters and Police/Fire bands. No missed calls. Crystal controlled. Bypass/Off switch allows transmitting (up to 5 watts). Use AAA battery. 2 1/4x1 1/2x1 1/2 in. BNC connectors.



## MFJ/BENCHER KEYS COMBO

MFJ-422  
**\$109.95**

The best of all CW worlds-

a deluxe MFJ Keyer in a compact configuration that fits right on the Bencher iambic paddle! MFJ Keyer - small in size, big in features. Curtis 8044-B IC, adjustable weight and tone, front panel volume and speed controls (8-50 WPM). Built-in dot-dash memories. Speaker, sidetone, and push button selection of semi-automatic/tune or automatic modes. Solid state keying. Bencher paddle is fully adjustable; heavy steel base with non-skid feet. Uses 9 V battery or 110 VAC with optional adapter, MFJ-1305, \$9.95.



## VHF SWR/WATTMETER

Low cost

VHF SWR/Wattmeter! Read SWR (14 to 170 MHz) and forward/reflected power

**MFJ-812 \$29.95**



at 2 meters. Has 30 and 300 watts scales. Also read relative field strength. 4x2x3 in.

## 1 KW DUMMY LOAD

MFJ-250 **\$39.95**

Tune up fast, extend life of finals, reduce QRM! Rated 1KW CW or 2KW PEP for 10 minutes. Half rating for 20 minutes, continuous at 200 W CW, 400 W PEP. VSWR under 1.2 to 30 MHz, 1.5 to 300 MHz. Oil contains no PCB. 50 ohm non-inductive resistor. Safety vent. Carrying handle. 7 1/2x6 3/4 in.



## 24/12 HOUR CLOCK/ID TIMER

MFJ-106  
**\$19.95** NEW

Switch to 24 hour UTC or 12 hour format! Battery backup

maintains time during power outage. ID timer alerts every 9 minutes after reset. Red LED .6 inch digits. Synchronizable with WWV. Alarm with snooze function. Minute set, hour set switches. Time set switch prevents mis-setting. Power out, alarm on indicators. Gray and black cabinet. 5x2x3 inches. 110 VAC, 60 Hz.



## DUAL TUNABLE SSB/CW/RTTY FILTER

MFJ-752B **\$99.95**



Dual filters give unmatched performance!

The primary filter lets you peak, notch, low pass or high pass with extra steep skirts. Auxiliary filter gives 70 db notch, 40 Hz peak. Both filters tune from 300 to 3000 Hz with variable bandwidth from 40 Hz to nearly flat. Constant output as bandwidth is varied; linear frequency control. Switchable noise limiter for impulse noise. Simulated stereo sound for CW lets ears and mind reject QRM. Inputs for 2 rigs. Plugs into phone jack. Two watts for speaker. Off bypasses filter. 9-18 VDC or 110 VAC with optional adapter, MFJ-1312, \$9.95.

ORDER ANY PRODUCT FROM MFJ AND TRY IT-NO OBLIGATION. IF NOT DELIGHTED, RETURN WITHIN 30 DAYS FOR PROMPT REFUND (LESS SHIPPING).

- One year unconditional guarantee • Made in USA.
- Add \$4.00 each shipping/handling • Call or write for free catalog, over 100 products.

# MFJ

MFJ ENTERPRISES, INC.  
Box 494, Mississippi State, MS 39762

TO ORDER OR FOR YOUR NEAREST DEALER, CALL TOLL-FREE

**800-647-1800.** Call 601-323-5869 in Miss. and outside continental USA. Telex 53-4590 MFJ STKV



Each month, 73 brings you ham-radio news from around the world. In this collection of reports from our foreign correspondents, we present the latest news in DX, contests, and events, as well as keep you abreast of the technical achievements of hams in other countries.

If you would like to contribute to your country's column, write to your country's correspondent or to 73: Amateur Radio's Technical Journal, Pine Street, Peterborough NH 03458, USA, Attn: Perry Donham KW10.



## AUSTRALIA

J. E. Joyce VK3YJ  
44 Wren Street  
Altona 3018  
Victoria  
Australia

### OUR 75TH ANNIVERSARY

1985 will be a very interesting year for both VK and overseas amateurs as some of the special events planned to celebrate the WIA's 75th year as a national amateur-radio body look to be great fun for all those concerned. Every division or state in Australia is trying to do something significant towards celebrating this most special event. For example, the VK3 division has a RTTY art contest planned, among other things, with prizes for original RTTY pictures and further prizes for reproductions of classic paintings. This contest is open to all WIA members.

There has been a great upsurge in RTTY in VK3 of late, due mainly to what appears to be an unlimited supply of used Siemens 100 teleprinter machines, most of which are complete right down to the supply of paper. These machines are being sold at a very low cost—the average price being around A\$50.00. As most of these machines have been checked and serviced by a volunteer group of local amateurs called "The RTTY Fixers Group," it represents an easy way for local amateurs to get involved in this aspect of amateur radio.

### THE RTTY FIXERS GROUP

This is a band of dedicated RTTY operators led by Fred McConnell VK3BOU. They have spent countless hours servic-

| Band | Segment     | Calling Frequency |
|------|-------------|-------------------|
| 160m | 1825-1835   | 1825              |
| 80m  | 3620-3640   | 3630              |
| 40m  | 7040-7060   | 7050              |
| 30m  | 10140-10150 | 10140             |
| 20m  | 14070-14110 | 14090             |
| 17m  | 18100-18110 | 18100             |
| 15m  | 21075-21125 | 21090             |
| 13m  | 24920-24930 | 24920             |
| 10m  | 28050-28150 | 28090             |
| 6m   | 52080-52100 | 52080             |

Fig. 1.

ing these machines and adjusting them to 45.45 baud. This group also conducts RTTY workshops at the VK3 WIA club rooms to help the newcomer learn the finer points of maintenance on these fine teleprinters.

Several of these machines have been sent to other divisions, so we can expect an upsurge of RTTY from all VK in the very near future.

### Places to Look

Queensland (VK4) has a RTTY broadcast on 7.035 MHz at 1000 UTC from the Southeast teletype group, with their weekly news bulletin each Monday night.

The frequency segments and calling frequencies in Fig. 1 are recommended for use on the various amateur bands Australia-wide.

In 1983, Bill VK8ZWM, with other RTTY enthusiasts, formed a group called "The Territory Amateur Radio Teleprinter Society." They transmit a weekly broadcast on 3.555 at 0915 UTC each Sunday. This broadcast is transmitted by Mr. H. Anderson VK8HA, the Darwin Radio Club's president.

### VK9Z—WILLIS ISLAND

Willis Island is active again with Andy VK9ZA, who is on his third trip there, taking over from Graham VK9ZW at the end of June. Andy is operational on most bands, including six meters. As usual, all QSLs for Willis Island operations go to Jill VK6YL, either direct or via the bureau.

### QSL PROBLEMS IN VK2

Headlining the uncollected QSL problem (this time in VK2), in line with an earlier Divisional Council decision, the QSL manager of VK2 placed the following in the Public Notices section of the *Sydney Morning Herald* on Saturday, June 16, 1984!

W.I.A. (N.S.W. Division) Q.S.L. Bureau, as from the 31st July, 1984, and regularly thereafter, all cards held at the bureau, whether for members or non-members, and unclaimed for two years, will be destroyed without further notice being given.

Signed: D. Pearson (Manager)  
Box 73  
Teralba 2284, N.S.W.



## BRAZIL

Gerson Rissin PY1APS  
PO Box 12178 Copacabana  
20000 Rio de Janeiro, RJ  
Brazil

### THE FIRST CWRL AWARD

The state of Rio de Janeiro is known around the world for the beautiful beaches it has along its coast. Among them, Copacabana, Ipanema, and Leblon, located in the city of Rio de Janeiro, are the main ones. Many cities in the state of Rio de Janeiro have their own beaches, and especially in the region called Big Lakes, we can find paradisiacal spots such as the beaches of Marica, Saquarema, Cabo Frio, and Araruama. The amateurs of that region, headed by

a group located in Araruama, established a CW group called Grupo de CW da Região dos Lagos, which means CW group of the Lakes Region. The group sponsors the CWRL Award, which never has been requested by any foreign station. The award is very beautiful—and the secretary, Aylton T. Campos PY1AZG, is anxious to issue the first certificate for an amateur outside Brazil. The CWRL Award is available to all licensed amateurs for confirmed contacts with: (A) 29 Brazilian stations whose first suffix letters form the phrase "Araruama—onde o sol passa o inverno" (which means: Araruama—where the sun spends the winter), and (B) three CWRL members (any prefix or suffix).

Contacts must have been made after January 1, 1983, on any amateur band. Only two-way CW contacts are allowed. Send GCR log of stations worked (call, date, time, band, and report) and 10 IRCs for mailing expenses to: CWRL Bureau, PO Box 91, 28970 Araruama, RJ, Brazil. There are no special endorsements for the CWRL Award.

SWL: Same rules.

CWRL members are PY1s AFA, APS, ASI, AZG, BVY, CC, COA, DPG, DEA, DFF, DGB, DJY, DMX, DQV, DWH, DWM, EBK, ECL, ER, EWN, GO, MIZ, PA, PL, QN, QP, RD, RW, TBW, TG, TQ, TQZ, TZ, UZ, VEH, VMV, WXU, and YT.

Most of them are very active and 100% QSL. A few members changed their call-sign suffixes of 3 letters to two letters. So, if you have any QSL of a station not mentioned above but clearly written on the QSL card, "CWRL Member," it will be good for credit.



## CYPRUS

Aris Kaponides 5B4JE  
PO Box 1723  
Limassol  
Cyprus

Summertime in Cyprus, as in every country, is holiday time. So most amateurs go on holiday either abroad or in their own country. For this reason, amateur activity was restricted and not many 5B4s were on the HF bands. However, many 5B4s were hamming, on the move enjoying their recently-approved mobile licenses or from their holiday QTHs. The fine temperate climate of Cyprus during the summer gives a chance for all from the amateur fraternity to get together outdoors on picnics and other outings.

The Nicosia group had two social occasions, a dance and dinner in Nicosia and a barbecue under the Cyprus pines on Troodos mountain, where every ham showed his ability and capacity in eating and drinking. Hi!

The Limassol group also organized an excellent get-together in the wonderful surroundings of Pissouri Beach, where the blue sea, the beautiful women, the idyllic scenery, the tasty food, and especially the friendliness of all the hams and members of their families made this a 100% success. Besides the Limassol group, on this occasion were also members of the Paphos group such as Sotos 5B4JX with his XYL, Maria 5B4JZ and daughter YL, Flora 5B4PO, and other friends and guests of the group.

The Limassol group also organized a second social event by having dinner and then going midnight swimming in Limassol Bay, which was also very successful.

Radio activity by Cyprus amateurs is hoped to increase during the autumn and wintertime. Quite a few HF beams have been bought, with 3 or 4 elements, and lots of young people got their licenses recently, so (I am sure) the 5B4 callsign is going to be heard regularly on the bands. Some 5B4 stations, such as those of 5B4IT, 5B4MD, 5B4MC, and 5B4NG are equipped with RTTY facilities, and very soon 5B4CV will be active with SSTV with his home-brew equipment.

Generally, during the summertime, the activity was mostly on VHF and 20m, with the occasional DXing of 5B4JE on 40m and 80m. During the winter I hope to operate more on 40m, 80m, and 160m, so readers may look for me around 7.045 MHz, 7.083 MHz, 3.795 MHz, and 1.835 MHz, or 1.850 MHz usually between 2100 and 2200 UTC.



## CZECHOSLOVAKIA

Rudolf Karaba (OK3KFO ARC)  
Komenskeho 1477/B  
955 01 Topolcany  
Czechoslovakia

CRC, PO Box 68, 113 27 Praha 1, Czechoslovakia, is giving these awards for non-European countries:

**100-OK**—This diploma is awarded for contacts with various OK/OL stations. The contacts are valid if since January 1, 1954. Endorsements are given for 200, 300, 400, 500, and 1000 stations. 5 IRCs and the application should be sent to CRC.

**OK-SSB**—This can be gained for contacts with OK stations if the number of 25 points is reached, irrespective of the date. For contacts in the bands of 28, 21, and 14 MHz there is one point. For contacts in the bands of 7, 3.5, and 1.8 MHz there are two points. 5 IRCs and the application should be sent to CRC.

**Be careful!** The following general conditions are valid for all the diplomas awarded in Czechoslovakia: In case the contacts are made in the *OK-DX Contest* (annually the second Sunday in November), it is not necessary to present QSL cards. Send only the application together with a log from the contest to CRC.

### RTTY

In Brno (the capital of Moravia), two further radio clubs, OK2KBR and OK2KFR, have been put into operation on RTTY. They use teletypewriters RFT T-51 and our T-100; converters have been operating together with active filters. OK2BFS had tested the Intel 85 microprocessor system and found out that a high-frequency field from the transmitter, 250 Watts, does not matter. It cannot be said, however, about ZX-81, where 30 Watts was obstructive.

### AMSAT-OSCAR 10

The number of DXCC countries which have appeared when operating AO-10/B has increased to 102 (for the last time thanks to the DXpedition to San Marino—T77A, T77C, T77U).

Excessive trespassing of recommended ERP has been continuing further on. For these reasons, for example, here in Czechoslovakia RSGB bulletins broadcast by GB2RS on AO-10/B with a prescribed ERP cannot be understood. Therefore, "crocodiles" usually roar with the intensity of S8!

At present, 4 stations have been working actively in the region of East Slovakia: Ondrej OK3AU from Kosice, Stano OK3ZFA from Poprad, Viktor OK3LW from

Michalovce, and Fero OK3FH from Presov. OK3AU heard, by means of AO-10/B, another station from New Zealand. It was ZL1TFI. Unfortunately he did not establish any contacts this time either.



## GREAT BRITAIN

Jeff Maynard G4EJA  
10 Churchfields  
Widnes WA8 9RP  
Cheshire  
England

### THE UK SCENE

The major news on the UK amateur scene at the time of writing is the issue by the Department of Trade and Industry (the UK regulatory body) of the new amateur license schedule. The schedule takes the form of an annex to the main license and defines the detailed technical constraints within which the licensee's station must be operated.

I have written before of the love of bureaucracy in the UK establishment, particularly those parts involved in the issue, control, and regulation of licenses related to radio broadcasting in any shape or form. Those of you who thought that a revised 1984 license schedule might be couched in plain English can return to your drawing boards. Lovers of legalistic jargon can rest easy!

I won't bore you with extensive quotations from the complete schedule (reproducing it fully would take up all my column space), but you may be interested to know of some of the restrictions placed on UK amateurs.

Perhaps the main change (certainly in terms of the number of words) is the adoption of the revised symbols for classes of emission as defined by the International Telecommunications Union (ITU) in Geneva in 1982. Now we have to write J3E in the log when using single-sideband transmissions, or F3C for some types of facsimile transmission. The schedule adds to the confusion by listing the permitted types of transmission by frequency band in simple terms (such as Morse, telephony, RTTY, and so on).

This same chart lists the "status of allocation" for each band; in other words, it defines the basis under which each particular band is available for use by amateurs. These range from simple definitions such as "Primary" and "Secondary" to "Secondary, Users must accept interference from the ISM allocation in this band," and

"Secondary, This band is not available for use within the area bounded by 53N OZE, 55N OZE, 53N 03W, and 55N 03W."

UK amateurs need to be good at geography as well as everything else!

Antenna buffs may also like to know that the schedule explains that erp (effective radiated power) is used below 1 GHz and eirp (effective isotropically radiated power) above 1 GHz. It adds (helpfully?) that eirp is 2.1 dB greater than erp.

I don't know whether or not it's coincidence, but within days of publication of the new schedule, the DTI agreed to supply the RSGB with statistics relating to successful prosecutions under the new Telecommunications Act.

NASA astronaut Tony England W0ORE visited RSGB HQ recently and outlined his plans to repeat W5LFL's earlier shuttle mission. I do hope he has thought of a new way to institute and conduct QSOs. I wrote previously of the debacle on 2m when a million lids tried simultaneously to cause chaos (and largely succeeded, I might add).

The RSGB has just published an up-to-date list of QSL bureau sub-managers, which prompts me to reflect on the effort put in by this dedicated bunch. The RSGB QSL bureau is free to all RSGB members. Outgoing cards are sent to a single point for distribution to overseas bureaux. Incoming cards, though, are handled by no less than 58 sub-managers, each of whom deals with a particular range of calls. For example, my incoming cards, as for all cards in the range G4EAA to G4EZZ, are handled by G8OPA. The volume of mail such work must generate, to say nothing of the need for storage and sorting space, requires a certain dedication not found easily. I can well imagine some of the bureau sub-managers spending more time sorting QSL calls than conducting QSOs.



## ITALY

Mario Ambrosi I2MQP  
Via Stradella, 13  
21029 Milano  
Italy

### ITALIAN AWARDS

The rules of the Marco Polo Award already have been published in 73 and here is the follow-up of the results of North American stations. The US leader is WB3CQN with 151 points, followed by WA3HUP with 148 points and WB4UBD, 131 points, W7ULC, 129 points, and N3KR, 87 points.

Also, the rules of the Italian Islands Award have been in 73. It is not an easy certificate, but a couple US stations have managed to get it. They are N3BGY and W1RFW for the moment, but we are waiting for more applications considering that this summer there has been much activity from the islands and many contacts have been made with Ws.

### ISLANDS FOR VACATION

Italy is surrounded by the sea and, particularly in the south, there are large and small islands. It has become a habit here to take the holidays during July or August and to go south. Many of the people working in the big industrial towns originate from the south and they just go back to see the relatives and the birthplace. The others go simply for the beauty of the coasts and of the sea, for the nice food, and for the sun (Sicily is on the same line as Algeria or Tunisia). So when the big factories close for 3 or 4 weeks (all of them together, unluckily), millions of cars take the speedways to the south.

I remember a friend in Los Angeles showing me a traffic jam and saying it was an American invention. I am sorry to say that here it has become an art. You can spend hours traveling at just 10 mph while the speed limit is 90.

The distance from Milano to Sicily is 1000 miles, more or less, and you have to cross the sea and then make another short trip inland and then take another boat if you want to get to one of the beautiful islands surrounding Sicily. But when you arrive you can really rest, enjoy the wine and the fish, sail, look for girls, and perhaps spend some time with the radio.

This is becoming more and more popular since the start of the Italian Island Award, and this summer it was possible to work more than 10 different islands in the different seas.

One of the operations has been from the Tremiti group with the callsign I2DMK/IL7. He has activated all 5 islands of the group, as each one is valid for the award. The largest of them is San Domino—where a population of 70 becomes 1000 during summer.

Another good prefix was IA5DFS, during July, the same period as the mini-ex-

pedition of I2PFY/ID9 and ID7UDB.

In August, it was possible to catch IM0LYN, I3ON/ID9, IT9ZRQ/IG9, IT9HLO/IF9, I2KAJ/IG9, IP1GJK, and IM0WON.

The photo shows the Linosa camp in the IG9 group, activated during August.

It has become a popular sport to do some ham radio from an island, and it will be the same again next year; if you want any details please write me, and if you plan to come to Italy next summer, I can put you in contact with some of the local people. You will surely enjoy the warm southern people.

### THE FIRST YL STATION FROM 3V8

From July 27 to August 8 there was an operation from Tunisia with the callsigns 3V8ZY and 3V8AI. Operators were Dieter IN3RZY and Angela, his wife, IN3XAI. They have operated from the shack of 3V8PS, the only station in Tunisia, of which Dieter is the QSL manager.

Angela is the first YL who has been active from Tunisia and therefore has been much requested on the air. They had 6600 QSOs with 140 countries worked and very poor propagation. You can QSL to their home address. The operation has already received the OK from the ARRL desk.

3V8PS has been in Tunisia a couple of years and is very active on all bands, mainly SSB. He works with an ICOM 720 and a 2-element beam, so his signal is not too strong, but he has managed to get 230 countries and is always looking for a new one. It's very easy to find him at 14213 kHz talking to his manager. The photo shows Angela in the garden of the house.

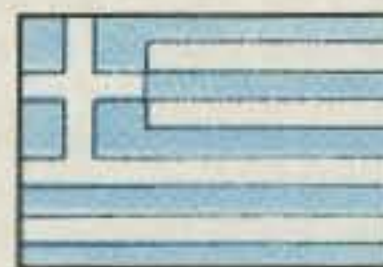

## GREECE

Manos Darkadakis SV1IW  
Box 23051  
Athens 11210  
Greece

By the time you read this, the Radio Am-



The DXpedition camp on Linosa Island.



Angela IN3XAI in Tunisia.

ateur Association of Greece will be at a new address. So people who would like to contact RAAG officials will now have to use the address: RAAG, 23-24, Platia Eleftherias, 105 53 Athens, Greece. The offices will be on the third floor, but at the time of writing I don't know the new phone numbers. I will pass them along in my next column. Keep in mind that you can always use the address: RAAG, PO Box 3564, 102 10 Athens, Greece, as this one is not changing.

When on the band you hear a J4 prefix, don't panic and start looking at your DXCC Countries List for the new one. It is Greece, alright, and this prefix is given on special occasions such as contests, celebrations, etc. By the way, in the last WPX contests, some of my SV fellows participated, and from the first results according to CQ magazine, it looks like Greece is going to have (for the first time in our amateur history) a winner as the top European scorer. The station is J41JG (or SV1JG, if you like). You may remember Cliff from my presentation in this column a few months ago. He scored 1,667,576 points, and as the evaluation of the contest logs still goes on at CQ headquarters, we don't know the final results, but I have a strong feeling that they will bring to J41JG the reward. Cliff was 10th in the single-operator, all-band category last year, and if he is not going to be the continental leader for this year, I'm sure he will have some similar position. Anyway, I still have my fingers crossed!

I have written this column for about a year now and you have probably noticed that I never mentioned anything about awards. Well, up to now (since a few years ago) Greece is not issuing any awards at all. There have been some in the past, but for a very complicated reason which is difficult to explain in these lines, they have stopped for maybe 6 years now. Anyway, as this all belongs to the past, there is a big effort for some new awards which will start again this RAAG's dead and buried activity.



**JAPAN**

Roy Waite W9PQN  
Tomigaya Grand-301, 2-19-5 Tomigaya  
Shibuya-Ku  
Tokyo 151  
Japan

#### EARTHQUAKE

Until now, most offers by amateur-radio operators to assist in disasters in this country have been spurned or met with scoffs or outright ridicule. After all, "amateurs" are not "professionals" and are not really qualified, and they might even get in the way and impede the professionals in aiding the public during disasters—so the argument went. But is ham radio in this country finally coming of age?

In the early morning of September 14, 1984, a death-dealing earthquake registering six on the scale struck an area north of Tokyo (specifically, the village of Ohtaki in Nagano Prefecture). The thing to note here is that on September 18th, the Asahi newspaper, with a national circulation of over 9,000,000 (!), reported on the situation with a headline that announced, "...POOR EMERGENCY COMMUNICATIONS... HAM RADIO TOOK OVER!" That kind of publicity can't be bought at any price.

In recent years, ham radio, long thought by the general public to be the exclusive

domain of schoolboys, has been gradually gaining attention and respect, much of that due to the JARL's singular efforts. Especially effective have been the articles regarding satellite communications, which seem to capture the imagination of laymen everywhere. But in Japan there is not a great amateur emergency network like RACES, that we have in the United States. Part of this is due, of course, to apathy on the part of the amateur-radio community, but mostly it is due to ignorance on the part of society as to just exactly what part amateur radio could play. And those who are apathetic can't be blamed either. As one Japanese ham told me, "No need to waste your effort trying to convince the local officials. We've tried, but they won't listen." But this may change now, although gradually, no doubt, as most changes in this country take half an eternity.

Anyway, let's get back to the Asahi story. The newspaper report explains that the residents of the village of Ohtaki, where the residences are scattered at the foot of Ontake Mountain, were actually all "tied together" with the village office by wire—in other words, a sort of public address system where the city officials make public announcements from time to time to the 427 families living there. There was also an ordinary telephone circuit. But when the quake hit, it hit with such force and magnitude that most of the poles holding the wires were either toppled or tilted, ripping out the wires for the entire system, including power lines.

Nearby, 140 employees of the Forestry Bureau who work in the mountains and forests in various scattered locations all escaped to safety. They were the main and most effective rescue group, as many of them are ham-radio operators. They, of course, played a major role in guiding citizens to safety and summoning help.

During the past few years, Ohtaki village had been considering the installation of an emergency radio communications system, but had not yet accumulated enough funds in the village budget.

Soon after the quake hit, some of the wired communications were restored, but three days later some homes were still without communications of any kind. There are some 40 wireless stations throughout the village including mobile stations in the fire engines. Base stations are located in the village office and in a public hall in the Takigoshi area in the far west. But Takigoshi couldn't use its transmitter because they are not equipped with a generator—and the power lines were down there, too. Therefore, 120 people in that area were completely isolated from the outside world.

There was one active radio emergency circuit between an adjacent city office in the prefecture and Ohtaki, but it was tied up continuously, talking to various departments and prefectural offices, and couldn't really give much information on damage areas and where help was needed. Here is where ham radio came to the rescue.

The forestry employees, located in several different areas, communicated with each other by ham radio on UHF as soon as it became apparent that a devastating earthquake was in progress. Some at first tried to get to the disaster areas in their vehicles, which are equipped with ham rigs, and made contact with other hams in Ohtaki, the hardest hit area. It soon became apparent that vehicles would be of little or no use as the quake had damaged many of the roads to the extent that they were no longer passable. As one observer put it, "The roads were all cut up." So they proceeded on foot to the hardest hit areas, reporting on the situation through

their hand-helds as they walked.

This mobility enabled the various forestry groups to summon help and advise of areas where there were high-velocity landslides in progress, sudden swelling of streams and rivers, other areas to avoid, safe evacuation areas, areas that were not passable, and determining the areas where help was not needed and to recruit help from those areas and direct those people to places where immediate help was needed. The ham rigs of these forestry people became the main emergency network. Some hams in the village refrained from transmitting, but carefully noted the information they heard and passed it on to the village officials and others in charge of disaster rescue operations. One important link was a forestry station location at midpoint that acted as relay between points where signals were weak.

Because of the efforts of these men and their ham rigs, many people were able to escape to safety and many others were pulled from rubble and mud, resulting in saved lives. In spite of these commendable efforts, two weeks after the quake hit the toll was 8 dead and 21 missing, which gives us an idea how strong and destructive an earthquake it was.

Departing from the Asahi newspaper report, my own comments are that I would hope that this story might encourage ham groups to once again resume their efforts to form emergency groups. Each Field Day (in Japan it's the first weekend in August) is well attended by various eager groups around the country. I wonder how many people realize that the real intended purpose of Field Day is to practice emergency communications?

It is a sad commentary on us human beings that it often takes violent events such as death and destruction to open our eyes and hearts. It would even be sadder if, in spite of that, we did nothing.



**NEW ZEALAND**

D. J. (Des) Chapman ZL2VR  
459 Kennedy Road  
Napier  
New Zealand

A very busy month at this QTH! What with weekend conferences for a first aid organization that I am concerned with, a reunion of old retired Post Office Mail Section employees in Auckland, where I worked in the Mail Section for 30 years, and being installed as first principal of my chapter, I haven't had much time to research a special topic for the column. However, I have borrowed a few paragraphs from our local amateur magazine, *Break-In*, that I thought might prove of interest to 73 readers.

#### BITS 'N' PIECES

AMSAT-UK was host recently to an amateur satellite planning meeting at Cheltenham, England. Representatives from European and worldwide satellite groups were present, including G3YJO, W3GEY, DJ4ZC, KA9Q, KE3D, HA5WH, W4PUJ, NK6K, VE1SAT/VE6, G8DQX, DK1YQ, ZS6BNT, and ZL1AOX. The group discussed many topics and technologies pertaining to satellites, as well as information dissemination and fund raising. The formation of an "Amateur Satellite Service Council" was proposed to expedite the topics discussed with representation from all bona fide amateur satellite groups worldwide. Further details of this

Council will be provided when the draft proposal is refined.

From the meeting in England, Ian ZL1AOX, VE1SAT/VE6, KA9Q, and DK1YQ went on to Marburg, Germany (headquarters of AMSAT-DL) for an intensive Controller Command training session with Karl Mainzer DJ4ZC. As a result of the training, Ian and the others are now authorized to undertake the full range of attitude and control commands associated with the long-term control of OSCAR 10. A major advantage of the increased number of command stations is that the general beacon information can now be updated weekly, bringing more information more quickly to eagerly-awaiting users.

*Special Victorian Callsign*—From early November, the call VK3WI will be heard on all bands in SSB, CW, and RTTY. This call will be operated by the Wireless Institute of Australia (Victorian Division) to commemorate the 150th anniversary of the State of Victoria. The call will be used for a period of approximately six months. QSL to VK3WI, 412 Brunswick Street, Fitzroy, 3065, Australia, or via the Bureau.

*Changes in Vanuatu*—The Vanuatu P and T Department is to tighten up on licensing procedures in the Republic and, in addition, carry out stiffer policing of radio operations within the Territory. The YJ0 prefix will be allocated to nonresident and short-term bona fide amateurs who can produce documentary evidence from one of the major countries that have amateur status. Long-term residents, including expatriates on long-term employment, will continue to be allocated two-letter calls with the YJ8 prefix. The YJ0 calls will consist of three suffix letters in the series YJ0AAA to YJ0AAZ. Any marine mobile (.../MM) calls will be valid for use only within Vanuatu waters.

*From ZK-Land*—Victor ZK1CG has been operating on RTTY with gear kindly donated by Gin JA1ACB, but unfortunately is off RTTY for a while until he acquires a green or amber screen monitor, then he will be back on the air on RTTY again.

Victor and his XYL, Marsha, are Mine Hosts of Tiare Village Holiday Chalets near the airport of Rarotonga and Avarua town. Included in the amenities offered by Tiare Village is the hire of ham radio to any licensed operator. Write to Victor Rivera at Box 489, Rarotonga, if you desire information to obtain a ZK1 license for use on a Rarotongan holiday. Take your own 2-meter gear to work via OSCAR.

*The March of Time*—It is 60 years since the first contact between Ivan O'Meara 2AC and C. Braggio CB8 in Argentina on May 22, 1924, and Frank Bell ZL4AA's two-way contact with American 6BCB on September 21, 1924, and also his two-way contact with Cecil Goyder 2GZ on October 18, 1924!

*VHF Activity*—6-meter activity in this area has finally slowed down to the expected level for a "minima" sunspot year. Only sporadic-E, tropo, and meteor-scatter propagation noted, with only VK, ZL, and FK8 being worked consistently. The VK2RSY beacon was copied in New Plymouth on several occasions during the late-May to mid-July period with good signal strengths ranging from 5 x 4 through to 5 x 9 + 10 dB, giving a good indication of sporadic-E propagation between ZL and VK on those occasions. ZL DX on 2 meters was minimal during this period, but a surprising amount of tropospheric duction-type of propagation still took place, and could be monitored by watching the 2m beacons and FM repeaters.

*Exams*—The first of the new-style amateur examinations mentioned in a recent column has come and gone; from local comment in this area, the candidates seem happy with the format, and to this

date no adverse comments have been heard. Time will tell, though, especially when the results come out, as that's when most of the postmortems take place.

OTC Silent Keys reported this month are Henry Bunn ZL1JY, ex ZL1HO and ZL2SU, on July 23, 1984, aged 78, W. (Bill) Crook ZL4LT at Milton, Otago, another long-serving amateur, and Anthony Blake ZL1RQ, on July 18, 1984, aged 71 years. All these old-timers had had many years of active service in the ranks of amateur radio in New Zealand.

I trust that all readers enjoyed a very happy Christmas and that the coming New Year will be prosperous, happy, and bountiful for all. As I have said before, we are in the midst of our summer here in this hemisphere, enjoying long sunny days and pleasant evenings—I trust you all in the north are having a reasonable holiday period, too.

Happy New Year to all from us here "down under" in ZL-land.

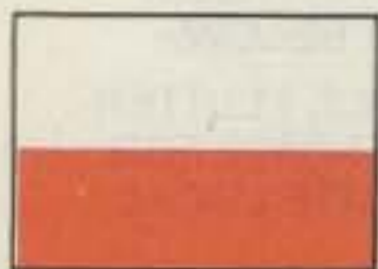

### POLAND

Jerzy Szymczak  
78-200 Białogard  
Buczka 2/3  
Poland

Debaters attending electoral meetings taking place in clubs and District Boards of PRAA rightfully appreciated the work of many hams—activists under hard conditions of martial law. The majority of members of District Boards were reelected delegates to the National Congress of PRAA that took place at the end of 1984. Actual members of Presidium and Headquarters of PRAA took part in electoral meetings to make notes of demands for the State Radio Surveillance, the Ministry of Communications, and PRAA itself. Participants of the assemblies brought forward first drafts of improvements of an inadequate organization, an acceleration of the technical information turnover. They discussed a possibility of giving Polish hams access to the new amateur bands, 10, 18, and 24 MHz, and demanded facilities for working on another QTH without special permission. They wanted to take for granted a QRZ in motion at least on UHF.

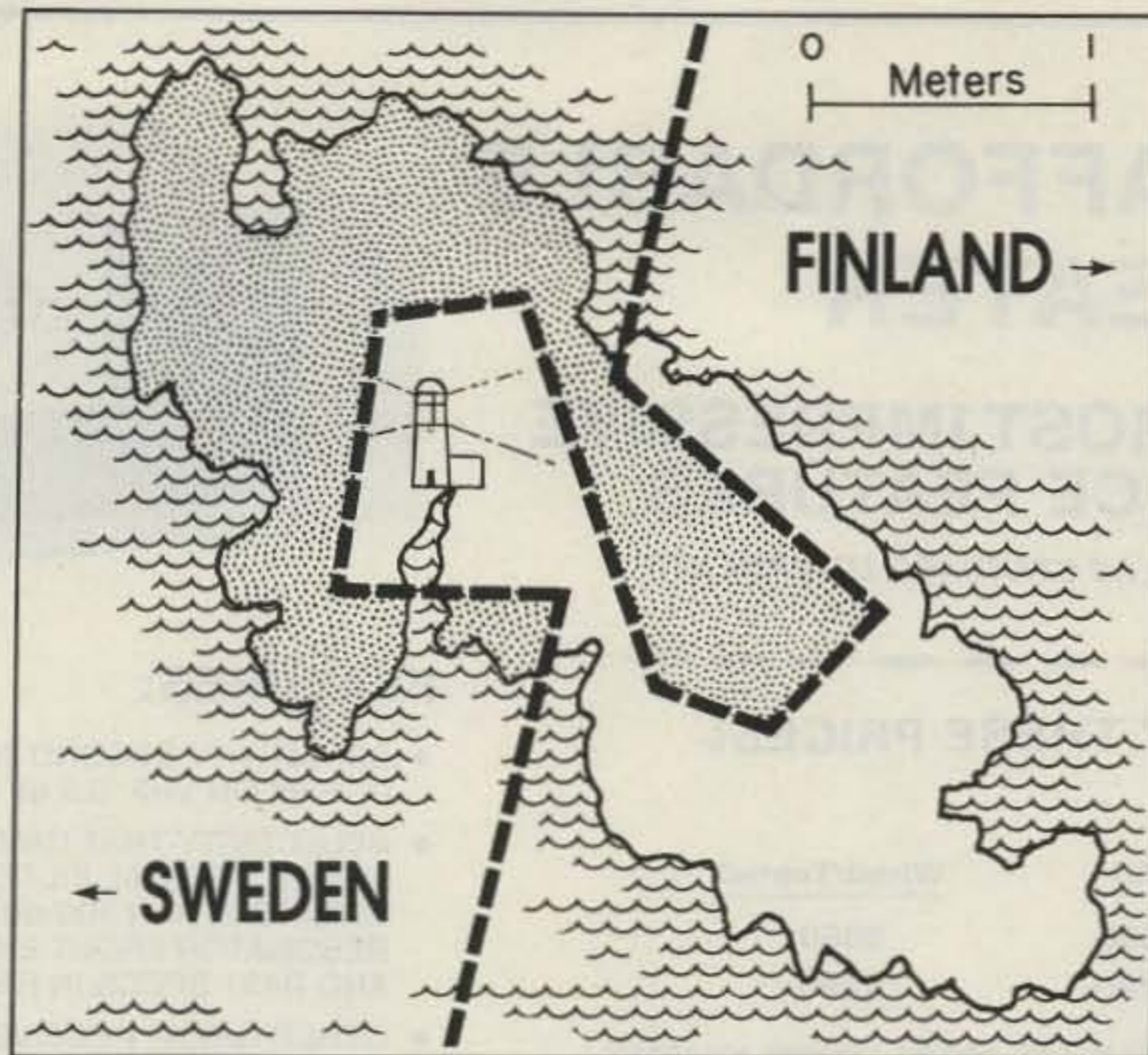

Fig. 1.

Serious financial difficulties, particularly of poorer clubs, brought discussion on the problem of an increase of membership fees.

The Deputy Chairman of the PRAA in charge of technical matters, Jerzy Niewada SP7HF, died on April 26, 1984.

Ryszard Reich SP4BBU resigned his office of the Deputy Chairman of PRAA Headquarters in charge of organization affairs. Wiktor Chojnacki SP5QU took the office.

April 8-13, 1984, the general conference of the 1st Region of IARU took place in the hotel Costa Verde (Sicily). Prof. Dr. Eng. Andrzej Zielinski SP5LVV, the President of PRAA, and Assistant Prof. Dr. Janusz Konopka SP5JC, the Microwave Manager of PRAA, represented Poland at the conference. Moreover, Wojciech Nietyksza SP5FM, Vice-President of the Executive Committee of the 1st Region, M. Eng. Henryk Cichon SP9ZD, the President of the working group in charge of electromagnetic compatibility, and M. Eng. Krzysztof Słomczyński SP5HS, the President of the working group in charge of amateur radio-location, were present, too. Wojciech Nietyksza of the 1st Region was reelected the Vice-President.

In March and April this year there took place successive UHF competitions, "Activity Day SP." Inspired by PRAA, it brought together 150 radio stations on 144 MHz and 8 stations on 432 MHz (in March) and 142 stations on 144 MHz, 8 stations on 432 MHz (in April). In the March contest, senior category, winners were SP6GZZ, SP6AZT, and SP2DDV and junior category, SP3MFI, SP3MFJ, and SP3MLK (on 144 MHz). On 432 MHz, senior, SP6AZT, SP6GWN, SP9BGS, and SP9EWO won. SP6MLK worked on 432 MHz in the junior category.

In the April contest on 144 MHz, senior category, winners were SP6GZZ, SP3GCL, and SP6AZT, while SP3MFI, SP3MIE, and SP3MFJ won in the junior group. On 432 MHz, senior, SP6AZT, SP6GWN, and SP6CIY won. As in the previous month, only one junior was on 432 MHz, SP6MLK. After competitions, SP6GZZ had 3442 points and SP3MFI had 1271 points in the 144-MHz category, and SP6AZT had 63 points in the 432-MHz category.



### SWEDEN

Rune Wande SM0COP  
Frejavagen 10  
S-155 00 Nykvarn  
Sweden

### MARKET REEF OJ0 NOW IN FINLAND

For over 90 years a Finnish lighthouse has been standing on the Swedish side of the small rocky island called Market Reef, 300 meters long and 100 meters wide, in the Baltic Sea between the Swedish mainland and Aaland Island, Finland. The border line was drawn after the peace treaty in 1809 when Sweden had to give up possession of Finland to Russia. In 1875, Finland built a lighthouse on this reef, which happened to be placed on the Swedish part of the island.

Every 25 years national border lines are checked over. Not until the latest check, in 1981, was the discovery made that Finland was using a part of the Market

Reef that in fact belonged to the Royal Kingdom of Sweden! Now, in 1984, this problem has been settled and the border line has been redrawn (see Fig. 1). The amateur-radio operations from OJ0, valid as a separate DXCC country, will from now on be from the correct side of the national border!

### CW ACTIVITY GROUP

In 1974, a group of Scandinavian radio amateurs formed the Scandinavian CW Activity Group, SCAG. During the early seventies, there was a noticeable decrease in ham activity on the low-frequency shortwave bands here. Two possible reasons were the introduction of 2-meter FM repeaters and the new code-free VHF license. The forming of SCAG was intended to give new enthusiasm to the low-band activity, especially on CW.

### Message Handling

Due to the restrictions put on the ham operators in Region 1, we have very few possibilities in making our activities recognized by the authorities and the general public. Most countries have a state monopoly for telecommunications. This has made sending of radiograms between third parties through ham radio impossible. However, SCAG started nets for message handling for practicing purpose.

In contrast to the USA, we do not regard another ham operator as a third party. This makes it possible for us to relay messages to other ham operators in our nets. In a possible emergency it is important that all participants in a net are familiar with the procedures in order to get messages handled efficiently. If you have no practice, the risk is that you mess it all up. In the beginning some hams here were afraid of participating because they thought it would not be accepted by the authorities. However, the licensing authorities in the Scandinavian countries have stated that the way SCAG handles messages, for hams, between hams, does not violate the third-party restriction in the radio regulations. Unfortunately, in the USA a ham operator not contacted directly is regarded as a third party. This makes it impossible for us to expand our nets on a broader basis.

Four times a year SCAG issues a newsletter. The editor, Borge OZ2NU, has been doing a good job through the years. The new editor now is Gunnar SM6AWA and the president for the group is Holger SM7GNF.

SCAG was started by some dedicated Swedish hams, and among those working hard to get the activities going were Frasse SM5TK, Sven SM0IX, and Kjell SM0CCE. Further on, some Danish hams got interested and Eric OZ5BO and Rick OZ5RM have over the years kept SCAG growing in Denmark. For some reasons, difficult to pinpoint, the Norwegian and Finnish hams have not been hooked by this SCAG idea and only a few LA and OH hams are members of the group.

SCAG activities include Straight Key Day twice a year with increasing popularity, rag-chew and slow-speed nets, and nets for message handling. From time to time the group arranges other activities and issues various awards like Worked SCAG Areas and SCAG Rag-Chew Award. SCAG Net Manager, Rolf SM6NFF, is trying to start a DX net with the USA and Canada on 14.055 MHz at 1430 UTC Sundays.

The SCAG motto is to support and encourage amateur radio telegraphy and to work for good operating behavior on the ham bands. The group celebrated its 10th anniversary in 1984 and will continue its efforts in bringing more hams closer together.

# HAM HELP

I would like to hear from anyone who has converted a Cobra 146GTL to 10-meter SSB/AM, or a Cobra 21XLR to 10-meter FM.

Robert Good N0FFF  
6134 SE 89th St.  
Berryton KS 66409

I need several items: parts for an HP-608, an address for the Jerrold Antenna Corporation, and service manuals for an IBM model B typewriter and a 3M model 149 copier.

Kevin Neal  
Route A, Box 221A  
Flippin AR 72634

I need the manual, schematic, and parts

list for the Millivac Instruments, Inc., model 77B dc multimeter. I also need the attachment that goes to the panel jack marked Output. I will gladly pay mailing and/or copying costs.

Vernon Jones WB1BVH  
32 Cat Mousam Road  
Kennebunk ME 04043

I am in desperate need of a shop manual for a Motorola Multi-XFL portable repeater. It is possibly an SP version of the Lookout repeater and was manufactured in 1973. I'll pay all costs incurred.

Derek W. Kelly  
100 Sylvan Court  
Alexandria VA 22304  
(703)-765-5227

# THE MOST AFFORDABLE REPEATER

## ALSO HAS THE MOST IMPRESSIVE PERFORMANCE FEATURES

(AND GIVES THEM TO YOU AS STANDARD EQUIPMENT!)



### JUST LOOK AT THESE PRICES!

| Band             | Kit   | Wired/Tested |
|------------------|-------|--------------|
| 10M, 6M, 2M, 220 | \$680 | \$880        |
| 440              | \$780 | \$980        |

Both kit and wired units are complete with all parts, modules, hardware, and crystals.

### CALL OR WRITE FOR COMPLETE DETAILS.

Also available for remote site linking, crossband, and remote base.

### FEATURES:

- SENSITIVITY SECOND TO NONE; TYPICALLY 0.15  $\mu$ V ON VHF, 0.3  $\mu$ V ON UHF.
- SELECTIVITY THAT CAN'T BE BEAT! BOTH 8 POLE CRYSTAL FILTER & CERAMIC FILTER FOR GREATER THAN 100 dB AT  $\pm$  12KHZ. HELICAL RESONATOR FRONT ENDS. SEE R144, R220, AND R451 SPECS IN RECEIVER AD BELOW.
- OTHER GREAT RECEIVER FEATURES: FLUTTER-PROOF SQUELCH, AFC TO COMPENSATE FOR OFF-FREQ TRANSMITTERS, SEPARATE LOCAL SPEAKER AMPLIFIER & CONTROL.
- CLEAN, EASY TUNE TRANSMITTER; UP TO 20 WATTS OUT (UP TO 50W WITH OPTIONAL PA).

## HIGH QUALITY MODULES FOR REPEATERS, LINKS, TELEMETRY, ETC.

### HIGH-PERFORMANCE RECEIVER MODULES

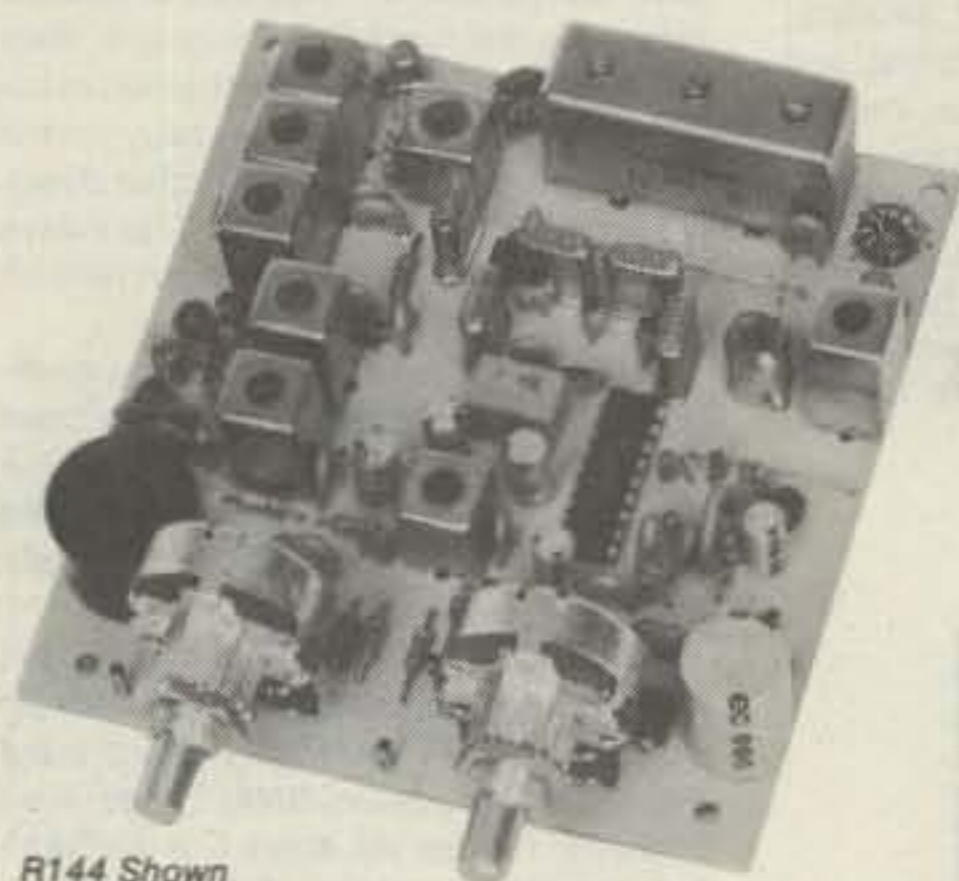

R144 Shown

- **R144/R220 FM RCVRs** for 2M or 220 MHz. 0.15 $\mu$ V sens.; 8 pole xtal filter & ceramic filter in i-f, helical resonator front end for exceptional selectivity, more than -100 dB at  $\pm$ 12 kHz, best available today. Flutter-proof squelch. AFC tracks drifting xmtrs. Xtal oven avail. Kit only \$138.
- **R451 FM RCVR** Same but for uhf. Tuned line front end, 0.3  $\mu$ V sens. Kit only \$138.
- **R76 FM RCVR** for 10M, 6M, 2M, 220, or commercial bands. As above, but w/o AFC or hel. res. Kits only \$118. Also avail w/4 pole filter, only \$98/kit.
- **R110 VHF AM RECEIVER** kit for VHF aircraft band or ham bands. Only \$98.
- **R110-259 SPACE SHUTTLE RECEIVER**, kit only \$98.

### TRANSMITTERS

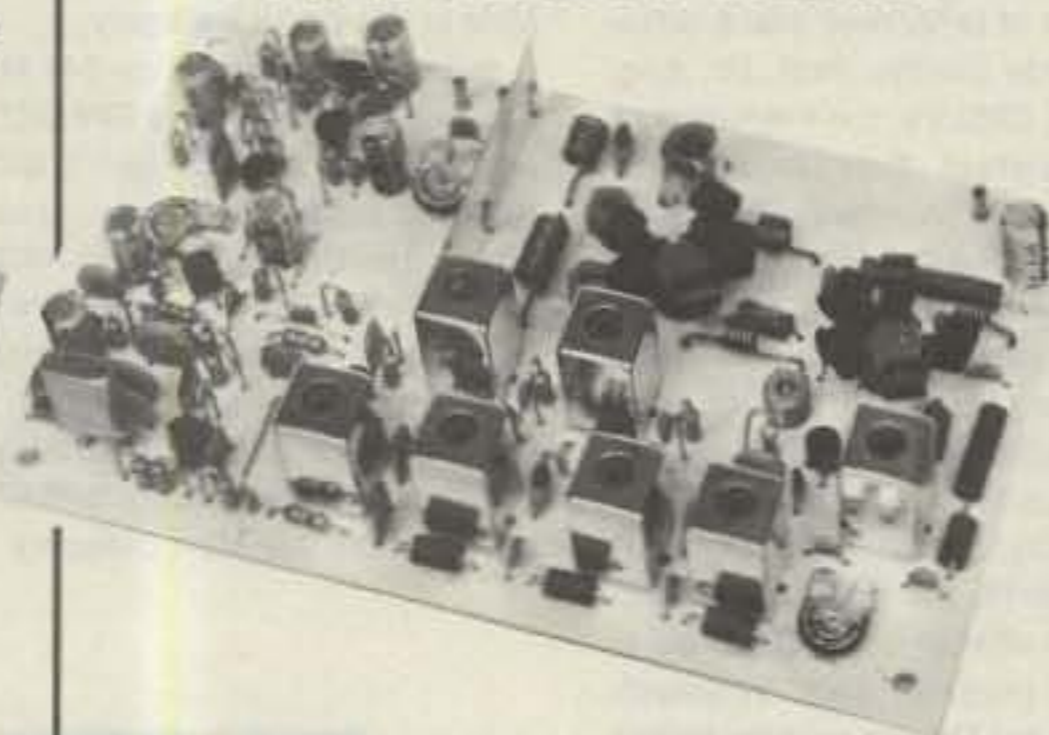

- **T51 VHF FM EXCITER** for 10M, 6M, 2M, 220 MHz or adjacent bands. 2 Watts continuous, up to 2 1/2 W intermittent. \$68/kit.

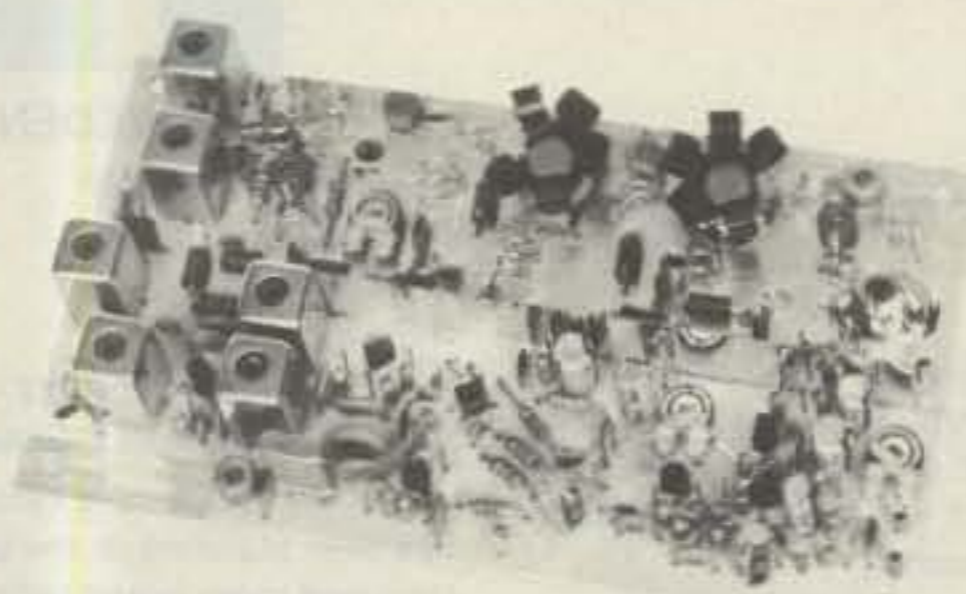

- **T451 UHF FM EXCITER** 2 to 3 Watts on 450 ham band or adjacent freq. Kit only \$78.
- **VHF & UHF LINEAR AMPLIFIERS.** Use on either FM or SSB. Power levels from 10 to 45 Watts to go with exciters & xmtg converters. Several models. Kits from \$78.
- **A16 RF TIGHT BOX** Deep drawn alum. case with tight cover and no seams. 7 x 8 x 2 inches. Designed especially for repeaters. \$20.

### ACCESSORIES

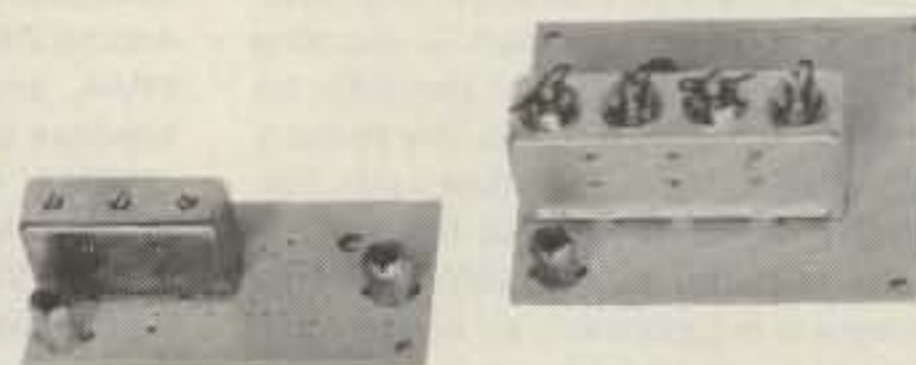

- **HELICAL RESONATOR FILTERS** available separately on pcb w/connectors.  
HRF-144 for 143-150 MHz \$38  
HRF-220 for 213-233 MHz \$38  
HRF-432 for 420-450 MHz \$48
- **COR-2 KIT** With audio mixer, local speaker amplifier, tail & time-out timers. Only \$38.
- **COR-3 KIT** as above, but with "courtesy beep". Only \$58.
- **CWID KITS** 158 bits, field programmable, clean audio, rugged TTL logic. Kit only \$68.
- **DTMF DECODER/CONTROLLER KITS.** Control 2 separate on/off functions with touchtones<sup>®</sup>, e.g., repeater and autopatch. Use with main or aux. receiver or with Autopatch. Only \$90
- **AUTOPATCH KITS.** Provide repeater autopatch, reverse patch, phone line remote control of repeater, secondary control via repeater receiver. Many other features. Only \$90. Requires DTMF Module.
- **NEW - SIMPLEX AUTOPATCH** Use with any transceiver. System includes DTMF & Autopatch modules above and new Timing module to provide simplex autopatch and reverse autopatch. Complete patch system only \$200/kit. Call or write for details.

**hamtronics**®

# NEW LOW-NOISE PREAMPS RECEIVING CONVERTERS TRANSMIT CONVERTERS



**Hamtronics Breaks the Price Barrier!**



**No Need to Pay \$80 to \$125 for a GaAs FET Preamp.**

## FEATURES:

- Very Low Noise: 0.7 dB VHF, 0.8 dB UHF
- High Gain: 18 to 28 dB, Depending on Freq.
- Wide Dynamic Range for Overload Resistance
- Latest Dual-gate GaAs FET, Stable Over Wide Range of Conditions
- Rugged, Diode-protected Transistors
- Easy to Tune
- Operates on Standard 12 to 14 Vdc Supply
- Can be Tower Mounted

| MODEL   | TUNES RANGE | PRICE |
|---------|-------------|-------|
| LNG-28  | 26-30 MHz   | \$49  |
| LNG-50  | 46-56 MHz   | \$49  |
| LNG-144 | 137-150 MHz | \$49  |
| LNG-220 | 210-230 MHz | \$49  |
| LNG-432 | 400-470 MHz | \$49  |
| LNG-40  | 30-46 MHz   | \$64  |
| LNG-160 | 150-172 MHz | \$64  |



Models to cover every practical rf & if range to listen to SSB, FM, ATV, etc. NF = 2 dB or less.

|                    | Antenna Input Range | Receiver Output |
|--------------------|---------------------|-----------------|
| <b>VHF MODELS</b>  | 28-32               | 144-148         |
|                    | 50-52               | 28-30           |
| Kit with Case \$49 | 50-54               | 144-148         |
| Less Case \$39     | 144-146             | 28-30           |
| Wired \$69         | 145-147             | 28-30           |
|                    | 144-144.4           | 27-27.4         |
|                    | 146-148             | 28-30           |
|                    | 144-148             | 50-54           |
|                    | 220-222             | 28-30           |
|                    | 220-224             | 144-148         |
|                    | 222-226             | 144-148         |
|                    | 220-224             | 50-54           |
|                    | 222-224             | 28-30           |

|                    | Antenna Input Range | Receiver Output |
|--------------------|---------------------|-----------------|
| <b>UHF MODELS</b>  | 432-434             | 28-30           |
|                    | 435-437             | 28-30           |
| Kit with Case \$59 | 432-436             | 144-148         |
| Less Case \$49     | 432-436             | 50-54           |
| Wired \$75         | 439.25              | 61.25           |

**SCANNER CONVERTERS** Copy 72-76, 135-144, 240-270, 400-420, or 806-894 MHz bands on any scanner. Wired/tested Only \$88.

## SAVE A BUNDLE ON VHF FM TRANSCEIVERS!

**FM-5 PC Board Kit - ONLY \$178** complete with controls, heatsink, etc. 10 Watts, 5 Channels, for 2M or 220 MHz.



Cabinet Kit, complete with speaker, knobs, connectors, hardware. Only \$60.

**REPEAT OF A SELLOUT!**

While supply lasts, get \$60 cabinet kit free when you buy an FM-5 Transceiver kit. Where else can you get a complete transceiver for only \$178

For SSB, CW, ATV, FM, etc. Why pay big bucks for a multi mode rig for each band? Can be linked with receive converters for transceive. 2 Watts output vhf, 1 Watt uhf.

|   | Exciter Input Range | Antenna Output |
|---|---------------------|----------------|
| For VHF, Model XV2 Kit \$79<br>Wired \$149 (Specify band) | 28-30               | 144-146        |
|   | 28-29               | 145-146        |
|   | 28-30               | 50-52          |
|   | 27-27.4             | 144-144.4      |
|   | 28-30               | 220-222*       |
|   | 50-54               | 220-224        |
|   | 144-146             | 50-52          |
|   | 50-54               | 144-148        |
|   | 144-146             | 28-30          |

|  | Exciter Input Range | Antenna Output |
|--|---------------------|----------------|
| For UHF, Model XV4 Kit \$99<br>Wired \$169 | 28-30               | 432-434        |
|  | 28-30               | 435-437        |
|  | 50-54               | 432-436        |
|  | 61.25               | 439.25         |
|  | 144-148             | 432-436*       |

\*Add \$20 for 2M input

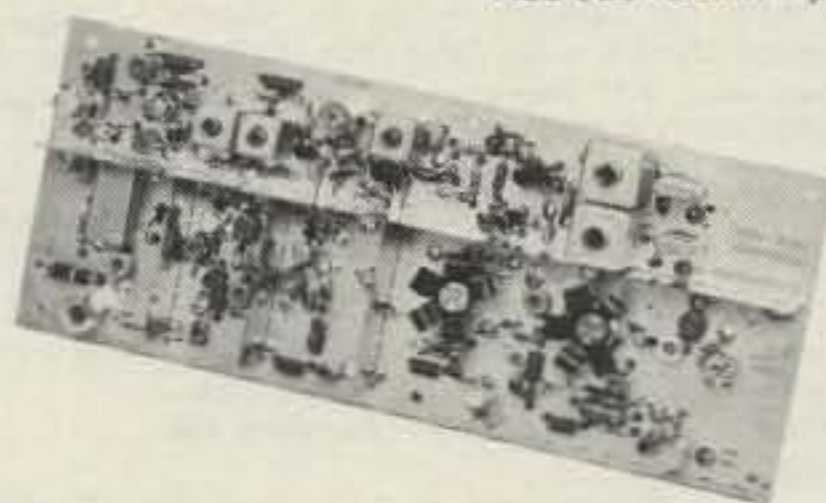

**VHF & UHF LINEAR AMPLIFIERS.** Use with above. Power levels from 10 to 45 Watts. Several models, kits from \$78.

## LOOK AT THESE ATTRACTIVE CURVES!

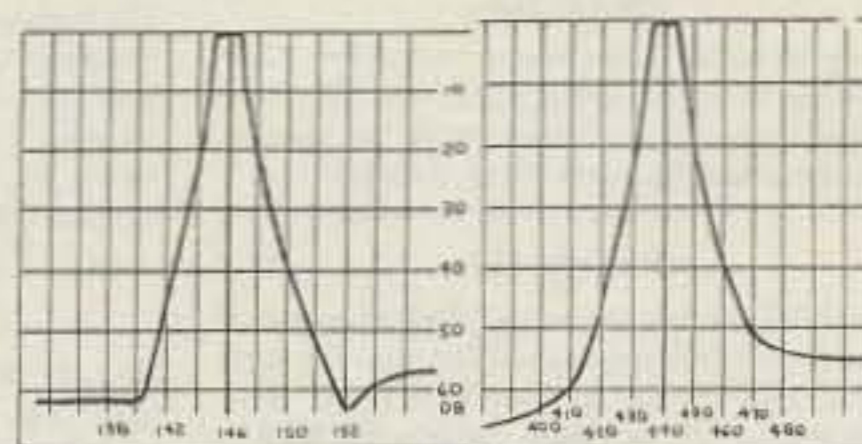

Typical Selectivity Curves of Receivers and Helical Resonators.

## HELICAL RESONATOR PREAMPS

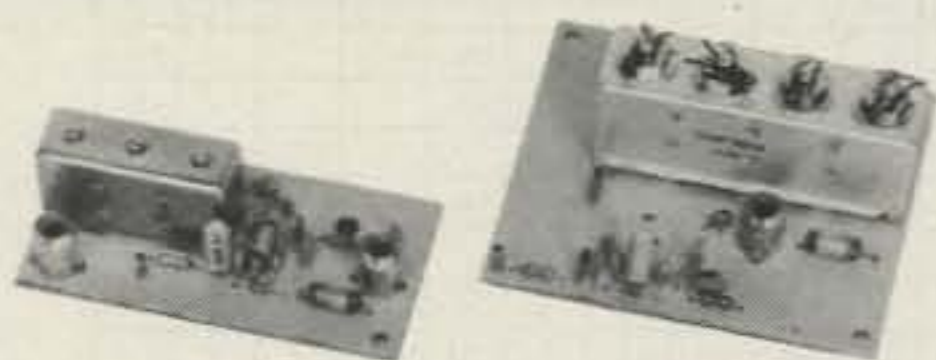

Our lab has developed a new line of low-noise receiver preamps with helical resonator filters built in. The combination of a low noise amplifier and the sharp selectivity of a 3 or 4 section helical resonator provides increased sensitivity while reducing intermod and cross-band interference in critical applications. See selectivity curves at right. Gain = approx. 12 dB.

| Model   | Tuning Range | Price |
|---------|--------------|-------|
| HRA-144 | 143-150 MHz  | \$49  |
| HRA-220 | 213-233 MHz  | \$49  |
| HRA-432 | 420-450 MHz  | \$59  |
| HRA(-)  | 150-174MHz   | \$69  |
| HRA(-)  | 450-470 MHz  | \$79  |

## IMPORTANT REASONS WHY YOU SHOULD BUY FROM THE VALUE LEADER:

1. Largest selection of vhf and uhf kits in the world.
2. Exceptional quality and low prices due to large volume.
3. Fast delivery, most kits shipped same day.
4. Complete, professional instruction manuals.
5. Prompt factory service available and free phone consultation.
6. In business 21 years.
7. Sell more repeater modules than all other mfrs. and have for years. Can give quality features for much lower cost.

- Call or Write for **FREE CATALOG**
- (Send \$1.00 or 4 IRC's for overseas mailing)
- Order by phone or mail • Add \$3 S & H per order (Electronic answering service evenings & weekends) Use VISA, MASTERCARD, Check, or UPS COD.

**hamtronics, inc.**

65-D MOUL RD. • HILTON NY 14468  
Phone: 716-392-9430

Hamtronics® is a registered trademark

# DEALER DIRECTORY

## Culver City CA

Jun's Electronics, 3919 Sepulveda Blvd., Culver City CA 90230, 390-8003. Trades 463-1886 San Diego, 827-5732 (Reno NV).

## Fontana CA

Complete lines ICOM, DenTron, Ten-Tec, Mirage, Cubic, Lunar, over 4000 electronic products for hobbyist, technician, experimenter. Also CB radio, landmobile. Fontana Electronics, 8628 Sierra Ave., Fontana CA 92335, 822-7710.

## San Jose CA

Bay area's newest amateur radio store. New & used amateur radio sales & service. We feature Kenwood, ICOM, Azden, Yaesu, Ten-Tec, Satec & many more, Shaver Radio, Inc., 1775A S. Winchester Blvd., Campbell CA 95008, 370-6665.

## New Castle DE

Factory Authorized Dealer! Yaesu, ICOM, Ten-Tec, KDK, Kenwood, AEA, Kantronics, Satec. Full line of accessories. No sales tax in Delaware. One mile off I-95. Delaware Amateur Supply, 71 Meadow Road, New Castle DE 19720, 328-7728.

## Boise ID

Rocky Mountain area's newest ham dealer. Call BJM first for AEA, Azden, KDK, Ten-Tec, Butternut, Cushcraft, and more! BJM Electronics, 4204 Overland, Boise ID 83705, 343-4018.

## Preston ID

Ross WB7BYZ has the largest stock of amateur gear in the Intermountain West and the best prices. Call me for all your ham needs. Ross Distributing, 78 So. State, Preston ID 83263, 852-0830.

## Littleton MA

The reliable ham store serving NE. Full line of ICOM & Kenwood. Yaesu HTs, Drake, Daiwa, B&W accessories. Curtis & Trac keyers. Larsen, Hustler, Telex/Hy-Gain products. Mirage amps., Astron P.S., Alpha Delta protectors, ARRL & Kantronics instruction aids. Whistler radar detectors. Full line of coax fittings. TEL-COM Electronic Communications, 675 Great Rd. (Rt. 119), Littleton MA 01460, 486-3400/3040.

## Lincoln NE

G&C Communications is a full-line distributor of major-line amateur equipment and accessories, antennas, and everything. 4230 Progressive Ave., Lincoln NE 68504, 46-RADIO.

## Derry NH

Serving the ham community with new and used equipment. We stock and service most major lines: AEA, Astron, Azden, B&W, Cushcraft, Hy-Gain, Hustler, ICOM, Kenwood, KLM, Larsen, Mirage, Mosley; books, rotors, cable and connectors. Business hours 9-7 Monday through Thursday, and 9-5 Friday and Saturday. Rivendell, 68 Warner Hill Road, Derry NH 03038; 434-5371.

## Albany, New York UPSTATE NEW YORK

Kenwood, ICOM, Ten-Tec, Belden, Cushcraft, Larsen, Hustler, ARRL, Hy-Gain, B&W, MFJ, Mirage. New and used equipment. Serving the amateur community since 1942. Adirondack Electronics, Inc., 1991 Central Avenue, Albany NY 12205, 456-0203 (one mile west of Northway exit 2W).

## Columbus OH

The biggest and best ham store in the Midwest featuring Kenwood and other quality products with working displays. We sell only the best. Authorized Kenwood service. Universal Amateur Radio, Inc., 1280 Aida Dr., Reynoldsburg (Columbus) OH 43068, 866-4267.

## Dallas TX

IBM PC/XT kits, supplies, expansion products; video restorer kits for pay TV, CATV, satellite hobbyists' electronic project kits/app-notes. More than 9000 parts in stock: semiconductors, ICs, discretes, video accessories, tools, audio, automotive, cabinets, computer peripherals. Please write for your free 60-page catalog. Sabet Electronics, 13650 Floyd Rd., Ste. 104, Dallas TX 75243; 783-4950 (formerly I.E.).

## DEALERS

Your company name and message can contain up to 25 words for as little as \$150 yearly (prepaid), or \$15 per month (prepaid quarterly). No mention of mail-order business or area code permitted. Directory text and payment must reach us 60 days in advance of publication. For example, advertising for the April '85 issue must be in our hands by February 1st. Mail to 73 Magazine, Peterborough NH 03458. ATTN: Nancy Ciampa.

# PROPAGATION

Jim Gray W1XU  
73 Staff

## EASTERN UNITED STATES TO:

| GMT:         | 00  | 02 | 04 | 06 | 08 | 10 | 12  | 14  | 16 | 18 | 20 | 22 |
|--------------|-----|----|----|----|----|----|-----|-----|----|----|----|----|
| ALASKA       | 15  |    |    |    |    |    | 20  | 20A | 15 |    |    |    |
| ARGENTINA    | 20  |    |    |    |    |    |     |     |    |    | 15 | 15 |
| AUSTRALIA    | 20  |    |    |    |    | 40 | 40  |     |    | 20 | 20 | 15 |
| CANAL ZONE   | 40  | 40 |    |    |    |    | 20  | 15  | 15 | 15 | 15 | 20 |
| ENGLAND      | 40  | 40 | 40 | 80 | 80 |    | 20  | 15  | 15 | 15 | 20 |    |
| HAWAII       | 20  |    |    |    |    | 40 | 20  | 20  |    |    | 15 | 15 |
| INDIA        |     |    |    |    |    |    | 20  | 20  |    |    |    |    |
| JAPAN        | 15  |    |    |    |    |    | 20  | 20  |    |    |    | 15 |
| MEXICO       | 40  | 40 | 40 | 40 | 40 | 40 | 20  | 15  | 15 | 15 | 15 | 20 |
| PHILIPPINES  |     |    |    |    |    |    | 20  | 20  |    |    |    |    |
| PUERTO RICO  | 40  | 40 | 40 | 40 | 40 | 40 | 20  | 15  | 15 | 15 | 15 | 20 |
| SOUTH AFRICA | 40A | 40 |    |    |    |    |     | 15  | 15 | 20 |    |    |
| U. S. S. R.  |     | 40 |    |    |    |    |     | 15  | 15 | 20 |    |    |
| WEST COAST   | 15  | 20 | 40 | 40 | 40 | 40 | 40A | 20A | 15 | 15 | 15 | 15 |

## CENTRAL UNITED STATES TO:

|              |    |    |    |    |    |    |    |    |    |    |     |     |     |
|--------------|----|----|----|----|----|----|----|----|----|----|-----|-----|-----|
| ALASKA       | 20 |    |    |    | 40 | 40 | 20 | 20 |    |    |     | 20  |     |
| ARGENTINA    | 20 | 40 | 40 | 40 |    |    |    |    |    |    | 15  | 15  | 20A |
| AUSTRALIA    | 15 |    |    |    |    | 40 | 20 | 20 | 20 |    | 15  | 15  |     |
| CANAL ZONE   | 20 |    | 40 | 40 | 40 |    |    | 20 | 15 | 15 | 15  | 15  |     |
| ENGLAND      | 40 | 40 | 80 | 80 |    |    |    | 15 | 15 | 15 | 20  |     |     |
| HAWAII       | 20 | 20 |    |    | 40 | 40 | 20 | 20 | 20 | 15 | 15A | 15A |     |
| INDIA        |    |    |    |    |    |    |    | 20 |    |    |     |     |     |
| JAPAN        | 20 |    |    |    | 40 | 40 | 20 | 20 |    |    |     | 20  |     |
| MEXICO       | 20 |    | 40 | 40 | 40 |    |    | 20 | 15 | 15 | 15  | 15  |     |
| PHILIPPINES  | 20 |    |    |    |    |    |    | 20 | 20 |    |     |     |     |
| PUERTO RICO  | 20 |    | 40 | 40 | 40 |    |    | 20 | 15 | 15 | 15  | 15  |     |
| SOUTH AFRICA | 20 | 40 | 40 |    |    |    |    |    | 15 | 15 | 15  | 20  |     |
| U. S. S. R.  |    | 40 | 40 |    |    |    |    |    | 15 | 15 | 20  |     |     |

## WESTERN UNITED STATES TO:

|              |     |    |    |    |    |    |    |     |     |     |    |    |    |
|--------------|-----|----|----|----|----|----|----|-----|-----|-----|----|----|----|
| ALASKA       | 15  | 15 | 20 |    |    | 40 | 40 | 40  |     |     |    | 20 |    |
| ARGENTINA    | 20  | 20 |    | 40 | 40 |    |    |     |     |     | 15 | 15 |    |
| AUSTRALIA    | 15  | 15 | 20 |    |    |    | 40 |     | 20  | 20  | 20 | 15 |    |
| CANAL ZONE   | 20  | 20 |    | 40 | 40 | 40 | 40 | 40  | 15  | 15  | 15 | 15 |    |
| ENGLAND      |     |    | 40 | 40 |    |    |    |     | 20A | 20A |    |    |    |
| HAWAII       | 15  | 20 | 20 |    |    | 40 | 40 | 40  |     |     |    | 15 |    |
| INDIA        |     | 20 | 20 |    |    |    |    |     |     |     |    |    |    |
| JAPAN        | 15  | 15 | 20 |    |    |    | 40 | 40  | 40  |     |    | 20 |    |
| MEXICO       | 20  | 20 |    | 40 | 40 | 40 | 40 | 40  |     |     |    | 15 |    |
| PHILIPPINES  | 20A | 20 |    |    |    |    |    |     |     | 20  |    |    |    |
| PUERTO RICO  | 20  | 20 |    | 40 | 40 | 40 | 40 | 40  |     |     |    | 15 |    |
| SOUTH AFRICA | 20  | 20 |    |    |    |    |    |     |     | 15  | 15 | 15 | 20 |
| U. S. S. R.  |     |    |    |    |    |    |    |     | 20  | 20  | 20 | 20 |    |
| EAST COAST   | 15  | 20 | 40 | 40 | 40 | 40 | 20 | 20A | 15  | 15  | 15 | 15 |    |

A = Next higher frequency may also be useful.  
B = Difficult circuit this period.

G = Good, F = Fair, P = Poor.

| JANUARY |     |     |     |     |     |     |
|---------|-----|-----|-----|-----|-----|-----|
| SUN     | MON | TUE | WED | THU | FRI | SAT |
|         |     | 1   | 2   | 3   | 4   | 5   |
|         |     | G   | G   | G-F | F-P | P   |
| 6       | 7   | 8   | 9   | 10  | 11  | 12  |
| F       | P-F | F-G | G-F | F   | G   | G   |
| 13      | 14  | 15  | 16  | 17  | 18  | 19  |
| G       | G   | G   | P   | P   | F   | P-F |
| 20      | 21  | 22  | 23  | 24  | 25  | 26  |
| F       | F-G | G   | G   | G   | F   | P   |
| 27      | 28  | 29  | 30  | 31  |     |     |
| P       | P-F | F-G | F   | F-G |     |     |



# RAMSEY

# THE FIRST NAME IN ELECTRONIC TEST GEAR

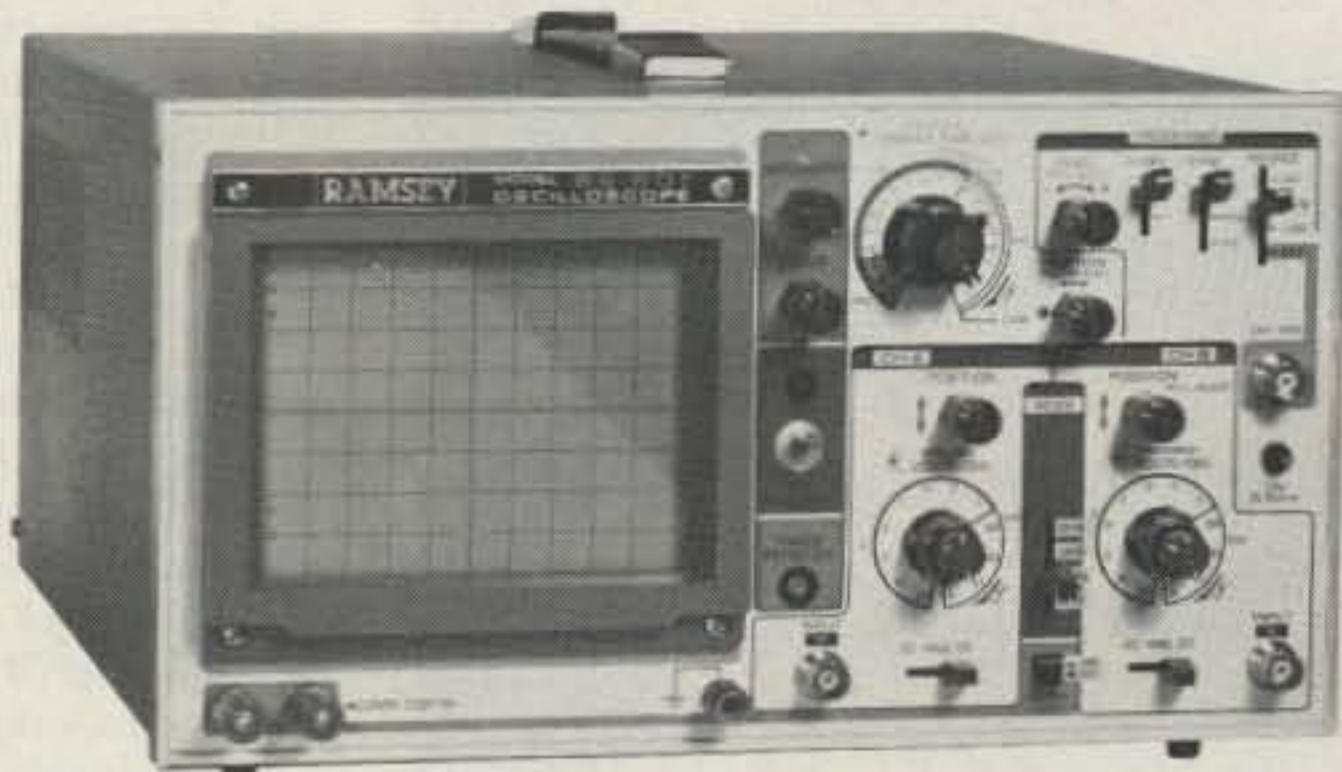

## 20 MHz DUAL TRACE OSCILLOSCOPE

Unsurpassed quality at an unbeatable price, the Ramsey oscilloscope compares to others costing hundreds more. Features include a component testing circuit for resistor, capacitor, digital circuit and diode testing. • TV video sync filter • wide bandwidth & high sensitivity • internal graticule • front panel trace rotator • Z axis • high sensitivity x-y mode • regulated power supply • built-in calibrator • rock solid triggering • USA—Add \$10.00 per unit for postage, overseas orders add 15% of total order for Insured Surface Mail

**\$399.95\***

high quality hook on probes included

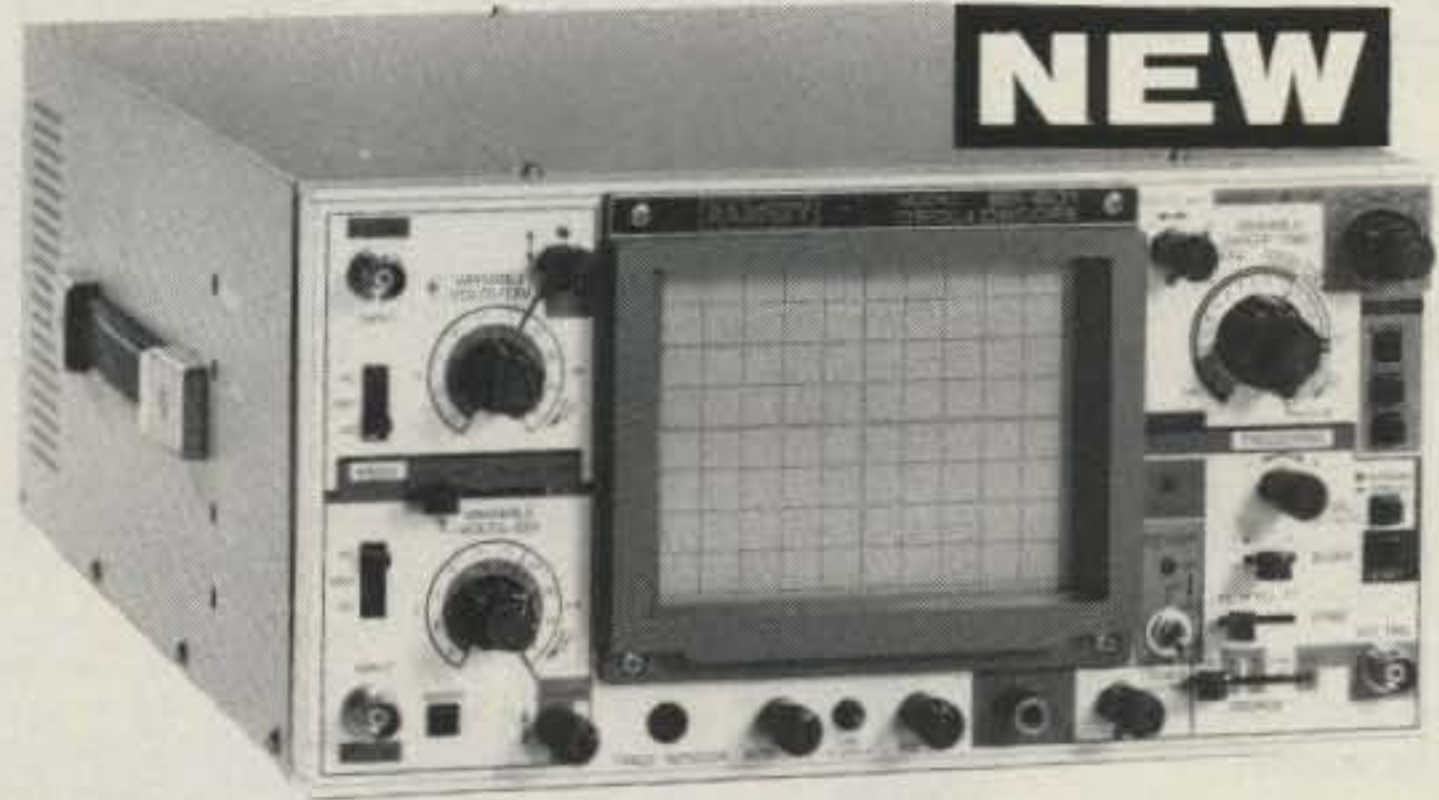

**NEW**

## 45 MHz DUAL SWEEP OSCILLOSCOPE

The Ramsey 625 is a dual time base, delayed sweep unit that includes a built-in signal delay line to permit clear viewing during very short rise times of high frequency waveforms. Other features include: variable trigger holdoff • 20 calibrated sweep time ranges from 0.5 s/div to 0.2 μs/div • fully adjustable sweep time • X5 sweep magnification • five trigger sources: CH1, CH2, LINE EXTERNAL and INTERNAL (V mode) • front panel x-y operation, Z axis input • sum difference of CH1, and CH2 waveforms displayed as single trace • sweep gate and sweep output • auto focus • single sweep • USA—Add \$10.00 per unit for postage, overseas orders add 15% of total order for Insured Surface Mail.

**\$799.95\***

high quality hook on probes included



## RAMSEY D-1100 VOM MULTITESTER

Compact and reliable, designed to service a wide variety of equipment. Features include • mirror back scale • double-jeweled precision moving coil • double overload protection • an ideal low cost unit for the beginner or as a spare back-up unit.

**\$19.95** test leads and battery included



## NEW RAMSEY 1200 VOM MULTITESTER

Check transistors, diodes and LEDs with this professional quality meter. Other features include: decibel scale • 20K volt metering system • 3 1/2" mirrored scale • polarity switch • 20 measuring ranges • safety probes • high impact plastic case

**\$24.95** test leads and battery included

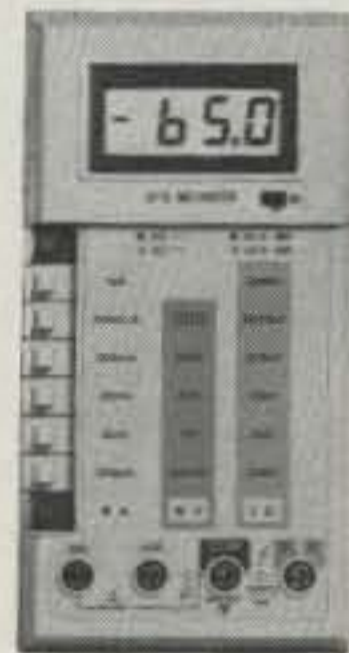

## RAMSEY D-3100 DIGITAL MULTIMETER

Reliable, accurate digital measurements at an amazingly low cost • in-line color coded push buttons, speeds range selection • abs plastic tilt stand • recessed input jacks • overload protection on all ranges • 3 1/2 digit LCD display with auto zero, auto polarity & low BAT. indicator

**\$49.95** test leads and battery included



## CT-70 7 DIGIT 525 MHz COUNTER

Lab quality at a breakthrough price. Features • 3 frequency ranges each with pre amp • dual selectable gate times • gate activity indicator • 50mV @ 150 MHz typical sensitivity • wide frequency range • 1 ppm accuracy

**\$119.95** wired includes AC adapter

CT-70 kit ..... \$99.95  
BP-4 nicad pack ..... 8.95



## CT-90 9 DIGIT 600 MHz COUNTER

The most versatile for less than \$300. Features 3 selectable gate times • 9 digits • gate indicator • display hold • 25mV @ 150 MHz typical sensitivity • 10 MHz timebase for WWV calibration • 1 ppm accuracy

**\$149.95** wired includes AC adapter

CT-90 kit ..... \$129.95  
OV-1 0.1 PPM oven timebase ..... 59.95  
BP-4 nicad pack ..... 8.95



## CT-125 9 DIGIT 1.2 GHz COUNTER

A 9 digit counter that will outperform units costing hundreds more. • gate indicator • 24mV @ 150 MHz typical sensitivity • 9 digit display • 1 ppm accuracy • display hold • dual inputs with preamps

**\$169.95** wired includes AC adapter

BP-4 nicad pack ..... 8.95



## CT-50 8 DIGIT 600 MHz COUNTER

A versatile lab bench counter with optional receive frequency adapter, which turns the CT-50 into a digital readout for most any receiver • 25 mV @ 150 MHz typical sensitivity • 8 digit display • 1 ppm accuracy

**\$169.95** wired

CT-50 kit ..... \$139.95  
RA-1 receiver adapter kit ..... 14.95



## DM-700 DIGITAL MULTIMETER

Professional quality at a hobbyist price. Features include 26 different ranges and 5 functions • 3 1/2 digit, 1/2 inch LED display • automatic decimal placement • automatic polarity

**\$119.95** wired includes AC adapter

DM-700 kit ..... \$99.95  
MP-1 probe set ..... 4.95



## PS-2 AUDIO MULTIPLIER

The PS-2 is handy for high resolution audio resolution measurements, multiplies UP in frequency • great for PL tone measurements • multiplies by 10 or 100 • 0.01 Hz resolution & built-in signal preamp/conditioner

**\$49.95** wired

PS-2 kit ..... \$39.95



## PR-2 COUNTER PREAMP

The PR-2 is ideal for measuring weak signals from 10 to 1,000 MHz • flat 25 db gain • BNC connectors • great for shifting RF • ideal receiver/TV preamp

**\$44.95** wired includes AC adapter

PR-2 kit ..... \$34.95



## PS-1B 600 MHz PRESCALER

Extends the range of your present counter to 600 MHz • 2 stage preamp • divide by 10 circuitry • sensitivity: 25mV @ 150 MHz • BNC connectors • drives any counter

**\$59.95** wired includes AC adapter

PS-1B kit ..... \$49.95

## ACCESSORIES FOR RAMSEY COUNTERS

Telescopic whip antenna—BNC plug .. \$ 8.95  
High impedance probe, light loading ... 16.95  
Low pass probe, audio use ..... 16.95  
Direct probe, general purpose use ..... 13.95  
Tilt bail, for CT-70, 90, 125 ..... 3.95



PHONE ORDERS CALL  
**716-586-3950**  
TELEX 466735 RAMSEY CI

TERMS: • satisfaction guaranteed • examine for 10 days; if not pleased, return in original form for refund • add 6% for shipping and insurance to a maximum of \$10.00 • overseas add 15% for surface mail • COD add \$2.50 (COD in USA only) • orders under \$15.00 add \$1.50 • NY residents add 7% sales tax • 90 day parts warranty on all kits • 1 year parts & labor warranty on all wired units.

**RAMSEY**

RAMSEY ELECTRONICS, INC.  
2575 Baird Rd.  
Penfield, N.Y. 14626 ✓ 268

## What To Look For In A Phone Patch

The best way to decide what patch is right for you is to first decide what a patch should do. A patch should:

- Give complete control to the mobile, allowing full break in operation.
- Not interfere with the normal operation of your base station. It should not require you to connect and disconnect cables (or flip switches!) every time you wish to use your radio as a normal base station.
- Not depend on volume or squelch settings of your radio. It should work the same regardless of what you do with these controls.
- You should be able to hear your base station speaker with the patch installed. Remember, you have a base station because there are mobiles. ONE OF THEM MIGHT NEED HELP.
- The patch should have standard features at no extra cost. These should include programmable toll restrict (dip switches), tone or rotary dialing, programmable patch and activity timers, and front panel indicators of channel and patch status.

**ONLY SMART PATCH HAS ALL OF THE ABOVE.**

## Now Mobile Operators Can Enjoy An Affordable Personal Phone Patch. . .

- Without an expensive repeater.
- Using any FM transceiver as a base station.
- The secret is a SIMPLEX autopatch, The **SMART PATCH**.

### **SMART PATCH Is Easy To Install**

To install **SMART PATCH**, connect the multicolored computer style ribbon cable to mic audio, receiver discriminator, PTT, and power. A modular phone cord is provided for connection to your phone system. Sound simple? . . . IT IS!

# With SMART PATCH You are in CONTROL

With **CES 510SA Simplex Autopatch**, there's no waiting for VOX circuits to drop. Simply key your transmitter to take control.

**SMART PATCH** is all you need to turn your base station into a personal autopatch. **SMART PATCH** uses the only operating system that gives the mobile complete control. Full break-in capability allows the mobile user to actually interrupt the telephone party. **SMART PATCH** does not interfere with the normal use of your base station. **SMART PATCH** works well with any FM transceiver and provides switch selectable tone or rotary dialing, toll restrict, programmable control codes, CW ID and much more.

**To Take CONTROL with Smart Patch - Call 800-327-9956 Ext. 101 today.**

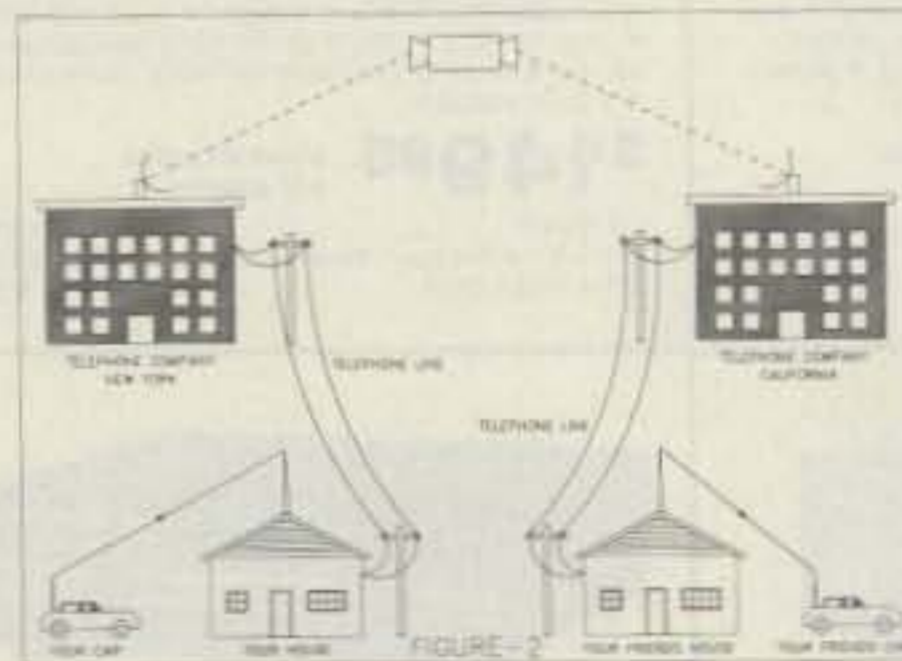
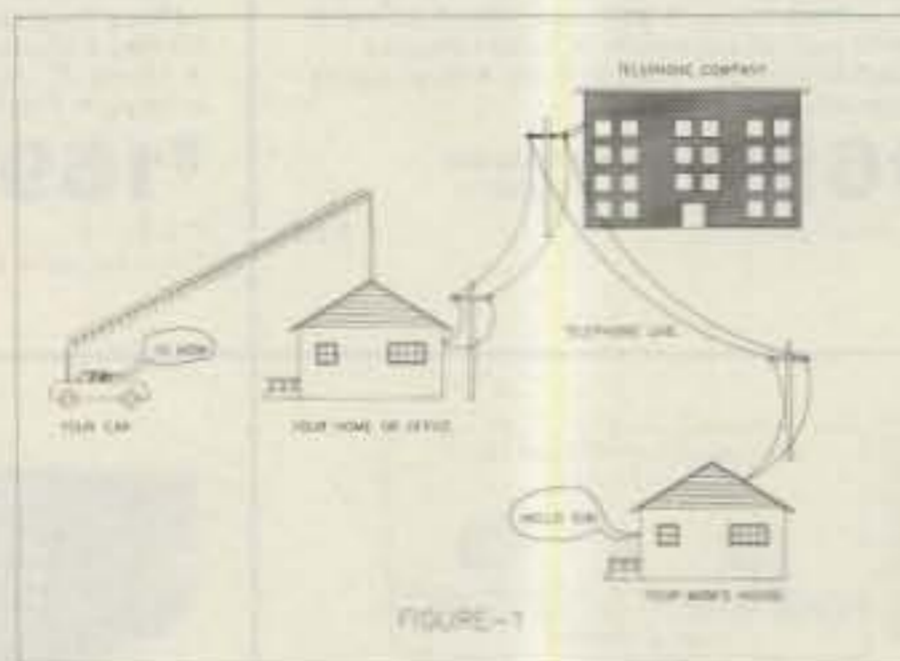

## How To Use SMART PATCH

Placing a call is simple. Send your access code from your mobile (example: \*73). This brings up the Patch and you will hear dial tone transmitted from your base station. Since **SMART PATCH** is checking about once per second to see if you want to dial, all you have to do is key your transmitter, then dial the phone number. You will now hear the phone ring and someone answer. Since the enhanced control system of **SMART PATCH** is constantly checking to see if you wish to talk, you need to simply key your transmitter and then talk. That's right, you simply key your transmitter to interrupt the phone line. The base station automatically stops transmitting after you key your mic. **SMART PATCH** does not require any special tone equipment to control your base station. It samples very high frequency noise present at your receiver's discriminator to determine if a mobile is present. No words or syllables are ever lost.

## SMART PATCH Is All You Need To Automatically Patch Your Base Station To Your Phone Line.

Use **SMART PATCH** for:

- Mobile (or remote base) to phone line via Simplex base. (see fig 1.)
- Mobile to Mobile via interconnected base stations for extended range (see fig. 2.)
- Telephone line to mobile (or remote base).
- **SMART PATCH** uses **SIMPLEX BASE STATION EQUIPMENT**. Unlike your ordinary base station, **SMART PATCH** does this without interfering with the normal use of your radio.

### WARRANTY?

YES, 180 days of warranty protection. You simply can't go wrong. An FCC type accept coupler is available with **SMART PATCH**.

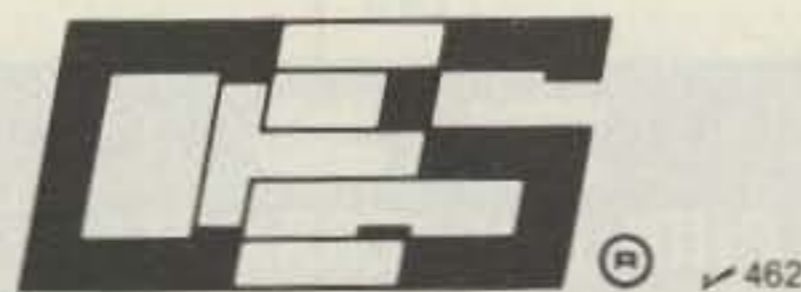

**Communications Electronics Specialties, Inc.**  
P.O. Box 2930, Winter Park, Florida 32790  
Telephone: (305) 645-0474 Or call toll-free (800)327-9956



# Presenting two small cases for a lot of mobile power.

You won't find a 45-watt, 2-meter FM mobile rig that's built smaller than the Yaesu FT-270RH.

Nor will you find a dual-band FM mobile that offers the crossband full-duplex capability found in the 25-watt Yaesu FT-2700RH.

It shouldn't be surprising. We've been coming up with a lot of innovative concepts lately.

The FT-270RH measures just 2 x 6 x 7 inches. Conveniently fitting its high-power punch into many small spaces of your car. Places where other 45-watt mobiles just won't fit.

The FT-2700RH is small too. Smaller than other dual-banders. But with one big difference: a "DUP" button. Push it, and you're operating full duplex, 2 meters on one VFO, 440 MHz on the other. Each at 25 watts. So you can simultaneously

transmit and receive in true telephone style.

Once installed, you'll find the FT-270RH and the FT-2700RH equally simple to operate. Just turn the rig on, dial up a frequency, select offset or duplex split, and you're on the air.

Each rig gives you 10 memories for storing your favorite frequencies. Dual VFO capability. A clean, uncluttered LCD display for easy readout. Push-button jumps through the band in 1 MHz steps. Band scanning with programmable upper and lower limits. And priority channel operation.

You don't even have to take your eyes off the road to determine your operating frequency and memory channel. An optional voice synthesizer announces them both at the push of a button on the microphone. The FT-2700RH announces both your

2-meter and 440 MHz operating frequencies.

Also, tone encode and encode/decode capability is programmable from the front panel, using an optional plug-in board.

So when you need a lot of power in a compact mobile radio, discover Yaesu's FT-270RH and FT-2700RH. There's nothing else like them on the road.

## YAESU 83

### Yaesu Electronics Corporation

6851 Waltham Way, Paramount, CA 90723  
(213) 633-4007

### Yaesu Cincinnati Service Center

9070 Gold Park Drive, Hamilton, OH 45011  
(513) 874-3100

Prices and specifications subject to change without notice.



# KENWOOD

*pacesetter in amateur radio*

## Pocket-size performers! TH-21AT/41AT

Kenwood's advanced electronic technology brings you a new standard in pocket/handheld transceivers! The TH-21AT/41AT features a high impact molded case and is designed to deliver convenient, reliable performance in a package so small, it will slip into your shirt pocket! It measures only 57 (2.24) W x 120 (4.72) H x 28 (1.1) D mm (inch) and only weighs 260 g (0.57 lb) with batteries. In typical Kenwood fashion these transceivers provide superior transmit and receive performance.

Both the 2 meter and 70 cm versions deliver one watt R.F. output on HI power and 150 mW low, for really extended battery life! Functional design includes three digit thumb-wheel switch for easy frequency selection along with a built-in 5 kHz UP-Shift switch and repeater offset switch. ( $\pm 600$  kHz or simplex, 2m version and  $\pm 5$  MHz or simplex 70 cm version.)

Both the 2 meter and 70 cm pocket/handheld transceivers are available in standard or 16-key autopatch DTMF encoder versions. Kenwood thread-loc antenna connector is also provided.

See your authorized Kenwood dealer and take home a pocket full of 2 m or 70 cm performance today!

### Optional accessories:

- HMC-1 headset with VOX
- SMC-30 speaker microphone
- PB-21 Ni-Cd 180 mAH battery
- DC-21 DC power supply
- BT-2 battery case
- EB-2 external C manganese/alkaline battery case
- SC-8 soft case for TH-21A/41A
- SC-8T soft case for TH-21AT/41AT
- TU-6 programmable sub-tone unit
- AJ-3 thread-loc to BNC female adapter

More information available from authorized dealers of Trio-Kenwood Communications, 1111 West Walnut Street, Compton, CA 90220.



TH-21A/41A  
Standard versions.

TH-21AT/41AT  
Specifications and prices are subject to change without notice or obligation

