

73 Magazine

for Radio Amateurs

- 26 **Four-Wheel Frenzy!**
—hams and the Baja Internacional K6WS
- 32 **T-R Exotica**
—rf switching with PIN diodes W4VGZ
- 34 **The Autodialer Revisited**
—a circuit board and other
improvements W7JSW
- 36 **Watergate Special**
—create your own 18-minute gap HB9BLU
- 40 **Be Legal**
—build an ID reminder AD4A/WA4MFY
- 44 **Another IC-22S Scheme**
—for oddball repeaters WA1ZMQ
- 46 **Improving the SWTPC UDI**
—self-preservation made easy K3MPJ
- 48 **Graduate to a Better Operating Desk**
—lots of class WB6EKO
- 50 **The SWL Bible**
—tuning the ends of the world W2XQ
- 58 **The Mobile Dream Machine**
—Kenwood, Drake, Larsen ... and
Ford K9SQG/B
- 62 **Be A Surplus Survivor**
—don't get burned by a boat anchor WB4APC
- 64 **Tracking the Wild Turkey**
—DF tips WA8BHR
- 68 **High Q Antennas**
—stop worrying about swr K4KI
- 72 **When In Doubt, Improvise!**
—adding TT convenience to your
HT-144B W6LTV
- 74 **Relief for the Rockbound**
—continuous tuning for FM rigs WB2EQG
- 78 **Power Supply Magic**
—the forgotten voltage doubler Burt
- 82 **DVM Scrapbook**
—the basics McClellan
- 88 **Meet Mr. Blizzard**
—Dayton hams were ready K8YQH/AA8P
- 92 **The Blizzard of '78**
—a real snow job W8HXR
- 94 **How Do You Use ICs?**
—part X WA2SUT/NNN0ZVB
- 98 **Relax and Unwind**
—your antenna wire WA4TJJ
- 100 **☛ Nuclear Attack!**
—WWIII on your SR-52 WA7WKA
- 106 **☛ Computerized QSO Records**
—who needs a logbook? WA7VZR
- 112 **☛ RAM Checkout's A Snap**
—this tiny program does the job WA7NEV
- 118 **The Case of the Missing Offset**
—adding to the HW-2021 K3JZD
- 122 **What Do You Do With A Timekubel?**
—when in doubt, modify it! Staff
- 126 **Gourmet Guide To Capacitors**
—for that project you have cooking W5JJ
- 128 **The ARC Tuner**
—rejuvenated surplus K9QLL
- 132 **Home-Brew Circuit Boards**
—cheap and simple W9IWI
- 136 **73 Reveals Bias!**
—transistor operation exposed! W5JJ
- 138 **CB to 10**
—part X: Realistic's Mini 23 K5LUW/K5SA
- 140 **Kerchunk . . . Kaboom!**
—safe distances between dynamite and
rf N5KR
- 142 **Be Mr. Clean!**
—simple RTTY trash remover WB4FXD
- 144 **Build the Triple Threat Keyer**
—great Novice project W8FX/4
- 146 **The Ten Meter AM Antenna Special**
—\$5 vertical also works on SSB or FM W6RCL
- 152 **Buddy, Ya Got A Match?**
—build one L of a matcher K4KI
- 164 **Another Trick for the 22S**
—now it's a remote control system WB7SHW
- 168 **"Stop Timeouts!" Revisited**
—PC board for K3VTO's timer WB3ELV
- 170 **Maintain Control!**
—keeping power tools in their place Stanfield
- 172 **CB to 10**
—part XI: Hy-Gain's PLL rigs WB5BSG
- 174 **Active Voltage Divider**
—for dividing active voltage PY1AQL/CT1EM
- 201 **Charge!**
—your nicads W4VGZ
- 204 **Light Right?**
—do-it-yourself photo exposure meter Mills
- 214 **Micoder™ Magic**
—improve it with easy mods K4BJF
- 220 **Build the IC Experimenter**
—getting started with TTL and CMOS Leonard
- 222 **A New Type of 10 GHz Receiver**
—use it or lose it Kopeika, 4Z4TJ
- 224 **Two Meters At the Summit**
—a backpacker's delight W6FJT

TEMPO... still the best value in quality 2-meter equipment



TEMPO FMH-2, FMH-5 & FMH-42 (UHF)
 ...portables you can depend on at a price you can afford

6 channel capability • selectable 1 or 2 - 1 or 5 Watts output (VHF) • Solid-state • Battery level meter • Earphone jack • Built-in charging terminals and separate charging jack for Ni-cad batteries • Flex antenna • Carrying case standard • Excellent frequency stability allows use with booster amplifier for high power output over 100 Watts • External microphone capability • 8 AA batteries or 10 AA Ni-cads.*

*Batteries not furnished
 FCC Type accepted models available.
 Accessory holder shown

Watch our October ads for 1978's most exciting technological breakthrough in 2-meter FM communications

TEMPO VHF & UHF solid state power amplifiers

Boost your signal... give it the range and clarity of a higher powered base station.

VHF (135 to 175 MHz)

Drive Power	Output	Model No.	Price
2W	130W	130A02	\$209
10W	130W	130A10	\$189
30W	130W	130A30	\$199
2W	80W	80A02	\$169
10W	80W	80A10	\$149
30W	80W	80A30	\$159

UHF (400 to 512 MHz)

Drive Power	Output	Model No.	Price
2W	70W	70D02	\$270
10W	70W	70D10	\$240
30W	70W	70D30	\$210
2W	40W	40D02	\$165
10W	40W	40D10	\$145
2W	10W	10D02	\$ 75

Lower power and FCC type accepted models also available

TEMPO POCKET RECEIVERS

Low priced, dependable and the most compact receivers available

MS-2, 4 channel scanning receiver for VHF high band, smallest unit on the market. MR-2 same size as MS-2 but has manual selection of 12 channels. VHF high band. MR-3, miniature 2-channel VHF high band monitor or paging receiver. MR-3U, single channel on the 400 to 512 UHF band. All are low priced and dependable. Now available with accessory CTCSS and 2-tone decoders.



TEMPO FMT-2 & FMT-42 (UHF)

An exciting approach to mobile communication

Compact transceivers offering versatility and performance. Supplied with an unbreakable remote control

head for hide-away mounting in mobile use and to provide a small neat package for base applications. 6 channel capability with one supplied. A hand-held PTT microphone and 20 foot cable supplied. 2 watt power output for low current, low power applications, but designed for output up to 120 watts on VHF, and up to 100 watts on UHF. With AC power supply becomes a base station with 120 watts VHF or 100 watts UHF.



TEMPO VHF/ONE PLUS

Still the best buy in a mobile transceiver... compare features... compare prices.

Full 2 meter coverage, 144 to 148 MHz for both transmit and receive • 25 watts or low power output selectable •

Remote tuning on microphone • Sideband operation with SSB/ONE adapter • MARS operation capability • 5 kHz numerical LED • Full phase lock synthesized (PLL) • Automatic repeater split-selectable up or down • Two built-in programmable channels • All solid state • 800 selectable receive frequencies with simplex and ± 600 kHz transmit frequencies for each receive channel. Still only \$399.



BIRD Model 4362 Thruline Wattmeter

... the perfect accessory for any 2-meter operation. Bird directional wattmeters are insertion type instruments for measuring forward or reflected power in 50-ohm coaxial transmission lines. \$94.00.

HF model 4360 (\$94.00) and a complete line of BIRD products also available.

Sold at Tempo dealers throughout the U.S. and abroad. Please call or write for further information.

Prices subject to change without notice

Henry Radio

H3

11240 W. Olympic Blvd., Los Angeles, Calif. 90064
 931 N. Euclid, Anaheim, Calif. 92801
 Butler, Missouri 64730

213/477-6701
 714/772-9200
 816/679-3127

ASK ANY HAM WHO OWNS ONE: THE **Wilson**

SYSTEM ONE™ 20-15-10 METER TRIBANDER



"One thing is for sure. If you can't hear the DX you can't work it. With my new System One by Wilson, that problem is all but eliminated. I can hear a lot of stations that others seem not to hear. Sure helps with the DX"

... **RON-WB4GWA**
HERMITAGE, TN.



"Just put up a System One ... went up as slick as a whistle ... more pile-ups than I can handle".

... **JOAN-WD6BNH**
SANTA BARBARA, CA.



"... As far as performance, the operation of the new System One is expressed by my increased success among the ruthless 20 meter pile-ups"

... **RICK-WB9ZAH**
FT. WAYNE, IN.



"After using the System One to contact DX stations throughout the world, I am convinced that it would take a much larger antenna to make any significant difference at either end. A frequent comment from European stations on 15 meters was, 'You are the only West Coast Station coming through'.

On 10 meters I worked all continents in less than 3 hours."

... **AL-K7ICW**
LAS VEGAS, NV.



"The System One is providing good results ... it takes the waiting out of a pile-up."

... **LES-N1BH**
NARRAGANSETT, R.I.

... THE ACCEPTED INDUSTRY STANDARD

From the seasoned professional operator to the novice ... all agree that the System One™ outperforms anything available ... the ultimate Tribander! Real monoband performance with 4 full elements on 20 and a separate 10 meter reflector, all on a 26' boom.

You can obtain more information on the System One™ and Wilson's other antenna, radio, tower and rotor products by contacting your nearest amateur dealer.



Consumer Products Division

W2

Wilson Electronics Corp.

4288 S. Polaris / P. O. Box 19000 / Las Vegas, Nevada 89119 / (702) 739-1931 / TELEX 684-522

Staff

EDITOR/PUBLISHER
Wayne Green W2NSD/1

EXECUTIVE VICE PRESIDENT
Sherry Smythe

ASSISTANT PUBLISHER
Jeffrey D. DeTray WB8BTH/1

ADMINISTRATIVE ASSISTANT
Dotty Gibson

ASSISTANT BUSINESS MANAGER
Robert R. LaPointe

MANAGING EDITOR
John C. Burnett

ASSISTANT MANAGING EDITOR
Susan G. Philbrick

NEWS EDITOR
Gene Smarte WB6TOV/1

BOOK PUBLICATIONS
Christopher E. Smith

PRODUCTION MANAGER
Lynn Panciera-Fraser

ART DEPARTMENT
Craig Brown
Gayle Cabana
Bob Drew
Bruce Hedin
Carl Jackson
James Lamothe
Dion Owens
Noel R. Self WB1ARP
Robin M. Sloan

PRINTING
Gary Steinbach
Andy Comeau
Dan Morgan

PHOTOGRAPHY
Bill Heydolph
Tedd Cluff

TYPESSETTING
Barbara J. Latti
Mary Kinzel
Marie Walz

BOOKKEEPER
Knud E. M. Keller KV4GG/1

CIRCULATION
Barbara Block
Laura Barnicle

DATA ENTRY
Judy Brumaghim
Linda Cate
Mary Kinzel

DIRECTOR OF MARKETING
Daniel D. Savage

BULK SALES MANAGER
Judy Waterman

SHIPPING
Theresa Toussaint
Ethan Perry
Bill Barry

RECEPTIONIST
Doni Jarvis

ASSOCIATES
Robert Baker WB2GFE
E. H. Barnett WB0IX
Schley Cox WB9LHO
Tom DiBlase WB8KZD
Terry Fox WB4JFI
W. Sanger Green
Dave Ingram K4TJWJ
Larry Kahaner WB2NEL
Joe Kasser G3ZCZ
Bill Pasternak WA6ITF
John Schultz W4FA
Walter Scott K8DIZ
Peter Stark K2OAW
Bill Turner WA0ABI

COMPUTER PROGRAMMING
Richard J. Dykema
Ron Cooke
Steven B. Lionel

CUSTOMER SERVICE
Florence Goldman
Joyce Tarr

ADVERTISING
Aline Coutu
Marcia Stone
William G. York
Nancy Ciampa

W2NSD/1 NEVER SAY DIE

editorial by Wayne Green



ATLANTA, DALLAS, ETC.

The last few months have been exceptionally busy and exciting for me. They have taken me to several countries and a number of hamfests and computer shows. More important, in the long run, are the political implications... and by that I mean with regards to the future of amateur radio... of these last few weeks.

A year ago, in a newsletter to the ham industry (dated May, 1977), I outlined the dangers of the coming WARC conference in Geneva. Being one of the few surviving delegates from the last WARC conference (1959), I perhaps have a little more perspective on the whole situation than people who have not been through one of those conflicts. That was twenty years ago and most of the people involved have either died or retired by now, so we have a new generation of innocents preparing for what promises to be a bloodbath.

Those few of you readers who have hung in there with me for the last twenty years or so have read all of this before. Hmm... I wrote my first editorial in a ham publication just 26 years ago. Luckily I didn't suspect what I was getting into.

To go over history very briefly. In 1959, I arrived at Geneva to meet with the delegates from over 100 countries of the world. I found that though a few were amateurs, they were representing commercial or military interests, not amateur. The only country that permitted amateurs to be represented on their delegation was the U.S., with me and a chap from the ARRL being it. In reading over the of-

ficial positions of the other countries, I found that few had any respect for amateur radio and that most were proposing drastic slashes in amateur frequencies.

In general, we were in a little better shape with the European countries, with the worst positions for us being proposed by Australia and India. Australia was demanding that all ham bands be cut to 50 kHz... and this was their official proposal. India wanted them cut to 20 kHz. Bless India.

Through an almost unbelievable stroke of good fortune, the U.S. managed to get reallocations in the 3-30 MHz bands put off until the next conference, scheduled for 1969. If a writer used a coincidence as weird as the one that happened, he would be laughed at. The U.S. was not trying to save the ham bands by this move; they were just trying to hold on to the disproportionate number of frequencies they had grabbed for many services at Atlantic City in 1947 and at previous ITU conferences.

The fact is that, even though the official U.S. WARC proposal called for continuing the ham bands as they were, I found that the members of the U.S. delegation had private orders to replace any losses to their service by taking frequencies from the nearest ham band. We had no friends at that conference, believe me... and the most predatory of all of the delegates turned out to be hams wanting to take ham frequencies for their employers. This is one of the reasons I laugh a little when I hear an ARRL president tell a gullible audience that we don't have to

worry, hams on the foreign delegations will help us protect ham frequencies. Ha.

By 1965, the newly-chartered African countries were joining the ITU and swinging the balance of power. By 1966, I became concerned enough about the situation to look into it and see what I could do. I had been visiting the ITU pretty regularly, keeping in touch with the hams there and getting the inside information on what was really going on. I visited the ITU in 1958, 1959, 1961, 1963, 1965, and 1966. My visit in the spring of 1966 made it seem important to me to arrange for a trip to visit some of the countries involved and see some of the top ITU people.

That summer I went to Africa and visited the hams in Kenya, Uganda, Ethiopia, Sudan, and Egypt. While in Addis Ababa, I had the opportunity to get together with the just-replaced secretary-general of the ITU. I talked with him about the importance of amateur radio to emerging nations as an inexpensive source of technicians, and he thought this was an important concept which should be brought to the attention of the current secretary-general, an Indian. I DXed my way up to India, stopping off on the way to visit and operate in Lebanon, Syria, Iran, and Afghanistan. I visited Iraq, but was unable to get permission to operate there.

Mr. Sarwate, meeting me in Delhi, was most interested in what I had to say about amateur radio and its benefits to new nations. We discussed getting the ITU to back a plan for developing amateur radio in these countries, and I agreed to

**You can still
buy one of the world's
best HF transceivers
for under \$1,000**

TS-820

Even without the digital display, Kenwood's TS-820 provides extremely sensitive and accurate tuning, plus all of the electronic and mechanical advantages found only in the TS-820S. Its reliability has been proven through thousands of hours of use under all environmental conditions.

The TS-820 stands out from all the other rigs on the band. Its adjustable RF speech processor, utilizing a 455 kHz circuit to provide quick-time-constant compression, will get your message through the pile ups. RF negative feedback is applied from the final to the driver to improve linearity, and third-order products are at least -35 dB. Harmonic spurious emissions are less than -40 dB and other spurs are less than -60 dB. RF input power is 200 W PEP on SSB, 160 W DC on CW, and 100 W DC on FSK. Receiver sensitivity is better than 0.25 μ V for 10 dB S/N. The TS-820 is known for its superb receiver selectivity, and its famous IF shift easily eliminates heavy QRM. That's why the TS-820 series is the DXer's choice.

And, of course, anytime you might want to add a digital display, it's simply a matter of installing the DG-1 option.



TS-820 VFO-820S SP-820

Kenwood's unbeatable combination. The VFO-820 solid state remote VFO adds greatly to the versatility of your TS-820. It has its own RIT circuit and control switch and is a perfectly matched accessory. The SP-820 deluxe external matching speaker includes audio filters for added versatility on receive and two audio inputs.

write a set of rules for small countries which would encourage amateur radio to develop. Many countries were completely unaware of amateur radio and, even if they were interested, didn't know how to get it going.

Upon returning home, I set about preparing a set of regulations for the ITU to recommend. Before I could get them to Mr. Sarwate, he had the bad luck to drop dead and I found myself back on square one. I would have liked to take a trip to visit his replacement, but when I returned from my three-month trip, I found *73 Magazine* in terrible shape. We were over a month behind in publication and virtually bankrupt. It took me a couple of years to get *73* back into good enough shape so I could even think of leaving it for more than a few days.

My visit to the ITU in 1968 confirmed that the African nations had taken control. The European countries still had enough clout to prevent the scheduled 1969 WARC, but not enough to hold their frequencies if the conference had been permitted. By the '70s, the Europeans couldn't even prevent the 1979 conference, though they knew it would be a terrible experience.

The African countries have been voting in a bloc to rectify the frequency situation. Their view is that 10% of the world grabbed 90% of the frequencies in the past, and they, by damn, are now going to get their share and then some. They flexed their muscles in 1971 at the satellite conference when they wiped out all of the ham microwave satellite allocations. We went in with 239,249 MHz of ham satellite channels, enough so every ham in the world could have been in contact with any other via a set of three synchronous satellites within a few years. We lost every single Hz of those allocations. The report is in *QST*, where the ARRL admits that they went into the conference unprepared and lost everything. Oh, we did keep a little bit of the VHF's, but not enough to be of much use . . . and the real future of amateur radio, the microwaves, were cut off.

The white countries ran into this African buzz saw again in 1973 when the maritime interests got together for an interim ITU conference and the African bloc wiped them out, ignoring all technical advice and grabbing every channel they could—even the totally landlocked nations. What will they be doing with these frequencies? None of our business, they say, and if they want to rent them out or sell them, that's their prerogative.

JORDAN

During my visit to Jordan in 1970, I talked with King Hussein about the advantages to his country of amateur radio. I explained about the hobby as a way of getting almost free technicians, particularly as compared to the cost of bringing in Swiss or German technicians and engineers, which often run to \$500 a day or more. He liked the idea and had me explain it to his government.

They started right in with this idea, even though Jordan was in the middle of a civil war between the Palestinians and the Jordanians. They set up ham stations in every youth club in the country and got the kids interested in amateur radio. His Majesty asked me to come back in 1973 and see what had come of my idea, and I met about 500 enthusiastic Jordanian hams, all in their teens, as I visited ham clubs from one end of the country to the other. They were just about to start work on the first Jordanian electronics factory . . . something which would have been impossible just three years before.

Just recently, I noted a piece in the *Herald Tribune* quoting a communications student at the University of Amman! From zero technicians to communications graduates in so few years . . . It shows what can be done.

ARMA

When ARMA (Amateur Radio Manufacturer's Association) was first formed in 1977, I brought up the problem of getting African votes for amateur radio at WARC, but the manufacturers were too busy worrying about bylaws, who was going to be president of the group, FCC hassles, etc. This was why I put the information on the subject in my May, 1977, newsletter to the industry. I hoped that something would come of it at their Atlanta '77 meeting . . . nothing did.

I brought it up again at the next ARMA meeting in Vegas during SAROC '78. Nothing happened again. Though I was elsewhere during the Dayton Hamvention, I did get a tape of the ARMA meeting and nothing more happened. With Atlanta being the last meeting of the year, I sent out one more newsletter in May, 1978, outlining the problem and my proposed solution.

ATLANTA

HR Report (I called it half-right reports, but then I am often accused of exaggeration) said . . . "Wayne Green will present a WARC '79 'progress report' to the ARMA meeting in Atlanta next week. Since he has yet to participate in any of the U.S. WARC preparation that's been going on in Washington since 1975, it should be an interesting presentation. Noel Eaton

VE3CJ, who has attended WARC preparation meetings throughout the world for the IARU, will also be present and may contribute some appropriate observations."

Hopefully, the sarcasm of the above is not lost on you.

Indeed, I did report to ARMA, though not on WARC directly . . . as *HR* very well knew. In view of the lack of support for the U.S. position at WARC, I didn't think it worth a lot of time to argue endlessly over it. What a waste of time. I presented my perspective on the possible outlook for WARC, and I played several minutes of a tape recording I had made four days earlier in Geneva when I interviewed one of the hams at the ITU. The tape is unofficial, so I can't quote it directly. Visitors to *73* or to some of my talks at hamfests will have a chance to hear it. The impact is strong: I was unable to find anyone at ITU who held out much hope for ham bands after 1979. The idea of a mission to Africa to interest countries in the value of amateur radio to them, with the example of Jordan to show, was deemed the only hope.

ARMA also listened to Eaton, and I also have a tape of that for those interested. He reported that the IARU, the international arm of ARRL, had approached many African countries for support at WARC. That sounded good. ARMA members pushed for more details, which were finally drawn from Eaton. It seems that the IARU has worked *only* in countries where they already have an IARU member society. Obviously these are countries where they already have an IARU member society. Obviously these are countries where amateur radio is relatively well developed and not a serious problem in the first place. Eaton was asked about contact with the so-called "black bloc" . . . no, none of them, only the IARU member countries, and those on a lower level, not on top, where it counts.

After hearing that, ARMA voted overwhelmingly (one way) to support a mission to Africa and to fund it by asking amateurs and the industry to send in \$10 to \$20 a week each for a period of three months. With the full cooperation of the industry, this would more than provide the \$20,000 a month a mission would cost.

Joe Brunzo of *Ham Radio* magazine volunteered to prepare a letter to be sent to the industry within the next few days to get the money started. I discussed this with him, pointing out that, in view of *Ham Radio* magazine's rigid support of ARRL policies, he might not be permitted to prepare the let-

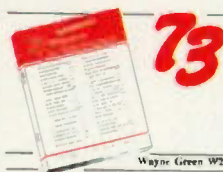

73 magazine LOOKS AT

- ARMA Trade Mission
- New ARRL Law
- Atlanta

Wayne Green W2NSD—Editor/Publisher

May 18, 1978

NEXT YEAR HAS BEEN CANCELLED

The ham business is going along pretty well these days. Teles picked up the Hy-Gain empire, lost when Hy-Gain didn't plan for the future of CB as many people forecast it. Even the underground CB amplifier manufacturers are desperately trying to get into the ham business as a means of survival. Most ham manufacturers are having more problems with keeping up with orders than looking for more business. With very few exceptions things are going great and the worries are over immediate problems, not what is going to happen next year or what happened last year.

How much serious thought have you given to what you would do if amateur radio were totally cancelled next year? Whether or not a possibility is a remote chance or a sure thing depends upon whom you consult. My own contacts are knowledgeable and wide in this field and I can say that I know of no one involved with the coming ITU conference next year who holds out much hope for our survival.

Many amateurs point out that certainly the ARRL is aware of this and must therefore be working hard to do something about it. To prepare. While this does seem both likely and reassuring, the League has had a clear history of not preparing for these ITU meetings in the past and there is no hint that they are doing anything this time.

One has merely to consult the report of their representation of amateur radio at the ITU satellite conference in 1971. This report was published in *QST*, but in very fine print in the back, so most League members missed it. The report was that amateurs went into the conference with satellite ham bands allocated in eleven UHF bands for a total of 237,249 MHz of frequencies. This was enough to allow amateurs to consider putting up a set of synchronous satellites which would permit every amateur in the world to talk with any other via satellite and relatively low power UHF ham antennas.

And what was the result of this ITU allocation conference as reported in *QST*? Buried in the back pages in fine print was the report that they lost all but 5 MHz of those allocations. That's right, they went in with 237,249 MHz of ham satellite UHF frequencies and came out with 5 MHz. Obviously this cut off forever most of the future development of amateur radio unless there is some question in your mind about the development of microwaves and satellites as being the future of communications.

The *QST* report lamented that the ARRL had not made the necessary preparations for the conference. Indeed, in light of the things that happened, it was obvious that even a modicum of prepara-

tions could have substantially changed the outcome. I see no sign that the League has learned from their debacle.

Exactly what ham bands did we lose in 1971 for satellite operation? We lost 50-54 MHz completely. We lost 146-148 MHz. We lost 220-225 completely. We lost 420-435 and 438-440 MHz, keeping just 3 MHz of that band out of the 30 MHz we had going in. We lost everything above that. The microwave horizons of amateur radio were wiped out completely. Every indication is that unless something is done and done immediately the ham short wave bands will go the same route as the UHF bands and for the same reasons. I explained this situation in a letter to advertisers dated May 1977 . . . and it fell on deaf ears. No one did anything about it at Dayton last year, or even at the Atlanta ARMA meeting. Now we've had another Dayton ARMA meeting with nothing more than some sniffing and jostling and nothing concrete accomplished. The very last chance to do something will be at Atlanta.

LAST CHANCE: ATLANTA

There are two major moves that the ham industry must make if it wants to take any positive action toward survival. The alternative is the ARRL route of just letting things happen and hoping for the best . . . as we did in 1971. Well, we lost 99.99684% of our satellite frequencies at that ITU meeting. If we suffer the same loss on the short waves we would come out of the meeting with 109.4 Hz of

ham bands in which case amateur ingenuity with narrow bandwidths would be called into play.

What can be done? The problem, of course, as reported in *QST*, was the ITU system of one vote for each country. With the African and Asian emerging nations now in the majority, they are calling the shots. There is little reason for these countries to voluntarily give up exceedingly valuable short wave frequencies for what they consider as an American hobby. This calls for a personal sacrifice on their part for something which is of no interest to them.

The real fact is that these amateur bands could be the single most valuable resource these countries could have in radio spectrum. Jordan proved that within three years a very small and poor country could develop enough radio amateurs to make it possible for them to get involved in the manufacture of radio equipment. In just three years Jordan went from having zero hams to having over 500 licensed amateurs, almost all teenagers, and most of them thus interested in technical careers.

With imported technicians and engineers costing up to \$1,000 per day, and few available at much under \$200 per day, emerging nations can't afford much in telephone or radio communications development. Thus both business and government work is hobbled by poor phone operation and slow international communications. A corps of interested hams in a country make it possible to get a lot

New, Remotable 2meter Mobile!



ICOM's New IC-280

ICOM introduces its new 2 meter mobile radio with the detachable microprocessor control head, the **IC-280**. Bright, easy to read LED's and a new style meter grace the brushed aluminum "new look" front panel of the detachable control head, which provides memory and frequency control for the remotely mountable main section.

The **IC-280** comes as one radio to be mounted in the normal manner: but, as an option, the entire front one third of the radio detaches and mounts by its optional bracket and the main body tucks neatly away out of sight. Now you can mount your 2 meter mobile radio in places that seemed really tight before.

With the microprocessor head the **IC-280** can store three frequencies of your choice, which are selected by a four position front panel switch. These frequencies are retained in the **IC-280**'s memory for as long as power is applied to the radio. Even



when power is turned off at the front panel switch, the **IC-280** retains its programmed memories; and when power is completely removed from the radio, the ± 600 KHz splits are still maintained!

Frequency coverage of the **IC-280** is in excess of the 2 meter band; and the new band plan (144.5-145.5 MHz repeaters) can easily be accommodated, since it was included in the **IC-280**'s initial planning by the ICOM design team.

The main section of the **IC-280** puts you up to the minute with the latest state of the art engineering. The new **IC-280** includes the latest innovations in large signal handling FET front ends for excellent intermodulation character and good sensitivity at the same time. The IF filters are crystal monolithics in the first IF and ceramic in the second, providing narrow band capacity for today and tomorrow's crowded operating conditions. Modular PA construction with broad band tuning provides full rated power across the full 2 meter band (plus a little).

All ICOM radios significantly exceed FCC specifications limiting spurious emissions.

Specifications subject to change without notice.

IC-280 Specifications: Frequency Coverage: 143.90—148.11 MHz Operating Conditions: Temperature: -10°C to 60°C (14°F to 140°F). Duty Factor: continuous Frequency Stability: ± 1.5 KHz Modulation Type: FM (F3) Antenna Impedance: 50 ohms unbalanced Power Requirement: DC 13.8V $\pm 15\%$ (negative ground) Current Drain: Transmitting: 2.5A HI (10W), 1.2A LO (1W), Receiving: 0.630A at max audio output, 0.450 at SQL ON with no signal Size: 58mm(h) x 156mm(w) x 228mm(d) Weight: approx. 2.2 Kg Power Output: 10W HI, 1W LO Modulation System: Phase Max. Frequency Deviation: ± 5 KHz Spurious Output: more than 60 dB below carrier Microphone Impedance: 600 ohms dynamic or electret condenser type, such as the SM-2 Receiving System: Double superheterodyne Intermediate Frequency: 1st: 10.695 MHz, 2nd: 455 KHz Sensitivity: 1 μV at 5 +N/N at 30 dB or better, Noise suppression sensitivity 20 dB, 0.6 μV or less Selectivity: less than ± 7.5 KHz at -6 dB, less than ± 15 KHz at -60 dB Audio Output: More than 1.5W Audio Output Impedance: 8 ohms

HF/VHF/UHF AMATEUR AND MARINE COMMUNICATION EQUIPMENT

DISTRIBUTED BY:



ICOM

ICOM WEST, INC.
Suite 3
13256 Northrup Way
Bellevue, Wash. 98005
11 (206) 747-9020

ICOM EAST, INC.
Suite 307
3331 Towerwood Drive
Dallas, Texas 75234
(214) 620-2780

ICOM CANADA
7087 Victoria Drive
Vancouver B.C. V5P 3Y9
Canada
(604) 321-1833



Here's Helen Harris W1HOY/KP4 on the left, me, and Sam Harris W1FZJKP4 on the right. Sam had a serious bout with lung trouble last year, but is back in fighting trim now. He's stopped smoking. For newcomers to amateur radio, Sam was the chap who invented the first parametric amplifier—he built it to work on 6m—and he was the promoter of a series of moonbounce developments, including the use of the 1000-foot dish at Arecibo for 1296 MHz ham moonbounce a few years back. Sam runs the lab at Arēclbo, the world's largest radio telescope.

I first visited Sam when he was W8UKS out in Burton, Ohio, when we were both involved with 75m DXing. Later he moved up near Boston and became the VHF editor of CQ while I was editor of that magazine. When CQ got over a year behind in paying him, he switched over to QST, where he battled their anti-Technician policies for some years, finally quitting them.

Sam today is one of the foremost microwave scientists in the world, though a scientist in the historic sense in that he designs and builds things himself, not just with a computer doing the calculations and some technician the dirty work.

ter. He laughed.

THE ITU

My travels started back in late April with a trip to Los Angeles for a microcomputer show. This was the same weekend as Dayton, so other 73 Magazine staffers covered for me at Dayton. While in L.A., I got together with several ARMA members and discussed the WARC situation, and was able to make arrangements for the Japanese Ham Manufacturer's Association to fund and supply a very well qualified man for the proposed African mission, thus making it an international affair.

From there, I flew back to New York for a day at the Premium Show, then on down to Arecibo for a visit with Sam Harris W1FZJKP4 and his wife Helen W1HOY/KP4. The big dish there has been substantially improved since my last visit (1968), and there is growing interest in using it for a ham moonbounce weekend again. I was surprised and pleased to find that much of the dish's time is spent in looking for LGMs. They have a very big computer which analyzes everything coming in for anything which has a pattern, affectionately called looking for Little Green Men.

Eastern Airlines has one of

the darnedest fares yet . . . for about \$20 less than round trip to California, Sherry and I were able to fly to California, Atlanta, New York, Puerto Rico, Saint Martin, and back to Boston. We spent a couple days skin diving on Saint Martin (FS7/PJ7), then flew back to New Hampshire for a couple days . . . next to Birmingham for their hamfest . . . home again for a couple more days, then off to London to visit microcomputer stores and manufacturers . . . Paris for Micro-Expo, where I spoke to a packed house on microcomputer software . . . then up to Switzerland for the visit with the ITU.

I felt that the visit to the ITU headquarters was very important as a way of reinforcing my own observations on what has happened, what is happening, and what appears as if it will happen. The projection that looks likely to me is so terrible that I just couldn't really believe it. I felt the same as the high ARRL staffer I talked to recently who answered when I asked him about the possibility of our losing all ham bands next year, "They can't cancel amateur radio!" It is just unthinkable.

Unfortunately, I am able to at least consider the possibility of the totally unthinkable, so I

guess I was searching for reassurance and I felt that if anyone in the world might have a finger on the pulse of the WARC, it would be the people who are in the middle of it in Geneva. I decided to extend my Paris trip to Geneva and try for some encouraging words at the ITU. As I said earlier, I was unable to find anything to be optimistic about at Geneva. I talked with a number of people there, most of whom I have known for many years and have found most dependable and strongly on the conservative side.

Since I seem unable to really do anything about the situation, I will resume my complacent pose and join the ARRL and the rest of you with crossed fingers as a shield against the future, hoping that all will indeed be well and that I have been a worrywart for nothing. The ARRL may just be right—perhaps the ITU can't cancel amateur radio.

What are the chances of the U.S. ignoring the WARC decisions? I asked at the ITU about this. They say that this is impossible. What about the U.S. getting a footnote into the allocations table so U.S. amateurs can carry on? That's possible, but there wouldn't be much DX. This could keep 2m going, if such a move could be gotten through the ITU meeting. I'll be investigating these options.

THE MONEY NEEDED

The amount of money needed for the proposed mission is so insignificant when compared to ham sales that the resistance of manufacturers to funding is difficult to understand. I calculate it would run about \$20,000 a month. I based this on a rough estimate of \$100 per day per person, which is about what things cost in Europe these days. I also figured that since the people on the trip would be business people, they would have to get back to the U.S. every now and then to keep their businesses going. Figuring four people for three weeks, plus a round trip fare once a month, plus a couple gift ham stations for each of the three countries visited during each monthly trip, I came up with around \$20,000.

On the one hand, that's a lot of money, but compared to the U.S. ham sales of over \$100,000,000 per year, it's peanuts. With 231 different advertisers in the most recent issues of 73 and QST, I figured that if each of these put up just \$20 a week for one month, we would have our \$20,000. Check that out on your hand calculator. We have about 500 ham distributors plus over 1000

manufacturers, and who knows how many hams who could afford to send in money. No, the twenty thou should be easy to get, if anyone asked for it.

WHAT HAPPENED

When I got back from my latest round of ham and computer shows, I called Jack Burchfield of Ten-Tec to see what had come of the letter from *Ham Radio* asking for the industry to send money to ARMA for the mission and to the request for same in *HR Reports*. Jack said that the *HR* mention was minimal and no letter had been written and that, as far as he was concerned, that was the end of it. I agreed.

I explained to Jack that the *Kilobaud* exhibit at NCC in Anaheim had shown our new line of mass-produced software for the Radio Shack TRS-80 and the Commodore PET microcomputers. The orders already received and promised showed that we had a bull by the tail and I was needed at home to organize our growth to meet this new market. I said that while I would do everything I could to help amateur radio, I was not going to be foolish enough to be the only one to make the effort. Now that the industry knew the score, the ball was in ARMA's court.



INSTANT SOFTWARE

The concept behind our publishing software just as we do books and magazines was to make a large number of programs available for microcomputers. Without these programs, I could see a gradually growing public resistance to buying computers and another disaster something like the CB debacle coming. Computers are of no earthly use if you don't have programs for them.

Since it takes a lot of experience and time to write significant programs, I figured that the people who were doing this should get proper rewards in the form of royalties when their programs were sold. So far there has been little effort to do this, with the result that there are virtually no programs available for microcomputers.

The first thing I did was set

Continued on page 148

The evolution of the MLA

When the MLA-2500 was first introduced it was a new concept in high performance amplifiers. Low and sleek yet powerful enough for the military. Some wondered . . . needlessly.

A promise kept.

The MLA-2500 promised 2000 watts PEP input on SSB. A heavy duty power supply. Two Eimac 8875's. And as thousands of Amateurs across the world have proven, the MLA-2500 delivers!

Now DenTron is pleased to bring you **The new MLA-2500 B.** Inherently the same as the original MLA-2500, the B model includes all of the above specifications plus a few refinements. New high-low power switching for consistent efficiency at both the 1KW and 2KW power levels and 160 - 15 meters.

Tested and proven.

What better test for an amplifier than the Clipperton DXpedition? Even after 32,000 QSO's, and an accidental dunk in the ocean, the same 3 MLA-2500's are still amplifying other rare DXpeditions around the world - listen for them.

Convinced? Isn't it time you owned the amplifier that powered Clipperton and thousands upon thousands of radio stations throughout the world?

MLA-2500 B \$899.50.



DenTron[®]
Radio Co., Inc.

2100 Enterprise Parkway
Twinsburg, Ohio 44087
(216) 425-3173

ou soon don't ever probic
lousy manuscripts from bat
bur in the rock...
you...
I insist that you print ev
tell Ma Bell that she shou

LETTERS

THE CRRL AND 2M

I would like to enclose a copy of a letter from the CRRL concerning a proposal which, if passed, would eliminate all amateur activity on the two meter and 1 1/4 meter bands. One has to wonder about the intelligence of some of our overpaid and underemployed civil servants. As the Experimenter's license was to demand a high degree of technical knowledge, I wonder if there would be more than 100 people in all of Canada who would be interested. If the qualifications were to be lowered so as to include the CB types, not much interest would be shown in pulse or packet emissions. As this proposal would, if accepted, seriously affect two meter and 1 1/2 meter activity adjacent to the border, perhaps you will find this of interest.

I enjoy your magazine, although I believe the ARRL receives more than its share of criticism. I like the Ham Help letters, as it appears that amateur radio is becoming sort of impersonal and many contacts are only for the purpose of collecting QSL cards.

I don't consider it a QSO to exchange name, address, and signal reports. We seem to be losing the ability to communicate with each other. We need a lot more rag chews on the bands. Amateurs have too many repeaters on the air, sitting idle most of the time. Many are built out of spite or disagreement with other groups. You find that after an initial contact through a repeater, it is in many cases impossible to find anyone to talk to, as all the listeners feel they know who you are and where you are from. Is not one of the reasons for being a ham a sense of belonging to a group of people with similar interests? Perhaps we need to cultivate our abilities to talk to each other. We have lots to discuss, even the bureaucrats' attempts to get rid of us entirely.

As the present restrictions being placed on amateurs are due to the problem created by the illegal operation of CBers, a better solution could be a resumption of fees and a use of the money thus collected to ap-

prehend and impose severe penalties on these people. At the present time, there appear to be only feeble attempts to apprehend the illegal CBers or HFers, and if they are caught, they receive nothing more than a slap on the wrist. The ban on 10 meter linears I don't believe is any hardship on anyone. In fact, amateur radio would probably be better off if linears of all types were banned.

Willis Wood VE5WV
Estevan, Saskatchewan
Canada

I am grateful to Jack Reed VE3GMT for presenting this opportunity of briefly addressing you concerning a recent DOC proposal of far-reaching importance to the welfare of the Canadian Amateur Experimental Service, both nationally and internationally.

On March 1st, DOC issued its formal Canada Gazette proposals for their new code-free Experimenter's License. These proposals contained many surprises to your national organizations, many of which were at variance with discussion results at the recent DOC Amateur Symposium. Experimenter frequencies are proposed from 144 MHz up (no HF privileges), but of extremely serious consequence is the proposal to permit *only* Experimenters pulse modulation emissions on our two meter band, and, in addition, the deletion of *all* present emission forms between 220 and 225 MHz, except that of "packet radio." Packet radio is a technique through which packets of data may be broadcast over a communication channel which is shared by a number of users.

Although not conclusive at this point in time, the League considers that permitting pulse modulation over practically the entire two meter band could seriously interfere with and otherwise jeopardize present extensive repeater operations. Additionally, the present two meter OSCAR frequencies on this band could be seriously affected. Of equal if not perhaps greater concern is the Department's proposal to limit 220-225 MHz emission to that of "packet radio" only, thereby effectively precluding our projected repeater growth into this presently authorized band, not to mention the resultant in-

terference which will occur to present and future U.S. repeaters adjacent to the border.

Dr. deMercado (Director General of the DOC Regulatory Service), the apparent architect of these proposals, strongly feels that the implementation of these new regulations will launch Canadian amateurs into orbit as the world leaders in the development of these new communications techniques. We regret that we are unable to share his enthusiasm, especially with respect to the specified frequencies. The League does not wish to contradict the concept envisaged by Dr. deMercado, but we are *categorically opposed* to the particular spectrum frequency space which has been stipulated.

We suggest that there are other higher frequencies available, just as technically suitable, which would not severely handicap our present well-justified operations in the 144-148 and 220-225 MHz bands.

Technical progress and investigations are, of course, important justification factors for our service, but not, we respectfully suggest, if it should negate or otherwise sacrifice the other important facets of the amateur service by which amateurs have become acknowledged and proven national resources to our nation in both peace and war!

The CRRL shall shortly be making a complete and technically qualified presentation to the Department in respect to these proposals; however, we strongly wish to urge all individual amateurs to make their comment known direct to the DOC (Department of Communications, 300 Slater Street, Ottawa, K1A 0C8).

Thank you for your cooperation in helping us to help you.

Ron J. Hesler VE1SH
Director, CRRL

PRIORITY OVERRIDE

Your plan for converted CB sets on ten meters is the most logical I've seen to date, but it has one very important flaw.

As the Coast Guard found out decades ago, an emergency channel has to be used for calling and working channels for traffic after contact is established, so that people will always be listening.

Your idea to use the channel one position of converted sets for calling and listening is good, except for one thing: Many of the CB sets include a "Priority Override" switch which allows channel nine to interrupt reception on any

other channel, as long as the switch is on. This feature, if used by hams, would allow QSOs on other channels to be interrupted by a call on channel nine, thus allowing the owner to monitor both a local channel and the calling channel.

I suggest, therefore, that you should change the calling and listening channel to channel nine, at 29.065 MHz.

Ernest W. Horne WD6FZY
Isla Vista CA

A BETTER FEEDTHROUGH

I read with extreme interest the article, "A Better Feedthrough for Cables," page 50, June, 1978, issue of 73.

It was my choice for June's article winner, and an excellent one it is.

I submitted that same design to the ARRL and they published it in the July, 1976, issue of QST, page 41. I feel you gave the design a better layout than QST did mine. Anyway, keep up the fine magazine—I really enjoy reading it and have been a subscriber since last year.

By the way, this method has been used at my QTH for over two and a half years.

Keith H. Gilbertson WB0LXM
Detroit Lakes MN

A WORD FROM THE NBS

While we are delighted with Mr. Bloom's enthusiasm for the frequency calibration service using the TV network color subcarrier, there are some misleading and/or inaccurate statements in his article that should be clarified (see "In Search of the Ultimate—an Incredible counter calibrator," April, 1978, issue, p. 66).

NBS operates two HF radio stations, WWV in Ft. Collins, Colorado, and WWVH on Kauai, Hawaii. At the present time, both stations transmit on 2.5, 5, 10, and 15 MHz. The accuracy of the WWV/WWVH frequencies as *transmitted* is better than 1×10^{-11} (not 1×10^{-9} as stated by Bloom). The frequencies are generated by cesium beam atomic frequency standards located at the stations which are steered in long-term to agree with the NBS Frequency Standard in Boulder, Colorado. *Received* accuracy, correctly stated by Bloom, may be degraded to 1×10^{-7} by propagation path disturbances.

Mr. Bloom also referred to NBS station WWVL. These VLF transmissions, formerly operated at 20 kHz on an experimental basis, were terminated on July 1, 1972.

It is *not* true that NBS LF station WWVB on 60 kHz radiates

only frequency information. The format contains a BCD time code at a one-pulse-per-second rate, providing day of year, hours, minutes, seconds, and the difference between Coordinated Universal Time (UTC) and astronomical time, UT1.

NBS did not consult with the four TV networks, nor did NBS suggest that the networks stabilize their color subcarriers (control the frequency of the color burst). The networks began using atomic rubidium standards in 1968-1969 to solve an operational problem relating to synchronization of "remote" color broadcasts, such as sporting events. The stability of rubidium standards allowed these remote pickups to be "locked" to the network centers using one of several techniques described in the SMPTE (Society of Motion Picture and Television Engineers) journals in 1969-1970.

When we at NBS learned that the networks were installing atomic standards, we began looking into methods of utilizing the network subcarriers as frequency transfer standards, and many people are now using this technique for oscillator calibration. It is a quick, relatively inexpensive calibration method, and with care, one can achieve accuracies better than 1×10^{-10} with a high confidence level.

This would also seem to be an appropriate time to mention a new development in the use of the color subcarrier technique. The networks began using rubidium standards to solve some of their synchronization problems. However, the digital frame synchronizer now allows them to solve the same problems in a more flexible manner. Unfortunately, when a local station places a frame synchronizer "in series" with the network line, the highly stable atomic subcarrier reference is lost. Several of the network-owned stations are now using frame synchronizers so the viewers in their service areas can no longer receive the network subcarrier.

We at NBS are currently planning to survey all TV stations to determine how many stations are now using or plan to use frame synchronizers. We still feel that the color subcarrier is useful for frequency calibrations, but persons using this method should make measurements on more than one network so that the use of frame synchronizers by the local stations can be detected.

Dick D. Davis
Time and Frequency Division
National Bureau of Standards
Boulder CO

MINERAL OIL

This is in regard to the article, "Home Canned Dummy," page 154, 73 *Magazine*, May, 1978. The author suggests filling the dummy load can with motor oil. This can be an unsafe practice. A little arcing, and presto, instant fire! A much better choice is mineral oil, available from any drugstore or pharmaceutical house at very reasonable cost, and very nearly impossible to ignite. Also, transformer oil, once a favorite for this application, has been found to cause cancer, though it has good dielectric properties and a high ignition point. My choice is light mineral oil.

Ed English W6WYQ
San Luis Obispo CA

BUILDING JAMMERS

I just subscribed to 73 *Magazine* for 3 years and now I am beginning to wonder if I didn't make a mistake. You see, I made a special trip to the local ham store to purchase the May, 1978, issue in order to fill out the '78 series, and what should I find but an article telling hams to build police radar jammers.

Now seriously, Wayne, do you think a reputable ham magazine should be publishing this kind of information? Don't you think hams could spend their time to better advantage than building jammers? What about the legal aspects? Last time I looked at the regs, it was against the law to willfully cause interference to another service! If we want deregulation and a proud, self-governing hobby, then this is not the way to get it.

I hope the quality of articles improves or you will have to send the \$36.00 back. I also subscribe to *Kilobaud* and hope I never see an article like that in it, either!

George H. "Bud" Saum K0GS
Westminster CO

HUMAN RELATIONS

In the June, 1978, issue, in an article by K5LUW entitled "Disguised Birdhouse Antenna," the author makes a very poor statement, i.e., "Also, if the sight of large antenna arrays automatically makes your neighbors' television sets start acting up and you are tired of those annoying phone calls every time you start operating, maybe what you need is a disguised antenna..."

Maybe you need an FCC citation or at least a course in human relations somewhere. It

seems that the ARRL has you here—for many years, they have talked about the "proper" ways to handle TVI problems (and I cannot recall one solution being to "disguise" your antenna).

Yes, the author was talking about "cliff-dwelling" in an apartment where antennas were verboten (the "birdhouse" title is apt), but the statement does stand alone in the article as a means to avoid TVI complaints.

Granted, manufacturers do not design TVs, stereos, etc., with sufficient discrimination to reject a strong (but legal) ham signal. Nevertheless, I've always thought the ham should make himself known in the community and through goodwill (and maybe some extra effort like installing filters) solve the problem!

If the reason you're "disguising" your antenna is to circumvent a prohibition in your rental contract against outside antennas, I can understand it (but you are still acting illegally). If, in addition, it is to avoid TVI complaints, I contend it is not in the best interests of ham radio, even if your signal is entirely clean.

G. S. Wren K5EAT
Helotes TX

ANOTHER BELIEVER

Put me down as a believer, too! After two months with your code tapes, I passed the General test on 6/27. I started with a 5 wpm base and spent an average of one hour per day in practice. Who needs a receiver!

D. T. Capasso WB2NBI
Haddonfield NJ

RADIO LAW ENFORCEMENT

Perhaps we should have some further discussion in your magazine about what Dan Gingras said in his letter on radio enforcement (June, 1978, p. 61). I personally feel that some system of dealing promptly and without having to involve three agencies should be set up, and further, I understand revision of the Communications Act of 1934 is under consideration, so the time is now.

I am not a lawyer, but I have some training in criminal law. Traditionally, police officers have been permitted to arrest without warrant for breach of the peace. There are two ways this might be useful. First, Congress might rule that FCC inspectors and engineers were officers for this purpose. Certainly many of the offenses in-

volved would be breaches of the peace if committed in a public place, and the radio waves, with as many people on them as we have presently, should be considered a public place. The other method, which will not endear me to the FCC, who would like to maintain complete jurisdiction, is to declare the radio waves to be a public place for the purposes of breach of the peace laws, thereby opening jurisdiction on non-technical violations such as swearing, interfering with emergencies, and other mischief to local law enforcement authorities.

For example, New Hampshire law provides for legal action against a person who "makes unreasonable noises in a private place, which can be heard in a public place..." Were the radio waves declared a public place, much could be done under this provision and other parts of the disorderly conduct law.

One idea that might be useful in such cases where FCC personnel were authorized to act on their own would be for them to go back to using inspectors. Field personnel at the moment are mostly field engineers, graduate engineers that cost more than a police lieutenant. They used to have a force of people with either a lot of experience or a tech school education, and could get more personnel for the money that way, for handling routine matters. Perhaps a system of part-time inspectors, as many towns use the "special police officer" to control fairs or other situations where personnel are needed temporarily, could be applied to radio. The knowledge that someone within 30 miles could be complained to, and had the authority to act, would cool off some of the regular offenders around here.

Perhaps you could have an attorney write an article on the subject and/or put some editorial weight behind this.

Joel S. Look W1KCR
Claremont NH

PIONEER LOST

The unfortunate and untimely death of Mr. R. R. Freeland, Sr., President of International Crystal Manufacturing Company, Incorporated, has left a great void in the electronic industry.

Mr. Freeland and his wife Virginia were killed instantly when their twin engine Turbo-Commander exploded in midair just west of Oklahoma City on Saturday morning, May 27. He

Continued on page 96

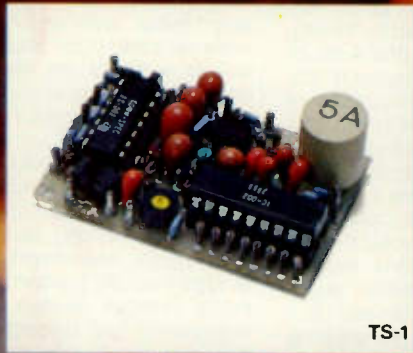

TS-1

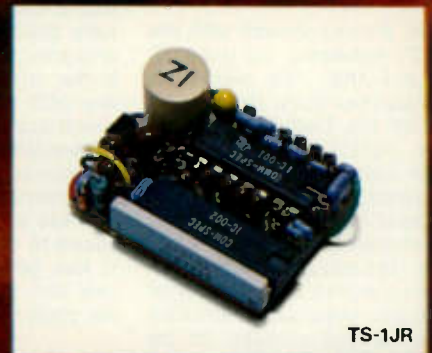

TS-1JR



PE-2



SD-1

THE DAWNING

The age of tone control has come to Amateur Radio. What better way to utilize our ever diminishing resource of frequency spectrum? Sub-audible tone control allows several repeaters to share the same channel with minimal geographic separation. It allows protection from intermod and interference for repeaters, remote base stations, and autopatches. It even allows silent monitoring of our crowded simplex channels.

We make the most reliable and complete line of tone products available. All are totally immune to RF, use plug-in, field replaceable, frequency determining elements for low cost and the most accurate and stable frequency control possible. Our impeccable 1 day delivery is unmatched in the industry and you are protected by a full 1 year warranty when our products are returned to the factory for repair. Isn't it time for you to get into the New Age of tone control?

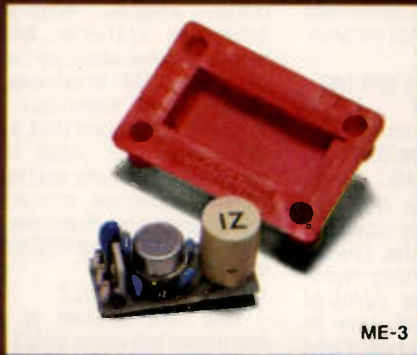

ME-3

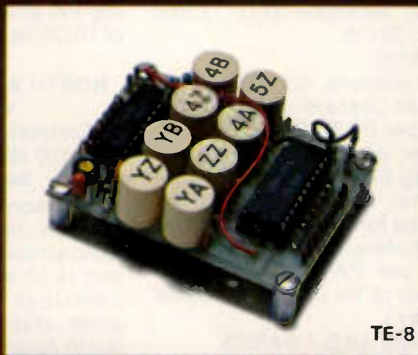

TE-8



TE-12

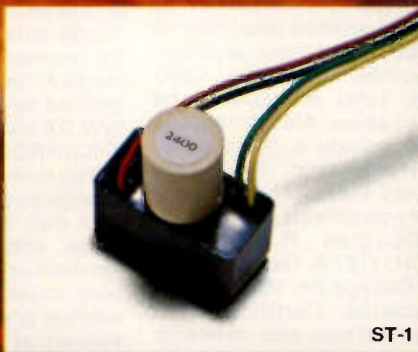

ST-1

OF A NEW AGE.

TS-1 Sub-Audible Encoder-Decoder • Microminiature in size, 1.25" x 2.0" x .65" • Encodes and decodes simultaneously • **\$59.95** complete with K-1 element.

TS-1JR Sub-Audible Encoder-Decoder • Microminiature version of the TS-1 measuring just 1.0" x 1.25" x .65", for hand-held units • **\$79.95** complete with K-1 element.

ME-3 Sub-Audible Encoder • Microminiature in size, measures .45" x 1.1" x .6" • Instant start-up • **\$29.95** complete with K-1 element

TE-8 Eight-Tone Sub-Audible Encoder • Measures 2.6" x 2.0" x .7" • Frequency selection made by either a pull to ground or to supply • **\$69.95** with 8 K-1 elements.

PE-2 Two-Tone Sequential Encoder for paging • Two call unit • Measures 1.25" x 2.0" x .65" • **\$49.95** with 2K-2 elements.

SD-1 Two-Tone Sequential Decoder • Frequency range is 268.5 - 2109.4 Hz • Measures 1.2" x 1.67" x .65" • Momentary output for horn relay, latched output for call light and receiver muting built-in • **\$59.95** with 2 K-2 elements.

TE-12 Twelve-Tone Sub-Audible or Burst-Tone Encoder • Frequency range is 67.0 - 263.0 Hz sub-audible or 1650 - 4200 Hz burst-tone • Measures 4.25" x 2.5" x 1.5" • **\$79.95** with 12 K-1 elements.

ST-1 Burst-Tone Encoder • Measures .95" x .5" x .5" plus K-1 measurements • Frequency range is 1650 - 4200 Hz • **\$29.95** with K-1 element.



**COMMUNICATIONS
SPECIALISTS**

426 W. Taft Ave., Orange, CA 92667
(714) 998-3021

Editor:
Robert Baker WB2GFE
15 Windsor Dr.
Atco NJ 08004

CONTESTS

For rules on the ARRL September VHF QSO Party, check the August issue of *QST*. The official rules were not available at the time this went to press and there will probably be a change or two from last year's rules!

PENNSYLVANIA QSO PARTY

Starts: 1700 GMT Saturday, September 9
Ends: 2359 GMT Sunday, September 10

Sponsored by the Nittany ARC; all amateurs are invited to participate. A "super activity" period has been arranged for Saturday evening, 2400 GMT and 1700 GMT, when it is hoped that many "casuals" will join the fun. PA stations may work both PA and non-PA stations. Each station may be worked once per band and mode (CW and SSB).

EXCHANGE:

QSO number, RS(T), county or ARRL section.

FREQUENCIES:

CW—1810, 3550, 7050, 14050, 21050, 28050; SSB—1815, 3980, 7280, 14315, 21380,

28560; Novice—3715, 7160, 21115, 28115.

SCORING:

PA stations score 3 points per out-of-state QSO and 1 point per PA QSO. Multiplier is number of ARRL sections, including EPA and WPA. One additional multiplier may be counted for DX QSO (limit: one). Out-of-state stations score 1 point per PA QSO times the number of PA counties worked (67 max.).

ENTRIES AND AWARDS:

Logs must include dates/times in GMT, stations worked, RST sent/rcvd., band, mode, and number of new section or county as worked (multipliers). Summary sheet required, showing number of QSOs, QSO points, total multiplier, and claimed score. Also, all entries should include a checklist of counties worked. Mail logs, summary sheets, checksheets, and any comments by Oct. 14th to: Douglas R. Maddox W3HDH, 1187 S. Garner Street, State College PA 16801. SASE appreciated. Certificates to section winners and outstand-

ing PA entries, with minimum of 10 QSOs required for awards.

NORTH AMERICAN SPRINT CONTEST

Contest period runs from 0100 GMT to 0500 GMT September 10

Sponsored by the *National Contest Journal*; any licensed radio amateur may enter. The object is to work as many North American stations (and/or other stations if you are in North America) as possible and as many multipliers as possible during the contest period. All contest contacts must be made on CW on the 80, 40, or 20 meter bands only. Each station may be worked once per band. North American stations are as defined by the rules of the CQ WW DX contests.

EXCHANGE:

You must make the entire exchange as given below: his call, your call, serial number, your name, and your state or VE province or country. Serial numbers must begin with serial number one (001) and must be sequential thereafter.

FREQUENCIES:

3530-3550, 7030-7050, 14030-14050.

SCORING:

North American stations: Multiply total valid contacts by the sum of states, VE provinces, and other worldwide countries (do not count USA and VE as countries) to get the

final score. Non-North American stations: Multiply total valid contacts by the sum of states, VE provinces, and other North American countries (do not count USA and VE as countries). KH6 is not counted as a state and is not a North American country. VE multipliers are: maritime (VE1, VO1, and VO2) and VE2 through VE8 (8 total).

SPECIAL QSY RULE:

This rule applies to North American stations only! If any North American station solicits a call by sending "CQ, QRZ?, QRZ?," etc., he is permitted to work only one station in response to that solicitation. He must thereafter move at least 1 kHz before he works another station, or at least 5 kHz before he again solicits other calls.

ENTRIES:

Entry classification is single operator only, with the use of helpers or spotting nets not permitted. Regardless of the number of licensed callsigns issued to a given operator, one and *only* one callsign shall be utilized during the contest by that operator. Proper logging requires including the time of each contact along with the contact exchange and the band or frequency. Only completely copied and logged two-way exchanges between a North American station and another station are valid for this con-

CALENDAR

Sept 2-4*	Four Land QSO Party
Sept 9-10	Pennsylvania QSO Party ARRL VHF QSO Party
Sept 10	North American CW Sprint
Sept 16-18	Washington State QSO Party Maryland/DC QSO Party Scandinavian Activity Contest—CW Scandinavian Activity Contest—Phone Delta QSO Party
Sept 23-24	Rocky Mountain Division QSO Party
Sept 30-Oct 1	QRP QSO Party
Oct 7-8	California QSO Party VK/ZL/Oceania DX Contest—Phone & RTTY
Oct 14-15	VK/ZL/Oceania DX Contest—CW Nine Land QSO Party RSGB 21/28 MHz—Phone Manitoba QSO Party ARRL CD Party—CW
Oct 21-22	Jamboree-on-the-Air RSGB 7 MHz SSB ARRL CD Party—Phone
Oct 28-29	CQ Worldwide DX—Phone CQ-WE Contest
Nov 4-5	ARRL Sweepstakes—CW RSGB 7 MHz CW
Nov 11	OK DX Contest
Nov 11-12	IPA Contest
Nov 18-19	ARRL Sweepstakes—Phone
Nov 25-26	CW Worldwide DX—CW
Dec 2-3	ARRL 160 Meter Contest TOPS CW Contest
Dec 9-10	ARRL 10 Meter Contest

*described in last issue

RESULTS

RESULTS OF THE 1978 BARTG RTTY CONTEST

Top 10 Single Operator Stations

Station	Points	QSOs	Countries
W3FV	447,678	261	39
SM6GVA	440,578	297	26
I3FUE	432,066	315	36
W2NZ	403,374	249	37
F9XY	401,980	282	31
I5WT	380,482	261	35
W1GKJ	365,904	252	28
I5KPK	345,000	244	32
I5MYL	338,142	240	28
HB9AVK	325,686	197	33

Top Multi-Operator Entry

DL0TS	329,910	212	34
-------	---------	-----	----

Top SWL Entry

H. Ballenberger (DL)	417,452	246	35
----------------------	---------	-----	----

Several US entries were received too late for inclusion in the official results, due to serious delays in overseas surface mail.

test. Entries must be sent to Rusty Epps N6SF, 35 Belcher Street, San Francisco CA 94114. Entries must be received not later than 30 days after the Sprint to be eligible for trophies and awards. An entry consists of (1) a summary sheet showing valid contacts by band, total multipliers, total score, name and callsign of the operator, station callsign, and station location; (2) a complete, legible log of all contacts (including dupes marked as such) with indication by numbered sequence of each multiplier claimed; and (3) a separate checksheet for each band. Logs, summary sheets, and checksheets may be homemade or patterned after those shown in the June/July issue of the *National Contest Journal*. Any entry may be disqualified for illegibility, incorrectness, or illegal or non-ethical operation. Such disqualification is at the discretion of the NCJ Contest/Review Committee.

AWARDS:

A trophy shall be awarded to the highest scoring entrant. Certificates of merit shall be awarded to the highest scoring entrant from each USA call district, Canada, and other country, to each of the ten highest scoring entrants, to each member of the winning team, and to the highest scoring entrant on each team.

TEAM COMPETITION:

Team competition is limited to a maximum of 10 operators as a single entry unit. Clubs having more than 10 members may submit more than one team entry. *Precontest requirement:* To qualify as a team entry, the name, callsign of each operator, and callsign of the station operated should the operator be a guest at a station other than his own must be

registered with N6SF. The team information may be contained either in a letter, which must be received by N6SF before the start of the Sprint, or in a Western Union Mailgram dated at least 24 hours before the start of the Sprint. There are neither distance limitations nor meeting requirements for a team entry. The only requirement is a pre-registration of the team.

DELMONT WAS CONTEST

Starts: 0000Z GMT September 16
Ends: 2400Z GMT September 17

The Delmont Radio Club of Hatboro PA will be conducting a Worked All States contest for a 48-hour period from 8 pm EDT, Friday, September 15, to 8 pm EDT, Sunday, September 17. Each club member will try to work as many states as possible, with awards based on 1 point per QSO and 1 point per QSL of same.

WASHINGTON STATE QSO PARTY

Operating Periods:
0100 to 0700 GMT
September 16;

1300 GMT September 16 to
0700 GMT September 17;
1300 GMT September 17 to
0100 GMT September 18

Sponsored by the Boeing Employees' ARC (BEARS), the contest is open to all amateurs. All bands and modes may be used. Stations may be worked once per band and mode, and may be worked again if they are a new multiplier.

EXCHANGE:

WA stations send QSO number, RST, and county; others send QSO number, RST, and state, province, or country.

FREQUENCIES:

CW—1805, 3560, 7060, 14060, 21060, 28160; phone—1815, 3925, 7260,

14305, 21380, 28580; Novice—3725, 7125, 21150, 28160.

SCORING:

Score 2 points per QSO. WA stations multiply QSO points by total number of states, provinces, and other countries worked. All others score 2 points per WA QSO and multiply by number of WA counties worked (39 max.). For non-WA stations only, there is an extra multiplier of one for each group of 8 contacts with the same WA county.

Washington county checkoff list for non-Washington State entries: Adams, Asotin, Benton, Chelan, Clallam, Clark, Columbia, Cowlitz, Douglas, Ferry, Franklin, Garfield, Grant, Grays Harbor, Island, Jefferson, King, Kitsap, Kittitas, Klickitat, Lewis, Lincoln, Mason, Okanogan, Pacific, Pend Oreille, Pierce, San Juan, Skagit, Skamania, Snohomish, Spokane, Stevens, Thurston, Wahkiakum, Walla Walla, Whatcom, Whitman, Yakima.

ENTRIES AND AWARDS:

Certificates to high scores in both single and multi-operator classes. Five BEARS awards are also available to anyone working 5 club members. All contest entries will be screened by the contest committee for possible Worked Five BEARS Awards. The Worked 3 BEAR Cubs Award is also available for working 3 Novice members. Logs must show dates/times in GMT, stations worked, exchanges, bands and

modes, and scores claimed. Include a checksheet for entries with more than 100 QSOs. Each entry must include a signed statement that the decision of the Contest Committee will be accepted as final. Logs will *not be returned*. Results of the QSO Party will be mailed to all entrants; an SASE is *not* required. Logs and scores must be postmarked no later than October 18th and sent to: Boeing Employees' ARC, c/o Contest Committee, Willis D. Propst K7RS, 18415 38th Ave. S., Seattle WA 98188.

SCANDINAVIAN ACTIVITY CONTEST CW

Starts: 1500 GMT September 16
Ends: 1800 GMT September 17
Phone

Starts: 1500 GMT September 23
Ends: 1800 GMT September 24

All amateur bands from 80 to 10 meters may be used. The general call is "CQ SAC" and "CQ Scandinavia." Scandinavians will use "CQ Test" or "CQ Contest." Non-Scandinavians should try to work as many Scandinavian stations as possible. The same station may be worked once on each band. No crossmode QSOs are allowed. The prefixes used in Scandinavia are: LA/LB/LG/LJ—Norway; JW—Svalbard; JX—Jan Mayen; OF/OG/OH/OI—Finland; OH0—Aland Islands; OJ0—Market Reef; OX—Greenland; OY—Faroe

Continued on page 80

RESULTS

RESULTS OF THE 1978 MARAC COUNTY HUNTERS SSB CONTEST

Fixed Station Scores

*N7TT/2 1,898,642
**N7SU 986,206
**W7JYW 451,875
**W8WT 394,350
**WA5DX1 385,382
**WA9MSW 332,450
**WB4UPW 283,024
**WB0JUS 171,120
**K9BG 168,041
**K9GTQ 135,080
**WB4ERM 127,200

Mobile Station Scores

*WA0RJJ 849,176
*K3KX 457,306
**N4UF 273,819
**W5VQR 216,410
**WB5BBS 191,290
**W0BK 150,600
**WA0YJL 108,186
**N5BO 43,670
**W1EXZ 32,844
**K9DZG 10,560
**WB8MDG 144
W0QWS 7,655 (Check log)

DX Station Scores

*CT1BY 19,740
**OK1DKS 2,100
CT1UA 160

*Plaque awards
**Certificate awards

RESULTS

RESULTS OF THE 1977 CALIFORNIA QSO PARTY

Single Operator

Top Ten California

W6YX (N7MH op)	1709	58	198,244
K6LL	1496	58	173,536
K6SE (WA6OYV op)	1334	55	146,740
WB6NHF	1164	57	132,696
W7CB/6	964	55	106,040
K6XO	931	54	100,548
WB6ION	865	58	100,340
K6ZM	747	56	83,664
W6TPH	705	54	76,140
N6VB	585	53	62,070

Top Ten Out of State

K9BG	511	57	58,254
N7ZZ	488	54	52,704
K5TM (K5ZD op)	417	52	43,368
W5KLB	253	46	23,276
W3HDH	217	48	20,832
VE7DSA	218	46	20,056
WA8CZH (N8UM)	212	41	17,384
K9EG	193	44	16,984
WB0SAA	207	41	16,974
WB0PYD	199	41	16,318

This year's club competition winner is the Wireless Institute of the Northeast, which beat out second-place Mad River by only 200 points.

Looking West

Bill Pasternak WA6ITF
24854-C Newhall Ave.
Newhall CA 91321

ARMA could be a great boon to amateur radio if it would only stop its infighting and get its act together. We need it. There is nothing else. We face a crisis which threatens the very existence of the amateur service, and "Mother Newington" just sits and procrastinates. Come WARC '79, we had better have a well-oiled machine in the form of ARMA or we could all go down the tubes.

ARMA, the Amateur Radio Manufacturer's Association, is the best thing to come along in years. It is composed of those companies which import and/or manufacture the equipment that virtually all of us use. These are people who understand the world of big money, big business, and big politics. They have the collective ability to "bargain" for us in a way that the ARRL can never match. We need them and they need us. Together we can turn WARC '79 from a disaster into a successful exercise in international diplomatic relations. With their help, amateur radio as we know it can continue to grow and prosper.

Therefore, in the name of *all* concerned amateurs, I appeal to individuals who comprise ARMA to "bury the hatchet" with one another and work *with us* to turn the tide at WARC '79. If you want to fight among yourselves about matters not directly concerning WARC, fine. Do it in 1980. Right now, only one thing should concern you: being sure you have a market in 1980 to bicker about.

SPECTRUM MANAGEMENT

For all intents and purposes, on July 1, 1978, the Southern California Repeater Association was laid to rest. Not that it had been unsuccessful. Far from it. But thanks to the deregulation that made FM a blockbuster in a neighborhood in which it did not belong, it became evident that the day when repeaters could isolate themselves from the rest of the amateur society was long gone. In the short time since 21033's implementation, problems had begun to take shape which could easily have led to an intermode war—with FM coming up as the sure loser. Already, important ranging experiments and DX contacts on SSB in this geographic area, including an "opening" to Hawaii, had been obliterated by FMers plogging down indis-

criminated to hold local rag chews. It was apparent that, as a repeater owner organization only, the SCRA could do little or nothing to help rectify this situation. However, if a way could be found to open organizational membership to all spectrum users, then a dialogue could be developed to negate such problems in the future and avoid any intermode confrontation.

At 12:30 pm on Saturday, July 1, Chairman Paul McClure WA6HGK called to order what was to be the last SCRA meeting under its old format. By 5:00 pm, when the meeting ended, the structure of the SCRA had been reorganized into two parallel total spectrum management organizations, one each for two meters and 220 MHz. Membership in either organization is open to all interested spectrum users (the 2 meter organization has the minimal limitation of a Technician class license, while the 220 organization requires only an amateur license). In either organization, all members carry voting privileges. The 220 organization is named the Southern California 220 Spectrum Management Association ("SMA-220" for short), and its interim president is Bob Buas K6KGS. For the moment, the 2 meter organization has retained the SCRA logo (with the additional Spectrum Management tag added on). This will shortly change, probably to SMA-144 or something along those lines. Both organizations intend to incorporate. In addition, dues have been cut in half, so if one's interest is in one band only, he only pays half of what he did before (while if his interests are twofold, his personal dues structure remains the same).

Attending the meeting were not only repeater people, but also representatives from other non-relay modes, including a three-member delegation from Sidewinders On Two's southern California chapter. Even a guy claiming to represent AM interests showed up. The vote was close, but in the end the forward thinkers prevailed and restructuring became a reality. For the first time, a repeater council had changed its character to welcome input from all areas of amateur operation on VHF.

DISSENT?

While many spectrum users seem elated at the results of the restructuring, there are some who are very disturbed at

the outcome. This seemed obvious from the lack of attendance at the meeting by a good number of two meter repeater owners, even though the meeting was announced in *HR Report* and on the Westlink taped newscasts. The 220 MHz people showed up en masse, but two meter participation was obviously lacking.

It is no secret that many of what I term "old-line" repeater owners feel that no one other than themselves should have any say-so in the matter of council operations. In the past, the question of non-owner voting participation had been voted down, usually after heated and emotional debate. It usually lost by a large majority—a vote carried by the two meter faction. However, at this meeting no such voting bloc was on hand, so a coalition of the "new line" two meter people and the 220 owners carried us into a new era. What, if anything, the old-liners will do to show their displeasure is unknown, but rumors are running rampant about the formation of a new owner-only organization to challenge the new dual SCRA/SMA 220 structure. I hope this doesn't happen, because owner/user relations are already quite strained.

DECENTRALIZATION OF GOVERNMENT

Government? Well, that's as close a term as I can come up with right now, so it will have to do. In this case, the term is being applied to the "Centralized 2 Meter Technical Committee," a committee which I currently happen to chair on an interim basis for the SCRA. If you never get the chance to serve in a position such as this, consider yourself lucky. It's a nightmare and a headache. However, there are rewards which make it all worthwhile, such as those times when you are able to prevent a "brushfire" dispute from erupting into total warfare, and the few and far between ones when you send out a coordination letter and receive a written thank-you note.

Anyhow, something recently occurred to me, something which I hope to try out here to help minimize coordination problems. When you have a single central committee (or individual coordinator) handling everything, the work load can be unbelievable—even for a committee which meets bi-monthly like ours does. Is there a better way? Maybe, but perhaps not one which would be applicable everywhere. The reason? Terrain.

In southern California, most repeaters sit on high places such as mountains and serve

users in low(er) places. Because of their altitude, it would seem that our repeaters' ranges would be almost limitless. Not so. Mother Nature has placed other mountains in strategic positions and has seen fit to make them inaccessible enough to make their use as potential repeater sites impractical. Until solar power on a truly operational scale becomes a reality, they shall remain untouched. Thanks to these "bumps," southern California is approximately divided into four geographic zones. They are the high desert, the low desert, the Ventura/Santa Barbara and inland area, and the Los Angeles/San Diego rf corridor.

Rather than have one central committee handle everything, I hope to institute a regionalized subcommittee structure in which several smaller regional committees could handle the needs of the local amateurs by investigating the technical aspects of an intended relay operation and making a recommendation as to which channel pair offered the best chance for minimal environmental impact—i.e., interference to existing operations. While I may know what I can hear in the LA area, Santa Barbara is a whole new ball game. A regional technical subcommittee could do far better than a group of Angelinos or San Diegoites or high desert people in coming up with a viable operation. However, to delegate such duties could result in chaos if there were not some form of control, and here is where the Central Technical Committee comes into play. The regional subcommittees will make recommendations based upon what they determine is best suited to the area's needs, but all such recommendations will be reviewed by the Central Committee prior to implementation. If all looks copesetic, then it's only a matter of saying "yes" and sending out the letter. However, if something exists in another geographic area that experience has shown to be a no-no, it is hoped that such will be caught by the Central Committee before disaster strikes. In this way, the self-determination of a given area's setup can become a viable part of the overall coordination process, and no one need ever feel that he or she has been left out of the process.

I don't know if it can be made to work. I do think that the idea holds merit and is a viable alternative to having a myriad of councils, each duplicating the other's work. Any opinions?

Continued on page 77

BOARDS INSIDE CABINET

- 1 CARR OSC unit
- 2 VOX unit
- 3 AF unit
- 4 IF unit
- 5 Filter unit
- 6 Noise Blanker/RF Processor
- 7 Rectifier unit
- 8 Rectifier unit
- 9 Power XFMR
- 10 Final Amplifier unit
- 11 VCO unit
- 12 TUNE control
- 13 PLL unit
- 14 RF unit
- 15 Counter Display unit
- 16 FM unit

FT-901DM

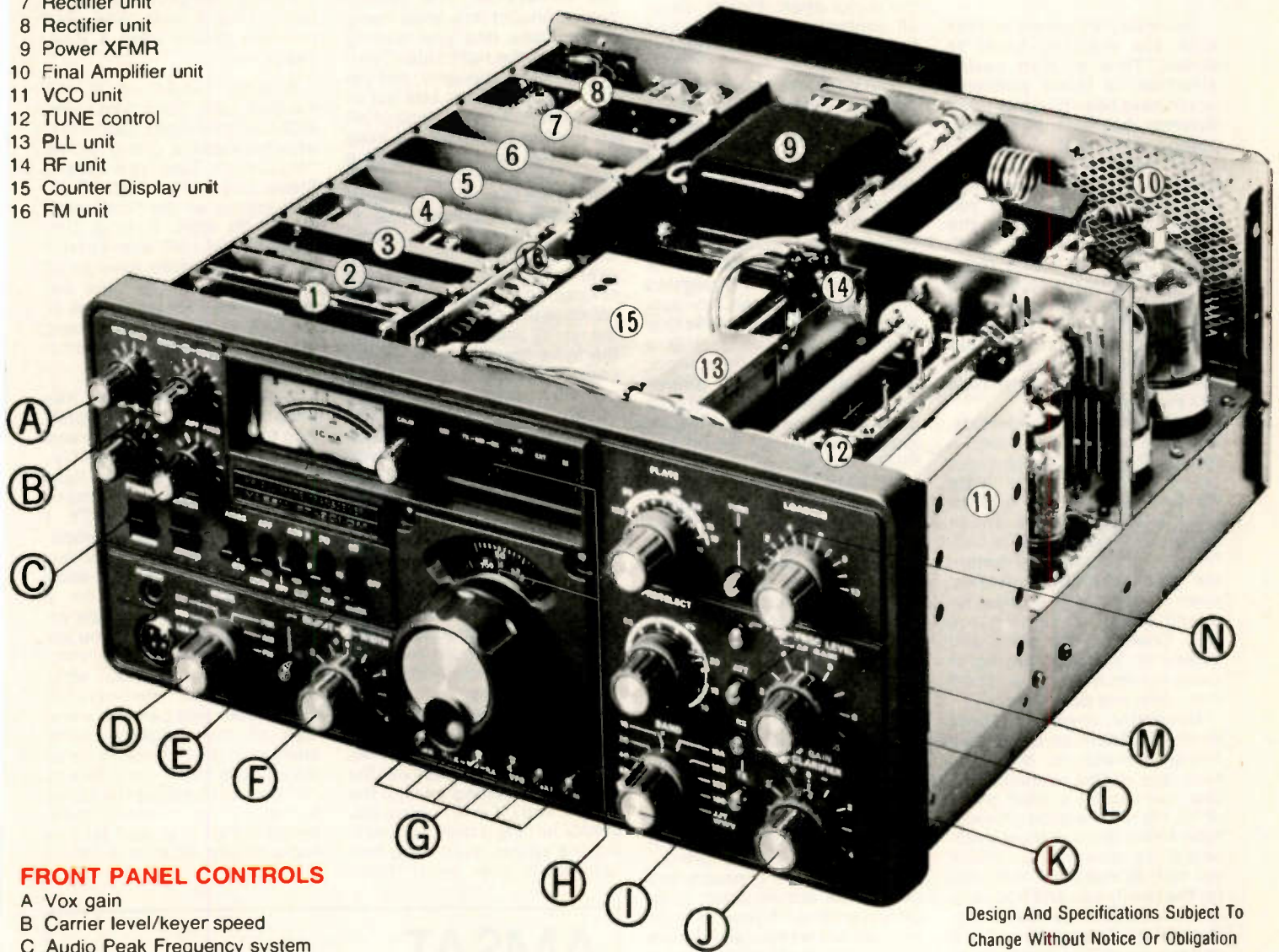

FRONT PANEL CONTROLS

- A Vox gain
- B Carrier level/keyer speed
- C Audio Peak Frequency system
- D MODE switch (SSB, CW, FSK, AM, FM)
- E Crystal calibrator/Noise blanker
- F Rejection tuning/variable IF passband tuning
- G Frequency memory system
- H Digital plus analog frequency readout
- I Band switch (160-10 meters + WWV/JJY receive)
- J Clarifier control
- K RX/TX Clarifier selector
- L RF Processor level
- M RF attenuator
- N TUNE control (Places transmitter in "TUNE" condition for ten seconds, then returns to "receive" condition to protect final tubes from excessive key-down time)

Design And Specifications Subject To
Change Without Notice Or Obligation



THE SYMBOL OF TECHNICAL EXCELLENCE

YAESU The smart radio

1C78



YAESU ELECTRONICS CORP., 15954 Downey Ave., Paramount, CA 90723 (213) 633-4007
YAESU ELECTRONICS CORP., Eastern Service Ctr., 613 Redna Ter., Cincinnati, OH 45215

RTTY Loop

Marc I. Leavey, M.D. WA3AJR
4006 Winlee Road
Randallstown MD 21133

Labor Day is upon us, and the kids are starting back to school. Time to start paying attention to those problems which have been bugging us all summer, but that we've been putting off 'til fall!

For those of you who own mechanical TTY machines, when was the last time you cleaned and lubricated the beast? I know, Teletype™ built them to run for years, but a dose of benign neglect can shorten their life expectancy dramatically. If you have a Model 15 or 19, lubrication should not take more than a half hour, and your machine will thank you!

Let's start with the outside. Wipe the cabinet down with a damp cloth, and spray some glass cleaner on the little window. If yours has a black crinkle finish, some black liquid shoe polish, such as Griffith, will do wonders to restore the "new" look. Other finishes, such as my green crinkle, respond nicely to some paste wax. Check all the wires and cables for signs of fraying or loose connections. Now, lift off that cover and peer inside.

Basically, there are three types of lubrication points in a Teletype machine: oil cups, felts, and sliding contacts. The first two require a good grade of oil, the latter a good grease. I have found that the most available and economical oil is plain old 10W-30 motor oil. Intended for the family car, and frequently available at discount houses, it normally is priced under a dollar a quart. The grease most used by TTY enthusiasts is Lubriplate®, although any good grease such as auto grease (not Brylcreem®) should work well.

Now that you have the cover off, and the machine unplugged, hopefully, unscrew the three large bolts which hold the printing unit on, and the two holding the keyboard in, and break the unit down to its component parts. Turning first to the base, wipe up any accumulated oil or grease, and clean away the typical gunk around the motor. While you're there, look for the ball bearing on each end of the motor shaft. These are oil points. Depress the ball bearing with the spout of your oil can and deposit a large drop of oil therein. If it has been a while since you've done this (or perhaps this is the first time), rotate the motor by hand

for a bit, then do it again! Put a small dab of grease on the pinion gear—that's the one on the motor shaft. Finally, clean all contacts on the base and tighten the screws on the terminal block.

The keyboard gets our attention next. First off, look at the row of contacts that produce the pulses. Are they all gooky and covered with a paste of dust and oil? *Clean them!* Use a piece of bond paper and lightly burnish the contacts, too. Check all the springs on the underside of the keyboard for proper seating, and straighten or replace damaged keytops. Now, look at the top of the keyboard. Next to the gear is a small cup, set at a right angle, with a spring-loaded, hinged lid. This is the first of several oil cups we will be filling. They all look the same. Lift the lid and fill the cup with oil. Follow the shaft back to the contact area and you'll find five felt washers between metal surfaces. These are called "felts" and act as oil soaked pads between rotating metal surfaces. Depending on the age of your machine, and your aggressiveness in servicing it, they may be grayish-brown or dark and oil-soaked. If they are not soaked, soak them! Just dabble on oil while rotating the shaft manually until they look saturated, then wait 30 minutes and do it again. Some replenishment drops will do if they look pretty good.

While you set the keyboard aside to let the oil soak in, turn your attention to the printer. Again, clean the contacts and get all the accumulated gunk off everything. If your wife (or mother) will let you, and the accumulation is not too greasy, a vacuum cleaner with a circular brush attachment works wonders in de-linting nooks and crannies. Now, look along the main shaft and fill the three oil cups. Also, notice the felts interspersed. Saturate them the same as you did on the keyboard. Don't forget the felt on the selector magnet assembly!

The next step depends on your familiarity with the machine. We want to take off the typing basket and clean it and the rails and vanes. To accomplish this, place the basket on the far right-hand side by first depressing the manual carriage return lever, and, while holding the basket immobile, slide the basket to the extreme right. Depressing the dashpot lever should lock it in position. Now, firmly hold the drum which winds the carriage return

band while removing the band from the rear of the typing basket. Hook the free end over the end-of-line bell lever. Now re-press the carriage return lever, which should allow the basket to move freely back and forth, and flick the stop lever on the underside. The typing basket should now slide freely off the rails, into your waiting hands, on the right side. Clean all the keys thoroughly, and get the dust and paper bits out of the basket. A small drop of oil on the ball bearings will keep things rolling along, singing a song. While the basket is off, wipe down the vanes and apply a thin layer of grease here. In fact, apply grease to all sliding surfaces, and a little dab to gear teeth, too. Now, *carefully* reverse the sequence of the previous directions and replace the typing basket. Make sure all the forks correctly seat on the vanes at the front of the machine. Also, be sure the basket is locked with the dashpot *before* you re-attach the carriage return band. If you have any difficulty understanding these admittedly sketchy instructions, or have never removed the typing basket before, **DO NOT** attempt it! Either ask someone who has done it to help you, or clean it as best you can without removing it. While it sounds simple enough to do, and it really is, one slipup can totally disable a working machine.

Now put everything back together. Hopefully you haven't any extra pieces left over. While you're at it, check out the ribbon. Is it getting worn to the ragged end? If it is not too old, simply turning it over, by reversing the spools, may bring new contrast to your print. Other-

wise, be a sport and replace it. If you don't have a new one, pay a visit to your local drugstore. Any ribbon listed as a replacement for the Underwood Standard will fit. This is usually Number 1 in most replacement lines.

Follow this procedure carefully twice a year, and your machine should have a long, happy life.

A letter turned up in the mailbag from Steve Alexander WD6EQP of Vallejo, California, who enclosed a photo of his "mystery" Teletype. Well, Steve, this is the AN/UGC-20, also known as the "compact" Model 28 KSR. It is a fine machine, but I will admit that it is not as frequently covered as the 15/19 in ham literature. So, next month, I will take a look at the Model 28 and pass along what I can about this beautiful machine.

Quite a bit of response has been heard on the computerized RTTY covered in June and July. More importantly, WD6EQP's letter brings to light the diversity of equipment presently in use on RTTY. I would be interested in compiling some data on just what our readers are using. I invite each of you to send me, on a postcard or QSL, the stats on what kind of RTTY gear you are running, if you have a computerized station setup, what kind of CPU, memory requirements, and perhaps some idea of the program. Send along your information to me at the address shown, or in care of 73; they will forward the cards to me. I'll try to make some sense out of it all and let you know what's what in a future RTTY Loop.

AMSAT

OSCAR SATELLITE PHOTOGRAPHS

Full color 8" x 10" photographic prints are available of WA6TUF's artist illustrations of AMSAT-OSCAR 7, AMSAT-OSCAR 8, and AMSAT Phase III for \$3.25 each. Also available are custom-painted 16" x 20"

duplicates of each illustration. AMSAT-OSCAR 7 is \$100, AMSAT-OSCAR 8 is \$80, and AMSAT Phase III is \$125. Write: Mike Smithwick AA6XI (ex-WA6TUF), 25215 La Lome Drive, Los Altos Hills CA 94022.

Ham Help

I want a copy of the instruction manual and/or schematic for the CDE/CDR TR-4A or TR-11A (series 12307) antenna rotator. Thank you.

M. McDaniel W6FGE
940 Temple St.
San Diego CA 92106

I would sure like to get in touch with Sgt. William "Scotty" Scott ex-DL4ZD. We sort of got out of touch after we both retired.

Russell L. Lawson K1MOU
124 South Grand St.
West Suffield CT 06093

YOU ASKED FOR IT YOU GOT IT DSI QUIK-KIT®

550 MHZ COUNTER KIT Performance You Can Count On



OPERATES ON

- Batt 6-C Size
- DC 8.2 To 14.5 VDC
- AC Batt. Eliminator

\$99.95
MODEL 3550 KIT

DSI OFFERS THE BEST OF TWO WORLDS . . .

An unprecedented DSI VALUE . . . in a high quality, LSI Design, 550 MHZ frequency counter kit. And, because it's a DSI innovation, you know it obsoletes any competitive makes, both in price & performance. The basic 550 MHZ counter & time base are factory assembled, tested and burned-in. The problems of bad LEDES, IC's, capacitors, are a thing of the past with DSI QUIK-KIT®. But you can take pride in assembling the power supply, PC mounted selector switch, input connectors, and the final mechanical assembly of your 550 MHZ counter, into its' handsome cabinet. **GO WITH THE LEADER . . . BUY A DSI FREQUENCY COUNTER KIT. SAVE TIME & MONEY AND BE ASSURED IT WILL WORK THE FIRST TIME.**

SPECIFICATIONS

Time Base TCXO 1PPM 65° to 85°F
 Frequency Range 50HZ to 550MHZ
 Resolution 1HZ to 55MHZ, 10HZ to 550MHZ
 Gate Time 1 second - 1/10 second
 Sensitivity 25MV 150 & 250MHZ 75MV 550MHZ
 Display Eight 1/2-inch LEDES
 Input Two SO239 Connectors
 Power 6C-Size Batt., 15HR, or 8.2VDC to 14.5VDC
 Current 150 Ma standby 300 Ma operational

3550 KIT INCLUDES

- Pre-assembled, tested counter board
- Case, power supply, connectors, hardware
- Built-in prescaler & preamp
- Gate Light - Automatic Zero Blanking
- Automatic Decimal Point
- One to two hours assembly time
- One Year Warranty on all parts
- All new parts - not factory seconds or surplus

3550 Kit \$99.95
 T-101 Telescopic Antenna 3.95
 AC-9 Battery Eliminator 7.95
 Cigarette Lighter DC Adapter 2.95

TERMS: Orders to U.S. and Canada, add 5% to maximum of \$10.00 per order for shipping, handling and insurance. To all other countries, add 15% of total order. California Residents add 6% State Sales Tax.

SEE YOUR LOCAL DEALER
OR

CALL TOLL FREE (800) 854-2049

California Residents, Call Collect (714) 565-8402

DSI INSTRUMENTS, INC.

7914 Ronson Road No. G, San Diego, CA 92111

VISA • MC
AMERICAN EXPRESS
CK • MONEY ORDER
COD

New Products

KANTRONICS FREEDOM VFO

Sitting unused in shacks, on closet shelves, in attics, cellars, and garages all over the country are thousands of perfectly good transmitters in the 20- to 200-Watt range. Why are they collecting dust instead of QSOs? Because they are crystal controlled. On today's crowded bands and with current operating practices, using a crystal-controlled transmitter and a few crystals can be a very tedious and unproductive way to operate. Gone are the days when (as I once did) with as little as 30 Watts and three or four crystals, you could work the world with relative ease and regularity. (I ended up with over 120 countries worked on 10 and 15 meter CW with a base-loaded vertical mounted on the side of the house.)

Those days may be gone forever, but there is no need to let those otherwise perfectly good rigs lie unused, especially in view of the current prices for new equipment. With the addition of a good vfo, all those old Heath DX-20, DX-35, DX-40, HW-16, WRL Globe Chief, Globe Scout, Johnson Viking, and countless other rock-bound rigs can still provide years of good service and lots of QSOs.

Happily, Kantronics' Freedom VFO is just what the doctor ordered. Add it to one of those old "boat anchors" and you'll be ready for action. And, perhaps best of all, you may end up spending only the affordable price of \$69.95 for the vfo since the old rigs can often be had for the asking. The unit covers 3.65 to 3.75 MHz and 7.0 to 7.2 MHz. Operation on 15 meters (21.0 to 21.2 MHz) may be possible with the band-switch in the 40 meter position

if the transmitter's buffer stage acts as a frequency tripler. Power for the vfo may be furnished by a single 9-volt transistor radio battery or a well-regulated 12-to-15 V dc supply. Current requirement at 9 V dc is 8 mA.

Dial markings are every five kHz on 80 meters, and every 10 kHz on 40 meters. The vernier dial works smoothly and has a good feel. In view of the rather sparse dial calibration points, it would probably be a good idea, as well as reassuring, to use the Freedom VFO in conjunction with a receiver with an accurate frequency calibration source such as Kantronics' The Standard. All of the components of the vfo's two-transistor circuit, except for the tuning capacitor, switches and connectors, are contained on a single small PC board solidly mounted to a heavy piece of aluminum which is secured to the bottom of the cabinet.

The Freedom VFO was tried with the Kantronics Rock Hound 1-Watt 40 meter transmitter and a vintage tube-type home brew transmitter, providing good results with both units. The CW note sounded good and clean when monitored on a Yaesu FT-101B, and signal reports were all T9. Vfo output is 2 milliwatts (1 volt peak-to-peak).

Packaged in an attractive black and gray cabinet, the Freedom VFO measures 3 x 5 x 7 inches. Price is \$69.95. Kantronics, Inc., 1202 East 23rd Street, Lawrence KS 66044.

Morgan W. Godwin W4WFL
Peterborough NH

GENAVE GTX-800 2 METER TRANSCEIVER

Genave's GTX-800 2 meter

transceiver created a good impression when the first four contacts made with it produced such unsolicited comments on its signal quality as "beautiful, really outstanding audio," "excellent modulation," "sounds great... much better than your other two rigs," and "terrific-sounding signal." Subsequent QSOs have resulted in many more favorable comments on the GTX-800's signal. In fact, it's been downright embarrassing when I've compared the Genave with two other 2 meter transceivers: one, a rather expensive HT of excellent quality, the other, one of the leading multi-mode units. On their own, the other two rigs have always produced good results and received favorable comments on signal quality. However, the GTX-800 outstrips them in audio quality and, when in the 1-Watt (nominal) position, it appears to do about as well as the multi-mode rig does with approximately 10 Watts.

With its coverage of the entire 144-148-MHz range, the GTX-800 provides coverage of the new U.S. repeater subband as well as repeater frequencies in Europe and elsewhere, making it a good choice for the amateur who travels. A VHF, dual-modulus, prescaling, digital, phase-locked-loop synthesizer gives access to 800 channels from 144.0 to 148.0 MHz.

On transmit, the voltage-controlled oscillator (vco) output is on the desired operating frequency with no multiplication. In the receive mode, the vco output frequency is raised by 10.7 MHz, again with no multiplication, to reduce the possibility of spurious responses. Interference from strong signals on adjacent channels is minimized by a 10.7-MHz, eight-pole monolithic crystal filter and a MOSFET receiver front end.

A front-panel mounted meter indicates relative signal

strength for signal comparison, antenna adjustments, etc., when in the receive mode; in transmit, the meter indicates when rf power is being delivered by the final amplifier stage.

A two-position switch mounted on the front panel selects either high or low transmit power. In the high-power position, transmit power is typically 25 Watts (20 Watts minimum). With the switch in the low position, power is reduced to 1 Watt (0.5 Watt minimum). The low-power position is internally adjustable up to approximately 5 Watts.

An "out-of-lock" circuit with a red LED indicator is provided to let you know when the synthesizer is unlocked and to disable the transmitter during an "out-of-lock" condition. The LED goes on when the synthesizer fails to lock on frequency. In this event, the transmitter is locked out to prevent inadvertent operation on an unauthorized frequency such as below 144.0 or above 148.0 MHz.

Frequency selection is made with the three front-panel-mounted frequency selector lever switches. These three switches select and display the desired transmit frequency. The left-hand lever selects unit MHz frequencies (144, 145, 146, 147, and 148). The center lever selects tenth-MHz frequencies from .0 through .9. The right-hand lever selects ten kHz frequencies from 0 through 9. For example, 146.600 MHz would be displayed on the lever switches as 6.60 while 146.930 MHz would be shown as 6.93.

A receive-mode switch selects either simplex or +600- or -600-kHz offset for repeater operation. The kHz-frequency switch has two positions, 0 and +5. In the +5 position, 5 kHz is added to the frequency set by the lever switches. As an example, with the lever switches set to 6.60



Kantronics' Freedom VFO.



The Genave GTX-800 2 meter transceiver.



WE'LL KEEP YOUR COMMUNICATIONS NEEDS FROM GETTING OUT OF HAND.

Introducing the PALOMAR MINI-1 VHF FM TRANSCEIVER . . . the Amateur Hand-Held set that's small enough to fit in your palm.

You're never out of touch with thousands of repeaters, so you're never out of touch with home . . . associates . . . friends. The PALOMAR

MINI-1 operates normally in the Amateur 144-148 VHF region and with the AUTO-PATCH OPTION, you can access the telephone repeater and communicate through the telephone system.

The PALOMAR MINI-1 VHF FM TRANSCEIVER is only 152 mm high by 67 mm wide. Transmitter minimum output is one watt of power, with a total of 18 channels available, utilizing up-down split, down-up split or simplex, all with only 6 crystals.

The PALOMAR MINI-1 VHF FM TRANSCEIVER . . . it has all your communications needs well in hand.



*Worth every dollar.
(And about the same size!)*



Send for your spec sheet of the MINI-1 VHF FM Transceiver to: PALOMAR ELECTRONICS, 665 OPPER STREET, ESCONDIDO, CA 92025.

The parameters of the Palomar PTR-130k are the outer perimeters of logic technology.

Never before has any transceiver approached the capabilities of the Palomar PTR-130k!

It's the first completely multi-functional transceiver ever made available to the public!

The Palomar PTR-130k is a miniaturized mobile transceiver

capable of operating in 100 cycle resolution from 100 KHz to 30 MHz in all modes of transmission and reception. Instant frequency selection is available with the touch of a finger.

The Palomar PTR-130k.

technology is pure space age . . . the price is strictly down-to-earth.

Send for our full color brochure to:
Palomar Electronics Corporation
665 Opper Street
Escondido, CA 92025
Telephone: (714) 746-2666



and the kHz switch set to +5, the actual transmit frequency is 146.605 MHz. The +5 position also adds 5 kHz to the receive frequency. With the switch set in the 0 position, frequency is as indicated by the three lever switches.

The GTX-800 comes with microphone, power cable, and mobile-mounting bracket. The mobile mount may, if you wish, also be used for fixed-station operation by simply repositioning it below the unit so that it functions as a "tilt-type" supporting stand. Current requirements in the transmit mode are 2.3 Amps in the low-power position and 6.5 Amps for full (25 Watts) power. Genave makes a suitable ac power supply, the model PSI-10, for fixed operation of the GTX-800. Overall size is 3-3/8" x 9-3/4" x 12"; weight is approximately 6 lbs. It is priced at \$399.95. *General Aviation Electronics, Inc., 4141 Kingman Drive, Indianapolis IN 46226.*

Morgan W. Godwin W4WFL
Peterborough NH

500 WATT RF TRANSFORMER

Palomar Engineers has introduced a new broadband rf transformer. It matches vertical and mobile antennas to 50-Ohm coaxial cable. Impedance values of 8, 12.5, 16, 22, 32, and 50 Ohms are selected by a panel switch.

The transformer is mounted in a diecast aluminum case 4" x

5" x 2" fitted with UHF (SO-239) connectors. The rf ferrite toroid core is wound with Teflon™ insulated wire and is rated 500 Watts in continuous commercial service. Operating frequency range is 1 through 30 MHz (1 through 10 MHz below 20 Ohms).

The price is \$35. Add \$2 shipping in U.S. and Canada. For free descriptive brochure, write to *Palomar Engineers, PO Box 455, Escondido CA 92025.*

NEW DPMS FROM NLS FEATURE NEMA/DIN CASES AND LARGE LCD OR LED READOUTS

A new RM Series of Digital Panel Meters has been added to the NLS Thriftmeter DPM line.

The RM Series fit standard NEMA/DIN cutouts. Readouts can be either .6" high LCDs or .5" high LEDs. Electrical connections to meter can be made by PC edge connector or, for industrial users, terminal connections are supplied, depending on the model number ordered.

The RM Series meter case is 1.9" high by 4" wide by 4.2" deep.

The basic RM Series meters are powered by 5 volts dc primary power and measure dc voltage. They will also be made available in configurations that provide the capability of measuring ac voltages and/or being powered by 115 V ac

power.

LCD models draw only .002 Amp at 5 V dc.

The basic RM Series meters bear model numbers RM-350 for the LED version and RM-351 for the LCD model. Adding TB to the model number designates terminal connections. /AC specifies an ac input, while /115 specifies a line-powered unit.

Voltage ranges available are .2, 2, 20, 200, and 1000 volts full scale. The .2 V range is not supplied for ac inputs.

Dc accuracy is .1%. The RM meters utilize the latest in LSI chips, which contributes to a low component count and best reliability.

The prices for RM meters start at \$59/unit selling price. Quantity discounts make them cost effective for OEM users.

RM-350 and RM-351 are currently available from local electronic distributors worldwide. For details, contact *Non-Linear Systems, Inc., PO Box N, Del Mar CA 92014; (714)-755-1134.*

NEW HAMTRONICS 2 METER CONVERTER

A recent rekindling of interest in 2 meter operation, plus a growing curiosity about OSCAR satellite activity, happily coincided with the opportunity to try one of Hamtronics'

new C144 receiving converters. Connected to my FT-101B, the converter outperformed my multimode 2 meter rig by a very clear margin. The converter was received in assembled form but a visual check left me with the impression that even a relatively slow worker such as myself could put one together without difficulty in an hour or two. As explained in their catalog, Hamtronics' kits are not accompanied by the meticulous step-by-step instructions and illustrations provided, for example, with Heathkits®. However, anyone who has even a modest acquaintance with home brewing or kit building will find that construction is simple and straightforward.

The C144 covers the 144-146-MHz portion of the 2 meter band while two other versions, the C145 and C146, cover the 145-147 and 146-148 segments. Standard i-f frequency for the converters is 28-30 MHz. By the way, crystals can be switched to cover multiple band segments, if desired. (Extra crystals for other ranges in the same band are available for \$5.95.)

Features of the new design, which replaces Hamtronics' popular C25 series, include easy-to-wind high-Q slug-tuned coils, extensive ferrite bead



Palomar Engineers' rf transformer.



RM Series LCD (top) and LED (bottom) Digital Panel Meters.

HATRY ^{H15} electronics

500 Ledyard St., Hartford CT 06114
203-527-1881

(1 block east of Wethersfield Ave. off Airport Rd.
Rte. 6)

See Ward W1WRQ — John W1JJR

HEADQUARTERS for 2M FM

Tempo VHF/ONE, SSB/ONE adaptor, Tempo VHF amplifiers, FMH-2, FMH-5; Drake TR 33C, AA 10, AC 10; Regency HR 2B, HR 312, AR 2, P 110 & crystals for all lines listed above.

FM GAIN ANTENNAS

For mobile, fixed or portable operation by Cush-Craft, Hy-Gain, Antenna Specialists & New-Tronics.

ANTENNA STUFF

Open wire feedline — #18, #14, #12 ga. bare copperweld wire — #14, #12 enamel copper — insulators — W2AU baluns 1-1 or 4-1 — lowloss coax cable — Rohn 25G towers & accessories — Blitzbug lightning arrestors — glassline guy — B&W antenna switches — Belden 72 & 300 ohm KW twinlead — Amphenol UHF & BNC connectors.

AMATEUR GEAR

Drake, Swan, Tempo, Ten-Tec, Dentron, Regency, Mosley, Hy-Gain, CushCraft.

(Canadian Amateurs Send U.S. Funds Only)
F.O.B. Hartford
Please include postage

CONNECTICUT'S OLDEST HAM STORE

new FROM ALLIANCE!



HD-73 HEAVY-DUTY ROTATOR

with exclusive Dual-Speed Control!

For antennas up to 10.7 sq. ft. of wind load area. Mast support bracket design permits easy centering and offers a positive drive no-slip option. Automatic brake action cushions stops to reduce inertia stresses. Unique control unit features DUAL-SPEED rotation with one five-position switch. SPECIFICATIONS: Max. wind load bending moment—10,000 in.-lbs. (side-thrust overturning); Starting torque — 400 in.-lbs.; Hardened steel drive gears; Bearings—100- $\frac{3}{8}$ " diameter (hardened); Meter — D'Arsonval, taut band (backlighted). There's much, much more — so get the whole story!

Mail this coupon for complete details!

YES! Send me complete details on the new HD-73!
 Give me the name of my nearest dealer!

NAME _____

ADDRESS _____

CITY _____

STATE _____ ZIP _____



The **ALLIANCE** Manufacturing Co., Inc., Alliance, Ohio 44601
A NORTH AMERICAN PHILIPS COMPANY A57

Maker of the famous Antenna Rotator . . . Alliance Tenna-Rotor® . . . "TV's Better Color Getter!"

© 1978 The Alliance Mfg. Co., Inc.

decoupling and compartmentalized shielding, as well as built-in detector circuits for simple injection-chain tuning. Stable, grounded-gate FET amplifier and mixer stages contribute to the converter's excellent performance. Alignment requires only a strong signal source and a VTVM and can be accomplished in a few minutes.

Measuring 2 3/4 x 4 1/2 x 1 inches, the converter board can be mounted in existing equipment, or a separate case of your own design, or Hamtronics' model A9 Case Kit. The case kit is a 2-7/8 x 4-5/8 x 2-inch extruded box with an attractive brushed aluminum finish. The top panel is machined for BNC jacks which are included, as are phono plugs and cable for connection to the converter board.

The C144 and its other 2 meter versions are just one example of an extensive and growing line of receiving and transmitting converters, exciters, amplifiers, preamps, and other items for the VHF/UHF enthusiast. If you've got an HF rig and are contemplating satellite operation, you'll certainly find Hamtronics' complete line of modules and accessories an excellent way to get in on the OSCAR fun and excitement with a setup that combines flexibility, simplicity, ease of construction and alignment, high performance, and modest cost.

Price of the C144, C145, and C146 2 meter receiving converter kits is \$34.95. The A9 Case Kit is \$12.95. A new free catalog describing the complete Hamtronics product line plus many other items including hard-to-find components is available on request. All Hamtronics products are available from *Hamtronics, Inc.*, 182



Wyle's digital logic modules.

Belmont Road, Rochester NY 14612.

Morgan W. Godwin W4WFL
Peterborough NH

SINGLE IC FOR KEYBOARD KEYS

A single IC containing most of the electronics for a deluxe keyboard keyer has been introduced by Curtis Electro Devices. Called the 8045, the 40-pin CMOS device uses one or more FSC 3341s, a Curtis 8043 or 8044 keyer, and a set of keyswitches to produce the equivalent of the Curtis KB-4200 keyboard keyer including an electronic paddle keyer. By adding the new 8047 Message Memory Control IC, 2102 RAM, and a 4028 CMOS decoder, the equivalent of a KM-420 memory is added.

The 8045 allows a nominal fifty-seven position keyboard containing all the commonly used letters, figures, punctuation, space bar, and special characters (AA, KN, AS, SK, AR), all without shifting. It affords two-key rollover for "burst" typing; 32-, 64-, or more

character storage for smooth transmission; access to four message memories via buffer; analog output for buffer status meter; full- and empty-buffer indication, plus a preload function. It operates from +5 V dc and requires less than 10 mA of supply current.

Priced at \$59.95 in single quantities, the 8045 is available from stock. A semi-kit (8045-1) containing the 8045, 3341, PCB, sockets, and edge connector is priced at \$89.95. (The 8044-4 keyer semi-kit is priced at \$54.95.)

For further information, contact *Curtis Electro Devices, Inc.*, Box 4090, Mountain View CA 94040; (415)-964-3136.

DIGITAL LOGIC MODULES

The Wyle line of digital logic includes over 200 modules covering all types of logic elements. Available on the 3 1/4" x 4 1/2" modules are gates, flip-flops, decoders, counters, one-shots, line drivers/receivers, electronic switches, and many more. Additional modules include relays, test-point

modules, extenders, lamp, toggle switch, and a wide variety of socket, wire-wrap, and blank modules. Also available are card files and card drawers for rack-mount or custom installations and logic power supplies.

The Wyle logic line is also fully compatible with the Wyle uP Series microcomputer.

For additional information, contact *Wyle Laboratories/Computer Products*, 3200 Magruder Boulevard, Hampton VA 23666; (804)-838-0122.

CSC DM-1 DESIGN MATE® COMBINES SOLDERLESS BREADBOARD, METER, AND POWER SUPPLY FOR ELECTRONIC LAB STUDY

The Continental Specialties Corporation Model DM-1 Design Mate® provides the three elements most basic to electronic circuit investigations—a power supply, breadboarding area, and meter—in one convenient package for \$69.95.

The meter measures 0-15 V dc (5% accuracy) and is independent of the power supply, with leads brought out to a pair of five-way binding posts. Thus, the meter can be used to set the adjustable power supply's voltage, and then to monitor circuit action.

The built-in power supply is adjustable from 5-15 V dc output at up to 600 milliamperes, with better than 1% load and line regulation and less than 20 mV ripple and noise at full load.

The solderless breadboarding area is configured from CSC QT-series ("Quick Test") socket and bus strip elements. It provides enough area to comfortably breadboard a circuit with 6 DIP ICs, plus associated components.

The compact 3 pound DM-1

Continued on page 37



The Curtis 8045 keyboard keyer.



CSC DM-1 Design Mate®.

think of yourself as an **antenna expert!** —you select your components!

1 Get optimum performance band for band. Choose from medium or high power resonators for your favorite bands.

2 Fold over, 360° swivel mast for quick band change or easy garaging. Select from two versions, fender/deck or bumper mount location.

3 Stainless steel ball mount, 180° adjustable, commercial duty for superior mechanical and electrical performance.

4 Get exceptional reports, broadest bandwidth, lowest SWR. Use with any convenient length 50 ohm coax. Matching devices not required.

5 For convenience, use the Hustler stainless steel resonator spring, and special design quick disconnect.

...and you'll mobile with the experts' foremost choice... **HUSTLER**

Get fixed station reports from your mobile—operate 6-10-15-20-40-75 or 80 meters with the experts and join the vast majority using Hustler for nearly two decades.



Model SSM-2 Ball Mount



Model BM-1 Bumper Mount



Model QD-1 Quick Disconnect



Model RSS-2 Resonator Spring



Model L-14-240 Mil Spec 50 Ohm Feedline



Model MO-1 For Deck or Fender Location



Model MO-2 For Bumper Mount Location



Super Resonators RM(S) 2 KW PEP Greatest Coverage



Standard Resonators RM 400 Watts PEP

"the home of originals"



Available from all distributors who recognize the best.

new-tronics corporation
15800 Commerce Park Drive
Brookpark, Ohio 44142
(216) 267-3150

N2

HUSTLER ANTENNA PRODUCTS—for sixteen years—original designs—created and manufactured by American ingenuity, labor and materials—used by communicators throughout the world.

Hustler designs are patented under one or more of the following assigned to New-Tronics Corporation 3287732, 3513472, 3419869, 3873985, 3327311, 3599214, 3582951.

Four-Wheel Frenzy!

Hams and the Baja Internacional



Antennas at El Rodeo, checkpoint six.

June and November are special months to many hams in Mexico, California, and other western states. From many areas, they converge on San Diego or Mexicali for points south. They come in cars, 4-wheel drive vehicles, luxurious motor homes, trucks, and airplanes. It's Baja time! Baja 1000 and Baja Internacional have become everyday words in many ham shacks. XYLs know it's time to pack up supplies and camping gear, and the harmonics look forward to three or four days of fun and freedom in the friendly XE2 land.

During the late 1950s, the first automobile drove over 900 miles of the rugged, rough, and rocky Baja Peninsula from Ensenada to La Paz. The drivers made their own route where there was none. Racing began over the route from Ensenada to La Paz in 1965. These early events were loosely organized. However, from the beginning, radio amateurs operated portable stations along the way, relaying information and keeping track of the racers' safety. The amateurs drove incredible roads to camp in lonely, wildly beautiful spots. They erected portable antennas, brought their own generators, and experienced hurricanes, torrential rains, dust storms, hot, humid days, blizzards, and cold shivery nights, never failing to provide the type of communications for which

amateur radio has become famous.

Although the early Baja races were from Ensenada to La Paz, completion of Mexican Highway 1 along the old route necessitated establishing a new course in the early 1970s. The new route was a loop instead of a line which terminated in La Paz, 1000 miles south of the United States border. Recent races have started and ended in Ensenada.

About the same time as the course was changed, in 1972, the Southern California Off-Road Enthusiasts (SCORE, Int.) was organized by Mickey Thompson, a top racer, to sponsor future events. In 1975, Sal Fish, former publisher of *Hot Rod Magazine*, became president of SCORE, Int. Under Sal's leadership, SCORE has grown even stronger. Each event sees increased participation and interest. SCORE has improved relations and negotiated long-term agreements with the Mexican government to insure the future of off-road racing on the Baja Peninsula.

During this period of off-road racing's development, the amateurs who participated in these events formed an unofficial organization which became known as the Baja Amateur Racing Fellowship, or BARF. BARF was soon changed, for obvious reasons, to the Baja Amateur Radio Racing Association, familiarly known as BARRA.

Early communications used HF SSB amateur bands. The first use of VHF FM for an off-road racing event was in 1975 when the Anaheim Amateur Radio Association provided communications for the Big River 400 race out of Parker, Arizona, on 146.52 MHz simplex. VHF FM and VHF repeaters have been used for all races since, as well as HF SSB.

The 1977 Baja Internacional was the largest off-road race in history with approximately 450 entries.

They ranged, in eleven classifications, from motorcycles to 4-wheel drive trucks. All competed over the same course for overall honors, as well as for individual classification awards.

Extensive communication circuits are necessary to handle the volume of traffic for such an event. Amateur radio stations using the call-sign XE2BCM are authorized by the Mexican government to provide communications for the duration of the race. These operations are coordinated with the Mexican National Radio Amateurs and the Liga Mexicana de Radio Experimentadores, A.C. BARRA wishes to extend special thanks to the members of the Ensenada Radio Club, owners of the fine 146.22/.82 repeater in Ensenada, who graciously allowed its use for interunit communications while the BARRA network was being installed.

This network was designed to provide up-to-the-minute vehicle passing times at each numbered checkpoint directly to Ensenada Race Control. Passing times are computed, and the standings of the leading racers are continuously available.



WA6GQF coordinated race communications.

Portable stations were located at the start/finish line, Ensenada Control, and seven major checkpoints. Two aircraft and five off-road mobiles provided communications from any section of the 430-mile course and to the paramedic teams.

The race course climbs rapidly after leaving the starting line, going over the mountains, past Ojos Negros, to the

first checkpoint at El Rayo, which nestles in lovely high mountain pine groves. There it turns south through the ruins at Santa Caterina before challenging the formidable Sierra de Juarez. It soars over rugged Jamalú Summit and descends rapidly to the hot sandy desert, passing checkpoints 2 and 3 as it continues to the picturesque seaport city of San Felipe on Baja's



K6WS reports injured driver's condition to Ensenada Control.



Racers passing Nuevo Junction.

eastern coast. Most of the racers make a pit stop in San Felipe before departing to the west into the dry barren Laguna de Diablo. The foothills of Picacho del Diablo are a welcome relief after several hundred miles of dusty desert. The course steers through Mike's Sky Ranch,

the road stretches out, and the race for Ensenada is stepped up. Once past checkpoints 6 and 7, the racers challenge the mountains guarding the finish line at Ensenada.

Many vehicles fail to finish. A simple form called a "stuck stub" is carried by

each driver. If disabled, he sees that his stuck stub is delivered to the officials at the next checkpoint, where the information is transmitted to all stations. Officials and racing teams can keep track of their entries by periodically checking the posted stuck stubs.

Ensenada
146.52 FM
147.39/.99 FM
3880 kHz SSB

Ensenada Mountains
Repeater #1 147.39 (in from Ensenada)
146.19 (out to Mt. Diablo)
Repeater #2 146.79 (in from Mt. Diablo)
147.99 (out to Ensenada)

Checkpoints
1, 2, 3, 4, 5, 6, 7, Start-Finish
146.52, 146.19/.79, or 147.39/.99 at Start-Finish
3880 kHz SSB

Visual Checkpoints and Aircraft
Same as checkpoints, except some rescue teams had VHF only.

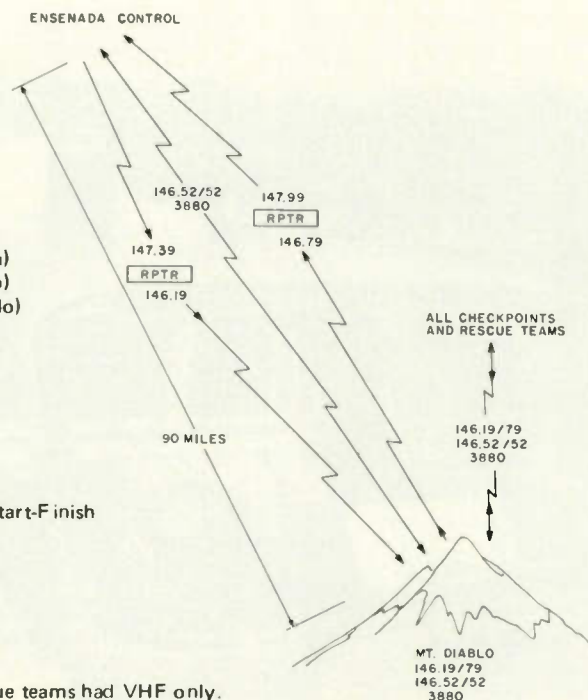

Baja Internacional communications system.

Trained paramedics stationed at the checkpoints are dispatched by the chief paramedic through the radio network. Mobile units can accompany the paramedics to provide communications directly at the scene of an accident.

This year, more than fifty members of BARRA and their families made the long trek to the remote areas of Baja. Hundreds of hours of planning had already gone into preparing for this event. BARRA's technical committee had completed three new VHF solid state repeaters using Motorola components. They are designed for unattended battery operation because of a blizzard during last November's Baja 1000 which forced the repeater crew to evacuate Mt. Diablo with the vacuum tube repeater and 5 kW generator, leaving the network to function on the HF SSB circuits only.

All stations have emergency power sources provided by the amateurs. Ensenada Control used its own standby generator extensively during the 1975 Baja Internacional when a helicopter hit power lines and caused a sustained power blackout in the city.

BARRA obtains the necessary practice to achieve and maintain a high level of emergency preparedness by providing routine communications to organizations such as SCORE. Each event generates different solutions to difficult communication problems, and experience enables BARRA to become more efficient. This is important to the achievement of BARRA's primary objective of being able to establish and maintain an organized communications system during emergencies to assist law enforcement and relief agencies.

Net control was located at the Baja Internacional Race Headquarters at the Bahia Hotel in Ensenada. The 75 meter SSB transceiver used an inverted vee antenna. A 22-element beam and 100-Watt

VHF FM transceiver provided direct communications with Mt. Diablo 100 miles away.

A solid state repeater with a vacuum-tube backup was installed on Mt. Diablo. A cavity and 9 dB collinear antenna could be used by either repeater. Although the primary 146.19/.79 repeater was designed to run on battery power throughout the race, a portable 5 kW generator was used to power the 100-Watt simplex VHF transceiver, HF SSB transceiver, and the backup repeater. All of this equipment was transported more than sixty miles each way from the highway to be installed at the 9400-foot level of the 10,126-foot mountain, the highest in Baja.

Many of the checkpoints are inaccessible except by 4-wheel drive vehicles. The radio team for checkpoint 3 spent the night before the race in a Jeep trying to reach the assigned location, only 10 miles from a major highway.

For those who like to be close to nature, Baja offers many attractions. The mobile unit at Nuevo Junction reported seeing two rattlesnakes within the first thirty minutes.

All stations had checked in on site by 8:00 pm on Thursday, except for checkpoint 3, whose staffers reported that they were still underway despite deep sand conditions.

The VHF link repeaters installed on the mountaintops around Ensenada operated on 147.39/146.19 and 146.79/147.99. This allowed VHF units using 147.39/.99 in Ensenada to tie directly into the primary 146.19/.79 repeater atop Mount Diablo.

The race began at dawn Friday. Checkpoint 1 reported the first motorcycles an hour later and the first 4-wheel vehicles fifty minutes after that. Interest at race headquarters rose perceptibly with each passing moment — "Who's in the lead?" "Who's behind him?" Answers to these questions began to pour from the SCORE computers.



El Rodeo, checkpoint 6.

Operators along the network were busy copying passing times and stuck stubs. This constant activity continues all day and throughout the night. Questions were being asked — "Where is 321?" "Out of race at Nuevo Junction." "Driver OK." Concerned parties were kept informed via radio throughout the race.

At 11:30 am, a mobile unit reports an accident in the mountains. Paramedics are dispatched. Angel 1, an aircraft mobile unit, is contacted and heads for the area. Routine traffic continues to flow over the network. Reports come into Ensenada advising them of the driver's condition. Another mobile unit is directed to pick up a doctor at Valle de Trinidad and rendezvous with the rescue team on the highway near checkpoint 6. Angel 1 contacts the crew at checkpoint 6 to obtain information on the possibility of landing. Ensenada approves and Angel 1 lands at El Rodeo.

Another accident occurs at El Rodeo, so Angel 1 is told to leave with this injured driver while the paramedic team continues on the highway to Ensenada. Medical authorities are able to make efficient decisions with up-to-the-minute information avail-

able through the BARRA network.

During the hot afternoon, a helicopter is dispatched in answer to a paramedic team's request to transport an injured driver in the eastern desert.

An amateur operator in Vista, California, keeps emergency facilities in San Diego informed of rescue activities. Because of his efforts, everything is ready when injured drivers arrive later in San Diego.

Ensenada Control authorizes closing checkpoint 1. The radio team leaves to become a mobile team at Ojos Negros to provide communications in case of trouble where the course crosses the main highway from Ensenada to San Felipe.

At nightfall, another paramedic team is dispatched to a remote area. The team requests that an ambulance meet them at the highway when they come out, and an efficient effective transfer is accomplished.

The use of amateur-radio-equipped mobile units and aircraft in the communications plan made it possible to communicate from Ensenada Control to rescue units at the scene for the first time in Baja off-road racing. This contributed greatly to driver

safety. SCORE regulations are very strict concerning safety rules, and BARRA is proud to play its part with efficient communications.

Toward the end of the race, when most of the cars are past the finish line, the "sweepers" began their lonely trek from one checkpoint to the next to report abandoned vehicles along the course and pick up any lonely drivers who may be discovered along the way. Many of the sweepers are radio teams on their way back to the highway after the last racer has passed. The radio voices in the night are reassuring to the tired hams as they make their way down the rough worn course and on to Ensenada or Mexicali.

Relatives and friends receive reassuring news about drivers and learn where a few unreported race cars are located. By dawn, only a few stragglers are still on the course. The pit crews and spectators have gone. The tired radio operators dismantle their antennas, pack their equipment, and head back to their home QTHs. They are already thinking of the next Baja race, planning new and better methods for next time, and carrying with them a sense of pride in a job well done. ■



YAESU
The radio.



Is Our Number **1** Line At

Cohoon Amateur Supply C83

TO SERVE YOU BETTER **3 LOCATIONS**

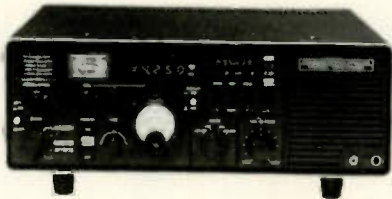

Cohoon Amateur Supply

SOUTH

Hwy. 475 Trenton, Kentucky 42286

502-886-4534



Cohoon Amateur Supply

NORTH

Box 4073 Austintown, Ohio 44515

216-538-3424



Cohoon Amateur Supply

WEST COAST OUTLET

728 Juniper Lompoc VAFB, CA. 93437

805-734-4693



1. Full Repair Service
 2. Sub-Dealers Welcome
 3. Good Prices
 4. Ship UPS The Same Day
 5. All Used Gear
- Has A 90 Day Warranty.

Also Stocking:

KENWOOD	KANTRONICS
TEN-TEC	ATLAS
TEMPOC	DENTRON
WILSON	CUSHCRAFT
INFO-TECH	

Write for used equipment sheets and dealer inquiries.

TOWER//TUNER

RESONATES YOUR TOWER
ON 40, 80 AND 160 !

NOW
available for 160
meters

Now you can easily use your entire tower and present beam system as a complete low angle radiator on 40, 80 and 160 meters. It is common knowledge that a dipole or inversed-vee must be at least 1/2 wave length high (120 feet on 80 meters!) in order for it to be a low angle radiator. But your existing tower, if fed with the Stuart Electronics **TOWER TUNER**, can be made to be an optimum low angle radiator on 40, 80 and 160 meters. The Stuart **TOWER TUNER** can be installed and easily adjusted to a low swr on any tower no matter what the size or type. Tower can be grounded or not. Radials not necessary. No more haywire appearance of dipoles and I-V's. Even your wife will love it. The Stuart **TOWER TUNER** takes up virtually no extra space but greatly outperforms dipoles and I-V's at the same height plus it is easily adjustable from ground level. Start making better contacts on the 40, 80 and 160 meter bands with an antenna system that really gets out. The Stuart **TOWER TUNER** will handle 500 watts output.



We are so confident that you will like it that we offer a 30 day money back guarantee if you are in any way dissatisfied. Priced from \$129.95 includes shipping in continental United States.

STUART ELECTRONICS

Dept. 9
578 KENNEDY RD.
AKRON, OHIO 44305
(216) 798-9431

S38

Synthesizer II & Synthesizer 220



FEATURES

- T²L Logic
- Maximum offset versatility — easily programmed to any IF and transmitter offset between 100 KHz and 30 MHz in even 100 KHz increments.
- Jumper wire programmable for most common TX multiplying ratios
- All frequencies locked to one master crystal oscillator.
- 2 pole output filter on receive line.
- Virtually no measurable difference in spurious outputs from crystal.
- Lockup time typically 150 milliseconds.
- Easily interfaced to most rigs.
- Transmit offsets are digitally programmed on a diode matrix, and can range from 100 KHz to 10 MHz.
- No additional components are necessary!

SYNTHESIZER II

A 2 meter frequency synthesizer. Frequency is adjustable in 5 KHz steps from 140.00 MHz to 149.995 MHz with its digital readout thumb wheel switching.

SPECIFICATIONS

- Frequency: 140.000 — 149.995 MHz
- Transmit offsets: Simplex, +600 KHz, — 600 KHz plus 3 additional field programmable offsets.
- Output: 3 volts to a 50 load
- Input voltage: 11 — 18VDC at .900 amps
- Size: 8" long x 5 1/2" wide x 2 1/4" high
20.32CM x 13.97CM x 5.715CM
- Complete kit including all electronics, crystal, thumb wheel switch, cabinet, etc.

SYNTHESIZER 220

Comparable with virtually all 220 transceivers; Clegg, Midland, Cobra, etc..... Frequency is adjustable in 5 KHz steps from 220.00 MHz to 225.00 MHz with its digital readout thumb wheel switching.

SPECIFICATIONS

- Frequency: 220 — 225 MHz
- Transmit offsets: Simplex, +1.6 MHz, — 1.6 MHz plus 3 additional field programmable offsets.
- Output: 3 volts to a 50 load.
- Input voltage: 11 — 18 VDC at .900 amps
- Size: 8" long x 5 1/2" wide x 2 1/4" high
20.32CM x 13.97CM x 5.715CM
- Complete kit including all electronics, crystal, thumb wheel switch, cabinet, etc.

Shipping weight — 2 lb. 4 oz.

Price for either unit: Kit — \$169.95, Wired & tested — \$239.95

arma
analog radio manufacturer's division

Vhf engineering

V5

Division of Brownian Electronics Corp.

320 WATER STREET / BINGHAMTON, N.Y. 13901 / Phone 607-723-9574

Prices and specifications subject to change without notice. / Export prices slightly higher.



T-R Exotica

—rf switching with PIN diodes

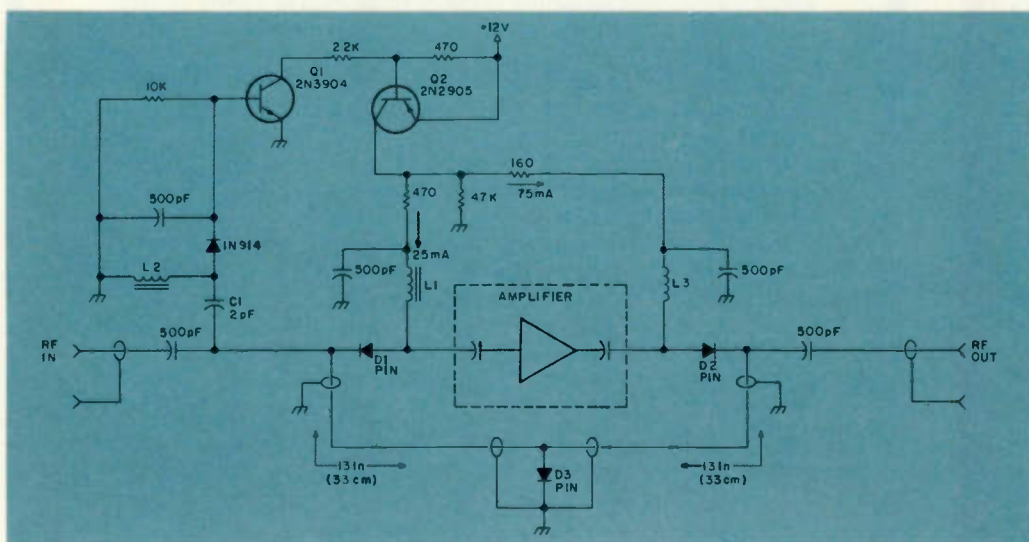

Fig. 1. PIN diode rf switching.

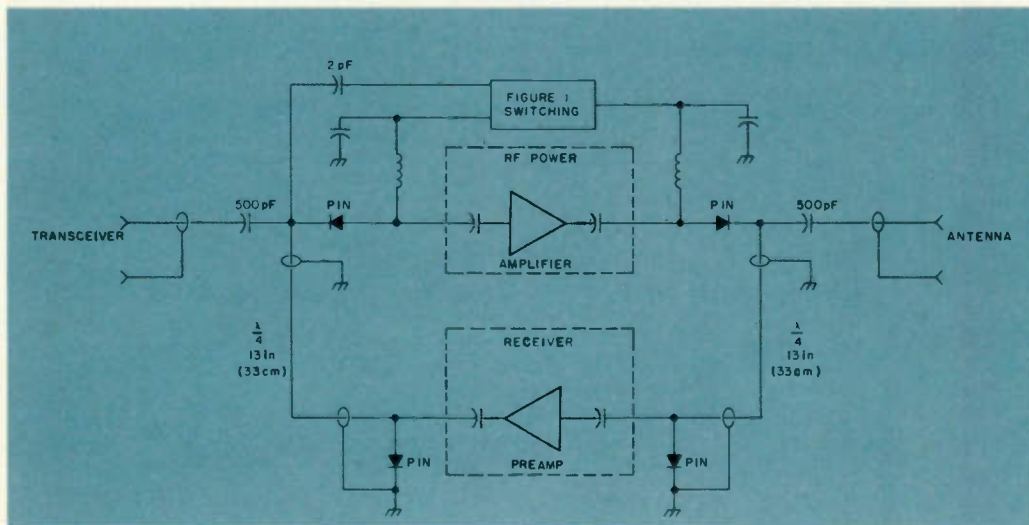

Fig. 2. Power amplifier and preamplifier switching scheme.

I always thought that exotic parts like PIN diodes were not for ordinary folks like hams—we should just stick to the “meat and potatoes” and leave the space-age components to the scientists. It was only after I learned the law of this part (how it works) that I discovered a really neat application.

How It Works

Its name describes its construction: P stands for P-type semiconductor, N stands for N-type semiconductor, and I stands for intrinsic (no P or N doping). If you put a forward bias on the diode, it will conduct. Back biasing the diode will result in no (very little) current flow. That’s just like a conventional diode, right? What is happening is that, in the forward bias case, there are excess (free) electrons in the intrinsic region. Moreover, the electrons will remain in this region for a few microseconds after the bias is removed. The time is called the “majority carrier lifetime” and is a property that can be put to use. The reverse bias

properties that are useful are a high resistance and an extremely low capacitance, typically tenths of picofarads. At zero bias, the capacitance is only 1 or 2 picofarads.

This diode can pass Amperes of rf power with only a few milliamperes of dc bias. The secret is in the long "lifetime" property. If the period (1/f) of the rf is shorter than the lifetime, then, during the time the rf voltage is reversed, there will be enough electrons in the intrinsic region to allow conduction.

Application

The circuit in Fig. 1 shows how I used three of these diodes to switch a two-stage two meter amplifier. You can see from the photograph that the circuit board was made by the cut-and-peel method. Locate the quarter-wave lines, and you will find the diodes at the ends. This amplifier is used with 2 Watts input and 45 Watts out and is utilized to boost my hand-held portable while in the car.

The two quarter-wave transmission lines are made with RG-188; you could use any of several kinds of small 50-Ohm cable. The small capacitor is a gimmick made of 20-gauge insulated wire, twisted for 3/4" (2 cm). This capacitor couples a small amount of rf, which is detected, filtered, and used to turn on the NPN switching transistor, Q1. This then turns on Q2 (a PNP switching transistor).

The 100 milliamperes of collector current divides, with 25 milliamperes through D1 and the other 75 milliamperes through D2. The current recombines in D3. This small amount of dc is enough to pass 45 Watts! The low impedance of D1 couples the input power to the amplifier. The low im-

pedance of D3 is reflected as a high impedance at both the input and output. During receive, the diodes are zero biased and have a capacitance of only one picofarad or so. The receive signal, therefore, takes the bypass route through the quarter-wave sections, as the diodes now present a high impedance.

Preamp Switching

The circuit in Fig. 2 is offered as a suggestion for those who enjoy adventure. This one will give a boost both going and coming.

I just don't have the nerve to put a sensitive, delicate receiver preamp in the same box with that brute. I have not tried this, so don't blame me if rf eats your preamp up! Seriously, though, it ought to work just fine.

Up Your Coax

Why not supply the required 12 volts via the coax and put the amplifier/pre-amp right at your antenna? It won't do much for transmit, but it should give you an advantage over the coax loss for receive. Use chokes to isolate the dc from the rf, as shown in Fig. 3.

Diode Source

The first diodes I tried were expensive microwave types that were discarded from a test-and-evaluation program. Exotic parts like this rarely find their way into the surplus market, so, after I decided to write this article, I began to look for an inexpensive dependable diode source. Unitrode has

such a diode—part number UM4001B.

I will gladly correspond about this and other articles I have written if you will send an SASE. ■

Reference

James K. Boomer W9KHC, "Pin Diode Transmit/Receive Switch for 80-10 Meters," *Ham Radio*, May, 1976.

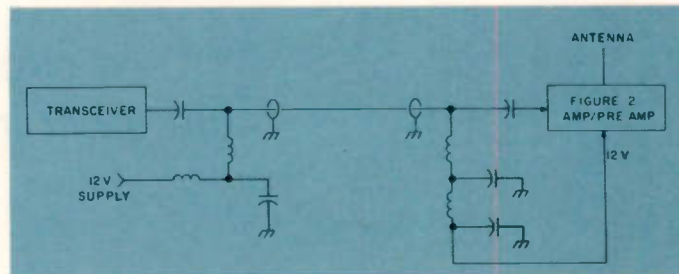
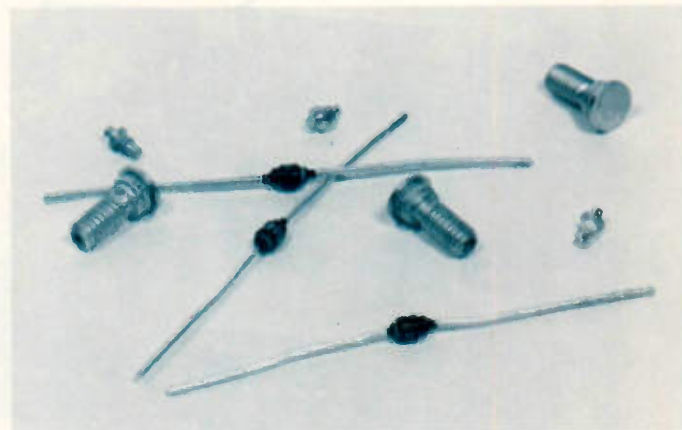
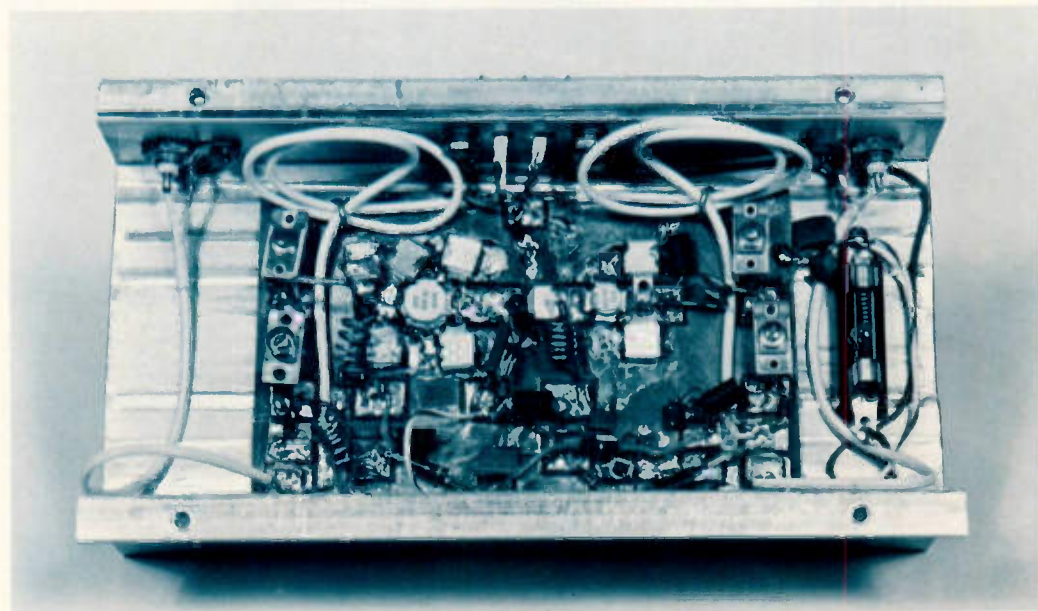

Fig. 3. Send 12 volts up your coax to supply the amp/preamp located near the antenna.



PIN diodes come in many shapes.



A two meter amplifier with PIN diode switching.

The Autodialer Revisited

— a circuit board
and other improvements

William Hosking W7JSW
8626 E. Clarendon
Scottsdale AZ 85251

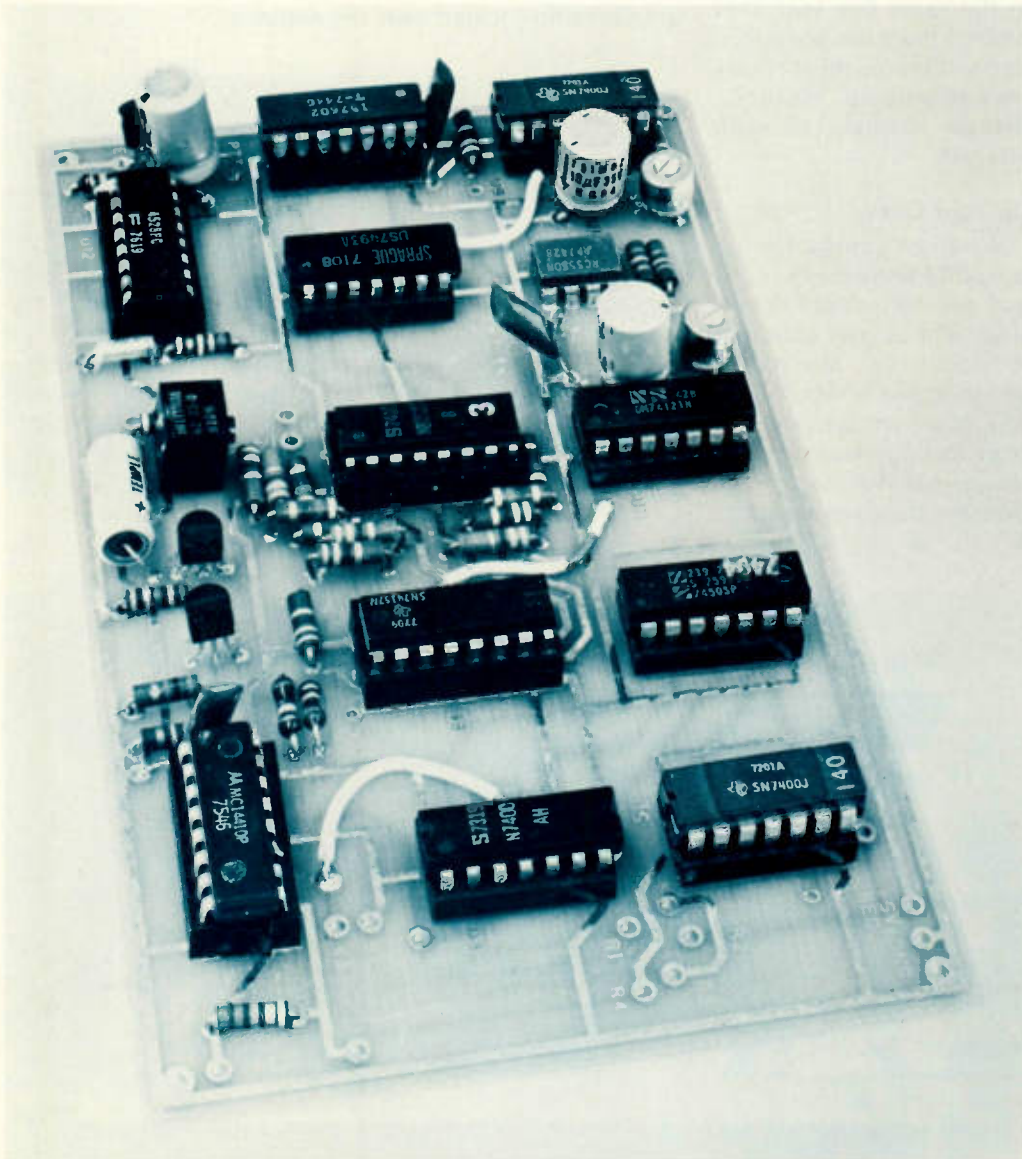

Photo A. This is a photograph of the completed autodialer printed wiring board. The memory (center) should always be in a socket.

It often happens that six months to a year elapses between the time an article is purchased and the time it is out in print. Also, it may take a couple of months to put an article together. Therefore, it may be as much as two years between the time an article gets designed and the time it gets into print. For various reasons, my autodialer (73, February, 1977) took almost 2½ years, and, in that time, several things came about which I felt might be of interest to you.

The first thing that happened was that there was

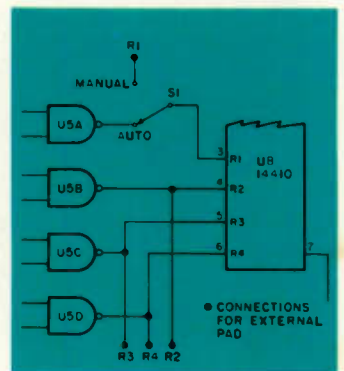

Fig. 1. Partial schematic of the autodialer. S1 is the added SPST switch in order to use an external pad.

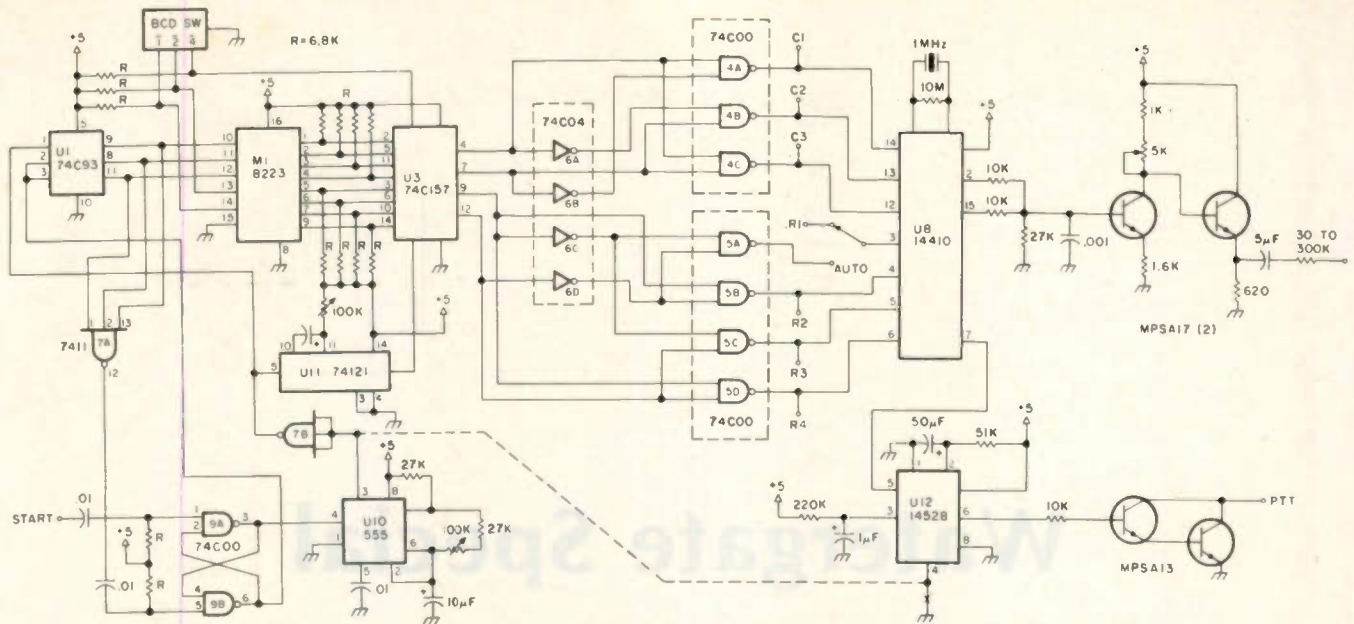

Fig. 2. Complete schematic of the dialer. All resistors marked R are 6.8k, 1/4-Watt, 10%. A printed wiring board is available from W7JSW.

sufficient local interest from my friends that I developed a board for it. The circuit was moderately complex and a board made the thing a whole lot easier to put together. Photo A shows the completed circuit board. The boards are available from me for \$13.50 ppd.

Circuit Changes

One problem came to light very early with the eight-number version of the dialer. The necessity to encode two memory lines to four row select lines left no unused code. This means that the R1 line is active all the time the device is idle. The way the device (14410) works, this presents no direct problem since no tone will be sent until both a row and column are energized. What it did do was make it impossible to use an external pad switch with the dialer. Addition of an SPST switch took care of this problem with little effort or expense. The change is shown in Fig. 1.

I had a couple of complaints about the power consumption which I largely ignored, not wishing to either lay out the printed wiring board again or redesign the circuit (I'm kind of lazy). Another obstacle to redesign-

ing the circuit was the absence of an eight-bit, low-power, field-programmable read-only memory. Well, in the couple of years since the circuit's inception, a line of pin-compatible TTL to CMOS devices was introduced in the 74Cxx line. In this line, a 74C00 is a pin-for-pin replacement for a 7400, only CMOS instead of TTL.

I looked the old circuit over carefully for circuit loading and device types and came up with seven TTL devices that can be replaced with CMOS substitutes. Table 1 shows the devices replaced and shows that they should save about 100 to 150 milliamps. If you are just building up the circuit, you can change the 4.7k pull-up resistors to 6.8k with no degradation of circuit performance.

A couple of people have told me that the transistor PTT switch will not pull their PTT line low enough to properly key the transmitter. In this case, I recommend driving a low-power relay with the output switch and then use the relay contacts to key the radio.

Depending on how fast you run the dialer and how slow your transmitter comes up, you can lose anywhere

DEVICE	CURRENT	DEVICE	CURRENT
7400	20	74C00	2
7400	20	74C00	2
7400	20	74C00	2
7404	30	74C04	2
7493	26	74C93	4
74157	30	74C157	4
TOTAL:	146	TOTAL:	16

Table 1.

from half to all of the first digit tones. One remedy for this is shown in Fig. 3. With this connection, the PTT switch operates off the clock and therefore comes up earlier. This connection is shown as a dotted line in the schematic of Fig. 2.

By way of alternate (or devious) assembly methods, a local ham concocted a small version of the dialer using wire-wrap techniques instead of printed circuit board. He could not find real small thumbwheel or other BCD coded switches so he used miniature toggle switches coupled with a BCD to 7-segment decoder and LED to give a readout of the selected phone number.

Conclusion

The board turned out quite well, and the change to CMOS has cut the current consumption way down. As time goes on, I'm sure I'll

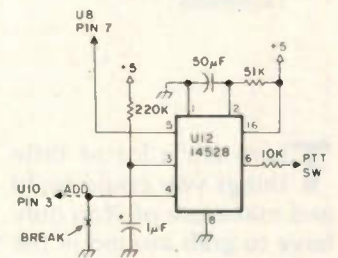

Fig. 3. Circuit modification to allow the output switch to start with the clock.

come up with more changes or modifications.

If any of you have come up with something neat using this or any of my circuits (for example, using the dialer with a microcomputer), I'd love to hear about it. If you write and want a speedy reply, though, please include an SASE. For those who might not have the February, 1977, issue of 73 handy (heaven forbid), I have included the complete schematic of the dialer as Fig. 2. ■

Watergate Special

— create your own 18-minute gap

*Toni Ruepp HB9BLU
Landstrasse 169
CH5422 Ob. Ehrendingen
Switzerland*

There are a lot of little things you could build and make use of. You only have to grab around in the junk box and then develop ideas. One such item is the following. It doesn't cost

you one cent, but it can be very useful.

There are many reasons why you might want to erase a tape before rerecording on it. Also, you may have to erase a recording very quickly. This could be a help for secretaries who want to erase a dictation after the letter is written, or for members of the government after they've been elected ...

The construction is very easy. All you need is an old final transformer (tube-type, with an impedance of about 7k Ohms), a bell switch (isolated, good for your line voltage), and a plastic box.

The transformer must have an E/I-shaped core. Remove the I part of the core, cut the secondary wires (heavy wires), and put the transformer into that plastic box. Wire it according to Fig. 1, and glue it with epoxy. Then seal the

box, so nobody can get an electrical shock.

Here's how to use it:

1. Put the cassette on top of the (hidden) transformer.
2. Push the button and move the cassette around in the magnetic field for about 3 to 8 seconds.

3. Remove the cassette and then release the button.

Do not exceed 10 seconds, as the coil might get too warm, especially when using 220 V.

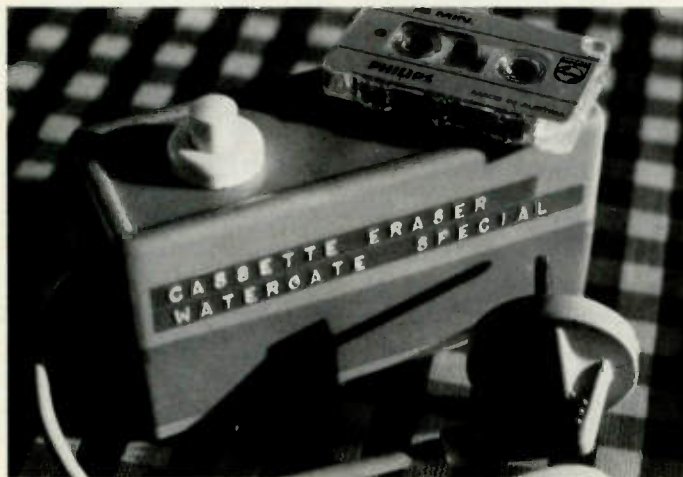

The Watergate special.

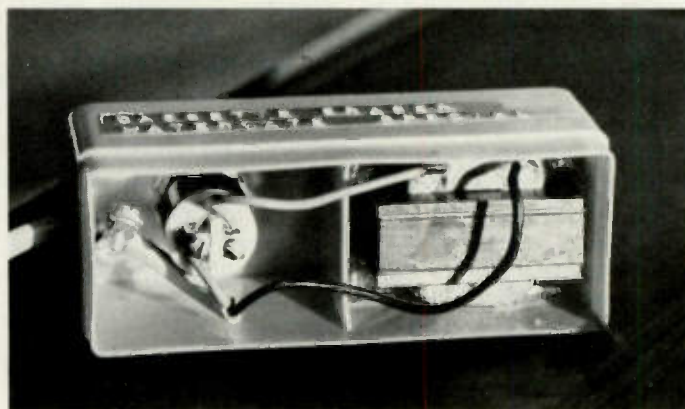

Bottom view.

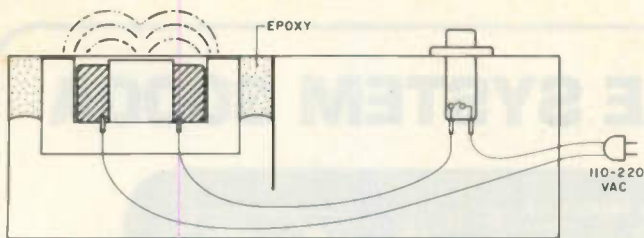
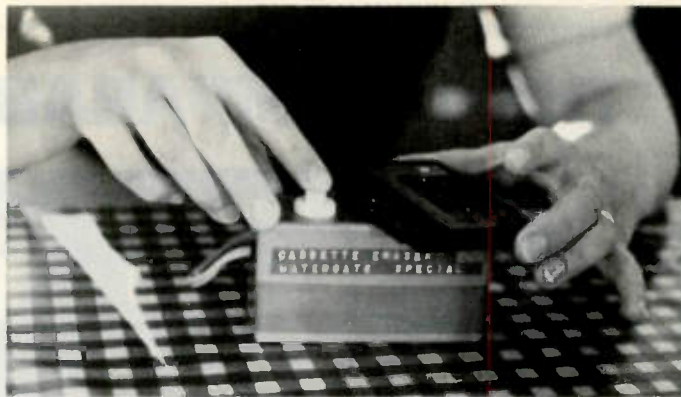

Fig. 1.

This way of demagnetizing tapes works very well, and the disadvantages of other ways do not exist.

There is less noise on the tape, and there are no magnetic springs in the cassettes. ■



How to use it.

New Products

from page 24

package requires only 12 Watts or less at 117 V ac, 60 Hz. A 220 V ac 50/60 Hz version is also available at a 10% additional cost.

The DM-1 is one of four instruments in CSC's Design Mate series. For additional information, contact *Continental Specialties Corporation, 70 Fulton Terrace, New Haven CT 06509; (203)-624-3103.*

HEATH 100 MHZ TO 1 GHZ BIDIRECTIONAL WATTMETER

Using Heath's new Bidirectional RF Wattmeter Model IM-4190, I've been able to tune up my 2 meter rig and antenna system so that it's working more efficiently and effectively than ever before. Now I'm looking forward to using it to get a 70 cm mode J setup going so I can join the activity taking place via OSCAR 8.

A simple, easy-to-assemble one evening project, the RF Wattmeter measures rf output up to 300 Watts within the frequency range of 100 MHz to 1 GHz. There are three switchable ranges for forward power (30, 75, and 300 Watts) and three for reflected power (3, 7.5, and 30 Watts.) The 3-Watt range is read on the 30-Watt scale. Power is read directly in Watts in both forward and reflected positions. Swr may be readily determined by referring to the graphs on page 11 of the illustration booklet that accompanies the kit, or by using the formula on page 33 of the assembly and operating manual.

Housed in a small, attractive blue and white cabinet, the RF Wattmeter is an easy-to-use, self-contained unit that does not require additional power in-

“slugs” or modules to cover its power and frequency ranges. Power is obtained from a 9-volt transistor radio battery (NEDA #1604). The Wattmeter's portability is enhanced by a large D-ring handle on the rear of the cabinet that can be snapped onto a belt hook, making it convenient to use on towers and in other situations where both hands must be used for climbing or making adjustments.

Assembly of the Model IM-4190 RF Wattmeter makes a nice evening's project. Everything goes together in a smooth and trouble-free fashion. Initial test and adjustment may be done in a couple of minutes using a small screwdriver. Calibration requires more time and equipment. To accurately calibrate the RF Wattmeter, you will need a signal generator capable of producing a signal in the 400-MHz range with a variable power output from 3 to 300 Watts, a power meter capable of measuring the frequencies and power levels previously mentioned, and an rf load which presents an swr of 1.1:1 or better. The accuracy of the RF Wattmeter will, of course, depend upon the accuracy of the calibration instruments.

Calibration of my own Wattmeter produced the following readings:

Forward

30-Watt range = 30 Watts
15-Watt range = 15.5 Watts
75-Watt range = 75 Watts
300-Watt range = 302 Watts

Reflected

30-Watt range = 30 Watts
7.5-Watt range = 7.6 Watts
3-Watt range = 3 Watts

The RF Wattmeter may be permanently connected be-

tween the output of the transmitting equipment and the transmission line to provide an accurate means of determining the swr in the transmission line and terminating load, and as an aid in tuning the equipment for optimum output. Cables with either Type N or UHF (50-Ohm) male connectors may be used with the Wattmeter (do not use UHF connectors and UG-146/U coax adapters for frequencies above 300 MHz). By the way, Heath thoughtfully includes a pair of UG-146/U Type N to UHF adapters with the kit.

The Wattmeter may be used with any matched transmission line without affecting equipment performance. If, however, there is a mismatch in the line, prepare a four-inch length of cable with connectors to replace the length of line lost when removing the unit from the line. Before using the Wattmeter, always turn the function switch to the BATTERY CHECK position and observe if the pointer falls within the BATT OK range of the meter scale. If the battery does not check OK, replace it before proceeding.

For use in the forward or normal mode of operation, your transmitting equipment should be connected to the input of the Model IM-4190 RF Wattmeter and the antenna or dummy load to the load connector. However, the RF Wattmeter is *bidirectional*, enabling you to connect equipment with limited output in the reverse or reflected direction. A couple of typical examples of use for the Wattmeter in the reverse mode would be determining if an extreme mismatch exists in the transmission line or at the load, or, using it as a peaking indicator to adjust your equipment in the same way as when the unit is connected in the normal (forward) mode.

With the RF Wattmeter connected in the reverse mode, it becomes an excellent tuning

aid when tweaking a low-power rig for optimum power output, particularly when set to the 3-Watt range, since the reflected power scales actually show forward power. Of course you seldom get something for nothing, and when using the RF Wattmeter in the reverse mode, the reflected readings taken from the forward ranges are of such negligible values as to be of little use in determining swr.

An important feature of the Wattmeter is that it is capable of withstanding full-power overloads on its lower scales without damage to the meter movement.

The Bidirectional RF Wattmeter Model IM-4190 kit retails for \$114.95 and an assembled version, the SM-4190, is \$195.00 (mail order from Benton Harbor). *Heath Company, Benton Harbor MI 49022.*

Morgan W. Godwin W4WFL
Peterborough NH

10 METER CB

American Crystal Supply Company's Engineering Department has put together approximately 55 different 10 meter kits which convert relatively inexpensive SSB CB rigs to cover any part, or all, of the 10 meter band. Kits are available for the Novice segment only, or phone band only, or both.

The builder can request an order form and pick the kit that will best suit his needs, or he can send them the make and model number of his radio. They will then send him the appropriate kit, if available. If not, they will make a kit especially for him.

The prices range from \$10.00 for the Novice band only, to \$40.00 for the super-deluxe full-band kit on certain radios, depending on the parts required for his radio. Prices vary, but most will run under \$20.00 for full 10 meter coverage.

Continued on page 42

THE INCOMPARABLE SYSTEM 3000A



HAS A BUILT-IN \$450 DISCOUNT

\$450 discount? When you buy SYSTEM 3000A, you're getting \$1000+ worth of unequaled performance for \$549. Examine the unique features of SYSTEM 3000A, add up what it would cost to duplicate (if you could) this small, feature-filled radio and you will quickly realize what a remarkable bargain you're getting. By marrying the best transceiver available to a microcomputer-controlled PLL synthesizer, Edgecom has produced a 2-meter FM system with such unique and incomparable operating flexibility it is almost unbelievable. A few of the extraordinary features of SYSTEM 3000A found in no other transceiver are:

- **TWENTY FRONT-PANEL-PROGRAMMABLE CHANNELS.** Just dial in the frequency and transmitter offset, press the Enter switch and you're in memory. Two channels are instantly recallable as priority channels at the flip of a switch.
- **TWO BUILT-IN SCANNERS** with adjustable pause and pause-defeat features. One scanner lets you tune the band in one or four MHz segments. The other scans the memory.
- **MEMORY-CHANNEL MONITOR.** Lets you operate on one frequency while monitoring one or more others.
- **ANY TRANSMITTER OFFSET.** In addition to the standard ± 600 kHz you can program any offset from 5 kHz to 4 MHz.
- **FULL TWO-YEAR WARRANTY.** Every SYSTEM 3000A is warranted to be free of defects for two years. And it is American made so servicing is no problem.

Combine these, and the other unique operating features of SYSTEM 3000A with a receiver of unsurpassed selectivity and intermod performance, a transmitter that produces over 25 watts of (adjustable) power and you have a fantastic \$1000+ transceiver for the remarkable price of \$549.

SYSTEM 3000A . . . PERFORMANCE THAT CHALLENGES YOUR IMAGINATION
See one at selected dealers or write for more information.

Edgecom Inc.

2909 Oregon Ct.—A3 • Torrance CA 90503 • (213) 533-0433

EXPORT INQUIRIES H & H Industries • Box 639 • Redondo Beach CA 90277

E19

NOW FROM EDGECOM . . . ANOTHER INCREDIBLE BARGAIN



THE FMS-25 . . . ONLY \$439

For the discriminating amateur desiring the maximum operating flexibility at the lowest possible price, **EDGECOM** proudly presents the **FMS-25** 2-meter FM transceiver. Featuring the same receiver/transmitter and several of the outstanding features that have made the **EDGECOM SYSTEM 3000A** the industry standard, the **FMS-25** provides superior performance for the same price you would normally pay for a "bare-bones" radio. Compare the fantastic features of the **FMS-25** with the other transceivers on the market and you will quickly conclude that there is no question of which one offers the most for the least amount. Some of the many features of the **FMS-25** are:

- **BUILT-IN SCANNER**
- **TEN FRONT-PANEL-PROGRAMMABLE MEMORY CHANNELS**
- **ANY TRANSMITTER OFFSET**
- **ELECTRONIC PUSH-BUTTON TUNING**
- **25 WATTS OUTPUT**
- **SUPERIOR INTERMODULATION PERFORMANCE**

Like the **SYSTEM 3000A**, the **FMS-25** also enjoys a full two-year warranty, it's American made and it is small (the photo above is full size). The **FMS-25** . . . at the unbelievable price of \$439 you're getting the best transceiver available with free scanner, a free amplifier, and a free ten channel memory. See the fantastic **FMS-25** at selected dealers or write for a descriptive brochure.

FMS-25 . . . PERFORMANCE THAT CHALLENGES YOUR IMAGINATION

Edgecom Inc. E19

2909 Oregon Ct.—A3 • Torrance CA 90503 • (213) 533-0433

EXPORT INQUIRIES H & H Industries • Box 639 • Redondo Beach CA 90277

Be Legal

— build an ID reminder

Ronald Miles AD4A/WA4MFY
RFD 1, Box 216
Rustburg VA 24588

Although several designs for highly accurate ID reminders have appeared recently in amateur radio publications, they have generally fallen into one of two categories. Either they are intended for use with specific digital clock circuits, or they have been designed as units in themselves, having digital readouts or various other options. Many operators, though, may have already purchased one of the

inexpensive clock kits on the market today. They make excellent station timepieces and, with the addition of the circuit below, may also be used as precision ID reminders.

In addition, since the circuit is complete in itself, normally requiring only power and a line-frequency input from the unit to which it is added, it may be used in various other ways. For example, one might add it to an existing transmitter or receiver so that the digital dial or pilot lamp would begin to flash when it's time to identify. Its usefulness is further enhanced by the fact that it may be prepro-

grammed for various delays, and it can be made to operate with a line frequency of fifty, as well as sixty, Hertz. Also, supply voltage requirements are not at all critical, as anything between six and fourteen volts will suffice. The cost of the unit is minimal. The basic timer can be built for approximately six dollars. If the optional power supply and indicator circuit are also used, the cost will run a few dollars more.

The circuit is shown in Fig. 1. Here a 110-volt power supply has been added, as well as IC5, which is used to drive an indicator circuit. If the unit is to derive its power from existing equipment,

components T1, D5-D8, and R8 may be eliminated. In addition, C2 may be reduced in value and, in some cases, deleted. If the circuit is to drive a high-impedance load, such as the enable of a clock chip, IC5 and its associated circuitry may also be eliminated. As shown, the 60 Hz (or 50 Hz) waveform is injected at point "A". For reliable operation, it should have a peak amplitude anywhere between V_{dd} and $2V_{dd}$. Thus, if the supply voltage used was 10 volts, the peak value of the input waveform could be anywhere between 10 and 20 volts. This will always be the case if the input is derived directly from the transformer, as shown, but, if other means are contemplated, the above should be taken into consideration. The signal passes through D1, which eliminates the negative half cycle, to the low-pass filter consisting of R2 and C1. It then enters a Schmitt trigger consisting of IC4A, IC4B, R3, and R4. The low-pass filter and the hysteresis of the Schmitt combine to make the circuit insensitive to any rf or noise present on the input waveform. The high gain of the circuit produces a square wave at pin 9 of IC4B which will adequately drive the clock input of IC1, a 4020 binary ripple counter. By tying various output combinations from the counter to AND gate IC2, various timing intervals may be selected. That of the circuit hereafter

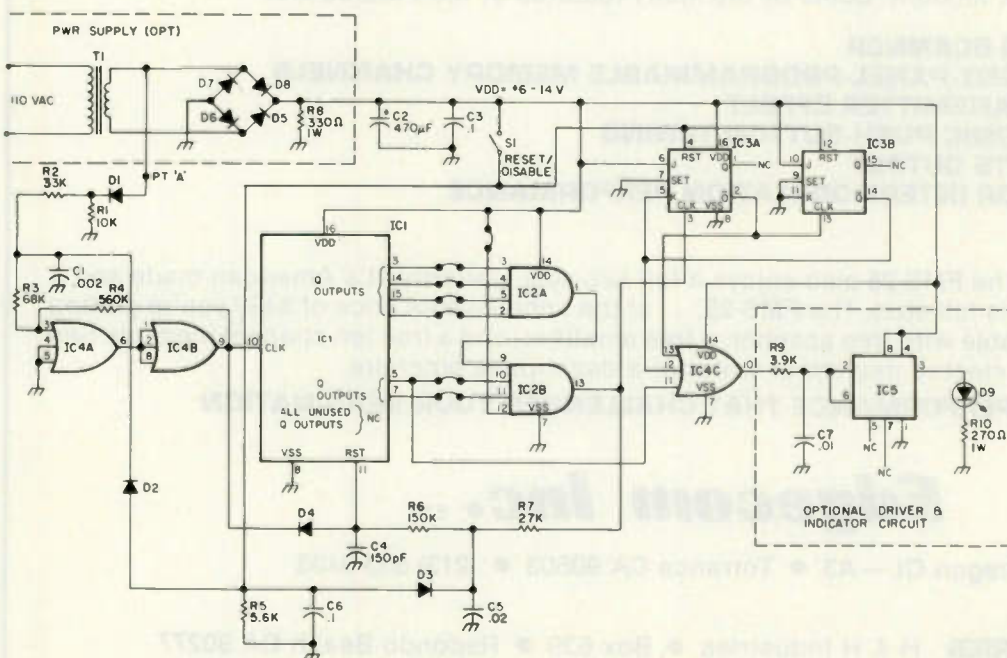

Fig. 1.

described will be 9 minutes, 50 seconds at 60 Hz line frequency. Circuit operation for other intervals is completely analogous. I'll say more on this later. IC1 counts the pulses at its input until output pins 3, 14, 15, 1, 5, and 7 are simultaneously high. This will first occur exactly 3 minutes, 16-2/3 seconds after the timer is activated, or after exactly one third of the required 9-minute, fifty-second timing period.

The high output of IC2B is fed to IC3A and to a circuit consisting of R7, R6, C5, C4, and D4, whose purpose is to reset IC1. It does so in the following manner: IC1 toggles on the negative-going edge of its clock input. Assume that the final 60 Hz pulse just before the completion of the 3-minute, 16-2/3-second interval is occurring. As the clock input at pin 10 of IC1 is going low, the inputs of IC2 go high. This causes the output of IC2B to go high. When this occurs, capacitor C5 begins to charge up through R7. Since the level at pin 10 of IC1 has gone low, however, reset pin 11 is also held low by D4 during this period, so the counter cannot yet reset. Finally, after C5 is fully charged, the input at pin 10 again goes high. This allows the voltage on C5 to be transferred through R6 to pin 11, thereby resetting the counter. When it does reset, pin 13 of IC2B is again driven low. C5 then discharges back through R7, thus completing the process and allowing the counter to count again. IC3 is a dual J-K flip-flop, connected to act as a divide-by-three counter. After 9 minutes, 50 seconds, when the above process has occurred three times, pin 2 of IC3A and pin 14 of IC3B will both be low. The highs on pins 12 and 13 of OR gate IC4C are thus removed, and it responds to the 1.875 Hz input present on pin 11. Therefore, after the preset time has elapsed, a 1.875 Hz square wave will be present at

pin 10 of IC4C. This point can often be connected directly to the enable of the clock chip, since the current requirements of such are small, and R9, C7, IC5, and the indicator circuit are eliminated. IC5 is a 555 timer, used as a buffer-driver in this case to increase the drive capability of the preceding CMOS circuitry. Pin 3 can source or sink about 150 mA when the supply voltage is 10 volts. The output circuit consists of an LED indicator and current-limiting resistor, though many other possibilities exist, of course. R9 and C7 serve an unusual purpose. It was originally desired to drive pins 2 and 6 of IC5 directly from pin 10 of IC4C. The moderately fast rise time of the waveform at this point, however, tended to cause erratic operation of the 555. This is not surprising, since IC5 was designed for use as a timer, not as a buffer driver. R9 and C7 were then added to increase the rise time of the input at pins 2 and 6, after which no further problems were encountered.

All operating functions are controlled by switch S1. When the unit is not in use, S1 should be left closed. This applies a high through D3 and R6 to reset pin 11 of IC1, and a second directly to the reset terminals of IC3A and IC3B. A high level is also applied through D2 to the junction of R2 and R3. This disables the Schmitt trigger and holds output pin 9 of IC4B high. A high is required at this point during the reset process. Otherwise, diode D4 would clamp pin 11 of IC1 to ground and prevent the counter's resetting. The timing cycle is begun when S1 is opened, and the timer can be reset at any time by simply closing S1 and immediately opening it again.

As may be gathered, installation is normally not difficult. In general, you only need to connect the circuit across the clock-chip power supply, connect its output to the clock enable, and tie the

Time interval	Line frequency	Pins IC1 used
10 min., 0 sec.	60 Hz	1, 3, 4, 6, 13, 14, 15
9 min., 50 sec.	60 Hz	1, 3, 5, 7, 14, 15
5 min., 0 sec.	60 Hz	2, 4, 5, 6, 12, 14, 15
10 min., 0 sec.	50 Hz	3, 5, 12, 14, 15
9 min., 49.98 sec.	50 Hz	3, 4, 6, 7, 9, 14, 15
5 min., 0 sec.	50 Hz	2, 7, 12, 13, 14

Table 1.

60 Hz input to a suitable point. Still, in a few cases, this might not be feasible. Perhaps the correct supply voltage is not available, or maybe you desire to control a frequency display instead of a clock. In that case, you might build the circuit of Fig. 1 in its entirety, including both the optional power supply and IC5. It is normally no problem to replace the indicator circuit shown with a simple interface circuit suitable for the occasion. Often a single transistor will suffice. Regardless of the installation employed, however, you should take note of the following: When IC4 is a 4075 OR gate, as shown, output pin 10 will be high during the counting period (and when the timer is disabled) and alternate at its conclusion. The high level occurs because, at that time, there is also a high present at its input — either on pin 12, pin 13, or both. Since a high is required on the enable of most clock chips to activate the display, this means that it will be visible during the counting period and flash at its conclusion, as desired. Should it be observed in any installation that the display is being blanked during the counting period, the enable logic for that particular situation is reversed. In that case, you should replace IC4 with a

4025 NOR gate (a pin-for-pin replacement) to correct the difficulty. When IC5 is employed, it acts as a voltage inverter, so the above process would be reversed. In general, then, using one type of IC4 will cause the display (or other indicator) to be blanked during the counting period, while using the other will cause it to be visible. The choice will depend on the type of indicator circuit chosen, as well as the preference of the builder.

I stated at the beginning that this circuit is programmable. A brief explanation is now in order as to how this is accomplished. I will, therefore, demonstrate how the connections between IC1 and IC2 for the circuit previously described, i.e., the 9-minute, 50-second 60 Hz version, were determined. Those for other timing intervals can be obtained in a similar manner.

This circuit is basically a counter. Therefore, you must determine how many 60 Hz pulses will occur in a 9-minute, 50-second or 590-second period. $590 \text{ sec.} \times 60 \text{ pulses/sec.} = 35,400 \text{ pulses}$. IC1 only counts up to one third of the required number before it is reset, however. It therefore resets after $35,400 \div 3 = 11,800 \text{ pulses}$. IC1 is a true binary counter, so the 11,800 figure must be converted to binary. It is equal to

Parts List

All resistors	1/2 Watt, 10% tol., except as noted
All capacitors	25 V or greater breakdown voltage
D1-D4	Silicon diode, 1N914 or equivalent
D5-D8	Silicon rectifier, 1 A at 50 V piv
D9	50 mA LED (Radio Shack 276-026 or equivalent)
IC1	4020 binary ripple counter
IC2	4082 dual 4-input AND gate
IC3	4027 dual J-K flip-flop
IC4	4075 triple 3-input OR gate, or 4025 triple 3-input NOR gate (see text)
IC5	555 timer
T1	110/9 V power transformer
S1	SPST switch

10111000011000. Now, starting at the right-hand side of the number, count left until the first "1" is found. It will be four digits from the right. The second will be five digits, the third ten digits, the others eleven, twelve, and fourteen digits. The corresponding Q outputs of IC1 must be tied to IC2. Thus, tying Q4, Q5, Q10, Q11, Q12, and Q14 to the various inputs of IC2 will produce a 9-minute, 50-second counting

period. These outputs correspond to pins 7, 5, 14, 15, 1, and 3 of IC1. For this particular delay, I needed only six of the AND gate inputs. The unused input was tied to V_{dd} . From the above, it can be seen that many counting intervals are possible with this circuit, but not all. For example, if the binary number for a particular interval had ten "ones" in it, there would not be enough AND gate inputs to handle them. Never-

theless, a great many are possible. Even when exact intervals may not be had, they may generally be approximated very closely. Table 1 shows the connections for some of the more popular ones, each of which was determined by using the procedure above. All unused inputs of IC2 should be tied to V_{dd} . In one case, an exact interval could not be had, so the table shows that of the nearest approximation.

Lastly, remember that the above circuit consists primarily of CMOS ICs, which are much more easily damaged by improper handling and installation than TTL. I therefore heartily recommend that you review the operation of CMOS circuitry in general before building the circuit above — especially if you are considering adding it on to some existing circuit. It could, in the long run, save time and expense. ■

New Products

from page 37

Some of the PLL radios will include the M-20 Kit to get the radio out of 27 MHz.

The instructions are very simple to follow and are explained in a step-by-step procedure or installation of these kits can be performed at the factory for those desiring such a service. Write for specific prices and include the make and model number of the CB you wish to have converted. Contact *American Crystal Supply Co., PO Box 638, West Yarmouth MA 02673; (617)-771-4634.*

HAMTRONICS' NEW VHF EXCITERS AND POWER AMPLIFIERS

Hamtronics, Inc., has a new series of FM transmitters for the 6 meter, 2 meter, and 220-MHz amateur bands. The new model T50 exciter module is constructed on a 3" x 7½" PC board. It features 2 Watts rf output, good clear audio, built-in test points for easy align-

ment, and six channels. The price for this FM exciter kit is only \$49.95.

As a companion for the new T50 exciter and Hamtronics' XV2 series of VHF SSB transmitting converters, a new line of VHF linear/class C power amplifiers has been released. The model LPA 2-15 features 15 W SSB or 20 W FM/CW output with 2 W drive. The model LPA 2-45 provides 45 W output. These PA units and others are available for 6 meters, 2 meters, and 220 MHz as semi-kits, with the critical parts of assembly already done. The prices of the linear power amplifiers start at \$59.95.

A free catalog is available on these and other VHF and UHF kits, preamps, receiving converters, FM receivers, and transmitting converters. For more information, contact *Hamtronics, Inc., 182-F Belmont Rd., Rochester NY 14612; (716)-663-9254.*

PACE-TRAPS FLYING DUCKY

Two meter FM operators

should find the new Pace-Traps Flying Ducky a handy and useful addition to their present setup. The Flying Ducky was designed to fill the performance gap experienced by most 2 meter mobile operators when using their HT in an automobile. Within the confines of the car body, the rubber ducky with which most HTs are equipped does only a marginal job at best. This generally limits communications to very nearby repeaters and mobile and fixed stations in the immediate vicinity.

The Pace-Traps Flying Ducky eliminates the handicap of operating from inside the car by providing the means for quickly and simply positioning and connecting an external antenna to the HT. The arrangement takes full advantage of the excellent ground plane provided by the vehicle's metal roof. No additional antenna is required as in the Pace-Traps system. The HT's rubber ducky itself becomes the outside radiator.

The device consists of the following: a chrome-plated magnetic mount which has a hold-down power of 50 pounds and which will stay securely in place at speeds well in excess of the 55 mph limit; a mount which is equipped with a connector that mates with that on the rubber ducky; a matched length of coax cable (105 inches) provided with a connector to fit the HT.

Installation takes ten or fifteen seconds. The rubber ducky antenna from the HT is inserted into the magnetic mount. The mount is placed in the center of the car roof and the cable is routed either through the door jamb or an open window. (The thick rubber weather stripping on most cars makes closing the door on the cable possible without damage.) Then connect the coax cable to the HT and you're all set.

Not the least advantage to using the Flying Ducky mount and your rubber ducky antenna as opposed to a fixed outside antenna is its low profile and the portability of the HT itself. When installed, it has a very low rip-off attraction and when removed, it has none!

While no lab-type test were performed, several on-the-air checks bore out the manufacturer's claims that the Flying Ducky's performance is better than a gutter-mounted quarter-wave and superior to a 5/8-wave mounted on the trunk deck.

The Flying Ducky (\$13.95) can be used with your own antenna or with one of Pace-Traps' rubber duckys (\$7.95). An accessory quarter-wave whip (\$5.95) is also available. *Pace-Traps, Box 234, Middlebury CT 06762; (203)-758-9228.*

**Morgan W. Godwin W4WFL
Peterborough NH**

ALLIANCE INTRODUCES HD-73 HEAVY-DUTY ROTATOR

The HD-73 Heavy-Duty Rotator has been introduced by the Alliance Manufacturing Company.

Designed especially for the amateur who wishes to increase his capability with in-tower or mast-mounting option, the HD-73 features a unique dual-speed control with one five-position switch, providing a one minute-per-revolution speed for rotating over an extended arc, and slower speed control permitting fine adjustments.

The improved automatic brake action simplifies positioning and reduces risk of antenna damage by sudden stops.

Designed to operate antennas with a maximum of 10.7 square ft. of load capacity, mast-mounted, the HD-73 develops a wind-load bending moment of 10,000 in. lbs., capable of withstanding most

Continued on page 45

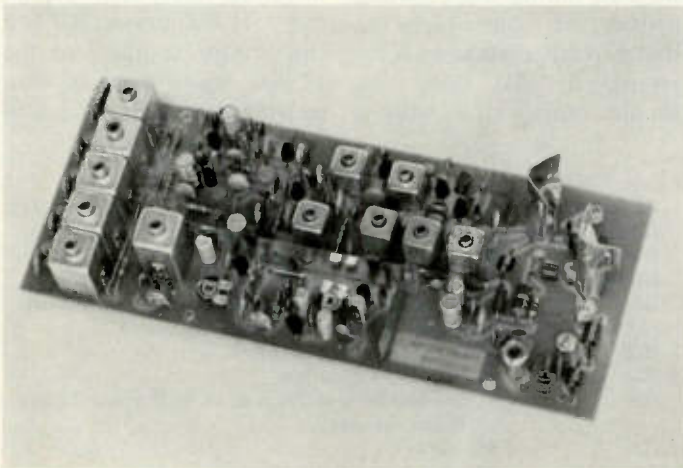

Hamtronics' 6 meter exciter.

UNFORTUNATELY...



**Radio
equip-
ment
doesn't
grow
on
trees!**

You have worked hard for your money—don't gamble when you buy that next rig, antenna or even accessories. Contact C&A where they have been serving the amateur and commercial market for almost two decades. C&A can offer you the best prices plus the assurance that they will be there to back up your purchase with their staff of experienced LICENSED technicians and a genuine desire to add your name to their long list of satisfied customers.

CALL OR WRITE for all your needs to:



C&A Electronic Enterprises

Distributors of Commercial and Amateur Radio Equipment C88

Two locations to serve you better:

22010 S. Wilmington Ave., Suite 105
Carson, CA 90745
(213) 834-5868

5773 Overland
Boise, Idaho 83705
(208) 377-5274

Another IC-22S Scheme

— for oddball repeaters

R. B. Palmer WA1ZMQ
Box 3141
Lynnwood WA 98036

Worried about handling those odd 2m splits that still exist around this country and in Canada? Does the fact that Podunk, California, where you plan to vacation, has a repeater with input on 146.085 MHz have you down? Icom has done a good job, but, alas, there are more than 22 repeater combinations, as any traveler can testify. Here is a simple solution to enable your Icom 22S to send and receive on *any*

frequency within the allocated two meter band and to enable you to work those repeaters with odd splits — those other than the standard 600 kHz for which the Icom and most other transceivers are precalibrated.

The solution is very simple. It involves no electronic components, no tedious Boolean logic or complex switching arrangements, and no modification of the interior of your Icom 22S. Essentially, either of two pre-programmed eight-pole dip switches are selected by a toggle. The dip switches are

programmed in a straightforward manner, according to the Icom instruction manual, which offers the diode combination for attaining a given frequency. Dip switches are recommended, for their small size makes them compact for mobile use and enhances the ease with which they may be covered after programming — thus keeping them dust-free and eliminating the possibility of accidentally rearranging the switch combination in the dark while groping

for the toggle.

The other parts needed are an eight-pole, double-throw toggle switch (two 4-pole slide switches may be substituted, with the handles connected to facilitate operation) and a suitable 9-conductor, color-coded cable to run the diode leads from your Icom to the external switch box. Any small package, such as a jewel or ring box, which is durable enough for mobile use, makes a compact case for your Icom All Frequency Selector.

Position 22 on the selector of the Icom was chosen, as the leads can be taken off from this end position more easily, without crowding them down onto other permanently programmed diodes, and, also, this “end-of-the-dial” position is easy to remember. The hot (when switched to position 22) lead is taken from the solder blob of the wire coming up to position 22 of the programming board within the Icom. All eight diodes are soldered into their banded end positions; the other leads of the diodes are cut one third of an inch long and bent over at right angles to the vertical diodes. Color-coded cable leads are soldered to these latter diode leads and the corresponding leads at the other end of the cable are soldered to the pins (in some numerical order) on the accessory socket at the back of your Icom 22S. The same

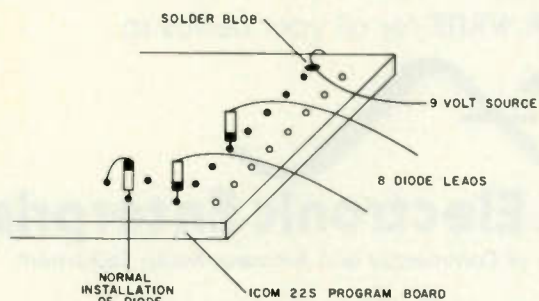

Fig. 1. All eight diodes are installed by the banded end in position 22. Eight wires lead from the diodes to the accessory socket. A ninth lead connects the 9 volt lead from the selector to the remaining position on the socket.

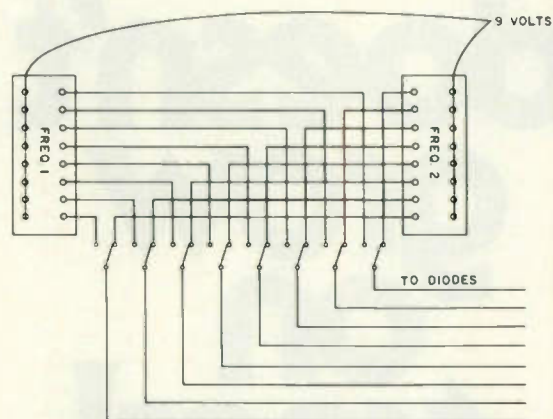

Fig. 2. Schematic for two dip switches and the 8-pole, double-throw toggle. A rotary switch or two 4-pole slide switches may be substituted for the toggle.

colored leads are soldered to the pins of the plug supplied with your Icom.

The umbilical cable, with the eight diode leads and the 9 volt hot lead, must enter the bottom of the back of the external switch box, and, from there, the leads are routed to the appropriate switch terminals or toggle terminals, accordingly. To facilitate simpler programming later on, it is advisable to position the switch banks

to present a facade for the user of "down is off for all" and "up is on for all." In a field situation, with flashlight illumination and the random complexity of the Icom diode positioning instructions, it behooves the user to make his switching as visibly straightforward as possible. Similarly, wiring the leads to the switch terminals should follow the Icom frequency recipe; that is, viewed from the top by the user, the left-most switch

should be connected to D7 inside your Icom 22S, the right-most to D0. Programming is then straightforward: Look up the frequency you want to use in the Icom list, turn off all switches, and turn on the switches for the proper diodes required by the Icom instructions.

Either switch bank may be used for transmit or receive by toggle selection. And so one switch bank may be set

up for transmit for an odd split, the other set up for receive. Place your Icom in simplex mode (central position of right-hand toggle), throw your toggle to the "transmit" position, and transmit; let go of the mike button, throw your toggle to the "receive" position, and listen. That's all there is to it, and remember: Podunk, California, is no threat any more, nor are any of the other odd splits around the continent. ■

New Products

from page 42

prevailing wind conditions. Icing is overcome by a rotator torque of 400 in. lbs., made possible through the use of heavy steel, hardened pitch gear teeth. Consistent performance of the unit in all-weather conditions is enhanced with a lifetime, factory-installed lubricant that withstands temperature ranges of +120°F to -20°F.

Constructed of heavy-duty cast aluminum, and weighing only 9-1/8 lbs., with one set of brackets, the HD-73 rotator provides a vertical balanced weight capacity of 1,000 lbs., due to two full raceways of 100 3/8" dia. hardened ball bearings. Unique support bracket design permits a centering procedure for in-tower application without shims or difficult trial-and-error adjustments. The base design permits easy four-

bolt, in-tower mounting without spacers.

The HD-73's 20-volt ac, capacitor split-phase reversible motor and its transformer are protected by fuse and thermal protectors against shorts, possible connection error, or prolonged operation. No voltage on motor or leads exceeds U.L. safety limits.

The meter, a dc, taut band D'Arsonval, is calibrated in S-W-N-E-S as well as a degree-graduated scale for full 360° position recording. The voltage supply for meter indication is solid state and regulated in a range of 105 to 129 volts to assure accuracy regardless of wide line voltage or load variation. A rock-bar switch permits dual-speed rotor control with accuracy and ease.

Voltage input is 117 volts ac, 60 Hertz, ± 12 volts; mast-mounting size range is 1-3/8" o.d. to 2-1/2" o.d.; cable is 6

conductor. Total shipping weight (rotator with 2 pair brackets and control) is 17 lbs. For further information, contact *The Alliance Manufacturing Company, Inc., Alliance OH 44601.*

CSC DM-3 DESIGN MATE® NULLING R/C BRIDGE IDENTIFIES JUNKBOX AND ANONYMOUS PART VALUES

Where unmarked, unreadable, or unknown component values are a problem, the Continental Specialties Corporation Model DM-3 Design Mate® provides an inexpensive solution. This compact R/C bridge with its solid-state null detector provides a level of performance beyond its \$74.95 price. \$74.95 price.

"Hi" and "Lo" LEDs lead quickly to an exact null with the unknown part in the bridge. Resistance is covered in 6 ranges, from 10 Ohms to 10 megohms; capacitance in 5 ranges from 10 pF to 1 uF; and the dial accuracy is better than 5%.

The DM-3 comes completely assembled, tested, and

calibrated, with detailed instructions and special application notes. It weighs just 2 pounds and needs only 3 Watts at 117 V ac, 60 Hz. A 220 V ac 50/60 Hz model is available at a 10% additional cost.

The DM-3, other CSC Design Mate instruments, and other Continental Specialties Corporation products are available at leading electronics dealers and distributors, or direct from the factory.

For additional information, contact *Continental Specialties Corporation, 70 Fulton Terrace, New Haven CT 06509; (203) 624-3103.*

MOTOROLA ANNOUNCES LINEAR, WIDEBAND COMPLEMENTARY AUDIO DRIVER TRANSISTORS

A series of NPN/PNP audio power driver transistors in popular TO-220 packages from Motorola produces low distortion and good transient response because of current gain linearity specified and

Continued on page 47



The Alliance HD-73 rotator.

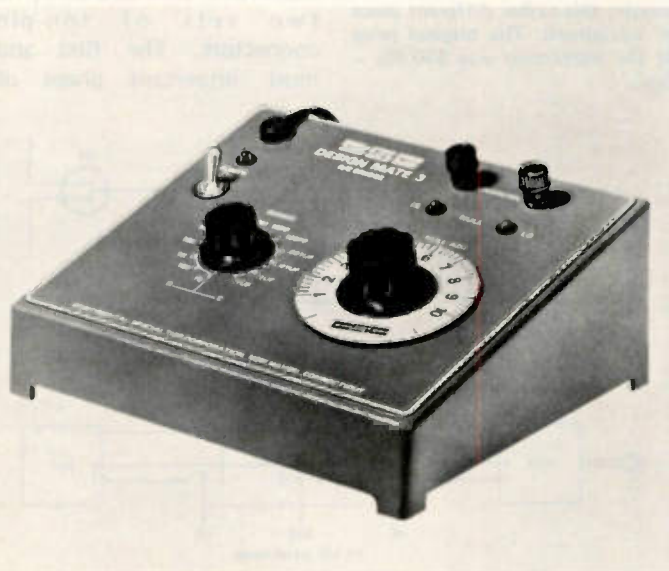

CSC's DM-3 Design Mate® R/C bridge.

Improving the SWTPC UDI

— self-preservation made easy

James R. Avoli K3MPJ
1261 Brinton Road
Pittsburgh PA 15221

The most flexible piece of test equipment that I have ever used is the Universal Digital Instrument from Southwest Technical Products Corporation.* This is a series of kits which are designed to work together to form a basic set of digital test instruments (including a counter and a DVM, among others) at a very reasonable cost. The basic concept and

*The UDI is no longer being produced, but we offer this article as a thought stimulus to those who already have or may wish to acquire this rather different piece of equipment. The original price of the mainframe was \$59.95. — Ed.

design make the system so very flexible in itself that it almost defies true design changes. But each individual accessory can be modified to suit its owner. Furthermore, SWTPC even gives enough detailed circuit description and theory of operation to allow you to design your own accessories. The system is not without its limitations, however, and I will take two of these to task in this article.

The basic unit is known as the UDI mainframe. It consists of a 1 MHz crystal-controlled timebase, digital logic circuits, a four-digit display, and an overflow indicator. All the other kits are accessories that plug into this mainframe (one at a time) via two sets of ten-pin connectors. The first and most important phase of

improvement deals with one of the plug-in kits.

The Protection Racket

The FC-3 is the frequency counter accessory, rated at 20 MHz. Whether or not you consider four digits at that frequency adequate for your needs, the price is right. I only use it at lower frequencies, anyway. The counter's only other drawback is the ease with which the isolation FET (Q1) can be wiped out by too potent an input signal. The first couple of zaps only got me to be more careful about what level of signal I applied to the input. But that, as you already may have guessed, wasn't very reliable. So I made three modifications to

this instrument to help protect it from me. Refer to the schematic diagram in Fig. 1 throughout the following description.

The first modification was to install a pair of crowbar diodes to shunt the disastrous portion of an overly potent input signal to ground when it exceeds the diode's threshold voltage. In this circuit, the location of these diodes right at the gate of Q1 won't load down the circuit under test. However, the diodes must be very fast-switching devices if they are to conduct before the input signal can destroy the FET. I used 1N914s (GE-300) with success here.

The second modification was to change the value of R1 to limit the flow of input current. The value was changed from 100 Ohms to 600 Ohms, so the current flow would be restricted but the sensitivity wouldn't be affected too drastically. In actual practice, this value has met with success in relation to the added diodes.

The third modification was to install a transistor socket so that I could replace the FET more easily if these protective enhancements didn't work well enough to overcome my own faux pas! I used a junk box variety with success here, but remember that I'm not concerned with its performance at 20 MHz.

So far, I haven't had to

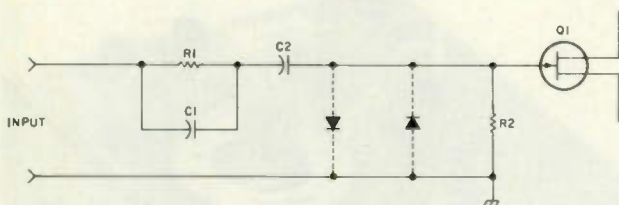

Fig. 1.

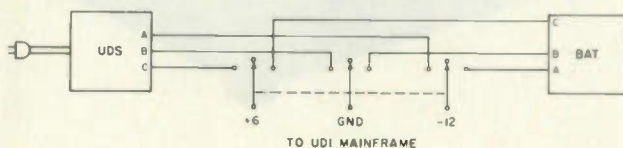

Fig. 2.

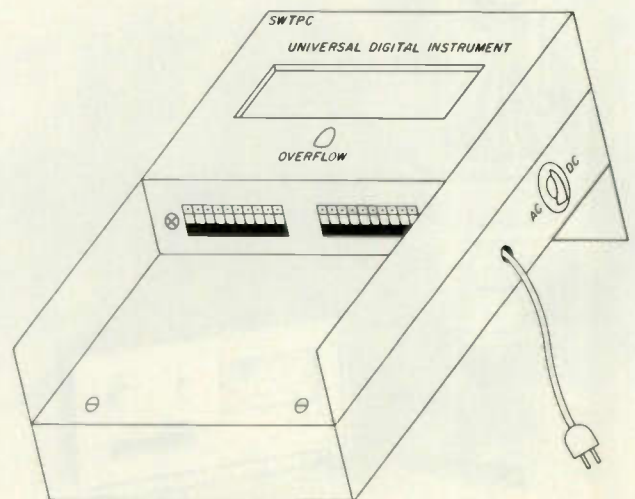

Fig. 3.

replace either the diodes or the FET. Incidentally, Radio Shack's #276-2035 (2N3819) N-channel FET does the job as a 99¢ replacement for the specified TIS-58.

Assault On the Battery

The second phase of improving the overall system was to alter the power source. Since I am more interested in versatility and ease of access for tuning and maintenance than I am in compact design, I undertook the next logical

step. I acquired and built the UDS line supply kit, and then removed the batteries that are jammed into the mainframe. I combined the two power sources in a common chassis, along with a 3PDT selector switch, as shown in Fig. 2. You may even want to switch the ac line, thus requiring a 4PDT switch.

This second chassis, identical to the mainframe chassis, was then piggybacked, back to back, onto the mainframe. The back piece was then fab-

ricated to double as both the rear cover and as a convenient tilt stand. See Fig. 3 for the mechanical denouement of this project. I have purposely used a sketch instead of a photograph for the following reasons:

1. The angle of slope is really up to you; design it to suit your own needs.
2. Alternate construction methods are to use a triangular rear cover or to build a separate sloped stand.
3. Even after all these years,

the mechanical quality of my constructions has never been able to equal the electronic quality of my constructions!

Conclusion

As with any commercially-available product, there are always going to be ways to change (improve?) the original. I urge you to look into this flexible system of test equipment. Because of its cost and flexibility, you will find that it can open up a new horizon for you. ■

New Products

from page 45

matched between complementary pairs, and a 30-MHz current gain-bandwidth product. The series replaces popular types FT317 and FT417 with better performance.

The 8-Ampere devices, available in 120-volt and 150-volt versions, exhibit gain linearity deviating only by a factor of 2:1 over a 0.1- to 3.0-A collector current range, with PNP/NPN linearity matched within a 3:1 ratio. Combined with wide bandwidth, these open-loop characteristics make excellent performance possible under closed-loop feedback conditions.

Capable of 50-Watt dissipation, the TO-220 plastic devices are available from stock at the prices shown in Table 1.

For further information, con-

tact *Motorola Semiconductor Products, Inc., PO Box 20912, Phoenix AZ 85036; (602)-244-6900.*

NEW REALISTIC SOUND LEVEL METER

Noise may be a minor irritant, a definite disturbance, or even a threat to your hearing, depending on the level and duration, according to Radio Shack.

The new Realistic Sound Level Meter from Radio Shack may be used for measuring sound intensity in homes, schools, offices, or other environments for compliance with noise standards established by federal, state, and local agencies. It can also be used to check the acoustics of studios, auditoriums, and home hi-fi installations.

The hand-size meter features

a weighting selector for measuring either wideband sound level ("C" weighting), or the 500- to 10,000-Hz range ("A" weighting), which is the area of greatest sensitivity to the human ear.

A range switch selects six sound-level ranges, each spanning 16 dB, for an overall range of 60 to 126 dB and includes a position for checking battery condition. The meter also has a slow/fast response switch for checking average or peak noise levels.

Other features include the large, easy-to-read calibrated meter and tripod adapter that allows the sound level meter to be mounted on a camera tripod (1/4" thread) to eliminate hand

noise and minimize the effects of sound reflected from your body.

A phono-type output jack permits use of the sound level meter as a high-quality, dual-response microphone, or for connection to high-impedance headphones, an oscilloscope, frequency analyzer, or other test equipment.

Accuracy of the Realistic Sound Level Meter is said to be ± 2 dB at 114 dB sound level, and measurements are referenced to a 0.0002 ubar standard. Distortion is given as less than 2% at 1 kHz, 0.5 volt.

The meter is 6-1/4" x 2-7/16" x 1-3/4" (160 x 62 x 44 mm) and

Continued on page 49

Type	Polarity	V _{ceo} (sus)	Price (100-up)
MJE15028	NPN	120 V	\$1.22
MJE15029	PNP	120 V	\$1.22
MJE15030	NPN	150 V	\$1.40
MJE15031	PNP	150 V	\$1.40

Table 1.

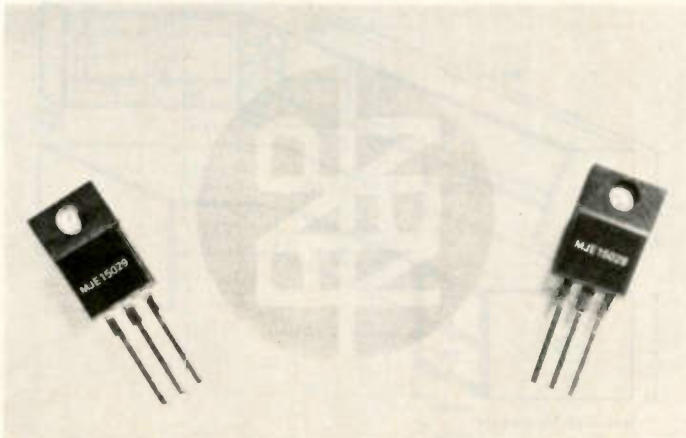

Motorola's audio driver transistors.



Realistic Sound Level Meter.

Graduate to a Better Operating Desk

—lots of class

A couple of months ago, I came home from a long day of work all set to relax out in the shack and work a few guys on my trusty old Swan. After a brisk hello and good-bye to the XYL, I headed straight to my desk, sat down, moved a few things here and there to get at the key, turned on the rig, and sat back to let it warm up a little.

It took a second or two for it to sink in that I'd actually had to move things around in order to get enough operating space to do what I like best, which is working DX via CW. So, after a couple attempts to

get through the worst QRM I'd seen in quite awhile, I started sketching out a desk design to suit my needs.

I like something flashy, yet simple and inexpensive and unique and functional at the same time. After getting a rough copy on paper, I thought others might like the design as well. This draft is not meant for minimum cost nor is the emphasis on shooting the moon; it's more a middle-of-the-road design. With a little research and imagination, you can add or delete as you see fit.

First, you'll notice that the desk is divided into two

sections. Unless you're planning to make this a permanent fixture, don't try to move a 4'3" desk through a 28" door. It's been known to be downright difficult.

The lower section of the desk is very simple. I'm using 1" x 2" x 12' pieces of pine, as in Fig. 1(a), cutting and staggering these pieces. This, incidentally, makes a very handsome finish for this desk. I recommend nailing and gluing these strips together, except for those pieces used for the facing.

The sides can be made the same way, or you can

use 3/4" (fine-grade) plywood. The backing, C in Fig. 2, is of 3/8" (shop-grade) plywood with the knots reversed to the back. Frame the backing with 1" x 2" pine for rigid support of the desk top.

All doors and drawers are made of 3/8" (fine-grade) plywood. There are too many ways to describe the construction of drawer slides, so I'll leave this to your own ingenuity.

The top section, made much the same way as the lower, is purposely made separately. Again, unless the entire desk is made as a

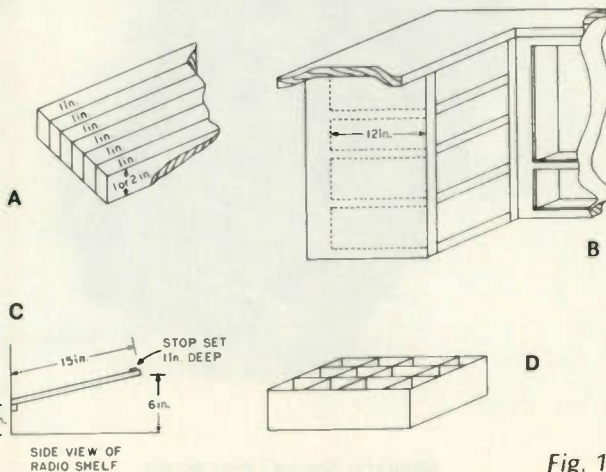

Fig. 1.

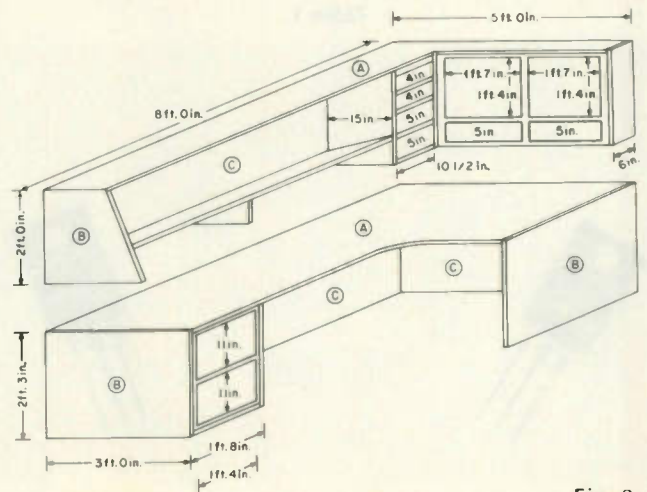

Fig. 2.

permanent structure, follow the drawings. Once set on top of the desk, it can be anchored by any of several different ways. The main idea is to be able to take it apart when you're ready to move.

In Fig. 1(b), I've left 3 inches of space for coax and electrical wiring. In Fig. 1(c), an old idea of slanting the radio shelf was incorporated into the desk for easier readability of

dials and meters. Beneath this shelf is ample space for storing keys, logs, paper, pencils, and, in some cases, swr meters, all within reach of the operator but out of the way.

Box dividers, such as in Fig. 1(d), if made 2¼" to 2½" high, can be placed one on top of the other inside a couple of drawers for storage of small items. The cabinet space was pur-

posely made narrow to maximize desk work space, but it is still ample for storage of hand tools either by hanging or laying them in the shelf space.

A folding bench can be added to the desk top next to the cabinet end by using a sturdy piano hinge and folding legs to save on space when it's not in use.

Finishing can be done in any of a number of ways. If you wish to use an enamel

paint, you won't have to make such an elaborate desk top. If you wish to use a stain, I definitely recommend using spare pieces of the same wood to test for desired results. I'm using Varathane liquid plastic for a durable finish.

I've almost finished my desk and certainly hope you enjoy your desk as much as I intend to enjoy mine. Take your time, and best of luck to you. ■

New Products

from page 47

weighs 7-3/4 ounces (220 grams). It operates on a standard, self-contained 9-volt battery.

The Realistic Sound Level Meter is priced at \$39.95. Available exclusively from Radio Shack stores and dealers, nationwide.

Radio Shack, 1400 One Tandy Center, Fort Worth TX 76102; (817)-390-3272.

RUGGED TV VIDEO OUTPUT TRANSISTORS IN INEXPENSIVE DUOWATT PACKAGE

Motorola's new MDS20 and MDS21 high voltage power transistors combine a high 60-MHz current gain-bandwidth product with the ability to withstand cathode ray tube arc currents in the economical, 2-Watt free-air dissipation Duowatt package.

The MDS20 (\$0.50, 100-up) is rated at a c-e breakdown voltage of 250 volts, while the MDS21 (\$0.55, 100-up) achieves the 300-volt breakdown needed for higher-powered color TV designs. Saturation voltage is better than 0.6 V at 30-mA collector current. The gain is specified at a minimum 40 at 30 mA, with linearity from 1 mA to 40 mA. The low collector-base capacitance (3.0 pF max) eases video and chroma output design problems, while small drive requirements allow the transistor to be directly driven by many types of IC chroma demodulators.

Used as a color difference output, where drive and bandwidth requirements are less severe, the MDS20 and MDS21 can safely be operated without any heat radiator to ambient temperatures of 112°C. The plastic Duowatt package pro-

vides a metal tab for those applications where heat sinks are required. For further information, contact Motorola Semiconductor Products, Inc., PO Box 20912, Phoenix AZ 85036; (602)-244-6900.

CSC INTRODUCES 500-MHZ PRESCALER FOR \$59.95; EXPANDS COUNTER RANGE TEN TIMES

Continental Specialties Corporation introduces their 500-MHz Prescaler which is capable of extending the performance of almost any frequency counter ten times, up to at least 500 MHz.

It features a BNC input connector, diode protected 50-Ohm input, and 250-mV sensitivity from 50 to 500 MHz. Its output is a minimum 400 mV (peak-to-peak) capacitively coupled signal, available at a phono jack connector. Direct or ÷10 prescale outputs are switch-selectable.

Power is supplied to the unit through a coaxial dc-type power connector. Power requirements are 7-12 V dc at 100 mA maximum. An on-board voltage regulator assures trouble-free operation even from troublesome power sources.

The entire PS-500 package is 1" x 2" x 3½". Suggested price

in unit quantities is \$59.95. Available accessories include 110 and 200 V ac power supplies—each \$9.95; a power connector-to-alligator clip cable at \$2.95; a cigarette lighter power cord at \$3.95; a 3-foot BNC-to-BNC input cable at \$5.95; and a 3-foot phono plug-to-phono plug output cable at \$3.95.

The PS-500 interfaces directly with CSC's MAX-100 MHz frequency counter (\$134.95), and their new Mini-Max 50-MHz hand-held frequency counter (\$89.95) to extend the counting range of either counter. In addition, it can be used with almost every counter available.

The high-speed performance of the PS-500 is specified and guaranteed to 500 MHz. Typically, the ECL-III logic used in its design is capable of reliable performance up to about 600 MHz. This 500-600-MHz performance, in combination with its low price, suggests the PS-500 for a number of VHF applications, including radio common carrier, aviation radio, amateur radio, business radio, government and public service radio, telephone, marine radio, television, navigation, radar, and other communications applications;

Continued on page 60

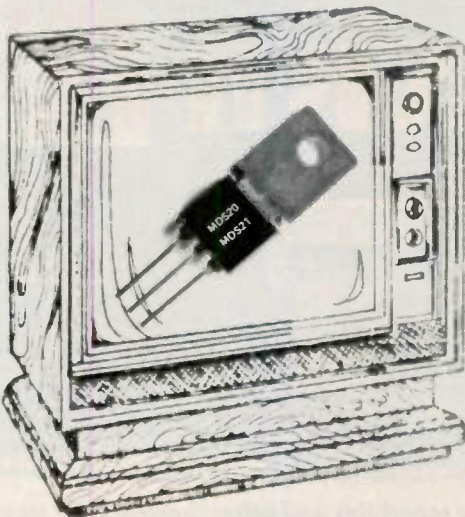

Motorola TV video output transistor.

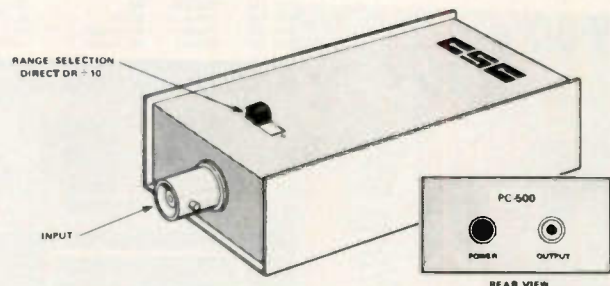

CSC's 500-MHz prescaler.

The SWL Bible

— tuning the ends of the world

IO JAPAN NEW
 NIPPON HOSO KYOKAI Japan Broadcasting Corpora
 For German & French versions please see pages B & C.
 May 1975
 Lunches in Japan

WRITE TO RADIO AUSTRALIA, MELBOURNE, 3000. FOR NEXT SCHEDULE

FREQ. MHz	METRE BAND	18	19	20	21	22	23	24	01	02	03	04	05	06	07	08	09	10	11	12	13	14	15	16	17	LOCATION	POWER kW	
SOUTH AND SOUTH-EAST ASIAN SERVICE																												
2235	41				200	11																				SHEP	100	
9530	31																										SHEP	100
9570	31																										SHEP	100
9624	31																										SHEP	100
9627	31																										SHEP	100

WORLD SERVICE - WESTERN HEMISPHERE
 7th Sept - 1st Nov 1975
 Atlantic Islands and Antarctica

HCJB International
 the voice of the Andes

RADIO SWEDEN
 HIGH FREQUENCY BROADCASTING SCHEDULE
 PERIOD: 0100 GMT 7th SEPT - 0100 GMT 2nd NOV

PEST INTERNATIONAL

RADIO NEDERLAND WERELDOMROEP
 Engineering Services
 SCHEDULE OF TRANSMISSIONS, effective March 2nd - May 4th, 1975
 All times GMT

NRIK 3

A SHADE OF GREE

Time	Language	Area served	Stations and Frequencies
0630-0750 (D)	Dutch	WZ	B 9715
0750 (D)	English	WZ	311730
0820 (D)	Dutch	WZ/AT	B 9710
0920 (D)	Dutch	aaAS/wAT	H17780
0920 (D)	Dutch	X1B/aaAP	L15185 L11730 L 7210 L

KEY-DIE STIMME DER TURK
 THE VOICE OF TURKEY

RSA calling
 NOVEMBER 1978 / APRIL 1979
 DE STEM VAN SUD-AFRIKA THE VOICE OF SOUTH AFRICA

BELGISCHE RADIO
 INTERNATIONALE ORDEET
 SERVICIO INTERNACIONAL
 RADIODIFFUSION-TELE

Most larger stations will put you on their mailing lists for programming schedules and other literature. To stay on, you have to show them you are still alive with an occasional reception report or letter indicating an interest in receiving the mailings.

A wide range of programming, from pure propaganda to strictly local business, can be found on the air. The international bands above 6 MHz are populated with high-powered (100 kW or more) "voices" of governments disseminating news and commentary cast in the mold of the democratic western world or of the communist bloc or somewhere in between. Stories broadcast by the United States Information Agency's Voice of America, Radio Moscow, and the neutral Swiss Broadcasting Corporation take on remarkably different flavors even though the same incident is the particular item under comment. Interesting opposing versions of events in the Middle East are offered regularly by the Israel Broadcasting Authority and Radio Cairo.

The large stations also broadcast other kinds of programs. The British Broadcasting Corporation offers a host of dramas, game shows, and sporting events. One of the most popular programs on the air is the Music USA and Jazz Hour aired by the Voice of America, Washington. And guess what—no commercials!

In addition to government-sponsored stations, there are a number of religious stations on from such countries as the Philippines, Ecuador, Liberia, and Ethiopia. Of all such outlets, HCJB in Quito, Ecuador, is probably the largest and best known, programming in a variety of languages to all areas of the world.

International broadcasts are in all languages, but the bulk of them directed to North America are in English. Broadcasts are directed to all continents,

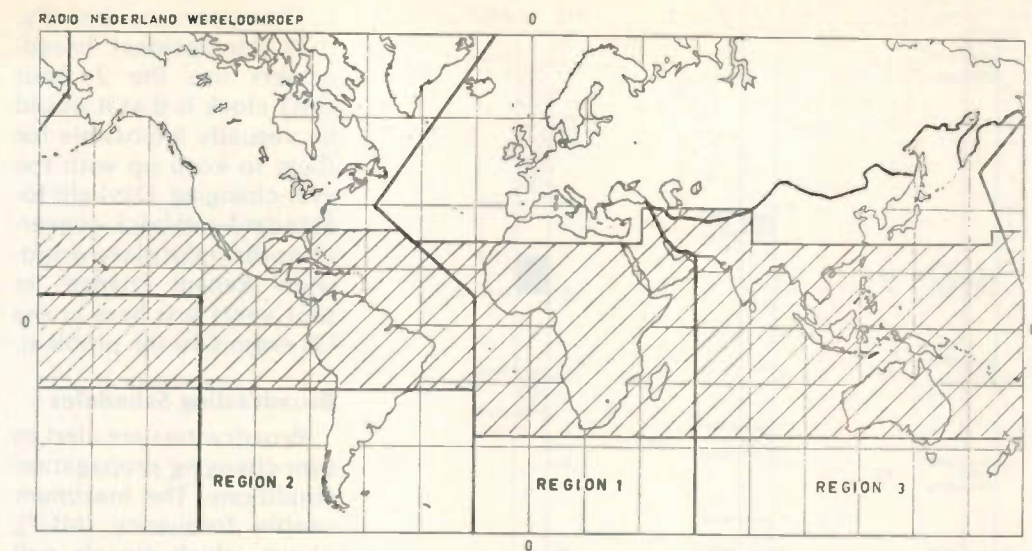

Fig. 1. This map depicts regions I, II, and III as established by the ITU. The crosshatched center section shows the area of the world in the tropical broadcasting zone. The map is from the "Radio Spectrum Course" offered by Radio Nederland, Hilversum, Holland; enrollment in the course is free for the asking.

even Antarctica, by governments on all continents—with the notable exception of South America, which has been the slowest to get into the fracas.

A third type of broadcast consists of the regional and local ones found in the tropical bands below 6 MHz. These frequencies are called the tropical bands because the bulk of the stations using them to penetrate the back country, out of the range of conventional medium-wave (standard AM broadcast) stations, are located between the Tropic of Cancer and the Tropic of Capricorn.

The regional broadcasts are quite interesting because programming is untainted by international politics, but most of these low-powered outlets are not in English. Particularly in Latin America, many of these stations are privately owned and relay MW outlets. Many of the African tropical voices provide interesting DX challenges for North America-based listeners. Conveniently, the best opportunity for hunting the Africans is just before the dinner hour and

just after the late television news.

I'm getting ahead of myself. To have an understanding of SWBC listening, there is a universal "language" that has to be learned. It's not complicated, but it is necessary. So let's look at some terminology, get an idea of what can be heard, and conclude with some information on publications and equipment.

Frequency Factors

If you have a ham license and are active on the low bands, you are already aware that frequencies can be expressed in terms of meters (m), kilohertz (kHz), or megahertz (MHz).

Most "voices" nowadays have updated their announcements and use kHz, but watch out for the eastern Europeans. Most of these government-controlled stations still announce frequencies in meters, expressed to two decimal places.

You'll have to do the conversion:

$$m = \frac{300,000}{\text{kHz}}$$

or

$$\text{kHz} = \frac{300,000}{m}$$

Rounding errors will occur when calculating the exact frequency, but you'll be within 5 kHz of the actual frequency.

Let's Get High

The high frequency region, above the standard AM broadcast band and below the public safety bands used by police and firemen, is transitory in nature, exhibiting all modes of propagation at one time or another; this is the area with which I will be concerned in this article.

High frequencies (HF) are the only consistent frequencies to "bounce" off the various layers in the ionosphere with any degree of predictability, and the competition for space is fierce.

Fixed (point-to-point utility) services, both government and private common-carrier, occupy over 10 MHz, and mobile services (aeronautical and marine) take up another 5 MHz. Broadcasters and amateurs are low on the list, with 3 or 4 MHz each.

As the underdeveloped countries, especially in

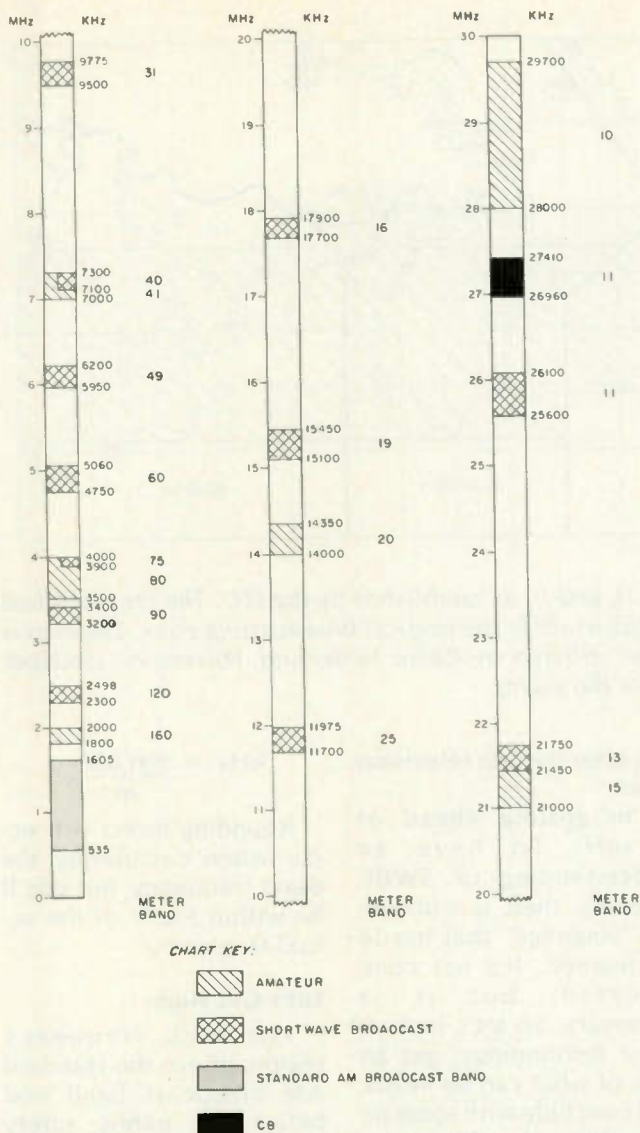

Table 1. A simplified radio spectrum shows the placement of the shortwave broadcast bands, the radio amateur bands, the CB band, and the domestic AM broadcast band tuned by most general-coverage receivers. The blank spaces are occupied by fixed (utility) and mobile (aero and marine) stations, for the most part.

South America and Africa, expand their economic muscle, their collective impact and need to be heard will put an even greater demand upon the available frequency space. Back in 1934, when the present International Radio Regulations were adopted by the International Telecommunications Union, things were quite different, and such pressures did not exist. Table 1 depicts the HF spectrum with frequency allocations for today.

Time Constants

Broadcasting schedules

are referenced to the standard Greenwich Mean Time. GMT or Universal Time (UT), which is the same thing for our purposes, is expressed as a 4-digit number in a 24-hour clock. Don't forget to adjust day and date when converting.

If you are active on the low bands, you are already probably keeping your log in GMT. If you are a newly-licensed Novice or active only on VHF, just tune to WWV on 2.5, 5, 10, or 15 MHz and you'll hear the time given in GMT each minute.

The reason, incidentally, that international broadcasters use the 24-hour GMT clock is that it would be virtually impossible for them to keep up with the ever-changing Daylight-to-Standard-and-back conversions that take place worldwide. Recent changes in past years just here in the US exemplify the problem.

Broadcasting Schedules

Broadcasters are alert to ever-changing propagation conditions. The maximum usable frequency (MUF), above which signals will not be reflected by the ionosphere, and the optimum traffic frequency (having ionospheric support 90% or more of the time), which is lower than the MUF, are affected by three cycles: a daily, a seasonal, and an 11-year cycle.

Short-run variations, caused by solar storms, resulting in radio blackouts and stupendous displays of the northern and southern lights, only add spice to the everyday life of the broadcaster.

Most broadcasters will change transmitting frequencies quarterly to compensate for the fairly predictable seasonal changes.

International frequency coordination has been carried on, since 1960, by the International Frequency Registration Board (IFRB) of the International Telecommunications Union (ITU) in Geneva, Switzerland. Broadcasters must submit quarterly schedules in advance of their intended use. The four periods are the March schedule (March and April), the May schedule (May through August), the September schedule (September and October), and the November schedule (November through February). Each schedule starts on the first

Sunday of the month. The proposed schedules are required by the IFRB five months before the expected implementation date.

The IFRB assembles all the submitted information into a tentative schedule and distributes it to ITU members about two months prior to implementation date. The IFRB points out problems and suggests alternatives to resolve on-the-air conflicts, and there is time to make adjustments and negotiate terms if the problem is unusually difficult.

At the conclusion of the period, a final HF master schedule is compiled showing which frequencies worked and which did not. The broadcasters can use this hindsight to prepare future proposed schedules. Any time a frequency, either during the proposal period or on the air, is changed, the broadcaster must inform the IFRB.

The work of the IFRB has reduced the number of on-air conflicts, but they're not able to address out-of-band operation.

It should be noted that the frequency allocations in Table 1 are those established by the various conferences, but that a number of countries do not follow the ITU regulations and will slide up or down a bit as they did to escape the interference that was especially bad during the bottom of cycle 20-to-21. The communist bloc countries are noted for sitting on or outside the band edges.

The Broadcast Bands

The various bands have unique personalities and can offer different DXing challenges, so let's look at what the ITU is dealing with.

120m (2300-2498 kHz)

This tropical broadcast band is dominated by low-

powered stations in Latin America and Indonesia, with a few Africans thrown in for good measure. On the west coast, Indonesians can be heard before dawn, but, elsewhere, you can hear Guatemalan outlets on 2360 and 2390 or Brazil on 2470 and 2450 kHz. On the east coast at sunset, listeners may log the most powerful station on this band—the 20 kW Rhodesian outlet on 2425 kHz, scheduled 0355-0445 GMT.

90m (3200-3400 kHz)

Another tropical band, used for low-powered relays of medium-wave stations but intended for an audience in the hilly country of Latin America or the bush country of Africa, this band is dominated by stations in some pretty rare countries. The beginning DXer will first note the powerful voice of the 24-hour South African Broadcasting Corporation, the domestic voice, on 3250 kHz. Sunset would be the best time to hear other Africans, such as Swaziland on 3223, Liberia on 3255, Rhodesia on 3306, and Sierra Leone on 3316 kHz. After the Africans sign off, stations from Guatemala, Brazil, and Venezuela populate the airwaves; a popular station is the English-speaking Belize on 3285 kHz. On the west coast, Indonesians, Chinese, and Indians can be heard before dawn.

75m (3900-4000 kHz)

This band is classified as an international band in regions I and III, with region I restricted to just the top 50 kHz. Region II amateurs, who share the frequencies, complain bitterly, but there is no foreseeable change except, perhaps, a lessening of the interference as we get into cycle 21 and broadcasters move to the

optimum traffic frequency that should get up to 25 or 19 meters at night. Now, Radio RSA, South Africa, and Deutsche Welle, German Federal Republic, share 3995 kHz. Other easy-to-hear stations are the Swiss Broadcasting Corporation on 3985, the British Broadcasting Corporation on 3975 and 3952, and the South African Broadcasting Corporation outlets on 3980 and 3965 kHz. The low-powered Far Eastern outlets between 3900 and 3950 kHz can be heard before dawn on the west coast, when interference from east coast stateside amateurs is the lowest. One of the most interesting challenges now on 75m is Radio Afghanistan, heard around 0200 GMT on 3999.8 kHz.

60m (4750-5060 kHz)

WWV and other time and standard frequency stations mark this band by occupying the exact frequency of 5 MHz. This band is probably the most productive tropical band for the experienced DXer. On the east coast, Africans fade in an hour or two before sunset, and countries such as Benin on 4870, Guinea on 4910, Ivory Coast on 4940, Cameroon on 4972, the Central African Republic on 5039, and Togo on 5047 can be heard. Colombians and Venezuelans dominate the band after the Africans sign off, but, by 0400 or 0500 GMT, most of these powerhouses have also gone off the air, leaving clear frequencies for the low-powered outlets in Peru and Ecuador. Africans can be heard once again signing on after midnight, before dawn on the continent. Around 1100 or 1200 GMT, DXers have a chance to log such things as Burma on 4725 or Indonesia on 4767, providing that solar conditions are "quiet" enough to permit a trans-

polar path. Of all the outlets in Oceania, the easiest to hear is Port Moresby in English on 4760 kHz, whose signal peaks about an hour before local sunrise on the east coast. And let's not forget a country most hams would love to work—Galapagos Islands, on 4810 kHz, which has been widely heard lately up to 0400 GMT following the sign-off of the Venezuelan that controls the frequency during the early evening.

49m (5950-6200 kHz)

This is the lowest international band used in all three regions, but, among the superpowers, there are still elements of a tropical band within. In the middle of the day, low-powered Canadians (relaying AM outlets) can be heard on 6005, 6010, 6070, and 6130 kHz and, in the Gulf states and the southwest, some Mexican and other Central American stations may be heard. By late afternoon and into the late evening, however, Europeans and Africans totally dominate almost every frequency. Not until sunrise in Europe does the congestion begin to ease, and some low-power Latins can be heard prior to dawn stateside. Australian outlets on 6140 and 6150 kHz are best heard around 1000 to 1200

GMT.

41m (7100-7300 kHz)

This band is assigned to broadcasters based in regions I and III only, and international broadcasters are not supposed to beam programs to the western hemisphere. Unfortunately, many do, and the entourage is led by Radio Moscow, with as many as six frequencies in parallel operation. Unfortunately, the Novice, restricted to 7100-7150 kHz, has to bear the brunt of the interference with Moscow on 7105 and the Tirana relay of Radio Peking on 7120 kHz leading the way. Out-of-band operation is notable here, especially with multi-language programming of Tirana on 7065, heard as early as 1900 GMT, and the British Broadcasting Corporation during the late afternoon on 7075 kHz. One of the more interesting stations noted on 41m is Radio Pakistan on 7095 kHz, noted with good signals on an English language transmission to Europe at 2100-2145 GMT. West coast DXers will also hear the Asiatic Russians, Chinese, and Manilans on 7225 kHz before dawn around 1000-1100 GMT.

31m (9500-9775 kHz)

This is the first of the in-

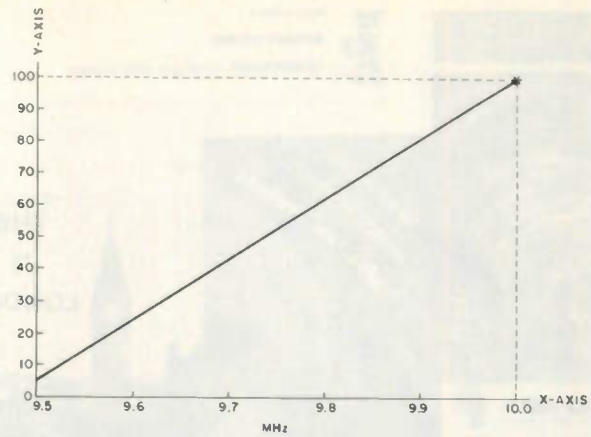

Fig. 2. Band calibration charts can be prepared for each frequency range you want to tune. A calibrator is a useful tool in making accurate graphs. A graph for 31 meters should look something like this.



Colorful verification cards can be obtained from most of the shortwave broadcasting stations. Note the self-prepared card in the lower right-hand corner. That was for a reception report of Radio Swan on 6000 kHz in 1960, a front for the CIA operation on Swan Island prior to the Bay of Pigs fiasco.

ternational bands that has something audible on it 24 hours a day. At sunrise, Chinese and Australian broadcasters dominate (look for Radio Australia 1100-1300 kHz), but, by late morning, high noise levels preclude hearing most signals excepting those from Cuba, Haiti (on 9770 kHz), and HCJB in Ecuador. Europeans and Africans fade in by midafternoon and peak during the dinner hour on the east coast. Tuning signals, which are characteristic melodies unique to each broadcaster and precede the opening of transmission, can be heard every half-hour. By midnight, all that will be left are some of the western hemisphere broadcasters, except, if conditions are right, VLW9, Perth, may be logged on 9610 kHz in a transmission beamed to the South Pacific. On the west coast, the regional and general service broadcasts from Japan and China can also be heard.

25m (11700-11975 kHz)

This is another mainstay, with the band center loaded with the European and African powers. Morning openings to the Far East and Oceania will usually turn up numerous Soviet and Chinese regional services found above and below the nominal band edges. Now, the afternoon and early evenings are best for Europe and Africa, but, with the move into cycle 21, this band should remain open later and later into the night. After 0300 or 0400, look for the south sea music of Tahiti in French on 11825 kHz and for New Zealand on 11705 kHz. The relatively low-power Brazilians populate this band and can be heard best after 0000 GMT on 11785, 11805, 11865, and 11915 kHz, as well as elsewhere.

19m (15100-15400 kHz)

During the summer, this band can stay open all day, with Europeans in the morning and Asia/Oceania in the late evening into the night. Tahiti's second

outlet on 15170 often is better than the parallel outlet on 11825 kHz. Peking can be found on 15030, 15045, 15060, 15070, and 15080 kHz, and, usually 15060 or 15080 kHz has an English-to-North America beam repeating each hour for four or five hours commencing at 0000 or 0100 GMT. Japan beams English to North America's east coast at 2345-0045 GMT on 15270, 15300, or 15445 kHz. During the middle of the day, as a contrast, only the major countries are heard, with Cuba and HCJB, Ecuador, predominant.

16m (17700-17900 kHz)

This band, at the minimum between sunspot cycles 20 and 21, was very uninteresting, but is now open into the late evening. Europeans and Africans (notably Cairo) can be heard in the late morning. HCJB's programming to Europe can be heard during the afternoon. Radio Australia's North America beam at 0100-0300 GMT on

17795 kHz and Japan (17825, 2345-0045 GMT) are audible during the evening.

13m (21450-21750 kHz)

Another daytime band with only the superpowers such as the British Broadcasting Corporation, Radio Cairo, and the Voice of America, this makes for another dull band from a DXer's point of view. This band should become quite active as cycle 21 peaks around 1980-81, as forecasts indicate the adjacent 15 meter amateur band will be the mainstay for DXers.

11m (25600-26100 kHz)

Until late 1977, this band was just plain dead, but cycle 21 should bring it to life as a daytime-only proposition. One of the first occupants was the Israel Broadcasting Authority, running 1400-1630 on 25605 kHz in Russian, Yiddish, and Georgian. Due to the seasonal variations of the MUF, 11m will be best during the summer months.

Information Sources

There are more than 20 nonprofit clubs in North America publishing monthly bulletins packed with information on members' loggings of up-to-date frequency and time changes, new "voices" on the air, and tips on improving your DX listening post. Some clubs specialize in a particular aspect of DXing, whereas others cover a broad range of interests.

Most clubs are members of the Association of North American Radio Clubs (ANARC). In addition to being a unified voice for publicity of the hobby, ANARC has a number of committees: frequency recommendation (to advise on clear frequencies for North America-beamed broadcasts); technical (to encourage receiver manu-

facturers to install SWL-oriented features); and a representative to the FCC Broadcasting Service Working Group working on the WARC 1979 proposals.

ANARC offers a current list of all ANARC members, free upon receipt of a no. 10 self-addressed stamped envelope with 28¢ postage affixed. The data sheets detail the main interests and publications of each club, the cost of membership, and a sample bulletin. When you write ANARC, 557 North Madison Ave., Pasadena CA 91101, requesting the list and enclosing the SASE, tell them 73 sent you.

Whereas a club bulletin is essential for current information on changing broadcasting schedules, other, more static, information must be obtained elsewhere. One such source is the annual *World Radio TV Handbook* available through Gilfer Associates, Box 239, Park Ridge NJ 07656. All kinds of data—addresses, personnel, master schedules, tuning signals, and more—are included. As the *Callbook* is the authority for radio amateurs, so is the *WRTH* the book for shortwave broadcast listening.

Another source of DX tips is through the "DX shows" aired by a number of different broadcasters. The *WRTH* has a master list of those, and the club bulletins keep you up to date on changes in the airing of them. There are some excellent "DX shows" produced by Radio Australia, Radio RSA (South Africa), Radio Sweden, and Radio Nederland.

Reception Reports and Verifications

Just as the radio amateurs on the HF bands exchange QSL cards to "prove" or "confirm" a QSO, so do SWLs write

reception reports to broadcasters to elicit a verification card.

The data in the ham QSL and SWL report is much the same—date, time in GMT, and frequency—but the SWL report has an added description of the program content which should normally be 30 minutes long as a minimum. In addition, a few sentences on signal quality and interference are in order, unlike the RST format used by hams.

If the report can be verified against the program logs, the writer can usually expect a verification card in the return mail. A few stations still send letters, and a few others— notably Canada—no longer send QSLs.

Some stations depend upon a technical monitoring staff, which is derived from those listeners' reports showing the most value and a consistency in reporting. Radio RSA and Radio Japan are two such examples, each maintaining a network of monitors to whom they provide advance news on schedule changes, special newsletters with some "inside" information, and reimbursement for postage.

By the way, unlike the radio amateurs' QSL bureaus, SWLs have no such clearinghouse and reports must be sent directly to the stations. Return postage is often not required by the larger governmental outlets, but the smaller stations do require International Reply Coupons or mint stamps. When in doubt, always send return postage of some sort.

Accessories

If you have one of the new digital readout receivers or something like the very popular Drake SPR-4 receiver, you may not be interested in adding

anything to your shack. However, if you are using one of the older receivers—Hammarlund, Hallicrafters, and National used to dominate the market in the 1940s, 1950s, and 1960s—there are a number of devices to facilitate DXing.

A must is to be able to tell what frequency you are tuned to. The add-on 100 kHz calibrator is almost passé now, as there are a number of manufacturers marketing calibrators that put out markers down to every 5 kHz for less than \$40.

A calibrator is used to set up a reference marker on a 0-100 bandspread dial where, for example, 10 MHz is set to equal 100. On a sheet of graph paper, mark the x-axis with the frequencies of 9.5, 9.6, 9.7, 9.8, 9.9, and 10 MHz. Mark the y-axis with 0, 10, 20, 30, 40, 50, 60, 70, 80, 90, 100. The calibrator will give precise markers at, say, 25 kHz as the bandspread dial is turned from 100 to 0. Plot the points and connect them for a visual graph of the 31 meter band. See Fig. 2.

When tuning the band in the future, just set the top end to have 10 MHz coincide with the bandspread dial at 100. The graph will get you into the ballpark and the 5 kHz markers will enable you to fine tune any frequency by counting markers from the nearest 25 kHz point.

In a similar manner, other graphs can be made up for any band desired. It doesn't take long. Use 10 x 10 log paper to make interpolation easy.

An alternative to this is to add digital frequency readout. It is more expensive and, to date, there hasn't been much available unless you build your own from scratch. Digital frequency readout is really nothing more than a frequency counter with the added ability to offset a

receiver's intermediate frequency.

For example, if the i-f is 455 kHz and you are tuned to a broadcast station on 1000 kHz, the counter will normally display 1455 kHz. If the counter has five digits to the left of the decimal point, the offset has to be 99545. When 1455 is added to the 99545, the counter with an offset calculates 101000. Given a five-digit display, the sixth digit (the "1") will be lost and the proper frequency—1000 kHz—will be displayed.

The problem is that counters which have the ability to load in any offset are rare and expensive. The breakthrough on the cost front may have been made, however. David L. Mattis describes a "Digital Frequency Readout for Shortwave Receivers" in the February, 1977, *Popular Electronics*; a kit of parts is available for \$110.

As calculators have dropped in price over the recent years, I am sure that technology will soon lower these prices as well.

Another useful accessory is the active audio filter. One of the best ones for shortwave listening is the Autek Research (Box 5127E, Sherman Oaks CA 91403) QF-1, which has a variety of controls for selectivity and heterodyne rejection. The problem with many of the other filters commercially produced is that they are designed for CW only and cannot be adjusted to optimize AM reception.

Properly adjusted, an audio filter can make a poor or mediocre receiver "sparkle" in heavy interference conditions. Most filters are outboard and can be moved from receiver to receiver; connection is through a head-phone plug into the receiver, and the speaker or headphones are plugged

into the audio filter.

For the shortwave listener trying to listen to broadcasts on 75 or 41 meters, or for the radio amateur trying to copy CW or SSB through the broadcasters, a good audio filter can do the trick. I can either notch out a CW heterodyne or roll off the tonal response to diminish SSB splatter when listening to the broadcaster; as a Novice, I tightened up the filter's bandpass and frequently worked within 1 kHz of the broadcaster's carrier frequency.

Don't forget that most receivers offer a 400 Hz CW filter, but a decent active audio filter can cut that bandpass down to 80 or 100 Hz, and that makes a big difference. There is one company on the west coast that offers a filter for Drake receivers, replacing the 400 Hz filter with one at 125 Hz, but that has to be wired in and costs about \$125. It's good for the CW DXer, but not so good for the broadcast listener, so pick and choose carefully.

Another interesting device is the panadaptor. Unfortunately, commercial units manufactured today are very costly, but there are still a number of the Heath SB-620 pieces around for about \$100 to \$125.

The panadaptor visually displays, on a cathode ray tube (CRT), the receiver's i-f bandpass. Depending upon the settings, the SB-620 displays as little as 6 kHz (± 3 kHz) or as much as 100 kHz (± 50 kHz), centered on the i-f. Adjacent frequencies, occupied or empty, are readily seen, and the culprit causing the adjacent channel splatter cannot hide from view. With a 5 or 10 kHz calibrator, fairly precise frequency measuring can be done by displaying pips on the CRT and calibrating the baseline through the setting of the panadaptor

controls.

If you pick up one of the SB-620s, try to get the extra coils that came with the unit. Heath provided a number of wiring options depending upon the receiver i-f. The Heath gear of the SB-series was set up on 3395 kHz, but it could be wired for anything from 455 kHz to 5200 kHz.

Another useful trick is to add a tape recorder jack to the receiver. The easiest way to do this is to mount a phone jack on the rear apron of the receiver and route lightweight shielded cable (such as is used in turntable arms) over to the volume control. Solder the shield to the end lug that is grounded, and solder the center conductor to the opposing end lug.

If you've done the job properly, the taping level will be independent of the volume control setting. This exercise is useful when you want to tape something without listening to it live. An auto-level-control cassette tape recorder works quite nicely in this capacity.

As an aside, I use an ALC cassette tape recorder when CW DXing. I don't have to worry about level settings, and, if I miss a call or want to check on an unusual spelling of a name, I'll have it on tape to check.

For longer taping jobs, consider putting a reel-to-reel tape recorder on a timer when you are out of the shack. You can turn the receiver volume down, and your wife won't even know that something's running. The tape can be replayed at your leisure.

If you have a tape with a poor signal due to interference and heterodynes, just replay the tape through your Autek QF-1 or other audio filter until you find a setting that does the trick. Don't have an audio filter? Replay the tape through your house-

hold stereo system and adjust the bass, treble, and "cut" controls until you find a setting that cleans it up for you.

Antenna tuners are another useful tool for the serious DXer. You can roll your own or look at Gilfer's catalog. A couple of 365 pF variables, a coil tapped at intervals, and a rotary switch are enough to make up a simple tuner.

If you have an antenna tuner for your ham band work, you will probably find that your unit will have enough latitude to resonate your antenna on the adjacent broadcast bands. Just peak it for maximum S-meter deflection on the receiver.

Antennas

What can be said on this topic that hasn't already appeared in 73 or in the books distributed by 73? One premise says, "Put up antennas resonant to each band you want to listen to." That's a lot of hard work, and I suggest something a lot easier.

Receiving antennas are a lot more forgiving than transmitting antennas, and I just try to put up as long a wire as possible. I like to get up something at least 100 feet long and then tune it as needed—the higher, the better, and don't worry about the twists and bends around trees. If you have an option, run the bulk of the antenna perpendicular to the adjacent power lines to minimize noise pickup.

As always, don't cross under or over power lines and don't attach the end to a power pole. Even though you are dealing with a receiving antenna, the same safety rules apply.

Can't put up a long wire? Mount a steel 102" CB whip on the roof, and feed the receiver through RG-58/U and an antenna tuner. A vertical up high, free of the ground clutter, can be a respectable antenna,

although verticals are usually more susceptible to local electrical noise.

Obviously, if you are active on the ham bands of 160-10 meters, just make use of the antennas you have up now. You'll find that you'll still be able to take advantage of the ham band antenna's features. For example, the 15 and 20 meter segments of a tri-bander beam will still exhibit directional effects on 25 through 13 meters.

In Closing

The shortwave broadcast bands offer some interesting challenges for the DXer. Most broadcasters run higher power than most DX stations, and listening to of some "flagship" stations can give an indication of propagation conditions in the adjacent amateur bands.

If you have a regular schedule with friends in a far distant land, listen to the news broadcasts by that country's "voice" and you'll have more interesting QSOs through your knowledge of their environment.

If you travel overseas, most stations welcome visits from their listeners. You probably will strike up a dual friendship as a listener and an amateur, as no doubt you will find a number of licensed amateurs at the larger stations you visit.

Frankly, citizens of the United States are spoiled by an extensive array and variety of AM, FM, and TV stations on the domestic bands. Elsewhere in the world, there are some vast areas not served by any particular domestic service, and shortwave broadcasting provides much-wanted information for those "armchair travelers" in remote areas.

The world is at the end of your antenna—just tune it in! You'll be a more interesting person for it. ■

WITH COMPETITIVE PRICES GOING SKY-HIGH THE YAESU FT-101 SERIES IS STILL YOUR BEST BUY!



FT-101E

Top of the series, the FT-101E has everything—RF speech processor, AC and DC operation, plug-in PC boards for easy servicing—nothing has been omitted for excellent 160-10 meter performance.

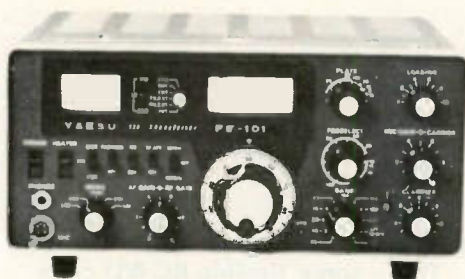

FT-101EE

Just one step down is the FT-101EE identical in every respect—but less the RF speech processor—an item many hams can live without, thus saving a few dollars.



FT-101EX

The FT-101EX is the same basic unit, less DC/DC converter, 160M, WWV, and three of four 10 meter crystals and the RF speech processor. Many hams do not need these features and would just as soon save the money. All accessories may be added later and the "EX" can then become an "E".

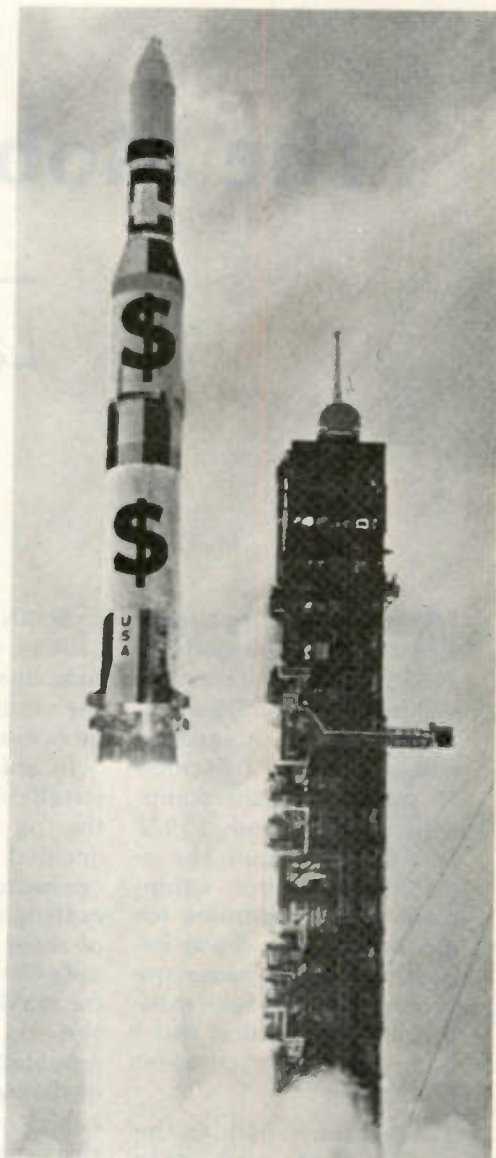

Amateur radio's first all plug-in PC board transceiver, the FT-101 series has a long pedigree of success dating back to the FT-101 and FT-101B. More than a quarter million are in use all over the world! Refinements have been added over the years to update the equipment and we believe it is the most thoroughly satisfactory and trouble-free transceiver money can buy. Compare price and features with any "Brand X" and you'll choose Yaesu!



YAESU
The radio.



The Mobile Dream Machine

—Kenwood, Drake,
Larsen . . . and Ford

After purchasing a long-awaited Kenwood TR-7400A, Drake tone encoder microphone, and 5/8-wavelength Larsen magnetic-mount antenna, I decided to put my dream equipment into the family's 1972 Ford station wagon. The installation of this equipment was a nightmare for me, not because it was impossible, but because my profession deals with man-machine interaction and I had some rather stringent objectives:

1. Operation had to be convenient and safe whether I was driving the car or riding as a passenger in the front seat.
2. The wiring for the tone encoder had to be via the microphone jack rather than the accessory tone jack on the side of the 7400.
3. Coax had to be routed to the antenna with as little damage to the car as possible.
4. The mount and coax had to be secure and blend with the color of the car in order to please the XYL.

5. Scratching of the 7400's cabinet, side rails, and heat sink, due to insertion into the mobile mount, had to be minimized.

In order to enable easy installation and removal of the rig from the car, I decided to use a master connector panel. This is nothing more than a piece of sheet metal with all the necessary connectors on it for making connections to the rig. The panel is mounted close to the rear of the rig so that only short cables are necessary. Note that all connectors mounted on this panel must be insulated from ground and each other in order to avoid ground loop problems which, for me, initially appeared as alternator whine, ignition noise, etc. The only connection of the transceiver to ground should be via the negative power lead at the battery terminal and the coax braid at the antenna mount.

In order to be able to use the rig from anywhere in the front seat, I decided to mount it under the dash, in

the center above the transmission hump. This tends to minimize spotting by thieves, but it's still best not to leave a rig in a car unattended. To further ease operation, I decided to run an extension microphone cable to the left side of the dash from the master connector panel so that the driver could use the microphone with his left hand and steer with the right hand. For right-handed drivers, this is safer, particularly when engaged in city driving with many turns and frequent use of turn signals.

By switching the microphone from the left side of the car to the center, anybody in the front seat can use the rig. A microphone holding clip is present in both locations. Also at the center of the dash on the master connector panel, where the microphone cable plugs in from the 7400, is a coax connector and Jones connector to allow easy hookup of the antenna and power leads.

This scheme, used with some flexible RG-8/U coax (Columbia number 1198, Superflex) gets the coax over to the antenna connector with no large bends. The antenna connector, on the master connector panel, is mounted with plastic washers to insulate it from ground.

It was immediately observed that the cable for the microphone had a large loop where it entered the front panel of the 7400; it looked bad and invited abuse. A 90-degree bend would solve the problem, only they don't exist. So I made one! It was necessary to use two connectors to make the bend, but it really improved the appearance.

For the ultimate in appearance, I decided that the power to and output from the tone encoder microphone should be routed via the 7400's front panel connector, not the tone pad jack on the side. It sounded simple. However, on-the-air reports said it was just about impossible. One fel-

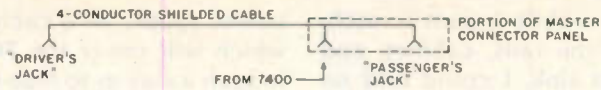

Fig. 1.

low said a local shop was doing it for \$25. I looked at the photos in the owner's manual and could understand why. A phone call to Kenwood got me the scoop from a very courteous gentleman. My suspicions were confirmed—it can be done, but it takes time (a full 2 hours from plugging in the soldering iron to on-the-air use) and caution.

In addition to getting all the tools out, one would be wise to secure a magnifying glass, an X-acto™ knife, flashlight or high-intensity lamp, and jeweler's screwdrivers. Use these as needed. The project should start with a prayer; I don't think I could have done it otherwise. The following are the steps used, but they can be performed in any order; whatever order agrees with you is fine if it works. Placing the unit on a soft towel and using muffin tins for the parts is recommended.

1. Note all knob positions, preferably fully clockwise or counterclockwise, and then loosen setscrews and remove the knobs. The megacycle "lever" pulls off, since it has no setscrew.
2. Remove the screws for the bottom shell of the cabinet and remove the shell. Repeat for the top shell but be careful of the speaker leads. Disconnect the speaker leads on the circuit board (white lead goes to "SP" and black lead to "E").
3. Remove the rubber spacer pad from above the frequency display and the foam from above the tone squelch LED.
4. Remove the four screws around the perimeter of

the front panel and, being careful not to scratch the plastic which will come loose from the frequency display window, remove the front panel.

5. Remove the six LED frequency display digits by unplugging them *in order*; they are *not* identical.

6. Unfasten the subassemblies for the tone squelch LED, the "on-air" LED, and the ± 600 kHz offset LED, and store them out of the way.

7. Unfasten the dual pots used for the volume and squelch and store them out of the way.

8. Remove the four screws used to hold the PC board for the frequency display to the frame. Set it out of the way as best you can.

9. Depending upon your dexterity, approach the microphone connector from either above or below with the X-acto knife. Use the knife to cut the ground lead away from pin 4 and make sure there is no chance of it touching the other pins. Use a piece of small-gauge insulated wire and solder one end to pin 4. If your soldering iron is too large, wrap a length of bare 12-gauge wire around the tip and extend it out about one inch, parallel to the original tip. This will be a good "tip extension." Run the lead upward from the connector to the top side and route it along the left portion of the rig.

10. Locate a point labeled "T10" on the front edge of the TX unit board labeled X56-1230-10. Connect one end of a 1/4- or 1/2-Watt, 470-Ohm resistor to the point labeled T10 with a lead as short as possible. The resistor should rest against the metal shield with the other lead facing

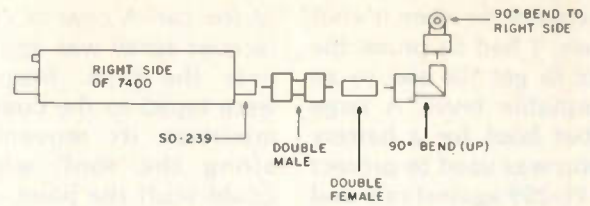

Fig. 2.

the left side of the cabinet.

11. Slide a piece of tubing about two inches long over the wire going to the microphone connector. The tubing should be large enough to fit over the resistor. Connect the other end of the wire to the resistor lead, keeping it as short as possible. After soldering the lead to the resistor, slide the tubing over the resistor.

12. Reassemble the cabinet and subassemblies in reverse order.

13. Modify the Kenwood microphone supplied with the rig and any other microphones you plan to use to ensure that they do not have a lead which grounds pin 4. This pin has the supply voltage for the tone encoder when the rig is in transmit. Although the 470-Ohm resistor will limit the current, this is undesirable and could cause problems. Use pin 3 for the shield and PTT grounds.

14. Adjust the encoder output level, if needed, which is done via a pot

inside the Drake microphone.

Routing the coax to the roof can be done in more than one way—via door openings or around windows. But these methods are susceptible to water leaks, pinched cable, and untidy installation. Investigation showed that the mounting posts for the luggage rack were hollow. Hence, the coax was routed under the carpet and up the side pillar to the roof. A hole was drilled through the roof after removing the post for the luggage rack. An SO-239 fitting was mounted in the post, and this allowed easy attachment of coax for the magnetic-mount antenna. The fitting was of the type which uses two nuts on the shell to mount it in a single hole rather than the type needing four mounting screws. The connector and hole through the roof were sealed with silicone sealer to guard against water leakage and chafing of the cable. A plastic cap covers

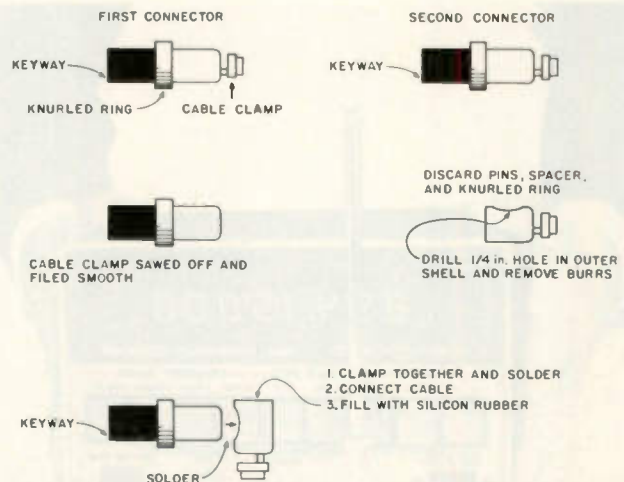

Fig. 3. Ensure that there is a cable sheath, or add spaghetti, where the wires pass through the soldered junction. This will prevent chafing.

the connector when it's not in use. I had to prune the coax to get the SWR to an acceptable level. A large rubber boot for a battery clamp was used to protect the PL-259 against rain and snow.

In order to make the antenna more pleasant, if that can ever be done for an XYL, it was decided to cover the magnetic mount with plastic tape which roughly matched the color

of the car. A coat of clear lacquer spray was applied over the tape. Magnets were taped to the coax to minimize its movement along the roof, which could scuff the paint. The XYL, being extremely considerate, agreed that the installation was perfectly acceptable—as long as the final approval could be handled over dinner at a nice restaurant.

As far as the problem of

the mobile mount scratching the rails, cabinet, and heat sink, I could find no solution other than to put plastic tape on the cabinet. This is the only flaw I have found with the 7400, and it was quite unexpected considering my favorable experiences with my TS-520 and TS-820. Nobody said mobile was easy on equipment, so this is the price you pay. There are plans to house the fixed station

power supply in a cabinet which will cover the 7400 in such a way as to hide the scratches.

I would appreciate hearing from others concerning their experiences with the 7400 and, more generally, with mobile operation to increase safety and ease of operation. This two meter installation is very enjoyable to use and is still very exciting, even for a seasoned ham. ■

New Products

from page 49

as well as very high speed clock and control in computers and other equipments.

For additional information, contact *Continental Specialties Corporation, 70 Fulton Terrace, New Haven CT 06509; (203)-624-3103.*

SENCORE OFFERS EASY-TO-USE, INTERFERENCE-FREE 1 GHZ FREQUENCY COUNTER —MODEL FC51

A new, 1 GHz, all direct-reading push-button frequency counter has been introduced by Sencore for measurements in the newly authorized 806-947-MHz two-way communication business and police band. .5 parts-per-million accuracy also enables testing to FCC specifications in the 902-928-MHz medical electronics and industrial scientific band, the 470-806-MHz UHF TV

band, and the 947-952-MHz oral broadcast band.

A 50-Ohm Input is provided for communications measurements from 10 MHz to 1 GHz at an average sensitivity of 100 millivolts to assure a clean, interference-free signal pickup with either the supplied untuned pickup loop or the supplied adjustable antenna. An external, optional 30-dB wide-band amplifier, Model WBA52, simply plugs into the 50-Ohm cable system to increase sensitivity to 5 millivolts for troubleshooting low-level stages, measuring any communication generator accuracy, or for remote transmitter documentation. The FC51 is powered by 115 volts ac or plugs into the 12-volt cigarette lighter of any vehicle for these remote checks.

An easy-to-use crystal check is included as an integral part of the frequency counter be-

cause crystals are the first suspect when measurements are not to FCC specifications. The FC51's highly-accurate 10-MHz crystal clock oscillator is also buffered and brought out the back to serve as a check against WWV or to calibrate less accurate frequency counters or other equipment. The clock oscillator is plugged in and removable for exchange with the factory Service Department for calibration purposes to assure no down time. The oscillator is also available for separate purchase. Price of the FC51 is \$975.

Sencore, 3200 Sencore Drive, Sioux Falls SD 57107; (605)-339-0100.

THREE NEW OSCILLOSCOPES FROM HICKOK

Quick and easy setup and operation are the key features in a new line of push-button triggered oscilloscopes being introduced by the Hickok Electrical Instrument Company. The line consists of three low-priced models, all of which feature automatic triggering,

color-coded front panels, and conveniently grouped controls that speed up and simplify operation. All three models are aimed at industrial, commercial, and consumer service applications. The scopes are also suitable for cost-conscious production testing applications which usually do not require extremely wide bandwidths.

The Model 532 at \$995 (including probes) is a dual-trace 30-MHz scope with 11.7 ns rise time and a built-in delay line for leading edge viewing of fast rise time pulses. Among its many features is a full-time 4x expansion that allows any portion of a pulse train up to 40 full divisions long to be viewed without the use of a multiplier. Well suited for logic and pulse circuit applications, it is capable of testing most digital logic circuits—including microprocessors.

The Model 517 is a dual trace 15-MHz scope with 5 mV/cm sensitivity and reliable trigger-

Continued on page 63

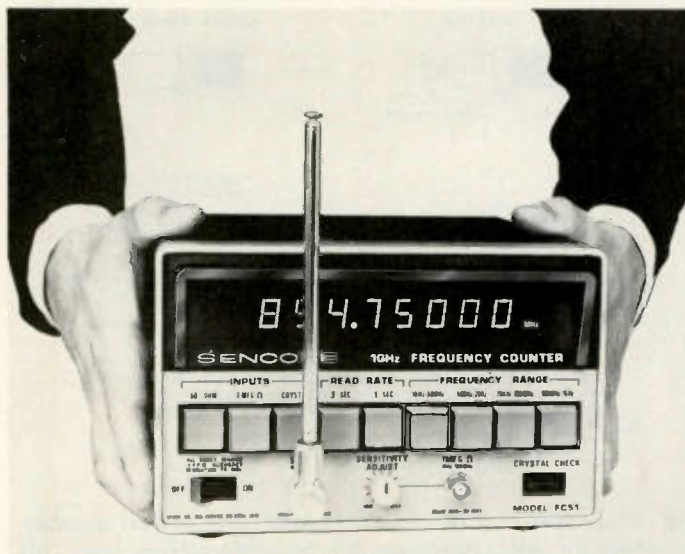

Sencore's FC51 1 GHz counter.

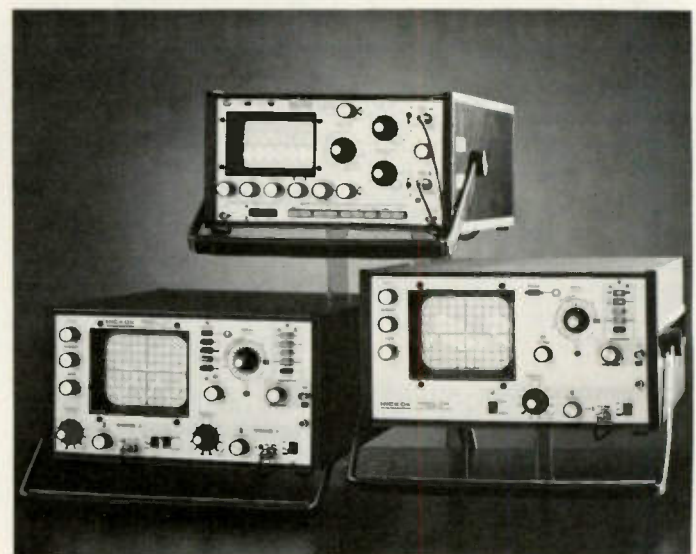

Hickok's new oscilloscope line.

This NEW MFJ Versa Tuner II . . .

has SWR and dual range wattmeter, antenna switch, efficient airwound inductor, built in balun. Up to 300 watts RF output. Matches everything from 1.8 thru 30 MHz: dipoles, inverted vees, random wires, verticals, mobile whips, beams, balanced lines, coax lines.

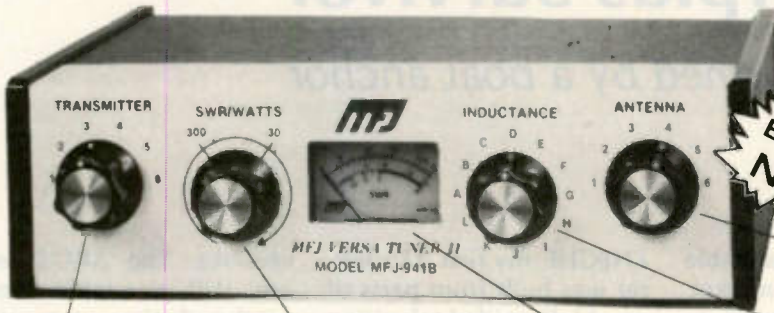

NEW, IMPROVED MFJ-941B HAS . . .

- More inductance for wider matching range
- More flexible antenna switch
- More sensitive meter for SWR measurements down to 5 watts output

\$89⁹⁵

Transmitter matching capacitor. 208 pf. 1000 volt spacing.

Sets power range, 300 and 30 watts. Pull for SWR.

Meter reads SWR and RF watts in 2 ranges.

Efficient airwound inductor gives more watts out and less losses.

Antenna matching capacitor. 208 pf. 1000 volt spacing.

Only MFJ gives you this MFJ-941B Versa Tuner II with all these features at this price:

A **SWR and dual range wattmeter** (300 and 30 watts full scale) lets you measure RF power output for simplified tuning.

An **antenna switch** lets you select 2 coax lines direct or thru tuner, random wire/balanced line, and tuner bypass for dummy load.

A **new efficient airwound inductor** (12 positions) gives you less losses than a tapped toroid for more watts out.

A **1:4 balun** for balanced lines. 1000 volt capacitor spacing. Mounting brackets for mobile installations (not shown).

With the **NEW MFJ Versa Tuner II** you can run your full transceiver power output — up to 300 watts RF power output — and match your

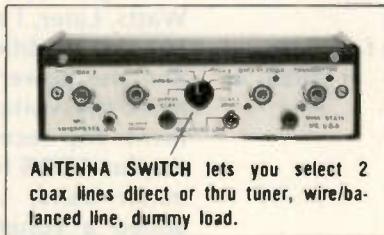

ANTENNA SWITCH lets you select 2 coax lines direct or thru tuner, wire/balanced line, dummy load.

transmitter to any feedline from 160 thru 10 Meters whether you have coax cable, balanced line, or random wire.

You can tune out the SWR on your dipole, inverted vee, random wire, vertical, mobile whip, beam, quad, or whatever you have.

You can even operate all bands with just

one existing antenna. No need to put up separate antennas for each band.

Increase the usable bandwidth of your mobile whip by tuning out the SWR from inside your car. Works great with all solid state rigs (like the Atlas) and with all tube type rigs.

It travels well, too. Its ultra compact size 8x2x6 inches fits easily in a small corner of your suitcase.

This beautiful little tuner is housed in a deluxe eggshell white Ten-Tec enclosure with walnut grain sides.

SO-239 coax connectors are provided for transmitter input and coax fed antennas. Quality five way binding posts are used for the balanced line inputs (2), random wire input (1), and ground (1).

NEW 300 WATT MFJ VERSA TUNER II'S: SELECT FEATURES YOU NEED.

NEW MFJ-945 HAS SWR AND DUAL RANGE WATTMETER.

\$79⁹⁵

BRAND NEW



Same as MFJ-941B but less 6 position antenna switch.

NEW MFJ-944 HAS 6 POSITION ANTENNA SWITCH ON FRONT PANEL.

\$79⁹⁵

BRAND NEW



Same as MFJ-941B but less SWR/Wattmeter.

NEW MFJ-943 MATCHES ALMOST ANYTHING FROM 1.8 THRU 30 MHz.

\$69⁹⁵

BRAND NEW



Same as MFJ-941B, less SWR/Wattmeter, antenna switch, mounting bracket. 7x2x6 in.

ULTRA COMPACT 200 WATT VERSA TUNERS FOR ALL YOUR NEEDS.

MFJ-901 VERSA TUNER MATCHES ANYTHING, 1.8 THRU 30 MHz.

\$59⁹⁵

BRAND NEW

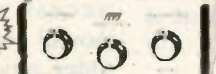

Efficient 12 position air inductor for more watts out. Matches dipoles, vees, random wires, verticals, mobile whips, beams, balanced lines, coax. 200 watts RF, 1:4 balun, 5x2x6 in.

MFJ-900 ECONO TUNER MATCHES COAX LINES/RANDOM WIRES.

\$49⁹⁵

BRAND NEW



Same as MFJ-901 but less balun for balanced lines. Tunes coax lines and random lines.

MFJ-16010 RANDOM WIRE TUNER FOR LONG WIRES.

\$39⁹⁵

BRAND NEW



1.8 thru 30 MHz. Up to 200 watts RF output. Matches high and low impedances. 12 position inductor. SO-239 connectors. 2x3x4 inches. Matches 25 to 200 ohms at 1.8 MHz. Does not tune coax lines.

For Orders

Call toll-free 800-647-1800

Order any product from MFJ and try it. If not delighted, return within 30 days for a prompt refund (less shipping).

Order today. Money back if not delighted. One year unconditional guarantee. Add \$2.00 shipping/handling. For technical information, order/repair status, in Mississippi, outside continental USA, call 601-323-5869.

Order By Mail or Call TOLL FREE 800-647-1800 and Charge It On



MFJ ENTERPRISES

P. O. BOX 494

MISSISSIPPI STATE, MISSISSIPPI 39762 M52

Be A Surplus Survivor

— don't get burned by a boat anchor

After you have that new Novice ticket, you have to think about getting on the air. Having seen the prices of some of the new solid state equipment, I am going to offer another possible route for getting started. There are many inexpensive allband rigs

available at a reasonable price in the surplus market. In addition to being in some cases very inexpensive, the surplus gear also offers the new Novice a chance for actual hands-on experience.

When I was first licensed as a Novice in 1958 as

KNØGHF, my first transmitter was built from parts of an old discarded television receiver. It consisted of a 6AQ5 oscillator, a 6AQ5 buffer, and a 6AQ5 final running a whopping ten Watts. Later, I acquired an 807 and modified the final and the power supply to meet the voltage requirement. My receiver was a surplus ARC-5 for the forty meter band, to which I added a volume control, an on-off switch, and a bfo on-off switch. I had the receiver B+ dropped down from the transmitter supply, controlled through a relay.

I will never forget the thrill of my first Novice QSO. At that time, I was stationed near a small town in mid-Missouri, and my first contact was a ham in eastern Virginia. I think the biggest thrill was having the satisfaction of seeing the home-brew transmitter putting out a good clean signal.

But enough of the past. Let's take a look at what is available in the surplus market today. The most popular, and the most converted, is the old ARC-5 equipment. There have been numerous articles written in amateur radio publications, so I will not go into any elaborate con-

versions. The ARC-5 sets are still available from surplus dealers at a price range of \$18 to \$20 for the receivers and \$14 to \$16 for the transmitters. An added extra is the use of an ARC-5 for the station vfo, and the low-frequency receivers can be modified into Q-5ers.

Another old favorite was the Navy TCS series of receivers and transmitters. Quite a few conversions have been written on both sections of this old set, both separately and as a complete station. A unit currently being advertised by Fair Radio Sales Company which shows promise for the more advanced builder/conversionist or experimenter is the RT-380/AR or the old Collins Model 18S4 transceiver.

I would like to point out one thing to beware of in selecting a piece of surplus equipment. Unless one has access to a 400-cycle power source, do not consider any of the autotune units without being prepared to perform some extensive modifications. Otherwise, the only thing to remember is that almost all of the military equipment was designed to operate from a 24-volt dc source, and, in many cases, the high voltage supply was a separate unit. With a

Bary Electronics Corp. 512 Broadway New York NY 10012	1,2
Fair Radio Sales Co., Inc. PO Box 1105 Lima OH 45802	1,2,3
Edlie Electronics, Inc. 2700 Hempstead Turnpike Levittown NY 11756	1,2,3
Slep Electronics Co. PO Box 100 Otto NC 28763	1
Selectronics 1206 Napa Street Philadelphia PA	1,2
Gadgeteers Surplus Electronics, Inc. 5300 Vine Street Cincinnati OH 45217	1,2
G & G Radio Supply Company 75-77 Leonard Street New York NY 10013	1,2
Columbia Electronics Sales 4365 West Pico Blvd. Los Angeles CA	1,2
Arrow Sales-Chicago, Inc. 2534 South Michigan Avenue Chicago IL 60616	1,2

Table 1. Surplus dealers. Notes: 1—equipment; 2—parts and components; 3—manuals and schematics.

few exceptions, the tube lineup consisted of a number of twelve-volt tubes in a series-parallel arrangement. A study of the set diagram will reveal whether or not six-volt tubes may be substituted and the heater string run from twelve volts. The plate, screen, and bias supply can be built from a discarded TV set. I have found many a discarded TV set which contained a

good husky power transformer, as well as a choke and some tubes. It should be noticed that the TV power transformer was designed to furnish filament voltage for ten to fifteen tubes plus the high voltage for the various tubes.

When converting surplus equipment, it is always advisable to obtain and study thoroughly the schematic diagram. In this

way, a better understanding of what is being done in the conversion is acquired. Although many of the original manuals have long been out of print, schematic diagrams of most of the useful sets are available from *CQ Magazine* as well as Editors and Engineers (Howard Sams and Co., Inc., Indianapolis IN). Back issues of *CQ*, *73*, and *QST* also have many schematics as

well as conversion articles on just about anything worthy of conversion. A list of some of the surplus dealers as well as sources for technical manuals is included in Table 1 for your information. I will also make my library available for those who run into difficulty or need information. Please include a self-addressed stamped envelope with your request. Happy hamming. ■

New Products

from page 60

ing up to 30 MHz. Priced at \$695 (including probes), the Model 517 features automatic selection of chopped or alternate operation in dual-trace mode depending on sweep speed selected. Complete with algebraic sum and difference capability as well as TV line and frame sync circuits, the Model 517 is ideal for TV, VCR, audio, and video maintenance and repair as well as design

and troubleshooting of most digital logic circuits.

The Model 515 offers most of the features of the Model 517 in a lower-priced (\$495 including probe), single-trace version well suited to industrial and consumer servicing as well as laboratory and educational applications. TV sync separators are built in for easy locking to complex TV video waveforms at any sweep speed and, like the Model 517, it provides x-y operation for vectorscope

measurements.

Engineered and designed for fast, reliable operation with minimal training or familiarization, the new line of Hickok scopes is currently in stock at Hickok distributors throughout the country.

The Hickok Electrical Instrument Company, 10514 Dupont Ave., Cleveland OH 44108; (216)-541-8060.

NEW MODEL 3300 HAND-SIZE 3½ DIGIT DVOM FROM TRIPLETT HAS BETTER READABILITY, ACCURACY, AND BATTERY LIFE

The new 3½ digit Model 3300 digital VOM just introduced by the Triplet Corporation features an easily read .3" high digit LED readout display with polarity indication, .5% accuracy, and low power-Ohms. The five-function, 22-range Model 3300 offers complete portability with precision measurement capability, and sells for only \$175, complete with long-life nicad batteries and ac adapter/charger plus test probes with safety boots.

It is only 3" wide by 5-3/8" long by 1-3/8" deep. Ideal for test bench or field use, for circuit testing, design work, production line checks, industrial maintenance, and general-purpose applications.

A snap-in Battery-Pac™ with the nicad batteries and ac adapter/charger recharges separately or within the tester.

The Triplet Model 3300 is a safety-conscious design with no exposed metal parts and it includes a high energy 2 A, 600 V fuse for ample overload protection. A fused probe provides for both high-energy and normal-use circuit protection. The molded gray high impact thermoplastic case with a non-slip finger tread finish offers structural strength, light weight, and professional instrumentation styling.

Overrange is indicated by a

blinking display and a low-battery warning is included. Dc polarity is automatic with indication directly on the readout display.

Single-selector switch ranges include: .2-600 V dc; .2-600 V ac (60 Hz) with 10 megohm/100 picofarad input impedance on all ac ranges; Low-Power (200 mV FS) 0-2 megohms with zero adjust for lead resistance; Hi-Power (2 V FS) 0-20 megohms; ac and dc milliammeter reads 0-200 mA. Typical dc accuracy is .5% of reading.

Full details on the new Model 3300 DVOM and its complete line of accessories may be obtained by contacting *Triplet Corporation, Bluffton OH 45817; (419)-358-5015.*

NEW MOBILE DISGUISE ANTENNAS AVAILABLE FROM ANTENNA INCORPORATED

Antenna Incorporated has introduced a new line of Mobile Disguise Antennas that are visually indistinguishable from standard broadcast antennas. These antennas are for the growing land mobile two-way business radio market.

The Mobile Disguise Antennas are available in two mounting configurations: Ford style or standard universal cowl mount, for either the single band or combination AM/FM land mobile models. A special matching harness is included with either model.

Offered in three frequency ranges, 25-54 MHz, 130-174 MHz, and 406-512 MHz, the Disguise Antennas are factory tuned to the frequency the customer specifies. Maximum power is over 150 Watts for the single-band model, or 100 Watts for the combination AM/FM land mobile model. The radiation pattern is essentially omnidirectional, dependent on



Triplet's Model 3300 DVOM.

Continued on page 71

Tracking the Wild Turkey

— *DF tips*

Mike Naruta WA8BHR
4466 Burtch Rd.
North Street MI 48049

How would you like to find that repeater jammer? Maybe you're in a small boat. The compass tells you in which direction you are pointing, but not

your location. Perhaps you want to reject stations from one direction and listen to another direction. Or maybe you just want to know if that transmitter is really where he says he is. How do you do it?

Well, the simplest type of directional system is using a directional antenna. The half-wave dipole antenna has rather broad peaks. See Fig. 1. The

secret in using directional antennas for direction-finding is not using the peak response, but rather the nulls. It is much easier to hear the difference between a small signal and no signal than it is between a large signal and a larger signal.

A better antenna would be the common "loop" antenna. If the circumference of the loop is about one wavelength, the pattern is similar to the dipole: The peaks are perpendicular to the plane of the loop. If the loop is a small part of a wavelength, the pattern changes: The loop's strongest reception

is in the direction of the plane of the loop. See Fig. 2. This occurs because the antenna operates on the difference in strengths between one side of the loop and the other.

The loop antenna can be improved with the addition of a ferrite core, as is used in the common pocket transistor radio. The basic broadcast transistor radio is a very sensitive direction-finding device. At one New Year's Eve party, my friends had a transmitter hunt using pocket BC radios. The technician of the group had built a very small oscillator, less than half a cubic inch. We took

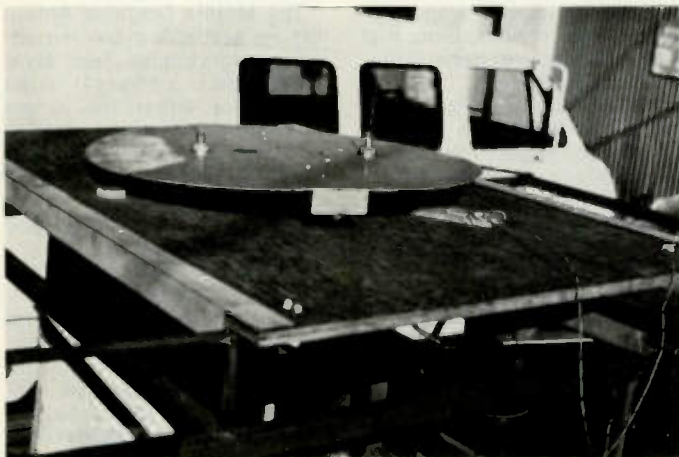

Why not try out this strange-looking direction-finding device?

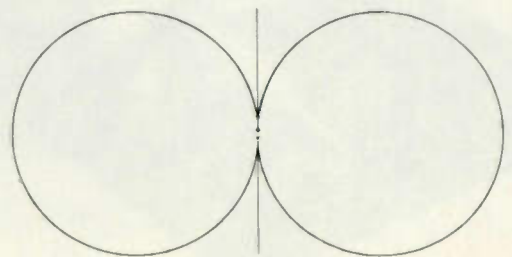

Fig. 1.

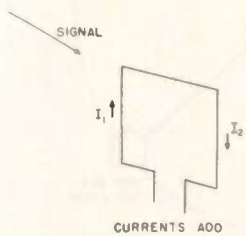
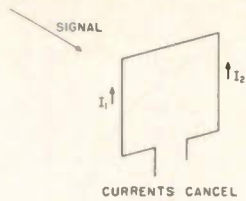

Fig. 2.

turns hiding the oscillator and tracking it down with the radios. It didn't take long to find the oscillator in the most unlikely places, and it was great fun.

Many years ago, some guy didn't like turning the loop around constantly, so he figured out a way to motorize it. By taking the output of the receiver, amplifying it, and feeding it to a motor connected to the loop, the loop would keep turning until the signal dropped off, at the null. If you added some kind of position-indicating device to the antenna, such as a senslyn, the antenna could be quite a distance from the operator.

There is a problem with this system. The loop antenna is bidirectional, a figure eight pattern. That means there are two peaks and two nulls which it can lock onto. However, by adding another antenna, a vertical this time, and combining the signals properly, a cardioid pattern with one sharp null is produced. See Fig. 3. Now our system automatically points in the proper direction and indicates where the station is. Indeed, ADF (Automatic Direction-Finding) or "Radio Compass" has been used on aircraft and ships for many years.

If you don't want a loop antenna spinning around

outside the aircraft, the loop can be brought inside and fooled into thinking it is still outside. A goniometer is a set of fixed loops that receives the signal and brings it inside the instrument. Inside, another loop responds just as if it were outside. See Fig. 4. The instrument and leads must be well shielded. Just attach a pointer to the movable coil and you have only one moving element. Used primarily for 90 to 1800 kHz, it provides a good system for indicating the direction of a station. You can fly "to" a station or "away from" a station. To find your position, or the position of a transmitter, you need another "fix." See Fig. 5.

Another aircraft navigation system is VOR. It stands for VHF Omni Range and is transmitted from 108 to 118 MHz. To get an idea of how VOR works, try visualizing a lighthouse. Picture the beam as it sweeps around. Imagine that whenever the light beam points exactly north, the lighthouse sounds its foghorn. If you were on a boat, and you knew the time it took the beam to go around completely, you could determine which direction you were from the lighthouse just by waiting until the foghorn sounded and counting the time until you saw the flash of the light. See Fig. 6. This is just how it works in VOR. The signal is transmitted as if it were rotating very fast. An omnidirectional pulse is transmitted when the

beam is pointing north. A VOR navigation receiver times the interval between the sync pulse and the reception of the "searchlight" beam. This system tells the pilot which "radial" he is on. Note the difference between ADF and VOR: ADF tells the pilot which direction the station is with respect to his craft. VOR tells the pilot which direction he is with respect to the station.

Another method of finding yourself is loran. If we know that two stations transmit a pulse at the same time, we can time the difference between their arrival times at our location, thereby learning our relative position between the two stations. If we receive the pulses from the two stations at exactly the same time, we know that we are equally distant from both stations. See Fig. 7, ship X. If we find station A's pulse arriving before station B's, we know that we're somewhere between the centerline and station A. See Fig. 7, ship Y. By using at least three loran stations (see Fig. 8), we can find our position. Like VOR, loran tells us our position, but not what direction we are facing. Loran operates on four frequencies, 1750, 1850, 1900, and 1950 kHz, with 40-microsecond pulses occurring about 25 times each second. It's quite a racket, as anyone who has listened to the 160 meter band can tell you.

Somewhat similar to loran is the omega system. Originally designed as an

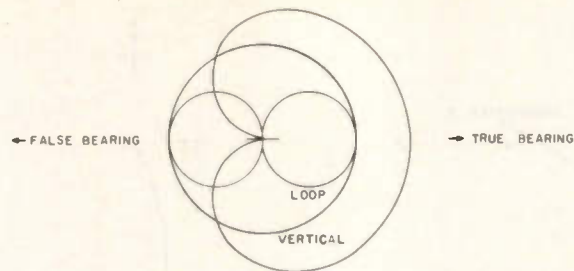

Fig. 3.

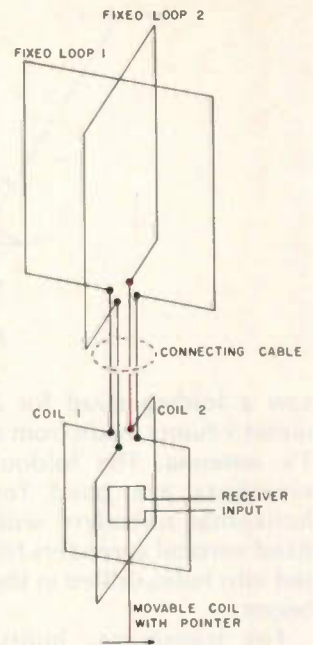

Fig. 4.

ocean locating system, omega uses the VLF band (10 to 14 kHz). With only eight stations and the advantage of VLF, it covers the world. Using a nice, long wavelength, omega devices analyze the phase difference of signals being received.

The military uses "stationary" satellites for a high band position-finding system. The receiver is very accurate. You can march around the world with a little box on your back, always knowing exactly where you are.

If you would like to experiment with direction-finding, try out a loop antenna. They are not hard to make. Just make sure that with a shielded loop, you don't close the shielding entirely; leave a small gap at the top or you won't hear anything. A shielded loop reduces electrostatic noise and increases accuracy. When using the loop for receiving, you may find it more convenient to tune the null to reduce QRM from another station, rather than try to peak on the desired station.

On VHF you might want to try a quad antenna. I

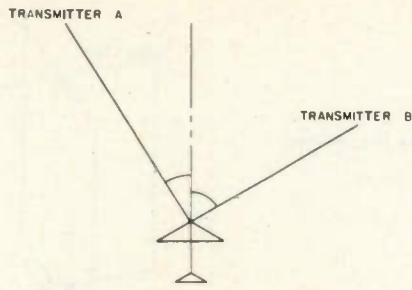

Fig. 5.

saw a folding quad for 2 meter T-hunts made from a TV antenna. The foldout elements are used for horizontal spreaders, with fixed vertical spreaders fitted into holes drilled in the boom.

For transmitter hunts, the loop is pretty slow. If you are trying to locate a repeater kerchunker, in the second or two it takes you to rotate the loop, he is gone. While working at a business radio shop in California, they were having trouble with their radios disappearing from customers' vehicles. After the theft, the customers would be hit with all sorts of jamming. The solution was the strange-looking device shown in the photo. The big circular plate is aluminum. Two quarter-wave vertical antennas are exactly 1/2 of a wavelength apart. This gives a figure eight with sharp nulls. To catch the short transmis-

sions, the disk is spun about three times a second by an electric motor on the frame below. The feedline from the antenna array runs down a water pipe shaft, terminating in a BNC connector, but the outer shell is not tightened, providing an excellent rotating contact.

At the edge of the disk is a block with a small magnet. On the plywood base under the path of the magnet is a reed relay. When the magnet passes the reed relay, it closes to give a reference pulse indicating that the antenna is pointing straight ahead. Now the clever part. Using an oscilloscope, the vertical amplifier is fed from the receiver just before the limiter. The horizontal sweep is set to approximately the amount of time it takes the disk to make one revolution. The reed relay sets off the sync circuit. On the scope display,

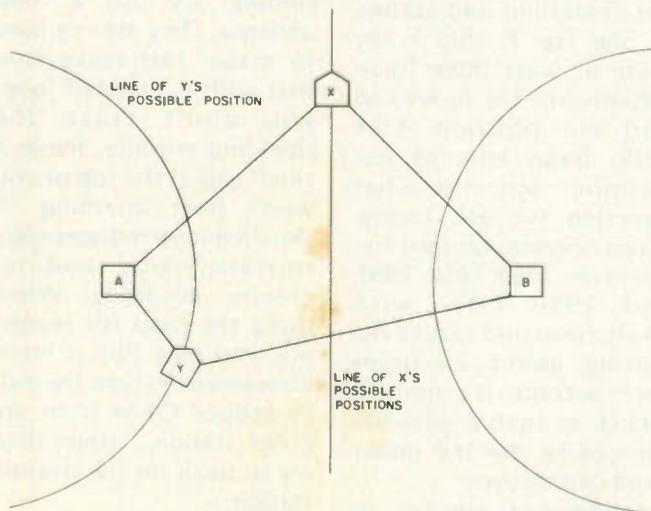

Fig. 7.

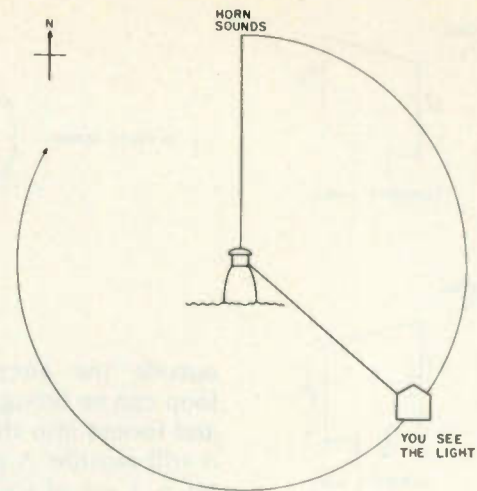

Fig. 6.

the null is a dip in the trace. If the null occurs right at the start of the trace, you know the source is directly ahead. If the null is one quarter of the horizontal distance across the trace, the transmitter is to the right or left of you. Since the array is revolving so fast, it only takes a fraction of a second to get a bearing. In the time it takes to key up the repeater, you can get a fix on the transmitter. (Don't forget to do your transmitter hunting on the input frequency of the repeater.)

If you don't want to

build it yourself, manufacturers offer ready-built direction-finders. L-Tronics of Santa Barbara CA has several models, starting in the \$135 price class.

There are other forms of direction-finding and position-locating. Remember, direction-finding usually depends on some type of antenna array. Position location can use direction-finding techniques, but often examines some characteristic of transmitted signal. You can start out in direction-finding with just a simple loop antenna. Give it a try. It's fun. ■

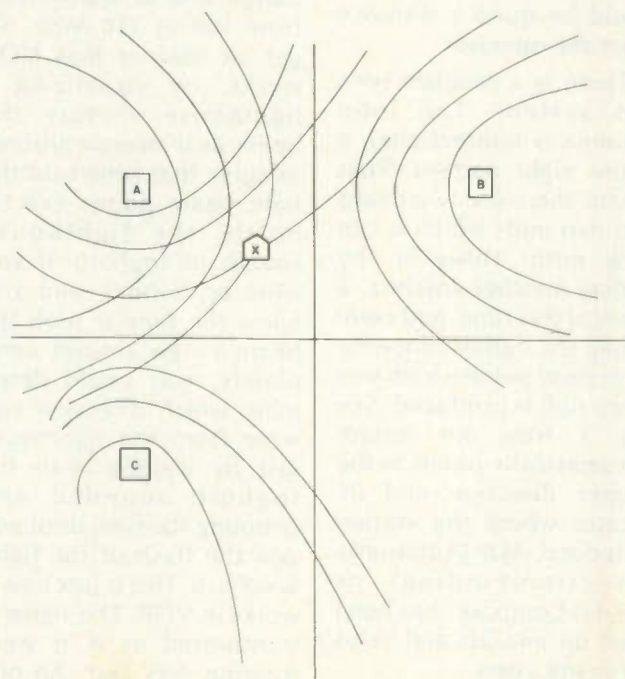
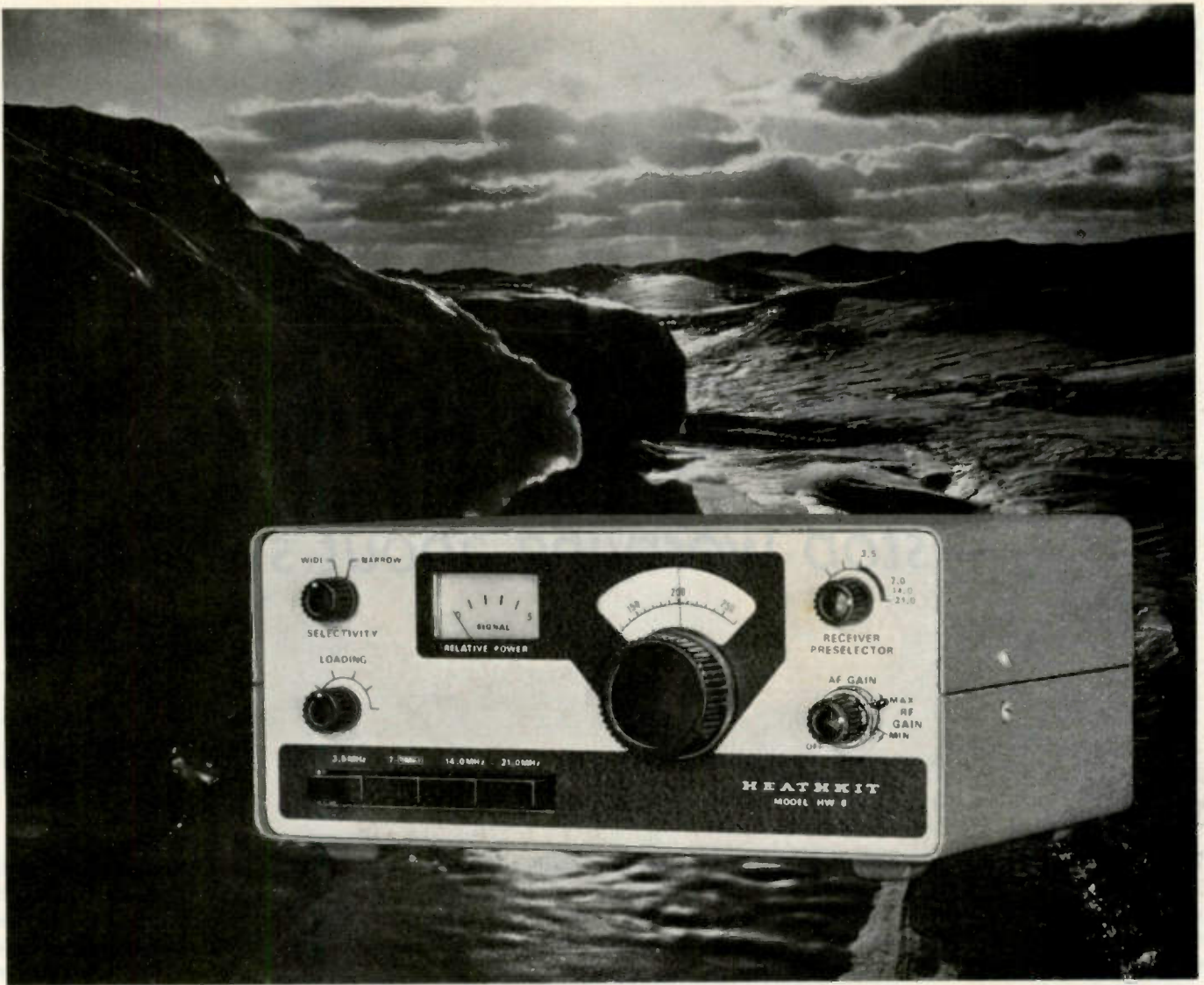

Fig. 8.



The HEATHKIT® HW-8

...it works the world on a couple of watts!

In 1977 Norm North, WA1D3R, was assigned to Thule, Greenland. With him went his Heath HW-7, a dipole antenna, and a goal...work all 50 states!

Norm failed! But what he did accomplish in three months' time, with his HW-7 and the call OX5AB, is nothing short of amazing! Worked: 41 states, 30 countries, including a PY4 in Belo Horizonte, Brazil, and First Place, High-Band CW Greenland, in the '77 ARRL International DX Competition! Quite a record!

In Norm's words: "I honestly believe that I could have worked all states and perhaps DXCC if I had stayed in the Arctic a bit longer. This is quite a tribute to that little rig..."

We'd agree, and we bet Norm would have done even better had he been using a new Heath HW-8! Why? Because our engineers felt they could give you a much finer QRP rig than the HW-7. One with better sensitivity, lower hum and noise figures, an RF gain control, sharper preselector, switchable selectivity, more bands to operate, and even a bit more power!

They succeeded in a big way! And the result of their efforts is a truly superb CW transceiver for the QRP operator that costs just \$129.95*...the Heathkit HW-8!

Why don't you take up the challenge? Build an HW-8 kit, then join the growing ranks of outstanding QRP operators, like Norm, who are proving you really can work the World on a couple of watts!

*Price is mail order, F.O.B. Benton Harbor, MI. Prices and specifications subject to change without notice.

Catalogs also available at the 50 Heathkit Electronic Centers coast-to-coast (units of Schlumberger Products Corp.) where Heathkit products are displayed, sold, and serviced. Retail prices on some products may be slightly higher. See your phone book white pages.

FREE Heathkit Catalog



HEATH
Schlumberger

Heath Company
Dept. 011-450 H5
Benton Harbor,
MI 49022

Gentlemen, please send me my free Heathkit Catalog.
I am not on your mailing list.

Name

Address

City State

AM-375 Zip

High Q Antennas

— *stop worrying about swr*

When a friend of mine once proudly told me that his ordinary eighty meter dipole had a band-edge swr of about 1.8:1, instead of congratulating him, I said, "Oh, isn't that too bad." Well, he almost flipped. But after we started to talk a bit about antenna losses, his pride turned to consternation. Actually, his antenna was an inverted V, quite low, with the ends about seven feet from the ground. There were enough trees and bushes nearby to provide losses. And, in addition, the ground was sandy, so there were losses from that, too.

When the same antenna was later relocated with a better overall height, without nearby trees and bushes, sure, his swr went up, but so did the overall antenna performance.

Although I am in favor of special antennas, such as the parallel stub double bazooka, discones, bow ties, and others that can lower swr because of their basic broadband characteristics, I am concerned at

low swr in an ordinary dipole. It generally means high losses. So take a good look at lossy objects near your antenna that might be causing problems. Although any object near an antenna can induce both resistive losses and a change in the antenna reactance and Q, to simplify thinking, I will disregard such changes in reactance for two reasons. First, a change in antenna reactance is not a power loss, and, second, it would be almost impossible to predict such reactance changes in an amateur antenna system.

And that is why I thought it would be both interesting and useful to expand some basic antenna theory into a presentation that will relate antenna resistance, Q, and swr. The graphical presentation allows for easy understanding without having to delve through pages and pages of complicated mathematics that too often obscure what one is really trying to say. Radio amateurs come from all walks of life, and the high

mathematics of the specialist can and always should be boiled down to a level where they are easily understood by all of us.

Now that I've decried high math, and also to prove my point, I'll show how simple, easily understood and explained calculations will be used for those who want to do a bit of figuring on their own. Specific calculations will be shown for those who have rf bridges and would like to translate their measurements into useful information. My calculations will show rf bridge measurements can easily be translated into swr and Q. And, by showing how the curves were derived, you should understand them a bit better.

Conditions and Stipulations

In order to keep the basic math and concepts as simple as possible and yet not lose the overall concept of the presentation, the following conditions and stipulations are made.

1. A basic eighty meter

dipole, resonant at 3.75 MHz, will be used as reference. Its characteristics will be described as a simple series circuit with R being the antenna resistance at resonance. The antenna inductive reactance will be shown as X_L , and the capacitive reactance will be shown as X_C .

2. It will be assumed that the antenna resonant resistance will stay the same over the entire band. It does vary to some degree, but this assumption is quite common in simplified antenna analysis.

3. The swr values will be shown for the band-end condition of 3.5 MHz. The values of swr at 4.0 MHz, if calculated, would be found to be slightly lower, but this in no way invalidates the aim of understanding concepts.

4. Q is designated as antenna inductive reactance divided by antenna resistance at the resonant frequency, which, as I said, was chosen to be 3.75 MHz.

5. A feedline impedance of fifty Ohms will be used for

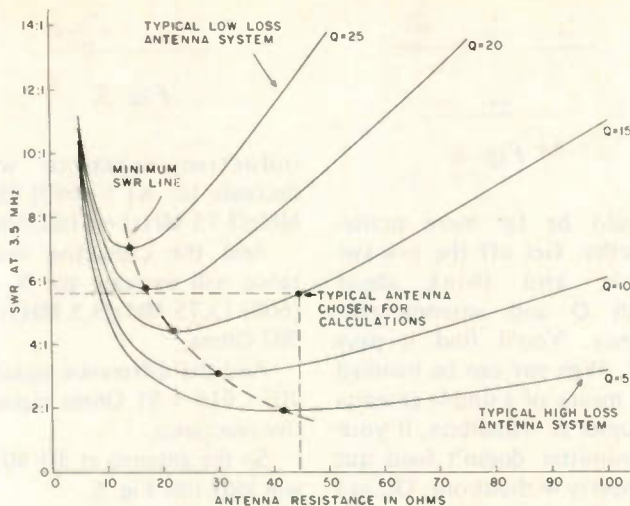

Fig. 1.

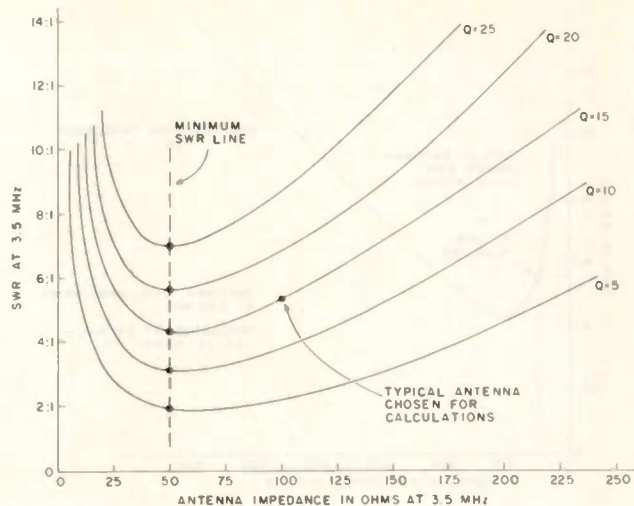

Fig. 2.

the Q curves, Q equals 5 to Q equals 25, shown. Fifty Ohms was chosen, as that is the value of feedline impedance used by most amateurs. However, an additional curve will be shown for a specific stipulated antenna to show how swr can vary with feedline impedance for a given aerial. The specific antenna will be the same as the one chosen for the calculations, namely one of 44 Ohms resistance with a Q of 15, which means an antenna with a resistance of 44 Ohms and a capacitive reactance of 91 Ohms at 3.5 MHz. By using a specific antenna with numerical values, it will be very simple to show how rf bridge antenna measurements can be translated into swr and Q later on.

Losses and Swr

If you could conveniently neglect antenna losses, you would realize that a low swr antenna has several advantages. Low swr means that the loss in your feedline is a bit less for the same power transmitted at a high swr. Low antenna swr also means that it is much easier to match your transmitter which is designed for a 50-Ohm load into your 50-Ohm antenna feed system. And, if your transmitter does not have good matching capability at high swr loads, this can mean, in some cases, lowered equipment efficiency. And, also, a

high swr can cause excessive voltages and currents to be developed in your transmitter. So low swr does have advantages. But, if your low swr is obtained by a lossy antenna system, you haven't gained anything. You are actually losing some of your power to trees, bushes, roofs, or what have you. So low swr isn't always the blessing you might have thought it to be.

You know that Q in a tuned series circuit is both a figure of merit and also a function of selectivity. Also, briefly, the lower the Q, the less the selectivity. If you think of the Q of an antenna circuit, you realize that the antenna resistance is not just a loss resistance. The antenna resistance is made up of two components: a radiation resistance, which is desirable, and a loss resistance, which is undesirable. Like a tuned circuit, the lower the resistance, the higher the Q, and the higher the Q, the higher the selectivity. High selectivity means a high swr. So basically, the higher the Q, the higher the swr. And, all things being equal, the higher the Q, the less your losses, and the more efficient your antenna is. Antenna losses from outside sources are coupled into your antenna just like the resistance that can be coupled into a tuned circuit. Although complicated engineering measurements and

calculations can be used to differentiate between useful radiation resistance and useless loss resistance, such an analysis is far beyond the scope of this article. To emphasize the desirability of keeping losses down, don't worry about a high swr. It means that, if your antenna resonates properly at your center frequency, your band-end swr just shouldn't worry you. But if it's low, you had better start looking at what the causes are.

The Graphs

And now to look at what the curves tell. Fig. 1 is a plot of antenna resistance versus swr for five different values of Q. The curves are shown for the band end of 3.5 MHz. One thing is immediately apparent — the lower the Q, the lower the swr, and the higher the antenna losses. You also see that, for a specific value of antenna Q, there is one value of antenna resistance that gives the lowest possible value of swr. And you also see that two different antennas both having the same value of Q can have differing values of swr. To show this point, I'll pick off some values from the Q=15 curve. At an antenna resistance of 44 Ohms, you have an swr of 5.6:1. But, if the antenna resistance drops to 21.75 Ohms, the swr drops to

4.38:1. If the antenna resistance was to drop even lower, the swr would increase.

Although the factors of Q and antenna resistance are not readily controllable in an ordinary dipole antenna, it clearly shows that differing antenna systems can show differing values of swr. In addition, you know that antenna resistance among other things is dependent upon height. This is why it is impossible to make any broad generalizations about swr. That's all the more reason it should be more thoroughly understood.

On Fig. 1, you can, as a matter of interest, connect the points of minimum swr for the various Q curves and see how minimum swr relates to Q and antenna resistance. As a further interesting item, I'll say now and later show that, at all of these points of minimum swr, the antenna impedance at the band end of 3.5 MHz is fifty Ohms. And this value of impedance is the same numerical value of the feedline which I had established as fifty Ohms as the reference. But it is very necessary to say numerical value, as you shall see, is a complex quantity made of resistance and reactance. It is only at the resonant frequency that the antenna ever looks like a pure resistance.

If, for example, you took

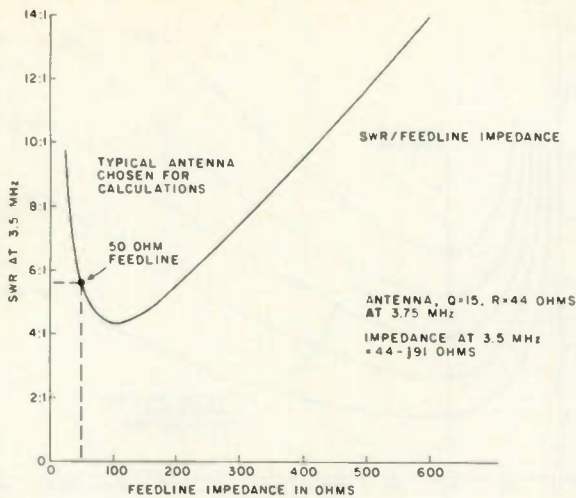

Fig. 3.

the point of minimum swr on the Q=15 curve and measured the impedance at 3.5 MHz, you would find it to be equal to R equals 21.75 Ohms and X equals 45.1 Ohms capacitive reactance. The absolute value of the impedance Z equals:

$$\sqrt{R^2 + X^2} \text{ equals } \sqrt{21.75^2 + 45.1^2}$$

equals 50 Ohms impedance. And you would find that the swr at this impedance would be 4.38:1. To show this relationship even more clearly, Table 1 indicates all of the relevant data for different values of Q. Fig. 2 shows a plot of antenna impedance Z versus swr for the Q curves.

The curves of Fig. 2 and the data of Table 1 tell that, even though the impedance is fifty Ohms for the minimum value of swr, you have to think about the resistance and reactance values rather than just the impedance Z. At the low swr, low Q, the antenna has a predominantly resistive component. At the

high Q-curve, the antenna is predominantly reactive. It also tells that, if you want to make any meaningful antenna measurements, you will need a bridge that can measure both R and X. A bridge that will only measure the absolute quantity Z can very easily lead to erroneous conclusions. But simple rf bridges to measure R and X can be easily built or obtained commercially. There is nothing more conducive to learning about antennas than making your own measurements and calculations and analyzing the results.

Conclusions

The curves themselves show the various interrelationships between Q, swr, and antenna resistance along with the concept of a minimum swr. It is now clear that a low swr on an ordinary dipole means a lossy antenna system, and also that a low swr is really not something to be proud of. A high-Q antenna

R	X	Q	swr	Z
10	48.99	35.47	9.90	50
15	47.70	23.03	6.51	50
20	45.825	16.59	4.79	50
25	43.3	12.54	3.73	50
30	40	9.65	3.00	50
35	35.71	7.38	2.45	50
40	30	5.43	2.00	50
45	21.79	3.50	1.60	50

Table 1. This table shows minimum swr values of different antennas of varying Q at the band edge of 3.5 MHz. It indicates how widely the values of X and R can vary, even though the impedance looking into the feedline antenna system is 50 Ohms (complex impedance) in each case.



Fig. 4.

Fig. 5.

would be far more praiseworthy. Get off the low swr kick, and think about high Q and antenna efficiency. You'll find it pays off. High swr can be handled by means of a simple antenna coupler or matchbox, if your transmitter doesn't load out properly without one. Or, as I mentioned, specialized antennas designed to give broadband performance, such as the parallel stub double bazooka (August, 1977, 73 Magazine), the discone, or the bow tie, can be utilized. The curve of Fig. 3 is important in that it shows the relationship of swr to feedline impedance for a specific antenna. The antenna values chosen are 44 Ohms resistance and a Q of 15. This means a band-end impedance of 44 Ohms resistance and 91 Ohms capacitive reactance at 3.5 MHz. You see that, at a feedline impedance of fifty Ohms, the swr is 5.6:1. But, if a feedline impedance of 600 Ohms is used, the swr goes up to 13.95:1. And yet the antenna is the same in both cases. This shows one other variable that can affect your swr value.

It is hoped that these observations will lead to a better understanding of why a dipole often acts as it does and also that they will encourage the experimentation that is really a fun thing in our fascinating hobby of amateur radio.

Calculations

Let's first draw a simple dipole antenna at resonance at 3.75 MHz and represent it as the series circuit of Fig. 4. If you assume a resistance of 44 Ohms and a Q of 15, it is easy to calculate the inductive and capacitive reactance in Ohms: $X_L = X_C = Q \cdot R = (15)(44) = 660$ Ohms.

Now, if you tune the antenna to 3.5 MHz, the

inductive reactance will decrease to: $X_L = (660) (3.5 \text{ MHz}/3.75 \text{ MHz}) = 616$ Ohms.

And the capacitive reactance will increase to: $X_C = (660) (3.75 \text{ MHz}/3.5 \text{ MHz}) = 707$ Ohms.

And the difference equals: $707 - 616 = 91$ Ohms capacitive reactance.

So the antenna at 3.5 MHz will look like Fig. 5.

The absolute value of antenna impedance will be equal to Z:

$$Z = \sqrt{R^2 + X^2} = \sqrt{44^2 + 91^2} = 101 \text{ Ohms.}$$

The swr is calculated from the basic equation: $\text{swr} = (|Z_a + Z_c| + |Z_a - Z_c|) / (|Z_a + Z_c| - |Z_a - Z_c|)$, where Z_a is the antenna impedance and Z_c is the feedline impedance. The notation $| |$ actually means $\sqrt{R^2 + X^2}$ as you shall see when you put actual numerical figures in. The specific value of antenna impedance will be: $Z_a = 44R$ and $91X$. I have identified the four parts of the swr equation as (1), (2), (3), and (4), as follows, to make the calculations easy: (1) $|Z_a + Z_c|$; (2) $|Z_a - Z_c|$; (3) $|Z_a + Z_c|$; and (4) $|Z_a - Z_c|$. So (1) equals $Z_a + Z_c$, and Z_c , the feedline, is $50R$. (1) of the swr equation = $|44R - 91X + 50R| = |94R - 91X|$. This equals

$$\sqrt{94^2 + 91^2} = 130.8.$$

And, also, (1) equals (3).

Now, if you put in figures for items (2) and (4) of the swr equation, you see that (2) = (4) = $|Z_a - Z_c| = |(44R - 91X) - 50R| = |-6R - 91X|$. Evaluating, you see that this equals $\sqrt{6^2 + 91^2}$, which equals $91.2 = (2) = (4)$.

Now, putting (1), (2), (3), and (4) in the swr equation together, you see that $\text{swr} = [(1) + (2)] / [(3) - (4)] = (130.8 + 91.2) / (130.8 - 91.2) = 222/39.6 = \text{swr} = 5.6$ at 3.5 MHz.

So you see that it really isn't difficult to calculate swr if you know the resistance

and reactance of your antenna at 3.5 MHz and know what your feedline impedance is.

The only remaining thing to do is to show how you can calculate the antenna Q. To simplify things, you will have supposedly measured the antenna resistance as 44 Ohms and its reactance as 91 Ohms at 3.5 MHz. By means of the easily derived equation below, you can, with this information, determine the reactance of the antenna at

resonance. The equation is as follows: X_1 at 3.75 MHz = $[(X_{3.5}) (3.5 \text{ MHz}) (3.75 \text{ MHz})] / [(3.75 \text{ MHz} + 3.5 \text{ MHz}) (3.75 \text{ MHz} - 3.5 \text{ MHz})]$.

So X_1 at resonance = $(91) (3.5) (3.75) / (7.25) (.25) = 660 \text{ Ohms}$.

Knowing that, $Q = X_1/R = 660/44 = 15 = \text{antenna } Q$.

So you see that, with the information given, it will be readily simple to calculate swr and antenna Q if you know the measured values of

R and X.

This article has not taken into account line losses, as this would perhaps complicate the general approach desired. But briefly, line losses will decrease both swr and Q values calculated. It is realized that some of the calculations can be done by means of Smith charts. However, as simple hand calculators are almost in common use by all amateurs, I felt that the approach used here would show how to actually do

calculations, instead of teaching the specialized approach of the Smith charts. And, lastly, very few amateurs actually have Smith charts in their possession. As the calculations are of value only to those amateurs who have rf bridges, I felt that the general approach would give the most information to most amateurs reading this article. Math is only essential for those who actually are going to use it. It is not necessary to understand general principles. ■

New Products

from page 63

vehicle and mounting location. VSWR is 1.5:1 or less.

The antennas feature 32" whips made of permanent set, impact resistant 17-7PH stainless steel. High-quality 17' coaxial cables with matching transformers and PL-259 connectors are used to ensure dependable performance. All antenna connections are solderless. In-line cable connectors are provided on AM/FM models for easier installation and routing through openings as small as 3/8".

For further information on the new Mobile Disguise Antennas for land mobile applications, contact *Antenna Incorporated, 26301 Richmond Road, Cleveland OH 44146; (216)464-7075*.

INTEGRATED CW MESSAGE MEMORY MATCHES 8043/4 KEYERS

A one-chip message memory control IC has been introduced by Curtis Electro Devices. Called the 8047, this 28-pin CMOS device requires only a 2102 (1K x 1 RAM) or equivalent memory IC plus an 8043/8044 or equivalent keyer to provide a program set of four 32-character CW messages. Features include variable pause repeat and automatic "end-of-message" reset.

A unique "instant-start" (non-freerunning) message load system allows easy and accurate message insertion with complete freedom of "pause" and "stop" placement. Additional 2102s can be added for almost unlimited memory storage (message length or quantity).

The 8047 operates from 5 V

dc and draws less than 10 mA of current. It is priced at \$39.95 in quantities of one. An 8047-1 kit, containing the 8047, sockets, PCB, 2102 memory, and manual, is priced at \$69.95.

For additional information, contact *Curtis Electro Devices, Inc., Box 4090, Mountain View CA 94040; (415)964-3136*.

NEW BUDGET-PRICED POWER SUPPLY FROM STACO

Staco, Incorporated, of Dayton, Ohio, a manufacturer of variable ac voltage controls and dc power supplies for mobile electronic equipment, announces the introduction of a new budget-priced filtered power supply.

Staco's Model FPS-4 Filtered Power Supply provides an economical answer for operating CB radios, stereos, tape decks, and other automotive equipment in the home, shop, or office.

The Model FPS-4 operates on a 120 volt ac, 60 Hz input, and provides 12-volt dc output at 5.5 Amps surge, 4 Amp continuous duty.

The Model FPS-4 features automatic overload and short-circuit protection. The ventilated steel housing is clad with black and white vinyl. Bottom pads are also vinyl covered to prevent scratches or mars on furniture.

Each unit is complete with input power cord, on-off switch, pilot light, and operating instructions. A terminal board on the rear of the unit provides easy-to-make output connections. The Staco Model FPS-4 is backed by a 90-Day Limited Warranty. For more information, contact *Staco, Incorporated, 301 Gaddis Boulevard, Dayton OH 45403*.

NEW VIZ RELAY-PROTECTED 100,000Ω/V VOM IS HALF THE PRICE OF COMPETITIVE UNITS

VIZ Test Instruments Group of VIZ Mfg. Co. has added a new high-quality, moderately-priced VOM to its line of electronic test instruments.

The WV-520B general pur-

Continued on page 73

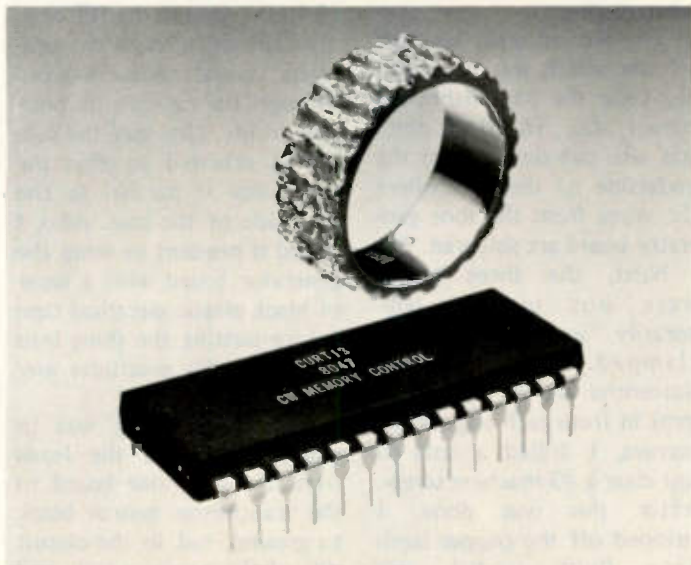

The Curtis 8047 CW message memory.



Staco's FPS-4 power supply.

When In Doubt, Improvise!

—adding TT convenience to your HT-144B

After being bitten by the 2m FM bug, I decided the only antidote was to go as inexpensively as possible on the 2m band.

I purchased an HT-144B from VHF Engineering and

spent one weekend assembling the kit. The instructions were very explicit and clear. Except for one error (cockpit trouble), the unit performed very well.

Then, of course, the inevitable followed: I *had* to have a telephone touchtone™ pad. After considering a number of possibilities, I finally settled on a unit from Data Signal. The unit was their SME style "C" model with 12 characters.

This unit uses a tactile plastic pad and is very thin. (In fact, it looked so fragile, I considered returning it, as it had no mounting bezel. After writing Data Signal and learning that they wanted a 10% restocking charge, I decided to keep it. I was assured by them that, in spite of its appearance, it was very durable and reliable.)

I tried to use acoustic coupling in my first attempt, but there was considerable distortion present both on the air and on the scope. Rather than rebuild the acoustic coupler (after all, I did want to use the thing before old age set in), I decided to mount the pad directly on the HT-144B.

The instruction sheet accompanying the SME pad

suggested mounting it with double-backed polyfoam tape. Being of a more conservative nature, I decided to make a bezel for it and attach it with screws. Besides, I decided, a bezel would make it look more professional and finished.

The bezel I made was laminated from three pieces of one-sixteenth-inch-thick-copper, one-side-glass epoxy board. I fashioned the top layer with twelve cutouts to frame the characters on the pad. This included beveling and rounding the inside edges of each cutout for better appearance and finger comfort when dialing.

The second layer was just a frame which was cut out to just clear the pad within the cutout area. The third piece was also cut out to clear the underside of the pad where the wires from the tone generator board are soldered.

Next, the three pieces were put together temporarily in sequence and clamped. About three-sixteenths of an inch (1.5 mm) in from each edge at the corners, I drilled a hole to just clear a #3 machine screw. After this was done, I stripped off the copper laminate, finish sanded, and cleaned the whole assembly

with lacquer thinner. Then I sprayed the front layer and all edges with a flat fast-drying lacquer. (A word of caution here: Clean the unit and spray only in a well-ventilated area, preferably out-of-doors. If you have a packing box that makes a good spray booth, you will avoid the spray getting on unprotected surfaces.) The unit was then disassembled and the pad was placed in the "sandwich." This was re-assembled, and all was ready for mounting on the HT.

I chose to wire the generator board to the tactile pad before installing the unit on the HT-144B to facilitate assembly.

The next problem was determining just exactly where there was sufficient clearance for the wiring and generator board inside the HT. After pondering and making a few dry runs, I found I could readily mount the pad just below the speaker and the fastening screws for the HT-144B circuit board. A close inspection revealed that the generator board would snuggle up partially between the HT-144B circuit board and the case with a small amount protruding into the battery area. With this in mind and using the bezel for a pattern, I drilled the holes to mount the assembly; then I made a cutout 1.1 inches (2.8 cm) long and 0.93 inch (2.4 cm) wide in the HT case. This cutout allowed the generator board to be worked through the case to its position inside. (Be sure the cutout is oriented so that the short side is parallel to the long side of the case. Also, I found it prudent to wrap the generator board with a layer of black plastic electrical tape before putting the thing into the unit; this precludes any short circuits.)

After everything was in place, I soldered the leads from the generator board to the transmitter board: black to ground, red to the circuit side of the power switch, and green to the point where the

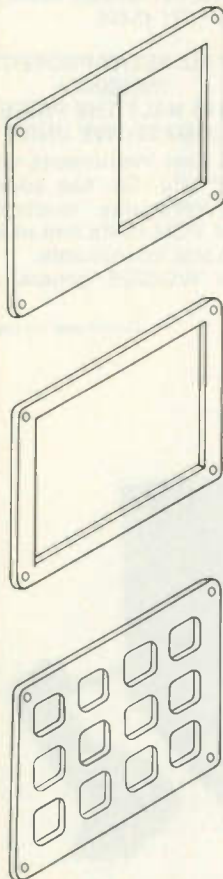

Fig. 1. Exploded view of bezel assembly.

speaker lead runs to the audio IC input coupling capacitor. (In this rig, the speaker doubles as the mike.)

I attempted to dial up the repeater, but it refused to cooperate. Well, old-timers make mistakes, too. Mine was that, since the speaker had only eight Ohms to ground, the impedance was too low for the pad output, and the pad was effectively grounded.

That was the last problem to solve and, since I needed a quick solution, I decided on a

mechanical switch.

Now, it just so happened that the good people at S.D. Sales in Dallas had included as a premium with a recent order to me a quantity of miniature SPDT slide switches. They were perfect for the job, so I used one. I drilled mounting holes and made the cutout for the button just above and centered on the dialing pad. Be careful to make sure you bend the lugs of the switch down a bit. If you don't, there's a chance

they will short against the assembly inside.

After all the parts were mounted, I removed the speaker lead and the generator board lead from the transmitter board and soldered them to opposite poles of the switch. The common lug of the switch was connected to the audio input coupling capacitor, the point from which the speaker lead had been removed. Then everything was replaced in the HT case.

This lash-up works well, and the only inconvenience is moving the switch from the "listen" position to the "dial" position the three times necessary to use the pad. (I say three times because I always dial up the repeater, switch back to make sure I have a dial tone, switch to "dial," dial the number, and then switch back to "listen.")

Now, if someone will only come up with a logic switch for this application . . . ■

New Products

from page 71

pose 100,000Ω/V dc VOM is fuse- and relay-protected against overload on all ranges and functions. It employs a high-quality, easy-to-read taut-band meter movement with color-coded scales and mirror, and precision resistors are used throughout for long-term stability and accuracy. Its price is \$68.00.

The instrument measures dc voltages as low as 1 mV, and up to 1,000 V in eight ranges; ac (rms) from 100 mV to 1,000 V in five ranges; dc current from 0.1 uA to 10 A in seven ranges; resistance from 0.25Ω to 20 megohms in four ranges; and decibels from -20 to +36 dB. It has a special jack that can be used to measure ac current from 0-10 A, and a polarity switch to permit dc measure-

ments without reversing test lead connections.

A push-button on the front panel permits rapid reset of the protective relay should the meter be accidentally overloaded.

The VOM's dc voltage, ac voltage, and dc current accuracy is ±3% full-scale. Its rugged light blue ABS plastic case measures 6-5/8" (17 cm) x 5" (12.6 cm) x 2-3/4" (7 cm), and it weighs 1.5 lb (0.69 kg). It is supplied with two test leads, a spare fuse, and an operating manual.

For further information, contact Robert Liska, VIZ Test Instruments Group, 335 E. Price Street, Philadelphia PA 19144; (215)-844-2626.

EICO ADDS NEW MODEL 4A4 MULTIMETER TO TRUVOHM LINE

EICO Electronic Instrument Co., Inc., is adding a new multimeter, Model 4A4, to its TruvoHm® line of low-cost, high-quality factory-assembled VOMs.

The new multimeter is a 4000

Ohms/volt general-purpose instrument with 17 ranges. The meter measures up to 1000 volts dc and ac, up to 250 mA dc and up to 2 megohms resistance. Accuracy is ±3 percent on dc and ±4 percent on ac. It features a recessed selector switch and an easy-to-read 3-inch meter with mirror-back scale. The movement is diode-protected. A high-impact plastic case is used; it measures 5" by 3½" by 1-7/16". Suggested price of the new Model 4A4 is only \$17.95, assembled and complete with batteries and test leads.

The EICO TruvoHm line includes a highly sensitive 100k Ohms/volt bench-size multimeter and a clamp-on ac current tester. The line also includes seven other instruments ranging from a simple, inexpensive 1000 Ohms/volt meter to a 20,000 Ohms/volt mirrored-scale meter.

For further details, contact EICO Electronic Instrument Co., Inc., 108 New South Road, Hicksville NY 11801; (516)-681-9300.



VIZ's relay-protected VOM.

Ham Help

I am in need of information on adding AM phone capability to a Heath SB-102 transceiver.

David Unkles WA2UIS
Box 212
Mendham NJ 07945

Being a subscriber to your magazine for five years, I feel disappointed in not being able to find any articles on how to build beam antennas for 35, 155, and 454 MHz. I am a monitor buff and would like to increase my listening range, but futile trips to local electronic houses have not produced one magazine that lists charts to build or modify existing products. The *VHF Handbook* only lists amateur beams,

with no conversion to go higher or lower. Those commercial beams are out of sight, so perhaps you or one of your readers could supply this info. I would be eternally grateful.

John P. Snyder, Jr.
355 Lackawanna B-8
Reading PA 19601

I have an ASR-32 machine. Could anyone help me find the local loop and convert the machine to operate a TU unit?

I am just getting into RTTY. Any information would be greatly appreciated. Thank you.

Joseph Schwartz K2VGV
43-34 Union Street
Flushing NY 11355

Relief for the Rockbound

— continuous tuning for FM rigs

John F. Sehring WB2EQG
PO Box 306
Oradell NJ 07649

Since tuning the bands has always been a favorite amateur pastime, having your 2 meter FM receiving capabilities "rockbound" can be a frustrating experience. Crystals for each channel would be too costly (not to say impractical), and synthesizers are nice, but costly. "Rolling your own" tunable front end for 2 meters would be a challenge, but...

Presented here is a simple

modification to add continuous 2 meter receive tuning to FM transceivers (or receivers) presently using crystal control for receive. It is adaptable to most FM equipment, whether tubed or solid state, wide or narrow band, just as long as the unit has a 10.7 MHz i-f frequency at some point in its signal-processing chain. Depending on the particular model involved, this modification may require few or no changes in the existing circuitry and will not alter crystal-control or squelch functions.

A Heathkit GR-98 VHF

AM monitor receiver, picked up cheaply at a swap session, will provide the necessary parts for this project. It is solid state with 108 to 136 MHz coverage (in its original form), has a 10.7 MHz AM i-f strip, and has a completely separate shielded tuner, 6:1 vernier, and tuning dial. This tuner uses bipolar devices with tuned rf, mixer, and oscillator stages and has a low-impedance 10.7 MHz output. See Fig. 2 for a GR-88 schematic (similar to the GR-98).

Now, the plan of attack is

to modify the tuner to cover 2 meters (with full bandwidth), remove it from the donor GR-98 receiver, and use it to inject a 10.7 MHz signal into a suitable point of the transceiver's i-f strip. Thus, the original input frequency of the transceiver is not relevant — just be sure that its i-f frequency is 10.7 MHz (or close to it), as you will be bypassing its original front end. See Fig. 1.

If the GR-98 donor receiver is working at all, it would be easiest to modify the tuner to cover 2 meters before removing it. In case the donor receiver is not working, the following re-tuning may be done after the tuner is electrically connected to the transceiver. To get the tuner on 2 meters, back off on the tuner's rf, mixer, and oscillator padder capacitors and inductors, T101 and C102 (rf), L101 and C109 (mixer), and L102 and C112 (oscillator). See Fig. 3. A signal source would be helpful, but on-the-air signals will do for rough calibration. To bandwidth 145 to 148 MHz over the entire range of the tuning capacitor, remove all but the end rotor plate from each of the three sections of the variable tuning capacitor. Then, readjust the oscillator

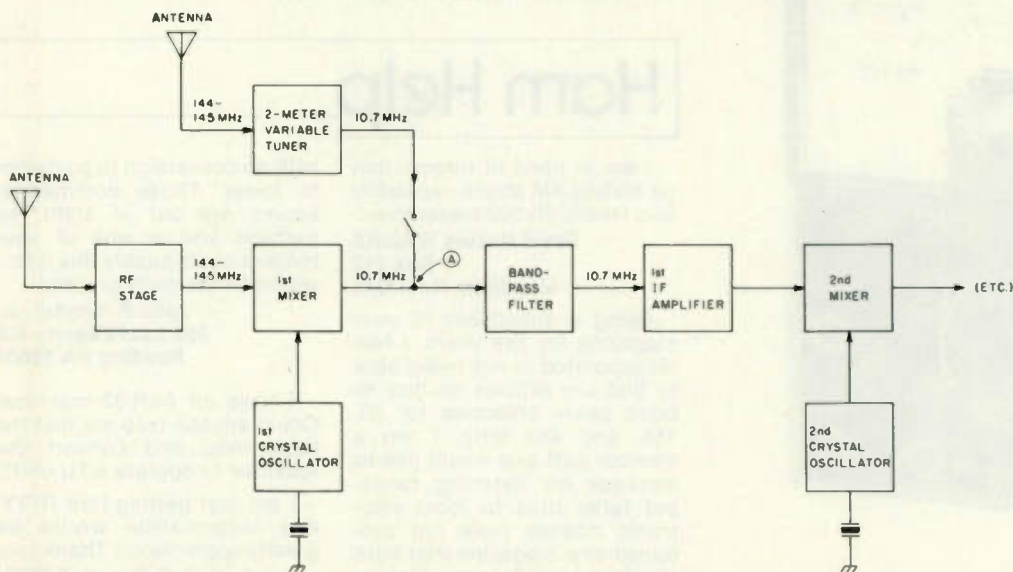

Fig. 1. Block diagram. Typical crystal-control double-conversion FM receiver strip.

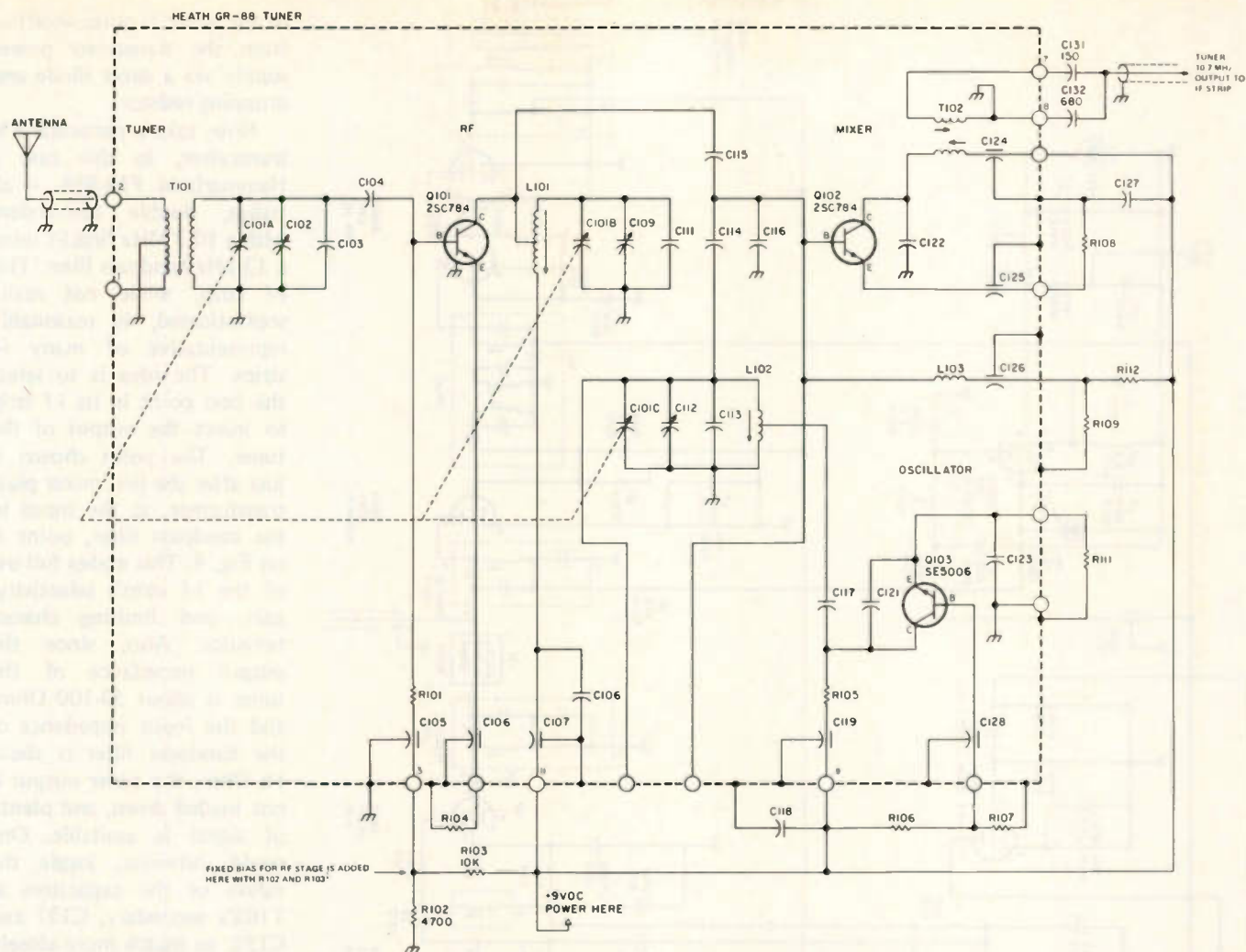

Fig. 2. Schematic of GR-88 tuner. All resistors and capacitors shown outside of the dotted line and without a value are included with the basic tuner package. *Instead of R102 and R103, a 10k pot could be a sensitivity control.

with L102 at the low end and C112 at the high end of the band for the exact band-spread you desire. Next, alternately trim T101 and L101 (rf and mixer stages) at the low end of the band and trim C102 and C109 (rf and mixer stages) at the high end of the band until the rf and mixer stages track with the oscillator as well as possible. You may want to knife the rotor plates slightly to obtain even better tracking, but do it

carefully — the rotor plates are quite fragile. It's worth the effort to perform these adjustments carefully to achieve best cross-modulation rejection and sensitivity.

To get the tuner operating with the new transceiver, a few simple things need to be done. First, this tuner, being part of an AM receiver, gets agc voltage from its associated AM i-f strip. For FM service, the rf stage should be run at fixed high gain to

insure adequate sensitivity and limiting in subsequent stages. Fig. 2 shows how fixed bias can be added using only two resistors, R102 and

R103, at point 3. A coaxial antenna connection is made at point 1 or 2. Then install a short piece of low-impedance coaxial cable from the tuner

Parts List		
Description	Heath part number	Approximate price
Tuner for GR-98 (108-132 MHz)	110-52	\$25.00
6:1 vernier	100-863	\$ 2.80
Tuning dial	464-57	\$.70
Tuning knob	462-230	\$ 1.90
Tuner mounting bracket (need 2)	204-955	\$.65 each

Available from: Heath Company, Parts Department, Benton Harbor MI 49022, or local Heath retail outlets may have some of these parts and/or can order them for you.

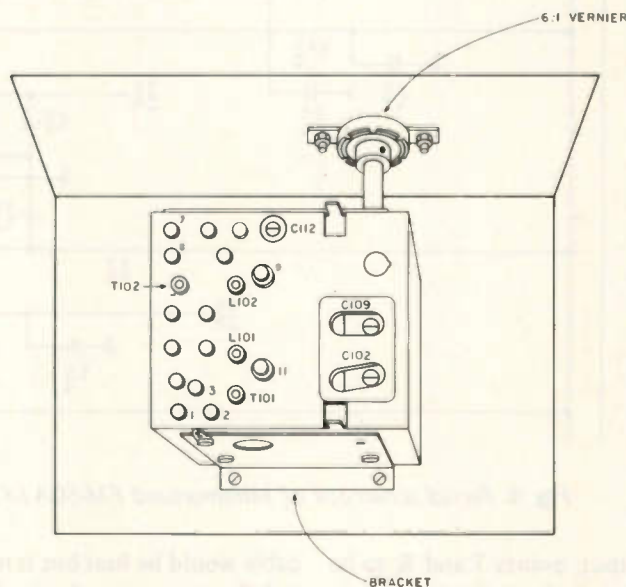

Fig. 3. Plan view of GR-88 tuner.

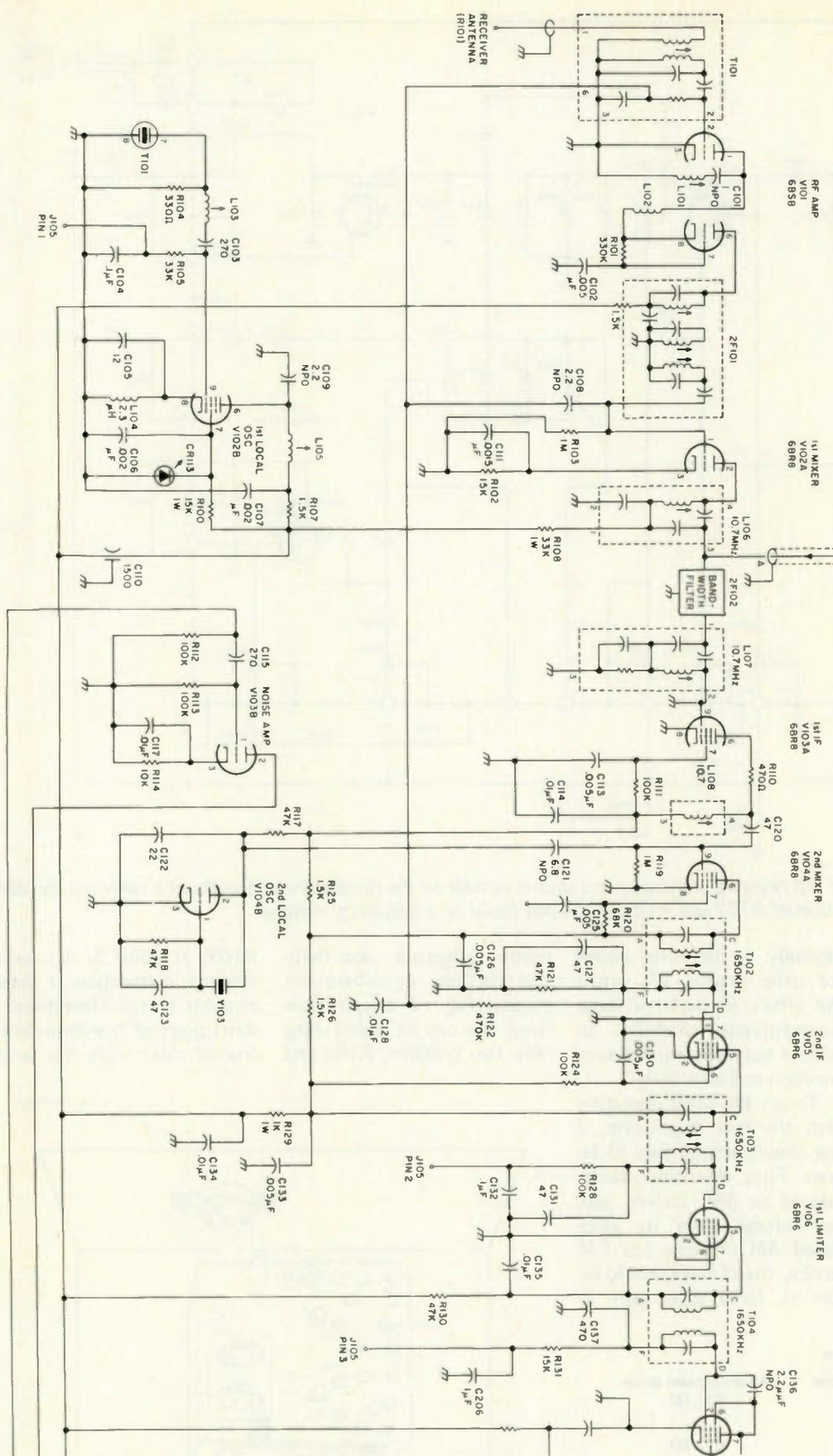

Fig. 4. Partial schematic of Hammarlund FM-50A i-f strip showing injection point.

output, points 7 and 8, to be connected to the transceiver i-f strip. Low-capacitance

cable would be best but is not strictly necessary. Last, the tuner will need +9 V dc at

point 11, as shown in Fig. 2. This voltage can be supplied from batteries (current drain

of the tuner is quite small) or from the transceiver power supply via a zener diode and dropping resistor.

Now, take a particular FM transceiver, in this case a Hammarlund FM-50A — all tubes, double conversion, with a 10.7 MHz first i-f using a 13 kHz bandpass filter. This i-f strip, while not really sophisticated, is reasonably representative of many i-f strips. The idea is to select the best point in its i-f strip to inject the output of the tuner. The point chosen is just after the first mixer plate transformer, at the input to the bandpass filter, point A on Fig. 4. This makes full use of the i-f strip's selectivity, gain, and limiting characteristics. Also, since the output impedance of the tuner is about 50-100 Ohms and the input impedance of the bandpass filter is about 1k Ohm, the tuner output is not loaded down, and plenty of signal is available. One could, however, juggle the values of the capacitors at T102's secondary, C131 and C132, to match more closely the input impedance of the i-f filter or strip used. If you do decide to change the capacitors, remember that the total series capacitance across T102's secondary winding must remain about the same so that T102 continues to resonate at 10.7 MHz.

If you can't find a junked or used GR-98, order the tuner from Heath; see the parts list for details. As mentioned, Heath also manufactures a virtual twin to the GR-98. It is the GR-88 VHF FM monitor receiver. The GR-88 has the same kind of tuner as the GR-98, except for a frequency coverage of 152 to 174 MHz, and has an FM i-f strip. Using the GR-88 tuner might be a satisfactory alternate choice. To cover 2 meters, though, it would be working at the low end of the tuning range instead of the upper end, as with the GR-98 tuner. The conversion would be the same with one exception: After pulling the

variable capacitor rotor plates to achieve enough bandwidth, there would not be enough total circuit capacitance in the rf, mixer, and oscillator stages to tune down to 2 meters. Therefore, extra fixed disc ceramic capacitors would have to be added across C103 (rf), C111 (mixer), and C113 (oscillator) to provide more capacitance.

Some final notes: As with any oscillator running at 136 MHz, mechanical rigidity and

power supply stability are important for ease of tuning and low drift. I used the matching 6:1 vernier, tuning dial, and brackets that came with the GR-98. It all fits together well and makes for smooth tuning. The tuner is small enough (about 3"W x 3"D x 2"H) to fit inside the Hammarlund case but could more easily have been externally mounted in its own case. To restore crystal receive operation in the Ham-

marlund, I simply remove the voltage from the tuner and plug the receive crystal back into its socket; something more elegant could be arranged. The tuner's output frequency may be adaptable to 11.5 MHz, but I haven't tried it.

The sensitivity of this combination is quite okay for local work, about 1 uV for 20 dB SNR. Selectivity is mostly dependent on the particular i-f strip and filter used. The

Hammarlund can easily separate three strong repeaters spaced on adjacent channels with little problem. Cross-modulation is sometimes a problem from a very local repeater (line of sight from my location). The tuner's tuned rf and mixer stages help minimize such problems, but, with bipolar devices, you can't expect perfection. No images or other spurious responses have been noted. FB QSY on 2! ■

Looking West

from page 16

SMA VS. REPEATER COUNCIL: WHAT'S THE DIFFERENCE?

Since repeaters sit in the same spot day after day, a way had to be found to keep them from interfering with one another. Out of this need was born the concept of voluntary coordination. The end result in many cases was the repeater council. By and large, most councils are political in nature and have the technical aspects of their operation delegated either to an individual or to a committee. The council itself acts as a political voice in the amateur community, letting people know what its area's FMers are doing and why. At times, the political and technical aspects of operation intersect, especially when a council is called upon to mediate a confrontation between two or more systems.

When deregulation came along, FM was suddenly set free to roam and wander like any other mode. Not that it had had any real restraints before. However, with the repeater activity centered in the upper two megahertz of two meters (with the exception of a few isolated places like California, we are addressing a 2 meter question here), very few FMers bothered to wander into the area below 146 MHz. Those who did were the ones with the multi-mode radios, and below 146, their FM operations gave way to SSB, CW, and AM for the most part. Then came deregulation and a new repeater subband from 144.5 to 145.5 MHz. FM was no longer isolated as it had been. Suddenly, it was all over the place—sometimes in places it really didn't belong. It was on top of EME contacts, or atop a DX opening to Hawaii on SSB.

Needless to say, the other spectrum users, a good number of whom had never even bothered to listen to FM above 146 MHz, were more than slightly irked. It was obvious that if the transgression were to continue unchecked, an intermode confrontation would develop. In this case, FM would lose. Solving this potential problem would require the establishment of lines of intercommunication among all spectrum users, for the purpose of working to develop the guidelines and peer pressure necessary to insure the sanctity of all modes and all spectrum users. To do this, the SCRA had to open its structure and give voting rights to all interested parties. When it did, it ceased being a "repeater only" entity. Since it was now concerned with the whole band, it had entered into total spectrum management.

Now that the foundation has been poured, the real work begins. Already, an open dialogue exists with the southern California chapter of Sidewinders On Two, and very shortly the two will begin working together on a large-scale education project aimed at all spectrum users. After all, education and cooperation are the real keys to good use of the two meter spectrum in southern California. This education project will include such things as a guide to overall operations on the band (which will be supplied to all equipment outlets), a taped QST explaining and demonstrating the operation of various modes (to be made available to area repeaters), and formalized two meter band plan (for use in all area repeater directories).

I would like to give credit to three people who are really

responsible for the turnaround. If it had not been for them, there is a good chance that what we now have might never have come into existence. First there is Herbert "Pete" Hoover III W6ZH. His speech to the SCRA that we reprinted in this column was the impetus that we needed. Thanks to him, the idea took root and began to grow.

Then there is Bob Thornburg WB6JPI. Bob is a very forward-thinking individual who believes in people. Bob cared, and

that helped make it happen.

Finally, it was Art Gentry W6MEP who sold the concept of an open organization with a broad-based voting membership. Had he not come out publicly for it, there is a good chance that it might not have sold.

Thanks in good part to these three gentlemen, the coming of a new ideal in overall spectrum development has become part of the southern California VHF environment. We are lucky to have them.

Ham Help

I need a manual or schematic for a Collins R-389/URR, 15- to 1500-kHz receiver. I also need information on the Rycom 2174A Freq. Selective Voltmeter. Also, I would like to contact people in my area who are interested in the 1575 meter band.

Larry Bearse WA1LQG
132 Christine Drive
East Hartford CT 06108

I'm looking for either the Hammarlund PRO-200 or HXQ-300 transceiver or any information on these units, i.e., manuals for copying, old ads, etc. They were built about mid-1960, could both operate on 160 through 10 meters, and were rated at 300 Watts input on SSB.

Rick Markey WB3CFG
157 Weidman St.
Lebanon PA 17042

I have been an amateur radio operator for almost thirty years. During this time, I have had an E. M. Sargent multiband receiver, Model 31, serial number 3019, in good working condition.

Does anyone know the value this receiver would have, either

historically or as an antique? I would appreciate hearing from anyone who knows something about the assessment of this receiver.

William Stradley W0BHK
8450 West Vassar Dr.
Lakewood CO 80227

I will pay for an original, or copy, of a schematic diagram for an Eldco SSB-1000 or SSB-1000F kilowatt linear amplifier. The oscilloscope in this 1958 vintage unit is not working properly, and I would like to have the schematic before attempting to repair it. Thanks for any help.

Steve Zahos WB2UNH
128 Tomcyn Dr.
Williamsville NY 14221

I need information on the Olivetti TE300 terminal. I am specifically interested in a service manual for the keyboard/printer unit, ideally with electrical information. A wiring diagram for the power supply unit would also be helpful, but I would appreciate any information. Thank you.

Charles Boelens
7311 Coronado Dr.
Burnaby, B.C.
Canada V5A 1P9

Power Supply Magic

—the forgotten voltage doubler

If you are anything like me, you have at one time or another found yourself in the middle of a very interesting IC project with a board or two full of nice easy-to-use TTL logic parts with a few discretes and the usual complement of resistors and capacitors. Everything is going just fine, and your tally sheet, on the side that you should use to keep track of power supply requirements, is showing a single 5-volt supply running up to about 2.5 Amps. You think to yourself with a smile that here is the perfect place to use that "super zapper" 12.6 volt c-t at 99 Amps transformer that you have hidden at the back of the junk box. It is a real monster with a single secondary and all kinds of reserve for future expansion to the system.

All of a sudden, here comes a subsection to your design that you could accomplish with one moderately-priced MOS/LSI chip instead of 27 TTL packages and 920 assorted resistors and capacitors. The only problem is that it requires three voltages from the power supply you have already designed with just one output—specifically, plus 5, minus 5, and minus 12. The two minus voltages are both at quite low current, such as 50 mA each.

You are now faced with the decision of how to obtain these new power requirements. There are a number of ways to go, and each has its own specific advantages and pitfalls.

The first one which might logically fall to mind would be to use a transformer with a higher output voltage and then

divide it down from this level to obtain the various outputs that you need. This approach would be fine if the higher voltages required higher current levels, but, unfortunately, this is not the case here. If you set an upper level of approximately 12 volts and then regulate it down to 5 volts for your TTL logic devices, you would have to use a series-pass transistor or other regulating scheme capable of dissipating 21 Watts for a 3-Amp supply plus a safety margin. This is fine if you want to spend the money, but I don't care to spend the money, and neither do I care to have that much heat floating around inside my otherwise very neat package. You also have to consider here that, since the two minus voltages are at very low current relative to the plus 5 current level, you are effectively wasting the capacity of half of the power transformer. In this day and age of energy conservation and awareness, this just won't do!

The next idea to arrive in the logical route of design choices is the use of a power transformer with

multiple secondary windings. Now, if you have had occasion to check the prices on this method lately, you will dismiss the thought just as quickly as I did. I am sure there are those of you out there who will jump up and say, "Why not rewind your own transformer?" This is a perfectly acceptable solution, if you are adept at this sort of thing. But, once again speaking for myself, the last time I got involved with one of these projects, after several days of fighting 9 miles of stiff and kink-prone wire, I was wishing that I could get my hands on the guy who wrote the article about "Winding Your Own Transformers For Fun and Profit."

Another method would be to just add a second transformer for the exclusive use of these two minus voltage levels. I would argue against this idea solely on the basis of the cost of the transformer and all the other miscellaneous parts necessary for this method.

As you may have guessed after reading this far, I have a design to provide all the needed levels for this project which, in my not-so-humble opinion, shoots all these other ideas full of holes. In a way, it could be considered almost something for nothing.

It is based on a circuit which will be familiar to most hams who have been around long enough to have worked with tube circuits. In this modern day and age of transistors and ICs, with their low voltages and high currents, it has fallen into disuse. I am speaking of the voltage doubler, although, when I get done with it, you might not recognize it at first glance.

I believe that, at this point, a bit of background

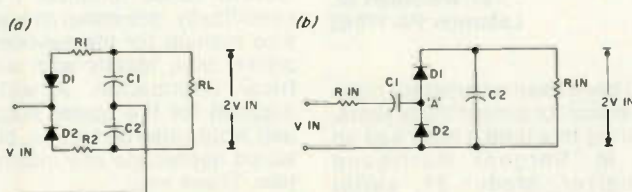

Fig. 1. (a) Conventional or full-wave doubler. (b) Cascade or half-wave doubler.

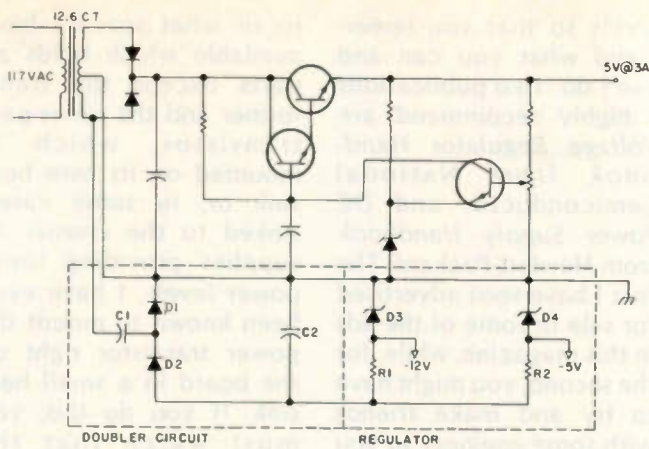

Fig. 2.

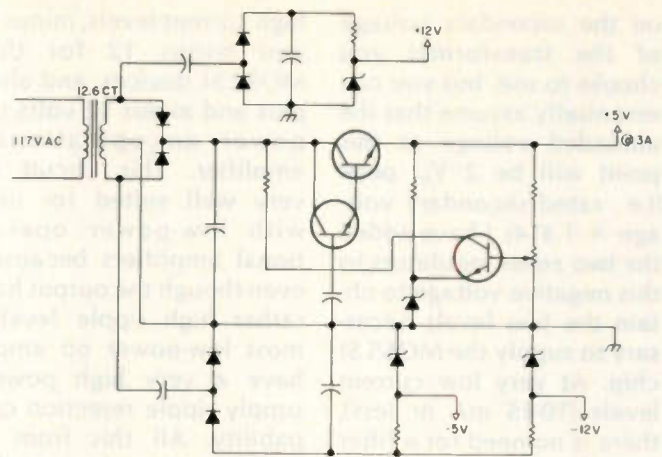

Fig. 3.

on the internal functions of the voltage doubler circuit itself would be in order.

Fig. 1 shows two common voltage doubler circuits. In Fig. 1(a) is the conventional full-wave doubler, and in Fig. 1(b) is the cascade or half-wave doubler circuit. Each of these circuits offers the same advantages or disadvantages as its namesake in the standard rectifier circuit. The full-wave doubler offers higher average output in both current and voltage, depending on the load applied to it, and requires less filtering. The half-wave circuit uses fewer parts but does require much heavier filtering to achieve a similar output.

For the needs in this application, the half-wave circuit has one major feature which dictates its use. It has a common input and output side that can be grounded for a reference to the main power supply.

To understand how a voltage doubler operates, please consider Fig. 1(b). The voltage of this supply is taken across capacitor C2, which is charged on alternate half cycles. When the input is in its negative half cycle, D2 conducts and charges capacitor C1 to the peak input voltage. On the next half cycle of input, the input signal reverses polarity

and is now in series with the voltage across C1. The voltage at point "a" is now equal to E_{in} plus V_c , or twice the peak input voltage. Diode D1 now conducts and charges capacitor C2 to this higher voltage. The output voltage of the doubler is already partially filtered, due to the presence of the charged capacitor across the output terminals. This filtering should be quite adequate for most uses for which you might consider this circuit, but there is no reason why you could not provide more filtering or even some sort of regulating circuitry. It should be mentioned that the output voltage of a voltage doubler circuit is quite load dependent and neither the full-wave nor the half-wave circuit provides much in the way of self-regulation.

There is nothing really critical in the selection of parts for use in a doubler, except that I would definitely recommend the use of very good high-quality capacitors, since they must carry the total load current continuously. I have not come across any set formulas for calculating the size of these capacitors. In the days of tube usage, it was common to use 40 to 50 μF for C1 and C2, but I have found in my development of the cir-

cuit I am about to describe that values of 220 μF have provided adequate current levels. The working voltage of the capacitors should be at least twice the input voltage. The upper 5-volt section is quite conventional, with an NPN series-pass transistor driven by another NPN transistor set up as a "differential amp." A number of articles have been written regarding this type of circuit, so I will not go into it in detail, except to say that this particular one uses a 2N3055 for the series-pass transistor, and I draw a continuous 3 Amps from it without any problems. I do, however, have a hefty heat sink mounted for the 2N3055. Proper selection of the transformer, diodes, series-pass transistor, and heat sink would allow you to draw almost any current level you might desire.

Up to this point, I have been speaking of a type of circuit which will give a positive output with respect to common line. However, at the start of this article, the problem was that I needed two negative voltages. As simple as it may seem, I can do this by taking the basic cascade or half-wave doubler circuit and reversing the polarity of everything.

The details of this procedure are shown in Fig. 2. This is the schematic of a

power supply that I have used with considerable success in a number of projects which have been custom made at my company. The upper 5-volt section is quite conventional, with an NPN series-pass transistor driven by another NPN transistor set up as a "differential amp." A number of articles have been written regarding this type of circuit, so I will not go into it in detail, except to say that this particular one uses a 2N3055 for the series-pass transistor, and I draw a continuous 3 Amps from it without any problems. I do, however, have a hefty heat sink mounted for the 2N3055. Proper selection of the transformer, diodes, series-pass transistor, and heat sink would allow you to draw almost any current level you might desire.

The lower section is the one to be more concerned with. If you will compare it to Fig. 1(b), you will see the similarity. It is the mirror image of the half-wave doubling circuit and, as a result, provides a negative output. You can connect the input to the doubler to either side of the transformer secondary, but just be sure you connect it in front of the rectifiers for the other section of the power supply. The actual voltage on the more negative end of C2 will depend

on the secondary voltage of the transformer you choose to use, but you can essentially assume that the unloaded voltage at this point will be $2 V_{in}$ peak (i.e., rated secondary voltage $\times 1.414$). I have added the two zener regulators to this negative voltage to obtain the two levels necessary to supply the MOS/LSI chip. At very low current levels (10-15 mA or less), there is no need for a filter capacitor on these regulated voltages. However, if you wish to draw more current, they would most likely be necessary. If you understood the previous explanation of the mechanics of a voltage doubler circuit, you should be able to see the workings of this circuit with very little study.

To expand on the possibilities of this type of circuit, look at Fig. 3. Here you have a power supply which provides 5 volts at

high current levels, minus 5 and minus 12 for the MOS/LSI devices, and also plus and minus 12 volts to power an operational amplifier. This circuit is very well suited for use with low-power operational amplifiers because, even though the output has rather high ripple levels, most low-power op amps have a very high power supply ripple rejection capability. All this from a transformer with a single 12.6 volt secondary. How simple and efficient can you get? To me, the word efficiency is one of the most important things to consider with this method.

Should you require higher voltages, you could easily employ higher orders of voltage multiplication as long as they have a common input and output. However, I would recommend that you spend a little time "in the books" before you attempt these

levels so that you understand what you can and can't do. Two publications I highly recommend are *Voltage Regulator Handbook* from National Semiconductor and *DC Power Supply Handbook* from Hewlett-Packard. The first I have seen advertised for sale in some of the ads in this magazine, while, for the second, you might have to try and make friends with some engineer so you could beg, borrow, or steal his copy. There may also be others among 73's publications from which you could gain further information on the subject. Many libraries have a small section on electronics, and you might be fortunate enough to find something there.

You could build this supply with almost any type of construction practice with which you are comfortable. I generally lay out a small printed circuit board

to fit what space I have available which holds all parts except the transformer and the series-pass transistor, which is mounted on its own heat sink or, in some cases, sunked to the chassis. In supplies providing lower power levels, I have even been known to mount the power transistor right on the board in a small heat sink. If you do this, you must watch that the temperature of the device will not rise high enough to damage the board itself or cause problems with some of the other parts on the PC board.

I have used this circuit or variations of it in several hundred devices manufactured by my company over the last 5 years without any problems whatsoever. Within the limitations outlined previously regarding power capabilities and ripple, the circuit will do an excellent job for you. ■

CONTESTS

from page 15

ISLs.; OZ—Denmark; SJ/SK/SL/SM—Sweden. Not all of these prefixes are geographically in Scandinavia, but they are considered so for the contest. Operating classes include: single operator, multi-operator/single xmtr, and multi-operator/multi-xmtr. Club stations, even if operated by only one operator, are in the multi-operator class. Multi-operator/multi-xmtr entries are to use separate series of serial numbers for each band. Only allband entries are allowed.

EXCHANGE:

RST and serial number starting from 001, transmitted as a five or six digit sequence.

SCORING:

European stations count 1 point for each complete QSO on any band. Non-European stations count 1 point per QSO for each complete contest QSO on 20, 15, or 10 meters, and 3 points per QSO on 80 and 40 meters. Count each call area in the above mentioned countries on each band as a multiplier, e.g., LA1 = LB1 = LJ1 and SM3 = SK3 = SL3. A portable sta-

tion in Norway or Denmark counts as the tenth call area there, e.g., W4XXX/OZ counts for OZ0 and G4XYZ/LA counts for LA0. SJ9 is the 9th call area in Sweden. OH0 is the 10th call area in Finland, and OJ0 is a separate call area. Some countries have no geographical call areas, but count as if they had. The final score is the sum of all complete QSO points from all bands multiplied by the sum of all multipliers from all bands.

AWARDS:

Certificates will be awarded to the highest scoring station in each operating class on both CW and phone in each participating country as well as in each USA call area, reasonable score provided. Depending on the number of contestants in each country, the Contest Committee will consider more certificates.

ENTRIES:

Contest logs are to be filled in in the following order: date/time in GMT, station worked, sent/received message, multiplier, and points. Separate logs for each band and CW/phone are recommended. On the summary sheet the contestant will

write his/her callsign, name, address, the final result, and the operating class, along with a signature that he/she fully agrees to the rules. The logs must not be mailed later than October 15th and should be sent to: EDR Contest Manager, Leif Ottosen OZ1LO, Bankevejen 12, Kong, 4750 Lundby, Denmark.

DELTA QSO PARTY

Starts: 1800 GMT September 23
Ends: 2400 GMT September 24

All amateurs are invited to participate in the ninth annual event sponsored by the Delta Division of the ARRL. There are no time or power restrictions. Amateurs outside of the Delta Division will attempt to contact as many amateurs inside of the Delta Division (Ark.-La.-Miss.-Tenn.) as possible. Delta Division amateurs will attempt to contact as many amateurs as possible both inside and outside of the Delta Division. Stations may be worked on each band and mode. Portables may be reworked on the same band/mode if they change counties. DX stations may be worked by Delta Division stations, but do not count as multipliers.

EXCHANGE:

QSO number, RST, and QTH: ARRL section for non-Delta

Division, county and state for Delta Division.

FREQUENCIES:

CW—3550, 7050, 14050, 21050, 28050; SSB—3990, 7290, 14290, 21390, 28590; Novice—3725, 7125, 21125, 28125.

SCORING:

Delta Division score number of QSOs times number of ARRL sections (75 max.). Outside division score number of QSOs times number of counties worked (316 max.).

AWARDS:

Delta Achievement Award to all amateurs contacting 5 different stations in each of the 4 states comprising the Division. Section award certificates to the 3 highest scoring stations in each state in the Delta Division. Fourth and fifth place awards if warranted. Section award certificates to the high scoring stations in each ARRL section and country outside of the Division. Second and third if warranted. Plaque will be awarded to the highest scoring station both inside and outside of the Division. Plaques will also be awarded to the high scoring portable and mobile stations operating in the Division. A portable or mobile station is here defined as a station operating outside of his home

Continued on page 85

HAMTRONICS USED GEAR • TEST EQUIPMENT • SPECIALS

30-DAY GUARANTEE ■ 90-DAY FULL CREDIT TRADE-IN ■ FREE SHIPPING VIA UPS ONLY

Limited quantities. First come, first served. (if weight or size exceeds UPS max., we will ship freight collect)

<p>Allied</p> <p>AX-190 Receiver \$159</p> <p>Ameco</p> <p>PV-50 \$ 9 CN-50 29 CN-144 39 TX-62 79 621 VFO 45</p> <p>B&W Waters</p> <p>Nuvertor 2+6 Conv. \$ 75 6100 SSB Xmmitter 395 670 SSB Adaptor 39 Co-Oax Keyer 95</p> <p>Central Electronics</p> <p>100V Transmitter 325 MA-2 Scope 69 20-A SSB Adaptor 79</p> <p>Clegg</p> <p>22'er FM \$129 66'er 6M Xcvr 115 99'er 6M Xcvr 59 Interceptor BRCUR 275 Ant Pre Amp 22 All Bander 125 HT-146 259 2 Vess 259 FM-27-B Xcvr 325</p> <p>Collins</p> <p>75 A4 Receiver \$395 75S3B Receiver 695 75S1 Receiver 349 KWM-2 Xcvr 595 32S1 Xmmitter 349 PM-2 AC Supply 95 516 F2 AC Supply 139 312B5 Console 425 361O2 Mount 29</p> <p>Drake</p> <p>2A Receiver \$149 2B Receiver 189 2AQ SPKR QMULT 29 R4 Receiver 289 R4-B Receiver 349 R4-C Receiver 399 MS-4 Speaker 19 2NT Transmitter 125 2NT Transmitter 99 TR-6 695</p>	<p>TR-22.2 Meter 140 T-4X Transmitter 339 TR-72.2 Meter FM 225 AC-4 AC Supply 95 TR-4 C Transceiver 449 CC-1 Console CPS-1 Supply SC-2 Conv SC-6 Conv SC-1 Calibrator The above all assembled complete pkg. Only \$200</p> <p>Dycomm</p> <p>10-0.2 M Ampli \$125 35-0 401N 110 Out 130 470-25 450 MC 120 P-1416 16 Amp Supply 95</p> <p>Eico</p> <p>720 Transmitter \$ 49 722 VFO 39 730 Modulator 39</p> <p>Eimac</p> <p>AF-67 Transmitter \$ 45 PMR-8 Receiver 79</p> <p>Genave</p> <p>GTX 22M FM \$165 GTX-200 2M FM 149</p> <p>Globe/Galaxy</p> <p>VHF 6+2 Transm \$ 39 Chief Transmitter 39 Galaxy III Xcvr 159 Galaxy V Xcvr 189 Galaxy V Mk II 239 GT-550 Xcvr 279 GT-500A Xcvr 329 AC-400 Supply 79 FM-210 2M FM 95</p> <p>Gonset</p> <p>Com II 2M \$ 75 Com II 6M 69 Com IV 2M 129 GC-105 2M 115 G-28 Xcvr 149 G-50 Xcvr 149</p> <p>Hallcrafters</p> <p>S-108 Receiver \$ 99 SX-101 Receiver 159 HT-32 Transmitter 179 HT-32B Transmitter 269 SX-99 Receiver 79 SX-115 Receiver 349</p>	<p>HT-37 Transmitter 159 HT-40 Transmitter 49 SX-99 Receiver 99 SX-117 Receiver 189 SR-150 Xcvr 259 SR-160 Xcvr 159 SX-146 Receiver 175 HT-44 Transmitter 159 SX-111 Receiver 149 SX-122 Receiver 249 S-36 UHF Receiver 125</p> <p>Hammarlund</p> <p>HQ-110 A VHF Receiver \$189 HQ-110C Receiver 119 HQ-110AC Receiver 149 HQ-145X Receiver 169 HQ-170C Receiver 159 HQ-180 Receiver 379 HQ-215 Receiver 259 SP-600 Receiver 179 HX-50 Transmitter 169</p> <p>Heathkit</p> <p>SB-300 Receiver \$199 SB-301 Receiver 229 HR-10-B Receiver 69 SB-303 Receiver 269 SB-220 Linear Amp 449 SB-102 Trivcvr 379 DX-60B Transmitter 69 HW-32 Transmitter 85 HW-100 Transceiver 249 SB-100 Transceiver 299 SB-401 Transmitter 249 SB-101 Transceiver 349 SB-650 Digital Freq. Display 149 HW-30 Twoer 29 Also Sixer 29 H-10 Monitor 69 VHF-1 Seneca 79 HW-12 Transmitter 75 HP-23 AC Supply 49 HP-23B AC Supply 59 HW-202 2M FM Xcvr 159 SB-620 Spectrum Analyz 120 SB-102 Xcvr 369 SB-610 Scope 95 HA-20 6m Linear 125 SB-634 Console 175 SB-604 Spkr 29 50 SB-644 VFO 129 50 SB-230 Linear 359 SB-104 Transceiver 625</p> <p>ICOM</p> <p>IC-21 2M FM Xcvr \$299 IC-230 Demo 369 IC-22A 2M FM Xcvr 185 IC-30A 432 MCFM 269</p>	<p>Johnson</p> <p>1-KW Matchbox/SWR \$195 Courier Linear 139 Ranger I Transmitter 85 Ranger II Transmitter 139 Vallant I Transmitter 129 Invader 2000 Xmmit 495</p> <p>Kenwood</p> <p>T-599 Transmitter \$289 R-599 Receiver 289 TS-520 Tranc 429 QR-666 299 QR-666 Receiver 239 TV-502 Transverter 179</p> <p>Knight</p> <p>T-60 Transmitter \$ 39 r-100 Receiver 59 TR-108 Trancur 2M 79</p> <p>Lafayette</p> <p>HA-800 Receiver \$ 89 HP-350 Receiver 149 HE-45 Transceiver 49</p> <p>Midland</p> <p>509 H.T. \$149</p> <p>Millen</p> <p>92200 Transmatch \$149 90651-A Grid Dipper 95</p> <p>National</p> <p>NC-270 Receiver \$119 NC-300 Receiver 129 NCX-5 Transceiver 279 GT-5MKII Transcvr 299 NC-303 Receiver 199 AC-500 AC Supply 69 NCX-500 Transceiver 199 NCX-3 Transceiver 169 NC-150 Receiver 149 NC-105 Receiver 69</p> <p>Regency</p> <p>HR-2B 2M FM \$169 HR-220 FM 220 MC 185 AR-2 2M Amplifier 85 HR-25 2M FM 225 HR-6 Meter FM 189</p> <p>SBE</p> <p>SB-34 Transceiver \$249 SB-33 Transceiver 189 SB-144 2M FM 175 SBZ-LP Linear 179</p>	<p>Standard</p> <p>SRC-146 HT \$149 826 M Trncsvr 195 SRC-144 395 SRC-851T 250</p> <p>Swan</p> <p>700-CX Xcvr \$459 260 Cygnet 289 279 Cygnet 329 500 Xcvr 299 500 CX Xcvr 389 117-XC AC Supply 95 14X DC Module 39 MK II Linear 475 K K VI 6 Meter 550 250 C 6M Xcvr 349 FM 2X2M Xcvr 249 FM-1210A 2M 269 350 Transceiver 299 350C Xcvr 339 600R Receiver 399 600T Transmitter 79 410 VFO 79</p> <p>Tempo</p> <p>Tempoone Xcvr \$299 AC One Supply 79 FMH 2M H.T. 149 CL-220 Trncur 220 MC 179 FMH 2M w/Talkie 149</p> <p>Ten Tec</p> <p>PM-3 Trnsur \$ 49 Argonaut Xcvr 199 KR-40 Keyer 79 RX-10 Receiver 49 S-30 Signalizer 29 Trilon II 479</p> <p>Yaesu</p> <p>FT-401 Xcvr \$499 FRDX 400SD Rec 325 FT-2 Auto 2M FM 249 FT-101B Xcvr 549 FL-2100B Linear 295 FV-101 VFO 79 101E Xcvr Demo 695</p>
---	---	--	---	---

Test Equipment Bargains

Boonton "Q" Meter	\$295
Tektronix 5140	249
Tektronix 545A	950
5 3/4A Plug-in wide band preamp	75
Hickok 695 Generator	69
Bendix BC221 Freq Meter	39
Polarad Spectrum Analyzers A84T	1695
Hewlett Packard 400C	75
Precision E-400 Signal Generator	125
Electro Impulse Spectrum Analyzer	395
Dyna/Sciences Model 330 Digital Multimeter	195
Hewlett Packard 4905A Ultra Sonic Detector	550
Hewlett Packard 120A Scope	250
TS-323/UR Frequency Meter	175
Hewlett Packard 4910B Open Fault Locator	650
Bird Mod 43	80
General Radio 650A	150
Measurements Mod 80	195
Nems Clark 1400	495
Ballantine 300H	175
PACO Scope Mod-S-50	75
Singer FM-10C	3495
Simpson 260 V.O.M.	49.50



ICOM IC22S
Regular \$299, save \$50; buy an ICOM IC22S for \$299 (no trades) and take a \$50 credit for another purchase.

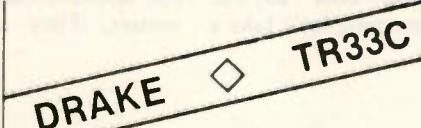

DRAKE TR33C
Regular \$229, save \$30; buy a Drake TR33C for \$229 (no trades) and take a \$30 credit for another purchase.



MIDLAND 13-510
Regular \$399, save \$50; buy a Midland 13-510 for \$399 (no trades) and take a \$50 credit for another purchase.



KENWOOD
TS820 \$ 919.00
TS80S \$1098.00



YAESU
FT101E - 799.00
FT101EE - 759.00
FT101EX - 699.00



DRAKE
TR4CW - \$799.00

MAIL & PHONE ORDERS WELCOMED. BANK AMERICARD ACCEPTED. ALL UNITS GUARANTEED

HAMTRONICS

DIVISION OF

Trevoze Electronics

4033 BROWNSVILLE ROAD
TREVOSÉ, PA. 19047
Telephone: Toll Free:
(215) 357-1400 1 800-523-8998
(215) 757-5300

DVM Scrapbook

— the basics

Gary McClellan
Box 2085
La Habra CA 90631

Quite a few people are unaware that digital voltmeters can be very useful to them, and quite a few

others think that DVMs are good for nothing but digital multimeters. I am going to do something about those notions in this article!

But before I get started showing you how to use digital voltmeters, let's take a

quick look at the advantages of the DVM, and, to be honest, a few disadvantages, too. DVMs are rapidly being incorporated into electronic equipment as replacements for conventional analog-type meters. They are far more

than "window dressing," as they give a bright unambiguous reading that is hard to ignore. This feature makes them great in places where the public has to read them. Have you seen a digital gas pump or cash register yet? And DVMs will be seen in even more places as prices decrease. DVMs (and many other digital instruments for that matter) do have one serious disadvantage: It is hard to spot trends by the readout. By this I mean that, supposing you are monitoring the level of a slowly emptying water tank, watching the slowly changing readout is hard. But science has come to the rescue with analog bar graph displays that solve that problem!

Let's take a quick look inside a typical digital voltmeter, for example, the Gary McClellan and Co. model 101 DVM kit. Actually, this kit is for a digital panel meter, or DPM for short. DPMs are the building blocks of modern

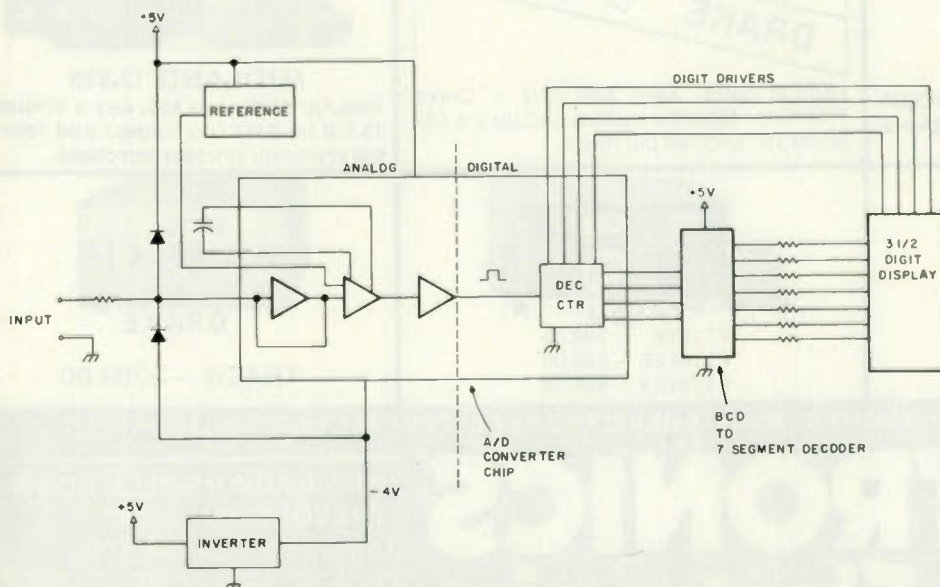

Fig. 1. Block diagram of the model 101 DVM kit. This is a typical modern DVM circuit. The A/D converter is a Motorola MC-14433 IC chip. Only the basics are shown here.

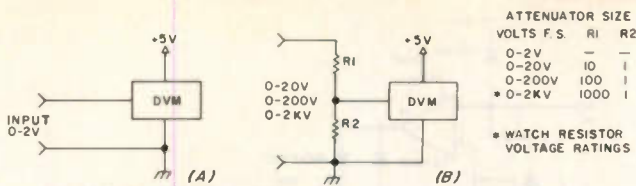

Fig. 2. DVM hookup schemes. A shows the direct connection for a 0-1.999 voltmeter (0-2 volts, for short). B shows some basic attenuators for higher voltages.

equipment, and they usually replace analog meters directly with only a source of power needed to run the unit. The model 101 is shown in the block diagram of Fig. 1. As you can see, this digital voltmeter is a marriage of analog circuitry and digital circuitry. This is true of all digital voltmeters. This unit has the bulk of the circuitry on a single IC chip, and that makes a difference. In fact, this unit has only two other IC chips — one drives the display, and the other acts as an inverter, changing the 5-volt power into minus 4 volts for the internal op amps on the DVM chip.

This DVM kit uses the dual slope method of converting an analog signal into a digital one. This is the standard method of signal conversion, and, since it features high accuracy at low cost, it is used everywhere. Basic operation is something like this: The first step is for all op amps to be zeroed and the digital counter section (which drives the display) reset. Then any positive input voltage (the one you want to measure) is compared with the reference voltage (did you notice the reference block in Fig. 1?), and the ratio of these two voltages is converted into a stream of digital pulses. The pulses are counted up and displayed as voltage. Next, any negative voltage you may apply is compared to the reference; then the ratio is counted and displayed as voltage, like before. In the final step, everything is zeroed out and the process repeats itself. These steps are controlled by a built-in digital timer, a necessary feature of the dual

slope voltmeter. I've left out a lot of the theory to keep this section painless, but you should have an idea of how the dual slope system works in its basic form.

The quickest and easiest use for DVMs is as a simple dc voltmeter. Fig. 2 shows a typical hookup. If you are like most people, you will want to measure more than the 0 to 2 volt scales these meters measure, so you will need an attenuator as shown. You can use precision resistors for the values shown; Radio Shack and others have offered a resistor pack that will give close values (hopefully). Anyhow, it's worth looking into. If you don't need the 10-meg input impedance of the divider shown, you can use other values of resistors. Let's assume that you are measuring the output of a 0 to 20-volt power supply. Just pick two resistor values that come close to make the 10 to 1 voltage divider you need. You can probably use something like 166k for R1 and 16k for R2 with no problem. The calibration control on the meter will adjust for this. In fact, I did just this trick in the power supply featured in the original MC-1405 DVM article and it worked like a charm! The only real restrictions you should worry about are that the resistors must be precision wire-wound or film type and you must not use values so low that you load down the circuitry you measure.

Another use for a dc voltmeter is in communications gear. How about a digital plate voltage meter? Or how about a digital circuit checker in a communications rack

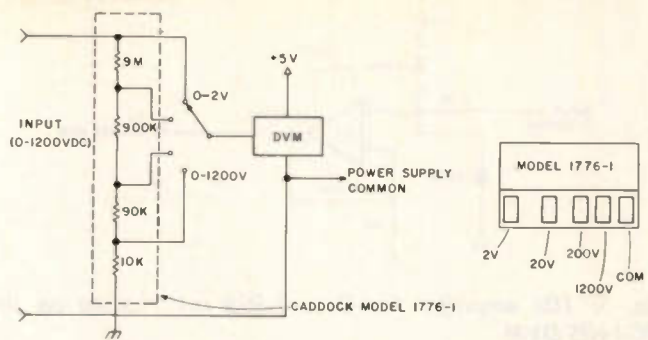

Fig. 3. A full-blown attenuator scheme, like those used in commercial digital multimeters. Note that the ranges are 0-2 volts, 0-20 volts, 0-200 volts, and 0-1200 volts.

(say a 2 meter repeater)? Perhaps someday soon all quality communications gear will have some sort of circuit tester built in. Wait and see! If you wish to build that classy digital plate voltage meter, the job is pretty simple. Find out what voltages you will be measuring and plan the attenuator accordingly. Suppose you want to measure 1 kV full scale in your linear. That means you must provide 1,000 volt or so to the meter. You need an attenuator of 1000 to 1, of course, and Fig. 2 shows some suggested values. Some important tips: For safety, always run the meter common at chassis ground potential. This will mean safer operation for the meter. If its power supply transformer arced to ground, the DVM could be damaged. Also, use several high-value precision resistors in series; many precisions have 500-volt ratings. Of course, you will have an easier time finding lower values to put in series. After you install the meter, you may want to add a switch so you can measure other voltages. The amplifier

bias voltages are good candidates; just select an appropriate R1 for your application. Note: The MC-1405 DVM will not measure negative voltages, so keep this in mind if you build this DVM.

Moving along further, you might want a multiple-range dc digital voltmeter for the lab. Fig. 3 shows how to do it. The easiest and best way I have found to tackle a multi-range attenuator is to buy a commercial resistor network. You get all the tough-to-get resistor values in a single package, and it's ready to go — just add a switch! The attenuator shown in Fig. 3 will measure 0-2 volts, 0-20 volts, 0-200 volts, and 0-1200 volts. The reason the top range is 1200 volts and not 2000 volts is due to the voltage limitations of the resistor. This part is made by Caddock Electronics¹ and the part number is 1776-1. You can also get it from me, as well as a switch, for \$12.95 plus \$1.50 postage and handling. Since this price is about the same as theirs (\$12.00), you can get both parts and save money. Or, if you prefer, you

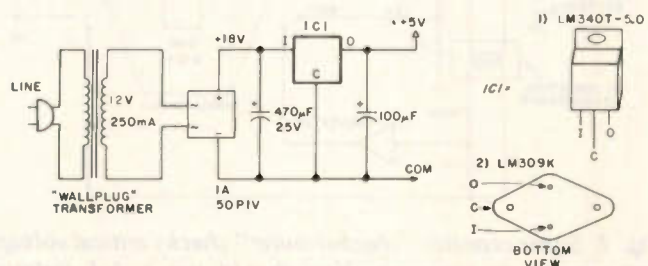

Fig. 4. Simple DVM power supply for model 101 DVM. See text for MC-1405 power supply.

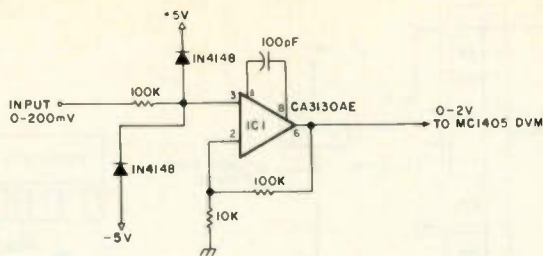

Fig. 5. 10x amplifier for 0 to 1.999 mV reading on the MC-1405 DVM.

can get 0.1% resistors in the values shown from Mepco-Electra and others.

Here are a few other uses for a dc voltmeter: Why not attach a permanent magnet dc motor and make a digital tachometer? Or rig up a photocell pickup for a more accurate noncontact tach. How about a simple digital thermometer? These DVMs will read the output of a thermocouple directly on a 200 mV input range. You can check circuitry for destructive "hot spots," check heat sinks, appliances around the home, and much more. Now surely you can think up more uses than that!

A few words about powering your voltmeter! Always use a separate power supply to run it. The one shown in Fig. 4 will do nicely. Don't be tempted to tap power from the circuit you are going to measure; the DVM may inject noise back into the supply through the power leads. I

even used a separate source of power on my Heath lab supply. It paid off in a quite dc output. Look for an extra transformer winding in your equipment of at least 6 volts or more at around 100 mA. If you have one (the Heath supply did), you can eliminate the expensive power transformer shown in Fig. 4.

After you have the meter running, calibration is in order. Simply measure the high voltage, power supply output, or whatever with a digital multimeter of known accuracy. Then adjust the pot in the 101 DVM until the readings jibe. If you built the MC-1405 DVM, the procedure is the same, but you must zero it before you adjust the calibration. Do this with zero output voltage from the equipment your meter is built into, tweak the zero adjust, and apply power. Adjust the MC-1405 calibration pot until both meters agree, and you are all set.

These two DVMs have the potential for being far more

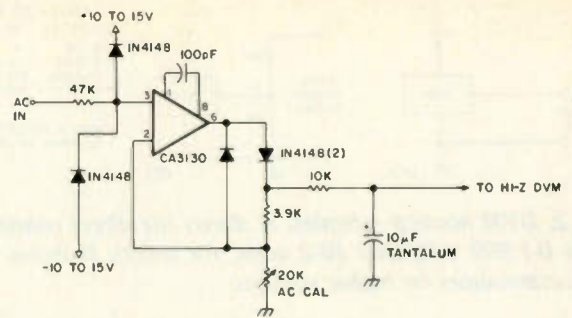

Fig. 6. Simple high-quality ac converter. Circuit from Motorola MC-14433 application notes.

accurate (like about $\pm 0.03\%$ typical short term) on a single range than many low-cost digital multimeters around, so get the best meter you can find to do your calibration. By "low cost," I mean the \$89.95, 3-digit, 1% accurate TV service-type digital multimeters.

If you would like a 0 to 199.9 mV scale on your DVM for measuring gadgets like thermocouples and the like, the conversion to these meters is easy. On the MC-1405 voltmeter, rewire the input buffer to a 10x noninverting amplifier, as shown in Fig. 5. I would suggest that, if you have the MC-1405 DVM, you use RCA CA-3130AE mini-DIP op amps in place of the LM-308s used in the original unit. The MOSFET op amps have far higher input impedances and they drop in the same socket. If you are working with the model 101 DVM, simply change R4 from 470k to 27k and recalibrate the unit for 199.9 mV full scale. This job takes only minutes.

There's another good reason for converting your meter to 0 to 199.9 mV full scale. If you plan to add current shunts, you should use this range. Why? To minimize something called "insertion loss" or, in other words, the voltage drop across the current shunt. If you lose too much voltage in the shunt, you can cause problems in the circuit you are trying to test and goof up your current readings. Play it

wise and use the 199.9 mV scale if you can.

Sometimes it is desirable to read ac volts with your basic dc-type DVM. All you need is an ac converter. Fig. 6 shows the details. You might also want to use the circuit in any digital multimeter designs you are working on, as this is a pretty good circuit. Accuracy is typically better than 0.2% at 60 Hz. Response is good from 30 Hz to over 5 kHz. To my knowledge, this is the first time anyone has published a decent ac converter circuit. This circuit converts 0 to 1.999 volts effective value ac to 0 to 1.999 volts dc. For higher voltages, use the same attenuator shown in Fig. 2. Build this circuit on a piece of ground-plane (PC with perforated copper on one side) perfboard or on a well laid out PC board. Keep all leads short and shield the input leads, as hum pickup comes easily in a circuit as high impedance as this. This ac converter is useful for current measurements, too, as it works well at low voltage levels.

So what can you do with an ac voltmeter? You can build a power line monitor. That's a rather gimmicky project, to be sure, but you could build it into a piece of equipment to check critical line voltages. You would probably want to combine other functions (such as dc volts and current) with this circuit. Fig. 7 shows the culmination of this idea. It's a complete electronic "checker-outer" for a piece of equip-

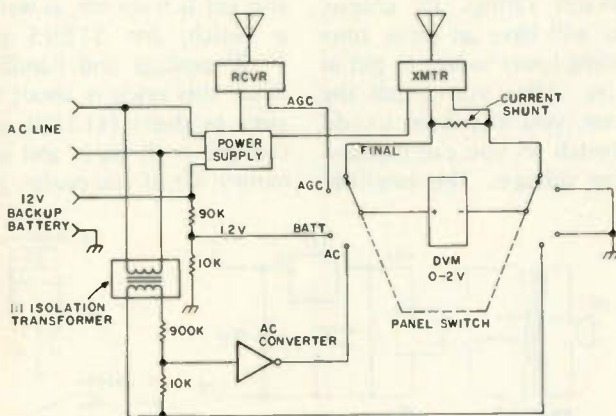

Fig. 7. Super repeater "checker-outer" checks critical voltages and current in repeaters. You should use a 1:1 isolation transformer in the front of the ac line to check the circuit for safety.

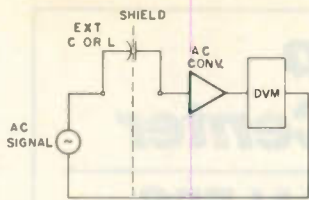

Fig. 8. Simple C or L meter. The signal source is ideally from a constant amplitude signal generator, but a filament transformer will work.

in capacitance/inductance meters. I am offering this idea as is because I haven't tried it. If you do, be sure to carefully shield ac input from the 60 Hz source, to reduce hum pickup. And try to use a stable ac signal source. A couple of op amps would work for this, and you can use frequencies such as 60 Hz and 1 kHz, which are popular in LC bridges. Fig. 8 shows the details.

ment such as a 2 meter repeater or you name it. As shown, you can check line voltage, battery backup voltage, current consumption from ac battery, agc check, and final collector current. If this tester were located in a remote repeater station, the selector switch would be remote controlled, and the readout would be converted to audio and "read out" at a distant location. Does this give anyone any ideas? How about a computer "handshake" system?

I saved the current measuring techniques for last because they can use all the stuff just mentioned. Fig. 9 shows how current is measured. Just use Ohm's Law to get the shunt(s) that you need. I didn't really have to make many comments about current measurement, but I will repeat that you should use the 199.9 mV meter range here. You can cut some slack and use the 1.999-volt range in some applications, such as with tubes, but this isn't always the case. A few comments

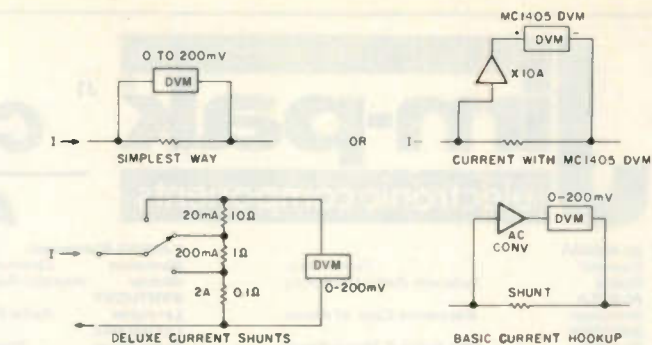

Fig. 9. Current measuring techniques.

about the resistors you use: All resistors have tempcos, or, in other words, they change resistance with temperature. So the moral is, don't heat them up. Calculate the wattage with full-scale current and use a resistor of 10x or better this value. If you wind your own resistor with wire, be careful to use very heavy wire or, better yet, resistance wire. One of the worst current shunts I ever made was a 0.1-Ohm resistor made out of #18 wire. The tempco was so bad it easily showed up on an analog

meter. Commercial resistor wire is made of nichrome or similar wire and has a better tempco.

I hope these circuits can be of use to you. Stay tuned for some more applications in nature, and perhaps more useful. If you have any questions and you write, please enclose an SASE or I'll send a ton of sales literature! ■

Reference

1. Caddock Electronics, 3127 Chicago Ave., Riverside CA 92507.

CONTESTS

from page 80

county for the purpose of operating in the Delta QSO Party. A plaque will also be awarded to the high scoring Delta Division Club station. No limit to the number of operators or transmitters; however, all QSOs must be made from the same location. The Lafayette (LA) ARC will sponsor the plaques.

ENTRIES:

Logs must include date/time, station worked, exchange, band, emission, and multiplier. Logs must be postmarked no later than October 21st to be eligible for award consideration. Logs will be returned if requested. Send logs to Malcolm P. Keown W5RUB, 213 Moonmist, Vicksburg MI 39180.

ROCKY MOUNTAIN DIVISION QSO PARTY

Contest Periods:

2000 GMT September 30 to
0600 GMT October 1
2000 GMT October 1 to
0200 GMT October 2

Call will be CQ de RM on CW or "from Rocky Mountain" on phone. Non-Rocky Mountain

stations should refrain from calling CQ! A station may be worked once per band regardless of mode.

EXCHANGE:

Non-Rocky Mountain stations send consecutive serial number and section; foreign stations send RST and serial number. In-division stations send serial number, county, and section.

FREQUENCIES:

3560, 7060, 14060, 21060, 28060, 3920, 7230, 14280, 21360, 28560.

SCORING:

SSB QSOs are one point, while CW QSOs are two points each. Out-of-division stations multiply QSO points by the number of counties. Stations within the division multiply QSO points by the sum of division counties, sections, and foreign countries worked.

AWARDS:

A certificate will be awarded to the highest scoring station in each ARRL section, provided a minimum of ten QSOs have been made, and each foreign country. Second place will be awarded where noteworthy score warrants. A certificate

will be awarded to the high scorer within each division, county, and state. County hoppers, defined as stations operating from three or more counties, are eligible for county awards and for certification as high scoring county hopper in the division. Division multi-operator stations are eligible only for certification as division high multi-operator. A plaque will be awarded to the highest scoring single operator station within the division and outside the division.

ENTRIES:

Logs must have county of operation clearly marked; county hoppers should indicate separate county totals as well as a grand total. All logs must be postmarked by October 30th and sent to: Bill Wageman, 35 San Juan, Los Alamos NM 87544 (with an SASE if contest results are desired). By entering, one agrees that all decisions of the contest committee will be accepted as final.

MISS AMERICA STATION

Station K2BR will be operating from the Miss America Pageant, Atlantic City NJ, from September 1 through 10, 1978. Approximate frequencies: CW—3555, 7055, 14055, 21055; phone—3935, 7235,

14280, 21380; Novice—3730, 7130, 21130. QSL to K2BR. Sponsor: Southern Counties Amateur Radio Association (SCARA).

THE NEW JERSEY ALL COUNTY AWARD (NJAC)

Sponsored by the Jersey Shore Amateur Radio Society, this new award is offered for working NJ counties on any band as follows: seven counties for the certificate, and endorsements for each additional seven counties (for a total of 21 counties). Send log information plus \$1.00 and two 5¢ stamps to: Wally Eichorn K2CYX, 105 Seaside Place, Sea Girt NJ 08750.



Jim-pak[®] J1

electronic components

One-Stop Component Center

AUTHORIZED DEALERS

ALABAMA
Cropwell
Mobile
ALASKA
Anchorage
ARIZONA
Flagstaff
Fountain Hills
Tempe
Sierra Vista
Yuma
CALIFORNIA
Bellflower
Berkeley
Brea
Cypress
El Monte
Fontana
Fullerton
Glendale
Lake Tahoe, South
Lancaster
Long Beach
Mission Viejo
Modesto
Monterey
Oceanside
Palmdale
Palo Alto
Pasadena
Riverside
Sacramento
Sacramento
Sacramento
San Bernardino
San Carlos
San Diego
San Diego
San Fernando
San Francisco
San Francisco
San Jose
San Luis Obispo
San Rafael
Santa Barbara
Santa Cruz
Santa Maria
Santa Monica
Sunnyvale
Torrance
Vallejo
Van Nuys
Ventura
Walnut Creek
Westminster
Whittier
Whittier
COLORADO
Aurora
Steamboat Springs
CONNECTICUT
Bridgeport
FLORIDA
Ft. Lauderdale
Gainesville
Lakeland
Orlando
Tampa
Tampa
GEORGIA
Atlanta
HAWAII
Aiea
Honolulu
IDAHO
Boise
Caldwell
Idaho Falls
ILLINOIS
Carbondale
Evanston
Evanston
Granite City
Groveland
Mount Prospect
Niles
Oak Park
Rockford
Schaumburg
INDIANA
East Chicago
Hammond
IOWA
Clinton
Davenport
Indianola
KANSAS
Kansas City

Tucker Bros.
Lafayette Radio Electronics
Electronics Corp. of Alaska
Jim's Audio & Stereo Repair
P & C Communications
Computerworld Inc.
B & S Electronics
Yuma Electronics
Earl's Hobby Shop
Al Lasher Electronics
Century Electronics
SCR Electronics
Kimball & Stark
Fontana Electronics
Orvac Electronics Inc.
Eagle Electronics
CalPine Electronics
Consumer Electronics
Scott Radio Supply Inc.
Tower Electronics Corp.
Computer Magic
Zackit
Electronic Center
Radio Shack A.S.C. Palmdale
Zack Electronics
Dow Radio Inc.
Computer Center
Heathkit Electronic Center
The Radio Place
Zackit
Inland Computer & Electronics
J & H Outlet Store
Radio Shack A.S.C. Mira Mesa
Radio-Tronics Inc.
San Fernando Electronics
Zack Electronics
Zenith Distributing Corp.
Quement Electronics
Mid-State Electronic Supply
Electronics Plus
Lombard Electronics
Santa Cruz Electronics
Caps Electronics
Mission Control
Sunnyvale Electronics
SE Electronics
Zackit
Thrifty Electronics Supply
Lombard's Electronics Inc.
Byte Shop of Walnut Creek
JK Electronics
D & S Electronics
Whittier Electronics Co.
Com Co Electronics
Norm's TV & Electronics
Bridgeport Computer
Computers For You
Lafayette Radio
Lakeland Specialty Electronics
Altair Computer Center
AMF Electronics
Microcomputer Systems
Atlanta Computer Mart
Delcoms Hawaii
Integrated Circuit Supply
Custom Electronics
A-Gem Supply Inc.
Audiotronics
Lafayette Radio
Itty Bitty Machine Co.
Tri-State Electronic Corp.
Computer Systems Center
Moyer Electronics
Tri-State Electronic Corp.
Computer Land
Spectronics Inc.
Imperial Computer Systems
Data Domain
Acro Electronics Corp.
Quantum Computer Works
Bridge Elec. Computer Center
Computer Store of Davenport
Electronix Limited
Electronic Surplus Sales

KANSAS (Continued)
Manhattan
Wichita
KENTUCKY
Lexington
LOUISIANA
Baton Rouge
New Orleans
MARYLAND
Baltimore
Baltimore
La Vale
Rockville
Silver Spring
Towson
Towson
MASSACHUSETTS
Medford
North Adams
Waltham
Worcester
MICHIGAN
Ann Arbor
Flint
Grand Rapids
Lansing
Mt. Clemens
Communications Specialties Ltd.
Amateur Radio Equipment Company
Radio-Electronic Equipment Co.
Davis Electronics Supply Co.
Wm. B. Allen Supply Co.
Computer Workshop of Baltimore
Everything Electronic
J & M Electronics
Computer Workshop Computers Etc.
Baynesville Electronic Inc.
Computers Etc.
Tufts Electronics
Electronics Supply Center
Computer Mart Inc.
RM Electronics Inc.
Airway Electronic Communications
Hobby Electronic Center
Micro Computer World
Fulton Radio Supply Co.
The Computer Store

NEW YORK (Continued)
Rensselaer
Rochester
Troy
Utica
White Plains
Williamsville
NORTH CAROLINA
Durham
Greensboro
Raleigh
NORTH DAKOTA
Fargo
OHIO
Bucyrus
Cincinnati
Columbus
Dayton
Reynoldsburg
OKLAHOMA
Guyton
Oklahoma City
Tulsa
OREGON
Albany
Coos Bay
Medford
Ontario
Portland
Salem
PENNSYLVANIA
Drexel Hill
Erie
Hershey
Murrysville
Phoenixville
Pittsburgh
Wilkesbare
York
RHODE ISLAND
Cranston
Pawtucket
SOUTH CAROLINA
North Charleston
TENNESSEE
Chattanooga
Clarksville
Knoxville
Memphis
Memphis
Oak Ridge
TEXAS
Amarillo
Dallas
Houston
Houston
San Antonio
UTAH
Provo
VIRGINIA
Alexandria
Alexandria
Alexandria
Charlottesville
Hampton
Richmond
Roanoke
Springfield
Virginia Beach
WASHINGTON
Kennewick
Longview
Pasco
Richland
Seattle
Seattle
Spokane
WEST VIRGINIA
Morgantown
Morgantown
Ripley
Wheeling
CANADA
Alberta (Calgary)
Ontario (Willowdale)
Quebec (Montreal)
PANAMA
Panama City
Panama City
FRANCE
Paris
SINGAPORE
SINGAPORE
Com-Tech Electronics
2001 Microsystems
Trojan Electronics
Am-Cor Electronics
The Computer Corner
Hirsch Sales Co.
Futureworld
Byte Shop
Byte Shop of Raleigh
The Computer Company
Mead Electronics
Digital Design
Heathkit Electronic Center
Altair Computer Center
Universal Amateur Radio
Sound Service
Bits, Bytes & Micros
High Technology
Oregon Ham Sales
Herrick Electronix
Portland Radio Supply
Miller Electronics
Portland Radio Supply
Computer Pathways
Kass Electronic Distributors
Warren Radio
Microcomputer Systems Inc.
Computer Workshop of Pittsburgh
Stevens Electronics
Tydings Company
Hamline Electronics
G. Y. C. Company
Jabbour Electronics City
Jabbour Electronics City
Technical Services Inc.
William's Data Comp Division
Masstronics
Byte Shop
Bluff City Electronics
Sere-Rose & Spencer Electronics
Computer Denn
Computer Encounters Inc.
CompuShop
Altair Computer Center
Interactive Computers
Sherman Electronics Supply Inc.
Alpine Electronic Supply Co.
Computer Hardware Store
Computers Plus Inc.
Heathkit Electronic Center
Lafayette Electronics
Lafayette Radio
Computers-To-Go
The Computer Place
Computer Workshop of North Virginia
Heathkit Electronic Center
C & J Electronics
Progress Electronics
Riverview Electronics
C & J Electronics
C-Cor
Empire Electronics
Personal Computers
The Computer Corner
Electro Distributing Co.
Thompson's Radio Shack
Lafayette Radio Asso. Store
The Computer Shop
Home Computer Centre
Wang's Microcenter
Electrotecnia S.A.
Sonitel, S.A.
Computer Boutique
Inter-Trade (PTE) Ltd.
Systems Technology Ltd.



MINNESOTA
Duluth
Eagan
Hopkins
St. Paul
MISSOURI
El Dorado Springs
Florissant
Parkville
Northwest Radio of Duluth
Computer Room Inc.
Heathkit Electronic Center
Heathkit Electronic Center
Beckman Electronics
Computer Country
Computer Workshop of Kansas City
Conley Radio Supply
Electronic Service & Distributing
NEBRASKA
Lincoln
North Platte
Omaha
NEVADA
Las Vegas
NEW JERSEY
Bayville
Bricktown
Cherry Hill
Hoboken
Paterson
Pompton Lake
Ramsey
A. R. S. Communications Services
Radio Shack Associate Store
The Computer Emporium
Hoboken Computer Works
All-Tronics
Computer Corner of New Jersey
Typetronic Computer Store
Fort Orange Electronics
Greylock Electronics
Computer Mart of New York

SEE YOUR LOCAL Jim-pak[®] DEALER TODAY!

For Dealer Information, write or phone JIM-PAK[®], 1021 Howard Ave., San Carlos, California 94070 (415) 592-8097

Choosy People LOVE Standard! ♥



Standard Communications offers you a choice of 2 meter handheld radios in either the pocket sized C-118 or the professional sized 146A.

Why Buy The C-118?

- Compact — can be slipped in pocket or purse
- 6 channels but affords 18 channels transmit with unique offset switch which produces transmit offset of ± 600 kHz
- Requires only one crystal for each channel
- BNC antenna connector
- Rubber flex antenna at no additional charge
- LED status lights indicate channel busy and RF output
- 1+ Watts output

Why Buy The 146A?

- More room means larger battery capacity
- Larger case affords greater audio fidelity
- Room for tone options
- Provisions for remote speaker mic
- Full size telescoping antenna is standard feature
- 5 channels
- Meter for RF and signal strength
- 2+ Watts output

Both the C-118 and 146A...

- ... Are ready to operate on 146.94 simplex and 34/94 repeat
- ... Have excellent sensitivity and selectivity characteristics

 **Standard
Communications**

member:



Attn: Advertising Manager
Standard Communications Corp.
P.O. Box 92151
Los Angeles, CA 90009

Gentlemen:

Please send me additional information on

- C-118 2 meter 1 Watt FM Handheld Radio
- 146-A 2 Watt VHF Handheld Radio

Name _____

Address _____

City _____ State _____ Zip _____

S18

C

Meet Mr. Blizzard

—Dayton hams were ready



National Guard Medivac helicopter prepares to land at National Guard armory near Dayton. This was one of several Guard units used to rescue stranded motorists and farm families in the Ohio area.

If you had asked a dozen hams living in the Illinois, Indiana, and Ohio area to define a blizzard on Wednesday, January 25, 1978, you probably would have been hard pressed to get a good answer. By noon the next day, however, that problem would have no longer existed—they were living through one!

The weather authorities say that this was the worst winter storm to hit the area since we began keeping records in the late 1800s. In Dayton, new records were set for lowest barometric pressure (28.66 in.), highest winds (68 mph), and most snow in a 24-hour period (12 in.), all accompanied by subzero temperatures. This, indeed, was a blizzard.

For the next 24 hours, virtually nothing that didn't have four-wheel drive could move in the region.

An area newspaper was headlined "Ohio Closed," and that probably summed it up best of all.

It was daylight Thursday morning before the full impact of the storm began to sink in. Due to the loss of electric power in large areas and the anticipated need to shelter stranded travelers, a massive relief effort was going to be required. Before these efforts were concluded, thousands of amateurs throughout the area would be involved in making the operation a success.

In the greater Dayton area alone, nearly 300 amateurs worked in around-the-clock shifts for four days, assisting the Red Cross in setting up and stocking shelters, dispatching four-wheel drive vehicles on rescue and transport missions, and handling health and welfare traffic to all parts of the country.

The majority of the communications were handled through the Miami Valley F.M. Association WR8ACV repeater systems on .04-64 and .31-91. The .04-64 machine primarily functioned as a link for Red Cross shelter operations and was directed from a station at their headquarters in downtown Dayton.

The .31-91 machine handled the bulk of the four-wheel drive vehicle dispatching, which was directed from a command post at the Centerville Police Department south of the city. A second station on .31-91 at Red Cross coordinated their requests with the Centerville group.

Health and welfare traffic was routed locally through the Dayton Amateur Radio Association WR8ADP repeater on .34-94 to several HF stations working the traffic nets. The D.A.R.A. machine also provided overflow

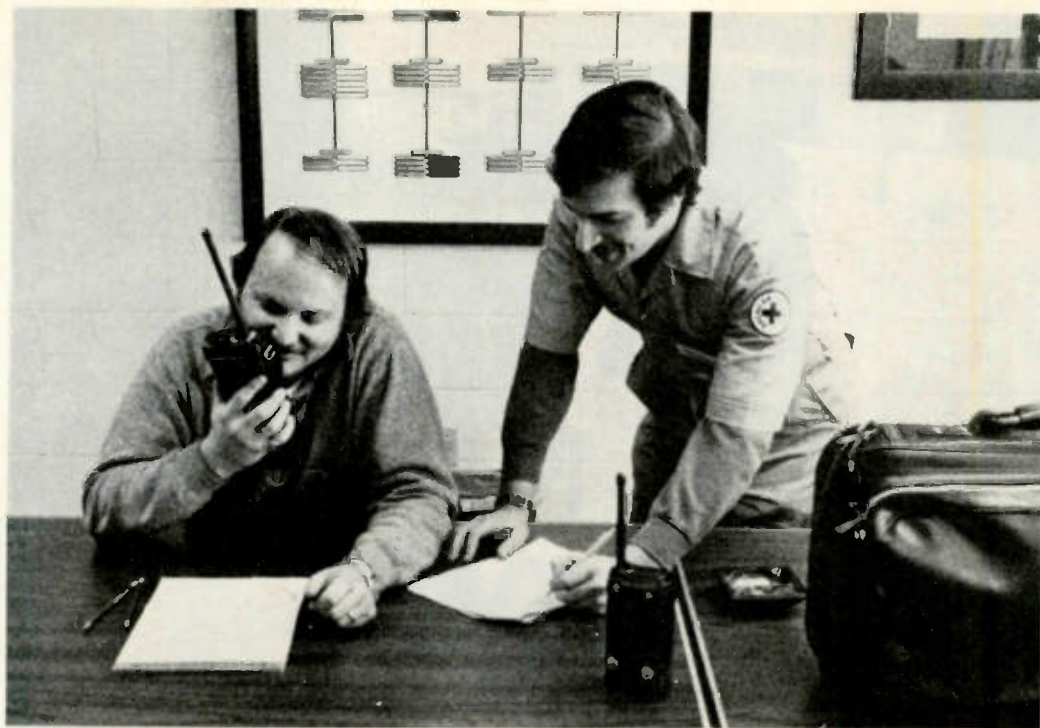

Where's all your radio gear? That's what National Guard officers asked Stu K8ST when he and a Red Cross volunteer set up an emergency fuel-oil distribution system out of National Guard headquarters. The HT was all Stu needed to maintain contact with the Guard tank truck over a two-county area.



Roger W8LHL plants a two meter magnet-mount antenna on the roof of a four-wheel drive Blazer at Red Cross headquarters in Dayton. This was one of countless volunteer vehicles that were used to deliver food and supplies to shelters and otherwise inaccessible homes in the snowbound Miami Valley area.

capacity when the two primary machines were fully loaded.

The biggest problem faced by the amateur

volunteers was simply getting to where they were needed. In some areas, amateurs living near shelters were picked up

and transported by city or county snowplows. By late Thursday, satellite shelter communications had been established with Phillips-



Rick WB8WMY prepares to help a young man with an emergency supply of fuel oil for his family. Rick was one of a number of hams who rode the National Guard tank truck and helped with the oil deliveries, sometimes making as many as eight trips a distance of a quarter of a mile on foot to deliver the fuel.

burg, Brookville, Xenia, Englewood, Union, and Bellbrook.

Another serious problem was telephone service. By midmorning on Thursday, several telephone exchanges were so overloaded with either real or imagined emergencies that it became almost impossible to get a call through.

A similar problem existed on the Citizens Band channels. The local REACT group did a superb job of trying to help stranded motorists by dispatching CB-equipped four-wheel drive vehicles, but the QRM was unbelievable. Channel 9 sounded like channel 19 during rush hour.

By midday Thursday, the appeals broadcast by local radio and TV stations for four-wheel drive volunteers to report to Red Cross and area hospitals began to pay off. Several area auto dealers volunteered their four-wheel drive inventories to police and fire departments, and we

began to team up hams with four-wheel drive operators.

Dispatches to transport nurses and doctors to and from area hospitals became commonplace. Many trips were made delivering prescription drugs and food to homes where these items were in critically short supply.

On Friday morning, the wind and snow began to subside, but road conditions had actually worsened from the day before. To relieve the radio traffic load at the Red Cross, the command post at the Centerville Police Department was established and coordinated with area hospitals to handle personnel shift changes. This operation continued through the afternoon of Saturday, the 28th, by which time most of the roads were at least passable for normal passenger cars.

During the day on Friday, the Red Cross operation took on added func-

tions, as food and fuel-oil supplies began to run short in homes that were still cut off. Food deliveries in amateur-radio-equipped vehicles began on Friday and carried on through Sunday, the 29th. On Sunday, a separate fuel-oil delivery program was initiated using a National Guard tank truck dispatched by amateur radio from Guard headquarters. This service continued through the middle of the following week.

In retrospect, one of the most impressive aspects of the snow emergency was the high level of preparedness and adaptability displayed by amateur radio. Portable antennas and cigarette-lighter power plugs were in evidence everywhere, which made equipping four-wheel drive vehicles and National Guard trucks with two meter equipment relatively easy.

Rarely was there a lack of qualified volunteer radio operators. Indeed,

the hardest problem at times was convincing some of them to get some sleep. Radio procedures were generally excellent, with short transmissions and rapid acknowledgements the rule rather than the exception.

The technical capabilities of the repeater systems really paid off, as well. Following the Xenia, Ohio, tornado in 1974, the need for a more reliable, better-coverage repeater system for the Dayton area became evident, and a system was designed. With the financial assistance of several local foundations and many hours of work by a dedicated technical committee, the system was installed and received its first real test under emergency conditions during the blizzard.

The machines performed flawlessly. With their saturation coverage of the two-county area of responsibility, hand-held portables and low-power mobiles were able to be used with an absolute minimum amount of time being spent on setup and installation.

Taken together, the combination of trained, willing amateur radio operators, flexible, properly-operating equipment, and a good, reliable repeater system was unbeatable for this situation. None of us had ever trained for an emergency like this—few would ever have expected a situation like this to occur. When the time came, though, the pieces fell into place, and ham radio went to work for the good of the community.

As one of my friends in the local REACT organization later told me, "I was listening on my police monitor, and you guys really sound professional. You sounded like you do that every day." That's about the nicest compliment I can think of. ■

SCR 1000 - Standard of Comparison

In Repeaters - Now Available with Autopatch

- And Many Other Options!

Autopatch features:

- Normal patch, or secure reverse patch accessed by a control op.
- 3 digit anti-falsing access — single digit disconnect
- 3 digit on-off control of repeater transmitter
- 4 sec. time limit on access
- Built-in adjustable time-out function — patch shuts down in 30-90 sec. if no carrier is received
- Wide range audio AGC on input and output.
- User can mute phone line audio simply by keying his mic button — prevents embarrassing language from being repeated
- Patch access and repeater control — either over the air or over the land line



2 Mtr. & 220 MHz!

Now Spec Comm has taken the hassle out of putting an autopatch repeater on the air! The SCR1000/SCAP is a fully self-contained 30 watt repeater with built-in autopatch and land line control. You simply plug in the phone line, hook up the duplexer, and you're on the air! The usual months of problems are eliminated! The SCR1000/SCAP has been meticulously engineered to provide the smoothest performing patch together with a positive land line control of the repeater. The system is fully assembled, set-up and checked-out in our lab.

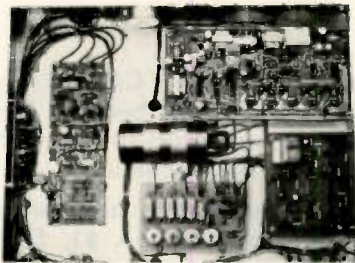

Under chassis view of SCR1000 with Autopatch installed.

- The SCR1000—simply the finest repeater available on the amateur market... and often compared to "commercial" units selling for 3 times the price! This is a 30 Wt. unit, with a very sensitive & selective receiver. Included is a built-in AC Supply, NEW Expanded Memory CW IDer, full metering and lighted status indicators/control push-buttons, crystals, local mic, etc. Also provided are jacks for emergency power, remote control, autopatch, etc.
- A full complement of options are available: Duplexers, Cable, 'PL', Touch Tone™ Control, HI/LO Power, Autopatch, 60-70 W 2-4 Chan. ID, Transmitter, Cabinets, etc. Please inquire.
- The Spec Comm Repeater System... a sound investment... available only by direct factory order. Get your order in A.S.A.P.!

SCR 1000 Specifications

RF Output 30 Watts typ.
 Infinite VSWR proof
 Sensitivity 0.3uV/20dB Qt.
 Selectivity... -6dB @ ±6.5 kHz;
 - 75dB @ ± 15 kHz;
 - 100dB @ ± 30 kHz.
 Includes 8 Pole Xtal Filtr. (Sharper 10 Pole Filtr. Available)
 Desense/Overload... W/1uV desired signal, desense just begins @ approx. 50,000uV @ ± 600 kHz.
 Spurious Response... -70dB min.

FEATURES

- Full Metering of critical levels.
- Front Panel Controls for timers & AF levels.
- Lighted push-buttons for control/test functions & status indicators

- State of the Art CMOS control logic & timers—No Relays!
- Built-in CW IDer—Low current draw, 250 bit PROM Memory! Adjustable speed, pitch, time, etc.
- Exclusive Spec Comm MOS-FET/Hot Carrier Diode rcvr. front end—reduces 'dense' & IM problems!
- Built-in AC Supply w/instant btry. switchover for emergency pwr.
- Supplied with .0005% Sentry xtals and a Turner local mic.
- Jacks Provided for Remote Control, Auto-Patch, DC out, AF in/out, COR Switch, etc.
- True FM—For Rpt. Audio so good, It "sounds like direct"!

SCR 1000 WITH FL-6 PRESELECTION	\$1055.00
SCR 1000 WITHOUT PRESELECTION	\$ 970.00
SCR 1000 SCAP & FL-6 PRESELECTION	\$1605.00
SCR 1000 SCAP FL-6 WP641 DUPLEXER	\$2100.00

Commercial prices somewhat higher.

See our August 73 Ad for more details!
 (Add \$3.75 ship/handling. PA residents add 6% tax.)

SPEC-COMM REPEATER BOARDS, SUB-ASSEMBLIES & ACCESSORIES

2M & 220 MHz!

- FL-6 Preselector. Rcvr. Front-End Filter/Preamp. Exc. rejection of strong "out of band" sigs. -60dB @ ± 6 MHz \$85.00
- SCR100 Receiver Board, w/xtal \$115.00
 (8 Pole IF Filter + \$18.95)
 (10 Pole IF Filter + \$29.95)
- SCR100 Receiver Assembly, SCR100 mounted in shielded housing. \$185.00
- SCT110 Xmtr./Exciter Bd. 7 or 10 Wt. bd. \$135.00 w/xtal. BA-10 30 Wt. Amp. bd. & Ht. Sink. \$51.95
- SCT110 Transmitter Assembly. SCT110 mounted in shielded housing. \$199.95
 (30 Wt. Amp. + 65.00)
- CTC100 COR/Timer/Control Bd. \$35.00
- ID250 CW ID/AF Mixer Bd. Programmed \$65.00
- SCAP Autopatch Bd. \$225.00
- RPCM "Reverse Patch" & control bd. \$79.95
- TTC100 Touch Tone Control bd. 3 digit ON, 3 digit OFF. \$85.00
- TRA-1 Timer Reset Annunciator Bd. \$20.95
- WP641 Duplexer. \$495.00

EXPORT ORDERS—CONTACT HERE IN OUR INTERNATIONAL DEPARTMENT

Send for Data Sheets!

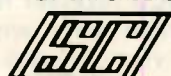

SPECTRUM COMMUNICATIONS

1055 W. Germantown Pk., Norristown PA 19401 (215) 631-1710

The Blizzard of '78

— a real snow job

At 2:00 am EST on January 26, 1978, the wind began to blow and the snow began to streak across the landscape, causing a whiteout that would do credit to an Antarctic winter storm. At 3:30 am, the furnace blower stopped and we lost our heat. The power had gone off all over Washington Court House. The loss of power knocked out both my two meter transceiver and the local 87/27 repeater.

Luckily, the power came back on in our section of the city at 8:30 am. Soon after that, I received a call from Paul Woods, the Deputy Director of the Disaster Services Agency, asking that I alert the ham radio emergency network. Since I am both the Disaster Services Agency Communications Officer and the newly-appointed Fayette-County Emergency Coordinator, it was my job to get the amateurs together. Although there had been no real advance planning, I made a call on the repeater for volunteers. The results were im-

mediate and exciting. Many local hams had promptly gone to the repeater frequency. It was practically instant mobilization.

Eventually, twenty-six amateurs took part in our operation. We had a use for each of them — it certainly was a gratifying response.

Last year, the DSA director had depended on CBers, with very poor results. The emergency channel (9) was deluged with calls for the sheriff, and the other channels were loaded with people discussing the storm. High-powered amplifiers used by CBers in a nearby town on channel 10 caused so much adjacent channel interference that attempts to relay calls for help through CBers out of town failed. I had told him that next time I would show him what ham radio could do.

I asked first for someone to go to the DSA headquarters to set up a unit for communication with mobile units, as well as for quick connection with the

office (since its line was also swamped with calls). To get in, I first had to wait several minutes for a dial tone, and then I would get a busy signal and have to start all over. The office could not call out, either. (The deep, drifted snow made it impossible for the telephone company to install lines, as had been done last year.)

Art Swadner WB8EEB said that he would go if someone would pick him up. Only four-wheel-drive vehicles could get through in most cases.

Since none of the DSA rescue people were hams, we had to have a mobile operator with each driver. Frank Johnson WD8OLN put about 300 pounds of old generators and radio equipment in the back of his Ford station wagon for ballast, and went after Art. He also volunteered for a mobile job, and even used his own car. Another volunteer, Mark Workman WB8TYC, needed transportation, so Frank picked him up. Bill Burns WA8IEJ also used his own car, and Mike Gray WA8HNS, Jim Turner

WB8FTL, and Gary McCoy WD8LPK all became mobile operators to ride with the DSA rescue units.

The mobile units were designated DSA #1, DSA #2, and so on, so that the director, who was not a ham, would not have to remember ham calls. The mobiles identified with both their call and with their DSA unit number. They handled more than fifty trips, either to bring in people or to take others medicine, food, or even fuel oil.

Jack McKirgan II WD8BNG handled messages via repeater relays for surrounding cities; there were about seventy-six messages handled.

I handled the telephone calls, and several Novices monitored channel 9 on the CB and called me for the phone calls to the sheriff. They also monitored our repeater on scanners, since they could not work two meter FM. This scanner/CB receiver method worked very well. I replied via 2 meters and they returned the channel

9 call with the information that they were going to be helped by either the sheriff or a wrecker, as the need appeared.

I had to dial the sheriff up to ten times to get a line. Each time, there was a wait of several minutes for a dial tone.

While we had offers of snowmobiles, the experience of last year taught us that they had limited usefulness. With a driver and a communicator, there was no room for evacuating people, and the intense windchill factor, due not only to the natural wind but also to the high speed of the snowmobiles, made it necessary that all occupants be warmly dressed. The four-wheel-drive vehicle is the real workhorse.

I averaged about four calls an hour, for over forty hours, and all this with only two hours sleep in the first twenty-four. This totalled more than one hundred sixty calls.

Gerald Ragland WA8BOB is a pharmacist at the local hospital, Fayette County Memorial. He was very active in the net, and also had to arrange for 3000 pounds of I.V. solution to be delivered from Dayton. The hospital administrator was so impressed with the smooth operation of the amateurs that the hospital is purchasing a two meter FM unit for future use, so that there will always be a unit there for emergencies.

Al Dixon WB8SRN also served at DSA headquarters, eventually being relieved by Jack McKirgan II WD8BNG. They were so pleased with Al Dixon that they have asked him to become a member of DSA. He has also been appointed Assistant Emergency Coordinator. He enjoyed being of service so much that it renewed his lasting interest in ham

radio.

We did not, as some cities did, operate as a controlled net. Having everything funneled through net control may be necessary for large groups, but for a small one (26 active hams in the net), it would have been too slow.

Each ham did what he could do best, and all monitored the repeater. Several also were monitoring channel 9, and some were periodically reporting to other repeaters to get road and weather conditions. There are about a dozen repeaters in our range.

Each one knew at all times the entire story. I could drop out for lunch and someone would take my place until I came back. We notified the local radio station that messages for surrounding cities could be transmitted by telephoning Frank Johnson's number. He then gave them to Jack McKirgan II and they were passed on. We took no incoming health and welfare messages.

We learned a lot as we went along. For example, not to expect any road information from the sheriff or the state patrol, but to call the highway department. They plow and salt the roads, and know exactly what conditions are. We also realized the importance of having backup batteries for the 2 meter gear and the repeater, so that they are not "dead" when the power goes off. Extra flashlight batteries and a kerosene lamp or lantern should also be kept handy.

If you have an emergency generator, or anything else, be sure it is where you can get it. One ham had an emergency generator in his garage, but the garage door was drifted shut and so was his house door.

One ham lost his sixty-

foot tower (which blew over), and his triband beam fell across the power line to his house. As a further irony, all his gear was away at the manufacturer's being serviced. All he had left was his phone. Even his 40 meter vee came down with the tower.

We were fortunate that Phil Brooks WD8DPI, who is a minister at the Grace Methodist Church, also had 2 meter FM available. He handled all the coordination of getting blankets, food, and other supplies, and arranging for the influx of stranded people who had to leave their cars in snowdrifts on the interstate. Four other churches cooperated, and the Red Cross furnished food orders when needed.

There were no messages received by us directly from CBers. The ones who were calling on channel 9 did not know at any time that they were being received by hams. The credit therefore went to the CBers, but both we and the CBers knew better.

The only time CB was used at all in any useful manner that we knew about was when a woman called the Red Cross here from Kansas City and wanted to know the whereabouts of her trucker husband, who had been bringing a load to a plastics company here and had not reported in some hours. I told the Red Cross that I would not undertake such a search with ham radio, but would turn it over to a CB club. I did this, and I heard several hours later that they finally located him at a motel.

Some people were even playing music on channel 9, but since most of this type of operation was in the city, we were able to have our outlying monitors copy calls. By contrast, in Wilmington, Ohio, 22 miles away, a REACT team

operated with perfect discipline, and channel 9 was silent except for emergency calls. If you have such a well-operated CB group in your area, it would be well to make contact — otherwise, forget it.

There is great satisfaction in handling an emergency well, and it brings new pride in being a ham. Don't plan for any certain type of emergency. Everyone here thought that the most likely catastrophe was a tornado, after Xenia got hit. Then last year we had very low temperatures and freezing water pipes were a problem, as well as homes without heat and fuel. Still, one could get around, even to the grocery. Then this year a different type of storm hit. It was just plain snow — 26" of it, with high winds to blow it into drifts. No one could move. We could not even get to our car in the carport because of neck-high snow drifts. All roads into town were completely blocked. Snowplows bogged down and went into the ditch. If you didn't have something in your house, you did without it.

Even though our operation went smoothly, we are determined that the next emergency, with more planning, will involve more amateurs. We must have battery backup power for all the receivers, and must have a plan that will allow for efficient operation of our increased coverage and for helping other counties if they need help. We would like to be able to use CB units more effectively, and we would like for interested CBers to see how the ham system works. We also need a call-up system, in case the emergency is not as obvious to all as the snowfall was.

For experience, the Great Blizzard of '78 sure beat a Simulated Emergency Test. ■

How Do You Use ICs?

— part X

First, what is an ac clock circuit? It's a circuit that gives you a timing pulse keyed to the 60-cycle ac line frequency. This is accurate enough for many purposes, including, surprisingly enough, a number of the digital clock kits that are available.

The circuit performs one very important function. The ac line frequency is a 60-cycle sine wave. The digital circuitry runs on square-wave pulses.

Woe to the circuit that dumps sine waves into digital. They object. So there has to be a nice little circuit that will turn your sine wave into a digital signal.

I usually like to start off articles with examples of how easy it is just to steal the circuit you want from someone else's piece of equipment and use it for your own. Unfortunately, going through a number of back issues, I did not come across any line-frequency circuits published

recently, so I will have to start off cold.

There was one type of ac circuit, though, which was quite common, and a simple method of designing this will be described.

There are two specific things the circuit must do to make the line frequency compatible with digital ICs. It has to convert it to a suitable voltage level, and it has to fool the digital ICs into thinking that it is a digital signal. This takes two different operations, each one of which is very simple. Refer to Fig. 1, which is the basic circuit.

There are many places in the equipment where you may be able to steal the ac voltage. The usual place is from an unused filament winding on the power transformer. You may even be able to couple it from the rectifier winding with a capacitor.

You do not need much current for the job — just an ac signal of sufficient voltage and no more. That is the

function of R1. This may be a potentiometer, as shown, or two fixed resistors, or a combination of both. It depends on what voltages you have and what parts you may have.

The total resistance is a function of Ohm's Law. The only critical part is that the resistance should be high enough so that it does not draw appreciable current. A figure of five to ten mA would be a good start. Measure the available ac and figure the total resistance for current appropriate to the ratings of the resistors.

The next part is a little more tricky. You need the correct signal voltage to switch the 7400 gate. A look in a data book will give you a hint.

According to the data, you need a minimum of 2 volts to switch to high and less than 0.8 volts to go to low.¹ The maximum input voltage is listed as 5.5 volts. This gives you a ball-park figure, but it doesn't help all that much. That is a square-wave voltage, not the sine wave your meter is calibrated for. There is a simple way out, though.

That is how you get the voltage. Fig. 1 has a plain ordinary rectifier in the circuit. The output of the half-wave rectifier looks con-

siderably like the pulse that it wants to a digital IC. Fig. 2 shows its waveform. Notice that it goes from zero to maximum and back again. The IC doesn't care that it hits zero instead of some low voltage state. It looks the same to the IC.

This makes it easier. Your meter will read a voltage even though it is not correctly calibrated. Simply start at no voltage from the resistor rectifier network and slowly increase the voltage to the rectifier until the IC starts pulsing. You can see it on a scope or a logic probe, or even on a meter. There will be a change in the voltage when the IC starts to pulse.

Go slowly and note the point at which the action starts. Then measure the voltage to the input to the IC. This will be in the few-volt range. Note the reading and then increase the voltage until you read ten or twenty percent more. This should give you some margin to take care of voltage variations.

As a final check, see that the new voltage is not too close to the stated maximum. It shouldn't be; mine wasn't. Then check again for correct switching action. If all is okay, you should be in business. The extra gate section

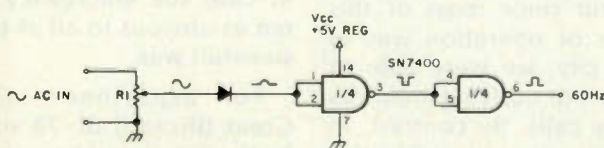

Fig. 1. Basic 60-Hz-sine-wave-to-60-Hz-square-wave circuit.

buffer is common in such circuits.

That is the simplest way to do it. When I was experimenting, I tried a few zener diodes in the circuit as the rectifier and to regulate the voltage. According to my meter, it didn't make all that much difference. The voltage across the diode never did reach its reference voltage. It did appear to have some smoothing effect when the voltage was increased, but it did not seem to be a significant factor in the circuit. Nor did it make much difference which way the diode was hooked up with either type of rectifier. It could be reversed or used with the diode across the IC instead of in series.

As long as the IC got the voltage, it appeared to work properly. For simple equipment, if I were going to use such a circuit, I would not bother with a more complex arrangement. I would try the simple way and see how it worked.

However, simple though this is, it does appear to be the hard way to do things. There ought to be some clever little gizmo that you can feed an ac signal into one side of so that a digital signal will pop out the other.

There is. It is called a Schmitt trigger. Its function is to turn an ac signal into a proper square wave, and it does a smoother job of it than the simple circuit.

Here we are blessed with a surplus of riches. There is not just one such device, but two — the SN7413 and the SN7414. There are some differences between them, but they can be easily fudged.

The 7413 is really a dual 4-input NAND Schmitt trigger. The 7414 is simpler (Fig. 3) — just one input pin and one output pin. There are, however, six of them in the package, which is a lot of Schmitt triggers to play with.

The 7413 is a bit of a maverick. It is shown as a NAND gate with a Schmitt trigger following that and a NAND gate output stage. There is a Schmitt trigger in there somewhere, though. How you hook it up depends on how strong your stomach is.

From the pictorial (Fig. 4), it would look like the resistor rectifier combination should be used to feed it so that the NAND gate got a digital signal of sorts. I recollect that, when I was using them on the bench, I fed the sine wave directly to the input and got the square wave output just the same. My inclination would be to use the rectifier anyway, and just rely on the Schmitt trigger part for good smoothing of the output pulse. That way you get the best of both.

You can tie all four inputs together as you would with the unused inputs of the 7400, or you can tie the three unneeded inputs to the Vcc pin through a common 1000-Ohm resistor. Just remember that you will have to do something to account for all the inputs.

You determine the input voltage needed in the same way you do for the other devices, starting from zero and working your way up until the circuit works.

Often an extra NAND gate section of another IC is used

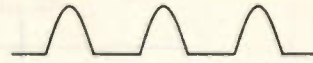

Fig. 2. Half-wave rectifier waveform.

as an output buffer for the 60-cycle stage in a fully built piece of gear. What comes after that? Usually two more simple stages (more if needed). A divide-by-six stage followed by a divide-by-ten stage² will give you a one-second pulse (Fig. 5). More divide-by-ten stages can be added if needed for slower timebases.

There is a limiting factor to this circuit. It is so simple that you would think that everyone would want to add it to equipment because it is so easy, so there have to be some drawbacks.

One drawback is its frequency accuracy. The accuracy is only as good as the accuracy of the timebase, which in this case is the incoming ac line frequency. This is a nominal 0.05%. That sounds pretty good when you are just measuring a few seconds or so, but as you increase the time and start measuring fractions, you get problems.

To make it easy, think in terms of frequency. At 1000 Hz, 0.05% is not so bad — only 0.5 Hz. What's half a cycle to most audio use? At 10 MHz, it becomes 5000 Hz or 5 kHz, and, at 30 MHz, it becomes 15 kHz. When you hit the UHF frequencies, it Hertz even worse.

That's why you don't see too many frequency counters around with ac clock timebases. Even when you are measuring time, when you dig down into the microseconds, the accuracy is just not there.

There is one other common complaint with this circuit — ac line glitches. A glitch is not one specific problem, but a class of them.

They are the digital equivalent of gremlins. In this case, it is any extraneous pulse that manages to get in through the ac line. Machinery starting up in the area, stray electrical pulses, or static and lightning discharges, among other things, can cause a pulse on the ac voltage. This will come right in on the line and probably get right through the transformer primary and appear at the secondary.

The digital ICs are very sensitive and will happily follow any little pulse they see. This can give you a timing pulse that is out of time or phase with the 60-cycle frequency you want to establish. This actually is not that much of a problem with the counter-type circuit. It keeps updating its reading, and a stray counting error will be corrected at the next counting period.

However, in its normal usage, as the timing pulse for a digital clock, you have another problem. Once the timing error gets in, it stays in. There is no way the circuit can correct itself. That is why you see so many clock kits with crystal timebases and so many surplus crystal units giving 60-cycle output.

While the accuracy is much greater with the crystal unit than the ac line fre-

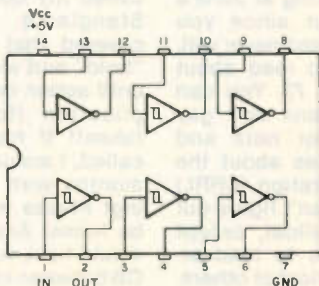

Fig. 3. SN7414 hex Schmitt trigger.

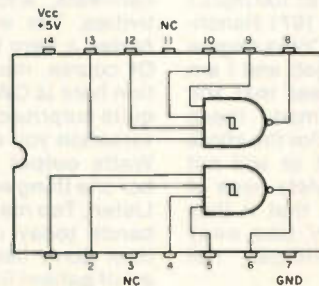

Fig. 4. SN7413 dual 4-input NAND Schmitt trigger.

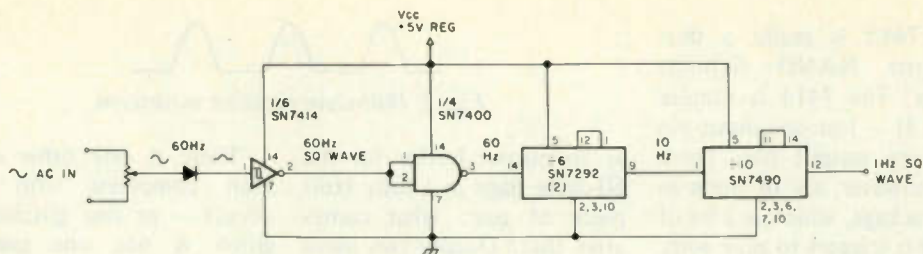

Fig. 5. 60 Hz ac timing chain.

quency, for most applications, the primary reason the crystal timebase is used is not for its accuracy but to

divorce the timebase from the ac line, thus getting rid of the major source of timing error, the notorious glitch.

However, if all you want is a quick way to tell the time, or you need a quick and easy timing circuit, the ac line

frequency timebase is hard to beat.

My recommendation would be the rectifier and 7414 combination with a 7400 buffer or an additional 7414 section buffer. That should be about the most reliable simple combination. ■

References

1. *TTL Data Book*, National (Radio Shack), February, 1976.
2. "How Do You Use ICs? — part III," MacLean, *73 Magazine*, November, 1976, p. 106.

ou rooms don't ever profit
lousy manuscripts from that
buried in the past
you'll never see them again
I insist that you print ev
tell Ma Bell that she shou

LETTERS

from page 11

was the founder of International, and at one time held the amateur license W5EMH. He had not been active in amateur radio for the past several years.

Mr. Freeland was a pioneer in the manufacture of precision quartz crystals and frequency-measuring equipment. International was the first company in the United States to market a Citizens Band transceiver. The electronics industry would be put to task to find a person with a greater dedication to quality in manufacturing.

International will continue its operation in his tradition. Mr. Freeland's son, Royden WB5KDC, will be active in the company.

Bill G. Moore K5HTF
Russellville AR

GOVERNMENT BS?

Tell them all to go to hell—I like your way of thinking. I agree with your thoughts on government BS.

If I want to drive at 100 mph, I do so, as I have a 1971 Ranchero with a 375 HP Cobra engine which will do the job and I am not dead yet. I feel that the government has made these stupid regulations for the idiots that either cannot or will not learn about the safety rules of driving, and I feel that if they cannot drive safely, take away their driving privileges, not mine.

As far as this radar thing is concerned, the State of Cali-

fornia is considering letting the CHP have radar. If they do, I shall proceed to purchase or build (ha) a receiver and then I will know where they are. I do not believe in jamming, but it is our privilege to receive. See you on 20.

Terry Downey W6TD
Bishop CA

SHOP AROUND

Okay, Wayne, this is in response to your request on working DX without going broke. I agree with Mr. Todd WB5SYP (June, 1978, issue) that ham gear today is beyond the reach of most of us. I, until recently, have been using a DX-60B Heath transmitter, a DX-150A Realistic receiver, and an old Johnson T-R switch with a low-pass filter. Total cost of this station is \$230.00, including coax and a home brew 40 meter antenna. This setup has served me quite well and I have worked DX on many occasions. Almost all of the gear was acquired from want ads, hamfests, and local club activities. The whole trick is to *barter*, a term that is not dead. Of course, most of the operation here is CW and you will be quite surprised how long a conversation you can hold with 40 Watts output power. Remember one thing when working DX: Listen. Too many people on the bands today call CQ DX and then don't listen around. The art of patient listening was how I made my first QSO after passing my General test. It was with

OY3H and he was using 100 Watts of power. There was a person next to me calling CQ continuously. Too much, in fact, to realize OY3H was there. However, after hearing me call and converse with OY3H just a few kHz away, he was next in line in the pileup that ensued after my QSO. What a feeling it is to answer a CQ from a semi-rare DX contact with only a few Watts and then sit back and chuckle at everybody else falling over each other trying to work the same station I had. In summary, there is quite a lot of good used gear around. You have to spend the time to survey your prospective gear and then barter for a satisfactory price. Don't tie yourself down to only one type of brand name gear. Shop around, that's the name of the game. Good things come to those who have patience.

Curtis D. Law WA2PIV/2
New Haven CT

TOO BAD?

A friend of mine left me the June issue of 73 to read because of the antenna info and, like a nut, I could not resist flipping through it. As always, I see that you have not changed in your attacks on the ARRL. Don't you ever get tired of writing about QST in 73? Poor 73 cries like a second-rate cousin about her big sister, QST. I will admit to a passing weakness in looking at June's Issue of 73, but since you haven't changed and never will, I will continue to read about QST in QST, not 73. You can keep your CB fans and gay advertisement for nets and your eternal gripes about the best ham organization (ARRL) around today. I can't figure out what keeps 73 afloat, except some people like to read articles that are critical of others. You are so hung up on the ARRL and QST that you have

ruined what might have been a good mag, but it's too late now. Too bad. The ARRL haunts you like a bad dream that will not go away. By the way, you are right about one thing. Your attitude doesn't sell mags—it turns hams off.

Wayne Brandon WB5HMB
Garland TX

WARNING

The new regulations concerning linear amplifiers make me wonder if somebody slipped something in the FCC water coolers. It really makes good sense to clobber hams in the name of cracking down on illegal CBers. Suppose hams were getting on the 550-1600 kHz band—would the FCC ban the sale of broadcast band equipment? Probably! Why, they could carry that further—if drugs are smuggled into the country by plane, why not ban the sale of aircraft capable of international flights? Or maybe just the sale of suitcases.

While the heavy thinkers at the FCC were thinking up how to dump on hams, I took the Novice code test in early March. The 610 went in, but the written test didn't arrive until the end of April—weeks after I passed the General class exam on April 5th. After 10 weeks of waiting for my call letters, I called the FCC and was told to be patient—it could be another 8-12 weeks! Out of curiosity, I called my congressman (Rep. Stangland). His office discovered that my file was on "hold" and would remain there until action on my previous application (for Novice) was taken!! If his office had not called, I would have waited for months with nothing happening! Please warn other would-be hams. Another week and I would have wished I had put a CB between channel 40 and the

Continued on page 104

Clegg is...



...ICOM Headquarters

No one else offers as diversified a transceiver line as ICOM, and no one else can fill your ICOM needs better than Clegg!

Take your pick for your favorite mode and band:

IC-701 160-10 meters, Synthesized, Solid State Digital readout, 200 watt PEP input.

IC-211 144-148 MHz, Synthesized, FM/USB/LSB/CW Digital readout, 10 watt output Solid State. 13.8 VDC and 115 VAC operation.

IC-245/SSB 144-148 MHz, Synthesized, FM/USB/CW digital readout, 10 watts output, Solid State Multi-Mode Mobile.

IC-280 143.9-148.11, Microprocessor controlled memory. 1 and 10 watt FM'er. Remote controllable.

IC-30A 440-450 MHz FM, 22 Channels, 10 watts

IC-202S 2 Meter SSB Portable

IC-502 6 Meter SSB/CW Portable

IC-215 2 Meter FM Portable

IC-402 432 MHz SSB/CW Portable

Call us TOLL FREE for quote on the ICOM of your choice!

1-(800) 233-0250

(In PA call (717) 299-7221 collect)

Call Clegg for best price

Clegg

C3

Looking for a different brand? Clegg also stocks all other major product lines including Dentron, Alpha, Yaesu, Drake, Wilson, KLM, Hustler and MFJ, and—of course—Clegg transceivers.

Communications Corp.
1911 Old Homestead Lane
Lancaster, PA 17601

Relax and Unwind

— your antenna wire

With few exceptions, almost everyone up till now has experienced the curse of kinks in copperweld antenna wire. Number 14 gauge copperweld consists of a steel core and an integral copper jacket, approximately 30 percent copper by weight. As the wire is drawn down to size, it becomes work-hardened and springy. When wound into the fifty-foot continuously connected coils in which it is stocked and sold, it is in a stressed state. Do not remove the ties from a fifty-foot coil and let it drop unless you wish

to be confronted with a minor demon in the form of a tangle of wire which is most difficult to tame (Amen!—ed).

An interesting experiment was once performed by an electrician friend who carefully tied one end of two fifty-foot coils to a power pole in his backyard and carefully unrolled the one hundred feet of copperweld which he attached to the bumper of his car. He then let the car roll a short distance down the sloping driveway to "stretch and straighten" the wire, when it suddenly snapped at the bumper and

wrapped itself around the pole in an impossible mess. He cut the wire into short lengths, disposed of them in the trash, and went to his supplier for more wire.

By following the instructions given below, you can unroll and straighten copperweld so that an antenna can be strung without the kinks, snarls, and uncouth comments commonly associated with the devilish stuff. To accomplish this minor miracle, proceed as follows:

1. Determine the length needed and purchase (or cut off) sufficient fifty-foot coils for the job at hand.
2. Hold one coil securely so that the many turns cannot flip out of the plane of the coil, and remove all of the ties from that one coil.
3. Carefully permit the coil to relax and expand in your hands, with assistance as required, until the stored stress is relieved.
4. Retie the relaxed and expanded coil.
5. Repeat steps 2, 3, and 4 for each coil.
6. Make a simple wire straightener from scrap wood as shown in Fig. 1. The guide holes are just big

enough to pass the wire. One block is fixed and the other is pivoted on one screw and then clamped when properly adjusted.

7. Place the coils as shown. Insert a short length of wire from the bottom coil through the guide holes, and then remove the ties from the bottom coil.

8. Pull about three feet of wire through the straightener device, making necessary adjustments to the movable block.

9. Tie the end of the wire to a solid anchor point, such as a tree, post, or antenna mast, and back away in such a manner that you control the rotation of the coils and keep them flat against the board.

You should now have your copperweld lying across the yard with only a slight waviness—provided your adjustment was correct. The straightener works by bending the wire in the opposite direction from that in which it was coiled, just enough to leave the wire in a reasonably straight condition. Now you can get on with the routine business of putting up your antenna with manageable ease. ■

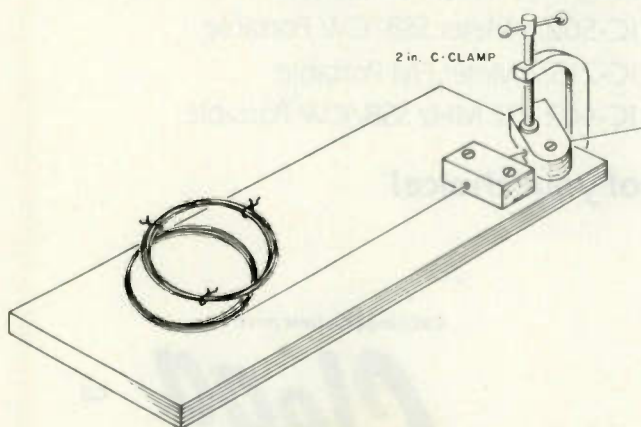

Fig. 1. Wire straightener construction: base—1/2" or 3/4" plywood; guide blocks—1" × 1" × 2" pine. Nail or screw to base.

TRY kilobaud... ON US!

Return the attached postage-free card, and we'll have your trial copy of Kilobaud on the way to you within a few days. Wayne is willing to go to this expense because he feels that all hams can profit (and he means \$\$\$) from an understanding of the basics of microcomputing. The fact is, there's a revolution going on, even more important than the one that replaced vacuum tubes with solid state, and you'll want to be a part of it and join the fun. **Over 20,000 hams already have their own computers up and running and are having a ball.**

Kilobaud is the only magazine in the field written specifically for newcomers to computers, and many of the articles are ham-oriented . . . after all, many of the pioneers of microcomputers are hams. Don't let this revolution pass you by. Return the subscription card and your trial issue will be on the way, along with a bill for a year's subscription at a special introductory rate of \$12. If you're not completely satisfied, just write "cancel" on the bill and return it to us within 30 days . . . and keep the trial copy.

Rush me my trial copy of Kilobaud and enter my subscription at half the newsstand price (\$12). If I'm not completely satisfied, I'll return the bill marked "cancel" within 30 days and keep the trial copy.

Name _____

Address _____

City _____ State _____ Zip _____

Please allow 30 days for shipment of first copy.

50

S91

kilobaud

peterborough nh 03458

Nuclear Attack!

— WWIII
on your SR-52

Dan Everhart WA7WKA
293 Lander Hall
University of Washington
Seattle WA 98105

Uh-oh, here's another violent and destructive computer game. And it uses nuclear weapons, yet, in this age of detente. I'll bet Texas Instruments never dreamed that their SR-52 would be used to stage World War III battles. Read on, and see how to make yourself a world

power! If you don't like the game, at least you may pick up a couple of interesting programming tricks for the SR-52.

The game itself is a new twist on the old "sub search" type of game. Most people get sick of sub searching after a few games, because the game

isn't really challenging. It's a simple matter to narrow down your coordinates with each shot, and the game becomes a sort of three-dimensional high-low. The twist in this game is that you are shooting at more than one target at once (six in this version), and you have to be a lot

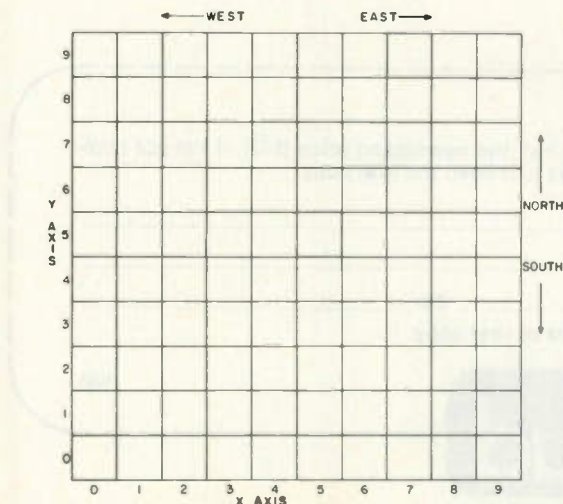

Fig. 1. This is how the board is set up. It represents your enemy's missile base.

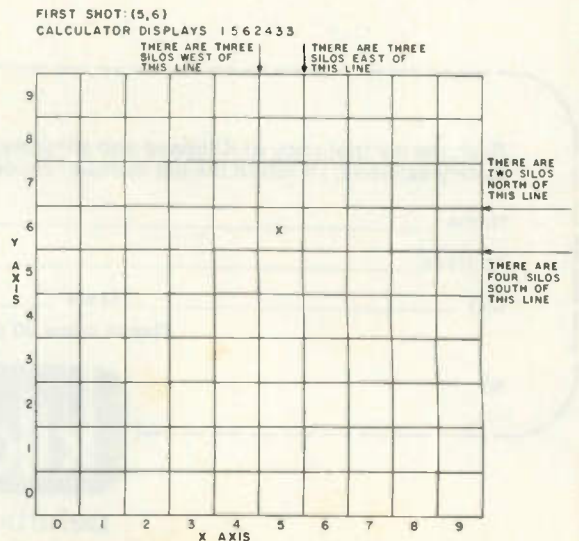

Fig. 2. Diagram of example used in text.

more clever to figure out where they are.

How To Play

For equipment (besides the calculator), you will need a pencil and a sheet of paper marked off into one hundred squares in a ten-by-ten array. This sheet of paper represents your enemy's military base which you are attacking. You don't have to use this paper diagram, but, without it, keeping track of your play is nearly impossible. The columns are numbered 0 through 9, from left to right, and the rows are numbered likewise, from bottom to top (Fig. 1). In this way, the board could be looked at as the first quadrant in an x-y plane, so I will refer to the west-east direction as the x-axis and the north-south direction as the y-axis.

Your enemy has six ballistic missile silos hidden at random on this base. You, on the other hand, have a remotely-controlled offensive weapons satellite from which you can drop guided nuclear bombs upon the enemy base. You input the coordinates of the square upon which the bomb is to fall. It is your task to destroy all six silos using as few of your bombs as needed. The only information you are given is the number of silos that lie to the north, to the east, etc., of each bomb you drop. How well you do depends on your skill at organizing and interpreting this information. There is no upper limit on the number of shots you may take.

Each time you load the program, you will have to enter a seed for the random number generator that locates the silos at the beginning of each game. Enter your number and press A. You can use the time of day, your age in minutes, the Dow-Jones

average, whatever. I usually just hit the decimal point and then seven or eight digits at random. Any number between 0 and 10⁹ will work (except the number one—the random number generator chokes on the number one).

To start the game, press B. The calculator will take about thirty seconds to randomly locate the six silos and will display a zero when ready. You need only randomize once for each series of games you play. Each successive start will give a different pattern of silos.

Now select which square you want to bomb first (example: 5,6—five is the west-east, or x-, coordinate, and 6 is the north-south, or y-, coordinate). Press 5 and then D to enter the x-coordinate, followed by 6, then E to enter the y-coordinate and run the program. Congratulations, you have just destroyed everything within square 5,6. And you didn't even have to file an environmental impact statement! After about 25 seconds, the calculator will come back with a confusing string of digits, like 1562433. Let's break this display down digit by digit and explain what it means.

Taking the digits from left to right, the first digit, 1, means shot number one. The next two digits, 56, are an echo of which square you bombed. The next digit, 2, means that there are two silos to the north of this shot. This doesn't necessarily mean that they are directly north along the same column, but *only that their y-coordinates are greater*. This is a major point of confusion among new players (see Fig. 2). The remaining digits are similarly south, east, and west, respectively.

Wait a minute! The example says 2433. That adds up to twelve silos. Is there

a bug? No, each silo counts twice—once as being either north or south of where the bomb was dropped, and again as being either east or west. Note that, if a silo lies along the same line as your shot, it won't show up in either of the two indicators for that direction. In other words, a silo on the same vertical column as your shot counts as neither east nor west, and one along the same horizontal row counts as neither north nor south.

When you hit a square that contains a silo, the display will flash. Press CE to stop the flashing. When a silo is hit, it is destroyed and will not show up on subsequent shots. Although it doesn't happen very often, two or more of the silos may be placed in the same square. When this happens, they are both destroyed when the square is bombed.

When the last silo is hit, the last four digits will be 0000, and the game is over. To start a new game, press B.

Different people have come up with different strategies for this game, and I will leave you to find your own. Among people I

know, the best players average about thirteen shots per game. The record low at this writing is eight bombs. However, at the other end of the spectrum, I saw one person give up after fifty shots. That base must have really been smoking!

About the Program

Writing a program for a programmable calculator is very different from writing a program in microprocessor assembly language or a higher level language such as BASIC. The greatest disadvantage of the programmable calculator is its small amount of program memory. The simplicity of pushing each key to enter its function into the program makes coding a program, say from a flowchart, very simple and straightforward. However, a more complex program will need more keystrokes than there is memory to hold them when using the straightforward approach. So the programmer must resort to tricks to condense the program to a usable size. The trade-offs involved with these tricks are: (1) They make the program harder to debug and harder for someone other

Register	Contents
99	random seed
19	number of shots taken
18	x-coordinate of shot
17	y-coordinate of shot
16	number of silos north of shot
15	number of silos south of shot
14	number of silos east of shot
13	number of silos west of shot
12	silos #1 x-coordinate
11	silos #1 y-coordinate
10	silos #2 x-coordinate
09	silos #2 y-coordinate
08	silos #3 x-coordinate
07	silos #3 y-coordinate
06	silos #4 x-coordinate
05	silos #4 y-coordinate
04	silos #5 x-coordinate
03	silos #5 y-coordinate
02	silos #6 x-coordinate
01	silos #6 y-coordinate
00	dsz and pointer

Fig. 3. Register usage table.



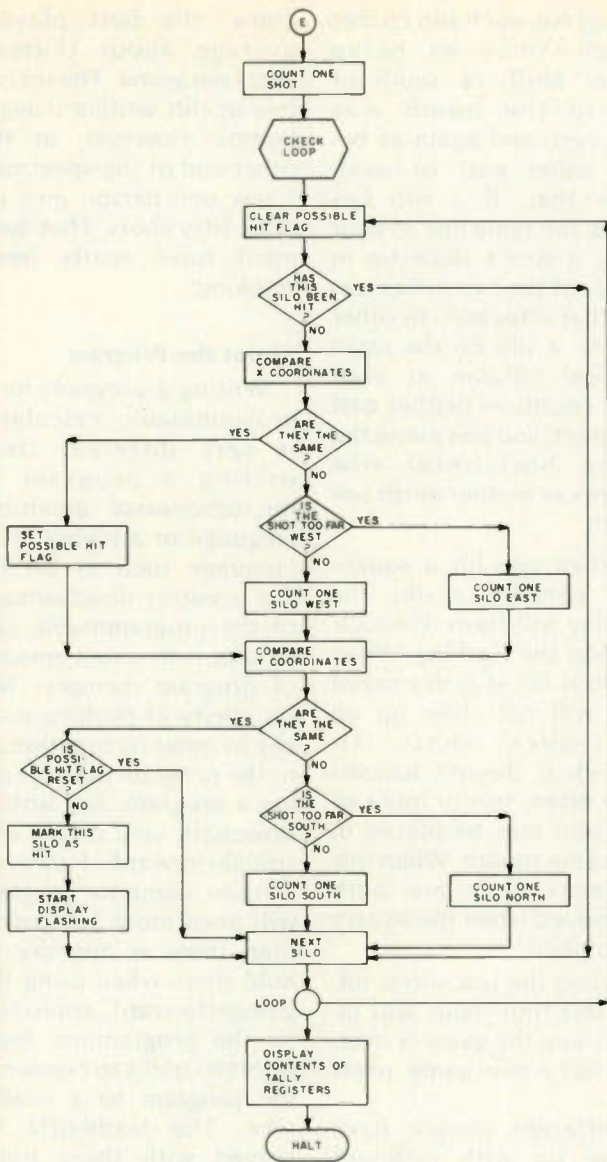

Fig. 4. Flowchart.

than the programmer to understand, and (2) they usually slow the program down. So, as vital as informative remarks and good documentation are for regular programs, they become even more important for the programmable calculator's programs.

In this game, the x- and y-coordinates of each silo are stored in registers 01 through 12 (see Fig. 3). When a game is started by pressing B, 12 is stored in register R00, which is used as a pointer. The program generates a random digit, which is stored in the register pointed to by R00 using an IND STO instruction (step 197). The IND key is one of the most

useful programming functions on the SR-52. It tells the calculator that it is to perform the memory function immediately following the IND (STO, RCL, EXC, SUM, etc.), not on the register specified in the instruction, but on the one whose number is stored in that register. For example, if R00 contains the number 9, then the command IND STO 00 would perform the same function as STO 09. The displayed number would be stored in register 09.

Using the dsz instruction (decrement and skip or zero) after each random number is stored, the program decrements the value in R00 by 1 and checks to

see if it has reached zero. If it hasn't, the program loops back to LBL *7' and repeats the process. So, effectively, the first time through, the loop R00 contains 12 and the IND STO 00 stores the random digit in R12. The next time through, R00 contains 11 and the random digit goes in R11 and so on. When R00 finally reaches zero, the dsz doesn't cause a branch, but just lets the program continue and halt. Now R01 through R12 each contain a random digit, and these are the coordinates of the silos (Fig. 3).

The Silo Shuffle

The random number generator (steps 179-196) has its random seed stored in register 99. This is because R99 and R98 are surplus registers which are unaffected by the CMs instruction which clears R00 through R19. The seed is recalled, INdx, and then squared and stored back in R99 as the new seed. This number is multiplied by the degrees/radians constant (57.295779513) and the part to the left of the decimal is chopped off, leaving a decimal fraction. The decimal is multiplied by ten, and the digits to the right of the decimal are removed, leaving an integer from 0 to 9. This approach can be modified to produce random integers from zero to N by replacing the multiplier of 10 in step 193 with a multiplier of N+1.

Pressing D stores the x-coordinate of your shot in R18. E stores the y-coordinate in R17 and continues on to the main body of the program.

Each silo is checked individually. First the xs are compared by subtracting the shot x from the silo x. If the result is zero, then that means that the shot and silo are on the same column. Flag zero is set when this happens so that the

calculator will remember later in the program that the xs were the same in case the ys are the same, too, which would mean a hit. If the difference between the x-coordinates is positive, then the silo x was greater than the shot x, and the shot must have fallen to the west of the silo, so R14, which contains the number of silos to the east, is incremented by one. If the difference is negative, then the opposite is true, and R13 (west) is incremented instead.

Now, since we are using R00 as a pointer to tell which coordinate of which silo we are working on, we must decrement it by one to get to the y-coordinate. We do this with a dsz command that branches just ahead of itself. The same procedure as was used on the x-coordinates is applied to the y-coordinates, except that now, if they are the same, we must check to see if flag zero is set. If it is, then both silo coordinates match the shot coordinates, and we have a hit. When a silo is hit, the program changes its x-coordinate to -1 as an indicator that it has been hit and is to be skipped over on later shots. Then a \sqrt{x} establishes an error condition so the display will flash when execution is completed. If the y-coordinates are not the same, then, like before, the north register or the south register is incremented, depending on which side of the silo the shot fell.

Now another dsz instruction loops back to the beginning of the check procedure and moves the pointer to the x-coordinate of the next silo, or, if there are no more silos to check, passes control on to the display routine.

The display segment demonstrates a useful way to display the contents of several registers at once. Again R00 is used as a

pointer, but this time it starts at 19 and is decremented until it reaches 13, and the program halts. The calculator keeps a running total of the contents of each register times a decreasing power of ten. Thus we get $(R_{19}) \times 10^6 + (R_{18}) \times 10^5 + \dots + (R_{13}) \times 10^0$. Each register contains only a one-digit number, so the resulting sum is a number made by stringing together the contents of registers 19 through 13. Of course, the proper things are stored in each register in order to have the display come out in the order we want.

For the Sake of Speed

Looking over the program listing, you may be wondering about the strange order in which the segments of the program are arranged in memory. The user-defined labels are near the end, and the program branches and subroutines come before the program. The best way I can answer this question is to have you try the following experiment:

Run the four programs in Fig. 5, and time the execution using the second hand of a clock or a stopwatch. Make sure you turn the calculator off to clear the program memory before entering each program.

You can see that the four programs do exactly the same thing. They only differ in their locations in memory and their dsz instructions. Two of them are labeled branches, and two are directly addressed. On my calculator, all programs run in about ten seconds except number two, which takes more than forty. It seems reasonable to me to assume that, when the calculator is told to branch to a particular label, it must search through the program memory starting from the beginning. Naturally, the farther down in the pro-

gram memory a label is, the longer the calculator must take to find it and the slower the execution will be. In program one, the

sought-after label B is almost at the beginning, so the calculator finds it quickly, and the loop executes swiftly. In program

two, however, the machine must search through almost the entire memory before it locates label B. Consequently, this loop takes

Step	Keystrokes	Comments
000	*LBL *1'	
002	*dsz *8'	Skip this silo.
004	*LBL *2'	
006	*st flg 0	Set the "possible hit" flag.
008	GTO *5'	
010	*LBL +	
012	1 SUM 14	Count one silo east.
016	GTO *5'	
018	*LBL *9'	
020	1 SUM 16	Count one silo north.
024	GTO *8'	
026	*LBL *3'	
028	INV *if flg 0 *8'	If flag set, then we have a hit.
032	1 SUM 00	Change x-coordinate
036	± *IND STO 00	of silo to -1.
041	*√x *dsz *8'	Start display flashing.
044	*LBL *B'	Integer-part subroutine.
046	(STO - . 5)	Subtract rounding constant.
052	*fix 0 *D.MS	Eliminate fractional digits.
055	*rtn	
056	*LBL E	
058	STO 17 CE	Store y-coordinate of shot.
062	1 SUM 19	Count one shot.
066	0 STO 16 STO 15 STO 14 STO 13	Clear N.,S.,E.,W. registers.
079	12 STO 00	Initialize check loop.
084	*LBL *4'	Beginning of loop.
086	INV *st flg 0	Clear "possible hit" flag.
089	*IND RCL 00	Get x of silo.
093	INV *if pos *1	Branch if it's been hit.
096	- RCL 18 =	Compare to x of shot.
101	*if zro *2'	If same, set flag.
103	*if pos +	If greater, count one silo east,
105	1 SUM 13	else count one silo west.
109	*LBL *5'	
111	*dsz 115	
115	*IND RCL 00 - RCL 17 =	Move to y-coordinate.
124	*if zro *3'	Compare silo y to shot y.
126	*if pos *9'	If same, check for hit.
128	1 SUM 15	If greater, count one silo north,
132	*LBL *8'	else count one silo south.
134	*dsz *4'	
136	20 STO 00 0	Branch back if more silos.
142	*LBL *6'	Initialize display loop.
144	+ *dsz 149	Beginning of loop.
149	*IND RCL 00 X 10 y ^x	Move to next register.
157	(RCL 00 - 13)	Get contents of this register and
165	INV *if zro *6'	multiply by decreasing powers of ten.
168	= HLT	
170	*LBL B	Begin new game.
172	CLR CMs	Clear everything.
174	12 STO 00	Initialize setup loop.
179	*LBL *7'	Beginning of loop.
181	RCL 99 ln x *x ² STO 99	Make a random digit
189	INV *D/R - *B' X 10 = *B'	from 0 to 9.
198	*IND STO 00	Store it as a silo coordinate.
202	*dsz *7'	Branch back for the next one.
204	CLR HLT	Ready to play.
206	*LBL A	
208	STO 99 HLT	Store initial random seed.
212	*LBL D	
214	STO 18 HLT	Store x-coordinate of shot.

Program listing.

much longer to execute. In programs three and four, the branches are made directly to a specified address. The calculator doesn't have to waste time searching, because it has been told exactly where to put the program counter. Thus, both of these loops execute quickly no matter where they are placed in program memory.

As I said, this explanation is an educated guess on my part, and perhaps

someone who knows what goes on in the mind of a TI calculator will write in and clarify this point.

Anyway, this is the reason for placing the branches and subroutines before the main program—the closer they are to the beginning of program memory, the faster the calculator can find them and the faster the program will run. It does make the program more confusing to look at, and I

don't recommend that you try to write your programs this way. But, when you finish a long program and have it running, you may find that rearranging things will speed it up considerably.

Go, Team, Go

The game was popular enough in the dorm where I live that we decided to hold a tournament. Each contestant would play three games and total his

scores, lowest score winning. To make things fair, each person would play the same three configurations of silos. This was accomplished by randomizing with the same initial seed before each game. For example, we used sin 1, sin 2, and sin 3. The random number generator then generates the same sequence each time, and the silos come out in the same spots. I find that it's handy to write down the number you initialize with anyway. That way, if the system crashes (batteries go dead), it's simple to set the same game up again after plugging in the charger. It's really frustrating to lose a game half way through, especially when you were just about to blast a silo.

And you certainly don't have to be a computer buff to enjoy the game. My roommate won the tournament—he's a political science major! ■

step	keystrokes		
Program one		Program three	
000	*LBL A	000	*LBL A
002	100 STO 00	002	100 STO 00
008	*LBL B	008	*LBL B
010	*dsz B	010	*dsz 008
012	HLT	014	HLT
Program two		Program four	
200	*LBL A	200	*LBL A
202	100 STO 00	202	100 STO 00
208	*LBL B	208	*LBL B
210	*dsz B	210	*dsz 208
212	HLT	214	HLT

Fig. 5.

LETTERS

from page 96

10 meter band, at a kW, and worked the world with no hassle by the FCC!

Please, Wayne—don't say anything sarcastic or derogatory about the FCC until my call letters come. Maybe the truth hurts and they become even more vindictive. I hope there will still be some frequencies left for hams by the time I can go on the air!

Walter Kimmel
Ponsford MN

FORGET ABOUT THIS ONE

Enclosed is the renewal form you sent me for renewal to your magazine. While I like your magazine very much, there are certain things that I cannot tolerate. I now take all the ham magazines, QST, CQ, and Ham Radio; I am a life member to

QST and have all the rest paid for until 1981.

Now, all four magazines are real good magazines, and I like them very much. But up to this point, I have yet to hear one of them badmouth your magazine, but every month, and I do mean every month, you have your nasty snide remarks about them. I don't like it; it is the act of a 3-year-old child, to say the least.

There is nothing I can do about it, but I don't have to sit here and read it, so just forget about this renewal. When you grow up into a grown man, I might consider renewal.

Just remember, Mr. Green, the other magazines are just as good as yours, and that is supported by a lot more opinions than mine.

I hold no magazine rating over the top of the other one. I don't hold QST over 73 or 73 over QST. I read them all with interest and really learn a lot

from them all.

It is your magazine; run it the way you want, as I know you will. But remember, it takes customers to keep it going. Look at the renewals you did not get and ask yourself why you did not get them.

Carl Manion W4BDC
Shepherdsville KY

... AND THIS ONE

I'll be only too happy to renew my subscription to 73 as soon as Wayne recovers from his total fascination with microprocessors et al, and begins to print stories on some other aspects of amateur radio again!

Bob Kuehn W0HKF
Saint Paul MN

LET'S DO SOMETHING!

Wayne, is there anyone who can represent the hams and let their desires be known? The ARRL does not and will not represent anyone but the ARRL. You've pretty well said it all in your editorials. I feel that if we keep sitting on our duffs, we will have exactly what the ARRL would like for us to have—nothing! The "Spark

Forever" boys in Newington are too busy making a buck. Wonder if they've heard of micros yet? The point is, if you are willing to accept the ambassadorship, I'm willing to donate ten bucks to the cause and I would bet a large percentage of your readers would do likewise. Why not ask them and get a campaign started? At any rate, let's do something!

Jim Best WA0RZI/4
Woodbridge VA

KA CONFUSION

I am writing on behalf of the members of the Far East Auxiliary Radio League (FEARL) and all others assigned call-signs with a KA prefix to request your assistance in disseminating information on a problem we are having here in Japan.

Since shortly after the close of World War II, U.S. Forces personnel in Japan have been issued call-signs prefixed with KA. KA call-signs in Japan are issued by the military authorities in a 2 x 1, 2 x 2, or 2 x 3 format, and there are currently authorized stations assigned KA1, 2, 3, 5, 6, and 8 prefixes with the possibility of KA areas

Continued on page 124

FREE PROBES FREE PROBES FREE PROBES

NLS MS-215 DUAL TRACE MINISCOPE \$435.00

NLS MS-215 DUAL TRACE MINISCOPE \$435.00



- LM3A 3 dig 1% DC \$134.00
- LM3.5A 3 1/2 dig .5% DC \$158.50
- LM40A 4 dig .1% DC \$209.00
- LM4A 4 dig .03% DC \$250.00

Rechargeable batteries and charger included
Measures DC Volts, AC Volts, Ohms and Current
Automatic polarity, decimal and overload indication

Rechargeable batteries and charger
Measures DC Volts, AC Volts, Ohms and Current
Automatic polarity, decimal and overload indication

- No zero adjustment and no full-scale ohms adjust
- Battery-operated — NiCad batteries, also AC line operation.
- Large LED display for easy reading without interpolation
- Size: 1.9" x 2.7" x 4.1"
- Parts & labor guaranteed 1 year
- Tin stand option \$ 3.50
- Leather case \$20.00

Purchase any of the LM series Meters and buy the LEATHER CASE for 1c



MS-15 MINISCOPE With Rechargeable Batteries & Charger Unit

- 15 megahertz bandwidth.
- External and internal trigger.
- Time base — .1 microsec to 0.5 Sec/div - 21 settings - 1.3%.
- Battery or line operation.
- Automatic & line sync modes.
- Power consumption < 15 watts.
- Vertical Gain — .21 to 50 Volts - 12 settings - 3.3%.
- Viewing area 1.7" x 3.35"
- Case size 2.7" H x 4.4" W x 7.8" D, 3 pounds.
- Parts & Labor guaranteed 1 year
- Up to 1.5 Meg probe
- Leather carrying case

PROBE 1c with the purchase of SCOPE and the MENTION of THIS MAGAZINE

MS-215 Dual Trace Version of MS-15 \$435.

S-100 BUS EDGE CONNECTORS

\$1100 810 80 100 Core 125 pins DIP SOLDER Tail on 740 support lead. Top VECTRO and M840 multi-pin. "NABCO" on metal case. \$ 8.1 10 24	\$1100 870 80 100 Core 170 pins DIP SOLDER Tail on 740 support lead. Top VECTRO and M840 multi-pin. "NABCO" on metal case. \$ 9.9 10 24
\$1100 810 80 100 Core 125 pins DIP SOLDER Tail on 740 support lead. Top VECTRO and M840 multi-pin. "NABCO" on metal case. \$ 8.1 10 24	\$1100 870 80 100 Core 170 pins DIP SOLDER Tail on 740 support lead. Top VECTRO and M840 multi-pin. "NABCO" on metal case. \$ 9.9 10 24
\$1100 810 80 100 Core 125 pins DIP SOLDER Tail on 740 support lead. Top VECTRO and M840 multi-pin. "NABCO" on metal case. \$ 8.1 10 24	\$1100 870 80 100 Core 170 pins DIP SOLDER Tail on 740 support lead. Top VECTRO and M840 multi-pin. "NABCO" on metal case. \$ 9.9 10 24

Other Popular Edge Connectors

- M844 8 32 44 Core 154 pins with 125 pin con. \$12.95
- M844 8 32 44 Core 154 pins with 125 pin con. \$12.95

3 LEVEL GOLD WIRE WRAP SOCKETS

	1-24	25-49	50-99	100-249	250-999	1K-5K
8 pin*	.41	.38	.35	.31	.27	.23
14 pin*	.39	.38	.36	.32	.29	.27
16 pin*	.43	.42	.39	.35	.32	.30
18 pin	.63	.58	.54	.47	.42	.36
20 pin	.80	.75	.70	.63	.58	.53
22 pin*	.90	.85	.80	.70	.61	.57
24 pin	.90	.84	.78	.68	.63	.58
28 pin	1.10	1.00	.90	.84	.76	.71
40 pin	1.50	1.40	1.30	1.20	1.04	.89

Sockets purchased in multiples of 50 per type may be combined for best price.

All sockets are GOLD 3 level closed entry * End and side stackable. 2 level, Solder Tail, Low Profile, Tin Sockets and Dip Plugs available. CALL FOR QUOTATION

Vector

8803 MOTHER BOARD FOR \$100 BUS MICRO-COMPUTERS

- Not includes 12 tantalum capacitors for +5, +12, -12 buses and other mounting spacers.
- Wiring side shown. Components side shown. Glass with white markings for component locations.
- C10 epoxy glass board with 2 ounce copper, solder plated and J2833 Game for holes for leads.
- Solder mask with solder windows attached circuits to avoid accidental short circuits.
- Mounts 118 microchips with 100 contacts (2 rows) in 125 centers with .250 row spacing. Vector part number: M828-2, or mounts 10 microchips with 100 contacts in 150 center/row spacing.
- Includes circuit diagrams and instructions for optional active, pass, or floating terminations.
- Large buses — 5V and GND to 800mA, ±12V or 16V (1 AMP). Current ratings are per MIL-STD-275 with 10°C rise.
- Fits in Vector bus enclosures.
- Fits in MSAI 8080 microcomputer as expander board.

Price: \$29.50

Vector Plugboards

8800V
Universal Microcomputer/processor plugboard, use with S-100 bus. Complete with heat sink & hardware. 5.3" x 10" x 1/16"

3682 9.6" x 4.5" \$10.97
3682-2 6.5" x 4.5" \$9.81

HI-Density Dual-In-Line Plugboard for Wire Wrap with Power & Grd. Bus Epoxy Glass 1/16" 44 pin con. spaced .156

3677 9.6" x 4.5" \$10.90
3677-2 6.5" x 4.5" \$9.74

Gen. Purpose D.I.P. Boards with Bus Pattern for Solder or Wire Wrap Epoxy Glass 1/16" 44 pin con. spaced .156

3662 6.5" x 4.5" \$7.65
3662-2 9.6" x 4.5" \$11.45

P pattern plugboards for IC's Epoxy Glass 1/16" 44 pin con. spaced 156

3690-12
CARD EXTENDER
Card Extender has 100 contacts-50 per side on .125 centers. Attached connector is compatible with S-100 Bus Systems. \$26.00
3690 6.5" 22/44 pin .158 ctrs. Extenders \$12.00

1/16" BOARD
.042 dia holes on 0.1 spacing for IC's

Phenolic

PART NO.	SIZE	PRICE
64P44XXXP	4.5x6.5"	\$1.49 1.34
169P44XXXP	4.5x17"	\$3.51 3.16

Epoxy Glass

PART NO.	SIZE	PRICE
64P44	4.5x6.5"	\$1.70 1.53
84P44	4.5x8.5"	\$2.10 1.89
169P44	4.5x17"	\$4.30 3.87
169P84	8.5x17"	\$7.65 6.89

ELL-N-WRAP

Wires insulated with .025" square holes
FOUR TIMES FASTER than regular manual wire wrap

P180 with two 100' spools of 28 ga. wire \$24.50

P180-4T including charger, wire \$75.00

SLIT-N-WRAP \$21 Package
NO. 28 GAGE INSULATED WIRE, 100' SPOOLS
W28 24 Pkgs. 3 Green W28 20 Pkgs. 3 Blue W28 20 Pkgs. 3 Red

2708 8K 450 ns

EPROM FACTORY PRIME \$10.00 EA.
25 + Call For Price

14 & 16 PIN GOLD 3 LEVEL WIRE WRAP SOCKETS

14 - G3 100 for \$30.00
16-G3 100 for \$30.00
50 of each for \$32.00

Sockets are End & Side stackable, closed entry

LIQUID CRYSTAL DIGITAL CLOCK-CALENDAR

- For Auto, Home, Office
- Small in size (2x2 1/2x 1/2)
- Push button for seconds release for date.
- Clocks mount anywhere with either 3M double-sided tape or VELCRO, included.
- 2 MODELS AVAILABLE
- LCD-101, portable model runs on self-contained batteries for better than a year
- LCD-102, runs on 12 Volt system and its back lighted.
- LCD-101 or LCD-102 your choice.

\$34.95 \$2.00

LEDU MG 10A List \$72. SPECIAL \$49.95

Perfectly balanced, fluorescent lighting with precision magnifier lens. For profi. techn. & hobbyist. Has die cast protective shade, self start 3 diopter lens, 42" reach.

with T-8 fluorescent lamp (included) \$49.95
convert. Drop of Black Chromatic Lens \$20.00

SC-5 With Rechargeable Batteries & Charger Unit \$98

FM-7 With Rechargeable Batteries & Charger Unit \$215

Features include: * By using the new NLS SC-5 Prescaler, the range of the FM-7 Frequency Meter, which is 10 Hz to 60 MHz, may be extended to 512 MHz (the upper VHF & UHF frequency bands). * The FM-7 utilizes an LED readout, providing 1 digit resolution. * The FM-7 can be calibrated to an accuracy of 0.30001%. * The SC-5 is accurate to one part per million. * Each unit has 30 millivolts sensitivity, is battery powered and has a charger unit included. * Dimensions of each are 1.9" H x 2.7" W x 3.8" D. * The units may be obtained separately or as a "Frequency Duo". * Parts & Labor guaranteed 1 year. \$ 3.50
Tin stand option \$20.00
Leather case

MICRO-KLIP
for .042 dia. holes (all boards on this page)

T42-1 pkg. 100 \$ 1.50
T42-1 pkg. 1000 \$11.00
P-149 hand installing tool \$ 2.03

12:28 1.8" LED ALARM CLOCK

12 hr. LED Alarm Clock uses 3 1/2 digit .8" LED Display with AM/PM indicators and colors. Direct Drive PIN to PIN Interface with **ST998A** I.C. Just add switches, AC Supply, Alarm. Display and I.C. only.

\$7.95 or 2/51.00

Price Breakthrough! \$17.50

MA1003 CAR CLOCK

Bright Green Fluorescent Display Crystal Time Base Assembled, just add switches and 12 VDC.

SPECIAL
14CS2 100 for *14"*
16CS2 100 for *16"*
14 pin CS2 10 for *12"*
18 pin CS2 8 for *12"*

These low cost DIP sockets will accept both standard width plugs and chips.

For use with chips, the sockets offer a low profile height of only .125" above the board. These sockets are end stackable.

Vector WRAP POST
for .042 dia. holes (all boards on this page)

T-44 pkg. 100 \$ 2.28
T-44 pkg. 1000 \$14.00
A-13 hand installing tool \$ 2.80

P21 PRIORITY ONE ELECTRONICS

4911S West Rosecrans, Hawthorne, CA 90250

Terms: VISA, MC, BAC, check, Money Order, C.O.D., U.S. Funds Only. CA residents add 6% sales tax. Minimum order \$10.00. Orders less than \$75.00 include 10% shipping and handling; excess refunded. Just in case please include your phone no. "Sorry, no over the counter sales"

Good thru Sep. 1978

phone orders welcome (213) 973-4876 OEM and Institutional inquiries invited

24 PIN DIP PLUGS WITH COVERS

3 / \$1.00
40 / \$10.00

FREE PROBES FREE PROBES FREE PROBES

Computerized QSO Records

— who needs a logbook?

Well, enough already of computer games — let's get down to serious application programming! I've always wanted a computerized log and inquiry system to rid me of trying to relate callsigns to names ...

"Gee, that call is familiar. Did I work him before? What's the handle? QSLs? Aw, rats! What's the handle, old man?" This program (Fig. 2) will take care of all those questions. It will allow you to quickly enter log entries by

using data statements beginning at line 1000. The end-of-data file is indicated as DATA 999999, as shown at line 1005. You can have as many data lines as your memory can hold. In the inquiry mode (RUN), the program will

print out (display) log entries by date, callsign, or just print out all of the entries, by entering its function number.

To add log entries, type in function 1 and a LIST function starting at line 1000 will begin and take you out of BASIC. This will allow you to change the DATA 999999 line to a log entry. The DATA format is: (line number) DATA (year, month, day), (time), (callsign), (frequency), (mode), (power), (QSL), (QTH-name).

Note that "QTH" and "name" share the same data item definition.

Note that the date must be entered as YYMMDD (year, month, day). I'll explain why soon. After the entries are made, add (line number) DATA 999999 to end the data file. Type RUN again to begin the program.

Function 2 selects log entries for printing by entering two dates in the YYMMDD format. What comes out is all log entries between and including the dates specified. The logic is located in line 416. With the YYMMDD format, dates run in ascending numerical order, which makes the logic just plain simple.

Function 3 selects log entries for printing by entering a callsign. What comes out is every log entry for that callsign. The logic is very simple and is located in line 510. Function 4 prints out all the log entries.

By using subroutines to

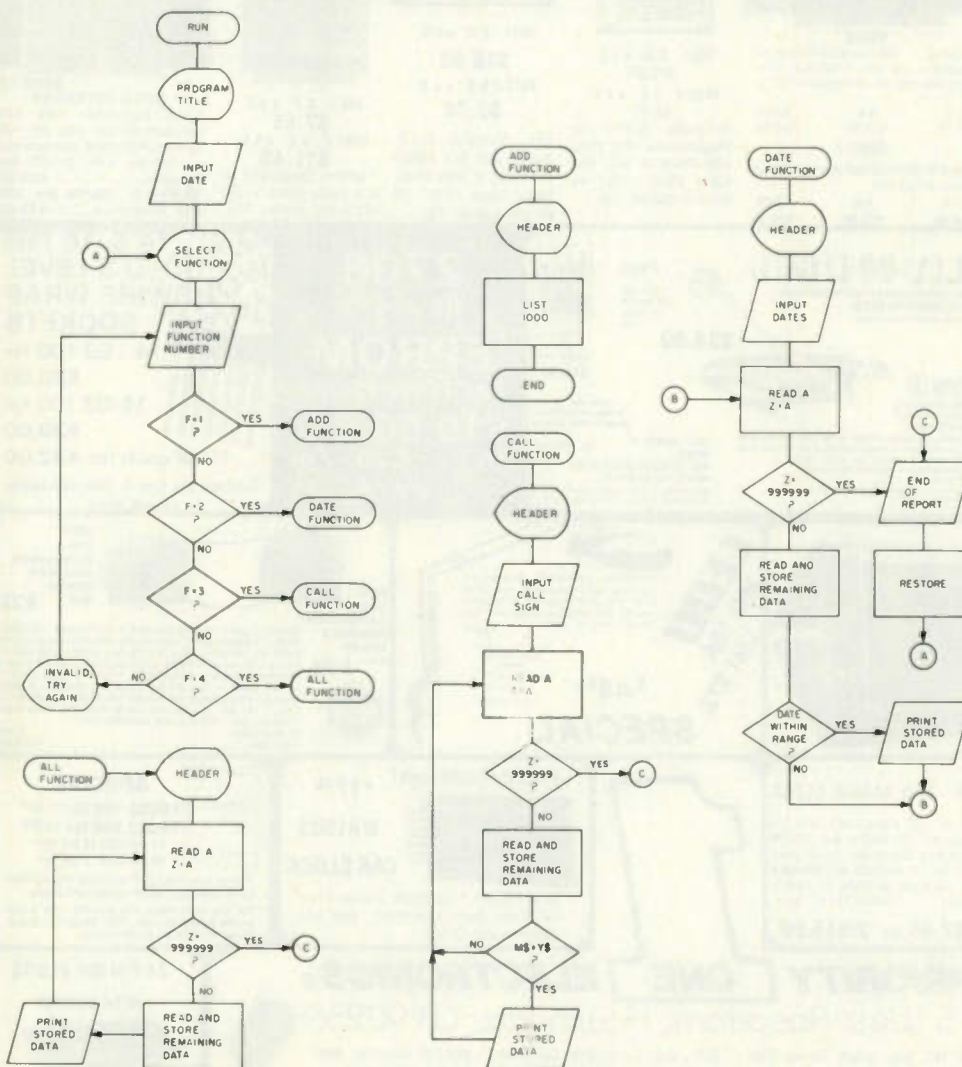

Fig. 1. System flowchart.

```

LIST
10 REM ***** AMATEUR RADIO LOG AND INQUIRY SYSTEM *****
11 REM             BY COMPUTER
12 REM WRITTEN BY CHUCK ZAPPALA WA7ZR 8051 NE 143RD BOTHELL WA 98011
13 REM
14 REM THIS PROGRAM IS RELEASED TO PUBLIC DOMAIN             MAY 1977
15 REM
16 REM VERSION 1.0     WRITTEN IN ALTAIR 8K BASIC VERSION 3.1
17 REM
18 REM *****
100 PRINT:PRINT"AMATEUR RADIO LOG AND INQUIRY SYSTEM":PRINT
102 PRINT:INPUT"ENTER TODAY'S DATE (YYMMDD)":JD:PRINT
103 PRINT:PRINT"SELECT ONE OF THE FOLLOWING FUNCTIONS":PRINT:PRINT
110 PRINT" 1. ADD LOG ENTRIES"
115 PRINT" 2. PRINT LOG ENTRIES BY DATE"
120 PRINT" 3. PRINT LOG ENTRIES BY CALL SIGN"
125 PRINT" 4. PRINT ALL LOG ENTRIES"
145 PRINT:INPUT"ENTER FUNCTION NUMBER":F
148 IF F=1 THEN GOTO 300
149 IF F=2 THEN GOTO 400
170 IF F=3 THEN GOTO 500
175 IF F=4 THEN GOTO 600
200 PRINT"INVALID. TRY AGAIN":GOTO 145
300 REM ADD LOG ENTRIES
302 PRINT:PRINT
304 PRINT"ADDING LOG ENTRIES BY DATA STATEMENTS":LIST 1000
400 REM PRINT LOG ENTRIES BY DATE
402 PRINT:PRINT
404 INPUT"ENTER FIRST DATE (YYMMDD)":J1:PRINT
406 INPUT"ENTER NEXT DATE (YYMMDD)":J2:PRINT
408 PRINT"LOG ENTRIES BETWEEN "J1;" AND "J2":PRINT:GOSUB 800
412 GOSUB 700
414 IF Z=999999 THEN 950
416 IF Z>=N1 AND Z<=N2 THEN 420
418 GOTO 412
420 GOSUB 720
422 GOTO 412
500 REM PRINT LOG ENTRIES BY CALL SIGN
502 PRINT:PRINT
504 INPUT"ENTER CALL SIGN":J3:GOSUB 800
506 GOSUB 700
508 IF A=999999 THEN 950
510 IF M$=X$ THEN 514
512 GOTO 506
514 GOSUB 720
516 GOTO 506
600 REM PRINT ALL LOG ENTRIES
602 PRINT:PRINT
604 GOSUB 800
606 GOSUB 700
610 GOSUB 720
612 GOTO 606
700 REM READ DATA FILE
702 READ A:Z=A:IF Z=999999 THEN GOTO 950
704 READ A$:Y$=A$
706 READ B$:X$=B$
708 READ C$:V$=C$
710 READ D$:W$=D$
712 READ E$:U$=E$
714 READ F$:T$=F$
716 READ G$:S$=G$
718 RETURN
720 REM PRINT DATA RECORD
722 PRINT Z;" "J1;" "J2;" "J3;" " "J4;" " "J5;" " "J6;" " "J7;" " "J8;"
724 RETURN
800 REM REPORT HEADER
801 PRINT "REPORT DATE "JD:PRINT
802 PRINT "DATE      TIME CALL      FREQ MODE PWR QSL QTH NAME"
804 FOR N=1 TO 51:PRINT" "J:PRINT" "J:PRINT" "
806 RETURN
900 REM END OF REPORT
902 PRINT"END OF REPORT":RESTORE:GOTO 105
999 END
1000 DATA 770502,1805,K9QAG,14.2,55B,260,N,IL,MEARNIE
1001 DATA 770502,1832,VB6RRF,14.2,55B,260,N,CA,GLENN
1002 DATA 770503,1158,ZLIBAG,14.2,55B,260,N,NZ,HAL
1003 DATA 770504,0914,VA0ZDR,14.3,55B,260,N,KA,SKIP
1004 DATA 770505,1105,WB5WCG,14.3,55B,260,Y,NM,DAVE
1005 DATA 999999

```

Fig. 2. Program listing.

read, store, control, and print, the program becomes quite small. For example, lines 700 to 718 read the data, test for end of data, and store the data in string variables Z, Y\$, X\$, W\$, V\$, U\$, T\$, and S\$. After reading, control returns to the calling portion of the program, usually to test either variable Z for dates or X\$ for callsign. If variable Z is within the date range, variables N1 and N2 or X\$ equal variable M\$. Then the printing subroutine (lines 720 to 724) is executed. In any case, the next

data line is read and tested again at line 702. If Z = 999999, then "END OF REPORT" is printed, the data pointer is RESTORED, and a new function is requested. Storage in lines 702 to 716 was done to accommodate any changes which might destroy the A to G\$ variables by intermediate printing, logic, or data manipulation. These same lines could easily have been written with FOR ... NEXT commands, as could the printing subroutines, but I decided to keep the program simple for

```

RUN
AMATEUR RADIO LOG AND INQUIRY SYSTEM
ENTER TODAY'S DATE (YYMMDD)? 770530
SELECT ONE OF THE FOLLOWING FUNCTIONS
1. ADD LOG ENTRIES
2. PRINT LOG ENTRIES BY DATE
3. PRINT LOG ENTRIES BY CALL SIGN
4. PRINT ALL LOG ENTRIES
ENTER FUNCTION NUMBER? 4
REPORT DATE 770530
DATE      TIME CALL      FREQ MODE PWR QSL QTH NAME
-----
770502 1805 K9QAG 14.2 55B 260 N IL MEARNIE
770502 1832 VB6RRF 14.2 55B 260 N CA GLENN
770503 1158 ZLIBAG 14.2 55B 260 N NZ HAL
770504 0914 VA0ZDR 14.3 55B 260 N KA SKIP
770505 1105 WB5WCG 14.3 55B 260 Y NM DAVE
END OF REPORT
SELECT ONE OF THE FOLLOWING FUNCTIONS
1. ADD LOG ENTRIES
2. PRINT LOG ENTRIES BY DATE
3. PRINT LOG ENTRIES BY CALL SIGN
4. PRINT ALL LOG ENTRIES
ENTER FUNCTION NUMBER? 3
ENTER CALL SIGN? ZLIBAG
REPORT DATE 770530
DATE      TIME CALL      FREQ MODE PWR QSL QTH NAME
-----
770503 1158 ZLIBAG 14.2 55B 260 N NZ HAL
END OF REPORT
SELECT ONE OF THE FOLLOWING FUNCTIONS
1. ADD LOG ENTRIES
2. PRINT LOG ENTRIES BY DATE
3. PRINT LOG ENTRIES BY CALL SIGN
4. PRINT ALL LOG ENTRIES
ENTER FUNCTION NUMBER? 2
ENTER FIRST DATE (YYMMDD)? 770503
ENTER NEXT DATE (YYMMDD)? 770504
LOG ENTRIES BETWEEN 770503 AND 770504
REPORT DATE 770530
DATE      TIME CALL      FREQ MODE PWR QSL QTH NAME
-----
770503 1158 ZLIBAG 14.2 55B 260 N NZ HAL
770504 0914 VA0ZDR 14.3 55B 260 N KA SKIP
END OF REPORT
SELECT ONE OF THE FOLLOWING FUNCTIONS
1. ADD LOG ENTRIES
2. PRINT LOG ENTRIES BY DATE
3. PRINT LOG ENTRIES BY CALL SIGN
4. PRINT ALL LOG ENTRIES
ENTER FUNCTION NUMBER? 1
ADDING LOG ENTRIES BY DATA STATEMENTS
1000 DATA 770502,1805,K9QAG,14.2,55B,260,N,IL,MEARNIE
1001 DATA 770502,1832,VB6RRF,14.2,55B,260,N,CA,GLENN
1002 DATA 770503,1158,ZLIBAG,14.2,55B,260,N,NZ,HAL
1003 DATA 770504,0914,VA0ZDR,14.3,55B,260,N,KA,SKIP
1004 DATA 770505,1105,WB5WCG,14.3,55B,260,Y,NM,DAVE
1005 DATA 999999

```

Fig. 3. Sample run.

small BASIC interpreters. By changing lines 100, 115, 120, 125, 304, 408, 504, 802, and the data lines, just about any kind of data record search can be accommodated. Other functions could easily be added, also. For example, you may want a printout of all the contacts that have or have not sent a QSL. This could be done by a comparison just like the one

in line 510. Only change X\$ to V\$, then add the required function call number and assign the line numbers. By using AND/OR logic operators, such as in line 416, a varying and quite flexible search can be established. You could print out log entries, such as by date and/or call, or whatever the data statements and logic are set up to look for. ■



DIP/IC INSERTION TOOL WITH PIN STRAIGHTENER



STRAIGHTEN PINS RELEASE PICK-UP INSERT

14-16 Pin Dip IC Inserter INS-1416 \$3.49

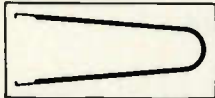

DIP/IC EXTRACTOR TOOL

The EX-1 Extractor is ideally suited for hobbyist or lab engineer. Featuring one piece spring steel construction. It will extract all LSI, MSI and SSI devices of from 8 to 24 pins.

Extractor Tool EX-1 \$1.49

P.C. BOARD



The 4 x 4.5 x 1/16 inch board is made of glass coated EPOXY Laminata and features solder coated 1 oz. copper pads. The board has provision for a 22/44 two sided edge connector, with contacts on standard .156 spacing. Edge contacts are non-dedicated for maximum flexibility.

The board contains a matrix of .040 in. diameter holes on .100 inch centers. The component side contains 76 two hole pads that can accommodate any DIP size from 6-40 pins, as well as discrete components. Typical density is 18 or 14-Pin or 16-Pin DIPs. Components may be soldered directly to the board or intermediate sockets may be used for soldering or wire-wrapping.

Two independent bus systems are provided for voltage and ground on both sides of the board. In addition, the component side contains 14 individual busses running the full length of the board for complete wiring flexibility. These busses enable access from edge contacts to distant components. These busses can also serve to augment the voltage or ground busses, and may be cut to length for particular applications.

Hobby Board H PCB-1 \$4.99



PC CARD GUIDES

TR-1 consists of 2 guides precision molded with unique spring finger action that dampens shock and vibration, yet permits smooth insertion or extraction. Guides accommodate any card thickness from .040-.100 inches.

QUANTITY - ONE PAIR (2 pcs.)

Card Guides TR-1 \$1.89

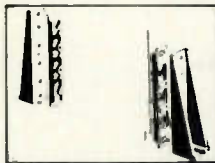

PC CARD GUIDES & BRACKETS

TRS-2 kit includes 2 TR-1 guides plus 2 mounting brackets. Support brackets feature unique stabilizing post that permits secure mounting with only 1 screw.

QUANTITY - ONE SET (4 pcs.)

Guides & Brackets TRS-2 \$3.79

QUANTITY - ONE SET (4 pcs.)

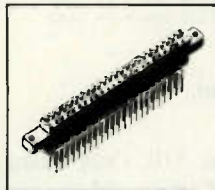

PC EDGE CONNECTOR

44 Pin, dual read out, .156" (3,96 mm) Contact Spacing, .025" (0,63 mm) square wire-wrapping pins.

P.C. Edge Connector CON-1 \$3.49

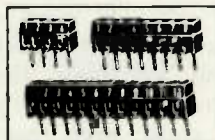

P.C.B. TERMINAL STRIPS

The TS strips provide positive screw activated clamping action, accommodate wire sizes 14-30 AWG (1,8-0,35mm). Pins are solder plated copper .042 inch (1mm) diameter, on .200 inch (5mm) centers.

4-Pole	TS-4	\$1.39
8-Pole	TS-8	\$1.89
12-Pole	TS-12	\$2.59

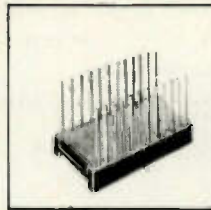

DIP SOCKET

Dual-in-line package, 3 level wire-wrapping, phosphor bronze contact, gold plated pins .025 (0,63mm) sq., .100 (2,54mm) center spacing.

14 Pin Dip Socket	14 Dip	\$0.79
16 Pin Dip Socket	16 Dip	\$0.89

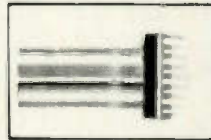

RIBBON CABLE ASSEMBLY SINGLE ENDED

With 14 Pin Dip Plug 24" Long (609mm)	SE14-24	\$3.55
With 16 Pin Dip Plug 24" Long (609mm)	SE16-24	\$3.75

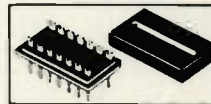

DIP PLUG WITH COVER FOR USE WITH RIBBON CABLE

14 Pin Plug & Cover	14-PLG	\$1.45
16 Pin Plug & Cover	16-PLG	\$1.59

QUANTITY: 2 PLUGS, 2 COVERS

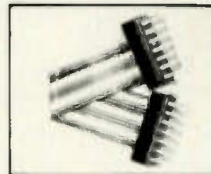

RIBBON CABLE ASSEMBLY DOUBLE ENDED

With 14 Pin Dip Plug -2" Long	DE 14-2	\$3.75
With 14 Pin Dip Plug -4" Long	DE 14-4	\$3.85
With 14 Pin Dip Plug -8" Long	DE 14-8	\$3.95
With 16 Pin Dip Plug -2" Long	DE 16-2	\$4.15
With 16 Pin Dip Plug -4" Long	DE 16-4	\$4.25
With 16 Pin Dip Plug -8" Long	DE 16-8	\$4.35

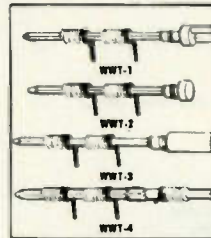

TERMINALS

- .025 (0,63mm) Square Post
- 3 Level Wire-Wrapping
- Gold Plated

Slotted Terminal	WWT-1	\$2.98
Single Sided Terminal	WWT-2	\$2.98
IC Socket Terminal	WWT-3	\$3.98
Double Sided Terminal	WWT-4	\$1.98

25 PER PACKAGE

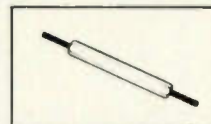

TERMINAL INSERTING TOOL

For inserting WWT-1, WWT-2, WWT-3, and WWT-4 Terminals into .040 (1,01mm) Dia. Holes.

INS-1 \$2.49

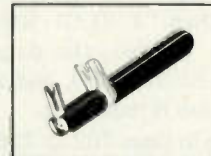

WIRE CUT AND STRIP TOOL

Easy to operate... place wires (up to 4) in stripping slot with ends extending beyond cutter blades... press tool and pull... wire is cut and stripped to proper "wire wrapping" length. The hardened steel cutting blades and sturdy construction of the tool insure long life.

Strip length easily adjustable for your applications.

DESCRIPTION	MODEL NUMBER	ADJUSTABLE "SPINNER" LENGTH OF STRIPPED WIRE INCHES TO INCHES	Price
24 ga. Wire Cut and Strip Tool	ST-100-24	1 1/8" — 1 1/4"	\$ 8.75
26 ga. Wire Cut and Strip Tool	ST-100-26	1 1/8" — 1 1/4"	\$ 8.75
26 ga. Wire Cut and Strip Tool	ST-100-26-875	7/8" — 1 1/8"	\$ 8.75
28 ga. Wire Cut and Strip Tool	ST-100-28	7/8" — 1 1/8"	\$11.50
30 ga. Wire Cut and Strip Tool	ST-100-30	7/8" — 1 1/8"	\$11.50

THE ABOVE LIST OF CUT AND STRIP TOOLS ARE NOT APPLICABLE FOR NYLON OR TEFLON INSULATION

MINIMUM ORDER \$25.00, SHIPPING CHARGE \$1.00, N.Y. CITY AND STATE RESIDENTS ADD TAX

OK MACHINE & TOOL CORPORATION

3455 Conner St. Bronx, N.Y. 10475 ■ (212) 994-6600 ■ Telex 125091



wire wrapping center

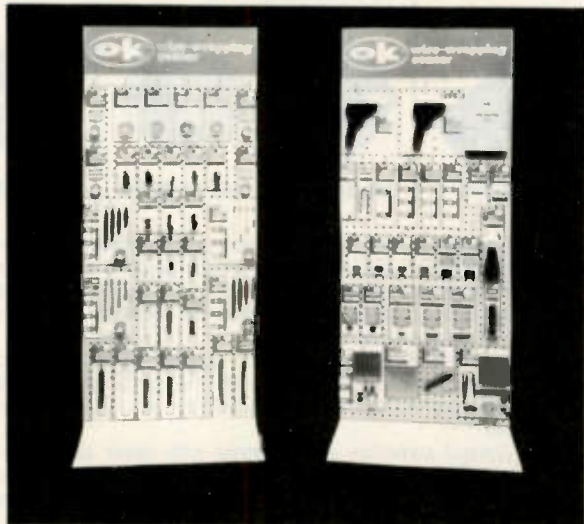

for quality electronic parts and tools.

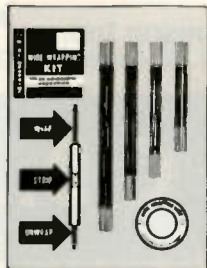

WIRE-WRAPPING KITS

Contains: Hobby Wrap Tool WSU-30, (50 ft.) Roll of wire
Prestripped wire 1" to 4"
lengths (50 wires per package)
stripped 1" both ends.

Wire Wrapping Kit, (Blue)	WK 2 B	\$12.95
Wire Wrapping Kit, (Yellow)	WK 2 Y	\$12.95
Wire Wrapping Kit, (White)	WK 2 W	\$12.95
Wire Wrapping Kit, (Red)	WK 2 R	\$12.95

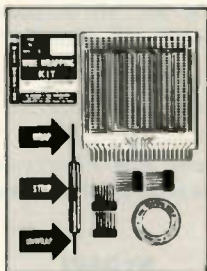

WIRE-WRAPPING KIT

Contains: Hobby Wrap Tool WSU-30,
Roll of wire R-30B-0050, (2) 14
DIP's, (2) 16 DIP's and Hobby Board
H-PCB-1.

Wire-Wrapping Kit	WK-3B (Blue)	\$16.95
-------------------	--------------	---------

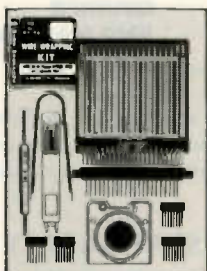

WIRE-WRAPPING KIT

Contains: Hobby Wrap Tool WSU-30 M,
Wire Dispenser WD-30-B, (2) 14 DIP's,
(2) 16 DIP's, Hobby Board H-PCB-1,
DIP/IC Insertion Tool INS-1416 and
DIP/IC Extractor Tool EX-1

Wire-Wrapping Kit	WK-4B (Blue)	\$25.99
-------------------	--------------	---------



HOBBY WRAP TOOL

Wire-wrapping, stripping, unwrapping tool for
AWG 30 on .025 (0,63mm) Square Post.

Regular Wrap	WSU-30	\$6.95
Modified Wrap	WSU-30M	\$7.95

NEW

HOBBY WRAP
Model BW-630



Battery
wire
wrapping
tool
COMPLETE
WITH BIT
AND SLEEVE

WIRE-WRAPPING TOOL

For .025" (0,63mm) sq. post
"MODIFIED" wrap, positive
indexing, anti-overwrapping
device.

For AWG 30	BW-630	\$34.95*
For AWG 26-28	BW 2628	\$39.95*

Bit for AWG 30	BT-30	\$3.95
Bit for AWG 26-28	BT-2628	\$7.95

*USE "C" SIZE NI-CAD BATTERIES
(NOT INCLUDED)



ROLLS OF WIRE

Wire for wire-wrapping AWG-30
(0.25mm) KYNAR® wire, 50 ft. roll,
silver plated, solid conductor,
easy stripping.

30 AWG Blue Wire 50ft. Roll	R 30B-0050	\$1.98
30 AWG Yellow Wire 50ft. Roll	R 30Y-0050	\$1.98
30 AWG White Wire 50ft. Roll	R 30W-0050	\$1.98
30 AWG Red Wire 50ft. Roll	R 30R-0050	\$1.98



WIRE DISPENSER

- With 50 ft. Roll of AWG 30
KYNAR® wire-wrapping wire.
- Cuts the wire to length.
- Strips 1" of insulation.
- Refillable (For refills, see above)

Blue Wire	WD-30-B	\$3.95
Yellow Wire	WD-30-Y	\$3.95
White Wire	WD-30-W	\$3.95
Red Wire	WD-30-R	\$3.95

PRE CUT PRE STRIPPED WIRE

Wire for wire-
wrapping AWG-30
(0.25mm) KYNAR®
wire, 50 wires per
package stripped
1" both ends.



30 AWG Blue Wire 1' Long	30 B 50 010	\$.99
30 AWG Yellow Wire 1' Long	30 Y 50 010	\$.99
30 AWG White Wire 1' Long	30 W 50 010	\$.99
30 AWG Red Wire 1' Long	30 R 50 010	\$.99
30 AWG Blue Wire 2' Long	30 B 50 020	\$ 1.07
30 AWG Yellow Wire 2' Long	30 Y 50 020	\$ 1.07
30 AWG White Wire 2' Long	30 W 50 020	\$ 1.07
30 AWG Red Wire 2' Long	30 R 50 020	\$ 1.07
30 AWG Blue Wire 3' Long	30 B 50 030	\$ 1.16
30 AWG Yellow Wire 3' Long	30 Y 50 030	\$ 1.16
30 AWG White Wire 3' Long	30 W 50 030	\$ 1.16
30 AWG Red Wire 3' Long	30 R 50 030	\$ 1.16
30 AWG Blue Wire 4' Long	30 B 50 040	\$ 1.23
30 AWG Yellow Wire 4' Long	30 Y 50 040	\$ 1.23
30 AWG White Wire 4' Long	30 W 50 040	\$ 1.23
30 AWG Red Wire 4' Long	30 R 50 040	\$ 1.23
30 AWG Blue Wire 5' Long	30 B 50 050	\$ 1.30
30 AWG Yellow Wire 5' Long	30 Y 50 050	\$ 1.30
30 AWG White Wire 5' Long	30 W 50 050	\$ 1.30
30 AWG Red Wire 5' Long	30 R 50 050	\$ 1.30
30 AWG Blue Wire 6' Long	30 B 50 060	\$ 1.38
30 AWG Yellow Wire 6' Long	30 Y 50 060	\$ 1.38
30 AWG White Wire 6' Long	30 W 50 060	\$ 1.38
30 AWG Red Wire 6' Long	30 R 50 060	\$ 1.38

® KYNAR-PENNVAL

MINIMUM ORDER \$25.00, SHIPPING CHARGE \$1.00, N.Y. CITY AND STATE RESIDENTS ADD TAX

OK MACHINE & TOOL CORPORATION

3455 Conner St., Bronx, N.Y. 10475 (212) 994-6600 Telex 125091

05

New!

Throw rocks on 40 meters for \$19.95*.



only \$19.95

Kantronics Rockhound transmitter

Jump into QRP.

The **Kantronics Rockhound QRP transmitter** generates a one watt CW signal anywhere on 40 meters. With the right crystal, and a little luck, Granite Falls, MI is just a stone's throw from Boulder, CO.

Slip the Rockhound in your pocket for mountain hikes or camping trips. Our **8040-B** receiver makes a lightweight companion. For power, just hook 12-15 VDC in-line with your key.

Start throwing today, our address is below.

*22.95 with 7.125 MHz crystal.

K13 **KANTRONICS**
The Lightweight Champs.

1202 East 23rd Street
Lawrence, Kansas 66044 Phone: 913-842-7745
We accept Visa, Master Charge, check and money orders.

Four against the Lightning!

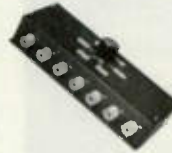

Model 595



Model 376



Model 590G



Model 375

Grounding is still the best protection against lightning damage. These four switches automatically ground all but the selected antenna. Leave one output for a dummy load, and you can ground all outside antennas. (Model 376 can ground all 5 outputs at once.)

Protect your valuable equipment against induced static charges from nearby strikes. Small enough to get past a spark gap protector, they can still burn out a solid-state front end.

B&W coaxial switches are ceramic with silver alloy contacts, handle 1000 watts CW, 2000 watts SSB. Negligible insertion loss. VSWR less than 1.2:1 to 150 MHz. Models 375 and 595: 6 outputs. Models 376 and 590G: 5 outputs.

At your B&W dealer. If you don't need grounding, ask him about our other ceramic coaxial switches.



Made in U.S.A. by **B23**
Barker & Williamson Inc.
Canal Street, Bristol, Pennsylvania 19007

THE NEWEST KEY IN THE WORLD...TRY QUIK-KEY!

1. Downward Pressure Assures, Key Will Not Walk or Slide
2. Adjustable Tension & Finger Spacing
3. Works With Any Keyer, Iambic Too!
4. Small & Compact size 2 1/2" x 5" x 1 1/8"



5. Precision Machined Highest Quality
6. Black Plastic Top Satin Chrome Base
7. Personalized, With Your Call (Specify)
8. It's Engineered, Try It.... You'll Like It

PAT. PEND.

SEE YOUR DISTRIBUTOR OR ORDER DIRECT

ONLY \$39.95 PLUS \$2.00 POSTAGE

QUIK-KEY P.O. BOX 73
KATONAH, N.Y. 10536

Q6

FOREIGN ORDERS: U.S. FUNDS / N.Y. STATE RESIDENTS
PLUS POSTAGE & INSURANCE / ADD 5% SALES TAX

Immediate Delivery-Order Now Dealer Inquiries Invited

10 METER C.B.?

SURE!!

With the proliferation of used SSB CB transceivers out there it's a perfect way to go QRP on TEN: Look around your neighborhood and come up with that 23 channel or 40 channel SSB. We make kits for 55 different radios that will put you on the 10 Meter C.W. and Phone Band. Perfect for Oscar work.

- Low cost (from \$10.00).
- Easy to install with all instructions.
- Tune up procedure.
- Alignment for base and mobile. We presently stock kits for most:

SBE	BROWNING	HYGAIN
REALISTIC	LAFAYETTE	MIDLAND
TRAM	TEABERRY	ROYCE
COBRA	REGENCY	COURIER
PRESIDENT	PACE	AND MANY MORE

Write or call today for free specification sheets or tell us the make and model of your transceiver and if we don't stock a kit for it, we will make one for you at the same price. For more information write:



AMERICAN CRYSTAL SUPPLY CO.
PO BOX 638 A58
W YARMOUTH, MA 02673
(617) 771-4634



IC-215 FM PORTABLE/MOBILE

- 15 channels (12 on dial/3 priority)
- Fully collapsible antenna or "rubber duck"
- Compatible mount for mobile operation
- Dual power (3 watts high/400mw low)
- External power and antenna easily accessible for mobile operation
- Lighted dial and meter
- Double-size, long-lasting internal batteries with optional Ni-Cd pack and charger available

ICOM's **IC-215** is the FM radio that puts good times on the go. Now an outstanding mobile mount and quick-change features for external power, speaker and antenna conversions make moving from base, to vehicle, to hill top fast and easy: and the **IC-215 portable/mobile** provides continuous contact for even the busiest FM enthusiast.

The **IC-215's** three narrow filters provide quality not usually found in portable VHF equipment. With 15 channel capacity and an MOS FET RF amp with 5 tuned circuits in the front end, the **IC-215** gives optimum FM portable performance.

You'll be carrying quality, performance and versatility with your **IC-215 FM portable/mobile**.

Specifications: Frequency Range: 146-148 MHz Voltage: 13.8 VDC negative ground Size: 183mm(h) x 61mm(w) x 162mm(d)
 Weight: 1.9 kg Number of Channels: 15 total, 12 on main switch, 3 priority Power Output: 3.0 W or 0.5 W Microphone Impedance: 600 ohms Spurious Level: lower than -60 dB Receiver Sensitivity: 4 dB below 1 UV or lower Spurious Response: 60 dB or better

All ICOM radios significantly exceed FCC specifications limiting spurious emissions.

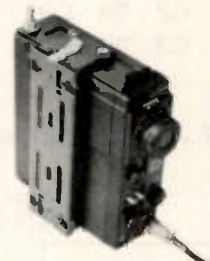

This new mobile mount is now available for your IC-215. Fast insertion and removal is a snap, and the mount is collapsible when not in use.

HF/VHF/UHF AMATEUR AND MARINE COMMUNICATION EQUIPMENT

DISTRIBUTED BY:



ICOM

ICOM WEST, INC.
 Suite 3
 13256 Northrup Way
 Bellevue, Wash. 98005
 (206) 747-9020

ICOM EAST, INC.
 Suite 307
 3331 Towerwood Drive
 Dallas, Texas 75234
 (214) 620-2780

ICOM CANADA
 7087 Victoria Drive
 Vancouver B.C. V5P 3Y9
 Canada
 (604) 321-1833

RAM Checkout's A Snap

— this tiny program does the job

Rod Hallen WA7NEV
P.O. Box 73
Tombstone AZ 85638

This "memory monitor" is a simple assembly language program designed to load zeros or sequential num-

bers into a block of memory for testing purposes. My original version would only load 256 bytes at a time, which made testing a new 8K board somewhat of a chore, since it had to be run 32 times (256 x 32 = 8K). This final version will load from 1 to 65,536 (64K) bytes of memory. That should be enough to satisfy everyone.

SOL Operations

First, let me describe how my SOL system works so that you can decide how the following explanation pertains to your machine. The SOL has a program in PROM called CONSOL, which handles the keyboard, video, and other routines. I can enter data to memory by typing "ENTER - (address) - (data) - CR," and I can dump memory to the video screen by typing "DUMP - (start address) - (finish address) - CR." If the difference between the start address and the finish address is less than 256 bytes, all of the data requested will fill the screen. If more than 256 bytes are requested, the read-out will start at the top of the screen and, when it reaches the bottom, will scroll upward until all of the requested data has appeared.

Apparently, the same ENTER and DUMP (examine) operations will work on a computer which uses front panel switches, but they will be done at a much slower rate. Testing a memory board can be accomplished on any machine by first manually loading data into each memory location on the board and then dumping or examining each location to determine that the correct information was indeed written. My memory monitor does it much more quickly! See Fig. 1. I am very much a novice when it comes to programming, so I make no claim that this is the easiest, fastest, or best way to get the job done.

Breakdown

If you are not familiar with assembly language, you might be interested in how the memory monitor does what it does. In fact, let's look at it line by line. Since SOL and I talk to each other in a number form called hexadecimal, all numbers in this program are hexadecimal (hex for short).

The first column in Fig. 1 is headed "Address," and that tells me where this program will be located in memory. When I tell SOL, "EXECUTE C900," it will go to memory location C900, execute the instruction located there, and then continue down the list of instructions until told to stop.

The second column is headed "Op code." These are the instructions, addresses, and data that the computer will use to perform its task.

Column three is headed "Mnemonic" (mnemonic means something that helps the memory). Mnemonics are the assembly language abbreviations for the op codes (machine language codes).

I started the program at location C900 because the SOL has 1K of onboard RAM beginning at that location. You can put it anywhere you like, but you must rewrite the two JNZ (jump non-zero) in-

Address	Op codes	Mnemonics
C900	0E 01	MVI C 01
C902	11 FF 1F	LXI D FF 1F
C905	21 00 00	LXI H 00 00
C908	36 00	MVI M 00
C90A	7E	MOV A M
C90B	81	ADD C
C90C	23	INX M
C90D	77	MOV M A
C90E	1B	DCX D
C90F	3E 00	MVI A 00
C911	BA	CMP D
C912	C2 0A C9	JNZ 0A C9
C915	BB	CMP E
C916	C2 0A C9	JNZ 0A C9
C919	C3 04 C0	CALL TO RESIDENT COMMAND MODE

Fig. 1. A complete listing of the memory monitor.

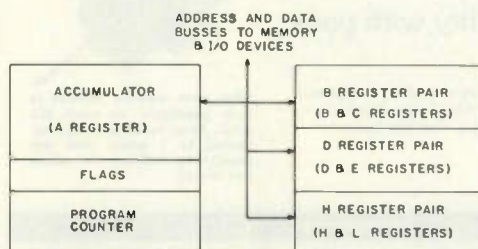

Fig. 2. A simplified drawing of the 8080. The registers which make up the B-, D-, and H-register pairs can be used either in pairs or as individual registers, depending on your requirements. The 8080 contains many other features which are not shown here.

structions. As they stand, a jump will be made to C90A (8080 address and register pair instructions are always written with the address or data backwards). If you wanted to load the memory monitor at location 8000, for instance, you would change C9 to 80 at each place that it appears in the program. This is called relocating the program.

In the first line, 01 in location C901 tells the computer how you want it to load the memory locations. 00 here would load all zeros (erase memory), and 01 would load sequential numbers, 00, 01, 02, etc. 02 would load 00, 02, 04, etc.

The FF 1F at locations C903 and C904 tells the computer how many address locations you want to load. FF 1F is actually 1FFF (backwards), which is 8K in the hexadecimal number system. See Fig. 3. If you wanted to load a 4K board, then line C902 would read 11 FF 0F.

Line C905 lets the computer know which address to start the loading at. The addressing of most memory boards is determined by setting on-board switches or by running jumpers. For this test, I addressed my 8K board to start at address 0000, but it could be set to start anywhere you want, and instruction C905 should reflect this address. If you wanted to locate this board at 6000 because you already had something at 0000, line C905 would read 21 00 60 (address reversed as usual).

Enter the program into the memory locations you have selected. Execute the first address, and the computer will load 00 into the starting address on the board to be tested, 01 in the next location, 02 in the next, and so on, until it has loaded as many locations as you requested. Then it will stop.

Fig. 2 is a simplified drawing of the internal makeup of the 8080 microprocessor. Making use of Figs. 1 and 2, let's step through the mem-

ory monitor as the computer would and see what happens. First, my "EXECUTE C900" command will load C900 into the program counter in the 8080 and start processing instructions from there. The program counter keeps track of which instruction comes next in the program.

The microprocessor can always tell from the first byte of an instruction whether it is a one-, two-, or three-byte instruction. As a start, it will fetch 0E, which is what it found at location C900, and, since it knows that 0E is a two-byte instruction, it will also fetch 01, which is in C901. 0E (MVI C) tells the processor to take the byte that follows 0E and load it into the C-register. The PC (program counter) then steps to C902 and starts a new fetch which is 11 plus FF 1F (LXI D FF 1F). 11 says load the following two bytes into the D-register pair (registers D and E). C905 - 21 00 00 (LXI H 00 00) loads 00 00 into the H-register pair (registers H and L), and C908 - 36 00 (MVI M 00) tells the processor to load 00 into the location whose address is found in the H-register pair. In other words, you put the address where you want to start your memory board test into the H-register pair (0000) and then tell the

processor to load 00 at that location.

Next, move the contents (00) of the start test location (0000) into the A-register (accumulator) C90A - 7E (MOV A M), which means that you are about to work on it. The next instruction C90B - 81 (ADD C) will add the contents of register C to the accumulator (00 + 01), and C90C - 23 (INX M) increases the address in the H-register pair by one. C90D - 77 (MOV M A) takes the contents of the accumulator (01) and puts them into the location whose address is now in the H-register pair (location 0001). Now you have 00 in location 0000 and 01 in location 0001. C90E - 1B (DCX D) subtracts one from the contents of the D-register pair, and C90F - 3E 00 (MVI A 00) puts 00 into the accumulator.

At the start, the D-register pair contained the total number of locations you wanted to load. After you've gone through the program once and subtracted one from D, check to see if you are finished. The accumulator contains the 00 which you loaded there. C911 - BA (CMP D) compares the contents of the D-register with the contents of the accumulator (00) and, if they are equal, sets the zero flag. If they are not

Decimal	Hexadecimal
256	FF
512	1FF
768	2FF
1024 (1K)	3FF
2048 (2K)	7FF
3072 (3K)	BFF
4096 (4K)	FFF
8192 (8K)	1FFF
16384 (16K)	3FFF
32768 (32K)	7FFF
65536 (64K)	FFFF

Fig. 3. A decimal-to-hexadecimal conversion table.

equal, C912 - C2 0A C9 (JNZ 0A C9) will take you back to C90A for another run through the program.

If they are equal (both 00), the program counter will move to C915 - BB (CMP E) and compare the E-register, which is the lower half of the D-register pair, to see if it is zero also. C916 - C2 0A C9 (JNZ 0A) works the same as C912 and reruns the program or passes to the next instruction, depending on the condition of the zero flag. When both registers of the D-register pair are equal to zero, then you have loaded as many memory locations as you originally asked for.

It is now time to exit the program. C919 - C3 04 C0 is a call to the command mode in the SOL CONSOL operating system. When SOL is

0000	00	01	02	03	04	05	06	07	08	09	0A	0B	0C	0D	0E	0F
0010	10	11	12	13	14	15	16	17	18	19	1A	1B	1C	1D	1E	1F
0020	20	21	22	23	24	25	26	27	28	29	2A	2B	2C	2D	2E	2F
0030	30	31	32	33	34	35	36	37	38	39	3A	3B	3C	3D	3E	3F
0040	40	41	42	43	44	45	46	47	48	49	4A	4B	4C	4D	4E	4F
0050	50	51	52	53	54	55	56	57	58	59	5A	5B	5C	5D	5E	5F
0060	60	61	62	63	64	65	66	67	68	69	6A	6B	6C	6D	6E	6F
0070	70	71	72	73	74	75	76	77	78	79	7A	7B	7C	7D	7E	7F
0080	80	81	82	83	84	85	86	87	88	89	8A	8B	8C	8D	8E	8F
0090	90	91	92	93	94	95	96	97	98	99	9A	9B	9C	9D	9E	9F
00A0	A0	A1	A2	A3	A4	A5	A6	A7	A8	A9	AA	AB	AC	AD	AE	AF
00B0	B0	B1	B2	B3	B4	B5	B6	B7	B8	B9	BA	BB	BC	BD	BE	BF
00C0	C0	C1	C2	C3	C4	C5	C6	C7	C8	C9	CA	CB	CC	CD	CE	CF
00D0	D0	D1	D2	D3	D4	D5	D6	D7	D8	D9	DA	DB	DC	DD	DE	DF
00E0	E0	E1	E2	E3	E4	E5	E6	E7	E8	E9	EA	EB	EC	ED	EE	EF
00F0	F0	F1	F2	F3	F4	F5	F6	F7	F8	F9	FA	FB	FC	FD	FE	FF

Fig. 4. A memory dump of the first 255 bytes of memory in the SOL. As can be seen, the computer has counted from 0 to 256 in hexadecimal.

turned on or the reset switch is pushed, the computer enters the command mode, puts a prompter (>) on the screen, and waits for me to tell it what to do. This line can be a jump or call to any location you desire and will depend on your machine's operating characteristics.

In order to determine how the test went, I type "DUMP 0000 1FFF," which covers all of the memory locations of this 8K board, and the screen will scroll through these loca-

tions. It's much too fast to really check individual locations, but I'm really only interested in the last location. Since the contents of each location are the contents of the previous location plus one, the contents of 1FFF should be FF, if the test went well. If they aren't, then it is necessary to dump 256 byte pages one at a time until the problem area is found. With this program, I found three 2102 pins that were bent under the IC instead of in-

serted into the sockets. Fig. 4 is what the first 256 bytes of memory look like after running the program.

Summary

Instruction information for the 8080 is contained in the *Intel 8080 Microcomputer Systems User's Manual* and the *Intel 8080 Assembly Language Programming Manual*. The "Intel 8080 Assembly Language Reference Card" is also useful. Anyone who is serious

about assembly language programming the 8080 should have all of these.

Any program, whether it is very simple or incredibly complex, is nothing more than a logical progression through a series of instructions. Pick some little chore that you'd like your machine to do, break it down into logical steps, convert those steps into assembly language instructions, and you'll be surprised and happy with the results. ■

Corrections

We would like our readers to note that ECONORAM, as it appeared in our July, 1978, issue ("RAMmed by Morrow—ECONORAM III lauded"), page 110, should have been written ECONORAM™.

John C. Burnett
Managing Editor

I have received quite a bit of mail about my article which you published in the Aug., 1977, issue of 73 entitled, "Build a Double Bazooka." A great deal of interest was evinced, and there were quite a few comments about the fact that the article had been written in a simple enough style that the average ham could understand it. I've naturally fully answered all letters. However, there was one small item, having to do with the printing, that has caused a bit of trouble.

As I have received several requests about its clarification, would you be able to put in a corrected sketch of Fig. 7? I believe that will help some amateurs who did not clearly see what the sketch was intended to show. The clarified sketch is shown below.

The correction may be particularly useful to fellows who are in other countries, and to those who perhaps did not easi-

ly understand the parallel coaxial bazooka that I developed.

Bill Vissers K4KI
Cocoa Beach FL

I would like to take this opportunity to apologize to you and your readers for not notifying you sooner through the "Letters" section of the demise of CONTACT, which I mentioned in most of my articles.

Inflation has hit the PC business just like everywhere else, and, since I refuse to sell junk or home-etched boards, we were forced out of the business by the last couple of boards. I still have on hand a couple hundred dollars of inventory of the COR and Auto-Dialer boards which never sold, and I was looking at expenses in the neighborhood of \$2000 to prepare boards for the next series of articles, so CONTACT went under, at least for the time.

Again, I regret not publishing this earlier and the inconvenience it has caused some readers of my articles.

Bill Hosking W7JSW
Scottsdale AZ

We erred. In "Yes, You Can Build A Synthesizer!" (July, 1978), several schematics were out of place. The correct Fig. 3

(p. 126) was printed on page 131 as Fig. 16. The correct Fig. 16, which was omitted, is shown below. The correct Fig. 17 was printed on page 126 as Fig. 3.

Finally, page 130, column 4, line 8 should read: "equal to the receiver's first $i-f + 10$ kHz."

John C. Burnett
Managing Editor

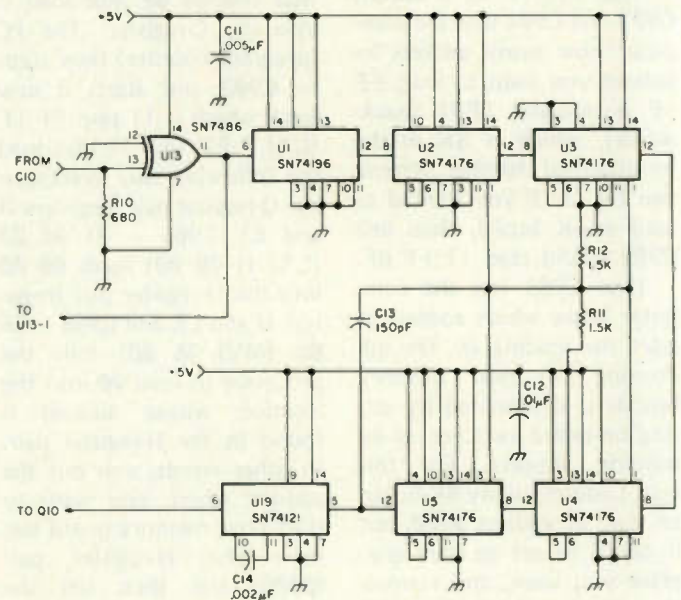

Fig. 16, "Yes, You Can Build A Synthesizer!"

Ham Help

I have recently obtained a General Electric closed circuit television camera which I plan to use on amateur slow scan. My problem is that the unit came minus control cables. The cable terminates in two Amphenol series 67 connectors with 42 pins. Some assistance would surely be appreciated. Thank you.

Jim Davis WD5IMS/8
24712 E. Woodside
Farmington Hills MI 48018

I'm looking for the maintenance manuals and schematics for the National HRO-500 receiver. These receivers have been used in MARS programs

over the years. I am willing to pay for duplication costs, if not too exorbitant.

Anton M. Giroux DA1NF/
WD6AXL
HHT, 2d ACR, SigO
APO NY 09093

I need a manual or setup procedure and schematic for a "Panoramic Sonic Analyzer," model AP-1, made by Panoramic Radio Products, Mt. Vernon, New York. This unit is a 40-Hz-20-kHz spectrum analyzer. I will gladly pay any reasonable price for a manual or readable copy.

Jerrold S. Tiers
6330 Southwood
Clayton MO 63105

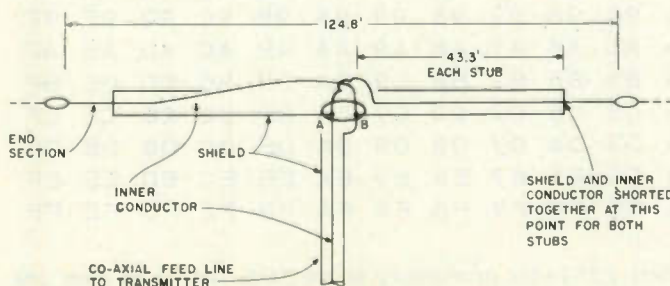

Fig. 7, "Build A Double Bazooka."

Pace-Traps Box 234
Middlebury CT 06762
P15

ICOM-22S OWNERS!!

Get rid of the CB dial. Go to direct frequency read-out in 30 minutes and minimum cost. PACE-DIAL will do the job. An accurately silk-screened replacement dial and enough dry-transfer numbers to make hundreds of frequency combinations. Tailors the dial to exactly the frequencies you have set-up in your ICOM. Complete dial-kit and full instructions furnished. \$3.25 ppd.

Check or MO to:
Box 234
Middlebury CT 06762
(203) 758-9228

MORE GOODIES FROM ISLAND

An unusual combination of ruggedness, compactness, and bandwidth is offered by these monoband heliwhip antennas. For 10, 15 & 20, all models use 6' tapered element halves.

WHIP Our hi-Z winding minimizes ground return losses for mobile service. \$18.

VEE 2 whip inverted V. Featherweight, efficient radiator goes way up there easily. Use with a kite or balloon for super DX. Direct 50Ω feed. 2 lb. \$35.

BEAM 4 whips: 2 el., driven & reflector. Cuts QRM, covers the band like a big antenna, but weighs only 4 lb. 10 dB 1/6" 6' boom, 12" el., direct 50Ω feed \$75.

MINI LP 8 whips: 4 el. Log periodic cell. Featured in June '78 73. Big signal from an 8 lb. antenna. 10' boom 12" el. \$175

2 week refund privilege on all antennas.

Island Antennas
Block Island, RI 02807
Custom antennas our specialty.

119

Trans Com T35
Tone Signaling Equipment

Featuring the TG-1B Sub-Audible Tone Encoder
Compatible with P.L., CG and other systems

Features:

- Low sine wave distortion of less than 1.5% THD
- Plug in tone element
- Excellent Temperature & frequency stability
- Low current draw using CMOS IC's
- Immunity to RF

Two year warranty

Priced at \$27.95
wired and tested
with tone element

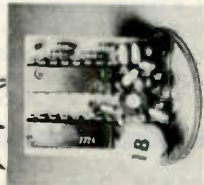

Also Available

DTMF encoder, from \$29.95, DTMF Decoders, and two tone sequential tone encoders and decoders.

Order from or for further information contact

Trans Com

P.O. Box 120, Addison, Illinois 60101 312-653-6724

RADIO WORLD

CENTRAL NEW YORK'S FASTEST GROWING HAM DEALER



Featuring Yaesu, Icom, Drake, Atlas, Dention, Ten-Tec, Swan, Regency, Standard, Tempo, KLM, Hy-Gain, Mosley, Larsen, Midland, Wilson, Southwest Technical Products. We service everything we sell! Write or call for quote. YOU WON'T BE DISAPPOINTED.

We are just a few minutes off the NYS Thruway (I-90) Exit 32

RADIO WORLD

ONEIDA COUNTY AIRPORT TERMINAL BUILDING ORISKANY, NY 13424
Warren K21XN Bob WAZMSH
315-337-2622

DISCOUNT SCANNERS

The Touch™



\$255.00 Prepaid USA

CHECK, M.O., MASTERCHARGE, VISA

BAY-COM B32

196 FRONT STREET
SCITUATE MA 02066
617-545-9700

Other Regency models at similar savings—send for list

Mass. residents please add 5% tax.

FREE!

NEW CATALOG OF HARD-TO-FIND PRECISION TOOLS



Jensen's new 144-page catalog is jam-packed with more than 3000 quality items. Your single source for hard-to-find precision tools used by electronic technicians, scientists, engineers, instrument mechanics, schools, laboratories and government agencies. This wanted catalog also contains Jensen's world-famous line of more than 40 tool kits. Plus 10 pages of useful "Tool Tips" to aid in tool selection. Send for your free copy today!

J7

JENSEN TOOLS & ALLOYS
1230 SOUTH PRIEST DRIVE - TEMPE, AZ. 85281

TELETYPE MODEL 33 ASR

COMPUTER I/O COMPLETE WITH:

- Tape Punch • Ready to Go
- Tape Reader • Line/Local Wired
- Guaranteed 30 Days

\$840.00

INCLUDING PACKING P.O.B. - NLE FACTORY

COMPLETE COVER READY TO INSTALL	\$ 39.00
COPY HOLDER (EEOC)	\$ 16.00
TAPE UNWINDER (12" NEW)	\$ 16.00
WIND-UP PAPER TAPE WINDER (12")	\$ 50.00
ELECTRIC PAPER WINDER (LFW 300 NEW)	\$ 50.00
DIC TYPE READER BURCARD	\$ 45.00
ACOUSTIC COUPLER	
ONLINE (DIA LINE)	\$180.00
READER POWER PACK (120V)	\$ 35.00
8 1/4 RES. I/O INTERFACE	\$ 15.00
ACOUSTIC COVERS with FAN (NEW)	\$265.00

If its for TELETYPE® We Have It.

If you don't see what you need

CALL or WRITE!



TELETYPEWRITER COMMUNICATIONS SPECIALISTS
350 Springfield Avenue, Berkeley Heights, N.J. 07922
(201) 464-5310 • TWX: 310 396-3016 • TELE: 13 6479

T13 SUBSIDIARY OF VAN'S W2DLT ELECTRONICS.

Key Electronics



Full ASCII Professional Keyboard Kit, Model 756

- Full 128 Character ASCII • Tri-Mode MOS Encoding • MOS/DTL/TTL Compatible Output
- Two-Key Rollover • Level and Pulse Strobe
- Shift and Alpha Lock • Selectable Parity
- Positive or Negative Logic • All New, OEM Grade Components • Gold Contact, Low Bounce Key Switches • Rugged G-10 Printed Circuit Board • Low Power Consumption ... and More

Model 756 Keyboard Kit	\$69.95
Model 701 Plastic Enclosure	\$14.95
Model 702 Steel Enclosure	\$29.95

Send for catalogue of other NEW merchandise, Semis, Sockets, ICs, Res., Caps, and MORE.

N.Y.S. Residents Add 4% Sales Tax

Send to: Key Electronics
P.O. Box 3506
Schenectady, NY 12303

K14

THE CRITIC'S CHOICE

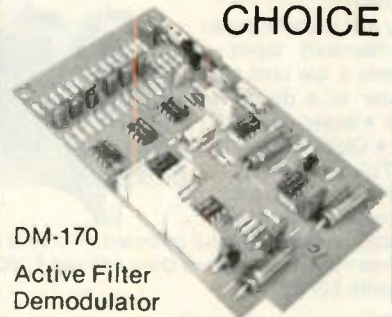

DM-170
Active Filter Demodulator

Critical buyers are choosing the DM-170 RTTY demodulator to give them more features at lower cost. Write for information and compare. Discover what the critics have: \$39.95 Kit \$59.95 Wired

FLESHER CORP.

P.O. Box 976 F5
Topeka, Kansas 66601

(913) 234-0198



SAVE

COMPUTER INTERFACES & PERIPHERALS

SAVE

For free catalog including parts lists and schematics, send a self-addressed stamped envelope.

APPLE II SERIAL I/O INTERFACE *

Part no. 102
Baud rate is continuously adjustable from 0 to 30,000 • Plugs into any peripheral connector • Low current drain. RS-232 input and output • On board switch selectable 5 to 8 data bits, 1 or 2 stop bits, and parity or no parity either odd or even • Jumper selectable address • SOFTWARE • Input and Output routine from monitor or BASIC to teletype or other serial printer. • Program for using an Apple II for a video or an intelligent terminal. Also can output in correspondence code to interface with some selectrics. Board only — \$15.00; with parts — \$42.00; assembled and tested — \$62.00.



T.V. TYPEWRITER

Part no. 106
• Stand alone TVT
• 32 char/line, 16 lines, modifications for 64 char/line included • Parallel ASCII (TTL) Input • Video output • 1K on board memory • Output for computer controlled cursor • Auto scroll • Non-destructive cursor • Cursor inputs: up, down, left, right, home, EOL, EOS • Scroll up, down • Requires +5 volts at 1.5 amps, and -12 volts at 30 mA • All 7400, TTL chips • Char. gen. 2513 • Upper case only • Board only \$39.00; with parts \$145.00



8K STATIC RAM

Part no. 300
• 8K Altair bus memory • Uses 2102 Static memory chips • Memory protect • Gold contacts • Wait states • On board regulator • S-100 bus compatible • Vector input option • TRI state buffered • Board only \$22.50; with parts \$160.00

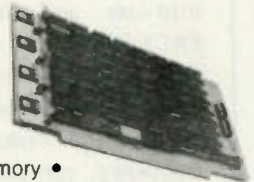

MODEM *

Part no. 109
• Type 103 • Full or half duplex • Works up to 300 baud • Originate or Answer • No coils, only low cost components • TTL input and output-serial • Connect 8 ohm speaker and crystal mic. directly to board • Uses XR FSK demodulator • Requires +5 volts • Board \$7.60; with parts \$27.50

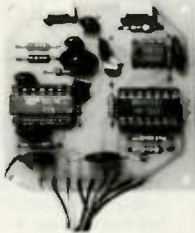

TIDMA *

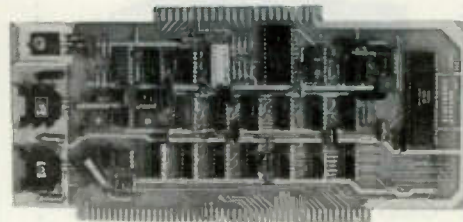

Part no. 112
• Tape Interface Direct Memory Access • Record and play programs without bootstrap loader (no prom) has FSK encoder/decoder for direct connections to low cost recorder at 1200 baud rate, and direct connections for inputs and outputs to a digital recorder at any baud rate. • S-100 bus compatible • Board only \$35.00; with parts \$110.00

DC POWER SUPPLY *

Part no. 6085
• Board supplies a regulated +5 volts at 3 amps., +12, -12, and -5 volts at 1 amp. • Power required is 8 volts AC at 3 amps., and 24 volts A.C.T. at 1.5 amps. • Board only \$12.50; with parts excluding transformers \$42.50



RS 232/TTY *

Part no. 600
• Converts RS-232 to 20mA current loop, and 20mA current loop to RS-232 • Two separate circuits • Requires +12 and -12 volts • Board only \$4.50, with parts \$7.00

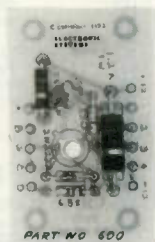

TAPE INTERFACE *

Part no. 111
• Play and record Kansas City Standard tapes • Converts a low cost tape recorder to a digital recorder • Works up to 1200 baud • Digital in and out are TTL-serial • Output of board connects to mic. in of recorder • Earphone of recorder connects to input on board • No coils • Requires +5 volts, low power drain • Board \$7.60; with parts \$27.50



UART & BAUD RATE GENERATOR *

Part no. 101
• Converts serial to parallel and parallel to serial • Low cost on board baud rate generator • Baud rates: 110, 150, 300, 600, 1200, and 2400 • Low power drain +5 volts and -12 volts required • TTL compatible • All characters contain a start bit, 5 to 8 data bits, 1 or 2 stop bits, and either odd or even parity. • All connections go to a 44 pin gold plated edge connector • Board only \$12.00; with parts \$35.00 with connector add \$3.00

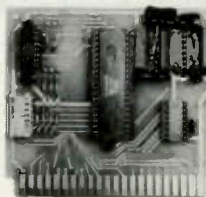

RS 232/TTL *

Part no. 232
• Converts TTL to RS-232, and converts RS-232 to TTL • Two separate circuits • Requires -12 and +12 volts • All connections go to a 10 pin gold plated edge connector • Board only \$4.50; with parts \$7.00 with connector add \$2.00



ELECTRONIC SYSTEMS Dept. 73, P.O. Box 21638, San Jose, CA. USA 95151

To Order:

Mention part number and description. For parts kits add "A" to part number. In USA, shipping paid for orders accompanied by check, money order, or Master Charge, BankAmericard, or VISA number, expiration date and signature. Shipping charges added to C.O.D. orders. California residents add 6.5% for tax. Outside USA add 10% for air mail postage, no C.O.D.'s. Checks and money orders must be payable in US dollars. Parts kits include sockets for all ICs, components, and circuit board. Documentation is included with all products. All items are in stock, and will be shipped the day order is received via first class mail. Prices are in US dollars. No open accounts. To eliminate tariff in Canada boxes are marked "Computer Parts." Dealer inquiries invited. 24 Hour Order Line: (408) 226-4064



* Circuits designed by John Bell

FREQUENCY STANDARD



- ✓ Precision crystal.
- ✓ Markers at 100, 50, 25, 10, 5 KHz.
- ✓ Zero adjust sets to WWV.

The Palomar Engineers Frequency Standard gives sharp clear markers throughout the high frequency band from 160 through 6 meters.

With the panel switch in 100 KHz position the markers can be heard every 100 KHz for checking calibration of your receiver, transceiver, or VFO. Additional markers can be turned on with the panel switch every 50, 25, 10 or 5 KHz.

The exclusive Palomar Engineers circuit generates only the wanted markers. No extra "ghost" markers appear.

Connection to your receiver is simple. A twisted-wire capacitor from the Standard to the receiver rf amplifier or mixer. Or a short "antenna" connected to the Standard may radiate enough marker signal.

The Frequency Standard is factory set to frequency and the setting can be checked and adjusted with the "zero" trimmer while listening to WWV or a broadcast station. All markers are as accurate as the WWV calibration, typically .0001%.

Don't take chances; check your frequency. Use the Standard with the wide range of selectable markers, the time-proven Palomar Engineers Frequency Standard.

Send for free brochure.

The price is \$42.50 (9-v battery not included) in the U.S. and Canada. Add \$2.00 shipping/handling. California residents add sales tax. **ORDER YOURS NOW!**

PALOMAR P1
ENGINEERS

BOX 455, ESCONDIDO, CA 92025

Phone: (714) 747-3343

MFJ INTRODUCES NEW

SUPER CW/SSB FILTERS

This new MFJ-721 Super Selector CW/SSB Filter gives you 80 Hz BW, steep SSB skirts, noise limiting, 2 watts for speaker plus more.



**BRAND
NEW**

\$59⁹⁵

This New MFJ-721 Super Selector CW/SSB Filter gives you a combination of performance and features available only from MFJ: • Razor sharp 80 Hz non-ringing CW filter • Steep skirt SSB filter • Selectable peak and trough noise limiting • Plugs in phone jack • Two watts for speaker • Simulated stereo reception • Inputs for 2 rigs • Speaker and phone jacks • Auxiliary 2 watt amplifier, 20 dB gain.

The CW filter gives you 80 Hz bandwidth and extremely steep skirts with no ringing for razor sharp selectivity. Lets you hear just one CW signal on the crowded Novice bands.

Bandwidth is selectable: bypass, 80, 110, 150, 180 Hz. Response is 60 dB down one octave from center freq. for 80 Hz BW. Center freq. is 750 Hz. Up to 15 dB noise reduction.

8 pole active IC filter. Low Q cascaded stages eliminates ringing. Hand matched components.

The SSB filter dramatically improves readability by optimizing audio bandwidth to reduce

sideband splatter, remove low and high pitched QRM, hiss, static crashes, background noise, and hum.

Makes listening for long periods pleasurable and less fatiguing. Ideal for contest and DX.

IC active filter includes 375 Hz highpass cut-off plus selectable lowpass cutoffs at 2.5, 2.0, 1.5 KHz (36 dB per octave rolloff).

Switchable automatic noise limiter for impulse noise; trough clipper removes background noise.

For Simulated Stereo, the raw signal goes to one ear and the filtered signal to the other. The signal appears in both ears and the QRM in only one. The ears and brain reject QRM yet off-frequency calls can be heard. Requires stereo phones.

Switch selects one of two rigs. OFF position connects speaker to rig. Speaker disables when phones are used. Requires 9 to 18 VDC, 300 ma. max. 5x2x6 inches. Optional AC adapter is \$7.95. Order yours now.

This New MFJ-720 Deluxe Super CW Filter gives you 80 Hz BW, no ringing, 2 watts out.

Same 8 pole Super CW Filter as in MFJ-721. 80 Hz BW, extremely steep skirts with no ringing for razor sharp selectivity. Selectable BW: 80, 110, 180 Hz. Center freq. 750 Hz. Automatic noise limiter. Plugs in phone jack to drive speaker to 2 watts. 2x4x6 in. Requires 9-18 VDC, 300 ma. max. Optional AC adapter, \$7.95.

**BRAND
NEW**

\$44⁹⁵



These MFJ active filters are the most copied in Industry.

CWF-2BX MFJ SUPER CW FILTER

SBF-2BX MFJ SSB FILTER

\$29⁹⁵ each



But performance is not copied. Only MFJ hand selects components so the center frequency of each CW stage is within one Hz of each other.

CWF-2BX and the SBF-2BX are the same CW and SSB filter as in the MFJ-721 but less speaker amplifier and noise

limiter. Plugs in rig to drive phones or connect between audio stage for full speaker operation. Uses 9 V battery. 2x3x4 inches.

For Orders, Call Toll Free

800-647-1800

ORDER TODAY BY MAIL OR CALL TOLL FREE 800-647-1800 AND CHARGE IT ON VISA OR MASTER CHARGE. Order any product from MFJ and try it. If not delighted, return it within 30 days for a prompt refund (less shipping). One year unconditional guarantee. Add \$2.00 shipping/handling. For order/repair status, in Mississippi and outside continental USA, call 601-323-5869.



MFJ ENTERPRISES, INC.

P. O. BOX 494 MISSISSIPPI STATE, MISSISSIPPI 39762 M52

Jody Nelis K3JZD
132 Autumn Drive
Trafford PA 15085

Photos by John Dugan



Photo A. Heathkit HW-2021 with the touchtone pad and 1/4-wave antenna installed.

The Case of the Missing Offset

—adding to the HW-2021

After using the Heathkit® HW-2021 2 meter FM hand-held for a little over a year, it has come time to answer the most often asked question of the missing +600 kHz offset once and for all.

Heath has made available to us an inexpensive kit complete with nicad batteries, charger, and rubber ducky antenna. Mine

was assembled carefully and has worked fine from the beginning. The transmitter power is adequate, and the receiver is both sensitive and selective. Since all the needed accessories are included with the kit, it is one of the best buys in the hand-held market.

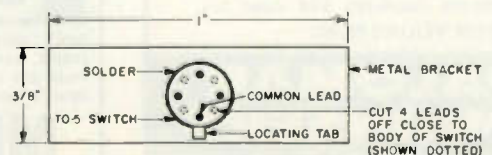

Fig. 1. Offset switch, bottom view (lead end).

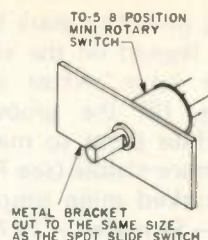

Fig. 2. Offset switch assembly.

There is a unique battery-saver pulsing circuit built into the receiver to extend the hours of operating time before the batteries require charging. Rather than the receiver remaining on all of the time, it is pulsed on five times per second, staying on only an instant, unless a signal is present. The battery drain at this time is barely measurable. When a signal breaks the squelch, the receiver stays on and operates normally.

Only one crystal per channel is required, bringing about a further savings when filling up the five available channels. The crystal used is cut for the receive frequency. The crystal netting capacitor can be tweaked just about exactly on frequency with a discriminating ear by listening to the incoming audio. This is great for the times you don't have access to a frequency counter but want to plunk in another channel. The transmit frequency is determined by offsetting the receive frequency, and that's where the rub comes in.

Heath, through some oversight, has overlooked the popularity of 147 MHz repeaters in the crowded suburban areas. As received from Heath, the HW-2021 comes with a two-position transmitter offset switch and two crystals to allow for simplex operation or a -600 kHz offset for the 146 MHz repeaters. The closest Heath comes to accom-

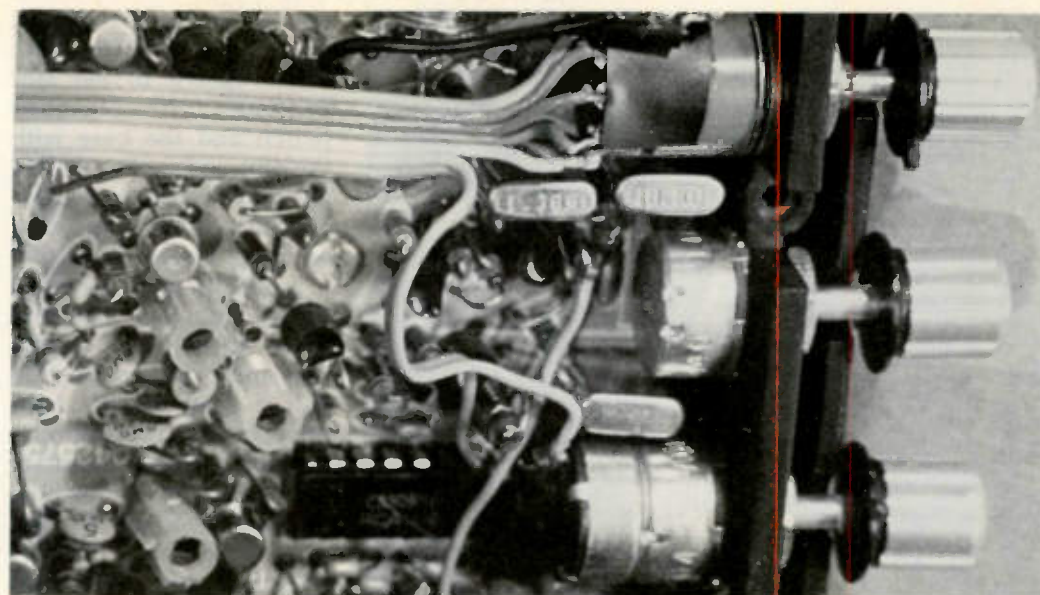

Photo B. Interior wiring details showing new switch and new crystal location.

modating a +600 kHz offset for the 147 MHz repeaters is to list the specifications for a 11.3 MHz crystal to do the job. To use it without making any further changes, you have to sacrifice either simplex operation or the -600 kHz offset. I wanted to work through the repeaters in both ends of the band without giving up simplex operation. The modification outlined here was planned before I even purchased the rig.

The size of a hand-held unit makes any modifications more difficult than they would be in a larger piece of gear. In this instance, finding an SP3T slide switch that would fit in place of the original SPDT switch turned out to be a hopeless task. It seems that nobody makes a sub-miniature SP3T. I didn't want to alter the HW-2021 case too drastically. The 11.3 MHz crystal had been ordered through an ad in 73 but sat gathering dust for want of a suitable switch.

Then one day it came to me—if an SP3T switch won't fit, why not try a SP8T switch? There are times when the electronic surplus market brings new and exotic components

down to a reasonable price. This time, just that happened. The TO-5 mini rotary switch had just appeared in a James ad in 73 *Magazine* for less than a dollar. I quickly ordered a handful and got back in gear again. Actually the switch is an SP7T with the eighth position being an off function. It was, however, small enough to use.

After identifying the common lead on the switch and making certain it was saved, alternate leads were cut off close to the body of the switch (see Fig. 1). I removed the extra leads to allow more space to wire to the remaining four. You now have an SP3T rotary switch with valid positions spaced at ninety degrees. There are five dead positions. Remove the original offset slide switch, unsoldering the three bare leads at the switch. Leave the three leads connected in the PC board, at the same length, for now. Cut a metal bracket from a piece of thin metal to the size of the original slide switch, so it will fit in the molded slot in the case. Drill the bracket in the center a little larger than the diameter of the plastic shaft of the TO-5

switch. Orient the TO-5 switch with the locating tab, as shown in Fig. 1, and solder the switch case to the metal bracket.

Insert the rotary switch in the slot in the bottom half of the case. Fit the top half of the case loosely. You will see where the tab on the top half interferes slightly with the switch shaft. File the tab on the top half with a round file, as necessary, to allow the switch to turn freely. It doesn't take much.

Reconnect the three bare wires still connected at the PC board to the new switch, as shown in Fig. 3. Trim the lengths so the wires just reach past the respective leads on the switch. You don't want the typical good mechanical connection prior to soldering here, since future removal of the PC board from the case is more easily accomplished by removing the offset switch first.

Remove the two existing crystals for the simplex and -600 kHz offset. You will move them around to make the switch positions more logical when you are finished. Insert the -600 kHz offset crystal (10.100 MHz) in the PC board socket where shown in Fig. 4. Similarly, insert the new

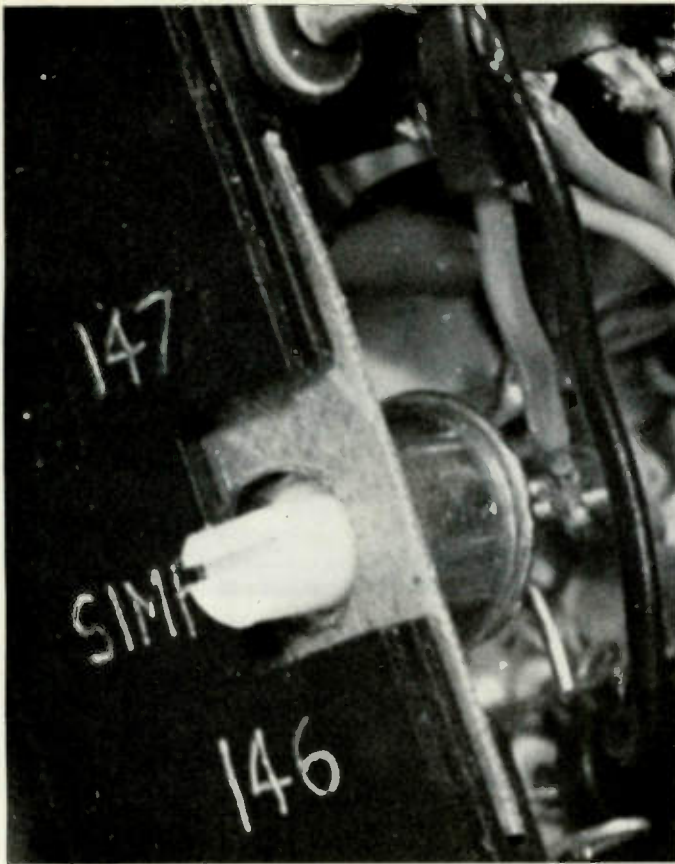

Photo C. Offset switch legend.

+600 kHz offset crystal (11.300 MHz) where shown in Fig. 4.

No location exists in the PC board for the third crystal, which is now the simplex crystal (10.700 MHz). There is a very convenient spot beside the channel selector switch which this crystal will fit into with a minimum of effort. First bend the pins on the crystal very slightly to the side (see Fig. 5). My kit from Heath conveniently included two additional crystal pin sockets (part #432-878). Maybe they all do or maybe it was just

luck, but I used them for the third crystal rather than soldering directly to the pins. Slip on the extra pin sockets if you have them, and solder a short length of insulated wire to each socket or crystal pin. I used shrink tubing over this connection for further insulation.

Loosen the channel selector switch mounting nut, and move the switch as close to the squelch control as the mounting hole in the case will allow. There is a little slop in the mounting hole. Put a piece of plastic electrical tape over the

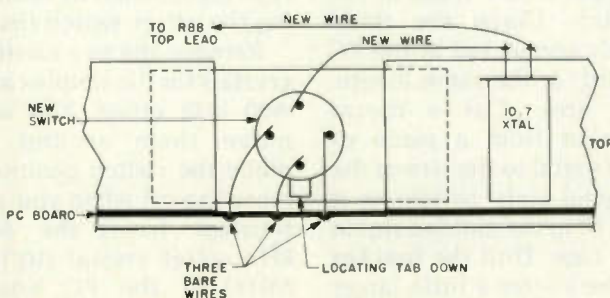

Fig. 3. Offset switch wiring diagram.

channel switch terminals. Insert the 10.700 MHz crystal down in the slot between the channel switch and the case with the pins up (see Fig. 4). The crystal will remain captive without anything else securing it in this location.

Carefully mate the case halves together. Do not force them. The crystal pins may rub on the top half if they are not bent enough. As a precaution, I scraped a little of the silver paint from the inside of the top case half where they might touch. This is metallic paint and is at ground potential. If the channel selector switch binds after adding this crystal, rather than turning freely as before, it must be moved even closer to the squelch control. The case may go together a little more snugly now, but it shouldn't require enough force to damage anything.

After the crystal is mechanically installed, solder the wire coming from the near pin on the crystal to the remaining pin on the offset selector switch (see Fig. 3). The remaining lead from the crystal goes to ground. I connected it to the top lead of resistor R88 which is convenient and at ground potential.

I used an electric en-

graving pencil to mark the switch legend on the side of the case. After engraving, fill the grooves with white paint to make them more visible (see Fig. 6). I marked mine simply, "146—Simplex—147," rather than the usual +600 and -600; it's less to remember. If you oriented the switch the same as I did, the flat side of the TO-5 shaft acts as the pointer. I painted the flat side red for quick identification in the light. At night or when operating mobile, the flat is easily identified by feel. Switching positions on the switch is done by thumbnail, using the slot cut into the end of the shaft.

As with any other 2m rig using a plus or minus 600 kHz offset switch, a certain amount of memory must be programmed into the operator at this time. You will find, as I have, that transmitting with the -600 kHz offset dialed in and a 147.09 receive crystal selected will never break the squelch on a 69-09 machine. It probably puzzles anyone using 146.49 simplex at the time, though! Another error to watch out for is using 146.52 with the -600 kHz offset. I imagine this is a probable source of the occasional FM signal that

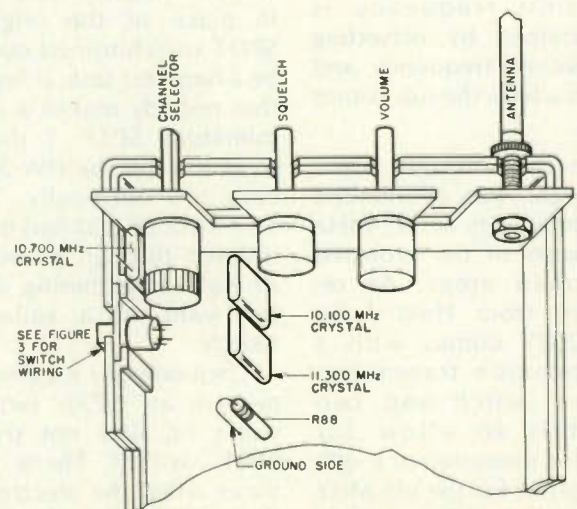

Fig. 4. Parts placement diagram.

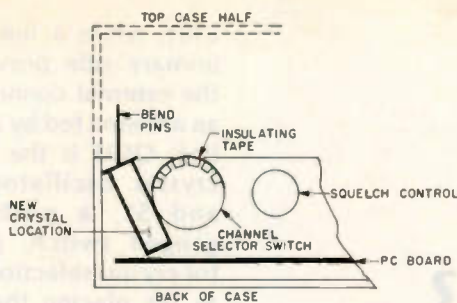

Fig. 5. New crystal location.

tears up the OSCAR satellites. 145.92 MHz is in the input range of both OSCAR 6 and OSCAR 7.

Now that you have the HW-201 operating on the whole 2 meter FM band, here are a few other features you can add to improve its performance and versatility. As with any other hand-held, a 1/4-wave antenna extends the usable range of this rig far beyond that possible with the rubber ducky provided. Heath has made it a little tougher than usual due to their fixation with nonstandard rf connectors. The HW-201 antenna has a 1/4 x 32 threaded connection, rather than the usual BNC connector. This causes no problem for mobile use. Although unusual, the shorting phone jack provided allows easy connection to an external roof-mounted mobile antenna. There is a problem when you want a 1/4-wave or 5/8-wave whip on top of the hand-held. The 1/4 x 32 is not a common thread. The standard readily-available 1/4-inch diameter bolts are 1/4 x 20 or 1/4 x 28. I eventually ended up at a local machine shop where they were able to turn a length of brass rod to the 1/4 x 32 thread. They also came up with some matching 1/4 x 32 nuts.

I used a 21-inch collapsible whip from a broadcast radio for my 1/4 wave. Use a two-inch length of the threaded rod drilled at one end to accept the collapsible whip. Solder the two together. Double nut the

threaded rod about 1/2 inch from the other end to provide a stop when screwing it into the HW-201. Put a piece of shrink tubing over the connection to make it look neat. Fig. 7 shows my system. Final operating length for the whip was determined by varying the length while getting signal reports from another station about ten miles away.

As the photographs show, I also added a touchtone encoder for autopatch and remote-control use. Heath makes an encoder kit for the HW-201, but I shied away from it because of the possible temperature sensitivity of the 555 timer circuitry, as well as the frequency adjustments it requires. Instead, I chose an encoder sold by the Barber Corporation in Waynesville, Ohio. As advertised in 73, their pad sells for \$34.50 postpaid. A matching case is required for surface mounting the pad to the face of the HW-201. Barber also has the case for an additional \$2.00 postpaid.

The sixteen-button pad was used rather than the more common twelve-button pad only because the matching case is not available for a twelve-button. The Barber unit comes assembled and is self-contained, using a Motorola MC-14410 chip and a 1 MHz reference crystal. No frequency adjustment is required for this unit, nor do the extremes of Pennsylvania's temperatures seem to af-

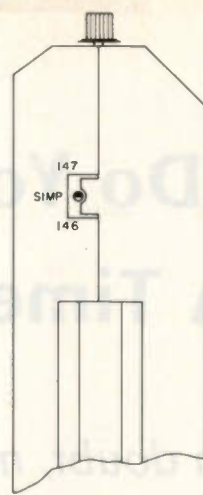

Fig. 6. Switch legend.

fect it.

I hooked the pad up using the three-wire circuit in the Barber Corp. instructions. The HW-201 has a high impedance input. Take the power for the pad from the transmitter circuit. Use the +12 volts from pin Z which Heath provided on the PC board for a TTP. The ground connection goes to pin Y, also provided on the PC board. The audio out from the Barber pad goes to the TTP input pin on the HW-201 (pin H). My kit included three extra matching female connectors (part #432-120), making these connections a snap. No additional coupling capacitors are required in the audio line, but I did need a 47,000-Ohm resistor in series to keep the level compatible with my local repeaters. Some experimentation is usually required here, since no two repeaters have the same input requirements.

Start with an adjustable pot in series with the audio line to set the level to suit your repeater. Measure the final value and replace the pot with the nearest fixed value resistor. Put this resistor in the line inside the HW-201 case where it is accessible in the event that a change in value is ever required.

The holes provided in

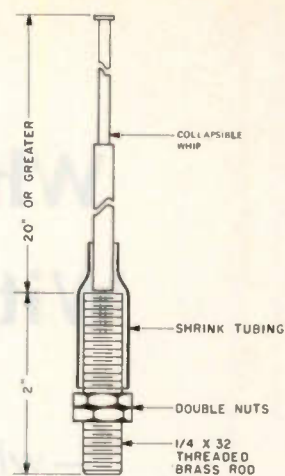

Fig. 7. 1/4-wave whip details.

the top of the HW-201 case for the Heath TTP are not usable for this pad. I used plastic model cement and glued the plastic TTP case to the face of the HT case. The touchtone pad itself was also glued into its case with a light dab at each corner. Maintenance should rarely be required, but, if it is, a knife blade breaks the bond on the glue joints easily.

For mobile work in the hills of Pittsburgh, I built the TR22/15 amplifier from the article in the April, 1976, issue of 73. The HW-201 drives this amplifier to between ten and fifteen Watts.

I glued some spring steel clips found in a stationery store to the back of the HW-201 for a belt clip. Later, the information on how to acquire a Motorola belt clip appeared in 73 Magazine. It looks a little better. See the letter titled "Bug IV" on page 14 of the November, 1976, issue for ordering information for this clip.

If you have kept up with me on these modifications and improvements to your HW-201, you are now ready to hold your head high when asked the question and reply: "What do you mean it's a nice looking rig but it won't operate on the 147 MHz repeater? Mine does!" ■

What Do You Do With A Timekube?

— when in doubt, modify it!

73 Magazine Staff

Radio Shack has introduced its Timekube WWV receiver. Actually, one must say that it has been reintroduced. Many hams will remember using the former model of this WWV receiver in their shacks. However, the former receiver proved too expensive for Radio Shack to continue to have manufactured to sell at a price level which they felt would generate a good sales volume for such a type of receiver. So the receiver

was discontinued for a time.

It is interesting, then, to examine what Radio Shack has now been able to come up with in a low-priced (\$35) crystal-controlled HF receiver. After all, to receive WWV well in most areas of the country, considering WWV's signal strength and the QRM, the receiver used has to have a fairly good sensitivity and reasonable selectivity. Its performance has at least to start to approach that of a regular communications receiver.

To say it in a nutshell, the Timekube performs its intended function very

well. So it is interesting to examine the receiver in a bit of detail to see what circuitry is used and to speculate on what other uses the receiver might be put to around the ham shack.

As its name implies, the Timekube is a compact 8 x 12 x 9 cm box that provides for the crystal-controlled reception of WWV at 5, 10, or 15 MHz. It has its own internal speaker and telescoping whip antenna and operates from a standard 9 V transistor radio battery. There is a sliding time scale on the front of the receiver, so local time in any part of the U.S. can be read off continuously opposite the GMT time scale. The only external connection provided for is to an external antenna. Operation is extremely simple in that a push-button is depressed for the desired WWV frequency.

Fig. 1 is the complete schematic of this interesting little receiver. The circuit is that of a simple single-conversion superheterodyne. A few circuit details deserve a little bit of attention. Q104 is the grounded base rf amplifier state which is tuned both at its input and output by L101 and L103, respectively. The rod antenna is connected across the high-impedance side of

L101, while a link on the primary side provides for the external connection of an antenna fed by a coaxial line. Q105 is the untuned crystal oscillator stage, and S1, a push-button ganged switch, provides for crystal selection as well as for placing the proper capacitance across L101 and L103 to tune those circuits. Q101 is the mixer stage, and the rest of the receiver is basically a conventional 455 kHz i-f amplifier/AM-detector/audio amplifier configuration. The only exception is the method used to obtain improved i-f selectivity by using "crystal bypassing" in the emitter lead of Q102. This method of getting a single crystal filter into an i-f amplifier with a minimum of fuss was used years ago in some amateur circuits but rarely appeared in commercial equipment. The idea is to replace the emitter bypass capacitor with a crystal. The stage gain will be greatest at the series resonant frequency of the crystal.

Radio Shack claims a ½-microvolt sensitivity (10 dB S/N), but the actual sensitivity which could be measured was from 1 to 3 microvolts throughout the 5 to 15 MHz range. This is more than adequate for WWV reception or for a wide variety of other uses. The selectivity was what was to be expected from a single-pole crystal filter and very adequate for WWV reception. The 200-milliwatt audio output is adequate when WWV is strong, but a bit marginal when WWV is weak and one would like to hear the WWV tones with good volume. Of course, the audio output has to be a compromise with the battery life, and 200 milliwatts is the best one can do working from a 9-volt transistor radio battery.

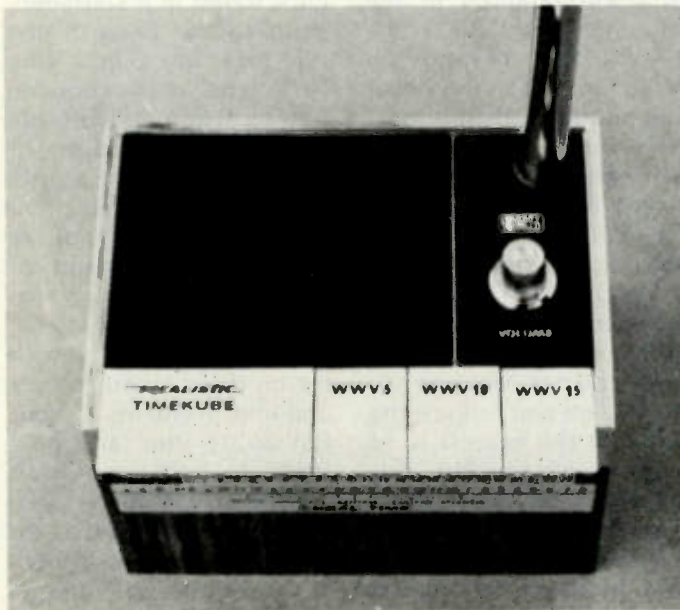

Photo A.

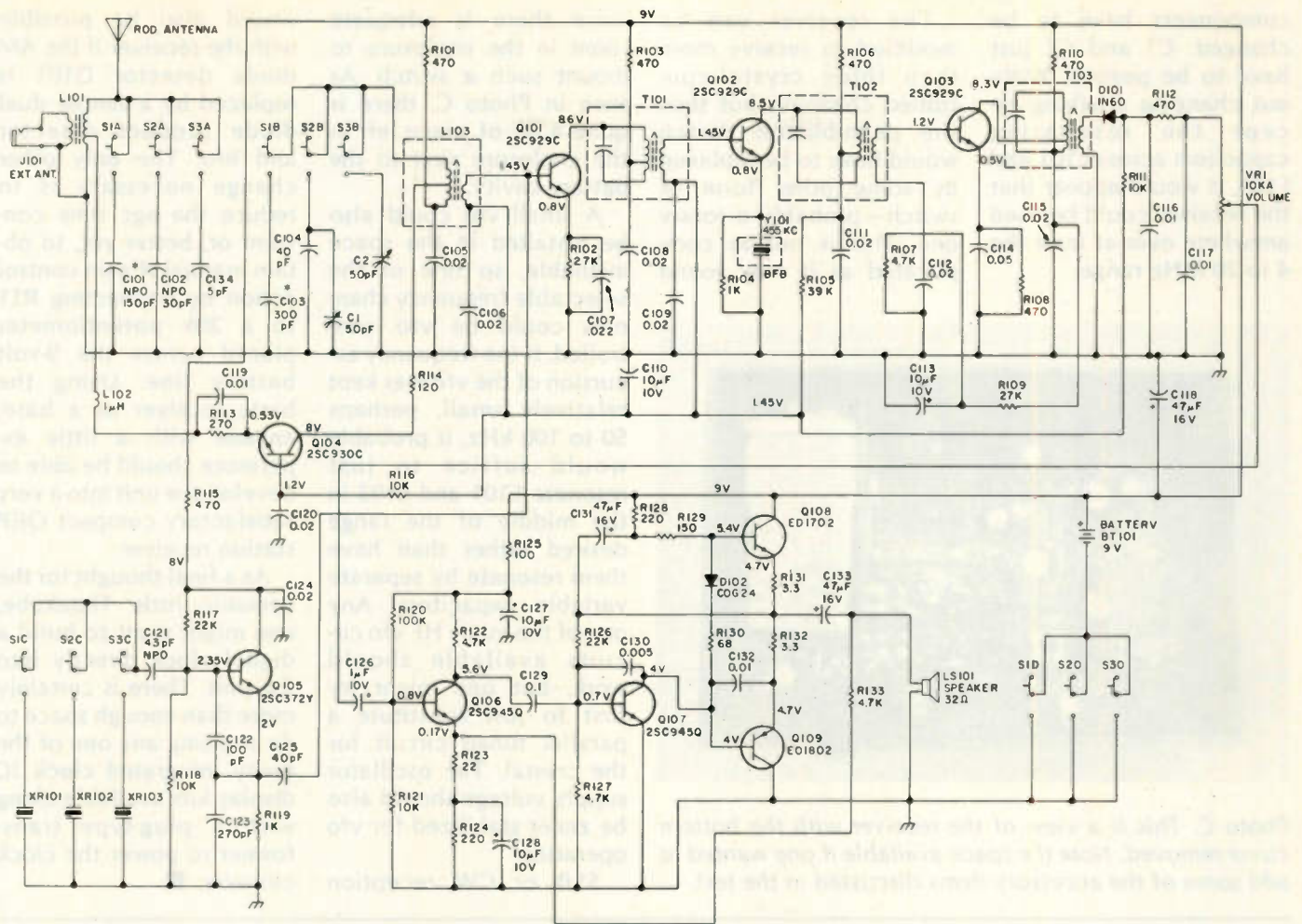

Fig. 1. This is the complete schematic of the Timecube WWV receiver. Unless otherwise specified: resistors—in Ohms, 10% tolerance, 1/4-Watt carbon; capacitors—in microfarads; voltages—dc measured with high input impedance voltmeter without signal reference to ground. *For Canadian model (12-158), C101 = 60 pF; C103 = 120 pF.

If one purchased and used the receiver only for WWV reception, there are just two minor modifications one might consider. The antenna jack on the receiver is really an audio type commonly used for the "external speaker" or "headphone" function on a portable radio. It can be replaced by a BNC or phone plug jack for the antenna connection and is itself used as an external speaker/headphone jack.

If one considers other uses for the receiver, there is quite a range of possibilities. One of the most interesting, which requires very little modification, is to use the receiver for reception in the HF international broadcast bands. One such receiver was actually used in Europe and

equipped with crystals for some VOA and BBC frequencies. So, when one wanted to hear a bit of news, etc., all one had to do was press a button and there it was. The telescoping antenna, which does not retract completely into the receiver, was removed for compactness. A short length of wire—about 5 feet—provided excellent reception.

The guts of the receiver are shown in Photo B. The whole receiver circuitry is contained on one double-sided PC board measuring slightly smaller than 11 x 7½ cm. As can be seen from the photo, changing crystals for any or all of the original three WWV crystals is not complicated. Miniature HC-25/U crystals are used and are readily

obtainable from sources such as Jan Crystals at a reasonable price (\$4-5). The crystal frequency is simply calculated as the desired reception frequency plus 455 kHz. The components switched in with different

crystals to resonate L101 and L103 may also have to be changed depending upon how far away the new reception frequencies fall from 5, 10, or 15 MHz. For reception in the 9 and 15 MHz broadcast bands, no

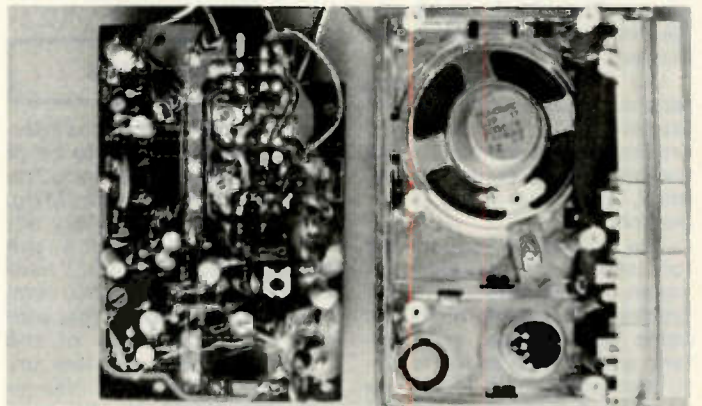

Photo B. This view shows the receiver PC board removed from the receiver enclosure. Two of the three possible crystals are installed. The bandswitch is located on the other side of the board.

components have to be changed. C1 and C2 just have to be peaked. Without changing anything except the resonating capacitors across L101 and L103, it would appear that the receiver could be used anywhere over at least the 4 to 20 MHz range.

The receiver can be modified to receive more than three crystal-controlled channels, but then the push-button switch would have to be replaced by some other form of switch—probably a rotary one. This is not as complicated as it may sound

since there is adequate room in the enclosure to mount such a switch. As seen in Photo C, there is quite a bit of space left in the enclosure next to the battery cavity.

A small vfo could also be installed in the space available, so one of the selectable frequency channels could be vfo controlled. If the frequency excursion of the vfo was kept relatively small, perhaps 50 to 100 kHz, it probably would suffice to just resonate L101 and L103 in the middle of the range desired rather than have them resonate by separate variable capacitors. Any one of the many HF vfo circuits available should work, but one might try first to just substitute a parallel tuned circuit for the crystal. The oscillator supply voltage should also be zener stabilized for vfo operation.

SSB or CW reception

would also be possible with the receiver if the AM diode detector D101 is replaced by a simple dual diode product detector and bfo. The only other change necessary is to reduce the agc time constant or, better yet, to obtain manual rf gain control action by connecting R11 to a 20k potentiometer placed across the 9-volt battery line. Using the basic receiver as a base, anyone with a little experience should be able to develop the unit into a very satisfactory compact QRP station receiver.

As a final thought for the versatile little Timekube, one might want to build a digital clock directly into the unit. There is certainly more than enough space to do so using any one of the many integrated clock IC display kits available along with a plug-type transformer to power the clock circuitry. ■

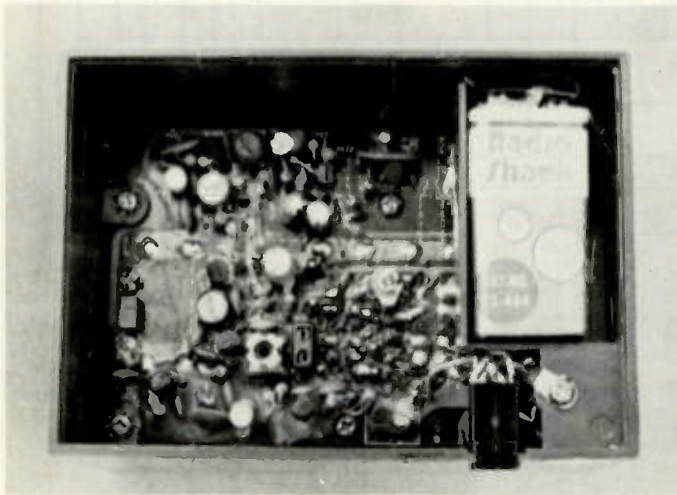

Photo C. This is a view of the receiver with the bottom cover removed. Note the space available if one wanted to add some of the accessory items discussed in the text.

ou goons don't ever proof
lousy manuscripts from bat
burch
you
I insist that you print ev
tell Ma Bell that she shou

LETTERS

from page 104

7, 9, and 0 being activated. The FCC recently began issuing KA prefix call signs to stations within the 48 contiguous states. That is our problem. KAs in Japan and KAs in the States!

Our QSL bureau is already receiving cards destined to stateside KAs, but our funds are limited and we must return the cards to the states via bulk mail, thus delaying their delivery.

The authorities responsible for issuing KA call signs in Japan do plan to look into this problem, but it will probably be some time before any long-term solution can be found. Until that solution is found, we can only suggest that anyone sending a QSL to a KA should clearly mark the card to indicate whether it is destined for Japan (an APO or FPO address) or a stateside station.

If anyone has any questions or any suggestions, please contact me at the address below.

Ralph H. Fellows II KA2RF
Box 2785
APO San Francisco CA 96328

MICODER MOD

I have come upon some information which is sure to be of some use to your readers. The Icom IC-215 portable 2m FM rig, which seems to be a very hot seller this year, and the Heathkit Micoder seem to have a place together for a nice combination. But it seems that with the high impedance of the microphone and the low impedance of the radio mike input, the result is low tone volume and bad audio. This situation may be corrected by placing a resistor of about 560-680 Ohms between the white audio lead and ground in-

side the microphone. Results on several units thus far have been excellent.

William Michalson WB2VRJ
Clay NY

GET OUT OF THE ITU

I think you are 100% correct. Get out of the ITU before it's too late. Why Outer Mongolia with no hams and fewer radios should have the same vote as the USA is absurd. It's time this nation acted like a first-rate power instead of a fifth-rate one. I hope your editorial was read by the people who control whether or not we stay in the ITU.

Ron George K7UL
Phoenix AZ

... AND THIS ONE

I have enjoyed my last year's subscription to your magazine, but I cannot renew the subscription.

I am a member of, and support, the ARRL, and will not be a party to an organization that demeans the ARRL viciously in every issue the way your Mr. Green does. (Your cartoon does him justice—all negative.) The ARRL makes mistakes as any-

one who tries to do something will do, and I will be the first to say we should point out these mistakes. But the way 73 does this—via Mr. Green's sarcastic attacks every month—is not the way.

If you decide to change this part of your magazine, I would enjoy subscribing again.

R. C. Cranford WA4SSI
Wallace NC

10M AM

I have seen quite a few references made to channelized 10m AM operation lately and you have also asked if your readers are interested in this type of operation. I have followed this very carefully and as yet have not read much about it in the letters column of 73. Rest assured there are hams interested in this, even over here in Germany! I have converted a CB set using the 73 band plan, channel 1 being 28.965, and I monitor this frequency nearly every day of the week. In case any of your readers are interested, I am on the air weekdays from 1700 GMT until about 2200 GMT and on weekends from 0800 GMT until

Continued on page 127



Get into "220" Mobile the Easy Way with Midland

Midland has a pair of proven performers, crystal controlled or P.L.L. synthesized . . . both designed to be easy on the pocketbook

To start with, here's Midland's Model 13-509. It's a compact, rugged mobile with capacity for 12 crystal-controlled channels. The "509" transmits with 10-watt or 1-watt output. Its receiver has a dual gate MOS FET front end with hi-Q resonator and ceramic filters. There are SWR and polarity protection circuits, internal DC filtering and electronic switching. With its jack for optional tone burst and discriminator meter, the "509" has even been the basis for many repeaters.

Midland's choice alternative in "220" is P.L.L. synthesized Model 13-513. Here's advanced design with modular construction and digital frequency readout. It's programmed for 500

frequencies between 220 and 225 MHz, with a 5 KHz shift up giving 500 more . . . and 4 offsets are available for repeater use. The receiver has a multiple FET front end with monolithic crystal and ceramic filters. The transmitter switches for 20-watt 10-watt or 2-watt output. With automatic SWR and polarity protection, internal DC filtering, electronic switching and a jack for tone burst and discriminator meter, the "513" is a very desirable "220" mobile . . . or base.

Pair either of Midland's "220" mobiles with Midland's trunk/roof mount or magnet mount antennas (Models 18-950 and 18-951) for top-notch performance on the band.

 **MIDLAND**
INTERNATIONAL

For more about Midland "220" Mobile, write: Midland Amateur,
P.O. Box 1903, Kansas City, Missouri 64141

Gourmet Guide To Capacitors

— for that project you have cooking

Electronic experimenters and just about all builders of radio equipment use fixed capacitors in various applications. But how many know how to select the particular type best suited for a proposed use? This article will point

out the factors one ought to consider while making a decision as to what type to buy. Of course, price and availability always are of major importance, but sometimes other factors should not be overlooked.

Here are some points for consideration for critical applications:

- Capacitance vs temperature
- Insulation resistance vs temperature
- Voltage vs frequency
- Current vs frequency
- Dissipation vs temperature
- Dissipation vs physical size

Add these considerations: What are you planning to use it for? Do you want dc blocking? rf bypass? af bypass? part of a time constant? surge absorption? arc suppression? You might opt for a different type for each one of these applications.

What types of construc-

tion does the market offer? Would a wound type do the job you have in mind? Or does it require flat plates of minimum inductance? Must the equivalent series resistance be low? What voltage will be put on it? Must it withstand unexpected voltage surges? Will it have to take the high circulating currents of a resonant circuit?

There's no all-inclusive answer to these many questions, but you can narrow them down to certain categories. Then, answers, or at least suggestions, become feasible.

Let's start with resonant circuits. These call for stability—good capacitance-vs-temperature characteristics. If, in a transmitter, a high-voltage breakdown will be necessary and that transmitter has any appreciable power, an ability to accommodate high circulating current becomes im-

perative. Satisfying such requirements usually calls for either mica or a special grade of glass as the dielectric. Be sure both voltage and current ratings are adequate. Voltage ratings are easy to come by. Current ratings, especially at the frequency you might want to operate, are not. Nevertheless, current is a critical specification for any capacitor used in a resonant circuit handling more than peanut power.

Next, let's take a look at rf bypass capacitors. These, too, may call for high-voltage capabilities, but seldom do they need to pass heavy current. Usually, low inductance is a required specification. This means short and broad leads, plus proper internal construction. You can buy acceptable rf bypass capacitors with ceramic, mica, polyester, polycarbonate, polystyrene, polysulfone, and polypropylene dielectric. Each

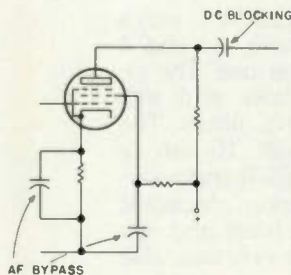

Fig. 1.

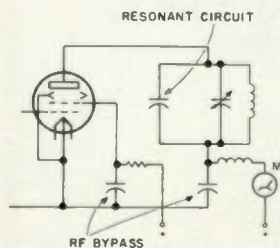

Fig. 2.

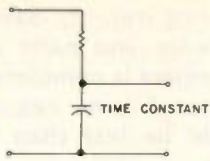

Fig. 3.

of these has some particular characteristic that makes it preferable for some specific use. None is universally superior.

If you're looking for the highest capacitance for a given physical size, then you'd pick a ceramic capacitor with barium titanate as its dielectric. Then you'd have to put up with its variations attributable to temperature, voltage, and frequency!

One of the best of the several "poly" varieties is polystyrene. It, however, has a sharp upper temperature limit of 85° C. Polycarbonate and polysulfone approach polystyrene in merit, even excelling in some respects.

Of course, if that bypass application involved high voltage, you'd opt for mica dielectric. One company, Semtech, offers a ceramic capacitor in voltage ratings of 1, 2, 3, 4, and 5 kilovolts. Their small size would make them appear to be a desirable alternative to micas.

Audio bypasses are much less critical. Although paper and a number of the "poly" types are made in capacitances as high as 10 microfarads, aluminum or tantalum electrolytics are a much more common choice. Of these two, tantalum is the better in all respects other than price.

For dc blocking use, the requirements are largely the same as for rf bypass. Voltage ratings, of course, must be high enough to take care of both the dc component plus the superimposed rf or af component. High insulation

resistance is vital in blocking use.

Time-constant application, where holding calibrated values is important, calls for a superior type of dielectric. Polystyrene has an edge over competitors. For very long time constants, it may be necessary to use tantalum electrolytics in order to get sufficient capacitance, even though stability will suffer.

Surge absorption and arc suppression call for capacitors capable of handling momentary loads of both high voltage and heavy current. Not only is the type of dielectric important, but also the interior and exterior construction. The capacitor must be designed to be effective at quite high frequencies, as the spikes of voltage surges are made up of high-frequency components.

Also, it may be desirable

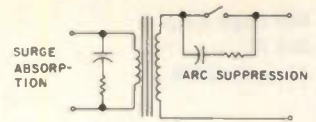

Fig. 4.

to have a self-healing type of dielectric. Metallized polyester (mylar) offers this characteristic. It's not often available in high-capacitance values, though. A few manufacturers offer it in sizes up to 10 microfarads. In all instances, it is important to have a minimum equivalent series resistance. Physical size may be important, too, for the capacitor will have to dissipate the power contained in the surges.

It's hoped that this bit of exposition on the various types of fixed capacitors may help the reader to make the optimum choice when he buys a capacitor for a specific application. ■

ou rooms don't ever proof
lousy manuscripts from bat
burch "TROCK" on
you'd: in
I insist that you print ev
tell Ma Bell that she shou

LETTERS

from page 124

about 2300 GMT. I frequently give calls on the frequency and monitor constantly.

Surprisingly, there is quite a lot of AM activity on 10 over here using low power. There are many local rag chew groups and coverage throughout Europe is quite good at times. Recently, conditions were such that stations in Berlin were heard working mobiles and fixed stations as far north as Hamburg. I hope to work some stateside DX one of these days.

Richard J. Molby
DA1DB/WB7NZG
APO New York NY

SUPER TAPES

Just this past Wednesday I went to Albany NY and took my General exam and passed it. If it hadn't been for those 73 code

tapes, I don't think I would have been able to pass the code part. You were right! If it hadn't been for my nerves, I would have gotten 100% copy. As it was, I did manage to get 100% on the code test. Keep up the good work on the mag.

Dave Kessler WB2JUU
Hoosick Falls NY

DON'T FORGET GOGGLES

With reference to W7RXV's article in the July, 1978, issue of 73 entitled "Instant Engraving—to protect your equipment," I hope readers realize that if they use this method for engraving, they must also protect their eyes. Glowing carbon rods and arcs from such rods emit dangerous ultraviolet rays which will damage the eye. I would strongly suggest to those who can still read this magazine that they wear good

quality ultraviolet protective goggles while using RXV's etching method. This is a precaution I have learned in college while using a carbon arc lamp to expose photosensitive circuit boards.

James T. Schug WA2YEI
Middle Village NY

GRIPES

In a recent issue of your fine magazine, you made a comment about the "Canadian" portion of the 20 meter phone band (14.1 to 14.2). I think it might be a little more justified if your phone band expanded to 14.125, leaving 25 kHz as a little breathing room for our 15,000 amateurs.

On another subject, we in Canada are finding, just as you did, that it is almost impossi-

ble to fight the ARRL. The League has used its large financial backing to attempt to kill our only national organization (Canadian Amateur Radio Federation) ever since it was devised. How would you feel if, for example, the national organization of Mexico tried to represent the USA amateurs in front of the FCC? Well, that is what the ARRL is attempting to do in Canada. They have gone as far as to call themselves "The Canadian Radio Relay League." I could go on for a whole book, Wayne, but I just wanted to let you know that you weren't the only one with gripes.

Rob Bareham VE3ACY
Ottawa, Ontario
Canada

Write the book, Rob, and let hams know what the ARRL has done in Canada.—Wayne.

Ham Help

I am interested in obtaining my Novice class amateur radio license. Any help would be greatly appreciated. Thank you.

Hugo Harmatz
2 Ferris Ct.
Oakhurst NJ 07755

I would like to exchange technical ideas with anyone interested in the 160-190 kHz band.

Ted Swift WB7OQQ
Rt. 1 Box 5248
Richland WA 99352

The ARC Tuner

—rejuvenated surplus

A recent article on antenna tuners entitled "The London Bus Tuner," 73 Magazine, June, 1977, provided the final push for this tuner. I believe that it meets the criteria for an inexpensive, yet flexible, tuner for

power levels up to 500 Watts and from 160 through 10 meters, depending on the configuration. It also provides for simple packaging and convenience of readout with a minimum of mechanical gimmickry. The only parts

needed, in addition to an ARC-5 transmitter, are a 4½" by 6½" piece of Plexiglas™, a 1" piece of 3/8" dowel (plastic or wood), and one or two chassis-mount coax connectors. The ARC-5 is available from Fair Radio Sales, Box 1105, Lima OH 45802, as a BC-457 for \$14.95.

Most of the configurations in the Bus Tuner article may be used with this setup. Fig. 1 shows the tuner wired in a configuration similar to Fig. 1(c) of the Bus Tuner article and I found this meets most of my needs.

The only special tool required is a bristol wrench needed to remove the gear from the antenna coupling coil and the hardware from the PA padder capacitor. However, a small-bladed screwdriver may be filed down to fit.

The first step is to strip the chassis, leaving only the rotary inductor, PA tuning capacitor, and antenna

coupling controls. Save all hardware and parts until the project is completed—the total time required should be less than four hours.

Strip the chassis as follows: Remove top and bottom covers, remove tubes, crystal, antenna relay, and its associated hardware. Carefully remove the antenna binding post and reassemble it so that the parts are not lost. Remove the antenna contact from the end of the rotary inductor—do this carefully as the ceramic threads are fragile. Replace the screw that holds the spring clip on the end of the coil. Remove the PA coil. Carefully remove the fiber gear from the PA coil—use solvent (or nail polish remover) to loosen the two setscrews before trying to remove them. Set the gear and setscrews aside—these are an important part of the finished product!

Remove the oscillator cover, padder capacitor, and coil. To remove the coil, remove the three screws holding it, lift up gently, and cut all the leads going to the bottom of the coil.

Turn the unit over and remove the pin (I used a small finishing nail as a punch) from the flexible shaft at the front capacitor. Save this pin.

Remove the rear variable capacitor. Remove the PA padder capacitor (second variable from the front).

Now remove the tube sockets, rear power plug, relay, all wires, the resistor

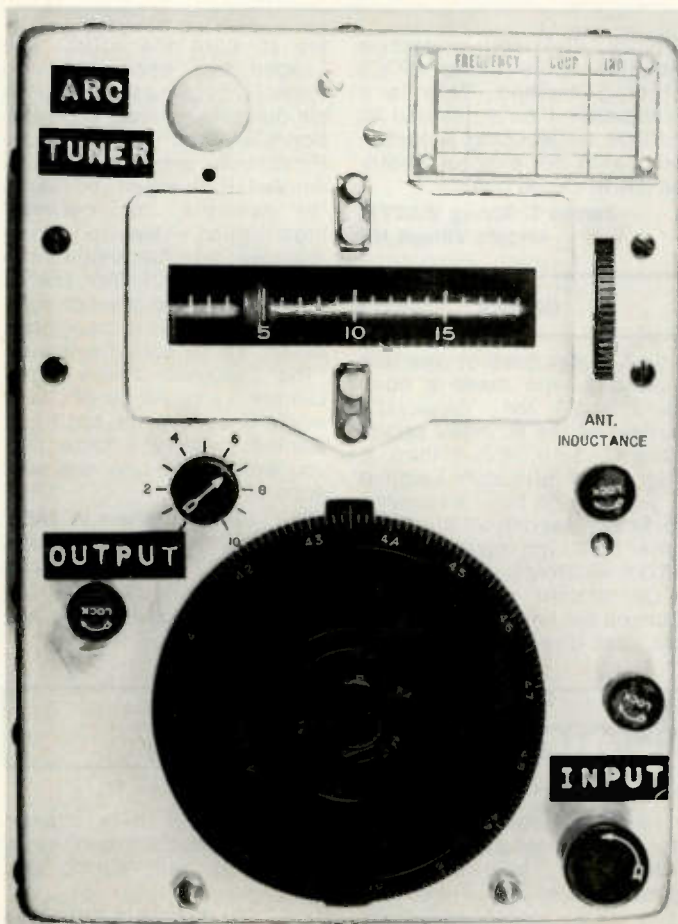

Front view of completed tuner.

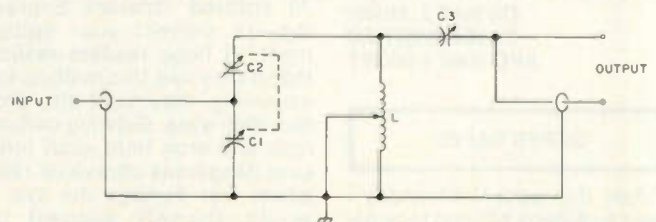
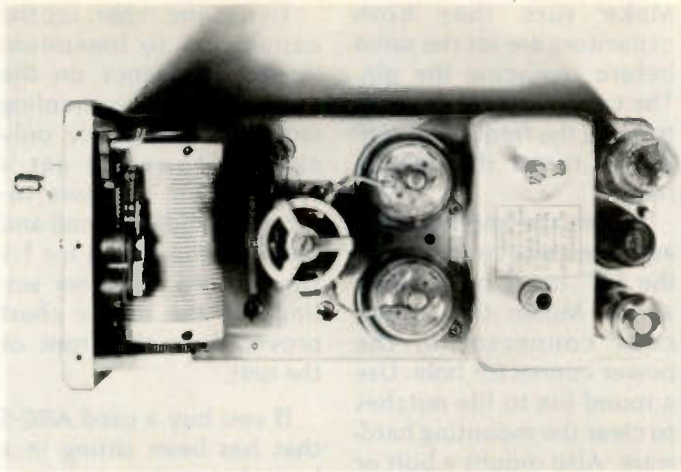

Fig. 1. ARC tuner schematic diagram.



Top view of unconverted ARC-5.

on the rear panel, and the bracket that held it. Also remove the mica feed-through and the widgets that hold the oscillator coil cover in place. The transmitter tube sockets, feed-throughs, and power plug on the rear apron must be "persuaded" off with a hammer and screwdriver.

Modify the chassis as follows: Cut out a 4" by 4" section of the top of the chassis starting about 3/8" in front of the tube socket holes at the rear of the chassis. Part of this hole will include the space left by removing the PA tube sockets.

If you want coaxial output in addition to single-wire feed, make a 5/8" hole on each side of the power plug hole on the rear apron—one hole for the coax connector, the other for the antenna binding post. Of course, the post

can be used in its original hole if desired. Remove the large hole plug from the side of the chassis and use it to fill the hole in the front panel left by the antenna post.

Remove the locking hardware from the PA padder capacitor. Use solvent (or nail polish remover) to loosen the setscrews.

You must now drill out the fiber gear to fit on the shaft of the PA padder. Do this very carefully, clamping it in a vise on the metal part only. DO NOT drill all the way through. A mistake might be rectified with epoxy glue.

Mount the gear on the PA padder capacitor. Lubricate the bearings on this capacitor as they will be a bit stiff (WD-40 works fine).

Now, place the 4 1/2" by 6 1/2" piece of Plexiglas on top of the chassis and

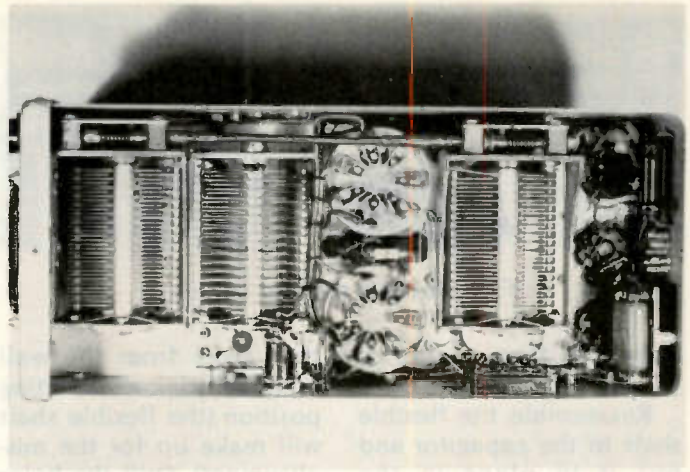

Bottom view of unconverted ARC-5.

place the PA padder on it so that the gear meshes with the gear on the antenna coupling control. Mark the position of the capacitor and the mounting holes. Remove the Plexiglas and drill these holes. Using the Plexiglas as a template, drill two large (5/8" or so) holes in the chassis to provide clearance for the mounting screws on the front of the PA padder capacitor.

Mount the Plexiglas on the chassis and mount the PA padder capacitor. It should operate freely with no binding as the antenna coupling control is operated through its range. If the mounting holes are made slightly larger than the screws, the capacitor may be adjusted to provide a good mechanical fit.

The next step is to

modify the flexible coupling shaft. Remove the shaft from the capacitor by removing the pin. Make a mark 1" from one of the metal ends of the shaft and 1 1/4" from the other end. Measure from where the metal coupling connects to the flexible shaft material. Solder around the shaft at each mark—this prevents the shaft from unraveling. Then cut the shaft to the marked length. Make the insulated coupling by drilling a 3/8" deep hole in each end of the 1" long piece of plastic or wood dowel. Use a number 25 drill.

Apply epoxy glue and force each end of the flexible shaft into the coupler. While the glue sets, remove the third fastener on the right side of the bottom plate—this is a safety measure to prevent the

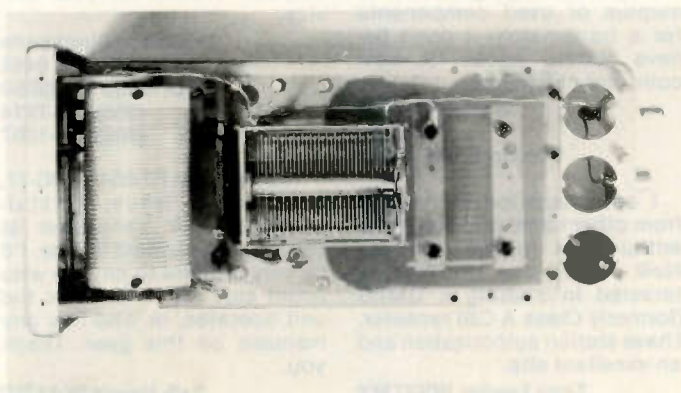

Top view of completed tuner.

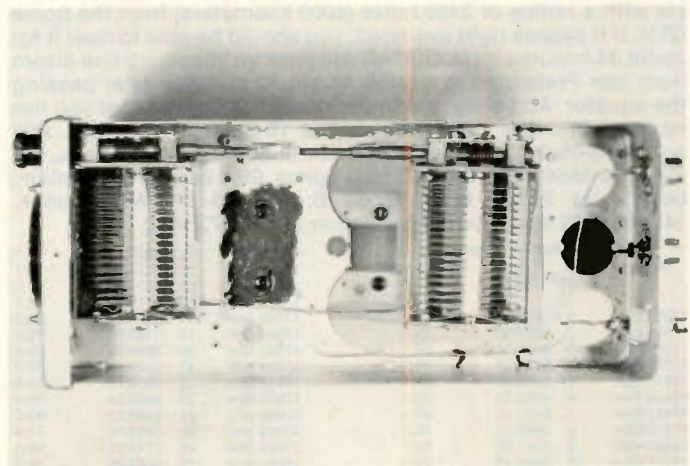

Bottom view of completed tuner.

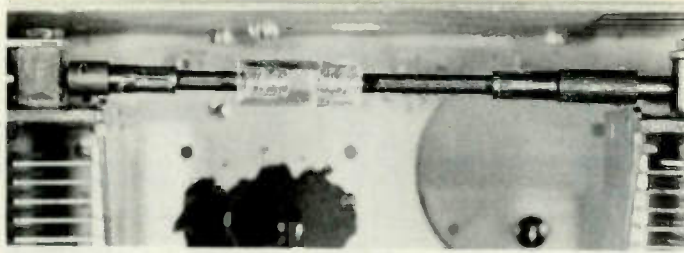

Flexible-shaft coupler details.

capacitor from arcing to ground.

Reassemble the flexible shaft to the capacitor and put it in place in the chassis. Set it slightly fur-

ther away from the wall than the original mounting position (the flexible shaft will make up for the misalignment). Drill the holes and mount the capacitor,

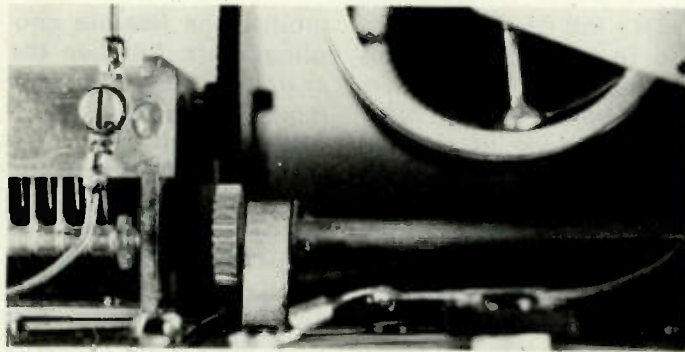

Padder gear assembly details.

Make sure that both capacitors are set the same before replacing the pin. The capacitors should now track as the frequency control is tuned through its range.

Mount the antenna post and one coax connector in the 5/8" holes on the rear apron. Mount the second coax connector in the power connector hole. Use a round file to file notches to clear the mounting hardware. Also mount a bolt or binding post on the rear apron for a ground connection.

I used the wire from the PA and oscillator coils to wire the unit. Ground both ends of the roller contactor using solder lugs and the existing holes. Place a solder lug under the screw holding the spring clip on the end of the roller inductor. Also place a solder lug under one of the mounting screws on the rear capacitor.

To use the tuner, set the capacitors to maximum (lowest frequency on the dial and 10 on the coupling indicator) and apply only enough power to get a reading on the swr indicator. Adjust the coil and then the capacitors for 1:1 swr. Record the tuner settings on the handy chart provided on the front of the unit.

If you buy a used ARC-5 that has been sitting in a barn for a few years, a thorough cleaning will be in order. Use a pencil eraser to clean the rotary inductor, the rotary contactor, and the rod on which the contactor rides. Lubricate the capacitor bearings and the drive shafts and gears.

I would like to thank K9OIC for testing the various models of this tuner and for providing unflinching support for this project. ■

OSCAR Orbits

The listed data tells you the time and place OSCAR crosses the equator in an ascending orbit for the first time each day. To calculate successive orbits, make a list of the first orbit number and the next twelve orbits for that day. List the time of the first orbit. Each successive orbit is 115 minutes later (two hours less five minutes). The chart gives the longitude of the first crossing. Add 29° for each succeeding orbit. When OSCAR is ascending on the other side of the world, it will descend over you. To find the equatorial descending longitude, subtract 166 degrees from the ascending longitude. To find the time it passes the North Pole, add 29 minutes to the time it passes the equator. You should be able to hear OSCAR when it is within 45 degrees of you. The easiest way to do this is to take a globe and draw a circle with a radius of 2480 miles (4000 kilometers) from the home QTH. If it passes right overhead, you should be able to hear it for about 24 minutes total. OSCAR will pass an imaginary line drawn from San Francisco to Norfolk about 12 minutes after passing the equator. Add about a minute for each 200 miles that you live north of this line. If OSCAR passes 15 degrees from you, add another minute; at 30 degrees, three minutes; at 45 degrees, ten minutes. Mode A: 145.85-.95 MHz uplink, 29.4-29.5 MHz downlink, beacon at 29.502 MHz. Mode B: 432.125-.175 MHz uplink, 145.975-.925 MHz downlink, beacon at 145.972 MHz.

Oscar 7 Orbital Information			17518 Bbn	14	0027:45	66.1	
Orbit	Date (Sept)	Time (GMT)	Longitude of Eq. Crossing °W				
17355 Bbn	1	0011:41	61.9	17531 Abn	15	0122:02	79.7
17368 Bbn	2	0105:58	75.5	17543 Bbn	16	0021:23	64.5
17380 Abn	3	0005:19	60.3	17556 Bbn	17	0115:40	78.1
17393 Bbn	4	0059:36	73.9	17568 Abn	18	0015:01	63.0
17406 Bbn	5	0153:53	87.5	17581 Bbn	19	0109:18	76.6
17418 Abn	6	0053:14	72.3	17593 Bbn	20	0008:39	61.4
17431 Bbn	7	0147:31	85.9	17606 Abn	21	0102:56	75.0
17443 Bbn	8	0046:52	70.8	17618 Bbn	22	0002:16	59.9
17456 Abn	9	0141:09	84.4	17631 Bbn	23	0056:34	73.4
17468 Bbn	10	0040:29	69.2	17644 Abn	24	0150:51	87.0
17481 Abn	11	0134:47	82.8	17656 Bbn	25	0050:12	71.9
17493 Abn	12	0034:07	67.7	17669 Bbn	26	0144:29	85.5
17506 Bbn	13	0128:25	81.3	17681 Abn	27	0043:49	70.3
				17694 Bbn	28	0138:07	83.9
				17706 Bbn	29	0037:27	68.8
				17719 Abn	30	0131:45	82.4

Ham Help

Help! I built the noise bridge of Floyd Jones W6DOB (73, April, 1978), but *nobody* has *miniature 360 pF* variable capacitors anymore. The junked radios I have used are either old, full-size ones, bigger than the rest of the components put together, or minis that are short by 100 or so pF. I would appreciate hearing from someone with a larger junk box. Radio Shack no longer carries theirs, which were pretty inexpensive.

I am also trying to locate surplus or used components for a transmatch—I don't believe current prices for new coils and capacitors!

Walter Kimmel
Box 56
Ponsford MN 56575

I am turning to the amateur radio community as my only possible route to reach a fellow with whom I was close friends over 10 years ago, but haven't heard from in some time. I don't know his present call but he got his Extra about 1968. His name was Philip Staub, of the Benton Harbor, Michigan area, in his high-school days. I would very much appreciate hearing from him directly or from any acquaintances having his current mailing address or phone number. Thanks for your vice.

James Finckbone
PO Box 6464
Orlando FL 32853
(305)-894-7814
(305)-275-1607

I am interested in hearing from other hams and computer enthusiasts in the northern New Jersey area who are interested in starting a GMRS (formerly Class A CB) repeater. I have station authorization and an excellent site.

Tony Loving WB2TMX
72 Shepard Avenue
Teaneck NJ 07666

I acquired an RT-654A/TRC-77, government issue, crystal-controlled CW transceiver at the BirminghamHamfest in May. I'd be very grateful to anyone who could clue me in on how the unit operates, or who has any manuals on this gear. Thank you.

Bob Howle WA4ZID
2710 Blazuma Avenue, Apt. 1
Birmingham AL 35205

Pick a card... any card

CALL TOLL FREE

1-800-228-4097
Communications Center
 443 N 48th Street C58

Lincoln, Nebraska 68504
 In Nebraska Call (402)466-8402

1-800-634-6227
Communications Center
West

1072 N. Rancho Drive
 Las Vegas, Nevada 89106
 In Nevada Call (702)647-3114

Sale subject to limited supply

K

YAESU
FT-901 DM
 List \$1299
 Price too low to print, call for quote.

9

 Buy a FT-301 digital for **\$935** and get a power supply & CW filter free!

J

YAESU
FT-101E
 List \$799
 Price too low to print, call for quote.

J

YAESU
FT-7 Mobile
 List \$499
 Call for discount price

Q

KENWOOD
TS-820S
 List \$1099
 Call for low price

K

KENWOOD
TS-520s
 List \$739
 Our price too low to print, call for it!

2

KENWOOD
TR 7400
 List \$399
 Call for discount price

K

 R4C List \$699
 Your price \$599
 T4XC List \$699
 Your price \$599

10

YAESU
FT-227R
 List \$319
 Call for discount price

Home-Brew Circuit Boards

— cheap and simple

Hand wiring circuit boards is a not-uncommon means of making quite satisfactory boards which can match in effectiveness, if not always in appearance, those which have been etched. It is the purpose of this article to pass along some ideas which have worked for me to make the job easier and/or more economical.

Some projects in which the usual procedures of applying a resist (mechanical-

ly or photographically) and then etching do not pay, include: one-of-a-kind devices with complex patterns, those for which commercially-available boards are not available or are inordinately expensive, those in which the builder wishes to make changes from a published design, and those for which the builder does not have facilities for applying resist, etching, and drilling. Of course, there is always the

tinkerer who stubbornly insists on doing a job in his own way, trying something new and different from the established methods of handling a project.

One has to start with a board of some kind. The phenolic, prepunched board sold by Radio Shack (catalog 276-1395) for 99¢ is good, given the shortcomings of phenolic. It is punched .100 × .100 inches for IC sockets and other small components. This is a 2-3/4" × 6" board and two larger sizes are also sold. You will probably need to cut boards to size for specific use; a fine hacksaw or model railroad track saw works well with phenolic or epoxy boards.

Higher-quality board, usually glass epoxy, is available as surplus cards from computers and other devices. The trick here is to buy boards which have high-density packaging so that there are many ICs mounted on them. This leaves a lot of holes from which to select when you come to arranging your own layout. I once found an 8-

1/2" × 14" board which included 82 ICs, neatly arranged in rows, plus a 1.8 MHz crystal and associated transistors, capacitors, and resistors, all for \$1.75. A better buy was an etched board without any components for a couple of cents. Cut into pieces (after the components were removed from the first board), these boards have provided numerous smaller boards for various projects.

A surplus board must be cleaned off. Removing the capacitors and resistors is an easy trick, even if you want to be careful enough to use them again. Slip a small screwdriver under the component, heat one lead on the other side of the board, pry up gently, and repeat with the other lead. Test all items before using them again. You don't know why the board was declared surplus.

ICs are another matter. It is almost impossible, without a special soldering iron, to heat seven or eight pins all at once. The solder can be removed with one

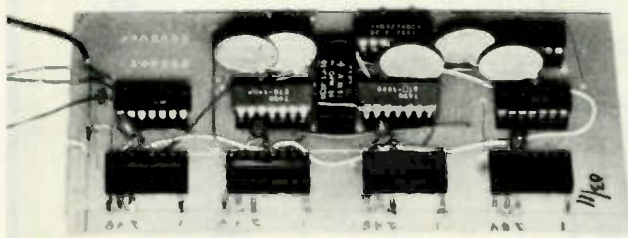

Jumper wires on the component side of the board are useful at times to avoid too much clutter on the foil side. Push-in terminals (Radio Shack 270-1392) were used here as junctions for anchoring the light-colored 5-volt line, and as soldering points for connection to the IC sockets on the other side of the board. Terminals are also used along the front edge of the board to bring out leads which will later be soldered to them. Board here is 2-1/2" × 5-1/4".

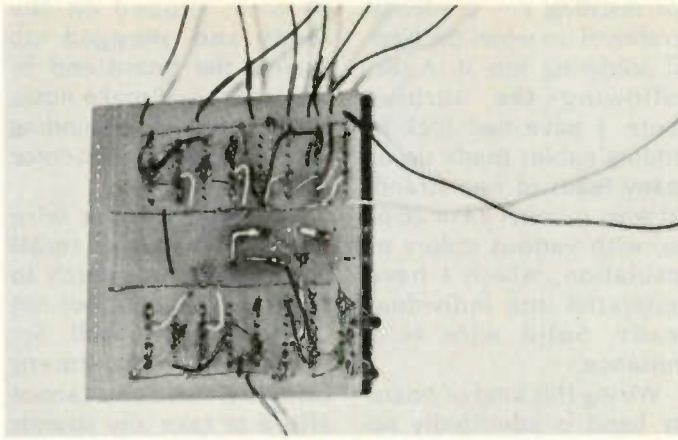

Bare wire can often be used to an advantage, as shown in the thin horizontal lines on this board. The center two lines are the 5-volt dc supply; lines at top and bottom edges are common bus. Leads coming off the board also show small sleeves of colored insulation slipped on for color-coding. Board is three inches square.

of the de-soldering "wick" products on the market. I use small size shielding from unwanted mike cable or the like, dip it in soldering paste, lay it on the line of pins, and heat it with an iron. It sucks the solder up so that the IC can be pried off, one side at a time. The heat is likely to ruin the ICs, of course, but these are usually house-numbered and you do not know what they are; thus, they are of no use to you anyway. If you have facilities for determining IC types, you would probably be testing the devices at the same time, so you can discover what they are and whether they are good all at once.

Now you have a board with a lot of empty holes and connections among them, and the next job is to remove the excess foil. The quickest and easiest way to do this is to dump the board (or any portions that you have cut off for use) into PC etchant and let it do its dirty work. Dab spots of resist (fingernail lacquer, paint, candle wax, etc.) on the pads at each IC location. This will permit the pads to remain while everything else is etched away, and will give you

something to anchor the IC sockets to when you begin soldering your own circuit. It may be handy to save a ground (common) bus, or pads for external connections to the board, if these will not get in your way. I have tried to compare the pattern on a board with the pattern of a circuit on which I am working, in an effort to save any connections which may be useful, but I do not recommend this. Especially on a double-sided board, or in a complex circuit, it is the road to instant insanity.

Follow the safety notes and instructions on the etchant bottle carefully. The stuff stains hands and clothing, and is definitely injurious to eyes and other sensitive skin areas. It is convenient to have a pail of water handy to dip the board into as a rinse to check things as you go along. Likewise, it is worthwhile to use a pair of plastic tweezers (photo print tongs, for example) to handle the board in the solution. Do not bother to heat the solution according to the instructions unless you are in a hurry. When all of the unwanted foil has etched away, wash the board, clean off the

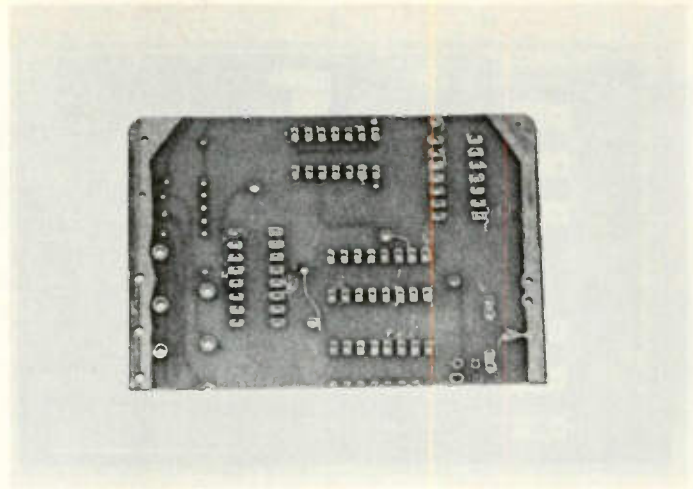

Section cut from a larger computer board and then etched clean, leaving pads for anchoring IC sockets, foil strips on edges for ground bus, as well as other leads which seemed to be useful. Board is 2" x 3½".

resist with chemical solvent, a "Rescue" pad, or with fine steel wool, and wash the board again.

I am a great believer in IC sockets because I am not a believer in the specs of the bargain ICs I buy. Sockets are cheap—30¢ or less by mail—and they save hours when you have to change the ICs around to find which ones do not work. Molex sockets are a dubious bargain. They do not slip into the holes easily, and, after a few insertions and removals, they are not reliable. At first glance, it would appear that IC sockets with long pins for wire-wrap applications

would be easier to solder to, but I find that the extra length gets in the way of precision work and I wind up with two or three pins soldered together.

A word about the holes in the board. You will find many of them plugged with leftover solder, and you will find need for a few where the original manufacturer neglected to foresee your requirements. Stop at your friendly neighborhood hobby shop and buy a couple of fine drills; number 62 or smaller is good. At the same time, if you do not have one, get a cheap pin vise. With this combination, you can ream

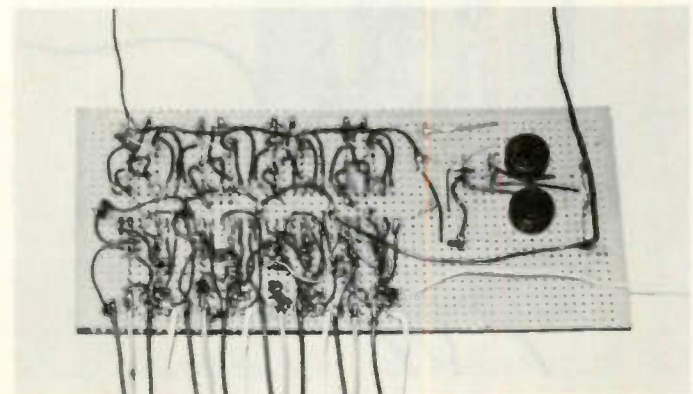

Circuit built on a 3" x 6" Radio Shack board 276-1395. It looks like a rat's nest of wiring, but color coding and a little care made everything come out right. This kind of sloppy wiring is permissible only when there is no rf or audio circuitry involved.

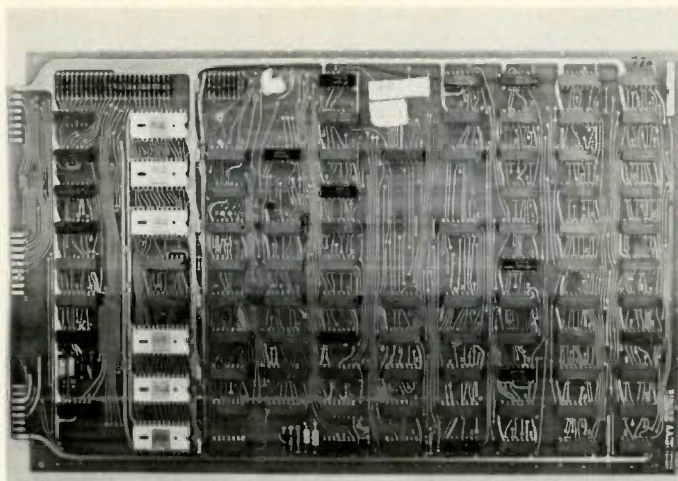

One example of the "raw material"—a surplus computer board measuring 8-1/2" × 14". ICs are not removed until a smaller piece is hacked out for a specific purpose. More than three dozen resistors, diodes, capacitors, and transistors were carefully taken out for future use. A board such as this would make an excellent "mother board" for a project which is made up of several smaller modules.

out plugged holes and drill new ones. You can do this while holding the board in one hand and the pin vise in the other, and thus make holes after you have begun mounting components. You cannot do this safely with a hand drill or drill press.

At the hobby shop, you can also get a small egg-

beater-type hand drill made by X-Acto® which is light and, if handled carefully, will not break too many of the little twist drills. However, buy several twist drills at a time as they go fast!

The wire that you use should be as fine and as flexible as you can find. Teflon™ insulation is good



Unused holes which remain after etching a board clean may be used to anchor leads and other components. On this 2-1/4" × 3-1/2" scrap of board, a strip of foil was allowed to remain as a ground bus. Etchant crept under the resist, leaving a ragged edge, but enough foil was left to be useful.

for resisting any tendency to shrivel up when the heat of soldering hits it. Again following the surplus route, I have had luck in finding cables made up of many leads of fine stranded wire, number 24 or 26 or so, with various colors of insulation, which I have separated into individual leads. Solid wire is a nuisance.

Wiring this kind of board by hand is admittedly no fun. There are too many repetitious operations, since so many ICs use the same connection schemes. After a while, it becomes a question of "Did I wire pin number five and which pin is number five?" If you have an etching pattern for the device, make a Xerox® copy of it to follow, inking in each connection as you solder it. If not, do the same on a circuit diagram. Yes, this is the same way that beginners did it in the old days of metal chassis and 240-volt transformers, but it works.

Solder two or three corner pins of each IC socket to the pads which you thoughtfully left on the board. This will hold the sockets in place while you get down to serious business. Then, again following the old octal socket tradition, wire in the "high-voltage" leads first, then the ground (common) leads. After that, tackle the rest of the wiring.

As with any other complex wiring job, color coding will help keep matters straight so that you know where you are. I use yellow or red for Vcc, black for common, and one or two additional colors for other leads. Leads coming off the board for interconnection to other boards, switches, etc., must be color-coded or you can get hopelessly lost. If you do not have enough colors of insulation for this, use bits of colored insulation from larger sizes

of wire, slipped on the leads and snugged up against the board end of the leads. And make notes as you proceed, reminding yourself of what each color indicates.

You will want a wire stripper, and the small plier-type with a notch to cut the insulation, but not the wire, works well. Set the closure adjustment carefully, since you cannot afford to take any strands of wire off with the insulation. There is not that much wire! Other handy tools include a couple of small screwdrivers, small long-nose pliers, a small pair of diagonal cutters, a small soldering iron, and possibly a small file. The key word in the whole operation is "small."

Preform the leads before you solder them in. Strip about 3/8 inch of insulation, tin the end of the wire, cut the lead to approximate size, then strip and tin the other end. Bend a hook in each end small enough to fit snugly on the IC socket pin and solder it on. Where leads are in the clear, with no possibility of shorting to other leads or pins, you can strip and tin a longer piece of wire. Bend a hook in it as before, solder it to a pin, pull it against whatever else it is to be connected with, solder it, and clip off the excess. This speeds things up a bit. If you have an etching pattern, try to follow it fairly closely with your wire leads. The designer may have had some reason for lead placement.

A circuit board wired in this manner will probably win no prizes for neatness, and some unkind friends may compare it with a rat's nest. But the system works and is a suitable substitute for drawing artwork, sensitizing, exposing, developing, etching, and drilling boards, which may be beyond the experimenter for one reason or another. ■

THOMAS COMMUNICATIONS

— Newington Connecticut —

— "Near the ARRL Headquarters" —



"over 50 Brands in Stock"

Kenwood • KDK • Dentron • Wilson • MFJ • Swan • Drake • YAESU
Saxton • Larson • Tempo • Bearcat • B&W • ICOM • ARRL Publications
Cushcraft • Mosley • Regency • Astatic • Microlog • Ham Key • Pipo

AND MUCH MORE ● ● ●

"AUTHORIZED DEALER"

Kenwood—Yaesu—Dentron—ICOM—Wilson

● COMPLETE RADIO SERVICE SHOP ●

FAST, EFFICIENT SERVICE ● MOST REPAIRS DONE AND SHIPPED BACK WITHIN 7 DAYS
AMATEUR EXTRA/FIRST CLASS LICENSES ● FREE SHIPPING BOTH WAYS IF REPAIRS ARE MADE
WE REPAIR ALL BRANDS ● ALL WORK GUARANTEED ● SEND US YOUR DEFECTIVE EQUIPMENT
UPS COLLECT

YOU SHIP IT—WE FIX IT

- NEW AND USED Equipment
- TRADES WELCOME
- FREE Catalog
- Same Day U.P.S. Shipping



THOMAS COMMUNICATIONS T34

95 KITTS LANE, Newington, Connecticut 06111 (203) 667-0811

OPEN MON.-FRI. 10-6 • THUR. 10-8 • SAT. 10-4

Easy Directions: RT. 91 to RT. 15 South—2 Blocks Past McDonald's (Berlin Turnpike)

73 Reveals Bias!

—transistor operation exposed!

Much mystery is attached to what, in most instances, is quite a simple subject. That subject is the biasing of bipolar transistors.

Let's look at a transistor in a circuit with no biasing, as in Fig. 1. As it stands, no collector current will flow unless, of course, the collector voltage is raised past the breakdown point. We'll consider operation only

under normal voltages. If you were going to use that transistor in class B service, whether radio frequency or audio frequency (we'll ignore distortion!), it will operate without bias. It's often used that way. You could apply some bias between the emitter and the base, being careful to have the opposite polarity on the base as on the collector, and operate it class C. However, you'd gain very little over class B operation. The transistor might run a little cooler, the radio frequency power output (for a given power input) might be a trifle greater, but you'd pay a price. That price would be a much greater generation of harmonics. At their best, transistors are notorious generators of harmonics. Many users hesitate to encourage them by biasing to class C.

But suppose you want to run that transistor in audio frequency service, operating in class A. Now you're concerned with getting a maximum voltage swing between collector and ground (presuming the "common- or grounded-emitter" configuration) while maintaining precisely the same waveform at the output as at the input,

differing only in magnitude. This calls for biasing — not just any biasing, but careful biasing, with each move made to accomplish a desired result.

Let's look at Fig. 2. Note that three more resistors have been added. R1 remains between collector and +Vcc. R2 has been added between +Vcc and base. R3 is connected between emitter and -Vee. R4 goes between base and -Vee. The numbers assigned to these resistors are not haphazard. They're assigned in order of importance. The circuit will not work without R1. It will not work in class A without R2. It will work better in class A with R3. And the transistor derives some protection from R4.

What should the values be for these resistors? Really, there's nothing sacred about their values. You start out by selecting some figure for R1. It can be just about anything between 1k and 20k Ohms. Let's say 5k Ohms. Now you could toss in R2, making it some value large enough to permit only a moderate flow of current through R1, but never over half the rated collector current. The circuit would work, but its

long-term and short-term stability would be poor and there'd be a high probability of audio distortion. To make the circuit more stable and to lessen distortion, you'd need to add R3. Its value, however, is affected greatly by R4 and R2. Let's consider R4 first.

R4 is in the circuit for two reasons. One is to lessen the chance of thermal runaway. As a transistor warms up (for any reason at all), its collector current increases. This causes it to get warmer, which pushes the collector current even higher. You can see the outcome of such a rat race. To halt the rat race, R4 is inserted. As the emitter-collector current goes higher, so does the IR drop across R4. The polarity of this drop is such that, applied between base and emitter, it tends to reduce the collector-emitter current. This, to a great extent, cancels the effect of heat on the transistor.

There's another, but less important, effect. By putting a linear resistor in series with a nonlinear resistor (the transistor), variations of the characteristics of one resistor to another are, to some extent, smoothed out. This is

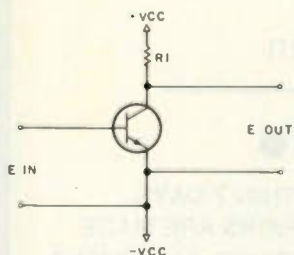

Fig. 1. Transistor with no bias provided.

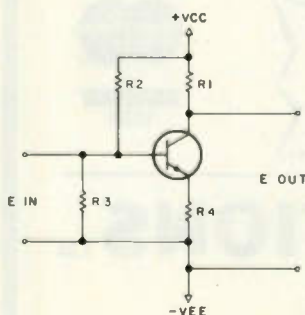

Fig. 2. Typical transistor biasing arrangement.

important to a manufacturer but makes little difference to a one-of-a-kind builder.

What resistance for R4? There's a wide latitude. Keep it less than 10 percent of R1. If you made R1 5k Ohms, try 200 Ohms for R4. With both R1 and R4 established, you're ready for serious consideration of R3 and R2. Start with R3. Just how heavily do you want to load the device (amplifier stage, microphone, etc.) driving this particular transistor? Keep in mind that the base-emitter junction resistance is going to be quite low, so there's no need to try for a high input resistance. So just pick some value around 2k to 5k Ohms.

Now you're ready to tie down the all-important value of R2. There's no way you can make an accurate guess for R2. Oh, you can say it'll probably be between 5 times and 10 times

R3, but such an estimate will not ensure maximum undistorted output. There's just one way of doing that, and that way entails the use of an audio frequency sine wave generator and an oscilloscope.

Connect the equipment as shown in Fig. 3. Apply a very small audio frequency voltage to the input and observe the output on the scope. The image should be a sine wave. Now increase the input voltage until the scope waveform shows a flattening of one peak, positive-going or negative-going. Adjust the resistance of R2 to restore the waveform to an undistorted sine wave, then increase the input voltage until distortion shows again. Repeat this sequence until the waveform shows equal, simultaneous flattening on the positive-going and negative-going peaks. Measure the resistance of R2 and place a

fixed resistor of that value in the circuit. Now you have a class A transistor audio amplifier stage custom-trimmed for maximum undistorted output!

If you have an acute ear tuned to detect audio distortion, you might make that final adjustment without a sine wave generator and an oscilloscope. A nonchalant disregard for niceties also helps! But for near perfection, follow the suggested procedure. If you're concerned with a transistor

in class A radio frequency service, the procedure is equally effective, provided, of course, that you maintain equal loads for both test and use conditions. An rf stage adjusted in such a manner will be less susceptible to being driven into distortion by a strong signal near the desired signal.

All in all, it's well worth your while to set the bias correctly for a transistor stage operating in class A. ■

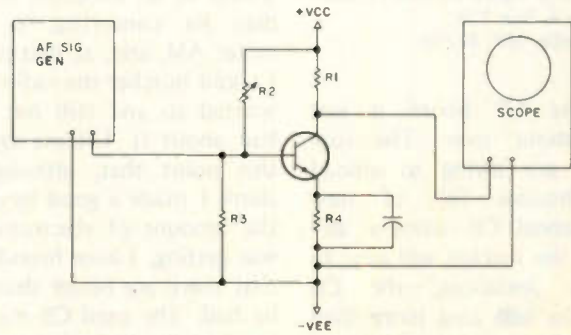

Fig. 3. Test setup for bias adjustment.

The LEADER In the Northwest!

ATLAS • ICOM • KENWOOD • YAESU



CALL Toll-Free
For Price Quotes
1-800-426-6937



Atlas 350-XL



Yaesu
FT 101E
FT 101EE



Kenwood TS-820S



Yaesu FT-301D

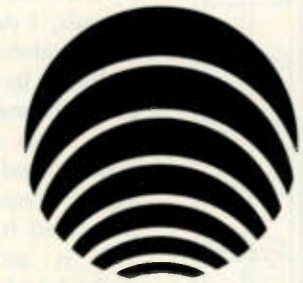

ABC
COMMUNICATIONS

A46

17550 15th Ave. N.E. • Seattle WA 98155 • (206) 364-8300

TO PLACE ORDER
CALL TOLL FREE
IN STATE OF WASH.
1-(800) 562-7625



Other locations: (Walk-in customers only) • Bellevue - 12001 N. E. 12th • Everett - 6920 Evergreen Way • Open Mon. thru Sat.

CB to 10

—part X: Realistic's Mini 23

Leland H. Agard K5LUW/K5SA
Route 5, Box 735
Starkville MS 39759

The CB boom is just about over. The suppliers are trying to unload warehouses full of new 23-channel CB radios at any price the market will pay. In many instances, the CB antenna will cost more than the radio — amazing but true.

I was in the local Radio Shack store and noticed that the new Realistic Mini 23 CB radio was selling for \$29.95. This had to be a bargain, as this radio normally sold for \$109.95. I thought this radio

would be an excellent candidate for converting to ten meter AM, and, at that price, I could butcher the radio all I wanted to and still not feel bad about it. Let me say at this point that, although I think I made a good buy for the amount of electronics I was getting, I have found out that there are better deals to be had. The used CB market is virtually nonexistent and an enterprising ham can find a broken CB rig for \$5.00 or less. At these prices, it will be hard to go wrong when purchasing a CB rig for conversion to ten meters.

With new two meter rigs

costing \$200.00 and more and new CB rigs selling for one tenth of that amount, it should not be long before ten meter AM is just as popular as two meter FM. All that is needed is a little coordination to keep everyone on the same frequency.

Frequency Conversion

Upon investigating the schematic of the Mini 23, I noticed that the frequency scheme for obtaining 23 channels was simply heterodyning any one of six master oscillator crystals against any one of eight local oscillator crystals to obtain the desired frequency. The local oscillator crystals range from 10.150 MHz to 10.180 MHz and 10.595 MHz to 10.635 MHz in 10 kHz steps. The master oscillator frequencies range from 37.600 MHz to 37.850 MHz in 50 kHz steps. In order to come up with a workable plan and in order to purchase the fewest number of crystals, I decided to change the frequency of the master oscillator by 2.035 MHz. This puts channel 1 on 29.000 MHz. This is a nice round number, and it seems that the higher frequencies formerly were used for AM operation. This is accomplished very easily by changing the crystals as shown in Table 1. The new crystals can be purchased from International and other manufacturers for around \$4.95 each. This puts the rig on frequency in the ten meter band.

Transmitter Alignment

The transmitter section is peaked up using a VTVM and a wattmeter and dummy load. The probe of the VTVM is connected to the base of Q12, and the oscillator is peaked for maximum output by adjusting T10, T11, and T12 for maximum voltage on the VTVM.

The driver is peaked by connecting the VTVM probe to the base of Q14. Once again, key the mike and then adjust T13 for maximum voltage, and next adjust T14 for maximum voltage on the VTVM. This peaks up the driver section. At this point, some rf output should appear on the wattmeter.

Tune the final by adjusting T15 and T16 for four Watts output on the wattmeter. Do not try to tune the final for maximum output on the wattmeter. The transistor will put out more than seven Watts but, in order to do so, will pull excessive collector current, and the transistor will not hold up to this abuse. The final transistor will open. Take my advice and tune for no more than four Watts out. I know because I learned the hard way and now am using a replacement final transistor.

Receiver Alignment

The receiver can be aligned by using a signal source such as your regular station transmitter tuned to 29.000 MHz and fed into a dummy load or any other suitable weak signal source, such as a nearby ham transmitting on 29.000 MHz. The Mini 23 does not have an S-meter, so I connected the VTVM probe to diode D3, which is the AM detector. It then becomes a simple matter to tune T2, T3, T4, T5, and T6 for maximum voltage on the VTVM. This completes the conversion, and the rig is now ready to go on ten meters.

Antennas

For mobile use, I took a used base-loaded mobile CB antenna and simply started

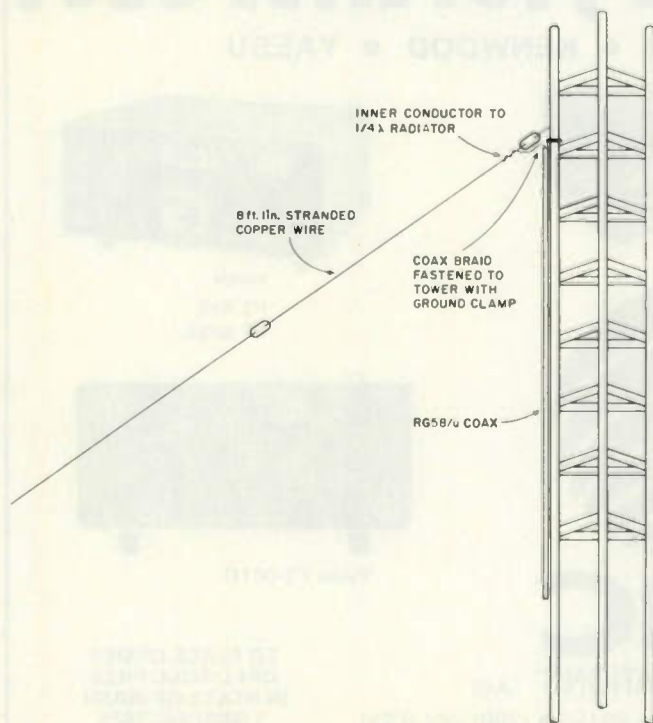

Fig. 1.

trimming the whip until I reached an swr of 2:1 while operating on ten meters. On the whip I was using, I took a little more than two and a half inches off. This will vary with different types of mobile antennas, of course, and a good method is to insert the swr bridge in line and trim until a good match is obtained. The frequency change of 2 MHz or so should work out okay with most mobile whips that are base loaded.

For a base station setup, any existing ten meter antenna could be used, even a trimmed down CB ground plane. I wanted an independent rig and did not want to tie up my ten meter beam with the little rig, so an extra ten meter antenna was a must. I finally decided on the sloper-type antenna shown in Fig. 1. This antenna is easy to install, is small, is cheap to build, and is vertically polarized for working mobiles. The sloper should be cut for the

middle of the group of frequencies you are using. In my case, it worked out to be eight feet and one inch for just a little below 29.000 MHz. The inner conductor of the coax feedline is attached to the quarter wavelength radiator, and the braid of the coax is clamped to the tower leg using a ground clamp. This system works quite well and cuts the length of the sloper in half.

Results

The ten meter AM rigs compare very favorably with the two meter rigs. The cost is drastically lower, but range seems to be about as good. Mobile-to-mobile coverage is about three miles, and mobile-to-base coverage is six to seven miles. With base station-to-base station contacts running four Watts output and sloper antennas up forty feet at both ends of the path, consistent ground wave coverage of better than 20 miles is maintained.

Indeed, it seems that ground wave on this band is about equal to line-of-sight paths on two meters. This is a great club project to bring all those members back together on some common ground. It is

also a good project for a couple of guys who just want a little privacy to discuss the stock market or whatever. For under \$60.00, this is a good way to keep ten meters alive. See you on ten AM. ■

Crystal	From	To
X1	37.600 MHz	39.635 MHz
X2	37.650 MHz	39.685 MHz
X3	37.700 MHz	39.735 MHz
X4	37.750 MHz	39.785 MHz
X5	37.800 MHz	39.835 MHz
X6	37.850 MHz	39.885 MHz

Table 1.

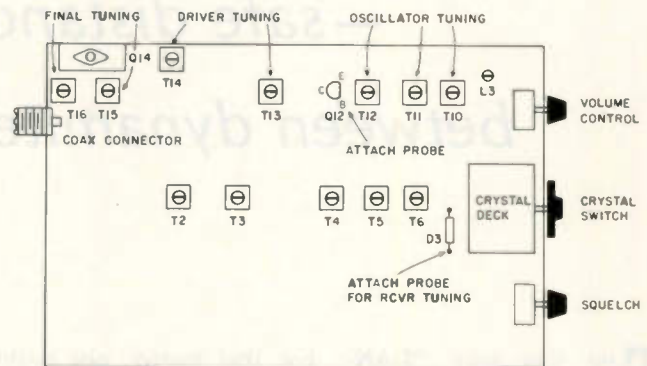
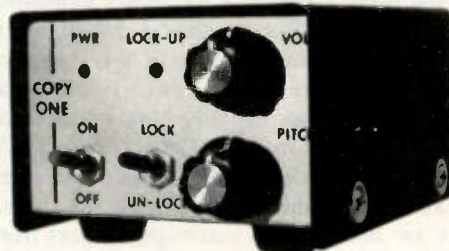

Fig. 2. Realistic Mini 23, bottom view.

The "ULTIMATE" in CW Reception!

ACTUAL SIZE
3 1/2" WIDE
2 3/8" HIGH
4 3/8" DEEP



COPY ONE®
\$99.95

COPY ONE IS NOT A FILTER! This station accessory is a must for the discriminating amateur who operates CW, whether he is an avid CW op or one who engages in CW for proficiency. The CW signal is **processed** (not filtered) in a manner which allows true **ULTIMATE STATION REJECTION**, a mode which has been previously unavailable. The circuitry* is **totally unique** (patent pending), a must for emergency CW operations. If you haven't had the opportunity to operate a **COPY ONE**, ORDER YOURS TODAY!

COPY ONE CW PROCESSOR SPECIFICATIONS & FEATURES:

- Ultimate station rejection (almost unbelievable but true!)
- Pitch & volume independent of receiver or transceiver
- Full quieting (i.e., no background noise) without squelch
- COPY ONE is not a filter, there is absolutely no ringing or background noise
- Plugs into transceiver or receiver/transmitter combo without modification
- Discriminates signals in 80 to 100 cycle increments
- Full break-in CW operation
- Includes 115 volt AC power supply or may be battery operated
- Built in code practice oscillator
- LED lock-up controls front panel mounted

ORDER YOURS TODAY!
send \$99.95 by check
or money order to:

LOGITRONICS, INC. L11

3135 North Cole Road Boise, Idaho 83704 [208] 377-1562

Kerchunk . . . Kaboom!

— safe distances between dynamite and rf

The sign says, "DANGER—BLASTING, Turn Off All Radio Transmitters." What are the hazards, and how do they affect you as an amateur radio operator? The fact is that dangers do exist, and the average ham might encounter them from time to time, so let's take a brief look at how to recognize and avoid them.

First of all, this article is not intended as a text for the ham who is a commercial user of explosives. He already knows his business in far greater detail than I will go into here. On the other hand, most of us occasionally come into the proximity of explosives through visits to (or near) construction sites, or perhaps on a farm or ranch.

For that matter, one might pass quite close to a blasting site as he simply travels along a public road. These are the occasions where potentially dangerous situations might arise, and these are the situations we would like to avoid.

In the way of background, you should know how explosives are categorized under three rather broad classifications:

1. Primary explosives (also called igniters or detonators) — these are quite sensitive to heat, flame, and shock. This category includes the various percussion, fuse, and electrical blasting caps.

2. Secondary explosives — these are less sensitive to outside influences and are normally detonated through the use of blasting caps. Dynamites fall in this category.

3. Tertiary Explosives — these are quite insensitive and include certain industrial chemicals and compounds. Detonation can normally be triggered only through the use of a secondary explosive. (But accidental detonation is still possible. It was a load of tertiary explosives that accidentally blew up in Texas City, near Galveston, in 1947, killing 561 people and completely destroying the town.)

As you might suspect from the above, secondary and tertiary explosives are not by themselves sensitive to rf energy. *Certain primary explosives — and, in particular, electrical blasting caps — are quite sensitive, however, and the accidental detonation of a cap will in turn detonate all of the secondary and tertiary explosives in the vicinity.

The electrical cap consists of a small piece of resistance wire imbedded in an explosive charge. A pair of wires lead out from the cap for connection to the firing circuit.

Fig. 1 shows how the wires, when unconnected, can act as a dipole antenna. With sufficient rf energy induced into the leads, the internal resistance element will heat to the firing point.

Shorting the wires together (Fig. 2) or placing the cap in a completed firing circuit does not necessarily improve the situation. In fact, this creates a loop antenna, which in some cases is even more efficient than the dipole. This can be true no matter how close to the cap the wires are shorted. If you don't believe it, bend a 4-inch piece of wire into a loop and solder the ends to the two contacts of a #47 bulb (Fig. 3). Then move the loop up and down your transmission line or in front of your antenna with the transmitter on, and watch the bulb light up.

A number of years ago, I observed an accident at a MARS station which underscores the danger I am discussing. A military photographer had come to take some pictures for the base newspaper and had outfitted himself with a pocketful of flash bulbs. As he strolled under the antenna system, several of the bulbs went off, much to his dismay. It should be realized that the firing currents of blasting caps are not only similar to those used

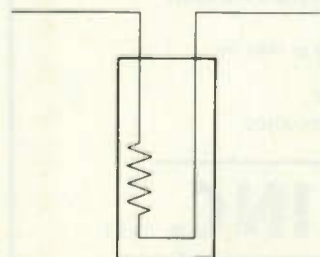

Fig. 1.

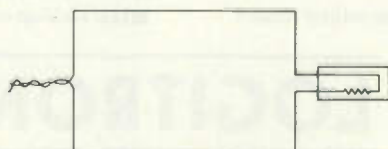

Fig. 2.

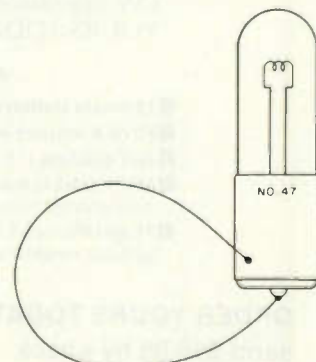

Fig. 3.

for flash bulbs, but, in addition, the caps have wire leads which act as fairly efficient antennas.

The fundamental question then is, at what distance from a blasting site does it become unsafe to use a transmitter?

The minimum safe distance is a function of both the transmitter output power and the frequency of operation. Explosives manufacturers have determined that electrical caps (for unknown reasons) tend to be more sensitive to rf in the vicinity of 21 MHz, but only slightly less sensitive at other frequencies. For all practical purposes, the frequency of operation is unimportant.

Table 1 gives the minimum safe distance between the transmitter and the closest part of a blasting circuit. Remember that, while the charges may be set some distance away, the wires of the blasting circuit could be routed anywhere — very close to a road or parking area, for

Effective radiated power (ERP)

Watts
10
50
100
250
500
1,000
10,000

Minimum safe distance between transmitting antenna and closest part of electrical firing circuit

Feet	Meters
100	30
225	70
325	100
500	150
675	200
1,000	300
3,000	915

example. Fortunately, due to the fact that the rf energy decreases away from the transmitting antenna according to the inverse square law, only very high ERPs require extreme separation distances. Such high effective radiated power is most likely to be encountered only at an amateur's fixed station, and blasting operations are not likely to occur anywhere near a residence.

We can see that the primary danger arises from the use of mobile and hand-held transmitters at or near a site where blasting operations are underway. It is here that a

transmitter can easily be inadvertently carried within a few feet of a live firing circuit, and it is here that one must be especially cautious. Remember, the explosive charge may be some distance away, but you might be standing right on top of the firing circuit. An accidental detonation would probably not only kill the workers preparing the charges, but would probably also kill the operator of the transmitter, unless by chance he happened to be at the extreme far end of the circuit.

The best rule of thumb to follow is simply to refrain

from transmitting at any location where you have the slightest suspicion that blasting operations might be carried out, or where blasting supplies might be stored. Certainly, if you see a warning sign, shut down the transmitter immediately.

The hazards I've mentioned are not a daily concern to most amateurs, but they do arise at one time or another for almost everyone. An informed ham is a safe one, and, with the basics discussed here, he will know when, and when not, to operate his radio transmitter. ■

Table 1.

Perfect CW is Automatic with TEN-TEC ULTRAMATIC KEYERS

(A) TEN-TEC KR50 Deluxe Dual-Memory, Dual-Paddle Keyer — \$110

Here's the completely automatic electronic keyer you control. Fully adjustable to your own operating style and preference for speed, touch and weighting (ratio of length of dits and dahs to space between them). Dual memories individually defeatable, for operation as full iambic (squeeze) keyer, or with single memory, or as conventional keyer. Self-completing characters. User-adjusted fixed or automatic weighting (50-150%) controlled by speed setting. Adjustable paddle force (5-50 gms). Adjustable speed (6-50 wpm). 500 Hz side-tone oscillator. Built-in "straight key" button. Operates on 117 VAC, 50-60 Hz or 6-14 VDC.

(B) TEN-TEC KR20-A Electronic Single-Paddle Keyer — \$69.50

Factory adjusted actuation force for smooth keying; factory set weighting factor for smoothness and articulation. Self-completing characters. Adjustable speed (6-50 wpm). 500 Hz side-tone oscillator. Built-in "straight-key" button. Operates on 117 VAC, 50-60 Hz or 6-14 VDC.

(C) TEN-TEC KR5-A Electronic Keyer — \$39.50

Same as KR20-A less side-tone and power supply. Operates on 6-14 VDC.

(D) TEN-TEC KR1-A Deluxe Dual Paddle — \$35

Same paddle as KR50; for iambic or conventional keyers.

(E) TEN-TEC KR2-A Single Paddle — \$17

Same paddle as KR20-A; for "TO" or discrete character keyers.

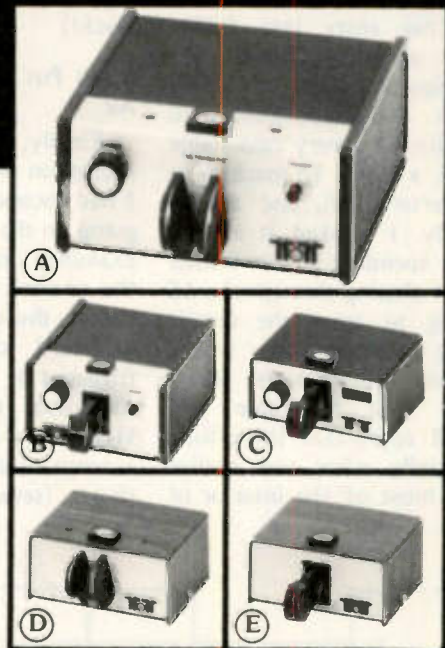

TEN-TEC, INC.
SEVIERVILLE, TENNESSEE 37862
EXPORT 9715 LINCOLN AVE. CHICAGO, ILL. 60644



Be Mr. Clean!

—simple RTTY trash remover

Like most ham projects, my entry into RTTY was neither planned nor anticipated. One day I was given the opportunity to acquire, at a very reasonable price, a Model 15 machine, a converter (TU), and a loop supply. I hooked it all up, after spending a few frantic hours chasing through the 15 trying to trace the circuit along grease-coated wiring whose insulation is black. (Try that sometime and you'll appreciate the effort, especially when you realize that most of the interior of

my machine is painted black!)

Don't Put This Thing on the Air

Finally, I got the thing typing on the local loop, but I had second thoughts about going on the air with it after I examined the output from the ancient keyboard. Looking at the output from the keyboard contacts with a triggered dc scope, I saw that the usual mark and space signals were sometimes accompanied by some very short (several milliseconds

wide) space "glitch" signals (see Fig. 1). These are due to the keyboard contacts opening when they are not supposed to and can be eliminated by careful transmit contact adjustment. They may appear between consecutive mark bits when you have a character code that consists of two or more consecutive mark bits, such as in the letter M (A in Fig. 1). Or they can appear during a mark bit if one transmit cam has a low spot that allows the contacts to open momentarily (B in Fig. 1). To all

mechanical printers and to those electronic systems that use mid-bit sampling, this extra narrow space bit poses little or no problem. However, transmitting such a trashy signal would mark you as a definite klutz, and besides, it requires more bandwidth to transmit that dirty signal than it does to transmit the correct code. On the older machines, the contact adjustment mentioned will not hold for any appreciable time, so I deemed it not feasible to adjust, but better to eliminate.

The Solution

The quick and easy solution that I used to clean up the serial Baudot from the keyboard is shown in Fig. 2. The heart of the circuit is the National LM3302 quad comparator, only one section of which is used. Other comparators can be used with appropriate pin changes. Parts are not critical, nor is layout. I used a PC board because it was convenient to do so, but perfboard construction would do an admirable job.

Circuit Operation

Isolation from the high-voltage loop is afforded by the optical coupler; mark current will cause a 12 V high at pin 4 of the optical coupler. The resistor-capacitor combination connected to pin 7 of the comparator acts as a low-pass filter that turns the narrow dropout space into a rather shallow dip in the overall mark amplitude. Resistors R1 and R2, connected to pin 6 of the comparator, set the comparator reference level, which should be chosen to be below the lowest point of the dip. I have mine set at 6 V. As long as the voltage at pin 7 stays above the comparator reference level, the output from the comparator at pin 1 will remain high. During the normal mark-to-space transition, the voltage at pin 7 drops well below the comparator reference level, and the comparator output

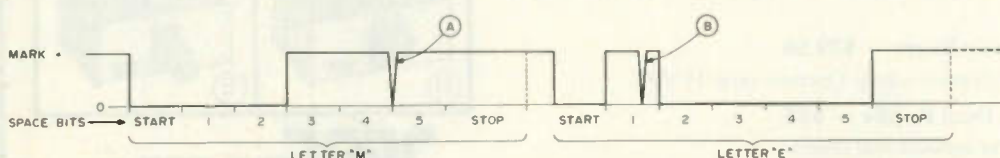

Fig. 1. The Baudot letter "M" has a narrow dropout (A) between bits 4 and 5. The letter "E" has a dropout (B) during the bit period. The dropouts are quite common in worn or misadjusted keyboards.

switches low. Therefore, the output from the comparator looks just like what the input from the keyboard should look like, the dropouts having been neatly removed.

It may be necessary to juggle the values of the resistor and capacitor in the low-pass filter to accommodate various widths of dropouts. An alternative would be to change the comparator reference level by altering the values of resistors R1 and R2. The formula for finding a particular reference level is:

$$V_{ref} = V_{cc} \times R2 / (R1 + R2).$$

Resistors R1 and R2 can be any value, but keep the total of R1 + R2 at least 10k to minimize the current.

Output Sense Selection

By interchanging the two input pins to the comparator, you can invert the output waveform. In the configuration shown, the output at pin 1 will be the same as the input. By interchanging pins

6 and 7, the output then becomes the complement of the input. This may be necessary depending upon the circuits that are connected after this circuit. Either way will work equally well. One small note of caution is in order: The LM3302 has the uncommitted collector of a rather "spongy" NPN transistor internally connected to pin 1, so keep the current into pin 1 less than about 4 mA. Much more than this will give you problems, especially at the higher baud rates.

Supply Voltage

Supply voltage for the comparator is not critical, and the whole thing draws less than 10 mA. Use a well regulated supply, especially if you are following this circuit with an FSK circuit. The chip that I used will operate with a Vcc of 5 V to 28 V. I chose 12 V dc because that voltage was already available from a CMOS source elsewhere in my RTTY system. Values

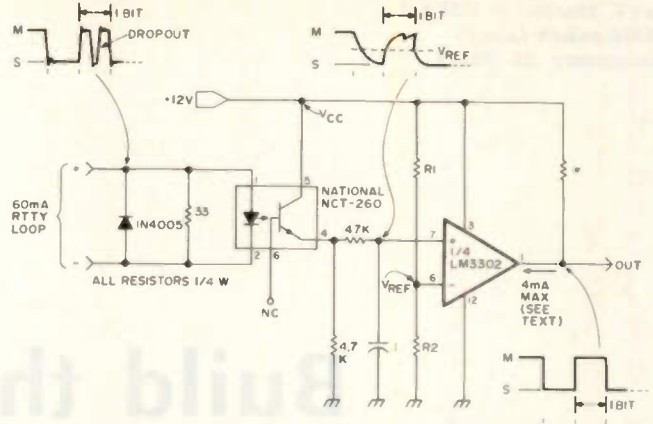

Fig. 2. Trash remover neatly strips unwanted dropouts from the RTTY signal. *Choose the value that, when in combination with the circuit that follows, will limit current into pin 1 to 4 mA (see text).

shown on the schematic are for Vcc of 12 V dc.

Physical Location

The completed circuit can be located almost anywhere. I installed mine on the loop-supply chassis because I am using the other sections of the quad comparator for other things. You could mount the whole thing inside

the machine. There is room for a power supply back behind the mechanism on the Model 15 typing unit. Remember the oil problem, however, and use good components if you mount it in the machine. Petroleum-based lubricants can raise havoc with insulation and other materials that are not classified as "oil-proof." ■

30 YEARS...

of experience in supplying top quality antennas to Ham Radio operators at rock bottom prices guarantees high quality and low prices to novice and experienced operator alike.

TWO ELEMENT QUAD with full wavelength driven element and reflector. All metal construction. Gain is equal to that of a three element beam and directivity is exceptional. Assembled weight 25lbs. 10/15/20 quad, totally complete and ready for simple assembly . . . **JUST \$59.95.**

FULL SIZE BEAMS for full size performance. Includes boom, all hardware and gamma match.

12 EL 2M Beam \$56.95	6 EL 6M Beam \$54.95	5 EL 10M Beam \$59.95
4 EL 6M Beam \$45.95	3 EL 10M Beam \$45.95	3 EL 15M Beam \$54.95
5 EL 6M Beam \$49.95	4 EL 10M Beam \$49.95	4 EL 15M Beam \$59.95

FREIGHT PREPAID on 2, 6, and 10M beams shipped to the 48.

ALL BAND VERTICAL ANTENNAS absolutely complete including loading coil.

V40 vertical antenna for 40, 20, 15, 10 and 6 meter bands. Especially suitable for the novice who operates 40 and 15. **JUST \$25.95**

V80 vertical antenna for 80, 40, 20, 15, 10 and 6 meter bands. Used by thousands of novices, technicians and general license hams. **JUST \$27.95**

V160 vertical antenna for 160, 80, 40, 20, 15, 10 and 6 meter bands. Same as other vertical antennas, but with larger loading coil. **JUST \$29.95**

How to order: Remit total amount with order. We ship verticals, 2, 6, and 10M beams (except 5 EL 10M Beam) prepaid to the 48. Other beams and all quads sent freight collect cheapest way, due to size of package. Check your local truck lines for estimated freight rates. For fast COD service on all prepaid antennas, call (305) 573-2080. For literature, send self-addressed stamped envelope.

GOTHAM, INC.

2051 N.W. 2nd Avenue Dept. 73
Miami, Florida 33127

**VERTICALS SHIPPED
FREIGHT PREPAID
ANYWHERE IN
THE WORLD!**

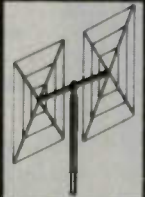
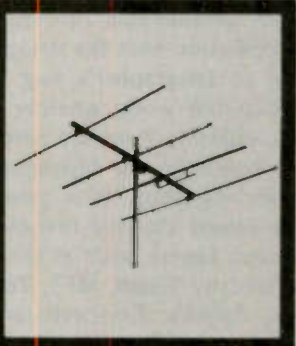

Build the Triple Threat Keyer

—great Novice project

The new versatile electronic keyers now available, particularly the second-generation "memory" types, offer considerable flexibility of operation over the straight key or telegrapher's bug in serious CW work, whether it be contesting, field day portable operation, or high-speed traffic handling. It is generally agreed that the first-generation keyers such as those offered by Heath, MFJ, Ten-Tec, Palomar Engineers, and others, as well as those home brew units described in the amateur literature over the past several years, are gener-

ally excellent units, some featuring built-in paddles and others requiring the use of an external paddle mechanism. The newer units, such as the recently-introduced "CW Sendin' Machine," the Daytonics Contester, and the Autek Research MK-1, are definitely way out in front as truly state-of-the-art devices. They will probably rapidly replace the former as costs come down with mass production and simplified circuitry.

Most of these newer keyers and many of the simpler types require external

paddle mechanisms. For portable and field day use, the station's expensive delicate paddle mechanism is something you'd rather not take along, when the unit may be dropped, scratched, or otherwise mishandled. To reduce the risk of damage, I have designed and built a simple three-in-one unit that combines a paddle, sideswiper key, and straight key in one box, along with a simple CW clipper/filter thrown in on the side. The little unit, fulfilling the need for a small, dependable, and lightweight (not to mention rugged and inexpensive) keying mechanism, is little more than two carefully adjusted lever-action switches — one SPDT switch arranged so as to function as either a keyer paddle or sideswiper key* (QCWA types may remember those) at the flick of a switch, and the other wired as an SPST device to act as a simple straight key. Added as a convenience

feature is a miniature momentary-contact SPST push-button switch across the straight-key contacts for use in tune-up. This design is simple in operating principle and is far superior to push-buttons as the dash and dot contacts in small portable keyers; the latter are frequently unreliable and difficult to use properly, not to mention being uncomfortable after any extended period of use.

The Blitz-Box, as this little gadget has been dubbed, is built into a small Radio Shack #270-251 enclosure and can be used in any of the three ways described. For quick trips, you might consider leaving the regular keyer home entirely and bringing along the little box for use as a sideswiper.

Practically any of the Switchcraft "Lev-R" line of switches can be used. These cost from \$3-4, depending on the number of sections and contacts. This series of switches has the advantage of being narrow and not too large, requiring only a 1/2" mounting hole. Actually, any lever-action, spring-return switch could be used, as long as you can get one set of SPDT contacts for the paddle and a set of SPST contacts for the straight key. I used two identical multiple-section junk box switches obtained on the local surplus market for about 50¢ each. Just be sure that the switch selected has a center-off position and is spring loaded and that you have the right type of contact arrangement to give you the SPDT and SPST contacts (the ones I used had to be taken apart and some contacts reversed — a two-minute surgical operation). The additional unused contacts on the lever switches provide convenient mounting points for the various components. Conventional wiring techniques are used throughout. Don't omit the bypass capacitors, as they offer some degree of key click and contact sparking protection.



*David H. Atkins W6VX, "QLF? Not with the Great Lakes Sideswiper!", 73 Magazine, March, 1977.

As can be seen from Fig. 1, the keyer switch is wired so that, by moving the lever in one direction or the other, a dot or dash closure is obtained. Keying feel on both paddle and straight key is easily adjusted to suit individual taste by judicious spacing of the switch leaf contacts to control travel, using a pair of long-noise pliers. In making these adjustments, take care to strike a balance between feel, operating comfort, and reliable contact closure. Also, if the cabinet slides around on the operating table while pounding brass, epoxy a couple of small lead fishing weights inside the cabinet or place a piece of double-backed tape under each mounting foot.

The photo shows that the original plastic knobs have been left on the lever switches, no real paddle, as such, being installed at all. A paddle can be made from a piece of Plexiglas™, Bakelite™, or fiberglass PC board material and painted black. File down the original switch knobs, or remove them. Surprisingly, I have found that the rather large knobs which came with the switches provide a satisfactory feel and do not cause excessive finger fatigue or glass arming. Try building the unit without the paddle extensions, and install them only if necessary, cutting and filing them to slide over the original plastic knobs and epoxying them into place.

As a matter of convenience,

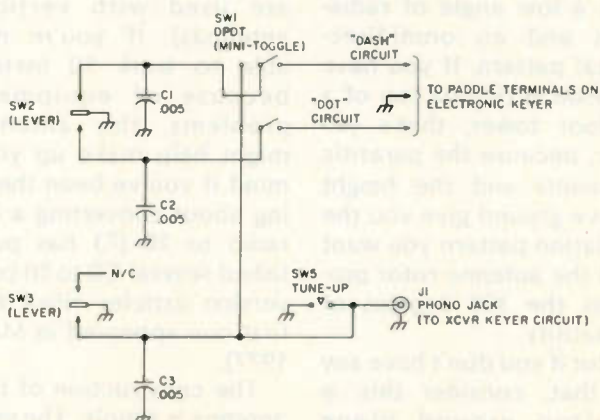

Fig. 1. Keying portion. All component values nominal.

nience, particularly for portable and field day use, a simple audio clipper/filter is installed in the same enclosure to cut high-frequency response and to control the volume of received signals to prevent blasting, particularly in weak-signal CW work where agc may be disabled (a real ear-saving device). The clipper simply chops off the audio above a certain threshold (determined by the operator and the diodes installed), reducing the potential for blasting and at the same time clipping strong noise peaks. The filter, which consists simply of a couple of selected capacitors, is not intended to substitute for good receiver i-f selectivity, a must for serious CW work; it is intended to be used in conjunction with a receiver that has at least a fair degree of selectivity of its own, serving mainly to roll off high-frequency audio response to reduce annoying static crashes, adjacent channel splatter, receiver audio hiss, and noise.

As far as the filter shown in Fig. 2 goes, the two silicon diodes are simply connected back to back across the headphone line, and, with a threshold conduction point of about .6 volts or so, prevent the amplitude at the headphones from rising further. Signals below the threshold of conduction are not significantly affected by the action of the diodes. R1 and R2 are selected to enhance the clipping action and do slightly cut headphone

volume. However, most receivers have adequate gain to allow for the loss caused by the clipper and the roll-off filter capacitors. R1 is not critical but should be around 47 Ohms, while R2 should be several times the headphone impedance. I used a 100-Ohm pot to allow adjustment of the headphone level when the clipping point is reached. Adjustment of this pot, and the receiver's regular audio gain control, is best determined by trial, and should be a compromise between desired clipping action and headphone volume level. Usually, it will be found that the best clipping condition is that which just starts to take hold on fairly strong signals, leaving the weak ones and the noise background untouched. I have found that it is generally best to run with the audio gain well advanced and to adjust clipping level by riding the rf gain control. Note, too, that the clipper makes it a bit more convenient to run with agc off and to work break-in, since there is no thumping or gain recovery time, distinct advantages when trying to work full break-in.

The desired filter characteristic is enhanced by C4 (medium/wide bandpass) or by paralleling C4 with C5 by use of SW4 in the narrow position. I have found that, with the capacitor values shown in Fig. 2, the medium/wide position works quite nicely on SSB (and on CW when interference isn't too great), while the narrow position, with its roll-off probably less than 1000 cycles or so, is helpful in crowded-band CW work. Although only two capacitors are used in my circuit, a fancier arrangement

might use a single-pole, five-position switch to cut in four different values of capacitors (say, .1, .22, 1, and 2.2 uF), with the fifth position being not connected and used to cut out the filter entirely. Larger values of capacitance should not be used, as the filter will tend to simply short out the receiver audio. The capacitor values are best determined by trial.

Assuming the filter is used with a receiver with decent i-f selectivity (or even one of the newer SSB transceivers without the optional CW filter installed), its simplicity becomes its own advantage in that excessive audio selectivity can become extremely monotonous and fatiguing over long periods of operation. It is then not practical to vary the tone much while operating, and you're stuck with the beat-note tone you've tuned up the filter for. Use of the simple untuned filter described has been found to be entirely adequate with a Tempo 2020 (which has a 600-cycle CW filter) and with several receivers primarily designed for SSB work. In either the wide or narrow positions, it cuts out a great deal of background noise, improving signal-to-noise ratio and noticeably reducing operating fatigue. You get all these features at a total construction cost of less than \$10 for the whole unit.

Though the designs incorporated in the little 3¼" x 2-3/16" x 4" unit are by no means novel or unique, taken together as a package they afford a great deal of flexibility to portable operation with various transceivers, receivers, transmitters, and keyers. ■

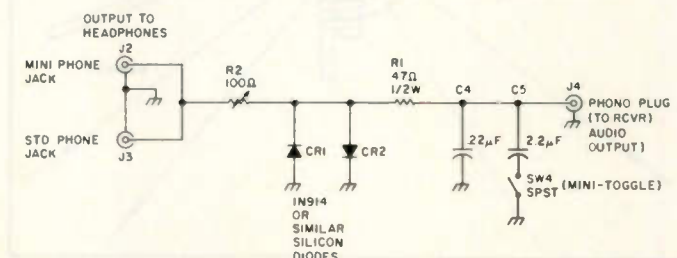

Fig. 2. Clipper/filter portion. All component values nominal.

The Ten Meter AM Antenna Special

— \$5 vertical also works
on SSB or FM

Alan Kaul W6RCL
9731 Nevada Ave.
Chatsworth CA 91311

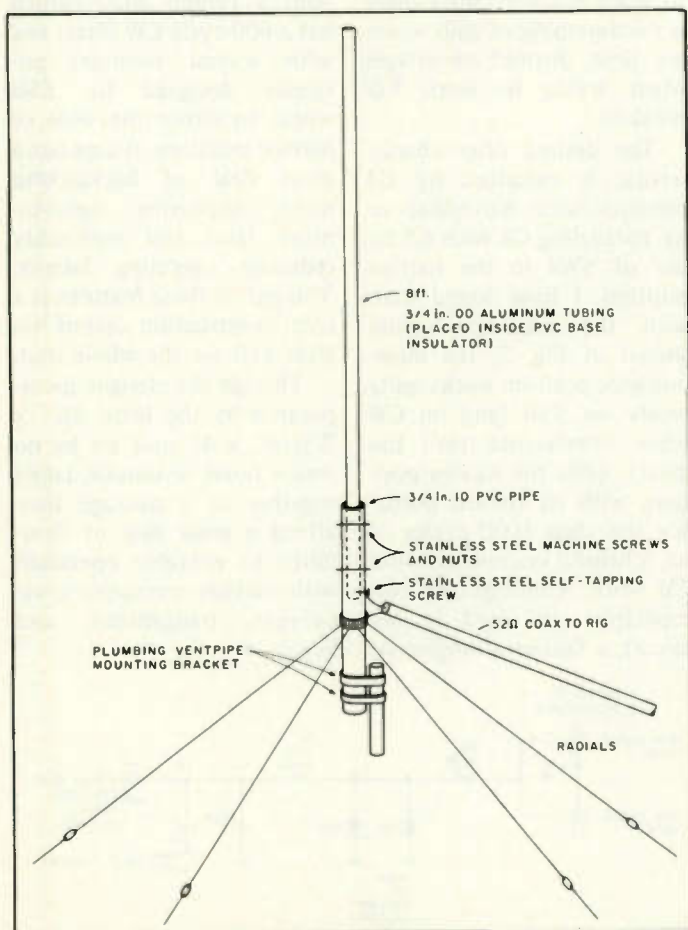

Fig. 1. Design of the \$5 vertical.

Ten meters is a funny, band—not funny, ha-ha, but funny, peculiar. Sometimes it “opens” to what sounds like everywhere. Sometimes it isn’t “open” at all. And, occasionally when it is open, it is open only in one direction. To take advantage of the band’s peculiarities of propagation, you need an antenna which will give you a low angle of radiation and an omnidirectional pattern. If you have a beam sitting on top of a 70-foot tower, that’s terrific, because the parasitic elements and the height above ground give you the radiation pattern you want and the antenna rotor provides the 360 degrees of versatility.

But if you don’t have any of that, consider this: a rooftop ground plane which is wind resistant and

can be built from scratch with new parts for less than \$5. The vertical polarization gives you the low angle of radiation needed for long skip, but it won’t cause cross-polarization problems when working DX because the signal tends to get unpolarized when it bounces off the F-layer. The vertical polarity will also help with local QSOs when working from your base to someone else’s mobile (most, if not all, 10 meter mobile rigs are used with vertical antennas). If you’re not able to work 10 meters because of equipment problems, this antenna might help make up your mind if you’ve been thinking about converting a CB radio to 10 (73 has published several CB to 10 conversion articles since the first one appeared in May, 1977).

The construction of this antenna is simple. The only tools you’ll need are a

hacksaw, screwdriver, soldering iron, and wire cutters. Installation is simple, too. This antenna uses a commercially-available mounting bracket (I'm using a plumbing ventpipe mount which I bought for my TV antenna at a hardware store for less than \$2, but a chimney mount or eave mount would work equally well). The antenna will handle several hundred Watts PEP, and, if constructed to the proper dimensions, you can expect a standing wave ratio of less than 1.5 to 1 (mine is below 1.5:1, between 28.5 and 29.0 MHz). While this particular antenna is designed for 10 meters, the same basic pattern can be used on 15 meters using the same size diameter tubing. If you want to design a similar antenna for 20 or 40 meters, I'd recommend doubling or tripling the diameter of the tubing for strength and placing nylon guy ropes

near the top of the completed antenna for stability.

Everything you need for 10 meters is shown in the parts list.

Construction is straightforward. The aluminum radiator slips inside the PVC tubing and is held in place with the two stainless steel screws. The self-tapping screw goes through the PVC insulator into the aluminum near its bottom end, and the coax center conductor attaches to the self-tapping screw. The radials are soldered together at one end and affixed to the PVC base tubing with the hose clamp. The coax ground braid is soldered to one of the radials. If you want to get the antenna aluminum tubing more than a foot or two above the roof, the radials should be tied down firmly as guys. If you want to put the antenna even higher—8 to 10 feet above the roof—I'd recommend you

invest in an inexpensive television antenna mast of the same inside diameter as the outside diameter of the PVC. Slide the PVC inside the mast and fasten it using two more stainless steel screws.

The angle at which the radials meet the base insulator will have an effect on swr. If the radials drop vertically from the radiator, the antenna essentially would be a vertical dipole and a good match would be obtained with 72-Ohm coax. An angle of 40 to 50 degrees

should be a good match for 52-Ohm coax. As the angle approaches 90 degrees, the impedance of the antenna decreases and the mismatch is reflected in an increasing swr.

That's all there is to it. The rest is in Fig. 1. Oh, yes, one more thing—the last time I wrote an article for 73, I received 35 inquiries by mail requesting more information. I'll be happy to answer all letters, but only if you send a self-addressed stamped envelope.

See you on 10. ■

Parts List

- one piece of aluminum tubing (8' x 3/4" outside diameter)
- one piece of PVC pipe (any length x 3/4" inside diameter—double-wall is recommended for strength)
- two stainless steel screws with nuts and washers (8 x 32/1 1/2" works fine)
- one self-tapping sheet metal screw
- one automotive-type hose clamp (1 1/2" inside diameter)
- four 8'8" lengths of copper wire for radials (copperweld or similar if vertical element is sufficiently above the roof requiring the radials to double as guy wires)
- four strain insulators
- one piece 52-Ohm coax, any length to transmitter
- one installation bracket, your choice



STAMP-IT ETCH-IT

Reduces Printed Circuit Board Art Work From 2 Hours to 10 Min.

Simple as A.B.C.

A. Stamp Components on P.C. Board. B. Use Pen to Interconnect Lines. C. Etch Board.

Are you tired of the hours of small, detailed, eye-straining art work that goes into making printed circuit boards? "STAMP IT, ETCH IT" is introducing a NEW product called "STAMP IT, ETCH IT" Kit. This Kit will take the tedious art work and many tiresome hours out of printed circuit board preparation. In just a few short minutes you have a professional looking etched printed circuit board ready for drilling!

The "STAMP IT, ETCH IT" Kit is exactly as the name implies. Following the step by step simple instructions, you can have a printed circuit board and have saved hours of frustration. As easy as you use a rubber stamp to stamp messages on paper, you stamp your component connections on copper clad printed circuit boards.

In your "STAMP IT, ETCH IT" kit we supply all component stamps shown in SE-2 Kit. In the SE-2 kit we also have resist ink enough for months and months of experimenting. Ink stamp pad, resist pen, and etching containers. The most revolutionary item in your "STAMP IT, ETCH IT" Kit is... The Fool Proof System of etching your printed circuit boards.

With our kits and our etching containers, you are able to etch a printed circuit board as fast as bubble etching machinery and the results are as good or better.

AT LAST COMPLETE LINE OF STAMP-IT ETCH-IT DIP IC SOCKETS A DREAM COME TRUE

No Previous PCB Experience Necessary

IC-40	IC-36	IC-28
10000000000000000000	10000000000000000000	10000000000000000000
IC-40 1/2 SOCKET	IC-36 1/2 SOCKET	IC-28 1/2 SOCKET

IC-24	IC-18	IC-16	IC-14	IC-8
10000000000000000000	10000000000000000000	10000000000000000000	10000000000000000000	10000000000000000000
IC-24 1/2 SOCKET	IC-18 1/2 SOCKET	IC-16 1/2 SOCKET	IC-14 1/2 SOCKET	IC-8 1/2 SOCKET

PRICE EACH	
IC-40	\$4.95
IC-36	\$4.95
IC-28	\$4.95
IC-24	\$4.95
IC-18	\$4.95
IC-16	\$4.95
IC-14	\$4.95
IC-8	\$4.95

FOR COMPLETE KIT ORDER	
SE-2 KIT	\$29.95
SE-8 KIT	\$29.95

RAINBOW INDUSTRIES MADE UP A SE-D 400 KIT FOR THE PRINTED CIRCUIT BOARD MAKER WHO WANTS EVERYTHING

And Just For You... One Complete Package Pictured Below

SE-2 KIT

- 16 PIN DUAL IN LINE IC SOCKET
- 10 PIN ROUND IC SOCKET
- 8 PIN ROUND IC SOCKET
- TO-5 TRANSISTOR SOCKET
- TO-18 TRANSISTOR SOCKET
- LARGE & SMALL ODNUT PAD
- RESIST INK
- INK PAD
- RESIST PEN

ONLY \$9.95

PLUS 1 LB. POSTAGE

ADDITIONAL STAMPS:

Bread board stamps for all integrated circuits "Good" for experimenters.

Only \$2.95 each or all four \$9.95

#1 DUAL IN LINE



#2 FLAT PACK



#3 8-PIN ROUND



#4 10-PIN ROUND

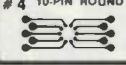

- RESIST INK .95c per bottle
- RESIST PEN ea. 95c
- INK PAD ea. \$1.15
- Etching Containers .10 for 95c

ONE COMPLETE SE-D8 KIT

ALL FOR ONLY **\$54.95**

PRINTED CIRCUIT BOARDS

G-10 FIBERGLASS

Size	1 Side	2 Sided
2"x 4"	.25	.35
3"x 6"	.50	.65
4"x 6"	.65	.90
6"x 6"	.90	1.35
6"x 12"	1.50	2.50
12"x 12"	2.95	3.95

AMPHENOL PL259's

10/\$4.50

100/\$39.95

OTHER R.F. CONNECTORS AVAILABLE. SEND FOR CATALOG

MUFFIN FANS PULL OUTS

4 3/4" Sq.

GUARANTEED LIKE NEW

\$8.95 each

RAINBOW INDUSTRIES

P.O. BOX 2366 R10

Indianapolis, Indiana 46206

\$5.00 Minimum Order PLEASE ADD POSTAGE

MASTER CHARGE PHONE ORDERS WELCOME 317-297-2717

W2NSD/1 NEVER SAY DIE

editorial by Wayne Green

from page 8

up a lab with the latest in microcomputers up and running so submitted programs could be tested for accuracy and interest. Next, I encouraged programmers to get cracking. The first of these programs to be published were introduced at the National Computer Conference in early June and the response was immediate—just what everyone needs.

Our facilities for duplication are limited. We have about 50 top-notch cassette recorders set up in parallel for copying. We've been using these for our code and Novice theory cassettes. With these, we can crank out perhaps 500 per day, if everything runs smoothly. That's pitiful when we look at the demand for program cassettes.

We're gearing up to turn out four new programs a day... that's 20 per week. With about 1,000 computer stores already up and running and another thousand being planned for the near future, we would need to turn out a bunch of cassettes just to keep new programs going to the stores. Say we shipped them ten of each new program... that means we would be shipping 40,000 cassettes per day, not including any repeat orders. Obviously this means high speed duplicators, a rather large new

plant, another computer to keep track of the business, packing and shipping machinery, a bigger computer lab, more editors to check out programs and prepare master tapes, etc.

There are more millions to be made in microcomputing in making accessories for the popular systems. I'll be surprised if there aren't more millionaires in the next few years than ever before in the history of the country. Interested parties can contact me for my consulting fees. Ahem.

In view of my grandiose software plans, you can perhaps understand why my reaction to the lack of a letter to ask for funds for an African mission was mixed. I'm reminded of the old joke about the mixed emotions of the chap watching his mother-in-law go over a cliff in his new Cadillac.

After being on the poor side for most of my life, the prospect of money is fun to contemplate and, like the loss of frequencies, I don't actually believe it. If it really happens, I'll try to believe it. In the meantime, whether I believe it or not, we have to get going on the new plant, getting tapes out, etc. This means hiring a lot more people—anyone interested with some of the backgrounds we'll be needing in management, cassettes, programming, financial planning, production,

packaging and shipping, automated machinery, etc.?

EUROPE '78

Sherry and I arrived in London in late May to find my favorite hotel full. We had to settle for rabbit-warren-type accommodations. Most surprising of all was the prices—about double those at home for most things. Would you believe \$4.50 for a simple roll and coffee "continental" breakfast? After two days of this, plus a meeting with a microcomputer manufacturer and a visit to a microcomputer store, we went to Paris. The prices were not lower.

The main event in Paris was Micro-Expo, a microcomputer show. It was mobbed and we sold a bunch of subscriptions to *Kilobaud*. One of the high points of this show for me was my talk to the assembled multitudes... the room was packed, with the audience spilling over into the aisles, on the stage, and backed up out in the halls. There's enough showman in me to enjoy an enthusiastic crowd liked that, and to know that word of *Kilobaud* had spread even to Paris and the continent.

I spoke on the microcomputer \$300 million fraud, the selling of microcomputers without the programs to back them up. I emphasized the need for the developing of software for microcomputers along with the hardware, if we are not to suffer a devastating disillusionment by the general public. I offered some proposed solutions to the dilemma. The response was very good.

From Paris, after checking out the Louvre carefully and trying some meals in Moroccan, Greek, and Vietnamese restaurants, we went on to Zurich, switching from French food to

fondues. We rented a car and drove through Berne to Geneva and talked almost a full day with the amateurs on the permanent staff there, and with the chaps at 4U1ITU. The ham station there has seen better days and possibly is reflecting the low morale of the hams who see the coming ITU meeting as no reason for joy.

In addition to a vintage Yaesu FT-101 station, there was a wonderful old Collins rig. They also had one of the ARRL low-powered CW stations which have been developed for use in third world countries. This is on display for any representatives from these countries who might visit the ITU.

The truly unfortunate aspect of this rig is that the whole concept involved is abhorrent to most of the emerging nations. The ARRL meant well when it developed and backed this idea, trying to make it possible for a real low-cost personal ham rig to be made available for hams with next to zero budgets. The idea is fine, as long as you have never visited these countries and are ignorant of their situations.

The fact is that there are few of the emerging nations where the rulers are interested in citizens having personal communications. Most of these countries are shaky and the rulers are quite interested in staying in power. They know that if individuals are able to develop communications, the same thing could happen to them that the British set up when they permitted all those ZC6 hams to operate... and they quickly became the communications network which helped Israel to get started. It is doubtful if Israel would have made it without the hams.

Remember that King Hus-

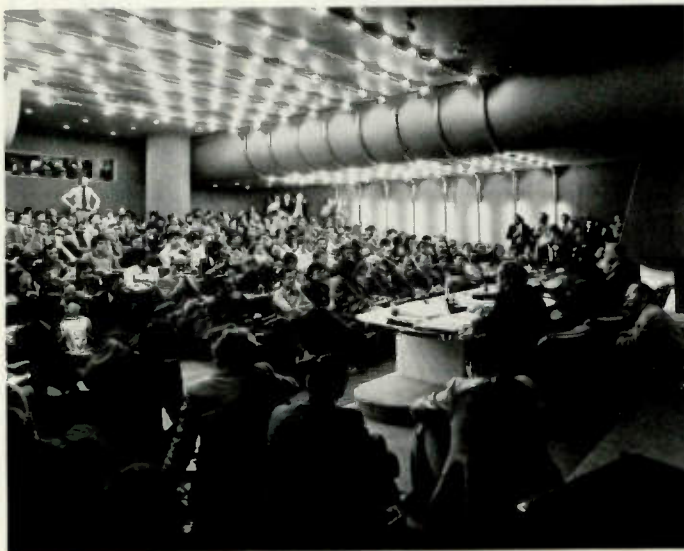

W2NSD/1's address at the Paris micro show was made to a packed house.



At the Paris Exposition of Microcomputing, Monika and Reinhard Nedela, the European Kilobaud representatives, did a brisk business at the KB booth.

sein set up ham communications even though his country was involved in a civil war. This never would have been permitted on an individual basis... too much chance for enemies to use the radios for fighting against the government. But the setting up of club stations for the youths gave enough control of the situation so there was no worry. The same holds true for most small nations—club stations are okay, personal communications, no way. Put it this way... how many personal stations have you contacted in Russia? The chances are that, with very few exceptions, you've worked only club stations.

After talking with the hams at the ITU and making an hour tape of some of the more important aspects of the interviews to be played to ARMA at Atlanta, we drove off to Luzern, one of the most beautiful of Swiss cities. The next day we drove on to Liechtenstein for lunch, a quick drive through Austria and Germany to make it four countries in one day, then back to Zurich.

The next day we flew back to the U.S. and, after one day at home, grabbed our suitcases and were off to Atlanta for the ARMA meeting and the Atlanta Hamfest-Computerfest.

I've covered the ARMA meeting pretty well. The hamfest was excellent, as usual. I had a good audience for my talks on computer software and the state of microcomputers today, and for my talk on WARC and the African situation. I would appreciate getting a tape of the ARRL forum on Sunday, for I understand that, while most of the meeting was devoted to a critique of *QST* covers, just at the end Eaton got up and said that the manufacturers were going to send a trade mission to Africa to try and develop a market for ham gear there. I think the innuendo was that this would then stop the Africans from building equipment just as the industry has stopped building here. This is an old anti-manufacturer line from the ARRL and is a crock. Hams are building more than ever before in history; you have but to look at the dozens of pages of parts ads in 73 to know what the real story is, and then compare that with the parts advertising from any period in the past.

It sure looks to me as if *QST* is afraid to let the manufacturers get together and form an organization and will do what they can to torpedo the effort. The manufacturers made *QST* eat crow on their demand that ham gear only be sold to hams, and more crow is on the menu after the recent *QST* proclama-

tion that manufacturers would have to submit equipment for *QST* evaluation for purity of signals before ads can be run in *QST*. If *QST* would ask, the industry would probably bend over backwards, but no one likes to be commanded.

From Atlanta, we headed for Anaheim and the National Computer Conference (NCC). Some 40,000 people gathered to see the latest in computers and systems, with a separate exhibit area for microcomputers. Our booth was there, in the Disneyland Hotel. We were there four days and never had one hour to spare to go next door and see Disneyland!

The main exhibit for us was our new software packages. We're getting geared up to turn out about four new computer programs a day. These are written by *Kilobaud* readers and we are just publishing them and putting them on cassettes for users. The response to our software was fantastic; every manufacturer was enthusiastic and my talk at NCC on the subject was well received.

While in town, I had dinner with Pete Hoover K6ZH and discussed the WARC situation with him. Though the ARRL has been trying to cover it up, many influential hams have been pressuring it to do something about the African bloc situation. The heads of the ARRL Foundation tried to organize a fund drive to help with this, but Baldwin cut it off and the officers of the Foundation resigned in protest, including Pete. Pete is the son of Herbert Hoover, Jr., past president of the ARRL, by the way.

One of the large publishing firms also took us to dinner, wanting to buy out the magazines. That's ego-gratifying to hear, even though I can't think of any reason to sell. With our computer software plans about to dwarf the magazines in sales, this is not a good time to think about selling, even if I was of that mind. I enjoy publishing too much to change.

From Anaheim, we made a quick trip to San Francisco to visit Lomac and talk with John Peers, a most enthusiastic and intelligent chap. We sat down and found his Adam computer a delight to program, so much easier than anything else we've tried—a dream. From there we checked out some high speed cassette duplicating equipment—should cost about \$200,000 for what we need—and then off to dinner with Bill Godbout, George Morrow, and Bob Mullen. What a fantastic trio!

When Godbout throws a dinner for friends, he does it first class... complete with a flight in his plane for a half hour or so, then a long taxi ride to Mark



The Birminghamfest was indoors this year in mid-May and brought a nice turnout. About half of the displays were in the flea market area, seen here.

West for dinner. All three of them are so full of ideas that even a few minutes with them is exhilarating. One of the delights of both the ham and computer business is that talking business is fun. We talked over new product ideas, advertising approaches, possible ways for the market to go, the

impact of various new systems, and before we knew it, the restaurant was closing and we had to come back to the real world.

The next morning, Sherry and I headed for Los Angeles, then on to Atlanta for a short appointment there, staying for the first time at the Omni. You can



Though a good part of the trade exhibit area was occupied with ham stores, there were a few manufacturers such as Ten-Tec, Kenwood, etc., seen here.

bet I'll be getting to the Atlanta Omni as often as I can. It's no wonder that Underground Atlanta has been hurting. They have the same type of entertainment in the Omni, but without the junk. We're both Frogurt fans and, sure enough, the Omni had a Frogurt stand ... and several restaurants ... and a fudge store (why does one pound of fudge help me put on five pounds of weight?) ... love their orange fudge ... a McDonald's (I like their breakfasts) ... etc.

The next morning we were off again to Puerto Rico. We only had a couple hours between planes, so we caught a taxi to town and went to El Morro, the fort commanding the entrance to the harbor. Then we flew down to Martinique for three days of rest and recuperation. Again we were on an Eastern special fare tour which costs less than the round trip to California. The islands are packed all summer as a result of this new Eastern fare ... what a great idea that turned out to be ... and the Eastern planes are packed, too.

Martinique is beautiful, but there must be a rule against the natives smiling. Everywhere we went, the natives were dour. In the restaurants, they did their job but cast gloom everywhere they went. The prices in Martinique, like St. Martin and Paris, were horrendous. Four dollars for a breakfast with two cups of coffee and a couple rolls, a pat of butter, and a dab of jam. It sure makes McDonald's look good. At least in Paris, you could go to McDonald's ... two of them on the Champs-Elysees.

As usual, I had ordered a Budget rental car to be waiting for me. I had a bit of a hassle getting the car, and then when I started to drive off, I found it was almost out of gas! Ugh. We had about two francs of French money, so I had to pay for gas with American money, it being Sunday night and there being no banks open. The gas station ripped me off for half the regular exchange rate, bless 'em.

The hotel was about 20 miles from the airport and the route signs were minimal, so I drove through the blackest night I've seen in a long time, nursing a very crummy Fiat car along. The light switch panel was hanging out of the dashboard by its wires, and the rest of the car was not in much better shape. Just as we got to one of the darkest places, a tire let loose. I was still dressed in nice clothes, the temperature was around 85°, and I had not the slightest idea where to find the spare tire, the jack, or the tools.

Luckily, I had a flashlight

with me. Am I glad I carry that! It's part of my kit ... camera, spare lens, film, cassette recorder, battery, and a couple games to play on planes, such as Boggle and Cribbage. Also the flashlight. I found the tool kit, but the jack was a bit more difficult to locate ... finally found it up under the front hood, along with the spare tire. The spare looked as if it would give out shortly, too.

Much to my amazement, a native stopped his car and offered to help. I was organized by this time, but he did help out and gave confidence. We got the tire changed in short order and I continued on to the hotel.

The next morning, I discovered a Budget office right across from the hotel, so I went on over and asked them to fix the tire. No, I'd have to take the car back to the airport where I rented it. I looked at the spare, which never would have made it that far, and got up a head of steam. I got out my camera and took a picture of the spare tire, the car, and then tried to take a picture of the gal who was giving me the hard time. This changed things. She wanted to know what the pictures were for and I announced that I was a journalist and knew when I had the makings of a story. She quickly pointed to another nearby car and said I could exchange my jalopy for that one, even though it should rent for more. It was a slightly better Flat, so I said okay. I hate having to rattle my magazine at people, but dammit, I sure don't like being victimized.

Something similar happened the next day. Eastern had included a prepaid tour of Martinique in our fare. I checked with the hotel and asked about it. They pointed across the street to a tour office. I went there and asked about the tour, showing them my coupons. They set it up for the next morning.

Sherry and I arrived for the tour on time, got into the taxi provided, and we set off. The driver went about a quarter mile and stopped, asking what we wanted to see. I said we were supposed to get a tour of Martinique and he said, oh no, that those tours left only from the capital, Fort de France, and that we should have taken the ferry across the bay and met him there. Oh, he could drive us up to Fort de France, but that would be \$14 extra. Beginning to suspect foul play, I asked to be returned to the tour office.

At the office, I went back over the scenario and asked why I had suddenly been presented with a bill for \$14 for a tour which was supposedly prepaid. They suddenly had trouble speaking English ... perhaps

something could be arranged for tomorrow from Fort de France, they suggested? I said no, we're going to Dallas tomorrow. I said that this had all the appearance of taking advantage of tourists and, as a journalist, I found this most fascinating. They then decided that the taxi would take us on the tour of the island without our paying the \$14. I'd lost a lot of interest in the deal, but eventually they wheedled me into going. I'm glad I did, for it was a fantastic drive, even though the driver sulked the whole time.

If you have a chance to get to Martinique, I would recommend that you be sure to take this drive up through the rain forest and back down the coast, stopping off at St. Pierre, which used to be the capital of the island. We did see one interesting thing during the trip in addition to the fantastic beauty, and that was an old jalopy stopped at a bend in the road where a pipe came out of the side of a hill. Two people were there filling some plastic bottles with water. We could see the blue and orange labels on the bottles and I said I'd bet that they were going to sell the water.

That evening, back at the hotel, Sherry ordered her usual Perrier water ... all out, but we have some good local mineral water. They brought out one of the same bottles we'd seen being filled. It tasted exactly like water. Quite a business at \$1 a bottle.

There were three restaurants right next to our hotel, the Del La Marina, one Chinese and two French. On the mineral water episode evening, we picked the Brasserie Restaurant and presented ourselves for dinner. The woman seating people ignored us for a while and then pointed across the room at an empty table and went on about other business. After fifteen minutes, a waitress stopped and asked what we wanted to drink. This resulted in the Martinique water bottle. A half hour later, we still had had no further attention, not even any bread. We gave up and left, going next door to another restaurant where we were served promptly, if unsmilingly. What a bunch of unhappy people!

The hotel room was spartan, but comfortable, and had a kitchenette, complete with refrigerator. And right next door was a small grocery store, so we enjoyed bananas, coconuts, ripe pineapples, cheese, and lots of Perrier water.

Since we only had a three-day visit sandwiched in between shows, I didn't take a big along. Licenses are not diffi-

cult to get there and I think the next trip will see a rig under one arm.

DALLAS

Eastern picked us up on schedule, stopped by St. Martin for a few more passengers, and then took us to San Juan for a plane change. We had to go through a customs inspection here and that was frustrating. We had two hours between planes and we spent one solid hour on line at customs, watching a woman go through every square inch of every piece of luggage of every person on the line. It seemed to take forever.

Since we had bought absolutely nothing, not even a postcard, she was a little speedier in going through our six pieces of luggage. Martinique prices are not much different from Paris prices, an effective economy measure for us. I needed shoes badly, but at \$75 a pair for \$25 shoes? Phooey.

The Eastern route from San Juan to Dallas went to Miami, Atlanta, and then Dallas. Naturally, the plane broke in Miami and our flight would be delayed an hour. We had a one-hour wait at Atlanta scheduled, so this meant we would lose that connection. A little look at the flight schedule showed a plane leaving later going direct to Dallas from Miami, arriving a few minutes after our originally scheduled flight. We changed ... and hoped for the best on the luggage.

The best was not to be.

An hour after we arrived in Dallas, a plane came in bringing two of my three bags. The third bag was located a couple days later, having detoured to Chicago for some obscure reason. Naturally this was the bag with my clothes, so I had to rush out and buy a new suit to use at the show. I was scheduled for two performances, one on computer software and the other on WARC.

We'd shipped a couple of suitcases and four boxes of stuff from Los Angeles to Dallas, hoping to pass up taking all that to Martinique. The suitcases were waiting for us (with subscription blanks), but no boxes. Eventually, we did find three of the four boxes ... they'd been shipped to Atlanta ... and got them back in time for the show. Between the boxes and the missing suitcase, we spent many hours and bucks on phone calls.

RENTAL CAR RIPOFF?

Budget pulled a stunt on me at Atlanta that bugged me. I've been using 'em for years and

Continued on page 162



Germantown Amateur Supply, Inc.

G-12
MEMPHIS, TENNESSEE

NO MONKEY BUSINESS!

- (A) Complete Service Facilities
- (B) Good Deals on most Brands
- (C) Shipping within 24 Hours
- (D) All inquiries handled by Active Hams with over 20 years experience in ham radio

CALL TOLL FREE
1-800-238-6168

IN TENNESSEE, CALL 901-452-4276
MONDAY - SATURDAY 8:30-5:30
FOR YOUR SPECIAL.

Write: 3202 Summer Ave., Memphis, Tennessee 38112

Remember Our 45th Anniversary

OPEN HOUSE and TRADE SHOW

Two days—Sept. 15 & 16 1978
Hours: 9 AM to 4:30 PM

OPEN HOUSE AT EVANS

Rt. 3A Bow Junction

TRADE SHOW AT N.H. HWY HOTEL

Exit 14 off I-93—Shuttle Bus Service—

Parking at Hwy Hotel



E33



- Concord: PO Box 893/Concord NH 03301/224-9961
- Nashua: 3 Progress Ave./Nashua NH 03060/882-2761
- Portsmouth: 100 Coakley Rd./Portsmouth NH 03801/431-5570

FREQUENCY COUNTERS

BY POPULAR DEMAND — we are continuing to offer with any purchase of \$99 or more from ad or flyer, a **free** Fairchild Clock Module FCS-8100A (suggested retail price of \$20).



look at these Summer Specials

COMPLETE KITS: CONSISTING OF EVERY ESSENTIAL PART NEEDED TO MAKE YOUR COUNTER COMPLETE. HAL-600A 7-DIGIT COUNTER WITH FREQUENCY RANGE OF ZERO TO 600 MHz. FEATURES TWO INPUTS: ONE FOR LOW FREQUENCY AND ONE FOR HIGH FREQUENCY; AUTOMATIC ZERO SUPPRESSION. TIME BASE IS 1.0 SEC OR .1 SEC GATE WITH OPTIONAL 10 SEC GATE AVAILABLE. ACCURACY ± .001%, UTILIZES 10-MHz CRYSTAL 5 PPM.

COMPLETE KIT.....\$149.....\$129

HAL-300A 7-DIGIT COUNTER WITH FREQUENCY RANGE OF ZERO TO 300 MHz. FEATURES TWO INPUTS: ONE FOR LOW FREQUENCY AND ONE FOR HIGH FREQUENCY; AUTOMATIC ZERO SUPPRESSION. TIME BASE IS 1.0 SEC OR .1 SEC GATE WITH OPTIONAL 10 SEC GATE AVAILABLE. ACCURACY ± .001%. UTILIZES 10-MHz CRYSTAL 5 PPM.

COMPLETE KIT.....\$124.....\$109

HAL-50A 8-DIGIT COUNTER WITH FREQUENCY RANGE OF ZERO TO 50 MHz OR BETTER. AUTOMATIC DECIMAL POINT, ZERO SUPPRESSION UPON DEMAND. FEATURES TWO INPUTS: ONE FOR LOW FREQUENCY INPUT, AND ONE ON PANEL FOR USE WITH ANY INTERNALLY MOUNTED HALTRONIX PRE-SCALER FOR WHICH PROVISIONS HAVE ALREADY BEEN MADE. 1.0 SEC AND .1 SEC TIME GATES. ACCURACY ± .001%. UTILIZES 10-MHz CRYSTAL 5 PPM.

COMPLETE KIT.....\$124.....\$109

ATTENTION RADIO CLUBS For club or group projects, request FREE information about our DISCOUNTS on any of the HAL-TRONIX kits. Discounts range from 10-25%, depending upon the quantity needed.

We are experienced in supplying kits in volume quantities to schools, laboratories, clubs, and common-interest groups. Nobody beats HAL-TRONIX quality and price. Just try us and see for yourself.



FROM
HAL-TRONIX

DELUXE 12-BUTTON TOUCHTONE ENCODER KIT utilizing the new ICM 7206 chip. Provides both VISUAL AND AUDIO indications! Comes with its own two-tone anodized aluminum cabinet. Measures only 2 3/4" x 3 3/4". Complete with Touch-Tone pad, board, crystal, chip and all necessary components to finish the kit.

PRICED AT.....\$29.95

For those who wish to mount the encoder in a hand-held unit, the PC board measures only 9/16" x 1 3/4". This partial kit with PC board, crystal, chip and components.

PRICED AT.....\$14.95

PRE-SCALER KITS

HAL 300 PRE.....\$19.95

(Pre-drilled G10 board and all components)

HAL 300 A/PRE.....\$29.95

(Same as above with preamp)

HAL 600 PRE.....\$34.95

(Pre-drilled G10 board and all components)

HAL 600 A/PRE.....\$39.95

(Same as above but with preamp)

SPECIAL OFFER—While they last

FND-70 Common cathode readouts direct replacement for the FND-359 same pin-out.

10 units (.40¢) — 10/ 4.00

100 units (.35¢) — 100/ 35.00

500 units (.30¢) — 500/150.00

1000 units (.25¢) — 1000/250.00



HAL-TRONIX H24

P. O. BOX 1101
SOUTHGATE, MICH. 48195
PHONE (313) 285-1782

"HAL" HAROLD C. NOWLAND
W8ZXH

SHIPPING INFORMATION

ORDERS OVER \$15.00 WILL BE SHIPPED POSTPAID EXCEPT ON ITEMS WHERE ADDITIONAL CHARGES ARE REQUESTED. ON ORDERS LESS THAN \$15.00 PLEASE INCLUDE ADDITIONAL \$1.00 FOR HANDLING AND MAILING CHARGES. SEND SASE FOR FREE FLYER.

Buddy, Ya Got A Match?

—build one L of a matcher

William Vissers K4KI
1245 S. Orlando Ave.
Cocoa Beach FL 32931

Although the L-network is theoretically capable of matching any two impedances, many amateurs have encountered problems in its use. The difficulties are often twofold. The first is a failure to fully appreciate exactly how the network wants to work for various load conditions. And, secondly, the size of the variable capacitor required often reaches values that are generally unobtainable. However, both of these problems are very easily overcome. The first can be surmounted by a fundamental review of matching principles. And the second obstacle can be readily overcome by a simple design change that allows a small variable capacitor to be used where formerly a large one would have been required.

An experimental breadboard unit has been successfully used here at K4KI. It was economical and simple to

build and also is easy to use. The basic L-unit, a simple switching circuit, and a small fixed inductance allow full matching capability to be readily realized on all bands from 10 through 80 meters.

Mathematics

Unfortunately, I'm going to have to keep the mathematics really simple because of something that happened to me many years ago at the little two-room school where I started my education. One day, the teacher asked me, "Willie, if I take three apples from eight apples, how many apples do I have?" Well, naturally, I told her that, if she took three apples, she'd have three apples. The expression on her face somehow indicated that this wasn't the answer she expected. So she started to explain that when she said she took three apples, she really didn't have three apples, but, just as we were getting into it, the recess bell rang. Well, when we got back to our math class the next day, our teacher must have forgotten all about it, as she didn't ask me again, and that's why I never did get

into higher math. But the lack of it has actually been a blessing, because it really helps you understand things by keeping them simple. And you'll be surprised how simple the understanding of the L matching unit really is.

The Basic L-Unit

The easiest way to understand the basic L-unit will be by the calculation of an actual numerical example, combined with a set of tables that show network values and configurations for a range of loads representative of various antenna impedances. I'll start by calculating network values required to match a pure resistive load to the transmitter. And then later, I'll make the load a combination of resistance and reactance. Finally, I'll show how, with the addition of a small fixed inductance, you can reduce the size of the variable capacitor required.

As almost all transmitters nowadays have a fifty-Ohm output, I'll use that as a basic reference. For the numerical example, let's say the load is thirty Ohms of resistance. You can say that you are

matching the high fifty-Ohm output resistance of the transmitter to a low resistance, which means you are matching from high to low. This concept is important, as the basic equations are given in terms of high and low. The transmitter, the L-network, and the 30-Ohm load are shown in Fig. 1. The network is made up of a series and a shunt arm. For matching a resistive output to a resistive load, one of the arms has to be inductive, while the other arm has to be capacitive. The equations used for calculating the reactance of the series and shunt arms when the load is a pure resistance are as follows:

$$X \text{ in Ohms of series arm} = \sqrt{(\text{low})(\text{high} - \text{low})}$$

$$X \text{ in Ohms of shunt arm} = \frac{(\text{high}) \sqrt{(\text{low})/(\text{high} - \text{low})}}{}$$

Substituting in the numerical values, we obtain:

$$X \text{ series} = \sqrt{(30)(50 - 30)} \\ = \sqrt{600} = 24.5 \text{ Ohms}$$

$$X \text{ shunt} = \frac{(50) \sqrt{(30)/(50 - 30)}}{50 \sqrt{1.5}} = 61.2 \text{ Ohms.}$$

As you will, for purposes of illustration, want to add or

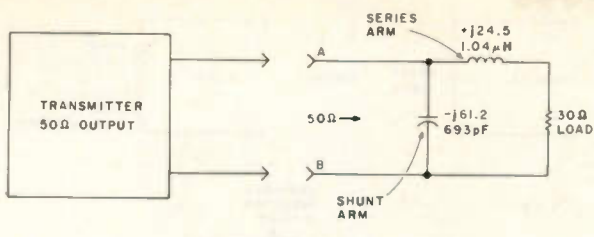

Fig. 1.

subtract reactances and also show whether a reactance is inductive or capacitive, you can use the standard notation that inductive reactance is +j and capacitive reactance is -j.

So Fig. 1 shows the inductive reactance as +j 24.5 Ohms and the capacitive reactance as -j 61.2 Ohms. With these values, you would find that the impedance looking in at terminals A and B is exactly 50 Ohms resistance.

There is, however, one other thing to do, and that is to translate the values of reactance into actual values of inductance and capacitance. In the two following equations, the term frequency will occur, so I chose the value of 3.75 MHz, the center of the 80 meter band, as the reference for all further work. Naturally, the values of inductance and capacitance can be calculated for any frequency desired.

$$C_{pF} = \frac{1,000,000}{(2\pi)(F\text{MHz})(X_C)}$$

$$= \frac{1,000,000}{(2)(3.1416)(3.75)(61.2)}$$

$$= 693 \text{ picofarads}$$

$$L_{uH} = \frac{X_L}{(2\pi)(F\text{MHz})}$$

$$= \frac{24.5}{(2)(3.1416)(3.75)}$$

$$= 1.04 \text{ microhenries}$$

At this point, it would be well to ask why the configuration of Fig. 1 was used in the L-network. It can best be understood by looking at Table 1(b) and again calculating the values of X_L and X_C and then finding the actual values of L and C. The values of shunt and series reactance have the same numerical values as previously. However, if you

calculate the values of L and C in Table 1(b), you find them to be $L_{uH} = 2.6$ microhenries, and $C_{pF} = 1732$ picofarads. The values are shown in Table 1(b), also. It is seen that the configuration of Table 1(a) is most desirable, as you require only 693 picofarads, as compared to 1732 picofarads, as in Table 1(b). It should be noted that either configuration will give a 50-Ohm match to the transmitter. Switch SW2 will allow either configuration to be selected as desired in the final circuit.

Complex Impedance Loads

Now that the values of the network for a resistive load of 30 Ohms have been calculated, let's assume that the load has changed to the one shown in Fig. 2. Here, the resistance is still 30 Ohms, but there is also a capacitive reactance of -j 50 Ohms. If you look at Fig. 2, you see that the shunt capacity is still 693 picofarads. And you also see that the +j 24.5 Ohms is still used. These values just mentioned are basic in matching to the 30 Ohms of resistance. But, if somehow you could add an additional reactance of +j 50 Ohms in the series arm, it could be used to cancel out the -j 50 Ohms in the load. And you see that the total inductive reactance needed in the series arm is nothing more than (+j 24.5) + (+j 50), which equals +j 74.5 Ohms. This total inductance calculates out to be 3.16 microhenries. As these two inductances can be combined into one, the final network will be that shown in Table 1(d). So you see that the L-network can be used to match a complex impedance.

Now knowing the basics of

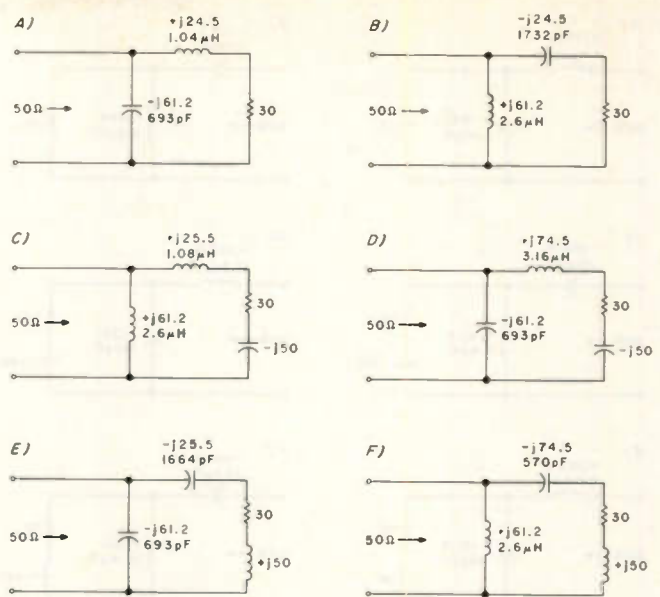

Table 1. Fifty Ohms to low-impedance loads.

calculating the values of the L-unit, it would be possible to further calculate the values of the series and shunt arms for quite a variety of loads. But let's not do this for several reasons. First, very few amateurs actually have rf bridges that let them know their exact values of resistance and reactance of their antenna. Secondly, as you already understand the basics of the calculations involved, and, as a picture is worth a thousand math symbols, it was believed that a set of tables showing values of reactances, capacity, and inductance for a range of loads generally encountered would be preferable to a lot of additional math. And, lastly, by seeing the actual values of inductance and capacity required, it will be easy to understand why the switches in the final circuit are needed to obtain the most desired configuration. The calculations used in making up the charts were based upon the basic equations for matching

into a resistive load plus simple series-parallel equations when the loads shown are complex impedances.

Table 2 shows that you can also match the transmitter into a higher impedance than 50 Ohms. But, in that case, the series arm of the network is on the transmitting side rather than the load side of the circuit. This transformation is readily made by switch SW1 of the final circuit.

Canceling Capacitive Reactance

If you inspect the tables, you find that the value of capacitance needed using the most desirable configurations to match the range of loads is 693 picofarads. Well, this is sure a good-sized capacitor, and that kind is about as scarce as hen's teeth and twice as expensive. This value of capacitance is equivalent to a reactance of -j 61.2 Ohms, and you need this value of reactance to obtain a proper match. Is there any

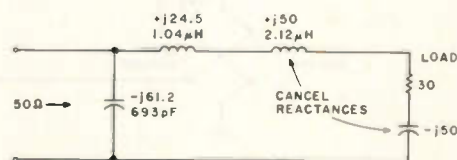

Fig. 2. The total inductance in the series arm is $1.04 \mu\text{H} + 2.12 \mu\text{H} = 3.16 \mu\text{H}$. The total reactance in the series arm is +j 74.5 Ohms.

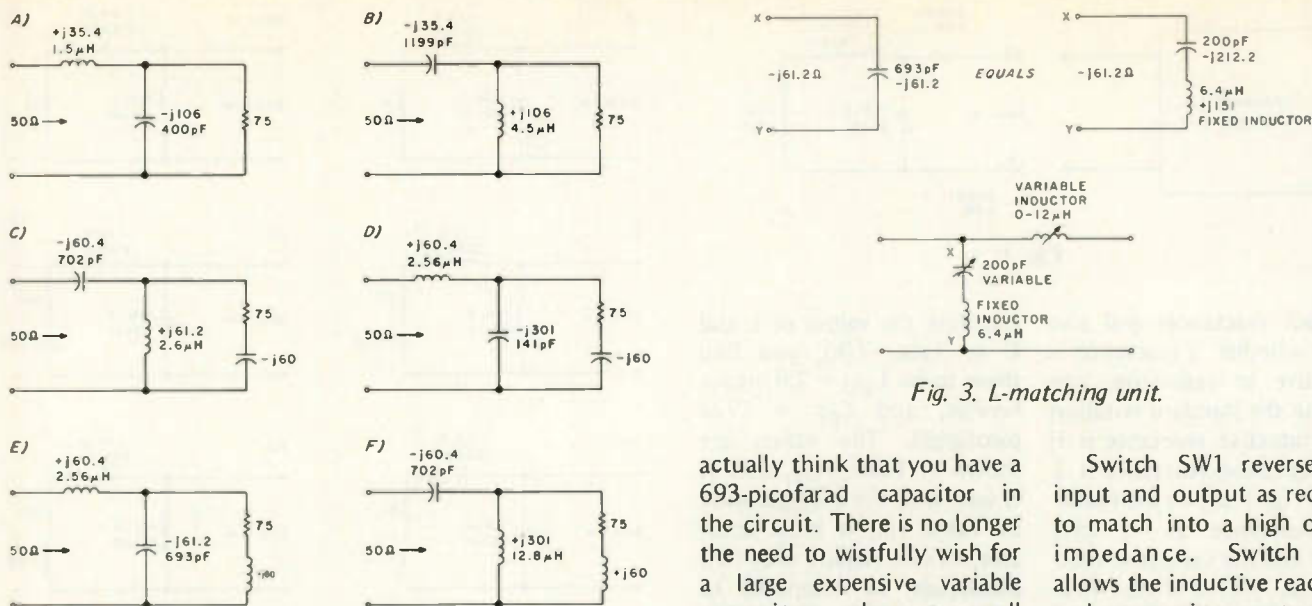

Fig. 3. L-matching unit.

Table 2. Fifty Ohms to high-impedance loads.

other way to obtain a reactance of $-j 61.2$ Ohms without using such a large capacitor? Sure, and a bit of math no more difficult than subtraction will show you how to do it. Well, actually a bit of subtraction plus a small fixed inductance. And it's so easy that, at times, I feel a bit guilty at fooling the L-network that way, but it works and saves buying an expensive large capacitor where a small one will do the job.

Assume you only have a 200-picofarad variable available to use in the matching unit. Using the equation for reactance, you find that:

$$X_{200 \text{ pF}} = \frac{1,000,000}{(2)(3.1416)(3.75)(200)}$$

$$= -j 212.2 \text{ Ohms.}$$

Now, if you put an inductive reactance of $+j 151$ Ohms in series with the 200-picofarad capacitor with a reactance of $-j 212.2$, you will find the net result is $-j 61.2$ Ohms. This is the exact reactance needed for the series arm when a 693 pF capacitor is required. The value of fixed inductance is calculated as:

$$L_{\text{fixed } \mu\text{H}} = \frac{151}{(2)(3.1416)(3.75)} = 6.4 \text{ microhenries.}$$

So a little bit of "magical math" shows that, by using a fixed inductance in series with the 200-picofarad capacitor, you make the circuit

actually think that you have a 693-picofarad capacitor in the circuit. There is no longer the need to wistfully wish for a large expensive variable capacitor when a small readily available one will do the trick. The basic matching circuit described is shown in Fig. 3.

The Final Circuit

The completed circuit is shown in Fig. 4. As the amount of capacity required becomes less with an increase in frequency, it was found that the fixed inductance was not required on the 10, 15, and 20 meter bands and should be shorted out. As the amount of fixed inductance required is less on 40 meters than on 80 meters, a tap is used on the coil to reduce the inductance. All of these necessary switching functions are accomplished with switch SW3, a DPST with a capability of being left in the center position when the unit is used on 80m.

Switch SW1 reverses the input and output as required to match into a high or low impedance. Switch SW2 allows the inductive reactance and capacitive reactance to be switched from series to shunt to effect a proper match, as needed.

Although the network was designed to provide maximum flexibility, my personal experience has been that, in many cases, the feedline can be adjusted for a 1:1 SWR over an entire band without any switching at all being necessary. However, this depends upon the characteristics of the antenna being used. My design uses a 200-picofarad variable donated by K4YS, our president of the Indian River Amateur Radio Club, who was very much interested in the project. But, if a larger-sized capacitor is available, it can be used. In that case, you may want to make the fixed coil somewhat smaller. The 0-12 uH variable rotary inductor was picked up at a ham convention. Apparently, it came out of a piece of surplus equipment (probably a BC375 or 191 tuning unit).

There is no reason why a tapped coil with a rotary switch could not be used instead of the variable rotary inductor I used. The rotary inductor does have an advantage in that the exact reactance can be cranked in as desired. However, a properly designed tapped coil instead will allow you to get your SWR down to a low level. In building the unit, the general precaution of keeping leads short

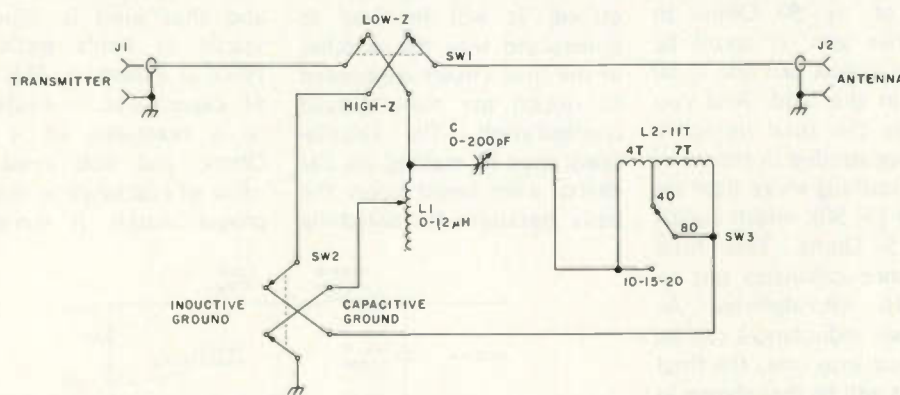

Fig. 4. Low-capacity L-type antenna matching network. L1 — 0-12 uH rotary inductor; L2 — 11 turns #12 enamel, space-wound 2-5/8-inch diameter, 1-3/4-inch long, tapped at the 4th turn, fixed inductor; C — 0-200 pF variable capacitor; SW1, SW2 — DPDT toggle switch; SW3 — DPST toggle switch with center-open position; J1, J2 — coaxial connector, chassis type.

is to be observed. But this is not difficult to do. By placing switch SW1 between the input and output coax connectors, the leads can be kept quite short. Proper placement of the other two switches will keep the remaining leads to a reasonable length. There were no current loops observed caused by stray capacity. A bit of experimenting with the size of the fixed coil may be desirable to insure the best tuning for the variable capacitor you use.

There are undoubtedly a number of purists who will throw up their hands in horror for whatever variety of reasons they may conjure up. It will be found that because the 200-picofarad capacitor actually thinks it's a 693-picofarad one, that the tuning may be a bit sharper, but that is no problem at all. It can be argued that the rf voltage across the 200-picofarad capacitor will be a bit higher than that of the capacitor in a conventional network. This is

true, but I have been unable to induce any kind of arcing across the capacitor plates, no matter how much I twiddle the knobs. It can also be said that, if the fixed inductance is large enough, it will be possible to develop a series resonant circuit with the fixed inductance and capacitor. This is true, but you just don't make the coil that large.

Although I was able to obtain the parts for the unit rather inexpensively, even if

new components are used, the price will still be quite low.

A lot of the fun was in developing the method used and generating the tables in which an easy quick understanding of how the basic L-unit works can be obtained. The knowledge of how the L-unit works is a valuable addition to any amateur's technical store of information. And so a bit of "magical math" proved to be a lot of fun and practical, too. ■

DOVETRON



MPC-1000C

Multipath Correction
In-Band Diversity &
AFSK Tone Keyer

Amateur Net: \$545.00

Standard features include CONTINUOUSLY tuneable Mark and Space channels (1000 Hz to 3200 Hz), Dual Mode (MARK or FSK) Autostart and internal high level neutral loop keyer (20 to 60 ml). Both EIA and MIL FSK outputs are provided for direct interface to microprocessor and video terminal peripherals.



MPC-1000CR

Signal Regeneration &
Speed Conversion

Amateur Net: \$645.00

A front panel switch permits internal TSR-200 Signal Regenerator-Speed converter assembly to electronically "gear-shift" between 60, 67, 75 and 100 WPM. All incoming and outgoing signals are regenerated to less than 0.5% bias distortion. Also available with DIGITAL Autostart (TSR-200D): Amateur Net: \$695.00



MPC-1000R/ TSR-500

Dual UART Regeneration,
Speed Conversion, 200
Char. Memory, Word Cor-
rection & DIGITAL
Autostart

Amateur Net: \$895.00*

The MPC-1000R/TSR-500 provides Preloading and Recirculation of the 200 character FIFO Memory, a keyboard-controlled Word Correction circuit, Variable Character Rate, Tee Dee Inhibit, Blank/LTRS Diddle, a Triple Tone-Pair AFSK Tone Keyer and a Character Recognition/Speed Determination DIGITAL (DAS-100) Autostart mode.

*The MPC-1000R is also available without a TSR assembly and functions as a MPC-1000C with a Triple Tone-Pair AFSK Tone Keyer. This "Basic-R" permits future expansion with a TSR-100, TSR-200, TSR-200D or TSR-500 by simply lifting the lid and plugging in the appropriate TSR assembly: Amateur Net (Basic-R): \$595.00

Your QSL will bring complete specifications, or call: 213-682-3705.

D23



627 FREMONT AVENUE
(P. O. BOX 267)
SOUTH PASADENA, CA. 91030

FOR THE HAM

A BELT BUCKLE
From The COLORADO SILVER CO



APPROX. SIZE 2 1/2 x 3 1/2 INCHES
CAST IN SOLID BRONZE
ENGRAVED WITH CARE

This buckle can be yours for only
\$12.50, plus \$1.00 for postage.

COLORADO SILVER CO., DEPT. H
P.O. BOX 1755, ASPEN, CO. 81611
COLO. RES. ADD 3%



C63

DIP RELAY

SPST 5 vDC coil. Contacts
10 VA at .5A \$1.00 ea.



8 CONDUCTOR CORD

6 1/2 feet long, extra flexible with strain relief
at one end. 3/32 OD. 50¢ ea., 10/\$4.00

COMPUTER GRADE LYTICS

1000 Mid 50 vDC	\$.85
2000 Mid 50 vDC	1.25
8000 Mid 25 vDC	\$2.25
23000 Mid 15 vDC	2.50



MOLEX IC SOCKET PINS

80¢/100 \$7.50/1000



All merchandise 100% guaranteed. Please
include postage with your order.

Write for FREE Catalogue. CHICAGOLAND-
Our Store Open Daily at 10:00 A.M.

R.W. ELECTRONICS, INC.

3203 North Western Avenue
Chicago, Illinois 60618

312-248-2480

When you think of KENWOOD . . . Call

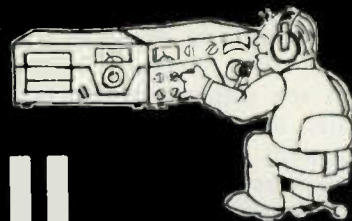

1-800-633-3410

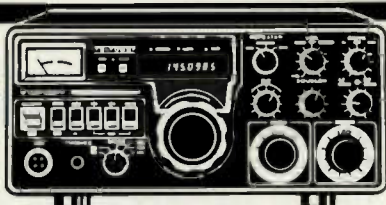

KENWOOD TS-700SP all mode 2m transceiver

Includes SSB, CW, FM, AM, Semi-break-in CW. Features:

- Sidetone monitor
- Digital frequency readout
- Receiver preamp and ± 600 KHz repeater offset operation within all 2m repeater subbands including the new 144.5-145.5 MHz subband
- 10 watts RF output complete with AC & DC power supply.

729.00 list. Call for quote.



KENWOOD R-599D receiver

The most complete receiver ever offered. It is entirely solid-state, reliable and compact.

- Full coverage: 10 thru 160 meters, plus WWV and CB bands
- Highly stable VFO and oscillator for 5 fixed channels
- Crystal filters are built in
- Noise blanker
- Squelch circuit, and more.

499.00 list. Call for quote.



KENWOOD T-599D transmitter

T-599D is solid-state, except for driver and final stages

- Frequency range is 3.5 to 29.7 MHz
- Modes: CW, LSB, USB, AM and FM
- Input power — SSB: 200 watts PEP, CW: 160 watts, AM: 80 watts
- Highly stable VFO
- 8-pole crystal filter and more.

499.00 list. Call for quote.



KENWOOD MC-50 desk microphone

The MC-50 dynamic mike has been designed expressly for amateur radio operation.

- Complete with PTT & LOCK switches
- Easy conversion from HI to LOW impedance
- Unidirectional
- Mike plug on coil cord for instant hook-up to any Kenwood rig.

39.50 list. Call for quote.

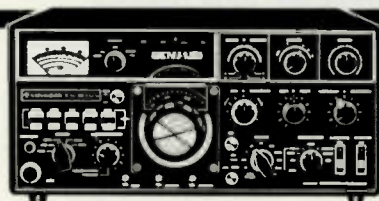

KENWOOD TS-820S transceiver

The NEW Kenwood TS-820S features a factory installed digital frequency readout.

- 160 thru 10 meter coverage
- Integral IF shift
- RF speech processor
- VOX
- Noise blanker
- PLL
- Built-in 25 KHz calibrator
- CW side tone & semi-break-in
- IF OUT, RTTY, & XVTR
- Phone patch IN and OUT terminals.

1098.00 list. Call for quote.



KENWOOD TR-7400A 2m FM transceiver

Features:

- CTCSS provisions, encode and decode
- 25 watt output RF
- Solid-state final stage
- LED readout
- PLL gives 800 discrete channels
- Repeater offset circuit
- PLL unlock protection circuit
- MOS FET.

399.00 list. Call for quote.

Remember, you can call TOLL FREE: 1-800-633-3410 in U.S.A. or call 1-800-292-8668 in Alabama for our low price quote. Store hours: 9:00 AM til 5:30 PM, Monday thru Friday.



Long's Electronics



MAIL ORDERS: P.O. BOX 11347 BIRMINGHAM, AL 35202 • STREET ADDRESS: 2808 7TH AVENUE SOUTH BIRMINGHAM, ALABAMA 35233

When you think of YAESU . . . Call 1-800-633-3410

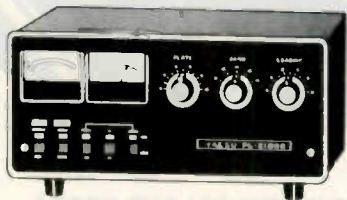
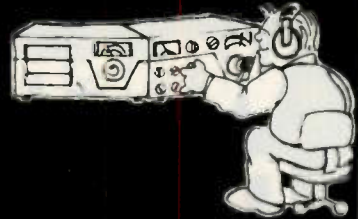

YAESU FL-2100B linear amplifier

The FL-2100B has: • 1200 W PEP • Input on 80-10 meters • Primary voltage change 117 to 234 VAC • Dual meters for plate current voltage • Adj. SWR meter • Individually tuned input coils on each band • Drive requirement: 30 to 100 W.

529.00 list. Call for quote.



YAESU SP-101PB speaker/phone patch

The SP-101PB features: • A shaped response speaker from 300 to 3000 Hz • Built-in hybrid phone path with individual gain controls • VU meter. Full VOX operation • Receiver input impedance: 4 or 600 ohm • Output impedance: 600 ohm or high impedance.

67.00 Call for yours today.



YAESU FRG-7000 general coverage receiver

Triple-conversion superhet receiver • All solid-state • Digital frequency display • 24 hr. digital clock for local and GMT time • Receives 0.25 MHz-29.9 MHz • Built-in AC power supply • Plug in circuit boards.

629.00 list. Call for quote.



YAESU YH-55 Headphone set

Comes equipped with a soft pad for long hours of listening with maximum comfort. Compatible with all Yaesu equipment. 8 ohms impedance.

15.00 Call for yours today.



YAESU FT-7 HF transceiver

The NEW FT-7 features: • Frequency coverage: 10 thru 80 meters • Sensitivity: 0.5 micro volts for S/N 20 dB • Emissions: LSB, USB, CW • Input power: 20 watts DC • Completely solid-state, single knob tune-up • 100 KHz calibrator built-in • Semi-break-in with sidetone • Receiver offset tuning • Extremely compact for installation under dashboard.

549.00 list. Call for quote.

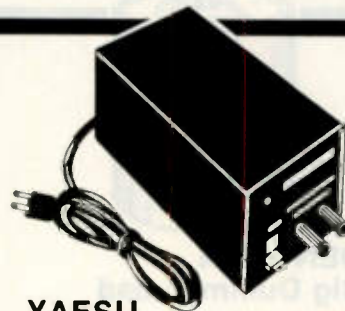

YAESU FP-4 power supply

The FP-4 is designed for base station operation of the FT-7, FT-227R or similar transceivers. Provides a DC output of 13.8 volts at 4 amps. Also features overload & short-circuit protection threshold of 5 amps.

49.95 list. Call for yours today.

Remember, you can Call Toll Free: 1-800-633-3410 in the U.S.A. or call 1-800-292-8668 in Alabama for our low price quote. Store hours: 9:00 AM til 5:30 PM, Monday thru Friday.



Long's Electronics

L9



MAIL ORDERS: P.O. BOX 11347 BIRMINGHAM, AL 35202 • STREET ADDRESS: 2808 7TH AVENUE SOUTH BIRMINGHAM, ALABAMA 35233

When you think of DENTRON . . . Call 1-800-633-3410

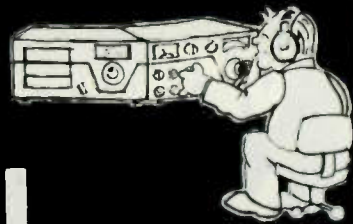

DENTRON MT-3000A antenna tuner

The MT-3000A is Dentron's "ultimate tuner". Tunes 3 coax, random wire and balanced feed system, just select the one. Handles in excess of 3KW PEP

- Built-in 50 ohm - 250W dummy load
- Dual watt meters
- 3 core heavy-duty Balun.

349.50 list. Call for quote.



DENTRON 160-10AT super tuner

Balanced line, coax cable, random, or long wire antennas, the 160-10AT will match it — 160 thru 10 meters

- Continuous tuning, 1.8-30 mc
- 3 inputs
- Handles 500 watts DC, 1000 watts PEP
- Heavy duty, 2-core Balun (3½" dia. x 3" H)
- Tapped inductor #12 ga. wire.

129.50 list. Call for quote.



DENTRON MT-2000A antenna tuner

An economical, full power tuner designed to handle virtually any type of antenna. Features:

- Continuous tuning 1.9 to 30 MHz
- Handles a full 3 KW PEP
- Front panel coax bypass switching
- Built-in 3-core balun. Front panel grounding switch.

199.50 list. Call for quote.

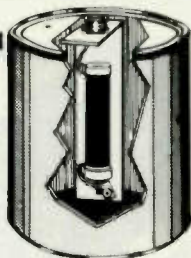

DENTRON Big Dummy Load

Tune-up off the air with Dentron's Big Dummy Load. All full power dummy load, it has a flat SWR, full frequency coverage from 1.8 to 300 MHz. A high grade industrial cooling oil is furnished with the unit. Fully assembled and warranted. Help cut out the QRM factor NOW!

29.50 Call for yours today.



DENTRON MLA-2500 linear amplifier

- Continuous duty power supply
- 160 thru 10 meter coverage
- 2000+ watts PEP input on SSB
- 1000 watts DC input on CW, RTTY, SSTV
- Two external-anode ceramic/metal triodes operating in grounded grid
- Covers MARS w/o modifications
- 50 ohm input/output impedance
- Built-in RF watt meter.

899.00 list. Call for quote.

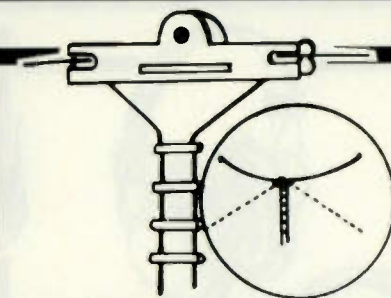

DENTRON All Band Doublet antenna

- Has a total length of 130 feet (14 ga. stranded copper)
- Center fed through 100 ft. of 470 ohm PVC covered balanced transmission line
- Assembly complete
- Tune 10 thru 160 with one antenna
- (Requires antenna tuner).

24.50 Call for yours today.

Remember, you can call TOLL-FREE: 1-800-633-3410 in U.S.A. or call 1-800-292-8668 in Alabama to place your order. Store hours: 9:00 AM til 5:30 PM, Monday through Friday.



Long's Electronics



MAIL ORDERS: P.O. BOX 11347 BIRMINGHAM, AL 35202 • STREET ADDRESS: 2808 7TH AVENUE SOUTH BIRMINGHAM, ALABAMA 35233

When you think of KLM . . . Call



1-800-633-3410

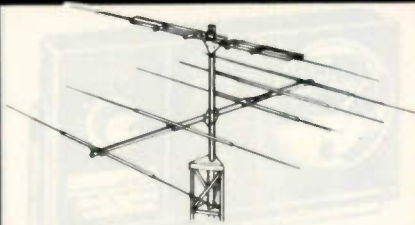

KLM 7.2-1 40m rotatable diopole

May be mounted above, and on the same mast as your existing beam • High Q linear loading for low loss • Only 46 ft. long & weighs 15 lbs. • Element is split for direct 50 ohm feed • (KLM3-60-1:1 balun optional 24.95). • Wind area 2 sq. ft. • Max. mast size 3"

119.95 list. Call for quote.

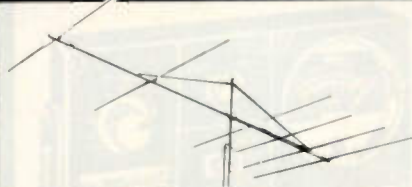

KLM-28-30-6 10 meter 6-element "Big Sticker" antenna

• Gain 11 dB plus or minus 0.3 db • Frequency range 28-30 MHz • Front to back 30dB typical • VSWR less than 1.5:1 • Longest element 18.33' • Boom length 27.52' • Wind area 4 sq. ft. • Feed impedance 200 ohms balanced • KLM-3-60-4:1 Balun optional 24.95.

161.95 list. Call for quote.

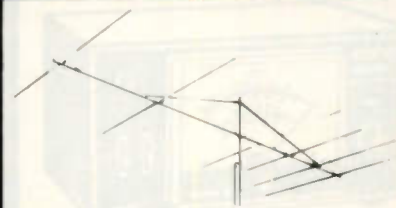

KLM-13.9-14.4-6 6 element 20m monobander

Freq: 13.9-14.4 MHz • Longest element 37.33 ft. • Gain 11.0 plus or minus 0.3dBd • Front to back, 35dB • Feed imp. 200 ohms balanced (KLM 3-60-4:1 balun opt. 24.95) • Boom length 57.25 ft. • Wind area 12.84 sq. ft.

539.95 list. Call for quote.

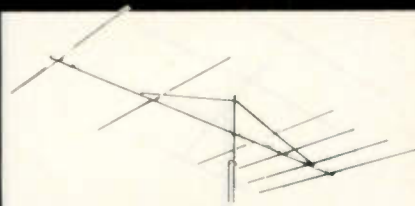

KLM-21-21.5-6 15m 6-element "Big Sticker" monobander

Freq: 21-21.5 MHz • Longest element 24.66 ft. • Gain 10.5 dBd • Front to back 30 dB typical • VSWR less than 1.5:1 • Feed imp. 200 ohms balanced (KLM-3-60-4:1 balun opt. 24.95) • Boom length 38.5 ft. • Wind area 8.5 sq. ft.

323.95 list. Call for quote.



KLM-13.9-14.4-5 5 element 20m monobander

Freq: 13.9 - 14.4 MHz • Longest element 37.33 ft. • Gain 9.7 plus or minus 0.2 dBd • Front to back 30 dB typical • Feed imp. 200 ohms balanced (KLM-3-60-4:1 balun opt. 24.95) • Boom length 42 ft. • Wind area 9.25 sq. ft.

359.95 list. Call for quote

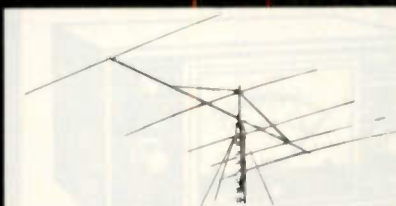

KLM-28-30-5 10m 5-element "Big Sticker"

Freq: 28-30 MHz • Longest element 18.33 ft. • Gain 9.7 dBd plus or minus 0.2 dBd • Front to back 30 dB typical • VSWR less than 1.5:1 • Feed imp. 200 ohms balanced (KLM-3-60-4:1 balun opt. 24.95) • Boom length 21 ft. • Wind area 4 sq. ft.

139.95 list. Call for quote.

Remember, you can Call Toll Free: **1-800-633-3410** in the U.S.A. or call **1-800-292-8668** in Alabama for our low price quote. Store hours: 9:00 AM til 5:30 PM, Monday thru Friday.



Long's Electronics

L9



MAIL ORDERS: P.O. BOX 11347 BIRMINGHAM, AL 35202 • STREET ADDRESS: 2808 7TH AVENUE SOUTH BIRMINGHAM, ALABAMA 35233

When you think of SWAN . . . Call

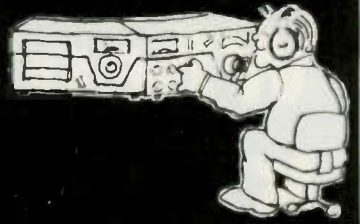

1-800-633-3410

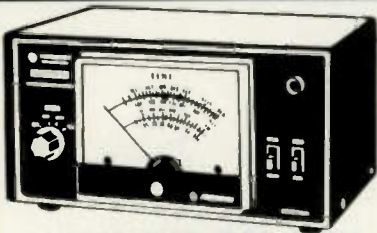

SWAN WM-3000 precision PEAK/RMS wattmeter

Read forward or reflected power with maximum accuracy from 3.5 to 30 MHz. RMS readings available with the flick of a switch. Four scales from 0 to 2000 watts. Requires 117V AC power source.

87.95 Call for yours today.



SWAN WMM200 SWR and power meter

Designed for mobile operation and illuminated for night operation • Directional coupler measuring method • Impedance 50 ohms • Power range: 0-20 watts and 200 watts in the second range • VSWR 1:1-3:1.

45.95 Call for yours today.



SWAN HFM-200 SWR and power meter

Frequency 1.8-30MHz • Two power ranges: 0-20 and 0-200 watts • VSWR 1:1-3:1 • For mobile installation, directional coupler may be located separate from main indicator • Meter is lighted for night use.

49.95 Call for yours today.

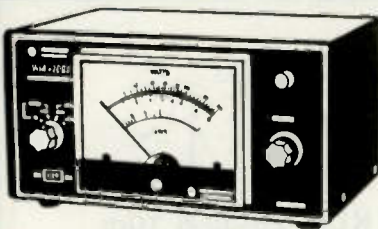

SWAN WM200A through-line wattmeter

Reads 20 and 200 watt scales • Includes expanded VSWR scale • Reads PEP or RMS values • Directional coupler permits reading of forward or reflected power from 50-150 MHz • Requires 117V AC in peak reading position.

87.95 Call for yours today.

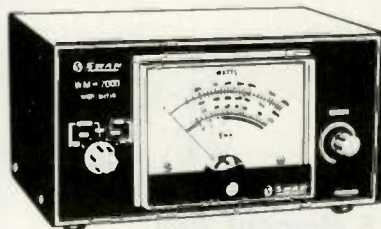

SWAN WM-2000 In-line wattmeter

Frequency range: 3.5 to 30MHz • 3 scales: 0-200, 1000, and 2000 watts • VSWR scale permits reading from 1:1 to 3:1 • Uses two SO-239 connectors.

64.95 Call for yours today.

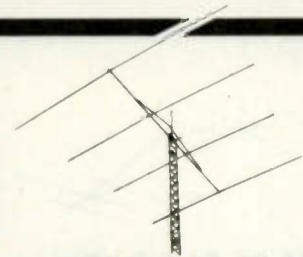

SWAN TB4HA 4 element tri-band beam

All four elements active on all three bands. The heavy duty TB4HA features: • Gain 9dB • Front to back 24-26dB • Boom length 24' • Longest element 28 ft. 10 in. • Wind surface area 6 sq. ft. • 10 - 15 - 20 meters.

259.95 list. Call for quote.

Remember, you can call TOLL-FREE: 1-800-633-3410 in U.S.A. or call 1-800-292-8668 in Alabama to place your order. Store hours: 9:00 AM til 5:30 PM, Monday through Friday.



Long's Electronics



MAIL ORDERS: P.O. BOX 11347 BIRMINGHAM, AL 35202 • STREET ADDRESS: 2808 7TH AVENUE SOUTH BIRMINGHAM, ALABAMA 35233

When you think of TELEX . . . Call 1-800-633-3410

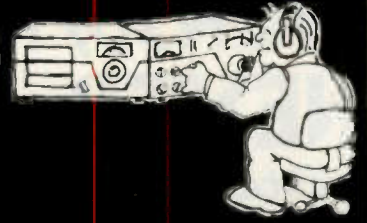

TELEX CM-1320 headset

"Top of the line" with a boom microphone - ceramic, high impedance. The choice of DX-peditions. Model CM-1320S same as above but with single ear piece 57.25.

71.70 Call for yours today.



TELEX CM-1210 headset with microphone

Ceramic, 50,000 ohms. Ideal for traffic nets.

59.75 Call for yours today.



TELEX Mobile "FM"

VHF House or Mobile-high performance audio on transmit and receive. Fet amplifier, low Z microphone. Earphone 8 ohms - in-line PTT.

59.95 Call for yours today.



TELEX C-1320 headphone

"Top of the line" fully cushioned, audiometric type drivers are ultra-sensitive - DX'ers choice. 20-20,000 Hz. Low impedance 8-20 ohms.

39.80 Call for yours today.



TELEX ProCom II Electret mobile microphone

"Broadcast quality" - "clarity and crispness," describe the audio of the electret. Useable in low or high impedance. 1.4 volt battery (included) also powers the 10dB amplifier.

29.95 Call for yours today.



TELEX CM-610 headset

The CM-610 headset features high impedance, ceramic microphone, 50,000 ohms. Professional convenience at an economical price.

44.99 Call for yours today.

Remember, you can Call Toll Free: **1-800-633-3410** in the U.S.A. or call **1-800-292-8668** in Alabama for our low price quote. Store hours: 9:00 AM til 5:30 PM, Monday thru Friday.



Long's Electronics

L9



MAIL ORDERS: P.O. BOX 11347 BIRMINGHAM, AL 35202 • STREET ADDRESS: 2808 7TH AVENUE SOUTH BIRMINGHAM, ALABAMA 35233

W2NSD/1 NEVER SAY DIE

editorial by Wayne Green

from page 150

this was a new one. I used a car for a couple days during the Atlanta hamfest, keeping it parked in the hotel garage almost the entire time. I turned it in and went to the Budget booth to settle. They said that there was a dent on the car and that this would cost an extra \$250. This got my attention.

Normally, I report to an airport a few minutes before my plane is scheduled to load, but for some reason on this day, we arrived a couple of hours early. The hamfest had closed, we'd had to check out of the hotel by noon, and our flight didn't leave for Los Angeles until 6 pm. Having the time, I grabbed my camera case and went back to the place I'd dropped off my car, making sure that the booth called 'em and told them to hold it.

I got to the parking area and the gal there said the car had already been sent to the garage. I said to dammit get it back, that I wanted to see that dent which was costing me \$250. I hadn't noticed any dents and I knew darned well the car hadn't been touched while I was driving it.

It took a half hour to get it back, but it finally arrived. Atlanta was about 90° and I was boiling. I looked over the car and could find nothing. The gal then showed me a place under the driver's door where the body had been pushed in maybe a half inch. It looked like the body design, but sure enough, the other side had no indent. I looked for scratch marks and there were none. I can't even imagine how the dent was made... or if it was an old one and painted over. There was no scratch at all! I took pictures of the dent, of the girl, the booth, etc., and the next thing I knew I was told that the dent was not significant, that there would be no charge. Please don't worry about it.

To me, the whole act sounded like a ripoff. Most people would be catching a plane and would just have to trust Budget that the car was okay when they got it and dented now. I was lucky to have the time and the gall to challenge them.

You can bet that the next time I stopped at Atlanta, I looked over my car very careful-

ly and made the girl at the parking lot make a note of the two dents. When I turned the car back, I asked them to see if the records for the car had any dents mentioned... none! It looked to me as if I was being set up again for the same scam. I made darned sure that they knew the dents had been there when I picked up the car, so I didn't have trouble.

Has anyone else run into this problem?

ONE LAST WORD

When the ARRL HQ chap said they *can't* take away the ham frequencies, I told him about my visit a couple days before to St. Pierre. In the museum are several copies of the newspaper warning residents that Mt. Pelee could blow up at any time and that they would do best to get away from that end of Martinique. Few people paid any attention to the newspaper warnings and in May, 1902, the volcano blew up and 40,000 people were killed in one day. There was one single survivor out of the entire population of the town.

HAM OF THE YEAR AWARDS

It has been a long time since there has been a significant award for hams who have been outstanding, and there should be such an award.

We should have some award for the ham who, in the estimation of the rest of us, has done the most to help amateur radio. This might be in a technical development, a pioneering effort, an emergency situation, or perhaps just plain hard work hamming such as in traffic handling or DXpeditioning.

In order to provide a recognition of work done to benefit amateur radio, 73 will award a "Ham of the Year" award each year at one of the major hamfests. Nominations for this award must be made by readers and each nomination must be accompanied by a sheet giving the reasons for the nomination in 500 words or less. Nominations from clubs citing a club member who is worthy of recognition are particularly solicited.

Nominations will be published in 73 and the readers asked to vote for the "Ham of the Year."

In the past, we have had

several amateurs who were worthy of lasting honor. I can think of Lloyd and Iris Colvin for their exemplary DXpeditions. There is John Kraus W8JK and his antenna work. Sam Harris W1FZJ and his moonbounce work should have gotten an award. John Costas and his double sideband developments deserve mention. Jack Babkes W2GDG came up with narrow-band FM—another winner.

The deadline for all nominations for "Ham of the Year" will be November 15, 1978. This will give us time to get them into the February issue of 73. This in turn would allow a month for the readers to send in their votes and a winner could possibly be announced as early as March at Dayton.

Please be sure to mark all entries "Ham of the Year" when you send them in.

SAROC CANCELLED?

Rumor has it that the winter CES has put the kibosh on SAROC for January, 1979, and that, if it is to be run at all, it will have to be moved to some other dates.

There was no question that with CES in town there was no real room for any other shows. CES pulls 40,000 or more in attendance and has exhibits covering most of the consumer end of electronics. The 1978 CES in Vegas was a big hit with everyone who went to see it. I spent far more time there than at SAROC, as did almost everyone else.

SAROC is one hamfest we could well do without, anyway. It has been years since there has been a good program there and the attendance has been getting smaller and smaller, year after year, as hams find themselves without reserved rooms, and with nothing more than a few commercial exhibits to see for their money.

Tufts Electronics went to SAROC to exhibit last January and said never again. I heard the same comments from many other disillusioned exhibitors and attendees. It's a pity... the show is the right time of the year and in a good spot, if only it were run for amateurs instead of as a way to make a maximum amount of money for the chap who puts it on.

TEN LIVES!

The band plan for ten meter channelized communications is to move 27 MHz CB rigs up exactly 2 MHz, normally a simple change requiring a new crystal. This scheme puts channel 1 on 28.965 MHz. It is suggested that this be used as a listening channel in order to help alert channelized

operators to band openings and to help with propagation studies. It is recommended that ten meter beacon transmitters running low power be set up on 29.005 MHz, which is channel 4. Those with 40-channel sets will be able to hear OSCAR on channel 40 and are asked not to transmit on this channel and thus perhaps interfere with OSCAR. Both the Standard and Bristol 10m sets are set up for this band plan. The Bristol Ham-100 transceiver runs 100 Watts and thus does not need a hard-to-get 10m amplifier. 73 is interested in reports of DX worked or any unusual contacts made using this channelized mode.

NEW GIMMICK

Last year, when I went to Washington to testify before the FCC on the subject of ten meter linear amplifiers, I told them flatly that trying to write rules against amateur radio equipment as a way to stem the tide of CB amplifiers was a waste of time. There is always a way for a crook to get around the rules.

Sure enough, the ink on the new regulations was hardly dry when the first mail-order ads for amateur radio ten meter CW transmitters were getting to CBers. The ads, followed a day or so later by a letter in a plain envelope which gave explicit instructions on converting the ten meter CW rig into a nice eleven meter linear amplifier, showed the usual cruddy design and construction we have come to identify with underground CB amplifiers. They obviously haven't gone very far underground.

So what is the answer? It is the same as it was when I testified before the FCC. If they want to curb this type of activity, the FCC has to bite the bullet and go after it strongly... and to hell with the political pressures. Well, both of us know that the FCC is never going to do such a thing. The CBers have too much clout and amateurs are almost totally impotent, so amateurs get it in the neck.

In view of the above, it is a bit difficult for me to get all uptight over the "ham" 10m CW rigs. How about you?

MAY WINNER

The most popular article in our May issue, as voted by our readers, was "Official FCC RFI Report," a reprint of a handbook produced by the FCC. At the suggestion of Mr. C. Phyll Horne, Chief of the Field Operations Bureau, we have donated the \$100 prize to our favorite charity.

2 FOR 1

2 FOR 1

2 FOR 1

2 FOR 1

2 FOR 1

Subscribe to 73 this month and you will have the unprecedented opportunity to renew your subscription at half-price . . . for the rest of your life. Simply fill out the special subscription form attached, and you will begin receiving 73 each month at 2 issues for the price of 1. Your name will be placed with a select group of subscribers who will always be able to renew their subscriptions at half the newsstand price. This unbelievable offer expires on October 1, 1978, so act today. Return the postage-free card, and we'll bill you later.

YES! Enroll me as a "2 for 1" subscriber, which makes me eligible for half-price rates for life.

- 1 year—\$12 (saves \$12)
- 3 years—\$36 (saves \$36)
- Payment enclosed Bill me

Name _____

Address _____

City _____ State _____ Zip _____

01

Please allow 30 days for shipment of first copy.

S91

73 magazine
Peterborough NH 03458

Another Trick for the 22S

— now it's a remote control system

Richard M. Kriss WB7SHW
8130 Via del Futuro
Scottsdale AZ 85258

Like many Icom 22S owners, I have enjoyed expanding the frequency capability of the unit. The trick I have discovered is one that will be of interest to unmodified-IC-22S owners, as well as those who have the VIP-switch or the DIP-switch

modification already incorporated.

Briefly, the trick is a modification of the DIP-switch programmer that was described in detail by WA4VAF in the June, 1977, issue of *73 Magazine*. The modification is to use three BCD switches in lieu of the 8-pin DIP switch.

For those interested in the programmer, I suggest you get a copy of Bill Richard's (WA4VAF) article entitled "More Channels for the Icom

22S." The article is an excellent explanation of how to activate channel 23 and how to bring the matrix board connections to the Icom's 9-pin accessory plug. Photo A shows how I implemented Bill Richard's basic modification. The significant difference (Photo B) is that I mounted the DIP switch on

an umbilical cord and enclosed it in a box with magnets so that it could be mounted on the top of the radio. Note in Photo C that I did not use the PC board suggested in the article. The diodes are mounted on the DIP switch.

The DIP switch works fine. The only problem is

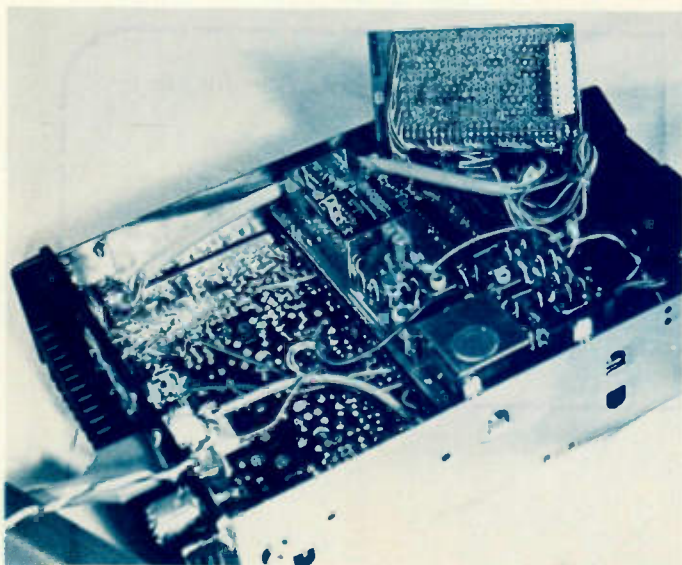

Photo A.

Top back view of BCD switch		
NC	●	8
D2	●	4
D1	●	2
D0	●	1
9V	●	C

Back of BCD switch			
From Icom 22S	#3	#2	#1 (thumbwheel position)
9V	C	C	C (bus "C" together)
D0	1		
D1	2		
D2	4		
D3		1	
D4		2	
D5		4	
D6			1
D7			2

- Note 1: Most BCD switches have connections on the back numbered C, 1, 2, 4, and 8 from bottom to top.
- Note 2: The thumbwheel position numbers used above are numbered 1, 2, and 3, left to right, from the front view.
- Note 3: Pin 8 on the BCD is not used, nor is pin 4 on position #1 (NC = no connection)
- Note 4: The "C" positions should be tied together to bring the 9 volts into the BCD switch.
- Note 5: Correct hookup is the key to the frequency lookup table in this article.

Table 1.

trying to push the right switches while mobile and trying to remember eight-digit numbers. I compared this problem with Jerry Armstrong WA7ZVT of Seattle, Washington. He gave me the idea and a lookup table for using a three-position BCD

switch that several people in the Seattle area were using. Photos D, E, and F are pictures of my current programmer using a \$1.95 three-position BCD switch. The key to the modification described in this article is the interface from the Icom 22S matrix

Frequency	Switch	147.000	256
146.010	154	.015	257
.025	155	.030	260
.040	156	.045	261
.065	157	.060	262
.070	160	.075	263
.085	161	.090	264
.100	162	.105	265
.115	163	.120	266
.130	164	.135	267
.145	165	.150	270
.160	166	.165	271
.175	167	.180	272
.190	170	.195	273
.205	171	.210	274
.220	172	.225	275
.235	173	.240	276
.250	174	.255	277
.265	175	.270	300
.280	176	.285	301
.295	177	.300	302
.310	200	.315	303
.325	201	.330	304
.340	202	.345	305
.355	203	.360	306
.370	204	.375	307
.385	205	.390	310
.400	206	.405	311
.415	207	.420	312
.430	210	.435	313
.445	211	.450	314
.460	212	.465	315
.475	213	.480	316
.490	214	.495	317
.505	215	.510	320
.520	216	.525	321
.535	217	.540	322
.550	220	.555	323
.565	221	.570	324
.580	222	.585	325
.595	223	.600	326
.610	224	.615	327
.625	225	.630	330
.640	226	.645	331
.655	227	.660	332
.670	230	.675	333
.685	231	.690	334
.700	232	.705	335
.715	233	.720	336
.730	234	.735	337
.745	235	.750	340
.760	236	.765	341
.775	237	.780	342
.790	240	.795	343
.805	241	.810	344
.820	242	.825	345
.835	243	.840	346
.850	244	.855	347
.865	245	.870	350
.880	246	.885	351
.895	247	.900	352
.910	250	.915	353
.925	251	.930	354
.940	252	.945	355
.955	253	.960	356
.970	254	.975	357
.985	255	.990	360

Table 2. Icom 22S BCD switch programmer.



Photo B.

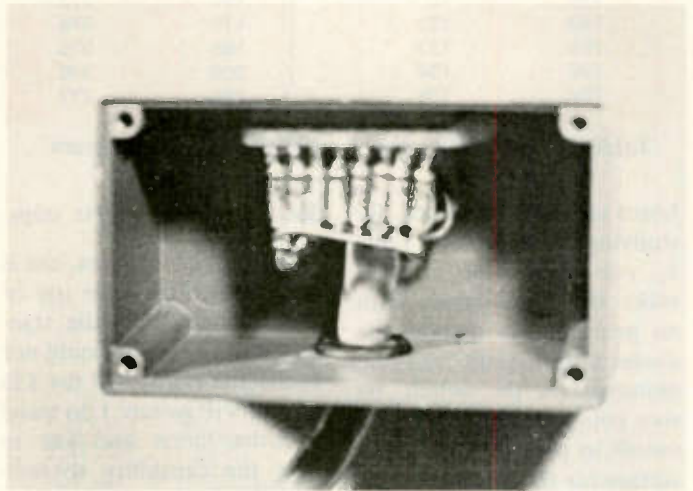

Photo C.



Photo D.

Frequency	Switch		
145.350	100	.800	136
.365	101	.815	137
.380	102	.830	140
.395	103	.845	141
.410	104	.860	142
.425	105	.875	143
.440	106	.890	144
.455	107	.905	145
.470	110	.920	146
.485	111	.935	147
.500	112	.950	150
.515	113	.965	151
.530	114	.980	152
.545	115	.995	153
.560	116		
.575	117		
.590	120		
.605	121		
.620	122		
.635	123		
.650	124		
.665	125		
.680	126		
.695	127		
.710	130		
.725	131		
.740	132		
.755	133		
.770	134		
.785	135		

MARS and CAP frequency			
		148.005	361
		.020	362
		.035	363
		.050	364
		.065	365
		.080	366
		.095	367
		.110	370
		.125	371
		.140	372
		.155	373
		.170	374
		.185	375
		.200	376
		.215	377

Table 3. Icom 22S extended range BCD switch program.

board to the BCD switch. By studying Photo F and Table 1, you should be able to make the modification with no problems. Note how the diodes and hookup wires are mounted on the switch. Be sure you cut the track on the switch to provide a mounting surface for the diodes.

Other keys to this modification are the lookup tables (Tables 2 and 3) that you can cut from this article for future use. The lookup tables give you the capability of going from 145.35 MHz (switch position "100") to 148.215 MHz (switch posi-

tion "377") in 15 Hz steps.

In the Phoenix area, one is hard pressed to make use of all 22 channels of the standard Icom 22S, so I could not justify the expense of the \$25 to \$30 VIP switch. I do travel to other areas and like to have the capability to temporarily reprogram my 22S. The DIP switch gave me this capability, but the BCD programmer is easier to use and may be of interest to other Icom 22S users. It can be used with the VIP switch to pick up the missing frequencies.

As indicated, I do not

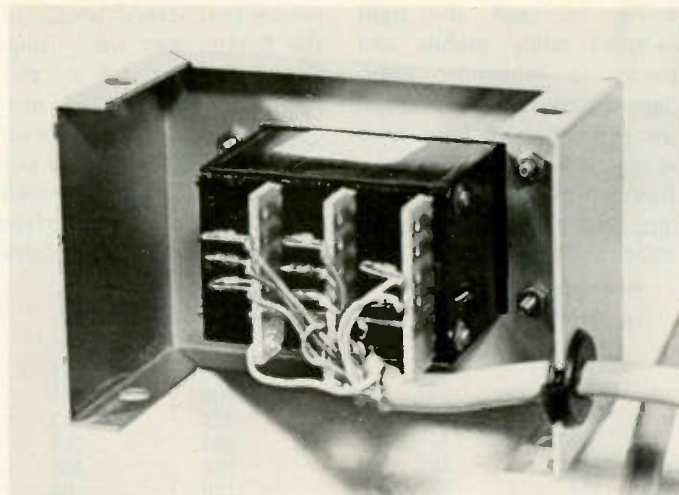

Photo E.

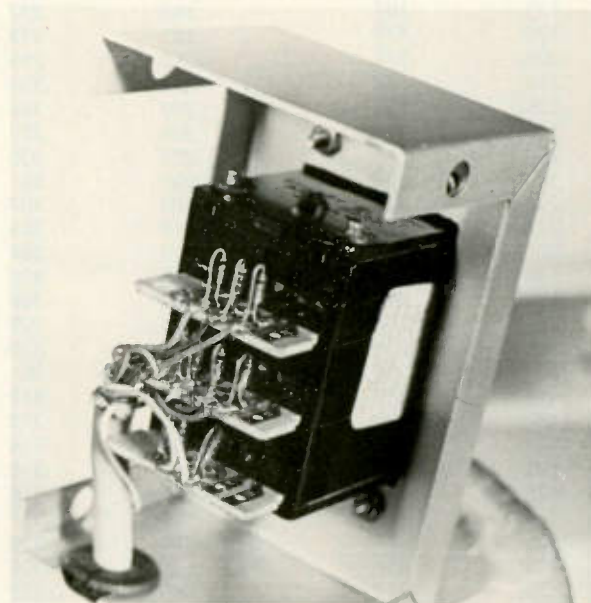
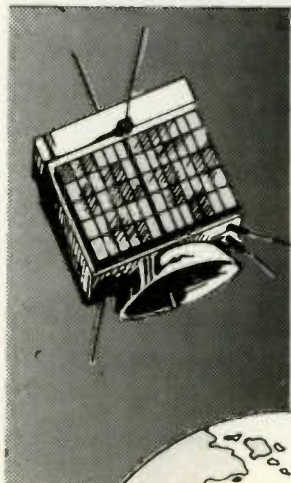

Photo F.

claim credit for this modification. Credit goes to Bill Richards WA4VAF for the DIP switch idea, Jerry Armstrong WA7ZVT for the BCD conversion, Nick Hall

WB7RZR for the photographs, Jack Hanny WB7SAF who revised the lookup tables, and Earl Sexton who helped me with the assembly. ■



There's a new, eighth OSCAR satellite in orbit, and the AMSAT team helped put it there!

Your help is needed for future satellites. Join AMSAT and support the new, advanced Phase III series of OSCARs, engineered to provide communications over transcontinental distances for hours at a time.

Send \$10 membership dues to AMSAT, P.O. Box 27, Washington, D.C. 20044. Life membership is available for a tax-deductible donation of \$100 or more, payable in quarterly installments if you wish.

Phase III satellite solar cells may be sponsored for \$10 each, and we'll send you a certificate specifying the cells you are sponsoring.

For a tax-deductible contribution of \$1,000 or more, we'll even inscribe your name on a plaque to be placed in orbit aboard the Phase III spacecraft for posterity, and we'll send you a replica honoring your contribution.

Dues and contributions may be charged to VISA or Master Charge. Phone us at (202) 488-8649.

Radio Amateur Satellite Corporation
P.O. Box 27, WASHINGTON, D.C. 20044



DSI Instruments Inc.

Performance You Can Count On



MODEL 3550W
\$149.95
INCLUDES TCXO ± 1 PPM



MODEL 3600A
\$199.95
INCLUDES OVEN TIMEBASE $\pm .5$ PPM



MODEL 3240HH
\$119.95
BATT. OPERATED

The 3600A, 3550W and 3240HH Frequency Counters represent a significant new advancement, utilizing the latest LSI Design... which reflects DSI's ongoing dedication to excellence in instrumentation, for the professional service technician and amateur radio operator. Before you buy a DSI instrument you know that the specification is. We publish complete and meaningful specifications which state accuracy over temperature and sensitivity at frequencies you need. And we guarantee those specifications in writing. **JOIN THE RANKS OF THOUSANDS OF SATISFIED CUSTOMERS. PLACE YOUR ORDER TODAY AND BE THE ONE ON FREQUENCY.**

DSI — GUARANTEED SPECIFICATIONS — MADE IN U.S.A.

Model	Frequency Range	Accuracy Over Temperature	@150MHZ	@250MHZ	@500MHZ	Number Of Readouts	Size Of Readouts	Power Requirements	Size
3600A	50HZ-600MHZ	OVEN .5PPM 50° to 100°F	10MV	10MV	50MV	8	.5 inch	115VAC or 8.2-14.5VDC	2 1/2" H x 8" W x 5" D
3550W	50HZ-550MHZ	TCXO 1PPM 65° to 85°F	25MV	25MV	75MV	8	.5 inch	115VAC or 8.2-14.5VDC	2 1/2" H x 8" W x 5" D
3240HH	2MHZ-250MHZ	3PPM 65° to 85°F	100MV	100MV	NA	7	.4 inch	4AA Batt.	5" H x 3" W x 2" D

**ALL UNITS ARE FACTORY ASSEMBLED,
TESTED AND CARRY A FULL 1 YEAR WARRANTY.**

See Your Dealer
OR

Call Toll Free (800) 854-2049 DSI Instruments, Inc.
California Residents, Call Collect (714) 565-8402

VISA • MC • AMERICAN EXPRESS • CHECK • MONEY ORDER • COD
7914 Ronson Road, No. G, San Diego, CA 92111

• NO EXTRA COSTS •

FREE Shipping anywhere In U.S.A.
& Canada. All other countries, Add \$10.00.
Strongest warranty in the counter field.
ONE YEAR Parts and Labor
Satisfaction Guaranteed.

"Stop Timeouts!" Revisited

—PC board for K3VTO's timer

I read with great interest the article "Stop Timeouts!" by K3VTO in the May, 1977, issue of 73. It is nice to know that others have trouble getting electrons to go where the schematic diagram indicates they should go. After reading the article over several times, I decided to build the 10-minute timer even though I had no experience with TTL circuitry. I also thought that this would be a good time to try my hand at designing

a printed circuit board to avoid the rat's nest of wires.

I purchased several packages of printed circuit (PC) drafting aids (Heathkit) and began the task of transforming K3VTO's circuit diagram to a printed circuit diagram that I could photoprocess onto a copper PC board. I checked and double-checked the wiring to be sure that I didn't leave out a connection. Finally, the drawing was complete and

I was ready to transfer the diagram to the copper board. Needless to say, I spent several evenings and one weekend trying to photoprocess my circuit board. I even followed the suggestions of KL7AE on page 57 of the April, 1977, issue of 73.

At last, I got an image on the copper, and, within minutes, I had the printed circuit board ready for drilling the many holes.

I mounted all the

goodies on the board, connected the 6.3 V transformer to the power supply section, and, without fear, plugged it in. Alas, the decimal point did not blink, the readout remained on "8" no matter what, and the alarm howled constantly. I again checked the wiring diagram against the PC board and could not find any apparent discrepancies. So I checked with several other hams and was informed that TTLs must be attached to Vcc (+5 volts) before they will function properly. Also, they suggested that all unused connections be tied to Vcc. So I connected pin 16 of the 7448 and pin 14 of the 7400 to Vcc and pin 7 of the 7400 to ground (these connections were omitted from K3VTO's diagram).

With that, the timer was working with just a few glitches. After replacing several of the ICs, the timer finally worked as well as K3VTO claimed.

I made several changes in the schematic when I designed the PC board. I used a dual 555 IC (556) instead of 2 single 555s and provided connections for a variable volume control. Fig. 1 shows my PC board

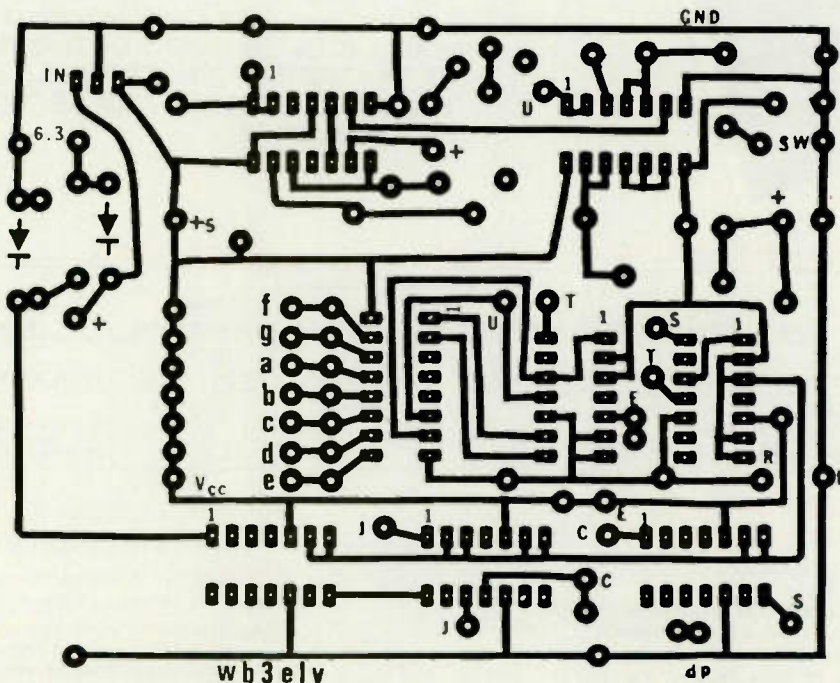

Fig. 1. PC board for 10-minute timer, including the 5-volt power supply.

design, which includes the +5-volt power supply. No provision was made to mount the 6.3-volt transformer on the PC board. I found a 2 x 4 x 6-inch enclosure at Heathkit which works quite well even with the larger read-out (0.8 LED).

I must admit that, if the circuit had worked the first time, I would only have a 10-minute timer and would still not know anything about TTL circuitry. As it is now, I have studied and experimented with simple TTLs to the point where I can even check them for proper operations before using them in a circuit. I feel that the kinds of projects that are featured in 73 are beneficial to the beginner, as well as practical for the old-timers, and help prepare them for more sophisticated circuitry. ■

Predrilled PC boards are available from the author for \$3.50 each.

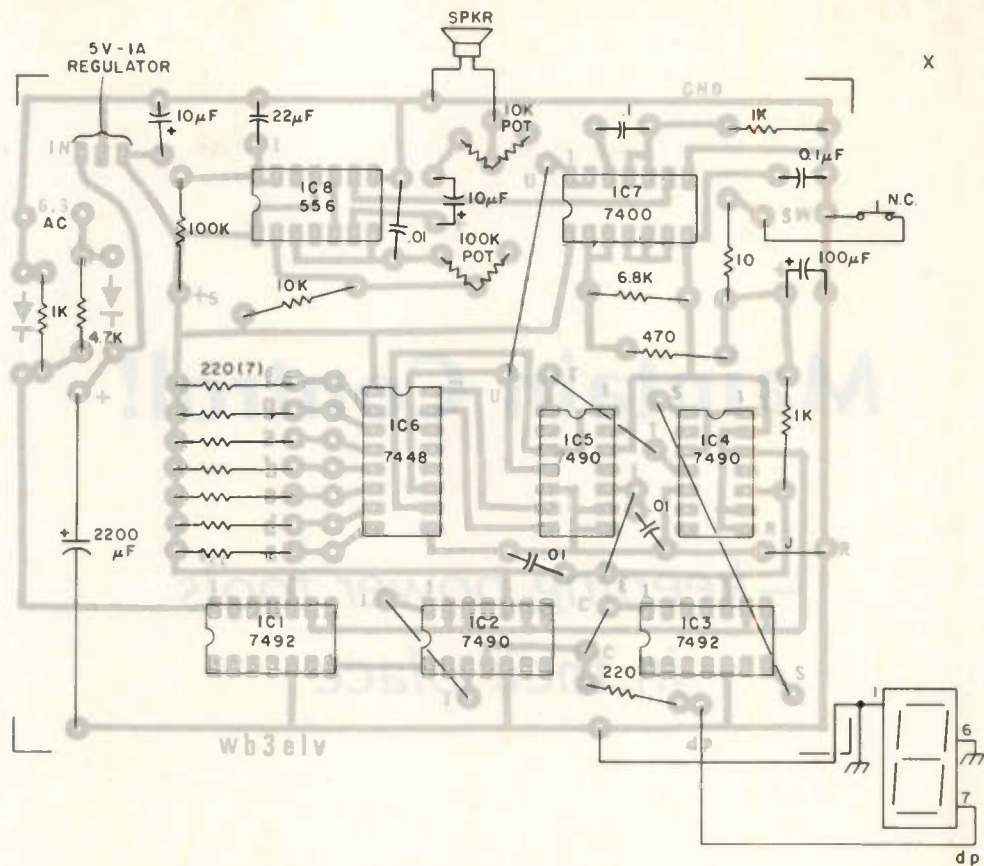

Fig. 2. Parts placement (foil side view).

JAN CRYSTALS HOLD THE FREQUENCY

- CB
- CB standard
- 2 meter
- Scanners
- Amateur Bands
- General Communication
- Industry
- Marine VHF
- Micro processor crystals

easy to charge

we accept **master charge** **BANKAMERICARD**

Send 10¢ for our latest catalog
Write or phone for more details

2400 Crystal Drive
Ft. Myers, Florida 33901
all phones (813) 936-2397

JAN CRYSTALS, INC.

CURTIS 8043 retires with honors

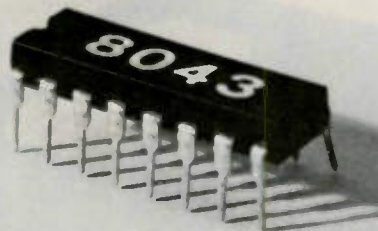

but look at our NEW STARS!

- ★ 8044; Keyer-On-A-Chip* (Replaces 8043) . . \$14.95
Apr '75 HR, Feb '76 OST, Radio Hdbk '75, ARRL Hdbk '77-78
 - ★ 8044-3; IC, PCB, Socket, Manual 24.95
 - ★ 8044-4; Semi-Kit 54.95
 - ★ 8045; Morse Keyboard-On-A-Chip IC 59.95
 - ★ 8045-1; IC, PCB, FIFO, Sockets, Manual 89.95
 - ★ 8047; Message Memory-On-A-Chip IC 39.95
 - ★ 8047-1; IC, PCB, RAM, Sockets, Manual 69.95
(add \$1.75 on above for postage and handling)
 - EK-430; CMOS Keyer* (Feb '76 OST) 124.95
 - IK-440A; Instructokeyer* (Mar '76 OST) 224.95
*now with dash memory as standard
- System 4000 Ham Computer (see Jan '78 OST). (write)
- Curtis Electro Devices, Inc.
18618-2 PARTHENIA ST. • NORTHRIDGE, CA 91324
(213) 993-5159
- Box 4090, Mountain View, CA 94040

JBW

Specializes in 220 MHz equipment

Contact JBW for pricing on the new JBW 220 MHz repeater

CRYSTALS IN STOCK
MIDLAND 13-509
COBRA 200
CLEGG 76
WILSON HAND-HELD

ALL CRYSTALS GUARANTEED

JBW ELECTRONICS ALSO FEATURES
LUNAR, ESC & MIDLAND
Product Lines

JBW ELECTRONICS, INC.
18618-2 PARTHENIA ST. • NORTHRIDGE, CA 91324
(213) 993-5159

David E. Stanfield
3408 Catalina Dr.
Atlanta GA 30341

Maintain Control!

*—keeping power tools
in their place*

No matter how carefully I use a center punch, it seems that the bit invariably slips as soon as I trigger an ordinary electric hand drill. And, most of the time, the bit will suddenly bite into the metal after it has slipped out of place. When this happens, I end up with a hole in the wrong place. If this isn't an earth-shaking problem, it is certainly annoying.

My method of dealing with this situation is simple and easy to apply. It is low in cost and can be used for a number of applications. It makes a great project for the beginner but can also be used by the pro.

Essentially, what I did was wire a light dimmer control in series with an ac socket and mount everything in a box. When I plug an electric drill into the socket, I can conveniently control its speed by turning the knob on the dimmer. At very low speeds, the bit doesn't try to wander off. Once I have the hole started, I can crank up the speed and finish the job.

After I built the unit shown in the photo, I found that I could use it to control the speed of a saber saw. Low speeds make it easy to start cuts accurately. Once started, I found it easier to control the saw by running it at about half speed.

I also found that the unit does a fine job of controlling the tip temperature on my soldering iron. Due to thermal lag, it takes a little time to find the proper setting of the knob, but, once you find it, it's easy to reset. This allows you to operate at reduced temperatures when soldering sensitive parts and then pour it on when you need extra heat.

Finally, I use this unit to control up to 600 Watts of photographic flood lamps. Before, my only means of regulating the intensity of light on the subject was to move the lamps closer or fur-



As this photo shows, the unit is fairly compact. What isn't shown is how easy the whole project is to put together.

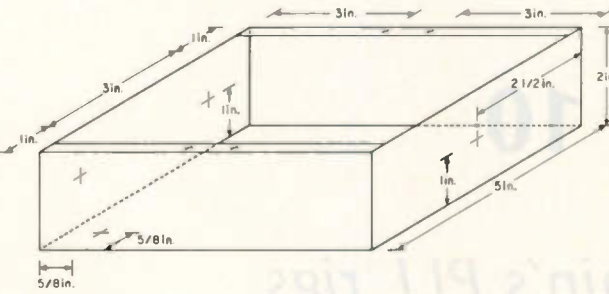
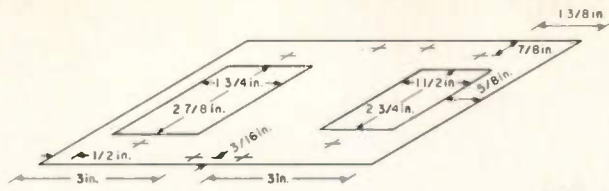

Fig. 1.

Parts List

- Chassis — 5 x 7 x 2 inches, Radio Shack catalog number 270-246
- Ac wall socket
- Ac extension cord — 6 feet long (used as power cord)
- Ac wall socket cover
- Ac wall switch cover
- Handle—kitchen cabinet type
- Light dimmer control, 2-wire type
- Machine screws, nuts, and lockwashers
- Wire caps
- Hookup wire
- Rubber feet
- Self-adhesive paper
- Sheet of scrap wood 5 x 7 x 1/8 inches (for top piece)

ther from whatever I was photographing. Now I turn a knob. I should add that this procedure isn't recommended for color work, as the shift in color temperature is quite pronounced.

There isn't much point in my giving detailed instructions for a project as simple as this. Fig. 1 can be used to locate the holes and openings in the chassis and top plate, if you wish to duplicate my unit. All but four of the holes are drilled slightly larger than the machine screws which will pass through them. These screws are then secured with nuts and lock washers.

On opposite sides of the top of the chassis are two ridges. The four holes I drilled in them are used to fasten the top plate and are drilled slightly smaller than the screws used in them. If care is used, these screws will act as self-tapping screws and thread their way through the ridges. This eliminates the need for trying to use nuts

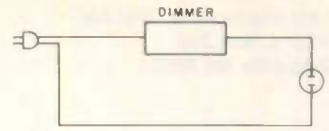

Fig. 2.

under the ridges, which would be difficult, at best.

And finally, the hole drilled in the right end of the chassis is used for the power cord. It must be drilled large enough for both the power cord and a protective grommet. As you can see in the photo, I used self-adhesive paper to cover the top and seal it to the chassis. A sharp hobby knife made trimming excess paper an easy task. The handle makes it a very portable unit and serves as a good place to wrap the cord. I didn't include an on/off switch, as one is built into the dimmer. If you don't care for the uses I've suggested for this controller, you can always use it to dim room lamps. What you do with dim lighting is beyond the scope of this article. ■

2 METER CRYSTALS MANY IN STOCK

FOR THESE RADIOS ON STANDARD ARRL REPEATER FREQUENCIES

- | | |
|-----------------------------|----------------------|
| Clegg HT-146 | Regency HR-212 |
| Drake TR-22 | Regency HR-2B |
| Drake TR-33 (rec only) | Regency HR-312 |
| Drake TR-72 | Regency HR-2MS |
| Genave | S.B.E. |
| Heathkit HW-2021 (rec only) | Sonar 1802-3-4, 3601 |
| Heathkit HW-202 | Standard 146/826 |
| Icom/VHF Eng | Standard Horizon |
| Ken/Wilson | Swan FM 2X |
| Lafayette HA-146 | Tempo FMH |
| Midland 13-505 | Trio/Kenwood |
| Regency HR-2 | Trio/Kenwood TR2200 |
| | Trio/Kenwood TR7200 |

\$3.95 EACH — IN QUANTITIES OF 10 OR MORE, \$3.50 EACH

Certified check or money order only — NO CODS

ROLIN DISTRIBUTORS
 P.O. Box 436 R15
 Dunellen NJ 08812
 (201)469-1219

QUASAR VIDEO TAPE RECORDER SALE!



We are constantly testing ham and other electronic equipment for review in 73 Magazine. In order to be able to keep this not inexpensive project going we have to sell off the equipment used for test. Most of it has been used for a few days and is in every way as good as new. In many cases it is better than new since 95% of the equipment failures come within the first few hours of operation.

In this case we are running a series of tests of VTR systems, using them for regular, ham TV, SSTV, and even micro-computer programming tests. One of the best we've found so far is the Quasar system, but we still have to go on and test the RCA, JVC, and many other systems . . . so our Quasar is up for sale. We paid well over \$1,000 for the Quasar . . . used it for a few days and have gone on to test more systems.

Quasar VTR System special like new \$675.
 Quasar two hour cassettes, each (new \$25) .special like new \$12.50

Major Credit Cards Accepted.
 73 Magazine • Peterborough NH 03458

ALUMA TOWERS A47

VERO BEACH, FLORIDA 32960

MFG'S OF ALUMINUM TOWERS

- ★ TELESCOPING (Crank Up)
- ★ WALL MOUNTED
- ★ TILT-OVER
- ★ GUYED MODELS (to 100 Ft.)

Excellent for Ham Communications.

HIGH QUALITY — LOW PRICES

MADE IN LONG-LASTING NO-RUST ALUMINUM!

McCLARAN SALES TAKES IN ANYTHING ON TRADE FOR NEW ALUMA TOWERS.

NEED: Scanners, CB, 2 Meter, Marine, Antiques, Coins, Ham Gear.

We accept Master Charge & Visa Cards

FOR SALES & TRADES CONTACT **R.D. McCLARAN SALES**

430 Franklin at Beach
 Indianton, Florida 32903
 (305) 723-4793



CB to 10

—part XI: Hy-Gain's PLL rigs

Almost every late-model CB rig on the market is capable of operating on 10 with excellent sensitivity and output. No model requires very extensive changes to modify. I picked an inexpensive and easily converted rig for my first research run and achieved some rather gratifying results. A little fancy telephone work got me in touch with Charlie Conners KØNG in Nebraska, who I knew had spent many hours in design work on PLL circuits. As it turned out, Charlie has done extensive work on 10 meter conversions, and, without his advice and knowledge, my conversion could have been very painful the first time.

The Hy-Range model 681A,¹ which I chose for conversion, can be modified in about an hour and performs well (better than manufacturer's specs). Is it phase locked loop? You bet — it only requires the purchase of one crystal instead of two, four, or possibly six on some rigs, and the receiver sensitivity is right on with a little realignment. No circuit changes are necessary, and there is no compromise on sensitivity.

Do I have you interested? Get out your alignment tool, VTVM, and signal generator

(necessary equipment), and set aside one hour of your day's schedule.

Finding your way inside should be no problem. Locate X101 and replace it with a new crystal which is determined by the formula: $(N/2) + 9.510$ MHz, where $N = \text{kHz}$ above CB channel 1 (26.965) that you wish to operate.

For example, suppose we move up exactly 2 MHz to 28.965 for channel 1. Then, $28.965 - 26.965 = 2000$ kHz; $2000/2 = 1000$ kHz or 1 MHz; $1000 \text{ kHz} + 9.510 = 10.510$ MHz for new crystal frequency.

With the new crystal installed, set the channel selector to channel 1, attach a VTVM to TP8 on the PC board (junction of R114 and R115), and adjust T101 for 1.5 V dc \pm .1 volt. This step is critical and must be done carefully, as it allows the vco to operate within "capture" range of the PLL circuitry. This accomplished, loosely couple an accurate signal source to the antenna jack, flick the channel selector to channel 11, and carefully peak T104, T105, T106, L112, and L115 for maximum receive sensitivity.

Next, attach a power meter and dummy load to the output and key up the trans-

mitter. Watch the power meter and tune T102, T103, L103, L104, L106, L109, and L110 for maximum power output. If the power output exceeds 4 Watts at this point, readjust L110 counterclockwise until it is 4 Watts or less. This last step will assure an output free of spurious radiation. Also, remember that these adjustments are interactive and should be gone over more than once for peak performance.

And there you are! It's a first class 10 meter rig in anybody's book — in about an hour.

Now you need an antenna for the little jewel. There is one CB antenna on the market that will operate "as is" on 10 with less than 2-to-1 swr through a full megahertz. The M400 "Starduster" made by Antenna Specialists is a natural, the only modification necessary being to change the coax connector from the CB rig to the 10 meter rig. But, for the ham who's got to have everything just right, slip the capacitance hat off the top radiator, prune the radiator to 96" and the three radials to 98", and you have a fine vertical antenna which will

show unity gain with a good dipole.

A mobile antenna presents little more difficulty than a simple retuning. Most commercially produced mobile CB antennas fall into three categories, and all can be modified successfully with very little effort. Quarter-wave whips are simply pruned to resonance with an swr meter in the line. Center- and top-loaded antennas usually have an adjustable metal whip which requires a slight shortening.

Helically wound antennas may be carefully shortened and resealed against the weather. There's nothing really difficult about the conversion, and most can be accomplished in 30 minutes or so.

By this point, you should have under \$100 and about an hour and a half worth of time invested in a slick 10 meter station. ■

Reference

1. Hy-Gain model 682 uses the same conversion. Models 2680, 2681, 2682, and 2683 require a different crystal formula: $\text{Crystal X101} = N/3 + 11.80666$ MHz, but tune-up is exactly the same. Service manuals (very comprehensive) are available from: Hy-Gain Electronics, 4900 Superior St., Lincoln, Nebraska 68504, for \$5 each.

EXTRA

Hamfest News

EXTRA

Special Edition For Those Seeking a Good

**HURRY! EARLY BIRD
TICKETS ARE GOING FAST!**

THOUSANDS in PRIZES Biggest Show in the East

N.E. Convention Escapes to Country

Conventioneers and city dwellers alike breathed a sigh of relief when the news was released from Newington. The New England ARRL Convention, formerly held in Boston for several years was moved to the tiny hamlet of Boxborough, Massachusetts on Interstate Route 495. Free parking and easy access were given as two main reasons for the move. Home of the big show will be the Sheraton Boxborough Hotel, Exit 28, Route 495.

Prizes Awarded Both Days of Show

Through the generous cooperation of the manufacturers and exhibitors lucky conventioneers will be taking home transceivers, antennas, microphones, amplifiers . . . the list goes on endlessly.

The event is a non-profit affair and surplus funds go directly into the prize fund.

Every Manufacturer Will Attend

Virtually everybody who is anybody will be there. A partial listing at presstime included Icom, HyGain, Dentron, Tufts, 73, Spectrum International, Mosley, Drake, ARRL, Ham Radio, Yaesu, CushCraft, Robot, Atlas, Ten-Tec, Digital Group, CQ, Kenwood, Byte, Tri-Ex, Hamtronics, Harrison, Science Workshop, TPL, ETO, Newtronics, HAL, Heath, Bay State, Evans, Radio Shack, Alda, DSI, Tel-Com, Harco, etc., etc.

Big Events All Weekend

Included will be movies of the Clipperton expedition, YL fashion show, bus trip to ARRL, night club show and banquet, seminars on antennas, ATV, you name it!

There will be 2 meter fox hunts and bargains in the flea market!



FLEA MARKET

at the 1978 New England
ARRL CONVENTION

October 14 & 15
Saturday & Sunday

Outdoors & Indoors
PERMITS \$2 per space EACH DAY PERMITS \$4 per space

First Come — Best Spaces!

10 A.M.-5 P.M.

TELL YOUR FRIENDS!

Discount Coupons Mailed September 8th 23,700 Sent to New England Hams

Registration will be \$4 early bird, \$5 at the door. If you were in the spring 1978 callbook you were sent a flyer. You can order tickets directly from the ticket chairman: George Stewart, W1ZQQ, 17 Barnes Avenue, East Boston, Ma. 02128. Children under 16 admitted free. Hotel reservations should be made directly with the Sheraton Boxborough, Boxborough, Massachusetts 01719.

Active Voltage Divider

— for dividing active voltage

P. G. Lefevre PY1AQL/CT1EM
 Vasco Camara 9A
 Carcavelos, Portugal

If you intend to perform experiments that require dual power supplies and you only have a single-ended supply, then the circuit in Fig. 1 is for you. Pin numbers

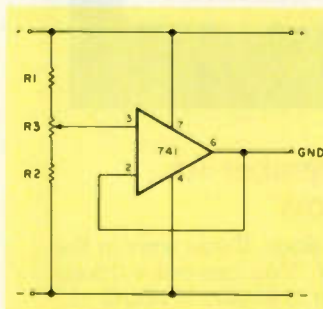

Fig. 1. Pin numbers are for the mini-DIP and TO-5 packages.

are for the mini-DIP or TO-5 packages.

Actually, it is nothing more than a voltage follower, just textbook stuff, but maybe not widely known in hobbyist circles. As its name implies, the operational amplifier, by virtue of its intrinsic properties, will cause the voltage at its output to follow the voltage impressed upon its noninverting input. This voltage can be conveniently selected by means of a potentiometer.

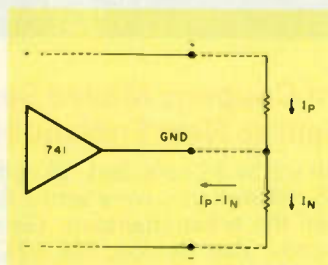

Fig. 2(a). Current at the positive branch is greater.

The op amp's output will then play the role of a "synthetic" ground, and you will enjoy the possibility of selecting the potential of the ground terminal, provided that it does not come closer than 3 volts to either supply line.

In addition to the above limitation, the maximum current output of the op amp will dictate the maximum current differential between the two branches of the circuit that it can handle. If the

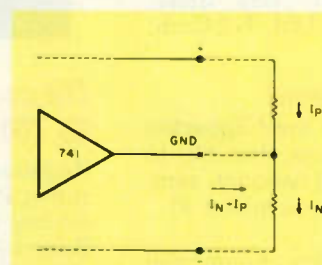

Fig. 2(b). Current at the negative branch is greater.

two currents are identical, the op amp will be just loafing along and, theoretically, there will be no current whatsoever flowing into or out of the op amp. If, however, one of the two branches draws more current than the other, the op amp will have to source or sink that difference. See Fig. 2. The arrows indicate conventional current flow.

The 741, like most other op amps, is internally protected against short circuits and can indefinitely withstand a short between its output and either supply line. Therefore, do not be afraid of blowing up the device. If you try to exceed its capabilities, it will just refuse to cooperate, and you will lose control of the voltage at the ground terminal.

This limitation raises another question: How much current can you expect out of this circuit? There is not one single answer to this question. If the positive and negative currents are nearly identical, the limitation will be imposed by the capabilities of the single-ended supply, but if, on the other hand, those currents differ widely, the limitation will be imposed by the maximum output of the 741. It so happens that this device was never intended to be a current driver and, in fact, manufacturers do not guarantee or even specify the current that you can expect out of one of those little beasts. If you sift through available literature, you will see this parameter quoted at anywhere between 5 and 15 mA.

Confronted with this situa-

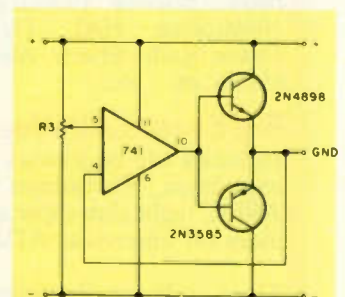

Fig. 3. Pin numbers are for the 14-pin DIP.

MADISON ELECTRONICS SUPPLY, INC.

M35

1508 McKINNEY
713/658-0268

HOUSTON, TEXAS 77002

M35

Nites 713/497-5683

NEW! EXCITING! BREAKTHROUGH! DRAKE TR-7 TRANSCEIVER & ACC.



TR-7	\$886.00
TR-7 & DR-7 DIGITAL R/O	\$1072.00
PS-7 POWER SUPPLY	\$166.00

CALL FOR QUOTES ON:

YAESU	KENWOOD
FT901 DM	TS820S
FT625	TS520S
FT225	TR7400A

ALDA, AMCOMM, ETO ALPHA
TEMPO VHF ONE PLUS



ANTENNAS

Model OJA-146

TWO METER AMATEUR BAND 146-148MHz

- NO GROUND PLANE REQUIRED
- USE FIXED, MOBILE, OR PORTABLE
- 5dB GAIN OVER ISOTROPIC IN MOST MOBILE APPLICATIONS
- OVERALL LENGTH: LESS THAN 64 INCHES
- COLLAPSIBLE TO 22 INCHES. MAY BE PACKED IN SUITCASE FOR THOSE OUT-OF-TOWN TRIPS
- STEEL WHIP AND ADAPTER INCLUDED FOR MOBILE AND FIXED APPLICATIONS
- VSWR: LESS THAN 1.2:1

PRICE \$39.95 UPS Prepaid

220 MHz — \$37.95 450 MHz — \$37.95

AMATEUR BEAMS — in stock —

FINCO A62 6/2m	\$61.00
TELREX TB5 EM	\$415.00
RIW 432-19	\$49.95

CALL FOR FAST QUOTES SPECIAL ORDERS WELCOME

TERMS: All prices FOB Houston. Prices subject to change without notice. All items Guaranteed. Some items subject to prior sale. Send letterhead for Amateur dealers price list. Texas residents add 5% tax. Please add postage estimate.

MADISON FABULOUS FALL BUYS

KLM: Antennas, Linears, Accessories All in Stock. Free balun w/2 meter base antenna.

FINCO AMATEUR BEAMS in Stock — Call! A62.6 and 2 Meter \$61.00

2 + 2 Horiz/vertical \$37.50

BIRD 43 Wattmeter plus slugs, in stock, prepaid freight.

BENCHER keyer paddles in stock \$39.95; chrome \$49.95

YAESU

FT-301D + Free FP301 \$935

FT-301 + Free FP301 \$769

YAESU FT-901D series Call for Quote

TELE-TOWER: 40' w/breakover \$299

55' w/breakover \$399

MICROWAVE MODULES MMT 432-28S \$259

UPS Paid.

F9FT TONNA antennas: 144/16 el \$55.95

9/19 OSCAR \$53.00

JANEL Preamps QSA-5 \$39.95

TECHNICAL BOOKS: ARRL, Sams, TAB, TI, Rider, Radio Pub., Callbook, Cowan, TEPABCO, may others call

HAM X ROTOR (New Model) Turns 28 sq. ft. of antenna. List \$325. In stock Your Price \$249

CDE HAM-III \$129.00

SWAN METERS: WM 6200 VHF Wattmeter \$49.95

SWR 3 Mobile \$9.95

TELEX HEADSETS: In stock

CETRON 572B \$27.95 ea.

RAYTHEON 572B \$24.95

ADEL nibbling tool, \$6.45; punch \$3.50

CABLE 5/32", 6-strand, soft-drawn guy cable. For mast or light tower, 3¢ foot.

BELDEN COAX CABLE: 9888 double shield RG8 foam coax, 100% braid, suitable for direct bury 39¢ ft., 8237 RG8 21¢ ft., 8214 RG8 foam 25¢/ft., 8448 8-wire rotor cable 16¢ ft., 8210 72 ohm kw twinhead \$19/100 ft., 8235 300 ohm kw twinlead \$12/100 ft., Amphenol PL-259, silverplated 59¢, UG175 adapter 19¢, PL-258 dbl female \$1.00. BNC female chassis mount 59¢ ea.;

BELDEN 14 gauge cop. stranded antenna wire \$5/100 ft.

TIMES 1/2" foam hardline 60¢/ft. connectors \$15 ea.

7/8" Foam Hardline 1.50 ft. Connectors \$25.00 ea.

KESTER SOLDER 1 lb. 60/40 .062 \$6.50

LEADER — GDM LDM815 \$89.95

MALLORY 2.5A/1000 PIV epoxy diode 19¢ ea.

.001 MFD 20 KV CAP \$1.95

GE receiving tubes 50% off list

GE6146B,8950 \$7.95 ea.

SWAN 750CW + Free PSU-3 \$675

THIS MONTH'S SPECIAL

KENWOOD TR7500A \$249

16 ELEMENTS — F9FT — 144 MHz



The 'Tonna' You've been hearing about

144/146 MHz	SWR 1.2:1
17.8 dBi	Wt. 4.4 kg.
50 ohms	Horiz./Vert.
length 6.4 m.	F/B ratio 22 dB
Side lobe attenuation 60 dB	
Horizontal aperture 2 x 16° (-3 dB)	
Vertical aperture 2 x 17° (-3 dB)	

\$55.95

AUTHORIZED DEALER

Vhf engineering

Makers of the World's Most Complete Line of VHF-FM Equipment

tion, I decided to find out for myself and, scrounging around, was able to gather some twenty-five different units from several manufacturers and in different packages. Their short circuit current was measured with unexpected results: Mini-DIPs and metal cans gave about 16 mA, whereas 14-pin DIPs gave a surprising 30 mA!

Inasmuch as the output current limitation is temperature dependent, I also ran some tests with heat sinked DIP packages with inconclusive results, and it is doubtful whether it is worth the trouble.

There are in existence other op amps capable of greater current output, but they are not only difficult to find, but expensive, as well. The circuit of Fig. 3 is a more practical solution if the unaided 741 is not capable of delivering the performance you need. I designed this circuit after unsuccessfully trying 2 different designs published on separate

Device	Polarity	BVCBO	BVCEO	BVEBO	I _c	P _d	Condition
S9101	NPN	60	60	5	4 A	40 W	Ambient T = 25°C
S9121	PNP	60	60	5	4 A	40 W	Ambient T = 25°C
TIP 110	NPN	60	60	5	2 A	50 W	Case T = 25°C
TIP 115	PNP	60	60	5	2 A	50 W	Case T = 25°C

Table 1.

occasions by trade magazines. The first design only worked if the negative branch drew a heavier current, and the second one was plagued by oscillations.

In the unit I built, which is now a permanent fixture of the workbench at CT1EM, I used 2N4898 and 2N3585 transistors for the simple reason that they were available from my junk box. Any power transistor in a TO-66 or TO-220 package should be okay. It would be futile to try a big brute like a 2N3055 because the 741 would be unable to provide the base current necessary to fully exploit its power capabilities. With the transistors above, my unit can provide currents with an imbalance exceeding 1 Amp.

If you are still not satisfied

with that, you may use Darlington amplifiers instead of plain transistors. These amplifiers from the outside look just like any transistor, and they are inserted in a circuit as if they were just that. The main characteristic of such devices is a phenomenal static current gain. Therefore, the skimpy current output of even a 741 will be sufficient to provide the necessary base drive. Suitable devices would be Motorola's HEPS9101 and HEPS9121. Texas makes the TIP 110 and the TIP 115, which are lower in power capability and would require heat sinking. See Table 1 for the main parameters.

On the schematic, R₁ and R₂ are optional and, if installed, should be about 10% of R₃. The pot should

be about 50k and the bypass capacitors (from ground to the supply rails) should be .1 ceramic disc. It will be advantageous to use the 14-pin package, rather than the mini-DIP or metal can, and have all pins soldered to the board rather than socketed, for improved heat transfer.

Before you decide to go the Darlington way, make sure that your power supply has enough beef to exploit the performance afforded by the very high current gain of these devices. Remember that the tremendous amplification is obtained only under static conditions and falls off quite rapidly with increasing frequency. Eventually you may run into a circuit whose current demands fluctuate too rapidly for the Darlington to follow. ■

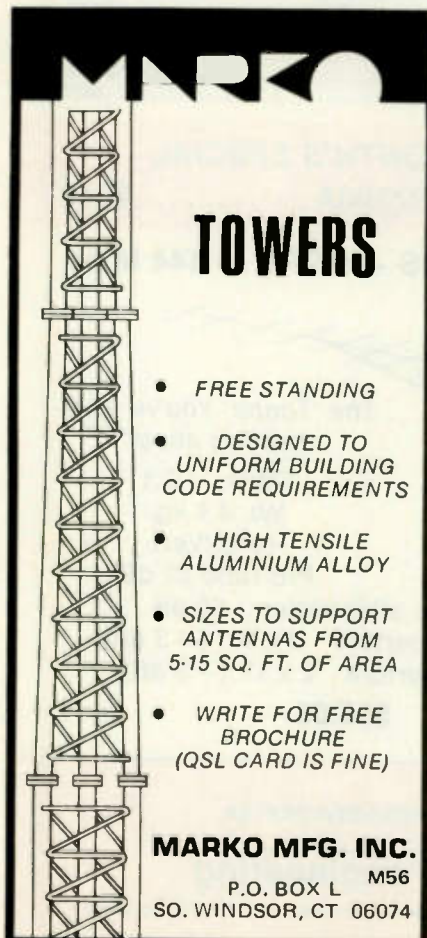

TOWERS

- FREE STANDING
- DESIGNED TO UNIFORM BUILDING CODE REQUIREMENTS
- HIGH TENSILE ALUMINIUM ALLOY
- SIZES TO SUPPORT ANTENNAS FROM 5-15 SQ. FT. OF AREA
- WRITE FOR FREE BROCHURE (QSL CARD IS FINE)

MARKO MFG. INC.
M56
P.O. BOX L
SO. WINDSOR, CT 06074



HAM REPEATER AUTOPATCH

Offer your club COMPLETE emergency communications

Commercial quality, gold plated contacts, plug in, epoxy glass PC boards. 12 volt DC or 115 volt AC operation - Power supply included. Four digit access - Single digit releases - field programmable. Hybrid network - No switching required. FCC certified telephone line coupler. Auxiliary "In Use" contacts supplied. Land line "call-in" signalling control contacts provided.

Price complete \$498 + \$3 shipping & handling. Master Charge, Bank money order, or certified check acceptable.

Accessories: CES-300 powered tone pad - \$59 BUS-COM Soft-touch® telephone powered mike/elec - \$34.95. M76

MONROE ELECTRONICS, INC.
100 Houslet Ave., Dept. 412, Lyndonville, N.Y. 14096

September Specials

HY-GAIN	
TH6DX-6 el. Tribander	\$189.95
TH3MK-3 el. Tribander	150.00
TH3JR-Low Power Beam	104.00
18AVT/WB-10-BOM Vertical	70.00
MOSLEY	
TA33-3 el. Tribander	145.00
CL-36-6 el. Tribander	210.00
RV-4C-10-40M Vertical	43.00
RV-8C-80M Kit for RV-4C	27.00
RKV-345-Roof Mount Kit	9.00
Antenna Weather Guard	3.00
WILSON	
System One-5 el. Tribander	209.00
System Two-4 el. Tribander	167.00
DB 54-5 el. 20M, 4 el. 15M	299.00
DB 43-4 el. 15M, 3 el. 10M	136.00
DB 33-3 el. 10 & 15M	114.00
CUSHCRAFT	
ATB-34 Tribander	189.00
ROTORS	
Cornell Dubilier Ham III	117.00
Cornell Dubilier Ham T-X	217.00
Alliance HD-73	99.00
POWER SUPPLIES BY SAT	
Overvoltage & Overcurrent Protec.	
SPS-4: 4 AMPS	\$49.95 List, 33.50
SPS-8: 8 AMPS	89.95 List, 60.00
SPS-20: 20 AMPS	149.95 List, 99.00
SPS-30: 30 AMPS	179.95 List, 120.00
WIRE ANTENNA COMPONENTS	
Wire It	
by Sexton—sold in 50 ft. increments—price per foot:	
5300-18 ga. Copperweld(TM) 2 1/4 ft. over 300 ft. 1.24	
5302-14 ga. Copperweld(TM) 4 1/4 ft. over 300 ft. 2.94	
5303-12 ga. Copperweld(TM) 4 1/4 ft. over 300 ft. 3.84	
8283-RC-8/U Foam, 95% Braid, 13 ga.-200 ft. up 13.5c	
8285-RC-8/U Foam, 95% Braid, 11 ga.-200 ft. up 15.5c	
8291-RC-58AU Foam, 95% Braid, 20 ga.-200 ft. up 5.74	
1596-RC-174/U Miniature 50 Ohm 200 ft. up 3.64	
Hy-Gain End Insulators #156-List \$3.95/pr. \$2.85	
Hy-Gain Center Insulator #155-List \$5.95, \$4.30	
2502-300 Ohm Open Wire Line, 100 ft. Coils 4c/ft.	
2500-450 Ohm Open Wire Line, 100 ft. Coils 4c/ft.	

C89 COMMUNICATIONS SERVICES



**326A WEST MAIN STREET
PHILADELPHIA MS 39350
PHONE: 601-650-5345
HOURS: 8-5 Mon-Fri.**

Send stamp for price sheet or \$1 check for full line catalog. \$1 refundable on first order. We do not export. All shipping is collect.

slinky

SLINKY! \$43.95 Kit A LOT of antenna in a LITTLE space New Slinky® dipole with helical loading radiates a good signal at 1/10 wavelength long!

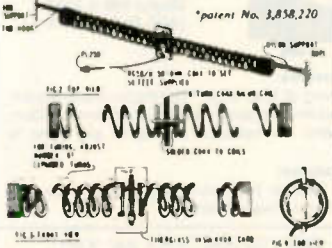

This electrically small 80/75, 40 & 20 meter antenna operates at any length from 24 to 70 ft. ● no extra balun or transmatch needed ● portable — erects & stores in minutes ● small enough to fit in attic or apt. ● full legal power ● low SWR over complete 80/75, 40 & 20 meter bands ● much lower atmospheric noise pick-up than a vertical & needs no radials ● kit incl. a pr. of specially-made 4" dia. by 4" long coils, containing 335 ft. of radiating conductor, balun, 50 ft. RG58/U coax, PL259 connector, nylon rope & manual.

YAesu



FT-301 or FT-301D

COMPETITION GRADE HF XCVR	
FT-901DM 160-10M XCVR	\$1450
FT-901D 160-10M XCVR	1250
FT-901DE 160-10M XCVR	1250
INTERNATIONAL GRADE HF XCVR	
FT-101F 160-10M XCVR	799
FT-101FE 160-10M XCVR	759
FT-101FX 160-10M (AC Only)	699
SOLID STATE HF XCVR	
FT-301D 160-10M 240W Digital	935
FT-301 160-10M 240W Analog	769
FT-7 80-10M 20W XCVR	549
VHF TRANSCEIVERS	
CPU-2500 FM Mobile	TBA
FT-225R 2M XCVR	860
FT-225RD 2M XCVR W/Digital	895
FT-227R FM Mobile 2M	349
FT-227RA AutoScan 4 Mem. 2M	TBA
FT-625RD All Mode 6M	895
FT-625R All Mode 6M	840
SOLID STATE RECEIVERS	
FRQ-7 Communications RCVR	315
FRG-7000 All Band HF RCVR	629
FR-101S 160-2M RCVR	599
FR-101SD 160-10M/SW Digital	749
INTERNATIONAL GRADE TRANSMITTER	
FL-101 160-10M XMTFR	649
LINEAR AMPLIFIER	
FL-2100R 80-10M Linear	529
TEST EQUIPMENT	
YC-5001 500 MHz 10 PPM	239
YC-3005 500 MHz 1 PPM	399
YC-3006 500 MHz 0.02 PPM	537
YC-150 Dummy Load	96
ACCESSORIES FOR ALL MODELS	
YM-50 Headset	15
YL-QZ Desk Mike	30
YL-844A HL-QZ Desk Mike	30
YL-846 HL-QZ Hand Mike	16

YM-8 LQZ Hand Mike	16
FFd250 520 Lo Pass Filter	34
Code/PRTY Decoder	TBA
WTR-24 World Clock	35
ACCESSORIES FOR FR-101 RCVR	
FC-2 2M Converter	25
FC-4 6M Converter	24
FM-1 FM Adapter	20
FM-300 FM Filter	40
— AUX/SW Crystals	5
ACCESSORIES FOR 901 SERIES	
FA-9 Fan	20
FM-901 FM Adapter	45
KYV-901 Keyer Unit	124
MU-901 Memory Unit	60
DC-301 DC-DC Unit	35
SP-901 Speaker	74
SP-901P Speaker/Patch	TBA
FTV-901 2/8/10cm XVTR	TBA
YO-901 Monitor Analyzer	TBA
FV-901 Synthesized VFO	415
YC-901 Antenna Tuner	199
XF-9 HC Filter	45
XF-9 B Filter	45
ACCESSORIES FOR 301 SERIES	
FC-301 Antenna Tuner	170
FV-301 VFO	125
PS-301 Power Supply	187
FP-301D PS Identifier	239
YO-301 Monitor Scope	263
EX-301 External Speaker	25
XF90B AM Filter	40
CW-900 CW Filter	40
XF2A SSB/Proc. Filter	45
E.R.B. External Relay Box	17
LL-301 Phone Patch	49
MMB-8 Mobile Mount	23
ACCESSORIES FOR 101 SERIES	
FTV1000 6M Transverter	239
FTV250 2M Transverter	275
FV-101B VFO	137
SP-101B Speaker	25
SP-101PB Speaker/Patch	87
FA-9 Fan	20
XF308 AM Filter	40
CF-308 CW Filter	40
DC-1 DC/DC Converter	79
RFR-102 Processor (earth)	79
RFR-104 Processor (100Hz)	79
FT-101 Serv/Maint. Manual	25
YO-101 Monitor Scope	320
YC-101B Digital Readout	233
Frequency Counter	23
Mobile Mount	23
ACCESSORIES FOR VHF EQUIPMENT	
PB-1424 Marker Unit (FT820B)	25
MMB-2 FT2A Mobile Mount	23
MMB-4 S20B/21 Mob. Mount	23
FT-221 Serv/Maint. Manual	15
YC-221 Digital Display	119
MMB-5 FT272R Mobile Mount	8
4 amp Power Supply	50
Communicators Receiver	315
FRG-7000 All Band HF Receiver	629
QTR-24 World Clock	35

TUFTS CATALOG INDEX

Advanced Electronics—2
AMECO—7
Amphenol—17
Antenna Specialists—20
Astatic—1
Atlas—8, 12
Autek Research—2, 5
Bencher—17
Bird—7
Bomar—4
B & W—16, 24
CDE—5
CES—9
CIR—18
Covercraft—9
Cushcraft—10, 11
Data Signal—2, 8
Dentron—4, 16
Drake—3
ETO—18
F9F—21
Finco—6
Ham Key—13
Hustler—12
HyGain—1, 22, 23
ICOM—15
JMR—17
KLM—8
Kenwood—7
Larsen—15
MFJ—13
Microwave Filter—8
Microwave Modules—17
Morgain—15
Mosley—19
Nemarc—17
NPC—2
Nye Viking—2, 19
OK Tools—9
Pana Vise—1
Pipo Communications—17
Radio Amateur Callbook—19
Regency—2
Rohn—6
Sams—20
Save Your Radio—19
Sharp Calculators—24
Slinky—1
SST—10
Stinger—6
Swan—4
Ree/Ax—17
Teletower—5
Telex—7, 23
Tempo—8
Ten Tec—18
Texas RF—17
Tonna—21
Triplet—2
Tri Ex—10
Van Gorden—9
Vibroplex—19
Vista—5
VHF Eng—14
Wilson Electronics Corp.—19
World Radio TV Handbook—10
W2AU—8
W2VS—8
Yaesu—1

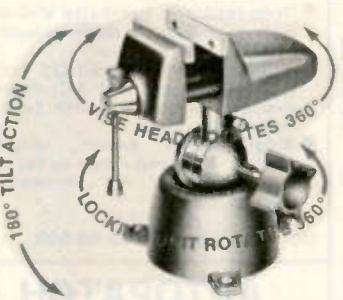

PANAVISE offers a variety of interchangeable work holding heads, bases and accessories for every imaginable function. But, just because it's small, doesn't mean you can't use PANAVISE for some pretty rugged work. It's a vise every craftsman deserves.

MODEL 300 Original Base
Designed for all normal permanent installations. Three lugs spaced 120 degrees apart provide maximum mounting stability. Overall height: 3-13/16" (97 mm). Base diameter: 5" (127 mm).

MODEL 303 Original Vise Head
Wide 2 1/2" (63 mm) jaws open to 2 1/4" (57 mm). Head is pressure diecast aluminum alloy, with steel and brass inserts. Hammertone gray/green finish. Replaceable nylon jaws. Package includes both Models 300 & 303 for \$21.95.

PANAVISE
It's like no other tool you've ever used. Its head rotates a full 360 degrees — and tilts 180 degrees from vertical to horizontal. Imagine how that kind of versatility simplifies work procedures, just one convenient knob locks work in any desired position.

ASTATIC MICROPHONES

T-UGB-D104 transistorized w/loop bar base \$64.20
T-UGB-D104 transistorized \$52.80
T-UGB-D104 "Silver Eagle" transistorized \$71.40
UG-D104 ceramic on crystal \$46.80

HY-GAIN'S MODEL 269

Continuously headed VHF antenna designed for portable and walkie-talkie applications. Constructed to withstand rough handling, completely insulated with special vinyl coating. It can be bent at all angles without destroying or cracking protective finish. Cannot be accidentally shorted out.

RUBBER DUCKIES

No. 269 — Fits Standard, Motorola, Hy Gain \$8.00
No. 274 — BNE Base \$9.00
No. 226 — TMC Base Wilson & Watts \$10.00
No. 228 — "T" Base & Wilson 2 Watt & Tempo \$10.00
No. 273 — SO 239 Base, Kenwood, Drake \$9.00

GIANT FLEA MARKET! THOUSANDS OF \$\$\$\$ IN PRIZES!

Don't Miss The N.E. ARRL Convention
Oct. 14th-15th
At The Beautiful Sheraton Boxborough
Boxborough, Mass.



Name _____ Call _____
Address _____
City _____ State _____ Zip _____

Order: _____
_____ Check enclosed Visa Master Charge American Express _____

Credit card # _____
Signature _____ Card expiration date _____

Prices FOB Medford MA. MA residents add 5% sales tax.
Minimum \$3.00 for shipping & handling on ALL ORDERS.

TUFTS

Radio Electronics
209 Mystic Avenue
Medford MA 02155
(617) 395-8280

TUFTS RADIO CATALOG TUFTS RADIO

TUFTS RADIO ELECTRONICS

THOMSON-CSF		MODEL	NET PRICE		
	12V4		\$19.95	104R	\$49.95
	102		\$24.95	108RA	\$79.95
	107		\$28.95	108RM	\$99.95
	103R		\$39.95	109R	\$149.95

MODEL 109R
NPC 25 Amp Regulated Power Supply. 4-Way Protected. Output Voltage and Current Meters.

Extra heavy-duty unit quietly converts 115 volts AC to 13.6 volts DC ± 200 millivolts. 10 amps continuous. 25 amps max. All solid state. Features dual current overload, overvoltage and thermal protection. Ideally suited for operating mobile Ham radio and linear amplifier in your home or office. Excellent bench power supply for testing and servicing of mobile communications equipment.

Output Voltage	13.6 ± 2VDC	MAXIMUM	13.6 ± 3VDC
Line/Load Regulation	50 mV		100 mV
Ripple/Noise	5 mV RMS		10 mV RMS
Transient Response	20 μSec		
Current Continuous	10 Amp		
Current Limit	25 Amp		
Current Feedback	14.5 V		15 V
Overvoltage Protection	14.5 V		
Thermal Overload	180°F		

Case: 4" (H) x 8" (W) x 5" (D). Shipping Weight: 15 lbs.

MODEL 108RM
NPC 12 Amp Regulated Power Supply. Solid State. 3 Way Protected. Current Meter.

This heavy-duty unit quietly converts 115 volts AC to 13.6 volts DC ± 200 millivolts. 8 amps continuous. 12 amps max. All solid state. Features dual current overload and overvoltage protection. Ideally suited for operating mobile Ham radio. 2 meter AM-FM-SSB transceivers in your home or office. Can also be used to trickle-charge 12 volt car batteries.

Output Voltage	13.6 ± 2VDC	MAXIMUM	13.6 ± 3VDC
Line/Load Regulation	20 mV		50 mV
Ripple/Noise	2 mV RMS		5 mV RMS
Transient Response	20 μSec		
Current Continuous	8 Amp		
Current Limit	12 Amp		
Current Feedback	2.5 Amp		
Overvoltage Protection	14.5 V		15 V

Case: 4" (H) x 7" (W) x 5" (D). Shipping Weight: 8.5 lbs.

ALSO AVAILABLE AS MODEL 108RA WITHOUT METER AND OVERVOLTAGE PROTECTION.

MODEL 107
NPC 4 Amp Power Supply. 6 Amp Max. Solid State. Overload Protected.

Functions silently in converting 115 volts AC to 12 volts DC. 4 amps continuous. 6 amps max. Enables anyone to enjoy CB radio, car 8-track cartridge, cassette player or car radio in a home or office.

Continuous Current (Full Load)	4 Amp
Output Voltage (No Load)	16 V max
Output Voltage (Full Load)	12 V min
Filtering Capacitor	10,000 μF
Ripple (Full Load)	5 V RMS
Current Limit	2.5 Amp
Current Feedback	3 Amp
Short Circuit Protection	Thermal Breaker

Case: 3" (H) x 4" (W) x 5" (D). Shipping Weight: 5 lbs.

MODEL 103R
NPC 4 Amp Regulated Power Supply. Solid State. Dual Overload Protection.

Converts 115 volts AC to 13.6 volts DC ± 200 millivolts. Handles 2.5 amps continuous and 4 amps max. Ideally suited for applications where no hum and DC stability are important such as CB transmission, small Ham radio transmitter, and high quality eight-track car stereos. Can also be used to trickle-charge 12 volt car batteries.

Output Voltage	13.6 ± 2VDC	MAXIMUM	13.6 ± 3VDC
Line/Load Regulation	20 mV		50 mV
Ripple/Noise	2 mV RMS		5 mV RMS
Transient Response	20 μSec		
Current Continuous	2.5 Amp		
Current Limit	4 Amp		
Current Feedback	3 Amp		
Short Circuit Protection	Thermal Breaker		

Case: 3" (H) x 4" (W) x 5" (D). Shipping Weight: 4 lbs.

MODEL 104R
NPC 6 Amp Power Supply Regulated. Solid State. Dual Overload Protection.

Converts 115 volts AC to 13.6 volts DC ± 200 millivolts. Handles 4 amps continuous and 6 amps max. Ideally suited for applications where excellent DC stability is important such as CB transmission, small Ham radio transmitter, and high quality eight-track car stereos. Can be used to trickle-charge 12 volt car batteries.

Output Voltage	13.6 ± 2VDC	MAXIMUM	13.6 ± 3VDC
Line/Load Regulation	20 mV		50 mV
Ripple/Noise	2 mV RMS		5 mV RMS
Transient Response	20 μSec		
Current Continuous	4 Amp		
Current Limit	8 Amp		
Current Feedback	2 Amp		
Short Circuit Protection	Thermal Breaker		

Case: 3" (H) x 5" (W) x 6" (D). Shipping Weight: 6 lbs.

MODEL 12V4
NPC 1.75 Amp Power Supply. 3 Amp Max.

Functions silently in converting 115 volts AC to 12 volts DC. Ideally suited for most applications including 8-track stereo, burglar alarm, car radio and cassette tape player within power rating.

Continuous Current (Full Load)	1.75 Amp
Output Voltage (No Load)	16 V max
Output Voltage (Full Load)	12 V min
Filtering Capacitor	5,000 μF
Ripple (Full Load)	4 V RMS
Current Limit	3 Amp
Short Circuit Protection	Thermal Breaker

Case: 3" (H) x 4" (W) x 5" (D). Shipping Weight: 3 lbs.

MODEL 102
NPC 2.5 Amp Power Supply. 4 Amp Max. Solid State. Overload Protected.

Functions silently in converting 115 volts AC to 12 volts DC. 2.5 amps continuous. 4 amps max. Enables anyone to enjoy CB radio, car 8-track cartridge, cassette tape player or car radio in a home or office.

Continuous Current (Full Load)	2.5 Amp
Output Voltage (No Load)	16 V max
Output Voltage (Full Load)	12 V min
Filtering Capacitor	5,000 μF
Ripple (Full Load)	6 V RMS
Current Limit	4 Amp
Short Circuit Protection	Thermal Breaker

Case: 3" (H) x 4" (W) x 5" (D). Shipping Weight: 4 lbs.

Model MB II S285 (with Balun) S315

MB II provides:

- Constant SWR monitoring.
- Precision tuning of final amp.
- Harmonic suppression.
- Receiver input impedance-matching.
- Maximum power transfer to antenna.
- Continuous frequency coverage 1.6 to 30 MHz.
- Precision tuning of any wire 1/8 wavelength or longer, with SWR of 1:1.

MB II features:

- Finest quality, made-in-USA components.
- Large, precision, easy-to-read dials with 360° readout.
- Optional 3000 watt Balun for twin lead antennas.

TRIPLETT

Drop-resistant, hand-size V-O-M with high-impact thermoplastic case.

- 20,000 Ohms per volt DC and 5,000 Ohms per volt AC; diode overload protection with fused Rx1 Ohms range.
- Single range switch; direct reading AC Amp range to facilitate clamp-on AC Ammeter usage.

RANGES
DC VOLTS: 0-3-12-60-300, 1, 200 (20,000 Ohms per Volt).
AC VOLTS: 0-3-12-60-300-1, 200 (5,000 Ohms per Volt).
OHMS: 0-20k-200k-2m Ω -20M Ω (200 Ohm center scale on low range).
DC MICROAMPERES: 0-600 at 250 mV.
DC MILLIAMPERES: 0-6-60-600 at 250 mV
ACCURACY: ±3% DC; ±4% AC; (full scale).
SCALE LENGTH: 2-1/8".
METER: Self-shielded; diode overload protected; spring backed jewels.
CASE: Molded, black, high impact thermoplastic with slide latch cover for access to batteries and fuse, 2-3/4" x 1-5/16" d x 4-1/4" h.
BATTERIES: NEDA 15V 220 (1), 1 1/2V 910F (1): Complete with 42" leads, alligator clips, batteries and instruction manual. Shpg. Wt. 2 lbs.
MODEL 310 Cat. No. 3018\$53.00

AUTOPATCH — Ready to go!

A Complete Autopatch facility that requires only a repeater and a telephone line. Features include single-digit access/disconnect, direct dialing from mobile or hand-held radios, adjustable amplifiers for transmitter and telephone audio, and tone-burst transponder for acknowledgement of patch disconnect.

RAP-200 P. C. Card \$199.50
RAP-200R Rack Mount \$249.50

AEA ADVANCED ELECTRONIC APPLICATIONS, INC.

The AUTO DIALER that really works!

- you get 18 numbers from a 1-2 punch
- for making Quick and Safe Auto-Patch Calls
- with Key-Pad Programmable Memory

Check These Features:

- Automatically dials with 1 or 2 buttons
- Exclusive MOS Microprocessor
- Automatic Push-to-talk
- Programmable tone duration
- Programmable time between tones
- High quality tactile Key-Pad
- Built In speaker
- Program RAM memory with Key-Pad (10 numbers in less than a minute)
- Optional ROM adds 8 permanent numbers
- Crystal controlled
- Mates with virtually all amateur FM transceivers

Model AD-1 \$129.95

Autek Research QF-1 Active Filter
For CW & SSB \$59.00

AUTEK pioneered the ACTIVE AUDIO FILTER way back in 1972. Today, their fantastic performance is widely acclaimed. But, today, we're still way ahead with the most advanced — our QF-1. Thousands are already in use improving Yaesu, Kenwood, Drake, Swan, Atlas, Tempo, Collins, etc. Hooks up in minutes to ANY rig. Plugs into phone jack. Drives a speaker with 1 watt, or phones.

Its secret is an exclusive "Infinitely-variable" cascaded design. You can vary frequency over the ENTIRE audio range — 250 to 2500 Hz — in all positions. Vary selectivity 40:1 or more. Instantly zero-in on signals or optimize response! PEAK CW or voice with 50 Hz bandwidth, variable to 2000 Hz. Imagine what the NARROWEST CW FILTER MADE will do to QRM! Reject whistles, carriers, etc. with the most flexible NOTCH you've heard. Wide or narrow. Depth to 70 dB. Cope with SSB hiss and splatter in LOW-PASS. Steep skirts in all positions add to your rigs skirts.

EXPERIENCE the Ultimate in Scanners

The Touch.™
by Regency

- Over 15,000 frequencies at your fingertips
- Scans the Channels in 1.3 Seconds
- Special Weather Alert™ and Priority Scan features

\$249.95

Most Orders shipped the same day

Most Orders shipped the same day

LINEAR AMPLIFIER Model L-4B



L-4B Linear Amplifier . . \$995.00
 • 2000 Watts PEP-SSB • Class B Grounded-Grid — two 3-500Z Tubes • Broad Band Tuned-Input • RF Negative Feedback • Transmitting AGC • Directional Wattmeter • Two Tauband Suspension Meters • L-4B 13-15/16" W, 7-7/8" H, 14-5/16" D. Wt.: 32 lbs. • Power Supply 6-3/4" W, 7-7/8" H, 11" D. Wt.: 43 lbs.

age with coil cord and connector. Fully wired and ready for use.

- High accuracy IC tone generator, no frequency adjustments.
- High reliability Digitran® keyboard.
- Power for tone encoder obtained from transceiver through microphone cable. No battery required. Low current drain.
- Low output impedance allows use with almost all transceivers.
- Four pin microphone plug: directly connects to Drake TR-33C without any modification in transceiver. Compatible with all previous Drake and other 2 meter units with minor modifications.
- Tone level adjustable.
- Hang-up hook supplied.



Drake T-4XC

Solid State Linear permeability-tuned VFO with 1 kHz dial divisions. Gear driven dual circular dials. High mechanical, electrical and temperature stability. Covers ham bands with crystals furnished. Covers all of 80, 40, 20 and 15 meters, and 28.5-29.0 MHz of 10 meters.

Covers 160 meters with accessory crystal. Four 500 kHz ranges in addition to the ham bands plus one fixed-frequency range can be switch-selected from the front panel.



Drake R-4C

Solid State Linear permeability-tuned VFO with 1 kHz dial divisions. Gear driven dual circular dials. High mechanical, electrical and temperature stability. Covers ham bands with crystals furnished. Covers all of 80, 40, 20 and 15 meters, and 28.5-29.0 MHz of 10 meters.

Covers 160 meters with accessory crystal. In addition to the ham bands, tunes any fifteen 500 kHz ranges between 1.5 and 30 MHz, 5.0 to 6.0 MHz not recommended. Can be used for MARS, WWV, CB, Marine and Shortwave broadcasts.

Touch-n-go with DRAKE 1525EM



Push-Button Encoding Mike

Drake 1525EM, microphone with tone encoder and connector for TR-33C, TR-22, TR-22C, ML-2 — Microphone and auto-patch encoder in single convenient pack-



DRAKE TR 7 TRANSCEIVER

sections for sharp cut off below channel 2, and to attenuate transmitter harmonics falling in any TV channel and fm band. 52 ohm. SO-239 connectors built in.

Drake TV-3300-LP Model 1608 1000 watts max. below 30 MHz. Attenuation better than 80 dB above 41 MHz. Helps TV i-f interference, as well as TV front-end problems.

DRAKE TVI FILTERS

High Pass Filters for TV sets provide more than 40 dB attenuation at 52 MHz and lower. Protect the TV set from amateur transmitters 6-160 meters.



Drake TV-75-HP Model No. 1610. For 75 ohm TV coaxial cable; TV type connectors installed

LOW PASS FILTERS FOR TRANSMITTERS have four pi



Drake TV-300-HP Model No. 1603. For 300 ohm twin lead

Drake TV-5200-LP Model No. 1609. 200 watts to 52 MHz. Ideal for six meters. For operation below six meters, use TV-3300-LP or TV-42-LP.



Drake TV-42-LP Model No. 1605 is a four section filter designed with 43.2 MHz cut-off and extremely high attenuation in all TV channels for transmitters operating at 30 MHz and lower. Rated 100 watts input.



DRAKE

COMMUNICATIONS RECEIVERS AND ACCESSORIES		
DSR-2	VLF-HF Digital Synthesized Communications Laboratory Receiver SSB, AM, CW, RTTY, ISB	\$ 3200.00
R4C	Amateur HF Receiver, 160-10 meters	699.00
4-NB	Noise Blanker for R4C	74.00
FL-250	Accessory I.F. Filter	52.00
FL-500	Accessory I.F. Filter	52.00
FL-1500	Accessory I.F. Filter	52.00
FL-4000	Accessory I.F. Filter	52.00
FL-6000	Accessory I.F. Filter	52.00
TRANSCEIVERS AND ACCESSORIES		
TR-7	HF Transceiver 160-10 meters	886.00
DR-7	Analog Dial Readout	
	Digital Readout/Gen. Cov. Board	186.00
TR-7/DR-7	Allows continuous receive from 1.5-30 MHz	
Aux-7	Above units, factory installed DR-7 Range Program Board for TR-7 and TR-7/DR-7	1072.00
	Allows receive 0-1.5 MHz and transceive or receive 1.5-30 MHz. Accommodates any B 500 kHz ranges. Must be used with either RRM-7 range receive module or RTM-7 range transceive module. Use one mode per 500 kHz range. Modules are customer programmable, instructions provided. Proof of license necessary for RTM-7, contact sales dept.	38.00
RRM-7	Range Receive Module — plugs in to Aux-7. Customer Programmable in any 500 kHz range 0-30 MHz.	5.00
RTM-7	Range transceive module — plugs in to Aux-7. Customer Programmable in any 500 kHz range from 1.5-30 MHz except 26-28 MHz. Send proof of license.	5.00
RV-7	Remote VFO for TR-7	156.00
FA-7	Fan for TR-7 or PS-7	24.00
NB-7	Noise Blanker for TR-7	74.00
SL-300	Crystal filter, 300 Hz	49.00
SL-500	Crystal filter, 500 Hz	49.00
SL-1800	Crystal filter, 1800 Hz	49.00
SL-6000	Crystal filter, 6000 Hz	49.00
TRANSMITTERS		
T4XC	Amateur HF Transmitter 160-10 meters	699.00

TRANSCEIVERS AND ACCESSORIES		
TR33C	2-meter FM transceiver, 12 channel portable	229.95
MMK-33	Mobile/Dash/Desk Mount for TR33C	12.95
UMK-3	Remote trunk kit for UV-3 system	69.95
UV-3	144	595.00
UV-3	144-220	695.00
UV-3	144-440	695.00
UV-3	144-220-440	795.00
UV-3E	144-430, European model	695.00
*Prices above include factory installed modules for bands as listed. Factory installed "add-on" 220 or 440 modules. (Modules not sent to field).		
POWER SUPPLIES		
AC-4	110/220V power supply for 4 line transmitters and transceivers	150.00
PS-3	AC Supply [120/240 V.A.C.] for any UV-3 Model	89.95
DC-4	12 VDC power supply for 4 line transmitters, transceivers, & receivers	160.00
PS-7	120/240V A.C. supply for TR-7	166.00
MAJOR ACCESSORIES & MISCELLANEOUS		
L4B	Linear Amplifier with Power Supply & Tubes	995.00
MN4C	Antenna Matching Network, 160-10 meters, 250 watts	165.00
MN-7	Antenna Matching Network, 160-10 meters, 250 watts.	165.00
MN2000	Antenna Matching Network, 2000 watts.	250.00
B-1000	4:1 Balun Designed for use with MN4C/MN-7	24.95
MS-4	Matching Speaker for 4 line	33.00
MS-7	Matching Speaker for 7 line	33.00
W-4	HF RF Wattmeter 1.8 to 54 MHz 200/2000 watts	79.00
WH-7	HF RF Wattmeter 1.8 to 54 MHz 20/200/2000 watts	89.00
1525EM	Encoder Microphone w/plug for TR33C/UV-3	49.95
7079	Vinyl Case for TR33C	9.95
HIGH PASS FILTERS		
TV 300HP	High Pass Filter for 300 ohm twin lead	10.60
TV75HP	High Pass Filter for 75 ohm TV coax, type F	13.25
LOW PASS FILTERS FOR TRANSMITTERS		
TV42LP	For transmitting below 30 MHz, 100 watt continuous/50 ohms/SO-239 connectors	14.60
TV3300LP	1000 watts continuous to 30 MHz with sharp cutoff above MHz/50 ohms/SO-239 connectors	26.60
TV5200LP	100 watts continuous on 6 meter amateur band	26.60

TUFTS RADIO CATALOG TUFTS RADIO



MODEL	DESCRIPTION	BEAMS	AMATEUR PRICE
TB4HA	4 Element 20/15/10. All four elements function in all bands and are full sized		\$279.95
TB3HA	3 Element 20/15/10		\$219.95
TB2A	2 Element 20/15/10		\$149.95
MB40H	2 Element 40 meter		\$219.95
VERTICALS			
1040V	10-40 Golden Swan Trap		\$122.95
75-MK	75 meter add-on kit for 1040V		\$ 39.95
4010V	10-40 Slim-line trap		\$ 79.95
75-AK	75 meter add-on kit for 4010V		\$ 39.95
MOBILE			
45	75/40/20/15/10, 1000W PEP Gold Plated contacts, Manual band switching		\$119.95
742	75/40/20, 500W PEP, no manual switching required. Fully automatic after initial tune-up to desired frequency.		\$109.95
M34	20/15/10 slim line tri-band 500W PEP. Coil for 40 or 80 or 160 with top section may be added to make unit four bander.		\$ 69.95
M34T	Top section used with 40/80 or 160 coils. Not required for basic M34.		\$ 6.95
M34E	Base extender rod for use when mounting M34 on bumper.		\$ 13.95
M34/160	160 meter coil (M34T required)		\$ 21.95
M34/80	80 meter coil (M34T required)		\$ 19.95
M34/40	40 meter coil (M34T required)		\$ 19.95

*M34/1127 MHz coil available only upon special request. Delivery six weeks. \$16.95. May be utilized in lieu of 10 meter coil on basic M34.

NEW TRANSCEIVERS



750 CW—\$679.95

If you're ready for 700 loud-talking watts, you're ready for the new 750CW. 700 watts P.E.P. input on SSB. 400 watts DC input on CW. CW audio filter selectable 80 or 100 Hz. CW sidetone monitor with adjustable pitch and volume control. 80 through 10 meters, USB, LSB, CW. Selectable 25 or 100 KHz crystal calibrator. Standard 5.5 MHz, 2.7 MHz bandwidth crystal filter or optional accessory 15 pole filter available with 140 Db ultimate rejection.

Accessories:
- VX-3 Vox
- MK-II Linear amplifier
- DD-75 Digital Dial

The 750CW is a CW man's dream come true. What's more there's a long list of accessories you can add later for increased performance.



350B—\$649.95

300 watts P.E.P. input SSB. 200 watts DC input on CW. 80 through 10 meters, USB, LSB, CW. 5.5 MHz, 2.7 MHz bandwidth crystal filter. Oscillators are solid state and IC regulated for stability. CW sidetone monitor with adjustable pitch and volume. CW audio filter 80 and 100 Hz selectable. Built in 117 VAC power supply and speaker. (220 VAC power supply available on special request!)

Accessories:
- VX-2 Vox
- 14A DC Converter
- 1200X linear amplifier
- Crystal Calibrator (350A only)



350D—\$749.95

Same basic features as 350A except added feature of:
- 6 digit LED frequency display with read out to 100 KHz.

Both the 350A and the 350D are compatible with the same line of Swan accessories that has built a reputation for reliability and performance that is second to none. Including linear amplifiers to boost your power to the legal limit.

So they're perfect for novices or anyone else because you can build capability as you need it.

OUR NEW M-34 EXPANDABLE MOBILE ANTENNAS

The M-34 mobile antenna gives you 10, 15, and 20 meters and great performance in a tough, rugged design for only \$52.75.

Then whenever you want it you can buy the optional 160, 80 or 40 meter coil and top section for \$20.00 to \$25.00 depending on the band and make a full-capability four-band unit out of it. One that never needs coil changes or adjustments after initial tuning.

What's more, at no extra cost you get features like 500 watts PEP, low standing wave ratio at resonance, independent resonance adjustments on each of the four bands, exceptional bandwidth and a neat, clean, low wind resistance profile that also goes great with mobile homes, motor homes and apartments.

That's the kind of innovative, problem-solving thinking that goes into Swan mobile antennas. Not just the M-34 but these, too.

742 Automatic. Swan automates mobile antennas with the 742 tri-band antenna. Works 20, 40 or 75 meters with your 742 without need for coil change or other adjustments after initial tuning. A high Q mobile antenna designed for maximum efficiency. Capable of 500 watts PEP. \$109.95

Mobile 48. This switch-adjustable 5 band antenna features a Swan Hi-Q coil and positive-stop, 9 position switch with GOLD-PLATED contacts. Select 10, 15, 20, 40 plus five positions for 75 meters and go to work knowing this rugged antenna's doing its job. \$119.95



SWAN METERS



THESE WATTMETERS TELL YOU WHAT'S GOING ON. With one of these in-line wattmeters you'll know if you're getting it all together all the time. Need high accuracy? High power handling? Peak power readings? For whatever purpose we've got the wattmeter for you.

WM2000 IN-LINE WATTMETER WITH MUSCLE. Scales to 2000 watts. New flat-response directional coupler for maximum accuracy. \$69.95.



WM3000 PEAK-READING WATTMETER. Reads RMS power, then with the flick of a switch, true peak power of your single sideband signal. That's what counts on SSB. \$87.95



WM1500 HIGH-ACCURACY IN-LINE WATTMETER. 10% full scale accuracy on 5, 50, 500 and 1500 watt scales, 2 to 30 MHz. Forward and reflected power. Use it for troubleshooting, too. \$74.95

THE SWAN METER SHOWCASE.



Sniffs out radiated power wherever it is. This little unit is so compact it could measure relative radiated power in your pocket. Telescoping antenna and a frequency range of 1.5 MHz all the way to 200 MHz. FS-1 Field Strength Meter. \$13.95



Easy-on-the-pocket pocket SWR. Mighty mite SWR meter with high accuracy. SWR-3 gives you 1:1 to 3:1 SWR at 50 ohms on frequencies from 1.7 to 55 MHz. Precision PC board directional coupler makes it a solid value at a rock-bottom price. SWR-3 Pocket SWR Meter. \$14.95



SWR bridge bridges the price barrier. This little jewel gives you relative forward power and SWR on two 100 microampere meters at a remarkably low price. Indicates 1:1 to infinity VSWR or up to 1000-watt signals on frequencies from 3.5 to 150 MHz. With low insertion loss, it's great for mobile operations, too. SWR-1A Power Meter and SWR Bridge. \$29.95



At last. A precision wattmeter for the 6 and 2-meter man. We design the WM-6200 for the upper-band man who needs to know with ± 7% accuracy. Reads power of 50 to 150 MHz signals on two scales to 200 watts plus SWR on expanded range scale from 1:1 to 3:1 with ± accuracy. WM-6200 In-Line Wattmeter. \$87.95



Put your power up in lights. The new WM-6200 does everything our WM-6200 does and ends guesswork, interpolation errors and eyestrain besides with a 4 digit readout. 50 to 150 MHz, power to 200 watts with an accuracy of ± 10%. SWR from 1:1 to 19.99:1 with ± 3% accuracy. WM-6200A Digital SWR Power Meter. \$269.95 (requires AC source)

The new WM-200A does it all. As an in-line wattmeter it gives you power to 200 watts on two scales plus SWR from 1:1 to 3:1 for signals from 50 to 150 MHz. And as a peak reader it reads true peak envelope power of your voice modulated signal. Flat response forward or reflected power on scales to 200 watts in switch-selected RMS or peak. WM-200A Peak Reading Wattmeter. \$89.95



Nifty little meter just for VHF mobile. This brand new, easy-to-install screw-mount unit is the perfect illuminated wattmeter for 2-meter mobile. Compact and capable, it gives you two scales, 0-20 watts and 0-200 watts at 10% accuracy. SWR from 1:1 to 3:1. Frequencies from 50 to 150 MHz. WM-200 SWR Power Meter. \$49.95



DenTron MLA-2500 \$899.50

DenTron Radio has packed all the features a linear amplifier should have into their new MLA-2500. Any Ham who works it can tell you the MLA-2500 really was built to make amateur radio more fun.

- ALC circuit to prevent overloading
- 160 thru 15 meters
- 1000 watts DC input on CW, RTTY or SSTV Continuous Duty
- Variable forced air cooling system
- Self-contained continuous duty power supply
- Two EIMAC 8875 external anode ceramic metal triodes operating in grounded grid
- Covers MARS frequencies without modifications
- 50 ohm input and output impedance
- Built-in RF wattmeter
- 117V or 234V AC 50-60 Hz
- Third order distortion down at least 30 db
- Frequency range: 1.8MHz (1.8-2.5) 3.5MHz (3.4-4.6) 7MHz (6.0-9.0) 14MHz (11.0-16.0) 21MHz (16.0-22.0)
- 40 watts drive for 1 KW DC input
- Rack mounting kit available (19" rack)
- Size: 5 1/2" H x 14" W x 14" D Wt. 47 lbs.

Novice Crystals (Specify Band Only)

BOMAR Crystal Company

TWO METERS
CRYSTALS IN STOCK
Motorola HT 220 Crystals
In Stock!

Standard • Icom • Heathkit • Ken • Clegg • Regency • Wilson • VHF Eng • Drake • And Others!

LIFETIME GUARANTEE!
NOW ONLY \$7.00 A PAIR!

Make/Model	Xmit Freq.	Rec. Freq.

PROGRAMMABLE CMOS KEYS

AUTEK RESEARCH CALLS CQ WHILE YOU RELAX!

Also remembers name, QTN, contest exchanges, etc

MODEL MK-1

ONLY \$99.50

- 4 Messages
- Instant record or reprogram
- Designed for Novice, as well as CW "Pro" and Contest OP

PLUS A GREAT AUTOMATIC KEYSER

- Dot AND dash memories "forgive" your minor timing mistakes. Most keyers have just a dot memory or none at all. The MK-1 makes sending easier.
- IAMBIC OPERATION. Squeezing dot and dash paddles produces alternate dots and dashes, making it easier to send letters such as C, F, K, Q, R, etc. Most keyers put out only dots, or only dashes when paddles are squeezed, making you work harder.
- FULL CMOS construction. No TTL logic to heat up or draw heavy current. Battery operation if desired. (50 ma @ 9V, 60 ma @ 12 V, typical)
- SELF-COMPLETING characters: Jamproof.
- Extensive RFI protection. 8-50+ WPM.
- Sited transistor output. No clicking relays to fail. (Max. 2300 V., 15 ma. grid blocked rigs, +200 ma cathode heated rigs, at key)
- TRIGGERED CLOCK (except when recording) starts instantly at key closure. No confusing wait, or need for you to "keep time," as with many keyers.
- Built-in monitor/speaker. Volume control (panel). Widely adjustable tone (internal trimpot).



An Advanced Programmable Keyer - Yet Priced Lower Than Many Ordinary Keyers

Programmable memory keyers are the biggest advance to come along in years for CW. When you use one, CW truly becomes FUN again! Until the MK-1, quality memory keyers cost \$150 to \$400. But now, anyone can afford a "miniature computer," instead of an ordinary keyer. It's an investment in enjoyable operation for years to come. And an incredible bargain at our breakthrough low price!

ADVANCED "MOS" MEMORY

- Just tap button to start any of four messages.
- You record CQ, contest exchanges, name, QTN, or anything you want in the four messages.
- Record instantly by simply sending the message.
- Play out recording as often as desired.
- Change by simply recording over the old message. No factory-programmed extra cost! C's to buy.
- Range 1024 bit total memory stores about 100 characters. Each message holds about 25 characters, depending on character length and pauses, e.g. "CQ CQ DE W6DYD W6DYD CQ TEST K"
- "Combine CD" switch combines 2 of the 4 messages for extra length of about 50 characters, e.g. "QTH IS LA LA NAME IS BILL BILL RIG NR IS KW ES BEAM ES NEW MEMORY KEYS"
- REPEAT SWITCH repeats message forever until reset. Very useful for longer CQ's, or leave a moderate pause at end of CQ. If no answer, the keyer automatically repeats the CQ until answered, YOU SIT BACK AND WAIT FOR A CALL!
- ADDED CONTEST FEATURES: Instant memory reset with button, or by tapping paddle when playing. Tapping message button restarts message.

To prevent loss of recorded messages when AC power is lost, a 9 V. battery may be connected to the rear battery input. No power is drawn from a battery if AC power is on. The maker, the MK-1, is for field day or expeditions. The MK-1 may be set on continuously in fixed stations. All desired. (Option less than \$5 extra AC). The MK-1 may be used with any paddle. A dual-beam (two-level) paddle is recommended to take advantage of contest operation, but a single-level paddle will also work.

115 VAC or 9-14 VDC. 6x3x5 1/2". 2.8 lbs. Handmade light grey panel with silver lettering. Black steel case. Comes assembled and tested with full instructions.

VISTA power supplies

quality power conversion products for car, boat, home, trailer, truck or recreation vehicle



deluxe regulated R series

convert 120 vac, 60 Hz to 13.8 vdc ± 0.5 vdc

The VISTA series of regulated models is of the highest quality, utilizing the latest in integrated circuit (IC) technology, designed for long life and superior performance with hum-free, highly regulated stabilized output voltage... the standard of the industry.

models

- VISTA IIR... 2 amps continuous, 4 amp surge auto-reset breaker. UL listed, case size 3 1/2x4 1/2x5 1/2 inches \$29.95
- VISTA IIR... 3 amps continuous, 5 amp surge auto-reset breaker. UL listed, case size 3 1/2x4 1/2x5 1/2 inches \$33.95
- VISTA IIR... 4 amps continuous, 6 amp surge current limiting, crowbar over-voltage protected. fused UL listed features, case size 3 1/2x4 1/2x5 1/2 inches \$43.95
- VISTA VIR... 6 amps continuous, 8 amp surge current limiting, crowbar over-voltage protected. fused UL listed features, case size 3 1/2x4 1/2x5 1/2 inches \$51.95
- VISTA XR... 8 amps continuous, 11 amp surge current limited, crowbar over-voltage protected. fused UL listed features, case size 4 1/2x4 1/2x6 1/2 inches \$79.95
- VISTA XRD... 10 amps continuous, 13 amp surge current limiting, crowbar over-voltage protected. fused UL listed features, case size 4 1/2x4 1/2x6 1/2 inches \$94.95
- VISTA XXR... 16 amps continuous, 20 amp surge current limiting, crowbar over-voltage protected. fused UL listed features, case size 4 1/2x4 1/2x6 1/2 inches \$103.95
- VISTA XXRD... 20 amps continuous, 26 amp surge current limiting, crowbar over-voltage protected. fused UL listed features, case size 4 1/2x4 1/2x6 1/2 inches \$139.95
- VISTA XXXR... 30 amps continuous, 40 amp surge current limiting, crowbar over-voltage protected. fused UL listed features, case size 4 1/2x4 1/2x6 1/2 inches \$164.95

applications

- Home use of low power mobile AM-CB radios, quality car tape players, trickle battery charging.
- Home use of high power mobile AM-CB radios, quality car tape players, trickle battery charging.
- Home use of mobile single side band CB, high power AM-CB and small ham radios, quality car tape players, tape recorders.
- Home use of single side band CB radios, high power car stereo, for the HiFi perfectionist, low power 2 meter ham radios.
- 10 watts, 2 meter ham, FM-CB, marine and business band radios, low power linear amplifiers.
- 25 watts, 2 meter ham, FM-CB marine and business band radios, low power linear amplifiers.
- 50 watts, 2 meter ham and FM-CB band radios, linear amplifiers.
- 50 and 75 watts, 2 meter ham band linear amplifiers, test bench power supply.
- 100 and 160 watts, 2 meter ham band linear amplifiers, test bench power supply.

*Output 12.5 VDC ± 0.5 VDC

GIANT SALE NOW IN PROGRESS!

GIANT SALE NOW IN PROGRESS!

GIANT SALE NOW IN PROGRESS!

GIANT SALE NOW IN PROGRESS!

GIANT SALE NOW IN PROGRESS!

GIANT SALE NOW IN PROGRESS!

GIANT SALE NOW IN PROGRESS!

GIANT SALE NOW IN PROGRESS!

GIANT SALE NOW IN PROGRESS!

GIANT SALE NOW IN PROGRESS!

The only completely free-standing, telescoping, breaker tower you can buy.

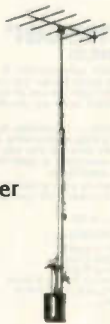

The only completely free-standing, telescoping, breaker tower you can buy.

They telescope. Crank up or down easily to pinpoint best reception. They breaker. Your feet never have to leave the ground when you pull maintenance — even on our tallest breaker tower.

One-piece price. You get the whole tower, ready to install. No extra charges for base plates, guy wire, etc. Old-fashioned craftsmanship. Every Tele-Tower is cut, assembled, and welded by hand.

Old-fashioned value. Orville Bond found a way to make better towers for less money. Our model 40, which we believe is the most durable, convenient non-breaker 40-footer you can buy, is \$224.21. Our Breaker Model 55, the only tower you can buy that is totally free-standing, telescoping, and a breaker, is just under \$500. Completely free-standing. No guy wires, no brackets. Yet, by stretching the windload over the entire tower, we've made them stronger than wired or bracketed towers.

55 Concrete Sleeve \$32.00
40 Concrete Sleeve \$32.50
Model 40 (extends from 23'-40') \$224.21
Model 55 (extends from 23'-55') \$410.16

Breaker Model 40 (extends from 23'-40', with breaker at ground level) \$381.30

Breaker Model 55 (extends from 23'-55', with breaker at ground level) \$572.65

TELE TOWER



Two NEW Rotors from Cornell-Dubilier



TAIL TWISTER™



HAM III

- For the New Super Communications Antennas
- New Thickwall Casting
- New Steel Ring Gear
- New Metal Pinion Gear
- New Motor Prebrake
- New Super Wedge Brake
- New L.E.D. Control Box
- Safe 26 Volt Operation

Designed for the newest of the king-size communications antennas, the TAIL TWISTER™ is the ultimate in antenna rotational devices. The TAIL TWISTER™ starts with a deluxe control box featuring snap action controls for brake and directional controls; L.E.D. indicators signal rotation and brake operation, while the illuminated meter provides direction readout. This new control box couples to the newest bell rotor. Using the time tested bell rotor principle, the TAIL TWISTER™ is a brand new design with thickwall castings and six bolt assembly. A brand new motor with prebrake action brings the antenna system to an easy stop, while the massive square front brake wedge locks the assembly in place. A new stainless steel spur gear system provides final drive

into a new steel ring gear for total reliability. Triple race, 138 ball bearing assembly carries dead weight and maintains horizontal stability.

An optional heavy duty lower mast adaptor is available for lighter loads with mast mounting. Price: \$259.00

The HAM III sets new levels of performance. Snap action switched wedge brake and rotational controls brings pinpoint accuracy to large directional arrays popular in communications. A new motor provides pre-brake action to assist in slowing down rotational mass, and the new thicker wedge brake offers far stronger lock-in phase action. To take full advantage of this new design, the HAM III is designed for in-tower mounting. A new optional heavy duty lower mast adaptor is available when the HAM III is to be mast mounted with smaller arrays. A stainless steel spur gear system multiplies the torque into the dual race 98 ball bearing support assembly assuring years of trouble free performance. Price: \$139.00.

TUFTS RADIO CATALOG TUFTS RADIO

FINCO STINGER VHF/UHF Antennas

2 meter

Stinger A 2-10—\$41.15

The model Stinger A 2-10 is a high performance wide spaced ten-element 2-meter yagi designed for the serious VHF operator. Utilizing the Stinger construction features, the A 2-10 is almost indestructible no matter what weather conditions are encountered. Complete coverage of the 2-meter band and low V.S.W.R. is assured through the use of non-linear spaced elements thus also achieving maximum forward gain. Power rating—2,000 watts P.E.P.

The A 2-10 can be mounted for vertical polarization, thereby making the antenna quite useful in repeater accessing, or mounted for horizontal polarization for station to station VHF DX work. Elements of the A 2-10 can be easily stacked for even greater gain and front-to-back ratio.

SPECIFICATIONS — A 2-10

ELECTRICAL—	MECHANICAL—
Forward Gain 13.8dB	Boom Length 10 ft.
Front-to-Back Ratio 25dB	Longest Element 42 in.
V.S.W.R. (at resonance) 1.1:1	Turning Radius 71 in.
Half Power Beam Width 40°	Maximum Surface Area 2.36 sq. ft.
Bandwidth 144 to 148 MHz	Wind Load at 80 MPH 26.2 lbs.
Impedance 50 Ohms	Weight 9.8 lbs.
Matching System Adjustable Gamma	

Stinger A 2-5—\$25.60

The model Stinger A 2-5 is a five-element high gain antenna similar to the A 2-10 but having physically a flatter profile. The A 2-5 finds excellent application as a portable antenna as it disassembles into a very compact package. Like the A 2-10, the antenna can be mounted for vertical or horizontal polarization for repeater or general coverage work. Constructed of the Stinger heavy duty materials, the A 2-5 is ideal for locations encountering adverse weather conditions. Power rating 2,000 watts P.E.P.

SPECIFICATIONS — A 2-5

ELECTRICAL—	MECHANICAL—
Forward Gain 9.5dB	Boom Length 5.5 ft.
Front-to-Back Ratio 22dB	Longest Element 41 in.
V.S.W.R. (at resonance) 1.1:1	Turning Radius 42 in.
Half Power Beam Width 51°	Maximum Surface Area 1.23 sq. ft.
Bandwidth 144 to 148 MHz	Wind Load at 80 MPH 13.3 lbs.
Impedance 50 Ohms	Weight 6.5 lbs.
Matching System Adjustable Gamma	

Stinger A 2+2—\$41.75

The model Stinger A 2+2 is a ten-element, dual polarization 2-meter antenna designed for OSCAR communication or where switching from horizontal to vertical polarization is required. The A 2+2 can even be phased to operate on both horizontal and vertical polarization at the same time. This is not only ideal for OSCAR work but gives your station versatility for ground communications.

Wide, non-linear element spacing gives the A 2+2 superior gain, however, since it is a five element beam in one given plane, the half power beam width does not make satellite tracking difficult because of star directivity. The dual gamma match assemblies provide for a very low V.S.W.R. and will withstand 2,000 watts P.E.P.

The Stinger construction features make the A 2+2 extremely heavy duty. Provisions are made for mounting the antenna at the end of the boom—for azimuth control—or at the middle of the boom for normal applications.

SPECIFICATIONS — A 2+2

ELECTRICAL—	MECHANICAL—
Forward Gain 9.5dB	Boom Length 6 ft.
Circular Gain 10.5dB	Longest Element 41 in.
Front-to-Back Ratio 22dB	Turning Radius 5.5 ft.
Half Power Beam Width 51°	End Mount 5.5 ft.
Horizontal Polarization—	Center Mount 13.4 ft.
E Plane 52° H Plane 58°	Maximum Surface Area 1.51 sq. ft.
Vertical Polarization—	Wind Load at 80 MPH 13.4 lbs.
E Plane 58° H Plane 52°	Weight 11 lbs.
Circular Polarization—	
E Plane 52° H Plane 52°	
Bandwidth 144 to 148 MHz	
Impedance 50 Ohms	
Matching System Adjustable Gamma	

1 1/4 meter

Stinger A 1 1/4—\$29.85

The model Stinger A 1 1/4 is a ten element 1 1/4-meter (1270 MHz) high performance yagi designed for all 220 MHz communication needs. Designed to be mounted in either the vertical or horizontal plane, the A 1 1/4 is adaptable for OSCAR, repeater, or general communication work. Incorporating the Stinger heavy duty elements, boom and boom to mast assemblies, the antenna easily withstands 120 mph wind loads under 1 1/4" ice conditions. A low loss gamma matching system assures a low V.S.W.R. and is power rated at 1,000 watts.

SPECIFICATIONS — A 1 1/4

ELECTRICAL—	MECHANICAL—
Forward Gain 13.8dB	Boom Length 8 ft.
Front-to-Back Ratio 25dB	Longest Element 28 in.
V.S.W.R. (at resonance) 1.1:1	Turning Radius 42 in.
Half Power Beam Width 40°	Maximum Surface Area 1.32 sq. ft.
Bandwidth 220 to 226 MHz	Wind Load at 80 MPH 17.9 lbs.
Impedance 50 Ohms	Weight 8 lbs.
Matching System Adjustable Gamma	

10 meter

Stinger A 10-4—\$57.15

The model Stinger A 10-4 is a wide spaced, full size, high gain four element 10-meter monobander designed for optimum DX performance. Utilizing the exclusive Stinger Series square boom construction, the A 10-4 is light enough to be easily stacked for an additional 3 dB gain yet strong enough to withstand the most adverse weather conditions. The highly efficient gamma match system will withstand 2,000 watts P.E.P. of power and maintains a relatively low V.S.W.R. across the entire 10-meter amateur band.

SPECIFICATIONS — A 10-4

ELECTRICAL—	MECHANICAL—
Forward Gain 10dB	Boom Length 16 ft.
Front-to-Back Ratio 25dB	Longest Element 18.2 ft.
V.S.W.R. (at resonance) 1.1:1	Turning Radius 7.4 ft.
Half Power Beam Width 55°	Maximum Surface Area 4.4 sq. ft.
Bandwidth 28 to 30 MHz	Wind Load at 80 MPH 118 lbs.
Impedance 50 Ohms	Weight 12.5 lbs.
Matching System Adjustable Gamma	

6 meter

Stinger A 6-5—\$41.95

The model Stinger A 6-5 is a highly directional 6-meter five element beam specifically designed for maximum forward gain with a "no compromise" front to back ratio. The elements are constructed of high tensile strength seamless aluminum tubing plus the exclusive Stinger square boom and bracket assemblies. For maximum power transfer and low V.S.W.R., a carefully designed gamma matching assembly capable of withstanding 2,000 watts P.E.P. is incorporated. Wide element spacing assures optimum DX performance and good operating efficiency across the entire 50 to 54 MHz 6-meter band. The square boom allows optional vertical mounting for accessing 6-meter repeaters.

SPECIFICATIONS — A 6-5

ELECTRICAL—	MECHANICAL—
Forward Gain 11dB	Boom Length 13 ft.
Front-to-Back Ratio 25dB	Longest Element 10 ft.
V.S.W.R. (at resonance) 1.1:1	Turning Radius 8.3 ft.
Half Power Beam Width 52°	Maximum Surface Area 3.23 sq. ft.
Bandwidth 50 to 54 MHz	Wind Load at 80 MPH 40.2 lbs.
Impedance 50 ohms	Weight 11.5 lbs.
Matching System Adjustable Gamma	

Stinger A 6-3—\$27.30

The model Stinger A 6-3 is a 3 element high gain 6-meter beam similar to the A 6-5 but expressly designed for the casual 6-meter enthusiast. The A 6-3 also finds excellent application for portable use as it disassembles into a compact package. Due to the units light weight and minimal wind load, the antenna is ideal for double stacked, and stacked arrays for the real 6-meter DXer. The A 6-3 is rated at 2,000 watts P.E.P. and incorporates a square boom and high tensile strength aluminum elements.

SPECIFICATIONS — A 6-3

ELECTRICAL—	MECHANICAL—
Forward Gain 7.0dB	Boom Length 6.0 ft.
Front-to-Back Ratio 21.0dB	Longest Element 10 ft.
V.S.W.R. (at resonance) 1.1:1	Turning Radius 5.4 ft.
Half Power Beam Width 50°	Maximum Surface Area 1.75 sq. ft.
Bandwidth 50 to 54 MHz	Wind Load at 80 MPH 17.8 lbs.
Impedance 50 Ohms	Weight 7 lbs.
Matching System Adjustable Gamma	

6 and 2 meter

Stinger A 62—\$68.60

The model Stinger A 62 is a truly remarkable combination 6 and 2-meter beam designed for optimum performance on both bands yet only requiring ONE transmission line. This is accomplished through the use of exclusive phasing elements to accomplish dual band operation with no sacrifice to either band—NO SWITCHING REQUIRED!

On 2-meters, the A 62 has 6 collinear elements—equivalent to three 1/2" 6 element yagis stacked side by side—thus giving outstanding performance. Maximum forward gain is assured on 6-meters through the use of four wide spaced elements. The heavy duty Stinger construction is used throughout so that the antenna will withstand 100 mph plus wind loads.

The A 62 is ideal for mounting on the same mast as your tri-bander or other antenna thus easily opening up the world of 6 and 2 meter VHF communication.

SPECIFICATIONS — A 62

ELECTRICAL—	MECHANICAL—
Forward Gain 6 meters 9.5dB	Boom Length 10.1 ft.
Front-to-Back Ratio 2 meters 12.0dB	Longest Element 10 ft.
V.S.W.R. (6 & 2 meters) 6 meters 1.3:1	Turning Radius 6.7 ft.
Half Power Beam Width 2 meters 22dB	Maximum Surface Area 4.48 sq. ft.
Bandwidth 6 meters 50 to 54 MHz	Wind Load at 80 MPH 43 lbs.
Impedance 2 meters 144 to 148 MHz	Weight 13.8 lbs.
Matching System Adjustable Gamma	

ENGINEERING FEATURES

□ Antenna design engineering is a specialty at FINCO. Top quality lab standard test equipment is used throughout the development and design of all antennas. The FINCO antenna test range has been carefully checked for erroneous reflection characteristics that could cause errors in antenna designs. Shown is the sophisticated stub and matching system that has been developed for the Stinger A62, 6 and 2-meter dual band beam. No traps or coils to burn out or detune, thus assuring you of the highest possible performance on both 6 and 2-meters.

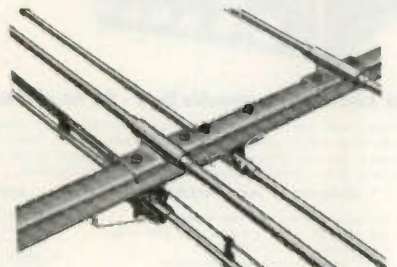

□ Exclusive Stinger square boom construction is used on all amateur antennas. The 1 1/2" square booms are of .054 wall high tensile strength aluminum which is many times stronger than its round counterpart. Also, special bracket assemblies have been developed to allow instant element to boom alignment—plus they stay aligned in the highest wind and ice loads. All elements are of thick wall high tensile strength aircraft quality aluminum.



□ All Stinger Series Amateur Antennas incorporate heavy duty fully adjustable gamma matching systems to allow for maximum power transfer. The design provides for minimum V.S.W.R. and a wide band-width. A built in SO-239 type connector assembly is utilized plus the matching systems are power rated at 2,000 watts P.E.P.



□ A 4" x 6" x full 1/8" thick heavy duty plated steel mast to boom mounting assembly is used on all Stinger Series of Amateur antennas. The bracket assembly locks permanently on the square boom and thus withstands high wind loads and torque without twisting or becoming misaligned. The assembly accepts mast diameters of up to 2" O.D. Provisions for mounting either in a vertical or horizontal plane is incorporated in several models.

ROHN NO. 25G TOWER & ACCESSORIES



- SB25G 3/4" SHORT BASE section for concrete — \$17.90
- SBh25G* 3/4" HINGED SHORT BASE section for concrete — \$29.15
- HGB25G* 3' HINGED GROUND BASE (use without concrete) — \$58.35
- SDB25G* SINGLE DRIVE-IN BASE — \$25.00
- BPH25G* HINGED BASE PLATE for concrete — \$50.00
- FR25G* FLAT ROOF MOUNT — \$34.10
- PR25G* PEAK ROOF MOUNT — 26.25

- AS25G ACCESSORY SHELF (for mounting Ham-M rotor) — \$8.35
- GA25G GUY ASSEMBLY with torque bars — \$15.85
- GB25G GUY BRACKET ONLY without torque bars — \$10.00
- Adjustable House Brackets
- HB25AG 0-15" — \$14.15
- HB25BG 0-24" — \$17.50
- HB25CG 0-36" — \$20.85
- Eave Brackets
- EB2515G 15" — \$8.35
- EB2524G 24" — \$9.15
- EB2525G UNIVERSAL EAVE BRACKET — \$10.00
- TB-2 THRUST BEARING — \$41.65
- TB-3 HEAVY DUTY THRUST

- BEARING — \$58.35
- WP25G WORK PLATFORM — \$24.60
- Side Arm
- SA25G-224 — \$45.70
- SA25G-524 — \$45.70
- 24" SIDE ARM
- SAB25G-2 — \$28.90
- SIDE ARM BRACKET — \$28.90
- SA25G-67 67" SIDE ARM — \$45.70
- UHF25G SIDE ARM MOUNT (for UHF & FM antenna) — \$6.65
- BPC25G* CONCRETE BASE PLATE — \$29.60
- 25G — (10' straight section of tower) — \$49.50
- 25AG-3 — (top section 2 1/4" tube type; 2" most fits snugly inside) — \$55.00

- 25AG-4 — (top section, upper end terminates in 11" flat plate for mounting TB-2 or TB-3 thrust bearing) — \$55.00
- 3/8" TBE&J — (turnbuckles 3/8" x 6" 6,000 lbs ultimate strength) — \$8.45 each.
- 3/16" CCM — cable clamps — 45¢ ea.
- 1/4" TH — thimbles — 30¢ ea.
- 1/2" TBE&J — (1/2" x 12" turnbuckles; 11,000 lbs. ultimate strength) — \$14.35 each.
- 3/16" EHS — Guy wire:
 - 250' — \$27.50
 - 500' — \$55.00
 - 1000' — \$110.00
- GAC-25-3 — concrete guy anchor — \$16.65 each

(NOT UPS SHIPPABLE)

TELEX

PROFESSIONAL HEADPHONES & HEADSETS

BOOM MIC HEADSETS

For the ultimate in communications convenience and efficiency, select a boom mic headset. Longtime favorites of professional communications, boom mic headsets allow more personal mobility while always keeping the mic properly positioned for fast, precise voice transmissions. Boom microphones are completely adjustable to allow perfect positioning. And, boom mic headsets leave both hands free to perform other tasks.

All models are supplied with "close talking" microphones to minimize ambient noise pick-up and provide superior intelligibility. Each model has a convenient, ratchet push-to-talk switch, which can be used for either push-to-talk (direct control of mic circuit) or push-to-mute (for voice operated transmitters). The switch may be used as a momentary push button or it can be locked in the down position. All models have a high, flexible, 8 foot cord which are stripped and tinned, uninterminated. Communication gray with black trim.

MODEL	C 610	SWL 610	C 1210	C 1320	CM 610	CM 1210	CM 1320	CM 1320S
Headphone Sensitivity Ref. 0002 Dynes/cm ² at 1kHz input, 1kHz	103dB SPL ±5dB	103dB SPL ±5dB	103dB SPL ±5dB	105dB SPL ±5dB	103dB SPL ±5dB	103dB SPL ±5dB	105dB SPL ±5dB	105dB SPL ±5dB
Headphone Impedance	32 20 ohms	200Ω ohms	32 20 ohms	32 20 ohms	32 20 ohms	32 20 ohms	32 20 ohms	32 20 ohms
Microphone Frequency Response					50 8000 Hz	50 8000 Hz	50 8000 Hz	50 8000 Hz
Microphone Impedance					High	High	High	High
Microphone Sensitivity Below 1 volt/microbar at 1kHz					-51dB ±5dB	-51dB ±5dB	-51dB ±5dB	-51dB ±5dB
Price	\$9.95	\$11.65	\$28.30	\$37.90	\$42.80	\$56.90	\$68.30	\$54.50

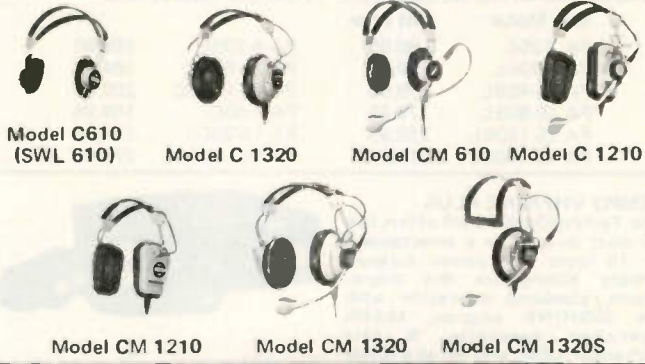

Model C 610 (SWL 610) Model C 1320 Model CM 610 Model C 1210
Model CM 1210 Model CM 1320 Model CM 1320S



The NEW KENWOOD TS-820S transceiver

TS-820S now has factory installed digital readout • 160 thru 10 meter coverage • 200 watts PEP • Integral IF shift • Noise blanker • VOX & PLL circuitry • DRSDial • IF out, RTTY, XVTR capabilities • Phone patch IN and OUT terminals • RF speech processor. \$1098.00.

KENWOOD PRICE LIST

Model	Description	Price
HF EQUIPMENT 820 PACESETTER SERIES		
TS-820S	TS-820 Deluxe Transceiver with Digital Display (DG-1) Installed. 160-10 meters, IF shift	1,098.00
TS-820	Deluxe HF Transceiver 160-10 meters, RF speech processor, IF shift, RF negative feedback	919.00
DG-1	Digital Frequency Display for TS-820	179.00
VFO-820	Deluxe Remote VFO for 820 Series. Includes its own RIT circuit; frequency reads out on transceiver's digital display	149.00
SP-820	Deluxe External Speaker. Includes audio filters for added versatility on receive; 2 audio inputs	49.00
CW-820	500 Hz CW Filter for TS-820	49.00
520 SERIES		
TS-520S	160-10 HF Transceiver. Digital Display (option) speech processor, RF attenuator, super noise blanker	739.00
DG-5	Digital Display for TS-520S. Doubles as a frequency counter, too! Adaptable to TS-520 and 599 series	189.00
VFO-520S	Remote VFO for TS-520S. Built in RIT circuit provides super operating flexibility	135.00
SP-520	Matching External Speaker for TS-520S. 8 Ohms. Frequency response 100-5000 Hz	30.00
CW-520	500 Hz CW Filter for TS-520	49.00
599D Series		
R-599D	160-10 Solid State Amateur Receiver. 2 and 6 meters (optional), SSB, CW, AM, FM Transceivers/splits with T-599D	549.00
T-599D	80-10 Meter Amateur Transmitter. Solid State (except driver and finals). Semi break-in, sidetone, built in power supply	549.00
S-599	External Speaker for 599 Series. 8 Ohms. Frequency response: 100-5000 Hz	25.00
CC-29A	2 Meter Converter for R-599D	35.00
CC-69A	6 Meter Converter for R-599D	35.00
FM-599A	FM Filter for R-599D	45.00
HF MISCELLANEOUS		
R-300	All Band Communications Receiver. 170 kHz to 30 MHz - 6 bands, AC/DC/Batteries; built in speaker	249.00

the indispensable BIRD 43

THRULINE WATTMETER



Power Range	Frequency Bands (MHz)				
	3-30	25-60	100-250	200-500	400-1000
5 watts	—	5A	5C	5D	5E
10 watts	—	10A	10C	10D	10E
25 watts	—	25A	25C	25D	25E
50 watts	50H	50A	50C	50D	50E
100 watts	100H	100A	100C	100D	100E
250 watts	250H	250A	250C	250D	250E
500 watts	500H	500A	500C	500D	500E
1000 watts	1000H	1000A	1000C	1000D	1000E
2500 watts	2500H	2500A	2500C	2500D	2500E
5000 watts	5000H	5000A	5000C	5000D	5000E

MODEL 43 Elements (Table 1) 2-30 MHz \$125.00
Elements (Table 1) 25-1000 MHz 45.00
Carrying case for Model 43 & 6 elements 38.00
Carrying case for 12 elements 27.50
Carrying case for 12 elements 17.00

READ RF WATTS DIRECTLY! (Specify Type N or SO239 connectors) 0.45 - 2300 MHz, 1-10,000 Watts ±5%, low insertion VSWR - 1.05. Unequaled economy and flexibility. Buy only the element(s) covering your present frequency and power needs, add extra ranges later if your requirements expand.

Now you can receive the weak signals with the Ameco PT-2 pre-amplifier!

Model PT-2 is a continuous tuning 6-160 meter Pre-Amp specifically designed for use with a transceiver. The PT-2 combines the features of the well-known PT with new sophisticated control circuitry that permits it to be added to virtually any transceiver with No modification. No serious ham can be without one. Price: \$69.95.



- Improves sensitivity and signal-to-noise ratio.
- Boosts signals up to 26 db.
- For AM or SSB.
- Bypasses itself automatically when the transceiver is transmitting.
- FET amplifier gives superior cross modulation protection.
- Simple to install.
- Advanced solid state circuitry.
- Improves immunity to transceiver front-end overload by use of its built-in attenuator.
- Provides master power control for station equipment.

ALL BAND PREAMPLIFIERS



MODEL PLF employs a dual gate FET providing noise figures of 1.5 to 3.4 db., depending upon the band. The weak signal performance of most receivers as well as image and spurious rejection are greatly improved. Overall gain is in excess of 20 db. Panel contains switching that transfers the antenna directly to the receiver or to the Preamp. Model PLF 117V AC, 60 Hz. Wired & Tested \$44.00

- 6 THRU 160 METERS
- TWO MODELS AVAILABLE
- RECOMMENDED FOR RECEIVER USE ONLY
- INCLUDES POWER SUPPLY

AT-200	Antenna Tuner. Includes an antenna coupler, SWR meter, power meter, antenna switch, 200W	149.00
TL-922	Deluxe 160 10 Linear Amplifier. 2 KW PEP	TBA
DK-520	2 x 3-500Z tubes, rugged built in power supply	
DS-1A	Digital Adaptor Kit (TS-520)	
TS-600	DC-DC Converter for TS-820/TS-520S Series	65.00
VHF/UHF EQUIPMENT		
TS-600	6 Meter All Mode Transceiver. SSB, CW, FM, AM, 10 watts. Built in AC/DC power supplies	699.00
TS-700S	2 Meter All Mode Transceiver. SSB, CW, FM, AM, semi break-in, CW sidetone. Digital readout, receiver pre-amp	729.00
VFO-700S	External VFO for TS-700S. Frequency displays on TS-700S. Special "frequency check" feature	129.00
SP-70	8 Ohms External Speaker Matches TS-600 and TS-700S. Excellent frequency response	30.00
TR-2200A	2 Meter Portable Transceiver. FM, 12 channels (6 supplied); Ni-CAD batteries, charger are included	229.00
TR-7400A	2 Meter Synthesized Transceiver. 25 Watts, 800 channels, 4 MHz, continuous tone-coded squelch (option)	399.00
TR-7500	2 Meter FM Transceiver; digital readout, one knob channel selector system, 10 watts output	299.00
TR-8300	70 CM FM Transceiver. 23 channels (3 supplied). 10 watts, broadband design	299.00
TV-502S	2 Meter Transverter, 8 watts; SSB and CW easily hooks up to 520/820 Series	TBA
TV-506	6 Meter Transverter, 10 watts; SSB and CW, easily hooks up to 520/820 Series	249.00
OTHER ACCESSORIES		
HS-4	KENWOOD Headphone set (8 Ohms)	16.00
MB-1A	Mobile bracket for TR-2200 A	13.00
MC-50	Dynamic Microphone for all KENWOOD stations (Hi/Lo Z)	39.50
PS-5	AC Power Supply; 12 VDC @ 3.5 Amps, matches TR-8300; built-in digital clock with timer	79.00
PS-6	AC Power Supply; 12 VDC @ 3.5 Amps; matches TR-7500; 8 Ohm speaker included	79.00
PS-8	AC Power Supply; 12 VDC @ 8 Amps; matches TR-7400A, well regulated; current limiting	129.00
VOX-3	VOX Unit for TS-700A and TS-600	25.00

GIANT FLEA MARKET!
THOUSANDS OF \$\$\$\$ IN PRIZES!
 Don't Miss The N.E. ARRL Convention
 Oct. 14th-15th
 At The Beautiful Sheraton Boxborough
 Boxborough, Mass.

GIANT FLEA MARKET!
THOUSANDS OF \$\$\$\$ IN PRIZES!
 Don't Miss The N.E. ARRL Convention
 Oct. 14th-15th
 At The Beautiful Sheraton Boxborough
 Boxborough, Mass.

ATLAS 350-XL

- ALL SOLID STATE
- 350 WATTS P.E.P. OR CW INPUT
- SSB TRANSCEIVER
- 10 THROUGH 160 METER COVERAGE



Illustrated with optional AC supply, Auxiliary VFO, and Digital Dial.

The all new Atlas 350-XL has all the exciting new features you want, plus superior performance and selectivity control never before possible Price: \$1195.00

- 10-160 Meters
- Full coverage of all six amateur bands in 500 kHz segments. Primary frequency control provides highly stable operation. Also included is provision for adding up to 10 additional 500 kHz segments between 2 to 22 MHz by plugging in auxiliary crystals.
- 350 WATTS P.E.P. and CW input.
- Model 350 XL - \$1195.00

IDEAL FOR DESKTOP OR MOBILE OPERATION
 Measuring just 5 in. high x 12 in. wide x 12 1/2 in. deep, and weighing only 13 pounds, the Atlas 350-XL offers more features, performance and value than any other transceiver, regardless of size, on the market today!

- 350-PS matching AC supply - \$225.00
- DD-6XL plug-in digital dial readout - \$229.00
- 305 plug-in auxiliary VFO - \$155.00
- 311 plug-in crystal oscillator - \$135.00
- DMK-XL plug-in mobile mounting kit - \$65.00

DELUXE RECEIVER PREAMPLIFIERS

Ideal for Receivers - Converters
 High Gain - Low Noise

FEATURES:

- Small size
- Increases sensitivity of most receivers
- Gold-plated copper shielding
- Single or double stage models
- Diode protected, dual-gated FETs

SPECIFICATIONS:
 Power: 6 VDC to 18 VDC (12 VDC recommended)

Size: a. Single stage: 1" x 1 1/4" x 1/2"
 b. Double stage: 2" x 1 1/4" x 1/2"
 MOSFET: FT 0601, 500 MHz, dual-gate diode protected MOSFET

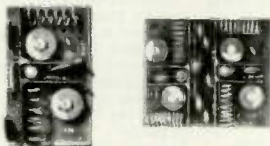

When ordering be sure to specify:
 1. frequency of operation
 2. single or double band stage
 3. kit or assembled version

FREQ. (MHz)	USE	STAGES	DELUXE PREAMPLIFIER	
			GAIN dB	NF dB WIRE
50 to 54	6 METER	SINGLE	25	2
		DOUBLE	48	2
108 to 144	VHF AIRCRAFT	SINGLE	20	2.5
		DOUBLE	40	2.5
135 to 139	SATELLITE	SINGLE	20	2.5
		DOUBLE	40	2.5
144 to 148	2 METER	SINGLE	20	2.5
		DOUBLE	40	2.5
146 to 174	HIGH BAND	SINGLE	20	2.5
		DOUBLE	40	2.5
220 to 225	1 1/4 METER	SINGLE	18	2.5
		DOUBLE	35	2.5
225 to 300	UHF AIRCRAFT	SINGLE	15	2.5
		DOUBLE	30	2.5

DATA SIGNAL, INC.



Highest quality, American-made "brand" transistors are fully protected for VSWR, short and overload, reverse polarity. Highly effective heat sinking assures long life, reliable performance. Black anodized containers... exclusive KLM extrusions, have seven, full length fins on both sides!

KLM RF Power Amplifiers

- A simple, add-on-immediately RF amplifier.
- Merely coax-connect amplifier between antenna and transceiver.
- No tuning! Efficient strip-line broad band design.
- Automatic! Internal RF-sensor-controlled relay connects amplifier whenever transmitter is switched on.
- Manual, remote-position switching is optional.
- Models for 6,2,1 1/4 meters, 70CM amateur bands plus MARS coverage.
- Two types: Class C for FM/CW. Linear for SSB/AM/FM/CW.
- Negligible insertion loss on receive.
- American made by KLM.

New Model	List Price		List Price
PA 2-25B	\$ 69.95	PA 4-70BC	189.95
PA 4-70BL	189.95	PA 15-60BC	164.95
PA 15-40BL	109.95	PA 45-120BC	209.95
PA 15-80BL	179.95	PA 4-40C	169.95
PA 15-160BL	259.95	PA 15-35CL	154.95
PA 45-140BL	219.95	PA 15-110CL	279.95

TEMPO VHF/ONE PLUS

The Tempo/ONE PLUS offers full 25 watt output or a selectable 3 to 15 watt low power output, remote tuning on the microphone, sideband operation with the SSB/ONE adapter, MARS operation capability, 5 kHz numerical LED, and all at a lower price than its time tested predecessor... the Tempo VHF ONE.



The Tempo VHF/One Plus is a VHF/FM transceiver for dependable communication on the 2 meter amateur band • Full 2 meter coverage, 144 to 148 MHz for both transmit and receive •

Full phase lock synthesized (PLL)
 • Automatic repeater split - selectable up or down • Two built-in programmable channels • All solid state • 800 selectable receive frequencies with simplex and +600 kHz transmit frequencies for each receive channel. Price: \$399.00

THE BIG SIGNAL



World Famous Among Hams, Armed Forces, Communications Industry, Why?
 • Each BALUN 25W PEP tested
 • Lightning Arrester
 • 600V Pull-In Insulator
 • Nonodot

THE OLD RELIABLE



Turns Your Antenna Into A Multi-Band Professional Demand Rayco! Why?
 • Precision Matched
 • Frequency-Matched Pairs
 • Only 8 oz. and 5 1/2" diameter

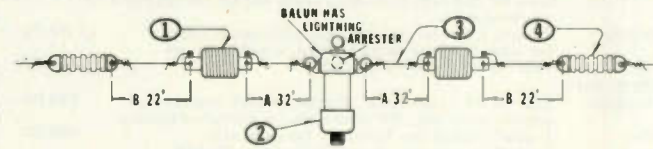

W2AU/W2VS • 5 BAND 10/80 METER ANTENNA KIT by UNADILLA/REYCO

GIVES YOU OPERATION ON 10 • 15 • 20 • 40 • 80 METERS
 (DESIGNED CLOSELY TO 5 BAND TRAP DIPOLE PARAMETERS PER A.R.R.L. HANDBOOK, HF ANTENNA CHAPTER 21 'A MULTIBAND TRAP ANTENNA')

& ARMED FORCES FACILITIES - AROUND THE WORLD - FOR OVER 10 YEARS!
COMPLETE KIT (Nothing else needed)

- 2 ea. W2VS REYCO KW-40 TRAPS
- 1 ea. W2AU 'BIG SIGNAL' BALUN 1:1
- 120 Ft. RUGGED #14-7 Strand Copper Wire
- 2 ea. W2AU SHATTERPROOF END-sulators
- INSTRUCTIONS
- \$48.25

Every Component of This Kit is a Highly Crafted, old Line UNADILLA/REYCO Product Time Tested by HAMS, COMMERCIAL





DIP/IC INSERTION TOOL with PIN STRAIGHTENER

STRAIGHTEN PINS RELEASE PICK UP INSERT

14-16 Pin Dip Ic Insertor INS-1416 \$3.49

DIP/IC EXTRACTOR TOOL

Extractor Tool EX-1 \$1.49

P.C. BOARD

The 4 x 6 1/2 inch board is made of glass coated EPOXY Laminated and features solder coated 100 copper pads. The board has provision for a 22/44 two sided edge connector with contacts on standard .356 spacing. Edge contacts are non-dedicated for maximum flexibility.

The board contains a matrix of .060 in. diameter holes on .100 inch centers. The component side contains 78 two hole pads that can accommodate any DIP size from 8.00 pins, as well as discrete components. Typical density is 18 of 14 Pin or 18 Pin DIP's. Components may be soldered directly to the board or intermediate sockets may be used for soldering or wire-wrapping.

Two independent bus systems are provided for voltage and ground on both sides of the board. In addition, the component side contains 14 individual buses running the full length of the board for complete test flexibility. These buses enable access from edge contacts to distant components. These buses can also serve to equalize the voltage or ground buses, and may be cut to length for particular applications.

Hobby Board H-PCB-1 \$4.99

PC CARD GUIDES

Card Guides TR-1 \$1.89

PC CARD GUIDES & BRACKETS

Guides & Brackets TRS-2 \$3.79

PC EDGE CONNECTOR

P.C. Edge Connector CON-1 \$3.49

P.C.B. TERMINAL STRIPS

4-Pole TS-4 \$1.39
8-Pole TS-8 \$1.99
12-Pole TS-12 \$2.59

WIRE-WRAPPING KIT

Wire-Wrapping Kit WK-4B (Blue) \$25.99

STRIP WRAP UNWRAP

WIRE-WRAPPING TOOL

Regular Wrap	WSU-30M	\$6.95
Modified Wrap	WSU-30M	\$7.95

NEW

complete with bit and sleeve

WIRE-WRAPPING TOOL

For .025" (0.63mm) sq. post "MODIFIED" wrap, positive indexing, anti-overwrapping device.

For AWG 30	BW-630	\$34.95*
For AWG 26-28	BW-2628	\$39.95*

BIT for AWG 30 BT-30 \$3.95
BIT for AWG 26-28 BT-2628 \$7.95

*USE "D" SIZE Ni-CAD BATTERIES (NOT INCLUDED)

ROLLS OF WIRE

Wire for wire wrapping AWG-30 (D.25mm) KYNAR® wire. 50 ft. roll, silver plated, solid conductor, easy stripping.

30 AWG Blue Wire 50ft. Roll	R-30B-0050	\$1.99
30 AWG Yellow Wire 50ft. Roll	R-30Y-0050	\$1.99
30 AWG White Wire 50ft. Roll	R-30W-0050	\$1.99
30 AWG Red Wire 50ft. Roll	R-30R-0050	\$1.99

WIRE DISPENSER

- With 50 ft. Roll of AWG 30 KYNAR® wire-wrapping wire.
- Cuts the wire to length.
- Strips 1" of insulation.
- Refillable (For refills, see above)

Blue Wire	WD-30-B	\$3.79
Yellow Wire	WD-30-Y	\$3.79
White Wire	WD-30-W	\$3.79
Red Wire	WD-30-R	\$3.79

PRE CUT PRE STRIPPED WIRE

Wire for wire wrapping AWG-30 (0.25mm) KYNAR® wire. 50 wires per package stripped 1" both ends.

30 AWG Blue Wire 1' Long	WS-30B-010	\$1.99
30 AWG Yellow Wire 1' Long	WS-30Y-010	\$1.99
30 AWG White Wire 1' Long	WS-30W-010	\$1.99
30 AWG Red Wire 1' Long	WS-30R-010	\$1.99
30 AWG Blue Wire 2' Long	WS-30B-020	\$1.99
30 AWG Yellow Wire 2' Long	WS-30Y-020	\$1.99
30 AWG White Wire 2' Long	WS-30W-020	\$1.99
30 AWG Red Wire 2' Long	WS-30R-020	\$1.99
30 AWG Blue Wire 3' Long	WS-30B-030	\$1.99
30 AWG Yellow Wire 3' Long	WS-30Y-030	\$1.99
30 AWG White Wire 3' Long	WS-30W-030	\$1.99
30 AWG Red Wire 3' Long	WS-30R-030	\$1.99
30 AWG Blue Wire 4' Long	WS-30B-040	\$1.99
30 AWG Yellow Wire 4' Long	WS-30Y-040	\$1.99
30 AWG White Wire 4' Long	WS-30W-040	\$1.99
30 AWG Red Wire 4' Long	WS-30R-040	\$1.99
30 AWG Blue Wire 5' Long	WS-30B-050	\$1.99
30 AWG Yellow Wire 5' Long	WS-30Y-050	\$1.99
30 AWG White Wire 5' Long	WS-30W-050	\$1.99
30 AWG Red Wire 5' Long	WS-30R-050	\$1.99
30 AWG Blue Wire 6' Long	WS-30B-060	\$1.99
30 AWG Yellow Wire 6' Long	WS-30Y-060	\$1.99
30 AWG White Wire 6' Long	WS-30W-060	\$1.99
30 AWG Red Wire 6' Long	WS-30R-060	\$1.99

WIRE-WRAPPING KIT

Wire-Wrapping Kit WK-3B (Blue) \$16.95

DIP SOCKET

Dual in-line package. 3 level wire-wrapping, phosphor bronze contact, gold plated pins. .025 (0.63mm) sq., .100 (2.54mm) center spacing

14 Pin Dip Socket	14 Dip	\$0.79
16 Pin Dip Socket	16 Dip	\$0.89

RIBBON CABLE ASSEMBLY SINGLE ENDED

With 14 Pin Dip Plug 24" Long (609mm)	SE14-24	\$3.55
With 16 Pin Dip Plug 24" Long (609mm)	SE16-24	\$3.75

DIP PLUG WITH COVER FOR USE WITH RIBBON CABLE

14 Pin Plug & Cover	14-PLG	\$1.49
16 Pin Plug & Cover	16-PLG	\$1.99

QUANTITY 2 PLUGS, 2 COVERS

RIBBON CABLE ASSEMBLY DOUBLE ENDED

With 14 Pin Dip Plug 2" Long	DE 14-2	\$3.75
With 14 Pin Dip Plug 4" Long	DE 14-4	\$3.85
With 14 Pin Dip Plug 8" Long	DE 14-8	\$3.95
With 16 Pin Dip Plug 2" Long	DE 16-2	\$4.15
With 16 Pin Dip Plug 4" Long	DE 16-4	\$4.25
With 16 Pin Dip Plug 8" Long	DE 16-8	\$4.35

TERMINALS

- .025 (0.63mm) Square Post
- 3 Level Wire-Wrapping
- Gold Plated

Spotted Terminal	WWT-1	\$2.98
Single Sided Terminal	WWT-2	\$2.98
IC Socket Terminal	WWT-3	\$3.98
Double Sided Terminal	WWT-4	\$1.98

25 PER PACKAGE

TERMINAL INSERTING TOOL

For inserting WWT-1, WWT-2, WWT-3, and WWT-4 Terminals into .040 (1.01mm) Dia. Holes.

INS-1 \$2.49

WIRE CUT AND STRIP TOOL

Easy to use wire strip wire (up to 4) in stripping slot with an etching beyond outer blades. Great tool and well made in cut and strip to proper "wire wrapping" length. The hardened steel cutting blades and sturdy construction of the tool insure long life.

Strip length easily adjustable for your applications.

DESCRIPTION	MODEL NUMBER	ADJUSTABLE LENGTH OF STRIPPED WIRE	Price
24 ga. Wire Cut and Strip Tool	ST-180-24	1/2" - 1 1/2"	\$1.00
26 ga. Wire Cut and Strip Tool	ST-180-26	1/2" - 1 1/2"	\$1.10
28 ga. Wire Cut and Strip Tool	ST-180-28	1/2" - 1 1/2"	\$1.20
30 ga. Wire Cut and Strip Tool	ST-180-30	1/2" - 1 1/2"	\$1.30

THE ABOVE LIST OF CUT AND STRIP TOOLS IS NOT NEARLY EXHAUSTIVE FOR SUPPLY OR FOR CONSULTATION.

WIRE WRAPPING KITS

Contains: Hobby Wrap Tool WSU-30, (50 ft.) Roll of wire Prestripped wire 1" to 4" lengths (50 wires per package) stripped 1" both ends

Wire Wrapping Kit (Blue)	WK 2 B	\$12.95
Wire Wrapping Kit (Yellow)	WK 2 Y	\$12.95
Wire Wrapping Kit (White)	WK 2 W	\$12.95
Wire Wrapping Kit (Red)	WK 2 R	\$12.95

HI-Q BALUN

- For dipoles, yagis, inverted vees, doublets & quads
- For full legal power & more
- Puts power in antenna
- Broadbanded 3-40MHz.
- Small, light, weather-proof
- 1:1 Impedance ratio
- Replaces center insulator
- Helps eliminate TVI
- Fully Guaranteed

\$9.95 PPD U.S.A.

Van Gorden Engineering

DUST COVERS

Our covers are custom designed to protect all popular equipment models. They are made of rugged high quality vinyl and are machine stitched for extra strength. They add that professional look to your station. \$3.95.

COVER CRAFT

Model 210

Model 300

Model 221

Model 220

CES Touch Tone Pads

- Model 300 - acoustic coupling \$49.95
- Model 210 - for mounting on walkies or hand-helds \$39.95
- Model 220 - CES can now offer you a TOUCH TONE back for Standard Communications hand-held radios. This is the complete back assembly with the TOUCH TONE encoder mounted and ready to plug into the private channel connector. Also included is a LEO tone generator indicator and an external tone deviation adjustment. \$59.95.
- Model 215 (miniature version of 210) - \$39.95
- Model 221 long - \$59.95
- Model 221 short - \$59.95
- Motorola MT220 Back with Pad Mounted

ATB-34



4 ELEMENT BEAM

10-15-20 METERS

Cushcraft engineers have incorporated more than 30 years of design experience into the best 3 band HF beam available today. ATB-34 has superb performance with three active elements on each band, the convenience of easy assembly and modest dimensions. Value through heavy duty all aluminum construction and a price complete with 1-1 balun.

SPECIFICATIONS		
FORWARD GAIN -	EXCELLENT	LONGEST ELEMENT - 32' 8"
F/B RATIO -	30 db	TURNING RADIUS - 18' 9"
VSWR -	1.5-1	WIND SFC - 5.4 Sq Ft
POWER HANDLING -	2000 WATTS PEP	WEIGHT - 42 lbs
BOOM LENGTH/DIA -	18' x 2 1/8"	WIND SURVIVAL - 90 MPH

UPS SHIPPABLE complete

ENJOY A NEW WORLD OF DX COMMUNICATIONS WITH ATB-34

VHF - UHF DX-ARRAYS 144, 220, 430 mhz



20 ELEMENT DX - ARRAYS

20 ELEMENT SPECIFICATIONS			
Forward Gain	14.2 db	Impedance	52 ohms
F/B Ratio	20 db	VSWR at Frequency	1 - 1
Fwd. Lobe at 1/2 Pwr. Point	48°	Bandwidth W/VSWR	Less than 2 - 1 - 4 mhz
horizontal	26°	Power Handling	2 KW PEP
vertical	144 Mhz	220 Mhz	432 Mhz
Height	118"	78"	42"
Width x Depth	75" x 30"	53" x 20"	29" x 11"
Turning Radius	48"	32"	18"
Maximum Mast Dia.	1 1/2"	1 1/2"	1 1/2"
Net Weight Lbs.	8	7	6

Vertical support mast not supplied
 2 Meter DX-120 1 1/2 Meter DX-220 3/4 Meter DX-420
 Am. Net \$47.95 \$42.95 \$36.95

40 ELEMENT DX - ARRAYS

40 ELEMENT SPECIFICATIONS			
Forward Gain	17 db	Impedance	52 ohms
F/B Ratio	20 db	VSWR at Frequency	1 - 1
Fwd. Lobe at 1/2 Pwr. Point	48°	Bandwidth W/VSWR	Less than 2 - 1 - 4 mhz
horizontal	32°	Power Handling	2 KW PEP
vertical	26	144 Mhz	220 Mhz
Height	118"	78"	42"
Width x Depth	192" x 30"	132" x 20"	72" x 11"
Turning Radius	101"	65"	38"
Maximum Mast Dia.	2 1/2"	2 1/2"	2 1/2"
Net Weight Lbs.	32	22	12
Wind Rating	90 mph	90 mph	90 mph
Stack Kit No.	DXK-140	DXK-240	DXK-440
Amateur Net	\$ 65.95	\$59.95	\$45.95

80 ELEMENT DX - ARRAYS

80 ELEMENT SPECIFICATIONS			
Forward Gain	20 db	Impedance	52 ohms
F/B Ratio	20 db	VSWR at Frequency	1 - 1
Fwd. Lobe at 1/2 Pwr. Point	32°	Bandwidth W/VSWR	Less than 2 - 1 - 4 mhz
horizontal	12°	Power Handling	2 KW PEP
vertical	144 Mhz	220 Mhz	432 Mhz
Height	275"	182"	97"
Width x Depth	192" x 30"	132" x 20"	72" x 11"
Turning Radius	101"	65"	38"
Maximum Mast Dia.	2 1/2"	2 1/2"	2 1/2"
Wind Rating	90 mph	90 mph	90 mph
Net Weight Lbs.	64	43	24
Stack Kit No.	DXK-180	DXK-280	DXK-480
Amateur Net	\$119.95	\$99.95	\$89.95

HF MONOBEAMS 10 15 20 METERS

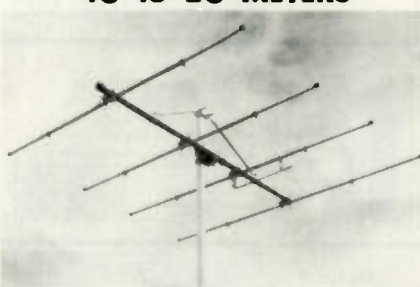

10 METERS

3 ELEMENT BEAM: You can have an outstanding signal using this compact three element beam. It is easily mounted on a lightweight rotator and takes only a limited amount of space. Model No. A28-3—\$79.95
 4 ELEMENT BEAM: A real DX'er's beam for the active ham who wants a top signal on 10 meters. Mount on a good ham rotator. Model No. A28-4—\$89.95

SPECIFICATIONS		
BOOM	A28-3 1 1/2" x 10"	A28-4 1 5/8" x 18"
LONGEST ELEMENT	17' 6"	18'
ELEMENT DIAMETER	7/8" - 1/2"	7/8" - 3/4"
TURNING RADIUS	10'	14' 3"
FORWARD GAIN	8 db	10 db
FRONT TO BACK	22 db	25 db
SWR @ FREQUENCY	1 to 1	1 to 1
WEIGHT	11 lbs.	21 lbs.

15 METERS

3 ELEMENT BEAM: A high quality beam which can be mounted on a mast with other antennas. A heavy duty TV rotator will handle it. Model No. A21-3—\$99.95
 4 ELEMENT BEAM: For the 15 meter enthusiast this beam will give real DX performance. When mounted on a good ham rotator it will withstand the most adverse weather conditions. Model No. A21-4—\$129.95

SPECIFICATIONS		
BOOM	A21-3 1 5/8" x 12"	A21-4 1 3/8" x 21' 6"
LONGEST ELEMENT	22' 10"	22' 10"
ELEMENT DIAMETER	7/8" - 3/4"	7/8" - 3/4"
TURNING RADIUS	13' - 3"	15' - 8"
FORWARD GAIN	8 db	10 db
FRONT TO BACK	22 db	25 db
SWR @ FREQUENCY	1 to 1	1 to 1
WEIGHT	16 lbs.	32 lbs.

20 METERS

2 ELEMENT BEAM: Full size beam performance for the active 20 meter ham with limited space and budget. Model No. A14-2—\$119.95
 3 ELEMENT BEAM: A real DX'er's beam with full 15 wave-length element spacing. The heavy duty construction gives years of trouble-free service. Model No. A14-3 \$159.95

SPECIFICATIONS		
BOOM	A14-2 1 5/8" x 10"	A14-3 1 5/8" x 20' 6"
LONGEST ELEMENT	35' 10"	35' 10"
ELEMENT DIAMETER	1 1/8" - 3/4"	1 1/8" - 3/4"
TURNING RADIUS	18"	21"
FORWARD GAIN	5 db	8 db
F/B RATIO	13 db	22 db
SWR @ FREQUENCY	1 to 1	1 to 1
WEIGHT	20 lbs.	35 lbs.

World Radio TV Handbook 1978

A Complete Directory of International Radio and Television.

The most exhaustive and authoritative guide to broadcasting and television stations around the world today. **WORLD RADIO TV HANDBOOK 1978** is an indispensable reference for anyone with a working interest in radio and television.

Features:

- Names and addresses of broadcast companies and stations by country
- Names and titles of leading officials and personnel
- Listing by frequency of shortwave stations around the world
- Program data including frequencies, wave lengths, transmitter power, call signs, times, announcements (in each language)

Plus a special, in-depth editorial section with professional articles, suggestions and tips—and much, much more. **WORLD RADIO TV HANDBOOK 1978** is available now for only \$11.95.

HF Verticals 10-80 Meters

- efficient top ring
- fiberglass trap forms
- enameled wire coils
- solid aluminum capacitors
- no tuning required
- full compression coverage
- reinforced base
- mast or ground mounting
- pre-marked sections
- easy assembly
- superior quality

3 BAND 20-15 meters/Model ATV-3 \$49.95
 4 BAND 4'20'15'10 meters/Model ATV-4 \$89.95
 5 BAND 80'40'20'15'10 meters/Model ATV-5 \$109.95

Speak up.

We know all about up. In fact, we're number one from the ground up...when it comes to amateur communications towers. We've been building them for HAMS for more than two decades.

Whether you're thinking crank-up, guyed or free-standing, check with us first. We're Tri-Ex. Reliable, dependable.

When we say number one from the ground up, we're talking about towers like Tri-Ex's new "Big W" shown here. It's a free-standing crank-up with a height of 80-ft. providing good DX capability at low cost. Ideal for serious HAMS.

Model W51
 (51' Self-supporting)
 \$850.00

SST T-1 RANDOM WIRE ANTENNA TUNER

All band operation (160-10 meters) with any random length of wire. 200 watt output power capability — will work with virtually any transceiver. Ideal for portable or home operation. Great for apartments and hotel rooms — simply run a wire inside, out a window, or anywhere available. Toroid inductor for small size: 4-1/4" x 2-3/8" x 3". Built-in neon tune-up indicator. SO-239 connector. Attractive bronze finished enclosure. Only \$29.95

SST T-2 ULTRA TUNER

Tunes out SWR on any coax fed antenna as well as random wires. Works great on all bands (160-10 meters) with any transceiver running up to 200 watts power output. Increases usable bandwidth of any antenna. Tunes out SWR on mobile whips from inside your car. Uses toroid inductor and specially made capacitors for small size: 5/4" x 2 1/4" x 2 1/2". Rugged, yet compact. Attractive bronze finished enclosure. SO-239 coax connectors are used for transmitter input and coax fed antennas. Convenient binding posts are provided for random wire and ground connections. Only \$49.95

SST T-3 IMPEDANCE TRANSFORMER

Matches 52 ohm coax to the lower impedance of a mobile whip or vertical. 12 position switch with taps spread between 3 and 52 ohms. Broadband from 1-30 MHz. Will work with virtually any transceiver — 300 watt output power capability. SO-239 connectors. Toroid inductor for small size: 2-3/4" x 2" x 2-1/4". Attractive bronze finish. Only \$19.95

6 METER BEAMS

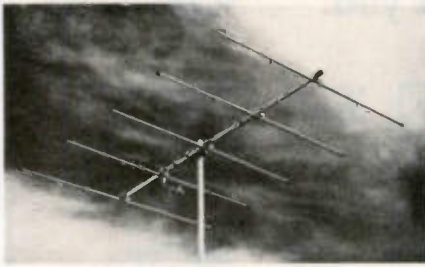

3-5-6-10 ELEMENTS

Proven performance from rugged, full size, 6 meter beams. Element spacings and lengths have been carefully engineered to give best pattern, high forward gain, good front to back ratio and broad frequency response.

Booms are .058 wall and elements are 3/4" - 5/8" .049 wall seamless chrome finish aluminum tubing. The 3 and 5 element beams have 1 3/8" - 1 1/4" booms. The 6 and 10 element beams have 1 5/8" - 1 1/2" booms. All brackets are heavy gauge formed aluminum. Bright finish cad plated bolts are adjustable for up to 1 5/8" mast on 3 and 5 element and 2" on 6 and 10 element beams. All models may be mounted for horizontal or vertical polarization.

New features include adjustable length elements, kilowatt Redd Match and built-in coax fitting for direct 52 ohm feed. These beams are factory marked and supplied with instructions for quick assembly.

Description	3 element	5 element	6 element	10 element
Model No.	A50-3	A50-5	A50-6	A50-10
Boom Length	6"	12"	20"	24"
Longest El.	117"	117"	117"	117"
Turn Radius	6"	7 1/2"	11"	13"
Fwd. Gain	7.5 dB	9.5 dB	11.5 dB	13 dB
F/B Ratio	20 dB	24 dB	26 dB	28 dB
Weight	7 lbs.	11 lbs.	18 lbs.	25 lbs.

COAXIAL DUAL STACKING KITS

Double your effective radiated power by stacking 6 meter beams. Cush Craft coaxial stacking kits provide a simple and efficient method for realizing 3 db additional gain while maintaining the superior characteristics of our single beams. The stacking kits are complete with RG-59/U cable and preassembled fittings for direct 52 ohm feed.

Model No.	For stacking:	Amateur Net
A535-SK	A50-3 or A50-5	\$17.95
A561-SK	A50-6 or A50-10	\$19.95

new RINGO RANGER for FM

4.5 dB* - 6 dB**
Omnidirectional
GAIN
BASE STATION
ANTENNAS
FOR
MAXIMUM
PERFORMANCE
AND
VALUE

Cush Craft has created another first by making the world's most popular 2 meter antenna twice as good. The new Ringo Ranger is developed from the basic AR-2 with three half waves in phase and a one eighth wave matching stub. Ringo Ranger gives an extremely low angle of radiation for better signal coverage. It is tunable over a broad frequency range and perfectly matched to 52 ohm coax.

- ARX-2, 137-160 MHz, 4 lbs., 112"
- ARX-220, 220-225 MHz, 3 lbs., 75"
- ARX-450, 435-450 MHz, 3 lbs., 39"

* Reference 1/4 wave dipole.
** Reference 1/4 wave whip used as gain standard by many manufacturers.

Work full quieting into more repeaters and extend the radius of your direct contacts with the new Ringo Ranger.

You can up date your present AR-2 Ringo with the simple addition of this extend kit. The kit includes the phasing network and necessary element extensions. The only modifications required are easy to make saw slits in the top section of your antenna.

ARX-2K CONVERSION KIT

2 METER FM ANTENNAS

A-FM RINGO 3.75 dB Gain (reference 1/4 wave whip). Half wave length antennas with direct dc ground. 52 ohm feed takes PL-259. low angle of radiation with 1:1 SWR. Factory preassembled and ready to install. 6 meter partly preassembled, all but 450 MHz take 1 1/2" mast. There are more Ringos in use than all other FM antennas combined.

Model Number	AR-2	AR-25	AR-6	AR-220	AR-450
Frequency MHz	135-175	135-175	50-54	220-225	440-480
Power—Rdgr. Watts	100	500	100	100	250
Wind area sq. ft.	.21'	.21'	.37'	.20'	.10'

B-4 POLE Up to 9 dB Gain over a 1/4 wave dipole. Overall antenna length 147 MHz - 23' 220 MHz - 15'. 435 MHz - 6'. pattern 360° - 6 dB gain. 180° - 9 dB gain. 52 ohm feed takes PL-259 connector. Package includes 4 complete dipole assemblies on mounting booms, harness and all hardware. Vertical support mast not supplied.

AFM-4D	144 - 150 MHz, 1000 watts, wind area 2.58 sq. ft.
AFM-24D	220 - 225 MHz, 1000 watts, wind area 1.85 sq. ft.
AFM-44D	435 - 450 MHz, 1000 watts, wind area 1.13 sq. ft.

D-POWER PACK The big signal (22 element array) for 2 meter FM, uses two A147-11 yagis with a horizontal mounting boom, coaxial harness and all hardware. Forward gain 16 dB, F/B ratio 24 dB, 1/2 power beamwidth 42°, dimensions 144" x 80" x 40"; turn radius 80", weight 15 lbs. 52 ohm feed takes PL-259 fitting.

A147-22 146 - 148 MHz, 1000 Watts, wind area 2.42 sq. ft.

D-YAGI STACKING KITS VPK includes horizontal mounting boom, harness, hardware and instructions for two vertically polarized yagis gives 3 dB gain over the single antenna.

A14-VPK,	complete 4 element stacking kit
A14-SK,	4 element coax harness only
A147-VPK,	complete 11 element stacking kit
A147-SK,	11 element coax harness only
A449-SK,	6 + 11 element coax harness only

E-4-6-11 ELEMENT YAGIS The standard of comparison in VHF-UHF communications, now cut for FM and vertical polarization. The four and six element models can be tower side mounted. All are rated at 1000 watts with direct 52 ohm feed and PL-259 connectors.

Model Number	A147-11	A-147-4	A449-11	A449-6	A220-11
Boom/Longest ele.	144"/40"	44"/40"	60"/12"	35"/28"	102"/28"
Wght./Turn radius	6 lbs., 72"	3 lbs., 44"	4 lbs., 60"	3 lbs., 18"	5 lbs., 53"
Gain, F/B ratio dB	13.2/28	9/20	13.2/28	11/25	13.2/28
1/2 Power beam	48°	66°	48°	60°	48°
Wind area sq. ft.	1.21	.43	.39	.30	.50
Frequency MHz	146-148	146-148	440-450	440-450	220-225

F-FM TWIST 12.4 dB Gain: Ten elements horizontal polarization for low end coverage and ten elements vertical polarization for FM coverage. Forward gain 12.4 dB, F/B ratio 22 dB, boom length 130", weight 10 lbs., longest element 40". 52 ohm Redd Match driven elements take PL-259 connectors, uses two separate Feed lines.

A147-20T 145 - 147 MHz, 1000 watts, wind area 1.42 sq. ft.

HIGH PERFORMANCE VHF YAGIS

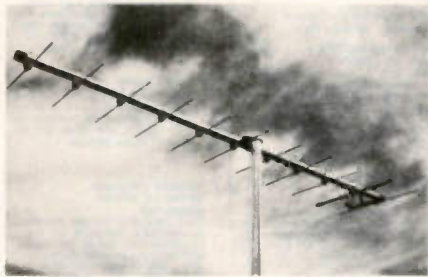

3/4, 1-1/4, 2 METER BEAMS

The standard of comparison in amateur VHF/UHF communications Cush Craft yagis combine all out performance and reliability with optimum size for ease of assembly and mounting at your site.

Lightweight yet rugged, the antennas have 3/16" O. D. solid aluminum elements with 5/16" center sections mounted on heavy duty formed brackets. Booms are 1" and 7/8" O. D. aluminum tubing. Mast mounts of 1/8" formed aluminum have adjustable u-bolts for up to 1-1/2" O. D. masts. They can be mounted for horizontal or vertical polarization. Complete instructions include data on 2 meter FM repeater operation.

New features include a kilowatt Redd Match for direct 52 ohm coaxial feed with a standard PL-259 fitting. All elements are spaced at .2 wavelength and tapered for improved bandwidth.

Model No.	A144-7	A144-11	A220-11	A430-11
Description	2m	2m	14m	km
Elements	7	11	11	11
Boom Length	98"	144"	102"	57"
Weight	4	6	4	3
Fwd. Gain	11 dB	13 dB	13 dB	13 dB
F/B Ratio	26 dB	28 dB	28 dB	28 dB
Fwd. Lobe @ 1/2 pow. PL	46	42	42	42
SWR @ Freq.	1 to 1	1 to 1	1 to 1	1 to 1



AMATEUR FM ANTENNAS

A147-4	\$ 22.95
A147-11	34.95
A147-20T	59.95
A147-22	99.95
A220-7	23.95
A220-11	32.95
A220-22	82.95
A449-6	23.95
A449-11	32.95
AFM-4D	64.95
AFM-24D	62.95
AFM-44D	81.95
AR-2	24.95
AR-6	36.95
AR-25	32.95
AR-220	23.95
AR-450	23.95
ARX-2	36.95
ARX-2K	14.95
ARX-220	36.95
ARX-450	36.95

AMATEUR FM STACKING KITS

A14-SK	\$ 17.95
A14-VPK	26.95
A21-SK	17.95
A220-VPK	28.95
A147-SK	17.95
A147-VPK	32.95
A449-SK	17.95
A449-VPK	28.95

BIG WHEEL ANTENNAS

ABW-12S	\$ 17.95
ABW-14S	27.95
ABW-144	36.95
BLITZ BUG	
LAC-1	\$ 4.95
LAC-2	4.95
DX-ARRAYS-20 ELEMENT	47.95
DX-120	42.95
DX-220	36.95

DX-ARRAY BALUNS

DX-18N	\$ 14.95
DX-28N	14.95
DX-48N	14.95
DX-VPB	10.95

SQUAD ANTENNAS

ASO-2	\$ 19.95
ASO-6	29.95
ASO-22	42.95
ASO-6SK	17.95
ASO-M	17.95

DX-ARRAY-40 ELEMENT

DXK-140	\$ 85.95
DXK-240	59.95
DXK-440	45.95

DX-ARRAY-80 ELEMENT

DXK-180	\$119.95
SXK-280	99.95
DXK-480	89.95

HF MONOBEAMS

A14-2	\$119.95
A14-3	159.95
A21-3	98.95
A21-4	129.95
A28-3	79.95
A28-4	89.95

MULTI BAND HF ANTENNAS

AFB-1	\$ 15.95
ATB-34	259.95
ATV-3	49.95
ATV-4	89.95
ATV-5	109.95

PROLINE VHF BEAMS

APL-25K	\$ 24.95
APL-65K	29.95
APL-85	159.95
APL-210	119.95

TWIST ANTENNAS

A147-WB	\$ 17.95
A144-10T	39.95
A144-20T	59.95
A144-50CT	389.95
A432-20T	54.95

VHF/UHF BEAMS

ASO-3	\$ 36.95
ASO-5	54.95
ASO-6	79.95
ASO-10	109.95
A144-7	23.95
A144-11	34.95
A20-11	27.95

VHF/UHF STACKING KITS

A11-SK	\$ 17.95
A17-SK	17.95
A41-SK	17.95
A535-SK	17.95
A561-SK	19.95
AQK-144	99.95
AQK-444	79.95

MOBILE ANTENNAS

AMS-147	\$ 34.95
ATS-147	32.95

TUFTS RADIO CATALOG TUFTS RADIO



For all you hams with little cars ...

We've got the perfect mobile rig for you.



The Atlas 210x or 215x measures only 9 1/4" wide x 9 3/4" deep x only 3 1/2" high, yet the above photograph shows how easily the Atlas transceiver fits into a compact car. And there's plenty of room to spare for VHF gear and other accessory equipment. With the exclusive Atlas plug-in design, you can slip your Atlas in and out of your car in a matter of seconds. All connections are made automatically.

BUT DON'T LET THE SMALL SIZE FOOL YOU!

Even though the Atlas 210x and 215x transceivers are less than half the size and weight of other HF transceivers, The Atlas is truly a giant in performance.

200 WATTS POWER RATING! This power level in a seven pound transceiver is incredible but true. Atlas transceivers give you all the talk power you need to work the world barefoot. Signal reports

constantly reflect great surprise at the signal strength in relation to the power rating.

FULL 5 BAND COVERAGE The 210x covers 10-80 meters, while the 215x covers 15-160 meters. Adding the Atlas Model 10x Crystal Oscillator provides greatly increased frequency coverage for MARS and network operation.

NO TRANSMITTER TUNING OR LOADING CONTROLS With your Atlas you get Instant QSY and band change.

MOST ADVANCED STATE OF THE ART SOLID STATE DESIGN not only accounts for its light weight, but assures you years of top performance and trouble free operating pleasure.

PLUG-IN CIRCUIT BOARDS and modular design provides for ease of servicing.

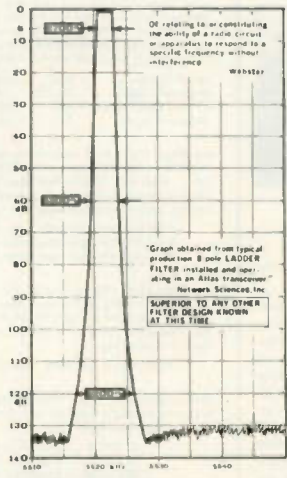

PHENOMENAL SELECTIVITY The exclusive 8 pole crystal ladder filter used in Atlas transceivers represents a major breakthrough in filter design, with unprecedented skirt selectivity and ultimate rejection. As the above graph shows, this filter provides a 6 db bandwidth of 2700 Hertz, 60 db down of only 4300 Hertz, and a bandwidth of only 9200 Hertz at 120 db down! Ultimate rejection is in excess of 130 db; greater than the measuring limits of most test equipment.

EXCEPTIONAL IMMUNITY TO STRONG SIGNAL OVERLOAD AND CROSS MODULATION. The exclusive front end design in the receiver allows you to operate closer in frequency to strong neighboring signals than you have ever experienced before. If you have not yet operated an Atlas transceiver in a crowded band and compared it with any other receiver or transceiver, you have a real thrill coming.



A WORLD WIDE DEALER NETWORK TO SERVE YOU. Whether you're driving a Honda in Kansas City or a Mercedes Benz in West Germany, there's an Atlas dealer near you.

- Atlas 210X or 215X \$765.00
- w/noise blanker \$810.00
- Accessories:
- AC Console 110/220 V \$155.00
- Portable AC supply 110/220 V \$105.00
- Plug-in mobile kit \$55.00
- 10X Osc. less crystals \$65.00
- Digital Dial DD-6B \$235.00

For complete details see your Atlas dealer, or drop us a card and we'll mail you a brochure with dealer list.



HUSTLER

"the home of originals"

AMATEUR ANTENNAS

STANDARD GAIN MOBILES

Two Meters

- 5/8 wavelength — 34 db gain over 1/4 wave mobile
- Frequency coverage—143 to 149 MHz
- Power rating—200 watts FM

MODEL BBL114

47" antenna complete with easy to install, no holes to drill, trunk lip mount, impact spring and 17 MIL SPEC RG-58-U and PL-259. Antenna removable from mount. Price: \$33.75

MODEL BBL144

47" antenna mounts on any flat surface, roof, deck or fender in 3/8" hole. Includes impact spring, 17 MIL SPEC RG-58-U and PL-259. Antenna removable from mount. Price: \$31.65

HUSTLER "BUCK-BUSTER"

MODEL SF-2

51" two meter, 5/8 wavelength, 34 db gain over 1/4 wave mobile. Designed with 3/8" base to fit your mount or a wide selection of Hustler mobile mounts. (Mount or cable not included). Price: \$9.00

DELUXE MOBILE MOUNTS

For medium length, light weight antennas with 1/2" — 24 base.

MODEL TLM

Trunk lip mount for no holes installation on side or edge of trunk lid. Includes 17 RG-58-U connectors attached. Price: \$14.85

MODEL MLM

Deluxe trunk lip mount with 180 degree swivel ball for positioning antenna to vertical. Easy — no holes — installation. Includes 17 RG-58-U cable and connectors attached. Price: \$17.20

MODEL GCM-1

Rain gutter mount fits all shapes, angles even latest trim line gutters. Includes 180° swivel ball. Price: \$9.00

MODEL MM-1

Coil mount installs in 1" hole. Includes 180° swivel ball and SO-239 connectors. Price: \$7.50

MODEL TGM-1

Trunk groove mount installs in hidden area of groove under trunk lid. Mounting hardware included. Price: \$8.00

MODEL C-32

Ball mount complete with mounting hardware. Price: \$8.20

SUPER GAIN MOBILES

Two Meters

- 5.2 db gain over 1/4 wave mobile antenna
- Frequency coverage—143-149 MHz
- SWR at resonance—1.1:1 typical
- Power rating—200 watts FM

TWO AND SIX METERS—TRUNK LIP MOUNT

MODEL HFT

Four section telescopic antenna permits separate adjustment for simultaneous resonance on two and six meters. Operational height: 40". Complete with trunk lip mount, 17 MIL SPEC RG-58-U and factory attached PL-259. Price: \$22.55

VHF/UHF ANTENNA—ROOF MOUNT

MODEL UMT-1

Field trimmable radiator for 1/4 wave operation on any frequency from 140 to 500 MHz. Cutting chart included. Mounts on any flat surface, roof, deck, fender in 1/2" hole. Includes 15 RG-58-U. Price: \$9.95

RESONATOR SPRING—STAINLESS STEEL

MODEL RSS-2

Resistor between Hustler mast and resonator. Absorbs shock when antenna springs absorbing vibrations. Supplied ready for easy installation. Price: \$1.00

MODEL R55-2

1/2" x 1/2" x 1/2" stainless steel ball mount for deck, fender or any flat surface. Price: \$19.20

QUICK DISCONNECT—100% STAINLESS STEEL

MODEL QD-1

Removes antenna from mount with easy press and twist release. Complete spring and all parts 100% stainless steel, 1/4 threads—female one end, male the other. Price: \$16.95

FEED LINE MODEL L14-240

Get known performance maximum handling for minimum noise pickup in this MIL SPEC 20 length of RG-58-U cable! Supplied with connectors attached for use with ball or bumper mount and transceiver. Price: \$6.55

MODEL G6-144A—Deluxe, Two Meter, Colinear for Repeater or any fixed station operation. 6 db gain over a 1/2 wave dipole. Maximum radiation at the horizon! Shunt fed with O.C. grounding. Radiator 3/4 wave lower section, 1/4 wave phasing 3/4 wave upper section. Height: 117". Survival: 100 MPH. Installs on vertical pipe up to 1 1/2" O.D. SO-239 coax connector. Price: \$67.55

MODEL CGT-144

Get big signal performance, superior receiving capability with this 85" colinear antenna. Easy installation on side or edge of trunk lip without drilling—complete with 17 MIL SPEC RG-58-U and PL-259. Price: \$41.30

MODEL CG-144

Same characteristics as CGT-144 supplied with 3/8" base to fit all mobile ball mounts—Length is 85". Mount and cable not included. Price: \$25.50

VHF/UHF ANTENNA—TRUNK LIP MOUNT

MODEL THF

Field trimmable radiator permits quarter wave operation on any frequency from 140 to 500 MHz. Cutting chart included. Complete with trunk lip mount, 17 RG-58-U and PL-259. Price: \$16.55

STAINLESS STEEL BALL MOUNT FOR DECK, FENDER OR ANY FLAT SURFACE

MODEL SSM-2

Heavy 2" reinforced stainless steel 180° adjustable ball mount easily supports any amateur mobile antenna. Includes cycloc ball, steel nut-up plate and mounting. Price: \$19.20

MODEL G6-144A

Deluxe, Two Meter, Colinear for Repeater or any fixed station operation. 6 db gain over a 1/2 wave dipole. Maximum radiation at the horizon! Shunt fed with O.C. grounding. Radiator 3/4 wave lower section, 1/4 wave phasing 3/4 wave upper section. Height: 117". Survival: 100 MPH. Installs on vertical pipe up to 1 1/2" O.D. SO-239 coax connector. Price: \$67.55

All resonators are precision wound with optimized design for each band. Assembly includes 17-7 PH stainless steel adjustable tip rod for lowest SWR and band edge marker. Choose for medium or high power operation.

STANDARD HUSTLER RESONATORS

Power Rating: 400 Watts SSB

Model	Band	Price
RM-10	10 meters	\$ 6.50
RM-15	15 meters	6.95
RM-20	20 meters	7.30
RM-40	40 meters	13.20
RM-75	75 meters	15.50
RM-80	80 meters	15.95

SUPER HUSTLER RESONATORS

Power Rating: Legal Limit SSB

Supers have widest bandwidth

Model	Band	Price
RM-10S	10 meters	\$11.30
RM-15S	15 meters	12.65
RM-20S	20 meters	13.00
RM-40S	40 meters	15.50
RM-75S	75 meters	30.00
RM-80S	80 meters	30.40

For 6-10-15-20-40-75-80 Meters

Fold over mast for quick and easy interchange of resonators or entering a garage. When operating, mast is held vertical with stakeproof sleeve clutch. Mast also serves as 1/4 wavelength 6 meter antenna. Stainless steel base has 3/8" threads to fit mobile ball mount or bumper mount.

HUSTLER MASTS

The Majority Choice of Amateurs Throughout the World!

MODEL MO-2

For bumper mounting—Fold is at roof line 27" above base. Price: \$22.00

MODEL MO-1

For deck or fender mounting—Fold is at roof line 15" above base. Price: \$22.00

Covers 10 - 15 - 20 - 40 Meters

Only Hustler Gives One Setting for Whole Band Coverage

MODEL 4-RTV

- Lowest SWR—PLUS
- Bandwidth at its broadest! SWR 1.6 to 1 or better at band edges.
- Hustler exclusive trap covers "Sprite" extruded to otherwise unattainable close tolerances assuring accurate and permanent trap resonance.
- Solid one inch fiberglass trap forms for optimum electrical and mechanical stability.
- Extra heavy duty aluminum mounting bracket with low loss—high strength insulators. Mounting hardware included.
- All sections 1 1/2" heavy wall, high strength aluminum
- Stainless steel clamps permitting adjustment without damage to the aluminum tubing
- Guaranteed to be exact! Assembly of any multi-band vertical.
- Antenna has 3/4" stud at top to accept RM-75 or RM-75-S Hustler resonator for 75 meter operation when desired.
- Top loading on 75 meters for broader bandwidth and higher radiation efficiency!
- Feed with any length 50 ohm coax
- Power capability—full legal limit on SSB or CW
- Mounting: Ground mount with or without radials, or roof mount with radials.

Lengths 21' 5"
MODEL 4-RTV
Weight: 15 lbs.
Price: \$99.95

This NEW MFJ Versa Tuner II . . .

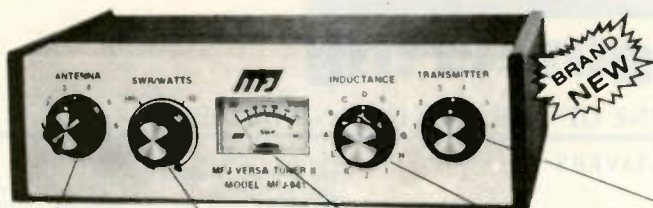

has SWR and dual range wattmeter, antenna switch, efficient airwound inductor, built-in balun. Up to 300 watts RF output. Matches everything from 160 thru 10 meters: dipoles, inverted vees, random wires, verticals, mobile whips, beams, balance lines, coax lines. \$79.95.

Antenna matching capacitor, 208 pf. 1000 volt spacing.

Sets power range, 300 and 30 watts. Pull for SWR.

Meter reads SWR and RF watts in 2 ranges.

Efficient airwound inductor gives more watts out and less losses.

Transmitter matching capacitor, 208 pf. 1000 volt spacing.

Only MFJ gives you this MFJ-941 Versa Tuner II with all these features at this price:

A SWR and dual range wattmeter (300 and 30 watts full scale) lets you measure RF power output for simplified tuning.

An antenna switch lets you select 2 coax fed antennas, random wire or balance line, and tuner bypass.

A new efficient airwound inductor (12 positions) gives you less losses than a tapped toroid for more watts out.

A 1:4 balun for balance lines: 1000 volt capacitor spacing. Mounting brackets for mobile installations (not shown).

With the NEW MFJ Versa Tuner II you can run your full transmitter power output — up to 300 watts RF power output — and match your

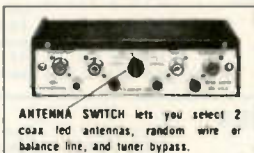

ANTENNA SWITCH lets you select 2 coax fed antennas, random wire or balance line, and tuner bypass.

transmitter to any feedline from 160 thru 10 Meters whether you have coax cable, balance line, or random wire.

You can tune out the SWR on your dipole, inverted vee, random wire, vertical, mobile whip, beam, quad, or whatever you have.

You can even operate all bands with just

one existing antenna. No need to put up separate antennas for each band.

Increase the usable bandwidth of your mobile whip by tuning out the SWR from inside your car. Works great with all solid state rigs (like the Atlas) and with all tube type rigs.

It travels well, too. Its ultra compact size 5 1/2 x 6 inches fits easily in a small corner of your suitcase.

This beautiful little tuner is housed in a deluxe eggshell white Ten-Tec enclosure with walnut grain sides.

\$0.239 coax connectors are provided for transmitter input and coax fed antennas. Quality five way binding posts are used for the balance line inputs (2), random wire input (1), and ground (1).



\$59.95

BRAND NEW

MFJ-901 VERSA TUNER

New efficient air wound coil for more watts out!
Only MFJ uses an efficient air wound inductor (12 positions) in this class of tuners to give you more watts out and less losses than a tapped toroid. Matches everything from 160 thru 10 Meters: dipoles, inverted vees, random wires, verticals, mobile whips, beams, balance lines, coax lines. Up to 200 watts RF output. 1:4 balun for balance lines. Tune out the SWR of your mobile whip from inside your car. Works with all rigs. Ultra compact 5 1/2 x 6 inches. \$0.239 connectors. 5 way binding posts. Ten-Tec enclosure.



\$49.95

MFJ-900 ECONO TUNER

Same as MFJ-901 Versa Tuner, but does not have built-in balun for balance lines. Tapers coax leads and random lead.



\$39.95

MFJ-15010 RANDOM WIRE TUNER

Operates 160 thru 10 Meters. Up to 200 watts RF output. Matches high and low impedances, 12 position inductor. \$0.239 connectors. 2 1/2 x 4 inches. Matches 75 to 200 ohms at 1.0 MHz.



\$49.95

BRAND NEW

MFJ-202 RF NOISE BRIDGE

This MFJ RF Noise Bridge lets you adjust your antenna quickly for maximum performance. Maximum frequency response, minimum resistance and reactance. Exchange range extender and expanded capacitance range (2.150 pF) gives you much extended measuring range. Tells resonant frequency and whether to shorten or lengthen your antenna for minimum SWR. Adjust your single or multi-band dipole, inverted vee, beam, vertical, mobile whip or random system for maximum performance. 1 to 100 MHz. \$0.239 connectors. 2 1/2 x 4 inches. 9 volt battery.

THE HAM-KEY NOW 5 MODELS

NEW MODEL HK-5 ELECTRONIC KEYS \$69.95



- Lambic circuit for squeeze keying.
- Self completing dots & dashes.
- Dot memory.
- Battery operated with provisions for external power.
- Built-in side-tone monitor.
- Speed, Volume, tone & weight controls.
- Grid-block or direct keying.
- Use with external paddle such as HK-1.



Model HK-1 \$29.95

- Dual lever squeeze paddle.
- Use with HK-5 or any electronic keyer.
- Heavy base with non-slip rubber feet.
- Paddles reversible for wide or close finger spacing.



Model HK-2 \$19.95

- Same as HK-1, less base for those who wish to incorporate in their own Keyer.

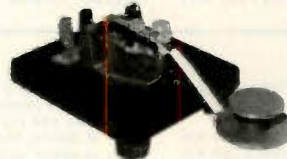

Model HK-3 \$16.95

- Deluxe straight key.
- Heavy base, no need to attach to desk.
- Velvet smooth action.



Model HK-4 \$44.95

- Combination on HK-1 & HK-3 on same base.

400% MORE RF POWER PLUGS BETWEEN YOUR MICROPHONE AND TRANSMITTER



\$49.95

LSP-520BX. 30 db dynamic range IC log amp and 3 active filters give clean audio. RF protected. 9 V battery. 3 conductor, 1/4" phone jacks for input and output. 2-3/16 x 3-1/4 x 4 inches.

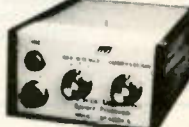

\$59.95

LSP-520BX II. Same as LSP-520BX but in a beautiful 2-1/8 x 3-5/8 x 5-9/16 inch Ten-Tec enclosure with uncommitted 4 pin Mic jack, output cable, rotary function switch.



\$29.95

CWF-2BX Super CW Filter

By far the leader. Over 5000 in use. Razor sharp selectivity. 80 Hz bandwidth, extremely steep skirts. No ringing. Plugs between receiver and phones or connect between audio stage for speaker operation.

- Selectable BW: 80, 110, 180 Hz • 60 dB down one octave from center freq. of 750 Hz for 80 Hz BW • Reduces noise 15 dB • 9 V battery • 2-3/16 x 3-1/4 x 4 in.



\$54.95

CMOS-8043 Electronic Keyer

State of the art design uses CURTIS-8043 Keyer-on-a-chip.

- Built-in Key • Dot memory • Lambic operation with external squeeze key • 8 to 50 WPM • Sidetone and speaker • Speed, volume, tone, weight controls • Ultra reliable solid state keying • 300 volts max • 4 position switch for TUNE, OFF, ON, SIDETONE OFF • Uses 4 penlight cells • 2-3/16 x 3-1/4 x 4 inches



\$17.95

NEW

CPO-555 Code Oscillator

For the Newcomer to learn the Morse code. For the Old Timer to polish his list. For the Code Instructor to teach his classes.

- Send crisp clear code with plenty of volume for classroom use.
- Self contained speaker, volume, tone controls, aluminum cabinet • 9 V battery • Top quality U.S. construction • Uses 555 IC timer • 2-3/16 x 3-1/4 x 4 inches



\$29.95

MFJ-40T QRP Transmitter

Work the world with 5 watts on 40 Meter CW.

- No tuning • Matches 50 ohm load • Clean output with low harmonic content • Power amplifier transistor protected against burnout • Switch selects 3 crystals or VFO input • 12 VDC • 2-3/16 x 3-1/4 x 4 inches

- MFJ-40V, Companion VFO \$27.95
- MFJ-120C, IC Regulated Power Supply, 1 amp, 12 VDC \$27.95



\$29.95

SBF-2BX SSB Filter

Dramatically improves readability.

- Optimizes your audio to reduce sideband splatter, remove low and high pitched QRM, hiss, static crashes, background noise, 60 and 120 Hz hum • Reduces fatigue during contest, DX, and ragchewing • Plugs between phones and receiver or connect between audio stage for speaker operation • Selectable bandwidth IC active audio filter • Uses 9 volt battery • 2-3/16 x 3-1/4 x 4 inches



\$27.95

MFJ-200BX Frequency Standard

Provides strong, precise markers every 100, 50, or 25 KHz well into VHF region.

- Exclusive circuitry suppresses all unwanted markers • Markers are gated for positive identification. CMOS IC's with transistor output. • No direct connection necessary • Uses 9 volt battery • Adjustable trimmer for zero beating to VFW • Switch selects 100, 50, 25 KHz or OFF • 2-3/16 x 3-1/4 x 4 inches



\$49.95

MFJ-1030BX Receiver Preselector

Clearly copy weak unreadable signals (increases signal 3 to 5 "S" units).

- More than 20 dB low noise gain • Separate input and output tuning controls give maximum gain and RF selectivity to significantly reject out-of-band signals and reduce image responses • Dual gate MOS FET for low noise, strong signal handling abilities • Completely stable • Optimized for 10 thru 30 MHz • 9 V battery • 2-1/8 x 3-5/8 x 5-9/16 inches

Vhf engineering

THE WORLD'S MOST COMPLETE LINE OF VHF-FM KITS AND EQUIPMENT

		RECEIVERS	
RX28C	28-35 MHz FM receiver with 2 pole 10.7 MHz crystal filter	\$ 64.95	
RX28C W/T	same as above—wired & tested	117.95	
RX50C Kit	30-60 MHz rcvr w/2 pole 10.7 MHz crystal filter	64.95	
RX50C W/T	same as above—wired & tested	117.95	
RX144C Kit	140-170 MHz rcvr w/2 pole 10.7 MHz crystal filter	74.95	
RX114C W/T	same as above—wired & tested	119.95	
RX220C Kit	210-240 MHz rcvr w/2 pole 10.7 MHz crystal filter	74.95	
RX220C W/T	same as above—wired & tested	117.95	
RX432C Kit	432 MHz rcvr w/2 pole 10.7 MHz crystal filter	84.95	
RX432C W/T	same as above—wired & tested	129.95	



		TRANSMITTERS	
TX50	transmitter exciter, 1 watt, 6 mtr.	44.95	
TX50 W/T	same as above—wired & tested	64.95	
TX144B Kit	transmitter exciter—1 watt—2 mtrs	34.95	
TX144B W/T	same as above—wired & tested	59.95	
TX220B Kit	transmitter exciter—1 watt—220 MHz	34.95	



		POWER AMPLIFIERS	
PA2501H Kit	2 mtr power amp—kit 1w in—25w out with solid state switching, case, connectors	64.95	
PA4010H Kit	2 mtr power amp—10w in—40w out—relay switching	64.95	
PAS0/25 Kit	6 mtr power amp, 1w in, 25w out, less case, connectors & switching	54.95	
PA144/15 Kit	2 mtr power amp—1w in—15w out—less case, connectors and switching	44.95	
PA144/25 Kit	same as PA144/15 kit but 25w	54.95	
PA220/15 Kit	similar to PA144/15 for 220 MHz	44.95	
PA432/10 Kit	power amp—similar to PA144/15 except 10w and 432 MHz	54.95	
PA140/10 W/T	10w in—140w out—2 mtr amp	219.95	
PA140/30 W/T	30w in—140w out—2 mtr amp	189.95	

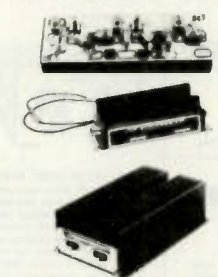

Model	BAND	Power Input	Power Output	
BLC 10/70	144 MHz	10W	70W	149.95
BLC 2/70	144 MHz	2W	70W	169.95
BLC 10/150	144 MHz	10W	150W	259.95
BLC 30/150	144 MHz	30W	150W	239.95
BLD 2/60	220 MHz	2W	60W	164.95
BLD 10/60	220 MHz	10W	60W	159.95
BLD 10/120	220 MHz	10W	120W	259.95
BLE 10/40	420 MHz	10W	40W	179.95
BLE 2/40	420 MHz	2W	40W	179.95
BLE 30/80	420 MHz	30W	80W	259.95
BLE 10/80	420 MHz	10W	80W	289.95

		POWER SUPPLIES	
PS15C Kit	15 amp—12 volt regulated power supply w/case, w/fold-back current limiting and overvoltage protection	94.95	
PS15C W/T	same as above—wired & tested	124.95	
PS25M Kit	25 amp—12 volt regulated power supply w/case, w/fold-back current limiting and ovp, with meter	154.95	
PS 25M W/T	same as above—wired & tested	179.95	

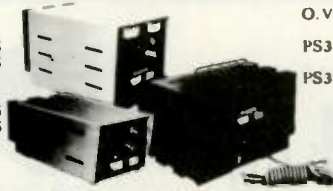

O.V.P.	adds over voltage protection to your power supplies, 15 VDC max.	12.95
PS3A Kit	12 volt—power supply regulator card with fold-back current limiting	10.95
PS3012 W/T	new commercial duty 30 amp 12 VDC regulated power supply w/case, w/fold-back current limiting and overvoltage protection	249.95

		REPEATERS	
RPT50 Kit	repeater—6 meter	499.95	
RPT50	repeater—6 meter, wired & tested	799.95	
RPT144 Kit	repeater—2 mtr—15w—complete (less crystals)	499.95	
RPT220 Kit	repeater—220 MHz—15w—complete (less crystals)	499.95	
RPT432 Kit	repeater—10 watt—432 MHz (less crystals)	579.95	
RPT144 W/T	repeater—15 watt—2 mtr	799.95	
RPT220 W/T	repeater—15 watt—220 MHz	799.95	
RPT432 W/T	repeater—10 watt—432 MHz	849.95	



DPLA50	6 mtr close spaced duplexer	575.95
DPLA144	2 mtr, 600 KHz spaced duplexer, wired and tuned to frequency	379.95
DPLA220	220 MHz duplexer, wired and tuned to frequency	379.95
DPLA432	rack mount duplexer	319.95
DSC-U	double shielded duplexer cables with PL259 connectors (pr.)	25.00
DSC-N	same as above with type N connectors (pr.)	25.00

		TRANSCIVERS		OTHER PRODUCTS BY VHF ENGINEERING		
TRX50 Kit	Complete 6 mtr FM transceiver kit, 20w out, 10 channel scan with case (less mike and crystals)	244.95		CD1 Kit	10 channel receive xtal deck w/diode switching	\$ 7.95
TRX144 Kit	same as above, but 2 mtr & 15w out	234.95		CD2 Kit	10 channel xmit deck w/switch and trimmers	15.50
TRX220 Kit	same as above except for 220 MHz	234.95		CD3 Kit	UHF version of CD1 deck, needed for 432 multi-channel operation	13.50
TRX432 Kit	same as above except 10 watt and 432MHz	254.95		COR2 Kit	carrier operated relay	22.75
TRC-1	transceiver case only	29.95		SC3 Kit	10 channel auto-scan adapter for RX with priority	19.95
TRC-2	transceiver case and accessories	49.95		Crystals	we stock most repeater and simplex pairs from 146.0-147.0 (each)	5.00



CWID Kit	159 bit, field programmable, code identifier with built-in squelch tail and ID timers	39.95
CWID	wired and tested, not programmed	54.95
CWID	wired and tested, programmed	59.95
MIC-1	2,000 ohm dynamic mike with P.T.T. and coil cord	12.95
TS1 W/T	tone squelch decoder	59.95
TS1 W/T	installed in repeater, including interface accessories	89.95
TD3 Kit	2 tone decoder	35.95
TD3 W/T	same as above—wired & tested	59.95
HL144 W/T	4 pole helical resonator, wired & tested, swept tuned to 144 MHz ban	29.95
HL220 W/T	same as above tuned to 220 MHz ban	29.95
HL432 W/T	same as above tuned to 432 MHz ban	29.95

		SYNTHESIZERS	
SYN II Kit	2 mtr synthesizer, transmit offsets programmable from 100 KHz—10MHz, (Mars offsets with optional adapters)	169.95	
SYN II W/T	same as above—wired & tested	239.95	
SYN 220 Kit	same as SYN II Kit except 220-225 MHz	169.95	
SYN 220 W/T	same as above—wired & tested	239.95	





IC-211
4 MEG, Multi-mode
2 Meter Transceiver
ALL MODE

- 144-145 MHz operation on SSB and CW as well as 146-147 MHz operation on FM is possible with the IC-211. Try 144 MHz DX or just local rag chew with friends. Work the Amsat Oscar six or seven using the IC-211 for either the receiver or transmitter.

TUNING SYSTEM

- A large weighted flywheel knob mounted with low friction ball bearings is used to drive an optical chopper to provide pulses to the ICOM LSI synthesizer. A breaking mechanism, which operates inertially, changes to provide a smooth feel at slow speeds similar to the old PTO type units.

FULL FUNCTIONS BUILT IN

- pulse type noise blinder
- VOX with adjusting VOX gain, antilock semi-break-in C. W. Operation
- Built in SWR bridge
- CW monitor
- automatic power control
- AC or DC operation
- The synthesizer designed by ICOM and implemented in the proprietary LSI chip operates in 100 Hz steps from 144 to 146 MHz and in 5 KHz steps from 146 to 148 MHz for FM operation.
- The IC-211 contains both the 117VAC and the 13.6VDC power supplies.



IC-245
146 MHz FM 10 W Transceiver

- The ICOM developed LSI synthesizer with 4 digit LED readout in the IC-245 offers the most for mobile. In FM, the synthesizer command frequency is displayed in 5 KHz steps from 146 to 148 MHz, and with the sideband adapter the step rate drops to 100 Hz, from 144 to 146 MHz. For maximum repeater flexibility, the transmit and receive frequencies are independently programmable on any separation. The IC-245 even comes equipped with a multiple pin Molex connector for remote control.
- Optional equipment for the IC-245 includes a single sideband adapter which attaches as an integral part of the transceiver. With this easy to make conversion, your IC-245 operates in both FM and SSB/CW modes.

Master Charge and VISA accepted!

Master Charge and VISA accepted!



IC-502
6 Meter SSB & CW Portable

- Get in on the fun of working 6 meters with this great portable radio. Operate QRP on 6 SSB or CW with this self contained transceiver, including antenna and battery pack. (Nicads and charger are now available.) Grab it and take it with you wherever you go... hill top, lakeside or car. The aluminum diecast frame provides a rugged radio for travel. Three watts PEP and the stable VFO make for fun and FB QSO's. There is even an RIT for the receiver, as well as a true I.F. noise blinder that really works on six meters!
- The VFO used in the IC-502 covers the first 800 KHz of the 6 meter band where most of the activity is. The excellent stability of the VFO and the smooth tuning dial make operating the IC-502 even in cold mountain top climates a pleasure worth the effort of getting there. The three watt PEP signal really gets through when the band is open and provides sufficient drive for an AB1 type linear amplifier.



IC-215
2 Meter FM portable

- An extremely rugged, high quality, radio with 15 channel capacity.
- The C size cells may be replaced with rechargeable cells of the same size and very simple modification made to provide FULL CHARGE from either the auto electrical system or the IC-3PS power supply while the IC-215 is in operation. This feature is possible due to the BC-20 battery pack and charger.



IC-202
2 Meter SSB Portable

- A full 3 watts PEP from this compact transceiver is plenty of punch when the band is open. Three watts PEP will also dim most home-brew amps to full output or our optional amplifier to 10 watts.
- This unit also includes a true I.F. noise blinder that really gets the job done on reducing pulse type interference.
- The band switch selects 144.0, 144.2 or two other 200 KHz bands as selected by the user. Your ICOM distributor stocks 145.0-145.2 MHz and 145.8-146.0 MHz for the technician calling frequency and the satellite band.



MODEL	PRICE	RM-2	PRICE
IC-30A	399.00	IC245/SSB	444.00
IC-202	259.00	IC-502	249.00
IC-20L	98.00	IC-50L	98.00
IC211	799.00	IC-701 AC	1,499.00
IC215	229.00	IC-701 DC	PRICE
IC215/BC-20	249.00	IC-3PS	99.00
IC202S	335.00	IC-3PE	99.00

MIC-500M	Mobile Mic (specify model)	\$18.00
SM-2	Electret Base Mic (for 4 pin mic conn)	34.50
IC-MM	Mobile Mount (specify model)	13.95
IC-DCC (22S)	DC Power cord (245,22S,211) w/fuse	3.00
IC-DCC (std)	Power cord (specify model AC or DC)	2.00
IC-PC	Power connector (specify model)	.50
RRD	Reverse dial (22A, 30A, 22S)	2.00
9PP	9 Pin Plug	2.00
BC-20	900 mAh Batteries & Charger for 202, 215, 502	49.95
24PP	24 Pin Plug	3.00
24PP set	24 Pin Set w/Bracket (22S)	6.00

DON'T FORGET \$3.00 minimum

DON'T FORGET \$3.00 minimum

DON'T FORGET \$3.00 minimum

DON'T FORGET \$3.00 minimum

DON'T FORGET \$3.00 minimum

Larsen Kølrod® Antennas

- Handle full 200 watts
- low-low V.S.W.R.
- Deliver 3 dB gain and more!
- Pick the one that best fits your needs:

MAGNETIC MOUNT
stays put even at 100 mph!

MM-JM-150 for 144 MHz use } Only \$38.50 complete
MM-JM-220 for 220 MHz use }
MM-JM-440 for 440 MHz use }

TRUNK LID MOUNT
No holes and low silhouette too!

TLM-JM-150 for 144 MHz use } Only \$38.50 complete
TLM-JM-220 for 220 MHz use }
TLM-JM-440 for 440 MHz use }

And 1/4 wave antenna for trunk and magnetic mount - \$18.50

ROOF or FENDER MOUNT
Goes on quick and easy in 3/8" or 3/4" with fewest parts.

JM-150-K for 144 MHz use } Only \$31.50 complete
JM-220-K for 220 MHz use }
JM-440-K for 440 MHz use }

And 1/4 wave antenna for roof and fender mounts \$11.50

Above antennas all complete with mounting hardware, coax, connector plug, allen wrench and complete instructions.

FULLY AIR TESTED - THOUSANDS ALREADY IN USE

#16 40% Copper Weld wire annealed to it handles like soft Copper wire - Rated for better than full legal power AM/CW or SSB-Coaxial or Balanced 50 to 75 ohm feedline - VSWR under 1.5 to 1 at most heights - Stainless Steel hardware - Drop Proof Insulators - Terrific Performance - No coils or traps to break down or change under weather conditions - Completely Assembled ready to put up - Guaranteed 1 year - ONE DESIGN DOES IT ALL.

MOR-GAIN

MODEL	BANDS (Meters)	PRICE	WEIGHT (Oz/Kg)	LENGTH (Ft/Meters)
40-20 HD	40/20	\$49.50	26/73	36/10.9
40-10 HD	40/20/15/10	59.50	36/1.01	36/10.9
80-40 HD	80/40 + 15	57.50	41/1.15	69/21.0
75-40 HD	75/40	55.00	40/1.12	66/20.1
75-40 HD (SP)	75/40	57.50	40/1.12	66/20.1
75-20 HD	75/40/20	66.50	44/1.23	66/20.1
75-20 HD (SP)	75/40/20	66.50	44/1.23	66/20.1
75-10 HD	75/40/20/15/10	74.50	48/1.34	66/20.1
75-10 HD (SP)	75/40/20/15/10	74.50	48/1.34	66/20.1
80-10 HD	80/40/20/15/10	76.50	50/1.40	69/21.0

NO TRAPS - NO COILS - NO STUBS - NO CAPACITORS

MOR-GAIN HD DIPOLES... One half the length of conventional half-wave dipoles. Multi-band, Multi-frequency. Maximum efficiency - no traps, loading coils, or stubs. Fully assembled and pre-tuned - no measuring, no cutting. All weather rated - 1 KW AM, 2.5 KW CW or PEP SSB. Proven performance - more than 15,000 have been delivered. Permit use of the full capabilities of today's 5-band xcvrs. One feedline for operation on all bands. Lowest cost/benefit antenna on the market today. Fast QSY - no feedline switching. Highest performance for the Novice as well as the Extra-Class Op.

EXCLUSIVE 66 FOOT, 75 THRU 10 METER OIPOLES

- All models above are furnished with crimp/solder lugs.
- All models can be furnished with a SO-239 female coaxial connector at additional cost. The SO-239 mates with the standard PL-259 male coaxial cable connector. To order this factory installed option, add the letter 'A' after the model number. Example: 40-20 HD/A.
- 75 meter models are factory tuned to resonate at 3950 kHz. (SP) models are factory tuned to resonate at 3800 kHz. 80 meter models are factory tuned to resonate at 3650 kHz. See VSWR curves for other resonance data.



NEW
Jx Monitor Antenna Tuner

- Continuous tuning 1.8-30 MHz
- Forward reading relative output power meter
- 300 watt power capability
- Built-in encapsulated balun
- Mobile mounting bracket
- Ceramic Rotary Switch 12-position
- Capacitor spacing 1000 volts
- Tapped toroid inductor
- Antenna Inputs:
 - a. Coax unbalanced SO239
 - b. Random wire
 - c. Balanced feedline 75-660 Ohm
- 5 1/2" w. x 2 1/4" h. x 6" d.
- All metal black wrinkle finish cabinet
- Weight: 2 1/2 pounds

DenTron

AMPLIFIERS

MLA-2500 Amplifier (with Built-in Power Supply) \$899.50
 MLA-1200 Amplifier 399.50
 AC 1200 / AC Power Supply for MLA-1200 159.50
 DC-1200 / DC Power Supply for MLA-1200 199.50

TUNERS

MT-3000A Tuner 349.50
 MT-2000A Tuner 199.50
 160-10AT Super Tuner 129.50
 Jr. Monitor Tuner 79.50

ANTENNAS

160M Mobile Antenna "Mobile Top Bander" (160 meters) . 59.50
 Center Feed All Band Doublet Antenna 24.50

ACCESSORIES

Big Dummy with coolant . . 29.50
 W-2 Wattmeter 99.50
 160 XV Transverter "Top Bander" 249.50



Model 333 dummy load wattmeter - Favorite Lightweight Portable-250 WATT RATING - Air Cooled. Ideal field service unit for mobile 2-way radio - CB, marine, business band. Best for QRP amateur use, CB, with zero to 5 watts full scale low power range.

Frequency Range: DC to 300 MHz
 VSWR: Less than 1.3:1 to 230 MHz
 Power Range: 250 watts intermittent
 Wattmeter Ranges: 0.5, 0.50, 0.125, 0.250
 Connector: SO-239
 Size: 4" x 7" x 8"
 Shipping Weight: 2 lbs.
 Price: \$98.50



High Power - 1000 WATT RATING - Oil Cooled - model 334A dummy load wattmeter. Our most popular combination unit. Handles full amateur power. Meter ranges individually calibrated. Can be panel mounted.

Frequency Range: DC to 300 MHz
 VSWR: Less than 1.3:1 to 300 MHz
 Power Range: 1000 watts CW in intermittent. Warning light signals maximum heat limit.
 Wattmeter Ranges: 0-10, 0-100, 0-300, 0-1000
 Input Connector: SD-239 (hermetically sealed)
 Size: 4 1/2" x 9" x 10 1/2"
 Shipping Weight: 12 lbs.
 Price: \$174.00



Read forward and reflected watts at the same time

READ FORWARD AND REFLECTED WATTS AT THE SAME TIME. Tired of constant switching and guesswork? Every serious ham knows he must read both forward and reverse wattage simultaneously for that perfect match. So upgrade with the DenTron W-2 Dual in line Wattmeter. \$99.50.

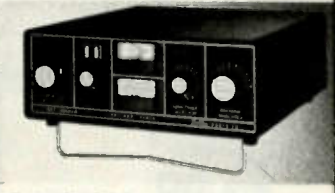

The MT-3000A SPECIFICATIONS:

- Power handling capability in excess of 3 KW PEP
- Front Panel Antenna Switch with 5 Antenna Inputs plus Tuner bypass position
- Built-in 50 Ohm - 250 Watt dummy load
- Dual Wattmeters
- Compact: 5 1/2" x 14" x 14", 18 pounds
- Continuous Tuning 160-10 meters
- 3 Core Heavy-Duty Balun

160 XV MARS Dual
 Band 279.50
 100 ft. 2kw 300 Transmission Line 19.50
 100 ft. 470 Ohm Ladder Line 12.00
 1 Kilowatt Balun 4:1 Chassis Mt. 27.50
 3 Kilowatt Balun 4:1 Chassis Mt. 29.50



Model 374 dummy load wattmeter - Top of the Line - 1500 WATT RATING - Oil Cooled. Our highest power combination unit. Rated to 1500 watts input (Intermittent). Meter ranges are individually calibrated for highest accuracy.

Frequency Range: DC to 300 MHz
 VSWR: Less than 1.3:1 to 230 MHz
 Power Range: 1500 watts DC Intermittent. Warning light signals maximum heat limit.
 Wattmeter Ranges: 0.15, 0.50, 0.300, 0-1500
 Input Connector: SO-239 (hermetically sealed)
 Size: 4 1/2" x 9" x 10 1/2"
 Shipping Weight: 12 lbs.
 Price: \$218.00



Wide range attenuator - Model 371-1. Seven rocker switches provide attenuation from 1 dB to 61 dB in 1-dB steps. Switches are marked in dB, 1-2-3-5-10-20-20. Sum of actuated switches (IN position) gives attenuation. With all switches in OUT position, there is NO insertion loss. Attenuator installs in coaxial line using UHF connectors.

Power Capacity: 1/2 watt
 VSWR: 1.3:1 maximum, DC to 225 MHz
 Impedance: 50 ohms
 Accuracy: 1 dB/dB, DC to 60 MHz
 0.1 dB/dB, 60 to 48 dB, DC to 160 MHz
 0.1 dB/dB, 48 to 0 dB, DC to 225 MHz
 Size: 9 1/2" x 2 1/2" x 2 1/2"
 Shipping Weight: 1 1/2 lbs.
 Price: \$49.50



THE MLA-2500 SPECIFICATIONS

- 160 thru 10 meters
- 2000+ watts PEP input on SSB
- 1000 watts DC input on CW, RTTY, or SSTV Continuous Duty
- Variable forced air cooling system
- Self-contained continuous duty power supply
- Two EIMAC 8875 external-anode ceramic/metal triodes operating in grounded grid.
- Covers MARS frequencies without modifications
- Harmonic Suppression better than 50 dB
- Built-in LC Tuner
- Built in RF Wattmeter
- 117V or 234 V AC 50-60 Hz
- Third order distortion down at least 30 dB
- Frequency Range: 1.8 MHz (1.8-2.5) 3.5 MHz (3.4-4.6) 7 MHz (6.0-9.0) 14 MHz (11.0-16.0) 21 MHz (16.0-22.0) 28 MHz (28.0-30.0)
- 40 watts drive for 1 KW DC Input
- Rack mounting kit available (standard 19" rack)
- Size: 5 1/2" H x 14" W x 14" D
- Weight: 47 lbs.



Model 331A transistor dip meter - Portable RF single generator, signal monitor, or absorption wavemeter. Lightweight (1 pound, 6 ounces with all coils), battery-powered unit is ideal for field use in testing transceivers, tuning antennas, etc. Can also be used to measure capacity, inductance, circuit Q, and other factors. Indispensable for experimenters, it is easily the most versatile instrument in the shop. Continuous coverage from 2 MHz to 230 MHz in seven ranges.

Accuracy: 1000 Hz, 25% to 40%
 Modulation: 9 volt transistor battery, Burgess 2U6 or equivalent
 Power: 7" x 2 1/2" x 2 1/2"
 Size: 1 lb., 6 oz.
 Shipping Weight: 12 oz.
 Price: \$120.00



Coaxial antenna changeover relay, Model 377.

Power Rating: 1000 watts CW (3000 watts SSB)
 VSWR: Less than 1.15:1, DC to 150 MHz
 Power Requirements: 0.015 Amperes, 48 to 130 volts AC
 Connectors: UHF Type SO-239
 Dimensions: 3 1/2" x 1 1/2"
 Shipping Weight: 1 lb.
 Price: \$17.95



Model 359. Increase your transmitter's effective speech power up to four times. This two stage, transistorized Audio Preamp/Limiter can be used with all types of transmitters.

Input Impedance: 100,000 ohms
 Input Level: 5 millivolts to 20 millivolts
 Voltage Gain: 10 dB
 Output Level: 60 millivolts
 Output Impedance: 80,000 ohms
 Power: 9-volt transistor battery, Burgess 2U6 or equivalent
 Size: 2 1/2" x 3" x 4 1/2"
 Shipping Weight: 6 oz.
 Connectors: Terminal strip
 Price: \$37.50

Match everything from 160 to 10 with the new 160-10 MAT



NEW: The Monitor Tuner was designed because of overwhelming demand. Hams told us they wanted a 3 kilowatt tuner with a built-in wattmeter, a front panel antenna selector for coax, balanced line and random wire. So we engineered the 160-10m Monitor Tuner. It's a lifetime investment at \$299.50.



Meet the SuperTuner

MEET THE SUPER TUNER 160-10 AT. The DenTron Super Tuner tunes everything from 160-10 meters. Whether you have balanced line, coax cable, random or long wire, the Super Tuner will match the antenna impedance to your transmitter. All DenTron tuners give you maximum power transfer from your transmitter to your antenna, and isn't that where it really counts? 1 KW MODEL \$129.50.



Model 372 CLIPREAMP. Get maximum legal modulation without danger of splatter.

Input Impedance: 100,000 ohms
 Input Levels: 5 millivolts to 20 millivolts
 Voltage Gain: 10 dB
 Output Level: 60 millivolts
 Output Impedance: 50,000 ohms
 Power: 9-volt transistor battery, Burgess 2U6 or equivalent
 Size: 3 1/2" x 3" x 4 1/2"
 Shipping Weight: 7 oz.
 Connectors: Terminal strip
 Price: \$27.50



PHONE PATCH

Universal hybrid coupler II phone patch. Model 3002W and model 3001W. The hybrid circuit provides for effortless VOX operation of the phone patch. A built-in Compreamp speech preamplifier/limiter (in Model 3002W) increases the level of weak phone signals and also prevents overmodulation when the local telephone is used as the station microphone. (The Compreamp also functions as a preamplifier/limiter with the station microphone, if desired.)

Model 300 2W with Compreamp \$125.00
Model 300 1W without Compreamp \$85.00

Inputs from: Line 600 ohms
 Receiver 4 ohms
 Microphone High impedance (50,000 ohms) crystal or dynamic
 4 ohms
 Tape Recorder: 4 ohms
 Transmitter: 50,000 ohms
 Receiver Speaker 4 ohms
 Tape Recorder: 0.5 megohm
 Size: 6 1/2" x 7 1/2" x 3"
 Shipping Weight: 3 1/2 lbs.
 Power: 9-volt battery, Burgess 2U6 or equivalent
 Connectors: Phone

2-meter mobile AT-200 Antenna Matcher. Use your cars AM/FM antenna for your 2-meter mobile rig. Tunes from the front panel for max. output, min. VSWR (1.2:1 or less for most car antennas). \$24.95



JMR MOBIL-EAR
MODEL 1015-A
\$69.95

Two-way-radio headset with superior fidelity Electret-Capacitor boom microphone and palm-held talk switch.

FOR BROADCAST-QUALITY TRANSMISSION AND RECEPTION FOR BOTH MOBILE UNITS AND BASE STATIONS.

- Boom-mounted electret-capacitor microphone delivers studio-quality, undistorted voice reproduction. Variable gain control lets you adjust for optimum modulation.
- Cushioned earcup lets you monitor in privacy -- no speaker blare to disturb others. Blocks out environmental noises, too. Made of unbreakable ABS plastic.
- Headband self-adjusts for comfortable wear over long hours. Spring-flex hinge lets you slip headset on and off with just one hand. Reversible for right or left ear.
- Headset can be hung on standard microphone clip.
- Compact palm-held talk switch lets you keep both hands on the wheel for safer driving. Made of unbreakable ABS plastic.
- Built-in FET transistor amplifier adapts microphone output to any transceiver impedance.
- Compatible with most two-way radios including 40-channel CB units.
- Built-in Velcro pad for easy mounting of the talk switch.
- Made in U.S.A.

SPECIFICATIONS
Earphone impedance and type: 8 ohms, dynamic
Microphone type: Electret capacitor
Microphone frequency response: 200-6000 Hz
Amplifier type: FET transistor, variable gain
Amplifier battery 7-volt Mallory power: TR-175
Switching: Relay or electronic

IDEAL FOR EVERY TWO-WAY RADIO COMMUNICATIONS NEED...

- CB operators • Amateur radio operators • Police and fire vehicles • Ambulances and emergency vehicles • Taxis and trucks • Marine pleasure and work boats • Construction and demolition crews • Industrial communications • Security patrols • Airport tower and ground crews • Remote broadcast and TV-camera crews • Foresters and fire-watch units •

GIANT SALE NOW IN PROGRESS!

GIANT SALE NOW IN PROGRESS!

GIANT SALE NOW IN PROGRESS!



The Bencher Ultimate Paddle... a dual lever, iambic keyer paddle that will increase your speed, accuracy & operating comfort.

- **ADJUSTABLE CONTACT POINT SPACING** - Precision screw adjustments on each set of contacts make exact settings easy. Contact posts are split and locked by set screws, eliminating the need for locknuts.
- **WIDE RANGE OF TENSION ADJUSTMENT** - Tension on finger knobs is maintained by a long expansion spring. Dual screw adjustments adjust spring tension to match your "fist".
- **SELF ADJUSTING NEEDLE BEARINGS** - Keying shafts pivot in nylon bearings that "float" on machined brass fittings. Spring tension prevents free play and slop; eliminates contact bounce and backlash.
- **SOLID SILVER CONTACT POINTS** - The contact points are solid silver for a lifetime of flawless keying.
- **PRECISION-MACHINED COMPONENTS** - Main frame, contact posts, spring post and bearing ring are all machined from solid brass... polished and chrome plated for durability and rich appearance. The Bencher Paddle looks as good as it works!
- **HEAVY STEEL BASE; NON-SKID FEET** - Finished in an attractive black wrinkle finish (chrome plating optional), the base measures 9.5cm x 10.2cm x 1.3cm thick. It weighs 1 kilogram, and with its non-skid rubber feet is as solid as a rock.

Model BY-1 Standard Black Base... \$39.95, Model BY-2 Polished Chrome Base... \$49.95.

BENCHER, INC.

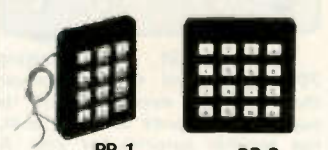

M series is for mounting to surfaces inaccessible from the rear (walls, mobiles, systems interface, panels, test equipment). K series is self-contained with a relay inside the encoder. When keys are pressed contact closer occurs with a 2 sec. delay (adjustable). Contacts are rated at 110 mA @ 28 volts switched, 500 mA carry. PP-2K contains delay exclusion for the fourth column. However, by jumping D-5, 4th column is restored. Unit is operable from 4.5-60 volts at temperatures from 0°-140° F. Output level will drive any transmitter or system. Adjustable output level is controlled with an extremely stable multi-turn trimpot, w/access from the front of the encoder (not behind), saving time for level setting, which amounts to hours when involved w/a system.

PP-1 \$55 (12 keys), PP-1m \$55 (lettering optional add \$1), PP-1K \$66, PP-2 \$58; PP-2m \$58 (lettering optional add \$1); PP-2K \$69, PP-1A \$68 (for standard comm hand-held).

Pipo Communications

MICROWAVE MODULES TEXAS RF

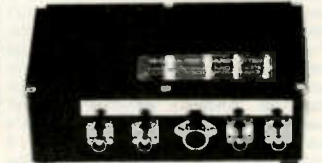

MICROWAVE MODULES HIGH PERFORMANCE UNITS FOR 144, 432 and 1296 MHz

144 MHz MOSFET CONVERTER - MMC144/28
With dual protected gate Mosfet RF Amplifier and Mixer stages
Input frequency: 144-146 MHz
I.F. output frequency: 28-30 MHz
Typical gain: 30 dB
Guaranteed maximum noise figure: 2.6 dB
Typical image rejection: 65 dB
Crystal oscillator frequency: 116 MHz (zener controlled)
Maximum frequency error at 144 MHz: 3 KHz
Power requirements: 12 volts DC 325% at 50 mA
Other I.F. output frequencies available: 12-14, 14-16, 18-20, 24-26 MHz

144 MHz MOSFET CONVERTER - MMC144/28 LC
Similar to the MMC144/28, this unit features an additional 116 MHz output amplifier to provide a local oscillator signal suitable for transmitter use.

144 MHz DOUBLE CONVERSION MOSFET CONVERTER - MMC144/2
This unit has been developed to meet the requirement for a converter suitable for use with receivers having better performance at lower frequencies.
Input frequency: 144-146 MHz
I.F. output frequency: 2.4, 4.6 MHz
Oscillator frequency: 71 MHz (2.4 MHz IF), 70 MHz (4.6 MHz IF)
Maximum frequency error at 144 MHz: 3 KHz
Typical gain: 30 dB
Guaranteed maximum noise figure: 2.5 dB
Power requirements: 12 volts DC 325% at 30 mA

144 MHz DUAL OUTPUT MOSFET PRE-AMPLIFIER - MMA144
This two-stage mosfet preamplifier has two separate isolated outputs, for leading two receivers, for example.
Input frequency: 144-146 MHz
Typical gain: 18 dB
Guaranteed maximum noise figure: 2.5 dB
Bandwidth: 5 MHz at 3 dB, 8 MHz at 10 dB
Power requirements: 12 volts DC 325% at 25 mA

432 MHz MOSFET CONVERTER - MMC432/144
Two RF Amplifiers and a Mosfet Mixer combine high sensitivity and low cross-modulation characteristics.
Input frequency: 432-434 MHz
I.F. output frequencies available: 14-18, 18-20, 28-30, 144-146 MHz
Typical gain: 30 dB
Guaranteed maximum noise figure: 3.8 dB
Crystal oscillator frequency: 101 MHz (28-30 MHz IF)
Zener controlled: 96 MHz (144-146 MHz IF)
Maximum frequency error at 432 MHz: 5 KHz
Power requirements: 12 volts DC 325% at 45 mA

1296 MHz CONVERTER - MMC 1296/28
A hybrid ring mixer with a matched pair of hot-carrier diodes, driving a dualgate mosfet I.F. amplifier.
Input frequency: 1296-1298 MHz
I.F. output frequencies available: 28-30, 144-146 MHz
Typical gain: 25 dB
Guaranteed maximum noise figure: 8.6 dB
Crystal oscillator frequency: 105.666 MHz (28-30 MHz IF)
Zener controlled: 96 MHz (144-146 MHz IF)
Maximum frequency error at 1296 MHz: 20 kHz
Power requirements: 12 volts DC 326% at 50 mA
Connectors: 50 ohm BNC

TRANSVERTERS:
MMT 144/28 198.95
MMT 144/50 198.95
MMT 432/28S 259.95
MMT 432/50S 259.95
MMT 432/144S 298.95
RECEIVING CONVERTERS:
MMC 144/28 55.95
MMC 144/28LO 60.95
MMC 432/28S 65.00
MMC 432/144 65.00
MMC 1296/28 71.95
MMC 1296/144 71.95
VARIABLE TUNING:
MVV 1296 81.50
ATTENUATORS:
MTA 15 16.00

TEE/AX
Coax Toggle Switch - \$39.95

Patent Pending Model SW-5000
TEE/AX
Coax Toggle Switch - \$39.95



• All brass construction • Teflon insulated • Captivated internal contacts • available in UHF, BNC, N, E, all series. • 52 Ohms • SPDT, DPDT • Power 1 Kw
TEE/AX, INC.

AMPHENOL BUNKER RAMD

SERIES 31 - BNC CONNECTORS
Amphenol's BNC connectors are small, lightweight, weatherproof connectors with bayonet action for quick disconnect applications.
Shells, coupling rings and male contacts are accurately machined from brass. Springs are made of beryllium copper. All parts in turn are ANTI-OXIDIZED to give you connectors that can take constant handling, high temperatures and resist abrasion.

BNC BULKHEAD RECEPTACLE 31-221-385 UG-1094
Mates with any BNC plug. Receptacle can be mounted into panels up to 1/4" thick.
BNC (M) TO UHF (F) ADAPTER 309-2900-385 UG-255
Adapts any BNC jack to any UHF plug. \$3.63
DOUBLE MATE ADAPTER 83-877-385
Both coupling rings are free turning. Connects 2 female components. \$2.72
JACK ADAPTER 575-105-385
Adapts 83-1SP-385 to Motorola type auto antenna jack or pin jack.
PANEL RECEPTACLE 83-1R-385 SO239
Mounts with 4 fasteners in 21/32" diameter hole. \$1.17
PANEL RECEPTACLE

BNC (F) TO UHF (M) ADAPTER 31-028-385 UG-273
Adapts any BNC plug to any UHF jack. \$2.39
PUSH-ON 83-5SP-385
Features a spring shell to push fit on female connectors. \$2.27

LIGHTNING ARRESTOR 575-105-385
Eliminates static build-up from an antenna. Protects your valuable equipment against lightning damage. \$4.80
BNC PLUG 31-002-385 UG-88
Commonly used for communications antenna lead cables. For RG 55/U & RG 58/U cables. \$1.59
BNC STRAIGHT ADAPTER 31-219-385 UG-914 1 9/32"
long, allows length of cables to be joined. Mates with BNC plugs. \$2.12
BNC PANEL RECEPTACLE 31-003-385 UG-290
Mounts with 4 fasteners in 29/64" diameter hole. \$1.74

83-87A-385 SO239SH
Mounts in single 21/32" diameter hole. Knurled lock nuts prevent turning. \$1.59
BNC ANGLE ADAPTER 31-009-385 UG-306
Adapts any BNC plug for right angle use. \$4.23
BNC TEE ADAPTER 31-008-385 UG-274
Adapts 2 BNC plugs to 31-003-385 or other female BNC type receptacle. \$4.56

PL-259 ... 90d UG-175 (Adapter for RG 58U) ... 25d

Model M-1S

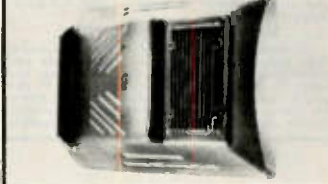

- Nemarc Auto Console Model M-1S
- Universal mount for CB and amateur radios, tape players, AM & FM tuners, & scanners.
 - Sculptured design for "original equipment" look.
 - Low profile for non-slip mounting: 13-1/2" x 10-1/2" x 5-5/8" high.
 - Easy-to-install & remove for theft protection.
 - Tough unbreakable copolymer with rich brown textured finish.
 - Integral cup holder and coin tray. \$14.95
 - Auto Console Model M-1S: Same features as above model PLUS:
 - Specially designed 3" x 5" oval speaker for voice communication. Frequency response: 150 Hz-7 KHz, voice coil: 9/16" diameter. \$19.95

Nemarc

TUFTS RADIO CATALOG TUFTS RADIO



ARGONAUT, MODEL 509

Covers all Amateur bands 10-80 meters. 9 MHz crystal filter. 2.5 kHz bandwidth. 1.7 shape factor @ 6/50 dB points. Power required 12-15 VDC @ 150 mA receive, 800 mA transmit at rated output. Construction aluminum chassis, top and front panel, molded plastic end panels. Cream front panel, walnut vinyl top and end trim. Size HWD 4 1/2" x 13" x 7". Weight 6 lbs.

LINEAR AMPLIFIER, MODEL 405

Covers all Amateur bands 10-80 meters. 50 W output power, continuous wave. RF wattmeter SWR. Power required 12-15 VDC @ 8 A, max. Construction aluminum chassis, top and front panel, molded plastic end panels. Cream front panel, walnut vinyl top and end trim. Size HWD 4 1/2" x 7" x 8". Weight 2 1/2 lbs.

DISCONTINUED

TRITON IV Digital Model 544

The new ultra-modern fully solid-state TRITON makes operating easier and a lot more fun, without the limitations of vacuum tubes. For one thing, you can change bands with the flick of a switch and no danger of off-resonance damage. And no deterioration of performance with age. But that's not all. A superlative 8-pole i-f filter and less than 2% audio distortion, transmitting and receiving, makes it the smoothest and cleanest signal on the air. The TRITON IV specifications are impeccable. For selectivity, stability and receiver sensitivity. And it has features such as full CW break-in, preselectable ALC, offset tuning, separate AC power supply, 12 VDC operation, perfectly shaped CW waveform, built-in SWR bridge and on and on.



TEN-TEC

KR20-A ELECTRONIC KEYS

A fine instrument for all-around high performance electronic keying. Paddle actuation force is factory adjusted for rhythmic smooth keying. Contact adjustments on front. Weighting factor factory set for optimum smoothness and articulation. Over-ride "straight key" conveniently located for emphasis. QRS sending or tune-up. Reed relay output. Side-tone generator with adjustable level. Self-completing characters. Plug-in circuit board. For 117 VAC, 50-60 Hz or 6-14 VDC. Finished in cream and walnut vinyl. Price \$69.50

KR5-A ELECTRONIC KEYS

Similar to KR20-A but without side-tone oscillator or AC power supply. Ideal for portable, mobile or fixed station. A great value that will give years of trouble-free service. Housed in an attractive case with cream front, walnut vinyl top. For 6-14 VDC operation. Price \$39.50

KR1-A DELUXE DUAL PADDLE

Paddle assembly is that used in the KR50, housed in an attractive formed aluminum case. Price \$35.00

KR2-A SINGLE LEVER PADDLE

For keying conventional "TO" or discrete character keys, as used in the KR20-A. Price \$17.00

KR50 ELECTRONIC KEYS

A completely automatic electronic keyer fully adjustable to your operating style and preference, speed, touch and weighting, the ratio of the length of dits and dahs to the space between them. Self-controlled keyer to transmit your thoughts clearly, articulately and almost effortlessly. The jumble

(squeeze) feature allows the insertion of dits and dahs with perfect timing.

Memories provided for both dits and dahs but either may be defeated by switches on the rear panel. Thus, the KR50 may be operated as a full jambie (squeeze) keyer, with a single memory or as a conventional type keyer. All characters are self-completing. Price \$110.00

SPECIFICATIONS

Speed Range: 6-50 w.p.m.
Weighting Ratio Range: 50% to 150% of classical dit length.

Memories: Dit and dah. Individual defeat switches.

Paddle Actuation Force: 5-50 gms.

Power Source: 117VAC, 50-60 Hz, 6-14 VDC.

Finish: Cream front, walnut vinyl top and side panel trim.

Output: Reed relay. Contact rating 15 VA, 400 V max.

Paddles: Torque drive with ball bearing pivot.

Side-tone: 500 Hz tone.

Adjustable output to 1 volt.

Size HWD: 2 1/2" x 5 1/4" x 8 1/4"

Weight: 1 1/4 lbs.

KR50



tuning, crystal frequency stability at each frequency of operation, and over 40,000 HF channels displayed in 100 Hz increments... 150 Hz fine tuning for continuous ham band coverage.

Each circuit board is "baked-in" for over 100 hours prior to installation in the transceiver assembly.

Discover the ease and accuracy of electronic tuning. Calibrate all bands with WWV at the turn of a switch. Lowest frequency drift, with no VFO to calibrate. Only 2.8" high x 9.5" wide x 12.3" deep. Ideal for mobile use or with accessories, provides complete fixed station operation. Price \$995.00.

Accessories AC Power supply \$135.00. Speaker in cabinet \$29.95. Station operating console with phone patch, 24 hr. digital clock, speaker, 10 min. timer \$295.00. Desk microphone \$38.00. Mobile mount \$12.00. Mobile mic \$15.00. 400 Hz narrow band CW filter \$50.00.

ICB
FRANCIERE

ACCESSORIES

206	Crystal Calibrator	\$29.00
207	Ammeter for Models 251, 252G, 262G	14.00
208	CW Filter, for Model 509	29.00
212	Crystal, for Models 540, 544, 29.0-29.5 MHz	5.00
213	Crystal, for Models 540, 544, 29.5-30.0 MHz	5.00
215P	Microphone, Ceramic with plug	29.50
240	One-Sixty Converter, for Models 540, 544	97.00
241	Crystal Oscillator, for Models 540, 544	29.00
242	Remote VFO, for Models 540, 544	169.00
244	Digital Readout/Counter, for Model 540	197.00
245	CW Filter, for Models 540, 544	25.00
249	Noise Blanker, for Models 540, 544	29.00
271	Crystal, for Model 570, 21.0-21.5 MHz	5.00
272	Crystal, for Model 570, 28.0-28.5 MHz	5.00
273	Crystal, for Model 570, 28.5-29.0 MHz	5.00
276	Crystal Calibrator, for Model 570	29.00
1102	Snap-Up Legs, per pair	1.00

POWER SUPPLIES

210	117 VAC, 13 VDC, 1 A	30.00
210/E	Same as Model 210, but 115/230 VAC	35.00
251	117 VAC, 13 VDC, 9 A	85.00
251/E	Same as Model 251, but 115/230 VAC	92.00
252G	117 VAC, 13 VDC, 18 A	109.00
252G/E	Same as Model 252G, but 115/230 VAC	116.00
262G	Same as Model 252G, with VOX & speakers	139.00
262G/E	Same as Model 262G, but 115/230 VAC	146.00

LINEARS AND TRANSCEIVERS

509	Argonaut Transceiver, SSB/CW, 5 W. 3.5-30 MHz	359.00
540	Triton IV, SSB/CW, 200 W. 3.5-30 MHz	699.00
544	Triton IV, Digital, SSB/CW, 200 W. 3.5-30 MHz	869.00
570	Century/21, CW, 70 W. 3.5-30 MHz	299.00
574	Century 21, Digital	399.00

KEYERS

670	Single Paddle, for Model 570 only	29.00
KR-1A	Paddle Assembly, Dual	35.00
KR-2A	Paddle Assembly, Single	17.00
KR-5A	Single Paddle Keyer, 6-14 VDC	39.50
KR-20A	Single Paddle Keyer, 117 VAC/6-14 VDC	69.50
KR-50	Ultramatic, Dual Paddle, 117 VAC/6-15 VDC	110.00

THE SURPRISE OF THE CENTURY



0.3" high, accurate to nearest 1 kHz. Model 570: marked in 5 kHz increments from 0-500 kHz, MHz markings for each band displayed, tuning rate typically 17 kHz per tuning knob turn.

Century 21, the exciting 70-watt, 5-band CW transceiver that surprised everyone with its super performance and low cost, has another surprise for you. A second model with digital readout (and a mod kit for those who would like to convert their dial model). Both Models 570 and 574 have the same unique circuitry that has won raves from everyone - both have the same fine features:

• Direct Frequency Readout (Model 574:5 red LED digits,

• Full Break-In • Full Band Coverage on 3, 5, 7, 14, 21 MHz Bands, 1 MHz on 28 MHz Band • 70 Watts Input • Total Solid-State • Receives SSB and CW • Receiver Sensitivity 1 μV • Instant Band Change, No Tune-up • Offset Receiver Tuning • 3-Position Selectivity • Adjustable Sidetone Level • Linear Crystal-Mixed VFO • Overload Protection • Built-In AC Power Supply • Black & Gray Styling • HWD: 6-1/8" x 12-1/2" x 12", 15-1/2 lbs. • Matching Accessories

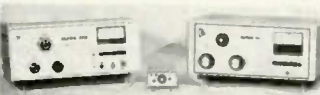

• ALL THE ROCK-CRUSHING POWER YOUR LICENSE ALLOWS - on all modes -
• INSTANT BANDCHANGE 'NO-TUNE-UP' all the way from 10 through 80 meters, with the ALPHA 374A?
• COVERAGE ALL THE WAY DOWN TO 160 METERS with the smooth-tuning, extra-rugged ALPHA 76A powerhouse?
• CRISP, PENETRATING "TALK POWER" - as much as

10 dB extra to 'punch through', with the ALPHA/VOMAX split band speech processor?

• THE PROTECTION OF A FACTORY WARRANTY THAT RUNS A FULL 18 MONTHS - six times as long as competitive units? [ETO tries to build every ALPHA to last forever... and we're making progress: not one single case of ALPHA 76A, 77DX, or 374A power transformer failure has ever been reported!]

• ALPHA 76A - \$1195.00, ALPHA 77DX - \$3295.00, ALPHA 374A - \$1595.00.

ETO ENRHORN TECHNOLOGICAL OPERATIONS INC.

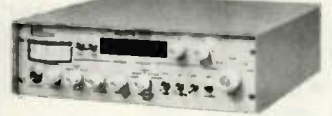

FIRST WITH SSB HF DIGITAL TUNING, IS ONLY THE BEGINNING OF WHAT THE AMATEUR GETS FROM THE CIR ASTRO 200A.

Standard Features:
Electronic Tuning / All Solid State / Digitally Synthesized / 200 Watts PEP Input / Full RF Filtering / Digital Readout / Noise Blanker / Squelch / Variable Speech Processing / Full Metering / WWV Receiver / VOX / LSB-USB-CW

The heart of the ASTRO-200A is the frequency synthesizer. The latest in phase-lock-loop technology is incorporated to provide the built-in versatility of all electronic

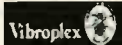

THE IMPROVED "ORIGINAL" VIBROPLEX. Suitable for All Classes of Transmitting Work Where Speed and Perfect Morse Are Prime Essentials. This great new Vibroplex is a smooth and easy working BUG. It has won fame on land and sea for its clarity, precision and ease of manipulation. Can be slowed down to 10 words per minute or less or geared to as high rate of speed as desired. Maintains the same high quality signal at whatever speed, insuring easy reception under all conditions. Weight 3 lbs. 8 oz. DeLuxe - Chromium base and top parts, with jeweled movement. \$59.95



THE "LIGHTNING BUG" VIBROPLEX High Quality Signals at All Speeds. Flat pendulum model. Weight 3 lbs. 8 oz. Standard - Polished Chromium top parts, grey base. \$49.95



THE "CHAMPION" VIBROPLEX Weight 3 lbs. 8 oz. Without circuit closer. Standard finish only. Chromium finished top parts, with grey crystal base. \$46.50



VIBRO-KEYER Over the years, we have had many requests for Vibroplex parts to be used for construction of a keying mechanism for an electronic transmitting unit. This beautiful and most efficient "Vibro Keyer" is ideal for this job.

FEATURES OF THE "VIBRO-KEYER"

- Beautiful beige colored base, size 3 1/2" x 4 1/2", weight 2 1/2 pounds
- Same large size contacts as furnished on Deluxe Vibroplex.
- Same main frame and super finished parts as Deluxe Vibroplex
- Colorful red finger and thumb pieces.
- Has the same smooth and easy operating Vibroplex trunion level
- A real "Gem" adjustable to suit your own "taste".

Standard - \$46.50; Deluxe Finish \$58.50

There's nothing like it



RADIO AMATEUR CALLBOOK - There's nothing like it! Foreign Radio Amateur Callbook DX Listings - \$13.95; United States Callbook - All K&W Listings - \$14.95.



No. SSK-1 \$23.95
No. SSK-1CP Chrome - \$29.95

NYE VIKING SQUEEZE KEY

Extra-long, finger-fitting molded paddles with adjustable spring tension, adjustable contact spacing. Knife-edge bearings and extra large, gold plated silver contacts! Nickel plated brass hardware and heavy, die cast base with non-skid feet. Base and dust cover black crackle finished. SSK-1 - \$23.45. SSK-1CP has heavily chrome-plated base and dust cover. Price - \$29.45

CODE PRACTICE SET

You get a sure, smooth, Speed-X model 310-001 transmitting key, linear circuit oscillator and amplifier, with a built-in 2" speaker, all mounted on a heavy duty aluminum base with non-skid feet. Operates on standard 9V transistor type battery (not included). Price - \$18.50

PHONE PATCH Model No. 250-46-1 measures 6-1/2" wide, 2-1/4" high and 2-7/8" deep. List price, \$36.50. **Model 250-46-3**, designed for use with transceivers having a built-in speaker, has its own built-in 2" x 6" 2 watt speaker. Measures 6-1/2" wide, 2-1/4" high and 2-7/8" deep. Price - \$44.50



No. 114-320-003 - \$9.90
No. 114-322-003 - Brass - \$10.30



No. 114-320-001 - \$8.30
No. 114-322-001 - Brass - \$8.65



No. 114-310-003 - \$8.25
No. 114-312-003 - Brass - \$8.65

NYE VIKING SPEED-X KEYS

NYE VIKING Standard Speed-X keys feature smooth, adjustable bearings, heavy-duty silver contacts, and are mounted on a heavy oval die cast base with black wrinkle finish. Available with standard, or Navy knob, with, or without switch, and with nickel or brass plated key arm and hardware.

Pamper yourself with a Gold-Plated NYE VIKING KEY! Model No. 114-31C-004GP has all the smooth action features of NYE Speed-X keys in a special "presentation" model. All hardware is heavily gold plated and it is mounted on onyx-like jet black plastic sub-base. Price \$50.00

Wilson Electronics Corp.



COMMON FEATURES

- 6 Channel Operation
- Individual Trimmers on all TX/RX Xkals
- All Xkals Plug-in
- Microswitch control of TX/RX
- Rubber Flex Antenna furnished
- Converter Size... Fits in hip pocket
- 90 Day Warranty
- Can be modified for MARS or CAP
- Built for rugged use
- Inexpensive power source with rechargeable Ni-Cad
- Easily accessible circuitry
- One pair Xkals furnished with each radio installed

NEW 2 METER MARK II AND MARK IV

As the smallest size hand-helds ever marketed, the radios feature excellent adjacent channel selectivity, and innermod/image rejection. The attractive blue-gray Lexan® outer case is rugged and durable. Mark II (2.5 watt) \$229.98. Mark IV (4 watt) \$259.98

Riding the crest of the new wave of multi-channel two-meter rigs is the Wilson WE-800. Designed as an all-purpose mobile or portable unit, the WE-800 is loaded with enough features to satisfy even the most discriminating amateur. The "800" is for channels, from 144 to 148 MHz in 5 KHz steps, up or down 500 KHz for your local repeater. There are even provisions for pre-programming five of your favorite frequencies or changing to two optional offsets, in case your area repeater is nonstandard. Add to these features; internal rechargeable power pack optional (uses 10 AA NiCad cells, not included), detachable rubber flex antenna, built-in S-meter/output Indicator, built-in

high-low power option switch (1 or 12 watts, when used mobile or base), built-in connectors for external antenna, speaker and power. Whether you're just getting your feet wet on two-meters, or a seasoned amateur, you'll find the WE-800 to be the most lightweight, versatile base/mobile/portable rig on the market today. The WE-800 comes complete with plug-in speaker-microphone, mobile mounting bracket/handle, rubber flex antenna, 12V DC Charger Cord, instruction booklet and 90 day limited warranty. Rechargeable internal battery pack optional.



GENERAL SPECIFICATIONS

- Frequency range: 144.000 - 147.995 MHz
- No. of channels: 700K & 147.995 & 10 kHz
- Operating mode: Direct frequency modulation (10 to 15 VDC range)
- Type of communication: Simplex or transmitter offset (4600 kHz)
- Operating voltage: 12V VDC, regulator ground
- Current drain: Transmitter - 700 mA in 1 watt output
2 watts @ 12 watt output
Receiver - 45 mA quiescent
250 mA full A.F. audio output
- Antenna impedance: 50 ohms nominal
- Size: 8-1/4" x 6-3/4" x 1-7/8" inches
(205.6 x 171.5 x 47.2 mm)
- Weight: 1 lb. 15 oz. (4.13 kg)
1 lb. 11 oz. (4.16 kg) with batteries
- Frequency determination method: CW/CW phase locked loop
- Offset Option: Two optional offset 1.5 channels also available

LEATHER CARRYING CASE

- LC-1 for 1402 SM - \$18.95
 - LC-3 for Mark II, IV - \$16.95
 - LC-2 - all others - \$18.95
- 110V-AC DESK BATTERY CHARGER**
For new units Mark II, IV - use the Model BC-2; for Models 1402, 1405, 1407, 2202 and 4502, use Model BC-1. \$40.95



- Model TA-33
- Model TA-33, 3 elements, 10.1 dB forward gain (over isotropic source) - \$206.50
- Model TA-33 Jr., 3 elements, 10.1 dB forward gain (over isotropic source) - \$151.85
- Model MPK-3, 7500 Watts AM/CW and 2000 Watts P.E.P. SSB - \$52.25
- Model TA-36, 6 elements - \$335.25
- AK-60 mast plate adapter - \$11.15
- Model CL-33, 3 elements - \$232.50
- Model CL-36, 6 elements - \$310.65
- Model CL-203, 3 elements - \$227.65
- Model TA-40 KR - 40 meter conversion kit - \$92.25
- Signal-master antenna - \$267.50

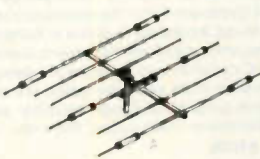

WATT BATTERY CHARGER
110 V-AC Charger... use WC-12 (\$19.95) for 1402, 1405, 1407, 2202, 4502; use WC-14 (\$15.95) for Mark II, IV.

ACCESSORIES
BC-12 - \$14.95
CIGARETTE LIGHTER MOBILE POWER PLUG

SPEAKER MIC
SM1 - for Models 1402, 1405, 1407, 2202, 4502.
SM3 - (Mark II, Mark IV)
SM2 for Models 1402, 1405, 1407, 2202, 4502. (\$30.95).

RECHARGEABLE BATTERY PACKS

Use the following Ni-Cad Packs for the unit you select:
BP-1 - 10 loose cells - 500 mA (1402, 1405) - \$18.95
BP-2 - strapped cells - 600 mA (1405, 2202, 4502) - \$24.95
BP-4 - Mark II, Mark IV pack - \$20.95
BP-7 - 1407 SM high power pack - \$24.95

Other options include: Touch Tone® Pad (installed only), TE-1 Tone Encoder, TE-2 Encoder/Decoder, BNC Rubber Duck Antenna, TNC Rubber Duck Antenna.



SAVE YOUR RADIO!



DESIGNED FOR COMMERCIAL USE UP TO 1000 MHz.
The TUFTS SAVE-YOUR-RADIO bracket can save you a bundle... and a lot of hassle. Why worry about rig theft? The TUFTS SVR bracket mounts quickly and easily in your car and makes it possible to snap your rig out of its bracket when you park and put it out of sight.
The connector system has a special coaxial cable connector which will provide you with a lossless connection right up to 1000 MHz! No loss! In addition to the quick coax connector there are also four power and accessory connections which are made automatically when the rig is slid into its bracket... just what you need for feeding power and loudspeaker connections to the rig.
This is a rugged bracket and connector system... it'll take a beating. There is a hole on each side of the 18 gauge steel plate for a padlock in case you want to leave the rig for short periods in its bracket. They'll have to rip out the dash to get it... and it won't be the first time for that.
With two of these brackets you can bring the mobile rig into the house and use it in seconds. On this unit you can take an AC supply for the rig and use it in your living room. Price: \$29.95

TUFTS SELECTED TITLES OF POPULAR SAMS PUBLICATIONS

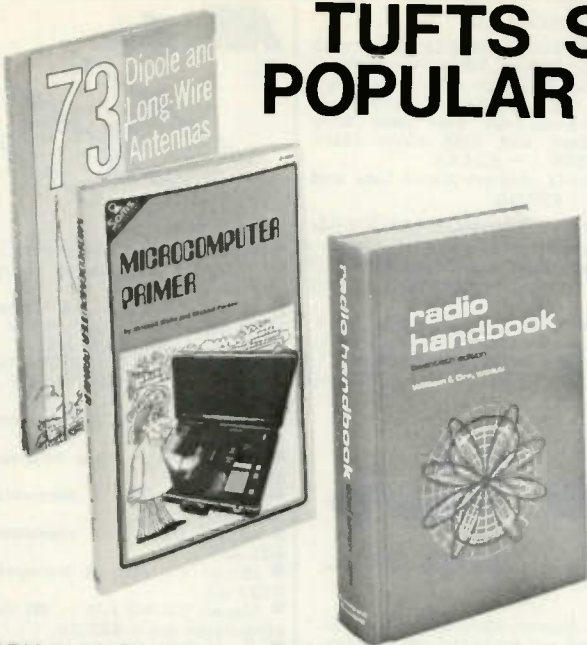

RADIO HANDBOOK (20th Edition)

by William I. Orr, W6SAI. A completely updated 20th edition of the famous communications handbook that is the electronics industry standard for engineers, technicians, and advanced amateurs. Explains in authoritative detail how to design and build all types of radiocommunications equipment. Contains greatly enlarged section on semiconductor and IC circuit design. Includes ssb design and equipment; rty circuits; linear amplifiers, both solid-state and tube types; vhf and uhf transmitters and converters; as well as special-purpose and logic circuitry, plus completely revised chapter on electronics mathematics. 1080 pages; 6½ x 9¼; hardbound.

No. 24032

\$19.50

HAM AND CB ANTENNA DIMENSION CHARTS

by Edward M. Noll, W3FQJ. Tabulates dimension information in feet and inches for all the popular antenna configurations. Gives data for dipole antennas, quarter-wave verticals, two-element beams, quads, triangles, inverted dipoles, and inverted vees. Includes information for cutting transmission lines to a preferred wavelength, dimensioning phasing lines, cutting a matching stub, and spacing antenna elements. 64 pages; 6 x 9; softbound.

No. 24023

\$2.75

COMMERCIAL RADIOTELEPHONE LICENSE QUESTION & ANSWER STUDY GUIDE (3rd Edition)

by Edward M. Noll. Prepares the reader to take the examinations for the various grades of radiotelephone licenses. Emphasizes those subjects that are most important or most likely to be misunderstood. The questions are representative of those used in the FCC examinations. 304 pages; 6 x 9; softbound.

No. 24033

\$8.50

RADIO TRANSMITTER PRINCIPLES AND PROJECTS

by Edward M. Noll, W3FQJ. Devoted entirely to the subject of radio transmitters, this book is a helpful gathering of modern transmitter principles, ideas, circuits, techniques, and learn-by-doing projects. Covers Bipolar CW and A-M Transmitter Circuits, Transistor/Tube Circuits, Basic Principles of SSB-DSB Generation, Integrated Circuit Fundamentals, VHF/VHF Circuits and Principles, Frequency Modulation, and more. 320 pages; 5½ x 8½; softbound.

No. 24031

\$6.95

73 DIPOLE AND LONG-WIRE ANTENNAS

by Edward M. Noll, W3FQJ. Covers practically every type of wire antenna used by amateurs. Gives dimensions, configurations, and construction data for 73 different antennas, plus appendices covering construction of noise bridges, line tuners, and data on measuring resonant frequency, velocity factor, and swr. 160 pages; 5½ x 8½; softbound.

No. 24006

\$5.50

73 VERTICAL, BEAM, AND TRIANGLE ANTENNAS

by Edward M. Noll, W3FQJ. The second book in a series of practical antenna construction and design methods. Contains data on practically all types used by amateurs. Not a rehash of previously published data, but a compilation of the author's own experiments with various antenna configurations. The 73 different antennas have all been built and air-tested by the author. 160 pages; 5½ x 8½; softbound.

No. 24021

\$5.50

FIRST-CLASS RADIOTELEPHONE LICENSE HANDBOOK (4th Edition)

by Edward M. Noll. An excellent study guide for the first-class radiotelephone license examination. Contains all the material needed to pass Element IV of the FCC examination, including all the questions and answers found in the latest FCC Study Guide. Has three simulated examinations, presented in the multiple-choice form of the FCC tests, as well as answers and evaluations to help the reader find his weak areas. 416 pages; 5½ x 8½; softbound.

No. 21144

\$7.95

SECOND-CLASS RADIOTELEPHONE LICENSE HANDBOOK (5th Edition)

by Edward M. Noll. Provides all the study material needed to pass the FCC second-class radiotelephone license examination (Elements I, II, and III). All material is based on the FCC Study Guide and Reference Material for Commercial Operator Examination. Two tests are included to simulate the actual examination. 448 pages; 5½ x 8½; softbound.

No. 21111

\$7.95

THIRD-CLASS RADIOTELEPHONE LICENSE HANDBOOK (4th Edition)

by Edward M. Noll. Serves as a practical study guide for the aspiring radio operator as well as a ready reference for those working in the field. Designed as a study aid for obtaining licenses up to and including the Radiotelephone Third-Class Operator Permit with Broadcast Endorsement, this newest edition contains questions and answers similar to those given on the actual examination. 208 pages; 5½ x 8½; softbound.

No. 21353

\$5.95

CMOS COOKBOOK

by Don Lancaster. Tells all you need to know to understand and profitably use this inexpensive and genuinely fun to work with digital logic family. First an explanation of what CMOS is, how it works, and how to power it, plus usage rules, state testing, breadboarding, interface, and other basics is given. Then a minicatalog of over 100 devices, including pinouts and use descriptions is given. Subjects covered include gate fundamentals, tri-state logic, redundant logic design techniques, multivibrators, non-volatile memory techniques, clocked JK and D flip-flops, counter and register techniques, op amps, analog switches, phase-locked loops and much more. A must for the student, hobbyist, teachers, technician, or engineer who wants to learn about CMOS. Filled with practical applications. 416 pages; 5½ x 8½; softbound.

No. 21398

\$9.95

IC OP-AMP COOKBOOK

by Walter G. Jung. The first book of its kind to be published. Covers not only the basic theory of the IC op amp in great detail, but also includes over 250 practical circuit applications, liberally illustrated. Organized into three basic parts: introduction to the IC op amp and general considerations, practical circuit applications, and appendixes of manufacturers' reference material. 592 pages; 5½ x 8½; softbound.

No. 20969

\$12.95

IC TIMER COOKBOOK

by Walter Jung. Provides an excellent introduction to the field of IC timers by presenting a collection of various circuit "recipes" useful in applying the devices. Arranged in three parts, the first part gives basic and generalized information. Part II, the applications section, is the "meat" of the book and includes over 100 different circuits for a wide range of uses. Part III contains reproductions of manufacturers data sheets, second-source manufacturers, and more. This book is a valuable reference for the hobbyist, the technical or engineering student, or professional. 288 pages; 5½ x 8½; softbound.

No. 21416

\$9.95

TTL COOKBOOK

by Donald Lancaster. A complete and detailed guide to transistor-transistor logic (TTL). Explains what TTL is, how it works, and how to use it. Discusses practical applications, such as a digital counter and display system, events counter, electronic stopwatch, digital voltmeter, and a digital tachometer. 336 pages; 5½ x 8½; softbound.

No. 21035

\$8.95

HOW TO BUY & USE MINICOMPUTERS & MICROCOMPUTERS

by William Barden, Jr. Discusses these smaller computers and shows how they can be used in a variety of practical and recreational tasks in the home or business. Explains the basics of minicomputers and microcomputers, their hardware and software, peripheral devices available, and the various programming languages and techniques. Includes selection, buying, and programming your own system and gives detailed descriptions of currently available systems. 240 pages; 8½ x 11; softbound.

No. 21351

\$9.95

MICROCOMPUTER PRIMER

by Mitchell Waite and Michael Pardee. Introduces the beginner to the basic principles of the microcomputers. Discusses the five main parts of a Computer—Central processing unit, memory, input/output interfaces, and programs. The important characteristics of several well-known microprocessors are given and a chapter is included on programming your own microcomputer. 224 pages; 5½ x 8½; softbound.

No. 21404

\$7.95

THE 8080A BUGBOOK: MICROCOMPUTER INTERFACING AND PROGRAMMING

by Peter H. Rony, David G. Larsen, and Jonathan A. Titus. The principles, concepts, and applications of an 8-bit microcomputer based on the 8080 microprocessor IC chip. The emphasis is on the computer as a controller. Covers the four fundamental tasks of computer interfacing: (1) generation of strobe and device select pulses; (2) latching of accumulator output; (3) acquisition of input data by the accumulator; (4) generation of interrupt signals to the computer. Intended to help develop the skills needed to use an 8080-based breadboard microcomputer system. 5½ x 8½; softbound.

No. 21447

\$9.95

TUFTS RADIO CATALOG TUFTS RADIO

F9FT TONNA ANTENNAS

TUFTS RADIO CATALOG

144 Elements—144 MHz
—\$27.95

TECHNICAL DATA

Frequency range MHz	144/146
Gain ISO	14 dB
Horizontal aperture angle	2 x 19°
Vertical aperture angle*	2 x 23°
Front-to-back ratio	15 dB
Side lobe attenuation	>50 dB
SWR	≤ 1,3
Impedance	50
Weight	1,9 kg
Physical length	3,3 m
Windload*	6,4 kgp

*The indicated value is given at -3 dB

16 Elements—144 MHz
—\$55.95

TECHNICAL DATA

Frequency range MHz	144/146
Gain ISO	17,8 dB
Horizontal aperture angle*	2 x 16°
Vertical aperture angle*	2 x 17°
Front-to-back ratio	22 dB
Side lobe attenuation	>60 dB
SWR	≤ 1,2
Impedance	50
Weight	4,4 kg
Physical length	6,4 m
Windload*	16 kgp

*The indicated value is given at -3 dB

21 Elements—432 MHz
—\$45.95

TECHNICAL DATA

Frequency range MHz	432/435
Gain ISO	19 dB
Horizontal aperture angle*	2 x 12°
Vertical aperture angle*	2 x 13°
Front-to-back ratio	23 dB
Side lobe attenuation	≥ 40 dB
SWR	≤ 1,1
Impedance	50
Weight	2,6 kg
Physical length	4,6 m
Windload*	6,4 kgp

*The indicated value is given at -3 dB

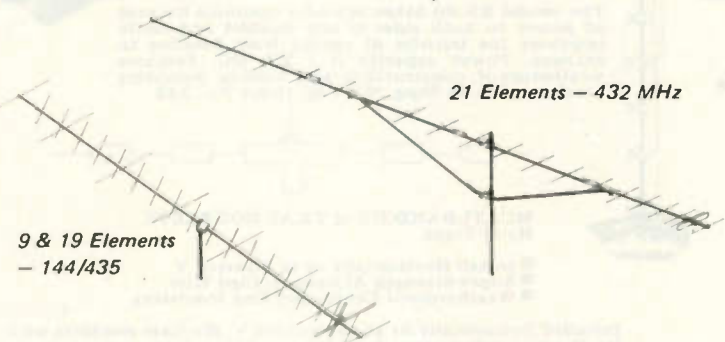

Special OSCAR—9 & 19 Elements—
144/435—\$53.00

TECHNICAL DATA

Frequency range MHz	144/146	430/440
Gain ISO	14 dB	17 dB
Horizontal aperture angle*	2 x 19°	2 x 14°
Vertical aperture angle*	2 x 23°	2 x 16°
Front-to-back ratio	15 dB	23 dB
Side lobe attenuation	>50 dB	> 38 dB
SWR	≤ 1,3	≤ 1,2
Impedance	50	50
Weight	1,9 kg	1,1 kg
Physical length	3,3 m	3,2 m
Windload*	6,4 kgp	5,4 kgp

*The indicated value is given at -3 dB

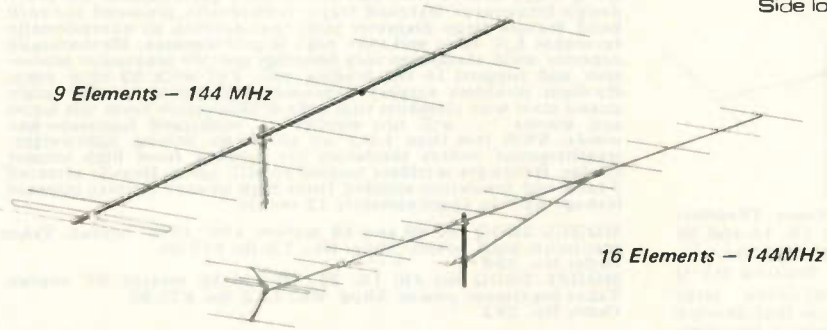

3 dB Gain High Performance Vehicular Antenna Series

HM-179 Low Profile Mount—\$29.00
 HM-180 Trunk Mount—\$33.50
 HM-187 Magnet Mount—\$36.50

All new low profile antennas feature a 5/8 wavelength high conductive whip. Spring and whip may be removed leaving only 1 3/16" high base for minimal air wash clearance. Coils are low-loss, shock-resistant, directly fed ungrounded configuration and encased in plastic base. New high conductive whips are made of 17-7 PH stainless steel... coated with copper and nickel for high conductivity and greater heat dissipation. Mounts are Teflon-insulated, aluminum and plated steel.

ELECTRICAL SPECIFICATIONS

Antenna power rating	100 watts
Frequency range	144-146 MHz
VSWR	1.5:1 or less
Nominal input impedance	50 ohms
Transformer	16 AWG copper wire, low loss coil, waterproof cover
*Gain	3 dB over 1/4 λ whip



HM-224 Trunk Mount—\$33.50 (220 MHz)

The most powerful mobile antenna available for 1-1/4 meter mobile activity. 4 dB gain is achieved by stacking a 5/8 λ and 1/4 λ radator. "Quick Grip" trunk mount means easy no hole mounting. Whip is quickly removed for car washes or storage. 17 RG-58/U and connector.

ELECTRICAL SPECIFICATIONS

Gain	4 dB
Bandwidth	5 MHz
Power rating	100 watts
Impedance	50 ohms

MECHANICAL SPECIFICATIONS

Radator	157 PH stainless steel plated with copper and nickel, 100g 48"
Length	48"

HM-225 Unity Gain (marine mobile service) —\$45.00 (220 MHz)

Unity Gain 3' fiberglass antenna for marine use. No ground plane required. Can be mounted at masthead on sailboats or on any vertical surface on power boats. Comes with 2' RG-58C/U cable.

ELECTRICAL SPECIFICATIONS

Gain	Unity
Bandwidth	20 MHz
Power rating	250 watts
Impedance	50 ohms

MECHANICAL SPECIFICATIONS

Length	Approx. 3'
Radator material	Copper encapsulated in fiberglass
Mount	Anodized aluminum bracket

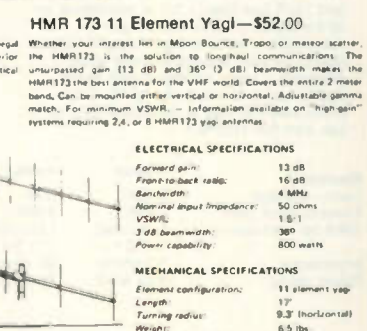
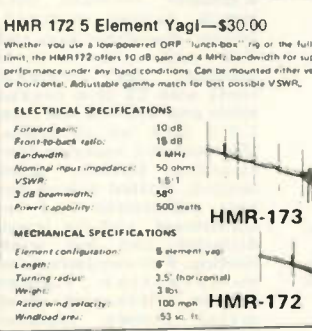

HM 20 Marine Mobile Service—\$39.00

Unity gain 5' fiberglass antenna for marine use. No ground plane required. Can be mounted at masthead on sailboats or on any vertical surface on power boats. Comes with 2' of RG-58C/U cable.

ELECTRICAL SPECIFICATIONS

Gain	Unity (reference 1/4 λ dipole)
Bandwidth	25 MHz
Power rating	250 watts
Frequency range	146-148 MHz
Nominal impedance	50 ohms

MECHANICAL SPECIFICATIONS

Length	Approximately 5'
Radator material	Copper encapsulated in fiberglass
Mount	Anodized aluminum bracket

ASPR 619 Coupler—\$17.00

Coupler for simultaneous 2 meter and ABL/FM broadcast radio usage.

There is no substitute for quality, performance, or the satisfaction of owning the very best.

Hence, the incomparable Hy-Gain 3750 Amateur transceiver. The 3750 covers all amateur bands 1.8-30 MHz (160-10 meters). It utilizes advanced Phase-Lock-Loop circuitry with dual gate MOS FET's at all critical RF amplifier and mixer stages. There's a rotating dial for easy band-scanning and an electronic frequency counter with digital readout and a memory display that remembers frequencies at the flip of a switch. And that's just the beginning.

Matching speaker unit (3854) and complete external VFO (3855) also available.

See the incomparable Hy-Gain 3750 at your radio dealer or write Department MM. There is no substitute.



3854

3750

3855

There is no substitute.

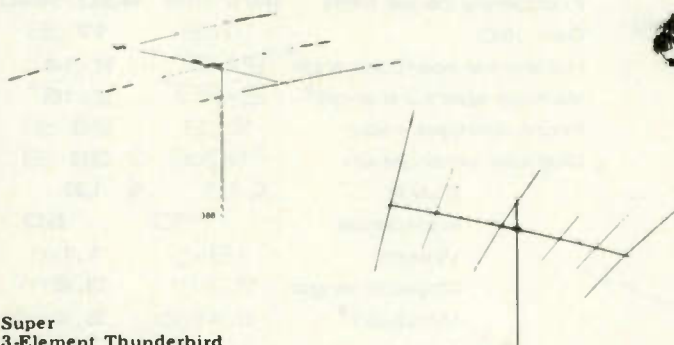

Super 3-Element Thunderbird for 10, 15 and 20 Meters Model TH3Mk3 — \$199.95

Hy-Gain's Super 3-element Thunderbird delivers outstanding performance on 10, 15 and 20 meters. The TH3Mk3 features separate and matched Hy-Q traps for each band, and feeds with 52 ohm coax. Hy-Gain Beta Match presents tapered impedance for most efficient 3 band matching, and provides DC ground to eliminate precipitation static. The TH3Mk3 delivers maximum F/B ratio, and SWR less than 1.5:1 at resonance on all bands. Its mechanically superior construction features taper swaged slotted tubing for easy adjustment and larger diameter. Comes equipped with heavy tiltable boom-to-mast clamp. Hy-Gain ferrite balun BN-86 is recommended for use with the TH3Mk3.

Electrical	TH6DXX	TH3Mk3
Gain—average	8.7dB	8dB
Front-to-back ratio	25dB	25dB
SWR (at resonance)	Less than 1.5:1	Less than 1.5:1
Impedance	50 ohms	50 ohms
Power rating	Max legal	Max legal

Mechanical	TH6DXX	TH3Mk3
Longest element	31.1'	27'
Boom length	24'	14'
Turning radius	20'	15.7'
Wind load at 80 MPH	156 lbs.	103.2 lbs.
Maximum wind survival	100 MPH	100 MPH
Net weight	57 lbs.	36 lbs.
Max diameter accepted	1 1/4" to 2 1/2"	1 1/4" to 2 1/2"
Surface area	6.1 sq. ft.	4.03 sq. ft.

6-Element Super Thunderbird DX for 10, 15 and 20 Meters Model TH6 DXX \$249.95 Separate HY-Q traps, featuring large diameter coils that develop an exceptionally favorable L/C ratio and very high Q, provide peak performance on each band whether working phone or CW. Exclusive Hy-Gain beta match, factory pretuned, insures maximum gain and F/B ratio without compromise. The TH6DXX feeds with 52 ohm coaxial cable and delivers less than 1.5:1 SWR on all bands. Mechanically superior construction features taper swaged, slotted tubing for easy adjustment and re-adjustment, and for larger diameter and less wind loading. Full circumference compression clamps replace self-tapping sheet metal screws. Includes large diameter, heavy gauge aluminum boom, heavy cast aluminum boom-to-mast clamp, and heavy gauge machine formed element-to-boom brackets. Hy-Gain's ferrite balun BN-86 is recommended for use with the TH6DXX.

HY-GAIN'S INCOMPARABLE HY-TOWER FOR 80 THRU 10 METERS

- Model 18HT
- Outstanding Omni-Directional Performance
- Automatic Band Switching
- Installs on 4 sq. ft. of real estate
- Completely Self-Supporting

By any standard of measurement, the Hy-Tower is unquestionably the finest multi-band vertical antenna system on the market today. Virtually indestructible, the Model 18HT features automatic band selection on 80 thru 10 meters through the use of a unique stub decoupling system which effectively isolates various sections of the antenna so that an electrical 1/4 wavelength (or odd multiple of a 1/4 wavelength) exists on all bands. Fed with 52 ohm coax, it takes maximum legal power... delivers outstanding performance on all bands. With the addition of a base loading coil, it also delivers outstanding performance on 160 meters. Structurally, the Model 18HT is built to last a lifetime. Rugged hot-dipped galvanized 24 ft. tower requires no guyed supports. Top mast, which extends to a height of 50 Ft., is 6061ST6 tapered aluminum. All hardware is iridite treated to MIL specs. If you're looking for the epitome in vertical antenna systems, you'll want Hy-Tower, Shpg. Wt., 96.7 lbs. Order No. 182. Price: \$279.95

NEW Special hinged base assembly on Model 18HT allows complete assembly of antenna at ground level... permits easy raising and lowering of the antenna.

BROAD BAND DOUBLET BALUN for 10 thru 80 meters Model BN-86 \$15.95



The model BN-86 balun provides optimum balance of power to both sides of any doublet and vastly improves the transfer of energy from feedline to antenna. Power capacity is 1 KW DC. Features weatherproof construction and built-in mounting brackets. \$15.95 Shpg. Wt. 1 lb. Order No. 242



MULTI-BAND HY-Q TRAP DOUBLET'S Hy-Q Traps

- Install Horizontally or as Inverted V
- Super-Strength Aluminum Clad Wire
- Weatherproof Center and End Insulators

Installed horizontally or as an inverted V, Hy-Gain doublets with Hy-Q traps deliver true half wavelength performance on every design frequency. Matched traps, individually pretuned for each band feature large diameter coils that develop an exceptionally favorable L/C ratio and very high Q performance. Mechanically superior solid aluminum trap housings provide maximum protection and support to the loading coil. Fed with 52 ohm coax, Hy-Gain doublets employ super-strength aluminum clad single strand steel wire elements that defy deterioration from salt water and smoke... will not stretch... withstand hurricane-like winds. SWR less than 1.5:1 on all bands. Strong, lightweight, weatherproof center insulators are molded from high impact cycloac. Hardware is iridite treated to MIL specs. Heavily serrated 7-inch end insulators molded from high impact cycloac increase leakage path to approximately 12 inches.

MODEL 2BDQ for 40 and 80 meters. 100' 10 1/2" overall. Takes maximum legal power. Shpg. Wt., 7.5 lbs \$49.95

Order No. 380
MODEL 5BDQ for 10, 15, 20, 40 and 80 meters. 94' overall. Takes maximum power. Shpg. Wt., 12.2 lbs. \$79.95
Order No. 383

CENTER INSULATOR for Multi-Band Doublets Model CI



Strong lightweight, weatherproof Model CI is molded from high impact cycloac. Hardware is iridite treated to MIL specs. Accepts 1/4" or 3/8" coaxial. Shpg. Wt., 0.6 lbs. \$5.95 Order No. 155

MULTI-BAND ANTENNA Dipole Antenna — Model DIV-80 \$13.95

For 10 thru 80 meters — choice of one band

A dipole antenna for the individuals who prefer the "do-it-yourself" flexibility of custom-designing an antenna for your specific needs. (Work the frequencies you wish in the 10 through 80 meters bands).

The DIV-80 features: Durable Copperweld wire for greater strength. Mosley Dipole Connector (DPC-1) for RG-8/U or RG-58/U coax and all the technical information you will need to construct your custom-designed antenna.



END INSULATORS for Doublets Model EI

Rugged 7-inch end insulators are molded from high impact cycloac that is heavily serrated to increase leakage path to approximately 12 inches. Available in pairs only. Shpg. Wt., 0.4 lbs. \$3.95 Order No. 156

WIDE BAND VERTICAL for 80-10 Meters Hy-Gain's 18 AVT/WB

Take the wide band, omni-directional performance of Hy-Gain's famous 14AVQ/WB, add 80 meter capability plus extra-heavy duty construction—and you have the unrivalled new 18AVT/WB. In other words, you have quite an antenna.

- Automatic switching, five band capability is accomplished through the use of three beefed-up Hy-Q traps (featuring large diameter coils that develop an exceptionally favorable L/C ratio).
- Top loading coil.
- Across-the-band performance with just one furnished setting for each band (10 through 40).
- True 1/4 wave resonance on all bands.
- SWR of 2:1 or less at band edges.
- Radiation pattern has an outstandingly low angle whether roof top or ground mounted.



CONSTRUCTION... of extra-heavy duty tapered swaged seamless aluminum tubing with full circumference, corrosion resistant compression clamps at slotted tubing joints... is so rugged and rigid that, although the antenna is 25' in height, it can be mounted without guy wires, using a 12" double grip mast bracket, with recessed coax connector.

Order No. 386 Price: \$97.00

The Versatile Model 18V for 80 thru 10 Meters

The Model 18V is a low-cost, highly efficient vertical antenna that can be tuned to any band, 80 thru 10 meters... by a simple adjustment of the feed point on the matching base inductor. Fed with 52 ohm coax, this 18 ft. radiator is amazingly efficient for DX or local contact. Constructed of heavy gauge aluminum tubing, the Model 18V may be installed on a short 1 1/2 inch mast driven into the ground. It is also adaptable to roof or tower mounting. Highly portable, the Model 18V can be quickly knocked down to an overall length of 5 ft., and easily re-assembled for field days and camping trips. Ship. Wt., 5 lbs.

Order No. 193 Price: \$33.00

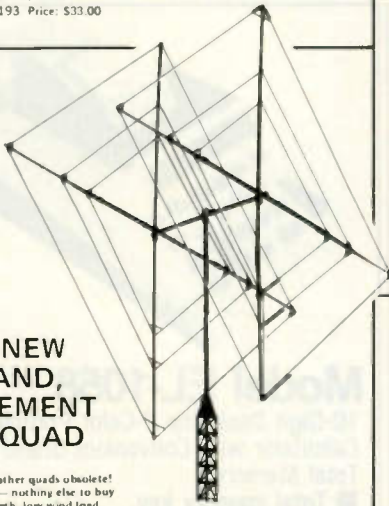

ALL NEW 3-BAND, 2 ELEMENT HY-QUAD

- Makes all other quads obsolete!
 - Complete—nothing else to buy
 - High strength, low wind load
- The Hy-Quad from Hy-Gain makes all other quads obsolete! Here's why: First, it's the only quad that is complete. There is nothing more to ship for or buy. Secondly, it is uniquely designed so that it overcomes all of the previously undesirable features inherent in quads. The all aluminum structure stays up! The single feed line and diamond shape simplifies feed line routing. Hy-Gain's all new Hy-Quad will outdo all other quads because it's engineered to do just that. The Hy-Quad is new, it's superior, it's complete, it's the first quad to have everything. Spreader bars are broken up at strategic electrical points with Cyclocal Insulators / tri-band 2 element construction with individually resonated elements with no interaction / Hy-Quad requires only one feed line for all three bands / individually tuned gamma matches on each band with Hy-Gain exclusive vertex feed / full wave element loops require no tuning stubs, traps, loading coils or baluns / heavy duty mechanical construction of strong swaged aluminum tubing and die formed spreader-to-boom clamps / extra heavy duty universal boom-to-mast clamp that fits and mounts on any mast 1 1/4" to 2 1/2" in diameter / aluminum stranded wire. You can open and close the bands with this antenna. You'll experience the thrill of real DX.

Order No. 244 Price: \$219.95

SPECIFICATIONS

Overall length of spreaders	25'-5"	Forward gain	8.5 db
Turning radius	13'6"	Input impedance	52 ohms
Weight	42 lbs.	VSWR	2:1 or better at resonance on all bands
Boom diameter	2"	Power	Maximum legal
Boom length	6'	Front-to-back ratio	25-35 db
Mast diameter	1 1/4" to 2 1/2"	Polarization	depending upon electrical height
Wind survival	100 mph		
Surface area	6.4 sq. ft.		
Wind load at 100 mph	256.0 lbs.		



For 10, 15, and 20 Meters
New Hy-Gain Model 12 AVQ

Completely self-supporting, the Model 12AVQ features Hy-Q traps...12" double-grip mast bracket...taper swaged seamless aluminum construction with full circumference compression clamps at tubing joints. It delivers outstanding low angle radiation. SWR is 2:1 or less on all bands. Overall height is 13'6". Shipping weight 7.2 lbs. Price: \$47.00
Order No. 384

New, improved successor to the world's most popular vertical!
Hy-Gain Model 14 AVQ/WB for 40-10 Meters.

- Wide band performance with one setting (optimum settings for top performance furnished)
- New Hy-Q Traps • New 12" Double-Grip Mast Bracket • Taper Swagged Seamless Aluminum Construction

The Model 14AVQ/WB, new improved successor to the world famous Model 14AVQ, is a self-supporting, automatic band switching vertical that delivers omni-directional performance on 40 through 10 meters. Three separate Hy-Q traps featuring large diameter coils that develop an exceptionally favorable L/C ratio and a very high Q, provide peak performance by effectively isolating sections of the antenna so that a true 1/4 wave resonance exists on all bands. Outstandingly low angle radiation pattern makes DX and other long haul contacts easy. Superior mechanical features include solid aluminum housing for traps using air dielectric capacitor...heavy gauge taper swaged seamless aluminum radiator...full circumference compression clamps at tubing joints that are resistant to corrosion and wear...and a 12" double-grip mast bracket that insures maximum rigidity whether roof-top or ground mounted. The Model 14AVQ/WB also delivers excellent performance on 80 meters using Hy-Gain Model LC-80Q Loading Coil. Overall height is 18 feet. Shipping weight 9.2 lbs. Unsurpassed portability...outstanding for permanent installations. Price: \$67.00
Order No. 385

TYPICAL 14AVQ/WB VSWR CURVES

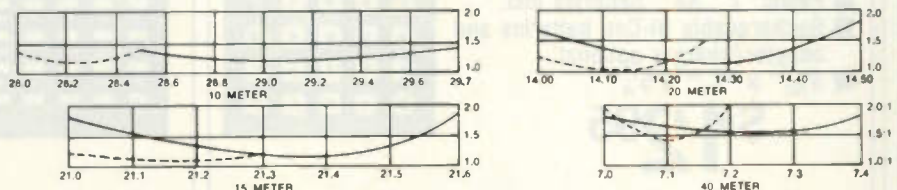

ROOF MOUNTING KIT—Model 14RMQ provides rugged support for Model 14AVQ/WB.
Order No. 184. Price: \$28.95

Hy-Gain REEL TAPE PORTABLE DIPOLE for 10 thru 80 Meters Model 18TD

The most portable high performance dipole ever...

The Model 18TD is unquestionably the most foolproof high performance portable doublet antenna system ever developed. It has proven invaluable in providing reliable communications in vital military and commercial applications throughout the world. Two stainless steel tapes, calibrated in meters, extend from either side of the main housing up to a total distance of 132 feet for 3.5 mc operation. 25 ft. lengths of polypropylene rope attached to each tape permits installation to poles, trees, buildings...whatever is available for forming a doublet antenna system. Integrated in the high impact housing is a frequency to length conversion chart calibrated to meter measurements on the tapes...makes installation foolproof. Feeds with 52 ohm coax. Delivers outstanding performance as a portable or permanent installation. Measures 10x5 1/2x2 inches retracted. Wt., 4.1 lbs.
Order No. 228 Price: \$94.95

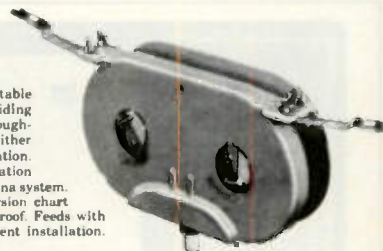

PRODUCTS OF SOUND RESEARCH
TELEX
COMMUNICATIONS, INC.

Lightweight Headphones

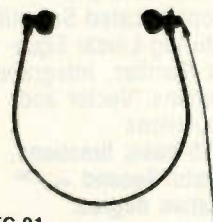

HFC-91
Ultra-light underchin. Acoustic delay of 1 millisecond enhances intelligibility on CW or SSB. Low impedance 8-20 ohms. Shaped response—100 - 3,000 Hz. 1.5 ounces
Order by Catalog No. 18135-013 \$8.95



HMC-2
Featherweight—Underchin, rugged aluminum tone arms direct signals into the ear—great for contests. 1.2 ounces. 100 - 3,000 Hz. Low impedance. 8-20 ohms, weight 12 ounces
Order by Catalog No. 18183-002 \$13.85



HTC-2
Lightest! Dual driver headset. Choice of the pros who must wear them for hours. 1.6 ounces. 100 - 3,000 Hz. Low impedance. 8-20 ohms
Order by Catalog No. 3775-002 \$22.00



PC-100 Headphone
Full cushion comfort—performance and long life make these dynamic phones ideal for novice or extra 50 - 12,000 Hz. Low impedance. 8 - 200 ohms, weight 12 ounces
Order by Catalog No. 63510-010 \$16.95



Headphone Jack Box
Ham Clubs, field day, contest operation. No more "jury rigs" for multiple headphones, six 1/4" phone jacks with individual volume controls, 4 foot cord with 1/4" phone plug
Order by Catalog No. 62753-000 \$16.25



CALCULATORS

Model EL-8131

8-Digit Calculator with Memory, Square Root and Percent

- 5-key direct access memory.
- Large, bright 8-digit display.
- Square root key.
- % -key.
- Clear and clear entry keys.
- Overflow error check device.
- Power: 2 "AA" batteries incl.
- Rechargeable Ni-Cad batteries and adapter/charger optional.
- $3\frac{5}{32}$ " x $2\frac{5}{32}$ " x $5\frac{1}{8}$ "

\$12⁹⁵



Model EL-500

6 + 2 Digit Scientific Calculator

- Scientific notation up to ± 99 dynamic range.
- Direct access memory.
- Degree, minutes, seconds to decimal degree conversion.
- Trigonometric, inverse trigonometric & logarithmic calc.
- Square root, root and pi keys.
- Power: 2 penlight batteries incl.
- AC adapter optional.
- $1\frac{3}{16}$ " x $3\frac{5}{32}$ " x $5\frac{1}{16}$ "

\$16⁹⁵

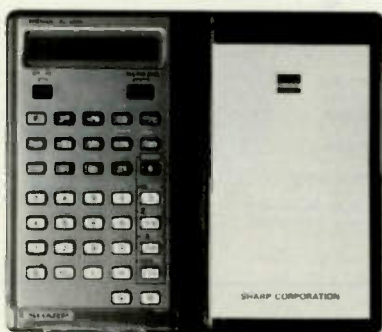

Model EL-5806

Billfold Type Advanced Scientific Calculator only 7.6mm Thin

- 8-digit mantissa/2-digit scientific notation.
- Pre-programmed for 24 functions.
- Statistical calculations.
- Easy to read Hi-Contrast LCD.
- Indicators for minus, memory, battery and statistical mode.
- Constant, chain, power, scientific and statistical calculations.
- 1,000 hours on 2 watch batteries.
- Soft vinyl carrying case included.
- $1\frac{9}{16}$ " x $2\frac{23}{32}$ " x $4\frac{31}{32}$ "

\$29⁹⁵



Model EL-5001

10 + 2 Digit Sophisticated Scientific Calculator Featuring Linear Equations, Complex Number, Integration, Quadratic Equations, Vector and Statistical Calculations

- More than 25 basic functions.
- Degree/Minute/Second \leftrightarrow decimal notation degree.
- Polar coordinates \leftrightarrow rectangular coordinates.
- Degree - Radian - Gradian mode.
- Power: Ni-Cad batteries and AC adapter/charger included.
- 6" x 1" x 3 $\frac{1}{2}$ "

\$49⁹⁵



Model EL-1058

10-Digit Desk Top 2-Color Printing Calculator with Convenient Grand Total Memory

- Total memory key.
- 2-color printer (red & black).
- Easy to operate "Human Engineered" keyboard layout.
- Handy non-add/sub-total key.
- Add mode, decimal (0,2,3) and constant/floating decimal selector.
- Power: 120V.
- 6" x 9" x 3 $\frac{1}{2}$ "

\$74⁹⁵

When I began to think seriously about a charger for my portable radio, I looked through all my old issues of *73 Magazine*. I found quite a few articles on this subject, but none of them would fill the bill for the kind of charger that I needed. My new charger should charge at the proper rate until the battery is full and automatically switch to a trickle.

I have observed two properties of nicads whenever they become fully charged. One is the rise in temperature that occurs due to the inability of the cell to make a chemical conversion, which is dissipated as heat. The other is the slight rise in cell voltage from approximately 1.35 to above 1.4 volts. I don't know whether this rise in voltage is due to the increased temperature or is a physical property of a "flooded" cell quite apart from the temperature. A scheme of placing a thermistor next to the cells to control the charge was abandoned in favor of a means of sensing the voltage increase.

The general circuit is shown in Fig. 1. The filtered dc is current limited by R1 to a value one-tenth of the Ampere hour rating of the battery. Zener diode D1 provides a voltage offset so that all the voltage variation will appear across R2. This pot is adjusted so that the SCR will trigger on the voltage rise that occurs at the end of charge. Whenever the SCR triggers, R3 and R4 shunt most of the current away from the battery so that the battery is getting only a trickle. The LED will light, showing that the end of charge has been reached.

The switch S1 is used to take the SCR out of conduction and start the charge cycle.

Method

As there are many combinations of transformer voltage and number of nicad cells possible, I am going to leave

the calculation up to you and will show the step-by-step design procedure. Only seven steps are required for your own situation:

- (1) Specify battery —
N = number of cells,
A = Ampere-hour rating;
- (2) Specify transformer —
E = rms secondary voltage,
 $V = 1.414E - 1.4$;
- (3) Calculate capacitor value — $C = A/120 V$ (farads);
- (4) Calculate R1 —
 $R1 = [V - N(1.4) - 0.7]/(A/10)$;
- (5) Calculate offset zener voltage —
 $D1 = N(1.4) - 2.7$;
- (6) Calculate R3 —
 $R3 = [N(1.4) - 0.7]/[(A/10 - A/100) - .01]$;
- (7) Calculate R4 —
 $R4 = [N(1.4) - 1.8] 100$.

Example

Assume you have a battery of ten cells rated at 500 mAh and a transformer rated at 24 volts (a common voltage available in most junk boxes).

- (1) N = 10, A = .5;
- (2) E = 24, V = 32.5;
- (3) $C1 = .5/120(32.5) = 128$ uF (use 200 uF, 35 V);
- (4) $R1 = (32.5 - 14 - .7)/.05 = 356$ (use 360 Ohms);
- (5) $D1 = 14 - 2.7 = 11.3$ (use 11 or 12 V zener);
- (6) $R3 = (14 - .7)/(.05 - .005 - .01) = 380$ (use 390

Charge!

— your nicads

Ohms);

- (7) $R4 = (14 - 1.8)100 = 1220$ (use 1200 Ohms).

Construction

If you presently have a desk-top charger for your portable, you can modify the existing circuit. If you're not that lucky, then you may still get a professional-looking unit by ordering the plastic parts for the charger from the manufacturer. I have built this unit for both a GE-PE and Motorola HT-220. Other portables have a jack for plugging in a charger. In this case, you can build your charger in any of several "project box" enclosures available at hobby electronics stores.

Testing

Substitute a variable resistor for the battery, and with R2 turned off (wiper at ground), adjust the battery substitute until the desired trip point voltage is reached

(1.4N volts). Then adjust R2 until the LED lights and stop there. Now connect your battery and push the switch; the LED should go out. The battery voltage should be between 1.25 and 1.35 volts per cell during charge and rise above 1.4 volts per cell at the end of charge.

Parting Shots

You should not trust this charger if ambient temperature is allowed to vary from that which is considered comfortable by most people. Too much heat or too much cold could alter the trip point. You may want to instrument this charger with a milliammeter and measure the various currents for the first few charge cycles, just to gain assurance that it is working okay.

I think I have told you all I know on the subject (not much really), but, if you have any questions, send an SASE and I will reply. ■

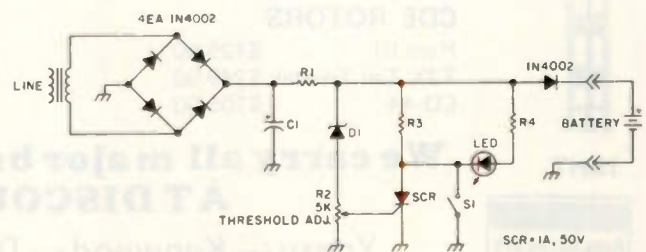

Fig. 1. General schematic for automatic-shutoff battery charger. For component values, see text.

CALL TOLL FREE

1-800-228-4097
Communications Center
 443 N 48th Street C58
 Lincoln, Nebraska 68504
 In Nebraska Call (402)466-8402

1-800-634-6227
Communications Center
West C58
 1072 N. Rancho Drive
 Las Vegas, Nevada 89106
 In Nevada Call (702)647-3114

Antenna Sale!

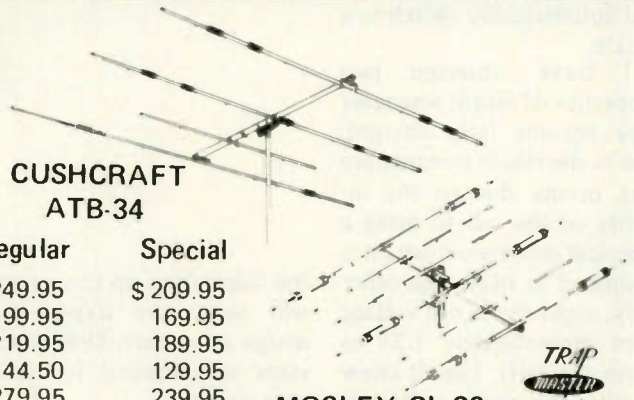

CUSHCRAFT
ATB-34

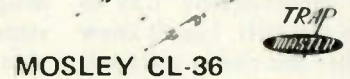

MOSLEY CL-36



18HT

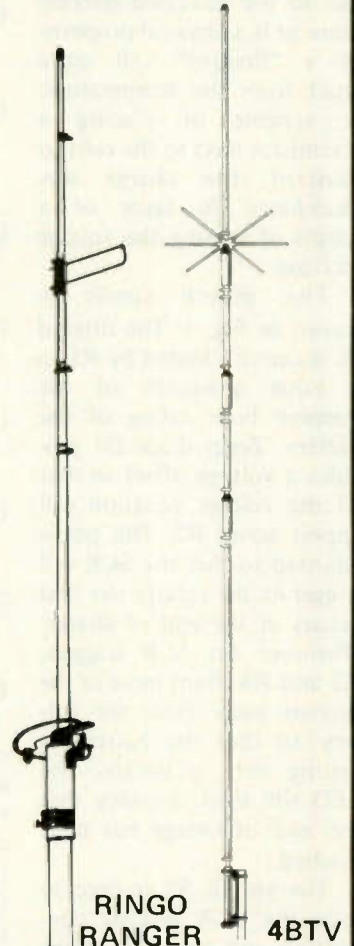

RINGO
RANGER

4BTV

HY-GAIN

		Regular	Special
TH6-DXX	Super Thunderbird	\$249.95	\$209.95
TH3-MK3	3 ele. 10, 15, 20 Mtr. beam	199.95	169.95
Hy-Quad	2 ele. Quad 10, 15, 20 Mtr.	219.95	189.95
TH3-Jr.	3 ele. 10, 15, 20 Mtr. beam	144.50	129.95
18 HT	Hy-Tower 10-80 Mtr. Vertical	279.95	239.95
14AVQ/WB	10-40 Mtr. Trap Vertical	67.00	57.00
18AVT/WB	10-80 Mtr. Trap Vertical	97.00	84.95
203	3 ele. 2 Mtr. beam	12.95	
205	5 ele. 2 Mtr. beam	16.95	
208	8 ele. 2 Mtr. beam	19.95	
214	14 ele. 2 Mtr. beam	26.95	

MOSLEY

Classic 33	3 ele. 10, 15, 20 Mtr. beam	232.50	189.95
Classic 36	6 ele. 10, 15, 20 Mtr. beam	310.65	249.95
TA-33	3 ele. 10, 15, 20 Mtr. beam	206.50	169.95
TA-36	6 ele. 10, 15, 20 Mtr. beam	335.25	279.95
TA-33 Jr.	3 ele. 10, 15, 20 Mtr. beam	151.85	129.95
TA-40KR	40 Mtr. add on	92.25	74.95

CUSHCRAFT

ATB-34	4 ele. 10, 15, 20 Mtr. beam	259.95	209.95
ARX-2	2 Mtr. Ringo Ranger	36.95	32.95
A147-20T	2 Mtr. Twist	59.95	52.95
A144-10T	10 ele. Twist 2 Mtr.	39.95	32.95
A144-20T	20 ele. Twist 2 Mtr.	59.95	52.95

HUSTLER

4BTV	10-40 Mtr. Trap Vertical	99.95	82.95
RM-75	75 Meter Resonator	15.50	13.50
RM-75s	75 Meter Super Resonator	30.00	26.50
G6-144-A	6 db. 2 Mtr. Base Colinear	67.55	57.95

WILSON

System One	5 ele. 10, 15, 20 Mtr. beam	274.95	239.95
System Two	4 ele. 10, 15, 20 Mtr. beam	219.95	189.95

CDE ROTORS

Ham III	\$125.00
T2X Tail Twister	\$249.00
CD-44	\$105.00

**We carry all major brands of ham radios
 AT DISCOUNT PRICES**

Yaesu — Kenwood — Drake — ICOM — Dentron —
 Ten-Tec — Swan — Tempo — Midland — E.T.O. — Wilson



SST T-1 RANDOM WIRE ANTENNA TUNER



All band operation (160-10 meters) with any random length of wire. 200 watt output power capability—will work with virtually any transceiver. Ideal for portable or home operation. Great for apartments and hotel rooms—simply run a wire inside, out a window, or anyplace available. Efficient toroid inductor for small size: 4-1/4" x 2-3/8" x 3", and negligible loss. Built-in neon tune-up indicator. SO-239 connector. Attractive bronze finished enclosure.

only **\$29.95**

THE ORIGINAL Random Wire Antenna Tuner... in use by amateurs for 6 years.

SST T-2 ULTRA TUNER

Tunes out SWR on any coax fed antenna as well as random wires. Works great on all bands (80-10 meters) with any transceiver running up to 200 watts power output.

Increases usable bandwidth of any antenna. Tunes out SWR on mobile whips from inside your car.

Uses efficient toroid inductor and specially made capacitors for small size: 5-1/4" x 2-1/4" x 2-1/2". Rugged, yet compact. Negligible line loss. Attractive bronze finished enclosure. SO-239 coax connectors are used for transmitter input and coax fed antennas. Convenient binding posts are provided for random wire and ground connections.



only **\$39.95**



only **\$19.95**

SST T-3 Mobile Impedance Transformer

Matches 52 ohm coax to the lower impedance of a mobile whip or vertical. 12-position switch with taps spread between 3 and 52 ohms. Broadband from 1-30 Mhz. Will work with virtually any transceiver—300 watt output power capability. SO-239 connectors. Toroid inductor for small size: 2-3/4" x 2" x 2-1/4". Attractive bronze finish.

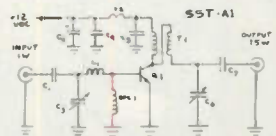

only **\$29.95**

\$49.95 wire and tested

SST A-1 VHF Amplifier Kit

1 watt input gives you 15 watts output across the entire 2 meter band without re-tuning. This easy-to-build kit (approx. 1/2 hr. assembly) includes everything you need for a complete amplifier. All top quality components. Compatible with all 1-3 watt 2-meter transceivers. Short and open protected—not damaged by high SWR.

Kit includes:

- Etched and drilled G-10 epoxy solder plated board.
- Heat sink and mounting hardware. All components—including pre-wound coils.
- Top quality TRW RF power transistor.
- Complete assembly instruction with details on a carrier operated T/R switch.



GUARANTEE



All SST products are guaranteed for 1 year. In addition, they may be returned within 10 days for a full refund (less shipping) if you are not satisfied for any reason. Please add \$2 for shipping and handling. Calif. residents, please add sales tax. COD orders OK by phone.



ELECTRONICS

P.O. BOX 1 LAWNOLE, CALIF.
90260 (213) 376-5887

S10

Light Right?

—do-it-yourself photo exposure meter

Joy L. Mills, Jr.
5960 Dueber Ext.
East Sparta OH 44626

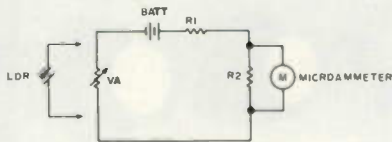

Fig. 1. Basic circuit for measuring resistance.

Many exposure timing devices have long been available to the photographer. Once this factor has been selected, we only need a dependable method of measuring the intensity of light striking the printing paper emulsion. My project, which I shall describe in this article, deals with a proven device for making these light intensity measurements with accuracy.

For many years I used the common and cheaper device

consisting of a 117 volt ac line source, a neon lamp, a photo dependent resistor (LDR), and a variable resistant element potentiometer with linear-dial scale.

I learned to live with this for several years, and even after getting into color printing, decided that I was using too much time coordinating the enlarging lens aperture with the rheostat setting (which required two hands). A very unreliable potentiometer didn't help either. I always ended up in the ball park with this method, but not always exactly where I wanted to be. With many solid state devices and LDR cell types available, I embarked upon a new project, and after over two and one half years of actual use and testing, I can now present the project briefly. It can be built by anyone with radio equipment construction experience.

The instrument, a device for measuring light density, consists of three basic parts:

1. Light sensitive probe.
2. Dc differential amplifier.
3. Specially calibrated meter and face plate.

The Light Probe

The probe shown in Fig. 3 is constructed of semi-hard wood, such as poplar, a Clairex type 905HN light dependent resistance element, a 5 ft. cord (Belden #8411), and a standard Cannon

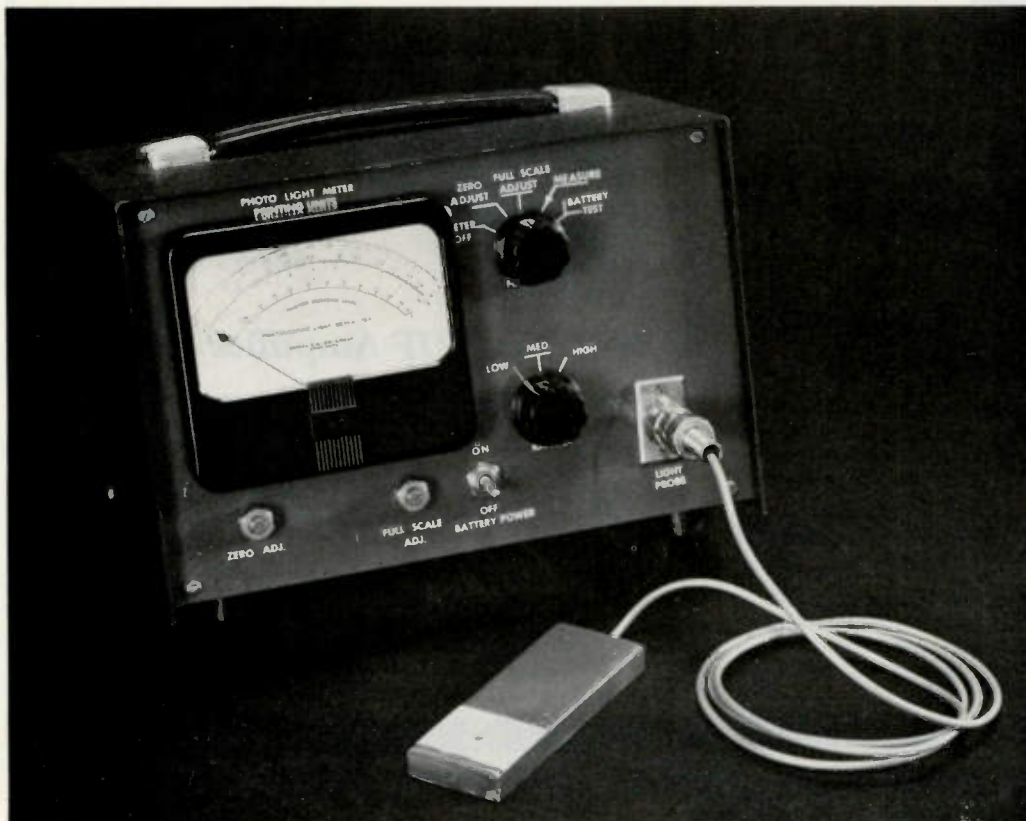

Fig. 2.

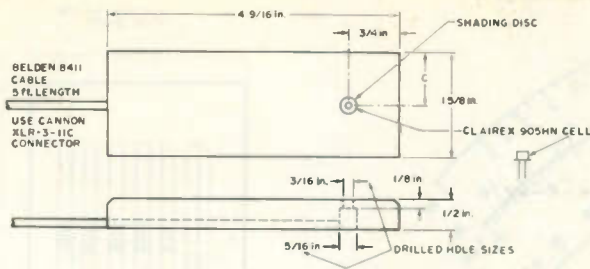

Fig. 3. Easel probe.

XLR-3-11c cord end-type connector. Epoxy cement and filler such as "Duro Epoxe #200H" manufactured by Woodhill Chemical Sales Corporation, Cleveland, Ohio, is used for filling and sealing the unit. I chose the Clairex 905HN light cell (after I had conducted tests on many of their types) because of its low "residual" characteristics, especially at the extremely low light levels used on most photographic sensitive papers. The sensitivity of the cell, along with its small cell aperture, makes it very complementary to the final calibrated probe. In constructing the probe, the case is grooved out through the center of the entire length, deep and wide enough so that the Belden type 8411 shielded cable will embed clear of the bottom probe surface. The photocell is mounted by insertion from the bottom of the case through a 5/16" hole drilled to within 1/8" of the top of probe case (where the hole continues through the top at 3/16" diameter). After the cell has been positioned and set, the two leads are connected to the shielded cable and soldered lightly (one center conductor, the other the shield). The small splices are then taped with plastic tape. Press the splices and cable into the groove channel, and then fill the entire groove channel with the epoxy cement. After over-filling the groove with epoxy cover, case the bottom with masking tape to prevent epoxy from seeping out (until it is set, in about 5 hours). After the epoxy has hardened, the masking tape can be removed and the case sanded down on the bottom to a finished sur-

face. The top of the probe can now be painted white to within 1/4" of the cell.

The Cannon XL3-11c can now be attached to cable end. Connect the shield to pins 1 and 2, and the center conductor to pin 3. Since the probe is not wired permanently to the electronics unit, more than one probe may be prepared for use with the instrument with flexible applications.

Calibrating the Light Probe

Since the photocells vary considerably (even within the same manufacturer's type) as to the effect they will have in this particular application, it was necessary in designing my system to permit or require aperture reduction in all cases to permit proper and consistent calibration of the instrument.

The procedure used to calibrate the probe requires the following equipment: a controlled light source (use your enlarger), an accurate standard exposure meter, and an accurate "ohmmeter" (range to over 100 megohms).

To begin, arrange the top of the probe at the exact level along with the exposure meter facing the projected light source. The exposure meter should be in the "direct" or "unshaded mode" if it has these options. Adjust the ASA setting on the exposure meter to 100. Adjust the projected light level (at least 1.5 ft. from the meter) using the enlarger lens aperture adjustment until the "F stop" indication is 5 for 1 second exposure.

With the "ohmmeter" or resistance measuring device connected to the end of the probe cable leads (shield and

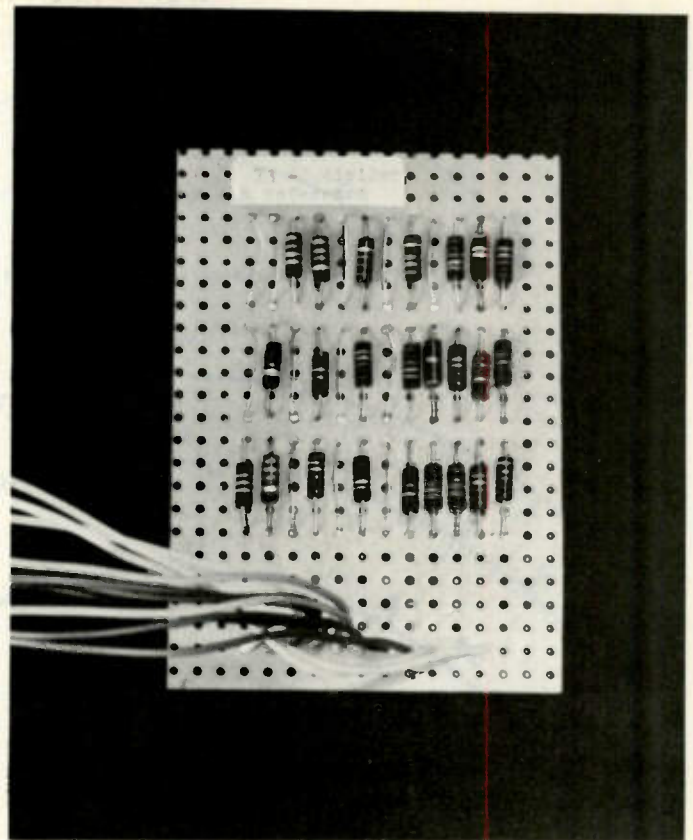

Fig. 4.

conductor), observe the resistance value. Normally, with the cell being used in this probe, the reading will fall in an area between 3.5 and 5.5 megohms. The cell is now calibrated by cementing a disc with a center hole or aperture drilled to a diameter

large enough to produce a resistance reading of 6.4 megohms. The inside disc hole surface should be painted with flat black paint, especially if it has a reflected metal surface. The disc cemented to the top surface of the probe should be truly

Resistance at P1,
2 & 3 term.

Linear scale reading

LOW RANGE

78 megohms	1 (10%)
62 megohms	3 (30%)
55 megohms	5 (50%)
50 megohms	6 (60%)
42 megohms	8 (80%)
35 megohms	10 (100%)

MEDIUM RANGE

70 megohms	1 (10%)
50 megohms	3 (30%)
35 megohms	5 (50%)
29.5 megohms	6 (60%)
16.8 megohms	8 (80%)
6.4 megohms	10 (100%)

HIGH RANGE

31.5 megohms	1 (10%)
21 megohms	3 (30%)
14.5 megohms	5 (50%)
11.3 megohms	6 (60%)
5.3 megohms	8 (80%)
0.5 megohms	10 (100%)

Table 1. Linear scale meter readings for corresponding resistance values placed across P1 terminals 2 and 3.

Fig. 5.

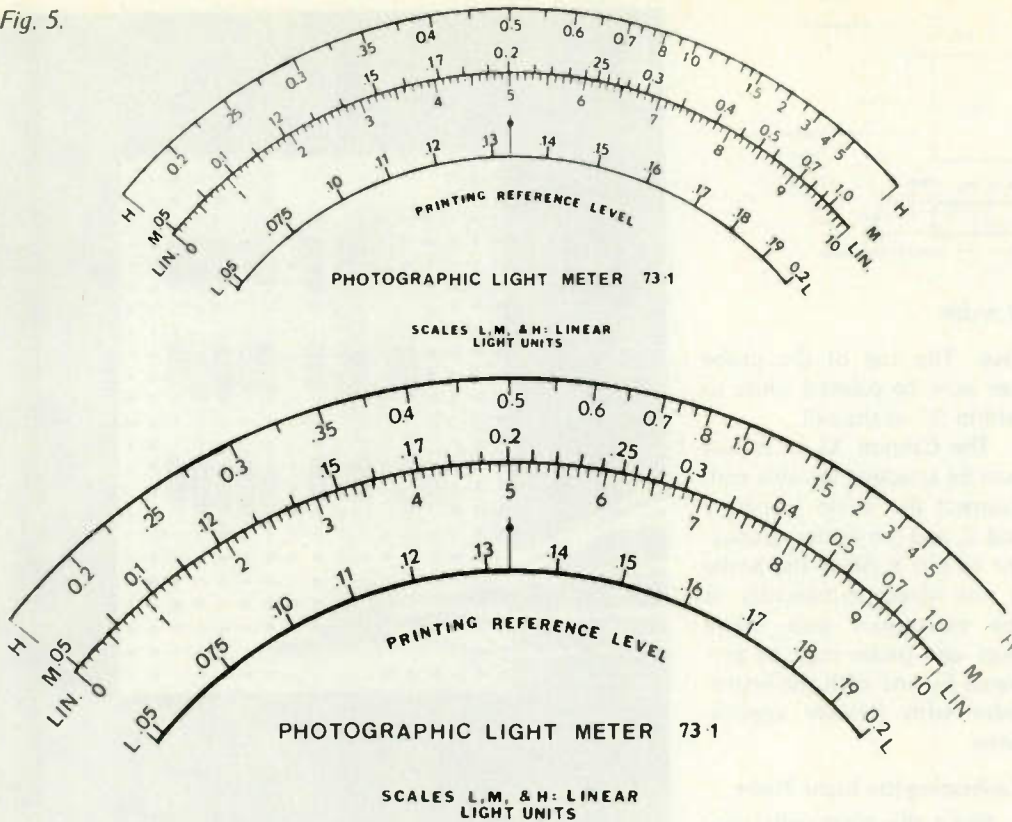

centered over the photosensitive cell. After the cement is set, the calibration should be rechecked. If the resistance falls short of 6.4 megohms, a slight additional amount of shading can be accomplished by small pen and black lacquer. The temperature in the room area while calibrat-

ing probe should be approximately 75°F. If lacquer is used for final shading, the calibration should be checked several hours later for possible drift. The Clairex cell face is glass, and if reasonable care is taken, the black lacquer may be scraped off without damaging the cell face.

The Electronics Amplifier System

The electronics system consists of a divider card and dc amplifier. The divider card is very critical, but circuit-wise very simple. Working with such high resistance values presents problems if

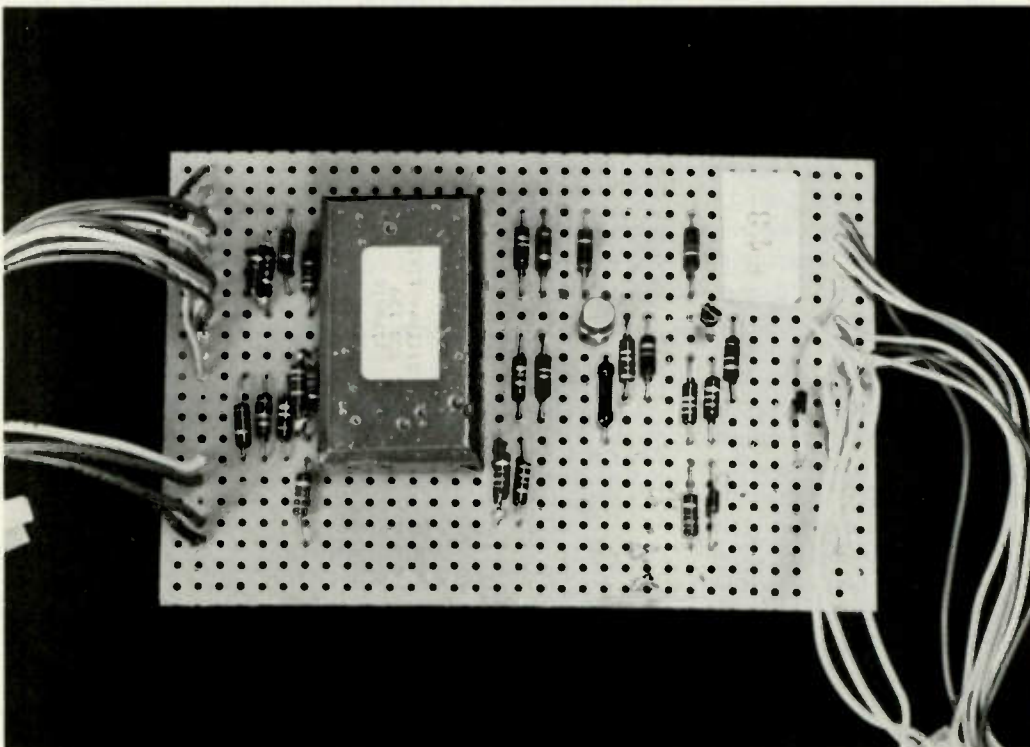

Fig. 7.

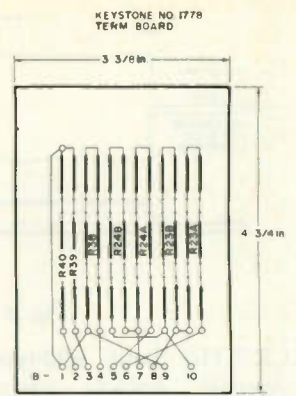

Fig. 6. Divider and Ref. card.

care is not taken to use materials that will prevent leakage in the circuitry; spray the entire card and resistor parts with clear lacquer under low humidity conditions after construction and calibration. I use several resistors in series to acquire most of the "total" values specified in this circuit, usually not exceeding 22 megohms each in value. Also, this provides great flexibility in arriving at the exact total value in each leg of the circuit. This portion of the electronics provides us with the very broad ranges and the unique meter scale shown. The divider card provides calibration references for the three ranges of this instrument. By designing the instrument so that the meter physical scale (full scale) is approximately one third of the theoretical full scale, the meter movement is the greatest for the smallest amount of input change, thus providing an instrument with greater accuracy in each scale range.

In soldering the resistors on the divider card, cooling time must be allowed before the total resistance value can be finally accepted for each circuit branch leg. A Keystone circuit board and Keystone 1562-2 connecting terminals are used in the model shown here.

The Dc Amplifier Circuit

As with most transistors, I find that great variations exist between the same manufacturer's types. The industrial grades vary more so, and for convenience and economy I

RTTY Can Be Easy!

Have You Wondered . . .
What Owning a RTTY Station Would be Like?
Have You Thought . . .
About Finding Out but Didn't Know Who to Ask?

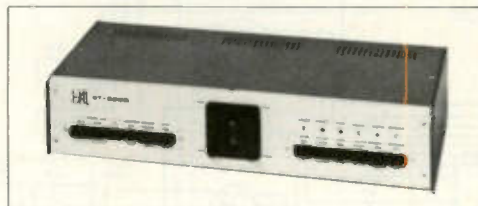

ASK THE GUYS AT HAL!

Our sales and service staff will be happy to assist you in your choice of RTTY equipment, answer questions about RTTY, and provide assistance if problems do arise. In addition, all HAL amateur RTTY equipment manuals can be purchased for \$10.00 each for an advance look (applicable to future purchase of that unit).

Answers to common RTTY questions are featured in the center-fold of our new amateur radio catalog. Such questions as "What do I need?," "How do I hook it up?," and "What frequencies do I use?" are discussed. Technical points concerning RTTY pulses, FSK and AFSK, and high-tones vs low-tones are covered.

Write today for HAL'S new catalog and RTTY guide and discover how much fun RTTY can be.



HAL COMMUNICATIONS CORP.
Box 365
Urbana, Illinois 61801
217-367-7373



For our European customers
see HAL equipment at:

Richter & Co.: Hannover
I.E.C. Intereko: Bissone
Primetek Systems: Handen, Sweden
Radio Shack of London

H6

specify "experimental" line transistors, GE FET N-channel, and GE 21 type in the final differential dc amplifier output stage. If the two transistors in the output-differential circuit are sealed closely in a common epoxy case, better calibration and less drift can be had. Using low leakage, wafer-type switches is a must in this device. The switching circuit provided here allows a constant check on the 22.5 volt battery supply. When the 4.5 volt battery falls below operational limits, full scale adjustment cannot be attained. Included in the switching system, I provided a quick "full scale" and "zero" adjustment test position. After running many tests under varying temperature conditions, a slight recalibration check was sometimes necessary; however, due to the "balance" leg arrangement in

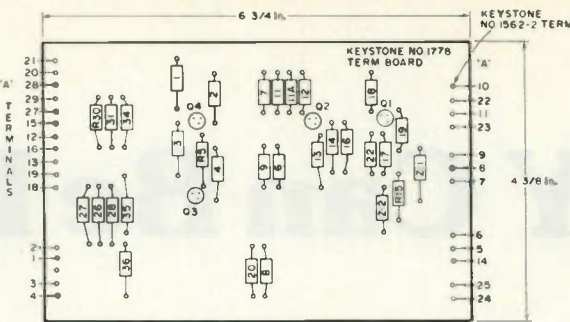

Fig. 8. Electronics card.

the divider card, the system is quite self-compensating.

The model which I show here includes Waldom "molex" connectors. This does permit removing the divider card from circuit for testing purposes or replacing with spare. Another reason for using the connectors was for changing to divider cards for use with other light probe devices.

Final Calibration of the Instrument

By using the "actual" meter scale illustrated here with the Simpson Model #29 4" meter, the meter circuit is properly functional when the following test procedure is applied:

With the light probe disconnected from P1 (front panel), connect a resistance of exactly 35 megohms to pins 2 and 3 of the front panel connector. Next "ZERO" adjust the meter scale with function switch in the "ZERO ADJ" position.

Now set the function switch to the "MEASURE" position, and the "RANGE" switch to the "LOW" range position. The meter should read full scale on "LOW" range. Now, set the "RANGE" switch to "MEDIUM." The meter should read half scale exactly. Note that there is a true linear scale on the meter face. On this scale, mid-scale would be "5."

If the foregoing procedure indicates meter calibration does not meet the specifications, the problem can be in two different areas. If the low range scale does not meet requirements, the problem lies in the dc amplifier gain and R11 may be adjusted either way to bring the "LOW" scale in. Once the "LOW" scale meets requirements, the "MEDIUM" scale is adjusted in the meter series and shunt resistance circuit for the "MED" range switch position. The divider card circuit remains the same for the "LOW" and "MEDIUM" ranges. The divider card circuit switches when the "RANGE" switch is set in the "HIGH" range position.

Since precise calibration procedures can become rather lengthy in discussion, it is assumed that anyone building this device is already sufficiently advanced in meters and dc amplifiers to proceed with the basic circuit schematic I provide here and understand the accompanying table.

The exact meter scale readings versus input terminal resistance values will provide you with the necessary information to attain the end result in final and correct calibration. A 40 micro-ampere movement (Simpson shown here) allows for more latitude in final calibration, but more damping is had by using the more sensitive movement. I have run tests using a meter movement with a full scale deflection sensitivity of 5,000 Ohms per volt. Lower sensitivity meters don't have the extreme damp-

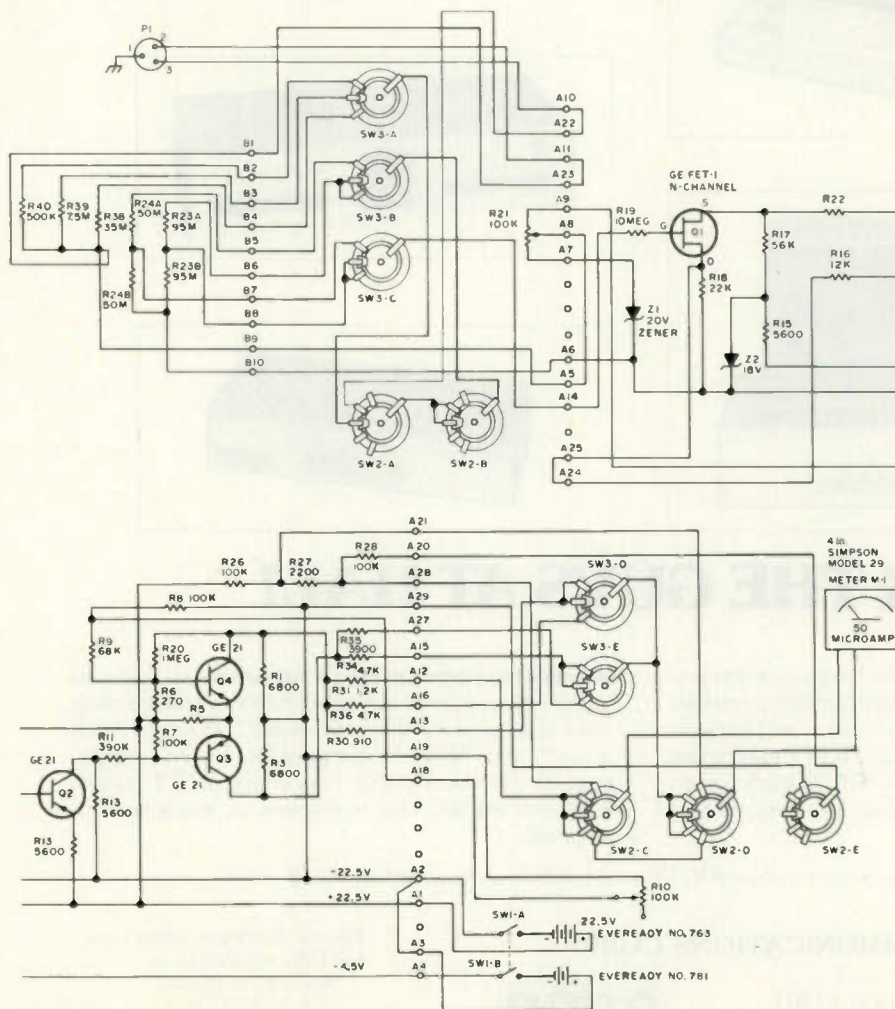

Fig. 9. Circuit schematic.

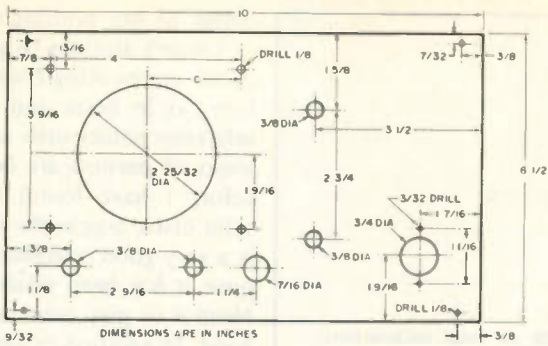

Fig. 10. Front panel.

ing and don't require "tapping" the meter housing to establish the correct meter reading.

Going over the calibration procedure briefly, we have three separate sectional considerations in this device: (1) the meter divider card, which provides the inherent scale characteristics; (2) the dc amplifier, which provides the overall gain to drive the meter movement; and (3) the meter "dropping" and calibration circuit, which also is included in switching between the "LOW" and "MEDIUM" ranges.

An actual "cutout" meter scale which I provide in this article may be used by cutting it out and cementing it to the meter face of the Simpson model 29 meter. A larger illustration is shown, if a different basic meter movement is to be selected. I direct your attention to the 4 different scales on the meter. The three scales, "LOW," "MEDIUM," and "HIGH," are actual linear light level units, where the true meter linear scale is divided into 10 parts. This is universal and can be applied with accuracy in the original meter circuit calibration. It can be used alone if desired, so long as we have a reference point in our actual photographic printing. The light linear scale, however, is much more useful when, for instance, we wish to double or divide our exposure time by half, etc. Here, there is no guessing.

Using the Instrument

The instrument may be used in black and white or

color photo printing work. The important feature on my instrument is the small aperture in the meter probe and the large meter movement for a small change in enlarger projected light intensity. In *any* case, a "test print" must be run off to establish a reference point in making subsequent prints. The reference point, of course, applies to one specific paper type and emulsion group. In the paper alone we have at least three variables to consider: paper emulsion sensitivity guide number, contrast curve, and emulsion age.

In using the printing meter, set the probe under a good reference spot right on

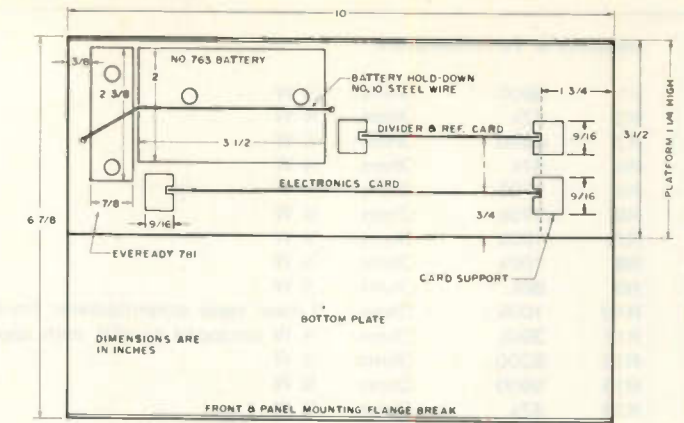

Fig. 11. Top view of chassis.

the easel. Where people are included in the picture, the *best* spot to make all exposure measurements is on the open skin area such as the face. The arms or hands make an excellent place to take all readings. When making very small enlargements, it is very important here that the aperture or opening on the light probe *only* include the skin or flesh area. If other picture parts are included, the readings will cause great exposure error. I designed this instrument to solve this one common problem. I noted more errors on smaller enlarge-

ments than larger ones with several "beginners" who have used my instrument. If we had a constant "grey" reference area included on all negatives, it would be a perfect situation; however, many pictures don't even include a person for reference. In this case we may choose to use a sky area as a steady reference point, or a backdrop. In color photography the exposure is much more critical than black and white work. It was in doing color that I ran into problems with other light measuring instruments and finally became involved in the

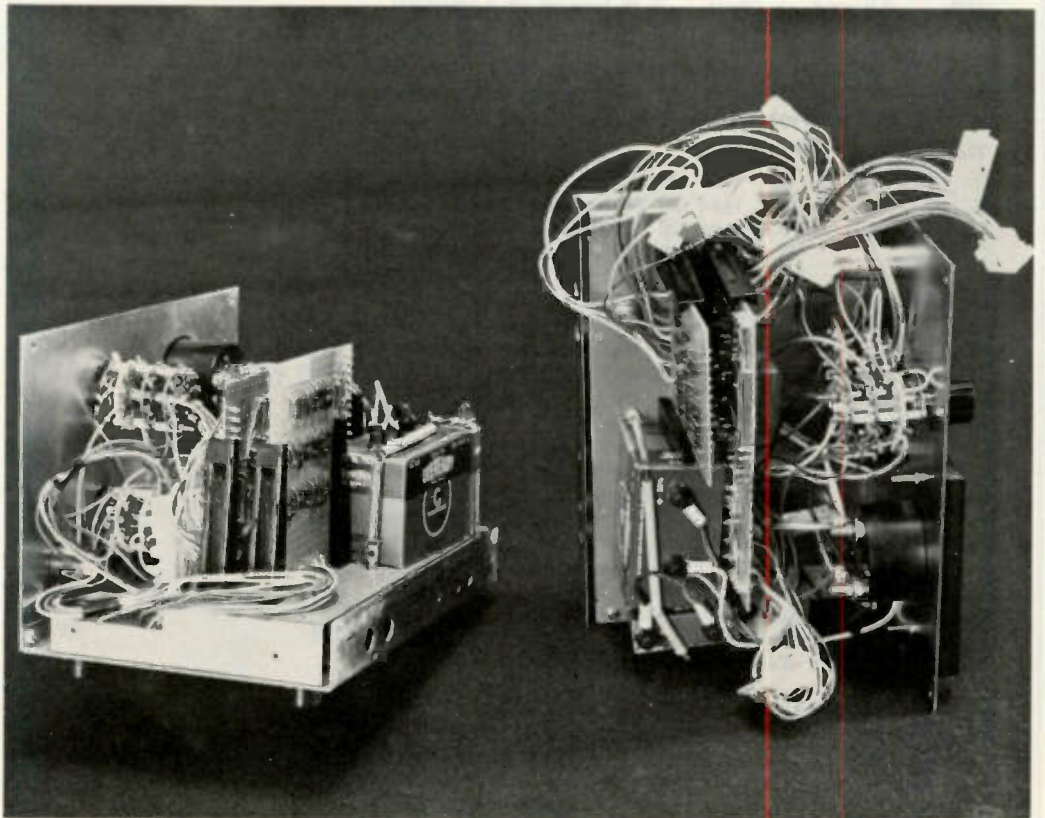

Fig. 12.

Resistors & Potentiometers

R1	6800	Ohms	½ W
R2	47k	Ohms	½ W
R3	6800	Ohms	½ W
R4	47k	Ohms	½ W
R5	4700	Ohms	½ W
R6	270k	Ohms	½ W
R7	100k	Ohms	½ W
R8	100k	Ohms	½ W
R9	68k	Ohms	½ W
R10	100k	Ohms	Linear taper potentiometer (zero adjust)
R11	390k	Ohms	½ W (strapped parallel with approx. 470k on final calibration)
R12	8200	Ohms	½ W
R13	5600	Ohms	½ W
R14	47k	Ohms	½ W
R15	5600	Ohms	½ W
R16	12k	Ohms	½ W
R17	56k	Ohms	½ W
R18	22k	Ohms	½ W
R19	10 meg	Ohms	½ W
R20	1 meg	Ohms	½ W
R21	100k	Ohms	Linear taper potentiometer (full scale adjust)
R22	180k	Ohms	½ W
R23a	95 meg	Ohms	½ W (combination of up to 6 resistors each not to exceed 22 megohms)
R23b	95 meg	Ohms	½ W (same as above note)
R24a	50 meg	Ohms	½ W (see above note)
R24b	50 meg	Ohms	½ W (see above note for R23a)
R25			(no)
R26	100k	Ohms	½ W
R27	2200	Ohms	½ W
R28	100k	Ohms	½ W
R29			(no)
R30	910	Ohms	½ W
R31	1200	Ohms	½ W
R32			(no)
R33			(no)
R34	4700	Ohms	½ W
R35	3900	Ohms	½ W
R36	4700	Ohms	½ W
R37			(no)
R38	35 meg	Ohms	½ W (use up to 6 resistors, each not to exceed 22 meg.)
R39	7.5 meg	Ohms	½ W (use up to 3 resistors)
R40	500k	Ohms	½ W (use up to 3 resistors)

Note: The divider card includes R23a, R23b, R24a, R24b, R38, R39, and R40. (Multiple resistance unit positions are provided as required to arrive at the precise value for each "R".)

Transistors

Q1	G.E. type FET 1
Q2	G.E. type GE 21 (Sylvania type ECG 129)
Q3	G.E. type GE 21 (Sylvania type ECG 129)
Q4	G.E. type GE 21 (Sylvania type ECG 129)

Switches

SW1	DPDT toggle switch
SW2	5 pole (5 position) wafer, use Centralab PA 2028 or equiv.
SW3	5 pole (3 position) wafer, use Centralab PA 2028 or equiv.

Other Items & Hardware

Z1	Zener diode, 20 volts
M1	Meter, Simpson Model 29, 50 microamp, 4½ inch face
P1	Cannon XL-3 M chassis mount connector
P2	Cannon XL-3 F Cord end type connector (probe cable)
LDR1	Probe element, Clairex type 905 HN
B1	Battery, Eveready type 763, 22.5 volts
B2	Battery, Eveready type 781, 4.5 volts
Card	Main electronics board, Keystone, cut to 4 3/8" by 6 3/4"
Card	Divider card, Keystone, cut to 4 3/4" by 3 3/8"
Z2	Zener diode, 18 volts 1 W

Connectors (Optional)

Connector A	Waldom (Molex) package # 1625 - 12 PRT
Connector B	Waldom (Molex) package # 1625 - 12 PRT
Connector C	Waldom (Molex) package # 1625 - 4 PRT
Connector D	Waldom (Molex) package # 1649 - 8 PRT
Connector E	Waldom (Molex) package # 1649 - 8 PRT

design of my printing meter.

I won't attempt to go into detail on printing color, but here, as in black and white, reference points such as flesh tones of persons are *best*. In color, I have found that a solid black area in the picture is a very good reference point once it has been established. Neutral or grey areas are very good. In addition to exposure and time, we have another problem in printing color from complementary color system negatives. Choice of proper light filtration is a very critical operation in color printing. Once we have established proper filter color balance, the last step is to arrive at the exact exposure for a selected exposure time.

Eastman Kodak Ektaprint 3 resin-coated back paper includes on each package the emulsion number, the reference color filtration compensation in yellow and magenta, and the emulsion sensitivity (speed) guide number. As an example: Choose 10 seconds as the exposure time on your timer. Now, keep it there. Select a picture color negative with a facial area in it. Turn the printing meter on and, having calibrated it for "ZERO" and "FULL SCALE," set the instrument to the "MEASURE" position. Place the probe cell aperture on the easel to include *only* the facial area. Adjust the enlarger lens aperture so that the reading on the printing meter "MEDIUM" scale is approximately .17 to .20 printing units. It will be found that this will be a good starting or reference point. It isn't my intention to go into color printing methods here, but with experience my instrument will save you time and money. The development of this printing meter is the result of long-time experience in the color field rather than just the need of a beginner. It is for this reason that I can say that it will serve you very well, whether you are a beginner or a professional.

I have been asked the question, "Why batteries?"

Well, here too from experience, the type of floor, humidity, and power distribution system in your area will cause great variations in external effects upon the instrument if it were common with a commercial power ac supply line. Longitudinal balance variations are avoided by the use of self-contained batteries. My system operates at extremely high input resistance values and, while it is advantageous instrumentwise, it is vulnerable to external

electrical influences. Again, the probe and the main instrument in one case are separate units. Thus the instrument has many applications because it is flexible. All the parts shown in this project are simple, and familiar to all radio men. My last figures on the cost of the entire unit using the best meter movement and the connectors with all the trimmings came to approximately \$150.00. This included the case and solid steel panel ready to go. ■

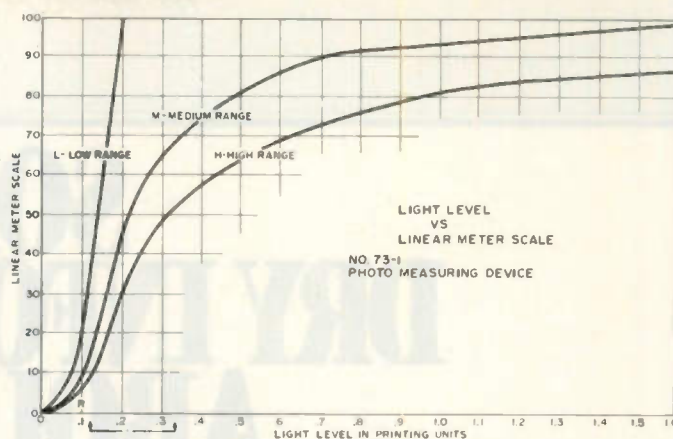

Fig. 13. Light level vs. linear meter scale.

CIRCUIT BOARDS

- REPEATER CONTROL
- COMPUTER PROJECTS
- SENSITIZED BLANKS
- NEGATIVES/POSITIVES
- PROTO-TYPE BOARDS
- PARTS KIT
- CUSTOM ETCH/DRILL

We can supply many of the items you need to make a p-c board. Send SASE + 25 cents for catalog.

O.C. Stafford S50

Electronic Service and Development
427 S. Benbow Rd.
Greensboro, NC 27401
919-274-9917 DAY/NITE

DELAWARE AMATEUR SUPPLY

D31

Serving amateurs in
Southern New Jersey,
Delaware, and Maryland
WITH
the largest stock of
amateur equipment and
accessories in Delaware



Paul WA3QPX
Rob WA3QLS

71 MEADOW ROAD
NEW CASTLE, DELAWARE 19720
(302) 328-7728

PARTS BONANZA

BC-191/BC-375 TRANSMITTER TUNING UNITS



We have these Plug-In Tuners available once again — as an excellent source of hard-to-find radio parts! Each includes a 2½" Vernier

Dial; a right angle Drive; three 100 Watt Variable Capacitors (except TU-26); Mica Capacitors; Coils; ceramic Band Switches; and more. All are unused. Listing of parts for each available with SASE. 9 x 17 x 7½"; Sh. Wt.: 18 lbs.

TU-5B, 1500-3000 Khz: \$1295 • TU-6B, 3000-4500: \$1295
TU-7B, 4500-6200: \$995 • TU-10B, 10000-12500: \$995
TU-26B, 200-500: \$895 • ALL Prices F.O.B., Lima, Oh.

VOLTMETER - VLF RECEIVER

ME-71C/FCC AUDIO LEVEL METER — useable as a VLF Receiver covering 20 Khz to 500 Khz with your tuned preamp. Input sensitivity —70 to +42 DBM indicated on 3½" rd. meter; 100 Khz Calibrator. 17 x 9 x 14". Sh. Wt.: 40 lbs. Used, repairable: \$500 —

Checked: \$7950 - Partial reproduction of Manual: \$750.
Use your VISA, BAC or Master Charge card!
Send for our FREE Surplus Electronics Catalog WS-78
Address Dept. 73 • Phone: 419/227-6573

FAIR RADIO SALES F1

1016 E. EUREKA • Box 1105 • LIMA, OHIO • 45802



RTTY
made
easy

TU-170 kit...\$149.95
wired...\$219.95

State of the art design features make the TU-170 ideal for HF and VHF autostart operation at an unchallenged price.

- SIZE: 7¼"Wx3¼"Hx7½"D
- Proved 170Hz shift 3 stage active filter demodulator
- Lighted tuning meter for easy tuning
- Current regulated loop keyer and power supply
- Autostart with threshold control and solid state relay
- Stable audio frequency shift oscillator, produces phase coherent sine wave tones
- TTL compatible inputs and outputs for auxiliary equipment
- High level output for scope tuning

FLEISHER CORP.

P.O. Box 976

Topeka, Kansas 66601

(913) 234-0198 F5



Sere-Rose & Spencer Electronics S39

1465 WELLS STATION ROAD
MEMPHIS, TENN. 38108
PH (901) 683-9125—685-8461

Authorized Dealer

DRAKE—ICOM—KENWOOD
REGENCY—TEMPO—DENTRON

CALL OR WRITE
FOR BEST DEAL

1315 BLUFF CITY HWY., BRISTOL, TN. 37620

Rusk Electronics Inc.

Quality Electronics Department Store R21



FT-101E

YAESU HF SSB FT-101E

160 thru 10M \$799.00 Retail

COMPLETE LINES
TEMPO
KOK
HYGAIN
DENTRON
CUSHCRAFT
LARSEN

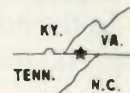

WRITE FOR
SPECIAL PRICES

CALL BOB BROWN WA4HAA
FOR SPECIAL QUOTE
615-764-0831 or 968-5343

SOME DRY INFORMATION ABOUT OUR ALL WEATHER ANTENNAS

Sooner or later almost all ordinary ham antennas are going to become victims of bad weather.

But Shakespeare's brand new line of two meter and HF antennas is anything but ordinary.

We're new to the ham market, but we've been making marine and military antennas for 26 years.

And those 26 years have taught us how to make a ham antenna that'll take just about anything Mother Nature can dish out.

Look at our 5705 omnidirectional VHF base antenna, for example.

Its radiating elements are non-ferrous brass and copper, the finest practical material available for conductivity and corrosion resistance. Surrounding the radiating elements and electrical components is a tough, flexible fiberglass shield. A shield that gives the antenna the strength to withstand winds in excess of 120 miles-per-hour.

The fiberglass keeps out rain, sleet and snow too. So the antenna's radiation pattern won't change, no matter how bad the weather.



Fiberglass protects radiating elements from rain and ice. Therefore no corrosion.

Fiberglass gives added strength to the antenna. Prevents breakage in wind and sleet.

Fiberglass shield protects electrical components from corrosion caused by rain or ice.

Fiberglass prevents radiation patterns from changing in wet weather.

The Model 5705

VHF Base Antenna

And you don't have to worry about radials breaking off, because the 5705 doesn't have any.

But it does have seven vertically polarized and phased 1/2 wave elements, stacked in colinear array and providing an impressive 10 dB gain.

And you can get optional style 5709 reflector that blocks out unwanted coverage and gives you an additional 2 dB gain in the opposite direction.

And here's another important piece of information: the 5705 is pre-tuned at our factory to operate in all environments. So it'll never have to be re-tuned.

Our full ham antenna line is featured in our new catalog: *The Complete Works of Shakespeare*. And

the catalog is yours. For free.

For additional information just write Shakespeare, Electronics and Fiberglass Division, Department C, Post Office Box 246, Columbia, South Carolina 29202.

Or call National Sales Manager John Hughes, (803) 779-5800 ■ WA4EAU.

Shakespeare[®]

We Guarantee...

she won't answer your phone call (as nice as that might be!) But we **do** guarantee every phone call and letter will be handled by an active, Licensed Ham with years of experience.



Ray WB4DXH Pudge W4LTX Jim WA4CDX Bill WD4LGF

Together we have more than 50 years experience in Ham Radio.

**Call us and see why if you're not buying from us.
We're Losin' and You're Losin'.**

1. Credit cards Welcome (except "cash deals")
2. Trades invited.
3. Fast — to your door — delivery via UPS.
4. Large inventory of major lines — most items are in stock NOW!
5. Send for our free catalog.
6. Cost of telephone calls will be deducted from your order.
7. We're "burning" to make Hot Deals at A.R.S.O.N., Inc.

Yes!! Now we are authorized dealers for

KENWOOD

We also carry:

Yaesu • Drake • ICOM • Dentron • HyGain • Wilson • Ten-Tec
Tempo • Swan • Standard • KLM • Larsen • Cushcraft
Newtronics (Hustler) • B & W • CDE • Shure • NYE
Pipo • Beldon and others.

Amateur Radio Supply of Nashville, Inc.

615 South Gallatin Road, Madison, Tennessee 37115 Phone (615) 868-4956

Store Hours
Mon. - Fri.
9 a.m. - 5 p.m.
Sun.
1 p.m. - 6 p.m.

NOW! The same policies and products in Atlanta

Cal K4JSR Lee WA4HUG Jerry WB4VPJ

Amateur Radio Supply of North Atlanta, Inc.

Pinetree Plaza Shopping Center • 5269-6 Buford Highway, Doraville, GA 30340 • (405) 455-1771

A40

NASHVILLE 615-868-4956

ATLANTA 404-455-1771

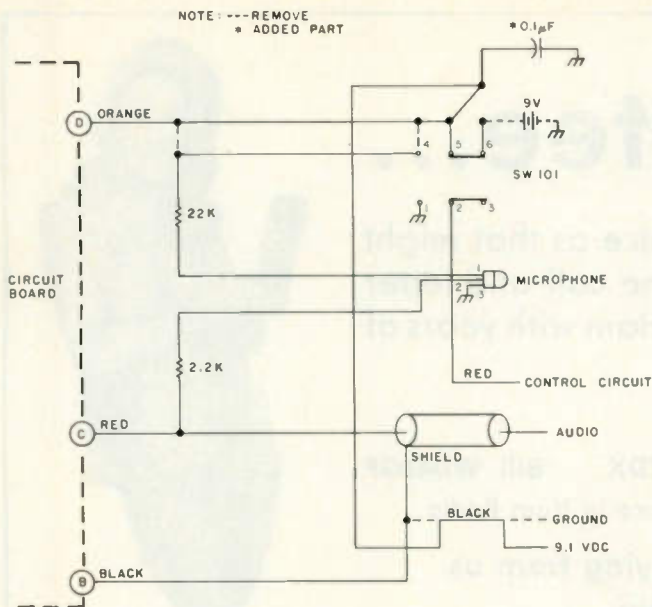

Fig. 1.

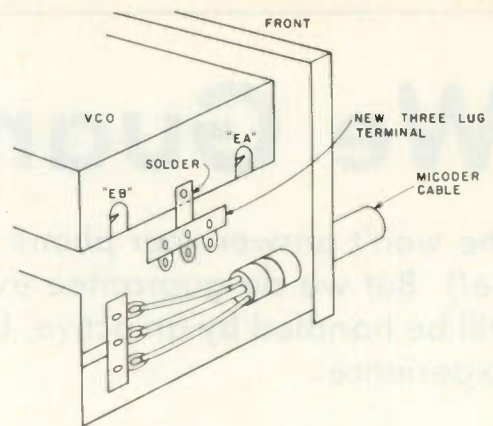

Fig. 2.

John C. Bull K4BJF
1383 S.W. 5th St.
Boca Raton FL 33432

Micoder™ Magic

— improve it with easy mods

I have made three changes on my Heathkit™ HW-2036 transceiver and the Micoder™ HD-1982 I use with it. The first two changes go together. They were instigated by my dislike of the nine-volt transistor battery. The third change is strictly an enhancement for ease of operation and to keep background noise from interfering with the tone while using the Micoder.

Following are the steps to use for the change that must be made to the Micoder to eliminate the 9-volt battery

and obtain the 9-volt supply from the HW-2036.

1. Remove the 9 V battery wire from switch terminal SW101-6.
2. Remove the negative 9 V battery wire from the two-lug ground terminal.
3. Remove the black cable wire from the two-lug ground terminal. This wire will be used to carry the 9 V from the HW-2036 to the Micoder.
4. Remove the orange wire from switch terminal SW101-4 and reconnect it to switch terminal SW101-5.

5. Connect a 0.1 µF disk capacitor from switch terminal SW101-5 to the two-lug ground switch.

6. Connect the black cable wire to switch terminal SW101-5.

7. To improve oscillator stability, add two 0.01 µF capacitors. One should go from IC102, terminal 5, to ground; the other from IC101, terminal 5, to ground.

Fig. 1 shows the details. This completes the Micoder change. A companion change must also be made in the HW-2036, as follows:

1. Use a three-lug terminal with a center terminal ground with an oscillator mounting strap and secure it to the longer side of the vco assembly so that the terminal lug is under the vco box. Use solder (see page 108 of the HW-2036 assembly instructions). The terminal should be mounted between the EB and EA solder lugs (see Fig. 2).

2. Assemble the capacitor, resistor, and zener diode to the three-lug terminal. Make sure the zener diode polarity is correct.

3. Remove the Micoder black cable wire from lug AT, terminal 2, and connect it to the new three-lug terminal 1.

4. Run a wire from the vco B terminal (11.1 V dc

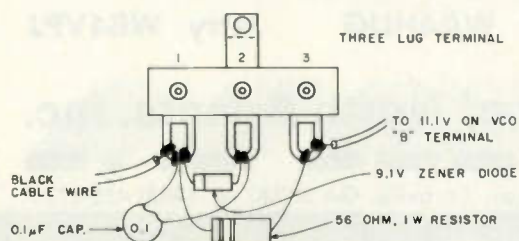

Fig. 3.

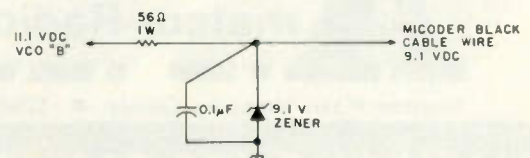

Fig. 4.

and connect it to the new three-lug terminal 3.

That completes the elimination of the 9-volt battery.

The third modification I made activates the push-to-talk when the encoder keyboard buttons are pushed (see Fig. 5). The R-C delay will keep the transmitter on while stepping from keyboard button to button. The PTT switch activator will not have to be squeezed. This will keep the microphone inactive so that background noise will not interfere with the tones. This modification can be accomplished only if the 9-volt battery has been removed. The circuit board will occupy its space. The new board fits between the microphone and the circuit board support posts. Secure the new board to the battery cushions on the lower case.

Diode D1 allows the 100 uF capacitor to charge when Q101 is active and blocks the 100 uF capacitor when it isn't active. When Q1 is

active, it turns on the Q1 transistor, activating the control circuit. That turns on the transmitter. Capacitor C1 will discharge via R1, a 1k Ohm resistor, and through the base-to-emitter path of Q1 when Q1 is turned off. This will keep Q1 on for a second or so. Diode D2 will protect the Q1 transistor if the control circuit goes directly to a relay coil. ■

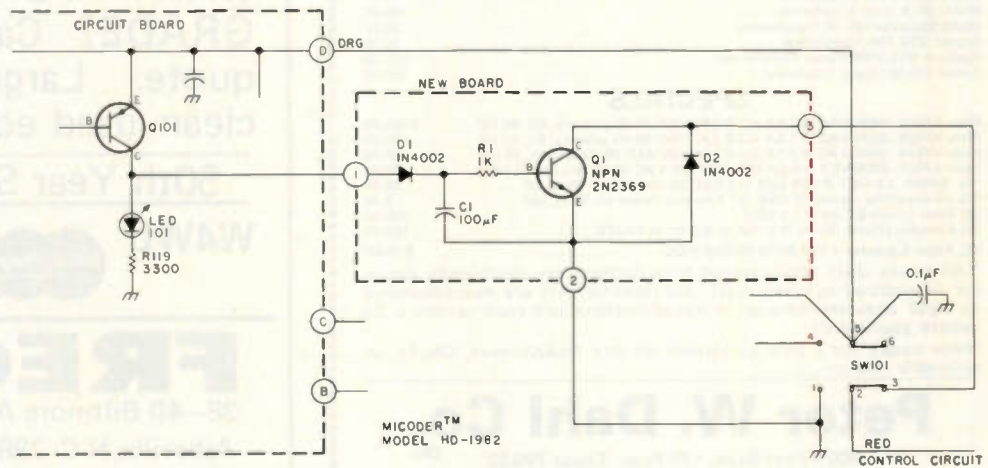

Fig. 5.

Parts List

- 2 0.1-uF disk
- 2 0.01-uF disk
- 1 56-Ohm, 1-Watt resistor
- 1 9.1-volt, 1-Watt zener
- 1 3-terminal connector
- 1 6-inch hookup wire, insulated
- 1 circuit board, approximately 29 x 45 mm
- 1 Q1 transistor NPN 2N2369
- 2 D1, D2 diode 1N002
- 1 R1 1000-Ohm, 1/4-Watt resistor
- 1 100-uF 25-V dc capacitor

VHF DF



We have a portable direction finder that REALLY works—on AM, FM, pulsed signals and random noise! Unique left-right DF allows you to take accurate bearings even on short bursts, with no 180° ambiguity. Its 3 dB antenna gain and .06 uV typical DF sensitivity allow this crystal-controlled unit to hear and positively track a weak signal at very long ranges—while built-in RF gain control with 120 dB range permits DF to within a few feet of the transmitter.

The DF is battery-powered, can be used with accessory antennas, and is 12/24V for use in vehicles or aircraft. This is a factory-built, guaranteed unit—not a kit. It has been successful in locating malicious interference, as well as hidden transmitters in "T-hunts," ELTs, and noise sources in RFI situations.

Prices start at under \$175. Write or call for information on our complete line of portable, airborne, vehicle, and fixed DF systems.

L-TRONICS

5546 Cathedral Oaks Rd.,
Amateur Dept.
Santa Barbara, CA 93111

W6GUX WD6ESW

L10

You can't go wrong with a Mobile 2.

With 5/8 wave ready, all we left out was a high price.

Now available in both 5/8 and 1/4 wavelengths, the **Mobile 2** antennas are great for 2 meters, 220 MHz or 440 MHz bands.

The original **Mobile 2** mounts to your trunk lid. The **Mobile 2** magnetic grabs on almost anywhere, and stays put. Even when passing big trucks.

Both antennas come with all cable, connectors and hardware **in one package.**

Either way, you can't go wrong with a **Kantronics Mobile 2.**

magnetic
\$19.95

trunk
\$11.95

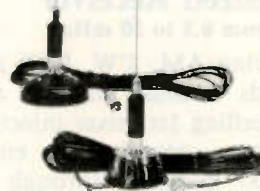

KANTRONICS
The Lightweight Champs.

K13

1202 East 23rd Street
Lawrence, Kansas 66044

Phone: 913-842-7745

We accept Visa, Master Charge, check and money orders.

CUSTOM TRANSFORMERS



HEAVY DUTY REPLACEMENT TRANSFORMERS*

Collins 30S-1 Plate Transformer	\$165.00
Collins 516F-2 Power Transformer	95.00
Hunter 2000B Plate Transformer	125.00
ETO A-770 Plate Transformer	125.00
Henry 2K Plate Transformer	140.00
Henry 2K-2 Plate Transformer	165.00
Henry 2K-2A Plate Transformer	135.00
Henry 2K-4 Plate Transformer	165.00
Henry 3K-A Plate Transformer	165.00
Heath Marauder HX-10 Transformer	95.00
Gonset GSB-100 Transformer	95.00
National NCL-2000 Power Transformer	125.00
Gonset GSB-201 Power Transformer	135.00

SPECIALS

Plate XFMR. 4600 VAC @ 1.5A ICAS 230 VAC 60 Hz primary, Wt. 60 LB	\$195.00
Plate XFMR. 3500 VAC @ 1.0A ICAS 230 VAC 60 Hz primary, Wt. 41 LB	125.00
Plate XFMR. 3000 VAC @ 0.7A ICAS 115/230 VAC 60 Hz pri, Wt. 27 LB	95.00
Plate XFMR. 6000 VCT @ 0.8A CCS 115/230 VAC 60 Hz pri, Wt. 41 LB	135.00
FIL XFMR. 7.5 VCT @ 21A CCS 117 VAC 60 Hz primary Wt. 8 LB	29.95
FIL Choke bifilar wound 30 AMP RF Filament Choke on 1/2x7 rod	8.95
DC Filter Choke 8.0 Hy @ 1.5 ADC	150.00
DC Swinging Choke: 30 Hy @ 0.15A to 5.0 Hy @ 1.0ADC	100.00
DC Filter Capacitors 100 MFD @4000 VDC	\$75.00

*All heavy duty replacement transformers are electrically superior to original equipment(s). All transformers are manufactured to rigid commercial quality specifications and each carries a 24 month guarantee!

Write today for a free quotation on any transformer, Choke, or saturable reactor.

Peter W. Dahl Co.

4007 Fort Blvd. · El Paso, Texas 79930 D6
Telephone (915) 566-5365 or (915) 751-4856

Choosy People LOVE Standard!



C-6500 Solid State, Synthesized Receiver Covers Broadcast Band From 0.5 to 30 mHz

The C-6500 is capable of receiving AM, CW, USB and LSB. Synthesizer design affords unusual stability and digital dial accuracy. Drift-cancelling 1st mixer injection system provides 30 tunable ranges, covering the entire broadcast band starting at 500 kilohertz through 30 megahertz, from a single 10 mHz crystal oscillator. This ensures the frequency stability necessary for excellent SSB reception. Operates from internal batteries or AC mains.



S18



Standard Communications

Standard Communications Corp. • P.O. Box 92151, Los Angeles, CA 90009

IN
STOCK

\$ 1299⁰⁰



WANT TO TRADE — UP-
GRADE? Call us — for best
quote. Large assortment of
clean used equipment on hand.

50th Year Serving Amateurs

W4WL



W4VOV

FRECK radio & supply co., inc.

38-40 Biltmore Ave. F3
Asheville, N C 28801
PHONE: (704) 252-8000

BRITT'S

2-Way Radio Service

B29

2508 North Atlanta Road
Belmont Hills Center
Smyrna,
Georgia 30080
Phone (404) 432-8006

North Georgia's

only Authorized Yaesu Dealer

Yaesu	Kenwood
Mosley Antenna	Vibroplex keys
Cush-Craft	B & W
Rohn-Tower	Swan meters
C.D.E. Rotors	Hustler
Shure	Saxton
Wilson	ARRL Books
M F J	Call Books

TPL 2 Meter Amplifiers

Complete service facilities

Call toll free 1-800-241-9961

Ham Help

I need a dial for a National model HRO7R receiver, and would also appreciate any information at all on HRO receivers.

Paul A. Yurko WD9HXM
230 West 45th Avenue
Gary IN 46408

I am looking for a meter for a Utica 650 six meter transceiver. I will pay for shipping.

Don W. Sartin WB3JYJ
10 Oak St.
Inkerman PA 18640

I am in need of diagrams and conversion help for a Gonset G-151 FM Communicator. I want to try to put it on 2 meters, if possible, and with 2 channels. I would appreciate any help.

Henry A. Simacek K0WJK
1600 Marion Rd. SE
Rochester MN 55901

I own a Heathkit HW-104 and would like to add RIT. Can someone who has added this modification send me information or make reference to an article already published?

Dan Atchison N3ND
112 Scotland Dr.
Newark DE 19702

I recently purchased a W9TO vacuum tube keyer at a hamfest. The problem is that the dots and dashes are the same length. I would greatly appreciate a schematic diagram or any information on this keyer. I am 13 years old and this is my first keyer.

Dave Preschel WB1FKO
20 Courtland Dr.
Shelton CT 06484

I need schematic diagrams for a Morrow 5BR-1 mobile converter, a Gonset model #3002 shortwave converter, and a Gonset model #3037 2 meter tuner. Any help would be greatly appreciated.

Joe Turkal K8EKG
1234 Concord NW
Massillon Oh 4646

I need the manual or copy of same for the Gonset Communicator III 6m with vfo. I also would like to know how to put the Gonset on FM. If anyone has what I need, I will gladly pay for it.

Jack Norris KL7IPM
PO Box 321
Talkeetna AK 99676

I, along with some other

Greek hams, am interested in getting started on RTTY. We only know the basics, and the Greek market doesn't offer much from which to choose, but we want to give it a try. We want to hear from those who would be interested in getting us started and offering us some

guidance. Thank you very much.

Manos Datkadakis SV1KB
PO Box 3751
Athens, Greece

I would like to borrow (for copy and return) a programming manual for a Tennelec Memory Scan programmable scanner. Or, if someone would send me the first ten, or so, frequencies and access codes from each band, I could work up

a program from there. I would also like to borrow the service manual so I can retune the scanner for two meters. I would also like a copy of the schematic for a mobile power supply, but the programming instructions are most important as the radio is useless without them.

Richard McSwain WH2AAA
601 E. Sunset Blvd.
NAS Guam
FPO San Francisco 96637

TROUBLE FREE TOUCH - TONE ENCODER



Pat. Pend.
375 2.00

PP-1

POSITIVE TOUCH (KEYS DEPRESS) • MOBILE • HANDHELD
POSITIVE MOUNT • NO POTTED PARTS (SERVICEABLE)
MIL. SPEC. COMPONENTS • NO RFI • SELF CONTAINED
XTAL CONTROLLED • LEVEL ADJUSTMENT FROM FRONT

Supplied with: Instructions, schematic, template, hardware. Operating Voltage: 4.5 - 60V. PP-1A, designed for Standard Communications Handhelds.
(California residents add 6% sales tax.)

PP-1=\$55.00, PP-2=\$58.00, PP-1A=\$58.00
PP-1M=\$55.00, PP-2M=\$58.00, M series-Mobile
PP-1K=\$66.00, PP-2K=\$69.00,
K-series = Self Contained Delay Relay

LETTERING OF UNITS OPTIONAL

Available at: Ham Radio Center (800) 325-3636
Denver Colo., CW Electronics (303) 893-5625
Medford, MA, Tufts (617) 395-8280
Los Angeles, Henry Radio (213) 272-0861
New York City, Harrison (800) 645-9187



2.5 2.65

PP-2

Available at: Ham Radio Center (800) 325-3636
Denver Colo., CW Electronics (303) 893-5625
Medford, MA, Tufts (617) 395-8280
Los Angeles, Henry Radio (213) 272-0861
New York City, Harrison (800) 645-9187

Mall Order To **Pipo Communications** P.O. Box 3435 Dept C
Hollywood, California 90028
213/852-1515

HIGH PERFORMANCE UHF CONVERTER FOR OSCAR



Model C-432A (408) \$5995

- Converts 432 or 435 MHz to 29 MHz. (Be sure to specify the input frequency you want)
- 2 tuned RF stages using low noise J-FETS eliminates the need for a separate UHF pre-amp
- Special RCA dual-gate MOSFET mixer gives good conversion gain and minimum cross modulation
- High frequency quartz crystal oscillator and multiplier stages use 1.2 GHz transistors for maximum efficiency
- Conversion gain is more than 20 dB (typically 25 dB) therefore assuring you .1 microvolt sensitivity when used with an average communications receiver
- Just connect a simple turnstile antenna (see Nov. '77 of 73 Magazine) and a 12 volts DC power source (only 30 mA required) and you're ready to receive.

See our other products in the full page ad of the Jan. '78 Issue or write for catalog sheet. For immediate shipment call (212) 468-2720 or mail your order with payment plus \$1.00 for air mail to:

VANGUARD LABS • 196-23 Jamaica Ave. • Hollis NY 11423

V1

NEW!

\$36.50

plus \$1.50 s/h
NY res. add tax



Features: CMOS Electronic Keyer

- State-of-the-art CMOS circuitry
- Self completing dots and dashes
- Dot and dash memory
- Iambic keying with any squeeze paddle
- 5-50 WPM
- Speed, volume, tone controls, side tone and speaker
- Low current drain CMOS-battery operation
- Deluxe quarter-inch jacks for keying and output
- Handsome eggshell white base - woodgrain top
- Compact and portable - 1-7/8 x 4-1/4 x 6-1/4
- Grid block keying
- Wired and tested - fully guaranteed - less battery

BRAND NEW!

\$25.95

Plus \$2.00 S/H
NY res. add tax



Features:

- Twin paddle squeeze key
- Extra heavy base—non skid feet
- Adjustable contact spacing
- Touch tension—comfort keying
- Smooth friction free paddle movement
- Handsome crinkle finish base and rich red paddles
- Five way binding posts
- Use with TRAC CMOS keyer or any keyer

TRAC-KEY

Electronics, Inc.
1106 Rand Bldg.
Buffalo NY 14203

T18

Social Events

MORGANTOWN WV SEP 3

The Monongalia Wireless Association will hold its second annual Mon Ham Gala on Sunday, September 3, 1978, at Westover Park, 300 yards off I-79, near Morgantown, West Virginia. The activities begin at 10:00 am and end at 5:00 pm. Talk-In on 16/76. For complete information, contact John Curtis WB8AHH, 817 Willowdale Road, Morgantown WV 26505.

PENSACOLA FL SEP 3

The Five Flags Amateur Radio Association will hold its annual Ham-A-Rama on September 3, 1978, at the University of West Florida field house in Pensacola FL. For additional information, write to the FFARA, PO Box 17343, Pensacola FL 32522.

SIERRA VISTA AZ SEP 9

The Cochise Amateur Radio Association will hold its fourth annual Cochise Amateur Radio Round-Up on September 9,

1978, at the Sierra Vista Community Center, Sierra Vista, Arizona, starting at 9:00 am. Talk-in on .16/.76 and .52/.52. First prize is an Atlas 210X, and there will be many other prizes. Tickets are \$3.00. For tickets and more info, write CARA, PO Box 1855, Sierra Vista AZ 85635.

UNIONTOWN PA SEP 9

The Uniontown Amateur Radio Club will hold its annual Gabfest on Saturday, September 9, 1978, at the Club Grounds on the Old Pittsburgh Road, Uniontown, Pennsylvania.

MELBOURNE FL SEP 9-10

The thirteenth annual Melbourne, Florida, Hamfest, sponsored by the Platinum Coast Amateur Radio Society, will be held Saturday and Sunday, September 9 and 10, 1978, from 9:00 am to 5:00 pm each day, in the air-conditioned Melbourne Civic Auditorium located on Hibiscus Boulevard. Donation is \$3.50 per family.

The program includes forums, meetings, swap tables, commercial exhibits, awards, and prizes. Talk-in on .25/.85 and .52. For more info, write PO Box 1004, Melbourne FL 32901.

SOUTH DARTMOUTH MA SEP 10

The Southeastern Massachusetts Radio Association will hold its annual Flea Market Festival on Sunday, September 10, 1978, from 9:00 am to 5:00 pm at the Stackhouse Street Fairgrounds, South Dartmouth, Massachusetts. Rain date is September 17, 1978. There will be prizes, games, displays, refreshments, and many other activities. Admission is free. Space is \$5.00 in advance; \$8.00 at gate. Tables are \$3.00 in advance; \$5.00 at gate. Talk-in on 147.60/147.00 and 146.52. For complete information, contact Bob WA1ZXG or Rocky K1VJZ, S.E.M.A.R.A., PO Box 105, South Dartmouth MA 02748. For reservations: Attention, Armand WB1BUG.

MONTGOMERY AL SEP 10

The Central Alabama Hamfest will be held Sunday, September 10, 1978, in the new Civic Center, Montgomery AL. There will be food service, prizes, air-conditioned exhibit areas, an indoor and outdoor flea market, and plenty of free parking. Admission and registration are free. For further information, contact Al Erdman W4CNQ, 3025 Pelzer Ave., Montgomery AL 36109, (205)-272-9130, or any amateur in the Montgomery area.

BUTLER PA SEP 10

The Butler County Hamfest, sponsored by the Butler County ARA, will be held on Sunday, September 10, from 11 am to 4 pm at the Butler County Farm Show Grounds, adjacent to Butler Roe Airport (with a paved runway for fly-ins). Check-ins on 147.90/.30 and .52 simplex. Contact John K3HJH or Cliff WB3CDA for more details.

FINDLAY OH SEPT 10

The second largest hamfest in Ohio, the 36th annual Findlay hamfest, will be held on September 10, 1978, rain or shine, at Riverside Park from 5 am to 5 pm. Watch for directional signs. There will be free parking, free reserved indoor space (bring your own tables), a massive swap and shop, and lots of prizes. A 2 meter hunt will be held at 1 pm and the main prize drawing at 3 pm. Tickets are \$1.50 in advance, \$2 at the door. Talk-In and prize

check-in on 146.52. For tickets, space reservation, and further information, send an SASE to Clark Foltz W8UN, 122 West Hobart Ave., Findlay, Ohio 45840.

WILKES-BARRE PA SEP 10

The Broadcasters Amateur Radio Club will hold its first annual hamfest at the Boston Store parkade, 30 South Franklin St., Wilkes-Barre PA on Sunday, September 10, 1978. In addition to ham exhibits, there also will be computer exhibits. Interested dealers and individuals should contact Charles Baltimore, 62 South Franklin St., Wilkes-Barre PA 18703, (717)-823-3101.

PECATONICA IL SEP 10

The Rockford Hamfest '78 and Illinois State ARRL Convention will be held on Sunday, September 10, indoors at the Winnebago County Fairgrounds, Pecatonica IL. Prizes include a Tempo VHF One transceiver, a Tempo FMH two-meter HT, and a DenTron Jr. Monitor™ Antenna Tuner. Flea market tables are available. Lots of parking and campsites. There will be speakers, forums, displays, and ladies' programs. Tickets are \$1.50 in advance and \$2.00 at the gate. Talk-in on 01/61 or 52. For details, contact R.A.R.A., PO Box 1744, Rockford IL 61110. Please include a business-size SASE.

ELLETTSVILLE IN SEP 10

The first annual Hoosier Backyard Hamfest, sponsored by the WR9AFY repeater and Community Broadcasting Corporation, will be held on Sunday, September 10, 1978, at the Phoenix Farm, State Highway 46 at the western city limits of Ellettsville, Indiana, approximately nine miles west of Bloomington, Indiana. There will be limited indoor space for noncommercial demonstrations, and a home brew contest. There will be acres of parking space for trunk sales, with limited overnight parking. Activities begin at 8:00 am and end at 4:00 pm. Admission is \$1.00 per person. Children under 12 are free. Talk-in on 147.78/.18 (touchtone™ 7) and 146.04/.64. For further info or advance sales (SASE required), contact CBC, 7391 W. Hwy 46, Ellettsville IN 47429.

CHERRY HILL NJ SEP 10

The South Jersey Radio Association hamfest will be held on Sunday, September 10, 1978, rain or shine, at the Ellisburg Shopping Center,

ZZZ ELECTRONICS, INC.



We Sell & Service
These Lines
Call Now For HAM Prices

ICOM
KLM
Dentron
SWAN
KDK2015R
Tentec
Wilson
Telex
Hustler
Mosley
Cushcraft

Ameco
SAY Power Supplies
B&W Switches
Shure
Integrated Electronics
LARSEN
ADI Auto Dialers
PanaVise
Amphenol
Aluma Towers
And Many More

Special Prices On These Items Now

ICOM 211
KDK 2015R
Ten Tec 570
Ten Tec 574
Dentrol All Band Doublet
SWAN TB4HA
SWAN TB3HA
Dentron MT2000A
Dentron MT3000A

ICOM IC215
KLM 144-148-16
KLM 144-148-14
KLM 144-148-50
RG8X COAX
Dentron Big Dummy
Dentron Jr. Monitor
YAESU 7T101EE
ICOM 245SSB
SAY Elect. Power Supplies
KLM 2-25B
10' & 15' Roof Top Tripods

We accept
MC & Visa & Interbank Cards
—will ship UPS C.O.D.
422 ARMOUR CIRCLE N E
ATLANTA GA 30324
(404) 876-0631

Come by or call William/WA4SVY



Cherry Hill, New Jersey, at the intersection of routes 41 and 70. There will be a flea market, an auction, activities, and many prizes. Family registration is \$2.00; tailgating is \$3.00. Talk-in on .52. For further information, contact K2KA, Box 2736, Cherry Hill NJ 08002, or phone (609)-429-6032.

**CONCORD NH
SEP 15-16**

Evans Radio, Inc., Electrical Supply Company of Concord, New Hampshire, celebrates its 45th anniversary with an open house and trade show. The open house will take place on Saturday and Sunday, September 15 and 16, 1978, 9:00 am to 4:30 pm, at the firm's headquarters at Route 3A, Bow Junction, New Hampshire. The trade show will be held at the New Hampshire Highway Hotel and will feature 85 displays of electrical and electronic manufacturers' products. Buses carrying guests will run continually between the headquarters and trade show throughout the two-day celebration.

**BUFFALO NY
SEP 16**

The seventh annual Hamburg International Hamfest presents HAM-O-RAMA 78. This event will be held on Saturday, September 16, 1978, 9:00 am to 5:00 pm, at the Erie County Fairgrounds, Buffalo NY. Activities include speakers, big prizes, ladies' programs, major manufacturers' displays, and indoor and outdoor flea markets. Recreational vehicle hookups available. Talk-in on 146.52 and 146.31/.91. The fairgrounds are located off New York State I-90 at exit 57. For additional information, contact Bert Jones (716)-873-3984 or Jim Ciurczak (716)-297-0539.

**HUDSONVILLE MI
SEP 16**

The Grand Rapids Amateur Radio Association will hold its annual swap-n-shop on Saturday, September 16, 1978, at the Hudsonville fairgrounds, west of Grand Rapids on Hwy. #21 approximately ten miles. Talk-in on 14.16/.76 and 146.52. This will be an indoor and outdoor swap and shop. Tables are free; you can sell from the trunk of your car. There will be prizes, with one main door prize. Admission will be \$2.50 at the gate. Room for 1,000 cars. Time: 7:00 am till 3:00 pm.

**FALLS CHURCH VA
SEPT 16**

The 1978 ARRL Technical Symposium will be held on Saturday, September 16, 1978, at the Tyson's Corner Ramada



Inn, Falls Church, Virginia, in conjunction with the National Capitol DX Association's DXPO 78. This American Radio Relay League technical symposium is managed by the Amateur Radio Research and Development Corporation (AMRAD) and sponsored by the Northern Virginia Amateur Radio Council (NOVARC).

**FALLS CHURCH VA
SEP 16-17**

The National Capitol DX Association will sponsor DXPO 78 on Saturday and Sunday, September 16 and 17, 1978, at the Tyson's Corner Ramada Inn, near Interstate 495,

Tyson's Corner, Virginia. The two half-day sessions will include DXpedition slide shows, contest tips, antennas, satellite DXing, and other special interest topics. A Saturday night banquet and hospitality session is included. The ARRL Technical Symposium is scheduled for the morning of September 16. Advance registration is recommended. Unless you have previously attended DXPO, write Dick Vincent K3AO, Rt. 1, Box 230, Bryantown, MD 20617 to be included on the mailing list.

**KENNER LA
SEP 16-17**

The Jefferson Amateur Radio Club, the Crescent City Computer Club, and the New Orleans VHF Club will hold their annual New Orleans Hamfest-Computerfest on Saturday and Sunday, September 16 and 17, 1978, at the Airport Hilton Inn in Kenner, Louisiana. Activities include forums on DX, antennas, hobby computers, and other phases of amateur radio, as well as demonstrations of satellite communication. FCC exams will be given to those with proper advance reservations. A luau with music

and entertainment is planned for Saturday night. Talk-in on 146.34/.94. For complete details and reservation information, write New Orleans Hamfest-Computerfest, PO Box 10111, Jefferson LA 70181.

**PEORIA IL
SEP 17**

The Peoria Area Amateur Radio Club will hold its 21st annual hamfest on September 17, 1978, at the Exposition Gardens on W. Northmoor Road in Peoria, Illinois. Admission to the grounds and swapfest is free; tickets will be sold for a drawing to be held in the Youth Building at 3 pm. Advance tickets are \$1.50; tickets at the door will be \$2. Camping space will be available Saturday night on the grounds. Space will be available for net meetings and a ladies' flea market; there will be movies and forums of interest to all throughout the day. Commercial exhibitors and manufacturing representatives will give product demonstrations. For the ladies, there will be a free bus trip to the Northwoods shopping mall with more than 100 different shops. An informal get-together will be held at

Continued on page 226



The only REALLY NEW 80-10 meter vertical design in 20 years!

Completely automatic bandswitching 80 through 10m I160-10m with optional TBR-160 add-on unit.
Low V.S.W.R. over entire 40, 20, 15, & 10m bands plus ANY 60-100 KHZ segment of 80/75m. NO ANTENNA TUNER NEEDED!
ENTIRE 26 ft. length active on 80, 40, 20, & 10m with full 1/4 wave resonance on 15m for greater bandwidth & superior DX performance. Ground, roof, or tower mount- no guys needed.
HIGHEST QUALITY CONSTRUCTION & WORKMANSHIP THROUGHOUT. HIGH STRENGTH ALUMINUM ALLOY AND FIBERGLASS DESIGN. Complete with 1-1/8 in. O.D. tubular mounting post, RG-11/U matching line, and connector for PL-259. Use any length of 50-52Ω coax.
V.S.W.R. at resonance: 1.5:1 or less; all bands.
Power rating: Legal limit SSB/CW 40-10m; 1200 W P.E.P./500W CW on 80/75m.

AT YOUR DEALER OR DIRECTLY FROM



**BUTTERNUT
ELECTRONICS CO.**

ROUTE ONE DEPT. 4
LAKE CRYSTAL, MN. 56055
PHONE 507-947-3126

OTHER MODELS, TOO! FREE INFORMATION.



15m trap



80m coil



Base

Model HF5V-II \$74.50 PPD. IN CONT. USA (BY UPS).
MN. RESIDENTS ADD TAX.

Build the IC Experimenter

— getting started
with TTL and CMOS

Mark Leonard
c/o Integral Electronics Corp.
PO Box 286
Commack NY 11725

For both the novice experimenter and the advanced digital circuit designer, the two most essential tools of the trade are a

basic power supply and a suitable signal source. Most modern digital circuit families (DTL, TTL, CMOS, and NMOS) either require, or will satisfactorily operate from, a regulated 5 V dc source. A one-Ampere supply will suffice for most medium-size TTL projects and will more than exceed the needs of even the most ambitious CMOS

undertaking. The signal source should provide square-wave (true and complement are helpful) and pulse outputs over a reasonable range of frequencies. A bounce-free variable one-shot output is also an absolute must.

The instrument described in this article will meet all of the above requirements; it is immune to accidental shorts

which often occur in the course of trying a new circuit and will, therefore, be a useful addition to any laboratory.

Condensed Specifications

Power supply: 5 ± 0.25 V dc at 1 Amp, short-circuitproof; automatic thermal shutdown.
Astable oscillator: 10 Hz to 100 kHz, providing simultaneous true and complementary square waves and 1 μ s pulses, TTL-compatible, short-circuit protected; manual and/or remote gating.
Monostable oscillator: Simultaneous true and complementary pulses variable from 5 μ s to 50 ms. TTL-compatible, short-circuit protected; manual and/or remote triggering.

About the Circuit

Power Supply

The power supply is shown schematically in the lower portion of Fig. 1. It is a basic full-wave rectifier, capacitor input supply, followed by an IC regulator capable of delivering in excess of 1 Ampere at 5 V, while being fully protected against

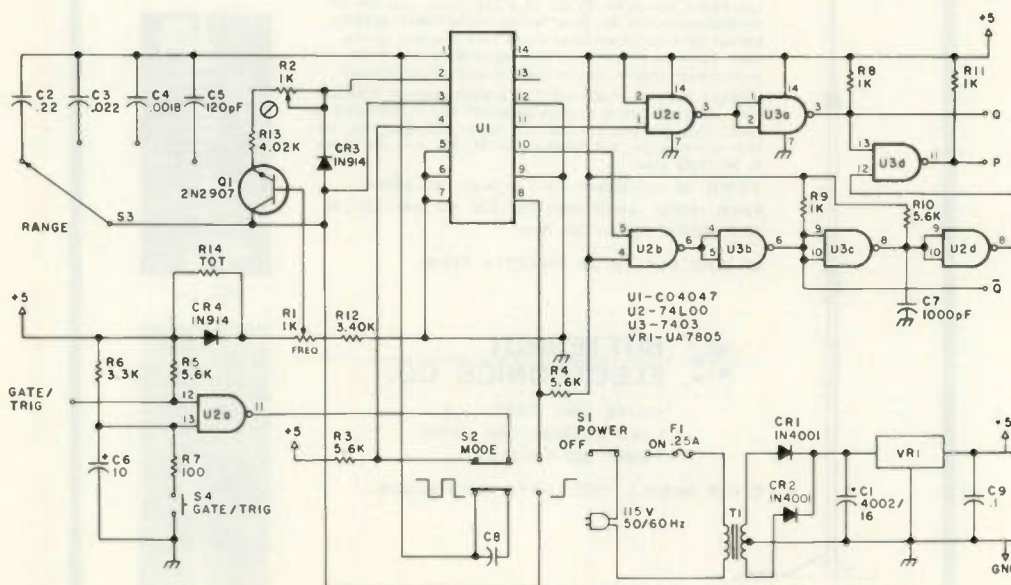

Fig. 1.

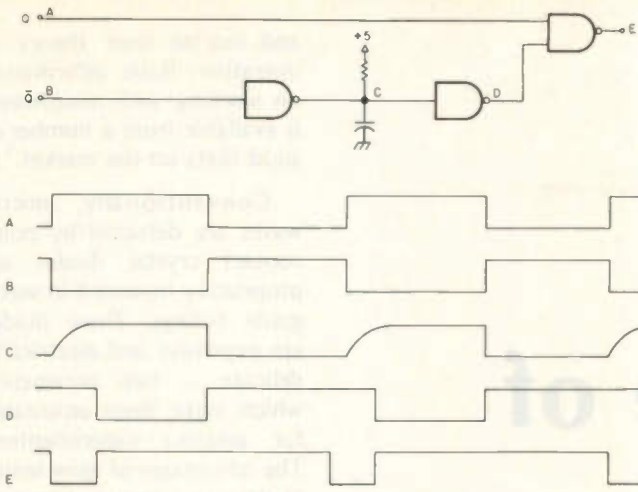

Fig. 2.

sustained shorts and overloads. The power transformer secondary is rated at 16 V c-t at 1.5 Amps; these are the minimum parameters to guarantee proper operation under worst case line and load. The IC regulator (7805) has internal thermal protection and must be heat sunked to at least 15 square inches of 1/16" aluminum sheet metal.

Astable oscillator

The heart of the oscillator circuit is U1, a CD 4047 IC. Its operating mode, i.e., astable or monostable, is controlled by the logic state at terminals 4 and 8. As shown in the schematic, with pin 4 grounded and pin 8 high, the astable mode is established. The oscillator may be inhibited by raising the level on pin 4; this is achieved by grounding either of the two inputs of gate U2A. The frequency of oscillation is determined by the charging time of the frequency range capacitors, C2-C5. When used in accordance with the IC manufacturer's recommendations, the frequency would be continuously varied by varying the resistance between pins 2 and 3. Unfortunately, this yields a frequency calibration proportional to 1/R and a highly nonlinear dial for a linear taper potentiometer. This problem has been overcome in this circuit by replacing the variable resistor with a variable current

source, consisting of Q1 and R2 + R13. The base voltage of Q1, adjusted by linear potentiometer R1, linearly varies the current through R2, and hence inversely varies the effective resistance between pins 2 and 3. A perfectly linear frequency calibration is thus achieved. CR4 and R14 act as a temperature-compensating network for the current source.

The CD 4047 has an internal divide-by-two flip-flop and therefore produces highly symmetrical square waves at terminals 10 and 11. Gates U2C and U3A couple and buffer the Q output, and gates U2B and U3B act similarly for the \bar{Q} output of the oscillator. An open-collector gate was chosen as the output device, in spite of its slower rise time, because of its wired-OR capability and, hence, its inherent immunity to accidental shorts to ground.

A 1 μ s pulse is generated by combining a delayed \bar{Q} with an undelayed Q. Fig. 2 shows this circuit and its corresponding timing diagram. As a rule of thumb, a 6000-Ohm pull-up resistor and a 1 μ F capacitor will yield a 1 ms delay; this relation is quite linear with capacitance. If, in your particular application, a pulse width other than 1 μ s is needed, just change C7 to the required value.

Monostable oscillator

The monostable mode is

Parts List

C1	4000 μ F, 16 V, electrolytic capacitor
C2	0.22 μ F
C3	0.022 μ F
C4	0.0018 μ F
C5, C8	120 pF
C6	10 μ F electrolytic capacitor
C7	1000 pF, disc capacitor
C9	0.1 μ F disc capacitor
CR1, CR2	1N4001 rectifier diodes
CR3, CR4	1N914 switching diodes
F1	0.25 Amp slow-blow fuse
Q1	2N2907 transistor
R1	1000-Ohm wirewound potentiometer
R2	1000-Ohm trimmer potentiometer
R3, R4, R5, R10	5600-Ohm, 1/4-Watt resistor
R6	3300-Ohm, 1/4-Watt resistor
R7	100-Ohm, 1/4-Watt resistor
R8, R9, R11	1000-Ohm, 1/4-Watt resistor
R12	3400-Ohm 1%, 1/8-Watt, metal film resistor
R13	4020-Ohm 1%, 1/8-Watt, metal film resistor
R14	Trim-on-test, 1/4-Watt resistor, approximately 1000 Ohms
S1	SPST slide switch
S2	DPDT slide switch
S3	1-pole, 4-position rotary switch
S4	NO momentary push-button switch
T1	Power transformer, 115 V 60 Hz primary; 16 V c-t at 1.5 Amps secondary
U1	CD 4047AE oscillator
U2	74L00 low-power quad two-input NAND gate
U3	7403 open-collector quad two-input NAND gate
VR1	UA7805 IC voltage regulator
Misc.	Perforated circuit board, suitable enclosure, line cord, 5-way binding posts, control knobs, fuse clips, hookup wire, solder, hardware.

established by grounding U1-8 (through U2A) and by applying a logic "1" to pin 4. The one-shot is triggered by momentarily raising the level at pin 8. This is accomplished by the output of gate U2A, which will go high when either the GATE/TRIG terminal is grounded or push-button switch S4 is depressed. R7 and C6 act as a debouncing circuit. The period of the one-shot is related to the astable frequency, such that $T \approx 1/f$. A correction capacitor C8 shunts all range capacitors (C2-C5) in the monostable mode.

Construction Notes

Hardware assembly is relatively simple and is most easily accomplished using a 0.1" perforated circuit board. IC sockets with wire-wrap or solder tails can be used, and the wiring layout is not particularly critical at the frequencies involved. An

aluminum sheet metal bracket may be attached to the circuit board to mount the various binding posts, switches, and controls. The IC regulator should also be directly mounted to this bracket, without insulator.

The frequency range capacitors must have a $\pm 5\%$ tolerance and must be matched to each other to 1 or 2% if good dial tracking between ranges is expected. R14 is selected such that the oscillator with R1 fully CCW is no higher than 0.9 of that range. Calibration potentiometer R2 is adjusted to yield a frequency of 12 at the full CW position of R1. The dial may then be linearly divided between 1 and 11.

For less ambitious readers, the instrument is available either in kit form or fully wired at \$64.50 and \$79.50, respectively, from Integral Electronics Corporation, PO Box 286, Commack NY 11725. ■

Norman S. Kopeika, Ph.D.
Dept. of Electrical Engineering
Ben-Gurion University of the Negev
Beer Sheva, Israel

Earl Rubin 4Z4TJ
12 Rotem St., Neve-Noy
Beer Sheva, Israel

A New Type of 10 GHz Receiver

— use it or lose it

Amateur band utilization has shown a trend towards shorter and shorter wavelengths. In the near future, amateurs will probably be using the microwave region, either because its utilization will become more practical or in order to "save our spectrum" from the CBers.

For most amateurs, a project involving microwaves probably conjures up visions of a silver-plated plumber's nightmare. Still, we occasionally get the urge to try out all those exotic klystrons, magnetrons, etc., bought over the years as *objects d'art* or to speculate on rising copper prices.

In all probability, your junk box now contains at least a few devices capable of performing credibly as microwave detectors. We are referring to the neon glow lamps commonly used as indicator lights.

In this article, we will provide data for experimenting with glow discharge detectors

and outline their theory of operation. Basic information on working with microwaves is available from a number of good texts on the market.^{1,2}

Conventionally, microwaves are detected by point contact crystal diodes appropriately mounted in waveguide fittings. These diodes are expensive and electrically delicate — two parameters which make them unsuitable for amateur experimenters. The advantages of glow lamps as detectors include low cost (less than \$1 for most commercial tubes), wide dynamic range (cannot be damaged by accidental large bursts of incident power), electronic ruggedness, broad spectral range (the same tube can operate in both the microwave and millimeter wave regions), and the ability to operate at relatively high temperatures and incident power levels. Glow-lamp detectors are simple to use (no refrigeration or magnetic fields required) and have the ability to play the role of receiving antenna and transducer simultaneously.³

Fig. 1 shows the basic setup for experimenting with glow-lamp detectors. The power supply should be well regulated and have a low noise level. The glow tube is positioned in front of the radiation source and connected through a preamplifier to an oscilloscope. The radiation source should be modulated with a function generator or mechanical chopper (fan with metal blades). The bias on the glow tube should be adjusted to a value appropriate to the particular tube you are using. Table 1 lists almost all the common types.⁴ Fig. 2 shows typical detector responsivity (R) plotted against discharge current (I).⁴ Sensitivity is affected by orientation of the lamp in the microwave field. In addition, the diameters of the lamps are about three times the electrode separation — the sensitive detecting area is, therefore, a small part of the lamp cross section. Radia-

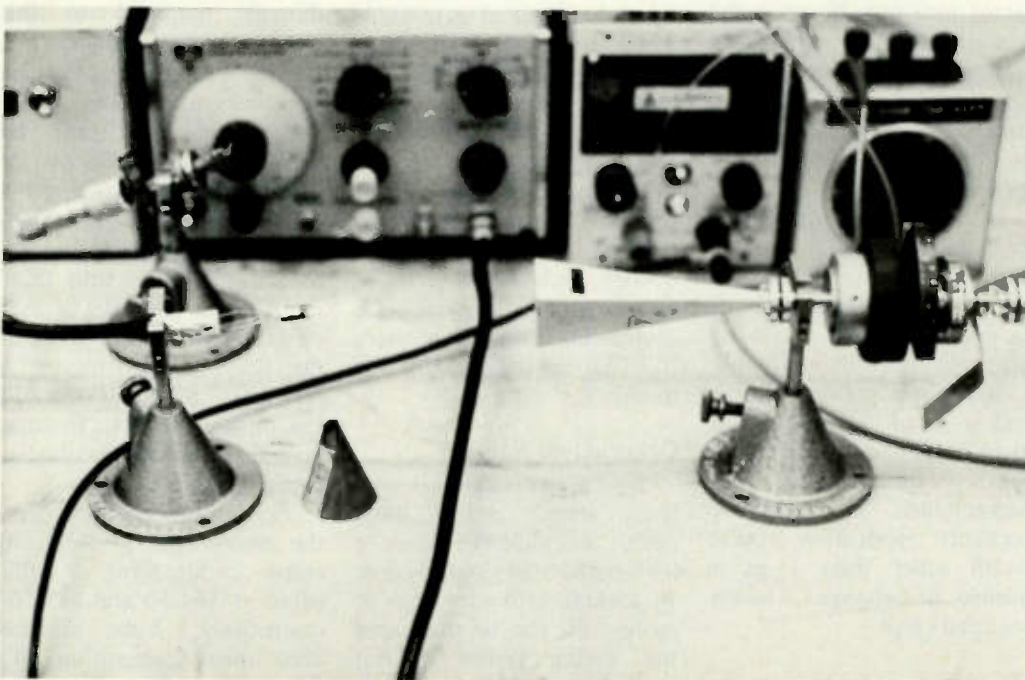

Experimental test setup.

tion can be focused on the plasma between the electrodes with inexpensive conducting cones of sheet metal or PlexiglasTM covered with conducting paint.⁵ Such homemade antennas, if focused properly on the sensitive plasma volume, make much more efficient use of the lamp cross-sectional area.

The mode in which a glow detector operates is quite simply explained. The gas is partially broken down with a dc source (as in Fig. 1). The microwave electric field enhances random electron velocity and, thus, the ionization collision rate of electrons with neutral atoms in the glow discharge plasma. The microwave envelope is detected as changes in discharge current, which can then be capacitor coupled to an amplifier.

Glow lamps can also be used as heterodyne detectors. The thermal sensitivity of crystal diodes usually limits the local oscillator power to an average of 10-20 mW or less. The diode is easily damaged by incident power levels greater than 50 mW. Glow discharge detectors can absorb power levels many orders of magnitude higher.

Because of their electronic ruggedness and large dynamic range, glow discharge detectors are capable, in principle, of being used with very large local oscillator powers and, thus, of detecting very low signal levels. Even with the local oscillator powers normally used in mixers designed for diodes, the sensitivity available with common, inexpensive, neon glow lamps is quite comparable, if not superior, to that achievable with diode detectors in heterodyne detection.

Another advantage of diode detectors is that the high sensitivity is achieved despite the high noise level, as a result of very high responsivity. This means that no special low-noise amplifier or similar equipment is required. A low-ripple power supply is, however, desirable. Rise times

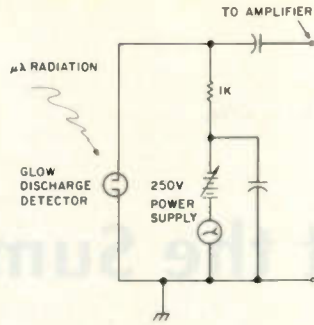

Fig. 1. Glow discharge detector biasing circuit.

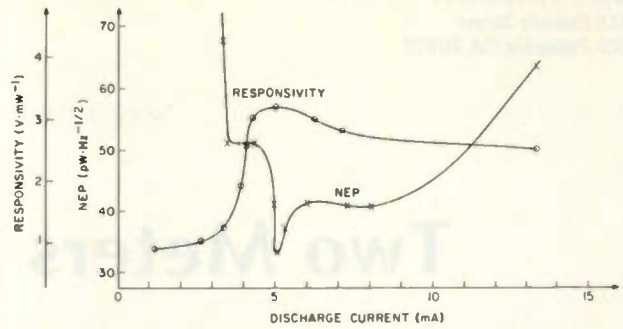

Fig. 2. Responsivity and NEP for X-band radiation as a function of discharge current (I) in the NE-84 glow lamp.

in commercial glow lamps are on the order of a microsecond.⁴ This limitation probably stems from reactance due to lamp construction, and not from the physics of the detection mechanism. The microsecond rise time limits the intermediate frequency to less than a megahertz — a limitation which may require PLL stabilization of the local oscillator in a practical receiver.

Table 1 shows the results of a survey of commercially-available glow tubes at X-band (10 GHz).⁴ The best detection results for each tube are compared with typical values for diode detectors. The glow tubes are listed by NEP. NEP is defined as

minimal detectable signal power (occurs at unity signal-to-noise ratio) per square root of bandwidth. V_n is the noise voltage over a 10 kHz-100 kHz bandwidth; A_r is the detecting area of the glow lamp; R is the glow lamp response per unit microwave power. To maximize A_r , the lamps were oriented with the electrode plane parallel to the microwave electric field and perpendicular to the microwave energy flow. In this case, A_r is the plasma area between the electrodes.

Glow lamps may also be used to detect optical (light) radiation.⁶ ■

References

1. S. Ramo, J. R. Whinnery, and T. Van Duzer, *Fields and Waves in*

Communications Electronics, New York, J. Wiley and Sons, Inc., 1965.

2. E. L. Jordan and K. G. Balmain, *Electromagnetic Waves and Radiating Systems*, New Delhi, Prentice-Hall of India, Ltd., 1969.

3. N. S. Kopeika and N. H. Farhat, "Video Detection of Millimeter Waves with Glow Discharge Tubes," *IEEE Transactions on Electron Devices*, Vol. ED-22, pp. 534-548, August, 1975.

4. N. S. Kopeika, B. Galore, D. Stempler, and Y. Heimenrath, "Commercial Glow Discharge Tubes as Detectors of X-Band Radiation," *IEEE Transactions on Microwave Theory and Technology*, Vol. MTT-23, pp. 843-846, October, 1975.

5. N. S. Kopeika, "Millimeter-Wave Holography Recording with Glow Discharge Detectors," *Int. J. Electronics*, Vol. 38, pp. 609-613, May, 1975.

6. Kopeika, *et al*, *Applied Optics*, June, 1976, pp. 1610-1615.

Tube	V_n (uV)	I (mA)	$R(V \cdot mW^{-1})$	$NEP(pW \cdot Hz^{-1/2})$	t_r (us)
A059-2	40	2	4.45	1.44	2.1
NE-4	46	3	3.69	2.17	3.0
NE-76	50	3	3.10	2.23	2.0
NE-3	39	3.4	3.81	6.20	2.4
NE-7	57	40.0	3.29	6.59	4.5
AR-9	84	2.5	4.26	7.51	2.5
NE-51-H	21	1.8	0.09	9.82	4.0
5AB-A	57	8.0	4.24	9.86	10.0
5AB-B	54	13.0	2.86	11.0	2.3
5AB	57	12.0	4.11	11.4	2.4
NE-81	73	15.0	3.67	15.9	2.0
A059-9	57	8.0	3.31	24.5	2.1
5AH-D	46	6.5	1.92	28.2	2.4
NE-2U	77	17.0	1.67	29.8	1.4
NE-84	137	4.2	2.32	30.7	1.0
A1B	72	17.0	4.46	34.9	0.8
5AHA	40	4.5	3.07	37.6	1.6
5AH	54	15.0	1.98	39.4	2.0
TRJ250	10	$I_1 = 2,$ $I_2 = 0.5$	0.50	39.5	2.5
A1C	70	12	9.00	41.1	2.0
1N238 crystal* diode (Sylvania)	7		211.0	0.318	—
MA-40207 Schottky-barrier — diode		0.02	5.0	1.1	—

*parameters measured in test setup.

Table 1. Glow discharge tube and diode sensitivities to X-band radiation. I is current, and t_r is rise time.

Two Meters At the Summit

— a backpacker's delight

In many years of going on backpacking or peak-bagging jaunts in wilderness areas of western mountains, I have often thought of how vulnerable I (if alone) or fellow mountaineers would be if something went drastically wrong. Usually, we would be miles from the nearest roadhead and then additional road miles from a source of help like a ranger station or a sheriff's office.

Taking along a 2 meter handie-talkie for use in emergency communications is a likely solution if there are other stations available for communication. It wouldn't increase the overall weight of a knapsack or a backpack by a great deal. And, further, it might even make things more pleasurable, using it to talk to fellow hams from camps, from rest spots along the trail, or from peaks.

In the spring of 1976, I finally succumbed to the VHF rage and acquired a Wilson 2-Watt handie-talkie (1402SM). After putting it to use in many enjoyable contacts around the Los Angeles area, I decided to try it out on some mountaineering jaunts. It was used on four peak-bagging trips during the summer of 1976, and I thought the consequences would be of some interest.

The HT got its first such initiation on July 14, 1976,

when I joined a group of about 25 Sierra Club members for a day hike to the top of Mt. Waterman (8,038 feet elevation) in the nearby Angeles National Forest. I had removed and left at home the rubber ducky antenna and connected a retractable quarter-wave whip in its place.

At the start of the hike, I made my first mistake. I put the HT rig in my knapsack with the antenna protruding upwards a bit. That was unfortunate because, about two-thirds of the way to the peak, it got snagged by a low overhanging tree branch and broken off at its base. On reaching the peak, all I was able to do was hold the antenna in place and listen — and stations were coming in from all over southern California. This painful experience pointed out what I should have done and did thereafter. The whip antenna was disconnected when being transported and placed along with the rubber ducky as a spare in a small plastic bag held by rubber bands to the body of the HT. Also, a small notebook and a pencil with a clip were added for record-keeping purposes. In addition, a spare set of alkaline batteries was carried along, wrapped in another plastic bag.

The second use was on a

backpacking trip in the Mt. Whitney region of California's High Sierra mountains. I was the leader for a group of 16 who started at the Whitney Portal roadhead (8,300 ft.) and backpacked to a base camp at Consultation Lake (11,700 ft.). From both locations, I was able to talk with stations in Owens Valley via 52 simplex and via the

.34/.94 Bishop repeater (WR6ACG). Excessive rains made things rather miserable, but, finally, July 28 dawned bright and clear, so 15 of us started for the big peak (Mt. Whitney at 14,495 ft., the highest mountain in the "lower 49" states).

As the day progressed, the weather got worse. By the time we got to the top, we

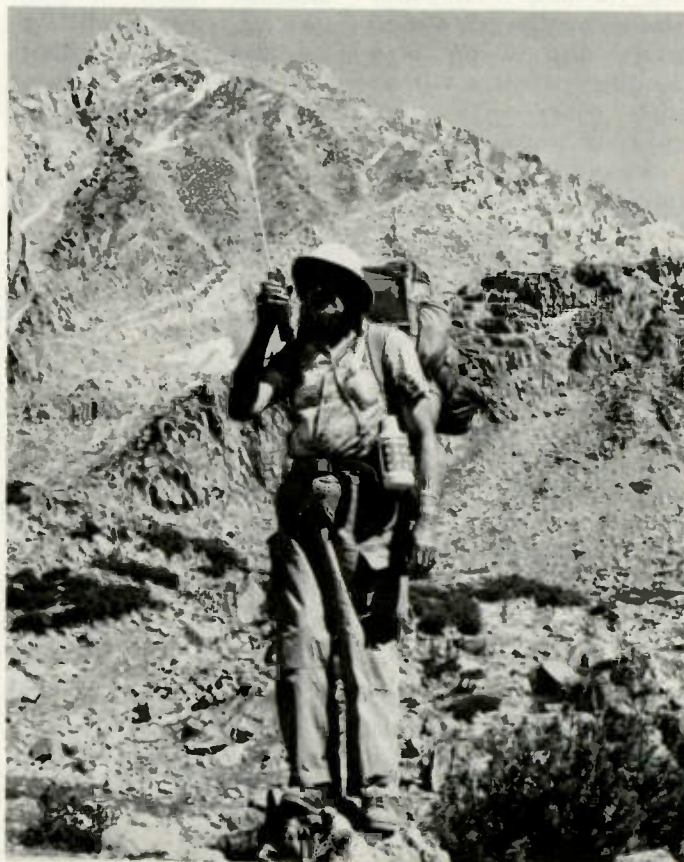

The author operating his HT from an excellent location in the High Sierra.

had experienced heavy rain, hail, lightning, and snow. But all 15 made it to the peak.

On the summit is an old two-room concrete-block hut which was originally used as a Smithsonian observatory. After a hurried lunch inside it, I rigged up the whip on the HT and, just outside the hut, made a few contacts via the Bishop repeater. While talking to a station in Bishop, I suddenly got a sharp shock from the charged clouds nearby and thereafter operated from inside the hut under the protection of a corrugated metal ceiling. The copy was equally good from there.

I next tried to contact some stations using the .34/.94 Fresno machine (WR6ACU). From their conversations, it was obvious they were hearing me, but they elected to continue their own QSO talking about diodes on the repeater's input circuit and such. Then I shifted to .22/.82 and heard a

fellow in Santa Maria and talked to him via the San Luis Obispo repeater (WR6AEL) 186 miles away. When we finished, an old friend gave me a call from Baywood Park, and we had a nice chat. About this time, the lightning was getting a little too close, so I buttoned things up and headed back down to camp. The jaunt down was rather precarious on the snow and over parts of the route that had been washed out. But, fortunately, we all made it, and the HT didn't have to be used for any emergency purposes.

A couple of weeks later, my wife and I were camping in the Medicine Bow National Forest of southern Wyoming when I decided to hike to the high point of the Snowy Range, Medicine Bow Peak (12,013 ft.). The jaunt up to the peak on August 20 was rather invigorating and rocky and was rewarded with a wonderful view and an excellent location for 2m QSOs.

Via the .22/.82 repeater in Laramie (WR7ADP), I talked to stations in Cheyenne and in Laramie. Via the .34/.94 repeater in Laramie (WR7ADK), I contacted additional stations in Laramie. Then also on .34/.94, I talked to a station in the Big Horn Mountains through the Casper machine (WR7ADR). I tried to break the .34/.94 repeater in Denver, but it was apparently too far away.

My fourth and last peak-bagging trip was on September 1 in the northern part of the High Sierra while camping with some of my family. I started at the Tioga Pass Ranger Station (9,946 ft.) and hiked and boulder-hopped to the top of Mt. Dana (13,053 ft.). Here again there was a terrific view and a super location for 2m operation. Being very high on the main crest of the High Sierra, I was able to break three repeaters simultaneously on .34/.94: the WR6ACG ma-

chine in Bishop, the WR6ACU machine in Fresno, and the WR6ADF machine at Oakland in the San Francisco Bay area. It was sometimes difficult to tell which repeater was being used for the QSOs I had with stations in Modesto, Davis, Alameda, Novato, and Owens Valley. Some of these contacts were also duplicated on .52 simplex, notably with a fellow in Novato, at a distance of 218 miles. In addition, I tried .22/.82 and, through the Oakland repeater (WR6ABM), contacted another station in Novato and one in Concord. One of the .34/.94 QSOs was a pleasant surprise, with a fellow in Bishop I had previously contacted from Mt. Whitney.

I thoroughly enjoyed these experiences with my reliable HT and recommend that others give it a try. Fortunately, there were no emergencies to report, but it does give one a feeling of security. ■

DEALER DIRECTORY

Fontana CA

We carry the following: ICOM, Midland, Amcom, DenTron, KLM, Swan, Drake, Ten-Tec, Wilson, SST, MFJ, Hy-Gain, Lunar, Nye-Viking, B&W, Redl-kilowatt, Cush Craft, Mosley, Blg Signal, Pipco, etc. Full Service Store Fontana Electronics, 8628 Sierra Ave., Fontana CA 92335, 822-7710.

Sacramento CA

Largest amateur radio selection in the Sacramento Valley. To serve you, Gary W6NJU, Dennis WB6ISO, Dan WB6RVU and Mike WA6DPN. Mon-Fri 10-6, Sat 10-5. The Radio Place, 2964 Freeport Blvd., Sacramento CA 95818, 441-7388.

Santa Clara CA

Bay area's newest Amateur Radio store. New & used Amateur Radio sales & service. We feature Kenwood, ICOM, Wilson, Yaesu, Atlas, Ten-Tec & many more. Shaver Radio, 3550 Lochinvar Avenue, Santa Clara CA 95051, 247-4220.

Colorado Springs CO

Finest selection of amateur equipment, antennas, & accessories in southern Colorado, including Tempo, Wilson, Cush Craft, Newtronics, KDK, Amphenol, Astatic, Alliance, Ham Key, & Nye. A.E.S. Communications, 404 Arrawanna St., Colorado Springs CO 80909, 475-7050.

New Castle DE

Paul WA3QPX, Rob WA3QLS—Serving amateurs in southern New Jersey, Delaware, and Maryland with the largest stock of amateur equipment and accessories in Delaware. Delaware Amateur Supply, 71 Meadow Road, New Castle DE 19720, 328-7728.

Bloomington IL

Retail—wholesale distributor for Rohn Towers—antennas by Cush Craft, Antenna Specialists, KLM, Wilson, Hy-Gain. Transceivers by Tempo, Regency, Wilson, Amcom. Also business and marine radios. Hill Radio, 2503 G.E. Rd., Bloomington IL 61701, 663-2141.

Terre Haute IN

Your ham headquarters located in the heart of the midwest. Hoosier Electronics, Inc., 43B Meadows Shopping Center, P.O. Box 2001, Terre Haute IN 47802, 238-1456.

Wichita KS

Microwave Modules—KLM—KDK—ICOM—Kenwood—Wilson—Standard—ICIR—SWAN—Lunar. We STOCK The Best Communications. Revcom Electronics, 6247 N. Hydraulic, Wichita KS 67219, 744-1083.

Tell them you saw their name in 73

Dalton MA

Western Massachusetts. Complete 2 meter FM headquarters. Yaesu, KDK, Regency, Larsen, Cush Craft. All kinds of ham gear. Blue Max Inc., Box 97, Dalton MA 01226, 684-0039.

Littleton MA

The ham store of N.E. you can rely on. Kenwood, ICOM, Wilson, Yaesu, DenTron, KLM amps, B&W switches & wattmeters, Whistler radar detectors, Bearcat, Regency, antennas by Larsen, Wilson, Hustler, GAM, TEL-COM Inc. Communications & Electronics, 675 Great Rd. Rt. 119, Littleton MA 01460, 486-3040.

Syracuse NY

We Deal, We Trade, We Discount, We Please! Yaesu, Kenwood, Drake, ICOM, Ten-Tec, Swan, DenTron, Midland, Cush Craft, KLM, Hy-Gain, etc. Complete 2-way service shop! Ham-bone Radio (div. Stereo Repair Shop) 3206 Erie Blvd. East, Syracuse NY 13214, 446-2266.

Syracuse-Rome-Utica NY

Featuring: Yaesu, ICOM, Drake, Atlas, DenTron, Ten-Tec, Swan, Tempo, KLM, Hy-Gain, Mosley, Wilson, Larsen, Midland Southwest Technical Products. You won't be disappointed with equipment/service. Radio World, Oneida County Airport-Terminal Building, Oriskany NY 13424, 337-2622.

Souderton PA

Tired of looking at ads ??? Come and try our new and used equipment yourself—personal advice from our staff's 60 years combined ham experience. Electronic Exchange, 136 N. Main St., Souderton PA 18964, 723-1200.

Port Angeles WA

Mobile RFI shielding for elimination of ignition and alternator noises. Bonding straps. Components for "do-it-yourself" projects. Plenty of free advice. Estes Engineering, 930 Marine Drive, Port Angeles WA 98362, 457-0914.

DEALERS

Your company name and message can contain as many as 25 words for as little as \$150 yearly (prepaid), or \$15 per month (prepaid quarterly). No mention of mail order business or area code permitted. Directory text and payment must reach us 45 days in advance of publication. For example, advertising for the November issue must be in our hands by September 18th. Mail to 73 Magazine, Peterborough NH 03458, ATTN: Aline Coutu.

Social Events

from page 219

the Heritage House Smorgasbord, 8209 N. Mt. Hawley Rd., at 7 pm on Saturday, September 16, for \$4.25 per person. 2 meter talk-in on 146.7-6; just call W9UVI. Local repeaters are .16-.76, .25-.85, and .37-.97. For information, write to John Sutton WD9BJJ, 608 W. Teton Drive, Peoria IL 61614, phone (309)-691-7073.

HARRISBURG PA SEP 17

The Central Pennsylvania Repeater Association will hold the fifth annual Electronic Swap Fest and Hamfest on Sunday, September 17, 1978, beginning at 8:00 am, at the Park-n-Shop Parking Garage (Center City), 200 Block Walnut Street, Harrisburg, Pennsylvania. This is a rain or shine event with indoor parking for 1100 cars. Registration is \$3.00 and wives and children are free. Food and refreshments are available. Talk-in on 146.16/.76, 146.34/.94, and .52 simplex. For more information, contact WB3HXH (717)-944-7017.

VENICE OH SEP 17

The Cincinnati Hamfest will be held on Sunday, September 17, 1978, at Stricker's Grove, State Route 128, Venice (Ross), Ohio. There will be exhibits, prizes, a flea market, a hidden transmitter hunt, and a sensational air show. Tickets are \$7.50 in advance; \$8.00 at the gate. For complete information, contact the Greater Cincinnati Amateur Radio Association, c/o John P. Haungs WA8STX, Treasurer, 10615 Thornview Drive, Evendale OH 45241.

NORFOLK VA SEP 23-24

Tidewater Radio Conventions, Inc., is pleased to announce its third annual hamfest, flea market, and computerfest to be held on September 23 and 24 at the Norfolk Cultural and Convention Center (SCOPE). This is an approved ARRL function. Large indoor, air-conditioned facilities for flea market and exhibitors. Tickets are \$2.50 by September 16 and \$3.50 at the door. Tailgaters' tickets are \$5.00 per day and \$7.50 for two days, in advance, and \$6.00 at the gate. For details, contact Norman V. Cohen WB4LJM, Box 9371, Norfolk VA 23505.

ERIE PA SEP 24

The third annual HamJam,

sponsored by the Radio Association of Erie, will be held on Sunday, September 24, 1978, from 9:00 am to 4:00 pm, at Waldameer Park in Erie, Pennsylvania. Admission is \$1.50 in advance; \$2.00 at the gate. There will be refreshments and prizes. Talk-in on 34/94, 22/82, and 52. For complete info, write HamJam '78, Radio Association of Erie, Box 844, Erie PA 16512.

ADRIAN MI SEP 24

The Adrian Hamfest will be held on Sunday, September 24, 1978, at the Lenawee County Fairgrounds, Adrian, Michigan. There will be a computerized ham radio station and a communications satellite seminar presented by Dr. Ralph E. Taggart WB8DQT. Prizes include an Icom IC-22S, a Bird 43 wattmeter, and a Heathkit HW-8. Tickets are \$1.50 in advance; \$2.00 at the gate. Tables are \$4.00 for full table; \$2.00 for half table. Trunk sales are \$1.00 per space. Talk-in on 146.31/.91 or 146.52 (W8TQE). For complete information, contact the Adrian Amateur Radio Club, Inc., PO Box 26, Adrian MI 49221, or phone (517)-265-8016.

VALPARAISO IN SEP 24

The Valpo Tech Alumni Association will hold its annual hamfest on Sunday, September 24, 1978, on the campus of Valparaiso Technical Institute. Admission to the event is \$2.00 for both visitors and exhibitors. For further information and directions, write Hamfest, Valpo Tech Alumni Association, Box 490, Valparaiso IN 46383, or phone (219)-462-2191.

NEW BERLIN IL SEP 24

The Sangamon Valley Radio Club of Springfield, Illinois will hold its third annual hamfest on Sunday, September 24, 1978, at the Sangamon County Fairgrounds, New Berlin, Illinois. There will be an indoor exposition building with no charge to set up. Overnight camping available for Saturday night. Food and refreshments will be available on the grounds. WA4WME, of the recent Clipperton Atoll DXpedition, will give his slide and movie presentation. There will be lots of other activities, including those for ladies and children. For further information, contact Richard I. Osland K9FNB, Publicity Chairman, 1025 South 6th Street, Springfield IL 62703.

GAINESVILLE GA SEP 24

Lanierland Amateur Radio Club will hold its fifth annual HAMNIC at the Lanier Islands Dogwood Pavilion on September 24, 1978. There are two large covered pavilions and a large parking area for the swap shop and exhibits. First prize is a KDK FM2015R along with many other prizes. Food available. No entry fee for HAMNIC, but Lanier Islands charges \$2.00 entry fee per car. Picnic, hiking and swimming for the kids. Talk-in on .07/.67. For further information, write Bob Cochran W4DNX, 607 East Lake Drive, Gainesville GA 30501.

FLINT MI SEP 24

The Greater Genesee Valley Amateur Radio Club, in conjunction with the Bay Area Amateur Radio Club, Genesee County Radio Club, Lapeer County Amateur Radio and Repeater Club, Saginaw Valley Amateur Radio Association, and the Shiawassee Amateur Radio Association, presents a Five County Swap-n-Shop at 1420 W. 12th St. On I-69, south, take Hammerberg Rd. off and turn left at 12th St. Tickets are \$2.00 per person and \$3.00 per family. Tables available. Talk-in on 147.27, 146.91, and 146.52. For more information, write to Five County Swap-n-Shop, Box 7671, Flint MI 48507.

CORPUS CHRISTI TX SEP 30

The Corpus Christi ARC and the South Texas Amateur Repeater Club will hold a South Texas Swapfest on Saturday, September 30, 1978, 9:00 am to 5:00 pm, at the Texas National Guard Armory, 1430 Horne Rd., Corpus Christi, Texas. Admission and tables are free. There will be dealer displays, contests, and door prizes. Talk-in on .34/.94 and .28/.88. For additional information, contact J. E. Rehler W5KNZ, 526 Pasadena, Corpus Christi TX 78411.

ELMIRA NY SEP 30

The third annual Elmira Amateur Radio Association Hamfest will be held at the Chemung County Fairgrounds on September 30. Gates open at 9:00 am. A grand prize and several door prizes will be offered. No extra charge for flea market space. Indoor space available on a first come, first served basis. Several dealers will also be on hand with their displays. Talk-in on 146.52/52, 146.10/70, and 147.96/36. For advance ticket sales and further info, contact John Breese WA2FJM, 340 West Ave., Horseheads NY 14845.

WILLOW GROVE PA SEP 30

The second annual Mid-Atlantic States VHF Conference will be held on Saturday, September 30, 1978, at the Treadway Inn on Easton Rd. (Route 611, Exit 27 of the PA turnpike), Willow Grove, Pennsylvania, on the day before Hamarama 78. The conference will be an all-day VHF program moderated by prominent VHFers. For advance registration, contact Ron Whitsel WA3AXV, Chairman, PO Box 353, Southampton PA, 18966; (215)-355-5730. Indicate motel registration forms required.

GRAYSLAKE IL SEP 30-OCT 1

Radio Expo '78 will be held on Saturday and Sunday, September 30 and October 1, 1978, at the Lake County Fairgrounds, Grayslake, Illinois. The fairgrounds are located at Routes 45 and 120. The convention center is at the Mundelein, Illinois, Holiday Inn. There will be dozens of manufacturers' and distributors' exhibits, indoor and outdoor flea market areas, seminars, and free camping. The flea market will be open Friday for setup. Tickets are \$2.00 in advance; \$3.00 at the gate. Talk-in on .16/.76. For details, write Radio Expo '78, PO Box 305, Maywood IL 60153.

LOUISVILLE KY SEP 30-OCT 1

The eighth annual Greater Louisville ARRL hamfest will be held on Saturday, Sept. 30, and Sunday, Oct. 1, at the West Hall of the Kentucky Fair and Exposition Center. There will be a gigantic indoor air-conditioned exhibitor's area and flea market with meetings and forums and ladies' programs both days. Admission is \$3.00 for adults with children 12 years and under free. Flea market vendors pay admission plus \$3.00 per space for one day only, or \$5.00 per space will cover both days. Camping is available on the grounds, free with no hookup. For more information contact Denny Schnurr K4GOU, 2415 Concord Drive, Louisville KY 40217, phone (502)-634-0619.

WEST GHENT NY OCT 8

The Northeastern States 160 Meter Amateur Radio Association will hold its annual banquet on Sunday, October 8, 1978, at Kozel's Restaurant, West Ghent, New York. A roast beef dinner will be served at 6:00 pm. Cost is \$8.00 per person. From 1:00 pm to 4:00 pm there will be a flea market. Cocktail hour is from 4:00 pm till dinner time.

**hot summer sales
while present
stock lasts!**

Some items subject to prior sale.

All items new

all prices FOB Reynoldsburg, Ohio.

**ASTRON POWER SUPPLIES
ELECTRONICALLY REGULATED.**

- RS-4A. 3A. Cont. 4A. ICS
Regular \$39.95 \$ 33.75
- RS-6A. 4.5A. Cont. 6A. ICS
Regular \$49.95 \$ 40.95
- RS-20A. 16A. Cont. 20A. ICS
Regular \$89.95 \$ 76.95
- RS-35A. 25A. Cont. 35A. ICS
Regular \$129.95 \$119.95

ASY Electronic Power Supplies

- SPS-8 8A. Cont.
current limit 9.2A. \$ 78.71
- SPS-8M 8A. Cont.
(with meter) \$104.95
- SPS-20 20A. Cont (with
meter) current limit 35A. \$157.20
- Wilson Portable Synthesized
2 meter Transceiver
Internal Battery or External
Supply 1 or 12 Watts
WE-800 — less batteries \$414.95
- Midland Synthesized
2 Meter Transceiver
43-510 1 Watt and 25 watt \$344.95
- Amcomm S225 2 Meter
Transceiver 25 watts
continuously variable
from 1 to 25 watts \$344.95
- Tempo 8010 External VFO \$120.00
- Tempo 8120 Speaker \$ 25.00
- Yaesu FT-7 Mobile
Transceiver \$440.00
- DSI Frequency Counters
Model 3600A. \$174.95

WHILE THEY LAST!



**universal
amateur
radio inc**



U6

1280 AIDA DRIVE
COLUMBUS, OHIO
(Reynoldsburg) 43068

(614)-866-HAMS

**MFJ INTRODUCES A NEW
24 HOUR DIGITAL CLOCK**

with HUGE 1-5/8 inch digits that you can keep set to GMT.
Alarm and snooze functions let you use it as an ID Timer.
Assembled, too!



\$29⁹⁵

**BRAND
NEW**

MFJ Enterprises brings you a new 24 hour digital alarm clock with HUGE 1-5/8 inch orange 7 segment digits that you can see clear across the room.

This one is strictly for your ham shack, one that you can leave set to GMT. No more mental calculations to get GMT.

Use the alarm to remind you of a SKED or with the snooze function as an ID timer to buzz you in 8 minute intervals.

A constantly changing kaleidoscopic pattern indicates continuous operation.

Beige. 2-1/4 x 4-1/8 x 8-3/4 inches. UL listed. Requires 120VAC, 60Hz.

Order from MFJ and try it — no obligation. If not delighted, return it within 30 days for a re-

fund (less shipping). One year limited warranty by MFJ Enterprises.

To order, simply call us toll free 800-647-1800 and charge it on your VISA or Master Charge or mail us a check or money order for \$29.95 plus \$2.00 for shipping and handling.

Don't wait any longer to enjoy the convenience of a "Hams Only" clock. Order today. M52

MFJ ENTERPRISES, INC.

P. O. BOX 494

MISSISSIPPI STATE, MS 39762

CALL TOLL FREE 800-647-1800

For technical information, order/repair status, in Miss., outside continental USA, call 601-323-5869.

electronic calculators

TEXAS INSTRUMENTS ELECTRONIC CALCULATORS

- | | | |
|-------------|----------------|---|
| LIST | HAM NET | T.I.-89, 960 STEP PROGRAMMABLE SCIENTIFIC |
| \$299.95 | \$269.95 | T.I.-58, 480 STEP PROGRAMMABLE SCIENTIFIC |
| 124.95 | 112.45 | T.I.-57, 150 STEP PROGRAMMABLE SCIENTIFIC |
| 59.95 | 53.95 | T.I.-55, 32 STEP PROGRAMMABLE SCIENTIFIC |
| 49.95 | 44.95 | T.I. PROGRAMMER, CONVERTS DECIMAL/OCTAL/HEX |
| 59.95 | 53.95 | T.I. MSA, SUPER PREPROGRAMMED FINANCIAL |
| 69.95 | 62.95 | |

HEWLETT-PACKARD ELECTRONIC CALCULATORS

- | | | |
|-------------|----------------|--|
| LIST | HAM NET | H.P.-97, 224 STEP PROG SCIENTIFIC PRINT/VISUAL |
| \$750.00 | \$675.00 | H.P.-87, 224 STEP PROG SCIENTIFIC |
| 450.00 | 405.00 | H.P.-19C, 98 STEP PROG SCIENTIFIC PRINT/VISUAL |
| 275.00 | 247.50 | H.P.-29C, 98 STEP PROG SCIENTIFIC |
| 175.00 | 157.50 | BASIC HAND HELO PRINTER/VISUAL |
| 175.00 | 159.50 | H.P.-91, PREPROGRAMMED SCIENTIFIC PRINT/VISUAL |
| 325.00 | 292.50 | H.P. 33E, 49 STEP PROG SCIENTIFIC |
| 100.00 | 90.00 | H.P.-32E, PREPROGRAMMED SCIENTIFIC WITH STAT |
| 80.00 | 72.00 | H.P.-31E, PREPROGRAMMED SCIENTIFIC |
| 60.00 | 54.00 | H.P.-92, PREPROGRAMMED FINANCIAL PRINT/VISUAL |
| 485.00 | 445.50 | H.P.-38, 8 STEP PROGRAMMABLE SUPER FINANCIAL |
| 120.00 | 108.00 | H.P.-37, PREPROGRAMMED FINANCIAL |
| 75.00 | 67.50 | |

WE STOCK ALL HEWLETT-PACKARD CALCULATOR SOFTWARE AND ACCESSORIES

SEND ME THE CALCULATOR(S) INDICATED BELOW, COMPLETE WITH INCLUDED ACCESSORIES, INSTRUCTIONS, AND MANUFACTURERS WARRANTY. I UNDERSTAND THAT IF I AM NOT COMPLETELY SATISFIED, I MAY RETURN IT WITHIN 10 DAYS FOR A COMPLETE REFUND (LESS SHIPPING)

MODEL(S) _____ QUANTITY _____ AMOUNT ENCLOSED \$ _____

WE HONOR _____ VISA _____ MASTERCHARGE _____ MONEY ORDERS _____ COD _____

ADD \$2.00 FOR POSTAGE AND HANDLING. PLEASE ALLOW 10 DAYS FROM DATE OF RECEIPT OF ORDER FOR DELIVERY. TEXAS RESIDENTS ADD 5% SALES TAX

CARD NUMBER _____ EXPIRATION DATE _____

FULL NAME _____ CALL _____

STREET _____ CITY _____ STATE _____ ZIP _____

MORE LITERATURE MODEL(S) _____

*****DEALER INQUIRIES INVITED*****



H26

MAIL TO: 6810 LARKWOOD
HOUSTON, TEX 77074
ATTN: STEVE, WARDEN
PHONE: A.C. (713) 777-2673

"THE PROFESSIONALS"

NEW MODEL CTR-2A • 500 MHz & 1 GHz **COUNTERS**

NEW
Period
Measurement



NEW
Built-in
Pre-Amp

1 us to
1 sec.

10 mv @
150 MHz

The New Model CTR-2A Series Counters are designed and built to the highest standards to fulfill the needs of commercial communications, engineering labs and serious experimenters. With an accuracy of + .00005% (oven option) the CTR-2A can handle the most critical measurements and is about half the cost of other commercial counters.

If you need a reliable counter at an affordable price, the CTR-2A is the answer.

- Built-in Pre-Amp 10 mv @ 150 MHz
- 8 Digit .3" LED Display
- High Stability TCXO Time Base
- Built-in VHF-UHF Prescaler
- Automatic Dp Placement
- TCXO Std. ± 2 ppm
- Period Measurement (Optional)
- Input Diode Protected
- 12V-DC Operation (Optional)
- Oven Controlled Crystal (Optional) ± .5 ppm
- Selectable Gate Times - .1 & 1 sec.

500 MHz Kit CTR-2A-500K	\$249.95
500 MHz Assembled CTR-2A-500A	349.95
1GHz Kit CTR-2A-1000K	399.95
1GHz Assembled CTR-2A-1000A	549.95

OPTIONS			
02) Oven Crystal	\$49.95	05) 10 sec. Time Base	\$ 5.00
03) .43" LED	10.00	06) Period	15.00
04) 12 V-DC	10.00	07) Handle	10.00

PROBES
Hi-Z
\$15.00
•
Low Pass
\$15.00



D10

DAVIS ELECTRONICS 636 Sheridan Dr., Tonawanda, N.Y. 14150 716/874-5848

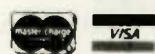

Talk is cheap.

Here are some of the actions your company can take to prevent the suffering caused by poor parenting patterns and child abuse.

We want to stop the hurt.

- We are enclosing a tax-deductible donation in the name of our company.
- We want to help. Please call our company and tell us what you're doing to stop the hurt of child abuse in our community.
- We will plan a day for employees' children to visit our place of work to learn what we do and why.

prevent child abuse.
Write: Box 2844, Chl., IL 60690
National Committee for Prevention of Child Abuse

Ad Council A Public Service of This Magazine & The Advertising Council

Next time you light up a cigarette, get a look at your kid's face

AMERICAN CANCER SOCIETY

THIS SPACE CONTRIBUTED BY THE PUBLISHER

ATTENTION KENWOOD & YAESU OWNERS!!!

the W6TOG* RECEIVER MODIFICATION KIT

- INCREASES SELECTIVITY
 - IMPROVES SENSITIVITY
 - LOWERS INTERNAL NOISE
 - COMBATS BLOCKING FROM LOCAL SIGNAL
 - IMPROVES NOISE BLANKER OPERATION
- | | | |
|-------------------|-------|---------|
| TS-520 KIT | | \$27.50 |
| TS-520S KIT | | 32.50 |
| TS-820 & 820S KIT | .. | 34.50 |
| FT-101 SERIES KIT | .. | 32.50 |
| FR-101 SERIES KIT | .. | 34.50 |

EXPLICIT INSTRUCTIONS MAKE MODIFICATION A CINCH
*WELL KNOWN DXer WITH OVER 300 COUNTRIES CONFIRMED.

Order from
S-F AMATEUR RADIO SERVICES
4384 KEYSTONE AVE., CULVER CITY, CA. 90230 S33
(213) 837-4870

IT'S MAGIC—IT'S "MAGICOM" PROCESSOR MODIFICATION KIT

IMPROVES AUDIO PUNCH • IMPROVES PROCESSED SPEECH QUALITY

Converts **TS-820** speech processor from RF compressor to RF clipper

The "MAGICOM" RF processor module provides up to 6db increase in output with smooth, clean, non-distorted audio and more penetration for those pile-ups. Price \$27.50

ENDORSED BY W6TOG AND BIG GUN DXers WORLD WIDE

SATISFACTION GUARANTEED OR MONEY REFUNDED
All prices postpaid - in Calif. add 6% sales tax - Mastercharge & Visa accepted

\$95 Stand Alone Video Terminal

0123456789:;<=>?
 !"#\$%&'()*+,-./0123456789:;<=>?
 @ABCDEFGHIJKLMNPOQRSTUVWXYZ[\]^_`
 abcdefghijklmnopqrstuvwxyz{|}~

SCT-100 FEATURES:

- 64 X 16 line format with 128 displayable characters
- Serial ASCII or BAUDOT with multiple Baud rates
- \$187 Assembled or \$157 Kit (Partial Kit \$95)
- Full cursor control with scrolling and paging
- On board power supply
- Many additional features

Call or write today. MC/VISA accepted

XITEX CORP. F.O. Box #20887

Dallas, Texas, 75220 ● Phone (214) 386-3859
Overseas orders and dealer inquiries welcome

50 144 REPEATERS 220 450 Mhz

THE NEW Hi Pro Mk I

- * State-of-the-art, full-feature repeaters that boast broad range temperature and electrical stability for use in an uncontrolled environment
- * Low current drain - A plus for emergency 12 volt standby battery operation
- * The receivers develop maximum usable sensitivity and sideband rejection
- * The transmitters develop 15 Watts Minimum of clean rf and a faithful reproduction of the input signal insuring an extremely good sounding repeater.
- * Includes a high quality dynamic microphone and a detailed instruction manual

PA Res. add 6% tax

50 MHz \$789.95 450 MHz 799.95

144 + 220 MHz \$699.95 PLUS SHIPPING

5 1/4" x 19" x 13"

OPTIONS

- Duplexers
- Basic auto patch
- Matching cabinet
- .0005% High stability crystals



Maggiore Electronic Laboratory

M36

845 WESTTOWN RD.

WEST CHESTER, PA. 19380 PHONE 215 436-6051

solid state continuous coverage

THE COMM CENTER



C75

The Drake TR-7

AREA CODE (301)

WASHINGTON 953-9535 - BALTIMORE 792-0600
9624 FT. MEADE RD. LAUREL, MD. 20810

INC.

Build Your Own CW Keyboard Keyer



Save Over \$175

QSL for full details

ECM

ECM Corporation
412 N. Weinbach Ave.
Evansville, IN 47711
812-476-2121

E1

REGULATED POWER SUPPLY

- Fully regulated, dual protected, 13.8 volts
- Illuminated on/off switch
- Hammertone metal case
- NEW 5-YEAR WARRANTY

33 Amp (30 Amp continuous) \$119.95
20 Amp (16 amp. cont.) \$64.95
8 Amp (6 amp. cont.) \$39.95

TIMES CABLE

RG-8U - 100' multiples 18c/ft.
RG-213U - (Non-contaminating jacket)
-100' multiples 22c/ft.

1/2" Aluminum Jacketed hardline—50 ohm.
500' rolls or more 37c/ft.

WILSON ANTENNAS

System One Tribander (4 ele.) \$228.20
System Two Tribander (3 ele.) \$182.55
WW-1 40-10 Meter Vertical \$ 66.35
WR-500 Rotor (List price \$164.95) .. \$112.95

Send S.A.S.E. for additional information. Include shipping charges with check or money order. (Ohio residents add 4 1/2% sales tax). We also ship C.O.D.

JRS ELECTRONICS J8

P.O. Box 1893—Cincinnati, Ohio 45201

FT-227 "MEMORIZER" OWNERS SCANNER KIT

- Selectable sweep width (up to full band)
- Scans *only* the portion of band you select
- Scans at the rate of 200 kHz per second
- Switch modification on mike allows you to scan past, or lock on, any occupied frequency
- Complete kit with detailed instructions
- Installs *inside* rig; no obtrusive external connections
- Rig can easily be returned to original condition whenever desired
- Scans to preset limits and reverses
- Automatic bypass of locked frequency in 3 1/2 seconds unless you press lock-on switch

Kit \$34.95
Pre-assembled and tested \$54

Add \$1.50 Postage & handling

DEALERS INQUIRIES INVITED



ELECTRONICS

V16

750 LUCERNE RD
SUITE 120
TEL. 514-737-7293

MONTREAL, QUEBEC
CANADA H3R 2H6

10 thru 80 the easy way!!!

"BIG SIGNAL" W2AU BALUN *

"OLD RELIABLE" W2VS ANTENNA COILS *

ANTENNA KIT

These two old friends* get together with 120 feet of high quality # 14-7 strand copper antenna wire and a pair of "END-SULATORS" end insulators to create a superior 80 through 10 meter. 108 foot long, full power (1,000 watts/2,000 watts P.E.P.) antenna. Instructions included.
Price \$48.25 plus \$1.00 handling charge.

In Calif. add 6% sales tax. Mastercharge & Visa accepted.

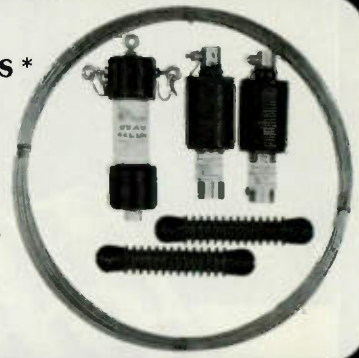

Order from: S-F AMATEUR RADIO SERVICES

4384 KEYSTONE AVE., CULVER CITY CALIFORNIA 90230 Ph. (213) 837-4870

7th ANNUAL HAMBURG INTERNATIONAL HAMFEST PRESENTS

HAM-O-RAMA "78"

H22

SEPTEMBER 16th — 9 A.M.-5 P.M.

ERIE COUNTY FAIRGROUNDS

BUFFALO, N.Y.

Speakers—Big Prizes—Ladies' Programs—Major Manufacturers—R.V. Hookups—Indoor/
Outdoor Flea Markets—Talk In On 52 & 31/91—Off N.Y.S. 1-90 at Exit 57
Details: H.I.H. Committee, 10404 Cayuga Dr., Niagara Falls, NY 14304
Phone 716-297-0539

716-873-3984

ALL BAND TRAP ANTENNAS!

PRE-TUNED - COMPLETELY ASSEMBLED - ONLY ONE NEAT SMALL ANTENNA FOR UP TO 6 BANDS! EXCELLENT FOR CONGESTED HOUSING AREAS - APARTMENTS LIGHT - STRONG - ALMOST INVISIBLE!

FOR ALL MAKES & MODELS OF AMATEUR TRANSCEIVERS - TRANSMITTERS - GUARANTEED FOR 2000 WATTS SSB 1000 WATTS CW. FOR NOVICE AND ALL CLASS AMATEURS!

COMPLETE AS SHOWN with 90 ft. RG58U-52 ohm feedline, and PL259 connector, insulators, 30 ft. 300 lb. test dacron end supports, center connector with built in lightning arrester and static discharge - molded, sealed, weatherproof, resonant traps 1" X 6" - you just switch to band desired for excellent worldwide operation - transmitting and receiving! WT. LESS THAN 5 LBS.

80-40-20-15-10 bands 2 trap --- 102 ft. with 90 ft. RG58U - connector - Model 998BU ... \$49.95
40-20-15-10 bands 2 trap --- 54ft. with 90 ft. RG58U coax - connector - Model 1001BU ... \$48.95
20-15-10 bands 2 trap --- 26 ft. with 90 ft. RG58U coax - connector - Model 1007BU ... \$47.95

SEND FULL PRICE FOR POST PAID INSURED DEL. IN USA. (Canada is \$5.00 extra for postage - clerical - customs - etc.) or order using VISA Bank Americard - MASTER CHARGE - AMER. EXPRESS. Give number and ex. date. Ph 1-308-236-5333 9AM - 6PM week days. We ship in 2-3 days. PRICES MAY INCREASE SO - ORDER NOW AND SAVE! All antennas guaranteed for 1 year. Money back trial! Made In USA. FREE INFO. AVAILABLE ONLY FROM.

WESTERN ELECTRONICS

Dept. A7- 9

Kearney, Nebraska, 68847

ANTENNA SPECIAL

- 1) Wilson System One Tribander
 - 2) Wilson WR-500 Rotor
 - 3) 100 ft. RG 8-X
 - 4) 100 ft. 8 wire Rotor Cable
 - 5) 2PL259—List \$465 for \$385
- with Ham III Rotor add \$30.00
with Sy II Ant. minus \$36.00
with Cushcraft ATB-34 minus \$20.00

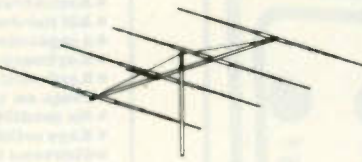

Kenwood TS 820S for \$1098 get SP-520 and MC-50 mic free. Kenwood TS 520S \$739 choice of SP 520 or MC 50 mic.

Dentron • Tempo • Wilson • Larsen • Cushcraft • Hy-Gain and many more.

Before you buy your next Ham Radio "STOP" and take time to send or call for our price sheets. You won't be sorry you did. We service what we sell. Charge it! with BANKAMERICARD or MASTERCARD or we will ship C.O.D.

Jim WB2JON

BANKAMERICARD (716) 235-7540 MASTERCARD

Amateur Radio of Rochester

1185 SCOTTSVILLE RD., ROCHESTER, NEW YORK 14624 A51

The Lightweight Champ.



only \$79.95

Kantronics 8040-B Receiver

The **8040-B** is a versatile CW receiver at a modest price! This **battery-powered** unit makes a great camping and vacationing rig.

Prospective hams can **copy real QSOs** with a reasonable investment. Watch for our **companion transmitter**, available soon!

Coverage runs from 3.650 to 3.760 MHz, and 7.050 to 7.150 MHz. **Write us for more details!**

KANTRONICS
K13 The Lightweight Champs.

Telephone 913-842-7745
Lawrence, Kansas 66044

1202 East 23rd St

PEOPLE BUY BIRD FROM US



Model 43: \$120
CC-1 Leather Case: \$25
Elements: \$36 to \$42

who live in Florida, Georgia and Louisiana.

We have regular Bird customers in Texas, Alaska, Minnesota and dozens of other states as well as Washington. They come to us because they know we have a gigantic stock of Bird and that we ship the same day and that we prepay Bird orders over \$145. Add to this the fact that we are the oldest and largest Amateur store in the Pacific Northwest and you get a glimpse of why we're so popular —

AMATEUR RADIO SUPPLY SEATTLE

A55

6213 13th Ave. So., 98108 (206) 767-3222

Washington Residents: To order, CALL TOLL-FREE 1-800-562-8326.

ARRL HUDSON DIVISION CONVENTION

PLAYBOY RESORT & COUNTRY CLUB

AT GREAT GORGE

McAFEE, NEW JERSEY

SPONSORED BY THE HUDSON AMATEUR RADIO COUNCIL, INC.

NOVEMBER 10, 11, 12, 1978

SPECIAL PROGRAM FRIDAY NIGHT

EXHIBITS --- LECTURES --- FORUMS --- FLEA MARKET

FREE PARKING --- COME FOR THE DAY OR THE WEEKEND

LOW ROOM RATES --- INDOOR POOL --- FAMILY FUN

ATTEND THE SATURDAY NIGHT BANQUET AND ENJOY

RON SWOBODA WA2HVM AND JEAN SHEPHERD K2ORS



ADDITIONAL INFORMATION CAN BE OBTAINED FROM: HANK WENER WB2ALW, CHAIRMAN, BY WRITING TO HIM AT 53 SHERRARD STREET, EAST HILLS, N. Y. 11577

FLEA MARKET INFORMATION: Write to Peter Karpak, 23 Rowland Avenue, Clifton, N.J. 07012. Please enclose a large S.A.S.E. You can call Pete nights at 201 779-4590 or Dave Rettig, days at 201 354-1600.

USE COUPON (OR FACSIMILE) TO ORDER REGISTRATION AND BANQUET TICKETS

TO: NANCY ISCARO WA2GKC
P.O. BOX 274
BRONX, NEW YORK 10463

MY CHECK TO "HUDSON DIVISION CONVENTION" FOR \$ _____ IS ENCLOSED.
THE NAMES AND CALL SIGNS (IF ANY) FOR THOSE WHO WILL BE USING THESE BANQUET TICKETS ARE ATTACHED.

HERE IS MY LARGE S.A.S.E. - PLEASE SEND:

REGISTRATION(S) AT \$35.00 - _____ NAME _____ CALL _____
ADDRESS _____
BANQUET TICKET(S) AT \$15.00 - _____ CITY _____ STATE _____ ZIP _____



now 125!

the all new 2 meter VHF amplifier from Westcom.

- An add-on unit, no internal connections or adjustments required to associated equipment • Standard Amplifier Models operate FM, Linear Models operate all modes: SSB, FM, AM, RTTY, CW, etc.
- "Microstrip" design provides high stability and optimum performance over wide bandwidth • Factory adjusted, no tuning required.
- Mobile mounting bracket included • RF sensing T/R switching, adjustable dropout delay • Remote keying capability • Thermally coupled biasing • Reverse Voltage protected and fused • Conservatively rated with oversized heat sink • Red LED indicators for monitoring DC and RF • Ninety day material and workmanship warranty

MODEL NO.	INPUT POWER (watts)	MINIMUM OUTPUT W (at max input)	MAXIMUM CURRENT 13.8 VDC	PRICE
<i>FM Mode: 144-149 MHz</i>				
2M 15x90	5-15	90	11	139.95
2M 25x125	10-25	125	18	169.95
<i>All Mode - Linearized: 144-149 MHz</i>				
2M 15x90L	2-15	90	11	149.95
2M 25x125L	5-25	125	18	179.95
<i>FM Mode: 220-225 MHz</i>				
1.3M 15x70	5-15	70	10	available soon

*Linear; AM, CW, FM, SSB, RTTY. Linear models work well with low power transmitters of 2-3 watts to yield 30-40 w output. size: 4 1/8 x 5 1/2 x 2 5/8
technical specifications and data subject to change without notice

IF NOT AVAILABLE FROM YOUR LOCAL DEALER, CONTACT:

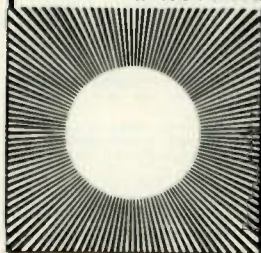

WESTCOM

ENGINEERING

W17

1320 Grand Avenue San Marcos
California 92069 (714) 744-0728

TR-80 OWNERS NOW SEND MORSE CODE!

- Level I & II cassettes included
- 4 or 16K
- Assembled & tested PC board
- All hardware • complete instructions
- 4 separate recallable messages
- Keyboard buffer • you type ahead
- Keyboard one-key speed change
- Plugs on the TRS-80 port
- No modifications to TRS-80 required
- Keys solid state & grid block rigs
- Sidetone included
- Machine language program • not basic

SEND PERFECT CW

VISA **\$39.95** MasterCard



M58



CONNECTOR ASSORTMENT

\$25.00 **\$23.50** each
Postpaid lots of three

Includes: 5- PL259, 5- SO239, 5- UG175, 5- UG176, 2- PL258, 1- DM, 1- M358, 2- M359, 1- UG255, 1- UG273, 2- PL259PO, 1- 1021-20, 1- Lightning Arrestor.

Master Charge & Visa accepted / Send for Free Catalog

COAKIT

P.O. Box 101-A Dumont, N. J. 07628

Circle C21 on Reader Service Card

MILITARY SURPLUS WANTED



WE NEED:

ARC-34, ARC-51BX, ARC-92, ARC-94, ARC-102, ARC-109, ARC-115, ARC-116, ARC-131, ARC-134, ARC-164, ARN-82, ARN-83, ARN-84, ARA-48, ARA-50, APN-81, APN-133, APN-147, APX-64, APX-72, 618T, 490T-1, CU-1658A, CU-1669A, 807A, GRC-106, URC-9.



Top dollar paid or trade for new amateur gear. Write or phone Bill Slep, (704)524-7519. Slep Electronics Company, Highway 441, Otto, North Carolina 28763.

PCP™ TYPE-A PATENT PENDING

PCP TYPE-A TRANSFER FILM lifts the ink DIRECTLY from printed paper!
(NO CHEMICALS or PHOTOGRAPHY required!)

Only additional materials required are: Sensitized boards, developer, & etchant!

SEE POPULAR ELECTRONICS FEB '78 ISSUE!

FINALLY you can make HIGH QUALITY printed circuit boards directly from magazine construction articles! Can also be used to make specialized meter faces, front panel decals, component placement decals & others.

Small Pkg. 6pcs 4x6 \$5.49
Med. Pkg. 4pcs 6x9 \$6.95
Large Pkg. 3pcs 9x12 \$7.95

PCP PRINTED CIRCUIT PRODUCTS CO.
P.O. BOX 4034
MELDEN, MT 59611

AMATEUR TELEVISION ON 439.25 MHz

INTERESTED? ACTIVITY IS INCREASING EVERYWHERE YOU CAN GET ACTIVE IN YOUR AREA WITH OUR PRODUCTS—

- AMIB FSTV CONVERTER complete \$150.00**
- AXIOB FSTV TRANSMITTER complete \$385.00**

CALL 812-336-4775, OR WRITE US, FOR COMPLETE DETAILS

APTRON LABORATORIES
PO BOX 323 BLOOMINGTON, INDIANA, 47401

PET OWNERS SEND-RECEIVE RTTY & CW

M65 K \$69.95 KIT **M65 A \$99.95 WIRED**

- Automatic send & receive: RTTY and CW
 - Complete hardware and software package
 - Connects to your PET User Port and the key/headphone jacks of your rig
 - Ten message memories—255 char. each
 - Keyboard buffer—allows typing ahead
 - Uses built-in PLL or external TV
 - Morse trainer—random 5 letter words
 - Includes hardware, cassette & manual
 - TRS-80 version available soon
- Write or call for detailed brochure

MICROTRONICS M48
Dept. S.

5943 Pioneer Rd.
Hughson, CA 95326
(209) 634-8888

California residents add 6% tax

JUST GETTING ON THE AIR? See Adirondack for



- New Equipment
- Used Gear
- Friendly Advice

ADIRONDACK Radio Supply

185-191 West Main Street • P.O. Box 88
Amsterdam, N.Y. 12010 Tel (518) 342-8350
Just 5 minutes from N.Y. Thruway—Exit 27

P.O. Box 44300 Santa Clara, CA 95054

For will call only: (408) 988-1640
2322 Walsh Ave.

Q3 ELECTRONICS

Same day shipment. First line parts only. Factory tested. Guaranteed money back. Quality IC's and other components at factory prices.

INTEGRATED CIRCUITS

7480TTL	74LS280	41	LM3015-15	10	CMOS	CD4511	94	2127-2	3.95
7480N	74LS280N	25	LM3015-15	10	CMOS	CD4515	252	214	8.90
7482N	74LS33	39	LM3401-24	10	CMOS	CD4516	1.0	218	24.95
7484N	74LS33N	30	LM3401-24	10	CMOS	CD4518	1.02	253R	8.30
7410N	74LS138	35	LM3277	4.50	CD4001	21	2122-1	1.95	
7410N	74LS138N	47	LM3175	9.00	CD4002	21	2122-1	1.95	
7410N	74LS138N	51	LM3175N	9.00	CD4003	21	2122-1	1.95	
7420N	74LS154	51	LM3804	1.00	CD4007	21	2122-1	1.95	
7420N	74LS154N	1.99	LM3822	1.60	CD4008	21	2122-1	1.95	
7420N	74LS154N	2.00	LM3278	4.00	CD4009	39	2122-1	1.95	
7420N	74LS154N	35	LM3278N	4.00	CD4010	39	2122-1	1.95	
7420N	74LS154N	35	LM3278N	4.00	CD4011	39	2122-1	1.95	
7420N	74LS154N	35	LM3278N	4.00	CD4012	39	2122-1	1.95	
7420N	74LS154N	35	LM3278N	4.00	CD4013	39	2122-1	1.95	
7420N	74LS154N	35	LM3278N	4.00	CD4014	39	2122-1	1.95	
7420N	74LS154N	35	LM3278N	4.00	CD4015	39	2122-1	1.95	
7420N	74LS154N	35	LM3278N	4.00	CD4016	39	2122-1	1.95	
7420N	74LS154N	35	LM3278N	4.00	CD4017	39	2122-1	1.95	
7420N	74LS154N	35	LM3278N	4.00	CD4018	39	2122-1	1.95	
7420N	74LS154N	35	LM3278N	4.00	CD4019	39	2122-1	1.95	
7420N	74LS154N	35	LM3278N	4.00	CD4020	39	2122-1	1.95	
7420N	74LS154N	35	LM3278N	4.00	CD4021	39	2122-1	1.95	
7420N	74LS154N	35	LM3278N	4.00	CD4022	39	2122-1	1.95	
7420N	74LS154N	35	LM3278N	4.00	CD4023	39	2122-1	1.95	
7420N	74LS154N	35	LM3278N	4.00	CD4024	39	2122-1	1.95	
7420N	74LS154N	35	LM3278N	4.00	CD4025	39	2122-1	1.95	
7420N	74LS154N	35	LM3278N	4.00	CD4026	39	2122-1	1.95	
7420N	74LS154N	35	LM3278N	4.00	CD4027	39	2122-1	1.95	
7420N	74LS154N	35	LM3278N	4.00	CD4028	39	2122-1	1.95	
7420N	74LS154N	35	LM3278N	4.00	CD4029	39	2122-1	1.95	
7420N	74LS154N	35	LM3278N	4.00	CD4030	39	2122-1	1.95	
7420N	74LS154N	35	LM3278N	4.00	CD4031	39	2122-1	1.95	
7420N	74LS154N	35	LM3278N	4.00	CD4032	39	2122-1	1.95	
7420N	74LS154N	35	LM3278N	4.00	CD4033	39	2122-1	1.95	
7420N	74LS154N	35	LM3278N	4.00	CD4034	39	2122-1	1.95	
7420N	74LS154N	35	LM3278N	4.00	CD4035	39	2122-1	1.95	
7420N	74LS154N	35	LM3278N	4.00	CD4036	39	2122-1	1.95	
7420N	74LS154N	35	LM3278N	4.00	CD4037	39	2122-1	1.95	
7420N	74LS154N	35	LM3278N	4.00	CD4038	39	2122-1	1.95	
7420N	74LS154N	35	LM3278N	4.00	CD4039	39	2122-1	1.95	
7420N	74LS154N	35	LM3278N	4.00	CD4040	39	2122-1	1.95	
7420N	74LS154N	35	LM3278N	4.00	CD4041	39	2122-1	1.95	
7420N	74LS154N	35	LM3278N	4.00	CD4042	39	2122-1	1.95	
7420N	74LS154N	35	LM3278N	4.00	CD4043	39	2122-1	1.95	
7420N	74LS154N	35	LM3278N	4.00	CD4044	39	2122-1	1.95	
7420N	74LS154N	35	LM3278N	4.00	CD4045	39	2122-1	1.95	
7420N	74LS154N	35	LM3278N	4.00	CD4046	39	2122-1	1.95	
7420N	74LS154N	35	LM3278N	4.00	CD4047	39	2122-1	1.95	
7420N	74LS154N	35	LM3278N	4.00	CD4048	39	2122-1	1.95	
7420N	74LS154N	35	LM3278N	4.00	CD4049	39	2122-1	1.95	
7420N	74LS154N	35	LM3278N	4.00	CD4050	39	2122-1	1.95	
7420N	74LS154N	35	LM3278N	4.00	CD4051	39	2122-1	1.95	
7420N	74LS154N	35	LM3278N	4.00	CD4052	39	2122-1	1.95	
7420N	74LS154N	35	LM3278N	4.00	CD4053	39	2122-1	1.95	
7420N	74LS154N	35	LM3278N	4.00	CD4054	39	2122-1	1.95	
7420N	74LS154N	35	LM3278N	4.00	CD4055	39	2122-1	1.95	
7420N	74LS154N	35	LM3278N	4.00	CD4056	39	2122-1	1.95	
7420N	74LS154N	35	LM3278N	4.00	CD4057	39	2122-1	1.95	
7420N	74LS154N	35	LM3278N	4.00	CD4058	39	2122-1	1.95	
7420N	74LS154N	35	LM3278N	4.00	CD4059	39	2122-1	1.95	
7420N	74LS154N	35	LM3278N	4.00	CD4060	39	2122-1	1.95	
7420N	74LS154N	35	LM3278N	4.00	CD4061	39	2122-1	1.95	
7420N	74LS154N	35	LM3278N	4.00	CD4062	39	2122-1	1.95	
7420N	74LS154N	35	LM3278N	4.00	CD4063	39	2122-1	1.95	
7420N	74LS154N	35	LM3278N	4.00	CD4064	39	2122-1	1.95	
7420N	74LS154N	35	LM3278N	4.00	CD4065	39	2122-1	1.95	
7420N	74LS154N	35	LM3278N	4.00	CD4066	39	2122-1	1.95	
7420N	74LS154N	35	LM3278N	4.00	CD4067	39	2122-1	1.95	
7420N	74LS154N	35	LM3278N	4.00	CD4068	39	2122-1	1.95	
7420N	74LS154N	35	LM3278N	4.00	CD4069	39	2122-1	1.95	
7420N	74LS154N	35	LM3278N	4.00	CD4070	39	2122-1	1.95	
7420N	74LS154N	35	LM3278N	4.00	CD4071	39	2122-1	1.95	
7420N	74LS154N	35	LM3278N	4.00	CD4072	39	2122-1	1.95	
7420N	74LS154N	35	LM3278N	4.00	CD4073	39	2122-1	1.95	
7420N	74LS154N	35	LM3278N	4.00	CD4074	39	2122-1	1.95	
7420N	74LS154N	35	LM3278N	4.00	CD4075	39	2122-1	1.95	
7420N	74LS154N	35	LM3278N	4.00	CD4076	39	2122-1	1.95	
7420N	74LS154N	35	LM3278N	4.00	CD4077	39	2122-1	1.95	
7420N	74LS154N	35	LM3278N	4.00	CD4078	39	2122-1	1.95	
7420N	74LS154N	35	LM3278N	4.00	CD4079	39	2122-1	1.95	
7420N	74LS154N	35	LM3278N	4.00	CD4080	39	2122-1	1.95	
7420N	74LS154N	35	LM3278N	4.00	CD4081	39	2122-1	1.95	
7420N	74LS154N	35	LM3278N	4.00	CD4082	39	2122-1	1.95	
7420N	74LS154N	35	LM3278N	4.00	CD4083	39	2122-1	1.95	
7420N	74LS154N	35	LM3278N	4.00	CD4084	39	2122-1	1.95	
7420N	74LS154N	35	LM3278N	4.00	CD4085	39	2122-1	1.95	
7420N	74LS154N	35	LM3278N	4.00	CD4086	39	2122-1	1.95	
7420N	74LS154N	35	LM3278N	4.00	CD4087	39	2122-1	1.95	
7420N	74LS154N	35	LM3278N	4.00	CD4088	39	2122-1	1.95	
7420N	74LS154N	35	LM3278N	4.00	CD4089	39	2122-1	1.95	
7420N	74LS154N	35	LM3278N	4.00	CD4090	39	2122-1	1.95	
7420N	74LS154N	35	LM3278N	4.00	CD4091	39	2122-1	1.95	
7420N	74LS154N	35	LM3278N	4.00	CD4092	39	2122-1	1.95	
7420N	74LS154N	35	LM3278N	4.00	CD4093	39	2122-1	1.95	
7420N	74LS154N	35	LM3278N	4.00	CD4094	39	2122-1	1.95	
7420N	74LS154N	35	LM3278N	4.00	CD4095	39	2122-1	1.95	
7420N	74LS154N	35	LM3278N	4.00	CD4096	39	2122-1	1.95	
7420N	74LS154N	35	LM3278N	4.00	CD4097	39	2122-1	1.95	

VARIABLE POWER SUPPLY KIT \$11⁹⁵

- Continuously Variable from 2V to over 15V
- Short-Circuit Proof
- Typical Regulation of 0.1%
- Electronic Current Limiting at 300mA
- Very Low Output Ripple
- Fiberglass PC Board Mounts All Components
- Assemble in about One Hour
- Makes a Great Bench or Lab Power Supply
- Includes All Components except Case and Meters

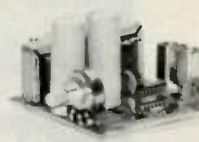

ADD \$1.25 FOR POSTAGE/HANDLING

SPECIALS — THIS MONTH ONLY

1N34A	Germanium Diode 50V 10mA	10/51	LM308H	Low Bias Current Op Amp Super 708	\$0.84
1N270	Germanium Diode 80V 200mA	4/81	LM309K	5 Volt Regulator TO-3	.84
1N914	Silicon Diode 100V 10mA	25/51	LM317K	Adjustable Voltage Regulator 2.37V	3.50
1N6283	Hot Carrier Diode (MP2800, etc.)	\$1.00	LM380M	2 Watt Audio Power Amplifier	.94
F7	Power Vector 1-2W Out @ 432MHz		NE555A	Phase Locked Loop	DIP .94
	(Spacers & Capacitors included with F7)				
DIODE GRAB BAG - Mixed diodes, rectifiers, etc.		\$2.00	LM723CN	Precision Voltage Regulator	DIP 3/51
		\$0/51	LM747	Dual 741 Compensated Op Amp	DIP 2/51
2N706	NPN High Speed Switch 15mA	4/51	2102	1024-Bit Static RAM (1024 x 1)	DIP \$1.75
2N918	UMF Transistor - Osc/Amp up to 1 GHz	4/51	27400E	FET Input Op Amp like RE 536 /A740	1.98
2N2609	P-Channel FET Amplifier 2500, mhos	\$1.00	CA3018A	4-Transistor Array/Darlington	.99
2N2920	NPN Dual Transistor 3mV Match β 225	2.95	CA3028A	RF/F Amplifier DC to 120MHz	1.45
2N3904	NPN Amp/Switch 100 40V 200mA	8/51	CA3075E	FM IF Amp/Limiter/Detector	DIP 1.45
2N4122	PNP RF Amplifier & Switch	3/51	RC4558	Dual High Gain Op Amp	mDIP 3/51
2N4489E	N Channel Audio FET Super Low Noise	2/51	MS556V	Precision Fast Op Amp	mDIP 2/51
2N4388	150 Volt PNP Transistor for Relay	2/51	MS558V	Dual Hi Gain Op Amp Comp.	mDIP 3/51
E112	N Channel FET VME RF Amp	3/51	8038	Function Generator/VCO with circuits	\$3.75
T574	N Channel FET High Speed Switch 481	3/51			
			LP-10	LOGIC PROBE kit—TTL, CMOS, etc.	
				Machined case included—1/2 hr. assembly	\$7.85

SEND FOR ADVA'S NEW 1979 CATALOG
NEARLY 1000 SEMICONDUCTORS, KITS, CAPACITORS, ETC. SEND 25¢ STAMP.

OTHER ADVA KITS:

LOGIC PROBE KIT—Use with CMOS, TTL, DTL, RTL, HTL, and most MOS IC's. Built-in protection against polarity reversal and overvoltage. Draws only a few mA from circuit under test. Dual LED readout. Complete kit includes case and clip leads. **ONLY \$7.85**

FIXED REGULATED POWER SUPPLY KITS—Short-circuit proof with thermal current limiting. Compact size and typical regulation of 0.5% make these ideal for most electronic projects. Available for 5V @ 500mA, 6V @ 500mA, 9V @ 500mA, 12V @ 400mA, 15V @ 300mA. Specify voltage when ordering. **\$8.95 ea.**

These easy-to-assemble kits include all components, complete detailed instructions and plated fiberglass PC boards. Power supply kits do not include case or meters. Add \$1.25 per kit for postage and handling.

MAIL NOW! FREE DATA SHEETS supplied with many items from this ad. FREE ON REQUEST—741 Op Amp with every order of \$5 or more—7409 Dual Op Amp or two E100 FET's with every order of \$10 or more, postmarked prior to 12/31/78. One free item per order. ORDER TODAY—All items subject to prior sale and prices subject to change without notice. All items are new surplus parts—100% functionality tested.

WRITE FOR FREE CATALOG #79 offering over 700 semiconductors carried in stock. Send 25¢ stamp.

TERMS: Send check or money order (U.S. funds) with order. Add 5% postage for U.S., Canada and Mexico. \$1.00 handling charge on orders under \$10. Calif. residents add 6% sales tax. Foreign orders add 10% postage. CDO orders add \$1.00 service charge.

MORE SPECIALS:

RC4195DN	±15V @ 50mA VOLTAGE REGULATORY IC. Very easy to use. Makes a neat Highly Regulated ±15V Supply for OP AMP's, etc. Requires only unregulated DC (18-30V) and 2 bypass capacitors. With Data Sheet and Schematics. 8-pin mDIP	\$1.25
RC4136	Quad 741 Low Noise Op Amp mDIP	\$0.95
LM1304	FM Multiplex Stereo Demodulator DIP	0.99
LM2111	FM IF Subsystem (IF Amp, Det., Limiter) DIP	0.99
IN6283	Hot Carrier Diode 0.4V @ 1mA 0.1nt DO-35	1.00
ZENERS—Specify Voltage 3.3, 3.9, 4.3, 5.1, 6.8, 8.2, 9.1, 10, 12, 15, 16, 18, 20, 22, 24, 27, or 33V (±10%)	1 Watt 4/51, 0.1 Watt 3/51, 0.0	

- MONEY-BACK GUARANTEE
- ALL TESTED AND GUARANTEED

ADVA ELECTRONICS
BOX 4181 GB, WOODSIDE, CA 94062
Tel. (415) 328-1500

FREE

IC or FET's WITH
\$5 & \$10 ORDERS.
DATA SHEETS
WITH MANY ITEMS.

DIODES	TRANSISTORS	TRANSISTORS	TRANSISTORS	LINEAR IC's
ZENERS & RECTIFIERS	2N706 50/26	2N4091 3/51	2N1638 2/78	LM309A-6 \$1.20
	2N718 24	2N4092 50/75	2N1640 2/78	LM309A-9 1.28
1N458 to 1N458 to	2N720 48	2N4121 3/51	CP43 54.00	LM309A-12 1.20
1N458 6/51	2N918 3/51	2N4122 3/51	CP50 50.00	LM309A-16 1.20
1N462 to 1N462 to	2N1813 50/29	2N4124 5/51	CP51 50.00	LM309A-24 1.28
1N486 2/51	2N1711 28	2N4246 5/51	E101 4/51	LM309A-28 1.28
1N746 to 1N746 to	2N1890 38	2N4249 5/51	E101 3/51	LM309A-35 .55
1N758 1/51	2N1903 38	2N4250 4/51	E102 3/51	LM309A-38 2.50
1N814* 15/51	2N2270 24	2N4274 4/51	E173 3/51	LM309M 1.20
1N962 to 1N962 to	2N2222 0/51	2N4275 50/28	MPF112**	NE555V* 2/51
1N974 4/51	2N2222A 6/51	2N4303 28	MPF114 3/51	NE558A 80.00
1N3064 0/51	2N2368 5/51	2N4338 3/51	MPF112 4/51	LM709C 28
1N3600 0/51	2N2506 to 2N2506 to	2N4350 2/51	MPF5515 3/51	LM709CN 29
1N4001* 12/51	2N4208 32	2N4391 3/51	SE1001 4/51	LM723M 2/51
1N4002 12/51	2N4205 50/26	2N4392 50/26	SE1002 4/51	LM723M 2/51
1N4003 12/51	2N4206A 24	2N4416 2/51	SE2001 4/51	LM730M 81.00
1N4004 12/51	2N4207 5/51	2N4418A 50.80	SE2002 4/51	LM741CM 3/51
1N4005 10/51	2N4353 51.50	2N4456 to 2N4456 to	SE5001 to SE5001 to	LM741CM* 2/51
1N4006 10/51	2N4363 8/51	2N4461 81	SE5003 3/51	LM741CM14 34
1N4007 10/51	2N4364 4/51	2N4462 2/51	SE5020 53.00	LM747CN 86
1N4148 8/51	2N4366 6/51	2N4463 2/51	T1813 to T1813 to	7482 DIP 35
1N4154* 25/51	2N4368 6/51	2N4464 82.50	T1875 3/51	7482 DIP 1.00
1N4370 to 1N4370 to	2N4370 8/51	2N4488 8/51	DIGITAL IC's	84CCP mDIP 80
1N4372 to 1N4372 to	2N4383A 5/51	2N4495 3/51	MM5739M \$2.91	LM1304M 1.10
1N4454 16/51	2N4384 5/51	2N4508 4/51	SM7400M .18	LM1458M* 3/51
1N4728 to 1N4728 to	2N4342 5/51	2N4518 3/51	SM7400M .18	LM2111M 1.10
1N4751 1/51	2N4343 6/51	2N4526 to 2N4526 to	SM7402M .18	LM2555CP 1.55
1N5231 to 1N5231 to	2N4346 4/51	2N4535 8/51	SM7402M .18	2J40DE 1.98
1N5236 4/51	2N4349 4/51	2N4538 5/51	SM7402M .18	CA3028A 1.25
	2N4388 3/51	2N4539 5/51	SM7402M .18	CA3046 .86
	2N4390 3/51	2N4543 5/51	SM7402M .18	LM3075M 1.05
	2N4392 4/51	2N4547 3/51	SM7402M .18	CA3088 .02
	2N4394 4/51	2N4549 3/51	SM7402M .18	LM309M .55
	2N4396 4/51	2N4551 3/51	SM7402M .18	RC4194KT 2.50
	2N4398 4/51	2N4553 3/51	SM7402M .18	RC4195KT 1.25
	2N4400 4/51	2N4555 3/51	SM7402M .18	RC4195KT 1.25
	2N4402 4/51	2N4557 3/51	SM7402M .18	RC4195KT 1.25
	2N4404 4/51	2N4559 3/51	SM7402M .18	RC4195KT 1.25
	2N4406 4/51	2N4561 3/51	SM7402M .18	RC4195KT 1.25
	2N4408 4/51	2N4563 3/51	SM7402M .18	RC4195KT 1.25
	2N4410 4/51	2N4565 3/51	SM7402M .18	RC4195KT 1.25
	2N4412 4/51	2N4567 3/51	SM7402M .18	RC4195KT 1.25
	2N4414 4/51	2N4569 3/51	SM7402M .18	RC4195KT 1.25
	2N4416 4/51	2N4571 3/51	SM7402M .18	RC4195KT 1.25
	2N4418 4/51	2N4573 3/51	SM7402M .18	RC4195KT 1.25
	2N4420 4/51	2N4575 3/51	SM7402M .18	RC4195KT 1.25
	2N4422 4/51	2N4577 3/51	SM7402M .18	RC4195KT 1.25
	2N4424 4/51	2N4579 3/51	SM7402M .18	RC4195KT 1.25
	2N4426 4/51	2N4581 3/51	SM7402M .18	RC4195KT 1.25
	2N4428 4/51	2N4583 3/51	SM7402M .18	RC4195KT 1.25
	2N4430 4/51	2N4585 3/51	SM7402M .18	RC4195KT 1.25
	2N4432 4/51	2N4587 3/51	SM7402M .18	RC4195KT 1.25
	2N4434 4/51	2N4589 3/51	SM7402M .18	RC4195KT 1.25
	2N4436 4/51	2N4591 3/51	SM7402M .18	RC4195KT 1.25
	2N4438 4/51	2N4593 3/51	SM7402M .18	RC4195KT 1.25
	2N4440 4/51	2N4595 3/51	SM7402M .18	RC4195KT 1.25
	2N4442 4/51	2N4597 3/51	SM7402M .18	RC4195KT 1.25
	2N4444 4/51	2N4599 3/51	SM7402M .18	RC4195KT 1.25
	2N4446 4/51	2N4601 3/51	SM7402M .18	RC4195KT 1.25
	2N4448 4/51	2N4603 3/51	SM7402M .18	RC4195KT 1.25
	2N4450 4/51	2N4605 3/51	SM7402M .18	RC4195KT 1.25
	2N4452 4/51	2N4607 3/51	SM7402M .18	RC4195KT 1.25
	2N4454 4/51	2N4609 3/51	SM7402M .18	RC4195KT 1.25
	2N4456 4/51	2N4611 3/51	SM7402M .18	RC4195KT 1.25
	2N4458 4/51	2N4613 3/51	SM7402M .18	RC4195KT 1.25
	2N4460 4/51	2N4615 3/51	SM7402M .18	RC4195KT 1.25
	2N4462 4/51	2N4617 3/51	SM7402M .18	RC4195KT 1.25
	2N4464 4/51	2N4619 3/51	SM7402M .18	RC4195KT 1.25
	2N4466 4/51	2N4621 3/51	SM7402M .18	RC4195KT 1.25
	2N4468 4/51	2N4623 3/51	SM7402M .18	RC4195KT 1.25
	2N4470 4/51	2N4625 3/51	SM7402M .18	RC4195KT 1.25
	2N4472 4/51	2N4627 3/51	SM7402M .18	RC4195KT 1.25
	2N4474 4/51	2N4629 3/51	SM7402M .18	RC4195KT 1.25
	2N4476 4/51	2N4631 3/51	SM7402M .18	RC4195KT 1.25
	2N4478 4/51	2N4633 3/51	SM7402M .18	RC4195KT 1.25
	2N4480 4/51	2N4635 3/51	SM7402M .18	RC4195KT 1.25
	2N4482 4/51	2N4637 3/51	SM7402M .18	RC4195KT 1.25
	2N4484 4/51	2N4639 3/51	SM7402M .18	RC4195KT 1.25
	2N4486 4/51	2N4641 3/51	SM7402M .18	RC4195KT 1.25
	2N4488 4/51	2N4643 3/51	SM7402M .18	RC4195KT 1.25
	2N4490 4/51	2N4645 3/51	SM7402M .18	RC4195KT 1.25
	2N4492 4/51	2N4647 3/51	SM7402M .18	RC4195KT 1.25
	2N4494 4/51	2N4649 3/51	SM7402M .18	RC4195KT 1.25
	2N4496 4/51	2N4651 3/51	SM7402M .18	RC4195KT 1.25
	2N4498 4/51	2N4653 3/51	SM7402M .18	RC4195KT 1.25
	2N4500 4/51	2N4655 3/51	SM7402M .18	RC4195KT 1.25
	2N4502 4/51	2N4657 3/51	SM7402M .18	RC4195KT 1.25
	2N4504 4/51	2N4659 3/51	SM7402M .18	RC4195KT 1.25
	2N4506 4/51	2N4661 3/51	SM7402M .18	RC4195KT 1.25
	2N4508 4/51	2N4663 3/51	SM7402M .18	RC4195KT 1.25
	2N4510 4/51	2N4665 3/51	SM7402M .18	RC4195KT 1.25
	2N4512 4/51	2N4667 3/51	SM7402M .18	RC4195KT 1.25
	2N4514 4/51	2N4669 3/51	SM7402M .18	RC4195KT 1.25
	2N4516 4/51	2N4671 3/51	SM7402M .18	RC4195KT 1.25
	2N4518 4/51	2N4673 3/51	SM7402M .18	RC4195KT 1.25
	2N4520 4/51	2N4675 3/51	SM7402M .18	RC4195KT 1.25
	2N4522 4/51	2N4677 3/51	SM7402M .18	RC4195KT 1.25
	2N4524 4/51	2N4679 3/51	SM7402M .18	RC4195KT 1.25
	2N4526 4/51	2N4681 3/51	SM7402M .18	RC4195KT 1.25
	2N4528 4/51	2N4683 3/51	SM7402M .18	RC4195KT 1.25
	2N4530 4/51	2N4685 3/51	SM7402M .18	RC4195KT 1.25
	2N4532 4/51	2N4687 3/51	SM7402M .18	RC4195KT 1.25
	2N4534 4/51	2N4689 3/51	SM7402M .18	RC4195KT 1.25
	2N4536 4/51	2N4691 3/51	SM7402M .18	RC4195KT 1.25
	2N4538 4/51	2N4693 3/51	SM7402M .18	RC4195KT 1.25
	2N4540 4/51	2N4695 3/51	SM7402M .18	RC4195KT 1.25
	2N4542 4/51	2N4697 3/51	SM7402M .18	RC4195KT 1.25
	2N4544 4/51	2N4699 3/51	SM7402M .18	RC4195KT 1.25
	2N4546 4/51	2N4701 3/51	SM7402M .18	RC4195KT 1.25
</				



T.M.

ETCO SUPER BUYS

FREE

WITH EACH ORDER OF \$10.00 OR MORE -
(one gift per order) our famous MAGIC
SOUND SWITCH - Request No.
037SU210. (2 oz.)

ETCO-PAK

PARTS KITS

"BOXES & BAGS" OF THE FINEST PARTS AT
WONDERFUL SAVINGS!

- 037PT339 1 lb. of single sided CU clad epoxy PC
pc board (1 lb.) \$2.95
- 037PT338 1 lb. of double sided CU clad epoxy PC
board (1 lb.) \$2.95
- 037OP263 5 asst. optical lenses (2 oz.) \$1.98
- 037MS391 10 "fly spec" micro thermistors (1 oz.) \$3.99
- 037PT003 50 asst. disc capacitors (3 oz.) \$1.99
- 037PT097 5 lb. electronic surprise box (5 lb.) \$2.95
- 037PT043 200 asst. terminal lugs (5 oz.) \$2.49
- 037PT048 275 selected sheet metal screws (1 lb.) \$2.95
- 037PT056 50 3/8-32 volume control nuts (1 lb.) \$1.99
- 037PT110 2 lb. of self tap screws (2 lb.) \$2.89
- 037PT100 2 lb. of mixed hardware (2 lb.) \$2.95
- 037PT109 2 lb. of asst. steel washers (2 lb.) \$1.99
- 037PT101 2 lb. of asst. machine nuts & screws
(2 lb.) \$2.89
- 037MS390 10 mini bead thermistors (3 oz.) \$2.99
- 037PT166 10 asst. thermistors (2 oz.) \$1.99



Sansui QC-04 CD-4

FOUR-CHANNEL
QUAD RECORD
DEMODULATOR!

12⁹⁵

\$9.95 ea./3 lots
\$8.95 ea./100 lots

A sensational Factory Surplus Purchase! A goldmine of
parts and semiconductors. 1500 in stock! Schematic
included. (5 lb.) 037HP099

ELECTRET SHOTGUN
MICROPHONE!

59⁹⁵

19 INCHES LONG!

Amazing Directional Characteristics—very
similar to studio models selling for 5 times
our low price! 20-20,000 Hz, 500 ohms.
This is a professional mike, designed for TV
studio use. Superb, carefully selected electret
cartridge powered by 1.5V pencil sol-
ves all requirements of sharp directivity,
wide response, startling sensitivity—even at
50 feet! With windscreen, cable, stand
clamp. (2 lb.) 037MP112

SPECIAL!



24 HOUR-7 DAY-A-WEEK TELEPHONE ORDER SERVICE!
Call in your chargecard orders at low weekend and evening
rates: DIAL: 1-518-561-8700.

DEALER
INQUIRIES
INVITED

E31

BUILD YOUR OWN PARABOLIC MICROPHONE!

THIS IS DIFFERENT

Giant 22" transparent plastic "dish" Use it to
construct long distance parabolic micro-
phones, sound concentrators and projectors.
Exclusive design provides high gain and audio
capture capability. High front to back ratio.
Construction ideas included. (4 lb.)
037MP233

19⁹⁵



TELEPHONE KEYBOARD SPECIAL!



Similar to Western
Electric - Matrix Encoded.

SEPTEMBER SPECIAL! Nice, non-
tactile pad action. Exactly as pic-
tured. Terminated for PC board
mount or wire wrap. 3" x 2 1/2". Use
to build encoders, decoders, dialers,
computer entry systems, electronic
locks, control keyboards, etc. (3 oz.)
037SW263

OLD FASHIONED PAYPHONES!

MAIL YOUR ORDER TODAY

A FUN ITEM! as removed from ac-
tive service. Clean 'em up, fix 'em
up, wire 'em up and you have a
super conversation piece for home
or office. An ideal gift for a friend!
With wiring instructions. (26 lb.)
037PH014

39⁹⁵



TELEPHONE
OPERATORS
HEADSETS!

39⁹⁵

2/\$69.95

SURPLUS SALE!

No. 52, 53 FACTORY RECONDI-
TIONED - LIKE NEW! 100 ohm
carbon mike - 200 ohm headset. Use
to build "hands free" intercoms for
industrial applications. (1 lb.)
037PH017.



NICE 7 INCH, 6VDC ALARM BELL!

9⁹⁵ SURPLUS

3/\$26.95

Brand new factory surplus - manufactured
by "Knight Watch Systems". Rugged for
alarm applications. Operates on 6 VDC @
.3A. A real beauty. (2X 1 lb.) 037HM187.

6" x 4" COPPER CLAD
EPOXY BOARDS!

Sold Out to
ETCO

49¢

SEPTEMBER SPECIAL! Beau-
tiful quality EPOXY, neatly cut-
just right for etching those pro-
ject boards. Single side. (2 oz.)
037PC034

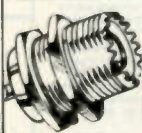

POPULAR SINGLE-HOLE
MOUNT SO-239 SOCKET

69¢

SPECIAL PURCHASE!
(2 oz.) 037MS027.

10/\$5.95

SAVE!

SWITCHCRAFT
MIKE CONNECTORS!

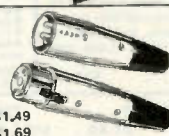

SEPTEMBER SPECIAL!

- 037MS337 3P male (A3MX) 3 oz. \$1.49
- 037MS251 3P female (A3F) 13 oz. \$1.69



6500
in stock!

SURPLUS SALE!

16-PIN IC SOCKETS!

19¢

SPECIAL OF THE MONTH! Short "spring
claw" pins for PC board mount. High profile
(Berg No. 5). Brand new factory surplus.
(1 oz.) 037JK155

Semiconductor SPECIALS

SPECIAL PURCHASE OF "EXCESS INVENTORY"—
PRIME DEVICES - NO REJECTS OR "OFF SPEC"
MATERIAL!

- 037DR156 RCA CD4013 CMOS (1 oz.) .39c, 10/\$3.59
- 037QS169 RCA 40374 c/w heat sink (3 oz.) \$1.39, 10/\$10.88
- 037DS168 RCA 40536 c/w heat sink (3 oz.) \$1.29, 10/\$9.95
- 037DR155 DIALIGHT 521-9186 micro LED (1 oz.) 19c, 10/\$1.79, 100/\$15.95
- 037DR061 48SX106 switching transistor (1 oz.) \$1.89, 10/\$15.88
- 037DS173 T.J. GA1742 transistor (1 oz.) 69c, 10/\$5.95, 100/\$49.95
- 037DS172 T.J. 29694 (CA1344) transistor (1 oz.) 69c, 10/\$5.95, 100/\$49.95
- 037DS171 2SA6738 power transistor (1 oz.) 69c, 10/\$5.95
- 037DS170 2CS1213C power transistor (1 oz.) 69c, 10/\$5.95
- 037DS090 2N169 Germanium PNP (1 oz.) 69c, 10/\$5.95
- 037DR934 2N241A transistor (1 oz.) 69c, 10/\$5.95

**FREE
SURPLUS
CATALOG!**



No. AA catalog. Packed with
electronic bargains and unusual
items! Write or circle the in-
formation card number below.

ETCO

T.M.

Rush Your Order Today

ETCO ELECTRONICS CORP. U.S.A.
North Country Shopping Center,
Route No. 9, Plattsburgh, N.Y. 12901.

MERCHANDISE SUBJECT TO PRIOR SALE. Full remittance with each order, please. Money Order, Certi-
fied check, BANKAMERICARD, VISA, MASTERCHARGE or CHARGE. Add 15% for UPS (or postage)
and handling (w/ refund excess). Please try to bring your order total to \$10 or more. Worldwide export or-
ders solicited. Open account to Government agencies, schools, Institutions and "Triple A" rated industrial &
commercial accounts. Special quotes for quantities. N.Y. state residents: add 7% sales tax.

ELECTRONICS LIQUIDATORS OF EXCESS
ELECTRONIC INVENTORIES

NEW

Frequency Counter \$89.95 kit



UTILIZES NEW MOS-LSI CIRCUITRY

You've requested it, and now it's here! The CT-50 frequency counter kit has more features than counters selling for twice the price. Measuring frequency is now as easy as pushing a button, the CT-50 will automatically place the decimal point in all modes, giving you quick, reliable readings. Want to use the CT-50 mobile? No problem, it runs equally as well on 12 V dc as it does on 110 V ac. Want super accuracy? The CT-50 uses the popular TV color burst freq. of 3.579545 MHz for time base. Tap off a color TV with our adapter and get ultra accuracy — .001 ppm! The CT-50 offers professional quality at the unheard of price of \$89.95. Order yours today!

- CT-50, 60 MHz counter kit \$ 89.95
- CT-50 WT, 60 MHz counter, wired and tested 159.95
- CT-600, 600 MHz prescaler option for CT-50, add 29.95

SPECIFICATIONS

Sensitivity: less than 25 mv.
 Frequency range: 5 Hz to 60 MHz, typically 65 MHz
 Gate time: 1 second, 1/10 second, with automatic decimal point positioning on both direct and prescale
 Display: 8 digit red LED .4" height
 Accuracy: 2.0 ppm, .001 ppm with TV time base
 Input: BNC, 1 megohm direct, 50 Ohm with prescale option
 Power: 110 V ac 5 Watts or 12 V dc @ 1 Amp
 Size: Approx. 6" x 4" x 2", high quality aluminum case

Color burst adapter for .001 ppm accuracy

- CB-1, kit \$14.95

MINI-KITS



CLOCK KIT 6 digit 12/24 hour

Want a clock that looks good enough for your living room? Forget the competitor's kludges and try one of ours! Features: jumbo .4" digits, Polaroid lens filter, extruded aluminum case available in 5 colors, quality PC boards and super instructions. All parts are included, no extras to buy. Fully guaranteed. One to two hour assembly time. Colors: silver, gold, black, bronze, blue (specify).

- Clock kit, DC-5 \$22.95
- Alarm clock, DC-8, 12 hr only 24.95
- Mobile clock, DC-7 25.95
- Clock kit with 10 min ID timer, DC-10 25.95
- Assembled and tested clocks available, add \$10.00

VIDEO TERMINAL KIT \$149.95

A compact 5 x 10 inch PC card that requires only an ASCII keyboard and a TV set to become a complete interactive terminal for connection to your microprocessor asynchronous interface. Its many features are single 5-volt supply, crystal controlled sync and baud rates (up to 9600 baud), 2 pages of 32 characters by 16 lines, read to and from memory, computer and keyboard operated cursor and page control, parity error display and control, power on initialization, full 64-character ASCII display, block type set-thru cursor. Keyboard/computer control backspaces, forward spaces, line feeds, rev. line feeds, home, returns cursor. Also clears page, clears to and of line, selects page 1 or 2, resets from or to memory. The card requires 5 volts at approx. 900 ma and outputs standard 75 ohm composite video.

- TH3216 Kit \$149.95
- TH3216, Assembled and Tested 239.95
- VD-1, Video to RF Modulator Kit 6.95

CAR CLOCK KIT \$27.95



- 12/24-Hour 12 Volt AC or DC
- High Accuracy (1 minute/month)
- 6 Jumbo .4" LED readouts
- Easy, no polarity hook-up
- Display blanks with ignition
- Case, mounting bracket included
- Super instructions
- Complete Kit, DC 11 \$27.95

AUTO-DIMMER \$2.50

Automatically adjusts display brightness according to ambient light level. For DC 11 Car Clock.

CHEAP CLOCK KIT \$8.95

- DC-4 Features:
- 6 digit .4" LED
- 12 or 24 format

- Does not include board or transformer
- PC Board \$2.95
- Transformer \$1.49

600 MHz PRESCALER



Extend the range of your counter to 600 MHz. Works with all counters. Less than 150 mv sensitivity. Specify #10 or #100. Wired, tested, PS-1B \$59.95
 Kit, PS-1B \$44.95

30 watt 2 meter Power Amp

The famous RE class C power amp now available mail order! Four Watts in for 30 Watts out, 2 in for 15 out, 1 in for 8 out, incredible value, complete with all parts, instructions and details on T-R relay. Case not included.
 Complete Kit, PA-1 \$22.95

CALENDAR ALARM CLOCK

Has every feature one could ever ask for. Kit includes everything except case, build it into wall, station or even car!

- 6 Digits, .5" High LED
- Calendar shows mo./day
- True 24 Hour Alarm
- Battery back up with built-in on chip time base
- Complete Kit, less case, DC-9 \$34.95

	LINEAR	REGULATOR	TRANSISTORS
5314 Clock	\$2.95	555 \$.50	78MG \$1.49
74500	.35	556 .75	309k .89
74S112	.75	566 1.49	309H .99
7447	.79	567 1.49	340K-12 .99
7473	.35	1458 .50	7805 .89
7475	.50	LED DRIVER	7812 .89
7490A	.55	75491 .50	7815 .89
74143	3.50	75492 .50	7818 .89

DIODES: 1KV,2.5A 5/\$1.00 100V,1A 10/\$1.00 1N914A type 50/\$2.00

LED DISPLAYS

- FND 35975
- FND 510 1.25
- DL 707 1.25
- HP 7730 1.25
- Red Polaroid Filter 4.25" X 1.125" .59

741 OP-AMP SPECIAL

Factory prime mini dip with both Xerox and 741 part numbers
 10 for \$2.00

SOCKETS

- 14 PIN 5/\$1.00
- 16 PIN 5/\$1.00
- 24 PIN 2/\$1.00
- 40 PIN 3/\$2.00

FERRITE BEADS

- with info and specs 15/\$1.00
- 6 hole Balun Beads 5/\$1.00

ramsey electronics

P.O. Box 4072 Rochester NY 14610
 (716) 271-6487

TELEPHONE ORDERS
 WELCOME



Satisfaction guaranteed or money refunded.
 COO, add \$1.00.
 Orders under \$10 add \$.75 NY residents add 7% tax.
 Add 5% for postage, insurance, and handling. Minimum order \$6.00.

COLOR ORGAN/MUSIC LIGHTS

See music come alive! 3 different lights flicker with music or voice. One light for lows, one for the mid-range and one for the highs. Each channel individually adjustable, and drives up to 300 watts. Great for parties, band music, nite clubs and more.
 Complete Kit, ML-1 \$7.95

LED BLINKY KIT

A great attention getter which alternately flashes 2 Jumbo LEDs. Use for name badges, buttons, or warning type panel lights. Runs on 3 to 9 volts.
 Complete Kit \$2.95

POWER SUPPLY KIT

Complete triple regulated power supply provides variable ±15 volts at 200 mA and ±5 volts at 1 Amp. 50 mv load regulation good filtering and small size. Kit less transformers. Requires 6-8 V at 1 Amp and 18 to 30 VCT.
 Complete Kit, PS-3LT \$6.95

SIREN KIT

Produces upward and downward wail characteristic of police siren. 5 watts audio output, runs on 3-9 volts, uses 8-45 ohm speaker.
 Complete Kit, SM-3 \$2.95

DECADE COUNTER PARTS

Includes: 7490A, 7475, 7447, LED readout, current limit resistors, and instructions on an easy to build low cost frequency counter.
 Kit of parts, DCU-1 \$3.50

NEW FM/CW EXCITER KITS

BUILD UP YOUR OWN GEAR FOR MODULAR STATIONS, REPEATERS, & CONTROL LINKS

- Rated for Continuous Duty ● Professional Sounding Audio ● Built-in Testing Aids



T50 Six Channel, 2W Exciter Kit for 2M, 6M, or 220 MHz \$49.95

FAMOUS HAMTRONICS PREAMPS

let you hear the weak ones!

Great for OSCAR, SSB, FM, ATV. Over 10,000 in use throughout the world on all types of receivers.

P9 Kit \$12.95

P14 Wired \$24.95

Deluxe vhf model for applications where space permits.



- 1-1/2 x 3" ● Covers any 4 MHz band ● 12 Vdc ● Ideal for OSCAR ● Diode protection ● 20dB gain

MODEL	RANGE
P9-LO	26-88 MHz
P9-HI	88-172 MHz
P9-220	172-230 MHz
P14 Wired	Give exact band



P8 Kit \$10.95

P16 Wired \$21.95

- Covers any 4 MHz band ● 20 dB gain ● 12 Vdc

Miniature VHF model for tight spaces - size only 1/2 x 2-3/8 inches.

MODEL	RANGE
P8-LO	20-83 MHz
P8-HI	83-190 MHz
P8-220	220-230 MHz
P16 Wired	Give exact band

P15 Kit \$18.95

P35 Wired \$34.95

- Covers any 6 MHz band in UHF range of 380-520 MHz ● 20 dB gain ● Low noise



YOU ASKED - HERE THEY ARE! VHF Linear PA's

- Use as Linear or Class C PA's ● For XV-2 Xmtg Converters, T50 Exciters, or any 2W Exciter

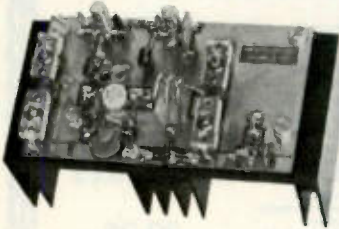

LPA 2-15 Kit \$59.95

- 15W out (linear) or 20W (class C) ● Solid State T/R Switching ● Models for 6M, 2M, or 220 MHz

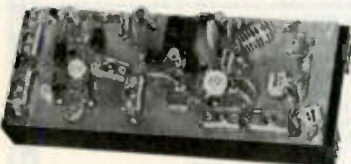

LPA 2-45 Kit \$109.95

- 45W out (linear) or 50W (class C) ● Models for 6M or 2M
- LPA 8-45 Kit \$89.95
For 2M, 8-10W in, 45W out

AT LAST! 6M, 2M, & 1 1/4 M SSB TRANSMITTING CONVERTERS At a price you can afford

Use inexpensive recycled 10 or 11 meter ssb exciter on VHF bands!



FEATURES:

- Linear Converter for SSB, CW, FM, etc.
- A fraction of the price of other units
- 2W p.e.p. output with 1 MW of drive
- Use low power tap on exciter or attenuator pad
- Easy to align with built-in test points

Frequency Schemes Available:

XV2-1	28-30 MHz =	50 - 52 MHz
XV2-2	28-30 MHz =	220-222 MHz
XV2-4	28-30 MHz =	144-146 MHz
XV2-5	28-29 MHz =	145-146 MHz
XV2-6	26-28 MHz =	144-146 MHz

XV2-() TRANSVERTER KIT \$59.95

A25 Optional Cabinet for Xverter&PA \$20

New VHF&UHF Converter Kits

let you receive OSCAR signals and other exciting SSB, CW, & FM activity on your present HF receiver.



either one
- ONLY \$34.95
including crystal

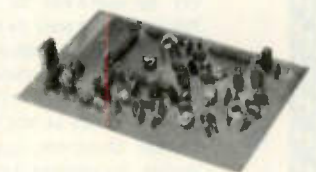

MODEL	RF RANGE (MHZ)	I-F RANGE
C50	50-52	28-30
C144	144-146	28-30
C145	145-147 (OSCAR)	28-30
C146	146-148	28-30
C110	Aircraft	28-30
C220	220 band	28-30
Special	Other i-f & rf ranges available	

MODEL	RF RANGE (MHZ)	I-F RANGE
C432-2	432-434	28-30
C432-5	435-437 (OSCAR)	28-30
C432-7	427.25	61.25
C432-9	439.25	61.25
Special	Other i-f & rf ranges available	

A9 Extruded Alum Case/Connectors \$12.95

VHF/UHF FM RCVR KITS

- ★ NEW GENERATION RECEIVERS
- ★ MORE SENSITIVE ★ MORE SELECTIVE (70 or 100 dB)
- ★ COMMERCIAL GRADE DESIGN
- ★ EASY TO ALIGN WITH BUILT-IN TEST CKTS
- ★ LOWER OVERALL COST THAN EVER BEFORE



R70 6-channel VHF Receiver Kit for 2M, 6M, 10M, 220 MHz, or com'l bands..... \$69.95
Optional xtal filter for 100 dB adj chan 10.00



R90 UHF Receiver Kit for any 2 MHz segment of 380-520 MHz band..... \$89.95

* FREE 1978 CATALOG *

NEW JUNE 1978 CAT. IS YOURS FOR THE ASKING!

IT'S EASY TO ORDER!

☛ CALL OR WRITE NOW FOR FREE CATALOG OR TO PLACE ORDER!

☛ PHONE 716-663-9254. (Answering service evenings and weekends for your convenience. Personal service 9-5 eastern time.)

☛ Use credit card, c.o.d., check, m.o.

☛ Add \$2.00 shipping & handling.

IN CANADA, send to Comtec; 5605 Westluxe Ave; Montreal, Que H4W 2N3 or phone 514-482-2640. Add 38% to cover duty, tax, and exchange rate.

hamtronics, inc.

182-J Belmont Rd; Rochester, NY 14612 H16

BULLET ELECTRONICS

P.O. Box 19442E Dallas, TX. 75219 (214)823-3240



MC3301P HOUSE #
4 OP AMPS IN ONE PACKAGE. USES SINGLE SUPPLY. (4 to 28VDC). INTERNALLY COMPENSATED. SIMILAR TO MC3401, BUT HIGHER GAIN. **49¢**

MC1437P DUAL 709 OP AMP
HIGH OPEN LOOP GAIN, LOW NOISE. 14 PIN DIP **3/1.00**

MC1351P FM-IF AMP AND DISCRIMINATOR

USED IN FM & TV SOUND CIRCUITS. REQUIRES MINIMUM EXTERNAL COMPONENTS. 14 PIN DIP. DIRECT REPLACEMENT FOR HEPC 6060, ECG 748 AND MANY OTHERS. HOUSE # **50¢** WITH SPECS

HOUSE #

LM3900 QUAD NORTON AMP

WE BOUGHT A LARGE QUANTITY OF THESE HOUSE NUMBERED PARTS AT A BARGAIN PRICE THAT ALLOWS US TO SELL THEM AT A LOW, LOW **39¢**

TIL312 COMMON ANODE READOUT



3" CHARACTER SIZE WITH PINOUT .65 **6/3.00**

MPPF131 N-CHANNEL DUAL GATE MOSFET



50¢

DESIGNED FOR AMPLIFIER AND MIXER APPLICATIONS TO 200 MHZ. PLASTIC CASE. UNITS ARE HOUSE NUMBERED WITH SPECS.

IL-1 OPTO ISOLATORS

BY LITRONIX 6 PIN DIP STANDARD PINOUT LED-TRANSISTOR COMBINATION. **50¢** WHILE THEY LAST!



SMALL SKIRTED BLACK INSTRUMENT KNOB.

FITS 1/8" SHAFT WITH SET SCREW. **5/1.00**



MJ900 - MJ1000

COMPLIMENTARY PNP, NPN DARLINGTON POWER TRANSISTORS. 8 AMPS. WE SUPPLY A SCHEMATIC TO BUILD A HIGH POWER (35W) LOW DISTORTION AUDIO AMP WITH ONLY ONE ADDITIONAL TRANSISTOR AND A DOZEN INEXPENSIVE COMPONENTS! TO-3 CASE STYLE BUY A PAIR FOR **\$3.00!**

1N4148 DIODES

LEADS ARE TARNISHED BUT CLEAN UP EASILY. THE BOSS SAYS "DUMP 'EM"...SO CHECK THIS PRICE! **50/1.00**



HOUSE # PNP POWER

TO-3

150 WATTS
80 VCEO
10 AMPS



IDENTICAL TO 2N3790 **1.00**

MC1469R POSITIVE VOLTAGE REGULATOR

1/2 AMP COMPLETE SPECS AND APPLICATIONS SHOW HOW TO BUILD FIXED OR VARIABLE POWER SUPPLIES FROM 3 TO 30VDC. DRIVE EXTERNAL SERIES PASS FOR CURRENT TO 20 AMPS!

1.25 EA. 10/10.00
HOUSE #



FANTASTIC SOUND EFFECTS CHIP

AVAILABLE ONLY FROM BULLET!

THIS 28 PIN MARVEL CONTAINS A LOW FREQUENCY OSCILLATOR, VCO, NOISE OSCILLATOR, ONE SHOT, MIXER AND ENVELOPE CONTROL. WITH 8 PAGE MANUAL. 5 to 9VDC **3.95**

ALL COMPONENTS 100% GUARANTEED

- CA3011 WIDEBAND IF AMP w/specs **50¢**
- 2N3569 NPN EPOXY 1W **6/1.00**
- 741 OP AMP 8 PIN DIP **5/1.00**
- 723 VOLTAGE REG. 14 PIN DIP **50¢**
- MPS6530 NPN HOUSE # **8/1.00**
- 725 OP AMP LOW NOISE HOUSE # **99¢**
- 7815 15V 1A REGULATOR HOUSE # **69¢**
- LM340T-12 12V 1A VOLT. REG. w/specs **75¢**
- TCA430 QUAD OSCILLATOR 1/specs **69¢**
- 2N4343 P CHANNEL J FET **4/1.00**
- 2N6111 PNP MED PWR 40W TO-220 **3/1.00**
- 2N6028 PROGRAMMABLE UNIJUNCTION w/specs **50¢**
- TRIAC 200V 8A UNMARKED **3/1.00**

INCANDESCENT PANEL LAMP

WITH TINNERMAN NUT YOUR CHOICE OF RED, GREEN, YELLOW, WHITE 12-24VDC **15¢**

POWER SUPPLY METERS

Quality 3 1/2" meters for the P-514, 0-15VDC & 0-25A. Matched set, individually packaged. NOT SURPLUS! **12.95/set**

CAPACITORS

SMALL SIZE!

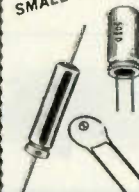

- 2200 MFD @ 16 VDC RADIAL **3/1.00**
- 500 MFD @ 35VDC **5/1.00** AXIAL
- 220 MFD @ 25VDC **7/1.00** AXIAL
- .1 MFD @ 20VDC DISC CERAMIC **15/1.00**

FND510 69¢

COMMON ANODE READOUT 1/2" CHARACTER **LIMIT 24 PER CUSTOMER!**



Miniature 7K Pot w/switch PC Mount or panel mount 1/8" shaft .49 Black plastic knob for above **FREE**

LIMITED QTY Computer Grade FILTER CAP Screw Terminals 2 x 8kV 9900 mfd@75V 2.95 or 4.95

NEW! → **ULTRASONIC SENDER RECEIVER KIT US-02** →

TOTAL SECURITY! Completely invisible ultrasonic (23KHz) Sound beam works like a photoelectric beam but is unaffected by light, heat or noise. Separate Transmitter and Receiver can be used from 6 inches to 25 feet! A solid object breaking the beam causes an output to go low that will sink up to 150 MA to Drive a Relay, TRIAC, etc. Complete electronics are provided. Works on 12VDC (unregulated) and draws less than 100 MA. Use it for burglar alarms, object counters, automatic door openers, automatic door bells, electronic rat trap(?) and more. **COMPLETE KIT LESS CASES 21.50**

Optional entry delay and Alarm Timeout Circuit **3.95**
Will source or sink up to 200 MA DC.

LED'S JUMBO: RED 5/.89 GREEN 4/.89
MEDIUM: RED .15 MINI: GREEN .16 RED .10 YELLOW .16
1.5V 10-30 ma



POWER SUPPLY KIT PS-14

- Better than 200MV load and line regulation
- Foldback Current Limiting
- Short Circuit Protected
- Thermal Shutdown
- Adjustable Current Limiting Less than 1% ripple
- 15 amps 11.5 to 14.5V
- All parts supplied including heavy duty transformer.
- Quality plated fiberglass PC board.

Less Case, meters & jacks

39.95 UPS SHIPPING PAID!

OVERVOLTAGE PROTECTION KIT 6.95

Provides cheap insurance for your expensive equipment. Trip voltage is adjustable from 3 to 30 volts. Overvoltage instantly fires a 25A SCR and shorts the output to protect equipment. Should be used on units that are fused. Directly compatible with the PS-12 and PS-14. All electronics supplied. Drilled and plated PC board. (Order OVP-1)

Public Notice!

THE PS-14 HIGH CURRENT POWER SUPPLY KIT HAS BEEN SELLING FOR 39.95 FOR OVER A YEAR. IN EXCESS OF ONE THOUSAND KITS HAVE BEEN SOLD AT THIS PRICE.

WE WOULD LIKE TO GIVE OUR CUSTOMERS A CHANCE TO PURCHASE THE KIT AT THIS PRICE BEFORE A SCHEDULED INCREASE TO 49.00 IN SEPTEMBER.

MINI GRANDFATHER CLOCK KIT

- Chimes the hour (up to 3 times for 3 O'clock)
 - Unique "swinging" LED pendulum
 - Tick tock sound matches pendulum swing.
 - Large 4 digit, 5" LED readout
 - All CMOS construction
 - Complete electronics including transformer & speaker; drilled and plated PC boards measure 4.5" x 6.5"
- BEAUTIFUL SOLID WALNUT**
Custom case for above kit. Over 9 1/2" tall. **19.95**

MK-03A CLOCK/TIMER KIT

Features 24 hour Zulu time and up to 24 hours of elapsed time on the same set of six digit LED readouts. Totally independent operation of both functions. Clock has pre-settable alarm with 10 minute snooze. Timer has reset, hold, and count functions. Full noise and overvoltage protection. 24 hour only. Readouts has dimmer feature or they can be turned off without disturbing the clock or timer. Timebase Included (.01% accuracy). Because of the many options and mounting considerations the case and switches are not included. Switches are standard types. Will fit inside standard aircraft instrument case. **9-14VDC 28.95**

WARBLE ALARM Kit 2.50

A fun EASY kit to assemble that emits an ear piercing 10 watt dual tone scream. Resembles European siren sound. Great for alarms or toys. Operates from 5-12VDC at up to 1 amp (using 12VDC 8 ohm speaker). Over five thousand have been sold. All parts including PC board, less speaker. **ORDER WB-02**

★ NO C.O.D.'S
★ SEND CHECK M.O. OR CHARGE CARD NO.
★ PHONE ORDERS ACCEPTED ON VISA AND MASTERCARD ONLY.

★ ADD 5% FOR SHIPPING
★ TX. RES. ADD 5% STATE SALES TAX
★ ORDERS OF \$50. & OVER TAKE 10% DISCOUNT
★ FOREIGN ORDERS ADD 10% (20% AIRMAIL) U.S. FUNDS ONLY.

600 MHZ. FREQUENCY COUNTER ±0.1 PPM TCXO

OPTO-8000.1

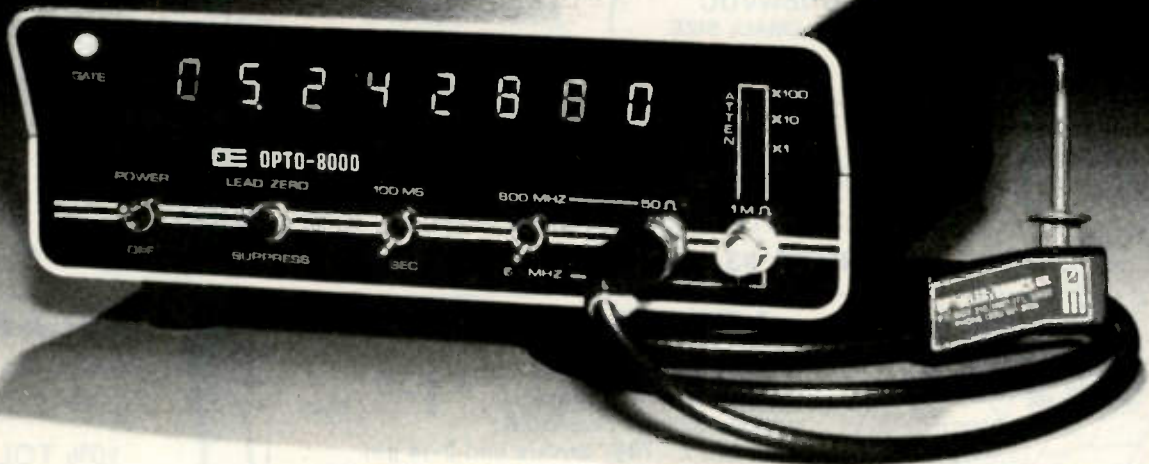

This new instrument has taken a giant step in front of the multitude of counters now available. The Opto-8000.1 boasts a combination of features and specifications not found in units costing several times its price. Accuracy of ± 0.1 PPM or better — *Guaranteed* — with a factory-adjusted, sealed TCXO (Temperature Compensated Xtal Oscillator). **Even kits require no adjustment for guaranteed accuracy!** Built-in, selectable-step attenuator, rugged and attractive, black anodized aluminum case (.090" thick aluminum) with tilt bail. 50 Ohm and 1 Megohm inputs, both with amplifier circuits for super sensitivity and both diode/overload protected. Front panel includes "Lead Zero Blanking Control" and a gate period indicator LED. AC and DC power cords with plugs included.

SPECIFICATIONS:

Time Base—TCXO ± 0.1 PPM GUARANTEED!
 Frequency Range—10 Hz to 600 MHz
 Resolution—1 Hz to 60 MHz; 10 Hz to 600 MHz
 Decimal Point—Automatic
 All IC's socketed (kits and factory-wired)
 Display—8 digit LED
 Gate Times—1 second and 1/10 second
 Selectable Input Attenuation—X1, X10, X100
 Input Connectors Type —BNC
 Approximate Size—3" h x 7½" w x 6½" d
 Approximate Weight—2½ pounds
 Cabinet—black anodized aluminum (.090" thickness)
 Input Power—9-15 VDC, 115 VAC 50/60 Hz
 or internal batteries
 OPTO-8000.1 Factory Wired **\$299.95**
 OPTO-8000.1K Kit **\$249.95**

ACCESSORIES:

Battery-Pack Option—Internal Ni-Cad Batteries and charging unit **\$19.95**
 Probes: P-100—DC Probe, may also be used with scope **\$13.95**
 P-101—LO-Pass Probe, very useful at audio frequencies **\$16.95**
 P-102—High Impedance Probe, ideal general purpose usage **\$16.95**
 VHF RF Pick-Up Antenna-Rubber Duck w/BNC #Duck-4H **\$12.50**
 Right Angle BNC adapter #RA-BNC **\$ 2.95**

FC-50 — Opto-8000 Conversion Kits:

Owners of FC-50 counters with #PSL-650 Prescaler can use this kit to convert their units to the Opto-8000 style case, including most of the features.

FC-50 — Opto-8000 **Kit \$59.95**
 *FC-50 — Opto-8000F **Factory Update \$99.95**
 FC-50 — Opto-8000.1 (w/TCXO) **Kit \$109.95**
 *FC-50 — Opto-8000.1F **Factory Update \$149.95**

*Units returned for factory update must be completely assembled and operational

TERMS: Orders to U.S. and Canada, add 5% to maximum of \$10.00 per order for shipping, handling and insurance. To all other countries, add 10% of total order. Florida residents add 4% state tax. C.O.D. fee: \$1.00. Personal checks must clear before merchandise is shipped.



OPTOELECTRONICS, INC.

5821 NE 14 Avenue
 Ft. Lauderdale, FL 33334
 Phones: (305) 771-2050 771-2051
 Phone orders accepted 6 days, until 7 p.m.

03



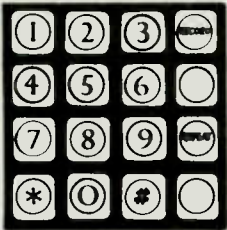

CHOMERICS 16 KEY - KEY PAD

Brand New. Originally used in a data entry-medical Electronics system. Very limited stock. As shown at left, two keys are blank. Perfect for computer experiments or HAM's.

\$3⁹⁵ EACH

3 FOR \$10

LIMITED QTY.



FILTER CAP
2200 MFD 16WVDC
BY PANASONIC. SMALL SIZE.
FRESH! 3 FOR \$1.25

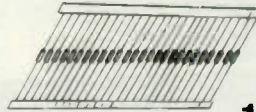

1N4148 DIODE SALE!

FULL LEADS! BRAND NEW!
COMPUTER MFG. SURPLUS

100 FOR \$2

1000 FOR \$17.50

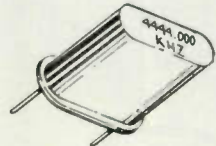

MORE CRYSTALS!

EXPERIMENTER CRYSTAL #2 - 4.444000 MHZ - \$1.25

EXPERIMENTER CRYSTAL #3 - 64.000 KHZ - \$1.49

NOTE: #3 can easily be divided by 64 to give 1000 HZ.

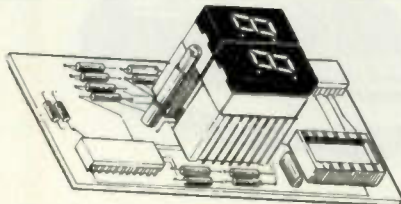

LED READOUT BOARD

Mfg. by Xerox. Has two OPCOA SLA-1 common anode, .33 Inch Readouts. Also has 2 - 7447 drivers and 2-14 pin W.W. sockets plus 2 small lamps. Used in word processors.

\$1⁵⁹ EACH



MYLAR CAPS

DIPPED, RADIAL LEADS
.1MFD 250 WVDC
10% TOLERANCE

NEW! 10 FOR \$1

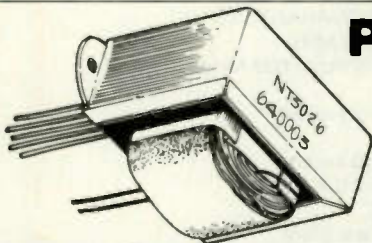

POWER SUPPLY TRANSFORMER #2

PRIMARY: 115 VAC 60HZ
SECONDARY #1: 24 VAC AT 1.5 AMPS
SECONDARY #2: 20 VAC C.T. AT 1.5 AMPS

BRAND NEW!!!

\$3⁹⁵

EACH

PART # 640003

RCA MICRO-POWER OP AMP.

#CA3078T. Metal Can. Most OPAMPS require ±15V to operate. But the CA3078 is designed to operate from ±.75 V to ±6V!!! Perfect for battery use. Standby power as low as 700 NW.! High Gain: 92 DB typical Open Loop Gain. Requires only one capacitor for compensation. See RCA Linear Data Book for more details. Similar to National LM112. Originally cost about \$2 each.

75¢ EACH 3 FOR \$2



KEMET TANTALUM CAPS

6.8 MFD 15 WVDC
10% TOL. METAL CASE

6 FOR \$1

30 FOR \$4.25

VECO PRECISION THERMISTORS

GLASS BULB TYPE. SUPER SMALL. VECO #41A72. 8.2K OHMS AT ROOM TEMP. VERY SENSITIVE.

\$3 VALUE!

75¢ EACH 3 FOR \$2



INDIVIDUALLY PACKED IN PLASTIC VIALS.

ROTRON FANS

#CT3A52 - CENTAUR. 4 1/4" SQUARE.
220 VAC 60 HZ. WILL WORK ON 117 VAC.
REMOVED FROM NEW EQMT.

LIMITED STOCK **\$5⁹⁵** EACH

REQUESTED ITEMS:

SIGNETICS 8T26 - QUAD BI-DIRECTIONAL BUSS DRIVER. TRI-STATE. **\$1²⁵** EACH

FAIRCHILD 3348 MOS - HEX 32 BIT SHIFT REGISTER 24 PIN DIP **\$1⁹⁵** EACH

IC SPECIALS

74L73 - DUAL JK FF - LOW POWER - **10/\$1**
945 - ITT HOUSE #. DTL FLIP FLOP - **20/\$1**
BOTH ARE 14 PIN DIPS. NEW. PRIME!

2N706 TRANSISTOR

NPN. TO-18. A WORK HORSE RF UNIT. **8/\$1**

D20 **Digital Research Corporation**
(OF TEXAS)

P. O. BOX 401247 • GARLAND, TEXAS 75040 • (214) 271-2461

TERMS: Add 30¢ postage, we pay balance. Orders under \$15 add 75¢ handling. No C.O.D. We accept Visa, Mastercharge, and American Express cards. Tex. Res. add 5% Tax. Foreign orders (except Canada) add 20% P & H. 90 Day Money Back Guarantee on all items.

New!

16K E-PROM CARD

IMAGINE HAVING 16K OF SOFTWARE ON LINE AT ALL TIME!

KIT FEATURES:

1. Double sided PC board with solder mask and silk screen and gold plated contact fingers.
 2. Selectable wait states.
 3. All address lines & data lines buffered!
 4. All sockets included.
 5. On card regulators.
- KIT INCLUDES ALL PARTS AND SOCKETS (except 2708's). Add \$25. for assembled and tested.

S-100 (Imsai/Altair) Buss Compatible!

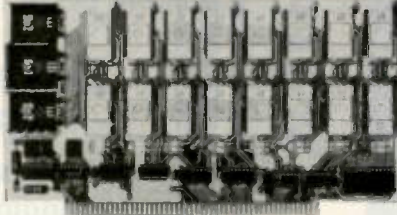

PRICE CUT!

\$57.50 kit

SPECIAL OFFER: WAS \$69.95
Our 2708's (450NS) are \$12.95 when purchased with above kit.

Fully Static!

KIT FEATURES:

1. Doubled sided PC Board with solder mask and silk screen layout. Gold plated contact fingers.
2. All sockets included.
3. Fully buffered on all address and data lines.
4. Phantom is jumper selectable to pin 67.
5. FOUR 7805 regulators are provided on card.

ADD \$20 FOR 250NS

8K LOW POWER RAM KIT - \$149.00

S-100 (Imsai/Altair) Buss Compatible!

2 KITS FOR \$279

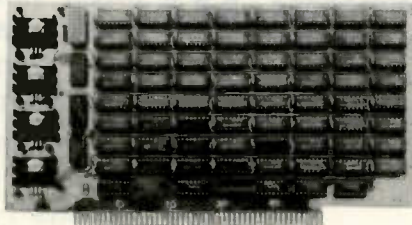

USES 21L02 RAM'S!

Fully Assembled & Burned In \$179.00
Blank PC Board w/ Documentation \$29.95
Low Profile Socket Set 13.50
Support IC's (TTL & Regulators) \$9.75
Bypass CAP's (Disc & Tantalums) \$4.50

MOTOROLA QUAD OP - AMP MC 3401. PIN FOR PIN SUB. FOR POPULAR LM 3900. 3 FOR \$1	ALARM CLOCK CHIP N.S. MM5375AA. Six Digits. With full Data New! \$1.95 each	FULL WAVE BRIDGE 4 AMP. 200 PIV. 69¢ 10 FOR \$5.75	NOT ASSOCIATED WITH DIGITAL RESEARCH OF CALIFORNIA. THE SUPPLIERS OF CPM SOFTWARE.
MOTOROLA 7805R VOLTAGE REGULATOR Same as standard 7805 except 750 MA output. TO-220. 5VDC output. 44¢ each or 10 for \$3.95	450 NS! 2708 EPROMS Now full speed! Prime new units from a major U.S. Mfg. 450 N.S. Access time. 1K x 8. Equiv. to 4-1702 A's in one package. \$15.75 ea.	4 FOR \$50⁰⁰	

INTEL 2102 RAM SALE! BRAND NEW 2102A-4. FACTORY PRIME! WE MADE ANOTHER SUPER SURPLUS BUY!

PERFECT FOR USE WITH OUR BLANK 8K PC BOARD SHOWN ABOVE.

THESE PARTS HAVE BEEN SCREENED TO MEET THE LOW POWER SPEC. AND ARE GUARANTEED BY US TO BE 40 MA. MAXIMUM ICC. (28 MA. TYPICAL)

LOW POWER

450 N.S.

8 FOR \$7⁹⁵
32 FOR \$28

"A" VERSION FOR BATTERY BACKUP!

4K STATIC RAM'S 2114. The new industry standard. Arranged as 1K x4. Equivalent to 4-21 L02's in 1 package! 18 pin DIP. 2 chips give 1Kx8. 2/\$24. 8/\$85.	OPCOA LED READOUT SLA-1. Common Anode. .33 inch character size. The original high efficiency LED display. 75¢ ea. 4 FOR \$2.50	Z-80 PROGRAMMING MANUAL By Mostek, The major Z-80 second source. The most detailed explanation ever on the working of the Z-80 CPU CHIPS. At least one full page on each of the 158 Z-80 instructions. A MUST reference manual for any user of the Z-80. 300 pages. Just off the press. \$12.95
--	--	---

NATIONAL SEMICONDUCTOR JUMBO CLOCK MODULE

MA1008A BRAND NEW!



\$6⁹⁵

2 FOR \$13 (AC XFMR \$1.95)

- FEATURES
- FOUR JUMBO 1/2 INCH LED DISPLAYS
 - 12 HR REAL TIME FORMAT
 - 24 HR ALARM SIGNAL OUTPUT
 - 50 OR 60 HZ OPERATION
 - LED BRIGHTNESS CONTROL
 - POWER FAILURE INDICATOR
 - SLEEP & SNOOZE TIMERS
 - DIRECT LED DRIVE (LOW RFI)
 - COMES WITH FULL DATA

ASSEMBLED! NOT A KIT!

ZULU VERSION!
We have a limited number of the 24 HR Real time version of this module in stock
#MA1008D — \$9.95

PERFECT FOR USE WITH A TIMEBASE.

COMPARE AT UP TO TWICE OUR PRICE!

MANUFACTURER'S CLOSEOUT!

SALE!
1N4148 DIODES. SILICON. Same as 1N914. New, factory prime, Full Leads.
100 FOR \$2
1000 FOR \$17.50

New! REAL TIME Computer Clock Chip
N.S. MM5313. Features BOTH 7 segment and BCD outputs. 28 Pin DIP. **\$4.95 with Data**



MICRO-MINI TOGGLE SWITCH

99¢ EACH

SPDT. By RAYTHEON. MADE IN USA! WITH HDWR.

6 FOR \$5

Digital Research Corporation

(OF TEXAS)

P. O. BOX 401247 • GARLAND, TEXAS 75040 • (214) 271-2461

TERMS: Add 30¢ postage, we pay balance. Orders under \$15 add 75¢ handling. No C.O.D. We accept Visa, MasterCard, and American Express cards. Tex. Res. add 5% Tax. Foreign orders (except Canada) add 20% P & H. 90 Day Money Back Guarantee on all items.

satisfaction starts here

NO-HASSLE

THE

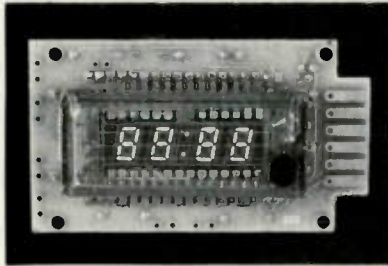

CLOCK

The MA1003 is a complete clock module, requiring only time-setting switches, case, and 12V DC. With built-in crystal controlled timebase (ideal for car or van clock) and low power, highly visible fluorescent blue readouts. If you can find a simpler or better way to build a clock . . . tell us about it!
\$16.50 each or 3 / \$46.

REGULATORS SOLD HERE SPECIAL \$1.00

Last two digits indicate voltage; 78 series regulators are positive and cost ~~\$1.25~~ each, 79 series regulators are negative and cost ~~\$1.55~~ each. Voltages available: 7805, 7806, 7808, 7812, 7815, 7824; 7905, 7906, 7908, 7912, 7915, 7918, 7924.

COMPETITIVE PRICES ON QUALITY SOCKETS

Sockets simplify maintenance and servicing, eliminate heat damage while soldering, and minimize CMOS static problems . . . we've got the right sockets at the right prices.

Low Profile Solder-tail (tin plated)

SKL8	8 pin	10/ \$1.85
SKL14	14 pin	10/ 1.95
SKL16	16 pin	10/ 2.15
SKL18	18 pin	8/ 2.25
SKL20	20 pin	8/ 2.75
SKL22	22 pin	8/ 2.95
SKL24	24 pin	3/ 1.10
SKL36	36 pin	5/ 2.75
SKL40	40 pin	2/ 1.25

YES, WE HAVE COMPONENTS.

That means passive components, semiconductors (FETs, transistors, etc.), ICs (TTL, CMOS, low power Schottky, and linears — including the 78 and 79 series of voltage regulators), kits, power supplies, Vector products, readouts . . . but we could go on all day. Just send for our flyer, and you'll get all the details.

We want to be your memory supplier: and that means offering a superior product at the lowest possible price.

MEET THE ECONORAM FAMILY . . .

These static memory kits deliver outstanding performance at prices even the dynamics can't match. What others consider "extras" we consider necessities, such as buffering on all lines, reliable DMA, sockets, gold-plated card fingers . . . and all the other signs of quality that make up an Econoram.

More good news: Our memory kits (except Econoram II) are now "Unkits". All sockets and bypass caps are pre-soldered into place, turning an otherwise tedious assembly job into a pleasurable, one evening project.

24K ECONORAM VII™

A dense and flexible S-100 board that draws less than 2500 mA. Configured as two 8K and two 4K blocks with independent addressing and protection. Use with or without phantom lines. Add \$40 for assembled/tested.

\$445

16K ECONORAM IV™

Ideal for S-100 buss system builders who need a big chunk of memory that draws less than 2000 mA. Manual write protect for 4K blocks; use with or without phantom line. Add \$35 for assembled/tested.

\$279

8K ECONORAM II™

Just try to find a more cost-effective S-100 package! Better yet, get 3 kits (24K of memory) for only \$375. Add \$20 per board for assembled/tested.

\$135

GODBOUT

G4

BILL GODBOUT ELECTRONICS
 BOX 2355, OAKLAND AIRPORT, CA 94614

TERMS: Please allow up to 5% for shipping; excess refunded. Add \$1 handling for orders under \$10. Cal res add tax. COD OK with street address for UPS. For VISA® /Mastercharge® orders (\$15 min) call our 24 hr. order desk at (415) 562-0636. Prices good through cover month of magazine.

ELPAC POWER SUPPLIES

Completely Assembled

SPECIFICATIONS:
105-125/210-250 Vac, 47-440 Hz input

Line Regulation $\pm 0.1\%$
Load Regulation $\pm 0.1\%$ no-load to rated-load
Output Ripple and Noise $\pm 0.1\%$ p.d.c. to 10 MHz
Input/Output Isolation 100 megohm dc, 900 Vac
Short Circuit Current 35% rated current

PART NO.	RATINGS	PRICE		
	WATTS	VOLTS	AMPS	
SOLV15-5	15	5	3	\$36.95
SOLV15-12	15	12	1.5	36.95
SOLV30-5	30	5	6	59.95
SOLV30-12	30	12	3	59.95
OVP over voltage protection for SOLV30-5,-12				
SOLV15-5, -12	includes OVP installed			39.95

NEW! BULB-ENERGY SAVER

BULB-ENERGY SAVERS save for years by major industrial users — now available for home or office use. Bulb Savers can cut electrical bills by as much as 3%.

Bulb-SAVERS lengthen light life by:

- Acting as an electrical "shock absorber" turns the bulb on slowly, eliminating the "thermal shock". Bulb life increases 300 percent.
- Banishes Current "Surges". Cushions line voltage surges when other loads cut power line.
- Reduces Energy Consumption.

Bulb lasts 3 or more times longer.
Fits Standard Socket
6 watts to 200 watts

BES-1	1-9	10+
	1.39 ea.	1.20

CRYSTALS

THESE FREQUENCIES ONLY

PART NO.	FREQUENCY	CASE	PRICE
CY1A	1.000MHz	HC33	5.95
CY1B	1.8432MHz	HC33	5.95
CY2A	2.000MHz	HC33	5.95
CY2 D1	2.010MHz	HC33	1.95
CY2 50	2.500MHz	HC33	4.95
CY3 27	3.2768MHz	HC33	4.95
CY3 57	3.579545MHz	HC33	4.95
CY3A	4.000MHz	HC18	4.95
CY4 91	4.916MHz	HC18	4.95
CY7A	5.000MHz	HC18	4.95
CY5 18	5.185MHz	HC18	4.95
CY6 14	6.144MHz	HC18	4.95
CY6 40	6.400MHz	HC18	4.95
CY6 55	6.5536MHz	HC18	4.95
CY12A	10.000MHz	HC18	4.95
CY14A	14.31818MHz	HC18	4.95
CY19A	18.000MHz	HC18	4.95
CY18 43	18.432MHz	HC18	4.95
CY22A	20.000MHz	HC18	4.95
CY30A	32.000MHz	HC18	4.95

TRIMMERS

10MM size trimmers - .394" Dia.

Part No. 1-9 10-24 25-49 100+
TR-11 (value) .35 .30 25 20

Resistance values - 100, 500, 1K, 2K, 5K, 10K, 20K, 50K, 100K, 200K, 1 meg

TRIMPOTS

Single-Turn - 1/2 Watt
Square - Top Adjust - 3/8" Size

Part No. 1-9 10-24 25-49 50-99
840P (value) .99 .89 80 70

Resistance Values - 50, 100, 500, 1K, 2K, 5K, 10K, 20K, 50K, 100K, 200K, 500K, 1 meg

15-Turn - 3/4 Watt

Rectangular Slide Adjust 3/4" x 1/4" Size

Part No. 1-9 10-24 25-49 50-99
830P (value) 1.35 1.25 1.20 1.15

Resistance Values - 50, 100, 500, 1K, 2K, 5K, 10K, 20K, 50K, 100K, 200K, 500K, 1 meg

1/16 VECTOR BOARD

Part No.	Q.1 Hole Spacing	P Pattern	L	W	1-8	10 up	Price
PHENOLIC	64P44 062XXXP	4.50	6.50	1.72	1.54		
	169P44 062XXXP	4.50	17.00	3.69	3.32		
EPOXY	64P44 062WE	4.50	6.50	2.07	1.86		
	64P44 062WE	4.50	8.50	2.56	2.31		
	169P44 062WE	4.50	17.00	3.04	4.53		
	169P44 062WE	8.50	17.00	9.23	8.28		
EPOXY GLASS	169P44 062WEC1	4.50	17.00	6.80	6.12		
COPPER GLAD							

CONNECTORS

25 Pin-D Subminiature

DB25P (as pictured)	PLUG	\$3.25
DB25S	SOCKET	4.95
DB51226-1	Cover for DB25 P or S	1.75

MOLEX CONNECTOR PINS

M-530-1	\$1.95/100 pins (minimum order)
	\$16.00/1000 pins

Pre-packaged in strips

INSTRUMENT/CLOCK CASE

Injection molded unit.
Complete with red bezel.
4 1/2" x 4 1/2" x 1-9/16"

\$3.49

MICROPROCESSOR COMPONENTS

PARTS	PRICE	CPU	PRICE
P8085 CPU	\$29.95	CDP 1802 CPU	\$19.95
8080A CPU	10.95	Z80 CPU	24.95
8212 8-Bit Input/Output	4.95	2650 MPU	26.50
8214 Priority Interrupt Control	7.95	MC6800 MPU	19.95
8216 Bi-Directional Bus Driver	4.95	MC6810A 128 x 8 Static Ram	5.95
8224 Clock Generator/Driver	5.95	MC6820 Periph. Interface Adapter	7.95
8228 System Controller/Bus Driver	5.95	MC6821 Periph. Interface Adapter	11.50
8251 Prog. Comm. Interface	9.95	MC6830 8 Bit ROM	14.95
8255 Prog. Periph. Interface	10.95	MC6850 Asynchronous Comm. Adapter	14.95

RAM'S	PRICE	PROMS	PRICE
1101 256 x 1 Static	\$ 1.49	1702A 2048 x 1 Famous	\$ 5.95
1103 1024 x 1 Static	.99	5203 2048 x 1 Famous	14.95
2101 256 x 4 Dynamic	5.95	82523 32 x 8 Open C	5.00
2102 1024 x 1 Dynamic	1.75	825115 4096 x 1 Bipolar	19.95
2107-5280 4096 x 4 Dynamic	4.95	825123 32 x 8 Tri-state	5.00
2111 256 x 4 Static	6.95	745287 1024 x 1 Static	7.95
2112 256 x 4 Static	5.95	2708 8K EPROM	10.95
2114 4K x 1 Static 450ns Low Power	10.95	2716 T.J. 16K EPROM	29.95
2114L-3 1K x 4 Static 300ns Low Power	11.95	6301-1 1024 x 1 Tri-State Bipolar	3.49
7489 16 x 4 Static	1.75	74186 512 x 1 TTL Open Collector	3.95
8101 256 x 4 Static	5.95	74188 256 x 1 TTL Open Collector	3.95
8111 256 x 4 Static	6.95	SHIFT REGISTERS	
8599 16 x 4 Static	3.49	MM50134 1024 84 Accumulator Dynamic	2.95
21102 1024 x 1 Static	1.95	MM50151 500/512 Bit Dynamic	8.99
74200 256 x 1 Static	6.95	MM50171 1024 Dynamic	3.95
93421 256 x 1 Static	2.95	2504T Hex 32 Bit Static	2.95
MM5027 (JPD414) 4K DYNAMIC 16 PIN	3.95	2519 Hex 40 Bit Static	4.00
MM4116 (JPD416) 16K DYNAMIC 16 PIN	29.95	2522 Hex 132 Bit Static	2.95
TM54044-45H 4K STATIC	14.95	2524 512 Dynamic	2.95
ROM'S			
2513(2140) Character Generator (upper case)	\$ 9.95	2525 1024 Dynamic	2.95
2513(3021) Character Generator (lower case)	9.95	2527 Open 256 Bit Static	2.95
2516 Character Generator	10.95	2528 Dual 250 Static	4.00
MM5230M 2048 Bit Read Only Memory	1.95	2529 Dual 240 8K Static	4.00
USER MANUALS			
1902M CDP1802 Manual	\$ 7.50	2532 Dual 80 Bit Static	2.95
280M Z80 Manual	7.50	2533 1024 Static	2.95
2650M 2650 Manual	5.00	3341 Fifo	6.95
		74LS670 4 X 4 Register	1.95
		UART'S	
		30K 30K DAU	\$ 5.95

SPECIAL REQUESTED ITEMS

TELEPHONE KEYBOARD CHIPS	ICM CHIPS	MEMORIES	MISCELLANEOUS
AT-5-0100 \$14.95	ICM7045 \$24.95	MC68511 \$13.50	11090 \$19.95
AT-5-9000 14.95	ICM7205 19.95	MC68574 13.50	MC3051P 11.95
AT-5-9500 4.95	ICM7207 7.50	MC68675 13.50	MC1408L 4.95
AV-5-2376 14.95	ICM7208 19.95	MC68675 13.50	MC1408L 5.75
H00185 7.95	ICM7209 6.95		MC1408L 5.75
74C922 9.95			MC1408L 5.75

The Sinclair PDM35

A personal digital multimeter for only \$59.95

Now everyone can afford to own a digital multimeter:

The Sinclair PDM35 is supplied completely assembled with test leads and prods, protective wallet and Operator's Manual.

The Sinclair PDM35 is tailor-made for anyone who needs to make rapid measurements. Development engineers, field service engineers, lab technicians, computer specialists, radio and electronic hobbyists will find it ideal.

A digital multimeter used to mean an expensive, bulky piece of equipment. The Sinclair PDM35 changes that. It's got all the functions and features you want in a digital multimeter, yet they're neatly packaged in a rugged but light pocket-size case, ready to go anywhere.

TECHNICAL SPECIFICATION

DC Voltage (4 ranges): Range: 1 mV to 1000 V Accuracy of reading: 1.0% ± 1 count Note: 30 mA input impedance

DC Current (4 ranges): Range: 1 mA to 200 mA Accuracy of reading: 1.0% ± 1 count Note: Max. resolution 0.1 μ A

Resistance (8 ranges): Range: 1 Ω to 20 M Ω Accuracy of reading: 1.5% ± 1 count Note: Also provides 9 automatic test ranges. Dimensions: 8 1/2" x 4 1/2" x 1 1/2"

Weight: 8 1/2 oz.

Power supply: 9 V battery or Sinclair AC adapter (battery not included)

Size: Standard 4 mm hole retractor plug

Options: AC adapter for 117 V 60 Hz power. Delux padded carrying case.

PART NO.	DESCRIPTION	PRICE
PDM35	Digital Multimeter (Completely Assembled)	\$59.95
PDM-AC	117 volt AC Adapter	6.95
PDM-DP	Deluxe padded carrying case	6.95

3 1/2-Digit Portable DMM

Model 2800 \$99.95

Accessories:
AC Adapter BC-28 \$9.00
Rechargeable Batteries BP-26 20.00
Carrying Case LC-28 7.50

Features:
• Overload Protected
• 3 1/2 High LED Display
• Battery or AC operation
• Auto-Zeroing
• 19m, 19% 0.1 ohm resolution
• Overrange reading
• 10 meg input impedance
• DC Accuracy 1% typical
Ranges: DC Voltage - 0-1000V;
AC Voltage 0-1000V;
Freq Response 50-400 Hz
DC/AC Current 0-100mA
Resistance 0-10 meg ohm
Size 6 1/2" x 4 1/2" x 2"

100 MHz 8-Digit Counter

Model 100 - \$134.95

Features:
• 20 MHz-100 MHz Range
• 4 Batteries, 110 or 220V with auto
• 8 LED Display
• Crystal-controlled timebase
• Fully Automatic
• Portable - completely self contained
• Size - 1.75" x 7.38" x 5.63"

Accessories for MAX 100:
Mobile Charger/Eliminator use power from car battery Model 100 - CLA \$3.95
Charger/Eliminator use 310 V AC Model 100 - CAI \$9.95

63-Key Unencoded KEYBOARDS

Hexadecimal Encoder

This is a 63-key, terminal keyboard newly manufactured by a large computer manufacturer. It is unencoded with SPST keys, unattached to any kind of PC board. A very solid molded plastic 13 x 4" base suits most applications. IN STOCK

19-key pad includes 1-10 keys, ABCDEF and 2 optional keys and a shift key.

\$29.95/each \$10.95/each

Jameco ELECTRONICS

PHONE ORDERS WELCOME (415) 592-8097

MAIL ORDER ELECTRONICS - WORLDWIDE
1021 HOWARD AVENUE, SAN CARLOS, CA 94070
Advertised Prices Good Thru September

The Incredible "Pennywhistle 103"

\$139.95 Kit Only

The Pennywhistle 103 is capable of recording data to and from audio tape without critical speed requirements for the recorder and is able to communicate directly with another modem and terminal for telephone "banning" and communications for the day. In addition, it is free of critical adjustments and is built with non-precision, readily available parts.

Features:
• Data Transmission Method: Frequency-Shift Keying, full duplex (half duplex selectable).
• Maximum Data Rate: 300 baud
• Data Format: Asynchronous Serial (return to mark level required between each character).
• Receive Channel Frequencies: 2025 Hz for space, 2225 Hz for mark.
• Transmit Channel Frequencies: Switch selectable. Low (normal) = 1070 space, 1270 mark; High = 025 space, 2225 mark.
• Receive Sensitivity: ± 16 dbm acoustically coupled.
• Transmit Level: ± 15 dbm nominal. Adjustable from -6 dbm to -20 dbm.
• Receive Frequency Tolerance: Frequency reference automatically adjusts to allow for operation between 1800 Hz and 2400 Hz.
• Digital Data Interface: EIA RS-232C or 20 mA current loop (recover is optoisolated and non-polar).
• Power Requirements: 120 VAC, single phase, 10 Watts.
• Physical: All components mounted on a single 5" by 9" printed circuit board. All components included.
• Requires a VOM, Audio Oscillator, Frequency Counter and/or Oscilloscope to align.

The Original the 3rd Hand

\$9.95 each

Leaves two hands free for working
Clamps on edge of bench, table or work bench
Position board on angle or flat position for soldering or clipping
Sturdy, aluminum construction for hobbyist, manufacturer or school rooms

DIGITAL STOPWATCH

• Bright 8 Digit LED Display
• Times to 59 minutes 59.99 seconds
• Crystal Controlled Time Base
• Three Stopwatches in One
• Times, Single Event - Split & Taylor
• Size 4 1/2" x 2 1/2" x 1/2" (4 1/2 ounces)
• Uses 3 Penrite Cells

Kit - \$39.95
Assembled - \$49.95
Heavy Duty Carry Case \$5.95

Stop Watch Chip Only (7205) \$19.95

EMK 3 1/2 DIGIT DPM KIT

Model KB500 DPM Kit \$49.00
Model KB503 5V Power Kit \$17.50

• New Bipolar Unit
• Auto Polarity
• Auto Zeroing
• 5 LED
• Low Power
• Single IC Unit

JE700 CLOCK

12 or 24 Hour

The JE700 is a low cost digital clock, but is a very high quality unit. The unit features a simulated walnut case with dimensions of 10 1/2" x 1 1/2" x 1 1/2". It utilizes a MAX7219 high brightness readout, and the M45514 clock chip.

KIT ONLY \$16.95

JE803 PROBE

The Logic Probe is a unit which is for the most part indispensable in trouble shooting logic families. TTL, DTL, RTL, CMOS. It derives the power 4 needs to operate directly off of the circuit under test, drawing a scant 10 mA max. It uses a MAX3 readout to indicate any of the following states by these symbols: (H) 1 (LOW) 0 (PULSE) P. The Probe can detect high frequency pulses to 45 MHz. It can't be used at MOS levels or critical damage will result.

\$9.95 Per Kit
printed circuit board

T-L 5V 1A Supply

This is a standard TTL power supply using the well known LM309K regulator IC to provide a solid 1 AMP of current at 5 volts. We try to make things easy for you by providing everything you need in one package, including the hardware for only

JE225 \$9.95 Per Kit

PROTO BOARDS

PROTO BOARD 6 \$15.95 (6 1/2" long X 4 1/2" wide)

PB100 - 4.5" x 6"	\$ 19.95
PB101 - 5.8" x 4.5"	29.95
PB102 - 7" x 4.5"	39.95
PB103 - 9" x 6"	59.95
PB104 - 9.5" x 8"	79.95
PB203 - 9.75 x 6 1/2 x 2 1/2	80.00
PB203A - 9.75 x 6 1/2 x 2 1/2	129.95 (includes power supply)

PROTO CLIPS

14 PIN	\$4.50
16 PIN	4.75
24 PIN	8.50
40 PIN	13.75

DIODES/ZENERS				SOCKETS/BRIDGES				TRANSISTORS, LEDS, etc.					
1N914	100v	10mA	.05	8-pin	pcb	.20	ww	.35	2N2222	NPN (2N2222 Plastic .10)	.15		
1N4005	600v	1A	.08	14-pin	pcb	.20	ww	.40	2N2907	PNP	.15		
1N4007	1000v	1A	.15	16-pin	pcb	.20	ww	.40	2N3906	PNP (Plastic - Unmarked)	.10		
1N4148	75v	10mA	.05	18-pin	pcb	.25	ww	.75	2N3904	NPN (Plastic - Unmarked)	.10		
1N4733	5.1v	1 W Zener	.25	22-pin	pcb	.35	ww	.95	2N3054	NPN	.35		
1N753A	6.2v	500 mW Zener	.25	24-pin	pcb	.35	ww	.95	2N3055	NPN 15A 60v	.50		
1N758A	10v	"	.25	28-pin	pcb	.45	ww	1.25	T1P125	PNP Darlington	.35		
1N759A	12v	"	.25	40-pin	pcb	.50	ww	1.25	LED Green, Red, Clear, Yellow		.15		
1N5243	13v	"	.25	Molex pins .01	To-3 Sockets	.25			D.L.747	7 seg 5/8" High com-anode	1.95		
1N5244B	14v	"	.25	2 Amp Bridge	100-prv	.95			MAN72	7 seg com-anode (Red)	1.25		
1N5245B	15v	"	.25	25 Amp Bridge	200-prv	1.95			MAN3610	7 seg com-anode (Orange)	1.25		
									MAN82A	7 seg com-anode (Yellow)	1.25		
									MAN74A	7 seg com-cathode (Red)	1.50		
									FND359	7 seg com-cathode (Red)	1.25		

C MOS		- T T L -									
4000	.15	7400	.10	7473	.25	74176	.85	74H72	.35	74S133	.40
4001	.15	7401	.15	7474	.30	74180	.55	74H101	.75	74S140	.55
4002	.20	7402	.15	7475	.35	74181	2.25	74H103	.55	74S151	.30
4004	3.95	7403	.15	7476	.40	74182	.75	74H106	.95	74S153	.35
4006	.95	7404	.10	7480	.55	74190	1.25			74S157	.75
4007	.20	7405	.25	7481	.75	74191	.95	74L00	.25	74S158	.30
4008	.75	7406	.25	7483	.75	74192	.75	74L02	.20	74S194	1.05
4009	.35	7407	.55	7485	.55	74193	.85	74L03	.25	74S257 (8123)	1.05
4010	.35	7408	.15	7486	.25	74194	.95	74L04	.30		
4011	.20	7409	.15	7489	1.05	74195	.95	74L10	.20	74LS00	.20
4012	.20	7410	.15	7490	.45	74196	.95	74L20	.35	74LS01	.20
4013	.40	7411	.25	7491	.70	74197	.95	74L30	.45	74LS02	.20
4014	.75	7412	.25	7492	.45	74198	1.45	74L47	1.95	74LS04	.20
4015	.75	7413	.25	7493	.35	74221	1.00	74L51	.45	74LS05	.25
4016	.35	7414	.75	7494	.75	74367	.75	74L55	.65	74LS08	.25
4017	.75	7416	.25	7495	.60			74L72	.45	74LS09	.25
4018	.75	7417	.40	7496	.80	75108A	.35	74L73	.40	74LS10	.25
4019	.35	7420	.15	74100	1.15	75491	.50	74L74	.45	74LS11	.25
4020	.85	7426	.25	74107	.25	75492	.50	74L75	.55	74LS20	.20
4021	.75	7427	.25	74121	.35			74L93	.55	74LS21	.25
4022	.75	7430	.15	74122	.55			74L123	.85	74LS22	.25
4023	.20	7432	.20	74123	.35	74H00	.15			74LS32	.25
4024	.75	7437	.20	74125	.45	74H01	.20	74S00	.35	74LS37	.25
4025	.20	7438	.20	74126	.35	74H04	.20	74S02	.35	74LS38	.35
4026	1.95	7440	.20	74132	.75	74H05	.20	74S03	.25	74LS40	.30
4027	.35	7441	1.15	74141	.90	74H08	.35	74S04	.25	74LS42	.65
4028	.75	7442	.45	74150	.85	74H10	.35	74S05	.35	74LS51	.35
4030	.35	7443	.45	74151	.65	74H11	.25	74S08	.35	74LS74	.35
4033	1.50	7444	.45	74153	.75	74H15	.45	74S10	.35	74LS86	.35
4034	2.45	7445	.65	74154	.95	74H20	.25	74S11	.35	74LS90	.55
4035	.75	7446	.70	74156	.70	74H21	.25	74S20	.25	74LS93	.55
4040	.75	7447	.70	74157	.65	74H22	.40	74S40	.20	74LS107	.40
4041	.69	7448	.50	74161	.55	74H30	.20	74S50	.20	74LS123	1.00
4042	.65	7450	.25	74163	.85	74H40	.25	74S51	.25	74LS151	.75
4043	.50	7451	.25	74164	.60	74H50	.25	74S64	.15	74LS153	.75
4044	.65	7453	.20	74165	1.10	74H51	.25	74S74	.35	74LS157	.75
4046	1.25	7454	.25	74166	1.25	74H52	.15	74S112	.60	74LS164	1.00
4049	.45	7460	.40	74175	.80	74H53J	.25	74S114	.65	74LS193	.95
4050	.45	7470	.45			74H55	.20			74LS367	.75
4066	.55	7472	.40							74LS368	.65
4069/74C04	.25										
4071	.25										
4081	.30										
4082	.30										
MC 14409	14.50										
MC 14419	4.85										
4511	.95										
74C151	1.90										

9000 SERIES			
9301	.85	95H03	1.10
9309	.35	9601	.20
9322	.65	9602	.45

MCT2				LINEARS, REGULATORS, etc.			
MCT2	.95	LM320T5	1.65	LM340K15	1.25	LM723	.40
8038	3.95	LM320T12	1.65	LM340K18	1.25	LM725N	2.50
LM201	.75	LM320T15	1.65	LM340K24	1.25	LM739	1.50
LM301	.45	LM324N	1.25	78L05	.75	LM741 (8-14)	.25
LM308 (Mini)	.95	LM339	.75	78L12	.75	LM747	1.10
LM309H	.65	7805 (340T5)	.95	78L15	.75	LM1307	1.25
LM309K (340K-5)	.85	LM340T12	.95	78M05	.75	LM1458	.65
LM310	.85	LM340T15	.95	LM373	2.95	LM3900	.50
LM311D (Mini)	.75	LM340T18	.95	LM380 (8-14 PIN)	.95	LM75451	.65
LM318 (Mini)	1.75	LM340T24	.95	LM709 (8,14 PIN)	.25	NE555	.35
LM320K5(7905)	1.65	LM340K12	1.25	LM711	.45	NE556	.85
LM320K12	1.65					NE565	.95
						NE566	1.25
						NE567	.95

MICRO'S, RAMS, CPU'S, E-PROMS			
74S188	3.00	8214	8.95
1702A	4.50	8224	3.25
MM5314	3.00	8228	6.00
MM5316	3.50	8251	8.50
2102-1	1.45	8255	10.50
2102L-1	1.75	8T13	1.50
2114	9.50	8T23	1.50
TR1602B	3.95	8T24	2.00
TMS 4044	9.95	8T97	1.00
		2107B-4	4.95
8080	8.95	2708	9.50
8212	2.95	Z80 PIO	8.50

INTEGRATED CIRCUITS UNLIMITED 19

7889 Clairemont Mesa Boulevard, San Diego, California 92111
(714) 278-4394 (Calif. Res.)

All orders shipped prepaid	No minimum
Open accounts invited	COD orders accepted

Discounts available at OEM Quantities California Residents add 6% Sales Tax
All IC's Prime/Guaranteed. All orders shipped same day received.

24 Hour Toll Free Phone 1-800-854-2211	American Express / BankAmericard / Visa / MasterCard	SPECIAL DISCOUNTS
		Total Order Deduct
		\$35 - \$99 10%
		\$100 - \$300 15%
		\$301 - \$1000 20%

POLY
PAKS'



REBELLION

WE'RE FIGHTING BACK INFLATION WITH THIS EXCLUSIVE 1¢ SALE
BUY 1 AT SALE PRICE, GET 2ND FOR 1¢ MORE!!!

THIS SPECIAL ONE
CENT SALE IS FOR
MAGAZINE ADS ONLY

LED WATCH GUTS

2 for
\$1.95 2 for
\$1.96

Factory "lay-arounds." Do they work? Who knows! A micro digital technician's bonanza. The complete guts are there. With clear case and leatherette band. 5 functions. HOURS, MINUTES, SECONDS, MONTH, & DATE. Sorry, no space. Cat. No. PA5287. Wt 4 oz.



IMAGINE GETTING A CALCULATOR REJECT FOR ONLY A PENNY!!!!
Your Choice
\$5.95

PARTS
ALONE
ARE
WORTH
MORE
THAN
PRICE!

LED OR FLUORESCENT CALCULATOR GAMBLE!

The gamble of a lifetime... YOU CANNOT LOSE! Factory dumps his production-line rejects and customer returns. Why are these rejects? Mostly keyboard problems, we are told. But at these prices, who cares! Vent pocket size; only 3 1/2" x 1 1/2" deep.

Choose from 2 styles: GREEN fluorescent 5 1/2" digits, or RED! all LED, 12 1/2" digits. Both styles feature 8 digits, 22 keys, 4 arithmetic functions, 4 memory functions, percent, equals, clear. All units complete, and include operation manual (Batteries not included, Wt. 6 oz.)

SALE

PARTS & SEMI "ONE CENTERS"

Quan.	Description (Order by Cat. No. in parentheses)	Sale	1¢ SALE
1-40 CHANNEL CB SELECTOR, w/knob, for PLL circuits (#9A5043)		L00	2 for 1.01
1-23 CHANNEL CB SELECTOR, w/knob, for PLL & Ret (#9A5044)		L00	2 for 1.01
18-"POP" OPTICAL LENSES, plano convex, 1" dia, plastic (#9A5045)		L19	2 for 1.20
10-IC "OICE", microcircuit, teaches theory (#9A5065)		L19	2 for 1.20
1-8" MI-FI SPEAKER, full range, for car/home use (#9A3294)		4.95	2 for 4.96
1-LED WATCH GUTS, men's, new good? We don't know (#9A287)		1.95	2 for 1.96
1-UMF TUNER, solid state, standard type (#9A287)		1.95	2 for 1.96
10-SLIDE SWITCHES, ass't pop styles (#9A1495)		1.00	20 for 1.01
4-TANTALUM CAPACITORS, 0.5 uF 35V, dipped (#9A281)		1.00	6 for 1.01
8-PANCAKE PHOTOCELLS, 400 to 15K ohms (#9A293)		1.00	10 for 1.01
1-100KHZ MARKER CRYSTALS, approx for marker gen (#9A389)		1.95	2 for 1.96
1-MOTHERBOARD EDGE CONNECTOR, 104 pins, 125" (#9A397)		3.50	2 for 3.51
1-88 PIN EDGE CONNECTOR, 156" spacing (#9A396)		1.95	2 for 1.96
1-METER, 50uA, 15k w/knob, for PLL circuits (#9A370)		1.19	2 for 1.20
1-SPST RELAY, norm. open 12 Vdc, 1250 ohms, dip body (#9A517)		2.00	2 for 2.01
1-VEEDER ROT COUNTER, 000-999, resettable, panel mt. (#9A508)		1.49	2 for 1.50
2-DUAL GATE MOSFET, atm. to 3M200, 3M187, for RF & Mixer (#9A510)		1.00	4 for 1.01
2-LED THERMAL INDICATORS, 28-108 1/2", 7x1", flexible (#9A519)		1.00	4 for 1.01
1-10V SWITCH, four 100K pots, with knob (#9A305A)		4.95	2 for 4.96
1-ECCO THUMBWHEEL SWITCH, BCD, 0-7 (#9A2870A)		1.49	2 for 1.50
1-PLESSEY TV SIDEBAND FILTER, for chan. 3 or 4 (#9A378)		1.95	2 for 1.96
1-2V HI-CAD CHARGER PAK, plug in, 125ma, 12V VAC pri (#9A409)		1.49	2 for 1.50
20 DATA LINE 10V SWITCHING DIODES, 50K uA, 10V, for herbaria (#9A518)		2.00	40 for 2.01
75-8K7400 TTL ICs, untested 50%+ yield, pop types (#9A2615)		2.00	150 for 2.01
100-MINI DIP ICs, linear, untested 50%+ yield, pop types (#9A324B)		2.00	100 for 2.01
30-10M TRLO AUDIO IC's, 2 watts on a dip 50%+ yield (#9A325A)		2.00	60 for 2.01
7E-7E LINEARS, 400 to 15K ohms, 2.5 to 10V, marked, ass't (#9A2416)		2.00	200 for 2.01
100-TTL & LINEAR MIXED, with 7400s, 50%+ yield (#9A2431)		2.00	200 for 2.01
1-10V SWITCH, two 10K pots, for computers, TV games (#9A507)		2.95	2 for 2.96
1-B TRACK TAPE HEAD, with plug n' cord (#9A348)		2.50	2 for 2.51
150-PREFORMED DISC CAPACITORS, mark'd values, ass't (#9A281)		2.00	60 for 2.01
150-TRIMMER CAPACITORS, mica compression, piston, ass't (#9A374)		2.00	120 for 2.01
60-10W JACKET MYLAR CAPACITORS, marked, pop values (#9A378)		2.00	180 for 2.01
100-GLASS ZENERS, 400 MW, untested, better than 50% yield (#9A2740)		2.00	300 for 2.01
7E-CARBON FILM REGULATORS, 5k, 6k, 8k, 10k, marked, ass't (#9A2416)		2.00	150 for 2.01
250-UNMARKED CAPACITORS, polystyrene, molded, pop values (#9A385)		2.00	500 for 2.01
300-SILICON SIGNAL DIODES, micro, glass, zenera test 50% yield (#9A282B)		2.00	600 for 2.01
8-IC SOCKETS, 16, 18 pin, solder tab, (#9A3621)		2.00	18 for 2.01
100-1N4149/1N4 SWITCHING DIODES, 50K uA, 10V, marked, ass't (#9A2416)		2.00	200 for 2.01
30-PC TRIM POTENTIOMETERS, thumbwheel, screwdriver ass't (#9A3345)		2.00	60 for 2.01
15-SLIDE VOLUME CONTROLS, ass't values, duals, gings (#9A3057)		2.00	30 for 2.01
75-4" CABLE TIES, plastic, like "Ty-wrap" (#9A518)		2.00	150 for 2.01
10-CRYSTALS, var. freqs, 32.768, 340, 70, 3 (#9A330)		2.00	20 for 2.01
100-TERMINAL STRIPS, from 2 lugs up to (#9A3138)		2.00	60 for 2.01
30-NE-ZEON LAMPS, all 100% good, pop values (#9A261)		2.00	60 for 2.01
40-N. SHIELDED CABLE, 1 cond, milibec, phone, (#9A357)		2.00	80 for 2.01
3-SOUND TRIGGERS, sound triggers exc w/knob (#9A281)		2.00	60 for 2.01
10-IC CRYSTALS, for phase lock loop, NAM, KC, 18 (#9A505)		2.00	20 for 2.01
100-DISC CAPACITORS, long leads, marked, ass't (#9A259)		2.00	200 for 2.01
100-CAPACITOR SPECIAL, discs, nylon, ltyca, more (#9A2730)		2.00	200 for 2.01
10-VOLTAGE REGULATORS, 5k, 6k, 8k, 10k, marked, ass't (#9A2416)		2.00	200 for 2.01
30-PANEL SWITCHES, slides, rotary, med. etc (#9A326)		2.00	60 for 2.01
200-RESISTOR SPECIAL, 1/4 to 1W, carbon, metal (#9A305A)		2.00	400 for 2.01
200-HALF WATTERS, resistors, carbon, metal (#9A305A)		2.00	400 for 2.01
100-NATIONAL IC BOARDs, linear, 7400s, 50%+ yield (#9A2416)		2.00	200 for 2.01
15-1M3407 VOLTAGE REGULATORS, 5 to 24V, TO-220 (#9A2835)		2.00	30 for 2.01
100-POLYSTYRENE CAPS, ass't values, voltage, hi-Q (#9A272)		2.00	200 for 2.01
90-THERMISTORS, resistors that change with temp (#9A409)		2.00	100 for 2.01
20-BRIDGES, 2k, 4k, 8k, 10k, marked, ass't (#9A281)		2.00	20 for 2.01
2E-LAMP'S SOCKET TEST, micro, LSV, 72 (#9A3957)		2.00	30 for 2.01
1E-MIXED READOUTS, hobby, untested, 127, 3, 5, etc. (#9A341)		2.00	30 for 2.01
180-QUARTER WATTERS, resistors, metal film, marked (#9A341)		2.00	300 for 2.01
100-PLASTIC TRANSISTORS, untested, TO-18 (#9A281)		2.00	200 for 2.01
200-PREFORMED RESISTORS, 1/4, 1W, 1W, marked, ass't (#9A260)		2.00	400 for 2.01
200-PRECISION RESISTORS, 1/4, 1W, 1W, 1W, marked (#9A242B)		2.00	400 for 2.01
90-DIPPED MYLARs, shiny finish, ass't values (#9A2597)		2.00	120 for 2.01
30-VOLUME CONTROL, audio, hobby, ass't values (#9A2416)		2.00	60 for 2.01
30-CLOCK CHIPS, National, hobby & untested, alarm (#9A509)		2.00	60 for 2.01
30-1MMS202 2K RAMs, hobby, untested (#9A340)		2.00	60 for 2.01
10-PUSH SWITCHES, push-to-break, ass't, alarm (#9A281)		2.00	20 for 2.01
2E-CD-4000 SERIC CMOS, linear, ass't values (#9A281)		2.00	50 for 2.01
1-CANCAPER GENERATOR, 5 x 7 Moteck MK 200P (#9A388)		4.95	2 for 4.96
1-CONDENSER MIKE, sensitive, 500 ohms 1.5 Volts (#9A317)		4.95	2 for 4.96

7-SEGMENT READOUTS

Quan.	Description	Price
2	2 1/2" DIGIT LCD WRISTWATCH DISPLAY (#9A3940)	3 for \$1.19
1	SPERRY FLAT MIXIES, orange, 3" dual digit (#9A5014)	3 for 1.19
1	SPERRY FLAT MIXIES, orange, 3", 1 1/2" dig (#9A5015)	3 for 1.19
1	MAN-3 BUBBLE READOUT, 1 1/2" red, com. cath. (#9A3338)	6 for L00
1	MAN-4 READOUTS, bubble, 1 1/2" red, com. cath. (#9A3339)	6 for L00
1	FND-300 BLOCK READOUT, 1 1/2" com. cathode (#9A2082)	2 for 1.19
1	8-DIGIT READOUT, led, com. cathode, red (#9A3190)	1 for 1.95
1	FND-303, 3" red, com. cathode, 7 seg. (#9A294)	1.50
1	FND 500, 3" red, com. cathode, 7 seg. (#9A2950)	2 for 1.51
1	FND 800, 3" red, com. cathode, (#9A3030)	1.95
1	FND 803, 3" red, com. cathode, (#9A3327)	3.95

RELAYS!

1	1-SPST 24V REED RELAY, norm open, dip, 1250 ohms (#9A517)	1.49
---	---	------

AMPLIFIERS!

3	3 WATTS ON A CHIP, Toshiba TA7205 (#9A5057)	4.95
3	3 WATTS ON A CHIP, GE PA 203 (#9A1522)	1.50

DIP SWITCHES!

2	2 SWITCHES ON A DIP (#9A 3658)	3 for \$1.20
3	3 SWITCHES ON A DIP (#9A 3656)	3 for 1.19
6	6 SWITCHES ON A DIP (#9A 3671)	1.29 1.30

IC SOCKETS!

8	8-PIN MINI-DIP (#9A2123)	4 for \$1.19
14	14-PIN DIP (#9A1309)	3 for 1.10
18	18-PIN DIP (#9A3378)	3 for 1.10
24	24-PIN MS1/DIP (#9A388)	2 for 1.19
28	28-PIN MS1/DIP (#9A387)	2 for 1.19

FULL WAVE BRIDGE RECTIFIERS!

50	50	\$1.29
100	100	1.49
200	200	1.69
400	400	1.99
600	600	2.25
800	800	2.50
1000	1000	2.75

REBELLION

YOUR CHOICE IS \$1.00
1¢ SALE

Order by Cat. No.

- 9A1788 MICRO TOPHAT REO
- 9A1795 JUMBO TAPER CLOUDY
- 9A1802 MICRO SINGLE PIN REO
- 9A1848 MICRO YELLOW
- 9A2135 JUMBO RED
- 9A2136 JUMBO REO
- 9A2137 MICRO REO
- 9A2190 JUMBO RED CLEAR

Terms: Add postage. Rated: net 30
Phone: Wakefield, Mass. (617) 245-3826
Retail: 16-18 Bet Carmine St., Wakefield.

POLY PAKS
Send for FREE CATALOG

P.O. BOX 942-A9
LYNNFIELD, MA 01902
ZIP 01940

TTL'S AT "CENT-CIBLE" PRICES

Order by Cat. No. 9A1981 & Type No.	Each	2 For	Type No.	Each	2 for	Type No.	Each	2 for
9A17400	\$.19	\$.20	9A17445	.19	.20	9A17483	1.29	1.30
9A17401	.19	.20	9A17470	.19	.20	9A17484	1.75	1.76
9A17403	.35	.36	9A17471	.35	.36	9A17485	1.75	1.76
9A17404	.19	.20	9A17472	.19	.20	9A17486	.39	.40
9A17405	.19	.20	9A17473	.19	.20	9A17487	.99	1.00
9A17407	.39	.40	9A17474	.39	.40	9A17488	.99	1.00
9A17409	.39	.40	9A17475	.39	.40	9A17489	1.25	1.26
9A17410	.25	.26	9A17476	.25	.26	9A17490	1.39	1.40
9A17418	.35	.36	9A17477	.35	.36	9A17491	.99	1.00
9A17420	.39	.40	9A17478	.39	.40	9A17492	1.25	1.26
9A17421	.49	.50	9A17479	.49	.50	9A17493	1.75	1.76
9A17423	.29	.30	9A17480	.29	.30	9A17494	.79	.80
9A17430	.29	.30	9A17481	.29	.30	9A17495	.89	.90
9A17438	.29	.30	9A17482	.29	.30	9A17496	.99	1.00
9A17450	.19	.20	9A17483	.19	.20	9A17497	.99	1.00
9A17451	.19	.20	9A17484	.19	.20	9A17498	.99	1.00
9A17452	.19	.20	9A17485	.19	.20	9A17499	.99	1.00
9A17453	.19	.20	9A17486	.19	.20	9A17500	.99	1.00
9A17454	.19	.20	9A17487	.19	.20	9A17501	.99	1.00
9A17455	.19	.20	9A17488	.19	.20	9A17502	.99	1.00
9A17456	.19	.20	9A17489	.19	.20	9A17503	.99	1.00
9A17457	.19	.20	9A17490	.19	.20	9A17504	.99	1.00
9A17458	.19	.20	9A17491	.19	.20	9A17505	.99	1.00
9A17459	.19	.20	9A17492	.19	.20	9A17506	.99	1.00
9A17460	.19	.20	9A17493	.19	.20	9A17507	.99	1.00
9A17461	.19	.20	9A17494	.19	.20	9A17508	.99	1.00
9A17462	.19	.20	9A17495	.19	.20	9A17509	.99	1.00
9A17463	.19	.20	9A17496	.19	.20	9A17510	.99	1.00
9A17464	.19	.20	9A17497	.19	.20	9A17511	.99	1.00

POP-AMPS AT "CENT-CIBLE" PRICES

Case code: T=TO-220 Power Tab; V=Mini dip; K=TO-3; H=TO-5; N=DIP.

Type No.	Each	2 for	Type No.	Each	2 for	Type No.	Each	2 for
LM300H	\$.79	.80	LM340T-5	1.49	1.50	LM703N		
LM300N	.49	.50	LM340T-6	1.49	1.50	LM704H		
LM301V	.45	.46	LM340T-8	1.49	1.50	LM709N		
LM301H	.45	.46	LM340T-12	1.49	1.50	LM709W		
LM302V	.45	.46	LM340T-15	1.49	1.50	LM709Y		
LM303V	.45	.46	LM340T-18	1.49	1.50	LM711V		
LM303H	.29	.30	LM340T-24	1.49	1.50	LM711W		
LM308V	.69	.70	LM337M	2.25	2.26	LM714H		
LM308H	.29	.30	LM337V	.29	.30	LM714W		
LM311V	1.49	1.50	LM337M	2.25	2.26	LM717H		
LM311H	1.49	1.50	LM337V	.29	.30	LM717W		
LM313V	.99	1.00	LM338N	1.39	1.40	LM719H		
LM320M-5	.99	1.00	LM338N	1.39	1.40	LM719W		
LM320H-12	.99	1.00	LM338P	1.39	1.40	LM721H		
LM320H-15	.99	1.00	LM338P	1.39	1.40	LM721W		
LM320T-6	1.49	1.50	LM339V	1.49	1.50	LM723H		
LM322N	1.19	1.20	LM339V	1.49	1.50	LM723W		
LM324N	1.79	1.80	LM339V	1.49	1.50	LM725H		
LM324N	1.79	1.80	LM339V	1.49	1.50	LM725W		
LM311V	1.79	1.80	LM339V	1.49	1.50	LM725H		
LM340R-5</								

ASSOCIATED RADIO

AMERICA'S #1 Real Amateur Radio Store



OUR
32ND
YEAR

Actual current photos of some of our reconditioned equipment.

We have hundreds of reconditioned items. Save big with confidence. Reconditioned units carry a guarantee.
We trade - USED on NEW or USED on USED
We sell - ALL major brands NEW & USED
We buy - Many types of amateur equipment.

ASSOCIATED RADIO

8012 CONSER BOX 4327
OVERLAND PARK, KANSAS 66204

913-381-5900



CALL US WITH YOUR REQUIREMENTS

NOTE:

WE ALSO SELL MUCH OF OUR TRADE-IN EQUIPMENT BEFORE WE RECONDITION IT. THIS WE SELL AT GREATLY REDUCED PRICE. REAL BARGAINS FOR THE EXPERIENCED HAM. SEND \$1.00 AND YOUR NAME - CALL LETTERS AND ADDRESS TO US AND WE'LL SEND YOU NOT ONLY OUR REGULAR CATALOG BUT A CURRENT LIST OF UNSERVICED BARGAINS.

A50

Call our toll-free number first

... and it's the last call you'll have to make!

(NO CHARGE TO CALLING PARTY)

1-800-325-3636

**CALL FOR THE BEST PRICE AND FAST DELIVERY
ON THE FOLLOWING LINES:**

ATLAS
COLLINS
DENTRON
DRAKE
HY GAIN

ICOM
INFO-TECH
KENWOOD
MOSLEY
STANDARD

SWAN
TEMPO
TEN-TEC
WILSON
YAESU

... AND MANY OTHERS.

HAM RADIO CENTER

8340-42 Olive Blvd. P.O. Box 28271 St. Louis, MO 63132



Radio Bookshop

NEW ADDITIONS



● **A GUIDE TO HAM RADIO—BK7321**—by Larry Kahaner WB2NEL. What's Amateur Radio all about? You can learn the basics of this fascinating hobby with this excellent beginner's guide. It answers the most frequently asked questions in an easy-going manner, and it shows the best way to go about getting an FCC license. A Guide to Ham Radio is an ideal introduction to a hobby enjoyed by people around the world. \$4.95.*

● **VOLUME IV—IC TEST EQUIPMENT—LB7362**—it's easy and fun to build your own test equipment with ICs! Here in this fourth volume of the 73 TEST EQUIPMENT LIBRARY are 42 home construction projects for building test equipment to work with your ham station and in servicing digital equipment. Counters, scalars, frequency standards, synthesizers, logic probes... **JUST ABOUT EVERYTHING** you need and can build with ICs. \$4.95.*

**SPECIAL:
PRE-PUBLICATION OFFER**
(orders will be filled on
a first-in, first-out basis)

● **HOW TO BUILD A MICROCOMPUTER—AND REALLY UNDERSTAND IT—BK7325**—by Sam Creason. The electronics hobbyist who wants to build his own microcomputer system now has a practical "How-To" guidebook. Sam Creason's book is a combination technical manual and programming guide that takes the hobbyist step by step through the design, construction, testing, and debugging of a complete microcomputer system. This book is must reading for anyone desiring a true understanding of small computer systems. \$9.95.*

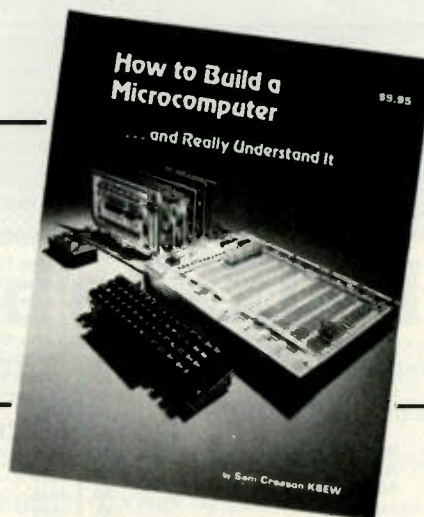

● **SSB... THE MISUNDERSTOOD MODE—BK7351**—by James B. Wilson. Single Sideband Transmission... thousands of us use it every day, yet, it remains one of the least understood facets of amateur radio. J. B. Wilson presents several methods of sideband generation, amply illustrated with charts and schematics, which will enable the ambitious reader to construct his own sideband generator. A must for the technically-serious ham. \$5.50.*

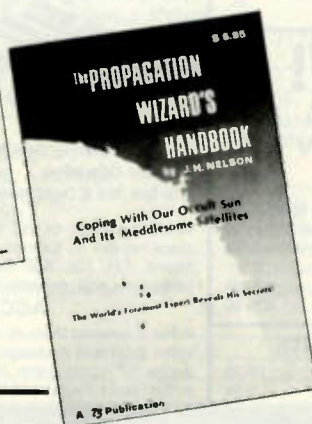

● **PROPAGATION WIZARD'S HANDBOOK—BK7302**—by J. H. Nelson. When sunspots riddled the worldwide communications networks of the 1940's, John Henry Nelson looked to the planets for an answer. The result was a theory of propagation forecasting based upon interplanetary alignment that made the author the most reliable forecaster in America today. The book provides an enlightened look at communications past, present, and future, as well as teaching the art of propagation forecasting. 6.95.*

Use the order card in the back of this magazine or itemize your order on a separate piece of paper and mail to:
73 Radio Bookshop • Peterborough NH 03458. Be sure to include check or detailed credit card information.

* Add \$1.00 handling charge for orders under \$10.00. Note: Prices subject to change on books not published by 73 Magazine.

FOR TOLL FREE ORDERING CALL 1-800-258-5473

RADIO BOOKSHOP

license study guides & TAPES

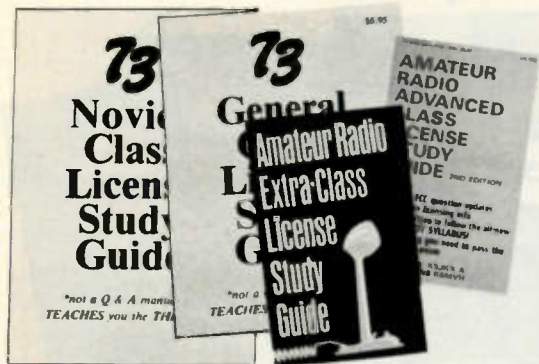

● **NOVICE STUDY GUIDE—SG7357**—Here is a completely new study guide and reference book for the potential ham. This is not a question/answer memorization course. Electronic and radio fundamentals are presented and explained in an easy-to-understand fashion, preparing the beginner for the Novice exam. Includes the latest FCC amateur regulations, as well as application forms. Easily the best path into the exciting world of ham radio! \$4.95.*

● **GENERAL CLASS STUDY GUIDE—SG7358**—A complete theory course for the prospective General or Technician. This reference explains transistor, amplifier, and general radio theory, while preparing the Novice for the "big" ticket. After getting your ticket, you'll use this guide again and again as an electronic reference source. Not a question/answer guide that becomes dated when the FCC updates the amateur exams. \$5.95.*

● **ADVANCED CLASS STUDY GUIDE—SG1081**—Ready to upgrade your license? To prevent retaking the FCC theory exam, you need the 73 Advanced theory guide. SSB, antenna theory, transmitters, and electronics measuring techniques are covered in detail in this easy-to-follow study guide. Special modes and techniques, such as RTTY, are also treated. An engineering degree is *not* necessary to master Advanced theory—try this book before visiting the examiner's office! \$5.95.*

● **EXTRA CLASS LICENSE STUDY GUIDE—SG1080**—Before going for your 1 x 2 call, it pays to be a master of the Extra class electronic theory. This study guide is the logical extension of the 73 theory course. All the theory necessary to pass the exam is presented. Antennas, transmission lines, swr are discussed, as well as noise, propagation, and specialized communication techniques. This book is not a classroom lecture or memorization guide, but rather a logical presentation of the material that must be *understood* before attempting the Extra exam. Save yourself a return trip to the FCC and try the 73 method first! \$5.95.*



NOVICE THEORY TAPES Startling Learning Breakthrough



● **NOVICE THEORY TAPES—CT7300**—Startling Learning Breakthrough. You'll be astounded at how really simple the theory is when you hear it explained on these tapes. Three tapes of theory and one of questions and answers from the latest Novice exams give you the edge you need to breeze through your exam. 73 is interested in helping get more amateurs, so we're giving you the complete set of our tapes for the incredibly low price of **ONLY \$15.95.***

Scientists have proven that you learn faster by listening than by reading because you can play a cassette tape over and over in your spare time—even while you're driving! You get more and more info each time you hear it.

You can't progress without solid fundamentals. These four hour-long tapes give you all the basics you'll need to pass the Novice exam easily. You'll have an understanding of the basics which will be invaluable to you for the rest of your life! Can you afford to take your Novice exam without first listening to these tapes? Set of 4—\$15.95.*



SSTV

● **SLOW SCAN TELEVISION TAPE—CT7350**—Prize-winning programs from the 73 SSTV contest. Excellent for Demo! \$5.95.*

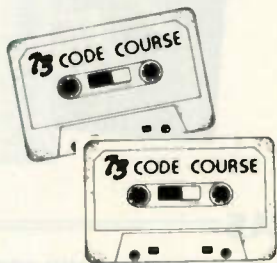

73 CODE SYSTEM TAPES

Any Four Tapes For \$15.95! \$4.95 Each!*

"GENESIS"

5 WPM—CT7305—This is the beginning tape for people who do not know the code at all. It takes them through the 26 letters, 10 numbers and necessary punctuation, complete with practice every step of the way using the newest blitz teaching techniques. It is almost miraculous! In one hour many people—including kids of ten—are able to master the code. The ease of learning gives confidence to beginners who might otherwise drop out.

"THE STICKLER"

6+ WPM—CT7306—This is the practice tape for the Novice and Technician licenses. It is made up of one solid hour of

code, sent at the official FCC standard (no other tape we've heard uses these standards, so many people flunk the code when they are suddenly—under pressure—faced with characters sent at 13 wpm and spaced for 5 wpm). This tape is not memorizable, unlike the zany 5 wpm tape, since the code groups are entirely random characters sent in groups of five.

"THE CANADIAN"

10+ WPM—CT7310—73 hasn't forgotten the Canadian hams—our 10 WPM tape prepares you to breeze through your country's licensing exams. Like the other code groups, the tape is not memorizable and, once mastered, provides a margin of safety in the actual text situation.

"BACK BREAKER"

13+ WPM—CT7313—Code groups again, at a brisk 13 per so you will be at ease when you sit down in front of the steely-eyed government inspector and he starts sending you plain language at only 13 per. You need this extra margin to overcome the panic which is universal in the test situations. When you've spent your money and time to take the test, you'll thank heavens you had this back-breaking tape.

"COURAGEOUS"

20+ WPM—CT7320—Code is what gets you when you go for the Extra class license. It is so embarrassing to panic out just because you didn't prepare yourself with this tape. Though this is only one word faster, the code groups are so difficult that you'll almost fall asleep copying the FCC stuff by comparison. Users report that they can't believe how easy 20 per really is with this fantastic one hour tape.

"OUTRAGEOUS"

25+ WPM—CT7325—This is the tape for that small group of overachieving hams who wouldn't be content to simply satisfy the code requirements of the Extra Class license. It's the toughest tape we've got and we keep a permanent file of hams who have mastered it. Let us know when you're up to speed and we'll inscribe your name in 73's CW "Hall of Fame."

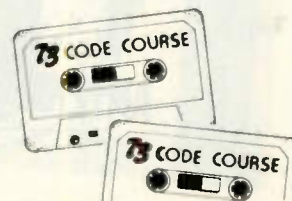

Use the order card in the back of this magazine or itemize your order on a separate piece of paper and mail to:
73 Radio Bookshop • Peterborough NH 03458. Be sure to include check or detailed credit card information.

* Add \$1.00 handling charge for orders under \$10.00. Note: Prices subject to change on books not published by 73 Magazine.

FOR TOLL FREE ORDERING CALL 1-800-258-5473

Radio Bookshop

73 TECHNICAL LIBRARY

● **BEHIND THE DIAL**—BK7307—By Bob Grove. Get more fun out of shortwave listening with this interesting guide to receivers, antennas, frequencies and Interference. \$4.95.*

● **THE CHALLENGE OF 160**—BK7309—is the newest book in the 73 technical library, dedicated to 160 meter operating. Si Dunn provides all necessary information to get started on this unique band. The all-important antenna and ground systems are described in detail. The Introduction contains interesting photos of Stew Perry's (the King of 160) shack. This reference is a must for new and experienced "Top Band" operators. Price: \$1.95.*

● **IC OP-AMP COOKBOOK**—BK1028—by Walter G. Jung. Covers not only the basic theory of the IC op amp in great detail, but also includes over 250 practical circuit applications, liberally illustrated. 592 pages, 5½ x 8½, softbound. \$12.95.*

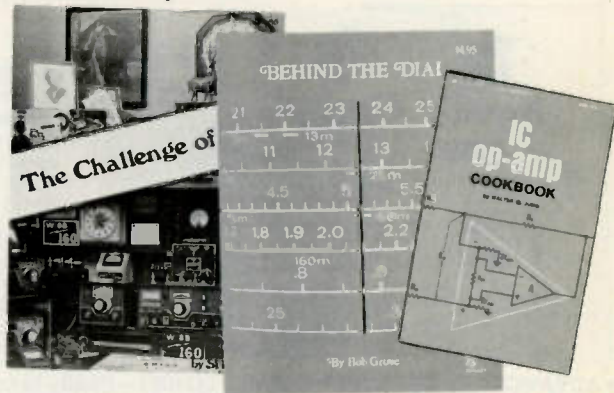

● **INTRODUCTION TO RTTY**—BK7380—A beginner's guide to radioteletype including teletypewriter fundamentals, signals, distortion and RTTY art. You can be a RTTY artist! A 73 publication. \$2.00.*

● **THE NEW RTTY HANDBOOK**—BK7347—is a new edition and the only up-to-date RTTY book available. The state of the art has been changing radically and has made all previous RTTY books obsolete. It has the latest circuits, great for the newcomer and expert alike. \$5.95.*

● **PROPAGATION WIZARD'S HANDBOOK**—BK7302—by J. H. Nelson. When sunspots riddled the worldwide communications networks of the 1940's, John Henry Nelson looked to the planets for an answer. The result was a theory of propagation forecasting based upon interplanetary alignment that made the author the most reliable forecaster in America today. The book provides an enlightened look at communications past, present, and future, as well as teaching the art of propagation forecasting. \$6.95.*

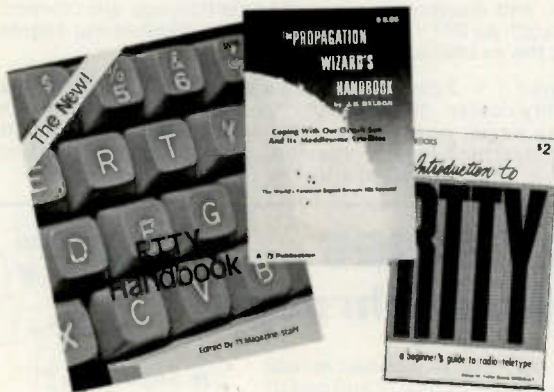

● **SSB . . . THE MISUNDERSTOOD MODE**—BK7351—by James B. Wilson. Single Sideband Transmission . . . thousands of us use it every day, yet it remains one of the least understood facets of amateur radio. J. B. Wilson presents several methods of sideband generation, amply illustrated with charts and schematics, which will enable the ambitious reader to construct his own sideband generator. A must for the technically-serious ham. \$5.50.*

● **SSTV HANDBOOK**—BK7354(hardcover), BK7355(softcover)—This excellent book tells all about it, from its history and basics to the present state-of-the-art techniques. Contains chapters on circuits, monitors, cameras, color SSTV, test equipment and much more. Hardbound \$7.00, softbound \$5.00.*

● **WEATHER SATELLITE HANDBOOK**—BK7370—Simple equipment and methods for getting good pictures from the weather satellite. Antennas, receivers, monitors, facsimile you can build, tracking, automatic control (you don't even have to be home). Dr. Taggart WB8DQT. \$4.95.*



ANTENNAS

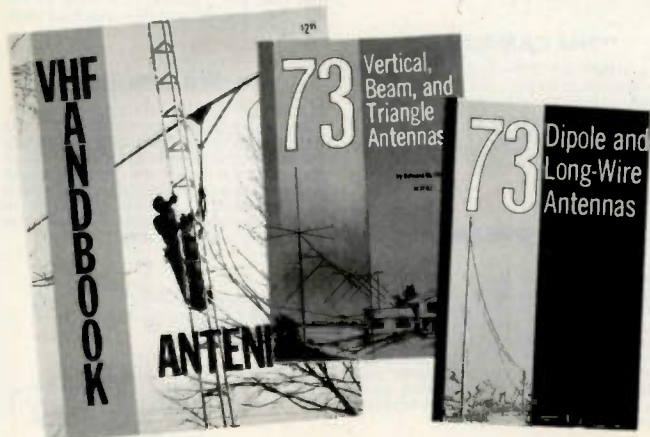

● **73 DIPOLE AND LONG-WIRE ANTENNAS**—BK1016—by Edward M. Noll W3FQJ. This is the first collection of virtually every type of wire antenna used by amateurs. Includes dimensions, configurations, and detailed construction data for 73 different antenna types. Appendices describe the construction of noise bridges, line tuners, and data on measuring resonant frequency, velocity factor, and swr. \$5.50.*

● **73 VERTICAL, BEAM AND TRIANGLE ANTENNAS**—BK1069—by Edward M. Noll W3FQJ. Describes 73 different antennas for amateurs. Each design is the result of the author's own experiments covering the construction of noise bridges and antenna line tuners, as well as methods for measuring resonant frequency, velocity factor, and standing-wave ratios. 160 pages. \$5.50.*

● **VHF ANTENNA HANDBOOK**—BK7368—The NEW VHF Antenna Handbook details the theory, design and construction of hundreds of different VHF and UHF antennas . . . A practical book written for the average amateur who takes joy in building, not full of complex formulas for the design engineer. Packed with fabulous antenna projects you can build. \$4.95.*

Use the order card in the back of this magazine or itemize your order on a separate piece of paper and mail to:
73 Radio Bookshop • Peterborough NH 03458. Be sure to include check or detailed credit card information.

* Add \$1.00 handling charge for orders under \$10.00. Note: Prices subject to change on books not published by 73 Magazine.

FOR TOLL FREE ORDERING CALL 1-800-258-5473

Radio Bookshop

TEST EQUIPMENT

● **RF AND DIGITAL TEST EQUIPMENT YOU CAN BUILD**—BK1044—Rf burst, function, square wave generators, variable length pulse generators—100 kHz marker, i-f and rf sweep generators, audio osc, af/rf signal injector, 146 MHz synthesizer, digital readouts for counters, several counters, prescaler, microwave meter, etc. 252 pages. \$5.95.*

● **VOL. I COMPONENT TESTERS**—LB7359—... how to build transistor testers (8), diode testers (3), IC testers (3), voltmeters and VTVMs (9), ohmmeters (8 different kinds), inductance (3), capacity (9), Q measurement, crystal checking (6), temperature (2), aural meters for the blind (3) and all sorts of miscellaneous data on meters... using them, making them more versatile, making standards. Invaluable book. \$4.95.*

● **VOL. II AUDIO FREQUENCY TESTERS**—LB7360—... jam packed with all kinds of audio frequency test equipment. If you're into SSB, RTTY, SSTV, etc., this book is a must for you... a good book for hi-fi addicts and experimenters, too! \$4.95.*

● **VOL. III RADIO FREQUENCY TESTERS**—LB7361—Radio frequency waves, the common denominator of Amateur Radio. Such items as SWR, antenna impedance, line impedance, rf output and field strength; detailed instructions on testing these items includes sections on signal generators, crystal calibrators, grid dip oscillators, noise generators, dummy loads and much more. \$4.95.*

● **VOL. IV IC TEST EQUIPMENT**—LB7362—Become a troubleshooting wizard. All you need to know about pulse, audio and sync generators, frequency counters, digital component testers, logic probes and more! Plus a cumulative index for all four volumes of the 73 Test Equipment Library. \$4.95.*



THE WELL-EQUIPPED HAM SHACK



● **NEW REPEATER ATLAS OF THE ENTIRE WORLD**—BK7345—150% as big as any list ever available—nearly 900 more repeaters listed. New improved maps show the locations by frequency of every repeater in the States. Only \$1.95.*

● **QSL CARDS**—73 turns out a fantastic series of QSL cards at about half the cost of having them done elsewhere because they are run as a fill-in between printing books and other items in the 73 Print Shop. 250 Style W—QW0250—for \$8.95*; 500 Style W—QW0500—for \$13.95*; 250 Style X—QX0250—for \$8.95*; 500 Style X—QX0500—for \$13.95*; 250 Style Y—QY0250—for \$8.95*; 500 Style Y—QY0500—for \$13.95.*



Style X



Style W

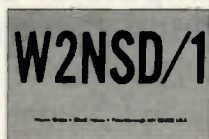

Style Y

● **73 MAGAZINE BINDERS**—Preserve and protect your collection for your lifetime! There's no excuse for lost issues when you have these handsome red binders with gold lettering. Order 1—BN1001—for \$6.50*; 2 or more—BN1002—for \$6.00 each.*

● **BACK ISSUES**—Complete your collection—many are prime collectibles now, classics in the field! A full collection is an invaluable compendium of radio and electronics knowledge! \$2.00 each*, or 5 for \$5.00.*

● **LIBRARY SHELF BOXES**—These sturdy white, corrugated, dirt-resistant boxes each hold a full year of 73 or Kilobaud. With your order, request self-sticking labels for any of the following: 73, Kilobaud, CQ, QST, Ham Radio, Personal Computing, Radio Electronics, Interface Age, and Byte. Order 1—BX1000—for \$2.00*; order 2-7—BX1001—for \$1.50 each*; order 8 or more—BX1002—for \$1.25 each*.



Use the order card in the back of this magazine or itemize your order on a separate piece of paper and mail to: 73 Radio Bookshop • Peterborough NH 03458. Be sure to include check or detailed credit card information.

* Add \$1.00 handling charge for orders under \$10.00. Note: Prices subject to change on books not published by 73 Magazine.

FOR TOLL FREE ORDERING CALL 1-800-258-5473

**21,560
pages.**



**That's the size of the world's
most comprehensive guide to
the subject of ham radio:
18 years of 73 Magazine.**

The back issues of 73 are a gold mine of interesting articles. Unlike the other magazines, which fill their pages with activity reports, there's little to go stale in 73. You'll find pioneering articles on SSTV, FM, repeaters, ICs, and computers. Even the editorials are fun as Wayne Green's dire predictions, like the debacle of incentive licensing, have come to pass.

Clip the coupon below and send for 73's new back issue catalogue. Treat yourself (or a friendly ham) to some fun, and a fantastic bargain to boot.

YES! Rush me 73's FREE Back Issue Catalogue!

Name _____

Address _____

City _____ State _____ Zip _____

S91

73 **magazine**
PETERBOROUGH NH 03458

IS HARD COPY STORAGE A PROBLEM?



73, as thick as it is, is more like a floppy when it comes to standing on the bookshelf. Try the 73 Library Shelf Boxes, . . . sturdy corrugated white dirt resistant cardboard boxes which will keep them from flopping around. We have self-sticking labels for the boxes, too, not only for 73, but also for Kilobaud . . . and for CQ, QST, Ham Radio, Personal Computing, Radio Electronics, Interface Age, and Byte. Ask for whatever stickers you want with your box order. They hold a full year of 73 . . . or Kilobaud. Your magazine library is your prime reference, keep it handy and keep it neat with these strong library shelf boxes . . . One box is \$2.00, 2 boxes are \$3.00 and eight boxes are \$10.00. Be sure to specify which labels we should send. Have your credit card handy and call our toll-free order number 800-258-5473, or use the order card in the back of the magazine and mail to:

73 magazine
PETERBOROUGH NH 03458

Propagation

by
J. H. Nelson

EASTERN UNITED STATES TO:

GMT: 00 02 04 06 08 10 12 14 16 18 20 22

ALASKA	14	14	7	7	7	7	7	7	7	7	7A	14	14
ARGENTINA	14	14	7A	7	7	7	14	14	14A	21	21A	21A	21A
AUSTRALIA	14A	14	7B	7B	7B	7	7	7	7	7B	7B	14A	21
CANAL ZONE	14	7	7	7	7	7	14	14	14A	21	21	21	21
ENGLAND	7	7	7	7	7	7	7B	14	14	21	21	14	7B
HAWAII	14A	14	7B	7	7	7	7	7B	14	14	14	14A	14A
INDIA	7	7B	7B	7B	7B	7B	14	14	14	7A	7	7	7
JAPAN	14	7A	7B	7B	7B	7	7	7	7	7	7A	14	14
MEXICO	14	7A	7	7	7	3A	7	14	14	14	14A	14A	14A
PHILIPPINES	14	7A	7B	7B	7B	7B	7	7	7	7	7	7	14
PUERTO RICO	14	7	7	7	7	7	7A	14	14	14	14	14	14
SOUTH AFRICA	7A	7	7	7	7B	14	14	14A	21	21A	21A	14	14
U. S. S. R.	7	7	7	7	7	7B	14	14A	14A	14	14	7B	7
WEST COAST	14A	14	7	7	7	7	7	14	14	14A	14A	21	21

CENTRAL UNITED STATES TO:

ALASKA	14	14	7A	7	7	7	7	7	7A	14	14	14	14
ARGENTINA	14	14	14	7	7	7	14	14	14A	14A	21A	21A	21A
AUSTRALIA	21	14A	14B	7B	7B	7B	7	7	7B	7B	14A	21	21
CANAL ZONE	21	14	7	7	7	7	7A	14	14A	21	21	21	21
ENGLAND	7	7	7	7	7	7B	7B	14	14A	14A	14	7B	7B
HAWAII	14A	14	7A	7	7	7	7	7B	14	14A	14A	21	21
INDIA	7	7B	7B	7B	7B	7B	7B	14	14	14	7	7	7
JAPAN	14	14	7A	7B	7B	7	7	7	7	7	7A	14	14
MEXICO	14	7	7	7	7	3A	7	14	14	14	14A	14A	14A
PHILIPPINES	14	14	7B	7B	7B	7B	7	7	7	7	7	7	14
PUERTO RICO	14	7A	7	7	7	7	7A	14	14	14A	14A	14A	14A
SOUTH AFRICA	7A	7	7	7	7B	7B	14	14	14	14A	14A	14	14
U. S. S. R.	7	7	7	7	7	7	7B	14	14	14	14	7B	7

WESTERN UNITED STATES TO:

ALASKA	14	14	7A	7	7	3A	3A	7	7	14	14	14	14
ARGENTINA	14A	14	7A	7	7	7	7B	14	21	21	21A	21A	21A
AUSTRALIA	21A	21A	21	14	7	7	7	7	7	7B	14	21	21
CANAL ZONE	21	14	7	7	7	7	7	14	14A	21	21	21	21
ENGLAND	7B	7	7	7	7B	7B	14	14	14A	14	7B	7B	7B
HAWAII	21A	21	14A	14	7	7	7	7	14	14	14	21	21
INDIA	14	14	14	7B	7B	7B	7B	7B	7	7	7	7	7
JAPAN	14	14A	14	7B	7B	7	7	7	7	7	14	14	14
MEXICO	14	14	7	7	7	7	7	14	14	14	14A	14A	14A
PHILIPPINES	14A	14A	14	7B	7B	7B	7	7	7	7	7A	14	14
PUERTO RICO	14A	7A	7	7	7	7	7	14	14	14	14A	14A	14A
SOUTH AFRICA	7A	7	7	7	7B	7B	7B	14	14	14	14A	14A	14A
U. S. S. R.	7	7	7	7	7	7	7	14	14	14	7A	7	7
EAST COAST	14A	14	7	7	7	7	7	14	14	14A	14A	21	21

- A = Next higher frequency may also be useful
- B = Difficult circuit this period
- F = Fair
- G = Good
- P = Poor
- SF = Chance of solar flares

september

sun	mon	tue	wed	thu	fri	sat
☉ ☽	☽ ☿	☿ ♁	♁ ♃	♃ ♅	♅ ♁	♁ ♄
1	2				1	2
G	G				G	G
3	4	5	6	7	8	9
G	F	G	G	G	P/SF	P/SF
10	11	12	13	14	15	16
P/SF	G/SF	G/SF	F/SF	P/SF	P	G
17	18	19	20	21	22	23
G	G	F	F	F	P	F
24	25	26	27	28	29	30
F	G	G	G	G	G	F

Hot Item!!

WEATHER SATELLITE HANDBOOK \$4.95

Weather Satellite Antenna Systems, Receivers, How To Find & Track Satellites . . .



A complete satellite ground station can be built for less than the cost of a good television set! And you don't have to be a mechanical or electrical genius, either. This text is fully illustrated and you will find information on simple equipment, methods for producing good pictures from the weather satellite, antennas, receivers, monitors, tracking & automatic control.

73 magazine
PETERBOROUGH NH 03458

MOVING?

Let us know 8 weeks in advance so that you won't miss a single issue of 73 Magazine.

Attach old label where indicated and print new address in space provided. Also include your mailing label whenever you write concerning your subscription. It helps us serve you promptly. Write to:

73 magazine
PETERBOROUGH NH 03458

- | | |
|---|---|
| <input type="checkbox"/> Address change only | <input type="checkbox"/> Payment enclosed |
| <input type="checkbox"/> Extend subscription | (1 extra BONUS issue) |
| <input type="checkbox"/> Enter new subscription | <input type="checkbox"/> Bill me later |
| <input type="checkbox"/> 1 year \$15.00 | |

If you have no label handy, print OLD address here.

AFFIX LABEL

Name _____ Call _____

Address _____

City _____ State _____ Zip _____

print NEW address here:

Name _____ Call _____

Address _____

City _____ State _____ Zip _____

TICKETS TO COMPETENCE!

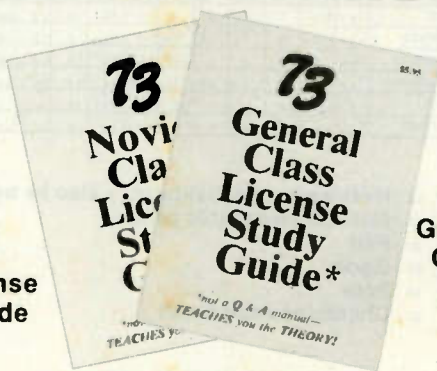

Novice Class License Guide

General Class License Guide

Novice Guide — This excellent reference will launch you into the exciting world of ham radio! Covers radio and electronic fundamentals, preparing you to pass the Novice exam; also includes the latest FCC amateur regulations and application forms. \$4.95

General Guide — If you're looking ahead to your General or Technician exam, or are already licensed, this excellent reference work is a must for you! Covers completely transistor, amplifier, and general radio theory; you'll use it again and again! \$5.95.

73 Magazine • Peterborough NH 03458

73 magazine

ADVERTISER index

- A46 ABC Communications 137
- A1 Adirondack Radio Supply 233
- A24 Adv Electronics 234
- A60 AEO Electronics 230
- A2 Ajelco 251
- A57 Alliance Manufacturing Company 23
- A47 Alum Tower Company 171
- A51 Amateur Radio of Rochester 231
- A55 Amateur Radio Supply 231
- A40 Amateur Radio Supply of Nashville, Inc. 213
- A58 American Crystal Supply 110
- A34 Amsat 166
- A6 Apron Laboratories 233
- A50 ARRL Hudson Division 231
- A50 Associated Radio 245
- B23 Barker & Williamson 110
- B32 Bay Com 115
- B29 Brit's 2-Way Radio 216
- B6 Bullet Electronics 238
- B8 Butternut Electronics Company 210
- C80 C&A Electronic Enterprises 43
- C3 Clegg 97
- C21 Coakitt 232
- C83 Cohoon Amateur Supply 30
- C63 Colorado Silver Company 155
- C75 Comm Center, Laurel 229
- C58 Communications Center, NE 131, 202
- C89 Communications Services 176
- C6 Communications Specialists 12, 13
- C90 Curtie Electric Devices, Inc. 169
- D6 Peter W. Dahl Company 216
- D30 Davie Electronics 228
- O10 Datsware Amateur Supply 211
- D15 Dan Tron 215
- D20 Digital Research Corporation 240, 241
- D23 Dovetron 155
- D25 DSI Instruments 19, 167
- E1 ECM Corporation 230
- E10 Edpacom 38
- Electronic Systems 116
- E12 Engineering Specialist 250
- E31 ETCO Electronics 235
- E38 Evans Radio Electrical Supply 151
- F1 Fair Radio Sales 211
- F5 Fleisher Corporation 115, 211
- F3 Frack Radio & Supply 218
- O12 Germantown Amateur Supply 151
- O4 Godbout Electronics 242
- O10 Gotham, Inc. 143
- HAL Communications Corp. 207
- H24 Hal-Tronix 151
- H2 Ham Radio Center 247
- H22 Ham-D-Rama 231
- H18 Hamtronics, NY 237
- H8 Hamtronics, PA 81
- H26 Hartwell's Office World 227
- H15 Hatry 23
- H5 Heath Company 67
- H3 Henry Radio Cl
- I ICDM 7, 111
- I8 Integrated Circuits 244
- Island Antennas 115
- J1 Jameco Electronics 243
- J2 Jan Crystals 169
- J8 JBW Electronics, Inc. 169
- J7 Jenson Tools & Alloy 115
- J1 Jim-Pak 86
- J8 JRS Electronics 230
- K13 Kantronics 110, 215, 231
- Kenwood CIV, 5
- K14 Key Electronics 115
- L10 L-Tronics 215
- L11 Logitronics 139
- L9 Long's Electronics 156-161
- M35 Madison Electronics Supply 175
- M36 Maggione Electronics Labs 229
- M56 Marko Manufacturing, Inc. 176
- M52 MFJ Enterprises 81, 117, 227
- M58 Micro Keyer 232
- M46 Microtronics 233
- M41 Midland International 125
- M57 Monroe Electronics 176
- N2 New England ARRL 173
- N5 New-Tronics 25
- O5 OK Machine & Tool 108, 109
- O3 Optoelectronics, Inc. 239
- P15 Pace-Traps 115
- P30 Palomar Electronics 21
- P1 Palomar Engineers 117
- P29 Pipe Communications 217
- P2 Poly Paks 245
- P26 Printed Circuit Products 233
- P21 Priority One 105
- O3 Quest Electronics 233
- O6 Quik-Key 110
- R1 Radio Amateur Callbook, Inc. 249
- Radio World 115
- R10 Rainbow Industries 147
- R6 Ramsey Electronics 236
- R15 Rolin Distributors 171
- R21 Rush Electronics 211
- R18 R. W. Electronics, Inc. 155
- S38 Sere-Rose & Spence Electronics 211
- S33 S-F Amateur Radio Services 228, 230
- S58 Shakespeare 212
- S4 Step Electronics Company 232
- S8 Spectrum Communications 91
- S10 SST Electronics 203
- S50 D. C. Stafford Electronics 211
- S18 Standard Communications 87, 216
- S38 Stuart Electronics 31
- S43 Surplus Electronics 248
- T13 Teletypewriter Communications Specialists 115
- Ten-Tec 141
- T34 Thomas Communications 135
- T18 Trac Electronics, Inc. 217
- T35 Trans Com 115
- T3 Tufts Radio Electronics 177-200
- U8 Universal Amateur Radio Service, Inc. 227
- V1 Vanguard Labs 217
- V5 VHF Engineering 31
- W17 Westcom Engineering 232
- W18 Western Electronics 230
- W2 Wilson Electronics 3
- X1 Xifax 225
- Y1 Yessu Electronics Corp. C11, 17, 57
- Z1 ZZZ Electronics, Inc. 218

From 73... 163, 252-258

*Reader Service inquiries not honored.

BOOKS — etc.

- BK1016 73 DIPOLE & LONG WIRE ANTENNAS \$ 5.50
- ST0000 73 BACK ISSUE \$ 3.00
- ST2500 73 BACK ISSUES—25 OUR CHOICE \$10.00
- ST0500 73 BACK ISSUES—5 YOUR CHOICE \$ 5.00
- ST1000 73 BACK ISSUES—10 YOUR CHOICE \$12.00
- ST2501 73 BACK ISSUES—25 YOUR CHOICE \$20.00
- BK7307 BEHIND THE DIAL \$ 4.95
- BN1001 BINDER—73—1 \$ 6.50
- BN1002 BINDER—73—2&3UP \$ 8.00
- BK7309 CHALLENGE OF 160 \$ 4.95
- CT7305 CODE TAPE—5 WPM \$ 4.95
- CT7306 CODE TAPE—6 WPM \$ 4.95
- CT7310 CODE TAPE—10 WPM \$ 4.95
- CT7313 CODE TAPE—13 WPM \$ 4.95
- CT7320 CODE TAPE—20 WPM \$ 4.95
- CT7325 CODE TAPE—25 WPM \$ 4.95
- CT7399 CODE TAPE—LEARN MORSE CODE \$ 4.95
- CT7394 CODE TAPES: ANY FOUR ABOVE) \$15.95
- BK7321 GUIDE TO HAM RADIO \$ 4.95
- BK7225 HOW TO BUILD A MICROCOMPUTER \$ 9.95
- BK1028 IC OP AMP COOKBOOK \$12.95
- BK7380 INTRO TO RTTY \$ 2.00
- CT7300 NOVICE THEORY TAPES \$15.95
- BK1100 PRACTICAL TEST INSTRUMENTS \$ 4.95
- BK7302 PROPAGATIONS WIZARD'S HANDBOOK \$ 6.95
- QW0250 OSL CARDS—STYLE W—250 \$ 8.95
- QW0500 OSL CARDS—STYLE W—500 \$13.95
- QX0250 OSL CARDS—STYLE X—250 \$ 8.95
- QX0500 OSL CARDS—STYLE X—500 \$13.95
- QY0250 OSL CARDS—STYLE Y—250 \$ 8.95
- QY0500 OSL CARDS—STYLE Y—500 \$13.95
- BK7345 REPEATER ATLAS \$ 1.95
- BK1044 RF DIGITAL TEST EQUIPMENT \$ 5.95
- BK7347 RTTY HANDBOOK \$ 5.95
- BK1000 SHELFBX BOX—1 \$ 2.00
- BK1001 SHELFBX BOX—2 \$ 1.50
- BK1002 SHELFBX BOX—8UP \$ 1.25
- BK7359 SSB THE MISUNDERSTOOD MODE \$ 5.50
- BK7354 SSTV HANDBOOK (HARDCOVER) \$ 7.00
- BK7355 SSTV HANDBOOK (SOFTCOVER) \$ 8.00
- CT7350 SSTV TAPE \$ 5.95
- SG1080 STUDY GUIDE—ADVANCED CLASS \$ 5.95
- SG1080 STUDY GUIDE—EXTRA CL. ASS. \$ 5.95
- SG7358 STUDY GUIDE—GENERAL CLASS \$ 5.95
- SG7357 STUDY GUIDE—NOVICE CLASS \$ 4.95
- LB7350 TEST EQUIP LIB V1—COMP TESTERS \$ 4.95
- LB7360 TEST EQUIP LIB V2—AUDIO TESTERS \$ 4.95
- LB7361 TEST EQUIP LIB V3—RADIO EQUIP \$ 4.95
- LB7362 TEST EQUIP LIB V4—HC TEST EQUIP \$ 4.95
- BK1069 VERTICAL BEAM & TRIANGLE ANTNS \$ 5.50
- BK7368 VHF ANTENNA HANDBOOK \$ 4.95
- BK7370 WEATHER SATELLITE HANDBOOK \$ 4.95

Don't forget to complete the attached Reader Service Card and return "postage paid" to 73 Magazine—Our advertisers want to hear from you. DO IT NOW!

SEND FOR YOUR FREE PRODUCT CATALOGS

Return this card to receive full information on the many products advertised in this issue. Simply circle the Reader Service # below for each advertised product. The codes appear in the index of advertisers on this page, and near the company's logo on the ad pages. Please provide a full address and zip code. (Limit: 25 requests) Subscriber Newsstand

A1	A57	C6	D10	E33	H8	J7	M41	O5	R1	S33	T35
A2	A58	C21	D15	F1	H15	J8	M48	P1	R8	S38	U6
A6	A59	C58	D20	F3	H16	J9	M52	P2	R10	S39	V1
A24	A60	C63	D23	F5	H22	K13	M55	P15	R15	S43	V5
A40	B8	C75	D25	G4	H24	K14	M56	P21	R18	S50	W2
A46	B23	C83	D31	G12	H26	L9	M57	P26	R21	S58	W17
A47	B29	C88	E1	G19	I1	L10	M58	P29	S4	T3	W18
A50	B32	C89	E19	H2	I9	L11	M59	P30	S8	T13	X1
A51	C3	C90	E19	H3	J1	M35	N2	Q3	S10	T18	Y1
A55	D6	E31	H5	J2	M36	O3	Q6	S18	T34	Z1	



kilobaud

This month's **ARTICLE WINNER** (title page number): _____

Name _____

Address _____

City _____ State _____ Zip _____ 89

FIRST CLASS

Permit No. 17

Peterborough NH 03458

BUSINESS REPLY MAIL

No postage stamp necessary if mailed in the United States

Postage will be paid by

73 magazine

44 Main Street
Peterborough NH 03458

Attn: Mail Order

SEND FOR YOUR FREE PRODUCT CATALOGS

Return this card to receive full information on the many products advertised in this issue. Simply circle the Reader Service # below for each advertised product. The codes appear in the index of advertisers on this page, and near the company's logo on the ad pages. Please provide a full address and zip code. (Limit: 25 requests) Subscriber Newsstand

A1	A57	C6	D10	E33	H8	J7	M41	O5	R1	S33	T35
A2	A58	C21	D15	F1	H15	J8	M48	P1	R8	S38	U6
A6	A59	C58	D20	F3	H16	J9	M52	P2	R10	S39	V1
A24	A60	C63	D23	F5	H22	K13	M55	P15	R15	S43	V5
A40	B8	C75	D25	G4	H24	K14	M56	P21	R18	S50	W2
A46	B23	C83	D31	G12	H26	L9	M57	P26	R21	S58	W17
A47	B29	C88	E1	G19	I1	L10	M58	P29	S4	T3	W18
A50	B32	C89	E19	H2	I9	L11	M59	P30	S8	T13	X1
A51	C3	C90	E19	H3	J1	M35	N2	Q3	S10	T18	Y1
A55	D6	E31	H5	J2	M36	O3	Q6	S18	T34	Z1	



kilobaud

This month's **ARTICLE WINNER** (title page number): _____

Name _____

Address _____

City _____ State _____ Zip _____ 89

reader service

reader service



THE 901DM "SMART RADIO" FAMILY

HERE NOW
left to right

- YD-844A High/Low Impedance Microphone (50K/600 Ohms)
- FC-901 Antenna Tuner
- FV-901DM Synthesized Scanning VFO
- FT-901DM HF All Mode Transceiver
- FTV-901 Multi Band Transverter—2 meter/6 meter/3/4 meter
- SP-901P Speaker Phone Patch

Price And Specifications Subject To
Change Without Notice Or Obligation

THERE'S MORE TO COME . . .



YAESU
The radio.

YAESU ELECTRONICS CORP., 15954 Downey Ave., Paramount, CA 90723 • (213) 633-4007
YAESU ELECTRONICS Eastern Service Ctr., 9812 Princeton-Glendale Rd., Cincinnati, OH 45246